

\*\*\*\*\*3-DIGIT 605  
 S103723D08 9502  
 THOMAS E BRAXTON  
 MTS  
 AT&T BELL LABS/ROOM 2B-217  
 2000 N NAPERVILLE RD  
 NAPERVILLE IL 60563 1443



The U.S. Army tested its new mobile radio station on the expanded band. See page 9

# RadioWorld®

Vol 20, No 5

Radio's Best Read Newspaper

March 6, 1996

## Crossownership Rule Snags Disney, Others

by Lynn Meadows

**WASHINGTON** Crossownership may be the next regulatory ribbon to be loosened now that ownership deregulation is finished.

Disney got wrapped in that ribbon last month when the Federal Communications Commission (FCC) reviewed the company's purchase of Capital Cities/ABC.

The FCC refused to grant permanent waivers for radio/newspaper combinations in Fort Worth, Texas, and Detroit. Instead, Disney received a 12-month waiver on the rule and a wink that a rulemaking on crossownership might take place this year and make divestitures unnecessary.

The crossownership rule prohibits

owners of newspapers from receiving AM, FM or TV licenses if the signal will encompass the entire community in which the newspaper is published.

When the crossownership rule was adopted in 1975, ABC's newspaper/radio combinations in Fort Worth and Detroit were grandfathered with the warning that if they were ever sold, the waivers would have to be reissued.

All of the commissioners expressed regret that the rule was still on the books. Commissioners James Quello and Rachelle Chong approved the merger but disagreed with the temporary waiver for crossownership favoring permanent waivers instead.

"This afternoon, the commission

adopts a decision that while mostly positive — in that it approves the marriage of two vital creative companies — includes a throwback to the days of ill-advised over-regulation," said

Quello sternly.

Quello said a divestiture is "particularly illogical" in Detroit with its 53 broadcast voices. According to Quello, Disney's newspaper in Detroit has a

continued on page 3 ►

## Forecast Predicts New Uses for Radio

by Bob Rusk

**WASHINGTON** Along with many other juicy tidbits, the Delphi Forecast Study recently released by the National Association of Broadcasters (NAB) reports that the traditional disk jockey will soon be an endangered species.

But the bottom line of the "Digital Radio Broadcasting Technology Applications: A Delphi Forecast Study," is if radio wants its own lane on the Information Superhighway, stations must head for the on-ramp quickly.

During a focus group on the future of radio, one station manager suggested that with computer automation and satellites, disk jockeys will simply no longer be needed.

The Delphi panel confirms this observation, adding that hard-disk recording and storage are becoming major factors in encouraging off-site creation of programming elements.

### Automation for all

By 1999, computer automation is expected to be used in some form by virtually every radio station in markets big and small. When that happens, the panel believes radio still will maintain its ties to the community if only by airing local commercials.

The report gives examples of three different radio stations possible in the future. In the first example, a station would have five channels divided into regular programming and commercials; a news channel; rebroadcasts of the

morning show all day; TV audio of a co-owned station; and long-form specials or data transmission on the last channel.

Another station in the future might be a news/talk station that also transmits a continuous business data channel sending stock prices and other information to subscribers.

Still another scenario suggested by the forecast was a station whose announcer works in a different city using digital technology to create a custom show which airs on the station and five or six others. The show would sound local, current and credible far beyond earlier satellite or automation attempts.

In the ongoing discussion of what is to come in the 21st century, broadcasters and the Federal Communications Commission (FCC) appear to be on the same wavelength. Commissioner Andrew C. Barrett was quoted in the study stressing that "radio operators will be required to make themselves attractive to audiences that become accustomed to a variety of interactive program choices."

### Radio to be integrated

Barrett added that the FCC recognizes that station operators might want to use part of their spectrum allocation to provide digital technology applications. Radios will no longer be just boxes with speakers but will be integrated into computers and other appliances that can use data streams received from radio stations.

The report concludes that broadcasters will have many uses for the digital radio

continued on page 6 ►



CTT's AL-1

### Buyers Guide: page 35

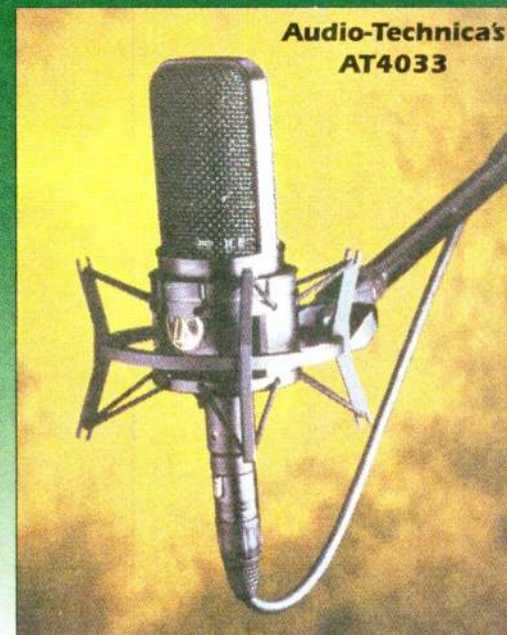

Audio-Technica's AT4033

Looking for new mics for your air studio or live performances?

Check out the March Microphone Buyers Guide for the inside scoop.

## Don't miss these Hot Prices!



STEREO/MONO	SALE!
50 MIN. /100 MIN.	\$5779.00
70 MIN. /140 MIN.	\$6195.00
100 MIN. /200 MIN.	\$6395.00
180 MIN. /360 MIN.	\$6669.00

ALL MODELS SHIPPED WITH CUSTOM CONTROL PANEL AND THE NEW HENRY MATCHBOX.

With tape, you're toast.

With VoxPro™ you're smokin'!

1-800-622-0022

FAX 317-966-0623

<http://www.broadcast.harris.com>

**HARRIS**

# NEWSWATCH

## Mercury Awards Deadline

**NEW YORK** It is not too late to submit a late entry for the 1996 Radio-Mercury Awards honoring the creators of the year's best radio advertising. The late deadline is March 8.

Awards totalling \$200,000 in cash will be presented on June 12, in the Grand Ballroom of the Waldorf-Astoria Hotel in New York. In addition to a \$100,000 Best of Show Radio Mercury Gold Award, a \$20,000 Gold Award and \$5,000 Silver Award will be given in four categories. The categories are Humor, Narrative, Music and Sound Design, and Radio-

Station Produced. Another award is presented every year for the best public service announcement. Obtain an entry form by calling 212-681-7207 or faxing 212-681-7223. Entries must have aired for the first time during the 1995 calendar year on a commercially-licensed radio station.

## Emmy for AES

**NEW YORK** The National Academy of Television Arts and Sciences (NATAS) awarded the Audio Engineering Society (AES) an Emmy for its work in forming international standards for digital audio data transmission. The award commemorates the development of the AES3 digital

audio interface, commonly known as AES/EBU. Originally created for use in digital audio studio operations, AES/EBU has become the basis for transporting digital audio associated with digital television.

## Harris Expands in China

**QUINCY, III.** Harris Corp. signed a joint-venture agreement with Anshan Broadcast Television Equipment Group Corporation (ABEGC) to create Anshan Harris Broadcast Equipment Company.

Anshan Harris will offer radio and television transmitters as well as China-based customer service and support. The

move helps Harris expand its presence in the Chinese broadcast equipment market.

Harris solid-state modules will be incorporated into the product line at ABEGC's Anshan Broadcast Equipment Plant. Later, Anshan Harris will develop and produce a new line of advanced broadcast transmitters for distribution in China and other selected world markets. Harris also wants to establish Chinese distribution channels for other products like broadcast systems and studio equipment. ☺

# Index

## Studio Sessions

<b>Penny &amp; Giles: Total DAW Control</b> by Alan Peterson	18
<b>E-Belt: An Alternative Controller</b>	19
<b>Breathing Life into Documentaries</b> by Bruce and Jenny Bartlett	21
<b>The Real Angle on Head Asimuth</b> by Rich Rarey	22
<b>MiniDisc Replicator</b>	22

## Running Radio

<b>KRZZ: Neat-O Site with a Bite</b> by Alan Haber	25
<b>Planning Ahead for New Facilities</b> by Sue Jones	26
<b>'Can You Top This' Classic Comedy</b> by Read Burgan	27

## Features

<b>Workbench</b> by John Bisset	14
<b>WKZ: All Bets Are On This AM</b> by Lee Harris	31
<b>The Dream of Earle C. Anthony</b> by Barry Mishkind	32

## Buyers Guide

<b>Oktava Comes with Many Surprises</b> by Janis V. Bers	35
<b>Sanken Jazzes Up Live Broadcasts</b> by Malcolm H. Harper, Jr.	36
<b>AirCorp Is Standard Fare at KDMM/KVIL</b> by Bill Ryan	37
<b>Voices Shine on Audio-Technica Mic</b> by Stuart A. Rosenthal	37
<b>KCRW Finds Aphex to Be Essential</b> by John C. Huntley	38
<b>Even the Geese Sound Good on Audix</b> by Alan R. Peterson	42
<b>Crown SASS Provides Vintage Pizzazz</b> by Ward Lionel Kremer	46
<b>AKG Microphones Offer Diversity, Consistency</b> by Pat Dorn	48
<b>Lectrosonics Glides through Tough Remote</b> by Bill Pace	49

## Technology Updates

<b>Vega</b>	38
<b>ATI</b>	40
<b>BSS Audio</b>	40
<b>SoundField</b>	45
<b>PSB Engineering</b>	45
<b>Sennheiser</b>	45

## Take a LOOK at THIS:

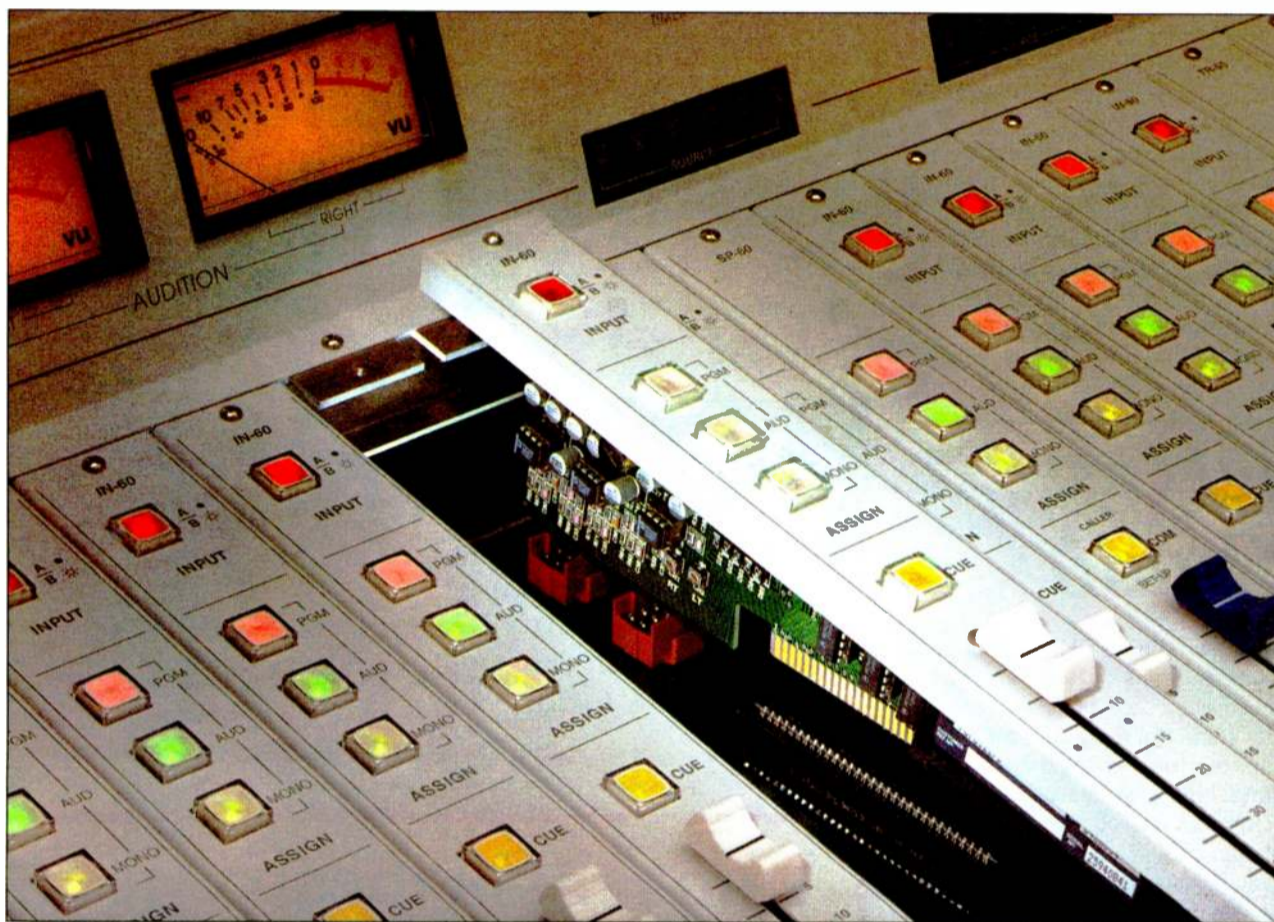

## Then look at our competition.

**OF COURSE** many stations are cost-conscious these days—just remember why you wanted a new console in the first place: to **UPGRADE**.

**The R-60** has what's needed, with all the right features: our **SIMPLE PHONE®** module for easy error-free talk segments; twin six bank preselectors, so you won't run out of input capacity; onboard machine control panel, clock, timer, a well-designed cue system, and a truly effective control room and studio monitor interface. And because it's totally modular, service is easy—even while you're on-the-air! Documentation: this can determine whether you have an installation day or an installation week. We've done it right to guide you through. And **PERFORMANCE?** Of course we've handled that; simply compare our specs.

**DON'T MISS** your opportunity to upgrade. Choose the R-60 radio console from AUDIOARTS.

<b>FREQUENCY RESPONSE</b>	
Line (10Hz-20KHz)	±1/10dB
Mic (20Hz-20KHz)	±1/10dB
<b>THD+N (20Hz-20KHz)</b>	
Line, +4dBu	.005%
Mic & Line, +16dBu	.005%
<b>IMD (SMPTE)</b>	
Mic & Line, +4dBu	.004%
<b>DIM</b>	
Mic & Line, +16dBu	.005%
<b>DYNAMIC RANGE</b>	
Line	114dB
Mic	98dB
<b>HEADROOM</b>	
ref +4dBu	24dB
<b>OFF &amp; ASSIGN ISOLATION</b>	
1 KHz	-110dB
20 KHz	-105dB
<b>BUS CROSSTALK</b>	
1 KHz	-100dB
20 KHz	-75dB

7305 Performance Drive, Syracuse NY, 13212  
tel 315-452-5000 / fax 315-452-0160  
E-mail Wheatstone@aol.com



**AUDIOARTS ENGINEERING**

# KROE Launches Wyoming News Co-op

by Alan Haber

**SHERIDAN, Wyo.** KROE-AM-FM has launched The Wyoming News Co-op, a central source of local news for radio stations in Wyoming, from its studios.

According to Co-op creator and KROE General Manager Kim Love, the Co-op is the first service of its kind in Wyoming. It was conceived as an alternative source of Wyoming news for stations that may not want to commit to a long-term contract with any of the traditional wire services.

Stations which buy into the Co-op, launched last October, contribute their own local news stories in text form into a pool which gets e-mailed to Co-op members three times a day, seven days a week, by way of a standard list server located at KROE's local Internet service provider.

Co-op member stations pay a \$50 monthly fee to participate; stations that contribute stories on a regular basis pay only \$25 a month. The Co-op is maintained at KROE by news director Jake Boltz.

Currently, only KROE and KGWY-FM in Gillette are contributing stories to the service, although several other stations are receiving it.

Kent Smith, president and general manager of KYCN-AM-FM in Wheatland,

Combs said using the Co-op makes him aware of stories he might otherwise miss or that might be overlooked by the wire services. He noted that it is nice to know what is going on in other communities in Wyoming, even if he cannot use some of

International (UPI), thinks the Wyoming News Co-op is going to be very successful. He suggested that the Co-op concept could work in other states as well.

"It's going to give options to the local broadcasters," he noted. "Typically," said Walker, "what you find in small markets like Wyoming, Montana (and) Idaho, (is) there's just not a lot of population there, so, consequently, there's not a lot of TV stations (and) radio stations in the state. There's not a lot there, so the cost of gathering news can be very expensive when you start taking that cost and looking at what you can generate from revenue."

There is a strong possibility that UPI will be working with the Co-op in one capacity or another; this could include selling components of UPI's national news service to the Co-op to be distributed to its member stations or taking the stories generated by the Co-op and reformatting them for use on the UPI wire.

Stations in Wyoming or in nearby states interested in participating in the Wyoming News Co-op can contact Kim Love at 307-672-7421.

**'Any radio station with a computer and Internet access would be foolish not to be in on it.'**

said he checks what is available from the Co-op every day and finds the stories usable. He said he might start uploading stories from his station to the Co-op in April. Love expects more stations to sign on in the near future.

Bill Combs, news director at country KGWY-FM, has been using the Co-op since last fall and is a big fan of the service.

"If something is going down big in the state, we want to know about it," he said. "And the more people we get in the Co-op, the better it is for all of us."

the stories.

"If there is something that's newsworthy that we feel that our audience would appreciate, obviously we would use it," he said.

Combs is committed to using the Co-op for the long haul.

"I'm excited about the fact that it is going to grow," he said. "Any radio station with a computer and Internet access would be foolish not to be on it."

Bob Walker, northwest regional accounts manager for United Press

Originally, the newly passed telecommunications bill included wording that eliminated crossownership rules. But the idea made several congressmen uneasy and it was dropped.

Disney will not be the only company to benefit if crossownership rules are relaxed. David Segrove, publisher of the Shelbyville Times Gazette in Shelbyville, Tenn., has an empty studio he built a year ago when the Gazette tried to buy one kilowatt daytime station WLIJ(AM).

Crosstown stations WHAL(AM)-WYCQ(FM) filed an objection based on the current rule. Shelbyville has only 12,000 people and the county has only three stations, explained Sally McClanahan, general manager of WHAL and WYCQ. Cromwell Group, which owns the local duopoly, opposed the purchase because it would have left

few sources for local media.

"It would have been wonderful for the radio station," said Nadine Hopkins, co-owner of WLIJ. According to Hopkins, all the Nashville stations can be heard locally.

But the local media concern was echoed by Commissioner Ness in the FCC meeting.

"Often times, living in the shadow of a large market," she said, "there are fewer avenues for information to the inhabitants who are concerned about their local governments not the government in the major city."

Still, McClanahan said she is not opposed to relaxing the crossownership restrictions. She said Cromwell Group has benefitted from relaxed ownership rules and will be flexible if the FCC does loosen the crossownership restrictions.

## FCC to Re-examine Crossownership Rule

► continued from page 1

weekly circulation under 80,000. Quello compared that to the 537,000 daily circulation of the Detroit Free Press and the 351,000 circulation of the Detroit News.

"It is hard to see how a combination that includes a relatively small suburban newspaper and two radio stations will negatively impact diversity or economic concentration in a large market that meets all criteria for waivers," said Quello.

While Chairman Reed Hundt and Commissioners Andrew Barrett and Susan Ness agreed that the rule was outdated, they said a rulemaking needed to be done to change it.

Roy Stewart, chief of the Mass

Media Bureau, recollected only two waivers to the crossownership rule that have been issued since 1975 — one in Chicago and one in New York. Both involved financially failing media outlets.

Commissioner Susan Ness and Chairman Reed Hundt said they favor a rulemaking on crossownership this year. That might enable the FCC to reconsider its decision to make Disney divest in Fort Worth and Detroit.

"We don't have input on this particular policy change from a whole range of possibly interested parties," Hundt said. "We don't have input from the NAB (National Association of Broadcasters) or the Newspaper Publishers Association on this topic."

## Waivers for Disney

**WASHINGTON** "I hope that just as it happens in most Disney stories, this couple lives happily ever after," said Commissioner Rachelle Chong blessing the marriage of Disney and Capital Cities/ABC last month.

With the acquisition of Cap Cities, Disney now owns 11 television broadcast facilities, 10 FM stations, 11 AM stations and several newspapers. But Disney, which owned only one television station prior to the purchase, needed to rejustify the waivers Cap Cities had already been granted to hold broadcast and media interests exceeding FCC ownership limitations.

The commission granted Disney a permanent waiver of the duopoly rule for common ownership of a television station in New York and one in Philadelphia. Disney also received permanent waivers of the

one to a market rule for radio/television combinations in six markets including Chicago, New York, and Los Angeles.

Despite protests from Commissioners Quello and Chong, the commission granted only 12-month waivers in Detroit and Fort Worth, Texas, for the newspaper/broadcast cross-ownership rule. In those cities, Disney will have to break up radio and newspaper combinations that Capital Cities/ABC operated for over 20 years.

Disney received a six month waiver for common ownership of two out of seven television stations licensed to Los Angeles. According to the commission, Disney did not prove an extended waiver was justified. It now must divest itself of either KCAL-TV or KABC-TV.

### Your Problem Solvers

from **ATI**



- Matching • Monitoring
- Processing • Distribution
- Mike • Line • Phono • Mixing • Metering • Rack Mounting

**AUDIO TECHNOLOGIES, INC.**  
 328 Maple Avenue, Horsham, PA, 19044 • (215) 443-0330  
 FAX (215) 443-0394 • 800-959-0307



Circle (11) On Reader Service Card

See Us At NAB Booth 8460

# Hand-Crank Radios Equal Sex Appeal in Africa

**WASHINGTON** Sen. Larry Pressler (R-S.D.), chairman of the Senate Committee on Commerce, Science and Transportation and principal author of the Pressler-Bliley-Hollings telecommunications reform bill, was on hand to witness its signing into law by President Clinton. The ceremony took place at the Library of Congress. Vice President Gore as well as other congressional and administration leaders were on hand for the Feb. 8 signing.

In a release, Pressler wrote: "This bill is the most sweeping, fundamental change Congress has passed in decades. It will affect the lives of every man, woman and child in this country. It plants our country's feet squarely in the information age for the next century and beyond."

Pressler further added that he was proud to have authored the bill and worked hard to develop and maintain bipartisan support to ensure passage of the bill.

"I am very proud to be here, and to be a part of this today," said Pressler.

It seems ironic that they chose to sign the thing in the hallowed halls that symbolize this country's past commitment to free expression. Ironic because of course, the bill plants the V-chip seed, which just send chills up my spine.

The whole issue of protecting our children from violence and sex and other televised mayhem is, on the surface, a laudable one. To truly protect a child you must educate him or her. The best defense against the vast wasteland of programming out there is the ability to make a choice to not watch it.

Do you really believe that industry types, or political types or government types are best suited to ensure your child's moral and intellectual upbringing? This industry needs to do something fast to get rid of the V-chip and make sure that no similar audio chip sneaks in. I mention the audio chip because when Lynn Meadows and I interviewed FCC Chairman Reed Hundt last year, he brought it up more than once. So the idea is out there people. We need to quash it before this industry becomes fodder for an Orwellian novel.

\*\*\*

From the so-called seat of democracy to the poorest villages in Africa, radio struggles along. The ever-alert Frank Beacham passed along a great little tidbit from the New York Times News Service the other day.

If any of you have traveled to South Africa, you may know that roughly 50 percent of the homes have no electricity. In fact, according to the report by Donald G.

McNeil Jr., if you go far enough away from the cities into the rural villages, there aren't even places to buy batteries. Ergo, the portable radio is of little use in most of the country.

But things are looking up. During the past eight weeks or so, a small factory located just north of Cape Town has been cranking out radios — get this —

with cranks!! Writes McNeil: "Give the handle a few aerobic turns and the Freeplay radio holds forth for half an hour."

This neat technology can save you a fortune. In a radio played five to 10 hours a day, a

Freeplay will save \$500 to \$1,000 in battery costs over its three-year life span, according to the marketing director of the manufacturer, BayGen Power.

Technical specs you ask? The radio weighs 6 pounds and is built like "an over-stuffed lunch box." The speaker is tinny sounding. Wholesale price is \$40 and the unit receives AM, FM and shortwave, meaning it can pick up Voice of America and British Broadcasting Corp. broadcasts.

Ghana has requested 30,000 of the units, according to BayGen executives. It seems that there is an election looming and politicians want to get their messages out to the voters.

And if you're not convinced that some cash-poor rural population will be tempted to part with its money to listen to political messages and information, there's the sex appeal factor.

According to McNeil's report, a radio is one of three big African status symbols. Quoting a Zambian by the name of Maluma, McNeil reports: "If you have one (a radio) you are considered above average. A bicycle, even more so. A motorcycle, well that's a Cadillac. But on the basis of just a radio, make no mistake — you can procure a wife."

The patent is the work of Trevor Bayliss, a British scientist who was inspired to build the prototype when listening to a program about AIDS in Africa that mentioned the lack of accessibility and affordability of batteries.



The Library of Congress was the scene of President Clinton's signing of the telecommunications reform bill. Not even the inspiration of some of the world's greatest authors' works could stop the V-chip from becoming law.

It would be two years before Bayliss hooked up with BayGen Power, founded by British Foreign Aid, the Life Liberty Foundation, the philanthropic arm of a South African insurance company and the socially conscious owners of the Body Shop cosmetics chain. Fittingly enough, they found out about Bayliss from a BBC radio program on his invention.

There are 13 patents covering the mainspring and gears that drive the little dynamo. The spring does not resemble a Swiss watch's. Unwound, according to the report, it is 30 feet long and designed for rewinding car seat belts. A double spool mechanism keeps the tension constant.

The units are built in a factory that houses 110 workers who each earn \$80 a week to put together a radio every 30 seconds.

Who said the romance of broadcasting is dead?

**ARC-16: the logical choice for LMA and duopoly transmitter control.**

The ARC-16 is available through:

**BURK TECHNOLOGY**

**Put us in your sites.**

**NORTHEAST BROADCAST LAB, INC.**

MAIN OFFICE:  
**518-793-2181**

**BURK TECHNOLOGY • 7 Beaver Brook Rd., Littleton, MA 01460 • Phone (508) 486-0086 • Fax # (508) 486-0081 • email control@burk.com**

# READERS FORUM

If you have comments for Radio World, call us at 800-336-3045 or send a letter to Readers Forum (Radio World, Box 1214, Falls Church, VA 22041 or MCI Mailbox #302-7776). All letters received become the property of Radio World, to be used at our discretion and as space permits.

**Guest Commentary**

## Windows Runs Smoothly With Proper Software

by Kevin Lockhart

**OGALLALA, Neb.** A recent article in *RW* included quotes from our DOS-based competitors insinuating that Windows is an unstable operating system. Nothing could be further from the truth.

In actuality, Windows is a phenomenally stable system. It is poorly written software or poorly configured system files that cause any instability.

If the software is written correctly and the configuration files are correct, Windows will run forever without any problems.

For a test, simply bring up your copy of Windows but don't start any packages. Now leave it run for a day or even a month. I bet you it will be running fine a year later. This is what we mean: Windows runs just fine until it runs poorly written software.

The same holds true for DOS. It will run just fine until it runs poorly written software. The difference is that Windows is a much more robust, multitasking system. It does a whole lot more than DOS, which is not multitasking in any way.

If a software package such as Audio Wizard for Windows can take advantage of the robustness of Windows while keeping an eye on stability, then the customer truly gets the best of both worlds — robustness (does lots) and stability (doesn't hang).

Prophet Systems Inc. is eminently qualified to compare DOS and Windows systems. We have spent almost seven years developing digital audio systems.

The first three years were spent developing systems for the DOS operating system, the last four exclusively for Windows. Take it from us, Windows is far, far superior. Its built-in multitasking is infinitely superior to anything that we or our competitors can program under DOS.

Let's be reasonable: how can anybody in the digital audio game match the efforts of Microsoft's 8,000 programmers with one or two people? It simply cannot be done.

Additionally, Prophet Systems has Windows-based systems ranging from single workstation systems to a 100-workstation Goliath running 14 radio stations from one system that cost nearly \$1 million.

You can see that we have been successful running Windows because we have taken the time to configure Windows correctly. The end result is an extremely stable system that is amazingly flexible.

Our customers agree. "The Windows platform is easy to operate. It has been extremely stable, which is important for a walk-away station," said Norm Laramee of KKPT/KSYG/SRN in Little Rock, Ark. "We're very pleased with the system."

"The Windows interface is very easy to operate. It is extremely reliable. Very little training time is necessary," said Joe Reed of KRDOAM/FM in Colorado Springs, Colo.

One of the most common compliments we hear is how amazed our customers are that our system can do so many things at one time so smoothly. Windows is a large part of the reason we can do this.

The built-in multitasking of Windows allows us to run several programs in the background — transparently and smoothly.

And because we didn't have to waste time "reinventing" the multitasking wheel, we were able to devote our programmers' time to developing new features — many more features than DOS systems have.

Much of the bad press for all types of Windows comes from the immense number of stories focusing on Windows 95. We have tested Windows 95 extensively here and feel that it definitely has merits, but it is still six months to a year away from being the stable operating system that Windows 3.1 is.

When any major operating system comes out, there are always bugs that need to be fixed. Windows 95 is no different. Remember when DOS 6.0 came out? Thousands of stories documented known bugs that would corrupt hard drives, hang the computer, etc. But now DOS 6.22 is fine. The same thing will happen with Windows 95. A year from now, Microsoft will be on release 2 or 3, and it will be as stable as Windows 3.1 is now. The bugs of Windows 95 should not reflect on the stability of Windows 3.1.

Windows is a marvelous tool and now you can see why we wonder how anyone buy-

## The Time Is Now

The decisions broadcasters will make concerning digital technology in the next few years could be the beginning of a wonderful chain of events. Radio of the future may not be so much about CD-quality radio, as it will be about the business of transmitting data.

And the key word is business, for the decision on what technology to invest in and how quickly a station ramps on to the information superhighway is purely a business decision. Station operators now are even considering whether there is a way to turn a profit with this slew of new, digital technologies — for now limited to global positioning, paging service and other data market niches.

The question of whether new wired or wireless data services will happen became the question of when will they occur. With the passage of the Telecommunications Reform bill last month, Congress freed broadcasters from cumbersome business constraints that hindered operations from benefiting from the efficiencies of scale present in other industries.

The Federal Communications Commission continues to auction spectrum to consolidated media giants to establish personal communications services (PCS). Soon, the FCC is expected to grant satellite entrepreneurs frequencies for orbital DAR service with substantial data capacity.

What do broadcasters have to fight such awesome technical and monetary competition? — the upper hand.

It will take unknown billions of dollars to build the fiber optic infrastructure to support PCS nationwide. The network will probably still be incomplete 10 years into the next century. Satellite entrepreneurs will have to find backing to build and launch their birds, which also will take years and cost billions.

FM signals reach every square inch of U.S. Interstate highways today. Broadcasters could be the established wireless data leaders well before PCS and satellite DAR get started.

What it will take is continued investment in technology — first RBDS, then high-speed data and then digital audio broadcasting once in-band, on-channel DAR is in place.

The time to start making those beneficial choices is now. —RW

ing a digital audio system could even consider a system that doesn't use Windows.

If you are considering buying a digital audio system, buy one that is multitasking, flexible, feature-rich and that utilizes the latest hardware.

### Jock Station

Dear RW,

I read Alan Haber's report on the Chicagoland jock reunion on WJMK(FM) and now I want to hear it.

As a huge radio fan of WLS in my teen years, all those names brought back memories of hiding my transistor radio under the pillow and listening long into the night. Living in northern Michigan, I loved the wintertime because it got dark earlier and the radio skip would start as early as 5:30 p.m., giving me extended hours of rock and roll heaven. I'm sure this historic broadcast was recorded, please tell me how I can get a copy.

Jay Alexander  
Independent Engineering  
Lompoc, CA

**EDITORS REPLIES:** *The good folks at WJMK requested that anyone interested in information about the oldies reunion program send a written request to the station. Write to the program director at 180 N. Michigan Ave, No.1200, Chicago, IL 60601.*

### Talk FM

Dear RW,

Who says talk can't work on FM in smaller markets? The Greater Lafayette, Ind. metro has about 125,000 people (283,000 in our 10-county TSA), and has 14 stations claiming the market as home. WASK(FM) at 98.7 FM went on the air May 1, 1995.

The station, simulcast on our sister AM frequency (1450), is programmed for hot talk

Why start out with yesteryear's technology? If it doesn't run Windows, you should be running away from it.

Kevin Lockhart is president of Prophet Systems Inc. in Ogallala, Neb.

and is consulted by Doug Silver out of Orlando, Fla. Our local hosts, Don Pratt (mornings), and Ski Anderson (afternoons), feature lifestyle topics done in a irreverent rock 'n' roll style, and are rounded out by Limbaugh, Liddy, Dr. Laura, Leykis and Art Bell.

We own the news niche in this city, with a five-person local staff headed up by Eric Burch, a full-time sports director. Mark Johnson and traffic and weather together on early mornings and late afternoons. Expensive? Yes. Worth it? You decide.

This past Fall Arbitron survey was our first full book (Lafayette has two full Arbitron surveys annually) and WASK kicked out an 11.6 share 12+, compared to a 6.7 for our first partial book, and grew 150 percent in 25-54 (from a 3.2 to an 8). We are now fourth overall in the Metro (3rd 18+), doing a format conventional industry wisdom said couldn't work in markets below number 50.

WASK runs multiple in-studio local lines, an area-wide 800 number, a free cellular connection, a 24-hour interactive phone system, e-mail monitored every 60 seconds and a World Wide Web home page. Check us out at <http://www.wask.com/wask>

A committed ownership not afraid to tough out incredible initial resistance, a dedicated staff and a desire to win long-term are what it takes to make it happen. Even though it appears we have the highest market share of any FM talker in the nation, we aren't done yet!

Keith Harris  
Programming Manager  
WASK (FM)  
Lafayette, IN

# Radio World

Vol. 20, No. 5 March 6, 1996

Editor in Chief.....Lucia Cobo  
Managing Editor.....Whitney Pinion  
Technical Editor.....Alan Peterson  
Associate Editor.....Angela Novak  
Staff Writer.....Lynn Meadows  
Assistant Editor.....Christopher Nicholson  
Technical Advisors.....John Bisset, Tom McGinley  
Editorial Director.....Marlene Lane  
Assistant Editorial Director/Audio.....Alan Carter



Radio World (ISSN: 0274-8541) is published bi-weekly by Industrial Marketing Advisory Services, Inc., 5827 Columbia Pike, Suite 310, Falls Church, VA 22041. Phone: 703-998-7600. Fax: 703-998-2966. Second-class postage rates are paid at Falls Church VA 22046 and additional mailing offices. POSTMASTER: Send 3579 forms and address changes to Radio World, P.O. Box 1214, Falls Church VA 22041. REPRINTS: Reprints of all articles in this issue are available. Call or write Giselle Hirtenfeld, P.O. Box 1214, Falls Church, VA 22041; (703) 998-7600; Fax: (703) 998-2966. Copyright 1996 by Industrial Marketing Advisory Services, Inc. All rights reserved.

—PRINTED IN THE USA—

**Next Issue of  
Radio World  
March 20, 1996**

# Digital Future Nears

► continued from page 1

signal. Internally, the study suggests graphic displays of call letters, program schedules, music currently playing, headlines and bulletins. All of this is possible now with Radio Broadcast Data System (RBDS), but the report suggests that RBDS may be just a prelude to enhanced graphic displays.

External uses of digital technology could turn out to be more lucrative, according to the study. Datacasting may provide new revenue as competition for listeners and advertisers in a multimedia world increase the need for diversity among broadcasters.

"Information providers will want cost-

effective ways of electronic distribution as the boundaries between print and electronic media continue to blur," the report reads.

## Coupons by radio

The technology now exists using RBDS, developed by CouponRadio Inc., to send coupons to specially designed receivers. In cooperation with Arbitron and the Interep Radio Store, CouponRadio is conducting a major study this year to test how radio listeners will use RBDS-equipped receivers to download information about music they hear.

The information will be forwarded to a

"smart card" to be inserted into a reader/printer at a music retailer, resulting in a discount coupon.

The report predicts all of these technological changes will begin to occur very soon with digital radio broadcasting — both terrestrial and satellite are expected to be introduced before the turn of the century.

In less than two years, according to the study, consumers will be able to purchase radio/data receivers with multiple functions.

At NAB '95, National Semiconductor announced that it had developed an integrated circuit that it expects to market for (analog) AM/FM and (AM/FM IBOC) DAB receivers. The circuit should add only \$10 to \$15 to the cost of manufacturing the receivers.

Station owners wondering if they can afford to make all of the changes necessary

to enter the digital radio world should ask themselves if they can afford not to.

According to the Delphi study, new revenue streams from datacasting, computer automation, and ownership of multiple stations that share programming and are linked digitally will offer stations economic incentives and program quality never before imagined.

The Delphi report acknowledges that some broadcasters may be skeptical of these ideas. But change is a-comin' — and it makes the future of radio sound more exciting than ever.

"The Digital Radio Broadcasting Technology Applications: A Delphi Forecast Study" is available from the NAB at a cost of \$65 for members and \$85 for non-members.

Call (800)368-5644 or (202)429-5373 for more information. ☺

## What is this man doing?

...he is  
optimizing  
his audio  
processing!

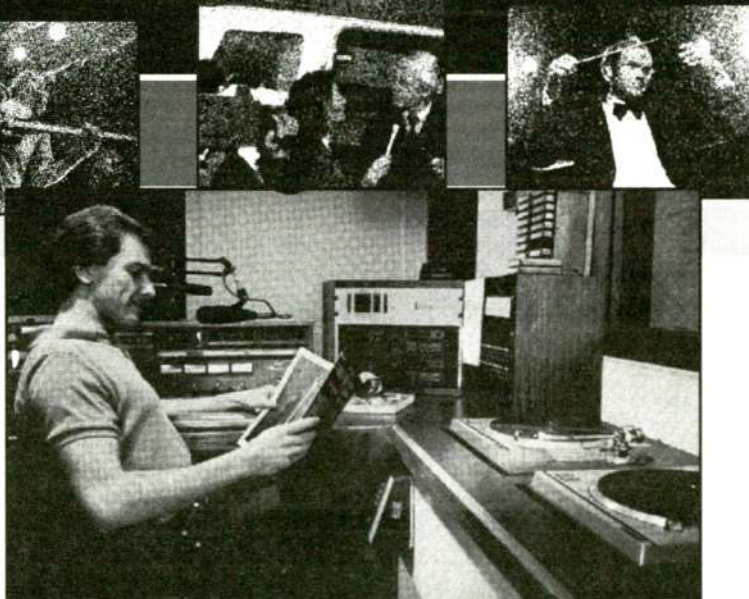

You no longer have to compromise your station's sound. Format changes, audience profile variations and cut-to-cut music inconsistencies present challenges that no ordinary processor can hope to deal with. That's why Inovonics pioneered the *Programmable Processor*.

Our Model 250 behaves just like five independent audio processing chains. The AGC action, Compression, Equalization and Limiting of each of these chains can be custom-tailored to any specific audio feed or to any station format. This gives precisely the proper processing to make any program source or format sound its very best. No compromise.

Controlled by station automation, a time clock, or simple manual selection, the 250 provides processing which can change with your programming throughout the broadcast day. What's more, our RS-232 Interface Option can put the 250 under continuous computer control with almost endless processing possibilities.

**Has the Inovonics 250 proved to be ahead of its time—  
or haven't you been keeping up?**



**MODEL 250  
PROGRAMMABLE BROADCAST AUDIO PROCESSING**

# Inovonics, Inc.

1305 Fair Avenue  
Santa Cruz, CA 95060 U.S.A.

TEL: (408) 458-0552  
FAX: (408) 458-0554



Circle (21) On Reader Service Card

World Radio History

## Radio Board Results Released

**WASHINGTON** The election for the National Association of Broadcasters' Radio Board continues. Ballots for run-offs in three districts were due back March 1.

Those results were to be announced March 4.

Run-offs were held in districts 4, 8 and 14 which originally had fields of three and four candidates. The run-off ballots read:

District 4 (Del., D.C., Md., Va.): William Poole, general manager of WFLS-AM-FM; David Roederer, vice president and general manager of WPSK-FM; District 8 (La., Miss.): Stephen C. Davenport, president of WKXG(AM) and WYMX(FM); Bill Hickman, president and general manager of WMFM(FM); District 14 (Iowa, Wis.): Mark Hedberg, vice president/general manager of KRIB(AM)/KLSS-FM; Mary Quass, president of KTOF(AM) and KDAT-FM.

And in the other districts, the new board members are:

District 2 (N.Y., N.J.): William O'Shaughnessy, president of WVOX(AM)/WRTN(FM); District 6 (N.C., S.C.): William L. McElveen, president/general manager of WTCB(FM)/WOMG-FM, and WISW; District 10 (Ind.): Kenneth S. Coe, president/general manager of WLOI(AM)/WCOE(FM); District 12 (Mo. and Kan.): Curt Brown, vice president and general manager of KTTS-AM-FM; District 16 (Colo., Neb.): Dick Maynard, owner/general manager of KEKB(FM)/KBKL(FM); District 18 (South Texas): John W. Barger, president and general manager of KRIO-FM; District 20 (Mont., Idaho, Wyo.): Larry Roberts, president of Sunbrook Communications; District 22 (Ariz., Nev., N.M., Utah): Jeff Lyon, general manager of KSNM(FM); District 24 (S. Calif., Guam, Hawaii): Howard B. Anderson, president of KHWW Inc.

Radio Board members serve for two years and can serve no more than two terms consecutively. The new board will convene for the first time in Washington in June. ☺

# Compatibility, Confidence, and Cost Savings



- The ideal solution for remote broadcasts, ad hoc networks, voiceovers, distribution of commercials, backup to satellite and microwave links, and many other applications.

- Designed by Telos specifically for radio applications over ISDN and Switched 56.

- Clean, uncluttered front panel for simple operation. Full metering, call duration timer, headphone jack, and mic/line inputs.

- Built-in input protection limiter. When your talent screams, your audio does not distort.

- Zephyr has an ISDN integrated terminal adapter designed for the non-technical operator. You can even place a standard voice-grade call to a Plain Old Telephone Service (POTS) telephone.

**N**o product lets you connect so easily to more sites via digital phone lines than Zephyr.®

Zephyr has Layer III which delivers 15kHz mono audio on just one of the two digital channels of an ISDN circuit. You save

just one ISDN circuit and one Zephyr. In stereo mode, Layer III and Zephyr preserve critical stereo information for superior

Why buy an ordinary codec, when for about the same price you can have a Zephyr?

## Zephyr will communicate with these codecs and more!

**CDQ1000**  
**CDQ2000**  
**CDQPrima**

**Comrex DXP**  
**Comrex DXR**  
**Comrex DX200**

**Micro 56**  
**Micro 66**  
**RE 660/661**

Contact us for complete compatibility details. Some codec modes of some codec models may not be presently supported.

Need to call a site that only has Layer II or G.722? No problem. Zephyr is backwards compatible with all Layer II implementations, such as MUSICAM. Connecting to another Zephyr site? Now you really have options!

because the transmission cost is half that of other schemes which require both channels for broadcast quality.

A split channel mode allows you to transmit two different mono programs to two separate locations using

musical events. And in all modes, Zephyr is full duplex for two-way transmissions.

Telos quality and value result from more than a decade of exclusive dedication to products for the broadcast-to-telephone interface.



*only from*



2101 Superior Avenue  
Cleveland, Ohio 44114  
+1.216.241.7225  
FAX: +1.216.241.4103  
email: info@zephyr.com



**The Best Way to Hear from There™**

**Telos Zephyr** DIGITAL NETWORK AUDIO TRANSMITTER

Telos Systems, the Telos logo, Zephyr, and The Best Way To Hear From There are trademarks of TLS Corporation. All other trademarks are property of their respective holders.

Find us on the World Wide Web at <http://www.zephyr.com>

Circle (26) On Reader Service Card

World Radio History

# [solutions]

can your codec do this?

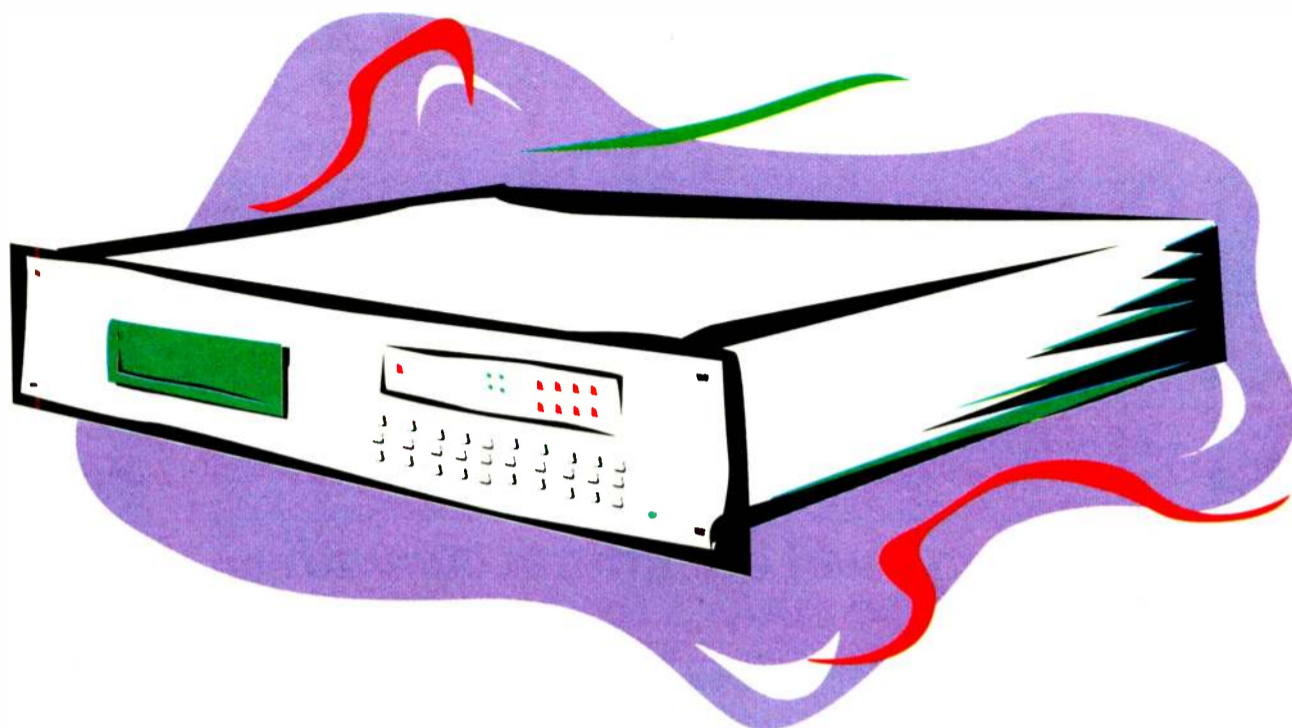

## “CDQPrima™ can!”



**Beatles in 1968:** From a studio in Liverpool, John, Paul, George and Ringo could have cut all the music for the feature film *Yellow Submarine* while it was being edited in Los Angeles at the same time! They could have sent SMPTE time code, text and CD-quality audio over a single ISDN line to Producer Al Brodat!



**Elvis In 1959:** From West Germany, Sgt. E. Presley could have remotely cut a hit without leaving the base and sent it to an empty studio in Nashville. At 0900 hours in West Germany, Elvis could have automatically started a tape recorder at the closed RCA Victor Studio B and had it ready for final mixing the next morning.



**Walt Disney in 1937:** From three different remote locations, Snow White's Director David Hand could have received voice-overs in stereo from Roy Atwell, Adriana Caselotti and Lucille LaVernes using a CDQPrima™. David Hand's Prima would have received each talent's voice-over, even though each incoming call came from a codec of a different configuration.

### Your Station Can Send & Receive CD-quality Sound Over [1] ISDN Line!

- Best CD-quality stereo sound for radio broadcasters, recording studios, film, voice-overs & satellite operators
- 20 kHz CD-quality stereo sound with better than 89 dB dynamic range and .01% total harmonic distortion
- Exclusive MUSICAM® enhanced encoder algorithm is compatible with all standard ISO/MPEG Layer II decoders
  - Psychoacoustic tuning with results in real time
  - CD-quality sound over 2 ISDN B channels
- Cascade-proof mastering quality with up to 6 ISDN B channels at 384 kb/s
- AND MUCH MORE!

CDQPrima™

For information and your nearest dealer call:  
Tel: 908-739-5600 Fax: 908-739-1818 Fax On Demand: 908-935-2777  
Internet: <http://www.musicamwest.com>  
MUSICAM USA™ 670 N. Beers St., Building 4, Holmdel, NJ 07733 USA



Circle (29) On Reader Service Card

World Radio History



FIELD IMPRESSION

# Doing Time on the Expanded Band

by Alan R. Peterson

**EDITOR'S NOTE:** *RW's technical editor, Al Peterson, was offered the unique chance to broadcast from the U.S. Army's Transportable Radio Station (TRS) during testing. His story follows.*

**FORT MEADE, Md.** The offer to do a shift on the TRS came from the designer himself, Donald S. Browne, who was enjoying his own time testing the station as "Big Don." It was an irresistible offer.

How could I say no? This station would be on the air only four days and was up in the expanded AM band. It was a rare flower that would bloom only once. Terrestrial and skip conditions would be unbelievable and the signal would be

heard over most of the known universe.

To miss this moment would have been like blinking during the most critical play of the World Series.

My last broadcast job was production only; I had not done an airshift since 1993 and was panicking. Sure, it was going to be a small select audience, but listeners were everywhere from Illinois to Maine to Florida ... one even called a DX report from Sweden.

Tell me that is not a little intimidating.

When I arrived at Fort Meade, the shiny steel tower was visible from the road. No orange and white paint here; it was designed for quick deployment and transmission. Impressive.

Radials were above the ground covered by snow. An Army generator was

thrumming along, powering the separate transmitter and studio trucks. Sergeant Wenz let me in. He had been on the air since 6 a.m. and it was now 1:30 p.m. By this time the station had undergone several call letter changes.

The original calls were "KTRK — K-Truck," until KTRK-TV, Houston, called to say knock it off. Next was simply ARMY radio, but they finally decided on ABS, for Army Broadcast Service.

I was ready to take over at two o'clock and do a four-hour shift. Until we went off the air.

It was a deliberate move. Field-strength tests were being done on 1670 kHz and it

was time to shift frequencies to 1143 kHz; the frequency the station would operate at in Bosnia.

I could only imagine the 3 kHz whistle heard by fringe listeners of WRVA(AM), Richmond, Va., at 1140 kHz.

Mr. Brown arrived at the site along with three FCC inspectors from the monitoring station in Columbia, Md. They were there for a look-see and not an inspection. One noted a styrofoam pizza box outside the studio and commented, "Yep, it's a real radio station."

By 3:20 p.m., tests were complete and it was time to fire up the transmitter again at 1670 kHz. I looked all around the studio for the transmitter remote control and found none.

Instead, a sergeant leaned out the door and made a revving motion with his arm

continued on page 11 ▶

# K-Truck Heard Far And Near in Tests

by Alan R. Peterson

**FORT MEADE, Md.** The United States Army Broadcast Service concluded construction and testing of a new, transportable radio station here in February and has sent it overseas for eventual use in Bosnia.

The radio station, originally dubbed KTRK (pronounced "K-Truck"), is officially known as a Transportable Radio Station (TRS) and was built from specifications written by engineer Donald S. Browne.

"This is not like any other radio station," said Browne. "This is a U.S. Government radio station. There are very subtle differences. The station operates under government rules, not the FCC's. Operators do not need licenses, there are no logs to keep, no public file."

Browne calls the TRS something unique that has never happened before.

"This is ABS — Alpha Bravo Sierra — conducting transmitter tests from Fort Meade, Maryland."

With that sign-on, listeners lurking on the expanded AM band discovered the new, albeit temporary, radio station on 1670 kHz, playing upbeat classic rock tunes and requesting reception reports from anyone tuning in. DX listeners had only four days to log the station before testing was concluded.

ABS is short for Army Broadcast Service and the tests were being done to evaluate the performance of the entirely

field-transportable radio station and tower.

Fittingly enough, the first song broadcast over the ABS radio station was "Keep On Truckin'" by Eddie Kendricks.

The studios are built inside a 19-foot-long camouflaged enclosure, divided into

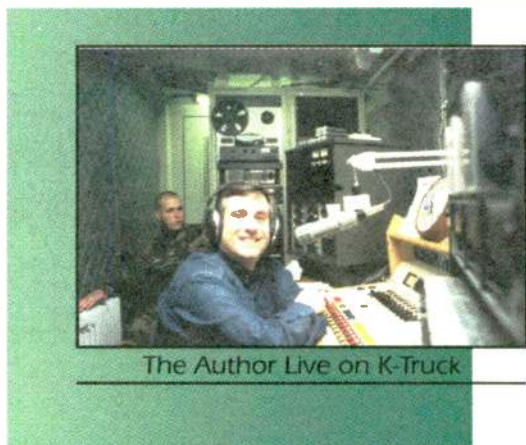

The Author Live on K-Truck

control room and multi-mic conference studio. The doors are windowless and heavily armored as any military vehicle. This is "Good Morning Vietnam" in a box.

State-of-the-art equipment includes a Pacific Recorders BMX-2 console, Denon 951FA CD cartridge players and ITC Delta cart machines. The control room doubles as a production room, with a Butler tube and spring reverb, Orban parametric EQ and an Eventide H3000B Harmonizer.

There is no hard-drive technology to be found anywhere in the K-Truck. Browne's design required durability far beyond any torture-test dreamed up by any DJ.

continued on page 11 ▶

**Conex Electro-Systems AS-101 Audio Switcher**

10 Stereo In - 1 Stereo Out

- Illuminated and legendable control buttons
- Instant or overlap switching
- Front panel accessible level controls
- Options include: RS-232 interface, remote control, relay-follow-switch outputs
- Network proven quality and reliability

P.O. Box 1342 Bellingham, WA 98227  
1-800-845-1061 FAX (206) 676-4822

**Conex Electro-Systems, Inc.**

Circle (34) On Reader Service Card

## Quantum FM

**Solid State**

**Solid Reliability**

from **QEI**

- Proven reliability
- Maintenance-free FET technology
- Self-contained modules with own power supply regulator
- Compact size reduces shipping costs, allows affordable air shipment
- Power levels between 300 Watts and 6 kW
- Modular design offers buy-only-what-you-need affordability and convenience

For the same price you pay for a tube transmitter, you can now have a superior solid state FM transmitter with high-power, advanced technology exciter and cableless combiner. The modular design of QEI's QUANTUM-Series FM transmitters offers the advantage of buying only the amount of power you need...and means that you can upgrade to higher power levels whenever you're ready.

QUANTUM from QEI—the people who have been designing and building solid state transmitters longer than anyone else in the industry.

You need to know more! Call Jeff Detweiler today toll free (800) 334-9154.

QEI Corporation  
One Airport Drive • P.O. Box 805  
Williamstown, NJ 08094

Tel (800) 334-9154  
Fax (609) 629-1751

24-Hour Service Hotline  
(609) 728-2020

Circle (39) On Reader Service Card

# We let Rick Dees use one and now he won't give it back!



**"Nope. No way. Forget it. This Instant Replay is mine."**

Hey, we understand. After all, Instant Replay puts 1,000 of his favorite noises right in front of him — ready for instant playback. No other audio player makes it so easy to be spontaneous and creative. It's fast, it's easy and it's fun.

Check it out. One Instant Replay can store up to 16 hours of stereo sound. That's 16 hours of sound effects, spots, promos, even entire songs — anything — and you can play any of them back instantly just by pressing one of 50 Hot-Keys! There's no need for a computer and no need for training. It's self-contained and it works right out of the box — just push the buttons and go!

**Try Instant Replay Free!  
Call 818-991-0360**

To prove how Instant Replay can make your station better, you can Test Drive one with no obligation! Call us now for free overnight delivery of your Test Drive unit. And like Rick Dees, once you get your hands on Instant Replay you won't want to give it back either.



Transfer one cut or one thousand between machines using the D-NET high-speed digital audio network.



Print hard copy lists of all stored cuts so you always know what's where!



Store up to 16 hours of CD-quality digital audio on Instant Replay's internal hard disk.

**360 Systems**

PROFESSIONAL DIGITAL AUDIO

5321 Sterling Center Drive • Westlake Village, CA 91361 • (818) 991-0360 • fax (818) 991-1360



If you're a call-letter station, you can try Instant Replay for 10 days with no obligation. If you decide to buy Instant Replay, we'll make arrangements through one of our authorized dealers. Offer good in the continental US only. Offer expires July 1, 1996.

\*Suggested retail prices: \$2995 for 4 hours of storage; \$3495 for 8 hours of storage and \$3995 for 16 hours of storage. 360 Systems Instant Replay is a registered trademark of 360 Systems. ©1996 360 Systems.

Circle (42) On Reader Service Card

See Us At NAB Booth 1605

World Radio History

# History Made at 1670 kHz

► continued from page 9

towards the transmitter truck. The carrier went up. Go figure.

Then came the moment I waited all afternoon for. With no knowledge at all of who was out there listening, I kicked out my first legal ID since May 1993:

*"This is ABS conducting transmitter tests from Fort Meade, Maryland. ABS is a U.S. Government radio station transmitting on 1670 kilohertz at five kilohertz. I'm Al Peterson of Radio World newspaper and this ... is ... ABS!"* and then right into music.

To my relief I realized there was no "rust on the machine," as I was dreading. It was like riding a bicycle; I never forgot how.

From 3:20 p.m. until 6 p.m., I fielded phone calls reporting reception of ABS in North Carolina, Fort Wayne, Ind., and Cleveland, among other cities.

Bill Sitzman of Independent Broadcast Consultants from Trumansburg, N.Y., with a report of 1.1 mV maximum signal strength from 375 kilometers away.

Skip was improving westerly as late afternoon crept across the time zones. By late night, ABS radio would probably be ricocheting around inside a good portion of the hemisphere. Not bad for a five-kilowatt.

I especially enjoyed hearing the "skooshing" of my voice through the headphones, as only a nicely-processed AM signal will do for you. It had been too long a time.

When I was done, I realized I forgot to sign the log when I came on. Browne reminded me the station was under the rules of the U.S. Government, which did not require logs or a Restricted Operator license. What a great excuse that would have made in my earlier jock days.

The studio closed up the next day and was sent to Frankfurt, Germany, where it was to continue on to Hungary or Bosnia. I packed myself up and headed back to the RW editorial office, flushed with a feeling that, up there in the expanded band, I was nearly all alone.

Except for WJDM(AM) who got there before most anybody else, I was Adam in a wide-open radio landscape. Michael Collins circling the moon all alone in Apollo XI. It was something of a rush.

My stomp into the wet cement of radio chronology is not being ignored by me. My resume now includes my one-day shift on the ABS radio station and notes what a kick it was.

To anyone and everyone who listened, called or wrote, thank you. It was a day to remember.

# Fold-up Station Tested

► continued from page 9

Browne said "This is going to be transported around the world in an aircraft, driven over bumpy roads and through bomb craters to its location." According to Browne, no hard-disk audio storage system he knows of could handle that kind of dropping and slamming.

K-Truck's console has the capacity to air live satellite broadcast material via AFTRS, UniStar and SMN. As designed, K-Truck is air-ready now to broadcast Unistar's "Adult Rock n' Roll" format.

The TRS was tested with a Harris Gates 5FA frequency-agile AM transmitter and a TUP-3 folded monopole antenna on a truck designed by LBA Technologies in North Carolina. The 5 kW transmitter was tested domestically on 1670 kHz but will broadcast on 1143 kHz in Bosnia. This shifting of frequencies is accomplished rapidly with the frequency-agile transmitter and quick retuning of the antenna by an antenna tuning unit (ATU) at the base of the antenna truck. The TRS can provide studio facilities for up to eight transmitters operating on any frequency between 530 kHz and 1705 kHz, in 9 or 10 kHz steps.

The Bosnia regional frequency of 1143 kHz was agreed upon by an understanding signed between the U.S. Army and Bosnia.

TRS is not limited to only AM operation. A frequency-agile FM transmitter and antenna could allow operation from 87.5 MHz to 108 MHz, in 100 kHz steps.

A number of volunteers were pressed into service to receive and evaluate the signal. Among them, a number of local amateur operators. Paul Courson, a former Associated Press writer now with Dow Jones, teamed up with area hams Steve Ickes, Ken Moffett and Fred Creasy to check audio quality and technical parameters.

"We did no actual proof of performance," said Courson. "but we were listening on car radios and amateur receivers and spread the word to other amateurs to dial down (from 1800 kHz) and listen to the station." The hams also listened for adjacent channel

noise, as the test frequency was only 10 kHz away from WJDM(AM) Elizabeth, N.J. Training of studio operators and transmitter engineers commenced Jan. 27, 1996. Representatives of Harris and LBA were present to instruct technicians on the operations of the transmitter and antenna.

Ed DeLaFuente of Pacific Recorders was on hand to make adjustments to the Aphex and Optimod processing chain.

On Feb. 2, tones were sent up the properly-tuned and loaded tower. Broadcasts of music and voice began 11 a.m. EST on Feb.



The K-Truck Main Studio

5. After four days on the air sending music by day and tones at night, the K-Truck studio and separate antenna assembly were packed and sent to a staging area in Frankfurt, Germany. From there, it was to continue on to Bosnia or to Hungary.

## The control you need, the price you like.



### Symetrix 528E Voice Processor

The 528E is a voice processor that performs six separate functions simultaneously; eliminating the need for separate voice processors. Microphone pre-amplification, de-essing (sibilance removal), compression/limiting, downward expansion, parametric EQ, and voice symmetry alignment are all functions performed by the 528E from Symetrix.

The 528E's compact yet easy-to-use design allows for ease of storage and maximum control. Separate LED meters monitor mic gain and dynamics gain making adjustments quick and easy. As a dedicated single-channel voice processor, the 528E delivers the same processing power found in an entire recording studio signal chain. Although the 528E is called a "Voice Processor," it can also be used to transform any signal, vocal or otherwise.

Revered as the choice for broadcast voices, the 528E gives you all the power for a fraction of the cost.

#### Features

- Works with any microphone.      Great for both voices and effects.
- Enhances vocal intelligibility.      Reduces off-mic noise.
- Increases perceived loudness.      Reliable, proven design.

Order today!

1-800-622-0022



© 1996 Harris Corp.

## FM STUDIES

- ◆ **SPACING/INTERFERENCE**  
determines channel availability
- ◆ **DETAILED INTERFERENCE**  
short-spaced commercial studies, educational FM studies
- ◆ **DISTANCE TO CONTOURS**  
plots projected coverage
- ◆ **POPULATION COUNTING**  
determine potential audience
- ◆ **COVERAGE MAPS**  
signal coverage, zip code boundaries, ethnic- demographic data, loyal listener locations

Visit Our Home Page At:  
<http://dataworld.com/>

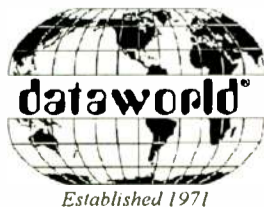

Established 1971

800-368-5754 FAX: 301-656-5341  
e-mail: [Info@dataworld.com](mailto:Info@dataworld.com)

Circle (46) On Reader Service Card

Circle (49) On Reader Service Card

# Volunteer Station KTOZ (AM) Still Angry

by Alan Haber

**SPRINGFIELD, Mo.** In the land of the free and the home of the brave, a 500-watt, all-volunteer radio station ought to be *persona grata* with its listeners and its government.

For awhile, though, KTOZ(AM) here in town, which bills itself as The "Unforgettable" Station, seemed to be *grata* with its listeners, but decidedly *non grata* with a branch of its government.

Although general manager Ron Johnson's tussle with the United States Department of Labor is officially over — at least from the

DOL's point of view — his dedication to seeing that what happened to KTOZ does not happen to any other radio station, business or individual is not.

Despite the sting of a nearly four-month long DOL investigation earlier this year, the station that Johnson and 18 other people purchased out of bankruptcy court and put on the air in June 1994 keeps rolling on with what Johnson calls an "adult variety" format.

KTOZ was born from a desire to fill the airwaves with what Johnson calls "good music." Harry Connick Jr., Glenn Miller and Tommy Dorsey commingle with Yanni,

Barbra Streisand and Lawrence Welk as the daytimer's volunteer voices reach out to their loyal listeners.

Only Johnson, who once was a top 40 disc jockey, and two other of KTOZ's 19 owners are radio people. None of the 19 draw a salary or receive any kind of financial reward.

They come from different walks of life: Johnson is in sales, another is a finance director for a local company, still another is a librarian. There is a federal prison guard, an engineer, a doctor and a mechanic. All work their air shifts around their day jobs. A few are retired.

The fiercely-dedicated "Springfield 19" decided to divide up the time necessary to keep the station running and work for free until money started coming in. Relating the station's volunteer status over the air brought some listeners to the station's door asking if they too could learn how to be radio people.

When the Springfield 19 took over the station, it was grossing \$120 dollars a month, which, said Johnson, paid about a quarter of the utility bill. Now there is enough green coming in for the station to pay its bills every month.

continued on page 13 ►

## WYNY(FM) Takes One Week to Develop the Beat

by Lee Harris

**NEW YORK** New York radio listeners experienced one of the strangest weeks of broadcasting ever as WYNY, the city's only country station, underwent a slow and sometimes painful transformation into an urban-dance operation.

There is speculation that the six-day format change, featuring simulcasts of Evergreen Media's Chicago, Los Angeles, San Francisco and Boston properties, was in part an attempt to impress Wall Street by parading the airpower of the publicly traded company.

While WYNY had more listeners than any country station in the United States, it was clear that Evergreen was not pleased with the station's performance. M Street Journal publisher Robert Unmacht pointed out in the New York Times that every article that said WYNY wasn't working tended to hurt Evergreen on Wall Street.

In the first of many unusual moves, Evergreen allowed WYNY's air-staff to

spend all day Sunday, Feb. 4, mourning the demise of the country format. There were many touching moments as the staff and listeners reminisced about the nine years they had spent together.

Word of the pending format change had been circulating for months, with many observers predicting that Evergreen would use WYNY to bring WRCX Chicago morning man Mancow Muller into the market for a face-off with arch-rival Howard Stern.

Sure enough when Monday morning dawned, there was Muller simulcasting on rock-formatted WRCX, indicating that he was in New York to stay and that he would demolish Stern, apparently by being even ruder than his nemesis.

Mancow unleashed a virtual hurricane of vitriol against Stern, and displayed an unwholesome interest in the physical development of Stern's preteen daughter.

Because both WRCX and WYNY operate at 103.5, the stations were identified as "Rock 103.5, Chicago-New York."

Mancow's show featured traffic reports for both cities. The simulcast continued throughout the day with the other WRCX jocks saying nothing to indicate that their time in the Big Apple would soon be over.

But the next morning New York listeners awoke to an entirely different format from a different city. WYNY was now simulcasting Evergreen's urban KKBT from Los Angeles.

Morning man John London made it clear that his crew wasn't in New York to stay. His show featured bi-coastal traffic reports and New York callers saying hello to relatives on the West Coast. The highlight of the day was a live but not very revealing interview with O.J. Simpson.

### Note of discord

The "format of the day club" continued Wednesday with a simulcast of Evergreen's flagship Chicago property, young-talk WLUP-FM. For the first time in the process, there was a note of discord in the air as Windy City morning legend Jonathon Brandmeier made frequent and only half-joking references to the fact that he wasn't being paid extra for his New York performance.

Brandmeier talked about suing Evergreen for eight billion dollars and contemplated mob-style hits on chief executives Scott Ginsberg and Jim DeCastro. By contrast,

WLUP-FM's afternoon drive talent (and former Partridge family member) Danny Bonaduce was ecstatic about being on in New York.

Overall, the rest of the WLUP-FM air-staff made few concessions to the simulcast with the exception of some "11 past the hour" type time-checks.

Less rancorous and more accommodating was Thursday's simulcast of adult contemporary KIOI, San Francisco, where morning man Don Bleu and his crew went so far as to deliver bi-coastal newscasts, with New York stories in the lead. Some lucky KIOI listeners even won a trip to New York.

Jock dissatisfaction with the simulcasting arrangements reached a low with Friday's final imported performance from Evergreen's newly acquired Boston station, CHR leader WXKS, Kiss-108.

Morning man Matt Seigel clearly had a bone to pick with his new employers. Like Brandmeier, he complained about not being paid extra, and then said "never mind the extra pay, why don't you just restore the benefits you cut when you bought the station?" The rest of the WXKS air staff made few references to the simulcast.

### The Beat

At 9:30 p.m. Friday, the whirlwind radio tour came to an end, as the WXKS signal was replaced with the sound of human heart, beating 84 times per minute. This led one wit on the Internet to speculate that the new WYNY format was a simulcast of the EKG machine at County Hospital.

The sound effect was in fact a clue to WYNY's new identity which was revealed on-air Saturday at noon by Chief Operating Officer Jim DeCastro. WYNY had been reborn as "The Beat, WKTU," New York's legendary disco station of the late '70s.

While the call letters haven't been officially changed, the station is identifying as "K-T-U" except as required by law at the top of the hour. For now, the new KTU is operating jockless with sweepers and a few spots that are probably running in spite of rather than because of the format change.

The magic of the original WKTU caused it to soar quickly to number one. But by reviving the ghostly station, Evergreen may have invoked some evil radio spirits as well: WKTU died a quick death when the disco craze fizzled.

The company has definitely racked up bad karma with country listeners. But with the format change and the parade of out-of-town talent before Wall Street's media analysts, Evergreen may start seeing some magical increases in its stock price. ☹

## Your Listeners Are Ready For RDS/RBDS... Are You?

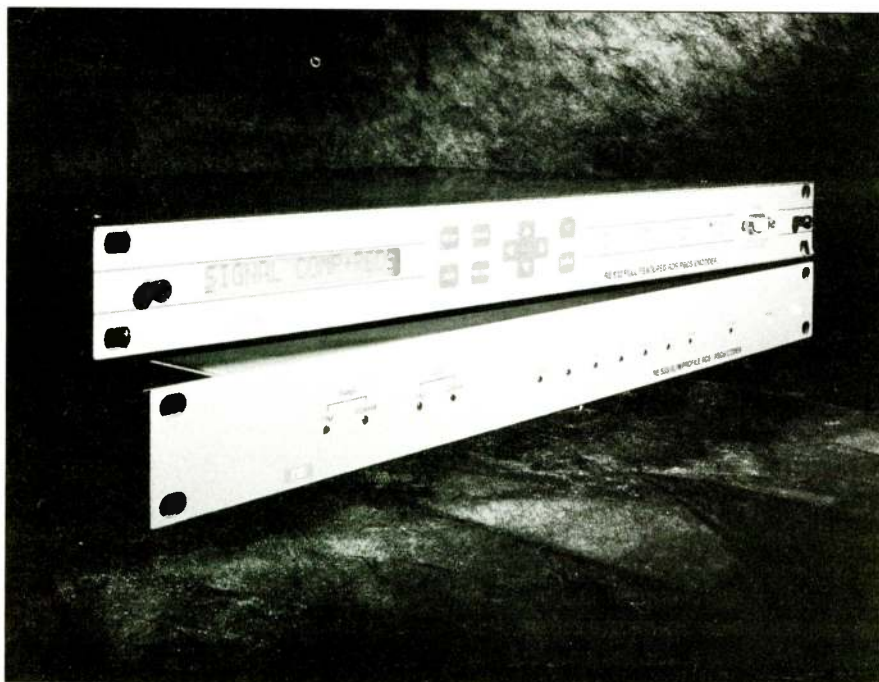

Available through: ▲ Broadcasters General Store ▲ Harris Allied ▲ RF Specialties

This year, RDS/RBDS consumer radios are being purchased by your listening audience, which means the time is right to pursue the revenue opportunities RDS/RBDS has to offer.

RE AMERICA continues its tradition as the leader in RDS/RBDS technology, now with a family of products. Whether you choose the RE 533 for single-user datacasting or the RE 532 for multi-user datacasting, RE has the right encoder to meet your budget and operational needs.

RE takes the risk out of choosing an RDS/RBDS encoder by employing flashprom technology in both the RE 533 and the RE 532. Future upgrades and enhancements are simply downloaded via disc software available from RE. You make the choice, the RE family has got you covered.



RE AMERICA, INC.  
31029 Center Ridge Rd.  
Westlake, Ohio 44145

Phone: (216) 871-7617 ▲ Fax: (216) 871-4303

Circle (52) On Reader Service Card

# KTOZ (AM) Working For New Labor Law

► continued from page 12

Johnson said he and his compatriots agree that they're not expecting anything out of their investment, money-wise. Only when it's appropriate will The Entertainment Network (TEN), the Missouri corporation in which they hold shares, declare a dividend.

Johnson wanted to take listeners in the station's 80 to 90 mile non-directional coverage area back to the way radio was "in the forties and fifties." He said he wanted "real live disc jockies, request lines open all the time," and interaction with listeners. And he wanted to have some fun with it all, "like radio used to be, instead of sterile, the way it is today."

### Roadblock

Less than a year into the adventure, the skies over KTOZ darkened a little. In May 1995, Charles Morgan, an inspector with the Wage and Hour Division of the DOL's Employment Standards Administration, paid a call on the station.

Morgan was looking for information about the sales revenue of KTOZ and the number of employees working there, according to a DOL spokesperson.

"When you're all-volunteer," Johnson remembered telling Morgan, "you don't have any payroll." Morgan "walked in here like the Gestapo, flashed his ID and said, 'My name is Charles Morgan. I'm with the Wage and Hour Division.'" Johnson recalled.

Johnson said he questioned Morgan about what he was doing and what he was after. Morgan told him that a determination would be made as to whether or not the station complied, he remembered. But with what? And how did that work? Johnson said he did not, right then and there, get answers to his questions.

Johnson said he had "this real feeling that this guy (was) stepping on my rights as a citizen." He remembered asking Morgan, "Are you telling me that we don't get a say in anything — we don't get a hearing on

this?" Morgan's answer, according to Johnson: "No, you don't."

The more Johnson thought about the situation, he said, "the madder I got, because I thought, 'Wait a minute - this guy is just all over me personally on my rights as an American citizen. I can do with my time what I want.'"

The DOL spokesperson said that the DOL's feeling "is that our investigator allowed a situation — obviously a kind of a personality clash — to escalate from the very beginning, and there wasn't an accurate communication of information going to Mr. Johnson. I think it led him to jump to some conclusions that kind of escalated the situation."

The nearly four month jig between KTOZ and the DOL was off and running.

### Paper trail

In a June 15, 1995, letter to Johnson, Terry Burger, district director of the Wage and Hour Division of the DOL's Employment Standards Administration in Kansas City, Kan., reiterated what Johnson had been told over the phone just two days earlier — that the investigation of KTOZ was being conducted under the Fair Labor Standards Act (FLSA) of 1938. The legislation provides, in part, that employees receive at least minimum wage payment for their services to an employer.

According to the DOL spokesperson, the investigation was prompted by a complaint that employees of KTOZ, under the current ownership, were being asked to work without pay, in exchange for some promise that they would be compensated in some way if the station became profitable in the future.

Two months later, the tussle between the DOL and KTOZ was over. In a letter dated Aug. 22, Burger informed Johnson that the Division had discontinued its investigation of the station.

"When this thing first started," said the DOL spokesperson, "what we were doing was asking Mr. Johnson for information about the sales revenue of the business and

the number of employees. Now, nobody blames him at all, because it wasn't explained to him, for suspecting that that meant he was under investigation. And that is the posture that he took and his attorneys took from the very beginning."

In other words, when Morgan went to KTOZ, he was simply trying to get the information needed to determine whether or not an investigation should be pursued. According to the DOL spokesperson, there was no official investigation at that point.

The spokesperson agreed that Morgan didn't communicate this properly to Johnson.

"It is a very, very rare occurrence that this kind of thing occurs and, unfortunately, it's been twisted around to reflect some secret mission here (at) the Department of Labor to crack down on volunteer agencies. That is not the case. It's never been the case."

The DOL spokesperson said that the DOL was trying to decide whether, "based on complaints," employees at KTOZ were "being asked to work a 40 hour week in exchange for some promise of compensation in the future. We determined that that was not the case."

Johnson is now working to pass Congressman Joseph K. Knollenberg's (R-Mich.) proposed standalone bill HR-1589,



Jim Cooper, Vicki Roberts and John Mayer

dubbed the Job Skills Development Act of 1995 now in the House.

The proposed bill, according to a release from Congressman Knollenberg's office, would amend the FLSA "to exempt individuals wishing to volunteer their time in order to enhance their occupational opportunities from the Act's minimum wage and overtime requirements."

Restrictions on "volunteer activities," the release noted, "are intended to safeguard against employer coercion. Protecting volunteers from unscrupulous employers is a laudable goal and must be preserved in our labor laws."

The FLSA is currently undergoing revision in Congress in an attempt to bring it "into the 21st century," according to Frank Maisano, spokesperson for Congressman Knollenberg. The FLSA "was a 1930's Act, and it was designed for the 1930s," he said.

The people working at KTOZ are "not

continued on page 34 ►

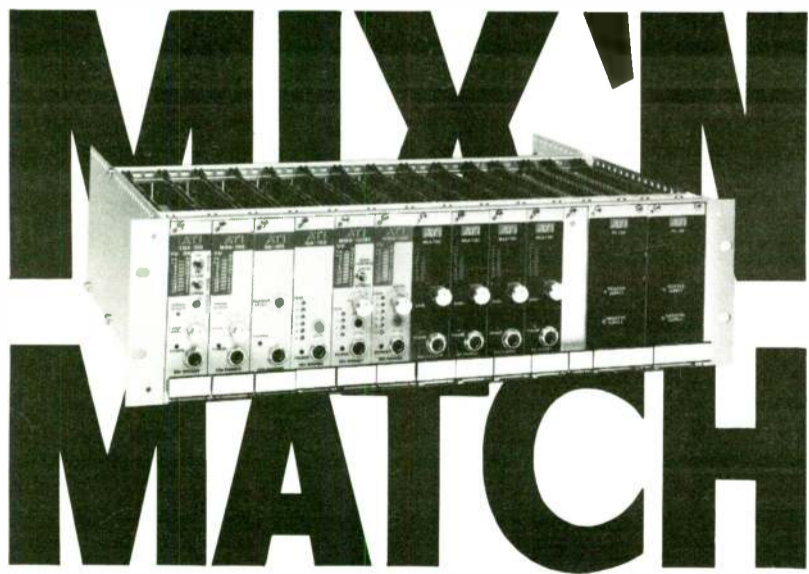

## System 10,000 Modular Amplifiers

Over 40 interchangeable Microphone, Line and Audio DA Modules for you to mix 'n match to your requirements.

Call, fax or write for free detailed brochure

**AUDIO TECHNOLOGIES, INC.**  
328 W. Maple Ave., Horsham, PA 19044, USA  
(215) 443-0330 • FAX (215) 443-0394



Circle (54) On Reader Service Card

**COMPETITION SOUNDS PRETTY GOOD THESE DAYS.**

**NEW PROCESSOR.**

**THEY DID THAT WITH A NEW PROCESSOR?!?**

**unity**  
the world's best-sounding FM & AM processors

**CUTTINGEDGE**

TEL: (216) 241-3343 • FAX: (216) 241-4103 • E-MAIL: INFO@CUTTINGEDGE.ZEPHYR.COM

Circle (57) On Reader Service Card

# WORKBENCH

## Event Controller Used for Remote

by John Bisset

**SPRINGFIELD, Va.** Readers on the East Coast may remember John Hutson, who sold Continental products to the mid-Atlantic region a few years ago. In the past, John was in field service at Continental Electronics, but most recently he joined Autogram Corporation — the console people.

I hadn't heard from John in a while, and

in his fax, he told me that Autogram is having a big sale right now on their Mini-mixers. If you're looking for an inexpensive remote console, call John for some literature, or circle **Reader Service 2**.

The other reason for John's fax was to alert me to an inexpensive remote control (under \$400) that he thought might be of interest to *Workbench* readers. The PT8-0C, manufactured by PageTap, is an eight-channel event controller that

remotely turns items on or off. Each event to be controlled can be momentary, time-delayed or latched, and the output is an open collector.

In addition to its low price, this device is further distinguished from others by its ability to operate over paging frequencies.

The open collector outputs are connected to a paging receiver, which decodes a six-digit security code and a two-digit control code that you key in using your touchtone keypad.

You can program the controller to work on your own personal pager number or purchase the unit from PageTap with a pager number already associated with it. A programming kit, which consists of

software and a cable, costs \$39.95, but can be used to program any number of PT8-0Cs.

Applications include turning on a back-up STL system at a remote site or controlling something at a location where there are no telephone lines. One TV station is using the PT8-0C to turn on microwave transmitters when doing live shots from a stadium. The system beats climbing up the catwalks before and after each game, as well as leaving the microwave on all the time.

In site management applications, the PT8-0C can be used to interrogate alarm systems, reboot modems, operate air conditioning systems or control or test tower lighting. At PageTap headquarters in

## Products & Services Showcase

For more information on the products shown below, circle the appropriate Reader Service No.(s) on the enclosed Subscription/Reader Service card or contact the advertiser directly.

### THE COST EFFECTIVE ALTERNATIVE TO MANUFACTURER SERVICE

#### SERVICE, REPAIR & CALIBRATION

- STL's • RPU's • TSL's
- Exciters • Optimods
- AM/FM Monitors
- Remote Control Systems

#### SPECIALIZING IN EQUIPMENT BY

- Belar • Marti
- Moseley
- McMartin
- TFT
- And others...

#### WE ALSO PROVIDE

Free, over-the-phone technical assistance  
STL loaner/rentals  
PCL 505 Certification

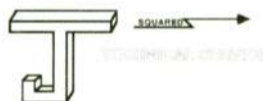

2198 Hubbard Lane, Grants Pass, OR 97527

**(541) 471-2262**

READER SERVICE NO. 53

### The CircuitWerkes TeleRadio Remote Controlled Listen Line



You can find out what's on the air in all of your markets without ever leaving your chair!

With the TeleRadio and a phone, you are ready to check up on your station *and* all of your competitors in real-time. You'll never have to get another station air-check plus you can punch around the dial as if you were right there. When the TeleRadio answers, its internal radio begins playing down the line to you. You control the tuner with the buttons on your phone. The TeleRadio is the next best thing to being there yourself.

The TeleRadio features include:  
Ten random memory presets.  
Remote scanning, tuning, band change & memory set.  
Remote controlled external audio jack lets TeleRadio double as a standard coupler for IFB, etc.  
List price is just \$689.

#### CircuitWerkes

6212 SW 8th Place  
Gainesville, Florida 32607  
(904) 331-5999 / fax 331-6999

READER SERVICE NO. 80

Cellcast

REMOTE BROADCAST STUDIO

#### THE CELLULAR DIFFERENCE

- Easy to Use
- Reliable
- Cost Efficient
- Portable
- Flexible



Technology & convenience combine to bring you on-the-spot remote broadcast capabilities with excellent sound quality. Cellular transceiver, frequency extender, and mixer all in one! Powered by Ni-cad rechargeable batteries *or* AC power supply — utilizes cellular technology *or* land lines.

For more information call

**1-800-852-1333**

READER SERVICE NO. 107



### Econco REBUILT POWER TUBES



Approximately One Half the Cost of New

3,000 Hour Unconditional Guarantee

Call for Our Price List

Econco 1318 Commerce Ave. Woodland, CA 95695  
Phone: 916-662-7553 Fax: 916-666-7760 Telex: 176756  
Toll Free: 800-532-6626 From Canada: 800-848-8841

READER SERVICE NO. 134

### Get rid of your %\$#@& patch bays and try this for a switch

Zercom CORPORATION

Do your audio routing through a Zercom Patch Switch system. Easy to install and use, a Patch Switch system provides you with front panel access to an unlimited number of input sources (by bussing units), Stereo or Mono selection, Phase reversal, signal summing, and a PCB that's set up for easy installation of audio pads. The enclosed audio switches have been tested to over 1,000,000 cycles for dependable performance. And *best of all...* it's a Zercom product with a two year warranty.



**The Zercom 'PS-2' Patch Switch \$379.00**

P.O. Box 84, Zercom Drive  
Merrifield, Minnesota 56465-0084  
218/765-3151 - Fax 218/765-3900

Available through all major dealers

READER SERVICE NO. 161

► continued from page 14

Colorado, they can set or interrogate their burglar alarm system. This feature alone saves trips back after hours to reset or "arm" an alarm.

For more information, contact Eric Guth at PageTap at 800-735-3650. For a brochure on the PT8-0C, circle Reader Service 7.

\*\*\*

Although Henry Engineering's Digistore is fast replacing cart machines as a source of recorded phone messages — like weather or ski reports — many stations have pressed their "retired" cart machines into recorded-message delivery systems. Hank Landsberg's got a box for that, too! It's called the Telecart, and it has been on the market for several years now.

In addition to interfacing the cart machine "start" logic to the telephone ringer, the device has a digital display that counts the number of calls received. The Telecart depends on voltage from the cart machine's "remote play light" to activate the counter. Noise or instability on the cart machine's remote play light circuit can sometimes cause the Telecart to register two or more counts, instead of one.

Figure 1 shows a modification that Hank provided, which will give the Telecart substantial immunity to contact bounce. R-32 is a 220 K resistor. The capacitor is a 0.1 µF/50 V ceramic. It is tack-soldered across the 220 K resistor.

\*\*\*

While we're on the subject of modifying equipment, Walt Lowery at Symetrix sent along a tip to users of the Symetrix 528 Voice Processor. Early last year, Symetrix made some changes to the 528. One of the changes included the taper of the MIC GAIN pot.

On Symetrix 528s and 528Es, units with plastic knob shafts, the usual mic gain pot setting falls at about 2 o'clock. With the first upgrade of the 528E, the company shifted to metal shaft pots. According to Walt, this was a good move, as the pots were then anchored to a metal subfront, providing a more solid "feel."

On most units produced in 1995, those with the "new" taper had an operating setting of 5 o'clock for the MIC GAIN control. Unfortunately, the new taper on the metal MIC GAIN control put most of the gain at the upper end of the pot's range. The back of these all-metal pots carry the marking "T15C2.5KC," designating the 15C taper.

After realizing the operating range problem this taper sometimes caused, Symetrix switched specifications back to the original taper — as used on the 528 and SX-202 Microphone Preamp. Custom parts take time, and now, all new Symetrix 528Es have the familiar 05C taper, which places the normal operating range at 2 o'clock.

Note that Symetrix is not recalling the 1995 vintage 528Es. The difference in taper is not a defect; however, some find it unnerving that old and new 528Es don't set up identically because of the taper difference. If the problem bothers you, Symetrix will replace the 15C taper pot at no charge. When you call the company at 206-787-3222, request a 2.5 K/05 C taper metal pot. Symetrix customer service technicians will replace the pot in their shop for a modest fee, if you prefer. For this service, contact the company for an RA number.

\*\*\*

Here's another contact to add to your

Radio World Workbench Resource card file. If you own a Continental FM transmitter, you are undoubtedly familiar with the gating card. Dried out or shorted electrolytics in these cards can cause plate breaker tripping for no apparent reason. You can replace the capacitors yourself; or you can have the gating cards repaired, matched and tested by PowerCon Electronics. Here are the particulars: POWERCON ELECTRONICS, 9420 Lazy Lane, E-3, Tampa, FL 33614; 800-783-9320, 813-932-7722; fax: 813-933-7867; Jim O'Donoghue; repairs Continental gating cards.

\*\*\*

Tell me if you've encountered this one. A Denon 951-FA, less than a year old, was cued up a song. The jock starts the machine. It plays for about two seconds, then the audio mutes; but the machine keeps run-

ning. Sound strange? We had two different clients experience this problem, which we brought to Denon's attention. It turns out Denon has heard of this phenomenon and has a fix for it. The repair involves replacement of the E-Prom, which is not a field modification. To get an RA number for this fix, contact Denon in California at 310-404-0200 and give them the serial number of your machine.

□□□

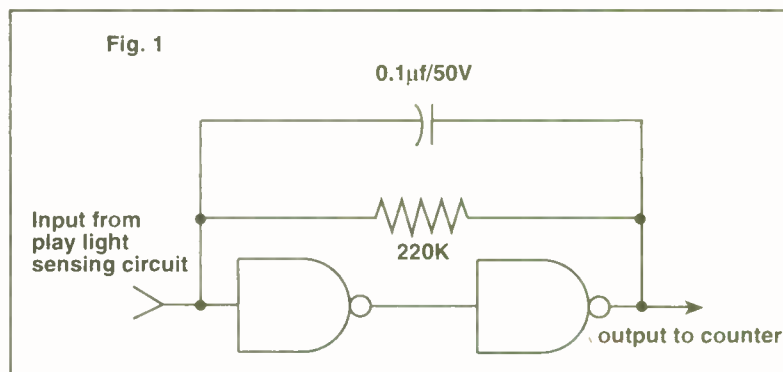

John Bisset is a principal with Multiphase, a broadcast engineering service company based in Washington, D.C. He can be reached at 703-323-7180. Published tips and suggestions qualify for SBE recertification credit. Fax them to 703-764-0751 or via America Online at [wwwbench@aol.com](mailto:wwwbench@aol.com)

# Wait till you see what Continental's got at NAB!



om and dad thought that I was a pretty

neat addition to their lineup, but that was before they saw the exciting new members of Continental's complete line of AM and FM transmitters. The guys in engineering have been busy putting the latest technological improvements into our reliable RF products, and the sales and marketing guys have made sure that all the right power levels are available. It's probably the most exciting thing I've ever seen! Well, that and the first time daddy changed my diaper.

I'm a little new to this broadcasting game, so don't take my word for it... make sure the Continental booth is on your NAB itinerary and see for yourself! And when you stop by, remember to ask them about the other recent additions to the Continental family: Continental Lensa S.A. and Continental TELEFUNKEN Sendertechnik GmbH. These new members of the family help make Continental your single source for the finest and most advanced transmission products available.

Booth 2605 

1946-1996. For 50 years, Continental Electronics has provided excellence in broadcast transmission products worldwide. Refuse to compromise... call Continental first!



**Continental Electronics Corporation**

P.O. BOX 270879 • DALLAS, TEXAS 75227-0879 • 214-381-7161 • FAX 214-381-4949

1.96.105

Circle (63) On Reader Service Card

World Radio History

IMAGE MAKING WITH OPTIMOD  
*First In A Series*

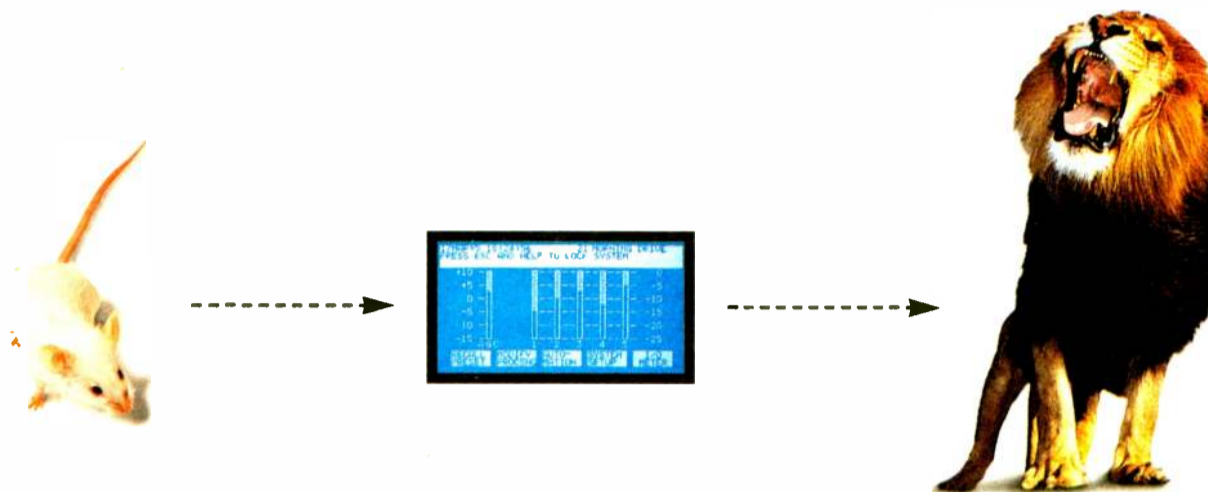

## The More Powerful Your Sound, The Stronger Your Image.

Using image to attract listeners is nothing new to radio. Just the rules have changed. Now even loyal listeners have become "dial scanners." More stations are broadcasting into every market. And, suddenly, everyone seems to be competing for the same listeners. To stand out, you need a sound that's as unique as your station's personality. And that's where the power of OPTIMOD comes in. No other FM processor lets you optimize your audio image so completely. You get loud, clear sound tuned precisely to your format, your audience, and your identity. And that's important, because: ***In Radio, Image Is Everything.***



OPTIMOD-FM 8200 Processor

**orban**<sup>®</sup>

H A Harman International Company



# Studio Sessions

Produce  
Award-Winning  
Documentaries  
See page 21.

Equipment and Applications for Radio Production and Recording

## PRODUCT EVALUATION

# Penny & Giles: Total DAW Control

by Alan R. Peterson

**SANTA MONICA, Calif.** Penny and Giles (P&G) is a name long familiar to anyone who has spent time behind consoles; P&G faders are everywhere.

The company has combined its years of experience with a curious new breed of optical fader to assist users of MIDI music producers and software-based digital audio workstations (DAWs). The result is the MM16 DAW Controller.

The MM16 DAW Controller uses 16 of the company's E-Belt digital controls. This intriguing component resembles a Star Trek transporter "energize" doodad, but uses optical circuitry driven by an endless translucent plastic belt. More about this later.

### Mouse-free control

Audio producers populating radio production studios and MIDI rooms require fine control over their product. Software-based digital systems are often limited to on-screen mousing of a virtual mixer window. This frequently confines a producer to only one move at a time.

A number of companies manufacture hardware MIDI fader devices to use with these systems, but these controllers might be limited in operation and often use pc-mount short-throw faders. Users frequently desire equipment that shares the robust feel of their favorite console.

The MM16 transmits data as MIDI information, and provides dedicated transport controls, programmable function keys, a scrub/shuttle wheel and 16 E-belt faders to regulate audio tracks or MIDI data.

P&G's MM16 is not an "orphan" product. The controller has support from a number of powerful and popular digital audio workstation manufacturers. MIDI jingle producers can use the MM16 with sequencer/automation programs such as Cubase, Notator and Performer. It even communicates with Mackie Design's Ottomix for automated mixes.

### Construction

The MM16 is built like a tank. The metal worksurface is a quarter-inch of machined aluminum. The entire controller fits into a 6-RU space, or it can be flush-mounted into a furniture cutout. Its slanted control surface allows comfortable tabletop operation.

Of interest is the E-Belt digital control. It takes a little getting used to, but affords great control and has a fast feel.

The resistive element found in conventional faders has been replaced by an LED source and a pair of optical detectors. The endless belt operates a rotary shutter similar to the insides of a

computer mouse, interrupting light between the LED and detectors.

The detectors send out TTL-level pulses for every interruption. Every 100 millimeters of belt travel outputs 256 counts from the detectors.

Because there is no audio on the E-Belt, there is no static that would normally be generated by dirty resistive controls.

A look at the back panel may be a little intimidating, as there are no less than 16 MIDI jacks on the rear. Not to worry; most are multiple output jacks that send the same data to other devices in the line. This avoids having to "daisy-chain" external devices, which corrupt data after multiple passes through several device's MIDI Thru jacks.



Penny & Giles MM16 MIDI Controller

The rear panel has connections for footswitches, a slot for PCMCIA RAM card storage and the power input plug.

Normally I take points off for wall-wart power supplies, but this one earned my admiration.

It delivers 9VDC at a full 1A through a three-pin screwlock DIN connector and weighs as much as a small steam iron. No milliamperage nonsense here.

Even if you loathe external supplies, you cannot help but throw a smile towards this little brick.

### Operation

The MM16 has two basic modes of operation: Workstation and MM16 mode.

The latter sets up the device as a general-purpose MIDI controller, with each E-Belt fader programmable to any MIDI controller function. Each can function as a Group Master as well.

What this means is, each fader need not be limited to simple volume control as a conventional mixer. They can be configured to manipulate reverb level, pan, pitchbend or any number of MIDI-controllable parameters. Choose the function through the selector buttons and shuttle wheel.

Belts can be electronically linked, so one fader can control two E-Belts.

The 16 key switches above the E-Belts can be programmed as Mute controls, Program Change buttons or can send switched MIDI control commands.

This is very handy in audio production

where a sampled sound effect needs to be triggered live on the fly. Transmitting MIDI Note On commands from the keys lets you fire up to 16 sounds from samplers.

A cluster of buttons along the top left of the control panel are for sequencer control and tape transport. The transport buttons are not limited to only tape; each button can be set to send a MIDI Machine Control (MMC) command. Any recorder/player that responds to MMC can be operated remotely from the MM16.

Because my interests include MIDI music production as applied to radio performance, I concentrated attention on the MM16's ability to alter mix parameters of three music software packages: PG Music's Band In A Box, Voyetra's Digital Orchestrator Plus and

### Product Capsule: Penny & Giles MM16 DAW Controller



#### Thumbs Up

- ✓ Solid construction
- ✓ Supported by DAW manufacturers
- ✓ Multiple MIDI outputs
- ✓ Clever controller design



#### Thumbs Down

- ✓ Cryptic display text
- ✓ Inconvenient RAM card slot

For more information, contact Penny & Giles at 1-310-452-4995; or circle **Reader Service 15**.

Cakewalk for Windows.

In every instance I had full control over all parameters, including a few I never had the courage to touch such as modulation and microtunings. The MM16 allowed me to rehearse a MIDI music mix and commit the moves to automated mix memory.

For someone who had been stuck with  
continued on page 19 ▶

# SATELLITE SYSTEMS

## Repairs

**Satellite Systems repairs and rebuilds all major brands of satellite equipment, including the Fairchild Dart 384 and Scientific Atlanta. Our turn-around time averages 24-hours. We also provide pre-and post-service technical support along with a 6-month warranty.**

## Service

**Looking for LNAs? LNAs? Splitters? Cables, etc? Call Satellite Systems! We are respected industry-wide for our prompt, accurate service to radio stations and networks.**

## Ariel Receiver

- 5 card slots for up to 10 audio channels
- next day shipment of replacement boards
- fully compatible with Fairchild Dart 384
- 1-24 transponder capability
- 24-hour technical support
- extra heavy-duty power supply
- 1-year warranty (with exception of shipping charges)



615 East Brookside  
Colorado Springs, CO  
80906  
Ph: (719) 634-6319  
Fx: (719) 635-8151

Circle (113) On Reader Service Card

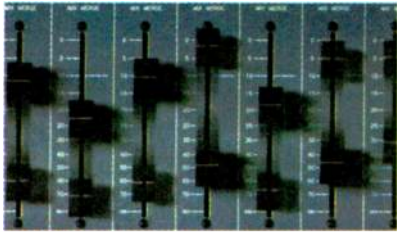

# YOU'VE GOT TO HAVE THE RIGHT TOOLS

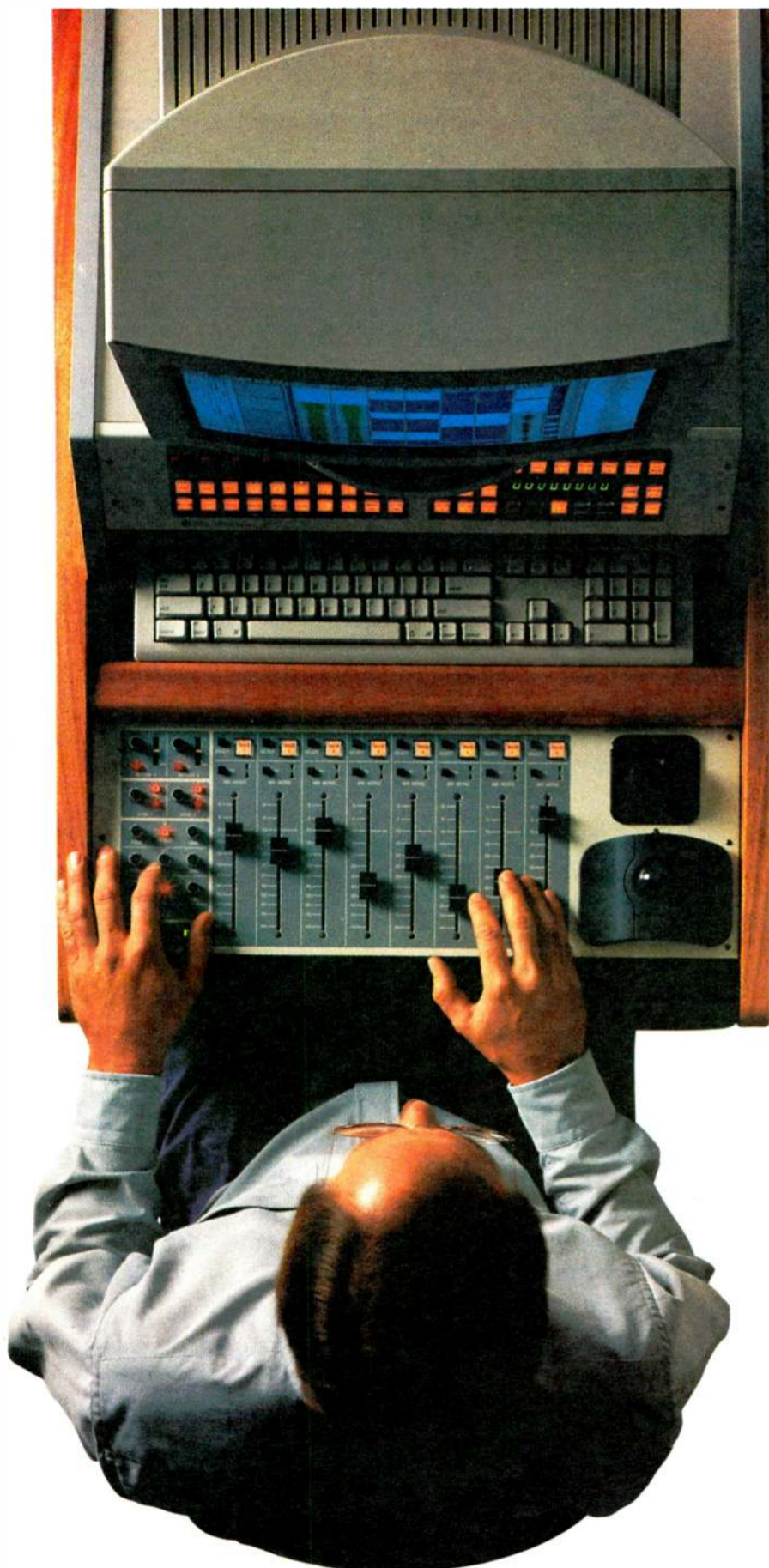

**THE ADX**

**ENSEMBLE.**

**REAL MOVING**

**FADERS.**

**REAL**

**PUSHBUTTONS.**

**REAL**

**INTUITIVE**

**SOFTWARE.**

**THE DIGITAL**

**WORKSTATION**

**FOR**

**REAL**

**SERIOUS**

**PRODUCTION.**

## YOU DID IT.

YOUR STATION MANAGED TO HIRE THE **HOTTEST** PRODUCTION GUY IN THE MARKET FROM YOUR CROSS-TOWN COMPETITOR. HE'S GOT THE CHOPS. HE'S GOT THE PIPES. YOU CAN'T WAIT 'TIL YOUR CLIENTS HEAR THE HOT NEW IMAGE LINERS AND SPOTS HE'S GONNA CUT.

OF COURSE, YOU HAD TO PROMISE HIM **ANYTHING** HE WANTED IN HIS NEW STUDIO. IT TURNS OUT THAT WHAT HE WANTS IS A REAL WORKSTATION BECAUSE HE OUTGREW THE TOYS AT HIS LAST GIG. HE NEEDS ONE THAT MAKES HIS COMPLEX PRODUCTION WORK EFFORTLESS. YOU COULDN'T AGREE MORE. AFTER ALL, THE HOTTEST TALENT SHOULD HAVE THE HOTTEST TOOLS, **RIGHT?**

YOU BOTH DECIDE ON AN ADX. THE ADX WORKSTATION WAS SPECIFICALLY DESIGNED FOR POWERHOUSE ARTISTS WHO CAN'T AFFORD TO WASTE VALUABLE PRODUCTION TIME WITH CREATIVITY-LIMITING TOOLS.

GIVE US A CALL AND WE'LL SHOW YOU HOW THE ADX WORKSTATION MAKES ANYTHING ELSE SEEM LIKE A TOY.



**DESIGNS THAT MAKE THE DIFFERENCE**  
PACIFIC RECORDERS & ENGINEERING  
2070 LAS PALMAS DRIVE  
CARLSBAD, CA 92009 USA  
619-438-3911  
FAX: 619-438-9277  
E-MAIL: SALES@PRE.COM  
GSA CONTRACT: GS-03F-4064B

# P&G MIDI Controller

► continued from page 17

having to mouse tracks for a long time, having the feel of a real console under my fingers was very nice indeed.

In Workstation mode, the MM16 operates as a controller and mixer panel for a number of major DAW manufacturers' products. Presently, the MM16 is supported by SADiE, Sonic Solutions, Soundscape and DigiDesign.

It may be safe to say most computer-based multitrack recorders utilizing MIDI control can be used with the MM16, but make sure you ask the manufacturer and consult the MIDI Implementation chart packaged with your DAW.

A handy feature on the MM16 is the inclusion of dedicated machine transport controls. There is no cryptic menu to wade through to get softkeys to work and an arrogantly bright red LED tells you when Record is locked in. The keys are selectable between standard MMC and workstation-compatible commands.

As long as your recorder can read either type of command string, you can start and stop your DAW right from the MM16's surface without reaching over to the computer.

Information on the MM16's functions and status comes from a backlit LCD display on the panel. There is enough illumination to see the screen comfortably from a seated position.

Limiting the screen to only two lines of text means some shorthanding of information will take place. This gets perplexing at times.

## Figure it out

One of the more baffling displays takes place when programming a Group Master belt. The display fills with the symbols !, -, \* and #, showing the status of each belt. Unless the manual is nearby or a user works enough with this feature to be good at it, this text will be very confusing.

It also helps to understand MIDI code a little bit, as the LCD will occasionally display a line of figures like *F0 00 F7* (an Empty Message, used as a template to edit specific MIDI commands).

Until this is understood, a user may just wonder just what a "foof 7" is.

PCMCIA RAM memory cards are turning up everywhere: laptop computers, Nagra's ENG field recorder and Roland's MS-1 sampler.

The MM16 also uses RAM cards for storing Programs and Snapshots of settings and configurations. When a card is detected, the Utility menu display will request if the user wants to access Internal or Card memory for the session.

The MM16 formats new RAM cards and has memory protection to avoid overwriting previous sessions.

While PCMCIA cards are inexpensive and convenient, it seems that a device the size and bulk of the MM16 would be likelier to write to a small-capacity hard disk, a floppy or (Omega) Zip or Jaz drive.

That may sound more like a subjective observation than a technical one, but sliding a dainty little card in and out of a device as solid as the MM16 seems incongruous.

I also found the back-panel location for the PCMCIA slot inconvenient. If the MM16 controller is racked or flush-mounted into a piece of studio furniture, getting a card in and out requires a circus contortionist.

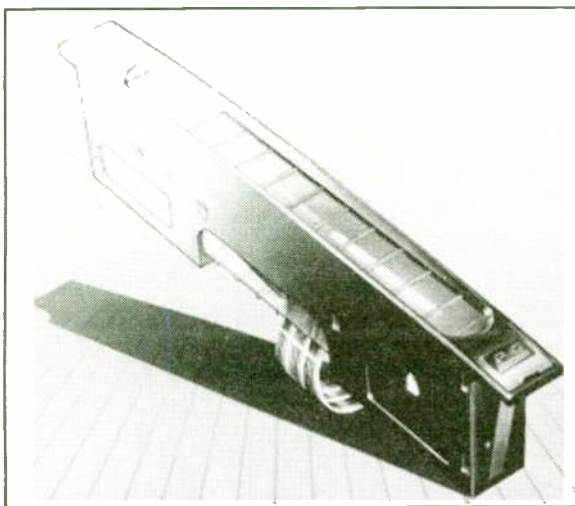

The E-Belt: See article this page

My location of choice for a cardslot would have been on the front panel, perhaps with a spring-loaded door to keep out dust.

## Ruminations

Penny & Giles' leap into self-contained controller consoles was nicely done. The enclosure and work surface have heft and a durable feel. Plenty of input went into the design of the MM16 DAW Controller: even little touches, like automatically sensing if NC or NO footswitches are connected, allowing use of whatever is on hand.

Understand the MM16 is just what it was designed to be: a controller for devices that read MIDI data. It is not a conventional mixer.

There is no sound, no control voltage, no glorified train transformer operation. This is a Cooper controller with a can of spinach and a fistful of steroids.

Transmission of MIDI messages is very clean. I tried sending MIDI slop by rapidly zipping faders all over the place while slamming on every button I could on the surface.

The MIDI monitor in my PC showed the MM16 tracked every move.

E-Belts require getting accustomed to. The ballistics are completely different from P&G's more popular analog faders. The weight and inertia of conventional faders are replaced by what one associate called a "plasticity" feel.

While not disagreeable, it calls for a touch that falls somewhere between P&G's analog faders and the little 40mm faders found on inexpensive semi-pro mixers.

Getting really picky, afterimage "tails" caused by the strobing action of dozens of bright red LEDs might annoy the eyes after several hours of a session in a dark control room. Maybe a dimmer circuit under the Utilities menu?

Will the P&G MM16 work with the DAW at your studio or station? It should, but again, contact the manufacturer for compatibility information. Major players in the DAW arena already support this device, so it has backing.

It already has the Penny & Giles name. That alone makes it worth looking into for your studio.

# E-Belt: An Alternative Controller

The E-belt's appearance and P&G logo will lead you into believing it is simply a souped-up analog fader. Because it is an optical data encoder, potential uses are far greater.

When removed from its role in the MM16, the E-Belt endless belt controller has interesting advantages and applications.

For example, there is no end-of-stroke bumper that would normally damage a fader if pulled down rapidly or violently. A digital-controlled amplifier (DCA) would go to zero level and ignore further motion.

Audio level control is not confined to a fader's physical length. Where analog faders go from zero to maximum over a finite length (normally 100 mm), an E-Belt audio circuit can be software-driven to ramp to maximum at any point along the travel.

In this way, an E-belt can behave as a 10-turn pot or go full at half-travel. A console's subjective "feel" can be different for individual operators.

Software can determine taper and response. A program can read an E-Belt as a linear, logarithmic or

reverse-log control. A panpot is also a likely use for the device.

Console automation decisions could be made from fader ballistics. A fast pulse train from a very rapid fadeout can be detected and interpreted as a command to go to Mute or Cue status.

Because an E-belt outputs a data stream much in the manner of a jog/shuttle wheel, one could be mounted horizontally and used as a "scrubber" for virtual reel-rocking of a DAW.

P&G makes E-Belts with or without a built-in LED display to show control level. The column of LEDs is visible through the belt itself.

Alternative controllers have been part of audio technology from the start. Witness the twin antennas of the 1920s Theremin and the ribbon voltage controller of 1960s synthesizers.

Analog audio has had rotary and linear faders for decades, but now the digital age could see the emergence of even more alternative controllers.

The E-Belt seems an interesting point of departure. Digital controllers will only get more interesting from here on.

## STATION/STUDIO SERVICES

**427 SOUND EFFECTS**  
**\$89.00**

For a 5-CD set with a 30-day money-back guarantee.

*Take an extra \$10 off if you mention this ad!*

Send \$79 to Ghostwriters  
2412 Unity Ave. N., Dept. RW  
Minneapolis, MN 55422

For credit card orders call  
**(612) 522-6256**

READER SERVICE 122

**BUY-OUT MUSIC — \$99**

Sixty 60-second music beds for ... \$99  
198 :30 & :60 music beds for ... \$198  
120 production effects "Zings, Zaps  
and Zoodads for ... \$99  
122 New Lasers & Sweepers for ... \$99

For FREE DETAILS on  
production music, sound  
effects, call

**Ghostwriters (612) 522-6256**

READER SERVICE 122

Doing business without  
advertising is like winking  
in the dark...  
You know what you are  
doing but no one else does!

### ATTENTION PROVIDERS!

Promote your services to **Radio World's** 18,000+ readers. Reach Radio Station and Recording Studio owners/managers and engineers with your message. For information on affordable advertising call **Simone at 1-800-336-3045.**

# Products & Services Showcase

For more information on the products shown below, circle the appropriate Reader Service No.(s) on the enclosed Subscription/Reader Service card or contact the advertiser directly.

## S.C.M.S., Inc. Charlotte, N.C.

Low Prices – Experienced Staff  
New and Re-built R.F. and Audio

**THIS MONTH'S SPECIAL**  
**MAKE YOUR OWN CD'S FOR**  
**LINERS, SINGLE CUTS, JINGLES,**  
**STATION I.D., etc.**  
**THE AMAZING**  
**PINNACLE 5040 CD RECORDER**  
**WITH S.C.M.S. COMPUTER**  
**COMPLETE COST - \$2,495.00**

— You Know We Know Radio —  
Toll-Free 800-438-6040  
FAX 704-889-4540

READER SERVICE NO. 167

## Composite Audio DA and Switcher!



The CDS-200 Composite DA/Switcher

### APPLICATIONS

- Switching Between Composite STL's
- Main/Alternate Processing Switching
- Feed Two Transmitters and an RDBS Encoder
- Feed one SCA Generator to Two Transmitters
- Distribute Composite with the Ease of Audio

### FEATURES

- 2 Input Switcher
- 3 Isolated Outputs
- Individual Level Control for Each Output
- Front Panel and Remote Control with Full Status
- Power Fail Memory with Bypass Mode
- Inputs Selectable for Balanced or Unbalanced Operation
- Front Panel Test Jack



Broadcast Devices, Inc.  
5 Crestview Avenue  
Peekskill, NY 10566

Tel: (914) 737-5032 Fax: (914) 736-6916

READER SERVICE NO. 194

## NEW EXPANDED COVERAGE

### AVCOM's PSA-65B Portable Spectrum Analyzer 1-1250 In One Sweep MHz!!

AVCOM's newest Portable Microwave Spectrum Analyzer, model PSA-65B, has an expanded frequency range from less than 1 MHz to 1250 MHz, for the amazing price of \$ 2930.

AVCOM's new PSA-65B is a low cost general purpose spectrum analyzer that's loaded with features and options. The PSA-65B covers frequencies thru 1250 MHz in one sweep with a sensitivity greater than -95 dBm at narrow spans. The PSA-65B is ideally suited for 2-way radio, cellular, cable, satellite, LAN, surveillance, educational, production and R&D work. Options include new 1250 MHz frequency extenders, BNG-1000A tracking (noise) generator, audio demod for monitoring, log periodic antennas, carrying case (AVSAC), and more. For more information, write, FAX, or phone.

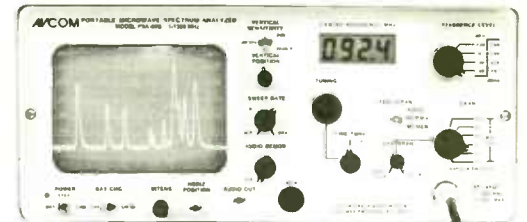

## AVCOM

500 SOUTHLAKE BOULEVARD  
RICHMOND, VIRGINIA  
804-794-2500 FAX 804-794-8284

Receive brochures ON-LINE via AVCOM's new AVFAX.  
Call from your fax and be ready to receive. 804-379-0500

READER SERVICE NO. 221

## TWO NEW ADDITIONS TO THE COAXIAL DYNAMICS WATTCHMAN® TRANSMITTER PROTECTION SYSTEMS

Models 81081 and 81082 with 15/30/60 kw Meter Scales



NEW!  
4-1/16 and 6-1/8  
series line sections  
and elements to  
add to our exciting  
line-up

WATTCHMAN—protects your transmitter and transmission line system. A permanent 19 inch rack installation used with any dual socket line section 7/8", 1-5/8", 3-1/8" and elements (additional) to monitor CW, TV, and FM power. Model 81070 features two easily read meters to monitor both forward and reflected power. The reflected meter provides a front panel adjustable set point which controls the trip level for fast transmitter shut down and alarm. Abnormal load conditions quickly cause transmitter shut down in less than 15 milliseconds including control relay. Both visual and audible alarms indicate system malfunction. Contacts provided for remote alarm and reset switching. Contact us for your nearest authorized Coaxial Dynamics Representative or Distributor in our World Wide Sales Network.



### COAXIAL DYNAMICS, INC.

15210 Industrial Parkway • Cleveland, Ohio 44135  
(216) 267-2233 or 1-800-COAXIAL • Fax: (216) 267-3142  
Service and Dependability... A Part of Every Product

READER SERVICE NO. 13

## UNIVERSAL SCPC

### XE-1000



## SCPC BROADCAST AUDIO RECEIVER

New, affordable, frequency-agile receiver, direct channel entry by keyboard, selectable companding 1:1, 2:1, 3:1, wide/narrow bandwidth, de-emphasis selectable, 950-1450 MHz, line output 600 ohms, muting, transponder agile, LNB power supply, 50-channel memory, full baseband output, high-quality audio. Every needed feature at a sensible price (lowest in the industry). Write or call for full information on this quality receiver—the answer for your station. Networks call for prices.

## UNIVERSAL

ELECTRONICS, INC.  
Communications Specialists

4555 Groves Road, Suite 12 Columbus, OH 43232  
Phone: (614) 866-4605 Fax: (614) 866-1201

READER SERVICE NO. 40

## Pull Listeners with the Finest Audio

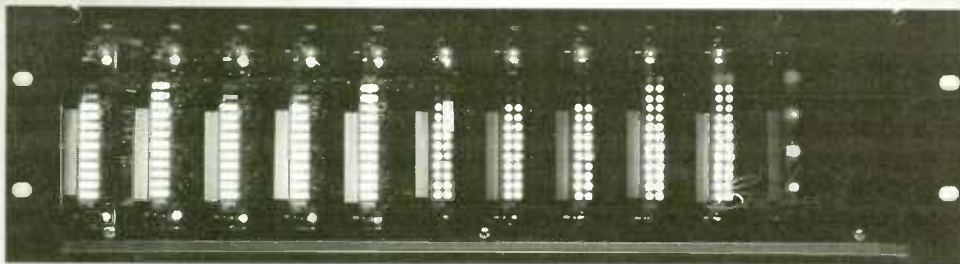

### The System 1000 Modular Audio Package

- Mono & Stereo Line Level Power DA™s
- Single & Dual Mic-Pre Power DA™s
- Remotely Controlled Daughterboards
- Mono & Stereo Card Edge Metering
- Redundant Power Supplies
- New - Instant Installation

The System 1000 delivers the absolute finest performance! All line level and mic-pre DAs use Power DA™ outputs for a signal that just won't quit. Daughterboards provide remote gain and mode control, tone, voice overs, reverse IFB, and more. 10 additional modules, from a 4x4 mixing router to a 10 channel loss of audio alarm, make the System 1000 the tool for your needs. Like NPR and SMN, do wonders for your sound by investing in the finest. Call Rory Rall today.

*Benchmark*  
...the measure of excellence!™

BENCHMARK MEDIA SYSTEMS, INC.

Phone 800-262-4675, FAX 315-437-8119

READER SERVICE NO. 67

## Attention Advertisers!

Reach over 18,000 readers!  
Radio World's

### Product Showcase

provides a perfect medium  
for test marketing your  
products and services. It's  
an efficient, effective and  
affordable advertising option!

For more information on  
rates and deadlines,  
Fax Christopher at

**1-703-998-2966**

or call

**1-800-336-3045**

.....

LINE-OUT

# Breathing Life into Documentaries

by **Bruce Bartlett**  
with **Jenny Bartlett**

**ELKHART, Ind.** How do you make a radio documentary that grabs your listeners?

I talked with Robin Alexander, news director at WVPE-FM. Her method of applying radio production techniques to documentaries gives her pieces life and animation.

Alexander has won awards for her in-depth news features. She tapes interviews and ambience, and edits it all together.

The documentaries she creates are sound-rich pieces that last five to 20 minutes. They are "soft" news pieces, not something hard or breaking.

**Night at the opera**

For example, there is her piece on a 100-year-old opera house. "I start by researching the building," Alexander says. "I phone the owners and say, 'Tell me about it.'"

Alexander also asks for names of people who know its history. "I want to know what their memories are. When and how was it built? Do they know any secret lore about the place?" Alexander finds that oral testimony is much better than written material.

"Real-life experiences can turn a dull interview into a lively one," says Alexander. "Interviews are boring when people just list the events. You know, the opera house burned down, funding was obtained to rebuild it."

"It's much better when they say, 'I remember the fire in 1930 — we were all trapped in the theater.' It's a graphic description of the event."

Alexander will ask people about their memories. Someone might remember back to the days of vaudeville, when they may have performed on the stage. During post production, she will mix that quote with appropriate music from that era.

"What makes a great production," says

Alexander, "is to enrich it with ambient sound. I might record a rehearsal of a performance, or find a recording of a past performance. I tape some theater ambience to put behind the spoken interview — an audience clapping, or part of a play. For a school piece, I might record lockers slamming, kids talking, and bells ringing.



News Director Robin Alexander

"You want the listener to be there. If you produce a sound-rich piece that provokes some memories, that makes the listener pay attention."

"I took some very beneficial workshops on reporting that were put on by NPR trainers. They gave tips on how to do things better. They suggested I put on my headphones, take out the mic and recorder, and just practice recording things. You learn by experience how to get a good sound in various situations."

To record interviews, Alexander will use a handheld omni dynamic mic. She has found handheld mics are great for walking interviews, and sound better than lapel mics.

"If you're sitting down, your arm gets tired holding the mic, and you have to sit close to your subject," she says. "A lapel

mic might be a better choice in that case. If I'm in a crowded, noisy room, I interview the subject near a wall to get away from the crowd noise."

Alexander records with a Sony TC-D5 Pro II cassette-corder. It has XLR mic inputs and VU meters.

**Pre-production**

Back in the studio, she will start to put together her story.

"I have all these great quotes on tape. What am I going to do with them? How am I going to weave them together to make sense? In the creative medium of the documentary, you have a lot more freedom to tell your story than in a news report, where you only tell what happened."

Alexander transcribes all the interviews word for word. "I print them out, then mark the quotes that best tell the story."

A difficulty is in keeping the story focused. Often the people Alexander interviews stray into unrelated topics.

"After choosing quotes," she says, "I'll write the intro copy, the leads into each quote, and decide where music should fade in and out."

**Production**

Alexander notes, "NPR trains you to do first-generation dubs from cassette to quarter-inch reel. Then you record your

copy, splice it all together and copy the edited tape to DAT."

Because her facility is not as sophisticated, she will use two cart machines, twin CD players, a reel-to-reel and a DAT. All the sound bites are dubbed from cassette to a two-minute cart.

"I record the feature all in one take. I turn my mic on, read my copy, put my mic down really fast, and hit the cart. I keep doing this for all the sound bites."

When that is complete, she will edit out any cart clicks and mic cable noise. Then she listens.

"I may not like how it came out. I'll reorganize it, or rewrite my copy. Later I might add music. While the DAT is recording, I'll play the edited reel and fade music up and down from the CD player."

Alexander hopes to get a digital audio workstation, but she says it is still necessary to know how to splice tape.

"Your computer can go down in a heartbeat but there is always the reliable razor blade to back you up. If your computer breaks down, you have to call the engineer, who calls several tech-support people. You spend countless hours getting it to work."

Part of Alexander's success is her drive to improve her work. After she has finished a piece, she evaluates it. "I decide how I could do it better, and apply that to the next piece I do."

□ □ □

*Bruce Bartlett is the author of Practical Recording Techniques, published by Howard Sams. Jenny Bartlett is a technical writer. Bruce can be reached at 219-294-8388.*

## ABG is Studio Furniture

"ANY SIZE, ANY SHAPE...  
INDIVIDUALLY BUILT TO  
YOUR SPECIFICATIONS"

If you're thinking of  
upgrading your  
facility, you can't  
afford not to call us!

FROM  
CONCEPT TO  
REALITY — ABG MAKES  
IT HAPPEN

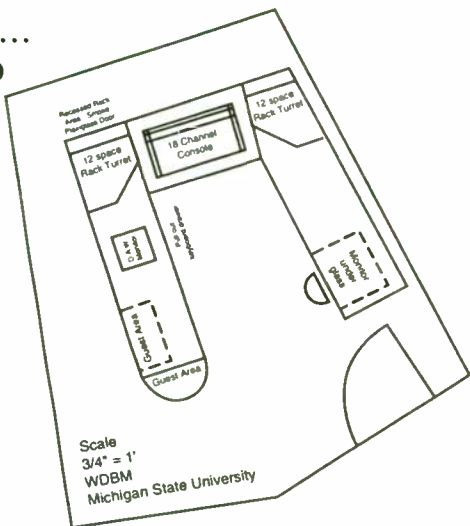

Please call today for full color brochure.

**SOUTHEASTERN SALES OFFICE**  
200 Fareway Drive, Suite 2  
Smithfield, North Carolina 27577  
Phone: 800-369-7623  
Fax: 919-934-8120

**MAIN SALES OFFICE**  
2342 S. Division Avenue  
Grand Rapids, Michigan 49507  
Phone: 800-999-9281  
Fax: 616-452-1652

**WESTERN SALES OFFICE**  
P.O. Box 1638  
Palmdale, California 93550  
Phone: 800-858-9008  
Fax: 805-273-3321

YOU MAY ALSO REACH US ANYTIME VIA ELECTRONIC MAIL  
cServe: 75371,144  
internet: support@abg.com  
web site: www.abg.com



Circle (79) On Reader Service Card

# Attention Duopoly Engineers:

Are you trying to adapt a single-site remote control system to your transmitters' requirements?

At **NAB '96**, we'll introduce a remote control system that exactly meets your needs.

In fact, it's so versatile--it will meet **ANYONE'S** needs for site control.

Check out the **NEW GSC-3000 Site Control** system from Gentner...the people who originated dial-up remote control.

See it at **NAB '96 — Booth 2016.**



**Gentner Communications Corporation**  
1825 Research Way  
Salt Lake City, UT 84119  
1-800-945-7730  
(801) 975-7200

Call for a free demo disk!

Circle (82) On Reader Service Card

# The Real Angle on Head Azimuth

by Rich Rarey

**WASHINGTON** Remember the old PSAs that bleated "Reading is FUN-damental?" I am discovering that the fundamentals of broadcasting need refreshing periodically as well.

Private pilots are required every two years to receive an FAA-approved flight review of their skills and hone them if found to be lacking. So should we review our techniques to eliminate any bad habits that creep in.

Here is a practical example. Lately I have been counseling reporters in the field about the quality of their audio and use of their equipment.

## The right angles

A frequent preventable problem is with analog cassette azimuth. Azimuth is the angle at which the tape passes across a head.

Ideally, the angle should be 90 degrees with respect to the head. If the head becomes loose from physical bumps and shocks, the angle changes and there cannot be the maximum transfer of magnetic energy from tape to head.

The unmistakable symptoms are a muddy, muffled sound lacking in sibilance ("s" sounds). You can simulate the effect by pressing the your hand over your mouth and trying to talk.

You can correct azimuth problems by purchasing and using a lab-standard alignment cassette, such as the Nortronics AT200B or similar cassette. After the heads have been cleaned and demagnetized, the laboratory-standard cassette is played back.

The output level at high frequencies is maximized by turning a screw that moves one leg of the head "up" and "down." A phase scope is appropriate monitoring for stereo cassette machines, and a regular meter or speaker will ballpark the alignment for mono machines.

Listening to the highest frequency and slowly turning the azimuth adjustment screw, you will hear the sound peak at the

loudest level possible, then diminish as the azimuth is adjusted away from the ideal angle.

Once the azimuth has been adjusted correctly, a small drop of red fingernail polish on the side of the azimuth adjustment screw will help keep the screw in place during normal knockabout use. It will also let you readjust the screw in the future.

An out-of-azimuth cassette machine will play back a tape that was recorded on it just fine. Problems arise the moment a cassette that was recorded in one particular machine is played back in a different machine.

If all machine head alignments are not measured against a single standard, all dubs from a particular machine will range from muddy to unintelligible. No amount of processing can replace what was rolled off by misalignment.

Cassette-to-cassette dubbing typically occurs in the field by reporters selectively copying sections of interviews from their master cassettes. The master is held for safety and a cassette copy is mailed or overnighted to the mix location.

When the reporter's cassette arrives it is dubbed to reel, edited, and mixed for air. Three generations have now occurred. It is obvious that we need the best quality possible in the original recording.

Azimuth problems can happen to anyone; small stations, big stations, even networks. The key is to listen to your tape with a critical ear. Is it muffled or muddy when you play it back on another machine?

## Don't chance that Marantz

Has your favorite tape recorder been banged around much lately? It is possible the heads have been banged out of alignment too.

We have modified a regular rack-mount cassette machine to become a dedicated adjustable-azimuth deck. A long threaded screw with a nylon bolt glued to the end protrudes from the deck's lid.

This assembly replaced the original azimuth screw and allows the technician to adjust azimuth without a screwdriver. Since the deck is only for adjustable azimuth playback, it does not need to be calibrated to be "in azimuth." Tapes from the field are tweaked by ear to sound the best, then dubbed as normal.

Another common error is made when recording voice tracks. We document quality-control comments following elements of a reporter's piece from reception to air. Some notations made by colleagues include room reverberation, boominess and hiss, distant-sounding audio and p-pops.

One reporter even forgot to turn his headphones down, and picked up the sound off his cassette's playback head. I honestly do



## PUBLIC DOMAIN

not know how one could read normally when there is slap echo in one's ears.

My advice has been to work the microphone more closely, mindful of mouth noise.

Having lived by the three-to-five-inch rule, I am now advocating breaking it.

Working a mic so closely so that one's lips almost touch the windscreen seems to overcome many room reverberation problems. With many modern condenser microphones, a low-end roll-off switch attenuates much of the proximity effect.

Working the mic this closely means potential problems, but if the mic can be placed near the corner of the mouth and slightly above, popped p's should "blow below" the mic.

One trick to hear how a room will sound with a single microphone is to cover one ear.

Your brain processes the sound from the remaining ear. Remarkably, it is similar to what you can expect to pick up from your mic.

## Security blanket

Is the room too live? Fabric covering will help. A reporter in Moscow covered herself with blankets to eliminate any room reflection. Caution though: You *must* be able to breathe and see your scripts. And beware of entirely too much sound absorption as well.

In recording interviews, some reporters have confused a uni-directional shotgun-type microphone with a parabolic microphone. I once believed a shotgun mic could magically pluck faint sounds from far away. Needless to say, I was distressed to hear the distant, indistinct result.

The point to remember: Shotgun mics will serve you well if you work them as close as practical to your sound source. They only attenuate sound from the sides, not accentuate sound from the front.

Many people are too shy to stick a mic into someone's face. Thirty seconds into the interview, the interviewees forget all about the microphone being in their face.

If they are going to forget about the microphone anyway, you might as well get it as close to them as practical. Holding the mic at chest level out of politeness simply will not deliver the sound you want.

My remarks about recording may strike you as so fundamental it becomes trivial. I cannot stress enough that it is the fundamentals upon which things of quality are made.

Until next month, I remain, Your ob'd'nt eng'r.

□ □ □

*Rich Rarey is the technical director for National Public Radio's "All Things Considered." He can be reached at rarey@npr.org*

## SHORT TAKE

# MiniDisc Replicator

In the February 21 *Studio Sessions*, we reviewed the Denon DN-1100R MiniDisc Recorder/Player.

Denon also manufactures a companion MiniDisc device: the DN-045R Replicator, which performs digital-to-digital dubs from one MiniDisc to another. This is an ideal mate to the 1100R for stations or studios using MiniDisc technology.

In the replication process, digital data bypasses the ATRAC compression circuitry. Audio information

escapes conversion and recompression and is recorded directly in compressed form to the new disc. This preserves the high-quality sound of the original.

Dubbing is performed approximately 3.5 times normal speed. A 74-minute recording can be duplicated in 21 minutes.

Operation is as simple as it can get. One slot accommodates the master recording, another receives the disc to be recorded. The Start button is

pressed and that is all. Status LEDs indicate the time remaining until the replication is complete. At the end, the eject keys on both bays are pressed and dubbing is done.

The DN-045R's back panel has a power switch and D-sub nine-pin serial

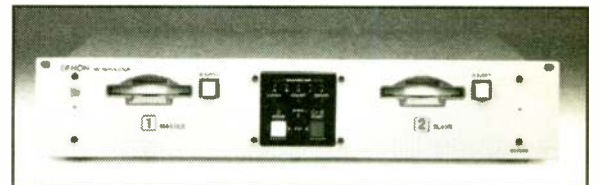

connector, switchable between RS-232C and 422A designations. This port connects to a PC for editing during replication.

A Windows version of the control software is provided as a standard accessory.

The DN045R Replicator is a suitable adjunct to the DN-1100R in situations where small numbers of dubs or a number of redundant backups are needed for an MD project.

## LET YOUR TOWER PAY YOU

**S**ignal One can locate tenants, execute lease agreements, & manage your tower site to produce revenue you never realized was available.

Signal One manages and owns communication sites throughout the USA and has a large customer base that includes BellSouth, PageNet, PageMart, Federal Express, motorcarriers, and other financially-sound users that can help you enhance your operations.

**Call Signal One today...** and let us demonstrate how we can fill your tower site with tenants.

Fax your tower site information to **(423) 954-3222**. We will include your information in our nationwide site database for our many customers to utilize and lease on.

**SIGNAL ONE**

"One Call and Your Signal Is On"™

**(423) 954-1111**

5700 Brainerd Road, Uptain Building, Suite 407  
Chattanooga, TN 37411

# The Future—Today.

Your on-air system isn't cutting it. You want something that was "made just for you." Look no further. The system of the future is here today from Gentner and Harris—your complete source for audio conferencing.



Simplify the process of bringing callers together with fingertip control from **Gentner's TS612 DCT**. The TS612's dual superhybrid technology provides crisp, clean caller audio with much more flexibility.

Callers will be less likely to switch since you'll get that smoother on-air sound you've been looking for.

The control surface is easy to use. It seems like an ordinary business telephone. But, ordinary it's NOT!

On-air talent can screen a call; transfer it from the handset to on-air conference with as many as four callers together; and lock in a VIP guest.

Thanks to line status indicators that are multi-colored, the user can instantly tell who's on the air, on hold, screened or talking to the producer.

With Gentner's SCREENWAIR software and a PC, the screener uses a keyboard and headset instead of the control surface and preselects calls for on-air and adding names, comments, etc. An additional monitor is placed in the studio

where the talent can see who is on screened hold.

With NETWORK INTERFACE you can expand the TS612 system into multiple studio configurations. Add a Network Interface for each mainframe and the communications link between studios for proper management of 12 phone lines is provided.

Telephone calls for broadcast teleconferencing and pro audio applications are made easy with **Gentner's TeleHybrid**. Simply connect it to your existing telephone to deliver full duplex audio to your console or conference system without the fear of echo or feedback.

The TeleHybrid "installs" between your telephone and its handset. Audio connections to your equipment are made with XLRs.

With the TeleHybrid, the hassle and expense of dedicated phone lines are a thing of the past. Your regular telephone system becomes your "on-air" system. Anyone in your facility can screen a call or transfer it to the studio or boardroom. Best of all, the TeleHybrid is very affordable.



The TeleHybrid is the key to simple, great sounding telephone calls on your professional audio system.

Your telephone can be single or multi-line, analog or digital—the TeleHybrid doesn't care. The only requirement is that your telephone have a detachable handset with a modular connector.

**1-800-622-0022**

**FAX 317-966-0623**

<http://www.broadcast.harris.com>

 **HARRIS**

© 1996 HARRIS CORP

Circle (87) On Reader Service Card

World Radio History

# Model SM-1 AM Splatter Monitor



## Features

- Inexpensive means of verifying FCC compliance
- Easy to operate and interpret measured results
- Measurement of I, Q, I+Q (chopped) and external audio signals
- 450 kHz to 1800 kHz phase-locked operation with 10 kHz or optional 9 kHz channel spacing
- Portable operation from external 12 VDC supply and optional active antenna for near field signal monitoring
- Quadrature modulation measurement enables transmitter adjustments for minimum IPM
- External audio input enables evaluation of audio processor's NRSC filter performance
- Optional peak hold circuit
- Optional spectrum analyzer 300 Hz resolution bandwidth model filter assembly
- Front panel speaker and headphone jack permit audible monitoring of interference
- Adjustable alarm output permits remote control monitoring of interference
- Rear panel I and Q outputs and buffered meter output

The Model SM-1 Splatter Monitor provides AM broadcast engineers with a means of accurately and easily measuring off-channel emissions to ensure compliance with the FCC (NRSC-2) emissions standard. Manufactured in response to the recommendations of the National Radio Systems Committee (NRSC) for AM improvement, the instrument provides many of the features of an expensive spectrum analyzer at a significantly reduced price. The Splatter Monitor measures the level of splatter or any other spurious emissions which fall between 11 kHz and 100 kHz away from both sides of the carrier.

## **"SPECIAL OFFER"**

**PURCHASE A SPLATTER MONITOR**

**GET A**

**SNG-1 STEREO NOISE GENERATOR AT A 40% DISCOUNT**

*Offer good thru  
April 30, 1996*

**Come See Us at  
NAB '96  
Booth 1602**

**DELTA ELECTRONICS**



**1-800-8-DELTA-8**  
Telephone 703-354-3350  
Fax: 703-354-0216

Delta Electronics, Inc.  
5730 General Washington Drive  
Alexandria, VA 22312



# Running Radio

Your Resource for Business, Programming & Sales

Scoring Big On The  
Laugh Meter  
See page 27.

## KRZZ: Neat-O Site with a Bite

by Alan Haber

**ALEXANDRIA, Va.** Greetings, loyal Haberspacers. It has been unusually busy here at the stately and plush *HaberSpace* Global Headquarters, where Webbers don't wobble — they just collapse from exhaustion as their pinky fingers hit the "Enter" key one last time to bring another URL to life on their computers.

My courageous (not to mention fearless) staff has earned some downtime after blazing one white-hot trail after another across the Web, seeking out the

example, overnight man J.T.'s shutter shot — you'll find that he was "kicked out of ZZ Top for being cooler than Dusty or Billy."

A nice selection of links, organized by category, is also available on KRZZ's site, which is, as the station says on its home page, under construction like ... you know who's face. Yup, this baby's just getting started, and what I see now looks real promising.

Operations manager Jack Oliver said new cool stuff is on the immediate horizon, including a virtual coupon that can be downloaded and used at a local merchant. Stop in at <http://www.southwind.net/krz/> and see what all the fuss is, and will, be about.

Three cyber-cheers for this month's Neat-O Site of the Month! But wait, there's more! Welcome our new monthly feature ...

This brand-spanking new Haberspace feature puts the spotlight on radio stations that are braving the new frontier of live broadcasting on the Internet. I talked about this topic in last month's Haberspace, and it won't be the last time, you can betcha!

This month, I'd like to single out two stations I linked to through Audio Net's handy-dandy site (<http://www.audionet.com>) (more on Audio Net next month). Dallas/Ft. Worth new rocker KDGE-FM has a great sound, which I played through the latest Real Audio player (version 2.0.0.7 Beta 2 for Windows 95). The fast-moving mix of music and afternoon drive

personality, "Alex on the Edge," made this edition of *HaberSpace* a joy and a breeze to write.

I also linked from Audio Net to "Unforgettable" KAAM(AM) in Dallas, which enabled me to type to the classic sounds of Barbara Streisand and Tony "Hey, the kids dig me!" Bennett. The quality of the sound wasn't as good as KDGE, but it certainly was more than simply listenable. And, remember, it is early in the game for this kind of thing. And it is going to get better!

### Up stuff

Other stuff that's up, radio-wise, on the Web includes the listener-supported WWFM Classical Network, comprising WWFM-FM in Trenton, N.J.; WWNJ-FM in Dover Township, N.J.; and nine translators in "Joisy" and Pennsylvania. Looks like this site is just getting started (station information and a list of links are available), but it's worth your time to take a look now at <http://www.thecore.com/wwfm>

It's always nice to stumble on something off-beat that's pretty cool, so imagine how happy I was to find myself at the Real Audio-enabled Real Voices site, the "Voice Talent Auditioning Gallery for the World Wide Web." You can listen to voice talent, hear a variety of special voice effects that include the ever-popular sounds of shouting, laughing and snoring, and even add your voice (or somebody else's voice you know — hopefully, you know the person, too!) to the roster. Check it out at

<http://www.realvoices.com/>.

News/talk KMOX, "The Voice of St. Louis," has a nice looking site at <http://www.kmox.basic.net/>. Love that white background, folks — as I've said before, solid design against a white background can be a great way to go for any site. Here, you can check out the station's sports talk shows, peruse schedules for the St. Louis Cardinals and Missouri Tigers basketball, and see what's happening on such shows as "The Morning Meeting" and "Total Information PM."

From Charlottesville, Va., adult rocker WWV, or 3WV, as it's called, is tearing up the Web with a groovy use of the latest Netscape craze: frames — meaning that the screen is partitioned to set certain information areas off from others. Frankly, I haven't been impressed with the use of frames so far, but I like what 3WV's doing with them.

On 3WV's site, you'll find information about the station's air staff, the 3WV "Music Hotlist," station promotions and local concerts. You can also e-mail requests for the station's "Business Lunch" feature and if you make a mistake, just click on the "Oops!" button and start over. The address: <http://www.vcstone.net/>.

Radio AAHS affiliate KKDS, out of Salt Lake City, Utah, has taken to the Web in a big way with some clever kids-like links to information about AAHS, programming and community sponsors. Dial 'em up at <http://kkds/intele.net/>.

Keep sending your e-mail my way. The address, as always, is [zoogang@ix.net-com.com](mailto:zoogang@ix.net-com.com). Gotta get back to Tony Bennett. Boy, that guy can sing!



best and brightest radio-oriented sites (and pausing, once in a while, to view the latest Dilbert cartoons). Let's get right to this month's goodies.

### Neat-O Site of the Month

I'm a sucker for radio sites with attitude, which makes Wichita, Kan., rocker KRZZ's cyberspace home my kinda place. From the colorful home page, which features an attention-getting, colorful custom background sporting the station's call letters and catch-phrase "Wichita's Rock 'n' Roll," you're transported to another page that gives you the choice of viewing the station's "Oh So Photogenic Jocks" or checking out "Other Cool Web Sites."

You know how a lot of Web sites tell you they are under construction? You know how much you hate that? (I do, I must admit — it's much better to keep upgrading your site's pages without telling Web surfers you're doing so). Well, KRZZ turns the "under construction" convention on its ugly head by proclaiming that its site "will always be under construction ... Kinda like Michael Jackson's face."

Attitude. You can't help but dig it.

On a nicely designed page that prompts you to "Say Cheese," (and presents you with a hunk of cheese just to drive the point home) you can click on the names of any of KRZZ's jocks and take a peek at their cyber-mugs. Don't miss, for

## THE SECRET'S OUT—DIGITAL FURNITURE

MODULAR  
FLEXIBILITY  
WITH A  
CUSTOM FIT

We Offer Six Elegant  
Lines of Studio Furniture

4153 BONITA STREET  
SPRING VALLEY, CA 91977  
PHONE 619/698-4658  
FAX 619/698-1268

**MURPHY**  
STUDIO FURNITURE

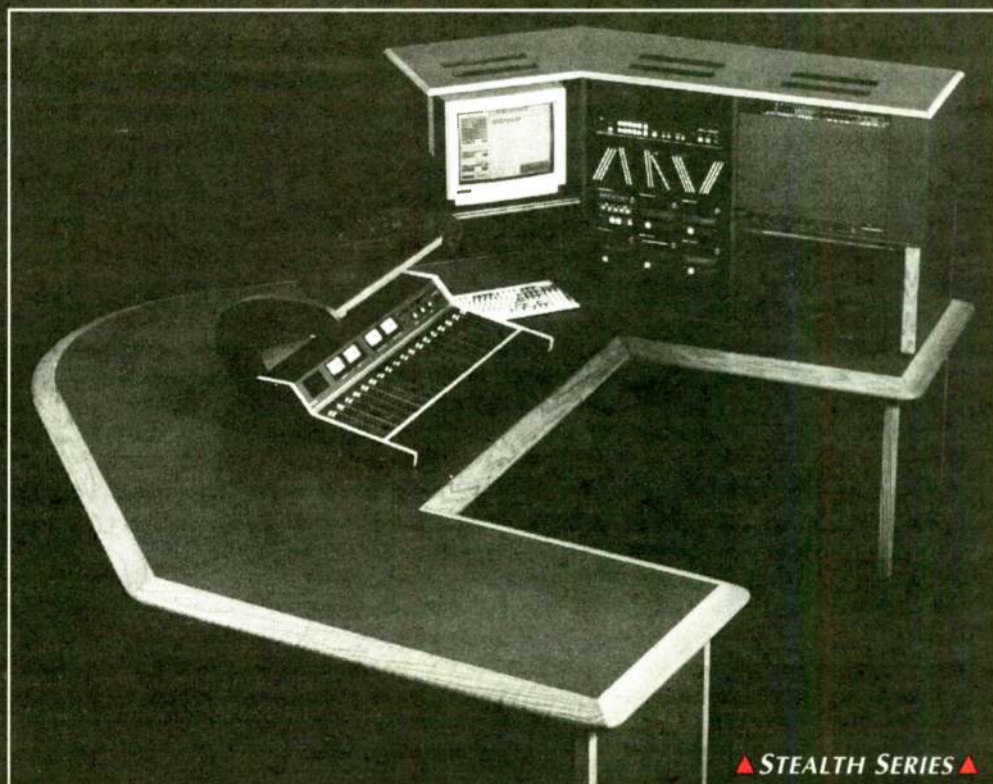

## MANAGER'S NOTEBOOK

# Planning Ahead for New Facilities

by Sue Jones

**BURKE, Va.** Will the lease on your station's space be coming up for renewal within the next six to 12 months? Has your station and staff outgrown your current leased or owned space? Perhaps you have consolidated some activities and had some natural attrition in staffing levels. Could you operate just as effectively in a smaller space for less cash outlay for office and studio space?

## Be aggressive

Managers often do not think of managing space as aggressively as they manage the general budget. Because space is one of the largest expenses, some aggressive planning and consideration could add a considerable amount to the bottom line profit. When considering occupancy cost, be sure to include rent, utilities, maintenance, taxes, parking, renovation costs and depreciation.

Also consider how the market forces could require different operations in the future. Factor in technological changes in broadcasting. Consider how re-engineering the space could change the station's layout requirements. Factor in how existing lease commitments should be adapted to such changes.

Before you start looking for additional space, there are some long-term planning

items that you need to consider and questions you need to answer: Amount: could you reduce the amount of space you are using? Price: could you reduce the price you are paying for space? Area: could you combine facilities with another station owned by the same owner to reduce overhead costs? Risk: could you reduce the financial risks of occupying your current space or new space?

At a minimum, you need to know the square foot per person costs. This will be the basis for comparison with potential new space and planning.

For example, a 14,000-square-foot station facility with 25 people would yield 560 square feet per person. If the rent is \$18 per square foot, the annual space amount is \$252,000 divided by 25 people or would be \$10,080 per person.

If you could reduce the occupancy cost per person by combining facilities, or build a newer facility with upgraded equipment, you may create more efficient space. The annual savings could be considerable.

Using the same example, reducing the amount of space needed from 14,000 square feet to 12,000 square feet with the same 25 staff members would be 480 square feet per person. Using the \$18/square foot, the annual space cost is \$216,000, which is a \$36,000 (14 percent) annual savings.

Calculate back in the renovation costs for

the new facility or for revamping the existing facility. It may take a year or more to recoup the renovation costs. However, over a five year plan the savings far outweigh the costs. In this example, if the renovation costs were \$36,000, the cost savings over a five year period would be \$144,000 (one year to recoup the renovation costs and four years at \$36,000 equals \$144,000).

If you consider reducing the price you are paying for the station facility, more savings could be realized. If the station facility is owned, under mortgage, consider refinancing when the interest rates drop as they have been in the past 12 months. Lower interest rates will translate to lower mortgage payments. That savings amount could be increased by increasing the term of the mortgage which will reduce the amount of annual cash outlay for space.

If you could reduce the price per square foot for leased space by moving to another facility or negotiating a better rate for a longer term lease, you could realize more savings. In the above example, if the price of \$18 per square foot was reduced to \$16 for 14,000 square feet the annual savings amount would be \$28,000 in savings annually or \$140,000 over a five year period.

Make sure that a longer lease period is consistent with the station's long and short term business objectives. A 10-year lease may be restrictive and a risk if

relocating the offices is a possibility before the end of the lease. A lease/buy-out could limit options in the short term.

The combined reduced space savings and the reduced price per square foot savings would be \$66,000 annual savings and \$284,000 over five years.

## Combined space

If more than one station is owned in a region, consolidation of office and tower facilities may be another type of savings. First, complete a space audit of the existing two facilities. Look at the major use of space such as circulation (corridors, aisles); core (lobbies, elevators); individuals (offices, furnishings); support (meeting rooms, closets, kitchen facility); and equipment (computers, copiers). Some of these office facilities could be shared. Certainly these would include circulation, core, support and equipment areas.

In addition to the lower square-foot cost for a larger space to accommodate two stations, additional savings could be realized in the renovation of the space for two stations. Improvements such as interior partitioning, fixtures and carpeting could be negotiated at a lower rate for one station compared with the same improvements for two stations. Equipment costs could be reduced or upgrades installed for the same costs.

Shared equipment savings could include telephone systems, kitchen/food facility, copiers and towers. You might consider leasing a color copier for the sales materials for the same cost that you would pay for leasing two high production black/white copiers for different stations.

continued on page 27 ►

THERE'S A DIGITAL SYSTEM IN YOUR FUTURE. YOU GET TO CHOOSE IT.

There are systems from software geeks, former PDs, and hardware guys.

THEY ALL FLASH THEIR SCREENS AND PROMISE MAGIC.

But this isn't about bells and whistles, is it?

THIS IS ABOUT WAKING UP TO YOUR pager.

THIS IS ABOUT YOUR reputation. THIS IS YOUR future.

Only AudioVAULT® has proven itself in the biggest, most technically demanding radio facilities in the world, and in stations like yours. But, all the computing power in the world is worthless without a long-term commitment to 'round-the-clock support. Broadcast Electronics will be here to fulfill that commitment.

**BE** BROADCAST  
ELECTRONICS, INC.  
WORLD LEADER IN RADIO BROADCAST TECHNOLOGY

Sample AudioVAULT on the  
World Wide Web:

<http://www.bdcast.com>

or e-mail, phone or fax us and we'll send you a demo kit.

[future@bdcast.com](mailto:future@bdcast.com)

217-224-9600

fax 1-217-224-9607

ROOTS OF RADIO

# 'Can You Top This' Classic Comedy

by Read G. Burgan

**LAKE LINDEN, Mich.** Did you hear the one about the barber who had been losing heavily betting on horses? This drove him to drink.

While in this condition, a minister came in for a shave and although he smelled liquor on the barber's breath, he didn't say anything.

After several minutes, the minister's face was a mess of blood from all of the nicks he received at the barber's unsteady hand. Unable to contain himself any longer, the minister remonstrated, "Now do you see the effect of liquor?"

"Yes," replied the barber, "it makes the face very, very tender."

Or about the man who was arrested for stealing petticoats from a department store? When he was brought before the magistrate, the judge asked him, "How do you plead? Guilty or not guilty?"

"Guilty, your honor. But can't you let me off this time? After all, this was my first slip?"

You may not be rolling in the aisles, but the first joke rated 900 on the "Can You Top This" laugh-meter and the second went over the 1,000 mark.

"Can You Top This" was one of those programs that was tailor made for radio. Four people sat around telling jokes, each one trying to outdo the other.

Only on radio could such a format survive and thrive. And thrive it did, for 14 years. In 1943 an estimated 10 million people listened to the weekly program and Time magazine said, "There is nothing quite like it on the U.S. air."

"Can You Top This" was the brainchild of Senator Edward Hastings Ford. The "Senator" part, like most of his jokes, was a made-up title.

The program itself was simply an outgrowth of a regular meeting at which Ford and the other participants would spend countless hours telling stories at New York's famous Lamb's Club. From the outset of the program in December

1940, Ford owned the rights to the program and was a regular participant.

The lynchpin for the program was actor Peter Donald who would begin each round of jokes by telling a joke submitted by a listener.

Donald was born in Bristol, England, into a theatrical family. By the time he was nine years old, he had traveled around the world twice. At the age of 10 he began acting in radio. Later he played Ajax Cassidy on the Fred Allen Show, and dramatized the voices of Winston Churchill, Field Marshall Montgomery, King George VI and the Duke of Windsor on the "March of Time."

Donald was quite a sight. He had red hair, a manicured mustache and black horn-rimmed glasses. He began on the "Can You Top This" program when he was only 22 years old. He was a wonderful

continued on page 30 ▶

## Facility Planning

▶ continued from page 26

More than one antenna could be installed on one tower depending on the stations' frequencies. However, a smarter/safer management decision may include keeping the two tower sites with auxiliary antennas for the other station on each tower. This would provide a backup for either station, in the event that one failed or was damaged, at a minimal cost. Also consider consolidated accounting functions on one computer accounting system. Combined automated accounting could provide separate and combined reporting for the combined facilities.

There are some additional practical considerations. Plan adequate time to renovate a new facility. Ordering, shipping and installing equipment can take longer than planned. Inclement weather conditions can significantly delay telephone installations and internal partitioning and wiring. Include your chief engineer on any facility relocation or renovation from the beginning of the planning stages. He can provide technical guidance that could save thousands of dollars. Your engineer will be aware of the station's FCC city of license and these limitations. Moving a station's facility 10 miles away could present a problem.

The chief engineer will want to know if a new building lease will permit antennas to be installed on the roof without additional costs. He will also be mindful of the microwave shot. Without his input, the geographical position of the new facility may require leasing expensive telephone lines or a two hop microwave. This type of information could make a significant cost difference in evaluating potential relocation sites.

Space planning and management can be an area of potential savings and should always be part of the strategic planning. Base decisions on solid business analysis instead of on standard practice. Using industry benchmarks is a useful guideline but will not reduce costs. You have to operate below industry standard costs to beat the competition.

□ □ □

Sue Jones is a principal in Bisset Communications Inc., a communications management firm located in the Washington area. She can be reached at 703-503-4999.

It's not whether you win or lose, but



where

you beam

the game.

For listeners all over the country, there is no big game unless you bring it to them through your sports network. And no one offers more trusted or reliable transmissions than we do. We're the *radio-only* experts at NPR, and we can help you design your very own sports network on Galaxy IV. Our C-band, Single Channel Per Carrier comes through, even in inclement weather. Plus, you get access to thousands of other stations. So, you may never be the hero who throws the bomb that wins the game, but you'll be the next best thing – the hero who beams the signal that brings the game. Call us today for more information at (202) 414-2626.



NPR Satellite Services<sup>®</sup>

Link up with us<sup>®</sup>

635 Massachusetts Ave., NW., Washington, DC 20001-3753 • (202) 414-2626

**NEW !!!**

# Digilink III-

## 4 x the power & On Sale !!!!



- **The #1 selling Digilink II has a new big brother !!!**
- **Digilink III has 4 times the processing power of Digilink II with...**
  - **Triple play capability (DL2 is dual play)**
  - **Dual audio outputs for On Air and Cueing (DL2 has one)**
  - **Do On Air & Production from a single workstation !!!**

Digilink III is a *NEW* multipurpose digital audio workstation for Live On Air, Production, and Automation. Fully compatible with the #1 selling and industry standard Digilink II, the Digilink III has four times the raw processing power of the Digilink II and features a second audio output for cueing an audio piece while playing on air.

The triple play and dual output capability of the Digilink III makes it ideal for very sophisticated Live On Air operation -*and*- makes it capable of operating an On Air & Production studio from a single workstation. For fast and complex live on air applications, the DL3 can play 3 files at once so that you can lay down a bed, play a phoner, and drop in a sound effect at the same time. Or, you can be playing on air with crossfade while independently recording, playing, and editing a phoner.

A unique capability of Digilink III is its ability to operate two studios from a single workstation. The most common application would be to use one workstation for both on air and production studios. The DL3 is placed in the production studio while a PCAT computer running Arrakis remote control software is placed in the on air studio.

The production studio has complete single play-record-edit capability while the on air studio can independently use dual play for on air. While not a redundant system, it does provide a dual studio workstation solution for under \$11,000.

To make the DL3 even more easy to use for air, a 99 button Gemini control panel can be added to the system for only \$1,195. It places hundreds of carts at the jocks fingertips and the files assigned to each button change to support up to 40 different jocks. The Smart\*Record feature of the controller even allows you to record a phoner at the push of a button. The DL3 will automatically trim the front and end of the phoner, and then you just push the button again to play it to air. The Gemini control panel makes the Digilink III workstation fast and easy to learn and use.



*The 99 button Gem-6CC control panel places hundreds of carts at your fingertips for only \$1,195*



*The 22,000 series console integrates the 99 button Gemini control panel into an easy to use console*

The powerful Digilink III is fully compatible with Arrakis Digilink II and Trak\*Star workstations so that it may be easily added to an existing network.

*Call now to find out how this amazing new workstation can be made to work for you.*

**for more information call... (303) 224-2248**

*in some areas, call (970) 224-2248*

# Sale !!!

DL3-600

# \$7,995

(a \$9,995 value)

#1 IN  
STUDIO  
FURNITURE

#1 IN  
AUDIO  
CONSOLES

#1 IN  
DIGITAL  
AUDIO

**arrakis**  
SYSTEMS INC.

2619 Midpoint Drive, Fort Collins, CO. 80525  
Voice- 303-224-2248, Fax- 303-493-1076

## Audio Consoles

The standout #1 leader in reliable, high performance, digital ready consoles for radio, Arrakis has several console lines to meet your every application. The 1200 series is ideal for compact installations. The modular 12,000 series is available in 8, 18, & 28 channel mainframes. The 22000 Gemini series features optional video monitors and switchers for digital workstation control.

### 1200 Series Consoles



1200-5	Five ch	\$1,795
1200-10	Ten ch	\$3,495
1200-15	Fifteen ch	\$4,995

### 12000 Series Consoles from \$3,995



### 22000 Series Consoles from \$6,995



## Digital Workstations

#1 in digital workstation sales, Arrakis has over 1,600 workstations in use around the world.

As a multipurpose digital audio record-play workstation for radio, it replaces cart machines, reel machines, cassette recorders, & often even consoles. Digilink has proven to be ideal for live on air, production, news, and automation applications. Place a workstation in each studio and then interconnect them with a digital network for transferring audio, text, & schedules between studios. Arrakis is the #1 choice of broadcasters.

### Satellite Automation



### CD Automation



Use for Live On Air, Automation, Production, News & Scheduling



### Digilink & Trak\*Star Workstations

## Studio Furniture

With over 1,000 studios in the field, Arrakis is #1 in studio furniture sales for radio.

Using only the finest materials, balanced laminated panels, and solid oak trim, Arrakis furniture systems are rugged and attractive for years of hard use.

Available in two basic product families with literally thousands of variations, an Arrakis studio furniture package can easily be configured to meet your specific requirement, whether it is simply off the shelf or fully custom.

Call Arrakis to find out how easy it is to design and build your next studio.

### Desk\*Star studio furniture systems



### Modulux studio furniture systems

## Complete systems...

As illustrated in the Sony Worldwide Networks master control studio on the right (one of seven Arrakis studios in the Manhattan, New York complex), Arrakis can provide complete major market studios with Arrakis consoles, digital workstations, video-audio switchers, furniture, and system prewiring.

With a choice of several console lines; digital workstations for live air, production, news, and automation; and two major studio furniture product lines, Arrakis can meet broadcasters needs from the compact news studio to the major market network origination center. Complete Arrakis equipped studios can be found around the world from Tokyo, to Moscow, to Japan, to Tahiti. Call Arrakis today for your equipment or studio needs,

**Sony Worldwide Networks**  
Manhattan, New York



# 'Top This' Was Tops

► continued from page 27

ful dialectician. When he recounted a listener's joke, it was in full dialect and dramatized to the hilt.

He gave you the feeling that you were sitting in a pub with friends who had hoisted just enough to become well oiled and were now telling their favorite jokes for all they were worth.

Each week from 3,500 to 12,000 letters were received from listeners submitting jokes that they hoped would be read over the air. If their joke was read and their rating on the laugh meter beat the jokes of the program's experts, they would receive cash prizes.

Only four or five listener jokes were

used in any given week. Ford claimed that they never received any new jokes, only variations on old ones that professional comedians had used for years.

No one got rich by having their jokes read. In the beginning, the listener received \$5, plus an additional \$2 for each of the experts he bested, for a maximum of \$11. Several years later, the minimum amount had increased to \$10, with a maximum of \$25 and some samples of the sponsor's products.

In later years, a listener also received a phonograph record of Peter Donald telling his story.

The task of reading through the 3,500 plus letters each week fell to Betty North,

who was a vaudeville veteran. In a small office not far from the Lamb's Club, she kept several filing cabinets full of jokes sent by listeners.

Certain subjects were taboo, including death, religion, race, deformities and stuttering. It makes you wonder where today's comedians would be with those restrictions.

Some listeners sent risqué jokes, knowing they would never be used but thinking that the unassuming Ms. North would nonetheless be amused by them.

An acceptable joke had to be one that could be told quickly and that did not require any visual cues for the audience to understand it. Ms. North was adept at selecting jokes that would make a hit with the "Can You Top This" audience.

The rules of the program were simple. Peter Donald first would read a joke

submitted by a listener. The studio's response was registered on a "laugh meter." The laugh meter consisted of a microphone aimed at the audience, amplified and displayed on a large meter shaped like a man's smiling face with a scale divided from 0 to 1,000.

Three guest joke experts appeared regularly on the program: Senator Ed Ford, Joe Laurie Jr. and Harry Hershfield. The three professional comedians boasted a combined collection of more than 15,000 jokes.

Joe Laurie Jr. was known for his diminutive size. He liked to quip that his greatest thrill was when a midget looked up at him. He was a writer for Al Jolson and Eddie Cantor, had a regular column in *Variety* and was in demand as an after-dinner speaker.

Harry Hershfield had been a cartoonist whose character "Abe Kabibble" appeared in comic strips. His regular column appeared in the *New York Daily Mirror*. He was also a photographer, reporter, banquet toastmaster and screenwriter.

Senator Ed Ford cut his teeth in vaudeville and authored a book titled, "After Dinner Speaking and Other Forms of Insanity."

## In the studio

The three studio joke experts were not given access to the listener's jokes prior to the program and they were not allowed to bring any written notes to the broadcast. Further, their jokes had to be in the same category as that of the one submitted by the listener, which could range from barbers to jealousy to drunks ... you name it.

Each time a joke was told, the highest rating it received was read on the laugh meter. If the listener's joke, as told by Peter Donald, received a higher rating than the expert's, a small sum was added to the amount the listener received.

If a listener's joke was topped by all three experts, he was sent a joke book written by the three experts.

The strength of the program was the manner in which the four studio joke tellers delivered their jokes. Most of the jokes were ethnic jokes, the majority falling into one of several categories: Jewish, Irish, Scottish, Italian, Swedish and German.

Each of the three experts was uninhibited in using the most outlandish, stereotypical dialect in acting out his story. Joe Laurie Jr. sounded like an international Joe Pesci.

The half-hour show originated in 1940 as a local program on WOR(AM) New York. In 1942, NBC put it on its Saturday night schedule under sponsorship by the Colgate Palmolive company.

The program moved to the Mutual network in 1948 then to the ABC network in 1950. In the best tradition of "What goes around, comes around," the program returned to NBC in 1953.

After a final year on NBC, "Can You Top This," like most of the other network radio programs, found that it could no longer top TV.

Special thanks to Bill McCracken of the Radio Historical Society of Colorado for providing material from their well stocked reference library.

□ □ □

Read Burgan is a free-lance writer and a former public radio station manager who can be reached at 906-296-0652; or through e-mail at [rgb@up.net](mailto:rgb@up.net)

## Strengthen Your Airchain

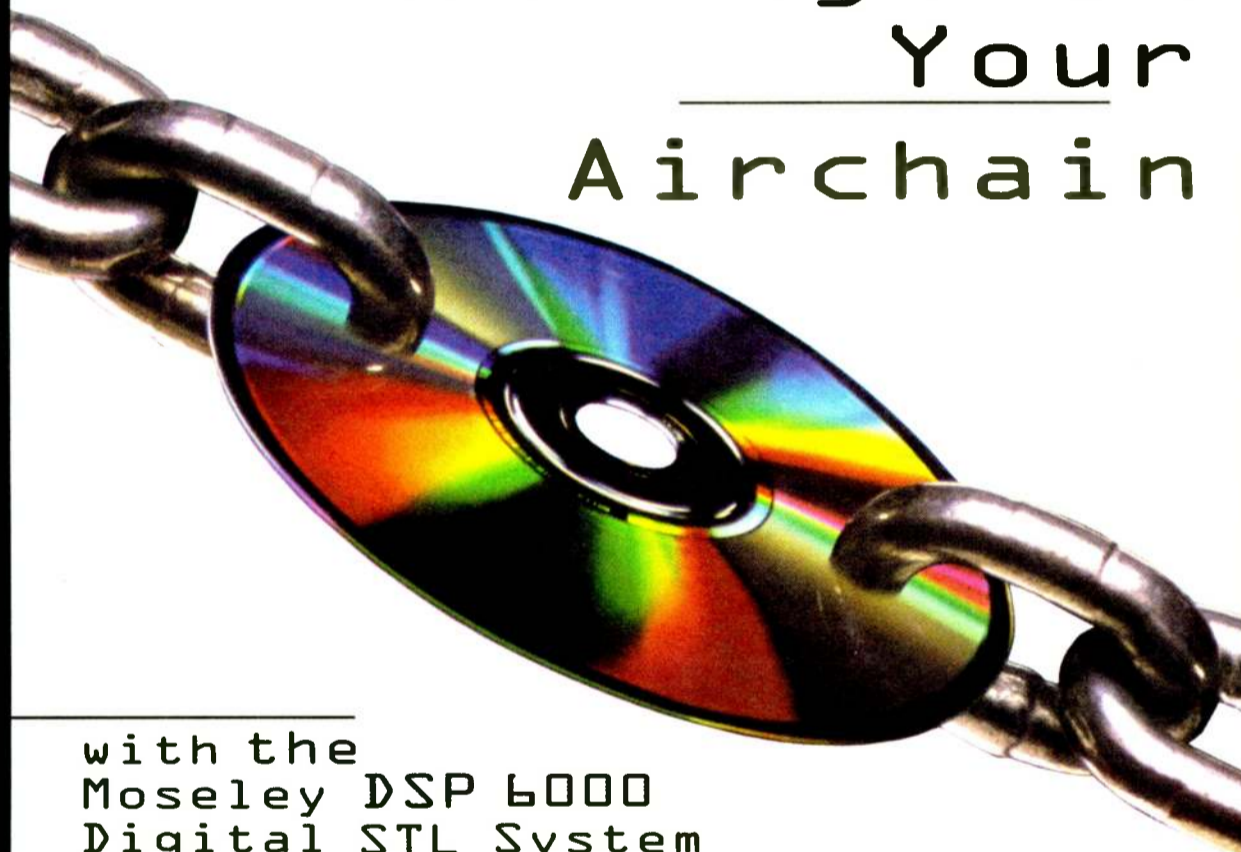

with the  
Moseley DSP 6000  
Digital STL System

The strength of any chain is always determined by its weakest link. Same is true of your Airchain. You may have the finest format, talent, studio facilities and audio processing, but if your link to the transmitter isn't a Moseley, you could be in for some tough breaks. Sonic clarity and reliability are what you and your listeners demand. Nothing fits the bill like a Moseley Digital STL System. The DSP 6000 virtually eliminates the problems associated with conventional analog transmission systems such as noise due to signal fades, birdies from intermod interference, and lack of spectrum for multiple audio feeds to LMA and Duopoly sites. The DSP 6000 digital encoder/decoder works with any existing Moseley composite system to give your link the digital upgrade necessary for today's audio purity.



Equipment Solutions To Keep You Number One

**BSW**  
BROADCAST SUPPLY WORLDWIDE

Phone: 800 • 426 • 8434 Fax: 800 • 231 • 7055  
Internet Website: [www.bswusa.com](http://www.bswusa.com)

Legendary Quality. Uncompromised Audio. Incredible Reliability.  
Moseley STLs — Strengthen your Airchain.

# WVKZ: All Bets Are on This AM

by Lee Harris

**NEW YORK** Some peculiar businesses and organizations have been the licensees of radio stations over the years, but one of the oddest licensees of the modern era would have to be Capitol District Off-Track Betting.

As the name implies, this is the agency that handles the lucrative off-track betting operations in the Albany, N.Y., area. The agency is also the owner and operator of WVKZ(AM), Schenectady, N.Y., operating on 1240 kHz with 1 kW full-time.

This strange mix of businesses results in some unusual programming, like a broadcast of the Catholic rosary followed by the latest racing results. However, the WVKZ story may provide some lessons for AM operators who no longer know what to do with their stations.

## Sprawling market

Under a succession of call letters and owners, the station now known as WVKZ had served the Albany market since 1942, but by all accounts it had never served it very well. There was of course a power problem for a class IV AM trying to cover a sprawling market. And there was the competition, most notably Schenectady's own WGY, a 50 kW clear-channel legend. The little station at 1240 always labored under the giant shadow cast by WGY with its killer signal and enormous resources. Then came FM.

By 1989, the owners of WVKZ were focusing all their attention on their new class A FM operation WWCP, which was also struggling in the over-radioed market. WVKZ was an unproductive nuisance. A deal was struck with the OTB people, who essentially offered to take WVKZ off the owners' hands.

The five-year agreement, signed in 1989, gave OTB the right to program almost all the air-time on WVKZ for \$35,000 a year, an amount to be paid lump sum to the cash starved owners every year. OTB also had an option to buy the station outright for the somewhat inflated price of \$350,000. Because WVKZ retained only 10 hours per week for its own use under the contract, OTB was paying a ludicrously low \$4.26 per hour for use of the radio station.

Station management considered it a good deal, because it relieved them of the responsibility of programming WVKZ and the even more formidable task of selling spots.

The OTB revenue, while nominal, was dependable. By 1995, the fight in the Albany market had become too costly for the owners of WVKZ and its sister FM. The operations were sold for a fraction of their acquisition cost. OTB snapped up WVKZ for about \$100,000.

OTB turned WVKZ into an adjunct of its substantial cable-TV operation. From

its own TV production facilities, OTB transmits races from local tracks and simulcasts from tracks all over the country. The audio from the race calls is also carried on WVKZ.

General Manager James Barber said the idea was to bring the races and betting

**Under a succession of call letters and owners, WVKZ had served Albany since 1942.**

information to people who are not served by cable or cannot access cable because they are at work. OTB cable and WVKZ also carry such shows as "Morning Line Handicapping" and "Post Time," electronic versions of the betting sheets old-time race track habitués used to keep stuffed in their back pockets.

## Praying for a winner

Of course, the ponies do not run 24 hours a day, so WVKZ carries the One-on-One Sports Network out of Chicago whenever there is a lull in the turf-side action. This amounts to about 12 hours a day. There is one other noteworthy departure from the banter of the "jockey-jockeys." Each morning at 8:30, WVKZ broadcasts a recital of the Catholic rosary. This is not to remind

listeners of the wages (or is that wagers?) of sin. It is paid programming inherited from WVKZ's pre-OTB days. The woman who personally foots the bill for the broadcast opted to continue with the program even after the format change, and OTB opted to continue to take her money.

WVKZ does not sell any spot time, nor does it originate any local radio-only programming. There are no employees assigned full-time to WVKZ. The station has no discernible ratings and program director Rick Parry said he gets relatively little feedback about WVKZ.

Management considers the station just another channel of distributing for OTB information and advertising, and in that respect Barber considers it a success. He said that Capitol District OTB has already attempted to purchase several other stations in its service area and is still looking for likely purchase candidates. Barber's main requirements are that the station be full-time and cheap.

It is clear that WVKZ does not fit the standard concept of a radio station serving the public interest. And the folks who first put the station on the air in 1942 might be shocked to learn what has become of their baby. Still, times have changed, and while station values are generally recovering, survival options remain limited for the WVKZ's of the world.

With hundreds of AM stations having pulled the big plug over the past five years, unorthodox approaches like WVKZ's could save some stations from oblivion while providing AM radio a place in today's information-on-demand environment.

## Next Generation Satellite Automation NOW !

(and a lot more)

**Top 10 reasons more radio stations and networks alike are choosing CartWorks for satellite automation?**

10. **Simple Operation.**  
CartWorks is undoubtedly the easiest digital audio system to learn and operate.
9. **Windows**  
Operators already familiar with Windows become instantly productive.
8. **Price.**  
Very competitive. Well below many.
7. **Powerful.**  
CartWorks' script based automation handles task previously not possible.
6. **Performance.**  
Developed by radio professionals, not database programmers.
5. **Reliable.**  
Only the latest and best industrial grade PCs and apt-X digital audio.
4. **Support.**  
24 hours a day by real world radio professionals. We've been there.
3. **Modern.**  
Hardware standards adjusted weekly to insure you get the best value at the time of purchase.  
Software, Windows' ... Need we say more.
2. **User manual.**  
Perhaps the most readable in the industry. However you probably won't need it, thanks to our exclusive Hyper Help system.
1. **Something big.**  
To be announced at NAB 96.

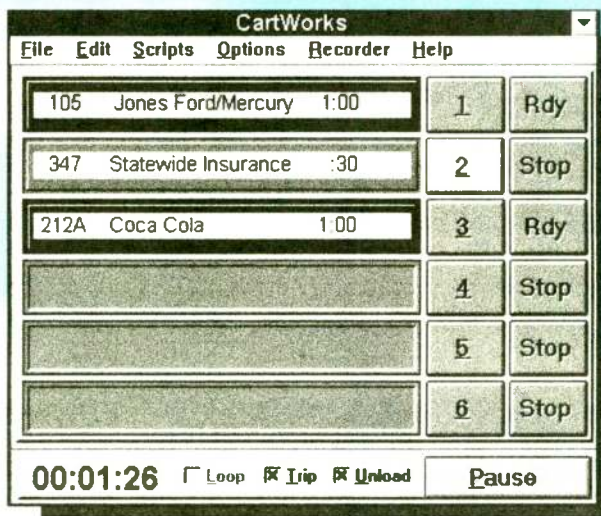

## CartWorks

Digital Audio Systems

Satellite Automation Starts at

**\$ 6,995 Complete!**

To learn more, call dbm Systems today.  
1-800-795-RADIO Fax (601) 853-9976

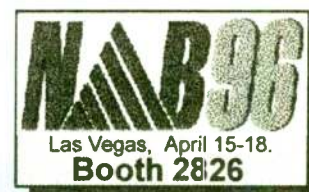

\*Windows is a registered trademark of Microsoft Corp.

## PIONEER PROFILES

# The Dream of Earle C. Anthony

by Barry Mishkind

**TUCSON, Ariz.** It was summer 1970, when I was hired on as a vacation relief engineer at KFI(AM). It did not take long for me to realize this was more than "just another radio station."

One quick example: the KFI intercom system was a series of telegraph keys in the control rooms. For many years, a criterion of who was qualified to work at this powerhouse had been whether the person understood and could tap out Morse code messages as the program sources moved from studio to studio.

It was not merely the five studios, nor

just the large amount of custom equipment built by the station's engineers over the years, nor a master control room filled with racks of patchbays and relays. Everything in the station was capable of being instantly replaced just by "patching around" it, from the microphones to preamps to key switches. There was "history" everywhere.

## Old-timers

Then there were the 25 names on the engineering staff list. The eye-popper was the date of hire on the right side. The two co-chief engineers started in 1924, more than 45 years before, just two years

after Earle C. Anthony had put his first 50 W transmitter on the air. Several more had over 40 years of service. The whole station seemed to "reek" of history.

It was anything but history, however, that moved Earle C. Anthony to construct KFI in 1922. Anthony been a keen technologist from youth. At 17, he built a working electric car, then a motion picture camera. With his father, he developed a car dealership and invented the "filling station," opening the first two in California. His symbol was the chevron, which he sold to Standard Oil a few years later. He even influenced the building of the Golden

Gate Bridge and started what would be the Greyhound Corp.

However, the reason we are talking about Earle C. Anthony today is yet another innovation that he grabbed hold of: radio. An article in *The Saturday Evening Post* sparked his interest in a potential way to communicate between his dealerships as well as an interesting hobby.

He built a transmitter literally on a breadboard on his kitchen table, and began broadcasting on April 16, 1922.

True to his entrepreneurial background, Anthony immediately saw the value of the radio station was for more than internal communication; it could be of value in bringing in new customers to his car business. Arranging with the Los Angeles Herald and Examiner newspapers for news reporting, regular programs began to go out every day. And lest you wonder who was responsible for it all, the station ID at the top of the hour would be "This is KFI, the Radio Central Superstation of

**The two co-chief engineers started in 1924, just two years after Earle C. Anthony had put his first 50 W transmitter on the air.**

Earle C. Anthony, Incorporated, California Packard Distributors."

Another early method of advertising the station was the mounting of signs emblazoned with "KFI-PACKARD" on the KFI towers up on the roof of the auto dealership. Even the dashboard plaques placed in his cars mentioned KFI. Through the years, Anthony worked hard to promote KFI and KECA, which he bought in 1929, only to be forced by the FCC to sell in 1944. Once he offered to give a crate of California oranges to every listener writing in.

However, even Anthony had failed to comprehend exactly how popular was this new medium. He got so many cards he was forced to find the smallest possible oranges so he could ship three in a miniature "crate" to each listener. A distinctive QSL stamp was also produced to send to listeners, incorporating the KFI towers, orange groves, mountains, and of course, a Packard radiator. (Figure 1)

Over the years, in order to maintain its place as a clear channel and showpiece facility, KFI kept increasing power until in 1931 it became the first in Southern California to be run at a full 50 kW.

## Long reach

Billed as the "country's most powerful station" (based on the combination 50 kW at 640 kHz), KFI certainly proved to have a long reach. Heard throughout the West, KFI was at least as important a station as any of the clears in the east and midwest.

NBC tried several times to purchase KFI, but Anthony was steadfast in refusing any offers. He told NBC "I wouldn't sell my wife. Why would I sell KFI?"

Of course, being such a successful radio operator permitted Anthony to be properly eccentric. Typical of the stories

continued on page 34 ▶

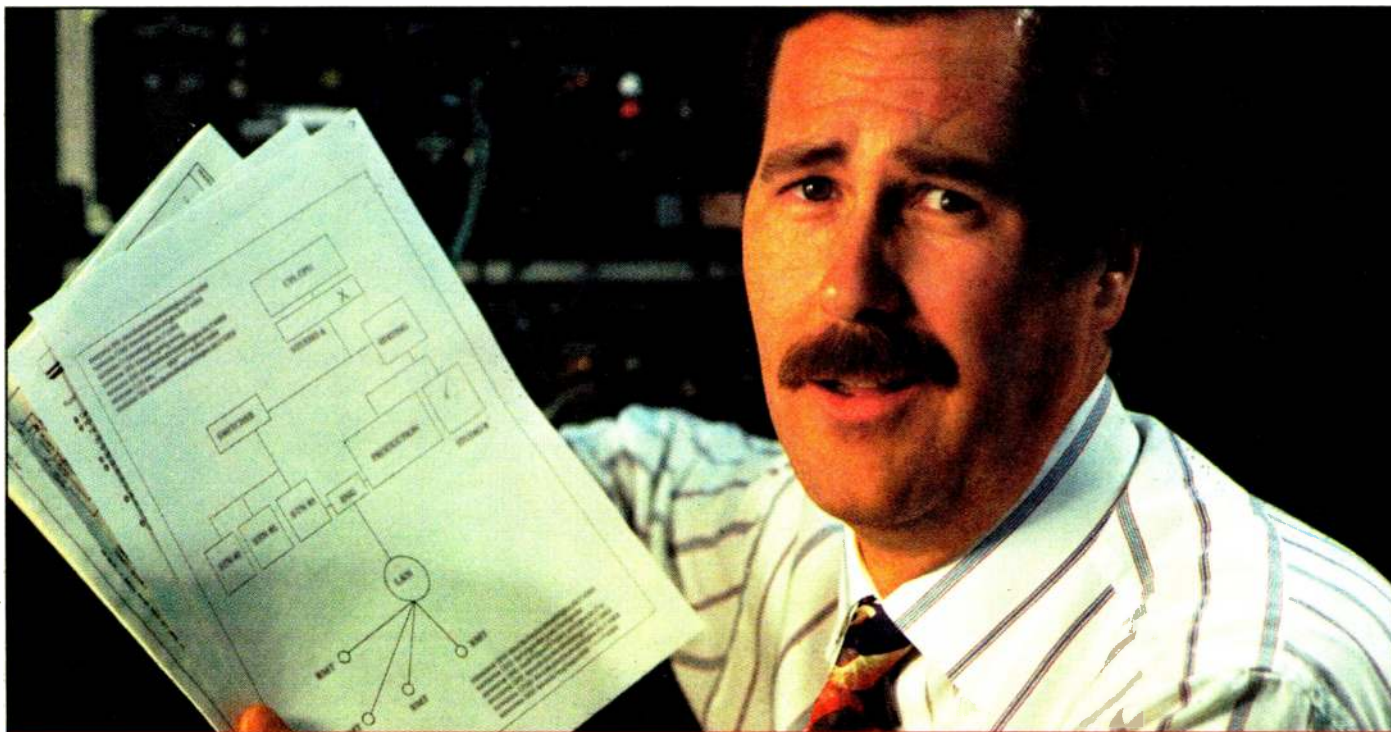

TRYING TO MAKE SENSE OUT OF DIGITAL AUDIO SYSTEMS?

## There is a better way!

It's not easy trying to understand the conflicting claims made by different manufacturers when you're buying a Digital Audio On-Air & Production System, whether a single, multipurpose Workstation or an integrated, multiple studio setup. At one end of the spectrum, you're faced with a wide variety of simple "Cart Machine Replacements," and on the other, products whose complexity confounds even the most seasoned broadcast engineer.

The ENCO DAD486x Digital Audio Delivery System solves the problem! DAD is simply the most powerful On-Air & Production system available, yet its uncomplicated approach and inherent ease of operation makes immediate sense to any user.

- Intuitive On-Screen displays that are immediately familiar to operators. Optional Touchscreen makes operation quick and easy.
- Complete On-Air flexibility with various "Virtual Machines" for Live Assist, Automation, or Satellite Programmed operations. Interface to other equipment plus scheduling and billing packages. Seamless segue and voiceover transitions sound "Live" in all modes. Script capabilities can be included.

- Full production capabilities, including Graphic Cut & Paste Assembly Editing. Includes analog and digital inputs/outputs. Interfaces with most multichannel editing packages.
- Runs on DOS for proven speed, reliability, and compatibility with other equipment; not an operating system originally intended for multimedia applications. This is a professional tool meant to produce efficiency and profits, not entertain the staff!
- Operates on common off the shelf computers and network architecture. You won't be locked into proprietary hardware that may not be available whenever you need service.
- No monthly licensing fees, DAD is an outright purchase. Software upgrades are free for the first year.
- DAD is proving itself everyday in radio and TV facilities worldwide.

Call Your DAD486x Dealer or ENCO  
For Complete Information

 **ENCO**  
SYSTEMS, INC.

24403 Halsted Road, Farmington Hills, MI 48335 USA  
TEL: 800-362-6797 or 810-476-5711 FAX: 810-476-5712



re·li·a·ble (ri lī'ə bəl), *adj.*

1. that may be relied on; trustworthy.
2. dependable in achievement, accuracy.
3. the PR&E BMX III.

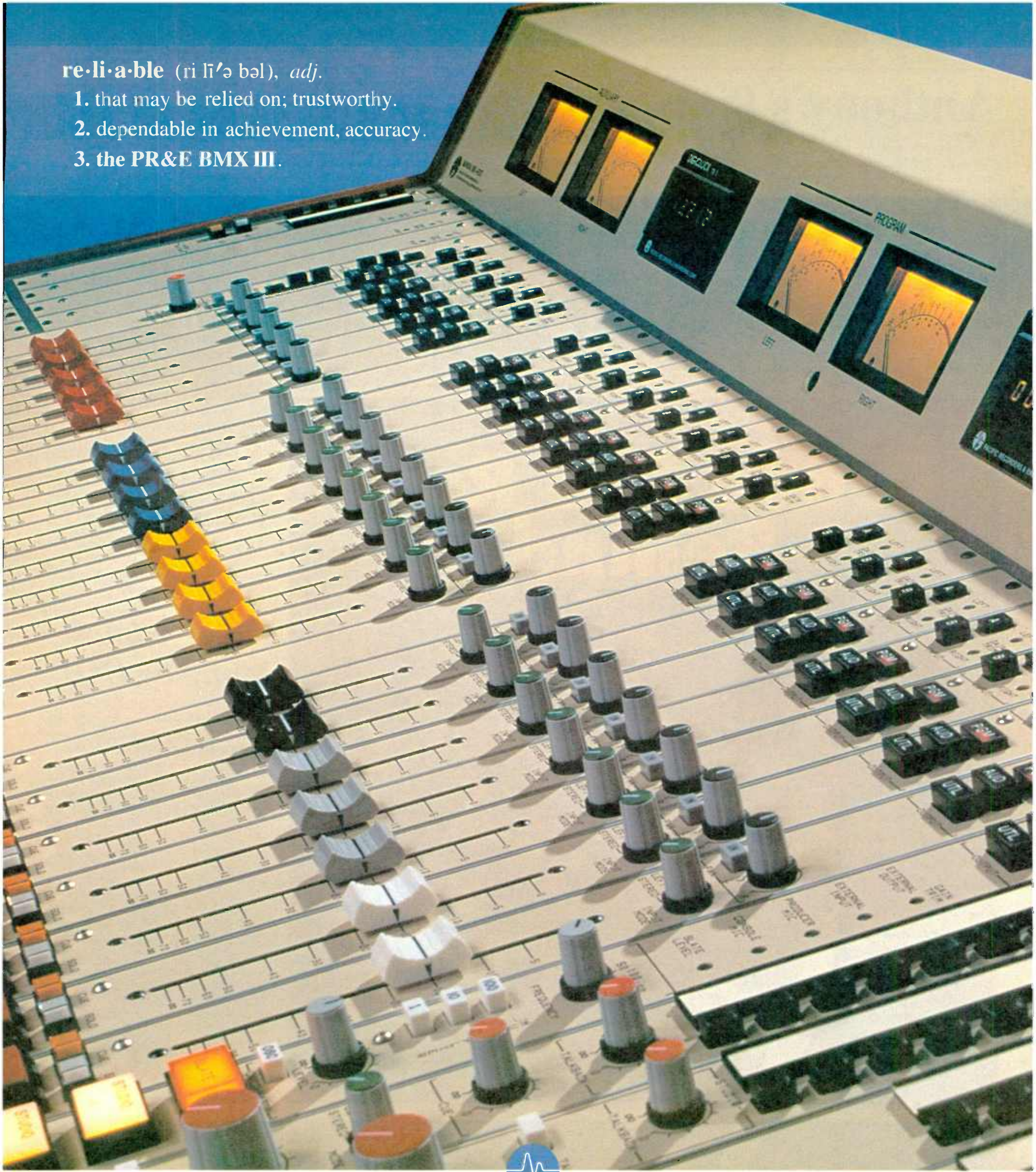

**PACIFIC RECORDERS & ENGINEERING  
DESIGNS THAT MAKE THE DIFFERENCE**

2070 Las Palmas Drive, Carlsbad, CA USA 92009      GSA Contract: GS-03F-4064B

Tel: 619-438-3911      Fax: 619-438-9277      E-Mail: [sales@pre.com](mailto:sales@pre.com)

Circle (103) On Reader Service Card

World Radio History

# Anthony's Pioneering KFI(AM)

► continued from page 32

told in the KFI hallways was one about the time Anthony was in his personal train car on the way to the Midwest. It was not uncommon for him to call in requests for his favorite records, but on occasion he would also instruct the staff to "turn it up louder so I can hear it better out here."

Another time late at night, tired of "cowboy songs," Anthony wrote "the ultimate cowboy song," had a singer brought to his mansion where they recorded it, and then immediately took it to the KFI studios to be put on the air. It was reported 20 people called in wanting to buy the new song!

KFI also pioneered in FM and TV operations, but these did not turn out to be as successful or profitable as the AM station and were sold off. Even when the Packard dealership began to wane in the 1950s, Earle C. Anthony took comfort in his KFI.

"Every morning before I get up, I kiss a microphone," he told his chief engineer.

I was not privileged to have been able to spend

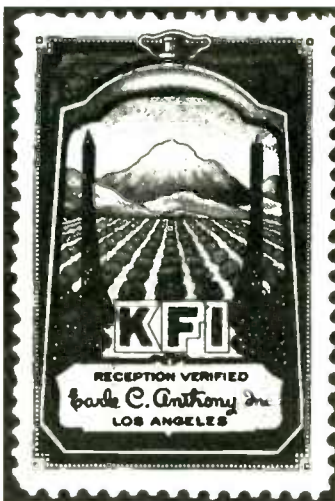

time with any of the gentlemen who built the station. Earle C. Anthony died in 1961. When I arrived in 1970, the station was being sold and the chief engineers were going into retirement. Today, I can only recognize and sigh over the loss of opportunity.

Nevertheless, during the time I worked at KFI, I was able to wander the halls, spend time in each studio. Even if I do not have photographs

to remind me, I still have strong memories of a station built for broadcasting. Later, when the movie "Lady Sings the Blues" came out, I was pleased to see they used the old Studio A auditorium as a set.

A grand old lady, turning 74 this year, KFI continues to cover the Western states from Los Angeles as a talk station.

My thanks to Marvin Collins, chief engineer of KFI, for his help in supplying some of the materials on Earle C. Anthony. Unfortunately, I couldn't talk him out of the original transmitter that sat in the lobby for many years.

Also, in response to several enquiries about Charles "Doc" Herrold, let me mention the PBS program written, directed and produced by Mike Adams of San Jose State University. A videotape of the hour program "Broadcasting's Forgotten Father — The Charles Herrold Story" can be ordered by phone from the Perham Foundation at 408-734-4453.

If you have suggestions for future *Pioneer Profiles* or would be willing to share materials, please help share and save broadcasting's history. My address is 2033 S. Augusta Place, Tucson, AZ 85710. Thanks!

□ □ □

Barry Mishkind can be reached at 520-296-3797, or [barry@broadcast.net](mailto:barry@broadcast.net) via the Internet. You can find his home page at <http://www.broadcast.net/~barry/>

## Leave The Rest Behind

**Travel light to your next remote.**

The Codec Buddy is a high-quality remote mixer that will work with any delivery system from POTS to RPU to ISDN. The Buddy handles program mix, headphone feeds, communications, codec return, and PA feed...with a built-in one-line frequency extender as a bonus.

All of this in a rugged 8 lb. package for only \$1900!

**COMREX**  
We make great connections



Call us for details  
**800-237-1776**

<http://www.comrex.com>

COMREX Corporation, 65 Nonset Path, Acton, MA 01720 USA Tel: 508-263-1800 Fax: 508-635-0401  
Email: [info@comrex.com](mailto:info@comrex.com) Fax-on-Demand: 508-264-9973 Toll-free: 800-237-1776 in N.A. or 0-800-96-2093 in the U.K.

Circle (44) On Reader Service Card

World Radio History

## KTOZ Almost Stung by DOL

► continued from page 13

being forced to work anywhere," said Maisano. "They're doing this out of a love. It's bad if the government's going to jump in the way of that. I think it's wrong."

Maisano has his doubts about the way the DOL acted in the KTOZ investigation. "It doesn't seem like they used common sense," he said.

Senator John Ashcroft (R-Mo.) reacted strongly to the DOL's action, saying that "if this is the most important thing they've got to do, they have seriously misunderstood the priorities of the Labor Department."

Ashcroft said that he thinks "people ought to be free to volunteer their time to promote causes as well as enterprises in which they believe, and we need to move in that direction. To have our labor department interfering with that right is disconcerting."

Johnson thinks he may be testifying in front of the Senate on the matter that's occupied much of his time for the past nine months. He already testified in front of the House of Representatives last Oct. 25. During that appearance in Washington, Johnson recounted the events leading up to the DOL's investigation and the eventual dropping of the investigation.

"We, as citizens of the United States of America," he said during his appearance, "feel that we should be able to volunteer our time, if we wish to do so, without some bureaucrat harassing us."

That same day, in a written statement, U.S. Secretary of Labor Robert B. Reich declared the DOL's full support of volunteers "who want to use their free time to help other people." Reich noted that, after investigating the complaints received by the DOL about KTOZ, the DOL "found there was no reason to suspect coercion."

USER REPORT

## Oktava Comes with Many Surprises

by Janis V. Bers  
President  
Ian Richards Production Studios  
Announcer  
WIOG(FM)

**SAGINAW, Mich.** When it comes to reviewing audio equipment, I feel most fortunate that by having a professional background in radio, television and commercial music production, it not only makes my task an easy one, but also a most pleasurable and interesting one that very often throws up quite a few surprises.

This was certainly the case during the latter part of 1995 when I noticed a most curious looking microphone enter the trade journals distributed by Harris. Named the Oktava MK219 studio condenser microphone, the unit boasts the classic design of a large diaphragm gold-plated capsule offering a true cardioid polarity pattern. Incorporated in its discrete active circuitry operated on 48 V phantom powering is a 10 dB switchable attenuation pad and a switchable low frequency rolloff at 50 Hz.

### From Russia with love

Not German, Austrian or even American, this little beauty comes from Russia with love, and its design has been around there for over 30 years. The Oktava company goes back even further than that, being well respected in its homeland for the manufacture of telephone equipment, speakers, headphones and radios.

Curiosity got the better of me and I simply had to have one. Out of the supplied plastic case, the MK219 is similar in appearance to

earlier Sennheiser designs — black-bodied with a mesh grill at the microphone head and XLR male connector at the base. Some have described the unit as ugly, whereas I would prefer to call it basic but business-like. The microphone is a bit like looking at a model of a coffin about 7 1/2-inches long. Plug this microphone in and the coffin very much comes to life.

My choice of test equipment was an easy one, and the same which I have used for auditioning all the other microphones I have had the pleasure of working with: a good pair of human ears and the shortest route to get signals from the microphone to speakers or headphones.

I adopt this philosophy simply because the intended destination of the sound that this or any other microphone is capable of achieving is common to all of us as listeners, and with very few exceptions do we as radio or hi-fi buffs possess banks of highly sensitive or accurate audio test gear. I believe our ears have always had the final say in what sounds good or not so good.

Using these ears, the Oktava MK219 does sound good. I chose to audition the MK219 as an announcer's microphone in on-air and production studios of a radio station.

### Warmth and clarity

In the air studio of WIOG(FM), the MK219 exhibited a warmth and clarity to my voice that was very reminiscent to the Neumann U87s I had been using in this capacity at the BBC in England for many years. The Oktava was run flat through a standard Audiotronics broadcast board with

no attenuation or bass rolloff and oozed with quality.

For the human voice, this unit benefits from being fairly close-miked (about 12 inches, 45 degrees side-on to the mouth) for a rich, rounded vocal range. No windshield or pop filter was required for this application since it was only dealing with the spoken word. Not one splat or explosive was heard during a full five-hour airshift.

I had my colleagues and friends listen to this particular show on car radios, hi-fis and portable radios and they all agreed that I sounded knockout. Similarly excellent results were observed in the station's commercial production suite running the MK219 flat through a Ramsa production board direct to tape. Several quality commercials using this microphone are presently airing on the radio station.

The Oktava began to show its true colors of versatility in the music recording studio. Again, to keep the audio chain as short as possible, the microphone was run flat into a Mackie 1604 recording mixer connected directly to an Emu Darwin digital hard-disk recorder running at 48 kHz sampling rate.

Starting with the human voice again, but this time to record singing, the MK219 benefitted from being placed about three feet away from the singer. The warmth and clarity that this microphone seems to enjoy giving the voice was in no way compromised by the distance.

### Quell the explosives

In some instances, a pop shield was required to quell some of the explosives



The Oktava MK219 tested well.

that the more powerful singers produce. In every case using solo male, solo female and a combination of both, the MK219 produced a wonderfully balanced vocal sound with every vowel and consonant clearly distinguishable.

You are probably thinking that there is nothing that this microphone is not capable of achieving and can do no wrong and, for the most part, you could be right. In each application I have auditioned this unit I have found it to be abundantly honest, versatile and downright useful. Sure it is a bit weird and antiquated looking, but in all the time I have used this microphone I can tell you that I have never noticed its physical presence; but I have noticed what it is capable of.

From a price point alone, if bang for the buck could be equated to the power-to-weight ratio of a formula one racing car, the Oktava MK219 would be the first across the line in grand prix audio.

□ □ □

For more information on Oktava from Harris, contact Deb Chagares in Indiana at 317-962-8596; or circle Reader Service 12.

## Running Radio Marketplace

### A Supermarket of Radio Station Services

For information on the services shown below, circle the Reader Service number on the enclosed card or contact the advertiser directly.

## Attention Advertisers!

Reach **18,000+** broadcast professionals. RADIO WORLD's **Running Radio Marketplace** provides a perfect medium for test marketing your products and services. It's an efficient, effective and affordable advertising option!

For more information, including rates and deadlines, Fax **Christopher Rucas** at

**703-998-2966**

or Call **800-336-3045**



Direct From Music City, USA  
The **Nashville Record Review**, hosted by Katie Haas and Bill Cody, counts down Country's Top 40 with a four-hour weekly syndicated radio program produced on compact disc.

For more information contact

East: **Francie Leader**  
(203) 965-6427

West: **Lynn Wells**  
(303) 771-9800

Reader Service No. 188

## USER REPORT

# Sanken Jazzes Up Live Broadcasts

by Malcolm H. Harper, Jr.  
Owner  
Reelsound Recording Co.

**AUSTIN, Texas** Having spent 27 years in location recording, the search for the best microphone and placement has always been my priority. Eight years ago when I became audio director for a classic jazz series, "Riverwalk, Live From the Landing," I was faced with the challenge again. The Jim Cullum Jazz Band was the target.

Jim's band plays nightly from its club on the banks of the Riverwalk in San Antonio, Texas. The Cullum band has

been dishing out the hottest classic jazz west of the Mississippi for the last 30 years and I had to capture it and send it live to the living rooms of avid listeners across the country.

## The CU-41 has the warmth and depth of a vintage tube transducer.

### A 1930s radio show

To give you a better idea of the concept of this series, it has the feel of a 1930s radio show with an opening theme, host announcer, guest artists, story line, interviews and old music playbacks crossfaded into live band performances.

The Landing is an intimate room where the patrons sit up close under the instrument bells of the performers, surrounded by photographs of Louis Armstrong, Jack Teagarden, Jelly Roll Morton and other greats from that era of music. All of this made for a wonderful environment to make music but my problem was the huge glass wall behind the band stage that looked into the lobby and beckoned guests to partake in what was happening inside.

Right away it became apparent that proper microphone placement was needed to keep the delicate balance between instruments. More importantly was the leakage factor between microphones and their phase relationship. I did not want a balanced stereo mix to cancel itself out when it was heard over the radio in mono.

By the middle of the second season we had 16 shows under our belts and the sound and microphone selection had

been established. It was that year that we started to use some CU-41 microphones by Sanken on the brass instruments. I connected the microphones to some class A microphone preamps into

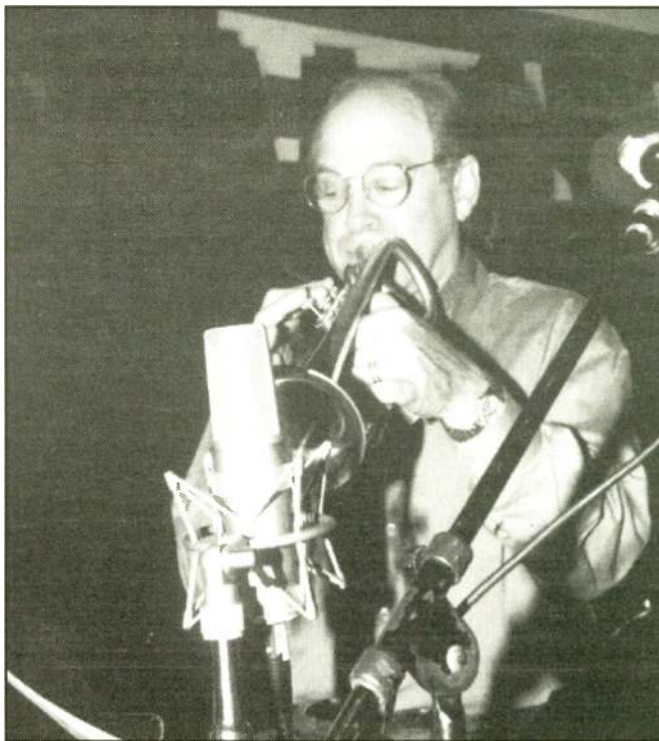

Sanken's CU-41 mics capture Jim Cullum dishing out hot jazz.

ed on top of a larger one), the sound is transduced like no other microphone today. The off-axis leakage of the cardioid pattern has given us the most pleasing results of any microphone we have used in our tight stage arrangement.

### Beautifully skilled microphones

As I mentioned, we have guest artists on our shows and many of the productions have been with dual grand pianos. This created havoc for our tiny stage arrangement and sound. But once again, Sanken had a surprise for us to try in its collection of beautifully skilled microphones. It was the CMS-2 stereo MS model.

The moment we heard the microphone we knew we had found the right one. The piano sound had always suffered because of its placement beside the drums and the glass wall. With the CMS-2 pick up pattern the sound of the piano was captured wonderfully.

Several of our productions have taken us to other venues to record shows. In each setting we have found our microphone selection for brass and piano has always been the Sankens. Riverwalk is in its eighth season with 75 shows completed and is heard on over 220 P.R.I. stations nationally. Give it a listen and see what you think.

□□□

For more information from Sanken, contact the company in California at 213-845-1155; or circle Reader Service 18.

## LMA/DUOPOLY CONTOUR MAPS

The **dataworld** LMA/DUOPOLY Contour Analysis is a precise electronic verification of overlapping and intersecting contours.

AM and FM City Grade contours are shown in full color, including transmitter site indicator. The map is supported with a printout showing all of the stations which appear on the map.

Daily updating of **dataworld's** AM and FM databases ensures the latest information.

### OTHER MAPPING OPTIONS

- Shadowing (Terrain Shielding)
- Contour Coverage
- Population Density
- Zip Code Boundaries
- Received Signal Level
- Custom Displays

### WHO ARE YOUR LISTENERS ?

Others give you 1990 Census Data. Only **dataworld** gives you CURRENT year data and FIVE year projections!

- Comprehensive Ethnic and Demographic Data
- Ethnic/Demographic Data Available for Each Zip Code Within Coverage Area
- Age Analysis by Ethnic Groups
- Resolution Increased to Block Level
- Percent of County Coverage Shown
- Projections into the next century

ETHNIC/DEMOGRAPHIC INFORMATION DISPLAYED USING MULTI-COLOR SHADING



Established 1971

800-368-5754 FAX: 301-656-5341  
e-mail: info@dataworld.com  
WWW: http://dataworld.com

Circle (22) On Reader Service Card

## The Wizard™ has gone STEREO!

The new **DIGITAL** FMSA-1 gives The Wizard System unmatched stereo monitoring capabilities. . .



Superlative stereo performance. Linear-phase filters that reveal the true performance of your audio processing. The stability of digital stereo demodulation. The sophisticated graphical presentation of The Wizard. And—with the RS-232 port—operation on site or off.

Contact Belar today for more details on what should be your next modulation monitor



**BELAR ELECTRONICS LABORATORY, INC.**

119 LANCASTER AVENUE • P.O. BOX 76 • DEVON, PA 19333-0076 USA  
(610) 687-5550 • FAX (610) 687-2686

Call, write or FAX for more information on Belar AM, FM, Stereo, SCA, and TV monitors.

Circle (43) On Reader Service Card

World Radio History

## MOVING?...

Don't leave us behind!

Mail or fax your current label and new address (with effective date) to:  
Circulation, RW,  
PO Box 1214  
Falls Church, VA  
22041  
or  
FAX 703-998-2966.

Address changes will be processed within four weeks of receipt.

Thanks!



## USER REPORT

# AirCorp Is Standard Fare at KDMM/KVIL

by Bill Ryan  
Engineering Manager  
KDMM(AM)-KVIL(FM)

**DALLAS** At KVIL(FM) and KDMM (AM), the AirCorp 500 microphone processor, with its unique silent gate-coupling feature, has solved some serious audio processing and room noise problems. The AirCorp is now our microphone processing standard.

## The AirCorp 500 is now our microphone processing standard at KDMM and KVIL.

With its simple, one-wire gate-coupling scheme, the 500 solves the flanging problem created when several microphones are open in a room at one time. By coupling more than one unit in a room, you have created a fully automatic, high quality microphone mixer with full, independent processing on each microphone.

### Natural choice

The 500 also allows you to use any microphone types you choose. I have used it successfully now for several years at KVIL and at other Dallas stations when it was first introduced. In fact, the AirCorp has become my natural choice whenever microphone or line processing is required in the studios or on remote.

At first glance, AirCorp provides most of the same features as some of the other processors on the market — compression, limiting, gating, tonal enhancement, de-essing and effects loop. But this unit does the job of processing and gating one better.

The AirCorp is housed in a single rack unit chassis with all the front panel controls and displays required for ready access to everything you need: Input and output gain, de-ess and insert switching, compression and metering and a stereo headset jack with enough level to easily monitor what is going on inside the box before it gets to the next stage.

### Setup and adjustments

In the case of an on-air microphone processor, you can set it up and make all adjustments before actually trying it on the air. The rear panel has a remote control connector for the unit's numerous remote capabilities and gate coupling, effects, send/receive jacks, input and output XLR for both line and microphone levels and the power switch.

Starting with a clean, wideband front end, the AirCorp provides a balanced and selectable input gain range from a low microphone level to a full program line input. Microphone phantom power is also available. A phase rotator to correct asymmetry normally associated with live voice sources can be jumped in or out as desired.

The input gain push button operates from nominal 0 to -50 to set the input gain range for the front panel variable input level control that lets you easily adjust the microphone or line levels within the selected range using the front panel metering.

Setup is a cinch with intuitive, easy to adjust input and output level controls, three effective tone controls, gating and de-ess switches, compression controls and LED metering to read input, output, gate and compression levels. Gating threshold level is fully adjustable and easily set up with the front panel metering as well.

Bass, mid-band and high tone type EQ controls provide variable boost or cut

with peaking EQ at carefully selected frequencies for control of a specific microphone or for matching dissimilar microphones operating together. The center frequencies can also be changed although it requires some component swapping. The factory will help if needed. We found the controls to be fine for our SM-5s. In fact, they offer more enhancement than we would ever need. These controls offer a wide range of voice or program line enhancement.

De-essing and the effects insert is switchable in and out from the front panel. TRS jacks are provided on the back

panel for effects send/receive to add any external boxes (phaser, flanger, time delay, echo, reverb, etc.) into the processing loop. Metering is provided for input level, output level, compression and gating.

Output level is accurately indicated on the front panel by both the knob position and metering and the outputs will drive whatever level is needed by the equipment being fed — microphone to line. The headset amplifier with volume control will give you plenty of level to make quality judgements.

The AirCorp combines an almost transparent compressor with a variable and silent audio gating system to provide the best sounding control of live microphone levels. While it controls very well, it maintains the naturalness of the original audio and accurately controls room ambience. Simultaneous microphone and line outputs are provided. For example, one can directly feed the phone system and the other the console microphone input.

### Strong feature

One of the strongest features of the AirCorp is its audio gate and coupling circuit. The adjustable gate can be set to handle many problem acoustic conditions in a control room, studio or remote location without the usual sudden death audio cut-off or switching sound associated with gates.

Additionally, using the remote connector on the rear panel, the gate control circuits of all AirCorp processors in a room can be tied together with a single wire to provide a complete automatic microphone processing system. This effectively controls comb filtering, phase shifting or hollow room sound, air conditioning fan noise or other room ambience problems encountered when several microphones are open in the same room.

Morning shows with two or more open microphones and a live phone speaker, talk shows with guests and a live phone speaker and multi-microphone interview shows, even in well designed studios, sometimes suffer from unpredictable, variable acoustic coupling of adjacent microphones, noises from guests' paperwork, air conditioning pickup with soft-spoken guests, table surface noises, etc. The AirCorp gate grouping goes a long way toward solving these problems without the usual up and down sound of audio gates used independently.

I have installed evaluation units for several program directors in several stations covering formats from easy listening to classic rock to new age to AC. They have never let a single unit go back.

□ □ □

For more information from AirCorp, contact Jim Loupas in Texas at 214-304-0455; fax: 214-304-0550; or circle Reader Service 157.

## USER REPORT

# Voices Shine on Audio-Technica Mic

by Stuart A. Rosenthal  
Technical Director  
Alaska Public Radio Network

**ANCHORAGE, Alaska** The Audio-Technica AT4033 large-diaphragm studio condenser microphone has proven to be an exceptional competitor in a fast and growing field of cost-effective studio microphones. In today's marketplace, radio producers, engineers and talent need to maintain a high-quality on-air presence. The old microphones of the past in your control rooms are probably in need of replacement.

The AT4033's tone quality is smooth, natural and has a sheen of brilliance. At times, this brilliance can result in an overly sibilant manner when confronted with a problem announcer. This problem has been easily remedied through the utilization of the A-T stock foam windscreens that can act as a low-pass filter for the oversibilant voice that one may encounter.

The use of a de-esser is also an option if one is available and one wishes to utilize additional electronic circuitry. However, I prefer not to use the windscreen when possible to allow the clarity of the announcers' voice to shine. Without the use of the foam windscreen, the AT4033 is very sensitive to popping and care must be taken with the microphone placement and the use of a popper stopper. I would never take the AT4033 into the field without the close control of an audio engineer who understands the details of location microphone placement.

The AT4033 provides me with a high-quality, cost-effective condenser microphone that sounds better than a majority of

microphones costing twice the price. Frequency response is noted in the specifications provided with each microphone. I prefer to let my ears be the judge and not rely upon measurements from the laboratory. How a microphone sounds in your facility depends on the microphone preamplifiers in your console (an often weak link) and the acoustics in both your studio and control room.

This is not a hypercardioid microphone and should not be installed in a facility that suffers from extraneous noise. This is a high-quality microphone that should be utilized with respect to room acoustics and proper positioning of the announcer to the microphone. If you are looking to improve the quality of your announcers' on-air presence and have other microphones that sound muddy and lack life, this may very well be the cost-effective choice.

□ □ □

For more information from Audio-Technica, contact the company in Ohio at 216-686-



The AT4033 from Audio-Technica.

2600; e-mail: pro@atus.com; or circle Reader Service 112.

## Walkaway:

Turn off the lights; lock the doors; go home. A few short years ago this level of automation at radio stations was impossible. But thanks to rapid advances in technology it's now an everyday occurrence. Anyone can go home, but to go home legally it takes specialized equipment. If you're contemplating a walkaway, you need to call about our RFC-1 Dial-Up Remote Control and our DAI-1 Dial-Up Audio Interface. For instant information 24-hours-a-day call our "Fax-On-Demand" from your fax machine and request documents 101 and 110.

24 Hour **FAX-ON-DEMAND**

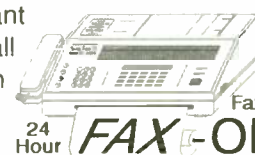

**SINE SYSTEMS**  
Voice: (615) 228-3500  
Fax: (615) 227-2367  
Fax-On-Demand: (615) 227-2393

## USER REPORT

# KCRW Finds Aphex to Be Essential

by John C. Huntley  
Chief Engineer  
KCRW(FM)

**SANTA MONICA, Calif.** At KCRW we are constantly evaluating the quality of the equipment used for our broadcasts. When I evaluate any equipment that may change the sound of KCRW(FM), my primary criteria is "first do no harm."

My memories of vacuum tubes in audio equipment are not always fond. I remember burnt fingers as I hurriedly replaced a tube that had failed in a critical circuit. However, the concept of returning to tubes where they may be appropriate intrigues

me. I remember the characteristic warmth of sound associated with tube amplifiers.

Over a year ago, we had the chance to try the Aphex model 107 Tubessence dual microphone preamplifier at KCRW. This device is a hybrid tube/solid state microphone preamplifier.

We installed the Tubessence where it

would receive the greatest use. It was placed in the interview studio at KCRW.

True to form, we have an unusual setup in this room. The microphones are amplified to line level and then split resistively to each of the three surrounding control rooms. The microphones are padded further and then fed into the microphone



The Tubessence preamp from Aphex is important gear at KCRW.

inputs of the control room consoles. The original design criteria was for minimum crosstalk into these microphone channels.

We made the assumption that the quality through microphone preamplifiers in surrounding control rooms would not be a limiting factor. For the sake of our testing we replaced one of the existing dual microphone preamplifiers with the Aphex Tubessence.

We determined for ourselves that there is an audible difference with most microphones between this preamplifier and the one we had been using. The difference is subtle on many dynamic microphones but can be rather striking with condenser microphones.

## Useful features

We do not use all the features that are available in this preamplifier. We do use various microphones including condenser types with their higher output levels in the interview studio. The most useful features are the availability of phantom power on the input of the preamplifier and the 20 dB pad on the input. Both of these features are a necessity when using most condenser microphones. The low-cut filter on the preamplifier is also used and performs as specified.

We have never had to use the muting features included in this preamplifier. The polarity inversion switch on the front panel may be useful in other circumstances but, other than a few quick tests, we have never used it.

The only disadvantages we have found for a fixed installation is the microphone input connector on the front of the unit. In our case, it is susceptible to damage from being kicked. We have the preamplifier mounted into the pedestal of the interview table/cabinet.

The output of the model 107 is via a 1/4-inch stereo phone plug. I personally avoid the use of 1/4-inch stereo phone plugs wherever possible at KCRW. However, this is a minor quibble on my part.

We have discovered that if gains are improperly set, the Tubessence will limit. It has a sound that I remember as characteristic of tube limiting. While it is not as shrill as clipping in a solid state amplifier, it is by now a very unfamiliar audio artifact. It has been described as tubby by several at KCRW who have heard it. The resolution of the problem is to simply reduce the gain. The gain range is more than adequate for our installation.

## Laudable effort

The preamplifier has no input transformer. It is constructed using metal film capacitors rather than electrolytics in the audio circuitry. While some persons may consider this to be an unusually audiophile approach, I consider this to be a laudable effort to construct a truly transparent microphone preamplifier.

We have recently installed a second Tubessence preamplifier into the interview studio at KCRW and all four microphones now have the same quality of sound.

The Aphex model 107 Tubessence microphone preamplifier is a useful and welcome addition to the audio systems at KCRW. They join the other Aphex products in daily use at our studios and transmitters.

□ □ □

For more information from Aphex, contact Chrissie McDaniel in California at 818-767-2929; or circle Reader Service 23.

**DDS**  
Digital Delivery System

## The Technology of DDS

An under-the-hood look at the Digital Delivery System from Radio Systems and Harris written for engineers, MIS personnel and anyone who is interested in how it works.

### The Operating System

Read most digital system brochures and you may never see the OS specified. But nothing is more important to the ultimate power and flexibility of a digital product. User screens and "bells and whistles" will come and go, but the right OS will charge a system with the flexibility and expandability to adapt to any environment for the life of your system.

The Operating System is multi-user and multi-tasking.

The micro-kernel design of QNX makes it an extremely efficient manager of the many programs and user requests made to a busy digital delivery system. That's why DDS can simultaneously manage multiple channel playback, background mirroring, logging, reporting functions, and front-end G.U.I. applications.

The Operating System is real-time.

Most computer systems, no matter how powerful their Pentium Processor, can be made to slow down if too much work is demanded (e.g. try running month-end traffic reports and file clean ups during the morning show!) But our real-time operating system prioritizes all tasks on 32 hierarchy levels. That means critical jobs like playing audio and data base sorts always get the primary attention of the CPU and are never delayed.

The Operating System has a built in network.

DDS doesn't need servers or a third party LAN to connect multiple CPUs. We just install network cards and plug units together! This true peer-to-peer network saves thousands in disc drive and hardware costs and dramatically improves total system performance.

No other system uses such a powerful OS. So, if you're serious about a digital on-air delivery product-look into DDS. Built on a solid foundation-it won't run out of steam.

Harris Corporation,  
Broadcast Division  
TEL: 800-622-0022  
FAX: 317-962-8961

<http://www.broadcast.harris.com>



**HARRIS**

Circle (122) On Reader Service Card

## VEGA

### Multichannel UHF Wireless Receiver from Vega

**BUCHANAN, Mich.** The Vega R-672 is a broadcast quality, 16-channel, front panel selectable, UHF true-diversity receiver. Using high-Q single-loop synthesizer circuitry, the receiver operates over the 512 - 806 MHz range with five equipment splits.

R-672 receivers are programmable with easy-to-use software through the RS-232 port and frequency selection can even be made via a modem with password protection. An additional 15-pin port allows the receiver to be remotely controlled and monitored with VegaNet software and hardware.

Helical resonator front ends provide tight frequency windows for reliable multisystem installations. Dynex III audio processing combined with well-designed audio and RF circuitry provides a S/N of 108 dB, A-weighted. Dual-mode squelch prevents noise signals from entering the audio

path without requiring an additional tone to ride on top of the transmitter audio.

Front panel switches permit selection of diversity operation or channels A or B as well as monitoring of the channels' RF and audio levels. The XLR output connector may be switched between microphone and line output levels; signal phase can be reversed and output may be balanced or unbalanced. The internal power supply is

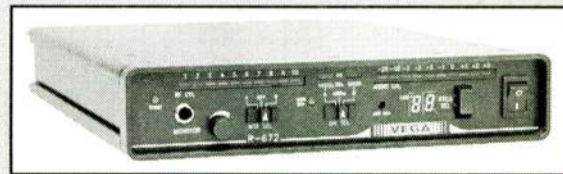

Vega's wireless UHF receiver.

switchable between 115 and 230 Vac and features a grounded IEC connector. The R-672 receiver is used with the Vega T-677 and T-678 bodypack and the T-680 series handheld UHF transmitters.

For more information from Vega, contact the company in Michigan at 616-695-6831; or circle Reader Service 61.



[ The DSE 7000 Version 5.0 ]

# With a workstation this fast, nothing can slow you down.



▲ "With time compression, the DSE has added ten years to my creative career."

*John Frost...Creative Director  
KROQ-FM, Los Angeles*



▲ "The ear is faster than the eye. And the DSE is still the best editing system for radio."

*Gundolf Weber...Tonmeister  
Producer MDR life, Leipzig, Germany*



▲ "Anyone can learn to do anything on the DSE in an hour. And UNDO it in a second."

*Debby DeLuca...  
Commercial Production Director  
HOT-97, WQHT-FM, New York*



▲ "Three stations, 36 commercials a day, who has time to fool with a waveform editor?"

*Peter Belt...Chief Engineer  
Radio 10, Amsterdam*



▲ "I've stopped looking for a better digital workstation for radio. With upgrades, the DSE is future proof."

*Russell Kerr...Planning & Development Manager  
IBC, Auckland, New Zealand*

From Auckland to Amsterdam, the DSE 7000 has earned a reputation as the fastest editing system for radio. Now, with time compression and expansion, nothing can slow your creativity down. The DSE is the only digital workstation that lets you edit by ear in real time. You don't

have to stare at a complex waveform screen, "name" every sound, or mix with a mouse. Just cut, leader, erase, move, loop, copy and mix in a completely natural manner. The DSE 7000. Now with Version 5.0 the New Speed of Sound is making quick work of the world of radio.

**orban**<sup>®</sup>

**H A Harman International Company**

© 1995 Orban and DSE 7000 are registered trademarks. 1525 Alvarado St., San Leandro, CA 94577 USA  
Phone 1•510•351•3500 Fax 1•510•351•0500 E-mail custserv@orban.com

Circle (126) On Reader Service Card  
World Radio History

## Company News

Symetrix has named **Innovative Marketing**, based in Norwich, N.Y., as its sales representative firm for the upstate New York area. Innovative Marketing will represent the entire Symetrix product line.

**Svetlana Electron Devices** announced that the Defense Enterprise Fund has invested \$3 million in its Russian/American joint venture. Svetlana is an American corporation that also owns a major share of the privatized Svetlana electron tube complex in St. Petersburg, Russia.

**Circuit Research Labs (CRL)** announced that it has increased its warranty to three years on its newest all-digital products.

**Wegener Communications** has signed **SatService Gesellschaft fur Kommunikationssysteme** as its new distributor in Germany. SatService will be responsible for the distribution of Wegener's full line of products in Germany, Austria and Switzerland.

**HHB Communications** has announced a major expansion of its distribution organization in the United States. Having formerly traded as Independent Audio, the company will now be trading as HHB Communications, Inc. The move signifies an increase in commitment to the U.S. market.

**J.L. Gorski & Associates** has been appointed U.S. distributor of **Elcor** broadcast products. Elcor has been manufacturing AM, FM and shortwave radio

transmitters and a complete line of accessories since 1960.

## People, Promotions and Appointments

**Ed Hawkins Jr.** has joined **Dataworld** as vice president of marketing. Hawkins was formerly president of Broadcast Services Co. as well as a teacher of electronics and broadcasting at Baltimore Technical Institute.

**Telecast Fiber Systems** has announced the appointment of **Michael Creamer** to the position of senior sales engineer. Creamer is a 17-year veteran of the audio industry, having started off as a recording engineer.

**Steve Cooper** has been named director of engineering for **Switchcraft Inc.** Cooper has more than 20 years of experience in engineering management and was previously research and development group manager for Eaton Corporation.



## FAMOUS LAST WORDS:

"I don't need a backup transmitter."



Crown's FM500

500 Watts

Fully Integrated

There When You Need It

Phone: 800-294-8050

Fax: 219-294-8222

See us at NAB Booth #2523

 **CROWN**  
broadcast

1718 W. Mishawaka Road, PO Box 1000, Elkhart, IN 46515-1000

Circle (129) On Reader Service Card

World Radio History

## ATI

Ultimike Amplifier  
From ATI

**HORSHAM, Penn.** The M100 Ultimike microphone amplifier from ATI eliminates dimmer noise, RF pickup, hum and rolloffs from long cable runs by mounting the small, full-featured preamplifier near the microphone. A quiet, servo-controlled instrumentation amplifier input offers excellent hum and RF rejection and accepts up to +20 dBu input. The M100 features a unique output driver that provides distortion-free transformer isolation.

The dual rack-mounting M100 includes a self-contained power supply and switchable gain and low cut filter. Also featured are 48 V phantom power, a phase reverse switch, a DC remote gain trimmer, and a switchable output trimmer.

For more information from ATI, contact Sam Wenzel in Pennsylvania at 215-443-0330; or circle Reader Service 37.

## BSS AUDIO

BSS Unit Replaces Individual  
Mixer Channels

**SAN LEANDRO, Calif.** The FCS-916 microphone preamplifier/parametric equalizer from BSS Audio is designed to replace individual mixer channels and features gain control and phantom power.

The unit includes a separate line input with gain control, four parametric filters (each with independent in/out switching), independent sweepable high-and low-pass filters, maximized band coverage that does not compromise control resolution, up to 30 dB notch on each parametric band, Bell/Shelf selection on bottom and top bands and a five-segment LED metering system.

The FCS-916 can be used in digital recording for microphone-to-workstation input; in analog recording for microphone-to-mixer or direct-to-tape; in post production for noise removal, EQing and sweetening; and in the creation of sound effects.

For more information from BSS, contact Paul Freudenberg in California at 818-895-3467; or circle Reader Service 70.



ABOUT THE ONLY THING  
IT CAN'T DO FOR  
YOUR TALK SHOW HOST IS  
MAKE EVERY  
CALLER SOUND  
INTELLIGENT.

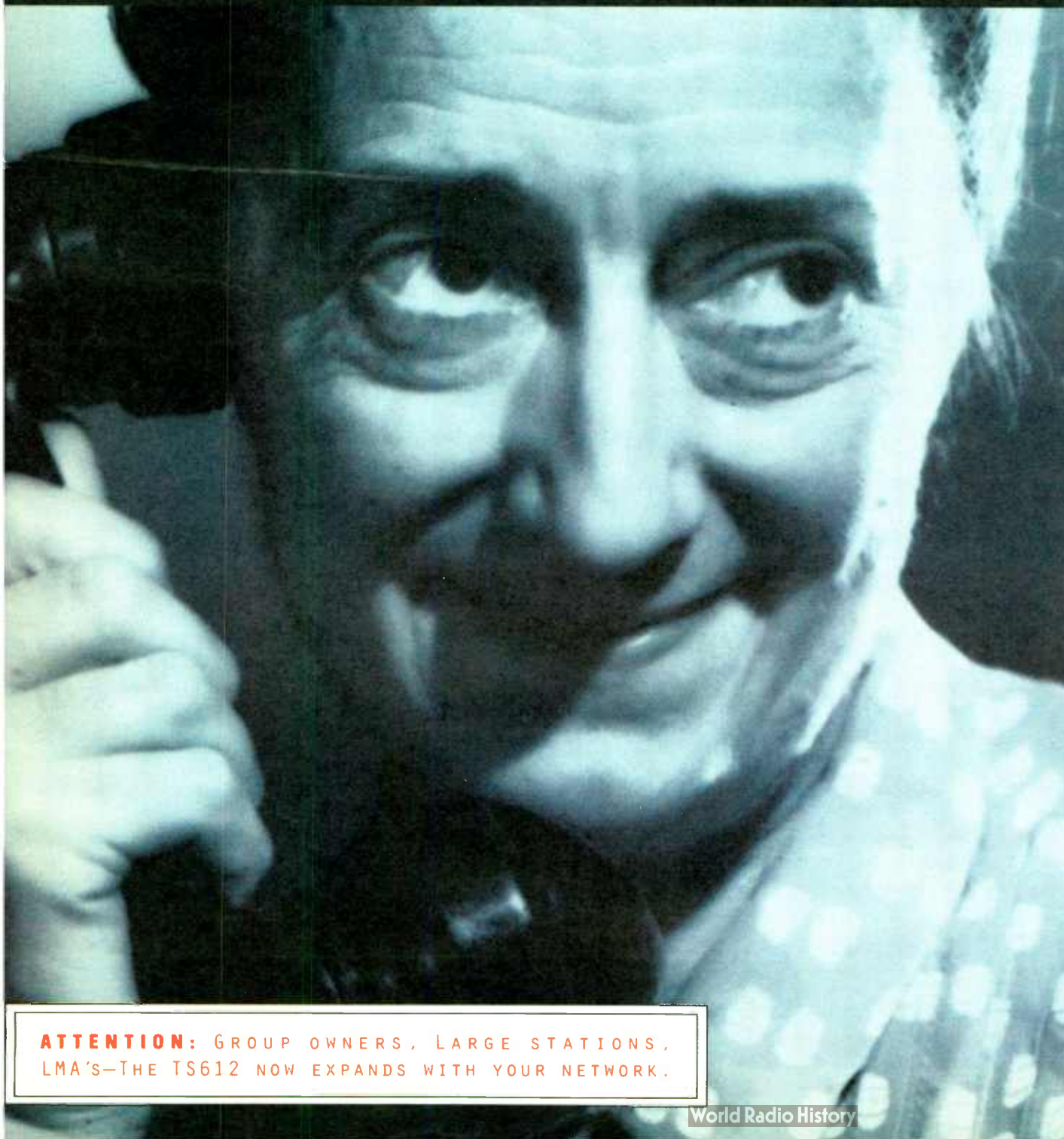

Occasionally, every talk show has to deal with an out of touch caller. But that's probably not the worst of your talk show host's problems. Chances are, your host is also trying to screen calls, conference multiple lines and make smooth transitions to commercial breaks — all while trying to come up with a snappy comeback for the space cadet on line 3. That's why we've updated the old talk show phone with the TS612. All the important functions are clearly marked and the phone lines color coded to make on-air decisions hassle free. Want to screen calls? Press SCRN. Want to conference up to

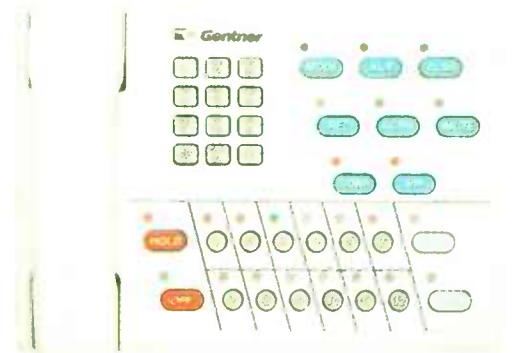

THE TS612 CAN NOW HANDLE YOUR MULTI-STATION, MULTI-STUDIO APPLICATIONS.

four lines? Press CONF. Don't want to lose a very important caller? Press VIP. Your host can even call for pastrami on rye while on-air some caller explains the finer points of cloud-watching. The point is, the TS612 is simple, versatile and lets your host concentrate on the show rather than the phone system.

To find out more, call us.

Circle (132) On Reader Service Card

 **Gentner**

1-800-945-7730  
OR 1-801-975-7200

**ATTENTION:** GROUP OWNERS, LARGE STATIONS, LMA'S—THE TS612 NOW EXPANDS WITH YOUR NETWORK.

## PRODUCT EVALUATION

# Even Geese Sound Good on Audix

by Alan R. Peterson

**WASHINGTON** Audix forwarded an SCX-1 microphone to the RW for an evaluation.

The SCX-1 is an electret condenser cardioid mic slightly more than four inches long with a black matte finish. It is phantom powered and comes in a high-impact, plastic foam-lined carrying case.

## The inside story

A small fiberglass double-sided PC board fitted with precision surface-mount components fits inside the barrel. Two electrolytic capacitors are the only discrete components

on the board. Two ferrite chokes mounted at XLR pins 2 and 3 isolate RF interference.

The mic barrel accommodates cardioid, hypercardioid and omni capsules, depending on application. Capsules are \$299 for the cardioid and omni and \$399 for the hypercardioid. The barrel alone is \$299.

One would not expect a warm bottom out of a small-diaphragm mic, but the Audix SCX-1 delivers nicely. On voice, the Audix is airy and well-defined without being thin-bottomed.

Condenser mics reveal all, while dynamic mics are more forgiving on sibilant Ss. The condenser element of the SCX-1 revealed how sibilant my reads can get

with astounding — and embarrassing — clarity. This is one very accurate mic.

When compressed and de-essed, the Audix gets punchier and still retains the high end. You can get a tasty Emie Anderson ("The Love Boat") sound out of the SCX-1 with the right settings.

This mic is ideal for what I call "museum reads"; those very clean, semi-documentary, nothing-but-the-facts recordings in multimedia shows and on walkaround tapes in larger museums. Recording voice with the SCX-1 in a tight, dead booth gives this sound.

The SCX-1 with cardioid is a suitable music mic. Its output is a little hot, but

Audix provides 10 dB attenuators for \$89.

The SCX-1 responded adequately when recording a Hofner violin. Up close the sound was edgy and rosiny, but when positioned two feet above the instrument, the mic began picking up too much of the room.

A hyper capsule would have been appropriate for this purpose, or even an omni capsule to take in even more room tone to sound like a live performance. Indeed, two such mics would make an admirable pair for recording overall room sound of performance.

Steel-string guitar is pleasantly reproduced. The SCX-1 captured a 1934 Martin with a nice balance between pick noise and the woodiness of the instrument.

Stations that air live performers in-studio should consider SCX-1s for miking acoustic instruments. Pointing the mic back towards the bridge of the instrument gives a clickety sound that makes flatpicked bluegrass guitar come to life.

Directing the mic towards the soundhole for a full-bodied acoustic sound would complement a female vocalist.

A nearby townhouse complex has a man-made pond where geese come to hang out. A fistful of Wonder Bread brought the little honkers in close enough to record.

The SCX-1 caught it all: Wing flaps, honks and the soft throaty vocalizations geese make up close. One especially loud whack was recorded when a goose mistook the boomed SCX-1 for either a Tootsie Roll or after-dinner stogie. No damage.

A creek was swollen from melting snow, so a water recording was a natural choice. The open high end of the SCX-1 was revealed when lowered down by the cable to mere inches of the surface.

The crystal-clear trickling sound captured by the SCX-1 rivals anything you would hear on those New Age meditation CDs.

## Conclusions

The Audix SCX-1 is a moderately-priced, accurate condenser mic for a variety of purposes. The fact you can swap capsules makes it a versatile mic to own, and saves on having to buy individual mics for each purpose.

This is not a jock-proof mic. These capsules are small and easily misplaced if unscrewed.

As a vocal mic, save this one for special occasions; the more durable dynamics around the studio are more appropriate for day-to-day abuse. You will not want it in the news bag for stock ENG recording, but will want to use it for quality recordings when the President comes to town.

I like the SCX-1 for its accuracy in music recording. Put one up close for solo instruments, put two further out for a string quartet, and think about a couple at the station for live performers.

Its small size may prevent anxiety in inexperienced performers, who gauge their degree of nervousness to a mic's size. Watch them around the big Neumanns or AKGs for proof.

Accurate field recording is possible with the SCX-1, but the need for phantom power will mean a big battery kit will have to come along with you.

This mic really does sound like capsule jobs costing many times the asking price of the SCX-1. If your station wants a good condenser mic for the special projects, try the Audix SCX-1. It will spare the budget, take up very little space and sound very good.

□ □ □

For more information from Audix, contact the company in California at 800-966-8261; or circle Reader Service 31.

*Looking for the ultimate affordable digital STL solution?*



# Look No Further!

## Moseley

▼  
Moseley Associates Inc.  
111 Castilian Drive  
Santa Barbara, CA 93117  
Voice (805) 968-9621  
Fax (805) 685-9638

**W**HEN Moseley introduced the DSP 6000 in 1992 it was immediately acclaimed by the broadcast industry as THE digital STL solution. Here's why. The DSP 6000 virtually eliminates the problems associated with conventional analog transmission such as noise due to signal fades, birdies from intermod interference, and lack of spectrum for multiple audio feeds to LMA and Duopoly transmitter sites. Almost three years later, the DSP 6000 is the de-facto industry standard for sonic clarity and reliability with sales approaching 2,000 installations worldwide. But you probably already knew all of that stuff, right?

What you may not have known, is that the DSP 6000 also works in conjunction with your existing Moseley analog composite STLs! If you've invested in a Moseley PCL 505/C, 600, 606, 606/C or 6000, a few simple modifications convert your entire system to digital! And it won't cost a pot of gold (just under \$6,000). Call us for modification instructions, or better yet, ship us your STL and for a mere hundred bucks, we'll make the modifications and do the setup for you.

Isn't it time you stopped chasing rainbows and started enjoying the sonic clarity of digital? "Digitally clear. Clearly digital. Just the way we planned it." ▼

# Products & Services Showcase

For more information on the products shown below, circle the appropriate Reader Service No. (s) on the enclosed Subscription/Reader Service card or contact the advertiser directly.

## New! StereoMixer!

**StereoMixer** is an 8-input 'mini-console' that can mix 4 stereo or 8 mono line sources. Both stereo and mono outputs. Ideal as an input expander or source combiner. Balanced inputs and outputs, with superb specs. *Dozens of uses...keep one on hand!*

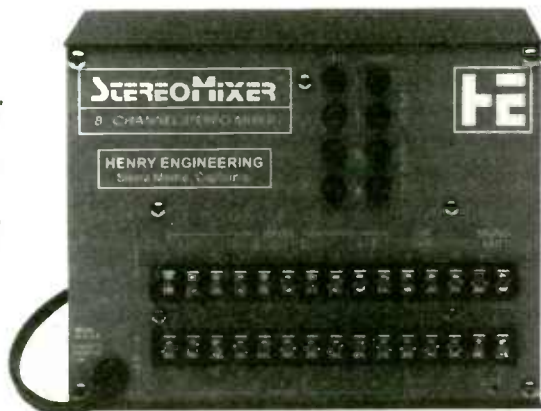

**HENRY ENGINEERING**  
503 Key Vista Drive  
Sierra Madre, CA 91024 USA  
TEL (818) 355-3656 FAX (818) 355-0077  
FAX-on-Demand Doc #122 (818) 355-4210  
http://www.broadcast.harris.com/henryeng



We Build Solutions.

READER SERVICE NO. 32

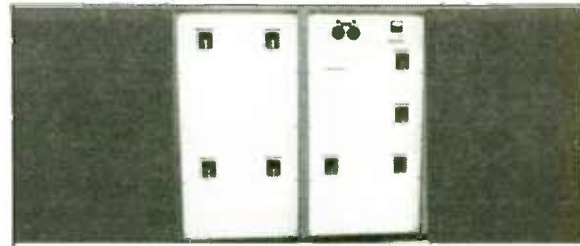

- CUSTOM ANTENNA PHASING SYSTEMS
- ANTENNA CONTROL SYSTEMS
- AM/MF ANTENNA TUNING UNITS
- DIPLEXERS & MULTIPLEXERS
- TRANSMITTER COMBINERS
- DUMMYLOADS (WITH MATCHING NETWORK)
- ASSOCIATED RF COMPONENTS
- CALL OR FAX FOR MORE INFORMATION

### PHASETEK INC.

550 CALIFORNIA RD. UNIT 11  
QUAKERTOWN, PA 18951

PHONE: 215-536-6648

FAX: 215-536-7180

READER SERVICE NO. 5

**REMEMBER THE CORTANA FOLDED UNIPOLE ANTENNA? WE STILL MAKE IT WITH THE SAME HIGH QUALITY MATERIALS AND WORKMANSHIP. IT FEATURES...**

- **BROAD BANDWIDTH** for better sound
- **GROUNDING ANTENNA** for lightning and static electricity
- **ELIMINATES ISOCOUPERS** on VHF and UHF antenna lines
- **BEST ANTENNA FOR DIRECTIONAL ARRAYS.**

Also

DETUNING SYSTEMS FOR ANYTHING THAT DISTURBS YOUR AM COVERAGE PATTERN: TOWERS, POWER LINES, TANKS OR ANY METAL STRUCTURE.

FOR INFORMATION CALL, FAX OR WRITE:

**nott ltd.**

4001 La Plata Hwy  
Farmington, NM 87401

Phone 505-327-5645 Fax 505-325-1142

READER SERVICE NO. 17

### Wireless IFB System



Used by hundreds of TV and radio stations for van-to-field cueing in ENG, SNG and remote broadcast applications. Transmitter provides a mix of program and instructions to rugged, pocket receivers.

- ✓ 100% duty cycle
- ✓ Wideband audio
- ✓ Excellent operating range

**COMREX**

Comrex Corp, USA Tel: 508-263-1800 Fax: 508-635-0401  
Fax-onDemand: 508-264-9973 (Doc. #101 #102 #103)

READER SERVICE NO. 86

### Factory Direct Sales

20 watt FM Translator



- Frequency Agile both input & output
- High quality performance
- One year limited warranty
- Station ID available

**\$2,990.00**

Solid State FM Transmitters

100 Watt .....\$2,990.00  
250 Watt .....\$3,990.00  
500 Watt .....\$5,990.00

2,500 & 5000 watt FM Transmitter



Complete with Solid State exciter and IPA  
2,500 watt .....\$12,990.00  
5,000 watt .....\$24,990.00

Jimmie Joynt Factory Direct Sales

17194 Preston Rd #123-297 Dallas TX, 75248  
Ph 214/335-3425 800/279-3326 Fax 214/377-4625

READER SERVICE NO. 140

For over 20 years . . .

You still want 'em!

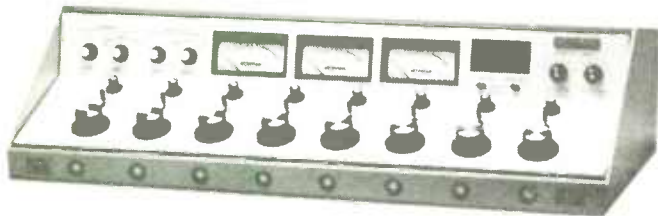

8 Rotary pots . . .

traditional reliability,  
90's audio!

We still build 'em!

The **DURABLE AC-8 Console** also available with 6 and 10 channels.

Only from . . .

**AUTOGRAM CORPORATION**  
Plano, Texas (800) 327-6901

READER SERVICE NO. 190

**PTERK**  
Your RF Power Amplifier Source

Compact FM Broadcast Power Amplifiers  
150W 300W & 500W

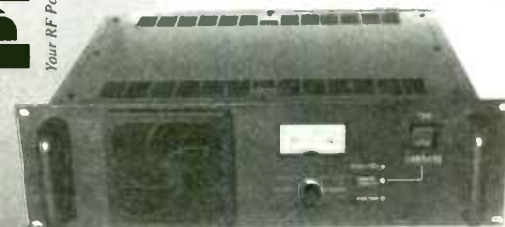

Power Outputs  
FM150.....50-175W  
FM300.....150-350W  
FM500.....250-500W

Drive  
10W will drive all 3 models to full power

1814 Schooldale Dr,  
San Jose, CA 95124

INTRODUCTORY PRICES

500W.....\$3,330  
300W.....\$2,500  
150W.....\$1,650

CALL 408 448 3342 OR  
FAX 800 416 7934  
For data sheet

READER SERVICE NO. 217

# Products & Services Showcase

For more information on the products shown below, circle the appropriate Reader Service No.(s) on the enclosed Subscription/Reader Service card or contact the advertiser directly.



## Excalibur Electronics

### CDA-1

Composite Distribution Amplifier



This 1 in, 3 out distribution amplifier allows you to distribute stereo composite and/or subcarrier signals as easily as audio.

- ◆ DC-100 kHz frequency response
- ◆ 90 dB signal/noise ratio
- ◆ +6 dB to -20 dB gain range
- ◆ Individual 20-turn output trimmers
- ◆ 1 1/4" rack mount enclosure

EXCALIBUR ELECTRONICS, INC., CHANTILLY, VIRGINIA  
Please circle our bingo number for a data sheet and a dealer list.

READER SERVICE NO. 215



CD CONTROL  
Satellite  
LIVE

Time Shifting  
NEWS  
AUTOMATION

*DigiCenter*™

Digital Audio Management Systems  
Custom Designed to YOUR needs

**INTELLIGENT INTERFACES:** In management of Traffic, Music, Accounting, Production, and Editing.

**YOUR TOTAL SERVICE SUPPLIER:** Consulting, Engineering, Manufacturing, Installation and Technical Assistance.

**CALL ITC TODAY!** Discover the benefits of a system tailored to YOUR needs.

**(309) 828-1381**

International Tapetronics Corporation 2425 South Main Street, Bloomington, IL 61702

READER SERVICE NO. 28



## PORTABLE OFF SITE EBS MONITOR \$350<sup>00</sup>

Tuneable AM/FM Receiver and  
FCC Certified Decoder Model C.D.



Ideal for use during hours of unattended operation at the studio and transmitter site. With modern remote control equipment the alert message can be put on the air with a telephone.

Decoder in a minibox (price \$250<sup>00</sup>) is available for use with receiver of your choice, or the decoder can be driven by phone line audio.

**Gorman Redlich Mfg. Co.**  
257 W. Union St. Athens, Ohio 45701  
FAX 614-592-3898 • Phone 614-593-3150

READER SERVICE NO. 55

# Shively

A good FM antenna is crucial to quality broadcasting. An antenna that is merely adequate will compromise the performance of even the best studio equipment and transmitter.

Shively regularly includes standard features that other companies either provide only as options or simply do not offer.

At Shively, we design and build antennas of uncompromising technical quality and performance. And, we build them to last.

call or write for more information

## Shively Labs

A Division of Howell Laboratories, Inc.

19 Harrison Road, Bridgton, ME 04009  
207-647-3327 FAX 207-647-8273

READER SERVICE NO. 136

## B-1000 POWER AMPLIFIER

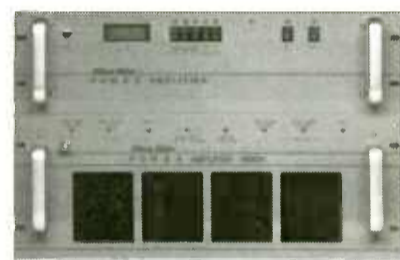

### READY TO GO

Reliable, all solid state, output power to 1250 watts. Never needs tuning. Steady output power tolerates wide a.c. voltage swings. Self starts after outage.

Efficient. Economic. Transportable.



Silicon Valley  
**POWER**  
AMPLIFIERS

1 800 986 9700

READER SERVICE NO. 163



*Pristine*  
**SYSTEMS**  
INCORPORATED

DIGITAL  
ON-AIR  
SOLUTIONS

- Feature Rich Live Assist and Walk Away
- On-Line Redundancy... No Black Box
- The Best Integrated Play List Scheduler (Music & Breaks) & On-Air Playback
- Dolby AC2 Overlapping Hard Disk Audio
- Music on Hard Disk and/or CD Jukeboxes
- Provide Computers/Players & Save \$\$\$ or Buy/Lease From Us

WEST/INT'L  
310/670-7500  
FAX 310/670-0133

EAST  
864/370-2400  
FAX 864/370-2314

READER SERVICE NO. 209

Digital Audio, Analog Audio,  
Communications and  
Computers ... It's Easy as ...



Please visit us  
on the  
World Wide Web:  
[www.abg.com](http://www.abg.com)

Since 1960, production and broadcast professionals have turned to ABG for solutions. As the world has changed, so have our products, and so have we. From cutting edge digital production gear to the latest designs in custom studio furniture to ISDN telecommunications gear, ABG stays ahead of the game so you can concentrate on what you do best.

You create the messages...you move the world...we'll give you the tools to make it possible.

**SOUTHEASTERN SALES OFFICE**  
200 Fareway Drive, Suite 2  
Smithfield, North Carolina 27577  
Phone: 800-369-7623  
Fax: 919-934-8120

**MAIN SALES OFFICE**  
2342 S. Division Avenue  
Grand Rapids, Michigan 49507  
Phone: 800-999-9281  
Fax: 616-452-1652

**WESTERN SALES OFFICE**  
P.O. Box 1638  
Palmdale, California 93550  
Phone: 800-858-9008  
Fax: 805-273-3321

YOU MAY ALSO REACH US ANYTIME VIA ELECTRONIC MAIL

cServe: 75371,144  
internet: support@abg.com



For 36 years

**ABG**  
Audio Broadcast Group Inc.

READER SERVICE NO. 109

# TECHNOLOGY UPDATES

## SOUNDFIELD

### Single Point Source Recording from QMI

**HOPKINTON, Mass.** The SoundField ST-250 microphone, distributed in the United States by QMI Pro Audio, is a comprehensive single point source recording system. Using SoundField's patented Tetrahedral Array and unique signal processor, the user is able to steer and move the microphone in both real and post-produc-



SoundField microphone system

tion time.

From a fixed physical position, the ST-250 allows for the virtual electronic rotation of the microphone to any horizontal position, vertical positioning  $\pm 45$  degrees, and the effect of moving the microphone closer or further from the sound source.

This combination of controls allows the user to replicate any microphone configuration, from omni through all cardioids to figure of eight, at any stereo crossed pair angle, pointing in any direction.

The ST-250 provides mono, stereo or 4-channel (B-format) outputs. The ST-250 is fully portable, battery powered and is supplied with the control unit, foam windshield, shock mount assembly, 20 meter cable and carrying case, making it the perfect choice for on-location broadcast and recording applications.

For more information from QMI Pro Audio, contact the company in Massachusetts at 508-429-6881; or circle Reader Service 75.

## PSB ENGINEERING

### PSB Engineering Microphone Windshield

**MELBOURNE, Australia** The GF-10 microphone windshield from PSB Engineering offers a strong, crush-resistant inner and outer cage that protects the microphone within. Three-hundred-and-sixty degree microphone shock mounting will hold the microphone firmly in place.

Time-saving features include built-in connectors whose leads can be plugged directly into the base of the handle with an inner connector that plugs into the microphone. The GF-10 comes in sizes that are able to fit most microphones and features high-quality wind covers and furs to cut down on wind noise.

PSB Engineering is looking to establish agents for its products outside of Australia.

For more information from PSB Engineering, contact Charles Sapiano in Australia at 61-3-9408-8055; fax: 61-3-9408-8066; or circle Reader Service 35.

## SENNHEISER

### Sennheiser 441 Adapts to Variety of Environments

**OLD LYME, Conn.** Sennheiser's MD 441 continues to be a vocal standard in radio applications worldwide. Engineered to offer studio-quality

sound, the 441 adapts to a wide variety of professional audio environments.

An accurate and versatile dynamic microphone, the MD 441, with a frequency response of 40 -20 kHz, performs much like a condenser microphone in producing impeccable high end articulation.

The 441's nearly frequency-independent supercardioid polar pattern provides excellent directional characteristics with minimal off-axis coloration.

A five-position bass attenuation contour switch adds flexibility while preventing over-emphasis of low frequencies in speech. Accentuated high end is available via a brilliance switch offering

a 5 dB boost at 5 kHz to enhance vocal intelligibility. An isolated double housing has solved the problem of mechanical noise while a superb front and rear suspension system yields extremely low sensitivity to handling noise.

The integral grille/pop filter reduces breath and wind noise for a quieter response and is virtually absent of clipping at extreme input levels. The features make the 441 ideal for speech applications such as live broadcasting and voiceovers.

For more information from Sennheiser, contact the company in Connecticut at 860-434-9190; or circle Reader Service 14.

## A cast of performers.

For more than 20 years, Inovonics has met the everyday needs of broadcasters the world over with sensible, top-quality broadcast products at down-to-earth prices.

### 222 Asymmetrical AM Low-pass Processor

Guarantees U.S. NRSC compliance, or is available in several versions for international shortwave service.

### 250 Programmable 5-band Stereo Processor

Gated AGC, 5-band Compression and EQ, split-spectrum Limiting—all with colorless PWM gain control. Manually pre-program 4 processing presets, or place entirely under computer/modem control via RS-232 bus.

### 255 "Spectral Loading" FM Processor

Triband-PWM Stereo Processor for contemporary music formats. Gated AGC, 3-band Compression and Limiting; unique "Spectral Loading" feature for a very aggressive sound.

### 260 Multifunction FM/TV Processor

Stereo AGC—Compressor—Limiter ideal for TV-aural and budget FM's. Split-spectrum dynamic control.

### 715 "DAVID" FM Processor / Stereo-Gen.

AGC—Compressor—Limiter, plus clean Digital Synthesis of the multiplex baseband signal. Internal RBDS/SCA combining; amazing performance at low cost!

### 705 & 706 Digital Synthesis Stereo Generators

Choice of a no-frills, basic Stereo-Gen., or a full-featured unit with metering and remote control. Both have patented overshoot compensation and a clean sound.

### 530 Off-Air FM Modulation Monitor

Tunable Mod-Monitor gives accurate measurement of total mod., pilot injection, stereo separation, etc. The peak flasher, metering and alarms may be remoted.

### 550 The "Sentinel" Monitor Receiver

All-mode radio tunes AMAX-spec C-QUAM® Stereo, FM/FMX® Stereo and all analog and digital RBDS/SCA subcarriers. Comprehensive audio diagnostics permit off-air evaluation, comparison and analysis.

**Coming soon:** An easy-to-use RBDS Encoder, and a Monitor/Decoder for use with any FM Mod-Monitor.

# Inovonics, Inc.

1305 Fair Ave., Santa Cruz, CA 95060 • TEL: (408)458-0552 • FAX: (408)458-0554



## USER REPORT

# Crown SASS Provides Vintage Pizzazz

by **Ward Lionel Kremer**  
**Producer/Engineer**  
**Reel Ting Records**

**FORT LAUDERDALE, Fla.** The Crown SASS is a microphone that hears like your head. It is a tidy looking package that resembles a trapezoid-shaped personal monitor speaker, only much lighter (17 oz.). The microphone uses Crown PZM boundary microphone technology. Whatever Crown has done, the results are dramatically real sounding.

next project, a vintage R&B album with all veteran players. I employed the SASS exclusively, except for a kick microphone for safety. I got great feedback from the executive and the session guys and it was a cinch to mix.

Note: If you need drums isolated for effects, i.e. lots of echo on snare, huge kick drum, just add more microphones. Crown SASS is now standard drum kit miking around here.

Sir Cedrick Lucas is a long-time client who plays multiple steel drum tracks

found a spot where there was a good stage/hall balance. The recorded sound was like a Broadway play. Warm vocals and solos somewhat low and blended into a smooth, easy listening sound — very forgiving.

## Piece of cake

Again, the sound field is compensating for whatever imbalance would be noticed in a strictly multitrack recording. Technically it was a piece of cake. The whole rig was made up of one SASS, one boom, one pair of tube microphone pre-amplifiers and a DAT. This could get habit forming.

Now we leave the comfortable realm of status quo for some real seat of your pants recording. Jazz fusion artist, Randy Bernsen, has a trio of his own consisting of bass (six string polyphonic synthesis, often in 16th and even 32nd notes) and guitar (more phonic synthesis in the guise of flutes, pianos, bells, strings, kudo drums, vromps, gnards and yes, sometimes even guitar). All of this is assisted by a kill-on-command drummer with chops even Buddy Rich would admit were ok.

SPLs from MCI pin drop to F-16 afterburner are the order here. These guys are awesome live and replicating their sound is, at best, a challenge. I have tried sever-

al classic microphone techniques but nothing gets it completely right. The real avant-garde stuff always sounds too busy, too loud and too hard.

I brought the previously described SASS rig along with a couple of pads to this gig and mentally assumed the position of a deaf freak slightly left of the drum kit where a balance of phonic crosstalk existed between all three instruments and the long, hard coffee house-sounding room. I have logged SPS of 136 dB with no appreciable distortion and the tape playback sounds just like the band. We were finally on our way to a much requested live CD.

## Avid fan

As you can see, I have become an avid fan of Crown SASS. Because of my biased opinion, I will add that this tool is no panacea, but it sure can be employed to capture live natural sound on location and in the studio. Whatever the shortcomings of the live scenario, sounds recorded this way seem to generally be outweighed by the natural ambience the SASS captures. The microphone capsules do an admirable job. They are very flat and relatively low noise, offering a minimum of coloration. If you need some vintage microphone pizzazz, plug in your favorite along with the SASS-P MK II.

□ □ □

For more information from Crown, contact the company in Indiana at 800-642-6939; or circle Reader Service 72.

## If you need some vintage microphone pizzazz, plug in your favorite along with the SASS-P MK II.

I gave the SASS its first shot with the studio's vintage Ludwig drum kit, usually covered with a nice array of classic drum kit microphones. The combo consistently does a great job ... no gripes, no problems.

## Live and exciting

I had someone play the kit while I walked in front and placed the SASS where my head said I had a good overall balance with some neat, early reflections coming off the wooden wall. When we played back I was surprised. The whole kit sound was exactly as it sounded in the room. Dynamics, timbre and low to high all sounded live and exciting.

Anyone who has ever mixed a drum kit knows you can get a killer kit solo sound that gets sucked up in the mix. It just does not fit right. Then you mess with it while the clock ticks away. Not so here. The stereo focus stayed put, coming right at you with no gimmicks. It sounded naturally wooden, just like the room. When the drummer plays fills or really wacks them, the sound blooms in space just like a real kit.

I was impressed enough to use it on the

along with keyboard synthesizers, guitars and drums in his music. I have had good luck using RCA 77s on figure 8 patterns while again, combining room and instrument sound. Steel drums must have their sound field because the sound varies with the playing, i.e. they have a moving sweet spot.

Repeating the drum kit technique, I again put the SASS where it sounded good to my head. I used it on both lead (solo) and rhythm (tenor) pan tracks. I used the lead track mono and the rhythm pan track stereo. The results gave me exactly the dimension between the two instruments I was looking for. Also, when you moved around in the monitor field the pans stayed where they were intended.

A graduate student asked me to record his five piece jazz combo live in concert. The room was a reverberant concert hall. If you have ever tried to close microphone in such a room, you know the experience of having the reverb everywhere in your mix except where you want it — Mud City.

I put the SASS on a long boom, climbed up and down a ladder a few times and

## I DARE YOU!

I dare you to try my FM FlexiMod on your station. I introduced the FM FlexiMod to broadcasters in April and the response has been fantastic! Over 97% of those who tried the FlexiMod added it to their processing chain. They discovered what high-tech composite processing can do for a station's sound.

I will be glad to send you a brochure and white paper that tries to use words to describe what improvements are possible over conventional composite processing, but a demo is the only sure-fire way to make a believer out of you. Join the 97% who sound cleaner and louder than they did with their old processor.

The FM FlexiMod is the best investment you can make in the sound of your station. It is not a re-hash of old processing ideas. It's distortion-cancelling, signal-enhancing circuitry is unique and unavailable in any other processor.



**CIRCLE THE BINGO NUMBER  
 OR CALL ME TODAY FOR MORE INFORMATION.**

You have nothing to lose but flat sound, grunge, and distortion.

**BECOME A BELIEVER!**

Sincerely,  
**Jim Somich**  
 Inventor of the FM FlexiMod  
 (216) 546-0967

Manufactured by MicroCon Systems Ltd. and sold by leading equipment dealers.

Circle (144) On Reader Service Card

## USER REPORT

## AKG Microphones Offer Diversity, Consistency

by **Pat Dorn**  
**Independent Engineer**  
**KSCA(FM)**

**LOS ANGELES** The magic of live music on radio has appealed to me for a long time. After a 15-year career of doing both live sound and recording engineering, I still have a lot of enthusiasm for the immediacy of a live performance, and the broadcast aspect gives you the satisfying sense that the performance is going well beyond the walls of a venue. A show like "Live From the Music Hall" on KSCA(FM) not only offers a regular dose of that immediacy but also is evidence of why an extensive collection of microphones is more critical than ever.

The list of performers who have appeared on "Live From the Music Hall" in the nearly two years the station has been on the air, is large and diverse. It includes Joan Osborne, Tori Amos, Toad the Wet Sprocket, Joan Baez, Joni Mitchell and Boz Skaggs. The show originates from our small production facility that is literally about 12 feet square.

The challenge has been to allow each act to maintain its sonic identity while adapting its performances to fit both the space and the needs of broadcast. We do not impose any particular formats on the performers, but we encourage them to scale their performance to match the intimacy of a small room. While I am usually familiar with the sound of their records, I stress to them the fact that we are not

trying to recreate the record on the air.

As a result, we have been able to accommodate entire bands. They tend to switch to an unplugged type of approach to the music, utilizing more acoustic instruments than they might during a regular show and mixing them with drums and electric instruments. Of course, no matter how much an act tailors its setup, sometimes it can get a bit crowded. When we had Roomful of Blues on, we had to put some of the nine-piece group into offices and in hallways, running microphone cables all over the station.

## Interviews and music

The 30-minute show is a combination of interviews and music. If we get a run-through before the broadcast, it is pretty minimal. I have tended to use virtually only AKG microphones, because their line offers a lot of sonic diversity while giving me consistency of performance. If there is a microphone technique philosophy at work here, it is close placement. There is rarely an audience in such a small room, but there is still a tremendous need to minimize the bleeding from one microphone to the next.

To get a little bit of ambience into the sound, I use tight hypercardioid polar patterns and then place the microphones back a bit further. Drums and percussion are the trickiest ones to apply this to. I use a pair of AKG 414s for overheads, keeping them pretty close (as you can imagine in such a

continued on page 48 ►

# Radio field strength extraordinaire.

**TEAM NORTHWEST**  
**BILL WOLFENBARGER**  
 TEL: 800-566-0773  
 TEL: 206-874-7444  
 FAX: 206-874-8866  
**CAL VANDEGRIFT**  
 TEL: 800-566-0773  
 TEL: 206-874-7444  
 FAX: 206-874-8866

**TEAM SOUTHWEST**  
**DALE NAMMINGA**  
 TEL: 909-941-1030  
 FAX: 909-941-1225  
**ED LONGCRIER**  
 TEL: 213-852-9003  
 FAX: 213-852-9037

**MI Zips 498,499**

**CANADA SALES**  
**RAYMOND QUESNEL**  
 TEL: 514-421-6272  
 FAX: 514-421-2712

**PA Zips 150 - 168**

**FRANK GRUNDSTEIN**  
 TEL: 610-642-3969  
 FAX: 610-642-5035

**MI (upper)**

**TOM HARLE**  
 TEL: 708\*-420-8899  
 FAX: 708\*-420-9171  
 \*area code becomes 630 Aug. 1996

**JIM MARWOOD**  
 TEL: 614-882-8506  
 FAX: 614-890-1844

**PA Zips 169 - 196**

**KEN PERKINS**  
 TEL: 303-670-1049  
 FAX: 303-670-8417

**QUINCY**

**RICHMOND**

**CARL DAVIS**  
 TEL: 919-469-0405  
 FAX: 919-481-0031

**STEVE SCHOTT**  
 TEL: 214-423-3644  
 FAX: 214-423-3642

**WILL BONE**  
 TEL: 334-277-4377  
 FAX: 334-271-0877

**DAN SESSLER**  
 TEL: 941-575-8788  
 FAX: 941-575-8688

**FL Zips 324,325**

**HARRIS BROADCAST, QUINCY, ILLINOIS**  
**NORTH AMERICAN RADIO FIELD SALES:**  
**DON TAYLOR, RADIO SALES MANAGER**  
 TEL: 217-221-7320; FAX: 217-224-1439  
**24-HOUR PARTS & SERVICE**  
 TEL: 217-222-8200

**HARRIS BROADCAST, INDIANA**  
**BROADCAST CENTER**  
**300-PLUS RADIO LINES**  
 TEL: 800-622-0022  
 8 a.m. - 8 p.m. Eastern Time  
 FAX: 317-966-0623



# HARRIS

Circle (147) On Reader Service Card

World Radio History

## AKGs Stand Heavy Usage

► continued from page 46

small room) and using them to add some ambient sound to the otherwise close-miked percussion instruments.

The AKG D112 is a classic kick drum microphone, but I have found that the AKG D3800 tri-powered microphone, which I have been using a lot on snare drums because of the tight, snappy attack it has, is also a good alternative on kick drums. It allows the attack in the mid-range frequencies to come through clearly and does not require any rolloff on the main lower frequencies on the kick drum.

The AKG C3000 has been the marvelous utility player of the collection. I use it on most of the other drums and cymbals and it works quite well on acoustic guitars and

background vocals. The C3000's response and performance is similar to that of the classic 414, but because it is less specific in terms of pattern, it works well covering more bases.

Acoustic guitars — and acoustic instruments in general — sound clear and articulate when I use the AKG C1000 on them. The C1000 has a very transparent high end but also a full lower-frequency response, allowing it to cover a lot of bases. When it comes to alternative music and broadcast, that is a significant advantage.

For instance, the band The Wild Colonial is a real challenge. The band has been on the show several times and each time it brings on different — sometimes truly bizarre and ethnic — instruments, from Australian

digeridoos to squeezebox accordions and interesting percussion instruments. An act like that demands a good deal of depth from a microphone collection.

For vocals, the AKG 535 is rapidly becoming the favorite of a lot of guests on the program. As a matter of fact, after I used it for Joni Mitchell's performance, her management company called back to ask what microphone I had used so she could use it herself in the future.

I use pretty much the entire line of AKG microphones and, while some of mine are as much as 10 years old, I have not yet had

to replace a single one — including my condenser microphones, which are the ones that get the hardest usage.

The AKG line gives me a sonic palette to work from that is more than sufficient to cover all the various kinds of broadcast performances we do. And with the increasing diversity of music that is coming out, a microphone collection with depth is no longer a luxury ... it is an absolute necessity.

□ □ □

For more information from AKG, contact the company in California at 818-894-8950; or circle Reader Service 41.

## MARKETPLACE

### Recently Introduced Products for The Radio Broadcast Professional

#### Multifunction Processors

The Marantz PMD820 and PMD850 multifunction processors are available from Superscope Technologies. The 820 and 850 feature a stereo preamplifier; an AM/FM/FM stereo tuner featuring 30 station presets and auto search; and a

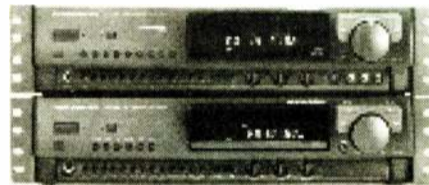

CD player with Bitstream D/A conversion, random play and tape recording synchronization. The PMD820 includes a stereo preamplifier with phone inputs, tape inputs/outputs and tone controls while the 850 offers 5-channel Dolby Pro Logic decoding with DSP surround processing.

For more information from Superscope, contact Hilarie Hackendahl in Illinois at 708-820-4200; or circle Reader Service 178.

#### Cable Connectors

Twelve coaxial connector styles are available to fit LMR-400 cable from Times Microwave. The connectors are available through RF Connectors and are also suitable for use with Belden 9913 and 9914 low loss cables.

BNC, N, TNC and UHF interfaces are offered now with several 7/16 DIN male and female styles to be released during the 1996 product year. Both nickel and silver plating is available and all connectors feature Teflon dielectric.

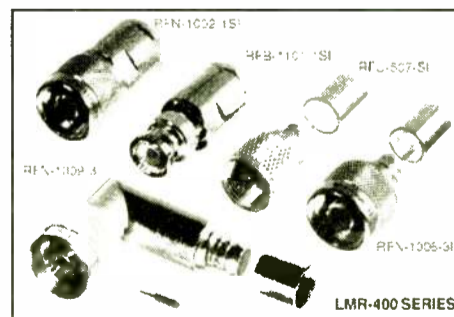

For more information from RF Connectors, contact the company in California at 619-549-6340; or circle Reader Service 133.

#### Advanced Mac Audio Editor/Processor

Available from Berkley Integrated Audio Software (BIAS) is Peak, an audio editor/processor program for the

PowerPC as well as most other Macintosh and PowerBook computers. Peak's features include full-featured, non-destructive digital audio editing and processing; unique sound design and compositional tools; and full support for MIDI sampler instruments.

Other features of Peak are LoopSurfer, built-in support for Adobe Premiere audio plug-ins and support of QuickTime and Red Book formats as well as 16- and 18-bit audio.

For more information from BIAS, contact the company in California at 415-331-2446; or circle Reader Service 139.

#### Digital Solid State Audio Field Recorder/Editor

The ARES-C from Nagra is a digital audio field recorder/player that uses standard PCMCIA cards instead of tape or disc as a storage medium. A single 64MB PCMCIA card holds more than



two hours of mono recording and by using multiple cards and a standard double battery "D" cell pack, the ARES-C has the capability to record for 10 continuous hours.

The ARES-C features built-in editing capabilities along with a standard two-way analog telephone transmission port as well as ISDN built-in circuitry.

For more information from Nagra, contact the company in Tennessee at 615-726-5191; or circle Reader Service 81.

#### Phase Shifters

Micro Communications, Inc. (MCI) has introduced a new series of high power variable phase shifters. Series 555000 provides a 0 to 405 degree phase change over a nominal bandwidth. The unit is designed with rigid 7/8 coax components giving it a power rating of 1000 W average at 950 MHz. Connector choices are 7/8 EIA, 7/16 DIN and "N".

For more information from MCI, contact Debra Bureau in New Hampshire at 603-624-4351; fax: 603-624-4822; or circle Reader Service 105.

## Make The Most Of Your Modern Rock!



The hippest sounds in the market belong to your station. Now maximize your dial presence with **StereoMaxx** from MSI.

StereoMaxx sets you apart from your competition by enlarging your stereo sound to its fullest. Your listeners will think you've improved the audio gear. The engineer won't mind the easy set up at the studio. The PD will smile. And the GM won't complain about the cost.

StereoMaxx won't give you the headaches you get with other processors. You picked the best of today's music for your sound. Now pick the box that sends your station through loud and clear.

Call MSI, the stereo authority at (800) 826-2603 and make the music work for you.

**ms modulation sciences inc.**

12A World's Fair Drive Somerset, New Jersey 08873  
Voice (908) 302-3090 • Fax (908) 302-0206

Circle (150) On Reader Service Card



USER REPORT

# Lectrosonics Glides through Tough Remote

by Bill Pace  
Pace Audio Services

**ALBUQUERQUE, N.M.** Pace Audio Services provides a range of contracted technical services to several radio stations in the Albuquerque area. Most of the time, our duties run along the lines of what would be considered typical.

Every once in a while however, we become involved in things that can best be described as unusual. Such was the case with a remote broadcast for Albuquerque's KZRR-FM. This particular project required us to find a way to deliver a live microphone feed from a hang glider descending from nearby Sandia peak — 10,000 feet above sea level.

### Making the jump

This morning show segment, expected to last several minutes, would feature the station's traffic reporter, Capt'n Crunch, making the jump. The brave Capt'n was to describe the experience and sensation of hang gliding around the peak several times before (hopefully) coming to a safe landing in the valley below.

Obviously, the only practical way to

obtain the live audio feed would be via a wireless microphone system. The key would be selection of a system that could be counted upon to provide the range and reliability this unique application required, along with good audio performance.

Given these demanding criteria, a Lectrosonics VHF Pro Series system — R185 VHF receiver and M187 belt-pack VHF transmitter — was the choice. The M187 transmitter operates at 150 - 216 MHz and supplies 50 mW of output power. It is housed in an aluminum case that also acts as an antenna, eliminating the need for an external wire antenna — a nice benefit for this situation.

Surface mount circuitry keeps the transmitter compact and also serves to minimize stray internal RF. The transmitter accommodates any type of microphone. For this project we used a standard clip-on lavalier.

The M187 and microphone were attached to the Capt'n before takeoff from the sheer face of the of the peak. The belt clip transmitter, also made of machined aluminum and spring-loaded, provided a firm grasp of the thick material of his flying suit.

At the takeoff point, the R185 receiver

was coupled to a Marti VHF transmitter for downlink to the studio. The R185 is also a compact unit, making it a natural for ENG use.

We have also found that the Marti's six-pole helical resonator front end with low-noise J-FETS are effective in rejecting overload. The unit is fixed frequency with a two-stage, calibrated oscillator ensuring frequency stability.

### Crucial selectivity

The selectivity of the Lectrosonics system was crucial, especially in light of the adjacent Marti transmitter. We had it running at about 20 W, yet did not have any stray energy or interference marring our wireless system performance. In addition, we had decided against using a special antenna, opting for the whip supplied with the receiver.

The entire on-air broadcast went off without a hitch. The signal was clean, intelligible and without a dropout as the Capt'n circled the peak screaming, yelling and trying to describe the experience. There was some wind noise which was to be expected given the location, altitude and rate of travel speed.

We continued to monitor the remote sig-

nal even after the on-air segment ended and the Capt'n made his descent to the valley. It stayed solid all the way down with some break-up experienced as he moved fully behind the face of another peak, but then picking back up to full quieting after he re-emerged.

The landing point ended up being the back yard of a valley resident and we continued to receive a strong, clear signal through touchdown. It was humorous listening to the Capt'n apologize to the resident for his choice of landing site. By the way, this site was more than a mile down and almost three miles away from the launch site hosting the receiver.

KZRR was so delighted with this unique remote that it was repeated. We used the same equipment and enjoyed the same great results. Lectrosonics should be complimented. Its wireless system maintained a high level of performance even in this uncommon application, which it certainly could not have foreseen during the system's design.

□ □ □

For more information from Lectrosonics, contact the company in New Mexico at 505-892-4501; or circle Reader Service 19.

## STATION SERVICES

News and Services for Business, Programming and Sales

### Free Public Affairs Programming

**SALT LAKE CITY** The Church of Jesus Christ of Latter-day Saints is making available "Times and Seasons: Family Edition," a 14-part public affairs series.

The series helps the station to address community issues for programming requirements. The 30-minute public service programs deal with significant moral and social family related issues in a straight-forward, documentary style.

Topics include: adoption, emotional abuse, family communication, family history, family traditions, marriage and values, the marriage partnership, the nurturing father, parenting, preventing divorce, preventing domestic violence, self-esteem, teaching children values and teens and choices.

The series is available on CD and broadcast quality audio cassette free of charge to all stations.

For information, contact Donald Russell at 800-453-3860, ext. 4397; or circle Reader Service 3.

### Management Made Simple by Omnia

**TAMPA, Fla.** Managers wishing to manage more effectively can improve their style with the use of Omnia MX3. The simple but powerful software-based management system helps build people and profits by building better managers.

With the Omnia MX3, managers increase their span of supervision by 50 percent because long, drawn out, after the fact performance evaluations are replaced by quicker, quarterly progress

reviews that help spot and correct performance problems before employees fail.

For information, contact the Omnia Group at 813-254-9449; or circle Reader Service 58.

### Wimbledon Tennis on the Radio

**LONDON** Radio Sports Creations in conjunction with GNG Communications will broadcast live, via satellite, the Men's and Women's Tennis Championships at Wimbledon.

This powerful vehicle the mornings of July 6 and 7 offer stations the opportunity to become associated with one of the most prestigious sporting events in the world.

In the car, at the beach,, from the club, at a picnic, people will tune in to hear top players like Agassi, Sampras, Becker, Graf, Seles, etc., battle it out.

For information, contact Radio Sports Creations at 310-398-5408; or circle Reader Service 66.

### New Programming for Women From USA Radio Network

**DALLAS** The Usa Radio Network launched "The Busy Woman's Time Saving Tips," with creator/host Dinah Monahan.

Dinah presents a unique approach to time management for women whose lives don't end when they leave the office.

This concept of time management was developed to work with different personalities, not a "one-size-fits-all" program. From the totally disorganized to the compulsively neat, every woman gets

something out of the concepts offered.

Best of all, they don't have to live up to impossible standards or change their personality to make effective time management work for them.

The broadcast is available on SatCom C5, Transponder 15 and Spacenet III, Transponder 7H.

For information, contact USA Radio Networks at 800-829-8111; or circle Reader Service 115.

### Hate Bait Radio Debuted In Southern California

**LAS VEGAS** America's favorite electro-shock fishing jock, Strayhorn

SpadeWater premiered his syndicated radio trout calvacade of stars on Feb. 11, on KNWK(AM) Simi Valley, Calif.

"TroutTalk," billed as two hours of interactive, virtual fly fishing radio, where grown men gather and share special moments about their flies, features SpadeWater and the TroutTalk prize lady, Fancy Damsel, radio's answer to Vanna Whitefish, the TroutTalk studio orchestra, the Tums Trio led by Gil Minnowski, the Angling Angels on loan from the Mormom Tacklenackle choir and the ever popular Pink Johnson.

For information, contact Sonny Sturn at Nelson Creative Radio at 800-433-0030; or circle Reader Service 138.

### SUBSCRIPTION/READER SERVICE FORM

		<b>Reader Service</b> March 6, 1996 Use until June 6, 1996 Please first fill out contact information at left. Then check each advertisement for corresponding number and circle below.																																																																																																																																																																																																																												
<b>FREE Subscription/Renewal Card</b> I would like to receive or continue receiving Radio World FREE each month. <input type="checkbox"/> Yes <input type="checkbox"/> No		<b>Purchasing Authority</b> 1. Recommend 2. Specify 3. Approve																																																																																																																																																																																																																												
Signature _____ Date _____ Please print and include all information: Name _____ Title _____ Company/Station _____ Address _____ City _____ State _____ ZIP _____ Business Telephone ( ) _____		<table border="1"> <tr><td>001</td><td>023</td><td>045</td><td>067</td><td>089</td><td>111</td><td>133</td><td>155</td><td>177</td><td>199</td></tr> <tr><td>002</td><td>024</td><td>046</td><td>068</td><td>090</td><td>112</td><td>134</td><td>156</td><td>178</td><td>200</td></tr> <tr><td>003</td><td>025</td><td>047</td><td>069</td><td>091</td><td>113</td><td>135</td><td>157</td><td>179</td><td>201</td></tr> <tr><td>004</td><td>026</td><td>048</td><td>070</td><td>092</td><td>114</td><td>136</td><td>158</td><td>180</td><td>202</td></tr> <tr><td>005</td><td>027</td><td>049</td><td>071</td><td>093</td><td>115</td><td>137</td><td>159</td><td>181</td><td>203</td></tr> <tr><td>006</td><td>028</td><td>050</td><td>072</td><td>094</td><td>116</td><td>138</td><td>160</td><td>182</td><td>204</td></tr> <tr><td>007</td><td>029</td><td>051</td><td>073</td><td>095</td><td>117</td><td>139</td><td>161</td><td>183</td><td>205</td></tr> <tr><td>008</td><td>030</td><td>052</td><td>074</td><td>096</td><td>118</td><td>140</td><td>162</td><td>184</td><td>206</td></tr> <tr><td>009</td><td>031</td><td>053</td><td>075</td><td>097</td><td>119</td><td>141</td><td>163</td><td>185</td><td>207</td></tr> <tr><td>010</td><td>032</td><td>054</td><td>076</td><td>098</td><td>120</td><td>142</td><td>164</td><td>186</td><td>208</td></tr> <tr><td>011</td><td>033</td><td>055</td><td>077</td><td>099</td><td>121</td><td>143</td><td>165</td><td>187</td><td>209</td></tr> <tr><td>012</td><td>034</td><td>056</td><td>078</td><td>100</td><td>122</td><td>144</td><td>166</td><td>188</td><td>210</td></tr> <tr><td>013</td><td>035</td><td>057</td><td>079</td><td>101</td><td>123</td><td>145</td><td>167</td><td>189</td><td>211</td></tr> <tr><td>014</td><td>036</td><td>058</td><td>080</td><td>102</td><td>124</td><td>146</td><td>168</td><td>190</td><td>212</td></tr> <tr><td>015</td><td>037</td><td>059</td><td>081</td><td>103</td><td>125</td><td>147</td><td>169</td><td>191</td><td>213</td></tr> <tr><td>016</td><td>038</td><td>060</td><td>082</td><td>104</td><td>126</td><td>148</td><td>170</td><td>192</td><td>214</td></tr> <tr><td>017</td><td>039</td><td>061</td><td>083</td><td>105</td><td>127</td><td>149</td><td>171</td><td>193</td><td>215</td></tr> <tr><td>018</td><td>040</td><td>062</td><td>084</td><td>106</td><td>128</td><td>150</td><td>172</td><td>194</td><td>216</td></tr> <tr><td>019</td><td>041</td><td>063</td><td>085</td><td>107</td><td>129</td><td>151</td><td>173</td><td>195</td><td>217</td></tr> <tr><td>020</td><td>042</td><td>064</td><td>086</td><td>108</td><td>130</td><td>152</td><td>174</td><td>196</td><td>218</td></tr> <tr><td>021</td><td>043</td><td>065</td><td>087</td><td>109</td><td>131</td><td>153</td><td>175</td><td>197</td><td>219</td></tr> <tr><td>022</td><td>044</td><td>066</td><td>088</td><td>110</td><td>132</td><td>154</td><td>176</td><td>198</td><td>220</td></tr> </table>	001	023	045	067	089	111	133	155	177	199	002	024	046	068	090	112	134	156	178	200	003	025	047	069	091	113	135	157	179	201	004	026	048	070	092	114	136	158	180	202	005	027	049	071	093	115	137	159	181	203	006	028	050	072	094	116	138	160	182	204	007	029	051	073	095	117	139	161	183	205	008	030	052	074	096	118	140	162	184	206	009	031	053	075	097	119	141	163	185	207	010	032	054	076	098	120	142	164	186	208	011	033	055	077	099	121	143	165	187	209	012	034	056	078	100	122	144	166	188	210	013	035	057	079	101	123	145	167	189	211	014	036	058	080	102	124	146	168	190	212	015	037	059	081	103	125	147	169	191	213	016	038	060	082	104	126	148	170	192	214	017	039	061	083	105	127	149	171	193	215	018	040	062	084	106	128	150	172	194	216	019	041	063	085	107	129	151	173	195	217	020	042	064	086	108	130	152	174	196	218	021	043	065	087	109	131	153	175	197	219	022	044	066	088	110	132	154	176	198	220
001	023	045	067	089	111	133	155	177	199																																																																																																																																																																																																																					
002	024	046	068	090	112	134	156	178	200																																																																																																																																																																																																																					
003	025	047	069	091	113	135	157	179	201																																																																																																																																																																																																																					
004	026	048	070	092	114	136	158	180	202																																																																																																																																																																																																																					
005	027	049	071	093	115	137	159	181	203																																																																																																																																																																																																																					
006	028	050	072	094	116	138	160	182	204																																																																																																																																																																																																																					
007	029	051	073	095	117	139	161	183	205																																																																																																																																																																																																																					
008	030	052	074	096	118	140	162	184	206																																																																																																																																																																																																																					
009	031	053	075	097	119	141	163	185	207																																																																																																																																																																																																																					
010	032	054	076	098	120	142	164	186	208																																																																																																																																																																																																																					
011	033	055	077	099	121	143	165	187	209																																																																																																																																																																																																																					
012	034	056	078	100	122	144	166	188	210																																																																																																																																																																																																																					
013	035	057	079	101	123	145	167	189	211																																																																																																																																																																																																																					
014	036	058	080	102	124	146	168	190	212																																																																																																																																																																																																																					
015	037	059	081	103	125	147	169	191	213																																																																																																																																																																																																																					
016	038	060	082	104	126	148	170	192	214																																																																																																																																																																																																																					
017	039	061	083	105	127	149	171	193	215																																																																																																																																																																																																																					
018	040	062	084	106	128	150	172	194	216																																																																																																																																																																																																																					
019	041	063	085	107	129	151	173	195	217																																																																																																																																																																																																																					
020	042	064	086	108	130	152	174	196	218																																																																																																																																																																																																																					
021	043	065	087	109	131	153	175	197	219																																																																																																																																																																																																																					
022	044	066	088	110	132	154	176	198	220																																																																																																																																																																																																																					
<b>I. Type of Firm</b> <input type="checkbox"/> D. Combination AM/FM station <input type="checkbox"/> F. Recording Studio <input type="checkbox"/> A. Commercial AM station <input type="checkbox"/> K. Radio Station Services <input type="checkbox"/> B. Commercial FM station <input type="checkbox"/> G. TV station/teleprod facility <input type="checkbox"/> C. Educational FM station <input type="checkbox"/> H. Consultant/ind engineer <input type="checkbox"/> E. Network/group owner <input type="checkbox"/> I. Mfg, distributor or dealer <input type="checkbox"/> J. Other _____																																																																																																																																																																																																																														
<b>II. Job Function</b> <input type="checkbox"/> A. Ownership <input type="checkbox"/> G. Sales <input type="checkbox"/> B. General management <input type="checkbox"/> E. News operations <input type="checkbox"/> C. Engineering <input type="checkbox"/> F. Other (specify) <input type="checkbox"/> D. Programming/production																																																																																																																																																																																																																														
Copy & Mail to: Radio World, PO Box 1214, Falls Church, VA 22041, or FAX to: 703-998-2966																																																																																																																																																																																																																														









TUBES...WTS

D and C Electronics Co.

Lowest Price on Tubes including:

- 4-1000A/3-1000Z/8877/4CX250B/833A 4-500/5-500/4-400/4CX 3500/5CX1500 and much more!

Factory Warranty!

1-800-881-2374 (352) 688-2374

Se habla Español FAX: (352) 683-9595

Svetlana ELECTRON DEVICES Quality\* Power Tubes 3CX2500A3 4CX15,000A 3CX2500F3 4CX15,000J 3CX2500H3 4X150A 3CX3000A7 5CX1500A 3CX3000F7 5CX1500B 3CX10,000A3 672B 3CX10,000A7 5U4G 3CX10,000H3 6550B 3CX15,000A3 6550C 3CX15,000A7 6AS7G 3CX15,000H3 6BM8 4CX250B 811A 4CX250BC 833A 4CX250BM 833C 4CX250R EL34 4CX350A SV811-3 4CX350AC SV811-10 4CX400A TH5-4 4CX800A TH5-6 4CPX800A TH6-3 4CX1500A TH6-3A 4CX1600B YC130/9019 4CX1600J 8550AS 4CX3500A SK300A 4CX5000A SK1300 4CX10,000D SK1320

- Watch this list grow. Shipment from USA stock. Manufactured in Russia's largest power tube factory. Generous\* warranty based on high quality. Honest prices based on quality at low cost.

Broadcasters

Phone: 800-239-6900 205-882-1344

FAX: 205-880-8077

OEMs, Distributors

Phone US: 800-578-3852 Int'l & US: 415-233-0429

FAX: 415-233-0439

Circle (128) On Reader Service Card

Want To Buy

5762 & 3CX3000F1 transmitting tubes. A Weiner, 97 High St, Kennebunk ME 04043. 207-985-7547.

Want To Sell

REBUILT ELECTRON TUBES

Partial List: 6623, 23791, TH150, 6425F, 6427, 8550, 6804, 6696, 6697, 5681, 5682, 5671, 7804, 3CX10,000H3, 3CX20,000H3, 4CX5000A, 4CX35,000C

Worn out power tubes purchased

Vacuum Tube Industries, Inc.

1-800-528-5014

508-584-4500 X75

TURNTABLES

Want To Sell

Russco 2B (2), 33/45 12" w/Shure tone arms & cartridges, \$100 ea +shpg. H McDonald, KKJV, POB 807, Veradale WA 99037. 509-484-4531.

Tanton 310 TT preamp, \$60; Audiometrics TT pre amp, \$75. Rene Hart, WASE, POB 2087, Elizabethtown KY 42702. 502-769-1055.

NEEDLES, CARTRIDGES, BELTS...all major brands including old/obsolete models, one of the largest stocks in the country. Expert consultation. NEEDLES EXPRESS (800) 358-2030.

Want To Buy

TT parts for Russco, need drive bearing. B Hatcher, Howling Dog Recdng, 1591 Eldonlas Ct, Stone Mtn GA 30087. 770-498-7600, e-mail: Billhatcher@AOL.COM.

Take note of these UPCOMING DEADLINES

Deadline for April 17 issue: March 22

Deadline for May 1 issue: April 5

ADVERTISER INDEX

This listing is provided for the convenience of our readers. Radio World assumes no liability for inaccuracy.

Table with 5 columns: Page No., Advertiser, Reader Service No., Page No., Advertiser, Reader Service No. Lists various advertisers like Harris, ATI, Arrakis, Audio Broadcast Group, etc.

Table with 2 columns: Role, Name. Lists staff roles like Publisher (Stevan B. Dana), Associate Publisher (Carmel King), etc.

Advertising Sales Representatives

Table with 2 columns: Region, Name/Phone/Fax. Lists representatives for U.S. East, U.S. West, U.S. Midwest, International, Europe, and Japan.

Free Subscriptions are available upon request to professional broadcasting and audiovisual equipment users. For address changes, send current and new address to RW a month in advance at P.O. Box 1214, Falls Church, VA 22041.

EMPLOYMENT

To place ads in this section, use the ActionGram form. To respond to box numbers write Radio World, PO Box 1214, Falls Church, VA 22041. Attn: \_\_\_\_\_

POSITIONS WANTED

12-yr vet avail now, programming/MD AC, Alternative, Oldies, rock, on-air, appearances, production, sports, computer exper, NE preferred. Laura, 518-943-5635.

Contract or Fulltime radio Chief Engineer of 20+ yrs, seeks position in Maine, New Hampshire or Vermont. Extensive engineering exper & a side-line income source & am seeking to return to small town New England. Send inquiries to: Radio World, POB 1214, Falls Church VA 22041. Attn: Box #96-2-21-1RW.

Experienced engineer, studio & xmtrs, seeking FT position w/air shift, prefer small community, easy living. Write: Eng, 7894 Palm Grove, Indianapolis IN 46219.

Voice to let on DAT or cassette, Dallas TX narrator/announcer, unaccented American, male. FAX 214-687-2432.

Sports/Public address announcer looking for assignments in greater Dallas area. High school, university, charity level preferred. Jay, 214-276-0999 or 214-373-7272.

Successful GM/PA, creative, achievement oriented pro, work atmosphere more important than \$, 30+ yrs in radio & still excited about its potential. Prefer adult formats and SE area, others considered. FAX: 803-534-4835.

World's most versatile production guy, multiple award winner, jingles, liners, voices, bits, creative, funny talk-show host, comes complete w/own 16 trk studio & crash helmet, will work as captive Prod Dir or on contract, prefer SE. Tape/Resume, 800-854-4002.

Experienced PD & air talent seeks on-air or programming position in the mid-west. Country, AC, oldies, standards. J Waters, 515-228-3060.

Assistant promotion director w/college degree & 2 yrs exper at Philadelphia Top 40 station seeks employment, willing to relocate. Eric, 610-497-1275.

Chief Engineer seeking FT, stable position in KS, CO, NE, MO, IA, OK, TX, SD, IL, AR, will consider other areas, w/over 17 yrs exper in FM, AM direction & studio work. Well organized & hard working. Larry, 319-386-9835 or 913-425-6509.

Prof Announcer w/23 yrs exper, seeks on-air pos w/MOR, easy listening, Country station, eastern PA, northern MD area, voice-overs, commercials, any format, complete references, demo. John, POB 365, Windsor PA 17366. 717-843-2730.

Programming or Eng position wanted w/station that wants to take risks & be creative, will relocate for great op. Bruce, 415-388-9005.

Promotions director looking to bring his bag of goodies to your station, knowledge in printing saves station money, any format, anywhere. Brian, 505-722-8989.

Mature, aggressive male with over 25 yrs experience in mgnt & sales. I can turn a loser into a profit maker. 904-837-9777.

HELP WANTED

STATION MANAGER with operations, programming and sales experience and leadership skills to directly manage a growing small market broadcasting operation. Call for information and details. Michael Tracy, GM, KMOR/KOAK/KOLT, 308-635-8453.

Afternoon Announcer - for new FM on the beaches of Gulf Shores, Alabama. Good production skills a must. We are looking for a pro that is a team player. Send T&R to PO Box 552, Forest, VA 24551. EOE.

CHIEF ENGINEER for top 10 market FM stations. Strong RF & studio construction skills required. Minimum 5 years experience in Mid to Major markets. EOE. Resume/salary requirements to: Radio World, POB 1214, Falls Church, VA 22041. Attn Box #96-3-6-1RW.

ABOUT OUR EMPLOYMENT SECTION

HELP WANTED

Any company or station can run "Help Wanted" ads for \$1.50/word or buy a display box for \$60/column inch. Payment must accompany insert, use your MasterCard or VISA; there will be no invoicing. Blind box numbers will be provided at an extra charge of \$15. Responses will be forwarded to listee, unopened, upon receipt. Call 800-336-3045 for details.

POSITIONS WANTED

Any individual can run a "Position Wanted" ad, FREE of charge (25 words max), and it will appear in the following 2 issues of Radio World. Contact information will be provided, but if a blind box number is required, there is a \$15 fee which must be paid with the listing (there will be no invoicing). Responses will be forwarded to the listee, unopened.

Mail to: BROADCAST EQUIPMENT EXCHANGE, PO Box 1214, Falls Church, VA 22041 Attn: Simone Mullins

# THE AUDITRONICS 2500 SERIES THE LAST SMALL CONSOLE YOU'LL EVER HAVE TO BUY



Some people believe small means limited. At AUDITRONICS we believe small is a challenge. That's why we have again defined a new standard of excellence by combining impeccable design, precision manufacturing, and value pricing in a full featured, compact audio console. The 2500 Series is loaded with all of the "me too" features found in the competition's "wannabe world class" consoles. Plus the 2500 Series delivers much more, including:

- **SOLID STATE SWITCHING** of all signal paths
- **DC CONTROL** of all level functions
- Telephone **CONFERENCING** capability
- **20dB HEADROOM** maintained throughout
- Easily accessible wiring on **MOTHERBOARD CONNECTORS**
- **ACTIVELY BALANCED** input, patch points, and floating outputs
- Linear **CONDUCTIVE PLASTIC** 100mm faders (P & G Standard)
- Comprehensive **A/B EXTERNAL LOGIC** control
- External line selector with **CUE AND HEADPHONE ASSIGNMENT**

And remember, AUDITRONICS is the company that still supports the first console it ever sold -- over 28 years ago. So you no longer have to compromise with a "wannabe". With the 2500 Series you get the real thing!

**THE ONLY WORLD CLASS CONSOLE AVAILABLE AT "wannabe" PRICES.**

**AUDITRONICS** 3750 Old Getwell Road, Memphis, TN 38118 (901) 362-1350 FAX (901) 365-8629

*We've taken all we know, all you've asked for,  
and the very best of today's technology to  
bring you our **FINEST AUDIO CONSOLE***

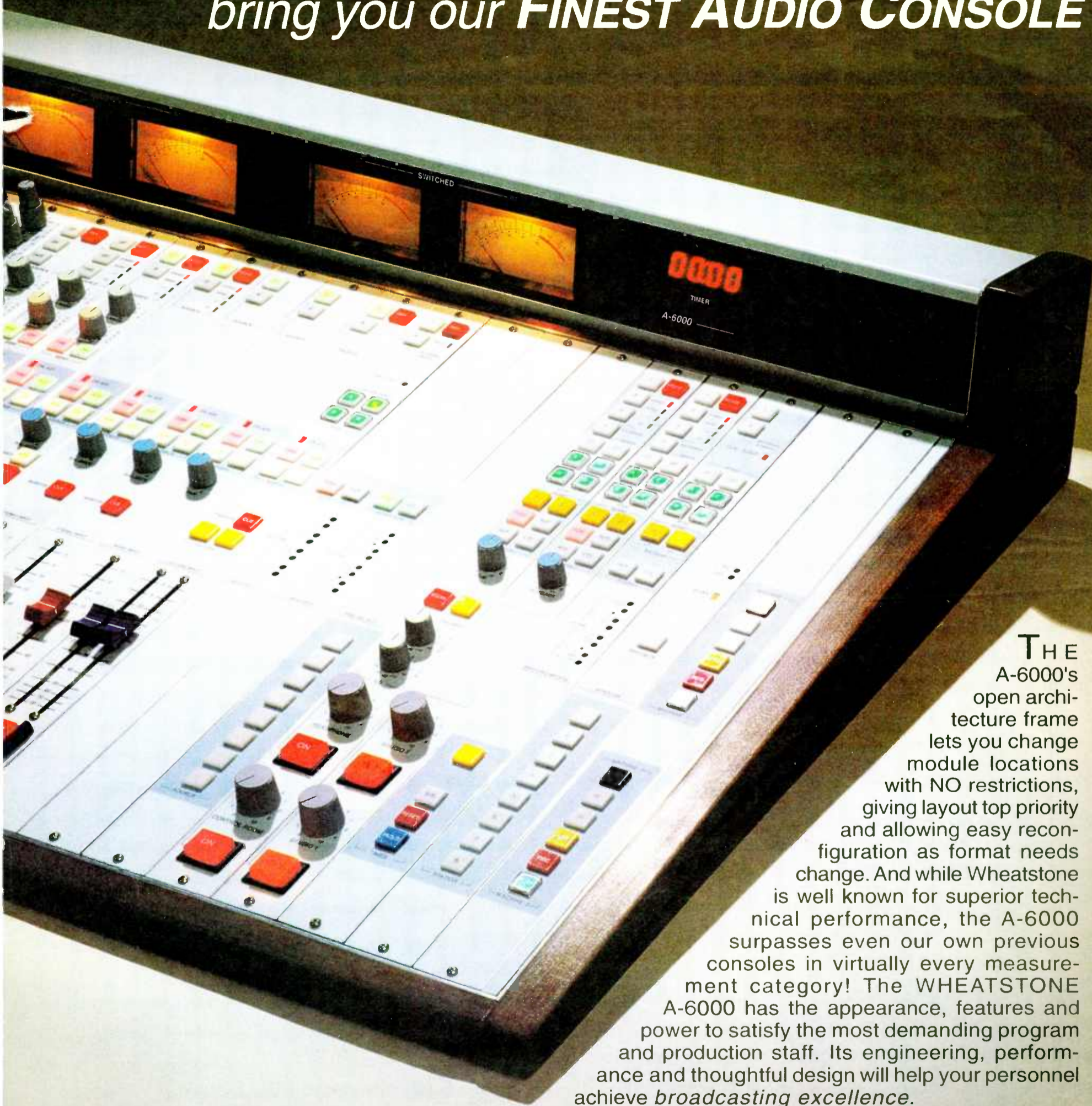

**T**HE A-6000's open architecture frame lets you change module locations with NO restrictions, giving layout top priority and allowing easy reconfiguration as format needs change. And while Wheatstone is well known for superior technical performance, the A-6000 surpasses even our own previous consoles in virtually every measurement category! The WHEATSTONE A-6000 has the appearance, features and power to satisfy the most demanding program and production staff. Its engineering, performance and thoughtful design will help your personnel achieve *broadcasting excellence*.

## **A - 6 0 0 0    B R O A D C A S T    C O N S O L E**

7305 Performance Drive, Syracuse, NY. 13212  
(tel 315-452-5000, fax 315-452-0160)

 Wheatstone Corporation