

Radio World



See pp. 25-33

Vol 19, No 14

Radio's Best Read Newspaper

July 12, 1995

Patent Snags EAS, May Delay Implementation

by Lynn Meadows

WASHINGTON The attempt by the Federal Communications Commission (FCC) to devise a non-proprietary Emergency Alerting System (EAS) and roll it out on schedule may have met a glitch.

A Kansas company believes it has a patent on the requirements for the new geographically-directed alerting system.

Quad Dimension Inc., based in Overland Park, Kan., received a patent for its Storm Alert For Emergencies (SAFE) system on June 9, 1992. A significant part of SAFE is its geographically specific emergency alerts. The patent describes a composite code string that includes "a location code string component and an alert code string component."

The FCC Report and Order on EAS, issued two-and-a-half years after the patent was granted, requires stations to purchase equipment that can decode a four-part digital coded message. Along with other information, the codes will indicate both the emergency event and the location of the area that is affected.

In June, several manufacturers of EAS equipment received letters from Quad

Dimension informing them that they need a licensing agreement to use technology covered by the patent. "We are interested in licensing this patent and will discuss it with anyone who is interested," said Quad Dimension Vice President Larry Ganzer.

Royalties paid for the technology by manufacturers could translate into higher costs for station owners looking to purchase EAS equipment.

FCC knowledge

FCC reaction to the news hinged on whether the person speaking was one of the handful of FCC officials aware of the patent. A review of the documents filed during the EAS development process revealed that Ganzer submitted at least three comments and the patent to the FCC.

Letters dated Oct. 9, 1992, and Dec. 19, 1992, were sent to Acting EAS Chief Frank Lucia. Another letter dated Oct. 20, 1994, went to FCC Chairman Reed Hundt. The letters discuss SAFE and its potential for the new EAS system. Ganzer also sent Lucia a videotape of SAFE being demonstrated at Kansas television station KCTV channel 5.

Lucia said his office was looking into

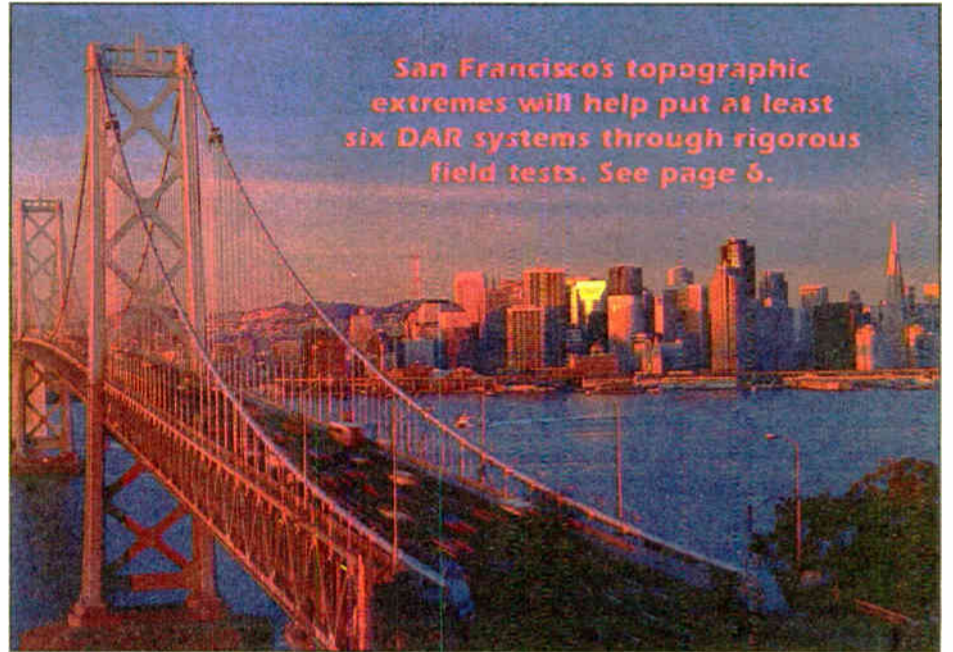

San Francisco's topographic extremes will help put at least six DAR systems through rigorous field tests. See page 6.

the patent matter now that manufacturers had expressed concern over increased costs for licensing fees. "I can't give an official reaction because the weather service is also looking into the matter," he said.

Dr. Helena Mitchell, assistant to the chief at the Office of Engineering and Technology expressed surprise that a patent existed. "We are mandating a protocol and a standard but not any special equipment," she said.

It was the FCC's intent that no one company or person would have a market hold on EAS. "The latest generation of equipment approved by EAS allows for a multitude of technologies to send and receive local, state, and federal alerts," Mitchell said.

She pointed out that EAS technology has been used for several years by the National Weather Service (NWS). NWS created the National Oceanic and Atmospheric Administration (NOAA) Weather Radio Specific Area Message Encoder (NWRSAME) in the 1980s.

Patent debate

There are several similarities between NWRSAME and SAFE. Like SAFE, the NWRSAME technology uses Frequency Shift Keying (FSK) to transmit its code. According to NWS documentation, NWRSAME also uses its codes to send information indicating both the hazard message to be broadcast and the geographical region affected.

According to sources at the NWS, the idea to use geographically specific alerts dates back 15 years or more. The NWS initial emergency plan was to generate a 1050 Hz tone on NOAA weather radio to alert listeners of emergencies. They quickly discovered that they needed a way to specify what geographic area to alert.

Although NWS has been using EAS technology since the mid-1980s, no patent was ever requested for NWRSAME.

Senate Reforms Radio

WASHINGTON Senator Larry Pressler, chairman of the Senate Committee on Commerce, Science and Transportation, met his self-imposed July 4 deadline for passing Telecommunication legislation.

On June 15, along with deregulating the cable, telephone, and television industries, the Senate swept away all barriers to radio group ownership and passed the historic bill 81 to 18. This is good news for group owners who want to expand beyond the current 20 FM/20 AM station limit.

In a statement, Pressler said, "This bill breaks up monopolies and tears down regulatory barriers. After it becomes law, the broadcasting, cable and telephone businesses will never be the same as before."

The House will debate its version of the bill next. That version, which is very similar to the Senate version, will probably be brought to the House floor before the August recess.

The Senate bill removes all caps on radio ownership and increases the license terms for radio stations to 10 years. If the bill becomes law, the industry could see a lot of shuffling as new and established group owners buy up the small stations ready to sell.

continued on page 14 ►

CCA Broadcast Transmitters... The Very Definition of Reliability.

30 YEARS

24-HOUR SERVICE, 365 DAYS-A-YEAR

re-liable *ri-'li-ə-'bil-ə-ti* **1:** the quality or state of being reliable **2:** the extent to which an experiment, test, or measuring procedure yields the same results on repeated trials **3:** the descriptive quality of any radio transmitter manufactured by CCA Electronics, Inc. in Fairburn, Georgia

re-li-able *ri-'li-ə-'bil-ə-dli* **1:** suitable or fit to be relied on **2:** giving the same result on successive trials **3:** possessing the same qualities of dependability

re-li-able-ly *ri-'li-ə-'bil-ə-dli* **1:** as a transmitter manufactured by CCA Electronics, Inc. in Fairburn, Georgia **2:** reliably

re-li-ance *ri-'li-'ə-'ns* **1:** the act of relying **2:** the condition or attitude of one who relies **3:** DEPENDENCE

re-li-ant *ri-'li-'ə-'nt* **1:** one who relies on military power to achieve political aims or someone

360 Bohannon Road • Fairburn, Georgia, USA 30213
(404) 964-3530 • FAX: (404) 964-2222

CCA

Circle (28) On Reader Service Card

NEWSWATCH

FCC Seeks Comments on DARS

WASHINGTON The Federal Communications Commission (FCC) issued its long-awaited notice of proposed rule-making (NPRM) on digital audio radio satellite service (DARS).

The commission is seeking comments on a variety of issues surrounding DARS including: 1) How many nationwide licenses should be awarded; 2) How much spectrum each licensee should be assigned; 3) How licensees should be elected if mutually exclusive applications are filed; 4) How the service should be regulated, and 5) Whether

licensees should be permitted to use some of their spectrum for non-DARS services.

Among the options for licensing at the FCC, is the consideration to assign all the spectrum to only the four current applicants for DARS, license some of the spectrum now and hold some in reserve for future applicants, and open up the spectrum to all interested parties.

In separate statements, Commissioners Quello and Ness both raised the issue of DARS' impact on terrestrial broadcasters. Ness favors making DARS a subscription-based service. The NAB as well restated its opposition to DARS.

Comment date for the NPRM is Sept.

15 and the reply comment period ends Oct. 13.

Marconi Radio Award Nominees Announced

WASHINGTON The National Association of Broadcasters (NAB) announced the nominees for the 1995 NAB Marconi Radio Awards. The awards will be presented at the close of the NAB Radio Show in New Orleans on Saturday, Sept. 9.

More than 100 stations and personalities have been nominated in twenty-two categories. NAB member radio stations will select the winners.

The coveted "Station of the Year Award" is divided into four categories based on market size.

Up for awards in the "Major Market" category are WALK-AM-FM in

Nassau/Suffolk, N.Y.; WBZ(AM) in Boston; WDVE-FM in Pittsburgh; WINS(AM) in New York City; and WJLB-FM in Detroit.

Nominees for the "Large Market" category are KSHE-FM in St. Louis; WFBQ-FM in Indianapolis; WHRK-FM in Memphis, Tenn.; WSOC-FM in Charlotte, N.C., and WZZK-AM-FM in Birmingham, Ala.

"Medium Market" nominees include
continued on next page ►

Index

FEATURES

How to Analyze Resistor Circuits	20
by Harold Hallikainen	
Computer Mayhem Unlike Any Seen on 'Star Trek'	22
by Al Peterson	
Age, Environment Can Affect AM Arrays	34
by Cris Alexander	
Cybernet Station Operates Two Channels	39
by Dee McVicker	
Workbench	40
by John Bisset	
Efficiency Modulation Transmission	45
by Tom Vernon	
Radio Is Building Digital Future Today	49
by Greg Dean	

STUDIO SESSIONS

Roland DM-800 Portable, Powerful	25
by Ty Ford	
Legendary Les Paul Turns 80 This Year	26
by Frank Beacham	
Maintenance Keeps DATs Error-Free	28
by Bruce & Jenny Bartlett	
Put Operations Manual on the Net	30
by Rich Rarey	
Oktava MK 219 Mic: The Soviet Sound Arrives	30
by Ty Ford	
Crown Listens, Improves Headset Mic	32
by Rich Rarey	
Beyer Big and Bassy	33
by Ty Ford	

BUYERS GUIDE

USER REPORTS

Audiovault Lauches Stations into '90s	50
by Phil Woods	
Hard Drive Leap Eased with Scott	52
by Jack Carter	
UDS2 Transforms Florida Stations	55
by Barry Grant Marsh	
DCS Draws Duopoly Back To Computer Concepts	55
by Dan Kelley	
DAD486x Takes on Demanding Facility	56
by Paul Barzizza	
Gemini Replaces Aging Analog Equipment	58
by Larry Wilkins	
Wizard Gives Stations Local Sound	60
by John Marquis	
WireReady Eliminates Paperwork	63
by Leroy Dietrich	
Sentry System Solid	63
by Shannon Milburn	
Programming Strength of DigiCenter	64
by John Mackley	
SMARTS Sensitive to Broadcasters	65
by Ray Kassiss	
CartWorks Built with Eye on Future	66
by Clint Webster	
Excellent Service Sets SALSA Apart	66
by Larry Mikesell	
No Experience Required with LYNX	68
by Bill Rogers	
PhoneByte Takes a Pounding at KYNG	69
by Katie Pruett	
Pristine System Fits Any Format	70
by Mark F. McNeil	
RDS Phantom Creates Happy Union	72
by Michael H. McDougald	
AXS Alleviates Traffic Nightmares	73
by Ted L. Turner	

TECHNOLOGY UPDATES

Columbine JDS	74
Digital Link	74
Dalet	74
Radio Systems	74
Euroson America	75
McCurdy	75
Datacount	75

When looking for a digital audio system for automation of satellite programming or live assist, there would appear to be many choices. But if you're looking for a system which is flexible enough to give you total control without sacrificing your sanity, there is only one choice. The Phantom by RDS.

You will see the difference as soon as you see the Phantom in action. The display provides you with all of the information you need to see in a clean, concise manner, without the crowded look that you'll find in other systems. If you are familiar with the most popular software on the PC, then you may already know how to use the Phantom. The Phantom's pull-down menus guide you through all of the steps involved in setup and daily operation, from creating and scheduling clocks to creating and editing logs.

The PHANTOM Digital Audio Automation

The Phantom ends the confusion of automation by keeping everything organized. The Phantom simplifies your daily operations by keeping information such as input changes, voice changes, and clock changes in their own individual schedules rather than in the log. You can leave those liners and other voice drops out of the log because the Phantom will do them for you. The Phantom allows you to date new schedules to begin weeks, months, or even years in advance. When your satellite network informs you that there will be a voice substitution on Thursday, two weeks from today, you can prepare for it *today*.

The Phantom can retime spots to fit them cleanly into a satellite break without inserting silence, overlapping, or running late. The Phantom



can create reports to keep you informed on a number of topics, from a list of expired spots to an analysis of potential mistakes in your log. The Phantom also maintains a history of system activity.

The Phantom has the features that others would want you to believe are theirs exclusively. The Phantom remains *completely* functional during recording, sensing relay closures and starting breaks as easily as it does when it is not recording. The Phantom can fill incomplete breaks with spots from a list you specify without ruining product separation.

While other systems tie your hands and limit your flexibility by only offering 3 or 4 inputs, the Phantom gives you 6 stereo inputs, using its AMX-84 solid state switcher, with the option of increasing the number of inputs to 14 or more. If your station is News/Talk, you know how important this can be.

The Phantom allows you to change the sampling rate, digital format, and stereo/mono settings at will to meet your needs for an individual spot. The Phantom offers a number of digital formats, including the new Dolby AC-2 format, as an option.

Call us today to find out how your station can benefit from the advanced technology of the Phantom and the experience of RDS.

1-800-521-5222
912-987-2501 • FAX: 912-987-7595
P. O. Box 980, Perry, GA 30169



**REGISTER
DATA
SYSTEMS**

KLBJ-FM in Austin, Texas; KLEF-FM in Anchorage, Alaska; WHO(AM) in Des Moines, Iowa; WILM(AM) in Wilmington, Del., and WMT(AM) in Cedar Rapids, Iowa.

Stations nominated for Station of the Year in the "Small Market" category are KOEL(AM) in Oelwein, Iowa; KROC(AM) in Rochester, Minn.; WDLB(AM) in Marshfield, Wis.; WHIZ(AM) in Zanesville, Ohio, and WQCB-FM in Brewer, Maine.

NAB Pleased with Legislation

WASHINGTON The National Association of Broadcasters (NAB) issued a statement saying it is pleased with the proposed House legislation to exempt broadcasters from a new performance right in digital sound recordings.

NAB President and CEO Eddie Fritts testified for the exemption in a hearing explaining that the broadcast and recording industries have a symbiotic relationship. In return for the use of its products, he said, the broadcasting industry has helped the recording industry "sell literally billions of records, CDs and cassettes, and sold millions of concert tickets."

TAB/SBE Conference

AUSTIN, Texas The Texas Association of Broadcasters & Southwest Region of the Society of Broadcast Engineers Annual Convention & Media Technologies Trade Show will be held Sept. 29 through Oct. 1 in San Antonio, Texas.

The conference includes a "futures" session with input from Microsoft, GTE, TCI, and others. Speakers at the convention include FCC Commissioner Susan Ness, Representative Jack Fields (R-Texas), chairman of the House telecommunications subcommittee, and Roy Stewart, chief of the Mass Media Bureau of the FCC.

New SPARS Board Appointee

HOLLYWOOD, Calif. The Society of Professional Audio Recording Services (SPARS) appointed Michael Tarsia to its Board of Directors. Tarsia is president of Sigma Sound and the son of the first SPARS president, Joe Tarsia.

"Having grown up with SPARS and seeing my father's contribution to the organization, it's really an honor to join the Board of Directors," he said.

Before becoming president of Sigma Sound, Tarsia earned over a dozen gold and platinum albums working with artists like Patti LaBelle, New Edition, Sheena Easton, and Bruce Hornsby.

CBS Newscaster Dies

MONTCLAIR, N.J. Dallas S. Townsend Jr., who worked for CBS News from 1941 to 1985, died June 1 at the age of 76.

Townsend wrote and anchored the "CBS World News Roundup," the longest running radio news broadcast in the nation. He received the duPont-Columbia University Broadcast Journalism Award, a Peabody Award, and an Armstrong Radio Pioneer Award for his 25 years of work on that show.

Eric Ober, president of CBS News said of Townsend, "In his more than four decades with CBS News, he distinguished himself as a great writer, reporter and broadcaster, and his loss is deeply mourned by his many, many friends and colleagues at CBS News." ☺

Sony Launches Automation Package

by Mel Lambert

LONDON It is often said that a successful innovation can be recognized by the fact that the totality of a particular system is far more powerful than the sum of its constituent parts. In the case of Sony's new Effective Radio Automation, or ERA, which received its worldwide unveiling at the recent Montreux ITVS in Switzerland, the full integration of digital recording, mixing, DSPs and replay capabilities represents a remarkable development.

Sony personnel in Montreux were the first to point out that the majority of the ERA's components have been seen before; it is the company's interconnection and inclusion of a new hard disk-based scheduling software that enables all on-air functions to be fully integrated.

The system is centered around the familiar DMX-B4000 Series all-digital mixer, available in two mainframe sizes to accommodate either 16 AES/EBU-format digital inputs routed via eight faders to one stereo output and two stereo aux busses (model B4016), or 30 inputs routed via 16 faders (model B4016). Full digital signal processing, including assignable EQ and filters, is also available.

Inputs to the DMX-B4000 can include DAT machines, for long-form playback, CD single/multiplayers (such as the CDK-3600 CD AutoChanger being demonstrated in Montreux), and MiniDisc players (including the MDS-B3 and B4P). Dual mic/line input modules with 20-bit A-to-D converters are also available for the B4000 Series mixer, to accommodate non-digital sources. And for off-rate digital sources, the DAF-1500 frame can be expanded to include sample-rate converters and other peripheral components.

What ties all of these various system components together in a unique way is Sony's new PC-based automation software. Designed to operate on a standard 90 MHz Pentium-based platform under Windows 3.1, the new controller is equipped with both RS-232 and RS-422 serial interfaces for connecting to the DMX-B4000 Series mixer and various digital playback devices. Additional PCs can be connected to the master controller via a convention local-area network—and which would be taking care of the overall scheduling and replay functions for a station—to allow off-line workstations to be used to prepare, for example, playlists and commercial schedules. All events within the automation system are available as standard-format information that can be sorted and otherwise manipulated using word processors and database software.

(For the technically curious, at the heart of Sony's new radio-studio automation system is an industry-standard database based on SQL—or structured query language interfaces that provide simple drag-and-drop manipulation of database information within the time-dependent playlist.)

The ERA System is scheduled to begin shipping by the end of this year; tentative price for a "typical" complement of PC-controlled CDs, DATs and MiniDisc players routing through a 16-fader DMX-B4000 Series mixer is in the

neighborhood of \$150,000. For radio stations wishing to automate an existing B4000 mixer and peripherals, the master PC-based controller is expected to be available for around \$12,000.

Because the DMX-B4000 Series is designed for full serial control, including the ability to off-load and recall entire system settings, it represents an ideal choice for automated broadcast applications. Having caused, for example, a CDK-3600 CD changer to load, pre-cue and then initiate playback mode of a selected title, it is a simple task to issue a command to the mixer that causes its microprocessor-controlled input matrix to route a designated stereo input source via EQ (if appropriate) to the stereo output at a pre-set level. Once that event has been completed, a relatively simple sequence of commands will set up and initiate the next event, and so on through the pre-programmed list of audio cues and playback elements.

In addition to a fully-automated mode of operation, with all playback events being triggered against a master clock, it is also possible to run the ERA System in operator-assist mode, whereby the PC handles playback of pre-determined sequences—a couple of music segments—followed by a station ID, for

example—opens the DJ's microphone channel, and then waits for a command from the console before initiating another pre-programmed sequence. Such "pause events" can be inserted into the playlist to allow the DJ or operator to throw forward or back-announce a segment, or to introduce other events such as a phone-in or studio interview.

Because pause events are often of an unknown duration, a visible countdown displays the unfilled time remaining in a timed show.

In addition, all playback events are tagged in a read-only file that can be used for traffic and commercials billing purposes. (The events history file can be retained for a user-defined period of time.)

All in all, Sony's ERA system represents an interesting development. Utilizing proven components and user-selectable playback media, it is possible to configure an all-digital system that can be full or partially sequenced, according to your station's format.

□ □ □

Mel Lambert is a principal of Media&Marketing, a Los Angeles-based consulting service for the professional audio industry. He can be reached at mediapr@aol.com, or 818-753-9510. ☺

Small, Reliable, and Runs Nearly Forever



Sound Familiar?

OK, so it may not be quite as familiar to you as that other shape, but Continental's 814H 1 kW FM broadcast transmitter delivers surprisingly powerful performance for such a small package.

Only about the size of your average four-drawer file cabinet, the completely self-contained 814H features continuously adjustable power from 150 to 1000 watts*, solid-state electronics, digital modulation indicator, and superior audio performance. And of course,

Continental's quality design and construction means years of trouble-free operation in all types of environments. Plus, in the unlikely event your 814H needs repair, Continental's team of trained professional technicians is available 24 hours a day.

Even the other little guy couldn't say that!

Call 800-733-5011

* Using the power output of a Continental 802B exciter. 4.95.103

For nearly 50 years, Continental Electronics has provided excellence in broadcast transmission products worldwide. Refuse to compromise... call Continental first!



Continental Electronics Corporation

P.O. BOX 270879 • DALLAS, TEXAS 75227-0879
214-381-7161 • FAX 214-381-4949

Circle (187) On Reader Service Card

Ranks of RDS-Ready Swell, But Promo Lags

WASHINGTON The EIA initiative to outfit radio stations with RDS capabilities is off to a great start. This issue's RDS Roll Call lists 50 more stations than the Roll Call page of just three months ago (see *RW*, April 19). The long-range goal is 500 stations in the top markets, so a 10 percent roll-out in the first three months is pretty good.

It would be nice, though, if the stations did something with RDS once they got it. Commercial stations in Washington still lag behind WETA-FM, the non-commercial station, in that department. While WETA-FM creatively promotes upcoming programming in a constantly changing scrolled message, I'm lucky to tune in more than call letters at any of the other outlets that are RDS-equipped so far.

Many important and successful radio groups own stations in this market and I find it hard to believe that RDS is such a difficult concept for them to master. Get with it, radio. Technology is passing you by...

★ ★ ★

On a related note, I received a call from a television engineer (who reads *RW*) the other day wanting to know why it was so tough for him to find a state-of-the-art radio for his car. His beef was that local retailers did not know or care about AMAX- or RDS-equipped radios for his car.

I must confess, I was very busy and did not spend a great deal of time with this engineer-in fact, I pointed out to him that *RW* is a trade publication and we do not deal with the consumer.

But since that phone call, I keep wondering if, as an industry, you are doing enough to promote yourselves technically speaking. I know you all know how to coordinate events and concerts and contests, but how about some time spent

promoting ways for listeners to get more enjoyment (audible enjoyment) out of your station?

Anyone giving away RDS-equipped receivers yet? Or AMAX Walkmans?

The younger crowd these days is pretty technically with-it. I'd bet good money that anyone willing to shell out \$60 to buy a computer game and \$15 for a CD (I remember when that would buy you a double album) would probably want technically superior receivers with all the "fixins."

★ ★ ★

The Radio Advertising Bureau (RAB) recently sent me a brand new publication it has put together to help market radio to advertisers.

The "Radio Marketing Guide and Fact Book for Advertisers" is packed with hundreds of marketing facts that stations can

use to their advantage. For example, do you ever tell potential customers that radio reaches almost every single person in the United States every week? And that the average listener spends more than three hours tuned in to his or her favorite radio station?

The new guide encompasses a broad range of data, including radio audience profiles, specific target consumer groups, competitive media and individual format profiles. Daily and weekly audience data is arranged demographically, and the book also includes information on average daily and weekly reach, time spent listening, daypart breakouts and listenership by location.

The guide features profiles of the Hispanic and African-American audiences.

The publication is a very nice, four-color book that can help just about any sales

presentation. If you'd like a copy, contact the RAB's services department in Dallas at 214-753-6700.

★ ★ ★

Last time out I wrote a little bit about the war between WPGC-FM and newly acquired WKYS-FM. A release landed on my desk this morning that proves Infinity will have its hands full keeping its station's position

of dominance in the market.

It seems that Radio One (founded by Cathy Hughes) just received an infusion of \$10 million from Burr, Egan, Deleage & Co. and BancBoston Capital Inc. in the form of subordinated debt. Funds "will be used to assist management in its acquisition of WKYS-FM in Washington." That is a lot of money. Stay tuned everyone.



Giving Something Back



SCOTTS VALLEY, Calif.

Jazz keyboard great Jason Miles hosted a multipart educational program sponsored by E-mu Systems. Held at San Francisco's Russian Hill Studios last month, the event was designed to expose the Grattan Public School second grade class to the magic of modern digital music technology.

Miles (pictured above with the second grade class) illustrated the power of digital sample-based audio technology as it relates to his composition and performance work on "People," an hour-long animated program honoring the 50th anniversary of the United Nations.

Miles explained the concept of digital sampling technology and illustrated its use through live application, computer MIDI sequences and animated clips from the program (Jason Miles employs an Emulator IV from E-mu for his work).

BDT-115 RF Data Link for remote control

- Wireless link for Burk ARC-16
- No "P" channel required
- Eliminates telco line charges
- Bi-directional communication
- 20 miles line of sight

Think of the possibilities.

BURK
TECHNOLOGY

7 Beaver Brook Road • Littleton, MA 01460
(508) 486-0086 • Fax (508) 486-0081
Toll Free 1-800-255-8090 • email: danrau@burk.com

Put Us In Your Sites.

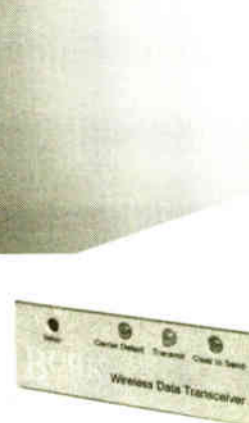

READERS FORUM

If you have comments for Radio World, call us at 800-336-3045 or send a letter to Readers Forum (Radio World, Box 1214, Falls Church, VA 22041 or MCI Mailbox #302-7776). All letters received become the property of Radio World, to be used at our discretion and as space permits.

Not naive

Dear RW,

In response to your editorial, "Politics Mires Digital Audio Radio Testing," (RW, June 14), the Electronic Industries Association appreciates the editorial coverage given to the DAR issue, however, we would like to rebut a few of your viewpoints.

Overall in the article, you accuse EIA of basic naivety in our quest to receive a "chunk of L-band" in order to complete our DAR testing efforts. We did assume we would receive the permission to use the L-band, but not because, as you put it, "it was EIA."

We have asked the FCC to grant us a temporary and secondary L-band license in an area in which governmental facilities will not suffer harmful interference from the proposed experiments. EIA's advanced coordination with IRAC (through the FCC in 1994) intended to reveal specific technical concerns that experimental operations might have to consider prior to filing with the FCC. The responses from the IRAC and the AFTR-CC presented no interference concerns, and the subsequent monitoring study by EIA reveals why—the entire band is almost completely unused in San Francisco. EIA's application for the experimental license remains consistent in all respects with the letter and spirit of the FCC's Experimental Radio Service rules.

In your editorial, you refer to the fact that L-band "has no chance of becoming a choice in the United States unless the entire spectrum allocation setup is reworked." However, the tests by EIA and the NRSC are not to determine which spectrum is best suited for digital audio radio, but rather to hold serious, objective, impartial, comparative evaluations of all proposed DAR technologies. At this stage, EIA believes all options

must be considered. The EIA and NRSC subcommittee architecture has allowed the industry to hold comparative evaluations needed to assess system performance and created a structure to voice disparate viewpoints in an open forum. We will evaluate all the technologies based on the test data to determine how best to implement digital audio radio in the United States.

This initiative is unique in the world. Other countries are looking to our efforts in their own evaluations on which technology to support. To date, EIA has received considerable government support and cooperation from both the FCC and the NASA Lewis Research Center. This private sector initiative can further and enhance the technical base for government consideration of the merits of DAR technologies.

Regardless if the United States does not use L-band for DAR, other countries are and will. If we want U.S. manufacturers to be able to develop and manufacture DAR products for those markets, they must be able to test products in realistic conditions throughout the design process. If no experimental licenses for L-band are available in the United States, then U.S. manufacturers will have to move sizeable research jobs, money and materials outside the United States to maintain technical competitiveness with other manufacturers not so constrained.

The implication of rejecting EIA's experimental L-band license, intentional or otherwise, will have long-ranging effects. By denying the application, the government will:

- 1) explicitly reject non-in-band DAR system approaches—a premature decision;
- 2) implicitly endorse the USA Digital Radio system—without comprehensive technical backup;
- 3) rely on foreign test programs in a non-comparative venue to access technology; and
- 4) move jobs outside the United States because domestic manufacturer product testing of export products cannot obtain similar experimental authorities at L-band frequencies.

The proposed field testing in San Francisco intends to test all DAR technologies simultaneously under identical real-world conditions to correlate field test results with laboratory data and to uncover any peculiar system performance not revealed with lab testing. Field data is needed on the Eureka-147 DAB system at L-band frequencies to complete the technical record on its performance credibility.

Since our application for the L-band frequency is in line with FCC rules and previous governmental support of our DAR testing efforts, is only for use for temporary and secondary experimental testing, does not interfere with aerospace or flight test operations in this spectrum in San Francisco, and recognizes that U.S. policy remains focused on preserving the use of the band for its current purpose, we assumed that permission for the L-band frequency would be obtainable.

Gary J. Shapiro, vice president
Consumer Electronics Group,
Electronic Industries Association
Arlington, VA

Without a Doubt

Futurists in government and the radio business dream of the all-digital radio station and the plethora of services and revenue made possible by that scenario. An hour or two spent perusing this issue's *Buyer's Guide* section on automation and live-assist hardware and software reveals what many of you know already: the convergence of radio and computer is well under way.

There is no doubt that the radio industry will develop digital services to offer to the public and create for themselves lucrative new revenue streams.

Half of that battle has been won with the furious pace of software development and the integration of new digital services into the hardware and daily routines of the radio industry.

Witness the growth of station automation software manufacturing—a fledgling business less than five or six years ago—and its acceptance by stations. Competitive music and news/talk stations find they almost cannot do without software packages that did not exist a short time ago:

- Live-assist programs that allow a talk show host to know everything about the listener waiting on the line. Name, address and various other demographics (as well as the topic the listener wants to talk about) are all flashed up on a computer screen, which also tells you when to play the commercial.

- Systems to automatically record and store satellite program material and integrate it into prepared broadcast schedules which may be programmed and ready weeks or months in advance. Some systems are capable of receiving and processing data files for later retransmission by Radio Broadcast Data Service, FM subcarriers and other means.

- Software to keep track of traffic and billing, ad sales and station maintenance schedules that is often flexible enough to fit into any sized operation, from a small rural station to a multistation duopoly/LMA—even a national group.

Innovative programmers, with suggestions from their radio customers, are continually making it easier to broadcast high-quality programming with significant long-term savings.

High-tech efficiency sometimes costs people their jobs at a station level—but witness the creation of all those new jobs at the manufacturing level.

That is all the more reason radio should seek to expand itself by finding ways to convert its already-demonstrated mastery of computer technology into new digital services for the consumer and business.

—RW

And the point is...

Dear RW,

In reply to Kevin Powell... OK, what is your point?

The way I see it, not only did you probably use a taxpayer funded word processor on your taxpayer funded job time to write a letter defending your tax funding, for all I know you mailed it to RW at my expense.

Worse than that, you apparently did not read what I wrote very closely.

I said, "Mind you, I am not against NPR or non-commercial broadcasting—just the federal funding of it."

If you can get enough listeners to pay for that mind-numbing liberal drivel that NPR pumps out, more power to you.

But absent that, if we cannot cut CPB, than that is a serious indication of the futility in trying to balance the budget.

It is not about competition. It is about wasting federal dollars which we have borrowed on our children's future incomes. Over \$4,100,000,000,000 of them to date.

I fully expect that new technologies will create places for lots of players. And if you have a high enough testosterone level to play the game, welcome to the world of free enterprise. I will be there (see us at <http://www.ktrt.com> on the web.)

But do it with your own money or money you raise in the free marketplace.

The difference between you and me is that the only danger to you is if your government paycheck were to disappear. And

I provide that paycheck.

And, by the way, any time we want to get back on the deregulation track, count me in, because I may think Stony Brook is a pretty good market, too.

Fred M. Weinberg, President
KTRT(AM) Tulsa, OK

Nail on the head

Dear RW,

GREAT *Page Four* ("Hey Reed..."). Again, you've hit the nail on its proverbial head with the courage to speak out for our great industry.

Pee Wee Herman would do a better job than Hundt. What a Chump! Keep up the terrific work.

Tom McCarthy
KOMO Radio
Seattle, WA

Clarification

Our Product Evaluation of the Fostex D-25 DAT Recorder (*Studio Sessions*, RW June 14) stated direct ID Search was possible only by repeatedly pressing the S-ID button to the desired cut. Rick Cannata at Fostex tells us the D-25's Jog Wheel is the faster way to directly enter search information. "Wheeling in" the numerical value moves the tape to the desired track.

Radio World

Vol. 19, No. 14

July 12, 1995

Editor in Chief.....Lucia Cobo
Technical Editor.....Alan Peterson
Associate Editor.....Whitney Pinion
Staff Writer.....Lynn Meadows
Contributors.....Frank Beacham/N.Y., Bruce Ingram,
Pamela Watkins, Nancy Reist, Alan Haber
Technical Advisors.....John Bisset, Tom McGinley
Editorial Director.....Marlene Lane
Assistant Editorial Director/Audio.....Alan Carter



Radio World (ISSN: 0274-8541) is published bi-weekly by Industrial Marketing Advisory Services, Inc., 5827 Columbia Pike, Suite 310, Falls Church, VA 22041. Phone: 703-998-7600. Fax: 703-998-2966. Second-class postage rates are paid at Falls Church VA 22046 and additional mailing offices. POSTMASTER: Send 3579 forms and address changes to Radio World, P.O. Box 1214, Falls Church VA 22041. REPRINTS: Reprints of all articles in this issue are available. Call or write Regan Deatherage, P.O. Box 1214, Falls Church, VA 22041; (703) 998-7600; Fax: (703) 998-2966. Copyright 1995 by Industrial Marketing Advisory Services, Inc. All rights reserved.

—PRINTED IN THE USA—

**Next Issue of
Radio World
July 26, 1995**

DAR Field Tests to Begin in San Francisco

by Lynn Meadows

WASHINGTON Historic San Francisco will host the long-awaited field tests of Digital Audio Radio (DAR). Famous for cable cars, the Golden Gate Bridge and Fisherman's Wharf, the city by the bay is also known for its complicated topography—making it an ideal place for phase two of the DAR testing process.

The site and test agenda were revealed in June by the Field Test Task Group, a sub-group of the Digital Audio Broadcast Subcommittee of the National Radio Systems Committee (NRSC). The NRSC's DAB subcommittee is conducting the tests in cooperation with the DAR subcommittee of the Electronic Industries Association (EIA).

Primary objective

The task group's primary objective is to see if the systems being tested provide a signal quality and durability that is greater than that which already exists on AM and FM systems. According to its release, the group hopes results of these tests will help broadcasters "make an informed decision on the future of digital audio broadcasting."

Many expect a DAR standard will be determined based on the test results. Types of systems being tested include IBOC (in-band on-channel), IBAC (in-band adjacent-channel), IBRC (in-band reserved-channel), and alternate band systems.

San Francisco was chosen primarily because of its eclectic terrain. With its mountain roads, woods, valleys, water, and suburban and urban architecture the city offers plenty of broadcasting obstacles.

Don Messer, broadcast satellite program manager for one of the seven systems being tested, VOA/JPL, said "I think the San Francisco metropolitan area has within it radio propagation conditions that represent most if not all of the United States."

Beginning in September, a van capable of receiving seven different DAR systems will begin trekking through the hills and valleys and over the bridges in and around San Francisco. The task group

The task group's primary objective is to see if the systems provide a signal quality and durability greater than that which already exists.

mapped out six paths which will last 30 minutes or more for the "Long Path" portion of the testing.

During the long-path tests, audio will be recorded and monitored for audio events. The two "events" listeners will track are either a change from listenable to unlistenable audio or a change from unlistenable to no audio. Any trouble spots like tunnels or woody areas where these events occur will be revisited during the "Short Path" testing phase.

Propagation measures

A third test, the point test, will be used to measure propagation characteristics for distances between 10 and 50 meters. The fourth and final test will measure how well the signal is received inside a variety of buildings.

Because the receivers are rack-mounted and too cumbersome to move in and out of several different buildings, a portable antenna will be used instead. The antennas will be connected to the van by a long run of coaxial cable.

Nikil Jayant, head of advanced audio technology for AT&T, says the plan is "ambitious." A spokesman for the National Association of Broadcasters (NAB) says testing is expected to be finished by the end of November.

The IBOC systems being tested are the one from AT&T/AMATI, and three

systems from USA Digital Radio: USADR-FM1, USADR-FM2, and USADR-AM. In-band, on-channel proponents like the fact that no extra spectrum is required for their service

because the digital service shares the same frequency as the analog signal.

AT&T will also be testing its IBAC and IBRC systems. The IBAC inserts a new station between existing stations. Because it has its own frequency, it can be more powerful than the IBOC method, according to AT&T. With the IBRC method, however, all the analog data is replaced by digital data providing the greatest power potential, said Jayant.

Shamrock Broadcasting's KBBG-FM and KNEW(AM) will supply the signal for the field tests. Testing for IBRC will be limited to early mornings because the completely digital signal will make it appear to ordinary listeners that the station is off the air.

At press time, prospects for testing Eureka-147, a European backed DAR system that transmits in the L-Band, did not look good. The National Telecommunications Information Administration (NTIA) would not yield the spectrum necessary to test it. The fact that the L-Band is tied up by military and governmental uses in the United States is considered a drawback to Eureka-147.

S-Band system

A satellite system, VOA/JPL, will also be tested this fall, although the system is not in direct competition with the others.

Proponents of the systems being tested are pleased with the plans for the field tests. "We just wished the field test would have been a little bit sooner," said Jeff Andrew, project manager at USA Digital Radio.

Still not settled at press time was the precise strategy for analyzing the audio recordings. "The subcommittee is leaning towards having some sort of expert listeners in a controlled environment," said Dave Wilson, staff engineer at the NAB. The listeners would identify instances of multipath propagation and poor audio.

Once the tests are finished, members of the NRSC and EIA subcommittees will review the data. The NRSC is expected to vote to either recommend a system or say none are satisfactory.

Harris Allied To Market Sage Gear

ATLANTIC CITY Harris Allied will market and distribute Sage Alerting's emergency alerting equipment. Harris Allied and Sage Alerting Systems Inc. made the announcement at the Mid-Atlantic States Expo last month.

Sage Alerting, a subsidiary of AmeriData Technologies Inc., is promoting a new product called the Sage ENDEC, designed to meet the new Emergency Alerting System (EAS) requirements mandated by the Federal Communications Commission (FCC).

The company worked closely with the FCC during the development of the EAS and says its equipment meets all the FCC's requirements and is the only system that integrates the Radio Data System (RDS) with EAS (see related story, page 1).

RDS transmits text to receivers that are equipped to receive it allowing stations to send extra information like letters, advertisements, or emergency announcements.

In its decision on EAS, the FCC encouraged but did not mandate the use of RDS. Only systems with the RDS could cause radios to be turned on automatically in the event of an emergency.

Sage Alerting was scheduled to meet early this month with the National Radio Systems Committee (NRSC) and others to write a standard for incorporating RDS into EAS. "We did the work before the standard and now we are writing the standard as we go," said Sage Alerting President Gerald LeBow.

This is Sage Alerting's first step into the realm of selling emergency equipment to radio stations. The company also sells systems to nuclear generating facilities and oil fields which alert surrounding areas of disasters.

Audio DA's for a
BROAD RANGE
of applications



- For every requirement and every budget.
- Single rack units to 4 in by 16 out.
- Modular mix and match to 10 in by 60 out.
- Multiple mic and line amplifiers, 4 to 8 channels.
- Transformer and active balanced outputs to +30dBm



**AUDIO
TECHNOLOGIES
INCORPORATED**

CALL OR WRITE NOW FOR FREE DETAILED BROCHURE.

328 Maple Ave. Horsham, PA 19044, USA (215) 443-0330 FAX: (215) 443-0394

Circle (27) On Reader Service Card

World Radio History

Your Best ISDN Solution —



Money Back Guaranteed!

Only CDQPrima™ with CCS MUSICAM® is guaranteed to make your ISDN digital audio sound the best

MUSICAM® is today's digital audio standard. Only CCS MUSICAM® has enhancements designed to sound best over ISDN phone lines. Only CCS gives you a 30-day money back guarantee.

Don't just take our word...

- Ask over 10,000 CCS MUSICAM® codec users worldwide
- Ask USA Digital Radio DAB
- Ask Swedish Broadcasting
- Ask RCA, LucasFilms and Top Recording Studios

We guarantee compatibility. Prima will even make your other brand decoder sound great!

Don't stake your next ISDN remote on five-year old Layer III or Layer II technology. And don't fall for any "hot air" product.

Call CCS for the facts.



CORPORATE COMPUTER SYSTEMS, INC.
670 N. Beers Street, Building 4, Holmdel, NJ 07733 USA
Tel: (908) 739-5600 Fax: (908) 739-1818



Public Radio Embraces DAW Technology

by Alan Peterson

WASHINGTON "Partnerships and Technology" was the theme of the 1995 Public Radio Conference held June 17-21 at the Washington Renaissance Hotel. Manufacturers of Digital Audio Workstations (DAWs) made it their theme as well with exhibits and hands-on demonstrations of their products.

Digital multitrack recorders, editors and audio retrieval systems are becoming more attractive for public broadcasting member stations as existing analog equipment enters "retirement" phase and needs to be replaced. Low cost and high quality audio lead the list of reasons

public radio stations—as their commercial counterparts—are replacing tape with digital.

Unlike commercial radio where most DAWs produce commercials and promos, public stations are embracing DAWs for long-form audio projects such as dramas, educational and public affairs programs and audio documentaries. Even the most basic workstation allows unprecedented power and speed over tape as well as assuring accurate timing of a project. Many DAWs are designed to sync to SMPTE or MIDI time code as well; with many non-commercial FM stations teamed up with TVs in their markets, a digital workstation that can perform tasks

and mix projects for both facilities is a great value.

Many of the major players in the DAW arena were present at the 1995 Public Radio Conference. Among them was Roland, demonstrating its new DM-800 workstation (see *RW*, June 14, and page 25, this issue). Roland's hands-on demonstration included use of the optional color video monitor for precise visual editing.

Digidesign's presence was felt with its Pro Tools III and Session 8 recording systems. Pro Tools III is a high-end recorder requiring a 68040-series Mac. The Session 8 is available on the Macintosh or PC platform and features eight channels of direct to disk digital

recording. The Session 8 works with a 486/25 PC, the Mac Quadra series or Power Mac 7100 or 8100.

Digidesign's big news is its Session Software 2.0 for PC users (it had previously been available for Mac users only), which allows desktop multitrack recording and editing at a low price. Session Software 2.0 requires Digidesign's Audiomedia II PCI card.

Among the veteran performers at the conference was Studer's third generation version of the Dyaxis workstation, the Dyaxis II. This was demonstrated in its broadcast production configuration, the Dyaxis IIbv, with built in dynamics control (limiter, compressor and gate), five band parametric EQ, and as a four-channel 8-track system. Using Dolby AC-2 4:1 data compression, the standard Dyaxis IGB hard disk handles 12 track hours; more than enough capacity for most major projects.

The least expensive DAW of the day was the Deck II from OSC, based around the audio recording capabilities of the Power Macintosh. Assuming a station already has such a computer, suggested retail price of the Deck II would be \$399.

Stations are embracing DAWs for long-form audio projects such as dramas, public affairs programs and audio documentaries.



The Old Way.

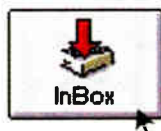

Digital Courier's Way.

Say Goodbye To Couriers And Dubs.

This is supposed to be the digital age. So why are you still waiting around for couriers, analog dubs or satellite feeds?

Join the Digital Courier International network. It's a fast, digital solution for audio delivery.

With DCI you can ship and receive CD quality audio spots over phone lines. In fact, commercials can be delivered to you from across the continent in as little as one hour. With traffic instructions attached.

This will cut down on the missed air dates and make-goods that you get all too often using couriers, satellite feeds

and any other digital delivery system.

DCI is the only two-way audio distribution network in the world that connects radio stations, production studios and distribution houses, too.

There's no charge to receive spots. We'll even pay for the lines and a 486 PC. All this for a one-time installation fee of only \$250.

So stop messing around with analog dubs.

Join Digital Courier International today.

Call Toll-Free 1-800-488-2021

for more information.



Digital Courier
INTERNATIONAL

Deck II also works with Mac IIx or higher computers with one of several audio cards already installed. Track playback capacity is dependent on computer power and SCSI throughput.

Stations requiring entire control room upgrades are considering self-contained digital "nerve centers." Such unified systems were exhibited by Radio Systems and Arrakis. The Radio Systems DDS, while not a workstation, provides control over recording, archiving and playback of digital audio, CD jukeboxes, satellite control and live feeds with controllers that emulate traditional broadcast equipment. Sixteen stereo channels can play back simultaneously and be controlled through a standard broadcast console.

Arrakis exhibited the Digi-Link workstation/control room along with the new Gemini controller. DigiLink's basic system provides ten hours of storage time and the optional Trak*Star feature adds an eight-track recorder and editor. Satellite and live control is also supported by the Arrakis Digi-Link.

The Gemini Command Center is Digi-Link's random access controller which emulates a "wall of carts"; buttons on the panel instantly retrieve and play back specific assigned audio files when pressed.

Workshops at the Public Radio Conference normally include sessions on cultural programming, grant writing and federal funding. This year's forums included "Digital Technology and Spoken Word Programming" and "DAWS: Local Area Networking Options." Clearly, public radio is moving predictably towards digital audio as its commercial cousin is doing.



HARRIS ALLIED

BROADCAST EXPRESS

JUNE 14, 1995

ISSUE NO. 4 VOLUME NO. 4

Audio On The Fly

The first digital sound editing system designed to replace reel-to-reel tape recorders used on the air. The VoxPro™ system by Audion allows DJs to record and edit phone bits, contests, actualities, sound effects, etc., on the fly with speed and precision—using the simplicity of “cut, copy and paste.” VoxPro’s most valuable benefit for on-air pros is the ability to record and edit audio quickly and to improve quality easily without the fear of making mistakes.

\$4,995⁰⁰

Order Today and Get Free Shipping

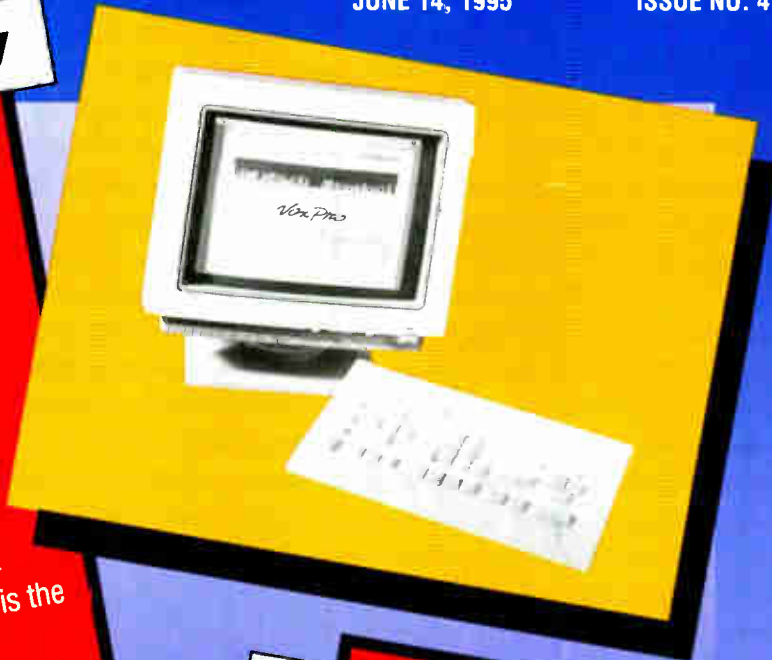

Dynamic Workhorse

Newest in a tradition of standard broadcast workhorses is the Otari MX5050 BIII. Every feature has been upgraded. You get all electronic switching in a professional broadcast standard 2 channel tape recorder with optional 1/4 track playback head and a great low price.

\$3,850⁰⁰

Price includes Free Shipping



Free Shipping



800-622-0022

800-622-0022

"On-Air" System

Turn your telephone into an "on-air" system with Gentner's new TeleHybrid. This is your key to simple, great sounding telephone calls on your professional audio system. TeleHybrid connects to your existing telephone.

\$949⁰⁰
Your Order is Shipped Free



No Feedback

Gentner's Digital Hybrid I is one of the most effective, yet least expensive ways to bolster your telephone calls to professional audio quality standards. Find out for yourself how Gentner's digital hybrid technology can work for you.

\$925⁰⁰

Free Shipping

Talk Studio In A Box

Designed for telephone calls with a live audience or in-studio guests, the Gentner G3200 has a built-in power amp and can accommodate up to 3 mics for a complete self-contained "talk studio in a box."

CALL FOR SPECIAL OVERSTOCK PRICE
Your Order Is Shipped Free Of Charge

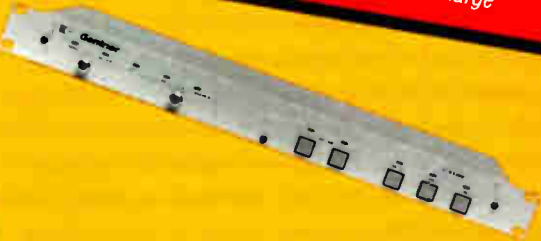

It's All You Need

In today's broadcasting and production studio environments, telephone interface equipment needs to provide superb audio quality, consistent performance and ease of use. Gentner's Digital Hybrid III addresses all of these needs.

CALL FOR SPECIAL OVERSTOCK PRICE
We Ship Free

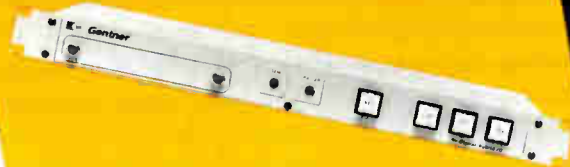

Free Shipping

800-622-0022

No Frills Needed

High quality, low priced, Russian-manufactured microphones now available in the U.S. exclusively from Harris Allied. The Oktava MK012 provides a choice of cardioid, hypercardioid or omni-directional pickup patterns. No Frills. Nothing fancy. Just great performance at a great low price.

\$549⁰⁰

Free Shipping



Dyna-Mic

A true cardioid microphone, the EV RE20 is the mic of choice for recording, broadcast, and sound reinforcement applications requiring essentially flat response over a very wide frequency range.

\$365⁰⁰

No Shipping Charge



Glorious Sound

Neumann's TLM193 large diaphragm condenser microphone is designed for critical recording, broadcast and live sound applications. Offering state of the art specs and performance in a value conscious package, the TLM193 stands on its own.

\$1,295⁰⁰

*Includes SM2 Shock Mount
Your Order Is Shipped Free*



Good Ol' Reliable

This one's been around for a while and is still one of the best overall values on the market. The rugged Sennheiser MD421 features cardioid polar pattern and excellent hum rejection.

\$349⁰⁰

Free Shipping With Every Order



HARRIS BROADCAST ALLIED EXPRESS

800-622-0022

Super Sonic

Looking for a simple, compact amp that has outstanding sonic accuracy and a proven track record for reliability— check out Crown's D-45 and D-75A. Perfect for moderate power applications, their ultra-low distortion make them ideal for a variety of applications.



Compact Reliability

Incredible sound. Compact size. Reliability that just doesn't quit. These amps have been in continuous production for over 25 years and are used in thousands of installations worldwide.



CALL FOR SPECIAL PRICE

Free Shipping With Every Order

More Bang, Less I

The Rane HC 6 Headphone is one of the most indispensable broadcast products in today's industry. Featuring 6 stereo amps, the HC 6 performs all necessary tasks, not all of which are headphone related. Call us

\$299

The Sh

CDs Direct-To-Air

Some things just get better and better. Like our AudioMetrics CD 10, Compact Disc Cartridge Machine...now the CD 10E with ORANGE BOOK capability. The same heavyweight player you've come to rely on to take compact discs direct-to-air.

\$1,149⁰⁰

Order It Today...We'll Ship It Free



HARRIS BROADCAST ALLIED EXPRESS



Charge it with MasterCard or Visa or use your

Pick Your Wedge

The goal: cleanest sound possible. The method: Paramount™ Accustical Products. The source: Harris Allied. The best solution for super critical listening or recording is 2" Ultrax™ Wedge Panels. Kills standing waves and flutter-echo. Up to 60% more effective than other name brand foams that can cost many times more. Long lasting formulation gives you years of service and doesn't crumble like that other stuff.

\$150.00

Price includes adhesive and shipping charges. Covers 96 sq. ft.



Digital Pioneer

Scientific Atlanta's Encore DSR-3610 Digital Satellite Receiver is a major achievement in satellite communications technology. More improvements and a much lower price than digital receivers in the past, the basic unit comes with two audio channels and is expandable to four.

\$3,195.00

Free Shipping With Every Order



Buck

...e Console
 ...le
 ... audio
 ... headphone
 ... number of
 ... which are
 ... for details.

...00
 ...ping Is On Us



QUANTITIES MAY BE LIMITED AND ARE SUBJECT TO PRIOR SALE.
 ALL SALES SUBJECT TO APPROPRIATE SALES TAX.
 FEDERAL EXPRESS AVAILABLE AT AN ADDITIONAL COST.
 PRICES, SPECIFICATIONS AND PRODUCTS ARE SUBJECT TO CHANGE WITHOUT NOTICE.

800-622-0022

Stick It

The STA-1 is part of a group of products in the "STICK-ON" Series by Radio Design Labs. It's both an electronic line transformer and an amplifier. With its compact size and bottom adhesive strip, you can put it wherever you want it.

\$96⁰⁰

Free Shipping

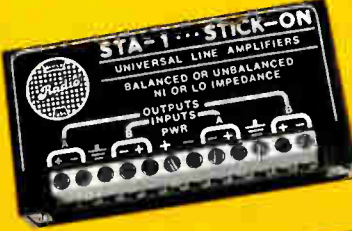

Anywhere You Want

The ST-DA3 STICK-ON Distribution Amplifier mounts just about anywhere or use it with RDL's STR-19 snap-in racking adapter. The ST-DA3 gives you the advantage of an audio distribution amp with a big plus—you can put it where you need it.

\$89⁰⁰

We Pay Shipping



Gets Highs & Lows

The STM-2 STICK-ON is a quality low-noise Microphone Preamplifier designed for use in commercial sound, broadcast, and recording. Its ultra-low distortion and low-noise performance make it a great choice, even when larger preamps could be used!

\$93⁰⁰

You Buy It... We Ship It FREE of Charge



Stick & Mix

The ST-MX3 STICK-ON is a Line Level Mixer. It provides audio mixing of three line level inputs with individual input gain adjustments. The line level output is capable of driving into either high or low impedance, balanced or unbalanced loads.

\$80⁰⁰

Free Shipping



Free Shipping

800-622-0022

No Ordinary EQ

Roland's E660 is a Parametric Equalizer that operates entirely in the digital domain. The E660 is designed for the ultimate in sound quality and in ease of use. The E660 represents the zenith of Roland's long history of design excellence.

\$410⁰⁰

Free Shipping... Our Treat



Easy Talk Radio

Talk radio can be difficult. Your telephone system shouldn't be. Gentner designed the TS612 DCT Multiline Telephone System to make it easy. The TS612 DCT is a six-line (expandable to 12) telephone system.

CALL FOR SPECIAL PRICE

We Pay the Shipping Bill



World Class

Impeccable design, precision manufacturing and value pricing in full-featured, compact audio consoles are the Auditronics 2500 Series. Call us for the console to meet your needs.

12 Channel **\$5,395⁰⁰**

18 Channel **\$7,195⁰⁰**

24 Channel **\$8,995⁰⁰**

Free Shipping



Endless Possibilities

A combination of high frequency shelving EQ and expansion gives you a single-ended noise reduction unit. Broadcasters are using the Symetrix 528E Voice Processor to improve sound quality everywhere in the station.

\$469⁰⁰

No Shipping Charges To Pay



HARRIS BROADCAST ALLIED EXPRESS

Open Until 5:00 P.M. Pacific Coast Time

800•622•0022

Unreel Deal

One thousand feet of quality Belden tinned copper audio cable at a great price from Harris Allied. Model 8451— polypropylene insulated, twisted pair.

\$89⁰⁰

Free Shipping



Off Limits

Your broadcast or recording studio will really be off limits when Fidelioac Model 340 Warning Lights are lit. Brilliant red lettering on jet black background.

We Pay Shipping

\$76⁰⁰

ON AIR

Ideal Connection

The Henry MatchBox is the industry's most used level and impedance converter. It's the ideal way to correctly interconnect consumer or semi-pro equipment with pro gear.

\$159⁰⁰

We'll Pay The Shipping For You



Get Switched

Our industry's standards are the Switchcraft 3-pin professional audio connectors. Get 25 ea. of A3Ms and A3Fs for one great low price...

\$94⁰⁰

...And Shipping Fee



Rack 'Em Up

ALINE CD 244 Solid Oak Frames holds all single CD cases. 44-7/16 x 22-1/2 x 5-5/8". Holds 244.

\$235⁰⁰

Free Stripping



Punch "66"

Siemon "66" Punch Blocks are the easiest way to accomplish complex wiring projects.

\$140⁰⁰ QTY. 10

No Shipping Charges



Free Shipping



HARRIS BROADCAST ALLIED EXPRESS

800•622•0022

Free shipping applies only to items featured in this circular.

All prices are for United States only.

Orders must be received by 5:00 PM Eastern for same day shipment.

Prices guaranteed through August 9, 1995.

INTERNATIONAL UPDATE

DAB Plan Enrages Canadian Broadcasters

by James Careless

OTTAWA Broadcasters here are grouching about a proposal from Canadian authorities to initially grant only temporary licenses for Digital Audio Broadcasting (DAB).

Although digital radio has always been intended as a replacement for AM and FM broadcasting in Canada, the Canadian Radio-television and Telecommunications Commission (CRTC) initiated a two-tiered approach to introducing digital service that may lead broadcasters to avoid embracing DAB technology.

3-year license

The crux of the problem is that the CRTC will issue broadcasters a conditional three-year license to help explore and establish L-band DAB service. During this trial period, the commission would simultaneously solicit public comments about long-range planning for DAB. That process is not expected to start until late 1996.

"This approach would allow Canadian radio broadcasters to retain their technological lead while contributing to the development of a well-thought-out strategy for the full-fledged introduction of digital radio, one that would benefit both the industry and the Canadian public in the long term," said CRTC Chairman Keith Spicer in a statement released 14 June.

Broadcasters, however, do not see things that way.

"An experimental license is not worth much," said Steve Edwards, vice president of corporate engineering and technology for Rogers Broadcasting, a major player in Canadian broadcasting and a strong supporter of Eureka-147.

What has Edwards and others upset is that there is no assurance that broadcasters will be able to make the temporary licenses permanent once the experimental period ends.

One paragraph in Public Notice 1995-95, which specifies the CRTC proposal, catches every eye: "The commission therefore reminds interested parties that any course of action or approach it may take regarding a licensing process for experimental digital radio undertakings in the short term shall not constrain the commission from modifying this approach or adopting another framework for the long term."

"I'm sure (the CRTC) does not mean that three years from now they will take the licenses away," Edwards said, "but it could be interpreted in that way by those who think that is a possibility, and therefore I should not invest any money until they are willing to give me something that says it is a worthwhile investment."

No guarantees

In other words, there are no guarantees that experimental licensees will ever receive a regular license, despite whatever money they invest to make their experimental station a reality.

Given the commission's long-proven desire to help existing Canadian radio broadcasters, it is unlikely the lack of a guarantee is some sort of sinister trap to

bankrupt stations that invest in digital radio.

If anything, it is probably the CRTC's way of warning broadcasters that rules may change over time—as they recently

There are no guarantees that experimental licensees will ever receive a regular license.

did for direct-to-home satellite TV when the federal government stepped in and overturned the commission's policy rulings. This change has let company, Expressvu, in a legal limbo as it aims for a September launch date.

In any case, the idea of three-year "experimental" digital radio licenses has upset broadcasters who worked closely with the government to make this medium a reality.

Canadian Association of Broadcasters (CAB) Executive Vice President Michel Tremblay echoes these concerns. "My point is, do you really know what you are getting involved with at this point, if there is going to be a new policy down the road?" he said.

"It may not be entirely different, but still, it may make me think twice. The label 'experimental' could introduce a bit of inhibition," Tremblay said.

While Eureka-147 proponents are concerned about delays the experimental licenses may cause, others like Gary Slaight, president and CEO of Standard Broadcasting in Toronto, owner of highly rated news-talk station CFRB(AM), are angry with the entire CRTC proposal.

"The process is being done backwards," said Slaight, whose own company has so far refused to follow other companies in investing CN\$75,000 in joint digital radio research efforts.

"Why not have public consultations first, then worry about issuing licenses? I do not know why they would want to put up signals for three years without having the overall rules of the game in place."

Look for alternatives

Referring to the CRTC emphasis on Eureka-147, Slaight said, "I think we should be looking at all alternatives, including IBOC (the U.S. developed in-band, on-channel system), before we commit ourselves."

The fact that the CRTC proposal displeases Slaight is hardly surprising, given his general opposition to the way in which digital radio has been pursued in Canada for the past few years. However, that both Edwards and Tremblay are not happy either should cause some concern at government levels.

Edwards and Tremblay are at the heart of Canadian plans for Eureka-147 on L-band. They are important not only because of the clout they carry within their own organizations, but because of their leadership within the industry. To help sell its proposals, the CRTC needs their enthusiastic support.

But that support may still be forthcoming. Some parts of the proposal are less than controversial, including the aim of making experimental licenses available

to existing on an expedited basis. Other applications for L-band licenses will be evaluated on a "case-by-case basis" and would not be granted if their entry into the market would hurt existing local

wealthy."

"The whole goal is to keep the thing flexible, and any limitations at this stage discourage people for doing it at all," Edwards said.

Additionally, the experimental digital radio licensees will not be able to use the transition to DAB to extend their coverage area.

On the positive side, however, broadcasters will be allowed to rent transmitter space from other companies, even those not in the radio business, and they can receive an L-band licensee for every single station—AM or FM—that they own.

For the moment at least, the commission's proposals are just that: proposals. They open for amendment and reconsideration after the deadline for public feedback closes on 17 July.

Given that some of the strongest Canadian supporters of Eureka-147 want changes made, it will be interesting to see what exactly the commission releases as its formal rules for introducing digital radio in Canada. Its choices could have a major impact on how eagerly broadcasters embrace this technology.

□ □ □

James Careless, an audio producer, covers the industry in Canada for Radio World. Contact him via e-mail at aa938@freenet.carleton.ca.



MODULATION WAR?

If you're getting your face pushed in the dirt by the guy across the street, it doesn't have to be that way. In these major markets, where competition is fierce and the rewards are large, broadcaster after broadcaster has picked the **COBALT BLUE™** Neural Network power booster for the **Optimod 8100*** in A/B comparisons.

- | | |
|---------------------|-------------------------|
| Atlanta | New York |
| Charlotte | Orlando |
| Cincinnati | Providence |
| Indianapolis | Washington, D.C. |

COBALT BLUE™ is the world's first Neural Network audio processor. It's a whole new technology. If you need more power and you need it now... if you have an existing **Optimod 8100** preceded by a **Compellor**** or a pair of **Audio Prisms*****, call (814) 235-1410. We'll do the rest.



208 West Hamilton Avenue - P.O. Box 20
State College, PA 16804-0020
Phone: (814) 235-1410 Fax: (814) 235-1462

* Optimod is a trademark of AKG Acoustics, San Leandro, California
** Compellor is a trademark of Aphex Systems, Ltd., Sun Valley, California
*** Audio Prism is a trademark of Gentner Electronics, Salt Lake City, Utah

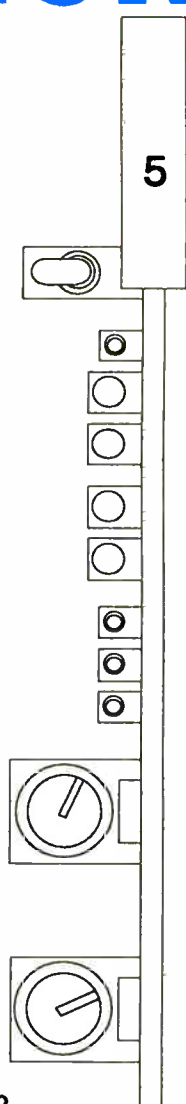

RBDS ROLL CALL

The following is **Radio World's** quarterly listing of RBDS stations, equipment and receiver manufacturers and service providers. If you would like to be included in the next listing, contact Lucia Cobo at 703-998-7600.

— RBDS STATIONS —

Station	Freq.	City	DISTRICT OF COLUMBIA			INDIANA			MONTANA		
ALABAMA			WAMU-FM	88.5	Washington	WSHW-FM	99.7	Frankfort	KCTR-FM	102.9	Billings
WZYP-FM	104.3	Athens	WETA-FM	90.9	Washington	WENS-FM	97.1	Indianapolis	KKBR-FM	97.1	Billings
WRJM-FM	93.7	Geneva	WDCU-FM	90.1	Washington	WZPL-FM	99.5	Indianapolis	NEBRASKA		
ARIZONA			WGAY-FM	99.5	Washington	WITZ-FM	104.7	Jasper	KNEN-FM	94.7	Norfolk
KZZZ-FM	94.7	Kingman	FLORIDA			WZWZ-FM	92.7	Kokomo	KESY-FM	104.5	Omaha
KKFR-FM	92.3	Phoenix	WAPN-FM	91.5	Daytona Beach	WVKI-FM	100.5	Kokomo	NEVADA		
KSLX-FM	100.7	Scottsdale	WSFP-FM	90.1	Ft. Myers	WMRI-FM	106.9	Marion	KKLZ-FM	96.3	Las Vegas
CALIFORNIA			WAOA-FM	107.1	Melbourne	WLEZ-FM	102.7	Terre Haute	KNPR-FM	89.5	Las Vegas
KSIO-FM	96.1	Brawley	WLRN-FM	91.3	Miami	WXKE	103.9	Ft. Wayne	KNPR-FM*	88.7	Boulder City
KFMF-FM	93.9	Chico	WTMI-FM	93.1	Miami	IOWA			KNPR-FM*	91.7	Beatty
KPPL-FM	107.5	Colusa	WMFE-FM	90.7	Orlando	WMT-FM	96.5	Cedar Rapids	KOMP-FM	99.3	Henderson
KLON-FM	88.1	Long Beach	WOCL-FM	105.9	Orlando	KRVR-FM	106.5	Davenport	KNPR-FM*	88.7	Indian Springs
KPCC-FM	89.3	Los Angeles	WUFT-FM	89.1	Gainesville	KMFG-FM	103.3	Des Moines	KNPR-FM*	88.7	Indian Springs
KTWV-FM	94.7	Los Angeles	WOWW-FM	107.3	Pensacola	KIAQ-FM	96.9	Ft. Dodge	KNPR-FM*	89.5	Laughlin
KCRW-FM	89.9	Los Angeles	WFLZ-FM	93.3	Tampa	KOEL-FM	92.3	Oelwein	KNPR-FM*	88.7	Moapa Valley
KKGO-FM	105.1	Los Angeles	GEORGIA			KUOO-FM	103.9	Spirit Lake	KNPR-FM*	88.7	Pahrump
KATM-FM	103.3	Modesto	WDMG-FM	99.5	Douglas	KAYL-FM	101.5	Storm Lake	KBUL-FM	98.1	Reno
KHOP-FM	104.1	Modesto	WSTR-FM	94.1	Smyrna	KENTUCKY			KNEV-FM	95.5	Reno
KSHA-FM	104.3	Redding	WABE-FM	90.1	Atlanta	WMMT-FM	88.7	Whitesburg	KNPR-FM*	88.1	Scotty's Junction
KNPR-FM*	88.1	Ridgecrest	WCLK-FM	91.9	Atlanta	LOUISIANA			KNPR-FM*	105.1	Searchlight
KSFM-FM	102.5	Sacramento	WKLS-FM	96.1	Atlanta	WGGZ-FM	98.1	Baton Rouge	KLUC-FM*	98.5	Las Vegas
KPBS-FM	89.5	San Diego	IDAHO			KOXL-FM	106.5	Baton Rouge	KFMS-FM	101.9	Las Vegas
KPLM-FM	106.1	Palm Springs	KCIX-FM	105.9	Boise	WYCT-FM	94.1	Kentwood	KWNR-FM	95.5	Las Vegas
KYXY-FM	96.5	San Diego	ILLINOIS			KFXV-FM	96.7	Morgan City	KEYV-FM	93.1	Las Vegas
KDFC-FM	102.1	San Francisco	WCIL-FM	101.5	Carbondale	WLMG-FM	101.9	New Orleans	KRRI-FM	105.5	Las Vegas
KECG-FM	88.1	San Francisco	WLRW-FM	94.5	Champaign	WMYZ-FM	95.7	New Orleans	KOMP-FM	92.3	Las Vegas
KEAR-FM	106.9	San Francisco	WBEZ-FM	91.5	Chicago	WNOE-FM	101.1	New Orleans	KEDG-FM	103.5	Las Vegas
KALW-FM	91.7	San Francisco	WXRT-FM	93.1	Chicago	KCIL-FM	107.5	Houma	KFBI-FM	107.5	Las Vegas
KKHI-FM	100.9	San Francisco	WLS-FM	94.7	Chicago	KMUJ-FM	100.1	Shreveport	KYRK-FM	97.1	Las Vegas
KKSF-FM	103.7	San Francisco	WNUA-FM	95.5	Chicago	MASSACHUSETTS			KLNR-FM*	91.7	Panaca
KCBX-FM	90.1	San Luis Obispo	WKKD-FM	95.9	Chicago	WAAF-FM	107.3	Boston	KTPH-FM*	91.7	Tonopah
KUSP-FM	88.9	Santa Cruz	WNIJ-FM	90.5	DeKalb	WBUR-FM	90.9	Boston	KEYV-FM*	103.5	Laughlin
COLORADO			WLLR-FM	101.3	East Moline	WGBH-FM	89.7	Boston	NEW HAMPSHIRE		
KMJI-FM	100.3	Denver	WAAG-FM	94.9	Galesburg	WBOQ-FM	104.9	Gloucester	WBHG-FM	101.5	Laconia
KCFR-FM	90.1	Denver	WWTE-FM	93.9	Lincoln	WBCS-FM	96.9	Newton	WLNH-FM	98.3	Laconia
CONNECTICUT			WSWT-FM	106.9	Peoria	WMJX-FM	106.7	Boston	NEW JERSEY		
WSHU-FM	91.1	Fairfield	WDBR-FM	103.7	Springfield	MARYLAND			WFPG-FM	96.9	Atlantic City
WPKT-FM	90.5	Hartford	WGFA-FM	94.1	Watseka	WHFS-FM	99.1	Annapolis	WKDN-FM	106.9	Camden
			WPGU-FM	107.1	Urbana	WEAA-FM	88.9	Baltimore	WBGO-FM	88.3	Newark
						WIYY-FM	97.9	Baltimore	WFME-FM	94.7	Newark
						WXYV-FM	102.7	Baltimore	WNNJ-FM	103.7	Newton
						WETH-FM*	89.1	Hagerstown	WPAT-FM	93.1	Patterson
									WADB-FM	95.9	Point Pleasant
									WCHR-FM	94.5	Trenton
									WBSS-FM	97.3	Millville
									NEW MEXICO		
									KKOB-FM	93.3	Albuquerque
									KKSS-FM	97.3	Santa Fe
									NEW YORK		
									WAMC-FM	90.3	Albany
									WGY-FM	99.5	Albany
									WZRO-FM	102.3	Albany
									WMHT-FM	89.1	Schenectady
									WSKG-FM	89.3	Elmira
									WHTZ-FM	100.1	New York
									WNEW-FM	102.7	New York
									WNYC-FM	93.9	New York
									WHUD-FM	100.7	Peekskill
									WBEE-FM	92.5	Rochester
									NEW MEXICO		
									KKOB-FM	93.3	Albuquerque
									KKSS-FM	97.3	Santa Fe
									NORTH CAROLINA		
									WMIT-FM	106.9	Black Mtn.
									WUNC-FM	91.5	Chapel Hill
									WSOC-FM	103.7	Charlotte
									WCXL-FM	104.1	Kill Devil Hills

Introducing the finest solid state FM technology now available up to 5 KW

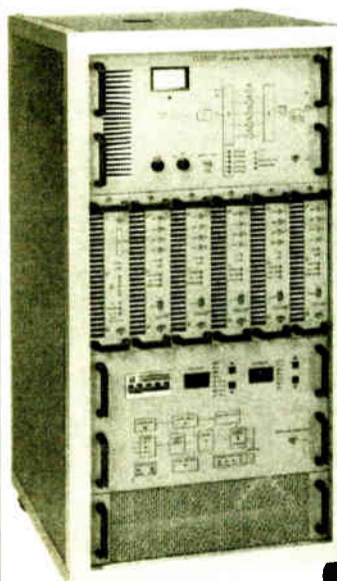

SF 5000 5KW FM

The new BEXT SF Series amps come in ten power levels from 150 watts to five kilowatts, with the excellent stability and consistent performance of very high efficiency Mosfet amplifiers.

Is the quality of BEXT FM truly world class? Your fellow engineers think so—we'll send you a user list, with phone numbers, along with with a full catalog at your request.

Find out more about BEXT and the finest in great-sounding exciters and STLs, amplifiers and complete transmitter systems.

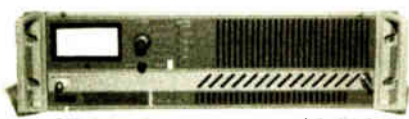

SF 500 500 Watt FM \$5,695

1045 10th Ave.
San Diego, CA 92101
619-239-8462 FAX: 619-239-8474



Circle (32) On Reader Service Card

NORTH DAKOTA

KSSS-FM 101.5 Bismark
 KDVL-FM 102.5 Devil's Lake
 KRRB-FM 92.1 Dickinson
 KFNW-FM 97.9 Fargo
 KNOX-FM 94.7 Grand Forks
 KODJ-FM 95.5 Jamestown
 KYYZ-FM 96.1 Williston

KTST-FM 101.9 Oklahoma City
 KXXY-FM 96.1 Oklahoma City

OREGON

KYTE-FM 102.7 Newport
 KOPB-FM 91.5 Portland
 KKRZ-FM 100.3 Portland
 KMCO-FM 104.5 The Dalles

PENNSYLVANIA

WRTI-FM* 97.1 Allentown/
 Bethlehem
 WITF-FM 89.5 Harrisburg
 WRVW-FM 97.3 Harrisburg
 WROZ-FM 101.3 Lancaster
 WDAS-FM 105.3 Philadelphia
 WFLN-FM 95.7 Philadelphia
 WHYF-FM 90.9 Philadelphia
 WMGK-FM 102.9 Philadelphia
 WMMR-FM 93.3 Philadelphia
 WRTI-FM 90.1 Philadelphia
 WPLY-FM 100.3 Philadelphia
 WUSL-FM 98.9 Philadelphia
 WXPB-FM 88.5 Philadelphia
 WIOQ-FM 102.1 Philadelphia
 WXTU-FM 92.5 Philadelphia
 WWDB-FM 96.5 Philadelphia
 WDUQ-FM 90.5 Pittsburgh
 WRTI-FM* 97.7 Reading

RHODE ISLAND

WWBB 101.5 Providence

SOUTH CAROLINA

WWDM-FM 101.3 Sumter

SOUTH DAKOTA

KOLY-FM 99.5 Mobridge
 KRRO-FM 103.7 Sioux Falls

TENNESSEE

WYPL-FM 89.3 Memphis

TEXAS

KEAN-FM 105.1 Abilene
 KNLE-FM 88.1 Austin
 KTTX-FM 106.1 Brenhane
 KTEX-FM 100.3 Brownsville
 KKYS-FM 104.7 Bryan
 KORA-FM 98.3 Bryan
 KTEX-FM 106.9 Bryan
 KAYD-FM 97.5 Beaumont
 KOXY-FM 94.1 Beaumont
 KYKR-FM 95.1 Beaumont
 KCBI-FM 90.9 Dallas
 KERA-FM 90.1 Dallas
 KBNA-FM 97.5 El Paso
 KILT-FM 100.3 Houston
 KUHF-FM 88.7 Houston
 KJMZ-FM 100.3 Irving
 KOOI-FM 106.5 Jacksonville
 KYKX-FM 105.7 Longview
 KFMX-FM 94.5 Lubbock
 KKMY-FM 104.5 Orange
 KATX-FM 97.3 Plainview
 KCRN-FM 93.9 San Angelo
 KXTN-FM 107.5 San Antonio
 WACO-FM 99.9 Waco

UTAH

KSOS-FM 106.9 Ogden
 KSOS-FM* 92.1 Salt Lake City
 KSOS-FM* 96.7 Salt Lake City
 KISN-FM 97.1 Salt Lake City
 KLZX-FM 93.3 Salt Lake City
 KSOS-FM* 98.3 Utah County

VIRGINIA

WLTY-FM* 95.7 Norfolk
 WNVZ-FM 104.5 Norfolk
 WESR-FM 103.3 Onley
 WKOC-FM 93.7 Virginia Beach
 WCDX-FM 92.7 Richmond

WASHINGTON

KFAE-FM 89.1 Richland
 KISW-FM 99.9 Seattle
 KUOW-FM 94.9 Seattle
 KMPS-FM 94.1 Seattle
 KMTT-FM 103.7 Seattle
 KDRK-FM 93.7 Spokane
 KEZE-FM 105.7 Spokane
 KRPM-FM 106.1 Tacoma

WEST VIRGINIA

WHCM-FM 99.1 Parkersburg

WISCONSIN

WIZM-FM 93.3 LaCrosse
 WERN-FM 88.7 Madison
 WNWC-FM 102.5 Madison
 WUWM-FM 89.7 Milwaukee
 WMYX-FM 99.1 Milwaukee
 WMSE-FM 91.7 Milwaukee

*translator

OHIO

WOUB-FM 91.3 Athens
 WGUC-FM 90.9 Cincinnati
 WVXU-FM 91.7 Cincinnati
 WWNK-FM 94.1 Cincinnati
 WCPN-FM 90.3 Cleveland
 WGAR-FM 99.5 Cleveland
 WENZ-FM 107.9 Cleveland
 WKSU-FM 89.7 Cleveland
 WLTF-FM 106.5 Cleveland
 WLVQ-FM 96.3 Columbus
 WDFM-FM 98.1 Defiance
 WKRJ-FM* 91.5 New Philadelphia
 WGLE-FM 90.7 Toledo
 WKKO-FM 99.9 Toledo
 WGTE-FM 91.3 Toledo
 WKRW-FM* 89.3 Wooster
 WKBN-FM 98.9 Youngstown
 WHIZ-FM 102.5 Zanesville
 WOUZ-FM 90.1 Zanesville
 WGLE-FM 90.7 Lima

OKLAHOMA

KSYE-FM 91.5 Frederick
 KIRO-FM 98.1 Lawton

— RBDS MANUFACTURERS —

**RBDS Equipment
 Manufacturers/Distributors**

AEV (Encoder)
 Via Saviolo Budrie
 Di S. Perisceto
 Bologna, Italy

Broadcast Supply Worldwide (Encoder)
 7012 27th St. West
 Tacoma, Washington 98406

Circuit Research Labs (Encoder)
2522 W. Geneva
Tempe, Arizona 85282
Contact: Valerie Hummer
602-438-0888
Reader Service 14



Harris Allied (Encoder)
 3712 National Road West
 Richmond, Indiana 47374

Modulation Sciences
 (Encoder/Monitor)
12A World's Fair Drive
Somerset, New Jersey 08873
Contact: Judy Englert
908-302-3090
Reader Service 73

modulation sciences

RDS Diagnostix (Test/Decoder)
74 Hanover Road
Mountain Lakes, New Jersey 07046
Contact: Boyd A Baker
201-299-8431
FAX: 201-334-7858
Reader Service 113

RDS Diagnostix

Audio Broadcast Group (Encoder)
2342 S Division Ave
Grand Rapids, Michigan 49507

Contact: Dave Howland
800-999-9281
FAX: 616-452-1652
75371.144@compuserve.com
Reader Service 124



AZTEC S.A. (Encoder)
 31 Rue Du Chemin de Fer
 67200 Strasbourg, France

RE America, Inc. (Encoder)
31029 Center Ridge Road
Westlake, Ohio 44145
Contact: Andy Bosworth
216-871-7617
Reader Service 62



Rohde and Schwarz (Encoder)
 4425 Nicole Drive
 Lanham, Maryland 20706

SCA Data Systems (Encoder)
 2912 Colorado Ave.
 Suite 200
 Santa Monica, California 92404

Teli AB (Encoder)
 14980 Nunashamn
 Sweden

Tectan (Encoder)
 Box 27157
 Concord, California 94527

VG Electronics (Encoder)
 Theaklen Drive
 Hastings East Sussex TN34 1YQ
 England

**RBDS Receiver Manufacturers
 with current U.S. models)**

Advanced Digital Systems
 (PC RDS Receiver)
13909 Bettencourt Street

Cerritos, California 90701
Contact: Mike McCoy
800-888-5244
Reader Service 45



Access (Paging)
 6620 Riverside Drive
 Suite 200
 Metairie, Louisiana 70003

AZTEC S.A. (Mobile Data Receiver)
 31 Rue Du Chemin de Fer
 67200 Strasbourg, France

Delco Electronics (Car)
 1 Corporate Center
 Mail Station CT-16A
 Kokomo, Indiana 46904

Denon (Car/Home)
222 New Road
Parsippany, New Jersey 07054
Contact: John Casey
201-575-7810
Reader Service 25



Grundig (Portable)
 3520 Haven Ave., Unit L
 Redwood City, California 94063

Indy Automotive Electronics
 2420 E 55th Place
 Indianapolis IN 46220

Modulation Sciences (Data)
 12A World's Fair Drive
 Somerset, New Jersey 08873

Onkyo (Home)
 200 Williams Drive
 Ramsey, New Jersey 07446

Philips Car Stereo (Car)
 9600 54th Avenue
 N. Minneapolis, Minnesota 55442

Pioneer (Car)
 2265 East 220th St.
 Long Beach, California 90810

RBDS Service Providers

Access/Spartan (Paging)
 6620 Riverside Drive
 Suite 200
 Metairie, Louisiana 70003

DCI (Global Positioning)
10121 Miller Ave,
Cupertino, California 95014
Contact: Jim Bradley
408-446-8350
Reader Service 139



Coupon Radio
 (Information Services)
 10 Rockefeller Plaza
 New York, New York 10020

Sage Alerting (EBS)
 700 Canal Street
 Stamford, Connecticut 06902

SATX (Data Broadcast Software)
 Milestone Technologies
 2221 Mariner Circle
 Raleigh, North Carolina 27603

Specialized Comm. (Music Information)
1638 153rd St. SE
Bellevue, Washington 98007
Contact: Allen Hartle
206-641-9043
Reader Service 176



Terrapin (IVHS Services/Diff-GPS)
 11958 Monarch Street
 Garden Grove, California 92641

Reel-Talk Functions Like Radio VCR

by Frank Beacham

NEW YORK Depending on your politics, Rush Limbaugh is a figure to be adored or despised. But now the talk show giant has a new claim to fame: inspiration for the most unique new table radio to come along in years.

Called "Reel-Talk" (\$129 including shipping), this new radio design includes a quarter-speed cassette recorder and a VCR-like timer that allows the user to record favorite radio programs for later playback.

Because it is optimized for the recording of talk shows and other spoken word

material, the Reel-Talk radio trades off sonic quality for up to four hours of recording time on each side of a standard C-120 audio cassette.

Timing problems

The inspiration for Reel-Talk came when Dale Stogner, an accountant, and Chris Moen, an electronics engineer, became frustrated over the difficulty of listening to Limbaugh, their favorite talk show host, during the middle of the work day. They wanted a simple way to time shift the program to a more convenient listening period.

After building a prototype and finding a manufacturer in Hong Kong, Stogner and Moen started advertising Reel-Talk last September on Limbaugh's television show and on local radio talk shows in California. It was an instant success, selling out the initial inventory immediately. "I talk to a lot of my customers personally and I can't tell you how many times I've been told they've been looking for a product like this for years," said Stogner.

An evaluation by **RW** found the Reel-Talk radio to be an excellent performer with better than expected audio fidelity on recorded programs. Operation, unlike many timer-based VCRs, is intuitive and user friendly. The instruction manual is simple, clear and ranks among the best I have seen for any electronic device.

The AM/FM radio section performed with the best of them in the crowded New York City area and the pre-sets for 10 AM and 10 FM stations offer added convenience. The buttons have the solid feel of a quality electronic component.

Tower design

Reel-Talk's unusual tower design (6.5 inches square by 12 inches tall) places the cassette recorder on top in order to keep the overall footprint of the radio small. This configuration works well, allowing a four-inch speaker and bass

port (powered by a 2.5 watt amplifier) in a very compact device. The recorder works only in the quarter-speed mode, emphasizing record time over audio quality. The manufacturer recommends high-quality TDK, Maxell, Sony, Fuji and BASF cassettes for best results.

Other features include a liquid-crystal function display, headphone jack, sleep



Reel-Talk works like a VCR.

function, clock alarm, bass boost, auto-stop tape deck, built-in condenser mic for live recording, one-touch recording, AC or battery (six D-size) operation, and battery backup for clock and station pre-sets.

Though audio quality is fine for voice recording, tapes made on the Reel-Talk radio are not compatible with standard audio cassette recorders. For now, at least, playback must come from the Reel-Talk radio itself. However, Stogner said his company will soon offer a quarter-speed Walkman-sized recorder that will allow portable playback of Reel-

Talk tapes. He said a wireless device will also be introduced that allows the portable to playback the tapes through any car radio.

Single-event timer

Another limitation of the current Reel-Talk design is its single event timer, which was originally conceived for long-form talk radio recording. On and off times can be set and repeated daily, but the device does not have the capability to record multiple shows at different times on different stations.

However, this limitation will be addressed soon, said Stogner, in a higher end version of the radio designed for music-quality recording. "We plan to offer a model with two standard-speed stereo cassette decks in a wooden cabinet," said Stogner. "This will be a killer unit with multi-event, multiprogram capabilities. Even with all the features it will offer, we still think we can bring it in for under \$250."

In addition to talk show buffs, the Reel-Talk radio has found a home in some of the radio stations that advertise the product. Stogner said, "We have some radio station sales managers who use the Reel-Talk to record their competition in off hours to get the names of their advertisers," he said.

Reel-Talk Inc. is located at 1704 Hilltop Circle, Opelika, Ala., 36801; telephone: 800-766-TALK (8255).

□ □ □

Frank Beacham is a writer, director and producer. His address is 163 Amsterdam Ave., No. 361, New York 10023. E-mail: beacham@radiomail.net.

Radio Reforms

► continued from page 1

Reed Hundt, chairman of the Federal Communications Commission said the bill affirms the FCC's responsibilities. The regulatory agency itself briefly came under the eye of the budget-cutting Congress. "I might note that Senate bill 652 affirms the serious responsibilities invested in the FCC to ensure fair competition in communications and to protect the public interest," Hundt said in a statement.

Edward Fritts, president of the National Association of Broadcasters (NAB), was pleased with the Senate bill. In a statement, Fritts said that radio ownership deregulation "will be instrumental in helping the radio industry remain an important and competitive player in tomorrow's communications marketplace." The NAB's Radio Board had voted unanimously in favor of ownership deregulation.

CREATE A MASTER CLOCK SYSTEM

ECONOMY MASTER CLOCK CAPABLE OF DRIVING 100 SLAVES FOR \$260.00

5 DIGITAL SLAVES FOR UNDER \$1000.00

MASTER CLOCK

- ESE TIME CODE OUTPUT
- EXTERNAL SYNC INPUT
- 1PPS OUTPUT
- 3 TYPES OF ENCLOSURES
- DRIVE 100 DIGITAL SLAVES
- NEW "LX" ENCLOSURE
- SYSTEMS UPGRADABLE TO CRYSTAL, WWV, MODEM AND GPS



ES-192A



ES-192AP



NEW! LX-192A

DIGITAL SLAVES

- 5 TYPES OF ENCLOSURES
- 4 SIZES OF L.E.D.'s
- DISPLAY TIME OR DATE
- OPTIONAL TIME ZONE OFFSET
- VIDEO INSERTER
- COMPUTER INTERFACE
- MANY OPTIONS AVAILABLE



3 YEAR WARRANTY
PRACTICAL SOLUTIONS SINCE 1971

142 SIERRA ST., EL SEGUNDO, CA 90245 • (310) 322-2136 / FAX: (310) 322-8127

Circle (8) On Reader Service Card

World Radio History

EAS Snag Surfaces

► continued from page 1

Sources said it was agreed the technology would be public domain so no one could "monopolize the technology."

A manual detailing NWRSAFE, "DCR-400," is listed as a publication reviewed before the patent was issued to Quad Dimensions. The technology described in that document would have to have been different enough from SAFE technology to warrant issuing a patent.

After reading the patent, a spokesman from the NWS said, "The underlying principal appears to be the same. The vehicle they are using—primarily television—is different."

Although television is specifically mentioned in the patent, Ganzer said the document also covers broadcasting in general. "We think the claims are broad and cover many uses of location codes," he said.

Part of the appeal of the new Emergency Alerting System is its non-proprietary nature. One of the goals of the commission was to give broadcasters a chance to choose from several companies when purchasing their equipment.

The news that Quad Dimension has a patent on the EAS system prompted surprise from manufacturers and disbelief that the FCC knew but did nothing about it.

EAS certification of manufacturing equipment has been held up for several months by Petitions for Reconsideration submitted after the December 1994 ruling. A re-examination of the patent could take longer than a year.

The hybrid you put between these cables is your most important connection for successful talk shows



Listeners and programmers agree.

The quality of your talk shows and call-ins are as critical as who you have talking.
And stations who are most serious about their sound and ratings use Telos.

Telos' digital hybrids have earned their reputation for exceptional performance.
In addition to full-duplex audio, Telos hybrids achieve consistent levels from caller to caller.

Our full range of products includes the top of the line Telos 100 Delta with a digital dynamic equalizer so advanced you won't find it anywhere else. When it comes to complete systems, the ONE-x-Six proves you don't have to spend a lot to get Telos quality and features.

Let Telos connect you to your callers. Isn't it time you experienced great phones?



2101 Superior Avenue • Cleveland, Ohio 44114 • Tel: +1.216.241.7225 • Fax: +1. 216.241.4103 • email: info@zephyr.com

Circle (142) On Reader Service Card

World Radio History

INTERNATIONAL UPDATE

Irish Debate Value of Commercial Radio

EDITOR'S NOTE: When radio broadcasters in Ireland gathered for the first Irish Radio Conference in April, the discussion centered on the fundamental issues affecting the industry.

At the heart of the debate was what the meaning of radio should be: Is it a "tool for democracy," a purely cultural activity or simply a means of earning profit?

The argument comes at a delicate moment in the history of Irish broadcasting. Concurrent with the conference was the release of a Green Paper outlining government proposals for the future of

the public broadcaster Radio Telefís Éireann (RTÉ), the RTÉ transmitter network, private broadcasting and public financing of radio broadcasting, most likely through the introduction of a tax on receivers. The Green Paper also addresses future uses and regulation of new technologies like satellite-based broadcasting, which is growing in popularity throughout Europe.

Radio World International Correspondent Maggi Taylor, who has covered the industry in Ireland for the newspaper since 1990, recorded what broadcasters have to say.

Michael D. Higgins, minister for the Arts, Culture and Gaeltacht: Pitting profit motive against collective rights can disfigure politically, homogenize linguistically and depress the inclinations for cultural expression.

He added, however, that he is confident that together "we can identify ways in which, through legislation, we can maximize the promise and reduce the threats."

Higgins said the recent Green Paper on broadcasting addresses the core philosophical issues behind the role and future of broadcasting as a cultural activity in the widest sense of the term. This paper

was issued at a time when many presumptions about the role of broadcasting that have stood unchallenged for over half a century appear to be under serious threat throughout Europe.

Historically, broadcasting played a vital role in contributing to education, culture and the arts, and in providing a service that should not neglect minorities who did not provide profitable audience shares for advertisers.

Higgins said that one could be forgiven for fearing that the demands of the marketplace are often in serious conflict with these presumptions.

Higgins stressed that he did not think Irish broadcasting had gone down this road but rather that it is being flooded by a multitude of transnational, commercially-driven broadcasting services where loyalty to shareholders rather than audiences is the rule.

Niall Stokes, chair of the Independent Radio and Television Commission (IRTC): There is a clear lack of a dialogue between public and private broadcasters, he said.

Shared experiences, ideas, insights and frustrations, he said, can be catalysts for change. It is easy to become locked into professional obligations and the pressures that go with them. These pressures are frequently felt even more intensely in the commercial sector.

A station manager in a franchise area with a potential audience of 80,000 may have the burning ambition to create great radio programs, but resources in that area will always be scarce. The chief executives at an independent station must keep one eye on the bottom line and another on the listenership figures.

Stokes urged against broadcasting for profit alone. Letting market forces determine what—and for whom—commercial radio offers would rob poorer, older and marginalized people of their right to the airwaves, he said.

The ultimate objective of broadcasters, Stokes said, must be to create a stronger, more vibrant, more creative and more diverse broadcasting infrastructure. Quality must become the central and sustaining consideration.

With a broadcast license comes a range of obligations, commitments and responsibilities, Stokes said. Some of these are clearly defined and others less so. Broadcasting is far too important a domain in the cultural and political life of Ireland, he continued, to ignore these less clearly defined obligations simply because of their more abstract, intellectual or social dimensions.

Stokes believes that experienced professionals should share their experience, skills, knowledge and accumulated insights with newcomers. There are issues that need to be discussed, and it is important that these should be approached on an industrywide basis without any resort to factionalism, he said.

Dan Collins, chief executive and program controller, Radio Kerry: Advertising is the only source of revenue for local radio, which severely limits the range and quality of broadcasting that

continued on page 37 ►

The Legend Continues.

The Old Standard.

Our M267 Mixer is more than the best selling mixer of the last ten years. It's the most versatile, the most durable, and the best performing. You trust it in your rack — you trust it on the road. And while production environments have changed, your mixer remained the same. Until now.

The New Standard.

Our new M367 Portable Mixer gives you all the reliability and durability of the M267, plus a list of new features and improvements. We made it over 25 dB quieter with a low noise circuit — ideal for digital formats. We added two more mic line inputs, bringing the total to six. We added peak LEDs. And we gave it 12 and 48-volt phantom power for your condenser mics.

What we didn't change was its toughness. It's still made with a rugged all-metal chassis and manufactured in the USA with legendary Shure durability.

The New Features.

Without increasing the size, we were able to pack in dozens of new features and improvements. The M367 has all the features of the M267, plus:

- Input peak LEDs
- Detachable power cord
- Two XLR outputs
- Easy-access side battery compartment
- Headphone monitor circuit
- Output peak/limiter LED
- Balanced, 2-position mix bus
- Adjustable limiter threshold
- Battery/AC VU meter illumination
- Monitor input sensitivity selector
- Program/monitor input selector

With the Shure M367 mixer, we've just raised the standards. It's time you raised yours.

**For The Shure Dealer Nearest You,
Call 1-800-25-SHURE.**



THE SOUND OF THE PROFESSIONALS ... WORLDWIDE.

SHURE®

Circle (197) On Reader Service Card

World Radio History

out there



on the CUTTINGEDGE



don't be afraid of **market dominance**

unity 2000i fm & unity am
broadcast processors



2101 SUPERIOR AVENUE • CLEVELAND, OHIO 44114 • TEL: (216) 241-3343 • FAX: (216) 241-4103

Circle (117) On Reader Service Card
World Radio History

LIKE FORT KNOX, WITH AN ATM

Imagine a towering stack of cartridges, open reels and DAT tapes—a vast wealth of audio cuts—representing hours of costly, painstaking production. Now imagine that treasury of sounds (like commercials, IDs, SFX, and stingers) securely stored, intelligently organized and instantaneously accessible. All within the confines of one very impressive



DigiCart/II's internal hard drive can't be beat for speed and convenience. Now with up to 32 hours of 20kHz stereo storage.

machine—the digital audio hard disk recorder, DigiCart/II.

Smart operating controls and easy-to-read displays makes scanning through DigiCart/II's massive vault of storage a snap. With a simple spin of a knob or keystroke on a remote control, you can call up any single cut, or even an entire playlist—instantly, effortlessly.

While DigiCart/II plays a pre-selected cut, its production-oriented software allows you to program the next series of cuts at the same time. All performed with reassuring reliability.

No dead air, no missed cues, no scrambling around.

Our remote controls enhance DigiCart/II with programmable Hot-Keys: fast find functions, and more.

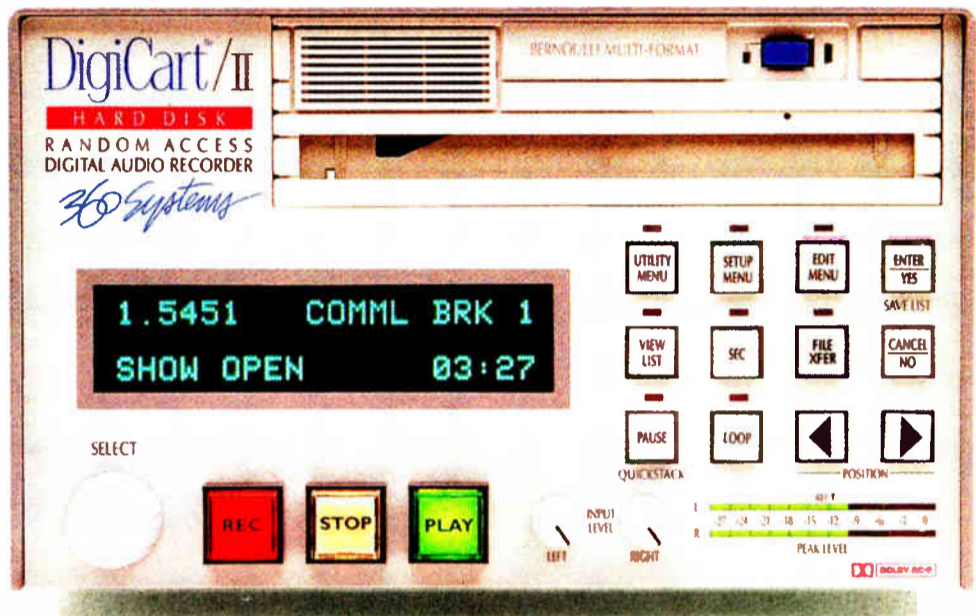

DigiCart/II holds 10,000 cuts, records in linear or with Dolby AC-2 data compression, allows precise edits, and features removable media for archiving, backups and transfers.



More digital audio between 360 Systems products at eight times normal speed

It's easy to see why DigiCart/II is fast becoming the industry standard for hard disk recording. If you're searching for the best place to bank your audio valuables, take a look—and listen—to DigiCart/II.

To see, hear and feel the true value of a DigiCart/II for yourself, contact us at 360 Systems and we'll arrange for a hands-on demonstration in your studio or production facility. Call (818) 991-0360.

DigiCart/II features both professional digital conversion formats.



360 Systems
PROFESSIONAL DIGITAL AUDIO

5321 Sterling Center Drive · Westlake Village, CA 91361 USA · Phone (818) 991-0360 Fax (818) 991-1360

DIGI-CART/II IS A REGISTERED TRADEMARK OF 360 SYSTEMS. DOLBY IS A TRADEMARK OF DOLBY LABORATORIES, INC. ©1995 360 SYSTEMS

Circle (94) On Reader Service Card
World Radio History

Madison's WOLX-FM Hosts Reunion

by Gordon Govier

MADISON, Wis. A new oldies/talk format version premiered on WOLX-FM as Program Director Jonathan Little invited radio personalities from Madison's past to return for a three-day on-air reunion.

More than 160 present and former disc jockeys, sports reporters and news broadcasters were contacted, about half of

noon, and made sure I played each one of those songs four times that night."

Music research was a little more sophisticated at WKOW, reported Jack Baker, who hosted "Madison's Pop Tunes" between 4:45 and 5:30 each afternoon from 1952-1957. He did a daily phone survey of the four Madison music stores, totalled the sales, and then ranked the records. "It drove me nuts, but we played a

through Saturday and for several more hours on Sunday, shift after shift of announcers from Madison radio stations shared their favorite on-air and off-air memories. At least most of them. "Even in the nineties, you can't tell some stories" on the air, said former WISM disc jockey Michael Hanson. For some reason, an announcer taking a bathroom break figured prominently in many pranks and mishaps.

DJ tribute

Announcers who are now deceased were remembered with a tribute, including WISM's Clyde Coffee and WIBA's Jim Mader, both morning radio fixtures for many years. The former was an incorrigible prankster and punster, the latter a molasses-smooth ad-lib talker and pitchman.

Coffee liked to tease his news announcer during the news and then beat it back to his own studio during the weather forecast. Former newsmen P.K. Powers and Bill Short both recalled being victimized by a chair pushed down the stairs outside the newsroom accompanied by feigned groans, making them worry about both an injured co-worker and the prospect of dead air coming up at the end of their newscast.

Another classic radio bit was re-created off the cuff as former WISM news director Wayne Wallace attempted to do a news update for old times sake. Halfway through, his copy was attacked first with scissors

and then a cigarette lighter.

Perpetual radio contest winner Bob Elholm also enjoyed the chance to renew acquaintances

again and meeting others whom they knew only by reputation.

Such a reunion is a natural for oldies stations in any market, especially during this 75th anniversary year of American radio. But was it good radio? Did the listeners like it?

DJ reunions are a natural event for oldies stations in any market.

with many of the announcers he had called over the years. He discussed his speed dialing technique and revealed he had collected over 800 giveaway albums and hundreds of other prizes from stations all over the midwest.

Many of the announcers are now out of the business. Others have moved up to major mar-

"The listeners who responded by telephone loved it," said Little. "Nobody complained about too much talk." Many said they enjoyed hearing the authentic old radio jingles from several stations. The whole weekend was taped and one listener requested all 21 hours of tapes.



WOLX-FM veterans (l to r): Elroy "Crazylegs" Hirsch and Bob Miller

them returned or sent recorded greetings for the celebration.

Little, who developed WISM (AM) and WZEE(FM) "Z-104" into locally dominant and nationally prominent music stations in previous decades, said he got the idea after bumping into several former colleagues in short succession while attending a recent NAB convention.

Easy to find

Many of the personalities fondly remembered by several generations of Madisonians were traceable with only a couple of phone calls. More and more names were recalled and soon the project snowballed, almost out of control. "It went crazy the last few days," Little said. "My phone rang non-stop."

The celebration began on the air Friday, June 9, as the eccentric former WISM disc jockey Stony Wallace took over the airwaves for an hour as a reception was held in an adjacent studio. He was followed in succeeding hours by Rockin' Rob Steele and Charlie "Rock n Roll" Simon.

The reminiscing was renewed the next morning with personalities from the fifties on-the-air first. Among them was Bill Dyke, who later became Mayor of Madison during the turbulent sixties.

Top-40 Rock 'n' Roll was taking over when he was an announcer at WISC radio. "Our six to midnight (shift) was in the doldrums," he recalled, and he got the assignment of doing something about it. So, "I watched Dick Clark every after-

lot of good records," he recalled. Baker went on to a long career at WTMJ in Milwaukee.

Technical snafus

Roy Guntow, WKOW farm director for 20 years, remembered the frustrations of using unreliable wire recorders for interviews with farmers. "Sometimes you had a recording and sometimes you didn't," he said. And added you only knew upon returning to the station.

Between the WOLX oldies,



WOLX-FM reunited former DJs Kurt Johnson and Larry Goodman.

kets. Some news reporters are now radio and television network correspondents and editors. It's clear they delighted in sharing their memories at the radio reunion, seeing old friends once

Gordon Govier went by the name Gordon Harris during his days as news reporter at WISM, and is now news director at WNBC-FM, in Madison. His e-mail address is scribe@xc.org.

FIVE BANDS, ONE COVER

Introducing the new PE 17 Parametric Equalizer/Notch



The Quietest Bands On Tour. The PE 17 boasts noise and dynamic range performance surpassing 20-bit digital audio quality! With both input and output level controls you can always achieve maximum headroom with minimum noise.

Clean Up Your Room. With each of 5 bands able to access the entire audio spectrum, you can aim as many guns at feedback or sweetening as the situation demands. And with a bandwidth range from 1/30 to 2 octaves there is not much that can get by the PE 17.

Handles Rejection Well. With two extra filters for high and low shelving, you can tune out entire trouble areas of the rumble and squeak variety.

"Is That All?" The typical response to learning the price of all this quality.

Rane performance, Rane value. The unbeatable combination.



PE 17 PARAMETRIC EQUALIZER/NOTCH FILTER

RANE CORPORATION 10802-47th Ave.W., Mukilteo, WA 98275 (206) 355-6000 Fax (206) 347-7757

Circle (72) On Reader Service Card

World Radio History

How to Analyze Resistor Circuits

Kirchoff's Law Solves Node Voltage Equations Where Ohm's Law Alone Cannot

by Harold Hallikainen

SAN LUIS OBISPO, Calif. In the first article of this series, I arrived at a "modified Ohm's Law" that determined current based on the voltage to ground at each end of a resistor.

This time I will use that concept along with Kirchoff's current law to analyze a simple three resistor circuit that cannot be analyzed with Ohm's Law alone. Further, I will continue to use MicroSim's PSPICE in my analysis.

DOS, Windows and Mac versions of PSPICE are available through our World Wide Web page at <http://slonet.org/~hhallika/> (look under Harold's Bookmarks) and on our BBS at 805-541-0201, then 5 (this will take you through the voice menu, but you may want to dial manually, work through the menu manually, then put your modem in originate mode, generally by typing ATX0D).

Kirchoff's Current Law

Gustav Robert Kirchoff (German physicist, 1824-1887) postulated two laws for electrical networks. These are Kirchoff's Current Law and Kirchoff's Voltage Law.

Kirchoff's Current Law (KCL) states that the algebraic sum of the currents into a "node" is equal to zero. A node is

where two or more components are connected. In figure 1, there is a node at the junction of V1 and R1, the junction of V2 and R3, the junction of R1, R2, and R3,

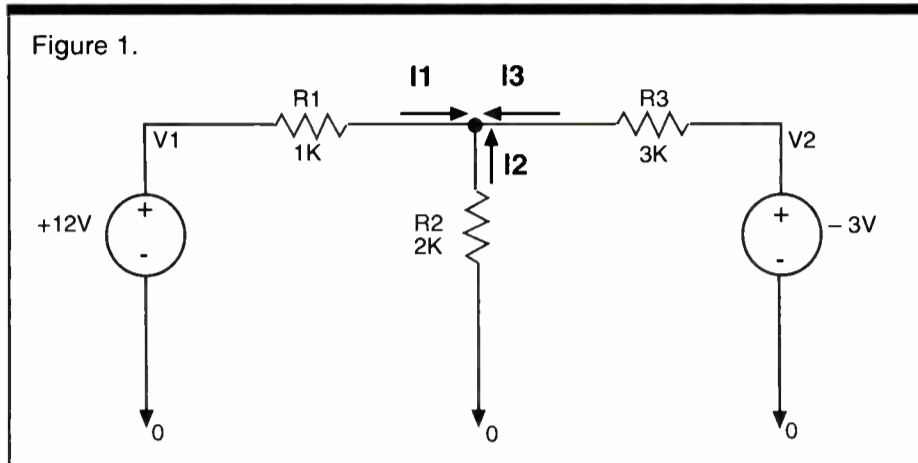

and ground. In CAD programs, a node is often called a "net." The CAD program (and PSPICE) generate a "netlist" indicating what components are connected to each node or net.

KCL is sometimes stated as "the sum of the currents going into a node equals the sum of the currents leaving a node." This is certainly true, but we then get carried away trying to determine which way currents are going. I prefer to assume they

are all going into the node (for now). Any currents leaving the node will end up negative.

Node voltage analysis

A common application of KCL is node voltage analysis. If you call the voltage at the junction of the three resistors Vn, you

voltages where working with Ohm's Law alone could not solve the problem.

Note that you could also state KCL as "the sum of all currents leaving a node equals zero." This would reverse the direction of the current arrows in figure 1, change the polarity of the currents, and get rid of a lot of minus signs. For example, I1 with the arrow reversed would become

$$I1 = \frac{Vn-12}{3K}$$

Using this form of KCL, you end up with some positive constant times Vn on the left side of the equal sign and another constant on the right. I generally use this form to avoid all the minus signs associated with Vn.

Using Spice

You can get PSPICE to analyze this circuit for you. For the DOS version of PSPICE, you can key in the components and node numbers as you did last time. A possible PSPICE listing is shown below.

: Three Resistor Network

```
V1 1 0 DC 12volts
R1 1 2 1K
R2 0 2 2K
R3 3 2 3K
V2 3 0 DC -3volts
.de V1 12v 12v 1v ; Sweep V1 from 12v
to 12v in 1v steps
.print v(2) i(R1) i(R2) i(R3)
.end
```

This listing would generate an output file that would tell you the voltage at node 2 (Vn in the previous analysis) and the currents through each resistor.

can determine it based on the following sequence of equations.

$$I1 + I2 + I3 = 0$$

equation 1

$$\frac{V1-Vn}{1K} + \frac{0-Vn}{2K} + \frac{V2-Vn}{3K} = 0$$

equation 2

$$\frac{12-Vn}{1K} + \frac{0-Vn}{2K} + \frac{-3-Vn}{3K} = 0$$

equation 3

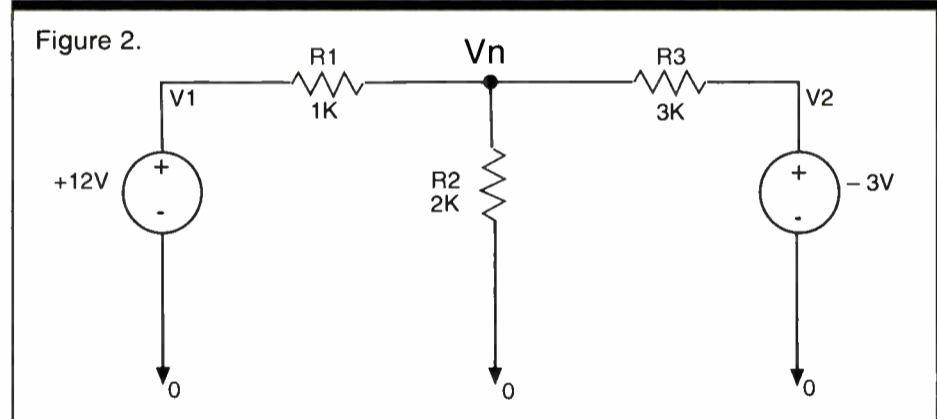

$$1e-3(12-Vn) + 500e-6(0-Vn) + 333e-6(-3-Vn) = 0$$

equation 4

$$(12e-3) - (1e-3)Vn - (500e-6)Vn - (1e-3) - (333e-6)Vn = 0$$

equation 5

$$(11e-3) - (1.833e-3)Vn = 0$$

equation 6

$$11e-3 = (1.833e-3)Vn$$

equation 7

$$6 = Vn$$

equation 8

Equation 1 is a restatement of KCL. Equation 2 substitutes the (Vtail-Vtip)/R form of Ohm's Law for each of the currents in equation 1. The remaining equations solve for Vn.

Now that you know Vn=6 volts, you can determine I1, I2 and I3, checking the results.

$$I1 = \frac{12-6}{1K} = +6mA \quad I2 = \frac{0-6}{2K} = -3mA$$

$$I3 = \frac{-3-6}{3K} = -3mA$$

So, KCL can be used to determine node

Note that in the node list for each of the resistors that the common node (node 2) is listed last.

PSPICE calculates the current going in to the first node and out the second node of a resistor. The node order here will result in current polarities agreeing with your previous calculations.

Schematic capture

Although generating a PSPICE input file by hand is not difficult, working from a schematic can sure be nice. The Windows version of PSPICE includes a schematic capture program. Once you have the program installed, double click on Design Center Eval 5. 4. Then double click on Schematics. You'll be presented with a blank A size drawing page. There are lots of capabilities here, but I will lead you through our simple circuit to get you started.

To start drawing parts, hit control-G to get a part, or select Get New Part from the Draw Menu. You can browse through the various libraries.

To draw a DC voltage source, select VSRC from the source.slb library, or

continued on next page ►

AUDISK®

Digital Audio Hard Disk Systems for AUTOMATION AND LIVE ASSIST

What if I don't have \$10,000! Can I still do automation?... YES, with AUDISK!

AUTOMATION- satellite and stand alone (music and spots)...**LIVE ASSIST**- spots, jingles, liners, ID's, music, programs, sound effects...**ANY MIX** of the above modes and more!...**RECORDING**- scheduled, background, production, multi-segment...**16 "NETWORK" SETUPS**-switch on the fly...**COMMANDS**- ON-AIR scheduled, immediate, keyboard "Hot Keys"...**SCHEDULE UP TO 7 DAYS IN ADVANCE**...**DUAL OUTPUTS**- Simultaneous playback of two stereo cuts while recording another!...**16 TRIGGER INPUTS**- for stopset, ID, liner and other external controls...**8 RELAY OUTPUTS**- for triggering external equipment, receivers, etc...**EXTERNAL DEVICE CONTROL**- DAT players, tape players, CD...**INTERNAL AUDIO SWITCHER/FADER** control Audio sources and distribution...**6 STEREO/12 MONO INPUTS AND 6 OUTPUTS**...**PROGRAMMABLE "LIVE ASSIST" KEYPAD READY**- separate layouts for each Jock...**MULTIPLE UNIT INTERCONNECT**- expand the outputs and share Audio...**TWO SEPARATE SCHEDULES**-separate satellite and live assist or spots and music...**DELAYED BROADCASTS**-record a show for later re-broadcast automatically...**UPLINK/DOWNLINK SYSTEMS**- remote downloading/control over satellite links...**DUBBING**- copy files or parts of files digitally from file to file, disk to disk...**MIRRORING**-automatically backup all or part of your audio files to backup disks...**HARD DRIVE**- basic system comes with over 550 one-minute files or any combination up to 9.2 hours of storage time.

\$7,295

Model DS1000:

PRICE INCLUDES THE ABOVE AND MORE!

SOME OF THE AVAILABLE ADDITIONAL OPTIONS.....(call for prices)
INTERFACE to virtually ANY traffic/billing software (with MAKELOG Software)...**MULTISTATION CONTROL**- simple upgrade to Multiple Workstation systems...**TOUCH TONE CONTROL**- add-on hardware available for DTMF control over phone lines...**ADDITIONAL HARD DRIVES**- basic system comes with 9.2 hours 15khz stereo drive, add more drives to get over 500 hours storage time...**REMOTE CONTROL**- control the system over the phone line with the addition of modem and commercial remote control software

Call us TODAY for important information and a FREE DEMO Disk

DHK Group "the AUDISK® people"
 (800) 501-9662

just key in VSRC at the Part prompt. A voltage source image will appear, and you can position it with the mouse. Click the left mouse button in each location you want a voltage source. Click the right mouse button to stop drawing voltage sources. If you do not get the part exactly where you want it, select the part with a single left mouse click. Then click and hold the left button while dragging the part to its new location.

Double clicking on a component lets you set that components parameters. If you double click on V1, a dialog box appears. Click on DC=, then click in the value field. Type in the voltage (12 V) followed by a return. The voltage must be in a form acceptable to PSPICE. The schematic will be converted to a standard SPICE input file. No space is allowed between the number and any metric prefix or the units. Click OK to store away the new settings for the voltage source.

Although generating a PSPICE input file by hand is not difficult, working from a schematic can sure be nice. The Windows version of PSPICE includes a schematic capture program.

To draw each resistor, get R from the analog library. As you are positioning each resistor, you can hit control-R to rotate the part as necessary. You can also rotate a part after it has been placed by clicking on the part, then hitting control-R. You can set the resistance by double clicking on the resistor and filling in the dialog box, as was done for the voltage source, or you can double click on the component value itself. A dialog box with just that a clue appears.

Similarly, the component instance (R1, R2, etc.) can be changed. The individual parts of a component (the symbol, the instance, and the value) can be selected individually and dragged around the schematic to give a nice appearance. The ground symbols are in the Port library.

Figure 3.

Small Signal Bias Solution Temperature = 27.000 Deg. C

Node	Voltage	Node	Voltage	Node	Voltage
(Vn)	6.0000	(\$N_0001)	12.0000	(\$N_0002)	-3.0000

Voltage Source Currents

Name	Current
V_V1	-6.000E-03
V_V2	3.000E-03

Total Power Dissipation 8.10E-02 Watts

AGND, EGND, GND ANALOG, and GND EARTH all connect to node 0, but have different schematic symbols. AGND and GND_ANALOG use the triangular symbol, while EGND and GND_EARTH use the parallel line symbol.

The components are wired together using Wire in the Draw menu, or control-W. Do a left click to start the drawing. Do another left click to complete each

wire segment. Do a right click to terminate the draw. Do another control-W to draw the next wire.

All the normal Windows edit capabilities are available, including copy to clipboard. You can then paste the schematic into documents.

An analysis on the circuit can be run at this point. With no other instructions, PSPICE

will determine the "bias point" of the circuit, doing a DC analysis. Select Run PSPICE from the Analysis menu. Select Examine Output in the Analysis menu to see the output listing. This output is difficult to interpret because PSPICE has assigned the names to the nodes.

You can assign node names by double clicking on a node (for example, the junction of the three resistors). A dialog box will pop up asking for a label for this point. Any valid PSPICE node name may

be keyed in. In the example, I keyed in Vn. The result is shown in figure 2.

The schematic capture portion of PSPICE supports .print and .dc using the VPRINT1 component and the DC sweep in Analysis Setup menu. For now, how-

ever, I will just use the default "bias point" calculation of PSPICE to check my results.

The results of the PSPICE run are shown in figure 3. Note that Vn does indeed have 6.000 volts, agreeing with all our calculations. Kirchoff was right!

Next month I will look at Kirchoff's Voltage Law and mesh analysis. I look forward to your comments.

□ □ □

Harold Hallikainen is president of Hallikainen & Friends, a manufacturer of transmitter control and telemetry equipment. He also teaches electronics at Cuesta College and is an avid contra dancer. He can be reached at 805-541-0200 (voice), 805-541-0201 fax, ap621@cleveland.freenet.edu (e-mail), and http://slonet.org/~hhallika/ on the World Wide Web.

Only Harris PT-CD FM Transmitters offer all of these features-- and more!!!

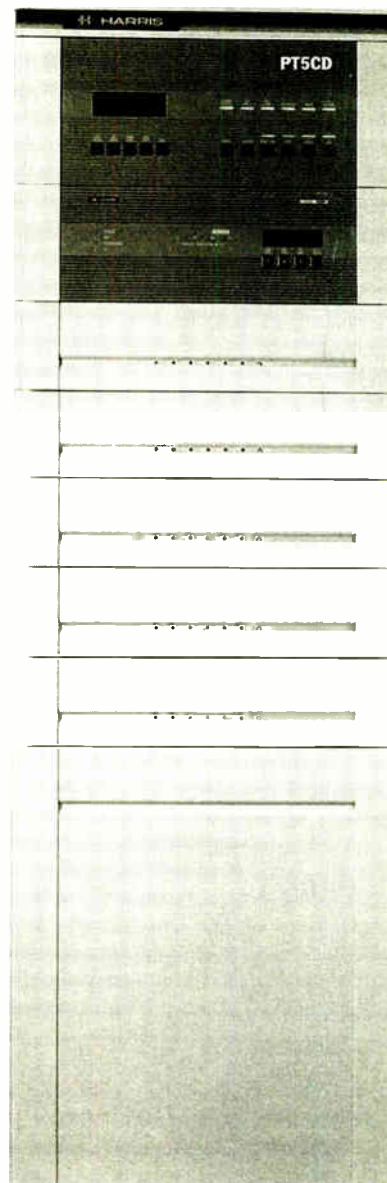

- DIGIT™ Clearly Digital FM exciter
- Hot-pluggable RF modules
- No IPA amplifier required
- Fully isolated combiner
- VSWR foldback
- **NEW LOW PRICE!!!**

To find out how easily you can have a Platinum Transmitter for aluminum prices, call us.

217-222-8200

**PT 5CD ONLY
US\$37,915!!!**



Communications Data Services
Incorporated

Online Engineering Services

- **LPTV Studies** - essential for filing LPTV station applications
- **FM Studies** - conduct spacing and interference studies for proposed FM facilities
- **Distance to Contours** - produce distance to contour tabulations and maps of predicted coverage area
- **Population Count** - produce detailed population analysis studies for a given facility
- **Zip Code Analysis** - produce zip code analysis studies to analyze market coverage
- **Terrain Data Analysis** - calculate HAAT and produce terrain profiles
- **Coverage Maps** - complete Real World™ propagation prediction services

6105 Arlington Blvd.
Falls Church, Va. 22044
800-441-0034/703-534-7884 (fax)
Richard P. & Richard L. Biby - Principals

MOVING?...

Don't leave us behind!

Mail or fax your current label and new address (with effective date) to:
Circulation, RW,
PO Box 1214
Falls Church, VA 22041
or
FAX 703-998-2966.

Address changes will be processed within four weeks of receipt.



Computer Mayhem Unlike Any Seen on 'Star Trek'

Dear Luci,

Yep, all it took was just one look at RW's "NAB in Review" issue to know computers have taken over. We all know there is one in traffic that puts the log together, one in the program director's office running the music software and the ones for the copywriter, engineer, newsroom, sales department, etc.

Now there is the one running spots on the automated AM, the one in FM handling commercials and zany effects for the morning show, the one in production disguised as a multitrack tape recorder, the one taking transmitter readings back by the shop and the one sequencing the CD jukeboxes on the duopolized FM.

Did we see it coming? You betcha. Pull out the service manual for the circa 1981 ITC 99 cart machine and check out that big beautiful microprocessor right there in the schematic. Don't look so surprised: There had to be a higher intelligence inside that deck running the show. And it has done so relatively flawlessly for years.

There are still way too many broadcasters not ready to embrace the computer as a necessary and meaningful part of the job. Too many problems, too many mistakes, too difficult to work. And when a computer crashes, it is a major inconvenience to the station. All I can tell these people is: just be glad it isn't 1966....

Back then, computers were designed to explode.

Diehard Trekkers will back me up on this. On any given episode of classic "Star Trek," the crew of the Enterprise defeated the enemy alien computer by flooding it with illogical equations, moral issues or demands to "execute your prime function." Within moments, flaming magnesium showered the screen and the evil machine was no more.

Never mind a nice simple "bad command or file name" prompt. Forget "file

not found." These machines quite literally went ballistic.

Computers at the radio station (almost never blow up. The worst that usually happens is the modem disconnects, data gets lost, a hard drive requires defragging or a Windows application locks up. In really rare occasions a monitor could die when the blanket of fuzz that collects inside gets too thick, trapping heat. But just imagine how things would be at a radio station if computers still carried the design specs "Star Trek" writers created nearly 30 years ago.

It would start in the traffic office. The coordinator would notice there are two nightclub spots in the same stopset, and moves one to a position later in the hour where it will conflict with a restaurant spot. Ignoring this, she goes ahead and schedules a live remote at a car dealer adjacent to a spot for a competing dealer, a McDonald's next to a Burger King and the Prom Promise PSA just before a beer commercial.

The screen will put up the red window announcing the conflicts, but the coordinator bypasses it and calls for the log to be printed. The computer, flooded with all this illogical information does the only thing it can when <ENTER> is pressed...

BOOM!!!... No log tomorrow.

Down the hall, the computer running the duopolized FM looks to find the next CD on the playlist and discovers it is the same CD now on-air. Worse, the computer sees it will end up playing two female vocal artists back-to-back. And with network news coming up, it can't find a shorter cut in the other CD jukebox to use as a fill tune to get to the hour. Painted into a corner, the automation computer does the only thing its programming will allow it to do:

KAPOW!!!... Thanks for listening.

In the AM studio, some poor soul decides to change the "cart number" of a

FROM THE TRENCHES

by Alan Peterson



spot recorded on a hard drive. Some systems won't allow you to do this and will tell you so. It may be possible to exit into DOS and do a REN or COPY command, allowing you to rename an audiofile with a new number. These systems come back with a "file corrupted" message, which is still much better than...

BABOOM!!! ...Oh well, it's only AM.

Do you remember the "Nomad" episode of Classic Trek (The Changeling)? The ship's computers got fried when Nomad "took in information faster than they could give it." Imagine the pyrotechnics taking place inside stations if two modems couldn't agree on a baud rate to exchange information and one tried to copy data too fast.

BAM!!! BAM!!!... Damn.

It won't stop. The first typo in a piece of commercial copy will trash the new PC in continuity, one demographic group misplaced in the sales terminal will smoke that machine, and one more spin of "All I Wanna Do" will vaporize the music director's 386 clone.

Even plugging the thing in and turning it on is dangerous, Luci. When you tell a computer to run its AUTOEXEC.BAT file, you're literally telling it to "execute its prime function". Even casual dinner-time Trek viewers duck under the table when they hear that one coming. Booting up the station's new file server will serve up Silicon Flambé.

Thanks to careful programming, ingenious design and especially to 3.5 volt CPUs, catastrophic spark showers from computers are a rarity. Tell a computer to do something it can't do and it will say so. Executing a prime function takes you to a C prompt. Illogical equations simply give you illogical answers.

Somewhere during the development of

the PC, a programmer who was a Trek fan realized there was a better way to do it than stink up the room. Clever software authors serving the broadcast community saw the potential for computers that didn't explode and incorporated them into the office and studio.

It's still not perfect, Luci. As the (relatively) old adage goes, "To really screw things up requires a computer." But at least the foresight of some now-forgotten computer pioneers are keeping things rolling safely and efficiently in the radio stations of the present.

Although, the presence of a bright flash and the smell of a hot fiberglass circuit-board would finally give the PD dramatic proof of what he's always somehow suspected in the past but could never catch in the act: jock error.

Maybe those Trek guys were onto something.

-Al

□□□

Alan Peterson wrote this from Harrisbrug...no, that should have been Harrisbrug...oh, no!.....BOOM!.....

EDITOR'S NOTE: This column is the last From the Trenches—as you all know by now, Al is the technical editor of RW and will be writing a slightly different kind of column for the newspaper henceforth.

With this installment, I'd like to invite anyone interested in contributing a similar column, i.e., a humorous look at the daily life of a radio professional, to submit a manuscript. Submissions should be 800 words, and can be sent on DOS diskette (WordPerfect 5.1) or via e-mail at 74103.2435@compuserve.com.

Submissions should include the author's biographical and contact information.

RBDS

EASILY
INSTANTLY
INEXPENSIVELY

... with these two, brand-new products, INOVONICS has you covered, coming and going!

710 ENCODER: Just \$995 and **no computer required!** The non-volatile memory holds 16 separate frames of program and format identifiers, alternate frequencies, radiotext messages and traffic or emergency flags. A built-in data interface lets you upgrade later to full dynamic operation for revenue-generating paging, GPS, coupons, contests, etc.

510 DECODER: Connects to your existing FM Mod-Monitor. The front-panel LCD display shows RBDS injection level and allows you to scroll through and read all the data groups. An RS-232 port gives unlimited access to raw RBDS data for telemetry and other in-house functions.

Inovonics, Inc.

1305 FAIR AVE., SANTA CRUZ, CA 95060 U.S.A.
TEL: (408) 458-0552 — FAX: (408) 458-0554



Circle (185) On Reader Service Card

63 Years Ago

Reprinted from Radio World July 9, 1932.

Editor's note: The RW of old, printed for a time in the 1920s and 1930s and today's RW are unrelated except in name.

Distributor Misaligned,

Auto Sets Pick up Motor

There are still a few installation men who have an occasional job on which they cannot get rid of all motor noise, says Transitone Automobile Radio Corporation.

Usually this is caused by the distributor. The high tension terminals or contacts are not lined up perfectly due to shrinkage or warping of the head or to wear in the distributor gears. The rotor may strike a few of the contacts and miss the rest.

Chalk the Contacts

When peening a rotor under such conditions, the best plan is to chalk the contacts or terminals and then after the rotor has been carefully peened, turn over the motor a few times with the

ignition turned off.

Remove the distributor head and examine the chalked terminals. If the rotor has cut the chalk on a few of the contacts, these contacts should be scraped down with a hard sharp tool and the rotor again peened.

Shielded Loom

This procedure should be carried on until the rotor just traces a line through the heavy chalk layer on all the contacts. Obstinate cases of interference can be eliminated this way.

As a further aid to installation there is a stock shielded loom for shielding the secondary ignition cable between the instrument panel and the dash. It is made up in eighteen-inch lengths.

YOUR CALL

This is a great time to add your station's call letters to this list of satisfied RS-Series Console owners (or, if you are already on this list, buy a second or third board).

That's because your favorite dealer is now authorized to include valuable factory extras with your console at no additional charge. These "freebies" include Radio Systems Distribution Amplifiers, Telephone Interfaces, and Studio Clocks and Timers.

So, call your favorite dealer* today and ask for details on RS-Series Consoles and then ask them to throw in something extra.

Factory Customized

- Custom engraved switch caps
- Pre-made source cables and harnesses
- Color-coded fader knobs

Popular Options

- Plexiglas copy stands
- Squawk-Box system
- Input extender switcher
- Remote interface modules
- Distribution amplifier card

Standard Features

- Two inputs per channel
- Three output buses: Program, Audition, Mono
- Full DC control
- Penny and Giles faders
- Complete VU metering
- Event timer — with automatic and manual modes
- Digital clock (on 18 channel models)
- Full remote control
- Pro audio specifications
- Mid-stage channel patch points
- Peak LED indicators
- Two year warranty, with no-charge next-day delivery
- Complete monitor section
- Heavy duty cue and headphone amplifiers
- Mic, line, or consumer level signal on any input
- Internal talkback system



RADIO SYSTEMS INC.

601 Heron Drive • Bridgeport, New Jersey 08014-0458 • (609) 467-8000 • FAX (609) 467-3044

*Broadcast Supply Worldwide is no longer franchised to sell Radio Systems products. If BSW was your Radio Systems distributor, contact us for an authorized RS-Console supplier in your area.

OUR PHYSICAL CONSOLE ISN'T AN OPTION. IT'S THE WHOLE IDEA.

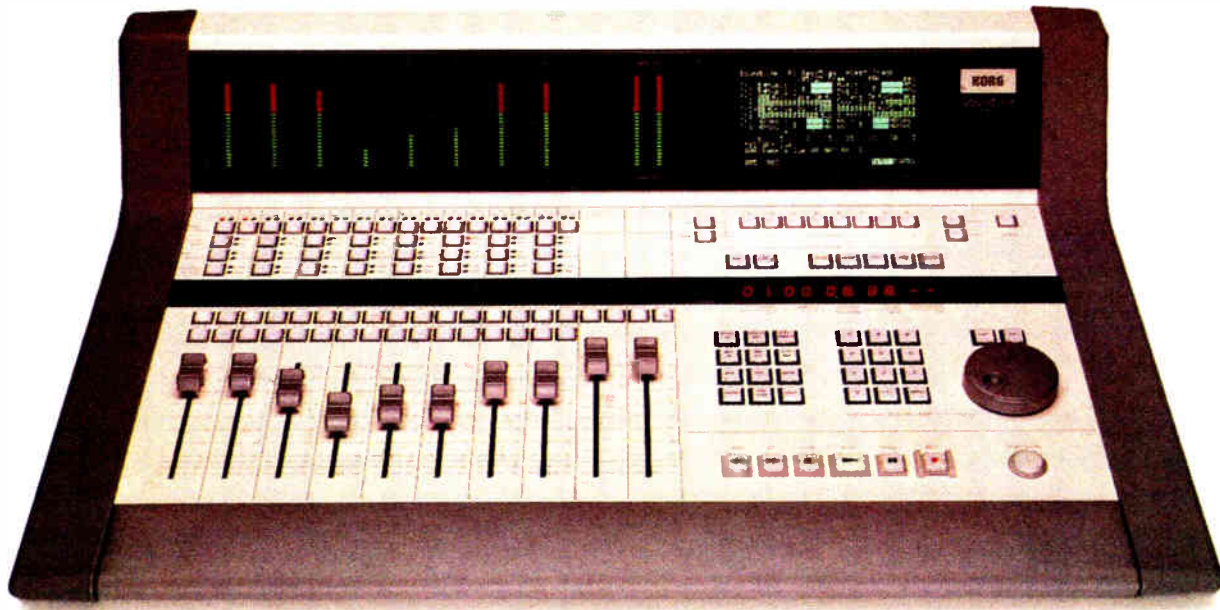

Random Access Digital Audio Production by SoundLink.

No mousing. No fumbling. And no nonsense. We designed the SoundLink Digital Audio Production System just as our most demanding customers asked us to: Without compromise.

We built an intuitive, full-featured console to give you complete control of random-access digital recording, editing and audio mixing. Along with digital signal processing, machine control, MIDI capabilities and synchronization.

So if you're working in radio or any other audio environment, now you can enjoy all the benefits of random-access digital editing with

the advanced features you need.

And instead of being forced to work on an imaginary desktop, you get all the comfort of the real thing.

Best of all, SoundLink is a perfectly integrated system, rock-solid and hassle-free—not a fragile mix of components.

For more information, just pick up your physical telephone and call Korg Professional Audio at 800-645-3188, ext. 280.

If you need complete control over your digital production, anything less really isn't an option.

"SoundLink has not only made every production operation faster, it's also expanded my creative capabilities to include things I could never tackle with analog equipment."

— Rick Wiggins, Creative Director
WJR-AM, Detroit
Capital Cities/ABC, Inc.

"It's one of the few pieces of equipment at the station I don't have to worry about."

— Fred Holub, Chief Engineer
KLAX-FM/KXED-AM, LA
Spanish Broadcasting System

"This is the 90s production room solution. Its integrated digital console, storage and editing combine to make one of the most efficient and cleanest operating studios you can find anywhere."

— Roy Pressman, Tech. Director
WLVE-FM/WZTA-FM/WINZ-AM
Paxson Broadcasting, Miami

SoundLink **KORG**
Professional Audio

© 1994 Korg USA, 89 Frost St., Westbury, NY 11590. SoundLink is a registered trademark of Korg USA.

Circle (208) On Reader Service Card

World Radio History

Studio Sessions

DAT
Maintenance Tips
See p. 28

Equipment and Applications for Radio Production and Recording

PRODUCT EVALUATION

Roland DM-800 Portable, Powerful

by Ty Ford

BALTIMORE In the last *Producer's File* (RW, June 14), I gave a general overview of Roland's new DM-800 workstation with two 500MB hard drives (\$7,495). In this part, I'll delve more into the actual operation and features of the unit.

First, no doubt about it, due to the 1-bit, 128x oversampling delta-sigma A/D conversion, 8x oversampling and 18-bit D/A converters, the sound quality of the DM-800 is extremely good. All internal processing, including digital EQ, is 24-bit processing.

Some Roland-speak

Although Roland gets good marks for the Troubleshooting, SCSI and SMPTE sections of the manual, many of the operational parts remain in Roland-ese: little things, like being told to hit the Record

LCD display is like viewing the Grand Canyon through a keyhole. I highly recommend using a monitor (NTSC, PAL, S-Video, Atari, NEC or IBM). They all may be ported directly from the DM-800 and will give an expanded view that includes metering, a four-track close-up view and a total overview of all tracks in a project.

Using the DM-800

The DM-800 uses dedicated controls and soft keys: there is no mousing around. There are seven mode buttons: Record, Trigger, Catalog and System. Within each mode, there are a number of "pages" that are accessed by the F-Keys positioned under the on-board LCD. Four cursor buttons and the Value/Time wheel are used to navigate to and from the various fields to change the values. Numbers can also be punched in via the keypad.

To start a project, go to the Catalog mode, choose the sample rate (32, 44.1 or 48 kHz), name the production and initialize. Set the Sample Clock Source to determine whether the DM-800 will be providing internal sync, receiving it from an external SMPTE source or from an external digital source. The Time Base is set independently from the Sample Clock

Source. If you are not trying to sync to outside sources, simply stay Internal. The time displays can be set to read in SMPTE, Min/Sec or Measure/Beats.

During setup, you can also change the length of audio heard in each of the Up To, Thru and From preview and scrub preview modes. You also get your choice of Trigger, Gate or Loop preview modes. Trigger plays the preview selection through once when any preview button is pushed. Gate mode passes audio only when the preview button is held down and Loop plays the selected audio in a



Roland DM-800

loop with one press of a preview button.

Monitor features

You can monitor either Source or Disk. When Source is chosen, the input source will be monitored when a track is in Record Ready. Use this mode if you want to play along until a punch-in. When Disk is chosen, a track will play back from disk at all times, except when actually recording and the Track Status Select

red light is on. Use this mode if you want to hear other recordings on the track so you can punch in at a specific point.

There is a separate window for setting punch-in/-out times and you can also punch in and out of record via a MIDI trigger or a footswitch, or by using the multi-purpose Shift/Marker buttons. This kind of housekeeping only needs to be done once, unless you need to alter a production for connectivity to the outside world.

One of the features I did not like about the earlier DM-80 was that the sound passed to the outputs in "scrub" mode was like hearing a CD in "pause." The DM-800 still operates the same way, but you can call up a waveform display that makes it a lot easier to find the edit point. The waveform display only shows one track at a time and shows only levels above -48 dB digital and -28 dBm analog. Even at the highest of the three vertical resolution levels, the display does not give you much of a visual idea of the location of a low-level sound.

Recording with DM-800

After hitting the Record mode button, press the In/Out F-Key to access the internal routing. This determines which analog or digital input is directed to which track, and whether the internal tracks are output directly or through the internal eight-channel Mix bus to any of the output busses.

There are three record modes: Manual, Auto and Loop. In the Manual mode the DM-800 operates much the same way as any tape recorder. Auto mode is used for automated punch-in/-out. Loop mode repeats a section, allowing you to record a

continued on page 33 ►

Product Capsule: Roland DM-800

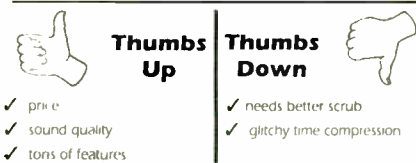

For more information, call Roland at 213-685-5141; or circle Reader Service 51.

button when what they really meant was the Rec button (yes, there are two). These oversights are really off-putting, especially to the new user.

(In the middle of writing this article, I received a "hot off the e-mail" 19-page tutorial. Its applications approach cuts through a lot of the mystifying rhetoric of the manual. There is also a three-part, color-coded applications video currently in production.)

As with many DAWs, the DM-800 stores audio on a SCSI system of internal and external hard drives. Even though the two 500MB internal drives are designed to operate without a cooling fan (and the drives themselves are less noisy than some I have heard), they generate enough noise to create problems if the DM-800 is to be used near an open mic. If you are used to a combo studio with half a dozen cart machines and other tape transports whirring in the background, the noise probably will not bother you, especially if you use an expander on the mic circuit. On the other hand, if you are trying to record pristine audio in the same room with one or more open mics, the drive noise will be a factor.

Speaking of hard drives, Roland suggests that if you are doing a lot of small projects, back up everything to tape and reinitialize (defragment) the drives once every two weeks, or before starting a new big project.

Editing eight tracks using the onboard



An integral tool in many of the world's top recording studios, KRK's close-field monitors have gained acceptance as the reference speaker of choice. Their extremely smooth frequency response, low distortion and superb imaging is without peer. This incredible performance can be attributed to a unique combination of exotic driver materials and fanatical engineering. Furthermore, each driver is extensively tested and monitor pairs are matched to within one-tenth of a decibel for unequaled accuracy. With a complete family of monitors to

choose from, KRK has a monitor for every application, including video-shielded models. KRK, fanatical by design.



Distributed by Group One
East Coast Office:
(516) 249-1349 • FAX (516) 753-1020
West Coast Office:
(310) 306-6823 • FAX (310) 577-8407
KRK Monitoring Systems
16402 Gothard St., Unit D
Huntington Beach, CA 92647
(714) 841-1600 • FAX (714) 375-4496

Circle (50) On Reader Service Card

Legendary Les Paul Turns 80 This Year

by Frank Beacham

NEW YORK Les Paul is such an easy-going, friendly, accessible man that it is sometimes hard to comprehend how important his contributions have been to both contemporary music and modern audio technology.

Of course his name is synonymous with the electric guitar (yes, he perfected it). But add to this such audio innovations as multitrack recording, reverb, sound-on-sound and overdubbing and you begin to understand the impact Les Paul has had on our music and culture.

This summer Les, who still performs

every Monday night at Fat Tuesdays in New York City, turned 80. To celebrate his extraordinary life and career, look

"test" to demonstrate the capabilities of his battered, war-torn SM-58, a mic that Les has obviously put to good use for

mic system. Though it is designed for consumer camcorder use, I immediately recognized the potential to use this elegant, sub-miniature system in some less-than-critical professional applications.

Could this be a useful wireless news conference mic for radio reporters and news writers? Well, it is too early to tell, but the system certainly has all the right features.

First of all, the system uses transmitter and receiver packs about the size of tiny pocket pagers, each weighing well under

Off the Shure assembly line came a one-of-a-kind, very limited edition SM-58 with the name "Les Paul" engraved in a circular band just under the metal screen.

for a Les Paul television special this fall from the Gibson Guitar company, maker of the legendary line of Les Paul-designed guitars. Also, honors will come to Les later this year at the Smithsonian Institution in Washington, D.C.

Since conducting an interview with Les a couple of years ago, I've stayed in touch with the man once known as "Red Hot Red, the Wizard of Waukesha" (his Wisconsin hometown) and have been rewarded with some wonderful evenings of music and great conversation. Recently, while on a visit to New York, I introduced Michael Pettersen, director of the applications group at Shure Brothers, to Les before his weekly gig at Fat Tuesdays.

The two hit it off well, with Les reminding Michael that he was hanging around the Shure Brothers factory in Chicago before Michael was even born. Les said he is a big fan of the venerable Shure SM-57 and 58 mics, which are staples of performing musicians everywhere. "Best f...ing microphones in the world," Les proclaimed enthusiastically, telling Michael he could take a \$100 SM-57, and with good technique and equalization, make it sound as good as a \$6,000 German microphone.

All this carried over into his stage performance later, where Les did a mock

many, many years.

As a token of all this good will, Michael decided it was time Les upgraded his vintage 58. So off the Shure assembly line this summer came a one-of-a-kind, very limited edition SM-58 with the name "Les Paul" engraved on a circular band just under the metal screen. Hopefully, by the time you read this, Les will be using the new "Les Paul" mic on stage with his "Les Paul" guitar at Fat Tuesdays.

Sony's Hot New Wireless

It is no secret that wireless microphones are getting better and cheaper, but until now, I had not been able to find a decent, inexpensive portable system small and convenient enough for routine recording of news events. Just before this column went to press, Sony sent us a sample of its new \$150 WCS-990 wireless

three ounces powered by two AAA batteries. The antennas are internal, so there are no protrusions from either device. This is absolutely the most minuscule wireless mic system I've ever seen.

The transmitter (which comes with its own electret lavalier mic) has Sony's plug-in power jack that can deliver phantom power to professional microphones. We tested the unit with Professional Sound Corporation's Millimic condenser mic and it performed flawlessly.

The receiver has an 18-inch output cable with mono minijack for tape recorders and a separate headphone jack for monitoring sound at the receiver. There is also a mic jack input for mixing with the microphone at the transmitter.

The new Sony system operates in the 912-916 MHz range, offers two switchable channels and has a transmission range of up to 100 feet. Frequency response is 100-15000 Hz and dynamic range is more than 78 dB.

We put Sony's new system through some quick tests and got excellent results with no interference. However, in the days ahead, we want see how it performs in real-world conditions on the mean RF streets of New York. We'll be back with the results.

□ □ □

Frank Beacham is a writer, director & producer. His address is 163 Amsterdam Ave. #361, New York, NY 10023. E-Mail: beacham@radiomail.net.

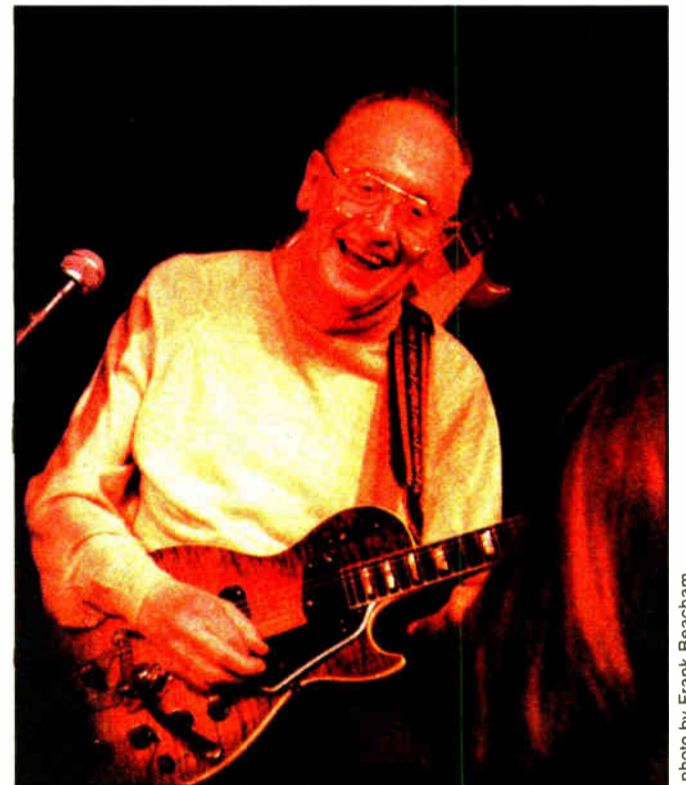

Les Paul performs at Fat Tuesdays in NYC.

photo by Frank Beacham

Think of Them as Reference Monitors You Can Wear

When you need to hear exactly what you've recorded... nothing more, nothing less... then only Sennheiser's HD 25 SP will do. Excellent isolation, with clear, accurate reproduction are the trademarks of these reference-quality headphones. Plus, they're MUCH more comfortable than wearing speakers.

Your project studio is incomplete without the HD 25 SP. Check them out today at your local Sennheiser dealer.



HD 25 SP



SENNHEISER

6 VISTA DRIVE, P.O. BOX 987, OLD LYME, CT 06371
TEL: 203.434.9190 - FAX: 203.434.1759
IN CALIFORNIA: 4116 WEST MAGNOLIA BLVD, SUITE 100,
BURBANK, CA 91505 - TEL: 818.845.7966 - FAX: 818.845.7140
IN CANADA: 221 LABROSSE AVE., PTE-CLAIRE, PQ H9R 1A3
TEL: 514.426.3013 FAX: 514.426.3953

Circle (82) On Reader Service Card

SINE SYSTEMS

Walkaway Specialist: Innovative Solutions

- EBS Compliance Tools
- Remote Transmitter Control & Monitoring
- Dial-up Remote Broadcast
- Program Automation Accessories & Studio Aids



(615) 228-3500
FAX 227-2367

972 Main Street, Nashville, TN 37206-3614

24 Hour FAX
ON-DEMAND
(615) 227-2393

Circle (48) On Reader Service Card

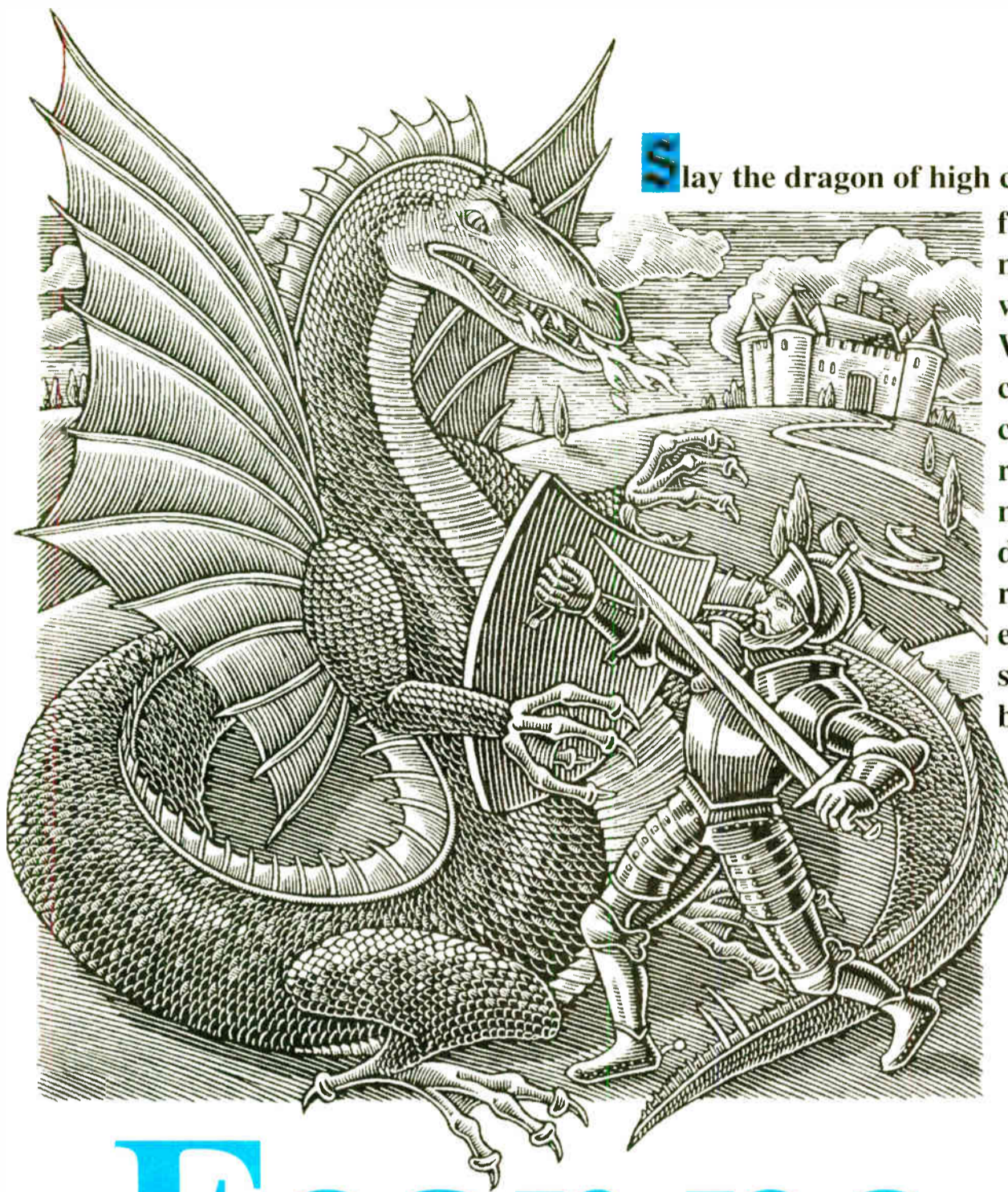

Slay the dragon of high costs and worry! Nothing strikes fear in the heart of an owner/general manager/chief engineer quite like the words, "the station's off the air!" Wizard For Windows™ Version 4.0 combines the best features of the centralized file server with the redundancy of the peer to peer network. If the central file server goes down, the system will automatically reconfigure itself into a stand-alone environment and continue to run your stations. Let Wizard For Windows™ be your knight in shining armor!

For information about radio's premier digital automation system, call:

Prophet Systems, Inc.
1-800-658-4403

In Australia, New Zealand, and Pacific Rim, contact Broadcast Solutions Pty Ltd. at (02) 439-6662.

Fear no competition.

- ◆ Runs 5 or more stations!
- ◆ Multi-track Wizard Editor!
- ◆ Expandable to 30 or more users!
- ◆ Live, satellite and automated modes!
- ◆ Backtime System, fills out each hour!
- ◆ Full Equipment and Data Redundancy!
- ◆ Instant audio access... NO transfer delay!
- ◆ Button Bar with Quick Record Capabilities!
- ◆ Automatically record and play network feeds!
- ◆ The ONLY true multi-user system on the market!
- ◆ Unsurpassed FLEXIBILITY, runs any program log!
- ◆ On-Line Copy Entry System, integrate your stations!
- ◆ Automatic Block Stretch / Squeeze for perfect timing!
- ◆ Exclusive Automated Time and Temperature Announce!
- ◆ The Leading Hard Drive Automation System in the industry!
- ◆ VoiceTRAC System, pre-record "live" shows weeks in advance!



Audio Wizard *for Windows*

The *Flexible* Digital Automation System featuring Windows and Novell Technology

Windows is a Registered Trademark of Microsoft Corporation. Novell is a Registered Trademark of Novell, Inc. Compaq is a Registered Trademark of Compaq Computer Corporation.

Circle (36) On Reader Service Card

LINE OUT

Maintenance Keeps DATS Error-Free

by Bruce Bartlett
with Jenny Bartlett

ELKHART, Ind. You just finished a perfect mix and recorded it on DAT. But when you play it back, you hear a glitch. It is either a noise burst or a short silence. What is going on, and how can you fix it?

Dust, oxide flakes, or tape misalignment can cause errors in the digital signal. A glitch occurs when the error-correction circuit cannot remove all the errors. Some DAT machines mute the audio when this happens, creating a dropout.

Errors are less probable if you use high-quality tape and keep the heads clean.

Good tapes and clean heads usually give error rates well below 50. If you hear glitches, or if the error display reads high (over 100), it is time to clean the heads.

You can do this in three ways:

- With a dry cleaning tape;
- With a wet cleaning tape,
- Manually with a swab and cleaning fluid.

Only manual cleaning gets to the entire tape path of rollers, tape guides and heads. Let's look more closely at each cleaning method.

Dry cleaning tape

The only maintenance that Sony recom-

mends is a dry cleaning tape. They say that dirt on the capstan is not much of a problem. Sony does not recommend cleaning the pinch roller and guides unless you are used to doing it. Tape tension is more often a problem, and usually only in new machines.

A dry cleaning tape works by scraping the head drum to remove dust and dirt, trapping it in the tape fibers. To clean your DAT machine, pop in a dry cleaning tape and press Play. Eject the tape after 10 seconds. Because the tape collects dirt, do not rewind or reuse it.

If a high error rate cannot be corrected by a dry-cleaning tape, send the DAT machine to the manufacturer's service department.

How often should you clean the heads? As little as possible, because the dry cleaning tape is abrasive. Use it only when you hear dropouts or when the error rate is too high. To be safe, clean the heads just before taping a live concert or a mixdown.

It is also a good idea to run a redundant machine in critical situations.

"DAT tape doesn't shed as much as analog tape," says Rick Canata of Fostex tech service.

So unless you are in a very dusty environment, he says, cleaning with a dry tape once a month should be enough.

Wet cleaning tape

One wet cleaning tape is the DAT-101 from American Recorder/Intraclean, Simi Valley, Calif., 805-527-9580. It uses a non-alcohol hydrocarbon based liquid that evaporates faster than alcohol.

Fostex does not recommend wet cleaning tape because excessive fluid can damage your DAT machine.

Manual cleaning

Bob Kozlarek of Panasonic tech service says, "Maintenance is more than head cleaning. Get the service manual for your machine and follow its periodic maintenance schedule. Use only an authorized factory service center. You will be rewarded with a smooth-running machine." A VCR repair facility, Bob says, is not equipped to properly service DAT machines.

Manual cleaning is best done by a qualified technician. If you feel comfortable doing it yourself, proceed with caution. Jimmy Yamagishi of Tascam tech support says, "Order the service manual for the particular machine you are using, since they vary." The manual also shows lubrication points.

You will need some foam-tipped swabs and cleaning fluid. Do not use cotton swabs because they can leave lint and can catch on the heads. Rick Canata of Fostex cautions against using chamois-tipped swabs or a chamois cloth because they can shred.

Some common cleaning fluids are denatured alcohol, freon-based chemicals, and halogenated hydrocarbon-based chemicals such as Intraclean S711. Alcohol is said to dry out rubber parts, so use a rubber cleaner on pinch rollers.

Clean everything the tape touches: the guides, rollers, pinch roller, and capstan. Dust and oxide deposits on the capstan can cause mistracking, so it is important to

clean it. Part of the capstan is covered by a half-cylinder, so you can clean only part of the capstan at a time. To expose the other half, turn on the deck, load and unload a tape, and turn off the deck. If you do this a few times, chances are that all sides of the capstan will be exposed for cleaning.

To get at the head drum, you might need to disassemble the tape loading mechanism. Once this is done, moisten the foam swab with cleaning fluid. While holding the swab very gently against the drum, turn the drum in one direction only. This action cleans the drum and each head.

Caution: Keep the swab stationary. Do not move it up or down while it is contacting the drum, or you may break off the head. Neither I nor RW are responsible for damage to your DAT.

Alignment

Does your deck play its own tapes, but does not reliably play tapes from other decks? Most likely, the problem is tape-to-head alignment. You cannot align the heads because they are stationary.

But you can adjust the posts that guide the tape correctly past the rotating heads. Caution: This is recommended only in an

Errors are less probable if you use high-quality tape and keep the heads clean.

emergency as a last resort. Again, we are not responsible for damage to your DAT or DAT tapes.

Because the tape guides are slotted, you can turn them with a small screwdriver to change the path of the tape relative to the heads. Play your problematic tape and adjust the guides until the tape plays OK.

Exercise a blank tape before using it. Fast forward the tape to the end and rewind to the top. This loosens the tape pack so it travels freely, and spreads the tape lubricants more evenly.

Store tapes wound all the way to the head or tail. Store tapes on end. Keep them away from heat and magnetic fields.

Some manufacturers have DAT tech support hotlines:

- Panasonic—The DAT Help Line at 800-524-1448; 800-624-1746 (New Jersey)
- Panasonic Pro Audio, 6550 Katella Avenue, Cypress, Calif. 90630, 714-373-7277;
- Sony—DAT Hotline at 908-SONY-DAT; 908-766-9328.

You can clean the I/O connectors with ProGold conditioning treatment, available from CAIG Labs, 16744 W. Bernardo Drive, San Diego 92127, telephone 800-CAIG-123; fax: 619-451-2799.

Following is a list of some vendors of dry cleaning points:

- The Tape Company (Dallas 800-992-0336; Chicago 800-437-2175; Twin Cities 800-831-3031; Cincinnati 800-437-2125);
- Polyline at 708-390-7744;
- PolyWest at 818-969-8555.
- Total Media Inc. at 800-848-4118.

Thanks to tech support at Tascam, Fostex, Panasonic, and Sony for their help with this article.

□□□

Bruce Bartlett is a microphone engineer and technical writer, and the author of "Practical Recording Techniques" published by Howard Sams. Jenny Bartlett is a technical writer. Bruce can be reached at 219-294-8388.

JOIN THE HUNDREDS WHO HAVE USED DIGILINK TO ACHIEVE ECONOMIC RECOVERY

- ☐ 10 hours of stereo digital audio storage for \$7,995* complete
- ☐ Satellite, CD, Tape, and Hard Disk Automation
- ☐ Simultaneous Play, Record, & Network transfer
- ☐ Digital Editor with Waveform Editing for tight production
- ☐ Crossfade CD's, sources, and hard disk audio
- ☐ Music Scheduling system built in for basic CD automation
- ☐ Digital Networking for transfer of audio and schedules

Digilink is the #1 selling digital audio hard disk system in radio today. You can replace your cart machines for live On Air and have an automation system for walk away at the same time! Link over 15 workstations & scheduling computers on our digital network and transfer audio and schedules between your studios.

For more information, call or write
ARRAKIS,

(303) 224-2248

the premier broadcast manufacturer of
consoles, furniture, Digilink and Trak*Star digital audio products.

Consoles
Modular
Trak*Star
Digilink
Modulink

ARRAKIS

* Suggested retail price. Complete system

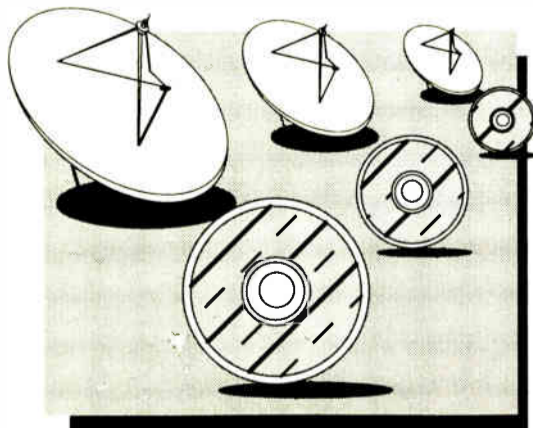

PRODUCT GUIDE

Companies with new product announcements for Studio Sessions Product Guide should send them to Radio World, c/o Studio Sessions Editor, 5827 Columbia Pike, 3rd floor, Falls Church, Va. 22041



Tascam CD-301MKII CD Player

Tascam announces availability of the new CD-301MKII compact disc player for on-air and production room use. Features include balanced/unbalanced analog and S/PDIF digital outputs, 1 bit delta-sigma D/A conversion and an Auto Cue function for on-air use which prevents dead air at the start of program material. Wired and wireless remote controls are optional and a single play feature stops playback at the end of a selection.

For more information, contact Tascam at 213-726-0303 or circle Reader Service 214.

Digitech Studio Vocalist

The DigiTech Studio Vocalist creates high quality vocal harmony, thickening and pitch correction. Six-octave shifting can be achieved without "chipmunking," making the Studio Vocalist ideal for in-house commercial jingle production and specialized voice processing. Features include balanced and 1/4" line/mic input with phantom power, MIDI and digital I/O.

For more information, contact DigiTech

at 801-566-8800, or circle Reader Service 79.

Audix Professional Monitors

Audix Corporation has developed the Mini-Monitor series, the Studio series and the Nile series of high-level monitor speakers. Applications include portable studios (remote vans) to critical production room monitoring. The Nile X monitor uses two 7" Kevlar

woofers, reproduces 40 Hz to 20 kHz and has a power capacity of up to 350 W.

For more information, contact Audix Corporation at 503-692-4426 or circle Reader Service 207.

Roland DM-80 Large Track

Roland's DM-80 DAW is now available in configurations from eight to 32 tracks.

The 24-track version provides 100 layers per track, three professional sampling rates, tape recorder-like operation and can be expanded to hold 72 hours of recording time with standard SCSI drives. Twelve digital inputs and 24 balanced analog inputs are available.

For more information, contact Roland Corp. at 213-685-5141 or circle Reader Service 160.



Soundcraft 10s Console

Soundcraft USA introduces the new Series 10s modular mixing console available in three frame sizes. Separate Audition and Program busses, full logic interface for start/stop machine control and auto muting of the pre-fader Cue circuit. The production version comes with

long throw P&G faders for Prog and Aud master levels and can be configured with the user's choice of modules.

For more information, contact Shannon T. Celia at Soundcraft USA/JBL at 818-895-3426 or circle Reader Service 54.

Analog & Digital A2-D Audio Measurement System

The affordable instrument Designed to meet the challenges of tomorrow's testing needs



Analog & Digital Generator and Analyzer

User friendly front panel

Stand-alone or remote control via RS-232 or IEEE-488

Portable

We set the standard in making audio testing AFFORDABLE

NEUTRIK AG Liechtenstein Tel: 075 / 237 24 24 Fax: 075 / 232 53 93
 NEUTRIK Instrumentation USA / Canada Tel: 0514 344 5220 Fax: 0514 344 5221
 NCV Germany Tel: 0941 98041 Fax: 0941 99 97 72
 NEUTRIK UK Great Britain Tel: 0983 811 441 Fax: 0983 811 433
 NEUTRIK Zürich AG Switzerland Tel: 01 734 0400 Fax: 01 734 3891

CONNECTING THE WORLD

Circle (39) On Reader Service Card

World Radio History

Put Operations Manual on the Net

by Rich Rarey

WASHINGTON Ever gone searching for the "right" information? Spec sheets, glossaries, and price lists squirreled away in file folders, three-ring binders and drawers, all in anticipation that one day you would need to retrieve that priceless artifact?

Did you ever have the need to create and maintain a compendium of knowledge across multiple computer platforms, so that many users could access it in meaningful ways?

We have, and we found a solution in an unlikely place: The World Wide Web.

Glancing back

Let me backtrack to the late 1970s at NPR. Our three studios and master control were each furnished with a thick three-ring binder describing nearly everything a broadcast technician would want to know: telco circuits and phone numbers, length of leader tape for reel duplicator masters, how the landline-based "Round-Robin" NPR broadcast circuits were routed and so on.

Needless to say, some of the binder's contents were always going out of date and there was no single individual designated to maintain the books. They gathered dust and became a historical artifact about how things "used to be done" at NPR.

In the mid 1980s, the master control technical director assumed responsibility for maintaining phone directories and information sheets about existing audio circuits. The book slowly grew, as useful information was inserted; everything from setup and diagnostics of overseas broadcast circuits to operating the Sony Beta (F-1) recording decks for network program re-feed backup.

This three-ringed resource increased in value because any overnight shift technician, regardless of experience, could properly manage the facilities by referring to it. Technicians who felt "rusty" on troubleshooting techniques, who needed to find telco numbers to report trouble or just liked to know how things worked

would refer to the book.

Managers discovered good documentation reduced on-air errors and made technicians more valuable—truly proving that information equals power.

Duplicating info

Unfortunately, maintaining multiple copies was a chore, and it became apparent that the most efficient way to keep technical material timely was to update a single source. But could we maintain effortless distribution with paper?

While we struggled to keep paper-based information current, NPR began expanding its VAX mainframe service and all NPR employees were given a computer account on a VAX mainframe. Digital Equipment Corporation terminals populated the company's headquarters and appeared at NPR's bureaus. After using VAX Help libraries we began experimenting with the creation of our own library to hold a text-only version of the thick three-ring binder.

Master Control Technical Director Norb Gallery authored the first version of the Master Control Help Library, created from plain text files and processed by invoking the VAX Librarian Application. Users could browse the library by entering the arcane command `HELP/LIB=SYSPGM_TP:[MASTER]MCHELP.LHLB`.

This information system worked reasonably well for several years and was easy to update: just rewrite the plain text source then re-compile the library. It was accessible: any NPR staffer could log on from anywhere to search for member station Switched 56 numbers, contact numbers, descriptions of NPR facilities in and out of Washington and other useful information.

Easy to use

It was keystroke-easy to use after a VAX "menu front-end" was implemented (insulating the user from the archaic command line interface). A typical search would begin with: "Do we have a member station in such-and-such town who could record a tape-sync?"

Eventually we came up against the limitations of the format. NPR was evolving from mainframe to desktop computing (PCs and Macs), and the VAX Help format was not translatable. We desired cross-platform accessibility, the facility to easily update text



PUBLIC DOMAIN

without having to re-compile, and we wanted to take advantage of the desktop's look and feel to make the library "friendly." The Microsoft Windows Help file system looked promising but was not compatible with the VAX and Mac file structure. Having a custom Help file system for each of the three platforms would only return us back to the days of multiple three-ring binders.

Almost simultaneously, a rapid rise of all-things-Internet brought World Wide Web viewers into the workplace. Norb Gallery then conceived an ingeniously simple solution: author Help files using HyperText Markup Language (HTML) and files will be virtually universal to any platform with a Web viewer written for

it. HTML files are simple text files that can be authored on a word processor (more elaborate HTML editors can be downloaded from Internet sites as desired). A big plus: graphics, logos, and diagrams can be easily rendered where appropriate, mindful of the text-only terminals VAX users have.

Wider Web scope

In the NPR implementation, the content of the "new" HELP files has been deepened and renamed Audio Engineering Help (AEDHELP) to reflect their wider scope. The files are not actually on the Web, but reside on a protected server accessible by PC and Mac users running Netscape, or by VAX users running Lynx. The Lynx interface is superior to the old VAX Help file system, and encourages users to browse and learn.

As of June 1995, the AEDHELP page contained a list of linkable topics including Public Radio Conference information, a white paper on M-S stereo authored by a colleague, searchable lists of member stations' ISDN numbers, complete descriptions of NPR facilities and their connections to the headquarters, and a glossary; any information technical people need to grab quickly will be put into AEDHELP.

Your station could use these techniques for authoring an electronic "info sheet." Volunteers and staff could refer to a searchable, easily maintained document

continued on page 32 ►

SHORT TAKE

Oktava MK 219 Mic: The Soviet Sound Arrives

by Ty Ford

BALTIMORE The Oktava MK 219 (\$549) shown at the spring NAB by Harris Allied is evidence of the continuing emigration of technology from the former Soviet Union. The first MK 219 to arrive on my doorstep had some circuit problems that resulted in it periodically passing a lot of low-frequency noise and crackles. By the time the second one got here, the first had started to behave.

The MK 219 is a large-diaphragm, cardioid-only condenser microphone. Frequency response is quoted at 40 Hz to 16 kHz, sensitivity at 11mV/Pascal (Pa). Output impedance is rated at 200 ohms.

At a working distance of about four inches, which is how close you have to get before hearing the proximity effect, the MK 219 showed a good 4 dB hotter than my Microtech Gefell M71. Curious, because the specs show the Gefell to be 2 dB more sensitive. The MK 219 uses magnetic reed switches for both the 10 dB pad and high-pass filter. Roll-off is at 50 Hz at a rate of 5 dB/octave set flat. With the high-pass filter on, roll-off starts at 400 Hz, with a 3 dB/octave slope. With a bright preamp—like those found

in the Mackie 1604—the MK 219 can sound "edgy" and a bit brittle.

Again, the application should determine the acceptance. If your radio station uses a lot of gain reduction and mic processing, the "edge" might be helpful in allowing the voices to cut through.

When compared to a Neumann U87 and an AKG 414, the MK 219 sounded more like the U87, but less open. Some might complain about the "lack of air" and "sparkle," but in a live, reflective environment (like lots of glass and hard parallel surfaces) the MK 219 can help by ignoring some of those unwanted high frequencies.

There was a noticeable difference in sound as the mic was moved more than two feet away from the sound source. With the U87 and 414, the distance matched the reduction in level. At a distance of two feet, the MK 219 sounded as though it was across the room.

Actually, on male voice, the MK 219 sounds a lot like a Sennheiser 421 with the EQ adjustment one click off "M" towards "S." If you like the sound of the 421, but have had noise problems while using it close to video or computer monitors, try an MK 219. Thanks to Dave Burns of Harris Allied for supplying the mics.



STATION/STUDIO SERVICES

BUY-OUT MUSIC — \$99

Sixty 60-second music beds for ... \$99
198 :30 & :60 music beds for ... \$198
120 production effects "Zings, Zaps and Zoodads" for \$99
122 New Lasers & Sweepers for ... \$99

For FREE DETAILS on production music, sound effects, call

.....
Ghostwriters (612) 522-6256

READER SERVICE 41

427 SOUND EFFECTS \$89.00

For a 5-CD set with a 30-day money-back guarantee.

Take an extra \$10 off if you mention this ad!

Send \$79 to Ghostwriters
2412 Unity Ave. N., Dept. RW
Minneapolis, MN 55422

For credit card orders call
(612) 522-6256

READER SERVICE 41

ATTENTION PROVIDERS!

Promote your services to **Radio World's** 20,000+ readers. Reach Radio Station and Recording Studio owners/managers and engineers with your message. For information on affordable advertising call **Simone** at **1-800-336-3045**.

The Pro CD Player that can read your playlist.



In broadcast circles, Denon CD Cart™ Players are the machines of choice. Now, broadcasters have an even greater choice—with the DN-951FA CD Cart™ and its Auto Track Select (ATS) system. This intelligent design reads bar-coded carts (easy-to-program ACD-5B cartridges) to lock-in, lock-out or auto-cue to a specific track.

Every Denon broadcast CD player reads Phillips Orange Book CDs. When used in conjunction with CD-R recorders, you no longer tie up your recorder for playback. Instead, record your tracks one at a time, and when your CD is full (99 tracks), write the TOC and archive spots for as little as 15c each!

Most importantly, both the DN-961FA Drawer Loading model and the DN-951FA are from Denon, who for 83 years has been serving the needs of audio professionals and for 21 years has been advancing the art of digital audio.



DN-951FA CD CART PLAYER



DN-961FA DRAWER LOADING CD PLAYER

PRODUCT EVALUATION

Crown Listens, Improves Headset Mic

EDITOR'S NOTE: In the month since this review was written, and after conversations with the factory, Crown has addressed the concerns raised in this article. These will be noted point for point in the text of the review. Rich Rarey and RW note Crown International's acceptance of and swift action on the reviewer's comments and points raised in the following.

by Rich Rarey

WASHINGTON A manufacturer's suggested uses for a product command the reviewer to create fair-use tests just to see if the product will perform as advertised. Frequently a product shines under these tests, but sometimes a product simply does not perform quite as well as expected.

This was the case with two head-worn microphones from Crown International. The CM-311HS and the CM-312HS are cleverly designed to attach to your Sony MDR-7506 or MDR-V6 headphones, making an inexpensive broadcast headset. I found the performance in the CM-312HS somewhat lacking, and the suggested applications for the CM-311HS inappropriate.

Similar construction

The 311 and 312 are constructed similarly; both have a high impact plastic semi-circular ring mount with tabbed

NPR, HTML Store Info

► continued from page 30

with station attributes such as mission statement, format, pledging guidelines and goals... just about anything you would find useful. If your station already has a networked computer system, one way would be to obtain a Web browser application such as Netscape (<http://home.netscape.com/> or 415-528-2555) for each PC or Mac on your network.

You need not have a connection to the Internet to use the Web browser. You can write your HTML files using any word processor, and place the files on your network server. Set up the Web browser to load your main HTML file from your server, and you are in business.

HTML files are text files with commands that tell the Web Browser to display a particular text size, insert a .GIF picture, and so on. Books describing how to write HTML files are in bookstores everywhere. The Internet is also a good place to find HTML documentation.

With more than 70 public radio stations already supporting their own World Wide Web home page, it is clear that the Web is a great medium for public Internet consumption. It is my feeling that this same technology is as valuable for within the station as it is "without."

Until next month, I remain, your ob'd'nt eng'r.

□ □ □

Rich Rarey is the technical director for National Public Radio's "All Things Considered." He can be reached at rrarey@npr.org

grooves that mount around the Sony's forked earcup yoke. The mount slips easily on and off the headphones. A thumbscrew at the bottom of the mount keeps the boom assembly from pitching up and down, and a second thumbscrew on a connecting block restrains side-to-side movement of the boom. The assembly as delivered is to be slipped over the right earcup, but can be transformed to mount to the left earcup in eight easy steps.

A slender, four-foot cable connects the boom assembly to the belt pack electronics, where an XLR connector outputs to your mic preamp. The belt pack contains a 9 V battery (if you are not using phantom power), a battery On/Off switch, and a "cough" button. Overall it weighs just 8 ounces, and the boom weighs in at 1.8 ounces for the CM-312HS, 2.3 ounces for the CM-311HS.

I was disappointed with the belt pack construction for several reasons. Personally, I have come to associate all-metal construction with rugged quality, but the belt pack cover is high impact plastic that screws to a steel shell. Although a 9 V battery is specified to last 134 hours, you may hope you do not have to use it at all; the battery clips are extremely stiff, making it difficult to change batteries.

I pricked my finger and drew blood from the sharp component leads while trying to wiggle the battery into place. The cough button is on the bottom of the belt pack, meaning you push up to activate. If the pack is clipped to your trousers, you have to clamp the top of the pack with your thumb and push up with your pointer finger, else the entire pack

will slip off your trousers. (Crown designers have recognized these problems and are now redesigning the belt-pack.)

In subjective tests, the CM-312HS was connected to a Benchmark preamp, and used the preamp's phantom power. We asked one of the local deep-voice talents



Crown CM312HS shown with Sony headset

to try the headset in a radio studio, a use suggested in the Crown instruction sheet. His voice sounded distinctly pinched as if he were holding his nose. When we adjusted the boom for a more natural sound, the sibilance disappeared, making his voice muffled.

Anchor the boom

We kept hearing scratching noises and realized the boom mic cable is extremely sensitive to motion and touch, so much so that Crown has included a small clip

for anchoring the boom cable.

The talent had difficulty adjusting the boom: when using a boom mic, one's natural inclination is to bend the boom to one's mouth. The rigid steel boom will not bend, and the user is forced to slide the boom forward and back to adjust for comfort and elimination of the plosives.

Adjusting the thumbscrews is awkward, as both the CM311-HS and CM-312HS have some degree of play when mounted on the Sony headphones, and tightening the screws will cause the assembly to slip. The CM-312HS is not forgiving on P-pops and other plosives. Regardless of the manufacturer's instruction sheet to the contrary, we did not have much luck positioning the boom to retain any sort of natural voice quality (Crown has recognized this and has revised the data sheet to include diagrams for proper mic placement.)

Because the Crown manual stated the CM-311HS rejected background noise extremely well and was "well suited for use in traffic-copters, sporting events, or car races," I wanted to test the microphone in that environment. Having already reserved a Cessna 172 fixed-wing airplane for the express purpose of practicing standard flight maneuvers, bringing the CM-311HS along with a DAT recorder seemed like a good incidental exercise. After stabilizing at 1,400 feet I began the recording.

In listening to the playback later, the microphone rejected engine noise well, but suffered from plosives and breath noise. Crown provided a two-stage pop filter that replaces the original, but I still had difficulty placing the boom where "p-pops" would be eliminated. The boom assembly was problematic again, as the boom cable tangles when one's head is turned towards the cable. The result is the boom is lifted above the user's mouth. My concern with the CM-311HS in these high noise situations does not involve the microphone, but rather the headphones. The Sony V-6 headphones are great for normal ambient recording, but are not isolating enough with a prolonged dose

continued on next page ►

It's Sleek.
It's Reliable.
It's Ergonomic.
It's Dead.

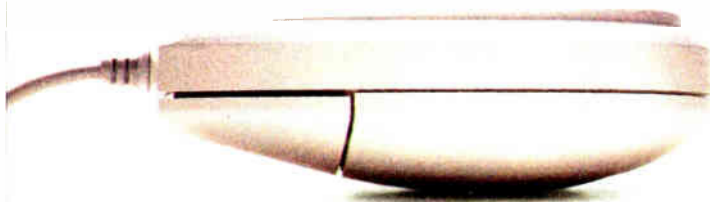

Presenting Foundation 2000RE. The ultimate recording/editing platform, and a darn good mousetrap for just \$10,000. Foundation is the fastest, most intuitive non-linear audio platform on Earth. No cursor. No mouse. Just an amazing array of delightfully direct controls, including a solid brass jog wheel and touch-sensitive screen. Designed for the veteran engineer — yet easily learned by those new to digital —



FOUNDATION

Foundation's joys are revealed the moment you begin using it. For starters, the superb 16-channel

Recording, Mixing Fast on DM800

► continued from page 25

section and listen back without stopping. Each recording can be saved as a different Take. You can then choose among the different Takes for the best ones.

Assume you have chosen Manual Record and have assigned the correct input to the correct track, checked and adjusted the analog input levels and put the desired tracks into Record Ready on the mixer using the Track Status Select buttons. You then hit the Rec button on the transport, which will begin flashing along with the Track Status light. When you are ready to roll, hit Play, and you are recording.

When you hit Stop, the DM-800 prompts you to keep or delete what you have just recorded, and what to name the Take and Phrase. You can enter that information via the built-in alphanumeric keypad or a PC XT/AT keyboard you provide before booting up. The audio you just recorded is stored as a Take on the

hard drive. The Phrase shows on the LCD display as a rectangular box, on whatever track you chose to record it.

You can mess with the Phrase all you want, including deleting it, and the Take remains intact. At any point you can go back to the Take and create a new Phrase to fit in your production. You can also make new Phrases from existing Phrases. Each project can contain as many as 128 Takes per four tracks and a maximum of 300 Phrases per four tracks. Each track can play only one Phrase at a time with a maximum of a one second crossfade. It is a good idea to name your first Phrases and Takes, because subsequent Takes will be similarly named with additive numbers (e.g. voice, voice 1, voice 2).

Location, location...

The dedicated Phrase Locate buttons move you quickly to the beginning or end of a take. The eight Marker buttons can be

used in Stop or on the fly in Play or Record. Although there are only eight buttons, you can "shift1, shift2," etc. to get five pages, each with eight marker points. The Marker buttons also do double-duty with the Shift button to allow quick choice of loop start/end points, punch-in/-out points, internal/SMPTE/MTC time base and Now Time capture.

Editing on the DM-800 is done in the Playlist mode. Editing abilities include Move, Trim in/out, Offset, Relative Move, Phrase edit, Copy, Insert time, Cut/Erase, Split Phrase and Overlap. Different Takes can be used by a selected Phrase. Groups of Phrases can be moved, copied or deleted.

The MIXER mode lets you access the faders, EQ and pan controls and their automation. In addition to dynamic automation of these controls, the DM-800 also does snapshot automation, fader grouping and micro-editing of

automation. The Tempo mode allows tempo maps to be created for MIDI sequencing.

Radio and theater production folks will really like Trigger mode because they can instantly fire sound elements using a MIDI keyboard or keypads 1-8 on the DM-800. Triggered events can be set to play all the way to the end, or as long as the key is held down. The Advance Trigger feature is used to fire successive phrases that you have positioned on a given track. This is Big Fun, but the manual fails to mention that the keyboard and DM-800 need to be on the same MIDI channel.

Compression depression

Although the DM-800 does time compression, pitch change or vari-speed, it has some problems, especially with voice only or voice-over-music. Even 5 percent time compression of a voiceover spot resulted in glitches. Curiously, the sung part of the jingle was unaffected. Compressing a 33-second mono voice track to 30 seconds took 4:12 using the "A" algorithm, 4:27 using the "B" algorithm and 5:09 with the "C" algorithm.

There are a lot of other features and uses of the DM-800, but no room left to write them in this article. Suffice it to say that the DM-800 is the first full-featured system I have seen that delivers so much at its price point. Watch for the DA-400 (\$545) which plugs into the two S/PDIF outputs to give you four extra analog outputs for a total of eight and the DIO-800 (\$900) for direct transfer to and from ADAT and DA-88 machines, eight tracks at a time.

□ □ □

Ty Ford has been known to disappear from time to time when he gets a neat piece of gear to play with. We haven't been able to reach him lately, but you can try. His e-mail address is Tford1010@aol.com.

SHORT TAKE

Beyer Big and Bassy

by Ty Ford

BALTIMORE Two of the most irritating things about headphones are that the cable breaks right at the ear piece and open-air headphones leak into mics, causing feedback when they are cranked up.

The Beyer DT 150 (\$179) addresses both problems with logical solutions. First, the cable attaches to the headphones with a sturdy six-pin plug. A small threaded bolt runs through the connector on the end of the cable and fastens into the backplate of the headphone cup. When the cord does wear out or break, it will probably take longer to remember where you put the replacement cord than it will to change it.

The closed-cup design reduces the possibility of on-mic feedback. The DT 150 is a relatively sensitive set of phones; 97 dB (1 Pascal) at 1 kHz. This makes them louder than most of the AKG 141 and 240 series phones, but not as loud as the Sony MDR series, for the same level of input. If you have a headphone amp that does not have the guts to drive your AKGs without hemorrhaging, the DT 150 is worth a listen.

Output impedance is 250 ohms and frequency response is 5 Hz-30 kHz. Without the cord it weighs a little over half a pound. The cushioned ear cups are easily replaceable and very comfortable, and the cushioned headband is removable as well.

I was surprised by the bass response on these phones. With some phones I have tried, the bass just makes it difficult for me to hear my own voice properly when doing voiceovers. The DT 150 has a great bottom that never gets in the way. The bottom line is, they are comfortable, loud and easy to fix.



Beyer DT 150 headphones

audio quality is perfect for broadcast promos, spot productions and shows of any length. Rugged Fostex hardware coupled with the most bulletproof software in the industry ensure each job gets done simply, quickly, and reliably. At \$10,000 it completely trans-

forms the price/performance equation for

digital audio workstations. Manufactured

in the U.S.A., the 2000RE is

backed by a worldwide

service and support

network. Why not build

your next project on a solid

Foundation? Call 1-800-7-FOSTEX for a demo or free video tape.

Discover for yourself what makes the Foundation 2000RE such a killer system.



One wheel everyone can get behind.

Grab hold of the solid brass jog wheel and feel the track. Foundation's unsurpassed audio scrubbing resolution sounds and feels like magnetic analog, so you'll park at exactly the right point—without circling the block.



The ultimate screen test.

Simply use your finger to select a waveform, edit envelopes, library information, and much more while you're recording or playing back. Foundation even lets you output your display to any video monitor.



The keys to your success.

Don't wait, do it now. Ergonomic controls unlock your creative power. Lighted transport and track ready buttons are right there. Dedicated editing buttons give you fast single stroke cut, paste, fade and trim functions.



Our Removable Project Environment puts everything in the palm of your hand.

Foundation's removable disk system stores all audio, edit, mix and project data. In a matter of seconds your work is loaded with total recall and you're on-line, ready to go.

Fostex Corporation of America, 1543 Blackburn Avenue, Newark, California 94661, U.S.A. Telephone: 415-921-1112 Fax: 415-802-1864

Improved Crown Mic

► continued from previous page

of engine roar.

The playback sound was of someone who could not quite hear himself over the engine, even though the headphone levels were adequate during recording. Crown must have realized the headphone's limitations too, because they make a boom mount available by special order, for the popular David Clark aviation headset which has more noise isolation. (*Crown's revised data sheet for the CM-311HS mentions the availability of the David Clark attachments.*)

In summary, I had a difficult time positioning both the CM-311HS and CM-312HS microphones against plosives, and concerns about having to "dress" the mic cable so it would not rustle against clothing. The revised data sheets coming from Crown recommend clipping the cable right to your clothing to minimize handling noise, and will also include diagrams describing proper mic placement.

As tested, these products are attractively priced for "off-air" uses; communication systems, computer workstation microphones, telephone attendant duties, live performing, etc.

□ □ □

To find out more, contact Crown International at 219-294-8000.

FEED LINE

Age, Environment Can Affect AM Arrays

by W.C. Alexander

DALLAS There are an awful lot of directional antenna systems currently operating that were built 50 or more years ago. These arrays were constructed using what was then "good engineering practice" and state-of-the-art technology. Some of them—many perhaps—sounded quite good and worked very well. Many others, however, while they may have once sounded and worked well, do not anymore.

Aging of components and environmental changes have altered the performance of these old arrays. The station may not sound very good because of bandwidth problems and mismatches, both at the common point and at other points in the array.

Another problem experienced at many stations operating old directional arrays comes when an old tube-type transmitter is replaced with a new, solid state unit. Perhaps the idea of a new transmitter was sold to the station owner as a means to improve the station's sound, coverage, reliability and efficiency.

Surprising moment

The surprise comes when the new transmitter will not operate properly into the load presented by the antenna system. I have seen arrays where modulation had to be reduced to prevent a solid state transmitter from kicking off due to VSWR on modulation peaks!

In these cases, sometimes a tune up of

the existing directional array is needed to get rid of mismatches, improve bandwidth and reduce losses. If the system is in really good shape, perhaps you can get away with tuning up what is already there. More often, however, tarnished inductors, frozen controls, inoperative turn counters and components of incorrect value make replacement of the entire phasing and coupling system more practical (and perhaps more economical) than working with the existing system.

Back in the days before the operating impedance bridge (OIB), driving point impedances were difficult to measure. Static measurements with a standard, low-level bridge did not give anything close to an accurate picture. Prediction

methods were such that great latitude had to be allowed in the design of phasing and coupling systems so that the correct pattern could be achieved with the actual hardware installed in the field. *Exempli gratia*, to allow for an unknown reactance at a tower's driving point, components would be chosen to allow a range of adjustment from, say, 100 ohms negative to 100 ohms positive. The resulting L-C combination often formed a high-Q circuit that limited bandwidth at that point. Multiply this by the number of elements in the array and you can see why a lot of old arrays tend to sound bad.

Today, we have at our disposal the cumulative knowledge, wisdom and experience of 60-plus years of directional antenna design and construction. We also have some scientific tools in the form of computer models, accurate prediction methods and excellent test equipment. We can design a system just knowing about what the behavior of each element in the system will be—even re-radiators! Modern designs, taking all the known factors into account, can provide an optimized bandwidth at each element and at the common point.

System Design

In updating an old array, it is first necessary to know the characteristics of the transmission lines in the system. Even in very old arrays, often the transmission lines have been replaced with modern coaxial lines. A designer will need to know the length, characteristic impedance and velocity factor of each line in the system. If these are existing lines, it can probably be assumed that the power handling capability of the lines are adequate. It would not hurt to reevaluate this at design time, however. A burned out transmission line can ruin your whole day. In systems with older lines, such as open six- or three-wire or even 65-ohm "water pipe" lines, it would pay to go ahead and replace the lines with modern coaxial cable.

(In a recent installment of *Feed Line*—RW, Aug. 24, 1994—I examined the principles of selecting the right transmission line for the job. I will not revisit those here, but those considering replacement of transmission lines would do well to dust off that issue or any of the texts written on the subject before placing any orders).

The next step in the design process is to find the operating parameters and characteristics of the array. These include not only the array geometry and theoretical parameters but also the mutual coupling between elements, driving point impedances and the like. Some of this information can be found on the station license; the rest has to come through actual measurements or through careful modeling of the array. Having the measured driving point impedances on hand is a real plus, both at design time and later, during troubleshooting.

Measure impedance

To measure the driving point impedances, insert the OIB between the output of the antenna tuning unit (ATU) and the array element, fire up the array at a power level that will not exceed the rating of the OIB, then tune the array to compensate for the insertion effect of the bridge. When the antenna monitor again reads at the licensed values, read the driving point resistance and reactance on the OIB. If

continued on page 47 ▶

What is DaX?

DaX
Digital Audio Xpress

CD-Quality Audio
Packaged copy, bits, program logs, local options, playlists in flexible format for seamless rejoins and accurate time checks.

Graphics
Send pictures to affiliates to enhance on-air descriptions of products, features and events.

News, Wire Feeds and E-Mail
Instantly update news. Send announcer cues, intros, outros, latest artist trivia, Billboard rank.

- Localize National Shows
- Deliver Targeted Commercials Instantly
- Delayed Broadcasts
- No Transcoding
- Update Breaking news
- Remote Live Assist or Automation
- Affidavit services for rapid billing/cash flow cycles
- Works with Satellite, ISDN, Switched 56 or Phone Lines
- Audio Waveform Editing, Text Editing and Graphics Available

Think of it as an audio fax machine!

An audio fax machine so powerful it can deliver CD-quality radio programming, music, news, commercials, or production instantly to individual stations, regions or the entire country. The basic DaX™ PC platform comes with information storage capability greater than 6 CD-ROMs and is expandable to greater than 100. A proven winner in the field for over a year, the DaX™ is the only store and forward system that's already operating successfully in the real world. The first and still the best.

(800) GO VIRTEX



CaliforniaDigital is now... VirteX

Virtual Express Communications, L.L.C.

Digital Audio Systems
California Digital Audio Systems, Inc.
P.O. Box 120
Moorpark, CA 93020
(805) 523-2310 Tel
(805) 523-0480 Fax

©1995 Virtual Express Communications, L.L.C.
Patents, copyrights and trademarks applied for

..... Math *for* Going DIGITAL

 +
  +
  = *Cart Replacement*
 MSRP \$1299 MSRP \$795

 +
  +
  = **AUTOMATION**
 MSRP \$1495

 +
 SAW +
  = **production**
 MSRP \$699 MSRP \$795

Go *completely* DIGITAL the *easy* way
 with software from **WireReady® NSI!**

Simple Cart Replacement:

- Buy a 386/486/Pentium computer with at least 4MB RAM and a 500MB drive.
- Install a CardD Plus digital audio card
- Load CartReady software from WireReady® NSI.
 - Great for Live-Assist and News
 - No more bulk erasing and waiting for recues.
 - Store up to 5000 different audio cuts on the hard-drive.
 - Multi-deck screens for back-to-back playing.
 - Automatic rotations of commercials, liners, IDs and promos.



- Accepts imports from ASCII compatible traffic logs
- Add wire services with WireReady® software
- Add news and copy with NewsReady™ software
- Do phone-bits, wraps and long-form programs with Reel-to-ReelReady™ software
- Group software licenses available

Simple Satellite/Talk Radio Automation:

- Load ControlReady™ software on top of any CartReady system.
- Connect a Broadcast Tools USN1616 universal input/relay controller
- Great for walk-away and live assist.
- Build a completely modular system with the following tools:

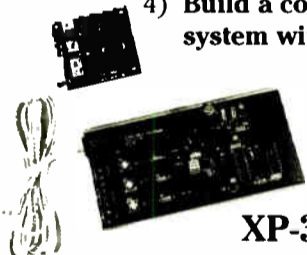

XP-3 \$299 MSRP

Satellite Transponder Controller

The XP-3 provides automated transponder selection for Scientific Atlanta, Comtech/Fairchild and Ariel Receivers. Control via USN1616 and computer running ControlReady.

SCC-8 \$299 MSRP

Satellite Channel Controller

The SCC-8 provides automated channel selection for DAT-SEDAT digital audio decoder cards installed in Scientific Atlanta, Comtech/Fairchild and Ariel Receivers. Control is via RS-232 or UNS1616 connection to computer running ControlReady and CartReady.



6X1A \$399 MSRP

Passive Stereo Switcher/Router

The 6X1A is a six input stereo switcher/router which can select up to six mono/stereo balanced inputs to one stereo output. front panel switches with LEDs provide interlocked source selection and status. Automatic control by ControlReady or operate manually. Optional rack shelf (RM-1) or mount on desktop.



Call for package pricing and a complete catalog.



Main Sales Office

2342 S. Division Ave.
 Grand Rapids, Michigan 49507
 Phone: 800-999-9281
 Fax: 616-452-1652



Southeastern Sales Office

200 Fairway Drive, Suite 2
 Smithfield, North Carolina 27577
 Phone: 800-369-7623
 Fax: 919-934-8120



Western Sales Office

P.O. Box 1638
 Palmdale, California 93550
 Phone: 800-858-9008
 Fax: 805-273-3321

Products & Services Showcase

For more information on the products shown below, circle the appropriate Reader Service No.(s) on the enclosed Subscription/Reader Service card or contact the advertiser directly.



STATI-CAT

makes
Lightning Prevention
Easy!

Cortana
Corporation

Write to us today for a **FREE** brochure!

P.O. Box 2548, Farmington, NM 87499
Call (505) 325-5336
FAX (505) 326-2337

READER SERVICE NO. 53

THE FINEST STUDIO SYSTEMS IN THE BROADCAST BUSINESS



Audio Broadcast Group Inc.
Studio Furniture & Prewired Systems

Your studio environment specialists for the last 35 years.

We Are The Industry Standard.

For additional information on how we can serve you, please call today.

SOUTHEASTERN SALES OFFICE 200 Fareway Drive, Suite 2
Smithfield, North Carolina 27577
Phone: 800-369-7623
Fax: 919-934-8120

MAIN SALES OFFICE 2342 S. Division Avenue
Grand Rapids, Michigan 49507
Phone: 800-999-9281
Fax: 616-452-1652

WESTERN SALES OFFICE P.O. Box 1638
Palmdale, California 93550
Phone: 800-858-9008
Fax: 805-273-3321

For 35 years



YOU MAY ALSO REACH US ANYTIME VIA ELECTRONIC MAIL
cServe: 75371.144
internet: support@abg.com

READER SERVICE NO. 49

The Headphone Amp that Can ...



- Please your talent with plenty of power
- Mount easily at talent station
- Drive high or low impedance phones

The low distortion HSA-100 Headphone Amplifier mounts easily with four mounting holes in its heavy-duty steel front panel. It runs on a ± 15 to 18 volt power supply. Its discrete transistor output can drive impedances as low as 16 ohms! Input level is jumper selectable from -10 to +8 dBm. Ideal for custom applications — call or fax for details.

* Power pack included (not pictured)

bdi Broadcast Devices, Inc.
5 Crestview Avenue
Peekskill, NY 10566

Tel: (914) 737-5032 Fax: (914) 736-6916

READER SERVICE NO. 138



Econco

REBUILT POWER TUBES



Approximately One Half
the Cost of New

3,000 Hour Unconditional Guarantee

Call for Our Price List

Econco 1318 Commerce Ave Woodland, CA 95695
Phone: 916-662-7553 Fax: 916-666-7760 Telex: 176756
Toll Free: 800-532-6626 From Canada: 800-848-8841

READER SERVICE NO. 184

WEATHER RADIO

Model CRW



Price \$540.00

Sensitivity .28 microvolts for 12 dB quieting. All 3 frequencies. Alert tone demutes receiver, closes relay and gates audio to 600 ohm rear terminals. Another set of rear terminals has continuous 600 ohm audio output. Double conversion crystal controlled, crystal filter in first I.F., ceramic filter in second I.F. Dual gate MOS FET front end. 50 ohm coaxial input. Adjacent channel (j25 kHz) down to 70 dB. 19" rack mount, 3 1/2" H, all metal enclosure. In stock—available for immediate delivery.

GORMAN REDLICH MFG. CO
257 W. Union St. • Athens, Ohio 45701
Phone 614-593-3150 • FAX 614-592-3898

READER SERVICE NO. 55

FREE SHIPPING*

FOR OUR COAX SWITCH FAMILY

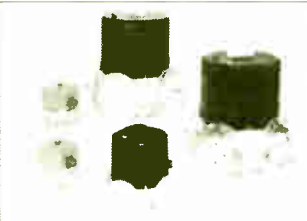

WHY SWITCH TO MCI?

- QUALITY - PRICE - 7/8" - \$2,450
- DELIVERY - 1 5/8" - \$2,800
- RELIABILITY - 3 1/8" - \$3,600
- PERFORMANCE - 4 1/16" - \$5,000
- BROADBAND - 6 1/8" - \$6,200
- COMPACT SIZE

Control Panel also available upon request.
*Continental USA regular ground service only

For More Information Call:
MICRO COMMUNICATIONS, INC.
P.O. Box 4365 • Manchester, NH 03108-4365
Toll Free: 1-800-545-0608 • Fax: 603-624-4822

READER SERVICE NO. 12

AXS (Ax'-sess)... Jocks Love It!

AXS is an entirely new approach to digital audio controllers. It starts with superb audio using the premium quality apt-X™ system. AXS is easy to learn, easy to use, and powerful beyond words.

AXS is a modular design that begins as a simple cart replacement and grows to any combination of CD, hard disk, satellite or specialty programming with ease.

AXS has all the sophisticated feature options including device independent multi-channel background audio record and replay. Macro programming makes tough to run event sequences easy. Software drives a powerful programmable real time IOMAP.

Jocks love AXS: A fast 99 page, 28 button Jock F/X panel that can be time linked and remote wired is standard.

Use a software driven four-channel stereo audio switcher with on-screen control or the powerful eight-channel dual-buss routing switcher, or include both if you wish. AXS is controlled through a trackball, touchscreen, keyboard, buttonbox, telco or remote modem.

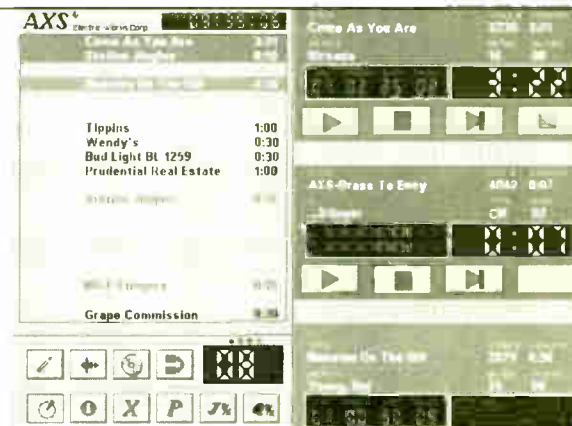

AXS Systems...

From \$6000.00 using your 486 computers and hard disks.

AXS
The Management
800-334-7823 • 817-625-9761
FAX 817-624-9741
P.O. Box 1-36457 Fort Worth, TX 76136
1700+ Stations • Our 14th Year

READER SERVICE NO. 166

Ireland Debates Commercial Radio

► continued from page 16

can be delivered because of the high costs associated with quality speech programming, he said.

Modern communications media give advertisers an opportunity to market their product or service, he added. Advertising and marketing strategies are important for all concerned. But seeing a local radio service as primarily a marketing tool is not realizing the full potential of the medium.

It also is a tool for democracy. In a unique way, the real potential of a local radio service depends on its interaction with the community. It is not only a delivery system but also a carrier for a sophisticated mix of music and marketing messages. That may indeed be a valid and entertaining use of the medium for many listeners, but it has the power and potential to do that and much more.

Collins explained that the human voice is central to the medium of radio. The interplay between voice and locale, origins and directions is the pulse of real local radio.

Local radio reaches deep into the heart of a community and monitors its heartbeat in times both happy and sad. This process, helping a community or region express its voice with confidence, must be of value.

Such a programming policy is clearly at the heart of public service broadcasting. It implies a commitment to the needs of the community and involves devising programs that respond to those needs and aspirations.

The popularity enjoyed by most local radio stations in Ireland, which include a significant level of public service broadcasting in their program schedules, indicates the real demand for this kind of broadcasting, Collins said.

It needs to be done well to be effective and this adds enormously to the cost of running a radio station. Much of the quality broadcasting on local radio is done of the goodwill of individuals, rather than with structures that are adequately resourced. Where a real commitment to quality programming has been demonstrated, it should be supported and encouraged, with public funding made available for clearly defined program objectives.

There is a complementarity between the national radio service provided by the state broadcaster Radio Telefís Éireann (RTÉ) and the local radio service.

However, when we compare the resources available to RTÉ radio and the resources available to Radio Kerry we are struck by the imbalance and the disparity as well.

As someone who has spent many years producing and presenting radio programs in both broadcast services, Collins explained that the immersion in the local broadcast setting after years in the national broadcast service was a shock to the system.

No amount of commitments and enthusiasm prepares one for the reality of sink or swim, he added.

If radio listeners get into the debate and make demands to have their broadcasting needs and interests addressed, he said this broadcasting debate could spark into a lively flame.

Mary Ruddy, station manager, Connemara West Community Radio, and a member of the IRTC board: Community radio is at a disadvantage Ruddy argued because it is a late arrival in the relatively new seven-year independent broadcasting regime in Ireland.

Ruddy said community radio must find a niche and an audience long after the commercial sector already was established. This does provide a long-awaited opportunity

and challenge for the new stations now being licensed, she added. Community radio should not accept a definition of being marginal or confine itself to operating only where it is otherwise commercially unattractive for other operators. It is a sector with a different role or function and has a contribution to make to the debate in the public sphere.

She said that where the character of community radio was different was the notion of access and participation, where listeners, if they abide by general broadcast principles and undergo some training can also make programs.

It has been the experience elsewhere that

those who have the confidence to do this are generally already active, middle-class and articulate.

The challenge for the new stations was going to be to find a way to ensure that those who feel otherwise alienated or marginalized will feel that they can also participate.

As small enterprises, community radio stations are very vulnerable to economic and regulatory changes and therefore need support.

Ruddy recalled the mantra of community radio around the world: Radio should be converted from a distribution system to a communications system.

Radio can be the most wonderful communications system imaginable—a gigantic system of channels, she said. Can be, that is, if it were not only capable of transmitting but of receiving; of making the listener not only hear, but also speak. ☺

Historically, broadcasting played a vital role in contributing to education, culture and the arts.

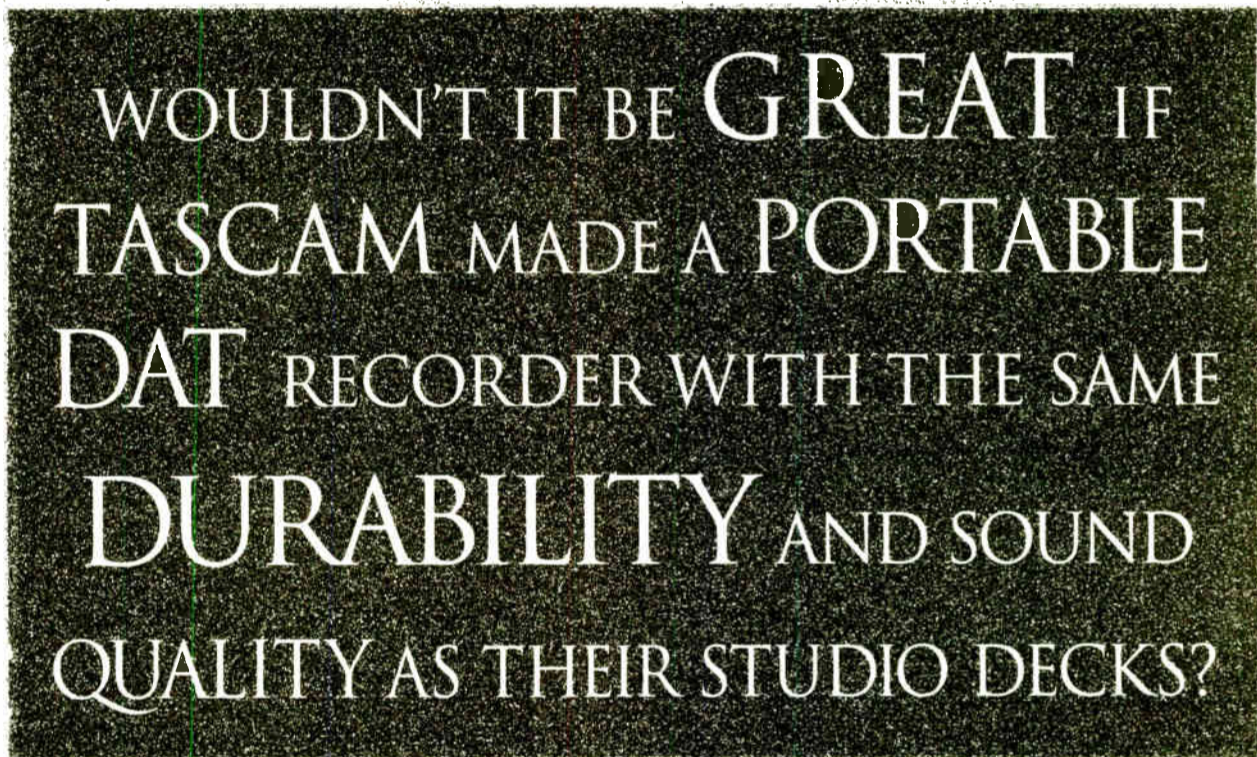

It's here. The TASCAM DA-PI. The ideal portable DAT for field recording in broadcast applications.

You need a durable and high-quality DAT recorder for your team to take into the field. You'll get higher quality digital audio, plus be able to dump it to a digital audio workstation for quick and easy editing. That's why TASCAM makes the DA-PI. It has the features demanded by broadcast professionals. Things like XLR-type MIC/LINE inputs with phantom power so you can use a wide range of microphones and input devices. A 20dB pad, and a versatile, easy-to-read display. But field reporters and production personnel will love the DA-PI's extended life 2-hour battery that recharges in just 1 1/2 hours.



If you can get the DA-PI back from your field personnel, you'll find it performs outstanding in the studio, too.



With a built-in SPDIF direct digital I/O, it integrates with DAWs, and other digital gear. Also, it supports multiple sample rates (48, 44.1 and 32 kHz) and utilizes next-generation A/D and D/A converters delivering studio-DAT quality sound.

Standard accessories include a shoulder belt, AC adapter and battery — carrying case optional.

So if you're torn between a new recorder for the field, or a DAT for the "B" suite, think no more. Pick up a DA-PI. You get the best of both worlds. In fact, once you get your hands on a

DA-PI, you may want to buy two. So get to your dealer today and order your new portable DAT from TASCAM.

TASCAM
Take advantage of our experience

MSRP \$1,899. For complete specs and information via TASCAM FaxBack, call 800-327-2268 document #2150. © 1995 TEAC America, Inc. 7733 Telegraph Road, Montebello, CA 90640. 213/726-0303. TEAC CANADA LTD. 340 Brunel Road, Mississauga, Ontario L4Z 2C2 Canada (905) 890-8008.



Products & Services Showcase

For more information on the products shown below, circle the appropriate Reader Service No.(s) on the enclosed Subscription/Reader Service card or contact the advertiser directly.

AUTO-ANSWER TELEPHONE COUPLER

Ideal for unattended situations such as listen lines, IFB feeds, dial-up networks, remote transmitter sites & satellite links.

- Clean connection to phone line
- Easy to install
- Send or receive program
- F.C.C. registered



COMREX®

Comrex Corp., 65 Nonset Path, Acton, MA 01720
Tel: 1-800-237-1776 Fax: 508 635-0401

READER SERVICE NO. 9



Why gamble on a lower-priced rebuilt?

Have your Eimac tube **REMANUFACTURED** by the trusted original manufacturer.

- Original Specifications
- Original Warranty
- 30 Day Turnaround

Call us: **VARIAN - EIMAC**
301 Industrial Way,
San Carlos, CA 94070
(800) 414-8823 or
fax (415) 592-9988



varian®
power grid tube products

READER SERVICE NO. 37



TELESCOPING MAST
for fast and easy deployment
of lightweight antennas

- Manually deployed with quick lock/release collars in one minute or less
- 25' extended height
- 6' retracted height
- 20 lb. top load capacity
- Rigid azimuth locking
- Over 50 mph wind speed capacity
- Free standing
- Universal vehicle mounting stand included
- Portable - 20 lbs
- High strength anodized aluminum construction
- Ideal for lightweight antennas
- Designed and built by the leading manufacturer of pneumatic telescoping masts.



W3
WILL BURT
P.O. Box 900
Orville, Ohio 44667-0900
Phone 216-682-7015
FAX 216-684-1190

READER SERVICE NO. 59

TWO NEW ADDITIONS TO THE COAXIAL DYNAMICS WATTCHEMAN® TRANSMITTER PROTECTION SYSTEMS

Models 81081 and 81082 with 15/30/60 kw Meter Scales



NEW!
4-1/16 and 6-1/8
series line sections
and elements to
add to our exciting
line-up

WATTCHEMAN—protects your transmitter and transmission line system. A permanent 19 inch rack installation used with any dual socket line section 7/8", 1-5/8", 3-1/8" and elements (additional) to monitor CW, TV, and FM power. Model 81070 features two easily read meters to monitor both forward and reflected power. The reflected meter provides a front panel adjustable set point which controls the trip level for fast transmitter shut down and alarm. Abnormal load conditions quickly cause transmitter shut down in less than 15 milliseconds including control relay. Both visual and audible alarms indicate system malfunction. Contacts provided for remote alarm and reset switching. Contact us for your nearest authorized Coaxial Dynamics Representative or Distributor in our World Wide Sales Network.



COAXIAL DYNAMICS, INC.

15210 Industrial Parkway • Cleveland, Ohio 44135
(216) 267-2233 or 1-800-COAXIAL • Fax: (216) 267-3142
Service and Dependability... A Part of Every Product

READER SERVICE NO. 205

The best compact way to squeeze a great sound through a telephone line...

Zercom CORPORATION

You don't have to settle for less than the best!



The 'Max-ZII' 2 channel remote console

P.O. Box 84, Zercom Drive
Merrifield, Minnesota 56465-0084
218/765-3151 - Fax 218/765-3900

Available through all major dealers

READER SERVICE NO. 213

The MicMan™ Jr. - A 2 Channel Preamp



The MicMan™ Jr. Portable Mic Preamp

- 1 dB noise figure
- Gain range +26 to +82 dB
- 0.001% THD @ 1 kHz, @ A=40 dB

- 160 kHz bandwidth for transparent sound
- Fixed, (external PS-1), or portable use
- Uses standard alkaline batteries
- +12 or +48 V phantom microphone power
- Great value-\$425 with external power supply!

Benchmark
...the measure of excellence!

BENCHMARK MEDIA SYSTEMS, INC.
Phone 800-262-4675, FAX 315-437-8119

READER SERVICE NO. 203

FM PROCESSING BREAKTHROUGH!

Now You Can Be Dominant and Sound Great at the Same Time



MicCon's answer to the breakthrough FM composite processing. Move up to the top of the FM game. The FM FlexiMod will control your station's dominant, dynamic new sound.

The FM FlexiMod is the combination of ten years of research and aggressive composite processing. Its new approach to loudness control without distortion will revolutionize the sound of your station.

The FlexiMod will add sparkle and body to over-processed, multi-generation audio, and enhance all program material for consistent, dominant on-air sound.

The secret behind the breakthrough

performance of the FM FlexiMod is our proprietary limiter circuit. The FM FlexiMod will control your station's dominant, dynamic new sound.

Loudness without grunge!
The FM FlexiMod is the only limiter for you will need to guarantee dynamic presence in the dial. It will mean up your sound and increase your loudness by at least 3db!

- FlexiMod. Already over-achieving in major markets nationwide.
- Only \$1395.
- Available direct from MicroCon Systems or from selected dealers.
- 30 day no-risk on-air trial.

For further information contact:

Jim Somich at MicroCon Systems Ltd. (216) 546-0967

READER SERVICE NO. 56

OFFBEAT RADIO

Cybernet Station Operates Two Channels

An Estimated Quarter of a Million Listeners in 140 Countries Tune in to Station on Regular Basis

by Dee McVicker

WASHINGTON Stay tuned to your local... cyberstation? It is true. Non-profit organization Internet Multicasting Service in Washington is "cybercasting" from the world's largest electronic watering hole, the Internet, and people are listening.

"We are estimating a quarter of a million listeners at this point on a regular basis," said Carl Malamud, a veteran Internet innovator who saw the need for researching radio on the Net and formed the cyberstation on that basis several years ago. The multimedia service went on the "air" April 1, 1993, billing itself as the first radio station to reach out across cyberspace to the Net's now estimated 30 million people in 140 countries.

Two service channels

The Internet Multicasting Service received its initial funding, in both money and equipment, from Sun Microsystems and O'Reilly & Associates. Continuing support is provided by a variety of institutions and it is now operating two service channels on the Internet, referred to as Internet Talk Radio and Internet Town Hall.

Although just about anyone with a multimedia or equivalent personal computer can access the cyberstation and download many of its audio files, listening to programs live requires a computer network capable of accepting 64 kilobits per second (kbps), the sound quality of ISDN. Standard Pulse Code Modulation (PCM) sound format is used—8,000 samples per second—with each sample being 8 bits. An hour of programming is 30MB and the organization typically publishes between 30 to 90 minutes of programming per day.

Recently, the cyberstation began supporting RealAudio! software that delivers real-time audio over the Net (see RW, May 31). On-demand retrieval of the cyberstation's audio files for playback is selectable at 14MB, 2.9MB, or 1.8MB.

Not FCC licensed

Like others on the Net, the cyberstation is not regulated by the Federal Communications Commission (FCC). The station licenses most of its material. Its carriage rights include satellite-based programming such as a 24-hour live data stream of audio from World Radio Network, network-based programming such as SoundBytes, and live links into the United States Congress. Speeches on the floor of the House and Senate are recorded by Internet Multicasting Service, indexed for search and find cues and made available in the form of audio files to users who want to hear the proceedings on their computers. Currently,

the organization is hard at work developing voice recognition software to distinguish floor speakers from each other by identifying idiosyncracies in each speaker's digital "voice print."

The cyberstation pipes in public broadcast programs Technation, Dialogue and Common Ground. Its more recent addi-

The response to the cyberstation has been overwhelmingly positive, an indication that there is a great need for more cyberstations on the Internet.

tion is the HarperAudio! program, featuring recordings from the arts with luminaries such as T.S. Eliot, Robert Frost, J.R.R. Tolkien and Ernest Hemingway reading their own works.

It has its own booth in the National Press Club, joining C-SPAN and National Public Radio as official licensees for the club's Luncheon series, which has aired distinguished speakers such as Bob Dole, Larry King and Yassir Arafat. The cyberstation was the first to

link up National Public Radio's Talk of the Nation/ Science Friday to the Internet for an hour of live national radio.

"We would like to do real talk radio sometime," commented Malamud, who said a limited staff makes this difficult programming to bring on line. Still, he added, "Real-time, full duplex voice is hard to do on the Net,

and there are so many other things you can do."

Radio geeks

Of the original productions that the cyberstation does, its most popular is "Geek of the Week," a 30-minute program interview of computer nerds. This program, which has wound up on a few radio receivers as rebroadcasts from college stations, has an old-time radio feel complete with campy theme song and Larry King-style interviews.

Then too, last winter the organization carried a virtual Santa Claus who could be reached on line and answered e-mail messages from around the world. Some 1.2 million Net visitors "visited" with Santa in 30 days, clicking onto a winter wonderland complete with Santa's elves. Net surfers were even able to stop at the North Pole for a while to listen to a few Christmas song originals.

"We're not just radio on the Net," clarified Malamud. "This is a multiprotocol, multidata, multimedia thing and so we use audio and video and images and text,

and we make it available using anything from downloading from CD to live for whatever is on your desk." Nor is Internet Multicasting Service limited to audio and video data. Given a grant from the National Science Foundation, the organization posts for free access on the Internet the full text of all 1994 U.S. Patent and SEC documents.

"I feel very strongly that this is a whole new medium, and after two years of doing this we have learned that very

rights, they are going to be selling one set of radio rights, another set of television rights, and a third set of Internet rights."

Overall, the response to the cyberstation has been overwhelmingly positive, an indication to Malamud that there is a great need for more cyberstations on the Internet. Cable companies, telephone companies and others are all rushing to provide Internet connection to home users, while fiber-optic is becoming the high-speed byway, making the Internet ripe for other cyberstations. The Internet continues to grow at a rate of 15 to 20 percent per month, by some estimations.

Said Malamud, "I think it is important that there be additional groups like ours, and we have been encouraging others to do that. One reason I took it non-profit is because, as the first station of its kind, we would have more flexibility to break new ground." Which the Internet Multicasting Service has most definitely done.

To learn more about Internet Multicasting Service, send electronic mail to info@radio.com.

□ □ □

Dee McVicker is a regular contributor to RW and can be reached at 602-545-7363.

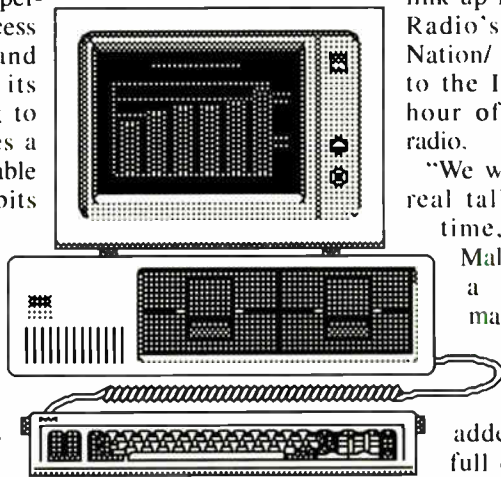

Expanded repair service. Dart 384 loaners at no extra charge.

With the acquisition of the Fairchild Dart 384 Repair Division, Satellite Systems is once again expanding. Our engineering department has grown. As we continue to grow, we stay committed to our special and personal style service. Case in point—there is no charge on loaners for Fairchild Dart 384 equipment in for repair.

Rich Bryan, former Program Director of Adult Rock & Roll format for Westwood One, has come on board as a full-time Broadcast Consultant! Call us for details.

SATELLITE SYSTEMS



Satellite Equipment for Radio

615 East Brookside
Colorado Springs, CO

80906

Ph: (719) 634-6319

Fx: (719) 635-8151

Circle (91) On Reader Service Card

WORKBENCH

Restored Ammeters Go Easy on Budget

by John Bisset

SPRINGFIELD, Va. Storage space at a transmitter site is always at a premium. That is why the scheme in the photo is so useful. Spare rigid line must be properly supported when stored. Line left to lie on its flanges can warp or bend, get kicked or dented. This ceiling storage system was easily prepared using a few pieces of Kindorf and some readily available conduit clamps.

The Kindorf provides enough spacing from the ceiling, so the flange does not touch, and the individual conduit clamps prevent the whole stack of line from coming down. Thanks to Chip Fetrow of Skyline Antenna Management for sharing this idea.

★ ★ ★

Ed Burkhardt of Burkhardt Monitoring sent us a card describing a free quarterly newsletter from Polyphaser. The newsletter is called "Striking News" and discusses lightning protection. Polyphaser products are available from Bernie O'Brien of S.C.M.S. For more information, contact Bernie at 800-874-7267. Polyphaser can be reached by circling Reader Service 71.

★ ★ ★
If you can find a dead analog clamp-on Ammeter, it is feasible to modify it to use

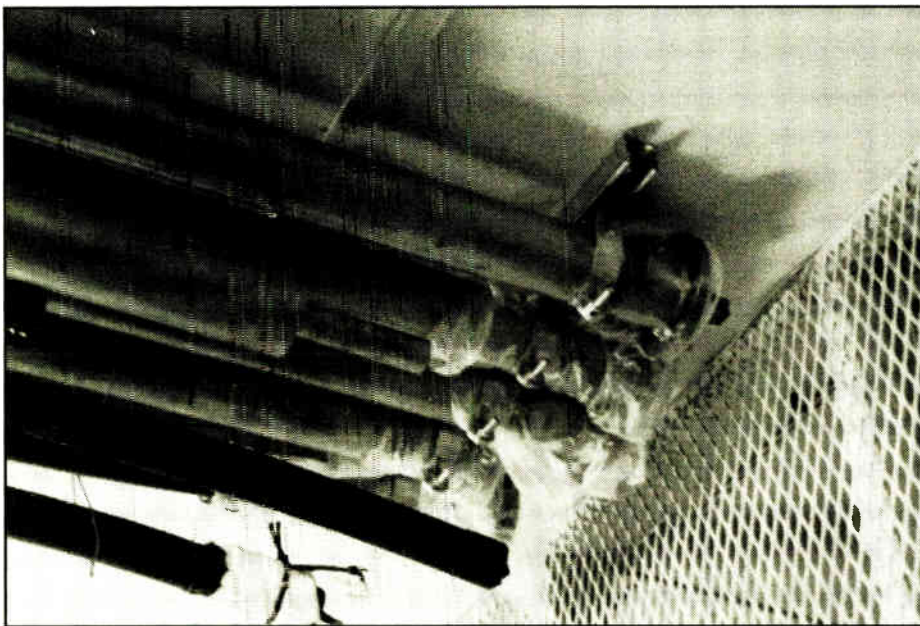

Inexpensive electrical supplies can be used to store spare transmission line.

with your digital multimeter. Lewis Downey of KRCL(FM) in Salt Lake City obtained such an ammeter at his local

power company. Because KRCL is a non-profit station, the power company donated the ammeter. Lewis suggests

unloaded voltage. A DVM or VTVM will do nicely for this determination. Lewis's unit gave the following frequency response:

Frequency	dB Loaded	dB Unloaded
60 Hz	0	0
180 Hz	+2	+9.2
300 Hz	+2.4	+13.1
540 Hz	+2.4	+17.4
900 Hz	+2.2	+20.8

You may have guessed what kind of problem we're preparing to check. You do not want power line harmonics giving you erroneous numbers, and if you have harmonics in your facility, you want to be able to measure them.

After loading the sample transformer, Lewis made a tabulation of the sampled AC voltage from the clamp-on meter output, versus the actual current the audio amplifier was putting into the load. You will want to use a resistive load of a known value, so that you can calculate the current with Ohm's Law. To do this, measure the voltage across the load resistor. If you have a spare AC Ammeter, you can leave it in the circuit and save some time. As you make your measurements, do not allow the amplifier to clip the signal—the harmonics generated by clipping will defeat your efforts.

By now, you have an idea of the clamp-on transformer's linearity (circuit current versus sample voltage), and what kind of voltage divider you will need to marry the unit to your DVM. A little work with Ohm's Law and some voltage divider

your local utility as a good place to start, because the clamp-on meters take a lot of abuse from linemen.

Invariably, they will end up with a broken meter movement, and will be ready to throw it away. Armed with your stash of station T-shirts, mugs or key chains, make your best trade.

When you open the meter, remove the dead movement, meter multiplier resis-

MIX IT UP.

High-Performance Rack-Mount Mixers from U.S. Audio™



MIX-8 • 8 stereo line inputs, headphone monitoring, remote mute, stereo aux sends on inputs 1-4, pans on inputs 5-8



MIX-6 • 4 mic/line XLR + TRS inputs, 1 stereo RCA input, 1 stereo TRS input, mic/line XLR & TRS stereo out, phantom, limiter, headphone



MIX-5S • 4 mic/line inputs with pans, 1 aux input, mic/line XLR & TRS stereo out, phantom power, Left & Right Master Controls



MIX-5 • Features / Performance of MIX-5S in a mono version

Figure 2.

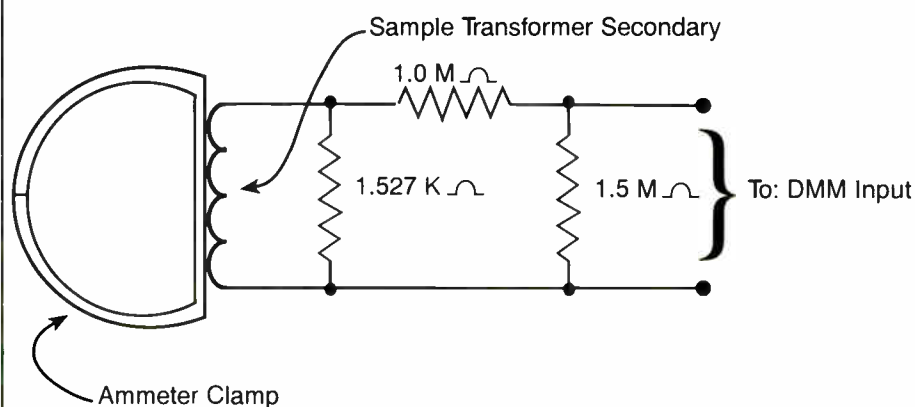

A simple voltage divider network matches an old clamp-on ammeter for use with a DVM.

tors, range switch and rectifier. Add the appropriate load across the secondary of the clamp-on transformer output, add the voltage divider, and then check the calibration with an audio amplifier pumping a 60 Hz signal into a resistive load. Install the appropriate cable and connector to use with your DVM.

It is important to load the transformer with the appropriate resistance. After you have your ammeter clamped around one conductor of the cable connecting the audio amplifier to the resistive load, connect a variable resistor across the clamp-on transformer output, and adjust it until you see the 60 Hz sample drop 6 dB as compared to the

resistors gives you a new tool. Lewis Downey calculated his network to give him a "10x" probe. In his case, you take the DVM reading and multiply it by 10 to get the circuit current in amps. A schematic of Lewis' finished product is shown in Figure 2.

Lewis Downey can be reached at KRCL, 801-363-1818.

□ □ □

John Bisset is a principal with Multiphase, a contract engineering and special projects company based in Washington. He can be reached at 703-323-7180. Fax submissions to Workbench to 703-764-0751. Printed submissions qualify for SBE Certification credit.

whirlwind

Compact, feature rich, with the performance you want and the reliability we're famous for — it's the U.S. Audio rack-mount mixer series from Whirlwind. Designed and built in the U.S. at our own factory, these mixers reflect years of real-world experience in broadcast, sound reinforcement, and institutional applications.

They deliver carefully planned flexibility and recording studio sonic performance — day in, and day out — at prices that fit today's budgets.

So call today and order a mixer from U.S. Audio

We're confident it *won't* be your last.



99 LING RD. ROCHESTER, NY 14612. PHONE +1 716-653-8320. FAX +1 716-655-8930

Circle (52) On Reader Service Card

Safe



LAYER III

- Both the superior audio of Layer III and compatibility with installed Layer II-only codecs. Zephyr costs about the same as Layer II-only equipment.
- Only Layer III permits mono 15kHz operation on a single ISDN "B" channel or one Switched 56 line. This can greatly reduce your transmission costs.
- Clean, uncluttered front panel for simple operation. Full metering, call-duration timer, headphone jack, and mic/line inputs.
- Split channel mode allows individual mono signals to be transmitted to separate sites.
- RS-232 bi-directional data at 9600 baud for communications and control.
- Four end-to-end "contact-closures" for remote machine operation.
- The ideal solution for remote broadcasts, ad hoc networks, voiceovers, distribution of commercials, backup to satellite and microwave links, and many other applications.

Bad weather. Finicky players. Losing streaks.

When it comes to sports, you can't control everything. But with Zephyr, you can guarantee that every game you broadcast will sound great.

Combining the most advanced digital audio techniques and the most practical features, Zephyr is the easiest way to use ISDN or Switched 56 for sports broadcasts.

Zephyr's Layer III provides the best broadcast sound quality, and Layer II and G.722 compatibility let your Zephyr connect to every major codec out there.

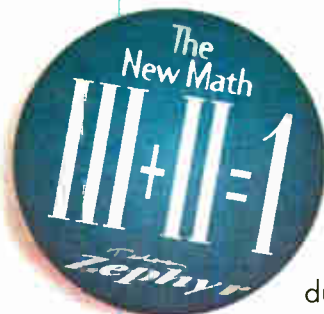
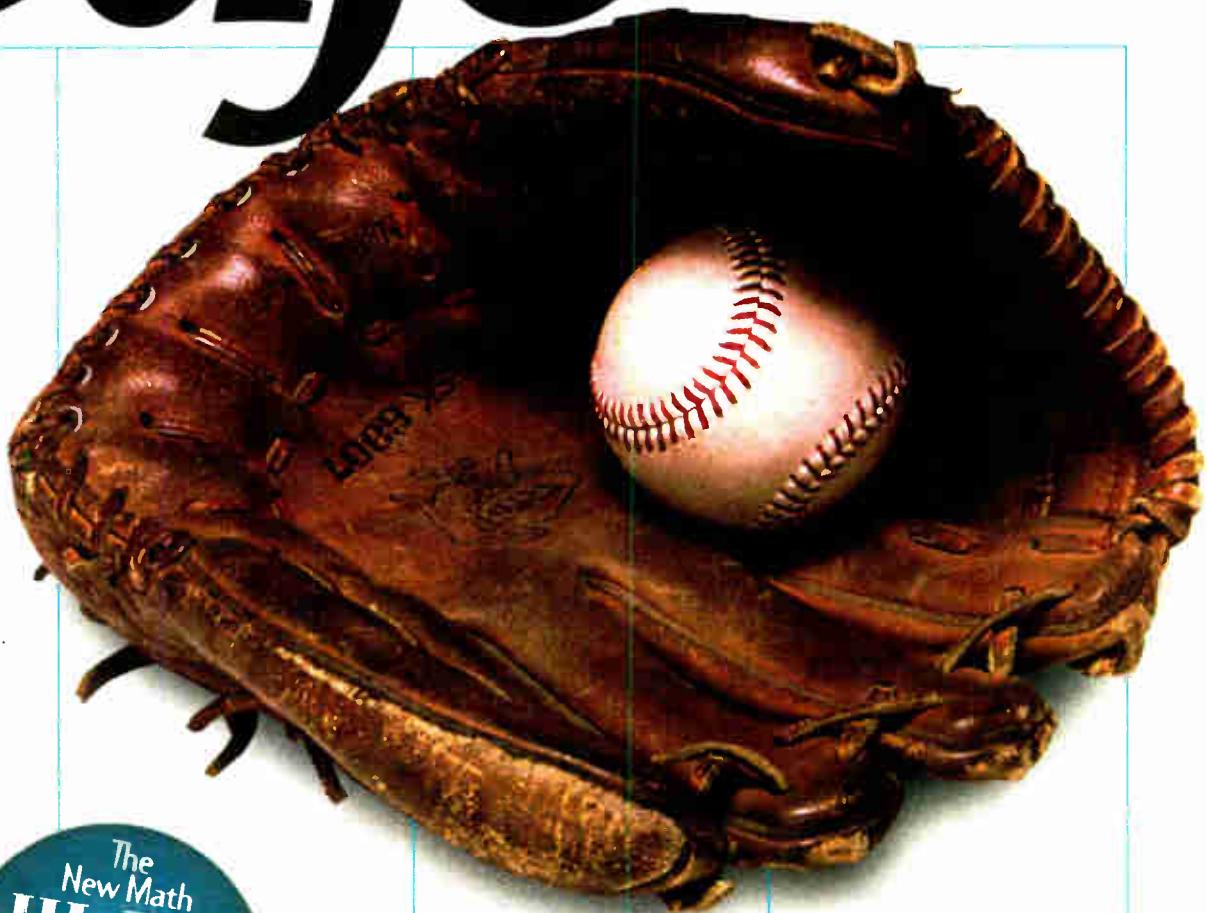

It's full duplex, so cues can be sent from the studio without the cost of additional phone lines.

Zephyr includes an ISDN terminal adapter and our ISDN Telephone mode allows you

to place a standard voice-grade call to a Plain Old Telephone Service (POTS) phone.

With Zephyr, you are always ready for the opening pitch, the kickoff, the jump ball, the face off... and your listeners.

only from



2101 Superior Avenue
Cleveland, Ohio 44114
216.241.7225
Fax: 216.241.4103
email: info@zephyr.com



The Best Way to Hear from There™

Telos Zephyr DIGITAL NETWORK AUDIO TRANSCIVER

AXS...is awesome!

Look carefully at this page. The screen shots tell it all.

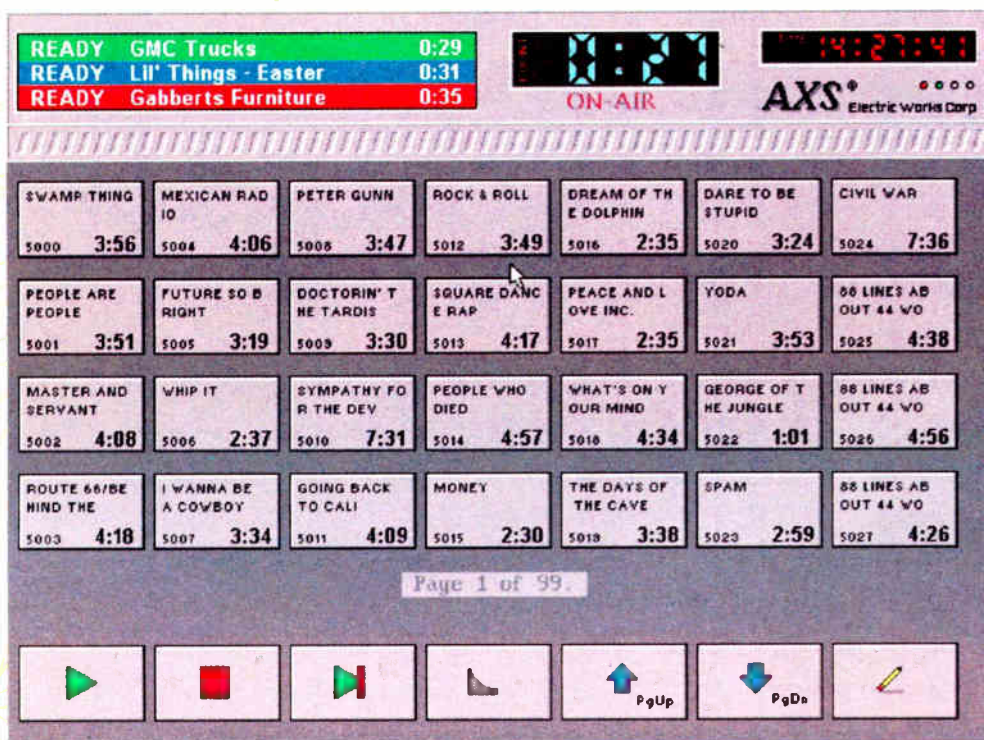

Now you see why AXS™ is the most powerful digital hard disk control system in the world. AXS does it all.

AXS is a powerful audio Cart replacement system.

AXS is a superb CD and HD music and live system.

AXS breezes through complex news/talk, feature and long form programming.

Live Operation

The Jock F/X screen is a part of all AXS systems. Live shows are a snap with 99 pages of 28 instant touch screen, touch pad or click buttons ready at any time.

Copy Tags and Text

All AXS systems are complete with Text writing and display so that rotating live Copy, Weather, News, Promos, Tags and other Text are always ready.

Audio Production

AXS offers simultaneous device independent Production and/or PBR background recording for time shifting audio Cuts. Audition any cut before it is aired.

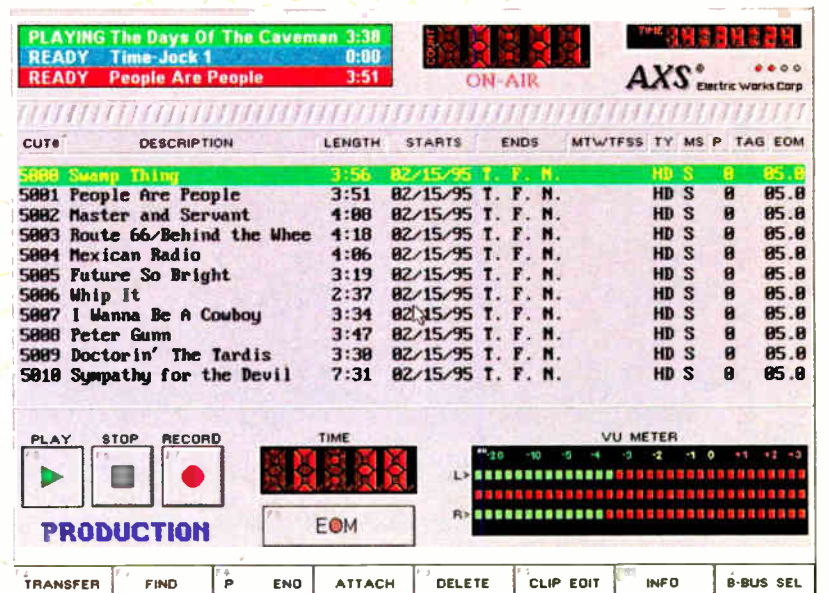
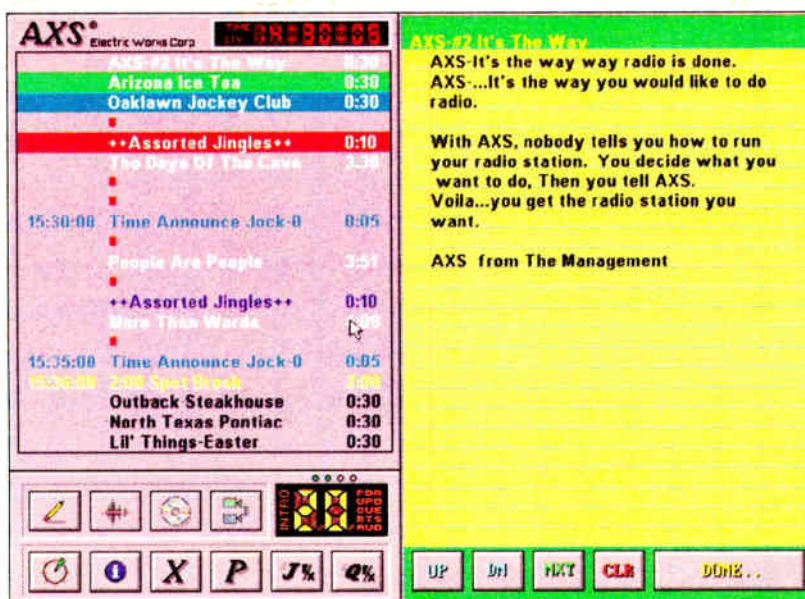

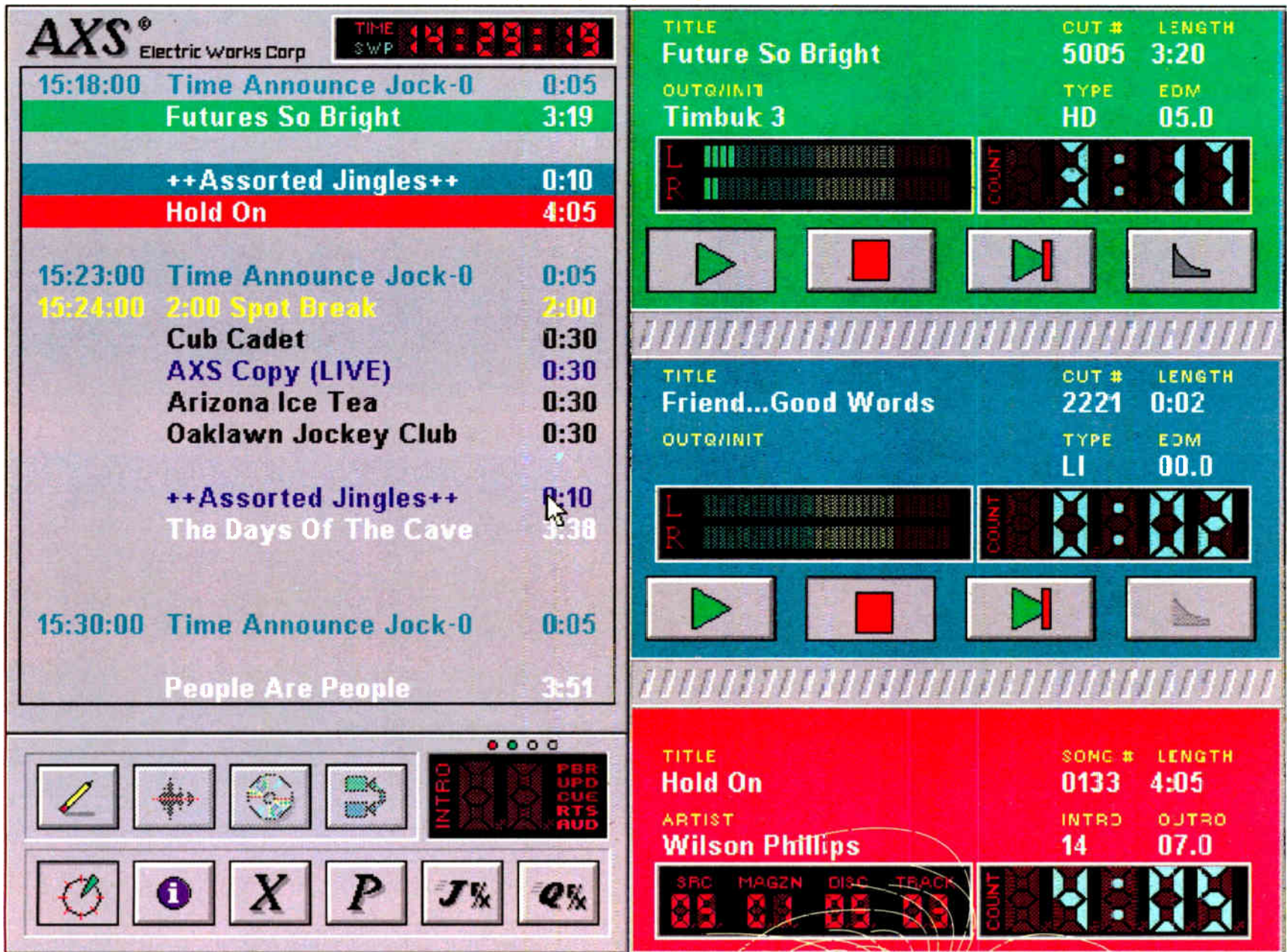

The AXS Main screen:

The AXS Main screen: Full program log display with quick editing and total audio control, including fade and overlap.

Options:

Other audio options include a digital clip editor and WAV2 APT file conversions.



The Management

A Division of

Electric Works Corporation

Box 1-36457, Fort Worth, TX 76136
800-334-7823 • 817-625-9761
Fax: 817-624-9741



LOG FOR LESS

Everyone loves Eventide digital audio-loggers. They've thoroughly obsoleted old-fashioned reel-to-reel logging recorders. But for some stations, our 24-channel model VR240 is more than the budget can handle. And many stations will never need to record up to 24 channels.

500 hours, half the price

The Eventide VR204 4-channel digital logger is the perfect answer. It costs less than half the price of a fully optioned Eventide VR240! The high density DDS2 drive of the VR204 can actually record more than 500 hours, divided among up to 4-channels, on a single DAT tape. That's twice the record time of our original models.

Built-in hard disk

The VR204 is a single drive machine, yet it can play and record simultaneously. That's because it features an ingenious built-in hard disk memory module that keeps recording even if the tape is playing back an

earlier segment (or if the tape runs out). When the tape resumes recording, the content of the hard disk is transferred to tape, maintaining the completeness of the taped log.

Two-way compatibility

There's also a play-only model, the VP204, which is ideal for the GM's or PD's desk or for the group's main office. And both the VR204 and VP204 can playback any of the 24 channels recorded on an Eventide VR240.

Keep an accurate audio record of everything that goes out on your air. Keep track of the competition as well. Contact your broadcast dealer or Eventide for the full story on the economical VR204. Because without an Eventide digital logger, you really don't know what you're missing.



**Now record
500+ hours on
one tiny DAT tape**



Efficiency Modulation Transmission

by Tom Vernon

HARRISBURG, Pa. The last decade has witnessed quantum leaps in AM transmitter efficiency. The improvements have been going on almost since the beginning of radio. Modulation schemes such as Ampliphase, modified Doherty, and PDM have been described extensively.

100 percent modulation. This is illustrated graphically in Figure 4.

Good linearity

When optimized for good linearity, peak efficiency will be around 66 percent. With no modulation, efficiency will be about half this figure, or 33 percent. In screen grid circuits, it is usually necessary to drive the screen grid slightly negative, because complete cut-off of plate current does not quite occur at 0 volts.

Power output of this configuration is about one-third that available by plate modulating a given tube. Here the relationship between screen voltage and current is non-linear, meaning that the modulator load varies as a function of modulating frequency. This problem may be largely

remedied by overall feedback.

From a practical standpoint, efficiency modulation had many advantages over high-level plate modulation. Most of these came from the elimination of the modulation transformer and reactor.

Without modulation iron, overall feedback may be utilized. In this scheme the RF is sampled, rectified, and returned to the first audio stage as negative feedback. Because the mod transformer is a non-linear device, such overall feedback is not possible with plate modulated

ubiquitous Class B modulator with its vast power consumption is eliminated. In its place, a 1 kW transmitter could be easily

modulated by a single 807 tube. Because peak plate voltages are much lower with efficiency modulation, smaller values of plate blockers and tank components may be employed, resulting in reduced size and cost. Densely processed audio can be a problem for plate modulated transmitters because of the resultant increase in temperature, particularly in the mod transformer. Recall from earlier that with efficiency modulation, optimum efficiency is achieved at 100 percent modulation. Thus, efficiency modulated transmitters actually prefer highly-processed audio, as it makes them run cooler. Historically, the use of efficiency modulation of Class C amplifiers by broadcasters is limited. In the mid-late '50s, Continental Electronics manufactured 1, 5 and 10 kW transmitters utilizing screen grid modulation of class C RF amplifiers. These were the 314-2, 315, and 316 models respectively.

Grid modulated transmitters were also popular with carrier current broadcasters during the early days when most equipment was home made. The motivating force here was cost, because college stations on a shoestring budget could not afford UTC CVM or LS series audio transformers.

If you would like to experiment with screen grid modulation circuits, there is a wealth of good information in

old copies of "The Radio Amateur's Handbook."

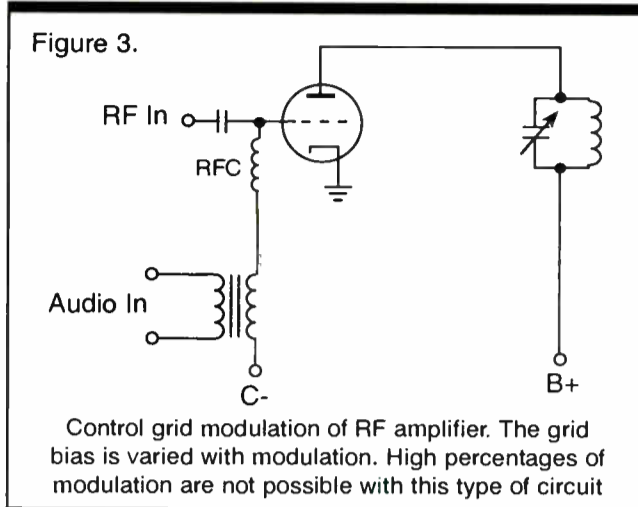
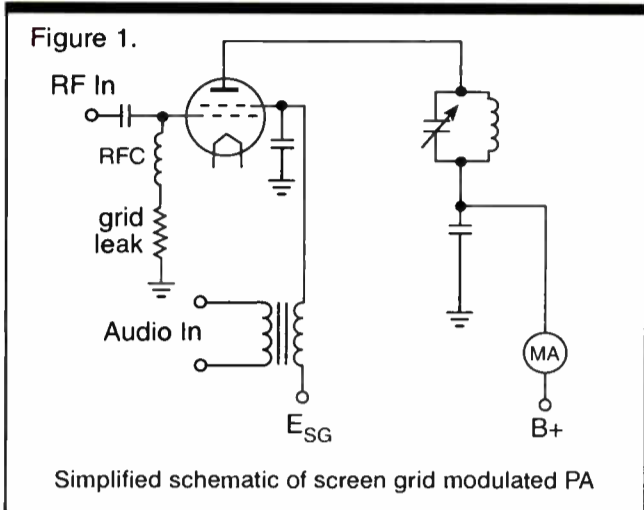

modulated by a single 807 tube.

Because peak plate voltages are much lower with efficiency modulation, smaller values of plate blockers and tank components may be employed, resulting in reduced size and cost.

Densely processed audio can be a problem for plate modulated transmitters because of the resultant increase in temperature, particularly in the mod transformer. Recall from earlier that with efficiency modulation, optimum efficiency is achieved at 100 percent modulation. Thus, efficiency modulated transmitters actually prefer highly-processed audio, as it makes them run cooler. Historically, the use of efficiency modulation

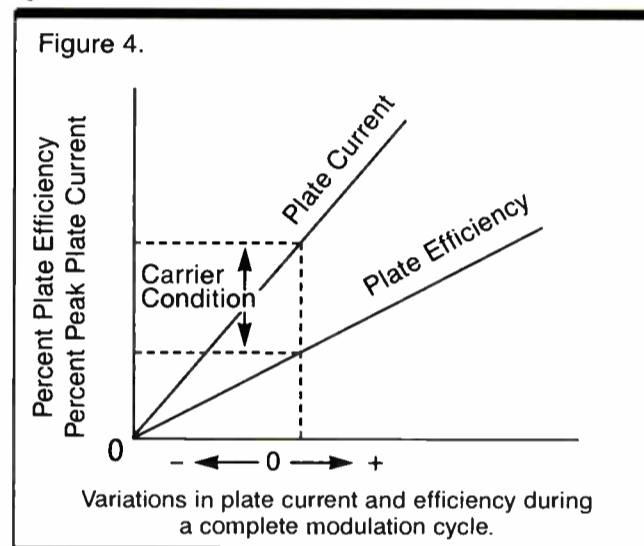

Tom Vernon writes about radio and multimedia. He is occasionally sighted around WXPN in Philadelphia. Reach him at 717-367-5595, or at TLVernon@AOL.COM.

Vacuum-tube days

Because high-level plate modulation was all-pervasive during the vacuum tube days, we sometimes forget that AM can also be created by modulating any of the other elements in the PA tube. When the modulating voltage is applied to the suppressor, screen, or control grids of the PA tube, it is known as efficiency modulation. Figures

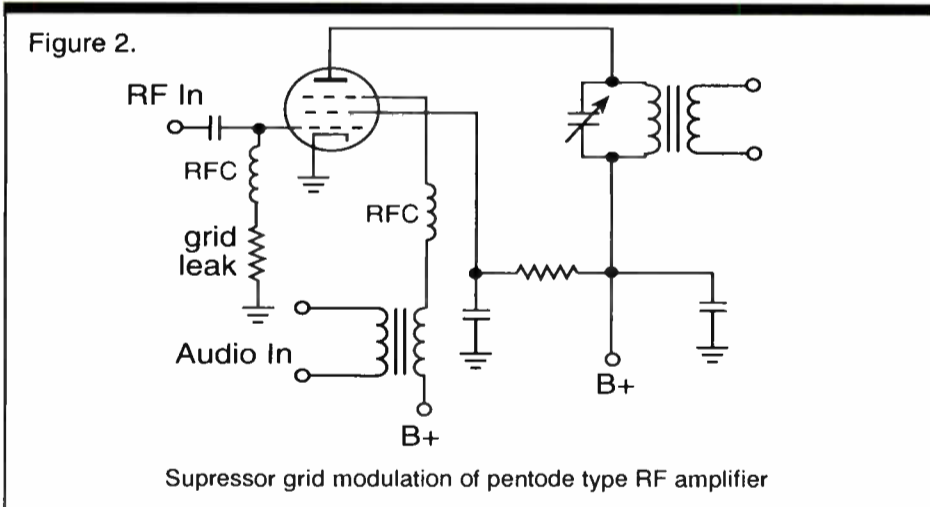

1, 2 and 3 present simplified schematics.

While it is theoretically possible to modulate any of the grids, in the real world control and screen circuits are most common, and I will focus on screen grid modulation here. Suppressor grid circuits are seldom seen on practical applications. This is because there are few power pentodes with the suppressor grid isolated from the cathode and brought out to a separate pin. Also, suppressor grid characteristics usually are not that well controlled by tube manufacturers. Thus, a suppressor grid circuit would require considerable readjustment each time the PA tube was changed, not a desirable situation.

Regardless of which grid is modulated, the principle is the same. Because the plate voltage must remain constant, the increase in power with modulation is achieved by varying the plate current and efficiency. To reach 100 percent modulation, both plate current and efficiency must be doubled from their un-modulated values. Optimum efficiency is realized at

transmitters. Overall feedback results in improved performance specs. Distortion is lower because the feedback loop now includes the PA stage, and any non-linearities there are canceled out. Noise and hum are reduced by the amount of feedback employed. Frequency response is improved by the elimination of the mod transformer with its attendant leakage reactance and shunt capacity at higher audio frequencies. Overall feedback also controls gain over the full audio range.

Simpler circuitry

Efficiency modulation was usually achieved with simpler circuitry than used in high level plate. This is because plate-modulated tetrodes must also have a means to modulate the screen grid to at least 70 percent modulation, and many times the RF driver stage is modulated as well, adding to circuit complexity.

The modulator power required in this type of transmitter is very low. Thus the

How The Americans Make Commercial Radio Pay!

Radio...the BOOK

by Steve Warren

A fun, practical, Programming Manual and Idea Book for Program Directors and Operations Managers

PLEASE PRINT ALL INFORMATION

I would like to order _____ copies of Radio...the book @ \$35.00 ea = \$ _____ * total. (*price includes shipping)

Mastercard Visa American Express

SHIPPING INFORMATION

Card Number: _____ Name: _____

Expiration Date: _____ Shipping Address: _____

Name on Card: _____

Signature: _____

Phone: _____ Fax: _____

TO ORDER BY FAX 1-800-827-9055

TO ORDER BY PHONE 1-800-827-1722

MAKE CHECKS PAYABLE TO: MOR MEDIA

Radio World
Tools of the Trade

OR MAIL TO:
Radio World
Tools of the Trade
P.O. Box 1214
Falls Church, VA 22041 USA

Products & Services Showcase

For more information on the products shown below, circle the appropriate Reader Service No. (s) on the enclosed Subscription/Reader Service card or contact the advertiser directly.

Freeland Products, Inc.
Power Tube Rebuilders Since 1940

AVERAGE SAVINGS OF 50% OFF NEW TUBE COSTS

RADIO • TV • INDUSTRIAL APPLICATION
UHF • KLYSTRONS



CALL OR WRITE FOR YOUR FREE
PRODUCT INFORMATION PACKET

75412 HIGHWAY 25
COVINGTON, LOUISIANA 70435
(504) 893-1243 • FAX (504) 892-7323
1 (800) 624-7626

READER SERVICE NO. 10

Integrated Excellence!

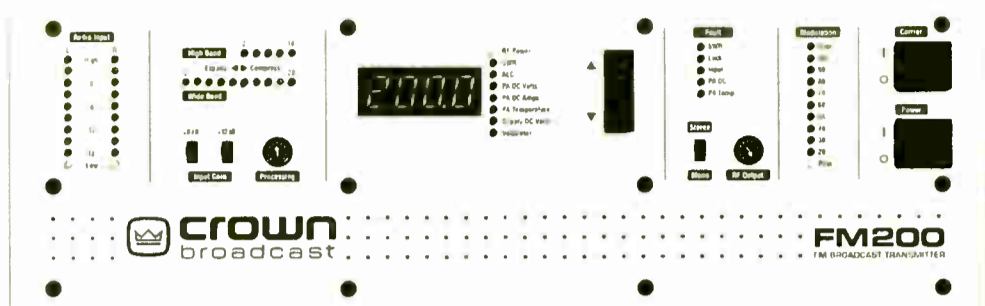

Integrated Excellence. The best way to describe Crown Broadcast FM transmitters. Available in 30, 100, 200 and now 500 watt models.

Each integrated FM package includes:

- FM Exciter
- Audio Processor
- Stereo Generator
- RF Amplifier

All of which operates from your AC or DC power source.

crown broadcast
A Division of Crown International, Inc.
1718 West Mishawaka Road
Elkhart, Indiana 46515-1000
Fax 219-294-8302
Broadcast Sales 219-294-8050

READER SERVICE NO. 141

THE WORLD'S BEST TELEPHONE COUPLER! AT THE LOWEST COST AND FEATURE LOADED!

INTRODUCING...

THE TAC AND TAC+

(shown)



By **SOUND AMERICA**

• manufacturer of the venerable Voice-Act

READER SERVICE NO. 102

- A must for radio reporters
- Tuck in field bag for remotes

TAC \$89.50

TAC+ \$99.95

Call your distributor or order direct

1-800-688-8208

Tac & Tac+: Mix voice with external feed (cassette, etc., 8-32 ohm input xfmr) • Monitor continuously • Output signal for recording • Modular plugs connect between handset & phone base • Two year full warranty
TAC+ features: 6 step, 10db/step attenuator in addition to coupler! • 8-32 or 600 ohm input xfms • Cough button

Shock padded vinyl carrying case available \$9.95

Excalibur Electronics CD-1 Interface Amp



The industry's favorite unidirectional interface amplifier is designed to match IHF output standards (10kΩ unbalanced, -10dBV) to broadcast input standards (+4dBm, balanced). DC coupling, <0.006% THD & IMD, and >90dB S/N make the CD-1 appropriate for use with the highest quality CD players, as well as with monitor tuners, cassette and tape playback, DAT playback, and ENG equipment. Table-top mounting or, using the included angle brackets, may be attached to a rack panel, your cabinetry, or anywhere convenient. A dual version, the CD-2, is also available.

EXCALIBUR ELECTRONICS, INC., CHANTILLY, VIRGINIA
Please circle our bingo number for a data sheet and a dealer list

READER SERVICE NO. 206

Airborne Pattern Studies

Can Solve Market Coverage Mysteries!

- FM and TV Channels 2-69
- Simultaneous H&V Measurements
- Azimuth and Elevation Patterns
- All-Digital Data Acquisition & Processing
- Pre- and Post-flight Calibration
- 60dB range, 0.25dB accuracy, 0.02dB resolution, 20000 sample-pairs typical
- Report available within 24 hours of flight
- Animated elevation display on your PC
- FAA-Certified Bell 206B3 Helicopters equipped with Differential GPS

A State-of-the-Science™ service
Ask your consultant and ask for us

Air System Technologies

Dallas, Texas (214) 402-9660

FAA-Certified aircraft based also in
Chicago • Denver • Miami • Pittsburgh

READER SERVICE NO. 114

A Broadcast Industry

BEST BUY

Cartridge Recorder / Reproducer
Mono R/P Stereo R/P

\$1550 \$1800

(F.O.B. Factory - U.S. \$)

RELIABLE / RUGGED
PROFESSIONAL DESIGN



DL Series

AUDI-CORD CORPORATION

1845 West Hovey Avenue
Normal, Illinois 61761 USA
Phone 309-452-9461
Fax 309-452-0893

Available Through Your Regular Distributor

READER SERVICE NO. 5

Updating Old Arrays

► continued from page 34

reading a negative (parasitic) element, you will have to reverse the bridge leads (and swap the sign of the reactance) to get a correct reading. Repeat this for each element in the array, being careful to tune out the OIB's insertion effect before reading.

With this information in hand, the design engineer can come up with a workable phasor design that is optimized for bandwidth and efficiency. Typically, this design will incorporate an "Ohm's Law" or shunt power divider. If the array has many elements, a capacitor may be shunted across the power divider bus to raise the impedance at that point.

A good designer will not only maximize performance but will find economical compromises in component selection and count. Vacuum capacitors are expensive as are many other components in a typical phasing and coupling system. There is much that can usually be done to cut down on such component costs while making only minor compromises in performance.

Placing the order

With the completed design in hand, the next step is to send it to several manufacturers for bid. Be sure that the specifica-

Modern designs provide an optimized bandwidth at each element and at the common point.

tions are narrow enough that the manufacturers will not substitute components in the system or make changes in the design without both your prior approval and that of the designer.

Antenna tuning units can come in either weatherproof cabinets or constructed on a chassis. If your existing system has "doghouses" and these are still in good condition or can be easily restored, using chassis-mounted ATUs are an economical and easily installed way to go. Otherwise, weatherproof cabinets are an excellent option. Be sure to specify to the manufacturers what form the ATUs will take.

Another often overlooked factor is the maximum size of the phasor cabinets. Remember, the phasor cabinets have to go inside the building, and they must enter through the door. If the cabinets are too big to fit through the door, you are going to have to enlarge the door. This runs the cost of installation way up and messes up your building. Be sure to specify the maximum size of phasor cabinets to be such that they will fit through the door with a little room to spare.

The bid submitted by each manufacturer should come complete with a written description of the RF and control portions of the phasing and coupling system. Compare these carefully to be sure they are comparable. Different manufacturers offer various features that you may or may not like. Some offer motorized RF contactors; others use solenoid-driven units. Motorized units are quiet and use little power, but they are slow. Solenoid units are noisy, violent and have a high current draw. These and many other factors should be considered along with price when selecting a manufacturer for your new phasing and coupling system.

The installation of the new phasing and coupling system is a project that must be carefully planned, particularly if the station must stay on the air throughout the project. I have successfully replaced the phasor and ATUs in a three-tower DA without losing any daytime airtime over a two day period, and with careful planning, down time in any such project can be kept to a minimum.

Start by realizing that reduced power non-directional operation will be necessary during the project. The daytime ND power level will likely be the one authorized during the last full proof-of-performance. At night, 250 watts is likely to be the maximum. Float all the towers but one and measure the self-impedance of the remaining tower. Calculate the tee-network (or L-network) values necessary to match this self-impedance to 50-ohms. Do this again with one other tower, giving yourself a choice of two different ND elements. In this manner you can shuffle ND operation between those two until the ATUs have been replaced at all towers. You will have to make whatever arrangements you need to in order to keep the transmitter connected to a radiating element. This may be a piece of RG-8 running across the floor!

Once the new phasor and ATUs have been installed, set all the networks to the design values. Often, manufacturers preset components prior to shipment. If this has been done, this step can be omitted. Simply check all connections for security, and it would not hurt to trace all RF wiring to be sure there have been no mistakes.

Straightforward procedure

The tune-up procedure is fairly straightforward, unless negative power flows complicate the process. Remember that a separate tune-up will be required for each pattern.

With the transmitter feeding the system at low power (say, 100 watts or so if that is possible—otherwise, as low as possible), check the antenna monitor for operating parameters. Adjust the phasor controls to achieve the licensed operating parameters on the antenna monitor, being careful to see that the phases are leading or lagging as specified on the license. Sometimes, particularly when the phase meter is close to the bottom or top of the scale, the phase can flip from leading to lagging (or vice versa) without your knowing it.

If the on-frequency driving point impedances were known in advance and the ATU tee networks were set to match these values, all you will have to do is adjust the phasor controls for proper antenna monitor readings. If the driving point impedances were not known, you may have to vary ATU settings and even the shunt legs of the phase shifter networks to achieve correct antenna monitor indications. Once this has been done, measure the driving point impedances as described above (being sure to tune out insertion effect), then recalculate and reset the ATU tee-networks to their proper values. With this done, you will have to again readjust the phasor for proper antenna monitor values, probably resetting any phase shifter shunt legs to their former values.

As a last check, insert the OIB at the

input of each ATU, tune out the insertion effect and read the VSWR at that point. If necessary, repeat the procedure in the preceding paragraph until a match is achieved at all ATU inputs.

Play with phase

Finally, you may wish to play with the phase shift at the input (common point) tee network to optimize bandwidth. Often, a more symmetrical and flatter bandpass can be achieved at a phase shift other than -90 degrees. This can only be found through experimentation in the field.

No proof or partial proof of the array should be necessary if you did not change anything above the base insulator of any of the towers, but you should check the monitor points before you pronounce the project done. If you accurately reproduced the licensed operating (not

theoretical!) parameters on the antenna monitor, the pattern will be correct.

The end result of the phasing and coupling system redesign and replacement should be better sound, better stability and higher efficiency. Chances are that if you ran a proof on the array you would see a higher RMS than was realized during the last proof with the old system. Take care of your new system, keeping controls lubricated (use silicon grease) and exercised, and keeping bugs out of the ATUs and phasor (use moth balls). It will last you at least as long as the original system, and that should be just about until AM DAB becomes a reality.

□ □ □

Cris Alexander is the director of engineering at Crawford broadcasting in Dallas. He can be reached at 214-445-1713 or care of RW.

I COULD HAVE BOUGHT A DIGILINK!

Are you thinking about replacing your old cart machines with 'Digital Carts' such as floppies, flopticals, Bernoullis, or Opticals??? Well, think about it a little more! Add up the list price for a digital cartridge recorder, just a single player, AND the floppy disks--- and you will find that you could have bought a Digilink workstation for \$7,995 that gave you 'Live' -AND- 'Automation' capabilities!!!

A Digilink workstation stores audio on an internal hard disk and comes out of the box with a capacity of 547 one minute, stereo carts for only \$7,995. Even better, the Digilink hard disk has an average 15 year life. Imagine how many floppies you will break, wear out, lose, and replace over 15 years. That doesn't count all of the floppy disk mechanisms that will jam, break, and simply fail...

Controls
Modulux
Trak*Star
Digilink
Modulink

Also with a Digilink, you get much more! You can stack up hundreds of 'carts' in the play list and just walk away. You get satellite automation in the Digilink workstation and can optionally add CD players. A digital audio cut and splice editor even comes standard with Digilink. Because Digilink will play and record at the same time, you can play a spot to air while it starts a scheduled network autorecord. You can even network delay with Digilink.

With all of these features, it is easy to see why there are more than 500 Digilink workstations around the world from Paris to Moscow to Taiwan to Jamaica and in your own backyard. Don't suddenly come to the realization that you could have bought a Digilink!

Call Arrakis now...

(303) 224-2248

ARRAKIS

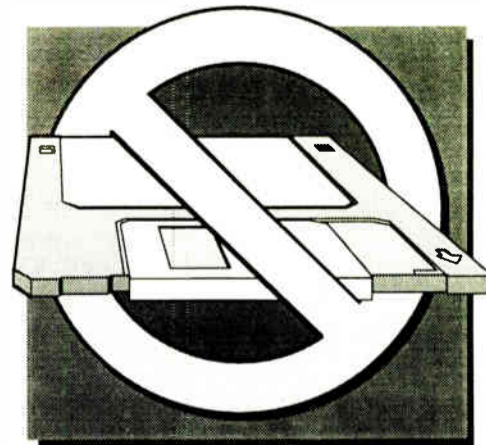

© 1993 Arrakis Systems inc. 2619 Midpoint Drive, Fort Collins, CO. 80525

Circle (23) On Reader Service Card

Products & Services Showcase

For more information on the products shown below, circle the appropriate Reader Service No.(s) on the enclosed Subscription/Reader Service card or contact the advertiser directly.

EZ RAZE
Antenna Mast

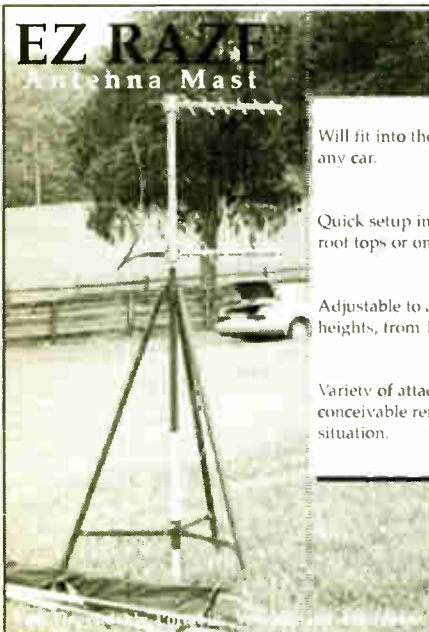

Will fit into the trunk of almost any car.

Quick setup indoors, outdoors, roof tops or on a rugged hillside.

Adjustable to a variety of heights, from 10 feet to 42 feet.

Variety of attachments for every conceivable remote broadcast situation.

Don't lose out on the next remote broadcast because of poor signal quality, expensive phone loops or cellular call cost. Improve the quality and the range of your next remote broadcast with affordable EZ RAZE™ Antenna Mast.

EZ RAZE
Old Stone Corporation
800-538-4977

We accept VISA & Mastercard

READER SERVICE NO. 57

Call For Rigid Line
MYAT & Components

Facing a "right now" emergency? Planning a new installation? Upgrading your facility? Whatever the need, MYAT is the solution. MYAT products are quality-built for maximum performance and long life. And we take delivery commitments seriously.

Call your favorite RF distributor or MYAT direct at 201-767-5380, or fax 201-767-4147 for our complete catalog and reference guide.



380 Chestnut St
P.O. Box 425
Norwood, NJ
07648

READER SERVICE NO. 13

ONLY COOL-AMP SILVERPLATES ON THE JOB.



Cool-Amp assures cool conductivity for copper, brass, bronze contacts. Prevents power loss from oxidation. *Applies easily on-the-job.* Even outperforms electroplating in recent tests. Time proven since 1944.

CONDUCTO-LUBE. THE SILVER-BASED CONDUCTIVE LUBRICANT.

The upstart, since 1952. Developed for switches. Uses continue to expand to all applications needing a conductive lubricant.

ORDER FACTORY DIRECT:
503-624-6426 or FAX 503-624-6436

Conducto-Lube **COOL-AMP**

READER SERVICE NO. 31

The CircuitWerkes AC-2 Autocoupler



More Features. Better Price.

- Auto-connect and disconnect.
- FCC Pt. 68 registered.
- Two-Year limited warranty.
- LED Indicators for audio clipping, incoming rings and line status.
- Answers on user selectable number of rings.
- Momentary or latching dry contacts at pickup.
- Momentary open collector output at pickup.
- Defeatable pickup inhibit function for car decks, etc.

- Can be combined with CircuitWerkes DTMF decoder board to form an inexpensive dial-up DTMF remote control.
- Optional ComboLok provides for secured access.
- Suggested list only \$199.

CircuitWerkes
6212 SW 8th Place
Gainesville, Florida 32607
(904) 331-5999
fax (904) 331-6999

READER SERVICE NO. 95

B-SERIES FM BROADCAST POWER AMPLIFIERS

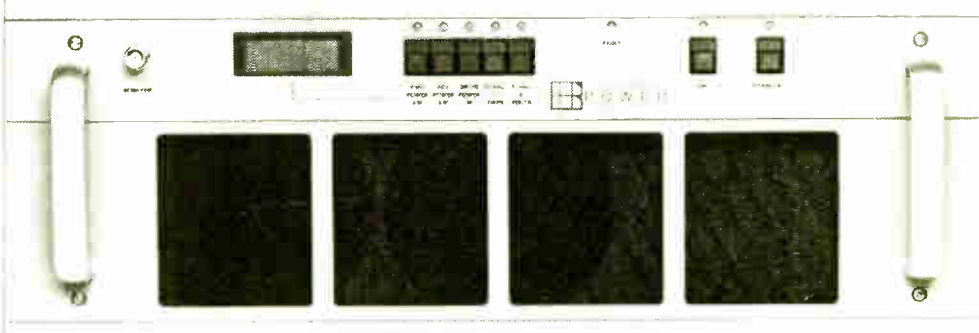

Reliability through design is the key to the B-series power amplifiers

Silicon Valley POWER AMPLIFIERS
The RF People

Silicon Valley Power Amplifiers, a quality supplier of OEM modules is now producing a range of compact power amplifiers. All units are complete with rack slide ready to install in a 19" rack system.

Power outputs 150W, 300W, 600W, & 1250W

For prices and delivery CALL 1-800-986-9700

READER SERVICE NO. 58

MATCHBOX II IS BEST FOR DIGITAL
with its HI-GAIN mode for Power-Mac* and other digital editor sound cards

NEW!!



Get MATCHBOX II to convert your Power-Mac* audio to *balanced* professional levels!

Only MATCHBOX II has *programmable gain* that's optimized for digital editor sound cards.

15,000 units in use worldwide!

- ◆ HI-GAIN mode for digital editors
- ◆ All four outputs adjustable
- ◆ Pro-grade gold-plated RCA jacks
- ◆ Over 110 dB dynamic range
- ◆ Self-contained power supply

HE HENRY ENGINEERING

TEL (818) 355-3656
FAX (818) 355-0077
FAX-on-Demand Doc #120 (818) 355-4210

*Power-Mac is a trademark of Apple Computer

READER SERVICE NO. 99

UPGRADE YOUR VOCALS



Adjustable control over pops and sibilance...
SOUNDS GREAT

Variable Acoustic Compression™

The only pop filter with adjustable distance between acoustic screens and the choice of one or two screens. YOU CONTROL the amount of 'pop & sibilance' filtering before the sound reaches the microphone. The result is better sounding vocals.

User List: Westlake Audio, Sony Music, MCA Music, Masterfonics, Paley Park, CBS, ABC, Z-100, Fox Broadcast...

"The new Popless VAC-6c voice screens are innovative in design, flexible in application, and elegant in appearance. Our clients have options never before available." Frank L. Wells, Chief Engineer MASTERFONICS, Nashville

- radio station models
- recording studio models
- 3.5 or 6 inch diameter screens
- priced from \$32 to \$54
- PROTECTS your microphone
- washable, replaceable screens
- LOW PROFILE design
- MONEY BACK GUARANTEE

For a FREE brochure, ordering information or the dealer nearest you call, fax or write:

POPLESS VOICE SCREENS
PO Box 1014
New Paltz, NY 12561

VOICE/FAX (800) 252-1503 or (914) 255-3367

READER SERVICE NO. 165

GUEST COMMENTARY

Radio Is Building Digital Future Today

by Greg Dean, President
Computer Concepts Corp.

LENEXA, Kan. The radio industry is at an interesting crossroads in its conversion to digital technology. Broadcasters are faced with almost too many choices and, at times, risks. On the manufacturer and vendor side, we have to try to forecast the future and determine what new digital technologies and formats to support.

I remember the comfort Novell provided to me some years ago when it appeared that IBM's NetBios might become the dominant standard of networking. Novell, having just announced its 286 version (which pre-dated the NetBios development), immediately announced total support for "whatever IBM does." Novell had some credibility in this regard because it had already demonstrated an amazing amount of adaptation for more diverse network topologies than any other solution available at the time.

IBM then signed up as a provider of "big red" in a "big blue" package. In the 18 months following its announcement, Novell's stock went through an astounding appreciation and its sales growth soared.

I think a similar situation exists today in the marketplace of digital systems for the radio industry. Any consumer with a budget large enough to accommodate a consideration of all available systems and technologies is faced with quite a formidable challenge—and risk. Spending a lot of money for a system that does not support the evolving standards is a mistake no one wants to make.

There are several important ways these concerns play out in the marketplace. Two major ones are file formats and compression algorithms. Microsoft has been venturing into MPEG formats with its .WAV file structure. Developers of various algorithms saw the multimedia concept being adopted and the ISO/MPEG specification reaching criti-

cal mass. The next step was the development of algorithm decoders on a single chip, for off-the-shelf implementation.

This has been a motivating force for companies on the cutting edge of technology. We, as manufacturers, face the need to adopt the widest number of formats in order to reach all possible customers. I do not believe there will be one single standard for some time, so we have to find a way to make sure our systems at the very least "talk" to all possible formats and, ideally, implement the emerging technologies without driving the costs of our equipment beyond our customer's reach.

Key to product planning and develop-

We, as manufacturers, face the need to adopt the widest number of formats in order to reach all possible customers.

ment will be the ability to provide seamless integration of new technologies in a comprehensive way. By seamless I mean not just that the choices in a single system exist, but that many different technologies and formats co-exist in a single system in a way that is completely unnoticed by the customer.

Seamless rate conversion is another important consideration. Sure, 32 kHz is fine for today's broadcaster who demands only 15 kHz frequency for even the best FM sound. But will single-rate systems, and those concentrating only on today's environment, end up costing stations money when they are made obsolete by digital audio broadcasting (DAB)

or digital conversion on a network level?

Regarding networks, transcoding of digital audio is another critical area. A single format at a low bit rate is fine for today, when a commercial hard disk system might be the only (probably actually the "first") block of digital equipment at the station. But what happens as networks, program providers and commercial producers convert to their chosen formats? Add DAB to the mix—now that it is more of a reality—and the possibility that a single piece of audio might go through several D/A conversions and several algorithm encode-decodes. Now the problem multiplies.

What is a savvy broadcaster to do?

The first step would be to urge the industry toward standards. As a manufacturer, it is not our place to impose standards on the marketplace. Unfortunately, there is no "Big Blue"

in the broadcast industry. But we can support the emerging standards and reassure customers that our equipment will continue to evolve as the standards change, and also that we will be there with the solutions when problems do arise.

Evolution of standards is going to happen no matter what manufacturers wish. We have to stay informed about changes that are taking place among large networks and major group owners so that when de facto standards begin to crystallize, we are not years away from implementing them.

For station owners trying to plan their futures, the caveat is to keep abreast of current digital formats and to question

potential suppliers as to the ease or difficulty of implementing and integrating them into systems they are considering purchasing.

The bottom line is that choosing digital equipment is a long-term investment. It is crucial to rely on those with a proven track record: companies who have stayed on the leading edge of technology that can implement and bundle a variety of formats, that provide ample and accessible support for their customers, and in the end, that will support not "whatever IBM does," but "whatever the radio industry wants."



LMA/DUOPOLY CONTOUR MAPS

The **DATAWORLD** LMA/DUOPOLY Market Survey Contour maps present a precise electronic verification of overlapping and intersecting contours.

AM 5 mV/m and FM 3.16 mV/m City Grade contours are shown in full color, including transmitter site indicator. The map is supported with a printout showing all of the stations which appear on the map.

Daily updating of **DATAWORLD'S** AM and FM databases protects against errors and omissions.

OTHER MAP OPTIONS

- SHADOWING (TERRAIN SHIELDING)
- CONTOUR COVERAGE
- POPULATION DENSITY
- ZIP CODE BOUNDARIES
- RECEIVED SIGNAL LEVEL
- SPECIAL REQUIREMENTS

1990 CENSUS

WHO ARE YOUR LISTENERS?

1990 BUREAU OF CENSUS POPULATION COUNTING

- Comprehensive Ethnic and Demographic Data
- Ethnic/Demographic Data Available for Each Zip Code Within Coverage Area
- Age Analysis Reflected in Ethnic Breakout
- Resolution Increased to Block Level
- Percent of County Coverage Shown

ETHNIC PIE-CHART DISPLAY

- Projects Ethnic Population in Multi-Color Pie Chart Form

dataworld®

800-368-5754 FAX: 301-656-5341

MOVING?...

Don't leave us behind!

Mail or fax
your current label
and new address
(with effective date) to:
Circulation, RW,
PO Box 1214
Falls Church, VA
22041
or
FAX 703-998-2966.

Address changes
will be processed
within four weeks of receipt.

Thanks!



The Wizard™ has gone STEREO!

The new **DIGITAL** FMSA-1 gives The Wizard System unmatched stereo monitoring capabilities. . .



Superlative stereo performance. Linear-phase filters that reveal the true performance of your audio processing. The stability of digital stereo demodulation. The sophisticated graphical presentation of The Wizard. And—with the RS-232 port—operation on site or off.

Contact Belar today for more details on what should be your next modulation monitor.



BELAR ELECTRONICS LABORATORY, INC.
119 LANCASTER AVENUE • P.O. BOX 76 • DEVON, PA 19333-0076 USA
(610) 687-5550 • FAX (610) 687-2686

Call, write or FAX for more information on Belar AM, FM, Stereo, SCA, and TV monitors.

USER REPORT

Audiovault Launches Stations into '90s

System Helps Station Automate, Interface and Ultimately Go Paper-free by Handling Variety of Tasks

by Phil Woods
Chief Engineer
WBAV-AM-FM

CONCORD, N.C. In January 1994, WPEG(FM)-WBAV(AM), owned by Broadcast Partners Inc., acquired WCKZ Radio—now WBAV-FM. Because of our use of satellite programming, we were in search of a system to automate our AM and one of our FMs.

We were looking for a system that not only would automate the stations but could also be expanded and used in other capacities, such as handling commercial audio, music audio, liners and interfacing with traffic, ultimately helping us achieve a paperless studio. The Broadcast Electronics Audiovault 100 fit the bill.

Heart of the system

A 486/33 MHz file server is the heart

of the system. This unit houses four 1 GHz hard drives for the storage of all audio, about nine hours of stereo audio. The AV100 audio boards are contained here as well. Each workstation is connected to the server via ethernet cards and uses Workgroup for Windows. We ordered boards for each of the four workstations.

Our first workstation is used for WBAV-FM, a station utilizing two satellite music network formats, along with two network affiliations. The workstation uses two AV100 boards so that we can record and play back at the same time. We use the Audiovault's AVSat screen for our on-air playback and the network delay screen for the recording of commercial feeds.

Because of the multiple on-air audio feeds and network commercial feeds, it was necessary to use 4x1 audio switchers for the AVSat screen and the network delay screen. These switchers are controlled by the workstation programming.

Trial playlist

Prior to implementing this workstation, we developed a trial seven-day playlist. We needed to be able to switch back and forth between audio sources

and use two different satellite commands for the AVSat screen. We also needed to be able to record at certain times of the day on the network delay screen.

The AVSat screen consists of one commercial playback machine which, when triggered manually or from a closure of a satellite decoder, plays all of

our commercials for that specified break. The AVSat screen also contains six ancillary decks that can be fired manually or by the satellite. These decks generally contain liners, magic calls and IDs.

During the satellite morning show, which is live-assist, we had some special needs for local news, contests and weather. Through the Audiovault 100 we recorded dummy carts (a specified time of blank audio). When these are played, our local announcer comes on live and does the local news, contests and weather forecast. After the morning show, we use time commands to switch back to our standard satellite format.

At various times during the day we also load stacks (a complete reload of the liners, magic calls and ID machines) in order to match the voices of the liners to the personality who is live on the air at that time.

Catching feeds

We use the network delay screen to catch all of our commercial feeds. We catch the satellite music commercial feeds during our two-minute mandatory break. During that two-minute break, when the satellite

sends a closure for the break, two things happen.

First, the closure fires deck one, our commercial machine and AVSat screen, which plays our commercials. It also fires the network delay record machine

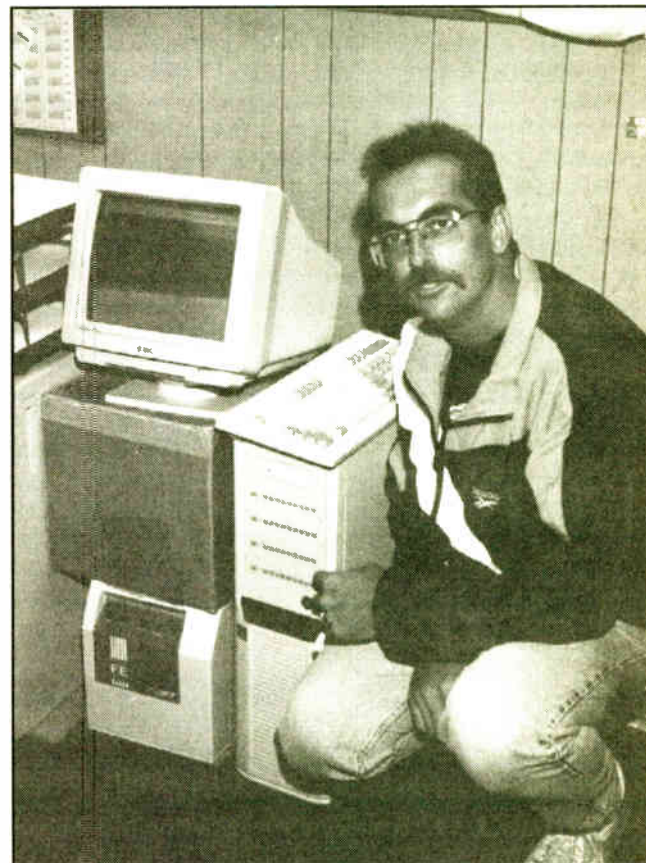

WBAV's Phil Woods and the Audiovault

We needed to be able to switch back and forth between audio sources and satellite.

of the system. This unit houses four 1 GHz hard drives for the storage of all audio, about nine hours of stereo audio. The AV100 audio boards are contained here as well. Each workstation is connected to the server via ethernet cards and uses Workgroup for Windows. We ordered boards for each of the four workstations.

that controls the network 4x1 switcher to choose the proper audio and records the commercial information received from the closed circuit feed from the network.

After this material is recorded onto the hard drives of the file server, our production director is able to access this information from workstation number two, the production studio.

The production room consists of an AVRPS screen for record/playback. The AVRPS screen is where all of the commercials are entered into the Audiovault system. A create/modify screen comes up, containing all the information about the client, such as category, cart number, description, start date, end date and client ID. After inputting all the information, he records the audio. The Audiovault automatically trims the recorded audio, removing any dead air.

File maintenance

All file maintenance and management of the Audiovault occurs in the production room. The commercials or files are either deleted or saved to DAT tape through our Roland DM-80 workstation. All information is saved in case the client wants to run their previous commercial at a later date.

Our third workstation is for our AM. We use the AVSat screen with our satellite format along with local live gospel from 7:00 p.m. to midnight. We also use the indicators to switch between satellite and audio, live audio, satellite

continued on page 52 ►

Heavy duty broadcast: McCart Audio Storage M/2000 Automation

The McCart Digital Audio Storage System removes limits: Size Limits, Accessibility Limits, Reliability Limits. Even the network was designed from the ground up for broadcast use. You don't need a network engineer to set it up or maintain it. McCart is used by major radio and TV broadcast networks for simple reasons: reliability, ease of use, ease of maintenance, complete expandability, heavy duty storage and retrieval capabilities. Have unusual needs? Our M/2000 Automation and McCart Audio System can be economically customized to meet your needs.

- Non Stop redundant architecture keeps you on the air!
- Automatic mirroring eliminates the need for backups.
- One to over two hundred stereo or mono channels per system, with no access limits.
- CD Jukebox control is fully integrated, play CD's from the McCart screen.
- Built in networking, no additional software or operating system required: very simple maintenance.
- Automate and play one to two hundred feeds from one fully integrated system, for multiple stations, networks, or news operations. Traffic from common or separate files.

Proven system. Proven company. We've been supplying broadcast automation systems for over 25 years. And with almost 50 years in the broadcast business, we understand the need for reliability in systems and suppliers.



McCurdy Radio Industries Ltd.

30 Kelfield Street
Toronto, Ontario, Canada M9W 5A2

800-267-8800
416-248-6755 FAX

VAR, Dealer and OEM inquiries welcome.

DIGITAL QUESTIONS

"I have two studios.
Can I afford a really good digital system?"

"Will I have to change the way I operate?"

"Are digital systems reliable enough yet?"

"Will I have back-up?"

"What happens when my system dies...
At 2 AM?"

"Can I network thirty studios on one system?"

"How fast can I convert to digital...
Realistically?"

"Who can I trust?"

DIGITAL ANSWERS

AudioVAULT® Digital Studio Systems

CALL BE DIRECT. (217)224-9600 FAX: (217)224-9607

BE BROADCAST
ELECTRONICS, INC.

WORLD LEADER IN RADIO BROADCAST TECHNOLOGY

4100 N 24TH • P.O. BOX 3606 • QUINCY, IL 62305-3606

USER REPORT

Hard Drive Leap Eased with Scott

by Jack Carter
Programming Consultant
Carter Consulting Co.

PUEBLO, Colo. Remember the day you pulled the turntables out of the control room to go all cart? No more cue burns, scratches, skips or songs at the wrong speed. Then you pulled out the cart racks to go all CD. No more dirty heads, un-cued carts or worn tape.

But those technological leaps pale in comparison to the day we turned on the Scott Studios system. Music, jingles, spots (and DJ voice tracks, if you choose) are all on hard drive. The system uses input from your music scheduling and traffic software and handles playback of everything.

Our first Scott System was installed in April 1994 on our oldies station, KDZA-FM. The system comes complete right down to the music library. It consists of

an on-air computer, the Production Bank, which contains a 9GB hard drive and handles playback chores, and the production workstation containing a record/play audio card used for dubbing into the system.

Installation

For the installation, Scott sends a knowledgeable technician who sets everything up and trains the staff. Do not plan for weeks of training; the system is

so simple, folks at our station picked it up in minutes. Scott also has excellent telephone tech support people available night and day.

The on-air system displays the event currently on the air and the next five coming up. You can move events around, delete items coming up, and with a simple key press, your music library is displayed. Pick a title and you have scheduled a request. The on-air system also includes "hot keys" for instant playback of designated items. We use hot keys mainly for breakers to drop in over intro times. Some of the on-air folks also use hot keys for applause, laugh tracks, contests, music beds, news beds, drop-ins, etc.

Touchscreen control

We opted for keyboard control of the system. If I had to do it over, I would buy the Scott touchscreen. With it, you touch the Play box inside the title and it plays. Touch the library title and it inserts. Touch the hot-key label and it fires.

continued on page 54 ►

RE2000

The Diaphragm
We vacuum-laminate gold—just a few molecules thick—to our ultrathin diaphragm. Its unique diameter provides an extremely uniform, supercardioid pattern, wide dynamic range and exceptional transient response.



The Performance
Self-noise is 5 to 10 dB lower than "industry standard" microphones. And we keep it that way even in conditions of high humidity with our Constant Environment System™ (CES), which keeps the element at a constant 125 °F.

The Transformer
Our custom-designed "Jensen" output transformer is low in distortion and a true 150 ohms. It provides the high rejection of electromagnetic noise that only a transformer can.

The Amenities
Shock-mount system, computer-grade power supply, external pop filter, hard-shell case, stand adapter and 20 ft. of premium cable with gold connectors.

The Awe-Inspiring, Uncompromising Studio Condenser Microphone

Even before its introduction, the RE2000 had earned an amazing reputation and an enthusiastic following. Its exacting performance elicited accolades from professionals who thought they had heard it all.

"The RE2000 has a richness of sound I have experienced only along the lines of a tube mic"— David Esch, Eschicago

"The perfect mic for recording any acoustic string instrument."—

John Beland, Flying Burrito Brothers

"The RE2000 has the warmth of a tube mic—extremely quiet and sensitive, allowing me to pickup low-level material without adding noise."—

Scott Weber, Buena Vista Sound, Walt Disney Studios

"The RE2000 has a crisp, clean and quiet response. I used less EQ to achieve what I look for. What goes in...comes out! It's also extremely versatile...from vocals to acoustic guitars to trumpets and violins."—

Tom Cusic, TM Century, Dallas, TX

"I think it's one of the most versatile I've ever used."— Roy Thomas Baker, Producer

In fact, all of these professionals asked one remarkably familiar question:

"When can I get one of my own?"

It's available now! And once you've heard it, we expect you'll be inspired to send us an accolade or two as well.



Launching Stations Into '90s

► continued from page 50

remote control and local remote control. We also flip screens to an AVRPS screen in which we input the daily playlist manually. We are currently looking at a file import/export filter to use with our Marketron traffic system, which will assemble the playlist automatically from the log generated by the traffic department.

Our fourth workstation, which will be used only for commercials on our live FM, is not installed as of yet. We are waiting to install the workstation when we have completed the import/export log file transfer with our traffic software.

Backup

We are also in the process of purchasing a 4GB DAT tape backup for the four hard drives that contain all of the audio files. We were without a backup when we suffered a hard drive crash in the first 90 days. We immediately received a new hard drive, but without the tape backup, we had to reconstruct all commercials that were lost.

As of this writing, we have experienced a direct lightning hit that wiped out our file server computer. Luckily, there was not any damage to the hard drives. With BE's help, we were able to reconstruct the file server in three days. Both stations operated in the live-assist mode until repairs were made.

Although we have encountered a few problems along the way, we still count on the BE AV100 system to be a viable part of our operation. Future considerations include expanding our audio storage time and redundant file servers with mirroring drives.

BE continuously updates this product through improvements in its software and hardware. As the Audiovault system grows and is refined, we hope to grow with the system as well.

For information, contact Bob Arnold in Illinois at 217-224-9600; fax: 217-224-9607; or circle Reader Service 4.

"Radio means the world to us" at Computer Concepts

THE NEW RADIO TIMES

Computer Concepts, serving broadcasters for over 20 years

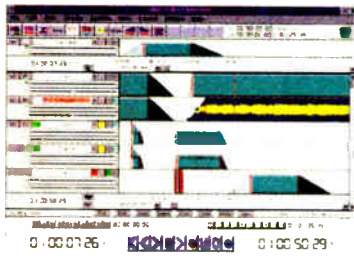

STUDIOFRAME PRODUCTION IS FAST, EASY.

In the production studio, time equals money. For the fastest, easiest multi-track production for commercials and station promos, Computer Concepts introduces the StudioFrame™ the complete audio workstation. "studio in a box." Every production feature from true 8 track input and output (expandable to 24 tracks) to time compression, digital EQ and filters is built into StudioFrame. Best of all, with its direct integration with DCS, produced spots can be on the air seconds after completion.

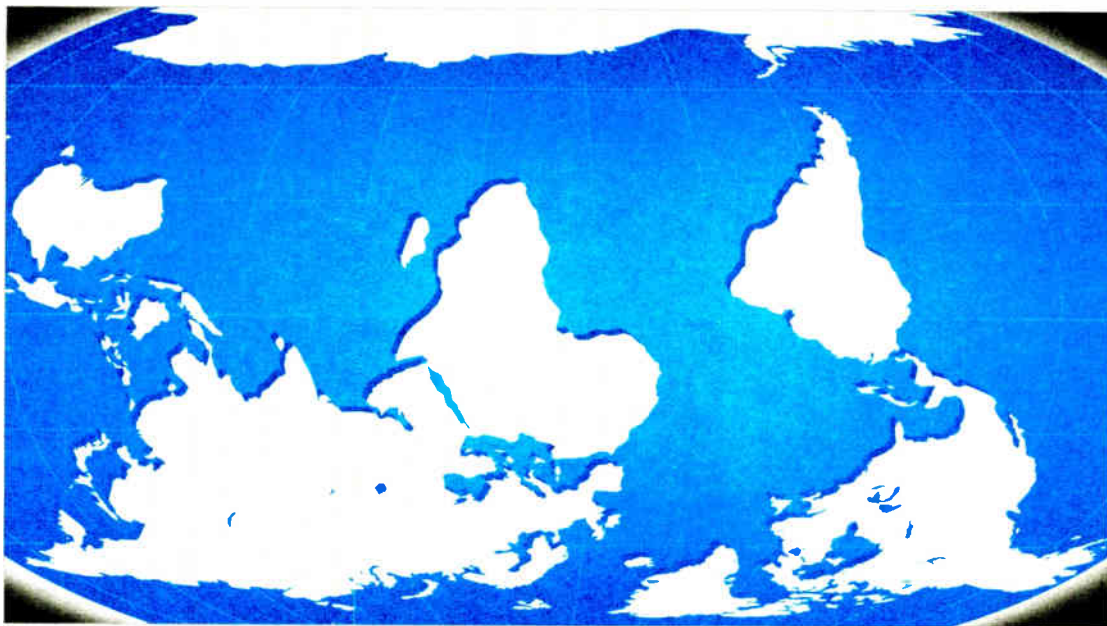

COMPUTER CONCEPTS IS TURNING THE WORLD OF RADIO UPSIDE DOWN

LAS VEGAS- Visitors to the 1995 NAB convention were amazed to see no fewer than six new products for radio from Computer Concepts, makers of DCS™, the world's leading hard disk system. For the first time, one company offers proven products for stations of every size — from 100% live major market powerhouses to fully automated local stations — all working together through the DCS architecture. Some of these new products, while new to the US, have been in use for years in international markets... another advantage of Computer Concepts' world-wide scope. With so many products to choose from, Computer Concepts can now custom-tailor a profit-making system for every radio operation.

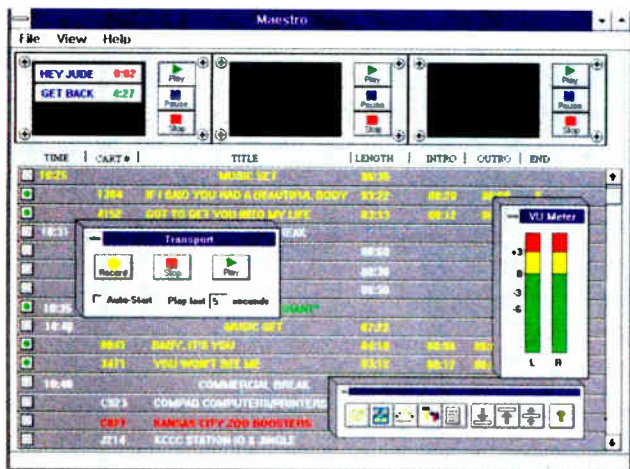

MAESTRO BRINGS MUSIC AND SPOTS TOGETHER.

DCS has always managed commercials and spots flawlessly. Maestro™ now does the same for music, integrating all music and commercial information and control with a Windows™-based on-screen interface. Maestro is the key to accessing music directly from hard disk. It interfaces directly with music scheduling database systems and gives on-air talent total flexibility to execute perfect song-over-jingle-over-song crossfades. Music search by type, artist, etc., intro and outro countdown display and instant access to news and weather info are just a few of the many features which make Maestro the perfect DCS interface for creative on-air control.

Newsroom keeps you up-to-the-minute.

Radio news can be a profit center with Newsroom™, the complete electronic news operation from Computer Concepts. The key word with Newsroom is *efficiency*. The system automatically takes both text and actualities from wire services, networks and other sources. A news person writes and edits copy on screen, linking sound bites to the copy — playing the wrong "cart" is a thing of the past. Editing of audio actualities is fast and precise. On-screen prompting lets talents read final copy right off the screen. Newsroom is fully integrated with DCS and Maestro and can be added to an installed system at anytime.

CARTRACK TAKES THE HASSLES OUT OF LIVE RADIO.

CartRack™ is a field-proven "front-end" to DCS which puts right on the screen all the carts your morning (or other) talent could ever want, for instant, no-hassle access. Individual "racks" of carts can be programmed for each show — there's no limit. Talent uses a touchscreen, trackball or mouse to "point and play" carts to three on-screen graphic "cart machines." Events played from DCS can be controlled by CartRack. It's the easiest way to handle live shows offered by any hard disk system. Let CartRack bring order into your hectic, live, money-maker drivetime shows, and then let DCS automation take over to handle other dayparts.

COMPUTER CONCEPTS - THE POWER BEHIND THE RADIO REVOLUTION.

What makes Computer Concepts stand out of the pack of companies now offering hard disk products for radio? We're customer-driven, and we have been since we started over 20 years ago. We maintain direct contact with our customers before, during and after the sale. We're so proud of our customer relationships that unlike most other vendors, we'll be happy to supply our entire customer list to any prospective purchaser.

DCS from Computer Concepts has long been the leader in automating commercials and spot insertion for stations of all sizes. But the big news this year is an unprecedented array of new products for every facet of on-air operations, and every kind of radio facility. All are field-proven and backed with the kind of customer service that has been instrumental in the success of Computer Concepts.

As your needs change, so can your DCS-based system. For example, DCS systems can be configured to store music, commercials, jingles and other audio cuts either centrally on an audio server or distributed on individual DCS workstations. A new option, Audio Central+ distributed audio, offers both capabilities plus complete fail-safe redundancy.

Another new DCS option developed in response to customer requests allows the system to start playing back material while it is still being recorded. Perfect for delaying network news-on-the-hour for a few seconds or minutes while giving local headlines first.

All the new and exciting Computer Concepts products integrate seamlessly to DCS. It's your assurance that — whichever components you choose to make up your DCS system today — your system can be expanded tomorrow.

Large stations or small, simple system or very complex, today more than ever, there's one place to call for total expertise and total customer responsiveness in hard disk systems. Call Computer Concepts at 1-800-255-6350 and profit from our experience.



8375 Melrose Drive, Lenexa, Kansas 66214 Tel: 913-541-0900 • Fax: 913-541-0169

Leap to Hard Drive Eased by Scott

► continued from page 52

Also on the on-air system is the Manual/Auto button. In manual mode the system finishes the event on the air and waits for a key press (or screen touch). A DJ could leave it in manual and start every audio event just like we have for years.

Events are fired using end-of-message (EOM) tones. Once the tone is in the right spot, the next event starting point will always be perfect. What a weird feeling to outro the song going into the stop-set, manually start the first spot, put it back in auto, and the spots, weather, jingle and next record all roll on their own, perfectly. Our staff runs it in auto-

mode and DJs jump in over intro times without ever touching the keyboard.

The Production Bank makes dubbing spots and music to hard drive easy. EOMs can be moved after they are

drive slot accommodates rotators, just like putting multiple cuts on one cart. The difference is that if you have a problem dubbing cut five, you do not erase and start over with cut one.

Do not plan for weeks of training; the system is so simple, folks at our station picked it up in minutes.

placed to assure they end up in the perfect spot. If the dub is too loose or too tight, it may be trimmed. Each hard

I mentioned that the system comes complete with music. Scott Studios must have an amazing record library.

**I F YOU'RE IN RADIO...
HERE'S YOUR
OPPORTUNITY TO TELL
YOUR STORY TO EVERY
MAJOR MARKETING,
ADVERTISING AND AGENCY
EXECUTIVE IN AMERICA.**

This special section will illustrate the incredible radio story, how for 75 years, America's first mass medium helped shape and mirror American life and history. How radio made most of the products and services we know today household brands.

This special radio section will illustrate each of radio's decades, its impact on America and the world. We'll take an in-depth look at the people, the music, the entertainment, the news, the research and radio's critical role in the marketing mix. We'll detail how radio works for American marketers yesterday, today and explore how it will work well into the 21st Century.

THE OPPORTUNITY:

If you're a radio network, representative, group owner, advertising or promotion agency, research company, syndicator or have any involvement in radio...this special 75th Anniversary section will be the most comprehensive vehicle you could ever have to deliver your message to virtually every major advertiser and agency in America.

THE CIRCULATION:

This story is so important to American marketers there will be one of the biggest bonus distributions in Adweek history in addition to the Adweek / Mediaweek / Brandweek circulation of 91,000 there will be a *Special Bonus* distribution of 15,000 to:

*NAB Radio '95 Convention (Sept. 1995)

*The Association Of National Advertisers (ANA) Annual Convention (Oct. 1995)

*AAAA (American Association Of Advertising Agencies) Media Conference (Feb. 1996)

*Ad Club Of NY-Radio 75th Birthday Luncheon (Nov. 2, 1995)

If you've been part of the radio story or are involved with radio this is an opportunity you can't afford to miss.

FOR MORE DETAILS AND ADVERTISING INFORMATION CALL:

Robin Haas	(NY)	212-536-6532
Steve Crane	(Chicago)	312-464-8530
Ami Brophy	(LA)	213-525-2276

ISSUE DATE: SEPT. 4TH, 1995

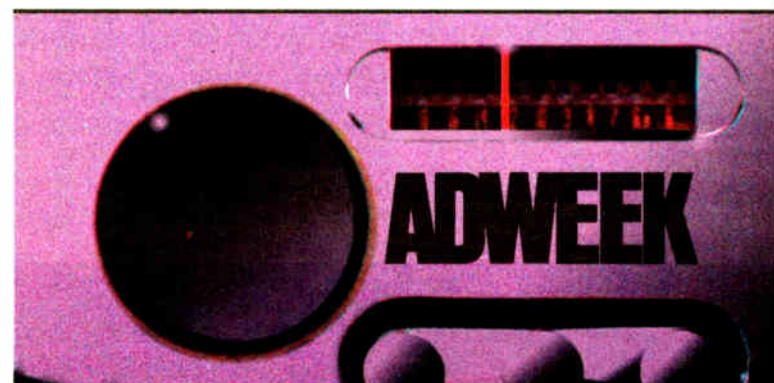

BE A PART OF
RADIO
HISTORY

Radio
1920-1995
75TH
Anniversary

ADWEEK
MAGAZINES
PRESENT

THE
SPECIAL
RADIO
75TH
ANNIVERSARY
COMMEMORATIVE
SECTION

Scott's music guy, Bob Stevens, has gone to great lengths to find the premier version of each cut. Everything is high quality with perfect EOM placement. You tell Scott Studios the songs you want, regardless of format, and they ship the system with your selections.

Music software

To run the Scott System, you need compatible music and traffic software. The Scott System merges the playlist and the traffic schedule for each day's programming.

Our music software is MusicMix, a program that I developed and market nationally. After installing the Scott System at KDZA, I rewrote many areas of the MusicMix software to more seamlessly integrate with Scott. It easily handles song intros and outros, which can be recorded up to a week in advance for unassisted operation. It allows scheduling jingles, liners, IDs, even programs, as well as the music, according to your format clocks and scheduling rules.

Because we operate automated overnights and Sundays, one of our main motivations for moving to the Scott System was our frustration with not being able to find part-time talent for those time slots. Now, our main talent is on the air around the clock. They go on vacation, they are still on the air. Somebody is sick, we just lay down some voice tracks, reschedule in MusicMix and get back to our normal day. It takes 10 to 20 minutes to track a four-hour show.

Triple overlap

Scott's voice-tracking ability was a major selling point for us. A unique part of the system is the use of three (rather than two) audio cards. They call it "triple overlap." As a song is fading on card one, card two activates with the intro and instantly fires card three with the next song under the intro. For a moment during the transition, all three sources are on air at once and you have a live-sounding radio show.

How much do we like our Scott System? In January we bought a second one for country KCCY(FM). This time our goal was not unassisted operation but rather the improvement in audio quality that comes with the hard drive.

A Scott System in a duopoly makes perfect sense. We send every commercial we produce to the hard drives of both stations. We never worry about what spot belongs where, and we always have a backup of everything we produce. Talent from one station is available to do voice tracks on the other.

What would I change? Sometimes it would be nice to listen to a spot or song on cue before putting it on air. We often need to verify if something has been updated, for example. Scott tells me this feature is coming soon. I would also love to have the music library section tell the jock when a song was last played.

This system is a new way of doing radio. It will make your station sound better and enable better utilization of your most expensive resource: your staff.

For information, contact Dave Scott in Texas at 800-726-8877; fax: 214-620-8811; or circle Reader Service 194.

USER REPORT

UDS2 Transforms Florida Stations

by **Barry Grant Marsh**
Operations Manager
WSTU(AM)/WHLG(FM)

STUART, Fla. On May 25, 1994, radio history was made and the way radio is done in the United States was changed forever.

That was the day WHLG(FM) became the first UDS2 radio station in the United States. The technology, developed by **TM Century**, was brand new. There were only two other radio stations in the world operating with UDS2: one in England, the other in Kuwait.

Daring

At the time, neither I nor my general manager realized how daring we were. UDS2 has changed our lives. It transformed our inconsistent on-air sound into a virtually trouble-free operation.

The UDS2 consists of the Z4000 professional computer that operates and interfaces with Computer Concepts' digital commercial system and the Sony CDK 3600 Jukebox, giving us a complete digital sound, as well as a competitive edge in the marketplace.

There are no cart or reel-to-reel machines in our control room. All commercials and promotional

Every second of our broadcast day is controlled via the UDS2 utilities software that interfaces with the



The UDS2 gives WSTU and WHLG digital sound and a competitive edge.

announcements play on the hard drive of the DCS through the UDS2 audio controller.

Powergold music scheduling program. Our sister station, WSTU(AM), was one of Powergold's earliest customers, so we were well acquainted with the software. But we could not believe the performance level we attained with the software program in UDS2. It schedules all of our stop sets and songs and

gives us a flexibility far beyond satellite music operations.

When we purchased our first UDS2 system from TM Century, WHLG was in the midst of a complete format change. We were the top radio station in the market with a beautiful music/nostalgia-type format and watching most of our audience of 25 to 54 year olds erode. We moved to a light AC format.

With the help of TM Century's Golddisc no-noise music library and the 360-CD capacity of the Sony CDK 3600, our delivery problems were solved. Our first Arbitron was a winner. We more than doubled our 25-to-54-year-old demographics, and our clients are pleased with the new audience.

Low maintenance

With any new technology, there are bound to be problems. I am happy to say the problems we have encountered with UDS2 have been minimal. The maintenance of the equipment has been incredibly low. We have kept it sheltered from power failures using Best interrupted power supplies. Our maintenance tool is a vacuum cleaner/blower for dusting purposes. There are no heads to buy or align, no pinch rollers to worry about. In fact, if the only thing our chief engineer had to worry about was repairing or maintaining the UDS2, he would resemble the Maytag repairman.

TM Century's trouble-shooting team has been tremendous. Its software

continued on page 56 ►

USER REPORT

DCS Draws Duopoly Back To Computer Concepts

by **Dan Kelley**
Operations Manager
KKFG(FM)-KDAG(FM)-KCQL(AM)

FARMINGTON, N.M. One way to determine if a company's product is successful is to see if a new customer becomes a repeat customer. By that definition, the **Computer Concepts'** DCS system is definitely a success for us.

We are a three-station duopoly that includes KKFG country FM, KDAG classic rock FM and KCQL oldies on AM. We also have an LMA AM in KRZE with a Spanish format.

Back for more

We purchased two DCS digital commercial systems from Computer Concepts several years ago, and two years later, we came back to buy two more systems. Now we have three of the systems running 24 hours in half-satellite-automated, half-live formats on KKFG, KDAG and KCQL with one system as a backup.

We went with Computer Concepts because of the company's reputation and because the DCS can perform several important functions simultaneously. DCS has the ability to air the satellite program—with full liners and local announcements—and at the same time record another satellite feed and put in its unique liners for later playback.

As far as I know, no other hard disk system has the ability to perform this 2+1, as it is called by Computer Concepts. This feature was important to us because we were considering adding a network feed that would require just such magic, and the DCS was the ideal choice. When I saw how seamless the whole process would be, I thought it was incredible.

I also like the automatic time-check feature that lets our jocks record specific and accurate time checks for later air. Because we never have to air those generic "10 past the hour" checks, we always sound local to our listeners. This really lets us cut costs, make full use of the satellite formats and do well in the ratings. Our two FMs are two of the top three FMs in the Farmington market.

It was easy to train our staffs to run the DCS without too much trouble; even the computer-phobic personnel adapted to it with little trouble. We also like the fact that DCS is connected to Computer Concepts' traffic system. Because of this, we always have verification that spots are aired when they should be.

I appreciate Computer Concepts' commitment to its customers and their around-the-clock support. Some time ago a power supply went bad, and I received a new one the next day. We have even called them late at night and gotten a quick turnaround.

The hub

We put DCS in as the hub of our station equipment so that all our equipment integrates with it. That is an important consideration as radio station gear becomes increasingly digital. It is also good to work with a company that we know will be there for us when we need to upgrade or add equipment.

Because of all this, it is not hard to understand why customers like us who start with DCS tend to return for more. In a digital hard-disk marketplace that is more crowded than ever, a satisfied customer is truly the best measure of success.

For more information, contact Computer Concepts Corp. in Kansas at 800-255-6350; fax: 913-541-0169; or circle Reader Service 148.

PROOFS IMPROVED

FM and TV-BTSC AUDIO PROOF TESTING is reduced from hours to minutes with System One from Audio Precision... Automatic proofs run properly at constant deviation, plotting the required generator amplitude... and when finished, the results are stored in graphic form for your records.

SPLIT SITE proofs are simple with System One's available separate generator and analyzer configuration. With immediate capability to view and control both instruments, it's like being in two places at once.

THE REST OF THE TIME System One is the universal audio test set for maintaining any audio device or channel... STLs, consoles, carts, cassettes and RDATs, digital recorders and workstations... System One is the only product that can completely test both your analog and digital audio.

Call 800/231-7350 for our 36 page color catalog... and when you're ready our representative will arrange for an on-site demonstration.



Audio precision

P.O. Box 2209
Beaverton, OR 97075-3070
503/627-0832, 800/231-7350
FAX: 503/641-8906

Circle [35] On Reader Service Card

USER REPORT

DAD486x Takes on Demanding Facility

by Paul Barzizza
Chief Engineer
WMC-AM-FM-TV

selves and subsequent calls to Enco, the DAD really began to set in our minds. Recording, playback, and cut-

prietary hardware.

We ordered seven workstations to operate on a local area network, uti-

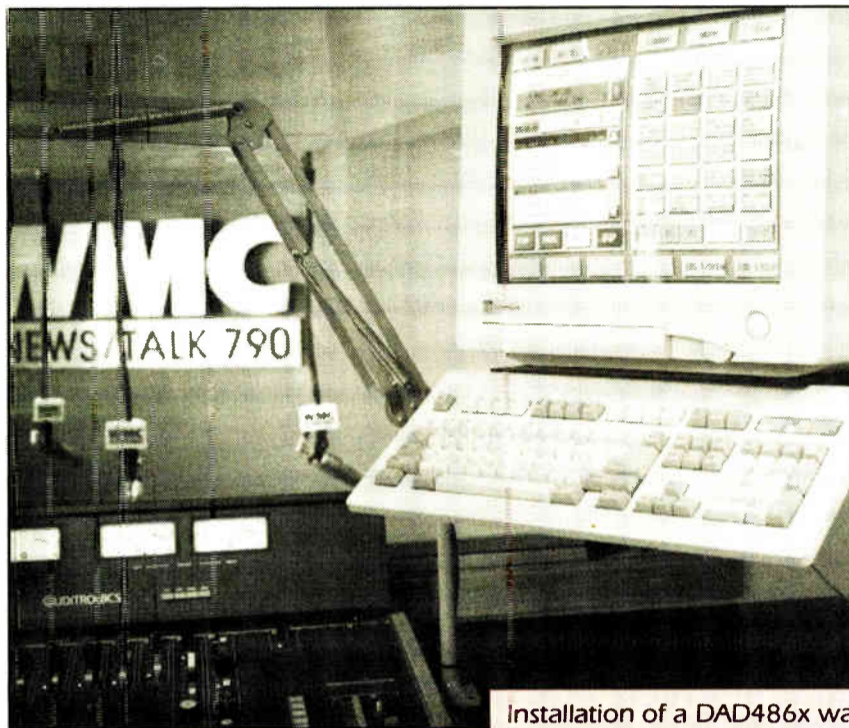

Installation of a DAD486x was part of a massive renovation at WMC.

and-paste editing are all done quickly and cleanly with the ease of tying your shoe. It interfaces with scheduling and other equipment and runs on non-pro-

lizing a common file server with redundant store. Although we felt that this was the right system, we were still apprehensive about tying the reputation and credibility of WMC to networked computers. Six months later, hindsight tells me that our fears were unwarranted.

WMC has not had to modify our operation procedures at all. The DAD486x dropped right in and was immediately productive. One of the fears that staff members had prior to the arrival of DAD was the fact that they could not hold a tape cart in their hands and carry it from one newsroom to another to be played. But with DAD

in a networked configuration, anything done on one workstation is immediately available at any other workstation. Any fears or hesitation were eliminated after the systems were put into use.

As a full-service, 24-hour station with live shows, traffic, news, weather and sports, WMC is a demanding facility. We also receive satellite feeds, some to be time-shifted, some edited, and we take great care to achieve a quality sound in all cases. DAD allows us to accomplish more with less equipment than before. The operators love DAD because we can throw anything at it and it performs flawlessly. The touchscreen interface makes operation a breeze.

Command cuts

Some of my favorite features of DAD include the ability to play, record and edit simultaneously on any one workstation; arrays and mini-arrays; panels of buttons that each jock can assign pieces of audio to for immediate playback; and auto-timed recording. Command cuts are helpful programmable logic macros that cause internal or external events to occur either manually or automatically and, to my knowledge, are not available in other systems. One of our Command cuts, for example, causes DAD to refer to our facility's master clock and "sync up" once every hour. This happens automatically, with no interruption of any operations on DAD at the same time.

DAD486x has been of significant benefit to the WMC stations. Later this year, we plan to install at least three more workstations for WMC-FM 100. Our reasons are simple. This equipment purchase has been enjoyable and beneficial for all of our departments, encompassing sales, programming, management and engineering.

Considering all of the economics—the product's flexibility, user-friendly operation and, above all, the 24-hour-a-day service and support from Enco—other choices have been eliminated.

For information, contact Larry Lamoray in Michigan at 810-476-5711; fax: 810-476-5712; or circle Reader Service 210.

MEMPHIS, Tenn. WMC(AM) underwent massive change during 1994. After almost 75 years of broadcasting under the same ownership, the station was sold to Ellis Communications.

In the age of automation and cutting the middle line, Ellis takes a bright, fresh approach of growing the top line. For WMC, this meant a total rebuild, including all new studios—four newsrooms, master control, production and a talent studio. We knew that we could not install tape-based equipment in 1995.

Not adequate

I researched every digital audio system I could find, from the smallest to the largest, but even the best-known systems were not adequate for our demanding needs. Then I saw an ad for the DAD486x from Enco Systems.

After calling Larry Lamoray at Enco and receiving a fax outlining the features and capabilities of the DAD486x, I decided that this product warranted a closer look. A quick day trip to Enco's facilities in the Detroit area and a hands-on demonstration of the DAD piqued our interest.

After the trip, discussions among our-

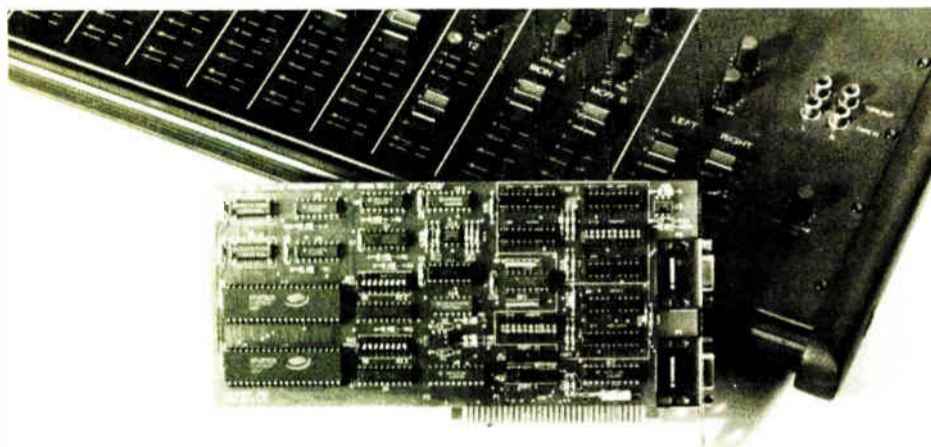

PC-Based Automation and Control

DAT / VTR Control

Synchronize intelligent DAT players and VTRs using SMPTE 207M machine control from your PC. The AV-COM provides two ports with Sony™ 9-pin connectors selectable as SMPTE 207M, PA-422, RS-232, or MIDI digital control.

Cart Deck Automation

Automate the playing of prescheduled ads and commercials from multiple cart decks. Your automation project will require more than 2 PC COM: ports. Our COMM+ products provide 2, 4, or 8 high quality ports to make your automation task simple and reliable.

Satellite Control

Control your Satellite system or video teleconferencing equipment. Use a PC to monitor and control dish positioning, frequency monitoring, and alarms. Our Digital I/O cards provide optically isolated inputs and reed/latching relay outputs to suit your task.

► continued from page 55

updates have made the UDS2 technology virtually bulletproof. If we noticed a problem or wanted UDS2 to do something better, TM's team offered a solution very quickly. It also helped Computer Concepts and Powergold update their software programs to communicate better with the UDS2 system.

Exactly nine months after the first installation, we installed our second UDS2 at our AM facility, WSTU. This installation took about half the time of the first. WSTU is an AM oldies station with a 40-year heritage in the Stuart/Ft. Pierce/Vero market. Westwood One's New Gold on CD supplied us with our library of songs from the 50s, 60s and 70s.

Rockin' and rollin'

I was able to rebuild our music database using Powergold and loaded the entire library of CDs into the Sony CDK 3600 Jukebox. We have been rockin' and rollin' ever since. UDS2 makes our AM sound like an FM. We use the audio controller and the UDS2

Net Join card to our advantage. WSTU is also an ABC Information Network affiliate. At the top of every hour, UDS2 fades out a song, plays our ID and joins ABC right on time.

Our announcing staff is bilingual—they speak AM and FM. The UDS2 technology enables us to utilize our talented staff on both stations at the same time in various dayparts. Our morning and afternoon drive personalities on AM are live. Our midday, evening and overnight personalities digitally produce their shows on the hard drive for WSTU while performing live on the WHLG. We save on overhead without sacrificing the local sound or control of the radio stations.

UDS2 allows you to become what your license says you are: a public trustee. It gives both our stations a major-market sound and the ability to edge out the competition. The only thing worse than not having a UDS2 from TM Century at your station is competing against one that does.

For information, contact John Schaab in Tex...as at 214-406-6800; fax: 214-406-6890; or circle Reader Service 173.



PO BOX 830
LIBERTY, SC 29657
(803) 843-4343

Other
Products
Available!

Circle (122) On Reader Service Card

Products & Services Showcase

For more information on the products shown below, circle the appropriate Reader Service No.(s) on the enclosed Subscription/Reader Service card or contact the advertiser directly.

Three's Company, Not a Crowd with RDL Rack-Ups™!

Compact tools to make your job easier. Three of these IHF-Pro Interfaces ... audio or video DAs ... Mic Preamps ... Line Amps ... Audio Meters ... and/or Video Attenuators fit in one rack space! All feature advanced circuitry and great specs ... plus reliability that's backed by a THREE YEAR Warranty! There are 9 RACK-UP™ audio and video tools from RDL™. Call us today at 800 281-2683 or 805 684-5415 for your free catalog to see which ones you need to solve your problems!

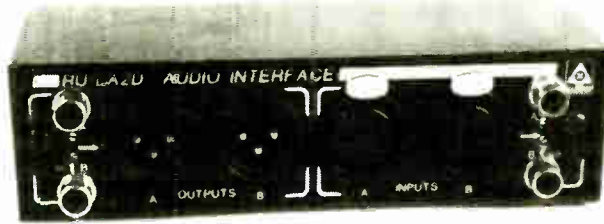

RDL Radio Design Labs

P.O. Box 1286 ■ Carpinteria, CA 93014

In Europe call (31) 20-6238 983 Fax (31) 20-6225 287

© Radio Design Labs

READER SERVICE NO. 211

Quality* Power Tubes

3CX15,000A7	4CX1600B	4CX250R/7580W
3CX15,000A3	4CX1500A	4CX250BT
3CX10,000H3	4CX800A	4CX250BC/8957
3CX10,000A7	4CX400A	4CX250B/7203
3CX3000F7/8162	4CX350AC	4X150A
3CX3000A7	4X350A/8321	5CX1500B
3CX2500H3		5CX1500A
3CX2500F3/8251		YC130/9019
3CX2500A3/8161		8560AS
4CX15,000A/8281		811A
4CX10,000D/8171		833A
4CX5000A/8170		833C
4CX3500A		



- Watch this list grow.
- Manufactured in Russia's largest power tube factory.
- Shipments from USA stock.
- Generous* warranty based on high quality.
- Honest prices based on quality at low cost.

Broadcasters

Phone: 205-882-1344
FAX: 205-880-8077
800-239-6900

OEMs, Distributors

Phone US: 800-578-3852
Int'l & US: 415-233-0429
FAX: 415-233-0439

READER SERVICE NO. 146

CartWorks Digital Audio Systems

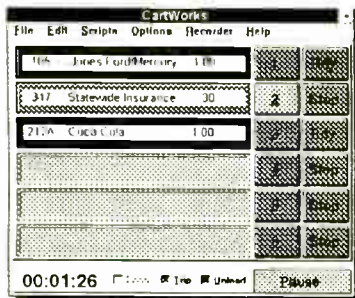

Going Digital just got easier!

The power of Windows* with the look and feel of broadcast equipment. CartWorks is the smart new choice for live or automated Radio. It's Built for Broadcasters...

To learn more, call dbm Systems today.
1-800-795-RADIO Fax (601) 853-9976
(7234) *Windows is a trademark of Microsoft

READER SERVICE NO. 7

Unique!

Shively FM Antennas offer standard features often unique in the industry: Our unique fine-matching transformer, included as standard equipment on Shively commercial antennas, can correct VSWR mismatches of up to 1.5:1 to compensate for tower effects. Unlike most others, it is tunable both under power and pressure, so it requires no disassembly of the system, and no adjusting of taped slugs for tuning. This means a better match, with less rigging time and costs. Watch future issues of **Radio World** for other unique Shively features.

Shively Labs

A Division of Howell Laboratories, Inc.
19 Harrison Road, Bridgton, ME 04009
207-647-3327 FAX 207-647-8273

READER SERVICE NO. 110

COST-EFFECTIVE PROGRAMMABLE PATCHING

REPLACE 16 PATCHCORDS IN A SINGLE KEYSTROKE



AM-16 SERIES PROGRAMMABLE AUDIO SWITCHER

- 16x16 switching matrix, balanced inputs & outputs
- Non-volatile storage of 100 programs
- Serial interface Expandable to 5 levels deep
- Multi-station remote control Level adjustment for each input Exceptional audio performance

Routing multi-channel audio and time code signals electronically outperforms patch bays for speed and reliability. The AM-16 allows for a variety of system configurations in small to medium size applications and is priced far less than any other alternative — a complete 16 x 16 matrix for only \$1,495.

360 Systems

PROFESSIONAL DIGITAL AUDIO
5321 STERLING CENTER DRIVE WESTLAKE VILLAGE, CA 91361
PHONE (818) 991-0360 FAX (818) 991-1360

READER SERVICE NO. 3

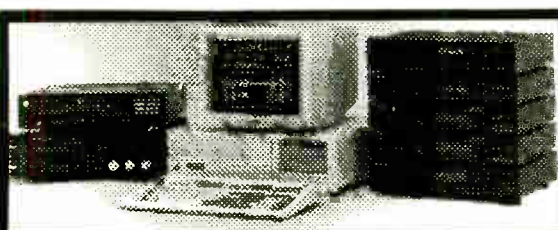

Pristine SYSTEMS INCORPORATED
DIGITAL ON-AIR SOLUTIONS

- Feature Rich Live Assist and Walk Away
- On-Line Redundancy...No Black Box
- The Best Integrated Play List Scheduler (Music & Breaks) & On-Air Playback
- Dolby AC2 Overlapping Hard Disk Audio
- Music on Hard Disk and/or CD Jukeboxes
- Provide Computers/Players & Save \$\$\$ or Buy/Lease From Us

WEST/INT'L EAST
310/670-7500 803/370-2400
FAX 310/670-0133 FAX 803/370-2314

READER SERVICE NO. 209

UNIVERSAL SCPC XE-1000

SCPC BROADCAST AUDIO RECEIVER

New, affordable, frequency-agile receiver. direct channel entry by keyboard, selectable companding 1:1, 2:1, 3:1, wide/narrow bandwidth, de-emphasis selectable, 950-1450 MHz, line output 600 ohms, muting, transponder agile, LNB power supply, 50-channel memory, full baseband output, high-quality audio. Every needed feature at a sensible price (lowest in the industry). Write or call for full information on this quality receiver—the answer for your station. Networks call for prices.

UNIVERSAL ELECTRONICS, INC. Communications Specialists 4555 Groves Road, Suite 12 Columbus, OH 43232
Phone: (614) 866-4605 Fax: (614) 866-1201

READER SERVICE NO. 168

USER REPORT

Gemini Replaces Aging Analog Equipment

by Larry Wilkins
Chief Engineer
Colonial Broadcasting

MONTGOMERY, Ala. In past years, new technology usually started out at major-market stations, then worked its way down to medium- and maybe small-market stations. With the digital revolution, this trend has reversed. As aging analog equipment approaches the end of its life, stations of all sizes realize that switching to new digital equipment is more cost effective.

One example of cost-effective digital

equipment is the Arrakis Gemini control panel. Simply put, this control surface interfaces with a standard Digi-Link and simulates some 250 cart decks, loaded and ready to play at the touch of a button. Like carts, files can be stacked and played. These 250 or so files can be different for each one of up to 40 announcers. Assigning files is as easy as point and click.

Cartwall buttons

These "cartwall buttons" replace cart machines in your studio. The Gemini panel also includes a replacement for

your reel-to-reel machines. These are called "smart record" buttons. By selecting a smart record button, you can record anything you like while you are on the air. Once the file is recorded, you can play the file with the same button, or drop it onto the edit screen to cut or splice however you like. These buttons work extremely well for recording phone conversations with listeners.

We use the smart record buttons to record weather forecasts from a local TV station. The feed contains four separate cuts that are recorded on one smart record button. Then the board operator simply drops the file on the edit screen and marks each cut and assigns it to a separate button for playback. All this can be done during one CD cut.

Often you get a great telephone comment that you would like to use on the air edited, but that you also

next-to-play. In the standard Gemini setup, each side uses a separate Digi-Link system. Each Digi-Link can use separate audio inputs, allowing cross-fades and level adjustments for each side.

At this year's NAB, Arrakis introduced the Gem1, which runs from one Digi-Link. This unit allows three different audio files to play at the same time.

Options

One of options with the panel is a video switcher. The top of the surface features six selectors, which allow the use of a mouse, keyboard and monitor for up to six separate computers, such as a newswire or your office computer. Five other buttons allow for the control of other Digi-Links. A clear overlay is available to label the buttons; however, we found it was just as easy to put stick-on numbers on the buttons, with

8 TRACK DIGITAL EDITING BREAKS PRICE BARRIER \$5,495*

- A digital audio editor designed for *Radio* production
- Learn to use in minutes, *much faster than tape*
- Cut, splice, move, and fade up to 4 stereo tracks
- Use Scrubbing to edit with your ears
- Use visual waveform editing to edit with your eyes
- An UNDO button enables you to go back and fix mistakes
- Digital Networking to transfer audio to your On Air machine
- Add Trak*Star-8 software to a DigiLink for only \$2,000

Trak*Star-8 is the first cost effective multitrack digital audio editor designed for the radio broadcast professional. Fast and easy to use, produce your commercials on Trak*Star and then transfer them in digital straight to the DigiLink in your On Air studio. Dramatically reduce production time and save money !!!

For more information, call or write
ARRAKIS,

(303) 224-2248

Consoles
Modulux
Trak*Star
DigiLink
Modulink

the premier broadcast manufacturer of consoles, furniture, DigiLink and Trak*Star digital audio products.

ARRAKIS

* Suggested retail price. Complete system

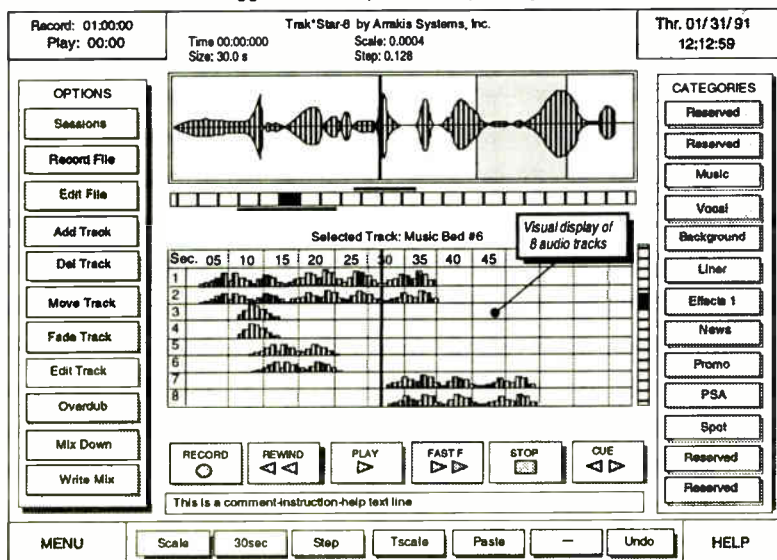

© 1993 Arrakis Systems inc. 2619 Midpoint Drive, Fort Collins, CO. 80525

Circle (118) On Reader Service Card



Larry Wilkins with the Gemini panel, installed in a Gem6 console.

want to save in its original form for use in a promo. Before editing, simply transfer the file to another machine in your station, or copy it to another file name on the cartwall. You then can edit and play it on the air. After your shift, go to the production room and create your promo from the original file.

Two sides

The Gemini control surface is divided into two sides, the left side, or cartwall, contains the cartwall and smart record buttons. Normally, these buttons contain jingles, promo, IDs, etc., that you drop over or between music cuts.

The right side consists of the playlist that normally contains your commercial files and traffic log. As with a standard Digi-Link, you can edit the spot playlist, changing the order or inserting files at either the end or

a legend sheet posted nearby.

Installation of the Gemini is easy. It comes as a standalone panel in its own table-top cabinet, or it can be installed in the center of an Arrakis console. All necessary cables and power supply are furnished.

The picture shows the panel installed in the Gem6 console. As an added feature, Arrakis can supply individual "smart modules" that fit in a standard 12,000 series console.

We found that the learning curve is very short because the panel operates like a reel-to-reel or cart machine. Editing is simply mark and cut, similar to using a grease pencil and razor blade. Both our FMs have been using the Gemini panel for several months with no failures or complaints.

For more information, contact Jon Young in Colorado at 303-224-2248; fax: 303-493-1076; or circle Reader Service 38.

Why are we so confident our consoles are RFI immune?
Because we've installed them in some of the most
hostile environments imaginable, in thousands of facilities
around the world.

With no RFI problems.

Guaranteed.



PR&E consoles. When reliability is the most important consideration.

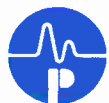

PACIFIC RECORDERS & ENGINEERING
2070 Las Palmas Drive, Carlsbad, CA USA 92009
Tel: 619-438-3911 Fax: 619-438-9277
GSA CONTRACT: GS-03F-4064B

DESIGNS THAT MAKE A DIFFERENCE

Circle 180 On Reader Service Card

USER REPORT

Wizard Gives Stations Local Sound

by John Marquis
Operations Manager
KOGA(AM)-FM/KMCX(FM)

OGALLALA, Neb. One of the keys to sounding local is to never think of your stations as anything other than live and not to use satellite programming as a crutch.

We use Westwood One programming

for all three of our stations. Our AM, with an adult standards format, uses Westwood One's "AM Only." KOGA-FM is adult contemporary, carrying Westwood One's AC, and KMCX(FM) uses Westwood One's Country. We broadcast a live morning show on our AM. All three 24-hour stations utilize off-premises control evenings and weekends for unattended operation.

We go to great lengths to make sure our satellite announcers sound as if they are sitting in our control room. The Audio Wizard for Windows digital audio system from Prophet Systems offers us a variety of ways to achieve this.

Inserting liners

Inserting call letter and image liners is simple with almost every satellite

automation system, but not every system is flexible enough to insert special liners in certain dayparts. The Wizard allows us to rotate specific liners with more generic ones to prevent the generic liners from burning out quickly and to add to the local live sound.

For instance, listeners depend on your station for weather forecasts and updates. Your satellite announcers can record liners such as: "We'll have highs in the 80s today. For all the latest weather information, stay with us on KOGA-FM."

Or maybe you want to use liners to promote your local ball game. Simply set up a rotation schedule to rotate these liners with others, and daypart them so they play only at the right time. You can also generate additional revenue by using your image liner availabilities as short commercials. Advertisers love this because it is an effective way of keeping their name before the public and not lost in a spot block.

You can also make your station sound local with temperature announcements. All day every day, even overnight and on weekends when no one is at the station, Audio Wizard for Windows announces

Never think of your stations as anything other than live.

the current temperature. Our local announcers record the complete range of expected temperatures and program the Wizard to play the current temperature after our recorded weather forecast. The Wizard allows us to tie satellite announcer temperature checks to some of the call letter liners.

Time checks

To add time to the mix, our satellite announcers record five-second time checks that can be played at the end of a spot block a couple of times per hour during their shift, or tied to a short image liner call. Also, our IDs at the top of the hour give the time in the satellite announcer's voice.

I cannot imagine any other digital automation system that would allow us to be as flexible with liners. In fact, the satellite DJs are so intrigued by the time and temperature announcements they have cut, they have asked me to record air checks.

There are a number of other features of Audio Wizard for Windows that make life easier, including hard drive automation, voice tracking, a real-time digital editor and digital reel-to-reel.

If you think that satellite radio sounds "canned," then you have not heard a station utilizing all of the Audio Wizard for Windows features. This system is the most flexible and powerful digital automation system on the market.

Before we bought the Wizard, we employed 18 to 20 full-time people and two to three part-timers for two stations. Now we operate three 24-hour stations with a full-time staff of 14 and two part-timers. The Wizard allows us to better utilize our staff, save money, sound better and, ultimately, better serve the community.

For information, contact Kevin Lockhart in Nebraska at 800-658-4396; fax: 308-284-3517; or circle Reader Service 158.



The Power Studio From Roland

The new DM-800 provides power, speed, portability and reliability like no other system available.

Power Eight discrete tracks with 100 layers per track. 12 channel automated mixing and EQ. Time compression and pitch correction. Nondestructive, full featured editing. Sub-frame accurate SMPTE sync. Optional ADAT, DA-88 or RS-422 interface.

Speed The DM-800 is easy, fast and quick to learn, using powerful hardware controls with tape recorder style punch in and out. No computer required.

MIDI Support The DM-800 supports MMC, MTC and dynamic functions like tempo mapping, bar and beat editing,

control of external sequencers and trigger mode for instant phrase playback.

Portability All the features and functions you need are contained in a single 12 pound unit. You can literally grab it and take it with you. Uses internal and external SCSI drives. View any level of information on the built-in LCD or plug the DM-800 directly into your video monitor.

Reliability The DM-800 is a completely dedicated piece of hardware with Roland's renowned reliability.

Price Incredible Power. Incredible Price. \$5995.

Call today for your free brochure and video.

Roland

Roland Corporation U.S. 7200 Dominion Circle Los Angeles, CA 90040 (213) 685-5141 Ext. 756 Fax (213) 726-3267
Roland Canada Music Ltd. 5480 Parkwood Way Richmond, B.C. V6V 2M4 (604) 270-6626 Fax (604) 270-7174

Circle (67) On Reader Service Card

The Next Generation Digital Audio System

Satellite • **A**utomation • **L**ive • **S**tudio **A**ssistant



The screenshot shows a software interface for audio control. At the top, it displays a timer '02:29:32' with an 'ON' indicator and a clock '22:09'. Below this are stereo level meters for 'L' and 'R', and status indicators for 'ON AIR', 'PAUSE', and 'ERROR'. A central table lists a music schedule with columns for time, artist, title, and duration. Below the table is a 'SPORTS NEWS' section with a text feed. On the right side, there are several control buttons: 'ON AIR', 'PAUSE', 'STEP', 'MENU', 'CLOCK', 'TIME EVENT', 'SEARCH', 'TEXT', 'TITLE', 'NEWS', 'ARTIST', 'SPORTS', 'ALBUM', 'WETHR', 'TEMPO', 'STOCKS', 'THEME', 'LOCAL REPORT', 'TIME', and 'FARM REPORT'. A callout box points to the 'ARTIST', 'SPORTS', 'WETHR', 'STOCKS', 'LOCAL REPORT', and 'FARM REPORT' buttons, stating 'User Programmable Database Search and Store Parameters'.

Live Assist Screen Pictured

User Programmable Database Search and Store Parameters

Now 486 Power!

LPB SALSA - \$8,995

~~386DX33~~ PC System with 1 Gigabyte Hard Drive
Open-ended architecture, always upgradeable
Simultaneous Record and Play of audio
Stereo and Mono audio

User-controlled variable audio overlap for live-sounding segues
Accepts downloads from all standard traffic and music scheduling systems
Provides a 31-Day historical log of everything that aired and when
System support available 24 hours a day, 365 days a year

Live Studio Assist (included)

Full color and easy graphics
Control completely by mouse
Play any hard drive audio immediately or via schedule
Search spots and music by up to 6 different categories
Identification of bad audio files - before they air

Satellite Automation (included)

Up to 15 stereo satellite networks, unlimited events/hour
Record for delayed broadcast - automatically
21 Format clocks - changing automatically as you wish
Up to 8 control outputs for other sources or equipment
Walkaway operation with full confidence

You Can Rely On LPB.

LPB SALSA Available Worldwide From LPB Audio Products Dealers
LPB, Inc. 28 Bacton Hill Road, Frazer, PA 19355 USA. Phone +610-644-1123, Fax +610-644-8651

Circle (125) On Reader Service Card

Move Up from Tapes to Touchscreen Digital Audio

Play Any Audio at a Touch

Nothing else makes radio as fast or easy as having all your spots, sounders and sweepers start with your fingertip—always on-line and ready to play from hard disk. And nothing else makes your station sound as good or as exciting as touchscreen digital and creative talent with Scott Studios' new CompuCarts!

If you've used carts, you already know how it works: Six "cart decks" on the computer touchscreen play what's on your program log. Scheduled spots, promos, PSAs and jingles come in automatically from your Scott Studios' Production Bank and your traffic computer. You see legible labels for everything, showing full names, intro times, lengths, endings, announcer initials, outcues, posts, and years. Your jocks can rearrange anything easily by touching any cart and moving it to any other cart. Spots with one number that rotate several cuts work just like carts, except additions, deletions and changes are much easier. Large digital timers automatically count down event times, and flash end warnings.

At the bottom, 10 "hot keys" start *unscheduled* jingles, sounders, effects, comedy bits or promos *on the spur of the moment*.

You also can select audio from lists of all your recordings.

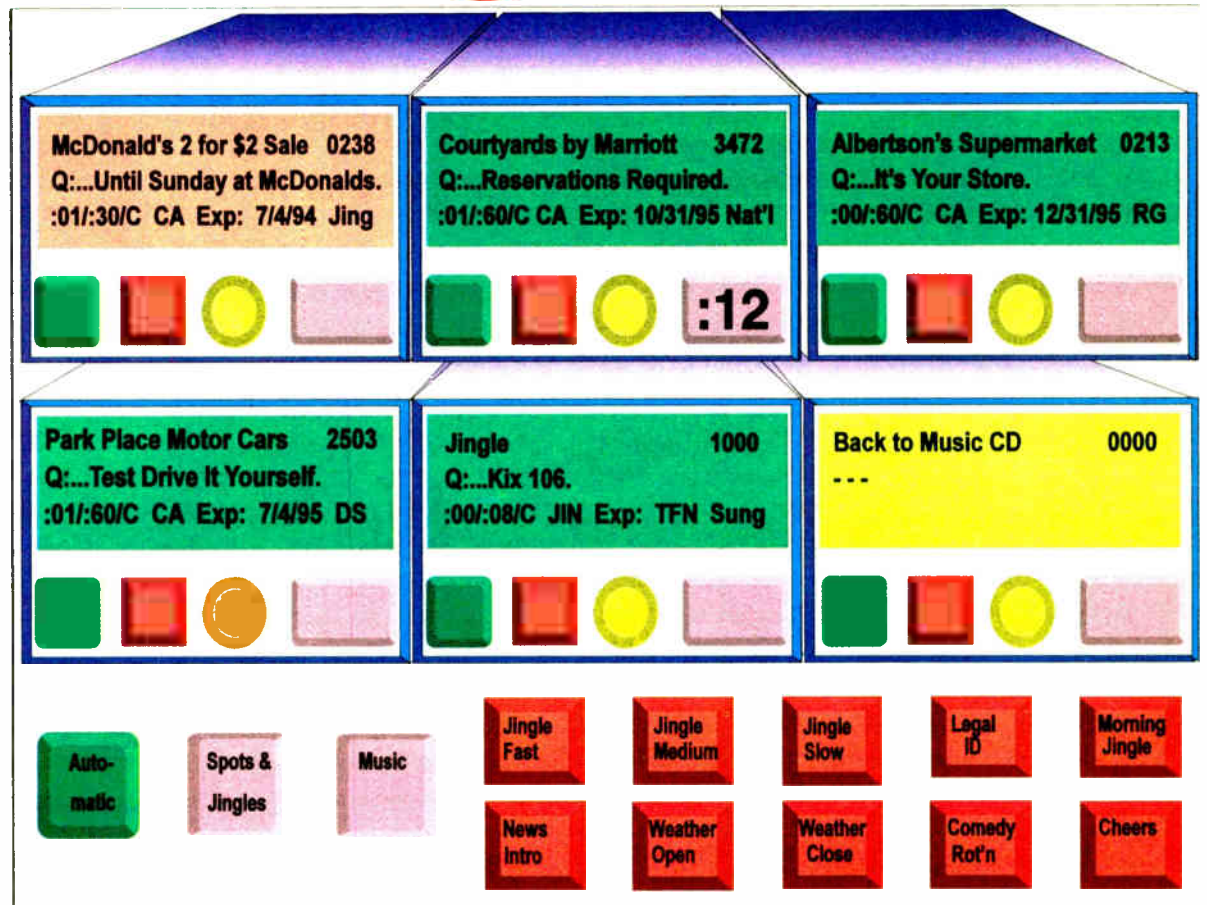

Your jocks *already know how to use Scott Studios' CompuCarts!* It's the impressive quality of digital audio without the confusion of keyboards. Each button on the touchscreen plays what you want instantly. Logs come in automatically from your traffic computer.



The World's Fastest Playback!

Touch either of the two buttons at the bottom left of the main screen to see our "Wall of Carts" with all your audio *on-line!* Touch the sound, spot, jingle, promo, PSA or comedy you want and it plays *instantly*. Or, you can put it anywhere you want in the next six "cart" machines. Audio is displayed any five ways you like.

Instant Music on Hard Drive

Our most popular option is 9 gigabyte disks with 1,000 songs pre-dubbed for *free!* The audio quality of digital music from the Scott CompuCart hard drive meets or beats the best CDs. You even get direct digital inputs so you can dub digitally from your CD players!

And nothing could be faster than song requests from Scott Studios' CompuCarts! You also get five "Wall of Carts" with music that plays at a touch! Songs are displayed by title, artist, year, length, category, or any ways you like.

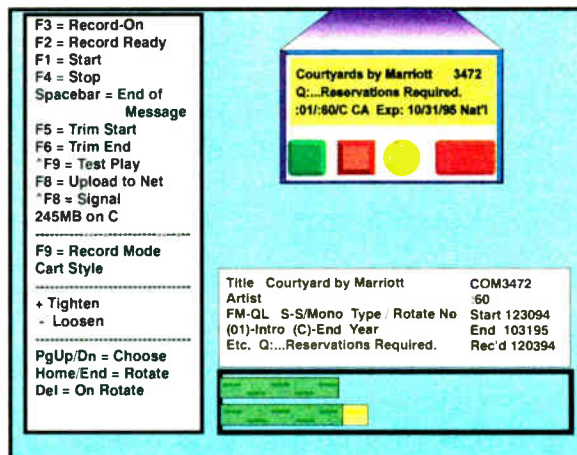

The Easiest Digital Audio

CompuCarts not only work like a "cart" player in the air studio, CompuCarts work like a "cart" recorder in your production studio. You get all the features your radio station needs, including start- and end-dates, rotations, out-cues and easy-to-read label information. And when spots, promos, PSAs, or any other digital audio events are recorded, they're immediately playable in *all* your Scott System air studios. Nobody wastes time carrying carts down the hall or redubbing spots for additional stations.

The Best Digital Audio

One question you *don't* have to worry about with the Scott System is "What if it breaks?" The Scott CompuCart System comes complete with *every* spot and jingle stored *redundantly* on *two* hard disks with a *split-second* switch to the "hot standby" outputs! You get touchscreen convenience, digital quality, and redundancy for no more than cart machines.

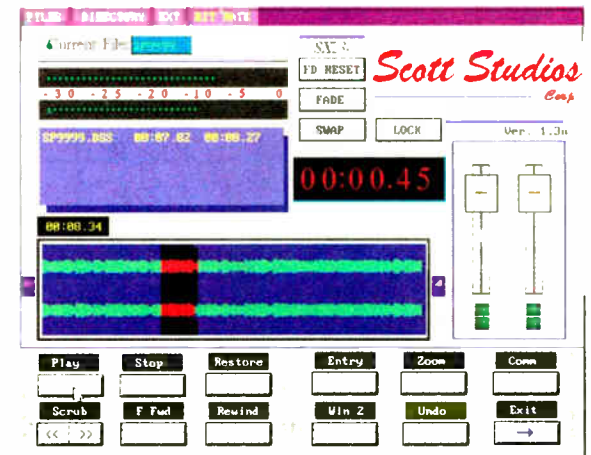

Sound Better With Digital Editing

Scott Systems' graphic waveform editors work wonders with phone calls in the air studio and creative spots and promos in production.

Your Best Investment

The Scott System *leads the industry* with the biggest broadcast groups like Shamrock, Alliance, Salem, Saga, Liggett, Regent, Tichenor, Heftel, Waterman, Max, Atlantic, and Rawlco in Canada. Our major markets include Detroit, D.C., Dallas, Houston, Miami-Ft. Lauderdale, San Diego, Denver, New Orleans, Oklahoma City, San Antonio, Greensboro, and others from Bangor to Bakersfield.

Scott Studios Corp.
13375 Stemmons Freeway, Suite 300
Dallas, Texas 75234 USA
8 0 0 7 2 6 - 8 8 7 7
(800) SCOTT-77

USER REPORT

WireReady Eliminates Paperwork

by Leroy Dietrich
Chief Operator &
Dir. of Technical Operations
KTSA(AM)-KTFM(FM)

SAN ANTONIO In April 1991, shortly before the NAB spring show in Las Vegas, our AM station KTSA instituted a news/talk format. With the goal of an all-electronic newsroom in mind, I attended the NAB and shopped around for the most cost-efficient electronic newsroom computer system. After visiting several potential vendors, the obvious choice was WireReady Newswire Systems.

Piles of paperwork

Operating a 24-hour news facility generated piles of paperwork and lots of trips to the copy machine with stories from one of the three wire printers. The WireReady system, although a new kid on the block in 1991, seemed to have the answers to an almost paperless newsroom, at a low price.

KTSA was one of the first stations, not the first to implement a WireReady system on a Novell computer network. The software was written with a news person in mind. At first the system was no more than a large electronic typewriter that did not require correction tape.

In December 1994 we purchased six CartReady kits for existing WireReady workstations. Once again the software was written for a news person, not an engineer. After two weeks, our cart machines and reel-to-reel recorders started collecting dust.

Tremendous savings

We noticed a number of results from our conversion to WireReady and CartReady. First, there was a tremendous savings on paper and typewriter ribbons. Second, we saved big on copy machine cost, as wire stories were available at all the terminals from the public wire file.

Also, CartReady simplicity improved newsroom productivity. We produced more and better audio cuts for on-air use. We have not bought a razor blade in more than six months, and we no longer search for a blank plastic cart.

Our association with Dave Gerstmann and all the fine folks at WireReady Newswire Systems has remained strong for four years. The 24-hour technical support is aimed at the computer-illiterate news person. The company can call in on our modem workstation and make changes on the fly.

The product has exceeded our expectations. Our conversion to CartReady was completed by WireReady personnel via modem. No paper and no tape, thanks to WireReady.

For information, contact David Gerstmann in Massachusetts at 800-833-4459; fax: 508-879-0080; or circle Reader Service 81.

USER REPORT

Sentry System Solid

by Shannon Milburn
Program Director
KMCO(FM)

THE DALLES, Ore. In a competitive world, where the bottom line better be good, you sometimes have to make concessions. Although I would prefer to staff our station with live bodies 24 hours a day to keep the sound local, I realize that such a scenario is unrealistic.

KMCO is one of seven stations serving about 65,000 people in Oregon and Washington in the Columbia River gorge area. The other six stations feature live morning shows, with satellite programming the rest of the day. Our station works live-assist during the day, automating the late evening and overnights.

Dilemma

Four years ago, we were faced with the dilemma of keeping qualified part-time employees. We were also using an old automation system that barely kept running. To solve both problems, we began looking for a new automation system.

What we found was the Sentry Systems Format Sentry Model FS12C and DS-1 hard drive storage and playback unit. The system seemed simple to operate, without the extra features we did not need. The FS12C matched up with the reel-to-reel automation system that was programmed in-house.

Installation and changeover proceeded smoothly, better than anticipated. Our engineer changed the music selectors, our midday guy worked on the music program and I, the computer-illiterate one, started putting commercials on the hard drive.

We hit the air. What we found was a system that was much easier to use than

our previous automation system. Our engineer seemed surprised when we said that we encountered no problems. The music segues were much smoother than before, and it sounded as if there were a live body in the studio.

One walk-through

For production use, the DS-1 is simple. Its on-screen instructions make it easy to follow. Any newcomer to the system requires only one walk-through of the recording or playback process.

We can quickly program changes and not miss a beat.

The best part of the changeover was that our commercials were in stereo. Some clients requested that their ads be played in stereo. We could now do this more easily with the DS-1. The DS-1 also allowed us to automate an hour here or there whenever we wanted to hold a staff meeting, or if someone was not feeling well.

It has been wonderful for vacations as well, as I do not have to bring in another person. Someone from the office usually can record a few breaks. We can

quickly program changes and not miss a beat.

The only complaint I have is that calls for technical support are not always handled in a timely fashion.

Format change

Last January we decided to make some changes to our format, moving from a softer adult contemporary to one more upbeat. After talking with Broadcast Programming about its Hot AC format, we decided that perhaps we should switch from reel-to-reel automation to CD.

This transition did not go as smoothly as the last. We needed new software for setting up the skeleton and command files. The only problem after that was the network delay for the news, which turned out to be a wiring detail and a computer command that I did not write properly.

The FS12C and DS-1 are a solid system, allowing us flexibility and giving our automated segments a live sound. The units are extremely user friendly; you do not have to be a computer whiz to operate them. If for some reason we have to automate when we are live, we can do so quickly and with little effort. Even more importantly, the system is reliable. It is nice not to be awakened at night by a caller who says that your weather forecast is playing over and over...

For more information, contact Dave Newton in Washington state at 800-426-9082; fax: 206-441-6582; or circle Reader Service 11.



WARD-BECK SYSTEMS

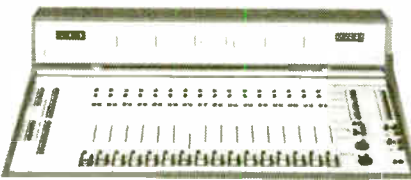

RENAISSANCE SERIES RADIO CONSOLES

The perfect choice for today's "desk-top" radio environment.

- Integrates easily with most automation systems
- Includes four telephone send outputs
- Fully modular to simplify expansion and service
- 8, 16 and 24 input channel mainframes available
- Operates in live, live assist and walk-away modes

Value priced to fit most budgets!

Ward Beck Systems Ltd.
841 Progress Avenue, Scarborough,
Ontario, Canada M1H 2X4
Phone: (416) 438-6550
FAX: (416) 438-3865
Now Toll Free 1-800-771-2556

Circle (42) On Reader Service Card

” AEV
CELEBRATES AN
UNPRECEDENT
OUTSTANDING
WORLDWIDE
SUCCESS!

Radio Stations from all continents
enthusiastically praise EXCLUSIVE FM as an
extraordinary and absolutely exclusive event!



**AEV Exclusive FM
AUDIO PROCESSOR**

ASK FOR IT,
the whole world is asking for it.



ELECTRONIC BROADCAST EQUIPMENT

AEV
ITALY
Phone:
39 + 51
950249
950350
Fax
950201

Circle (86) On Reader Service Card

USER REPORT

Programming Strength of DigiCenter

by John Mackley
General Manager
KIUP(AM)-KRSJ(FM)

DURANGO, Colo. When I made my initial investigation into digital technology I was skeptical, to say the least. I was so cautious, in fact, that I chose to wait a lot longer to purchase a system. Today, I am glad I did. After we closely examined all the systems on the market, we chose the ITC DigiCenter—and that caution has paid off.

After years of working with an antiquated computer system that was event-driven, we began the search for a digital system. Our system was adequate but lacked flexibility and sound.

We started looking into a digital system at least five years ago when digital technology was first starting to come along. We chose the ITC DigiCenter because of its ability to assist KIUP-KRSJ in being more efficient, more flexible and, of course, to provide better sound.

We are particularly pleased with DigiCenter's ability to convert KRSJ into an automated station that allows selected live broadcasts, while converting KIUP into a live-assist station. This added efficiency and flexibility is what I was waiting for in the development of digital technology.

We were not happy with the aspects of audio compression in our early digital investigations, so rather than enter at that point we decided to let the question of audio compression resolve itself through the marketplace. As technology advanced, we found that some players in the business were taking steps to give us the benefits of compression without compressing. We started investigating again.

Our primary goal for the new system was to automate KRSJ with a "live" sound. ITC had a super system and plenty of hard-drive space and flexibility. We felt it was the best way to add intros and outros to songs in advance. And when I say "in advance," I mean a day or even two or three days ahead of time. This is a true time-driven system. We know exactly when a particular song or commercial will play.

On weekends, basically one person runs both stations, so the automated FM station is virtually hands-free. It is extremely efficient and cost-effective for us.

ITC's reputation played a big part in our decision. We did not want to go with a company that perhaps had a great product, but not the track record. It is important to us that 10, 15 or even 20 years down the road, we are guaranteed this company will still be around.

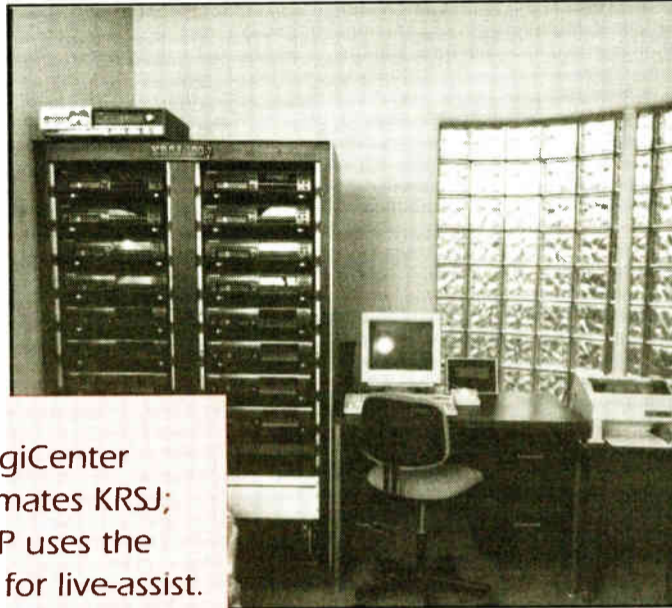

DigiCenter automates KRSJ; KIUP uses the system for live-assist.

Programming unique configurations is a strength of the DigiCenter. The help ITC lent the station during installation and programming was crucial. All of the staff, especially the programmer, Bill Kidd, have been fantastic.

As we dream up other aspects of programming, ITC writes the program and downloads it for us to make the DigiCenter do what we want it to do. It allows us to keep maximizing our system to meet our changing needs.

These changes and special needs have proven a challenge for ITC. Because we wanted it to sound live, there were some intricate programming details the company had to write. Bill spent many nights working

on programming. I have other friends in the business, and they have told me other companies have not gone the extra mile to set things up like ITC did.

One of the unique programming designs KRSJ implemented with the DigiCenter is automating the programming, while allowing breaks for live events such as news coverage or sports programming.

Most people are either automated or live, but we keep switching back and forth, which is not always easy. Any time you do something that is non-standard it takes a while.

We are working at becoming more proficient at using this DigiCenter feature. A mistake can result in dead air, two items playing at once, or the person on air sounding unsure of him- or herself. We want to make it easier for the person on the air. If he is thinking about something else, he is not going to be thinking about what he is going to say.

KIUP, on the other hand, is moving away from total live programming to live-assist. DigiCenter allows us to play back spots or a series of liners and promos unattended. If we want to run three commercials in a row, we can just fire up one button and it plays all three in sequence. That takes the pressure off whoever is running things and frees him or her up to do something else.

KIUP is also capturing many network events on AM. We use three different major networks and all these have subsets, so we are recording six different feeds.

The DigiCenter's ability to play back an event before recording is finished is one of its most unique features. As far as I know, DigiCenter is the only system that lets you play something back while you are still recording.

This feature enables us to better incorporate our sports programming. We air a lot of local sports, including Colorado University and Denver Broncos games. Now, if one game ends after the next one starts, we can just start recording the second game and delay it a short period of time. Then we can begin playback before the game is over.

These unique features give us the flexible and efficient system we were looking for. And we are still discovering all the ways we can use it to improve our station.

For information, contact Charlie Bates in Illinois at 800-447-0414; fax: 309-828-1386; or circle Reader Service 104.

Products & Services Showcase

For more information on the products shown below, circle the appropriate Reader Service No.(s) on the enclosed Subscription/Reader Service card or contact the advertiser directly.

EVEN THE BEST CAN BE MADE BETTER

Introducing the new

MINI-MIX 12A

THE COMPACT MIXER WITH A COMPACT PRICE FROM THE QUALITY LEADER

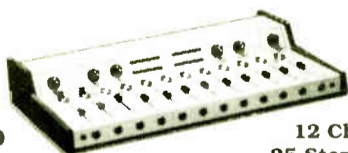

\$3499

12 Channels
25 Stereo Inputs

Service & Affordable Quality for Over 23 Years

AUTOGRAM CORPORATION

1500 Capital Avenue (214) 424-8585
Plano Texas 75074-8118 1-800-327-6901
FAX (214) 423-6334

READER SERVICE NO. 159

Cellcast®

REMOTE BROADCAST STUDIO

THE CELLULAR DIFFERENCE

- Easy to Use
- Reliable
- Cost Efficient
- Portable
- Flexible



Technology & convenience combine to bring you on-the-spot remote broadcast capabilities with excellent sound quality. Cellular transceiver, frequency extender, and mixer all in one! Powered by Ni-cad rechargeable batteries or AC power supply — utilizes cellular technology or land lines.

For more information call

1-800-852-1333

READER SERVICE NO. 29

ARE YOU LOOKING FOR A COST EFFECTIVE ALTERNATIVE TO MANUFACTURER SERVICE?

SERVICE, REPAIR & CALIBRATION

- STL's • RPU's • TSL's
- Exciters • AM/FM
- Broadcast Monitors •
- Remote Control Systems

SPECIALIZING IN EQUIPMENT BY

- Belar • Marti •
- Moseley • McMartin
- TFT • And others...

An authorized TFT service center

IN CASE OF EMERGENCY

We can help get you back on the air with our STL Loaner Program. We have STL's available that will be set to your frequency prior to shipping. We also provide over-the-phone technical assistance.



2198 Hubbard Lane, Grants Pass, OR 97527

(503) 471-2262

READER SERVICE NO. 121

USER REPORT

SMARTS Sensitive to Broadcasters

Ray Kassis
Technical Director
& Chief Engineer
WJFP(FM)

FORT PIERCE, Fla. I have been intrigued for a number of years by the thought of building a fully automated and unattended radio station. The opportunity presented itself when the principles of Black Media Works Inc. decided to build a state-of-the-art, low-budget, urban contemporary station in Fort Pierce. Arrangements were made for transmitter readings, EBS and station monitoring to be conducted by on-air personnel of WCNO(FM), Palm City, Fla., 20 miles away.

Selecting a system

After designing all the fail-safe circuits in the studio, microwave and transmitter sites, and interfacing the remote control system to alert WCNO, the next obstacle was selecting an automation system to meet the needs of an unattended station with a professional-sounding format.

Digital was my only choice. Then came the debate. Do we go with a CD playback system, digital cart system or music on hard drive? And then, which vendor could best meet our needs? To my surprise, I called Company "A" only to find that the factory sales and support staff were closed for the Thanksgiving, Christmas and New Year's holiday. In fact, it was after I completed my order for the SMARTS Broadcast Systems Smartcaster and

All SMARTS customers have access to a 24-hour support line.

signed the lease purchase contract for financing that I received literature from Company "A." Ironically, the day our Smartcaster was delivered, a salesman from Company "A" called to follow up on our inquiry, made three months earlier.

Broadcast sensitive

I cannot stress enough the importance of dealing with a broadcast-sensitive vendor. My experience with the sales, management and support team of SMARTS Broadcast Systems has been the best relationship I have had in over 30 years of broadcasting. All SMARTS customers have access to a 24-hour support line. They have never failed to call me back within one hour for even a routine question. Even if SMARTS had given me the system, I would still pay the same price for the service and follow-up support.

Our Smartcaster consists of a PC-IBM clone 486 computer with a 100MB hard drive and six 2.4GB hard drives. As of this date, we have over 1,600 songs, and all of our station IDs, liners, spot announcements, etc., run flawlessly. I opted for the Dolby AC-2 card, which gives us CD-quality playback. We have a remote terminal unit PC-386 clone with a 100MB hard drive in our production room for recording

music and logging. We utilize the Musicmaster option for selecting our music.

Because this operation is mostly unattended, we have an uninterruptible power supply backup system, which has come in handy in Florida during thunderstorms. I strongly recommend having your SMARTS system unpacked and installed by a SMARTS field technician. The field technician plays a valuable role in introducing the SMARTS system to the staff as well as establishing an overall familiarity with the station setup at the SMARTS home office.

The original manual supplied with our

Smartcaster left a lot to be desired. Because the software keeps changing, the manual lagged and, in some cases, was wrong. Of course, having a 24-hour support line helped to immediately resolve any questions. Smartcaster has since authored a new manual that is up to speed with the latest software.

Ultimate test

The ultimate test of support was when a power supply fan failed and our nighttime live-assist DJ turned off the air conditioner to save us money. The main tower holding the motherboard and four hard drives became extremely

hot and failed. SMARTS delivered a new power supply overnight and we were up and running unattended again within 14 hours.

When our hard-drive controller board became sensitive to the heat, SMARTS again responded overnight with a new board, all under warranty. I cannot describe the confidence and security in having a system 65 miles away from home and the support of SMARTS any time I need it.

WJFP has a staff of eight sales, production and live-assist DJs. All of them operate the Smartcaster for logging, billing, production and music selection with just basic training. I cannot wait to install another SMARTS system.

For information, contact Dave Potranz in Iowa at 800-498-0487; fax: 800-398-8149; or circle Reader Service 119.

The FM Transmitter of Choice

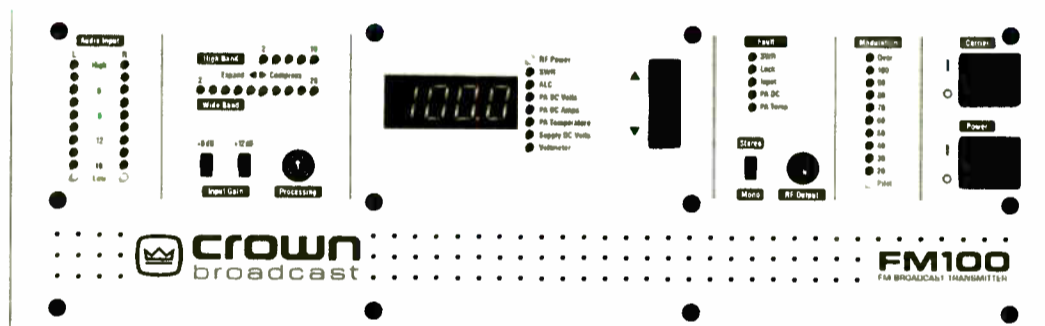

Integrated Transmitter Systems by CROWN®

Applications

- Suited for FM translator service
- Ideal for satellite or terrestrial-fed systems
- Use it as a stand-alone transmitter
- Use it as a stand-alone exciter with composite input
- Use it as an FM exciter with built-in IPA
- Great for community and campus radio
- A perfect backup transmitter system

Models

- FM30, adjustable from 3 to 33 watts output
- FM100, adjustable from 20 to 110 watts output
- FM250, adjustable from 20 to 250 watts output
- FM500, 50 to 500 watts (available third quarter '95)

Integrated System Components

- FM exciter (digitally tunable, frequency-agile)
- Audio processor (with compressor/limiter)
- Stereo Generator
- RF Amplifier
- Lowpass Filter
- New, optional FM Receiver Module
- New, optional FSK IDer

Features

- Excellent signal quality and reliable performance
- Lightweight, compact, easily shipped worldwide
- 110/120 VAC, 220/240 VAC or DC powered
- Built-in digital metering and diagnostics
- User tunable from 88 to 108 MHz
- Optional tuning for 65-73 MHz in 10 kHz steps
- Modular, flexible design
- Fully illustrated and detailed user information
- Type notified for FCC part 73 & 74; meets FCC, DOC, and CCIR requirements
- Quick setup; designed for easy installation even by non-technical people

For more information, contact Crown Broadcast Sales at (219) 294-8050 or fax (219) 294-8302.

crown
 broadcast

A Division of Crown International, Inc.
 1718 West Mishawaka Road
 Elkhart, Indiana 46515-1000
 Phone: (219) 294-8050; FAX: (219) 294-8302

USER REPORT

CartWorks Built with Eye on Future

by Clint L. Webster
General Manager
Radio Cleveland Inc.

CLEVELAND, Miss. Digital audio automation systems have been around longer than you might think. I purchased my first version of one in February 1991. At least, I thought that was what I was buying. It turned out to be vaporware. Brand "A" was a first-class piece of non-working satellite automation equipment. About one year later, I bought Brand "B"; it too was vaporware.

Dual role

As a broadcaster for 21 years and general manager of a group of radio stations, it is vitally important that my stations have equipment that is simple to use, efficient, versatile and dependable. As part owner, the cost effectiveness of a system is also a major consideration.

We have been using Brand "C" satellite and CD computer automation. The company has now written its software so that I will have to throw away all the computers sold to me if I ever want to get all the features I was promised. It seems that the company should have considered this problem before it began selling its systems.

This brings me to CartWorks from dbm Systems. It is the system I have searched for and that will allow me to upgrade in the future without throwing away my computers.

One of the most important aspects of purchasing a system is the installation. This is where dbm Systems excels. After my installation woes with the other brands, I was pleasantly surprised to receive both an installation manual and a manual for operating the system, both of which were up to date.

No junk

In just a few hours, the system was installed and running, without junk like quirky connectors or lousy un-

minated ribbon cables. Finally, someone did it right. It is immediately obvious from the quality of the supplied hardware that the CartWorks development team comes from the broadcast industry.

The CartWorks system has screens that are clear, uncluttered and do not resemble a database application. CartWorks was developed on sound platforms, too. The 486 DX2-66 MHz computer runs Microsoft Windows for Workgroups and uses apt-X digital audio compression.

For live-assist operation, CartWorks looks and acts exactly like a six-deck cart machine. There is also support for displaying end cues and live tags, as well as a countdown timer. And by simply clicking on the Help icon, instant help is displayed for every item on the screen. My staff was operating the system like pros the first day.

As for satellite automation, this system offers virtually unlimited walkaway time and is far more programmable than the other systems I have tried. This may explain why two radio net-

works have already chosen CartWorks for their operations.

Instant access

One of the newest features that CartWorks offers is the Instant Access button panel with 48 pushbuttons that

CartWorks looks and acts exactly like a six-deck cart machine.

can be preloaded with jingles, liners, bits, effects or whatever you need. At the press of a corresponding button, any of these will play instantly.

There are so many other features, such as simultaneous record and play with the same audio card, that I cannot describe them all here.

Support after the sale is something a lot of people take for granted. You quickly learn, though, that not everybody in business cares if you are happy or if the product works the way it is supposed to after they have your money. With dbm Systems, if you have a problem or even think you do, the company's support team is there to help. A phone call is all that is necessary.

If you are entering the world of digital audio for the first time, or, like me, are ready to chuck your current system, you could do no better than CartWorks.

For information, contact George Thomas in Mississippi at 601-982-1062; fax: 601-362-1905; or circle Reader Service 204.

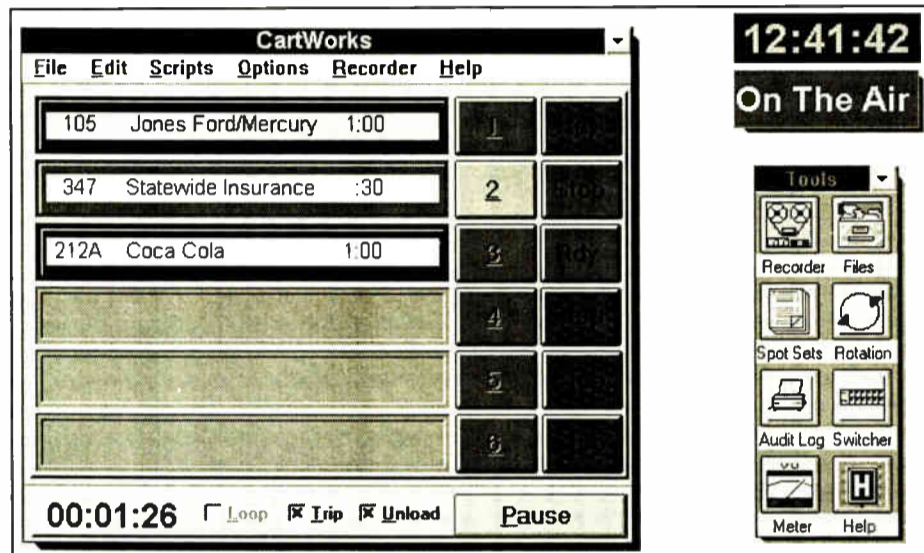

CartWorks allows for upgrades without discarding existing computers.

USER REPORT

Excellent Service Sets SALSA Apart

by Larry Mikesell
General Manager
KLBA-AM-FM

ALBIA, Iowa I took over the reins of a 500 W AM station in rural southern Iowa in June 1994. The station had a construction permit to build a 25 kW FM. One of the biggest decisions facing me was whether to go all-live or to automate.

If we were to automate, I wanted a system that was flexible, one that could be operated as a cart machine or run by itself. Chris Kreger of RF Specialties mentioned the SALSA from LPB. After a trip to Galesburg, Ill., to see the SALSA in action, along with several other trips around the area to see other automation systems in operation, I chose the SALSA.

This system is flexible and priced right, with all the features necessary in the radio business. I was looking for an automation system that could utilize CDs, go live at a moment's notice, play requests, cover a breaking news story and be left alone overnight or for holiday operations. The SALSA does it all.

Yes, most automation systems perform these functions. The feature that sets SALSA apart from the others is its service, which is available immediately any time. Bob Wille, designer of the unit, is the most patient, understanding and knowledgeable computer and automation systems person I know.

The extent of my computer knowledge was the operation of the Apple IIe. Most radio personalities I know who are putting in their first automation system generally need lots of help. The first two weeks with any automation system are pure havoc. You think it may never work or that you will never figure it out unless you bring in an expensive expert.

With SALSA, a phone call solves whatever problem you might have. Tell Bob what you want your SALSA to do, or what it is doing that you do not like, and he and his staff will take you step by step through the process to correct the problem.

We have experienced a couple problems with our SALSA that required a change of parts. The parts arrived in less than 18 hours. While we waited, Bob walked us through reprogramming, allowing us to stay on the air with the automation still working. When the parts arrived, Bob helped me through the installation. All this service is free for the first 90 days.

Any piece of equipment has its downside: SALSA has two: the internal clock and the installation and programming manual. The internal clock gains a second and a half per hour, and we must do a time sync every hour to keep things running tightly and cleanly. The manual is written for people who already have enough automation and computer knowledge that they probably would not need a manual. First-time automation system users may need a manual that is less technical.

Our system has been in use for about four months, and I am still learning, adjusting and seeking assistance from Bob. The first day of February I would have given the SALSA to someone I did not like. Now, Beulah, as I affectionately call my SALSA unit, is my best friend. It sits there and works, hour after hour; no showing up late for work, no bad-attitude days. If it ever does have a bad day, I know that good service is a phone call away. If I ever need to purchase another automation system, I would start with SALSA from LPB.

For information, contact John Devecka in Pennsylvania at 610-644-1123; fax: 610-644-8651; or circle Reader Service 143.

SUBSCRIPTION/READER SERVICE FORM



FREE Subscription/Renewal Card

I would like to receive or continue receiving Radio World

FREE each month. Yes No

Signature _____ Date _____

Please print and include all information:

Name _____ Title _____

Company/Station _____

Address _____

City _____ State _____ ZIP _____

Business Telephone () _____

Please check only one entry for each category:

I. Type of Firm

- D. Combination AM/FM station
- A. Commercial AM station
- B. Commercial FM station
- C. Educational FM station
- E. Network/group owner
- F. Recording Studio
- K. Radio Station Services
- G. TV station/teleprod facility
- H. Consultant/ind engineer
- I. Mfg, distributor or dealer
- J. Other _____

II. Job Function

- A. Ownership
- B. General management
- C. Engineering
- D. Programming/production
- G. Sales
- E. News operations
- F. Other (specify) _____

Reader Service

July 12, 1995 Use until October 12, 1995

Please first fill out contact information at left. Then check each advertisement for corresponding number and circle below.

Purchasing Authority											
1. Recommend				2. Specify				3. Approve			
001 023 045 067 089 111 133 155 177 199											
002 024 046 068 090 112 134 156 178 200											
003 025 047 069 091 113 135 157 179 201											
004 026 048 070 092 114 136 158 180 202											
005 027 049 071 093 115 137 159 181 203											
006 028 050 072 094 116 138 160 182 204											
007 029 051 073 095 117 139 161 183 205											
008 030 052 074 096 118 140 162 184 206											
009 031 053 075 097 119 141 163 185 207											
010 032 054 076 098 120 142 164 186 208											
011 033 055 077 099 121 143 165 187 209											
012 034 056 078 100 122 144 166 188 210											
013 035 057 079 101 123 145 167 189 211											
014 036 058 080 102 124 146 168 190 212											
015 037 059 081 103 125 147 169 191 213											
016 038 060 082 104 126 148 170 192 214											
017 039 061 083 105 127 149 171 193 215											
018 040 062 084 106 128 150 172 194 216											
019 041 063 085 107 129 151 173 195 217											
020 042 064 086 108 130 152 174 196 218											
021 043 065 087 109 131 153 175 197 219											
022 044 066 088 110 132 154 176 198 220											

Copy & Mail to: Radio World, PO Box 1214, Falls Church, VA 22041, or FAX to: 703-998-2966

RDS ~~OR~~ AND SCA?

STATE OF THE ART SUBCARRIER PRODUCTS FROM THE WORLDWIDE LEADER IN SUBCARRIER TECHNOLOGY.

RDS-1 Generator

The RDS-1 is a PC expansion card supplied with software to turn any PC ('286 or better) into a

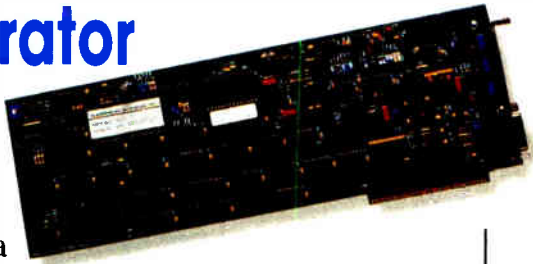

powerful cost effective RDS encoder/subcarrier generator. Store up to 255 radiotext messages of unlimited length, and run full RDS automation locally or by remote control. Buy the PC card and software, or buy the broadcast quality rack mounted PC system preloaded with your messages to go on the air. The RDS-1 is the only fully software definable RDS generator available.

RDS-MA & PRD-3000 Monitor-Analyzer Test System



The RDS-MA is a complete RDS receiver, monitor and analyzer test system (with or without the PC) enabling you to test your RDS system performance off the air, off your transmitter or in the studio; and to check out your competition!

Or choose the PRD-3000 Monitor/ Analyzer unit only, supplied with the software to turn your laptop PC into an RDS subcarrier test facility (using the serial port). The only fully software definable RDS test equipment available.

RDS-X Professional Data Receivers

The only professional user configurable RDS data receiver available. Unlimited addressability, full auto tuning, with antenna diversity for reliable mobile operation. Use it for EAS, GPS, signs, billboards. You name it, we can control it. RS-232 and five switched control outputs. Fully boxed and powered. Assembled and tested PC board available in OEM quantities.



SCA-186 SIDEKICK® SCA Audio Generator

The worldwide standard for professional and reliable performance. Quartz controlled stability. Built-in modulation monitor. Integrated audio processor provides best possible audio quality. Built-in noise generator and incidental noise meter for optimum transmitter adjustment and lowest possible cross-talk. Composite loop-through to simplify installation.



DSCA-188 DATA SIDEKICK® SCA Data Generator

Highest data rate throughput with async or sync operation. Quartz controlled subcarrier synthesizer. Built-in error test generator. Controlled baseband spectrum for minimum bandwidth. Built-in peak deviation meter. Standard RS-232/422 data input. The workhorse of the radio industry for stock quotation and radio data transmission.

SCA Receivers

Data and audio SCA receivers quoted in many configurations; fully packaged and as OEM assembled circuit boards. Customization to suit specific needs available.

Regain Modulation Lost To SCA

Get Eric Small's technical paper describing how to prevent power loss in your main program when running SCA or RDS. The secret is out.

Call or fax for our RDS/SCA Info Package. In the US, call toll free (800) 826-2603



MODULATION SCIENCES INC.

12A WORLD'S FAIR DRIVE SOMERSET NJ 08873
TEL (908) 302-3090 FAX (908) 302-0206

Circle (137) On Reader Service Card
World Radio History

USER REPORT

No Experience Required with LYNX

by **Bill Rogers**
 VP of Operations
 Rogers Broadcasting

FLORENCE, Ala. When I first started looking for a product that would meet my FM translator network needs, I had to keep in mind that I lacked computer experience. I needed a unit that was easy to use, easy to program and reliable. That is when I heard about the LYNX from **Digital Research Corp.**

The LYNX handles insertion of spots on a pre-programmed schedule. It also handles logging, billing and critiquing. In all,

the LYNX is the best remote-controlled device I have found for my FM translator needs.

Guinea pig

After seeing the LYNX in operation in Huntsville, Ala., I decided to purchase one. It was being used on a translator system there and was just being developed for commercial use. That is when I met Michael Chunn, president of Digital Research. Michael knew of my lack of computer experience, and he agreed to let me try the LYNX and offer my input on how to continue to develop the product.

One of Digital Research's goals was to create a product that was easy to use, and I was the perfect guinea pig.

I purchased a Gateway computer and a wave editor program to produce digital audio for the initial setup of my remote site. After learning some computer lingo and the wave editor, I was in operation in a matter of days with few problems.

Most of the problems I experienced were due to my lack of computer knowledge. However, one problem I had was in the scheduling of my announcements. Because I was doing the schedule differently, the LYNX did not allow me enough

room to schedule all my spots. I called the company with the problem and the correction was made to my LYNX the same day by downloading a new code.

Looking ahead

The main reason I bought the LYNX for my FM translator was for local insertion of spots, overlapping those from a full FM broadcast station. Looking ahead to a more advanced application, the LYNX allows a radio station that is functioning as a translator to be controlled as an unmanned broadcast facility.

The LYNX has two fans for cooling, a great feature for FM translators installed in hot places. The LYNX also uses the highest speed modem. Transferring a spot to the LYNX takes only about two to four minutes.

The LYNX was easy to install with the FM translator. You simply hook the audio and switching wires to the LYNX, set your audio to FCC requirements and you are in business.

The schedule of your spots, announcements, PSAs, etc., is easy as well. Provided you follow a few guidelines, you can schedule just about any way you want. If you goof, the LYNX will assist you in

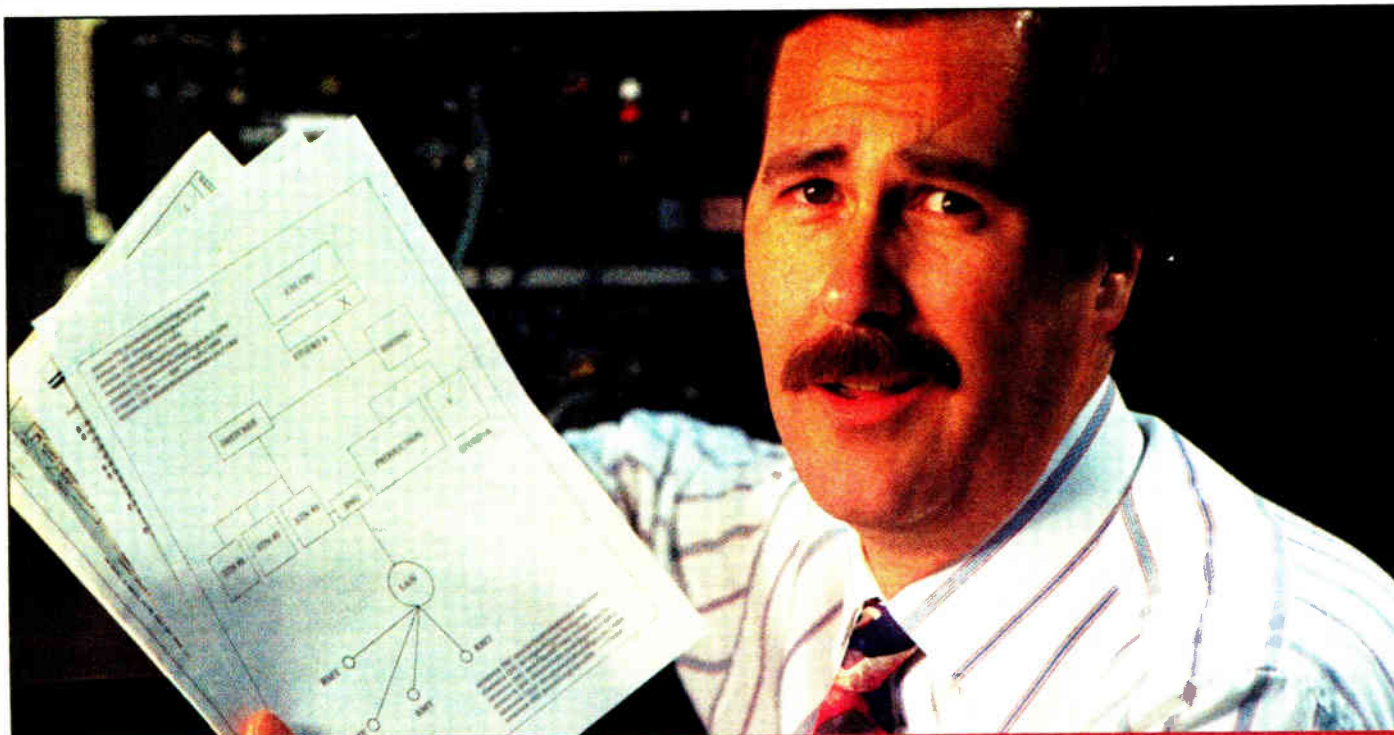

TRYING TO MAKE SENSE OUT OF DIGITAL AUDIO SYSTEMS?

There is a better way!

It's not easy trying to understand the conflicting claims made by different manufacturers when you're buying a Digital Audio On-Air & Production System, whether a single, multipurpose Workstation or an integrated, multiple studio setup. At one end of the spectrum, you're faced with a wide variety of simple "Cart Machine Replacements," and on the other, products whose complexity confounds even the most seasoned broadcast engineer.

The ENCO DAD486x Digital Audio Delivery System solves the problem! DAD is simply the most powerful On-Air & Production system available, yet its uncomplicated approach and inherent ease of operation makes immediate sense to any user.

- Intuitive On-Screen displays that are immediately familiar to operators. Optional Touchscreen makes operation quick and easy.
- Complete On-Air flexibility with various "Virtual Machines" for Live Assist, Automation, or Satellite Programmed operations. Interface to other equipment plus scheduling and billing packages. Seamless segue and voiceover transitions sound "Live" in all modes. Script capabilities can be included.



- Full production capabilities, including Graphic Cut & Paste Assembly Editing. Includes analog and digital inputs/outputs. Interfaces with most multichannel editing packages.
- Runs on DOS for proven speed, reliability, and compatibility with other equipment; not an operating system originally intended for multimedia applications. This is a professional tool meant to produce efficiency and profits, not entertain the staff!

- Operates on common off the shelf computers and network architecture. You won't be locked into proprietary hardware that may not be available whenever you need service.

- No monthly licensing fees. DAD is an outright purchase. Software upgrades are free for the first year.

- DAD is proving itself everyday in radio and TV facilities worldwide.

Call Your DAD486x Dealer or ENCO
 For Complete Information

ENCO
 SYSTEMS, INC.

24403 Halsted Road, Farmington Hills, MI 48335 USA
 TEL: 800-362-6797 or 810-476-5711 FAX: 810-476-5712



The LYNX installed as part of an FM translator

correcting your mistakes. The "spots filler" is great to have to fall back on if your daily schedule is not completely filled.

Excellent sound

When you connect to your LYNX via phone line, it is easy to monitor what spots have run and what spots will run next, as well as any errors that might come up. Also, the LYNX allows you to change the time your spots will run, your site ID and even the treble and bass of your spots.

The LYNX has excellent sound over the translator. Recently I added stereo to my spots on the translators, and I have had more compliments on the sound than I can remember.

To help me with billing, the LYNX produces a spot log and even prints out each day's log when you want it.

I have been using the LYNX for six months. It has exceeded all expectations at a price lower than you would imagine.

For information, contact Michael Chunn in Alabama at 800-310-5985; fax: 205-837-8320; or circle Reader Service 96.

USER REPORT

PhoneByte Takes a Pounding at KYNG

by Katie Pruett, Air Personality
& Bob Henke, Chief Engineer
KYNG(FM)

DALLAS Young Country KYNG is a personality-oriented music station, airing five to 15 phone bits per hour in every day-part. As a result, our needs for quick, easy phone-call editing were formidable when we purchased PhoneByte from **The Blue Group**. We needed an editing system that could weather heavy use and encourage us to edit our bits more.

Two thumbs up

PhoneByte has been installed in our station for over a year. On a scale of one to 10, we give it a 9.5. In Siskel-and-Ebert terms, it gets two thumbs up.

The biggest advantage of PhoneByte is that it enhances Young Country's programming even more than its digital playback enhances our on-air sound.

PhoneByte is a regular, IBM-compatible computer (ours is a 486); the software is DOS-based. It works like a conventional reel-to-reel machine, except that it is controlled by a computer keyboard. The software has some of the same commands that a reel does—play, stop and record—and these command buttons are color-coded on the keyboard.

Each phone call we receive automatically becomes a separate file to be edited on-screen. Calls are manually labeled and can be saved indefinitely. Digital-quality sound reproduction provides mono- or full-stereo output for easy connection to the main studio board.

PhoneByte is beneficial to us in a number of ways. Now we edit our bits more than than we used to on reel-to-reel, mainly because we can edit them more quickly and get them on the air faster. Record and playback are instantaneous. Also, locating a bit on PhoneByte is easier than finding one on tape.

When we first acquired PhoneByte, we

were skeptical. The product had no track record. We were one of the first customers and had absolutely no desire to be beta-testers. Every now and then we do find a small bug. But the bad bugs were eradicated before we installed the product.

We were also nervous about training our staff. Teaching DJs to use computers? We wrangled some training from the sales rep (something I recommend), then set up the unit in the production studio for a few days so we could practice.

The easy on-screen layout of the files, coupled with a user-friendly visual graph of each phone call, make it a fairly logical product to use. There are no hidden commands, so a user can simply look at the screen and figure it out. The best testament to its ease of operation is that all our jocks use the heck out of it. In fact, even though we still provide a reel-to-reel for our part-timers, they have generally picked up the system on their own and use PhoneByte instead.

Our station sounds better now. We edit our bits more. We routinely run bits with three and four edits in them. In fact, we probably cut the length of each bit down by about a third. The system allows for an unlimited number of edits, plus the edits are nondestructive, which means that an edit can be undone if a jock changes his mind.

Stacking function

A stacking function allows playback of several calls in a row, in any order, and calls can be saved for an unlimited time. The system can be set up to record every incoming phone call or record them only on command. This feature is extremely convenient when school is out and the request lines are flooded with kids' calls. Each DJ has his or her own file directory, so calls do not get mixed up.

PhoneByte is not without its flaws, but they are small compared to the benefits. The air staff must be disciplined about deleting extra files or the hard drive fills up. We are

discussing buying a larger hard drive, and we recommend starting out with the largest hard drive possible. Sound files are large, and we have run out of room on the system several times with our 500MB drive.

PhoneByte comes with a high-quality keyboard with trackball, but with the pounding it gets all day, it is wise to buy a spare. We have had to use ours extensively.

Slaving option

Additional equipment can be purchased to "slave" the system. Slaving allows a producer to edit calls at a separate station. Unfortunately, calls

cannot be played on the air while the producer is editing, nor can the system record calls during that time. We set up our slave to feed the production studio, but ultimately we found it easier to use one of our old reel-to-reel machines to record any calls to be included in promos.

Although the unit could use a "pause" feature for call playback, you can begin a call at any point in the playback.

Young Country has become a much better, more efficient radio station because we bought this system, and we recommend it highly. You just can't have ours.

For information, contact Ben Umberger in Florida at 813-442-1665; fax: 813-531-9689; or circle Reader Service 115.

Quantum FM

Solid
State

Solid
Reliability

from

QEI

- Proven reliability
- Maintenance-free FET technology
- Self-contained modules with own power supply regulator
- Compact size reduces shipping costs, allows affordable air shipment
- Power levels between 300 Watts and 6 kW
- Modular design offers buy-only-what-you-need affordability and convenience

For the same price you pay for a tube transmitter, you can now have a superior solid state FM transmitter with high-power, advanced technology exciter and cableless combiner. The modular design of QEI's QUANTUM-Series FM transmitters offers the advantage of buying only the amount of power you need...and means that you can upgrade to higher power levels whenever you're ready.

QUANTUM from QEI—the people who have been designing and building solid state transmitters longer than anyone else in the industry.

You need to know more! Call Jeff Detweiler today toll free (800) 334-9154.

QEI Corporation
One Airport Drive • P.O. Box 805
Williamstown, NJ 08094

Tel (800) 334-9154
Fax (609) 629-1751

24-Hour Service Hotline
(609) 728-2020

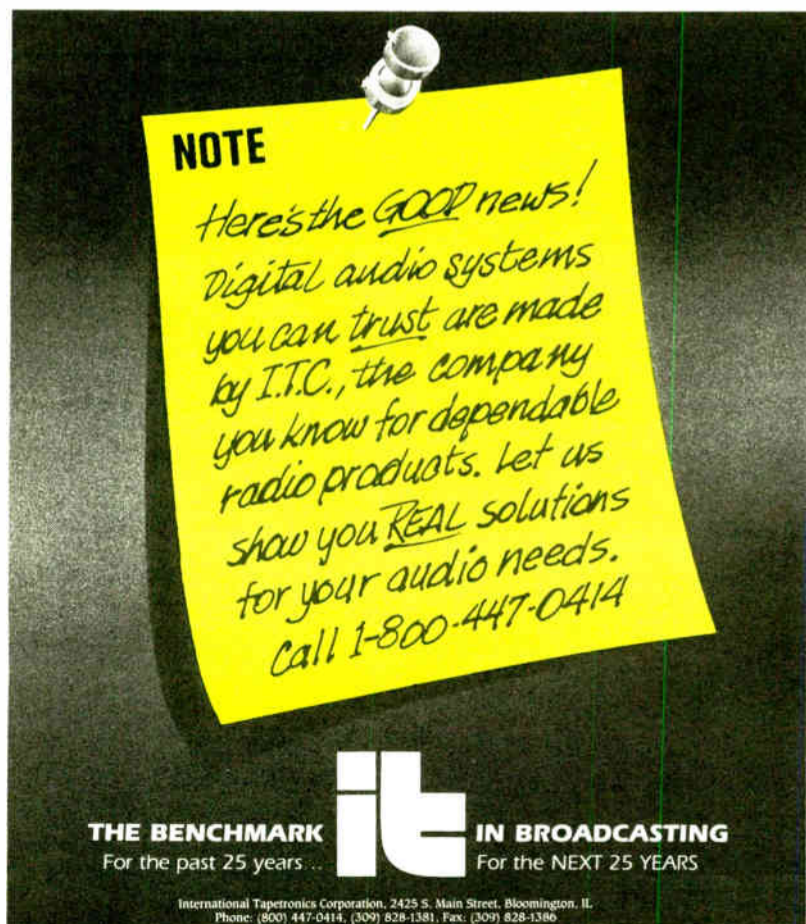

NOTE

Here's the GOOD news!
Digital audio systems
you can trust are made
by I.T.C., the company
you know for dependable
radio products. Let us
show you REAL solutions
for your audio needs.
Call 1-800-447-0414

THE BENCHMARK **it** **IN BROADCASTING**
For the past 25 years... For the NEXT 25 YEARS

International Tapetronics Corporation, 2425 S. Main Street, Bloomington, IL
Phone: (800) 447-0414, (309) 828-1381, Fax: (309) 828-1386

Circle (152) On Reader Service Card

World Radio History

Circle (161) On Reader Service Card

USER REPORT

Pristine System Fits Any Format

by Mark F. McNeil
President
Guardian Communications Inc.

CINCINNATI Guardian Communications Inc. owns nine stations in Albuquerque, N.M., Baltimore, Cincinnati, Cleveland, and Pueblo, Colo. We began installing Pristine Systems automation systems about three years ago, and because they have performed so well, we have just installed our eighth system.

The flexibility of the systems is amazing. Pristine can handle music, talk or satellite formats, live-assist or total walk-away or

any combination of the above. If your format changes, so what? Pristine reconfigures easily.

The components of a Pristine system are two 486 personal computers with large hard drives, Pioneer 18-stack or 300-stack CD players, Tascam DAT machines, Antex sound boards, Metrabyte relay boards, LANtastic and finally, the Pristine proprietary controller box and software.

Variety of combinations

The controller box coordinates up to 16 CD and/or DAT machines, and you can use up to three controller boxes in combination. On a

basic system, one computer would be used for on-air purposes, the other for production. With a more elaborate setup, such as our four-station operation in Albuquerque, we are using four on-air computers, two production computers, one scheduling computer and one billing computer—all networked together with LANtastic.

Pristine offers a variety of sound boards made by Antex. These are not your puny Sound Blaster models; these sound boards can take a beating and keep on playing. Compression is the key. A Z-1 board can compress a normal .WAV file 4:1. The top-of-the-line Dolby AC-2 board can compress

6:1. A song recorded in stereo at a 48,000 sampling rate with 6:1 compression translates to only 2MB per minute. One 3.5GB hard drive could hold more than 425 four-minute songs. This means instantaneous access (okay, say 12 millisecond access), CD quality and a hard drive whose mean time before failure is 10 years!

On-air computers need two sound boards if you want hard drive audio crossfade capability. Pristine's music scheduler is as sophisticated or as simple as you want. Not only do you have basic artist and song separation, you can control tempo, mood, shading, male/female/group rotation and lots more. If your music director can conceive of it, Pristine can handle it.

The music lists can be created as far as a month in advance with the commercial breaks added the day before airing. The playlists can be changed, modified or edited at a moment's notice, even when on the air. Pristine will also help you transfer CD libraries into the Pristine database, greatly reducing the amount of inputting required.

Spots, liners, etc.

How many spots, liners, sounders, bumpers or jingles can you have cued up ready to play? Two, four, or if you are a Jacor or Infinity powerhouse, eight? Every one of Guardian's stations with Pristine has up to 78 selections on line with instantaneous access. No cart machines to repair; no carts to erase, rethread, lose, misplace or store; zero wait time for re-cue; and CD quality first time, every time.

Technology is changing so rapidly and hard drive prices are dropping so dramatically, you can now replace the DAT machines and most of the CD players with additional large hard drives.

You must be wondering: "OK, Mark, are you telling me I do not need cart machines, turntables or DAT machines? And few, if any, CD players? And that the number of inputs becomes so small, I almost do not need an on-air console anymore?"

Not necessarily, but although you will still need a console, a small one such as a Mackie 1604 will work just fine, and you can use the savings for the better sound boards.

Talks to everyone

Our Albuquerque on-air console setup is as follows: two channels for the on-air microphone, four channels for the two computer sound boards, two channels for eight 18-stack CD players via a Rane SM-82, two channels for the satellite relay board (up to 16 inputs), two channels for a cassette machine to record on-air calls, two channels for the telephone feed and two empty channels.

Remember, the Mackie is a plug-in board (no soldering required) and can be chained with up to two more Mackie boards.

Pristine interfaces with all major traffic software. Guardian uses DARTS at six stations, Marketron at another, and two have old Radio Shack systems. Pristine offers a basic PCM Edit for production software. Five of Guardian's stations use PCM Edit and three have the Session 8 Digidesign. Session 8 is very sophisticated and has a substantial learning curve. PCM is a simple eight-channel production software that can be mastered in 10 minutes.

Frankly, PCM Edit is more than adequate for most applications. And here is the bottom line: \$10,000 a studio and you are totally digital and fully automated. It doesn't get much better than this.

For information, contact Boyce Williams in California at 310-670-7500; fax: 310-670-0133; or circle Reader Service 155.

Looking for the ultimate affordable digital STL solution?



Look No Further!

Moseley

Moseley Associates Inc.
111 Castilian Drive
Santa Barbara, CA 93117
Voice (805) 968-9621
Fax (805) 685-9638

WHEN Moseley introduced the DSP 6000 in 1992 it was immediately acclaimed by the broadcast industry as THE digital STL solution. Here's why. The DSP 6000 virtually eliminates the problems associated with conventional analog transmission such as noise due to signal fades, birdies from intermod interference, and lack of spectrum for multiple audio feeds to LMA and Duopoly transmitter sites. Almost three years later, the DSP 6000 is the de-facto industry standard for sonic clarity and reliability with sales approaching 2,000 installations worldwide. But you probably already knew all of that stuff, right?

What you may not have known, is that the DSP 6000 also works in conjunction with your existing Moseley analog composite STLs! If you've invested in a Moseley PCL 505/C, 600, 606, 606/C or 6000, a few simple modifications convert your entire system to digital! And it won't cost a pot of gold (just under \$6,000). Call us for modification instructions, or better yet, ship us your STL and for a mere hundred bucks, we'll make the modifications and do the setup for you.

Isn't it time you stopped chasing rainbows and started enjoying the sonic clarity of digital? "Digitally clear. Clearly digital. Just the way we planned it." ▼

There are lots of imitators But there is only one...

SMARTCASTER

But don't take our word for it, hear it for yourself

Call toll free

800-747-6278

Extension 700

For a complete demonstration of all SMARTS and SMARTCASTER products
including:

- SMARTCASTER Generation 2000 Digital Automation System
- SMARTCASTER Generation 2000 Digital Live System
- SMARTCASTER Generation 2000 Satellite System
- SMARTCASTER Generation 2000 Music On hard Drive System
- New SONICFAX Broadcast Audio fax system
- SMARTS Billing Accounting and Traffic System
- SMARTS Music Mix Scheduling System
- SMART TOUCH Live and recorded automated remote broadcast system

You'll hear it all, and see how a totally integrated digital system from
SMARTS Broadcast Systems can impact your station sound and your bottom
line.

 **SMARTS**
Broadcast Systems

P.O. Box 284 • 2102 Main Street • Emmetsburg, IA 50536
Office: 800-747-6278 • Office Fax: 800-498-0618 • Sales: 800-498-0487 • Sales Fax: 800-398-8149
Outside U.S.: +1-712-852-4047 • Outside U.S. Fax: +1-712-852-5030
Internet: 75677.211@COMPUSERVE.COM

Circle (22) On Reader Service Card

World Radio History

USER REPORT

RDS Phantom Creates Happy Union

by Michael H. McDougald, President/CEO
McDougald Broadcasting Corp.
WRGA(AM)-WQTU(FM)

ROME, Ga. When radio broadcasting began in the early 1920s, creative minds conjured up things that would be neat to do over the air. One of the more interesting concepts was to stage a marriage in the broadcast studio.

Atlanta's WSB was credited with the first radio wedding. Not long after that, WRGA in Rome, Ga., teamed up with WJBY(AM) in Gadsden, Ala., each station supplying a participant. And so it was that a deep-voiced announcer and a traffic director vowed their commitment to each other in a flapper-era broadcast.

Today's radio leaves that sort of union to TV shows. However, a different kind of wedding recently took place at WRGA-WQTU in Rome. We married two distinct and viable formats using a computer.

Not that getting computerized is unique. But some of the things we did may be worth noting by broadcasters who find themselves in a similar situation. Perhaps we should set the stage as it was a year ago.

WRGA was a 5 kW full-time AM featuring a mix of news and country music that had made it successful for more than 15 years. WQTU-FM, a 6 kW full-time station, offered an adult contemporary format with strong but limited news.

The objective in combining the two stations was to cut daily operational costs while improving the sound and the bottom line. We also wanted to attract listeners instead of ignoring them as some computer-driven operations have done.

We looked at several digital systems, settling on Register Data Systems' Phantom.

Phantom is not the least expensive system, but dollar for dollar, we think we came out ahead. Randy Quick, our operations chief, came to the table with a better-than-average working knowledge of the system. And with

RDS' toll-free number, it was fairly easy to iron out the few bugs we found.

We purchased a Phantom for WQTU, one for WRGA, one for production and a server unit for transferring files. For the newsroom, we chose a terminal, which connects to the AM Phantom. All of these units, though in different rooms, are networked together. After one year's experience, we are considering picking up an additional Phantom exclusively for the newsroom. We have encountered a modest amount of wait-time for news personnel who are loading news items and features on their consoles.

Our entire operation and the sound of both stations benefited from retiring our tired cart machines and getting things on hard disk. Editing and storage is much easier. Traffic loves sending up the logs by floppy, and we have cut down on paper consumption.

So what about the marriage? We used Westwood One's Bright AC as the basis for our adult contemporary sound on the FM, but supplemented it with a strong live and local morning show (6 to 10) and a similar drive-time afternoon show (3 to 7). We feed just enough news coverage to the FM to round out the listening experience. Our engineers improved our processing and enhanced the sound so that it literally leaps out at the listener.

Almost a year later, we are enjoying an Arbitron that makes us the strongest AC in the region, beating the competition by nearly 8 share points. That, however, was only the engagement process. The real wedding came when we made dramatic changes on the AM.

First, we dropped the country music that was woven into our news format to make room for a 24-hour all-news, information and talk combination. This move considerably lowered our licensing fees and allowed us to put money back into our news product.

We knew our future was in providing the market with more

news, especially local. News, however, is labor intensive, and we were outspending everybody in the market before we even started. How could we improve our news without spending more money? Or, perhaps, by spending less?

We arranged a three-way partnership between WRGA, the Phantom and the new Associated Press All News Radio.

In any given hour of the day, the computer takes five minutes from ABC Radio News, 15 minutes from CNN Headline News, five minutes from Georgia News Network, 25 minutes from AP All News Radio, and picks up the local newsroom feeds about four times each hour. Plus, the computer injects weather, sports, community calendars and commercials.

To say we get our money's worth out of the AM computer is an understatement. It provides us with 60 local news inserts, 46 sports pieces and 38 business segments during each 24-hour period, plus it switches between satellites and picks up the various news feeds on time.

We are pleased with how live and "with it" the station sounds. And the ratings prove this: we have an AM station audience equal to that of our FM, giving us two of the top three stations in this market.

We conduct both operations most efficiently with 12 full-time people, down from 16 to 18 before the changes.

We really scored by hiring additional news personnel to replace music personnel. We do not miss the music, and apparently neither do our listeners. With the enthusiasm over these two commanding sounds, we are selling more, and our operational costs have dropped dramatically.

We found tremendous community acceptance of our moves, and with fewer people to manage, we get much more efficiency out of the specialists that remain with us. And there is something special about knowing how good we sound. Under our new moniker The News Station, we happily carry the banner of leadership in the community.

Perhaps anybody's computer could do all this, but Register's Phantom seems to have been hand-crafted for us. And we appreciate Lowell, Russell, Brad and Janice, who are always as close as the phone.

For information, contact Brad Harrison in Georgia at 800-521-5222; fax: 912-987-7595; or circle Reader Service 85.

Discover the quality of audio à Capella

- ▶ Real-time audio transmission
- ▶ Real-time record-to and playback from disk
- ▶ ALL Sampling Rates up to 48 kHz
- ▶ Professional analog and digital interfaces
- ▶ MPEG Audio Layer II Compression
- ▶ G.722 for compatibility
- ▶ ISA PC-compatible
- ▶ Optional MPEG editing software

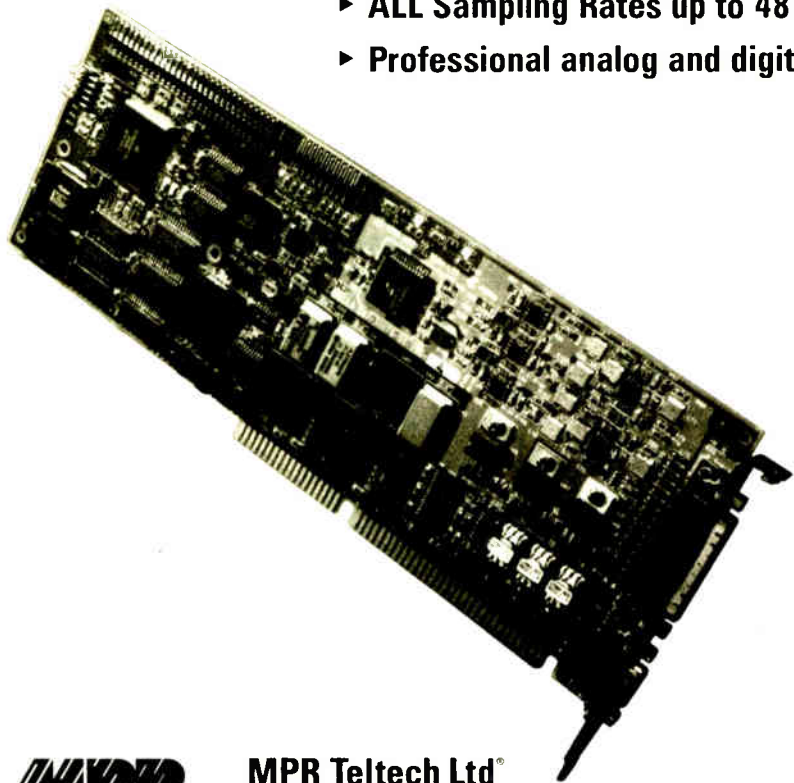

In addition to all these features, Capella offers exceptional audio quality for direct-to-disk recording, sampling, and reproduction. With an optional ISDN terminal adapter you can do real-time audio transmission up to 384 Kbit/s! Capella also comes with a software developer's kit that provides the perfect solution for tailoring your own audio application.

So if you are looking for the ultimate in flexibility and sound quality, discover the quality of audio à Capella today.

In Canada and
the Continental U.S.
call toll free:
1-800-555-7700

MPR Teltech Ltd
8999 Nelson Way
Burnaby, BC
Canada V5A 4B5
Tel: 604-294-1471
Fax: 604-293-5787

Europe: **MPR Teltech Ltd**
Postfach 1855
Ob. Hauptstr. 52
D-85354 Freising
Germany
Tel: 49-8161-42400
Fax: 49-8161-41234



MPR Teltech Ltd®

USER REPORT

AXS Alleviates Traffic Nightmares

by Ted L. Turner
Operations Mgr.,
Programming Dir. and
Chief Engineer
KWCO(AM)

CHICKASHA, Okla. After spending most of the first half of 1994 researching digital audio/automation systems, we finally settled on the Electric Works AXS. We were looking for a system that would automatically switch between live local studio audio from our FM station and a couple talk networks, and play spots scheduled by another vendor's traffic system, using both real-time and network cues.

Above the rest

What we got was a system that stands above any similar product in its price range, with capabilities far in excess of what I had expected. Not only does it have the best graphical interface display in the business, but the system is extremely easy to operate, even for our less computer-literate staff members.

Our system is configured as a main studio unit with two apt-X audio cards for playback and background recording, with the DMX-4 digital mixer and internal switcher option. We have an additional unit with one apt-X record/play audio card for production and editing using the AXS Digital Clip editor, which allows for quick digital razor jobs. All of these features are stored on two networked 486 SLC-66 platforms with 535MB drives, VGA monitors and trackballs. Because the

AXS can handle up to 50 rotating spots per "cart," and it rotates liners and IDs flawlessly.

system runs on two separate computers, we are able to keep a complete commercial inventory and operating system separate from the main studio unit.

Traffic nightmares

AXS allows us to breeze through the traffic nightmares that are common here. For example: "We can't play the network A spot here because the network B spot needs to run live. So we can record just the spot on the end of one feed and play it immediately after recording. And by the way, we need to write in three 60-second spots this hour. In fact, you'll have to dub those spots onto the system now, while it is playing commercials on the air, because someone is hogging the production room."

AXS can handle up to 50 rotating spots per "cart," and it rotates liners and IDs flawlessly, with the ability to daypart liner and ID lists. Plus, we can edit the log on-screen up to the actual event time. We can play locally produced pre-recorded news and sports

blocks while recording back-to-back network feeds for later insertion into the local blocks, with split-second timing between record and playback times. The system consistently hits a half-second window between cue tone and audio start on the ABC network. I can hardly get real-live jocks to do that.

Audio quality

As for audio quality, I cannot tell the difference between CDs and the AXS playing the same cuts. We are presently using the 32 kHz sampling rate,

though it can go up to 44.1 kHz. Audio transfers between the production room and studio are accomplished in less than the actual audio cut time.

We can also archive cuts to floppy disk at the rate of roughly three 30-second mono cuts per 1.44MB floppy. If we wanted to store a single 60-second stereo spot floppy, the media cost per cut is pennies compared to carts or tape reels. Floppy storage varies depending on cut length and sampling rate.

The system performs basically every live-assist task I have come up with

and features all of the user-programmable audio cut, jingle, liner or ID screens that we might need for instant access, as well as automatic live tag and copy displays. We have already made plans to install an AXS control room system for live-assist and CD playback in our FM studio. One thin piece of coax will then put us on-line with the existing system for unlimited cross-access to audio cuts.

Before you fall prey to the "central server" or "digital floppy cart machine" hype, check out AXS. Get the demo disk and take a look at a working system; then go out and compare.

For more information, contact Pete Charlton in Texas at 800-334-7823; fax: 817-624-9741; or circle Reader Service 103.

CELEBRATE RADIO'S 75TH ANNIVERSARY AS YOU PREPARE FOR THE FUTURE!

Join the industry's best at The NAB Radio Show and find real solutions to real problems. You'll address the issues of today and discover the tools needed to ensure your future success. From technological issues, new revenue streams and duopolies to creative leadership techniques and regulatory issues—**there is something here for everyone on your staff!**

Take part in an intense one day Digital Radio Seminar, a must for GM's, engineers, operations managers and group operators, and hear expert advice and solutions to prepare your radio facilities for the digital age without wasting assets on unproven technologies. A special emphasis will be placed on the first public release of DAB test data.

Management sessions will help you achieve maximum results from your station and staff; programmers will learn ways to improve listener loyalty and market share; and sales and marketing professionals will benefit from RAB's high-energy sales & marketing sessions.



RADIO THE NAB SHOW

SEPTEMBER 6-9, 1995
EXHIBITS: SEPTEMBER 7-9, 1995
New Orleans Convention Center
• New Orleans, Louisiana, USA •

DON'T MISS THESE NAB RADIO SHOW HIGHLIGHTS...

■ Mel Karmazin and Lowry Mays, CEOs of two of the worlds largest, most influential radio groups, explore "Radio: Today's Trends, Tomorrow's Opportunities."



■ At the NAB Radio Luncheon Ben Cohen and Jerry Greenfield of Ben & Jerry's Ice Cream share their



secrets to success and Nancy Widmann, President of CBS Radio, receives the National Radio Award.

■ "Opportunity '95 the Complete Radio Job Fair" provides managers and owners with an opportunity to meet qualified individuals seeking careers in radio.

■ Join FCC Chairman Reed Hundt at the Friday morning FCC Chairman's Breakfast and meet Commissioners James Quello and Susan Ness, along with other high level FCC



staff, as they take part in a variety of regulatory sessions.

■ Celebrate everything that makes radio great today at the NAB MARCONI Radio Awards Dinner & Show. Entertainment provided by Premiere Radio Networks.



■ "Radio: Profiting From Technology in the '90s." In an exciting FREE session for all World Media Expo and NAB Radio Show attendees, Dr. John D. Abel, NAB's Executive Vice President of Operations, will show you, through entertaining demonstrations, how innovations like data broadcasting, the Internet, the World Wide Web, digital compression and other exciting opportunities made possible by digital technologies can impact your business and your bottom line.



SEPTEMBER 6-9, 1995
Exhibits: September 7-9, 1995
New Orleans Convention Center
New Orleans, Louisiana, USA

DISCOVER INNOVATIVE PRODUCTS & SERVICES

By registering for The NAB Radio Show, you'll also have free access to World Media Expo, featuring over 400 of the world's leading suppliers and manufacturers of products and services for broadcasting, communications, and production/post-production. Don't wait until NAB '96 to see the latest products and services—Register Today!

YES! Please send me information on The NAB Radio Show and World Media Expo!

Name _____ Title _____

Company _____ Call Letters _____ AM FM

Address _____

City, State, Zip Country _____

Phone _____ Fax _____

E-Mail Address _____ E-Mail Service _____

FAX THIS COMPLETED FORM TO: (202) 429-5343

RW

You can also receive information from:

Fax-on-Demand—dial (301) 216-1847 from the touch-tone handset of your fax machine and follow voice instructions.

World Wide Web—<http://www.nab.org>

To speak with an NAB staff member call (800) 342-2460 or (202) 775-4970.

To learn more about exhibiting at World Media Expo, call (202) 775-4988.

TECHNOLOGY UPDATES

COLUMBINE JDS

Columbine JDS Offers Versatile Software

GOLDEN, Colo.

The newly merged Columbine JDS Systems Inc. provides radio with a choice of flexible, versatile traffic automation solutions.

Radio stations of every size, budget and operation style (single, combo and network) are part of the current worldwide client base.

A professional consulting staff assists in determining the current and future require-

ments of a station to assure both successful hardware and software installation. Technical support is available 24 hours a day, seven days a week.

Traffic software features include contract maintenance, availability, revenue projections, program logs, accounts receivable and sales analysis. Other available software applications include finance, media demographics, archiving, administration and program scheduling.

Columbine JDS automation products were designed by the pioneers of broadcasting software who have been providing technolo-

gy and service excellence to radio operators for over 30 years.

For information, contact the company in Colorado at 303-237-4000; fax: 303-237-0085; or circle Reader Service 163.

RADIO SYSTEMS

Digital DDS Looks Like Traditional Cart Machine

BRIDGEPORT, N.J. Radio Systems Inc. offers DDS, a digital storage and delivery system. DDS is designed to meet the needs of today's broadcasters, whether their operation is automated, live-assist, multiple-studio LMA or all of the above.

DDS replaces cart decks with familiar-looking, sophisticated digital cart machines. Your talent can immediately air digitally stored music, spots and promos.

DDS does not look or work like digital systems that utilize terminals. The main DDS interface looks like, operates like and fits in the space of a traditional cart machine, so the learning curve is virtually non-existent and the resistance to this technology minimal. In addition, the Sound Slate lets the user put frequently used audio segments at his or her fingertips.

DDS performs in multiple studios simultaneously because it is built on a UNIX-style, multi-user, multitasking, real-time operating system. Unlike other systems that use DOS and rely on multiple CPUs and networks to grow, each DDS server can support many users, multiple studios and up to 16 simultaneous stereo audio channels, with no need to pass audio on a network.

Modular architecture and SCSI drives support up to 36GB of storage per CPU. Each DDS is user-configurable for linear MPEFG-II compressed audio at sample rates of 32 kHz, 44.1 kHz and 48 kHz, resulting in up to 620 hours of stereo.

DDS is also a universal control system and may be used to control CD jukeboxes, audio switchers and satellite decoders.

For information, contact Dan Braverman in New Jersey at 609-467-8000; fax: 609-467-3044; or circle Reader Service 128.

DIGITAL LINK

Digital Link's DAP Features High-quality Compression Algorithms

MIAMI DAP (Digital Audio Processor) from Digital Link Inc. is a PC-based MS-DOS software for broadcast applications and full automation of radio stations. Although DAP was introduced six years ago, the company continues to launch improved versions of the system.

Main features of DAP include high-quality audio compression algorithms (ADPCME, apt-X, Dolby AC-2 and MUSICAM), analog/digital in/out, fully automated or manual operation, HDD and magneto-optical storage, automatic crossfades and professional CD-changer control.

The features of ADAS (Advanced Digital Audio Processor), Digital Link's Windows-based system, exceed those of DAP; ADAS also offers powerful graphic design capabilities. Production and air screens were designed separately for networking.

Main on-air features include simultaneous record/play, 800 preset live-assist buttons, automated time/weather events on playlists, full drag and drop, up to eight stereo channels simultaneously, and external control devices, such as multiple CD players, patch panel and control keyboard.

Main production features are LED or needle VU meters, autostart/autostop recording, user-defined subcategories for audio, automatic cue search, time/weather/speech recording, block generator and user-defined crossfade parameters.

For information, contact Carlos Sarraff in Florida at 305-888-4883; fax: 305-888-0812; or circle Reader Service 212.

DALET

Dalet Software Entirely Graphics-, Menu-driven

NEW YORK Dalet Digital Media Systems offers a wide range of digital audio products for radio. Among Dalet's many hard disk applications for radio are satellite automation, live-assist, music automation, news and multitrack editing. Dalet systems have been installed in over 300 radio stations around the world, from large public broadcasting stations to small private stations.

Dalet software is entirely graphics- and menu-driven. Operations are performed by drag-and-drop actions with the mouse, through fader starts or with remote control keyboards. Switching between live-assist and automation is as easy as pressing one button. DJs and production people can learn to operate the system in just a few hours.

Another advantage of the Windows-based system is the ability to run several applications simultane-

ously. While a standalone PC is inserting commercials into the satellite program, the user can record and edit audio on a separate audio channel. One on-air workstation can be used for two independent programs, one live and the other automated.

Dalet uses standard PC networks. Audio files and logs are stored on a central server and are immediately accessible to all workstations. The same audio file can be played from several workstations at the same time.

For information, contact Steve Kelley in New York at 212-370-0665; fax: 212-370-9610; or circle Reader Service 156.



Live-assist screen of Dalet software.

WELCOME TO THE DIGITAL WORLD OF DIGILINK

- Replace cart machines live On Air while adding walkaway CD, Satellite, or Tape automation
- On Air Base Price starts under \$8,000
- 8 Track Editor base price starts under \$5,500
- Smallest systems start at 10 hours stereo audio storage (20 hours mono)
- Network more than 15 Digilink workstations

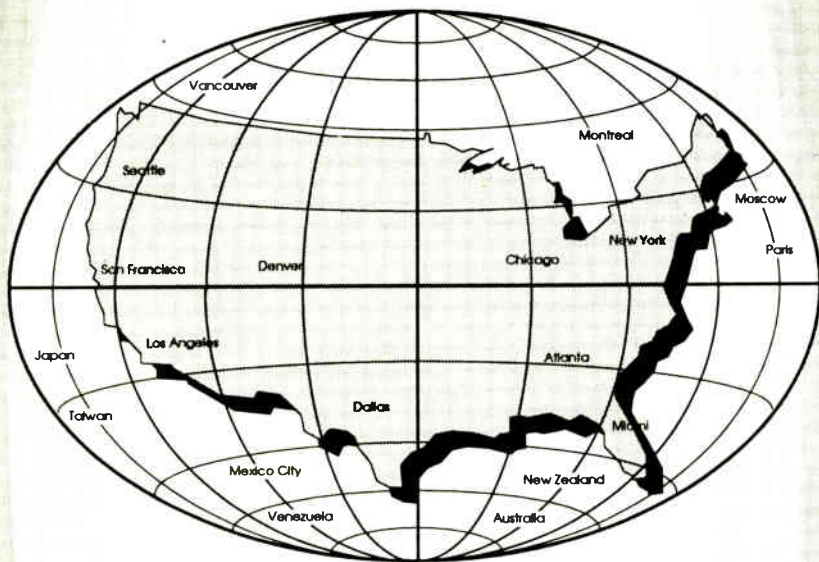

With over 500 workstations sold worldwide in the last 18 months and more than 400 of those workstations sold in the U.S.A, it is little wonder that Digilink is the #1 choice for a digital audio hard disk workstation for professional radio broadcasting. Whether for On Air, Production, News, or Automation... Digilink does it ALL.

For more information about the #1 selling digital audio workstation for Radio, call or write...

303-224-2248

ARRAKIS

© 1993 Arrakis Systems inc. 2619 Midpoint Drive, Fort Collins, CO. 80525

Circle (172) On Reader Service Card

EUROSON AMERICA

Track Scan Eliminates Handling of CDs, Leaves Talent Free to Run Show

BRENTWOOD, N.Y. Track Scan by Euroson America was developed specifically for live radio applications. The desire was to completely eliminate the physical handling of CDs, while

allowing manual creative segue control. Track Scan is easy to use because there are no keyboards to operate and no commands to learn. The day's music is selected using a bar code reader pen. Music for a five-hour shift can be "scanned in" in just minutes. Bar codes can be generated with many popular scheduling programs, or with the system software itself. All that the operator need do is press the start button on the console to start the next song.

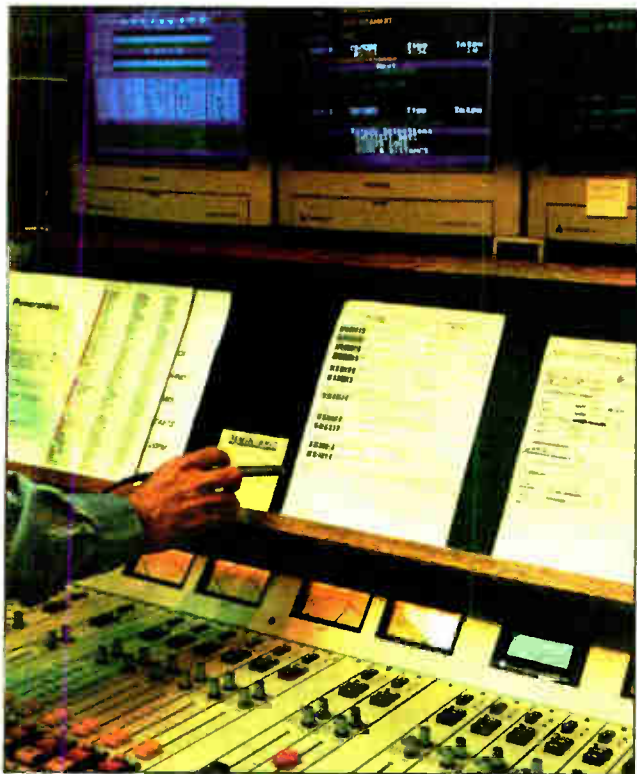

Music selections can be scanned into the system.

The rest is automatic. Reliable NSM 3101AC CD changers do the work, leaving the talent free to run the show. The preview function allows cuts to be previewed and re-cued automatically, and real-time RDS data output is standard. Track Scan provides absolute format control and eliminates lost, stolen or damaged CDs.

Tested on the air for over two-and-a-half years in two major-market stations, the system has proven to be virtually flawless. Engineers, air personalities and programming personnel agree that Track Scan is a convenient, reliable system that makes sense.

For information, contact Jon Taylor in New York at 516-273-4200; fax: 516-273-4240; or circle Reader Service 179

McCURDY

McCart System Plays Files Directly from Computers

TORONTO The McCurdy Radio McCart digital audio storage system plays files directly from storage computers (audio servers) with millisecond load time. There are no limits on how many channels can play or load files simultaneously. Automatic mirroring between storage machines provides complete data security with fallback against LAN or other hardware failures. Inexpensive control PCs provide multiple operator positions with full edit/record/play capabilities.

DATACOUNT

Revised DARTS Makes Doing Traffic More Efficient

OPELIKA, Ala. The new revision 7 of DARTS from Datacount Inc. takes advantage of a new programming language to maximize the benefits of computers with faster CPUs and expanded file sizes. DARTS 7 is compatible with 286-through-486 and Pentium microprocessors. The MS-DOS-based system is entirely menu-driven and provides on-screen help and online documentation.

DARTS 7 also has many features that make doing traffic easier and more efficient. DARTS handles up to 21 logs at one time. DARTS 7 allows traffic operators to do multistation combined traffic for up to eight stations, as well as customized history reporting, user-defined

The system is cost-effective in sizes ranging from one to hundreds of stereo or mono audio channels, allowing virtually unlimited future expansion or multiple station/network/news origination.

Storage options are available from 4.5 hours stereo (9 hours mono) to thousands of hours. Audio may be compressed (apt-X) or uncompressed. A fully documented automation protocol operates with McCurdy's M/2000 broadcast automation system, capable of originating one to over 200 audio channels from a single integrated system.

For information, contact the company in Canada at 800-267-8800; fax: 416-248-6155; or circle Reader Service 186.

credit coding, inventory frontloading/scheduling, data exports to spreadsheets, and expanded on-screen customer statement history reporting.

Datacount goes even further to make automation interfacing more flexible by offering downloads as well as automatic log reconciliation to more major digital automation systems.

DARTS 7 is fully compatible with Novell and Lantastic networks and may be purchased in multistation and multi-terminal versions. Network versions provide data security features. DARTS supports multiple printer control both for dot matrix and laser printers. Reports and logs may be spooled for later printing or on-screen viewing.

For information, contact Debbie Hamby at 334-749-5641; fax: 334-749-5666; or circle Reader Service 68.

Still think it's the future? Hurry, it is now.



The AEQ MAR System

- ▶ Transmission control can be totally or partially automated (night broadcasting, weekends, etc.)
- ▶ Touch-screen interface with proper graphics environment. Virtual keys "on screen" invite you to operate the System in an intuitive and friendly way.

Specifications and requirements:

- ▶ Audio coding and decoding in conformity with ISO/MPEG Layer II algorithm.
- ▶ DTMF or Continuous Data Channel telecommand permitting control of single or grouped remote stations.
- ▶ Automatic News Recording System, DTMF activated.
- ▶ Requires DOS 5.0 or later version. Also operates under NOVELL Netware 3.11 or later.
- ▶ Drivers for Touch-screen, mouse or track-ball included.
- ▶ AES-EBU format digital inputs and outputs.
- ▶ Storage capacity from 5 to 80 hours of stereo audio on hard disk.
- ▶ Unlimited storage on optical rewriteable disks.

Features:

- ▶ Selectable working language.
- ▶ Access for authorized users by password as assigned by supervisor.
- ▶ Selectable file sort criteria.
- ▶ Automatic News Recording remote controlled by users or journalists, using a pre-assigned password.
- ▶ Incorporates automatic news edition, audio file management and multi-track edition.
- ▶ Manual and automatic play lists and multiple templates (up to 24 simultaneous immediate access keys).
- ▶ Printable transmitted advertisement log lists.
- ▶ Every workstation associated with the System is multitask, enabling the management of recording, play list and template edition, automatic transmission, etc. from any of them.
- ▶ Audio resources stored in a common server, enables real time access to any audio file from any workstation, even from several simultaneously.



AEQ AMERICA: 2211 South 48th Street, Suite H - Tempe, AZ USA 85282
Phone: (1 602) 431 0334 - Fax: (1 602) 431 0497

CBSI

CBSI Classic Traffic and Billing Software Suits Operation of Any Size

REEDSPORT, Ore. CBSI/Custom Business Systems Inc. offers software solutions for traffic, billing, account and sales analysis for single or multiple stations, consolidations and duopolies. Nearly 2,000 stations worldwide now use CBSI systems.

CBSI's Classic traffic and billing system provides versatility and flexibility for every size operation. Classic is available in DOS and Windows applications for IBM PC-compatible computers in single or multiterminal configurations. The Elite traffic and billing

system is streamlined for the budget-minded operator.

InterAcct is the company's complete, interactive accounting system, ideal for duopoly and consolidated operations, LMAs, multistations and single-station operations. InterAcct is easy to use and includes General Ledger, Accounts Payable and a powerful report generator. It interacts with CBSI's Accounts Receivable and Payroll systems, and third-party spreadsheet software. Other CBSI software solutions include CustomRemote, CustomReports,

PowerPlus, CustomNet, CustomMusic and Sales Analyzer.

Digital Universe, the advanced digital audio storage and management system, is under development at CBSI. Digital Universe is easy to operate and is built around a low-cost computer platform using MicroSoft Windows NT.

Operate one or more radio stations from a single control point, perform multiple tasks simultaneously and access stored audio from any, or all, studios instantly. Digital Universe also handles compressed and uncompressed audio.

For information, contact Bob Lundstrom in Oregon at 800-547-3930; fax: 503-271-5721; or circle Reader Service 131.

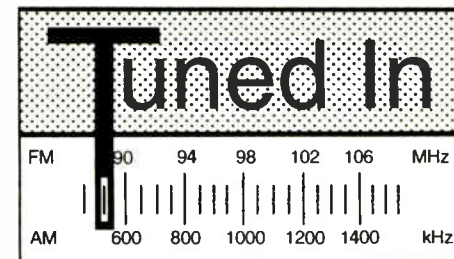

People, Promotions & Appointments

Nigel P. Fountaine was appointed to the position of sales manager, Pacific Region, for **Mobile Satellite Products**. Fountaine will operate from Lomita, Calif., serving the West Coast, Hawaii, Asia and the Pacific Rim.

Constance E. English, formerly of Grand Pro Audio, joined **Neotek Corp.** as director of sales and marketing. English will oversee all sales and marketing activities for the company's domestic and international markets.

Sabine appointed **Frank Bougher** to its sales and marketing department. Bougher comes to Sabine from Lipham Music Co., where he worked as a retail sales manager. Bougher is responsible for generating sales, offering technical support and helping set company policies and marketing strategies.

Premiere Radio Networks announced an exclusive three-year consulting agreement with **Ben Hoberman**, former president of ABC Radio, to advise Premiere on its entry into short- and long-form talk radio programming. Under the terms of the agreement, Hoberman will also serve as a member of Premiere's board of directors.

Continental Electronics Corp. added **Gale Gilbreath** to its domestic broadcast sales team. Gilbreath brings 34 years of experience in radio broadcast engineering to his new position. Based in New York, he can be reached at 914-687-9101.

The Arbitron Co. announced the appointment of **Dr. Thomas C.N. Evans** as vice president of research communications and market development. Evans' first task will be to coordinate the Electronic Media Ratings Council (EMRC) accreditation process for Arbitron's personal computer software.

Cal Vandegrift rejoined **Harris Allied** as a sales representative in the Pacific Northwest. Based in Seattle, Cal will represent Harris in Washington, Oregon, Idaho and Alaska. Broadcasters may contact Cal at 800-566-0773.

Crown International announced the appointment of **Bruce Peterson** as director of marketing for its audio division. Peterson was most recently head of marketing at Heath Zenith, a consumer division of Zenith Computer Group.

John I. Klusendorf joined **Lawrence Behr Associates Inc.** as shielding program manager. Klusendorf's background is in electronics design, service and program management. He will serve as principal interface with telecommunications clients requiring shielded sites and facilities.

INTRODUCING...



... THE MOST SIGNIFICANT ADVANCE IN GLOBAL AUDIO COMMUNICATIONS SINCE THE TELEPHONE.



The *complete* solution - only WorldNet provides all the equipment you need.

It's revolutionary.



Over 350 studios and broadcasters worldwide already on-line.

WorldNet™ provides the only fully integrated one-stop solution to the distribution of high quality audio over ISDN and Switched 56 digital networks.



Caters for every professional application from standalone reporter terminals to full bandwidth audio distribution - from one to eight channels.

WorldNet products cater for every requirement from 7.5kHz mono to full bandwidth 22.5kHz stereo and are fully compatible to protect your investment.



Aux data, timecode and machine control facilities.

Shrink the world - and your costs with WorldNet. Call to discover how.

**Audio
Processing
Technology**



U.S. TEL: +1 213 463 2963 HEADQUARTERS TEL: +44 1232 371110 JAPAN TEL: +81 3 3520 1020

Belden Wire & Cable Co. announced the appointment of **Stephen H. Lampen** to the newly created position of technology development manager. Lampen spent the last three years in field sales for the company.

Varian Associates Inc. named **Frank R. Blaha** business development manager for its microwave equipment products (MEP) business unit. Blaha will be responsible for MEP's worldwide sales, marketing and customer support.

Company News

Varian Associates Inc. and Leonard Green & Partners, L.P.(LGP), reached an agreement under which Varian will sell its Electron Devices business to LGP on behalf of its equity fund, Green Equity Investors II, L.P. for approximately \$200 million in cash, plus the assumption of certain liabilities.

Dynair Electronics Inc., manufacturer of switching and distribution systems and fiber optic transmission products, was acquired by Osicom Technologies Inc. of Santa Monica, Calif., for an undisclosed sum. Dynair is now a subsidiary of Osicom.

Ashly Audio Inc. of Rochester, N.Y., announced its new Internet service. The service offers color images and general product information, as well as a company history. Customers can request additional information and leave comments on-line.

Basic Measuring Instruments (BMI) of Santa Clara, Calif., purchased **Electrotek Concepts Inc.** of Mountain View, Calif. Under the agreement, the two companies will become subsidiaries of World Power Technologies and operate as separate firms.

Differential Corrections Inc. (DCI) of Cupertino, Calif., signed a public partnership agreement with the Minnesota Department of Transportation (Mn/DOT) to provide radio broadcast data system traffic message channel (RBDS-TMC) broadcast services for the federally-funded Mn/DOT Guidestar/Trilogy Operational Test. The objective of the project is to test innovative means of providing real-time traffic and travel information to drivers en route.

FSR Inc., manufacturer of electronic switching and control products, appointed the Burcaw Co. to cover the territory of Michigan. The Burcaw Co. can be reached at 810-616-9800.

Control Concepts Corp., a subsidiary of Liebert Corp. and a manufacturer of power protection products, was awarded ISO 9001 certification.

New Frontier Electronics, in developing a national representative network, appointed Ron Tunks Sales Inc. sales representative for the southeastern United States and Puerto Rico. In addition, Audio Associates of Columbia, Md., was appointed representative in Pennsylvania, southern New Jersey, Delaware, the District of

Columbia, Maryland and Virginia. **Mya L. Mitchell** was appointed director of administration.

Marti Electronics of Cleburne, Texas, was named a member of the 1995 Tarrant Export 40, the group of companies achieving the highest growth in export sales of all Fort Worth, Texas, area businesses. Marti was chosen for charting an increase of 17.61 percent in export sales from 1993 to 1994.

DGS Pro-Audio Inc. appointed Yale Electronics of Hollywood, Calif., as its southern California distributor.

Trompeter Electronics, supplier of RF interconnect products, was awarded ISO 9001 certification.

Unlike any other.



VoxPro™ Digital Sound Editing System *The Reel-To-Reel Replacement™*

VoxPro™ is the first digital sound editing system specifically designed to replace reel-to-reel tape recorders used on the air.

Now you can record and edit phone bits, contests, actualities, sound effects and more— on the fly, with speed and precision.

VoxPro operates like a word processor for sound. It begins by providing true one-touch recording.

Editing and playback couldn't get any easier than with VoxPro's "cut, copy and paste."

Unlike any other— VoxPro is fast. It's simple. And it's designed to meet the special needs of the on-air broadcast professional.

1-800-622-0022

Fax 317-966-0623

Southern CA 1-800-690-2828

**HARRIS
ALLIED**

©1995 Harris Corp.

traffic and billing systems

DATACOUNT

The DARTS traffic system
can help you make a
better connection to your
automation system . . .

DARTS is a traffic system that handles all facets of traffic, billing, management reporting and collections. It's also a system that supports digital audio interfacing like no other traffic system.

Datacount not only provides seamless downloads to automation systems but is also one of the only traffic systems to provide automatic log reconciliation from automation play logs back to the DARTS system.

Automatic Log Reconciliation (ALR) can provide tremendous time savings by eliminating the manual verification of your automation log. You could save hours and spot dollars with the accuracy of the DARTS ALR program.

How will DARTS and the
automation interface benefit
your station?

DARTS can easily provide a complete daily log that has been edited and finalized. The log can then be "downloaded" to the automation unit via diskette or over a LAN.

The benefit of the DARTS automation interface is twofold. It provides the ability to transfer error free data from the traffic program log to the automation unit and to transfer it in less time. Time once spent manually entering logs into the automation unit can be significantly reduced. An interface also reduces the human error factor and can eliminate missed or misplaced spots.

The DARTS system also
features . . .

- Flexible traffic scheduler
- Inventory Front Loading
- Data Exports and Imports
- Multi-Station version
- Sports Packages
- Management Reporting
- Integrated Billing Module
- Co-op Billing and Copy
- Multi-User version
- Entry Level version
- Satellite Format Compatible
- Music Scheduler
- Affordable quality Support and Enhancements

FINANCING IS AVAILABLE

DARTS

Datacount Accounts Receivable and Traffic System

Call or fax today for more
information!

Debbie Hamby - Sales Mgr

Tel: (334) 749-5641 FAX: (334) 749-5666
P.O. Box 3078 • Opelika, AL 36801-3078

MOVING?...

Don't leave us behind!

Mail or fax your current
label and new address

(with effective date) to:

Circulation, RW,
PO Box 1214
Falls Church, VA
22041

or

FAX 703-998-2966.

Address changes
will be processed
within four weeks of receipt.

Thanks!

RadioWorld

Broadcast Equipment Exchange

"Broadcast Equipment Exchange" accepts no responsibility for the condition of the equipment listed or for the specifics of transactions made between buyers and sellers.

RADIO RESOURCES

Over the last 2 years we have purchased \$1 million of quality pre-owned equipment from broadcasters. Fax or call us with a list of your excess equipment and we will let you know how we can increase your cash flow.

Looking to save dollars by purchasing a piece of quality pre-owned equipment? We have a variety of items available from turntables to transmitters. A partial list of available equipment can be obtained via fax by calling toll free 1 800 832 2329 ext 737, or call us with your specific requirements.

NRSC Splatter Measurements are coming again! Call early to reserve your rental of the Tektronix Spectrum Analyzer. We also have Potomac field strength meters (AM & FM), and a Delta impedance bridge plus receiver/generator for rent.

For competitive prices on new equipment items just give us a call for a price quote.

Call Steve or Chuck
1-800-54 RADIO
1-410-783-4635 (FAX)

Circle (135) On Reader Service Card

AMPLIFIERS

Want To Sell

Ramsa WP 9055 50 W stereo audio amp, needs work on 1 chnl, \$50. A McCarthy, 707-446-0200.

RCA/Belar stereo RF amp, \$395. Jose, 809-895-2725.

QEI amplifiers, exciters and stereo generators. All are reconditioned and are tuned and tested on your frequency. 6 month warranty is included. If you want quality used equipment, call or fax 609-232-1625 and ask for Bob Brown.

Want To Buy

Tube HiFi/Commercial amplifiers, preamplifiers, compressors, speakers etc. Altec, JBL, McIntosh, Marantz, Western Electric, Pultec, Ampex, etc. 405-737-3312 FAX: 405-737-3355.

ANTENNAS/ TOWERS/CABLES

Want To Sell

Bogen MO-100A tube 100 W booster amp, 2 ea 8417 (666) pwr tubes, 1 ea 7247 (12AX7) driver, \$100+shpg. R Evans, 704-524-7983.

3" HELIAX STANDARD COAXIAL CABLE

50-Ohm, unused, cut to length. Priced below market. Shipped instantly. Call Basic Wire & Cable (NANCY) 800-227-4292 FAX: 312-539-3500

6-bay medium pwr CP on or tunable to 100.1 MHz. D Michaels, 916-938-2833.

50 plus sections of 3 inch rigid transmission line, excel cond, will sell any quantity. 806-372-5130.

Moseley ICU-1D 940-960 MHz isocoupler, \$175. Paul, 912-632-1000.

Phelps-Dodge 2-bay antenna, hor/vert (CFM-LP2), 97.7 w/brackets, BO. Vern, 916-533-1340.

Jampro JLLP-2 antenna, less than 5 years old, with heaters, tuned to 94.5, can be retuned in field with factory instructions, \$2200. 505-538-3396.

Jampro JLCP-7 7-bay circular polarized, tuned to 106.3 MHz, BO. R Meyers, Sound Masters Rec, 4700 SW 75 Ave, Miami FL 33155. 305-264-5963.

Cablewave A 10R 50507 1 5/8 in coax foam filled, 6-approx 275' rolls w/connectors, \$1100/per roll. S Ross, Quinn Bldg, 733 N Green St, Brownsburg IN 46112. 317-852-9119.

TOWER LIGHTING CONTROLS

For Aviation Obstruction Lights, Beacons, and Strobe Light Systems.



PRECISION MULTIMEDIA CONTROLS, INC.
33 Greenwood Ave. • Middletown, NJ 07437
TEL (201) 444-0600 • Fax (201) 445-8575

Rohn 45 G tower sections, \$125/BO. Rick, KBZO, Lubbock TX, 806-763-6051.

Want To Buy

3 or more bay class A size antenna on 105.9 wanted to trade for cash or huge 4-bay Phelps-Dodge CFM-HP-4, end fed with 3 1/8" interbay line, prefer heaters, low wind load. K Tuckerman, WMMC, 217-826-8017.

Scala 5 or 10 element antenna on or near 98.9 FM or broadbanded log periodoid, McMartin or similar FM composite receiver. J Hart, KDAB, POB 949, Prairie Grove AR 72753. 501-846-0949.

AUDIO PRODUCTION

Want To Sell

Avcom Inc EBS-1000, BO; Belar FM & AM FM amps (2), BO; RF mod GTN 88S Gates radio component, BO; Yesco Music Syst 8-track model 820, BO. WYKS-FM, 904-331-2200.

Roland SRV 2000, \$525; dbx 503 expander/comp, \$290; Orban 414-A stereo compressor, \$425/BO; UA 565-filter, BO. T Coffman, 619-571-5031.

Symetrix 528 voice proc, brand new in box, \$425. J Johnson, KHTR, 509-332-6551.

Yamaha 2031 graphic EQ, \$175; Otari MX-5050BII 2-trk, \$1100. Tascam 22-4 4-trk, \$450; Aphex M-120 dist amp, \$100; Mod Assoc dist amp, \$100; Micro-trak 6411 phono preamp, \$50; Sennheiser MD-421, \$200. 510-895-6358.

Adams/Smith 605 resolver/synch to interface with videotape recorder & audio tape recorders utilizing SMPTE. \$300. G Zeinger, 213-953-5310.

Digidesign ProTools 2.51, 4-chnl workstation, cinl disk I/O card, 4-chnl audio interface, cable & software for both ProTools & Sound Designer, \$4500. Paul, Pissaurus Prod, 402-341-9153.

Good used studio tape 1/2" \$15. 1" \$30, 2" \$55. W Gunn, POB 2902, Palm Springs CA 92263. 619-320-0728.

Fostex 3180 24 msec pre-delay, will trade for old UREI "Cooper Time Cube"; AKG R-25 remote control with connector & 33' cable, will trade for Teac RC-170 or RC-90 remote control. J Roper, Imperial Sound, 383 N Studio St, Terre Haute IN 47803-9773. 812-877-2663.

ADC PATCH CORDS
NEW T.T. sale-\$6.95
NEW 1/4" sale-\$8.95
patchbays and used equipment too!
audio village 619/320-0728

ADC 1/4" patchbays and cords, NEW, UNDER HALF PRICE, ADC TT patchbays, \$129 up, NEW cords, \$9.95. W Gunn, POB 2902, Palm Springs CA 92263. 619-320-0728.

Bulk eraser, \$49; Stewart 4 ch D-box, \$95; Cue command decoder, \$125; NEW Tascam midizer MTS1000, \$450; Infonics 7" reel copier 1-3 copies, 2@ \$125 ea; Furman elec crossovers, \$95; Peavey M2600 power amp, \$375; Crest FA800 PWR AMP, \$475. W Gunn, POB 2902, Palm Springs CA 92263. 619-320-0728.

Want To Buy

MXR-Neve-API EQs, mic-pres, delay, etc. T Coffman, 619-571-5031.

Ampex tube mixers, plug-in mic pre-amp modules for PR10's, Altec or other tube compressors, Mackie mixers. W Gunn, POB 2902, Palm Springs CA 92263. 619-320-0728.

AUTOMATION EQUIPMENT

Want To Sell

BE Cntrl 16 compl, or will sell components separately, incl 5 Revox R-Rs, 3 16m Go-Carts, 2 triple-deck cart machines, BO. B Stanley, 616-925-9300.

Lowest Cost SATELLITE automation. The Auto-Mate Version 2.0 is here! Use for satellite or music on hard drive. Software works with your IBM(tm) compatible computer and SoundBlaster(tm) audio card. Save thousands of \$\$\$! Call for more information: (503)-769-2886.

Harris 7002 Instacart, 5 ITC 750's, 3 single plays, floppy disc backup, incl sample AC music library on 90+ reels, no monthly fees, BO. J David, KMPC/KSTG, POB 907, Skiston MI 63801. 314-471-1520.

Harris 9000 (5) ITC 750, Carousels, dual floppy drives, single cart deck, plus more, currently on-air, available 7/95, \$2500. Tom, 715-234-9059.

Schafer 7000 with Audiophiles, lvl 1A software, DAT backup, extras, good condition, \$3500. Jim, 814-255-4186.

Harris 9002 Instacart, 5 ITC 750s, 2 sngl plys, floppy disk back-up, incl compl AC music library on 90+ reels, no monthly fees, BO. J David, KMPL, POB 907, Sikeston MO 63801. 314-471-1520.

ITC 750 reel plybk only, as is, 5 decks avail, \$10+shpg. A McCarthy, 707-446-0200.

Sentry FS-12B compl automation system, good condition, including 2-stereo 48 Instacart 4 stereo Go-Carts, 2-24s, 1-48 & 1-42 computer, interfaces, manuals & cables, BO; IGM-EC compl automation system, good condition, including 2 stereo Instacart 48s & 1 stereo Go-Cart 24, computer, interfaces, manuals & cables, BO. C Mandel, 619-352-2277.

SMC Carousels (4), mono, BO. GM, KWED-AM, 210-379-2234.

CART MACHINES

Want To Sell

BE 5400C PB stereos (2), excellent condition, \$2500/ea. S Cooper, WRIC-FM, POB 838, Richmond VA 24641. 703-964-4066.

Scully L50313-9 not working, probably parts only, record/play with roller cabinet, BO; ITC triple deck mono cart machine, heads OK, motor weak, \$300. R Wittick, 916-283-1370.

SpotMaster stereo plyr, BO; Tapecaster 700RP, BO; ITC stereo rcdr, BO; ITC mono rcdr, BO; ITC ESL-4 plyr, BO; ITC Encore RP, BO; ITC SP, BO. WYKS-FM, 904-331-2200.

Roland DEP-5 (5), all work fine, \$225/ea-\$1000/all. S Russell, 616-782-9258.

Tapecaster cart machines (2), 1 R/P & 1 ply only, both have new motors with about 25 hours use, BO. D Kirby, Rhapsody Productions, POB 1543, Palm Springs CA 92263-1543. 619-320-1782.

Tapecaster X-701 mono PB, excellent condition, very clean, guaranteed with manual, \$295. K Lamson, 510-447-7405.



BE 5400C 3 stack stereo PB cart machine, 3 tones, excellent condition, low hrs, \$1295; Fidelipac CTR10 R&P stereo, 3 tones, \$900. Jose, 809-895-2725.

BE 5504B 5 deck stereo PB w/cue tones, good condition, duro-heads, no wear, meets factory specs, \$950. G Garcia, KPEZ Radio, 811 Barton Springs #967, Austin TX 78704. 512-474-9233.

BE 5400C 3 stack stereo PB, 3 tones, excellent condition, low hrs, \$1295; Fidelipac CTR10 R/P stereo, 3 tones, \$900. Jose, 809-895-2725.

BE 5300C tripledeck AB, clean, \$450; Harris PB, mono, works, \$185. Paul, 912-632-1000.

BE 3000A mono PB/delay recorder, rack mount, new, \$500, Dynamax ESD 10 eraser splice linder, good condition, \$400; BE 3000A stereo R/P with tones, very good condition, \$850; BE 3000 mono R/P with tones, good condition, \$650; B.E. 3000 2 ea mono PB with ones, \$450/ea. D Kelly, 402-372-5423.

ITC Delta mono cart plys (3), excellent condition, \$450/ea. G Zeinger, 213-953-5310.

Ramko Primus stereo R/PB w/manuals, excellent condition, almost new, \$1200. R Trumbo, New Life Bldg/KNFL, POB 117, Quincy CA 95971-0117. 800-397-4146.

Audicord mono cart machine, excellent condition, \$650. 806-372-5130.

BE 5300C tripledeck, stereo, PB, mint less than 50 hrs, BO. R Kaufman, Pams Prods, POB 462247, Garland TX 75046. 214-271-7625, after 3PM CDT.

BE 3 deck, \$275. G Perry, 915-550-0558.

ITC System 99B stereo record/play: tones, ELSA, auto head: \$1200/firm. C Scott, WKYU-FM, (502) 745-5489.

The Auto-Mate - The lowest cost digital cart machine replacement. Software uses your computer and SoundBlaster(tm) card! New Version 2.0 is here. Call (503)-769-2886 for more information.

No matter how you stack it...

Nobody reconditions tape heads like JRF.

- 1 heads restored to new performance spec at a fraction of new cost
- Cart machines and all open reel formats
- Full line of replacement heads for all manufacturers

Experience the difference experience makes. Ask around. Nobody treats you or your heads better than JRF.



249 Kennedy Rd. Greendell, NJ 07839
(201) 579-5773 Fax (201) 579-6021

Want To Buy

Audi-Cord 100 various circuit cards for R/PB machines. B Sheffield, WFDU-FM, 1000 River Rd, Teaneck NJ 07666. 201-692-2806.

ITC, BE, Fidelipac cart machines: single, triple, mono, stereo, play & record/play. Call M O'Drobinak @ 619-758-0888.

HE HALL Electronics
706 Rose Hill Drive Charlottesville VA 22901

MARTI

At last, a quality 40 Watt synthesized FM Broadcast Exciter Transmitter at a surprisingly low price.

The all new ME-40 from Marti combines world-class engineering, manufacturing and component quality to make this exciter comparable to the best available today. The ME-40 is an excellent choice to replace your older existing exciters or for use as a standby. It is a high performance FM exciter offering many technical features at a price well below that of the other high quality exciters. Here are some of the outstanding features of the ME-40:

- 40 watts VSWR protected power output
- Peak-Hold baseband modulation LED display
- State-of-the-Art composite stereo performance
- Meets FCC and CCIR requirements
- Full remote capability
- Test multimeter with Forward and Reverse power ranges
- Call for your HE Price!

NEW!

ME-40 FM Broadcast Exciter

Call us for the Best New & Completely Rebuilt Equipment! (804) 984-HALL (4255) Fax: (804) 984-FAXX (3299)

Circle (90) On Reader Service Card

CD PLAYERS

Want To Sell

Sony CDK-006 juke boxes (3), 2 totally refurbished to factory specs, 3rd in svc & wkg properly, \$1395/ea for refurbished units, \$995 for other. Jim, 717-692-2193.

Otari ARS 1000 open reel machine, Best Offer. C Mandel, 619-352-2277.

Otari 7308 8-trk 1" rcdr, very lw hrs, heads excellent, 1513/30 ips, w/remote, \$1500; Studer/Revox PR99 2-track tape deck, 7 1/2 & 15 ips, lw hrs, excellent cond, \$1400; Ampex 440 tape decks, 2-track, \$250-\$500; Ampex 300 & 440 exports, motors & parts, \$100-\$200; Teac A-2000 tape deck, 1/4-trk record & play, 7 1/2 & 3 3/4 ips, excellent cond, \$200. L Wagner, 407-299-1299.

Pioneer 300 deck jukeboxes (3), \$3500/ea; 18 deck Pioneer CD jukebox, \$450; 60 deck Sony jukeboxes (3), \$1000/ea; Digicart early model, \$2500; 16 source 360 System router w/stereo expander, \$650. R Lockhart, KOGA-AM/FM, Box 509, Ogallala NE 69153. 308-284-3633.

Studer B-67 recorder, 7.5, 15, 30 ips, 1/4" 2-track, compl w/rem cntrl, owners manual & export cover, fully serviced, excel cond gd heads, \$1600. R Streicher, 818-359-8012.

Want To Buy

Marantz 610 CD (red/orange book) recorder, perfect working order, manuals. Sound Dynamics, Box 278, Dennisport MA 02639-0278.

COMPUTERS

Want To Sell

Alesis MMT-8 & Datadisk, excel cond, MIDI sequencer & universal MIDI data storage to standard DSDD floppy disks, \$320. E Scholl, TGT Rcdg, 829 Seymour, Lansing MI 48906. 517-371-2226.

CONSOLES

Want To Sell

Autogram AC-8 stereo, excellent condition, \$2000. 510-895-6358.

Russco 50G mono, \$300; Ramko DC5AR, like new, \$200. J Parsons, 904-532-0192.

Gates Yard board, recently gone thru with new switches & condensers, has had proof, also complete set of new connectors to connect all inputs to board, Best Offer. D Kirby, Rhapsody Productions, POB 1543, Palm Springs CA 92263-1543. 619-320-1782.

Shure M267 4-chnl mic mixer, XLR inputs, good condition, \$275. B Taylor, 617-266-4220.

Soundtrax 16-channel prod console, \$950/Best Offer. B Pitts, WJBY, POB 930, Gadsden AL 35950. 205-442-1222.

Tascam 4-chnl mixer, recorder model ministudio, Porta-One, excellent condition, guaranteed with manual, \$295. K Lamson, 510-447-7405.

BE 5M250 5-input stereo broadcast console with audition buss, excel cond, \$450; Yamaha M512 12-input, 4-output production mixing console, excel cond, \$250; Stevenson-Interface 8 mic/line input 4 output buss port mixer in Zero case, \$250. G Zelinger, 213-953-5310.

Collins IC 6 audio console, BO. C Mandel, 619-352-2277.

McMartin stereo console, 8 pots, \$895. Jose, 809-895-2725.

Opamp Labs 2008-RS board, 20 input, 8 buss + stereo out, 2 16x2 remix/cue sections, \$1200. L Wagner, 407-299-1299.

Ramko DC 8-MS 8 pot solid-state stereo on-air console, 18 inputs, fully functional, gd cond w/book, \$900. J Cunningham, KEOR/KHRC, Rt 2 Box 113B, Stonewall OK 74871. 405-265-4496.

SNAKE 16 phantom-pwr inputs w/exl ps, 250' Belden 19-pr cable/ml connectors/ss strain reliefs, 10' Neumann XLR snake mates w/box or Belden snake, \$750. R Katz, FAX 818-505-0149.

Spotmaster, clean solid-state mono board, 16x2, looks & works great, lightly used, \$500+shpg. G Kirby, Gray Fox Video Prod, 13613 US 36, Marysville OH 43040. 614-261-8871.

Ramsa 820 20x8x16 with meter bridge, \$1795; Quantum 23x16x24 as used by LA Philharmonic, \$3750. W Gunn, POB 2902, Palm Springs CA 92263. 619-320-0728.

Ampro Microtouch 5-chnl stereo, gd cond, \$500; Russco 505 5-chnl mono, gd cond, \$400. M Persons, KLSK Radio, 402 Buffalo Hills Ln, Brainerd MN 56401.

Soundcraft 3200 32x24x2 with patch bay, 5 yrs old, excellent condition, \$56,000/BO. Jeff, 312-559-1845.

Sparta AS-30B 5 channel stereo, \$250. G Perry, 915-550-0558.

Want To Buy

API, Neve whole or parts, working or not. T Coffman, 619-571-5031.

Howe 7500 manual. G Jacques, KBZR-FM, 7434 E Stetson Dr #265, Phoenix AZ 85251. 602-423-9255.

Manual &/or parts for Micro-Trak 6509 5-chnl stereo Ditty Desk console. Steve, 214-491-2804.

DISCO-PRO SOUND EQUIPMENT

Want To Sell

Fostex 3180 reverb unit, will trade for UREI, Cooper Time Cube model #920-16. E O'Brien, Imperial Sound, 383 N Studio St, Terre Haute IN 47803-9773. 812-877-2663.

JBL 4410A(L) 3-way studio monitor speaker, used approximately 8 hrs, mint with warranty card, \$298+shpg. R Evans, 704-524-7983.

EV MTS speakers (1 PR), pulse 18" subs (1 PR), QSC 1700 amp, QSC USA 850 amp, EV 7300 amp, Crown D150A-2 amp, Technics SLP6340 CD players (2), Mackie 1604 mixer, DOD 3-way crossover, EV EX 18 crossover, Yamaha EQ, dbx 160 XLT limiters (2), Furman FL plus pwr conds (3), Optimus cass deck, Shure SM 58 mic, 2 Stagecraft PAR 56 light trees, dimmers & 8-chnl lite desk, over 1000' A/C assorted audio cabling, all equip road racked & only 1 yo, \$13,900/BO. 614-591-6874.

FINANCIAL SERVICES

Kenwood D-5 pair of carrying handles, new in box, BO. J Roper, Imperial Sound, 383 N Studio St, Terre Haute IN 47803-9773. 812-877-2663.

EQUIPMENT FINANCING

ON ALL RADIO EQUIPMENT

- Easy to qualify
- Fixed-rate, long-term leases
- Any new or used equipment
- 100% financing, no down payment
- No financials required under \$50,000
- Refinancing existing equipment



Call Mark Wilson
(800) 275-0185

LIMITERS

Want To Sell

Orban 424A gated compressor/limiter/de-esser, \$325. J Mueller, Family Stations Inc, 290 Hegenberger Rd, Oakland CA 94621. 510-568-6200 x240.

Texar Audio Prisms (2) w/Optimod card, will trade for S/A 7300 Sedat 4 card, BO. D Solinske, WWRM, 877 Exec Ctr Dr W, St Petersburg FL 33702. 813-576-1073.

Aphex II pro broadcast aural exciter, works OK, \$400; BBE 202-R audio processor, works OK, \$200; SAE Mark 7 stereo octave EQ, good condition, \$100. G Barnett, 619-328-1104.

CRL PMC 300A, \$500; CRL SMP 400A, \$500; CRL SMP 400B, \$500; CRL NRSC pre-emphasis/filter, \$300; CRL NRSC de-emphasis/filters (2), \$300/ea. GM, KWED-AM, 210-379-2234.

Want To Buy

Gates, Inovonics, Fairchild, RCA, UREI, Teletronics, all types, solid state & tube. T Coffman, 619-571-5031.

Fairchild 670 or 660 tube compressor/limiter, Teletronics LA-2A tube compressor/limiter or UREI LA-3A solid state compressor/limiter, call after 3PM CST. 214-271-7625.

MICROPHONES

Want To Sell

AKG D-140 dynamic cardioid mics, \$225/pair. R Streicher, 818-359-8012.

AKG C414 TL II, mint cond, orig box, case & manuals, \$1200. Mark S, 605-374-3424.

Electro-Voice 635A dynamic, omnidirectional mic with stand adapter, \$95. B Taylor, 617-266-4220.

Shure 330 uni-directional ribbon, very clean, in red Shure bag, \$75. G Hultman, Hultman Media Svcs, 300 Limp Creek Rd, Grants Pass OR 97527. 503-474-6466.

Shure 561 mic on Shure 540A desk stands, many avail, fair to good condition. \$10-\$50/ea. Al, 712-362-4119.

AKG 190E, excel, BO; EV 664 Judge Ito mic, excel, BO. Steve, 214-491-2804.

EV RE-20 recond & new paint, \$300. M Miller, WSDM Radio, POB 650, Brazil IN 47834. 812-446-2507.

Telefunken/Schoeps CM61 tube mic, extremely rare & compl, uses std 6AU6 plug-in tube, original ps, new cable, mint condition, BO/trade for C24. R Katz, FAX 818-505-0149.

NEW EQUIPMENT CHEAP! OR ALMOST FREE! Sennheiser HD44011 headphones; Electro Voice microphone; Shure M268 mixer series. Call Kim at 1-800-422-9997.

Sony ECM377 large dia. cond mic, \$495; RCA 77DX with new ribbon, Crown GLM200 lavalier like new, \$125. W Gunn, POB 2902, Palm Springs CA 92263. 619-320-0728.

Want To Buy

AKG 451-EB, AKG 460-EB, EV RE-27, more. T Coffman, 619-571-5031.

Inexpensive hand-held wireless mic w/receiver. Al, 712-362-4119.

Old mics, call plates, on-air lights. J Phillips, 414 Washington Ave, Defiance OH 43512. 419-782-8591.

AKG C24 mic. R Katz, FAX 818-505-0149.

77-DX's, 44-BX's, WE KU-3A's On-Air lights, recording lights & audition lights. Top price paid. Fast response. Bill Bryant Mgmt, 2601 Hillsboro Rd, G12, Nashville TN 37212. 615-269-6131, FAX: 615-292-3434.

RCA 77DXs/44BXs ribbon, chrome/TV grey, good cond, BO. R Kaufman, Pams Prods, POB 462247, Garland TX 75046. 214-271-7625, after 3PM CDT.

RCA ribbons, AKG 451's, Neumann KM84's, U87's AKG 414's. W Gunn, POB 2902, Palm Springs CA 92263. 619-320-0728.

MISCELLANEOUS

Want To Sell

Radio bdct booth w/A/C on 16' tandem tr, \$1795. Randy, 816-885-6141.

IBM System 36 mainframes (2), BO; Telrad office phone system with 30+ phones, BO; RCA 10-bay FM antenna (95.7) with radomes, BO. K Alford, 206-285-2295.

Onan/Cummins 30 kW gensets (2) diesel, one 800 hrs, \$7500; one 1500 hrs, \$9500; day tank w/auto oil level cntrl, \$16,000/all. R Witlick, 916-283-1370.

Singamo G4 .00062/30kV mica capacitor for transmitter or ATU, \$45+shpg; General Radio Type 5 3 ganged Variac, 5 amp, 0-135VAC, \$35+shpg. R Evans, 704-524-7983.

Spring cleaning has arrived, 3 page list of equipment including R-Rs, audio proc & tape NR for sale, call fax or e-mail for list & method of reply. C Scherer, CBRE, WMMS/WHK/WMI, 216-781-9667, 216-771-1007 FAX, chriss@wmms.com.

DISTRAMIX® 8x8 MATRIX MIXER

- More flexible than a routing switcher
- Fully adjustable crosspoints (64 mix pots)
- Creative audio mixing & distribution

For more information, contact:
510.769.1515 fax: 510.523.6296

MERIDIAN COMMUNICATIONS
P.O. BOX 97, ALAMEDA, CA 94501 USA

Circle (157) On Reader Service Card

RECORDERS

STUDER SERVICE SPECIALIST

Thousands Served • Unbeatable Rates
Precision Capstan Resurfacing

Audio Advantage

Tel: (615) 742-3834
PRICE-QUALITY-SERVICE
Let Us Prove It

Want To Sell

MCI JH110A stereo rcdrs (2) in variable profile cabinets, excellent condition, \$800/ea. G Zelinger, 213-953-5310.

Ampex 351 decks with Inovonics electronics, mono, BO; Ampex 351 deck with original tube electronics, mono, BO. GM, KWED-AM, 210-379-2234.

Ampex 600 1/2-trk 7.5 ips 7" reel, gd cond, will trade for Magnecord 748 or 1048 10.5" reel in gd cond, \$100+shpg. E Lightman, WEDL Radio, 550 Merchant St, Ambridge PA 15003-2463. 412-266-2802.

Ampex 440 1/2" 4-trks (2) w/stands, BO; Ampex 440 stereos (2) in stands, BO; Ampex 400 monos (2) in stands, BO; Ampex ATR 800 for parts w/stand, BO; Ampex 440 exports (3), BO; Ampex 440 wood stands (3), BO. K Alford, 206-285-2295.

MCI JH-110B stereo in roll-around console, BO; Otari MX-5050 MKIII 8-track, BO; Otari MX-70-16 with compl remote, BO; Scully 280 stereo in roll-around, BO. B Hildebrand, 314-427-2727.

REVOX PARTS/SERVICE

Cassette-CD-Open reel
NOS PR99 repros. CALL
Capstan resurfacing. ALL BRANDS
JM TECHNICAL ARTS
30 Music Sq. W. #156
Nashville, TN 37203 (615) 244-6892

Revox PR99R-RB (4) with 25 Hz, excellent cond, \$600/ea or \$2000/all. L Mariner, KDLK/KLKE Radio, 107 Center Dr, Del Rio TX 78840. 210-775-9583.

MX5050 BII-2 1/4" 2-track, completely rebuilt, excel cond, 90 day warranty, BO. 415-589-5206.

METROTECH DICTAPHONE LOGGERS

PARTS AND SERVICE

SEQUOIA ELECTRONICS
(408) 363-1646
FAX (408) 363-0957

Sony TC-630 early 70s stereo. vgc, sound wkg order, \$175+shpg. M Tam, Multi Path Prod, 7110 Cody St, Shawnee KS 66203-4332. 913-631-9638.

Tascam 32 2-chnl rcdrs/repros (2), vgc, \$1000/ea/BO. R Witlick, 916-283-1370.

Tascam DA-30 DAT recorder, like new cond, less than 100 hrs, never rack mounted, BO. T Alexander, WDOK-WRMR, 1 Radio Ln, Cleveland OH 44114. 216-696-0123.

DISTRIBUTOR DIRECTORY

The following distributors serving the broadcast industry would be glad to help you with any of your requirements.

...country, top 40, news, urban, talk, jazz, the classics, mixed bag...

RADIO! The beat goes on!

CROUSE-KIMZEY OF ANNAPOLIS

tops in broadcast equipment

1-800-955-6800

ask for Kathleen

CORNELL-DUBILIER MICA CAPACITORS

FROM STOCK

JENNINGS VACUUM CAPACITORS

FROM STOCK

JENNINGS VACUUM RELAYS

SURCOM ASSOCIATES, INC.

2215 Faraday Ave., Suite A
Carlsbad, California 92008
(619) 438-4420 Fax: (619) 438-4759

RECORDERS...WTS

Teac X7R R-R, like new, \$400. B Pitts, WJBY, POB 930, Gadsen AL 35950. 205-442-1222.

Telex stereo Copyette 1 to 1 cassette copier, new PB head, manuals, good condition, \$300. F Radeaux, The Musik Factory, 1812 Procter St, Port Arthur TX 77604-6746. 409-982-7121.

HEAD RELAPPING/
REPLACEMENT

All tape and film formats
30 years experience
iem
350 N. Eric Drive
Palatine, IL 60067
708-358-4622

Pentagon C4322 & C4422 hi speed cass duper, master & slave units, 7 copies per run, erase heads, auto rew, very good cond. \$2500/both. S Omlas, Zoo Prod, 1228 E 10 St, Brooklyn NY 11230-4719. 718-252-5274.

Revox PR-99 ply R-Rs (4), \$1495. Jose, 809-895-2725.

Studer B-67 rcdr, 7.5, 15, 30 ips 1/4" 2-trk, complete w/rem cntrl, manual & export cover, fully svcd, excel cond, gd heads, \$1600. R Streicher, 818-359-8012.

Studer C270/2, low hrs, \$2950/BO; Revox HS77 Mk IV full-track mono, 10 hrs use, \$750/BO/trade; port case for A77 with mon speakers & power amps, \$450. R Katz, FAX 818-505-0149.

Teac A7030SL, 40 hrs use, very clean mastering deck, \$700; Teac X3R, \$300; Realistic/Teac X3, \$300; Ampex AG-440C, \$550; Akai GX77, \$200; Inovonics 370 rcd amps (2), \$1250/ea. J Parsons, 904-532-0192.

Technics RS-M273 stereo cassette recorders (3), good condition, little use, semi-pro, newly overhauled, new manual, \$350/all. G Barnett, 619-328-1104.

Scully '100' recorders, record/play amplifiers, 8, 16, 24 track heads. Sequoia Electronics, 4646 Houndstaven Way, San Jose CA 95111. 408-363-1646.

ITC Reel-to-Reel Specialists.
Complete stock of spare parts.
Motor rebuilding and heads
for both reel-to-reel and
cart machines.

VIF INTERNATIONAL
PO Box 1555
Mtn View CA
94042 U.S.A.
Inside USA: 1-800-848-4428
Outside USA: 1-408-739-9740
FAX: 1-408-739-0809

Ampex ATR100 tape recorders for parts. Circuit cards, heads, motors, machine parts, or electronic parts. Call 818-907-5161.

Otari 5050-SHD 8 track 1/2" newly rebuilt, heads have full, life left, \$1800. W Gunn 619-320-0728.

One Otari 4 Track Tape Recorder... BQ-II series...good condition...might need some new heads... \$2400.00. Call 806-372-5130.

Otari Mark II-IV 1/2" 4-trk, multi-track, mint, less than 50 hrs, BO R Kaufman, Pams Prods, POB 462247, Garland TX 75046. 214-271-7625, after 3PM CDT.

Tascam ATR 60 8 trk w/tand, remote, \$2250; Otari 5050-8 new heads, rebuilt, \$1595; Ampex 440B-8, \$1950; Tascam 25-2, \$495; Ampex ATR700, \$495; Scully 16 trk 2", \$2950; Tascam 52 top of line, \$650; M79-24 fully rebuilt, \$9,500; Tascam locator for 85-16, \$375; Fostex E22 1/2" timecode deck, \$950; Fostex A80 8 trk w/450 mixer, \$995. W Gunn, POB 2902, Palm Springs, CA 92263. 619-320-0728.

Want To Buy

Stereo Nagra w/NAB heads. R Katz, FAX 818-505-0149.

Elmo DR-1 & SR-1 cassette tape recorders; Almo GS-1200 stereo projectors; Fisher Price PXL-1000 video recorders; Bolex & Arriflex 16mm cine equipment. Henry, 914-949-5920.

REMOTE &
MICROWAVE
EQUIPMENT

Want To Sell

Burke ARC-16 studio control unit, Best Offer. J David, KMPL/KS98, POB 907, Sikeston MO 63801. 314-471-1520.

Marti RPT-15 UHF transmitter, 2 freq with encode, BO; Marti CR-10 UHF receiver, 2 freq with decode, BO. B Hildebrand, 314-427-2727.

AT LAST EASY REMOTES: INTRODUCING new podium/19" rack combo on wheels! SAVES TIME, unit slides into vans! Prewired AC & XLRs, speakers, much more, CALL SPACEWISE 1-800-775-3660

Moseley TRL-1 syst, Moseley MRC-1600 RC system, TFT 7700 composite STL transmitter, Elgin phone coupler EC-30AR, BO. 510-895-6358.

Symetrix TI-101 phone hybrid, excel cond, \$350. M Persons, KLKS Radio, 402 Buffalo Hills Ln, Brainerd MN 56401.

BE VMC-16 transmitter rem cntrl, voice responsive, brand new, still in box, \$2000. C Walmer, WTHU, 10 Radio Ln, Thurmont MD 21788. 301-271-2188.

Burk ARC-16 studio central unit, BO. J David, KMPL, POB 907, Sikeston MO 63801. 314-471-1520.

RENT IT HERE! Call Steve Kirsch for Details

- COMREX 1, 2 & 3 Line Extenders Switched 56/ISDN Systems
- TELOS Zephyr Digital Phone Hybrids
- CCS "Prima" CODECS
- SHURE PP-410 Automatic Mixers
- REMOTE AUDIO PACKAGES

SILVER LAKE AUDIO • 516-623-6114 • FAX: 516-377-4423

Hewlett-Packard HP3581C freq selective voltmeter, clean cond, \$495. R Schall, Tech West, 1850 Olive Barber Rd, Coos Bay OR 97420. 503-267-6064.

WE RENT
TELOS ZEPHYR
CCS "Prima" CODECS
Stereo RPU, NO License
Frank Grundstein Audio/Video Consultants
COMREX 3-line extender
610-642-0978

Gentner EFT-3100 3-line freq extenders, lk new, \$5000/pair. Steve Kirsch, Silver Lake Audio, 2590 Hillside Ct, Baldwin NY 11510. 516-623-6114.

SATELLITE
EQUIPMENT

Want To Sell

Comstream ARB200 incl sat receiver, LNB-also sat-Q 400, \$2000. B Hearst, 814-226-4500.

Scientific Atlanta Dat cards (3), BO; Phasemaster 10.000 W single to 3 phase converter, very good condition, \$2000. R Wittick, 916-283-1370.

Zephyrus 304 mainframe satellite receiver, BO. C Mandel, 619-352-2277. Avcom SCPC-2000E SCPC satellite receiver, 1 year old, BO. E Stanford, WAFM WAMY, POB 458, Amory MS 38821. 601-256-9726.

Wegener 1601, country coast to coast, \$450. G Perry, 915-550-0558.

UNIVERSAL SCPC XE-1000

SCPC BROADCAST AUDIO RECEIVER

New, affordable, frequency-agile receiver, direct channel entry by keyboard, selectable companding 1:1, 2:1, 3:1, wide/narrow bandwidth, de-emphasis selectable, 950-1450 MHz, line output 600 ohms, muting, transponder agile, LNB power supply, 50-channel memory, full baseband output, high-quality audio. Every needed feature at a sensible price (lowest in the industry). Write or call for full information on this quality receiver—the answer for your station. Networks call for prices.

Phone: (614) 866-4605 Fax: (614) 866-1201

UNIVERSAL ELECTRONICS, INC. 4555 Groves Road, Suite 12 Columbus, OH 43232
communications specialists Phone: (614) 866-4605 Fax: (614) 866-1201

BUY

Satellite Systems pays cash for Westwood One Radio Networks satellite receivers!

REPAIR

Satellite Systems repairs all major brands of satellite equipment, including the Fairchild Dart 384 and Scientific Atlanta. Our turn-around time averages 24-hours. Plus, we provide pre-and post-service support along with a 90-day warranty.

SELL

The Ariel Digital Satellite Receiver

- 5 card slots
- 1 year warranty
- Compatible with Fairchild Dart 384
- Excellent technical support

SATELLITE SYSTEMS

Satellite Equipment for Radio
615 East Brookside
Colorado Springs, CO 80906
(719)634-6319 Fax: (719)635-8151

SOFTWARE/
DATABASES

Want To Sell

Affordable TRAFFIC & BILLING
PC SOFTWARE for DIGILINK & other popular digital systems. Excellent for non-automated stations, too. Try it for 60 days. No obligation. For demo, call ABA Software
(813) 643-3689

Available this FALL,
Ron Balonis' Broadcast Engineer's
COMPUTER TOOLBOX for WINDOWS.
For information, write to
COMPUTER TOOLBOXES
118 Rice St., Trucksville, PA 18708

STATIONS

Want To Sell

10K AM in North Central AZ. 520-774-0864.

5 kW AM radio station, 1410 kHz/300+ W, night 2 tower DA-Cuba, MO. perfect owner/op, poss FM, \$135,000/serious only. K Kuenzie, KFWE, 511 W 5th St, Washington MO 63090. 314-239-6800.

1000 watt AM located in Southern New England; includes all studio and transmitter equipment; 400 K or BO. Serious buyers call 1-800-845-0338.

Want To Buy

FM or AM/FM in SE US. S Clark, 305 Flannery Ct, Fountain Inn SC 29644.

Small AM/FM combo w/real estate, trouble, dark or cash buy-out. 718-893-4328.

STEREO
GENERATORS

Want To Sell

Conex CG-25 Hz generator, BO. C Mandel, 619-352-2277.

STUDIOS

Fisher 10'x10' acoustic studio, BO. L Leffingwell, U of MO-St Louis, 314-516-5364.

TAPES/CARTS/REELS
& CD's

Want To Sell

10 1/2" audio tapes, 110 A/C automation reels, 90 oldies reels, \$1.50/ea +shpg. J Egloff, 513-922-7049.

30-40 carts w/new tape, some require new foam pads, BO. D Kirby, Rhapsody Productions, POB 1543, Palm Springs CA 92263-1543. 619-320-1782.

Scotch radio prod facility deleting classic rock library in vinyl, 7 & 10.5" reels, \$300/BO. 703-578-3014.

C-90 cass tapes, use for blanks, dup overrun, new 1st quality, 20 cents/ea in 1000 qty or 25 cents/ea in 500 qty. L Wagner, 407-299-1299.

Scotch radio prod facility deleting classic rock library on vinyl, 7 & 10" reels, \$300/BO. 703-578-3014.

10.5 reels of Christian/inspirational music w/corresponding song lists. Ampex tape w/metal reel & box incl, \$2.50/reel+shpg; empty 10.5 Ampex metal reel & box, \$1.50/reel+shpg; empty 10.5 plastic reel & box, \$1/reel+shpg. R Snaveley, Family Life Network, POB 506, Bath NY 14810. 607-776-4151.

Gray Fidelipacs, red Fidelipacs, AA-3s, AA-4s, many different lengths & several hundred available, 25 cents/each+shipping. GM, KWED-AM, 210-379-2234.

Pams Jingles ref tapes, 1951-1976, BO. R Kaufman, Pams Prods, POB 462247, Garland TX 75046. 214-271-7625.

EMPLOYMENT

To place ads in this section, use the ActionGram form. To respond to box numbers, write Radio World, PO Box 1214, Falls Church, VA 22041. Attn: _____

POSITIONS WANTED

A fresh voice for sports radio that can do it all, play-by-play, reporting, sports talk. Andy, 412-687-8723.

CE 15+ yrs exper, upgrades, new construction. 805-473-0871.

Looking for radio news job in AL, MS, AR, I have over 25 yrs exper in all areas of radio, available immediately. Bill, 205-685-0795.

Radio rookie just out of school & eager & ready for an exciting career doing on-air, production or news, focusing on OK, AR or southern KS. Gail, 405-758-1224.

Ready to "age to perfection" w/your station, copy/prod, voice-overs, on-air, ready to travel! Smooth voice, any format. Brandee, 918-486-3987.

Ready to rock your listeners' sox off! Bright young talent, willing to do what it takes! Steve, 918-742-1227.

SWM seeks fun-loving station, trained rookie will satisfy your every desire, on-air, prod, sales, no job too weird. Randy, 405-478-7325.

Take your news dept to the top! Talented radio news pro seeks ND or reporter/anchor job @ medium-market station, prefer PA. Michael, 205-230-3754.

The Richie Rich Show will take an audience hostage, on-air, prod, copy, sales, rookie but ready! Any format...let's get ready to rumble! Richard, 405-677-4373.

Young, energetic, currently employed, play-by-play man with 6 years experience & strong production skills looking for better opportunity, can work alone, willing to relocate. Derek, 505-392-5367.

Prod engineer with over 4 yrs experience in the LA market would like to find F/T pos in medium to lg market, also have 1 yr voice-over exper. Oscar, 213-221-2864.

Major Market/large station experienced Chief Engineer considering supervisory/corporate chief's position. 25 years experience, directionals, applications, great organization, looking for stable company with excellent remuneration. Respond to: Radio World, POB 1214, Falls Church VA 22041. Attn: Box # 95-6-28-1RW.

I do voice-overs freelance, specialty: soft sell. Ready to work for you! Kim, 209-436-4669.

If your small/med market needs another voice, call me! On-air, copy & prod skills, also news & sales! Glenda, 918-742-1227.

MARATHON
PRODUCTS COMPANYAudio Cartridge
Rebuilding
Division

Rebuilding/reloading, like new, all brands, any length up to & including 3.5 minutes, \$1.95 for Standard Tape, \$2.15 ea. for HOLN Tape. FOB out plant, 48 hrs delivery. (New rate effective 3/1/95)
New NAB Marathon cartridges prices on request.

35 Years professional experience!
Lifetime member AES R.D. MYERS Sr.
Manufacturers of Audio Devices,
Continuous Tape Mag.
69 Sandersdale Rd. Charlton, MA 01507
1-508-248-3157 or 1-508-853-0988

Circle (2) On Reader Service Card

Want To Buy

Fidelipac/Audiopak Mastercart II gold or AA-4 light blue in 2:30 through 4:00 lengths, must be in very good condition, call after 3PM CST. 214-271-7625.

TAX DEDUCTIBLE

Broadcast equipment needed for university, anything useable, will pay shipping. R Kafarski, WONY, MOC West St, Oneonta NY 13820. 607-436-2507.

Non-comm/ed station looking for 250' tower w/lights, will disassemble & give tax receipt. Jarel, KADU 90.1 FM, 218-263-3000.

Missionary? No charge for radio consults for station building outside USA only, can help advise tech info & equipment, helpful charts & booklets available also designed for Missionary broadcasters. J Cunningham, KEOR/KHCC, Rt 2 Box 113B, Stonewall OK 74871. 405-265-4496.

TEST EQUIPMENT

Want To Sell

General Radio 724-A absorption wave meter, 16 kHz-50 MHz, 7 plug-in coils, as is in wood case w/instructions & schematic. \$50+shpg; General Radio 1931 distortion analyzer, extra clean, re-worked & ready to use, \$100+shpg; 500 W dummy load, \$50+shpg; Stoddart NM-30 tube type field strength meter w/case & manual, 20 MHz-40 MHz, spare parts mod, Tektronix pwr sply, \$200+shpg; various HP meters & military audio & RF generators, BO. R Evans, 704-524-7983.

Heathkit tube type FM tuner compact, \$20+shipping. R Evans, 704-524-7983.

Tektronix 7L12 spectrum analyzer for 7613/23 oscilloscope, 0.1-1800 MHz, 300 Hz RBW, svc manual, application notes, \$1225. J Lyles, 505-455-2565.

Tektronix 492 10MHz-40GHz spectrum analyzer, port w/all mixers & antennas, \$900. B Nagy, KOOP, 505 San Jacinto, Austin TX 78765. 512-471-4286.

HELP WANTED

Prism Radio Partners L.P.
is seeking a Chief Engineer for our stations in Tucson Arizona:

KWFM/KCEE/KNST
The position requires at least 8+ years experience in broadcast engineering or related field. SBE Certification with radio endorsement & strong people & leadership skills, experience in studio construction & maintenance, RF engineering with concentration in AM directionals. Strong computer networking & PC maintenance skills. The job includes design & implementation of our new digital facility, standard studio & AM & FM transmitter maintenance.

Contact: Mike Shields
VP/GM, KWFM/KCEE
2100 N Silverbell Rd.
Tucson, AZ 85745

Prism Radio Partners L.P. is proud to be an equal opportunity/affirmative action employer. Minorities are strongly encouraged to apply.

This employer does not discriminate on the basis of sex, age, race, age, religion, handicap, national origin, marital or veteran's status.

SERVICES

REMOTE EQUIPMENT RENTALS

COMREX and GENTNER
1, 2 & 3-Line Extender Systems
Now With The New TELOS ZEPHYR
MARTI VHF/UHF RPU Systems
ISDN & Switched-56 Systems
Call or FAX Dwight Weller

WELLER AUDIO-VISUAL ENGINEERING

Baltimore, Maryland
Phone: (410 or 800) 252-835 FAX: (410) 252-4261

G.K. PAINTING CORP.

Industrial/Commercial
Painting
Sandblasting/Waterblasting
Special Coating
(specialize in radio towers)
5141 Bradford Drive
Annandale, VA 22003
703-978-1824
FAX: **703-978-1824**

REMOTE BROADCASTS IN THE U.K. AND EUROPE

Planning remotes from the U.K. or Europe? we offer a one-stop service

- we organize venues for your shows
- we provide temporary equipment
- live links via ISDN/Switched 56
- experienced radio engineers
- we help you line-up guests

Contact London (44) 181-442-8900
Wired for Sound Ltd., London U.K.

HARRIS ALLIED



PARTS AND TECHNICAL SUPPORT
Now we can be reached online via e-mail.
TSUPPORT@HARRIS.COM
For your parts needs or with any technical problems you're having.

Tower Sales & Erection

Turnkey Site Development
Installation & Maintenance
AM/FM Broadcast TV
Microwave Systems
Antennas & Towers



TOWERCOMM
Communications Specialists
Ben Wall President
6017 Triangle Dr.
Raleigh, NC 27613
(919) 781-3196
Fax: (919) 781-6454

TEST EQUIPMENT...WTS

RCA clamp on ammeter, \$50; Potomac Instruments FIM-21, \$2800; B&K mod 820 capacitance meter, \$100; Dorrrough mod 610 prosser, \$250; MR test mod A-400 voltmeter, \$25; ITC ESL-IV splice locator, \$250; Heathkit IG-1272 auto generator, \$75; Heathkit IG-72 auto generator, \$75; Heathkit IM-5258 dis analyzer, \$75; Dorrrough dual loudness monitor, \$200; Sencore mod TR-139 transistor checker, \$35; B&W mod 410 distortion meter, \$100; Lectrotech mod U-7 vectorscope, \$50; Simpson mod 470 multimeter, \$50; 20 MHz 2 trace scope, \$100; Diehl supertech Mark 5 flyback tester, \$35; B&K mod 3050 auto generator, \$100; Fluke mod 8000A voltmeter, \$50. D Lany, 800-313-5313.



NEW McMARTIN BF-5K

Lowest priced tube replacements

5500 W FM, broadband grounded grid output circuit, VSWR protection, excellent efficiency 75-80% automatic recycling & overload status. Fully remote controlled. FCC approved to 5500 watts.

Goodrich Enterprises, Inc.

11435 Manderson Street
Omaha, NE 68164
402-493-1886
FAX: 402-493-6821

TRANSMITTERS

Want To Sell

CSI 1980 transmitter AM, 1 kW, like new, Best Offer. J Wood, FAX 807-840-1588.

Continental AM transmitters (2), 1 kW on 1240 kHz, 1 on 1340 kHz, 1 only new 65 W LPB plus ant on 1340 kHz, cheap. B Gillespie, 604-442-5844.

Bauer FB5000J AM 5 kW/1 kW, good condition, Best Offer. T Fuller, 704-633-1009.

New McMartin 20 W, IBM-8000 FM exciter, New McMartin IBM1005D FM relay/rebroadcast exciter; also some used McMARTIN B910 excitors 15W. Goodrich Inter., 11435 Manderson St., Omaha, NE 68164. 402-493-1886 fax 402-493-6821

Harris SX-1A 2.5 kW, good shape & reasonable. T Yarbrough, 615-967-2201.

BESCO World Leader in AM - FM Transmitters

"Now in our 30th year"

91 AM & FM Pre-Owned Units in Stock

- ✓ ALL - Powers
- ✓ ALL - Manufacturers
- ✓ ALL - Instruction Books
- ✓ ALL - Complete
- ✓ ALL - Spares

Call and take advantage of our liberal trade-in plan. Tune and test on your frequency, available on site. Complete inventory on request.

Phone: 214-630-3600
Fax: 214-226-9416

5 kW transmitter 21 FM AM, \$5000; 25 kW Collins 3 tower phasers, \$1500/ea. 805-772-2263.

BEXT

Great new or demoed FM transmitters, exciters, amps and STL's, some at discount prices
USA 619-239-8462
FAX: 619-239-8474

1 kW AM RCA transmitter with spare tubes, 1946. Vern, 916-533-1340.

CONSULTANTS

Consulting Communications Engineers

- Station improvement and modernization
- FCC Applications and Field Engineering
- Frequency Searches and Coordination
- AM-FM-CATV-ITFS-LPTV

OWL ENGINEERING, INC.

1306 W. County Road, F, St. Paul, MN 55112 (612) 631-1338 Member AFCCCE

EVANS ASSOCIATES

Consulting Communications Engineers

- TV • FM • AM • ITFS • Satellite
- FCC Applications, Design and Field Engineering
- Video/Data/Voice • Light Fiber & Microwave • Wide-Area Networks & STL's

210 S. Main Street
Thiensville, WI 53092
(414) 242-6000 • FAX (414) 242-6045
Member AFCCCE

PC - SOFTWARE

AM FM TV Search Programs
Contour Mapping-STL Paths
RF HAZ-1990 POP Count
FAA Tower-Draw Tower

Doug Vernier
Broadcast Consultant
1600 Picturesque Dr
Cedar Falls, IA 50613

800-743-DOUG

North America RF & Audio

Mirkwood Engineering Services

Broadcast and Telecommunications Consultants

Multidiscipline Engineering and Planning Firm including: Application & Allocation Services
• Project, Engineering & Construction Management • Site Acquisition
• Rural & Remote Site Installations
• Field Service • Studio Design & Installation

50 Park Ave., Claremont, NH 03743
(603) 542-6784

MLJ

Moffet, Larson & Johnson, Inc.
Consulting Telecommunications Engineers

Two Skyline Place, Suite 800
5203 Leesburg Pike
Falls Church VA 22041

(703) 824-5660
FAX: 703-824-5672

Member AFCCCE

MULLANEY ENGINEERING, INC.

Consulting Engineers
• Design & Optimization of AM Directional Arrays
• Analysis for New Allocation, Site Relocation, and Upgrades AM-FM-TV-LPTV
• Wireless Cable (MDS/MMDS/ITFS/OFS)
• Environmental Radiation Analysis
• Field Work
• Expert Testimony

9049 Shady Grove Court
Gaithersburg, MD 20877
Phone: (301) 921-0115
Fax: (301) 590-9757

E. HAROLD MUNN, JR. & ASSOCIATES, INC.

Broadcast Engineering Consultants

AM - FM - TV
WAYNE S. REESE
PRESIDENT

Box 220, 100 Airport Rd.
Coldwater, MI 49036
517-278-7339

W. LEE SIMMONS & ASSOC., INC.

BROADCAST TELECOMMUNICATIONS CONSULTANTS

5 Gracefield Road
Hilton Head Is., SC 29928

1-800-277-5417
803-785-4445
FAX: 803-842-3371

Teletech, Inc.

BROADCAST CONSULTANTS AND ENGINEERS

- FCC Applications & Field Engineering
- Frequency Searches & Coordination
- Tower Erection & Maintenance
- Facility Design & Construction

CONTACT:
Kenneth W. Hoehn
23400 Michigan Ave
Dearborn, MI 48124
(313) 562-6873

T. Z. Sawyer Technical Consultants

AM-FM-TV-LPTV

1-800-255-2632
FAX: (301) 913-5799

6204 Highland Dr.
Chevy Chase, MD 20815

- FCC Applications & Exhibits
- Experimental Authorizations
- AM Directional Antennas
- High Power Antenna Arrays
- Frequency Studies
- STL Applications
- Class Upgrades
- Station Inspections

Don't Gamble with your Advertising Dollars!

Advertise in Radio World and reach 22,000+ subscribers.
Call Simone at 800-336-3045 today!

WESTBERG CONSULTING

AM Radio Design Software

DIPLEX PROFESSIONAL

Diplexer design & schematic

PHASOR PROFESSIONAL

Phasor design & pattern plots

For Information: Jerry Westberg
3326 Chapel Valley, Quincy, IL 62301
(217) 223-5702

Internet: andywest@minor.rnet.com

INCREDIBLE FM RADIO TRANSMITTERS



TAYLOR
The Transmitter People
Taylor Bros. (Oldham) Limited, Lee St. Oldham, England.
Tel: 44 (0)61 652 3221 Fax: 44 (0)61 626 1736
US Sales Fax 407 363 2818
Satisfying Customers Since 1965

1 Watt	\$1,138
30W att	\$1,499
300 Watt	\$3,174
600 Watt	\$5,960
1K Watt	\$8,716
2K Watt	\$11,905
4K Watt	\$20,741

You Need It... WE MAKE IT!

Your one call for Quality, Reliability and Economy in FM transmitters

- **SST Series** — Low Power Solid State FM from 30 to 500 watts.
- **Legend Series** — Medium Power Solid State FM 1 to 11KW
- **ECO Series** — Medium Power Grounded Grid Triode, Single Tube FM from 4 to 11 KW.
- **MK Series** — Medium and High Power Grounded Grid Triode, FM from 1.5 to 50 KW

The **ECO - 10**

"The Transmitter People"
Energy-Onix
752 Warren Street, Hudson NY 12534
518-828-1690
FAX: 518-828-8476

TRANSMITTERS...WTS

Continental 802A FM exciter, program-mable frequency, \$3500. D Solinske, WWRM, 877 Exec Ctr Dr W, St Petersburg FL 33702. 813-579-3316.

Used equipment for sale: Belar SCM-1, Belar RFA-1, Belar FMS-1, Belar FMM-1, Moseley MRC 1600 system, TFT EBS rcvr/gen, Gentner patch panel, and Harris racks. Call Transcom Corp 800-441-8454 or 215-884-0888.

Gates BC-500GY 500W AM, \$1000; Gates BC-250GY 250W AM, \$800. T Toenues, WREW, 201 NW Hwy 24, Topeka KS 66608. 913-437-6549.

CCA AM 10,000 1974 in Albuquerque, 10,000W AM transmitter on 1000 kHz, good condition, \$10,000; Harris FM-2.5K in Albuquerque, 2500W FM transmitter on 97.7 MHz, including low pass filter & MS-15 exciter, good condition, \$9500. M McNeil, Guardian Comm, 800 Compton Rd #33, Cincinnati OH 45231. 513-931-8080.

Sparta/Bauer 602 1500 W FM xmr, \$4595; BE FX-30 30 kW, \$3495. Jose, 809-895-2725

Cetec-Sparta 602A 2.5 kW FM transmitter tuned to 100.9 MHz with exciter manuals, new final, \$8500; Jampco 3-bay antenna, 100.9 MHz with radomes, \$2500; package, \$10,000. R Mason, WKEY/WIQO-FM, 508 W Oak St, Covington VA 24426. 703-962-1133.

Bauer 607 1 kW FM transmitter, Best Offer; Gates (Harris) FM-10B 10 kW FM with TE-3 exciter with Optimod wide-band input card, Best Offer; RCA BTA-50H 50 kW AM, removed from service 11/94, Best Offer. R Meyers, Sound Masters Recording, 4700 SW 75 Ave, Miami FL 33155. 305-264-5963.

Want To Buy

Stereo FM exciter, good cond with manuals. B Spry, Spry Supply/ WHRD, 5114 Princeton-Glendale Rd, Hamilton OH 45011-2415. 513-887-0714.

McMartin AM/FM transmitter, any model, exciter or stereo modules. Goodrich Enterprises, 11435 Mander-sion, Omaha NE 68164. 402-493-1886.

Want to buy FM translators. E Kelley, 915-366-3711.

TURNTABLES**Want To Sell**

Technics SP-15 with Gray arm, cartridges, BO. GM, KWED-AM, 210-379-2234.

Sony servo controlled turntable system with pickup & base, excellent but needs belt, \$75. G Barnett, 619-328-1104.

Want To Buy

Technics SP-15 w/o w/o arm. D Dintenlass, 206-784-4803.

Record Cutting Equipment, records. 612-869-4963.

50 plus sections of 3 inch rigid transmission line, excellent condition, will sell any quantity. 806-372-5130.

TRANSCOM CORP.

Serving the Broadcast Industry Since 1978

Fine Used AM & FM Transmitters and Also New Equipment

For the best deals on Celwave products, Andrew cable and Shively antennas.

1 kW FM 1978	Collins 831C-2	1 kW AM 1980	Continental 314R-1
1 kW FM 1975	RCA BTF 1E2	5 kW AM 1977	RCA BTA 5L
2.5 kW FM 1983	Harris FM2.5K	10 kW AM 1974	CSI T-10-A
3 kW FM 1980	CSI 3000E	10 kW AM 1975	Continental 316-F
3 kW FM 1974	Harris FM3H		
5 kW FM 1974	Harris FM5H3		
5 kW FM 196?	Gates FM5B		
10 kW FM 1968	RCA BTF 10D		
20 kW FM 1976	Harris FM20H/K		
25 kW FM 1975	AEL 25,000KD		

1077 Rydal Road #101

Rydal PA 19046

800-441-8454 • 215-884-0888 • FAX No. 215-884-0738

Circle (133) On Reader Service Card

TUBES**Want To Sell**

4CX5000A mod tube, made in China, just tested, near new, \$300. R Wittick, 916-283-1370.

6072M, \$50; EL34HD, \$19; KT88, \$39. R Katz, FAX 818-505-0149.

FOR THE BEST PRICE
& 24 Hr service on transmitting tubes call Goodrich Ent Inc at 402-493-1886 day or night, FAX 402-493-6821.

Eimac 8877 1 HR & tested by RF parts, misc RX tubes, \$400. A McCarthy, 707-446-0200.

807, 811, 813, 8874, 8877, 4-400, 4-1000, 4CX250B, RCA, Amperex, EIMAC, etc. Westgate 800-213-4563.

ECONCO**Quality Rebuilt Tubes**

Approximately 1/2 the Cost of New

Call for Our Price List

800-532-6626

916-662-7553

FAX 916-666-7760

Circle (200) On Reader Service Card

Want To Buy

6072, 5651, 5691, 5692, 6005, 6084, 6386, 7308, 7591, 6AQ5, 6BL7, 6DN7, 6EJ8, 6EM7, 6GK5, 6HU8, 6JK6, 6XK8, ECC808, ECC808, ELL80, 300B, 2A3, 13CW4, VF14, AC701. R Katz, FAX 818-505-0149.

WANTED! Transmitting Tubes

We BUY & SELL all types of transmitting/receiving tubes.

C&N Electronics
Harold Bramstedt
6104 Egg Lake Road
Hugo, MN 55038

(612) 429-9397 ext.23
(800) 421-9397 ext. 23
FAX (612) 429-0292

Circle (116) On Reader Service Card

Advertise!

Call your advertising representative

800-336-3045

for details & deadlines

**Buy Factory Fresh
New Tubes**

- ✓ EIMAC, BURLE, SIEMENS, AMPEREX, NATIONAL, and more
- ✓ Off-the-shelf delivery
- ✓ 24-hour emergency service

Richardson Electronics, Ltd.

1-800-348-5580
FAX: (708) 208-2550



Power You Can Trust

Worldwide Power Tube Leadership

- Largest Selection
- Applications Support
- Committed to Quality

Made in U.S.A.

Call 800-414-8823
or Fax 415-592-9988

varian

power grid tube products

Circle (46) On Reader Service Card



Svetlana
ELECTRON DEVICES

Quality* Power Tubes

3CX15.000A7	4CX400A
3CX15.000A3	4CX350AC
3CX15.000H3	4CX350A/8321
3CX10.000H3	4CX250R/7580W
3CX10.000A7	4CX250BT
3CX3000F/8162	4CX250BC/8957
3CX3000A7	4CX250B/7203
3CX2500H3	4X150A/7034
3CX2500F3/8251	5CX1500B
3CX2500A3/8161	5CX1500A
4CX15.000A/8281	YC130/9019
4CX10.000D/8171	8560AS
4CX5000A/8170	811A
4CX3500A	833A
4CX1600B	833C
4CX1500A	
4CX800A	

- Watch this list grow.
- Shipment from USA stock.
- Manufactured in Russia's largest power tube factory.
- Generous warranty based on high quality.
- Honest prices based on quality at low cost.

Broadcasters

Phone: 800-239-6900

205-882-1344

FAX: 205-880-8077

OEMs, Distributors

Phone US: 800-578-3852

Int'l & US: 415-233-0429

FAX: 415-233-0439

Circle (89) On Reader Service Card

Page No.	Advertiser	Reader Service No.	Page No.	Advertiser	Reader Service No.
18	360 Systems	94	21	Harris Allied	92
57	360 Systems	3	9	Harris Allied	202
75	AEO	215	48	Henry Engineering	99
63	AEV SNC	86	69	ITC	152
6	ATI	27	22	Inovonics	185
54	Adweek	—	64	J Squared Technical Service	121
46	Air System Technologies	114	25	KRK Monitoring Systems	50
29	Amber/Neutrik	39	24	Korg	208
28	Arrakis	61	61	LPB	125
47	Arrakis	23	72	MPR Teltech	93
58	Arrakis	118	80	Marathon Products	2
74	Arrakis	172	50	McCurdy Radio USA	97
46	Audi-Cord Corporation	5	79	Meridian Communications	157
36	Audio Broadcast Group	49	36	Micro Communications, Inc.	12
55	Audio Precision	35	38	MicroCon Systems, Inc.	56
76	Audio Processing Technology	182	67	Modulation Sciences	137
83	Auditronics	127	70	Moseley	162
64	Autogram	159	48	Myat Inc.	13
49	Belar	60	73	NAB	—
38	Benchmark Media Systems	203	26	Neumann USA/Sennheiser	82
12	Bext	32	48	Old Stone Corp.	57
36	Broadcast Devices, Inc.	138	10	Orban	75
51	Broadcast Electronics	15	59	Pacific Recorders	80
4	Burk Technology	34	48	Popless Voice Screen	165
82	C&N Electronics	116	57	Pristine Systems	209
1	CCA Electronics	28	27	Prophet Systems	36
7	CCS	217	69	OEI	161
57	Cart Works	7	57	Radio Design Labs	211
64	Cellcast	29	78	Radio Resources	135
48	Circuit Werkes	95	23	Radio Systems	70
11	Clark Communications	134	19	Rane	72
38	Coaxial Dynamics	205	2	Register Data Systems	26
21	Communications Data Service	136	60	Roland Corp.	67
53	Computer Concepts Corp.	191	39	Satellite Systems	91
38	Comrex	9	62	Scott Studios	40
3	Continental Electronics	187	56	Sealevel Systems	122
48	Cool-Amp	31	57	Shively Laboratories	110
36	Cortana	53	16	Shure Brothers	197
46	Crown Broadcast	141	48	Silicon Valley Power	58
65	Crown International	164	26	Sine Systems	48
17	Cutting Edge	117	71	Smarts Broadcast Systems	22
20	DHK/Audisk	98	46	SoundAmerica Corp.	102
77	Datacount	87	82	Svetlana Electron Devices	89
49	Dataworld	78	57	Svetlana Electron Devices	146
31	Denon Electronics	126	37	Tascam/Teac	189
8	Digital Courier International	183	41	Telos Systems	6
14	ESE	8	15	Telos Systems	142
82	Econco	200	42, 43	The Management	76
36	Econco	184	36	The Management	166
52	Electro Voice	144	82	Transcom Corp.	133
68	Enco Systems	123	57	Universal Electronics	168
81	Energy-Onix	47	82	Varian	46
44	Eventide	69	38	Varian Eimac	37
46	Excalibur	206	34	VirteX	107
32, 33	Fostex Corp.	145	63	Ward Beck Systems Ltd.	42
46	Freeland Products, Inc.	10	84	Wheatstone	174
30	Ghostwriters	41	40	Whirlwind	52
36	Gorman Redlich	55	38	Will-Burt	59
78	Hall Electronics	90	35	Wirerady	169
77	Harris Allied	180	38	Zercom	213

Publisher Stevan B. Dana
Associate Publisher Carmel King
Marketing Consultant Al Leon
Marketing Assistants Regan Deatherine, Annette Deutscher
Production Director Lisa Stafford
Publication Mgr/Desktop Systems Mgr Julianne Shannon Stone
Classified/Showcase Production Coordinator Vicky Baron

Ad Traffic Coordinator Kathy Jackson
Ad Production Coordinator Lisa Lyons
Production Assistants Cristina Strigel, Laurie Anne Tarkington
Ad Coordination Manager Simone Mullins
Circulation Director Eleya Finch
Circulation Manager Steven Bowman
Accounts Receivable Steve Berto

Advertising Sales Representatives

U.S. East: Skip Tash 703-998-7600 Fax: 703-998-2966
U.S. West: Dale Tucker 916-721-3410 Fax: 916-729-0810
International: Stevan B. Dana +1-703-998-7600 Fax: +1-998-2966
Europe: Dario Calabrese +39-2-753-0274 Fax: +39-2-753-2697
Japan: Eiji Yoshikawa +81-3-3327-2688 Fax: +81-3-3327-3010

Free Subscriptions are available upon request to professional broadcasting and audiovisual equipment users. For address changes, send current and new address to RW a month in advance at PO Box 1214, Falls Church, VA 22041. Unsolicited manuscripts are welcomed for review; send to the attention of the appropriate editor.

INTRODUCING THE AUDITRONICS 2500 SERIES THE LAST SMALL CONSOLE YOU'LL EVER HAVE TO BUY



Some people believe small means limited. At AUDITRONICS we believe small is a challenge. That's why we have again defined a new standard of excellence by combining impeccable design, precision manufacturing, and value pricing in a full featured, compact audio console. The 2500 Series is loaded with all of the "me too" features found in the competition's "wannabe world class" consoles. Plus the 2500 Series delivers much more, including:

- **SOLID STATE SWITCHING** of all signal paths
- **DC CONTROL** of all level functions
- Telephone **CONFERENCING** capability
- **20dB HEADROOM** maintained throughout
- Easily accessible wiring on **MOTHERBOARD CONNECTORS**
- **ACTIVELY BALANCED** input, patch points, and floating outputs
- Linear **CONDUCTIVE PLASTIC** 100mm faders (P & G Standard)
- Comprehensive **A/B EXTERNAL LOGIC** control
- External line selector with **CUE AND HEADPHONE ASSIGNMENT**

And remember, AUDITRONICS is the company that still supports the first console it ever sold -- over 28 years ago. So you no longer have to compromise with a "wannabe". With the 2500 Series you get the real thing!

THE ONLY WORLD CLASS CONSOLE AVAILABLE AT "wannabe" PRICES.

AUDITRONICS 3750 Old Getwell Road, Memphis, TN 38118 (901) 362-1350 FAX (901) 365-8629

*We've taken all we know, all you've asked for,
and the very best of today's technology to
bring you our **FINEST AUDIO CONSOLE***

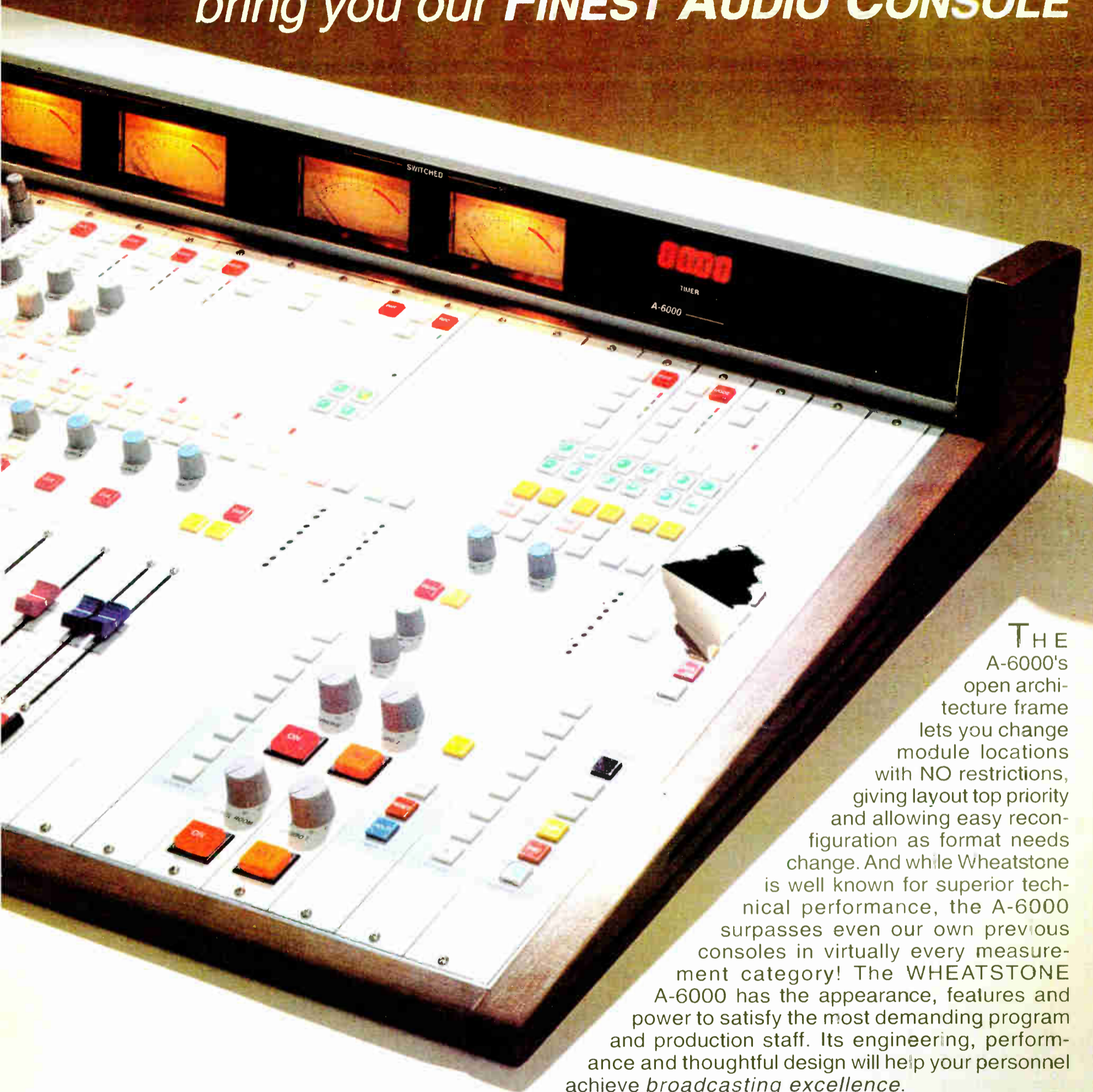

THE A-6000's open architecture frame lets you change module locations with NO restrictions, giving layout top priority and allowing easy reconfiguration as format needs change. And while Wheatstone is well known for superior technical performance, the A-6000 surpasses even our own previous consoles in virtually every measurement category! The WHEATSTONE A-6000 has the appearance, features and power to satisfy the most demanding program and production staff. Its engineering, performance and thoughtful design will help your personnel achieve *broadcasting excellence*.

A - 6 0 0 0 B R O A D C A S T C O N S O L E

7305 Performance Drive, Syracuse, NY 13212
(tel 315-452-5000 / fax 315-452-0160)

 Wheatstone Corporation