

*****3-DIGIT 857
J750970 D08 9203 5909 1005

TOM MILLER
ASST CE
KTZR
2033 S AUGUSTA PL
TUCSON AZ 85710

RadioWorld®



Running
Radio
pp. 11-24

Vol 17, No 23

Radio's Best Read Newspaper

December 8, 1993

NEW STUDIOS:

KABC(AM)
and
KLOS-FM
recently
built new
facilities.
See page 10.



FCC Mulls Over EBS Technology Comments

by Randy Sukow

WASHINGTON As of last month, FCC staff still intended to issue regulations for a redesigned Emergency Broadcast System in early 1994. It is likely to be based on a standard communications protocol so that several different companies, promoting vastly different technologies, will be able to market their products.

The problem is that hardly anybody supports all elements of the FCC plan.

The commission received comments last month from EBS system proponents and other interested parties analyzing the results of field tests held last June in the Denver area (RW, July 28) and last September in the Baltimore area (RW, Oct. 13).

Some agree with multiple transmission methods and many do not; likewise, some support a rapid decision in the matter and many do not.

There is absolutely no consensus about which of the three major proposed EBS systems is superior.

Most of the attention in the comments was over the merits of the Sage Emergency Warning System (EWS), developed by Sage Alerting Systems, Stamford, Conn.,

compared to the EIS 911 Emergency Information System, developed by TFT Inc., Santa Clara, Calif.

Sage EWS is based on the European Radio Data System (RDS) standard, which is compatible with the American radio broadcast data system (RBDS) standard. RDS receivers built into radios, TVs and other consumer electronics equipment can be activated automatically, even if they are turned off, when Sage emergency signals are transmitted. Both in-band and out-of-band versions of the system were tested in Denver and Baltimore.

EIS 911 is an in-band system that builds on the current EBS network, allowing broadcasters to keep much of their current EBS receiving equipment. The EIS box, however, allows for replacing the current "daisy-chain" emergency network with a "web" network of incoming EBS signals from multiple points.

A third major system, Information Systems Laboratories' (ISL) Emergency Broadcast Satellite System (EBSAT), attracted relatively little attention. Because it is a satellite system that does not necessarily involve alerting through broadcast stations, it is not a direct competitor of Sage and TFT, said Capital Cities/ABC's Kenneth J. Brown in an "engineering statement" attached to the network's comments.

"EBSAT is worthy of consideration by emergency management agencies as a technology useful for regional interconnection," especially if existing terrestrial links go down, Brown said.

Denver and Baltimore tests results seem to show that both the Sage and TFT systems effectively break the daisy chain and at the same time add a level of automation that should allow the FCC to eliminate its current rule requiring an EBS operator on duty at all times.

Sage supporters emphasized RDS's eye-catching features. "The RDS/RBDS system allows for silent and accurate testing of the signal with instantaneous delivery of alert codes to receivers...Sage Alerting is one system that utilizes RDS alerting to its fullest potential," said RE America, Westlake, Ohio, a leading manufacturer of RDS encoders.

All other systems tested "paled by comparison to the capabilities of the Sage system," said Axxess USA, Metairie, La., which has developed RDS pocket pagers and other products that can be activated with Sage EWS signals.

RDS also drew its share of critics. Data Broadcasting Corp. (DBC)—a San
continued on page 24 ▶

RUNNING RADIO

High-Tech Value-Added

by Nancy Reist

SAN FRANCISCO It has been an exciting year for radio promotions. Value-added promotions are becoming increasingly sophisticated as new techniques are developed to squeeze the last rating point out of every promotional dollar.

Technologies, such as listener databases

more listeners, to get more money from their advertisers," said Steve Tishman, promotions manager for Results Marketing, a firm that focuses on custom-printed specialties.

Wearables like hats and T-shirts are hot this year, Tishman said. He also encourages stations to put more emphasis on the kitchen

"The dreaded 'D' word in radio is continued on page 11 ▶

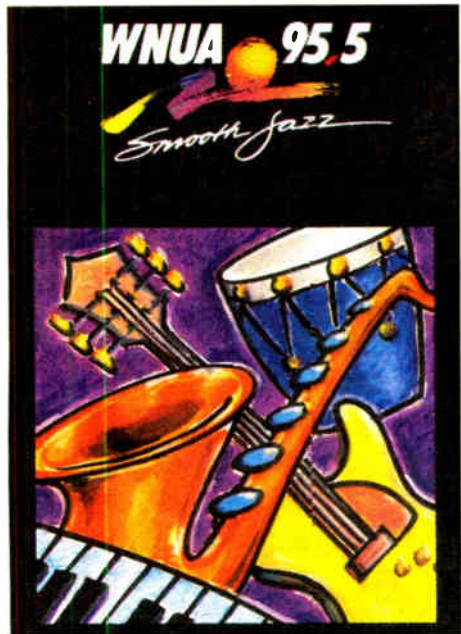

Broadcast Direct Marketing can jazz up your look.

and interactive systems, are playing a bigger role.

Media promotions professionals may differ on the strategies for presenting a fresh package to listeners and advertisers, but they agree that the business is booming.

Promotion budgets appear to be growing. "They're getting more money from their advertisers, hence they're spending more money on their promotions, to get

**AKG DSE 7000
Digital Editor**

So fast, you'll have the time to be creative and productive.
Produce the highest quality digital spots in one-third the time.
Call us toll-free.

Phone: 800-622-0022 Fax: 317-966-0623

HARRIS ALLIED

Circle (154) On Reader Service Card

World Radio History

NEWSWATCH

NAB Increases Show Conferences

WASHINGTON Twelve stand-alone conferences will be featured at NAB 1994 (March 20-24) in Las Vegas, including multimedia, HDTV, Institute of Electrical and Electronics Engineers (IEEE), Radio Advertising Bureau (RAB), and Society of Motion Pictures and Television Engineers (SMPTE) Post.

According to the NAB, the IEEE will hold a digital transmission tutorial, a half-day seminar that should be of interest to radio engineers.

By registering for any conference,

attendees get free admission to any of the others, according to NAB. For more information, use the NAB's fax on demand service: 301-216-1847.

The NAB spring conventions normally net well in excess of 50,000 in attendance. Last year the convention total included 64,000 in attendance and 400 exhibitors.

SPARS Holds Election

NEW YORK Elections were held for officers in the Society of Professional Audio Recording Services (SPARS) during the recent AES show.

The officers are: Dwight Cook, chairman of the board; Howard Schwartz, president; Steve Lawson, first vice president/treasurer; Paul Christensen, secretary; and Lee Murphy, John Fry, Tom Kobayashi, Stewart Sloke, Steve Davis, Gary Ladinsky, Rick Stevens, and Ian Terry, board of directors.

Exams Offered by Elkins

DALLAS The Elkins Institute has been certified by the FCC as a Commercial Operators License Examination Manager, which allows it to give FCC-required tests such as the general radiotelephone operator license.

Within the last year, the FCC has privatized many examination procedures to schools such as the Elkins Institute.

For more information about test locations and schedules, call the Elkins Institute at 800-944-1603; or write: Elkins Institute, P.O. Box 797666, Dallas, Texas 75379.

Radio Revenue Continues to Rise

NEW YORK Radio advertising continues on an upswing that began late last year. The latest Radio Advertising Bureau (RAB) shows that third quarter 1993 revenues are up 9 percent over the same time period in 1992.

According to the RAB, national spot revenue is up 7 percent, and network radio revenue was up 6.7 percent. Every region of the country has shown growth.

RAB President Gary Fries said the radio advertising growth rate "is currently the envy of other traditional media."

WJR Goes Digital

WESTBURY, N.Y. WJR(AM), Detroit's number one station for 24 consecutive rating periods, recently installed a Korg Soundlink digital audio workstation.

The station decided to modernize its production facility, but opted for the Korg system because it combined digital sound with the simplicity of an analog design, according to WJR Creative Director Rick Wiggins.

A Little Bit of MAGIC...



Revealed!

THE R-10 IS BASED ON A SIMPLE PREMISE: Low cost does not have to be synonymous with low quality (as is so often experienced). When you've got Audioarts' experience and expertise, value engineering becomes a task of carefully defining the features required and manufacturing in an efficient manner, utilizing the best of computer and machine technology.

THE RESULTS ARE SELF-EVIDENT: the R-10 is a fully modular console, with the componentry you'd expect to see in a much larger design. *No other console in its price range can even come close!*

The R-10 has gold audio switches, gold edgcard connectors, conductive plastic faders, conductive plastic monitor pots, fully burned-in socket-mounted ICs, industry standard machine control switches and, of course, documentation and instructions that make installation really simple.

With the R-10 you can take advantage of Audioarts' reputation and experience, and be assured that quality and performance will be yours.

AUDIOARTS ENGINEERING

6720 V.I.P. Parkway, Syracuse, NY (tel 315-455-7740/fax 315-454-8104)

Index

RUNNING RADIO

High-Tech Value-Added by Nancy Reist	1, 11
Recalling the Torturous Past of AM Stereo by Judith Gross	13
Say Merry Christmas with a Bonus by Sue Jones	16
CHR Radio Is Alive and Thriving in Dallas by Charles Taylor	19
Behind Radio's Zany Commercials by Dee McVicker	21
Know Your Competition by John Cummuta	21
Stock Your Promotions Closet Wisely by Mark Lapidus	22

FEATURES

Lightning Protection Is Worth Having by W.C. Alexander	29
Workbench by John Bisset	30
Planning Drives Radio Road Show by Steve Kirsch	32
Courts Will Decide Future of LPFM by Harold Hallikainen	36
Power Company Supplies Interference Aid by Ed Bukont	39
Programming Completes PLC Installation by Richard Mertz	40
Venerable Station Expands Audience by James T. Wold	42

GUEST EDITORIAL

Making Money With RBDS Coupons

by David Alwadish

NEW YORK Some references made with respect to CouponRadio in the November 10 feature "Radio Data: In Depth" were inaccurate. I thank RW for the opportunity to briefly explain CouponRadio and what the radio industry can look forward to.

By strategically using data technology, CouponRadio is completely focused on enhancing radio to become the ultimate medium available, making it more value- and service-oriented to advertisers and listeners, thereby attracting new customers.

CouponRadio is as effective as handing someone a business card. A broadcaster simply transmits Infomessages—64-character text messages pertaining to whatever a listener is listening to. If your audience is listening to a song, the name of the song, artist, label and catalogue number would be transmitted. When an advertisement is being aired, the listener would then be conditioned to expect pertinent information to be transmitted, such as the advertiser's name, address, telephone number or a special offer.

CouponRadio's patented technology allows these Infomessages to be displayed, and, if the listener desires, selectively saved at the push of a button on specially equipped radio receivers. At a safer and more convenient time, these Infomessages can be redisplayed on the radio receiver. As if an electronic memo pad was built into the radio, the burden of remembering important information heard during a broadcast now shifts from the listener's memory to the radio receiver's memory.

The patented technology provides for yet another dimension for radio's new interactive role: removable memory. Unlike built-in memory, removable memory is vital for merchandising through radio. All Infomessages saved

by the listener get stored on a removable credit card-like memory device. Simply bring the electronic memory card to your favorite record retailer and print out the list of songs you saved, or bring the card to an advertiser and cash in your elec-tronic coupon, verifying the time, date and station you heard the spot

CouponRadio is completely focused on enhancing radio to become the ultimate medium available, making it more value and service-oriented to advertisers.

on. The additional in-store promotions are limitless.

Receiver manufacturers have two options available to implement CouponRadio: to either build the small card reader assembly and the required electronics into the receiver, or, with simple modifications, make their existing receivers CouponReady. In this case, the receiver would be designed to interface with the plug and wire assembly of a remote, CouponRadio card reader/memory device, which a consumer would connect to a receptacle on the rear of a CouponReady receiver. About the size of a pack of cigarettes, the expense of this optional, low-cost unit would be borne by the consumer desiring the full interactive, multimedia and money-saving potential from the new radio.

The initial launch of the CouponRadio project will involve CouponReady receivers since the cost to manufacturers will be negligible.

CouponRadio utilizes RBDS. It is robust and proven. CouponRadio is easily adaptable to future technologies—in case another data system is an international standard and the choice of the consumer electronics industry.

Receiver manufacturers, looking at the potential of a CouponReady receiver, are beginning to realize that there are virtually no financially beneficial features in their proposed RBDS radios that would motivate broadcasters into rapid and widespread acceptance of RBDS in the United States.

is here now, and it's in consumer radios. Second, invest the technology in your core business: using the data to improve radio as a whole, attracting new customers, and significantly increasing gross income.

Signing a legal contract to lease away your RBDS subcarrier for "additional revenue" to improve another company's business, i.e., paging, etc., may seriously inhibit management's attempt toward a future goal of dramatically improving your radio business. At this critical time, it would be wise for a broadcaster to take all the time necessary to make the correct choice in using the RBDS subcarrier.

By the third quarter 1994, the first CouponReady radio receivers will be introduced, with removable memory, thereby making obsolete any other RBDS receiver that may be available. CouponRadio will be promoted with the help of the Interep Radio Store, retailers and broadcasters, which include New York's Z-100 FM, WQXR-FM, Detroit's Q95 FM and others.

CouponRadio's only hurdle is to get broadcasters to put aside the ratings war, which divides them, while others try to conquer them, and unite to achieve this common goal. In 1994, when asked, "What's new in radio?", broadcasters can respond: "It's interactive, multimedia (audio, visual, print), electronic coupons, direct marketing and accountability, on a real superhighway."

□ □ □

David Alwadish is president of CouponRadio. He can be reached at 212-595-1313.

Radiotext displays, without the CouponRadio memory capability, are of little business value to the broadcaster and a potentially unsafe feature to include in car radios. Naive proponents of RBDS would like broadcasters to believe that having their call letters displayed on the radio is the key to success. While this feature is a cute idea, it has no business merit.

Being sensitive to your customers' needs with respect to the marketplace has traditionally worked for businesses. Personally, I believe that the business decisions in "data transmission" facing the broadcaster are simple ones.

First, RBDS is the data medium. RBDS

A NEW FM MOD-MONITOR AT AN INCREDIBLE PRICE!



INTRODUCING THE INOVONICS 530 MODULATION ANALYZER

We've integrated precision demodulation and measurement functions into a laboratory-grade FM tuner to bring you an extraordinary value in accurate off-air modulation analysis. High-resolution metering shows Total Modulation, Pilot and Subcarrier injection levels, demodulated Left, Right, L+R and L-R program audio, as well as 38kHz residual, Signal Level and Multipath distortion readings.

Features include 8 station presets, separate antenna and "direct" inputs, audio monitor outputs, a composite (baseband) in/out, and selectable peak integration characteristics. Easy access is provided for user-defined options, such as remote metering, remote peak flasher, balanced program line outputs, and carrier failure and "dead air" alarms — all at no additional cost!

The best part is the price: only \$2200. Contact your preferred distributor, or write, call or FAX us for full technical particulars.

Inovonics, Inc.

1305 FAIR AVE., SANTA CRUZ, CA 95060 U.S.A.
TEL: (408) 458-0552 — FAX: (408) 458-0554



Circle (114) On Reader Service Card

The Backhaul Standard

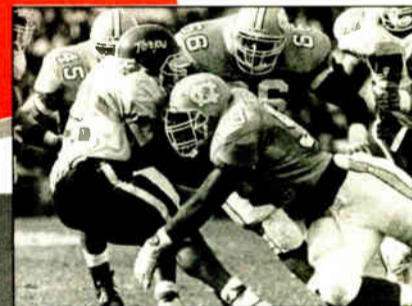

Features:

- Transmits 50 Hz - 5 KHz via Two Dial-up Phone Lines
- Provides Quiet Program Channel, Even on Noisy Long Distance Circuits
- Rugged, Portable Field Encoder



NCAA football photo courtesy of Host Communications

So many Comrex Two Line Frequency Extenders are in use throughout the world that they have become the industry standard for transmitting sports, news and other remote broadcasts. Because they work on normal analog telephone lines, the Two Line Extenders can be used anywhere. Ruggedly built for reliable, on-the-road duty, these "backhaul workhorses" provide high quality broadcasts across continents or just across town.

Call or fax us for complete information, including our "Try It Before You Buy It" offer.

COMREX

Comrex Corporation
65 Nonset Path, Acton, MA 01720
800-237-1776 508-263-1800
Fax 508-635-0401

Comrex (UK) Ltd.
75 The Grove, Ealing
London W5 5LL, UK
081-579-9143 Fax 081-840-0018

Circle (43) On Reader Service Card

Working the Mics for High School

WASHINGTON It's holiday time again and if you are like me, this is the hardest time of the year to concentrate on work. As I write this, Thanksgiving is just a few days away. As you read this, the Christmas season is swinging into full gear.

Aside from the chance to relax and catch up with members of the family and old friends, the holidays, of course, mean the chance to eat some great food and reflect on the year's events. Maybe I'm beginning to show my age, but I can't help wondering about the path that has led me to **Radio World**.

When I was in high school, first in



Spain and later on in Ecuador, I always knew I'd end up as a writer somewhere. And thinking back on those years of growing up with very little TV and lots of radio, it somehow seems appropriate that I'm now editing "Radio's Best Read Newspaper."

I was a student of radio, even without my realizing. In my junior year in high school, I had a very progressive teacher (or maybe just a little bit lazy) who agreed to let students sign contracts for a particular letter grade at the end of the school year. Among other things, my contract meant I didn't have to go to class, but had to produce a series of projects on my own.

I huddled with my three best friends (who also signed up for the "A" deal) and we decided our projects would be four literary classics, rewritten, produced and taped for the radio. I gained an inordinate amount of respect for the medium as we struggled to breathe vitality and

suspense into Fitzgerald's "The Great Gatsby," and O'Neill's "Morning Becomes Electra." (Our remaining two projects became a dramatized version of the famous Sacco and Vanzetti courtroom case and The Scopes-Monkey Trial.)

It was radio production at its most basic and I never had had so much fun doing school work. As the aspiring writer of the gang, I was responsible for writing the scripts. One of the group member's father had a beautiful AKAI reel-to-reel recorder, which became the center of our workstation. It was huge, taking up its own room in her house. It was the first time any of us had ever used microphones or even had to dream up what noise to make to create a certain sound effect.

One of the scenes I wrote into our script was to take place at one of Gatsby's parties. How to create the impression of hundreds of people dancing, drinking, talking and having fun? Our first step was to sneak some of my mom's crystal and some of my friend's mom's silver and, while the two involved in the scene recorded the dialog, the other two danced around in our socks to the tune of 1920's music while whispering, giggling, and softly tapping mom's crystal stemware with a fork. We had the tap running in the kitchen to reproduce the sound of the huge fountain in Gatsby's front yard.

We all held our breaths as we rewound and played back the tape. We had it. You would have sworn there were at least 50 people chattering away in the background (and you think teenagers are noisy today!). With this success under our belts, we armed ourselves with a portable cassette recorder (also belonging to my friend's father) and went out to record the highway sounds for the driving scenes.

The day we combined all our scenes and sound effects into the finished product was thrilling. We gathered our class into the school theater, dimmed the lights and presented our radio drama—replete with announcers, advertisements and sta-

tion IDs. Our stage consisted of a table with our little recorder. The tape rolled and the theater of the mind took center stage.

The play went over very well—so well in fact, that my enterprising teacher kept our only copy of the tape for herself. Thus we learned lesson No. 1, make duplicates of everything!

Our second effort went even better. By the time we produced our last radio drama (the Sacco and Vanzetti case) we considered ourselves pros, and we were presenting our "plays" to the entire International Section of the high school (a.k.a. the American section).

Even though those "radio days" took place 15 years ago, I remember vividly every last detail of the entire process. And while I feel a certain degree of nos-

talgia for those creative days of youth, I'm very pleased that my path has led me back to the radio.

I can't help but feel that broadcasting in general, and radio in particular, have a place in the information "superhighway" of the future. And though you now may be laying digital tracks on a Roland workstation and storing to CD and DAT, from where I'm sitting, I suspect that the thrill of creation is still there. From the guys writing zany radio ads (see Dee's article in this issue) to the guys wrestling with the best digital delivery system for broadcasting, this is a great business to be in (or in my case, observe).

For those radio broadcasters that weather the technological and economic changes without forgetting why they entered and loved the business in the first place, I believe, in the words of Timbuk 3, "The future's looking so bright, I gotta wear shades."

Mick Anselmo was appointed corporate vice president of Shamrock Broadcasting Inc. Anselmo is currently general manager of the company's KFAN(AM)-KEEY-FM in Minneapolis.

Jack Adamson, senior vice president of Bonneville International Corp., president of the company's Major Market Radio Group and a member of the board of directors, retired Nov. 1 after more than 25 years of service. Adamson will continue as consultant until his official retirement date of Jan. 1, 1994.

Adamson joined Bonneville in 1967 and held management positions at several of the company's stations prior to his current position. He spent four years as sales manager at KMBZ Kansas City, six years as vice president and station manager at KIRO Seattle, and seven years in Los Angeles as president and general

manager of KBIG-FM. He was president of KSL-AM-FM-TV from 1985-1991.

Effective Dec. 1, Frank Massam was appointed president of Siemens Audio Inc., to replace John Gluck, who is leaving the company to return to the U.K. for personal reasons.

Previously Massam was serving as sales and marketing director of AMS Neve, an entity he joined in 1990 as international marketing director.

Throughout the last 12 months, Massam has been active in the North American market, undertaking a strategic restructuring of Siemens Audio Inc., AMS Neve's exclusive North American distributor. As a result, the company has been regionalized to increase direct communication between its U.S. customer base and AMS Neve headquarters in the U.K.

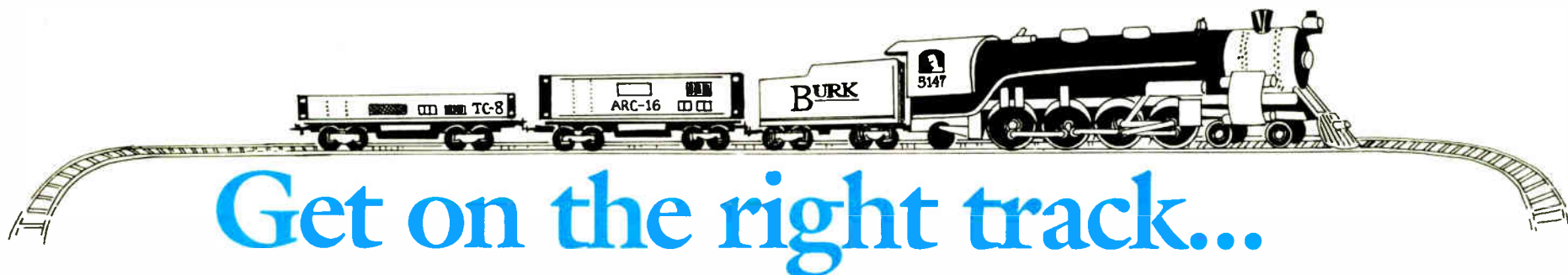
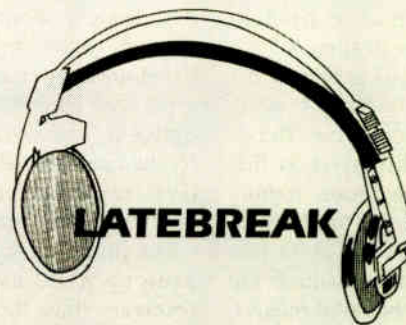

Unattended operation helps you operate your station profitably. All it takes is a satellite or automation program source, a good transmitter control system, and a way to handle EBS.

You take care of the program source... We'll help with the rest.

A transmitter control system from Burk Technology relieves you of the need to keep someone at the station just to take transmitter readings. Add our exclusive Studio I/O and we'll run EBS for you, too.

Burk gives you the flexibility to run your station the way you want, and in full compliance with FCC rules.

Call us now. We'll show you a new way to run a railroad.

TOLL FREE 1-800 255-8090

BURK
TECHNOLOGY

7 Lomar Drive, Pepperell, MA, 01463 (508) 433-8877

Circle (33) On Reader Service Card

World Radio History

READERS FORUM

If you have comments for *Radio World*, call us at 800-336-3045 or send a letter to Readers Forum (*Radio World*, Box 1214, Falls Church, VA 22041 or MCI Mailbox #302-7776). All letters received become the property of *Radio World*, to be used at our discretion and as space permits.

GUEST EDITORIAL

AM Stereo in Retrospect

by Robert D. Streeter, P.E.
AM Stereo Inc.

FORT WAYNE, Ind. AM stereo is in the headlines again.

I have not published an article in *RW* for some time, so I will re-introduce myself. I am the originator of the Magnavox AM stereo system. The 6th edition of the "NAB Engineering Handbook" carries my name as author of the section describing the PMX Magnavox AM stereo system.

There are a few items in the AM stereo articles of the October 12 issue of *RW* on which I wish to comment. My views are from the vantage point of a participant in the AM stereo proceedings since 1975.

On page 12, Philco was listed among the AM stereo proponents. Philco was actually a proponent in the AM stereo activity of the late 1950s, but not in the activity of the late 1970s. Belar Electronic Laboratories Inc. was the fifth participant. Belar sponsored the RCA AM stereo system as proposed and tested in the late 1950s. Credit should go to Belar for sponsoring and updating an AM stereo system of historic significance.

In the next paragraph, it is stated that the FCC "set a single US AM stereo transmission standard."

In fact, the commissioners instructed the staff to prepare rules for the Magnavox system as the U.S. standard, but the system was never adopted. It was this ambiguity which began the great AM stereo wars. As a result of legal requirements, the FCC eventually made public the basis of their interest in the Magnavox system. This was a decision matrix of scored technical parameters.

In 1982 the Commission did publish a matrix of performance scores for the various AM stereo systems. The matrix scores were based on the results of additional

testing following the initial FCC action on AM stereo. The system scoring placed the Magnavox system as the preferred system for both the initial and second technical examinations. The Motorola system placed third in both examinations.

Due to the possibility of legal action, the FCC selected the marketplace approach of AM stereo implementation. This is all fully documented in the FCC record.

In such a competitive environment, I believe any AM stereo system would flop. Every major consumer electronics manufacturer recognized the parallels to the four-channel quadraphonic FM broadcast debacle of the mid-1970s, but broadcasters and the FCC apparently failed to recognize the parallels.

AM stereo success, if you can call it that, was achieved only by massive funding effort directed toward a proponent. Even now, a decade later, the AM stereo broadcast penetration is only half that cited by major consumer manufacturers as a minimum installed base for adequate marketing of consumer product.

RW's analogy to the TV color wheel system initially selected by the FCC is well taken, but you might be aware that NASA has used the color-wheel system in some space exploration work. As is often the case, it is not the concept that is deficient but the hardware used at the time. Business politics have also been known to play a part in such activities.

I am pleased to see *RW* mention (p. 13) the Sony AM stereo receiver. The SRF-A100 by Sony was the best of the product line. Anyone who listened to it praised its AM quality and stereo performance. This receiver was an excellent Magnavox system receiver, as well as providing stereo performance for Kahn and the other proponents (some to a lesser degree).

Many readers may be confused by references to past arguments over the "best" AM stereo system. Such disagreements easily occur as a result of the different performance goals and system features established by the stereo system designer. Seldom are these items obvious to a casual reader.

The Kahn system is an excellent example. It was developed in the 1950s and was directed at the needs and technology of the time. A significant factor was the lack of any form of broadcast stereo entertainment. Given the situation, the Kahn system provided a direct means of achieving transmission and reception easily. In the three decades since then, the broadcasting environment and the technology of consumer electronics have changed drastically.

The current activity in digital audio broadcasting seems to me to foretell certain defeat for any of the current analog audio broadcasting techniques.

No analog system can withstand the marketing competition from a correctly designed digital system. The "inverse Cinderella" performance of the AM band (hi-fi at day, lo-fi to avoid interference at night) makes AM even less competitive with a well-designed digital system.

Radio's Beneficial Power

Talk radio was a significant power in shaping last month's debate over the North American Free Trade Agreement (NAFTA)—just as it always is when there are issues of pivotal local or national importance.

Vice President Al Gore, during his well-publicized debate with Ross Perot on CNN, was moved to call Rush Limbaugh, radio's champion Clinton Administration basher, a "distinguished American" in praise of Limbaugh's NAFTA support.

(Of course, the debate moderator, Larry King, rose to prominence by shaping opinions from a radio studio, and continues to do so when he isn't dabbling with his cable TV side interest.)

Fellow talk radio star Pat Buchanan filled the airwaves with the anti-NAFTA view. House Minority Leader Bob Michel (R-Ill.), final speaker before the NAFTA vote, lumped Buchanan with Perot and Ralph Nader as "the Groucho, Chico and Harpo of NAFTA."

Clearly, these politicians are listening to the radio and paying attention. They have to, because the American people are listening.

That is why it would be shameful if the Congress enacted speech-chilling policies like the so-called "fairness doctrine."

Fairness doctrine supporters say the policy will not force talk radio hosts off the air or even force them to mellow their rhetoric, as long as the station provides balance by airing opposing views later.

The problem is that a station will be forced to spend thousands in legal fees if it has not adequately afforded "reasonable opportunity for discussion of conflicting views on issues of public importance," according to some FCC bureaucrat's interpretation. In the real world, it is easier and safer to simply cancel controversial shows.

Anyone who feels Limbaugh's views are too narrow can easily hear the other side by moving the dial to Buchanan, King and many other free speakers.

Congressional efforts to enact the doctrine, thought to be a shoo-in a few months ago, recently lost momentum after Limbaugh and New York Governor Mario Cuomo put a national spotlight on the issue. But it is far from dead.

As the debate on NAFTA and several other issues prove every day, people hear all sides on radio. No further fumbling with the First Amendment is necessary.

—RW

RW's mention of the CBS color wheel TV system brings to mind another FCC decision of significance for AM broadcasters. In the late 1950s, the FCC was considering stereo broadcast systems for AM, FM and TV. Significant testing was performed on several systems.

In an effort to accelerate the development of FM broadcasting, the FCC indicated an interest in providing stereo broadcasting exclusively for FM radio. I believe it was this action that led to the current advantageous position of the FM broadcaster, although it was driven by consumer electronics marketing of the superior FM stereo performance.

I am amazed that AM broadcasters have

not called for an exclusive grant of DAB operation for the AM band. AM radio now appears to be in need of promotion just as badly as FM radio was in the 1950s. I can think of no better long-term improvement for AM, although DAB would make the current AM stereo activity rather moot.

The advent of DAB on AM will also likely provide additional signaling flow and work to provide features like the radio data system (RDS) techniques now considered for FM.

Only the Magnavox AM stereo system (in 1983) has ever publicly demonstrated such a capability while simultaneously transmitting full-fidelity AM stereo.

Data Compression Survey

Many of the latest digital products—such as recording and storage systems, digital audio workstations, STLs, telephone links and satellite program services—are programmed to reduce the amount of data sent over channels routed within the studio or between studios before airing. *RW* invites station managers and engineers to share their experiences with these digital "compression"—sometimes called "data reduction"—systems.

1. How many digital products using compression systems (such as MUSICAM, SEDAT, apt-X) do you currently use? (Please list them.)
2. Some studies suggest that noise and audio distortions are created when two incompatible compression systems—often referred to as "dueling algorithms"—are linked in the studio chain. Have you or other station personnel ever detected noise you believe was caused by dueling algorithms?
3. Have you ever received listener complaints about noise you believe to be caused by dueling algorithms?
4. If you had it to do over, would you purchase your current compression equipment and services again? Why or why not?
5. How do you perceive the problem of dueling algorithms—Very serious? Somewhat serious? Not very serious? No problem at all?

Also feel free to offer comments on any other aspect of digital systems and data compression.

Responses may be used in an upcoming "In-Depth" *RW* report. Please indicate whether your name and/or station affiliation should be used in the report.

Send responses by Jan. 28, 1994, to the attention of Randy Sukow, *Radio World*, 5827 Columbia Pike, #310, Falls Church, VA 22041; or fax 703-998-8505.

Radio World
Vol. 17, No 23 December 8, 1993

EditorLucia Cobo
Managing Editor.....Randy Sukow
News/Studio Sessions EditorJohn Gatski
Associate Editor.....T. Carter Ross
Contributors.....Frank Beacham/N.Y.

Bruce Ingram, Pamela Watkins, Nancy Reist
Technical EditorJohn Bisset
Technical AdvisorTom McGinley
Editor (International)Alan Carter
Managing Editor (International)Charles Taylor

 Radio World (ISSN 0274-8541) is published semi-monthly by Industrial Marketing Advisory Services, Inc., 5827 Columbia Pike, Suite 310, Falls Church, VA 22041. Phone: 703-998-7600, Fax: 703-998-2966. Second-class postage rates are paid at Falls Church VA 22046 and additional mailing offices. POSTMASTER: Send 3579 forms and address changes to Radio World, P.O. Box 1214, Falls Church VA 22041. Copyright 1993 by Industrial Marketing Advisory Services, Inc. All rights reserved.

—PRINTED IN THE USA—

**Next Issue of
Radio World
December 22, 1993**

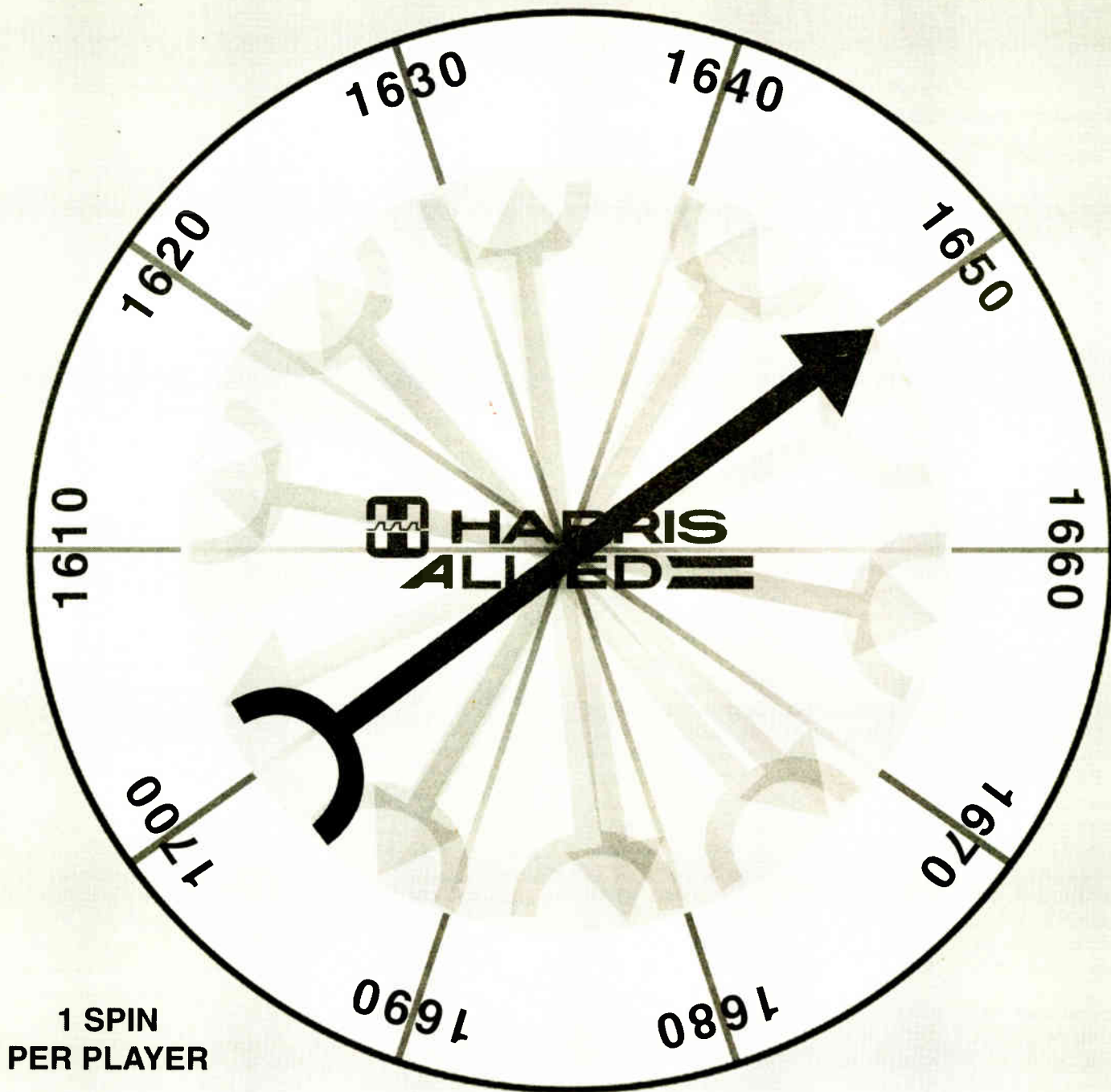

A No-Risk Game Plan For Expanded Band Applicants

If you're planning to move to the expanded band, count on Harris Allied to make the process safe and painless. We're ready to provide any assistance you need, from technical planning through installation and testing.

You'll find that our DX 10, 10 kW digital transmitter and AMS-G1 C-QUAM® stereo

exciter will provide superior AM stereo performance, exceptional reliability and unmatched efficiency.

And, with more than 10,000 products from over 350 leading manufacturers, we can provide virtually any other component you need as well-- freeing you from the hassle of working with numerous suppliers.

Find out how painless your move can be. For a personalized proposal, just give us a call.

Telephone:
217-222-8200

FAX:
217-224-1439



Madison Clinic Showcases Digital, NRSC AM

by Mark Persons

MADISON, Wis. The annual Wisconsin Broadcasters' Clinic in Madison had a new twist this year. The event also was the Upper Midwest Society of Broadcast Engineers Conference. It was the 39th such gathering for the Clinic and the first for the SBE at Madison. It appears this kind of cooperative effort will spread to the rest of the country as competing organizations link together for the benefit of all concerned.

Don Borchert of Madison has coordinated the Clinic for 19 years. Even though he is officially retired from his job at WHA-TV in Madison, he has no plans to retire from the event. Attendance this year was more than 170, which was up 20 percent from last year. Thirty-six equipment exhibitors showed their wares.

This year's conference was dedicated to the memory of well-known technical consultant Doug McDonell of Madison, Wis., who died earlier this year.

The Madison Broadcasters' Clinic has been one of the best regional conferences for radio and television broadcast engineers in the country. Interestingly, it even draws some station managers who are forward thinking enough to want to learn about the latest technology. The list of speakers is often as good as the spring NAB show, but with more regional flavor.

Digital was on the minds and lips of everyone this year. Virtually every presentation was related to digital audio storage, compression, editing, transmission or computers.

Greg Buchwald of Motorola talked on transmission standards for AM and FM. He reminded the audience that June 30, 1994, is the deadline for actual measurement of occupied bandwidth at all AM radio stations. These annual tests require a spectrum analyzer or a Delta Splatter Monitor. The tests will confirm that the AM NRSC low pass filters are installed and working properly. Some stations will

find that they do not comply even with a filter installed. The problem can be over-modulation, excessive clipping in the filters, soft transmitter tubes, transmitter mistuning and misadjusted antenna coupling networks.

Consulting Engineer Don Markley gave a talk about the importance of a written contract between contract engineers and the stations they work for. He said there will always be problems. Contractors should guard against lawsuits with well-written contracts.

Gareth Nelson gave technical information on the Sony Optical Mini-Disc, which is being positioned as a replacement for analog cartridge machines. The machines are not available yet but may be in a few months.

John Cummuta gave a talk entitled "Management's Perception of the Engineer: An Asset or an Anchor?" He told engineers to sell themselves better to management and that they should learn computers because that is where the future is.

Virtually every presentation was related to digital audio storage, compression, editing, transmission or computers.

Herb Squire of WQEW(AM)-WQXR-FM New York gave an audio demonstration of problems that can occur when different digital audio bit reduction (compression) systems are run in the same audio chain. He asked, "Is there anything left after you throw away all those bits?" The before and after audio he played sounded the same to some members of the audience but sounded obviously flawed to others. Apparently everyone hears these things differently. His "worst case" recording had many generations of every compression scheme he could lay his hands on. The

degradation was obvious, but not as bad as some radio stations I have heard.

George Werl and Steve Brown of Minneapolis did an excellent presentation entitled "Managing Your Consultant." It pointed out how communication between the station engineer, the consulting engineer and station manager are extremely important.

Mark Durenberger, well-known "futurist" and speaker at the Madison Clinic, told the audience about telephone and television cable company plans for wide-band data delivery to homes and business. His talk, "The Last Mile: Digits to Dial-tone," described the problems and costs of constructing fiber optic or an alternative technology from the present nationwide fiber optic network to each home. The options are many and the costs are high. The telephone company could be delivering our movies and the cable company could be supplying telephone service. Mergers and acquisitions of large companies are going on now in the battle for who is going to serve the

customer and reap the profit.

My talk focused on how computers have come into my life and how they are affecting the broadcast industry. Anyone who is not actively learning computers now will probably find it difficult to work in broadcast or for that matter almost anywhere else soon.

On Wednesday evening, there was a live national teleconference which originated in Madison. It was as SBE event that went via satellite to any and all SBE chapters nationwide that wished to view it on television. The teleconference was two-way in that live telephone calls were taken

from members at the chapter meetings. The one-hour session went smoothly.

Newly elected National SBE President Chuck Kelly announced an agreement between the Society of Broadcast Engineers and the National Association of Broadcasters. SBE will participate with the NAB in selection of technical papers to be presented at NAB '94 and the fall "Super Show."

Terry Baun, who is the new vice president, said the SBE will fail if it does not prepare its members for the realities of the 1990s.



LMA/DUOPOLY CONTOUR MAPS

The **DATAWORLD** LMA/DUOPOLY Market Survey Contour maps present a precise electronic verification of overlapping and intersecting contours.

AM 5 mV/m and FM 3.16 mV/m City Grade contours are shown in full color, including transmitter site indicator. The map is supported with a printout showing all of the stations which appear on the map.

Daily updating of **DATAWORLD'S** AM and FM databases protects against errors and omissions.

OTHER MAP OPTIONS

- SHADOWING (TERRAIN SHIELDING)
- CONTOUR COVERAGE
- POPULATION DENSITY
- ZIP CODE BOUNDARIES
- RECEIVED SIGNAL LEVEL
- SPECIAL REQUIREMENTS

1990 CENSUS

WHO ARE YOUR LISTENERS?

1990 BUREAU OF CENSUS POPULATION COUNTING

- Comprehensive Ethnic and Demographic Data
- Ethnic/Demographic Data Available for Each Zip Code Within Coverage Area
- Age Analysis Reflected in Ethnic Breakout
- Resolution Increased to Block Level
- Percent of County Coverage Shown

ETHNIC PIE-CHART DISPLAY

- Projects Ethnic Population in Multi-Color Pie Chart Form

dataworld®

800-368-5754 FAX: 301-656-5341

Multiple Amplifier Arrays
Have them your way!

Four or eight channels for **YOU** to easily configure as Microphone, Line Buffer, Distribution and Level Matching Amplifiers. Form sum and difference networks, Interface phone lines, Drive headphones, Make a simple Mixer or Press Box... just by changing jumpers. Gains to 82dB, Low noise balanced inputs. Clean +24dBm active or transformer balanced outputs.

Configurable circuitry... to fit **your** needs.
Call or write for free detailed brochure.

AUDIO TECHNOLOGIES, INC.
328 Maple Avenue, Horsham, PA 19044
(215) 443-0330 • FAX (215) 443-0394
800-959-0307

Circle (51) On Reader Service Card

Circle (129) On Reader Service Card

LISTENING IMPRESSION

Wave Radio Survives New York Jungle

by Frank Beacham

NEW YORK The old cliché "if you can make it here, you can make it anywhere" applies as much to radio receivers as to people in the urban life jungle known as Manhattan.

In my Upper West Side apartment, I've found that few radio receivers, regardless of cost, can successfully navigate the RF minefield of New York City. This city can bring a poor AM section to its knees and make even the most celebrated FM receiver drown in its own specifications.

So it was with a particular glee that I learned that Dr. Amar G. Bose, the distinguished professor of electrical engineering at the Massachusetts Institute of Technology and founder of the Bose Corp., had announced "a revolutionary new radio...so extraordinary it can't be compared to conventional radios."

Dr. Bose said, in announcing the product: "It is one of the most significant developments in the history of radio." Wow, I thought, strong words for the introduction of a simple AM/FM table radio.

Called "The Wave," the new radio is based on Bose Corp.'s proprietary "waveguide" technology, a system that uses a winding tube-like acoustic maze to enhance the sound reproduction of small speakers. Dr. Bose and his colleague, Dr. William Short, began work on waveguide technology back in the 1960s.

Prior to The Wave Radio, Bose Corp. had incorporated the technology in its

Acoustic Wave Music system, a portable boombox configuration selling for about \$1,000, and the Acoustic Wave Cannon, a 12-foot professional loudspeaker you might hear in stadiums and arenas.

The new radio, measuring 4.5 inches high by 14 inches wide by 8 inches deep, is the smallest implementation of the waveguide technology to date. It uses a pair of 2.5-inch speakers and incorporates a sealed 34-inch-long single ended waveguide chamber.

The Wave takes the form of a sleek clock radio and features dual alarm mode, 12 radio presets, mute, scan and automatic sleep features. One can fall asleep to one station and awake to another. Volume starts at a low volume and gradually increases to ease wake up. All functions can be accessed through a credit card-sized remote control.

The radio can serve as the centerpiece of a small sound system. Inputs and outputs allow full connectivity to other components. A stereo input allows a CD, cassette or video signal to be fed through The Wave. An output allows connection to powered speakers. There are also inputs for external AM and FM antennas.

Like the Acoustic Wave Music System, Bose sells The Wave radio only via mail

order (\$349).

When the shipment arrived, I connected the single wire FM antenna to the rear jack and the separate closed-loop AM antenna to its connector. AM reception, when I

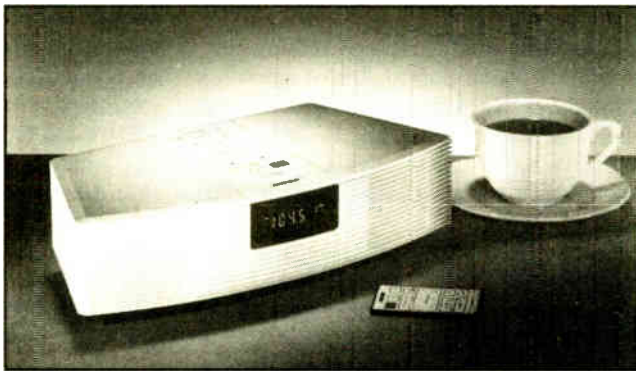

Bose Wave Radio

placed the loop antenna outside my 15th floor window, was fair.

Using only the wire antenna, FM reception was dismal, but took a giant leap when I attached a Recoton powered FM/AM antenna to the radio's FM antenna jack. Only with this antenna did The Wave come alive. The sound fidelity—full and rich—was simply amazing for a clock radio this size.

Good reception is the major problem in the city, so I did an ears-only tuner comparison. My current king-of-the-hill New York receiver is the Thomson-built GE Superadio III, which sells for under \$50 in

most stores. Its AM performance is yet to be matched by any currently available radio I've tried and it's FM performance, though mono, is hard to beat in even the best receivers.

In a side-by-side comparison, using the powered Recoton antenna, The Wave and the Superadio were very close on reception quality of the FM band. Based on the stations I tuned in, The Superadio was the clear winner on AM reception. Audio quality on FM and AM was superior—but not dramatically so—on The Wave.

Perhaps one of the best applications for The Wave is not as a conventional radio but as a set-top sound enhancer for television audio. With its convenience remote control and small size, it brought a major leap in quality to the audio from video cassettes, laser discs and standard over-the-air programming.

The Wave offers a genuine breakthrough in improved sound quality from a small, general-purpose table top radio. Though its tuner worked respectably in this cluttered radio battleground, it's not a particularly distinguished performer. The Wave does not have the low bass response or loudness of the pricier Acoustic Wave Music System either. I would compare it more with a bookshelf system than anything else.

At \$349, most of what you are buying in The Wave is enhanced bass response from a very small sound system. To enjoy it to the fullest, be sure you have strong broadcast signal reception or a separate sound source, such as a CD player or video recorder.

For more information about The Wave radio, call 800-358-BOSE.

We maintain a Double Standard

Audio Precision offers two different standard-setting product lines.

The automated System One — the industry standard for bench and factory.

- Graphic results on PC screen with hard copy to printers
- Automated proof procedures & limits testing
- State-of-the-art performance and speed

The self-contained Portable One Plus & Portable One — for service bench and field.

- Compact and affordable stereo test sets for applications not requiring automation
- Both offer comprehensive capability & high performance in a rugged package
- Portable One Plus adds sweeps, graphs and printer port

The System One and Portable One...two families of test sets designed for different jobs, each with the quality and performance that you have come to expect from Audio Precision.

Audio precision

P.O. Box 2209, Beaverton, OR 97075
503/627-0832 1-800/231-7350
FAX: 503/641-8906, TELEX: 283957 AUDIO UR

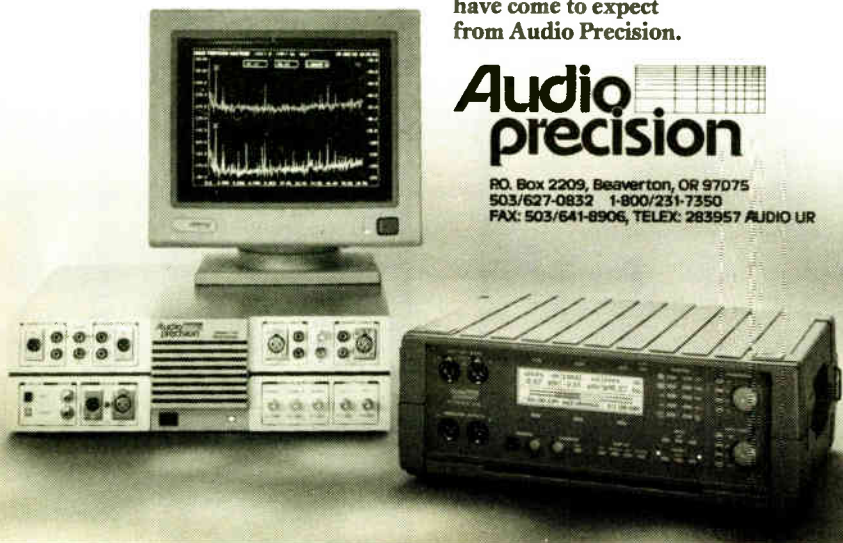

Circle (118) On Reader Service Card



Instant mix-minus from any console. Just add callers.

When you use Gentner's new G2500 Superhybrid, the last thing you need to worry about is feedback or echo. This innovative digital telephone hybrid compares incoming caller audio with its caller feed, and automatically creates a "mix minus" feed by removing audio that could cause feedback or distortion. You can use the G2500 with any console that uses line level inputs and outputs — even small mixers!

Another unique feature in the G2500 is ultra-easy conferencing. A single XLR cable will connect two G2500s for cross feeding and a combined caller mix to the console. Several units can be connected this way for clear, understandable caller conferencing.

The G2500 is available now at a price of only \$1,995. Call your favorite equipment dealer for details.

Gentner

Gentner Communications Corporation
1825 Research Way
Salt Lake City, Utah 84119
(801) 975-7200 FAX (801) 977-0087

Circle (202) On Reader Service Card

SmartMixer[®]

Uncomplicated, Automated



AT-MX341 Automatic Microphone Mixer

If you thought that automatic mixers required an advanced EE degree to install and years of experience to run, we've got great news for you. Introducing the Audio-Technica AT-MX341 four-channel SmartMixer[®] with unique digital microprocessor control.

Cleaner Sound...Automatically

At last a mixer anyone can set up in minutes, providing three modes of operation for exactly the control you want, automatically. The SmartMixer reduces background noises and other distractions by keeping the number of open channels to a minimum. And switching between channels is instant and completely transparent.

Easy System Setup

Mixer setup is a snap: 1. Adjust channel one gain... 2. Adjust "threshold level" to exclude ambient sound... 3. Adjust other mike gains... 4. Select which mikes you wish to control (all, some, or none). That's it! The last-mike-on stays on so that ambient sound is always heard through the system, eliminating "dead air." Channel LEDs indicate which mikes are active. Mixer output level is indicated by 6 LEDs.

Flexible Priority Control

Each channel has a switch to connect it to the digital control system.

If all channels are under digital control the system opens just one microphone at a time, switching only after the controlling channel falls quiet. The operation is so fast and silent that it is the recommended mode. A channel switched to priority will override all others any time the threshold level is exceeded, useful for moderators and chairpersons. Thus you can choose to have just one microphone open at a time, all microphones active, or any combination desired.



Digital Switching plus TTL Output

All switching is controlled by a digital microprocessor with proprietary algorithms for instant, seamless operation, far superior to older analog designs. By using digital control the AT-MX341 SmartMixer also offers TTL logic output control signals that can be used to turn speakers on or off, control cameras, light tally lights, or whatever else is needed. And it can easily interface with the Audio-Technica DT100 Teleconferencing System as well. Because the logic is in a socketed EPROM, a new IC from A-T can quickly revise or update the programming at any time.

Designed for Expansion

Using the provided link cable you can cascade as many SmartMixers as needed to create a system for large seminars or legislative bodies. The priority control system extends throughout the entire chain of SmartMixers. The SmartMixer mounts in a single 1/2-wide rack space and is powered by either 117V AC or 15V DC. It also provides 12V DC phantom power for condenser microphones. Security covers are included to limit access to controls if desired.

Great Sound...Everywhere

The SmartMixer is perfect for teleconferencing, meetings, seminars, and for use in broadcast and A/V studios. Its simplicity and unique abilities make the AT-MX341 ideal as the hands-free heart and soul of many sound or recording systems, from boardrooms to churches.

Get all the details on the AT-MX341 SmartMixer. Write, call, or fax today. Available in the U.S. and Canada from **Audio-Technica U.S., Inc.**, 1221 Commerce Drive, Stow, OH 44224. Phone (216) 686-2600. Fax (216) 686-0719.

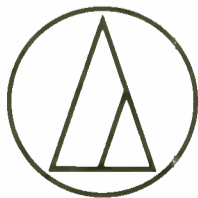

audio-technica[®]
INNOVATION □ PRECISION □ INTEGRITY

FACILITIES SHOWCASE

PR&E Outfits New KABC Radio Studios

by Dee McVicker

LOS ANGELES Building new studios in Los Angeles is akin to planning a military maneuver. It's a complex matter of where to build, how to build, and even city ordinances concerning equipment safety.

But none of that stopped KABC (AM)-KLOS(FM) Director of Engineering Norm Avery as he started out in 1990 to find a suitable place for Capital Cities/ABC's two highly ranked Los Angeles stations.

There was no urgency, but there was a

desperate need for new accommodations. KABC/KLOS's facility on La Cienega Boulevard was originally built in 1939 as a transmitter building, and had structural add-ons and renovations for just about every decade following.

Long overdue

The last major renovation to the old building was in 1982 when the stations were run exclusively by engineers and board operators. Yet another renovation—this time to accommodate the digital age—was not an option. In early 1990, the stations began planning for a

new building on the existing grounds.

As was the case during the 1982 renovation, Pacific Recorders & Engineering (PR&E) was called in to help with the studio design, furniture, system wiring and installation. Having PR&E involved in both studio changes offered a unique insight.

"We had the luxury to see the growth in the past 10 years and the direction these stations were moving in," PR&E President Jack Williams said.

KABC, with its "talkradio" format, and KLOS, with an album rock format and recent syndication of its Mark and Brian morning show, had separate requirements.

"It's hard to believe they share the same building, (yet) they're so radically different," said Williams, whose company set out to design 17 studios that would accommodate all the needs of KABC and KLOS, and then some.

Building 17 state-of-the-art studios (ABC declined to reveal how much the project cost), however, was not without its concerns. First and foremost was structural design and construction. This was given full consideration because the new building was to be built at ground zero of KABC's antenna field.

To ensure that nearby RF from KABC's tower would not affect broadcast gear—yet maintain a normal propagation pattern—several measures were taken.

First, a computer model of the building and antenna was done to determine what the maximum height of the building would be before it started to interfere with the antenna. Based on this model, the building was designed not to exceed 21 feet.

Next, an elaborate ground system was designed that incorporated the building as part of the ground system. A perimeter strap, connected to the structural steel of the building was placed around the building and bonded to ground radial straps that were intercepted by the building structure. Under the building foundation, another perimeter strap system bonded to the ground radials that met the building structure to shield out RF between two points of ground.

New ground system

"We had to integrate the ground system with the antenna so that it would not impact the transmitted signal," Avery said. "The contractors were not accustomed to this type of construction."

All on one level, the new building also meets stringent acoustical requirements with studios floating on discrete cement slabs and double walls throughout. The HVAC system, of which there are actually three 45-ton systems—including a spare for the studio complex—was designed to be high-volume and low-velocity.

Acoustical measurements by Smith Fause & Associates' acoustical engineers determined where and how much acoustical treatment was required. "Smith made reverberation measurements, and they did some computer modeling and built with the computer models the balance of the acoustical treatment for each room," Avery explained.

Five SAS Model 32000 routing switchers network the studio signals throughout the facility. The systems are used to route and distribute remote inputs, monitor feeds, IFB and mix-minus signals to all 17 studios, and on-air feeds from active control rooms to the transmission facilities and dial-up couplers.

Easy operation

The SAS controllers use alphanumeric displays for easy operation and set up. "The matrices can be configured in a variety of shapes and sizes. The alphanumeric displays and soft keys provide an excellent human interface. It has cut down the wiring bundles here by thousands of pairs, saving us a lot of time and money," Avery said.

For KABC's "talkradio" format, four control rooms were installed, two of which are identical, in order to alternate studios seamlessly and facilitate unhurried setup between shows.

The twin studios, dubbed Studio K and
continued on page 15 ►

some days,
it's tough to
stay humble

WEHM 96.7 FM

CUTTING EDGE TECHNOLOGIES
Mr. Frank Foti
2101 Superior Ave.
Cleveland, OH 44114

April 18, 1993

Dear Frank,

I just had to write to let you know what a great product you've got in the Unity 2000. Right out of the box, it was obvious that this was no ordinary processor. Its ease of use and above all its loud, but incredibly clean and I mean the cleanest processor I have heard put it head and shoulders above the rest. I cannot begin to tell you how many WEHM listeners have called us to simply say that our station's audio makes their receivers come alive. To quote one individual: "No radio station coming through my speakers ever sounded so crisp and clear. It sounds great". I have no doubt that the Cutting Edge Unity 2000 is the reason why. Bravo... on building the best Audio Processor available!

Sincerely,

Aaron Brodbar
Aaron Brodbar
Chief Engineer



EAST HAMPTON BROADCASTING GROUP, INC. 34 PANTIGO ROAD, EAST HAMPTON, NY 11937 516-329-0010 FAX: 516-329-5004

the unity 2000 i
the world's best sounding fm processor



CUTTINGEDGE

2101 SUPERIOR AVENUE, CLEVELAND, OHIO 44114 • TEL: (216) 241-3343 • FAX: (216) 241-4103

Circle (191) On Reader Service Card

Running Radio

CHR Radio Spotted Alive and Thriving in Dallas. See USAirplay, page 19.

Your Resource for Business, Programming & Sales

Art of Promotion Goes High-Tech

► continued from page 1

diaries. Most diaries are filled out in the kitchen. When we talk to radio station promotion people about what they should be using as giveaways, we suggest items geared toward the kitchen—the refrigerator magnets, the memo boards—that are going to be seen and recognized with that logo on it come diary time,” Tishman said.

Banners are important promotional tools at remote broadcasts. Joe Oppenheimer, marketing representative for Roll-a-Sign, a division of Reef Industries, said their plastic banners have become very popular because they are more economical than heavy-duty canvass banners.

“Listeners like to try to take home station banners once in awhile. They feel that they’re more set on being able to give these away as promotional items because they only cost a couple of dollars a piece at the most,” Oppenheimer said.

Byron Crecelius, vice president of sales and marketing for U.S. Tape and Label, said that cooperative promotions with recording companies is an up and coming thing: “In the last year or so we’ve been heavily concentrating on tying in radio promotions with recording companies, such as Arista and Virgin. They tend to promote on the back liner of the bumper stickers.”

Some stations get up to five different recording companies to buy 150,000 bumper stickers each, Crecelius said. The recording companies will print the cover of an album

they are promoting on the back liner. This is a practical way for cash-poor radio stations to pay for their bumper stickers.

“In fact many times we send the bill directly to the recording company, not the radio station,” Crecelius said.

Data draws

Listener data bases provide another method for stations to maximize their promotional efforts. Dave Dworkin, president of the Radio Mall, said that listener databas-

Artwork courtesy of U.S. Tape and Label



es provide stations with computerized information on as many listeners as possible, enabling stations to use direct mail to promote upcoming contests and appearances.

Dworkin said there is also a growing trend toward linking listener databases with the sales department.

“A radio station can offer a client a combination of a one-two punch, wherein

they would not only be able to advertise on the air, but they would be able to get a very selective mailing list of listeners,” he said. “The stations that do not attempt to do something with this are probably going to be left in the dust by the stations that do.”

Broadcast Direct Marketing President Courtney R. Thompson, who offers promotional databases, said: “The object of the game of listener data bases is to help the listener become bonded with the station or the station to become bonded with the listener.”

Thompson emphasized the potential of listener databases for providing the advertiser with additional net media reach. Broadcast Direct Marketing produces magazine-style brochures for many of its clients. Stations then send the magazines to the listeners in their database. Magazines may include articles about music, local community events, the station and its air personalities.

“That magazine-style product carries reg-

ular display, four-color ads like any normal magazine would carry,” Thompson said. Special coupon sections is an especially popular and lucrative section of the magazines. For some stations, these magazines may become new revenue centers. One station in a southwestern market brings in a net yield three times the cost of production, Thompson said.

Interactive promo

Listener databases may also be used in conjunction with interactive systems. The RadioPhone Interactive Voice Response System is an interactive service designed by The Media Gallery to allow listeners to call the station for a variety of information tailored to their particular interests, ranging from news and soap opera updates to local weather and sports scores.

The system has an extensive database capability and can be programmed to tabulate demographic information about listeners, as well as information about buying and listening habits. The system can draw upon the database to leave messages for specific listeners, alerting them to promotions or

continued on page 17 ►



THE MAN WHO DRAINED LAKE MICHIGAN AND FILLED IT WITH CHOCOLATE!

STAN FREBERG HERE!

JUST THE TIP OF THE FREBERG

RADIO SATIRICAL COMMENTARY FOR THE 90'S
FIVE TIMES EACH WEEK
DELIVERY VIA SATCOM - C5 - BARTER
FOR DETAILS CONTACT - DAVID P. WEST 201-385-6566
ANOTHER FINE RADIO PROGRAM FROM **DICK BRESCIA ASSOCIATES**

DBA reserves the right of final selection of affiliates for any of its programs.

Circle (165) On Reader Service Card

TRUE BLUE FOR



THE BLUES.

More stations play their music on the world's best-selling tape carts.

audiopak
BROADCAST CARTRIDGES

P.O. Box 3100 • Winchester, VA 22601
Tel: (800) 522-CART or (703) 667-8125
Fax: (703) 667-6379

Circle (81) On Reader Service Card

**OTARI'S NEW R-DAT:
PROFESSIONAL QUALITY WITHIN YOUR REACH.**



When you've had enough of unreliable "warmed-over" consumer decks, we've got a *professional* R-DAT for you at an affordable price.

Our new DTR-90 delivers the rock-solid reliability and superb sound that have made Otari audio machines the choice of professionals everywhere, and at the same time delivers all the performance and features you'll ever need.

For example, so you can make changes fast and easily, the DTR-90 is the only R-DAT available with individual record insert on Ch. 1, Ch. 2, and time-code channel. And its user-friendly front panel features an LCD screen that gives you powerful functions often relegated to DIP switches in other R-DATs—you can even detach the control section of the front panel and use it as a remote unit!

You'll also appreciate the optional Time-code Card with its chase synchronizer for tight lock with VTRs and ATRs, as well as features like read-after-write and punch-in, punch-out.

And if you need a complete electronic editing system, you can't do better than couple the DTR-90 with Otari's CB-149 editor for flawless digital editing.

For the complete story on this quality-built and affordable R-DAT, call Otari at (415) 341-5900.



Otari Corporation
378 Vintage Park Drive
Foster City, CA 94404
U.S.A.
(415) 341-5900
Fax: (415) 341-7200

Otari Corporation
U.S.A.
(415) 341-5900
Fax: (415) 341-7200

Otari Inc.
Japan
(0424) 81-8626
Fax: (0424) 81-8633

Otari
(UK) Ltd.
United Kingdom
(0753) 580777
Fax: (0753) 542600

Otari
Deutschland GmbH
Germany
02159/50861-3
Fax: 02159/1778

Otari Singapore
Pte., Ltd.
Singapore
(65) 743-7711
Fax: (65) 743-6430

TECH TALK

Recalling the Torturous Past of AM Stereo

by Judith Gross

NEW YORK AM stereo was the FCC's and AM industry's most shameful hour. It has come to be regarded as the great policy mistake to be avoided in the future, as in: "We don't want this to become another AM stereo."

The FCC has recanted the mistakes of its predecessors and finally chosen an AM stereo standard, 10 years too late.

AM stereo, even more than digital audio broadcasting or any other controversy, is the story of how technology can get tangled up in personal and political concerns. In a broad sense, it reflects U.S. politics shifting over time, from the let-the-marketplace-decide attitude of the Reagan years to the let's-right-past-wrongs drone of the Clinton era.

If we had decided on a standard for AM stereo when it still mattered, perhaps some failed stations would have survived.

In a narrower sense, AM stereo is the personal history of a large number of individuals, counting myself among them.

Stereo storm

In 1984, I was writing about broadcast technology for a now-defunct publication called *Broadcast Week*, and covering my first NAB show in Las Vegas. I decided to take in the AM stereo proponents seminar.

At the time, I was wondering if things like TV stereo and AM's problems would be as interesting as cornering the mayor of Binghamton, N.Y., into an exclusive on the controversial city mall.

The FCC had already blundered its way through several years of controversy on AM stereo by 1984, after doing a series of tests of the five proposed systems—Belar, Magnavox, Harris, Kahn and Motorola—eventually picking Magnavox. The industry rebelled at the decision and divided up into entrenched camps. The FCC threw up its hands in disgust and took its Reaganesque marketplace stand.

Belar was out in 1984. Magnavox was holding by a thread, Harris had abandoned its system in favor of Motorola's C-QUAM. Leonard Kahn's ISB had gained a foothold among a few stations. (The very first news headline in *RW* back in 1979 was that WABC New York had put Kahn's system on the air.)

Then Delco decided to back C-QUAM. Kahn fumed and the battle was on. Sony got into the fray, producing a wideband (15 kHz, originally) AM stereo radio that could switch back and forth between C-QUAM and the Kahn system.

I walked into an immense seminar room at the NAB show, where there were so many speakers on the panel that two stages had to be set up to accommodate them. No less than 12 AM stereo luminaries elbowed each other, including Bob Weirather (Harris, now Harris-Allied), Frank Hilbert (Motorola), John Reiser (FCC), Almon Clegg (consultant) and of course, Leonard Kahn.

Things steadily deteriorated into a screaming match, with grown men yelling at each other from across the room and respected engineers in the audience getting up and venting fury at the FCC or the system they opposed.

Binghamton paled next to this, I thought. Covering this AM stereo was going to be fun.

And it was for a while.

I have mental snapshots of the years of controversy that followed, such as sitting with Maine broadcaster Ron Frizzel in Motorola's C-QUAM demo car, comparing the Delco C-QUAM sound to Kahn stereo reception on that wideband Sony. Ron hated the Delco, loved the Sony and got into a heated argument with the demo staff who evicted us from the car.

Old snapshots

There was the time I was riding through the outskirts of Chicago with Motorola reps, listening to the Delco, which didn't sound bad to me.

Later I cruised through the streets of Manhattan with Leonard Kahn, listening to WQXR(AM) ISB broadcasts on his makeshift receiver.

There were endless telephone discussions with engineers. Everybody had an opinion.

Some would tell you inside info about backroom meetings where receiver manufacturers took a secret pact to exclude Kahn; about the "platform motion" of C-QUAM reception which caused masses of stations to turn the system off; about tests one proponent or another disputed. Most of the accusations could not be proved.

At *Broadcast Week*, and later *Radio*

World, I followed every wrinkle, got the quotes and I often found myself waking up at 2 a.m., unable to sleep for thinking about how the controversy could play out.

RW, for its part, elucidated the controversy and, in part, rose to prominence in the industry for its role. It was the first and only publication to go out on a limb and endorse a standard—C-QUAM.

RW backed C-QUAM, not for any personal gain (the amounts of advertising on AM stereo from any party have been minuscule), but because receiver makers had already made their decision. To this

continued on page 19 ►

SEND YOUR AUDIO ACROSS THE STREET OR AROUND THE WORLD™

When you think digital audio, think California Digital. We provide satellite/digital technology to make all these options available at low cost:

- ! Syndicate your top personality or format
- ! Add affiliates - gain revenue sources
- ! Share programming, talent and costs
- ! Off-site announcer feeds
- ! Create events with remotes
- ! CD-quality live coverage of news, sports, and concerts

California Digital offers expertise in:

- ! Digital Satellite Networks - C or Ku
- ! Regional, National, International Nets
- ! Remote Broadcasts
- ! Rugged Fly-away Systems
- ! Custom Ku Power Control Software
- ! System Design & Engineering
- ! FCC Licensing; Installation and Training
- ! Equipment sales, leasing and financing
- ! Switch 56 & ISDN program distribution

TOP TALENT IS LOCALIZING NATIONAL SHOWS WITH OUR LOW COST TECHNOLOGY
ASK US HOW YOU CAN DO IT TOO!

CALL:
CALIFORNIA
DIGITAL AUDIO

West Coast Office (805) 523-2310 Fax (805) 523-0480
Midwest Office (612) 631-5064 Fax (612) 631-5010

**MAKE MONEY BY CREATING A
MUSIC PROGRAMMING NETWORK!**

Circle (41) On Reader Service Card

World Radio History

STATION SERVICES

News and Services for Business, Programming and Sales

BRN Offers Political Humor

FAIRFAX, Va. Political satirist and former comedy troupe member Chris Manion, will be singing political parodies for BRN's newest talk show, "Floyd Brown's Talk Back to Washington." The program airs Monday through Friday, 9-11 a.m., ET, and debuted in 24 markets on Oct. 25.

Manion, a former Senate staffer and college professor, was an original member of the Capitol Steps. He has prepared two albums of political satire (due out later this year) and will be hosting a weekly television variety show, "Face the Music," on National Empowerment Television, the public affairs satellite network scheduled for launch earlier this month.

For information, contact Chris Manion

in Virginia at 703-532-4016; or circle Reader Service 149.

Radio Infomercial Series to Debut

PLEASANT HILL, Calif. Knapp Enterprises is offering "FutureNow," a direct radio response magazine that allows consumers to purchase anything from computer equipment and personal security devices to self-help tapes. "FutureNow" is designed to extend the boundaries of direct sales and mass marketing by distributing product to consumers through entertaining and informative one-hour radio programs.

The audience is provided a number to order product after each segment is broadcast. FutureNow handles delivery.

Consumers are protected by original manufacturer warranties on all products ordered, and are offered a 30-day money back guarantee from FutureNow.

For information, contact Myles Knapp at 510-372-5457, ext. 161; or circle Reader Service 59.

COPRA Media Introduces Oldies Program

DALLAS "Class Reunion" is a four-hour, weekly show focusing on the top rock 'n' roll hits of the '50s, '60s, and '70s. Each weekly program spotlights one artist through the use of interviews and greatest hits.

Dave Cowley hosts the program, which is designed to showcase the attitude, the people, the stories and the history of rock 'n' roll's legacy. "Class Reunion" is offered on a market-exclusive, barter basis and is distributed on DAT, reel-to-reel or cassette.

For information, contact Linda Cowley at 800-985-2665; or circle Reader Service 29.

Holiday Music Added to Energetic Music's Library

SEATTLE Holidays No. 1 is the thirteenth release from Energetic Music. It contains classic and modern arrangements of traditional Christmas music arranged in 30- and 60-second lengths as well as two-to-four-minute and bumper and stinger versions.

The music is licensed for royalty-free use and is designed for the production of TV and radio spots, holiday home movie transfers, special events, etc...

For information contact Monty Smith at 206-467-7101; or circle Reader Service 97.

'Buenas Noches America' Premieres on CBS Hispanic Radio

NEW YORK AT&T, the National Council of La Raza and CBS Hispanic Radio have combined forces to offer a live radio program in Spanish to address the need for information and orientation regarding immigration issues.

"Buenas Noches America" debuted Oct. 28 on 10 affiliates of the CBS Hispanic Radio Network at 11 p.m. ET. The hour-long weekly show will include a mix of immigration news briefs, questions from

callers and answers from a resident immigration issues expert as well as invited guests and educational segments dealing with consumerism and the telecommunications industry.

For information, contact Helene Blieberg at CBS at 212-975-3771; or circle Reader Service 188.

The Best in Australian New Music

WASHINGTON "The Big Backyard" is a bi-weekly music service available on CD from the Australian Embassy. The music service is designed to introduce stations to the latest new music from "down under."

For information, contact Radio Producer, OIB Canberra, c/o the Australian Embassy, 1601 Massachusetts Ave., N.W., Washington, DC 20036.

Jamie Foster Brown on Westwood One's UC Radio

LOS ANGELES Westwood One has added a new feature to its Urban Contemporary programming lineup with the debut of "Sister 2 Sister." Hosted by publisher, gossip columnist Jamie Foster Brown, the 2 1/2-minute, daily feature will premiere Jan. 3, 1994.

The program will be structured in a unique format whereby Jamie will pass on confidences about celebrities during the course of a conversation with an insatiably curious girlfriend.

For information, contact Laurie Peters at Westwood One at 310-840-4383; or circle Reader Service 112.

Judy Jarvis Show Heats Up Airwaves

HARTFORD, Conn. Multimedia journalist Judy Jarvis is hosting her own, nationally syndicated talk program, "The Judy Jarvis Show."

An award-winning writer, reporter, radio and TV talk show host, Jarvis provokes straight talk and debates on headlines of the day. Jarvis' call-in program features interviews with politicians, celebrities and listeners.

"The Judy Jarvis Show" is distributed through the Talk America Radio Network.

For information contact Tom Starr at 800-298-8255; or circle Reader Service 211.

STATION SERVICES

427 SOUND EFFECTS \$89.00

For a 5-CD set with a 30-day money-back guarantee.

Take an extra \$10 off if you mention this ad!

Send \$79 to Ghostwriters
2412 Unity Ave. N., Dept. RW
Minneapolis, MN 55422

For credit card orders call
(612) 522-6256

READER SERVICE 56

Radio Potato™ CD Demo

"I Love Radioe Potato"

—Dan Quayle

- Hot Production Music
- Killer Production
- Stuff for AM
- GMs //oovvee us!

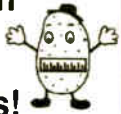

Call 1-800-468-6874
for a FREE DEMO!

READER SERVICE 122

Station Services are a great, economical way to get your company's message to Radio Station and Recording Studio owners/managers and engineers. Call Simone now and your ad could be in the next issue of Radio World.

Dump the file cards!

HOT MIX

music scheduling software
Get better and fresher rotations
Buy-out price only **\$495.00**
Programming Services Available
Music Logs/Programming
Format Restructuring

Call us today!

LA PALMA BROADCASTING

(714) 778-6382

READER SERVICE 37

MEDIA DIALUP

National Listen Line Network
Chicago • New York • Los Angeles • Dallas
Serving Top Ten Markets By Early '94

Real-time air checks as convenient as your telephone. Subscription based—No per minute fee. Call 214-330-8393 for information on our free Dallas listen line. Charter subscriptions available.

Universal Access • Affordable
Real-time Research • Monitor Competition
Scout for Talent • Audit Advertising
News • Sports

Media Dialup

214-330-8393 (24 Hour Info) 214-330-7060Fax

READER SERVICE 171

BUY - OUT HOLIDAY MUSIC

\$89⁹⁵ CASSETTE **\$99⁹⁵** CD

ENERGETIC MUSIC
P.O. Box 84583 • Seattle, WA 98124

1-800-323-2972

READER SERVICE 219

ATTENTION PROVIDERS!

Promote your services to **Radio World's** 22,000+ readers. Reach Radio Station and Recording Studio owners/managers and engineers with your message. For information on affordable advertising call **Simone** at **1-800-336-3045**.

HAVE THE BEST SOUNDING STATION IN TOWN... FOR A LOT LESS MONEY!

J.R. Nelson is offering his services to your radio station on a market exclusive basis now at an incredible price!!

J.R. Nelson
PRODUCTIONS

30% DISCOUNT FOR MULTIPLE STATION ORDERS. MONTHLY RETAINERS.

CALL/FAX FOR DEMO & RATE CARD:
Phone/Fax: 803-268-6521

Circle (87) On Reader Service Card

PR&E Outfits New KABC Radio Studios

► continued from page 10

Studio A, were designed with a main on-air control room and joining announce booth, screening booth, and talk studio. Another control room, dubbed Studio C, is a three-room complex with separate screener/production booth, control room and interview/talk studio.

Another KABC studio, Studio B, is a self-contained production studio for the station's commercial dubbing and production. The AM newsroom is designed to go

"We've equipped it with a snake box for musicians to plug in their headsets, plug in their instruments, and plug in their microphones directly into the console," Williams said.

Furthermore, he added, one of the talent wings has a large drawer for a musical instrument keyboard.

"From time to time, they've had some fairly famous musicians come in and actually play something they're just writing or compose something on the air, and

who callers are and what line they are on.

FM Studio S is an identical backup to Studio L, and is used to uplink the station's syndicated morning show. A multitrack studio also is part of the FM studio complex and is used for high-level production work.

PR&E consoles

All KABC and KLOS control studios are equipped with PR&E AMX 34-channel

the Los Angeles Dodgers.

Other new equipment purchases included Otari MTR15 reel-to-reels, Studer Model D730 CD machines, Westlake Audio speakers for monitoring, and two new Nautel AM stereo transmitters.

To satisfy the city of Los Angeles' electrical and fire safety requirements, Avery purchased only the equipment that met the city or Underwriters Laboratories inspection safety certification.

Equipment that didn't meet this city requirement was "summarily rejected," said Avery, who is adamant about adhering to the local ordinance.

□ □ □

Dee McVicker is a regular contributor to RW and a freelance writer for the broadcasting industry. She can be reached at 602-545-7363.

Figure 1. KABC-KLOS new studio floorplan.

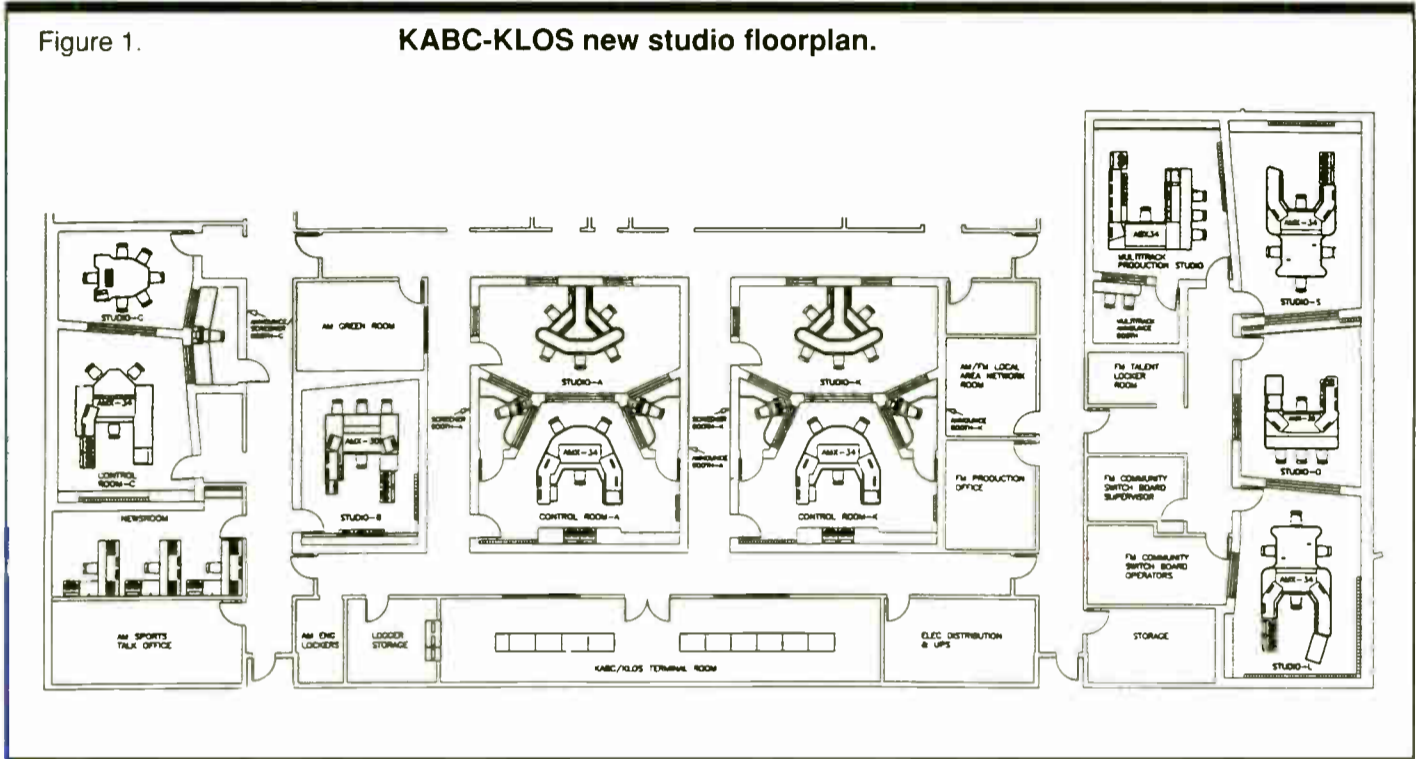

on the air as required, although it is used frequently for news editing and assembly.

Different needs

For KLOS, four large control rooms were designed with a different set of requirements in mind. Studio L, the heart of the station's album rock format, is designed for just about any on-air situation imaginable.

they can just pull out the keyboard in the drawer and play the thing. It's connected directly into the console," Williams explained.

Adjunct to Studio L is what is known as KLOS-FM's community switchboard room, where contest calls and other calls for the "Mark and Brian" show come in and are dispatched. Video cue monitors are set under glass surfaces to indicate

consoles, replacing BMX Series II consoles used by the stations in the old facility. The AMX's larger frame size, greater number of mix-minuses (the BMX had two; the AMX has four), and a greater number of busses (the AMX has three, plus two supplemental) convinced Avery to make the upgrade. The consoles proved to be critical to the many IFB remotes done for KABC, the flagship station for

Digital Audio Storage?



We have answers to questions you haven't even thought of.

Call us.
1-800-547-3930

Digital Universe

A Division of Custom Business Systems, Inc. / cbsi
P.O. Box 67, Reedsport, Oregon 97467

503 271-3681

THE SECRET'S OUT—DIGITAL FURNITURE

MODULAR FLEXIBILITY WITH A CUSTOM FIT

We Offer Six Elegant Lines of Studio Furniture

4153 BONITA STREET
SPRING VALLEY, CA 91977
PHONE 619/698-4658
FAX 619/698-1268

MURPHY
STUDIO FURNITURE



▲ STEALTH SERIES ▲

Circle (26) On Reader Service Card

Circle (141) On Reader Service Card

MANAGER'S NOTEBOOK

Say Merry Christmas with a Bonus

by Sue Jones

BURKE, Va. In December, every station manager finalizes the assessment of the year's success, the wins, the losses. The most important factor is the financial success of the station. If it has been a profitable year, it is common practice to share some of the success with the staff members who contributed to the station's prosperity in the form of a bonus.

Bonuses: who gets them, how often, and the amount are often the source of resentment among staff members. They are at least, a dicey issue for managers who make the distribution decisions.

Before you begin to divide up the bonus money this year, give some thought to what you want to accomplish with it. Bonuses are motivational tools. Typically, the sales staff's compensation includes a bonus linked to individual sales figures. Bonuses are also used as a reward for making and exceeding goals.

It is common for senior management to receive year end bonuses if goals have been met or exceeded. Bonuses can also be used as team building tools. The chosen method can enhance your team building efforts or seriously damage them.

Two-edged sword

One of the high points of management is telling a staff member what a terrific job he

or she is doing and rewarding him or her with a bonus. How can something as wonderful as a bonus turn into a smoldering problem? Staff bitterness often flares when

directly generate revenue for the station. In many major markets, the contracts for the on-air and programming staff have bonuses dependent on ratings.

Figure 1.

	Chief Engineer	DJ	Admin. Asst.	Program Dir.	Sales Mgr.	Sales Staff	
Level of Responsibility in the organization Management = 3 On Air Staff = 2 Support Staff = 1	3	2	1	3	3	1	
Over all personal performance evaluation rating Excellent = 4 Above Average = 3 Full Performance = 2 Below Average = 1 Poor = 0	3	3	2	2	4	3	
Special contribution to the station One point for each occurrence	1	2	1	1	1	1	
Special team efforts One point to each occurrence			1	1	3		
Years of Service (0.25 per year)	1.25	.25	.75	1	1.5	.25	
Totals	8.25	7.25	5.75	8	12.5	5.25	47
\$63.82 per point	\$526.51	\$462.70	\$366.97	\$510.56	\$797.75	\$335.06	
Bonus Pool = \$3,000							

there is a perceived uneven distribution of bonuses throughout the staff.

Bonuses have traditionally been reserved for senior management and those who

Pilots cannot fly airplanes without the assistance of the maintenance crews, air traffic controllers, ticket agents and support staff. On-air talent cannot broadcast with-

out the assistance of engineers, sales representatives, promotions and other support staff.

Progressive managers today are viewing the success of the station as the result of contributions from the entire staff. Each position has a vital role in its smooth operation and profitability. They recognize the value of bonuses for the whole staff and see benefits that impact the bottom line.

Bonus money distributed to everyone will be returned several times over in higher performance levels. Staff members who know they will have a stake in the profits at the end of the year not only complete their assigned tasks, they look for additional ways to earn or save money for the station. Moreover, teamwork is significantly enhanced. Peer pressure often increases marginal performer's volume and quantity. A poor performer is not only damaging his own success but the group's success as well.

A method in mind

Once you include yourself in the new breed of managers, the next task is determining how to structure the bonuses. There are several other issues that must be addressed. Should years of service be considered? How can bonuses be objective instead of subjective? How can they be tied to individual performance?

Like forms of government, there is no perfect system. Most organizations tailor bonuses to fit their operation and needs. Formula and point systems have several advantages. They provide a more objective framework for distribution of bonus
continued on next page ▶

It's Here . . .

THE NEW GENERATION OF FM TRANSMITTERS.

Throughout the years Continental has built the world's most reliable transmitters and other RF products. The new generation of three bay transmitters is no exception. This family of transmitters offers the broadcaster efficiency and excellent audio performance.

Standard features include:

- A Solid-State IPA
- Front Panel Indicators and Breakers
- Internal Harmonic Filter
- Automatic Power Level Control
- "Exclusive Soft Start™"
- Totally Self Contained (except 35kW)

The 3 bay family of transmitters is available in power levels from 21.5kW to 70kW and comes with the 50 watt 802B exciter, tuned and tested on your frequency and ready for easy installation. Continental can outfit your facility with the best products in the industry.

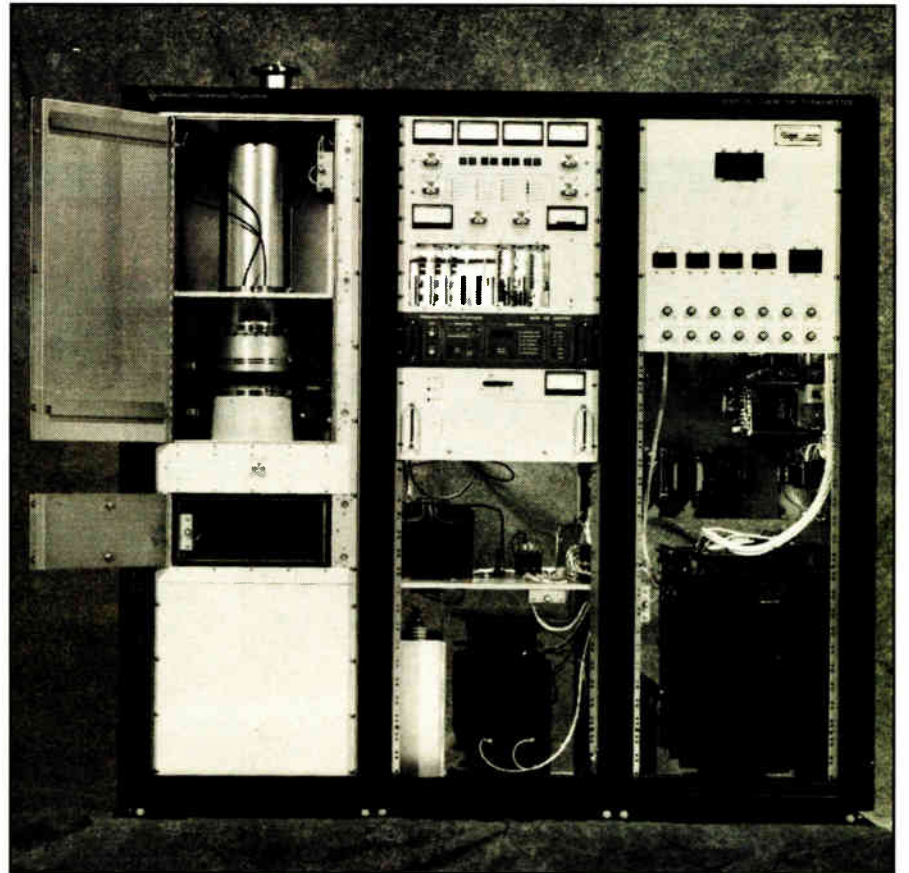

CONTACT CONTINENTAL FIRST



Continental Electronics Corporation

P.O. BOX 270879 DALLAS, TEXAS 75227-0879 214-381-7161 TELEX 73-398 FAX 214-381-4949

RUNNING RADIO

► continued from previous page money. A weighted point system would use several factors in calculating the bonus amount for each individual. Some of those might include:

- *Level of responsibility in the organization*—This category addresses management, on the air personalities, and support staff.
- *Overall personal performance evaluation rating*—The usual performance levels include Excellent, Above Standard, Full Performance, Below Standard, and Poor. Give increasingly higher points for each higher level.
- *Special contributions to the station*—These are special contributions throughout the year, beyond a staff member's usual duties.
- *Special team efforts*—This category might include a successful execution of a high profile promotion.
- *Years of service.*

Point system

This is not an all-inclusive list. Modify it by adding or deleting the factors that make sense for your station. However, keep the

factors broad and general enough to include everyone. The list of factors can be as brief or as complex as desired.

Each one of these factors can be assigned a given number of points depending on its relative importance to the station. Some factors will be more important and therefore should be given more points. For example, a management position carries greater responsibility than a staff position. You may want to recognize years of service by giving it a lower point or fraction of a point value.

The value of each factor is your judgement call. Design a spreadsheet-type matrix with the factors on left and the staff names/posi-

tions on the top. See Figure 1. Give the appropriate points to each staff member for each factor.

In the example, there were 47 total points. Divide the bonus pool of money (\$3,000 in the example) by the total number of points to determine the value of each point. In the example, each point value is \$63.82. Multiply each staff member's total points by their individual points to determine individual bonuses.

Fair methods

If you evaluate each staff member's bonus with such a matrix you will have a more objective bonus allocation. It will be more objective because it was applied

to everyone and several factors were used.

Consider telling the entire staff how the bonuses were determined. Give them a copy of the matrix or formula. You will gain several advantages by making the bonus plan known. They are:

1. Elimination of speculation and rumors.
 2. Logical explanation why some staff members got a bigger bonus.
- If the matrix point system is consistently and fairly applied, employees will understand it and be more tolerant of the differences. They will appreciate your candor and professional confidence in them. You may also find that those who are earning lower

level bonuses might be motivated to earn a higher one next year.

3. Provide a road map for new staff and low performers to improve their efforts, the station's revenue and their compensation.

4. Provide a clear statement that individual and team performance makes a difference to the station and is directly tied to bonus compensation.

If handled properly, a bonus can be a very effective motivator. The best part is handing out the rewards for jobs well done.

□ □ □

Sue Jones is a senior manager for Computer Data Systems Inc., in Rockville, Md. She can be reached at 703-323-0491.

High-Tech Promotion

► continued from page 11 special sales, based on the information gathered about them.

Media Gallery President Ruth Presslaff said the system sends the message: "We're finding out what's important to you and we're superserving you on those things. Every radio station uses it differently. This is a touch between the listener and the station. A high-personality station should have a high-personality system."

Interactive telephone systems also provide radio stations with a specialized advertising opportunity for their clients. For example, a company could sponsor a health line or a soap opera update. This meets station needs for value-added promotions and also helps keep air clutter to a minimum, Presslaff said.

"Purse strings are loosening up," for interactive systems, she said. "It's an on-going promotion, on-going sales tool and on-going listener benefit." She estimated the cost of an interactive system like RadioPhone at \$20,000 to \$40,000, depending on the complexity of the system and the number of phone lines required.

Interactive systems once intimidated program directors because they feared the systems would take too much time to maintain. That feeling has changed, Presslaff said. "It's easy to support, it doesn't take as much time as it used to. Your jocks should cut things that don't have to be changed every day, but the news that has to be updated frequently, we can provide for you. It's a huge difference."

ARE YOU GAMBLING WITH YOUR MARKETING BUDGET?

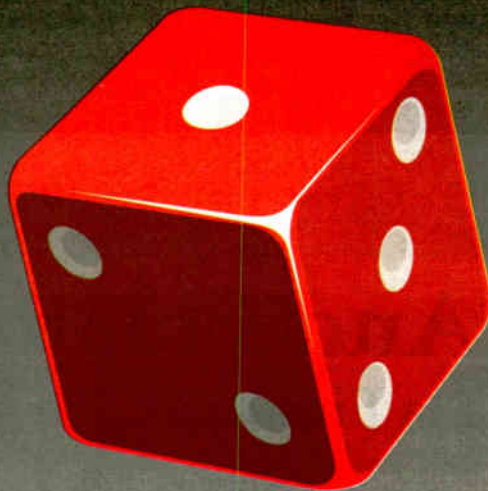

TELEVISION

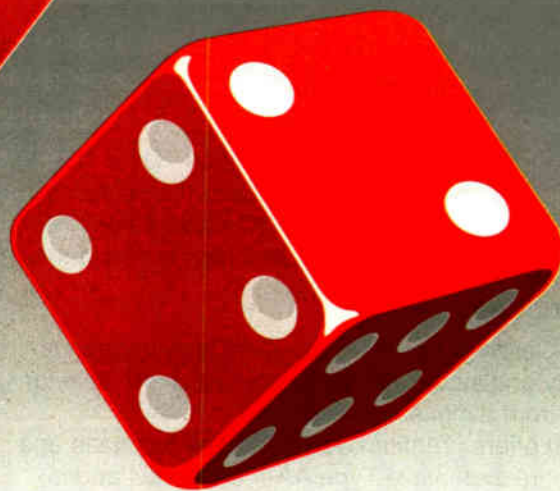

OUTDOOR

RADIO WORLD EXCLUSIVE!
 FREE DATABASE OR REPLY POSTAGE WITH YOUR ORDER NOW THROUGH DEC. 31, 1993.
(Restrictions apply. Call for details.)

It takes a lot more than a lucky roll, good idea or a well-budgeted marketing plan to win the marketing battle.

It takes keen insight, strong knowledge, years of experience and precise research along with a highly detailed strategic plan and the best team of dedicated people.

Broadcast Direct Marketing consistently delivers results on our clients' CUME, TSL and revenue-driven marketing needs. From the largest

of groups to the most entrepreneurial of ventures, we're regarded as "partners" to some of America's most successful and dynamic broadcasters.

So, as you look for your next campaign answers, call us first. We'll deliver our unique marketing planner, market guide, and a comprehensive statistical profile of your market, free. Then, we'll confidentially work together to evaluate your goals and develop your winning strategy.



DIRECT MAIL • TELEMARKETING • DATABASE

MIAMI 305-858-9524 • CHICAGO 708-382-5525 • LOS ANGELES 818-782-9524

Circle (205) On Reader Service Card



Meat And Potatoes à la Fidelipac

Cartridge Machines

The DYNAMAX CTR10 Series needs no introduction. Over 10,000 units are installed in all four corners of the globe. Over the years, the unit has been refined and now includes a brushless DC servomotor. The CTR10 Series combines good value, reliability and high quality audio.

Tape and Tape Cartridges

DYNAMAX COBALT Cartridges provide excellent high frequency response, high sensitivity and increased head room, and are ideal for top quality reproduction from a digital audio source.

The AUDIOMAX 4000 offers premium quality as well as phase and bias compatibility with more expensive Type AA-4 cartridges and is suggested for stereo applications requiring elevated recording levels.

The MASTER CART yields maximum performance at standard operating levels and is well suited for general purpose stereo recording.

The MODEL 300, workhorse of the broadcast industry for thirty years, this cartridge is intended for monophonic use at standard recording levels.

DYN-400X Professional Back Lubricated Recording Tape is a low noise mastering tape for use at standard recording levels and is available on NAB hubs or 7 inch reels.

Magnetic Erasers

The DYNAMAX ESD10 uses dual full-track erase heads to ensure deep cart erasure of 75 dB or more. The patented splice detector which requires no sensitivity adjustments rapidly locates the splice and positions it perfectly before recording.

The BLANK-IT hand held eraser is molded of rugged plastic for light weight, easy to handle, quick and accurate tape erasing in any setting.

The MODEL 400 table-top eraser features a hardwood case, scuff resistant laminate top and removable aluminum pivot pin permitting erasure of audio, video or computer tape reels up to 11 inches in diameter x 1 inch wide.

Other Accessories

Fidelipac offers CARTRIDGE STORAGE SYSTEMS in numerous configurations including a 25 slot vertical wall rack, a 200 slot mobile carousel rack mounted on heavy duty casters, and table-top units which hold 96 cartridges or up to 48 cartridges (as shown above).

Fidelipac's world standard WARNING LIGHTS are available in eight different languages plus custom versions on request. Back illuminated brilliant red letters on an opaque black foreground command attention and visibility.

In addition, other useful accessories (not shown) include alignment cartridges and precision gauges for head insertion and right angle zenith calibration.

For a complete menu or information about our digital audio products, call Fidelipac.



Fidelipac Corporation □ P.O. Box 808 □ Moorestown, NJ 08057 U.S.A. □ TEL 609-235-3900 □ FAX 609-235-7779

Circle (157) On Reader Service Card
World Radio History

USAirplay

CHR Radio Is Alive and Thriving in Dallas

by Charles Taylor

DALLAS For many a radio station in the 1990s, CHR—contemporary hit radio—has signified the kiss of death. In a number of markets, ratings have plunged as programmers wrestle unsuccessfully with a changing musical playing field and thus, with the very definition of top 40.

Formula for success

In Dallas, the nation's number eight radio market, however, it is KISS 106.1—KHKS—that has proven once and for all that despite the negative hype, top 40 still can sound good, make money and satisfy the needs of its audience.

In less than a year, the station took its November 1992 CHR debut from a 2.3 share in Arbitron 12+ audience ratings to a Spring 1993 figure of 4.1. The station currently ranks No. 1 for 18- to 24-year olds.

According to Program Director J.J. McKay, the formula for success depends primarily on the music, along with personality, promotion and a one-to-one relationship with listeners. But, he stresses, it also takes conviction in the format and tireless creativity to make it an essential daily feed in the lives of a hip, media-savvy, urban demographic, in this case females 18-34.

In any market, these are the ingredients for CHR success, according to Alan Burns, an industry consultant specializing in the format. But that doesn't make prosperity a given.

ply is no longer possible to merge the extremes of popular music—from rap to metal to alternative—into a single frequency on the dial, and thrive. But perhaps it was such a goal that was misguided, not CHR as a format.

"The key to the format is balance—finely focused music—playing the hits."

—J.J. McKay, KHKS Dallas

"You can't look at it from the standpoint of how many ballads and how many alternative songs. The key to the format is balance—finely focused music—playing the hits," McKay says. "My philosophy is whenever someone tunes in, give them a total picture in a four-song sweep. If they don't like the song on now, then the next song will be different enough to make them want to hang around."

An urban lean

In Dallas, that calls for an urban lean, such as Haddaway, Snap, Ace of Base and Inner Circle. The mix is balanced with a base of strong hit artists: Mariah Carey, Duran Duran, Janet Jackson and Madonna.

"You have to be compatible with your audience's listening habits. That's important for CHR to win," McKay says. "The music being played on CHR before its demise was absolutely wrong. It became so trendy that it forgot to listen to what the audience wants. We don't want to get into the old habit of CHR being all over the place."

At KISS, "We don't break that much music. We're mass appeal, a little rhythmic but not rap."

To help define the station's signature, KISS relies on its disc jockeys to maintain the energy level, while developing a bond with the audience.

"So many CHR stations in the last couple years have taken personality away from jocks and put them in the (liners). The art of entertainment is essential," McKay stresses. A number of KISS's DJs have been working at stations in the Dallas market for more than a decade—they not only know the city and its people, but are a part of them.

"We reflect lifestyle. We're fun, we get out there and we promote what the community wants," McKay says.

The station also frequently puts its listeners on the air, which he says gives the station a feel of accessibility. "Interaction with the public is very important. We're all in this together, so you don't want to give the impression that we're mightier than them. We're doing the same things they're doing on a daily

basis so why not reflect that?"

This includes high-profile weekly appearances at Dallas clubs, involvement in local events, a KISS van that roams city neighborhoods and sponsorship of events that complement listeners'

lifestyles. The station also has invested in billboards, busboards and television advertising.

Touch the people

"Being on the streets is the most important way to touch the people," says Joy Melendy, KISS promotions director. "More with CHR than any other format it's important to be a little off the edge."

And like most CHRs, KISS has hosted its share of on-air contests. One recent stunt was called, "Who Do You Know,"

in which listeners were asked to have their "famous friends" call during the morning show. At the end of a given time period, DJs would decide which celebrity was the "most famous," and award \$1,000 to the listener and the celebrity to donate to a favorite charity.

"We got calls from Chuck Berry, Billy Crystal, Amy Grant and Mel Gibson," Melendy says. "It creates good word of mouth, and gives the audience a little bit more than the music. We use contests and promotions to enhance, not to overshadow the music."

With such a package, KISS 106.1 intends to continue its attack on the Dallas airwaves, proving that with proper regard for the music and audience, contemporary hit radio has a bright future.

Says McKay, "Make sure you're servicing who you're going after and then deliver that. People want to be entertained and they want to hear the hits. As long as we focus on that, CHR will continue to be well received in any market."

Revisiting AM Stereo

► continued from page 13

day, there is no commercially manufactured radio that can receive Kahn's ISB system—the wideband Sony was discontinued long ago. They are now collectors items.

But Kahn has not given up. There are lawsuits pending.

When I read in *RW* (Oct. 13) that the FCC now was declaring C-QUAM the AM stereo standard, I didn't know whether to laugh or cry. Only a small percentage of stations ever embraced stereo, and now an in-band, on-channel digital system may make the switch to stereo impractical.

Some AM stations play music, but with AMAX radios picking up about a 7.5 kHz frequency response (if that), are AM music stations really a draw against FM stereo music stations or CDs?

I guess the whole irony of AM stereo can be summed up in a recent newspaper ad I saw for WABC here in New York.

This was the station I used to listen to under my pillow in the middle of the night so I wouldn't miss the latest release from the Beatles, the Rolling Stones or the



The 1984 NAB AM Stereo Seminar included all the controversial parties involved in the issue. How many can you recognize?

Supremes. This was the same station that jumped into the AM stereo controversy early when it became one of the first stations to install the Kahn system.

Today WABC draws listeners with newspaper ads displaying a musical note in a big red circle with a red line drawn through—"No Music." Doesn't that say it all?

I know AM still has its place in our industry. But the FCC's decision to make C-QUAM the standard is almost moot. It is no longer the exciting technology that might have resuscitated an ailing patient.

It should have been AM's milestone. Let's hope it's not its tombstone.

□□□

Judith Gross is vice president/head copywriter for Media/Scan, an advertising marketing agency specializing in broadcast and pro audio. She can be reached at 212-929-6108.

106.1 KISSFM

Sample Hour KHKS — Saturday, 2-3 p.m.

That's the Way

Love Goes/Janet Jackson

Dreamlover/Mariah Carey

Rain/Madonna

Rhythm Is a Dancer/Snap

What Is Love/Haddaway

What's Up/4 Non Blondes

More and More/Captain Hollywood

Chains of Love/Erasure

Another Sad

Love Song/Toni Braxton

Free Your Mind/En Vogue

Come Undone/Duran Duran

Sweat/Inner Circle

Always Something

There to Remind Me/Naked Eyes

Show Me Love/Robin S.

"CHR is very alive, especially in situations where the station and the individuals involved can cope with change—in their markets, in the music, in the format and in the audience," Burns says. "One of the things CHR has always been about is change and being fresh."

Those stations slow or unable to react to these changes have given CHR a dubious standing over the past few years. The impression has been nurtured that it sim-



Touch & Go.

The ENCO DAD486x Digital Audio Delivery System is a true cart machine replacement. With a touch screen, it really performs at your fingertips.

This system was planned for use in the real world. DAD's graphic user interface emulates a standard analog audio cartridge machine's



controls. Push PLAY and DAD plays the cut shown in the Playback "slot." The number of playlists you can store in DAD's memory

is unlimited. And its powerful ARRAY feature puts 144 audio events at your fingertips for instant playback. ARRAY buttons are especially useful for sound effects, jin-

gles, liners, intros, promos, music beds and other effects. These selections can be of any type or length to further increase DAD's

flexibility and ease of use. Because the DAD system is designed for use on a standard 486 PC platform, you can choose to purchase a complete system or select



your own hardware platform and let ENCO provide the DAD486x software. Add the friendliest digital audio delivery system

to your station. Simply touch & go . . . with DAD from Harris Allied. Call us toll free. **8:00 a.m. to 8:00 p.m. EST**
1-800-622-0022
FAX 317-966-0623



Behind Radio's Zany Commercials

by Dee McVicker

LOS ANGELES It has been said that a radio station is only as good as its commercials. That axiom has served Paul Fey and Walt Jaschek well.

Widely acclaimed for their sharp sense of humor, the team is nationally recognized as the creative genius behind a number of

radio spots promoting the seasonal lineup of shows for TV networks.

Their client list includes King World, Warner Brothers Television, 20th Century Television and CBS Television Network.

"If a commercial is boring and doesn't hold their attention, we can't blame them if they reach up and hit the button on the car radio," said Paul Fey, founding partner of

Paul & Walt Worldwide. "We want to stop them in their tracks."

Fey and Jaschek have been on the laugh track since high school, winning some 400 awards for excellence in commercial production, including three Clios and two regional Emmys. The team walked away with the five Ollies in one evening, setting a record for the most awards won by one

company in the Hollywood Radio & Television Society's annual competition.

One Ollie was presented for a Paul & Walt commercial, "Auditions," in which Patrick Stewart is featured among the voices trying out for the part of Jean Luc Picard in "Star Trek."

Of all the awards (which stream in at a rate of 50 a year), Fey is most partial to the team's first Clio. Fey aspired to win a Clio since his high school years, and recalls vividly the magic feeling of creating the spot.

It was a radio ad featuring a "laugh catalog." "The whole spot was kind of invented on Walt's front porch. It just sort of came out...It wrote itself," he said.

What keeps this team on the leading edge? "We never want to get satisfied with doing the same thing," Fey said, pointing out that too many comedy teams rely on formulaic humor.

"Once upon a time, and it wasn't that long ago, funny dialogue radio spots were what broke through the clutter. Now, I feel that funny dialogue spots are becoming the clutter because there is so much of it out there," Fey said.

Radio in particular lends itself to production-oriented spots, where a hybrid of audio effects, humor and dialogue work together. "It's much easier to do a gigantic-scale production on radio because a lot of it is letting people's minds fill it in," he said.

A recent Paul & Walt commercial for a cellular telephone carrier, for example, camped up the Beach Boys' "I Get Around" with a polka beat accompanied by amusing dialogue, delivered in a deadpan voice:

"I get around, so I signed up for voice mail. I used to be leery about sending voice mail. I wasn't sure if I was putting enough stamps on it."

As the music cuts in and out abruptly, the deadpan voice again speaks up:

"Voice mail is easy. Think of it as rolling up a yellow sticky-note, jamming it into your cellular phone, and having it pop out somewhere else."

Life begins for a Paul & Walt spot with an idea, either dreamed up by Fey, the production genius of the team, or Jaschek, the

continued on page 22 ►

MARKETING & MANAGEMENT

Know Your Competition

by John Cummuta

ALGONQUIN, Ill. Every radio salesperson knows that newspapers are evil.

The Radio Advertising Bureau says that newspapers can't stand up to radio as an advertising medium, and many salespeople see the local paper as their main competition.

But if you understand how both radio and newspapers can fit into your client's advertising strategy, you can lower the tension level and find ways to propose complementary radio and newspaper campaigns that will provide maximum benefits to your client and repeat business for you.

Some of this information will also help you persuade a client, who may be misusing newspapers, that his or her money could be more effectively invested on radio.

By definition, database marketing means targeted marketing, reaching specific people who meet definable demographics and psychographic criteria.

Radio targets by the composition of its audience, which tends to match a given profile, but newspapers are an almost untargetable medium. They reach a cross-section of everyone in a given geographic area. So how could we use newspapers in database marketing?

Newspapers reach a lot of people, but that doesn't mean that a given ad will be seen by a major portion of them. In fact, McGraw Hill conducted a now-famous study, "Laboratory of Advertising Performance," showing that the average full-page newspaper ad will be read by about 16 percent of a paper's readership.

The average two-page spread will be read by about 22 percent. Doubling the size and nearly doubling the cost of a full-page ad only increases the exposure by 37.5 percent.

Why so low? Because people don't read a newspaper cover to cover, straight through. They read selectively, bopping around, stopping at whatever catches the eye and lingering only as long as it continues to interest them.

Another factor is the day-and-time patterns of newspaper readers. On a given day of the week, each reader spends about the same amount of time reading the paper. If a certain day's paper comes out fatter and contains more ads, readers will still give the whole paper approximately the same amount of time they are accustomed to giving it.

If you have an ad in a fat, crowded issue, it is less likely to be read. Conversely, if the paper is skinnier than normal for that day of the week, your exposure is likely to go up.

A newspaper's short lifespan is another drawback to ad exposure. Some magazines stay around the house for weeks, but the newspaper usually gets a day on the table and then it's out with the potato peeling and puppy messes.

Physical limitations will also blunt a newspaper ad's productivity. You can only say so much in six column inches, or even on a full page. The less your prospect already knows about your product or service and its relative value to them, the less likely you'll be able to say enough in a newspaper ad to make the sale.

For example, if I run a half-page newspaper ad that says, "BRAND NEW CADILLAC SEDAN DeVILLE—TODAY ONLY—\$400!," chances are that I'll get lots of response. Almost every human seeing that ad will already be aware of the relative value of a Cadillac and know that \$400 is a fabulous bargain.

But suppose I take the same half-page and say, "UNIQUE NEW HAND-HELD COMPUTER—FITS IN YOUR POCKET—TODAY ONLY—\$400!" I may get no response.

Many readers have little or no frame of reference to weigh a hand-held computer's value. With a longer, more detailed explanation, they might decide that the computer is also an exceptional deal, but they aren't likely to be motivated to buy one based on a few words in a newspaper ad.

One of the riskiest and costliest assumptions you can make is that your prospects are aware of their need for your product or service. If they aren't completely aware, you're going to have to educate them, and

that takes space and words. Don't make the mistake of trying to cram all those words into a small display ad.

There are newspaper ads designed to look like editorial copy. They often carry the same number of columns as the paper's regular pages and use the same type faces in attempts to appear like a regular news piece. They usually include a response coupon or toll-free number at the end, so readers can buy directly from the ad. These ads can work for certain products and services, but they are expensive to test.

In general, when talking about direct marketing, newspapers can most often be effectively used in a two-step strategy. Readers see an ad and ask for more information. You then respond to their request by mailing them a complete information package with brochure, testimonials and other elements that can carry enough words and pictures to make the sale.

If your product gives you a large enough gross profit margin, you might even want to employ a three-step strategy and follow up the mailed information package with a telemarketing call.

In either case, the newspaper is used to do what it does best, create interest in a product.

□□□

John Cummuta is an independent marketing and management consultant and the author of the "Sales Machine" database marketing course and "Sales Machine" PC database marketing software. He can be reached at 708-658-9107.

ARE YOU READY FOR COMPRESSION?

New DIGI-READY™ Phase-Locked Commercial LNBS from Cal-Amp

These new *Digi-Ready*™ LNBS fulfilled the need for phase-locked downconverters necessary to receive digitally compressed satellite programming signals. Although some digital compression formats are undefined, phase-locked commercial LNBS, which maintain low Bit Error Rates, are recommended to ensure proper reception of digitally compressed signals. *Please call your commercial distributor for additional details.*

DIGI-READY™ LNB Specifications:

- Input Frequency 3.7-4.2 GHz
- Output Frequency 950-1450 MHz
- 45° K Noise Figure, Typical
- Phase Noise -80 dBc / Hz @10 KHz
- PLL Oscillator Stability ± 2.3 ppm (± 12 KHz)
- Input VSWR 1.5:1 (Isolated Model: Part No. 31814)
- 2 year Warranty
- Made in the USA



California Amplifier, Inc.

460 Calle San Pablo Camarillo, CA 93012
Phone (805) 987-9000 Fax (805) 987-8359

California  Amplifier

Circle (100) On Reader Service Card

World Radio History

PROMO POWER

Stock Your Promotions Closet Wisely

by Mark Lapidus

FAIRFAX, Va. "Hey, you got any free t-shirts?" This may be the most commonly asked question by listeners and clients alike. They both expect you to have freebies in abundant supply. If you answer negatively, you'll encounter first disbelief and then disappointment.

Everybody wants something for nothing—as a business, radio has built an expectation that we promote ourselves by placing our call letters on cool stuff and giving it away. Most radio staffs don't

think about what this "stuff" costs, how it's selected or how it's manufactured.

Rather than stumbling through another year by ordering the same old things and hoping your supplies don't run out, let's open up the old prize closet and examine the goods.

Vendors

There may be more specialty item dealers than used car dealers. This is good and bad. Good because it means you can demand and get the best deals and service. Bad because specialty people will

call you incessantly attempting to get your business. I'm very loyal to vendors who treat me well. I look for reliable people who provide quality merchandise at the best price without major haggling.

Select two dealers to work with regularly. Each should have a major specialty: one might be the Titan of t-shirts and one the chairman of trinkets (assorted small goodies). They should know that each exists and that they both have good relationships with you. Tell them you're looking for the best price and design for annual deals and that free delivery for locally produced items should be part of the agreement.

They should not bother you by calling unless you wish to be bothered. While you'll want them to keep you up to date with the latest items, you don't wish to be called every day. Have them mail you samples you wish to see along with written descriptions.

Costs

How much do you budget for these types of giveaways? It depends on the size of your station, market and competitive situation. A good rule of thumb is 4-8 percent of your total promotion budget. Make sure you break down your budget on a monthly basis and be cautious about overspending during any given month. You should have a separate budget for sales/client requirements. If you don't, you'll never know if your sales staff is schmoozing at appropriate levels with station freebies.

There are many avenues for defraying expenses. Most items you give away have room for client logos; however, this

continued on page 24 ▶

Zany Radio Ads...

▶ continued from page 21

primary writer. Fey works from the Paul & Walt Worldwide office in Los Angeles, while Jaschek works from his office in St. Louis, the city where both grew up.

They communicate through faxes and computer modems to tighten ideas, copy and production of radio ads.

The spot takes life in the imagination long before it is committed to tape. "It's no exaggeration for me to say that I know exactly what a spot sounds like before it's recorded," Fey said. "The key is trying to put on tape what's in my head."

Paul & Walt fleshes out the characters, relying on a pool of creative talent from an audio studio in the same building as its Los Angeles office.

"People get accustomed to thinking of radio in a certain way," said Fey, who claims the company owes its success to breaking those conventions. The plan for the future is to continue carving out new niches in radio commercials.

Paul & Walt Worldwide is now working on a project that Fey hopes will set a new milestone in how people perceive radio. He was mum about who the client is and the product, saying only that he is not bound to the conventions of 30 or 60 seconds for the spots.

"We've barely scratched the surface of what we can do with radio," he said.

THE INDUSTRY'S RDS/RBDS LEADER HAS JUST CRUSHED THE COMPETITION

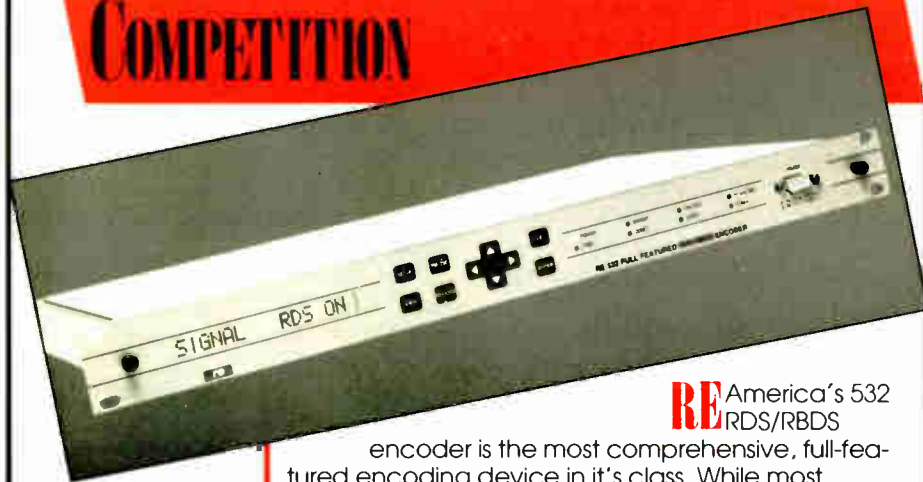

RE America's 532 RDS/RBDS

encoder is the most comprehensive, full-featured encoding device in its class. While most American RDS/RBDS encoder manufacturers are building their first product, the RE 532 represents RE's third-generation RDS/RBDS encoder. The RE 532 provides five data ports to enable broadcasters to take full advantage of the revenue potential that RDS/RBDS offers.

Ancillary RDS/RBDS data services such as Paging and Differential Global Positioning (DGPS) are now emerging as major revenue sources for broadcasters. The RE 532 will intelligently manage these services as well as maintain the integrity of the stations RDS/RBDS data, such as call signs, format and radio text.

The RE532 comes complete with its own proprietary PC control software which enables the unit to be set up and programmed quickly. Remote data control and phone-line communications can be accomplished with any Hayes compatible modem.

Without a doubt, the RE 532 is the most cost-effective, revenue-generating, piece of equipment your station could ever purchase. Now that a U.S. standard for the Radio Broadcast Data System exists, it promises to provide broadcasters with new and exciting opportunities for increasing the bottom line.

- ▲ Full-featured RDS/RBDS encoder in a compact single rack space
- ▲ Includes Paging and DGPS capability
- ▲ Five data ports for main and ancillary data usage
- ▲ Front panel keypad for easy setup adjustments
- ▲ Backlit LCD displays menu of all parameters
- ▲ Two discrete pilot sync inputs for main and back-up transmitters
- ▲ 16 data records may be programmed and sequenced automatically
- ▲ PC control program is included
- ▲ Operates as a stand-alone RDS/RBDS subcarrier generator plus loop-through mode

Available through:

- ▲ Broadcasters General Store
- ▲ Harris Allied
- ▲ RF Specialties

re

RE AMERICA, INC.
31029 Center Ridge Rd. ▲ Westlake, Ohio 44145
Phone: (216) 871-7617 ▲ Fax: (216) 871-4303

Circle (138) On Reader Service Card

You can measure...
with the best monitor and the most accurate test set.

The FMM-2/FMS-2 series monitors provide an even greater degree of precision measurement than ever before... **You can measure S/N below 90 dB, You can measure crosstalk below 85 dB, You can measure separations of better than 70 dB, You can measure frequency response to better than 0.25 dB, You can measure distortions to lower than 0.01%, and much more...** Our uncluttered panels and autoranging voltmeters make these measurements a dream.

BELAR
ELECTRONICS LABORATORY, INC.
LANCASTER AVENUE AT DORSET, DEVON, PENNSYLVANIA 19333
Call or write for more information on Belar AM, FM, Stereo, SCA and TV monitors.

(215)687-5550

Circle (107) On Reader Service Card

Why are so many broadcasters buying AM transmitters from that "FM transmitter company?"

1. Because only Broadcast Electronics AM transmitters come with C-QUAM® AM Stereo already built in.
2. Because only Broadcast Electronics AM transmitters utilize advanced Class "E" PA amplification, to save power (and money), run cooler, and provide high lightning resistance.
3. Because broadcasters know they can rely on Broadcast Electronics products and people.

Why should you buy your next AM transmitter from Broadcast Electronics?

1. Because we build the newest, most reliable, most technically advanced AM transmitter line.
2. Because we offer a wide selection: 1kW, 2.5kW, 5kW, 10kW, all outstanding audio performers, even at reduced power levels.
3. Because you'll be surprised how inexpensive the best transmitter can be. And you *won't* be surprised at the way we always back all our products with personal service. Let's talk personally about your AM. We're waiting by the phone.

1-217-224-9600



**BROADCAST
ELECTRONICS, INC.**

WORLD LEADER IN BROADCAST TECHNOLOGY

Stock Your Promotions Closet Wisely

► continued from page 22

approach doesn't come problem free. Foremost it means that you're not getting the full value of exposure because you're sharing the limelight with others. Secondly, it means that you may not be able to give away some of these items at all events.

For example, I once did tens of thousands of station compact disc greatest hits packages. Budweiser was the sponsor, and their logo appeared with the station on the CD. I was unable to give these away at any event sponsored by another beer or by a sponsor that felt negatively about beer in general. Let's examine a few specific "gimmies":

T-shirts: Men, women and children wear them and any format can use them. More often than not they are badly manufactured and poorly designed. If your shirts are so thin you can see your hand through them, then you're just wasting money. Not only will most people not wear them, they also fall apart quickly.

Your logo design should be colorful and attractive. Order 90 percent of your shirts as extra-extra large. Don't bother with small and medium. Once a year you may want to place an order for infant size (12 to 18 months) for

special client and staff gifts.

Long-sleeve t-shirts are great in the winter, but it may mean you'll have to cut back on quantity due to the extra expense. Don't be afraid to do all kinds of colors, but make certain that your logo can be easily read from a distance. Keep your shirt design as clutter free as possible. One nice big logo is the best approach.

When doing special shirts for races or other events that require a lot of clients, put them on one side and save a full side for yourself. (By the way, expenses for race/

event shirts should always be covered as part of any entry fee and not part of your annual budget.)

Here's a very common problem: If you notice after a couple of washings that logos are fading, your supplier has not been properly drying your t-shirts. After shirts are inked, they're put into huge dryers. Because suppliers work on volume, they move quickly, so this is something you need to monitor. Prices on t-shirts vary widely due to multiple colors, complexity of logo design and percentage of cotton. I'd start looking for another supplier if you're not in the \$3-4 range for quality shirts.

Keychains, refrigerator magnets and

pens: These are marvelous mainstays, but don't just buy the cheapest available. You want them to look good and to last. The quality of these babies varies, so before consuming large quantities, ask the company to supply you with a few names and phone numbers of people that have used them already. Call and get opinions.

Coffee mugs, plastic cups, beer huggies: Got a mouth....you need one of these! Because radio is such an "in-car" choice, I prefer the coffee mugs that can be easily used on the move with a lid. Sporting events are made for large distribution of your call letters on big plastic cups. I bet the beer company will split the cost of the cups with you. Beer huggies are custom made for bar parties and beach communities. They're the best of the three for an 18-34 target because they're inexpensive to make, light to carry and easy to use.

Fixed frequency radios, watches and

clocks: When decently made, these items will run you more than \$5 a pop, so they're more for clients than listeners. The radios only work if you give them to clients already in love with your station. The watches will be given directly to their kids when they get home that night. If clocks are attractive enough (such as CD clocks), space will be found for them. Don't do any of these if somebody else in your market has done them in recent memory.

Closing thoughts: You'll never have enough money to buy all the freebies you're being pestered for. Treat this much like a good comedian treats his audience. Enjoy always leaving them wanting more. That means they like you. Oh.... and don't forget to lock the prize closet and hide the key!

□ □ □

Mark Lapidus has worked in radio for more than 20 years, as a DJ, program director and promotion director in markets as diverse as Ohio, West Virginia, North Carolina, and most recently, Washington, D.C.

Open up the old prize closet and examine the goods.

FCC Sifts Through EBS Technology Comments

► continued from page 1

Mateo, Calif.-based data subcarrier service operating on some stations' 69 kHz subcarrier—said Sage transmissions on the 57 kHz subcarrier should be prohibited "or, at the very least limited to an injection rate of no more than two percent so as to eliminate interference to DBC's system and other preexisting users of the 69 kHz subcarrier."

During the Denver tests, DBC received customer complaints about interference to its service which was being transmitted side-by-side with Sage over KCFR(FM). Interference was perceptible when Sage EWS injection was above 2 percent and was extremely serious at five percent, DBC said.

Modern receiver technology would allow DBC subscribers to filter out RDS interference, but the company said the cost of replacing the 60,000 DBC receivers now in the field "would be approximately \$200 per receiver, or a total as high as \$12 million."

Dane Ericksen, senior engineer with Hammett & Edison, San Francisco, and a director of the Society of Broadcast Engineers, confirmed DBC's observations. He was stationed at KCRF as an observer during the Denver tests and said he "saw firsthand the compatibility problems between the DBC data subcarrier system and the RBDS signal."

Because the RBDS standard allows for injection levels up to 10 percent, and the most commonly used level is 5.3 percent, "a potential problem may exist," and should be considered more closely before approval of an RBDS-based EBS, Ericksen said.

For its own part, Sage said the tests demonstrated the superiority of its system. "Sage EWS demonstrated its ability to perform each of the required tasks utilizing both in-band and out-of-band signaling in a reliable, rapid and effective manner. In comparative tests with other technologies, the Sage EWS system proved superior each time," Sage said.

Sage claimed victory in robustness, mobile reception and security from hackers. Based on its analysis of the results,

Sage called for approval of EWS as the single national standard "to provide continuity, interoperability and cost efficiency."

TFT said its EIS was the winner and that if any system is named the single standard, it should be EIS. But TFT said it preferred the commission's multiple-suppliers plan.

All three major systems as they now stand can decode WRSAME, the current National Weather Service alert codes. The TFT EIS employs an "Extended WRSAME" coding scheme, which the company suggested as the standard communications protocol for all systems rather than standardizing the delivery technology. "TFT will offer (Extended WRSAME) use on a nonproprietary, no-charge, no-fee basis," the company said.

The National Association of Broadcasters appeared to agree with this approach: "A standard protocol would provide the basis for a flexible EBS so that states and operational areas can implement emergency alerting and communications systems that suit their specific requirements."

Ericksen argued against such an implementation, saying that stations near state boundaries where different EBS technologies are in operation may be forced to buy more than one receiving system to maintain the "web" network.

"Even the selection of the least efficient of the three competing delivery systems would far better serve the broadcasting industry than the AM stereo-like morass that would ensue if the commission fails to mandate one mandatory delivery medium," Ericksen said.

CapCities/ABC was the lead voice among those favoring no immediate decision. "The field tests did not collect sufficient data to permit an informed choice of an enhanced alerting system," it said.

Several unanswered questions were left by the Denver and Baltimore tests, CapCities/ABC said, not the least of which is the probability that the new EBS technology could soon be obsolete: "As long as the compatibility of the proposed systems with digital broadcasting is unclear, no definitive selection should be made."

DB ELETTRONICA FM TRANSLATOR

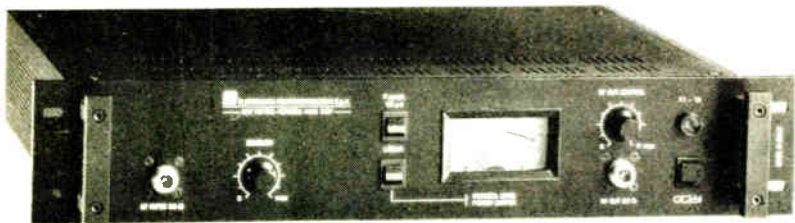

- Synthesized input frequency
- Adjustable output power
- 10.7 MHz IF output
- External adjustable squelch
- Synthesized output frequency
- Thermostatically controlled crystals
- Demodulated AF output
- Conveniently located controls
- Optional battery power supply

**The DB line of FM equipment ranges from
20W Solid State exciters to STLs and stereo generators,
including 2.5 kW and 5 kW transmitters.**

Factory Direct Sales
17194 Preston Road
Suite 123 #125
Dallas, Texas 75248
1-800-279-3326
Fax (214) 335-3425

DB

Elettronica Telecomunicazioni

CEWC
Importer
1620 West 32nd Place
Hialeah, Florida 33012
(305) 822-1421
(305) 362-8717



Model MX18E above
under \$7,300 list

The Dynamax MX Series

With Enhanced New Feature Set

Now Available in up to 18 Channels

- True modular design
- Ultra-reliable motherboard construction
- VCA mixer and monitor control
- Active balanced line inputs, transformer isolated mic inputs
- Active balanced main and monitor outputs
- Full monitoring/cueing facilities with VCA level control and active source selection
- Built-in cue amp with speaker and amplified stereo 8-ohm headphone output
- Independent remote start for each "A" and "B" input
- Opto-isolated remote module on/off
- Selectable fader start
- Two inputs per module, mic/line or line/line – line inputs may be mono or stereo, consumer or professional format
- Four assignable outputs – two stereo plus two mono
- Available in 10, 12, 14, 16, or 18 channel models
- Independent level controls for each "A" and "B" input
- Separate audio and logic power supplies
- Sturdy, all-steel construction
- Durable Lexan overlay control surfaces
- Count-up event timer standard
- Two input expansion switches standard
- Excellent RF immunity

IF YOU'RE THINKING OF UPGRADING YOUR FACILITY YOU CAN'T AFFORD NOT TO CALL US!



For over 32 years
**AUDIO
BROADCAST
GROUP**

Main Sales Office
2342 S. Division Avenue
Grand Rapids, Michigan 49507
1-800-999-9281

Southeastern Sales Office
200 Fareway Drive-Suite 2
Smithfield, North Carolina 27577
1-800-369-7623

Western Sales Office
36956 Desert Willow Drive
Palmdale, CA 93550
1-800-858-9008

from Moscow to NY & from Paris to Tokyo...

MORE STATIONS BUY ARRAKIS!!!



DIGILINK... THE #1 DIGITAL SYSTEM starting at under \$8,000

- 10 hours of stereo digital audio storage for \$7,995 complete
- Satellite, CD, Tape and Hard Disk Automation
- Simultaneous Play, Record, & Network transfer
- Digital Editor with Waveform Editing for tight production
- Crossfade CD's, sources, and hard disk audio
- Music Scheduling system built in for basic CD automation
- Digital Networking for transfer of audio and schedules

Digilink is the #1 selling digital audio hard disk system in radio today. You can replace your cart machines for live On Air and have an automation system for walk away at the same time! Link over 15 workstations & scheduling computers on our digital network and transfer audio and schedules between your studios.

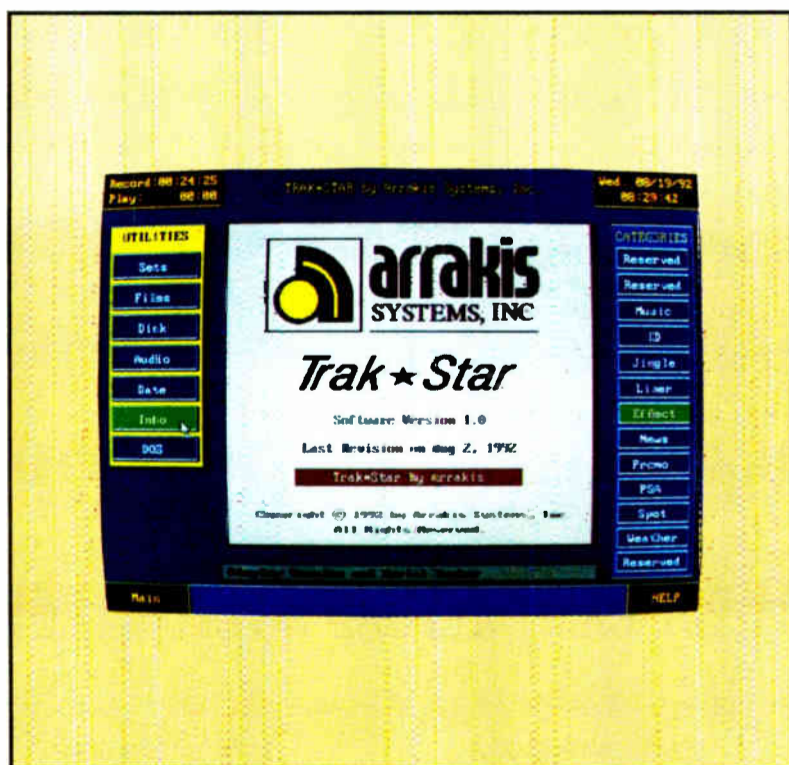

TRAK*STAR-8 THE 8 TRACK DIGITAL EDITOR starting at under \$5,500

- A digital audio editor designed for Radio production
- Learn to use in minutes, much faster than tape
- Cut, splice, move, and fade up to 4 stereo tracks
- Use Scrubbing to edit with your ears
- Use visual waveform editing to edit with your eyes
- An UNDO button enables you to go back and fix mistakes
- Digital Networking to transfer audio to your On Air machine
- Add Trak*Star-8 software to a Digilink for \$2,000

Trak*Star-8 is the first cost effective multitrack digital audio editor designed for the radio broadcast professional. Fast and easy to use, produce your commercials on Trak*Star and then transfer them in digital straight to the Digilink in your On Air studio. Dramatically reduce production time and save money!!!

2619 Midpoint Drive, Fort Collins, CO. 80525

Voice (303) 224-2248

Experience the Delta Difference at a New, Lower Price

What is the **Delta** Difference?

The difference is that the **100 Delta** digital hybrid telephone interface uses Telos' all-digital approach and proprietary digital signal processing. The result is full-duplex, natural sounding conversation on even the most difficult phone lines.

In addition, smart digital gain control and equalization offer increased caller intelligibility. The **100 Delta's** dynamic digital equalizer is so advanced its technology is not currently found in any other broadcast product!



Other digital processing components include logarithmic (dB) dynamics control, context sensitive output AGC, and feedback suppression for greater gain before feedback when monitoring callers through open speakers.

Thanks to the popularity of the **100 Delta**, it's list price has been lowered nearly \$300 to \$2180. Isn't it time you experienced the pleasure of great phones?

Ugrade Your New Switch Console for Half Price

Since the introduction of our new **Switch Console** at the beginning of the year, many owners of the older, metal-chassis version have asked us to provide them with an upgrade path. Well, here it is!

If you own an old-style **Switch Console**, you can trade it in for a new model for only \$325. That's half off the current list price. You will need to return your old model and you may only purchase one new **Switch Console** for each old one you own.

In addition to the sleek design, the new **Switch Console** will be able to put new features at your fingertips. Contact **Telos Systems** for full details.



Q & A Continued

It sounds as if perceptual coding can create problems if not performed properly. Can you assure me that Layer III sounds good?

You don't have to take our word for it. The sound quality of Layer III has been demonstrated in several tests performed by the International Consultative Committee on Radio (CCIR) and the International Standards Organization (ISO).

To draw up a CCIR recommendation for the use of low bit-rate codecs for digital sound broadcasting applications, an international large-scale test was carried out from January to July 1992. Nearly all available worldwide low bit-rate codecs were evaluated. Layer III was the only codec that provided an acceptable sound quality for mono coding at 60kbps. See the chart to the right for a comparison of the three International Standards Organization/Motion Picture Experts Group (ISO/MPEG) layers.

Of course, the best way to know how good Layer III sounds in **Zephyr** is to hear it for yourself.

It sounds like Layer III is the perfect choice for ISDN and Switched 56. How come more manufacturers are not using it in their products?

Good question. Implementation of Layer III requires significant computer power and carefully engineered digital signal processing (DSP). Telos Systems has been the world's leader in DSP for the broadcast-to-telephone interface for nearly a decade. We know the technology, we know the ups and downs of connecting to telephone networks, and we know our customers. This puts Telos in a unique position to launch an ISDN transceiver.

How can I learn more?

Call or fax us and we will send you a copy of the paper presented at the 1993 AES Convention by Steve Church, President of Telos Systems.



Telos Systems

2101 Superior Avenue
Cleveland, Ohio 44114
Phone (216) 241-7225
Fax (216) 241-4103



Zephyr™ Transmission Modes

Stereo Mode

- Bidirectional, full duplex stereo at 15kHz for maximum fidelity.
- Stereo 15kHz stereo transmission with stereo 7.5kHz return for reduced end-to-end delay.

Dual-Mono Mode

- Bidirectional, full duplex dual-mono at 15kHz.
- Dual-mono 15kHz stereo transmission with dual-mono 7.5kHz return.
- Dual-mono 7.5kHz transmission and return for compatibility.

Split-Channel Mode

- Send individual mono signals to separate sites. Your choice of 15kHz Layer III or 7.5kHz G.722 on transmit and return paths.

This diagram shows the audio paths and the data paths available when using Zephyr in stereo or dual-mono mode.

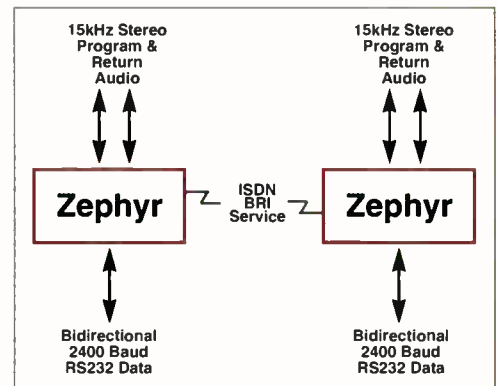

Zephyr™ Features and Benefits

- No other telephone based system provides this full broadcast bandwidth with equal quality.
- 2400 baud RS-232 bidirectional data for communications and control.
- Four "end-to-end" simple parallel contact closures for summary alarm and control of recorders and other devices.
- The ISDN terminal adapter is built-in and no separate boxes are needed.
- V.35/X.21 port allows **Zephyr** to be connected to one or two Switched 56 lines. (External CSU/DSU required for Switched 56.) Port also provides compatibility with spread spectrum wireless modems, satellite links, and other data paths.
- Designed for simple operation with full metering, analog audio limiting, and straightforward controls.
- Each unit can serve as either a transmitter or receiver.
- **Zephyr** will be available within the next few months.

Zephyr™ Features and Pricing Update

- Full duplex, 15kHz stereo operation on one ISDN line or two Switched 56 lines using Layer III coding.
- Compatibility with installed 7.5kHz codecs that use G.722
- Split-channel mode allows individual mono signals to be transmitted to separate sites!
- Stereo Zephyr \$4980 USD for stereo, dual-mono, and split channel operation.
- Mono Zephyr \$3980 USD for single channel operation.
- Mono unit can be upgraded in the field for \$1000 USD.

Q & A

Questions and Answers about Layer III Coding

I keep reading that ISO/MPEG Layer III is used in Zephyr. What is Layer III?

Layer III is the most sophisticated method for the coding of digital audio. (Some folks say coding, some say compression. Either way, it is the same process.) When combined with Integrated Services Digital Network (ISDN), our Layer III codec (coder/decoder) makes it possible to transmit broadcast-quality audio with the convenience, global availability, and low cost of the dial-up telephone network.

Why is audio coding required?

Without data rate reduction, high quality audio requires a transmission capacity of about 700kbps for each audio channel. Channels that can handle data rates that high are very expensive and hard to get. More affordable and accessible channels, such as the two 64kbps channels in each ISDN line, offer a rate of only about 9% of that of a compact disc. That means you must do some coding to get "12 gallons of water into a one gallon container."

How can that be accomplished?

One might think that lossless, redundancy-reducing methods (such as those used for computer hard-disk compression) would be ideal for audio. Unfortunately, there is not enough redundancy in the audio signal for the significant reduction required by ISDN. Other methods, such as Adaptive Delta Pulse Code Modulation, have limited bandwidth and fidelity, as evidenced by 7.5kHz codecs that use G.722.

To develop coding algorithms with sufficient power to achieve the desired reduction, the audio industry has turned to psychoacoustics. Using carefully researched psychoacoustic principals, coding processes have been designed to reflect the way in which human hearing interprets audio information. There are several perceptual coding algorithms available with varying complexity and performance levels.

How does perceptual coding work?

With perceptual coding, only information that can be perceived by the ear and the brain is retained. It has been discovered that certain audio creates a "mask" that hides other audio. These masks occur in both the frequency and time domains. (See the figures.) Perceptual coding takes advantage of masking by deleting signals that fall below the mask that would not be perceived even if they were left untouched.

Layer III is the only audio coding scheme to use both perceptual coding and redundancy reduction. Layer III also incorporates a short-time "bit reservoir" buffer for critical music segments. An additional advantage of Layer III is a joint stereo mode that takes advantage of the redundancy in stereo program material.

Continued on back page of Direct Connection

ISO/MPEG Layers Easy as 3, 2, 1

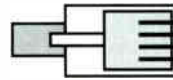

Layer III

The most complex scheme in the family, this layer is recommended for use at the very low bit rates of ISDN and Switched 56. Layer III has 576 bands for a superior resolution of 28Hz at 32kHz sampling. Audio that has been encoded and decoded using Layer III is nearly indistinguishable from the source material. Its performance at the lowest bit rates is comparable to that of the other layers operating at their higher recommended rates. And only Layer III can operate in a dual-mono mode at 56/64kbps, demonstrating that stereo can be transmitted without loss of separation.

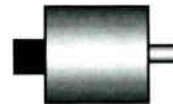

Layer II

This layer is currently being considered for Digital Audio Broadcast for both in-band and new-band schemes. MUSICAM is Layer II and is recommended for use at 128kbps per channel. Layer II's filterbank has 32 bands for a resolution of 500Hz at 32kHz sampling. While some manufacturers are using Layer II for ISDN and Switched 56, it is not recommended for these applications by CCIR as there is a significant loss in audio bandwidth, stereo information, and/or fidelity.

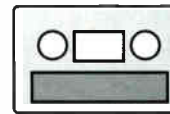

Layer I

This is the least complex in this family of coding schemes. A Layer I-like method is used in the Digital Compact Cassette. Layer I is not generally considered for audio transmission as it is recommended for use at 196kbps or greater per channel.

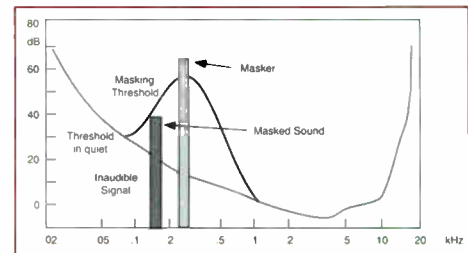

Masking effects in the frequency domain. A masker inhibits perception of coexisting signals below the masking threshold.

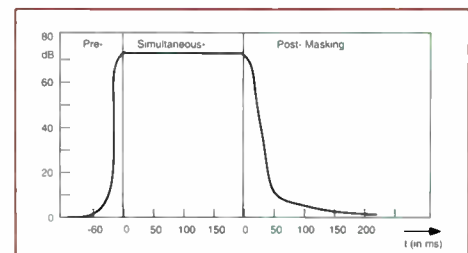

Masking effects in the time domain. Masking occurs both before and after the masking signal.

The Tonight Show Puts Telos On The Line With Jay Leno

It's probably America's biggest party line – the telephone that connects Jay Leno to an audience of eavesdroppers at home and in the studio. Since inheriting the throne from late night TV king Johnny Carson in May of 1992, comedian Jay Leno has dialed up America as one of the tactics to keep his crown. With ratings and revenues on the line, The Tonight Show relies on the **Telos 100 Delta** to produce seamless, two-way conversation that can be monitored through cranked-up open speakers without feedback. After all, nothing kills the chat, or more important, the laugh, like bad phones.

On stage, Leno uses a standard telephone hand set to call his eager "victims." After dialing the number, he flicks a switch that deactivates the phone and triggers the **Telos 100 Delta**. The output of the **100 Delta** is fed into the phone's ear piece. Guests on stage sitting on the couch hear the conversation through a small, hot-spot speaker secreted under the host's desk, while the audience listens in on speakers aimed at the house.

With a need to play to and play off his big studio audience, Leno's is not a typical telephone talk show, acknowledges Tonight Show Director of Audio Bob Whyley. "We need to pump hefty amounts of volume into the PA," he says.

Leno not only taps the telephone to call the funny and the famous. Before airtime, he warms up the studio crowd by ringing their friends and family in a zany reach out to America routine. Before Whyley introduced the **Telos 100 Delta** as part of the show's recent audio redesign, "the producers complained there was never enough gain in the house to allow the audience to hear and react to Jay." With other hybrids, when the PA volume was loud enough for the audience to hear, Whyley continues, "the PA would produce feedback that confused other units, but not the **Delta**. Its AGC is very smooth. The DSP (Digital Signal Processing) means every call sounds great."



Installation of the **Delta** was a snap says Whyley. Technicians from NBC's own telephone company who traditionally handle all the network's phone needs, had rigged up a switch array to accommodate the previous hybrid. "First day, we hooked up the **Delta** where the old hybrid had been and it was perfect right out of the box."

Night after night, Whyley lets the **100 Delta** juggle the many factors which effect the end-to-end frequency response of a call, each one presenting a different set of tonal conditions. "We have the ability to switch to Telos on any one of eight pair (phone lines)," says Whyley. "I particularly like the way the **Delta** lets me shape the sound of incoming phone calls. And, the way the unit auto nulls itself, sits there and compares incoming and outgoing signals and how quickly it responds. The **Delta** has saved me more than once."

Behind the scenes, the **100 Delta's** dynamic, digital equalization works to correct phone line frequency response problems, while its advanced digital AGC ensures that processing is only as dense as required for consistent caller levels. Digital acoustic ducking and pitch shifting provide greater gain before feedback when using open speakers to monitor calls. The unit's level processing, like the human ear, relates to loudness on a logarithmic (dB) scale yielding processing that is consistent across all audio levels.

During coast-to-coast broadcast, there's no second chance to get it right. "I've worked with all the major hybrids and none has performed better, for two reasons: One, none is as easy to use, and two, none is as good-sounding as the **Delta**," concludes Whyley.

Turn The Page...

- **To learn the latest on Zephyr. Our digital telephone network transceiver will now provide full duplex, 15kHz stereo audio on a single, dial-up ISDN line.**
- **To get answers to your questions about how digital audio is compressed.**
- **To get the scoop on an upgrade offer on our Switch Console and a price reduction on the standard setting Telos 100 Delta digital telephone hybrid interface.**

Direct Connection is provided by Telos Systems to keep our customers up-to-date on using the dial-up telephone network in broadcast and recording applications.
Copyright © 1993, TLS Corporation.

12,000 Series Consoles

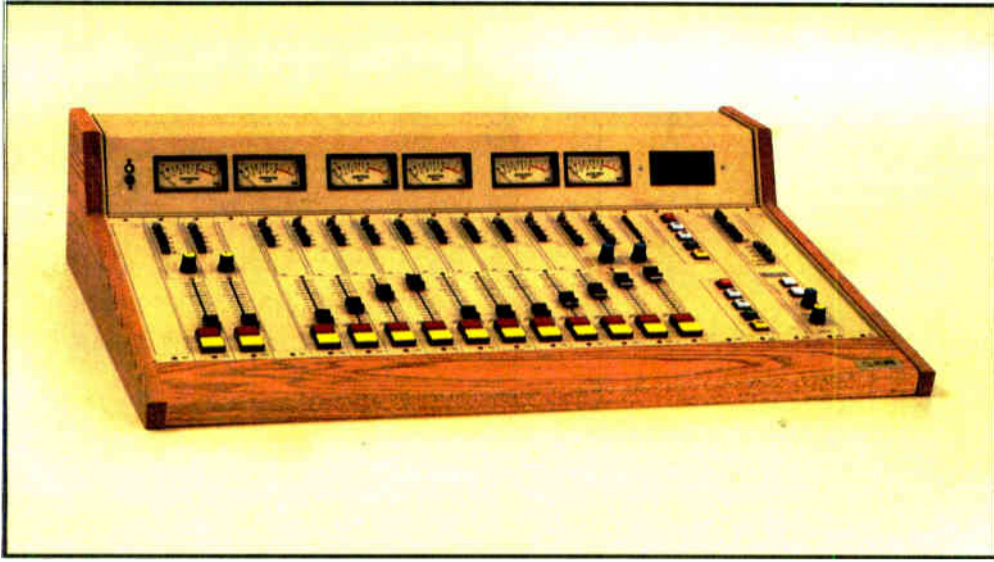

Standard Tabletop Mainframe displayed above

- Totally Modular Console-Input-output-monitor
- Three Mainframe Sizes - 8, 18, 28 input channels
- High Quality Construction-P&G Faders, etc.
- Polycarbonate overlay-for scratch resistance
- VCA Controlled Faders-for ultra reliability
- Universal Mainframe-any module in any position
- Inputs-2 per channel
- Outputs-3 stereo, Pgm, Aud, Utl
- CR Monitoring-stereo Monitor, Earphone, & Cue
- Studio Monitoring-two studios supported
- Talkback-two studios w/monitor dim
- Telephone interface-2 internal mix minus buses
- Timer-60 minute digital up timer standard
- Options-DA module, Remote selector module, Dual Machine Control Module

Typical List Price

\$4,000 - \$7,000

From France...to Moscow...to Japan and Taiwan, and around the world...the 12,000 console is On the Air.

The 12,000 is the #1 selling Arrakis console line from the #1 console manufacturer. With three stereo output buses and two mix-minus buses for telephone interface, the 12,000 can fill any application. The 12,000 also supports a control room and two studios standard. Panning or Mode select are available on the four models of input modules, VCA control of audio delivers reliability and performance.

Quality, performance, and durability make Arrakis consoles the leader around the world.



Deluxe thru-table mainframe displayed below

14 1/4" x 20 3/4"

Arrakis Systems is a world leader in radio studio technology. In Japan, Digilink is a brand name for hard disk audio for radio. For use around the world, the United States Air Force chose the 10,000 series console from among all competitors as its console of choice. When the United Nations needed 6 entire studios with consoles and furniture for a rush shipment to Cambodia early this year, they chose Arrakis 10,000 consoles and Modulux furniture. In Jamaica, Tahiti, and elsewhere, entire factory assembled and tested Arrakis studios are on the air. Around the world and of course in the United States...more stations buy Arrakis for their digital audio, console, and furniture needs!!!!

FAX (303) 493-1076

by **ARRAKIS SYSTEMS inc.**

Products & Services Showcase

For more information on the products shown below, circle the appropriate Reader Service No. (s) on the enclosed Subscription/Reader Service card or contact the advertiser directly.

S.C.M.S., Inc. Charlotte, N.C.

Low Prices - Experienced Staff
New and Re-built R.F. and Audio

THIS MONTH'S SPECIAL

GET YOUR CHRISTMAS
COMPUTER FROM THE S.C.M.S.
COMPUTER DIVISION

386/SX 33	System	\$845
486/DX 33	System	\$1485

CALL FOR CONFIGURATION OF THESE AND
OTHER CUSTOM COMPUTERS AND ACCESSORIES

Toll-Free 800-438-6040

FAX 704-889-4540

READER SERVICE NO. 116

ALAN DICK & CO. (USA) INC. LDL COMMUNICATIONS INC.

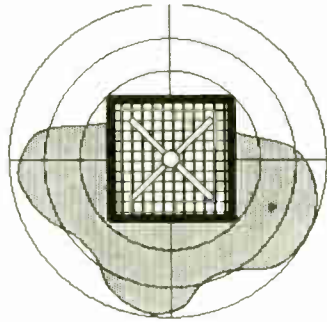

For your full turn-key or individual components needs... ADC/LDL supplies a full range of product and services for the FM broadcaster. RF transmission products include low power, side-mount antennas as well as high power, broadband, multi-channel antennas and combiners.

LDL COMMUNICATIONS INC.

14440 CHERRY LANE CT, #201
LAUREL, MD 20707

301-498-2200 FAX: 301-498-7952

ADC (USA) INC.

9 CLINTON DRIVE, HOLLIS, NH 03049
603-598-4500 FAX: 603-598-4212

READER SERVICE NO. 93

WIRELESS IFB SYSTEM

Used by hundreds of TV stations for van-to-field cueing in ENG & SNG applications. Transmitter provides mix of program and instructions to rugged, pocket receivers.

See us at NAB
Radio Show
Booth #809

- 100% duty cycle
- Wideband audio
- Excellent operating range



COMREX[®]

Comrex Corp., 65 Nonset Path, Acton MA 01720
Tel: 1-800-237-1776 Fax: 508 635-0401

READER SERVICE NO. 1

AUTOMATED FM ANTENNA PATTERN MEASUREMENTS

Using the Dept. of Defense Global Positioning System (GPS), and our hi-tech airplane, let us show you the signal your station is really transmitting. We measure each and every degree of both the horizontal and vertical patterns. Your signal is your most important asset! Don't guess. Be sure you're getting the maximum possible coverage. Call us today for a brochure or confidential consultation.

STEPHENS COMMUNICATIONS INC.
Little Rock, AR • (501) 821-5756

READER SERVICE NO. 208

RECORDABLE CDs

Convert from your old unreliable
cart machines to Compact Discs

- ✓ INSTANT CUEING
of station ID's and spots
- ✓ CONSERVE SPACE
consolidate selected cuts
- ✓ ULTIMATE FIDELITY

AS LOW AS \$59.00 PER DISK!

Our system offers a unique partial recording capability. This means that a partially recorded CD can be removed and played on any standard CD player. As new program material becomes available it can be recorded on the same disk. Save money on discs while getting the flexibility and quality you need.

Third Story Recording
5120 Walnut Street
Philadelphia, PA 19139

1 - 800 - 497 - DISK (3475)

READER SERVICE NO. 70

MAKE YOUR PC SPEAK FLUENT SMPTE

TCR-100

- Generate SMPTE time code locked to PC's clock.
- Lock PC clock to an external SMPTE code.
- Interrupt PC at TV frame or other rates.
- Access all SMPTE time code information.
- Synchronize multiple PC's and file servers.

Get more from your PC with the
TCR-100!

For more information or to order,
TEL: (309) 837-2244 - FAX: (309) 833-5175

Clark & Associates
318 E. Calhoun
Macomb, IL 61455



READER SERVICE NO. 24

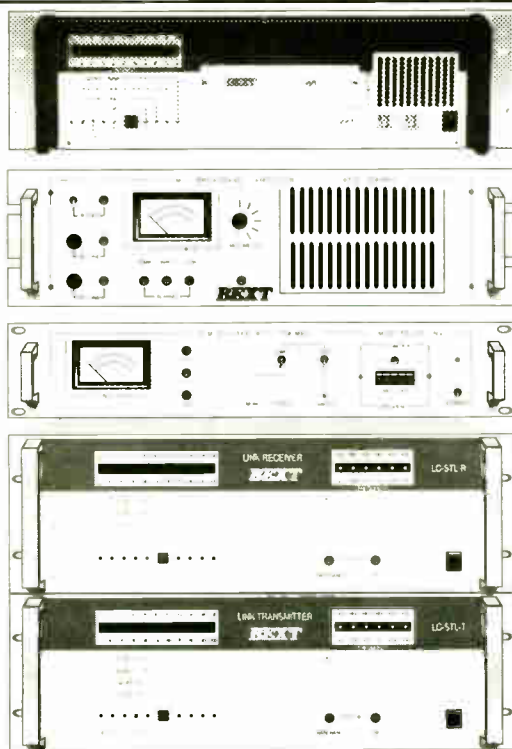

BEXT

High performance RF

Exciters
Amplifiers
Translators
Transmitters
STL's

Backed by our
two-year warranty and
the BEXT 24-hour
engineering hotline.

619-239-8462
FAX: 239-8474

739 5th Ave.
San Diego, CA 92101

READER SERVICE NO. 139

Radio World

Vol. 17, No 17 Radio's Best Read Newspaper September 22, 1993

Attention Advertisers!

Reach 22,000+ readers
world wide. Radio
World's Product
Showcase provides a
perfect medium for
test marketing your
products and services.
It's an efficient, effective and affordable
advertising option.

Product Showcase ads
always get impressive results!



Advertise in
the Product
Showcase
Directory!

"It Works! It's Great!"



Advertising
is good for
business!

For more information,
including rates and
deadlines,
Fax Simone at
1-703-998-2966
or call
1-800-336-3045

FEED LINE

Lightning Protection Is Worth Having

by W.C. Alexander

DALLAS Much has been written about transmitter lightning protection and many have spent large sums to keep lightning out of transmitter equipment.

My guess is, however, that even more has been spent mopping up after lightning has blasted high-tech equipment to kingdom-come.

Lightning strikes enter the transmitter plant via the antenna, tower structure, power lines, phone lines and through inductive coupling to inter-plant conductors. How often strikes occur depends upon several things, including local topography, tower height, proximity and height of other towers and structures and incoming power line routing.

RF power amplifier circuits are particularly vulnerable because they are more-or-less directly coupled to the outside world via the transmission line(s) and antenna(s), and the AC line rectifiers, which are tied to the incoming AC power service.

Before we get into specifics, let's consider the types and incidence of lightning strikes.

Weather lesson

As a rule, most thunderstorms that produce cloud-to-ground lightning are localized and short in duration, caused by convection (rising air due to localized heating).

The fortunately less-common air-mass

type storms, on the other hand, are caused by frontal boundaries of warm, moist air meeting cold air. These storms can cover a large area and persist for some time.

There are maps published by the National Weather Service showing the incidence of electrical storms for the various parts of the U.S. The region from Florida and across the southern states is the hottest area. Central Florida typically has 37 strikes per square mile annually.

Consider that a tower structure of h feet in height shields an area of about $9\pi h^2$ square feet, a radius of three times the tower height. That means that a 500-foot tower will shield an area of more than 1/4 square mile. In an area where there are 100 days with thunderstorms each year, a 500-foot tower may be struck nine times a year if air mass type storms are predominant, or only once in a year if convective storms are more common.

The main stroke of a lightning strike consists of a quick rise and almost exponential decay of current that is from a high impedance source made up of a long length of ionized air. It has been presumed that the inductance of the air path is responsible for the rate of rise of the current, and the resistance for the peak value and rate of decay.

An average lightning strike pulse has a peak amplitude of 20,000 amps lasting 40 microseconds. This is based upon the median value of gathered empirical data.

The rise time of a typical strike pulse is about 5 microseconds to peak amplitude.

Protection points

A lightning strike is a discharge from a cloud into the semi-infinite reservoir of electrons which is commonly known as "ground." "True ground" is an elusive connection at the earth's surface. Practical ground connections range from a few ohms to several hundred ohms to "true ground."

Assume that a typical strike occurs to a grounded tower. If the resistance between the tower's ground connection is 50 ohms and the stroke current pulse is 20,000 amps, the potential across the ground connection would be one million peak volts. If there are remote grounds also connected to the tower (such as transmission lines connected to grounded transmitters), the discharge current will be proportionately distributed among all the parallel paths to ground.

Obviously, then, the first and most important principle is to provide the very best, lowest impedance local ground at the tower. A ring of driven ground rods may be the best way to achieve such a local ground. Do not assume that a buried radial or mat ground system provides a good earth ground. Such a system may have a high capacitance to "true ground" and be ineffective as a local ground, even if it works well as an RF ground.

No matter how good the local ground is, some portion of the discharge current will

flow through the transmission line outer conductor to the remote ground(s). This will induce a high voltage between the inner and outer conductors of the coaxial cable at the transmitter end of the line. This must be met with spark gap or gas discharge devices, but the first concern is the path the current actually takes en route to remote grounds.

The second principle, then, is to prevent the current from flowing through the transmitter equipment itself. Have a clear knowledge and understanding of all the possible remote ground paths. These will consist of the local ground, the incoming AC supply, audio cables and remote control cables. A careful arrangement of the ground connections within the transmitter plant is essential.

Give each path between the tower and ground a solid connection directly to a single point, referred to as the "station reference ground point." This, in turn, is connected via short and heavy conductors to the ground post of surge protectors connected to all incoming AC supply, audio, control and metering cables. Between the connection point of each path to the reference ground point and the individual pieces of equipment, some inductance should be provided to resist the flow of the fast rise-time energy along that path. This forms essentially a low-pass filter between the tower and the equipment.

Surge protectors

Each conductor of all cables entering or leaving the transmitter building should be bypassed to the station reference ground point with the proper type of surge

continued on page 34 ▶

LISTEN TO WHAT SOME OF OUR CUSTOMERS ARE SAYING ABOUT THEIR CCA TRANSMITTER...

 WLKS ATLANTA, GA	 WWV FT. COLLINS, CO	 WBYN CHATTANOOGA, TN	 KWAN GUERNEVILLE, CA
 KSJL SAN ANTONIO, TX	 KFTZ IDAHO FALLS, ID	 WKGR W. PALM BEACH, FL	 WYAK MYRTLE BEACH, SC

ENOUGH SAID?

CCA Electronics, Inc.
P.O. Box 426 • 360 Bohannon Road
Fairburn, Georgia 30213 USA
(404) 964 3530 • FAX: (404) 964-2222
24 hour service, 365 days-a-year.

CCA

MEASURE YOUR COVERAGE...



SATISFY YOUR SPONSORS AND PROVE COMPLIANCE WITH GOVERNMENT REGULATIONS.

For More Information About AM, FM, VHF-TV and UHF-TV Field Strength Meters Please Contact Us.

POTOMAC INSTRUMENTS
932 PHILADELPHIA AVE.
SILVER SPRING, MD 20910
301-589-2666 FAX: 301-589-2665

WORKBENCH

AM Solutions Are in the Storeroom

by John Bisset

FALLS CHURCH, Va. My recollection is that Studer was one of the first companies to implement microprocessor technology in reel-to-reel machines. The set-up parameters for its machines are precision-controlled using soft touch switches and a readout. It makes for very precise adjustment, but a microprocessor can cause some interesting effects when the back-up battery starts to weaken.

Phil Blyveis, a long-time Studer maintenance technician now running his own broadcast equipment repair company, Audio Advantage, faxed a suggestion to engineers who own A-810 machines and find that the channel controls switch together, instead of independently.

In almost every case, the MPU battery is worn out, and the audio alignment parameters will be the next to suffer. While the independent/parallel channel control is switch-selected, this function will flip to parallel operation when the MPU battery fails.

The problem is simple to correct: Turn on the peripheral controller card (JS-8); then turn JS-3 on; reset the MPU; turn JS-3 off, and reset the MPU once again. Individual channel control should be restored.

Phil just refurbished two Studer machines for a client we've been working with, so I can recommend his services from first-hand experience. His shop is just down the road from Studer, in Nashville, so parts are usually just a short walk away.

For more information on Audio Advantage, contact Phil directly at 615-742-3834, or circle **Reader Service 120**.

Dwight Morgan from KNZZ(AM) and KJYE-FM Grand Junction, Colo., read Tom McGinley's article on loop antennas (*RW*, Aug. 25) and writes to say he solved his reception problem with equipment he already had on hand.

Dwight's studio location is separated from the transmitter site, and AM reception is a problem, especially at night.

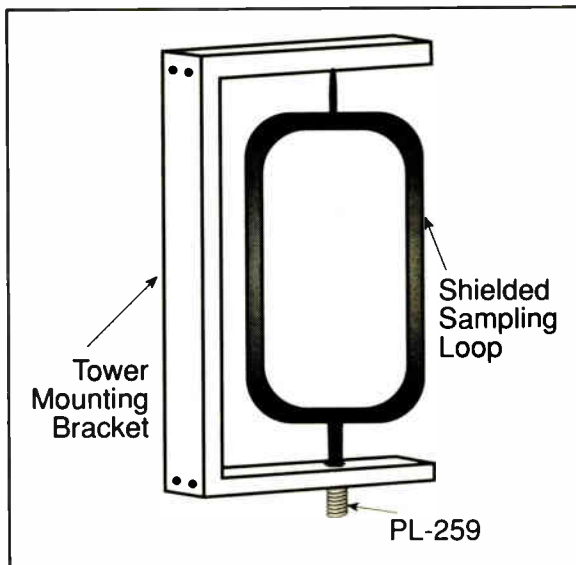

An old shielded sampling loop makes a great loop antenna, and usually comes with a built-in mounting bracket.

Dwight looked at a number of receive loop antennas, all priced at \$200 to \$300. The station didn't really have the budget for this expense, so for the interim, an RPU antenna was pressed into service.

After reading Tom's article, Dwight visited the storage room at the transmitter site and dug out one of the station's old sampling loops, consisting of several

loops of insulated wire placed within a formed copper pipe tube. The ends of the tube were insulated, terminating in a PL-259 jack. The loop and its mounting bracket were taken off the tower a few years earlier when the station switched to toroidal current transformers.

Dwight mounted the loop and its mounting bracket near the base of the studio STL tower, oriented it, and reports excellent reception. He cautions that if you mount the loop on a tower, be sure the added weight and wind loading doesn't compromise the structural integrity of the tower.

If you own some old sampling loops of the type Dwight found, you may want to press them into service for merchants who want to listen to your station. The metal shielding of these loops will reduce impulse noise for a clean AM signal. Dwight Morgan can be reached at 303-241-9230.

Jon Banks, chief engineer at WLTT(FM) Bethesda, Md., and frequency coordinator for Washington, D.C., recently prepared a list of UHF-TV channels available for wireless mic use in the area. Larger-market engineers may want to consider UHF for any new mics they purchase, because the heaviest congestion appears to be in the VHF-TV band.

If you are planning on purchasing a wireless system using next year's capital budget, you may want to discuss the proposed frequencies with your local frequency coordinator.

Jon also passed on a story that should make those of us with RPU or portable

satellite gear take notice. There is growing public concern about microwaves.

A network was at a local sports event recently and was using a hand-held 2 GHz link. The technicians were approached by a man who felt he had been irradiated by the dish. The man was familiar with microwave radiation, and was very concerned and angry.

The network personnel showed him a copy of the license (another good reason to carry a copy of the license with you in your remote truck), which indicated the low transmitting power level. They also explained that the system was pointed to a receive tower, and not toward the spectators, as the man charged.

The public's perception of radiation hazards is growing, and accurate or not, can create problems for stations using remote vehicles.

Speaking of frequencies, if you have a difficult STL shot, you may want to give one of the digital aural STLs a try.

John Diamantis, chief engineer for WTEM(AM)-WBIG(FM), and WGMS-AM-FM Washington, recently aimed his new Dolby digital STL through what had previously been described by two consulting engineers as a blocked path. His test utilized the worst conditions—he was hitting the 3 dB point of his receive antenna

Larger-market engineers may want to consider UHF for any new mics they purchase.

for the test. He wired the Dolby to the transmit antenna using 50 feet of RG-8 that was available, and both the transmit and receive antennas were Scala miniflectors.

Given that the antennas were not optimized, he still realized a 30-microvolt signal at the receive end, more than enough to make the system work. John expects to see a 4 to 6 dB increase when the path is optimized. But for now, the system is working fine, despite severe weather and leaves on the trees.

Apparently the squelch threshold on these systems is so low that they can operate on paths that would have defeated conventional STLs. We found this true for a client who had a very long grazing STL shot. For years he fought with noise and fades as his signal tried to get over the mountains. A two-hop system was financially out of the question, so he just endured, and prayed for fall or a dry spring/summer so the trees wouldn't grow any higher.

Enter the Digital STL systems. He couldn't believe how well his station sounded with the new Dolby technology. Fades were a thing of the past.

For more information circle **Reader Service 181**.

John Bisset is a principal in Multi-phase, a contract engineering and projects company. Workbench submissions can be mailed to *RW*, or faxed to his attention at 703-998-2966. Published submissions qualify for recertification credit for all levels of SBE certification.

THE SIMPLE SOLUTION FOR DIGITAL AUDIO TRANSPORTATION

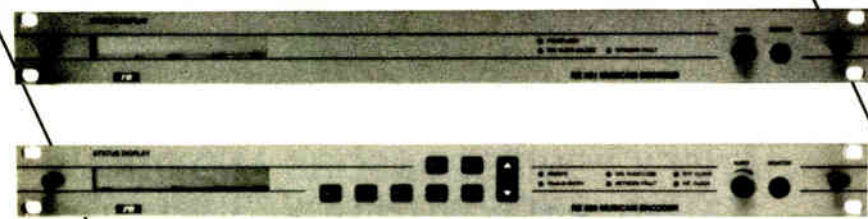

- ▲ MUSICAM ISO/MPEG Layer 2, 2A
- ▲ Switched 56, 64 kbit/s, ISDN, Fractional T-1
- ▲ User data channel from 300-9600 baud
- ▲ Easiest set-up locks to network or internal clock
- ▲ Fully automatic decoder reduces operator set up

- ▲ Multiplex or redundant two times 56/64 for 112/128 kbit/s
- ▲ Mono, Dual Mono, Stereo, Joint Stereo operation
- ▲ AES/EBU and SPDIF digital interface *included*
- ▲ Two-times V.35, X.21 or RS 422 interface *included*
- ▲ Headphone monitor *included*

The RE 660/661 MUSICAM Digital Audio Codec was developed to enhance MUSICAM technology, providing up to 20 kHz of audio bandwidth.

From satellite networks to switched 56 telephone lines, the full-featured RE 660/661 is completely bit rate flexible up to 384 kbit/s.

Applications range from network program distribution to remote pick-ups for sports, concerts, special events, news gathering, STL back-up, audio backhaul, recording and post production studios.

When it comes to digital audio transportation, nothing comes close to the RE 660/661 for providing quality audio with hassle free set up. Backed by 55 years of experience in analog and digital audio products, the RE 660/661 is the simple MUSICAM solution for all your digital audio transmission needs.

Available through Broadcasters General Store, Harris Allied and RF Specialties

re

RE AMERICA, INC.
31029 Center Ridge Rd. ▲ Westlake, Ohio 44145
Phone: (216) 871-7617 ▲ Fax: (216) 871-4303

Circle (196) On Reader Service Card

World Radio History

One Hour? No Problem!

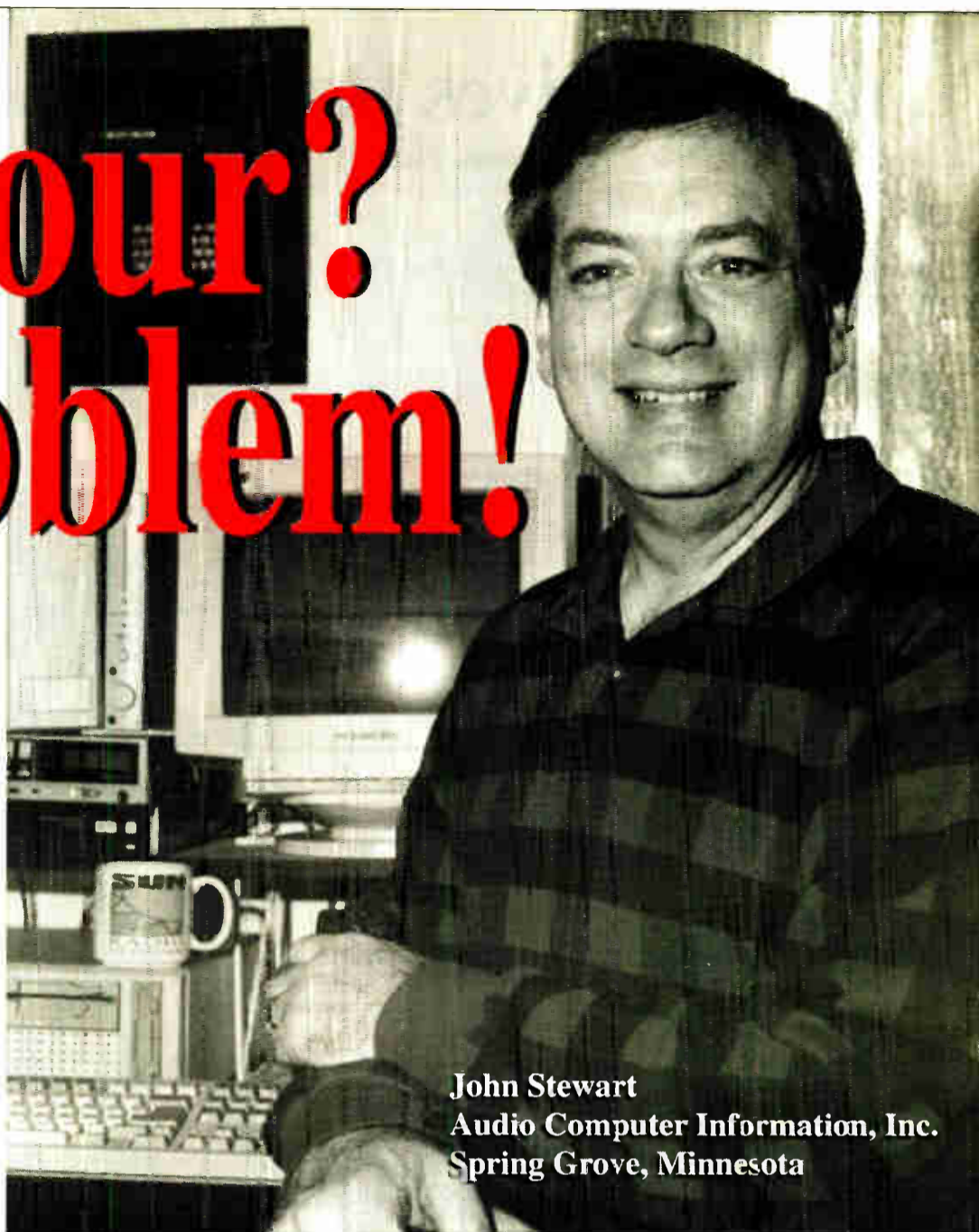

John Stewart
Audio Computer Information, Inc.
Spring Grove, Minnesota

Every week I produce the nationally syndicated "Radio Computer Magazine" for the Sun Radio Network using *The CardD* System and an off-the-shelf PC!

Starting with more than an hour of phone interviews, commentary, commercials, audio clips and bumper music, I end up with a polished final production that never touches tape! And I do it with a system from Digital Audio Labs that anybody can afford!

Nothing I've tried can handle **long** sound files like *The EdDitor!* I can bring an entire show up on the screen, zoom in anywhere and do fast cut-and pastes faster than you can say "uh," "duh" or "um!"

The *Edit History* lets me edit different ways, audition them and pick the one that sounds the best. Editing is non-destructive, with multiple undo's up to ten deep! *The EdDitor* will just not let me make a fatal mistake!

You can add *The CardD*, software and a sizeable hard drive to a regular PC for about the cost of a pro tape deck. Then you have more than a recording device, you have an entire broadcast quality production studio!

- The CardD.....\$795**
Stereo audio card for IBM AT-compatibles.
- The EdDitor for Windows.....\$250**
Stereo waveform editor program.
- The I/O CardD.....\$295**
Optional companion card for digital (S/PDIF) in/out.

Digital AUDIO LABS

14505 21st Avenue North, Suite 202
Plymouth, MN 55447
(612) 473-7626 FAX (612) 473-7915

Planning Drives Radio Road Show

by Steve Kirsch

BALDWIN, N.Y. "Costas Coast to Coast" was a hot property for Olympia Networks, a radio syndicator based in St. Louis, when I got involved with the show in fall 1987. But the show's host, NBC's Bob Costas wanted to take the live Sunday night sports talk show in a new direction.

Olympia decided to take the year-old show out of its set New York home, the studios of WFAN(AM), and take it on the road. This ambitious move has become weekly routine—we've been doing weekly remotes ever since. Organization, I've found, is the secret to making this potential logistics nightmare a success.

Out of the studio

There were a number of problems with the studio show in 1987. WFAN was located across the East River from Manhattan, in Astoria, Queens—some potential guests were reluctant to make the trip.

Also, Bob wanted to have a live audience to spice up the interviews.

Olympia chose to move the show to a sports restaurant on Manhattan's East Side, and I was given carte blanche to order whatever was necessary to get the job done.

We decided to uplink the entire program, including phone calls, music beds and commercials, from the remote site. This would be a little unorthodox, and a bit

risky without a studio base, but it gave us complete control over the final product.

I purchased the equipment, ordered the phone lines, and we were ready to go. We did our first show on location on Sept. 13, and things went smoothly. So smoothly, in fact, that when the spring rolled around, it was decided that we should take the show on the road, and originate from different locations around the country.

Setting up

We're usually looking for a sports bar or a lively location in a hotel, similar to our home in New York, when we're traveling. I look for a spot where the patrons can watch us, but at the same time, we can be separated from the crowd so we can control the show.

I'll also inquire about the public address system. Most bars have a sound system for piping music and TV audio around the place. If I can tap into that existing PA and shut off the speakers nearest our location, great. If not, I rent a small portable PA, such as the Anchor AN-256.

Because Olympia is an independent syndicator with over 200 affiliates, we uplink the show over two channels simultaneously on Satcom C-5. This gives most stations the flexibility to dial us up on their satellite receivers without changing crystals.

The remote audio is fed to IDB Communications at its Staten Island

Teleport. From there, IDB puts it up to Channel 15, and also hands it off to ABC Radio in Manhattan for uplinking to Channel 23. We use a variety of methods

Jimmy Weston's has our old 8K land-line to the teleport. At the Loews, we've installed a Switched 56 circuit. Both locations have four permanent dial-up phone lines, to coordinate the production with IDB and to put our phone guests on the air.

When we schedule a broadcast outside of New York, I'll use one of three



Steve Kirsch (left) and Bob Costas on site with "Costas Coast to Coast"

to deliver the program to IDB, depending on the facilities which are available to us in the originating city.

Almost half of our shows originate in New York, where we now have two locations, Jimmy Weston's sports bar and the Lexington Avenue Grill in the Loews New York Hotel.

options to deliver the signal to the teleport. If IDB has an uplink available, we'll do a satellite backhaul.

The second option is a digital phone line, but again availability is still inconsistent. The third choice, and admittedly easiest, is our dual-line Comrex.

continued on page 34 ►

THE SMART CHOICE!
MICRO SOUND
 Digital Audio Workstations

With the smart choice for Radio, you can:

- CUT** production time on spots, shows and promos
- USE 50 STEREO TRACKS** whenever you need them
- FAST** dialog editing for news
- DELIVER** superb quality digital mastered audio
- INCREASE** your creative freedom

The features you would expect to find in higher-priced Digital Audio Workstations:

- YES!** Play 50 segments at any location without bouncing
- YES!** Make instant non-destructive edits
- YES!** Easy to learn, full on-line context sensitive help
- YES!** Place independent stereo segments anywhere, in any order
- YES!** Archive multi-track projects to standard DAT
- YES!** True sonic transparency with -110db noise floor
- YES!** Automated effects sends
- YES!** Fully network capable, allowing file sharing
- YES!** Easily added to your 386/486, Windows 3.1 based system
- YES!** Affordable complete workstations start at \$7,695, peripherals at \$3,690

The Ultimate in Digital Audio Workstations

All the features you need...



... at a price you can afford.

MTUC

Micro Technology Unlimited

PO Box 21061, Raleigh, NC, USA 27619-1061

Quality digital audio since 1977

(919) 870-0344

Fax: (919) 870-7163

COMPETITIVE EDGE.



Today's AMs face too much competition for too few advertising dollars. That's why Orban's OPTIMOD-AM has become the weapon of choice for competitive broadcasters in every market.

OPTIMOD-AM produces maximum loudness, consistency and clarity on all types of AM radios, using every last watt of your authorized power to extend your listenable area and increase your billing opportunities.

A powerful six-band limiter and patented distortion-canceling multi-band peak controller deliver deep, tight lows and clean, transparent highs. You get the closest thing to FM sound, with maximum intelligibility in the essential voice frequencies.

Comprehensive controls and metering

allow you to easily fine-tune your sound, keeping it distinct and aggressive in a changing marketplace.

Fully NRSC and EBU/CCIR compliant

and with mono units easily field-upgradable to stereo, OPTIMOD-AM meets today's standards and protects your investment as you grow.

And Orban's superior customer service is there if you need it to provide world-class support for you and your in-house or contract engineering staff.

Give your programming a chance by making sure it gets heard. Call your Orban dealer today for an on-the-air evaluation, and put OPTIMOD-AM to work protecting your bottom line.



© 1993 AKG Acoustics, Inc.
Orban and Optimod are registered trademarks of AKG Acoustics, Inc.
AKG is a registered trademark of Akustische u. Kino-Geräte Ges.m.b.H., Austria.

orban[®]
A Division of AKG Acoustics, Inc.
1525 Alvarado Street, San Leandro, CA 94577 USA
Tel: (1) 510/351-3500 Fax: (1) 510/351-0500

Avoid Scrimping on Lightning Protection

► continued from page 29

arrestor. Surge protectors on the AC line should be capable of shunting up to 20,000 amps for 100 microseconds without deterioration. Protectors across remote cabling and phone lines can carry lower ratings due to smaller cable sizes and their corresponding higher impedances. Varistor type elements or back-to-back zener diodes can often be used for such bypassing.

Ferrite chokes

Ferrite beads, toroids and cylinders threaded over the cables connecting to transmitter equipment effectively raise the impedance of the current path along those conductors to fast rise-time pulses. Even the coaxial transmission line inner and outer conductors should be passed through such cylinders or toroids, unless the coax diameter exceeds two inches, where it is permissible to omit them.

Surge protectors across transmitter terminals

An air gap and a gas tube protector should be provided across the transmitter RF output terminals. The air gap provides a very high current shunt element, while the gas discharge device has a specific breakdown voltage.

ATU spark gap

A supplemental air spark gap should be provided at the ATU output. This gap can

be smaller and less rugged than the large ball gap at the tower base. Horn-type gaps are perfectly acceptable here. The gap should be selected so that normal modulated RF voltage will never jump across. In cases where the tower is not DC grounded by a tuning unit component, a static drain choke should be installed across the supplemental spark gap.

Antenna feed wire

A quick and easy way to reduce lightning current flowing into the ATU is to wind the antenna feed wire into a two- or three-turn coil en route to the tower. This will provide a series inductance that resists the fast rise-time lightning energy. The output leg of the ATU network should be adjusted to compensate for the additional series inductance at the station's operating frequency.

Ball gap across base insulator

For base insulated towers, the first line of defense is the ball gap at the tower base. The spacing should be adjusted as with the ATU spark gap, and the balls should be separated horizontally rather than vertically, to keep water drops from reducing the effective spacing.

Tower local ground

A minimum of four ground rods in a ring about the tower base driven below the frost level into the water table is necessary

to achieve a good local tower ground as discussed above.

As I already stated, much more has probably been spent over the years fixing lightning-damaged equipment than has been spent on lightning protection. Surge protectors aren't cheap—a series/shunt 200-amp 240-volt three-phase AC line protector can cost about \$8,000. If you consider that it will be protecting well over \$100,000 worth of transmitter equipment, though, this becomes much easier to swallow.

Knock on wood, but at our largest AM directional transmitter plant, we have not had any lightning-induced damage since

the site was constructed in 1989. All the procedures and principles outlined above were implemented into the plant when it was constructed. Both solid-state transmitters are still running fat and happy after four years of spark-gap-charring thunderstorms.

If lightning is a problem at your transmitter site, consider these principles. It is likely that you can make a big difference without spending much money.

□ □ □

Cris Alexander is director of engineering for Crawford Broadcasting. He can be reached at Box 561307, Dallas, Texas 75356.

Choosing the Right Gear Helps Keep 'Costas' Show on the Road

► continued from page 32

My philosophy in packing remote equipment is, of course, take what will give you the best sound. But sometimes a less-is-more approach can be a big help.

I try to select equipment that will serve two purposes if necessary—an extra mixer that can be used as a distribution amp, or a spare cassette machine to back up either record or playback decks.

I usually try to pack all my gear into three flight cases. When you check your baggage for a flight, three is usually the limit the Skycap will check for you at the curb.

Things to pack

Here's what goes into those 3 cases:

- *An ITC Delta 3 cart stack.* All of our commercials, music beds, promos and actualities are carted up before I leave. The Delta 3 can be a little risky if the motor goes on me, but we've managed to dodge that bullet so far. Just in case, I dub all the carts to a backup cassette before leaving the studio, carry that cassette with me.

- *Two Shure FP-410s mixers.* Feedback from the house PA is always a concern for us. Bob sometimes has three guests at once, for a total of four open mics. We always want the audience to be able to hear what's being said, but the broadcast audio is first priority. We aren't always able to push the PA as much as the audience would like, but if only one mic is open at a time, I know I can get a lot more level to the house and still be clean on the air.

- *The FP-410 performs this function,* turning down the unused mics when a guest is not speaking. "Comb filtering," which is the phase-shifting of the audio that occurs when multiple mics pick up the same voice, is also reduced.

- *Four Sennheiser MD 421 mics.* Microphones are kind of like ice cream, everybody likes a different flavor. These are my mint chocolate chip. Crystal clear highs, great presence, and ample lows are all built into a rugged dynamic package. An added feature that I use quite a bit is the low-end roll-off collar that enables me to step through the degree of attenuation, providing the ability to equalize, to some extent, right at the mic.

- *A Casio DA-7 portable digital audio tape recorder.* Boy, I couldn't get my hands on one of these fast enough. High-quality recordings of the program, both

for archives and possible rebroadcast, have always been important.

When we first began traveling, I had a TEAC reel-to-reel in a flight case. Not only was this sucker heavy, but my heart used to skip a beat or two as it came thundering down the luggage carousel at the airport.

Versatile DAT

DAT is really versatile in the field. Sometimes, we'll record a segment of the show in advance and play it right back to air later. I've even been able to do some pretty slick edits using two of them, although it takes some practice to get the timing down for punching in and out.

There are a few drawbacks to DAT which should be mentioned. It's very unforgiving with overdriven levels, sometimes resulting in distortion and a breakup of the bit stream. The fact that I can only monitor the input signal while recording also causes discomfort. In one instance, I found that my tape was blank at the end of a show. It turned out that the cassettes had been loaded inside out by the manufacturer.

- *A Marantz PMD 430 portable cassette machine.* After the things I've just said about DAT, I'd be foolish not to back it up. The Marantz records in Dolby B, and has three heads, so I can be sure something is going on the tape. Also, if something were to happen to my cart stack, the backup cassette with the commercials would play from here.

- *A Telos 1 portable phone hybrid.* We need to be able to put phone guests on wherever we go, or take reports on late-breaking sports stories. This unit is simply the best there is for this application, but isn't everything Telos makes?

These are the basic building blocks of my broadcast. Depending on the signal delivery method, other equipment may be needed as well.

Pete Rose once said that he couldn't believe how lucky he was to be getting paid for doing something he enjoyed so much: playing baseball. Working with Bob Costas and producer Bruce Comblatt on this program has been a lot like that.

□ □ □

Steve Kirsch owns Silver Lake Audio, an audio equipment rental and technical support firm in Baldwin, N.Y. He can be contacted at 513-623-6114.

Radio World

TOOLS of the TRADE

Radio World's showcase of interesting products useful in your everyday job or in related activities.

Be Prepared with the ParaTool®

A comprehensive, multi-purpose, quality-designed folding tool, the ParaTool offers the unique combination of compactness, versatility, one hand opening, and over 20 features.

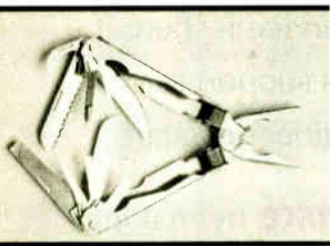

Components include an extended needlenose through full size pliers with fine, medium and coarse gripping surfaces; wire cutter capable of cutting chain link fence or paper; 3" straight point blade; 3" serrated sheepsfoot blade for cutting fibrous material such as nylon rope; three flathead screwdrivers (fine, medium and coarse); Phillips #1+ screwdriver; can opener/bottle opener; awl; both fine, coarse and edge-cut file; double tooth

saw; thumb tab/lanyard hole for attachment to belt, key ring or lanyard; measuring scale featuring both inches and centimeters; and stainless steel constructions.

Designed and built in the U.S. to exacting military standards, the ParaTool weighs just 7 ounces and is only 4" in size when closed (6.4" open, with the longest plier reach in its class). It comes complete with a lifetime guarantee against defects in workmanship and materials, and a molded "heavy tech" belt pouch for easy portability.

Order one today and take it everywhere with you — you'll never run out of uses for the versatile ParaTool!

A GREAT GIFT! Only \$64.95*

Charge your purchase with your Visa or Mastercard by calling 317-935-7087 (no CODs or collect calls please).

Or send check or money order and your shipping address (specify the ParaTool) to:



Radio World Tools of the Trade

P.O. Box 1214, Falls Church, VA 22041 USA



*price includes surface shipping in the U.S.A.

Value

R A D I O M I X E R
P R O D U C T I O N M I X E R

Many broadcasters know that PR&E provides the consoles and systems for market-leading radio stations and network facilities throughout the world. Unfortunately, with a client list that reads like a "who's who" of the industry, some broadcasters with more modest budgets feel that PR&E consoles are out of their reach. We'd like to introduce you to Radiomixer™, a first-class on-air console at a coach-class price.

Created by the same team of designers and engineers responsible for major-market "showcase" facilities, Radiomixer offers the reliability, performance, and many of the features of our world-famous BMX, at a price guaranteed to satisfy the most demanding budget. Using top quality components, Radiomixer delivers advanced features including the most elegant telephone mix-minus system available, along with uncompromising sound quality and reliability.

And when you add multitrack production power on top of the Radiomixer's standard features, you have Productionmixer, the most affordable high-performance production console in broadcasting. There isn't another console family in their price class that can offer the total value of Radiomixer and Productionmixer.

Why settle for less, when you can have genuine PR&E features, quality, reliability and service? Call today for your full color brochure.



Pacific Recorders & Engineering Corporation
2070 Las Palmas Drive, Carlsbad, CA 92009
Tel: 619-438-3911 Fax: 619-438-9277 GSA: GS-03F-2057A

DESIGNS THAT MAKE THE DIFFERENCE

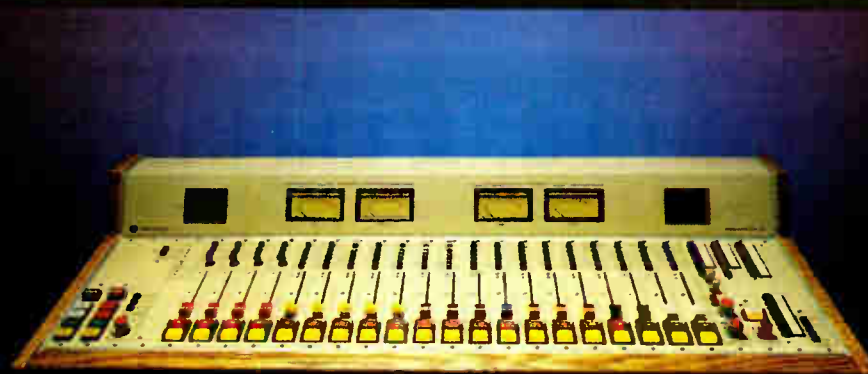

INSIGHT ON RULES

Courts Will Decide Future of LPFM

by Harold Hallikainen

SAN LUIS OBISPO, Calif. In the past I have questioned the FCC's reasoning in not establishing a low-power FM service, similar to what was done with television. Establishment of low-power unlicensed FM services raises several freedom of speech issues.

The FCC routinely fines unlicensed stations and orders them shut down, but many continue to operate. Some take their cases to court.

The case of William Leigh Dougan (operator unlicensed station KAPW(FM) Phoenix) v. FCC is a typical example.

Gap fillers

The FCC fined Dougan \$17,500 for the operation of a half-watt unlicensed FM station and refusing an inspection request.

Dougan disputes the FCC's jurisdiction over his station because it does not interfere with other licensed broadcasters or "otherwise enter into interstate commerce."

He also attacks the "appeals process" available to those who receive a forfeiture order from the FCC. Dougan's attorney argues that the FCC could decide not to turn the case over to the Justice Department for collection, leaving Dougan with an outstanding forfeiture order and no chance for his day in court.

The FCC is pressing for dismissal on the basis that the FCC fine order has not

"injured" Dougan.

The existence of a license-free, low-power broadcast service would have precluded the need for this conflict.

The FCC has said it is more spectrum efficient to license a few high-power stations, rather than many low-power stations because the coverage-area-to-interference-area ratio of high-power stations is greater. But such an allocations scheme creates gaps where low-power stations would fit without interference.

If, for simplicity's sake, we assume an omnidirectional, horizontal radiation pattern and make the prohibited overlap areas tangent, a small area without overlap occurs between the stations. If three stations each have an "interference radius" of 100 kilometers, and they are packed as closely as possible, it is possible to fit another station with an interference radius of 15 kilometers between the intersections of the other interference circles.

Is it spectrum efficient to not authorize stations to fill these gaps? If freedom of speech is applied to broadcasting, does the FCC have a "compelling governmental interest" to prohibit low-power stations that can operate without interference to existing stations?

Gap hunting

Determining the location of these "holes in the spectrum" and the maximum power that may be radiated without

interference, as currently defined by regulations on prohibited overlap, is an interesting problem.

The FCC could "find the holes" and define a maximum ERP and HAAT for each hole. As the antenna is moved from the "center of the hole," its power would have to be reduced to prevent interference. As an alternative, the FCC could define a simple procedure for determining where a low-power station could operate interference-free and a private organization could publish a list of frequencies and powers available.

Better yet, software writers could design programs to determine the frequency and maximum ERP/HAAT combination that could be operated at a user-specified latitude and longitude. Such software could be sold with FCC approved transmitters at retail stores, such as Radio Shack. These stations would be required to protect licensed stations and would not receive any interference protection.

Another way to prevent interference to licensed stations would be to set aside channels exclusively for the use of unlicensed stations. It's a bit late to do this for FM, but it could be done with the expanded AM band. If a new band is finally used for digital audio broadcasting, and the adopted technology allows for independent transmitters for each station (perhaps through the use of spread

spectrum techniques), a few channels (or different random-number codes for spread spectrum) could be set aside for unlicensed operation.

The FCC does allow unlicensed broadcasting in the AM and FM broadcast bands, but with extremely limited coverage. Intentional radiation in the AM band is allowed if the field strength is limited to 24000/F(kHz) microvolts per meter measured 30 meters from the radiator.

Education exception

An exception is allowed for educational institutions where the measurement point is extended to the perimeter of the campus. A 1 MHz signal that is 24 microvolts per meter 30 meters from the antenna will probably not be heard very far away.

Unlicensed operation in the FM band is limited to a field strength of 250 microvolts per meter measured 3 meters from the antenna. This works out to 165.8 picowatts per square meter. KAPW's 500 milliwatts appears to violate this requirement.

It is up to the courts to decide these various unlicensed broadcast station cases. Perhaps they will find that technology has invalidated some precedents and that the time is right for an era of micro-broadcasting to begin.

□ □ □

Harold Hallikainen is president of Hallikainen and Friends, a manufacturer of transmitter control and telemetry systems. He also teaches electronics at Cuesta College, San Luis Obispo. He can be reached at 805-541-0200. He can also be reached on internet at ap621@cleveland.freenet.edu.

THE RF EXPERTS KNOW—MYAT DELIVERS

MYAT DELIVERS QUALITY

You can rely on MYAT rigid line and components to deliver a clean, powerful signal to your antenna. Pure highest quality copper, brass and silver plus computer-aided design and manufacturing ensure consistency and accuracy. No wonder demanding broadcasters worldwide choose MYAT products for their passive systems. We take Quality Control very seriously.

MYAT DELIVERS RELIABLE PERFORMANCE

Our non-galling silver-plated beryllium copper contact springs, brass elbow reinforcements and virgin Teflon inner supports are designed for maximum velocity, minimum attenuation and long service life. Every MYAT component is tested before shipping and backed with a full one year warranty. MYAT products are built for the long run.

MYAT DELIVERS WHEN YOU NEED IT

Major transmitter manufacturers with strict production schedules rely on MYAT to deliver quality components on time and within budget. So do leading broadcasters like the Empire State Building's newest TV tenants. At MYAT, commitments are kept.

LET MYAT DELIVER FOR YOU

Whether you're planning a new tower, upgrading an older installation, or coping with an emergency, you can depend on MYAT rigid line and components. Thousands of RF experts around the world already do. Contact your RF distributor, or phone us for our catalog, installation planning guide and engineering reference. Its detailed drawings can help you put together an efficient, trouble-free transmission line that will last for decades. For a free copy call 201-767-5380 or fax 201-767-4147.

**RIGID LINE: RADIO'S EFFICIENT CHOICE**

40 YEARS OF EXPERIENCE. 40 YEARS OF EXCELLENCE.

380 Chestnut Street • P.O. Box 425 • Norwood, NJ 07648

Tel 201-767-5380 • Fax 201-767-4147

Products & Services Showcase

For more information on the products shown below, circle the appropriate Reader Service No. (s) on the enclosed Subscription/Reader Service card or contact the advertiser directly.

NEW! **Composite Audio DA and Switcher!**



APPLICATIONS

- Switching Between Composite STL's
- Main/Alternate Processing Switching
- Feed Up to 3 Transmitters with Identical Audio
- SCA or SAP Generator Switching
- Non-Intrusive Composite Testing/Monitoring

FEATURES

- 2 Input Switcher
- 3 Isolated Outputs
- Individual Level Control for Each Output
- Front Panel and Remote Control with Full Status
- Power Fail Memory with Bypass Mode
- Inputs Selectable for Balanced or Unbalanced Operation

bdi Broadcast Devices, Inc.
5 Crestview Avenue
Peekskill, NY 10566
Tel. (914) 737-5032 FAX: (914) 736-6916

READER SERVICE NO. 216

Cellcast
REMOTE BROADCAST STUDIO

The CELLCAST RBS-400 1.8 offers complete portability and flexibility for remotes. Complete with a 4-channel mixer, frequency extender, cellular transceiver and landline capabilities, 600 ohm line out, and Vu meter. It is powered by 10 Ni-Cad rechargeable batteries, 12v adaptor, and AC power supply. 24 hour product support standard.

Call Bridget Taylor today for our \$195.00 2 week trial at



Phone: 918-272-8504
FAX: 918-272-8452

READER SERVICE NO. 101

Uh-Oh . . . We Should Have Called **CORTANA**

STATI-CAT for Affordable Lightning Prevention.

Let Us Design a System for You

Stati-Cat provides a continuous, low-resistance discharge path for the static electric charge on tall structures. Dissipation points are 1/8", type 304 stainless steel rods ground to needle sharpness. They won't bend, not even from ice and severe weather.



CoranA Corporation

Write to us today for a **FREE** brochure!
P.O. Box 2548, Farmington, N.M. 87499
Call (505) 325-5336 FAX (505) 326-2337

READER SERVICE NO. 32

SOUND YOUR BEST ON THE AIR!

CART MACHINE SERVICES:
CART MOTORS REBUILT to quiet flutter-free perfection-shafts resurfaced
Single \$120.00 Triple \$140.00

CART HEADS RELAPPED guaranteed to perform like new
Same day turnaround
Replacement heads and motors available

REEL TO REEL SERVICES:
HEADS RELAPPED and precise digital/optical
ASSEMBLY ALIGNMENTS performed for maximum response & head life
CAPISTAN & REEL MOTORS REBUILT for MCI, OTARI and more.

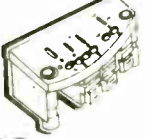

For peak performance from your recording equipment, call The Audio Magnetic Professionals

AMP SERVICES
224 Datura Street, Suite 614, West Palm Beach, FL 33401
Call 1-800-826-0601 for "Same Day Service" in Florida (407) 659-4805
Authorized Parts Dealers for: MCI • OTARI • TEAC/TASCAM

READER SERVICE NO. 185

EVEN THE BEST CAN BE MADE BETTER

Introducing the new **MINI-MIX 12A**

THE COMPACT MIXER WITH A COMPACT PRICE FROM THE QUALITY LEADER



\$3499 **12 Channels**
25 Stereo Inputs

Service & Affordable Quality for Over 23 Years

AUTOGRAM CORPORATION

1500 Capital Avenue (214) 424-8585
Plano Texas 75074-8118 1-800-327-6901
FAX (214) 423-6334

READER SERVICE NO. 9

Tired Of Replacing Expensive Headphones?

Designed to provide vivid sound reproduction when used with today's digital sources, these stereophones feature high-performance 40 mm drivers. The maximized power handling capability ensures full, accurate reproduction of the wide dynamic range found in digital program material.

The soft leatherette earpads and adjustable headband provide for hours of comfortable listening while the closed-back design of the earpieces allows for privacy and prevents unwanted outside sounds from interfering with your listening enjoyment. The 3.0 m (9.8 ft.) cable is terminated in a 3.5 mm mini plug, ideal for portable systems, and a 1/4" plug adapter is included for home use.



Only \$34.95

2342 S. Division Avenue
Grand Rapids, Michigan 49507
1-800-999-9281

200 Fareway Drive - Suite 2
Smithfield, North Carolina 27577
1-800-369-7623

AUDIO BROADCAST GROUP

READER SERVICE NO. 78

Complete DJ/2 System



\$6,995.00

Select a DJ/2 CD or Satellite System

Just \$6,995 for this total stand alone digital audio Satellite OR CD control system with a powerful 386SX-33 computer, VGA color monitor and 340 meg hard drive (5+ hours mono storage), plus all software and hardware control interfaces. Completely stand alone if you wish. Nothing else is required.

- Great Sound: Premium apt-X™ audio card standard
- Simultaneous record/play for foreground production
- Satellite system handles all standard formats
- CD system uses Pioneer 6 packs or 300 disc jukeboxes
- Live assist included, ready for Traffic & Music interfaces
- Many options: PBR time shift recording, external button boxes, audio Production room, LAN, more audio & I/O

The Management
1-800-334-7823 1-817-625-9761 FAX: 817-634-9741
P.O. Box 1-36457 Ft. Worth, TX. 76136
1600+ Stations - Our 13th year

* Production add-ons & second systems at special prices. Extra charge for combined Satellite & CD systems. No holds or splits, larger hard drives available at extra cost.

READER SERVICE 201

The Russians never abandoned tube technology . . .

And that's great news for your transmitter!

As the world's largest power tube manufacturer, Svetlana never stopped full-scale R&D for power tubes. From power tubes of over one-megawatt to a full line of high-performance triodes, tetrodes and pentodes, Svetlana is the world leader in power tube technology.

Now, Svetlana-developed tubes are available in the West in a growing number of standard tube types for AM and FM broadcast. These top-quality, long-life ceramic tubes are available at Russian prices direct from Svetlana and are backed by the most generous warranty in the industry.

Talk to Svetlana today about your requirements for standard and custom-designed power tubes. Broadcasters, call 800-239-6900 for sales; OEMs, distributors and volume purchasers, call 415 233-0429.



Broadcasters, contact:
8200 S. Memorial Parkway
Huntsville, Alabama 35802
800 239-6900

OEMs, Distributors, Volume Purchasers, contact:
3000 Alpine Road
Portola Valley, California 94028
415 233-0429

READER SERVICE NO. 193

Products & Services Showcase

For more information on the products shown below, circle the appropriate Reader Service No.(s) on the enclosed Subscription/Reader Service card or contact the advertiser directly.

Shape Up!

Coverage. Saturation. DBk contours. In FM broadcasting, the "bottom line" is always based on your pattern.

More than any other manufacturer, Shively has the experience and reputation for providing crucial pattern solutions for critical propagation problems. On any tower. At any power level. Remember, *it pays to be heard.*

A good pattern. The shape you need. Talk to your consultant. And contact us.

Shively Labs

A Division of Howell Laboratories, Inc.

19 Harrison Road, Bridgton, ME 04009
207-647-3327 FAX 207-647-8273

READER SERVICE NO. 170

MAX-Z II

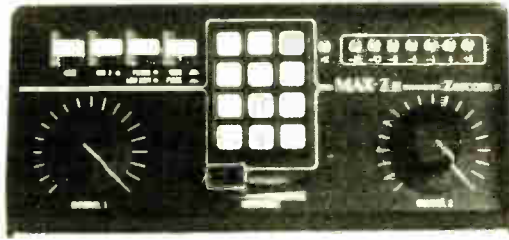

The Zercom MAX-Z II is an abbreviated version of the famous Zercom MAX-Z Remote Broadcasting Telephone System. High quality audio handling is maintained in the two channels of audio input. Headroom, noise performance and distortion are comparable in quality to studio consoles.

Features of the 6 lb, 8"x9.5" unit include frequency response of 200Hz to 7KHz \pm 0.5 db, 90Hz to 12KHz \pm 1.5 db; noise floor of -70 dbm with 0 dbm line level input, -61 dbm (mic level input); and harmonic distortion of 0.35% or less and intermodulation distortion of 0.2% or less. Head room is 16 db above 0 VU.

ZERCOM

Box 84, Merrifield, MN 56465 • 218-765-3151

READER SERVICE NO. 108

The Best Audio Test Meter Made!

Advantage Model 310

Precision Audio Signal And Noise Level Meter

Professional Price!

\$399



- Low THD/Hi RF Reject With Valley Audio's Trans-Amp™
- Lo-Noise Wideband Circuitry
- Large Dual Scale Meter
- Super-Accurate Filters
- Average, RMS Or Peak Det
- -100 dB to +30 dB Range
- Scope and Preamp Monitoring Outputs

Call For The Nearest Dealer:
1-800-800-4345



Valley People
Merriam, Kansas

READER SERVICE NO. 85



Econco REBUILT POWER TUBES



Approximately One Half the Cost of New

3,000 Hour Unconditional Guarantee
Call for Our Price List

Econco 1318 Commerce Ave. Woodland, CA 95695
Phone: 916-662-7553 Fax: 916-666-7760 Telex: 176756
Toll Free: 800-532-6626 From Canada: 800-848-8841

READER SERVICE NO. 131

Transport Digital Audio

RF Specialties has the RE660/661 ISO/MPEG Layer II, IIA Digital Audio Codec from RE America. The RE660/661 provides up to 20kHz of audio bandwidth. From satellite networks to switched 56 and ISDN, the full-featured RE660/661 ISO/MPEG Layer II, IIA Codec is completely bit rate flexible up to 384 kbits.

- ▲ ISO/MPEG Layer II, IIA
- ▲ Switched 56, 64 kbit/s, ISDN, Fractional T-1
- ▲ User data channel from 300-9600 baud
- ▲ Multiplex or redundant two times 56/64 for 112/128 kbit/s
- ▲ Easiest set-up locks to network or internal clock
- ▲ Mono, Dual Mono, Stereo, Joint Stereo operation
- ▲ Fully automatic decoder reduces operator set up
- ▲ AES/EBU and SPDIF digital interface included
- ▲ Two-times V.35, X.21 or RS 422 interface included
- ▲ Headphone monitor included



Northwest (206) 546-6546	Southwest (806) 372-4518 (214) 771-4235	Southeast (904) 678-8943
West Coast (805) 682-9429	Northeast (412) 733-1994 (215) 322-2410	Midwest (816) 635-5959

EACH OFFICE INDEPENDENTLY OWNED AND OPERATED

READER SERVICE NO. 39



CD100 • X Compact Disc Adapter-Amplifier

Matches any consumer compact disc player or cassette deck to broadcast console input. Only \$89.00 FOB factory or from any broadcast dealer.

Russ Friend & Associates
342 N. Sunnyside
Clovis, CA 93611

Phone 209-298-6838 FAX 209-298-8270

Turntable Parts/Felts
Russco, Collins TT-200, Sparta

READER SERVICE NO. 16

DIELECTRIC COAXIAL LOADS

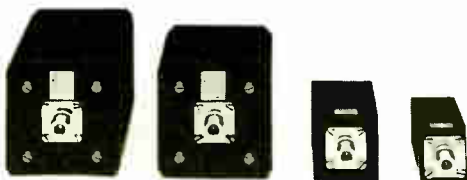

- * Dry Loads 5-150 Watt
- * Oil Filled 600-10,000 Watt
- * Water Cooled 25-100 kW
- * Heat Exchangers
- * New for '93...High Power Calorimeter

CALL FOR OUR NEW CATALOG!

Dielectric Communications
P.O. Box 949
Raymond, Maine 04071
207-655-4555
FAX 207-655-7120

READER SERVICE NO. 155

DIGITAL ANTENNA MONITORS

In-Stock-Available for Immediate Delivery



Price US\$2400.00 2 Towers
Will operate with any remote control equipment.



Price US\$1780.00 2 Towers
For AM directionals with studio located at transmitter site.

These monitors are state-of-the-art instruments of unequalled accuracy (.5% or better on ratio and .5° or better on phase) and stability. With typical modulation the true ratio readout of these monitors is a factor of 10 more stable than instruments that measure normalized amplitude, and their phase readouts are rock solid. Phase sign is automatic, no extra operation. In addition to the analog DC outputs for remote control the Model CMR has a multiplexed BCD digital output which can be used to drive the Remote Indicator Model CMR-1. RF inputs have dual protection. Gas discharge tubes across the sample line terminations plus relay protection.

GORMAN REDLICH MFG. CO.
257 W. Union St. Athens, Ohio 45701
Phone 614-593-3150 • FAX 614-592-3898

READER SERVICE 207

Manufacturers

Is your company or product featured in our pages? Distribute extra copies of **Radio World** articles to your customers with

Radio World's reprint service.

Print as many copies as you want for **one low price.**

For information, call Simone Mullins at

1-800-336-3045

Power Company Supplies Interference Aid

by Ed Bukont

WASHINGTON So you think a dim bulb is a sign of trouble with the incoming power line? Would you be surprised to find, however, that the dim bulb may in itself be the source of the problem?

At a recent monthly meeting of the Washington, D.C. chapter (37) of the Society of Broadcast Engineers (SBE), Michael Martin, an Interference Investigator for the Potomac Electric Power Company (PEPCO), detailed some of his experiences and general practices observed in nearly 15 years of removing interference products from power lines.

The engineers of SBE Chapter 37 represent stations who receive their power sources from three major utilities and other regional electric cooperatives. Of the three major utilities, PEPCO is the only one with a full time staff, vehicle and test gear devoted to removing interference.

In the Washington area, power companies are generally knowledgeable and sympathetic to the special needs of broadcasters for reliable, well-regulated power. Martin said PEPCO receives complaints from broadcasters rather more often than about broadcasters.

Providing assistance

While not a power company problem per se, PEPCO considers assistance to independent companies in resolving problems as good customer service.

One area of potential interference from broadcast signals is low-voltage cabling such as is used in telephone, data and alarm systems. These systems tend to use unshielded wiring over very long runs, which makes a good antenna, Martin said.

The often-employed solution is a pair of .1uf capacitors on each conductor to ground, he added.

Although distribution transformers are commonly believed to be typical noise problems, power companies find that they are actually an infrequent culprit. It is more likely that, the mounting and connections to the transformer may serve as the source of noise and transient

energy, Martin explained.

Even so, he said, only 20 percent of complaints can be traced to power company-related equipment. Another 15 percent are related to electrical equipment adjacent to the effected premises and only 5 percent are related to RF generating equipment. In 60 percent of the cases, it is the equipment or wiring within the customer's own premises that is generating the interference, Martin said.

Typical interference

Typical sources of interference are bell transformers, HVAC thermostat transformers and bimetallic heater controls such as found in fish tanks and thermostats. Recurrent, short duration patterns of regular interference can often be traced to such heater controls which may produce arcs lasting to upwards of five seconds. These devices can have the same effect on local equipment as more serious arcing in the outside distribution system may have on the local grid.

In one case, coupling of noise between a 230kV line and adjacent lower potential wires caused noise and transient energy to spread over lines extending for ten miles out of Washington and into nearby suburbs. The actual noise was caused by a loose connection between a sampling transformer and the buss bar which coupled it to the 230kV line.

Martin said the primary sources of noise generation are "garbage on the wires" and poor connections or degraded insulators that create unintentional paths and interruptions to the flow of current.

One interesting observation, Martin said, is that moisture can actually provide a temporary "fix" to some arcing problems of insulators by completing an otherwise higher resistance path. The high resistance path tends to exhibit a cycling effect whereby short duration arcs jump the damaged insulator.

Arcing most frequently occurs at points where lines are tapped together, spliced or attached to other fixtures such as pole-mounted hardware. The use of conductive

grease to coat these junctions can solve the arcing problem, Martin said.

Sometimes special clips are used to reattach loose or damaged lines to the appropriate hardware or to other lines. When a line emits noise, or becomes receptive to noise, it is often an indication of failure at a splice or within the pole hardware.

Tracing such problems begins with the complainant, Martin explained. Typically, 50 percent of complaints come from residents; about 10 percent are from businesses and 40 percent are from users of RF transmission gear, whether amateur or professional.

Upon receipt of the complaint, Martin and his crew first investigate the effected premises. This is often as far they need to go. Even when the complainant is sure the problem is coming from the antenna of the guy next door, the actual source of noise is often in that person's own home.

Pinpoint noise

In some cases, however, the inspection continues out to the street, where special RF sensitive probes are used to pinpoint the source of noise. Because the noise of arcing tends to create a broadband signal above 7 MHz, it can be

continued on page 42 ▶

CAT-LINK Digital STL :

TOP 25
MARKET SWEEP

It's no wonder 50 stations in the Top 25 markets are sold on QEI's CAT-LINK, the DIGITAL STL problem solver:

- Uses T1 data circuits or 23 GHz radio
- The only digital FM composite link*
- **NO COMPRESSION and NO DELAY**
- Full bi-directional capability
- Multiple discrete channel capability
- Ideal for LMAs

And that's why more savvy stations in the Top 25 and markets of every size are turning to CAT-LINK. Call QEI toll-free at 800-334-9154 and be swept away.



*U. S. Patent # 5,054,070



QEI CORPORATION
 QEI Corporation
 One Airport Drive P.O. Box 805 Williamstown, N.J. 08094 USA
 800 334-9154 FAX: 609 629-1751 INTERNATIONAL: 609 728-2020

SUBSCRIPTION/READER SERVICE FORM



FREE Subscription/Renewal Card

I would like to receive or continue receiving Radio World FREE each month. Yes No

Signature _____ Date _____

Please print and include all information:

Name _____ Title _____

Company/Station _____

Address _____

City _____ State _____ ZIP _____

Business Telephone () _____

Please circle only one entry for each category:

I. Type of Firm

D. Combination AM/FM station	F. Recording Studio
A. Commercial AM station	G. TV station/teleprod facility
B. Commercial FM station	H. Consultant/ind engineer
C. Educational FM station	I. Mfg, distributor or dealer
E. Network/group owner	J. Other _____

II. Job Function

A. Ownership	G. Sales manager
B. General management	E. News operations
C. Engineering	F. Other (specify) _____
D. Programming/production	

Reader Service

December 8, 1993 Issue Use Until March 8, 1994

Please first fill out contact information at left. Then check each advertisement for corresponding number and circle below.

Purchasing Authority

1. Recommend 2. Specify 3. Approve

001	023	045	067	089	111	133	155	177	199
002	024	046	068	090	112	134	156	178	200
003	025	047	069	091	113	135	157	179	201
004	026	048	070	092	114	136	158	180	202
005	027	049	071	093	115	137	159	181	203
006	028	050	072	094	116	138	160	182	204
007	029	051	073	095	117	139	161	183	205
008	030	052	074	096	118	140	162	184	206
009	031	053	075	097	119	141	163	185	207
010	032	054	076	098	120	142	164	186	208
011	033	055	077	099	121	143	165	187	209
012	034	056	078	100	122	144	166	188	210
013	035	057	079	101	123	145	167	189	211
014	036	058	080	102	124	146	168	190	212
015	037	059	081	103	125	147	169	191	213
016	038	060	082	104	126	148	170	192	214
017	039	061	083	105	127	149	171	193	215
018	040	062	084	106	128	150	172	194	216
019	041	063	085	107	129	151	173	195	217
020	042	064	086	108	130	152	174	196	218
021	043	065	087	109	131	153	175	197	219
022	044	066	088	110	132	154	176	198	220

Copy & Mail to: Radio World, PO Box 1214, Falls Church, VA 22041, or FAX to: 703-998-2966

World Radio History

Circle (110) On Reader Service Card

Programming Completes PLC Installation

by Richard Mertz

WASHINGTON This column concludes a series of articles on programmable logic controllers (PLCs) with instructions on programming the system.

First, however, the set-up information from the last installment should be fresh in your mind (RW, Nov. 10).

Short review

This project uses a PLC for the control and monitoring of a motorized coaxial switch. The inputs and outputs are connected as shown in Figure 1.

The sequence of events to be pro-

grammed is as follows: When the position-one pushbutton is pressed, a ground is connected to PLC input X0. This closes PLC relays Y4 and Y8, momentarily

transmitter B on the air.

Here are some of the programming codes used to put the PLC through its paces.

1. LD—load an input. This can be an

input like X0 to X11, the output of a timer, or an internal relay.

2. M—internal relays. Relays labeled M0 through M599 lose their settings when power is lost. Those relays labeled M600 and above retain their position during power failures. (We call these ref-

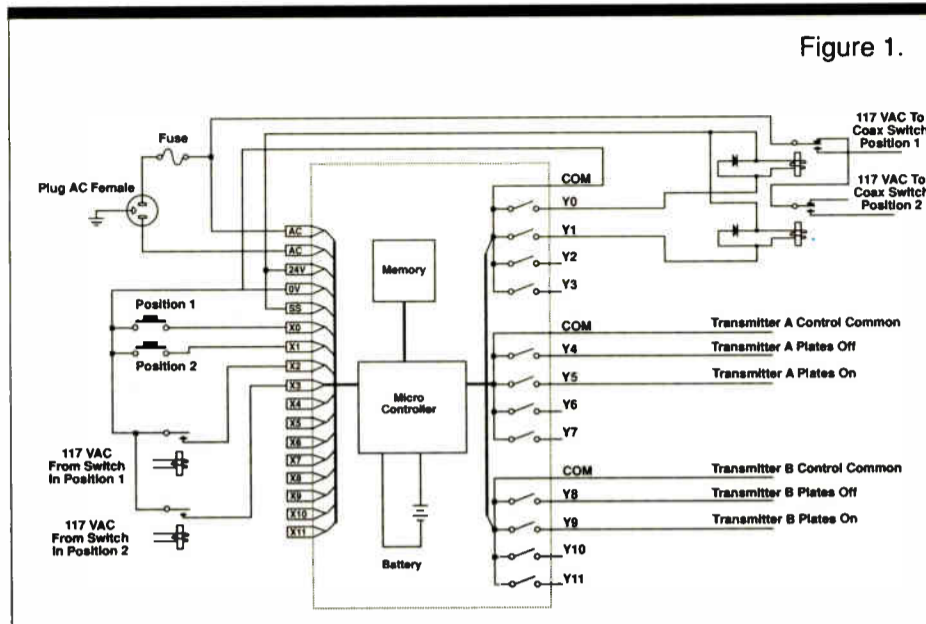

Figure 1.

While our example here shows 19 program steps, the actual programming I used was over 70 steps.

erence points relays, but they are really internal memory locations.)

3. T—timers. These are relays that close for a defined period of time. A two-line programming statement is used. The first line defines which timer is being used. The second line defines the length of time this relay

causing the plates to be turned off on both transmitters.

After about a half second, these relays open and the PLC closes output Y0, providing a ground that pulls in and holds the external relay that connects line voltage to the coaxial switch position-one input. The coaxial switch internal interlock switch opens preventing both transmitters from operating.

How it all works

Next, the RF contacts are opened and the coaxial switch rotates to position one. The RF contacts seat-connecting transmitter A to the antenna. The internal interlock switch closes. An auxiliary interlock switch contact also closes providing line voltage to the position-one tally relay. The relay contacts provide a ground to PLC X2 input, thus telling the PLC to momentarily close output relay Y5. This in turn activates the plates on transmitter A.

If you were to push the button for position two, the converse of these functions would be activated, placing

Example 1

Instruction Step	I/O	Name	Comment
0	LD	X0	Load input X0
1	OUT	Y0	When step 0 is active, close output relay Y0.

Example 2

Instruction Step	I/O	Name	Comment
0	LD	X0	Load input X0
1	OUT	T1	This closes an internal timing relay labeled as T1. This sets the time that T1 will close.
2	LD	T1	This loads the output from timer T1.
3	OUT	Y0	When T1 is activated, output relay Y0 closes until the time period has finished.

Example 3

Instruction Step	I/O	Name	Comment
0	LD	X0	Load input X0
1	OUT	T1	This closes an internal timing relay labeled as T1. This sets the time that T1 will close.
2	LDI	T1	This loads the inverted output from timer T1.
3	SET	Y0	When T1 time period is finished, output relay Y0 is latched closed.

Figure 2.

Instruction Step	I/O	Name	Comment
0	LD	X0	Pushbutton for position 1 is pressed.
1	SET	M1	Set a latching relay.
2	LD	M1	Load relay M1's position.
3	OUT	T1	Activate timer T1 for 1/2 second.
4	LD	T1	Load position of timer T1.
5	OUT	M2	Close relay M2
6	LD	M2	Load relay M2
7	OUT	Y4	Close output relay Y4 (transmitter A plates off) for duration of T1.
8	OUT	Y8	Close output relay Y4 (transmitter B plates off) for duration of T1.
9	LDI	M2	Invert the input of M2.
10	PLS	M3	When M2 opens, momentarily pulse relay M3.
11	LD	M3	Load relay M3 output
12	SET	M600	Set latch relay M600. This relay's position will be memorized should the power fail.
13	LD	M600	
14	OUT	Y0	Close output relay Y0 which causes the coaxial relay to rotate to position 1.
15	RST	M1	Reset relay M1 to its original position.
16	LD	X2	Look for activation of position 1 tally relay.
17	OUT	T2	If input X2 is active, then activate timer T2.
18	LD	T2	Load the output of timer T2.
19	OUT	Y5	Close output relay Y5 for the time T2 is active. This turns the plates on transmitter A.

Figure 3.

is closed.

Figure 2 shows three examples of how the program is listed and what it does, starting with a simple case and progressing to more sophisticated versions.

When input X0 is activated with the statements in Example 2, timer T1 is started and output relay Y0 closes. Output relay Y0 opens when the time period—about half a second, which is set by the statement K5—is finished.

Note the changes in statements 2 and 3 in the third example. Timer T1 is started when input

continued on page 42

Coming Soon!



Radio World's Annual Directory

All New for 1994!

Watch for it

OUR FAMILY OF PRODUCTS . . .

The Quiet One

RS² Dolby S-Type Noise Reduction



The Experienced Patriarch
DA-16 Distribution Amplifiers

Backbone of the Family

Our Adopted Son

TI-101 Telephone Interface



RS Series Mixing Consoles
in 6, 12, 18 and 24 channels

New Addition Clocks & Timers



"Super Clock" Up/down Timers and
Master Clocks



TM-3 Up-timer



RS-1000 Automation-Ready
DAT Machines



RS-6700 Broadcast DAT Machines

Overachiever of the Family

RS-2000; the world's
finest cart machine



Analog Master Clock System



2" Wall Mount Displays



Now available from
the country's finest dealers!

RADIO SYSTEMS INC.

110 High Hill Road • P.O. Box 458 • Bridgeport, NJ 08014-0458
(609) 467-8000 • FAX (609) 467-3044

Circle (144) On Reader Service Card
World Radio History

Who's running the ship?

Unattended operation is one way to keep your station profitable, but you still have to mind the store.

The acclaimed Burk Technology ARC-16 Remote Control System is the first step. You can control transmitter and studio from any phone.

But wait. There's more!



Introducing AutoPilot™ from Burk Technology.

AutoPilot is break-through computer software that makes automatic operation of your studio/transmitter facility a dream come true.

- Automatic power changes
- Automatic pattern changes
- Automatic site changes
- Automatic power trim
- Automatic fault recovery
- Automatic logging

Now your imagination is the only limit.

The new FCC fine schedule is imposing. Why risk a big penalty when AutoPilot can help you stay within the rules?

Call us at 508-433-8877
or toll free at
1-800 255-8090
for more information
and a FREE DEMO.

BURK

TECHNOLOGY

Circle (20) On Reader Service Card

ROOTS OF RADIO

Venerable Station Expands Audience

by James T. Wold

NORTHFIELD, Minn. St. Olaf College in the small town of Northfield (perhaps best known as the site of the last, unsuccessful raid of the James-Younger gang) celebrated the 75th anniversary of wireless transmission earlier this year.

This founding member station in National Public Radio would already be noteworthy for its many years of continuous news and music programming. Even more significantly, however, is its place at the beginning of public radio history.

To the best of anybody's knowledge, WCAL was the first listener-supported station in the U.S.

Pioneer roots

WCAL(AM) was officially assigned call letters in May 1922. Wireless transmission at St. Olaf College, however, began in 1918 as an experiment by Hector Skifter, a physics student. Skifter would continue his experimental transmissions on a regularly scheduled basis, until 1922 when the station was officially licensed. In those early years before radio signals blanketed the world, WCAL's signal could be heard as far away as New Zealand.

WCAL pioneered several forms of programming, such as radio drama with its 1924 adaptation of Shakespeare's "As You Like It."

But the school's funding to operate the station began drying up in 1924 and St. Olaf was forced to consider shutting it down. The town newspaper, the Northfield News, saved the station with a cash contribution, and began soliciting support from others in the community. Ever since, WCAL has operated on listener donations.

Before planning the 75th anniversary commemoration of wireless transmission, WCAL placed inquiries in several jour-

nals and trade publications in search of any other station that began supporting itself on donations before 1924. It has not received a reply to date.

Several noncommercial stations in the 1940s began "membership-support" drives, the most common form of public radio funding today. But WCAL's claim to be the first "listener-supported" station appears to remain intact.

FM too

WCAL-FM (89.3 MHz) went on the air in 1968, and in 1991 modified its antenna with an eye to increasing the station's coverage and listenership. A new million-dollar tower was built in nearby Rosemount, Minn., and mounted with a directional antenna aimed at Minneapolis-St. Paul, about 25 miles to the north.

An ad campaign was launched to let Twin Cities residents know that a new voice was in town. "The tower required us to become more energetic, systematic and persistent to create awareness of and interest in the station," said Station Manager Paul Peterson. "You can't expect people to find you by accident."

The station hired the Minneapolis ad firm of Colle & McVoy to help introduce WCAL to new listeners. Buses and bus stops were plastered with eye-catching blue-and-white ads with slogans like: "Where You Don't Have to Die to Hear Harp Music."

The ad campaign won WCAL and Colle & McVoy an award from the Corporation for Public Broadcasting, and, more importantly, won WCAL several new supporters. "The campaign led to the most successful membership drive of WCAL's 71-year history and increased volume of letters and calls on phone-in shows," Peterson said. "Hopes are high that the new ads (just unveiled) will be just as successful."

The 75th anniversary observance that began last June helped promote the sta-

tion even more. There was a "Great Summer Grab-Bag," giveaway of 100 prizes in July; the "Golf Classical" for music-loving golfers in August, and last month, an all-request classical music day.

The celebration even went national with a Sept. 11 broadcast of one of WCAL's most popular programs, "Whad' Ya Now? with Michael Feldman," over NPR originating from the historic State Theater in downtown Minneapolis.

All told, it has been a year of new life and vigor for an old, reliable small-town mainstay.

□□□

James T. Wold is a free-lance writer based in Minnesota. He is author of "Minnesota Microphones," published by Northstar Press. Wold can be reached at 1106 South Seventh St., Minneapolis, MN 55415.

Program Is PLC Finale

► continued from page 40

X0 is activated. When the time period has finished T1 open, then output relay Y0 is latched closed.

Just like a magnetic latching relay, the latched Y0 can be opened or reset by using the RST statement. Also we can use the logical functions of "AND" and "OR."

With all that under our belts, the problem at hand is tackled in Figure 3.

To move the coaxial switch into position two, push the position-two pushbutton, and the whole process starts again. However, this time, PLC output relay Y1 will close, causing the coaxial switch to rotate to position two. When the coaxial switch seats in position two, output relay Y9 will momentarily close placing transmitter B on the air.

Variations

When I built this project, I added statements to the programming that would insure that the position of the coaxial switch would remain unchanged after a power failure or if the run/stop switch for the PLC was toggled. There was additional programming to insure that if the coaxial switch was in position one when the position-one pushbutton was pressed, nothing would happen.

You can program the other unused inputs and outputs from the PLC to provide other control or status functions. The program listing shown in Figure 3 is only an example of how to program a PLC using the unit I used when I actually built this project as a model. While our example here shows 19 program steps, the actual programming I used was over 70 steps.

If you should decide to use a PLC for a project, be sure to consult the programming and operational manuals for your particular unit. There will be variations on the information given above.

□□□

Richard Mertz is senior engineer at Jules Cohen & Associates, P.C., 1725 DeSales St., N.W., Suite 600, Washington 20036. He can be reached at 202-659-3707.

PEPCO Relieves RF Ills

► continued from page 39

localized by listening and tuning for harmonic components. The closer to the source, the more harmonic energy will be revealed. Once located, corrective action is often immediately undertaken without an interruption in service.

Arcing causes the telltale horizontal crawling and wavy lines on a TV screen. Another approach is to use the tuned "sniffer" device to listen to each breaker within a distribution panel, Martin said. While turning breakers on-off, listen for changes in the noise to see if the problem is caused by a device on the branch circuit.

By a simple program of eliminating the variables, you can often solve your own problems quickly, without waiting for the power company, according to Martin.

If the noise occurs in a regular cycle, it almost always caused by some manufactured time source such as a clock, timer, heater or similar device. Complaints about broadcast interference are usually resolved by the installation of proper filters but can be difficult in very high fields and may necessitate more complex filtering

and shielding systems.

Whenever a noise problem occurs, look for changes in the electrical operation of the home or business. Does the device sound different? Does a light suddenly flicker, glow brighter, or not work at all compared to its function before the problem occurred.

Martin explained one case in which the homeowner complained of a recurring noise. The problem was clearly audible in the area of a bedroom. Looking around, Martin noticed a ceiling track light fixture that did not operate. He was told by the homeowner that the fixture had never worked.

He removed the fixture and found within it a button sized "efficiency improving" device designed to regulate the duty cycle of the lamp. The device had failed, and its intermittent action was actually wasting electrical power, and the internal arcing was causing interference.

Martin said he maintains contacts with other utilities across the country. He can be reached at 202-388-2249 or at PEPCO Substation Test Electronics, 3300 Benning Road, N.E., Washington D.C. 20019.

OVER
5 MINUTES
OF 15KHZ STEREO AUDIO
ON EACH 13MB FLOPPY DISC



The Dynamax DCR1000 with New Version 2.0 Software

THE OBVIOUS DIGITAL SOLUTION TO CART MACHINE PLUG-IN REPLACEMENT

The Recorder

- Selectable sampling rates
- Secondary and Tertiary cues
- AES/EBU digital input
- Start on audio
- Direct digital dubbing from CD
- PC keyboard for titling
- Cut & paste editing
- Variable length beds
- Kill date checking
- Disk label printing

New

New

New

New

The Reproducer

- Simple cart-like operation
- No on-air personality training
- Just three front panel buttons
- Instant start and cue
- Maintenance-free design
- Awesome audio quality
- Rotation & chaining
- Replay lockout
- Count-up/count-down timer
- RS232 logging/remote control

New

New

New

New

The Media

- 13MB stores over 5 minutes stereo audio with 15kHz bandwidth and 15 minutes mono with 10kHz
- Standard low-cost 2MB floppy disk holds 60-second commercials
- Non destructive media diagnostic test

New

8:00 a.m. to 8:00 p.m. EST • 1-800-622-0022 • Fax 317-966-0623
Canada 1-800-263-6817 • Toronto 416-731-3687

 **HARRIS
ALLIED**

Circle (47) On Reader Service Card

Radio World

Broadcast Equipment Exchange

"Broadcast Equipment Exchange" accepts no responsibility for the condition of the equipment listed or for the specifics of transactions made between buyers and sellers.

NOTICE

5 REASONS WHY YOU SHOULD CALL US TODAY

- 1 We can help you select new equipment and supplies available from quality manufacturers such as Digitation, Nel-Tech Labs, Scala, Henry Radio and many others.
- 2 We have available rental test equipment such as:
Potomac Field Strength Meters (AM & FM)
Tektronix Spectrum Analyzer
Delta Impedance Bridge
Delta Receiver/Generator
- 3 Looking for a piece of quality pre-owned equipment? We have a great selection of that is always sold with a 30 day guarantee! Let us know what you need.
- 4 Do you have excess equipment you would like to sell? We have customers looking for transmitters, optimods, fields strength meters, STL and RPU equipment plus many other items. Let us know what you have available.
- 5 Need just good sound advice on equipment selections that both fit your needs and your budget? Call the two best sources of information in the industry, Steve or Chuck. They can help you save money!

RADIO RESOURCES

1201 S. Sharp St.
Baltimore, MD 21230
1-800-54-RADIO

Circle (135) On Reader Service Card

ACOUSTICS

Want To Sell

STUDIOFOAM
SOUND ABSORBENT WEDGES
TESTS UP TO 40% BETTER THAN SONEX
* COSTS LESS - BETTER COLORS - BETTER CUT *

SONOMATT
4'x8'x2" Sheets - \$29.99 Ea. In Pairs - \$49.99
VENUS 12" x 2" x 4" - MRC 1.30 - Flat 10K-125Hz
Then They Really Kick In (125Hz MRC -
BASS TRAPS) 1.631 - Charcoal Gray - For Just \$15.00!

USA Form - Box 20384 - Indianapolis IN 46220 (317) 251-2323
1-800-95-WEDGE

Circle (204) On Reader Service Card

AMPLIFIERS

Want To Sell

Stanton 310 pre amp, BO. J Kesler, WOBZ-TV, POB 220, Livingston KY 40445. 606-842-2209.

Hafler DH500/DH200, \$325 ea; Symetrix A220 (4), \$250 ea. Los Angeles CA. 310-372-4329 or 818-763-2461.

Crown PS-MOD/X 2 chnl input module mic/line balanced, plug-in amp w/octal socket, used, \$25. MRG Prod, 516-447-1041.

Altec-Lansing 1588B transistor preamps (6), new, \$60. MRG Productions, 516-447-1041.

Belar RF-1 tuned to 89.3 FM, never used, \$200. O Dyson, KJIC, POB 34321, Houston TX 77034. 713-944-7959.

Crown DC-150A power amplifier, black face, \$250; Crown DC-300 power amplifier, silver face, \$350. B Wilson, Wilsound Studios, 4400 Old Lebanon Rd, Campbellsville KY 42718. 502-789-3683.

New 250 W solid state amplifier, \$1800. Call for details. Bill Hoffman, 518-583-9490.

Want to Buy

WANTED:

Pultec EQ's; Fairchild, Teletronix, dbx, UREI, Sontec Limiters. Neumann, Telefunken, AKG and RCA mics. MacIntosh or Marantz Gear; Lang, Neve and API gear. Misc old tubes and guitars.

DAN ALEXANDER AUDIO

1340 Mission Street
San Francisco, CA 94103
(415) 252-7102
FAX: (415) 252-7524

Fisher, McIntosh, Harmon-Kardon tube amplifiers, parts & tubes, any owner/service manuals. R Green, WJGR, 1718 Shanandoah Rd, Wimauma FL 33598. 813-634-1940.

ANTENNAS/TOWERS/CABLES

PLFM-100 obsolete exciter upgrade ... \$229.95
CSG-10 stereo generator w/comp clipper ... \$349.95
BIA-1 optimod balanced interface ... \$249.95
*FMT-15 15W FM xmitr ... \$1,495
*FMT-15S stereo FMT-15 xmitr ... \$1,895
*RTU-1 remote controlled tuner ... \$495

JT Communications
904-236-0744 fax 904-236-5130

Circle (18) On Reader Service Card

ANTENNAS/TOWERS/CABLES

Want To Sell

Tower, 500', 3' face, 2 yrs old, in place or re-locate, Charlottesville VA; 500' 1-7/8" transmission line; ERI 92.1 MHz FM antenna, 2 bay. R Fries, WVSY, 800-990-1019.

H&P PC-140 photo-eye tower light controller w/ext eye, weather proof housing & adjustable delay set, \$50/BO, trade possible. A Wasilewski, KMWX, POB 1460, Yakima WA 98907. 509-248-1460.

3-1/8" hard line bullets (8 ea), fair coned, free, you ship. M Everhart, KGON, 4614 SW Kelly, Portland OR 97201. 503-497-0313.

Andrew coax on spool, approx 400' of 4", w/connectors, BO. B Lacy, KARX, 3611 Soney, #6A, Amarillo TX 79121. 806-359-4000.

FM - ANTENNAS

Designed and built for your frequency. Choose from 1 to 12 bays and five power levels. Financing available. Call Jimmie Joynt at S.W.R. **214-335-3425**

DB Products DB264 base station antenna, tuned to 155.25 MHz, usable over wider range, \$200 plus shpg; Motorola 6073A base station fiberglass whip antenna, 150-159 MHz, \$200 plus shpg. Al or Wes, KZPX, HCR1 Box 286D, Merrifield MN 56465. 218-765-3333.

Windcharger 45G, 100' iron tower, 5-20' sections w/guys, on ground, BO. J Kesler, WOBZ-TV, POB 220, Livingston KY 40445. 606-842-2209.

ERI GP55 5 bay 4" end feed rototill, gd cond, top bay needs repair, tuned to 106.1, BO plus shpg. B Brintzer, WDNC, 1000 Park 40 Plaza, Durham NC 27713. 919-361-1429.

SWR 6 bay, A1 power, tuned to 101.3, on air only 2.5 yrs, anti-ice coating, avail 1/94. \$8000/BO. J Stevens, KCHQ, 269 W Alameda #D, Burbank CA 91502. 818-954-0214.

Gates FMC-3A 3 bay tuned to 103.1 MHz, avail 12/93, BO. P Johnson, KCRV, POB 909, Caruthersville MO 63830. 314-333-1370.

Low & High pwr FM antennas

Low pwr hor polarized
Low pwr vert polarized
Low pwr circular polarized
High pwr circular polarized
All antennas under \$500 ea
M. Calenza
64 Belmont Ave
Plainview, NY 11803
516-681-9535

Andrew 7/8" to 1-5/8", gas pass connector, BO. M Friend, STU-Comm, 2011 Lewis Mt Rd, Charlottesville VA 22903. 804-971-4096.

Shively 6813-2R medium power 2-bay with radomes, tuned to 88.9, excellent condition, can be returned or modified for 88.1-89.9, \$1500/BO, pick up only. F Berger, WERS, 126 Beacon St, Boston MA 02116. 617-578-8823.

Tower, 460', 30" face capable of holding 3 bay low power antenna, STL & 2 small 2-way antennas 607 guyed, mfg & installed in 1991 by Burkhalter Tower, presently standing, you dismantle & move, \$7500. D Eversoll, WRHQ, Box 1150, Richmond Hill GA 31324. 912-756-3111.

4-Bay FMD scale translator antenna on 95.3, good condition, \$800; Jampro 1-bay FM Class A on 94.3, good condition, \$800. R Phipps, KERV, 301 Jct Hwy Ste 333, Kerrville TX 78028. 210-896-1230.

ITC

REPAIR — REFURBISHMENT

Direct Factory Cartridge Machine Repair Service
Upgrades or Refurbishment
All Work Warranted

Call The ITC Technical Service Department
Toll-Free at



(800) 447-0414
(309) 828-1381



International Tapetronics Corporation
2425 South Main Street
Bloomington, IL 61704

TOWERS...bought and sold. Call 1-800-393-2266.

Dielectric BFC-7B (5.8db) with heaters and BFC-5B (4.3db) with radomes. Both 97.1 MHz. BO. Slater C&E 503-399-7010.

300'-24" face tower, ERI # FML-3E antenna, 320' of 1-5/8" coax, Harris transmitter #FM2.5K on freq. 99.3. Call 1-800-393-2266.

Want to Buy

Shively or comparable fairly recent FM antenna tuned to 106.3, 3-bay, 4200 W in need for back up. L Maierhofer, WOHG, Fairground Rd R.D. 4, Huntingdon PA 16652.

Self supporting tower 200' with marker lights; 4-bay antenna with deicers for use on 99.5, transmission line & mounting brackets. R Williamson, KWEI, POB 791, Weiser ID 83672. 208-549-2241.

Jampro/ERI 8-bay antenna on 95.9 in gd cond, must do upgrade fast & need bargain on both coax & antenna. D Winkle, KBST, POB 1632, Big Spring TX 79721. 915-267-6391.

1-5/8" rigid transmission line, unflanged. Elbows, bullets, couplings. **305-757-9207.**

AUDIO PRODUCTION

Want To Sell

Gates TA-1; RCA arm-head plus EQ. B Rose, Program Recdgs, 228 E 10th St, NY NY, 10003. 212-674-3060.

CASSETTES • CARTS • REELS

J & I AUDIO/VIDEO

A wholesaler in the Radio and Television market. Now running SPECIALS on audio and video:
BASF CASSETTES-AMPEX R-Rs
AUDIOPAK, FIDELIPAC & ITC CARTS
For more information call Kris Elliot at **1-800-942-1711**
or write to: J&I Audio/Video
20899 Kelvin Pl.
Woodland Hills, CA 91367

Circle (158) On Reader Service Card

Sennheiser wireless infrared stereo headphones & xmitr, \$195; dbx 4BX dynamic range expander, \$275. R McMillen, Super Duper Audio Duplicating, 1634 SW Alder St, Portland OR 97205. 503-228-2222.

Mackie 1202 Micro Series

AUDIO CONSOLE

- 90 dB S/N ratio
- 0.25% distortion
- Gain Control
- Pan & EQ on each pot
- Balanced and Unbalanced outputs
- Built-in power supply
- Built-in headphone amplifier
- 8 inputs Mic/line/mono/stereo

LIST \$399

Call for special HE Price.

We'll be glad to help with all your audio needs!

(804) 974-6466 • FAX: (804) 974-6450
1305-F Seminole Trail
Charlottesville, VA 22901



Circle (199) On Reader Service Card

OEM Tapeheads



For most cart machines:
Stereo \$99
Mono \$75

Quality Rebuilt Used Equipment



90 Day Warranty
Parts & Labor Manuals included
Call for Current In-Stock Items

Marantz PMD Packages



Pitch Control
MONO-Record/Play
Telephone Jack
Built-in Mic and Speaker
PMD 201, Free AKG Mic
and Cable \$299

Call for special Price!

AUDIO PRODUCTION...WTS

Datatek D507 audio DA cards (3) with D-507 GRA power supply, no rack frame, new, BO. MRG Productions, 516-447-1041.

Correlation / Phase Indicator



A compact alternative to X/Y displays for Stereo / Mono Compatibility Checks
Tape Head Azimuth Adjustment
Transmission Path Evaluation
Stereo / Mono Identification
Signal Polarity Testing
CPI-300 — \$265

recording studio services
PO Box 3004
Hendersonville, TN 37077
Ph: 615-824-9300 Fax: 615-824-9303
Compuserve: 75366,311

Circle 22 On Reader Service Card

Shure M64A stereo preamp, like new, \$25. G Hultman, Hultman Media Services, 300 Limp Creek Rd, Grants Pass OR 97527. 503-474-6466.

Looking for Audio Bargains?

**We BUY ★ SELL ★ TRADE
QUALITY USED EQUIPMENT
317-962-8596**



DigiDesign SoundTools 1 with DAT interface, \$1200/Best Offer; DigiDesign Session 8, \$3000; 1.55 Gig SCSI drive, \$1700. R McMillen, Super Duper Audio Duplicating, 1634 SW Alder St, Portland OR 97205. 503-228-2222.

Eventide BD-941 broadcast delay line with 3, 6, or 12 second delay, \$975. R Chambers, KSUE, 3015 Johnstonville Rd, Susanville CA 96130. 916-257-2121.

Studer Dyaxis 2+2, 2 hour with SMPTE sync & DSP opt, demo, warranty, \$8850; Sony PCM-2300 DAT, new, \$975. P Engel, 508-745-8522.

ADC 144 Pt TT patchbays, excellent condition, 1 rack space, 3 rows of 48, top 2 rows normalled, \$129 (you remove old wiring) or \$199, we totally refurbish with new front panel, ready to install. TT cords at cost with purchase! Also 1/4" PB's. Audio Village, POB 2902, Palm Springs CA 92262. 619-320-0728, or Fax 619-320-2454.

Want to Buy

Sony 601ES or another F-1 format PCM with S/PDIF digital in & out. K Baker, Radio Kansas, 815 N Walnut, Hutchinson KS 67501. 316-665-3555.

Fairchild 600 conac or 602 Conex high frequency limiters. J Gangwer, 942 32nd St, Richmond CA 94804. 415-644-2363.

I'm young, talented, and willing to travel, so put down the magazine and call, progressive, classic rock, AOR, CHR, AC. Dennis, 405-634-5741.

AAS Graduate with 3 years on-air/PD seeks FT in Atlanta, CHR, AC, HOT AC, Light Talk, quality without the price. Brian, 1104 Park Circle, Conyers GA 30207.

Family style air personality with 10 years experience, seeks country station in Midwest. Tom 319-568-2198.

General Manager for Florida medium or large market, 29 years experience in sales, programming & engineering, turn-arounds or start ups, available immediately. 813-849-3477.

Grandpa Big Jim, 30 yrs exp, play-by-play, news anchor, talk shows, DJ. Stability, loyalty, Florida only. Jim 813-924-6507.

Seek FT announcing, production, programming position, will work hard & be dependable, 5 yrs exper, will relocate. James Montana, 919-921-3384.

RCA Ampliphase sharpshooter available for PT projects, most other transmitters & engineering also. Stephen Weber, POB 453, Oakridge, OR 97463. 503-782-2901.

MERCENARY AUDIO

WANTS TO BUY YOUR:

NEVE-SSL-TRIDENT-AMEK
UREI-TELETRONIX-FAIRCHILD
PULTEC-LANG-LEXICON
UNIVERSAL AUDIO-NEUMANN
AKG-TELEFUNKEN-AMS

**ANYTHING THAT IS
OF EXCEPTIONAL
AUDIO QUALITY!**

"this is not a problem"
(508)543-0069 TEL
(508)543-9670 FAX

**AUTOMATION
EQUIPMENT**

Want To Sell

Systemation X-7 avail for use as parts, BO. B Kenney, WOYC, POB 1646, High Springs FL 32643. 904-454-3666.

Scully 100, BO. J Kessler, WOBZ-TV, POB 220, Livingston KY 40445. 606-642-2209.

SMC MSP12 controller, DAS12 switcher with (4) 452 Carousels, (4) Otari ARS1000 reel decks, (2) remote control heads, (2) Amdek video monitors, complete system in 3 racks, excellent condition, Best Offer. M Roberts, WKAA, 128 1st St #322, Tifton GA 31794. 912-386-5679.

SMC 350 Carousel, stereo in oak laminated cabinet, working when removed, \$350. D Koehn, KKPR, 403 E 25th, Kearney NE 68847. 308-236-9900.

Smartcaster, 2 yrs old, still in service, w/3 relay cards (24 relays), SX-8 audio card, monitor, keyboard, etc. A Clawson, WPF, POB 444, Sturgeon Bay WI 54235. 414-743-7443.

Sonomag Mini-Pro with remote head, (2) RS350 Carousel, RSC-100 random programmer, (4) Revox PR99, will sell separate or together, \$2750. S King, KGFL, Box 33, Clinton AR 72031. 501-745-4474.

SMC DP-1 (4) 350 Carousels, (2) dual play LA-246, DP-1 Brain & keyboard, remote (4) SMC R-R & tone sensors, all working; SMC DP-1 20 ch, (6) 352 Carousels, (2) dual play, (2) ITC R-R, DP-1 Brain & keyboard with remote, LA 246. L Nelson, WAUR, 1 Broadcast Center, Plano IL 60545. 708-552-1000 X150.

IGM SC, complete with 16 inputs, relay card plus spare cards, (5) IGM Go-Carts & (3) Otari ARS 1000 stereo PB R-R machines, IGM encoder with terminal & keyboard. J Lotspeich, KTSM, 801 N Oregon St, El Paso TX 79902. 915-532-5421.

Format Sentry FS-12C 48 tray Instacart, (4) ITC R-R, (2) 6' racks, DRS power supply, Tandy 1000 SL computer, Tandy DMP 134 printer, Spolmaster cart machine W 2500 tone, 2 years old, bought new, will sell for what's owing on equipment. A Terry, WODY, POB 545, Bassett VA 24055. 703-647-8493.

IGM Go-Cart 24 in excellent condition, \$750. M Ripley, KOZE, POB 936, Lewiston ID 83501. 208-743-2502.

IGM Basic A misc parts, Instacart 48 tray stereo, (4) Otari 1000 tape recorders, Wegener 1600 sat rcvr carded for country coast to coast & Microdyne 1100 rec. E Kazmark, KAZZ, POB 1359, Deer Park WA 99006. 509-276-8816.

Harris 9000 automation system with Micropolis 1055-2 floppy disk drives (not working), (2) IGM Go-Carts, 42 tray, one operational & one for parts; TEC 70X monitor & keyboard, plus misc parts, \$1000/BO. J Huffmann, KMCC, 503-298-5116 or 1-800-288-5116.

Satellite package with Systemation Superswitch, BE 3000 R/P cart deck, ITC single play cart deck, ITC 3D triple deck, \$2400. G McCoy, KEZH, 500 E. J St, Hastings NE 68902. 402-463-1314.

Harris 9002, (4) ITC 770 reel, (5) IGM Go-Cart 24, Delta deck/recorder, dual floppy drive, keyboard & CRT, manuals, BO. G Bamert, WHMS, POB 3939, Champaign IL 61826. 217-351-5300.

Want to Buy

25 Hz tone sensor, prefer rack mount. L Fuss, WDTL, POB 1438, Cleveland MS 38732. 601-846-0927.

CART MACHINES

Want To Sell

IT Delta record electronics, no transport, \$800. T Parks, WONU, POB 592, Kankakee IL 60901. 815-939-5330.

Spotmaster 500B R/P lever type, good heads, mono, excellent condition, \$600; Spotmaster 500B R/P lever type, mono, good shape, \$400. K Stevens, In House Audio, 5354 Cortez Ct, Mobile AL 36609. 205-666-4232.

Great Prices on original equipment tape heads for ITC, BE, Fidelipac, Otari, Tascam & others!

HE HALL Electronics
(804) 974-6466 • FAX 6450

Gates Cartridge II mono play only cart decks (2), \$150 ea. M Everhart, KGON, 4614 SW Kelly, Portland OR 97201. 503-497-0313.

BE Series 3000 PB cart decks, mono (5), \$250 ea. M Ripley, KOZE, POB 936, Lewiston ID 83501. 208-743-2502.

EMPLOYMENT

To place ads in this section, use the ActionGram form. To respond to box numbers write Radio World, PO Box 1214, Falls Church, VA 22041. Attn: _____

POSITIONS WANTED

GM, sales, announcer, PD, engineer, production, 30 yrs solid exper, south coastal Florida only. B Elliott, 813-849-3477.

Janet, 502-895-5888. For unconventional, overworked broadcasters knowing experience isn't only years, tapes. Computer literate, P/T announcing, marketing exper. Wants FT announcing, programming. Serious replies please.

Broadcasting graduate, young, energetic w/great voice seeks entry-level position, trained on-air, production, sales & more, will travel, Christian, AOR, AC. Allen, 405-360-5434.

Full time military reserve seeking PT radio work in Portland area, trained, willing to work odd hrs, eager to learn more. James Wilson, 503-244-7502.

CE SW only with 20 plus years all aspects, major market exper, high power AM & FM, directionals, audio, seeks position in southwest Top 100 market, good references. Write to: Radio World, POB 1214, Falls Church VA 22041. Attn: Box #93-11-10-01RW.

Recent grad, former program director with organizational skills galore looking for announcer or management position, will relocate, answering machine on-line. Jock, 901-989-9568.

I'm young, talented, and willing to travel, so put down the magazine and call, progressive, classic rock, AOR, CHR, AC. Dennis, 405-634-5741.

AAS Graduate with 3 years on-air/PD seeks FT in Atlanta, CHR, AC, HOT AC, Light Talk, quality without the price. Brian, 1104 Park Circle, Conyers GA 30207.

Family style air personality with 10 years experience, seeks country station in Midwest. Tom 319-568-2198.

General Manager for Florida medium or large market, 29 years experience in sales, programming & engineering, turn-arounds or start ups, available immediately. 813-849-3477.

Grandpa Big Jim, 30 yrs exp, play-by-play, news anchor, talk shows, DJ. Stability, loyalty, Florida only. Jim 813-924-6507.

Seek FT announcing, production, programming position, will work hard & be dependable, 5 yrs exper, will relocate. James Montana, 919-921-3384.

RCA Ampliphase sharpshooter available for PT projects, most other transmitters & engineering also. Stephen Weber, POB 453, Oakridge, OR 97463. 503-782-2901.

Air personality ready to boost your ratings, all formats. D.C. Sky, 918-425-3834. **Recent journalism grad** w/college/commercial radio experience seeks FT news/sports position in southeast, willing to sell. Andy, 205-956-0933.

Dedicated, experienced air personality, recent morning gig w/production skills, will relocate, AC/CHR/Oldies. Kevin, 609-863-1991.

AT w/3.5 yrs in CHR/A/C, & country seeks FT position in CO/NV/NM. Dances, news, board, op, production, live call-in show. Laura, 303-824-9650.

Recent grad, career minded work junkie entering bdctg, loyal & dedicated. Don, 918-742-1227.

Former Gannett employee seeking opportunity, young, team player, w/experience in prod, programming & promotions, board op, air talent, morning show producer, want FT or PT. R Boeker, 3315 Fleming, Baytown TX 77521. 713-421-7191.

For unconventional, overworked broadcasters knowing experience isn't only years, tapes. Computer literate, PT announcing, marketing experience, wants FT announcing, programming, serious replies please. Janet, 502-895-5888.

Funny guy with 8 years small market experience would like to tele-commute as copywriter/comedy writer. Brian Schaefer, POB 3545, Estes Park CO 80517.

Hands on Engineer w/over 30 yrs of AM/FM/TV. MF/HF/UHF background, desires position with Intl SW bdctg facility, FCC Gen SBE Cert, IEEE, AE Degree. Lou, 904-303-1002.

Small Market GM, creative & promotional minded with strong sales background seeking opportunity w/possible equity. Dave, 513-453-2262.

Radio program producer, medical, sports, celebrity interviews, adventures, your program needs filled creatively to meet your market or advertisers. L Engel, POB 71593, Las Vegas NV 89170. 702-361-7018.

Energetic, great sense of humor & timing, good production, on-air, copywriting skills, seeks CHR or contemporary Christian station. Paul, 918-742-1227.

Recent graduate, solid on-air, enthusiastic sports nut, newsworthy style & prod, seeking home in Oklahoma or Texas. Paul, 918-749-7935.

Rick Allen, also known as Rick Savage is now at Classic Oldies KOOL 92 WKZL in Canton, OH & seeking FT gig. 216-773-1549.

Exper GM-OM w/unbeatable track record is fired up to make your station the community's most well known, former major market sportscaster. Big Ed Edwards, 4009 17th St, Sarasota FL 34235. 813-366-0732.

Seeking a workoholic team-oriented AT w/wicked prod skills? Look no further. Relocation not a problem. AOR, Classic Rock, Modern preferred. Tommy, 314-348-5660.

Smooth, very energetic, good production skills, crisp on-air, real talker, authoritative news, excellent side-kick material, great voice. Caroline, 918-451-2323.

Sharp country on-air wizard, great on-air, prod & copywriting talents. Scott, 918-492-4213.

Combo talent: GM, sales, announcer, PD, engineer, production, airplane pilot, 30 years solid experience, south coastal Florida only. 813-849-3477.

Announcer really enjoys covering news, is adept at writing commercials, can't travel far, but will work hard, no sales. Joe, 918-245-3408.

Over 20 years experience, last 6 years Director of Engineering San Francisco stations, happy to relocate, also on-air experience. T Levin, 415-712-1239.

HELP WANTED

Engineer with broadcast, paging and two-way communication experience. Must have primary experience in communication equipment and AM and FM broadcast equipment maintenance and operation. Computer experience desired. Send resume and salary requirements to: Engineer, P.O. Box 362, Scottsbluff, Nebraska 69363-0362.

CHIEF ENGINEER
Pacific Northwest, Great Lifestyle!
AM-FM, knowledge requirements, transmitters (AM has critical pattern) studio audio, satellite reception, digital automation. Need team player. Good benefits. Send salary history, resume, references to Radio World, POB 1214, Falls Church, VA 22041. Attn: Box 93-12-02RW. EOE M/F

CHIEF ENGINEER
Virginia broadcast group seeking FM broadcast engineer with several years experience. Requirements. Technical school graduate, SBE certified, proficient at troubleshooting audio quality, radio station RF and studio systems, strong PC and digital system knowledge. Send resume and salary requirements to:
Radio World, Box 1214
Falls Church, VA 22041
Attn: Box #93-12-01RW EOE, M/F

ENGINEERING
FT/PT, strong equipment/transmitter maintenance, CE position possible, Radio/TV or both. Contact Gen. Mgr., WENY Inc., POB 208, Elmira, NY 14902.
607-739-0344/739-3636
EOE/MF

ELECTRONICS ENGINEER
National Public Radio has openings in the Engineering Services Unit of the Audio Engineering Division for Electronics Engineers. You will be responsible for designing, constructing, installing, testing, maintaining and repairing NPR's technical equipment. Candidates must have demonstrated ability to trouble-shoot to the component level; at least three years broadcast and/or recording studio equipment maintenance experience and working knowledge of drawing, word processing and spreadsheet applications. The position will require shift work. To apply send cover letter and resume to:
National Public Radio
Personnel Dept. #52
2025 M Street
Washington, DC 20036
NPR is an
Equal Opportunity Employer

TOO MANY OPENINGS!
We have too many positions to fill in the broadcast industry & not enough people to fill them. Radio openings for air talent, news, management, production & sales personnel & also dozens of engineering positions available in all aspects of broadcasting. Over 200 listings each week within a 4 week window. More info per listing than any other source plus we refer your name out to stations looking for your qualification FREE. Call toll-free for info.
BROADCAST EMPLOYMENT WEEKLY
1-800-922-JOBS
10480 Overland Rd. Ste. 328
Boise, ID 83709
Local B.B.B. Member

ABOUT OUR EMPLOYMENT SECTION

HELP WANTED: Any company or station can run "Help Wanted" ads for \$1.50/word or buy a display box for \$55/column inch. Payment must accompany insert, use your MasterCard or VISA; there will be no invoicing. Blind box numbers will be provided at an extra charge of \$10. Responses will be forwarded to listee, unopened, upon receipt. Call 800-336-3045 for details.

POSITIONS WANTED: Any individual can run a "Position Wanted" ad, FREE of charge (25 words max), and it will appear in the following 2 issues of Radio World. Contact information will be provided, but if a blind box number is required, there is a \$10 fee which must be paid with the listing (there will be no invoicing). Responses will be forwarded to the listee, unopened.

Mail to: BROADCAST EQUIPMENT EXCHANGE
PO Box 1214, Falls Church, VA 22041
Attn: Simone Mullins

CART MACHINES...WTS

ITC Delta mono players (3), vgc, \$675; ITC Delta mono recorder, vgc, \$1100. K O'Malley, WTKR, 804-446-1328.

Tapecaster cart machines (2), mono, one record w/150 Hz tone generator, one PB only, used seasonally, well maintained. A Slough, Ski Areas of New York, 2144 Currie Rd, Tully NY 13159. 315-696-6550.

Audi-Cord DL Series PB & R/PB stereo cart machines, sell as package, low use, still in service till 10/31/93, \$1100/both. J Hartmeyer, WCLT, POB 899, Newark OH 43058. 614-345-4004.

Tapecaster 700P stereo, play only, excel cond, \$275. Al or Wes, KZPX, HCR1 Box 286D, Merrifield MN 56465. 218-765-3333.

Audiocord DL Series PB only, mono, like new, \$650. B McKittrick, Recording Studio, 331 Mulberry St, Carasauqua PA 18032. 215-264-5295.

ITC PD-II (3), mono, \$300/BO. L Fuss, WDTL, POB 1438, Cleveland MS 38732. 601-846-0927.

Audi-Cord PB only (2) in good condition, \$350 ea. R Phipps, KERV, 301 Jct Hwy Ste 333, Kerrville TX 78028. 210-896-1230.

BE 5300C tripledeck, stereo, PB, mint less than 50 hrs, BO. R Kaufman, Pams Prods, POB 462247, Garland TX 75046. 214-271-7625, after 3PM CDT.

Want to Buy

ITC RPD, must be in gd cond, three tones w/rack ears. DJ Williams, Lincoln County Bldg, 1103 Utah Ave, Libby MT 59923. 406-293-6234.

BE 605-B needed, also TAM-1K6C 1 kHz sensor board. H Henderson, KDAP, 2031 N 6 Ave, Douglas AZ 85608. 602-364-3484.

ITC, BE, Fidelipac cart machines: single, triple, mono, stereo, play & record/play. Call M O'Drobinak @ 619-758-0888.

CASSETTE & REEL-TO-REEL RECORDERS

STUDER SERVICE SPECIALIST

Thousands Serviced • Unbeatable Rates
Precision Capstan Resurfacing
Audio Advantage
Tel (615)742-3834 FAX (615)254-8826
PRICE-QUALITY-SERVICE
Let Us Prove It

Want To Sell

Teac A-3300-SX 2T R-R, \$400; Teac X-1000 R-R, \$250; Audicord stereo double cart reproducer, \$300. T Parks, WONU, POB 592, Kankakee IL 60901. 815-939-5330.

REVOX PARTS/SERVICE

Cassette-CD-Open reel
Rebuilt A77s, \$800
Capstan resurfacing, ALL BRANDS.
JM TECHNICAL ARTS
30 Music Sq. W. #156
Nashville, TN 37203 (615) 244-6892

Ruslang R-R push carts (2), new, never used, fits Otari or other, oak finish, \$50 ea or \$75/both. A Wasilewski, KMWX, POB 1460, Yakima WA 98907. 509-248-1460.

Ampex MM1000 8 trk factory rebuilt heads by Ampex, less than 100 hrs on heads, mint cond, \$900; Ampex 400C 2 trk, very low hrs, \$1200. L Ponzek, Cypress Queen Recdg Std, 1019 New Market St, Philadelphia PA 19123. 215-934-6414.

Otari ARS 1000 (2), mint cond, BO. J Kesler, WOBZ-TV, POB 220, Livingston KY 40445. 606-842-2209.

Sony MCI 1" 8 trk, mint cond; Revox PR-99, mint cond; Teac 1/4", gd cond. Star Prod & Recdg Co, 618 Georgia St, Bethalto IL 62010. 618-377-5569.

Ampex, ITC, Scully Reel-to-Reel Tape Recorder Spare Parts, Accessories Motor Remanufacturing.

VIF INTERNATIONAL
PO Box 1555
Mtn View CA
94042 U.S.A.

Inside USA: 1-800-848-4428
Outside USA: 1-408-739-9740
FAX: 1-408-739-0809

Ampex 351 PB rack mount decks (2), \$300 ea. C Sigmon, WDKZ, POB 1398, York SC 29745. 803-684-4241.

Otari MTR-10 2 trk w/ctr trk time code, \$2800; Otari MX-5050 MK III 2 trk (4), \$950 ea; Revox PR-99 mono (2), \$75 ea. Los Angeles CA. 310-372-4329 or 818-763-2461.

Otari MX-5050 MK III 1/2" 8 trk, excel cond, low hrs, \$2500; Otari MTR-9011 24 trk, \$27,000/BO. Los Angeles CA. 310-372-4329 or 818-763-2461.

Nakamichi MR-2 cassette decks (5), set up for dubbing in vertical rack w/gang remote, \$1500/all or may sell separately. Los Angeles CA. 310-372-4329 or 818-763-2461.

Tascam 234 4 trk (5), \$325 ea. B Kenney, WYOC, POB 1646, High Springs FL 32643. 904-454-3666.

Telex 235 3:1 cassette duplicator, perfect cond, \$650 plus shpg. S Russell, Russell Studios, 60410 Klett Dr, Decatur MI 49045. 616-782-9258.

Tascam 22-2 2 trk, 7" reels, 15 & 7.5 ips, like new w/manual & original packing, \$575. J Ellingson, Jeff Ellingson Voice-Overs, 913 Warwick Dr, Cedar Falls IA 50613. 319-277-8535.

DAT Machines

Radio Systems/Sony RS-1000
Perfect for on-air, live sound, or automation.
Orig. \$3000 Sell \$1150

Panasonic SV-3900
Computer controllable
with RS-422 interface.
Orig. \$1850 Sell \$995

Pro Digital Inc.
DAT Recorder Service Specialists
215.328.6992
FAST, EXPERT REPAIRS

Ampex 350 (2) mono R-R recdr w/inovonics electronics solid state rack-mount units, \$300 ea. A Baker, BPA Inc, 804 E 38th St, Indianapolis IN 46205. 317-925-7371.

Ampex AG-440 1/4" FT P/R in Ruslang roll-around console, \$350 or unmounted for \$250; Ampex AG-440 1/4" 1/2 trk R/P in Ruslang roll-around console, \$500 or as is for \$400; Ampex AG-440 1/2" 4 trk heads w/only 2 sets of electronics, \$650; Ampex AG-440 1/4" 1/2 trk PB only in roll-around console, \$350 or as is for \$250, will trade for pro DAT recorder(s), cassette recorders & mics. D Flynn, Continental Recordings, 230 Adams St, Newton MA 02158. 617-630-0007.

Telex 6120XL high speed duplicator w/7 slaves & 4 cassette rewind unit, \$3500. W Sear, Sear Sound, 353 W 48th St, NY NY 10036. 212-582-5380.

Tascam 238 8 trk, mint cond, less than 20 hrs, \$925 includes shipping. M Bucco, The Michael Thomas Group, 407 Society Hill Blvd, Cherry Hill NJ 08003. 609-424-6481.

Otari ARS 1000 PB R-R's (4), \$650 ea or \$2450/all. A Miller, WKMX, 100 N Main St, Enterprise AL 36630. 205-347-2278.

Crown SX-722 1/2 trk stereo, 3-3/4 & 7.5 ips, very clean, \$300; Uher 4000 Report-L, very clean, case, AC supply & mic, \$100. G Hultman, Hultman Media Svcs, 300 Limp Creek Rd, Grants Pass OR 97527. 503-474-6466.

Ampex AG-350 mono R-R recdr w/solid state electronics from Ampex rackmount unit in custom console, \$500. A Baker, BPA Inc, 804 E 38th St, Indianapolis IN 46205. 317-925-7371.

Telex Magnecord 1022 2 trk P/R & 4 trk play only w/rack, gd cond, \$200 plus shpg. Al or Wes, KZPX, HCR1 Box 286D, Merrifield MN 56465. 218-765-3333.

Studer A-80 Autolocator 1 aux pwr supply & autolocator pwr supply OK, locator great for hard to find parts, complete, but glitches, \$250. D Bailey, Rock Shoppe Prod, 3422 Beech St, Rowlett TX 75088. 214-475-9796.

Scully 270 (5) 1/2 trk stereo, working, some w/Saki heads, \$100 ea or \$400/all, you pickup or ship. P Patton, WWAM, POB 279, Jasper TN 37347. 615-942-1700.

Revox B-77 open-reel recdr, 7.5 & 15 ips, 1/2 trk version w/direct input mod, improved output amps, spill-tape edit function, remote control, varispeed controller & hard fiber travel case, gd cond, \$575; Sony PCM-F1 digital recording system, complete recording system, \$1500, F1 processor only, \$1000. R Streicher, Pacific A/V Enter, 545 Cloverleaf Way, Monrovia CA 91016. 818-359-8012.

Studer Revox 77B in metal rail style roll around, \$600; Scully 280 stereo R-R's, \$250 ea. S Horner, KLAX, 5700 Sunset Blvd, Los Angeles CA 90028. 805-654-0577.

Long Life OEM Tape Heads

One year warranty
Flat response of
±1dB 35 Hz to 16 kHz

SEQUOIA ELECTRONICS

4646 Houndshaven Way
San Jose, CA 95111
(408) 363-1646
FAX (408) 363-0957

Tascam 464 Port-A-Studio plus RC-30P footswitch, (2) Carvin CM67 mics, Sony MDRV4 earphones, cables, adapters & stands, never used, \$650 plus shpg. J Tanis, Civitas Inc, 925 N Northlake Dr, Hollywood FL 33019. 305-920-4218.

Recorder heads, used Scully mono & 2 trk, \$25-50, ATR100's, 3M M79-16 & 8's, Otari 1/2" 8 trks, \$495. W Gunn, 619-320-0728.

16 trk 2", \$3450; Otari 1" 8 trk, \$2450; 5050 III-8, \$1950; Ampex ATR800 mono, \$750; Tascam 25-2, \$750; Tascam 52 mint, \$1200; MCI Locator III, \$1195; Ampex AG350 solid st electr, \$100/ch. W Gunn, 619-320-0728.

Otari Mark II-IV 1/2" 4-track, multi-track, mint, less than 50 hours, Best Offer. R Kaufman, Pams Productions, POB 462247, Garland TX 75046. 214-271-7625, after 3PM CDT.

CLEAN PATCH BAYS
NO DOWN TIME

VERTIGO BURNISHERS AND INJECTORS RESTORE ORIGINAL PERFORMANCE TO YOUR PATCH BAYS

\$34.95 Ea. Please write for additional information and order form.
VERTIGO RECORDING SERVICES
1215 Magnolia Blvd. #116 818-907-5161
North Hollywood, CA 91607 fax 818-784-3763

Otari MX 5050 BQII 1/4", in excellent condition, \$1000/BO. Jim, 206-783-4799.

Want to Buy

Nagra IV-STC or IV-S time code or stereo, Denecke TS-1 time code slate. G Warren, 3765 N Lakeview, Chicago IL 60613. 312-327-4785.

Tascam 42B rackmount RM 501. G Fitzgerald, Fitzmusic, 37-75 63rd St #B29, Woodside NY 11377. 718-446-3857.

Scully 280-B, bias oscillator & R/P amp. S Kirsch, Silver Lake Audio, 2590 Hillside Ct, Baldwin NY 11510. 516-623-6114.

Ampex ATR100 taperecorders for parts. Circuit cards, heads, motors, machine parts, or electronic parts. Call 818-907-5161.

Spotmaster TP-60B tape timers from cart tape winders (TP-1A or TP-1B). Mel Crosby, 408-363-1646.

Scully '100' recorders, record/play amplifiers, 8, 16, 24 track heads. Sequoia Electronics, 4646 Houndshaven Way, San Jose CA 95111. 408-363-1646.

CD PLAYERS

Want To Sell

Denon DN-950FA in excel cond, \$750. R Michaels, KQFX, POB 7762, Amarillo TX 79114. 806-355-1044.

Adult Contemporary CD library, approx 1300 titles on 65 CDs, titles are 1980 to present, \$1800. Karen or Bob, 703-382-6106.

Technics SL-P1200 CD player, \$600. M Osborne, WKSQ, POB 9494, Ellsworth ME 04605. 207-667-7573.

Technics SL-P1200 (3) with remotes manuals, \$600 each. A Garza, Foster Communications, 2824 Sherwood Way, San Angelo TX 26901. 915-949-2112.

COMPUTERS

Want To Sell

Vydec 1800 word processor with Cume daisy wheel printer, 2 tape drives, uses 7.5" floppy disks, \$300. D Flynn, Continental Recordings, 230 Adams St, Newton MA 02158. 617-630-0007.

CONSOLES

Want To Sell

Stellavox mixer prof & portable, sound mixer 5 input, 2 output, \$200. L Ponzek, Cypress Queen Recdg Std, 1019 New Market St, Philadelphia PA 19123. 215-934-6414.

BE 5-S-250 5 pot stereo board with rotary faders, \$495; UREI Mod One 5-pot stereo, slide faders & external power supply, \$425. M Everhart, KGON, 4614 SW Kelly, Portland OR 97201. 503-497-0313.

Autogram Pacemaker 828 8 channel stereo, slide control, excellent condition, \$3200. R Michaels, KQFX, POB 7762, Amarillo TX 79114. 806-355-1044.

TAC Scorpio 16x8x2, complete studio setup w/cabinetry, patchbay & interface wiring. Los Angeles CA. 310-372-4329 or 818-763-2461.

Autogram AC8, 8 channel in very good condition with documentation, \$1750/Best Offer. Barbara Feil, Survival Ministries, 795 Via Lata, Colton CA 92324. 909-370-3314.

Soundcraft 1600 24x16x2, wired for 24 trk prod w/oak cabinet w/producers desk, patchbay & interface wiring, \$7500. Los Angeles CA. 310-372-4329 or 818-763-2461.

Pacific Recorders interface modules, TT-3 TT interface, TCI-2A cart interface, \$95 each. M Everhart, KGON, 4614 SW Kelly, Portland OR 97201. 503-497-0313.

Audio Technica RMX64 6 input, 4 trk, phantom pwr, 2-speeds, 4 subs, parametric EQ's, \$899; Tascam M216, 16 trk mixer, \$799. G Fitzgerald, Fitzmusic Studios, NYNY. 718-446-3857.

MCI JH416B VO module with P&G fader, late version, excellent condition, \$300. D Bailey, Rock Shoppe Productions, 3422 Beech St, Rowlett TX 75088. 214-475-9796.

Gately 16x8 audio board w/EQ on every chnl, (4) effect buss, Canon connector for inputs & outputs, 7" long by 4" wide in custom console, \$800. A Baker, BPA Inc, 804 E 38th St, Indianapolis IN 46205. 317-925-7371.

Radio Labs Podular 8 mixer stereo console w/expandable modular design, works fine, \$1800. S Horner, KLAX, 5700 Sunset Blvd, Los Angeles CA 90028. 805-654-0577.

Soundcraft Spirit 163, 16 inputs, excellent condition, \$1550; Quantum 12A highly modified for live concert recording applications with ATA road case, complete, \$1300; Fostex 2050 line mixer, ten 8+2 line-level inputs, stereo outputs with rackmount adaptors, \$100. R Streicher, Pacific A/V Enter, 545 Cloverleaf Way, Monrovia CA 91016. 818-359-8012.

RCA BC-17 10 chnl stereo plus mono chnl, \$450 plus shpg. L Nelson, WAUR, 1 Broadcast Center, Plano IL 60545. 708-552-1000 X150.

Ramko DC5AR 5 channel mixers, 14 available, very good condition, \$225 each. 916-334-9449.

PHONE: 703-998-7600 FAX: 703-998-2966



Call Simone Mullins, Classified Ad Manager, to reserve space in the next issue. Use your credit card to pay, we now accept VISA and MASTERCARD.

Radio World

5827 Columbia Pike, 3rd Floor
Falls Church, VA 22041

Select from these categories for best ad positioning:

Acoustics	Consoles	Software
Amplifiers	Disco-Pro Sound Equip.	Stations
Antennas & Towers & Cables	Financial Services	Stereo Generators
Audio Production (Other)	Leasing	Tapes, Carts & Reels
Brokers	Limiters	Tax Deductable Equipment
Business Opportunities	Microphones	Test Equipment
Cart Machines	Miscellaneous	Transmitter/Exciters
Cassette & R-R Recorders	Monitors	Tubes
CD Players	Receivers & Transceivers	Turntables
Computers	Remote & Microwave Equip.	Positions Wanted
	Satellite Equipment	Help Wanted

Classified Advertising Rates Effective January 1, 1993

	1x	3x	6x	12x
1-9 col inch (per inch)	\$55	53	50	45
10-19 col inch (per inch)	50	48	45	40
Distributor Directory	90	85	80	75
Professional Card	60	55	50	45
Classified Line Ad		\$1.50 per word		
Blind Box Ad		\$10 additional		

To compute ad costs: Multiply the number of ad inches (columns x inches) by the desired rate schedule for your per unit cost. Example: a 3" ad at the 1x rate is \$165, at the 3x rate \$159, at the 6x rate \$150, at the 12x rate \$147, etc.

DISTRIBUTOR DIRECTORY

The following distributors serving the broadcast industry would be glad to help you with any of your requirements.

... Canada, the Caribbean, Shannon to Shanghai, the dynamite Fifty ...

RADIO! The beat goes on!

CROUSE-KIMZEY OF ANNAPOLIS

tops in broadcast equipment
1-800-955-6800
ask for Kathleen

CORNELL-DUBILIER MICA CAPACITORS

FROM STOCK

JENNINGS VACUUM CAPACITORS

FROM STOCK

JENNINGS VACUUM RELAYS

SURCOM ASSOCIATES
2215 Faraday Ave., Suite A
Carlsbad, California 92008
(619) 438-4420

CONSOLES...cont

Want to Buy

Spears A-20, A-20-2, prefer stereo version, will consider mono. DJ Williams, Lincoln County Bdctg, 1103 Utah Ave, Libby MT 59923. 406-293-6234.

McMartin B-501 8 in working or non working order. M Shannon, WAMJ, 1129 N Hickory, Mishawaka IN 46615. 219-234-1580.

DISCO-PRO SOUND EQUIP

Want To Sell

JBL studio monitors in gd cond. Star Prod & Recdg Co, 618 Georgia St, Bethalto IL 62010. 618-377-5569.

JBL 4411 (2 pr), \$250 pr; Auratones (2 pr), \$50 pr; Sony SP80 (2 pr), \$75/BO pr. Los Angeles CA. 310-372-4329 or 818-763-2461.

JBL 4341 studio monitors, \$1500/pr. L Ponzek, Cypress Queen Recdg Std, 1019 New Market St, Philadelphia PA 19123. 215-934-6414.

UREI 539 1/3 oct EQ (4), \$400 ea; UREI 525 crossover (4), \$400; Crown MX-4 crossovers (4), \$225. R McMillen, Super Duper Audio Duplicating, 1634 SW Alder St, Portland OR 97205. 503-228-2222.

JKR 985 rcvr/monitor programmable electronic keyboard simulator (2), BO. MRG Prod, 516-447-1041.

Bose 901 w/EQ unit, good condition, \$450/BO. M Friend, STU-Comm, 2011 Lewis Mt Rd, Charlottesville VA 22903. 804-971-4096.

dbx K9-22 type 1 NR cards (2), compatible w/TTM or Dolby frame/Cat 22 cards or Telcom C4, \$100 ea. D Bailey, Rock Shoppe Prod, 3422 Beech St, Rowlett TX 75088. 214-475-9796.

UREI 813 time-aligned speakers (pr), \$1600. D Flynn, Continental Recordings, 230 Adams St, Newton MA 02158. 617-630-0007.

Want to Buy

Roland DEP-5, used. S Russell, 60410 Klett Dr, Decatur MI 49045. 616-782-9258.

FINANCIAL SERVICES

EQUIPMENT FINANCING ON ALL RADIO EQUIPMENT

- Easy to qualify
- Fixed-rate, long-term leases
- Any new or used equipment
- 100% financing, no down payment
- No financials required under \$50,000
- Refinancing existing equipment



Call Mark Wilson (800) 275-0185

FURNITURE

Want To Sell

STUDIO FURNITURE - 2 Studios used for NAB demo, excellent condition, stand-up type, both have twin racks and one turret, will separate. Vince @ Studio Technology 215-640-1229.

LIMITERS

Want To Sell

Orban Optimod 8000A, recently in service, \$1200/BO. G Finney, WPWB, 7137 Heather Ln, Macon GA 31206. 912-788-2124.

Optimod 8000A \$1500. R Michaels, KQFX, POB 7762, Amarillo TX 79114. 806-355-1044.

Orban Optimod 8100A/1 FM in excel cond, factory update & re-alignment 8/92, \$2800 plus shpg. L Eichelberger, KCIX, 5257 Fairview Ave, Boise ID 83706. 208-376-6666.

Orban 8000A stereo/gen processor, gd cond, \$1695. C Sigmon, WDZK, POB 1398, York SC 29745. 803-684-4241.

Audioliner AVS-100 processor, BO. J Kesler, WOBZ-TV, POB 220, Livingston KY 40445. 606-842-2209.

Pultec EQH2 EQ, extremely nice shape Yamaha SPX-90, little use. Chuck, Foster Prod, 727 Hammond St, Bangor ME 04401. 207-947-4487.

dbx 165x (2), over easy limiter compressor, \$150 ea. R Phipps, KERV, 301 Jct Hwy Ste 333, Kerrville TX 78028. 210-896-1230.

Shure FP-31 3 chnl mono mixer/case, used, gd cond, \$500. Raider Prod, 1006 Stoneham Dr, West Chester PA 19382. 215-889-9565.

Orban 412A compressor/limiter, excel cond, \$125. G Faltus, 10 Executive Dr, Farmington CT 06032. 203-677-6700.

Behringer Composer, compressor/limiter/gate, 6 mos old, mint cond, \$295 includes shipping. M Bucci, The Michael Thomas Group, 407 Society Hill Blvd, Cherry Hill NJ 08003. 609-424-6481.

Elcom Bauer WBL composite clipper, \$150. L Fuss, WDTL, POB 1438, Cleveland MS 38732. 601-846-0927.

Modulation Science CP803 composite processor, \$100. M Hendrickson, Hedberg Bdctg, POB 249, Blue Earth MN 56013. Fax: 507-526-5720.

Want to Buy

Mono limiter for travelers information station (TIS). AJ Anello, Radio Free YBOR, 1915 W Waters Ave #1, Tampa FL 33604. 813-933-6009.

MICROPHONES

Want To Sell

Mic security holders (5), new, \$15 ea. MRG Prod, 516-447-1041.

AKG "The Tube" in mint cond w/light case & manuals, \$1495. P Trembley, Downtown Snd Prod, 23915 Via Rosa Linda Valencia CA 91355. 805-254-5213.

RCA 77DX & 44BX, gd cond, BO over \$800 for either; RCA 77A circa 1937, gd cond, BO; RCA 90-A mic stand & 180 mic boom, excel cond, BO. RF Burns, RF Studios, 1326 High Meadow Dr, Garland TX 75040. 214-271-4386.

E-V MD 257B pro vocal mics, brand new in box, \$135 ea. G Finney, WPWB, 7137 Heather Ln, Macon GA 31206. 912-788-2124.

Sennheiser U47, \$1500; AKG The Tube, \$2500; AKG 421, \$250; Countryman DI Box, \$60; (2) Beyer M160 ribbons, \$500/pr; Studer Revox A77 2 trk, \$350; Yamaha M216-16 chnl mixer, \$800. G Fitzgerald, Fitzmusic, 37-75 63rd St #B29, Woodside NY 11377. 718-446-3857.

AKG C460B/CK61ULS cardioid condenser mic, like new, (2) avail, \$350 ea. M Osborne, WKSQ, POB 9494, Ellsworth ME 04605. 207-667-7573.

Microtech Gefell UM-70S w/shock mount, demo, warr, \$975; Beyer M101, \$275/pr; Sony ECM-55B, \$135; Teac ME-120 cardioid/omni dual capsule condenser, \$100. P Engel, 508-745-8522.

Calrec Soundfield MK-IV complete system with mic, remote control/processor box, cable, shockmount holder, windscreen, carrying case, excellent condition, \$2900; AKG C422EB with remote pattern selector, 20 meter cable, windscreen & shockmount, excellent condition, \$1850; AKG D-140 dynamic cardioid mics, \$225/pr; HME System 82 diversity wireless mic system with bodypack transmitter with Audio Technica mic, receiver with 3 antenna diversity system, battery pack, road case, etc, complete, \$425. R Streicher, Pacific A/V Enter, 545 Cloverleaf Way, Monrovia CA 91016. 818-359-8012.

Audio Technica 811 bidirectional mic, new, \$150; Gitzo 14' fishpole internally wired w/AT mic mount, gd cond, \$125. Raider Prod, 1006 Stoneham Dr, West Chester PA 19382. 215-889-9565.

Sony C-37A condenser mic w/power supply, \$500. D Flynn, Continental Recordings, 230 Adams St, Newton MA 02158. 617-630-0007.

Gefell Neumann UM57 tube mics, New capsules for SM2 & many others, New AC701 tubes for Neumann mics, \$275. W Gunn, 619-320-0728.

AKG 414's, \$695, original D12 like the Beatles used, \$295, Sony ECM54, \$150, Beyer M500 lk new, \$300, Demeter 4-ch tube DI rack mt lk new, \$875. W Gunn, 619-320-0728.

Want to Buy

Neumann U-47 tube mic, dead or alive w/original tube cable & power supply. Nick, 317-579-7850 or 317-841-3342.

RCA 77DXs/44BXs ribbon, chrome/TV grey, gd cond, BO. R Kaufman, Pams Prods, POB 462247, Garland TX 75046. 214-271-7625, after 3PM CDT.

77-DX's, 44-BX's, KU-3A's On-Air lights. Top price paid. Fast response. Bill Bryant Mgmt, 2601 Hillsboro Rd, G12, Nashville TN 37212. 615-269-6131.

MISCELLANEOUS

Want To Sell

NEC hand held wireless remote control RD-310E for IDC-1000 ID converter, like new, BO. MRG Prod, 516-447-1041.

ADC ProPatch bay (2) 96 pt, 1/4" TRS w/punch block connections, \$300 ea. Los Angeles CA. 310-372-4329 or 818-763-2461.

Switchcraft 36 point balanced patch bay, \$75. T Parks, WONU, POB 592, Kankakee IL 60901. 815-939-5330.

Tascam 48 extender board set of two cards, BO. MRG Prod, 516-447-1041.

Retron Blowers for Elcom, Harris, CCA, CSI, McMartin, rebuilt & new. Goodrich Enterprises Inc. 11435 Manderson St. Omaha, NE 68164 402 493 1886 FAX 402 493 6821

Radio equipment, both studio & prod, send for complete list, very reasonable, no serious offer refused. S Friedman, Five Star Bdctg, 42 Marlo Rd, Wayne NJ 07470. 201-696-9662.

Big Radio w/gen & audio amps, speakers & lights, BO. R Plessinger, 1591 Boyle Rd, Hamilton OH 45013. 513-863-0774.

FOR SALE: Giant boom box, red in color, \$1750. Audio package, six months old, \$7500. 26 foot tandem axle trailer w/brakes, six months since total refurb/paint, air in control room, great for remotes, fairs, events & high visibility, \$17,500. BE 4100 series console, new from factory, \$2500. Harris SX1A 1990 1kw AM transmitter, you tune & ship, \$9500. Harris BC500H 500 watt AM, as is, \$2500. Potomac AAS1 distortion analyzer, new w/book, \$1500. Mosely MRC 1600, 2 studio/1 transmitter unit telco cards & subcarrier cards included, \$2000. Gates dualux, refurb/paint, \$1500. Call Dan Bryan or Chuck Porter at 217-357-3128 or fax 217-357-6610.

1988 Caterpillar generator set, 125KVA/100KW, 3208-V8 diesel w/water jacket heater 24 V battery charger, 400 amp breaker disconnect, full automatic CAT transfer switch, fully digital control panel, like new cond, \$15,700/firm. A Miller, WKMX, 100 N Main St, Enterprise AL 36630. 205-347-2278.

SERVICES

OBSTRUCTION LIGHTING
Beacons lights accessories
FAX inquiries on your letterhead to:
ROHN P.O. Box 2000 Peoria, Illinois 61656
PH: (309) 697-4400 FAX: (309) 697-5612

Tower Sales & Erection
Turnkey Site Development Installation & Maintenance AM/FM Broadcast, TV Microwave Systems, Antennas & Towers
TOWERCOMM Communications Specialists
6017 Triangle Dr Raleigh, NC 27613 (919) 781-3496
Ben Wall President Gen. Contractor #25891 Fax (919) 781 6454

REMOTE EQUIPMENT RENTALS
COMREX and GENTNER 1, 2 & 3-Line Extender Systems Now With The New GENTNER EFT-3100 MARTI VHF/UHF RPU Systems Switched-56 Systems Call or FAX Dwight Weller
WELLER AUDIO-VISUAL ENGINEERING Baltimore, MD Phone: (410 or 800) 252-8351 FAX: (410) 252-4261

LOCATION SERVICES IN THE UNITED KINGDOM
Planning remotes from the U.K.? we provide a comprehensive service
• we organize venues for your shows
• we provide temporary equipment
• live links via ISDN/Switched 56
• experienced radio engineers
• we help you line-up guests
Contact New York (212) 229-9118
Good Morning from Great Britain Wired for Sound Ltd., London N15

PC - SOFTWARE
AM FM TV Search Programs Contour Mapping-STL Paths RF HAZ-1990 POP Count FAA Tower-Draw Tower
Doug Vernier Broadcast Consultant 1600 Picturesque Dr Cedar Falls, IA 50613
800-743-DOUG

EVANS ASSOCIATES Consulting Communications Engineers
TV • FM • AM • ITFS • Satellite FCC Applications, Design and Field Engineering
Video/Data/Voice • Light Fiber & Microwave • Wide-Area Networks & STL's
216 N. Green Bay Road Thiensville, WI 53092 (414) 242-6000 • FAX (414) 242-6045 Member AFCCE

W. LEE SIMMONS & ASSOC., INC.
BROADCAST TELECOMMUNICATIONS CONSULTANTS
5 Gracefield Road Hilton Head Is., SC 29928
1-800-277-5417 803-785-4445 FAX: 803-842-3371

North America RF & Audio
Mirkwood Engineering Services
Broadcast and Telecommunications Consultants
Multidiscipline Engineering and Planning Firm including • Application & Allocation Services • Project, Engineering & Construction Management • Site Acquisition • Rural & Remote Site Installations • Field Service • Studio Design & Installation
50 Park Ave. Claremont, NH 03743 (603) 542-6784

Space Available!
For details, contact Simone at
1-800-336-3045

MLJ
Moffet, Larson & Johnson, Inc. Consulting Telecommunications Engineers
Two Skyline Place, Suite 800 5203 Leesburg Pike Falls Church VA 22041
(703) 824-5660 FAX: 703-824-5672 Member AFCCE

MULLANEY ENGINEERING, INC. Consulting Engineers
• Design & Optimization of AM Directional Arrays
• Analysis for New Allocation, Site Relocation, and Upgrades AM-FM TV LPTV Wireless Cable (MDS/MMDS/ITFS/OFS)
• Environmental Radiation Analysis
• Field Work
• Expert Testimony
9049 Shady Grove Court Gaithersburg, MD 20877 Phone: (301) 921-0115 Fax: (301) 590-9757

Consulting Communications Engineers
• FCC Data Bases
• FCC Applications and Field Engineering
• Frequency Searches and Coordination
• AM-FM-CATV-ITFS-LPTV
OWL ENGINEERING, INC.
1306 W. County Road. F, St. Paul, MN 55112 (612) 631-1338 *Member AFCCE*

T. Z. Sawyer Technical Consultants AM-FM-TV-LPTV
• FCC Applications & Exhibits • Frequency Studies
• Experimental Authorizations • Class Upgrades
• AM Directional Antennas • STL Applications
• High Power Antenna Arrays • Station Inspections
1-800-255-2632
FAX: (301) 913-5799 • 6204 Highland Dr. • Chevy Chase, MD 20815

Don't Gamble with your advertising dollars.
Advertise in Radio World and reach 22,000+ subscribers.
Call Simone at 1-800-336-3045 today!

Contact Radio World Newspaper for availabilities
P.O. Box 1214 Falls Church VA 22041
1-800-336-3045
MasterCard

MISCELLANEOUS...WTS

RCA 220 V heavy duty bulk eraser, \$1100; Audico 751 manual cassette loader, \$500. D Flynn, Continental Recordings, 230 Adams St, Newton MA 02158. 617-630-0007.

60 kW, 75 KVA diesel generator. Powered by 371 Detroit. Small belly tank. No auto-transfer switch. \$9500 delivered. John, 409-724-1292.

Want to Buy

Used phone patch, consoles, tape cart equip & remote pickup equip. C Beard, KQYY. 817-596-8767.

Tube output transformers by UTC, Triad, Freed, WE, Acrosound, Peerless. L Blackmon, RQ Studio, Larson Rd #4, N Reading MA 01864. 508-664-0174.

45 RPM record library's, all types, hits, promo, etc. D Schmidt, Midatlantic Radio, POB 11502, Wilmington, DE 19850. 302-323-0338.

Radio transformers by Chicago, UTC, Triad, Peerless, Freed, Sola, send list. J Gangwer, 942 32nd St, Richmond CA 94804. 415-644-2363.

Jazz record collections, 10" LP/12" LP be-bop, swing, dixie, highest prices paid. B Rose, Program Recdgs, 228 East 10th, NNY 10003. 212-674-3060.

Ampex tube recorders and mixers. W Gunn, 619-320-0728.

MONITORS

Want To Sell

TFT EBS generator/monitor, monitor tuned to 94.7, in great condition, \$250. B Brinitzer, WDCN, 1000 Park 40 Plaza, Durham NC 27713. 919-361-1429.

Gates GTM88F freq monitor, \$145. C Sigmon, WDKZ, POB 1398, York SC 29745. 803-684-4241.

Want to Buy

TFT mod monitor for FM. D Wrinkle, KBST, POB 1632, Big Spring TX 79721. 915-267-6391.

McMartin (buy & sell) any model. C Goodrich, 11435 Manderson, Omaha NE 68164. 402-493-1886 or fax 402-493-6821.

RECEIVERS & TRANSCEIVERS

Want To Sell

SCA RECEIVERS—ALL TYPES

Reading Service / Ethnic / Data Professional, Portable, Table

DAYTON INDUSTRIAL CORP.
(Manufacturer)
4411 Bee Ridge Rd. #319
Sarasota, FL 34233
Tel: 813 378 5425 FAX: 3394

Repro XJ-300 VHF 6 chnl radio, 30 W 150-174 MHz w/antenna, \$225. M Everhart, KGON, 4614 SW Kelly, Portland OR 97201. 503-497-0313.

AM STEREO RECEIVERS
From \$34.95 Portable, Home, Auto
RRADCO
Phone/FAX 708-513-1386

Celwave Minipler 6 cavity mobile duplexer & circulator tuned to 462.675, covers 450-470 MHz, \$100. P Russell, Bowdoin College, Sills Hall, Brunswick ME 04011. 207-725-3066.

Professional SCA demod card with excellent crosstalk rejection, \$20; Superadio III with SCA, \$85, performance guaranteed. 1-800-944-0630.

Sidekick 67 Khz SCA generators (2), \$1900 each. Mike, 915-646-0631.

Want to Buy

Marantz, Karg, REL, Scott, Fisher & McIntosh FM monitors. L Blackmon, RQ Studio, Larson Rd #4, N Reading MA 01864. 508-664-0174.

Marti SCG-10 92 kHz subcarrier generator, SCG-10 92 kHz subcarrier demodulator. R Rynders, 613 Fourth St #203, Santa Rosa CA 95404. 707-576-7542.

Realistic STA-2100D in excel cond, low cost as possible. Leslie Van Luven, WGMC, 60 Rochelle St, Rochester NY 14612. 716-621-3691.

REMOTE & MICROWAVE EQUIPMENT

Want To Sell

1A2 key phone system, 4 lines plus touch-tone intercom, 6 phones, w/2 Touch-A-Matics, one wall set, all 6-button touch-tone, BO. Chris Ware Recording, 10806 Normont, Houston TX 77070. 713-894-1569.

COMREX RENTALS

1, 2 and 3-Line Extenders
Switched 56 Systems
Call Steve Kirsch for details
Silver Lake Audio
(516) 623-6114 FAX: 377-4423

Wescom 4 wire-2 wire hybrids w/balance network & EQ, network built-in, dial up line, w/prints, \$100 plus COD. R Weaver, WHEV, 413 S Faquay Ave, Faguay-Varna NC 27526. 919-552-8036.

RENTALS RENTALS RENTALS

COMREX 3-line extender

Frank Grundstein 215-642-0978
Audio/Video Consultants

Moseley MRC-1600 currently in service, excel cond, setup for telco, \$1100. B Kenney, WYOC, POB 1646, High Springs FL 32643. 904-454-3666.

Moseley TAU-2 tolerance alarm unit, multiple input, hi/low settings, alarm output, int/ext references for alarm, \$100/BO, trade possible. A Wasilewski, KMWX, POB 1460, Yakima WA 98907. 509-248-1460.

Marti RMC2-AXT(A), RMC2-AXT(10), needs repair, \$350; Marti SCG-67, \$165. C Sigmon, WDKZ, POB 1398, York SC 29745. 803-684-4241.

Marti STL-10 stereo, 2 TX & 2 RX, \$4000. R Michaels, KQFX, POB 7762, Amarillo TX 79114. 806-355-1044.

Moseley PBR-30AW remote control, transmitter & std units, operating when removed, rebuilt stepper, new relays, recently aligned, \$300/Best Offer, trade possible. A Wasilewski, KMWX, POB 1460, Yakima WA 98907. 509-248-1460.

Switched 56

INC model 1056R CSU/DSU
4-wire V.35 rackmount
Single \$745 Dual \$1440

Digitronics

Two West Myrna Lane
Tempe, AZ 85284 602-831-5051

Micro Controls STU/TSL/remote control system, type accepted, \$3000/BO. J Stevens, KCHQ, 269 W Alameda #D, Burbank CA 91502. 818-954-0214.

VRC-2000 compatible data terminals, Qume QVT-101, \$140 ea. G Finney, WPWB, 7137 Heather Ln, Macon GA 31206. 912-788-2124.

TFT 9200 STL system, pair of 9200/9205 tuned to 944.875 & 945.125, new in factory sealed cartons, \$5600. G Levites, WEVD, 770 Broadway NNY 10003. 212-777-7900.

QEI Cat-Link, out of svcs, needs repair, \$6000/BO. D Fiedler, WVLT, 638 Landis Ave, Vineland NJ. 609-692-8888.

Marti STL-8 (2) in gd cond, \$2200 each. M Ripley, KOZE, POB 936, Lewiston ID 83501. 208-743-2502.

Moseley MRC-1600 xmtr/studio units, both wire modem 7 SCA cards incl 2 manuals, spare parts kit, excel cond, \$1000. J Norris, WMUU, 920 Wade Hampton Blvd, Greenville SC 29609. 803-242-6240.

Moseley 6020 composite rcvr only, excel cond, \$2300. G Faltus, 10 Executive Dr, Farmington CT 06032. 203-677-6700.

PBR-21-A 21 chnl remote control, 1 xmtr unit & 2 studio & parts, all working, \$350 plus shpg. L Nelson, WAUR, 1 Broadcast Center, Plano IL 60545. 708-552-1000 X150.

Marti STL-10 mono w/(2) 4' dishes, mounting hardware & 200' or 3/8" coax, like new, \$3000. C Ratliff, Long Pine Bldg, Rt 2, Box 178, Wadesboro NC 28170. 704-694-5040.

McMartin TBM-1100R VHF rcvr, \$100 plus shpg. L Nelson, WAUR, 1 Broadcast Center, Plano IL 60545. 708-552-1000 X150.

Moseley MCR 1600 remote control, \$1400. G McCoy, KEZH, 500 E. J St, Hastings NE 68902. 402-463-1314.

Want to Buy

TFT 8300 needed, have xmtr. P Lotsof, KAVV, Box 18899, Tucson AZ 85731. 602-290-9797.

Moseley RPL-2, RPL-3, RPL-4 xmtr, doesn't need to be in working cond, but complete, VHF or UHF OK. B Henry, KLLK, 12 W Valley St, Willits CA 95490. 707-459-1250.

Clean audio RPU truck/van w/mast, no electronics. J Steele, WKBX, POB 2525, Kingsland GA 31548. 912-729-6000.

SATELLITE EQUIPMENT

Want To Sell

Fairchild Dart 384 w/4 freq downconverter, 1-15 K card, 1-7.5 K card, 1-3 K cue card, \$4500. D Solinsfe, WWRM, 877 Executive Ctr Dr W, St Petersburg FL 33702. 813-576-1073.

CHANGING FORMATS?
CALL NOW FOR BEST BUY/SELL PRICES!

FAIRCHILD DART
S/A 7300/7325

MICRODYNE
ADCOM &
OTHERS.

Unistar
Zephyrus for Jones
Zephyrus 700 SPC

We Repair
& Rebuild, too.

Satellite Systems
(719) 634-6319
(Fax) 635-8151

Scientific Atlanta DAT-32 receiver, 7.5 kHz dual audio decoder card, fits SA DAT-32 receiver only, \$500. Chip, KCPS, POB 946, Burlington IA 52601. 319-754-6698.

Wegener 1601 with 2 audio demods & 35 Hz tone decoder, available immediately, Best Offer. A Clawson, WPF, POB 444, Sturgeon Bay WI 54235. 414-743-7443.

OuterSpace Experts!

We SELL *TRADE* BUY
SATELLITE EQUIPMENT
317-962-8596



Avcom SS-1000 SCPC audio demodulator, \$800/BO. J Roberts, Illinois News Network, 430 W Erie #505, Chicago IL 60610. 312-943-6363.

Want to Buy

Scientific Atlanta 3610 sat rcvr, DAT 32 7300-7330 or Fairchild Dart 384. C Boles, WCOD, 105 Stevens St, Hyannis MA 02601. 508-775-6800.

Scientific Atlanta 7300 digital sat receiver & down converter needed urgently. B Torstenson, WQSN, 4200 W Main, Kalamazoo MI 49006. 800-873-1074.

Fairchild Dart 384 Sedat digital audio card; Fairchild Dart 384 trip tone card for Fairchild audio rcvr. K Thompson, WWIC, 815 W Willow St, Scottsboro AL 35768. 205-574-2198.

SOFTWARE/DATABASES

Want To Sell

U.S. RADIO STATION DATABASE: stand-alone program containing 11,500+ stations. Many searches, prints mailing labels. MAC/IBM (specify disk size). Visa/MC \$99.95/yr. (+quarterly updates):
1-800-626-2360 ext. 300
BBH Software, Inc.

Ron Balonis' Broadcast Engineer's Computer Toolbox makes a computer a technical assistant for an engineer. For details, write COMPUTER TOOLBOXES, 118 Rice Street, Trucksville, PA 18708 or call 1-717-696-1490 <300/1200/8/N/1>.

FM Study 3.0 FCC allocation program for IBM and compatibles. Full EGA and mouse support, \$59.95 (+\$1.50 S&H). Database—\$35/first state, \$15 each after. Call or write—order/demo to: BEAM Software, 3N460 Coulter Lane, St., Charles, IL 60175, 708-584-1668.

STATIONS

Daytime 5 kW pre/post authority, \$12,000 down, assume note, located between Enterprise & Dothan AL, w/real estate & mobile home, \$80,000. N Davis, TV 24, POB 5180, DeFuniak Springs FL 32433. 904-892-4038.

AM/FM in small market needs committed owner/operator, great terms, nice studios, Fingerlakes region, BO. D Mance, Clancy-Mance Communications, 199 Wealtha Ave, Watertown NY 13601. 315-782-1240.

5 kW AM/3 kW FM permit w/acres Cuba, Missouri C-3 possible. Ken Kuenzie, 314-239-0209.

5 kW AM in Columbus, GA area, dark, xmtr 4 yrs old, 3.6 acres, tower & studio bldg, will finance, \$140,000. E Daugherty, CLW Comm, POB 22125, Chattanooga TN 37422. 615-894-6060.

5kW daytimer on Lake Champlain. Great opportunity, low overhead. \$289,000. 802-862-8255.

Want to Buy

Small station in NC.
Write W.T.P., Inc., POB
97668, Raleigh, NC 27624

TAPES/CARTS/REELS & CD'S

A&D
Cart Rebuilding
Do Bad Carts Have Your Temperature Rising?
Let A&D clean, load & pack your carts. They'll be serviced within 10 working days! *Guaranteed!*
3706 Vold Ct. 715-835-7347
Eau Claire WI 54701 Fax: 715-835-1151

MARATHON PRODUCTS COMPANY
Audio Cartridge Rebuilding Division

Rebuilding/reloading, like new, all brands, any length up to & including 3.5 minutes,
\$1.95 ea. FOB out plant, 48 hrs delivery.
(New rate effective 9/1/93)

New NAB Marathon cartridges prices on request.

35 Years professional experience!
Lifetime member AES R.D. MYERS Sr.
Manufacturers of Audio Devices, Continuous Tape Mag.
69 Sandersdale Rd. Charlton, MA 01507
1-508-248-3157 or 1-508-853-0988

Circle (45) On Reader Service Card

TRANSCOM CORP.

Serving the Broadcast Industry Since 1978

Fine Used AM & FM Transmitters
and Also New Equipment

For the best deals on Celwave products,
Andrew cable and Shively antennas.

1 kW FM 1978 Collins 831C2	1 kW AM 1974 Harris BC1H1
2.5 kW FM 1978 CCA 2500R	1 kW AM 1978 Harris MW1A
3 kW FM 1975 CCA 3000D	1 kW AM 1988 Harris SX1A
3 kW FM 1974 Harris FM3H	2.5 kW AM 1976 McMartin BA2.5K
5 kW FM 1979 CCA FM5000E	5 kW AM 1968 Harris BC5H
5 kW FM 1968 Harris FM5H	5 kW AM 1979 Continental 315F
5 kW FM 1987 Harris FM5K	5 kW AM 1977 RCA BTA 5L
10 kW FM 1976 Harris FM10H3	
25 kW FM 1981 Harris FM25K	

1077 Rydal Road #101
Rydal PA 19046

800-441-8454 • 215-884-0888 • FAX No. 215-884-0738

Circle (64) On Reader Service Card

TAPES/CARTS/REELS & CDs...WTS

Cart holders, brown (60), holds 20 per rack, \$5 ea. R Phipps, KERV, 301 Jct Hwy Ste 333, Kerrville TX 78028. 210-896-1230.

Fidellpac carts, approx 1800 avail, various lengths, \$.50 each. Jay, Nimbus Prod, POB 5903, Tacoma Park MD 20913. 301-507-3358.

Audiopak Blue carts, approx 1000 in various lengths w/country music; Dynamax cobalt carts, approx 600 in various lengths, country music, all in great cond, \$1 & \$1.50 each. Artis, KRXR, Box 565, Goodins ID 83338. 208-934-8630.

Pams Jingles ref tapes, 1951-1976, BO. R Kaufman, Pams Prods, POB 462247, Garland TX 75046. 214-271-7625.

Want to Buy

Jerrold Channel Commander II service manual w/schematics. Al or Wes, KZPX, HCR1 Box 286D, Merrifield MN 56465. 218-765-3333.

Spotmaster TP-60B tape timers from cart tape winders (TP-1A or TP-1B). Mel Crosby, 408-363-1646.

TAX DEDUCTIBLE

Want To Sell

High school radio station in Ohio seeks donation of 1 kW FM xmtr or amp to assist in pwr increase upgrade, will pay shipping or pick up. B Long, WSTB, 1900 Annalane Dr, Streetsboro OH 44241. 216-626-4906.

Educational recording studio needs all types recdg equip esp carts & used racks or storage units, will pay freight, receipt. M Tupper, USF Tampa. 813-974-6804.

TEST EQUIPMENT

Want To Sell

Elco 435 scope, cond unk, \$45. C Sigmon, WDZK, POB 1398, York SC 29745. 803-684-4241.

Heathkit scope, operating cond, ready to use, just rebuilt, \$50. J Cunningham, KEOR, Rt 2 Box 113B, Stonewall OK 74871. 405-265-4476.

Datatek D-607 color black generator cards (2) w/D607RA power supply (2) & mount for generators, no rack frame, new, BO. MRG Prod, 516-447-1041.

Potomac Instrument FIM 21 AM field strength meter, excel cond, \$3000. Steve, WPRZ, POB 3220, Warrenton VA 22186. 703-349-1250.

Elcom 300 10 Hz to 500 MHz freq counter w/5 & 10 MHz WWV rcvr, all manuals, rack mount, mint cond, \$350. G Heidenfeldt, WRGH, 2880 W Lake Rd, Wilson NY 14172. 716-751-6187.

Want to Buy

Heathkit FM deviation meter, late mdl needed for missionary radio testing, donations accepted, all types equip needed. J Cunningham, KEOR, Rt 2 Box 113B, Stonewall OK 74871. 405-265-4476.

AUL 6207-1 AN/ISM-213B instruction & service manuals. S Swanson, KBNL, Box 2425, Laredo TX 78044. 210-724-9211.

TRANSMITTERS

Want To Sell

JR Cunningham CM 30-50, type approved AM, adjusts 5-36 W, rack mount tube type, \$650. J Cunningham, KEOR, Rt 2 Box 113B, Stonewall OK 74871. 405-265-4476.

Gates BC-5P2 refurbished 2 yrs ago, on air now, perfect cond; also second xmtr several spare parts, \$5000/firm. R Elliott, KCGS, POB 368, Marshall AR 72650. 501-448-5566.

McMartin BF25-M 27.5 kW, 106.5 MHz, w/McMartin BFM8000 exciter, spare tubes, currently on air, avail Oct/Nov '93, \$17,500. B Exum, KOGA, 113 W 4th St, Ogallala NE 69153. 308-284-3633.

LPB 100P tuned to 1460, used only as backup, like new in excel cond, 100 W & less, \$4400. R Swan, WROY, 101 N Church, Carmi IL 62821. 618-382-4161.

DEMOED EQUIPMENT
BEXT Inc. has a few demoed exciters, amplifiers and STL's for sale. All demoed systems are sold first come first served and have the same 2 year warranty as BEXT's new equipment. For information:
619-239-8462

CSI T-1-F 1 kW xmtr in excel cond, \$6100; CSI exciter, 20 W, gd cond, \$1450. C Sigmon, WDZK, POB 1398, York SC 29745. 803-684-4241.

300 and 500 WATT FM AMPLIFIERS & MODULES from \$550 BROADCAST TECHNOLOGY (719) 336-3902 Fax (719) 336-4726

Energy-Onix SST-30 exciter, \$2000; Harris FM5K1, \$15,000; Harris MX-15 exciter, excel cond, \$2500; Harris FM5H, gd cond, \$8000. R Michaels, KQFX, POB 7762, Amarillo TX 79114. 806-355-1044.

CCA Electronics has the following trade-in equipment for sale: CCA FM10000D 10KW 3-phase transmitter, CCA FM100G 100 watt transmitter with FM20G exciter. Contact Steve, Howard, or Darrin, 404-964-3530.

Custom made power reducer for use in AM station, operates at or between 27 & 78 W, make offer. J Kesler, WOBZ-TV, POB 220, Livingston KY 40445. 606-842-2209.

Harris FM1K 1986 in excellent condition, available 1/94, \$8000/BO. J Stevens, KCHQ, 269 W Alameda #D, Burbank CA 91502. 818-954-0214.

RCA BTE-15A FM exciter, rebuilt, used 30 hrs on 107.9, excellent, complete specs upon request, \$700. B Carr, WYHK, POB 6, Perrysburg OH 43552. 419-837-9696.

FM - TRANSMITTERS
Factory new not used. Why buy a used Transmitter when you can own a new FM Transmitter for about the same cost? Call JIMMIE JOYNT at 214-335-3425.

Harris GM20H2 20 kW in excellent condition with new iron & Bext 80W exciter, \$20,000/BO. J Stevens, KCHQ, 269 W Alameda #D, Burbank CA 91502. 818-954-0214.

Collins 830F-1F 10 kW FM, 1963, spart parts & tubes, manuals, good condition, \$4500. J Norris, WMUU, 920 Wade Hampton Blvd, Greenville SC 29609. 803-242-6240.

NEW McMARTIN BF-5K
Lowest priced tube replacements



5500 W FM, broadband grounded grid output circuit, VSWR protection, excellent efficiency 75-80% automatic recycling & overload status. Fully remote controlled. FCC approved to 5500 watts.

Goodrich Enterprises, Inc.
11435 Manderson Street
Omaha, NE 68164
402-493-1886
FAX: 402-493-6821

CSI 3 kW in excellent cond, \$13,800; CSI 20 kW FM in excellent cond, recently upgraded by CCA factory, \$18,500. R Michaels, KQFX, 3639 B Wolfun Ave, Amarillo TX 79102. 806-355-1044.

RCA BTA-5F AM in excellent cond, with all manuals, plus shpg/loading, \$7500. G Heidenfeldt, WRGH, 2880 W Lake Rd, Wilson NY 14172. 716-751-6187.

RCA 1977 BTA-1S, 1 kW tuned to 1240 kHz, recently removed from service, good condition, extra parts & tubes included, \$3000/Best Offer. G Camp, KFMO, Box 36, Flat River MO 63601. 314-431-2000.

Exciters: McMartin B-910 tuned and calibrated to your frequency, guaranteed: Mono, stereo, SCA, Goodrich Ent. Inc. 11435 Manderson St., Omaha, NE 68164. 402-493-1886 FAX: 402-493-6821

TTC XL1FM 1 W power amps (3), \$375 ea; front panel power meters for XL1FM, 2 W full scale (2), \$60 ea. J Torsitano, KNIS, 6363 Hwy 50 East, Carson City NV 89701. 702-883-5647.

Collins 830D-1A 1 kW FM w/Harris TE-3 exciter, on-air now, selling due to upgrade, \$2000 or trade for 1 kW AM xmtr. L Fuss, WDTL, POB 1438, Cleveland MS 38732. 601-846-0927.

1 kW AM, 1H, on 1230, working when removed from service, \$3000. R Phipps, KERV, 301 Jct Hwy Ste 333, Kerrville TX 78028. 210-896-1230.

Harris MW-1A solid state 1 kW AM xmtr in gd cond, \$8500. E Longhi, KJBO, 6400 Uptown Blvd NE, Albuquerque NM 87110. 505-880-1118.

CCA Electronics has the following equipment for sale: Collins 831D-2.5 kW FM transmitter with exciter, both in excellent condition. Contact Steve, Howard, or Darrin, 404-964-3530.

Spare parts for CCA AM50,000D, including, HV transformer, mod. transformer, mod. reactor, HV filter choke, tube sockets and more. Call Transcom Corporation 800-441-8454 or 215-884-0888.

Transmitters, AM-FM-TV. Used and new. Great prices. 305-757-9207.

Want to Buy

Any 10 kW-20 kW FM xmtr needed for non profit Oklahoma gospel station, will pay reasonable price, prefer donation, tax deductible fair market value. J Cunningham, KEOR, Rt 2 Box 113B, Stonewall OK 74871. 405-265-4476.

FM 5 kW, used, need now. B Royer, WBBC/WKLV, Blackstone. 804-292-4146.

5 kW AM, tube or solid state. E Longhi, KJBO, 6400 Uptown Blvd NE, Albuquerque NM 87110. 505-880-1118.

10 W travelers information station (TIS) transmitter in useable condition. AJ Anello, Radio Free YBOR, 1915 W Waters Ave #1, Tampa FL 33604. 813-933-6009.

5 kW or 10 kW FM xmtr w/o exciter. G Hoppe, WHMH, 1010 2nd St North, Sauk Rapids MN 56379. 612-252-6200.

Collins 20V or 20V2 AM xmtr in decent shape, prefer Calif unit but will consider Western US. S Thompson, 1031 San Antonio Ave, Alameda CA 94501. 510-521-1429.

McMartin AM/FM xmtr, any model, exciter or stereo modules. Goodrich Ent, 11435 Manderson, Omaha NE 68164. 402-493-1886.

TUBES

Want To Sell

D and C Electronics Co.
Lowest Price on Tubes including:
4-1000A/3-1000Z/
8877/4CX250B/833A
4-500/5-500/4-400/
4CX 3500/5CX1500
and much more!
Factory Warranty!

1-800-881-2374 (904) 688-2374
Se habla Español
FAX: (904) 683-9595



Svetlana
ELECTRON DEVICES

Quality* Power Tubes

- 4X150A 4CX15,000A
- 4CX250B 4CX15,000J
- 4CX250BC 5CX1500A
- 4CX250R 5CX1500B
- 4CX350A 8560AS

- Watch this list grow.
- Manufactured in Russia's largest power tube factory.
- Generous* warranty based on high quality.
- Honest prices based on quality at low cost.
- Shipment from USA stock.

Broadcasters
Call: 800-239-6900
FAX: 205-880-0777

OEMs, Distributors, Volume Purchasers
Call: 415-233-0429
FAX: 415-233-0439

Circle (137) On Reader Service Card

Mercury vapor rectifier tubes #575 (4), cond unk, \$40. C Sigmon, WDZK, POB 1398, York SC 29745. 803-684-4241.

For the Best Price
& 24 Hr service on transmitting tubes call 402 493 1886 day or night. FAX 402 493 6821.

New tubes, (2) 833's, \$100 each. R Phipps, KERV, 301 Jct Hwy Ste 333, Kerrville TX 78028. 210-896-1230.

REBUILT ELECTRON TUBES
Partial List: 6623, 23791, TH150, 6425F, 5604, 6696, 6697, 5681, 5682, 5671, 7804, 3CX10,000H3, 3CX20,000H3, 4CX5000A, 4CX35,000C

Worn out power tubes purchased

Vacuum Tube Industries, Inc.
1-800-528-5014
508-584-4500 X75

Tubes, new RCA 5762, not rebuilt. Also 6166/7007, 4-1000A. Many more. 305-757-9207.



3CX10000A3, 3CX1500A7, 3-500G, 4CV10000C, 4CX1000A, 4CX1500B, 4CX1000D, 4CX250B, 4CX300A, 4CX35000C, 4CX350A, 4CX5000A, 4-400A, 4-400C, 572B, 6146B, PL328/TH328, PL347/TH347, 807, 813, 833A, 833C, and more...

CALL 1-800-783-2555 JOLIDA INC. Annapolis Junction, MD

4-1000A, 8877, 4CX250B, 4CX1500B, 4CX3000A & more. We carry large inventory all major brands, Eimac, Amperex, RCA, etc. Call Stew 1-800-842-1489.

ECONCO

Quality Rebuilt Tubes
Approximately 1/2 the Cost of New

Call for Our Price List
800-532-6626
916-662-7553
FAX 916-666-7760
Circle (206) On Reader Service Card

Want to Buy

VACUUM POWER TUBE REBUILDERS SINCE 1940

Freeland Products, Inc.

"If you don't need TO SAVE MONEY we can't help you."

However, if saving money interests you... WE CAN REBUILD YOUR DUDS (used tubes) for about 1/2 the cost of new tubes!

Call TODAY 1-800-624-7626 For a FREE Information Packet

WE BUY MANY TYPES OF USED TUBES

WANTED: TUBES

I pay cash or trade for all types of transmitting or special purpose tubes.

Nobody pays more or faster than us!

Mike Forman
1472 MacArthur Blvd.
Oakland CA 94602
(510) 530-8840
FAX: 510-530-0858

The Bad News Is: Every transmitter, regardless of make and model, will experience failure!

The Good News Is: Our FM transmitters are designed to keep you ON THE AIR when failure occurs!

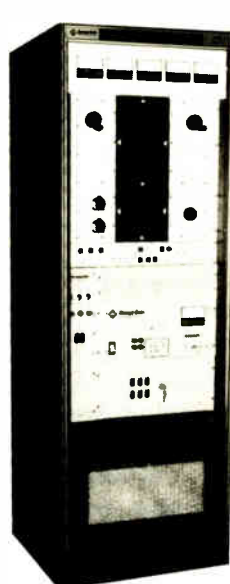

- **PA Failure - NO PROBLEM!** You're **ON THE AIR** with our self-contained Solid State IPA.
- **Controller Failure - NO PROBLEM!** You're **ON THE AIR** with our controller override panel.
- **Reoccurring Fault - NO PROBLEM!** Our exclusive '8 times' fault recycling system keeps you **ON THE AIR**. We're more 'fault tolerant' than any other transmitter.
- **Part Failure - NO PROBLEM!** Because we use locally available, non-proprietary parts, you're back **ON THE AIR** faster!

The Great News: 'MK' Series Grounded Grid FM transmitters are available at power levels from 1.5 kW to 50kW to meet your needs.

The Transmitter People
Energy-Onix

518-828-1690
FAX: 518-828-8476

752 Warren Street
Hudson NY 12534

Circle (68) On Reader Service Card

TURNTABLES

Want To Sell

Russco Mark IV TT's (4), no arms but has controllers & pre amps, \$60 plus shpg. D Rogosky, WTSR, Trenton State, Trenton NJ 08650. 609-771-2450.

Yamaha PX-1 linear tracking w/Signet moving coil cartridge, needs cueing fixed, \$395. R McMillen, Super Duper Audio Duplicating, 1634 SW Alder St, Portland OR 97205. 503-228-2222.

Neumark TT's (3) w/cover, \$100 ea; BE TT's (2), \$100 ea. R Phipps, KERV, 301 Jct Hwy Ste 333, Kerrville TX 78028. 210-896-1230.

Cetec/Sparta TT's (2) w/Audio-Metrics preamps, \$50 ea/BO. L Fuss, WDTL, POB 1438, Cleveland MS 38732. 601-846-0927.

Technics SP-15 (2) w/turnarm, base, isolator feet & manuals, \$350 ea. A Garza, Foster Comm, 2824 Sherwood Way, San Angelo TX 26901. 915-949-2112.

Want to Buy

Technics SL-M2 direct drive TT, woodgrain base, straight tonearm, must be lk new. Leslie Van Luven, WGMC, 60 Rochelle St, Rochester NY 14612. 716-621-3691.

Technics SP-15 in excel cond; Shure SME 3012R tonearm. J Hartt, Hartaudio Restorations, 2418 36th Ave West, Seattle WA 98199. 206-282-0720.

WE 109AA/B reproducer group, 9A cartridges, repeat coils, arms, EQs. L Blackmon, RQ Studio, Larson Rd #4, N Reading MA 01864. 508-664-0174.

ACTION-GRAM

Equipment Listings

Radio World's Broadcast Equipment Exchange provides a FREE listing service for radio stations and recording studios only. All other end users will be charged. Simply send your listings to us, following the example below. Please indicate in which category you would like your listing to appear. Mail your listings to the address below. Thank you.

Please print and include all information:

Contact Name _____

Title _____

Company/Station _____

Address _____

City/State _____

Zip Code _____

Telephone _____

I would like to receive or continue receiving Radio World FREE each month.

Yes No

Signature _____ Date _____

Please Circle only one entry for each category:

I. Type of Firm

- D. Combination AM/FM station
- A. Commercial AM station
- B. Commercial FM station
- C. Educational FM station
- E. Network/group owner
- F. Recording studio
- G. TV station/teleprod facility
- H. Consultant/ind engineer
- I. Mfg. distributor or dealer
- J. Other

II. Job Function

- A. Ownership
- B. General management
- C. Engineering
- D. Programming/production
- G. Sales Manager
- E. News operations
- F. Other (specify) _____

Brokers, dealers, manufacturers and other organizations who are not legitimate end users can participate in the Broadcast Equipment Exchange on a paid basis. Line ad listings & display advertising are available on a per word or per inch basis.

WTS WTB Category: _____

Make: _____ Model: _____

Brief Description: _____

Price: _____

WTS WTB Category: _____

Make: _____ Model: _____

Brief Description: _____

Price: _____

WTS WTB Category: _____

Make: _____ Model: _____

Brief Description: _____

Price: _____

WTS WTB Category: _____

Make: _____ Model: _____

Brief Description: _____

Price: _____

*Closing for listings is the first and third Fridays for the next month's issue. All listings are run for 2 issues unless pressed for space or otherwise notified by listee.

Broadcast Equipment Exchange

PO Box 1214, Falls Church, VA USA 22041
Phone: 703-998-7600 FAX: 703-998-2966

Advertising Space is Available in
RADIO WORLD
For details including rate information & deadlines, call Simone Mullins at
1-800-336-3045
703-998-2966

ADVERTISER INDEX

This listing is provided for the convenience of our readers. Radio World assumes no liability for inaccuracy.

Page No.	Advertiser	Reader Service No.	Page No.	Advertiser	Reader Service No.	Page No.	Advertiser	Reader Service No.
37	AMP Services	185	10	Cutting Edge	191	15	Murphy Studio Furniture	26
7	ATI	51	7	Dataworld	129	36	Myat	89
26,27	Arrakis	147	11	Dick Brescia Associates	165	33	Orban/AKG/dbx	178
37	Audio Broadcast Group	78	38	Dielectric	155	12	Otari Corp	209
8	Audio Precision	118	31	Digital Audio Labs	66	35	Pacific Recorders	160
9	Audio-Technica US Inc.	124	38	Econco	131	29	Potomac Instruments	61
2	Audioarts/Div. of Wheatstone	75	49	Econco	206	39	QEI	110
51	Audioarts/Div. of Wheatstone	91	14	Energetic Music	219	22	RE America	138
11	Audiopak	81	49	Energy Onix	68	30	RE America	196
37	Autogram	9	18	Fidelipac	157	38	RF Specialties of Washington	39
22	Belar	107	25	Fidelipac	62	14	Radio Potato	122
28	Bext	139	43	Fidelipac	47	44	Radio Resources	135
37	Broadcast Devices	216	8	Gentner	202	41	Radio Systems	144
17	Broadcast Direct Marketing	205	14	Ghostwriters	56	45	Recording Studio Services	22
23	Broadcast Electronics	150	38	Gorman Redlich	207	38	Russ Friend & Associates	16
4	Burk Technology	33	44	Hall Electronics	199	28	S.C.M.S.	116
42	Burk Technology	20	1	Harris Allied Bdct. Equip.	154	38	Shively Labs	170
15	CBSI	141	6	Harris Allied Bdct. Equip.	40,162	28	Stephens Communications	208
29	CCA Electronics	183	20	Harris Allied Bdct. Equip.	95,215	37	Svetlana Electron Devices	193
21	California Amplifier	100	3	Inovonics	114	49	Svetlana Electron Devices	137
13	California Digital	41	44	J & I Audio/Video	158	37	The Management	201
37	Cellcast	101	14	J.R. Nelson	87	28	Third Story Recording	70
28	Clark & Associates	24	44	JT Communications	18	48	Transcom Corp.	64
3	Comrex	43	28	LDL	93	44	U.S.A. Foam	204
28	Comrex	1	14	La Palma Broadcast	37	38	Valley Audio Products	85
24	Continental Electronic Wholesale	71	48	Marathon Products Co.	45	52	Wheatstone	175
16	Continental Electronics	14	14	Media Dialup	171	38	Zercom	108
37	Cortana	32	32	Micro Technology Unlimited	53			

Publisher	Stevan B. Dana	Production	Vicky Baron, Lisa Lyons, Lisa Mamo
Associate Publisher	Carmel King	Ad Coordinator	Regan Deatherage
Marketing Consultant	Al Leon	Ad Coordination Manager	Simone Mullins
Marketing Assistant	Annette Deutscher	Circulation Director	Tiana Hickman
Production Director	Kim Lowe	Circulation Manager	Rebecca Seaborg
Production Manager	Julianne Stone	Accounts Receivable	Steve Berto

Advertising Sales Representatives

U.S. East: Skip Tash	703-998-7600 Fax: 703-998-2966
U.S. West: Dale Tucker	916-721-3410 Fax: 916-729-0810
International: Stevan B. Dana	+1-703-998-7600 Fax: +1-998-2966
Europe: Dario Calabrese	+39-2-753-0274 Fax: +39-2-753-2697
Japan: Eiji Yoshikawa	+81-3-3327-2688 Fax: +81-3-3327-3010

Free Subscriptions are available upon request to professional broadcasting and audiovisual equipment users. For address changes, send current and new address to RW a month in advance at P.O. Box 1214, Falls Church, VA 22041. Unsolicited manuscripts are welcomed for review; send to the attention of the appropriate editor.

Wheatstone Has It!

Super Performance – Great Price!

OUR NEW A-300 CONSOLE HAS ALL THE RIGHT STUFF: Performance right at the limits of technology, the features you want, and a fresh clean look your clients will admire. It's got all the busses you'll need. It's got the crosstalk and bus off isolation you HAVE to have for LMAs and FM/AM combos. Its small footprint and low profile let you conserve valuable studio real estate. Its virtual audio bus™ architecture lets you place any module anywhere in the console—no dedicated slots!

Talent will love our easy-to-learn superphone module and the automated cue system that makes monitoring confusion-free. Our integrated intercom system lets them communicate with any other Wheatstone console or talent location—handsfree.

Your program director will really like the sound of this console: no VCA distortion—just flawless specs. And, because of its ultra-flexible architecture, it can be easily adapted to any format, anytime.

The A-300 has what engineers want: first class documentation, gold switches, gold connectors, a hinged meterbridge for easy re-lamping, straight-forward reliable logic technology, and the best I/O connection and tooling system in the industry.

The A-300 is the console that has followed the evolution of radio. Benefit from Wheatstone's experience and total commitment to your satisfaction. Contact us.



 Wheatstone® Corporation

A-300

7305 Performance Drive, Syracuse, NY, 13212 (tel 315-452-5000 / fax 315-452-0160)

Circle (91) On Reader Service Card
World Radio History

The Closer You Get...

WE MEAN IT—we really DO provide the quality, performance, technical support, and innovation we promise!

Our model A-500 is a thoroughly engineered on-air console: it delivers the level of performance your clients now expect, and DAB demands. All components are selected for long life—gold bus connectors, gold I/O connectors, all gold contact switches, gas-filled relays, triple burned-in integrated circuits, solid state ON/OFF lamps, and precision laminated Lexan control surfaces for a lasting, wearproof finish. And we back that up with a 3-year parts and labor warranty, complete with

factory support from a technically competent and responsive staff.

We've also handled your special requirements as well with a super family of accessories, including a choice of three different telephone modules, an intercom module, an off-line mixer module for your remote feeds, talent control stations, accessory panels, failsafe power supplies, and auto cart and CD sequencing options.

So take a close look: we've got the quality, we've got the innovations, and you've got our commitment to top-notch support.



The Better We Look!

A-500