

\*\*\*\*\*3-DIGIT 857  
J750737 D11 9007 51190 1320  
BARRY MISHKIND  
2033 S AUGUSTA PL  
TUCSON AZ 85712

# RadioWorld®



See pages 17-32

Vol 17, No 19

Radio's Best Read Newspaper

October 13, 1993

## FCC to Close Book on AM Stereo Standard

by Randy Sukow

**WASHINGTON** The FCC will set an AM stereo transmission standard this month.

It seems strange to say it—AM stereo standard this month—after the decades of in-fighting among AM stereo system developers at the commission and in the courts.

Now that the FCC standard is finally a reality, what comes next?

Is there enough interest among AM stations to install the system? Will there be ample consumer receivers available to support it? Does the prospect of an AM in-band, on-channel digital audio radio standard overshadow already aged AM stereo technology?

For some rural AM listeners last year, those questions didn't matter.

### Quiet conclusion

The FCC will approve a U.S. single AM stereo standard, almost certainly to be based on Motorola Inc.'s C-QUAM, with little fanfare.

"The item does not necessarily have to be handled on the commission agenda. That has yet to be decided," said Julius Knapp, deputy chief of the authorization and evaluation division in the FCC's Office of Engineering and Technology, Laurel, Md.

If the item is not settled during the FCC's regular agenda meeting scheduled for tomorrow (Oct. 14), it will be approved by circulation before Wed., Oct. 27.

In spite of the low-key approval process, some broadcasters will still consider C-QUAM standardization controversial. A significant number of AM broadcasters in comments to the commission last spring said they still consid-



er the Motorola system inferior to the Kahn ISB system developed by Kahn Communications Inc., Westbury, N.Y. (RW, May 12).

"I think there are still two competing standards, C-QUAM and Kahn," said Kenneth Brown of Capital Cities/ABC, which favors setting a standard, but does not endorse either system. "This has gone on too long and has been too painful for too many people. I'm not going to count any kind of craziness out."

The FCC would not be standardizing AM stereo at all if it had not been for an act of Congress. The 1992 Telecommunications Authorization Act, routine legislation to set appropriations limits for the National Telecommunications and Information Administration (NTIA), was amended at the last minute with a short provision ordering the FCC to set a standard within a year after enactment (Oct. 27, 1992).

Hardly anyone noticed when Senator Larry Pressler (R-S.D.) quietly introduced the AM stereo amendment. AM stereo had not been an issue of significant interest on Capitol Hill and at the FCC for several years.

Unlike legislators from other parts of the country, where most consumers had probably never heard of AM stereo, Pressler had constituents actually writing letters and

appearing at town meetings to demand an AM stereo standard.

"Thousands of farmers and ranchers in rural South Dakota, many of whom are without FM stereo, want to receive better quality sound. AM stereo technology offers an effective solution because AM

continued on page 8 ►

**NPR to install  
switcher in new  
Washington  
facility. See  
story page 3.**

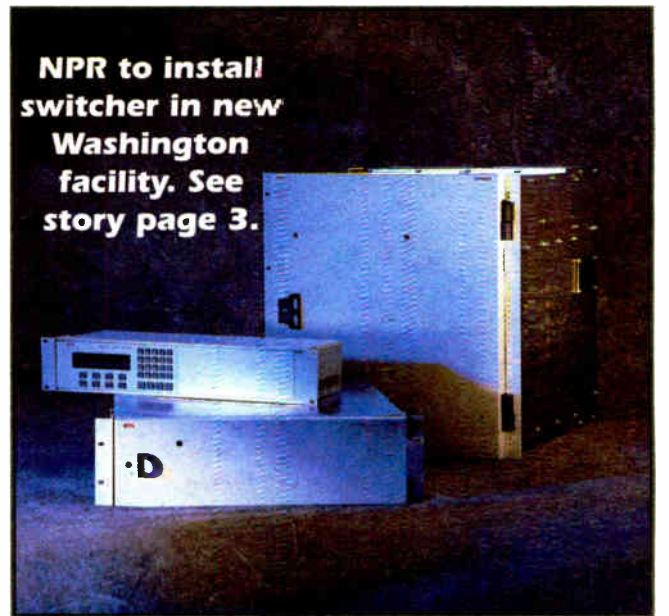

## Commission Is Ready To Write EBS Rules

**PIKESVILLE, Md.** The effort to complete the redesign of the Emergency Broadcast System (EBS) by early 1994 remains on track for early 1994, FCC officials said following a second round of field tests for the proposed new EBS technologies last month in the Baltimore area. "We're through gathering information," said Richard Smith, chief of the FCC's Field Operations Bureau.

What now follows is about a month of analyzing data from last month's tests and tests conducted last June in the Denver area (RW, July 28 and Aug. 11). The EBS office will then begin drafting a report and order.

Smith conceded that the still shorthanded FCC has a crowded agenda. "I don't remember the commission ever being busier than it is now, especially with the workload of the (1992) Cable Act," said Smith, who described the list of issues now in front of the FCC as top-heavy with "priority-one" items, ordered priority "1a, 1b, 1c and 1d."

But EBS is getting significant attention because of its potential lifesaving value, Smith said. "It is a priority one, but I don't know whether it's a 1c or 1d."

The Maryland field tests were "a lot

smoother" than the first round, said Helena Mitchell, chief of the FCC's EBS Office. "We learned so much from Denver to make it easier here."

### Improved format

Gerald LeBow, president of EBS system proponent Sage Alerting Systems, Stamford, Conn., described the Maryland tests as "much more scientific."

Mitchell gave most of the credit to the chief organizers of the Maryland tests—Morris Blum, chairman of the Maryland State Emergency Communications Committee; and John F. Warner, assistant chief engineer, WBAL-AM-TV/WIYY (FM) Baltimore—who both attended the Colorado tests and added improvements to the format where needed.

Some tests were scheduled for after midnight, just to avoid conflicts with participating stations' program schedules, which occasionally happened in Denver.

The basic format, however, was similar to the test in Denver. Three major EBS technology proponents tested the robustness and reliability of their systems with interconnections between state and local emergency officials and TV, radio and cable facilities,

continued on page 7 ►

The ENCO DAD486x Digital Audio Delivery System. A true cart machine replacement. With a touch screen, it really performs at your fingertips. It's the most user-friendly system you'll ever love to operate. While it improves your audio it improves your bottom line. Add the friendliest digital audio delivery system to your station. DAD from Harris Allied.

Phone: 800-622-0022 Fax: 317-966-0623

**HARRIS ALLIED**

Circle (104) On Reader Service Card

World Radio History



# NEWSWATCH

## Broadcaster Clinic Scheduled

**MADISON, Wis.** The University of Wisconsin, Madison, will hold its 39th annual Broadcasters Clinic Nov. 9-11 at the Holiday Inn East in Madison.

Topics to be covered will include KORG digital editing, advancements in radio technology, Sony's pro MiniDisc, management's perception of engineers, digital audio compression and DAB develop-

ments. The clinic also will have 35 exhibitors.

The fee for the seminar is \$150 for all three days, \$115 for any combination of two days. To register by phone or to get a form for mail-in registration, contact the University of Wisconsin at 608-262-2451, or fax 608-262-8516.

SBE has scheduled an All-Chapter National Teleconference of the Upper Midwest Regional Conference on Nov. 10, concurrently with the U. of Wisc. clinic. Chapters across the country are urged to hold their

November meetings around a satellite downlink and a telephone. The satellite uplink will be provided by Global Access.

## Marconi Awards Announced

**DALLAS** The Marconi Awards were announced at the NAB Radio Show last month.

WHO(AM) Des Moines, was recognized as the "Legendary Station of the Year."

"Personalities of the Year" were: Charles Osgood, CBS,

(network/syndicated); Dick Purtan, WKQI(FM) Detroit (major market); Bob Kevoian and Tom Griswold, WFBQ (FM) Indianapolis (large market); Jim Zabel, WHO(AM) Des Moines (medium market); Max McCartney WBIZ-FM Eau Claire, Wisc., and Tony "Wradio" Wright, KWOX(FM) Woodward, Okla. (small market).

"Stations of the Year" by market were: WGN(AM) Chicago (major market); WCKY(AM) Cincinnati (large market); WHO(AM) Des Moines (medium market), and KWOX(FM) Woodward, Okla. (small market).

"Stations of the Year" by for-

mat were: WHAS(AM) Louisville, Ky. (AC/EZ); WXRT (FM) Chicago (AOR/classical rock); WOKY(AM) Milwaukee (big band/nostalgia); WHRK (FM) Memphis, and WRKS-FM New York (Urban); KIIS-AM-FM Los Angeles (CHR); KLEF(FM) Anchorage (classical); WWWW-AM-FM Detroit (Country); WCBS-FM New York (oldies); WGN(AM) Chicago (news/talk); KGBT (AM) Harlingen, Texas, (Spanish), and WAVA(FM) Arlington, Va. (religious/gospel). KINK-AM-FM Portland, Ore.; KSDS(FM) San Diego, and WQCD(FM) New York, tied in the jazz and new age category.

## NAB Hires New Liaison, Regulatory Affairs VP

**WASHINGTON** Karen Fullum has been named the National Association of Broadcasters' vice president of regulatory affairs.

Fullum formerly worked with  
continued on next page ►

# Only AUDIOARTS Has It...

**WHEATSTONE'S STRENGTH!** With Wheatstone's professional experience, engineering know-how, support capability and corporate stability behind it, this AUDIOARTS console design is the right choice.

The A-50 is cost effective through clever engineering and the latest advances in CAD design and electronic assembly procedures. It was developed by the same design team that creates Wheatstone's high end equipment. This console's performance is light years beyond the competition.

Naturally, it has all of the most important features: machine control functions, programmable channel logic, and three busses (Program, Audition, and Telephone). It also has the monitors you need: control room, studio and headphone—each with its own level control. It's designed so you can expand or add accessory modules as your needs grow.

You can benefit from our major market experience. Take advantage of Wheatstone's expertise and reputation; call us today for immediate action.



**AUDIOARTS ENGINEERING**  
7205 Park... 1-800-300-1111 / Fax 313-432-0161

## Index

### RUNNING RADIO

<b>Gathering the Data Reduction Players</b>	by Judith Gross	17
<b>Seeking Successors to Toppled Top 40</b>	by Charles Taylor	19
<b>Positive Press Takes Serious Effort</b>	by Mark Lapidus	20
<b>Remotes From Fair Are Never Foul</b>	by Gary Hart	21
<b>Long-Term Planning Is a Budget Necessity</b>	by Sue Jones	23
<b>Radio Beams 'Frequency-Marketing' Signal</b>	by John Cummuta	27

### FEATURES

<b>Avoiding AM DA Transfer Trouble</b>	by Fred W. Greaves	30
<b>Firm Modifies Old STLs to FCC Specs</b>	by Bob Kirby	32
<b>BBC Renovates 40-Year-Old London Studios</b>	by Tim Frost	35
<b>Workbench</b>	by John Bisset	35
<b>Finishing Your AM Stereo Conversion</b>	by W.C. Alexander	36
<b>ASCAP Dispute Sparked 70-Year Associations Birth</b>	by James T. Wold	36
<b>Montgomery Station Promotes Itself to Top</b>	by Dee McVicker	37
<b>PLC as Coax Switch Saves Air Time</b>	by Richard Mertz	38



► continued from previous page

Price Waterhouse, Brown, Vance, Jackson & Smith and Sheridan Broadcasting, where she was a news reporter. She will be the NAB's chief liaison with the FCC and other federal agencies.

**FCC Chairman Candidate Hundt Near Confirmation by Senate**

**WASHINGTON** At deadline, the Senate was nearing a confirmation vote on Reed Hundt's nomination as FCC chairman. Hundt, a Washington attorney and long-time friend of Vice President Albert Gore, was expected to easily win confirmation.

A Senate Commerce Committee hearing on Hundt's nomination on Sept. 22 focused on children's TV programming and TV violence, 1992 Cable Act enforcement and universal access to future digital communications "super-highway."

Few radio issues, however, were raised. Hundt declined to answer Senators' questions concerning in-band, on-channel digital audio radio, asking for more time to study the issue.

**NAB Asks FCC to Allow Broadcasters Some Time**

**WASHINGTON** National Association of Broadcasters President Eddie Fritts wrote to the FCC late last month to request that the commission advance at a slower pace in Emergency Broadcast System (EBS) redesign (see page 1).

Fritts asked for a new round of comments to allow for further public analysis of Denver and Baltimore field test results before the commission proceeds with a report and order.

Regardless of when the order is written, Fritts also requested a slow-paced conversion timetable to give broadcasters time "to build any new equipment costs into their capital budgets."

**BTS Supplies Switchers to CBS, NPR**

by Jon Banks

**WASHINGTON** BTS Broadcast Television Systems has been selected by National Public Radio (NPR) and by CBS Radio to supply routing switchers for each company's Washington operations center. BTS is a Phillips and Bosch owned company, headquartered in Germany. The routing switchers are designed in the USA.

NPR will install four BTS routers at their new \$35 million center, under construction at 635 Massachusetts Avenue in Washington, D.C. The building was purchased and totally refurbished to NPR's specifications.

Three of the BTS routers are analog (the largest is a huge 320 input by 224 output matrix), and the fourth is an AES/EBU digital audio switcher in a 64 by 64 configuration.

Don Lockett, VP of Audio Engineering for NPR, said, "We're taking a disciplined approach to digital. We'll go digital wherever it's useful and cost effective, but we need to see a real advantage. We believe it's too early and too expensive to go all digital."

**Comprehensive routing**

Two of the routers will be used for satellite distribution, and two will serve the in-house audio distribution needs. The AES/EBU format digital router will allow NPR to provide a digital source, routing and compression of feeds for their satellite services.

Because of the size of NPR's largest router, they asked BTS to upgrade the software control package to support eight character mnemonic displays (instead of four) for the inputs and outputs, making it easier for the users to select the proper routing paths.

BTS also developed "path finding" software control and hardware integration to allow NPR to send mono feeds to stereo equipment and vice versa, auto-

matically. An operator will not need to know the format of a feed or a tape deck to patch the two together. The system can also reverse the polarity of a channel to fix an out of phase condition. Machine control options will allow operators to start and stop remotely located equipment through the routing system.

CBS Radio already is using its new router at its Washington location at 2020 M Street. The facility serves the CBS Radio Network with 440 affiliates, and it is also headquarters for CBS Radio Stations News Service, the Washington bureau for the CBS-owned stations. The router is a 128 by 96 single level analog mono matrix, since the news facility doesn't normally generate stereo programs.

Like NPR, CBS Radio also requires comprehensive computer control of its switcher at a reasonable cost, and switchers developed for the video market had the software features they needed, according to network officials.

**Already in use**

Ken Tankel, East Coast Director of Technical Operations for CBS Radio, said he uses the BTS switcher to handle the analog I/O from the facility to the outside world. Audio within the facility is digitized and carried on a LAN. The BTS switcher has the capability to mix analog and digital cards in the same frame, so CBS can upgrade to digital I/O if that's needed in the future, according to Tankel.

Tankel said he had a long wish list for CBS's routing switcher. The switcher had

to be serviceable over its projected fifteen year life, with solid vendor support. It had to be a recent, advanced design, yet still be field proven. The ability to handle analog and digital paths was a plus, and the software had to allow full integration into the overall operation, which is exclusively computer controlled. And, of course, it had to be delivered in time for the construction schedule.

Why would NPR and CBS Radio buy their audio routers from a television company? Because video users have always driven the development of very large routing systems; an audio router is just one separate component of a video router. The television companies have also created the demand for sophisticated features and advanced software control systems.

**Evaluate your needs**

Dave Russin, Mid Atlantic States regional sales manager for BTS, quotes CD quality specs for its audio routers, and suggests that customers consider several factors when evaluating these products for audio use.

He said systems should be expandable and capable of meeting the performance specs when fully expanded. The displays and control panels should meet the needs of the user, and the unit should offer the needed options: like redundancy, machine control, extra levels of cross-points, and mnemonic and status displays. The software control system should be easy to use and may include features such as dynamic control of

continued on page 7 ►

*"As an FM station, we need total flexibility and studio sound no matter where we broadcast from."*

**Solution:**

*"In three hours we went from a spur-of-the-moment idea to a live broadcast at a major rock concert. A million people in the market and we stole the show! The quality of the broadcast was so good it was frightening. With this kind of flexibility, we're constantly doing remotes - you name it, we're there."*

Jeremy Savage, Operations Manager  
WKSS-FM, (KISS 95.7) Hartford

**How are they doing it?**

With frequency extenders and regular dial-up phone lines. Total flexibility and great sounding programs.

We've got the solution. It's easier than you think, and affordable. We'll give you all the details. Simply.

Call or fax: 1-800-237-1776  
508-635-0401 (fax)



Specialists in Remote Broadcast Audio Transmission

Circle (142) On Reader Service Card

**NEW!**

LEVEL A 0.59 dBm    LEVEL B 0.47 dBm    PHASE A-B 0.1 deg

-15.00 dBm AUTORANGE 15.00 dBm

**PORTABLE ONE**

AUDIO PRECISION QUALITY IN A PORTABLE TEST SET

**PORTABLE - AFFORDABLE - EASY TO USE**

**Just press a button and take a measurement!**

- amplitude
- phase
- two-channel level
- noise
- frequency
- amplitude ratio
- THD + N
- wow & flutter
- crosstalk
- IMD\*
- generator load
- AC mains check

The Portable One—a two-channel analyzer at the price of single channel competitors!

**\$4,000\***

**Audio precision**

PO. Box 2209, Beaverton, OR 97075  
503/627-0832 1-800/231-7350  
FAX: 503/641-8906, TELEX: 283957 AUDIO UR

\*MSRP. Dealer price, includes tax and including IMD option or soft case

Circle (20) On Reader Service Card



# NAB Show Reflects Fun Side of Radio

by Lucia Cobo

**WASHINGTON** What stands over 13-feet tall, 30-feet long and 10-feet wide? Need another clue? It can also shoot flames, smoke and fog as well as a digital radio signal back to a studio. Give up? It is the Universal Studio's "Jaws" radio remote vehicle. It was but one of the many ingenious artifacts on display at this NAB's Fall Radio Show in Dallas last month. *RW* will have complete coverage of the show and related events in the Oct. 27 edition. In the interim though, I'd like to share some parting observations from the show floor.

But first, I'm happy to report that I did in fact make the *RW* Dream Team basketball game. It was held Saturday morning at 6 a.m., on the rooftop of the Hyatt Regency at Reunion Plaza. As you can see by the photo, it was still pitch black outside and fairly cold. You couldn't tell



though, from the enthusiasm with which Computer Concepts' Sean Bowers, Cutting Edge's Frank Foti and 360 Systems' Don Bird played that early a.m. (see photo). A good time was had by all, even though we only numbered four this time.

Saturday also was the last day the exhibit floor was open. Three days of walking the floor is enough to produce a sensory overload. So much to see—so little time. As you've read in *RW* before, computer and compression technology continued to dominate the technical displays. Gear of every style and flavor was available, from "Jaws" (pic-

hard-disk automation systems.

The issue of dueling algorithms was definitely a topic of conversation. Manufacturers and distributors want educated consumers and many of them pressed me to press you to ask questions and educate yourselves. Sony went on the record to volunteer its support of further research into the compression stacking issue. Even if you aren't planning any

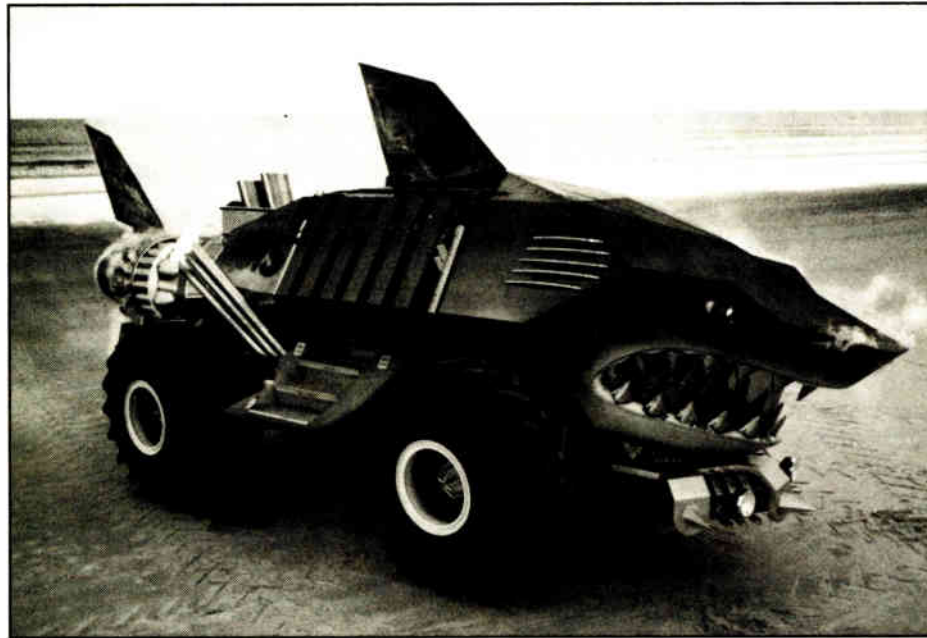

equipment purchases soon, stay abreast of what is going on in the debate.

A sampling of some of the exhibit floor offerings will give you an idea of the buzz on the floor. The all-digital radio station is here. Harris installed its first digital exciter, Digit™, and Sony is to begin delivery of various pieces of its digital product line, including the MiniDisc cart player and recorder/player (its replacement product for the NAB cart machine). Denon also unveiled an MD cart player.

Big news from Digital Broadcast Associates and AIR Corp. The companies have joined forces to come up with an alternative they believe is the cutting edge of source gear: compressionless digital carts. The companies have jointly agreed to observe the ASPECT (Audio Standard Precision Exchange of Coordinated

Technology). It means any number of manufacturers can produce equipment that records and plays re-recordable magneto-optical disks that are interchangeable, machine to machine, brand to brand.

The good news is that no matter what compression scheme you choose for the rest of your audio chain, when you record onto cart, it won't alter or add a compres-

sion scheme. The discs, capable of handling 11 minutes of uncompressed audio, are under \$20 apiece, and come with a lifetime warranty.

The DBA Laser-CART is available now. AIR Corp. is putting the finishing touches on its version and expects to deliver product in the first quarter of 1994.

Of course, compression was not the only thing happening at the Radio Show. As in the past, this year's gathering also served as a forum for company announcements. The trend is continued consolidation. StandardNews struck a deal to buy Virginia-based Zapnews. Many of you will recall that Zapnews came on the scene a few years ago as a fax-based, low-cost alternative to news services.

CBS Radio and Major League Baseball announced a six-year contract for the net-

work radio rights to regular and post-season games, including Spanish language and Canadian coverage, beginning with the 1994 season (CBS currently has the rights).

★ ★ ★

An interesting item was brought to my attention by *RW*'s John Gatski, News/Studio Sessions editor. Remember the demise of Heathkit a couple of years ago? *RW*'s Frank Beacham even did a story lamenting the proud American pastime of building your own Heathkit's products.

Well, another sacred electronics institution, Radio Shack, has done something nearly as shocking. It now charges \$3 for its catalogs that in past years you could go down to your local store every autumn and pick up for free.

*Radio World* put in a call to the Tandy Corp., Radio Shack's parent company, to get the official line on why they were charging for the catalog. A spokesman said that charging for the catalog would cut down on people picking up copies and not ever buying anything, thus depriving



the good customers of being able to get a catalog. For the regular customers, the Radio Shack spokesman, explained, there were various discount coupons inside that would more than get you your money back in the end.

But the money isn't the point. It's the service aspect. It seems that this is the latest example of declining service that abounds in many aspects of American industry. Having to buy the Radio Shack catalog is akin to putting a quarter in a machine to put air in your tires.



## Get on the right track...

**U**nattended operation helps you operate your station profitably. All it takes is a satellite or automation program source, a good transmitter control system, and a way to handle EBS.

You take care of the program source... We'll help with the rest.

A transmitter control system from Burk Technology relieves you of the need to keep someone at the station just to take transmitter readings. Add our exclusive Studio I/O and we'll run EBS for you, too.

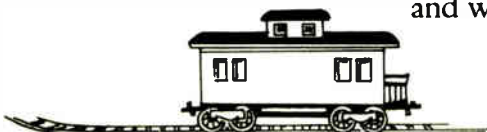

Burk gives you the flexibility to run your station the way you want, and in full compliance with FCC rules.

Call us now. We'll show you a new way to run a railroad.

TOLL FREE 1-800 255-8090

**BURK**  
TECHNOLOGY

7 Lomar Drive, Pepperell, MA, 01463 (508) 433-8877

Circle (157) On Reader Service Card

World Radio History



# READERS FORUM

If you have comments for Radio World, call us at 800-336-3045 or send a letter to Readers Forum (Radio World, Box 1214, Falls Church, VA 22041 or MCI Mailbox #302-7776). All letters received become the property of Radio World, to be used at our discretion and as space permits.

## An AM stereo plea

Dear RW,

Although I have never met Leonard Kahn (president of Kahn Communications), I feel as though I know him through the many articles I have read and the numerous seminars I have attended at both the National Association of Broadcasters and Radio Advertising Bureau.

Of the many impressions I gathered from his lectures, one was that he is indeed one of the few remaining loyal friends of AM radio. Over the years, more than one of his products helped the AM band to sound better than perhaps it should. His knowledge and devotion to the AM side was unparalleled.

Then came the AM stereo war. He gave it his best shot, but he lost. While I respect his right to fight, his right to protest, and I am proud that he stood up for what he thought was right, it is time to back off.

There is little time left for saving AM. AM stereo may not be the answer, but it is a shot. If we in Kentucky understand anything, it is what a last-second shot can accomplish. In the name of fair play, I hope Mr. Kahn allows that shot to be taken.

His legacy may well be based on his final stand on this issue. None of us wants it to be a bitter one. He has been a champion of the AM cause for too long to bring it to an unwanted and undeserved death.

As a fellow broadcaster, I urge Leonard Kahn to direct his efforts not against, but for the encouragement of AM stereo.

Ralph Hacker, president  
WLVK-AM-FM Lexington, Ky.

## Another look at Eureka

Dear RW,

Now that politics have stalled IBOC (in-band, on channel digital audio radio), it is time for broadcasters to look back to the new-band idea for digital, multiple-channel transmission.

We were first tempted with the dream of digital transmission by using TV transmitters

to generate digital radio. Eureka!—It was just that.

IBOC does nothing for AMs in ever-expanding markets. Directional patterns will remain. FM will always be king.

In these times of rising operating costs, I would still welcome a multichannel system. The thought of sharing this new technology, and its cost, wouldn't bother me one bit.

This would also ensure that the system would operate at saturation, which in turn would fuel receiver purchases and assure the success of digital broadcasting. Major markets would operate in a cell configuration, improving the coverage of everyone.

What? Level the playing field?

Why not?

AM and FM stations compete using the programming they deliver. The fact that one station can be heard better doesn't guarantee that it has the best programming. We have 81 channels on my cable TV system. All of them enter my home the same way, with one transmission method. I watch what I want to watch.

Now my cable also has Digital Music Express, offering CD-quality audio into my home. I swear a lot and refuse to buy it because I can't deliver the same quality audio into my home with my stations. Why should I support a non-broadcaster?

The telephone companies are gearing up for fiber optics. They will compete with the cable company for audio and video service. Before you know it, AM and FM will be those audio sources you listen to when you are in your car and forgot your CD case.

Let's get out of the "Dark Age of Radio" and into a DAR that keeps broadcasters in the broadcast industry.

Neil T. Schwanitz  
chief engineer

WXYZ(AM)-WMXD(FM) Detroit

## BMI position

Dear RW,

You published a letter entitled "Digital Music Future" by Doug Bell, a BMI employee in Nashville (Aug. 25). Mr. Bell's letter represented his own views and not those of BMI.

We are convinced that local radio broadcasters will play a successful and important role in the future of communications. While many new entrants will find novel forms of delivering music to the public, we believe that traditional broadcasters will continue to play an integral and vital part in the lives of their communities.

We look forward to continuing the mutually beneficial relationship between America's broadcasters and BMI that has benefitted broadcasters, song writers and the listening public for many years to come.

Lawrence P. Sweeney  
VP, telecommunications  
BMI, New York

## Cellcast fan

Dear RW,

I appreciated Edwin Bukont's article regarding the use of cellular phones (RW, Aug. 11). We're one of several broadcast stations that have found the cellular system to be a great tool for reaching out

## Receiver Makers Have Next Move

to be successful.

But AM stations still broadcasting music should take another look at stereo. In many cases stereo conversion might turn out to be a solid business decision.

More than one AM broadcaster over the years has said something like: "If one advertiser were to threaten to cancel his business if we didn't have stereo, we would install it."

Frankly, any advertiser demanding stereo for its commercials must have abandoned AM for FM and MTV years ago. (Wouldn't an FM station or MTV expect to lose some accounts if they were to abruptly cease stereo operation?)

AM stereo could be an optimal interim technology before digital audio radio. As the situation has developed recently, the most optimistic estimates place DAR introduction several years into the future.

Also, while in-band, on-channel DAR development for the AM band has made encouraging progress, it is still far from proven technology. If AM IBOC does not work, no one should count on getting an allocation for a new-band DAR system.

Meanwhile, AM mono through the typical low-quality receiver-available today, as many an engineer will say, sounds like that famous, four-letter excremental word. AM stereo on such receivers sounds like two channels of it.

The FCC has mandated the RF mask and several other improvements and is now setting an AM stereo standard. An interference-reduction strategy for expanded-band allocations has been adopted. The NAB and EIA are agreed on the AMAX high-fidelity receiver standard.

Broadcasters and government have done much, perhaps all that they can do. Adjacent-channel interference can no longer be used as an excuse. Higher-quality receivers are the next step.

The consumer electronics industry controls AM's future now. If it does not offer more than the currently sparse collection of poorly promoted high-quality receivers, this month's FCC action, and other efforts to improve AM, won't achieve anything.

—RW

even further and deeper into the communities we serve.

I was amazed to find not one sentence dedicated in your article to Cellcast. Cellcast Communications Products are sold from a company in Owasso, Okla. We have been a Cellcast user and customer for three years this November.

There is not a better tool for radio broadcasters to utilize for emergency situations and regular remote/sports kinds of coverage than the Cellcast. We use ours for almost everything. We also have and use Marti equipment as well.

I use Cellcast because:

1. It is reasonable to operate. The cost per minute is very flexible, especially if you use one of the professional plans that will let you accumulate 400 minutes of usage per month, like our \$89.95 monthly rate.

2. It is quick as a New Mexican jack rabbit. If you get a call and have to cover something in a matter of minutes, you can be there and ready to go by the time you pull your truck up into the broadcast area. You can't do it any other way.

I recommend Cellcast and urge any broadcaster looking for a cellular phone system to contact them.

Bob Flotte  
owner/general manager  
KPSA-AM-FM Alamogordo, N.M.

## Wireless wires crossed

Dear RW,

James Stoffo of Gient implied in his article ("Buyers Guide," July 28) that the Vega "600 Series" wireless system was used during MRN Radio's live broadcast of the Daytona 500.

MRN Radio doesn't use the Vega system and the statement, "The system supplies program audio to MRN Radio," is false. MRN Radio uses Sony 950 MHz wireless transmitters with Shure SM-58 microphones.

This month's FCC order officially setting an AM standard is meaningless, some say. A de facto standard has existed for years and simply making it official will change nothing.

But, better late than never is better.

True, many of the more profitable AM stations have adjusted to the current market and technological realities by airing news/talk programming that does not require stereo, or even high fidelity,

The Daytona International Speedway does not supply any audio to MRN Radio. In fact, it's just the opposite. MRN Radio feeds the public address system with its own audio.

John McMullin  
president, MRN Radio  
Daytona Beach, Fla.

## New listing

Dear RW,

The "Radio World 1993 Directory" shows definite improvement over past editions in several ways. Please keep up the good work.

However, no product source books were mentioned for RTW Micrographics, even though a full address was given in the "Supplier Source Book" section.

RTW Micrographics sells microfiche readers, reader-printers and a variety of other micrographics equipment and supplies.

Microfiche readers sold by RTWM are affordable and versatile instruments, which are usable by broadcasters for multiple purposes. FCC databases on microfiche are a primary use, and, readers can spot LP-record needle lopsidedness, pinhole flaws in compact discs and certain external flaws in electronic components.

Robert Wertime, owner  
RTW Micrographics  
Greencastle, Pa.

## Correction:

Ted Alexander is chief engineer of WRM(R) - WDOK(FM) Cleveland. Christopher Scherer, author of "Storm Forces Impromptu Broadcasting" (RW, Sept. 22), is assistant chief engineer. Alexander's home served as the WDOK temporary studio described in the article.

**Radio World**  
Vol. 17, No 19 October 13, 1993

Editor ..... Lucia Cobo  
Managing Editor ..... Randy Sukow  
News/Studio Sessions Editor ..... John Gatski  
Assistant Editor ..... Mary Ann Dorsie  
Contributors ..... Frank Beacham/N.Y.  
Bruce Ingram, Pamela Watkins, Nancy Reist  
Technical Editor ..... John Bisset  
Technical Advisor ..... Tom McGinley  
Editor (International) ..... Alan Carter  
Managing Editor (International) ..... Charles Taylor



Radio World (ISSN 0274-8541) is published semi-monthly by Industrial Marketing Advisory Services, Inc., 5827 Columbia Pike, Suite 310, Falls Church, VA 22041. Phone: 703-998-7600, Fax: 703-998-2966. Second-class postage rates are paid at Falls Church VA 22046 and additional mailing offices. POSTMASTER: Send 3579 forms and address changes to Radio World, P.O. Box 1214, Falls Church VA 22041. Copyright 1993 by Industrial Marketing Advisory Services, Inc. All rights reserved.

—PRINTED IN THE USA—

**Next Issue of  
Radio World  
October 27, 1993**

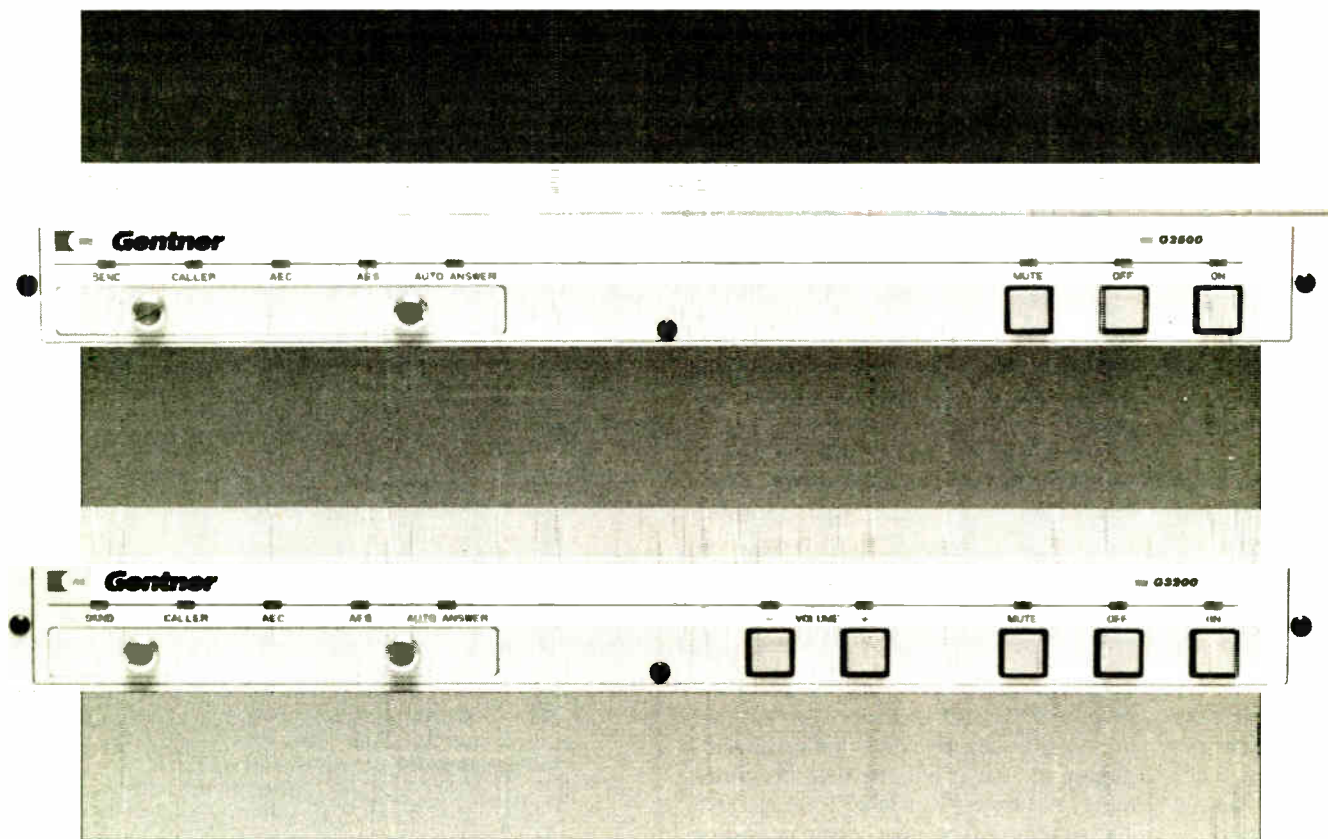

# Superhybrids.

Improve your telephone audio with Gentner's new G2500 and G3200 digital hybrids. These "Superhybrids" provide the very best telephone audio quality. The same quality you've come to expect from Gentner.

Use the G2500 with any audio board or console. Unlike other hybrids available today, the G2500's Auto Mix Minus allows you the freedom to feed program output down the telephone line, even when the output contains caller audio. The G2500 automatically removes the caller audio from its feed path.

Take the G2500 anywhere you like. The automatic answer/disconnect, nulling, re-null on new line selection, RS-232 control, and single-cable conferencing with another G2500 lets you take it with you. And an acoustic echo suppressor further reduces the chance of feedback.

Designed for large talk shows or talk shows with a live audience, Gentner's G3200 combines both digital hybrid technology and digital acoustic echo cancellation to provide clean telephone audio. No matter how good the studio's room acoustics, some of the caller audio

appearing on the studio speakers will work its way back to the mics. The G3200 recognizes this caller audio and digitally subtracts it from its SEND audio path. The result is clean, intelligible audio on both sides of the telephone call. And you won't have to worry about volume—turn the studio speakers up as loud as you want.

If you need additional feedback control (for poor acoustic areas), use the G3200's Acoustic Echo Suppressor (AES). It acts as a reverse "caller control," suppressing send audio when the caller talks.

The same automatic

features as the G2500, plus a built-in auto mic mixer (up to 3 mics) and power amplifier, make the G3200 ideal for use in any talk show location.

Consistent and superior telephone audio, call after call.

 **HARRIS  
ALLIED**

© 1993 Harris Corp.



# Second Round of Tests Completed

► continued from page 1

by way of in-band and out-of-band RF signals, telephone lines and satellite links. Some tests, however, were amended.

"We now have a good feeling for how originators will use these devices," Mitchell said. A major complaint following the Denver tests was the lack of representation from local emergency personnel compared to broadcaster participation. Emergency officials from the four surrounding counties in the Baltimore area were sought out to participate in the second round.

## Significant influence

One of the new trials in the cable domain (conducted over the local Comcast Cable system) tested how the three major proponents' encoders and decoders communicated with each other using the same digital protocol, the National Weather Services' WRSAME codes. This test could have a significant influence on the FCC's EBS report and order.

In fact, Barry Shay, senior scientist for system developer Information Systems Laboratories (ISL), Vienna, Va., said he wished more communications tests between the proponents had been conducted. "I don't think it is accepted at all" that the systems will communicate well under all conditions, he said.

The FCC's stated goal is to create EBS guidelines that will allow the current major EBS system developers to develop and market their systems, while at the same time avoiding "AM-stereo-like" standards confusion.

"The taxpayers have already paid for WRSAME," said Joe Wu, president of TFT Inc., Santa Clara, Calif., one of the three major EBS system proponents. "If we can send a coded WRSAME message, we can send any digital message."

"You have to assume that the system works and accommodate the diversity of technology, not only now, but what might come along in the future," the FCC's Smith said. "You don't change something

like this very often."

The major EBS systems tested were certainly diverse. TFT's EIS 911 Emergency Information System builds on current EBS routing technology to create an in-band, "web" network to replace the current, unreliable "daisy chain." It will allow broadcasters to use their current EBS receivers with the purchase of a \$750 decoder.

The Sage/RDS system relies on radio data service technology to deliver EBS alerts in a number of creative ways. Sage has contracted with consumer electronics companies to build radios that will automatically turn on when receiving emergency RDS commercials. Smoke alarms, pocket pagers and other devices with built-in RDS decoders also were demonstrated. Sage can operate either in band or out of band.

ISL's Emergency Broadcast Satellite System (EBSAT) is designed to link emergency mobile command centers to broadcast stations, cable systems and home satellite receivers by Ku-band satellite links, using very-small aperture terminal (VSAT) technology.

## Power struggle

If the FCC's flexibility goal is realized, most of the disagreements between these companies will evolve into competitive selling points rather than issues in a standards proceeding. A major disagreement has developed between Sage and TFT in the months since the Denver tests.

LeBow attacked TFT's claim that the EIS system was more powerful and robust than RDS out-of-band signals. He distributed copies of a Sage commissioned study by consultant James L. Lansford of the Green Mountain Falls Group, Green Mountain, Colo., which supported the Sage claims.

In response, TFT Marketing Manager Darryl Parker repeated his contention that EIS is actually 100 times more powerful than RDS.

The Lansford paper claims that in-band EBS signals require high injection levels that degrade the alert message in a sta-

tion's fringe areas: "Any claims for superiority of main-channel modulation are only valid at high pre-detection signal-to-noise levels (>20 dB), where bit errors are negligible no matter which system is used."

LeBow claimed the Baltimore tests supported the Lansford findings. "We beat the pants off them" by receiving signals from longer distances during propagation tests," he said.

TFT's Wu said he had not read the Lansford paper and declined to comment directly on it. But on its face, Wu found the paper's conclusion odd: "We are in-band. We are using the full power of the transmitter. He's using less than four percent."

Wu also challenged LeBow's claim to victory in the Baltimore propagation tests. The TFT system had a 60 percent success rate in the fringe areas compared to 20 percent for RDS, according to Wu.

## BTS Supplies Switchers

► continued from page 3

stereo, left, right, and mono channel assignments.

A typical analog router, in a 64 by 64 stereo matrix, prices out in the \$90,000 to \$115,000 range, but a buyer can expect to spend another ten to twenty percent for peripherals, such as controllers, displays, etc.

AES/EBU format digital routers are about a third less expensive than the analog version; there are fewer cross-points and outputs because the left and right signals are carried in a single data stream. It is not, however, possible to control the left and right channels separately.

□ □ □

Jon Banks is chief engineer for WLTT(FM) Washington, and a contributing writer to RW.



**VMC-16 VOICE REMOTE CONTROL SYSTEM**

- Provides continuous monitoring of transmitter or other remote site. Data relayed to remote operator in clear human voice.
- Controlled over standard, dial-up phone lines.
- Parameter Tolerance Monitor continuously scans all conditions.
- 20 user-definable input channels monitor value or status, as programmed.
- Automatically dials up to three preprogrammed 12-digit phone numbers, then announces alarm conditions.
- Monitored data reported via human voice message.
- Fail-safe circuit simultaneously monitors up to eight conditions.
- Internal clock/calendar with battery backup can be programmed for up to 99 events.
- Low cost of \$2,450.

**BE BROADCAST ELECTRONICS INC.**  
 4100 N. 24TH ST. P.O. BOX 3606  
 QUINCY, IL 62305-3606 U.S.A.  
 PHONE (217) 224-9600  
 FAX (217) 224-9607  
 TELEX 250142

# MIX 'N MATCH

## System 10,000 Modular Amplifiers

Over 40 interchangeable Microphone, Line and Audio DA Modules for you to mix 'n match to your requirements.

- Transformer or Active Balanced Outputs • VCA Option Available • Backup, Alarmed Power Supplies • RF Protected
- Clean & Quiet Performance • Attractive & Safe Design
- Cool Operation

**AUDIO TECHNOLOGIES, INC.**  
 328 W. Maple Ave., Horsham, PA 19044, USA  
 (215) 443-0330 • FAX (215) 443-0394  
 1-800-959-0307



Call, fax or write for free detailed brochure



Circle (206) On Reader Service Card

Circle (88) On Reader Service Card



# FCC to Approve AM Stereo Standard

► continued from page 1

radio covers areas not served by FM stations," Pressler said in 1991.

## It might work

A law meant to aid an isolated portion of the radio audience could turn out to be serendipitous for all AM radio.

AM broadcasters and equipment manufacturers agree that stereo will never reach the consumer popularity it might have commanded had the FCC adopted a universally accepted standard earlier.

But some recent market developments, both in the U.S. and abroad, suggest AM stereo may have a surprising amount of life left in it.

The economics of the AM business, which long endured steady profit erosion, are slightly improved. The new radio ownership rules adopted last year, which encourage the formation of duopolies and local marketing agreements, have placed many AMs on more solid ownership foundations. More stations are probably able to afford AM stereo than a year ago.

International interest in AM stereo appears to be growing as well. Several countries, including Canada, Mexico, Australia and Japan, adopted C-QUAM as their AM stereo standards years ago. Stereo broadcast equipment manufacturers say this is a growing segment of their business.

"I have probably done the most recent marketing analysis," said John DeLay, AM product manager for Harris/Allied, Quincy, Ill., which began offering an improved C-QUAM generator and transmitters with C-QUAM gear built in earlier this year. "Manufacturers of stereo generators have all experienced some very significant growth in the international segment over the last three years."

The AM technical environment also has changed since the 1980s. FCC adoption of the National Radio Systems Committee's (NRSC) "RF mask" standard, new skywave and groundwave propagation standards and several other

new rules have served to reduce AM interference, especially adjacent-channel interference, which for years forced receiver manufacturers to build narrow-frequency-response radios.

The FCC hopes the new expanded AM band (1605 kHz-1705 kHz) can be a model of high-quality AM broadcasting, where all stations will be bound to the new technical rules from the beginning. Assignment preferences are being given to stations planning to broadcast in stereo.

## Interest exists

"I'm ecstatic about the amount of interest the FCC has gotten" in reply to its request for expanded-band applications, said Michael Rau, senior vice president of science and technology with the National Association of Broadcasters. The commission is following an NAB-endorsed plan to fill the expanded band with stations from the established AM band.

The FCC is considering over 800 applications for as many as 300 expanded-band slots. (The number of slots could be much lower, depending on the technical and nontechnical eligibility factors of

individual applicants.) Harris' Delay predicted that stereo stations will fill 100 percent of those slots.

The FCC hopes higher fidelity and stereo in the expanded band will prompt competing AMs to invest in improvements of their own.

"I think (the expanded band) is a contributing factor (to AM stereo success), but not the only one," Rau said. "Another factor is the selection of a (C-QUAM) technical standard in Japan, requiring manufacturers in Japan to produce AM stereo receivers. Another reason may be our AMAX campaign."

AM stereo has been a hit with Japanese consumers (RW, March 24), and Japanese companies appear to be ready to expand that success to other countries. Sony recently announced plans to have AM stereo "Walkman" units, built to NRSC's high-fidelity AMAX specifications, available in the U.S. by Christmas.

Only one manufacturer, Denon, is currently offering AMAX receivers—high-priced, home units that have sold poorly in the year they have been available to

continued on page 11 ►

## Q: Which was the technically superior AM stereo system: Kahn ISB, Motorola's C-QUAM or one of the others?

*E. Glynn Walden, director of engineering, Group W Radio, Philadelphia:* "The Motorola system was best for one reason—it was a complete system...Kahn had developed a transmission standard, but never really developed a receiver. Motorola had a complete systems approach. But either system could have been made to work in the long run."

*Alan Parnam, director of transmission systems, CBS Radio (C-QUAM is installed in a majority of CBS's eight AMs):* "On a purely engineering

basis, probably the Kahn system is better. How much better? I would not say by leaps and bounds. But to have the technically inferior system become the standard is not at all



unprecedented. Look at Beta versus VHS. A lot of times these decisions are based on who did a better marketing job rather than who did a better engineering job."

## AudioVAULT + CORE

THE ULTIMATE IN DIGITAL  
AUDIO STORAGE  
AND CONTROL



## AudioVAULT

- Fully programmable, simultaneous record/playback.
- Instantaneous, random access to stored audio.
- Supports multiple channel audio inputs.
- Each input can be routed to any output pair.
- An ideal partner in satellite programming.

## CORE

- Automated program control via English language commands.
- Compatible with established as well as most recent source technology:  
CD Jukeboxes  
RDAT  
AudioVAULT
- Simultaneous addressability for up to 36 source inputs.
- Virtually unlimited event capability; insertions and deletions require no reprogramming.
- Log information stored on hard disk for review.



**BROADCAST  
ELECTRONICS INC.**  
4100 N. 24TH ST. P.O. BOX 3606  
QUINCY, IL 62305-3606 U.S.A.  
PHONE (217) 224-9600  
FAX (217) 224-9507  
TELEX 250142

Circle (145) On Reader Service Card



# Programmable SCADA Controller



**SPRINT-7010**  
Intelligent controller

SMC WIRELESS

The SPRINT 7010 Controller is the Ultimate in broadcast remote control equipment. It incorporates 16 analog input ports and 16 relay or transistor outputs. This fully programmable controller enables you to customize the unit to your specific application. The real time clock/calendar allows you to program timed events, such as power/pattern changes. Built in data logging is standard. User interface is accomplished via a standard RS232 serial connector. See how the Sprint 7010 can provide you with features and flexibility never before available in a remote control system.

Call or write today for your free color brochure.



P.O. BOX 1607 Tomball, Tx 77377  
(800) 527-1079 FAX: (713) 259-7801

Circle (59) On Reader Service Card



**AXS™** (ax'-sess)... a total control Cart machine replacement ✓ Fast ✓ Powerful ✓ Absolute.

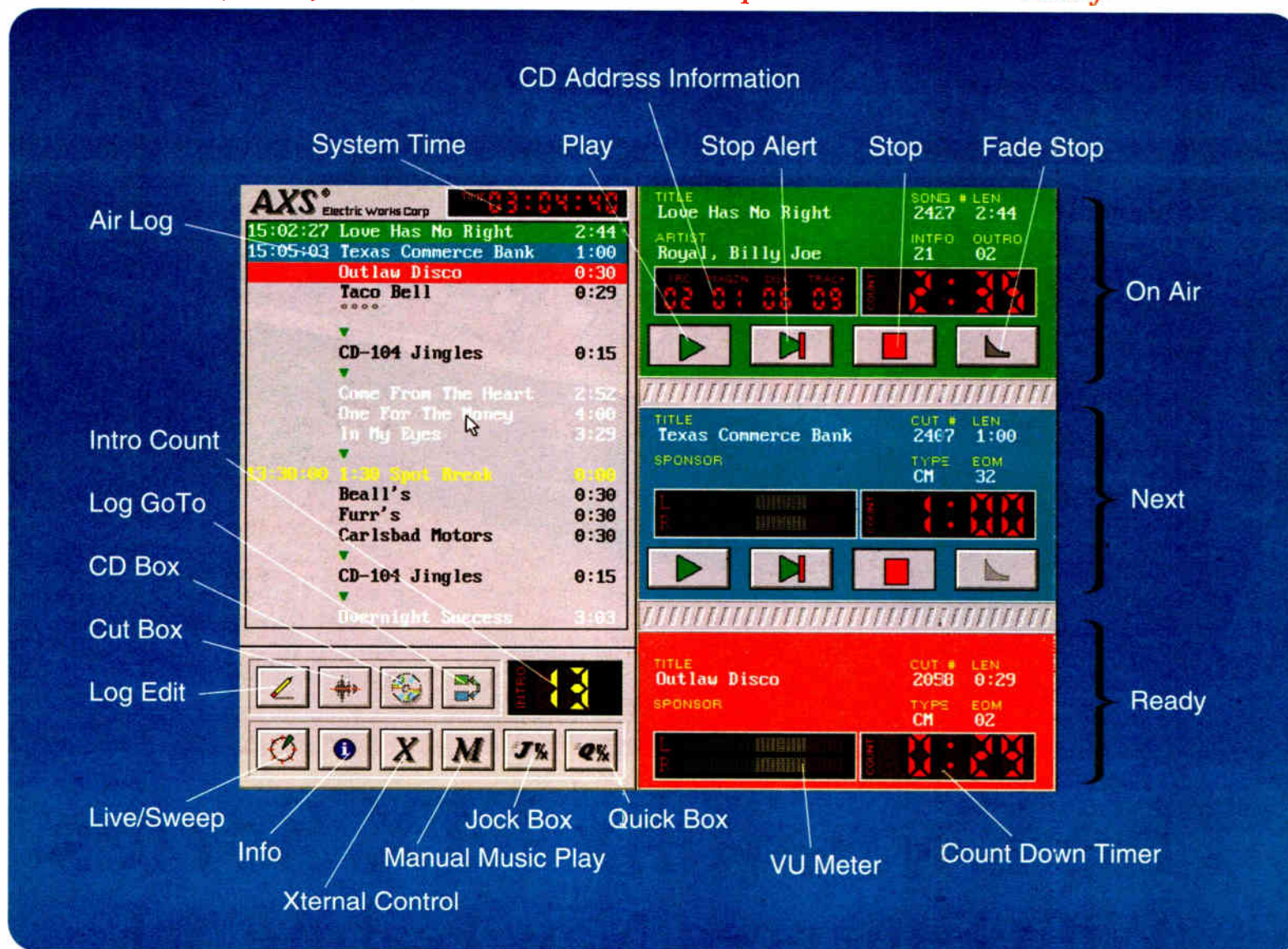

AXS replaces all the old audio Cart machines in one Production room and one Control room for just \$5,995.00\*  
 Add another AXS Control room for \$2,495.00\* — And that's just the beginning...

- AXS is a true Cart machine. Not a modified automation system, not a wannabe copy of an absolute idea, just the real thing.
- AXS is easy... your Jocks will love it. Get them up and running in about 10 minutes.
- AXS is instant. Any cut, any time, alone or in sets of 10 in sequence from eight Quick workboxes.
- AXS gives each Jock one or more of up to 36 Jock workboxes loaded with their instant audio production tools ready to go.
- AXS means total Jock control. One Cut or a sweep or a complex sequence, just the way you want it.
- AXS eliminates your paper Log, music play lists, copy notebooks, 3x5 cards and all the other Control room junk.
- AXS displays the entire daily Log, not just a set of boxes or a plain list. Scroll, edit, move, cut, goto, or change any event at any time.
- AXS Control replaces all the old Cart playbacks in your Control room and gives each Jock new tools to improve the sound.
- AXS Production replaces your obsolete Cart recorder with a sophisticated digital recorder and audio Cut manager. A full cut and paste Log editor is also included. An optional workstation will be available soon.
- AXS has optional interfaces for the popular Pioneer™ single or multi-magazine 6-pack CD players or the fantastic Pioneer™ 300 disk, dual platter CD Jukebox.

- AXS CD holds your entire music database ready to scan in the music pick box.
- AXS CD even airs single CD's for requests and countdown shows.
- AXS interfaces with most Traffic and music selector systems.
- AXS is complete. Each starter or add-on system includes the superb quality apt-X™ digital audio cards, AXS operating software and LAN network cards.
- AXS works with your 486 computers, monitors and hard disks or we'll supply the whole package.

**Contact your favorite broadcast dealer or distributor for AXS delivery information now!**

*\*Customer supplies computer, monitor & hard disk drive.*

**Call Electric Works Corp/The Management for demo disks and spec sheets at**

1-800-334-7823 or Fax 817-624-9741

**AXS™**

*AXS™ is a new product from the designers of Digital DJ™, Super Log and Music Log.*





Model MX18E above  
under \$7,300 list

# The Dynamax MX Series

## With Enhanced New Feature Set

### Now Available in up to 18 Channels

- True modular design
- Ultra-reliable motherboard construction
- VCA mixer and monitor control
- Active balanced line inputs, transformer isolated mic inputs
- Active balanced main and monitor outputs
- Full monitoring/cueing facilities with VCA level control and active source selection
- Built-in cue amp with speaker and amplified stereo 8-ohm headphone output
- Independent remote start for each "A" and "B" input
- Opto-isolated remote module on/off
- Selectable fader start
- Two inputs per module, mic/line or line/line – line inputs may be mono or stereo, consumer or professional format
- Four assignable outputs – two stereo plus two mono
- Available in 10, 12, 14, 16, or 18 channel models
- Independent level controls for each "A" and "B" input
- Separate audio and logic power supplies
- Sturdy, all-steel construction
- Durable Lexan overlay control surfaces
- Count-up event timer standard
- Two input expansion switches standard
- Excellent RF immunity



**Northwest**  
(206)546-6546

**West Coast**  
(805)682-9429

**Southwest**  
(806)372-4518

**Northeast**  
(412)733-1994  
(215)322-2410

**Southeast**  
(904)678-8943

**Midwest**  
(816)635-5959

Circle (203) On Reader Service Card

World Radio History



# AMs Face a DAR-or-Stereo Decision

► continued from page 8

the public. NRSC's recent decision to relax the noise-blanking qualification for portable radios carrying the AMAX seal is hoped to spur manufacturers to follow Sony's lead and offer low-cost, high-fidelity receivers.

generators in operation worldwide as of March 1993.

In spite of the recent trend toward increased international sales, a wide majority of the installations—67 percent—are in the U.S. (Another 13 percent are located in Canada and Mexico.)

part series on AM stereo installation, several other expenses must be considered:

"All parts of an AM station, from the production room to the transmitter are affected by the decision to broadcast in stereo...Making an AM station sound good in stereo is a lot more difficult than doing the same for an FM." (See page 36 and RW, June 9 and Aug. 11.)

With or without an FCC standard, Motorola's last competitor, Kahn Communications, could still hinder C-QUAM success years into the future.

Kahn Communications President Leonard Kahn is pursuing litigation initiated five years ago in the Southern District of New York charging General Motors (owner of Delco, the leading car radio manufacturer) with patent infringement. (A similar suit brought at the same time against Motorola has been dismissed.)

Discovery is concluded in the Kahn/GM suit, says Motorola attorney

be interviewed for this story.

The most serious threat to AM stereo's future may be digital audio radio (DAR). U.S.A. Digital, a consortium of CBS Radio, Gannett and Group W Radio, is proposing an AM in-band, on-channel (IBOC) DAR system, one of five systems scheduled for laboratory testing this winter, sponsored by the Electronics Industries Association (EIA) and the NRSC (RW, Sept. 8).

## Digital horizon

"DAR did have a negative impact (on AM stereo equipment sales) up to about six months ago. Some managers and nontechnical types were led to believe it is just around the corner,"

continued on page 12 ►



Successful marketing of high-fidelity AM receivers, such as the AMAX-labeled Denon TU-680, with or without stereo, is considered crucial to AM's future.

At the same time, some manufacturers, such as General Electric with the introduction of its SUPERRADIO III, appear to be interested in building higher-quality AM receivers, with or without the AMAX seal.

"The curve in the growth of CDs is down. DAT didn't take off. It doesn't look like DCC is going to take off. (Receiver manufacturers) are looking for anything to hang their hat on, because they don't sell receivers very much anymore," said E. Glynn Walden, director of engineering, Group W Radio, Philadelphia.

## Down side

Others are not as sanguine about the consumer electronics industry's intentions. If manufacturers were really serious about wide-band AM, ABC's Brown asks, why didn't they pour hi-fi receivers onto the market as soon as the NRSC standard went into effect in 1990? Why are only a handful of companies selling wide-band radios even now? "Most of them, I think, still do not have product in design," Brown said.

There are other reasons to set the odds against long-term AM stereo success. After more than ten years on the market, Motorola reports only 941 C-QUAM

Only 12 percent of approximately 5,000 domestic AMs operate C-QUAM. The need for stereo has diminished for many of the remaining 88 percent.

"We've seen certain AMs come back in talk formats and be very successful. For them, stereo is not as important," said Bud Walters, president, The Cromwell

## AM stereo will never reach the consumer popularity it might have commanded had the FCC adopted a universally accepted standard in the late 1970s or early 1980s.

Group, Nashville, which operates five AMs, none with stereo.

"Nobody wants to listen to news/talk in stereo and the AM stations that are broadcasting music don't have the wherewithal today to invest in AM stereo product," said Jesse Maxenchs of AKG Acoustics, San Leandro, Calif.

The economics of AM are improved, but are still not good for many. Stereo installation will be a major expense for some stations. The cost of C-QUAM equipment is modest, but as RW columnist W.C. Alexander said in his three-

Robert Krupka of Kirkland and Ellis, Chicago. A hearing to set a trial date was scheduled for late last month, but the suit is not on a fast track.

"The case is presently pending before a judge that has been nominated to move up to the court of appeals, so it is unclear when a trial might be scheduled," Krupka said. "Even if we had a trial, it's unclear how quickly we could get a decision after that. It's likely to be a considerable period of time before anything further happens."

Leonard Kahn declined RW's offer to



## LMA/DUOPOLY CONTOUR MAPS

The DATAWORLD LMA/DUOPOLY Market Survey Contour maps present a precise electronic verification of overlapping and intersecting contours.

AM 5 mV/m and FM 3.16 mV/m City Grade contours are shown in full color, including transmitter site indicator. The map is supported with a printout showing all of the stations which appear on the map.

Daily updating of DATAWORLD'S AM and FM databases protects against errors and omissions.

### OTHER MAP OPTIONS

- SHADOWING (TERRAIN SHIELDING)
- CONTOUR COVERAGE
- POPULATION DENSITY
- ZIP CODE BOUNDARIES
- RECEIVED SIGNAL LEVEL
- SPECIAL REQUIREMENTS

## 1990 CENSUS

### WHO ARE YOUR LISTENERS?

### 1990 BUREAU OF CENSUS POPULATION COUNTING

- Comprehensive Ethnic and Demographic Data
- Ethnic/Demographic Data Available for Each Zip Code Within Coverage Area
- Age Analysis Reflected in Ethnic Breakout
- Resolution Increased to Block Level
- Percent of County Coverage Shown

### ETHNIC PIE-CHART DISPLAY

- Projects Ethnic Population in Multi-Color Pie Chart Form

dataworld®

800-368-5754 FAX: 301-656-5341

# THE SIMPLE SOLUTION FOR DIGITAL AUDIO TRANSPORTATION



- ▲ MUSICAM ISO/MPEG Layer 2, 2A
- ▲ Switched 56, 64 kbit/s, ISDN, Fractional T-1
- ▲ User data channel from 300-9600 baud
- ▲ Easiest set-up locks to network or internal clock
- ▲ Fully automatic decoder reduces operator set up
- ▲ Multiplex or redundant two times 56/64 for 112/128 kbit/s
- ▲ Mono, Dual Mono, Stereo, Joint Stereo operation
- ▲ AES/EBU and SPDIF digital interface *included*
- ▲ Two-times V.35, X.21 or RS 422 interface *included*
- ▲ Headphone monitor *included*

The RE 660/661 MUSICAM Digital Audio Codec was developed to enhance MUSICAM technology, providing up to 20 kHz of audio bandwidth. From satellite networks to switched 56 telephone lines, the full-featured RE 660/661 is completely bit rate flexible up to 384 kbit/s.

Applications range from network program distribution to remote pick-ups for sports, concerts, special events, news gathering, STL back-up, audio backhaul, recording and post production studios.

When it comes to digital audio transportation, nothing comes close to the RE 660/661 for providing quality audio with hassle free set up. Backed by 55 years of experience in analog and digital audio products, the RE 660/661 is the simple MUSICAM solution for all your digital audio transmission needs.

Available through Harris Allied and Broadcasters General Store



**RE AMERICA, INC.**  
 31029 Center Ridge Rd. ▲ Westlake, Ohio 44145  
 Phone: (216) 871-7617 ▲ Fax: (216) 871-4303

Circle (31) On Reader Service Card

Circle (192) On Reader Service Card



# AM Stereo Standard Imminent

► continued from page 11

said Motorola's Frank Hilbert, chief inventor of the C-QUAM system. "It is not. It has yet to be proven."



Sen. Larry Pressler (R-S.D.) rescued AM stereo from political oblivion.

"I don't think anyone has had to alter any of their basic (equipment purchasing) decisions based on DAR... People have made a lot more changes based on

currently available digital products," said Tim Bealor, sales manager, Broadcast Electronics, Quincy, Ill.

But, as Harris's Delay said, many AM broadcasters "have a limited amount of money for investment, even though AM stereo is not a huge investment. They have to really think seriously about (DAR)."

The DAR conflict is heightened by the design of the AM-IBOC system. "We have doubts that our DAR system is compatible with the Motorola C-QUAM system, or any stereo system to be honest. We certainly haven't kept that secret," said Group W's Walden. "That might hold some broadcasters up from investing in stereo when the investment in DAB is not a whole lot more."

All AM stereo systems developed so far employ phase modulation to encode the stereo signal. The only major differences among them are their phase-modulation compression techniques. AM-IBOC, as it is now developed, could not operate with another phase-modulated system on the same channel.

"The burden is on (U.S.A. Digital) to show compatibility with stereo phase modulation," and not the other way around, Hilbert said.

AM stereo advocates say DAR should not weigh heavily into AM stereo purchase decisions. Laboratory tests of DAR transmission systems could take up to a year to complete. Several years of field tests, FCC inquiries and standardization proceedings and station implementation would follow before DAR becomes a business.

## THE LINEAGE CONTINUES...

### Today's 1900 Series Antenna Monitors



#### FEATURES

- 2 to 12 towers—Modular construction
- Fully Compatible with AM Stereo
  - Suited to diplexed arrays
  - Moveable Control & Display Panel option
- Jitter-free "True Ratio" Display
  - Unambiguous positive or negative angle sign display
  - Continuous remote outputs of all phase and ratio measurements
  - Microprocessor remote control system compatibility
- From the world's leading antenna monitor manufacturer

For complete information, contact your authorized Potomac distributor, or

**POTOMAC  
INSTRUMENTS**

932 Philadelphia Avenue • Silver Spring, MD 20910  
Phone: (301)589-2662 • FAX: (301)589-2665

...THE STANDARD FOR THE NEXT GENERATION

Circle (49) On Reader Service Card

# Standard Setters Avoid 'AM Stereo Syndrome'

It could be called the "AM stereo syndrome"—the chain of events broadcasters and equipment manufacturers specifically try to avoid whenever they embark on a technical standards project.

"There are a lot of technologies trying to get in the door and we don't want to have another AM stereo situation on our hands," said Ray Lockhart, president and general manager, KOGA-AM-FM Ogallala, Neb., during a digital audio technology discussion at the NAB Radio Show in Dallas last month.

Later in the same session, Jim Smith, general manager, KAKC(AM)-KMOD-FM Tulsa, Okla., urged broadcasters to support the radio broadcast data service (RBDS) standard to head off competition from satellite-to-car interactive radio data systems: "I think we're going to be in big trouble if we don't support it, and we could end up with another AM stereo fiasco."

That not-another-AM-stereo mantra has been heard again and again over the past several years in connection to proposed new technologies.

Whenever a major new technology approaches an advanced state of development, the decision to shift the focus to standardizing and building a system is usually difficult. The emergence of several competing systems makes the orderly transition from technical concept to tangible product even more difficult.

How did the AM stereo process become the model for how not to handle these decisions?

#### Long, hard road

"AM stereo goes back to 1947 when a presentation was done by RCA to the FCC," says Jesse Maxenchs of AKG, a long-time participant in broadcast standards proceedings. "The FCC gracefully said, 'Fellas, we're concerned about FM right

now. We can't talk about AM stereo.'"

The FCC occasionally received petitions over the next several years to approve AM stereo broadcasting, but none of them attracted significant interest among broadcasters. In the meantime, the FCC approved FM stereo broadcasting in 1961, in an attempt to boost the economically sagging new medium into a more competitive position with AM.

As listenership gradually shifted to FM, in part due to its exclusive grasp on stereo broadcasting, AM stereo began to get a more serious hearing. Several AM stereo

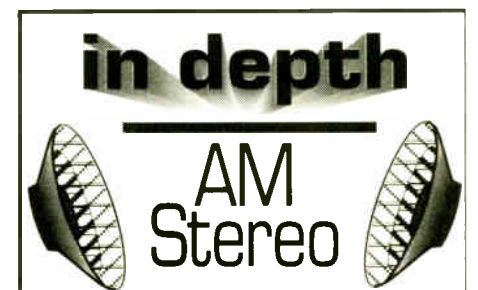

transmission systems were proposed to the FCC during the last half of the 1970s, including systems developed by Harris Corp., Kahn Communications, Magnavox, Motorola and Philco.

In 1980, the commission set a single U.S. AM stereo transmission standard, based on the Magnavox system. It was a flop. Broadcasters refused to install the system and pressed the FCC to reopen the proceeding.

Thirty years earlier, broadcaster and consumer apathy forced the FCC to repeal a two-year-old color TV transmission standard, based on the CBS color wheel system, and replace it with the current NTSC color standard, which had the overwhelming support of broadcasters and TV set manufacturers.

continued on next page ►

## A NEW FM MOD-MONITOR AT AN INCREDIBLE PRICE!



### INTRODUCING THE INOVONICS 530 MODULATION ANALYZER

We've integrated precision demodulation and measurement functions into a laboratory-grade FM tuner to bring you an extraordinary value in accurate off-air modulation analysis. High-resolution metering shows Total Modulation, Pilot and Subcarrier injection levels, demodulated Left, Right, L+R and L-R program audio, as well as 38kHz residual, Signal Level and Multipath distortion readings.

Features include 8 station presets, separate antenna and "direct" inputs, audio monitor outputs, a composite (baseband) in/out, and selectable peak integration characteristics. Easy access is provided for user-defined options, such as remote metering, remote peak flasher, balanced program line outputs, and carrier failure and "dead air" alarms — all at no additional cost!

The best part is the price: only \$2200. Contact your preferred distributor, or write, call or FAX us for full technical particulars.

**Inovonics, Inc.**

1305 FAIR AVE., SANTA CRUZ, CA 95060 U.S.A.  
TEL: (408) 458-0552 — FAX: (408) 458-0554



Circle (154) On Reader Service Card



► continued from previous page

The commission again stepped up to repeal a failed transmission standard in 1982. But this time there was no single industry consensus on one system as there had been for color TV in the 1950s. The commission settled the dilemma by deciding not to decide.

Under Reagan-appointed Chairman Mark Fowler, the FCC approved AM stereo transmission in any of the proposed formats with the hope that marketplace forces would eventually sift out a single, de facto standard.

The commission's decision was again a flop. A few stations installed the Kahn ISB system, several more installed Motorola's C-QUAM and the other proponents eventually stopped offering their own systems. A huge majority of AM stations chose to install no system at all and radio manufacturers were slow to offer consumer AM stereo receivers.

(Sony briefly marketed a radio capable of receiving both Kahn ISB and C-QUAM. It was the only Kahn decoder that was ever offered to the public.)

**Too little, too late**

As AM stereo languished, many accused Fowler and his successor, Dennis Patrick, of promoting an extremely conservative "marketplace" ideology that did not operate well with the strict limitations of broadcast transmission.

Broadcaster dismay led the National Telecommunications and Information Administration (NTIA), headed by Alfred C. Sikes (later FCC chairman during the Bush Administration), to conduct a study

and arrive at possible solutions. Said Sikes when the study was released in August 1987: "I don't think there's any doubt that C-QUAM is a de facto standard."

There were no technical barriers to the production of multisystem radios, NTIA concluded, but the fact that the only AM stereo receivers available at that time were C-QUAM and that a large majority of stations operating in stereo had chosen the Motorola system, suggested that C-QUAM had established itself as the U.S. system.

NTIA advised the FCC to avoid the inevitable law suits that would arise if it were to set a single standard. Instead, NTIA suggested protecting the C-QUAM pilot tone (the signal that turns on the stereo light on broadcast stereo receivers).

The commission had done something similar a few years before when it chose to protect the Zenith-developed TV stereo system's pilot tone, rather than standardizing it. Consumer electronics manufacturers interpreted the move as U.S. government recognition of a de facto TV stereo standard and began offering products to the consumer.

The same strategy would not work for AM stereo. The FCC followed NTIA's lead in January 1988 and protected the C-QUAM pilot tone. Chairman Patrick proclaimed that any doubt as to which of the two systems was dominant had been "substantially reduced, if not eliminated."

Kahn Communications President Leonard Kahn reacted with defiance. He accused the FCC of being out of touch with the marketplace and redoubled efforts to warn broadcasters of the defects he saw in the C-QUAM. Kahn and his partner in the devel-

opment of the ISB system, Hazeltine Inc., filed a number of suits against Motorola and General Motors (owner of Delco, the country's largest car radio manufacturer), some of which are still pending today.

Broadcasters and receiver manufacturers continued to ignore AM stereo. It became a non-issue for most broadcasters until Senator Larry Pressler revived it last year.

**Will it happen again?**

Many today still say most of the blame for the AM stereo fiasco lies with the FCC for not selecting a single standard in 1982. "The AM broadcaster was in much better condition 20 years ago to afford the transition to AM stereo than he is now," Maxenchs said.

But other factors and individuals outside the FCC's control also contributed. Industry confusion over standards was not

the only reason AM stations stayed away. The AM stereo battles of the 1980s coincided with a precipitous drop in revenues and market value for most AM stations. Some stations did not have the money to spend on an AM generator and the sometimes significant cost of preparing their stations for AM transmission. Other station operators that could afford the expense simply chose not to invest further in a declining asset.

"I think that a number of AM operators also had FM stations. They saw their FM revenues growing and FM listenership growing and their concentration turned to FM. That had something to do with it," said Robert L. Fox, chairman and CEO, KVEN(AM)-KHAY(FM) Ventura, Calif., and chairman of the NAB radio board. "The industry is not a half a dozen large

continued on page 15 ►

**Q: Will AM in-band digital broadcasting affect broadcasters' decisions to invest in AM stereo?**

*Robert L. Fox, chairman and CEO, KVEN(AM)-KHAY(FM) Ventura, Calif., and chairman, NAB Radio Board: "I think (DAR) has to have an effect on everything we do now...It depends upon how far down the road digital is and how long it will take to get to a critical mass with AM stereo. If we reach it about the time that digital starts to take over, the picture changes again."*



Robert L. Fox

*It's Here . . .*

**THE NEW GENERATION OF FM TRANSMITTERS.**

Throughout the years Continental has built the world's most reliable transmitters and other RF products. The new generation of three bay transmitters is no exception. This family of transmitters offers the broadcaster efficiency and excellent audio performance.

**Standard features include:**

- A Solid-State IPA
- Front Panel Indicators and Breakers
- Internal Harmonic Filter
- Automatic Power Level Control
- "Exclusive Soft Start™"
- Totally Self Contained (except 35kW)

The 3 bay family of transmitters is available in power levels from 21.5kW to 70kW and comes with the 50 watt 802B exciter, tuned and tested on your frequency and ready for easy installation. Continental can outfit your facility with the best products in the industry.

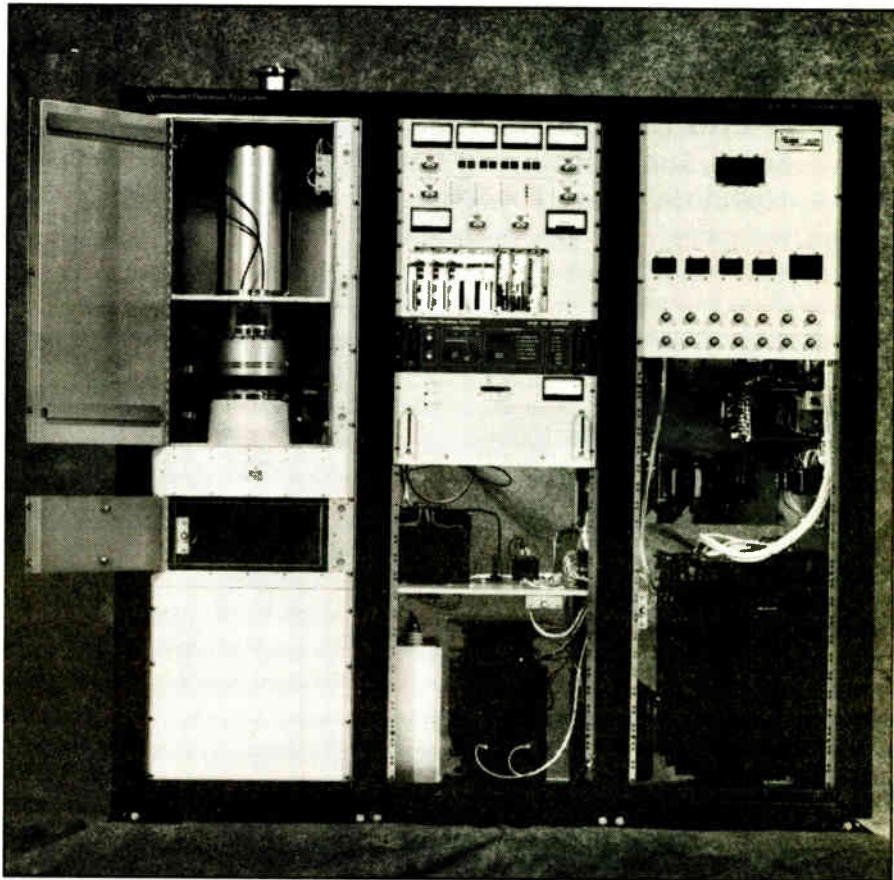

**CONTACT CONTINENTAL FIRST**



*Continental Electronics Corporation*

P.O. BOX 270879 DALLAS, TEXAS 75227-0879 214-381-7161 TELEX 73-398 FAX 214-381-4949



# Products & Services Showcase

For more information on the products shown below, circle the appropriate Reader Service No. (s) on the enclosed Subscription/Reader Service card or contact the advertiser directly.

## SOUND YOUR BEST ON THE AIR!



### CART MACHINE SERVICES:

**CART MOTORS REBUILT** to quiet flutter-free perfection-shafts resurfaced  
Single \$120.00 Triple \$140.00

**CART HEADS RELAPPED** guaranteed to perform like new

Same day turnaround

Replacement heads and motors available

### REEL TO REEL SERVICES:

**HEADS RELAPPED** and precise digital/optical

**ASSEMBLY ALIGNMENTS**

performed for maximum

response & head life

**CAPISTAN & REEL MOTORS REBUILT**

for MCI, OTARI and more.

For peak performance from your recording equipment, call The Audio Magnetic Professionals.



224 Datura Street, Suite 614, West Palm Beach, FL 33401  
Call 1-800-826-0601 for "Same Day Service" in Florida (407) 659-4805  
Authorized Parts Dealers for: MCI • OTARI • TEAC/TASCAM

READER SERVICE NO. 141

## Tired Of Replacing Expensive Headphones?

Designed to provide vivid sound reproduction when used with today's digital sources, these stereophones feature high-performance 40 mm drivers. The maximized power handling capability ensures full, accurate reproduction of the wide dynamic range found in digital program material.

The soft leatherette earpads and adjustable headband provide for hours of comfortable listening while the closed-back design of the earpieces allows for privacy and prevents unwanted outside sounds from interfering with your listening enjoyment. The 3.0 m (9.8 ft.) cable is terminated in a 3.5 mm mini plug, ideal for portable systems, and a 1/4" plug adapter is included for home use.



Only \$29<sup>95</sup>



**AUDIO BROADCAST GROUP**

2342 S. Division Avenue  
Grand Rapids, Michigan 49507

**1-800-999-9281**

200 Fareway Drive - Suite 2  
Smithfield, North Carolina 27577

**1-800-369-7623**

READER SERVICE NO. 126

## PIONEER'S 18-DISC AUTOCHANGER PROVIDES PROFESSIONAL QUALITY IN A COMPACT DESIGN

Pioneer's CAC-V180M CD Autochanger with 18-disc capacity provides commercial quality in a versatile, compact and easy to operate system. Pioneer developed this new generation CD Autochanger to meet the rapidly increasing demand for multiple disc storage and playback systems in a range of sizes.



The CAC-V180M features a built-in RS-232C computer interface connector. It can be programmed to automatically locate, load and play up to 18 CDs for extended program versatility with minimal operator involvement. The CDs are housed in three six-disc magazines, allowing categorization of the CD library while ensuring a protective environment.

The compact size and weight of the CAC-V180M make it ideally suited for a wide range of applications, from background music to post-production studios. For installations requiring additional disc capacity, multiple CAC-V180M units may be connected. Pioneer also offers other professional-quality CD Autochangers, including the industry's first 300-disc capacity and dual-player system.

**PIONEER**

To learn more about Pioneer's line of CD auto changers, contact your local Pioneer sales representative, or call 201-327-6400.

READER SERVICE NO. 69



## CD 100 • X Compact Disc Adapter-Amplifier

Matches any consumer compact disc player or cassette deck to broadcast console input. Only \$89.00 FOB factory or from any broadcast dealer.

### Russ Friend & Associates

342 N. Sunnyside  
Clovis, CA 93611

Phone 209-298-6838 FAX 209-298-8270

Turntable Parts/Felts  
Russco, Collins TT-200, Sparta

READER SERVICE NO. 60

## The Best Audio Test Meter Made!

### Advantage Model 310

Precision Audio Signal And Noise Level Meter

Professional Price!

\$399

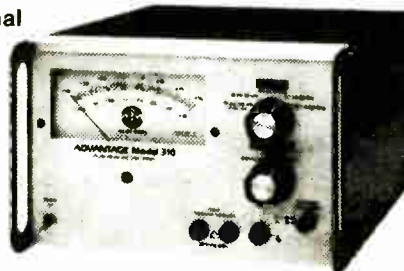

- Low THD/HI RF Reject With Valley Audio's Trans-Amp™
- Lo-Noise Wideband Circuitry
- Large Dual Scale Meter
- Super-Accurate Filters
- Average, RMS Or Peak Det
- -100 dB to +30 dB Range
- Scope and Preamp Monitoring Outputs

Call For The Nearest Dealer:  
**1-800-800-4345**



Valley People  
Merriam, Kansas

READER SERVICE NO. 144

Uh-Oh... We Should Have Called **CORTANA**

**STATI-CAT** for Affordable Lightning Prevention.

Let Us Design a System for You

Stati-Cat provides a continuous, low-resistance discharge path for the static electric charge on tall structures. Dissipation points are 1/8", type 304 stainless steel rods ground to needle sharpness. They won't bend, not even from ice and severe weather.

**Cortana**  
Corporation

Write to us today for a **FREE** brochure!

P.O. Box 2548, Farmington, N.M. 87499  
Call (505) 325-5336 FAX (505) 326-2337

READER SERVICE NO. 108

**Cellcast**  
REMOTE BROADCAST STUDIO

The CELLCAST RBS-400 1.8 offers complete portability and flexibility for remotes. Complete with a 4-channel mixer, frequency extender, cellular transceiver and landline capabilities, 600 ohm line out, and Vu meter. It is powered by 10 Ni-Cad rechargeable batteries, 12v adaptor, and AC power supply. 24 hour product support standard.

Call Bridget Taylor today for our \$195.00 2 week trial at



**1-800-852-1333**

READER SERVICE NO. 16

## NEW! Composite Audio DA and Switcher!



### APPLICATIONS

- Switching Between Composite STL's
- Main/Alternate Processing Switching
- Feed Up to 3 Transmitters with Identical Audio
- SCA or SAP Generator Switching
- Non-Intrusive Composite Testing/Monitoring

### FEATURES

- 2 Input Switcher
- 3 Isolated Outputs
- Individual Level Control for Each Output
- Front Panel and Remote Control with Full Status
- Power Fail Memory with Bypass Mode
- Inputs Selectable for Balanced or Unbalanced Operation

**bdi**

**Broadcast Devices, Inc.**

5 Crestview Avenue  
Peekskill, NY 10566

Tel. (914) 737-5032 FAX: (914) 736-6916

READER SERVICE NO. 184

World Radio History

## Attention Advertisers!

Reach 22,000+ Readers worldwide. RADIO WORLD'S Product Showcase provides a perfect medium for test marketing your products and services. It's an efficient, effective and affordable advertising option.

For more information, including rates and deadlines, Fax SIMONE at

**1-703-998-2966**

or Call

**1-800-336-3045**



# AM Stereo Has Convoluted History

► continued from page 13

companies. It's basically 10,000 small businesses who never really meet as a single group."

Many stations installed stereo and did nothing to follow up. "The public plain doesn't know much about it. That is probably the fault of the broadcasters for not promoting it as anything else," said Alan

Parnam, director of transmission systems, CBS Radio.

Consumer electronics manufacturers also draw a share of the blame, not only for making few AM stereo receivers and promoting them poorly. They are also criticized for producing low-fidelity AM receivers that sound poor in either stereo or mono.

"AM stereo is never going to be a success until you get something other than lousy receivers out there," said Kenneth Brown of Capital Cities/ABC. "You can have a resurgence of AM listening, but it won't be because of stereo, it will be because of quality."

Perhaps the most damaging factor was the continual lack of industry consensus for a single system. "There was an incredible loyalty among the various camps for the various systems that really surprised me," Motorola's Frank Hilbert said.

Broadcasters and consumer electronics companies seem to have learned their lesson from the AM stereo experience. They have formed joint committees to choose consensus HDTV, DAR, TV stereo, TV ghost-cancelling and RBDS systems, before approaching the FCC for standardization.

FCC commissioners and staffers in recent years have often publicly repented their

earlier decisions and praised the idea of setting standards. Time will determine how far FCC policy has really changed.

The FCC currently is considering approval of technologies to upgrade the EBS. The proposed technologies differ substantially and, again, there is no clear industry consensus behind any one approach. The commission says it hopes to approve a standard that will allow all manufacturers to market their systems, while at the same time avoiding the AM-stereo-like market confusion (RW, Aug. 11).

The FCC plan, as articulated so far, does not sound like the commission is back "in the standards business," said Tim Bealor of Broadcast Electronics. "It's in the political business where you try to work out a compromise so that you don't offend anybody."

**Q:** Will FCC approval of an AM stereo standard in 1993 still have an impact on the industry or will it be meaningless?

John Swanson, vice president, engineering, Cox Broadcasting, Atlanta: "In our particular case,



John Swanson

it's almost a non-issue. Most of our stations that put it in initially have taken it out. Program directors think it decreases the coverage. Since there are so few people out there that care, we just took it out. Not in all cases, but in most cases."

Frank Hilbert, chief inventor of the Motorola C-QUAM system: "Things appear to be moving (internationally) regardless of what the U.S. does. It appears that Japan is catching up with its own market, and will be able to start supplying radios at about the same time the commission goes forward with a standard."

## Digital Hard Disk Plays Spots and CDs. Scott Studios' Touchscreen Eliminates Paper Logs & Console

Copyright 1993 by Scott Studios Corp.

10:14:18A	(I Can't Get No) Satisfaction Rolling Stones :14/3:33/F 1965 C20105 10:14:18 #1 for 5 Weeks in the Winter of '65	:14	Studio Mic. 1	Manual 6
*Air* 2:37	Feelin' Stronger Every Day Chicago :25/4:03/F 1973 C12608 10:17:20	Recue Ins.	Guest Mic. 2	Jingles 7
Start F2	Back Announce - Linked to C12608 Dave Scott :00/0:08/C BAL VT0214 10:21:15	Move Down F9	News Mic. 3	Music Library 8
Start F3	McDonald's 2 for \$2 Special JT Q: Now Thru Saturdays Only. :00/1:00/C COM DA1103 10:21:23	F6 Move Up	Marti 4	Spots 9
Start F4	Bob's Bargain Barn BW Q: At Westland and East Park. :01/1:00/C COM DA4310 10:21:50	Move Down F10	Net-work 5	Options 0
Start F5	Uptempo Jingle - Linked to C02102 Q: Kiss FM. :00/0:06/C JIN DA1037 10:22:50	F7 Move Up	More Events	Delete Event Del
Start		F8 Move Up		
		Move Down F11		
		Move Down F12		
		Move Up		
		Move Down		

Scott Studios brings your commercials and music together on a clean, clutter-free control room computer screen.

### Play Anything At the Touch of a Finger

You get great-sounding digital spots and jingles from hard disk, and songs from CDs or hard disk. Turn microphones on and off at a touch. Rearrange sweeps and clusters. Add jingles, sounders and spots. Play requests with your entire music library displayed by titles, artists, lengths, years, albums or categories. There's no cumbersome computer keyboard, trackball or "mouse" in your studio. You choose to use either a simple start button box, touchscreen, or both.

### Throw Away Your Copy Book

When it's time for weather, spots, promos or trivia, a live copy window pops up unobtrusively on Scott Studios' screen. You can start other events while reading copy.

### Get It All Together

Scott Studios connects your traffic, music and programming computers to your air studio. You can add spots, revise music and update live copy from your office, without an expensive file server computer. You also get printouts showing exact times everything aired and discrepancy reports showing changes or missed spots.

### Multi-Studio Digital Audio

When spots are produced, they're electronically transferred to all your air studios. There's no time wasted carrying carts down the hall or redubbing for second or third stations.

### We Call It a 'Troll...

Short for "studio conTROLLer". It's easy to use and affordable. In fact, it'll pay for itself in savings. Call, FAX or write us in Dallas for details.

**Scott Studios Corp.**  
13375 Stemmons Freeway, Suite 200  
Dallas, Texas 75234

## MOVING?...

Don't leave us behind!

Mail or fax your current label and new address (with effective date) to:

Circulation, RW,  
PO Box 1214  
Falls Church, VA 22041  
or FAX 703-998-2966.

Address changes will be processed within four weeks of receipt.



(214) 620-2211 FAX: (214) 620-2707  
**(800) 330-3004**



# THIS CONSOLE



## LED A REVOLUTION

by proving that a low-priced console could offer major market features, rugged construction, and superb audio specifications.

IS AVAILABLE in 6, 12, 18 and 24 channel models for any size studio.

FEATURES AS STANDARD EQUIPMENT a mix-minus buss, full remote control, full metering, talk-back, two stereo outputs, P&G faders, cue and headphone amps, mic through line level on any input, timer, and much more.

IS WELL SUPPORTED by a caring factory staff via a toll-free service line, and a super next-day delivery no-charge warranty.

IS HIGHLY REGARDED by the 600+ owners who have purchased RS-Series consoles since their introduction. Over 90% rated their boards a "superior value". Over 250 owners bought another RS-Series console when they built another studio.

HAS A COMPLETE RANGE of available options including copy stand, distribution amplifier card, special application remote interface cards, input extender card, 4 and 2 buss mix-minus cards, squawk box card, and more. And even with all these standard and optional features, the factory is happy to modify the board when special user applications call for something different.

IS THE BEST VALUE available today in broadcast consoles, and is now available from select distributors. Call today for more information and the name of a dealer in your area.

**RADIO SYSTEMS INC.**

110 High Hill Road • P.O. Box 458 • Bridgeport, NJ 08014-0458 • 609/467-8000 • 800/523-2133 • FAX 609/467-3044

Circle (186) On Reader Service Card

World Radio History



# Running Radio

A Capital Budget  
Development Plan  
page 23.

Your Resource for Business, Programming & Sales

## TECH TALK

### Gathering the Data Reduction Players

by Judith Gross

**EAST ROCKAWAY, N.Y.** Are radio stations facing one of those awkward moments when quality and economy are pulling in opposite directions? It certainly wouldn't be the first time.

This time the point of argument is digital data compression, or data reduction, as audio-conscious observers are beginning to call it. Once again, if we can't even agree on what to call it (as in the case of DAB or DAR or DBR), what hope do we have of agreeing how best to cope with it?

At any rate, this subject was fuel for a debate I moderated at this year's NAB Radio Show in Dallas. It was spurred on by a compelling demonstration by New York's own WQEW(AM)-WQXR-FM Chief Engineer, Herb Squire. Herb began this campaign back at the spring show in Las Vegas.

In fairness, we were due for Herb's reality check of the digital situation in radio. All around us, digital technology has been making greater inroads into radio and it was about time to stop and look at the effects of submitting a signal to multiple generations of data reduction.

Reduction is actually the correct word for it, although a bit damning. Once the data is taken out, it is lost, and the signal at the decode end of any compression algorithm is reconstruct-

ing, not putting anything back in.

The entire debate becomes even more important when you begin to see all the actual products finding their way into radio air chains: source materials (DCC and MD), storage and playback systems (hard and floppy disk), digital audio workstations, STLs, digital processors, satellites and phone transmission for remotes (VSAT, switched 56/ISDN). Data reduction algorithms are, and have to be, integral to the design of every DAB system under consideration.

#### The experts

My panel of debaters represented all sides of the algorithm issue.

Larry Hinderks of Corporate Computer Systems (CCS), a MUSICAM licensee, and Larry Koos of Scientific Atlanta, developers of the SEDAT algorithm, represented the pro-algorithm contingent.

Bob Donnelly of ABC Radio Networks, Al Resnick of Capital Cities/ABC and Greg Urbiel of CBS represented broadcasters.

Tom Hartnett of Comrex and Marvin Caesar of Amphex were the concerned equipment vendors.

Greg also gave a rundown of recent CCIR test of cascading algorithms. The international engineering group has done listening tests and more or less defined the acceptable algorithms and bit rates for various applications, including direct

transmission to end-users and retransmission by affiliates.

Not surprisingly, the group found that the fewest pass-through of algorithms are the most desirable.

Herb showed this graphically as well, with a recording of Willie Nelson's "All of Me," which he said (and demonstrated) became "Most of Me" and finally "Not Much of Me," after repeated data reduction passes and conversions to analog between passes.

He noted that each generation of reduction becomes "an artifact enhancement generator," with the problem more in what is added than what is subtracted. Most dramatically, he said, it is hard to predict just when and in what form the artifacts will show up.

Sometimes it's a screechy quality to a high note; sometimes it's more apparent in the vocals, and sometimes it's a loss of

stereo imaging. There are even times when a tick becomes a chirp and a beat becomes a burp.

With Willie's song, it was the fingernails-on-a-blackboard effect as he hit the higher notes. By the time the hair on my neck was standing on end, several seminar attendees had begun to wonder, glumly, what's a broadcaster to do?

#### In a perfect world

As usual, there are no hard and fast answers. Everyone agrees that a problem exists, but the algorithm manufacturers maintain that it can be minimal when high-quality algorithms are applied correctly.

One way, of course, would be to avoid going back to analog in between generations of reduction. Have one point of encode and one of decode, preferably in a user-adjustable form at the end of the line: in the radio.

There's a nifty stab at utopia, which the selection of a DAB standard might foster. Take analog audio, go into one pass-through, don't add any more reduction,

continued on page 28 ▶

## ATTENTION P.D.s

Schedule the best in "OLD-TIME RADIO" with

# When Radio Was...

Hosted by ART FLEMING, original star of "JEOPARDY"

Five shows per week—54 minutes each.  
**BARTER, NO CASH PAYMENTS!**  
Delivered via Satellite (SATCOM).

For information and a free demo tape contact David West at  
**DICK BRESCIA ASSOCIATES (201) 385-6566**

*When Radio Was* celebrates its 4th year on 100 stations.

# Dalet runs the system you run the show

Dalet gives broadcasters the freedom to get creative

- Satellite automation, cartridge replacement, non destructive audio editing
- Inexpensive unlimited storage using standard PC networks
- True multitasking under WINDOWS
- Real time recording of mixes makes music automation sound better than live!

Find out why leading radio stations around the world have chosen Dalet. Call our US distributor:

**RF Specialties Group**

WASHINGTON	(206) 546-6546
CALIFORNIA	(805) 682 9429
MISSOURI	(816) 635 5959
TEXAS	(806) 372 4518
	(214) 771 4235
PENNSYLVANIA	(412) 733 1994
	(215) 322 2410
FLORIDA	(904) 678 8943





**DESTINY  
2000**

## What Would You Call A Console That Re-Invents Live Radio?

It looks like a console but it isn't...  
It works like a hard disk system but it's more...

**Sure, it looks simple. But that's because all the "brain power" is built into the software. In fact, Auditronics' Destiny 2000 is so different from anything you've seen in your air studio up until this point that we almost have to make up new words to describe it.**

- **Call it Revolutionary**

Take the familiarity and comfort of your control room console and add the capabilities and streamlined control of today's most efficient hard disk system. Mix in equal parts Live Assist, Automation and Manual control. Add a generous amount of economy and that's the Auditronics Destiny 2000: a revolutionary product for your air studio that speaks directly to your bottom line.

- **Call it Profitable**

Switch from live drive-time to automated overnights in an instant, with no additional equipment and no extra costs. And each Destiny 2000 module has multiple smart functions so you get more bang for the buck.

- **Call it Effortless**

No more problems getting all your digital sources talking to each other. Destiny 2000

integrates your spot load, CD jukeboxes, even digital boxes of the future into one smooth system that won't let you down.

- **Call it Smart**

Destiny 2000 does the thinking on routine tasks so your talent can focus on making your drive time a ratings winner. It's easy to operate, and simple to switch between manual, automation and live assist. Say good-bye to operator error.

Now call Auditronics at **901-362-1350** and find out how Destiny 2000 fits your station's format and your budget.

**THE AUDITRONICS DESTINY 2000:  
A WHOLE NEW WAY OF DOING BUSINESS**

**AUDITRONICS**

3750 OLD GETWELL RD • MEMPHIS, TN 38118

Circle (68) On Reader Service Card

World Radio History



USAIRPLAY

# Seeking Successors to Toppled Top 40

by Charles Taylor

**WASHINGTON** When 1993 newcomer girl group SWV sings, "I'm So Into You," don't think they're talking about love. Their interest is in demographics.

Over the past year, major market radio programmers nationwide have singled out young black women as their focal target group in an effort to limit the exaggerated fragmentation of popular music formats that has occurred in recent years.

The trend marks the latest attempt by pop music programmers to bail out the much-beleaguered top 40 radio format. In recent years, pop radio has suffered an identity crisis of such indelible impact that it is doubtful the format will ever make a comeback in the U.S., at least in its traditional role—that is, a place on the dial that brings together the best of any number of musical genres, whether dance, ballads, R&B or country.

The reasons behind its demise are

**Some stations switched last year to a hybrid of hard-edged pop and alternative rock that might be considered more accessible.**

numerous, the symptoms obvious in retrospect. And sadly, amid today's pop music playlist absorbed in scores of soundalike, lookalike, image-laden, talent-weary artists, hope for recovery is further daunted. Evidence: 1992's brightest prospect to liven the airwaves, Jon Secada, lost the Best New Artist Grammy to an eclectic rap act. Meanwhile, the exceptionally talented Tasmin Archer, Britain's 1993 Best New Artist, barely cracked the U.S. top 40 with her debut, "Sleeping Satellite." Message: The ability to sing is no longer a priority in popular U.S. music.

Interestingly, the U.K. chart, which often shares in the artistic progress of American radio, in no way resembles the single-minded programming philosophy encountered here. Acts in the U.K. top 10 are as diverse as the alternative 4 Non Blondes and Spin Doctors, the disco-oriented M People and Gloria Gaynor, the reggae flavor of UB40 and the traditional pop intentions of Gabrielle and Kim Wilde.

**Troubles began**

The format's troubles here began in the late 1980s when a diverse number of musical styles were popularized, including heavy metal and rap. These, when mixed with the usual blend of ballads and uptempo pop that was standard on top 40 radio, cooked up a pretty dreadful-tasting radio pie. Elvis, The Beatles and Little Richard may have worked together in their day, but Def Leppard, Amy Grant and Public Enemy created quite a rift in pop stations' long-term listenability.

As a result, ratings began shifting to format alternatives—adult contemporary stations quickly modernized their playlists and image and welcomed part of the 18+ crowd repelled by the heavy metal and rap on top 40. As well, country radio polished its outdated dateless n'drinking image into a mature and diverse listening post for those looking for something even more disparate from top 40.

It was during this time, over the past few years, that country enjoyed its biggest boon in history. Superstar acts like Garth Brooks and Billy Ray Cyrus supplanted Madonna and Michael Jackson on the

album charts. Country radio, meanwhile, became a viable format alternative for top 40 stations looking to bale; suddenly markets were left with no pure top 40 station and two competing country stations.

For pop stations determined to brave the challenge, it was a time to determine a new direction and attempt to lock in a specific demographic, since 12-25 had simply become too broad to encompass.

Some stations such as Power 99 in Atlanta, considered the most influential top 40 station in the southeastern U.S., switched last year to a hybrid of hard-edged pop and alternative rock that might be considered more accessible than a typical modern rock format station.

Most others have followed suit with the teen age trend of the day directed at young female black listeners. The sound treads both sides of the urban street scene, from accusatory rap relenting against the powers that be, to the lovesick crooning of today's power ballads that has prompted countless generic urban male ensembles (Boys II Men, Shai, Silk). And recently, there's the uprising of urban female groups like SWV and UNV, who similarly whine about being weak in the knees over their men. The real weakness here, sadly, is in originality.

**Oppression is in**

Radio's obsession with the image is only part of the trend's proliferation. The urban sound and look dominates many facets of American youth, from fashion to the cinema success of "Menace II Society," "Poetic Justice" and "Boys in the Hood." Oppression is in.

What remains, however, of top 40 is overt sameness and a format so specifically targeted that it has become nothing more than a hybrid of traditional R&B stations (though ironically, rap is more prominent on top 40 than on

urban formatted stations).

Can it be repaired? Perhaps reflection on a similar happening some 20 years ago might reveal insight. When disco romped across the land, top 40 found itself in a similar rut when older listeners felt betrayed. Recovery came, first, when the trend faded, and second, when artists like Michael Jackson, Cyndi Lauper and Madonna brought a fresh sound and attitude to the format.

This time, however, there may not be enough stations hanging onto top 40 for the format to heal itself when the nation's youth have had enough TLC and H-Town. Month after month, decreasing ratings, thus decreasing ad rates, are perpetuating the search for more lucrative formats.

For now, the only answer lies in the unknown territory known as tomorrow.

## At Your Fingertips!

Find the information you need in Radio World's 1993 Directory.

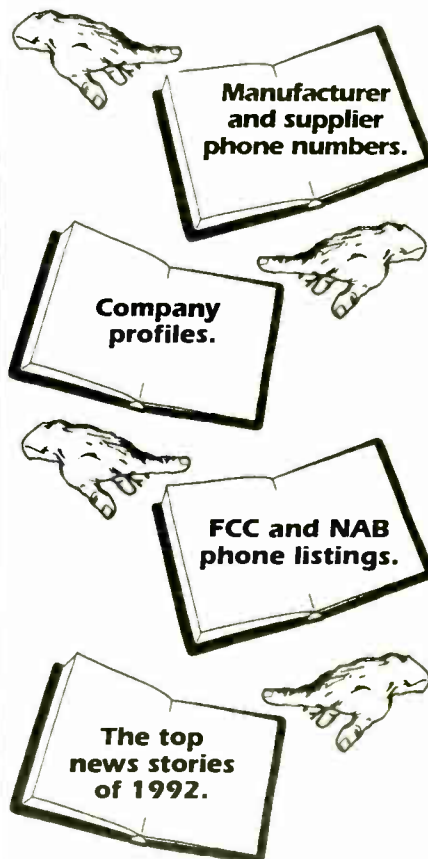

...And more.

We have a limited number available at \$14.95 each.

To order, call



**1-800-336-3045**

# THE SECRET'S OUT—DIGITAL FURNITURE

**MODULAR FLEXIBILITY WITH A CUSTOM FIT**

*We Offer Six Elegant Lines of Studio Furniture*

4153 BONITA STREET  
SPRING VALLEY, CA 91977  
PHONE 619/698-4658  
FAX 619/698-1268

**MURPHY**  
STUDIO FURNITURE



▲ STEALTH SERIES ▲



## PROMO POWER

# Positive Press Takes Serious Effort

by Mark Lapidus

**WASHINGTON** The Three Stooges are trying to get into a convention. Moe walks up to the attendant and says, "press." He's allowed to enter. Larry looks at the guard, says, "press" and is permitted in as well. Curley glares at the guard and says, "pull...nyuk...nyuk...nyuk," and is, of course, stopped immediately.

Everyone wants press because it has a lot of pull. Your job is to manipulate this.

Short of one of your disc jockeys committing a crime, there is absolutely nothing you can do that will guarantee press coverage. There are, however, many things you can do to increase the odds that your station's call letters will be seen on television or show up in print.

## Getting to know them

This is a big part of obtaining coverage. Reporters and editors are constantly being beaten up by those who want their names and faces out front. Over a long period of time it's important that these reporters learn to trust you and hopefully like you. If you know the personalities of the players, you should anticipate the questions you may be asked.

Be honest and direct. Don't attempt to hype a story to somebody when you know that it has little value. If you don't

know an answer to a question, speak truthfully rather than making something up. You can always find out the answer to a question later and return a call. Assume that anything you say can wind up in print or on the air.

With each story you're pushing, begin by developing a strategy.

Is the story visual enough for television? Is this just a local story or is it so incredible that you may be able to tackle the national media? Will every newspa-

**Be honest and direct. Don't attempt to hype a story to somebody when you know that it has little value.**

per cover it, or should you shoot for a paper that covers a specific section of town? Will a magazine be interested or will the material be too dated by the time the next issue comes out?

Before writing the press release or phoning any media, have a quick meeting with any of the other managers that could be called about the story you're trying to get covered. It's vital that each of you pump the press with the same important details.

At the end of the meeting it's a good idea to give each person a ten-point sum-

mary of what they're supposed to say. Some reporters' interrogation methods make people nervous. The ten-point summary can make the difference in getting your story across.

Create a list of all newspapers, television stations and magazines in your area. Design another for trade publications and national media. Each designation should include a fax number and at least one name of an assignment editor.

For print, take note of the circulation.

(You can find circulation information in the front of your most recent Arbitron book.) Most areas have many small newspapers and one daily that dominates. Your goal is to develop a relationship with many reporters, but if one paper has twenty times the circulation of all the others, it's clear where you should concentrate your efforts.

## Putting the word out

Now that you've gathered the details, you're probably wondering how in the world you're going to be able to reach all of these people consistently.

The fax machine is the quickest way. If you've got a computer, look into purchasing a modem and fax program. It's an amazing time saver.

You'll be able to set up fax groups so that at the press of a mouse, every newspaper in town gets your message. You can then take the time you saved sitting for hours at a regular fax machine and use it to follow up with phone calls. The whole package runs for about \$250.

Your information will always be time-

sensitive, so communicating by mail is your last resort. A follow-up phone call to all the big organizations is vital.

The purpose of a press release is to generate interest and ultimately coverage. News organizations receive hundreds of these fact-filled dull sheets each day. Your releases have to be creative and sell the reason why your story is important. Punchy headlines and bold description may cut through the clutter and into the mind of a reporter who is sick and tired of seeing the same stuff over and over again.

Your releases should be one page. If you've got two pages of copy, there's more information than required. Tease them into calling you so that you can sell them on coverage.

Be sure to include nighttime and weekend phone numbers where you may be reached. News organizations don't always make decisions weekdays from 9 a.m. to 5 p.m.

## If you've got it, flaunt it

Keep copies of coverage you've obtained. As soon as the story runs, it's old news for everyone except your sales staff and clients. Many will have never seen the coverage.

Press clippings and videos of your television pieces should be circulated immediately after your story has been covered. Another station in your market may actually get more coverage, but you'll get more credit with advertisers if you're the one who does the follow-up dance.

Does the press generate ratings? If I had the definitive answer to this one, I'd be Bill Clinton's press secretary.

It is safe to say that when you receive press coverage, you're doing something that may strike the public's imagination and curiosity. Imagination and curiosity are the intangibles that drive people to listen to radio.

If people are talking about you, it can't be bad.

□□□

Mark Lapidus is promotions director at WCPT(AM)-WCXR(FM) Washington. He can be reached at 410 King St., Alexandria, VA 22314.



## THE SMART WAY TO AUTOMATE

1. Let Music Master from SMARTS Broadcast Systems make a playlist that exactly fits your format.

2. Let the SMARTS Billing Accounting and Traffic System build your program logs the way you want your station to sound. It also bills, tracks your receivables and provides all the sales and management reports you need to run your station.

3. Use your own music, or use any of the music services, and record the music directly onto computer hard drive. (SMARTS will provide an optional music dubbing service.)

4. Use the SMARTCASTER music on hard drive digital automation system to totally automate everything, complete with Dolby® noise reduction, full CD quality audio, full overlap under user control. Your sound is tight and professional.

Now everything is in the box, a computer running the entire operation, without depending on satellite, or any external music source. Call for details.

**SMARTS BROADCAST SYSTEMS**  
BOX 293, EMMETSBURG, IOWA 50536  
(800) 747-6278 (712) 852-4047 FAX: (712) 852-3061

Circle (211) On Reader Service Card

THE MAN WHO DRAINED LAKE MICHIGAN AND FILLED IT WITH CHOCOLATE!

**STAN FREBERG HERE!**



**JUST THE TIP OF THE FREBERG**

RADIO SATIRICAL COMMENTARY FOR THE 90'S

FIVE TIMES EACH WEEK

DELIVERY VIA SATCOM - C5 - BARTER

FOR DETAILS CONTACT - DAVID P. WEST 201-385-6566

ANOTHER FINE RADIO PROGRAM FROM **DICK BRESCIA ASSOCIATES**

DBA reserves the right of final selection of affiliates for any of its programs.

Circle (94) On Reader Service Card



# Remotes from Fair Are Never Foul

by Gary Hart

**DU QUOIN, Ill.** Just as some people can't resist the bright lights of the carnival midway and others head straight for the quilt show, radio stations come to the State Fair in Du Quoin, Ill., with different goals.

WJPF(AM)-WEZS(FM) Herrin, Ill., was at this year's fair to establish a place in the Southern Illinois community. General Manager Kerry Jay described his project with relish. "We approached the Southern Illinoisian newspaper, the Player's International Riverboat Casino and the Southern Illinois Board of Tourism. They're partnering with us. They are our guests," he said.

## Carnival of goodies

A "core group" of 20 staffers, partners and advertisers gave away truckloads of newspapers, informational pamphlets, bumper stickers, St. Louis Cardinal baseball paraphernalia and sponsor freebies. Each day was devoted to a different sponsor.

Once a pet store brought its chimpanzee for pictures. Another day Miss Player's International signed autographs. All this was going on while station personnel did cut-ins and ran their own giveaways.

Jay says the effort won't end when the cows go home. "The people at the fair are wonderful. They make sure my needs are met and I make sure their needs are met. For instance, promotional activity on both our stations: we'll be talking to the fair officials quite a bit during the run and they are offering support for upcoming projects, whatever it takes."

Du Quoin Fair Space Rental Coordinator Kris Toler is just as enthusiastic about radio. Stations that stay all ten days get free commercial space and free electricity.

"They are responsible for phone lines. We also give them gate passes and parking passes so they can get their workers in. Any other station that's coming in just to do remotes for the car races, the harness races or the shows, we have 'Radio Row.' We have a space for them there, they bring a tent or a trailer and they're free to come and go," Toler said.

Bruce Welker, General Manager at WOOZ-FM Harrisburg, Ill., has become familiar with the fair's more tangible benefits in 16 years of broadcasting in Southern Illinois.

"The promotional package that we get from the fair is fairly intricate...It's pretty much packaged and customized for the station. In the past, when this station was oldies, we didn't get quite as many fringes, but maybe more cash [in the form of advertising buys]," Welker said.

## Country cousins

"We go there for two reasons. First, the fair has always been very country-oriented," Welker said. "Second, we like the interaction with the people, and we like to give things away."

The most popular radio station in the Southern Illinois Arbitron ADI is also a country station, WDDD-FM Marion, Ill. One might think five nights of country concerts and the obviously rural atmosphere would compel WDDD-FM to go wall-to-wall from the fair.

"I can do as much for the fair, in my humble opinion, doing ads for them and promoting their shows without necessarily being on the ground," says Station

Manager Jerry Crouse. "I have to judge based on what else I have going on at the time as to what's more beneficial, having my people set up there and show the flag or someplace else."

"We will be doing interviews with country artists, some just audio and shooting others on video" as part of a half-hour country music series 3-D is co-producing with a local TV station. WDDD-FM did not have a booth, but did everything from their van using a 40-watt Marti remote transmitter.

Crouse says WDDD-FM's involvement with the fair ranks about in the middle of its annual promotional projects, being more than a basic remote but not as

much as its two days of live broadcasts from "Hunting and Fishing Days" at a local junior college.

WDDD-FM has done full broadcast days from the fair in years past. "It all depends on what's going on up there and what's going on down here. This is more than I've done in the last couple of years. It's because there's more country and the fair and the artists probably recognize the value of the exposure."

## Another view

At the other end of the spectrum is WCIL-FM Carbondale, Ill. John Riley, the sweat streaking the dust on his face, became animated as only a morning jock

can when describing the station's temporary studio: "You gotta be larger than life!"

WCIL-FM's yellow tent is covered with "chaser" lights, against the blue wall at the back stands a triptych of black monoliths, each bearing a station logo and spattered with multi-colored phosphorescent paint. The huge logo on the central panel glowed in two colors when illuminated by klieg lights hanging from the pinnacle of the tent.

Riley and all the other WCIL-FM jocks ran their shows as if they were at the station, pushing buttons on the Sparta Board and throwing carts into the triple-decker Harris. All the sound went back to the station and out the transmitter over a pair of 15-kHz telephone lines.

Program Director Tony Waitekus says WCIL-FM has gone all out the last six years.

continued on page 26 ▶

## SEND YOUR AUDIO ACROSS THE STREET OR AROUND THE WORLD™

**When you think digital audio, think California Digital. We provide satellite/digital technology to make all these options available at low cost:**

- ▮ Syndicate your top personality or format
- ▮ Add affiliates - gain revenue sources
- ▮ LMAs - Increase market share/audience size
- ▮ Share programming, talent and costs
- ▮ Off-site announcer feeds
- ▮ Create events with remotes
- ▮ CD-quality live coverage of news, sports, and concerts

**California Digital offers expertise in:**

- ▮ Digital Satellite Networks - C or Ku
- ▮ Regional, National, International Nets
- ▮ Remote Broadcasts
- ▮ Rugged Fly-away Systems
- ▮ Custom Ku Power Control Software
- ▮ System Design & Engineering
- ▮ FCC Licensing; Installation and Training
- ▮ Equipment sales, leasing and financing
- ▮ Switch 56 & ISDN program distribution

**TOP TALENTS ARE LOCALIZING THEIR NATIONAL SHOWS WITH OUR TECHNOLOGY AT LOW COST!**

**ASK US HOW YOU CAN DO IT TOO!**

**CALL:**

**CALIFORNIA**

**DIGITAL AUDIO**

West Coast Office (805) 523-2310 Fax (805) 523-0480

Midwest Office (612) 631-5064 Fax (612) 631-5010

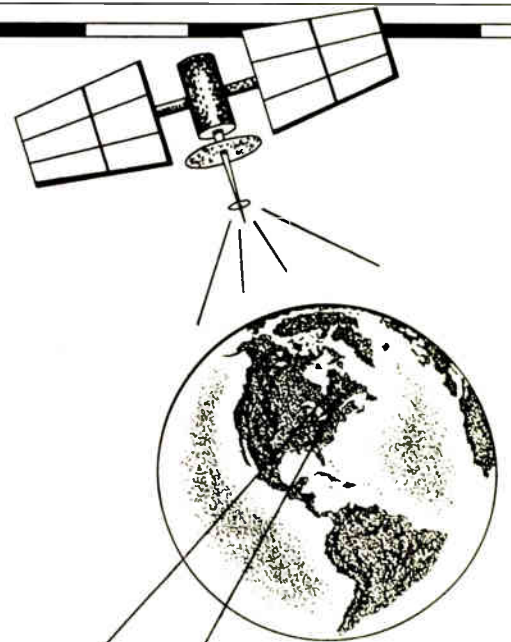
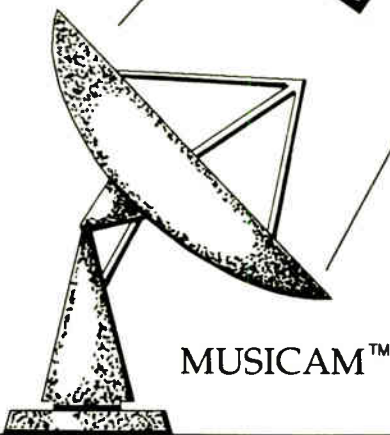

**DIGITAL AUDIO**

**MAKE MONEY BY CREATING A  
MUSIC PROGRAMMING NETWORK!**

Circle (81) On Reader Service Card



# STATION SERVICES

News and Services for Business, Programming and Sales

## Hicks, Muse & Co. Enters Radio Investment Business

**DALLAS** Investment firm Hicks, Muse & Co., specializing in leveraged acquisitions, says it has begun seeking investments in radio broadcast stations. The firm has set aside \$50 million in equity funds for AM and FM acquisition nationwide.

The firm has also established two subsidiaries to administer its broadcast properties. Owen Weber, executive V.P. and head of Summit Communications Group's radio division, joins Hicks, Muse and Co. as head of an Atlanta-based sub-

siary. Steven Dinetz, former president of D&D Broadcasting Inc., Denver, will head a Dallas-based subsidiary.

For more information, contact Weber at 404-391-0109, Dinetz at 214-348-8285, or circle Reader Service 17.

## Aphelion Promotions Offers Crossword for Radio

**FORT SMITH, Ark.** The Radio Crossword Puzzle, a turnkey promotion designed for news/talk stations, is available from Aphelion Promotions. Packages of three general-knowledge crossword puzzles are available. For an extra charge,

customized puzzles incorporating local information can be designed.

For more information, contact Robert Parson at 501-646-9332, or circle Reader Service 119.

## Dallas Company Introduces Real-Time Radio Monitoring

**DALLAS** Media Technology is offering "Media Dialup," a service that allows for real-time monitoring of all AMs and FMs in major markets over an easy-to-access, system with any touch tone telephone.

Service is sold by subscription only. Subscribers use their own long distance carriers to access "Media Dialup" numbers for the desired major market. Media Technology is offering free demonstrations to those interested in subscribing at 214-330-8821.

For more information, contact Wayne Kirkwood at 214-330-8393, or circle Reader Service 160.

## Michelson Prepared for Annual Martian Landing

**BEVERLY HILLS, Calif.** In time for Halloween, Charles Michelson Inc. is again distributing tapes of Orson Welles' "War of the Worlds." The show originally aired on Oct. 31, 1938 on CBS Radio's "Mercury Theatre of the Air," fooling many listeners into believing that martians were actually landing in the town of Grovers Mill, N.J.

Last year 323 stations ordered the hour-long show (two half-hour, reel-to-reel tapes). Tapes are available for lease for \$160, shipping included.

continued on page 27 ▶

CAT-LINK Digital STL :

TOP 25  
MARKET SWEEP

*It's no wonder 50 stations in the Top 25 markets are sold on*

*QEI's CAT-LINK, the DIGITAL STL problem solver:*

- Uses T1 data circuits or 23 GHz radio
- The only digital FM composite link\*
- **NO COMPRESSION and NO DELAY**
- Full bi-directional capability
- Multiple discrete channel capability
- Ideal for LMAs

*And that's why more savvy stations in the Top 25 and markets of every size are turning to CAT-LINK. Call QEI toll-free at 800-334-9154 and be swept away.*



\*U. S. Patent # 5,054,070

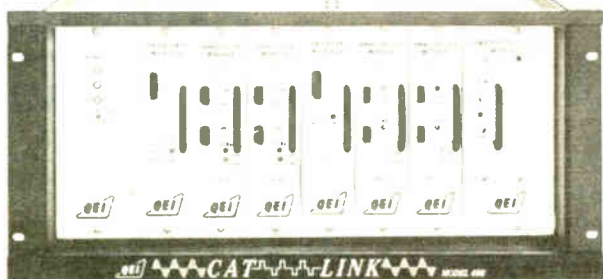

QEI Corporation  
One Airport Drive P.O. Box 805 Williamstown, N.J. 08094 USA  
800 334-9154 FAX: 609 629-1751 INTERNATIONAL: 609 728-2020

# STATION SERVICES

427 SOUND EFFECTS  
\$89.00

For a 5-CD set with a 30-day money-back guarantee.

*Take an extra \$10 off if you mention this ad!*

Send \$79 to Ghostwriters  
2412 Unity Ave. N., Dept. RW  
Minneapolis, MN 55422

For credit card orders call  
**(612) 522-6256**

READER SERVICE NO. 54

## Daytime/Fulltime AM's

*Tourism radio is a viable, profitable format. Limited consultation to turnkey, we can show you how.*

**SOUTHERN BROADCAST SERVICES, INC.**

**304-252-6452**

Contact: Shane Southern @ext. 25

READER SERVICE NO. 72

## UNBELIEVABLE LOW PRICES!!!

We'll cut your spots...  
Even write your copy...  
We'll save you time...  
money...  
and personnel headaches!

Call Mark Jones  
**Owensville Communications**  
Alexandria, Louisiana  
**318-449-1999**

READER SERVICE NO. 97

## DIGIFON

ISDN Audio Worldwide STUDIO  
Featuring  
• CCS CDQ2000ED 20-18kHz ± 0.3dB  
• Remote Hi-Fi Interview/NewsCast  
• Real Time TALENT Export/Import  
• Pro Tools Workstation w/SampleCells  
• Stereo Bi-Directional  
• SW56 Compatible  
• COMPETITIVE RATES

DAVE IMMER 212-242-2534  
Suite 12-S.W. 12 E. 12th St. New York, NY 10003  
AMERICAN EXPRESS CARDS WELCOME

READER SERVICE NO. 188

## MEDIA DIALUP

National Listen Line Network  
New York • Los Angeles • Dallas  
Serving Top Ten Markets By Early '94

Real-time air checks as convenient as your telephone. Subscription based—No per minute fee. Call our demo line in Dallas at 214-330-8821. Touch 1 for FM, 2 for AM, 4 to skip down the dial, 6 to skip up. Charter subscriptions available.

Universal Access • Affordable  
Realtime Research • Monitor Competition  
Scout for Talent • Audit Advertising  
News • Sports

Media Dialup Dallas, Texas  
Sales 214-330-8393 214-330-7060 Fax

READER SERVICE NO. 113

## BUY - OUT MUSIC

• Industrial • Technical • Logos  
• Dramatic • Romantic • Variety  
• Contemporary • Sports • Travel

11 Great Volumes! Low Buyout Pricing!  
Multi-Unit Discounts! CDs And Cassettes!  
Free Catalog!

**ENERGETIC MUSIC**  
P.O. Box 84583 • Seattle, WA 98124  
**1-800-323-2972**

READER SERVICE NO. 28

## ATTENTION PROVIDERS!

Promote your services to **Radio World's** 22,000+ readers. Reach Radio Station and Recording Studio owners/managers and engineers with your message. For information on affordable advertising call **Simone** at **1-800-336-3045**.



## MANAGER'S NOTEBOOK

# Long-Term Planning Is a Budget Necessity

by Sue Jones

**BURKE, Va.** Two basic elements are essential for managing a profitable station: planning and control. Budgets can help you maintain control over expenses. However, long range planning must be part of a budget, especially the capital budget.

Planning and budgeting for capital expenses is proactive management. The opposite is little or no long-range planning. This is reactionary crisis management that will be far more costly.

Long-range planning and capital budgets are inextricably linked. One cannot be discussed without the other. Capital budgets are one of the components of the "Annual Master Budget" as is the General and Administrative (G&A) budget discussed last month. Capital budgets require annual review and adjustment. A part of the annual expected revenues should be used for the capital budget.

## Capital budget components

Generally, capital budget items include large equipment that can be depreciated over time. There are several categories of depreciable items that should be part of your capital budget. Some examples include:

**Technical equipment**—transmitters, towers, antennas, studio consoles, back up power supplies/generators, sound reinforcement systems, replacement studio equipment such as CD/cartridge/tape machines, studio transmitter link equipment, and exciters for FM stations;

**Office Equipment**—office furniture, computer systems, telephone systems, and leasehold improvements;

**Promotional and Programming Equipment**—station vehicles, remote vans, new jingle packages, or a new production library.

Equipment and station needs vary widely depending on the station size. A good place to research your capital needs is the station equipment inventory. This list is not all inclusive, but it will get you started.

## Service life

When you have an accurate list of depreciable equipment, you should also list the purchase date of the equipment and the years of service expected for each piece of equipment. Transmitters can have a service life of 15 to 20 years or longer. A cartridge player may only last for three to five years. You could possibly get a longer/shorter service life.

Some equipment can become obsolete as a result of technical innovation before the end of the expected service life. A good example of this is the vast improvement of CDs over vinyl source material. Vendors of office equipment and promotional equipment will also be able to give you some guidelines. When you have this list compiled, you can begin to project what equipment will probably need to be replaced next year, the following year and over the next five years.

List the equipment that should be replaced each year for the next five years. Beside each piece of equipment, add the replacement cost. Keep in mind that the cost of equipment can fluctuate. The price that you paid for a production library may have increased over the last two years.

You may also discover that you can

replace and upgrade that five year old 286 PC to a 486 for \$1,000 less than you paid for the 286. Your engineer, vendors and prior year purchase invoices can again be helpful in projecting replacement costs.

At this point, you should have a fairly accurate idea how much capital budget money should be available for expected replacements. This will become the basis of your capital budget. You may be surprised that you might need a total of \$50,000 for replacement equipment. This may not cover obsolete equipment or other capital improve-

ments you may have been planning.

You may have enough projected revenue to cover the G&A budget and the projected capital expenses. Or you may discover that you will not have enough to cover the projected bonuses for the staff and pay for the projected capital expenses. At this point, one of the budgets would have to be adjusted. You may also be facing a projected \$15,000 to \$70,000 expense in two years to replace that aging 20-year-old transmitter. Long range planning now will significantly reduce the added replacement/upgrade

cost burden when it is needed, without digging into reserves, severely cutting the G&A budget, or borrowing the funds for emergency repairs.

## Annuity accounts

One way to assure that the funds will be available is to establish a capital budget annuity account. Each month, deposit an amount in an interest bearing account that would add up to the projected cost of major capital items at the projected time in the future.

continued on page 26 ►

## YOU CAN SHARE PROGRAMMING AMONG YOUR RADIO STATIONS ... At a Lower Cost Than Ever Before!

Share programming among your station group or with other stations by sharing day parts, entire formats or by delivering your top-rated talent to other markets coast to coast. You can spread overhead costs, increase the quality of programming at the local station and build your audience by creating a satellite radio network. And now new digital satellite technology makes radio networking more affordable than ever before. Let us offer you a complete solution for your radio networking needs.

Call us at (202) 822-2626.

### NPR SATELLITE SERVICES®

2025 M Street, NW, Washington, DC 20036  
(202) 822-2626



from Moscow to NY & from Paris to Tokyo...

# MORE STATIONS BUY ARRAKIS!!!

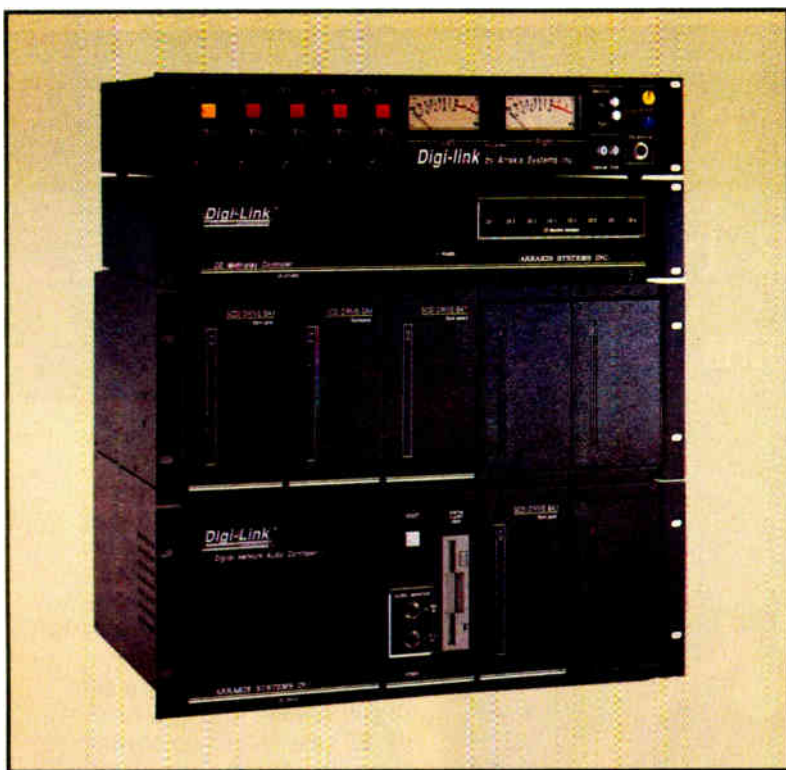

## **DIGILINK...** **THE #1 DIGITAL SYSTEM** **starting at under \$8,000**

- 10 hours of stereo digital audio storage for \$7,995 complete
- Satellite, CD, Tape and Hard Disk Automation
- Simultaneous Play, Record, & Network transfer
- Digital Editor with Waveform Editing for tight production
- Crossfade CD's, sources, and hard disk audio
- Music Scheduling system built in for basic CD automation
- Digital Networking for transfer of audio and schedules

Digilink is the #1 selling digital audio hard disk system in radio today. You can replace your cart machines for live On Air and have an automation system for walk away at the same time! Link over 15 workstations & scheduling computers on our digital network and transfer audio and schedules between your studios.



## **TRAK\*STAR-8** **THE 8 TRACK DIGITAL EDITOR** **starting at under \$5,500**

- A digital audio editor designed for Radio production
- Learn to use in minutes, much faster than tape
- Cut, splice, move, and fade up to 4 stereo tracks
- Use Scrubbing to edit with your ears
- Use visual waveform editing to edit with your eyes
- An UNDO button enables you to go back and fix mistakes
- Digital Networking to transfer audio to your On Air machine
- Add Trak\*Star-8 software to a Digilink for \$2,000

Trak\*Star-8 is the first cost effective multitrack digital audio editor designed for the radio broadcast professional. Fast and easy to use, produce your commercials on Trak\*Star and then transfer them in digital straight to the Digilink in your On Air studio. Dramatically reduce production time and save money!!!

2619 Midpoint Drive, Fort Collins, CO. 80525

Voice (303) 224-2248



## 12,000 Series Consoles

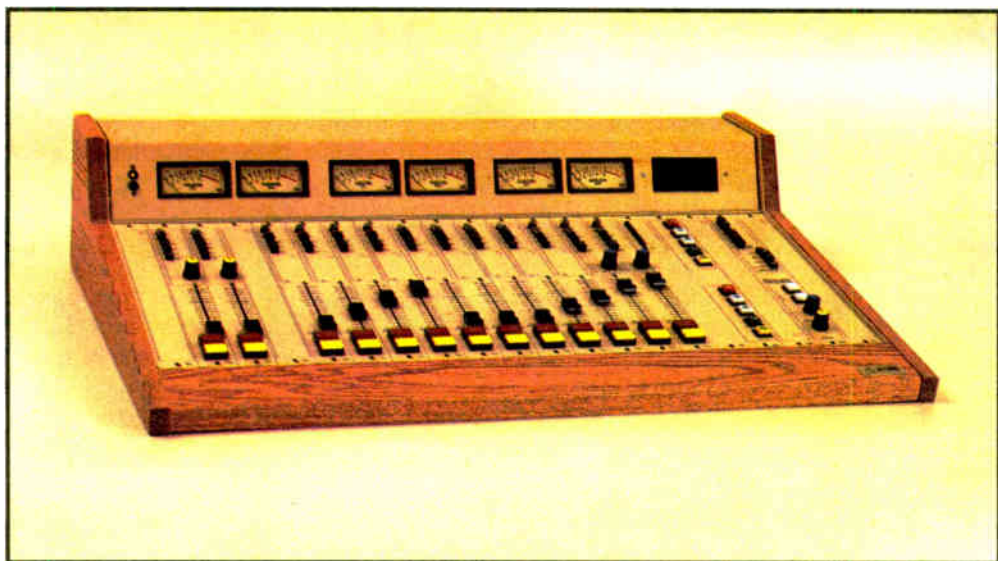

Standard Tabletop Mainframe displayed above

- Totally Modular Console-Input-output-monitor
- Three Mainframe Sizes - 8, 18, 28 input channels
- High Quality Construction-P&G Faders, etc.
- Polycarbonate overlay-for scratch resistance
- VCA Controlled Faders-for ultra reliability
- Universal Mainframe-any module in any position
- Inputs-2 per channel
- Outputs-3 stereo, Pgm, Aud, Utl
- CR Monitoring-stereo Monitor, Earphone, & Cue
- Studio Monitoring-two studios supported
- Talkback-two studios w/monitor dim
- Telephone interface-2 internal mix minus buses
- Timer-60 minute digital up timer standard
- Options-DA module, Remote selector module, Dual Machine Control Module

### Typical List Price

**\$4,000 - \$7,000**

From France...to Moscow...to Japan and Taiwan, and around the world...the 12,000 console is On the Air.

The 12,000 is the #1 selling Arrakis console line from the #1 console manufacturer. With three stereo output buses and two mix-minus buses for telephone interface, the 12,000 can fill any application. The 12,000 also supports a control room and two studios standard. Panning or Mode select are available on the four models of input modules, VCA control of audio delivers reliability and performance.

Quality, performance, and durability make Arrakis consoles the leader around the world.



Deluxe thru-table mainframe displayed below

14 1/4" x 20 3/4"

**Arrakis Systems is a world leader in radio studio technology. In Japan, Digilink is a brand name for hard disk audio for radio. For use around the world, the United States Air Force chose the 10,000 series console from among all competitors as its console of choice. When the United Nations needed 6 entire studios with consoles and furniture for a rush shipment to Cambodia early this year, they chose Arrakis 10,000 consoles and Modulux furniture. In Jamaica, Tahiti, and elsewhere, entire factory assembled and tested Arrakis studios are on the air. Around the world and of course in the United States...more stations buy Arrakis for their digital audio, console, and furniture needs!!!!**

FAX (303) 493-1076

by **ARRAKIS SYSTEMS inc.**



# Du Quoin Fair Provides High-Profile Radio Fun

► continued from page 21

"At staff meetings, before we started doing this, we always talked about, 'What are we gonna do from the fair?' I never thought cut-ins were very effective because most of the time the people at the event don't even know you're doing them. I thought, 'If we're going to be at the fair, why don't we become an exhibit and let people come and stare at us?' It's the perfect opportunity to really get in touch with the public and find out what each other is all about. There have been a lot of people who've come out to the fair specifically so that they could say 'hi' to their friends on the radio."

The fans don't go away empty handed. "We give away tapes and CDs we get from record companies. Sometimes we'll have bumper stickers printed up. We have a syndicated game called 'Scan and Win'... (for) a can of Pepsi or a CD or things like that," Waitekus said.

WCIL-FM's reward has been to get a prime location, right on the entrance to both the grandstand and the carnival midway.

## Manpower and business

Poor location was the reason Lester St. James, program director for WTOA(FM) Murphysboro, Ill., decided not to do a remote this year. It's a "manpower-and-business" decision and "when you're low on the seniority list, you get put out

where nobody sees you." St. James said. WTOA did show off its "Rolling Thunder" van with its 1,500-watt, 24-speaker Blaupunkt stereo during one concert at the Miller Beer tent.

Plenty of other stations decided entering the remote wars was worth it.

WQRL(FM) Benton, Ill., hoped to launch itself from 3,000 to 25,000 watts. The switch wasn't thrown by fair time, but they were there all 10 days.

It was a little jarring to step from the raucous music on the midway to non-commercial WSIU(FM) Carbondale's Broadcast Dome and hear Mozart. The dome was staffed with Southern Illinois University at Carbondale Broadcasting Service employees and volunteers from the "Friends of" organizations.

Hometown station WDQN-FM Du Quoin continued a tradition begun in 1955. "We broadcast the entire harness racing schedule, including the World Trotting Derby. We do our own live broadcast of the ARCA 200 and the USAC Silver Crown Dirt Track Race on Labor Day," General Manager Greg Showalter said. WDQN-FM's big giveaway prize was a gas-powered weed-eater.

□□□

Gary Hart is a freelance writer and assistant news director at WCIL-AM-FM Carbondale, Ill.

# Planning the Budget

► continued from page 23

Another way is to create an annual capital budget for the low to moderate priced items that will need to be replaced. If no replacement is needed, the money that was set aside for the purchase(s) can be deposited in the capital budget annuity account for large replacements in the future.

## Risks

The reactionary management method is to borrow funds for emergency replacements when they occur. This is short term gain at the risk of long term prosperity. You could double the cost of some replacements because of the overnight freight bills for equipment and/or premium time (weekend or holiday) labor costs to install the replacement equipment. If you are off the air for any significant time, you will have to provide make-goods which further reduces station revenue.

In addition to the added implementation costs, you have to pay interest on the line of credit or borrowed funds. All of these added costs will reduce your rate of return on your investments and reduce your overall profit margin.

An additional component to risk management of capital investments involves adequate natural disaster insurance. The station should have

natural disaster insurance for catastrophic disasters like hurricanes, tornados, icing, lightning, and earthquakes. If your tower is destroyed, the station is off the air and you will still have all of the overhead expenses with no income being generated until the emergency repairs/replacements can be made. Insurance of this type can make the difference between a profitable or unprofitable year.

## Benefits

The benefits that you will gain with an adequate capital budget and long range planning include fewer equipment failures and greater reliability of the equipment. This translates into reduced off-the-air time. Replacement/repairs can be completed at times that are the least disruptive to your staff.

You probably will not be challenged to solve a major equipment failure problem during your largest annual promotion. You will systematically manage the risks at the optimum costs and times for the station's benefit—not to mention your peace of mind.

□□□

Sue Jones is a senior manager for Computer Data Corporation, Inc. in Rockville, Md. She can be reached at 703-323-9391.

## THE RF EXPERTS KNOW—MYAT DELIVERS

### MYAT DELIVERS QUALITY

You can rely on MYAT rigid line and components to deliver a clean, powerful signal to your antenna. Pure highest quality copper, brass and silver plus computer-aided design and manufacturing ensure consistency and accuracy. No wonder demanding broadcasters worldwide choose MYAT products for their passive systems. We take Quality Control very seriously.

### MYAT DELIVERS RELIABLE PERFORMANCE

Our non-galling silver-plated beryllium copper contact springs, brass elbow reinforcements and virgin Teflon inner supports are designed for maximum velocity, minimum attenuation and long service life. Every MYAT component is tested before shipping and backed with a full one year warranty. MYAT products are built for the long run.

### MYAT DELIVERS WHEN YOU NEED IT

Major transmitter manufacturers with strict production schedules rely on MYAT to deliver quality components on time and within budget. So do leading broadcasters like the Empire State Building's newest TV tenants. At MYAT, commitments are kept.

### LET MYAT DELIVER FOR YOU

Whether you're planning a new tower, upgrading an older installation, or coping with an emergency, you can depend on MYAT rigid line and components. Thousands of RF experts around the world already do. Contact your RF distributor, or phone us for our catalog, installation planning guide and engineering reference. Its detailed drawings can help you put together an efficient, trouble-free transmission line that will last for decades. For a free copy call 201-767-5380 or fax 201-767-4147.



### RIGID LINE: RADIO'S EFFICIENT CHOICE

40 YEARS OF EXPERIENCE. 40 YEARS OF EXCELLENCE.

380 Chestnut Street • P.O. Box 425 • Norwood, NJ 07648

Tel 201-767-5380 • Fax 201-767-4147



MARKETING & MANAGEMENT

# Radio Beams 'Frequency-Marketing' Signal

by John Cummuta

**ALGONQUIN, Ill.** You fly on your favorite airline and it gives you "frequent flyer miles." You stay in your favorite hotel and it gives you "frequent guest points" or some similar bonus. You drive your favorite rental car brand and earn "frequent renter miles."

And lately, if you do any of the above, you may get all three kinds of bonuses. The hotels give away airline miles, the rental cars give you credit for bonus nights at the hotel, and so on.

It's called "frequency marketing," and it

rewards the customer for ignoring the competition's pitches and coming back to you for future purchases. This marketing strategy is spreading across all types of retail businesses, and it opens a window of opportunity to your advertisers and your station.

**Opportunity knocks**

The idea is simple. Just like the airlines, hotels and car rental agencies, your advertisers can build customer loyalty by rewarding purchase frequency. These retailers can either develop their own individual programs, or they can come together in a cooperative frequency marketing effort.

Let's look at an example.

One of the most obvious businesses for a frequency marketing program is the supermarket. We'll call ours "Groceryland."

Groceryland creates a "frequent shopper" card, for which the customer need do nothing more than fill out a simple application that gathers basic demographic information. Then, every time the customer shops at the store, a hole is punched in his/her card for each \$10 worth of purchasing, rounded up to the nearest \$10.

Then all that's needed is a redemption schedule. This is a list that details what the punched frequent shopper cards can be redeemed for.

For example: \$100 worth of punches could earn a free loaf of bread, \$500 worth of punches could earn a \$10 discount, \$1,000 worth of punches might earn him four T-bone steaks and all the trimmings for a great dinner, and \$1,500 in punches could earn a free \$50 worth of groceries and entry into a monthly sweepstakes to win a Caribbean weekend for two.

The motivation is direct and effective. Once a person has a few holes punched in his card, the potential rewards begin to outweigh the competition's price promotions. The customers get into the game of building up points, and so they keep

coming back to Groceryland.

Groceryland enjoys greater repeat business and market share, as well as more profitability, because it costs less to bring a customer back with a frequency promotion than it does with price-promotion advertising. The store can therefore invest more into stealing customers from its competition, using the frequent shopper program as the lure.

**Radio's role**

A more powerful and exciting frequency promotion combines several non-competi-

tive businesses in a cooperative. Your station could organize and orchestrate such a multi-merchant frequency promotion, and sell an accompanying advertising package to each of the participating businesses.

The neat thing about this kind of frequency promotion is that, like the airlines, hotels and car rental agencies, all the businesses in your cooperative would grant frequency points that accumulate into a single total. And they could all contribute products or services to the list from which the customer can redeem his

continued on page 32 ▶

## STATION SERVICES

▶ continued from page 22

For more information, contact Charles Michelson at 1-800-648-4546, or circle Reader Service Number 112.

### ESPN's "Gameday" Covers NFL on ABC Radio Networks

**DALLAS** "GameDay on ESPN Radio" has begun its first season on ABC's ESPN Radio Network, coinciding with the opening of the National Football League 1993 season on Sept. 5.

The program is hosted by ESPN's Mike Tirico and Steve Levy and airs Sundays, 11 a.m.-7 p.m. (ET). "GameDay" features on-site reports of games in progress, injury reports and interviews with players and coaches.

For more information, contact Kim Richmond at 214-991-9200, or circle Reader Service Number 129.



## Studio-In-A-Box.

Fast Trac II by Henry Engineering is an incredibly useful audio management system that has numerous applications in radio and television audio.

Fast Trac II functions as a stereo switcher, audio mixer, utility dubbing center, voice-over recording system, compact production facility, or as the "control head" of a multi-track digital editing workstation.

Fast Trac II incorporates all of the functions of a typical audio mixing console: input selection, level and balance control, mic-over-line mixing, and complete monitoring. Additional

features make Fast Trac II perfect for specialized broadcast production tasks. Automatic "ducking" permits efficient voice-over recording. The timed auto-start Machine Control System for source and recording equipment creates perfectly cued dubs reliably with one button ease.

In a nutshell, Fast Trac II is a complete 2-pot console "studio-in-a-box." Call the audio professionals at Harris Allied for all the details.

8:00 a.m. to 8:00 p.m. EST

1-800-622-0022

Fax 317-966-0623



© 1993 Harris Corp.

WHAT ELSE

do  
you  
want  
it  
to  
do?

The HPT Series from BEXT is everything you've heard it is: it can be an exciter, a transmitter, a translator and a booster in one high performance, fully featured package. From \$3,695 to \$3,985.

739 5th Ave. • San Diego, CA 92101  
619-239-8462 • FAX: 619-239-8474

Circle (85) On Reader Service Card

"Call me, I'm interested." Circle (44)

"Send me literature." Circle (162)



# Data Reduction Debate

► continued from page 17

then go back to analog once it hits the listener's ears—someday, perhaps in a perfect world.

## Only the best

Hinderks, Koos and others at the seminar agreed that broadcasters should insist on only the most advanced, highest-quality algorithm at the highest possible bit rate. Alas, with at least six major algorithms all finding a home in broadcast products these days, who could even agree on what "highest quality" might be, not to mention the tradeoffs between quality and delay, another whole area ripe for debate?

Marvin and Tom offered practical advice on how broadcasters themselves can direct the debate. Station managers

and program directors, they said, could start paying more attention to quality.

Marvin is especially vocal about this. Stations should reject sub-par audio from ad agencies and other sources and exercise their right to choice of "with or without compression" when possible in digital storage and playback devices, he said.

There are applications where Tom said he advises against reduction, even to the point of not selling a product, if it came down to that.

Unfortunately, the hope of having manufacturers, algorithm proponents and broadcasters all sit down and decide on some sort of standard anytime soon looks to be a vain hope at best.

Perhaps the largest dose of reality in the debate came from Bob and Al, who said

that stations aren't adding equipment with algorithms because they actually want to degrade their audio. When it comes to the real-world broadcasting, they are simply forced to choose the most economic way to send their signals from one place to another.

## Tough choices

Stations with LMAs find that digital STLs are a necessity, to get two stations' signals from a single studio to two separate transmitters. Stations with marginal AMs have to go to an automated satellite format with hard disk storage and playback just to stay afloat.

For a struggling FM, automated overnights could mean the difference between meeting payroll and going bankrupt. For a network such as ABC, with a myriad of program choices for a variety of affiliates, satellite delivery really is the only practical alternative.

As for quality, no one wants to say it's

a luxury broadcasters can't afford. Instead, the manufacturers are striving towards making the algorithms better, and truly hope their potential customers will have had their consciousness raised by Herb and others who have taken a good, long listen to data reduction and its effects.

For my own part, I got the shivers when Willie's vocals began to screech, but the room was quiet, the sound system was substantial and I was primed for the shock effect.

The question that gnawed at me later was, would I have noticed it at all on my car radio, traveling at 55 mph on the Long Island Expressway?

□□□

Judith Gross is VP and head copywriter for Media/Scan, an advertising/marketing agency specializing in broadcast and pro-audio technology. She can be reached at 212-929-6108.

# Products & Services Showcase

For more information on the products shown below, circle the appropriate Reader Service No.(s) on the enclosed Subscription/Reader Service card or contact the advertiser directly.

## Shape Up!

**Coverage.** Saturation. DBk contours. In FM broadcasting, the "bottom line" is always based on your pattern.

More than any other manufacturer, Shively has the experience and reputation for providing crucial pattern solutions for critical propagation problems. On any tower. At any power level. Remember, *it pays to be heard.*

A good pattern. The shape you need. Talk to your consultant. And contact us. See us at NAB Radio Show Booth 1005-1007.

## Shively Labs

A Division of Howell Laboratories, Inc.

19 Harrison Road, Bridgton, ME 04009  
207-647-3327 FAX 207-647-8273

READER SERVICE NO. 61

## DIELECTRIC COAXIAL LOADS



- \* Dry Loads 5-150 Watt
- \* Oil Filled 600-10,000 Watt
- \* Water Cooled 25-100 kW
- \* Heat Exchangers
- \* New for '93...High Power Calorimeter

CALL FOR OUR NEW CATALOG!

Dielectric Communications  
P.O. Box 949  
Raymond, Maine 04071  
USA

207-655-4555  
FAX 207-655-7120

READER SERVICE NO. 140

## FREE COMPUTERS!

Get it all! Pick either our new Simple-CD<sup>®</sup> automation with the DJ-Pro<sup>®</sup> production system OR our DJ-Lite<sup>®</sup> Satellite automation system with the DJ-Pro<sup>®</sup> production system. Get two computers, two monitors, two hard disks, a full LAN network and assembly, free!

**\$9,995.00**

Lease as low as \$229.00 per month

**Plug n' Play**

Package system price includes either a Simple-CD control system with a 16 unit Pioneer<sup>™</sup> CD six-pack interface OR a DJ-Lite satellite music system controller with I/O cards and software. Either system is connected by a fast LAN network to a DJ-Pro production workstation. Wire to your console audio and you're on the air.

Package system includes two premium apt-X<sup>™</sup> audio cards, two fast 386 SX-33 computers each with 340 meg hard disks (5+ hours mono recording), two VGA color monitors, two LAN cards & software, 15' LAN cable and Manuals.

Full Backup for Safety - Easy Production  
Use DJ-Pro for fast spot production, then send by LAN to Simple-CD or DJ-Lite. Relax! Your spots are backed up and safe.

**The Management**

1-800-334-7823 1-817-625-9761  
P.O. Box 1-36457 Ft. Worth, TX, 76136  
1600+ Stations - Our 13th year

READER SERVICE NO. 71

## WIRELESS IFB SYSTEM

Used by hundreds of TV stations for van-to-field cueing in ENG & SNG applications. Transmitter provides mix of program and instructions to rugged, pocket receivers.

- 100% duty cycle
- Wideband audio
- Excellent operating range



**COMREX<sup>®</sup>**

Comrex Corp., 65 Nonset Path, Acton MA 01720  
Tel: 1-800-237-1776 Fax: 508 635-0401

READER SERVICE NO. 109

## TIME CODE READER

TCR-100

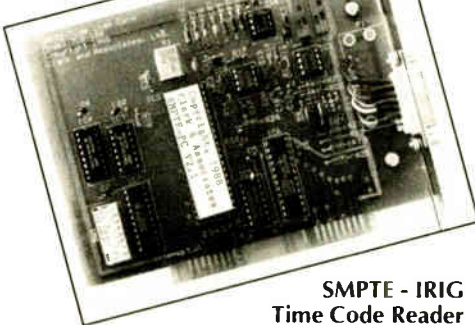

SMPTE - IRIG  
Time Code Reader  
for IBM-PC's, AT's and clones

- Locks PC's to SMPTE or IRIG time codes
  - Affordable, 1/3 AT slot configuration
  - DB-15 female connector.
  - Easy installation - software included
- For more information, call (309) 837-2244 or fax (309) 833-5175

CLARK & ASSOCIATES, LTD.  
318 E. CALHOUN  
MACOMB, IL 61455



READER SERVICE NO. 11

## Manufacturers

Is your company or product featured in our pages? Distribute extra copies of **Radio World** articles to your customers with **Radio World's** reprint service.

Print as many copies as you want for **one low price.**

For information, call Simone Mullins at

**1-800-336-3045**



# Products & Services Showcase

For more information on the products shown below, circle the appropriate Reader Service No. (s) on the enclosed Subscription/Reader Service card or contact the advertiser directly.

## DIGITAL ANTENNA MONITORS

In-Stock-Available for Immediate Delivery



Price US\$2400.00 2 Towers  
Will operate with any remote control equipment.



Price US\$1780.00 2 Towers  
For AM directionals with studio located at transmitter site.

These monitors are state-of-the-art instruments of unequalled accuracy (.5% or better on ratio and .5° or better on phase) and stability. With typical modulation the true ratio readout of these monitors is a factor of 10 more stable than instruments that measure normalized amplitude, and their phase readouts are rock solid. Phase sign is automatic, no extra operation. In addition to the analog DC outputs for remote control the Model CMR has a multiplexed BCD digital output which can be used to drive the Remote Indicator Model CMR-1. RF inputs have dual protection. Gas discharge tubes across the sample line terminations plus relay protection.

**GORMAN REDLICH MFG. CO.**  
257 W. Union St. Athens, Ohio 45701  
Phone 614-593-3150 • FAX 614-592-3898

READER SERVICE NO. 58

## ALAN DICK & CO. (USA) INC. LDL COMMUNICATIONS INC.

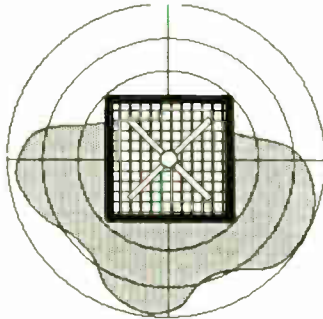

For your full turn-key or individual components needs . . . ADC/LDL supplies a full range of product and services for the FM broadcaster. RF transmission products include low power, side-mount antennas as well as high power, broadband, multi-channel antennas and combiners.

**LDL COMMUNICATIONS INC.**  
14440 CHERRY LANE CT. #201  
LAUREL, MD 20707  
301-498-2200 FAX: 301-498-7952

**ADC (USA) INC.**  
9 CLINTON DRIVE, HOLLIS, NH 03049  
603-598-4500 FAX: 603-598-4212

READER SERVICE NO. 189



## Econco REBUILT POWER TUBES



Approximately One Half  
the Cost of New  
3,000 Hour Unconditional Guarantee  
Call for Our Price List

Econco 1318 Commerce Ave. Woodland, CA 95695  
Phone: 916-662-7553 Fax: 916-666-7760 Telex: 176756  
Toll Free: 800-532-6626 From Canada: 800-848-8841

READER SERVICE NO. 202

## Zercom Patch Switch



\$350.00

Zercom Patch Switch (Model #PS-1) will put an end to your confusing and unsightly patch bay. It is easy to install and use. Its stereo 10 in and 1 out or 1 in and 10 out configuration allows you to reverse stereo phase and perform stereo to mono summing with the push of a button. It provides additional input switching on overcrowded consoles, for the selection of satellite, remote, or studio feeds at the push of a button. Zercom Patch Switches can be easily bussed together using optional ribbon cable for more complex applications.

High quality Switchcraft brand switches do channel selection. There is room to add resistors to make audio pads inside. No internal active electronics. We recommend the Zercom Gain Box to increase levels as necessary for some applications.

**ZERCOM**  
Box 84, Merrifield, MN 56465 • 218-7675-3151

READER SERVICE NO. 84

## AUTOMATED FM ANTENNA PATTERN MEASUREMENTS

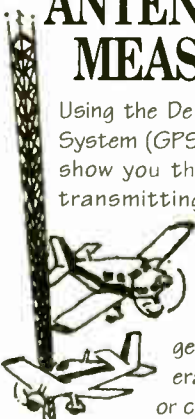

Using the Dept. of Defense Global Positioning System (GPS), and our hi-tech airplane, let us show you the signal your station is really transmitting. We measure each and every degree of both the horizontal and vertical patterns. Your signal is your most important asset! Don't guess. Be sure your getting the maximum possible coverage. Call us today for a brochure or confidential consultation.

**STEPHENS COMMUNICATIONS INC.**  
Little Rock, AR. • (501) 821-5756

READER SERVICE NO. 214

## S.C.M.S., Inc. Charlotte, N.C.

Low Prices – Experienced Staff  
New and Re-built R.F. and Audio

**This Month's Special**  
**NEW INOVONICS #530**  
**FM MODULATION ANALYZER**

- TUNEABLE ▪ PRESET ALARMS
- STEREO ▪ PEAK FLASHER

**Only \$1,990.00**

Toll-Free 800-438-6040

FAX 704-889-4540

READER SERVICE NO. 42

## NOW UPDATING ALL PCL 505s

FOR DETAILS, CALL



2198 Hubbard Lane  
Grants Pass, OR 97527  
**(503) 471-2262**

READER SERVICE NO. 18

The Russians never  
abandoned tube  
technology . . .

## And that's great news for your transmitter!

As the world's largest power tube manufacturer, Svetlana never stopped full-scale R&D for power tubes. From power tubes of over one-megawatt to a full line of high-performance triodes, tetrodes and pentodes, Svetlana is the world leader in power tube technology.

Now, Svetlana-developed tubes are available in the West in a growing number of standard tube types for AM and FM broadcast. These top-quality, long-life ceramic tubes are available at Russian prices direct from Svetlana and are backed by the most generous warranty in the industry.

Talk to Svetlana today about your requirements for standard and custom-designed power tubes. Broadcasters, call 800-239-6900 for sales; OEMs, distributors and volume purchasers, call 415 233-0429.



Broadcasters, contact:  
8200 S. Memorial Parkway  
Huntsville, Alabama  
35802  
800 239-6900

OEMs, Distributors, Volume  
Purchasers, contact:  
3000 Alpine Road  
Palo Alto, California  
94028  
415 233-0429

READER SERVICE NO. 198



# Who's running the ship?

Unattended operation is one way to keep your station profitable, but you still have to mind the store.

The acclaimed Burk Technology ARC-16 Remote Control System is the first step. You can control transmitter and studio from any phone. But wait. There's more!



Introducing AutoPilot™ from Burk Technology.

AutoPilot is break-through computer software that makes automatic operation of your studio/transmitter facility a dream come true.

- Automatic power changes
- Automatic pattern changes
- Automatic site changes
- Automatic power trim
- Automatic fault recovery
- Automatic logging

Now your imagination is the only limit.

The new FCC fine schedule is imposing. Why risk a big penalty when AutoPilot can help you stay within the rules?

Call us at 508-433-8877 or toll free at 1-800 255-8090 for more information and a FREE DEMO.



Circle (4) On Reader Service Card

# Avoiding AM DA Transformer Trouble

by Fred W. Greaves

**YORK, Pa.** Toroidal Current Transformers (TCT) are a convenient way to monitor tower phases and currents in a directional AM antenna system. They are fast replacing the conventional sample loop in new and upgraded systems.

The only problem with these units is if they are not installed properly, they can be destroyed or damaged by lightning. When this happens, they become very expensive paper weights.

When installing these units, be sure that the case is properly grounded, preferably with at least a two-inch copper strap connected securely to your main grounding system.

### Keeps on ticking

A TCT, when damaged, will not necessarily quit functioning, but instead will give a false indication either in its current or phase indication. Delta TCT-

Let me reinforce what you probably have been told many times by consulting engineers. If your antenna parameters go out of tolerance, before you do anything else, check your monitor points. If these points look normal, then you can be fair-

is operating correctly.

A simple test setup is shown in Figure 1. The 50 ohm loads should have a tolerance of one or two percent and be closely matched. If you do not have the proper loads, you can utilize the termination

Figure 1.

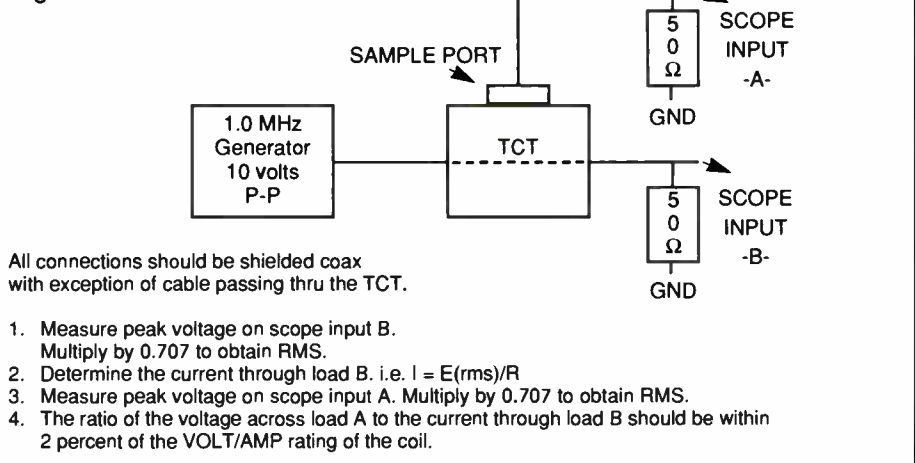
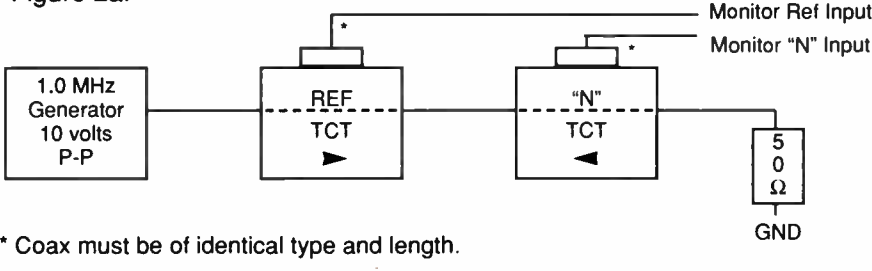

Figure 2a.



1, -2, and -3 are produced with an internal resistor, which, when severely stressed, will open. This will result in an approximate doubling of your ratio indication at the phase monitor. The phase indication will most likely not change.

Though it is a rare occurrence, sometimes this internal resistor will simply change value, resulting in a change of ratio that will have you going in circles trying to find. If you merely adjust the system to give proper parameters, you will find that everything looks normal with the exception of your monitor points and, more than likely, your common point impedance.

ly sure that the problem is either in the Sample System or the Antenna Monitor.

Ideally, the time to test TCTs is before you install them. The second best time for testing is when your system

resistors built into your antenna monitor. This test will verify that the internal resistor is within its proper value range. Delta Engineers say, "If this test shows OK, then it is almost a sure thing that the phase indication has not changed." The problem here is if this test shows there is a problem, what was the phase to begin with?

### Absolute accuracy

The manufacturer's stated "absolute phase accuracy" for the TCT-1 and TCT-2 is +/- 2.0 degrees, and for the TCT-3 is +/- 3.0 degrees. The stated "absolute magnitude accuracy" is +/- 2.0 percent. It should be noted here that the units as

Figure 2b.

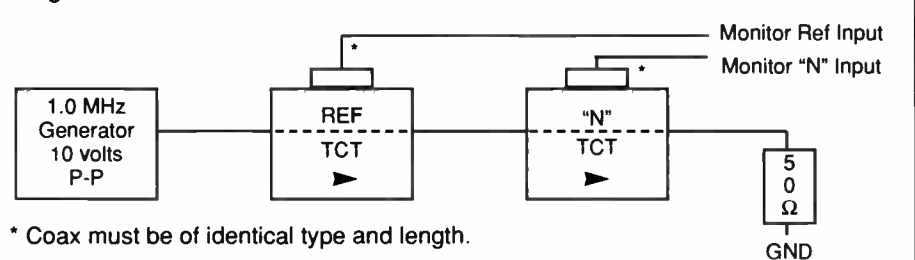

delivered from the factory usually have a lot closer tolerance than those stated in its literature. However, it would be wise to check the phase indications of all TCTs in your system. Again, the best time to do this is either before installation or while your system is operating properly.

Figures 2A and 2B show a setup for testing these units using your station's phase monitor. Keep a record of all tests, and be sure to record the serial number of the unit(s) under test. Delta Electronics will endeavor to replace a damaged unit with one exhibiting similar indications.

The setup shown in Figure 2A should result in a phase reading on the "N" input of the monitor approximately 180 degrees and a ratio of approximately 1.00.

The setup shown in Figure 2B should result in a phase reading on the "N" input of the monitor approximately 0.0 degrees, and a ratio of approximately 1.00.

□ □ □

Fred W. Greaves is director of engineering at Susquehanna Radio Corp.

## SUBSCRIPTION/READER SERVICE FORM



### FREE Subscription/Renewal Card

I would like to receive or continue receiving Radio World

FREE each month.  Yes  No

Signature \_\_\_\_\_ Date \_\_\_\_\_

Please print and include all information:

Name \_\_\_\_\_ Title \_\_\_\_\_  
 Company/Station \_\_\_\_\_  
 Address \_\_\_\_\_  
 City \_\_\_\_\_ State \_\_\_\_\_ ZIP \_\_\_\_\_  
 Business Telephone ( ) \_\_\_\_\_

Please circle only one entry for each category:

#### I. Type of Firm

- |                              |                                 |
|------------------------------|---------------------------------|
| D. Combination AM/FM station | F. Recording Studio             |
| A. Commercial AM station     | G. TV station/teleprod facility |
| B. Commercial FM station     | H. Consultant/ind engineer      |
| C. Educational FM station    | I. Mfg, distributor or dealer   |
| E. Network/group owner       | J. Other                        |

#### II. Job Function

- |                           |                    |
|---------------------------|--------------------|
| A. Ownership              | G. Sales manager   |
| B. General management     | E. News operations |
| C. Engineering            | F. Other (specify) |
| D. Programming/production |                    |

### Reader Service

Oct. 13, 1993 Issue Use Until Jan. 13, 1994

Please first fill out contact information at left. Then check each advertisement for corresponding number and circle below.

#### Purchasing Authority

- |              |            |            |
|--------------|------------|------------|
| 1. Recommend | 2. Specify | 3. Approve |
|--------------|------------|------------|

001	023	045	067	089	111	133	155	177	199
002	024	046	068	090	112	134	156	178	200
003	025	047	069	091	113	135	157	179	201
004	026	048	070	092	114	136	158	180	202
005	027	049	071	093	115	137	159	181	203
006	028	050	072	094	116	138	160	182	204
007	029	051	073	095	117	139	161	183	205
008	030	052	074	096	118	140	162	184	206
009	031	053	075	097	119	141	163	185	207
010	032	054	076	098	120	142	164	186	208
011	033	055	077	099	121	143	165	187	209
012	034	056	078	100	122	144	166	188	210
013	035	057	079	101	123	145	167	189	211
014	036	058	080	102	124	146	168	190	212
015	037	059	081	103	125	147	169	191	213
016	038	060	082	104	126	148	170	192	214
017	039	061	083	105	127	149	171	193	215
018	040	062	084	106	128	150	172	194	216
019	041	063	085	107	129	151	173	195	217
020	042	064	086	108	130	152	174	196	218
021	043	065	087	109	131	153	175	197	219
022	044	066	088	110	132	154	176	198	220

Copy & Mail to: Radio World, PO Box 1214, Falls Church, VA 22041, or FAX to: 703-998-2966



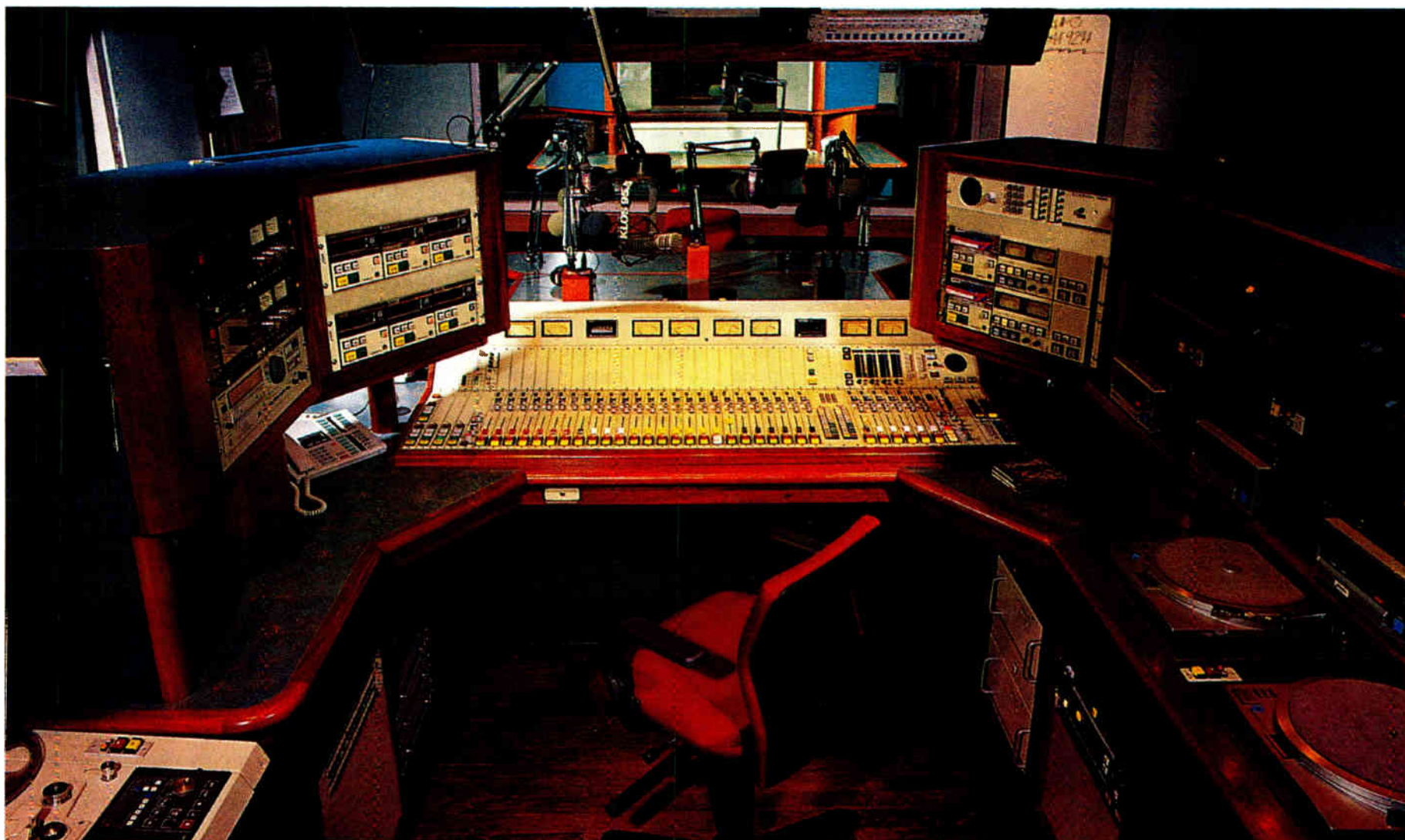

# Systems with Style

When KABC/KLOS decided to rebuild from the ground up, they called Pacific Recorders & Engineering to provide its expertise in studio systems planning and execution. After all, when you're dedicated to winning, you don't gamble with success. PR&E has a proven track record of building the world's leading broadcast facilities for over twenty years. This record translates into the uncommon depth and breadth of experience which we bring to each new project. From news to rock, talk, or full-service, we're comfortable and conversant with all formats.

When you see the attention to detail, the design elegance, and the fanatical commitment to quality, you quickly realize why PR&E consoles and studio systems are found in nearly every leading broadcast facility in the nation.

But what may really surprise you is how much money you can save by working with us. That's right, save money. You see, we design and build so many world-class studio systems, we avoid the "surprises" by having the details down to a science. Why don't you give us the opportunity to work with you on your next studio project? We think you'll be pleasantly surprised at how easy it is to realize the operational efficiency and benefits of a genuine PR&E system.



Pacific Recorders & Engineering Corporation  
2070 Las Palmas Drive, Carlsbad, CA 92009  
Tel: 619-438-3911 Fax: 619-438-9277 GSA: GS-03F-2057A

**DESIGNS THAT MAKE THE DIFFERENCE**





# Firm Modifies Old STLs to FCC Specs

by Bob Kirby

**GRANTS PASS, Ore.** Radio broadcasters using RF studio-transmitter links (STL) and intercity relays were to have had their primary transmitters "FCC type notified" by July 1 to comply with new FCC rules.

"Notified equipment" is a designation similar to type accepted equipment in that the FCC requires manufacturers to certify that equipment meets or exceeds power, bandwidth, modulation, spurious emission and frequency stability specifications mandated by the Commission.

STL equipment made in the past decade had little or no trouble qualifying for

"notification" status, according to Marti Electronics, Moseley Associates and TFT Inc., major manufacturers of 950 MHz aural STL gear.

## Compliance

For gear that didn't comply, manufacturers generally offered factory upgrades or rebates to buy new equipment. But for equipment such as the older Moseley PCL-505s, a reliable STL that had a production run of three or four thousand, it is not cost-effective for the factory to retool for the upgrades without greatly increasing customer costs.

To fill that void, independent equipment

repair service J-Squared Technical Service, a company that services current and extinct broadcast equipment, stepped in. The company is now offering to upgrade the popular Moseley PCL-505. In September, J-Squared received FCC authorization to perform PCL-505 modifications.

"Moseley has brought a lot of 505s up to spec," said J-Squared President Jim Jones, a former Moseley employee who began J-Squared in 1986. "But there were a tremendous number of them built prior to the point where they (Moseley) could cost-effectively bring them into compliance. We're going back to the very first one they manufactured."

A 1992 client advisory memo from Moseley Associates stated that factory upgrades for PCL-505s made after 1984 would be performed without charge. Moseley offered an upgrade cost range for units made between 1978 and 1984, but charged \$2,990 to bring pre-1978 units into compliance with FCC specifications.

"We will modify them," Moseley Executive Vice President Jamal Hamdani said. "It's just that it gets so cost prohibitive to modify units made before a certain time."

Hamdani said that stations may want to consider a new STL transmitter, which offers better performance, instead of spending money on refurbishing an old one. "At a certain point, you ask is it worth investing any more money in it or not."

For those who believe the PCL 505 is worth investing in, J-Squared will upgrade any unit for a flat fee (\$1,170) even the pre-1978s, according to Jones.

"These units have problems with fre-

quency stability and with spurious and harmonic radiation," Jones said.

His modification "includes a new power amplifier module and the whole frequency control part of the unit. We replace their AFC circuit, their high frequency divider and their AFC-out-of-lock modules with a synthesizer," he said.

Being so early in the process of getting STLs "type notified," the number of units that will be brought into compliance by Jones or by Moseley's factory is anybody's guess. "We expect to get a number of them," Jones said. Initially, he ordered circuit boards and components to perform 50 modifications.

## Frequency factors

"However, the FCC allowed broadcasters to use unapproved equipment for backup, so a lot of broadcasters kept their older stuff and bought new STL systems to meet the requirement," Jones said.

Because the modification incorporates a phase locked-loop synthesizer, the STL transmitter becomes frequency-agile, but the receiver remains frequency fixed.

While STL receivers are not included under the FCC rules and therefore require no modification, Jones recommends that stations get them tuned while having transmitter modifications performed. "We peak them up and replace an electrolytic capacitor," Jones said. "It doesn't cost but a bit more in freight. The same amount of time is basically involved whether we go through one piece of equipment or two, and if there's a problem, we can take care of it. Then, they'll be set for five years or so," he said.

□ □ □

Bob Kirby is a former radio general manager and news director and is a freelance technical writer in Kansas City. He can be reached at 816-941-4356.

# WHEN QUALITY COUNTS



## The DSM100 is the solution to economic permanent or temporary audio broadcast & studio links - worldwide.

Whether it's a full bandwidth live stereo concert broadcast from the other side of the world, or a voiceover between regional studios, the DSM100 Digital Audio Transceiver handles both with ease and economy. Incorporating acclaimed apt-X compression, the DSM100 utilizes the international digital telephone network to deliver unparalleled audio quality. For further details of the DSM100 with I-MUX and Timecode options, together with the new PRO-LINK Terminal Adapter - call APT.

**Audio Processing Technology**  
Edgewater Road  
Belfast BT3 9JQ  
Northern Ireland  
Tel 0232 371110  
Fax 0232 371137



**Audio Processing Technology**  
APT

**Audio Processing Technology**  
6255 Sunset Boulevard  
Suite 1026  
Los Angeles  
CA 90028 USA  
Tel 213 463 2963  
Fax 213 463 6568

apt-X and apt-X are registered trademarks of APT

## FM-Frequency Marketing

► continued from page 27

frequency points. They can also kick in money for cash prizes or bonuses that exceed the contribution level of a single participant.

One of the simplest ways to reward a customer who builds points by patronizing the businesses in your frequency promotion cooperative is to create gift checks or certificates that are honored by all the participating merchants. That way the customer can redeem his reward wherever it pleases him most.

Natural, ready-made cooperatives, to which you could market a frequency promotion, include existing merchant associations, malls and shopping centers.

### Do it yourself

Setting up the various advertising packages and promotions might be quite enough work for your staff, without tasking them with creating the entire frequency promotion, including participant ID cards, point-of-purchase promotional materials, coupons, bonus checks, redemption tracking and so on.

If this all sounds like more than you want to bite into, the folks at Gold Media Group (GMG) would be happy to help you.

I had a talk with Gold Media Group's Mark Jabara, and I found that GMG can not only help you create and manage any of the simple frequency promotions I mentioned above, but they have actually developed a magnetic ID card and reader technology that can collect valuable

information as a byproduct of a frequency promotion.

The simple scanning device, which does not interface with bar code scanners or a store's cash register system, gathers enough information from each participant's purchases that GMG can generate individual customer profiles, buying patterns and gross dollars spent (for conversion into frequent buyer points), as well as top-10 percent-of-customers lists for each participating merchant. They can also build and maintain a participating customer database, which can then be used for targeted direct mail promotions.

If you would like complete information on this kind of promotion, you might give Mark a call at 316-683-5454, or fax him at 316-683-5545. Gold Media Group is located in Wichita, but they work with stations across the country.

Just think of all the things your station does to increase its listenership, and all the contests and promotions you run to keep listeners tuned in longer. They are all forms of frequency marketing. Now you can offer this profit-building concept to your advertisers, in a way that builds both their appreciation of your station and your advertising revenue.

That idea should be right on frequency for your SM and GM.

□ □ □

John Cummuta is an independent Marketing and Management consultant, and the author of the Sales Machine PC database marketing software. He can be reached at 708-658-9107.



# BBC Renovates 40-Year-Old London Studios

by **Tim Frost**

**LONDON** The basement of the British Broadcasting Corp.'s (BBC) Broadcasting House in central London houses the majority of the organization's larger "talk" studios.

Constructed in the 1950s, these studios—the key to the organization's substantial news, arts and drama output—have been served by a single air-conditioning unit. The imminent prospect of this elderly and overworked unit failing, with no back-up available, spurred BBC's planning departments to look for a complete replacement of the system throughout the complex.

Since removal of the existing air-conditioning system meant the near total destruction of the upper half of each studio, it was deemed just as cost-effective to pull all the equipment out and start again fresh. In a building project that started in August last year, the studio complex has been stripped down to the fabric of the walls and the studios completely rebuilt.

## Two stages

The project was split into two stages, with one half of the studios being left operational so that broadcasting can continue while the first phase studios were being worked on.

In the first stage, due to be completed this October, studios B12, B13 and B14 were completely rebuilt, and studios B15 and B16 were refurbished. With this first stage completed and all the studios operational, work will commence on the second set of studios, B6-B9 and H9.

The three studios have been fitted with new Neve type 66 mixers. A decade ago it would have been the policy for studio rebuilds to replace nearly all equipment. But in continuing moves to stay within increasingly tighter financial restraints, hardware such as tape machines with substantial operational life left in them, have been refurbished rather than replaced.

One of the key features of the three larger studios is the introduction of a new treatment to deal with control room acoustics. Instead of going the traditional route of using sound absorbent material throughout to damp down the reflections, it was decided to use a new design developed in-house by the BBC's research and development team in Kingswood Warren.

This keeps the majority of the wall surfaces reflective and then angles the wall areas around the studio monitors area to control the acoustic reflections, dispersing them away from the engineers sitting at the control desks.

"The idea is that we don't absorb the reflections but place them away from the operator," Project Manager Nick Jennings said. "This has given us two benefits. First is a better stereo image, (while) we get away from the stereo 'hot spot.' Just as important, the new design makes the room less dead and oppressive to work in."

BBC's research and development team has worked with these ideas for some time and introduced some of them in the BBC's Maida Vale music studio when it was refurbished in the 1980s.

## Controlled image design

Since, the system has been refined with the aid of computer modeling monitor techniques into the "controlled image design" (CID) that has been used in these

three new Broadcasting House studios.

Unlike Maida Vale, which is more like a traditional music recording studio with the monitors set into the wall itself, the CID design was created to control the acoustics in a room where the monitors are free standing. The BBC uses its own free-standing LS5a monitors throughout the complex.

With CID, the rear wall of the studio is covered in absorbent material as would normally be used in a control room, but the ceiling, side and front walls behind the monitors are covered in a hard laminate with no sound absorbent characteristics.

To control the rear and side reflections

from the monitors, the wall surfaces are split into strips two feet wide, which are progressively angled, controlling and directing the reflections, and placing them away from the area where the operator sits.

The system does require a fixed position for the monitoring so that reflections can be correctly focused.

## Closely monitored

The design also is an aid to room layout flexibility, while maintaining a good overall sound, according to Jennings: "The design works equally well even if the speakers are not going to be placed symmetrically in the room."

As the studios become operational, the new acoustic treatment will be closely monitored by the BBC's development team. However, engineers working on commissioning the studios already seem happy with the more "normal" room acoustics it offers while maintaining accurate sound at the mixing position.

While there are no immediate plans to promote CID as a commercial design service, it seems that in the new "economically aware" structure of the BBC, that is by no means being ruled out.

□ □ □

*Tim Frost reports on radio from the U.K. for RW.*

cold cool

stale fresh

out

then now

in

**the unity 2000i**  
the world's best sounding fm processor

**CUTTING EDGE**

2101 SUPERIOR AVENUE, CLEVELAND, OHIO 44114 • TEL: (216) 241-3343 • FAX: (216) 241-4103

Circle (195) On Reader Service Card



# COMPETITIVE EDGE.



**Today's AMs** face too much competition for too few advertising dollars. That's why Orban's OPTIMOD-AM has become the weapon of choice for competitive broadcasters in every market.

**OPTIMOD-AM** produces maximum loudness, consistency and clarity on all types of AM radios, using every last watt of your authorized power to extend your listenable area and increase your billing opportunities.

**A powerful six-band limiter** and patented distortion-canceling multi-band peak controller deliver deep, tight lows and clean, transparent highs. You get the closest thing to FM sound, with maximum intelligibility in the essential voice frequencies.



## **Comprehensive controls and metering**

allow you to easily fine-tune your sound, keeping it distinct and aggressive in a changing marketplace.

## **Fully NRSC and EBU/CCIR compliant**

and with mono units easily field-upgradable to stereo, OPTIMOD-AM meets today's standards and protects your investment as you grow.

And Orban's superior customer service is there if you need it to provide world-class support for you and your in-house or contract engineering staff.

**Give your programming a chance** by making sure it gets heard. Call your Orban dealer today for an on-the-air evaluation, and put OPTIMOD-AM to work protecting your bottom line.

**orban**<sup>®</sup>

A Division of AKG Acoustics, Inc.  
1525 Alvarado Street, San Leandro, CA 94577 USA  
Tel: (1) 510/351-3500 Fax: (1) 510/351-0500

© 1993 AKG Acoustics, Inc.  
Orban and Optimod are registered trademarks of AKG Acoustics, Inc.  
AKG is a registered trademark of Akustische u. Kino-Geräte Ges.m.b.H., Austria.



# WORKBENCH

## Pack a Processor With Mertz Method

by John Bisset

**FALLS CHURCH, Va.** You probably saw Richard Mertz's column on the use of industrial computer/controllers in a broadcast setting to perform all the interlock and control functions for transmitter/dummy load transferring (*RW*, Sept. 8).

What Richard didn't show you was the unique way he packaged his controller. Using two Mid Atlantic rack drawers,

Richard's packaging has uniquely easy access to the components. We've all had to lay on our backs, or squeeze into a rack to reach a barrier strip terminal. Richard's solution is to simply slide the drawer out to work on the circuit. When you are done, slide the drawer shut. A locking tab insures the drawer will stay shut.

I've seen other engineers use similar rack drawers to store the transmitter log, jock's headphones and VCR logger tapes, but Richard's "works in a drawer" solves a lot of problems. Hand it to Mid Atlantic. These folks listen to their customers and keep unveiling useful products like the rack drawer. For more information, circle **Reader Service 74**.

★ ★ ★

Frank Konwinski is the chief engineer at WSOY-AM-FM Decatur, Ill., which, if you hadn't guessed, is in the heart of soybean country. Frank writes that he

solved the problem of replacing the burned out meter lamp on the station's Audiotronics model 212 console by substituting an "under-the-counter" kitchen fluorescent fixture.

Frank experienced the same frustration

trying to replace the bulbs that back light the VU meters, and after measuring the distance across the back of the meters, determined that an 18-inch kitchen fixture was ideal. He removed the backs from the VU meter covers and attached the lamp on the back panel. The meters are translucent (once the plastic backs are off), so the result is even, uniform back lit meters.

Frank disconnected the ballast and located that outside the console, about four feet away, to keep the AC hum out. The wiring from the ballast to the fixture was contained in shielded cable, and Frank made sure to avoid routing the wire near any audio cables. The fluorescent fixture does not generate heat.

After satisfactory results on the Audiotronics console, Frank made the same modification on his Arrakis 12,000 series console. The Arrakis board had no meter lighting at all and required a 36-inch tube to back light all the meters.

Frank Konwinski can be reached at WSOY, 217-877-5371.

★ ★ ★

If you're looking for some different ways to mount mikes, look into Accetera,

a Pittsburgh company that manufactures a variety of clamping systems and flexible mic extensions.

One of their most interesting inventions is a rubberized extender with molded male and female XLR connectors on the ends that won't creak when moved. The rubberized cover eliminates glare.

I installed several of these in a talk/interview studio with good results. Talk show guests always want to adjust their mikes. With this product, the creaking is gone.

For more information, circle **Reader Service 41**.

★ ★ ★

The new version of the NAB Test CD 2 is now available. Both Test CD 1 and 2 contain a wide variety of test frequencies and patterns for the broadcast engineer and are available from NAB Station Services in Washington. For more information, circle **Reader Service 166**.

□ □ □

*John Bisset is a principal with the contract engineering group Multiphase Consulting. He can be reached at 703-764-0751. Submissions to Workbench can be sent to his attention, in care of RW, or faxed to 703-998-2966. Published submissions qualify for recertification credit for all SBE certification levels.*

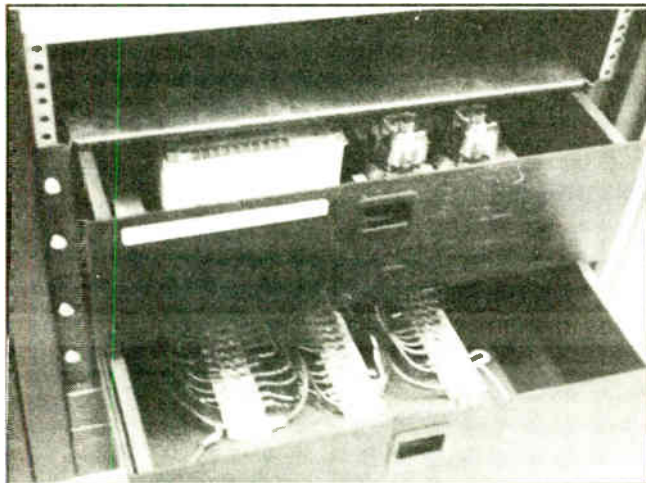

Sold as "storage drawers," these Mid Atlantic sliding rack drawers keep projects neat, without compromising access.

the controller and associated relays are mounted for easy access (see photo). Below the controller is a writing drawer that contains all the interface wiring to the transfer switch, the transmitter and remote control.

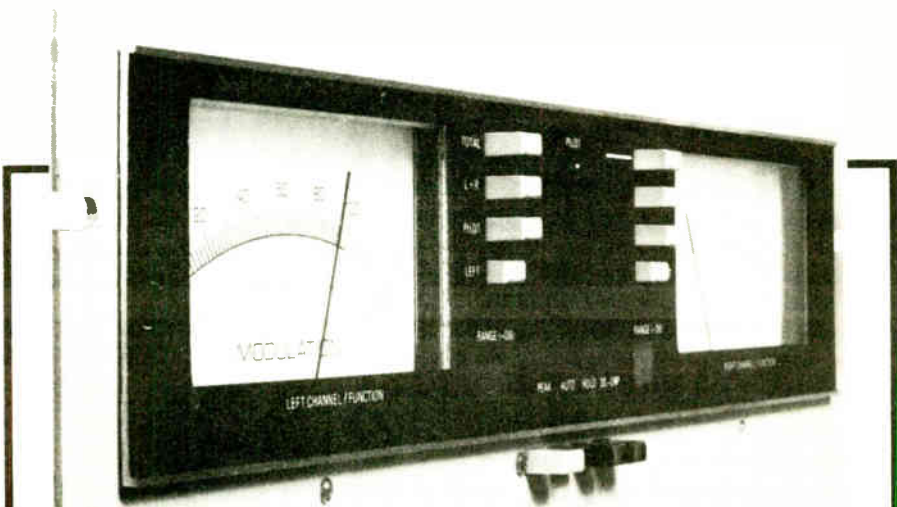

You can measure...  
with the best monitor and the most accurate test set.

The FMM-2/FMS-2 series monitors provide an even greater degree of precision measurement than ever before... You can measure S/N below 90 dB, You can measure crosstalk below 85 dB, You can measure separations of better than 70 dB, You can measure frequency response to better than 0.25 dB, You can measure distortions to lower than 0.01%, and much more... Our uncluttered panels and autoranging voltmeters make these measurements a dream.

**BELAR ELECTRONICS LABORATORY, INC.**  
LANCASTER AVENUE AT DORSET, DEVON, PENNSYLVANIA 19333  
Call or write for more information on Belar AM, FM, Stereo, SCA and TV monitors.

(215)687-5550

Circle (36) On Reader Service Card

## CCA Broadcast Transmitters

The Standard for Reliability Throughout the World.

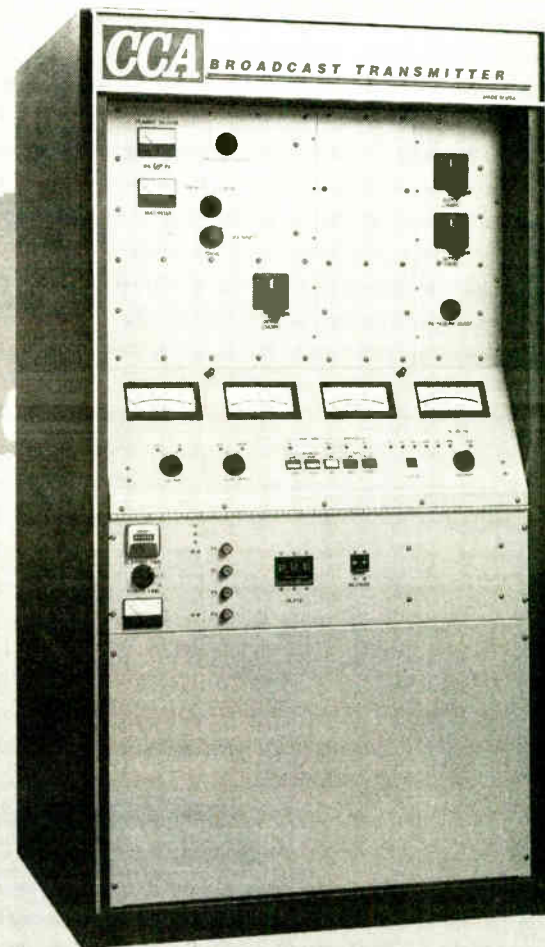

Available FM Transmitters:

- 2.5 KW 20 KW
- 4 KW 25 KW
- 5 KW 27.5 KW
- 8 KW 35 KW
- 10 KW 45 KW
- 12 KW



**CCA Electronics, Inc.**

P.O. Box 426 • 360 Bohannon Road  
Fairburn, Georgia USA 30213  
(404) 964-3530 • FAX: (404) 964-2222

# CCA

Circle (80) On Reader Service Card



## FEED LINE

# Finishing Your AM Stereo Conversion

by W.C. Alexander

**DALLAS** Previous columns outlined the initial steps to converting AM stations from mono to C-QUAM stereo, as the commission nears completion of a new standard (RW, June 9 and Aug. 11). A few final steps are needed to complete the installation.

All C-QUAM compatible exciters have some sort of RF drive output that contains a phase-modulated carrier. Some exciters offer two outputs—one at TTL level for driving late model transmitters and one with a variable level to drive just about any transmitter. You will have to determine which is needed to drive your particular transmitter, and this is best done before you order the exciter.

## RF interfacing

Newer transmitters readily accept TTL-level external RF drive. Many of these provide a BNC jack to accept the external drive, and provide some sort of switching between the internal oscillator and external drive. If your transmitter is so equipped, your job is easy when it comes to connecting the external drive.

Older transmitters use a crystal oscillator and one or more buffer stages preceding the actual RF driver or IPA stage. Pick the point farthest downstream in the transmitter where the AM stereo exciter can still provide RF drive.

(You may have to experiment a bit, and by all means, contact both the exciter and transmitter manufacturers. They more than likely have a file containing all kinds of information on modifying your particular model of transmitter for AM stereo.)

If no switch is provided, you will want to install an SPDT toggle switch that allows you to select between the internal oscillator and external RF drive. Sometimes you will need to run the transmitter on its own oscillator for testing and maintenance. The AM stereo exciter may occasionally need service, and having such a switch readily available will make bypassing it a snap.

I have found that the internal oscillator in some transmitters will couple or crosstalk into the external RF drive, causing a pulsing beat and all kinds of stereo performance problems. This is sometimes because of high oscillator output level, and sometimes it is simply due to the way the wiring is dressed in the transmitter.

It may be necessary to use a double pole (DPDT) switch rather than a single pole switch, using the second set of contacts to stop the internal oscillator from operating at all. This is easily accomplished by removing power to the oscillator circuit or opening the grid or base circuit to the crystal.

Finally, be careful to properly terminate

the external RF drive from the AM stereo exciter. Most exciters are designed to be terminated into a 50 ohm non-reactive load. Improper termination will cause poor stereo performance.

If the transmitter itself does not provide a 50 ohm termination, install one yourself. If the exciter output is DC coupled, you can insert a 0.1 uF capacitor in series with the external drive line followed by a 50 ohm carbon resistor to ground and another 0.1 uF capacitor in series feeding the transmitter circuits.

Pay attention to the power rating of the resistor, using  $E^2$  over  $R$  to find the needed value. Remember, for sine wave RF drive, use the RMS value of the drive voltage, and for square wave (TTL) drive, use the peak value.

Audio connections for AM stereo are fairly straightforward. Connect the left

and right from the matrix processor to the input of the exciter, being careful to connect them in phase. Then connect the L+R output of the exciter to the audio input of the transmitter. It is important to get the phase of this signal correct as well.

Use a good, 100 percent shielded audio cable for all audio connections, particularly the L+R feed to the transmitter. If there is RF pickup on the cable, you will have serious stereo performance problems. I would also suggest that you connect the shield at one end only to prevent any ground loops.

## Equalization

One important requisite for AM stereo broadcasting is that the L+R and L-R arrive at the transmitter's modulator at the same time. If they arrive at different times, the left and right channels will not be recovered properly in the receiver. Both amplitude and phase matching are used to accomplish this.

continued on page 46 ▶

## ROOTS OF RADIO

# ASCAP Dispute Sparked 70-Year Association's Birth

by James T. Wold

**MINNEAPOLIS** The National Association of Broadcasters was only a few months old when it held its first annual convention in New York 70 years ago this month—October 1923.

The meeting was held in conjunction with an already established "National Radio Show." It was a humble beginning for what has become an annual event, held every year since (except 1945), attracted several Presidents of the United States and other dignitaries.

In later years, other groups would seek to hold their meetings in conjunction with NAB, rather than the other way around.

Agenda items for the first show included prospects of federal government regulation of radio and ideas to deal with serious signal interference problems.

But the overriding concern—the one that sparked the birth of the NAB earlier that year—was the ASCAP problem.

## Dividing the rights

When radio was in its infancy, a key unanswered question was: How much should a station or network pay for the right to use copyrighted music? A great amount of music was aired, live and recorded, network and local.

Even before radio became a strong national medium, music composers and publishers could not keep track of all the new ways their copyrighted works were being performed. In 1914, they formed a nonprofit organization, the American Society of Composers, Authors and Publishers (ASCAP), to keep track of such performances for them.

As early as fall 1922, ASCAP was demanding payments for radio performances of musical works in its catalog. A small group of discontented broadcasters met in a grim, gloomy courtroom in Chicago's Federal Building a

few months later to discuss the ASCAP demands.

Those known to have been present at that first meeting included: Thorne Donnelly and Elliot Jenkins of WDAP (now WGN) Chicago; Dr. Frank Elliot of the Palmer School of Chiropractic, which operated WOC Davenport, Iowa; William Hedges, manager of "Chicago Daily News" station WMAQ; Powel Crosley of the Crosley Manufacturing Co., and Eugene F. McDonald Jr., of the Chicago Radio Laboratories (later renamed Zenith Electronics), which operated WJAZ Chicago.

One of the key outgrowths of the meeting was the decision to form an association to look after broadcasters' interests in copyright disputes. The subsequent organizational meeting of the NAB was held on April 25-26, 1923, at the Drake Hotel, Chicago.

Fifty-four people attended the meeting, many of whom were not directly connected with radio stations, such as radio trade press and radio equipment manufacturing company representatives. McDonald was chosen as the first president and Paul B. Klugh was hired as NAB executive director. After a vote, the group elected to establish headquarters in New York.

NAB wasted no time in combating ASCAP. It quickly established a radio music bureau and hired a man to head it.

## A continuing struggle

By the mid-1930s, in spite of NAB's efforts, ASCAP's demands had become intolerable to many broadcasters. NAB found its opportunity to do something decisive about it in 1937, when the Justice Department opened an antitrust investigation of ASCAP, leaving the licensing association in an unusually vulnerable position.

NAB formed its own music licensing organization, Broadcast Music Inc.

continued on page 38 ▶

# TRUE BLUE FOR THE MORNING ZOO.



**Drive time is your busiest time, so make sure your spots, liners and music are on the car more stations count on.**

## audiopak

**BROADCAST CARTRIDGES**

P.O. Box 3100 • Winchester, VA 22601  
Tel: (800) 522-CART or (703) 667-8125  
Fax: (703) 667-6379

Circle (124) On Reader Service Card



## OFFBEAT RADIO

# Montgomery Station Promotes Itself to Top

by Dee McVicker

**MONTGOMERY, Ala.** In June, while most stations were pumping their Arbitron ratings up with concert tickets, T-shirts and other promotional giveaways, WLWI-FM sponsored a contest for a dream house worth over \$120,000. The promotion proved to be another example of what it takes for small-market stations to succeed.

WLWI-AM-FM, in the 140th-ranked, \$10.3-million Montgomery market, along with 18 other stations, consistently bill \$4 million annually.

"I travel a lot, and I've been in this business since '59 and it's so refreshing to see someone doing it right," said Dave Burns of Radio NetWorks, WLWI's promotion company.

The Colonial Broadcasting Co. stations have been in the business over 16 years, and at times have seen unprecedented growth with a country format on FM and oldies on AM.

## Growth through promotion

"What recession? We didn't have a recession here. We had some soft years where we didn't accomplish double digit growth, but we still had some respectable growth," said General Manager David Coppock. Even in the years when economic growth in Montgomery was flat, he said, the stations grew.

Coppock attributes this success to "advertising-sales promotions...By that I mean investing in various vendor-provided mediums, such as printed brochures and calendars. We turn around and take it to our advertisers in a packaged manner, sometimes including spot sales, sometimes not," Coppock said.

## WLWI-AM-FM consistently bills \$4 million in the 18-station, \$10.3-million Montgomery market.

WLWI-FM's dream house promotion employed this strategy and something new. "The house giveaway was an opportunity for us to get into database (marketing)," said Coppock.

A database of Montgomery residents was used to compile a mailing list for a promotional flier, which included advertising inserts by station advertisers, who underwrote the cost of the promotion.

The company's first venture into database marketing, said Coppock, "was actually a profit center unto itself."

Construction of the 1900-square-foot, three-bedroom home was funded by the builders, Lowder New Homes and its subcontractors, who were given promotional consideration by WLWI-FM. The local Montgomery newspaper also got involved,

providing entry forms for those residents that did not receive the promotional mailing.

Each entry form had a unique set of serial numbers, which, if called off by the station on the air, qualified the recipient for a key, potentially the key to the dream house, and \$92 (WLWI-FM's frequency). To claim the prize, listeners had to call WLWI-FM

within nine minutes and 20 seconds of on-air announcement of the number.

A lucky 23-year-old woman walked away with the grand prize in June, culminating three months of effective promotion that also made the advertisers happy. "It was a good promotion...a big campaign on-air that cost us virtually no cash," said Coppock.

## Leading edge

Promotional campaigns like this have helped buoy WLWI-FM to a consistent 20 share in the Montgomery market. WLWI(AM) also shows consistent ratings, attributed in part to its flagship coverage of Auburn University sports. Colonial invests in sports promotion with the same vigor.

"Last fall (Colonial's) station in Chattanooga purchased a substantial

amount of World Series tickets and we did a lot of promotion locally," Coppock said. "(We) were able to generate revenue in the month of October that we normally would not have had an opportunity to get and, at the same time, put a very hot item on the air. Those are the kinds of things we always have a lot of success with."

Advertising-sales promotion is not the final word on small-market success, according to Coppock. "I would say most of the things we do here on a day-to-day basis are large-market-oriented or leading-edge, and both of those don't necessarily mean the same thing. For instance, our physical plant here is reaching 100 percent digital," he said.

Larry Wilkins, the engineer responsible for the stations' digital facility, installed Arrakis Digilink automation earlier in the year and recently purchased a digital Moseley STL. He has also engineered such innovations as an elaborate IFB (Interrupted Fold Back) and a pneumatic antenna mast for WLWI's RPU truck, which goes out on roughly 20 to 25 remotes each month.

All of this, according to Coppock, adds up to hard-won success in a small market.

□ □ □

Dee McVicker is a freelance writer specializing in the industry. She regularly contributes to *RW* and can be reached at 602-545-7363.

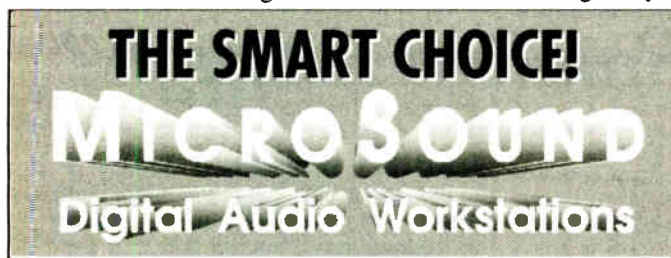

*With the smart choice for Radio, you can:*

- CUT** production time on spots, shows and promos
- USE 50 STEREO TRACKS** whenever you need them
- FAST** dialog editing for news
- DELIVER** superb quality digital mastered audio
- INCREASE** your creative freedom

*The features you would expect to find in higher-priced Digital Audio Workstations:*

- YES!** Play 50 segments at any location without bouncing
- YES!** Make instant non-destructive edits
- YES!** Easy to learn, full on-line context sensitive help
- YES!** Place independent stereo segments anywhere, in any order
- YES!** Archive multi-track projects to standard DAT
- YES!** True sonic transparency with -110db noise floor
- YES!** Automated effects sends
- YES!** Fully network capable, allowing file sharing
- YES!** Easily added to your 386/486, Windows 3.1 based system
- YES!** Affordable complete workstations start at \$7,695, peripherals at \$3,690

## The Ultimate in Digital Audio Workstations

*All the features you need . . .*



*. . . at a price you can afford.*

**MTU**

Micro Technology Unlimited

PO Box 21061, Raleigh, NC, USA 27619-1061

Quality digital audio since 1977

**(919) 870-0344**

**Fax: (919) 870-7163**



# PLC as Coax Switch Saves Air Time

by Richard Mertz

**WASHINGTON** If you missed last month's column, it was on the programmable logic controller (PLC), a box with a microcontroller, power supply and buffered inputs and outputs. Simply put, a box with smarts.

One practical application: use a PLC to control a coaxial switch.

I can already hear the groaning. Why would you need a microcomputer to monitor and control a coaxial switch that is only rotated for transmitter changes or for maintenance? You can do this with a toggle switch.

## RF considerations

Okay, you can, but it would not be automatic. Replace the toggle switch with a latching relay, and you can control the switch by remote control. The relay idea works, but are you sure that the transmitters' plates are off before the coaxial switch begins to move?

Remember the RF must be removed before the coaxial switch moves or the resulting arcing will damage the switch.

If the coaxial switch has been installed properly, the transmitter interlocks will be wired through the interlock contacts inside the coaxial switch. This method of turning off the RF relies on the interlock circuit to turn off the carrier. Any mistake in adjustment of the interlock contacts in the coaxial switch would cause RF to be present when the switch begins moving. When this happens, the coaxial switch can be damaged and you're off the air even longer.

Now imagine a nontechnically oriented transmitter operator trying to switch transmitters by remote control. That's right, the beeping noise you hear is your pager going off.

Before we continue, here are a few of my station design philosophies. First, the technical plant is the most important part of any station.

Backup systems must not only be in

place, but must function as quickly as possible. When you are off the air, even for a short time, you give your audience a reason to sample your competition.

Second, the transmitter or studio plant should be designed for the transmitter operator's ease of operation. Section 73.1860(d) of the FCC rules allows the station's licensee to have the transmitter duty operator perform other duties as long as those duties do not interfere with transmitter responsibilities.

The reality is that transmitter operators are usually disk jockeys. They are experts at producing on-air product, but on those occasions that require them to do something outside of their usual routine with the remote control, out comes the instruction book and a longer-than-desired stretch of time off the air.

That is why when I design and build a transmitter plant, I want something more than a toggle switch or latching relay controlling the major elements of the transmitter plant.

## Setting the switch

There are several elements in a completed coaxial switch controller. One push button to put the main transmitter on the air and another to put the auxiliary transmitter on the air. These push buttons' functions are duplicated by the remote control. Some of the newer remote controls have automatic control functions that automatically operate the controller.

The coaxial switch controller should facilitate interconnection of the interlock circuits from both transmitters, the dummy load, remote control and any antenna protection equipment. Finally, the transmitter must stay on the air when the PLC is turned off or if the power to the PLC's AC power is out.

The desired sequence of operation for the coaxial switch is fairly simple. Ask yourself how you would operate the system if you did it manually, step by step. Assume that the main transmitter is on the air or

## Going Back to NAB's Roots

► continued from page 36

(BMI), to compete with ASCAP. Competition, broadcasters hoped, would keep music fees low.

The BMI strategy was to license new artists willing to sell the rights to their music for lower prices. Stations would then play only BMI-licensed music and propel the new composers to fame, benefiting both composers and stations.

ASCAP fees were eventually forced down to meet broadcaster demands due to BMI competition. BMI would later break away and operate independently of NAB.

NAB began a new era in 1939, when it reorganized and hired its first paid president, Neville Miller. But at the same time, the NAB board made it clear that the copyright problem was to remain at the top of the group's agenda.

James T. Wold is a free-lance writer based in Minnesota. He is author of "Minnesota Microphones," published by Northstar Press. Wold can be reached at 1106 South Seventh St., Minneapolis, MN 55415.

has just failed.

The problem is that you are not sure whether RF is present. To make sure the RF is off, first push "PLATES OFF" on the transmitter that is connected to the antenna. If the auxiliary transmitter is being tested in the dummy load at the same time, also push "PLATES OFF" on that transmitter. I always push "PLATES OFF" on both transmitters just to be sure there is no RF in the coaxial switch.

Now rotate the switch into the next position. Make sure the contacts are seated properly and at the stop. Then push "PLATES ON" for the transmitter that is connected to the antenna and you are back on the air.

How long does this normally take? About ten to fifteen seconds? The PLC does all this with the on-air interruption as short as one or two seconds.

## Checklist

Given the sequence of events we want the PLC to perform, we need to list the various functions it will have to handle. Control functions, or inputs, for the PLC are:

1. Momentary closure, from either a local push button or the remote control to connect the main transmitter to the antenna.
2. Momentary closure, from either a local push button or the remote control to connect the auxiliary transmitter to the antenna.
3. Closure to indicate that the coaxial

switch has seated properly, connecting the main transmitter to the antenna (auxiliary transmitter connected to the dummy load).

4. Closure to indicate that the coaxial switch has seated properly, connecting the auxiliary transmitter to the antenna (main transmitter connected to the dummy load).

Controlled functions, or outputs, for the PLC are: 1. main transmitter, plates on; 2. main transmitter, plates off; 3. auxiliary transmitter, plates on; 4. auxiliary transmitter, plates off; 5. coaxial switch at position one; 6. coaxial switch at position two; 7. local indication and status closures for the remote control, showing the main transmitter is connected to the antenna, and 8. local indication and status closures for the remote control, showing the auxiliary transmitter is connected to the antenna.

Now that you have an idea what is expected of the PLC, the next column will layout the hardware, draw the schematic and begin preparation for bench testing of the software.

Remember, these PLC articles are merely an overview of possible applications and are not a step by step "how-to" project. The use of a PLC at a station must be carefully designed and programmed for a particular station's facilities. The detail required is beyond the scope of these articles.

□ □ □

Richard Mertz is former director of engineering for United Broadcasting and senior engineer at Jules Cohen & Associates, P.C. He can be reached at 1725 DeSales St., N.W., Suite 600, Washington, D.C. 20036.

## INSIGHT ON RULES

# What Is Random Enough?

by Harold Hallikainen

**SAN LUIS OBISPO, Calif.** Some have recently suggested to me that the FCC rule requiring a weekly EBS test is unclear. That section reads: "... these tests shall be conducted by all AM, FM and TV stations a minimum of once a week at random days and times between the hours of 8:30 a.m. local time and local sunset" (73.961(c)).

Does the "once a week" minimum indicate no more than seven days between tests? This would imply the test would tend to "drift" earlier and earlier in the calendar week. I have always assumed the requirement was that a test be run once each calendar week (Sunday through Saturday).

Frank Lucia of the FCC tells me the rule is indeed once each calendar week. FCC inspection records show that calendar weeks have been acceptable in the past.

I advise that station chief operators make a "station log review" form. This form could be the checklist for the required weekly chief operator review of station logs (see 73.1870(c)(3)). The form should have a space for the chief operator to write in the date and time of that week's EBS test transmission and reception.

This is an important part of the log review. Do not rely on your traffic person to get the EBS tests properly scheduled and your operators to get the tests properly logged. It is the chief operator's job.

Another EBS-related call dealt with the word "random" in the rule. How random is the test to be?

Some stations schedule the test to be bumped up an hour each week, rotating the test through the various hours and days. This hardly seems random.

But Frank Lucia says the important consideration is whether a cross-section of operators at the station have an opportunity to run the test. As such, it appears that stations using such a less-than-random EBS test scheduling method may not be cited for a violation.

My suggestion, however, is that stations go by the letter of the rule and make an attempt at randomness in scheduling EBS tests.

EBS test scheduling problems have come up at some stations because of computer traffic systems. Sponsors ordering spots to run once a week on a random basis between 8:30 a.m. and local sunset are rare. Many stations, therefore, end up scheduling the EBS test for the same day and time every week.

Some traffic systems do not allow for an open-ended contract. At some point the EBS contract expires and the EBS tests stop running. I have seen violation notices where the EBS test had "expired" months before an FCC inspection, and nobody noticed.

What to do? The chief operator could get a pile of sales contract forms, some dice (or other favorite method of generating random numbers) and make out a sales contract for each week of the year. Schedule the EBS test as a non-preemptible spot on the basis of your dice throws and hand the sales orders over to traffic.

□ □ □

Harold Hallikainen is president of Hallikainen and Friends, a manufacturer of transmitter control and telemetry systems. He also teaches electronics at Cuesta College, San Luis Obispo. He can be reached at 805-541-0200. He can also be reached on Internet at ap621@cleveland.freenet.edu.



**DO YOU KNOW YOUR MARKET?  
YOUR COMPETITION DOES!**

**DATAWORLD MAPS CAN**

- Depict your coverage!
- Market orient your sales people!
- Target your ethnic/demographic markets!
- Identify marginal signal areas!
- Plot any special requirements!

**MAP OPTIONS**

- SHADOWING (TERRAIN SHIELDING)
- CONTOUR COVERAGE
- POPULATION DENSITY
- ZIP CODE BOUNDARIES
- RECEIVED SIGNAL LEVEL
- SPECIAL REQUIREMENTS

**dataworld®**  
A Service of DW, Inc.

(301) 652-8822 (800) 368-5754

Circle (1) On Reader Service Card



OVER  
5 MINUTES  
OF 15KHZ STEREO AUDIO  
ON EACH 13MB FLOPPY DISC



# The Dynamax DCR1000 with New Version 2.0 Software

**THE OBVIOUS DIGITAL SOLUTION TO CART MACHINE PLUG-IN REPLACEMENT**

## The Recorder

- Selectable sampling rates
- Secondary and Tertiary cues
- AES/EBU digital input
- Start on audio
- Direct digital dubbing from CD
- PC keyboard for titling
- New • Cut & paste editing
- New • Variable length beds
- New • Kill date checking
- New • Disk label printing

## The Reproducer

- Simple cart-like operation
- No on-air personality training
- Just three front panel buttons
- Instant start and cue
- Maintenance-free design
- Awesome audio quality
- New • Rotation & chaining
- New • Replay lockout
- New • Count-up/count-down timer
- New • RS232 logging/remote control

## The Media

- 13MB stores over 5 minutes stereo audio with 15kHz bandwidth and 15 minutes mono with 10kHz
- Standard low-cost 2MB floppy disk holds 60-second commercials
- New • Non destructive media diagnostic test

*Equipment Solutions To Keep You Number One*

**BSW**<sup>®</sup>

BROADCAST SUPPLY WORLDWIDE

7012 27th Street West Tacoma, Washington 98466

Toll Free 800-426-8434

Toll Free Fax 800-231-7055

Circle (175) On Reader Service Card

World Radio History



# Radio World

## Broadcast Equipment Exchange

"Broadcast Equipment Exchange" accepts no responsibility for the condition of the equipment listed or for the specifics of transactions made between buyers and sellers.

### NEW! NEW! NEW!

We now buy & sell pre-owned video equipment!

### RADIO RESOURCES

1201 S. Sharp St.  
Baltimore, MD 21230  
**DO YOU HAVE EXCESS EQUIPMENT TO SELL?** Let us help you turn your excess equipment into CASH.  
**Some of our equipment needs are:**  
AM/FM TRANSMITTERS  
FIELD STRENGTH METERS  
MARTI VHF/UHF RPU EQUIPMENT  
MARTI STL EQUIPMENT  
OTARI MX 5050 REEL TO REEL  
DIGITAL SATELLITE EQUIPMENT  
CONSOLES  
ORBAN OPTIMODS

If there is a piece of pre-owned equipment you are looking for, give us a call, we can help!

### THE INDUSTRY'S BEST NEW & PRE-OWNED EQUIPMENT DEALER

Ask for Steve or Chuck for Radio Products or Bob or James for Video Products  
**Call 1-800-54-RADIO**  
The only # you need to know!  
**FAX: 1-410-783-4635**

Circle (10) On Reader Service Card

### ACOUSTICS

#### Want To Sell

**STUDIOFOAM**  
SOUND ABSORBENT WEDGES  
TESTS 18% BETTER THAN SONEX!  
COSTS LESS! BETTER COLORS!  
**1-800-95-WEDGE**

### AMPLIFIERS

#### Want To Sell

Rane HC-6 headphone amp in great cond, \$200. S Wytas, SWP, 165 Linden St, New Britain, CT 06051. 203-280-3913.

Ramko DA-16BR-E dist amp, \$150. J Vavricek, KSYZ, Grand Island, NE. 308-382-0108.

McMartin MX5 pro mixer pre-amp, bal/unbal, 2 mic, 2 phono, aux input w/rack ears, \$175. J Hayes, Radio Free New York, 1748 70th St, Brooklyn NY 11204. 718-234-9374.

LPB DA1 16 dist amp, new. J Gelo, J&H Music Programming, POB 1697, Marco Island FL 33937. 813-642-6899.

Dynaco ST120 factory built, gd cond, BO. R Robinson, 203-269-4465.

Harmon Kardon CA40 tube amp, 40 W, 4 low imp microphone inputs, quality unit, \$65; Magnecord 10 W tube monitor amp, been rebuilt, on rack panel, \$35; Altec preamp modules 1588A, B, C, 1578A, 1579A, \$20 to \$35/ea. E Davison, POB 7167, Springfield IL 62791. 212-787-0800.

New 250 W solid state amp, \$1800. Call for details. Bill Hoffman, 518-583-9490.

#### Want To Buy

### WANTED:

Pultec EQ's; Fairchild, Teletronix, dbx, UREI, Sontec Limiters. Neumann, Telefunken, AKG and RCA mics. MacIntosh or Marantz Gear; Lang, Neve and API gear. Misc old tubes and guitars.

### DAN ALEXANDER AUDIO

1340 Mission Street  
San Francisco, CA 94103  
(415) 252-7102  
FAX: (415) 252-7524

McMartin LT-80C, 108C, & MS105 amplifiers wanted working cond. E Davison, POB 7167, Springfield IL 62791. 212-787-0800.

### ANTENNAS & TOWERS

#### Want To Sell

Low power 6-bay HP FM antenna. K Diebel, KTJC, 1207 Louisa St, Rayville LA 71269. 318-728-5852.

200' 6" hard line lw loss 72 ohm for FM/TV w/hangers & elbows, BO. K Crosthwait, WTNN, 13206 Buttermill Rd, Knoxville TN 37932. 615-531-2297.

TOWERS... bought and sold. Call 1-800-393-2266.

Andrews 1861 3-1/8"-1-5/8" reducer & (2) 81GF 3-1/8" EIA female connectors w/gas barrier; Cablewave 1-5/8" air-dielectric coax, 160' with EIA connector one end. C Frodsham, KVSF, POB 7, Beloit KS 67420. 913-738-2206.

PLFM-100 obsolete exciter upgrade ... \$229.95  
CSG-10 stereo generator w/comp clipper ... \$349.95  
BIA-1 optimod balanced interface ... \$249.95  
\*FMT-15 15W FM xmtr ... \$1,495  
\*FMT-15S stereo FMT-15 xmtr ... \$1,895  
\*RTU-1 remote controlled tuner ... \$495

### JT Communications

904-236-0744 fax 904-236-5130

#### Circle (73) On Reader Service Card

Andrew 1/2" Hellax, 650', brand new, \$1.75/ft/BO, will sell shorter lengths. R McDaniel, KJRG, Box 567, Newton KS 67114. 316-283-5150.

Andrew 500' 5" air dielectric Heliac w/connectors, BO. J Kosobucki, Saga Comm, 1416 Locust, Des Moines IA 50313. 515-280-1350.

Decibel Products DB-224 antenna for Marti RPU system; Andrews 3' transmission line, 56', new; Cablewave 1-5/8" transmission line, 20', new; Cablewave 1/2" transmission line, 50', 100', 250', used. FB Nienow, WYTE, POB 1030, Stevens Point WI 54481. 715-341-8838.

ERI 1991 2-bay, tuned to 103.7, excel cond, BO. D Thornhill, WHHT, POB 457, Glasgow KY 42142. 502-651-6060.

### FM - ANTENNAS

Designed and built for your frequency. Choose from 1 to 12 bays and five power levels. Financing available. Call Jimmie Joynt at S.W.R. 214-335-3425

Mark 4' 950 MHz STL dishes (2) with 1/2" runs foam core coax, 2 runs of 200'+, currently on tower, free for the taking, insured tower climber only. P Urso, WWRX, 75 Oxford St, Providence RI 02905. 401-781-9979.

ERI 4-bay hi-powered, tuned to 103.7 FM with 350' 3" Heliac, good condition, currently on tower, \$8000 + you remove, insured climber only. P Urso, WWRX, 75 Oxford St, Providence RI 02905. 401-781-9979.

400' of 4" coax pressurized on spool, several various size lengths of 3" coax, new, perfect for repairs, assorted 3" & 1 5/8 connectors. K Looney or B Vance, 409-564-4444.

ERI 10 bay CP antenna on 93.3 MHz, \$6500. E Moody, KESE, 216 N Main, Bentonville AR 72712. 501-273-9039.

Jampro JMPC-10, 1 yr old on 107.1 MHz, 10 bay circular antenna. B Zellmer, KSIR, Box 2475, Greeley CO 80632. 303-353-6522.

Andrew 190' 1-5/8" coax foam dielectric, \$150/BO. J Morris, WFHB, POB 1973, Bloomington IN 47402. 812-824-4085.

Phelps-Dodge 2 bay tuned 90.5 & mounting hwr. J Waugh, WHVT, POB 273, Clyde OH 43410. 419-547-8254.

#### Want To Buy

6 bay around 92.1 MHz. J Hansen, WYRQ, 70SE 1st Ave, Little Falls MN 56345.

Phase monitor, 5 tower or more. George, WNQM, 1300 WWCR Ave, Nashville TN 37218. 615-255-1300/1377.

Low or medium power 3-bay CP FM antenna that operates on or near 99.5 MHz; also a low or medium powered 6-bay CP FM antenna on or near 92.3 MHz. K Diebel, KTJC, 1207 Louisa St, Rayville LA 71269. 318-728-5852.

Tower phase monitors, 5 or more needed; 5 or 10 kW dummy load, AM needed. George, WNQM, 1300 WWCR Ave, Nashville TN 37218. 615-255-1377/1300.

Four bay on or near 98.3 & 350' 3" coax for C-2 upgrade; also (3) 200' AM towers, etc for 50 kW DA-1 project. B Zellmer, KSIR, Box 2475, Greeley CO 80632. 303-353-6522.

2-3 bay CP antenna, tunable to 100.1 MHz, minimum 6 kW ERP. D Carver, 107 S Main, Brookfield MO 64628. 818-258-7458.

### AUDIO PRODUCTION

#### Want To Sell

ADC 48 patchbay phone jack. D Nelson, 619-758-0888.

## ITC

### REPAIR — REFURBISHMENT

Direct Factory Cartridge Machine Repair Service  
Upgrades or Refurbishment  
All Work Warranted

Call The ITC Technical Service Department  
Toll-Free at



(800) 447-0414  
(309) 828-1381



International Tapetronics Corporation  
2425 South Main Street  
Bloomington, IL 61704

Digital Music MX-28S pwrd MIDI patch bay, 2 in 8 out, mint, \$60. J Hayes, Radio Free NY, 1748 70th St, Brooklyn NY 11204. 718-234-9374.

ADC 144 point TT bay wired to 50 pin Telcos, \$75/BO. S Wytas, SWP, 165 Linden St, New Britain, CT 06051. 203-280-3913.

### CASSETTES • CARTS • REELS

#### J & I AUDIO/VIDEO

A wholesaler in the Radio and Television market.  
Now running SPECIALS on audio and video:

**BASF CASSETTES-AMPEX R-Ra AUDIOPAK, FIDELIPAC & ITC CARTS**

For more information call Kris Elliot at 1-800-942-1711

or write to: J&I Audio/Video 20899 Kelvin Pl. Woodland Hills, CA 91367

#### Circle (66) On Reader Service Card

Yamaha DEQ-7 digital EQ, stereo, BO; Moog 902 VCA module w/PS, BO. R Robinson, 203-269-4465.

Shure SE-30 comp mixers (2), (4) mic/line inputs, vg, \$150/ea or \$250/both or BO. B Strapko, Strapko Resources, 40 Fillmore Ln, Streamwood IL 60107. 708-830-0701.

Eddor AM 400 4-chnl automatic mixer, \$125. G Wachter, KFYI, 602-258-6161.

Burwen 7000A transient noise eliminator, rk mt, EC, \$275. S Hofmann, Sounds Impossible, 7109 NW Birch Pl, Lawton OK 73505. 405-536-0559.

Kurzweil Midboard & modules incl fullsize keyboard & 2 digital sound modules, 1000PX plus & 1000 Hx, will sell individ or as set, \$2800. M Osborne, WKSQ, POB 9494, Ellsworth ME 04605. 207-667-7573.

ADC 144 Pt TT patchbays, excellent condition, 1 rack space, 3 rows of 48, top 2 rows normalled, \$129 (you remove old wiring) or \$199, we totally refurbish with new front panel, ready to install. TT cords at cost with purchase! Also 1/4" PB's. Audio Village, POB 2902, Palm Springs CA 92262. 619-320-0728, or Fax 619-320-2454.

Burwen DNF-1201 dynamic noise suppressor for phono rcds, clean, \$50; Technics SH9010 5 band parametric EQ rack mntg, like new, \$275; Daven (2) 500/500 ladder atten with cue on panel w/ADC 1-1 xmtr, \$50; Surround sound processor, Shure HTS5000 Home Theatre, like new, \$100; Stereo EQs 5 & 6 band unbal RCA conn clean, \$35. E Davison, POB 7167, Springfield IL 62791. 212-787-0800.

## Mackie 1202 Micro Series

### AUDIO CONSOLE

- 90 dB S/N ratio
- 0.25% distortion
- Gain Control
- Pan & EQ on each pot
- Balanced and Unbalanced outputs
- Built-in power supply
- Built-in headphone amplifier
- 8 inputs Mic/line/mono/stereo

LIST \$399

Call for special HE Price.

We'll be glad to help with all your audio needs!

(804) 974-6466 • FAX: (804) 974-6450  
1305-F Seminole Trail  
Charlottesville, VA 22901



### OEM Tapeheads



For most cart machines:  
Stereo \$99  
Mono \$75

### Quality Rebuilt Used Equipment



90 Day Warranty  
Parts & Labor Manuals included  
Call for Current In-Stock Items

### Marantz PMD Packages



Pitch Control  
MONO-Record/Play  
Telephone Jack  
Built-in Mic and Speaker  
PMD 201, Free AKG Mic and Cable \$299

Call for special Price!

Circle (219) On Reader Service Card



**AUDIO PRODUCTION...WTS**

Smartcaster, computer, digital audio: live or automated. D Nelson, 619-758-0888.

UREI 537 27 ban graphic EQ's (3), \$200 ea; Eventide BD 955 bcd delay, 6.4 sec, 15 kHz, \$1000. C Scherer, WDOK, One radio Ln, Cleveland OH 44114. 216-696-0123.

ADC Paragrophic EQ like new, very versatile, \$250; BiAmp graphic EQ, balanced or unbalanced, I/O, \$100. Richard, 713-859-0531.

**Want To Buy**

Record cutting machines, tube amps, SME-3012 & other 16" arms, Firchild 602/670 limiters, ornate mics. Kim, 612-866-6183.

Digidesign Session 8 from someone wanting to upgrade. M Eaton, KAIM, 3555 Harding Ave, Honolulu HI 96816. 808-735-2424.

**Radio World**  
Your Ad Will Reach  
Over 22,000 Subscribers  
Advertise now!  
Call Simone at  
**1-800-336-3045**  
Call Today!

**MERCENARY AUDIO**

**WANTS TO BUY YOUR:**

NEVE-SSL-TRIDENT-AMEK  
UREI-TELETRONIX-FAIRCHILD  
PULTEC-LANG-LEXICON  
UNIVERSAL AUDIO-NEUMANN  
AKG-TELEFUNKEN-AMS

**ANYTHING THAT IS OF EXCEPTIONAL AUDIO QUALITY!**

"this is not a problem"  
**(508)543-0069 TEL**  
**(508)543-9670 FAX**

Fairchild 600 conac or 602 Conac high freq limiters. J Gangwer, 942 32nd St, Richmond CA 94804. 415-644-2363.

**AUTOMATION EQUIP**

**Want To Sell**

Shaffer 901 nds wk, w/all pts, \$1400. S McGrath, WGNV, 429 Little B Rd, Newburgh NY 12550. 914-551-2131.

Sentry Systems Format Sentry to sell or trade, has cntrlr, (2) 48-slot Instacarts, (3) R-R's, BO. R Carr, KXLE, 1311 Vantage Hwy, Ellens-burg WA 98926. 509-925-1488.

SMC automation complete with MSP-12 sat controller, DAS-12 audio switcher, (3) 452 Carousels, 350 Carousel, (2) video monitor & complete set of cabinets, excellent cond, still in operation, \$9995/firm. K Austin, KFXI, 1101 Hwy 81 N, Marlow OK 73055. 405-658-9292.

SMC 350 stereo Carousels (6), 3 in each rack, good condition, sell one or all, \$400 each or each rack, \$1000. P Swint, KIXQ, 2620 Dogwood Rd, Joplin MO 64804. 417-624-1310.

Stereo 350 Carousels (4), random access; (4) equipment racks, like new, 74" high & one 66" high; 10 assorted rack panels. FB Nienow, WYTE, POB 1030, Stevens Point WI 54481. 715-341-8838.

IGM RAM stereo automn cntrlr w/4096 events of memory, clock, silent sense, 9 audio inputs, 4 random access Carousel cds, manuals. FB Nienow, WYTE, POB 1030, Stevens Point WI 54481. 715-341-8838.

ABC Radio Networks tone decoders (2), 2 digit LED readout w/reset button, \$100 ea. C Scherer, WDOK, One Radio Ln, Cleveland OH 44114. 216-696-0123.

Sonomag MiniPro w/rem hd, 2 Carousels, RS-350, 4 Revox PR-99, RSC-100 Carousel programmer, new in late '82, \$3500. S King, KGFL/KHPQ, Box 33, Clinton AR 72031. 501-745-4474.

SMC DP-1, (3) 350 stereo Carousels, (2) dbl play cart decks, DP-1 Brain w/remote keyboard, (4) tone sensors, (6) ITC R-R PB, BO. M Casey, WKXS, Drawer I, Johnston SC 29832. 803-275-4444.

IGM Instacarts (3) in gd cond, (2) stereo, \$2500/ea or BO; 1 mono, \$1000/BO; BE stereo triple stack, \$900/BO; BE Econo sat automation w/encoder & interface, \$2000/BO; total system \$4950/BO. S Phillips, KMTX, 516 Fuller Avenue, Helena MT 59601. 406-442-0400.

Harris 9002, (5) ITC 750/720 PB's, 48 tray mono Instacart, 3 cart deck PB's, 2 VOT's, manuals & schematics, in case. J David, KMPL, POB 907, Sikeston MO 63801. 314-471-1520.

Cetec 7000 automation system, \$1000, Carousels 250, \$300 ea, Audiophiles (4), \$600, Carousels 350, \$400 ea. E Moody, KESE, 216 N Main, Bentonville AR 72712. 501-273-9039.

SMC MSP-12 3 rack unit, 3 random Carousels, 4 R-R ARS-1000, BO/will sell components separately. R Ness, WCSJ/WCFL, 1802 N Division Ste 403, Morris IL 60450. 815-942-0022.

Systemation X7-D automation syst w/16 inputs & 7 day memory, (4) Systemation cassette interface, 5 clone cassette interface, 8 Nakamichi MR-1 cassette decks, Systemation Main CR interface, Commo-dore SX-64 computer w/ Systemation firmware, color mon & internal 300 baud modem, (2) Commodore C-64 computers w/pwr splys, (2) monochrome monitors & (2) deck cntrl cards to increase capacity to 32 inputs, all equip wrkg, \$3500 FOB. L Barry, Manitowoc WI, 414-683-6800.

**BUSINESS OPPORTUNITIES**

**Want To Sell**

Two top quality music formats ready for partnership or sell outright, potential unlimited. J Gelo, J&H Music Programming, POB 1697, Marco Island FL 33937. 813-642-6899.

**CART MACHINES**

**Want To Sell**

Spotmaster D100 cart Fault/splice detector w/manual, reconditioned, very little use, \$140. 619-457-3535.

ITC PD2 (2) mono PB, excel w/manual & 50 carts, \$250. J Hayes, Radio Free New York, 1748 70th St, Brooklyn NY 11204. 718-234-9374.

ITC single play stereo cart decks (2); ITC R/P stereo cart deck, \$375 ea. J Vavricek, KSYZ, Grand Island NE. 308-382-0108.

**CART MACHINES:**

ITC, Fidelipac, BE  
For Sale: \$395 & UP  
Repairs: \$100 per deck + parts  
Recondition: \$150 per deck + parts. Call Mark @ 619-598-3311

Telex 36 cart deck, 4 trk head mono, w/auto trk switcher, rack mntg, brand new in box, \$100. E Davison, POB 7167, Springfield IL 62791. 212-787-0800.

Ampro CT2507 audio cart players, mono, cue tones, fast fwd, BO. Dave, Allmake Prod, 6130 S Dahmel Rd, Frankenmuth MI 48734. 517-652-6863, leave message.

Great Prices on original equipment tape heads for ITC, BE, Fidelipac, Otari, Tascam & others!



(804) 974 6466 • FAX 6450

Fidelipac Dynamax CTR12 PB (3), CTR14 R/PB, rack shelves (2), excel cond, \$4000 for set. Stu, First Take Recording, 301-963-7758.

## EMPLOYMENT

To place ads in this section, use the ActionGram form. To respond to box numbers write Radio World, PO Box 1214, Falls Church, VA 22041. Attn: \_\_\_\_\_

**HELP WANTED**

**ELECTRONICS ENGINEER**

Minimum 3 years broadcasting experience, with customer service exp. w/ electronic assembly/repair. Provide technical support with products including application, specification, theory of operation, troubleshooting, etc. Send resume to J. Murray AKG Acoustics, Inc. 1525 Alvarado Street San Leandro, CA 94577. EOE

**John Mack Flanagan**

New Voice of KLIF Dallas ID's—Sweepers—Liners \$100 per page...7 liner max **415-992-9070**

**TOO MANY OPENINGS!**

We have too many positions to fill in the broadcast industry & not enough people to fill them. Radio openings for air talent, news, management, production & sales personnel & also dozens of engineering positions available in all aspects of broadcasting. Over 200 listings each week within a 4 week window. More info per listing than any other source plus we refer your name out to stations looking for your qualification FREE. Call toll-free for info.

**BROADCAST EMPLOYMENT WEEKLY**  
**1-800-922-JOBS**  
10480 Overland Rd. Ste. 328 Boise, ID 83709  
Local B.B.B. Member

**For details on space availability contact Simone at 1-800-336-3045**

Immediate opening for motivated engineer with strong organization/communications skills, knowledge of FCC rules, transmitters, directional AM's. Salary, health insurance, 401K plan. Work/ Salary history to: James Zimmer, Zimmer Broadcasting, POB 1610, Cape Girardeau, MO 63702. EOE.

SALES ENGINEER for growing manufacturer. Only applicants with AM Radio/TV transmitting and sales experience considered. Excellent salary and commission. Prefer international experience, Spanish capability. Resumes and salary history to Human Resources, POB 8026, Greenville NC 27835.

**Product Manager**  
**WORLD-CLASS PERFORMERS PLACE QUALITY FIRST**



Harris, a \$3 billion Fortune 200 Corporation, is seeking world class candidates for a Digital Product Manager, for their Studio Distribution Product Line for the Allied Broadcast Division. Located in Richmond, Indiana, Harris Allied's Studio Distribution Operation is a worldwide distributor of broadcast and professional audio equipment.

This highly visible and critical position requires a driven technical professional, who can provide the leadership necessary to direct the development and sourcing of new products for the fast growing digital audio marketplace. The focus will primarily be in technology and products for the broadcast and professional audio production marketplaces. Responsibilities will include:

- o Sourcing and evaluation of new products
- o Development of strategies for the application of new technologies to our markets
- o Development of strategies for the product line's expansion into new markets
- o Education of extensive field and in-house sales organization in new products and technologies
- o Some Domestic and International travel
- o Product demonstrations

A Technical BS degree or equivalent experience is required. The successful candidate will be knowledgeable in professional audio and broadcast equipment, suppliers and customers, with five years of total experience in these market segments. Must be versed in digital technology standards, trends, and applications, with an understanding of basic marketing and sales techniques.

Harris Corporation offers a competitive starting salary, with a comprehensive benefits package and opportunities for advancement.

If qualified, please send resume (including salary history/requirements) in confidence to: William G. Kellner, Sr. Human Resources Representative, Harris Allied Broadcast Division Headquarters, Dept. PM, P.O. Box 4290, Quincy, IL 62305-4290.

An equal opportunity employer, M/F/D/V.



**POSITIONS WANTED**

Experienced, accountable AM/FM CE, excellent troubleshooting skills, SBE certified, FCC general degree. Currently employed, desire NE. Write to: Radio World, POB 1214, Falls Church VA 22041. Attn: Box #09-22-01RW.

Seeking FT announcing, programming gig, not sales, don't overlook what you haven't tried, Janet's no pricey, airheaded personality, PT announcing, computer literate, marketing experience. Janet, 502-895-5888.

On-air & management, 17 years experience, format flexible, small market a must, dedicated leader/player, use to long hours. Mike, 703-994-5555 after 3 PM ET.

Young man w/business degree w/exp in mgmt, radio announcing, news, talk shows & sales looking for the right opportunity, write to 417 South Story St, Boone IA 50036 or 515-432-1741.

AAS graduate, electronic engineering, board operating experience needing opportunity to get into the electronics field, leave message. Kerry, 405-622-2781.

Experienced air talent, music wants to help starting or changing oldies, classic rock station, will relocate, have references. Luke, POB 84, Mt Carroll IL 61053.

Sports reporter seeking full-time work at radio station; including play-by-play and/or analyst, can do it all. All sports, five years experience. Write to: Radio World, POB 1214, Falls Church VA 22041. Attn: Box #93-22-02RW.

Radio broadcaster with 6 yrs on-air experience with engineer background looking for FT position in NJ, prefer southern, but will travel. John Samuels, 814-539-3084.

Creative, talented broadcaster with announcing, production & sales experience seeks opportunity in talk radio. Drew, 309-755-0262.

Dedicated hard working confident young man looking for opportunity on-air news, sports, DJ, writing copy, willing to relocate. S Herrick, 216-442-5238.

Assistant Chief Eng high energy, dedicated, hard working personality seeks entry level, prefer FL, will consider all. S Flehry, 508-583-3168.

Young personality talker ready to roll, fluff, sports, N/T, looking to entertain, have fun, do my thing, open to all possibilities. Rocco, 716-283-4054.

General Manager for FLA medium or large market, 29 years experience in sales, programming & engineering, turn-arounds or start ups, avail immed. 813-849-3477.

Looking South & Gulf Coast available now, experienced prod/promo/AT, affordable, bags packed & ready. Steve, 806-385-3888.

Exper air talent, producer, programmer, NPR news format, country, folk, jazz, bluegrass music, supervisory & video exper also, call for tape & resume. 904-224-2900.

Got radio in my blood, experienced team player seeks FT AT in NE/New England, AOR/Modern/CHR, any shift, bloodtype FM. Blake, evenings, 908-241-0024.

Rick Savage also known as Rockin Rick Allen from Akron, Ohio is seeking a FT CHR, Hot AC, or Rock gig. 216-773-1549.

AT w/CHR, AC & country experience seeks position in CO/NV/NM, news, dances, call-in shows, board op, good voice, prof delivery, reliable. Laura, 303-824-9650.

Rocking Rick Allen also known as Rick Savage from Akron, OH is avail, call & let's talk radio. 216-773-1549.

Over 25 years experience all areas of radio, seeking program director/news director or General Manager for small market position, prefer South East. Bill, 816-699-2475.

## ABOUT OUR EMPLOYMENT SECTION

**HELP WANTED:** Any company or station can run "Help Wanted" ads for \$1.50/word or buy a display box for \$55/column inch. Payment must accompany insert, use your MasterCard or VISA; there will be no invoicing. Blind box numbers will be provided at an extra charge of \$10. Responses will be forwarded to listee, unopened, upon receipt. Call 800-336-3045 for details.

**POSITIONS WANTED:** Any individual can run a "Position Wanted" ad, FREE of charge (25 words max), and it will appear in the following 2 issues of Radio World. Contact information will be provided, but if a blind box number is required, there is a \$10 fee which must be paid with the listing (there will be no invoicing). Responses will be forwarded to the listee, unopened.

Mail to: **BROADCAST EQUIPMENT EXCHANGE**  
PO Box 1214, Falls Church, VA 22041  
Attn: Simone Mullins



**CART MACHINES...WTS**

BE 5300C tripledeck, stereo, PB, mint less than 50 hrs, BO. R Kaufman, Pams Prods, POB 462247, Garland TX 75046. 214-271-7625, after 3PM CDT.

Spotmaster 505 good condition, good heads, new paint, looks & works almost as new, \$250. R Franklin, 1004 Dekalb St #11, Norristown PA 19401. 215-646-7788.

**CASSETTE & R-R RECORDERS**

**STUDER SERVICE SPECIALIST**

Thousands Served • Unbeatable Rates  
Precision Capstan Resurfacing  
**Audio Advantage**  
Tel (615)742-3834 FAX (615)254-8826  
**PRICE-QUALITY-SERVICE**  
Let Us Prove It

**DAT**

Overhaul Service For PANASONIC:  
AV- 3500, 3700 & 3900  
**\$335.00**  
Includes: Pinch Roller, New Drum, Alignments & 1 Day Shipping  
**Wayne-Gilbert**  
Broadcast & Recording  
**805-294-1051**

**Want To Sell**

Scully 100 16 trk; Scully 280B 2 trk recorders. J Grill, Grill Studios, 619 Melwood Ave, Pittsburgh PA 15213. 412-681-5557.

Magnecord 728; Kenwood KW5066; Sony TC355; Sony 464CS, all work, BO. Gary, Fitzgerald Music Prod, 37-75 63rd St #B29, Woodside NY 11377. 718-446-3857.

Otari MC 5050. J Vavricka, KSYZ, Grand Island NE. 308-382-0108.

Studer Dyaxis with I/O cables 30 mm storage, \$5000; DSP card & software, \$1200; 60 min Studer drive, \$2000 or all for \$6500. G Blood, Blood Pro Audio Services, 16E Johnson St #10, Philadelphia PA 19144. 215-848-2040.

Ampex AG440B transport plus 2 chns electronics, needs little TLC, \$300/BO. Richard, 713-859-0531.

Otari ARS1000 (4) R-R's interfaced to SMC syst, gd cond, \$1000/all or \$400 ea. P Swint, KIXQ, 2620 Dogwood Rd, Joplin MO 64804. 417-624-1310.

MCI JH-110B (3) 2 trk stereo RRs roll around stands w/manuals, \$595/ea. D Matyis, KVET/KASE, 705 N Lamar, Austin TX 78703. 512-495-1300.

**REVOX PARTS/SERVICE**

Cassette-CD-Open reel  
Rebuilt A77s, \$800  
Capstan resurfacing, ALL BRANDS.  
**JM TECHNICAL ARTS**  
30 Music Sq. W. #156  
Nashville, TN 37203 (615) 244-6892

Revox PR 99 MK II, 2 trk, mint cond, w/service manuals & carton, auto loc, remote, sel sync, \$875. R Cannata, Cantrax Recd, 2119 Fidler Ave, Long Beach CA 90815. 310-498-6492.

Tascam MS-16 16 track 1" in excellent condition, full locator, dbx NR & roll-out stand, available 9/15/93, \$4500. J Block, Production Block, 906 E 5th St, Austin TX 78702. 512-472-8975.

Wollensak 1520-AV R-R recorder, built-in compressor, (10) new 7" reels of tape, \$80. R Franklin, 1004 Dekalb St #11, Norristown PA 19401. 215-646-7788.

Tascam 38 8 trk 1/2" open reel w/8 chns of dbx Type I NR, \$1500, w/out dbx, \$1200. P Cibley, Cibley Music, 138 E 38th St, NY NY 10016. 212-986-2219.

**DAT Machines**

Radio Systems/Sony RS-1000  
Perfect for on-air, live sound, or automation.  
**Orig. \$3000 Sell \$1150**  
Panasonic SV-3900  
Computer controllable with RS-422 interface.  
**Orig. \$1850 Sell \$995**

**Pro Digital Inc.**  
DAT Recorder Service Specialists  
215.328.6992  
**FAST, EXPERT REPAIRS**

Pioneer RE701, new hds, \$300; Ampex ATR700, gd cond, \$700; Tapesonic TR70, gd cond, \$250; Telex 235 with (2) RP110 electr, \$200; TVC MC 1636 Mark II, new in box, \$300. J Parsons, Parsons Snd Svc, 2781 Fayson Circle, Deltona FL 32738. 904-532-0192.

Otari Mark II-IV 1/2" 4-track, multi-track, mint, less than 50 hours, Best Offer. R Kaufman, Pams Productions, POB 462247, Garland TX 75046. 214-271-7625, after 3PM CDT.

Otari QXD5050 4 track with separate balanced line & mic in/out, 7.5 & 15 ips, 1/4" tape, 10-1/2" NAB reels, wired remote, 1 kHz test oscillator, exc cond, \$1000/BO plus shipping. R Maier, RMA, 8908 Centreville Rd, Manassas VA 22110. 703-361-7508.

**METROTECH  
DICTAPHONE  
LOGGERS**  
PARTS AND SERVICE

**SEQUOIA  
ELECTRONICS**  
4646 Houndshaven Way  
San Jose, CA 95111  
(408) 363-1646  
FAX (408) 363-0957

Teac A-3440 4 chnl multi trk deck, Simul-sync, 7.5 & 15 ips, pitch ctrl, 7 & 10" reels, exc cond, plus dbx 155 4 chnl NR, \$550. J Hayes, Radio Free New York, 1748 70th St, Brooklyn NY 11204. 718-234-9374.

Marantz PMD-221 cassette, 10 brand new units, never used, \$199 each. 208-376-3708.

Audio Technica RMH64 4 trk P/R, 6 chnl mixer/recorder 6 in 4 out, 2 cue sends, fanthorn power, low/high speed R/P, parametric EQ & shelving, \$995 w/schematics. Gary, Fitzgerald Music Prod, 37-75 63rd St #B29, Woodside NY 11377. 716-446-3857.

Tascam 34 4 trk in great cond w/manual, \$1200. C Downs, WVik, August-ina College, Rock Island IL 61201. 309-794-7500.

**CLEAN PATCH BAYS  
NO DOWNTIME**



**VERTIGO BURNISHERS AND INJECTORS RESTORE ORIGINAL PERFORMANCE TO YOUR PATCH BAYS**  
**\$34.95 Ea.** Please write for additional information and order form today  
**VERTIGO RECORDING SERVICES**  
12115 Magnolia Blvd. #116 818-907-5161  
North Hollywood, CA 91607 fax: 818-784-3763

Akai GX3650 1/2 trk R-R, 3 speeds, auto reverse, 7" NAB reels & remote, \$500/BO plus shpg. R Maier, RMA, 8908 Centreville Rd, Manassas VA 22110. 703-361-7508.

MCI JH-110B (2), play only, low chassis, BO; (2) MCI JH-110B, R/P, low chassis, BO; (2) MCI JH-110B, play only, tall chassis, BO; Ampex ATR-100 2 trk, BO; Inovonics electr for mono repro, \$200; Otari MX5050BQII 1/4" 4 trk, excel cond, \$2000. C Scherer, WDOK, One Radio Ln, Cleveland OH 44114. 216-696-0123.

All parts for Scully 280 machines, motors, cards, etc, 8 trk 1" R/P combo head, & erase hd to match for Scully 100 machine. R Robinson, 203-269-4465.

Sensul MR-6 6 trk cassette deck with built in Dolby C NR, high speed, 70 db SN ratio w/high bias cassette, pitch control, memory return, punch in, rack mount or table top, 2 years old, few hours hours, nice meters, \$300. J Hayes, Radio Free New York, 1748 70th St, Brooklyn NY 11204. 718-234-9374.

Tascam 58-OB, 1/2" 8 trk, mint cond, +4 and -10 in/out, connects for SMPTE lockup w/video, \$3000. Whirlwind Prod, 10356 W Warren Ave, Dearborn MI 48126. 313-584-9201.

Ampex, ITC, Scully Reel-to-Reel Tape Recorder Spare Parts, Accessories Motor Remanufacturing.

**VIF INTERNATIONAL**  
PO Box 1555  
Mtn View CA  
94042 U.S.A.  
Inside USA: 1-800-848-4428  
Outside USA: 1-408-739-9740  
FAX: 1-408-739-0809

Scully 284 8 trk recdr, \$4500. H Sewell, Oakridge Music Recdg Svcs, 2001 Elton Rd, Ft Worth TX 76117. 817-838-8001.

Tape-Athon 702 free to good home, (3) 7" & 10" bi-directional PB @ 3 3/4 ips, also spare parts, \$100/pkg&shpg, in Springfield IL; Ampex 601 in larger brown case, full track @ 7 1/2 ips, some wear, was working, 10 day money back guarantee, \$150. E Davidson, 217-787-0800.

16 trk 2", \$3450; Otari 1" 8 track, \$2450; 5050 III-8, \$1950; Ampex ATR800 mono, \$750; Tascam 25-2, \$750; Tascam 52 mint, \$1200; MCI Locator III, \$1195; Ampex AG350 solid st electr, \$100/ch. W Gunn, 619-320-0728.

Recorder heads, used Scully mono & 2 trk, \$25-50, ATR100's, 3M M79-16 & 8's, Otari 1/2" 8 trks, \$495. W Gunn, 619-320-0728.

**Want To Buy**

Otari Mk III-8 head bridge w/o heads. R Robinson, 203-269-4465.

Marantz PM 201 or PMD 221 any cond, physically complete preferred but not mandatory. J Glass, 317 Eureka, Genoa IL 60135. 815-784-2179.

Scully '100' recorders, record/play amplifiers, 8, 16, 24 track heads. Sequoia Electronics, 4646 Houndshaven Way, San Jose CA 95111. 408-363-1646.

Ampex ATR100 taperecorders for parts. Circuit cards, heads, motors, machine parts, or electronic parts. Call 818-907-5161.

**CD's/PLAYERS**

**Want To Sell**

Denon DN-950FA in excellent cond, \$750. R Michaels, KQFX, pOB 7762, Amarillo TX 79114. 806-355-1044.

**COMPUTERS**

**Want To Sell**

NEC P6 24 pin dot matrix printer w/8 internal fonts, \$125. P Cibley, Cibley Music, 138 E 38th St, NY NY 10016. 212-986-2219.

Technics SL-P1200 4 units, all need minor repair, BO. R Nees, WCSJ/WCFL, 1802 N Division Ste 403, Morris IL 60450. 815-942-0022.

Tandy 2000 w/software, \$375; Kaypro port, \$200; Texas Instruments 810 printer, \$450. R Robinson, 203-269-4465.

MSD super disk drive for Commodore-64, books & software, like new, \$100. R Franklin, 1004 Dekalb St #11, Norristown PA 19401. 215-646-7788.

**Want To Buy**

CD-plyr w/varispeed such as Denon 2560, DCD970 or DCD 660. R Robinson, 203-269-4465.

**CONSOLES**

**Want To Sell**

TAC Scorpion-22 mono, 2 stereo inputs, 16 buss, \$5000; Tascam M-3700 automated, new, never used, 24 inputs, 8 buss, on board automation, \$11,000. L Thompson, 4631 Insurance Ln, Dallas TX 75214. 214-559-4000.

Russco Mono 505 rack mount, 5 channel, \$300; Ramko DC5AR 5 channel mono, \$300; Grommes Precision M15 6 channel mono tube type, \$275. J Parsons, Parsons Snd Svc, 2781 Fayson Circle, Deltona FL 32738. 904-532-0192.

Wheatstone 32x24, full patchbay & producers desk, like new conditino, \$20K; Otari MTR-90 II, mint conditino, \$31K. L Walkup, Grace Recording, 159 Pelham Ave, Hamden CT 06518. 203-288-9771.

Autogram IC-10, \$3395 & AC-8 8 channel & 10 channel, \$2995, stereo, currently in use. B Ryan, KVIC, Box 5511796, Dallas TX 75355. 214-771-1008/4235.

Yamaha RM-1608 16 input studio console with sweepable EQ, phantom power & on board patchbay, talkback & tone gen, excellent condition, avail 9/15/93, \$2250. J Block, Production Block, 906 E 5th St, Austin TX 78702. 512-472-8975.

Audionics 110A 18 in, 4 out, 3 band EQ, 2 aux sends, 8 meters, \$2600. Gary, Pranava, 1226 Sierra Alta Way, Los Angeles CA 90069. 310-271-3235.

Gates Gateway 80 mono in mint cond, BO. D Goodale, WJRI, POB 1350, Lenoir NC 28645. 704-754-5361.

RCA BC-7A stereo 10 channel console w/manual. J Waugh, WHVT, POB 273, Clyde OH 43410. 419-547-8254.

Presto 900-A1 vintage port recording mixer used with disk recorder or early port tape deck, 3 mics, large VU, octal tubes, \$250. R Franklin, 1004 Dekalb St #11, Norristown PA 19401. 215-646-7788.

Tapco 6000 mxr w/reverb, 6x1, rough, was wkg, \$35. E Davison, POB 7167, Springfield IL 62791. 212-787-0800.

Shure SE30 remote mixer with rack ears, \$150. 708-448-1790.

Wheatstone 8X rcdg console, LED meters, lots of bells & whistles, extremely clean & can be expanded to 24 chns, perf cond, midwest delivery, \$4250. J Lee, JL Prod, 3215 Jackson St, Rockford IL 61107. 815-397-7005.

Have 32 input Audio Design audio for TV console & stand; want to trade for Mari 455 MHz RPU xmtr & receiver. Klay Anderson, 801-272-1814.

Yamaha DMP-7 digital mixer/processor, rk mt, EC, \$975. S Hofmann, Sounds Impossible, 7109 NW Birch Pl, Lawton OK 73505. 405-536-0559.

Audionics 110A, 18 in, 4 out, 3 band EQ, 2 aux sends, 8 meters, \$2600. Gary, Pranava, 1227 Sierra Alta Way, Los Angeles CA 90069. 310-271-3235.

LPB Monogram II 5 chnl, 12 input, mnl, \$800. C Hicks, WEAX, W Park Ave, Angola IN 46703. 219-665-7310.

Gates Yard II mono in good cond, just removed from service, BO. D Goodale, WJRI, POB 1350, Lenoir NC 28645. 704-754-5361.

Ward Beck 24 input, 3 band para. EQ, P&G faders, 2 comp/fm/deeser, 288 pt. bay, very clean, \$6000/BO. Russ Spice, 708-263-6400.

NEVE 5442, 8 in, 2 out portable console in Anvil road case, perfect, \$8000/BO. 215-793-2526.

Ramko DC5AR 5 channel mixers, 14 available, very good condition, \$225 each. 916-334-9449.

Consoles, \$500 & up. Call Mark at 619-758-0888.

**Want To Buy**

Altec 250 Series knobs, keys, manuals & schematics. D Walker, WLW-A, 1111 St Gregory, Cincinnati OH 45202. 513-241-9597.

Russco 505S stereo console. J Parsons, Parsons Snd Svc, 2781 Fayson Circle, Deltona FL 32738. 904-532-0192.

Audionics 200 modules, SLI-200-202 stereo input modules, MIC-200-202 mic input modules, TEL-200 modules, no junk! M McCarthy, WABT, POB 445, Mt Prospect IL 60056. Fax 708-439-1464.

**PHONE: 703-998-7600 FAX: 703-998-2966**



Call Simone Mullins, Classified Ad Manager, to reserve space in the next issue. Use your credit card to pay, we now accept VISA and MASTERCARD.

**Radio World**

5827 Columbia Pike, 3rd Floor  
Falls Church, VA 22041

**Select from these categories for best ad positioning:**

- |                            |                           |                          |
|----------------------------|---------------------------|--------------------------|
| Acoustics                  | Consoles                  | Software                 |
| Amplifiers                 | Disco-Pro Sound Equip.    | Stations                 |
| Antennas & Towers & Cables | Financial Services        | Stereo Generators        |
| Audio Production (Other)   | Leasing                   | Tapes, Carts & Reels     |
| Brokers                    | Limiters                  | Tax Deductable Equipment |
| Business Opportunities     | Microphones               | Test Equipment           |
| Cart Machines              | Miscellaneous             | Transmitter/Exciters     |
| Cassette & R-R Recorders   | Monitors                  | Tubes                    |
| CD Players                 | Receivers & Transceivers  | Turntables               |
| Computers                  | Remote & Microwave Equip. | Positions Wanted         |
|                            | Satellite Equipment       | Help Wanted              |

**Classified Advertising Rates Effective January 1, 1993**

	1x	3x	6x	12x
1-9 col inch (per inch)	\$55	53	50	45
10-19 col inch (per inch)	50	48	45	40
Distributor Directory	90	85	80	75
Professional Card	60	55	50	45
Classified Line Ad		\$1.50 per word		
Blind Box Ad		\$10 additional		

To compute ad costs: Multiply the number of ad inches (columns x inches) by the desired rate schedule for your per unit cost. Example: a 3" ad at the 1x rate is \$165, at the 3x rate \$159, at the 6x rate \$150, at the 12x rate \$147, etc.

**DISTRIBUTOR DIRECTORY**

The following distributors serving the broadcast industry would be glad to help you with any of your requirements.

... Canada, the Caribbean, Shannon to Shanghai, the dynamite Fifty ...  
**RADIO! The beat goes on!**  
**CROUSE-KIMZEY OF ANNAPOLIS**  
tops in broadcast equipment  
**1-800-955-6800**  
ask for Kathleen

---

**CORNELL-DUBILIER MICA CAPACITORS**  
FROM STOCK  
**JENNINGS VACUUM CAPACITORS**  
FROM STOCK  
**JENNINGS VACUUM RELAYS**  
**SURCOM ASSOCIATES**  
2215 Faraday Ave., Suite A  
Carlsbad, California 92008  
(619) 438-4420



**CONSOLES...WTB**

ABM CA1970's, need info to acquire all or parts, especially Audex buss-select cards. D Gaydos, Opal-Gaydos Stds, 295 Doubllass St, Brooklyn NY 11217. 718-875-6140.

Audionics 200 Series, white or blue, 12 or 18 fader capacity, complete with SLO-200, MNO-200 output modules, must be rebuildable, complement of MIC-200 mic & SLI-200 line modules, CRM-200 control room module, TEL-200 telephone module, PEQ-200 voice EQ, LS-B-200 switcher, timer & clock all desired. M McCarthy, WABT, POB 445, Mt Prospect IL 60056. FAX 708-439-1464.

**DISCO & SOUND EQUIPMENT**

**Want To Sell**

Base 402E speaker equalizer, EC, \$50. S Hofmann, Sounds Impossible, 7109 NW Birch Pl, Lawton OK 73505. 405-536-0559.

Korg DW8000 with heavy duty case, \$500; Arp Omni (2), \$450; Roland TR707 drum mach, \$250; Casio CZ101, \$175. Gary, Fitzgerald Music Productions, 37-75 63rd St #B29, Woodside NY 11377. 718-446-3857.

Echo plate #2, \$600. H Sewell, Oakridge Music Recdg Svcs, 2001 Elton Rd, Ft Worth TX 76117. 817-838-8001.

Numark DM1775 4-chnl DJ mixer w/ sampling, echo, delay, reverb, EQ, \$860. S Evans, Evans Technologies, 755 E Main, Greenwood IN 46142. 317-889-6969.

Realistic 10 band EQ (2) mint condition with spectrum display, \$50. J Hayes, Radio Free New York, 1748 70th St, Brooklyn NY 11204. 718-234-9374.

Aphex type III, \$500/BO; Furman comp/limiter LC3A, \$180/BO; Lexicon LXP-1, \$389/BO; Fostex 4030/4035 synchronizer, excel, \$947/BO. Peter, 607-734-1751.

Aphex Aural Exciter C, \$195; dbx 155 NR, \$250; dbx 140A, \$75; Eventide 910, \$425; DL 1745 delay, \$1200; FL 201 instant flanger, \$250; Fairchild 658A reverb, \$175; TC 2290, \$1700. Russ Spice, 708-263-6400.

**FINANCIAL SERVICES**

**EQUIPMENT FINANCING**  
ON ALL RADIO EQUIPMENT

- Easy to qualify
- Fixed-rate, long-term leases
- Any new or used equipment
- 100% financing, no down payment
- No financials required under \$50,000
- Refinancing existing equipment

**ENF** EXCHANGE NATIONAL FUNDING

Call Mark Wilson  
(800) 275-0185

**LEASING AVAILABLE**

SALE/LEASE BACKS, Sell your equipment to Carpenter for CASH. Carpenter LEASES your equipment back to you. You WRITE OFF the monthly payments and put the CASH to work. Carpenter & Associates, Voice 501-868-5023 Fax 501-868-5401.

**LIMITERS**

**Want To Sell**

Harris MSP-100 audio processor, BO. M Casey, WKSX, Drawer 1, Johnston SC 29832. 803-275-4444.

Aphex 250 type III aural exciter, new cond, '93 mdl, all papers, invoice, manual etc, orig carton, \$695. J Masters Ying, Ariel, 140A Bellevue Ave #5, Newport RI 02840. 401-846-9743.

McMarlin BFM-1514-15 mono & stereo audio processors, priced to sell. Goodrich Ent, 11435 Manderson St, Omaha NE 68164. 402-493-1886.

Optimod 8000A, \$1500. R Michaels, KQFX-FM, POB 7762, Amarillo TX 79114. 806-355-1044.

**Want To Buy**

**BUY-SELL-TRADE**  
**OPTIMOD 8000 & 8100**  
414-482-2638

**MICROPHONES**

**Want To Sell**

Shure SM 82 mic w/line level output, \$275/BO. J Daniels, WRAV, 333 Delaware Ave, Delmar NY 12054. 518-439-0945.

Shure M267 pro mic mixer, industry standard, 4 inputs, limiter, low pass filter, batt & A/C operation, \$300; Shure M67 pro mic mixer w/rack ears, \$150. J Hayes, Radio Free New York, 1748 70th St, Brooklyn NY 11204. 718-234-9374.

Neumann U-89's (2) w/shock mounts, Jeweler's cases, mint cond, \$3000/pr, \$1600 ea. Whirlwind Prod, 10356 W Warren Ave, Dearborn MI 48126. 313-584-9201.

Sennheiser 441, new w/all papers & response curves, \$425. R Payne, 313-786-1767.

AKG 414's, \$695, original D12 like the Beatles used, \$295, Sony ECM54, \$150, Beyer M500 lk new, \$300, Demeter 4-ch tube DI rack mt lk new, \$875. W Gunn, 619-320-0728.

Shure 540 omni probe dyn 12" long, black, 1" dia ideal for interviews, \$25/each or 5/\$100; Shure 578 omni probe satin chrome dyn 7/8" dia, a neat mic, new, \$35; AKG D110 lavalier dyn 7/8" dia, new good sound, large size, \$35; Eddor wireless lavalier EV CO90 mic on 49.83 Mhz, \$50; Shure 545-L dyn lavalier or stand MTG, 1 1/4" dia, unidirectional with cord & XLR, (3), \$25/each; Shure 571 lavalier dyn 1" dia with cord, & stand holder, as new, \$35. E Davison, POB 7167, Springfield IL 62791. 217-787-0800.

Neumann U87A mint cond, \$1600. M Osborne, WKSQ, POB 9494, Ellsworth ME 04605. 207-667-7573.

Audio-Technica 4033 exc recording/on-air studio large diaphragm mic, 2 avail, \$379/BO; Gefell UM-70 3 pattern studio mic large diaphragm as new, 2 avail with winde screen, \$895/BO. Peter, 607-734-1751.

Gefell Neumann UM57 tube mics, New capsules for SM2 & many others, New AC701 tubes for Neumann mics, \$275. W Gunn, 619-320-0728.

**Want To Buy**

Sennheiser KZU or K3U condenser mic pwr unit. E Davison, 217-787-0800.

77-DX's, 44-BX's, KU-3A's On Air lights. Top price paid. Fast response. Bill Bryant Mgmt, 2601 Hillsboro Rd, G12, Nashville TN 37212. 615-269-6131.

RCA 77DXs/44BXs ribbon, chrome/TV grey, good cond, BO. R Kaufman, Pams Prods, POB 462247, Garland TX 75046. 214-271-7625, after 3PM CDT.

**MISCELLANEOUS**

**Want To Sell**

Tie/Northcom telephone system, 6 line, 12 telephones, manuals. FB Nienow, WYTE, POB 1030, Stevens Point WI 54481. 715-341-8838.

Borg Warner console cabinets & racks, 1.00 per pd. Approx. 500' waveguide in 12' length, was on 6 ghz. G.E. Most 11 base/repeaters UHF or VHF. Other stuff, coll for list. D & L Specialties, Box 462 Foribault, MN 55021 507-332-8055

Broadcast Products 1988 Super Roving Radio remote bdct trailer equipped w/console, mast, amps & speakers, w/979 Chevy Blazer with 5 kW gen for towing & pwr, \$15000/BO. G Fullhart, WVKS, 4665 W Bancroft St, Toledo OH 43615. 419-531-1681.

Key Industries T2000-A2 rotary phase convertor, 1 phase input, 3 phase output, \$800/BO. M Hendrickson, Hedberg Broadcasting, POB 528, Spirit Lake IA 51360. 507-526-4044.

Western Union clocks —(3) different models Taking offers; call for details. Wan ON AIR light. Klay Anderson — 801-272-1814.

Eventide BD910 delay unit, like new, \$3000. S McGrath, WGNV, 429 Little B Rd, Newburgh NY 12550. 914-561-2131.

Rotron Blowers for Elcom, Harris, CCA, CSI, McMarlin, rebuilt & new. Goodrich Enterprises Inc. 11435 Manderson St Omaha, NE 68164 402 493 1886 FAX 402 493 6821

Sales training ideas, excellent content & prod, \$500. Richard, 713-859-0531.

Key rotary phase converters (2), 120 in, 230 out, \$3500 each plus shpg. P Urso, WWRX, 75 Oxford St, Providence RI 02905. 401-781-9979.

INVENTORY REDUCTION SALE! Over 500 Item list (fax or mail). Call Mark at 619-758-0888.

AKG BX20 spring reverb. J Grill, Grill Studios, 619 Melwood Ave, Pittsburgh PA 15213.

**Want To Buy**

Daven Step att 11061-KU, stereo w/cue, need two, F Cresce, Oxon Hill MD, 301-567-2012 evenings.

Copy of schematic for Collins 300 J-2 xmtr. Joe Eck, 913-263-7111.

UTC LS-10X, 12X, LS-15, LS-15X, LS-18, A-10, A-11, A-12, A-24, A-25, A-26 transformers, schematic for Western Electroacoustic Labs cond mic PS#120A; Hycor 4201 passive EQ, Cinema Eng 651E filters, 4031 EQ, Bunwen modules BC 302, VF 301, AT 200, manual & schematic for Gates Level Devil limiter, manual & schematic for CBS mdl 600 decibel meter. R Robinson, 203-621-7445.

## SERVICES

SPECIALIZING IN ERECTION, REPAIRING, PAINTING AND MAINTENANCE RADIO, TWO-WAY, T.V. TOWERS AND FLAG POLES

**ASTEPELJACK CO.**  
PAINTING AND STEEPLEJACK CONTRACTORS

FULLY INSURED FOR YOUR PROTECTION

DON HIGLEY 3722 ROMA  
713-462-6105 HOUSTON, TEXAS 77080

**E.T.S.**

Strobe Installation & Repair  
6 Mo. Labor & Parts Warranty  
Complete Tower Erection & Maint.

"Our Business is Climbing to New Heights"

419-424-0020  
FLASHTECH • E.G.G. • T.W.R.

**PC - SOFTWARE**

AM FM TV Search Programs  
Contour Mapping-STL Paths  
RF HAZ-1990 POP Count  
FAA Tower-Draw Tower

Doug Vernier  
Broadcast Consultant  
1600 Picturesque Dr  
Cedar Falls, IA 50613

800-743-DOUG

**EVANS ASSOCIATES**  
Consulting Communications Engineers

TV • FM • AM • ITFS • Satellite  
FCC Applications, Design  
and Field Engineering

Video/Data/Voice • Light Fiber & Microwave • Wide-Area Networks & STL's

216 N. Green Bay Road  
Thiensville, WI 53092  
(414) 242-6000 • FAX (414) 242-6045  
Member AFCCCE

**W. LEE SIMMONS & ASSOC., INC.**

BROADCAST TELECOMMUNICATIONS CONSULTANTS

5 Gracefield Road  
Hilton Head Is., SC 29928

1-800-277-5417  
803-785-4445  
FAX: 803-842-3371

North America RF & Audio

**Mirkwood Engineering Services**

Broadcast and Telecommunications Consultants

Multidiscipline Engineering and Planning Firm including • Application & Allocation Services

- Project, Engineering & Construction Management • Site Acquisition
- Rural & Remote Site Installations
- Field Service • Studio Design & Installation

50 Park Ave. Claremont, NH 03743  
(603) 542-6784

**OBSTRUCTION LIGHTING**

Beacons lights accessories

FAX inquiries on your letterhead to:

**ROHN** P.O. Box 2000  
Peoria, Illinois 61656  
PH: (309) 697-4400  
FAX: (309) 697-5612

**Tower Sales & Erection**

Turnkey Site Development  
Installation & Maintenance  
AM/FM Broadcast, TV  
Microwave Systems,  
Antennas & Towers

**TOWERCOMM**  
Communications Specialists

6017 Ttriangle Dr  
Raleigh, NC 27613  
(919) 781 3496  
Gen. Contractor #29801 Fax (919) 781 6454

Ben Wall  
President

**MLJ**  
Moffet, Larson & Johnson, Inc.  
Consulting Telecommunications Engineers

Two Skyline Place, Suite 800  
5203 Leesburg Pike  
Falls Church VA 22041

(703) 824-5660  
FAX: 703-824-5672

Member AFCCCE

**Where In The World Are You?**

Reach radio professionals worldwide by advertising in Radio World's international edition.

Call Simone for more information.  
1-800-336-3045

**MULLANEY ENGINEERING, INC.**  
Consulting Engineers

- Design & Optimization of AM Directional Arrays
- Analysis for New Allocation, Site Relocation, And Upgrades
- AM-FM TV LPTV Wireless Cable (MDS/MMDS/ITFS/OFS)
- Environmental Radiation Analysis
- Field Work
- Expert Testimony

9049 Shady Grove Court  
Gaithersburg, MD 20877  
Phone: (301) 921-0115  
Fax: (301) 590-9757

**Consulting Communications Engineers**

- FCC Data Bases
- FCC Applications and Field Engineering
- Frequency Searches and Coordination
- AM-FM-CATV-ITFS-LPTV

**OWL ENGINEERING, INC.**

1306 W. County Road, F,  
St. Paul, MN 55112  
(612) 631-1338 \*Member AFCCCE\*

**REMOTE EQUIPMENT RENTALS**

**COMREX and GENTNER**  
1, 2 & 3-Line Extender Systems  
Now With The New GENTNER EFT-3100  
MARTI VHF/UHF RPU Systems  
Switched-56 Systems  
Call or FAX Dwight Weller  
WELLER AUDIO-VISUAL ENGINEERING  
Baltimore, MD  
Phone: (410 or 800) 252-8351  
FAX: (410) 252-4261

**LOCATION SERVICES IN THE UNITED KINGDOM**

Planning remotes from the U.K.? we provide a comprehensive service

- we organize venues for your shows
- we provide temporary equipment
- live links via ISDN/Switched 56
- experienced radio engineers
- we help you line-up guests

Contact New York (212) 229-9118  
Good Morning from Great Britain  
Wired for Sound Ltd., London N15

**T. Z. Sawyer Technical Consultants**  
AM-FM-TV-LPTV

- FCC Applications & Exhibits
- Experimental Authorizations
- AM Directional Antennas
- High Power Antenna Arrays
- Frequency Studies
- Class Upgrades
- STL Applications
- Station Inspections

1-800-255-2632  
FAX: (301) 913-5799 • 6204 Highland Dr. • Chevy Chase, MD 20815

**Don't Gamble with your advertising dollars.**

Advertise in Radio World and reach 22,000+ subscribers.

Call Simone at 1-800-336-3045 today!

Contact Radio World Newspaper for availabilities

P.O. Box 1214 Falls Church VA 22041

1-800-336-3045





## MISCELLANEOUS...WTB

Operating manual for Hickok #605-A tube checker, copy ok; audio output transformers, Peerless #S-268-Q or AcroSound #TO-350. B Leslie, Pro Recording, 13709 Mapleleaf Dr., Cleveland OH 44125. 216-662-1435.

Jazz record collections, 10" LP/12" LP be-bop, swing, dixie, highest prices paid. B Rose, Program Recdgs, 228 East 10th, Nyny 10003. 212-674-3060.

Electro-Magnetic hi and low frequency drivers. 1-800-251-5454.

Western Electric amplifier, speakers, tubes. 1-800-251-5454.

Radio transformers by Chicago, UTC, Triad, Peerless, Freed, Sola, send list. J Gangwer, 942 32nd St, Richmond CA 94804. 415-644-2363.

Ampex tube recorders and mixers. W Gunn, 619-320-0728.

## MONITORS

## Want To Sell

Rust SFM-19 deviation mon for 19 kHz. BO; Indesys FM mod mon, BO; Collins FM mod mon for parts, BO. C Scherer, WDOK, One Radio Ln, Cleveland OH 44114. 216-696-0123.

Gates MO-2696 external rack mount monitor amp for very early Gates consoles, 666 output tubes, collectors delight, \$200. R Franklin, 1004 Dekalb St #11, Norristown PA 19401. 215-646-7788.

## Want To Buy

McMartin (buy & sell) any model. C Goodrich, 11435 Manderson, Omaha NE 68164. 402-493-1886 or fax 402-493-6821.

## RECEIVERS &amp; TRANSCEIVERS

## Want To Sell

SCA rcvrs, (9) Johnson electronic ST-4A SCA tuners, Seven Systems 851, all less than 1 yr old, BO/all. P Boone, Village Sports Radio Ntwk, POB 3300, Chapel Hill NC 27515. 919-968-4811.

## SCA RECEIVERS—ALL TYPES

Reading Service / Ethnic / Data Professional, Portable, Table

DAYTON INDUSTRIAL CORP.  
(Manufacturer)  
4411 Bee Ridge Rd. #319  
Sarasota, Fl. 34233  
Tel: 813 378 5425 FAX: 3394

Martl SCG-10 92 kHz subcarrier generator, SCD-10 92 kHz subcarrier demodulator. R Rynders, 613 Fourth St Ste 203, Santa Rosa CA 95404. 707-576-7542.

AM/FM/Cassette Delco car radio, new from '86 GMC van, \$35. E Davison, POB 7167, Springfield IL 62791. 212-787-0800.

AM STEREO RECEIVERS  
From \$34.95 Portable, Home, Auto  
**RRADCO**  
Phone/FAX 708-513-1386

Johnson Ranger II. \$75/BO. M Stain, WGOT, 457 Varney St, Manchester NH 03102. 603-625-1165.

Professional SCA demod card with excellent crosstalk rejection, \$20; Superadio III with SCA, \$85, performance guaranteed. 1-800-944-0630.

Attec 711A FM rcvr, early selective, \$75/BO+UPS. E Davison, 217-787-0800.

## REMOTE &amp; MICROWAVE EQUIP

## Want To Sell

Kreco SC 155AC VHF 152-171 MHz 6 db gain base antenna. C Frodsham, KVSF, POB 7, Beloit KS 67420. 913-738-2206.

Symetrix telephone interface, \$200. J Vavrick, KSYZ, Grand Island NE. 308-382-0108.

Micro Controls DLC-9 9 channel remote control studio & transmitter unit working when removed, \$400. S King, KGFL/KHPQ, Box 33, Clinton AR 72031. 501-745-4474.

## COMREX RENTALS

1, 2 and 3-Line Extenders  
Switched 56 Systems  
Call Steve Kirsch for details  
**Silver Lake Audio**  
(516) 623-6114 FAX: 377-4423

4 wire switched 56 data service unit, rack mount incl mdl 1056R, \$745. G Wachter, KFYI, 602-258-6161.

Martl STL-10 stereo, 2 TX & 2 RX, \$4000. R Michaels, KQFX-FM, POB 7762, Amarillo TX 79114. 806-355-1044.

450 Mhz 25 W RF amp for mobile Yaesu hand held radio w/mike & mounting, \$50; VHF NEC hand held radio/telephone, not wrkg, 4 chnls, \$20. E Davison, POB 7167, Springfield IL 62791. 212-787-0800.

## RENTALS RENTALS RENTALS

## COMREX 3-line extender

Frank Grundstein 215-642-0978  
Audio/Video Consultants

Telfax T31-B remote mixer w/telephone interface, perfect for sports bdct, \$300. Richard, 713-859-0531.

## SATELLITE EQUIPMENT

## Want To Sell

Microdyne 1100 PCDR(5) rcvr in exc cond, down cnvrtr or stable 70 mHz input reqd, \$1200. C Damon, KWST, POB 1890, Flagstaff AZ 86002. 602-774-5559.

**YOUR VERY LAST CHANCE TO SELL YOUR OLD DIGITAL RECEIVER BEFORE IT BECOMES OBSOLETE!**  
**CASH NOW FOR FAIRCHILD DART S/A 7300/7325**  
**1806-24'S, MICRODYNE & SELECTED OTHERS. CALL NOW!**

We buy & sell

We Repair & Rebuild, too.

Satellite Systems  
(719) 634-6319  
(Fax) 635-8151

Wegener satellite cards and mainframes. Call Mark at 619-758-0888.

## SOFTWARE/DATABASES

## Want To Sell

PRINTS MAILING LABELS!  
US RADIO DATABASE DIRECTORY: contains 11,400+ stations. MAC/IBM (specify disk size). Many searches + ASCII dump! US TV DATABASE: IBM-PC compatible directory of over 1,500 stations. \$99.95 each (incl. quarterly updates) VISA/MC: 1-800-626-2360 ext. 300 BBH Software Inc. (303) 592-3780

FM Study 3.0 FCC allocation program for IBM and compatibles. Full EGA and mouse support, \$59.95 (+\$1.50 S&H). Database—\$35/first state, \$15 each after. Call or write—order/demo to: **BEAM Software**, 3N460 Coulter Lane, St., Charles, IL 60175, 708-584-1668.

## STATIONS

## Want To Sell

KJJJ FM in SE Arizona market, 18 months old with positive cash flow, \$325,000 with excellent terms. S Greeley, KJJJ, POB 1726, Lake Havasu City AZ 86403. 602-855-1051.

250W daytimer near Springfield MO, \$50,000/BO. J Cooper, KMRF, POB K, Marshfield MO 65706. 417-866-5757 after 9:30 PM.

IT COULD BE THAT YOU'VE JUST FOUND YOUR PLACE IN THE SUN. 50 KW CP IN THE US VIRGIN ISLANDS. \$250,000 CASH, INCLUDING TOWER SITE OR \$110,000 WITHOUT LAND.  
**215-695-9339**

Beautiful coast of NC, 3 kW FM CP with 25 kW CP needs owner/operator, 25 kW will cover beach, \$165000 with \$65000 down, owner will finance balance. R Michaels, 806-355-1044.

700 Watts 90.5 FM w/seven room house on one acre, \$75000 firm. 314-686-1663 or 314-785-0006.

**For Sale**  
**FM-6KW, AM-1KW**  
**Leadville, Co.**  
**Fax Inquiries to**  
**(719) 630-0220**

FM station equip from mics to 4 bay antennas, complete, send best application + \$100, best application gets complete station equipment, no refunds. R Franklin, 1004 Dekalb St #11, Norristown PA 19401. 215-646-7788.

If you ever wanted to own a radio station, read this! Class A FM in small mkt about to boom, needs committed owner/operator ready for once in a lifetime opportunity, some TLC & \$39500. Richard, 713-859-0531.

5kW day/29W nite with new tower/ground system, with 4 acres in Jacksonville, FL metro market. Beautiful historic beach town. Best cash offer over \$200,000. Bill, 205-238-0281 or Mark, 205-236-6484.

## Want To Buy

Small station in NC.  
Write W.T.P., Inc., POB 97668, Raleigh, NC 27624

Husband/Wife broadcast professional with 25 plus years experience, wishing to relocate to small market, interest in FM only, or AM/FM combo, in Ohio, Michigan, or North Dakota only, will locally own/operate & pay fair price, no leverage buyout. We know the business! Send call letters of facilities with rate card & coverage map, all replies will be strictly confidential, include confidential contact address. Write to Radio World, POB 1214, Falls Church VA 22041. Attn Box: 93-10-2RW.

## STEREO GENERATORS

## Want To Sell

Hnat-Hindes UM2000 Ultra Mod with stereo generator, \$2250; Comp-Roc composite limiter, \$900. J Danials, WRAV, 333 Delaware Ave, Delmar NY 12054. 518-439-0945.

Dorrrough 80B stereo generator, \$200. J Danials, WRAV, 333 Delaware Ave, Delmar NY 12054. 518-439-0945.

## TAPES/CARTS &amp; REELS

**A&D**  
**Cart Rebuilding**  
Do Bad Carts Have Your Temperature Rising?  
Let A&D clean, load & pack your carts. They'll be serviced within 10 working days! *Guaranteed!*  
3706 Vold Ct. 715-835-7347  
Eau Claire WI 54701 Fax: 715-835-1151

## Want To Sell

1" Scotch 8206 on 10 1/2" metal NAB reels, \$5/ea. G Wachter, KFYI, 602-258-6161.

Pams Jingles ref tapes, 1951-1976, BO. R Kaufman, Pams Productions, POB 462247, Garland TX 75046. 214-271-7625.

Scotch carts (1000), music lengths, \$2 ea; (2) 500 wire rack cart Carousels, \$150 ea. J Vavrick, KSYZ, Grand Island, NE. 308-382-0108.

Fidelipac Red & Aristocart Blue carts, 528 :40 & :70; Fidelipac TR-96 cart storage rack; Aristocart AW-20 plastic cart storage racks (25), new. FB Nienow, WYTE, POB 1030, Stevens Point WI 54481. 715-341-8838.

Polyester/mylar tape, hundreds of 7" reels, all in boxes, some original, unopened, some recorded on, have 1200, 1800, 2300 & 3600' reels, BO. M Shlank, POB 850, Orange CT 06477. FAX 203-937-5961.

Approx 1000 carts, various lengths & brands including Fidelipac 300, Master Cart & Scotch Cart, most in good shape all in service, \$1 each. D Goodale, WJRI, POB 1350, Lenoir NC 28645. 704-754-5361.



Fidelipac Gold Master carts, several hundred music lengths w/dies & Big Band music, 2:30's, 3:30's & 4:30's, \$1.20 per cart. E Moody, KESE, 216 N Main, Bentonville AR 72712. 501-273-9039.

10.5" R-R's (9) of Elvis Presley's life & music as heard on NBC in the '70s, \$25 ea. G Erway, Erway Bdct Co., 3450 SE Martinique Trace, Stuart FL 34997. 407-283-6871.

Rare collection of Jazz tapes on 7" reels, Basie to Grover, all dbx mastered, no COD's, \$150. D Pulwers, Dave's Price Audio Prods, 310 N Howard St #103, Alexandria VA 22304. 703-751-9346.

Jingle masters (tracks) to Pams jingle packages, series 14, 16, 18, 19, 20, 23, 33 & other, also series pre-record masters, other company masters & demo masters, prime material for serious studio musician or collector in 2 trk & 4 trk format some with dbx Type I NR, \$20/complete inventory list & terms, no rights transfer, sale tape only, \$1500 firm to first buyer. Write to: Radio World, POB 1214, Falls Church VA 22041. Attn Box: 93-10-1RW.

## TAX DEDUCT EQUIP

## Want To Sell

Educational cable FM station needs production boards, carts, TT's, STL equipment & any other equipment. S Marvin, KBCC, 1801 Panorama Dr, Bakersfield CA 93305. 805-395-4523.

Non profit needs all types studio, recording & bdctg equip in working condition, educational use, will pay freight & give receipt. Dr Newcomb, 216-548-2053 or 216-893-4125.

High school radio station in Washington DC looking for tax deductible donation of 1 kW Am transmitter or amp. will pay shipping or pick up. M Jeakins, JSC Corp/Metcon, 13102 New Parkland Dr, Herndon VA 22071. 703-709-9084.

Christian mission needs all equip for Class A FM station incl 175' guyed tower, will pay shpg or pick up. L Harper, Western Indian Ministries, POB F, Window Rock AZ 86515. 505-371-5587.

FT educational college needs equipment including cart machines, telephone hybrid, consoles, microphones, etc in working order, tax deductible. E Slater, WNTI, 400 Jefferson St, Hackettstown NJ 07840. 908-852-4545.

Grant-a-Wish Foundation, non-profit helping children with life threatening illnesses, seeks donated 3/4" editing & character generator & production equipment for PSA. Call 1-800-933-5470 or FAX 1-410-242-8818.

## TEST EQUIPMENT

## Want To Sell

HP 120B X-Y oscilloscope; Tektronix 602 X-Y-Z scope, BO. Dave, Allmake Prods, 6130 S Dehmel Rd, Franklennuth MI 48734. 517-652-6863, lv mssg.

## MARATHON PRODUCTS COMPANY

## Audio Cartridge Rebuilding Division

Rebuilding/reloading, like new, all brands, any length up to & including 3.5 minutes, \$1.95 ea. FOB out plant, 48 hrs delivery. (New rate effective 9/1/93)

New NAB Marathon cartridges prices on request.

35 Years professional experience!  
Lifetime member AES R.D. MYERS Sr.  
Manufacturers of Audio Devices,  
Continuous Tape Mag.

69 Sandersdale Rd. Charlton, MA 01507  
1-508-248-3157 or 1-508-853-0988

Circle (133) On Reader Service Card

## TRANSCOM CORP.

Serving the Broadcast Industry Since 1978

Fine Used AM & FM Transmitters  
and Also New Equipment

For the best deals on Celwave products,  
Andrew cable and Shively antennas.

1 kW FM 1978 Collins 831C2	1 kW AM 1974 Harris BC1H1
2.5 kW FM 1978 CCA 2500R	1 kW AM 1978 Harris MW1A
3 kW FM 1975 CCA 3000D	1 kW AM 1988 Harris SX1A
3 kW FM 1974 Harris FM3H	2.5 kW AM 1982 CCA 2500D
5 kW FM 1968 Harris FM5H	2.5 kW AM 1976 McMartin BA2.5K
10 kW FM 1976 Harris FM10H3	5 kW AM 1979 Harris MW5A
25 kW FM 1981 Harris FM25K	5 kW AM 1968 Harris BC5H
	5 kW AM 1979 Cont. 315F
	5 kW AM 1977 RCA BTA 5L

1077 Rydal Road #101  
Rydal PA 19046

800-441-8454 • 215-884-0888 • FAX No. 215-884-0738

Circle (76) On Reader Service Card



**TEST EQUIPMENT...WTS**

Fluke 8012A true RMS digital multi-meter with battery opt & low ohm range, \$135; Tektronix 5441 50 MHz storage scope with dual timebase & differential input high sensitivity 1 Mhz audio plug in, \$295. G Wachter, KFYI, 602-258-6161.

**We Have RENTAL EQUIPMENT available to SAVE YOU MONEY**

Spectrum Analyzer  
Potomac Field Strength Meters  
Impedance Bridges  
Receiver/Generator  
Audio Test Set

ALSO

Other Equipment Available

**RADIO RESOURCES**

Ask for STEVE, BILL or Chuck  
**1-800-54-RADIO**

Heath 5G1275 lin/log sweep generator & SMS258 distortion analyzer factory wired, mint condition, \$325/both. 708-448-1790.

**Want To Buy**

AM field strength meter in gd cond, prefer Potomac mdl but will consider others. D Palmer, POB 128, Moberly MO 65270. 816-263-9390.

Manke M-1 wow & flutter meter in gd cond, top dollar paid. E Davison, 217-787-0800.

**TRANSMITTERS**

**Want To Sell**

Harris TE-3 solid state FM exciter, \$500. C Frodsham, KVSF, POB 7, Beloit KS 67420. 913-738-2206.

RCA BTA-5T on-air at 590 kHz with spare parts & manuals, avail 10/1/93, \$5000. K Harvey, KAQQ, E 300 Third Ave, Spokane WA 99202. 509-459-9800.

**DEMOED EQUIPMENT**

BEXT Inc. has a few demoed exciters, amplifiers and STL's for sale. All demoed systems are sold first come first served and have the same 2 year warranty as BEXT's new equipment. For information:

**619-239-8462**

Gates BC5-P 5 kW AM for parts, will sell any or all parts, very low price. Goodrich Ent, 11435 Manderson St, Omaha NE 68164. 402-493-1886.

Gates BC-5P 5K AM in service on 1220 kHz, \$5700. S McGrath, WGNV, 429 Little B Rd, Newburgh NY 12550. 914-561-2131.

TTC/Wilkinson 2500E 1983 FM with exciter, stereo generator & spare final, available mid Sept, \$5000/BO. G Blum, KOLV, Box 6, Olivia MN 56277. 612-523-1017.

300 and 500 WATT FM AMPLIFIERS & MODULES from \$550  
**BROADCAST TECHNOLOGY**  
(719) 336-3902  
Fax (719) 336-4726

Tepeco J317(M) FM in excellent condition, \$1455, also has mod card for local 30 sec/hour announcements, \$480. C Damon, KWST, POB 1890, Flagstaff AZ 86002. 602-774-5559.

Gates FM5H, rebuilt 11/90, 95.9 mHz, no PCBs with McMartin BFM 8000 exciter, currently on air, available 9/93, \$14,000. R Miller, Miller Media Group, 111 W Main Cross, Taylorville IL 62568. 217-824-3395.

Harris FM 5H, good condition, \$10000; Harris FM 5K, \$15500; Harris MX-15 exciter, excellent condition, \$3000; Energy-Onix SST-30 exciter, \$2000. R Michaels, KQFX-FM POB 8862, Amarillo TX 79114. 806-355-1044.

10 watt PA for Harris TE-1 or TE-3, updated version, never used, \$450. P Ryan, KYMC, 2122 Marconi Ave, St Louis MO 63110. 314-664-7080.

Compression/limiting device for low power AM mono travelers info radio station in useable cond. A Anello, 813-933-6009.

CSI 5000E FM transmitter, rebuilt in 1990 due to lightning damage, has been in perfect service until 3/93 when we upgraded, \$8000. H Beam, WAey, POB 5588, Princeton WV 24740. 304-425-2151.

**NEW McMARTIN BF-5K**  
Lowest priced tube replacements



5500 W FM, broadband grounded grid output circuit, VSWR protection, excellent efficiency 75-80% automatic recycling & overload status. Fully remote controlled. FCC approved to 5500 watts.

**Goodrich Enterprises, Inc.**

11435 Manderson Street  
Omaha, NE 68164  
402-493-1886  
FAX: 402-493-6821

Gates BC1G to sell of trade, needs work, BO. R Carr, KXLE, 1311 Vantage Hwy, Ellensburg WA 98926. 509-925-1488.

McMartin BA-1K 1 kW AM transmitter tuned to 1450 kHz, was on air until 3/93, currently kept in AC'd room, great condition, \$6000. R Vega, WOCN, 350 NE 71st St, Miami FL 33138. 305-759-7280.

Henry 3000-95D 3000 W FM transmitter, tuned to 97.5 MHz, full remote control, new cond, \$8000. R Wright, WLLX, 1208 N Locust Ave, Lawrenceburg TN 38464. 615-762-6200.

**FM - TRANSMITTERS**

Factory new not used. Why buy a used Transmitter when you can own a new FM Transmitter for about the same cost? Call JIMMIE JOYNT at 214-335-3425.

Rockwell/Collins 828E-1 5 kW, 3ph AM transmitter with 500 W option, on 1440, spare tubes, new 70 kHz filter, 3ph loss kit & other spares, great cond, currently on air, \$15000/BO. M Martindale, KVON, 1124 Foster Rd, Napa CA 94558.

ITA FM-15000 ITA FM power amp, 15000 W output, complete with power supply, BO. A Weiner, WHVW, 507 Violet Ave, Hyde Park NY 12538. 914-471-9500.

CCA 1000D FM transmitter with SI-10E exciter & TRC-15 Moseley remote control. W Wright, WTZE, POB 69, Tazewell VA 24651. 703-988-4150.

Exciters: McMartin 8-910 tuned and calibrated to your frequency, guaranteed. Mono, stereo, SCA, Goodrich Ent. Inc. 11435 Manderson St, Omaha, NE 68164. 402-493-1886 FAX: 402-493-6821

Major market general manager with the right experience, skills & abilities. History of successes & turnarounds. Excellent credentials & references. Station sold and I'm available! Write to: Radio World, POB 1214, Falls Church VA 22041. Attn: Box #93-10-13-01RW.

RCA BTF-50 new single phase power supply with manual & harmonic filter tuned to 90.5, extra tube. J Waugh, WHVT, POB 273, Clyde OH 43410. 419-547-8254.

Gates FM1C 1 kW FM w/M6146 stereo gen & M6095 exciter. J M Kissick, WYNI, 201 Office Park, Monroeville AL 36460. 205-575-9964/9966.

CCA Electronics has the following equipment for sale: CSI-3000E 3KW FM transmitter with EX-20F exciter; Harris FM2.5K 2.5 KW FM transmitter with MX-15 exciter. Contact Steve or Howard, 404-964-3530.

**Want To Buy**

10 kW AM. George, WNQM, 1300 WWCW Ave, Nashville TN 37218. 615-255-1300/1377.

50 watt carrier current xmt, metered line coupler & power splitters. P Ryan, KYMC, 2122 Marconi Ave, St Louis MO 63110. 314-664-7080.

Broadcast/Shortwave 1-3 kW AM needed such as Gates HF-1M, BC-1G or similar Collins equipment in working cond. G Lee, Radio KE6MS, HT Inc, 6345 Balboa Blvd, #111 Ste 270, Encino CA 91316. 818-774-9497.

Collins 310-Z2 modulator card. W Blackwelder, Broadcasters Unlimited, 3810 Brookside Dr, Tyler TX 75701. 903-581-0606 x 642.

Harris THE-1 wanted in good operating condition. F Nymeyer, KPER-FM, 1423 W Bender, Hibbs NM 38240. 505-393-1551.

25/30 kW FM & 50 kW AM with phasor, etc for 3-tower DA-1 project, older units OK if good condition & well maintained. B Zellmer, KSIR, Box 2475, Greeley CO 80632. 303-353-6522.

RCA Mdl ACT-150, pre-war, pair of 808s modulating a pair, all in a short rack, information also wanted, not a dealer, private. P Courson, 202-736-9548.

Collins 820 F1 10 kW AM transmitter in good condition. George, WNQM, 1300 WWCW Ave, Nashville TN 37218. 615-255-1377/1300.

McMartin AM/FM xmt, any model, exciter or stereo modules. Goodrich Ent., 11435 Manderson, Omaha NE 68164. 402-493-1886.

**TUBES**

**Want To Sell**

Eimac 3CX1000A7/8283, need several to complete scientific project, full output polls OK. R Stankus, Mid-Lo Bdcg, 10616 Savoy Rd, Richmond VA 23235. 804-320-1130 after 5.

**D and C Electronics Co.**

**Lowest Price on Tubes including:**

4-1000A/3-1000Z/  
8B77/4CX250B/833A  
4-500/5-500/4-400/  
4CX3500/5CX1500  
and much more!  
Factory Warranty!

**1-800-881-2374**  
**(904) 688-2374**

Se habla Español  
FAX: (904) 683-9595

Eimac 4-400C (2) new in box, \$125/ea; GE 833A never used, no box, \$75. E Duellman, WOMT/WQTC Radio, POB 1385, Manitowoc WI 54221. 414-682-0351.

**REBUILT ELECTRON TUBES**

Partial List: 6623, 23791, TH150, 6425F, 5604, 6696, 6697, 5681, 5682, 5671, 7804, 3CX10,000H3, 3CX20,000H3, 4CX5000A, 4CX35,000C

Worn out power tubes purchased

**Vacuum Tube Industries, Inc.**

**1-800-528-5014**  
**508-584-4500 X75**

4-1000A, 8B77, 4CX250B, 4CX1500B, 4CX3000A & more. We carry large inventory all major brands, Eimac, Amperex, RCA, etc. Call Stew 1-800-842-1489.

## ACTION-GRAM

**Equipment Listings**

Radio World's Broadcast Equipment Exchange provides a FREE listing service for radio stations and recording studios only. All other end users will be charged. Simply send your listings to us, following the example below. Please indicate in which category you would like your listing to appear. Mail your listings to the address below. Thank you.

Please print and include all information:

Contact Name \_\_\_\_\_  
Title \_\_\_\_\_  
Company/Station \_\_\_\_\_  
Address \_\_\_\_\_  
City/State \_\_\_\_\_  
Zip Code \_\_\_\_\_  
Telephone \_\_\_\_\_

I would like to receive or continue receiving Radio World FREE each month.  
 Yes  No

Signature \_\_\_\_\_ Date \_\_\_\_\_

Please Circle only one entry for each category:

**I. Type of Firm**

- D. Combination AM/FM station
- A. Commercial AM station
- B. Commercial FM station
- C. Educational FM station
- E. Network/group owner
- F. Recording studio
- G. TV station/teleprod facility
- H. Consultant/ind engineer
- I. Mfg. distributor or dealer
- J. Other

**II. Job Function**

- A. Ownership
- B. General management
- C. Engineering
- D. Programming/production
- G. Sales Manager
- E. News operations
- F. Other (specify) \_\_\_\_\_

Brokers, dealers, manufacturers and other organizations who are not legitimate end users can participate in the Broadcast Equipment Exchange on a paid basis. Line ad listings & display advertising are available on a per word or per inch basis.

WTS  WTB  Category: \_\_\_\_\_

Make: \_\_\_\_\_ Model: \_\_\_\_\_

Brief Description: \_\_\_\_\_

Price: \_\_\_\_\_

\*Closing for listings is the first and third Fridays for the next month's issue. All listings are run for 2 issues unless pressed for space or otherwise notified by listee.

**Broadcast Equipment Exchange**

Phone: 703-998-7600 PO Box 1214, Falls Church, VA USA 22041 FAX: 703-998-2966

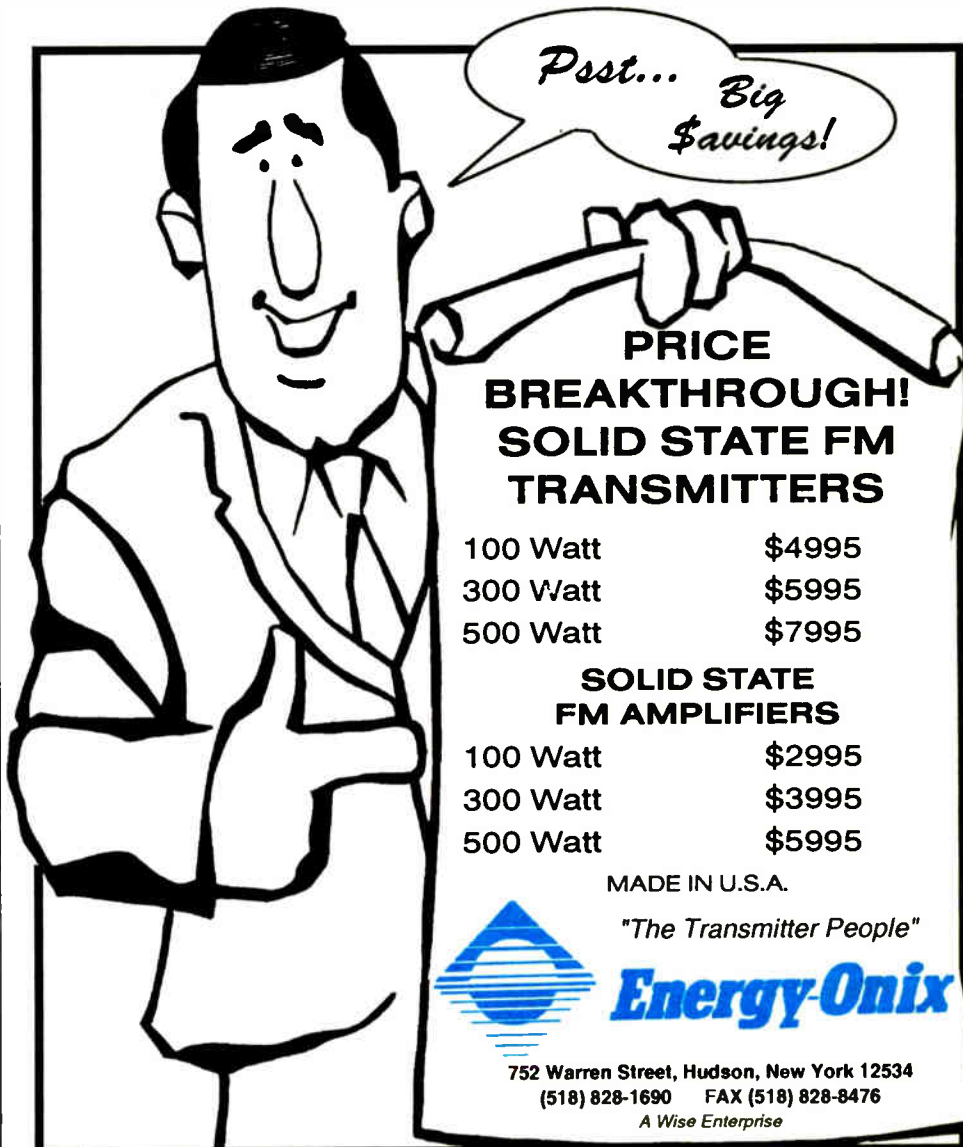

*Post... Big Savings!*

**PRICE BREAKTHROUGH! SOLID STATE FM TRANSMITTERS**

100 Watt	\$4995
300 Watt	\$5995
500 Watt	\$7995

**SOLID STATE FM AMPLIFIERS**

100 Watt	\$2995
300 Watt	\$3995
500 Watt	\$5995

MADE IN U.S.A.

*"The Transmitter People"*



752 Warren Street, Hudson, New York 12534  
(518) 828-1690 FAX (518) 828-8476  
A Wise Enterprise

Circle (132) On Reader Service Card



**TUBES...WTS**

**For the Best Price**  
& 24 Hr service on transmitting tubes  
call 402 493 1886 day or night. FAX 402  
493 6821.



3CX1000A3, 3CX1500A7,  
3-500G, 4CV10000C,  
4CX1000A, 4CX1500B,  
4CX1000D, 4CX250B,  
4CX300A, 4CX35000C,  
4CX350A, 4CX5000A,  
4-400A, 4-400C, 572B,  
6146B, PL328/TH328,  
PL347/TH347, 807, 813,  
833A, 833C, and more...

**CALL**  
**1-800-783-2555**  
**JOLIDA INC.**  
Annapolis Junction, MD

**ECONCO**

Quality  
Rebuilt Tubes  
Approximately 1/2 the  
Cost of New

Call for Our Price List  
**800-532-6626**  
**916-662-7553**

**FAX 916-666-7760**

Circle (24) On Reader Service Card

**Want To Buy**

VACUUM POWER TUBE REBUILDERS SINCE 1940

**Freehand Products, Inc.**

"If you don't need  
TO SAVE MONEY  
we can't help you."

However,  
if saving money  
interests you...  
**WE CAN  
REBUILD  
YOUR DUDS  
(used tubes)  
for about  
1/2 the cost  
of new tubes!**

Call TODAY  
1-800-624-7626  
For a FREE  
Information  
Packet

WE BUY MANY TYPES OF USED TUBES

**WANTED: TUBES**

I pay cash or trade for all types of  
transmitting or special purpose tubes.

**Nobody pays more  
or faster than us!**

Mike Forman  
1472 MacArthur Blvd.  
Oakland CA 94602

**(510) 530-8840**  
**FAX: 510-530-0858**

**TURNTABLES**

**Want To Sell**

**Ruasco fpsb fidelity pro stereo turntable pre amp, new, \$75. 708-448-1790.**

**Presto 6N lath, 500 ohm cutter, \$200; Presto M8 cutter, complete in case, \$120. J Parsons, Parsons Snd Svc, 2781 Fayson Circle, Deltona FL 32738. 904-532-0192.**

**JVC 4-DD-5 CD4 disc demodulator, low hrs, \$80/BO, no COD's. D Pulwers, Dave's Price Audio Prod, 310 N Howard St #103, Alexandria VA 22304. 703-751-9346.**

**Want To Buy**

**Eimac 3CX1000A7/8283 tubes, R Stankus, Mid-Lo Bdctg, 10616 Savoy Rd, Richmond VA 23235. 804-320-1130.**

**SME-3012 & other 16" tonearms, rod cutting lathes & heads, Fairchild 602/670 limiters, 45/78 records. Kim, 612-866-6183.**

**Need info on adding variable speed cntrl to Technics SP-10 turntable. R Robinson, 203-269-4465.**

**Fairchild 16" TT, 33/45 ips, \$100-125. H Sewall, Oakridge Music Recdg Svcs, 2001 Elton Rd, Ft Worth TX 76117. 817-838-8001.**

**Advertising Space Available!**

Call Today!  
**1-800-336-3045**  
for rates & information

# AM Stereo Conversion and Maintenance Finale

► continued from page 36

Transmitters differ widely in the amount of delay and amplitude equalization required for proper stereo operation, so exciter manufacturers provide a wide range of controls. There are no rules to follow when setting the equalization. Trial and error is the only way. Just follow the exciter manufacturer's instructions.

There are three types of equalization normally provided in a C-QUAM exciter. Group delay is used to provide a constant time delay to either the L+R or L-R signal paths, depending on which arrives at the modulator first. This primarily affects the low- to mid-frequency range.

Low-frequency equalization, the least-often-used method, is only necessary if the frequency response of the L+R path is not uniform (such as in older plate-modulated transmitters, where the reactance of the plate transformer causes phase and other nonlinearities).

High-frequency equalization is designed to complement the complex high-frequency response shape of most AM transmitters. This is the most difficult adjustment of the installation process. There may well be so many bumps and dips in a given transmitter's high frequency response curve, that it will be nearly impossible to correct them all. You will probably find a compromise is necessary, making the best of what is available work for all frequencies.

An X-Y oscilloscope is needed to successfully equalize an AM stereo installation. The X channel is connected to the left channel output of the AM stereo modulation monitor, and the Y channel to the right. Amplitude and phase errors will be readily visible on such a display, and the results of any adjustments you make can be quickly evaluated for good or bad.

Set the exciter's L+R (or envelope) level to get the correct amount of modulation for a corresponding L=R input. Feed a 1 kHz tone to both channels of the exciter with the left and right channels equal. Set the level such that the L+R meter on the exciter indicates 50 percent. Then adjust the L+R output of the exciter so that the L+R modulation as indicated on the modulation monitor equals 50 percent.

Next, feed a 1 kHz tone to the left channel only at a level equivalent to 50 percent amplitude modulation. The scope should show a horizontal line. If the line is seriously bowed, it is likely that the polarity of the L+R feed to the transmitter is reversed.

**Good separation**

Start the adjustments necessary for good separation by inserting and adjusting the coarse and fine L+R or L-R group delay controls so that the loop in the horizontal line closes as much as possible. Adjust the L+R output level of the exciter so that the display lies exactly on the horizontal.

Feed a 1 kHz tone to only the right channel input of the exciter at 50 percent amplitude modulation. The scope should show a vertical display with only phase error. Now insert the same type of group delay (L+R

or L-R) as was used for the left channel and adjust for a closed display.

It is a good idea to check the low-frequency separation at this point. Feed a 100 Hz tone to first the left, then the right channel only as with the previous two steps and observe the display on the scope. If the separation has degraded significantly, use the low-frequency equalizer to correct the problem. Be sure to recheck the 1 kHz separation again if you make low-frequency equalization adjustments, readjusting the group delay controls if necessary.

High-frequency equalization is achieved with the left-channel high-frequency equalization controls set at minimum. Insert the HF equalization circuitry into one of the paths. Input 7.5 kHz left channel at 50 percent envelope modulation.

Adjust the HF equalization and/or switch it to the other path until the display closes. Reset to 1 kHz and reset the group delay to regain good mid-frequency separation. Repeat this procedure until the 1 kHz and 7.5 kHz are equalized for phase.

Once this is done, you should use the HF peaking and HF cutoff controls to place the display on the X axis with minimum phase error at 7.5 kHz. Adjust the group delay control at 1 kHz to compensate. Repeat for the right channel.

This sounds difficult and time consuming, but it need not be if you are set up to switch quickly between left only, right only and L=R with your tone generator. If there are no transmitter problems (such as IPM), you can run through the whole procedure in less than an hour.

Once all the equalization adjustments have been made, run a full stereo and mono proof of performance. Pay particular attention to high-frequency distortion—you may have to sacrifice a few dB of high-frequency separation to obtain acceptable (less than 3 percent) THD at higher frequencies.

**Maintenance**

AM stereo installations typically require little in the way of routine maintenance. Watch for changes that affect the transmission system phase and amplitude response. Anytime such a change occurs (such as in common point impedance), it is a good idea to check the stereo performance and adjust accordingly.

Some manufacturers recommend two stereo-performance checks a year. This will help you keep on top of any variations that occur as a normal part of equipment aging.

Conversion to AM stereo is certainly no plug-and-play operation. It requires a lot of planning and, in some cases, a substantial investment. The end result, however, is often a big improvement in the station's mono sound plus the obvious stereo capability. Now that we are about to have a standard, stations making the conversion will reap the dividends of better sound and performance.

□ □ □  
*Cris Alexander is director of engineering for Crawford Broadcasting. He can be reached at Box 561307, Dallas, TX 75356.*

# ADVERTISER INDEX

This listing is provided for the convenience of our readers.  
Radio World assumes no liability for inaccuracy.

Page No.	Advertiser	Reader Service No.	Page No.	Advertiser	Reader Service No.
14	AMP Services	141	6	Harris-Allied	38,172
32	APT	33	27	Harris-Allied	44,162
7	ATI	206	1	Harris-Allied Broadcast Equipm	104
24,25	Arrakis	121	12	Inovonics	154
14	Audio Broadcast Group	126	29	J Squared Technical Service	18
3	Audio Precision	20	40	J&I Audio/Video	66
47	Audioarts Division of Wheatsto	212	40	JT Communications	73
2	Audioarts/Div. of Wheatstone C	56	29	LDL	189
36	Audiopak	124	44	Marathon	133
18	Auditronics	68	37	Micro Technology Unlimited	220
35	Belar	36	19	Murphy Studio Furniture	7
27	Bext	85	26	Myat	200
14	Broadcast Devices	184	23	National Public Radio	25
7	Broadcast Electronics	88	34	Orban/AKG/dbx	209
8	Broadcast Electronics	145	31	Pacific Recorders	57
4	Burk Technology	157	14	Pioneer	69
30	Burk Technology	4	12	Potomac Instruments	49
35	CCA Electronics	80	22	OEI	218
21	California Digital	81	11	RE America	31
14	Cellcast Communication Product	16	40	Radio Resources	10
28	Clark & Associates	11	17	Radio Spirits	12
28	Comrex	109	16	Radio Systems	186
3	Comrex	142	19	Radio World House Ad	
13	Continental Electronics	92	14	Russ Friend & Associates	60
14	Cortana	108	29	S.C.M.S	42
33	Cutting Edge	195	20	SMARTS Broadcast Systems	211
17	Dalet	137	8	SMC Wireless	59
11	Dataworld	192	15	Scott Studios Corp.	148
	Dataworld	1	28	Shively Labs	61
20	Dick Brescia Associates	94	29	Stephens Communications	214
28	Dielectric	140	29	Svetlana Electron Devices	198
29	Econco	202	9	The Management	101
46	Econco	24	28	The Management	71
45	Energy-Onix	132	44	Transcom Corp.	76
10	Fidelipac	203	14	Valley Audio Products	144
39	Fidelipac	175	48	Wheatstone	152
29	Gorman Redlich	58	29	Zercom	84
40	Hall Electronics	219			

Publisher .....	Stevan B. Dana	Production .....	Vicky Baron, Lisa Lyons, Lisa Mamo
Associate Publisher .....	Carmel King	Ad Coordinator .....	Regan Deatherage
Marketing Consultant .....	Al Leon	Ad Coordination Manager .....	Simone Mullins
Marketing Assistant .....	Annette Deutscher	Circulation Director .....	Tiana Hickman
Production Director .....	Kim Lowe	Circulation Manager .....	Rebecca Seaborg
Production Manager .....	Julianne Stone	Accounts Receivable .....	Steve Berto

**Advertising Sales Representatives**

U.S. East: Skip Tash .....	703-998-7600 Fax: 703-998-2966
U.S. West: Dale Tucker .....	916-721-3410 Fax: 916-729-0810
International: Stevan B. Dana .....	+1-703-998-7600 Fax: +1-998-2966
Europe: Dario Calabrese .....	+39-2-753-0274 Fax: +39-2-753-2697
Japan: Eiji Yoshikawa .....	+81-3-3327-2688 Fax: +81-3-3327-3010

Free Subscriptions are available upon request to professional broadcasting and audiovisual equipment users. For address changes, send current and new address to RW a month in advance at P.O. Box 1214, Falls Church, VA 22041. Unsolicited manuscripts are welcomed for review: send to the attention of the appropriate editor.



# Just RIGHT!

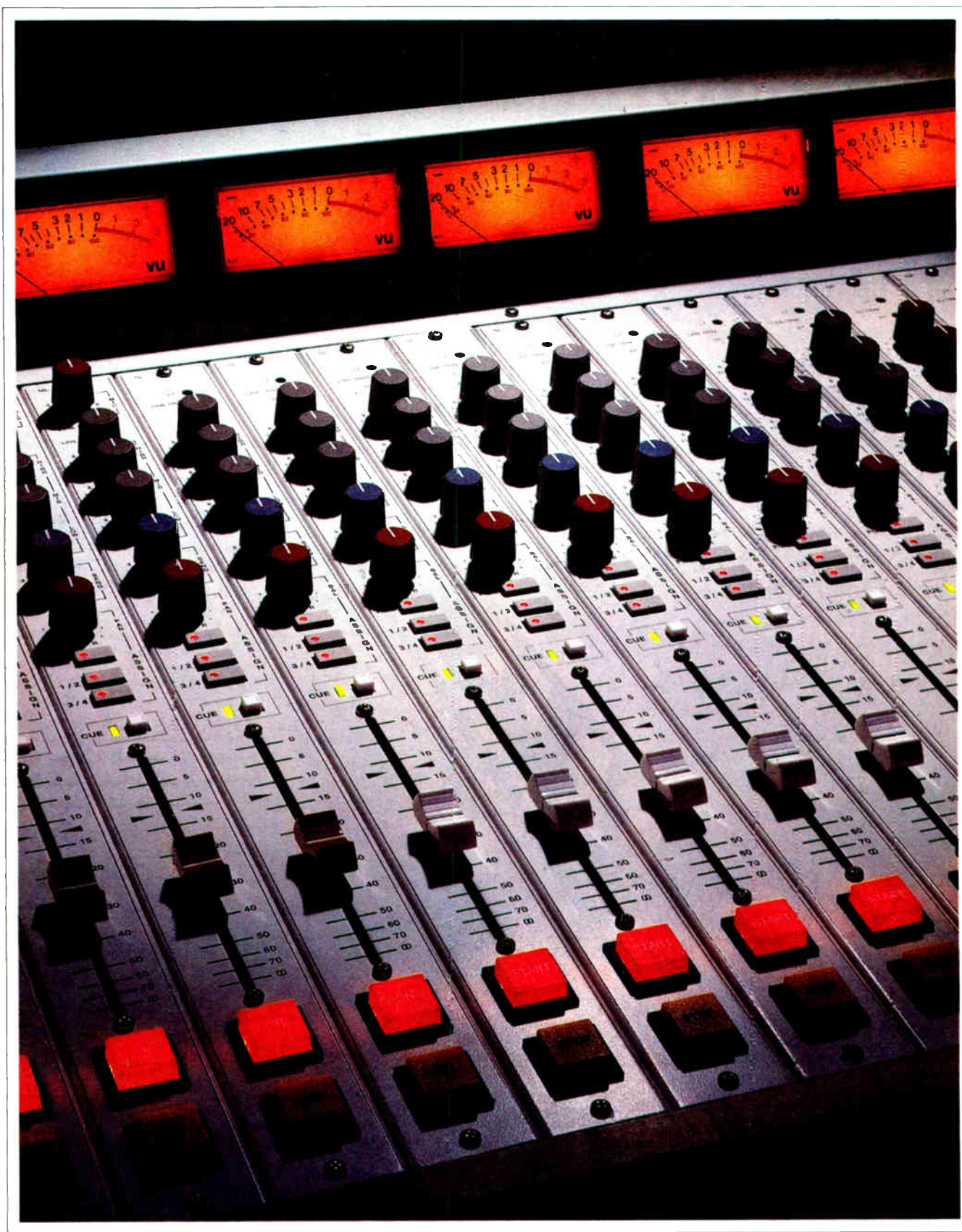

**MR-40**

**MULTI-TRACK PRODUCTION** doesn't have to be complicated. The MR-40 has just the features most stations are looking for: 4-track bus assign for your tape recorder; program assign so you can transfer direct to your 2-track—or go right on-air! It has machine Start/Stops just below the fader like an on-air console, but also includes a 3-band equalizer section so you can have the tone control that a normal radio console couldn't provide. It even has a stereo send bus that follows stereo channel balance controls—ever so important for today's stereo effects devices.

Mono modules have both mic and line inputs: mic for recording and line for track playbacks. Subgroup channels provide fader control for record levels and also have a second

track playback path for really quick sessions. And of course the MR-40 has an on-air type monitor section, complete with control room, headphone and studio outputs, plus all the necessary muting and tally functions you'd want. It even has a built-in cue speaker and power amplifier.

Small format doesn't mean we've cut corners either: all audio switches are gold contact; assign buttons are LED illuminated; all ICs are double burned-in, and all circuits are double-tested—we don't take any chances with reliability! The **MR-40** is a perfect blend of excellence in engineering and sensible size. It's just right for 4-track analog and digital work stations—it can even back up your on-air console! So contact Audioarts.



# Wheatstone Has It!

## Super Performance – Great Price!

**OUR NEW A-300 CONSOLE HAS ALL THE RIGHT STUFF:** Performance right at the limits of technology, the features you want, and a fresh clean look your clients will admire. It's got all the busses you'll need. It's got the crosstalk and bus off isolation you HAVE to have for LMAs and FM/AM combos. Its small footprint and low profile let you conserve valuable studio real estate. Its virtual audio bus™ architecture lets you place any module anywhere in the console—no dedicated slots!

Talent will love our easy-to-learn superphone module and the automated cue system that makes monitoring confusion-free. Our integrated intercom system lets them communicate with any other Wheatstone console or talent location—handsfree.

Your program director will really like the sound of this console: no VCA distortion—just flawless specs. And, because of its ultra-flexible architecture, it can be easily adapted to any format, anytime.

The A-300 has what engineers want: first class documentation, gold switches, gold connectors, a hinged meterbridge for easy re-lamping, straight-forward reliable logic technology, and the best I/O connection and tooling system in the industry.

The A-300 is the console that has followed the evolution of radio. Benefit from Wheatstone's experience and total commitment to your satisfaction. Contact us.



 Wheatstone® Corporation

**A-300**

7305 Performance Drive, Syracuse, NY 13212 (te! 315-452-5000 / fax 315-452-0160)

Circle (152) On Reader Service Card

World Radio History