

## DAB Testing Schedule Delayed

by Randy Sukow

**WASHINGTON** Testing of the five proposed digital audio radio (DAR) systems by the Electronics Industries Association (EIA) and the National Radio Systems Committee (NRSC) was postponed until Dec. 31.

The systems were scheduled to go into the laboratory on Oct. 4 at NASA's

Lewis Research Center in Cleveland for extensive testing extending into summer 1994. But leading in-band, on-channel DAR developer USA Digital said, during an NRSC test procedures planning meeting late last month, it would not be ready to test by the deadline.

The parallel nature of the EIA/NRSC test procedures forced EIA and NRSC to agree to the delay. The plan is for all five

systems to be tested at the same time rather than one at a time. The alternative, proceeding without USA Digital, was never considered.

USA Digital (a consortium of CBS, Gannett Radio and Group W) also said it will not conduct mobile demonstrations of its FM DAR system during the National Association of Broadcasters (NAB) Radio Show in Dallas next month.

The group attracted considerable attention following the NAB spring convention in Las Vegas when the long-anticipated FM mobile demonstration was cancelled. The consortium blamed the cancellation on shipping damage to the system's prototype acoustic charged transport (ACT) integrated circuits (RW, May 26).

The new test date was agreed upon by USA Digital and the other IBOC system developers—Amati Communications and AT&T—a week after the EIA/NRSC planning meeting.

Amati/AT&T and the other three DAR developers—AT&T (which also is building an in-band, adjacent-channel system on its own), Eureka/Thomson Consumer Electronics (L-band, terrestrial system) and NASA/Voice of America (satellite, S-band)—all indicated that they would be ready to test on Oct. 4.

"October, we thought, was late enough. We're a little disappointed that it has been pressed back as far as it has. We've got our stuff working and we'd like to get on with the test," said John Cioffi, vice president of engineering for Amati.

The four rival DAR developers agreed to the delay on condition that it not extend beyond Dec. 31.

"Basically it was agreed that you really can't wait any longer than that date to begin the testing process. It's really going to put people in a bind if it were to go past that," said John Marino, NAB manager, technical regulatory affairs, who monitors NRSC's DAR meetings.

continued on page 29 ▶

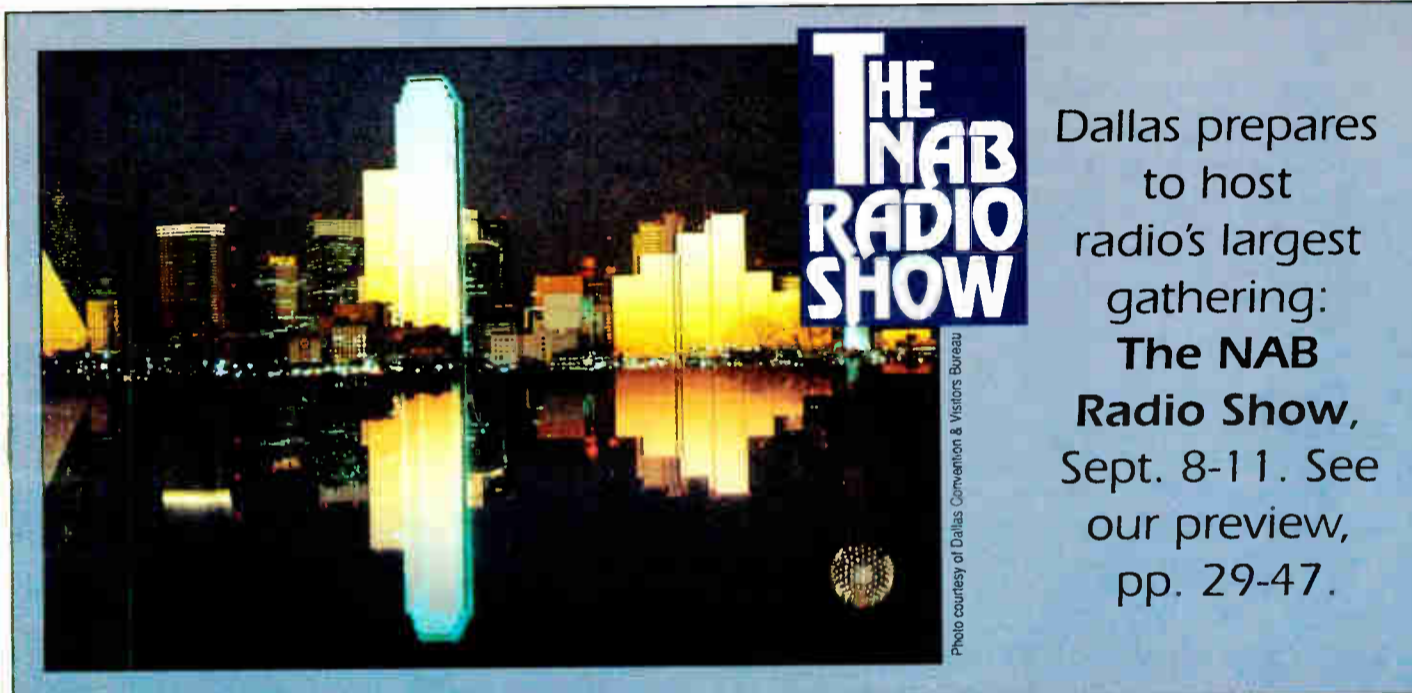

**THE NAB RADIO SHOW**

Dallas prepares to host radio's largest gathering: **The NAB Radio Show, Sept. 8-11.** See our preview, pp. 29-47.

Photo courtesy of Dallas Convention & Visitors Bureau

## 1994 'Super' Show Slated To Start In Los Angeles

by John Gatski

**WASHINGTON** The NAB's fall radio show is about to become a "super" trade show of sorts with an impending

agreement to combine with the Radio Television News Directors Association (RTNDA) and Society of Broadcast Engineers (SBE), starting in 1994.

With the major attendance at the radio show, both SBE and RTNDA see a potential to reduce the costs and improve on the quality of their fall shows. The RTNDA and SBE have collaborated before: during the 1993 show in San Jose and next month in Miami. Joining forces with NAB, however, has much greater potential.

At press time, NAB Senior Vice President of Technology Michael Rau said the agreement with RTNDA had been reached, and the contract with SBE was verbally approved. Each of the associations will conduct independent sessions, have separation registration, but there will be a common exhibit area. The first scheduled show with SBE and RTNDA is set for Los Angeles in 1994.

continued on page 11 ▶



**Running Radio**

Your Resource for Business, Programming and Sales, pp. 13-27

### CCA Broadcast Transmitters

The Standard for Reliability Throughout the World.



**Available FM Transmitters:**

2.5 KW	20 KW
4 KW	25 KW
5 KW	27.5 KW
8 KW	35 KW
10 KW	45 KW
12 KW	

**CCA Electronics, Inc.**  
P.O. Box 426 • 360 Bohannon Road  
Fairburn, Georgia USA 30213  
(404) 964-3530 • FAX: (404) 964-2222

**30 YEARS**

**CCA**

# NEWSWATCH

## Three-Year Rule to Return

**WASHINGTON** Under a new FCC proposal, successful applicants for broadcast licenses in comparative proceedings would be required to operate the stations three years before they become eligible to transfer them.

Prior to 1982, the commission rules had an anti-trafficking provision for at least three years, but it was repealed, with some

exceptions, during the deregulatory climate of the Reagan Administration. Instead, a one-year holding requirement was then put in place.

During deliberations on the extended holding requirement, the FCC also considered a "service continuity preference," in which applicants proposing to own and operate their stations for at least three years would receive comparative credit in hearings for a new broadcast authorization.

That concept was scrapped, however. "The commission further found that the public interest benefits of granting authorizations to those applicants with superior comparative attributes would be enhanced if the public were assured of service from those favored applicants for a longer period of time," the FCC said.

## Asbestos at NAB

**WASHINGTON** The carcinogen asbestos, formerly used in building construction as a fire-retarding agent, has been detected in National Association of

Broadcasters (NAB) headquarters. Asbestos was found during renovation of the sixth floor, where the executive offices, including the office occupied by NAB President and CEO Eddie Fritts, are located.

The D.C. government has been informed of the asbestos find, according to NAB, air-quality readings in the building are currently measured at safe levels.

Fritts will meet with the NAB executive committee later this month to decide how to proceed. One possible option is to move out for up to a year while the building is renovated. A preliminary search for temporary office

space in downtown Washington and Northern Virginia is said to have already begun.

## NAB Employment Seminar

**ATLANTA** The NAB will host a two-day employment/career seminar Sept. 1-2.

The seminar fee is \$40. The seminar is tailored for both broadcast professionals and aspiring professionals who want help assessing where the opportunities are in radio and television today.

For details, contact Karen Hunter or Hatim Hamer at 202-429-5498; or fax to 202-429-5343.

continued on next page ►

# Index

## RUNNING RADIO

Turning Radio's Losers into Winners by Gary Fisher	13
Huie: Radio is Poised for Bright Future by Judith Gross	15
Market Yourself to Ensure Longevity by John Cummuta	16
Spot the Right Personality Type for Sales by Dale Smrekar	17
Request-a-thons for Fun and Profit by Mark Lapidus	18
Learn to Manage Your Time Effectively by Sue Jones	19
Program Syndication	22
Radio Revenue on Upswing	23
Two Remote Monitor Alternatives by Karl Baehr	24
Change Is Intrinsic Part of Radio by Charles Taylor	27

## RADIO SHOW PREVIEW

DAB Testing Schedule Delayed	1,29
Digital Systems Headline Exhibits by Lucia Cobo	29
Sessions to Cover Digital Decision Making by Andy Butler	31
Radio Show Exhibitor Directory	34

## FEATURES

The Long and Winding Road to Harrisburg, Pa. by Al Peterson	48
Positioning Programs Clear the RF Path by Barry Mishkind	49
Some Places Are RF-Safe, Some Are Not by Gray Frierson Haertig	51
Setting Up a Mobile Stereo Studio by Jack Layton	56
FCC Policy Reforms Help AM and FM by Harry Cole	58
Efficient Transmitters Can Beat the Heat by Tom Vernon	61
Making the Large-Diameter Cable Link by John Bisset	65
Eliminating Microphone System Hum by Bruce & Jenny Bartlett	66
Loop Antennas Cut Through AM Noise by Thomas McGinley	68
AM Technology Boosts Shortwave by James Wood	72

## BUYERS GUIDE

<b>User Reports</b>	
KOLD 'Movin' on Up' with Audioarts' A-50 by Marc Musgrove	74
Radio Systems Excels at WJRZ by Mike Moran	75
WSOU(FM) Puts Vanguard to the Test by Michael Collazo	75
PR&E Console First Rate Board by Eric Wiler	76
TPR Targets Wheatstone A-500 by Tom Sittner	78
Dateq BCS 100 Proves Workhorse by William Pawner	80
LPB Receives the Nod-Again by Art Blum	80
<b>TECHNOLOGY UPDATES</b>	
Broadcast Electronics	82
Soundcraft	82
Comrex	84
Ward-Beck Systems	84
Logitek	84
AEO	84
Auditronics	88
Henry Engineering	88
Sony	88
Arrakis	89
Autogram	89
Harrison	89
Neotek	95
Yamaha	95
Fidelipac	95

# Only AUDIOARTS Has It...

**WHEATSTONE'S STRENGTH!** With Wheatstone's professional experience, engineering know-how, support capability and corporate stability behind it, this AUDIOARTS console design is the right choice.

The A-50 is cost effective through clever engineering and the latest advances in CAD design and electronic assembly procedures. It was developed by the same design team that creates Wheatstone's high end equipment. This console's performance is light years beyond the competition.

Naturally, it has all of the most important features: machine control functions, program-mable channel logic, and three busses (Program, Audition, and Telephone). It also has the monitors you need: control room, studio and headphone—each with its own level control. It's designed so you can expand or add accessory modules as your needs grow.

You can benefit from our major market experience. Take advantage of Wheatstone's expertise and reputation; call us today for immediate action.



**AUDIOARTS ENGINEERING**  
7300 Parkside Drive, Swanton, NY 13212 (315) 452-8000 / fax 315-452-0100

# House Debates Revival Of Fairness Doctrine

by Randy Sukow

**WASHINGTON** The Fairness Doctrine, considered to be headed for certain codification by the Congress, could potentially hurt radio stations' coffers as well as their First Amendment rights, according to the Radio-Television News Directors Association.

Controversial talk-radio hosts, such as Rush Limbaugh, could trigger numerous fairness-doctrine complaints and force stations to remove them from their schedules or spend extra to air opposing views to avoid FCC sanctions.

"A lot of radio stations, especially if they don't have the staff to keep track of all these (complaints), are just going to be inhibited from putting on programming that could cause it to have problems with the FCC," said J. Laurent Scharff, RTNDA's counsel and an attorney with Reed, Smith, Shaw & McClay in Washington, D.C. "It may not select a Rush Limbaugh if it thinks its going to have Fairness Doctrine problems because of it."

## For and against

Gigi Sohn, deputy director of the Media Access Project, a strong advocate for a Fairness-Doctrine bill, disputed RTNDA's claim. "I just don't agree with the premise that the Fairness Doctrine is a heavy-handed regulation that puts pressure on talk show hosts or licensees. What it requires is good journalism," she said.

When the rule was in effect, the FCC almost always trusted the editorial judgement of licensees and would continue to do so when it is reinstated, Sohn said.

The Fairness Doctrine, a four-decade-old FCC regulation, was repealed by the FCC in 1987. It reads: "A broadcast licensee shall afford reasonable opportunity for

discussion of conflicting views on issues of public importance."

There is broad bipartisan Congressional support for the doctrine. Congress attempted to codify the doctrine several times after the repeal, but was blocked by President Reagan's vetoes and threatened vetoes by President Bush. The doctrine is expected to have a clear path to enactment under the Clinton Administration.

Congressional support for the doctrine appears to have increased since floor fights over the issue in 1987. Former House Telecommunications Subcommittee member Thomas Tauke (R-Iowa), a key leader in the effort to sustain the Reagan vetoes, no longer serves in Congress.

## A changed climate

Fellow subcommittee member Michael Oxley (R-Ohio), another staunch doctrine opponent in 1987, says he is a convert. "Frankly, over the last few years I've seen so many outrageous examples of tabloid journalism and in some cases a rush to the bottom line, that this member has changed his mind," Oxley said during a Telecommunications Subcommittee hearing last month.

At the same hearing, the subcommittee's chairman, Edward Markey (D-Mass.), issued a draft of a bill he intends to introduce with Energy and Commerce Committee Chairman John Dingell (D-Mich.) and likely several other co-sponsors. It would amend the 1934 Communications Act to include the fairness language.

In the Senate, Commerce Committee Chairman Ernest Hollings (D-S.C.), Communications Subcommittee Chairman Daniel Inouye (D-Hawaii) and ranking Commerce Committee Republican John

continued on page 9 ►

## NEWSWATCH

► continued from previous page

### Viacom, Group W Swap Stations

**NEW YORK** Viacom Radio and Group W Radio have agreed to exchange radio stations in Houston and Washington, D.C.

According to Group W and Viacom's Radio Division, in addition to cash considerations from Group W, Viacom will acquire WCXR-FM and WCPT (AM) in Washington, and Group W will acquire KIKK-AM-FM in Houston.

KIKK is the second-ranked country station in the Houston market, just behind Group W's KILT-AM-FM. Viacom now owns three stations in the District of Columbia: WCXR, WCPT and highly ranked WMZQ-AM-FM, a country station.

### KMOX Helps With Flood Relief Network

**ST. LOUIS** During the recent Midwest flooding, KMOX implemented a relief network to help area victims.

As a clear channel 50,000 watt AM that reaches 42 states, KMOX set up a

nationwide network to raise money for flood victims. KMOX first donated \$15,000 to the St. Louis American Red Cross, then contacted over 30 top-ranked radio stations across the country to help with the effort.

Each station was then responsible for developing a flood relief drive in their market. All proceeds were sent to the Red Cross in Eastern Missouri and Western Illinois.

### Police Chief Fined For Radio Interference

**UNIOPOLIS, Ohio** The FCC has fined the police chief of Uniopolis, Ohio \$18,000 for "malicious interference" to local county police communications.

According to the FCC's Detroit Field Office, Ronald E. Roop of Wapakoneta, Ohio was discovered to have been interfering with Allen County, Ohio sheriff's department radio communications. Roop was transmitting "noises" on the police frequency, investigators said.

Roop was cited for willful transmission without valid station license, malicious interference and refusing to allow inspection of his radio transmitter.

## Your Station Operates 24 Hours a Day So Do We

Meet the Continental Service Team. They are available 24 hours a day, 365 days a year to assist you with solutions to any technical service questions. These people have many years experience troubleshooting equipment in the field and are knowledgeable about all Continental transmitters and accessories.

**Continental offers the best service in the broadcast industry.**

*Dave Chenoweth*

**Dave Chenoweth**

*Ken Branton*

**Ken Branton**

*John Hutson*

**John Hutson**

*Jan Aerts*

**Jan Aerts**

**Service 214-388-5800**



**Continental Electronics Corporation**

P.O. BOX 270879 DALLAS, TEXAS 75227-0879 214-381-7161 TELEX: 73-398 FAX: 214-381-4949

"How can ONE station serve TWO markets and be the best "local station" in both?"

### Solution:

"Our Morning Show co-hosts sound like they're in the studio together, even though they're sixty miles apart - Jim Scollin in Petroskey and Ron Jolly in Traverse City. Our new system lets us cover both markets in a way it takes our competitors two stations to do."

Tom Michaels, Program Director  
WMBN-FM, Petroskey & Traverse City, Michigan

### How are they doing it?

With digital phone service and audio codecs. Powerful savings and great sounding programs are just some of the benefits.

We've got the solution. It's easier than you think, and affordable. We'll give you all the details. Simply.

Call or fax: 1-800-237-1776  
508-635-0401 (fax)

**COMREX**

Specialists in Remote Broadcast Audio Transmission

# Radio Future Boasts All Star Cast

**BALTIMORE** It was one of those hot Washington days when I jumped in my car and headed north on the Baltimore Washington Parkway. My destination was Oriole Park at Camden Yards to soak in the sights and sounds surround-



ing the 64th All-Star Game.

CBS Radio Sports was kind enough to invite me to share in the excitement around broadcasting a real, live baseball game and meet some of the names that still inspire awe in sports history. Yes, that is the real Johnny Bench in the photo with yours truly.

That photo was shot in Babe Ruth's childhood home, a small and beautiful house close to the new baseball park. It has been turned into a museum now, and the bedroom where the Babe was born is cordoned off and displayed as it looked when he was an infant. The house features pictures of his life, both on and off the field, as well as memorabilia and photos of other baseball luminaries.

It is so easy to look back and see the great ones. It seems that now there are those who say that baseball isn't what it used to be. And there are those who say that radio isn't what it used to be. Gone are the Orson Welleses and the Edward Murrows. But my visit with the nice folks at CBS prompted me to think about radio's future.

Think back to radio's infancy. It was nurtured by sports. Play-by-play Pittsburgh Pirates' games were being broadcast by KDKA(AM) as early as August 5, 1921. That same year, KDKA

broadcast the first live, blow-by-blow description of a boxing match, and in October, WJZ(AM) New York recreated the World Series by telephone with Thomas H. Cowan at the mic.

So now AM is struggling. And FM is having its day in the sun. Soon, digital radio will take over and it won't matter (we hope) whether you are AM or FM. Stations will continue to consolidate operations and ownership. But the sound of baseball over the radio on a hot summer day will not change.

Which leads to the inescapable conclusion that radio has to rethink its role in a multimedia world. Your method of delivery is changing—that's a foregone conclusion. But what you put on the air is yours alone to craft and create.



Baseball's Johnny Bench with yours truly.

I, for one, will tune to AM, FM or even cable radio (if I have to) to hear a Jerry Coleman or Johnny Bench paint a picture of Nolan Ryan winding up for a fast ball. Or to hear the crack of the bat against horse hide as Juan Gonzalez sends one into orbit.

And if baseball isn't your bag, there are plenty of other programming options out there. Therein lies the answer. Most people don't care whether they are watching broadcast TV or cable. It is coming out of the same box—the television set.

People aren't going to care (for the most part) whether their radio programming is delivered via digital, analog or "yet-to-be-invented" technology. When they are driving down the road, or setting their clock radios, they just want to know if it is any good. If not, they'll just play a CD or a tape instead.

The stars of radio's infancy—Milton Berle and George Burns (and everyone who followed)—were entertainers. Radio was entertainment and compan-

ionship. Formulas are fine, if they work, but ask yourself, "What do people really want from their radio station?"

Lou Gehrig is gone, but Cal Ripken's exploits are on the radio every summer night. Maybe the Lone Ranger moved to TV, but in each market there is a local morning team that means more to its community than the "Golden Oldies" ever could.

Ask the question, heed the answer and apply it.

★ ★ ★

On another subject, the radio business appears to be on a fast track of record-breaking revenue growth despite a weak U.S. economy. Radio revenue gains surged to 9 percent over last year for the period January through June, according to the latest figures released by the Radio Advertising Bureau. Figures are based on the RAB's radio revenue index of more than 100 markets.

RAB reported local revenue up 9 percent and national up 7 percent for the

first six months. The market experienced its most significant upswing in June, when national revenue topped 14 percent, and local hit 10 percent.

The state of network radio is also something to cheer about: The Radio Network Association reported increases of 7.8 percent for the second quarter and 6.5 percent for the first half of the year.

RAB President Gary Fries attributes the increases to advertisers' recognition of the effectiveness of the medium.



Audio-Technica Corp. announced an international reorganization to optimize its worldwide engineering and marketing programs. As part of that effort, the company named Kazuo Matsushita president of Audio-Technica U.S. Inc.

Philip J. Cajka was promoted to executive vice president and chief financial officer; and Kenneth Reichel was promoted to executive vice president, marketing.

Continental Electronics Corp. appointed Steve Claterbaugh broadcast sales manager for Canada. Claterbaugh will handle all marketing and sales activities for Continental products, services and parts from the company's Dallas office.

JBL Professional appointed Roscoe Anthony as director of marketing communications. Roscoe joined JBL in 1992 as marketing manager.

Donald Jacques was named deputy chief for projects management, Office of Engineering and Technical Operations, at the United States Information Agency's Bureau of Broadcasting (VOA).

## Transmitter Control can be a Bear

You need to make sure you can stay on the air and stay legal. At the same time, you need to keep operating costs under control.

Choosing the right remote control system is the first step.

The ARC-16SA\* from Burk Technology lets you control your transmitter from any phone. You can establish off-premises control points for unattended operation, or supervise non-technical operators by phone. The annual savings can be thousands of dollars.

The ARC-16SA is part of a modular system. For full-time control, add a studio unit. Multi-site options make it easy to control several transmitter sites or even control studio equipment such as program automation.

Call now for your copy of our new catalog, then ask us to show you how we can improve your operation and your bottom line.

Call TOLL FREE  
1-800 255-8090

**BURK**  
TECHNOLOGY

7 Lomar Drive, Pepperell, MA, 01463 (508) 433-8877

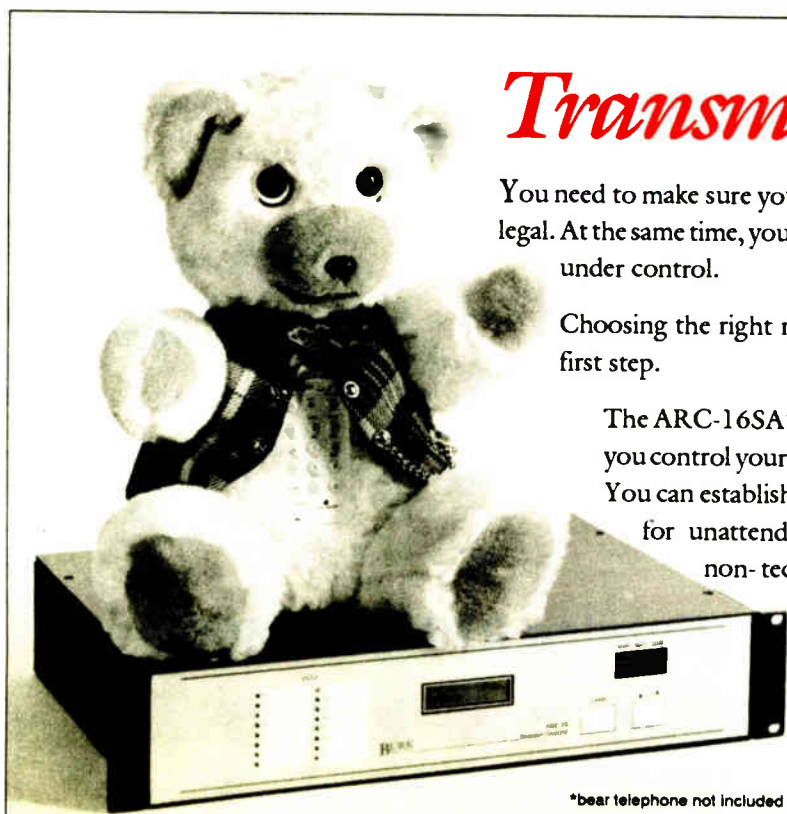

\*bear telephone not included

## READERS FORUM

If you have comments for Radio World, call us at 800-336-3045 or send a letter to Readers Forum (Radio World, Box 1214, Falls Church, VA 22041 or MCI Mailbox #302-7776). All letters received become the property of Radio World, to be used at our discretion and as space permits.

### Off the beam

Dear RW,

As much as we like Barry Mishkind's writing, we feel he has strayed too far from RW's agenda with his computer articles of late.

There is an abundance—indeed a surplus—of computer-related periodicals, magazines and user-net sources for information of prime interest to those who use this equipment.

It's a waste of RW's page space to devote anything more than a passing reference to computers as used in broadcasting. Most, in our experience, are supported by factory and contract staff, and not the radio engineer and broadcast technician we feel your magazine serves best.

Underscoring our point, you'll notice there is little explanation of just what MS-DOS 6 has to do with radio in his article and in the follow up more recently published (RW, April 28 and July 28).

If the focus of Keyboard Connection is the practical application of computers to broadcasting, we wholeheartedly await more articles. But if it is yet another troubleshooter's guide for computer geeks who have little connection with radio, please get rid of the feature in its entirety.

Quentin E. Powell  
Pioneer Engineers  
(Radio Design & Consulting)  
Annapolis, Md.

### Chart, but verify

Dear RW,

The National Association of Broadcasters is commissioning a study to come up with "non-measurement techniques" for broadcasters to use to show their compliance to the new FCC standard to be based on the ANSI/IEEE C.95.1-1992 (RF radiation) standard. This concept of "non-measurement" is disturbing.

Charts can be constructed to show safe distances for transmitter power and anten-

na location, but things can go wrong. Only measurement will guarantee that all is well.

I have been working in preventative maintenance on transmitters over the years and have been interested in predicting problems and failures of various kinds. Safety standards, I personally believe, should be drawn and maintained.

Yes, there is great pressure to minimize the cost. I have been helping out a college radio station that has its antenna on a virtually inaccessible bell tower. It will be expensive to measure the accessible area, but once the area has been properly surveyed, monitoring can be done with less exotic equipment.

I believe this approach would be best for all parties. Charts or computer models could show basically safe areas. Simple test equipment can then demonstrate the levels that are measurable. If any hot spots or changes show up, they could be investigated further.

My experience is that simple, easy-to-make measurements recorded in logs help to track trends and find problems that stand out. The more measurements are repeated, the more confidence can be placed in them.

A second approach would be to place smoke detector-like monitors in affected areas. The drawback would be frequent battery changes. What sort of fine would the FCC give if they were found to be inoperative?

David H. Lawry  
Norfolk, Mass.

### Digital music future

Dear RW,

Please continue your coverage of Digital Music Express and Digital Cable Radio (satellite-delivered digital audio services for cable TV subscribers) as they develop (RW, April 14). I believe, as many others do, that this is the future of radio.

Doug Bell  
Music Services  
BMI, Nashville

### Remote past

Dear RW,

Les Paul's recollections of early tape recorders (RW, May 26) bring to mind some of my early experiences.

I was discharged from the service in May 1945 and was hired by WGY(AM) Schenectady, N.Y., General Electric's flagship station. Late that summer I learned of four custom-built wire recorders at GE's research laboratory. They were not satisfactory for broadcast reproduction, I was told, but I received permission to experiment with one.

It had no volume unit meters. An orange light flickered when the gain was too high. This would start at about 5 1/2 on the gain-control dial.

Once Count Basie (with Sarah Vaughan as his singer) came to the Schenectady Armory. I placed the recorder on the stage ahead of the band. After recording each set for three numbers, I would play it back to check the quality. Finally at about 1/2 on the dial, it came through clear as a bell.

The Count came over as I was testing this final cut and asked, "What do you

## Future Holds Super Radio Show

"Endless ideas... Unlimited contacts." The National Association of Broadcasters (NAB) Fall Radio Show slogan seems appropriate for the annual radio-exclusive gathering (to be held September 8-11 in Dallas). Last year's show saw a widening in the scope of this event with management sessions tackling technical, programming, marketing and regulatory issues.

This year's show seems to have kept that spirit of camaraderie among diverse station elements intact. The agenda is once again full, with sessions and workshops geared toward every facet of radio operation.

What is more encouraging, however, is the announcement of next year's combination of forces by the NAB, the Society of Broadcast Engineers (SBE) and the Radio Television News Directors Association (RTNDA): one exhibit floor, three separate agendas.

For too long, engineers and equipment manufacturers dismissed the fall radio show as the "programmers" show. Broadcast equipment manufacturers now will have a valuable audience to reach. One trip to each of three separate conventions is now a trip to a single convention that has gathered three intended audiences. Cost savings in this arena can lead to more money to spend on development and marketing of products.

The SBE will better serve its members by not using its limited resources on a national convention that was rapidly declining. Last year's SBE gathering drew only 1,005 attendees; many exhibitors closed up booths early and left before the end of the second day.

In the past, this page has encouraged a "cross-pollination" of station personnel: education in the workings of management and news and programming will make an engineer a more valuable idea person, a credible asset that station owners can turn to for more than technical answers alone.

Managers who understand the technical terms and issues (EBS, digital compression, digital audio broadcasting, and workstations, to name a few) are better prepared to protect stations from the economic and technical upheavals that are most certainly to come. If you understand what you're buying, you are less likely to buy what you don't need.

Networking, ideas, the latest in technical wizardry. Both this year's show in Dallas and next year's in Los Angeles offer the best the industry has to offer. Attend the show and reap the rewards.

—RW

have there, man?"

"Dig your band, Count," I responded.

He did. Others gathered around to marvel. Our station manager, George Markham, who gave me permission to use the recorder, was also impressed.

I believe I was the first announcer to carry his own recording machine to remotes. Until then, we had to take the panel van with two 16-inch disk recorders and cut them on the spot.

The picture shows me (dark hair, holding mic head with right hand, sheet of



paper with the left) in October 1945 during what was perhaps the first use of a wire recorder for regular broadcast.

A paraplegic veteran had returned from the service and tradesmen had donated materials to build a home for him. I was there the day painters union worked on the house. I reported on the progress as 40 painters and wrapped up the job within the show's 29 1/2 minutes of allotted time.

I continued to use the same machine for several other remotes: dog shows, turtle races, boat races and local sports.

I was interested in Mr. Paul's recollec-

tion of the first Ampex machines. My recollection is that our government stole the plans for the tape machines from the Germans at the end of the war. They had been using tape while the Americans and British were still in the wire stage.

I recall reading in "Broadcasting" magazine in 1946 that the rights were auctioned to the highest bidder, Brush Soundmirror. The following year, they made the first commercial tape recorders, which were single-track. I had to carry one of them around. They weighed 40 pounds, but the quality was excellent.

I would imagine all tape recording companies would have had to pay royalties to Brush for a while. I recall that within a year or two, Revere introduced the twin-track recorder.

I hope this fills in a few holes on the history of these machines.

George Michael  
Merrimack, N.H.

### Also in Purdue

Dear RW,

We read with interest the recent article, "Purdue U.'s WBAA-FM Goes High Tech" (RW, July 14).

Fred Baumgartner notes that the modulation monitors were of special importance to WBAA-FM and were selected very carefully. The article neglects to mention that the monitors selected were the Belar FMM-2 and FMS-2 FM test set, driven by the Belar RFA-1A FM RF amplifier located 150 feet away from the monitors.

The Belar system was the only modulation test set capable of measuring the superior audio performance (90 dB S/N, +/-0.1 dB frequency response) of WBAA-FM's system.

David C. Hirsch  
Marketing Director  
Belar Electronics Laboratory  
Devon, Pa.

**Radio World**  
Vol. 17, No 16 August 25, 1993

Editor ..... Lucia Cobo  
Managing Editor ..... Randy Sukow  
News/Studio Sessions Editor ..... John Gatski  
Assistant Editor ..... Mary Ann Dorsie  
Contributors ..... Frank Beacham/N.Y.  
Bruce Ingram, Pamela Watkins, Nancy Reist  
Technical Editor ..... John Bisset  
Technical Advisor ..... Tom McGinley  
Editor (International) ..... Alan Carter  
Managing Editor (International) ..... Charles Taylor



Radio World (ISSN 0274-8541) is published semi-monthly by Industrial Marketing Advisory Services, Inc., 5827 Columbia Pike, Suite 310, Falls Church, VA 22041. Phone: 703-998-7600, Fax: 703-998-2966. Second-class postage rates are paid at Falls Church VA 22046 and additional mailing offices. POSTMASTER: Send 3579 forms and address changes to Radio World, P.O. Box 1214, Falls Church VA 22041. Copyright 1993 by Industrial Marketing Advisory Services, Inc. All rights reserved.

—PRINTED IN THE USA—

**Next Issue of  
Radio World  
September 8, 1993**

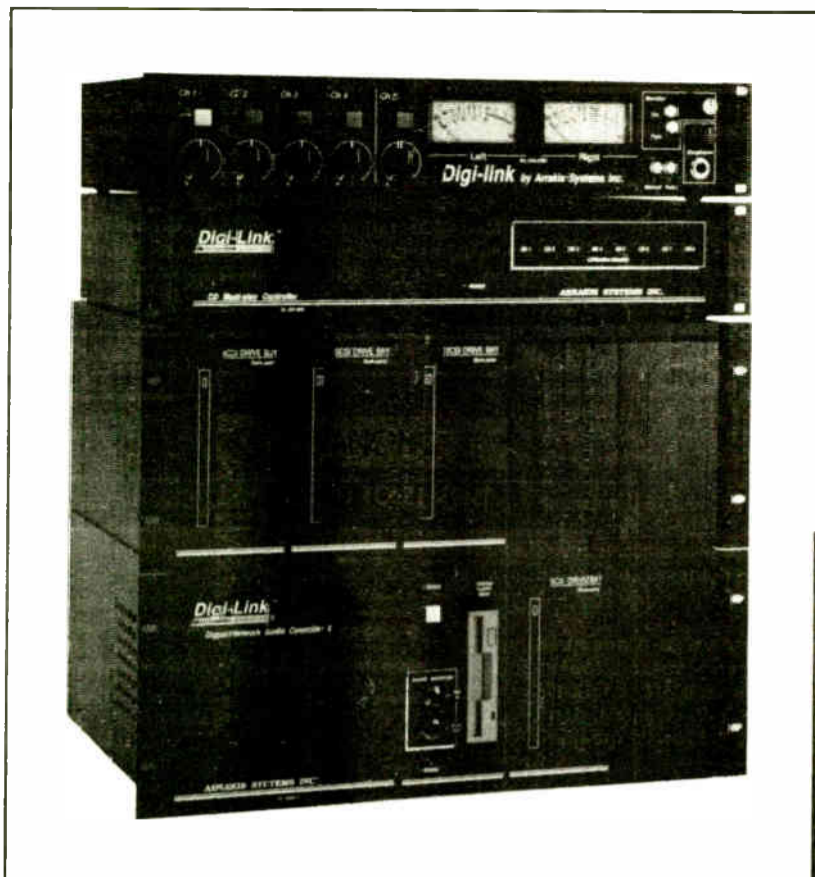

# Digilink...

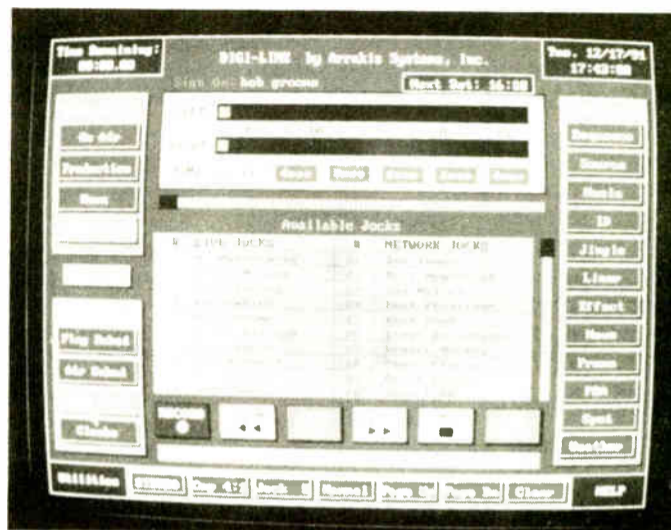

## ...The Worldwide Digital Audio Advantage.

Digilink by Arrakis is a digital audio workstation that saves your station money, reduces maintenance and staffing demands while improving your station's sound and production.

Digilink supports Spanish, French, Japanese, Russian and many other languages.

Digilink is the perfect replacement for magnetic tape based cart or reel machines. Cue virtually instantaneously. Digilink is the perfect audio record and play system for professional radio broadcast applications. And, it costs less than comparable analog cart or reel machines.

Digilink now supports audio overlap and crossfade of HD audio files that dramatically improves on-air sound, allows true HD automation and eliminates the need to edit the majority of files to adjust run times.

Digilink automatically fills stopsets that are too long or too short by intelligently determining if a PSA should be auto-auto selected or if time adjust is all that is required.

For fast and easy walk-away, let Digilink automatically select and schedule your music. Simply schedule or import your traffic and Digilink does the rest.

By typing in the first few characters of a file title, Digilink automatically finds the file which greatly speeds up audio file selection.

Digilink also supports cart rotation in manual, live assist, manual scheduling and schedule import.

With Digilink you can double the number of user definable clocks to handle the most demanding formats. And, the maximum number of satellite and live DJs has been increased to 40.

Digilink also allows imported traffic schedules to include spots not yet produced and will

automatically replace with a PSA if the spot is not produced by air time.

The Arrakis Digilink does all of this plus a whole lot more. Many new features were added and introduced at NAB '93. Contact the digital broadcast professionals at Harris Allied for complete details.

Start saving your station money now, while improving your production and your on-air sound.

8:00 a.m. to 8:00 p.m. EST  
1-800-622-0022  
Fax 317-966-0623

 **HARRIS  
ALLIED**

© 1993 Harris Corp.

Circle (95) On Reader Service Card

World Radio History

See Us At NAB Radio Show Booth 801

## GUEST COMMENTARY

# Use Appropriate Compression Algorithms

*Editor's Note: RW welcomes comments from those within the radio industry and encourages debate on important issues. The following columns discuss stacking of compression (or data reduction) algorithms.*

by Stephen Smyth  
and Mike Smyth

**BELFAST** The introduction of codecs in the broadcast industry recently ignited debate concerning the effects of tandem coding—or stacking—on audio signals.

Audio Processing Technology (APT) has been at the forefront in offering the broadcast industry a digital audio compression algorithm, apt-X100. Therefore, this challenge is of concern to us, and we feel the issue should be addressed.

Our discussion centers around demonstrations reported recently by Herb Squire

at the 1993 NAB show on the poor quality of broadcast audio signals having passed through a multitude of coding schemes in radio broadcast equipment.

Squire attributed the resultant poor quality to incompatibilities between the differing compression algorithms used, and advised that compression not be used.

## Use of algorithms

Why was the quality poor? How may it be fixed?

It is clear that substantial confusion exists as to the problem. Having spent the best part of 10 years researching and developing many different types of audio compression algorithms—including psychoacoustic—we can assure the industry that Squire's audio degradation was in the main, brought about through the inappropriate use of compression in his experimental broadcast chain.

It is true that other factors may slow down or speed up the degradation, for example, keeping the signal in the digital domain or having a common digital interface standard between equipment. However, neither of these factors cause the problem, and at worse may serve as smoke screen to hide the true culprit.

Using only "compatible" algorithms sounds like it should solve the problem, making the simplistic solution to use a standard compressions scheme at every stage in the chain. This would be an attractive answer, particularly for the proponents of the current ISO/MPEG standards. However, it can easily be demonstrated that even these algorithms are incompatible and their use will not solve the problem.

First, what exactly does "compatible" mean? All coding algorithms, including 16-bit linear PCM, introduce noise to the

signal, whether audible or not. With PCM, if the audio signal is transferred digitally via AES-EBU, no further noise will be added.

The problem of different bit-rates can be overcome using PCM sample rate converters, or by reducing the coding resolution. In neither case does the effect of each coding stage accumulate in the signal. Rather the lowest bit-rate stage simply defines either the maximum audio bandwidth or noise floor for the entire broadcast chain.

Similarly, for compatible audio compression algorithms, the lowest bit-rate stage would define either the noise floor or the bandwidth in the same chain. For example, supposing Herb Squire's circuit composed three stages: a 256 kbps channel (satellite feed), a 112 kbps channel (SW-56 telco), and a 256 kbps channel (digital STL). Is there any single codec, or family of "compatible" codecs, that could transmit audio through this circuit in such a way that noise would not accumulate in the signal at each stage?

The answer is definitely no. All codecs, including ISO/MPEG, would have to convert the audio signal back to PCM at each bandwidth mismatch in this chain, adding coding noise each time.

Squire alluded to the source of the problem by mentioning the psychoacoustic background of most (but not all) compression schemes. At each stage compression is achieved by adding noise at certain frequencies using the same basic psychoacoustic calculation.

The result is that as the audio signal passes through multiple psychoacoustic coders, the noise added at each stage accumulates at the same frequencies, sooner or later breaking through and becoming acutely audible due to its tonal quality.

This problem will exist even if only one algorithm (e.g., ISO/MPEG layer II) is used throughout the chain since the signal

## Educated Use Key to Compression Schemes

by Ken C. Pohlmann

**MIAMI** Anyone remotely interested in sports has seen "Squish the Fish" signs at any event in which the opposing team's mascot looks vaguely seaworthy. As a Miami Dolphins' fan, I've come to despise those signs, particularly if they're toted by the dumbest, most unwashed fans in football, Buffalo Bills' fans. All of which brings us to the topic at hand: Data compression and the problem of multiple generations of in-line coding.

No one can seriously question the benefits of digital audio, or the fact that the future will be a completely digitized one. Low noise, highly robust, relatively cheap, sounds great—brilliant stuff, that digital audio.

But digital audio has a bit of an appetite problem; the bandwidth required to convey or store even a modestly high fidelity signal is way beyond analog's demands. To efficiently employ digital audio, compression is mandated for many applications. Thus compression ratios such as 4:1, 6:1, and 12:1 are now common.

## Clever engineering

Thanks to very clever engineering, and the ear's own psychoacoustic limitations, compressed audio's fidelity can rival that of linearly-coded signals. For example, given a 20-bit master recording, a 4:1 recording (with a bit rate of 384 kbps) may be judged superior to a dithered linear 16-bit recording (with a data rate of 1.4 Mbps).

However, at least in one respect, the tremendous efficiency of compressed audio entails a very significant sacrifice. Whereas a linearly-recorded file can be digitally copied or conveyed again and again without degradation, multiple generations of compression can degrade quality.

The problem is a function of the degree of compression, and the method used to achieve the compression. From my own experience, I can say that some systems severely degrade the signal after ten generations, whereas in others the signal is virtually unaffected.

However, the weakness is aggravated, and the question made more complex, when different compression technologies are mixed and stacked one after the other. For example, a chain of devices using dif-

ferent compression methods (cart machine, hard-disk storage, STL, satellite, etc.) may require different compression/decompression methods at each device.

## Incompatibilities exist

These incompatible coding algorithms, each combing through the regenerated signal from the previous algorithms, can severely degrade signal quality. Moreover, in many cases, when the products cannot communicate digitally, analog/digital conversion must be performed for connection in the analog domain. This further degrades the signal.

In an ideal world, a central government would legislate the method in which digital audio is compressed and conveyed. This would virtually eliminate the problem of stacking. However, until the Soviet Union reconvenes, such legislation is not likely. Instead, in a market economy, competing manufacturers must fight it

out. In other words, each manufacturer must build the best possible product.

Algorithms which perform poorly outright must be replaced by better ones. Stacking tests with the same algorithm, and different algorithms, must be performed. Manufacturers must overcome the NIH (Not Invented Here) attitude and band together with compatible products and de facto standards.

For example, given a little cooperation, it could be entirely possible to create data transfer formats containing headers that identify the compression algorithms used on an audio file. As a file passes through an audio chain, its compression history would be recorded and appended to it. Subsequent compression systems could examine this history and select alternate algorithms that would minimize artifacts.

Finally, manufacturers must help educate users; where do problems lie, which

continued on page 10 ►

continued on page 9 ►

## Your Problem Solvers

from **ATI**



- Mike
- Line
- Phono
- Mixing
- Matching
- Metering
- Monitoring
- Processing
- Distribution
- Rack Mounting

**AUDIO TECHNOLOGIES, INC.**

328 W. Maple Ave., Horsham, PA 19044 • (215) 443-0330 • FAX (215) 443-0394



# Who's running the ship?

**U**nattended operation is one way to keep your station profitable, but you still have to mind the store.

The acclaimed Burk Technology ARC-16 Remote Control System is the first step. You can control transmitter and studio from any phone.

But wait. There's more!



**I**ntroducing AutoPilot™ from Burk Technology.

AutoPilot is break-through computer software that makes automatic operation of your studio/transmitter facility a dream come true.

- Automatic power changes
- Automatic pattern changes
- Automatic site changes
- Automatic power trim
- Automatic fault recovery
- Automatic logging

Now your imagination is the only limit.

The new FCC fine schedule is imposing. Why risk a big penalty when AutoPilot can help you stay within the rules?

Call us at 508-433-8877  
or toll free at  
1-800 255-8090  
for more information  
and a FREE DEMO.

# BURK

TECHNOLOGY

Circle (4) On Reader Service Card  
See Us At NAB Radio Show Booth 908

# AMAX AM Tuner Standard Softened

by John Gatski

**WASHINGTON** With few companies being enticed to build high quality AM radios that meet the industry AMAX tuner standard, the standard is being softened so that radios that almost met the original standard can now have the AMAX logo.

A joint standard implemented by the Electronic Industries Association (EIA) and the NAB in 1991, the original AMAX voluntary standard was perceived as a means to convince companies to build better AM sections into their receivers and tuners.

The criteria to be AMAX-certified included a frequency response of 50 Hz to 7.5 kHz, noise blanking, adjustable bandwidth, and external antenna connection. Portables and car radios were certifiable at 6.5 kHz until 1994. AM stereo radios meeting the AMAX conditions were given a separate designation.

## DC-powered radios exempt

The latest standard revision now exempts battery powered portables from having noise blanking, and portables that operate on battery and AC will have until Sep. 30, 1996 to add noise blanking to radios. This means radios such as the GE Superadio, the dual powered, high performance AM and FM mono portable (See RW March 24) can have the AMAX logo now.

Also, the relaxed standard allows portable radio and car radio manufacturers to make products that have response out to 6.5 kHz (plus or minus 6 dB), for two additional years, until Sept. 30, 1996. Originally, manufacturers had until Sept. 30, 1994 to use the 6.5 kHz response, at which time the performance had to be increased to 7.5 kHz to keep the AMAX certification.

Although there was much hope that an AMAX PR campaign by broadcasters would garner public enthusiasm for building high performance AM radios,

it, so far, has not worked, according to an informal poll of manufacturer product lists. (There have been charges that the NAB's campaign to get stations to air AMAX promotions was not pushed with much vigor in 1991 or 1992 anyway.)

Only a few AMAX models are available, including Delco car radios and the well-reviewed Denon TU-680NAB "super tuner." And now that the standard has been relaxed, the GE Superadio can join the list.

## Slow improvement

Beyond these radios, it does not appear that manufacturers are applying even incremental improvements, based on the AMAX standard. In a random sample of audio magazines that review tuners and receivers, most AM sections are still limited to 2.5 kHz-3 kHz response.

According to audio industry analysts, the problem maybe that the public perception of AM as inferior to FM may be so entrenched that manufacturers have placed AMAX radios low on the priority list.

**The latest standard revision now exempts battery powered portables from having noise blanking.**

NAB Manager for Technical Regulatory Affairs John Marino said there now may be a better chance for success because the recent standard revision will get a few more

AMAX certified radios out into the marketplace, and "spur" manufacturers to make more models available.

In addressing a renewed AMAX public relations effort, Marino said stations now can be more enthusiastic about the campaign because there are some radios to spotlight.

"The problem (in 1991 and 1992) was that there were no receivers available when the campaign first started," Marino said.

# Plane Clips WKTK's Antenna; Pilot, Passengers Die in Crash

by Paul Rebmann

**CRYSTAL RIVER, Fla.** A collision of a small airplane with a radio tower left four people dead in Florida last month.

But WKTK(FM), licensed to Crystal River, Fla., and serving the Gainesville-Ocala market, did not go off the air, according to Entercom executive vice-president John Donlevie. Entercom is the group which owns the FM station.

A resident of the area witnessed the crash around 9 a.m. on July 21, according to Capt. Dave Shewey of the Levy

County Sheriff Department, which is assisting the National Transportation Safety Board (NTSB) in investigating the accident. The witness said that the plane emerged from the base of some clouds north of the tower. Tim Monville, investigator for the NTSB, theorized that the left wing hit a guy wire, severing the wing at the fuselage.

The 1350-foot Stainless Tower "sustained relatively little damage," said Peter Starke of Stainless, "but there are a few parts that will have to be replaced." The FM antenna was twisted around the 100-foot monopole as a result of the impact, although the reflected power readings remained normal, according to Donlevie, who added that in addition to the antenna, the top section of the tower and the guy wire will likely require replacement.

The tower is located in southeast Levy County, between Gainesville and Crystal River, and was inspected by SG Communications following the accident. Starke said the tower had been erected in 1985.

Monville stated that inspection of the wreckage indicated that there had been nothing wrong with the Piper PA-28 Cherokee, although the altimeter still had to be checked. He added that both of the front seat occupants were rated pilots, and that they had taken off from Sanford, Fla., at 7:30 a.m.

The propeller and the carburetor were not found in the wreckage. Monville, along with the witness account, said that the engine RPMs increased and the plane banked to the right, which would collaborate prop separation, and that possibly the prop hit the guy wire as well.

Although no flight plan was filed, it is believed that the destination was Panama City, Fla.

The witness also said that the tower was visible at the time and that the strobe beacons were operating.

## Clark Listens...

Clark listens to its customers and designs its complete line of audio/video cable accordingly. Now you can listen to Clark's new 700 Series snakes that are designed, as usual, with the customer in mind. Why not give Clark a listen?



Cables available cut to length and terminated to your specs.

**CLARK** WILL A CABLE

1-800-CABLE-IT!

1801 Holste Road • Northbrook, IL 60062

**Listen to Clark!**

Circle (48) On Reader Service Card

World Radio History



# Use Appropriate Compression Codec

► continued from page 7

would still have to be converted back to PCM at each bandwidth mismatch. Hence, even the same psychoacoustic algorithm "duels" with itself. Psychoacoustic coders were developed expressly for the one-time delivery of audio to the ear. Clearly this particular standard has not, and will not, solve Squire's problem.

Other predictive compression schemes, such as G.722 and apt-X100, do not explicitly rely on psychoacoustics, but try to simply minimize the coding noise using prediction across the entire audio band. Since the added noise is spectrally flat, such algorithms are inherently more tolerant to tandem coding than psychoacoustic coders.

To reiterate, all codes commonly found in a typical broadcast chain are incompatible, i.e., noise accumulates in the signal from stage to stage.

How can this noise be minimized?

The answer must be to use "appropriate" algorithms at each stage. For the professional broadcaster, the definition of appropriate must reflect the coding noise level introduced by the algorithm, audible or inaudible, in addition to its subjective or perceptual quality. Because the noise level rises as the compression ratio increases, high compression ratio coders are less robust to tandem coding and are not appropriate for use in the initial stages of a broadcast audio circuit.

In our estimation, broadcasters should avoid the use of algorithms operating at less than 128 kbps per mono channel (256 kbps stereo) if there is a likelihood that the signal will undergo further compression in the future.

To summarize some general points about audio compression in professional applications may be helpful:

1. All codecs found in the broadcast market today are incompatible.
2. Psychoacoustic coders are, by definition,

susceptible to noise accumulation during tandem coding.

3. Predictive coders are inherently robust to tandem coding.

4. High compression ratio codecs (less than 128 kbps per mono channel) should be avoided since these will always produce higher levels of coding noise hidden beneath the signal, leaving the audio highly susceptible to breaking down on further compression or processing.

5. The lowest practical compression ratio

## The Fairness Doctrine

► continued from page 3

Danforth (Mo.) introduced a fairness bill (S. 333) last winter. Senate support for the doctrine is similarly broad and bipartisan.

### A different situation

There is even less scarcity today, Scharff said, with hundreds of channels available through cable TV and more broadcast TV stations now on the air. "Diversity in radio is even greater," he said.

Robert Peck, legislative counsel for the American Civil Liberties Union (ACLU), said Scharff misinterpreted Red Lion's diversity finding, which is that scarcity exists as long as there are more speakers than there are outlets for rebuttal. That is still the case today, he said.

ACLU favors the doctrine, Peck said, because requiring the airing of conflicting

views enhances, rather than restricts, the free-speech aims of the First Amendment.

Fairness Doctrine supporters also argued that the rule does not burden broadcasters. Most stations settle fairness privately before anything is filed with the FCC. The doctrine is needed to protect the public against the small percentage of "bad broadcasters" that refuse to provide balanced coverage of issues, doctrine supporters say.

Scharff argued that special interest groups with frivolous complaints could use the doctrine to place excessive pressure on broadcasters to change their programming. The threat of long and expensive license challenges will be enough to dissuade many from airing controversial shows, he said.

He also criticized the idea of government

should be used at every stage. Particular care must be taken at the front end, where 192 kbps per mono channel is recommended.

What Squire has shown is that it is no longer acceptable to assess subjective quality without reference to its underlying noise floor. Common sense must apply here together with an appreciation that there is no free lunch.

□ □ □

Stephen Smyth is a Ph.D and CEO of Audio Processing Technology in Belfast, Northern Ireland. Mike Smyth is a Ph.D and operations manager of the company in Los Angeles.

giving itself the power to define "reasonable opportunity" for conflicting viewpoints. "Five commissioners at the FCC is different from thousands of stations exercising their individual judgements on what is new and what are controversial issues," he said.

Only one broadcast station—WXUR-AM-FM Media, Pa., a religious station, which lost a Supreme Court appeal in 1973—has ever been taken off the air following a fairness challenge. (The National Religious Broadcasters cited the WXUR case as one reason for joining RTNDA in opposing the doctrine.)

The most famous Fairness Doctrine case was the 1967 FCC decision to apply it to the airing of broadcast cigarette commercials. Broadcasters that accepted smoking ads were forced to air (free) spots produced by anti-smoking groups. Congress later banned all broadcast cigarette advertising in the early 1970s.



*With the smart choice for Radio, you can:*

- CUT production time on spots, shows and promos**
- USE 50 STEREO TRACKS** whenever you need them
- FAST dialog editing for news**
- DELIVER superb quality digital mastered audio**
- INCREASE your creative freedom**

*The features you would expect to find in higher-priced Digital Audio Workstations:*

- YES! Play 50 segments at any location without bouncing**
- YES! Make instant non-destructive edits**
- YES! Easy to learn, full on-line context sensitive help**
- YES! Place independent stereo segments anywhere, in any order**
- YES! Archive multi-track projects to standard DAT**
- YES! True sonic transparency with -110db noise floor**
- YES! Automated effects sends**
- YES! Fully network capable, allowing file sharing**
- YES! Easily added to your 386/486, Windows 3.1 based system**
- YES! Affordable complete workstations start at \$7,695, peripherals at \$3,690**

## The Ultimate in Digital Audio Workstations

*All the features you need . . .*



*. . . at a price you can afford.*



Micro Technology Unlimited  
PO Box 21061, Raleigh, NC, USA 27619-1061

*Quality digital audio since 1977*

**(919) 870-0344**  
**Fax: (919) 870-7163**

# Educated Use Key to Compression

► continued from page 7  
hook-ups cause trouble?

Radio engineers must add stacking to the list of other do's and don't's and "goes-inta's" and "goes-outa's" that every engineer gets paid to deal with: Can you get fonts on this printer when it's hooked up to that computer? Can you digitally copy from this CD player to that DAT? Can you copy from DCC to MD and then use that telco line?

## Engineering responsibility

In addition, that great faceless force of technological evolution, the standards committees, must do their work. Standards

committees work too slowly, they are too cautious, there is too much political/national/economic backbiting, and they are absolutely crucial to the process of technological change.

There will never be a single compression standard. There are simply too many applications and users with diverse needs. However, even when not universally followed, standard coding methods will promote compatibility, and reduce cost. Standards in key areas act like interstate highways that tie together the state and local roadways.

One such standard will be the DAB standard introduced in the U.S. The

compression method specified in that system will certainly become the most widely-used broadcast compression method, in and outside the station.

## On-going activities

A more immediate example of standards in action is the new ISO/MPEG 11172-3 specification and its three layers of audio coding. Layer I defines a relatively unsophisticated compression method that requires relatively high stereo data rates (perhaps 384 kbps). Layer II is similar to Layer I but is more complex and employs lower stereo data rates (perhaps 256 kbps). Layer III conceptually differs from I and II and is more complex; it employs the lowest stereo data rate (perhaps 128 kbps) and outperforms I and II at low data rates.

Listening tests have shown that Layer I (at a data rate of 384 kbps) and Layers II and III (at 256 kbps) can process a stereo audio program with no audible degradation compared to a 16-bit linear signal. At rates as low as 128 kbps, Layers II and III can convey stereo signals that are just barely degraded compared to 16-bit signals.

Tests have also studied the effects of stacking these coders. In one test, audio was passed through four coders at 192 kbps and two stages at 128 kbps and the path was found to be transparent. On the other hand, a stack of five coders at 128 kbps was not transparent for all types of music.

It should be noted that these are first generation devices. As with any perceptual coder, the psychoacoustic model is contained in the encoder, and it is not complementary in the decoder, thus performance can be compatibly improved by revising the encoding model. This can improve performance outright, as well as stacking performance.

It is also important to note that the similarity between the layers promotes stacking; for example, with appropriate signal processing, Layer III data can be transcoded to Layer II without converting to the analog domain. More generally, the ISO/MPEG specification stipulates that a decoder must be able to decode its layer, and all layers below it. However, whereas ISO/MPEG 11172-3 defines decoding and bitstream rates, it does not define the file format itself. Thus more work is needed to ensure compatible digital exchange from one manufacturer's ISO-MPEG coder to the next. For now, the ISO/MPEG standard is a tremendous step toward a workable, stackable compression network.

## The shakeout

I never thought I'd be old enough to cite personal history, but apparently that time has come. In particular, today's controversy over compression stacking is typical of the gear-grinding that takes place whenever any new technology is introduced. For example, ten years ago, when I was still a youngster, the sampling rate controversy loomed large. A number of companies and organizations were early players in the stationary head PCM recorder industry, and most had their own sampling rate: Hitachi (35.7 kHz), BBC (32 kHz), Sony (32, 44.056, 48, 50, 50.4, 52 kHz), Toshiba (50 kHz), Matsushita (49.152, 50.4 kHz), Mitsubishi (44.1 kHz), SoundStream (50 kHz), 3M/BBC (50 kHz), and Ampex (50 kHz).

Everyone fretted that this kind of

incompatibility would wreck the digital audio industry. This concern was heightened by the fact that prototype sampling rate converters were far from trivial devices, and promised to rival the cost of the recorders.

Today, most of these companies don't make stationary head PCM recorders, and if they do, they use 44.1 and 48 kHz. Moreover, you can buy sampling rate converters on chips now, at low cost. In short, the marketplace worked its magic, with a little help from recommended standards.

So, should we ignore the issues associated with compression and stacking? Can we kick back, and let some clever engineers, and the marketplace, work things out? Of course not. As in any democratic process, every voice should be heard. Everyone involved must become educated, form an opinion, be vocal, and vote with your pocketbook. Only then will these issues begin to untangle, and the real benefits of data compression be realized.

So, in other words, if you're a Bills fan, and you're planning to paint a "Squish the Fish" sign when the Dolphins visit Buffalo next fall, think again. They're not fish, you moron, they're mammals.

□□□

*Ken C. Pohlmann is a professor of music engineering at the University of Miami. He is author of "Principles of Digital Audio, Advanced Digital Audio," and "The Compact Disc Handbook." He also is a fan of the Florida Marlins, which are fish.*

## FROM MOSCOW TO NEW YORK MORE STATIONS BUY ARRAKIS

Arrakis Systems is a world leader in radio studio technology. In Japan, Digilink is a brand name for hard disk audio for radio. For use around the world, the United States Air Force chose the 10,000 series console from among all competitors as its console of choice. When the United Nations needed 6 entire studios with consoles and furniture for a rush shipment to Cambodia early this year, they chose Arrakis 10,000 consoles and Modulux furniture. In Jamaica, Tahiti, and elsewhere, entire factory assembled and tested Arrakis studios are on the air. Around the world and of course in the United States... more stations buy Arrakis for their digital audio, console, and furniture needs !!!!!

Digilink is the #1 selling digital audio hard disk system in radio today. You can replace your cart machines for live On Air and have an automation system for walk away at the same time! For more information, call or write ARRAKIS,

(303) 224-2248

the premier broadcast manufacturer of consoles, furniture, Digilink and Trak\*Star digital audio products.

## ARRAKIS

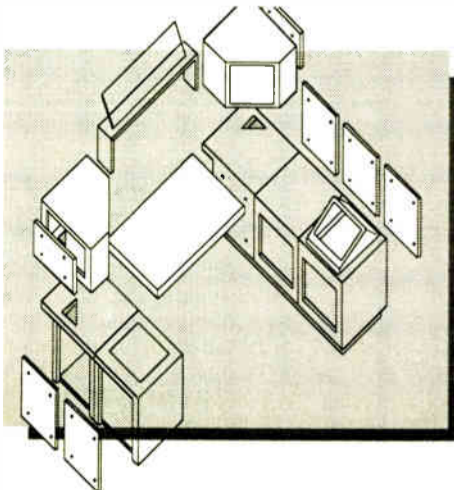

© 1993 Arrakis Systems inc. 2619 Midpoint Drive, Fort Collins, CO. 80525

Consoles  
Modulux  
Trak\*Star  
Digilink  
Modulink

## BE Acquires BP Programs & Sentry

**QUINCY, III.** Broadcast Electronics (BE) recently acquired Seattle-based Broadcast Programming and its sister company, Sentry Systems.

BE, a wholly owned subsidiary of Cirrus Technologies is the second largest manufacturer of radio broadcasting equipment in the U.S.

Broadcasting Programming (BP) is a major radio programming company, providing music formats and related products and services to more than 800 radio stations worldwide.

Sentry Systems manufactures radio format controllers and digital audio storage systems, now in place in more than 500 stations, according to a BE press release.

"The combined strength of these companies enables us to provide our radio customers better-engineered solutions for their operating problems," said Howard Crow, chairman of Cirrus Technologies. "Blending BP's programming expertise with the digital technology of BE and Sentry Systems enables us to connect radio hardware, software and service in a way no other company can."

BE President Jack Nevin said a "real synergy" exists between BP and Sentry Systems in their relationships with radio stations.

# Fall 'Super' Show to Start in Los Angeles

► continued from page 1

Because of the number of fall shows relating to the broadcast industry, Rau said the NAB/SBE/RTNDA collaboration will reduce costs for members, equipment manufacturers and the associations.

In the past, major fall shows included SBE, the NAB, the Audio Engineering Society (AES) and the Society of Motion Picture and Television Engineers (SMPTE).

## Cut expenses

"It is now very expensive for the radio industry to have so many shows in the fall," Rau said. He said transportation costs, room costs, and other convention-related costs will be cut by having a joint show.

SBE President Rick Farquhar said the combined show is a continuation of efforts to improve the association's conventions, which have had trouble in recent years with diminished attendance and dissatisfied members.

"I think the concept is great," Farquhar said. "It has been a long time coming."

Although one of the complaints about the SBE show was its annual location changes, the new show schedule also will move about the country. However, the new show will have an added draw strength the solo SBE conventions did not have: a larger equipment exhibit.

**The new show will have an added draw strength the solo SBE conventions did not have: a larger equipment exhibit.**

RTNDA Vice President Robert Vaughn said the larger show should enhance participation by RTNDA members, which now number about 3,600.

Because recent RTNDA shows have had a TV slant, due in part to the quickly changing technology, Vaughn said the radio show aspect now may draw more interest from radio news directors and management. Because of the NAB Radio Show's increasing global visibility, foreign attendance also could increase, he said.

Although there may be a perception that the fall show will be run by NAB, Vaughn said RTNDA controls its own activities. "We are totally responsible for our conference. We are not a subsidiary of the NAB. We are an independent body."

## Companies supportive

Manufacturers and distributors said they like the "mega show" concept because it reduces the number of shows

by two in the busy fall schedule.

Harris-Allied, the largest distributor of broadcast and related equipment in the U.S., sees the combination of the three shows in one venue as positive.

"It's very difficult for the equipment manufacturers to demonstrate at every show," Harris Allied's Ron Frillman said.

He estimated that vendors spend \$20,000 to \$100,000 per show, and when there are six or more trade shows each year, especially in the fall, they start picking and choosing the shows

that can translate into eventual sales. Some shows have to be ignored, according to Frillman.

Frillman said the broadcast industry has matured to the point it cannot adequately support so many trade shows. He suggested that the fall show could become the major radio show, and the NAB spring show could become the major television show.

Under Frillman's ideal show setup, the TV side of RTNDA and SMPTE would have to join forces with the NAB for the spring show.

Frillman predicted that the NAB/

SBE/RTNDA show "would be a more coherent place to show your product." He said instead of maybe just the engineer, program director and general manager going to the show, the news director and production people may go, too.

Radio Systems, also an exhibitor to numerous broadcast trade shows, sees the alliance with NAB as a good move to save the lagging SBE show.

"I think it is good. The SBE had to do something," Radio Systems President Dan Braverman said. "I think it was wise for them to do it."

When looking for a digital audio system for automation of satellite programming or live assist, there would appear to be many choices. But if you're looking for a system which is flexible enough to give you total control without sacrificing your sanity, there is only one choice. The Phantom by RDS.

You will see the difference as soon as you see the Phantom in action. The display provides you with all of the information you need to see in a clean, concise manner, without the crowded look that you'll find in other systems. If you are familiar with the most popular software on the PC, then you may already know how to use the Phantom. The Phantom's pull-down menus guide you through all of the steps involved in setup and daily operation, from creating and scheduling clocks to creating and editing logs.

## The PHANTOM Digital Audio Automation

The Phantom ends the confusion of automation by keeping everything organized. The Phantom simplifies your daily operations by keeping information such as input changes, voice changes, and clock changes in their own individual schedules rather than in the log. You can leave those liners and other voice drops out of the log because the Phantom will do them for you. The Phantom allows you to date new schedules to begin weeks, months, or even years in advance. When your satellite network informs you that there will be a voice substitution on Thursday, two weeks from today, you can prepare for it today.

The Phantom can retime spots to fit them cleanly into a satellite break without inserting silence, overlapping, or running late. The Phantom

Log	Audio	Inputs	Outputs	Rotation	Clocks	Timer	Options	Setup	Help
>	TIME	COST	NUM	DESCRIPTION	Duration	Code			
5:29:00p				3 Optional Break	2:40:00	B			
		5281		action Chrysler Corp	59:05				
		4881		colson Pepsi Cola	59:05				
		9319		colson KC Producers	59:05				
		7381		Fluro FTD-Selentone Day	59:05				
5:37:00p				4 Mandatory Break	1:20:00	MF			
		8317		Faral South Oaks Furniture	30:00				
		5236		Hotel Motel &	30:00				
		8512		Joel Taylor's Juniors	30:00				
5:45:00p				3 Optional Break	2:40:00	B			

Station: Magic 101	Source: The Touch
Timer: 6:15:00p Close Relay	Voice: Nancy Johnson
5:01:10p Log: Prohibit Opt: 02-12-93	Line: Mandatory Break
5:02:51p Expired Test Opt	Legal ID: Clock Sign
5:05:20p Edited Voice Sched # 1-1	Optional Break: Magic Call

Friday 02-12-93 THE PHANTOM 5:04:43pm

can create reports to keep you informed on a number of topics, from a list of expired spots to an analysis of potential mistakes in your log. The Phantom also maintains a history of system activity.

The Phantom has the features that others would want you to believe are theirs exclusively. The Phantom remains completely functional during recording, sensing relay closures and starting breaks as easily as it does when it is not recording. The Phantom can fill incomplete breaks with spots from a list you specify without ruining product separation.

While other systems tie your hands and limit your flexibility by only offering 3 or 4 inputs, the Phantom gives you 6 stereo inputs, using its AMX-84 solid state switcher, with the option of increasing the number of inputs to 14 or more. If your station is News/Talk, you know how important this can be.

The Phantom allows you to change the sampling rate, digital format, and stereo/mono settings at will to meet your needs for an individual spot. The Phantom offers a number of digital formats, including the new Dolby AC-2 format, as an option.

Call us today to find out how your station can benefit from the advanced technology of the Phantom and the experience of RDS.

**1-800-521-5222**  
912-987-2501 • FAX: 912-987-7595  
P. O. Box 980, Perry, GA 30169



**REGISTER  
DATA  
SYSTEMS**

# Our Affiliates are Talking About Us.

*"For the People [on PRN] has done several things for this grand ol' dame of a radio station, not the least of which is bring our ratings up... It pleases me to find something "unique" and good in a syndicated program. I have never experienced the "word of mouth" as that generated by your show... Likewise, I've never seen fans express so much devotion & loyalty to a show..." ... E. Brian Wilson, PD, KCMO (AM), Kansas City, Missouri*

*"We began carrying For the People [on PRN] about a year ago... [Now] a year later, PRN is our primary network... Chuck [Harder, Host of For the People] will definitely build a strong following on any station... Morning in America adds a real 'big market/big staff feel' to our morning news block." ... Bart Walker, President, WGNS (AM), Murfreesboro, Tennessee*

*"I think Chuck Harder [Host of For the People on PRN] is the single most honest person on the radio... maybe the best-informed, least emotional talk show host in this country. Our listeners in this area appreciate him more than we could ever tell you"... Alan Corbeth, GM, KOPE-FM, Medford, Oregon*

*"The listeners, I think, sum it up pretty well... We have boxes and boxes of unsolicited letters complimenting our decision to carry Chuck & other PRN Programs... [We've] never seen such a response from the listening public." ... Craig Bennett, GM, KBYR (AM), Anchorage, Alaska*

## We Don't Mind...

**KNEWS  
AM 1270**

July 2, 1993

Mr. Chuck Harder  
PEOPLES RADIO NETWORK  
3 River Street  
White Springs, FL 32096

Dear Chuck;

Upon the anniversary of For The People on K-NEWS Radio, let me express my profound appreciation for our productive relationship. After over five years of broadcasts on K-NEWS, the program continues to build momentum in the Palm Springs area. The Arbitron numbers are strong, however, numbers only tell part of the story.

The radio business has become dependent upon statistical data, we have great numbers, low turnover, one of the highest time spent listening in the market, and top five ranking during your hours, seven days a week, but we find in these tough economic times our ad revenues are up 70% due to programs like For The People that develop a strong, interactive audience.

"For The People" brings K-NEWS radio so much more than statistical data to throw around. Advertisers only need to place commercials in the program and the audience responds; that's what makes local advertisers talk. Currently, "For The People" just completed seven months sold-out on K-NEWS. Much to your credit, sponsor retention has been excellent due to the custom promos and commercials, and listeners who take the time to contact advertisers and let them know they heard the commercial on K-NEWS and Chuck Harder.

Chuck, thank you for your program and the wonderful folks at The Peoples Radio Network. We look forward to a continuation of our association for many years to come.

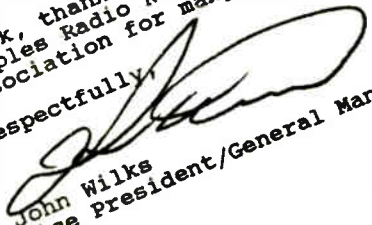
Respectfully,  
  
John Wilks  
Vice President/General Manager  
JW:hq

P.O. BOX 12700, PALM DESERT, CA 92255 / (619) 346-1270 • FAX (619) 341-62

**THE INFORMATION STATION**

News-Talk Radio  
Full Service Network  
24 Hours a day  
7 Days a week  
Consistent  
Informative  
Successful  
Proven  
Listener-Friendly  
Automation-Friendly  
2 Full-Time Satellite Feeds

**No Cost ...All Barter**

Voice (904) 397-2000  
Listen Line (904) 397-4258  
Fax (904) 397-4149



**(800) 397-TALK**  
*People's Radio Network*

# Running Radio

Your Resource for Business, Programming & Sales

Who's who in  
**Program  
Syndication.**  
See page 22

## Turning Radio's Losers into Winners

by Gary Fisher

**DETROIT** Increased sales. Improved revenue shares. Up Arbitrends. Juiced department heads. Happier campers. Improved morale. A stable infrastructure. Good market buzz. Well-regarded hires. Cash flow increases. Picture-perfect income-statements. Laughter in the halls. Food fights in the kitchen.

These are the unmistakable results of a successful radio turnaround. Every year the intra-format fragmentation and micro-niching that characterizes AC radio in the '90s produces dozens upon dozens of under-performing stations...and the same number of opportunities to engineer and experience the intense satisfaction of a successful turnaround. There aren't many radio endeavors with as huge a financial and psychic payoff as turning a loser into a winner.

Radio stations flow through product life cycles just like any other consumer product. An individual station's progress from one life cycle to another, however, is often bridged by a transitional period of lower yield, sluggish focus, and tired blood until a new team is formed and a new mission charted for entry into the next phase (what we often call in radio "taking the station to the next level").

### Everyone should have one

The abundant turnaround opportunities that exist in major market radio are nothing of which to be ashamed. Almost every successful radio group has at least

one major turnaround property in its portfolio right now. In addition, most groups have had the character-building experience of buying a successful station and "then turning it around" after it had slipped in productivity during its watch.

Start-ups, move-ins, and turnarounds are among the most passionate and challenging parts of the radio business and are a normal part of the radio dynamic. Effecting turnarounds also represents the tail-end and last phase of the rebuilding equity and reducing leverage process that our business entered three years ago at the start of the recession.

In a larger sense, just about any under-developed or over-performing station can benefit from the orderly application of turnaround management strategies. However, a successful turnaround requires a unique culture and managerial technique.

For starters, don't just target—segment and then hyper-target.

You can't build a house without a foundation and the foundation to everything in a successful turnaround is reliable and actionable research. Only the audience knows what medicine is needed to cure an ailing station. Ask them, listen to them, and obey them.

Research extensively to find out exactly what age-sex-cell, life group and/or musical cluster you want to serve and get ready to silver-cast toward it. In busy markets right now the AC audience is breaking up at an alarming rate. The audience is doing what the business did

two years ago—fragmenting into smaller and smaller particle markets. Niches are and will be the rage in radio from now on; make sure your turnaround is based on owning one.

To successfully reassert itself in a busy market, an emerging station needs not only a viable format but a different one. It must be distinctive enough from the rest of the environment to issue a promise and be the only station that can deliver on it. Once the chosen format is launched the station and company's commitment to it must be unwavering. These days most major market stations operate with a brain-trust consortium of group heads, consultants, national PDs and researchers and all must be of one mind about the format's viability and shelf-life.

### Ready, aim, fire...

A successful turnaround will usually come at someone else's expense.

It's important to estimate who will

probably subsidize the turnaround and to what extent. The overall population in most metros is not growing so the successful turnaround station's growth will probably come out of another station's hide by targeting better and selling better. Paint a target on someone's back and obsess about them daily. Most emerging stations do a better job when they have a target to rally around and aim for.

Sometimes you need to go back to the future. Take in as much data (both objective and subjective) from the staff about the recent past as you can handle. The first weeks of any turnaround effort should be filled with lots of individual staff meeting and de-briefings. Talk to the existing staff, find out who they are, what they're all about, and most of all what they think needs to be done to turn things around. You'll find some gems as you mine for data and the staff will feel more like helping you out to attain success.

Half of what everyone will tell you is probably true. The trick will be to distill the true factual history from the personal disappointments. It is important in

continued on page 20 ▶

## DON'T MISS THE CONNECTION!



### The Console For Your Future

- New DCA (Digitally Controlled Analog) technology
- The Great Sound of Direct Audio
- Optional bidirectional serial control interface
- Connect to computer based music & automation systems
- Truly modular frames hold up to 6, 12 or 22 mixers
- Four types of input mixers available
- 24 character displays dynamically label each mixer
- Mix-Minus, Machine Control, Talkback & much more!
- Prices start at \$3900

**Logitek**

Call:  
800-231-5870 or 713-782-4592  
for your nearest Logitek dealer

## ATTENTION P.D.s

Schedule the best in "OLD-TIME RADIO" with

# When Radio Was...

Hosted by ART FLEMING, original star of "JEOPARDY"

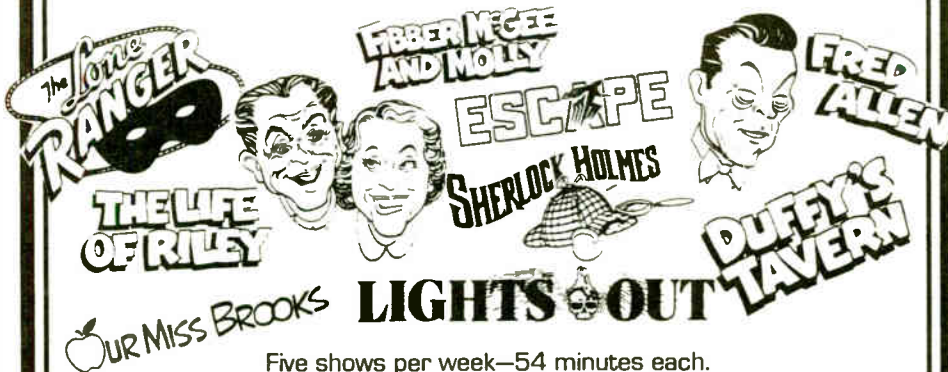

Five shows per week—54 minutes each.

**BARTER, NO CASH PAYMENTS!**

Delivered via Satellite (SATCOM).

For information and a free demo tape contact David West at  
**DICK BRESCIA ASSOCIATES (201) 385-6566**

*When Radio Was* celebrates its 4th year on 100 stations.



## FAMILIAR TERRITORY... WELCOME HOME!

The most powerful digital audio workstation is now also the easiest to use with the introduction of our new **Hardware Control Panel**.

The CB-158 control panel is designed to work specifically with the ProDisk 464 and its easy-to-use GUIDE editing screen -- this combination gives you the speed you need to save time, and money.

This new control panel places all recording and editing functions on dedicated keys, greatly simplifying the editing process and dramatically reducing the learning curve. And it provides machine control of up to 4 external video or audio decks!

Call Otari at (415) 341-5900 for more information about the easiest to use DAW on earth!

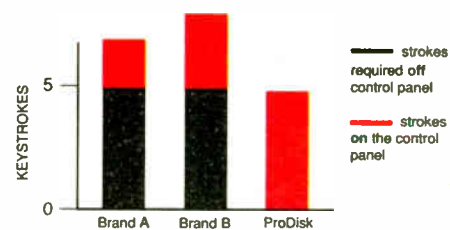

Otari's ProDisk 464 is fast and easy to use. Here's proof: To record a file and trim head and tail\*, it requires fewer total keystrokes. Even more significantly, ProDisk lets you work totally on the control panel while its two competitors force you to supplement with either keyboard or mouse.

\*Comparison of many other functions show similar key-stroke savings.

# OTARI

**Otari Corporation**  
U.S.A.  
(415) 341-5900  
Fax: (415) 341-7200

**Otari Inc.**  
Japan  
(0424) 81-8626  
Fax: (0424) 81-8633

**Otari U.K. Ltd.**  
Technical Center  
United Kingdom  
(U.K.) 44/0753-580777  
Fax: (U.K.) 44/0753-542600

**Otari Deutschland GmbH**  
Sales and Marketing Europe  
(Germany) 49/2159-50861  
Fax: (Germany) 49/2159-1778

**Otari Singapore Pte., Ltd.**  
(65) 284-7211  
Fax: (65) 284-4727

**Otari Corporation**  
Foster City, CA  
(415) 341-5900  
Fax: (415) 341-7200

**Otari N.E. Sales**  
N.Y., N.Y.  
(212) 297-6109  
Fax: (212) 986-1952

Circle (212) On Reader Service Card

TECH TALK

# Huie: Radio is Poised for Bright Future

*Editor's note: This spring, in the middle of a wave of station duopolies and renewed excitement over new technologies, Joseph Huie took over the reigns of Harris Allied when he became vice president/general manager. With 70 years experience serving the industry, the company is adapting its business to meet the challenges of a world that might look strange to founder Parker Gates.*

*Huie has been with Harris Corp. for 28 years and has radio engineering experience plus several degrees, including a master's in engineering. His interest in radio began when he was still a youth. He was recently interviewed by Tech Talk columnist, Judith Gross.*

*"Well, like so many teenagers I had my own little radio station on the air," Huie said. "When I went to college at Rensselaer (in upstate New York), I worked on two stations: WHAZ 1330 on AM and WPTR."*

*Huie is acutely aware of the changes in an industry that is now recovering from some tough economic times. He spoke about new businesses, new technologies, and the changing role of managers in technical broadcast operations.*

**RW:** *We've been hearing more positive news about the broadcast industry's eco-*



Joseph Huie

*omic health lately. What's your impression, is the industry bouncing back?*

**Huie:** I think that it is. I was at the NAB show this year and last, and this year there was improved activity. Generally, talking with our sales people, things are looking better, especially on a worldwide basis.

In the U.S., where few new stations are being built, it's primarily a replacement market. But in TV, we have HDTV on the horizon and lots of opportunity. Overall, we're upbeat and looking ahead with a positive outlook.

**RW:** *Today we've got a very rapidly changing situation in radio, with consolidation of ownership, LMAs, duopolies, big groups swallowing smaller ones...how is that going to change the way Harris Allied does business?*

**Huie:** With the FCC rules permitting multiple ownership and LMAs it's just an issue of focus on more productivity; people are more business-oriented now. Before, people were in broadcasting for the love of it; now it's a dollars-and-cents standpoint. So for us as well as everybody, cost is a factor—we have to aim toward

greater productivity. Some tangible examples are in our DX transmitters which give higher efficiency and reduce costs for customers. In Richmond, in our distribution of studio gear, digital equipment is replacing tape, again to improve productivity.

We see radio managers having more focus on, what can it do for us? Also, ongoing costs are important, that is, reducing maintenance and the station's operating costs.

**RW:** *How about the increasing digital revolution, what impact will it have on products and how they are marketed?*

**Huie:** Well, in the most obvious sense, stations are replacing tape and carts with hard disk and digital systems. Many in the U.S. are already sold on digital, but in some overseas areas we still have to educate and explain the benefits. We were first with a digital transmitter, and these typically give 84 percent efficiency. Another new recent product introduction from Harris was the digital FM exciter with direct digital synthesis and direct digital composite input.

**RW:** *What about the impact of other technologies: satellites, fiber optics, interac-*

*tive, phone companies and cable companies moving into video. How does a company like Harris Allied stay on top?*

**Huie:** We keep working on it constantly; we have our tentacles reaching out a long way. Radio nowadays serves people on the move, so we believe that direct over-the-air broadcasting will survive for a long while. In the U.S. and overseas, TV serves a fixed market and is more amenable to changes. We take all these changes into account. We have an R&D program and technology department in Melbourne and we're always looking for acquisitions and for new ideas.

continued on page 25 ▶

## SEND YOUR AUDIO ACROSS THE STREET OR AROUND THE WORLD™

**When you think digital audio, think California Digital. We provide satellite/digital technology to make all these options available at low cost:**

- ▮ Syndicate your top personality or format
- ▮ Add affiliates - gain revenue sources
- ▮ LMAs - Increase market share/audience size
- ▮ Share programming, talent and costs
- ▮ Off-site announcer feeds
- ▮ Create events with remotes
- ▮ CD-quality live coverage of news, sports, and concerts

**California Digital offers expertise in:**

- ▮ Digital Satellite Networks - C or Ku
- ▮ Regional, National, International Nets
- ▮ Remote Broadcasts
- ▮ Rugged Fly-away Systems
- ▮ Custom Ku Power Control Software
- ▮ System Design & Engineering
- ▮ FCC Licensing; Installation and Training
- ▮ Equipment sales, leasing and financing
- ▮ Switch 56 & ISDN program distribution

**COVER THE US WITH SATCOM K1: FULL TIME STEREO CHANNELS FROM \$1100/MONTH**

Call for details on cost effective solutions:

**CALIFORNIA**

**DIGITAL AUDIO**

West Coast Office (805) 523-2310 Fax (805) 523-0480  
Midwest Office (612) 631-5064 Fax (612) 631-5010

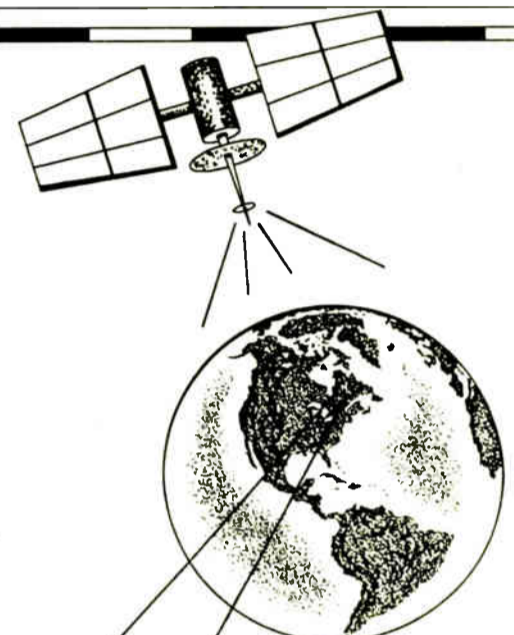

DIGITAL AUDIO

**MAKE MONEY BY CREATING A  
MUSIC PROGRAMMING NETWORK!**

## MARKETING &amp; MANAGEMENT

# Market Yourself to Ensure Longevity

by John Cummuta

**ALGONQUIN, III.** Remember the good old days? You know, when the transmitter needed a full-time engineer on site. When good stability was plus or minus two channels on the band, and every piece of audio equipment required almost daily alignment. Ahh....to be needed like that again.

Well, forget it.

The days of wine and roses are over for the average broadcast engineer, and we are clearly in an era where the adapters survive and thrive, while the stagnaters become casualties of downsizing and other corporate code words for getting rid of dead wood.

## You are a product

Most employees, particularly in larger companies, make the mistake of thinking of themselves as just that—employees. They simply do a job, in many cases just well enough not to get fired. But when things get tight for the business, the first things thrown overboard are marginal employees. Or, at least, those that appear marginal.

What the American worker seldom realizes is that they are really a product that their company buys, every week when they hand out paychecks. And since the reality is that the company is the customer, buying a given amount of

service, they can someday choose to make a different purchase, or to stop buying that particular service at all.

Once you see yourself as a product that is bought by your company each pay period, you begin to realize that they don't have to buy you. Just like you don't have to buy a particular loaf of bread at the supermarket. You can buy another loaf, or you can choose rolls or buns. Or you can choose to do without a bread-like product altogether.

## Your market

At that point you grasp the reality that you must continually make management aware of your value, so that they continue to choose to buy your services. This is marketing. You have to market yourself continually.

While this may sound impersonal and dehumanizing to you, it is true nonetheless. You can ignore this reality, but you cannot make it untrue.

To market yourself, like marketing any other product, you should start with a strategic analysis.

The first step in a strategic analysis is determining who is your target market. In the case of most broadcasting engineers their primary market is the station's upper management and ownership. But it would be a mistake to ignore other markets, such as lateral managers (program director, sales manager, etc.) and

the workers in other departments. Pleasing all these markets will reinforce the company's decision to continue buying your services.

It is important to determine what needs you can meet for these various markets. Remember, if there is any difference of opinion on what are the most important elements of your job, only the target market's opinion matters. If you cannot adjust to that, find another job.

You've heard the saying that the customer is always right. You hear that a lot because maintaining that attitude is how you stay in business. Well, you're in business. You are selling your services to a target market. They are your customers. It is the meeting of their needs, as they articulate those needs that they will keep you in business (getting paid).

If you're not sure what needs you could meet for them, ask. And then look for other needs that you can volunteer to meet without being asked or told first.

## Competition

Today's broadcast engineer is surrounded by competition, the least of which is from other engineers. Newer, less break-down-prone equipment is a form of competition. Changing technology, such as the proliferation of computer-controlled audio equipment, is a form of competition. And, finally, contract engineers are competition for the station engineer.

You should be brutally honest in your competitive analysis, so that you can know what you are up against in the mind of your station management.

Your position in the mind of your target market can be your greatest asset or your biggest liability. This is where many engineers make a tactical error. They do not see themselves as the outgoing "salesman" type, so they keep a low profile, and just expect their work to speak for itself. They don't concern themselves

with how they are perceived, as long as the equipment is working.

Sorry. That's not good enough. You must be perceived as a full and contributing member of the management team, and the only way to do that is to position yourself as such a member in the minds of the other members.

This means that you must do two things:

1). You must look, act and speak like a member of the management team.

2). You must continually be showing the value of the services you render. You can do this through memos, reports, and just plain bragging.

## Selling Yourself

Another important facet of positioning is that of currency. By this I mean that you must be able to show your value in light of current technologies, and the changing landscape of the modern broadcast station.

For example: while the transmitter doesn't need nearly as much attention as it would have a decade ago, the station is now littered with Personal Computers. So, while you can no longer show a lot of value as the man or woman who keeps the transmitter on frequency and on the air, you can and should be perceived as the indispensable resident computer guru.

Selling yourself to your markets is a continuing process, and the day you stop is the day you put your job in jeopardy.

Nothing is more irritating for a station manager than to have to pay an invoice (sign your paycheck) for a product or service for which he or she perceives little value to the station. Don't get into that position. Continue to successfully market yourself to your station throughout your career.

□ □ □

*John Cummuta is an independent marketing and management consultant, and the author of the "Sales Machine," database marketing course and "Sales Machine" database marketing software. He can be reached at 708-658-9107.*



## GET SMART AND SEE SMARTS IN DALLAS BOOTH 833/835

Full CD and hard drive automation systems using professional DENON CD decks!

Three processor automation, supervisory, scheduling and audio for reliable walk away!

Digital audio units that emulate CD players for drop in replacement of CD decks!

The full line of SMARTCASTER digital automation, satellite automation and live products!

The Point and Play—Just touch your logged spot on the screen and it's on the air!

We can make a station profitable in any size market! Come talk to us at NAB.

**SMARTS BROADCAST SYSTEMS**  
BOX 293, EMMETSBURG, IOWA 50536  
(800) 747-6278 (712) 852-4047 FAX: (712) 852-3061

Circle (199) On Reader Service Card



## A GREAT GIVEAWAY!

Roll-A-Sign™ disposable plastic banners are a great, cost-effective way to promote your station.

Indoors or out, Roll-A-Sign powers your message across and is an ideal giveaway for a concert, remote, etc. Co-op it with a sponsor and it more than pays for itself!

Depending on your logo's design, you'll get up to 338 banners on a 1,000' roll...just roll 'em off and cut.

Each banner is printed on high quality, sunstabilized plastic film, 4 or 6 mils thick, up to 36 inches wide. Fax us your logo and specifics on color separations, and we'll give you a free quote.

For any questions about quantities, sizes, imprints, colors, etc., call

**1-800-231-2417**

or FAX: 713-947-2053 or in Texas call collect 713-484-6892

Roll A Sign™ • Reef Industries, Inc. • P.O. Box 750245 • Houston, TX 77275-0245

Circle (14) On Reader Service Card



# Spot the Right Personality Type for Sales

by Dale P. Smrekar

**TAMPA, Fla.** If radio stations sold air time the way they hire account executives, the newspapers would be full of ads stating: "Radio station seeks advertising client willing to advertise on our station Monday through Friday. The right client will possess the ability to pay their bills on time, will purchase \$12,000 in air time annually, and will not complain when we raise rates. For consideration please send your advertising proposals."

Why do so many radio managers recruit new account executives by just placing an advertisement in the newspaper and reacting to whatever walks through the door in response? What happened to creativity?

Hiring account executives should never be a reactive endeavor, but a proactive endeavor. The Omnia Group's review of hundreds of existing radio account executives indicates that as many as 40 percent are not true sales personalities. How does the station owner/manager make the mistake of hiring a sales staff composed of a large number of non-sales personnel?

## Same old song

The answer for most industries is that managers often seek only experienced sales personnel. They assume because the individual is experienced they will need minimal training and will be able to

generate immediate cash flow. They are either unwilling, or unable because of often self-imposed time constraints, to invest their time training inexperienced people.

## Easy out

The radio executive looks for the easy way out of the personnel problem and focuses on short-term rather than long-term profits. Thus, hiring experienced account executives often means selecting from an applicant pool primarily inhabited by non-sales personalities. The typical sales applicant pool may be composed of as much as 90 percent non-sales personalities.

In order for the station owner/manager to take the first step in hiring, he/she must understand the realities of the employment market. The first question an owner/manager must ask himself is, "Why would a successful account executive in my industry want to come to work for me?"

The manager/business owner must come to grips with the primary reality of the employment market: *Top account executives are rarely available because they are happy with their current situations, and their current employer will make a maximum effort to keep them.*

Because true sales personalities are internally driven by a need for greater authority, responsibility and income, their employer has to limit their income potential or opportunities for greater

responsibility for them to leave. There are few radio executives who do not value their top performers.

Larger market stations do have potential experienced recruitment sources in smaller markets, because small markets can only charge so much for air time and have a limited list of businesses within their signal range. Thus, the account executive's income is limited by geographical and economic issues.

However the owner/manager needs to be aware that smaller markets can sometimes be more order-taking/service-focused than hard close sale situations. They may obtain a top account executive from a smaller market and find that the individual while somewhat competitive, does not possess the driven, fast-paced behavior necessary to succeed in the larger market.

## Look elsewhere

The only alternative to hiring experienced account executives is to seek new sales talent from outside the industry. The Omnia Group estimates that approximately 20 percent of the human population possess personalities compatible with radio sales. That is one of five. If there are so many, then why are they not beating your door down to sell air time for you? The most likely answer is that these sales personalities do not know of your opportunity.

Added to those numbers are the sales

personalities who have negative connotations of sales due to interaction with overly aggressive or unprofessional life insurance, auto or door-to-door sales types. To find new talent, the station manager/owner must seek true sales personalities; look for them in environments likely to attract sales personalities.

To begin the search for true sales types, the manager must understand that true sales personalities all share very defined traits: a need to compete, win, keep score and seek additional responsibility/authority. Thus, they are attracted to win/lose and leadership situations. Among the right environments for radio executives to seek new sales talent are athletic coaching and community groups.

Before the various athletic sport seasons, a station can begin recruiting new sales people by running special, on-the-air promotions involving interviewing local high school coaches regarding their upcoming seasons (with a hidden agenda to find out if the coach is competitive, and happy with what they earn for all their hours of effort).

This will place your station in front of a number of true sales types. You may even consider offering the right individual a summer job in radio sales to give them an opportunity to experience the excitement of radio sales.

Youth sports (Little League, soccer, bas-

continued on page 25 ▶

## Now 24-hour operation at a shadow of its former costs.

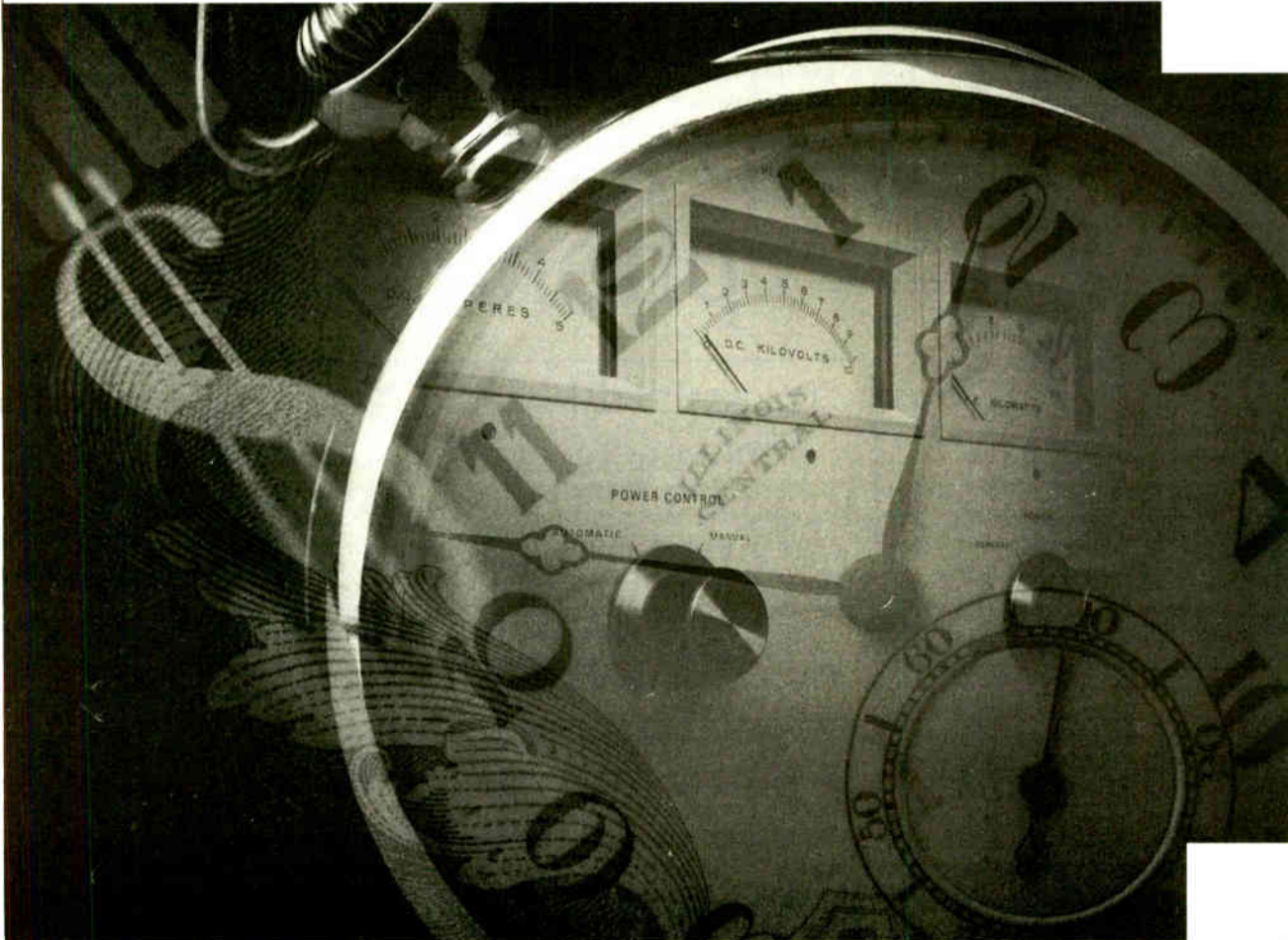

If the idea of 24-hour operation seems anything but profitable, consider ACCUWATCH.

ACCUWATCH is a fully automatic, FCC approved, transmitter and extended remote control service. Whether you're using automation tapes or satellite-delivered programs, ACCUWATCH keeps your profits in-house and not out-the-door with labor costs. For as little as \$250 a month you can literally leave your transmitter unattended anytime, day or night, while still providing your listeners with continuous, uninterrupted broadcasting. The Accuwatch designated control point system operates in complete compliance with all FCC rules for ATS, EBS, and emergencies such as lightning or power outages.

With ACCUWATCH you can legally operate 24-hours a day at a shadow of former costs and make your profits more than just a remote possibility.

For more information, contact Dave Woodworth at the Moody Broadcasting Network at 800-621-7031.

## AccuWatch

## PROMO POWER

# Request-a-thons for Fun and Profit

by Mark Lapidus

**WASHINGTON** Imagine a rock station breaking format to play "It's Only Make Believe," by Conway Twitty or "The Barney Theme Song" from the kid's television show. It happened recently here in the Nation's Capitol and I'd like to share this experience with you.

If a "Request-a-thon" has not been done in your market I strongly encourage you to investigate the possibility. It will create enormous talk about your station and remind you how exciting radio can and should be.

## Pay for play

What is a "Request-a-thon"? It's a designated period of time in which you suspend your regular programming and do "pay for play" requests to benefit a charity. You ask your listeners to call you with song requests: for a minimum donation you'll play their song and recognize them on the air. Here's a quick primer on how it works:

**Select a charity.** This is the most important decision you'll make. You'll be relying on this charity to take care of most of your manpower needs, so it should be relatively large and very well organized.

In addition, this must be an organization that your listeners truly care about; to generate results it's impor-

tant to strike an emotional chord.

Non-profits to consider include children's charities, AIDS organizations, and food banks. The charity will receive net proceeds after expenses are deducted for phone lines, broadcast lines, banners, and t-shirts. If your charity is well connected it may get these items donated in exchange for on-air recognition.

**Pick a broadcast location.** While you can do a "Request-a-thon" from your studios, you'll obtain more visibility and it'll sound better if it's coming from a popular shopping mall.

You're going to have a lot of workers, so ask the mall to provide free parking and a meal from the food court for each person. They'll be happy to comply as the event attracts publicity and shoppers.

**Pick the right date.** Allow three months for planning and then look for an open weekend that's good for the charity and the mall. Call your local newspapers to see if there are any other big events happening during the time you select. Start with morning drive Friday and finish by Sunday night. It takes time to build momentum.

Do you really play anything? Yes, but not all the time. Unusual requests create a buzz and prove to your audience that you're doing something really different. The key is placement. Play unusual songs during a very visible time in the

hour, surrounding them with regular music. Most of the requests will be for something in your format; after all, this is why people listen to your station.

Ask for a minimum song donation such as \$25 for a regular song. For something really unusual start at \$75 to \$100. (Tie-in a record store in the mall to provide you material you don't have.) If the phones are dead, announce that you'll play one of the worst songs in history if you don't raise enough money *not* to play it. To make them get the point, play about ten seconds of the song. "Kung Fu Fighting" works well.

Pick a few "big songs" that you won't play unless you've had a certain total donated for them. For example, if you're a rock station, don't play "Stairway to Heaven" until you've received at least \$200 in total donations for the song. Frequently mention that listeners don't have to make a song request to make a donation. You'll thank everybody on the air. Accept dedications and donations in memory of loved ones. Let businesses challenge each other.

## Going once...

**Other ways to raise money:** Auction items can be an excellent source of revenue and add credibility to your event. Obtain as many unusual autographed items as you can get. The non-profit group should assist in obtaining these items. Every time a celebrity comes to town, have them sign something: well-worn ties, jeans, tennis shoes, musical instruments, photographs, CDs, books, and hats work well. It sounds great to say you're auctioning off Robert Redford's pants.

The celebrity items will give the television stations and newspapers something to shoot. Donated items can also come from your clients. For example, a local BBQ restaurant could auction off dinner for thirty to the highest bidder. Perhaps you could

get an electronics store to auction off a big screen television set under your tent.

## Broadcast quality

**Ingredients for set-up.** Put the broadcast area up on a riser. Seat the telephone volunteers very close to the broadcasters. You'll need a rollover phone bank with at least ten phones. Place a large chalk board in front so that jocks and volunteers can see it, writing down the hourly auction items, the current amount bid, and the time the item expires. Put banners up everywhere in case you get television coverage.

They may refer to you as a "local radio station," so a lot of banners and custom made t-shirts could be the only way you get credit for the event. Make duplicate books for on-air talent, your floor director, and the volunteers. This book should contain a description for each auction item, premiums you may wish to insert to just generate calls ("for \$25 we'll give the next ten callers concert tickets"), directions to the mall, and anything else everybody needs to know.

What will it sound like? Even though you're raising money for a serious cause, make the mood upbeat. It works best with two announcers going back and forth on auction items, song requests, and straight donations. Invite local sports and television personalities to help. Because your air personalities may have difficulty expressing the emotional side of the cause, pre-produce short segments with people involved with your charity. If you've selected a children's charity, this is where you can feature those kids who need help.

Is there anything else? Plenty, but you'll learn as you go and time will fly because live community radio is the most vibrant type of broadcasting. After it's over there's one last request that you may wish to make... "Boss, can I have a short vacation?"

□□□

Mark Lapidus is promotions director at WCPT(AM)-WCXR(FM) Washington. He can be reached at 510 King Street, Alexandria, VA 22314.

## TRUE BLUE FOR THE MORNING ZOO.



Drive time is your busiest time, so make sure your spots, liners and music are on the car more stations count on.

**audiopak**  
BROADCAST CARTRIDGES

P.O. Box 3100 • Winchester, VA 22601  
Tel: (800) 522-CART or (703) 667-8125  
Fax: (703) 667-6379

## phone it in

Transmit HI-FI audio WORLDWIDE  
from midtown NYC studio using  
CCS CDQ2000/1000 codecs  
over ISDN/SW56 phone lines

- BI-DIRECTIONAL MONO/STEREO
- COMPETITIVE RATES
- LIVE TRANSMIT, RECORD TO DAT
- DIGITAL AUDIO WORKSTATION
- MIDI PRODUCTION, SFX LIBRARY

## DAVE IMMER MUSIC

12 E. 12TH ST. SUITE 12-S.W. NEW YORK, NY 10003

212-242-2534

# Learn to Manage Your Time Effectively

by Sue Jones

**Burke, Va.** Management By Objectives (MBOs) is not just for corporate America with staffs of thousands. If developed and implemented correctly, it can be one of your most effective management tools for improving the bottom line and market growth. Continual use will reward you with consistent improvements in areas where you choose to concentrate.

The concept of MBOs has been around for a few years and undoubtedly, you have some working knowledge of them. You may have thought about implementing them but never had the time to develop how it would work for your station. As we head toward the fourth quarter of the year and you begin to tally how the year is going in sales and market share, it is an excellent time to begin the planning process for the coming year.

## Where the buck stops

One of the major advantages of implementing MBOs is injecting accountability for work to be done and objectives to be met. The advantage of having department heads/managers list the objectives is that they will be making their own work plan and it will be directly linked to the station's overall strategic plan. They will be participating in and contributing to the management of the station, therefore having a vested interest in the overall operation of the station. Involving the managers in the planning, you will be giving them a voice in the station's management, improving their management skills and increasing their value and commitment to the station.

Start by using general terms to list five to 10 major goals that you would like the station to achieve next year. Your composite list should include all aspects of your station's operation including sales, engineering, programming, operations, etc. This will become the basis for your overall "strategic plan."

Examples might include: 1) increase sales by 15 per cent; 2) 10 percent of sales should come from new business that has never advertised on radio; 3) upgrade the technical plant to take advantage of state-of-the-art improvements, and; 4) improve profit margins by reducing make-goods. Once you have a balanced overall objective list, it is time to involve your department heads.

In a management planning meeting, share the overall plan objectives for the coming year with the department managers. Their task is to take the strategic objectives that apply to their department and list five or so ways to achieve each strategic objective.

## One department at a time

Each department's list of ways to achieve the station's objective will become the "tactical plan." Examples for the tactical plan for the strategic objective of increasing sales by 15 percent might include: 1) increase the discount rate for multiple spots; 2) implement a low introductory rate for first time advertisers; 3) have a bonus for the sales staff who brings in the most new advertising clients each quarter; 4) add X-number new advertisers per quarter, and, 5) begin a co-op advertising program.

Examples of the tactical plan for

upgrading the technical plant to take advantage of state-of-the-art improvements might include: 1) purchase new processing for improved station sound; 2) purchase a backup transmitter for emergency situations; 3) purchase one additional critical replacement part per quarter for equipment to have on hand in the event of equipment failure, and, 4) maintain the equipment so that no more than five minutes of down-time is experienced in a quarter.

Once the tactical objectives have been identified by each department manager, ask them to further define how they will achieve these goals by quarter. Some of

the earlier examples state the objective in terms of quarter goals. If possible, have each manager state their tactical objectives in quarter milestones.

Defining the tactical objectives in quarters will be invaluable in evaluating how well each manager is achieving his or her stated objectives. It is advisable to have pre-arranged dates marked on the annual calendar for the managers to evaluate how well he/she achieved his/her objectives. This can be done on a written review form or in a one-on-one conference with the department managers. Reviewing the strategic and tactical plans on a quarterly basis gives the

department managers and you an overview of performance to objective.

## Quarterly checks

It is best to do this analysis quarterly before it is too late to recover in the event that something has dramatically changed or objectives are not being met. Discovering unmet objectives at the end of a quarter is far easier to correct than discovering it six, nine or 12 months into the year. As the general manager, you will be able to provide guidance and oversight to strengthen weak spots before they become serious problems.

continued on page 23 ▶

## YOU CAN SHARE PROGRAMMING AMONG YOUR RADIO STATIONS ... At a Lower Cost Than Ever Before!

Share programming among your station group or with other stations by sharing day parts, entire formats or by delivering your top-rated talent to other markets coast to coast. You can spread overhead costs, increase the quality of programming at the local station and build your audience by creating a satellite radio network. And now new digital satellite technology makes radio networking more affordable than ever before. Let us offer you a complete solution for your radio networking needs.

Call us at (202) 822-2626.

**NPR SATELLITE SERVICES®**  
2025 M Street, NW, Washington, DC 20036  
(202) 822-2626

# Turning Radio's Losers Into Big Winners

► continued from page 13

any turnaround to not throw every baby out with the bathwater. Sometimes you need to study what was working (when it was working) and possibly remodel after that to rekindle any equity left in the market.

In the case of WNIC this meant rededicating to the Harper-and-Gannon concept in morning drive, "Detroit's Nicest Rock" as the slogan or brand name, a warm and fuzzy family-values based "stationality" and bringing well-known "Pillowtalk" host Alan Almond back to the party to handle nights.

## Ready your flanks

Don't just plan to "get around" to fixing sales.

Start fixing it first so that it is ready to capitalize as the first signs of the turnaround materialize. In a typical turnaround situation, the station's sales department is suffering from tired blood.

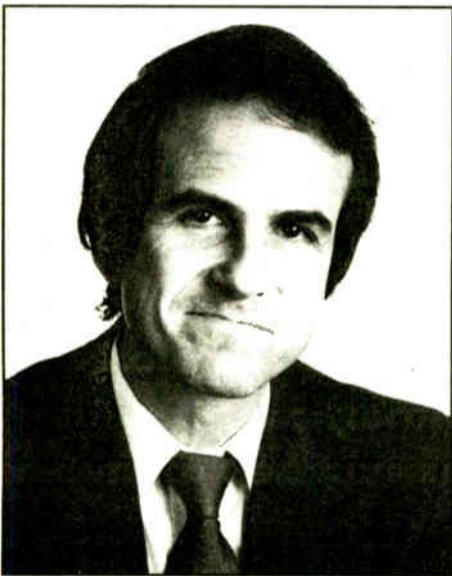

Gary S. Fisher

A history of not achieving budget, losing share of market and experiencing income erosion is bound to pull down confidence and morale. Given the urgent need for revenue and sales improvement in any turnaround situation, it's important to start upgrading the sales effort right away.

Start working in all possible ways to bring non-ratings-related demand to the station's inventory.

A key ingredient in a successful turnaround is momentum, or at least the perception of momentum. Make lots of direct retail sales and celebrate the orders internally. Commit totally to the law of massive numbers—massive numbers of sales people calling on massive numbers of accounts working in massive numbers of development areas selling massive numbers of commercials to generate massive results.

Nothing soaks up inventory at decent rates like retail sales, jingle sales, yellow-page sales, recruitment sales, prize catalog sales and the like. Do anything and everything to press the existing inventory.

## Demand more, subtly

Gradually and steadily raise the thresholds of acceptable performance in programming and sales.

This is far different and more complex than merely raising expectations via new sales budgets and ratings projections. Raising acceptable performance thresholds involves establishing a new vision for the

station, a new culture of winning and showing how even the most basic activities contribute to winning. New levels of productivity and new measures of winning need to be defined within the station's mission statement. The mission statement needs to be broken down into subgoals with a separate action plan for each goal.

Fortify the administrative and back-office ranks as soon as possible.

The station will need a smooth running business infrastructure to capitalize on a successful turnaround. Lock it in early and let it percolate while you work toward the turnaround. Always be in a constant state of readiness to upgrade

weak links as they become apparent. Aim for a smooth-running infrastructure,



savvy sales support and streamlined paperflow to better manage the results of an ever-improving product.

Do informal strategic planning with department heads each month.

Continually update the station's mission statement and regularly compare

where you are now with where you were, where you want to be and where you are budgeted or required to be. Analyze what is sure to be a fluid competitive environment and spotlight problems or opportunities as they become apparent. Continually update action plans for every subgoal in the station's turnaround plan.

## Take no prisoners

Create strategies and action plans for every hill you don't own but want to in programming, sales and promotion.

Also create defensive action plans for any hills you might already own but find  
continued on next page ►

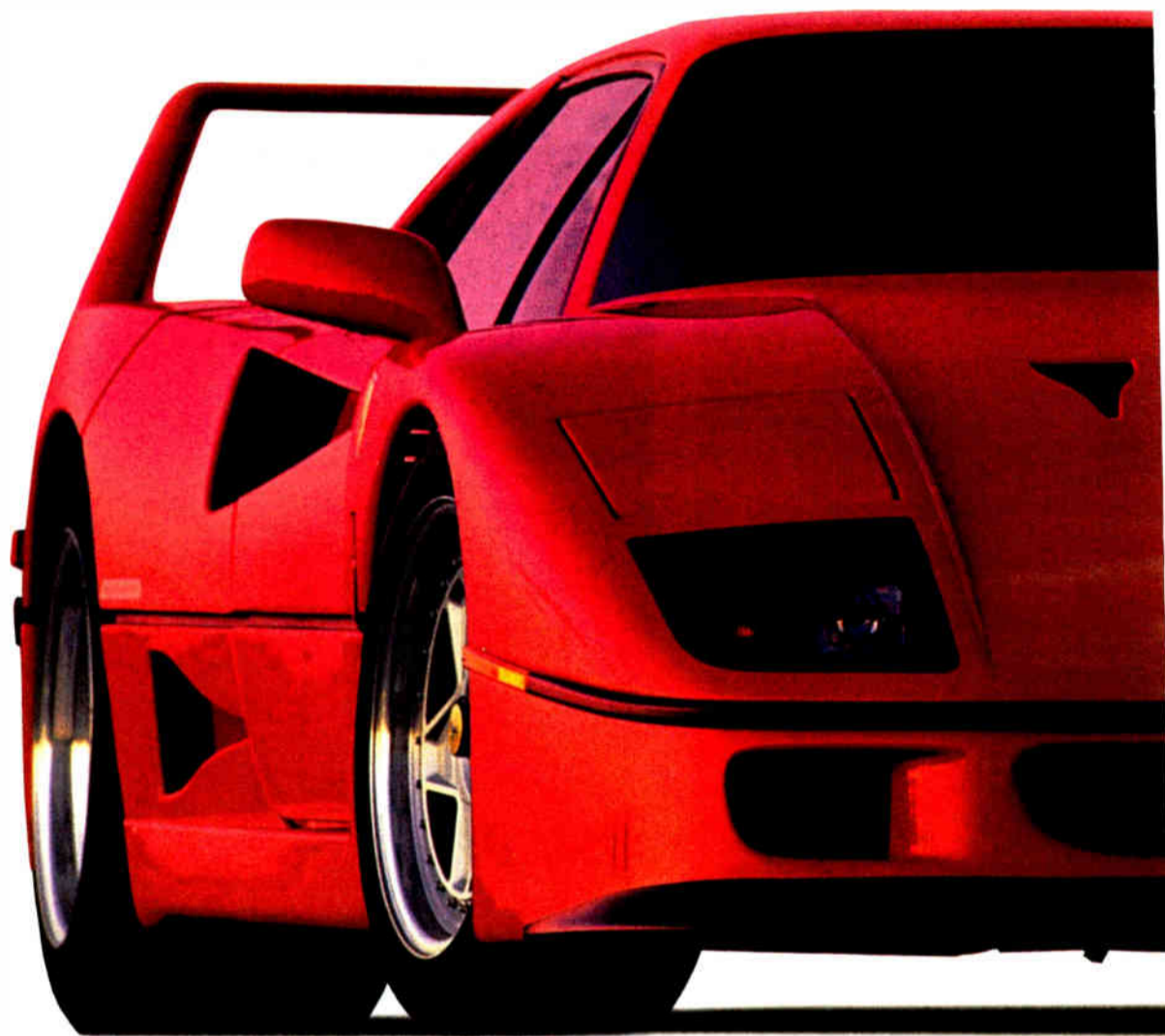

## IF IT CAME WITH A \$292,000 REBATE, IT WOULD BE AS COST

At ComStream we may not be offering rebates, but our turnkey digital audio satellite networks can save you up to 65% in distribution costs down the road.



ABR200 Digital Audio Receiver

Using the latest in digital satellite modem

technology and digital audio compression (MUSICAM), our

network is capable of an unsurpassed 12 to 1 compression ratio that can distribute full 20 KHz stereo audio at 128 Kbps. Yet the decompressed audio delivered at receive sites maintains CD-quality, thanks to our ABR200 - the world's first multirate, multimode integrated receiver/decoder.

So now you can receive significant savings (35-65%)

HEADQUARTERS: 10180 BARNES CANYON RD., SAN DIEGO, CA 92121 (619)458-1800 FAX (619)552-0488 • EASTERN U.S.: NO.1 JIANGUOMENWAI AVE., SUITE 2309, BEIJING, CHINA 100004 (861)-505-4824 FAX (861)-505-4842 • EUROP  
Authorized U.S. Distributors: National Supervisory Netw

See Us At NAB Radio Show Booth 840

World Radio History

► continued from previous page  
under attack. As an example, if your goal is to "own" vendor sales and to have the best vendor sales program and profile in your market your strategy might include hiring an experienced vendor director, allocating a start-up budget, setting up hotel and printing trades, and joining the proper associations.

The action plan could state what the vendor director would/should do, a timeline for critical path activities and how the program's progress would be measured.

Keep communicating omni-directionally and aim to be ultra-accessible whenever possible.

Everyone's individual role in helping turn the station around must be communicated. Every department head and staff member should have a clear understanding of how his/her performance influences

other departments. Department head meetings, state-of-the-art meetings, walk-a-mile-in-my-shoes, cross-training sessions all provide forums for celebrating wins and recognizing progress. Create an open door policy, making sure the needs people have for daily/weekly communications are known and workable.

In the early stages of a turnaround everyone's needs for productive access to the boss can sometimes be overwhelming. But as the turnaround gels and progresses, the staff will quickly get its sea-legs.

The one-minute manager is right on for radio.

#### Manage people, not paper

Roam the station with an eye to catching people doing things right. Put communications boards up, publish and celebrate small wins and successes, rave

about one department to another, lock in get-togethers and burn up the trade as fast as possible. Wipe out classism, lock in cross department thank yous.

Be a catalyst for the department heads successes—and then let them own those successes as their own.

A station full of "owners" will outperform a station full of employees every time. The best way to build a management team of owners and then keep them bought in over the long haul is to let them own their own piece of things. Decentralize at the outset.

It often takes 2-3 months for an infrastructure to form, another 2-3 months to design, field, and receive the results of a research project, and 2-3 more months after that, e.g. one or two books for the effort to start paying dividends. Thus long-term buy-in by the department heads

is key to sustaining the turnaround effort.

Hiring smart, managing loose, decentralizing quickly, and praising often is the sure-fire way to keep things high-tech yet high-touch. Mental preparedness and toughness will be needed in all the departments to blast through the plateaus and resistance levels that all turnaround efforts encounter. Help your staff stay excited, enthusiastic, and raring to go everyday. Help them build their staying power by showing them how much you enjoy the turnaround process yourself.

Cheerlead the staff along the road to success every day. Your optimistic, uplifting attitude must infect the staff and keep them pumped. An unwavering positive demeanor will be job one, especially during the rough periods.

#### Monitor everything

After the turnaround is under way, stay obsessively close to the station's three different constituencies: The listeners, the advertisers and the staffers. Right now WNIC is probably delivering on and reconciling expectations of its three constituencies better than at any time since its first life cycle in the 1980s... and we are doing it at a much better profit than ever. The staff is thrilled with the program and process—and everyone is now acting as a catalyst for it all to keep happening.

The uncertainties and delayed gratifications of a turnaround project require more one-to-one face time than other types of stations. All three of the station's constituencies—listeners, advertisers and staff members—need highly individualized attention. Go for meetings with clients rather than letters, grass roots and one-to-one direct mail rather than mass media, one-to-one huddles with staff rather than memos.

#### Achieve balance

Help your staff balance their lives long-term on behalf of the station.

Set station policies that allow department heads and other staff members to easily reconcile work/family issues. Make sure health care, medical, maternity and sick leave policies compliment your "employees first" stance so that they are not hidden obstacles to esprit de corps. If you've hired smart, you will be able to manage loose.

While sticks, start-ups and turnarounds are somewhat unbankable and unsalable today, they still represent tremendous opportunities for present owners to build equity, create asset values, and reignite cash flows... the three qualities that propelled the lender-driven '80s and the three qualities that will help radio be the healthy vibrant industry it has been.

Consumer confidence is back. The media has declared the recession all but over. The stock market continues to over perform. Most markets are growing once more. Advertisers are spending again. These are the happy byproducts of overall economic confidence. There is no better landscape against which to decide, commit, plan and succeed at a radio turnaround.

□ □ □

Gary Fisher is vice president and general manager of WMTG(AM)-WNIC(FM) Detroit. From 1983 to 1992, he was vice president and general sales manager, and then vice president and general manager of WHTZ(FM) "Z100" New York, one of the nation's fastest, most successful and enduring turnarounds.

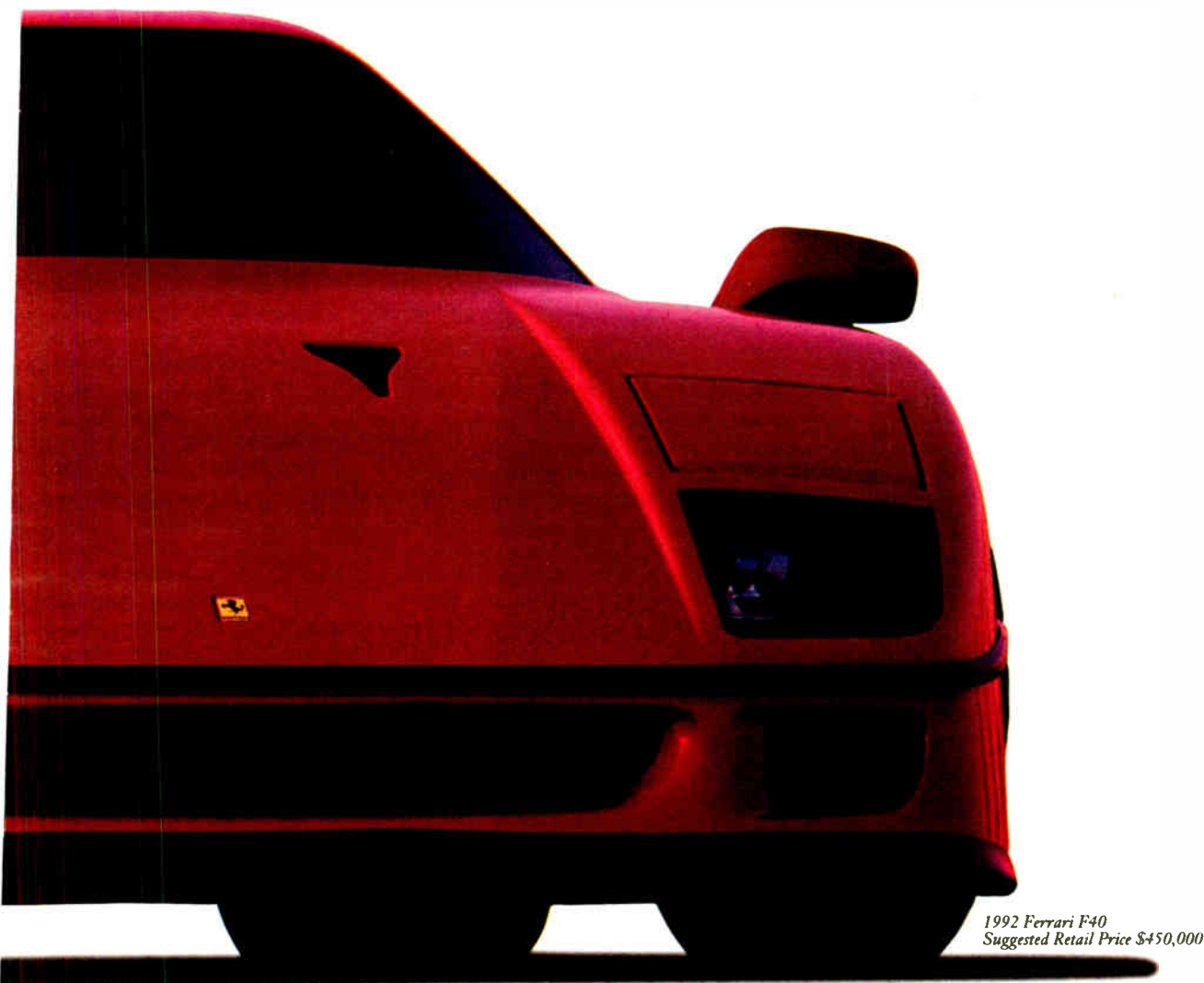

1992 Ferrari F40  
Suggested Retail Price \$450,000

## EFFICIENT AS OUR DIGITAL AUDIO SATELLITE NETWORKS.

made possible through reduced transponder costs. Or you can send multiple program channels for the same cost of your current transmission without sacrificing sound quality.

No wonder some of the world's largest retailers, national radio networks and news organizations rely on ComStream to keep them on the fast track. Our digital audio

networks provide them with multiprogram delivery service with advertising insertion, direct uplinks and remote broadcasts.

And we can do the same for you. Just give ComStream

a call. And get up to speed on how

cost efficient a digital audio

satellite network can be. Spar Communications Group

**SPAR**

COMSTREAM

Spar Communications Group

# Program Syndication

## ABC Networks

ABC's lineup, which consists of various formats such as talk and oldies will include "Home Sense," "Tom Joyner," "Paul Harvey," "Moneytalk," "American Gold with Dick Bartley" and "Bill Diehl's Spotlight."

For information, contact ABC Programming at 212-456-5200.

## Accu-Weather

Accu-Weather provides broadcasts, discussions, live reports and forecasts pinpointed to each station's coverage area and geared toward that station's format.

Accu-Weather uses Switched 56 digital voice transmission.

For information, contact Joel Myers at 814-237-0309.



## American Comedy Network

Along with a one-month trial period, ACN offers 10 features a week, which include song parodies, interactives and ongoing serials. In addition, ACN supplies a 19-CD set

with 1,044 classic ACN bits. Affiliates will also receive 10 custom drop-ins each month.

For information, contact ACN at 203-384-9443.

## Bonneville Broadcasting System

Bonneville Broadcasting System has a number of Signature Series Formats which include Hot, Soft and Mainstream A/C, Classic Easy, Verdery Environ-

ment, Easy Mix, Ultra, Bonneville Gold and Bonneville Country.

For information, contact Michael Krafcsin at 800-631-1600.

## Broadcast Programming

Broadcast Programming offers 14 digital music formats from Digital Today's Country to Digital Urban with rotations, safelists, CD music libraries and daily music schedules available on floppy disk or paper. Also available are 30 formats on reel-to-reel tape.

For information, contact Keith Chambers at 800-426-9082.

## Celebrity Radio Worldwide

Celebrity Radio Worldwide will produce and distribute "Success Talk!," a one-hour program incorporating discussion and testimonial about the product offered in particular episodes of the "infomercial"-like program.

For information, contact Doug Groner at 201-391-2800.

## Children's Satellite Network

The Children's Satellite Network offers a 24-hour radio format delivered via satellite, featuring contemporary family programming like "Story Time Theater," "Just Kids" or "Brain Games."

For information, contact Brian Heimerl at 818-990-3391.

## Crowley Broadcasting

Crowley Broadcasting will present "Steve Crowley's American Scene," a three-hour, Saturday morning radio show featuring live, in-studio expert guests, live remotes and listener call-ins. The theme of the show is how current news personally affects listeners.

For information, contact Ben Avery at 703-352-3787.

## Dick Brescia Associates

Dick Brescia's programming offerings include the daily, two-minute "Walter Cronkite's Twentieth Century" that looks back on significant events on a particular date in history; the 54-minute "When Radio Was..." that includes classic radio shows from the '30s, '40s, and '50s, like "The Shadow," "Lights out" or "Great Gildersleeve," and "Stan Freberg Here!" a two-and-a-half minute satirical comedy program.

For information, contact David West at 201-385-6566.

## Focus on the Family

Focus on the Family provides four programs "Focus on the Family," hosted by Dr James Hobson, who offers advice and encouragement on family matters; "Weekend," which takes the best clips from Focus on Family during the week; the radio drama series "Adventure in Odyssey"; and "Family News Focus," an information and analysis pro-family news show.

For information, contact Bob Dobbs at 719-531-3344.

## Halland Broadcast Services

Halland Broadcasting Services will introduce "Halland's Butt-Kicking Country," a new country format that will emphasize country hits from the mid-1980s through the present. HBS will offer its three other existing formats-

continued on next page ►

## The Aphex Audiophile Air Chain

### Higher Quality and Extended Coverage!

Smart broadcasters know that quality sound is essential to attract and keep loyal listeners ... and advertisers.

That's why premier stations around the U.S.A., and around the world, rely on the Aphex Audiophile Air Chain.

Now there's one more reason to turn to Aphex — better coverage of your listening area.

Stations that have installed the powerful combination of the Aphex *Compellor*® Model 320, *Aural Exciter*® Type III, *Dominator*™ II Model 720 and the *new Digicoder*™ digitally controlled stereo generator — as well as their listeners — are raving about better signal quality and a reduction in multipath.

"A surprise bonus has been the apparent increase of coverage in fringe areas — we are getting very positive responses from listeners in Sacramento, 100 miles away," - Tim Pozar, CE, KKSF-FM, San Francisco.

"Immediate improvements in fringe signal quality were noted. These improvements included a reduction in multipath and picket-fencing," - Gary Greth, CE, KLON, Long Beach, CA.

**APHEX SYSTEMS** Improving the way the world sounds<sup>SM</sup>  
11068 Randall Street, Sun Valley, CA 91352 ■ (818) 767-2929

Compellor, Dominator, Aural Exciter and Digicoder are trademarks of Aphex Systems Ltd.

©Aphex Systems

Circle (44) On Reader Service Card

World Radio History

► continued from previous page  
 "Rock 'N' Roll Graffiti," "The Seventies," and "the Eighties Plus."

For information, contact Steve Steinberg at 818-963-6300.

**John T. Brady Associates**

The 10-program 60- or 90-second "Forbes Report" and the Weather Channel Radio Network will be part of John T. Brady's menu of programming.

For information, contact John Patt at 212-688-2424.

**MRN Radio**

MRN Radio offers live, play-by-play broadcasts of 56 NASCAR racing events and other NASCAR-related feature programming such as "NASCAR Today,"

"NASCAR Live," "NASCAR Racing" and "World of Racing."

For information, contact David Hyatt at 904-254-6760.



**North American Network**

North American Network produces and syndicates Consumer Radio Network, a twice-a-year consumer series of 20 or 25 one-minute reports that air each fall in conjunction with

National Consumers Week. It also has radio interview booking source.

For information, contact Lisa Brusio Coster at 202-265-3689.

**NSE Radio Network**

Offered to individual radio stations by satellite, the NSE Radio Network is a 24-hour adult contemporary format targeted towards the 25-54 adult audience.

For information, contact Don Garrard at 716-381-0620.

**Premiere Radio Networks**

Premiere's programming includes five comedy networks, a number of Countdowns, and various other programs like "News from the Boonies" which presents bizarre yet true stories from around the world, or "Premiere Radio Anti-Jingles."

For information, contact Ed Mann at 818-377-5300.

**Standard Broadcasting Network**

Standard Broadcasting Network's programming include "Homecare with Jeff Williams," in which listeners call in with electrical problems, tool advice and other home maintenance information and "Nutz & Boltz," a live interactive talk program that discusses car problems and includes auto news and sound effects.

For information, contact Barbara Parks at 804-523-7794.

**Super Gospel Country Radio Network**

Super Gospel Country Radio Network offers a Christian/Positive Country Format and a weekly two-hour Top 10 Countdown program with interviews.

For information, contact Jim Black at 615-264-2441.

# Manage Time Effectively

► continued from page 19

Ask each manager to list the resources he will need to accomplish each of his objectives. This might include adding a new staff member to the sales department such as a co-op coordinator. It might include adding the costs associated with purchasing additional backup technical equipment to assure minimal off the air time.

When the tactical plans and resource requirements are established, ask each department manager to develop a budget to maintain his department and complete the tactical objects. Give them a list of the major budget line items as a guide for evaluating the resources needed.

You may also want to establish the merit pay increase ceilings at this time. For example, you might limit merit pay increases per department to 7 percent. This will be a factor for the managers to develop their budget salary recommendations. After completing these tasks, the managers will have first hand knowledge of how the strategic/tactical plans and the budget are developed and inter-related.

The combination of the tactical plan and budget will provide a framework for you to objectively evaluate each manager's performance. Advise the managers that their tactical objectives should be realistic but challenging because their ability to manage their tactical objectives within budget will contribute to their annual performance evaluation, raises and bonuses. I can assure you that if a manager's performance evaluation, raises and bonus are tied to the objectives and the budget, he will be continually mindful of them as the daily work is done.

When the managers have developed their tactical objectives and budgets to support those goals, ask them to submit them to you for review and approval. You

may need to modify grandiose objectives and increase some objectives and budgets.

**Game plan in place**

When this work is completed, you will have a comprehensive strategic and tactical plan for your station for the next year that was developed by your senior staff. That management staff will be fully aware of how it was developed. In addition, they contributed to it and will understand how their personal and departmental performance contributes to the success of the station. Your job, along with theirs, will be to monitor performance against plan.

If MBOs are developed, implemented and periodically reviewed, your station should continue to prosper and grow. Over a three year period, you might see an objective of decreasing the total amount of time off the air drop from five minutes to three to zero minutes. You might have an objective to add five new advertising accounts per quarter. Over a three year period, that is 60 new accounts added by consistently meeting a small quarterly goal. Over a five year period, that is 100 new advertising accounts.

MBOs can be one of your best management techniques that improves the overall performance of your management staff, profitability, and ratings. The concept is not difficult to develop and implement. The time invested in developing this management technique will strengthen the internal and external performance of your station.

□ □ □

*Sue Jones is a senior manager for Computer Data Corporation Inc. in Rockville, Md. She can be reached at 703-323-0491.*

# PREMIERE

## RADIO NETWORKS

NEW YORK • LOS ANGELES • CHICAGO

**Spear Communications**

Spear Communications' distributes "Modern Rock Live", a live syndicated music/talk program featuring top artists from the modern rock charts.

For information, contact Alan Korowitz at 212-486-0720.

**Sports Byline USA**

Sports Byline USA is a daily, national radio sports talk show that includes interviews with guest celebrities, toll-free listener call-ins from across the nation and many topical sports-oriented features such as "Olympic Preview and Updates," "Baseball Magazine," "Sports Trivia" contests and so forth.

For information, contact Darren Peck at 800-783-7529.

**Wall Street Journal Radio Network Dow Jones Report**

The two radio networks feature different finance related formats including the "Wall Street Journal Report," the "Dow Jones Report" and a package of three-minute news programming for weekend clearance that targets those that own, manage, or operate a small businesses.

For information, contact Jon Krongard at 212-416-2382.

**WOR Radio Network**

WOR's basic network feeds, transmitted on Satcom C5, Transponder 23 and SEDAT Channel 21 include "Dr. Joy Browne," "The Dolans" and "Gene Burns."

For information, contact Rich Wood at 212-642-4533.

6  
OF  
7

**6 of the first 7 Accu-Weather stations are still clients 21 years later! Here's why.**

**Accurate forecasts.**  
Detailed, precise forecasts by Accu-Weather's 70 expert meteorologists using proprietary techniques can give you the lead in forecast accuracy.

**Highly promotable.**  
Focus studies show the Accu-Weather name is the most trusted and most accurate weather source available.

**Top personalities.**  
Accu-Weather meteorologists are outstanding communicators, among the top-rated broadcast personalities in many markets.

**Tailored for you.**  
Accu-Weather is geared to your format and style, and to your coverage area.

**Studio sound.**  
Accu-Weather utilizes digital voice transmission.

**Call (814) 234-9601 x400.**

**Accu-Weather, Inc.**  
The World's Weather Leader™  
619 W. College Avenue, State College, PA 16801

**SEE US AT RADIO NAB Booth 434**

**FOR ~~SO'S~~ SAKE BE DIFFERENT!**  
YOUR

**IMAGE MAX-1**

**The Next Level In Jingle Imagery**

Prices start at 500.00  
Call (216) 239-2752 or Fax (216) 239-1359

## UPLINK

# Two Remote Monitor Alternatives

*Editor's note: This month, Uplink columnist Karl Baehr continues his look at remote monitoring services. This time he spoke with two companies that offer remote monitoring in two distinctly different ways.*

*Though Southern Communications has been around for about 12 years, the monitoring service is relatively new. Southern offers remote monitoring via telephone lines. Currently with 20 stations in nine states, the company is growing. Baehr talked with Southern Communications' president, Ray Reich.*

**RW:** First let's talk about cost. What does your service cost a station each month?

**Reich:** Up to 12 hours of monitoring a day, seven days a week (the minimum available) runs a station \$250 per month. After that a station can contract hour by hour as much as they need with 24-hour monitoring costing about \$750 a month.

**RW:** Does your service comply with FCC rules and regulations?

**Reich:** Yes it does. We become an auxiliary control point of your station. We even provide you with the necessary

paperwork to file with the commission. Our operators are trained, on duty around the clock, they take readings every three hours and can respond immediately when the need arises concerning transmitter problems, local or national EBS.

**RW:** What about contract length, equipment and startup costs?

**Reich:** We are very reasonable in these areas. First of all, there is no lengthy contract. In fact a station can discontinue service with as little as 14 days notice. The unit we use for EBS remains our property so the station is not charged for it. All that is required is a dial up remote and our system is compatible with most such units. If you have an adequate dial up remote, there is no startup cost, you simply receive a bill for your first month's service.

You can contact Ray Reich at Southern Communications directly at 803-773-7370.

*At the other end of the remote monitoring spectrum is the pioneer of satellite remote monitoring, the National Supervisory Network. Baehr talked with NSN General Manager, Muffy Montemayor.*

**RW:** You have been providing remote monitoring services for awhile now, how long?

**Montemayor:** Commercial service began in 1990. We actually began research and development of our system in 1988, so we've been around awhile.

**RW:** Does the service offered by NSN comply with FCC rules and regulations?

**Montemayor:** Absolutely. We also provide a degree of service above and beyond that compliance.

**RW:** For instance...

**Montemayor:** We have continual in-house monitoring of weather conditions nationwide. Combining this with the fact

that we have a two-way link with each of our stations allows us to detect and react to changing local and national weather conditions as they develop. We send weather text, and log summaries weekly via a local access terminal on line at each station

**RW:** So NSN does have local and national EBS capability. Are you prepared for pending changes in EBS policy whatever they are and whenever they might transpire?

**Montemayor:** Yes we are. We are concerned about the future of EBS like everyone is. The fact is that we will continue to offer full compliance in this area no matter what the outcome is.

**RW:** What about cost, equipment and contract term. What are your service options?

**Montemayor:** We offer what we call our Basic Service that is a 24 hour a day, seven day a week service. We do not break down service hour by hour. The equipment needs to come from us and is compatible with most remote control units. The 24-hour monitoring with equipment lease built in will run between \$850 and \$875 a month. Our contracts are four years.

To find out more about the National Supervisory Network call Muffy Montemayor at 303-949-7774.

So there you have two qualified options for remote control. Each different in the scope and cost of service, but both do comply with FCC regulations governing such services. You have a place to start.

As always we encourage your questions or comments. If you would like to get together in Dallas at the NAB Radio Show, by all means give me a call!

□ □ □

*Karl Baehr is president of KBE "Broadcasting By Design" a radio consultancy that provides support services for satellite radio stations and produces the Actual Radio Measurement (ARM) electronic survey system. He can be reached at 505-828-0488; fax: 505-821-4226.*

## CD AUTOMATION WITH DIGILINK ONLY \$9,490\*

- Play over 2000 songs on 144\* CD's (option up to 1100 CD's)
- Music Scheduling system standard
- 10 hours of stereo hard disk storage (20 hours mono)
- 4 standard switcher external inputs (11 optionally avail.)
- Schedule up to one week in advance
- Simultaneously play a Commercial and record a Spot

No matter how you add it up, it quickly becomes obvious why Digilink is #1 in digital audio for Radio. Features, price, and customer satisfaction have made Digilink the choice of broadcasters from Russia to Japan to your own back yard. Whether for live on air, satellite-CD-tape automation, or multitrack production, Digilink fills your needs now and in the future. For practise, price your system on the form below and then write, call, or FAX Arrakis for more information.

VOICE (303) 224-2248 , FAX (303) 493-1076

### ARRAKIS

DIGILINK ORDER FORM	
Name- _____	
Call letters- _____	
Address- _____	
Telephone- _____	
*10 hour system*, stereo (20 hours mono).....	\$7,995 <input type="checkbox"/>
*CD Controller* (for up to 8 Pioneer 18 disk players)..	\$1,495 <input type="checkbox"/>
<i>(the CD players must be supplied locally-\$3,500)</i>	
<b>Options-</b>	
16 hour system, stereo (32 hours mono).....	\$9,995 <input type="checkbox"/>
Add 7 more switcher inputs (Total 11).....	\$444 <input type="checkbox"/>
2nd switcher w 7 inputs for timed recording.....	\$295 <input type="checkbox"/>
Network Board plus software.....	\$495 <input type="checkbox"/>
<i>(for 2 or more Digilinks or a scheduling computer)</i>	
Video Doubler.....	\$1,395 <input type="checkbox"/>
<i>(control a Digilink from two places- up to 100')</i>	
<b>Add a Second Studio-</b>	
Add a Production studio to your Air studio.....	\$8,490 <input type="checkbox"/>
<i>(2nd 10 hours system w Network Card)</i>	
Trak*Star 8 Track Editing Software.....	\$1,995 <input type="checkbox"/>
<i>(add an 8 track editor for ultimate production)</i>	
Total List Price-	\$ _____

1993 Arrakis Systems inc. 2619 Midpoint Drive, Fort Collins, CO. 80525

Circle (206) On Reader Service Card

See Us At NAB Radio Show Booth 124

## LOCK THE DOORS AND GO HOME!!

### NOW YOU CAN OPERATE YOUR RADIO STATION LEGALLY WITHOUT AN OPERATOR IN YOUR STATION

We Will Monitor Your Transmitter  
Take Transmitter Readings  
Monitor Your EBS &  
Fax You A Transmitter Log Each Day

ALL FOR ONLY  
\$250.00 A MONTH

Call Today For Complete Details

SOUTHERN  
COMMUNICATIONS  
(803) 773-7370

Circle (7) On Reader Service Card

## TALK AMERICA Radio Network

The most outstanding program lineup in  
Network radio available at no cost  
on Satcom C-5 and Galaxy 2:

- Earl Jackson Across America
- Tom Donahue's America's Town Forum
- The Jack Anderson Program
- Judy Jarvis Live
- Bo Gritz On The Go
- Dr. Gabe Mirkin
- The Sports Final
- The Winning Line From Las Vegas

\* And on weekends: \*

- Dr. Alan Pressman
- Mort White's Magic Garden
- Winning Line Racing Show
- The Car Doctor
- Dick Syatt's Dating Show
- Inside Automotive
- Computer Exchange
- Glenn Brook's Personal Best
- Lou Kelfer, Esq. & Family Law

CALL 1-800 298-TALK  
FOR MORE INFORMATION

LIVE 24 HOURS A DAY  
7 DAYS A WEEK

SEE US AT NAB BOOTH #204

Talk America Radio Network is a Division of Sports Final Radio Network, Inc.

Circle (124) On Reader Service Card



# Huie Believes in Radio's Success

► continued from page 15

**RW:** With everything in such rapid flux, and engineers diminishing in numbers at radio stations, how much are managers getting involved in the technology?

**Huie:** They're being forced to get more involved but they are also using consultants and part-time technical experts. And they are relying more on manufacturers like us.

There is less knowledge out there but by talking more to suppliers, managers can learn and make decisions. We've been in the business for over 70 years and we work closely with radio and TV stations; if they come to a company with solid experience they can get a lot of help.

**RW:** How can managers learn more quickly? What are you doing to reach them?

**Huie:** We are continuing our 24-hour, seven-day-a-week service, so they can call our facility and get the technical help they need. We also run seminars on several different topics and managers do come in for those.

**RW:** Let's talk about new technology, like DAB. Harris Allied has already partici-

pated in USA Digital demos. What's ahead...are you moving into it in a big way?

**Huie:** We're certainly moving into it—it's an exciting new technology. We participated in tests at WILL-FM in Champaign-Urbana, Ill., where USA Digital is developing its FM DAB. We provided a Harris Platinum linear transmitter there. Next, we'll test our DX transmitter on linear in-band AM DAB. Geoff Mendenhall now heads our radio product line and he had been involved in DAB and of course is extremely knowledgeable about all new technologies.

**RW:** What about HDTV? What will Bob Weirather be doing?

**Huie:** Bob is heading up our planning activity and working closely with Frank Svet, our TV product line manager. Of course, this is the way of the future with the U.S. The "grand alliance" announced in May is a significant step forward and we expect a decision by the FCC on a system which combines the best of four systems. Harris participated by doing test instrumentation for the ATTC in Virginia; we've supplied a mobile van for

receive site and provided antennas. We're proposing to the "grand alliance" a layered architecture to insure future growth. We see it as a big opportunity and we're working right now to do the advance work.

**RW:** Harris Allied has been a digital pioneer, the first with digitally modulated transmitters, and so on. Will you continue to be such a pioneer?

**Huie:** Ground-breaking is a big order but we're continuing to work on digital transmitters; we're extending the power range for the DX line. A fair percentage of our R&D is devoted to breaking new ground.

Hilmer Swanson, a pioneer in his own right, continues to work on new ideas. So you can expect some new things. Look for higher power in AM digital, improvements in FM and more digital products for the studio.

**RW:** What do you think Parker Gates and other early radio pioneers would say if they could suddenly step into the world of radio today?

**Huie:** I think they'd be startled. Parker would be surprised at some of the developments; he might be disappointed that some of the technical aspects have been overshadowed by business concerns, but he'd be excited by the new technologies. He was a forward thinker so there's no question he would be excited about the future.

## Spotting the Right Types

► continued from page 17

ketball, football) are also sources for new sales talent. Ask around your station who has kids in youth sports. Find out who are the aggressive, competitive coaches. Watch that individual in action and introduce yourself to them.

Chances are, if they have the time to devote to youth sports, they may not have the kind of career they would like to have. They may have sought youth sport coaching as an outlet for their competitive nature because they do not have such opportunities in their job.

How good can coaches be? Ever heard of Art Williams, who started A.L. Williams, the insurance company which revolutionized the life insurance industry? He was a former high school coach who made millions, and created a number of millionaires in his effort.

Many stations work closely with community organizations to develop programs and events. Some leaders and project chairmen/women they interact with are potential sales people for the station. A true sales personality nature seeks leadership opportunities. Find out more about these community leaders, how competitive they are, what they do for a living. Exploit the opportunity.

There are also other places to find good account executives in your community. The successful radio executives should recruit every day for new account executives.

Notice those you come in contact with in your everyday activities. Look for the individual who does more than just wait on you. Look for the individual who hustles, talks of goals, seeks to sell you additional products without suggestive sales training.

### Get help from staff

Do not be afraid to ask staff to suggest potential sales candidates. Ask them to avoid relatives, their close

friends or the nice guy down the street. Tell them you want someone who is perhaps viewed by others as too competitive, has an edge, is always trying to better themselves, and who may not always be liked by everyone they come in contact with. You may even wish to offer financial incentives (after six months of successful performance) to staff who find the station successful account executives. This way you maximize the number of people helping you to look for new sales talent.

Another good source of new sales talent is college recruiting. Radio is unique. Unlike many other professional sales opportunities, "youth" is not considered a disadvantage. Talk to your local college placement office regarding scheduling interviews with potential graduates. Tell the placement office you want to interview highly competitive, leadership oriented types for a sales career with your station; their major or degree is unimportant.

Make sure the posting for your job interviews indicates "only highly competitive" men and women should apply. Because of restructuring and downsizing, larger companies are not conducting the amount of recruiting and hiring done in past years. There will be a large number of quality college graduates available for the foreseeable future.

The secret to sales recruiting is to find new methods to recruiting, and to recruit actively every day. If the radio executive is creative in the account executives search, he will not join the ranks of the general managers chorus singing "Why can't I find any good sales people?"

□□□

Dale Smrekar is vice president of The Omnia Group. Omnia offers personality testing services for the broadcast industry. For information, contact The Omnia Group at 800-525-7117.

## THE INDUSTRY'S RDS/RBDS LEADER HAS JUST CRUSHED THE COMPETITION

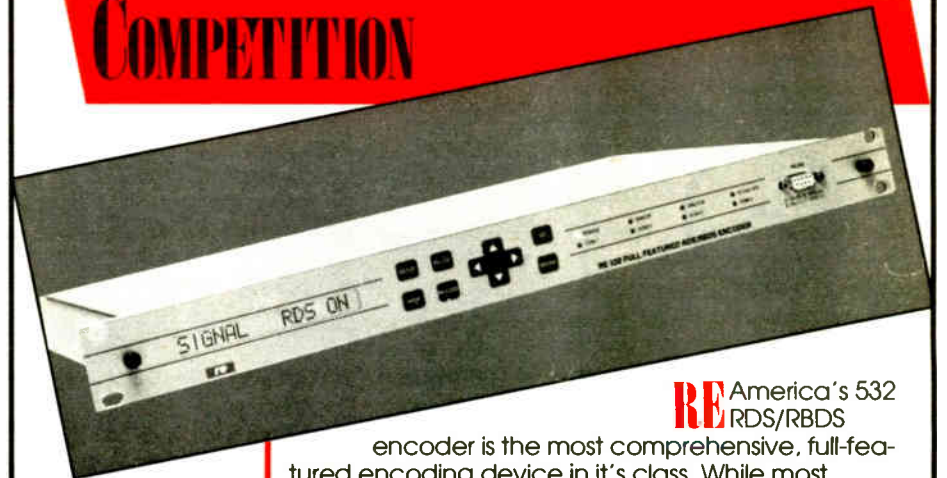

**RE** America's 532 RDS/RBDS

encoder is the most comprehensive, full-featured encoding device in its class. While most American RDS/RBDS encoder manufacturers are building their first product, the RE 532 represents RE's third-generation RDS/RBDS encoder. The RE 532 provides five data ports to enable broadcasters to take full advantage of the revenue potential that RDS/RBDS offers.

Ancillary RDS/RBDS data services such as Paging and Differential Global Positioning (DGPS) are now emerging as major revenue sources for broadcasters. The RE 532 will intelligently manage these services as well as maintain the integrity of the stations RDS/RBDS data, such as call signs, format and radio text.

The RE532 comes complete with its own proprietary PC control software which enables the unit to be set up and programmed quickly. Remote data control and phone-line communications can be accomplished with any Hayes compatible modem.

Without a doubt, the RE 532 is the most cost-effective, revenue-generating, piece of equipment your station could ever purchase. Now that a U.S. standard for the Radio Broadcast Data System exists, it promises to provide broadcasters with new and exciting opportunities for increasing the bottom line.

- ▲ Full-featured RDS/RBDS encoder in a compact single rack space
- ▲ Includes Paging and DGPS capability
- ▲ Five data ports for main and ancillary data usage
- ▲ Front panel keypad for easy setup adjustments
- ▲ Backlit LCD displays menu of all parameters
- ▲ Two discrete pilot sync inputs for main and back-up transmitters
- ▲ 16 data records may be programmed and sequenced automatically
- ▲ PC control program is included
- ▲ Operates as a stand-alone RDS/RBDS subcarrier generator plus loop-through mode



RE AMERICA, INC.  
31029 Center Ridge Rd. ▲ Westlake, Ohio 44145  
Phone: (216) 871-7617 ▲ Fax: (216) 871-4303

# STATION SERVICES

News and Services for Business, Programming and Sales

## Winning Line Hires New Producer; Kicks Off NFL Preseason Series

**LAS VEGAS** Kurt Kretzschmar was named producer of "The Winning Line" sports talk radio show, broadcast from The Las Vegas Hilton Superbook, weeknights from 7-10 p.m., Pacific Time. Kretzschmar will also serve as executive producer of Winning Line's "Weekly Racing Report" thoroughbred racing show.

The NFL Preseason Spotlight, began running as a nightly feature on "The Winning Line," on July 12 as NFL train-

ing camps began opening. Starting with the AFC West, the feature covers each team with analysis by sportswriters, broadcasters and executives from each NFL team.

For information, contact Kyle Heinrich at 206-285-5480; or circle Reader Service 220.

## Two New Hosts Join Talk America

**BOSTON** Conservative Black lawyer Earl Jackson and physician Gabe Mirkin have joined Talk America Radio

Network as daily talk show hosts.

Jackson, a Harvard-trained lawyer, airs weekday mornings at 8-10 a.m., Eastern Time. Mirkin, who practices medicine in Baltimore, will take listeners' call-in health questions at 6-7 p.m., Monday through Friday.

Jackson and Mirkin join a long list of Talk America call-in hosts, including Jack Anderson, Tom Donahue, Judy Jarvis and Bo Grist. The network also offers several weekend talk shows and overnight sports updates.

Talk America can be received over SATCOM C-5 or Galaxy 2.

For more information, contact 508-460-0588; FAX: 508-624-6496; or circle Reader Service 169.

## Oleary/Kamber Debate Comes to Radio

**WASHINGTON** Brad O'Leary and Vic Kamber will now debate opposing views over the radio in the new nationally syndicated "The O'Leary/Kamber Report."

The hour-long, weekly show will feature four guests—two liberal and two conservative—debating controversial global and national issues, including Clinton Administration policies on health care, gays in the military and the situation in Bosnia.

Members of Congress, members of the media such as "Newsweek" correspondent Howard Fineman, Washington analyst Norman Ornstein and prominent

activists like Ross Perot are on the show's guest list.

For information, contact Jim Monroe at 202-223-8700; or circle Reader Service 135.

## "Inside Politics with Bruce DuMont" Available Nationally

**CHICAGO** "Inside Politics with Bruce DuMont," political talk show aired in the Chicago area since 1980, is now available nationally. Show promises "in-your-face analysis" and "beyond the beltway" input from listeners, hosted by DuMont and joined by conservative Tom Roeser and liberal Grace Kaminkowitz.

The show includes live field reports from reporters and activists across the country.

For information, call 312-616-1441; or circle Reader Service 86.

## SuperRadio Expands Product Line

**SOUTHBOROUGH, Mass.** SuperRadio, makers of "Open House Party," now offer two versions of the award-winning program. The live satellite show will be broadcast in a top 40 version and a rhythm-based top 40 for urban radio.

Also available are five different versions of "Supermixx," the company's unhosted mix program.

For information, contact Gary Bernstein at 508-626-2000; or circle Reader Service 181.

# LOCK THE DOORS, WALK AWAY, YOU'RE ON THE AIR...

ON AIR



## ...FCC LEGAL

The National Supervisory Network is your duty operator 24 hours a day, seven days a week, providing:

■ FCC & FEMA Compliance for an Off-Premise Control Point ■ A Licensed, Trained, Experienced Operator on Duty ■ Transmitter Monitoring & Command ■ Emergency Broadcast System Monitoring & Command ■ Security & Fire Alarm Monitoring ■ Complete Operations Logs—Readings Every 30 Minutes ■ Trend Analysis Reports for Your Engineer ■ An On-Line Broadcast Data Base ■ Optional Private Data Sub-Networks for Station Groups ■ Optional CD Quality Digital Audio Sub-Networks

We supply the satellite and computer equipment for the basic data link as part of our regular service fee: \$1.09 per hour.

For Information

**1 (800) 345-VSAT**

**NATIONAL OFF-PREMISE CONTROL**

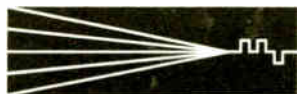

**NATIONAL  
SUPERVISORY  
NETWORK**

AVON, COLORADO

# STATION SERVICES

## THROW AWAY THOSE 3X5 CARDS

### HOT MIX

music scheduling software

Get better and fresher rotations

Buy out price only \$495.00

### Programming services available

- Music Logs / Programming
- Set-up and data entry for RCS Selector
- Hooks for auditorium tests

Call us today

**La Palma Broadcasting**

1-714-778-6382

## ATTENTION:

ALL  
MAJOR RADIO  
NETWORKS

OR ANY PARTY INTERESTED!!!

**KU BAND  
UPLINK FROM  
LAS VEGAS**

DIGITAL MUSICAM 20 KHZ AUDIO

**702-649-9126**

THE JERRY L. HECKERMAN  
LAS VEGAS TELEPORT

## BUY - OUT MUSIC

•Industrial •Technical •Logos  
•Dramatic •Romantic •Variety  
•Contemporary •Sports •Travel

11 Great Volumes! Low Buyout Pricing!  
Multi-Unit Discounts! CDs And Cassettes!  
Free Catalog!

**ENERGETIC MUSIC**  
P.O. Box 84583 • Seattle, WA 98124

**1-800-323-2972**

## ATTENTION PROVIDERS!

Promote your services to **Radio World's** 21,000+ readers. Reach Radio Station and Recording Studio owners/managers and engineers with your message. For information on affordable advertising call **Simone** at **1-800-336-3045**.

USAirplay

# Change is Intrinsic Part of Radio

by Charles Taylor

**LYNCHBURG, Va.** It was a simpler time for radio. An era before future technologies loomed so close and with such great promise that they were perceived by industry insiders as a threat.

The chief adversary of the masses in 1980, however, had existed for decades—FM. The band's delivery of stereo transmission was just becoming competitive, as it began to drain listeners from AM. Even as we witnessed, I suspect few realized just how soon the band would overtake AM as the standard for music.

I was a disk jockey at WWOD, a 5 kW AM radio station in Lynchburg, Va. At the time, we were the only country format in the market, enjoying steady revenue from national and local accounts. Our biggest threat was lightning, which, with most every storm, invariably knocked the station off the air.

## Red tower lights

I grew up in the city, a comfortable, conservative place where neighbors still call each other by name. WWOD, housed in a plain red brick building in the center of a residential neighborhood, was not more than a couple miles from my home. As a child, I remember watching the intimidating winking of the red tower lights from our front steps.

When I was 16, WWOD promoted over the air a tour of the station studios for interested listeners. Mind you, since 10, I had used a series of portable tape recorders to broadcast my own mock radio station for friends, and here, an opportunity to see the real thing.

Fatefully, it snowed in Lynchburg on the scheduled day of the tour. "We've canceled, but if you want to come in and see the station, we'll be here anyway," said the general manager, noting my disappointment. Desire exceeded sensibility and, with a reluctant but understanding parental nod, I maneuvered the family station wagon the short distance to the studio.

I guess years of playing disk jockey paid off. Wayne Campbell, the GM, asked if I was interested in a job. He had me read off the newswire in the production studio, just as I had done so many times in the microphone of my hand-held tape recorder. Apparently, he was convinced. I was offered weekend, fill-in and vacation shifts.

## Far from extravagant

The operation at WWOD was far from extravagant. Music was played from vinyl 45s and albums over two archaic turntables. One had a bad connection at the ON/OFF switch, often prompting deadly silence following a cut's voiced introduction. A quick manual spin of the turntable usually got it going.

Commercials aired over three cart machines, rebuilt so many times that I imagine few parts were actually manufacturer-sanctioned. In the back room, the tentative transmitter loomed, with faded instructions on kicking the unit back into action when a thunderstorm got the better of it.

While I loved radio as a teenager, country music was about as familiar to me as the wires behind the turntable switch. At best, I spent the first few months bluffing not only trivia about the artists—which I

picked up off the back of album covers—but the pronunciation of names.

I usually didn't get very far. "That's Janie Frick," I confidently announced after one song.

"It's Janie Frick-ie," said the caller not more than 45 seconds later. "Where're you from, anyway?" (The name is spelled "Fricke," I offer in defense.)

In time, however, the voices on the other side became my connection with the microphone. At that time, I often worked midnight to 6 AM shifts, which tend to draw listeners who call on the radio as a companion, whether they are working the late shift, whether ill or just searching out a familiar voice.

**The airwaves remain vibrant, thanks to the ambitions of new lights in the distance.**

I also grew to appreciate the voices I sent out over the airwaves. At 16, I had never heard of Patsy Cline, but with the help of consistent listener requests, in time I discovered her profound impact on the roots of country music. I came to end every shift with her timeless "Crazy."

And late at night, in between songs, I would raid the program director's desk, spending hours with music trade publications, station playlist reports and record company press releases touting developing artists. I didn't realize how much I was actually learning about the industry. It just seemed fun at the time.

## Air check reels

My time at WWOD lasted through my senior year of high school into the first summer following my freshman year of college.

Today, I have a dozen or so air check reels holding some of those early broadcasts. There's the music that I grew to appreciate, along with the nervous giggles as I tripped over a word during the news or the "Uh..." as I forgot a new song title midway through announcing. But there's not a moment of that time I would trade for anything.

Sadly, WWOD today is little more than a memory of the broadcast community in Lynchburg. In 1981, a new station began broadcasting country in FM stereo. It didn't take long for audience allegiance to succumb to the advantages of advancing technology, leaving WWOD a casualty of progress. The 1980s saw FM become the champion of music formats nationwide.

Traditional radio broadcasting faces even bigger challenges now, this time from potential outside interests. The entry of cable radio around the world is a viable threat to at-home listening habits, while the imminent knock of Digital Audio Broadcasting on the industry's door has yet to be determined a friend or foe of today's broadcasters.

The transition to the technology of tomorrow is painful, certainly, both from the standpoint of terrestrial radio's liveli-

hood and its heritage. Looking back at the good times of the past makes it difficult to embrace an unproven, albeit superior alternative.

But that is not a good reason to stand in its way.

WWOD is a tangible testament of the price of technology. There's something missing in the horizon when I look out from the front steps of my parent's home. And yet, the airwaves remain vibrant, thanks to the ambitions of new lights in the distance.

So must the radio industry confront the progress of tomorrow.

## Digital Audio Storage?



**We have answers to questions you haven't even thought of.**

**Call us.  
1-800-547-3930  
ext. 77**

**Digital Universe™**

A Division of Custom Business Systems, Inc. / CBSI  
P.O. Box 67, Reedsport, Oregon 97467

503 271-3681

Circle (32) On Reader Service Card

World Radio History

## Audio VAULT + CORE

**THE ULTIMATE IN DIGITAL AUDIO STORAGE AND CONTROL**

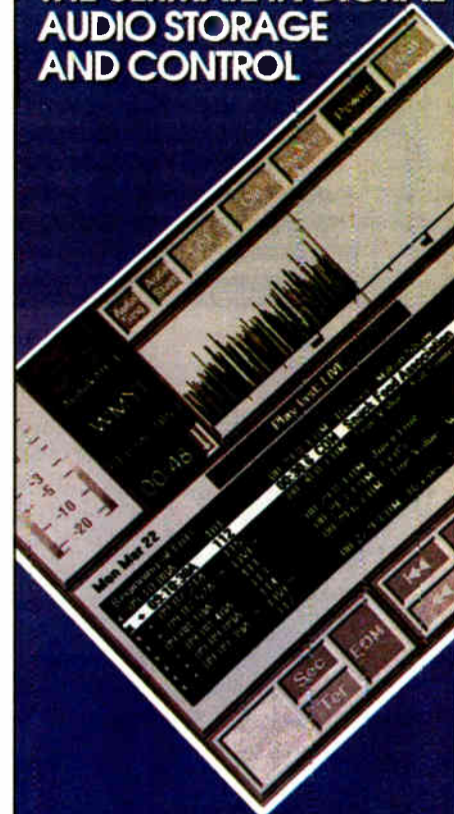

## Audio VAULT

- Fully programmable simultaneous record/playback.
- Instantaneous, random access to stored audio.
- Supports multiple channel audio inputs.
- Each input can be routed to any output pair.
- An ideal partner in satellite programming.

## CORE

- Automated program control via English language commands.
- Compatible with established as well as most recent source technology:  
CD Jukeboxes  
RDAT  
AudioVAULT
- Simultaneous addressability for up to 36 source inputs.
- Virtually unlimited event capability; insertions and deletions require no reprogramming.
- Log information stored on hard disk for review.



**BROADCAST ELECTRONICS INC.**  
4100 N. 24TH ST. P.O. BOX 3606  
QUINCY, IL 62305-3606 U.S.A.  
PHONE (217) 224-9600  
FAX (217) 224-9607  
TELEX 250142

Circle (2) On Reader Service Card  
See Us At NAB Radio Show Booth 513

# DIGITAL RADIO!

# RCS WORKS

## RCS WORKS...for you.

All the software you need for a complete, integrated, digital radio station:

- **Programming**
- **Research**
- **Traffic and Billing**
- **News**
- **Continuity**
- **Production**
- **On-Air Studio**

All working together to give you control, the fewest mistakes, the greatest profit, and the best possible sound.

All made and supported by RCS, for fourteen years THE radio software company.

- See RCS WORKS in action at Radio '93, booth 656.

Radio Computing Services  
Two Overhill Road, Suite 100  
Scarsdale, New York, 10583  
Tel.(914)723-8567 Fax(914)723-6651

# RCS

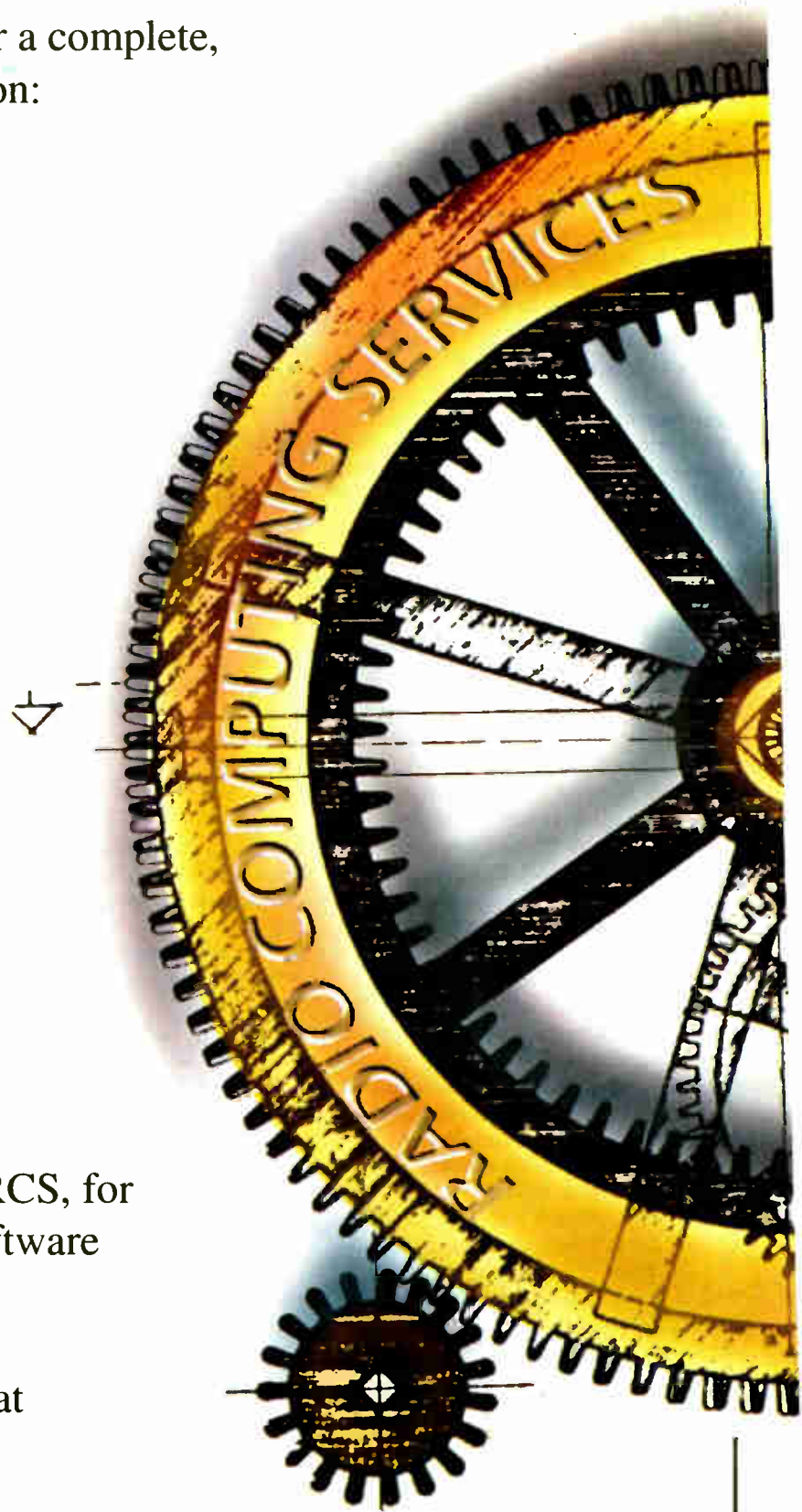

# The NAB Radio Show Preview

September 8-11, 1993 • Dallas Convention Center

## Digital Systems Headline Exhibits

by Lucia Cobo

**DALLAS** New and recently launched product offerings at the Fall Radio Show will include a variety of products designed to make life easier, faster and more cost-effective for the broadcaster.

Once again, the new product introductions will be dominated by digital technology. AEQ America will introduce the MAR System (Management of Audio Resources), a digital audio workstation and storage device. MAR System can be custom-designed to fit client needs, incorporating features that range from touchscreen control to digital editing to on-air broadcasting.

Sentry Systems will display the new

DS-2, a multitasking digital storage system with add-on option for automated recording of audio feeds from multiple networks. Fidelipac will showcase the Dynamax Air Marshall, a hard disk digital audio system.

SMARTS Broadcast Systems will display a new digital production unit that can be used in conjunction with the SMARTCASTER, and full touch screen control, enabling Point and Play control of digital audio functions by touching the screen.

Broadcast Electronics will exhibit the AudioVault 100 single-user digital audio storage device, and Media Touch Systems will display the MediaDisk "Auto-Record" digital audio workstation

and Pic'n Play automated cart system.

CCS (Corporate Computer Systems) will showcase its Pace digital audio editing workstation, based on MUSICAM ISO 11172.3 Layer II standard.

Pacific Recorders & Engineering Corp. will introduce the ADX digital audio production system. Look for the apt-X ACC-100 audio card from The Management, with balanced outputs and simultaneous record and playback in mono and stereo. Scott Studios Corp. will debut its CompuCart hard disk digital audio cart machine replacement.

CBSI (Custom Business Systems) will unveil the Digital Universe, a system to operate one or more radio stations from one control point, using Windows™.

Register Data Systems will offer its traffic and billing software package designed to run under Microsoft Word 3.1 and the DigiCorder II, an updated version of the original DigiCorder, a digital audio hard disk record playback system.

**New product introductions will be dominated by digital technology.**

Radio Computing Services will showcase an enhanced version of RCS Works!, an integrated system offering sales, traffic, music selection, production and news, with or without digital audio. New features include a multitrack digital editor.

If you already have the workstation, but need the furniture, look for the Arrakis Systems Inc. booth. The company will launch the DESK\*STAR studio furniture line, featuring digital workstation ergonomics as well as MIX\*STAR consoles in three configurations.

Prophet Systems will display its Windows™ and Novell Netware-based digital PC audio production and control systems. Digital technology has recently found its way into every aspect of the radio air chain. Belar Electronics Laboratory will showcase the AMMA-1 digital AM modulation analyzer. Circuit Research Labs will display its SC 100 RBDS generator with optional SCA generator cards, its new AMIGO AM, single-unit AM stereo audio processor, DAA-50

continued on page 32 ▶

## DAR Tests Rescheduled

▶ continued from page 1

The FM version of the USA Digital system (also known as Project Acorn) also was ready for testing. Delays are tied to the AM system, which is still in the final stages of development.

### AM on the plate

A preliminary version of the AM system played to good reviews at the spring NAB. None of the other DAR developers are proposing a system for digital audio in the AM band.

Paul Donahue, vice president, engineering, Gannett Radio, speaking for USA Digital confirmed the AM system was one reason for the delay, but not the only reason. "I hate to accept all the burden for that. They (NRSC) haven't even defined the AM tests yet. They're not done with multipath. We'd like to have a little bit clearer understanding of what all the tests are going to be," he said.

The immediacy of the new EIA/NRSC deadline was also a contributing factor in the decision to again postpone USA Digital's mobile demonstration. "They are working very, very hard to make technical progress. I think they're caught in the trap of showing it off to people while trying to do meaningful work developing the technology. It takes time and effort to put together something to ship to the show," said Andy Butler, NAB staff engineer, conference programs.

### Focus on business

USA Digital reserved space in the convention hall in Dallas, but the demonstrations there will be less impressive than the booths at past NAB shows—"maybe a demonstration of audio quality in AM and FM compared to analog," Donahue said. Otherwise, preparing for the Cleveland tests "is our focus," he said.

After the agreement to delay testing, Amati/AT&T decided to set up a Dallas demonstration of its system in computer-

simulation form. No further details were available at deadline.

USA Digital also is planning an in-depth informational presentation of its systems, including an update of its mobile channel characterization development, during the two-day Digital Radio Seminar at the Radio Show. The presentation will be part of a "DAB Proponents Forum" scheduled for 2:30 p.m. on Sept. 9.

All of the other proponents were invited to participate in the forum, but at deadline only USA Digital had confirmed its intent to participate. The three non-IBOC

developers said they did not plan to be present in Dallas.

Consulting engineer Robert Culver, chosen by the NRSC to supervise the opening rounds of the Cleveland testing, will follow the forum with a discussion of the issues and problems in evaluating the competing IBOC systems. Under the agreement between EIA and NRSC, EIA will evaluate all five systems and recommend one or more for FCC approval. NRSC will evaluate the IBOC systems only.

□ □ □

*Editor's note: RW's Sept. 8 issue will feature an in-depth analysis of digital audio radio on the eve of testing, including the possible outcomes after the testing and the controversies that still swirl around the test procedures.*

**RESONANT CAVITY**



Our bandpass, Series-Notch®, Vari-Notch® and combine resonant cavity filters have demonstrated long-term reliability and high performance in the toughest commercial radio sites in the world. From single-channel repeater sites to advanced multicoupler systems, our superior filter quality makes a difference.



**SERIES-NOTCH®**



**VARI-NOTCH® BANDPASS**



**NOTCH**



With silver-plated resonator parts and heavy-gauge, heliarc-welded end caps, our cavity and combine filters produce exceptional duplexer performance: 100 dB isolation at 240 KHz separation in the VHF range; 100 dB UHF isolation at 5 MHz separation with four 4" cavities; Wideband VHF, UHF, 800 MHz and GSM duplexers for trunking and radiotelephone system applications.



## FILTERS AND DUPLEXERS

IN RANGES FROM: **30 MHz - 960 MHz** | IN RANGES FROM: **30 MHz - 1.3 GHz**

**60 PUBLISHED MODELS**

**MULTICOUPLER SYSTEMS • SIGNAL BOOSTER SYSTEMS • DUPLEXERS • CAVITY FILTERS • RF SYSTEM PRODUCTS**

**TX RX SYSTEMS INC. 8625 INDUSTRIAL PARKWAY, ANGOLA, NY 14006**  
**TELEPHONE 716-549-4700 FAX 716-549-4772 (24 HRS.)**





Circle (155) On Reader Service Card

World Radio History

Please come visit our Booth #402 at IWCE-Fall in Philadelphia



# The Dynamax MX Series

## With Enhanced New Feature Set

### Now Available in up to 18 Channels

- True modular design
- Ultra-reliable motherboard construction
- VCA mixer and monitor control
- Active balanced line inputs, transformer isolated mic inputs
- Active balanced main and monitor outputs
- Full monitoring/cueing facilities with VCA level control and active source selection
- Built-in cue amp with speaker and amplified stereo 8-ohm headphone output
- Independent remote start for each "A" and "B" input
- Opto-isolated remote module on/off
- Selectable fader start
- Two inputs per module, mic/line or line/line – line inputs may be mono or stereo, consumer or professional format
- Four assignable outputs – two stereo plus two mono
- Available in 10, 12, 14, 16, or 18 channel models
- Independent level controls for each "A" and "B" input
- Separate audio and logic power supplies
- Sturdy, all-steel construction
- Durable Lexan overlay control surfaces
- Count-up event timer standard
- Two input expansion switches standard
- Excellent RF immunity

Call any Fidelipac Dealer for more information about the quality, features and unbelievably low prices of the modular Dynamax MX Series Console.



**DYNAMAX™**  
BROADCAST PRODUCTS BY FIDELIPAC®

Fidelipac Corporation □ P.O. Box 808 □ Moorestown, NJ 08057 U.S.A. □ TEL 609-235-3900 □ FAX 609-235-7779

Circle (57) On Reader Service Card

# Sessions to Cover Digital Decision Making

by **Andy Butler**  
NAB Science and Technology

**DALLAS** The 1990s have spawned a dizzying array of technical options for radio station managers.

Keeping up with changing equipment options can be like drinking from a fire hose. The Technology Management sessions at the Fall Radio Show will feature two extended workshops, the "Digital Radio Seminar" and the "AM Antenna Seminar" as well as panel sessions on "When Should I Switch to Digital" and "Competitively Implementing RBDS" to give you the background information you need to take advantage of the latest developments without wasting time and money.

## The latest in DAB

The Digital Radio Seminar will be Wednesday, Sept. 8 and Thursday, Sept. 9 from Noon until 5:30 p.m. at the Dallas Convention Center while the AM Antenna Seminar will be held on Saturday, Sept. 11 and Sunday, Sept. 12 from 8 a.m. until 5 p.m. at the Loew's Anatole Hotel in Dallas. The panel sessions are Friday, Sept. 10 at 9:00 a.m. and 10:30 a.m.

The Digital Radio Seminar is designed to supply broadcast managers and engineers with the knowledge they need to choose the right digital alternatives for their stations and the industry.

Dr. Kenneth Pohlmann, director of the

music engineering program at the University of Miami, has explained the digital essentials to thousands in the classroom and through his numerous books and articles. He has compiled a concise summary of essential theory and pertinent terms for the opening session, "The Phrases that Pay."

Author Skip Pizzi follows with "Technology that Pays - Evaluating Digital Alternatives." Pizzi takes the skills you've honed in evaluating analog equipment alternatives and applies them to the digital domain.

The opening day concludes with "Saving the Goods—A Survey of Digital Storage Alternatives." The core of every digital system is a recording device of some type but it seems that a new choice is introduced every week.

This session will provide an up-to-the-minute profile of your current options as well as solid advice on matching the method to your needs. At the end of day one, you'll be armed and ready to attack the exhibit hall with confidence.

On Thursday the seminar focus shifts from money to quality. At NAB '93, WQXR Chief Engineer Herb Squire highlighted the problem of maintaining predictable quality during repeated analog to digital conversions using different audio compression schemes. Squire returns with additional material in *Dueling Algorithms-Part II*.

In the following session, industry pundit Judith Gross gathers a group of experts to respond to Squire's concerns. Their suggestions may be the first step to a solution that saves the sound of your station.

The afternoon then moves from present problems to future possibilities. Two American companies are proposing In-Band DAB systems. Representatives from USA Digital and AT&T/Amati will provide comprehensive profiles of their proposed systems. The seminar will conclude with a status report on the EIA/NRSC DAB testing program.

## AM antenna updates

The AM Antenna Seminar has been restructured to provide both. The seminar opens with an "Introduction to AM Antennas," a review of basic antenna theory by Voice of America Engineer Karl Lahm. Consulting engineer Ben Dawson then reviews the latest rule updates in his AM Antenna Regulatory Review, a concise summary of the rules as they stand, along with a quick look at proposed changes that could impact your operation.

Jack Sellmeyer presents a profile of ingenuity in a detailed case study of a licensee who changed his AM frequency to increase coverage, then filed for his old frequency under the new duopoly rules and now operates both stations from the same sixty-year old transmitter site in the

"AM Antennas in the Age of LMAs and Duopolies" session.

Ron Rackley will expand on the possibilities for consolidation in "Shared Usage of AM Sites." The savings from combined operations can be substantial, but budgeting for such upgrades and improvements can be tricky.

Engineer and equipment vendor, Tom King, makes his living helping stations through the puzzle. He shares his insights in "Economic Considerations for AM Antennas."

Increasing coverage by adding transmitter sites is also a powerful strategy but dealing with interference zones and site synchronization can tax your ingenuity. Contract Engineer George Whitaker offers some practical advice on the advantages as well as the pitfalls in "Multi-Site Synchronous AM Systems."

Multi-tower directional antenna systems are a traditional tool for increasing AM coverage. Karl Lahm shows you how they work in "Directional Antenna Pattern Shape and Size." In addition to determining coverage, a directional antenna system has a dramatic impact on the station's audio quality and stereo image. Ron Rackley identifies the critical elements for good performance in the "Bandwidth Impact of Pattern Design" session.

A personal computer is a great tool for analyzing your AM antenna system.

continued on page 39 ▶

## How to tame transmitter power problems.

### WHR Series STABILINE® Voltage Regulators for AC power systems up to 660 volts.

Transmitters placed in remote, unattended locations such as mountain tops and wilderness areas depend on long utility power lines for service. Unfortunately, the lines often produce poor voltage regulation and other damaging power aberrations. Poor regulation can reduce power tube life by as much as 70% and the performance of associated equipment is similarly affected.

For example, a 15% undervoltage can decrease power tube life because cold operation promotes contaminant buildup in the tube. Conversely, a 10% overvoltage decreases life because increased temperature accelerates the decarburizing process.

The problems can be easily corrected.

Cost-effective WHR Series STABILINE® Voltage Regulators are the preferred choice of broadcasters worldwide for use with transmitters, receiving stations, studios and mobile production vehicles. These high power voltage regulators maintain constant voltage to your sensitive equipment even when the power line input voltage and system load vary widely.

#### Features include:

- Hold output voltage within  $\pm 1\%$
- Power ratings from 2 to 1680 kVA

- Maintenance bypass plus other standard options
- 99% typical efficiency
- High overload capacity
- 19-inch rack mount versions
- Designed for UL and CSA approvals

A host of options allow you to customize your application.

#### Standard options include:

- Single or three phase models
- Analog or digital control
- Bypass switch
- Ammeters
- Frequency trip meter
- Tropicalization
- Manual raise-lower switches
- Zig-zag neutral generation
- Single or individual phase control
- High energy transient suppression
- Input voltage range alarm contacts



For Catalog WHR692 and to learn how WHR Series STABILINE® Voltage Regulators can be the solution to your power problems, write, fax or phone Ted Gladis at

1-800-446-6161

**SUPERIOR ELECTRIC**  
WARNER ELECTRIC

383 Middle Street • Bristol, CT 06010  
203/582-9561 • Fax: 203/582-3784



"Our production vehicles don't leave without one."  
— Ron Crockett, SHOOK ELECTRONICS

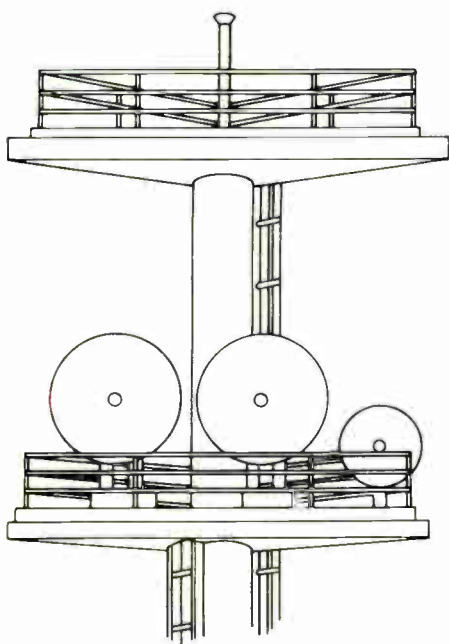

"I recommend STABILINE® Voltage Regulators for any brand of transmitter that is being placed in a harsh operating environment."

— Steve McElroy, CCA ELECTRONICS

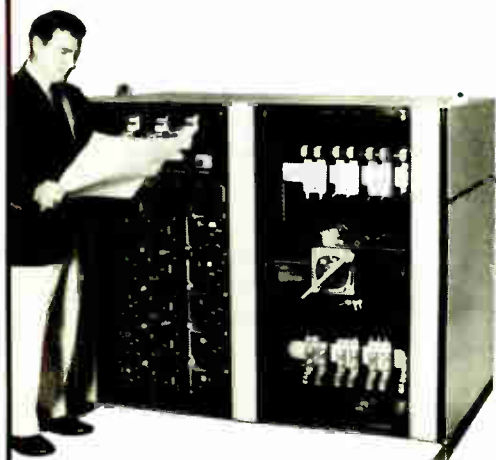

3-phase, 500 kVA WHR Series Voltage Regulator

# Digital Devices to Take Spotlight in Dallas

► continued from page 29

AES/EBU digital analyzer and DAA-100 digital analyzer and waveform generator.

The folks at Comrex Corp. will showcase the Cylink wireless digital audio modem as well as a new line of audio codecs designed to work with Switched 56 and ISDN services. Look for ComStream Corp.'s display of ABR75 and ABR75B SCPC digital audio receivers.

Dolby Laboratories will exhibit its four-channel DSTL (digital studio-to-transmitter link), capable of transmitting four program and two data channels in occupied bandwidth of 400 kHz.

Harris Allied will display its recently unveiled Digit™ digital FM exciter.

Marti Electronics will showcase its STL-15C composite studio-to-transmitter link. Moseley Associates will display its DSP 6000 spectral efficiency enhancer. Expect QEI Corp. to showcase its new FM Automod, a composite AGC, and the Q-MAX, a discrete 16-bit digital audio card for CAT-LINK.

Dataworld will unveil its international database of broadcast facilities and map information. Denon America will display the DN-1200FP 200-disc CD changer with dedicated controller, the DN-2700F production dual CD player and the DN-770R rack-mount bi-directional twin-output dubbing cassette deck.

Gentner Communications will debut the

G2500 and G3200 "Superhybrids" digital telephone hybrids, the Digital Hybrid IA and IIA telephone hybrids, as well as showcase the AUDISK 2000 digital audio storage/retrieval system.

Modulation Sciences will display its Model RDS-1 RDS/RBDS generator, which converts a PC into a full-function RDS/RBDS coder. Look for a new line of master clocks and programmable

timers from Radio Systems.

Sony will showcase its new line of digital gear for stations, including the PMD-C1 and PMD-C1P mini-disc cart machines; the CDK-3600 360-disc compact disc changer; and the CDP-3100 broadcast CD player.

Telos Systems will display its Zephyr Digital Network Audio Transceiver, a 15 kHz stereo on a single ISDN line, also for Switched 56 and satellite.

Wegener Communications will feature the SCPC digital audio receiver; and the QPSK subcarrier digital audio receiver.

## MODULUX & TRAK\*STAR STUDIO FURNITURE ARE THE BROADCASTERS CHOICE

- ☐ Select from among several Modulux and Trak\*Star lines.
- ☐ Complete systems start at under \$1,000.
- ☐ Rugged and attractive design for professional use.
- ☐ Video monitor and computer compatible systems.
- ☐ Complete, modular, off the shelf studios for fast delivery.
- ☐ Total in house design capability for any custom studio.

Modulux studio furniture systems can be found from Moscow, to Italy, to the savannas of Nigeria, to the high mountains of the Andes in Paraguay, in dozens of other countries around the world, and of course in hundreds of stations across the United States. Precision manufacturing to metalworking tolerances, use of the finest in high quality materials throughout, and an attractive design have made Modulux the largest selling furniture system and the choice of broadcasters around the planet.

Consoles  
Modulux  
Trak\*Star  
Digilink  
Modulink

For more information, call or write  
ARRAKIS,

(303) 224-2248

the premier broadcast manufacturer of consoles, furniture,  
Digilink and Trak\*Star digital audio products.

### ARRAKIS

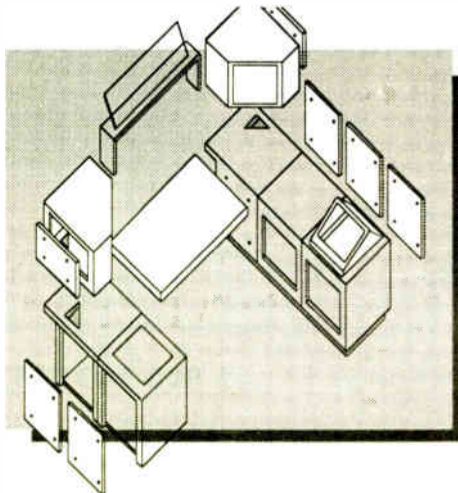

© 1993 Arrakis Systems inc. 2619 Midpoint Drive, Fort Collins, CO. 80525

Circle (122) On Reader Service Card

See Us At NAB Radio Show Booth 124

## DIGITAL RADIO SEMINAR

### Part I—Wednesday—Afternoon

12:00 - 12:15	Opening and Greeting .....	Michael Rau
12:15 - 1:30	The Phrases That Pay .....	Dr. Ken Pohlmann
1:30 - 2:30	Technology That Pays - Evaluating Digital Alternatives .....	Skip Pizzi
3:00 - 5:00	Saving the Goods - A Survey of Digital Storage Alternatives.....	Dr. Ken Pohlmann

### Part II—Thursday—Afternoon

12:00 - 1:00	Dueling Algorithms - Part II.....	Herb Squire
1:00 - 2:00	Dueling Algorithms: The Industry Responds .....	Judith Gross
2:00 - 2:30	Coffee Break	
2:30 - 4:30	DAB Proponents Forum	
2:30 - 3:30	USA Digital	
3:30 - 4:30	AT&T/Amati	
4:30 - 5:30	The NRSC Selection Process - Status Report	



You can measure...

with the best monitor and the most accurate test set.

The FMM-2/FMS-2 series monitors provide an even greater degree of precision measurement than ever before... You can measure S/N below 90 dB, You can measure crosstalk below 85 dB, You can measure separations of better than 70 dB, You can measure frequency response to better than 0.25 dB, You can measure distortions to lower than 0.01%, and much more... Our uncluttered panels and autoranging voltmeters make these measurements a dream.

**BELAR** (215)687-5550  
ELECTRONICS LABORATORY, INC.  
LANCASTER AVENUE AT DORSET, DEVON, PENNSYLVANIA 19333  
Call or write for more information on Belar AM, FM, Stereo, SCA and TV monitors.

Circle (81) On Reader Service Card

See Us At NAB Radio Show Booth 752



“The thing is just impossible to screw up! The DM-80’s non-destructive editing is the only way to go, and revisions are extremely easy and very quick!”

–David Esch, Director of  
Commercial Production  
WPNT Chicago

“We looked at DAWs for a year—no other product could even come close to the DM-80’s price/performance ratio.”

–Bill Robinson,  
Production Director  
WQCD N.Y., NY

“I love this machine! It’s reliable, and user friendly. I can edit in 1/3 the time, and I wasn’t familiar with disk recorders—the DM-80 is easy to learn and use.”

–Michael Cook,  
Program Director  
KSJJ/KPRB Redmond, OR

# Broadcast professionals speak out about the DM-80 Digital Audio Workstation!

“I’ve been editing on tape half my life, and was hesitant to give up “rocking the reels”—but I found this machine is incredibly easy to edit with. And its expandable storage put it way ahead of the competitors we compared.”

–George Zahn,  
Operations Director  
WVXU Cincinnati

“The DM-80 is a great production tool—it really changed our sound! I like its fast and easy editing capabilities.”

–Mike Britton,  
Production Director  
KODY/KXNP, North Platte, NE

“The DM-80 does more than DAWs costing twice as much. It’s very rugged—you can set it up and forget about it. And it’s easy to use.”

–Tony Diggs,  
Chief Engineer  
WKHK Richmond, VA

“It’s like a digital studio in your lap! The DM-80 is a very affordable, portable, high quality digital editing system.”

–Howard Silberberg,  
Sound Engineer  
United Nations Radio  
N.Y., NY

“We originally chose the DM-80 because of its user friendliness. Then we discovered the real magic of this device: a promo announcement that normally would take 4 hours can be done in 30 minutes.”

–Tom Collins, Director  
International College of  
Broadcasting & Recording, Dayton

“The DM-80 is easy to learn, and once learned...it’s fast, very fast! We also like its clean digital sound.”

–Barry Witherspoon,  
Program Director  
WSTO-FM, Evansville, IN

**We couldn't say it any better.**

Call (213) 685-5141, Ext. 337, or FAX (213) 722-0911 for more information about the DM-80 Digital Audio Workstation for the magic of hard disk recording and random access editing at your fingertips.



Circle (13) On Reader Service Card  
World Radio History

# NAB Radio Show Exhibitor Directory

The following is a partial preview of the products that companies will exhibit at The Fall Radio Show in Dallas. For a complete listing, see the official exhibition guide.

**360 Systems** 200, 202  
New: DigiCart/II digital audio hard disk recorder. RC-210 and RC-220 remote controls. Permanent Playback Series 1000 digital audio message player. Also: AM-16/B crosspoint routing switcher. Contact: Don Bird, U.S. Sales Manager 18740 Oxnard St. Tarzana, Calif. 91356 818-342-3127

**a**

**ABC Radio Networks (Satellite Music Network)** TBA  
New: SEDAT satellite receivers. Urban Gold 24-hour music format. Urban Features ("ABC Urban Newsbeat" and "ABC 411: Urban Show Prep," urban-format news and features. Nashville Notes, on-line country music news wire service. Also: ABC/SMN 24-hour formats (Z-Rock, Hot AC, Pure Gold, Country Coast-to-Coast, Classic Rock, StarStation, Kool Gold, Real Country, The Touch Stardust and Urban Gold). Long-form programs ("American Top 40 with Shadoe Stevens," "American Country Countdown," "American Gold," "Paul Harvey News and Commentary"). Newswire, 24-hour wire service. ABC Satellite Services, radio talk show distributor. Contact: Kim Richmond, Manager, Communications 12655 N. Central Expressway, Suite 600 Dallas 75243 214-991-9200

**Accu-Weather Inc.** 434  
New: State-of-the-art broadcast studio package. Switched 56 digital voice transmission system. Also: Accu-Weather forecasts, broadcasts, discussions and live reports. Contact: Michael A. Steinberg, Vice President 619 W. College Ave. State College, Pa. 16801 814-237-0309

**AEQ America** 747  
Contact: Gerardo Vargas 2211 S. 48th St. Tempe, Ariz. 85282

**AKG Acoustics** 233  
New: C5600 condenser mic. Also: AKG's DSE 7000 Digital Sound Editor and software upgrades. K270HC sports announcer headsets. Contact: Joey Wolpert AKG Acoustics 1525 Alvarado St. San Leandro, Calif. 94577 510-351-3500

**Arbitron** 313  
New: MAXIMIZER PC radio information system for custom ratings-book development using geographical and daypart data. Works with Windows™. Contact: Jay Guyther, Vice President, Sales & Marketing, Radio Station Services 142 W. 57th St. New York 10019 212-887-1348

**Arrakis Systems Inc.** 124  
New: DESK\*STAR studio furniture featuring digital workstation ergonomics. MIX\*STAR consoles in three configurations.

Also: DIGILINK digital audio system for on-air, cart machine replacement, satellite, tape or compact disc automation. TRAK\*STAR digital audio editor featuring direct transfer to on-air DIGILINK studio and optional on-air backup. 12,000 Series consoles. Contact: Jon Young, Vice President, Sales 2619 Midpoint Dr. Fort Collins, Colo. 80525 303-224-2248

**Audioarts Engineering** 901, 903, 905  
New: MR-40 combination four-track production and on-air console. (Also to be on display in booths 212, 423, 645 and 719.) Also: A-50 audio console in eight-, 12- and 18-input configurations. R-10 small-format console. Contact: Mark Kaltman, Sales Manager 7305 Performance Dr. Syracuse, N.Y. 13212 315-452-5000



Audioarts Engineering MR-40 Console

**Audio Broadcast Group** 613, 747, 228  
Contact: 2342 S. Division Ave. Grand Rapids, Mich. 49507 1-800-999-9281

**Audio Precision** TBA  
New: ATS-1 audio test set. Also: Portable One Plus audio tester. System One with Fast-Test analysis. Contact: P.O. Box 2209 Beaverton, Ore. 97075 503-627-0832

**Audio Processing Technology** 218  
New: ACE100PRO audio expansion card with increased

operating speeds than established ACE100CD. Also: DSM-100 digital audio transceiver for full duplex digital audio signal carriage over low capacity digital communication circuits. Contact: Mike Smyth, U.S. Sales 6255 Sunset Blvd., Ste 1026 Los Angeles, Calif. 90028 213-463-2963

**Auditronics** TBA  
Contact: Steve Sage 3750 Old Getinell Road Memphis, Tenn. 38118 901-362-1350

**Associated Press** 531  
News wires (AP Drivetime, AP Headlines, AP NewsPower, AP NewsTalk, AP Specialty Wires). Audio Services (AP Network News, Texas AP Network, New Jersey Sound). Software (AP NewsDesk and AP NewsDesk/LAN). Contact: Daryl Staehle, Director of Sales & Marketing 1825 K St. NW, Suite 710 Washington, D.C. 20006 202-736-1100

**ATI-Audio Technologies Inc.** 809  
New: NanoAmps series of compact utility amplifier modules featuring professional XLR and TRS connectors. Also: Audio amplifiers (MicroAmp and Encore Series). Broadcast stereo consoles. Headphone amplifiers (HD1000, expandable to four outputs, and HD100, single output). PB2x8 press box distribution system. System 10000 modular amplifiers. Emph'a Sizer microphone and line processor. Studio metering systems. Noise generators. Contact: Samuel B. Wenzel, President 328 W. Maple Ave. Horsham, Pa. 19044 215-443-0330

**Autogram Corp.** 810  
New: Mini-Mix 12A audio console with 12 slide pots and 26 inputs. Also: Mini-Mix 8A audio console. Pacemaker 1032 audio console. Contact: Ernest T. Ankele Jr., President 1500 Capital Ave. Plano, Texas 75074 214-424-8585

continued on page 37 ►

## MARTI

Don't wait 8 weeks to get your new STL system. We've been selling FCC approved STL systems since 1970, and we've got them in stock, ready to ship.



### STL-15C Composite Transmitter

Frequency synthesized \* Unexcelled narrow band performance \* Digital ready (with external modems)

See all of MARTI's performance-value products at Radio 93, Booth 802/804.

**MARTI Electronics, Inc.**

PO Box 661

Cleburne TX 76033-0661

Phone: (817) 645-9163 • FAX: (817) 641-3869

Circle (73) On Reader Service Card

Let **ERI** piece together your Antenna System Puzzle

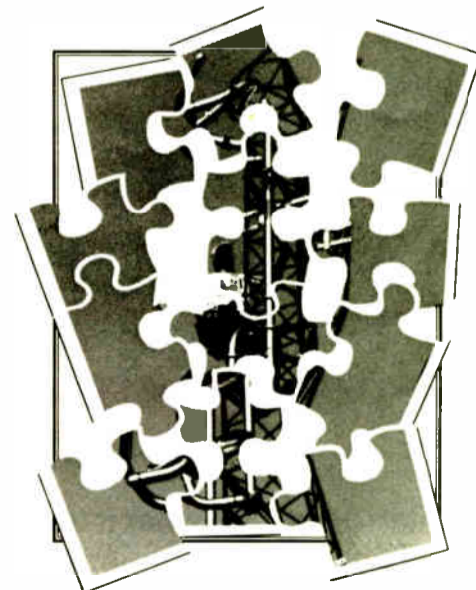

ERI will provide a complete system, including . . .  
ANTENNA, TOWER, LAMBDA™ SYSTEM  
and INSTALLATION

**ERI** ELECTRONICS RESEARCH, INC.  
812-925-6000

Circle (40) On Reader Service Card

See Us At NAB Radio Show Booth 800

# Which type of CD player is right for your station?



# Denon

With its hugely successful DN-970 and DN-950 CD Cart™ Players, Denon helped make CDs the broadcast media of choice. Given the success of these industry-standard players, there were only two things Denon could do: 1. Make a CD Cart player that is smaller, faster, smarter and better; 2. Make a pro CD player that is *not* a Cart player. Denon did both.



ACD-58 CARTRIDGE WITH ATS BAR CODE.

The new DN-961FA Drawer-Loading CD Player is Denon's answer to the many broadcasters who *formerly* had to choose between the drawer-type player they needed and the Denon performance they wanted.

its Eject-Lock during play adds another most-wanted feature to its list of attractions. Meanwhile, the new DN-951FA CD Cart™ Player dramatically improved functionality with its Auto Track Select (ATS) system, which reads bar-coded carts to *lock-in*, *lock-out* or *auto-cue* to a specific track.

That's not all; three-in-a-rack mounting, true instant start, and end-of-message signals with selectable time-to-end are just a few more key features of these cost-effective new players.

The DN-961FA and DN-951FA. Denon just made it twice as easy to decide which CD player is right for you.

**DENON**  
The first name in digital audio.

# PURE PROGRESS.



OPTIMOD-FM

8200

POWER

## Stations Are Profiting From It.

FM stations around the world are finding more sophisticated ways to keep their listeners from cruising the dial. And OPTIMOD-FM 8200 has become a critical part of their strategy. Why? Because the 8200 is a technological breakthrough with bottom line impact. It lets you create a distinct, powerful sound that results in larger audiences, higher ratings and improved profitability.

## Digital Makes the Best Even Better.

Digital technology not only improves the quality of the signal—it makes the OPTIMOD-FM 8200 more programmable, more flexible and more user-friendly. And it can actually help keep capital equipment costs down because it allows stations to expand and upgrade their system

with software, rather than expensive hardware.

A case in point: all current 8200 owners will receive a new software upgrade free of charge.

Version 1.0's sonic and operational improvements meet broadcasters' ongoing demands for superior audio performance and increased control—like customized bass response and automatic switching of presets for dayparting.

## The New Standard.

The OPTIMOD-FM 8200 is now the new industry standard for digital audio processors. Call your dealer now for a hands-on evaluation of the 8200. In a market where stations live and die by the ratings, you can dominate the dial.

**OPTIMOD-FM**  
DIGITAL

**FEATURE-PACKED  
1.0 SOFTWARE**  
✓ Improved Sound  
✓ Greater Control  
**CUSTOMIZE Your  
Sound**

**orban**

a division of AKG Acoustics, Inc.

1525 Alvarado Street, San Leandro, CA 94577 USA

Phone: (1) 510/351-3500 Fax: (1) 510/351-0500

© 1993 AKG Acoustics, Inc. Orban and OPTIMOD are registered trademarks of AKG Acoustics, Inc. AKG is a registered trademark of Akustische u. Kino-Geräte Ges.m.b.H., Austria.

**b**

**Belar Electronics Laboratory** 752  
 New: AMMA-1 digital AM modulation analyzer. FMRR-1A FM rebroadcast receiver for fixed frequency applications. FMRR-4 FM rebroadcast frequency-agile receiver.  
 Also: FMM-2/FMS-2 FM modulation monitor set. FMMA-1 ("The Wizard") digital FM modulation analyzer.  
 Contact: David Hirsch  
 P.O. Box 76  
 Devon, Pa. 19333  
 215-687-5550

**BIA Publications and BIA Consulting** 314  
 New: "Duncan's Radio Yearbook" with listings of technical, ratings, ownership, and station contact data.  
 Also: "Investing in Radio," "Investing in Television" and "Television Yearbook."  
 Contact: Debbie Metcalf, Assistant Vice President, Marketing  
 P.O. Box 17307  
 Washington, D.C. 20041  
 703-818-2425

**Broadcast Electronics** 613  
 New: AudioVault 100 single-user digital audio storage device. FM-100C, 100-watt solid state FM transmitter.  
 Also: CORE automation system. AudioVAULT multi-user digital audio storage device. AM-5, 5 kW solid state AM transmitter. FM-5B, 5 kW FM transmitter. FM-1C, 1 kW solid state FM transmitter. VMC-16 voice remote control. Consoles. Cart machines.  
 Contact: Kim Winking, Marketing Services Administrator  
 4100 N. 24th St.  
 Quincy, Ill. 62301  
 217-224-9600

**Broadcast Programming/Sentry Systems** 325  
 New: Broadcast Programming's Digital Two of Us (easy listening) format. Broadcast Programming's Digital Ultimate AC (aimed at 25-44). Sentry Systems' DS-2 multi-tasking digital storage system with add-on option for automated recording of audio feeds from multiple networks.  
 Also: Broadcast Programming's 30 formats (including Young Country, Hot AC, Oldies and Memory Music). Sentry FS-12 broadcast automation controller. DS-1 hard-disk audio recorder.  
 Contact: Keith Chambers, Marketing Director  
 2211 Fifth Ave.  
 Seattle 98121  
 206-728-2741

**Broadcaster's General Store** 815  
 New: Telos 1x6 multi-line telephone talk show system. RE America MUSICAM digital audio codecs.  
 Also: Roland DM-80 hard disk recording system. 360 Systems DigiCart II.  
 Contact: David Kerstin, President  
 2480 SE 52nd St.  
 Ocala, Fla. 34480  
 904-622-7700

**Broadcast Supply Worldwide** 339  
 New: KORGE multitrack digital workstation. Cylink wireless modems.  
 Also: Digital Audio Labs Card D for Windows™. 360 Systems DigiCart II.  
 Contact: Tim Schwieger, Vice President, Marketing  
 7012 27th St., W.  
 Tacoma, Wash. 98466  
 1-800-426-8434

**Burk Technology** 908  
 New: Model ESI enhanced-speech computer options for the ARC-16.  
 Also: ARC-16 transmitter remote control system. LX-1 six-input stereo selector.  
 Contact: Phil Halter, Sales Manager  
 7 Lomar Dr.  
 Pepperell, Mass. 01463  
 1-800-255-8090

**C**

**Cablewave Systems** 910  
 New: Flexwell Type HCC 214-50J FM broadcast antenna. Air dielectric cables. Flexwell pressurizing foam dielectric connectors. Bogner FM dipole antennas.  
 Also: Circularly polarized antennas. STL microwave parabolic antennas. Flexwell air and foam dielectric coaxial cable. RF connectors. Mounting hardware. Pressurization equipment and accessories.  
 Contact: Ilene Locke, Marketing Manager

60 Dodge Ave.  
 North Haven, Conn. 06473  
 203-239-3311

**California Digital** 639  
 Contact: Linda Donahue  
 530 New Los Angeles 114-96  
 Moonpark, Calif. 93021  
 805-523-2310

**CBSI/Custom Business Systems** 621  
 New: Digital Universe, system to operate one or more radio stations from one control point, using Windows™. Design Financial Reports software for station accounting. CustomReports spreadsheet and database manager. PowerPlus System for tracking ad agency accounts.  
 Also: Classic Traffic/Billing System. Elite Traffic/Billing System. InterAcct General Ledger & Accounts Payable System. CustomRemote. CustomSales. CustomMusic. Sales Analyzer. CBSI for Windows™. Payroll. Concert Music Library.  
 Contact: Steve Kenagy,

Vice President, Marketing and Sales  
 P.O. Box 67  
 Reedsport, Ore. 97467  
 503-271-3681

**CCA Electronics** 832  
 New: Solid state FM transmitters. 60-watt FM exciter. Also: FM broadcast transmitters from 500 watts to 65,000 watts. AM broadcast transmitters to 100 kW.  
 Contact: Steve McElroy,  
 Vice President, Sales  
 360 Bohannon Rd.  
 Fairburn, Ga. 30213  
 404-964-3530

**CCS (Corporate Computer Systems)** 639-641  
 New: CDO 1000 digital audio codec. Pace digital audio editing workstation, based on MUSICAM ISO 11172.3 Layer II standard.  
 Also: CDO 2000 Multi-rate digital audio codec.  
 Contact: David Lin, Product Manager  
 33 W. Main St.

Holmdel, N.J. 07733  
 908-946-3800

**Cellcast** 932, 934, 936  
 New: Receiver Decoder for established Cellcast Remote Broadcast Studio system.  
 Contact: Bridget K. Taylor  
 110 S. Main  
 Owasso, Okla. 74055  
 1-800-852-1333

**Central Tower** TBA  
 Contact: Marvin Beasley  
 2855 Highway 261  
 Newburgh, Ind. 47630  
 812-853-0595

**Circuit Research Labs** 747  
 New: SC 100 RBDS generator with optional SCA generator cards. AMIGO AM, single-unit AM stereo audio processor. DAA-50 AES/EBU digital analyzer. DAA-100 digital analyzer and waveform generator.  
 Also: AM, FM and shortwave audio processing

THE NAB/DENON TUNER

The NAB/DENON TUNER (TU-680NAB) is everything you've wanted in a radio and more! A must for audio program lovers who want to remain at the cutting edge of new technologies in AM/FM broadcasting.

Developed in cooperation with the National Association of Broadcasters, the NAB/DENON TUNER brings full reception standard compatibility to radio listening. AMAX-certified, this new receiver includes circuits which provide full AM and FM fidelity that is sure to change the world of radio technology. Some of its revolutionary features include:



- National Radio Systems Committee (NRSC) circuits for greater fidelity and reduced interference
- Automatic variable bandwidth on AM
- AMAX Stereo
- AM noiseblanking to cut static and impulse noise
- Expanded AM capability (the new 1605-1700 kHz range)
- Provision for an external AM antenna
- 30-station preset memory that can intermix AM & FM stations at the listener's choice
- Walsh function FM stereo decoder for the best possible immunity to noise and interference
- Infrared remote controller

To Order: NAB Services, 1771 N Street, NW, Washington, DC 20036  
 Call: 1-800-368-5644, 1-202-429-5373 Fax: 1-202-775-3515

Item	NAB Member Price	List Price	Shipping Charge
TU-680NAB Tuner	\$425.00	\$525.00	\$5.00
DENON PMA-680R Amplifier	\$379.00	\$400.00	\$10.00
DENON Speakers (SC7.5)	\$469.00	\$500.00	\$5.00
DENON Speakers (SC5.5)	\$189.00	\$200.00	\$10.00
Antenna	\$85.00	\$90.00	\$2.00
<b>Package Deal: Tuner, Amplifier, Antenna, SC7.5 Speakers</b>	<b>\$1,350.00</b>	<b>\$1,590.00</b>	<b>\$25.00</b>
<b>Package Deal: Tuner, Amplifier, Antenna, SC5.5 Speakers</b>	<b>\$1,089.00</b>	<b>\$1,290.00</b>	<b>\$20.00</b>

equipment. Dynaflex single-ended noise reduction system. SCA and FM stereo generators.  
Contact: William L. Ammons, International Sales  
2522 W. Geneva Dr.  
Tempe, Ariz. 85282  
1-800-535-7648

**Columbine Systems** 201  
PC 2000 traffic system with LMA/duopoly capability. Credit Management to monitor account payments and collection problems. Sales Analysis Plus for Windows™.  
Contact: 1707 Cole Blvd.  
Golden, Colo. 80401  
1-800-753-4000

**Communication Graphics** 703, 705  
New: Logo design service for specialized broadcast station purposes.  
Also: High-gloss folders. Printed decals. Bumper Stickers. Concert patches. Credit cards.  
Contact: Donna Albright, Sales Manager  
313 N. Redbud

Broken Arrow, Okla. 74012  
1-800-331-4438

**Computer Concepts** 345  
New: Operating features and enhancements for Digital Commercial System, a hard disk system.  
Contact: Della Northcutt  
8375 Melrose Dr.  
Lenexa, Kan. 66214  
913-541-0900

**Comrex Corp.** 247  
New: Cylink wireless digital audio modem. New line of new audio codecs designed to work with Switched 56 and ISDN services.  
Also: DXP/DXR G/722 digital audio codecs. Frequency extenders for one to three lines. Telephone interface products.  
Contact: Lynn Distler, Vice President, Sales and Marketing  
65 Nonset Path  
Acton, Mass. 01720  
508-263-1800

**ComStream Corp.** 840  
New: ABR75 and ABR75B SCPC digital audio receivers.  
Also: Digital Audio Distribution Network, featuring ABR200 digital audio receiver.  
Contact: John Puetz, Director, Audio Services  
10180 Barnes Canyon Rd.  
San Diego 92121  
619-458-1800

**Continental Electronics Corp.** 608, 610  
AM and FM transmitters and related products.  
Contact: Steve Claterbaugh  
P.O. Box 270879  
Dallas 75227  
214-381-7161

**Cutting Edge** 242  
Unity 2000 FM processor.  
Contact: Danelle Cline, Marketing Assistant  
2101 Superior Ave.  
Cleveland 44114  
216-241-3343

**d**  
**Dalet** 232  
Contact: David Amselem  
1 Rue Call  
75010, Paris  
33-1-40380139

**Datacount** 626, 628  
New: Multistation version of DARTS V software.  
Also: Established DARTS (Datacount Accounts Receivable and Traffic Scheduling) software. Datacount accounting hardware.  
Contact: Debbie Hamby, Sales Manager  
2207 Anderson Rd.  
P.O. Box 3078  
Opelika, Ala. 36801  
205-749-5641

**Dataworld** 340, 342  
New: International database of broadcast facility and map information. Improved AM and FM allocation map books. LMA and duopoly maps.  
Also: Databases. Directories. Allocation and interference studies. Terrain elevation information. AM daytime and nighttime channel studies. Unused call sign listings.  
Contact: John L. Neff, President  
4827 Rugby Ave., Suite 200  
Bethesda, Md. 20814  
1-800-368-5754

**dbx** 233  
New: 296 dual spectral enhancer for instrumental, vocals and mixed program material.  
Also: Audio processors. Equalizers. Noise control processors.  
Contact: J.X. Loeb  
AKG Acoustics  
1525 Alvarado St.  
San Leandro, Calif. 94577  
510-351-3500

**Denon America, Inc.** 212/214  
New: DN-1200FP 200-disc CD changer with dedicated controller. DN-2700F production dual CD player. DN-770R rack-mount bi-directional twin-output dubbing cassette deck.  
Also: DN-951FA broadcast CD cart player. DN-961FA broadcast CD player. DN-970FA production CD player. DN-720R rack-mount cassette deck. DTR-80PPR portable DAT recorder.  
Contact: Michael Stelts, Product Manager  
222 New Rd.  
Parsippany, N.J. 07054  
201-882-7460

**Dielectric Communications** 626  
Ring and panel style FM antennas. Filters. Combiners. Transmission line. Switches. Loads.  
Contact: Colleen Foster, Director, Marketing Services  
P.O. Box 949, Tower Hill Rd.  
Raymond, Maine 04071  
1-800-341-9678

**Dolby Laboratories** 240  
New: Four-channel DSTL (digital studio-to-transmitter link), transmits four program and two data channels in occupied bandwidth of 400 kHz.  
Also: Two-channel DSTL. Model 740 spectral processor.  
Contact: Kevin Tam, Director of Marketing, Communications Product Group  
100 Potrero Ave.  
San Francisco 94103  
415-558-0200

**e**  
**ENCO Systems** 1002-1004  
DAD486x digital audio hard disk/automation system.  
Contact: Brad Young, Sales Manager  
1866 Craigshire Dr.  
St. Louis 63146  
314-453-0060

**ERI (Electronics Research Inc.)** 800  
New: SHPX and LPX Series FM antennas.  
Also: Lambda mounting system. Omni and directional antennas. Towers. Filters. Combiners.  
Contact: David Davies, Engineer  
108 Market St.  
Newburgh, Ind. 47630  
812-853-3318

**Eventide** 532  
New: DSP4000 Ultra-Harmonizer. H3500-B Dynamic Broadcast Ultra-Harmonizer.

continued on page 41 ►

# Let Dalet run the system while you run the show

Dalet's digital audio system gives broadcasters the freedom to get creative

## SOLUTIONS FOR ALL BROADCASTING NEEDS

Dalet's system lets you do it all: satellite automation, cartridge replacement, digital audio editing (non-destructive) and music automation which sounds better than live!

## INEXPENSIVE UNLIMITED STORAGE

The use of standard PC networks with central storage guarantees unlimited and inexpensive storage. Record jingles, commercials and even your music library on a server. Any workstation on the network can then have access to the recorded material and play it back on one or several radios at the same time.

## TRUE MULTITASKING UNDER WINDOWS

Microsoft Windows makes Dalet's software interface powerful, elegant and straightforward. It allows you to perform several tasks at once. For example, you can be recording on a first track while you play back two different songs on the other two independent tracks available on your workstation.

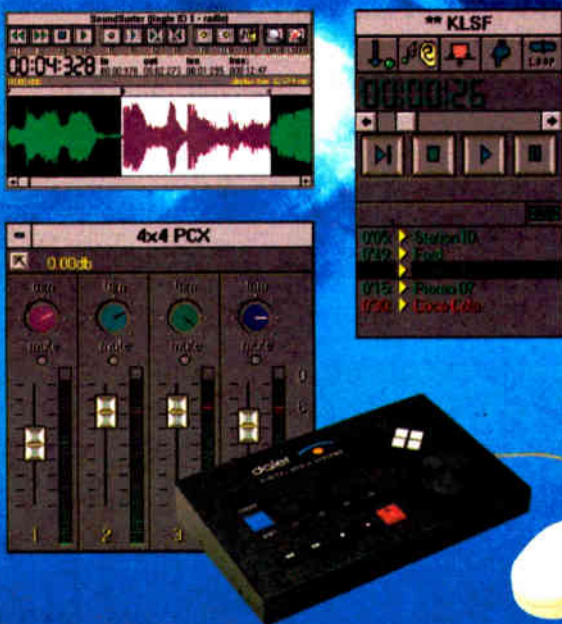

40 principales, Madrid



**Dalet is as flexible as you are!**

Find out why leading radio stations around the world have chosen Dalet. Call our US distributor:

**RF Specialties® Group**

NORTHWEST (206) 546-6546 • MIDWEST (816) 635-5959  
WEST COAST (805) 682-9429 • SOUTHEAST (904) 678-8943  
SOUTHWEST (806) 372-4518 • NORTHEAST (412) 733-1994  
(214) 771-4235 (215) 322-2410

Circle (202) On Reader Service Card

World Radio History

## NAB AM ANTENNA SEMINAR

Loews Anatole - Dallas, Texas

—Day One—

Saturday - September 11, 1993

8:00 - 9:15	Introduction and Opening Remarks.....	Michael Rau
8:15 - 9:15	Introduction to AM Antennas.....	Karl Lahm
9:15 - 10:00	AM Antenna Regulatory Review.....	Ben Dawson
10:00 - 10:15	Break	
10:15 - 11:00	AM Antennas in the Age of LMAs and Duopolies.....	Jack Sellmeyer
11:00 - 11:45	Shared Usage of AM Sites.....	Ron Rackley
11:45 - 1:00	Lunch Break	

Afternoon

1:00 - 1:45	Economic Considerations for AM Antennas.....	Tom King
1:45 - 2:30	Multi-Site Synchronous AM Systems.....	George Whitaker
2:30 - 3:15	Directional Antenna Pattern Shape and Size.....	Karl Lahm
3:15 - 3:30	Break	
3:30 - 4:00	Bandwidth Impact of Pattern Design.....	Ron Rackley
4:00 - 5:00	AM DAB Antenna Requirements.....	Bob Weirather

—Day Two—

Sunday - September 12, 1993

Morning

8:00 - 9:00	Computer Modeling of Directional Antenna Patterns.....	Karl Lahm
9:00 - 10:00	Modern Methods in AM Antenna System Design and Adjustment.....	Ron Rackley
10:00 - 10:15	Break	
10:15 - 11:15	Reradiation Considerations.....	Karl Lahm
11:15 - 12:00	Radio Frequency Radiation Protection at AM Stations.....	Ben Dawson
12:00 - 1:00	Lunch Break	

Afternoon

1:00 - 2:00	DA System Adjustment and Maintenance.....	Jack Sellmeyer
2:00 - 2:45	What To Do When Things Go Wrong.....	Ben Dawson
2:45 - 3:00	Break	
3:00 - 4:30	Problem Solving Forum.....	All Instructors

# AM DA Seminar Revised

► continued from page 31

Karl Lahm begins the second day of the seminar with a look at "Computer Modeling of Directional Antenna Patterns." Adjusting your AM array doesn't have to be a full time job. Ron Rackley suggests the right approach in the next topic, "Modern Methods in AM Antenna System Design and Adjustment." One of the greatest challenges in managing an AM antenna system is dealing with "extra" towers, like light posts, power lines and water tanks. Karl Lahm has some detailed suggestions in "Reradiation Considerations."

### The latest on RF

Protecting the public and employees from excessive RF exposure is the responsibility of every licensee. Ben Dawson offers some realistic guidelines for meeting your responsibilities in "Radio Frequency Radiation Protection at AM Stations."

No matter how well it is designed and built, every AM antenna requires routine periodic adjustments. If you plan for that need you can control the cost. Jack Sellmeyer suggests how to develop a realistic program for your station in "DA System Adjustment and Maintenance." No matter how thorough your maintenance program, sooner or later something will break. Ben Dawson helps you get ready by considering "What To Do When Things Go Wrong."

The seminar concludes with a traditional favorite. All of the seminar instructors will be on hand for the Problem Solving Forum. Bring your toughest AM question and get the best answer.

In addition to the seminars, two panel sessions will consider two hot topics. In the first, "When Should I Switch to Digital," a group of industry experts lead by Skip Pizzi tackle the question facing an increasing number of broadcasters. How do you know when its time to stop buying analog and take the digital plunge. Going too soon can be a costly mistake while waiting too long may put you at a serious competitive disadvantage. From production room to news gathering, the panel will help you consider a sane strategy for conversion.

The second panel looks at ways to make more money. RBDS (or RDS) can do a lot more than display format information on the front of a radio. It can actually become a completely separate income source for station owners and a powerful positioning tool for programmers. In "Competitively Implementing RBDS," a panel of existing service vendors explore the cost and the potential benefits of several Radio Broadcast Data System strategies.

Complete information for the Fall Radio Show is available from NAB's fax-on-demand service at 301-216-1847. Specific questions on technical seminars should be directed to Andy Butler at 202-429-5345.

## All CD, All the Time.

Marantz has put recordable CD technology and blank CDs within reach of your budget. End the confusion and clutter of endless carts, cassettes and the occasional record by transfer to CD. Gain the advantage of rapid random access and unparalleled digital audio performance for everything you put on the air.

Today most music goes on air from CD; why not consider transferring your IDs, commercials, and sweepers to CD as well. You can also create custom CDs from music libraries, and your sales staff will love to present new spots to clients on CD.

**marantz®**  
The affordable recordable



Marantz Professional Products • 1000 Corporate Blvd., Aurora, IL 60504  
phone: 708.820.4800, fax: 708.820.8103

### ARE YOU LOOKING FOR A COST EFFECTIVE ALTERNATIVE TO MANUFACTURER SERVICE?

#### IN CASE OF EMERGENCY

We can help get you back on the air with our STL Loaner Program. We have STL's available that will be set to your frequency prior to shipping.

We also provide over-the-phone technical assistance.

#### SERVICE, REPAIR & CALIBRATION

- › STL's › RPU's › TSL's › Exciters
- › AM/FM Broadcast Monitors
- › Remote Control Systems

#### SPECIALIZING IN EQUIPMENT BY

- › Belar › Marti › Moseley
- › McMartin › TFT › And others...

An authorized TFT service center

**T** SQUARED TECHNICAL SERVICE  
2198 Hubbard Lane  
Grants Pass, OR 97527

(503) 471-2262

# Products & Services Showcase

For more information on the products shown below, circle the appropriate Reader Service No.(s) on the enclosed Subscription/Reader Service card or contact the advertiser directly.

**NEW!!! from AVCOM**  
**PSA-65A Portable Spectrum Analyzer & SCPC-2000E Single Channel Per Carrier Receiver**



**PSA-65A Portable Spectrum Analyzer - \$2855**

AVCOM's PSA-65A Portable Microwave Spectrum Analyzer covers a frequency range from less than 2 MHz to 1000 MHz. The broad frequency coverage and high sensitivity of the PSA-65A make it ideal wherever a low cost, compact spectrum analyzer is needed. The light weight, battery or line operated PSA-65A Portable Spectrum Analyzer from AVCOM is the perfect instrument for field testing of RF systems, classroom instruction, satellite system alignment, electronic countermeasures, cable TV maintenance, cellular and production use.



**SCPC-2000E SCPC Satellite Receiver - \$1875**

AVCOM's Single Channel Per Carrier Receiver, model SCPC-2000E, has been developed for the reception of FM SCPC signals from satellites operating in the 3.7 to 4.2 GHz band. The SCPC-2000E is a complete receiver that can tune up to 4 specific crystal controlled audio or data channels from a given transponder and adapt to a variety of de-emphasis requirements. The SCPC-2000E is available in either wide or narrow band models and may be used with the SS-1000 (\$1027) Slave for simultaneous reception of additional channels.

**AVCOM OF VIRGINIA** 500 Southlake Blvd. Richmond, VA 23236 U.S.A.  
 Bringing High Technology Down to Earth Phone 804-794-2500 / Fax 804-794-8284

READER SERVICE NO. 26

**NOW! A QUALITY AGILE BROADCAST SCPC AUDIO RECEIVER**

**AT AN AFFORDABLE PRICE!**



**UNIVERSAL SCPC 300-C COMMERCIAL AUDIO RECEIVER**

**SPECIFICATIONS**

Frequency agile, C and Ku Band, stable microprocessor-controlled tuning, variable band widths, 3:1 and 2:1 companding built in. Transponder tuning, LNB supply, polarity control, tunes all SCPC frequencies 50 to 90 MHz, readout on LCD display, 50-channel memory, line output, de-emphasis select, muting system, phase lock loop for stability, LNB calibration set up, 2 frequency synthesizers, digital AFC and more.

**INTRODUCTORY PRICE: \$1345.00 plus S & H.**

**UNIVERSAL ELECTRONICS, INC.**  
 4555 GROVES RD., SUITE 13, COLUMBUS, OH 43232  
 (614) 866-4605 FAX (614) 866-1201

READER SERVICE NO. 17

**FREE COMPUTERS!**

Get it all! Pick either our new Simple-CD<sup>®</sup> automation with the DJ-Pro<sup>®</sup> production system OR our DJ-Lite<sup>®</sup> Satellite automation system with the DJ-Pro<sup>®</sup> production system. Get two computers, two monitors, two hard disks, a full LAN network and assembly, free!

**\$9,995.00**

Lease as low as \$229.00 per month  
**Plug n' Play**

Package system price includes either a Simple-CD control system with a 16 unit Pioneer<sup>™</sup> CD six-pack interface OR a DJ-Lite satellite music system controller with I/O cards and software. Either system is connected by a fast LAN network to a DJ-Pro production workstation. Wire to your console audio and you're on the air.

Package system includes two premium apt-X<sup>™</sup> audio cards, two fast 386 SX-33 computers each with 340 meg hard disks (5+ hours mono recording), two VGA color monitors, two LAN cards & software, 15' LAN cable and Manuals.

Full Backup for Safety - Easy Production Use DJ-Pro for fast spot production, then send by LAN to Simple-CD or DJ-Lite. Relax! Your spots are backed up and safe.

**The Management**

1-800-334-7823 1-817-625-9761  
 P.O. Box 1-36457 Ft. Worth, TX 76136  
 1600+ Stations - Our 13th year

See us at  
 NAB Radio  
 Show Booth  
 333/335

READER SERVICE NO. 180

Uh-Oh... We Should Have Called  
**CORTANA**



**STATI-CAT for Affordable Lightning Prevention.**

**Let Us Design a System for You**

Stabi-Cat provides a continuous, low-resistance discharge path for the static electric charge on tall structures. Dissipation points are 1/8", type 304 stainless steel rods ground to needle sharpness. They won't bend, not even from ice and severe weather.



Write to us today for a **FREE** brochure!

P.O. Box 2548, Farmington, N.M. 87499  
 Call (505) 325-5336 FAX (505) 326-2337

READER SERVICE NO. 69

**CONSOLE UPGRADE WITHOUT THE BIG EXPENSE**



Approach digital quality with your yesteryear audio console by using BDI plug-in retrofit electronics. If the cost of a new console is depriving you of a competitive air sound then BDI electronics are the answer. Better headroom,

lower noise, lower distortion, dynamic range approaching 90dB and improved reliability are just some of the advantages of our easy to install upgrades. Call us today direct for a competitive air sound tomorrow!

Our retrofit electronics currently support most.

Gates/Harris Consoles  
 RCA Consoles  
 McMartin Consoles  
 McCurdy Consoles

**bdi** Broadcast Devices, Inc.  
 5 Crestview Avenue  
 Peekskill, NY 10566 (914) 737-5032

READER SERVICE NO. 6

**Shape Up!**

Coverage. Saturation. DBk contours. In FM broadcasting, the "bottom line" is always based on your pattern.

More than any other manufacturer, Shively has the experience and reputation for providing crucial pattern solutions for critical propagation problems. On any tower. At any power level. Remember, *it pays to be heard.*

A good pattern. The shape you need. Talk to your consultant.

And contact us. See us at NAB Radio Show Booth 1005-1007

**Shively Labs**

A Division of Howell Laboratories, Inc.

19 Harrison Road, Bridgton, ME 04009  
 207-647-3327 FAX 207-647-8273

READER SERVICE NO. 146

**Attention Advertisers!**

Reach 22,000+ Readers worldwide. RADIO WORLD's Product Showcase provides a perfect medium for test marketing your products and services. It's an efficient, effective and affordable advertising option.

For more information, including rates and deadlines, Fax SIMONE at  
**1-703-998-2966**

or Call

**1-800-336-3045**

World Radio History

**WANTED**

**DEAD OR ALIVE**

**YOUR OLD FM BROADCAST ANTENNAS**

any brand-any size-working or not

Trade in your old antenna and receive a discount on the purchase of a new JAMPRO

**PENETRATOR Series**

**FM Antenna System**

See us at NAB Radio Show Booth 711

Send us your rustiest, crustiest, dustiest old antennas. We'll take 'em all.



**JAMPRO Antennas, Inc.**

When you want more than just an antenna

6340 Sky Creek Drive-Sacramento, CA 95828

(916) 383-1177 (916) 383-1182 fax

Certain rules and restrictions apply. Contact factory for details.

READER SERVICE NO. 70



Also: H3000-B Ultra-Harmonizer. VR240 digital audio logger. VP244 digital audio log player. BD941/942 broadcast delay line. BD980 broadcast delay.  
 Contact: Gil Griffith, Sales Manager  
 One Alsan Way  
 Little Ferry, N.J. 07643  
 201-641-1200

**IDB Broadcast 819**  
 New: SEDAT Service on SATCOM C5 Transponder 15. Direct dial digital service using APT codecs.  
 Contact: Julie Spira, Vice President, Audio Sales

**Independent Broadcasters Network 1045, 1047, 1049**  
 IBN will be broadcasting live from the exhibition with "Sonny Bloch Show," "Doug Stephan-Live Line America," "Paul Bloch-Animal Talk."  
 Contact: Steven E. Wiebner, President  
 2 Corporate Dr.  
 Clearwater, Fla. 34622  
 813-573-4402

systems.  
 Also: T1, E1 and variable-rate multiplexers.  
 Contact: Christine A. Doyle, Trade Show Coordinator  
 3 Lyberty Way  
 Westford, Mass. 01886  
 508-692-9000

**ITC Corp. 719/Loews Anatole Atrium**  
 Digicenter audio management system for live assist, satellite and program automation, networked multiple users, traffic, billing and scheduling interfaces, remote control hardware/software and multiple recorders.  
 Contact: Charles Bates, General Manager  
 2425 S. Main St.  
 Bloomington, Ill. 61702  
 1-800-447-0414



Eventide DSP4000 Ultra Harmonizer

**International Datacasting Corp. 919**  
 New: IDC SR250/DA digital audio and data multi-channel satellite receiver. SR250/MA ISO-MPEG MUSICAM products.  
 Also: Frequency agile multipoint data and audio transmission system.  
 Contact: Doug Kennedy, Director of U.S. Sales  
 3850 Holcomb Bridge Rd., Suite 420  
 Norcross, Ga. 30092  
 404-446-9684

**JAM Creative Productions 534**  
 JAM offers over 100 syndicated jingle packages, customized jingles and "The Answer for the '90s"

**E-Z UP International 812-814**  
 E-Z UP Instant Shelter.  
 Contact: Marty Dotterweich, National Sales Manager  
 5525 E. Gibraltar  
 Ontario, Calif. 91764  
 909-466-8333

10525 W. Washington Blvd.  
 Culver City, Calif. 90232  
 213-870-9000

**Intraplex 826, 828**  
 New: PT/PR-350 and PT/PR-355 audio transmission

**Fidellpac 228, 230**  
 New: Dynamax Air Marshall hard disk digital audio system. Dynamax MX Series console.  
 Also: Dynamax DCR1000 digital cartridge machines. Dynamax CTR10 Series analog cart machines. Broadcast audio consoles.  
 Contact: Scott Martin, Vice President, Sales  
 P.O. Box 808  
 Moorestown, N.J. 08057  
 609-235-3900

**Film House 525, 527**  
 Marketing campaigns for radio stations worldwide.  
 Contact: Wayne Campbell, Vice President, Marketing  
 230 Cumberland Bend  
 Nashville, Tenn. 37013  
 615-255-4000

**FirstCom Broadcast Services 306, 308**  
 New: Techsonics Music/Effects packages. Sound Designer II production library.  
 Also: Sound Designer Library. Maximum Impact Library. Digital Production Library. Custom Production Library. Direct Results Radio. Hot Tickets. Station IDs. CD Sales Library.  
 Contact: Carol Rowden,  
 National Sales Manager  
 13747 Montfort Dr., Suite 200  
 Dallas 75240  
 1-800-858-8880

**Gentner Communications Corp. 841**  
 New: G2500 and G3200 "Superhybrids" digital telephone hybrids. Digital Hybrid IA and IIA telephone hybrids; AUDISK 2000 digital audio storage/retrieval system. TC-200 telephone interface for non-studio applications.  
 Also: VRC-2000 remote control system. Prism II FM and Prism II AM, four-band audio processors. LAZER digital FM limiter and stereo generator.  
 Contact: Elaine Jones, Marketing Director  
 1825 Research Way  
 Salt Lake City 84119  
 801-975-7200

**Harris Allied 801**  
 New: Harris Digit™ digital FM exciter. Harris AMS-G1 C-Quam AM stereo exciter as feature with Harris Gates, SX and DX transmitters. Enco Systems DAD 486x digital audio delivery system.  
 Also: GATES FIVE 5kW solid state medium-wave transmitter. Arrakis and Gentner hard disk systems. AKG, Arrakis and Roland digital editors. Cylink wireless modem. Comrex digital codecs. RE America and CRL RBDS encoders. Tascam digital multitrack recording system. Audiometrics and Marantz CD equipment. Sony MiniDisk equipment. Sony, Panasonic and Denon DAT recorders. Scientific-Atlanta and Wegner satellite equipment. RE America MUSICAM encoder.  
 Contact: Martha B. Rapp  
 P.O. Box 4290  
 Quincy, Ill. 62305  
 217-222-8200, ext. 3577

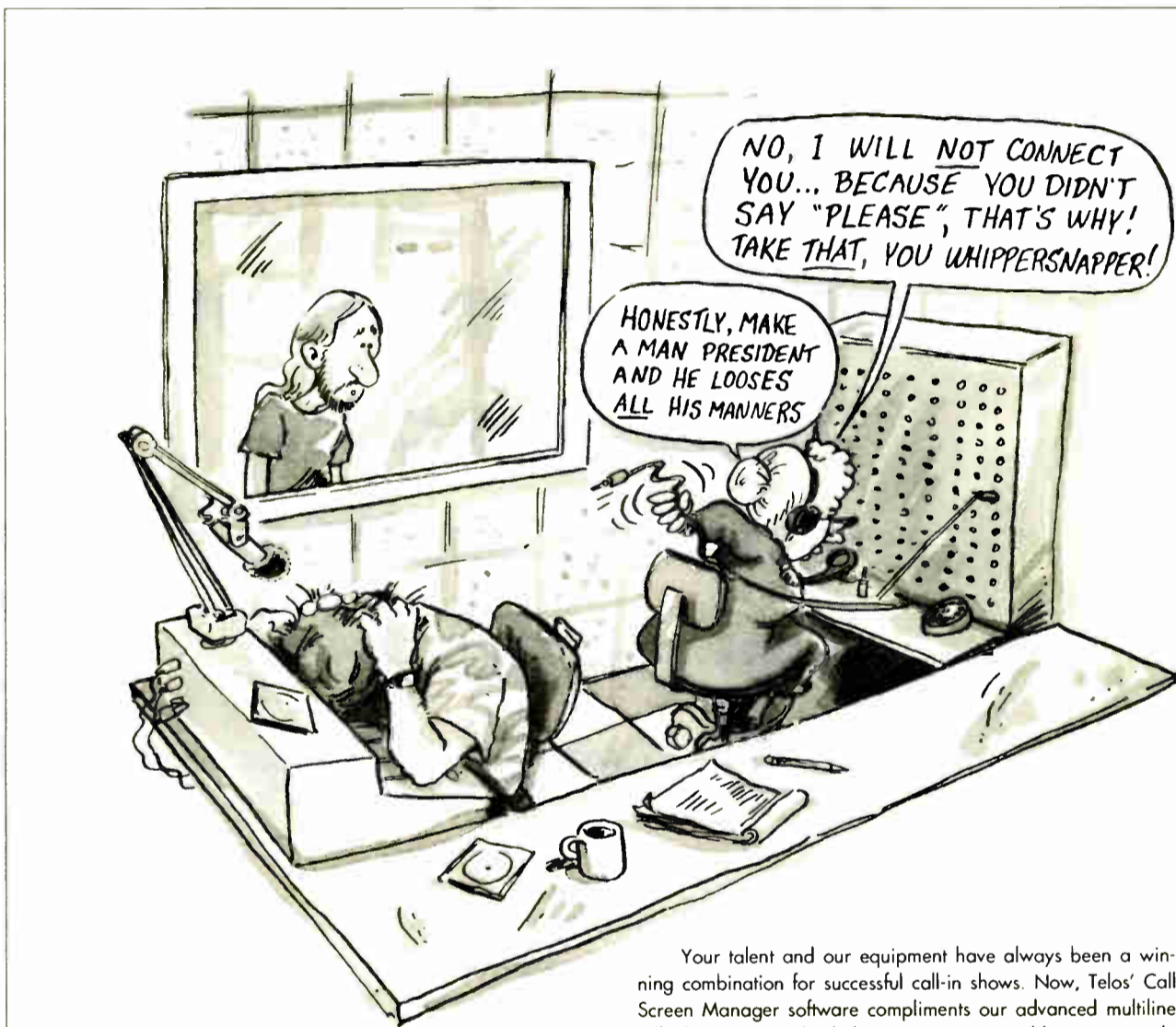

**Call Screen Manager**  
 Talk Show Management Software



Your talent and our equipment have always been a winning combination for successful call-in shows. Now, Telos' Call Screen Manager software compliments our advanced multiline talk show systems by helping your screener/director provide your talent with information on each caller.

Call Screen Manager uses inexpensive IBM-compatible PCs and peripherals and you can choose two different screen views, so information is always displayed in the most useful, easy-to-interpret format. Features include real-time display of line status; full page and quick messages that may be stored and sent with simple keystroke combinations; a caller information database module with modifiable data fields and report and export capabilities; and the ability to accomplish most critical screener functions from the computer keyboard.

Two versions of Call Screen Manager are available. Host Software provides for a director position and any number of talent positions using a single PC. Remote Software allows communications between the studio and talent located at a remote site via modem.

So hire the best and give them the tools they need. Isn't it time you experienced the pleasure of great phones?



2101 Superior Avenue • Cleveland, Ohio 44114  
 216.241.7225 • FAX: 216.241.4103

Circle (50) On Reader Service Card

production music library.  
Contact: Jonathan Wolfert, President  
5454 Parkdale Dr.  
Dallas 75227  
214-388-5454

**JAMPRO Antennas** 711  
New: JUHD all-band UHF antenna, top- or side-mount panel system with radomes.  
Also: JMDS MMDS antenna system.  
Contact: Marlene D. Young, Marketing/Sales Administrator  
6340 Sky Creek Dr.  
Sacramento, Calif. 95828  
916-383-1177

**Jefferson Pilot Data Services** 211  
JDS 1000 broadcast management system for radio sales and traffic.  
Contact: Antoinette Cheney, Trade Relations Coordinator  
785 Crossover Lane, Suite 141  
Memphis, Tenn. 38117  
901-762-8016

**K** **Killer Tracks** 624  
Sixty-CD production library.  
Contact: Diane Craig Lantz, Account Executive  
6534 Sunset Blvd.  
Hollywood, Calif. 90028  
1-800-877-0078

**LDL Communications** 135, 137  
New: Master FM diagnostic system. Alan Dick and Co. FM antenna systems for high-power broadband FM panel antennas and high-power combiners.  
Also: FM panel antennas. Multichannel combiners. Broadcast towers.  
Contact: Jim Wilson, President  
14440 Cherry Lane Court, Suite 201  
Laurel, Md. 20707  
301-498-2200

**m** **The Management** 333-335  
New: APT-X ACC-100 audio card with balanced outputs and simultaneous record and playback in mono and stereo. Programmable telephone interface. Music Log for CDs for use with the Pioneer™ six- and 18-disk players. Simple-CD compact disc automation system. DJ<sup>2</sup> digital audio storage and playback system.  
Also: Super Log traffic and billing system. Digital DJ hard disk storage and playback system. Music Log music rotation software.  
Contact: Adrian Charlton, General Manager  
Box 1-36457, Fort Worth, Texas 76136  
1-800-334-7823

**Marketron** 227  
New: Firstrate software for traffic, revenue, proposals, audience analysis, demand pricing, budget performance and other areas.  
Also: ACT II, a PC-based traffic and accounting system.

Contact: Mike Rooney, Sales Manager  
101 Lincoln Centre Dr., Suite 300  
Foster City, Calif. 94404  
415-341-4004

**Mart Electronics** 802, 804  
New: STL-15C composite studio-to-transmitter link. SC-48 parabolic antenna, from 450 MHz to 960 MHz.  
Also: STL-10 studio-to-transmitter link.  
Contact: Dan Rau, Director of Sales & Marketing  
1501 N. Main  
Cleburne, Texas 76031  
817-645-9163

**Media Touch Systems** 142  
New: MediaDisk "Auto-Record" digital audio workstation. Pic'N Play automated cart system.  
Also: OpLog live assist/austomation studio control system. Omniplay, integrates traffic and studio control. MTS Remote, PC remote control of station operations. MediaDisk, PC digital audio system.  
Contact: John Connell, President  
50 Northwestern Dr., #11  
Salem, N.H. 03110  
603-893-5104

**Modulation Sciences** 1009  
New: Model RDS-1 RDS/RBDS Generator, which converts a PC into a full-function RDS/RBDS Coder. Model DSCA-1 Data SCA Receiver.  
Also: FM ModMinder Modulation Monitor/Analyzer. StereoMaxx Spatial Image Enlarger. Composite Processor. Sidekick audio and data subcarrier generators. Wired STL composite line driver/receiver system. Composite distribution amplifier.  
Contact: Arthur Constantine, Vice President, Sales and Marketing  
12A World's Fair Dr.  
Somerset, N.J. 08873  
908-302-3090

**Moody Broadcasting Network** 935  
New: ACCU-WATCH automatic transmitter service (ATS), offers monitoring and automatic EBS alerts.  
Also: Gentner VRC-2000 and Zephyrus Electronics Ltd. satellite stereo audio and data channel receiving systems.  
Contact: David P. Woodworth, Administrator, Affiliate Development  
820 N. LaSalle Blvd.  
Chicago 60610  
1-800-621-7031

**Moseley Associates** 352-353  
New: DSP 6000 spectral efficiency enhancer.  
Also: MRC 1620 transmitter control.  
Contact: David Chancey, National Sales Manager  
111 Castilian Dr.  
Santa Barbara, Calif. 93117  
805-968-9621

**Music Director Programming Service** 701  
New: CD and DAT libraries of music from 1955 to 1992.  
Also: Christmas music on CD and DAT. Record research books will be for sale in booth.  
Contact: Budd Clain, General Manager  
P.O. Box 51978  
Indian Orchard, Mass. 01151  
413-783-4626

**n** **National Supervisory Network** 1010  
New: ComStream DT 7000 integrated VSAT earth station. 5-watt C-band systems. 2-watt Ku-band systems for digital audio networks. NSN Mustang integrated audio and data receiver for up to four data channels plus MUSICAM audio.  
Also: VISION, VSAT integrated operations network. Stand-alone audio and data networks for radio networks and station groups.  
Contact: Muffy Montemayor,  
General Manager  
P.O. Box 578  
Avon, Colo. 81620  
1-800-345-8728

**Nautel Maine** 747  
Ampfet ND2.5, 2.5 kW solid state AM transmitter with built-in AM stereo. Nautel FM4, a 4 kW solid state FM transmitter.  
Contact: Bruce MacKenzie, Broadcast Sales  
201 Target Industrial Circle  
Bangor, Maine 04401  
207-947-8200

**Network Music** 727, 729  
New: Brainstorm production library with more than 500 cuts on seven CDs.  
Also: Network Production Music, 120 volumes of

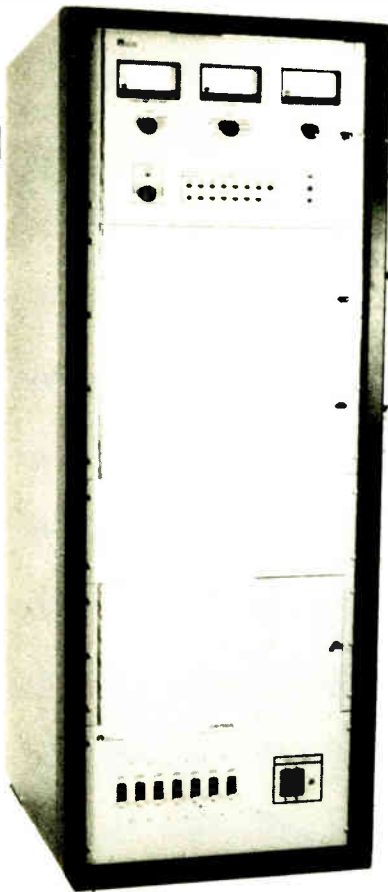

## The inventor of high powered solid-state AM has perfected solid-state FM

You know us as worldwide suppliers of cost-effective, power-efficient solid-state AM transmitters.

Now we're proud to offer Nautel reliability, efficiency and serviceability in three new solid-state FM transmitters.

**AMPFET FM4 4kW**  
**AMPFET FM7 7kW**  
**AMPFET FM10 10kW**

Get the full story on our complete line.  
Call, write or FAX today.

**Phone:** (902)823-2233 Canada • **Fax:** (902)823-3183 • **Telex:** 019-22552

**Nautel**  
(Nautical Electronic Laboratories Limited)  
R.R. #1, Tantallon, Halifax County,  
Nova Scotia, Canada B0J 3I0

**Nautel Maine Inc.**  
201 Target Industrial Circle  
Bangor, Maine 04401 U.S.A.





THE WORLD'S  
OLDEST DISC RETRIEVAL SYSTEM

VS.

THE WORLD'S  
NEWEST DISC RETRIEVAL SYSTEM

No matter how technologically advanced an industry may become, it's always a good idea to keep things simple. Well, what could be simpler than programming audio by hand? The Pioneer CAC-V3200 Compact Disc Autochanger.

As a professional audio user, you'll be impressed that it provides access to 300 CD's with uninterrupted playback thanks to dual CD players. And they can be connected together to program thousands of



CD's. You'll also appreciate that its built-in interface makes it pre-programmable for error-free playback by almost any computer. And its fade-in and fade-out capabilities, pitch control, and analog and digital outputs make it a remarkably ingenious piece of equipment.

However, if you just want to get practical about the whole thing, you can look at it this way, too. The CD Autochanger makes audio programming so absolutely efficient and error-free that your life will be made easier and your business could become more profitable. Which makes it seem rather impractical not to find out more.

Call Pioneer and ask about the CAC-V3200 Compact Disc Autochanger. You'll find it to be a simple decision that deserves a big hand.



 **PIONEER**  
The Art of Entertainment

**Be sure to see our products at the following NAB Show locations: Broadcast Electronics, Inc.-Booth #613; Custom Business Systems, Inc., #621; Enco Systems, Inc., #810 (Harris Allied); Media Touch Systems, Inc., #142; Pristine Systems, #701; Scott Studios Corp., #215; The Management, #333 & #335.**

music with new release monthly. Sound Effects, 60 volumes on CD with frequent updates. ShockWave, seven-CD package with 400 cuts. Primrose Music, European cuts on CD in wide range of styles.

Contact: Ken Berkowitz, Vice President of Sales  
11021 Via Frontera  
San Diego 92127  
619-451-6400

#### NPR Satellite Services 539, 541

Audio interconnection services, including fixed and transportable uplinking, digital audio transmission, digital fiber links and service to Galaxy and Satcom.

Contact: Miriam Lenett, Marketing Specialist  
2025 M St., NW  
Washington, D.C. 20036  
202-822-2626

#### NSE Radio Network 1000

Digital satellite music and personality programming.  
Contact: Ken Unger, Vice President

1794 Penfield Rd.  
Penfield, N.Y. 14526  
716-381-0620

**O**  
**Omnia Group 937**  
New: Omnia PriorityReports, background checking service for employers.

Also: Omnia Profile, personality testing service.  
Contact: Dale P. Smrekar, Vice President  
601 South Boulevard  
Tampa, Fla. 33606  
1-800-525-7117

**Orban 233**  
New: Orban 428 studio dynamics processor, dual-channel/stereo AGC-compressor with spectral enhancement.  
Also: OPTIMOD series audio processors and peripherals.

Contact: Phil Moore  
AKG Acoustics  
1525 Alvarado St.  
San Leandro, Calif. 94577  
510-351-3500

**P**  
**Pacific Recorders & Engineering Corp. 248**  
New: ADX digital audio production system.

Also: Radiomixer on-air console.  
Contact: Michael Dosch, General Manager  
2070 Las Palmas Dr.  
Carlsbad, Calif. 92009  
619-438-3911

**Peoples Network 1002**  
24-hour news-talk-information programing, via satellite.  
Contact: Gary Tomlinson  
3 River St.

White Springs, Fla. 32096  
904-397-4422

**Premiere Radio Networks 110**  
New: Mediabase/Premiere research on CHR, Rock, Urban and AC in top 100 markets. "Gerry House & the House Foundation," nationally syndicated morning show.

Also: Premiere CHR Comedy Network, Premiere Country Comedy Network, Premiere Gold Comedy Network. Premiere AC Comedy Network, weekly updated parody songs, commercials and movie drops, designed by format. The Cla'ence Update, 90-second review of "The Young and the Restless," Mon.-Fri. On the Phone with Ti-Rone, 90-second advice segment for urban stations. News from the Boonies, strange-but-true news stories with sound effects. "Reflections," two-hour classic soul music show.

Contact: Steve Lehman, President and CEO  
15260 Ventura Blvd., 5th Floor  
Sherman Oaks, Calif. 91403  
818-377-5300

**Prophet Systems 941**  
New: Windows™ - and Novell Netware-based digital PC audio production and control system.  
Contact: Kevin Lockhart  
Box 509, 111 West 3rd  
Ogallala, Neb. 69153  
308-284-3007

**Q**  
**QEI Corp. TBA**

New: QEI will feature the FM Automod, a composite AGC, and the Q-MAX, a discrete 16-bit digital audio card for CAT-LINK.

Also: digital and analog stereo generators and FM excitors.  
Contact: Jeff R. Detweiler, Sales Mgr.  
P.O. Box 805  
Williamstown, N.J. 08094  
609-728-2020

**R**  
**Radio Computing Services 631**

New: Enhanced version of RCS Works, an integrated system offering sales, traffic, music selection, production and news, with or without digital audio. New features include a multitrack digital editor.

Also: Selector, music scheduling, MusicBase, a music library system, Linker, a schedule management system, Prosonix, digital audio editing, Master Control, paperless-cartless studio, live assist or full automation system, and RCS Traffic, sales scheduling, billing receivables.  
Contact: Lee Facto, VP  
2 Overhill Rd.  
Scarsdale, N.Y. 10503  
914-723-8567

**Radio Systems 418, 420**  
New: Master clocks and programmable timers and the T1-102 Telephone Interface.

Also: the RS Series mixing consoles, RS-6700 DAT machines and Dolby S noise reduction.  
Contact: Gerrett Conover, Int'l Sales Mgr.  
110 High Hill Rd.  
Bridgeport, N.J. 08014  
609-467-8000

**RE America TBA**

The RE 532 full-featured RDS/RBDS encoder, an IU rack space unit fulfilling RDS/RBDS specifications and the management of data control inputs accommodating paging, DGPS and TDC applications; and the RE 660/661 MUSICAM Digital Audio Codec, which provides digital audio inputs with built-in sample rate conversion and 56 kbps to 384 kbps up to 20 kHz bandwidth.

Contact: John Casey  
31029 Center Ridge Rd.  
Westlake, Ohio 44145  
(216) 871-7617

**Register Data Systems 423**

New: Traffic and billing software package designed to run under Microsoft Word 3.1; and the DigiCorder II, an updated version of the original DigiCorder, a digital audio hard disk record playback system.

Also: The Phantom digital audio automation system, for use with station automation of satellite program sources and live-assist. RDS will display its PC-based traffic and billing software packages. Products range from basic traffic and accounts receivables on a single-user PC to fully integrated packages that include traffic, receivables, payables, payroll and

# Digital Hard Disk Plays Spots and CDs. Scott Studios' Touchscreen Eliminates Paper Logs & Console

Copyright 1993 by Scott Studios Corp.

10:14:18A	(I Can't Get No) Satisfaction Rolling Stones :14/3:33/F 1965 C20105 10:14:18 #1 for 5 Weeks in the Winter of '65	:14	Studio Mic. 1	Manual 6
*Air* 2:37	Feelin' Stronger Every Day Chicago :25/4:03/F 1973 C12608 10:17:20	Recue Ins.	Guest Mic. 2	Jingles 7
Start F2	Back Announce - Linked to C12608 Dave Scott :00/0:08/C BAL VT0214 10:21:15	Move Down F9	News Mic. 3	Music Library 8
Start F3	McDonald's 2 for \$2 Special JT Q: Now Thru Saturdays Only. :00/1:00/C COM DA1103 10:21:23	F6 Move Up	Marti 4	Spots 9
Start F4	Bob's Bargain Barn BW Q: At Westland and East Park. :01/1:00/C COM DA4310 10:21:50	Move Down F10	Net-work 5	Options 0
Start F5	Uptempo Jingle - Linked to C02102 Q: Kiss FM. :00/0:06/C JIN DA1037 10:22:50	F7 Move Up	More Events	Delete Event Del
Start		F8 Move Up		
		Move Down F11		
		Move Down F12		
		Move Up		
		Move Down		

Scott Studios brings your commercials and music together on a clean, clutter-free control room computer screen.

## Play Anything At the Touch of a Finger

You get great-sounding digital spots and jingles from hard disk, and songs from CDs or hard disk. Turn microphones on and off at a touch. Rearrange sweeps and clusters. Add jingles, sounders and spots. Play requests with your entire music library displayed by titles, artists, lengths, years, albums or categories. There's no cumbersome computer keyboard, trackball or "mouse" in your studio. You choose to use either a simple start button box, touchscreen, or both.

## Throw Away Your Copy Book

When it's time for weather, spots, promos or trivia, a live copy window pops up unobtrusively on Scott Studios' screen. You can start other events while reading copy.

## NAB Booth 215

(214) 620-2211 FAX: (214) 620-2707  
(800) 330-3004

## Get It All Together

Scott Studios connects your traffic, music and programming computers to your air studio. You can add spots, revise music and update live copy from your office, without an expensive file server computer. You also get printouts showing exact times everything aired and discrepancy reports showing changes or missed spots.

## Multi-Studio Digital Audio

When spots are produced, they're electronically transferred to all your air studios. There's no time wasted carrying carts down the hall or redubbing for second or third stations.

## We Call It a 'Troll...

Short for "studio conTROLLer". It's easy to use and affordable. In fact, it'll pay for itself in savings. Call, FAX or write us in Dallas for details.

**Scott Studios Corp.**  
13375 Stemmons Freeway, Suite 200  
Dallas, Texas 75234

# Just RIGHT!

The **MR-40** is a unique console with just the right features that make it practical for radio production and on-air use. The **MR-40** includes 4-track bus assign for multi-track recording and program assign for 2-track mix-down or live broadcasting. It has machine start/stops and channel cueing like an on-air console, but also includes a 3-band equalizer section so you can have the tone control that a normal radio console couldn't provide. It even has a stereo send bus that follows stereo channel balance controls - ever so important for today's stereo effects devices.

Mono modules have both mic and line inputs: mic for recording and line for track playback. Sub-group channels provide fader control for record

levels and also have a second track playback path for really quick sessions. And of course the **MR-40** has an on-air type monitor section, complete with control room, headphone and studio outputs plus all the necessary muting and tally functions you'd want. It even has a built-in cue speaker and power amplifier.

The **MR-40** is a perfect blend of excellence in engineering and sensible size. Yet, no corners have been cut to maintain it's small format: all audio switches are gold contact, assign buttons are LED illuminated, all IC's are double burned-in and all circuits are double tested.

Finally there's a console with the flexibility and reliability you need - the Audioarts **MR-40**.



See The MR-40 At  
NAB Booth 339

Available Through:

*Equipment Solutions To Keep You Number One*

**BSW**

BROADCAST SUPPLY WORLDWIDE

Phone 800 . 426 . 8434 Fax 800 . 231 . 7055

## MR-40 Audio Mixing Console



**AUDIOARTS® ENGINEERING**

Broadcast Supply Worldwide • 7012 27th Street West Tacoma, Washington 98466 USA

Circle (189) On Reader Service Card

World Radio History

general ledger running on single user or network systems.

Contact: Brad Harrison, Sales Mgr.  
P.O. Box 980  
Perry, Ga. 31069  
800-521-5222

**Rodman-Brown & Associates** 911  
New: The RDMS Traffic & Billing Software, which was recently acquired from Master Software Systems Inc.

Also: The Desk Jockey digital automation system and the EBS Central remote control EBS system will also be on display.

Contact: Tom Rodman, Pres. & CEO  
1544 Lighthouse Dr.  
Naperville, Ill. 60565  
708-983-0977

**Roll-a-Sign** 808  
The company will display plastic banners ranging from 18 inches to 36 inches width with up to four colors of ink promoting radio stations.

Contact: Joe Oppenheimer, Sales Rep.  
P.O. Box 750245  
Houston, Texas. 77275-0245  
800-231-2417

**S**

**S.W.R. Inc.** 331  
S.W.R.'s display will include the educated versions of the FMEC, the medium power FM3 and the high power FM10.

Contact: Edward J. Edmiston, Pres.  
R.D. #3, Box 182  
Ebensburg, Pa. 15931  
814-472-5436

**Scientific-Atlanta** 811, 813  
On display will be transmission and receiving products for satellite digital audio, featuring the Encore Series of receivers and the Symphony Series receivers. Also on display will be the SEDAT Studio Server, which provides digital encoding of audio programming sources.

Contact: Virginia Lee Williams, Sales & Mktg. Adm.  
420 N. Wickham Rd.  
Melbourne, Fla. 32935  
407-255-3030

**Scott Studios Corp.** 213, 215

New: CompuCart hard disk digital audio cart machine replacement. The company will offer free music pre-dubbed to hard disk with the purchase of a CompuCart digital player. The unit features troll touchscreen studio controller, automation with Pioneer CAC-V3200 CD jukebox containing 300 CDs and satellite automation with commercials on hard disk.

Contact: Dave Scott, Pres.  
13375 Stemmons, Suite 200  
Dallas, Texas 75234-5774  
800-330-3004

**Sentry Systems** 303  
New: Network Sentry Model FS-NET, which automates the capture and recording of network news, features and other feeds for unattended delayed

playback; and the Disk Sentry Hard Disk Audio Recorder Model DS-2, which features simultaneous record, play with overlap and networking capabilities. Also: The Format Sentry PC automation model FS-12.  
Contact: Bob Arnold, Mgr.  
2211 5th Ave.  
Seattle, Wash. 98121  
206-441-1971

**Shively Labs** 1005-1007

New: The Shively Model 6017LB, a top-mount, broad-band multistation or single frequency FM antenna which provides an extremely omnidirectional pattern (-0.6 dB) without the use of panels—reducing the weight and windload on the support structure. Also: The Model 6824 internal fed normal-mode helix FM broadcast antenna developed for low-ice environments where the tower cannot support radomes; and the Model 6016P four-around dipole panel antenna for square towers and directional requirements.

Contact: Jonathan R. Clark, Mktg. Mgr.  
71 Harrison Rd.  
Bridgton, Maine 04009  
207-647-3327

**ANNOUNCING!**

# Cellcast<sup>®</sup> 1.8



## Added Features, Same Price.

### Remote Possibilities Become Reality.

Cellcast<sup>®</sup> is the cellular difference. More efficient than your old portable, more cost-effective than a van full of expensive equipment.

**Remote Ready.** Everything you need to broadcast – including a frequency extender and mixer – in a compact and easy-to-carry unit.

**Sound Solutions.** Cellcast<sup>®</sup> broadcasts crisp and clear. It's as close to studio quality as you can get with state-of-the-art cellular phone technology.

**On-Air On-Time.** Cellcast<sup>®</sup> offers a transmission option of cellular or land-line remote broadcasting. So no matter what the situation calls for, you've got what you need to be on-site and on-air within seconds.

**Superior Support.** Cellcast<sup>®</sup> quality is backed by service you can count on. In addition to the standard 1-year warranty on every unit, we provide 24-hour, 7-day a week product support. A replacement unit will be sent to you OVERNIGHT if your unit fails to operate... All of this for the low price of \$2950.00, FOB, Owasso, Oklahoma.

**New Technology.** The Cellcast<sup>®</sup> 1.8 now has more features: Software Selectable encoder, 600 ohm Line out, Vu meter and more...

**2-Week Trial!** Call 1-800-852-1333 and ask for Bridget Taylor to try a Cellcast<sup>®</sup> RBS 1.8 for two weeks. For \$195.00, Cellcast<sup>®</sup> provides a unit ready to be activated by your local cellular service. Cellcast<sup>®</sup> will deduct the trial charges from your purchase.

Remote possibilities have become reality. Anytime, anywhere. With Cellcast<sup>®</sup>.

Lease Purchase Terms Available  
Call 1-800-852-1333 today!



(918) 272-8450

Fax: (918) 272-8452

110 So. Main, Owasso, OK 74055

© 1993 Cellcast Communication Products, Inc.

See Us At NAB Radio Show Booth 932/934/936

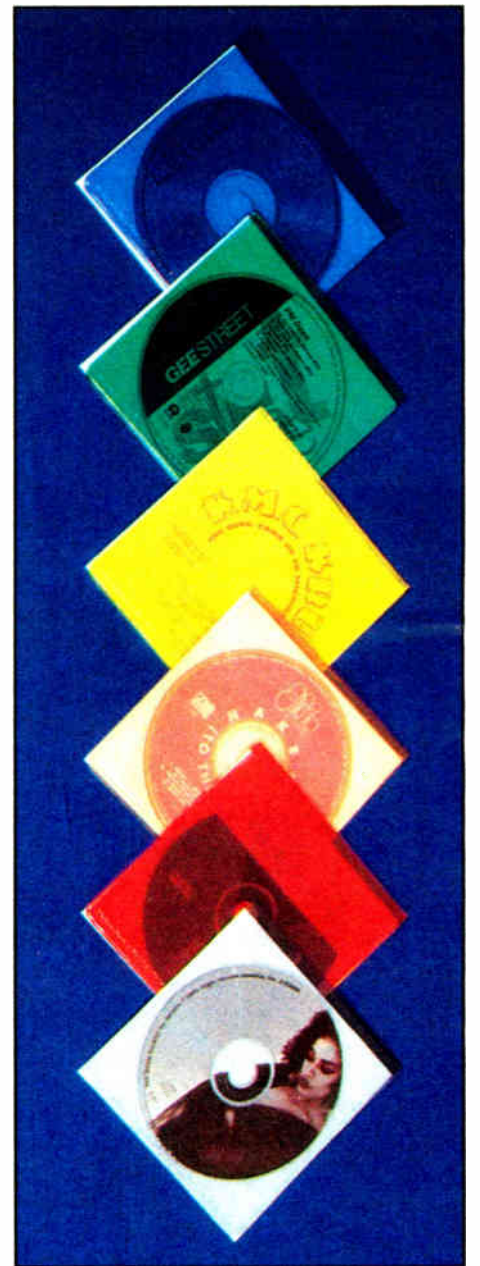

Univenture's colored Jewelpaks

**SMARTS Broadcast Systems** 833-835

New: A new digital production unit that can be used in conjunction with the SMARTCASTER, and full touch screen control, enabling Point and Play control of digital audio functions by touching the screen. Also: The SMARTCASTER, digital satellite automation system, The Jock in the Box, digital CD automation, and Hard Drive automation.

Contact: John Schad, Pres.  
2102 Main  
Emmetsburg, Iowa 50536  
712-852-4047

**Sony Electronics, Inc.** 136

New: The PMD-C1 and PMD-C1P mini-disc cart machines; the CDK-3600 360-disc compact disc changer; and the CDP-3100 broadcast CD player.

Contact: Ron Renschel, Mktg. Mgr.  
3 Paragon Dr.  
Montvale, N.J. 07645  
201-358-4196

**Sound Ideas** 127  
 Sound Ideas will present the Hanna Barbera and Warner Bros. Sound Effects Library.  
 Contact: Brian Nimens, Pres.  
 105 W. Beaver Creek Rd., Suite #4  
 Richmond Hill, Ontario, Canada L4B 1C6  
 416-886-5000

**Sports Entertainment Network** 123  
 New: Hourly sports news in both 5- and 2-minute spots.  
 Also: Broadcasts of regional college football games, live coverage of major sports events, and "Sports Talk," four hourly updates, 24 hours a day, seven days a week.  
 Contact: Jerry Kutner, Pres.  
 3333 Cambridge St.  
 Las Vegas, Nev. 89109  
 702-731-5200

**Superior Electric** 738  
 New: Heavy duty WHR Series STARLINE voltage regulators, including new 19-inch rack mount versions. New expanded STABILINE uninterruptible power supplies and power conditioners will be on display as well.  
 Also: POWERSTAR® variable transformers with ratings to 365 kVA, 5-WAY® binding posts in single assembly, double assembly, custom color ring and militarized styles, and SUPERCON® electrical connectors in ratings of 25, 50, 100, and 250 A.  
 Contact: Michael J. Miga, Sales & Mktg. Mgr.  
 383 Middle St.  
 Bristol, Conn. 06010  
 203-585-4500

**TAPSCAN** 427  
 TAPSCAN will offer its radio sales software systems, including MultiMedia and GridOne, which include complete scheduling capabilities. The company also will feature MusicSCAN, a music scheduling software system.  
 Contact: Gayla Rathbun, Conv. Coord.  
 3000 Riverchase Galleria, #850  
 Birmingham, Ala. 35244  
 205-987-7456

**Television Technology Corp.** 431-433  
 TTC's offerings will include the FMS4000 4KW Solid State FM transmitter, Model 8090X FM exciter, and the XL10FM translator.  
 Contact: Alex DeLay, Int'l Sales Mgr.  
 650 S. Taylor Ave.  
 Louisville, Colo. 80027  
 303-665-8000

**Telos Systems** 242  
 New: The Zephyr Digital Network Audio Transceiver, a 15 kHz stereo on a single ISDN line, also for Switched 56 and satellite.

Also: One-x-six talk show system; and a full line of call-in and talkshow equipment.  
 Contact: Danielle Cline, Mktg. Ass't.  
 2101 Superior Ave.  
 Cleveland, Ohio 44114  
 216-241-7225

Also: The Ultimate Digital Studio II, which allows complete control of all music and commercials for full automation or live assist.  
 Contact: P. Craig Turner, Pres./CEO  
 2000 Academy Way  
 Dallas, Texas 75234  
 800-TMCENTURY

Also: USA Radio Network News.  
 Contact: Al Ross, Mgr. Affil. Services  
 2290 Springlake Road,  
 Suite 107, Dallas, Texas 75234  
 800-829-8111



Fidelipac Dynamax

**TFT Inc.** 312  
 New: The EIS 911 Emergency Information System Manager, and the Model 923 AM Modulation Monitor/Analyzer with built-in pre-selector.  
 Also: The DMM92-100 Digital STL Modem & Multiplexer and the complete line of STLs, digital and analog.  
 Contact: Darryl E. Parker, Dir. of Mktg.  
 3090 Oakmead Village Dr.  
 Santa Clara, Calif. 95051  
 408-727-7272

**The Express Group** TBA  
 Contact: Byron Andrus  
 3518 Third Ave.  
 San Diego, Calif. 92103  
 619-298-2834

**Thompson Creative** 834, 836  
 New: Syndicated jingle packages, including WOR New York, KDMX Dallas, and Magic in San Antonio.  
 Also: The PromoPak station promotion production library on CD.  
 Contact: Ben Freedman, VP/Sales Mgr.  
 4631 Insurance Ln.  
 Dallas, Texas 75205  
 800-723-4643

**TM Century** 219  
 New: Jingles for a number of radio stations, a new production music library, new television campaigns and spots, the new GoldDisc and Modern Rock HitDisc Libraries.

**Weather Services Corp.** 709  
 Weather Services will again offer customized forecasting services to the radio industry in major and small markets in the U.S., Canada, and Caribbean.  
 Contact: Joe Zona, Mgr., Media Div.  
 131A The Great Road  
 Bedford, Mass. 01730  
 617-275-8860

**Wegener Communications** 733, 735  
 New: SCPC digital audio receiver; and the QPSK subcarrier digital audio receiver.  
 Also: The company also will show the ANCS Plus, an addressable network control system.  
 Contact: Ken Leffingwell, VP of Mktg.  
 11350 Technology Cir.  
 Duluth, Ga. 30136  
 404-623-0096

**Wheatstone Corp.** 901-905  
 New: Air and production consoles.  
 Also: Company line of modular studio furniture, the Wheatstone digital audio hard disk and radio audio console designs, including the new A-6000.  
 Contact: Ray Esparolini, Dir. of Sales  
 7305 Performance Dr.,  
 Syracuse, N.Y. 13212  
 315-452-5000

**Winner's Circle Network** 1036  
 The company offers two-minute short-form commentary with Lon Tice to U.S. and Canadian radio stations on a market exclusive basis. Commentaries cover a wide range of topics, geared toward helping listeners improve their quality of life.  
 Contact: Ken Fagan, Director of Affil. Relations  
 1932 First Ave., Suite 607  
 Seattle, Wash. 98101  
 800-RADIO-WCNY

**Univenture CD Storage** 530  
 New: Jewelpak Rack, a four-sided, rotating desk unit that holds 120 CDs; and Jewelpak Rack Wall Modules, which hold 15 CDs and can be mounted almost anywhere.  
 Also: New colored Jewelpaks, sleeves that hold a CD and graphics.  
 Contact: Michele Cole  
 P.O. Box 570  
 Dublin, Ohio 43017  
 614-761-2669

**USA Radio Network** TBA  
 New: The Ken Dowe Daily Magazine show.



## 7kHz High Quality Audio CODEC HQ7000 Series



HQ7000S (stereo)



HQ7000 (mono)

The HQ7000 series enables economical, high quality audio transmission just like a live performance.

- Features**
- Conforms to CCITT G.722
  - Automatically selects 56 or 64 kbps
  - Adopts Frame Mode conforming to CCITT H.221 and unframe

- Mode**
- Interfaces V.35, V10/11, V.36, X.21
  - Automatically Compensates Phase between Left and Right Channels (HQ7000S)
  - Provided with Cannon connector and pin Jack

The HQ7000 allows communication with almost all types of codecs through ISDN circuit or digital leased line. It can also be connected to most terminal adapters.  
 Please address your inquiries to:

**Oki Electric Industry Co., Ltd.**  
 New Business Dept.  
 Overseas Marketing & Sales Division  
 KAKIHARA ASahi EITAI BUILDING  
 3-7-13 TOYO, KOTO-KU, TOKYO 135, JAPAN  
 Tel: +81-3-5632-1411 Fax: +81-3-5632-1475 - 9

**OKI**  
 People to People Technology

## FM STUDIES

- SPACING/INTERFERENCE SEARCHES to locate a channel
- DETAILED INTERFERENCE STUDIES optimizing site location and directional antenna designs (calculates allowed ERP on all 360 bearings)
- TERRAIN ELEVATION RETRIEVAL determines HAAT for 8 or more radials
- DISTANCE TO CONTOURS plots projected coverage
- POPULATION COUNTING to determine potential listening audience
- COVERAGE MAPS AND OVERLAYS depicts signal coverage, zip code boundaries, received signal level, terrain shadowing and more

**dataworld**  
A Service of DW, Inc.

(301) 652-8822 (800) 368-5754

## PRISTINE MUSIC MANAGEMENT AND COMMERCIAL CONTROL SYSTEM

- COMPLETE DIGITAL AUTOMATION
- PC BASED (386/486)
- CONTROL UP TO 48 ON-LINE CD OR DAT PLAYERS
- DIGITAL HARD DISK AUDIO, INCLUDING DOLBY AC-2
- OVER 180 USERS WORLDWIDE
- LIVE ASSIST, SATELLITE OR COMPLETELY AUTOMATED
- NETWORK COMPATIBLE
- PRISTINE MUSIC PLUS SCHEDULER
- TECHNICAL SUPPORT AND CUSTOMER SATISFACTION ARE TOP PRIORITY
- COMPLETE SYSTEM WITH REDUNDANT COMPUTERS STARTING AT \$10,000

*Call for free demo disk.*  
**PRISTINE SYSTEMS, INC.**  
 WEST 213/662-0737  
 EAST 803/370-2400  
 CANADA 604/748-1580  
 Dallas NAB Booth 701

Circle (9) On Reader Service Card

World Radio History

Circle (53) On Reader Service Card

# The Long and Winding Road to Harrisburg, Pa.

Dear Luci,  
Well, it's been about three months at the new gig in Harrisburg, and I sure am being kept busy.  
Between games with the WINK Wackos volleyball team, softball squad and occasional forays onto the lanes with the WINK Bowling team...not to mention my activities with music and local theater in the Capitol City...I sometimes force myself to bang out a dub or two during the day.

Yeah, this job's really stressing me out. I think it's time for that raise.  
What do you suppose my first bit of business was once I unparked the hard drive on the old PC? Nope, I wrote my landlord only yesterday to tell him I moved.  
Actually, I used the time to generate a fiendish document; one shamelessly packed full of demented lies, flowery embellishments, arrogant half-truths and just plain old cow flop. I updated my resume.

## FROM THE TRENCHES

by Alan Peterson



I learned a long time ago it's always helpful to have that puppy handy when the Earth begins to shake and the cut-backs come (or when the assistant PD thinks you're gunning for his job and blows you out). In my opinion, you can't have an updated resume close enough at hand. The very nature of the

biz dictates the necessity.  
Besides, it gets funny to recall some of the places I've been and what memories they hold. For instance:  
Syracuse, N.Y., where "From The Trenches" had its humble start. There were Orangemen and Chiefs games, lotsa snow and a PD without a clue. In 1988, there were only two country stations there, a satellite-fed AM/DA and an FM two dozen miles away in Auburn. If I'm to believe current reports from friends, as many as five or six signals receivable in metro are now country. Yee-haw.

Garden City, N.Y., my old college station in the basement of what used to be the field hospital for Mitchell Field Air Base. It was all RCA gear with a Sparta Dittydesk for a production console. If you could flange through zero and hold it there, you were a god.

Great Barrington, Mass., was only a six month stay—nice station in ski country. Linda Ellerbee had a house nearby, as did Gene Shalit. Story has it he drove past the station several times looking for it, thinking it was only the transmitter shack. Post-sunset power was about four watts. Rubbing a cat on a dry day a mile away wiped out reception.

Northampton, Mass., four years under Cousin Brucie and Bob Sillerman. Ten years later a lot of old familiar faces and (unfortunately) a lot of old familiar gear. Kevin Eastman and Peter Laird created the Ninja Turtles two blocks away from my station. Calvin Coolidge once had a law office in town. Periscopes and toothbrushes were manufactured just up the street and the National Enquirer recently proclaimed the city "Lesbianville, U.S.A." I got to jam with Robert Cray, Roy Orbison and Otis Day & the Knights.

Springfield, Mass., full-service, AC, nostalgia...yeah, that was a busy couple of years. I had to dress up like George Washington for a car dealer's TV commercial, got to clown in the Shrine Circus (dropping a borrowed juggling prop into a fresh elephant pie) and tried unsuccessfully to blend in with motorcycle aficionados at the Indian Motocycle Museum one July. It was a good year for ad awards: I took three. The local NBC affiliate news team was on the TV Bloopers show a lot.

The list wouldn't be complete without a nod to my last city, Danbury, Conn. I've recently taken a lot of ribbing for this, as Danbury was the birthplace of the Hubble Space Telescope mirror. ("Hey Al, what does a NASA turkey sound like? Hubble-Hubble-Hubble.")

But when I think of the toxic dump next door to my first pro gig in Oswego, N.Y., and Three Mile Island only a ten minute drive from me now, the gags are easy to take.

"Til next month,  
—Al  
□ □ □  
Al Peterson is production director at WNNK-FM Harrisburg, Pa. Reach him at 717-238-1041.

## From San Francisco to Singapore From New Zealand to New York

CCS Audio Codecs Connect the World



### CDQ2000 Family

- 20 kHz Stereo Codec
- CD Quality Transmission
- ISO MUSICAM® Compression

New **CDQ1000**



- 10 kHz Mono
- Universal Compatibility
- G.722 or MUSICAM



### MICRO FAMILY

- 7.5 kHz Audio Codec
- Broadcast Quality Transmission
- CCITT G.722 Compression



Discover Crystal Clear Digital Audio™

Discover CCS



CCS Audio Products  
33 West Main Street  
Holmdel, NJ 07733, USA  
908-946-3800 FAX: 908-946-7167



CCS Europe GmbH  
Obere Hauptstraße 52  
D-8050 Freising, Germany  
49 8161 12222 FAX: 49 8161 12280



## KEYBOARD CONNECTION

# Positioning Programs Clear the RF Path

by Barry Mishkind

**TUCSON, Ariz.** An ad in one of those mail-order catalogues caught my eye: "Know exactly where you are."

I usually know where I'm at. It took a while to realize what the ad was hawking.

It turned out to be a global positioning system receiver, a little digital satellite receiver that tells you where on Earth you are. The system, designed for the military, lets you read out your latitude and longitude, accurate to within less than 100 feet.

What good is this for broadcasters? Actually, it's quite nice for stations doing a lot of remote broadcasts. A crew that knows just where everything is placed can literally orient the transmit antenna in seconds. This could make the difference between being first or last with a fast-breaking news story.

As handy as that may be, there are other factors at work when a crew is out in the field that be managed more easily with global positioning and a computer.

## Laying down the law

Not everyone can be in a market where the terrain is nice and flat, with a tall receive antenna smack dab in the middle of things. Murphy's Law of RPU and STL applications says that if you are trying to line up a feed, there will be an obstruction between you and the receiver—sometimes several.

When time is a factor, Murphy demands that the number and size of the obstructions grows in direct proportion to the urgency of the situation.

A corollary: When setting up a remote broadcast, the client's location will be the only one in the area without line of sight to the studio or repeater. Experienced broadcast engineers swear it happens too often to be mere coincidence. Some days it seems like the general manager or sales

staff picked the site just to give you a challenge.

One option is to drag out the U.S. Geological Survey topographical maps and plot the transmit path. The map you need is either missing or so marked up it's hard to see key points.

Wouldn't it be neat to just plug the locations into a computer and find out if the path will work? As luck would have it, there are a number of easy-to-use programs to accomplish just that.

## Portable programs

If you've ever spent hours over a pile of topographic maps, reading, tabulating, and calculating the elevations, listen to Larry Ellis of SoftWright: "A 35-mile path can be extracted and plotted in 90 seconds. Then, you can change the site by a quarter mile, and do it again in less than two minutes. It's that simple."

You might say, "I don't need a computer to look at a topo map and determine whether it will work." That may be, but it could help in complex terrain, or if you're new to an area. A slight mistake in calculating an STL path can be very expensive.

Similarly, going out to a marginal remote site and trying several different locations takes a lot more time than running the plots in the comfort of your office. One of the on-line services, like Communication Data Services or Dataworld, can do that for you. Such services provide listings of the terrain elevations above sea level between any two points. They are quick and accurate, but not dynamically interactive.

Over the past several years, a topographical database for the entire country

has been digitized and made available on diskette and CD-ROM. With that data and the right programs, you can enter the appropriate coordinates on your desktop computer and watch as the program draws out the path between the points, showing angle, distance, and the height of the intervening land.

Some TV crews do this while on the way to a site and find the ideal spot to transmit before they even arrive.

Several software vendors provide a wide range of programs to fit virtually every need. Some fit in as little as one megabyte of hard disk space. Others take considerably more space, but provide Windows interfacing and more complex display options.

At the National Association of Broadcasters Convention last spring, for instance, Com-munication Data Services (CDS) and Doug Vernier both exhibited

Windows versions of path analysis programs. Vernier has long marketed a variety of programs to consulting engineers and stations. CDS has recently made some programs formerly accessi-

ble only on their mainframe more widely available.

Both companies, as well as EDX Engineering and SoftWright, have been serving the broadcast industry for many years.

## At your fingertips

The program and database you should use depends on your demand for accuracy and whether the results will be used in FCC filings. Developing coverage patterns, searching for potential sites for facility upgrades or calculating the

height above average terrain are all quick and easy with these products.

Other programs and databases have been developed to provide your sales department with population counts, a wide variety of marketing categories by ZIP code, or the ability to extract coverage maps or detailed street maps to route your salesmen as they make their calls.

□ □ □

Barry Mishkind can be reached at 602-296-3797, or on FidoNet at 1:300/11.3 or "barry@coyote.datalog.com" on Internet.

**Have you ever spent hours reading over and tabulating topographic maps?**

## AM ANTENNA SYSTEMS



50 KW AM TUNING UNIT

**Antenna Tuning Units  
Transmitter Combiners  
Folded Unipole Antennas  
Diplexers, Triplexers  
RF Components**

Call LBA Technology for RF systems and excellent technical service. Products for AM, FM, Shortwave and TV are designed and built to international standards. LBA antenna systems will improve your efficiency, performance and reliability.

LBA is the world leader in single and multiple station folded unipole antenna systems for high efficiency, wide band and AM transmissions at all power levels. LBA systems are found from Alaska to Argentina, Kuwait to Saipan.

Our capabilities include the design and fabrication of RF equipment, complete system integration with products of other leading suppliers, project management, on-site installation, and commissioning. Consult LBA for fast response to your RF needs.

919-757-0279

919-752-9155 FAX

or Contact Our Representatives  
Worldwide



**LBA TECHNOLOGY, INC.**

P.O. Box 8026 Greenville, NC 27835 USA

30 YEARS OF  
WORLDWIDE ENGINEERING  
SERVICES

**COMPLETE LINE OF RF  
PRODUCTS**

An LBA Group Company

© 1993

- ✓ The Best In Digital Audio Management
- ✓ The Most Effective Profit Generator
- ✓ The Optimum Investment for Today and the Future
- ✓ Offered By The Company You Can Trust

*DigiCenter*™

Find out how easy it is to own or lease DigiCenter. Call our toll-free number today and let us show you DigiCenter's capabilities.



ITC Corporation  
2425 S. Main Street  
Bloomington, IL 61702  
1-800-447-0414  
Fax: (309) 828-1386



**GO WITH THE WINNERS.**

**DYNAMAX DCR1000 SERIES  
DIGITAL CARTRIDGE RECORDER**

*"With a full log, we have no time for make-goods. The DCR1000 has never let us down. We've had no problems, and we eliminated all cart related maintenance."*

*Fred Holub  
Chief Engineer  
KLAX  
#1 Station Overall  
Los Angeles, CA*

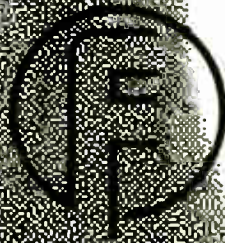

**DYNAMAX™**  
BROADCAST PRODUCTS BY FIDELIPAC®

**Fidelipac Corporation**  
 P.O. Box 808  
 Morrestown, NJ 08057  
 USA  
 609-235-3900  
 FAX: 609-235-7779

## GUEST COMMENTARY

# Some Places Are RF-Safe, Some Are Not

by Gray Frierson Haertig

**MILWAUKIE, Ore.** I feel compelled to respond to the *Reader's Forum* letter concerning radio frequency (RF) radiation issues that appeared in the May 26 edition.

In the example of the panel antenna on the tower, the author would have us believe that the laws of physics are suspended when it comes to RF radiation. Assuming, as he does, that there are two, back-to-back panels on this tower, and that the phasing and spacing is such that there is a field cancellation at the center of the tower, then the field at this point is zero.

If the field is zero, then the power density is zero; and if the power density is zero, then an infinitesimal blob of human flesh at this point would absorb no energy. A RF radiation hazard meter also would read zero.

However, if this blob of flesh were moved  $1/4 \lambda$  (approximately 2-1/2 feet at FM frequencies) toward either panel, then the field would be twice that produced by either antenna alone. The radiation hazard meter also would indicate double and the blob of flesh would be exposed to four times the power density. The point being: RF fields always add vectorially and not algebraically.

## Not so safe

Does this mean that a rigger located precisely in the center of the tower would be safe? Not necessarily.

If, for a moment, we assume that the field from each antenna individually is uniform, then the power densities as averaged over a sufficient volume is equal to the sum of the power densities of the two sources. Riggers are far from infinitesimal blobs of flesh; most have a quite finite volume. Therefore, while the center of the rigger may not be exposed to a radio frequency field, the rest of him is.

The example of the flashlights used to illustrate this point is a bit misleading. Because the wavelength of light is so small, when we look at it we are unaware that we are actually averaging the light intensity over a volume that encompasses many wavelengths.

ANSI C95.1-1991, the national standard regulating RF exposure, indicates that the maximum permissible exposure (MPE) is based on measurements that are spatially averaged over an area equivalent to the vertical cross section of the human body. If the spatially averaged power density at the center of the tower is less than the applicable MPE, then it is safe for the rigger to be there regardless of the level of power being radiated from either source.

It may not, however, be safe to approach this area because the spatially averaged fields may well be above the MPE. There are restrictions limiting the ratio of the peak measured field to the average field, though these are rarely exceeded at FM frequencies, except very close to antennas.

## Bear in mind

On a different matter, there are a couple of caveats one must

bear in mind when using the standard formulas for calculating the power density to determine safe areas on towers. The first is that the vertical elevation patterns supplied by antenna manufacturers bear only a passing resemblance to the vertical elevation pattern of your antenna on your tower.

These patterns are usually generated by measuring the elevation pattern of a single antenna

element in an approximation of free space. This element pattern is then multiplied by the theoretical array pattern to give the overall pattern of the antenna. The element elevation patterns can be seriously distorted by the mounting structure, as was demonstrated in the EPA research behind OST Bulletin No. 65.

To my knowledge, no one has investigated the effect of mounting structure on the array

patterns of FM antennas. One should not trust range measured vertical elevation patterns, either. It is a virtual impossibility to construct an antenna test range at 100 MHz that has the required uniformity of amplitude and phase over a volume large enough to swing an FM antenna array in. At best, these measured elevation patterns are useful checks to see that the

continued on page 55 ►

## THE DIFFERENCE IN SPECTRAL PURITY IS UNCANNY.

*Skip Como, Group Engineer, WRZE, Hyannis, MA*

*I wouldn't even consider any of the others.*

*Jim Bender, Chief Engineer, KZLO, Bozeman, MT*

Both systems were a breeze to install and they work great on our paths.

*Craig Bowman, Director of Engineering, Liggett Broadcasting, WLHT, Grand Rapids, MI; WLQT, Dayton, OH*

## THE SONIC CLARITY OF THIS DSTL IS UNBELIEVABLE.

*Grady Moates, Consulting Engineer, WWKX, Providence, RI*

*It's perfection!*

*Lyle Henry, Director of Engineering, KUSC, Los Angeles, CA*

*It's the most transparent STL we've ever used.*

*Don Ford, Director of Engineering, KACV, Amarillo, TX*

We were able to do our

46.5 mile link in one hop

with the added bonus of

the best stereo separation

and sound we've ever had.

*Michael Bradford, Consulting Engineer, WUPS, Mt. Pleasant/Houghton Lake, MI*

The management says they can't believe how much better it sounds.

*Mario Hieb, Chief Engineer, KXRK, Salt Lake City, UT*

## YOUR BOX IS A BOLT-IN CURE-ALL.

*Ed Trombley, Chief Engineer, WSAE, Spring Arbor, MI*

*We'll also be glad to quote you on a new STL.*

Dolby DSTL users are awed by the difference it has made to their stations. It has not only improved their RF performance, but its punchy, dynamic sound has grabbed the ear of management and programming alike. No wonder the Dolby DSTL Digital Studio-to-Transmitter Link has become the new standard in STL quality.

Dolby Laboratories Inc. • 100 Potrero Avenue, San Francisco, CA 94103-4813 • Telephone 415-558-0200 • Facsimile 415-863-1373 • Telex 34409  
Dolby Laboratories Inc. • Wootton Bassett • Wiltshire SN4 8QJ • England • Telephone 0793 842100 • Facsimile 0793 842101 • Telex 44849  
Dolby, Dolby Stereo and the double-D symbol are trademarks of Dolby Laboratories Licensing Corporation © 1993/Dolby Laboratories Inc. 593/9842



# **TM Century**<sup>®</sup> Inc.

**PRESENTS OUR NEWEST**

**fully INTEGRATED AUTOMATION AND LIVE ASSIST SYSTEM**

# **U**LTIMATE **D**IGITAL **S**TUDIO

**TO SEE ULTIMATE DIGITAL STUDIO II**

**VISIT NAB BOOTH 219**

**OR CALL YOUR PERSONAL SALES REPRESENTATIVE**

**TO SCHEDULE A PERSONAL DEMONSTRATION**

**AT OUR NEW FACILITIES IN DALLAS.**

# NEW FEATURES AND ENHANCEMENTS OF ULTIMATE DIGITAL STUDIO II INCLUDE:

NEW BARGRAPH DISPLAY SHOWS AT A GLANCE HOW MUCH TIME IS LEFT IN YOUR SONG, COMMERCIAL, JINGLE, ETC.

NEW COUNTDOWN CLOCK WARNS OPERATOR THAT END OF EVENT IS NEAR!

FULL WALKAWAY OR LIVE CONTROL WITH JUST ONE KEYSTROKE!



NEW AUDIO CONTROLLER WITH SOFTWARE-CONTROLLED AUDIO LEVELS AND MIXING.

NEW SUPPORT FOR TIME-SCHEDULED EVENTS, INCLUDING REAL-TIME NETWORK JOINS.

- ◆ NEW AUDIO CONTROLLER USES DIGITAL TECHNOLOGY FOR SOFTWARE CONTROL OF AUDIO LEVELS AND CROSS-FADES
- ◆ ENHANCED SUPPORT FOR SECOND-GENERATION COMPACT DISC CHANGERS
- ◆ POP-UP WEATHER, CALENDAR, PSA, AND LINER WINDOWS
- ◆ ENHANCED SUPPORT FOR LOCAL-AREA NETWORKS
- ◆ ENHANCED REAL-TIME FUNCTIONS, INCLUDING REAL-TIME NETWORK JOINS
- ◆ INCLUDES ALL THE FEATURES THAT MADE THE ORIGINAL UDS FAMOUS, INCLUDING TM CENTURY'S EXCLUSIVE AUTOSEQUENCE TECHNOLOGY, AND SUPPORT FOR ALL INDUSTRY-STANDARD MUSIC-SCHEDULING AND TRAFFIC SYSTEMS

## FOR MORE INFORMATION CALL (800) TM CENTURY

# There are just a couple of things we can't supply to broadcasters... buildings and voice talents.

Call AEQ and you will find almost everything you need for your local radio station or for your international broadcast network.

Our talented engineers can provide you with Systems Engineering Design, state of the art equipment, technical advice and, most of all, the expertise obtained through the set up of over a hundred radio stations using our own designed equipment over the last ten years.

Do not hesitate. Choose somebody who knows. Choose AEQ.

AEQ MP-10 Portable Mixer.  
Allows program production and news report from anywhere with an available telephone line.

AEQ SYSTEL-3000 Multipoint Multiconference System.  
Allows full duplex simultaneous intercommunication of up to 9 people.  
Controlled via PC or through AEQ CR-01 remote control console.

AEQ TH-02 Digital Hybrid.  
The ultimate solution to talk show problems.

AEQ BC-2000 Broadcast Mixing Console.  
Complete Modular design. 18, 25 or 35 module versions.

- ❖ Power Amplifiers
- ❖ Digital Telephone Hybrids
- ❖ Frequency Line Extenders
- ❖ Distribution Amplifiers
- ❖ Broadcast Mixing Consoles
- ❖ Broadcast Portable Mixers
- ❖ Self Powered Monitors
- ❖ Line Amplifiers
- ❖ Line Equalizers
- ❖ "Turn-key" Projects
- ❖ ...and much more !

 **aeq**

C/ Rey Pastor, 36 Pol. Ind. Leganés 28914 - Leganés (Madrid) ESPAÑA Tel.: + 34 1 686 13 00 Fax: + 34 1 686 44 92  
AEQ-America 2211 South 48th Street, Suite H - Tempe, AZ USA 85282 Tel.: (602) 431-0334 Fax: (602) 431-0497

Circle (134) On Reader Service Card

World Radio History

# RF Calculation Points to Consider

► continued from page 51

antenna is behaving qualitatively.

The second caveat is that these formulas assume far field conditions. There are three things to consider regarding whether you are in the near or far field.

The first is to evaluate whether the antenna pattern has had sufficient space to develop so that the antenna can be viewed as a unit, or whether the individual elements need to be treated separately. In this case, the far field is generally considered to be those areas that are farther away than ten times the largest linear dimension of the antenna array.

The second consideration is the reactive field of the antenna. In normal operation, an antenna stores considerable energy in magnetic and electric fields surrounding the antenna. This energy is given back to the antenna during part of the electrical cycle.

This power is not considered in the formula because it is not radiated outside of the near field. However human flesh cannot distinguish this field from the radiant field. In terms of the reactive field, the near field extends approximately  $1/2 \lambda$  from the radiating element.

## Then there's E and H

The third consideration has to do with the relationship of the E field (electric) and the H field (magnetic) of the electromagnetic wave. In the far field, these two fields are orthogonal (at right angles to each other and to the direction of radiation) and are related by the formula  $E^2 = H^2 \times 377$ .

Where this condition exists, it is sufficient to measure just one component as the other is implied. The ANSI standard allows this to be done above 300 MHz. Between 30 and 300 MHz the situation must be analyzed and a determination made to see if it is sufficient to measure only one field. Generally this distance is somewhere on the order of  $7 \lambda$ . However, the prudent course at FM frequencies is to measure both the E and H fields.

The letter's author is right in saying that Field Intensity Meters (such as the Potomac Instruments, FIM-71) or spectrum analyzers are inappropriate for making radiation hazard measurements but not for the reasons he stated. They are inappropriate because the physical dimensions of the calibrated antennas available for use with these instruments make it impossible to take measurements within several feet of the ground or other objects.

The antenna that is part of the FIM-71 is only calibrated at elevations of 7 and 30 feet above ground and for the horizontal polarization only. However, if one constructed a physically small antenna and calibrated it in a TEM cell, then accurate measurements could be made with an FIM or spectrum analyzer, as long as three orthogonal measurements were taken at each point and the root-sum-square of the three readings was then calculated. A separate set of readings would have to be taken at each frequency. This would be very tedious.

## The root question

This heads us back around to the root question brought up in the letter: Are measurements made with an RF radiation hazard meter sufficient to guarantee worker safety and compliance with the ANSI C95.1-1991?

In general, radiation hazard meters mea-

sure the aggregate ambient RF field accurately. (The exception to this are meters employing diode detectors that do not operate in the square law region of the diode. These act as peak detectors and tend to read high in the presence of multi-

workers on the tower, unless they are employed directly by the owner. This responsibility, under OSHA laws, falls to the employer of the climber. As owners it is wise to know where the safe places on the tower are, and owners should have

**The vertical elevation patterns supplied by antenna manufacturers bear only a passing resemblance to the vertical elevation pattern of your antenna on your tower.**

ple signals. However, this is an error on the side of safety.)

Some knowledge of the contributors to the field is necessary because these meters do not distinguish the individual frequencies, and the MPE is frequency dependent. These meters must be used by someone who is not only knowledgeable about the behavior of electromagnetic radiation and its component fields but who has a working familiarity with the appropriate safety standard and its underlying theory.

If it is necessary for a regulatory agency, such as the FCC or OSHA, to ascertain whether a station is in compliance or whether an overexposure has taken place, these agencies will rely on measurements taken with radiation hazard meters, not on calculations. As to ensuring safety at your own facilities, unless theoretical calculations show a very large margin of safety (10 dB or so) the prudent course is to measure before exposing workers or the public to the radiation. If there are questions as to the safety of workers making the initial measurements, these measurements may be made at considerably reduced power and the data then extrapolated. Power density is linearly proportional to power radiated.

In most states, it is not the responsibility of tower owners to ensure the safety of

measurements made so that they know.

But FCC licensees have a responsibility to assure that workers and the public are not exposed to RF fields in excess of those spelled out in the relevant standard.

I encourage all tower owners and licensees to make measurements independent of rigging contractors in order to monitor the contractor's compliance with safety regulations and to discharge their federal responsibilities.

However, owners and licensees should not assume the responsibility for the safety of another company's employees and therefore should insist that the contractor make measurements and have a radiation hazard safety plan in effect.

Since a licensee or tower owner usually does not have any contractual relationship with individual employees of the tower contractor, there is no method to enforce safety at that level. The licensee or owner only can enforce safety through his contractual relationship with the contractor.

It is in the industry's best interest to promote safety at all levels: worker, contractor, licensee and tower owner. With a few notable exceptions, tower rigging contractors are unwilling to assume the responsibility for their worker's RF radiation safety. They do not expect radio station owners to inspect their safety belts for wear, or

their extension cords for proper grounding. There is no reason that radio station owners should assume the responsibility of measuring ambient RF fields for them.

Every company offering to do work on radio facilities should have the ability to monitor their worker's safety and should do it. By insisting on this in the contractual arrangement with the contractor, we can push the tower climbing industry into learning about RF radiation safety issues, learning how to measure RF fields to assure safety and purchasing the necessary equipment to monitor worker safety.

□ □ □

Gray Frierson Haertig is a telecommunications engineer and principal of Haertig & Associates in Milwaukie, Ore. He can be reached at 17714A South East Addie St., 97267.

**Question:**  
Ever wonder why transmitter manufacturers operate Altronic dummy loads at NAB and other trade shows?

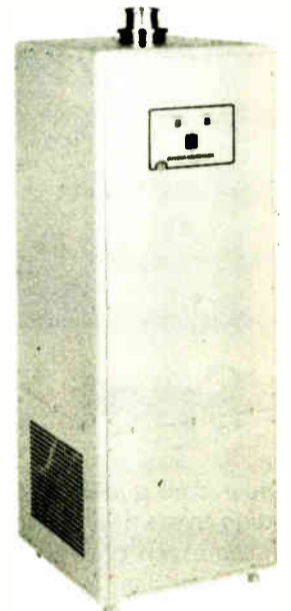

**Answer:**  
The best performance and the most dependable dummy loads built.



**ALTRONIC RESEARCH INC.**

WATER AND AIR COOLED MODELS FROM 1000 WATTS TO 1,500,000 WATTS

P.O. Box 249  
Yellville, AR 72687  
(501) 449-4093

## A NEW FM MOD-MONITOR AT AN INCREDIBLE PRICE!

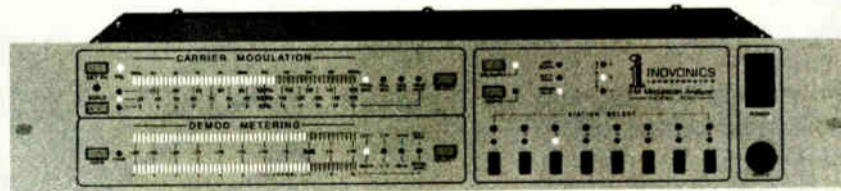

### INTRODUCING THE INOVONICS 530 MODULATION ANALYZER

We've integrated precision demodulation and measurement functions into a laboratory-grade FM tuner to bring you an extraordinary value in accurate off-air modulation analysis. High-resolution metering shows Total Modulation, Pilot and Subcarrier injection levels, demodulated Left, Right, L+R and L-R program audio, as well as 38kHz residual, Signal Level and Multipath distortion readings.

Features include 8 station presets, separate antenna and "direct" inputs, audio monitor outputs, a composite (baseband) in/out, and selectable peak integration characteristics. Easy access is provided for user-defined options, such as remote metering, remote peak flasher, balanced program line outputs, and carrier failure and "dead air" alarms — all at no additional cost!

The best part is the price: only \$2200. Contact your preferred distributor, or write, call or FAX us for full technical particulars.

**Inovonics, Inc.**

1305 FAIR AVE., SANTA CRUZ, CA 95060 U.S.A.  
TEL: (408) 458-0552 — FAX: (408) 458-0554



# Setting Up a Mobile Stereo Studio

Part I of II

by Jack Layton

**PITTSBURGH** How about stereo—from a mobile studio—delivered via a 450 MHz remote pick up system? It's easy, reliable, not too complicated, sounds just great and can easily be set up and operated by non-technical people. This system is in use at KDKA(AM) Pittsburgh.

At the heart of the stereo remote pick up system are two Marti RPT-15 fifteen watt RPU transmitters. There's nothing unique about these transmitters that make them

better or worse for this type of system. Mosley, TFT or other RPU transmitters would work equally well in this application. The frequency separation of the two transmitters—in this particular case—is 4.5 MHz.

## Ideal placements

The transmitters are rack-mounted with a cooling fan directed on their heat sinks to keep temperatures well within tolerance for continuous operation. The high level line input on many RPU transmitters is unbalanced. A stereo/mono switch along with one-to-one audio transformers are

mounted on a 1.75 in panel. The panel is mounted in the rack between the two transmitters.

This is the ideal place as it leaves space for air circulation between the two. In the mono position the switch parallels the transmitter inputs across the mono output of the console. The 1,000-ohm resistors in the input legs of the transformers prevent heavy loading of the console output when the switch is in the mono position.

There is adequate gain in the transmitter audio stages to compensate for the insertion loss of the resistors. If the transmitter line inputs are balanced the transformers can be eliminated and the inputs wired directly to the switch. This feature is useful should one of the transmitters fail.

It also makes it very easy to check out the audio phase of the RF system by putting a common tone through both transmitters and receivers. In the stereo position the right channel is fed to one transmitter and the left channel to the other. Figure 1 details this switching arrangement.

For proper stereo operation the gain in both channels must be the same. To accomplish this the audio compressor DC control voltages in both transmitters must be tied together. This will cause gain reduction, due to compression, to be the same on both the left and right audio channels.

If you use Marti RPT 15 transmitters, remove the wiring to the audio monitoring jack. Connect a 5K resistor from pin 16 on IC1C to the monitor jack on both transmitters. IC1C is located on the audio board.

This board is directly behind the front panel. A jumper cord with mini-plugs connects the two units together. When the jumper is removed the transmitters function normally. Figure 2 details this modification. Relabel the headphone monitor jack AGC.

## The RF option

After looking at duplexer losses and line losses—as you will see in a minute there is 75 feet of coax—it was decided to follow up each of the 15 watt transmitters with a TPC Communications PA6-1BC 50 watt

Figure 1.

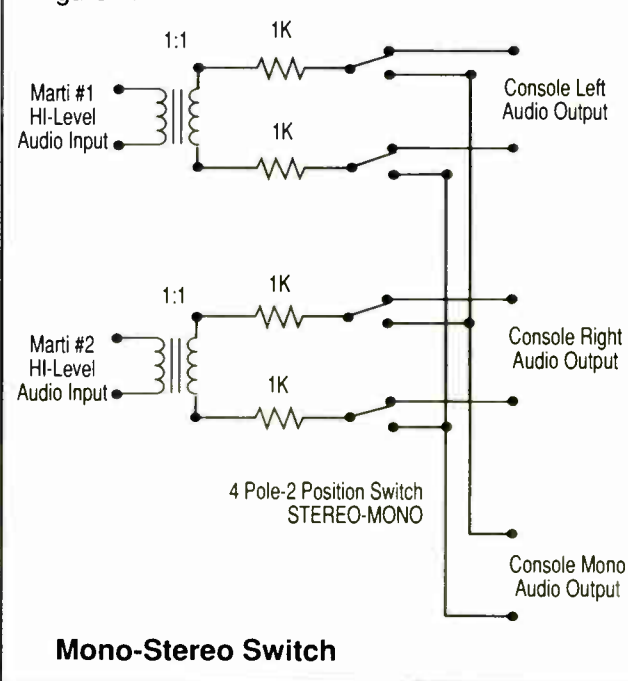

RF amplifier. These amplifiers were ordered with what TPC calls the RF option.

This option consists of a heavy duty heat sink and cooling fan. This equips the amplifier for continuous operation. The fan is controlled by a thermostat. This keeps the fan always running at a slow speed. If the heat sink gets hot enough the fan will come up to full speed.

The amplifiers were also ordered with the antenna switch option. This provides for the transmitter/drivers to be connected

continued on page 60 ►

## Reliability You Can Count On



## Spot After Spot.

A professional quality digital recording system at a price within the reach of every post-production facility, music recording or project studio, and radio or television station—Roland's DM-80.

At first, you'll be excited with the speed and power your new DM-80 delivers. As your needs for more capacity grow, upgrades are easily added at minimal cost. For example, the DM-80 uses standard SCSI disk drives so it can evolve as technology evolves.

The AES/EBU digital outputs deliver a true 24-bit digital signal for excellent noise and distortion specs and superb sound.

Why not get everything professional digital audio workstations have to offer? Create your best part out of 10 recordings and use it in five

different places; record 100 takes in the same place, on the same track; synchronize sound FX to a picture in less than a second; erase a word and bring it back a week later, and do all this on a machine that gives you instant access with incredible editing speeds, the sound quality you want, and the reliability you can count on.

And if you want the ultimate in flexibility and control, add the DM-80 Fader Board to the DM-80 Remote and get a 12 x 2 digital mixer with EQ and full automation.

Count on Harris Allied to continually bring you the latest in audio technology. Call us toll-free.

8:00 a.m. to 8:00 p.m. EST  
1-800-622-0022  
Fax 317-966-0623

**HARRIS  
ALLIED**

© 1993 Harris Corp.

Circle (91) On Reader Service Card

See Us At NAB Radio Show Booth 801

do  
you  
want  
it  
to  
do?

The HPT Series from BEXT is everything you've heard it is: it can be an exciter, a transmitter, a translator and a booster in one high performance, fully featured package. From \$3,695 to \$3,985.

**BEXT**

739 5th Ave. • San Diego, CA 92101  
619-239-8462 • FAX: 619-239-8474

Circle (66) On Reader Service Card



# Full function RDS for only \$1750



When you're ready for RDS, Modulation Sciences is ready for you. You already know us as the world's largest supplier of subcarrier equipment for radio and TV, with more Sidekick® SCA generators in use worldwide than all other brands combined.

Now we've made it easy and affordable for you to enjoy *all* the

benefits of broadcasting an RDS signal. Our RDS generator plugs right into your PC. And our included software gives you access to the entire CENELEC or U.S. RDS or RBDS Standard feature set.

So why buy an RDS coder offering only part of the RDS standard when, for even less money, you can have the whole thing?

*Modulation Sciences is a worldwide supplier of ModMinder® FM modulation monitors, StereoMaxx™ spatial image enlargers, composite audio processors and distribution amplifiers, Sidekick™ subcarrier generators and receivers for FM and TV, Wired STL™ line drivers & receivers, TV stereo generators, SAP and PRO channel generators, and the remarkable new PROceiver™*

*For details on the RDS-1 System or any MSI product, contact your MSI dealer or*

**modulation sciences, inc.**

12 A World's Fair Drive • Somerset, NJ 08873 USA

Toll Free (800) 826-2603 • FAX (908) 302-0206 • Outside USA (908) 302-3090

## COLE'S LAW

# FCC Policy Reforms Help AM and FM

by Harry Cole

**WASHINGTON** There's good FCC policy news for FMers and AMers alike.

The commission has streamlined the process for FM licensees seeking co-channel or adjacent channel upgrades.

AM operators are being offered directional antenna reform. The commission recently asked AM stations for thoughts on how directional array verification rules—some of which have been in place for more than 50 years—could be modified to fit current conditions.

Both of these exercises may actually make some people's lives easier. Unfortunately, they also invoke the traditional image of the barn door being locked after the horse has bolted.

## FM runaround

Let's talk FM first. As you may know, licensees seeking reclassified channels have historically had to jump through two sets of procedural hoops. First, they had to file a petition to amend the FM Table of Allotments to propose the particular channel change they had in mind. If a licensee on Channel 250A, for example, wanted to operate on that same channel, but as a C3 station, that proposal had to wend its way through the rulemaking machinery first.

For the innocents among you who have not suffered through this grind, here's a

quick primer. First, you file a "Petition for Rulemaking." Next, maybe two months or so later, the commission issues a "Notice of Proposed Rulemaking" and asks for public comment.

The comment period lasts 45-60 days, and the petitioner has to comment, even if its comments amount to: "I'm still out here and I really do want what I asked for in the first place."

Then maybe three to six months later—if you're lucky—the commission adopts the proposal, effective some 90 days later. Total elapsed time is generally about a year, sometimes more, even if you're lucky and don't run into opposition.

That's just part one. Once the channel change is adopted, next comes application for a construction permit for the modified channel. That application takes another six to nine months, even for simple, unopposed applications.

From start to finish, assuming all goes well, the process easily takes 18 to 24 months.

## Relief at last

Thanks to the new rules, that process has been shortened in a significant number of cases. The decision, released last month (July 1993), means you may be allowed to skip right to the construction-permit stage.

You qualify if the channel modification you have in mind involves your existing

channel; a first-, second- or third-adjacent channel; or an intermediate-frequency channel; if the modification will not require any other changes in the FM Table of Allotments, and if the application complies with allocation-proposal and modification-applications criteria.

(The commission didn't want to make life too simple.)

Actually, the first two requirements are pretty simple to satisfy. Complying with

The many years worth of changes—including new, more reliable equipment, computerized modeling programs, and increased urbanization in previously suburban or even rural areas—all affect directional performance. A number of consulting engineers have long suggested that many of the old rules could be scrapped or at least streamlined. The commission seems to agree.

The current inquiry asks a wide variety

**These two proceedings do offer some hope for streamlined operations in the future, and it is likely that there will be some, possibly many, who will be aided.**

both allocation and application criteria is a little trickier.

In the allocation/rulemaking process, the FCC does not permit applicants to take advantage of contour protection showings or to claim "substantial compliance" with the city-grade coverage rules. By contrast, in the normal application process, it is routine to consider both alternatives.

The commission has decided that a licensee using the new "one-step" channel-change application will have to show that a suitable site exists consistent with minimum-mileage separations and providing complete city-grade coverage, even if the applicant actually proposes to use some other site which might not meet either criteria.

Apparently the allocation site need only be "suitable." No showing of "availability" is necessary for allocation purposes. A "suitable" site will generally be one that is not offshore, in a national or state park where tower construction is taboo, or at an airport or other site which would necessarily present a hazard to air navigation.

On the upside, "one-step" applications will not be stalled by competing applications. If your "one-step" upgrade proposal is not in conflict with any pending applications on the day it is filed, it is immune from any future conflicting filings.

## Updating DAs

On the AM side, the commission has finally recognized that much has changed since 1939. That's when the commission first adopted its "Standards of Good Engineering Practice" on which many of today's rules relating to verification of AM directional antenna performance are still based.

of very fundamental questions. What types of instrumentation are appropriate for measuring directional operating parameters? How and where should that instrumentation be set up? What variations in the parameters are tolerable? How should field measurements be taken? To what extent should theoretical, as opposed to measured, parameters be acceptable?

All AM licensees, particularly anyone with a directional array, should put their two cents worth in on this one. If you have any thoughts at all about how best to regulate and/or verify directional antenna performance, let the FCC know. As of this writing the deadline for comments is Aug. 20; Sept. 7 for replies.

Both the FM and the AM proceedings are probably long overdue, and for some they may be too late. The main wave of FM channel upgrades may well have already crested. The "one-step" process will be helpful to far fewer than would have been the case, say, three-to-five years ago. Given the relatively weak state of AM these days, new directional antenna rules could easily be too little, too late.

But these two proceedings do offer some hope for streamlined operations in the future, and it is likely that there will be some, possibly many, who will be aided.

If you have any interest in either of these proceedings, you should know that they are both relatively complicated. A call to your communications counsel and consulting engineer would be well-advised before charging in with any action.

□ □ □

Harry Cole is a partner in the Washington-based law firm of Bechtel & Cole, Chartered. He can be reached at 202-833-4190.

**AS-101 Audio Switcher**

- Illuminated and legendable control buttons
- Instant or overlap switching
- Front panel accessible level controls
- Options include: RS-232 interface, remote control, relay-follow-switch outputs
- Network proven quality and reliability

10 Stereo In - 1 Stereo Out

P.O. Box 1342 Bellingham, WA 98227  
1-800-645-1061 FAX (206) 676-4822

**Conex Electro-Systems, Inc.**

## Join the LPB Signature Console Crowd



**Over 1000 licensed U.S. radio stations  
Hundreds of international stations  
Hundreds of college stations**

Discover *why* the LPB Signature may be radio's most popular console:

- an unparalleled record of reliability and longevity
- clearly labelled screw-terminal connections for painless installation
- modular electronics for easy maintenance
- superior RFI immunity

Signature's standard features set new standards of flexibility:

- 3 inputs per channel
- 2 identical output buses
- remote starts
- tape outputs for each bus
- internal monitor, headphone and cue speaker amps
- mono/stereo input switches (on stereo consoles)

Signature options add even more versatility:

- mix-minus plug-in module (mounting kit for mono consoles)
- mono mixdown plug-in module for stereo consoles

Signature is available in a size to fit your station and your budget:

- stereo 6, 8, 10 or 12 channel
- mono 6, 8 or 10 channel

It's easy to join the LPB Signature Console Crowd—just call your broadcast distributor. For full information and specifications, contact LPB.

**LPB®**

28 Bacton Hill Road • Frazer, PA 19355 USA • Tel: 215-644-1123 • Fax: 215-644-8651

Circle (142) On Reader Service Card

Circle (5) On Reader Service Card

# BROADCAST ELECTRONICS



## The **NEW** AudioVAULT 100™ digital audio storage system



**AV-100** is a PC board used in conjunction with IBM-compatible computers to record, store and play back audio material such as commercials, tags, liners and jingles, or satellite programs. Each PC can accommodate up to four AV-100 boards, each capable of running independently. The AudioVAULT 100 digital audio storage system brings incredible capabilities to your station...at an incredible price.

Operating in Microsoft Windows — with a software platform adapted from the popular AudioVAULT 90™, which has been field-proven over the past two years in all size markets — AV-100 is a system that gives you easy command over your audio inventory, improved signal quality, lower maintenance costs and higher profits.

### Consider these features:

▲  
Select one of five sampling rates.

▲  
Import/export capability for traffic and billing functions.

▲  
Compression ratios from 1:1 (uncompressed) to 12:1, applied by cut.

▲  
Stand-alone operation of satellite-delivered material with cross fade, ducking and real-time delay.

**Introductory price starting at \$2,995!**

**Call Broadcast Electronics for the full story on the incredible AV-100.**

Ask for Dave Buck or Ted Lantz.

**DON'T SETTLE FOR LESS!**



**BROADCAST  
ELECTRONICS INC.**

4100 N. 24th St. P.O. Box 3606 Quincy, IL 62305-3606

# Stereo Remote Start-Up

▶ continued from page 56

directly through to the antenna when the power switch on the amplifier is turned off.

The amplifiers draw about 7 amperes. Each is powered by an Astron RS-12-M power supply. These power supplies easily and coolly deliver the continuous 90 watts or so of DC power for each of the amplifiers.

The only fly in the ointment is that the protective circuitry in the RS-12—and other RS series supplies—does not let them come up under load. If there is an

power to the amplifier after the 13 volts appears on the power terminals. Details are shown in Figure 3.

## Combine RF outputs

A Celwave PD633-6A duplexer combines the RF outputs of the two transmitters. With a frequency split of 4.5 MHz between transmitters, the insertion loss is about 1.5 dB. Isolation between transmitters is between 75 and 80 dB.

The PD633-6A is small in physical size

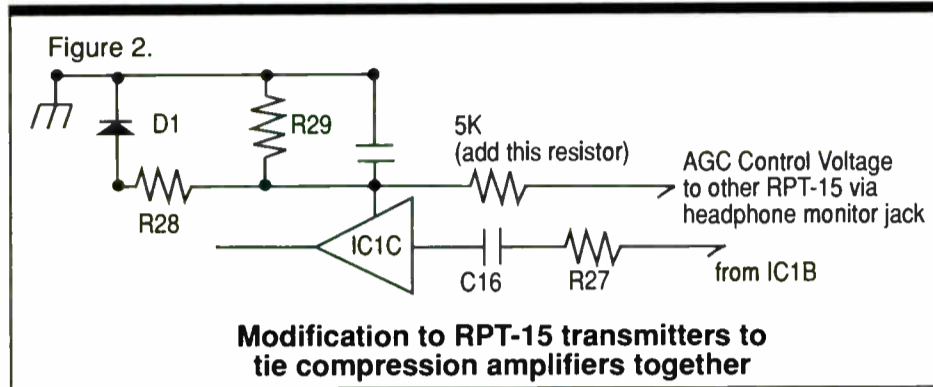

AC power failure during operation, with the supply and the amplifier turned on, the RS-12 will not come back up on line until the amplifier and supply are both turned off and restarted—power supply first then amplifier.

To get around this, and further foolproof the system, a mini step-start circuit has been incorporated in the RF amplifiers. It delays slightly the application of DC

(6 inches wide by 9 1/2 inches deep by 2 inches high) and relatively inexpensive—in the \$250 range. The duplexer specifications say it will handle 50 watts. Celwave says this means 50 watts per port when used to combine transmitters. The system has operated for hours and hours with 50 watts at each input port with no sign of heat or other problems.

The output of the duplexer feeds about

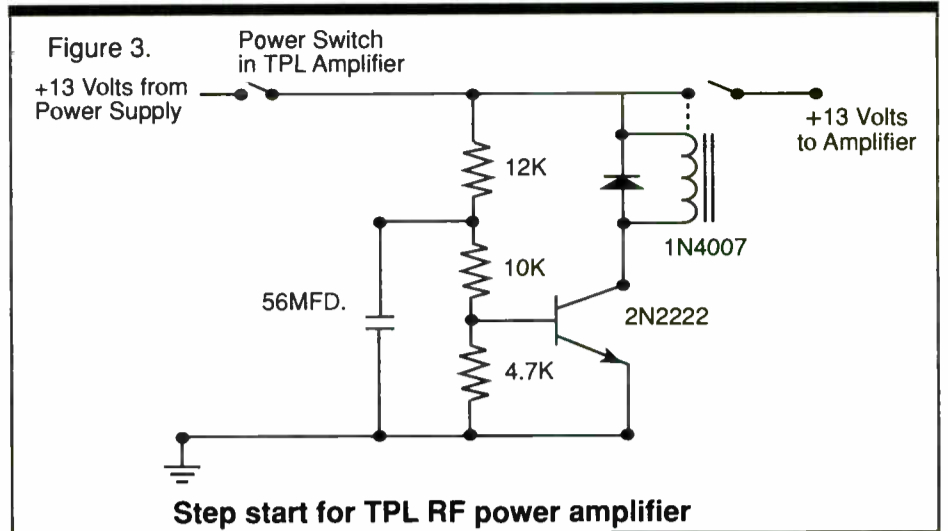

75 feet of foam dielectric RG8 coax. The cable is inside a spiral wound plastic conduit that allows extension and contraction of the thirty foot pneumatic mast on the vehicle.

The transmitting antenna for the stereo RPU system consists of two Antenna Specialists ASP760 vertically polarized side by side mounted seven-element yagis. The separation between antennas is 28 inches. An ASPA320 clamp holds the 28-inch piece of 2-inch pipe on which the individual antennas are mounted. Antenna specialists spec the gain of these seven-element yagis at 10 dB. The pair should provide 13 dB gain.

The feedline goes to an Antenna Specialists K526 two port power divider which is k526 locked to the boom on which the yagis are mounted. The pigtail coax cables from each antenna connect to

the output ports of the K526.

Originally, a ferrite isolator and harmonic trap were placed in the RF output of each transmitter. The system was carefully inspected on a spectrum analyzer and was clean of any intermod products. The isolators and harmonic traps were removed. Another check with the spectrum analyzer was made. The system was still clean of any spurs. The isolators and traps were put back on the shelf to be ready for another project.

□ □ □

Jack Layton is the former chief engineer of KDKA(AM) Pittsburgh. He is now the owner of Layton Technical Services, a firm that specializes in the planning and construction of radio studio and transmitter facilities, special projects and directional antenna field work. This stereo RPU system is in service at KDKA. Layton can be reached at 412-942-4054.

## THE RF EXPERTS KNOW—MYAT DELIVERS

### MYAT DELIVERS QUALITY

You can rely on MYAT rigid line and components to deliver a clean, powerful signal to your antenna. Pure highest quality copper, brass and silver plus computer-aided design and manufacturing ensure consistency and accuracy. No wonder demanding broadcasters worldwide choose MYAT products for their passive systems. We take Quality Control very seriously.

### MYAT DELIVERS RELIABLE PERFORMANCE

Our non-galling silver-plated beryllium copper contact springs, brass elbow reinforcements and virgin Teflon inner supports are designed for maximum velocity, minimum attenuation and long service life. Every MYAT component is tested before shipping and backed with a full one year warranty. MYAT products are built for the long run.

### MYAT DELIVERS WHEN YOU NEED IT

Major transmitter manufacturers with strict production schedules rely on MYAT to deliver quality components on time and within budget. So do leading broadcasters like the Empire State Building's newest TV tenants. At MYAT, commitments are kept.

### LET MYAT DELIVER FOR YOU

Whether you're planning a new tower, upgrading an older installation, or coping with an emergency, you can depend on MYAT rigid line and components. Thousands of RF experts around the world already do. Contact your RF distributor, or phone us for our catalog, installation planning guide and engineering reference. Its detailed drawings can help you put together an efficient, trouble-free transmission line that will last for decades. For a free copy call 201-767-5380 or fax 201-767-4147.



Manufacturers of electronic transmission equipment since 1951.

### RIGID LINE: RADIO'S EFFICIENT CHOICE

40 YEARS OF EXPERIENCE. 40 YEARS OF EXCELLENCE.  
380 Chestnut Street • P.O. Box 425 • Norwood, NJ 07648  
Tel 201-767-5380 • Fax 201-767-4147

STATION SKETCHES

# Efficient Transmitters Can Beat the Heat

by Tom Vernon

**HARRISBURG, Pa.** Besides lightning damage, the most common summertime problem for many AM stations is transmitter overheating, arching and short-lived power tubes.

Inadequate air conditioning explains some of the problem, but poor transmitter efficiency is also often accountable. There are methods to calculate efficiency and troubleshoot problems. AM transmitters are discussed here, but the basic principles apply to FM as well.

### Doing the math

Transmitter efficiency is expressed as a percentage and, in this case, represents the ratio of RF power to DC power input of the power amplifier (PA). This should not be confused with "overall efficiency," which is the ratio of RF power out to AC power in.

To determine PA efficiency, first multiply plate voltage times plate current. Assume a 5 kilowatt transmitter with a plate voltage of 5,000 volts and a plate current of 1.25 amps. That comes to 6,250 watts, which is the power input to the final amplifier.

Now assume the operating power is exactly 5,000 watts. To calculate efficiency, simply divide 5,000 by 6,200, to arrive at 0.8 or 80 percent. The remaining 1,200 watts are dissipated as heat, mostly in the power tubes, but also in the tank and coupling circuits.

You must measure only the plate voltage across the PA tubes when calculating true efficiency. The cathode resistor and modulation reactor in many transmitters are in the metered circuit as well.

Using the example above, assume the resistor and reactor both have a resistance of 50 ohms, for a total of 100 ohms. With a plate current of 1.25 amps, the voltage drop is 125 volts. If the plate voltage meter reads 5,125 volts, the 125-volt drop would be subtracted, giving a voltage of 5,000.

Having calculated efficiency, you need to know what is normal for your transmitter. This information should be in the instruction manual or test sheet. If these are missing, Table 1 gives some rough estimates.

These figures are for high-level plate modulated equipment only. Transmitters with other modulating schemes may have vastly different numbers.

Efficiency factors above 85 percent should be viewed with suspicion. Such readings are usually falsely optimistic due to inaccurate meters or inaccurate antenna resistance figures. After the measurement problem is found and corrected, calculate efficiency again and look for realistic numbers.

### Low-efficiency cases

Problems with low-efficiency usually fall in three categories: metering problems; problems within the transmitter, and problems in the antenna/transmission line system.

Isolate the problem by first connecting the transmitter to a good dummy load. Calculate efficiency again. If you come up with reasonable figures now, the problem is the transmission system. If the

Figure 1. Power (watts)	Efficiency (percent)
250	65-75
500	65-75
1,000	68-77
5,000	72-82
10,000	72-82

Table 1: Typical efficiency ranges for high-level plate modulated transmitters. Variations may be due to design differences, slight meter error, and overall fine tuning accuracy.

problem persists, it's in the transmitter. Before taking these measurements, be

sure the dummy load has a value of 50 ohms resistive, and is capable of handling full power at 100 percent modulation. This criteria blocks out strings of incandescent light bulbs and/or wire-wound resistors found in some stations. These are okay for insuring the transmitter isn't run into an open circuit while switching, but they have no value for

testing. They are not purely resistive at RF frequencies.

Begin tracking down transmitter problems by checking the meters. Meters are prone to failure, like all electromechanical devices, a fact many engineers overlook. The plate voltage meter is easily checked with an HV probe and DVM. Inaccuracies may be caused either by the meter itself or the dropping resistors. All resistors should be within one percent of their rated value.

Another method is to measure across continued on page 63 ▶

**In a typical broadcast day, DigiCart/II prepared and played more audio than its predecessors did in a week.**

DigiCart/II goes far beyond cart machines and reel-to-reel decks—and even most digital machines. It's a uniquely powerful digital audio recorder, with software tools that bring color and interest to your work. ■ In production, use DigiCart/II to make mistake-proof edits, precise fades, and seamless back-to-back cuts. ■ On-the-air, get instant access to music and effects loops, voice-overs, delayed news feeds, and QuickStack™ playlists. ■ DigiCart/II supports an eight hour hard drive, and three new high capacity cartridges—ideal for playing current inventory and moving audio between machines. ■ DigiCart/II is attractively priced and available now.

**30 Systems**  
PROFESSIONAL DIGITAL AUDIO

18740 ORNARD STREET, TARZANA, CA 91356 PHONE 818 342 3127 FAX 818 342 4372

# It's no surprise to 4,000 engineers around the world.



## Introducing the LPB 7000 Series of stereo slide-fader consoles.

LPB has created a professional, high-quality, low-cost broadcast console. Again.

With quality features like Penny & Giles linear faders, gold contacts throughout, **all** front panel push button switches rated for **5 million** operations, and modular plug-in electronics.

**Standard 7000 Series performance features include:** 3 stereo output busses • 3 mono outputs for optional mono-mixdown or mix-minus • 3 stereo tape outputs and 3 mono tape outputs • 2 inputs per channel • remote starts for all inputs with blinking ready light • remote control of channel start and stop • timer start and stop with channel • 5 muting busses programmable for each input.

Our new 7000 Series continues our tradition of easy-to-use, durable consoles. A tradition which has placed **over 4,000** LPB consoles into service worldwide. And a tradition you can count on tomorrow.

So don't be surprised. Choose LPB.

Model 7012 12-Channel Stereo: \$6,995.00

Model 7018 18-Channel Stereo: \$9,295.00

Available from the best audio product dealers. For further information, contact LPB.

# LPB<sup>®</sup>

28 Bacton Hill Road, Frazer, PA 19355, USA. Phone 215-644-1123, Fax 215-644-8651

Circle (205) On Reader Service Card  
World Radio History

# Efficiency Is Transmitter's Rescue

► continued from page 61

the plate current metering resistor, using Ohm's law. This is a useful scheme when the meter terminals are difficult to reach.

RF line current meters can be checked by inserting a good meter in series with the unit under test. If your antenna tuning unit is in the same building as the transmitter, the meter jack on the input is a convenient place to do this.

If the meters check out correctly, your efficiency problem is serious. The next step is to check the RF grid drive. Sufficient drive is necessary for both efficiency and low distortion. If the PA grid current is low, then the PA has to work harder to make rated power and runs hotter.

First replace the driver. If the new tube yields poor results, there may be a problem with the driver coupling network. Be suspicious of 20-year-old mica capacitors in LC networks. Transmitters that

adjustment and robbing you of efficiency. They can be checked by running at full power with 100-percent modulation for about 20 minutes. Shut down, discharge all HV points with a shorting stick and feel for hot spots.

Alternately, you may use a grid dip meter to determine whether circuits are properly tuned to your operating frequency. Finally, check the neutralization adjustments. Improper neutralization will show up through poor efficiency and frequent arching. Follow the procedure in the transmitter instruction manual and recheck these adjustments. A grid dip meter will be useful here too.

## Antenna system tests

Testing with the dummy load may suggest the problem is outside the transmitter. An investigation of the ATU antenna, transmission line and ground system is needed. An antenna coupler that does not match the transmitter to the line will

waste power and degrade efficiency. Again, feeling for overheated components after shutdown will help locate the trouble. You may have to call in a consultant with an RF bridge if the system is damaged or badly out of adjustment.

A ground system in poor condition will be unstable and give erratic antenna resistance measurements. This makes calculating power output (and thus efficiency) difficult at best. One indication of

this problem is when a station puts out a good signal when it rains, then tapers off as the ground dries. Careful excavation should determine the condition of the ground screen and radials. If they are badly corroded or missing, it may be time to bite the bullet and install a new ground system.

The antenna coupler is located some distance from the transmitter, so you'll

need to determine whether the transmission line or coupler is at fault. Take the dummy load and install it in place of the coupler and recheck efficiency. Good figures now mean the ATU is suspect, while continued poor efficiency suggests a damaged transmission line and standing wave problems.

You should be able to switch the transmitter from the antenna system to the dummy load and see little or no difference in readings. Shifts in plate current readings, power output or the need to retune for a dip in plate current are all signs that the antenna system is presenting something other than a 50-ohm

resistive load to the transmitter.

Proper safety precautions should always be observed when working around high voltage and RF. All high-voltage points should be tapped down with a shorting stick before working inside the transmitter, and AC power should be disconnected at the breaker panel. Try to have an assistant on hand who knows CPR or can at least dial 911.

Efficiency is a good indicator of overall transmitter health. With patience and a methodical approach, most problems can be found and corrected.

□ □ □

Tom Vernon divides his time between technical consulting and completion of a P.H.D. He can be reached at 717-367-5595.

Figure 2. Measure Transmitter Efficiency

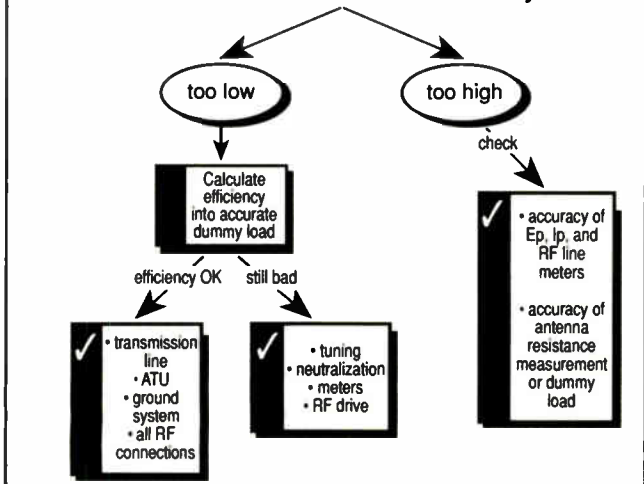

have had a frequency change in the field may not have had the driver circuit retuned properly.

While underdriving the PA is detrimental, so is overdriving. Excessive drive shortens the life of the driver, generates excessive heat and impairs the positive peak capability of the transmitter.

The tank components in the PA and output network may also be out of

## SUBSCRIPTION/READER SERVICE FORM

**Radio World**  
FREE Subscription/Renewal Card

I would like to receive or continue receiving Radio World FREE each month.  Yes  No

Signature \_\_\_\_\_ Date \_\_\_\_\_

Please print and include all information:

Name \_\_\_\_\_ Title \_\_\_\_\_

Company/Station \_\_\_\_\_

Address \_\_\_\_\_

City \_\_\_\_\_ State \_\_\_\_\_ ZIP \_\_\_\_\_

Business Telephone ( ) \_\_\_\_\_

Please circle only one entry for each category:

### I. Type of Firm

- D. Combination AM/FM station
- F. Recording Studio
- A. Commercial AM station
- G. TV station/teleprod facility
- B. Commercial FM station
- H. Consultant/ind engineer
- C. Educational FM station
- I. Mfg, distributor or dealer
- E. Network/group owner
- J. Other \_\_\_\_\_

### II. Job Function

- A. Ownership
- G. Sales manager
- B. General management
- E. News operations
- C. Engineering
- F. Other (specify) \_\_\_\_\_
- D. Programming/production

## Reader Service

August 25, 1993 Issue Use Until November 25, 1993  
Please first fill out contact information at left. Then check each advertisement for corresponding number and circle below.

### Purchasing Authority

1. Recommend 2. Specify 3. Approve

001	023	045	067	089	111	133	155	177	199
002	024	046	068	090	112	134	156	178	200
003	025	047	069	091	113	135	157	179	201
004	026	048	070	092	114	136	158	180	202
005	027	049	071	093	115	137	159	181	203
006	028	050	072	094	116	138	160	182	204
007	029	051	073	095	117	139	161	183	205
008	030	052	074	096	118	140	162	184	206
009	031	053	075	097	119	141	163	185	207
010	032	054	076	098	120	142	164	186	208
011	033	055	077	099	121	143	165	187	209
012	034	056	078	100	122	144	166	188	210
013	035	057	079	101	123	145	167	189	211
014	036	058	080	102	124	146	168	190	212
015	037	059	081	103	125	147	169	191	213
016	038	060	082	104	126	148	170	192	214
017	039	061	083	105	127	149	171	193	215
018	040	062	084	106	128	150	172	194	216
019	041	063	085	107	129	151	173	195	217
020	042	064	086	108	130	152	174	196	218
021	043	065	087	109	131	153	175	197	219
022	044	066	088	110	132	154	176	198	220

Copy & Mail to: Radio World, PO Box 1214, Falls Church, VA 22041, or FAX to: 703-998-2966

## CAT-LINK Digital STL :

# TOP 25 MARKET SWEEP

*It's no wonder 50 stations in the Top 25 markets are sold on*

*QEI's CAT-LINK, the DIGITAL STL problem solver:*

- Uses T1 data circuits or 23 GHz radio
- The only digital FM composite link\*
- **NO COMPRESSION and NO DELAY**
- Full bi-directional capability
- Multiple discrete channel capability
- Ideal for LMAs

*And that's why more savvy stations in the Top 25 and markets of every size are turning to CAT-LINK. Call QEI toll-free at 800-334-9154 and be swept away.*



\*U. S. Patent # 5,054,070

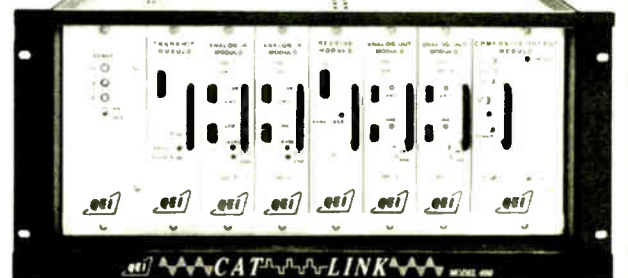

QEI Corporation  
One Airport Drive P.O. Box 805 Williamstown, N.J. 08094 USA  
800 334-9154 FAX: 609 629-1751 INTERNATIONAL: 609 728-2020

Circle (141) On Reader Service Card

# Products & Services Showcase

For more information on the products shown below, circle the appropriate Reader Service No.(s) on the enclosed Subscription/Reader Service card or contact the advertiser directly.

## ELIMINATE PODIUM CLUTTER.

**PB2X8** Pressbox/Microphone Distribution System

**MICROAMP SERIES**



Eliminate the usual press-conference microphone clutter with just a single or a back-up pair of microphones.

Feed each of eight transformer isolated channels from either input or both Mic/Line inputs mixed.

Drive a high level XLR and a medium or low level TRS line simultaneously from each output.

Use as a 2X8 DA, stereo 1X4 DA or two input mixer.

Studio grade performance, field proven ruggedness.

- Rack or desk mount
- Two low noise Mic/Line inputs
- Phantom power, low cut filter
- Loop thru expansion inputs
- Calibrated test oscillator
- Switchable bargraph VU meter
- XLR, 1/4" and 3.5mm TRS jacks
- Headphone output

See us at NAB Radio Show Booth 809

CALL OR WRITE FOR A FREE DETAILED BROCHURE.

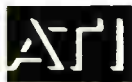

**AUDIO TECHNOLOGIES INCORPORATED**  
328 W. Maple Ave., Horsham, PA 19044, USA  
(215) 443-0330 (800) 959-0307  
FAX: (215) 443-0394

READER SERVICE NO. 29

Central to:

- Customer Needs
- Engineering
- Quality
- Fabrication
- Installation
- Specialized Services



Central to All  
Your Tower Needs

2855 Hwy. 261 • Newburgh, IN 47630-8642  
800-264-0595 • FAX 812-853-6652

READER SERVICE NO. 51

## AUTO-ANSWER TELEPHONE COUPLER

Ideal for unattended situations such as listen lines, IFB feeds, dial-up networks, remote transmitter sites & satellite links.

- Clean connection to phone line
- Easy to install
- Send or receive program
- F.C.C. registered



See us at NAB Radio Show Booth 247

**COMREX**®

Comrex Corp., 65 Nonset Path, Acton MA 01720  
Tel: 1-800-237-1776 Fax: 508 635-0401

READER SERVICE NO. 194

## Obstruction Lighting That's Not Sky High

### ElectroFlash™ Aviation Lighting Systems

- Medium and High Intensity Obstruction Strobe Lighting
- ETL Certified, FAA, Transport Canada and ICAO Approved
- Compatible with Dual Installations—Auto Restart
- Available with AC, DC or AC/DC Combination Input Voltage
- Installation and Service Maintenance Available
- Equipment Warranted for 24 Months—Includes Flash Tube

P.O. Box 329  
Nashua, NH 03060  
Tel: (603) 883-6500  
Fax: (603) 883-0205



READER SERVICE NO. 72

## The CircuitWerkes AC-2 Autocoupler



More Features. Better Price.

- Auto-connect and disconnect.
- FCC Pt.68 registered.
- Two-Year limited warranty.
- LED Indicators for audio clipping, incoming rings and line status.
- Answers on user selectable number of rings.
- Momentary or latching dry contacts at pickup.
- Momentary open collector output at pickup.
- Defeatable pickup inhibit function for cart decks, etc..
- Can be combined with CircuitWerkes DTMF decoder board to form a dial-up DTMF remote control.
- Optional ComboLok provides for secured access.

**CircuitWerkes**

6212 SW 16th Place  
Gainesville, Florida 32607  
(904) 331-5999  
fax (904) 331-6999

READER SERVICE NO. 39

## ANALOG METERING WENT OUT WITH SLIDE RULE HOLSTERS.



TEL 171 for the Moseley TRC-15A \$880

If you've decided to go digital this year, why not do it now? You'll not only save money, you'll prevent all the hassles brought on by misreading your existing analog remote controls.

Hallikainen and Friends' TEL Digital Telmetry with programmable decimal points will provide you with the add-on accuracy you're looking for. It's simple to install, monitor and calibrate. And, it's available now.

**Hallikainen & Friends**

141 SUBURBAN ROAD SAN LUIS OBISPO  
CALIFORNIA 93401 805/541-0200

READER SERVICE NO. 19

## "ITC" The Only Affordable Spectrum Analyzer

THREE FULL FUNCTION ANALYZERS TO CHOOSE FROM 600 MHz - 1000 MHz - 1800 MHz

**80 dB ON SCREEN DYNAMIC RANGE.** With ITC's Exclusive EFPLA Log Amp. (pat.pend.)  
**-110 dBm SENSITIVITY AT ALL SPAN WIDTHS.** ITC Analyzers have -110 dBm .7uv. sensitivity at all Resolution Band & Span widths.

**HIGH STABILITY** (<1KHz per Hr. after warm up)

**FEATURES** Baseline Clipper, Video Filter, 5" CRT, Preset plus variable Dispersion settings from 0 - 50 Mhz per/div, 100:1 tuning ratio for easy Center Frequency selection, & More.

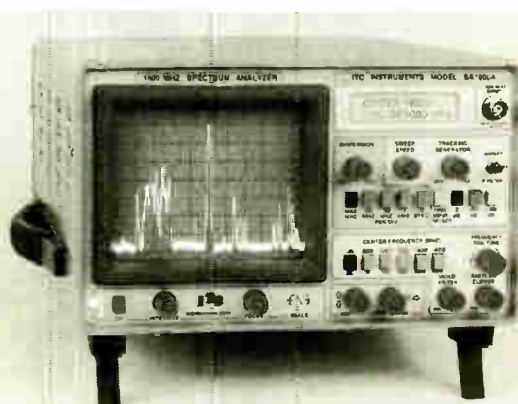

PRICES START AT  
**\$1295.00**  
MODEL SA600

- A MUST FOR:**
- AM-FM-SW-TV Stations-CATV
  - CHECKING SUB-CARRIES
  - SATELLITE FEEDS
  - UP LINKS, DOWN LINKS
  - AUDIO-VIDEO-SIGNAL LEVELS
  - HEAD-IN SYS. & MODULATORS
  - CHECK FCC REQUIREMENTS

### ITC INSTRUMENTS

9222 Chesapeake Dr. Suite A  
San Diego Ca. 92123 USA

**MADE IN THE USA**

TERMS: M/C, VISA, AE, CHECK,  
MO, COD, P.O. (OAC)

SA600A 600 MHz \$1295.00 Opt.1 50 MHz marker \$200.00  
SA1000A 1000 MHz \$1595.00 Opt.3 +/- 5 KHz Filter \$350.00  
SA1800A 1800 MHz \$1895.00 Opt.5 Tracking Gen. \$250.00  
Opt.6 Center Frequency Display \$275.00

**FOR MORE INFORMATION & INTRODUCTORY OFFER  
CALL 1-800-232-3501 619-277-4619 FAX-277-6736**

ITC Analyzers are the perfect low cost choice for All AM, FM Broadcast-VHF, UHF TV maintenance depts., and FCC compliance testing. You will save time & money with a ITC low cost Spectrum Analyzer.

READER SERVICE NO. 160

## ALAN DICK & CO. (USA) INC. LDL COMMUNICATIONS INC.

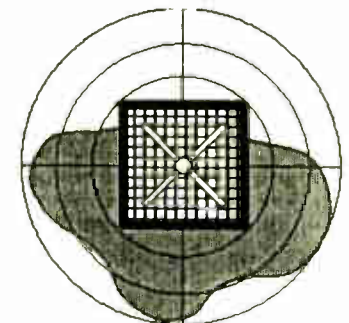

For your full turn-key or individual components needs... ADC/LDL supplies a full range of product and services for the FM broadcaster. RF transmission products include low power, side-mount antennas as well as high power, broadband, multi-channel antennas and combiners.

**LDL COMMUNICATIONS INC.**

14440 CHERRY LANE CT, #201  
LAUREL, MD 20707

301-498-2200

FAX: 301-498-7952

**ADC (USA) INC.**

9 CLINTON DRIVE, HOLLIS, NH 03049

603-598-4500

FAX: 603-598-4212

READER SERVICE NO. 186



# WORKBENCH

## Making the Large-Diameter Cable Link

by John Bisset

**FALLS CHURCH, Va.** A few issues back, I discussed a method of feeding large diameter cables through the rubber boot of Switchcraft connectors. That suggestion spurred some good replies.

Jim Cowan of Neutrik USA suggests using "X" series connectors, which accommodate larger-diameter cable than any XLR connector manufactured. They also feature excellent strain relief and no set screws to lose.

Neutrik USA also offers an XLR switch

has been ergonomically designed with a circular on/off switch to insure that the switch isn't accidentally turned off. It's not uncommon for the talent to bump the slide switch while holding the mic. Neutrik's switch requires a definite circular motion to turn the mic off.

For further information on the Neutrik connector, circle Reader Service 164.

★ ★ ★

Chriss Scherer of WRMR(AM)-WDOC (FM) Cleveland, has some Otari CTM-10 cart machines. There's a switch located under the deck plate, Chriss says, that is supposed to sense whether the pinch roller is engaged. This switch often fails making the machine believe the pinch roller is down when it is really still engaged.

The microswitch itself is not the problem. The arm attached to it has a form-curved end that is actuated by a cam arm on the pinch roller assembly. This curved end endures a lot of stress and eventually breaks off.

The bad news is that replacement switches are not available through Otari. The good news is that the broken switches can be reused.

The actuating arm can be attached in two different positions. When the new machine arrives from the factory, the arm is inserted into the end position. It can be moved to a second position on the switch after the curved section breaks. The pinch roller cam will still actuate the switch, even

though the curved piece is gone (See Figure 1).

Chriss Scherer can be reached in

Figure 2.

A view of the graphics screen for STLMAP, software that helps determine vacant STL frequencies in congested cities.

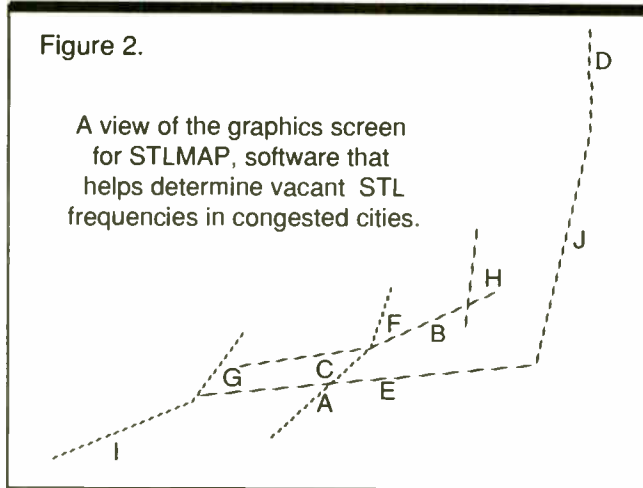

Cleveland at 216-696-0123.

★ ★ ★

Tim Walker, who does contract work in North Carolina, recently completed a computer program for AM chiefs that accurately calculates the distance to an AM field contour or determines the field strength at a specified distance, even when conductivity is not uniform.

The operator enters the non-standard dielectric constant values, the frequency, the reference unattenuated field strength at one kilometer and from one to eight conductivities along the path. He may then specify the desired field strength and the program will calculate the distance to that contour. The operator can also specify the distance in either miles or kilometers and the program will calculate the field strength at that distance based on the conductivity profile specified. The program uses the FCC's equivalent distance calculation method.

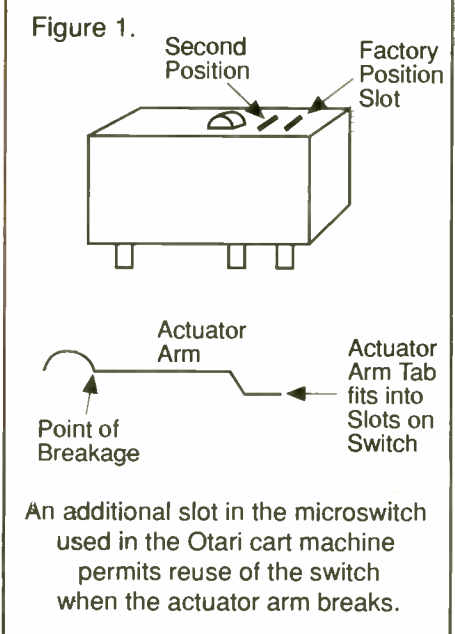

connector, similar to the Switchcraft T3F mentioned in an earlier column. Unlike the T3F, Neutrik's on/off switch connector mutes the signal. This prevents that annoying "pop" when public address mics are switched on and off.

The connector is shorter than the T3F and

## THE SIMPLE SOLUTION FOR DIGITAL AUDIO TRANSPORTATION



- ▲ MUSICAM ISO/MPEG Layer 2, 2A
- ▲ Switched 56, 64 kbit/s, ISDN, Fractional T-1
- ▲ User data channel from 300-9600 baud
- ▲ Easiest set-up locks to network or internal clock
- ▲ Fully automatic decoder reduces operator set up
- ▲ Multiplex or redundant two times 56/64 for 112/128 kbit/s
- ▲ Mono, Dual Mono, Stereo, Joint Stereo operation
- ▲ AES/EBU and SPDIF digital interface *included*
- ▲ Two-times V.35, X.21 or RS 422 interface *included*
- ▲ Headphone monitor *included*

The RE 660/661 MUSICAM Digital Audio Codec was developed to enhance MUSICAM technology, providing up to 20 kHz of audio bandwidth. From satellite networks to switched 56 telephone lines, the full-featured RE 660/661 is completely bit rate flexible up to 384 kbit/s.

Applications range from network program distribution to remote pick-ups for sports, concerts, special events, news gathering, STL back-up, audio backhaul, recording and post production studios.

When it comes to digital audio transportation, nothing comes close to the RE 660/661 for providing quality audio with hassle free set up. Backed by 55 years of experience in analog and digital audio products, the RE 660/661 is the simple MUSICAM solution for all your digital audio transmission needs.

Available through Harris Allied and Broadcasters General Store



**RE AMERICA, INC.**  
31029 Center Ridge Rd. ▲ Westlake, Ohio 44145  
Phone: (216) 871-7617 ▲ Fax: (216) 871-4303

Available through Harris Allied and Broadcasters General Store

Tim has developed other software for broadcast engineers. STLMAP helps you pick a frequency in the 950 band by plotting existing paths on topo maps (See Figure 2). The program takes the public-domain menu style STL calculation program a step further by permitting on-screen parameter changes along with instant display of new data based on those changes.

CONTOUR was developed after Scott Miller, chief engineer for WXTB(FM) continued on page 70 ►



### LMA/DUOPOLY CONTOUR MAPS

The **DATAWORLD** LMA/DUOPOLY Market Survey Contour maps present a precise electronic verification of overlapping and intersecting contours.

AM 5 mV/m and FM 3.16 mV/m City Grade contours are shown in full color, including transmitter site indicator. The map is supported with a printout showing all of the stations which appear on the map. Daily updating of **DATAWORLD'S** AM and FM databases protects against errors and omissions.

**OTHER MAP OPTIONS**

- SHADOWING (TERRAIN SHIELDING)
- CONTOUR COVERAGE
- POPULATION DENSITY
- ZIP CODE BOUNDARIES
- RECEIVED SIGNAL LEVEL
- SPECIAL REQUIREMENTS

**1990 CENSUS WHO ARE YOUR LISTENERS?**

**1990 BUREAU OF CENSUS POPULATION COUNTING**

- Comprehensive Ethnic and Demographic Data
- Ethnic/Demographic Data Available for Each Zip Code Within Coverage Area
- Age Analysis Reflected in Ethnic Breakout
- Resolution Increased to Block Level
- Percent of County Coverage Shown

**ETHNIC PIE-CHART DISPLAY**

- Projects Ethnic Population in Multi-Color Pie Chart Form



800-368-5754 FAX: 301-656-5341

# Eliminating Microphone System Hum

Part IV of VI

by Bruce Bartlett  
with Jenny Bartlett

**ELKHART, Ind.** In this series, we've been looking at ways to prevent hum in an audio production system. Mics are especially sensitive to hum pickup, since they require a lot of gain. Here are some tips you can use to minimize hum picked up by your mics:

- Use low-impedance balanced microphones (150-600 ohms), which pick up less hum than high-impedance, unbal-

anced microphones.

- Use a balanced cable from the mic to the input. If you have unbalanced microphone inputs on your recorder or mixer, solder the shield and pin-3 lead to the phone-plug sleeve or ground terminal; solder the pin-2 lead to the phone-plug hot or tip terminal.

- If the mic cable still picks up hum, unbalance the cable through a transformer that is plugged directly into the input.

- If hum pickup is severe with dynamic microphones, use dynamic microphones with humbucking coils built in. An example is the Shure Beta 58.

- To reduce pickup of magnetically induced hum, use a mic cable in which the conductor pair is twisted together. To

**Mics are especially sensitive to hum pickup since they require a lot of gain. RFI is heard as clicks, radio programs, buzzes, or "hash" in the audio signal.**

block electrostatic hum, the cable needs a shield. "Braided shields" generally offer the best shielding; "double-spiral

wrapped" is next best, and "spiral-wrapped" is worst.

- Routinely check the microphone cables to make sure the shield is connected at both ends.

- Check that the mic-connector set screw is securely screwed clockwise into the mic handle. This set screw is in the han-

dle near the connector.

- For outdoor work, tape over cracks between connectors to keep out dust and rain.

## Reducing RFI

RFI can be controlled by many of the techniques that prevent hum. RFI is heard as clicks, radio programs, buzzes, or "hash" in the audio signal. It's caused by CB transmitters, computers, lightning, radar, radio and TV transmitters, industrial machines, auto ignitions, stage lighting, and other sources.

To reduce RFI:

- Use wide copper straps or braids, rather than wires, for ground connections. This reduces the high ground resistance caused

## AN EXCLUSIVE EVENT.



**GOLDEN  
SERIES**

**Precious  
TOOLS**

AEV ELECTRONIC BROADCAST EQUIPMENT

There are moments in the course of a manufacturing Company's life that become historical milestones, not only for the Company itself, but for the whole industry. EXCLUSIVE FM, AEV's newest FM broadcasting processor, represents one of such milestones. It's an event. A truly extraordinary event, setting a faster pace in the evolution of FM broadcasting. To emphasize only some of EXCLUSIVE FM's features would be like diminishing it. AEV is pleased to invite Radio and TV Broadcasters the world over to contact its Dealers for detailed information, as well as to verify, in the course of a hands-on demonstration, the meaning of the word "extraordinary".

Phone 39 + 51 + 950249 / 950350 Fax 950201

Figure 1.

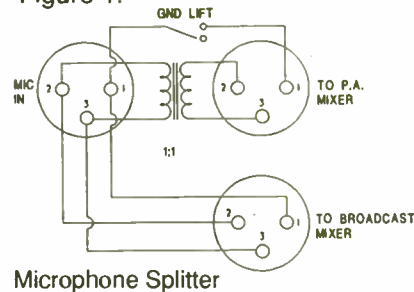

by skin effect, the tendency of RF signals to travel on the outside of a conductor.

- Install high-quality RFI filters in the AC power outlets.

- Physically separate the lighting power wiring from the audio cables.

- Avoid SCR dimmers; instead, use multi-watt incandescent bulbs to vary the studio lighting levels.

- Use enclosed equipment racks.

- Avoid long ground leads and unbal-

Figure 2.

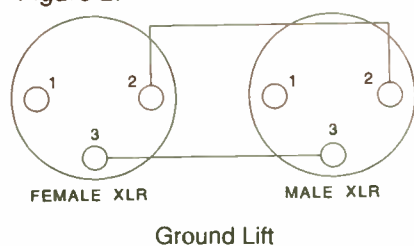

anced lines that are over ten feet long.

Also, for each unbalanced mic input, connect a 250 pF to 1000 pF capacitor between the hot terminal and ground (if the mixer doesn't already have such a capacitor). Then, if the shell of the mic-input connector isn't grounded to the mixer chassis, connect a 0.001 uF Mylar capacitor between the shell terminal and the mixer chassis (if the mixer doesn't already have such a capacitor).

Long speaker cables can act as an RF antenna, but you can shunt the RF to ground at the power-amp speaker terminals. Connect a 0.01 uF to 0.03 uF disk capacitor between one speaker lead and

continued on page 70 ►



# Systems with Style

When KABC/KLOS decided to rebuild from the ground up, they called Pacific Recorders & Engineering to provide its expertise in studio systems planning and execution. After all, when you're dedicated to winning, you don't gamble with success. PR&E has a proven track record of building the world's leading broadcast facilities for over twenty years. This record translates into the uncommon depth and breadth of experience which we bring to each new project. From news to rock, talk, or full-service, we're comfortable and conversant with all formats.

When you see the attention to detail, the design elegance, and the fanatical commitment to quality, you quickly realize why PR&E consoles and studio systems are found in nearly every leading broadcast facility in the nation.

But what may really surprise you is how much money you can save by working with us. That's right, save money. You see, we design and build so many world-class studio systems, we avoid the "surprises" by having the details down to a science. Why don't you give us the opportunity to work with you on your next studio project? We think you'll be pleasantly surprised at how easy it is to realize the operational efficiency and benefits of a genuine PR&E system.



Pacific Recorders & Engineering Corporation  
 2070 Las Palmas Drive, Carlsbad, CA 92009  
 Tel: 619-438-3911 Fax: 619-438-9277 GSA: GS-03F-2057A

**DESIGNS THAT MAKE THE DIFFERENCE**

# Loop Antennas Cut Through AM Noise

by Thomas R. McGinley

**WASHINGTON** AM radio stations invariably face special burdens and handicaps which their FM brethren usually escape. As if declining ratings, revenues

degrading effects of lower fidelity, noise, and interference is a constant challenge.

Today's listening venues are flooded with noise and interference sources of all kinds, many of which have just appeared in the past few years.

trying to secure a clean off-the-air signal to drive the studio modulation monitor RF amp and the air monitor and EBS receivers feeding the control room. If your studio is located within the 25 mV/m contour, the task is much easier of course, but this luxury is usually enjoyed by only smaller markets since many transmitter plants and studios in larger metro areas have been relocated much farther apart in recent years.

The new studio location often winds up in a null of the directional antenna pattern. To compound the problem, many studios have been moved into high-rise office buildings built of thick concrete and filled with computers, UPSs, fluorescent lights, video surveillance systems, digital telephones, and other obnoxious spectrum polluters.

### A tuned loop

I can recall a few years ago, a fellow engineer tried in vain to get a clean air monitor system set up with only 2 mV/m arriving at the studio. He installed a random length long wire on the roof of his ten story office building, connected to the AM tuner in the third floor studios with 150 feet of RG-58 coax, which ran down the electrical distribution shaft. Sorry Charlie, no go.

Such an antenna would have been more effective if a matching network was tuned up and placed between the coax and the long wire, with the shield connected to building ground. However, such antennas are generally broadband and mostly omnidirectional, pulling in unwanted signals

and all nearby noise generating sources.

But why go to all the work of fooling with an outside antenna when there is a very effective, easily obtained and installed indoor solution to this problem? I'm talking about a tuned loop antenna.

### Easy to make

The tuned loop is very old technology but for some reason, many engineers overlook it. Virtually all AM radios use a small built-in version of this antenna. It simply consists of a parallel resonant coil of wire and tuning capacitor, with a tap off the coil to match a 50 ohm coax feedline to the external antenna connection of an AM receiver.

The main advantages of this antenna are its impressive performance in a small physical size and high degree of directivity. It can be oriented to maximize signal strength and minimize unwanted noise. Obviously for indoor applications it works best when placed in or near a window facing the transmitter site.

For engineers who like to "roll their own," a tuned loop is very easy to make. I have built dozens of loops over the years in various different configurations and have found that using a thin piece of wood vernier, 18-by-10 inches is the easiest.

Use No. 20 enamel magnet wire and wind a flat "racetrack" coil, starting near the outside edge of one corner, laying down eight-to-10 turns, each spaced about 1/8-inch. End the coil at the same corner where you started. Secure the windings to the board initially with Scotch tape as you wind, then cover the entire coil with four strips of two-inch

continued on page 73 ▶

Figure 1.

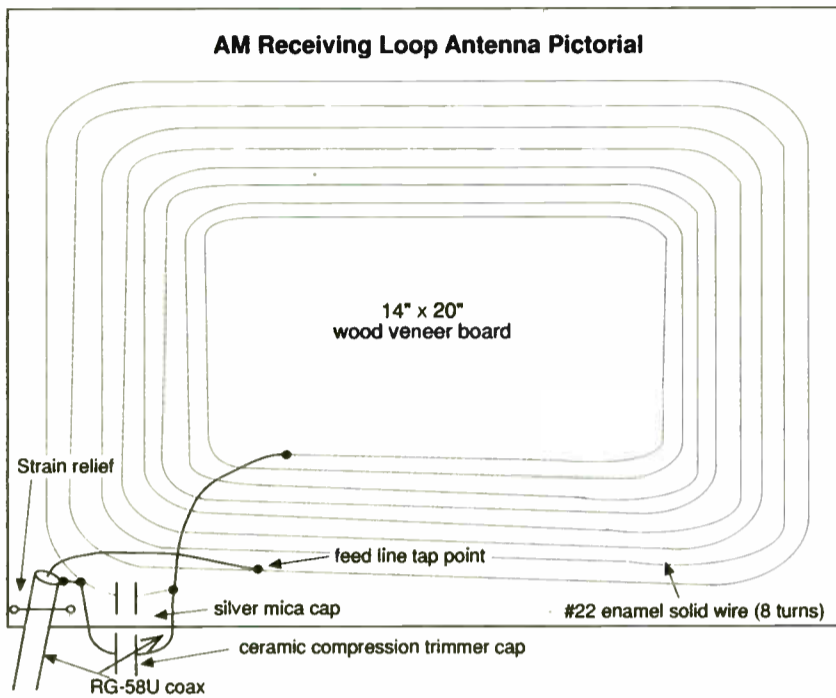

and market share aren't bad enough, just being able to listen to AM without the

The problem can become particularly acute for the AM station engineer who is

## A NEW WORKHORSE



900 Series Cart Machine  
High Quality at a Lower Cost!

**TAPECASTER®**

7174A 302 Industrial Drive Southaven, MS 38671  
Telephone: (601) 349-2881 Fax: (601) 349-2882

**HOTLINE: 1 (800) 638-0977 (USA)**

Circle (96) On Reader Service Card

World Radio History



**ARE YOU  
ANTICIPATING A MOVE TO  
THE EXPANDED AM BAND?**

**KINTRONIC LABORATORIES INC.**

**HAS THE HIGH PERFORMANCE, AFFORDABLE  
ANTENNA SYSTEM  
TO MAKE IT POSSIBLE!**

**WHETHER YOU ARE CONSIDERING  
MULTIPLEXING ON AN EXISTING SITE  
OR A NEW OMNI OR DIRECTIONAL SYSTEM  
WE CAN GET YOU ON THE MOVE TODAY!**

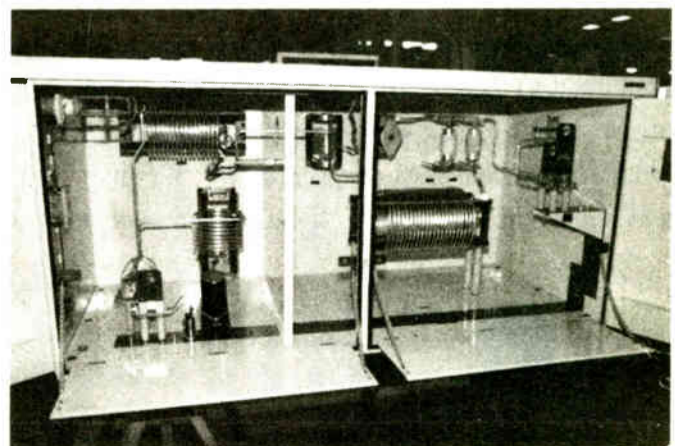

TYPICAL AM DIPLEXER

**CONTACT US FOR FURTHER INFORMATION!  
PHONE: 615-878-3141 FAX: 615-878-4224**

Circle (162) On Reader Service Card

# To Make Money in Radio Advertising, You've Got to Push the Right Buttons.

Since 1990, radio stations in every music market have been more creative, more efficient and more profitable with the DSE 7000. In order to increase profits in the competitive radio environment of the '90s, general managers have been asking more from their production directors, who in turn have had to do things faster and cheaper. Clearly, the trusty 8-track recorder wasn't going to lead radio stations through this new era.

Since it was impossible to become more efficient at tape splicing, astute production types contemplated digital technology. They found out



DSE 7000. In order to increase profits in the competitive

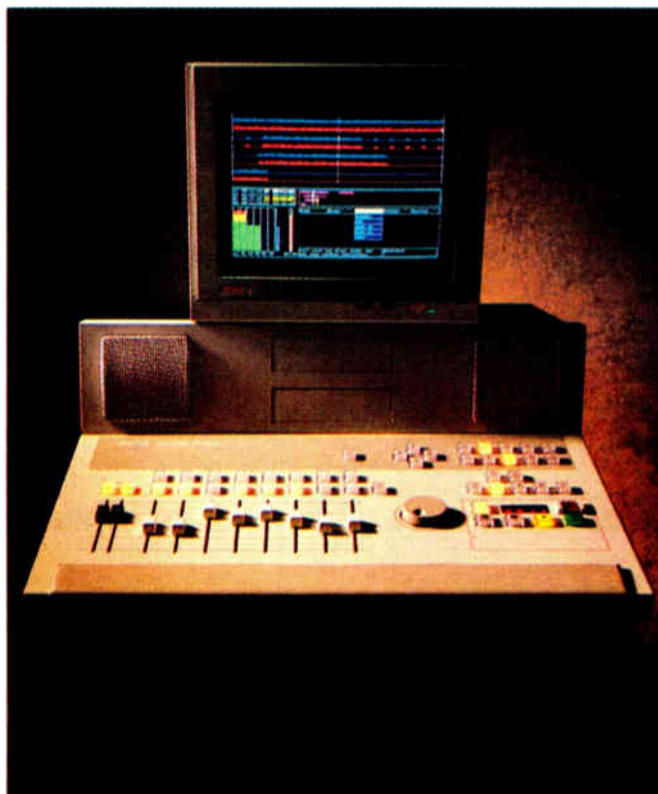

about a company with over 40 years experience manufacturing professional audio products, who was already shipping a digital sound editor for radio production. Not coincidentally, this system had many of the same controls and functions they were used to.

They tried a demo of the DSE 7000 and realized they could produce spots in one-third the time. Which meant they had time for a certain luxury called creativity. The DSE's UNDO button gave them room to experiment. And its audio quality raised their standards to an entirely new level.

Today, hundreds of radio stations are making more money producing radio commercials, because they're pushing buttons on the DSE. Now it's time to push some buttons on your telephone and call AKG.

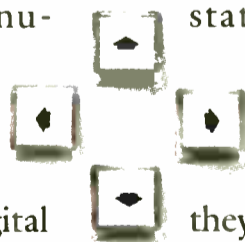

**DSE 7000 • THE NEW SPEED OF SOUND™**



AKG Acoustics, Inc. 1525 Alvarado Street, San Leandro, California 94577, USA, Tel: (510) 351-3500, Fax: (510) 351-0500

AKG is a registered trademark of Akustische u. Kino-Geräte Ges.m.b.H., Austria. ©1993 AKG Acoustics, Inc.

# Eliminating Mic Hum

► continued from page 66

the amplifier chassis ground. Use one capacitor per channel.

If RFI is still a serious problem, connect the unconnected end of each telescoping cable shield to pin 1 through a 0.01 uF capacitor. This bypasses the RFI to ground without connecting the audio signal to ground. Also, in microphone junction boxes, solder a 0.01 uF capacitor between pins 1 and 2, and between pins 1 and 3.

## Multiple systems

When doing a remote, you're outside the controlled environment of the studio.

So you need to be careful to avoid ground loops when you connect several sound systems together.

One of the most complex remotes is a live concert. When a concert is recorded, up to four separate sound systems may be used: house P.A., stage monitors, recording, and broadcast. These four systems share the stage-microphone signals by taking transformer-isolated, balanced feeds from a "microphone splitter," as shown in Figure 1.

To avoid ground loops between the systems, ground the cable shields to only one mixer. At the splitter, use the ground-lift switches to disconnect the

shields going to the other mixers. Ground to the mixer that provides the least hum. You might need to power all the mixers from outlets near the grounding mixer. That way, all the mixers share a common ground.

Sometimes a radio station or video crew takes an audio feed from a studio's mixing console. In this case, you can prevent a hum problem by using a console with transformer-isolated inputs and outputs. Or you can use a 1:1 audio isolation transformer between the console and the feeds.

Such a transformer is especially useful when you connect balanced to unbalanced equipment. Mount the transformer in a rack near the patch panel.

Suppose you connect two sound systems with a balanced line-level cable

between them, and you hear hum. The cause might be a ground loop. This can occur if pin 1 is tied to the shield on both ends of the cable. Prevent the loop by attaching a cable ground-lift adapter (Figure 2). It floats or removes the shield connection at one end, breaking the loop. The shield still works because it is grounded at one end of the cable.

Snakes and stage boxes are often used in remotes. If a stage box is grounded through the snake-cable shield, and the box contacts a metallic surface on stage, this condition can cause a ground loop. So don't ground stage boxes.

□ □ □

Portions of this article were excerpted from the authors' book, "Practical Recording Techniques." More on hum prevention next time. Bruce Bartlett is a microphone engineer and technical writer for Crown International. Jenny Bartlett is a technical writer. Bruce can be reached at 219-294-8388.



# Clearly Digital.

Moseley's DSP 6000 Digital Transmission System...  
the clear solution to your STL problems is now a reality.

- ▼ Convey up to four 15 kHz audio channels with CD quality specifications over a single STL.
  - ▼ 25 dB system gain improvement over analog STLs reduces new antenna & transmission line costs.
  - ▼ Fade and co-channel intermod problems have no effect on SNR, so even quiet passages remain crystal clear and noise free.
  - ▼ AES/EBU digital I/O allows direct digital interface to other digital hardware.
  - ▼ Interface to any composite STL, preserving the capital investment of your existing STLs.
  - ▼ Low coding delay of 3.8 ms keeps the air talent happy.
  - ▼ A built-in V.35/RS-422 interface opens the door for utilizing the DSP 6000 with Fractional T1 digital Telco circuits.
- To learn more about the digital transmission advantage, call today for our free color brochure.

**Moseley**

MOSELEY ASSOCIATES INC. • 111 CASTILIAN DRIVE • SANTA BARBARA, CA 93117 • (805) 968-9621 • FAX (805) 685-9638

## WORKBENCH

► continued from page 65

Clearwater, Fla., called looking for a program to calculate F(50,50) contours. The software is under \$50. For information circle **Reader Service 210**.

★ ★ ★

Larry Albert from Murray (Ky.) State University's Television Department always amazes me with his low-cost solutions to major problems. His latest idea solves pinched fingers, soaring blood pressure and profanity associated with mounting a piece of equipment in a rack by yourself.

You won't believe the solution—setscrews. Broadcast engineers usually think of setscrews as being small, but other industries think bigger.

A well-stocked hardware store or machine tool supply dealer will have setscrews large enough to fit your rack rails. Several different thread sizes are used in equipment racks and there are setscrews to fit them all. Although 3/8- or half-inch sizes work, the machine tool supply dealers can order one-inch lengths that offer better support.

First make sure the equipment fits into the rack space—measure it. Determine the location of the top two mounting screws (one on the left, one on the right). Install the two setscrews into these holes from the front of the rack. Install the screws so they protrude slightly from the front of the rails.

Now slide the equipment to be mounted onto the setscrew shafts that stick out from the front. The top two mounting holes should easily pass over the setscrew shaft. These two setscrews now control vertical motion and help support the weight of the unit. As you steady the equipment, install the rack screws in the bottom holes, snugly but not tight. Remove the setscrews from the upper holes, install the upper-rack screws and tighten all screws.

The setscrew has no head to interfere with installation, so equipment can be mounted quickly and efficiently. Setscrews are available with straight screwdriver slots or allen wrench heads.

□ □ □

John Bisset is a principal with Multiphase Consulting, a contract engineering and projects company. He can be reached at 703-379-1665.

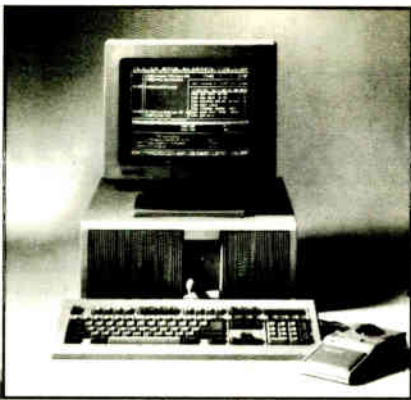

**BUYING YOUR FIRST HARD DISK SYSTEM?  
ASK DCS USERS WHO'VE BOUGHT THEIR  
2ND, OR 3RD OR 4TH...**



*"We needed a one-button operation to fire commands at each of our four simulcast stations and the DCS was the only system reliable and smart enough to trust with our spot load."*

MARK ROLLINGS,  
PRESIDENT, ROLLINGS  
COMMUNICATIONS,  
CHAMPAIGN/URBANA, IL



*"I have installed a half dozen DCS systems here and in other stations, and I think it's the most functional, flexible and complete system on the market."*

DENNIS EVERSOLL,  
VP ENGINEERING,  
WRHQ, SAVANNAH, GA



*"Computer Concepts leads the way, in my opinion. Our next system was delivered right after Radio '92... that says it all!"*

MARK VAIL,  
STATION MANAGER,  
KSJQ & KFEQ,  
ST. JOSEPH, MO



*"We are very pleased with the Computer Concepts hard disk system for both our stations, but I am most pleased with the support, especially the pleasant, knowledgeable and fast help from your staff."*

DAVE ANTHONY,  
STATION MANAGER,  
WCED/WOWQ DuBois, PA

**Profit From our Experience. Call 800-255-6350**

**apt-X** DIGITAL  
COMPRESSION

# SNEAK PREVIEW!

Computer Concepts has exciting new **WINDOWS OF OPPORTUNITY** to show you at Radio '93 in Dallas. This is the hot demo everyone will be talking about. Don't miss it at booth #345.

COMPUTER CONCEPTS CORPORATION • 8375 MELROSE DRIVE, LENEXA, KS 66214 • TEL: 913-541-0900 • FAX: 913-541-0169



# AM Technology Boosts Shortwave

By James Wood

**BERKSHIRE, England** AM technology is thriving in the world of shortwave (SW) international broadcasting. Broadcasters and manufacturers alike are acting on expansion plans that entail large investments of time and money.

Throughout the world, organizations including the Voice of America (VOA), Radio France International (RFI), and the Nauen shortwave station in Germany are driving the expansion with large orders of high-power transmitters.

VOA is in the midst of a scheduled addition of 29 SW 500 kW transmitters,

and RFI approved an expansion program that will make it the world's most powerful broadcaster after VOA. Plans at RFI include 17 additional 500 kW SW transmitters, 15 of which will be installed in Central France and two in French Guyana.

Nauen, which narrowly escaped destruction by Russian forces at the end of World War II, will procure six more 500 kW SW transmitters and six rotatable curtain arrays.

The history of Nauen dates back to the early 1900s when Telefunken started the facility as a LW wireless network linking German colonies with the Fatherland.

Following the partition of Germany after World War II, Nauen was in the East and during the Cold War, broadcast shortwave programs for the RBI. Now with the reunification of Germany, the facility is set for refurbishing.

## Useful tools

In the post-Cold War era, a series of political upheavals have occurred quickly and disparately to affect international broadcasting. Authorities running shortwave operations have turned to rotatable curtain arrays for the adaptability and ease of response they offer over an equal number of fixed HF curtains. Rotatable curtain arrays allow broadcasters to act quickly and precisely to direct all the transmit power to any area or region of the world.

The governments of western nations have long used the power of shortwave to broadcast propaganda to the people of communist nations. When the former USSR renounced communism and began the process of dismantling its own network of shortwave transmitters and jammers, agencies such as the VOA, the BBC, and Deutsche Welle quickly moved to rent these transmitters for use in broadcasting to the People's Republic of China.

## The manufacturers

The stations leased were located mainly in the far east regions of the former USSR, including in the cities of Tashkent, Chita, Irkutsk, Khavarovsk, and Vladivostok.

The manufacture of 500 kW, frequency agile SW transmitters is a highly specialized science that lists only five manufacturers in its ranks. These are: Continental Electronics Corp. of Texas; GEC-Marconi, England; Riz Transmitters AG, Croatia; Telefunken Sendertechnik, Germany; and Thomson-CSF, France.

As far back as the early 1980s, the high power SW transmitter market has been

dominated by Thomson and ABB (whose transmitter plants were acquired by Thomson-CSF). Based upon the author's calculations, the combined market share of Thomson and ABB represents a dominate share—a position that is expected to increase during 1994-1995.

What is not yet known is whether Thomson will continue to market ABB transmitters. I would venture to say that it would be desirable to do so for at least some years, because of the need to service existing ABB installations around the world.

Back in 1984 the ABB company introduced its cutting-edge (Pulse Step Modulator) PSM technology, and in 1991 extended its technological lead by introducing PSM with Insulated Gate Bipolar Transistor (IGBT)—a technology that achieved an even higher degree of performance, higher electrical efficiency and a choice of water or air cooling for the PSM stage.

## New transmitter line

Thomson-CSF recently launched its new transmitter line for high power SW broadcasting, the Series 6. The design for the Series 6 is based around a new Multi-Parameter Modulator (MPM) that uses 47 switching modules of 650 V each to generate the tube supply of 30,550 V to the anode. The only power grid tube in the transmitter is in the RF power amplifier.

The new Series 6 retains a number of the features of the Series 5 that made the transmitter a favorite with many of the world's international broadcasters.

At the 1993 Montreux exhibition, Telefunken revealed it was developing a transmitter to replace the now-aging S-4005 in service with Deutsche Welle, the BBC World Service and others. The company claims the S-4105 is an advancement on anything available now, particularly in the area of spectral audio response. It uses a new Multiphase PDM principle.

The PDM switching uses 32 modules (compared to the 47 used by Thomson in its Series 6). The design of the final RF

continued on next page ►

## DIGILINK SATELLITE AUTOMATION \$7,995

- 10 hours of stereo storage (20 hours mono)
- 4 switcher external inputs standard, for up to 4 networks
- Logic inputs for station ID, 4 liners, & commercial break
- Program up to 40 Clocks and 40 Jocks
- Schedule up to one week in advance
- Simultaneously play a Commercial and record a Spot

No matter how you add it up, it quickly becomes obvious why Digilink is #1 in digital audio for Radio. Features, price, and customer satisfaction have made Digilink the choice of broadcasters from Russia to Japan to your own back yard. Whether for live on air, satellite-CD-tape automation, or multitrack production, Digilink fills your needs now and in the future. Price your system on the form below and then write, call, or FAX Arrakis for more information.

VOICE (303) 224-2248 , FAX (303) 493-1076

## ARRAKIS

DIGILINK ORDER FORM	
Name- _____	
Call letters- _____	
Address- _____	
Telephone- _____	
10 hour system, stereo (20 hours mono).....	\$7,995 <input type="checkbox"/>
<b>Options-</b>	
16 hour system, stereo (32 hours mono).....	\$9,995 <input type="checkbox"/>
Add 7 more switcher inputs ( to Total 11).....	\$444 <input type="checkbox"/>
2nd switcher w 7 inputs for timed recording.....	\$295 <input type="checkbox"/>
Network Board plus software.....	\$495 <input type="checkbox"/>
(for 2 or more Digilinks or a scheduling computer)	
Video Doubler.....	\$1,395 <input type="checkbox"/>
(control a Digilink from two places- up to 100')	
<b>Add a Second Studio-</b>	
Add a Production studio to your Air studio.....	\$8,490 <input type="checkbox"/>
(2nd 10 hours system w Network Card)	
Trak*Star 8 Track Editing Software.....	\$1,995 <input type="checkbox"/>
(add an 8 track editor for ultimate production)	
Total List Price- \$ _____	

1993 Arrakis Systems inc. 2619 Midpoint Drive, Fort Collins, CO. 80525

## Belden® audio cables can make a difference.

Be honest. If you had the big guy on-mic, would he sound a little... thin? The problem could be your audio cables, particularly if you're not connected with the broadcast industry's No. #1 choice, Belden.

Belden is preferred for quality,

reliability, and availability by broadcast professionals who know what they're getting when they buy Belden. We offer the industry's most complete line of cables, with immediate availability through our extensive distributor network. Digital audio cables. Snake cables. Flexible mic cables. Audio multi-conductor and paired cables. You name it.

## If you had Pavarotti here,



Copyright ©1992 Cooper Industries, Inc.



FEATURES

► continued from previous page  
stage in the S-4105 is based on a brand new tube, the TH 576, from Thomson Tubes Electroniques. This tube is not a replacement for the TH 558, which powers four out of every five of the world's 500 kW transmitters. The TH 576 is a more powerful tube with a higher dissipation figure and an extended life.

**Worthy features**

A very worthwhile design feature of the S-4105 is a double stage band-pass filter at the output stage. The filter will reduce radiation from any neighboring antenna and will enable closer spacing of antennas for transmitter stations—and reducing feeder losses from the transmitter to the antenna.

Telefunken Sendertechnik hopes to win the contract to refit the Nauen SW station with six 500 kW S-4105s and six rotatable curtain arrays. A setup using the rotatable curtain array on boggy wheels and tram lines already is in service at several sites in Europe and elsewhere. The S-4105 is still in the final development stage and will be ready at the end of the year.

By the time the S-4105 goes into production, the driver stage to the PA will be changed to all solid state for those customers who require it. In this context the one-tube transmitter has become something of a trend, but a grounded grid tube as a driver is cheaper and is a proven classical design.

Marconi still is selling the B-6128, the same transmitter adopted by the VOA and built in the U.S. The B-6128 is a bit old by now and does not have the electrical efficiency as that of the newer B-6128S.

Continental Electronics Corp. introduced its new 500 kW SW transmitter in 1991 as a replacement for the 420-B. To date the new transmitter is selling well. The 420-C uses a completely new IGBT all-solid state switching modulator that enables the transmitter to maintain levels of performance excellence.

Moreover, the switching modulator is selling well in its own right as retrofit

equipment. General consensus is that Continental has a very good transmitter in the 420-C.

The newly-privatized Riz Transmitters AG is developing a 500 kW SW transmitter. Details on the new transmitter were not available at press time. Riz Transmitters is moving ahead with the high-power transmitter.

The decision to build a 300/500 kW SW transmitter is a logical consequence. The transmitter will fill the gap in its production program that extends from 20 kW to 2000 kW on long wave (LW) and medium wave (MW). Riz is one of the big three players in the super-power league, which includes the companies building 1,000 and 2,000 kW transmitters for

LW/MW. The other two are Continental and Thomson-CSF.

**New player?**

Before concluding, it is worth posing the question: Will Harris Allied ever enter the high power SW market? Harris Allied has never ventured beyond the 100 kW power mark in shortwave transmitters. Nor does it have the experience the others do when it comes to dealing with high power. Nevertheless, the company surprised many when it started to extend its medium wave capability to 300 kW and beyond.

It appears the company is sold on solid state technology as part of its overall strategy because solid state modules are

ideal for mass production. It seems feasible that in a few years solid state will penetrate to high power ranges of 300-500 kW SW.

Concurrently other companies—particularly Thomson-CSF/ABB—are innovating shortwave transmission technology. It is a fascinating science and there are still some barriers to be breached in other areas outside the obvious. Be prepared for some surprises a few years from now.

□□□

*James Wood, a consulting engineer and an author on high power AM based in Berkshire, England, writes regularly for the international edition of Radio World. Contact him in the U.K. at telephone: +44-344-54938.*

# Loop Over Interference

► continued from page 68

wide, clear packing tape. Mount a small solder lug type terminal strip in one corner to terminate the coil, mount the tuning capacitors, and attach the RG-58 feedline.

The loop will resonate at 1600 kHz with about 100 pf of capacitance and at 540 kHz with about 300 pf across the entire loop. Divide the amount of capacitance needed into two components: one, a fixed silver mica and the other, an adjustable compression type trimmer cap. The Q of the loop is rather high, so trying to use just one variable cap for the entire amount will result in very sharp tuning. The shield of the coax is attached to one side of the loop while the center conductor is tapped up from that end about one turn.

**Optimum tap**

The best way to find the optimum tap point is by using an AM field strength meter with an external input. Connect the loop to the field meter with the length of coax you will need in your final installation. Tune in the desired station, orient and resonate the loop for maximum signal, and then start moving the tap point in two inch intervals in both directions to find the optimum match.

You will have to repeak the loop's tuning cap after each new tap point. Be careful not

to position the field meter too close to the loop so as to prevent detuning.

The most powerful performance obtainable from a tuned loop is when it is used in conjunction with a preamplifier. Do-it-yourselfers may want to experiment with some simple homebrew single stage FET preamps with appropriate filtering to reduce noise amplification. Probably the best performing of such "active antennas" are those commercially available. Palomar Engineers in Escondido, Calif., makes an active AM loop antenna integrated into one small box (model BCB). The top-mounted loop rotates 360 degrees for easy adjustment.

AOR, a Japanese company, makes a similar but even smaller and sharper looking amplified loop. We have used the AOR

unit in very noisy office-building surroundings with great success (LA-320 amp and 320-M BC loop). The only downside to these units is that they are a bit pricey, costing about \$180.

A commercially made passive tuned loop for AM known as the Select-a-Tenna also works very well. This circular device, about a foot in diameter with tuning knob is amazingly effective when placed near an AM radio. Since it does not need an external antenna input connection and magnetically couples by proximity, it works best with radios that are not completely shielded by a metal case. Select-a-Tenna is made by Intensitronics, Hales Corners, Wis., and is available at many specialty gadget stores.

□□□

*Tom McGinley is director of engineering for Cook Inlet Radio Partners and technical advisor to RW.*

In fact, with over 60% of our line new in the last few years, we can probably offer you same day delivery on products the competition hasn't even heard of. All developed in cooperation with leading equipment manufacturers to guarantee compatibility, and assure you of Belden's renown reliability and signal integrity.

No wonder we're a match for the maestro! Call 1-800-BELDEN-4 for your FREE copy of our catalog, and see for yourself. Because, if it sounds too good to be true, it's probably Belden.



wouldn't you want Belden® here?



Circle (41) On Reader Service Card

**56000/112000 BPS  
REAL THROUGHPUT**

**DIGITAL**

**MODEM™**

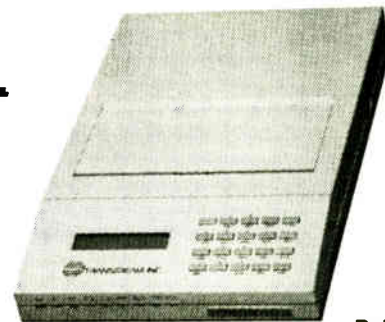

Price: \$1095 (Qty 1)

FOR

**DIGITAL AUDIO APPLICATION**



**TRANSTREAM, INC.**

(919)713-2400

(919)713-2420 Fax

3261 Atlantic Avenue  
Raleigh, NC 27604

Circle (77) On Reader Service Card

USER REPORT

## KQLD 'Movin' on Up' with Audioarts' A-50

by Marc Musgrove  
Chief Engineer  
KQLD(FM)

**NEW ORLEANS** When Beasley Broadcast Group decided to move its New Orleans studios to a better location, I was given a task any engineer would love (and hate): "Let's upgrade our on-air console. (But don't spend a lot of money.)"

Luckily, this order came during the NAB's 1992 Radio Convention here in New Orleans. On the convention floor, I

built the Wheatstone line—but with a mandate to provide the maximum features and performance with the minimum cost.

But the reliability and appearance still had to be deserving of the Wheatstone name—a tall order. I knew that if anyone could meet this goal, the Wheatstone team could. We quickly purchased and installed the A-50-18.

### Meeting the needs

The console is constructed around a fully-enclosed aluminum chassis. The

All logic and audio connections to the console are made through 12-pin molded connectors with insertable crimp pins. Audioarts supplies all the connector shells, pins and even a crimp tool and pin extractor.

Each input channel connector has two selectable audio inputs. Both are electronically balanced line level inputs, and each channel has a 15 dB gain trim to adjust levels. Mic level inputs are handled by the two mic preamps included with the console. Additional

the most complete of any console in its price range. Remote start and stop of any machine is easy with dry contacts from the module ON/OFF switches available on the logic connector. The module's On, Off, Talkback, and Cough functions are also available on the logic connector and can be remotely controlled.

### Sounding great

Everyone at the station is very pleased with the console. It looks like the Wheatstone team did it—our A-50

**The console's specs easily can hold their own in a digital broadcast environment, and the price came as a pleasant surprise.**

made a beeline for the Wheatstone display. I'd worked with the company on other projects and wanted to see what it had to offer.

After a quick conversation, it was pretty clear that the console I originally wanted was out of our reach. We had a very tight budget for the move and upgrade, and I began to see myself moving our old, obsolete console into the new facility.

That's when Mark Kaltman introduced me to the Audioarts A-50. I was familiar with Wheatstone, but didn't know much about the Audioarts division. Mark explained that the division consisted of the same team who designed and

power supply is an external rack-mount unit. The individually removable switch panels are each connected to the circuit boards by three plug-in connectors.

The switch panels are removable while the console is in operation, so you can service or replace any input's fader or switches without disturbing the other channels. All ICs in this console are socket-mounted, making troubleshooting and repair easy.

My installation started with removal of all the switch panels and circuit boards. This made it easy to mount and fasten the chassis to the cabinet and to inspect the console internally before power-up.



The Audioarts A-50 console is ready for broadcast at KQLD(FM).

preamps are available as an option, so you can have as many mic inputs as you need.

The logic functions of the A-50 may be

sounds great and looks great, and should keep on doing both for a long time.

Subsequently, when John Walton and Steve Johnson asked me to design and build the Mastervox Media studios, home of the syndicated Walton and Johnson Morning Program, they were looking for a digital-quality system.

They already decided on all-digital source machines, such as digital carts, R-DATs, etc., and digital delivery via Ku-band satellite. Because the console could not be the weak link in the chain, we needed one to work with equipment at this performance level.

At the same time, price was important. Mastervox had a reasonable budget, but every dollar saved on equipment freed a dollar for the other myriad expenses of a start-up business.

Based on my experiences with the A-50, I had no problem recommending it. The console's specs easily can hold their own in a digital broadcast environment, and the price came as a pleasant surprise to John and Steve. As I write this, we're preparing for the inaugural network broadcast using the A-50-18.

Until Wheatstone came out with the Audioarts line, purchasing a console in this price range meant making a lot of compromises. The value and quality of the A-50 have changed all that.

□ □ □

For information, contact Mark Kaltman in New York at 315-452-5000; fax: 315-452-0160; or circle Reader Service 112.

Valley Audio

MODEL 730 DIGITAL DYNAMICS PROCESSOR

The next generation of dynamics control from Valley Audio! Bridging the gap between high fidelity analog and modern digital innovation comes a breakthrough professional audio tool—the Model 730 Digital Dynamics Processor.

More than just a digital version of an analog stereo compressor, limiter, expander, sibilance controller or keyed gate, the Model 730 allows complex, easily programmable multi-threshold, multi-ratio dynamic transfer curves to be combined for total control of demanding audio signals. There's nothing like it, anywhere!

The Model 730 features zero-attack detection for distortionless broadband limiting, simultaneous multi-ratio compression and expansion, externally keyable gating and selectable high frequency limiting. An optional dual linear fader

remote control allows assignable "in-hand" parameter and volume control, great for remote zipper-free digital fade-ins and fade-outs on DAT to DAT transfers!

The Model 730 speaks every common signal and control protocol, from analog -10 to +4; digital 30 kHz to 50 kHz AES/EBU, S/PDIF, SDIF-2; TOSLINK optical, MIDI, RS-232, and RS-422.

Internal 24 bit architecture with 18 bit I/O conversion insures the utmost in high fidelity, and ROM resident software, flexible Aux connectors and daughter board modular expansion provide lots of room for future growth.

The options and functions could fill a brochure, which we'd be happy to send you. Or contact your favorite pro audio dealer for a test-listen of the Model 730.

A Whole  
New Concept  
With A  
Fresh Set  
Of Parameters....



Valley Audio Products Inc.  
9020 West 51st Terrace, Merriam, Kansas 66203  
Phone (800) 800-4345 FAX (913) 432-9412

Circle (45) On Reader Service Card

USER REPORT

# Radio Systems Excels at WJRZ

by Mike Moran  
Chief Engineer  
WJRZ-FM

**TOMS RIVER, N.J.** What began as a simple studio upgrade here several years ago resulted in a modern radio studio featuring Radio Systems' RS-18 console.

When Program Director Lance DeBock began assembling his wish list for our new control room, he asked me to research several console manufacturers. One manufacturer was Radio Systems, which is based in Bridgeport, N.J., less than an hour from our studios.

I took advantage of the company's close proximity and met with Radio Systems' Gerrett Conover. After reviewing an impressive list of specs and options we discussed customization of a console, an area in which Radio Systems excels.

We chose the RS-18, the console we felt best suited our needs. Then we began to modify. Through consultations with Mike Sirkis, the console's designer, we added a special "processing" bus so we could send post-fader audio from selected inputs into a reverb unit.

This is critical in maintaining the integrity of commercials and music, while adding some depth to our mics and tape feeds. The modification was inexpensive, but more importantly, it didn't adversely affect the board's specs.

Our studio contains other equipment representing much of radio's latest technology. The Ultimate Digital Studio (UDS) from TM Century provides the brains of our live-assist operation, as it directly controls five Sony CD Jukeboxes, a DigiCart from 360 Systems and a Radio Systems RS-1000 DAT machine.

The UDS presented the next challenge for the RS Console. Each Jukebox appears on its own fader on the console. We wanted the UDS to tell the lights on the board which CD Jukebox (hidden from the jock's view) was playing.

A quick phone call to Radio Systems and then to engineer Jim Broadwater at TM Century, and the modified UDS board was on its way. Further coordination between RS and TM Century resulted in full computerized control of our DAT machine.

Finally, Vince Fiola of Studio Technology in Malvern, Pa., worked closely with DeBock and General Manager Joe Knox in providing sleek housing for all of this equipment. It was designed ergonomically and, more importantly to me, with the engineers who have to wire up the equipment.

With the help of TM's Jim Broadwater and Engineer Bill Clanton, we had the system up and running in no time. And thanks to the collaborative efforts of Radio Systems, TM Century, 360 Systems and Studio Technology, we're sounding great.

□ □ □

For information, contact Paul McLane in New Jersey at 609-467-8000; fax: 609-467-3044; or circle Reader Service 208.

USER REPORT

# WSOU(FM) Puts Vanguard to the Test

by Michael A. Collazo  
General Manager  
WSOU(FM)

**SOUTH ORANGE, N.J.** If you could select one item in your on-air or production studio you would least like to see go down today, chances are it would be the audio console.

Despite the fact that radio stations have more equipment advancements and innovations available to them than ever before, the audio console remains the heart of any radio studio. Even most computer-controlled digital systems are tied into the console.

If a cart machine goes down, we take one out of another studio. If a CD player malfunctions, we replace it in a heartbeat. If the console goes down, you're in trouble.

When choosing the audio console for the station, we had the usual requirement list: it had to be durable, economical and easy to maintain. And because of our unique staffing situation, a quick learning curve and user friendliness were required.

**Large-staff demands**

WSOU(FM) "employs" over 100 staff members, most of whom are Seton Hall University students. While the main format is hard rock, Sunday programming is dedicated to religious and ethnic broadcasting serving the New York area's diverse ethnic populations.

Ostensibly a luxury, a large staff presents problems not found at most commercial radio outlets. Imagine training about 60

continued on page 76 ►

safe  
isn't always the winning strategy.

Play to win.  
The only thing you have to fear  
is success

sex

the unity 2000i  
the world's best sounding fm processor

CUTTINGEDGE

2101 SUPERIOR AVENUE, CLEVELAND, OHIO 44114 • TEL: (216) 241-3343 • FAX: (216) 241-4103

Circle (27) On Reader Service Card

# WSOU(FM) Puts Vanguard Through University Testing

► continued from page 75

new people each year in engineering, programming, news and announcing. While most radio stations employ perhaps seven or eight announcers working combo, WSOU(FM) has 40 show hosts running their own board each week.

Such a system requires an audio console capable of meeting such demands. For the last six years, the ATI Vanguard console has fulfilled our needs at a bargain price without missing a beat.

Our ATI is an eight-channel, linear-

fader model we control from two CD players, two mics, two turntables (rarely used), a cassette player, a three-tier cart machine, and auxiliary sound sources from other studios, phone lines, etc. We employ a RPU and a Cellcast unit for our sports remote broadcasts.

Operation of the ATI Vanguard is direct and nearly mistake-proof. Open microphones present no problem with switching noise, because nearly all switching is controlled by membrane switches, which are absolutely silent.

The polycarbonate overlay provides good protection from foreign elements and it's easily cleaned.

## List of successes

Station engineer Tom Parnham has been with WSOU(FM) since its sign-on in 1948. His list of Vanguard console "likes" includes ease of initial installation with punch-block type connections, external power supply making the unit very lightweight, and excellent support service.

Low cost is maintained through the use of VCAs on all level controls, eliminating fader noise and the need for expensive faders. In fact, eight replacement faders only cost about \$50.

Despite the heavy use and abuse handled by our ATI Vanguard console, our

only problem was an initial replacement of the membrane control panel. As previously mentioned, service support is excellent and a replacement was received within 48 hours of our call.

Some observers comment on how "basic" and "simple" the Vanguard appears. They are correct. While it may not look as impressive as some consoles with more bells and whistles, its simplicity and ease of operation and maintenance are strengths.

For less than half the price of most consoles, the Vanguard performs all functions necessary with ease and without problems.

The Vanguard reminds me of the pink bunny in the Energizer battery commercials—still going. In fact, we liked it so much, we bought another for one of our instructional production studios.

□ □ □

For information, contact Sam Wenzel or Edward Mullin in Pennsylvania at 215-443-0330; fax: 215-443-0394; or circle Reader Service 11.

## USER REPORT

### PR&E Console

### First Rate Board

by Eric M. Wiler  
Engineering  
Jones Satellite Networks

**DENVER** Jones Satellite Networks went on the air March 1 with a new format, "CD Country." As our first digitally-delivered format, a great deal of care and consideration went into the choice of equipment.

The decision was made to install the RadioMixer console by Pacific Recorders and Engineering. PR&E is well known to networks and premier radio facilities throughout America for quality, service and reliability.

In a tough economy, we were looking for a console that would take a no-compromise approach at a reasonable price. RadioMixer is PR&E's most affordable console, but it doesn't skimp on features.

Many features of PR&E's more expensive BMX-III series are included. Dual program busses, quality faders, real VU meters, and a clock with time code capability are all standard features.

Cost savings are made without sacrificing reliability. A single motherboard with connections made through the bottom of the console eliminates the need for tedious (and expensive) harness construction.

One of the most important features of the RadioMixer is serviceability. It has a true modular design, unlike some entry level consoles. Removal of modules while the console is "hot" is easy and creates no problem.

The installation was quick and painless. The use of PR&E's interface modules and prefabricated cables made the normally annoying task of interfacing cart machines, CD players, etc., simple enough that anyone can do it.

The RadioMixer is a first-rate console at an attractive price. In a budget-minded era of broadcasting, PR&E is again helping to set a standard for broadcast consoles.

□ □ □

For information, contact Mike Dosch in California at 619-438-3911; fax: 619-438-9722; or circle Reader Service 25.

## THE GOLD STANDARD IN DIGITAL AUDIO DATA COMPRESSION



Endorsed by the world's most innovative manufacturers of broadcast equipment, apt-X™ digital compression technology has been incorporated at the heart of a host of products designed for the transmission or storage and retrieval of broadcast quality stereo audio.

Designed specifically for professional applications, the apt-X system delivers field-proven performance and reliability with a multitude of powerful features offering negligible coding delay while maintaining audio transparency.

Discover more. Find out for yourself why the broadcast industry overwhelmingly prefers the apt-X solution - the first hardware solution - the first single IC solution - the first choice solution.

Broadcast equipment currently incorporating apt-X technology includes products from: Advent Communications • A.S.C. • Asaca • B.B.C. • Broadcast Electronics • Canopus • Computer Concepts • Digital Broadcast Associates • Eela Audio • E.R.I. • Fidelipac • Gentner • Hitachi Telecom Technology • International Datacasting Corp. • Ikegami • International Tapetronics • Intraplex • J.T.M. • Kowa • KW Electronics • Maycom • Moseley Associates • Positron • Scan Acoustic • Sonifex • Southern Broadcasting Systems • S.S.V.C. • Systembase • Tiesseci • TFT • The Management • Ubitech • Vistek.

apt-X™ means compression technology you can bank on. Call today for further information.

## The Industry Preferred Digital Audio Compression System.

Audio Processing Technology  
21 Stranmillis Road, Belfast BT9 5AF  
Northern Ireland  
Tel 0232 662714 Fax 0232 382208



Audio Processing Technology  
6255 Sunset Boulevard Suite 1026  
Los Angeles CA 90028 USA  
Tel 213 463 2963 Fax 213 463 6568

apt-X and apt-X are registered trademarks of Audio Processing Technology Ltd.

# AXS

(ax'-sess)

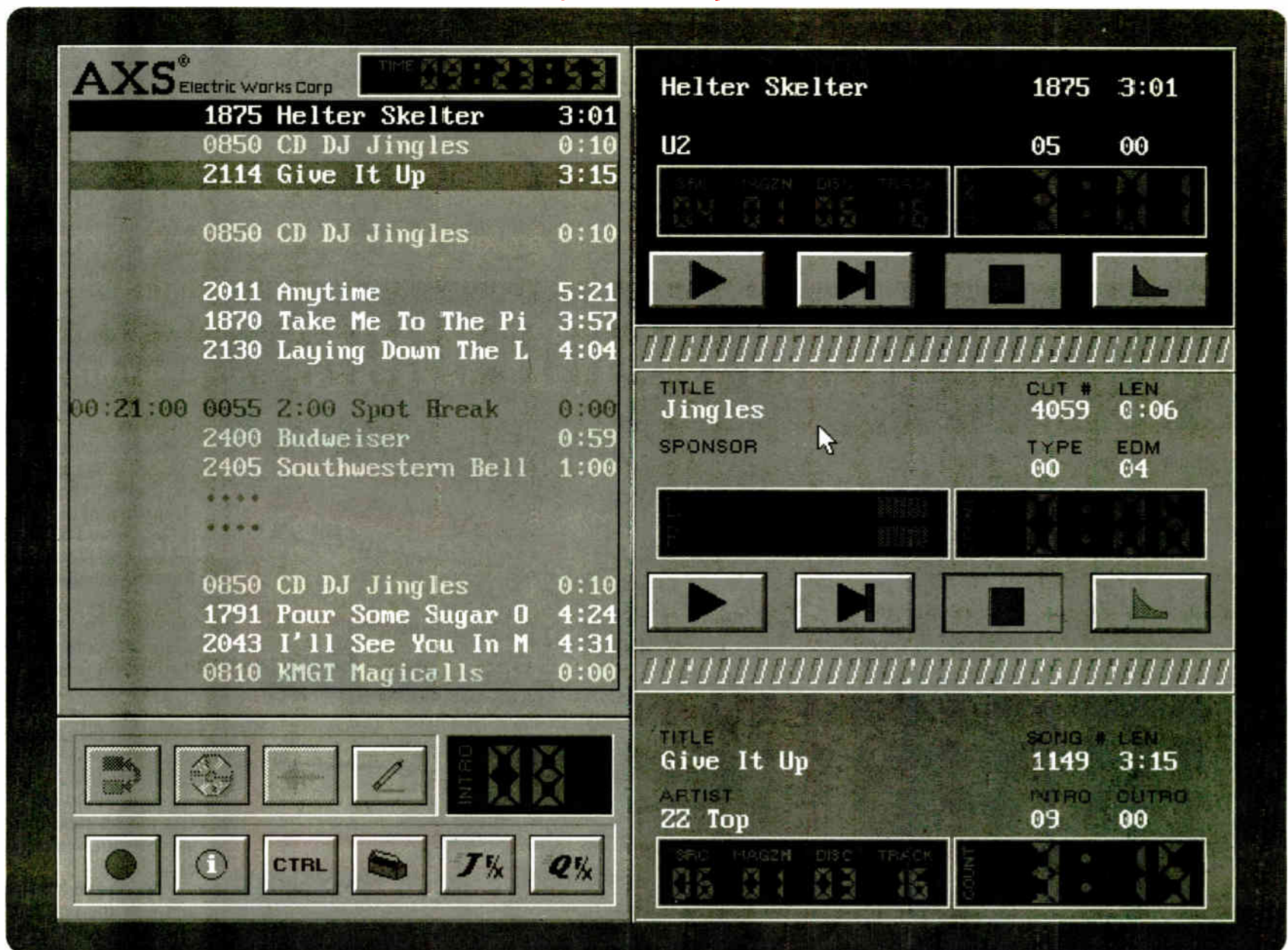

## *AXS... the first real Cart machine replacement and much more...*

Look at the AXS screen above. AXS replaces all the playback audio cart machines in the Control room. Every one of them! AXS stores all your spots; all your PSA's, Promos, Jingles, Liners, ID's; stores your sound bytes, featurettes, actualities, and audio junk. Store *thousands* of audio Cuts. — AXS airs them instantly and with beautiful quality.

AXS keeps you in control! Use the single step mode or run in sweeps. Edit play order on the fly or run direct from the Traffic Log. AXS your own Jock workbox loaded with your own production effects or AXS the *Quikplay* workbox to set up off the wall, off the Log inserts. Work the way you want to. AXS is everything!

AXS and your mind make a wonderful team... On your shift AXS is your machine with *your* effects and *your* production. Play, edit, select, set up, think or work on the phone while AXS airs spots or features, keeps you on time, cues your CD's and does your Log. AXS makes you sound even better than you are.

AXS hooks up like a cart machine. Runs like a cart machine. Just sit down and do it. Then forget cart stacking, forget scrambling for live tags or live copy and forget the paper Log. It's all on the AXS screen.

AXS does everything obsolete cart machines can do and does it better! AXS is also a total system that expands to your needs. AXS is LAN ready, CD ready and interfaces with most Traffic systems, computer music selectors and *Digital DJ™*.

### **Basic AXS — \$2,495.00**

Includes AXS software and a premium apt-X™ playback audio card ready for insertion into customer 486 SX-25 computer. Fully integrated systems available. Foreground recording, digital overlap, CD interface, touch screens, PBR, traffic interfaces and the AXS production system are optional. Call for complete pricing.

Contact your broadcast dealer or distributor for AXS delivery now!  
Call Electric Works Corp. for spec sheets and information at...

1-800-334-7823 or FAX 817-624-9741

AXS™ is a new product from the designers of *Digital DJ™*, *Super Log* and *Music Log*.

## USER REPORT

# TPR Targets Wheatstone A-500

by Tom Sittner  
Director of Engineering  
Texas Public Radio

**SAN ANTONIO, Texas**  
Texas Public Radio has two FM radio stations in San Antonio: KPAC(FM), which plays classical music, and KSTX(FM), which airs news and public affairs from NPR and APR, run-

ning BBC net overnight.

KPAC dates back to 1982. About half of the station's full-time programming is from CDs, and the rest is syndicated, network, and locally-produced shows.

KSTX went on the air from the same facility three years ago. Studio and office space were very tight, so a much anticipat-

ed studio move and equipment upgrade occurred last December.

Joe Gwathmey, the general manager wanted a technically-sound facility that looked professional and business-like and would last well into the future. We decided our money would be best spent upgrading the old audio consoles in the KPAC air

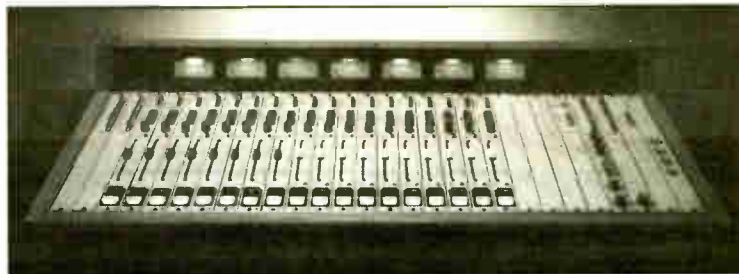

When Texas Public Radio looked to upgrade, it chose Wheatstone consoles and furniture.

studio and main production room.

The production room needed to produce multisource news bites and record interviews, debates and the occasional live

music group. In addition, furniture was needed for KPAC air and production studios and KSTX air studios.

We selected the **Wheatstone A-500** for the KPAC air studio and the **Wheatstone SP-44** for the production room. The A-500 is designed for on-air programming, while the SP-44 is a nice cross between radio production and recording studio consoles.

The Wheatstone furniture we selected was easy to assemble, and the two Wheatstone consoles slipped right in. The existing console from KSTX air resulted in a tight fit, but we made it work with a little cutting.

Wiring of the consoles went smoothly. We terminated the audio and control cables from the console connectors to 66 blocks located in the furniture.

It's important to wire the connectors on the console correctly the first time, as changing them can be tricky. We recommend wiring tools that are easy and fast to use, similar to the connector tool Wheatstone supplied.

The consoles are very clean and pass the program material transparently. We found, however, that the input buffers overload on high output devices.

The only way to control this is to lower the output level or pad the outputs on devices without level controls. It also would be nice if the console input level controls were on the buffer, not after them, and if there was a little more headroom.

Control logic muting and timer control is very flexible and probably handles any task asked of it. Headphone output level could be hotter, but it's adequate for efficient headphones. An outboard headphone amp is an easy cure for this, while it also supplies additional outputs for in-studio guests.

Non-LED lamps seem to burn out quickly, but there is a voltage adjustment for this in the power supply. Most lamps and indicators are solid state, with the exception of meter lamps.

Overall, we are very happy with these consoles. They are operator friendly, easy to install and sound great. The furniture looks sharp and Texas Public Radio is better than ever. And after seven months, yes, we would buy Wheatstone again.

□ □ □

For information, contact Ray Esparolini in New York at 315-452-5000; fax: 315-452-0160; or circle Reader Service 83.

# Studer unchains digital audio

**Introducing Dyaxis II™** Studer's 2nd generation digital workstation delivers real-time DSP power, unlimited channel capacity and immediate interchange between projects, in a modular multitrack system. Stack up to six 8-track systems for 48 tracks of simultaneous playback. Work with individual processors off-line, then combine all 48 tracks for final assembly.

Onboard Dolby AC-2™ 4:1 data compression lets you *Plug & Play™* optical removable media. Unleash your creative potential with the power of Dyaxis II. Call your Studer representative now for complete details.

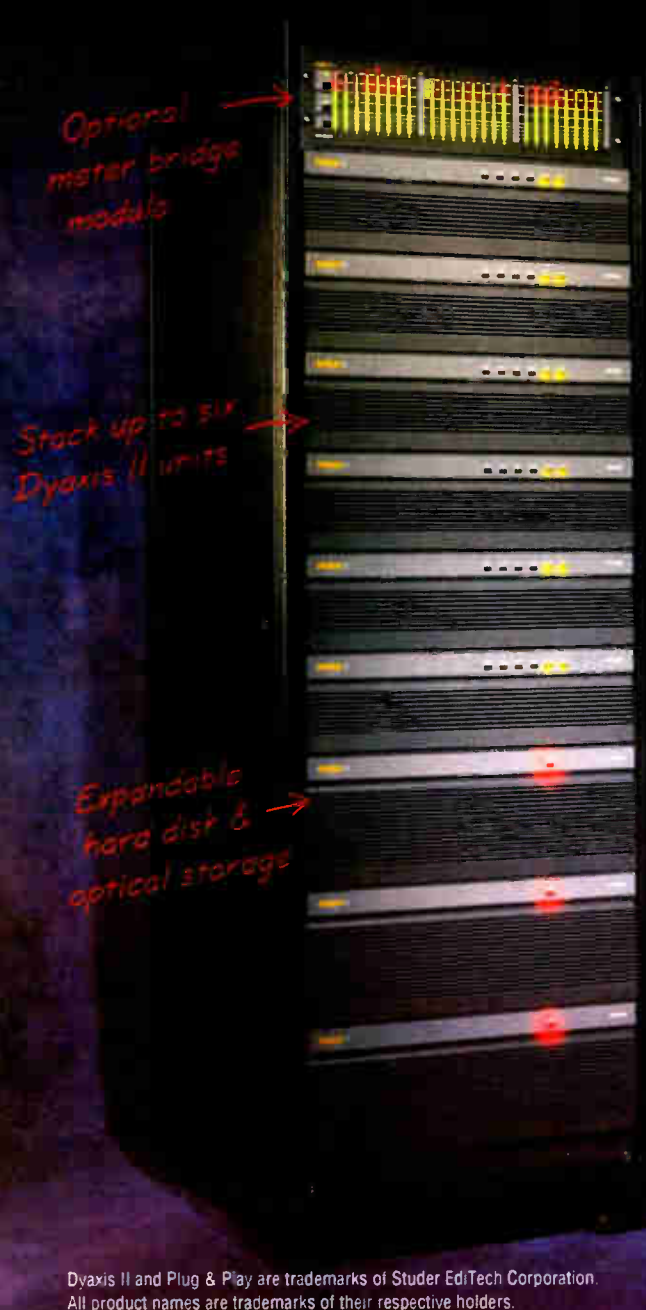

## STUDER

STUDER EDITECH  
1370 Willow Road, Suite 201  
Menlo Park, CA 94025  
415.326.7030 Fax 415.326.7039

STUDER REVOX AMERICA, INC  
1865 Air Lane Drive, Suite 12  
Nashville, TN 37210  
615.391.3399 Fax 615.391.5974  
New York 212.626.6734  
Los Angeles 818.703.1100

STUDER REVOX CANADA  
1947 Leslie Street, Toronto, Ont M3B 2M3  
416.510.1347 Fax 416.510.1294

Dyaxis II and Plug & Play are trademarks of Studer EdiTech Corporation.  
All product names are trademarks of their respective holders.

Circle (113) On Reader Service Card

World Radio History

# Products & Services Showcase

For more information on the products shown below, circle the appropriate Reader Service No. (s) on the enclosed Subscription/Reader Service card or contact the advertiser directly.

## RECORDABLE CDs

Convert from your old unreliable cart machines to Compact Discs

- ✓ INSTANT CUEING  
of station ID's and spots
- ✓ CONSERVE SPACE  
consolidate selected cuts
- ✓ ULTIMATE FIDELITY

AS LOW AS \$59.00 PER DISK!

Our system offers a unique partial recording capability. This means that a partially recorded CD can be removed and played on any standard CD player. As new program material becomes available it can be recorded on the same disk. Save money on discs while getting the flexibility and quality you need.

Third Story Recording  
5120 Walnut Street  
Philadelphia, PA 19139

1-800-497-DISK (3475)

READER SERVICE NO. 3

## NEW FROM TITUS TECH LABS THE SIMPLE TRUTH



### COMPOSITE AUDIO MONITOR

Very Fast—Wideband—Precision  
Baseband FM Stereo Level Measurements

- Accurately measures audio limiting and composite clipping levels
- Pilot and SCA injection levels
- Balanced, bridging, floating inputs
- scope, freq counter, peak hold outputs

AND MUCH MORE... CALL FOR DETAILS

**TITUS**  
TECHNOLOGICAL  
LABORATORIES

77 Kreiger Lane Glastonbury, CT 06033  
(203) 633-5472

READER SERVICE NO. 15

## MAX-Z II

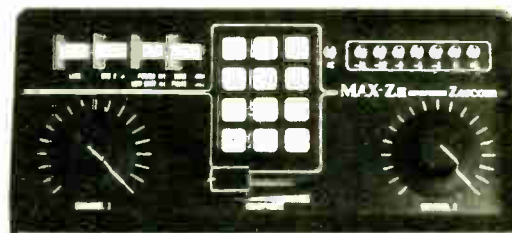

\$1,095 w/ case

The Zercom MAX-Z II is an abbreviated version of the famous Zercom MAX-Z Remote Broadcasting Telephone System. High quality audio handling is maintained in the two channels of audio input. Headroom, noise performance and distortion are comparable in quality to studio consoles.

Features of the 6 lb, 8"x9.5" unit include frequency response of 200Hz to 7KHz  $\pm 0.5$  db, 90Hz to 12KHz  $\pm 1.5$  db; noise floor of -70 dbm with 0 dbm line level input, -61 dbm (mic level input); and harmonic distortion of 0.35% or less and intermodulation distortion of 0.2% or less. Head room is 16 db above 0 VU.

**ZERCOM**

Box 84, Merrifield, MN 56465 • 218-765-3151

READER SERVICE NO. 132

## SOUND YOUR BEST ON THE AIR!

### CART MACHINE SERVICES:

**CART MOTORS REBUILT** to quiet flutter-free perfection—shafts resurfaced  
Single \$120.00 Triple \$140.00

**CART HEADS RELAPPED** guaranteed to perform like new

Same day turnaround

Replacement heads and motors available

### REEL TO REEL SERVICES:

**HEADS RELAPPED** and precise digital/optical

**ASSEMBLY ALIGNMENTS**

performed for maximum

response & head life

**CAPSTAN & REEL MOTORS REBUILT**

for MCI, OTARI and more.

For peak performance from your recording equipment, call  
The Audio Magnetic Professionals.

**AMP**  
SERVICES

224 Datura Street, Suite 614, West Palm Beach, FL 33401  
Call 1-800-826-0601 for "Same Day Service" in Florida (407) 659-4805  
Authorized Parts Dealers for: MCI • OTARI • TEAC/TASCAM

READER SERVICE NO. 59

## ARE YOUR LIGHTS ON?

The FCC requires that towers be lighted in accordance with the provisions of the station license. The Commission specifies (Section 17.47) that licensees shall make an observation of the tower lights at least once every 24 hours either visually or by observing an automatic and properly maintained indicator. The indicator should register any failure or malfunction of the tower lights.

Obstruction Lamp Alarm Relay  
SCR490D



**SSAC inc**

SOLID STATE TOWER LIGHTING CONTROLS

Senses Failed Obstruction Lights  
2 to 9 Steadily Burning Lamps can be Monitored

\$86.49

Universal Light Alarm Relay  
SCR430T



\$86.49

Shorted Flasher Alarm Relay  
SFA430T



\$74.89

Senses Flashing Beacon or Obstruction Lights  
Switch Selectable Number Voltage, and Wattage of Lamps

Senses a Constantly ON Beacon  
Operates with SCR430T to Provide Complete Beacon Monitoring

Max. Retail Price  
3341 S. Division Avenue  
Grand Rapids, Michigan 49508

1-800-999-9281



**AUDIO**  
BROADCAST  
GROUP

Southeastern Sales Office  
200 Foreway Drive, Suite 200  
Smithfield, North Carolina 27577

1-800-369-7623

READER SERVICE NO. 117

## DIELECTRIC

### FM Antennas

- \* Directional or Omni Patterns
- \* Single or Multistation
- \* Variable spaced for limited apertures.
- \* Stainless Steel Construction
- \* 5 year warranty on complete systems

Providing antennas, filters, combiners, switches, loads and transmission line to the broadcast industry worldwide for over 40 years.

**DIELECTRIC COMMUNICATIONS** **Gs**

1-800-341-9678

P.O. Box 949

FAX 1-207-655-7120 Raymond, Maine 04071

READER SERVICE NO. 201

## Byte it with



A Digital Recorder specifically designed to record phone calls and play them back quickly and easily.

Fast nondestructive editing.

Easy access and fast stacking of bits.

The most powerful way to record and air phone-bits.

**The Blue Group**

1001 Ridge Avenue  
Clearwater, FL 34615  
TEL 813.442.1665

READER SERVICE NO. 87

## Take Control...

The Jr. Audio Director provides output source selection between Left Only, Right Only, Mono, Stereo, and Stereo Reverse. Installation is easy, using the plug-in Euro-style barrier strip.



\$390.00

**BENCHMARK MEDIA SYSTEMS, INC.**

315/437-6300 800/262-4675 FAX 315/437-8119

### Features/Functions

- Stereo (normal)
- Mono
- Left Only
- Right Only
- Stereo Reversed
- Right Channel Polarity Inversion
- Rackmountable
- Built in mono mode gain reduction
- LED Indicators
- Balanced I/O's

*Benchmark*  
...the measure of excellence!<sup>TM</sup>

READER SERVICE NO. 133

## USER REPORT

# Dateq BCS 100 Proves Workhorse

by William Pawner  
Technical Manager  
NLB Radio

## GOUDA, the Netherlands

Part of my job as technical manager of NLB Radio involved selecting a new console for our radio station when our old console required replacement. It was a challenging job; with all the consoles currently available, often "you can't see the forest because the trees get in the way."



BCS 100 broadcast console

To make a good and fair comparison between the various models and brands of consoles, we conceived a practical scoring system. The system simply allowed us to award points for each console's ability in meeting our carefully considered technical and user-friendliness criteria.

It was very important that the console properly suit the many needs of our station. For example, we are not trendsetters; we wanted our new console to be a friendly workhorse that would work, and work, and work...

The console also had to be very serviceable. We don't expect our equipment to break down, but when it does, we want to get it fixed...quickly.

Another important consideration was user friendliness. We wanted the console to be conveniently arranged so all our engineers and announcers could work very quickly and easily. We didn't want a huge array of knobs and switches that would only distract the user and never be utilized.

Only at the last stage did we turn our attention to the price of the console. After totaling up the scores of almost all the consoles currently available, we

determined that the Dateq BCS 100 came out on top.

In the Netherlands, we've known Dateq for some time as a well-respected and long-established manufacturer of high quality pro audio products, specializing in broadcast products.

The company's most well-known products are the BCS 100 and the BCS 200 broadcast consoles. These consoles employ the very latest techniques in construction and design and are built to suit the demands of the professional broadcaster.

Both the BCS 100 and BCS 200 feature a unique "Dynamic Bus Assign System," ensuring the lowest possible noise floor. The BCS series consoles utilize extremely low distortion VCAs. All the modules are connected to a motherboard using gold-plated connectors with high RF immunity.

We also discovered that Dateq's newest and most cost-effective design, the BCS 50, will be exhibited at the AES Convention in New York.

In regards to our success with the BCS console, we can recommend it to any station considering a new console.

□□□

For information on the Dateq console, contact Barry Fox or Scott Berdell at QMI in Massachusetts at 508-435-3666; fax: 508-435-4243; or circle Reader Service 176.

## INDUSTRY ROUNDUP

## Today's Consoles Offer More Features to Users

by Mark Strausberg

**WASHINGTON** Today's broadcast consoles are more versatile than the earlier model boards that went before them. In addition to providing all of the functions as consoles of previous years, the new units have a variety of new features, a smaller size and a more affordable price tag.

The modifications of consoles is an ongoing process, with things changing quite rapidly, according to Murray Shields, director of sales for Auditronics. Current consoles are different from their predecessors, while these will be different from those of the future, according to various console manufacturers.

New features are constantly emerging and many people feel the new consoles must fill certain requirements—especially reliability and ease of service.

With the decline in number of studio engineers, consoles must be as simple as possible, both in terms of use and service, said Paul McLane, sales manager for Radio Systems.

"This is the digital era we're in, and the audio quality needs to be at least as good, if not better, than the digital quality of the source received," he said.

An issue that goes hand in hand with reliability is money. Station managers want the best consoles for the best price with the most features, many manufacturers said.

## USER REPORT

# LPB Receives the Nod-Again

by Art Blum  
Chief Operator  
KONA-AM-FM

**RICHLAND, Wash.** I've held the position of chief operator of KONA-AM-FM for the last five years. I'm responsible for keeping the station equipment operating, even though I'm not a chief engineer. If equipment doesn't work, we call contract engineers.

Because of the expense in hiring these professionals, people with less technical skills are often responsible for keeping the stations on the air.

When we remodeled our AM control room, a LPB S-13 console was chosen for a number of possible inputs. The consoles need very little maintenance, making my job easier and decreasing our need for contract engineers.

In addition, as the information station in our area, we run many different sources and programs through the board during our news blocks each day.

Our operators are kept busy recording programs from multiple sources, at the same time they are playing other features. Just about all sources appear somewhere on the console.

When we remodeled the two production rooms, all operators were questioned for suggestions on requirements and features of boards. The unanimous choice was LPB again. Both of our production rooms are heavily used all day, and they can double as control

rooms for either AM or FM if the need arises.

Both production LPB boards were wired as close to the control console configurations as possible. This makes it very easy for all operators to move from studio to studio, knowing all equipment appears the same place on each one.

One of the handiest features of the LPB boards is the

changed automation equipment. There was much discussion regarding whether the automation should be a source on the board or if the board should be a source on the automation. We decided to run the FM automation through a board, and a LPB S-13 was again the choice.

The new automation equipment uses 20 CD players with

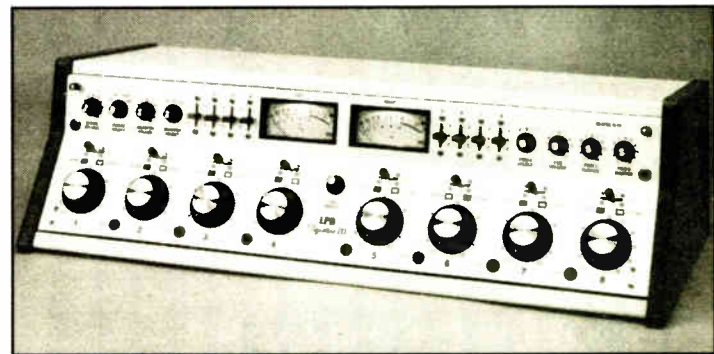

KONA-AM-FM considers its LPB console a trusted friend.

stereo/mono switch for each channel. Just under the top cover, behind each pot, is the switch that sets stereo or mono.

If you have a source in stereo, but you need a mono dub, a flick of the switch makes your source mono. With an AM and FM both in stereo, we're switching back and forth all the time.

With the standardization of the three LPB boards, maintenance was simplified. Of course, there wasn't much maintenance needed anyway. I can remember replacing the mic switch once, after an operator took his anger out on it.

Last January, we again

six CDs per unit as the music source. It uses a computer hard disk for commercials, liners, news, weather and sports.

All of this digitally-originated audio goes through our stereo LPB board and sounds outstanding, even to the station owner's discriminating ear. Now we have four LPB boards, and when we need the next one, we'll choose LPB.

□□□

For information, contact John Devecka in Pennsylvania at 215-644-1123; fax: 215-644-8651; or circle Reader Service 97.

"Console buyers are more concerned about cost than they were five years ago, and they are looking for more bang for their buck," said Scott Martin with Fidelipac.

One way for stations to purchase a console at a reasonable price is with a limited function console. This idea is particularly popular with smaller radio stations, said John Devecka, sales manager with LPB.

But he believes the sound quality of these consoles will not satisfy stations in the long run, with the trend going toward better production and on-air modules.

More tangible features in today's consoles include remote control and digital logic. According to McLane, broadcasters are doing more with fewer channels with on-air delivery and hard disk storage systems.

Mike Dosch, general manager for Pacific Recorders & Engineering, said current consoles deal with a wider range of source equipment, such as CDs, carts, DAT, reel-to-reels and hard disk recorders.

"They're more capable than before but they take up a lot less real estate," said Dave Buck, audio sales manager for Broadcast Electronics.

And the future will lead to even more advancement, many manufacturers said. Soon, playing digital radio through consoles will become more mainstream in radio stations, McLane said.

Martin thinks consoles eventually will proceed down one of two paths: towards computer integration and high digital capability, or toward extinction and replacement by other studio equipment.

Dosch predicts more communication between consoles and source equipment, and specialized features and mixes may evolve as programming requirements change.

"Console technology is driven by the requirements of radio, not the other way around," he said.





Come to grips with audio production that makes sense.

**N**ow's the time to get your hands on SoundLink - the first Random Access Digital Multi-track system with all the critical functions you need at a price you can live with.

An all-in-one system, SoundLink provides hard disk recording, mixing, nondestructive editing, signal processing and MIDI recording in one comprehensive and affordable package.

If you want a whole new feeling about digital audio production, please call Broadcast Supply Worldwide and ask to talk to our digital specialist.

**Come and see SoundLink at  
NAB booth # 339**

**SoundLink**  
**KORG**  
Professional Audio

*Equipment Solutions To Keep You Number One*

**BSW**

BROADCAST SUPPLY WORLDWIDE

Phone 800 · 426 · 8434

7012 27th Street West Tacoma, Washington 98466

Fax 800 · 231 · 7055

Circle 138 On Reader Service Card  
World Radio History

# TECHNOLOGY UPDATES

## BROADCAST ELECTRONICS

### AT-90 Table-Top Consoles Permit All Channels To Support Mic and Line Level Input Signals

**QUINCY, Ill.** The AT-90 family of consoles by Broadcast Electronics consists of six-, eight-, 12-, 18- and 24-channel versions. All units, which are table-top consoles, use the same remote, rack-mounted power supply. In addition, a combiner unit is available for dual power supply operation.

When designed, the AT-90 consoles were conceived as products with the same quality level and user friendliness

as in the top-of-the-line MT-90 console, but in a non-modular format. The consoles were also designed as solid state audio switching/DC control products in terms of the on-air signal.

All channels support both microphone and line level input signals, with source type intermixing possible at the input level.

Each of the three inputs per channel has separate remote machine control and supports sustained and momentary con-

trol requirements.

A polycarbonate overlay work surface with color-coded LED illuminated switches provides for an easy-to-use board.

The AT-90 also includes both mono and stereo output feeds for program and audition lines and a separate mono mix minus line. Fader cue and eight station headphone and control room monitor-



ing are provided for the board operator. For information, contact Dave Buck in Illinois at 217-224-9600; fax: 217-224-9607; or circle Reader Service 168.

## SOUNDCRAFT

### B100 Audio Mixing Console Offers 8- or 16-Input Frame Sizes, Mono or Stereo Inputs

**NORTHRIDGE, Calif.** The Soundcraft B100 is an audio mixing console for broadcast quality stereo recording or sound reinforcement. The B100 evolved from the BVE 100, which Soundcraft recently introduced in expanded frame sizes.

The B100 is ideal for studio or location mixing. Available in either eight or 16 input frame sizes, the modular console offers mono or stereo inputs.

Mono input modules have three-band EQ, high-pass filter and two auxiliary sends with selectable pre- or post-fader switch. Stereo inputs have two-band EQ with switchable frequencies and a high pass filter, and two aux sends.

The master module includes two auxiliary busses, a stereo bus with mono sum, a monitor phones/control room output with phase meter, and a mono switch and two stereo returns to mix. Six additional

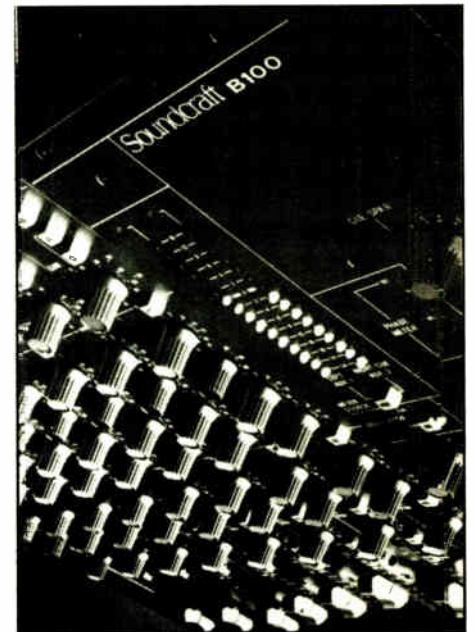

stereo sources can be monitored via headphones or the control room output.

For information on the B100, contact Soundcraft at 818-893-4351; fax: 818-893-3639; FlashFax™: (818) 895-8190; or circle Reader Service 92.

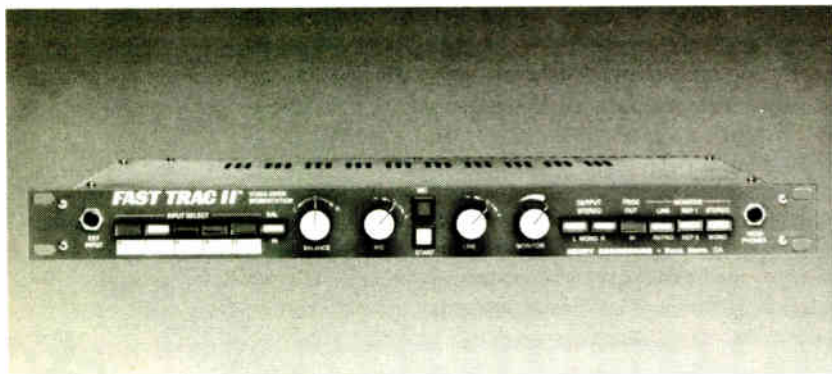

## Studio-In-A-Box.

Fast Trac II by Henry Engineering is an incredibly useful audio management system that has numerous applications in radio and television audio.

Fast Trac II functions as a stereo switcher, audio mixer, utility dubbing center, voice-over recording system, compact production facility, or as the "control head" of a multi-track digital editing workstation.

Fast Trac II incorporates all of the functions of a typical audio mixing console: input selection, level and balance control, mic-over-line mixing, and complete monitoring. Additional

features make Fast Trac II perfect for specialized broadcast production tasks. Automatic "ducking" permits efficient voice-over recording. The timed auto-start Machine Control System for source and recording equipment creates perfectly cued dubs reliably with one button ease.

In a nutshell, Fast Trac II is a complete 2-pot console "studio-in-a-box." Call the audio professionals at Harris Allied for all the details.

8:00 a.m. to 8:00 p.m. EST

1-800-622-0022

Fax 317-966-0623

**HARRIS ALLIED**

© 1993 Harris Corp.

## FM BROADCASTERS!!

We can meet all your FM transmitter needs!!



### SOLID STATE

Amplifiers and transmitters are available at the popular levels of 30, 100, 300, 500, 1000, 2500, and 5000 watts. All units are broadbanded and designed for local and remote operation.

### ZERO BIAS GROUNDED GRID TRANSMITTERS

#### SINGLE TUBE—MEDIUM POWER

Offered at 1.5, 3.5, 5.5, 7.5 and 12KW. These transmitters include a broadbanded solid state IPA, which can be used as emergency transmitters and a single zero biased grounded grid triode in their PA.



#### TWO TUBE—HIGH POWER

These transmitters utilize two grounded grid triodes and are available at standard outputs of 15, 22, 25, 30, 40 and 50 KW.

"The Transmitter People"

**Energy-Onix**

752 Warren Street, Hudson, New York 12534  
(518) 828-1690 FAX (518) 828-8476

A Wise Enterprise

VIRTUAL CART 1		PLAY	REC	LOG	UTILS	SHELF			
4 Th.Light End Voc		00:50		Jingle Pack		Promotions	Trails	Pack-ages	Dave Winds.
16 Most Music/BFBS		00:04		Permanent Blank		10 BFBS Sting	11 BFBS Sting	Eng Test	Fill Carts
VIRTUAL CART 2		500		1 Main Theme		:52.3 Instrumental	3.1	: 2.9	3.8
No Card Available		00:00		2 Main Theme		:52.2 Vocal	3.2	: 3.2	3.4
				3 Main Theme		:52.3 End Vocal	3.3	: 4.4	4.7
				4 Main Theme (Light)		:50.6 End Vocal	1.6	: 2.8	3.2
				5 Main Theme (Rock)		:52.5 End Vocal	3.3	: 4	4.2
				6 Short Main Theme		:13.5 End Vocal	4.3	: 4.5	4.8
				7 Short Main Theme		:13.7 No End Vocal	4.5	: 3.5	4.2
				8 BFBS Sting		: 2.2	2.8	: 2.5	2.7
				9 BFBS Acap		: 1.6	1.7	: 1.5	1.0
				Load Break in Cart 1		46		5 mins to 12	
				#1 #2 #3		14			
				(c) S.S.U.C. 1991-1993					



# The Dynamax AIR MARSHAL Digital Audio Hard Disk System

- Superb Audio Quality
- Standard Configuration Stores 8 hours of Stereo Audio
- User Friendly, Intuitive Interface
- Designed for Broadcasters by Broadcasters
- Flexible and Easily Expandable at Low Additional Cost
- Simultaneous Play, Record and Audition, With Up to 8 Audio Outputs/Unit
- Satellite Programming Compatible
- Robust, Proven Software in Use by British Forces Broadcasting Service
- Manufactured, Supported and Warranted by Fidelipac
- \$8950 or About \$300/Month Including Maintenance Contract

Visit Fidelipac at the NAB Radio Show or Call Today.



**DYNAMAX**<sup>TM</sup>  
BROADCAST PRODUCTS BY FIDELIPAC<sup>®</sup>

Fidelipac Corporation □ P.O. Box 808 □ Moorestown, NJ 08057 U.S.A. □ TEL 609-235-3900 □ FAX 609-235-7779

## COMREX

### Talk Console Puts Callers On Air in Compact, 4-Channel Mixer Ideal for Non-Technical Users

**ACTON, Mass.** The Comrex Talk Console incorporates all functions needed to put callers on the air in a compact, four-channel mixer.

Channel 1 connects a host microphone, while channel 2 handles either a second mic or a choice of line level inputs. Dual

hybrids are on channels 3 and 4, which conference two callers into the program; each caller level is separately controllable.

"Mix-minus" is included so callers don't hear themselves fed back on the phone line. Calls can be placed through a built-in dial pad, with incoming calls signaled both by a tone and a blinking light. There are also two headphone outputs and two separate program outputs.

The Talk Console, which sells for



\$2,495 (list), can handle everything from recording a traffic report to a full-blown talk show.

In addition, the unit is designed for "non-technical" people who want to syndicate programs from their home or office.

For further information, contact Lynn Distler in Massachusetts at 800-237-1776; fax: 508-635-0401; or circle Reader Service 104.

## WARD-BECK SYSTEMS

### RENAISSANCE Consoles Fit Desktop Radio Environments

**ONTARIO, Canada** The RENAISSANCE series of radio broadcast consoles by Ward-Beck Systems includes illuminated electronic switching and Penny and Giles actuated VCAs.

A digital shaft encoder controls the monitor VCA, while comprehensive tally/control logic makes the series ideal for integration into the desktop radio broadcasting environment.

Three standard mainframe sizes (eight, 16 and 24 input channels) provide a selection of output busses, including four stereo masters, four mix-minus sends, one stereo and one mono auxiliary send. Utilization of the busses is determined by the type of input modules installed.

For information, contact Eugene Johnson in Canada at 416-438-6550; fax: 416-438-3865; or circle Reader Service 158.

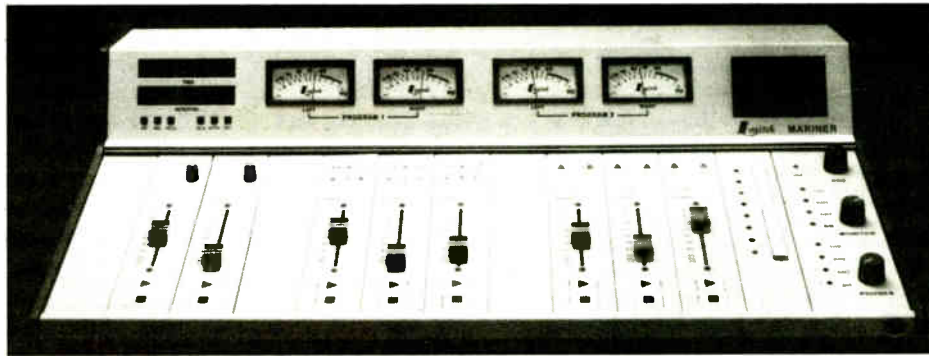

## LOGITEK

### Mariner On-Air Console Upgrade Highlights DCA Faders for Clean Sound

**HOUSTON** The newly enhanced Mariner on-air console, features improved performance and reduced cost while providing an interface to the expanding digital world.

The Mariner, produced by Logitek Electronic Systems, introduces the company's DCA (digitally controlled analog) fader technology. In this system, the fader position is measured by a small microcontroller in each mixer and then multiplied with the analog audio signal to create the

desired volume level.

DCA faders help provide the clean sound of direct audio faders without the problems of scratchy pots or zipper noise. The DCA faders also help provide reliability and precise left to right tracking without high noise and distortion.

An optional interface card allows complete control of the console's push buttons and gain levels via a standard serial port, making connection to computer-based music and automation systems easier. Another console option allows RDS information or song titles to be displayed above each mixer.

For information, contact Tag Borland in Texas at 800-231-5870; fax: 713-782-7597; or circle Reader Service 130.

## AEQ

### BC-500 Modular Design Permits Servicing While On-Air Mixing Console Remains in Operation

**TEMPE, Ariz.** The AEQ BC-500 mixing console, designed for radio stations seeking quality at a competitive price, features a modular design for flexibility and specialized modular functions.

One of the six double stereo modules may be placed anywhere in the BC-500 chassis. If a particular module needs service, it may be taken out, serviced, and replaced without interruption to the console's operation.

The BC-500 offers fader-controlled VCA, transformer balanced mic/line inputs, RF filters in the microphone inputs and interfacing for external tele-

phone hybrid input/output. One main stereo output and one stereo auxiliary output are included.

The unit comes with a standard chassis for 18 modules. The standard configuration offers four mono modules, six double stereo modules and a chassis with VU-meters and monitors. The BC-500 comes with four blank modules, and its monitoring and intercommunication modules include power supply.

For information, contact Gerardo Vargas in Arizona at 602-431-0334; fax: 602-431-0497; or circle Reader Service 34.

A Broadcast Industry

# BEST BUY

Mono Play

**\$920**

Stereo Play

**\$1000**

F.O.B. Factory

Reliable / Rugged / Professional Design

- All Metal Housing with Cast Aluminum Front Panel
- Half Inch Thick Aluminum Deck with Stainless Steel Overlay
- Air-Damped Solenoid with Telfon™-Coated Plunger
- Direct-Drive Capstan Motor
- Three-Point Adjustable Head Mounts
- Output Transformers
- CMOS Logic
- Straightforward / Serviceable Design
- Compact Size (1/3 Rack Width)
- 30-Day Guarantee of Satisfaction / 1-Year Warranty



**AUDI-CORD CORPORATION**

1845 West Hovey Avenue, Normal, Illinois 61761 USA  
Phone 309-452-9461 - Fax 309-452-0893

Available Through Your Regular Distributor

Circle (200) On Reader Service Card

## SIX Lines no Waiting.



**SIX** complete lines of studio furniture, from economical to elegant. Shipped in as little as two weeks.

**THE EXPRESS GROUP. (619) 298-2834**

Circle (56) On Reader Service Card



**DESTINY  
2000**

## **What Would You Call A Console That Re-Invents Live Radio?**

**It looks like a console but it isn't...  
It works like a hard disk system but it's more...**

**Sure, it looks simple. But that's because all the "brain power" is built into the software. In fact, Auditronics' Destiny 2000 is so different from anything you've seen in your air studio up until this point that we almost have to make up new words to describe it.**

- **Call it Revolutionary**

Take the familiarity and comfort of your control room console and add the capabilities and streamlined control of today's most efficient hard disk system. Mix in equal parts Live Assist, Automation and Manual control. Add a generous amount of economy and that's the Auditronics Destiny 2000: a revolutionary product for your air studio that speaks directly to your bottom line.

- **Call it Profitable**

Switch from live drive-time to automated overnights in an instant, with no additional equipment and no extra costs. And each Destiny 2000 module has multiple smart functions so you get more bang for the buck.

- **Call it Effortless**

No more problems getting all your digital sources talking to each other. Destiny 2000

integrates your spot load, CD jukeboxes, even digital boxes of the future into one smooth system that won't let you down.

- **Call it Smart**

Destiny 2000 does the thinking on routine tasks so your talent can focus on making your drive time a ratings winner. It's easy to operate, and simple to switch between manual, automation and live assist. Say good-bye to operator error.

Now call Auditronics at 901-362-1350 and find out how Destiny 2000 fits your station's format and your budget.

**Stop by the Auditronics booth at the NAB Radio Show and see the premiere of Destiny 2000!**

**THE AUDITRONICS DESTINY 2000:  
A WHOLE NEW WAY OF DOING BUSINESS**

**AUDITRONICS**  
3750 OLD GETWELL RD • MEMPHIS, TN 38118

# MARKETPLACE

A compendium of new and recently introduced radio broadcast products

## Surge Suppressor Plugstrips

The IPS-3 Series of Industrial Surge Suppressor Plugstrips by EFI are designed for manufacturing, warehouse and other "non-office" applications.

Made for heavy-duty use in a 120V AC, single-phase, direct plug-in environment, the IPS-3 Series consists of anodized-aluminum housing. It may be mounted either on the floor or 1/4-inch from a wall, cabinet or machinery surface with standard push-and-slide mounting brackets.

Each unit provides an industrial-grade ON/OFF switch, resettable circuit breaker, dual thermal fuses and a diagnostic LED for active suppression indication.

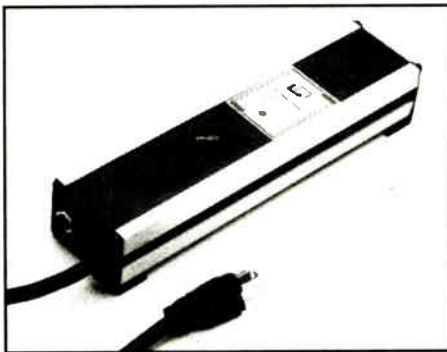

For more information, contact EFI in Utah at 800-729-3496; fax: 801-977-0200, or circle **Reader Service 149**.

## Digital Recorder

Phone Byte by BLU Electronics is a digital recorder designed to record phone calls and play them back as needed. The unit automatically lists the number of the recording, which can later be retrieved in a search.

Phone Byte also records the time and date of each recording, allowing you to later search for a particular recording by the time it was made.

Inputs include record, stop, play, quick audition, start mark and end mark. Outputs include recording now (for lights only while recording), end playback (to mute console, momentary) and start playback (to turn on console channel, if desired).

Phone Byte uses high quality PCM recording with a Dolby AC 2 option. And the system uses a Graphical User Interface (GUI), similar to Windows.

For information, contact BLU Electronics at 813-442-1665 or circle **Reader Service 136**.



## Photocontrols for Tower and Antenna Lighting

Precision Multiple Controls manufactures a line of high quality photocontrols for radio tower and antenna lighting.

The photocontrols satisfy FAA specifications for flashing red obstruction lights at 35 foot candles "ON" and 57 foot candles "OFF." The units are also available for white signal lights at two foot candles "ON" and six foot candles "OFF."

The complete line of photocontrols comes standard with MOV surge protection.

For more information, contact Precision Multiple Controls in New Jersey at 201-444-0600; FAX 201-445-8575; or circle **Reader Service 78**.

## FM ANTENNAS

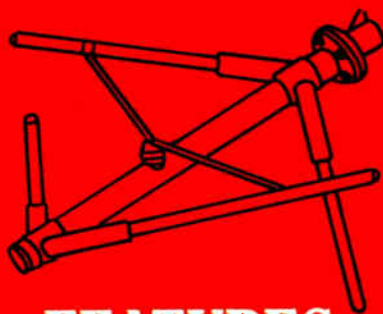

## FEATURES

Multi-Element Arrays

Input Powers from 100W to 240 kW

Circular, Vertical, or Horizontal Polarization

Custom Directional Antennas

Quality Construction Built to Last



**1-800-762-7743**

Systems With Reliability

Transmission Lines & Antennas  
Celebrating Our 25th Year

Cambria County Industrial Park  
Ebensburg, Pa. 15931-0856  
Fax: 814-472-5552

Circle (24) On Reader Service Card  
See Us At NAB Radio Show Booth 331



## Peak Power Meter

Upgrades to the Boonton 440 Peak Power Meter include 14 automatic power and time measurements for instant characterization of pulsed power signals from 30 MHz to 40 GHz.

Pulses can be captured with rise times of 10 nsec with its 47 dB of dynamic range.

For automatic measurement of minimum and maximum power levels, vertical time marker functions were expanded. The 4400 also performs continuous RMS integration on the area between these markers to determine the true average power within this area.

A new "peaking-mode" is provided, extending the analysis capabilities on the slower timebase settings.

For more information, contact Boonton Electronics Corp. in New Jersey at 201-584-1077; fax: 201-584-3037 or circle **Reader Service 125**.



## DO YOU KNOW YOUR MARKET? YOUR COMPETITION DOES!

### DATAWORLD MAPS CAN

- Depict your coverage!
- Market orient your sales people!
- Target your ethnic/demographic markets!
- Identify marginal signal areas!
- Plot any special requirements!

### MAP OPTIONS

- SHADOWING (TERRAIN SHIELDING)
- CONTOUR COVERAGE
- POPULATION DENSITY
- ZIP CODE BOUNDARIES
- RECEIVED SIGNAL LEVEL
- SPECIAL REQUIREMENTS

**dataworld**  
A Service of DW, Inc.

(301) 652-8822 (800) 368-5754

Circle (12) On Reader Service Card  
See Us At NAB Radio Show Booth 340/342



## Microwave Monitor

The HI-3520 Microwave Monitor by Holaday Industries Inc., is a pocket-sized, battery operated, non-ionizing radiation hazard detector.

The unit is able to detect electromagnetic radiation from RF and microwave sources in the 1 GHz to 18 GHz frequency range.

Potentially hazardous fields include areas around microwave ovens, medical equipment, radar installations, microwave heaters and dryers, communication systems and electronic warfare systems.

For more information, contact Holaday Industries in Minnesota at 612-934-4920, or circle **Reader Service 52**.



a leading Italian and European manufacturer of audio broadcasting equipment, particularly aimed at FM radio studios, is looking for dealers willing to market its products all over the US territory.

**AEV** Snc  
via Saviolo, 1/E  
I-40017 Le Budric di Persiceto, Italy  
tel. +39-51-950249 +39-51-950350  
fax +39-51-950201

Circle (106) On Reader Service Card

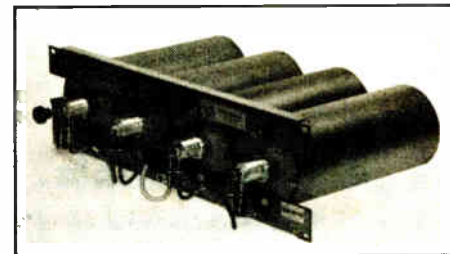

## UHF Duplexer

TX RX Systems Inc. introduced a low-loss, high-isolation Vari-Notch® duplexer, Model 28-70-02A.

Electrical specifications include 100 dB isolation per channel with 0.6 dB of total insertion loss. Mobile versions of the circuit duplexer are also available.

Other products patented by the company include the Series Notch/EMF Circuit, T-Pass Multicoupler System, Multicoupler Peg Rack and Tower Mount Preamp Backup System.

For more information, contact TX RX Systems Inc. in New York at 716-549-4700; fax: 716-549-4772; or circle **Reader Service 42**.

## Paging Protocol

Motorola's Paging Products Group of Boynton Beach, Fla., introduced the FLEX™ High Speed Paging Protocol, a new universal paging protocol for transmission of digital data to a radio receiver.

The protocol offers increased transmission speed, flexibility, improved data integrity and improved battery life. It operates at three different speeds: 1600, 3200 and 6400 bits per seconds.

The unit supports in excess of 600,000 numeric pagers per paging channel at typical U.S. rates.

The FLEX™ protocol is compatible with the majority of paging systems worldwide. It can be installed at bit rates as low as 1600 bits per second for mixing with existing POCSAG and GOLAY protocols.

For more information, contact Dan Blaton in Florida at 407-364-2895 or Jack Indeku at 407-364-3386, or circle **Reader Service 139**.

# MARANTZ CDR600 Compact Disc Recorder



Finally, a CDR for everyone  
at a price for anyone.

## Under \$3500

*In Stock At Your New Digital Headquarters*

# LPB<sup>®</sup>

28 Bacton Hill Road, Frazer, PA • (215) 644-1123 Phone • (215) 644-8651 Fax

## AUDITRONICS

### Destiny 2000 Helps Move Consoles into Digital Age By Interfacing with All Station Source Equipment

**MEMPHIS, Tenn.** The Destiny 2000 digitally-controlled console by **Auditronics** helps solve one of the biggest problems posed by the introduction of digital products into a radio station: system integration.

The unit, designed for the live-assist user, helps provide stations with power and the advanced technology of computers.

This on-air console can interface to a hard disk system, CD jukeboxes and source equipment. Every function of each console channel is under direct control of the computer, including input selection, channel ON/OFF and level control.

This permits the volume level of each channel to be under the direction of the system software, allowing for adjustments in the level required when recording mismatches on an event-by-event basis, or even fades and cross-

fades.

The unit's "device independence" helps ensure that all source equipment currently available can be connected to the system without the need for software rewrites.

The Destiny 2000 uses the Computer Concepts DCS system for all commercial and short-length audio material storage. The console features three modes of operation: Assist, Auto and Live.

The Assist mode allows the computer to precue each event in the source machine, but the talent is in full control of starting each element from the console's On button. In the Auto mode, the computer operates and starts each event at the EOM (end of message) of the previous event. Even in a live or mostly live show, this mode can be used to give talent some "walkaway time." In Manual mode, the Destiny

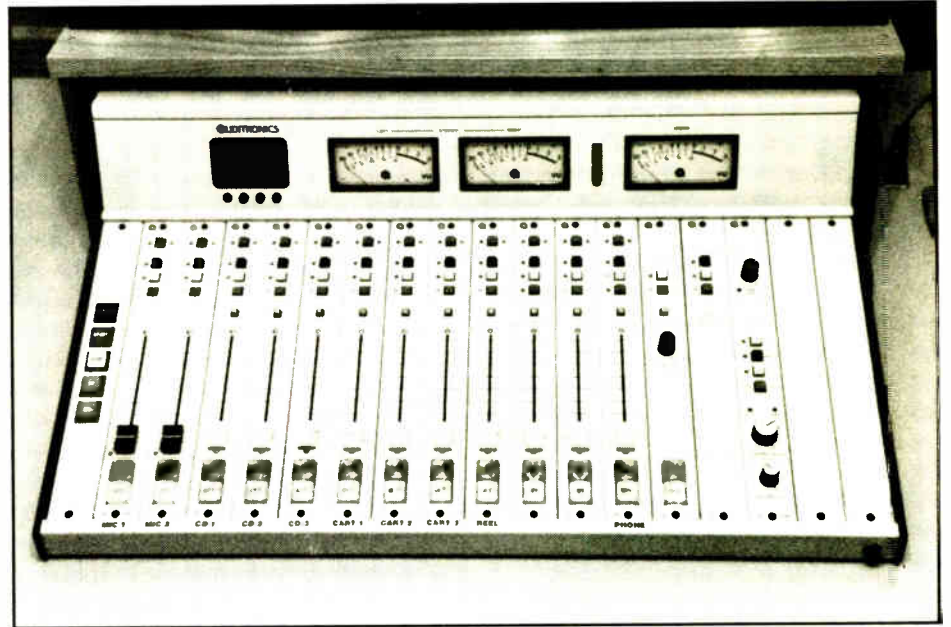

2000 becomes a standard manual console.

The Destiny 2000 uses a state-of-the-art DCA (Digitally Controlled Amplifier) to replace the VCAs often used in

other consoles. But several advantages of the VCAs remain: freedom from "scratchy" pots, good stereo tracking and the ability to be externally controlled.

For information on the Destiny 2000, contact Murray Shields in Tennessee at 901-362-1350; fax: 901-365-8629; or circle Reader Service 88.



## HENRY ENGINEERING

### Studio-in-a-Box: The Fast Trac II Combines Functions of Typical Audio Mixing Consoles

**SIERRA MADRE, Calif.** The new "Fast Trac II" Voice-Over Audio Workstation by **Henry Engineering** is designed for use as an audio mixer, stereo source switcher, voice-over recording system, utility dubbing center or as the "audio control head" of a multi-track digital editing system.

The workstation, which is essentially a compact "studio-in-a-box," incorporates many of the functions of a typical audio mixing console: input selection, level

and balance control, mic-over-line mixing and comprehensive monitoring.

There are inputs for six stereo line sources (tape, CD, DAT, etc.) that are push-button selected. The level and stereo balance of any line source selected are controlled using the line gain and balance controls.

The unit also has a mic input, and mic audio is controlled with the mic gain control and a mic ON/OFF push button. Mic audio can be mixed over any line source and the automatic "ducking" function can be used for voice-over recording. When the mic is turned on, line-audio is automatically reduced to a preset level.

One of the most unique Fast Trac II features is the automatic Machine Control System. When used in a dubbing

application, the system automatically starts both the source machine and the recorder to ensure perfectly-cued dubs with one-button ease. Pre-roll requirements of either machine are compensated for automatically.

The Monitor system permits monitoring of the main line outputs or either of two external sources, such as tape playback. Stereo recordings can be monitored in mono to check for mono compatibility. The Fast Trac II provides monitor muting when the mic is on.

For information, contact Hank Landsberg at Henry Engineering in California at 818-355-3656; fax: 818-355-0077; fax-on-demand: 818-355-4210, request Document 116; or circle Reader Service 46.

## SONY

### DMX-B4000 Targets On-Air And Production Situations With Digital Abilities

**MONTVALE, N.J.** Radio broadcasters with eyes on the future view the onset of direct satellite broadcasting (DBS) and the expected introduction of digital audio broadcasting (DAB) with enormous attention. With this in mind, **Sony** developed the DMX-B4000 series broadcast console, which targets on-air and production applications.

The DMX-B4000 mixing console offers two frame sizes: the DMX-B4000, which provides eight stereo channels and integrates a 16-stereo input AES/EBU routing switcher, and the DMX-B4016, which provides 16 stereo channels and integrates a 30-stereo input AES/EBU routing switcher.

Features of the console include an easy-to-use touch panel and EL display, which provides pinpoint operation.

The console's automation capacity allows for 99 user setups that can be stored and recalled instantly. Additionally, the console provides an integrated 3.5-inch FDD with storage of the setup memory registers, allowing users to work from other DMX-B4000 consoles.

For radio applications, over-the-air sound matches the sophistication of the music played on the same station with the 32-bit internal processing capability and full implementation of the AES/EBU digital I/O 24-bit word length. Sampling rates include 44.056 kHz, 44.1 kHz and 48 kHz.

Other capabilities consist of level control, EQ, filters, phase reverse, delay, PGM output, control room output, studio output, AUX send and 20-bit analog conversion. And options include redundant power supplies, analog mic/line input modules, an integrated six-machine RS-422 controller, table-top mounting kits, mixer stand and a VU meter panel.

For information, contact your regional Sony sales office or call 800-635-SONY.

## WANT TO KNOW THE BEST KEPT SECRETS IN DIGITAL AUDIO STORAGE?

- What the Dow Jones, CBC, NBC and Westwood/Mutual Radio Networks and many other broadcasters all know about CA products, and why **you** should know, too?
- Why the HDS-1000 was designed from the start **without** any audio compression?
- Why the HDS-1000 **wasn't** designed around a PC?
- Why the HDS-1000 allows front panel access to all cards, and why the system is **fully expandable**?
- Why anyone who's been looking to replace cart machines, reel-to-reels, and even Go-Cart/InstaCart systems, without reinventing the wheel, should look at the HDS-1000?

Then call (309) 837-2244 or fax (309) 833-5175 and get the answers!

CLARK & ASSOCIATES, LTD.  
318 E. CALHOUN  
MACOMB, IL 61455



Circle (167) On Reader Service Card

## TRUE VARIABLE LENGTH DIGITAL AUDIO DELAY!

- The C & A HDV-200; today's **ONLY** true variable length, simultaneous playback while recording digital delay!
- 10 second to 50 minute delay **standard**, longer lengths available.
- Record start activated with **contact closure**; delayed playback at any time with second contact closure.
- **Fully automated** for unattended background operation, simultaneous multi-channel access.
- **Expandable** up to 6 mono/3 stereo channels.

## SPECIAL INTRODUCTORY PRICE - \$7,995!

In Stock Now! Call (309) 837-2244  
or fax (309) 833-5175

CLARK & ASSOCIATES, LTD.  
318 E. CALHOUN  
MACOMB, IL 61455



Circle (105) On Reader Service Card





**ARRAKIS**

**Universal Bus Design of 12,000 Console Made to Support Almost Any Module, Any Slot Architecture**

**FORT COLLINS, Colo.** The Arrakis 12,000 console works in a number of broadcast situations, with the selection of eight-, 18-, or 28-slot mainframes providing stations the ability to select the necessary capacity and flexibility they need.

The design of the 12,000 "Universal Bus" supports any module, any slot architecture. And the unit's modular front panel facilitates rapid changes and repairs, saving technical staff many hours and headaches.

Available input modules include two mic-level types and two line level types.

Remote start, stop, and ready logic are designed for each module type, and control, studio, and talkback monitoring are provided.

Three stereo output busses are individually metered. Mix-minus is addressed by the two dedicated, internally assignable and transparent mix-minus busses.

Companies such as Penny and Giles and ITT Schadow underwrite the 12,000's electronic and mechanical infrastructure.

For information, contact Jon Young in Colorado at 303-224-2248; fax: 303-493-1076; or circle Reader Service 140.

**AUTOGRAM**

**MINI-MIX Flexibility Provides Answers to Compact Console Needs**

**PLANO, Texas** Autogram's MINI-MIX series consists of versatile, high quality, all-VCA professional broadcast audio consoles built for compact-console situations.

The MINI-MIX 8A features eight channels. The first two are dedicated to microphone inputs while the remaining six have two stereo inputs each for a total of 14 inputs. The MINI-MIX 12A features 12 channels configured with two microphone channels, nine channels with two stereo inputs each, and the last channel with seven stereo inputs for a total of 27 inputs.

Construction of the MINI-MIX series consoles is essentially one main board with support boards for specialized functions. The power supply is mounted externally and may be wired for either 115 or 230 VAC and 50 or 60 Hz. The front panel is hinged for easy access to the boards and the plug-in ICs.

The MINI-MIX 8A is available for \$2,499 and the MINI-MIX 12A (available September 1993) is tentatively priced at \$3,999.

For information, contact an Autogram dealer, or Ernie Ankele or Jim Laird at Autogram, at 800-327-6901; fax: 214-423-6334; or circle Reader Service 71.

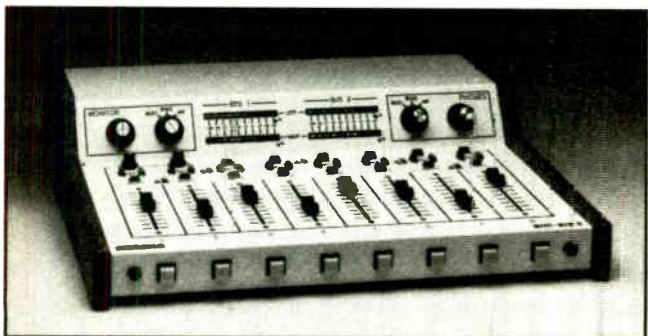

Two models, the MINI-MIX 8A and the MINI-MIX 12A, offer both professional balanced inputs and outputs and phone jacks for unbalanced applications. The "A" models use improved slide attenuators with a very smooth feel.

**HARRISON**

**PRO-790 Production Console Allows 8-Track Recording**

**NASHVILLE, Tenn.** The Harrison PRO-790 Production Console features two main stereo outputs, two separately-derived main mono outputs and two auxiliary sends with level trim. It's available with four stereo submasters to double its output routing capabilities and allow eight-track recording flexibility.

The inputs are available as mono or stereo mic/line (while also supporting up to eight M/S inputs to each module) with three-band phase-coherent equalizers and Hi/Lo-pass filters on stereo inputs.

Output routing is via the latest CMOS switching technology, virtually eliminating switching transients in the main outputs. The newly designed fader package features P&G 104mm linear faders, large, separate push-button switches for PFL and Channel On/Off, "in-Place" stereo solo and a unique PFL solo feature.

For information, contact Cynthia Rodgers in Tennessee at 615-331-8800; fax: 615-331-8883; or circle Reader Service 185.

**At Your Fingertips!**

Find the information you need in Radio World's 1993 Directory.

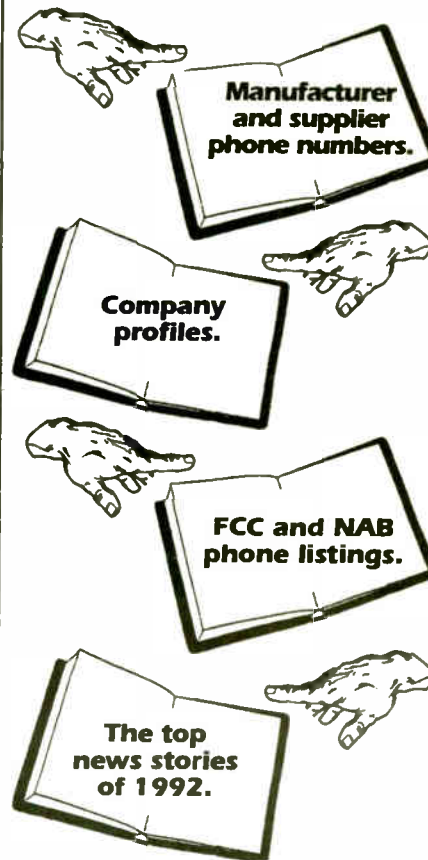

...And more.

We have a limited number available at \$14.95 each.

To order, call

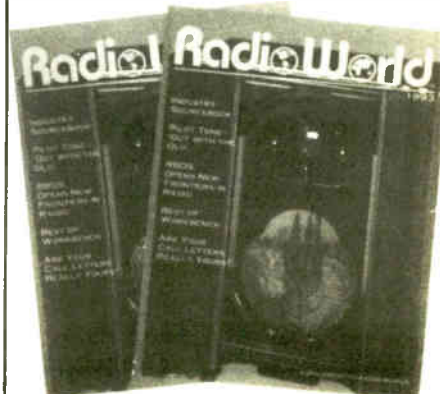

**1-800-336-3045**

**THE SECRET'S OUT—DIGITAL FURNITURE**

**MODULAR FLEXIBILITY WITH A CUSTOM FIT**

*We Offer Six Elegant Lines of Studio Furniture*

4153 BONITA STREET  
SPRING VALLEY, CA 91977  
PHONE 619/698-4658  
FAX 619/698-1268

**MURPHY**  
STUDIO FURNITURE

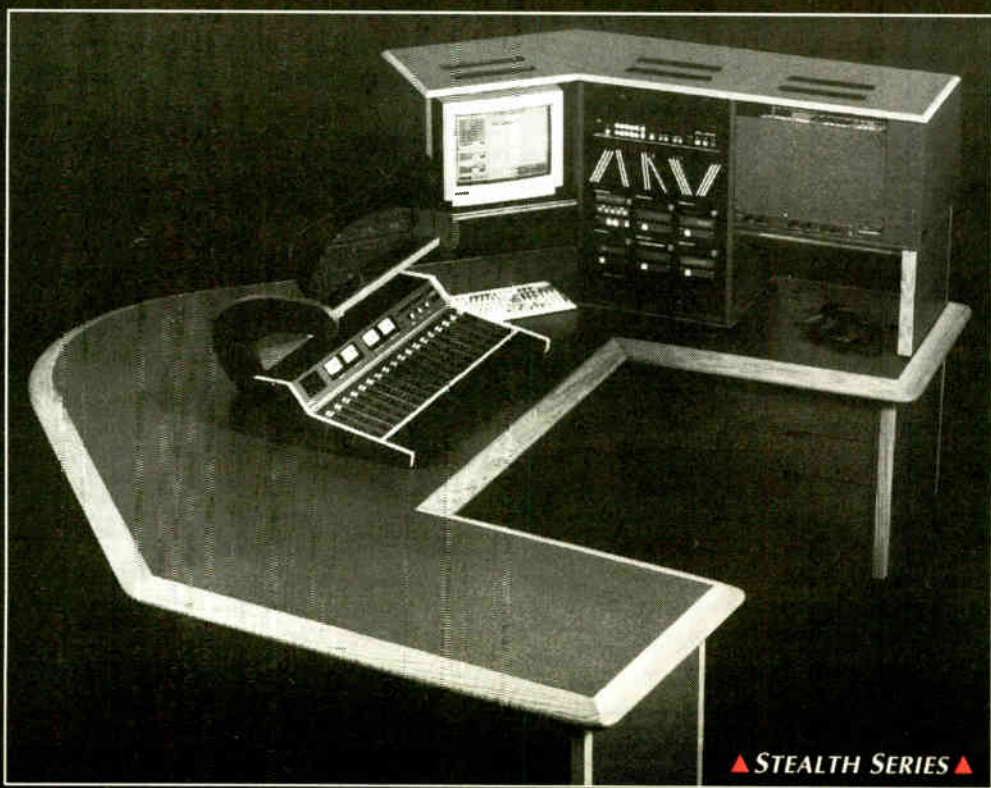

▲ STEALTH SERIES ▲

# REFERENCE GUIDE

## Studio Furniture

### **Arrakis Systems Inc.**

**Contact: Rod Graham**  
303-224-2248  
FAX: 303-493-1076

*Model Line:* Modulux II, Modulux, Modulux Supreme, Trak Star, Custom  
*Price Range:* \$550 to \$15,000  
*Materials:* Polylaminate, high pressure laminate, metal post and trim system, solid oak trim  
*Pre-wired:* Yes, optional  
*Features:* Flexible, modular, contemporary colors and styling, hand-rubbed solid oak trim  
*Delivery time:* 2-30 days depending on configuration  
*Reader Service No:* 120

### **Atlas/Soundolier**

**Contact: Nora Steele**  
314-349-3110  
FAX: 314-349-1251

*Model Line:* Enclosure systems—Cabinets, Racks, Consoles and Accessories  
*Price Range:* Contact factory  
*Materials:* Heavy-gauge CRS with decorative accents  
*Pre-wired:* Designs offer easy wiring access  
*Features:* Wide selection for configuration flexibility; sturdy welded construction; equipped with conduit knockouts  
*Delivery time:* Contact factory; some within 2 days  
*Reader Service No:* 64

### **Audio Broadcast Group**

**Contact: Dave Howland**  
800-999-9281  
FAX: 616-452-1652

*Model Line:* Custom Gold, Euro (digital ready), Executive, Executive Plus, Pro Studio Series-Design I, IV and V, Video 1000  
*Price Range:* \$1,700 to \$15,000  
*Materials:* High density furniture grade, composition board; 16th grade laminate; solid oak trim  
*Pre-wired:* Yes, if desired  
*Features:* Modular design, cooling fans and/or ventilation ducts, multiple access panels and slide-out racks, choice of colors and trims and stand-up designs  
*Delivery Time:* 1-4 weeks  
*Reader Service No:* 30

### **Audioarts Engineering**

**Contact: Mark Kaltman**  
315-452-5000  
FAX: 315-452-0160

*Model Line:* AudioArts Furniture  
*Price Range:* \$2,900 to \$8,600  
*Materials:* Birch plywood, laminated high-density particle board, oak hardwood trim, steel rack rails  
*Pre-wired:* Optional  
*Features:* No laminate to laminate seams, flexible configurations, leveling feet, extra large wire management area, rack space throughout furniture, major market looks, high quality  
*Delivery time:* 1-4 weeks  
*Reader Service No:* 75

### **The Express Group**

**Contact: Byron Andrus**  
619-298-2834  
FAX: 619-298-4143

*Model Line:* Series 1000, 2000, 3000, 4000, 5000, 6000 and custom  
*Price Range:* \$2,915 and up  
*Materials:* Void-free birch plywood, poplar wood supports, high grade laminate, solid oak or walnut  
*Pre-wired:* Yes, by Express Group distributors  
*Features:* Six flexible modular systems and unique custom designs. All series include oak or walnut trim, standard high quality laminates, premium birch ply and hardwood construction throughout (no particle board).  
*Delivery time:* 1-4 weeks  
*Reader Service No:* 214

### **Murphy Studio Furniture**

**Contact: Dennis W. Murphy**  
619-698-4658  
FAX: 619-698-1268

*Model Line:* Stealth Series (new line), Avant-Garde, Elite Series, Premier Series, Classic Series, Dub/Edit Stations  
*Price Range:* \$1,000 to \$15,000  
*Materials:* Solid oak, poplar, plywood, plexiglass, corian (Avant-Garde series only), high density particle board and steel  
*Pre-wired:* Yes, optional  
*Features:* Ergonomic design, bumper base and no laminate to laminate edges for durability, sloped faces on all returns, passive ventilation system, plexiglass covers over rack openings under main console area  
*Delivery time:* 2-8 weeks  
*Reader Service No:* 37

### **Pacific Recorders & Engineering Corp.**

**Contact: Dave Pollard**  
619-438-3911  
FAX: 619-438-9277

*Model Line:* Custom and Primeline  
*Price Range:* \$2,865 and up  
*Materials:* 3/4-inch birch plywood, high density particle board, plastic laminate, oak and selected hardwood trim, steel rack rails  
*Pre-wired:* Yes  
*Features:* Primeline offers a flexible, modular design; all custom cabinetry is designed and built with high quality standards.  
*Delivery time:* Custom: As quoted individually; Primeline: 2-4 weeks  
*Reader Service No:* 151

### **Studio Technology**

**Contact: Vince Fiola**  
800-676-0216  
FAX: 215-640-5880

*Model Line:* Studio Technology Custom Furniture  
*Price Range:* \$3,500 and up  
*Materials:* Cabinet grade birch plywood; particle board; any color, pattern, or brand of plastic laminate; solid red oak, or your choice of domestic and imported hardwoods; tapped steel rack rails  
*Pre-wired:* Available  
*Features:* Built completely custom to fit your needs and studio dimensions; built-in wire management; pull off panels; vented equipment areas are standard. Can be priced to include delivery and installation by Studio Technology  
*Delivery time:* 10-30 days  
*Reader Service No:* 21

### **Wheatstone**

**Contact: Suzin Harris**  
315-452-5000  
FAX: 315-452-0160

*Model Line:* Wheatstone furniture  
*Price Range:* \$5,000 to \$15,000  
*Materials:* Horizontal grade laminates, all oak trim, steel rack rails  
*Pre-wired:* Yes  
*Features:* 1.5-inch thick counters and partitions throughout, solid oak trim, easy access punch block housing, fast "on-site" assembly  
*Delivery time:* 4-10 weeks  
*Reader Service No:* 179



or



or



or



=

# Our summer console sale

This summer save \$500.00 on a Radio Systems RS-12 or RS-18 console plus get your choice of a stereo DA, phone interface, impulse clock system, or phase fixer for free!

It's a great way to save on broadcast's most popular console, plus get the accessory you need.

## The Products

- RS-12 12 channel stereo broadcast console
- RS-18 18 channel stereo broadcast console
- TI-101 Phone hybrid with equalization
- DA-16 Stereo eight output distribution amp
- AMD-1 Impulse master driver with two analog clocks
- PH-2 Stereo phase correction system

## The Deal

Contact your authorized Radio Systems dealer for your \$500.00 console discount and to choose your free product. Call Radio Systems for the name of your local dealer or for more product information. Offer expires September 30th, 1993.

### **RADIO SYSTEMS INC.**

110 High Hill Road • P.O. Box 458 • Bridgeport, NJ 08014-0458 • (609) 467-8000 • FAX (609) 467-3044

Circle (209) On Reader Service Card

See Our Furniture in Dallas at these booths

Broadcast Electronics Booth 613 • AEQ America Booth 747 • Fidelipac Booth 228, 230

# DIGITAL READY FURNITURE

## DESIGN LEADERSHIP AND PERFECTION

At the forefront of each industry are individuals who accept nothing less than perfection. They are people who are never satisfied with "good enough" but rather are always asking, "How can we make it better?" Their dedication and drive are instrumental in the creation of products by which others are measured.

Each Audio studio furniture piece is designed and crafted by people with this same drive for perfection. The result is a furniture design that places wires out of the way, where they belong. A design where everything is lined up and easy to reach. A comfortable ergonomic design that won't tire out your personalities, even on long shifts. And the creation of our own special frameless cabinet design, which eliminates bulky framework while adding strength, offers greater installation and expansion capabilities.

With the advent of digital products, such as hard disk storage systems and workstations, new innovative furniture designs are now available to address these new technologies in a functional, eye-pleasing manner.

By bringing together the very finest in design, manufacturing, and installation techniques, Audio Broadcast Group offers you the industry's most unique combination of top grade materials and outstanding workmanship — thus assuring you many years of usefulness, as well as the very best value for the money spent.



### BROADCAST STUDIO FURNITURE FEATURES & BENEFITS

#### FEATURES

- \* One Day Delivery and Set Up
- \* Outstanding Workmanship
- \* Built To Your Specifications
- \* Systems Manufactured with Furniture Grade, High-Density Composition Board
- \* We Use Only 16th Grade Pionite® Laminate for all Exposed Surfaces The Most for your Imagination™
- \* Separate Routing for Electrical and Interconnect Wiring
- \* Solid Oak Trim
- \* Modular Design
- \* Frameless Construction
- \* Cooling Fans and/or Ventilation Ducts for Heat Expulsion
- \* Internal Areas Sprayed with a Waterproof Sealant
- \* Leveling Feet at Each Module Corner
- \* Multiple Access Panels and Slide Out Racks
- \* Internal Lamps in Each Module
- \* Users List Challenge: Call Anyone for a Reference

#### BENEFITS

- No set up time or expensive freight charges on your part.
- Flawless installation when we leave, system is completely clean and ready to use.
- System is designed for the way YOU operate
- Much less prone to warping and cracking over time.
- Much less likely to crack or chip than a lesser vertical grade product.
- Helps to eliminate RF problems within the system
- Enhanced beauty and laminate protection.
- Can be disassembled and relocated in the future.
- All joints are nailed and glued for maximum strength and stability.
- Less damage of equipment due to inadequate air flow.
- Helps prevent damage and misalignment due to moisture or heat buildup.
- Insures a uniform work surface along top of system.
- Easy wire access without removing equipment.
- Provides lighting for wiring hookup and maintenance of equipment.
- YOUR COMPLETE SATISFACTION!

LEASING PLANS ALSO AVAILABLE

## UNEQUALED CRAFTSMANSHIP

We're located in Grand Rapids, Michigan, the contract furniture capital of the world and where crafting fine furniture is a centuries-old tradition. Because of our location we can employ master craftsmen who practice skills unique in the furniture world. This craftsmanship, ingrained in the hearts and hands of our people, gives the studio furniture you specify unsurpassed quality, function, economy and value.

Our furniture systems also offer you the industry's most extensive list of standard features, such as:

- Complete delivery, set-up and installation available anywhere in the USA and Canada
- Durable Pionite® laminate
- AC wiring and cable runs
- Cooling fans and ventilation ducts
- Solid oak trim
- Construction exceeds AWI standards
- Leveling feet at each corner
- Heavy duty EIA standard rack rails drilled and tapped
- Smoked plexiglass panels for unused spaces
- Choice of colors

Audio began studio furniture design and manufacturing in the late 70's. To date, over 250 systems have been delivered and installed in all areas of the United States.

**"ANY SIZE, ANY SHAPE . . . INDIVIDUALLY BUILT TO YOUR SPECIFICATIONS."**

Many studios require specialized furniture that is out of the norm. Specify any size or shape required and we'll build it.

Sophisticated attention to detail is the trademark of Audio's furniture, from the solid oak trim to the adjustable leveling feet. Audio is experienced in creating consoles and cabinets to meet any size or configuration requirement for broadcast, production and editing studios.

Complete prewire installation services are also available by our trained technicians to insure complete system satisfaction and reliability in the years ahead.

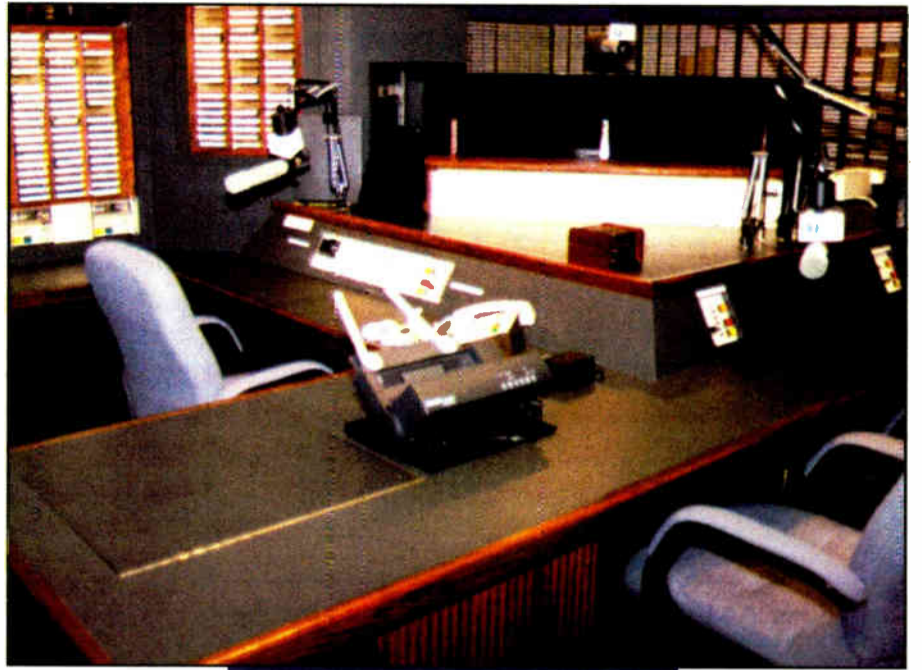

## TYPICAL CLIENT REACTION!

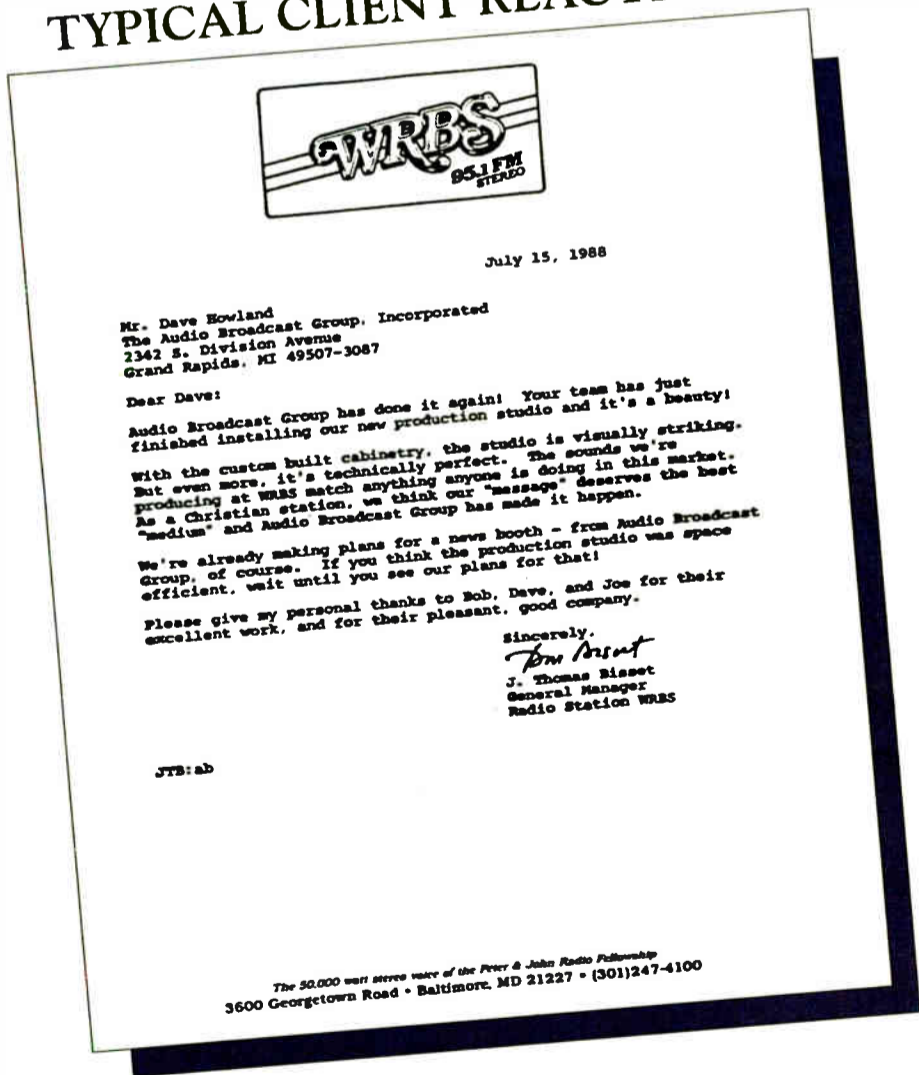

## A FEW OF OUR MANY SATISFIED CLIENTS

KSEE-TV 24	WKBD-TV 50	WIXC
Booth American	WRBT-TV	WKQI
Ohio University	WRBS	WOFX
CBN, CBN Center	WSJM	WLTI
Liggett Broadcasting	WVWW	WMUS
Michigan State University	WZNX	WNFL
WBT, Jefferson Pilot Communications	KQDS	WOOD
WGVU - Grand Valley State University	KGLO	WUPS
WFLD-TV - Fox Television	WALK	WPZA
WJPC, Johnson Publishing	WCSU	WTSO
WLAV, Adams Broadcasting	WBMX	WUSN
WMXV, Bonneville	WCUZ	WZPL
WMAQ-TV, NBC	WIBM	

**IF YOU'RE THINKING OF UPGRADING YOUR FACILITY YOU CAN'T AFFORD NOT TO CALL US!**



For over 32 years

**AUDIO BROADCAST GROUP**

**Main Sales Office**  
2342 S. Division Avenue  
Grand Rapids, Michigan 49507

**1-800-999-9281**

**Southeastern Sales Office**  
200 Fareway Drive - Suite 2  
Smithfield, North Carolina 27577

**1-800-369-7623**

# MARKETPLACE

A compendium of new and recently introduced radio broadcast products



## Analyzer Adapter

The PF 8681/36 adapter by John Fluke Mfg. Co. Inc. allows system designers and equipment manufacturers to check program flow and signal timing.

The adapter utilizes a 2-wire I<sup>2</sup>C bus for all interconnected

ICs, prevention of data corruption and on-chip filtering to reject spikes.

The 4-wire ACCESS.bus is a desktop-connectivity standard that enables accessory devices such as keyboards, scanners, mice, barcode readers, and

development tools to be connected to a single computer port. This allows computer peripherals to be connected or removed at any time, without rebooting or loading device-specific drivers.

The adapter connects to the serial data and the serial clock lines of any I<sup>2</sup>C bus or ACCESS.bus equipment.

Connection is then made from the adapter to the PM 3580 series logic analyzer. The PM 3580's dual-analysis-per-pin architecture allows simultaneous state and timing analysis on the operation of bus signals, correlated to a resolution of 5 ns.

For more information, contact John Fluke Mfg. Co. Inc. in Washington at 206-347-6100; fax: 206-356-5116; or circle **Reader Service 35**.

## Subcarrier Modulators

Wegener Communications is producing two new Frequency Agile Subcarrier Modulators for satellite, terrestrial microwave, and fiber optic transmission systems.

The Series 1678 and 1778 modulators are upgrades of older Wegener products and include new features requested by customers.

The 1678 modulator includes the PANDA® Adaptive Pre-emphasis audio processing technique to generate "spectrum efficient" narrowband subcarriers. The modulators are available with 15 kHz, 7.5 kHz, and 3.5 kHz audio bandwidths.

A key modulator feature is direct-reading, front-panel frequency selection. Standard fea-

tures include high linearity, low audio distortion, alarm circuitry, contact closure and LED status indicators.

The Series 1778 was designed to generate standard high-level, wide-band subcarriers in satellite, terrestrial microwave, and fiber optic transmission systems. The subcarrier range is expanded to cover 0.15 to 9.0 MHz in lieu of the normal 5 to 8 MHz range. So the unit can be used in FM<sup>2</sup>® subcarrier systems, eliminating the need for frequency translators.

Both new products are fully compatible with the Wegener Series 1600 products.

For more information, contact Wegener Communications in Georgia at 404-623-0096; fax: 404-623-0698; or circle **Reader Service 163**.

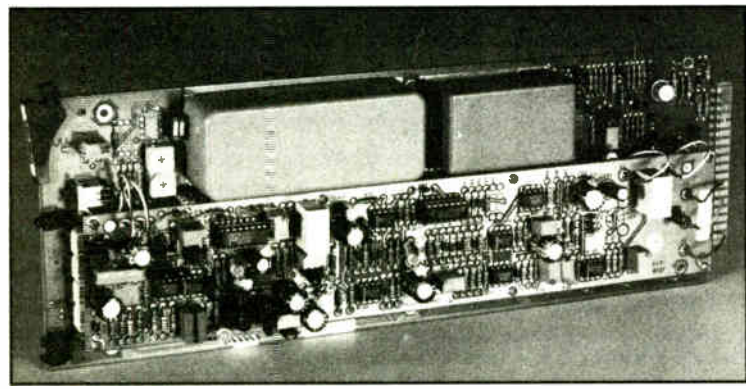

## AM Antenna Tuning Unit

The new TTU-1A LBA Technology Inc. tuning unit, designed to accommodate lower power AM broadcasters, performs all essential matching functions for typical AM antenna towers.

A variety of options are available, including local and remote RF meters, interlocks and lightning protection systems. The unit operates with either series fed or folded unipole antenna systems. Four frequency coverage options accommodate the entire 540-1700 kHz AM band.

The matching function between the 50 ohm transmission line and the antenna is performed by a T-network with a silver-plated coil used with mica capacitors. All components are enclosed in an aluminum, weather-resistant cabinet, with a J plug for current metering and a cabinet ground lug for interfacing with the system ground.

For more information, contact LBA Technology in North Carolina at 919-757-0279; fax: 919-752-9155; or circle **Reader Service 173**.

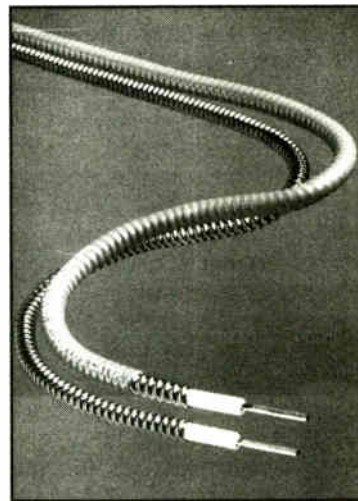

## 1/4-Inch HELIAX Coaxial Cables

Andrew Corporation has introduced 1/4-inch Superflexible, 50 ohm HELIAX® coaxial cables for high power/plenum applications. Type ETS1-50T is jacketed; type ETS1-50 is unjacketed.

## ProDisk Addition

Otari Corporation announces the addition of the BackUp Station to the company's ProDisk line of digital audio workstations. The BackUp Station helps solve the time-consuming process of backing up and restoring files for the workstations.

The BackUp Station consists of a storage unit chassis, which can hold up to five of Otari's removable disk drives, and an Exabyte model 8500 8mm tape drive. The system is controlled by any model Macintosh computer from a Classic II up.

A single BackUp Station can be placed in a transfer room and handle all of the backup and restore work for several systems configured with Removable Hard Drive in a single facility simultaneously.

The BackUp Station is supplied with Otari's 480 MB or 1

## HF/VHF

### Radio Transceiver

The Harris RF Communications 125W HF/VHF radio transceiver features full receive and transmit FM operation on all frequency bands.

The new RF-3201 HAWK Series covers both HF and VHF bands for long- and short-range communications. This includes low-band VHF (30 to 32 MHz) for interoperability with man-pack radios, and high-band VHF (146 to 172 MHz) for communication with VHF handheld radios, police and fire units, marine craft, and other local services.

The HAWK Series radios are designed for applications in which reliable, high-performance, multi-band communications are demanded. The transceiver was constructed for pro-

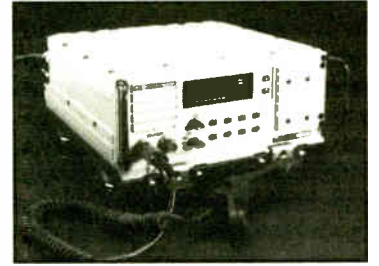

tection from shock, vibration, humidity and extreme temperatures.

An analog voice privacy module is standard in the HAWK radio transceiver.

The HAWK transceiver provides easy operation and configuration for any combination of continuous tuning and channelized operation. The radio can be programmed to permit operation only on preselected channels.

For more information, contact Harris Corporation in New York at 716-244-5830; fax: 716-325-1572; or circle **Reader Service 170**.

The new cables are designed for equipment room jumpers that must interface with high power transmitters. Super-flexible cables have a 1-inch (25mm) minimum bend radius for easy installation and routing in enclosed areas.

UL listing and a Type CATVP marking also allow them to be used within buildings, including risers and ducts, plenums, and other air-handling spaces, such as above a false ceiling.

The low-loss expanded PTFE dielectric handles 3.5 to four times the average power of foam polyethylene at 1,000 MHz. Average power at 1,000 MHz is 0.765 kW for Type ETS1-50T, and 0.856 kW for Type ETS1-50.

For more information, contact Andrew Corporation in Illinois at 708-349-3300; fax: 708-349-5673; or circle **Reader Service 126**.

GB removable disk drives, but the system was designed to expand to other media, like Magneto Optical, with no additional modifications.

For more information, contact Otari Corporation in California at 415-341-5900; fax: 415-341-7200; or circle **Reader Service 207**.

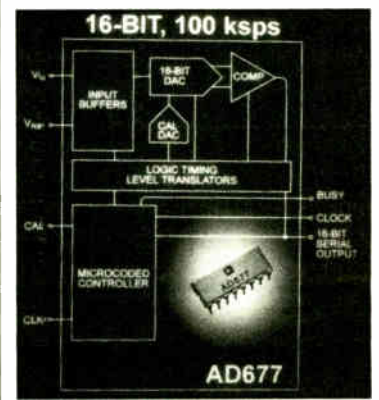

## A/D Converter

Analog Devices' AD677 analog-to-digital converter uses switched-capacitor architecture and autocalibration to provide 100 kilosamples/second (ksps) conversion with 16-bit resolution.

Fully specified for both AC and DC performance, the converter is packaged in a 16-pin ceramic package, with 16-pin plastic DIP and 28-lead SOIC packages to follow.

Features include an analog input range of  $\pm 5$  V to  $\pm 10$  V.

For more information, contact Analog Devices in Massachusetts at 617-937-1428; fax: 617-821-4273; or circle **Reader Service 174**.

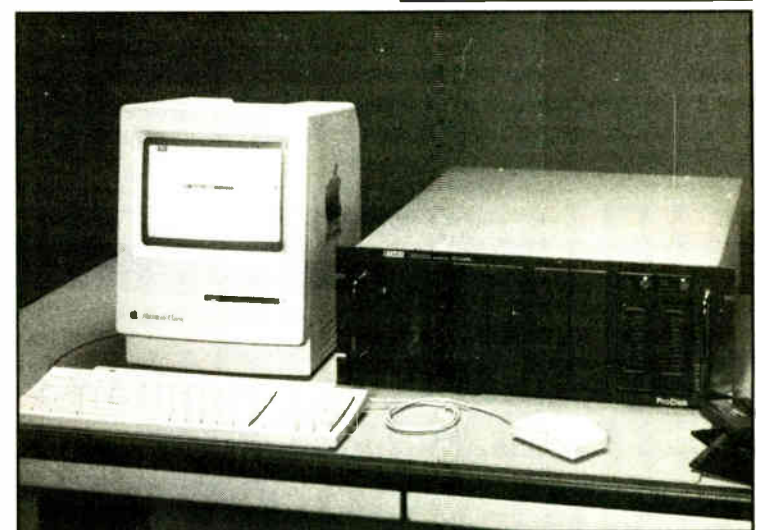

**NEOTEK**

**Esprit Provides Multiple Inputs and Outputs For Handling Complex Conditions**

**CHICAGO** Neotek Corporation introduced its Esprit console series, targeted for complex production and on-air requirements.

The Esprit provides multiple inputs—each mono mic/line or stereo input module has four inputs and four-band EQ. There are also many outputs: eight or 16 groups, two main stereo mixes and a final program output, two studios each with two headphone systems, eight aux busses, and direct and mix minus outputs from every input module, including the stereos.

The Esprit features talkback to each aux bus, to all the mix minus outputs or to each individually, to each of the studios' headphones and to additional output lines. The return talkback system uses line inputs or the console's on-air mic channels.

Esprits are designed to allow specification of any number and placement of mono or stereo input modules, any frame size, desks and patchbays, custom meters, fader automation, VCAs, and shock mount frames for vehicles.

For information on Esprit consoles, contact Tom Der in Illinois at 312-929-6699; fax: 312-975-1700; or circle Reader Service 204.

**YAMAHA**

**DMC1000 Incorporates Full Automation System; Allows Recording, Editing of Console Parameters**

**BUENA PARK, Calif.** The Yamaha DMC1000 is an all-digital recording/production console, ideal for use with digital tape or disk-based multitrack recorders.

Applications include professional pop and classical music recording and mix-down, CD mastering, audio-visual work, theater and broadcast situations.

The unit incorporates a full automation system, allowing recording, editing and replay of all console parameters, synchronized to external timecode.

It is suited for use with the Yamaha DRU8 digital recorder unit. But input/output formats are provided for connection to other professional digital multitrack and two-track recorders (both tape- and disk-based).

Bus outputs and channel and monitor inputs appear in S-DIF2 and ProDigi (Melco) formats, and in Yamaha formats. Stereo inputs are available in AES/EBU, S-PDIF and Yamaha formats.

For information, contact Yamaha Corporation of America, Professional Audio Products in California at 714-522-9011; fax: 714-739-2680; or circle Reader Service 165.

**People, Promotions and Appointments**

The Associated Press has appointed Paul Courson as Business Editor for the broadcast division. He will oversee coverage of business and consumer news and features on AP's radio and television news wires. He also is responsible for the network's "ConsumerWatch" program.

Scientific Atlanta promoted Jack Fenster to Director, Engineering and Operations, and George Waters to Principal Engineer, the company's highest engineering position.

Recently appointed to Government Consultant Relations Manager for Harris Allied Broadcast Division,

Samuel Edward (Ed) Hawkins, Jr., will represent the division's line of radio and television products, systems and service capabilities.

Jim Loorya was appointed Power Quality Product Manager at BMI. Loorya, who previously worked with Pacific Gas & Electric for 24 years, will be in charge of marketing the 8010 PQNode distributed power-quality monitor.

Randy Dahlin joined Broadcast Services Co. as the West Coast sales manager. Dahlin, formerly the West Coast sales manager with Harris Allied, can be reached in San Diego at 800-523-1037.

Audio Broadcast Group, Inc. hired Tony Mezey, formerly with Allied Broadcast Equipment, as a member of the sales team. He will cover the

West and Southwest areas for the company.

**Company News**

The Winsted Corporation expanded its sales representation in the United States: the territory of F.M. Valenti & Associates now includes Connecticut, New York and New Jersey; Multimedia Marketing will handle Northern California, Nevada, Oregon and Washington; and Daniels Marketing will represent Southern California and Arizona.

TGI North America, North American distributor of Tannoy, selected Image Marketing as its new Southern California representative.

Harris Allied Broadcast Division combined its U.S. direct radio sales force with a network of independent representatives. Four regional sales offices will be established, each managed by a Harris Allied sales employee.

Rodman/Brown & Associates acquired R.O.M.S., the Radio Office Management System, from Master Software Systems, a division of Radio One, Inc. R.O.M.S. is a traffic and billing software package.

Audient Marketing Services consolidated its two offices and moved to 5263 Corteen Place, Suite 8, North Hollywood, CA. 91607; phone: 818-752-1990; fax: 818-752-1992.

The Creative Marketing Group Inc. is the American distributor for the System 4 by Yellowtec, a company based in Langenfeld, Germany.

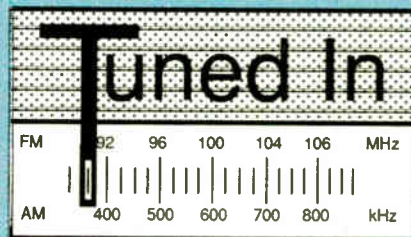

**FIDELIPAC**

**MX Series Audio Console Upgrades Offer Fader Start, Pre-Fader Patch Points and Gain Controls**

**MOORESTOWN, N.J.** The Fidelipac MX Series modular audio console line was recently expanded to include new features in the linear version such as fader start, pre-fader patch points, independent gain controls for A and B inputs, remote module ON/OFF and remote control terminals for easy installation.

The MX Series console is offered in a new configuration with 2-inch wide modules, extending the MX Series to 18 channels. The MXE console provides all the new features of the enhanced MX and several planned optional features.

An 18 mixer linear console is priced at \$7,270 list.

For information, contact Bob McNeill in New Jersey at 609-235-3900; fax: 609-235-7779; or circle Reader Service 196.

**Products & Services Showcase**

For more information on the products shown below, circle the appropriate Reader Service No.(s) on the enclosed Subscription/Reader Service card or contact the advertiser directly.

**WEATHER RADIO Model CRW**



Price \$540.00

Sensitivity .28 microvolts for 12 dB quieting. All 3 frequencies. Alert tone demutes receiver, closes relay and gates audio to 600 ohm rear terminals. Another set of rear terminals has continuous 600 ohm audio output. Double conversion crystal controlled, crystal filter in first I.F., ceramic filter in second I.F. Dual gate MOS FET front end. 50 ohm coaxial input. Adjacent channel (j25 kHz) down to 70 dB. 19" rack mount, 31/2" H, all metal enclosure. In stock—available for immediate delivery.

**GORMAN REDLICH MFG. CO**

257 W. Union St. • Athens, Ohio 45701  
Phone 614-593-3150 • FAX 614-592-3898

READER SERVICE NO. 38



**A-7550...10 kHz to 1 GHz PORTABLE SPECTRUM ANALYZER**

Synthesized tuning and phase locked frequency stabilization enable accurate swept frequency measurements over calibrated span widths from as wide as 100 MHz/div to as narrow as 1 kHz/div. A standard 300 Hz resolution bandwidth filter and peak hold mode provide NRSC measurement capability. Other A-7550 features include:

- +30 to -120 dBm measurement range
- DC operation from 12 to 30 volts (Built-in battery optional)
- Optional built-in tracking generator
- Optional built-in AM/FM/SSB receiver
- Optional IEEE-488 or RS-232 interfaces.

For more information or a demonstration of the A-7550 contact:



**IFR SYSTEMS, INC.**  
10200 West York St., Wichita, Kansas 67215  
Phone (316) 522-4981 Ext. 207. FAX (316) 524-2623  
DIRECT FACTORY RENTAL PLAN AVAILABLE

READER SERVICE NO. 178



**Econco REBUILT POWER TUBES**



Approximately One Half the Cost of New

3,000 Hour Unconditional Guarantee  
Call for Our Price List

Econco 1318 Commerce Ave. Woodland, CA 95695  
Phone: 916-662-7553 Fax: 916-666-7760 Telex: 176756  
Toll Free: 800-532-6626 From Canada: 800-848-8841

READER SERVICE NO. 152

# Products & Services Showcase

For more information on the products shown below, circle the appropriate Reader Service No.(s) on the enclosed Subscription/Reader Service card or contact the advertiser directly.



**Excalibur Electronics**  
**CD-1 Interface Amp**

The industry's favorite unidirectional interface amplifier is designed to match IHF output standards (10kΩ unbalanced, -10dBV) to broadcast input standards (+4dBm, balanced). DC coupling, <0.006% THD & IMD, and >90dB S/N make the CD-1 appropriate for use with the highest quality CD players, as well as with monitor tuners, cassette and tape playback, DAT playback, and ENG equipment. Table-top mounting or, using the included angle brackets, may be attached to a rack panel, your cabinetry, or anywhere convenient. A dual version, the CD-2, is also available.

EXCALIBUR ELECTRONICS, INC., CHANTILLY, VIRGINIA  
Please circle our bingo number for a data sheet and a dealer list  
**READER SERVICE NO. 177**

## CD Storage Systems

Rugged ABS cabinets designed for high density storage of CD's. Storage from 500 to over 1000 per cabinet, based on storage format and type of CD.

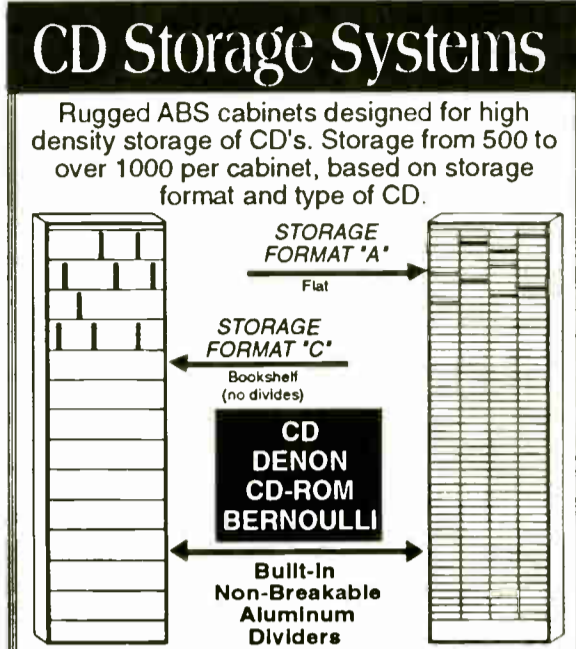

**Tape Storage Systems**  
Tripp Communications Sales • TCS  
P.O. Box 5267, Walnut Creek, CA 94596  
Tel: 510-256-6006 Fax: 510-256-6007

**READER SERVICE NO. 103**

the **Desk Jockey™**  
*Digital Automation That Makes Sense*

What a gamble - There are new digital automation systems on the market that only do satellite, or only do CD, or only do live assist. Change your format, and you've got a real expensive conversation piece.

Desk Jockeys not only grow as your station grows, they can also change as your station changes.

You may have a hunch about what the hot format will be five years from now, but are you willing to bet the cost of an automation system on it?

Booth #911  
Radio '93

**RB** Rodman \ Brown & Associates, Inc.  
**(708) 983-0977**

**READER SERVICE NO. 22**

## Affordable Custom Broadcast Furniture



**TEL: 1-800-676-0216**  
**FAX: 215-640-5880**

**STUDIO TECHNOLOGY**

4 Pennsylvania Avenue, Malvern, PA 19355

**READER SERVICE NO. 82**

## EBSCentral™

Until recently, there was only one way for unmanned radio stations to avoid EBS-related FCC fines...

Find an employee who'll promise to never have a life, and who can drive real fast and get to the radio station within minutes - 24 hours a day, 365 days a year.

Now, there's something a little more realistic. It's EBSCentral, the remote-control EBS device that lets you respond instantly to any emergency, and go on the air live from any touch-tone telephone. Best of all, it costs less than the fine.

Booth #911  
Radio '93

**RB** Rodman \ Brown & Associates, Inc.  
**(708) 983-0977**

**READER SERVICE NO. 76**

### Can you REALLY afford "specs"?

Sure, it's nice to have the latest & greatest products with specifications beyond belief... **BUT...** is the price of the specs really worth the results? **AND...** did some "manufacturer" buy an import & change the name to protect the guilty?

**CONSIDER THE ALTERNATIVE:**

**PLFM-100 Replacement Exciter Module**-\$229.95  
Connect to existing hard-to-maintain exciter & remain FCC compliant.

**CSG-10 Composite Stereo Generator**-\$349.95  
Complete Stereo Gen. module w/adjustable composite clipper.

**FMT-15 Broadcast Exciter**-\$1495.00  
15 Watt FCC notified exciter, 19" rack mount (Stereo for \$1895.00).

**BIA-1 Balanced I/O for OPTIMOD**-\$249.95  
Connect added EQ, proc., etc. to 8100 processors, w/o affecting chain, (\*OPTIMOD is a registered trademark of ORBAN/AKG)

ALL PRODUCTS ARE AVAILABLE FACTORY DIRECT OR THROUGH VARIOUS DISTRIBUTORS.

**JT Communications-Ocala, FL**  
904-236-0744 fax-904-236-5130

Note-unlike some companies, our products are 100% manufactured in the U.S.A.

**READER SERVICE NO. 107**

### The Remote Unit the Pro's Choose and Use

The Telfax GX-440 Phone Remote Mixer. It's easy to see why. It's very compact (1 5" x 6 1" x 9 4"), weighs only 3 pounds and is a snap to operate. The GX-440's built-in phone line interfacing makes it ideal for sports, news and special event broadcasts. It features pulse/tone dialing, headphone amp/cue, rechargeable batteries, ringer, limiter, squelch, tape in/out, four microphone inputs, event timer, second phone line capabilities and low frequency extender interface jack. Remotes have never been easier!

Price: \$1250 — Available from all major equipment dealers

Call 515-296-9911 for full details. Also ask about Mobilink II, our advanced cellular remote broadcast system.



"Serving broadcasters since 1978...over 2000 Telfax units in use."

**TELFAK** 2501 North Loop Drive  
Ames, Iowa 50010

**READER SERVICE NO. 213**

**World Radio History**

## ROMS™

*Radio Office Management System*

In this age of traffic & billing software that comes "packaged" with automation systems, it's important to understand the difference between software, and *shelfware*.

*Software* is the good stuff. It's full-featured, powerful, and it stands on its own.

*Shelfware* seems like a deal until the box is opened.

ROMS is traffic & billing *software*, and we can't wait for you to see the difference.

Booth #911  
Radio '93

**RB** Rodman \ Brown & Associates, Inc.  
**(708) 983-0977**

**READER SERVICE NO. 100**



# Radio World

## Broadcast Equipment Exchange

"Broadcast Equipment Exchange" accepts no responsibility for the condition of the equipment listed or for the specifics of transactions made between buyers and sellers.

**NEW! NEW! NEW!**  
We now buy & sell pre-owned video equipment

**RADIO RESOURCES**  
1201 S. Sharp St.  
Baltimore, MD 21230

**DO YOU HAVE EXCESS EQUIPMENT TO SELL?** Let us help you turn your excess equipment into CASH..

**Some of our equipment needs are:**  
AM/FM TRANSMITTERS  
FIELD STRENGTH METERS  
MARTI VHF/UHF RPU EQUIPMENT  
MARTI STL EQUIPMENT  
OTAR MX 5050 REEL TO REEL  
DIGITAL SATELLITE EQUIPMENT  
CONSOLES  
ORBAN OPTIMODS

If there is a piece of pre-owned equipment you are looking for, give us a call, we can help!

**THE INDUSTRY'S BEST NEW & PRE-OWNED EQUIPMENT DEALER**  
Ask for Steve or Chuck for Radio Products or Bob or James for Video Products  
**Call 1-800-54-RADIO**  
The only # you need to know!  
**FAX: 1-410-783-4635**

Circle (119) On Reader Service Card

### ACOUSTICS

Want To Sell

**STUDIOFOAM**  
SOUND ABSORBENT WEDGES  
TESTS 18% BETTER THAN SONEX!  
COSTS LESS! BETTER COLORS!  
**1-800-95-WEDGE**

Hafner P-125 (2) prof stereo audio amp, \$390. G Guarino, Sorcerer Snd, 19 Mercer St, Nyny 10013. 212-226-0480.

### AMPLIFIERS

Want To Sell

Dukane 17A350 100 W solid state, rack mount, vgc, \$75. A Ross, 8022 27th NE, Seattle WA 98115. 206-525-4624.

Stanton 310 phono preamp, vgc, \$75/BO. J Rudisill, Audio Independence, POB 746, Aptos CA 95001. 408-684-0605.

McMartin B-200B phono EQ pre-amp. C Watkins, KLCE, Blackfoot, Idaho Falls ID. 208-785-1400.

Perma-Power S-102 amp w/S1420 batt pack, mobile/portable PA unit, 12 W out, exc cond, \$100. R Sumner, CAVU Corp, 3322 Applegate Ct, Annadale VA 22003. 703-968-8894.

Crown D-75 pwr amp, \$300; Bogen C-100 100 W PA amp, \$125. J Parks, WCNX, River Rd, Middletown CT 06457. 203-347-2565.

Spectra Sonics 101-A 3-channel line amp, each channel has input level control, rack mount setup, 3" high & bridge input, 600 ohm line out, 40 dB gain each channel, \$100. S Lawson, KAK Prod, 928 Hyland Dr, Santa Rosa CA 95404.

New 250 W solid state amp, \$1800. Call for details. Bill Hoffman, 518-583-9490.

Want To Buy

Tube Amplifiers. 612-866-6183.

### ANTENNAS & TOWERS

Want To Sell

Shively 3-bay cir pol, 92.7 MHz, 70' Andrew 1-5/8" coax, 4 yrs old, exc cond. C Hall, KYKN, Box 165, Nephi UT 84648. 801-623-4010.

200', 6" hard line, 20' sections with stainless hangers, connectors & elbows, in storage, \$4650. K Crosthwait, WTNN, 13206 Buttermik Rd, Knoxville TN 37932. 615-531-2297.

Andrew LDF 750A 1-3/8" foam Heliac, new, any length, \$4/ft. M Gummer, Natl Audio, 7463 Canton St, Baldwinsville NY 13027. 315-635-9310.

ERI FMH-10AC 10 bay antenna, CP, tuned to 105.5, \$22,000. S Wodlinger, WIXI FM, 813-262-1000.

Large spool for 3" waveguide, new, \$500. S Wodlinger, WIXI, 3337 Tamiami Trail N, Naples FL 33940. 813-262-1000.

Marti 160 MHz 4-folded element beam antenna. C Watkins, KLCE, Blackfoot, Idaho Falls ID. 208-785-1400.

### FM - ANTENNAS

Designed and built for your frequency. Choose from 1 to 12 bays and five power levels. Financing available. Call Jimmie Joynt at S.W.R. **214-335-3425**

Cablewave CC300-50J, 3" 100', new, on spool, \$15/ft. S Wodlinger, WIXI, 3337 Tamiami Trail N, Naples FL 33940. 813-262-1000.

Rohn SA 25G-224 side arms (2), good condition, \$25 plus shipping; Rohn 25G (2) 10' section, damaged bottom 6", makes good base section; Andrew flanges, gas pass for 1-5/8" Heliac, new in box, \$125 each/Best Offer; 20' Pirod tower section built for 12' satellite dish, 42" face with 5-1/2" OD pipe at top; 6-bay high power ERI/Harris FM C-6, ring stud, 97.1 MHz; ERI/Harris FM C-2A 2-bay, maximum 5 kW input, ring stud, on 94.3, field tunable down to approx 91.5. D Carver, 107 S Main, Brookfield MO 64628. 816-258-7458.

Windcharger 200 100' of 45G tower, also includes guy wires, 300', \$2500/BO. J Kesler, WOBZ TV, POB 220, Livingston KY 40445. 606-843-2209.

Jampro JA4-B "V" type HP FM antennas, 4 bays on 94.5 with 1-5/8" feed divider, 2 bays on 89.9, no interbay cables, \$250 per bay/BO. M Benson, KWTY, 916-893-8737.

Dielectric, 50 kW 3" motorized coax switched, like new, \$3500. 800-833-6629.

Andrew EW 63A waveguide w/ends, 2 new rolls, 75' & 140' in boxes, BO/trade. M Kestler, KAWZ, 241 Main Ave W Box 271, Twin Falls ID 83303. 208-733-3133.

3-bay circularly polarized FM antenna, 105.3 MHz for Class A station with 260' of Andrew 1-5/8" line, excellent condition, \$3000. J Buffington, WWZQ, Aberdeen MS 39730. 601-369-4561.

Motorola 6073A base station antenna, 150-159 MHz, \$200 plus shipping; Cushcraft BR-4, 42-50 MHz, base station antenna, \$50 plug shipping; DB Products DB264, base station antenna, tuned to 155.625 MHz, \$200 plug shipping. W Martin, KZPX, HCR1 Box 286D, Merrifield MN 56465. 218-765-3333.

ERI FMH12AC antenna parts for miter cut antenna; Myat or Phillips 3-1/8" rigid line, 10 lengths of 20'. T Wortmann, WJAG, 309 Broasel, Norfolk NC 68701. 402-371-0780.

1983 Utility 30" face 280' hollow rod galvanized steel tower avail for no cost, you take down & remove. R Simmons, KRGT-FM, POB 50124, Austin TX 78763. 512-476-5200.

Want To Buy

Self-supporting towers, (3) 320', solid steel construction. A Schultz, Douglas Bdctg Inc, 415-978-5378 FAX 415-978-5380.

### AUDIO PRODUCTION

Want To Sell

Shure M-67 mic mixer, \$150; Shure M-675 prod master add-on for the Shure M-67 mixer, \$100. J Parks, WCNX, River Rd, Middletown CT 06457. 203-347-2565.

ADC 48 patchbay phone jack. D Nelson, 619-758-0888.

## STUDIO EQUIPMENT IMMEDIATE DELIVERY

- SIERRA AUTO SYS Audio Routing Switch
- BENCHMARK SYSTEM 1000
- YAMAHA YPDR 601 CD Recorder
- RANE SM82 / SP-15 / SM-26
- TASCAM 2 & 8 Trk Rcdr, CD & Cass Player
- SATELLITE DISHES . . . and MUCH MORE!

Call 617/267-8600 for complete configurations

Like New! • Sale or Lease

EQUIPMENT REMARKETING COMPANY • Boston, MA

Shure M-610 feedback cntrlr EQ, \$85. J Parks, WCNX, River Rd, Middletown CT 06457. 203-347-2565.

**SAVE \$300 ON T T 144 POINT PATCH BAYS**  
brokers of line and coarse used equipment  
audio village 619/320-0728

Smartcaster, computer, digital audio: live or automated. D Nelson, 619-758-0888.

ADC 144 Pt TT patchbays, excellent cond, 1 rack space, 3 rows of 48, top 2 rows normalised, \$129 (you remove old wiring) or \$199, we totally refurbish with new front panel, ready to install. TT cords at cost with purchase! Also 1/4" PB's. Audio Village, POB 2902, Palm Springs CA 92262. 619-320-0728, or Fax 619-320-2454.

Want To Buy

Fairchild 600 conac or 602 Conex high freq limiters. J Gangwer, 942 32nd St, Richmond CA 94804. 415-644-2363.

## MERCENARY AUDIO

WANTS TO BUY YOUR:

NEVE-SSL-TRIDENT-AMEK  
UREI-TELETRONIX-FAIRCHILD  
PULTEC-LANG-LEXICON  
UNIVERSAL AUDIO-NEUMANN  
AKG-TELEFUNKEN-AMS

ANYTHING THAT IS  
OF EXCEPTIONAL  
AUDIO QUALITY!

"this is not a problem"  
(508)543-0069 TEL  
(508)543-9670 FAX

### AUTOMATION EQUIP

Want To Sell

Microprobe Satmaster automated computer, mint cond, BO. J Kesler, WOBZ TV, POB 220, Livingston KY 40445. 606-843-2209.

## FM Transmitters have never offered this much for so little!

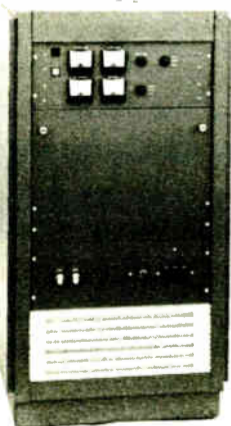

### HENRY RADIO FM AMPLIFIERS offer these standard features:

- Single tube grounded grid output with solid state IPA
- Modular construction using quality standard components
- CD quality audio
- Power levels from 100 watts to 15 kW
- Full 1 year warranty

We at Hall Electronics understand RF however large or small the need.

We'll be glad to help with all your RF needs!

(804) 974-6466 • FAX: (804) 974-6450  
1305-F Seminole Trail  
Charlottesville, VA 22901

**HE HALL Electronics**

## COMARK Antennas



FM Broadcast Antennas  
Circularly & Horizontally Polarized antennas available  
Multiple bays available

## Marti STL 15-C Composite STL System



Composite FM Stereo with 2 subcarriers  
140 - 960 Mhz freq. range available  
Digital Stereo Audio (with external Modems)

## SINE SYSTEMS



RFC 1-B Dial Up Remote Control  
Automatic Transmitter power control  
Alarm dial out for 6 numbers  
Timed functions for day/night power levels etc.  
Optional RS-232 computer interface  
Up to 64 channels of control and metering

## SINE SYSTEMS

### DAI-1 Dial up Audio Interface



Aviod Heavy Fines for EBS Non-Compliance  
Easily handles EBS requirements for "walk away" Operations  
Allows direct access to the air chain  
Remote Broadcasts (no one at the station)

Circle (31) On Reader Service Card

**AUTOMATION EQUIP...WTS**

**IGM RAM 500** 2K sequential memory, 6 inputs, Instacart random access interface card, good condition, with monitor panel, update clock, silence alarm, Best Offer. C Gennaro, WJMS, 222 S Lawrence, Ironwood MI 49938. 906-932-2411.

**Schafer 903** automation system, A-1 condition, on-air, avail late August, 3 mono IGM 48 Instacarts, (6) ITC-750 stereo tapes, Extel logger, full boat system in 5 racks, BO. V Killion, KRVN, POB 880, Lexington NE 68850. 308-324-6717.

**Schafer 902** w/3 near new Carousels, set to receive AM only, BO. M Zwerling, KSCO, 2300 Portola Dr, Santa Cruz CA 95067. 408-475-1080.

**SMC (3)** Carousels, Brain, keyboard, (2) cart time announce, (2) racks & misc, \$2500/BO. S Nestor, KMGK, Box 215, Glenwood MN 56334. 612-634-5358.

**CART MACHINES****Want To Sell**

**Spotmaster 505** mono desk top rec/PB, \$250; Spotmaster 500 PB mono desk top, \$200 or \$350/both. P Drake, 708-870-8252.

**CART MACHINES:**

For Sale: \$395 & UP

Repairs: \$100 per deck + parts  
Recondition: \$150 per deck + parts. Call Mark @ 619-598-3311

**Spotmaster 2000** R/P, \$400. J Parks, WCXN, River Rd, Middletown CT 06457. 203-347-2565.

**RCA RT 7A** 19" mono PB (5), \$100 ea/\$375 all. P Drake, 708-870-8252.

**BE Dura-Trak 90** stereo PB w/3 tones, \$1000/BO plus shpg. C Stalnaker, KDDK, POB 100, Little Rock AR 72203. 501-372-7740.

**ITC RP-829-0003-000**, mono R/P with triple cue, excellent condition, \$325; Tapecaster 700P stereo play only, excellent condition, \$275. W Martin, KZPX, HCR1 Box 286D, Merrifield MN 56465. 218-765-3333.

**Sparta BP-22B** portable cart players (2), one in attache case; UMC Beaucart II mono cart machine. C Watkins, KLCE, Blackfoot, Idaho Falls ID. 208-785-1400.

Great Prices on original equipment tape heads for ITC, BE, Fidelipac, Otari, Tascam & others!

**HALL Electronics**

(804) 974 6466 • FAX 6450

**Denon DN-950FA** CD cart player, \$695; Fidelipac CTR112 stereo (5), \$1250 each plus shipping. B Lord, Lord Broadcasting, 13313 SE 208th St, Kent WA 98042. 206-631-2374.

**ITC Delta I** stereo PB, new heads & in excel cond, low use, \$2500 both/BO. C Gulielmetti, Edgewater Co, 232 C St, S San Francisco CA 94080. 415-589-3313.

**ITC R/P** mono, \$600; Audi-Cord mono/play only, \$250; ITC mono/play only, \$350; ITC stereo SP 969 play only, \$400. J Randall, John Randall BBDC/Recording, 7276 Lakeside Dr, Indianapolis IN 46278. 317-299-0093.

**BE 5300** PB triple deck, works, with manual & connectors, mono single tone, \$800. B Oostenburg, KCKY, POB 6, Coolidge AZ 85228. 602-723-5448.

No matter how you stack it...



Nobody reconditions tape heads like JRF.

- Heads restored to new performance spec at a fraction of new cost
- Cart machines and all open reel formats
- Full line of replacement heads for all manufacturers

Experience the difference experience makes. Ask around. Nobody treats you or your heads better than JRF.



249 Kennedy Rd., Greendell, NJ 07839  
(201) 579-5773 Fax (201) 579-6021

**BE 5300C** tripledeck, stereo, PB, mint less than 50 hours, BO. R Kaufman, Pams Productions, POB 462247, Garland TX 75046. 214-271-7625, after 3PM CDT.

**CASSETTE & REEL-TO-REEL RECORDERS****STUDER SERVICE SPECIALIST**

Thousands Served • Unbeatable Rates  
Precision Capstan Resurfacing  
**Audio Advantage**  
Tel (615) 742-3834 FAX (615) 254-8826  
PRICE-QUALITY-SERVICE  
Let Us Prove It

**Want To Sell**

**Technics 1500** 1/4" 2 trk recorders, \$450. G Guarino, Sorcerer Snd, 19 Mercer St, Nyny 10013. 212-226-0480.

**1/4" stereo mounted head assembly** w/cables for Scully 280B, new, \$250. D Kocher, Digital Snd Makers, 1901 Hanover Ave, Allentown PA 18103. 215-776-1455.

**Tascam 22-2** R-R, 1/4" 2-trk, 15 & 7.5 ips, mic & line inputs, \$600. J Ellingson, Jeff Ellingson Voice-Overs, 913 Warwick Dr, Cedar Falls IA 50613. 314-277-8535.

**MCI/Sony JH-110-C-8 & JH-110-B-8**, 1" 8 trk w/remote, w/manuals, low mileage on heads, 7.5, 15, 30 ips, like new, BO. G Gates, Comm Recdg Stds, 6001 W Creek Rd, Independence OH 44131. 216-642-1000.

**HEAD RELAPPING/REPLACEMENT**

All tape and film formats  
30 years experience



350 N. Eric Drive  
Palatine, IL 60067  
708-358-4622

**Fostex 7-trk** R-R rec/rep, w/remote control, Dolby NR, metal reel, remote foot switch, original box w/manual, BO. W Dougherty Jr, WLD Recdg Std, Music Valley Rt 1, Mill Spring MO 63952. 314-998-2681.

**Ampex Bin Loop recorder** w/Saki heads, 4 slaves, mastering sys w/Telefunken M215 PB, (2) King loaders, \$39,900. J Peluso, Quality Cass, 403 S Woodlawn St, Wheaton IL 60187. 708-668-2787.

**Ampex ATR-800** 1/4" FT head, 2 chnl electr, great cond, BO. G Gates, Comm Recdg Stds, 6001 W Creek Rd, Independence OH 44131. 216-642-1000.

**MCI JH110** R/P 2 trk (4), \$1500/BO; R/P 4-trk, \$1750/BO. D Sedge, WBAP, One Broadcast Hill, Ft Worth TX 76103. 817-654-6136.

**Uher 4200** report monitor R-R stereo 1/2 trk portable, 3 hds, 4 speeds, new in box, \$500. R Sumner, CAVU Corp, 3322 Applegate Ct, Annadale VA 22003. 703-968-8894.

**Ampex AG440** in rollabout console, 3.75-7.5 ips 2-trk PB, (2) repro amps, FT erase & record, remote control, \$200/BO; Teac, American Concertone 1/4 trk stereo recorders, 3.75-7.5, remote controls, need some repair, BO; Uher 4000L portable R-R, mono, 4-speed, BO. M Muderick, Muderick Recdg, 101 Earlington Rd, Havertown PA 19053. 215-449-6970.

**Otari MX-5050** 8 trk, low hrs, vgc w/cables & all manuals, \$1500/BO plus S/H. S Mahaffey, Mahaf Prod, 3592 N Delsea dr #12, Vineland NJ 08360. 609-692-3439.

**Otari MX 5050 MK-III-8** excel cond w/cables & roll-around stand, \$2995. S St John, St John Prod, POB 641448, Kenner LA 70064. 504-464-8881.

**Scully 280B** 4 trk 1/2" servo motor, var speed 7.5-15 ips, \$1050; Teac 5 8x4x2 mixer, \$795 or both for \$1600. A Graves, Graves Recdg Svc, POB 5469, Eugene OR 97405. 503-345-3991.

**Otari MX 5050** FT, gd cond, remote, manual, \$650 plus shpg. J Rudisill, Audio Independence, POB 746, Aptos CA 95001. 408-684-0605.

**Otari 1000** (2), mint cond, \$500 ea/BO. J Kesler, WOBZ TV, POB 220, Livingston KY 40445. 606-843-2209.

**Ampex 602** mono w/622 speaker/amp, \$350; Ampex 351-2 stereo 7.5-15 ips, new heads, \$950. A Graves, Graves Recdg Svc, POB 5469, Eugene OR 97405. 503-345-3991.

**Ampex ATR-800** 4-trk R-R, needs repair, BO. J Harvill or T Rusk, KSSN, POB 96, Little Rock AR 72203. 501-227-9696.

**Tascam 58-OB**, 1/2" 8-trk, mint cond, low usage, +4 and -10 in/out, connects for SMPTE lockup w/video, \$3000. Wirlwind Prod, 10356 W Warren Ave, Dearborn MI 48126. 313-584-9201.

**Ampex 351** FT (3) unmounted w/book, \$200 ea/BO; Magnecord PT-6 w/7.5 & 15 capstans, needs TLC w/book, BO; Extension arm set to run 10.5" reels on PT6, BO. D Carver, 107 S Main, Brookfield MO 64628. 816-258-7458.

**Otari ARS-1000** (3) PB stereo, gd cond, \$500 ea; Revox PR-99 PB stereo, \$900. D Burton, WXCVC, 9244 W Fort Island Trail, Crystal River FL 34429. 904-795-9595.

**Telex Magnecord 1022** 2-trk R/P & 4-trk play w/rack, gd cond, \$200 plus shpg. W Martin, KZPX, HCR1 Box 286D, Merrifield MN 56465. 218-765-3333.

**Scully 280** mon R/P w/spare cards; Ampex mono tube-type R/P for 350. C Watkins, KLCE, Blackfoot, Idaho Falls ID. 208-785-1400.

**REVOX PARTS/SERVICE**

Cassette-CD-Open reel  
Rebuilt A77s, \$800  
Capstan resurfacing, ALL BRANDS.  
**JM TECHNICAL ARTS**  
30 Music Sq. W. #156  
Nashville, TN 37203 (615) 244-6892

**Infonics 200 Series** cassette duplicator, reel master, 7" or 10" reels, excellent condition, \$500; Kipps 8 channel head stack, very little use, some cables shortened, \$100; MCI JH5 solid state electronics with built-in sync (8) with all cables & power supply, \$100 each. T Boddie, Boddie Recording, 12202 Union Ave, Cleveland OH 44105. 216-752-3440.

**16 track 2"**, \$3450; Otari 1" 8 track, \$2450; 5050 III-8, \$1950; Ampex ATR800 mono, \$750; Tascam 25-2, \$750; Tascam 52 mint, \$1200; MCI Locator III, \$1195; Ampex AG350 solid state electronics, \$100/ch. W Gunn, 619-320-0728.

**Pioneer 1050** stereo R-R, RW 102 OL, \$300. J Randall, J Randall Broadcasting/Recording, 7276 Lakeside Dr, Indianapolis IN 46278. 317-299-0093.

**Nakamichi CR1A** cassette deck recently gone through by Nakamichi, \$175 plus shpg. P Trembley, 23915 Via Rosa Linda, Valencia CA 91355. 805-254-5213.

**ITC 770** (6) R-R decks, excel cond, in use, \$450 or \$2500/all. R Klotz, KCNQ, POB 3434, Lake Isabelle CA 93240. 619-379-5636.

**STUDER/REVOX**

Factory Authorized Service  
"Superlative Service"

Over 14,000 units serviced! Fast turnaround w/War. Huge parts inventory. New/Used Equip., Capstan shaft resurfacing.

**STUDIO-SONICS**

450 W. Rand Road  
Mt. Prospect, IL 60056

708-670-0025

**Otari Mark II-IV** 1/2" 4-track, multi-track, mint, less than 50 hours, Best Offer. R Kaufman, Pams Productions, POB 462247, Garland TX 75046. 214-271-7625, after 3PM CDT.

**Recorder heads**, used Scully mono & 2 trk, \$25-50, ATR100's, 3M M79-16 & 8's, Otari 1/2" 8 trks, \$495. W Gunn, 619-320-0728.

**NORTRONICS REPLACEMENT TAPE HEADS**

Test Tapes, Degaussers, Gauges, Cleaners, Swabs, Lapping Films, Splice Bars/ Tabs, and Demagnetizers

**SEQUOIA ELECTRONICS**

4646 Houndshaven Way  
San Jose, CA 95111  
(408) 363-1646

**Scully 280** 1/2" 4-trk. D Nelson, 619-756-0888.

**Want To Buy**

**Ampex AG440C**, need manual, original or will pay for copy; Ampex AG500, need 2-chnl electronics. A Ross, 8022 27th NE, Seattle WA 98115. 206-525-4624.

**Ampex ATR100** taperecorders for parts. Circuit cards, heads, motors, machine parts, or electronic parts. Call 818-907-5161.

**EMPLOYMENT**

To place ads in this section, use the ActionGram form. To respond to box numbers write Radio World, PO Box 1214, Falls Church, VA 22041. Attn: \_\_\_\_\_

**POSITIONS WANTED**

**GM for Florida** medium or large market, 29 yrs exper in sales, programming & engineering, turnarounds or start ups, avail immed. B Elliott, 813-849-3477.

**Experienced bdct engr**, xmtr, studio installations, directional proofs, 100 kW FM, seeking FT position, presently 2-way radio tech. Dan, 206-387-3558.

**Willing traveler** looking for A/C or contemporary Christian format as production, sales or FJ, avail ASAP, small to medium market, bass voice with music knowledge. Kurt, 405-691-5402.

**Broadcaster w/20 yrs** exper seeks announcing in TX, MO, KS, AR, OK, call after 5PM. 501-337-7218.

**GM for Florida** small or medium market, 40 yrs exper in mgmt, sales, turnarounds & ownership. Jim Smith, 813-923-3684.

**HELP WANTED****BROADCAST EMPLOYMENT WEEKLY**

New professional positions in the broadcast industry available weekly from coast to coast. Stations report job announcements to us daily from all departments. Information is updated weekly & available to you fresh. No more "cold" calls and large phone bills to find out who's hiring. Radio stations & job seekers leave job opening & job wanted info FREE! Call for more info.

**1-800-922-JOBS.**

"We take the hassle out of your career moves!" Local Better Business Bureau participant!

**Sales Engineer** for growing manufacturer. Only applicants with AM Radio/TV transmitting and sales experience considered. Excellent salary and commission. Resumes and salary history to Human Resources, PO Box 8026, Greenville NC 27835.

**FIRST CLASS ENGINEER**

Must have experience in AM, FM, Microwave, Satellite & current FCC rules & regs. Send resume and salary requirements to:  
**Phillip Robillard—WYLD Radio**  
2228 Gravier St.  
New Orleans, LA 70119.

**Radio Producers!****Come work for a company with:**

- A national reputation for high production standards
- Comfortable, well-equipped studios
- Full medical & dental paid
- Mandatory days off to avoid burnout
- No nighttime work

**In a beautiful city with:**

- Affordable, available real estate
- Low cost of living
- No traffic problems
- Mild winters
- A relaxed lifestyle

We're looking for a producer/engineer/talent director with a passion for excellent radio & TV audio. Must have experience working with advertising agencies. ProTools skills wouldn't hurt. You can produce great media audio and have a life!

Send a tape (DAT or cassette) and a chronology of your work experience to:

**Soundscapes**

3422 Old Cantrell Road, Little Rock, AR 72202  
No phone calls please!

**ABOUT OUR EMPLOYMENT SECTION**

**HELP WANTED:** Any company or station can run "Help Wanted" ads for \$1.50/word or buy a display box for \$55/column inch. Payment must accompany insert, use your MasterCard or VISA; there will be no invoicing. Blind box numbers will be provided at an extra charge of \$10. Responses will be forwarded to listee, unopened, upon receipt. Call 800-336-3045 for details.

**POSITIONS WANTED:** Any individual can run a "Position Wanted" ad, FREE of charge (25 words max), and it will appear in the following 2 issues of Radio World. Contact information will be provided, but if a blind box number is required, there is a \$10 fee which must be paid with the listing (there will be no invoicing). Responses will be forwarded to the listee, unopened.

Mail to: **BROADCAST EQUIPMENT EXCHANGE**

PO Box 1214, Falls Church, VA 22041

Attn: Simone Mullins

### CASSETTE & R-R...WTB

Scully '100' recorders, record/play amplifiers, 8, 16, 24 track heads. Sequoia Electronics, 4646 Hounds-haven Way, San Jose CA 95111. 408-363-1646.

### CD's/PLAYERS

#### Want To Sell

Magnavox 16 bit dual D/A convert CD players (2), \$100 ea. J Randall, J Randall Bdctg/Recdg, 7276 Lakeside Dr, Indianapolis IN 46278. 317-299-0093.

### COMPUTERS

#### Want To Sell

Heathkit H-89, \$60; Texas Instruments 700 printer, \$50. T Wortmann, WJAG, 309 Broasel, Norfolk NC 68701. 402-371-0780.

### CONSOLES

#### Want To Sell

Ramko DC-5RA radio 5 chnl mixer, unused, \$225. Marc, 916-334-9449.

Sparta A-15 mono 5 pot board w/remote type DJ set up, space for board & 2 TT's, \$200. B Oostenburg, KCKY, POB 6, Coolidge AZ 85228. 602-723-5448.

Allen & Heath Scepter rackmount console, 12x20x2x1, sweep EQ, high quality rackmount w/many features, \$1700/BO. M Ravain, Trinity Christian Music Ministries, POB 2479, Flagler Beach FL 32136. 904-439-3671.

Collins 212P-2 8 mixer audio console service manual & parts. L Douglas, KKPC, 900 W Orman, Pueblo CO 81004. 719-549-3472.

Pacific Recorders CI-2, TI-2, TT-3 console interface units, stereo carts (2) 3 inputs ea, stereo reels (2) one input ea & TT, 2 inputs, \$150 ea/\$600 all/BO. C Gulielmetti, Edgewater Co, 232 C St, S San Francisco CA 94080. 415-589-3313.

Tascam M-30 8x4 with submix, good condition, \$425. G Kintz, WLG1, Rt 2 Box 69, Hemingway SC 29554.

Ramko DC-55 5 chnl stereo mixer board, 2 inputs per mixer except #5 which offers 5 inputs, \$350. KSUE, 3015 Johnstonville Rd, Susanville CA 96130. 916-257-2121.

Consoles, \$500 & up. Call Mark at 619-758-0888.

GE 8-pot mono tube type, huge; McMartin BR-400 4-pot mono remote mixer; McMartin B-502 stereo console; Sparta AS-30 5-pot stereo console. C Watkins, KLCE, Blackfoot, Idaho Falls ID. 208-785-1400.

Gates M5133 Gateway console, \$100/BO. C Creager Sr, WTBI, POB 837, Pickens SC 29671. 803-878-0348.

Radio Systems RS12 (2), excellent condition with preamps & wiring, \$3000 each plus shipping; McMartin B502 5-channel stereo mixing console/news board, \$450. J Randall, John Randall Broadcasting/Recording, 7276 Lakeside Dr, Indianapolis IN 46278. 317-299-0093.

**Daven • SHALLCO**  
Rotary Step Attenuators for Console Upgrades

Gates	Langevin
Harris	Continental
Autogram	LPB
Collins	RCA
Cetec	McMartin

**Broadcast Electronics Sparta and others**

**Shallco, Inc.**  
308 Components Drive  
PO Box 1089 Smithfield, NC 27577  
919 934 3135 info  
800 876 3135 orders  
VISA and Mastercard Accepted

Altec 1567A mixer, excellent condition, \$75; RCA BC-3C 8 pot mono, needs work with book, \$200/BO; Gatesway (2) 8 pot mono, both need work with book, \$200 ea/BO; Harris Ambassador 5 pot mono, meter missing, otherwise appears OK, \$200/BO. D Carver, 107 S Main, Brookfield MO 64628. 816-258-7458.

### Want To Buy

Arrakis 2000, 2100 SCT or similar Arrakis board in good condition. D Koehn, KKPR, Box 130, Kearney NE 68848. 308-236-9900.

Manual for Ramsa WR-8616 audio mixer. J LaMond, WYRK, 500 Rand Building, Buffalo NY 14203. 716-852-7444.

### DISCO & SOUND EQUIPMENT

#### Want To Sell

AKG BX-10; Eventide H969 Harmonizer/delay; Yamaha r1000 digital reverbs (2); ART Proverb; MasterRoom XL404 plate synthesizer, all reverbs in great shape, rack mountable, with manuals, can sell separately, Best Offer. G Gates, Comm Recording Studios, 6001 W Creek Rd, Independence OH 44131. 216-642-1000.

UREI 539 room EQ's (2), third octave, excellent, \$375 each; Teletronix LA-2A classic tube audio limiter, \$2300; BGW 750B prof power amp, excellent, \$450. G Guarino, Sorcerer Snd, 19 Mercer St, Nyny 10013. 212-226-0480.

Sanyo stereo cassette deck fixer upper, needs belt, \$20; Realistic 12 band stereo EQ with expander, like new, will trade for mic or de-esser or BO. W Dougherty Jr, WLD Recording Studio, Music Valley Rt 1, Mill Spring MO 63952. 314-998-2681.

UREI 530 9 band stereo EQ, rack mountable with manual, BO. G Gates, Comm Recording Studios, 6001 W Creek Rd, Independence OH 44131. 216-642-1000.

dbx 150 Type I NR, 2 channel, good condition, \$150/BO. J Rudisill, Audio Independence, POB 746, Aptos CA 95001. 408-684-0605.

Shure Prologue 250 8" 2-way speakers, portable, 8 ohms, \$25. J Ellingson, Jeff Ellingson Voice-Overs, 913 Warwick Dr, Cedar Falls IA 50613. 314-277-8535.

SAE 5000-A impulse NR system, click & pop filter, \$80. S Lawson, KAK Productions, 928 Hyland Dr, Santa Rosa CA 95404.

EV Delta-Max 15 concert speakers (pair) with controller, mint condition, \$3000/ Best Offer. M Ravain, Trinity Christian Music Ministries, POB 2479, Flagler Beach FL 32136. 904-439-3671.

### FINANCIAL SERVICES

**FINANCING** ON ALL

**RADIO EQUIPMENT**

- Easy to qualify
- Fixed-rate, long-term leases
- Any new or used equipment & computers
- 100% financing, no down payment
- No financials required under \$50,000
- References available

**IMMEDIATE**

**Call Mark Wilson (800) 275-0185**

**EXCHANGE NATIONAL FUNDING**

Use Our Experience For Your Business

### LEASING AVAILABLE

SALE/LEASE BACKS, Sell your equipment to Carpenter for CASH. Carpenter LEASES your equipment back to you. You WRITE OFF the monthly payments and put the CASH to work. Carpenter & Associates, Voice 501-868-5023 Fax 501-868-5401.

### LIMITERS

#### Want To Sell

dbx 166 limiter/compressor, \$500/Best Offer. P Drake, 708-870-8252.

Aphex Type C 103A dual chnl aural exciter, audio signal processor, \$100. J Ellingson, Jeff Ellingson Voice-Overs, 913 Warwick Dr, Cedar Falls IA 50613. 314-277-8535.

CRL Audio SPP 800 ABG & SEP 800 4 band limiter, \$300 per unit or \$500/pair. S Karwan, KPSI, 2100 E Tahquitz Way, Palm Springs CA 92262. 619-325-2582.

#### Want To Buy

**BUY-SELL-TRADE OPTIMOD 800 & 8100 414-482-2638**

### MICROPHONES

#### Want To Sell

AKG 202E 2 element mic, excel cond, \$120; Starbird 180 studio, boom extends 146" w/tripod stand, \$250. D Kocher, Digital Snd Makers, 1901 Hanover Ave, Allentown PA 18103. 215-776-1455.

RCA 77DX & 44BX, both in perfect cond, BO over \$800 for either. R Burns, R.F. Studio, 1326 High Meadow Dr, Garland TX 75040. 214-271-4386.

Neumann U-67 tube mic w/power supply, vgc, \$2500. J Jackson, Sound Recorders, 9136 Mormon Bridge Rd, Omaha NE 68152. 402-465-3000.

Neumann U-89's (2) w/shock mounts, cases, mint cond, \$3000/pr or \$1600 ea. Whirlwind Prod, 10356 W Warren Ave, Dearborn MI 48126. 313-584-9201.

EV RE 10, \$100; Audio Technica AT 802, \$100; (3) mic stands, \$20 ea. J Randall, John Randall Bdctg/Recdg, 7276 Lakeside Dr, Indianapolis IN 46278. 317-299-0093.

AKG 414's, \$695, original D12 like the Beatles used, \$295, Sony ECM54, \$150, Beyer M500 lk new, \$300, Demeter 4-ch tube DI rack mt lk new, \$875. W Gunn, 619-320-0728.

Gefell Neumann UM57 tube mics, New capsules for SM2 & many others, New AC701 tubes for Neumann mics, \$275. W Gunn, 619-320-0728.

#### Want To Buy

77-DX's, 44-BX's, KU-3A's On-Air lights. Top price paid. Fast response. Bill Bryant Mgmt, 2601 Hillsboro Rd, G12, Nashville TN 37212. 615-269-6131.

RCA 77DXs/44BXs ribbon, chrome/TV grey, good condition, BO. R Kaufman, Pams Prods, POB 462247, Garland TX 75046. 214-271-7625, after 3PM CDT.

### MISCELLANEOUS

#### Want To Sell

Tip-sleeve patch bays wired to Xmas trees, 10 double row (48 jacks); rack mounted switch panel with 22 sets of 11-non-interlocking switch strips, all are 4PDT alternate action-lighted, wired to Amphenol 50-pin connectors. M Muderick, Muderick Recording, 101 Earlington Rd, Havertown PA 19053. 215-449-6970.

Assorted 1A2 telephone equip intercoms, KSU's, 6 & 10 & 20 button phones, 15 WE 52 headsets. M Muderick, Muderick Recdg, 101 Earlington Rd, Havertown PA 19053. 215-449-6970.

Anvil rack cases (1) 16 space 18" deep, \$250; (2) 5 space 14" deep, \$135. G Kintz, WLG1, Rt 2 Box 69, Hemingway SC 29554.

Kay Industries T-10,000 phase master, 1 in at 230, 3 out at 230, \$1500. R Allen, KLAD, POB 339, Klamath Falls OR 97601. 503-882-8833.

Switch, 3 pole enclosed, 400 amp (3), gd cond, \$100 ea/BO; RCA equip racks (3) 6', gd cond; WE 50B recorder coupler, appears OK; relay (12) P&B KRP11AN, 2 pole, double throw, coil 120 VAC, octal base, unused, \$2.50 ea/BO. Relay (12) P&B KRP14AG, 3 pole, double throw, coil 120 VAC, 11 pin octal style base, unused, \$2.50 ea/BO. D Carver, 107 S Main, Brookfield MO 64628. 816-258-7458.

Dictaphone Time-Master 116300 w/smashed mic; Dictaphone Time-Master 116025 trans w/pedal. C Watkins, KLCE, Blackfoot, Idaho Falls ID. 208-785-1400.

Superior Electric Stabaline pwr conditioner, handles up to 8 amps, \$135; JBL ceiling speakers, housing & volume controls (2), 433 ea; Lil Miss Moffat 48 volt phantom pwr sply (2), \$22 ea; 11 1/4" long frame patch cords, var lengths, \$4 ea; (2) 6' rack rails plus other sizes, all items plus shpg. B Lord, Lord Bdctg, 13313 SE 208th St, Kent WA 98042. 206-631-2374.

Power Transformers, 440VAC/220VAC, 3 phase, 50 and 75 KVA, \$1500 each, 800-833-6629.

**INVENTORY REDUCTION SALE! Over 500 item list (fax or mail). Call Mark at 619-758-0888.**

#### Want To Buy

Jazz record collections, 10" LP/12" LP be-bop, swing, dixie, highest prices paid. B Rose, Program Recdgs, 228 East 10th, Nyny 10003. 212-674-3060.

Ampex tube recorders and mixers. W Gunn, 619-320-0728.

Radio xfrms by Chicago, UTC, Triad, Peerless, Freed, Sola, send list. J Gangwer, 942 32nd St, Richmond CA 94804. 415-644-2363

### MONITORS

#### Want To Sell

Belar FM RF amp; FMM li mod mon, FMS stereo mon, \$2700. R Williams, KQFX, POB 7762, Amarillo TX 79114. 806-355-1044.

## PHONE: 703-998-7600 FAX: 703-998-2966



Call Simone Mullins, Classified Ad Manager, to reserve space in the next issue. Use your credit card to pay, we now accept VISA and MASTERCARD.

# Radio World

5827 Columbia Pike, 3rd Floor  
Falls Church, VA 22041

### Select from these categories for best ad positioning:

Acoustics	Consoles	Software
Amplifiers	Disco-Pro Sound Equip.	Stations
Antennas & Towers & Cables	Financial Services	Stereo Generators
Audio Production (Other)	Leasing	Tapes, Carts & Reels
Brokers	Limiters	Tax Deductible Equipment
Business Opportunities	Microphones	Test Equipment
Cart Machines	Miscellaneous	Transmitter/Exciters
Cassette & R-R Recorders	Monitors	Tubes
CD Players	Receivers & Transceivers	Turntables
Computers	Remote & Microwave Equip.	Positions Wanted
	Satellite Equipment	Help Wanted

### Classified Advertising Rates Effective January 1, 1993

	1x	3x	6x	12x
1-9 col inch (per inch)	\$55	53	50	45
10-19 col inch (per inch)	50	48	45	40
Distributor Directory	90	85	80	75
Professional Card	60	55	50	45
Classified Line Ad		\$1.50 per word		
Blind Box Ad		\$10 additional		

To compute ad costs: Multiply the number of ad inches (columns x inches) by the desired rate schedule for your per unit cost. Example: a 3" ad at the 1x rate is \$165, at the 3x rate \$159, at the 6x rate \$150, at the 12x rate \$147, etc.

## DISTRIBUTOR DIRECTORY

The following distributors serving the broadcast industry would be glad to help you with any of your requirements.

... Canada, the Caribbean, Shannon to Shanghai, the dynamite Fifty ...

RADIO! The beat goes on!

### CROUSE-KIMZEY OF ANNAPOLIS

tops in broadcast equipment  
1-800-955-6800  
ask for Kathleen

### CORNELL-DUBILIER MICA CAPACITORS

FROM STOCK

### JENNINGS VACUUM CAPACITORS

FROM STOCK

### JENNINGS VACUUM RELAYS

**SURCOM ASSOCIATES**  
2215 Faraday Ave., Suite A  
Carlsbad, California 92008  
(619) 438-4420

**MONITORS...WTS**

Harris AM stereo 5TM-1 mod mon, like new cond, \$1000/BO. J Baine, KKMO, POB 1277, Tacoma WA 98401. 206-922-3345.

TFT 760 EBS system w/AM rcvr, works but needs work, \$250/BO. D Carver, 107 S Main, Brookfield MO 64628. 816-258-7458.

**Want To Buy**

McMartin (buy & sell) any model. C Goodrich, 11435 Manderson, Omaha NE 68164. 402-493-1886 or fax 402-493-6821.

**RECEIVERS & TRANSCEIVERS**

**Want To Sell**

**AM STEREO RECEIVERS**  
From \$34.95 Portable, Home, Auto  
**RRADCO**  
Phone/FAX 708-513-1386

Onkyo T-33 AM/FM tuner w/mem-ory & 8 presets, \$90/BO. J Rudisill, Audio Independence, POB 746, Aptos CA 95001. 408-684-0605.

Professional SCA demod card with excellent crosstalk rejection, \$20; Superadio III with SCA, \$85, performance guaranteed. 1-800-944-0630.

Sony SRF-A1 AM stereo Walkman, new, several left, \$89. C Fox, WOLF, 4853 Manor Hill Dr, Syracuse NY 13215. 315-468-0908.

**RECORDING SERVICES**

PRODUCED SPOTS. Finished product on reel, FAST! Low rates. Veteran announcer. FAX your copy/info. Write or call:  
**Gene Davis**  
4473 N. Van Dyke Ave.  
Fresno, CA 93705.  
209-227-6458. FAX 209-229-1324.

## SERVICES

**REMOTE EQUIPMENT RENTALS**  
**COMREX and GENTNER**  
1, 2 & 3-Line Extender Systems  
Now With The New GENTNER EFT-3100  
MARTI VHF/UHF RPU Systems  
Switched-56 Systems  
Call or FAX Dwight Weller  
**WELLER AUDIO-VISUAL ENGINEERING**  
Baltimore, MD  
Phone: (410 or 800) 252-8351  
FAX: (410) 252-4261

**ROHN.**  
**Broadcast Towers**  
**Furnished & Installed**  
Guyed or Self-Supporting  
Solid or Tubular  
**20 Year Warranty!**  
Call Mike Fleissner  
toll free  
**1-800-225-ROHN**

**E.T.S.**  
Strobe Installation & Repair  
6 Mo. Labor & Parts Warranty  
Complete Tower Erection & Maint.  
"Our Business is Climbing to New Heights"  
**419-424-0020**  
FLASHTECH • E.G.G. • T.W.R.

**Space Available**  
for more information, call  
**1-703-998-7600**

TFT 7610R/C, 7610C, 7832C, 7610R, 7832R, 7620, BO. D Sedge, WBAP, One Broadcast Hill, Ft Worth TX 76103. 817-654-6136.

Gates RDC-10 one set worked when removed, other appears OK; also another xmtr unit appears OK w/book, all for \$100/BO. D Carver, 107 S Main, Brookfield MO 64628. 816-258-7458.

Marti RPT 40 dual frequency; TFT 7610; Moseley TCS-2. D Nelson, 619-758-0888.

**SATELLITE EQUIPMENT**

**Want To Sell**

Equitorial 5100 controller satellite rcvr. T Wortmann, WJAG, 309 Broasel, Norfolk NC 68701. 402-371-0780.

Satcue 400 satellite programming switcher. C Watkins, KLCE, Blackfoot, Idaho Falls ID. 208-785-1400.

Wegener 3" satellite cards and mainframes. Call Mark at 619-758-0888.

**SOFTWARE/DATABASES**

**Want To Sell**

**U.S. RADIO DATABASE DIRECTORY:** stand-alone program containing 11,300+ stations. Many searches, prints mailing labels. MAC/IBM (specify disk size). Visa/MC \$99.95/yr. (+quarterly updates): **BBH Software Inc.** 1-800-626-2360 ext. 300.

**STATIONS**

**Want To Sell**

1 kW daytimer 880 AM at Smith Mountain Lake, VA, oldies radio for Roanoke, Lynchburg, Rocky Mount, Bedford, owner retiring, some owner financing. Call 703-297-1188.

**PROFITABLE AM FOR SALE**  
Covering 5 counties, this 500 watt full-time AM station in Central Ohio, home of Honda of America, will go quickly! Some terms available, all offers considered. For more info contact:  
**Chamberlain**  
P.O. Box 69, Bellefontaine, OH 43311  
513-592-8606

50 kW AM in capital city, clear channel, mid/low dial position, unlimited time, non dir days, dir nights, sale/lease; also 3 kW FM, central ARK, can be upgraded to 50 kW, terms. 501-470-1525 aft 5PM.

**FOR SALE:** 50 kW FM C2. Tejano station in 25th largest Hispanic market. 495G, 225G down. Owner has terminal illness. (915) 366-3711.

WKZF FM, Bayboro, New Bern, Havelock, NC, 3000 kW FM with 25,000 upgrade, station must be sold, recently taken back after for-closure, \$325,000 with \$75,000 down, owner terms. R Michaels, KQFX, 3639-B Wolfun Ave, Amarillo TX 79102. 806-355-1044.

10,000 W non-dir day/500 W dir 1200 kHz, near Nashville, can be physically moved to Nashville & increase power to 50,000 W during days, non directional, this is CP, BO. PL Severy, WQZQ, 4706 Hazelwood Circle, Nashville TN 37220. 615-832-4653.

5kW day/29W nite with new tower/ground system, with 4 acres in Jacksonville, FL metro market. Beautiful historic beach town. Best cash offer over \$200,000. Bill, 205-238-0281 or Mark, 205-236-6484.

**Want To Buy**

Small, dark & troubled: experienced station owner will buy your AM (or FM) with no/low down and owner financing and give it new life, east only. Call 609-693-5048.

Station in Mid-Atlantic region, prefer So NJ, E PA or No DE, we are serious buyers. Details to: Professional Electronics, POB 463, Mt Laurel NJ 08054.

**STEREO GENERATORS**

**Want To Sell**

Bauer 682 stereo generator. D Nelson, 619-758-0888.

Advertise in **Radio World** and your ad will reach 22,000 subscribers.

**TAPES/CARTS & REELS**

**Want To Sell**

MRL-Teac calibration test tape, 1/4" & 1/2", excel cond, \$60. D Kocher, Digital Snd Makers, 1901 Hanover Ave, Allentown PA 18103. 215-776-1455.

Spotmaster TP-1B cart rewinders (3) all w/timers and in gd cond, \$89 ea, post pd, P Allen, BCBS, 5501 B Richland St, Greensboro NC 27409. 919-855-6726 aft 2PM EST.



Fidelipac/Audiopak carts, (106) various lengths, \$1 ea; (2) 50 cart wall mount cart racks, \$25 ea. J Randall, John Randall Bdcig/Recdg, 7276 Lakeside Dr, Indianapolis IN 46278. 317-299-0093.

BBC sound effects library, 50 12" vinyl discs, excel cond w/catalog, \$90 plus shpg. J Rudisill, Audio Independence, POB 746, Aptos CA 95001. 408-684-0605.

Reels (100) 7" w/1200' tape in mailers, \$1 ea/BO; (3) 5" reels w/600' tape in mailers, \$.75 ea/BO. D Carver, 107 S Main, Brookfield MO 64628. 816-258-7458.

## CONSULTANTS

**W. LEE SIMMONS & ASSOC., INC.**  
**BROADCAST TELECOMMUNICATIONS CONSULTANTS**  
5 Gracefield Road  
Hilton Head Is., SC 29928  
**1-800-277-5417**  
**803-785-4445**  
**FAX: 803-842-3371**

**Consulting Communications Engineers**  
• FCC Data Bases  
• FCC Applications and Field Engineering  
• Frequency Searches and Coordination  
• AM-FM-CATV-ITFS-LPTV  
**OWL ENGINEERING, INC.**  
1306 W. County Road. F,  
St. Paul, MN 55112  
(612)631-1338 \*Member AFCC\*

**MLJ**  
**Moffet, Larson & Johnson, Inc.**  
Consulting Telecommunications Engineers  
**Two Skyline Place, Suite 800**  
**5203 Leesburg Pike**  
**Falls Church VA 22041**  
**(703) 824-5660**  
**FAX: 703-824-5672**  
Member AFCC

**MULLANEY ENGINEERING, INC.**  
Consulting Engineers  
• Design & Optimization of AM Directional Arrays  
• Analysis for New Allocation, Site Relocation, and Upgrades  
• AM-FM TV LPTV  
• Wireless Cable (MOS/MMS/ITFS/OFS)  
• Environmental Radiation Analysis  
• Field Work  
• Expert Testimony  
9049 Shady Grove Court  
Gaithersburg, MD 20877  
Phone: (301) 921-0115  
Fax: (301) 590-9757

**T. Z. Sawyer Technical Consultants**  
AM-FM-TV-LPTV  
• FCC Applications & Exhibits  
• Experimental Authorizations  
• AM Directional Antennas  
• High Power Antenna Arrays  
• Frequency Studies  
• Class Upgrades  
• STL Applications  
• Station Inspections  
**1-800-255-2632**  
FAX: (301) 913-5799 • 6204 Highland Dr. • Chevy Chase, MD 20815

**Teletech, Inc.**  
BROADCAST CONSULTANTS AND ENGINEERS  
• FCC Applications & Field Engineering  
• Frequency Searches & Coordination  
• Tower Erection & Maintenance  
• Facility Design & Construction  
CONTACT:  
**Kenneth W. Hoehn**  
23400 Michigan Ave  
Dearborn, MI 48124  
**(313) 562-6873**

**PC - SOFTWARE**  
AM FM TV Search Programs  
Contour Mapping-STL Paths  
RF HAZ-1990 POP Count  
FAA Tower-Draw Tower  
**Doug Vernier**  
Broadcast Consultant  
1600 Picturesque Dr  
Cedar Falls, IA 50613  
**800-743-DOUG**

**EVANS ASSOCIATES**  
Consulting Communications Engineers  
TV • FM • AM • ITFS • Satellite  
FCC Applications, Design  
and Field Engineering  
Video/Data/Voice • Light Fiber &  
Microwave • Wide-Area Networks & STL's  
**216 N. Green Bay Road**  
**Thiensville, WI 53092**  
**(414) 242-6000 • FAX (414) 242-6045**  
Member AFCC

North America RF & Audio  
**Mirkwood Engineering Services**  
Broadcast and Telecommunications Consultants  
Multidiscipline Engineering and Planning Firm  
including • Application & Allocation Services  
• Project, Engineering & Construction, Management • Site Acquisition  
• Rural & Remote Site Installations  
• Field Service • Studio Design & Installation  
**50 Park Ave. Claremont, NH 03743**  
**(603) 542-6784**

**Don't Gamble with your advertising dollars.**  
Advertise in Radio World and reach 22,000+ subscribers.  
**Call Simone at 1-800-336-3045 today!**

**Contact Radio World Newspaper for availabilities**

**P.O. Box 1214 Falls Church VA 22041**

**1-800-336-3045**



**TAPES/CARTS & REELS...WTS**

Mix format on Scotchcart II's, 3274 songs, \$8850; Scotchcart II's, 420 3.5 min, \$2 each, also some longer sizes 2.25 each; Abco & Fidelipac Carousel wire cart racks hold 500 & 200 carts each, \$175 & 120 each plus shpg. all used 6 months then in storage. B Lord, Lord Bdcg, 13313 SE 208th St, Kent WA 98042. 206-631-2374.

Ampex 406 10" reel tape, new, only \$11.95 each. Call Mark at 619-758-0888.

Pams Jingles ref tapes, 1951-1976, BO, R Kaufman, Pams Prods, POB 462247, Garland TX 75046. 214-271-7625.

**TAX DEDUCT EQUIP**

**Want To Sell**

Educational FM seeks studio, remote, test equipment. P Kessler, KWSC, Wayne State College, Wayne NE 68787. 402-375-7473.

Need bdcg equip of all types, audio & video for educational FM and cable channel, audio boards, recording equipment & transmitter, video switchers, amps, cameras, VTR's, etc. G Chidester, Snow College, 150 College Ave, Ephraim UT 84627. 801-283-4021 X677.

Non-profit looking for all types recording & bdcg equip & studio, will pay freight & give tax receipt. 515-283-1867.

**TEST EQUIPMENT**

**Want To Sell**

Tektronix 529, mod 188D wave-form monitor, multi-standard version w/PAL frame selector, excel cond, \$525. R Sumner, CAVU Corp, 3322 Applegate Ct, Annadale VA 22003. 703-968-8894.

Westcom Hameg HM103-3 oscilloscope used 6 months then in storage, \$265 plus shipping. B Lord, Lord Bdcg, 13313 SE 208th St, Kent WA 98042. 206-631-2374.

Truetime 60-DC WWVB synchro-nized clock rcvr, mint, with manual, \$900/BO; Truetime 60-TF LF receiver freq comparator, mint, with manual, \$900/BO. A Ross, 8022 27th NE, Seattle WA 98115. 206-525-4624.

Sound Tech 17119 dist measurement system, BO. D Sedge, WBAP, One Broadcast Hill, Ft Worth TX 76103. 817-654-6136.

**We Have RENTAL EQUIPMENT available to SAVE YOU MONEY**

- Spectrum Analyzer
- Potomac Field Strength Meters
- Impedance Bridges
- Receiver/Generator
- Audio Test Set

ALSO

Other Equipment Available

**RADIO RESOURCES**

Ask for STEVE, BILL or Chuck  
**1-800-54-RADIO**

Tektronix 2710 spectrum analyzer with 2704 & 2705 batt charger, \$6000; Potomac Instruments FIM71 FM field strength meter in great cond, \$5000. S Karwan, KPSI, 2100 E Tahquitz Way, Palm Springs CA 92262. 619-325-2582.

B&K E-310B audio oscillator, vgc w/manual, \$75; IRT MK II color monitor comparitor w/manual, mint, \$100; Heath IG-28 color bar/dot gen, vgc, \$50. A Ross, 8022 27th NE, Seattle WA 98115. 206-525-4624.

Jerrold 704B field strength meter, gd cond w/AC pwr sply & book, \$75 plus shipping; HP 400D, AC VTVM, gd cond w/book, \$40/BO; pwr sply, regulated & metered, adjustable, 0-40V, 0-50A, 240 VAC in. D Carver, 107 S Main, Brookfield MO 64628. 816-258-7458.

Houston Instruments Omni-Scribe B5219-5 chart recorder. C Watkins, KLCE, Blackfoot, Idaho Falls ID. 208-785-1400.

EICO VTVM giant meter, works, \$30. J Rudisill, Audio Independence, POB 746, Aptos CA 95001. 408-684-0605.

General Radio 916A impedance bridge, \$300. T Wortmann, WJAG, 309 Broasel, Norfolk NC 68701. 402-371-0780.

**TRANSMITTERS**

**Want To Sell**

ERI 3-bay Rototiller Antenna, 1-5/8" Model 92.1 MHz, \$2500, excellent condition. 816-635-5959.

Harris FM 2.5K in exc cond, used as backup, tuned to 99.3 MHz, \$6800. R Looney, Tri Comm, POB 63-1111, Nacogdoches TX 75961. 409-564-4444.

RCA BTF5 5 kW tuned to 92.7 MHz w/new harmonic filter, 70' Andrew 1/8" w/connectors. C Hall, KYKN, Box 165, Nephi UT 84648. 801-623-4010.

RCA BTA-250M, freq 1330, 250 W output, gd cond w/manuals & some spares, \$2200. L Ward, WZKC, 401 N Blaine Ave, Youngstown OH 44505. 216-746-1330.

LPB RC-25B AM tuned to 640 kHz, needs audio xmtr, 20 W, gd cond, \$150/BO. R Schoedel, WMCR, 6630 Monclova Rd, Maumee OH 43537. 419-893-7968.

**DEMOED EQUIPMENT**

BEXT Inc. has a few demoed exciters, amplifiers and STL's for sale. All demoed systems are sold first come first served and have the same 2 year warranty as BEXT's new equipment. For information:  
**619-239-8462**

Continental 831-D-1A (2), working when removed, \$2000 ea or \$3800/ both. C Hastings, KSBL, 5565 Carpenter-ia Ave, Carpinteria CA 93013. 805-964-4120.

RCA BTA-1R freq 1330, 1000 W output, gd cond w/manuals & some spares, \$2900. L Ward, WZKC, 401 N Blaine Ave, Youngstown OH 44505. 216-746-1330.

Harris FM-5G 5000 W FM xmtr w/exciter, manual, some spare parts, fair cond, \$5000. R Wright, WLLX, 1208 N Locust Ave, Lawrenceburg TN 38646. 615-762-6200.

Harris FM 5H, 5 kW in good condition, \$10,000. R Michaels, KQFX, 3639-B Wolfun Ave, Amarillo TX 79102. 806-355-1044.

**NOTICE!**

To all buyers and sellers of used broadcast equipment including AM/FM/TV/shortwave transmitters, antennas, STLs and studio equipment—To better serve you, we have moved to our new location with over 40,000 square feet of warehouse and service facilities. For transmitter sales, parts, service and technical assistance, please make a note of our new address and phone number.

**ARMSTRONG**  
TRANSMITTER CORPORATION

4835 North Street Road  
Marcellus, NY 13108

TELEPHONE: 315-673-1269  
24 HOUR FAX: 315-673-9972

RCA BTA-10U 10 kW AM still in service, well maintained, BO; RCA BTA-1M 1 kW AM still in service, BO. M Zwerling, KSCO, 2300 Portola Dr, Santa Cruz CA 95067. 408-475-1080.

EMCEE HTU-100 TV translator, all tube type, channel 70 in, channel 78 out, good condition, \$650 plus shipping & crating. W Martin, KZPX, HCR1 Box 286D, Merrifield MN 56465. 218-765-3333.

**NEW 3 kW FM transmitters**  
for under \$14,000.  
Call for details  
Bill Hoffman  
**518-583-9490**

CSI 5000E 5000 W, rebuilt because of lightning damage, perfect service until March 1993 when upgraded, \$8000. H Beam, WAEY, POB 5588, Princeton WV 24740. 304-425-2151.

Harris MW-1 1 kW at 1240 AM, \$6750. R Chambers, KSUE, 3015 Johnstonville Rd, Susanville CA 96130. 916-257-2121.

LPB TX2-20 20 W AM broadcast transmitter, \$500. C Watkins, KLCE, Blackfoot, Idaho Falls ID. 208-785-1400.

**FM - TRANSMITTERS**

Factory new not used. Why buy a used Transmitter when you can own a new FM Transmitter for about the same cost? Call JIMMIE JOYNT at 214-335-3425.

Collins 830-D 1 kW FM with spare tube (4CX1000), remote interface panel, just removed, no exciter, \$2300/Best Offer. M Friend, WTJU, 711 Newcomb Station, Charlottesville VA 22904. 804-971-4096

Harris 3.5 kW FM, 6 years old, excellent condition, being replaced by 22 kW, \$15,000. S Wodlinger, WIXI FM, 813-262-1000.

Gates BC-1E complete but needs work with book, \$600/Best Offer. D Carver, 107 S Main, Brookfield MO 64628. 816-258-7458.

CCA FM1000D 1.5 kW FM transmitter, can be upgraded to 3 or 5 kW, in service, clean & reliable, \$5500. M Benson, KWTY, 916-893-8737.

General Electric TT-10 TV transmitter, 5 kW, channel 4, no PCB's, complete, \$25K. Many other AM-FM-TV transmitters. 800-833-6629.

**TRANSMITTERS**

5.0 kW	AM 1986 Harris	SX-5A
10.0 kW	AM 1980 Continental	316F
5.0 kW	FM 1975 RCA	BTF-5E1
20.0 kW	FM 1980 CSI	T-20-F

**PMA MARKETING, INC.**  
"TRANSMITTING SAVINGS TO YOU"  
414-482-2638 FAX 414-483-1980

**Want To Buy**

Gates BC-1T for parts, complete or not working & missing transformers OK. R Sheffer, KRIZ, 16009 7th SW, Seattle WA 98166. 206-433-2252.

McMartin AM/FM xmtr, any model, exciter or stereo modules. Goodrich Ent., 11435 Manderson, Omaha NE 68164. 402-493-1886.

**TUBES**

**Want To Sell**

4-1000A, 8877, 4CX250B, 4CX1500B, 4CX3000A & more. We carry large inventory all major brands, Eimac, Amperex, RCA, etc. Call Stew 1-800-842-1489.

**ECONCO**

Quality Rebuilt Tubes  
*Approximately 1/2 the Cost of New*

Call for Our Price List  
**800-532-6626**  
**916-662-7553**  
**FAX 916-666-7760**

Circle (8) On Reader Service Card

**TRANSCOM CORP.**  
*Serving the Broadcast Industry Since 1978*

Fine Used AM & FM Transmitters  
and Also New Equipment

For the best deals on Celwave products,  
Andrew cable and Shively antennas.

1 kW FM 1978 Collins 831C2	1 kW AM 1974 Harris BC1H1
2.5 kW FM 1978 CCA 2500R	1 kW AM 1978 Harris MW1A
3 kW FM 1975 CCA 3000D	1 kW AM 1988 Harris SX1A
3 kW FM 1974 Harris FM3H	2.5 kW AM 1982 CCA 2500D
5 kW FM 1968 Harris FM5H	2.5 kW AM 1976 McMartin BA2.5K
10 kW FM 1976 Harris FM10H3	5 kW AM 1979 Harris MW5A
25 kW FM 1981 Harris FM25K	5 kW AM 1968 Harris BC5H
	5 kW AM 1979 Cont. 315F
	5 kW AM 1977 RCA BTA 5L

1077 Rydal Road #101  
Rydal PA 19046  
**800-441-8454 • 215-884-0888 • FAX No. 215-884-0738**

Circle (191) On Reader Service Card

★ MADE IN THE USA ★ MADE IN THE USA ★

**1 kW FM Solid State Transmitter**  
**\$13,200 list includes Exciter!**

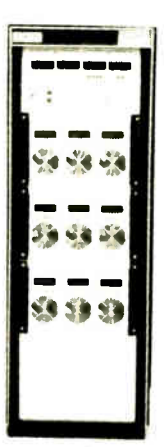

Legend 4000 pictured

**LEGEND 1000 Features**

- Automatic Power Output Control
- VSWR Foldback and Protection
- Remote Control Ready
- Full System and Individual Module Metering
- Motorola MRF151G MOSFETS

• PLUS MANY MORE FEATURES

"The Transmitter People"

**Energy-Onix**

752 Warren Street, Hudson, New York 12534  
(518)828-1690 FAX(518) 828-8476

★ MADE IN THE USA ★ MADE IN THE USA ★

Circle (61) On Reader Service Card

**TUBES...WTS**

New tubes, OD3, 2E26, 5AR4, 5Y3, 6AL5, 6AU6, 6AN8, 6AX8, 6BY6, 6BJ8, 6BJ6, 6AK5, 6AV6, 6SK7, 6J6, 6X8, 6U8, 6V6, 6DK6, 6J7, 62AU7, 12AY7, 12AX7, 12SK7, 12SQ7, 5763, 5847, 5847, 5879, 6201, 6267, 6386, 6681, 7025, ECC82, EF86, EF95. C Watkins, KLCE, Blackfoot, Idaho Falls ID. 208-785-1400.

**Want To Buy**

4CX5000A tubes, new/gd used, must make full pwr. D Carver, 107 S Main, Brookfield MO 64628. 816-258-7458.

**Space Available!**  
Call 1-703-998-7600

**WANTED!**  
*Transmitting Tubes*

We BUY & SELL all types of transmitting/receiving tubes.

**C&N Electronics**  
Harold Bramstedt  
6104 Egg Lake Road  
Hugo, MN 55038

(612) 429-9397 ext.23  
(800) 421-9397 ext. 23  
FAX (612) 429-0292

**Circle (10) On Reader Service Card**

**TURNTABLES**

**Want To Sell**

RTS-405 stereo TT preamp (2), \$180 ea plus shpg. B Lord, Lord Bldg, 13313 SE 208th St, Kent WA 98042. 206-631-2374.

**Want To Buy**

16" tonearm, record cutting machines, 45/78 records. 612-866-6183.

**Russco Cuemaster w/Shure arms** (2), one headshell missing, \$50 ea/BO; (2) QRK 3 spd w/Microtrak arms, gd cond, \$50 ea/BO; Gates CB 88 w/Gray arm & preamp, \$75/BO; Gates CB 77 w/Rek-O-Kut arms, gd cond, \$50/BO; (2) Russco 12-BID w/Rek-O-Kut arms, \$50/BO; several phono preamps, \$25 ea/BO. D Carver, 107 S Main, Brookfield MO 64628. 816-258-7458.

**Gates CB1200 33-45-78 rapid start TT & tonearm;** QRK custom two 33-45 rapid start TT; Russco Cuemaster 33-45-78 w/Micro-Trak tonearm. C Watkins, KLCE, Blackfoot, Idaho Falls ID. 208-785-1400.

**ADVERTISER INDEX**

This listing is provided for the convenience of our readers. Radio World assumes no liability for inaccuracy.

Page No.	Advertiser	Reader Service No.	Page No.	Advertiser	Reader Service No.
61	360 Systems	217	49	ITC	102
54	AEO	134	64	ITC Instruments	160
86	AEV SNC	106	18	Immer Music	192
66	AEV SNC	184	55	Inovonics	153
79	AMP Services	59	39	J Squared Technical Service	23
7	ATI	16	23	J.R. Nelson	20
64	ATI	29	96	JT Communications	107
23	Accu-Weather	183	40	Jampro	70
55	Altronic Research	33	68	Kintronic Labs	162
22	Aphex	44	49	LBA, Inc.	58
10	Arrakis	172	58	LPB	142
24	Arrakis	206	62	LPB	205
32	Arrakis	122	87	LPB	137
72	Arrakis	111	64	LDL	186
84	Audi-Cord	200	13	Logitek	18
79	Audio Broadcast Group	117	39	Marantz	99
92, 93	Audio Broadcast Group	79	34	Marti	73
76	Audio Processing Technology (APT)	94	9	Micro Technology Unlimited	123
2	Audioarts Division of Wheatstone	54	57	Modulation Sciences	171
18	Audiopak	60	17	Moody Broadcasting Network	116
B5	Audiotronics	47	70	Moseley	187
40	Avcom of Virginia	26	89	Murphy Studio Furniture	145
45	BSW	189	60	Myat	121
B1	BSW	138	37	NAB	101
32	Belar	81	19	National Public Radio	216
72, 73	Belden Wire and Cable	41	26	National Supervisory Network	147
79	Benchmark Media Systems	133	42	Nautel	36
56	Bext	66	47	OKI	53
40	Broadcast Devices	6	36	Orban/AKG/dbx	98
27	Broadcast Electronics	2	69	Orban/AKG/dbx	175
59	Broadcast Electronics	143	14	Otari	212
4	Burk Technology	219	67	Pacific Recorders	109
B	Burk Technology	4	12	Peoples Radio Network	110
102	C&N Electronics	10	43	Pioneer	198
27	CBSI	32	47	Pristine Systems	9
1	CCA Electronics	28	63	OEI	141
15	California Digital	67	25	RE America	166
46	Cellcast	55	65	RE America	159
64	Central Tower	51	28	Radio Computing Service	62
64	Circuit Werkes	39	97	Radio Resources	119
BB	Clark & Associates	167	13	Radio Spirits	80
BB	Clark & Associates	105	91	Radio Systems	209
B	Clark Wire and Cable	48	16	Reef Industries	14
71	Computer Concepts Corp.	93	11	Register Data	144
3	Comrex	161	96	Rodman/Brown Associates	76
64	Comrex	194	96	Rodman/Brown Associates	100
5B	Conex	5	96	Rodman/Brown Associates	22
3	Continental Electronics	85	33	Roland Corp.	13
4B	Corporate Computer System (CCS)	127	16	SMARTS Broadcast Systems	199
40	Cortana	69	20, 21	SPAR/Comstream	108
75	Cutting Edge	27	86	SWR	24
38	Dalet	202	44	Scott Studios Corp.	114
47	Dataworld	1	40	Shively Labs	146
65	Dataworld	74	24	Southern Communications	7
86	Dataworld	12	78	Studer	113
35	Denon America	218	96	Studio Technology	82
79	Digitation	87	31	Superior Electric	154
79	Dielectric Communications	201	52, 53	TM Century	118
51	Dolby	90	29	Tx Rx	155
34	ERI	40	24	Talk America	124
95	Econco	152	68	Tapecaster	96
101	Econco	8	96	Telfax Communications	213
82	Energy Onix	68	41	Telos Systems	50
101	Energy-Onix	61	84	The Express Group	56
96	Excalibur	177	40	The Management	180
30	Fidelipac	57	77	The Management	49
50	Fidelipac	182	79	Third Story Recording	3
B3	Fidelipac	157	79	Titus Technologies	15
64	Flash Technology	72	101	Transcom	191
95	Gorman Redlich	38	73	Transstream	77
97	Hall Electronics	31	96	Tripp Communications Sales	103
64	Hallikainen & Friends	19	40	Universal Electronics	17
56	Harris Allied Broadcast Equipment	91	74	Valley Audio Products	45
6	Harris-Allied Broadcast Equipment	95	103	Wheatstone	211
B2	Harris-Allied Broadcast Equipment	89	104	Wheatstone	215
95	IFR Systems, Inc.	178	79	Zercom	132

Publisher .....Stevan B. Dana  
Associate Publisher .....Carmel King  
Marketing Consultant .....Al Leon  
Marketing Assistant .....Annette Deutscher  
Production Director .....Kim Lowe  
Production Manager .....Julianne Stone  
Production .....Vicky Baron, Lisa Lyons, Lisa Mamo  
Ad Coordinator .....Regan Deatherage  
Ad Coordination Manager .....Simone Mullins  
Circulation Director .....Tiana Hickman  
Circulation Manager .....Rebecca Seaborg  
Accounts Receivable .....Steve Berto

**Advertising Sales Representatives**

U.S. East: Skip Tash .....703-998-7600 Fax: 703-998-2966  
U.S. West: Dale Tucker .....916-721-3410 Fax: 916-729-0810  
International: Stevan B. Dana .....+1-703-998-7600 Fax: +1-998-2966  
Europe: Dario Calabrese .....+39-2-753-0274 Fax: +39-2-753-2697  
Japan: Eiji Yoshikawa .....+81-3-3327-2688 Fax: +81-3-3327-3010

Free Subscriptions are available upon request to professional broadcasting and audiovisual equipment users. For address changes, send current and new address to RW a month in advance at P.O. Box 1214, Falls Church, VA 22041. Unsolicited manuscripts are welcomed for review; send to the attention of the appropriate editor.

**Radio World**

Your Ad Will Reach Over  
**22,000 Subscribers**

**Advertise NOW!**

Call Simone Mullins at

**1-703-998-7600**

**Call Today!**

**ACTION-GRAM**

**Equipment Listings**

Radio World's Broadcast Equipment Exchange provides a FREE listing service for radio stations and recording studios only. All other end users will be charged. Simply send your listings to us, following the example below. Please indicate in which category you would like your listing to appear. Mail your listings to the address below. Thank you.

Please print and include all information:

Contact Name \_\_\_\_\_ I would like to receive or continue receiving Radio World FREE each month.  
 Yes  No

Title \_\_\_\_\_ Signature \_\_\_\_\_ Date \_\_\_\_\_

Company/Station \_\_\_\_\_ Please Circle only one entry for each category:

Address \_\_\_\_\_

City/State \_\_\_\_\_

Zip Code \_\_\_\_\_

Telephone \_\_\_\_\_

**I. Type of Firm**  
D. Combination AM/FM station F. Recording studio  
A. Commercial AM station G. TV station/teleprod facility  
B. Commercial FM station H. Consultant/ind engineer  
C. Educational FM station I. Mfg distributor or dealer  
E. Network/group owner J. Other \_\_\_\_\_

**II. Job Function**  
A. Ownership G. Sales Manager  
B. General management E. News operations  
C. Engineering F. Other (specify) \_\_\_\_\_  
D. Programming/production \_\_\_\_\_

Brokers, dealers, manufacturers and other organizations who are not legitimate end users can participate in the Broadcast Equipment Exchange on a paid basis. Line ad listings & display advertising are available on a per word or per inch basis.

WTS  WTB  Category: \_\_\_\_\_

Make: \_\_\_\_\_ Model: \_\_\_\_\_

Brief Description: \_\_\_\_\_

Price: \_\_\_\_\_

WTS  WTB  Category: \_\_\_\_\_

Make: \_\_\_\_\_ Model: \_\_\_\_\_

Brief Description: \_\_\_\_\_

Price: \_\_\_\_\_

WTS  WTB  Category: \_\_\_\_\_

Make: \_\_\_\_\_ Model: \_\_\_\_\_

Brief Description: \_\_\_\_\_

Price: \_\_\_\_\_

\*Closing for listings is the first and third Fridays for the next month's issue. All listings are run for 2 issues unless pressed for space or otherwise notified by listee.

**Broadcast Equipment Exchange**

Phone: 703-998-7600 PO Box 1214, Falls Church, VA USA 22041 FAX: 703-998-2966

# Give Your Production People Some POWER!

**THE SP-6 IS LOADED WITH FEATURES!** Like a powerful equalizer section that gives your talent greater creative freedom; four auxiliary sends that can be used for special effects, headphone feeds, or IFB mixes; both 8-track and stereo bus assigns for multi-track and dubbing work; plus a choice of mono mic/line or stereo input channels. And, to keep things fast and productive, it even includes full machine control logic, control room and studio mutes, plus tally systems—just like you'd expect on an on-air console. The SP-6 provides independent headphone, control room and multiple studio monitors, and (of course) an automatic stereo cue/solo

system. Our unique track monitor section will speed your production pace, allowing simultaneous stereo mixdown during the multi-track bed session.

A powerful group of accessory modules will increase your production control, like a 7-station intercom module that links this console with other Wheatstone consoles and talent stations throughout your complex; a full-function tape recorder control panel; an 8-position source selector to enhance input capability; additional studio modules to accommodate multi-studio installations; and finally, a digital event timer and a precision clock.

So contact Wheatstone, the company with the integrity and experience you can count on.



 Wheatstone® Corporation

6720 V.P. Parkway, Syracuse, NY 13211 (tel 315-455-7740 / fax 315-454-8111)

Circle (211) On Reader Service Card

See Us At Radio Show Booth 901

# Wheatstone Has It!

## Super Performance – Great Price!

**OUR NEW A-300 CONSOLE HAS ALL THE RIGHT STUFF:** Performance right at the limits of technology, the features you want, and a fresh clean look your clients will admire. It's got all the busses you'll need. It's got the crosstalk and bus off isolation you HAVE to have for LMAs and FM/AM combos. Its small footprint and low profile let you conserve valuable studio real estate. Its virtual audio bus™ architecture lets you place any module anywhere in the console—no dedicated slots!

Talent will love our easy-to-learn superphone module and the automated cue system that makes monitoring confusion-free. Our integrated intercom system lets them communicate with any other Wheatstone console or talent location—handsfree.

Your program director will really like the sound of this console: no VCA distortion—just flawless specs. And, because of its ultra-flexible architecture, it can be easily adapted to any format, anytime.

The A-300 has what engineers want: first class documentation, gold switches, gold connectors, a hinged meterbridge for easy re-lamping, straight-forward reliable logic technology, and the best I/O connection and tooling system in the industry.

The A-300 is the console that has followed the evolution of radio. Benefit from Wheatstone's experience and total commitment to your satisfaction. Contact us.

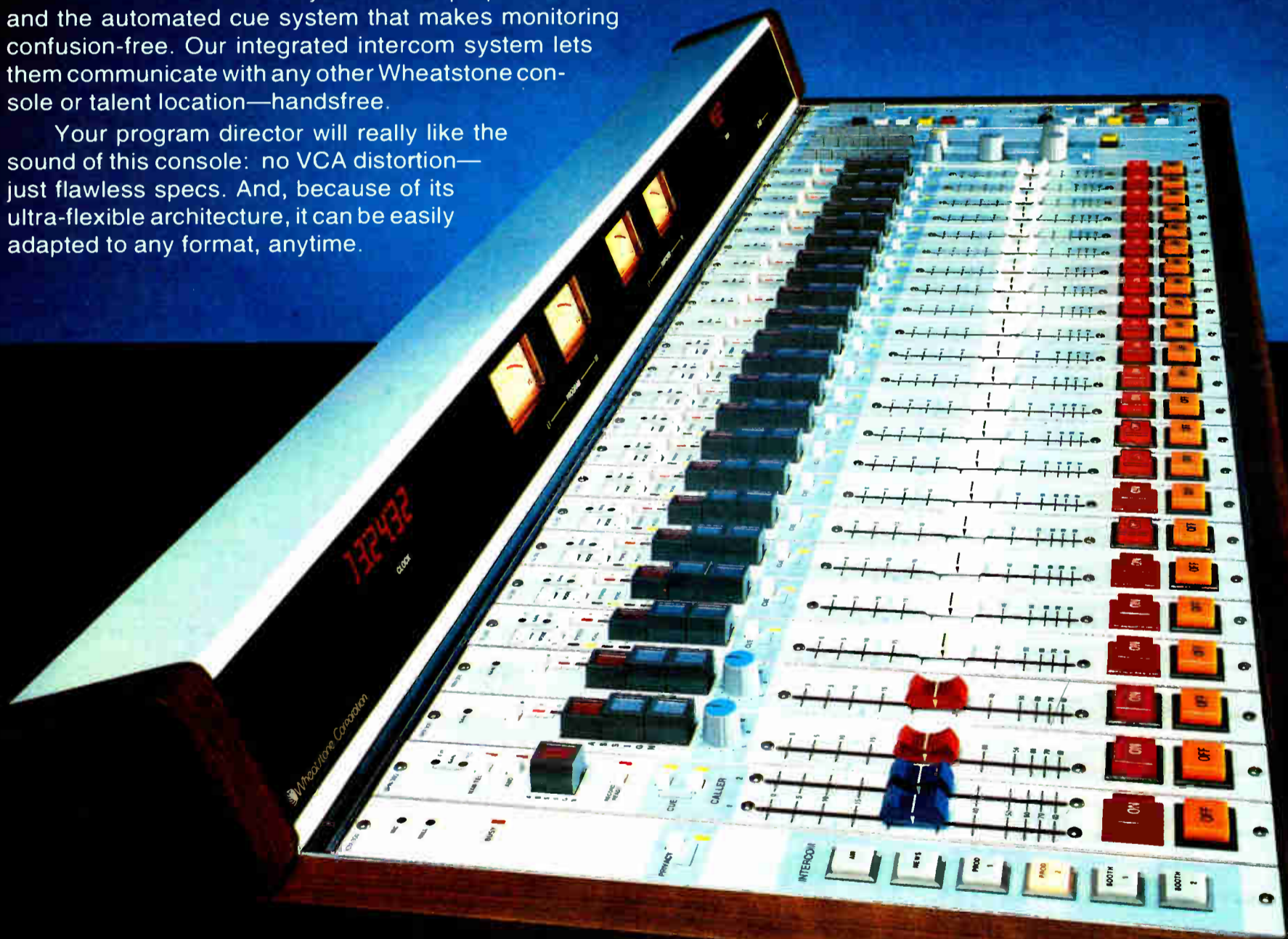

 Wheatstone® Corporation

**A-300**

7305 Performance Drive, Syracuse, NY, 13212 (tel 315-452-5000 / fax 315-452-0160)