

## Manufacturers Discuss Compression Stacking

### Executives Support Industry Standard

by Frank Beacham

**NEW YORK** The broadcast industry needs a standard for the seamless interconnection of digital audio devices using incompatible data compression schemes, an informal RW survey of industry executives suggests.

The comments came in response to a series of "real world" audio tests that combined devices using various data compression schemes in a typical broadcast audio chain. Conducted by chief engineer Herb Squire of New York City's WQXR-FM and WQEW(AM) with cooperation from several broadcast organizations, the tests found that repeated signal passes through devices using incompatible data compression results in severe sonic degradation of overall audio quality.

"Here's a situation where you have different algorithms which in and of themselves are essentially transparent to the listener. So the impression is they can talk to each other, when in reality they can't," said Clint Pinkham, manager of technology applications at Thomson Consumer Electronics. Thomson is U.S. representative for the Eureka 147 digital broadcast system that employs the MUSICAM algorithm.

#### Going their own way

"The result has been a proliferation of various and sundry pieces of hardware where everybody has their own algorithm...and, of course, they are incompatible," Pinkham said. "The ultimate solution is to develop standards."

Pinkham compared the current problem to a mythical situation in which 15 different companies had their own idea of FM pre-emphasis characteristics. "If this were the case, FM radio would be a confused mess of different tone qualities from different stations," he said.

Bob Donnelly, ABC Radio's manager of the network's satellite operations, believes the sound degradation problems illustrated in Squire's tests have more to do with transcoding from the analog to digital and back again than they do with the compression schemes.

"I am comfortable with the belief that it's more of an A to D issue than it has to do with any of the algorithms," Donnelly said. However, Donnelly, whose network helped with the tests, said he and his network support Squire's work even though he does not completely agree with the WQXR engineer as to exactly what caused the degradation.

"I agree with Herb's goal. But it's sort of like the difference between the Republicans and the Democrats in an ideal sense," Donnelly said. "We all have the same goals, we just don't agree on how to get there. I think Herb's goal,

continued on page 10 ►



#### Hi-Tech Facility:

The EIA will test digital radio systems at the NASA Lewis Research Center in Cleveland, see p. 7.

## Cost Estimates for DAB

by John Gatski

**LAS VEGAS** A recent evaluation of a digital radio broadcasting system (DAR) costs estimated that in-band, on-channel (IBOC) would be the cheapest to implement for stations.

According to Skip Pizzi, a digital consultant, the IBOC systems, such as USA Digital Radio's proposal, have a "slight edge" over in-band-co-channel and out-of-band (or new band) systems, in terms

of equipment conversion costs.

But Pizzi said that the numbers are based only on current trends for transition to digital, "and cost is certainly only one among many issues to be considered in the choice of a format." (Overall, the factor of hardware cost difference among the systems actually is minor compared to other cost factors, such as regulation, Pizzi said.)

With regard to IBOC, Pizzi estimated \$60,000 to \$65,000 for a station's equipment conversion costs. That would include \$20,000 for a digital exciter and an additional \$25,000 for a low-power transmitter, which was thought to be unnecessary in earlier DAR conversion estimates, according to Pizzi.

"It now seems evident that the Class C amplifiers used in analog broadcast transmitters do not possess sufficient linearity to adequately handle digital signals in the IBOC model," Pizzi said. "Therefore, in addition to a digital exciter, a separate low-power transmitter Class A or Class AB will be needed for the digital signal."

#### Same antenna for IBOC

Antenna, tower and transmission line, will not require additional investment for IBOC since existing equipment can be used, according to Pizzi.

The in-band adjacent channel or in-band interstitial (IBI) would require \$55,000 to \$75,000 in equipment conversion costs, Pizzi noted. That system would likely need the same digital exciter and low-power transmitter combination that IBOC requires, although "the digital exciter used in an IBI model may be less complex and, therefore, cheaper than an IBOC unit."

Pizzi said there are some potential

continued on page 22 ►



HARRIS DIGIT™

### Digital Excitement!

The world's first truly digital 50 watt FM exciter provides 32-bit Direct Digital Synthesis precision. The Harris Digit™ will deliver exceptional signal quality on the day of final test, and a year, even a decade, after installation.

Phone: 800-622-0022 Fax: 317-966-0623

HARRIS ALLIED

**Running Radio**  
Your Resource for Business, Programming & Sales, pp. 11-26

# NEWSWATCH

## How to Acquire A Radio Station

**WASHINGTON** The NAB has made available a free brochure, "Radio Station Ownership: Four Steps to Making a Station Yours."

The brochure details the legal and technical requirements for radio station acquisition and includes a brief description of the radio ownership rules. The brochure also explains the pre-buy evaluation and research stage, itemizes station inspection

procedures, and outlines contracts and FCC forms needed to complete the transaction.

To get a copy, call the NAB's Radio Department, 202-459-5420. Brochure quantities are limited.

## FCC Cites WWWT For Power Violation

**RANDOLPH, Vt.** The FCC has fined WWWT(AM) \$20,000 for operating in excess of its nighttime power authorization.

According to the FCC, WWWT operated at its daytime power of 1000 watts 24 hours a day from at least May 1992 to September 1992, instead of powering down to the 66 watts nighttime authorization. The original complaint had alleged that the station had operated at higher-than-authorized power since September 1991.

In its response to the complaint in Sept. 1992, station management said its automated computer system had software problems, but that the chief engineer was making repairs. In a February 1993 letter, the station asked the FCC to consider its overall record of compliance with

Commission rules in making a determination about a fine.

## EEO Violation Fine Upheld

**AVALON, N.J.** The FCC recently upheld its decision to fine WWOC-FM for failure to comply with the Commission's equal employment opportunity (EEO) rule.

The station had contested the amount of the fine (but not the original EEO violation findings, according to the FCC) on "its purported inability to pay," a press release said.

However, the Commission ruled that additional information

provided by owner Group Six, the former licensee of the station, did not convince the staff that the \$20,000 was excessive.

"The Commission concluded the statement did not contain a payment-to-principals entry and appeared to reflect funds available to cover a forfeiture," the press release said.

## CD Players Increase In Radio Stations

**NEW YORK** According to a recent survey by the Professional Audio Market-place, radio stations replaced cart machines with CD players for on-air playback in large numbers in 1992.

SC Research, Inc. said CD players totaled almost 42,000 units in early 1993 with 18,630 purchased last year. Cart machines, on the other hand, declined quite sharply, the survey revealed, from 71,268 units last year to 32,780 this year.

"Those numbers represent a trend toward one-for-one replacement of carts by CD players," SC Research's Doug Sheer said.

As for other cart alternatives such as floppy disc-based systems,

continued on next page ►

# Only AUDIOARTS Has It...

## WHEATSTONE'S STRENGTH!

With Wheatstone's professional experience, engineering know-how, support capability and corporate stability behind it, this AUDIOARTS console design is the right choice.

The A-50 is cost effective through clever engineering and the latest advances in CAD design and electronic assembly procedures. It was developed by the same design team that creates Wheatstone's high end equipment. This console's performance is light years beyond the competition.

Naturally, it has all of the most important features: machine control functions, programmable channel logic, and three busses (Program, Audition, and Telephone). It also has the monitors you need: control room, studio and headphone—each with its own level control. It's designed so you can expand or add accessory modules as your needs grow.

You can benefit from our major market experience. Take advantage of Wheatstone's expertise and reputation; call us today for immediate action.



**AUDIOARTS ENGINEERING**  
7305 Park Avenue, New York, NY 10022-1100 / Tel: 315-452-3000 / Fax: 315-452-0150

# Index

## RUNNING RADIO

### Make the Most of Bar-Hopping Remotes

by Mark Lapidus 11

### Techniques for Reliable Stitching in Time

by Sue Jones 15

### Generate Non-Traditional Revenue

by Lucia Cobo 16

### Latest in On-Going DAB

Panel Talks  
by Judith Gross 17

### Remote Possibilities for Affiliates

by Karl Baehr 18

### When Technology Means Less Choice

by Charles Taylor 21

## FEATURES

### Commission Checklist Plain and Useful

by Harold Hallikainen 27

### Duopolies Change Radio Moneymaking

by Dee McVicker 28

### Well-Modulated Radio An Unrealized Reverie

by Barry Mishkind 29

### Modulation War; Digital Escalation

by John "Q" Shepler 30

### Workbench

by John Bisset 32

### Be Ready, AM Stereo Has Returned

by Cris Alexander 33

### Simple, Time-Saving Printer Alarms

by Ed Bukont 34

### Fireside Chats Soothed the Nation

by James Wold 37

► continued from previous page

Sheer said "they are promising, but have not yet shown up in big enough numbers to truly challenge CD players or NAB carts at radio stations."

**Deadline for Expanded Band Applications Closes June 30**

**WASHINGTON** The window for AM station owners to file for a channel in the expanded AM band (1605 kHz to 1705

kHz) is June 30.

The filing period opened May 3. First-step filing procedures require a letter requesting migration, a short description of the licensee's current operation, and statement of intent (or not) to broadcast AM stereo.

The FCC will use the application information in a computer program to create a priority list with preference to stations that will relieve interference by moving to the new frequency.

Stations eventually granted expanded

band licenses will be allowed to broadcast on the new and the original frequency for five years, at which time they will be required to turn in their original license.

**Synclavier Consortium Assumes NED Product Line**

**LEBANON, N.H.** The Synclavier Owner's Consortium has completed acquisition of New England Digital's (NED) assets and has resumed sales and service

of the Synclavier and PostPro digital audio workstations.

BayBank of Boston foreclosed on New England Digital's assets last year after the company defaulted on a \$3 million loan.

The new company acquired all New England Digital's patents, trademarks, and software/hardware technologies. The Synclavier Owner's Consortium will be headed by former executive Griffith McCree, and will operate from New England Digital's former location in Lebanon, N.H.

**Germany Delays Eureka Evaluations**

by John Gatski

**BERLIN** A German broadcast organization has announced a two-year delay in consideration of the new-band Eureka 147 digital audio broadcast system. The setback for Eureka in Germany, however, is not seen as an immediate impediment to adopting the technology in other pro-Eureka countries such as Canada, France, Britain or Sweden.

And Germany's decision is likely to have minimal effect on U.S. digital broadcasting plans—other than to perhaps create an opportunity for U.S. in-band proponents to challenge the European-developed Eureka system on its own turf. Although the Eureka project had been heavily promoted two years ago by the NAB for U.S. implementation, in-band proponents, such as the USA Digital consortium, now have more broadcaster support.

The German public broadcasting group, ARD, voted to delay consideration of the technology from 1995 to 1997. The group said the delay was necessary because

of financial concerns and questions surrounding the technology's ability to broadcast all programming. The latter issue involves frequency allocation.

USA Digital's Paul Donahue said that when the consortium looked at digital audio transmission systems three years ago, it had the same concerns that Germany, now has. "Our concerns were that it didn't accommodate all the broadcasters, and it was too costly," Donahue said.

As for Germany's delay in consideration of Eureka being seen as an opportunity for USA Digital to make inroads in Europe for its system, Donahue said "they (the Germans) haven't made any official overtures to us."

But, Donahue said, there was a lot of interest from European broadcasters at USA Digital's booth at the 1993 NAB convention.

USA Digital's AM DAB in-band demonstration at NAB was considered successful, but neither the Europeans or anyone else got to hear the planned mobile FM in-band demonstration because of technical problems with the power supply feeding the

mobile equipment.

In Canada, where Eureka testing and planning have been on-going, officials said the German decision has no bearing on Eureka DAB plans. "We're right on schedule," Canadian Broadcast Consultant Wayne Stacey said.

In the America's, Mexico also is considering Eureka. Other European countries are candidates for Eureka as well.

In Britain and France, both countries are proceeding with Eureka implementation plans, officials said. "We seem to have overtaken the Germans as the ones that are most likely to introduce DAB first, said Mark Thomas, head of Britain's Radio Authority. Britain, however, is still sorting through spectrum and cost issues relating to implementation.

France's interest remains strong in Eureka, but communications officials said they are still working to find the desired VHF spectrum if possible. French communications officials also are closely considering L-band (1500 MHz).

□ □ □

Alan Carter, Tim Frost and Michael Lawton of **RW International** also contributed to this article.

**the Desk Jockey™**

Digital Automation That Makes Sense

**Radio Automation Terms**

If you've shopped for an automation system lately, you've been faced with all kinds of new terms like "RAM," "Megabytes," and "Sample rate."

Rather than bore you with more of the same, we'd like to take this opportunity to describe The Desk Jockey digital automation system in terms you can better understand. To do that, we'll quote our customers - real broadcasters, like you...

*"I'm tickled pea green." "This is really neat." "That's all there is to it?" "Wow!" "You folks have a winner here." "Are you boys selling any stock in this outfit?"*

If you still have questions, please call us today.

When it comes to satellite or CD format automation, every company talks about experience. We're shipping it, backed by the most experienced team of broadcasters in the business.

You don't need another headache. You need a Desk Jockey.

**RB** Rodman \ Brown & Associates, Inc.

**(708) 983-0977**

Circle (78) On Reader Service Card



**Features:**

- 56/64 Kb/s Switchable
- Built-in Power Supply
- Portable or Rack Mount
- Complies with CCITT G.722
- 7.5 KHz Full Duplex Audio
- Ideal for Studio-to-Studio Links

**COMREX DIGITAL CODECS** provide wideband, two-way audio to put listeners right at the scene for sports, news, weather and more. The Comrex Codec allows broadcasters to take advantage of the new digital telephone services which are fast becoming an excellent low-cost alternative to satellite links or dedicated lines.

Our codecs can be used with switched 56 Kb/s and 64 Kb/s (ISDN) services as well as dedicated digital lines. The versatility and intelligence built into the Codec assure compatibility with virtually any digital telephone network, so all you have to do is plug it in and turn it on.

*Call or fax us for complete information plus our useful notes on "How to Order and Use Digital Phone Service."*

**COMREX**

Comrex Corporation  
65 Nonset Path, Acton, MA 01720  
800-237-1776 508-263-1800  
Fax 508-635-0401

Comrex (UK) Ltd.  
75 The Grove, Ealing  
London W5 5LL, UK  
081-579-9143 Fax 081-840-0018



Circle (182) On Reader Service Card

# Army Van a Radio Oasis for U.S. Troops

There is a steady trickle of international news to tell you about. The U.S. market continues to attract international players. The latest hopeful is HHB Communications. The London-based distributor recently announced that it has appointed Independent Audio of Portland, Me., as its North American business coordinator.



Independent Audio Proprietor Fraser Jones is the brother of HHB's managing director Ian, and he worked for the company for ten years before emigrating to the U.S. in 1989.

According to HHB, the move is in response to a growing demand for its product lines in both Canada and the U.S. The range of products offered by HHB includes its own brands. Products available through Independent Audio include: the HHB Advanced Media Product DAT Tape Range; the HHB IPRO professional portable DAT recorder, and the HHB CDR Indexer.

In addition to the company products, Independent Audio will warehouse and distribute two of HHB's most successful product lines, ATC (a British loudspeaker manufacturer) and Cedar (makers of the DC-1 de-clicker).

For more information on either HHB or Independent Audio, call Fraser Jones at 207-773-2424.

★ ★ ★

Those of us who attended the Baltimore SBE Chapter meeting for the month of May got an unexpected treat. The Army Broadcasting Service (ABS) Mobile Radio Station was on display in the parking lot at Duffy's (the regular meeting place for the Chapter).

As you can see in the pictures, the station

is housed in a small truck, but is packed full of goodies. In keeping with Army preparedness, the unit contains two of everything that is essential, including: two QEI 150 W transmitters, two BE exciters, two Belar monitors, two Gentner stereo limiters/generators, two Eventide digital delays and two TASCAM decks.

The DJ station features an audionics console and a set of five Denon CD players.

According to Sergeant Major Suttles, an ABS engineer, the unit is a contingency vehicle, for use when U.S. troops are overseas and don't have access to radio facilities. It broadcast to U.S. troops during Operation Desert Storm in the Persian Gulf.

The station has been designed to automatically play satellite programming from both Unistar and

stereo operation, it can transmit in mono during a complete failure of the stereo audio chain.

★ ★ ★

Our condolences to the family and friends of James Weldon, founder, former owner and past president of Continental Electronics, who passed away on April



Satellite Music Network. The SATCUE 400 activates control pulses for the cart machines. Each machine has been selected to play a specific pre-produced event when called for by either network.

The station is equipped with its own power supply, and can broadcast news, command information and entertainment to the troops. The troops are issued portable radios (the station is furnished with 250-300 units).

Other interesting gear in the van includes a telephone hybrid designed to protect the telephone interface module from high voltages and other anomalies that can be present on a foreign telephone system. Although the station is a fully

19. Weldon began his career in radio as a chief engineer in 1927 in a station in Topeka, Kan. His path eventually led him to XER in Villa Acuna, Mexico, where he oversaw the increase in power of the station to 500 kW. His transmitter was the first to use a "Doherty" amplifier in that power range, and eight, newly designed 320A tubes built by Western Electric (only nine were ever built).

In 1940, Weldon was a consultant with the Federal Telephone and Radio Corp.,

and helped design and build several 50 kW stations in the New York City area. After World War II, he moved to Dallas and organized a manufacturing company to build transmitters and phasing and coupling equipment that consulting firms were specifying. That company was the beginning of today's Continental.

Weldon sold Continental to Ling Electronics in 1959, but remained involved with the company. In 1972, he purchased Continental and took the company private. Weldon led Continental to prosperity in the 1970s and 1980s. He purchased Collins Radio AM/FM Broadcast product line from Rockwell and absorbed that production into the Buckner facility.



Bill Hoelzel, senior vice president of sales and marketing, and one of the founding members of QEI Corp., is leaving the company to pursue interests outside of the broadcast industry. In a release, company president and co-founder, Charles Haubrich said, "As a founder and active member of the QEI management team for 23 years, Bill will certainly be missed."

BEC Technologies, maker of modular digital fiber optic transmission systems, appointed Tom Makofske chief financial officer and Herb Clann production manager.

Makofske comes to BEC with experience in finance and operations for companies such as Vernitron Corp. and GTE Corp. Clann will coordinate all aspects of manufacturing, as well as design engineering. He previously worked as a sales and applications engineer for Time Electronics.



## Get on the right track...

Unattended operation helps you operate your station profitably. All it takes is a satellite or automation program source, a good transmitter control system, and a way to handle EBS.

You take care of the program source... We'll help with the rest.

A transmitter control system from Burk Technology relieves you of the need to keep someone at the station just to take transmitter readings. Add our exclusive Studio I/O and we'll run EBS for you, too.

Burk gives you the flexibility to run your station the way you want, and in full compliance with FCC rules.

Call us now. We'll show you a new way to run a railroad.

TOLL FREE 1-800 255-8090

# BURK

TECHNOLOGY

7 Lomar Drive, Pepperell, MA, 01463 (508) 433-8877

Circle (94) On Reader Service Card

World Radio History

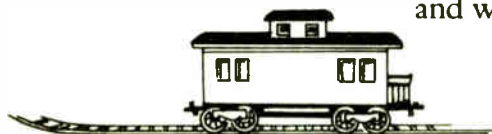

## READERS FORUM

If you have comments for Radio World, call us at 800-336-3045 or send a letter to Readers Forum (Radio World, Box 1214, Falls Church, VA 22041 or MCI Mailbox #302-7776). All letters received become the property of Radio World, to be used at our discretion and as space permits.

### Mics from another angle

Dear RW,

Your recent article on stereo microphone placement (RW, March 10) was interesting. You mention that too narrow an angle between two coincident cardioids creates a narrow image, and vice versa. In writing an article a few years ago, I had a tendency to say the same thing. But actually, as the angle is gradually changed just the opposite seems to happen. Granted, when one reaches an extreme an image can seem to jump back and forth between two speakers without any smooth lateral movement.

Try to think of it this way (or better yet do some more experimenting): To a listener in the true environment, his or her ears define the angle. When played back over speakers, their angle relative to the listener becomes the representation of whatever the original angle was. As one narrows the angle between the cardioids, one is taking this narrow angle and recreating it over a pair of speakers whose angle (and "sound stage") is fixed by their fixed spacing, therefore, spreading it out. When increasing the included angle between the cardioids picking up the sound, the image heard by a person while recording will be reproduced over the narrower angle defined by the speakers.

Larry Glenn, Audio Specialist  
University of Wisconsin-Eau Claire

### Deletion is no mistake

Dear RW,

Your story on the Arbitron deletion in Bakersfield (RW, May 12) is not entirely accurate.

Your last paragraph about KELI(AM) Tulsa, Okla., implied that it was a similar situation. That is not the case as Arbitron's subsequent press release would indicate.

In 1985 (not 1986), two partners and I

acquired KELI for \$2.375 million and spent another half a million dollars turning it into a news/talk station.

I didn't think that the typical 0.6 share Arbitron would give us would go very well with all the attention we were attracting, so I asked them to delete us from their list.

They told us they wouldn't, so I forced them to by spending about \$15,000 on a campaign which made fun of their ratings and offered \$14.30 for every diary a recipient brought us.

We made clear our intentions from the start by sending the diaries back to Arbitron in a plastic garbage bag and speculating on the air about a bidding war between Federal Express, Airborn, UPS, Express Mail and any other interested carrier.

Arbitron responded by trying to sue me out of existence. That didn't work. Their initial round of chest beating in the Bakersfield case ignored the court order settling the suit which prohibited any party from discussing the terms and conditions of the settlement.

In my defense, I would say that Arbitron's characterization of that settlement was not accurate in addition to violating the court order.

But the difference is that the station in Bakersfield was clearly trying to tilt the book by changing the diaries.

We were only trying to make Arbitron go away and I think it is very unfair to lump our campaign in with what appears to be a device to fraudulently tilt the book.

I want to emphasize that as bad as I think Arbitron's methodology is, there are plenty of ways to kick their butt without resorting to out and out cheating. My station in Tulsa today—KTRT(AM)—has never shown up in their book despite an average of 200 calls per day on our talk lines and we don't have any trouble selling advertising without cheating.

Please don't associate the campaign of my former station with the Bakersfield situation—it's apples v. bananas.

Fred Weinberg  
President and General Manager  
KTRT(AM) Tulsa, Okla.

### Six-minute rules

Dear RW,

The otherwise excellent *Feed Line* column by W.C. Alexander (March, 10) contains a common but significant error. In discussing compliance with the FCC's "Human Exposure to RF Radiation" standards, Mr. Alexander correctly points out that exposure to RF radiation in excess of the maximum may be permissible if time-averaging is taken into account. He then cites, as an example, a situation in which an engineer, while reading base currents, is exposed to a level of radiation equal to 3 1/2 times the allowable level. He states this can be done "...if he is in and out in less than one minute 42 seconds (six minutes/3.5)."

This points up both a common fallacy with regard to six-minute time averaging and the basic problem with relying on time averaging to assure compliance. In

## U.S. Controls DAR Future

This is one of those times when a deluge of information pours in on one particular subject. Anyone interested in digital audio radio (DAR) transmission — not to mention digital audio studio gear — could spend a gainful hour or two with this edition.

Two inescapable conclusions can be drawn from recent developments. Conversion to digital technologies will not be terribly costly, or at least not terribly costly compared to most watershed technologies.

Secondly, those investments will not have to be made overnight. DAR is turning out to be an evolution after all.

It is impossible to be exact about the eventual digital transmission costs, but one set of numbers released at the NAB convention estimates \$55,000 as the best-case scenario cost for in-band interstitial, \$60,000 for best-case in-band, on-channel conversion and \$141,000 or less for worst-case new-band.

Best-case new-band is projected at about \$66,000, perhaps worth the extra money if new-band quality is found to be significantly superior to in-band and the new band is miraculously found somewhere.

A just-released survey of NPR affiliates suggests the digital evolution is already progressing rapidly in the studio. Ninety-nine percent of the respondents were operating with CD players; 90 percent had DAT recorders, and the trend lines seemed to indicate that digital audio workstations will soon be nearly as popular. (A survey of commercial stations would probably yield similar results.)

Other countries' opportunities to establish global L-band DAR services while U.S. developers work with in-band appear to be fading. German implementation of Eureka 147 has been postponed until 1997. Canada's plans for a national network of Eureka 147 service are go, but are too modest to displace U.S. efforts to forge on with in-band.

The latest word on U.S. digital transmission tests is that the EIA tests could well be delayed to end in mid-1994 concurrently with NRSC tests. In fact, there should be no cause for alarm if tests are delayed even more (and testing of new technologies often has a way of being delayed).

Most of the recent digital audio news has been good, suggesting that the U.S. radio industry is in control of the situation. And that's the way it should be.

—RW

the example cited, the engineer would use up his total exposure "allowance" for any six-minute period by remaining one minute 42 seconds in a field 3 1/2 times the maximum. Thus, to be in compliance, he would be required to spend both the four minutes 18 seconds before the period and the four minutes 18 seconds after the period in an environment where he is exposed to no RF radiation what so ever.

Obviously, this is not possible around the typical transmitter plant. Indeed, rather than being able to "...remain a bit longer..." as suggested in the column, the permissible period would actually be much shorter than one minute 42 seconds.

The time one can spend exposed to a field in excess of the maximum is determined both by the maximum level of field to which he will be exposed and by the levels of exposure for the remainder of the six-minute periods on both sides of maximum exposure. In order to evaluate this properly, it would be necessary to account for the employee's exposure during each portion of every six-minute period which includes the overexposure. (Usually, but not necessarily, the worst case exposure would occur during the six-minute period centered on the period of overexposure.)

Taking this approach to assuring compliance demands, for example, that the employee follow the same route to and from the tower, that he always travel at the same rate (or at least, no slower) and that he not pause at any point for any reason during the pertinent six-minute periods. Stated simply, he can't stop to shoo the snakes, spray the bees, pet the dog, tie his shoes, or anything else until he's satisfied the six-minute time averaging requirement.

In practice, its much easier, and, in the long run, more cost effective to remote the base current meter to a point far enough from the tower that it can be approached and read without subjecting the employee to RF radiation in excess of the standard.

It should also be noted ANSI C-95.1-1982, which forms the basis of the commission's present policy, is now an outdated standard. The IEEE has adopted a revised IEEE C95.1-1991 which supersedes the 1982 publication, and the commission recently voted to adopt and issue a Notice of Proposed Rulemaking (NPRM) aimed at accepting it as the new guideline. If adopted, the new standard will slightly relax the requirements for some AM stations, but is otherwise somewhat more restrictive than the 1982 ANSI standard.

J.M. "Bix" Bixby  
Senior Engineer  
Moffet, Larson & Johnson Inc.  
Falls Church, Va.

*W.C. Alexander replies: Reader Bixby is correct. The only way to comply by limiting one's exposure time to an absolute, calculated value might be to "beam in" and "beam out" of the excessive field area, and then only if the transporter room is RF-free. Limiting exposure time can be used as a tool to safely enter high RF fields for short periods of time, provided that sufficient allowance is made for transit time and the exposure received entering and exiting. Either removing the base current ammeter to the transmitter building or incorporating other shielding in the vicinity of the tower base (such as a shielded tuning house with ATU components separately shielded) can be used to avoid exposure altogether.*

# Radio World

Vol. 17, No 11 June 9, 1993

Editor.....Lucia Cobo  
Managing Editor.....Randy Sukow  
News/Studio Sessions Editor.....John Gatski  
Assistant Editor.....Mary Ann Dorsie  
Contributors.....Frank Beacham/N.Y.  
Bruce Ingram, Pamela Watkins, Nancy Reist  
Technical Editor.....John Bisset  
Technical Advisor.....Tom McGinley  
Editor (International).....Alan Carter  
Managing Editor (International).....Charles Taylor



Radio World (ISSN 0274-8541) is published semi-monthly by Industrial Marketing Advisory Services, Inc., 5827 Columbia Pike, Suite 310, Falls Church, VA 22041. Phone: 703-998-7600, Fax: 703-998-2966. Second-class postage rates are paid at Falls Church VA 22046 and additional mailing offices. POSTMASTER: Send 3579 forms and address changes to Radio World, P.O. Box 1214, Falls Church VA 22041. Copyright 1993 by Industrial Marketing Advisory Services, Inc. All rights reserved.

—PRINTED IN THE USA—

**Next Issue of  
Radio World  
June 23, 1993**



# The Heavyweight Player At A Lightweight Price.

The Audio-Metrics CD 10 Compact Disc Cartridge Machine is *the* heavyweight player. But, the price ain't heavy. Just \$1,049— for a limited time.

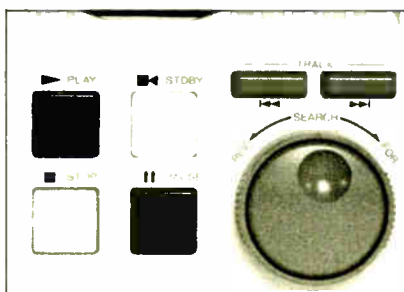

The CD 10 features cartridge autolock, programmable EOM indicator, instant start with music, and true broadcast standard construction. It's the only cartridge tape player with a STOP function to reduce maintenance.

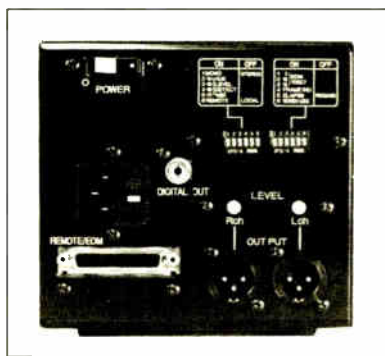

Designed and built for easy configuration and remote interface, it accepts open collector or dry contact control. Dubbing to DAT in the digital domain is as easy as running a cable with appropriate connectors from the CD 10 to the DAT machine. An optional rack mount lets you install three units side-by-side.

Vertically slotted plug-in cards permit easy access and service. Superior phase characteristics were achieved by using eight times over-sampling and an FDNR



analog filter. For convenience and better control, the in-built remote port supplies a 'ready'

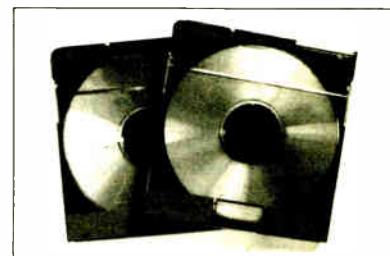

signal when a disc cartridge is inserted.

You'll find the CD 10 a friendly, likeable programming tool that will encourage you to take compact discs direct-to-air.

Order soon and get the lightweight price.

**8:00 a.m. to 8:00 p.m. EST**  
**1-800-622-0022**  
**Fax 317-966-0623**

**HARRIS**  
**ALLIED**

# Time and Place Set for EIA DAR Test

by John Gatski

**WASHINGTON** The Electronic Industries Association (EIA) announced at press time (May 25) that its self-imposed July 1 deadline for start-up of digital audio radio (DAR) systems tests have been firmly resched-

uled for "early October."

EIA also announced that NASA's Lewis Research Center, Cleveland, was chosen over a handful of other potential test facilities. About five systems are expected to be submitted to EIA for testing in Cleveland. System developers were given until June 18 to indicate

whether they will participate.

Before the announcement, EIA officials said a facility could be equipped very quickly once the site was chosen. However, set-up by July 1 was eventually deemed impossible. Earlier, EIA was forced to postpone testing from its original April 1 start-up target.

EIA's plan, which is being implemented by the EIA DAR Subcommittee, includes testing and evaluation of in-band, satellite and out-of-band DAR systems. Requests for testing submissions were initiated by the EIA in 1992. The current schedule calls for completion and evaluation of the systems by the end of the year, but recent activities have made the late 1993 completion deadline unlikely.

Gary Shapiro, executive vice president of the EIA's Consumer Electronics Group, said the EIA schedule has always been somewhat tentative, and the DAR Subcommittee is looking for "thoroughness and fairness over speed" during the testing and evaluation process.

One significant area that could affect the testing completion deadline is the recent involvement of the National Radio Systems Committee (NRSC), which will evaluate the EIA's in-band testing data and make separate recommendations on that technology.

The NRSC's involvement stems from NAB opposition in 1992 to the EIA conducting the DAR tests. The NAB said the EIA plan did not have suffi-

cient broadcaster input, and that broadcasters were only interested in-band anyway.

Earlier this year, the EIA compromised by agreeing to allow NRSC to guide the in-band testing and evaluation phase of the process (although EIA will still do the actual hardware testing).

With its new clout in the DAR testing plan, the NRSC, at press time, was scheduled to put out a call for in-band proponents to submit systems for testing under the revised guidelines. The in-band proponents had the same opportunity to respond to EIA's original request for proposals in 1992, prior to NRSC involvement in the process.

USA Digital, the most publicized in-band system, had agreed to submit its systems under the original EIA request, but backed out when broadcasters criticized the process. USA Digital said it is likely to resubmit its systems for testing to the NRSC.

The NRSC in-band process is supposed to be completed in mid-1994, which means the EIA will probably revise its timetable to be concurrent.

Meanwhile, the EIA subcommittee and its working groups have been busy drawing up the test parameters, according to consultant Bob Culver who made a presentation at NAB '93.

In mid-May, work began on field testing of transmission characteristics of digital signals in the FM band. The in-band evaluations were to be conducted at an advanced television facility in Charlotte, North Carolina, according to Culver.

# Canada's Eureka Tests Indicate Workability

by James Careless

**OTTAWA** Canadian field tests have proven that a Eureka 147 DAB receiver can extract a usable signal in conditions where two transmitters are overlapping on the same L-band frequency.

Based on the tests, Canadian officials believe that it is possible to establish a national DAB single frequency network on radio.

The extensive field tests were conducted by Canada's Task Force on the Introduction of Digital Radio.

The task force is composed of Canada's Federal Department of Communication (DOC), the Canadian Broadcasting Corporation (CBC) and the Canadian Association of Broadcasters, (CAB) which represents the vast majority of Canadian private broadcasters. The report was released earlier this year and was featured at NAB '93.

## L-band tests

The task force conducted these tests using two L-band transmitters; one mounted on Toronto's CN tower; the other located 83 kilometers north on the CKVR television tower, at Barrie.

During the tests, the two towers transmitted both carrier waves and Eureka DAB

signals on 1468.75 MHz. (The carrier-only broadcasts have been in stages to measure propagation; the other to assess the performance of a second-generation COFDM Eureka receiver.)

Although the CN tower antenna remained fixed at 300 meters, the Barrie transmissions were broadcast from two heights—97 and 230 meters—to compare the difference that height makes to L-band propagation. The gain of the signal output also was varied, from 6.2 kW ERP on a 120 degree beam, to 17.4 kW ERP on a 40 degree beam.

The signals themselves were received and measured using a specially-equipped mini-van. The van was driven back and forth between the two transmitters on Ontario's Highway 400.

The point of the experiment was not only to measure Eureka's performance in a single frequency network environment, but also to see if the theory of "DAB gap filling" works. CAB technical advisor Wayne Stacey said, "the main thing was to experiment with filling in the gap between (areas of good signal reception), because in our previous tests, we've discovered that when you get about 40 kilometers north of Toronto, the terrain does produce a gap."

continued on page 9 ▶



## Is it digital or is it Dolby S?

Get up to 24 db of noise reduction on your audio carts, phone lines, RPU, or any analog program feed.

RS<sup>2</sup> is a simple-to-use, economical, encode-decode, multiband noise reduction system featuring Dolby S and built-in phase correction for stereo sources.

Up to three stereo encode or decode cards can be packaged in a single 19" rack unit frame.

Also available in phase correction version only.

**RADIO SYSTEMS INC.**  
800/523-2133 or FAX 609/467-3044

Circle (97) On Reader Service Card

## CCA Broadcast Transmitters

The Standard for Reliability Throughout the World.

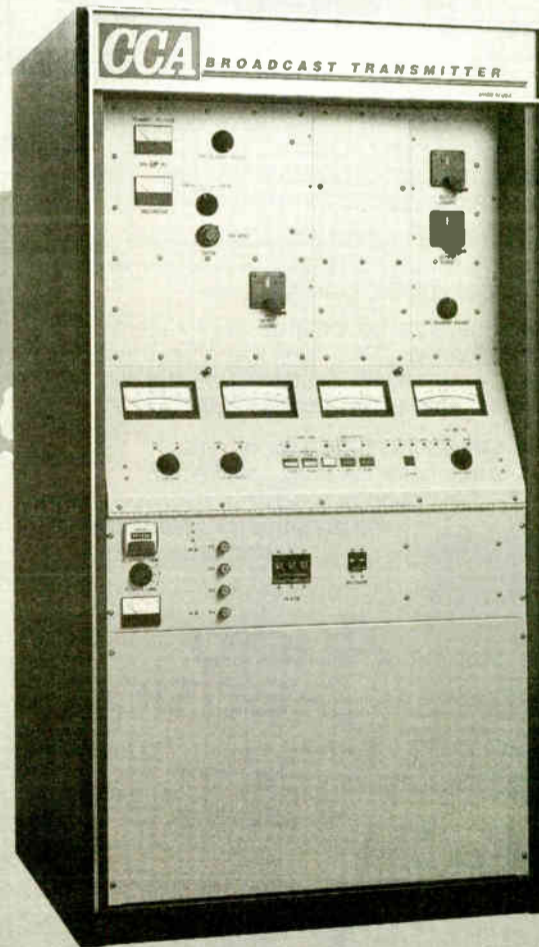

### Available FM Transmitters:

- 2.5 KW 20 KW
- 4 KW 25 KW
- 5 KW 27.5 KW
- 8 KW 35 KW
- 10 KW 45 KW
- 12 KW



**CCA Electronics, Inc.**  
P.O. Box 426 • 360 Bohannon Road  
Fairburn, Georgia USA 30213  
(404) 964-3530 • FAX: (404) 964-2222

# CCA

Circle (161) On Reader Service Card

# Public Broadcasters Make DAB Plans

by Randy Sukow

**WASHINGTON** During last month's Public Radio Conference (PRC), a Corporation for Public Broadcasting official said public broadcasters have "both time to change and there is a need to change" as the radio industry prepares for digital transmission.

In addressing the conference, Corporation for Public Broadcasting (CPB) President Richard W. Carlson said the "CPB is not sitting back, waiting to receive an answer on the subject of digital. We're looking at the critical questions digital raises, running the gamut from costs to standards quality to technical feasibility."

But public broadcasters also believe they have plenty of time to complete the transition and are well-advised to use it.

"It is crucial that public broadcasters be involved at all stages of DAB development. It's just as crucial that your energy and resources are not diverted to a premature investment," said Paul Bortz, president of Bortz & Co.

## Distinguished company

This year's three-day PRC gathering of officials from CPB, National Public Radio (NPR), American Public Radio (APR) and managers from non-commercial radio stations nationwide drew some of Washington's biggest names, such as Senate Majority Leader Robert Dole

(one of public broadcasting's harshest critics; see related story), Labor Secretary Robert Reich and a surprise guest at the conference's opening reception, President Bill Clinton, who declared himself and his wife "NPR junkies."

But the PRC's distinguished company did not distract from the main business of the show, including digital audio transitions.

Satellite digital radio, widely expected to be the first form of DAB to be ready for FCC approval and delivery to the public, will not be a reality until 1998 at the earliest, "even if everything went perfectly," said Skip Pizzi, author of the book "Digital Audio Basics."

The delay for satellite DAB could well be even longer, not so much because the technology is not ready, but because of regulatory considerations. FCC commissioners, including interim Chairman James Quello (see **RW**, May 12), appear to be paying more attention to broadcasters who fear the effect satellite DAB could have on current terrestrial services.

"Many broadcasters today view digital radio delivered by satellite as a sort of Docket 80-90 from the sky, as yet another powerful competitor being thrust upon them by technology and the FCC in the name of greater choice and more competition," FCC Commissioner Ervin Duggan said.

Duggan proposed "coordinating" the

introduction of satellite DAB and terrestrial, in-band digital service so that they become available to the public at about the same time. "I am not sure at this point how that concept of 'managed competition' might work. I simply want to begin thinking out loud about it," he said.

"Certainly (satellite DAB proponents) are further along than the terrestrial developers," but coordination, Duggan speculated, could evolve naturally, without heavy-handed FCC policies. The cost of launching DAB satellites, for example, will run into hundreds of millions of dollars and none of the current satellite DAB developers currently have that kind

of financing, he said.

The problem of international spectrum coordination could also affect satellite DAB rollout. While much of the world, including Canada and Mexico, have DAB allocations in the L band (frequencies near 1.5 GHz), the U.S. allocation is in the S band (frequencies near 2.3 GHz). It is widely believed S band will be suitable for satellite digital audio only.

## What to do now

Regardless of when it comes, non-commercial stations appear less fearful of satellite DAB than their commercial counterparts. CPB and some individual stations are actively seeking non-commercial set-asides of satellite spectrum.

"The digital revolution might strengthen  
continued on next page ▶

## Station Remarks Irk Dole

**WASHINGTON** Senate Minority Leader Robert Dole (R-Kan.), who last year led the Senate coalition that won language in the Corporation for Public Broadcasting's authorization bill to improve "balance" in CPB-funded political programming, caused another stir among public broadcasters by singling out Pacifica Radio's KPFK(FM) Los Angeles for its "message of hate."

"Now anti-semitism and racism may be covered by free speech, but it shouldn't be given a free ride when the American public is being asked to pay for it through public-service grants," Dole said during an appearance at the Public Radio Conference in Washington last month. "Those grants should be given the highest scrutiny and be subject to the highest standard when CPB hands them out."

The controversy stems from Pacifica's airing last year of a full weekend of programming produced by spokesmen of the "Afro-centrist" movement. A number of anti-semitic remarks, including charges that Jewish doctors have purposely spread diseases among poor blacks, were allegedly made over the weekend.

CPB President Richard Carlson complained that he cannot be sure what exactly was said during the broadcast because KPFK has never sent CPB a transcript or tape. Nevertheless, the CPB board has decided not to halt its grants to Pacifica stations.

Pacifica Chairman David Salniker, praised CPB for its decision. "Pacifica will put those voices on the air and we appreciate the strength (CPB) had to protect our First Amendment right to do that," Salniker told Carlson.

"The thorny questions come in when public funds are involved, which they are," Carlson replied. "I personally think that (irresponsible) program speakers...deserve to be censured. They don't deserve to be censored."

# PROOFS IMPROVED

**FM and TV-BTSC AUDIO PROOF TESTING** is reduced from hours to minutes with System One from Audio Precision... Automatic proofs run properly at constant deviation, plotting the required generator amplitude... and when finished, the results are stored in graphic form for your records.

**SPLIT SITE** proofs are simple with System One's available separate generator and analyzer configuration. With immediate capability to view and control both instruments, it's like being in two places at once.

**THE REST OF THE TIME** System One is the universal audio test set for maintaining any audio device or channel... STLs, consoles, carts, cassettes and RDATs, digital recorders and workstations... System One is the only product that can completely test both your analog and digital audio.

Call 800/231-7350 for our 36 page color catalog... and when you're ready our representative will arrange for an on-site demonstration.

**Audio precision**

P.O. Box 2209  
Beaverton, OR 97075-3070  
503/627-0832, 800/231-7350  
FAX: 503/641-8906



Circle (32) On Reader Service Card

## SIX Lines no Waiting.



**SIX** complete lines of studio furniture, from economical to elegant. Shipped in as little as two weeks.

**THE EXPRESS GROUP. (619) 298-2834**

Circle (165) On Reader Service Card



► continued from previous page these networks (aimed at narrowly targeted audiences)," Carlson said. "For instance, it might permit the introduction of (a non-commercial) Hispanic station in Los Angeles," where spectrum scarcity blocks the formation of such a station on the AM or FM dial today, Carlson said. "Other public network radio networks are possible, such as networks for children, for the elderly or for people who are blind."

Asked what stations could do today to secure set-asides, Duggan suggested, "begin the Chinese water torture (of FCC lobbying) as soon as possible."

Most issues the FCC deals with are not partisan in nature, Duggan said, but now that Democrats have control of the White House and Congress, issues like non-commercial spectrum for digital audio will get a slightly more favorable hearing.

Stations also can prepare for satellite and terrestrial DAB, said Jim Troutman, a vice president with Bortz & Co., by investing in "transition technologies," such as radio broadcast data systems (RBDS), and by seeking to place digital audio services on cable TV systems. Such moves will prime the listening audience for the types of audio and ancillary services that will be available when full DAB transmission begins.

(One of the major attractions of this year's PRC was a mobile demonstration of RE America's RBDS system, which was transmitted over American University's WAMU-FM Washington.)

**Cost considerations**

"Conversion costs look to be manageable. This is not something that's going to be a back-breaker in terms of implementation," Troutman said about the expected eventual transition to terrestrial DAB. Troutman is participating in the preparation of a three-part Bortz study of DAB transitions, commissioned by CPB.

Best-case scenario for transmission equipment costs is \$50,000 to \$60,000 per station for in-band equipment, Troutman said. The worst-case scenario for new-band conversion would be about

\$150,000. "Even the new-band scenarios could have, in most instances, very manageable conversion costs," he said.

As for studios at non-commercial stations, the transition is very much in progress. A survey of NPR affiliates released at the PRC finds that 99 percent of respondents have compact disc players and on average maintain six players. (One respondent said it had 13.)

The survey also finds nearly 90 percent of NPR stations with digital audio tape recorders, "a pretty significant jump in just the past few years," said Michael Starling, NPR's director of technical operations. "That was a higher percentage than I expected to see."

Most of those stations have more than 10 DAT recorders and a few indicated owning 18 or 19. A major application, Starling said, appears to be recording of satellite-delivered programs.

Fifteen percent of the respondents said they have at least one digital audio workstation. "I'm sure if we did this a year from now, the percentage would be much higher," said Starling, noting the large number of workstation product introductions at April's NAB convention.

Only 10 percent of respondents said they now have hard disk audio storage and retrieval systems, "the one that's really going to change the way studios operate," Starling said.

The same deliberate-but-steady philosophy on digital conversion prevails at NPR headquarters. NPR is now in the process of moving its Washington headquarters from M St. (one block from the FCC) to Massachusetts Ave. (near the Washington Convention Center).

"It may be one of the last great analog facilities," said Jan Andrews, NPR senior project engineer. "This may seem a little short sighted, but we feel (full digital conversion) is still a few years away."

As much of the old headquarters' equipment as possible, including every tape machine—most of which are analog—will be moved to the new studios. But once NPR is ready for the new equipment, the new facility is designed to accept it smoothly.

# Canada's Eureka Tests

► continued from page 7

According to Stacey, "backfilling it from Barrie meant that those holes didn't exist anymore...You don't find any places where the signal actually disappears."

**Less-than-perfect**

However, just because the Canadians succeeded in getting complete coverage in their Toronto-Barrie test corridor, it didn't mean that the second-generation Eureka set received perfectly all of the time.

Problems occurred in the area where the Toronto and Barrie signals not only overlapped, but were more than 32 microseconds out of phase with each other.

The task force team had anticipated such problems. In fact, they had set out to minimize them by synchronizing the transmitter outputs.

The logic behind doing this, of course, is that the time delay for the synchronized signals to travel to the midpoint would be equal; thus, the phase differences between the two would be minimized, if not eliminated.

The realities of propagation (including multipath), combined with the mini-van's changing position on Highway 400, meant that out-of-phase signals did arrive at the Eureka receiver.

The second-generation set could deal with signals that were up to 32 microseconds out-of-phase, according to the DOC's Royce Trenholm. But when this limit was exceeded, he said "there were problems of interference," specifically, a decrease in usable incoming signal strength.

However, the task force team isn't overly concerned by this problem, Trenholm said, because "those cases we noticed we felt could be resolved by a slight change to the COFDM system" by extending the Eureka's out-of-phase signal threshold to 64 microseconds.

Interference notwithstanding, the Canadian broadcast officials are optimistic about the test results. In fact, Stacey said the tests not only prove that

DAB L-band transmitters can match FM for cost-efficient performance, but, when ganged in "single frequency networks," such equipment could be attractive to coverage-minded AM broadcasters as well.

Since DAB has multiple channel capability, the heavy cost of establishing such a network could be split by up to six AM stations, which could essentially "share" the network facility.

As a veteran of the DAB in Canada, Wayne Stacey sees this last option as a potent argument: one that might help win some support among U.S. AM operators.



## LMA/DUOPOLY CONTOUR MAPS

The DATAWORLD LMA/DUOPOLY Market Survey Contour maps present a precise electronic verification of overlapping and intersecting contours.

AM 5 mV/m and FM 3.16 mV/m City Grade contours are shown in full color, including transmitter site indicator. The map is supported with a printout showing all of the stations which appear on the map.

Daily updating of DATAWORLD'S AM and FM databases protects against errors and omissions.

**OTHER MAP OPTIONS**

- SHADOWING (TERRAIN SHIELDING)
- CONTOUR COVERAGE
- POPULATION DENSITY
- ZIP CODE BOUNDARIES
- RECEIVED SIGNAL LEVEL
- SPECIAL REQUIREMENTS

## 1990 CENSUS

**WHO ARE YOUR LISTENERS?**

**1990 BUREAU OF CENSUS POPULATION COUNTING**

- Comprehensive Ethnic and Demographic Data
- Ethnic/Demographic Data Available for Each Zip Code Within Coverage Area
- Age Analysis Reflected in Ethnic Breakout
- Resolution Increased to Block Level
- Percent of County Coverage Shown

**ETHNIC PIE-CHART DISPLAY**

- Projects Ethnic Population in Multi-Color Pie Chart Form



800-368-5754 FAX: 301-656-5341

**On Target.**  
Performance, value, and reliability through innovative technology.

5 models available.

- BC6DSL
- BC6DSR
- BC8DSL
- BC8DSR
- BC12DSL

# Vanguard Series

STEREO BROADCAST CONSOLES



Call or write for free detailed brochure.  
328 W. Maple Ave. Horsham, PA 19044, USA  
(215) 443-0330 FAX: (215) 443-0394



Circle (119) On Reader Service Card

Circle (119) On Reader Service Card

World Radio History

# Overnite Hits\*

## EV RE-20

The world-standard broadcast microphone. Only Broadcast Services buys in bulk to save you more!  
BSC PRICE \$338



## Marantz PMD-201

Portable mono cassette recorder features two heads and has an optional carry case and battery pack.

BSC PRICE \$230

## Comrex TCB-2

This auto-answer coupler connects your caller to your listen line. Also useful for dial-up networks, remote sites, etc. Optional AC supply powers up to 4 units. BSC PRICE \$275



## Comrex LX-T & LX-R

Want frequency expansion on a budget? These units are ideal for networks, remotes, sporting events. Optional rack mount available. BSC PRICE \$699



## Tascam DA-30

This is a proven RDAT two-track digital master recorder built to withstand broadcast use. BSC PRICE \$1080



## Tascam 112B

A rugged 2-head, two-channel cassette recorder complete with rack ears and balanced XLR in & out. BSC PRICE \$575

\* All items are in stock and available for overnite shipment if approved order is entered by 5 pm Eastern time. Quantities may be limited.

Eastern  
& Central  
VOICE  
800/525-1037  
FAX  
919/934-1537



**BROADCAST SERVICES CO.**

The Davis Communications Group, Inc.

*The Preferred Source*



Mountain  
& Pacific  
VOICE  
800/523-1037  
FAX  
619/277-6319



# Compression Problems

► continued from page 1

from the point of view of a radio station engineer, has to be concerned with the whole system...the sum of the parts. He did what he felt was a real world randomization."

## Test again

Scientific-Atlanta, whose SEDAT technology was used in Squire's tests, issued a challenge to the audio industry to conduct the tests again with the same audio material, this time employing its SEDAT OSI (Open Systems Interconnection). OSI is a proposed set of digital interface standards for broadcast equipment that allows compatibility between digital audio devices using different data compression schemes.

"This clearly points out the need for the industry to adopt an interface standard that allows for digital interconnectivity between devices," said Kent Malinowski, vice president of Scientific's Broadcast Radio and Data Systems Division. "We would like to show a comparison of how the audio material would sound through the same devices if the OSI interface is used."

Squire's demonstration had an impact on Sony's audio engineers, whose data-reduced MiniDisc (MD) format was used in the tests. Sony Pro Audio Product Manager Art Gonzales said Sony's MiniDisc engineers plan to run their own tests in Japan using the MD with different compression schemes.

He said there also is discussion at Sony

concerning offering a professional MiniDisc cart format with no data compression. "It's technically possible to remove the compression and get shorter play time," Gonzales said. "The problem is there's an existing format here that we can't change readily overnight. We would be modifying the existing format. I can't say we have a plan to do that, but

I can say we are talking about it."

**"We all have the same goals, we just don't agree on how to get there."**

—Bob Donnelly  
Manager of ABC Radio  
Satellite Operations

## An MD caveat

However, Gonzales said, the first MD broadcast cart machines, due for delivery at the end of the year, will use the same data reduction scheme used in consumer devices.

Gonzales warned broadcasters not to

use the new MD cart with other devices using data compression. (Gonzales said he was expressing his own opinion, and not speaking for Sony.)

"If you've got a digital STL that uses a digital compression algorithm or you are using some sort of compressed satellite transmission, I wouldn't recommend the MD cart machine," Gonzales said. "It should be used only in a path with no other algorithms. But if you want to copy a CD to it and put it on the air in an all-analog environment, I'd say go with it."

ABC's Donnelly said the industry has to confront the "murky issue" of compression incompatibilities. "If anything cries for a committee this does. I hate committees. There are millions of them. We are all experts and we know everything. But let's sit down and then make this thing work for us as an industry. I think that's what Herb is saying here and I support that."



## It thinks it's a cart machine.

Only RS-DAT features end-of-message signals, large lighted buttons, standard broadcast remote control, balanced audio ins and outs, automatic cue-up and satellite recording ability.

These features make the RS-6700 perfect for automation, network capture, on-air playback and production applications.

If you want to use DAT for broadcast, contact the pro DAT experts for more information on the RS-6700.

**RADIO SYSTEMS INC.**

800/523-2133 or FAX 609/467-3044

## PROMO POWER

### Make the Most of Bar-Hopping Remote

by Mark Lapidus

**WASHINGTON** One of my friends recently asked me why stations spend so much time in bars. The question took me by surprise, but when you stop to think about it, very few other businesses encourage (or even pay) their employees to hang out at local watering holes on a regular basis.

Of course what he really meant by his question was, "Why do the stations I listen to spend so much time in bars?" My friend is a thirty-five-year-old male who listens to the AOR, Classic Rock, Lite Rock and Oldies stations in town. I replied that it is because these stations believe it's a good way to reach their audience. Bars and beer companies also pay these stations to sell their products.

My friend seemed satisfied with the

answer and then said that even though he hadn't gone, he really enjoyed hearing about our Velcro Jumping Parties at various clubs around town. He then changed the subject and offered me a beer.

#### Pros and cons

But my friend's question got me thinking. What are some of the advantages and disadvantages of bar parties?

Stations that have a fairly young core (25-34) should do parties and appearances in clubs. As your audience gets older it will spend less time in these establishments, but active people still go and it's a great place for your listeners to feel like they're getting to know your DJs personally. Talking about these parties on the radio adds to the feeling that yours is an active station.

Bars are also great staging areas for stunts, as crowds are more accepting in a

loose atmosphere. Besides, your sales-force will want the beer and bar business that goes with the beer buys.

Adding a twist can make your events memorable. When discussing bar parties, the one thing my friend remembered was that we did something unusual (Velcro Jumping). Just showing up at a bar for a few hours of handing out t-shirts and asking trivia questions will not be a memorable experience—either for people at the establishment or for your listeners when you're on the air promoting this appearance.

#### Do it first and best

It's the "twist" that adds the fun. Usually this "twist" is an activity that you can't do anywhere else and your listener's reaction will hopefully be something like, "Wow...those guys really do neat stuff...I'd like to try that." When

Velcro Jumping first became popular at one club in New York, we had a portable unit constructed that we could take from bar to bar. At the time, nobody else was doing it. Now it's become fairly common.

After you've figured out the "twist" be the first in your market to do it and when you do, play it out bigger than everyone else. Paint the fantasy by using appropriate sound bites in recorded spots. When your DJs talk about the twist, make sure they've had the experience of really doing it. Make sure your jocks get a chance to do whatever you're promoting. It's a lot easier to talk about an experience that you've really had instead of just reading a boring liner card.

Here are a few "twists" for you to look into:

—Velcro Jumping: Wearing a velcro suit, your participants jump on a trampoline and stick to the wall in front of them;

—Sumo Wrestling: Two people climb into huge inflatable suits and try to knock each other over;

continued on page 17 ▶

## THE RF EXPERTS KNOW—MYAT DELIVERS

### MYAT DELIVERS QUALITY

You can rely on MYAT rigid line and components to deliver a clean, powerful signal to your antenna. Pure highest quality copper, brass and silver plus computer-aided design and manufacturing ensure consistency and accuracy. No wonder demanding broadcasters worldwide choose MYAT products for their passive systems. We take Quality Control very seriously.

### MYAT DELIVERS RELIABLE PERFORMANCE

Our non-galling silver-plated beryllium copper contact springs, brass elbow reinforcements and virgin Teflon inner supports are designed for maximum velocity, minimum attenuation and long service life. Every MYAT component is tested before shipping and backed with a full one year warranty. MYAT products are built for the long run.

### MYAT DELIVERS WHEN YOU NEED IT

Major transmitter manufacturers with strict production schedules rely on MYAT to deliver quality components on time and within budget. So do leading broadcasters like the Empire State Building's newest TV tenants. At MYAT, commitments are kept.

### LET MYAT DELIVER FOR YOU

Whether you're planning a new tower, upgrading an older installation, or coping with an emergency, you can depend on MYAT rigid line and components. Thousands of RF experts around the world already do. Contact your RF distributor, or phone us for our catalog, installation planning guide and engineering reference. Its detailed drawings can help you put together an efficient, trouble-free transmission line that will last for decades. For a free copy call 201-767-5380 or fax 201-767-4147.



### RIGID LINE: RADIO'S EFFICIENT CHOICE

40 YEARS OF EXPERIENCE. 40 YEARS OF EXCELLENCE.  
380 Chestnut Street • P.O. Box 425 • Norwood, NJ 07648  
Tel 201-767-5380 • Fax 201-767-4147

OTARI

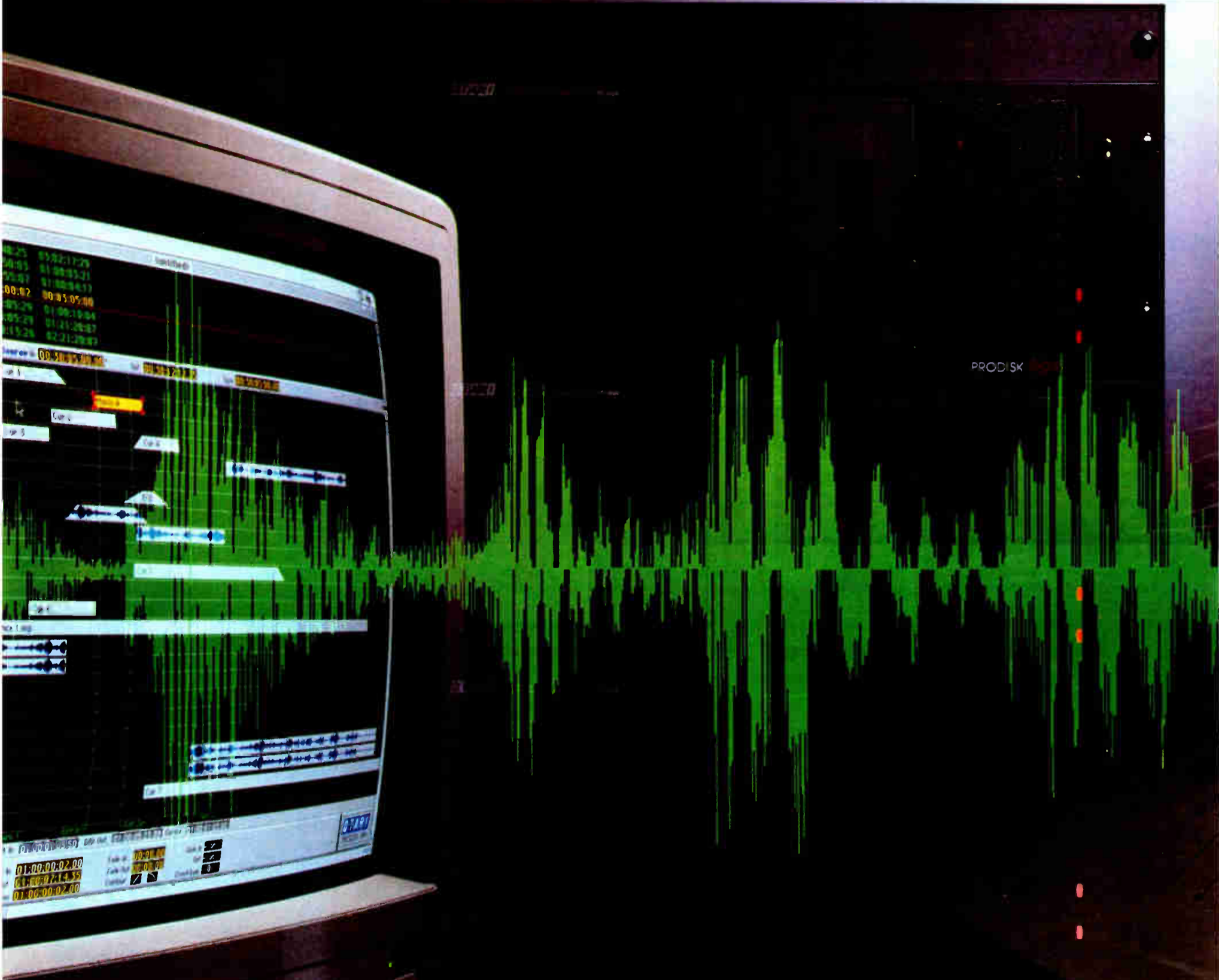

# There are a lot of multitrack digital audio workstations out there, but only one with Otari's name on it.

Right now, it seems like everyone is building audio disk recorders. The difference is, we'll still be building them three years from now.

Speaking of the future, you can be sure that ProDisk's open architecture allows for hardware, software, and storage media enhancements as they come along, and that it's plug-compatible with your current equipment. And if you're familiar with Otari's product philosophy, you know you're getting the best possible value on the market.

Most of all, you can be sure you've purchased "The Technology You Can Trust."

Call Otari at (415) 341-5900 for complete information.

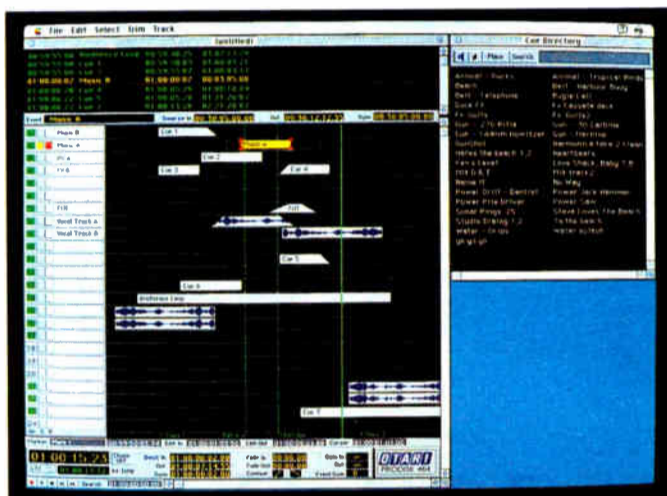

ProDisk's new Graphical User Interface for Digital Editing (guide™) combines several windows into an intuitive, easy-to-use display. Far from just an EDI list, the relationship between all tracks is shown.

Sure, Otari's new ProDisk™ 464 is the only system to give you up to 64 tracks. True, it's one of the few to use standard SCSI devices so you won't be locked-in as technology advances. But as much as we'd like to tell you about the rest of its great features, the most important thing about the ProDisk system (given the changes that are certain to occur in this technology) is the Otari name up front — a name that professionals around the world have come to trust for product support and customer service.



**OTARI**

Otari Corporation  
378 Vintage Park Drive  
Foster City, CA 94404  
U.S.A.  
(415) 341-5900  
Fax: (415) 341-7200

Otari Corporation  
U.S.A.  
(415) 341-5900  
Fax: (415) 341-7200

Otari Inc.  
Japan  
(0424) 81-8626  
Fax: (0424) 81-8633

Otari  
(UK) Ltd.  
United Kingdom  
(0753) 580777  
Fax: (0753) 42600

Otari  
Deutschland GmbH  
Germany  
02159/50861-3  
Fax: 02159/1778

Otari Singapore  
Pte., Ltd.  
Singapore  
(65) 743-7711  
Fax: (65) 743-6430

OVER  
5 MINUTES  
OF 15KHZ STEREO AUDIO  
ON EACH 13MB FLOPPY DISC



# Digital Made Simple

## The New Dynamax DCR1000

### Digital Cartridge Recorder

#### The Recorder

- Selectable sampling rates
- Secondary and Tertiary cues
- Extended scale peak metering
- AES/EBU digital input
- Start on audio
- Direct digital dubbing from CD
- PC keyboard for titling

#### The Reproducer

- Simple cart-like operation
- No on-air personality training
- Just three front panel buttons
- Instant start and cue
- Maintenance-free design
- No head cleaning or alignment
- Awesome audio quality

#### The Media

- 13MB stores over 5 minutes stereo audio with 15kHz bandwidth and 15 minutes mono with 10kHz
- Standard low-cost 2MB floppy disk holds 60-second commercials

The Dynamax DCR 1000 now is available with Version 2.0 software at a special introductory price until July 30.  
**4 REPRODUCERS AND A RECORD MODULE COMPLETE PACKAGE \$9995.00**

*Equipment Solutions To Keep You Number One*



Toll Free 800-426-8434

Toll Free Fax 800-231-7055

7012 27th Street West Tacoma, Washington 98466

Circle (169) On Reader Service Card

World Radio History

# Techniques for Reliable Stitching in Time

by Sue Jones

**BURKE, Va.** "Lost time is never found again," said Ben Franklin in 1748 in his famous "Poor Richard's Almanac." We are often slaves to our schedules rushing from one meeting to the next task. At the end of the day we are dragging and wondering where the time went and what we actually accomplished. So how does one gain control of time instead of time controlling the person?

Several commercial products are available today to help us get organized and manage our time. Some are simple and inexpensive like a calendar. Other complex systems can cost \$75 or more. The simplest time management tool that I have used for years is one 8 1/2 x 11-inch sheet of paper with the day divided into 15 minute increments. Each fifteen minute period has enough space to write a note about my activity for that time frame.

### Work time analysis

This work time analysis sheet is a simple chronology of daily activities. It has been an invaluable tool for me and everyone with whom I have shared it. You can create your own version with a typewriter or word processor. Photocopy the form for as many days that you want to analyze.

To use this time management sheet effectively, you should update it once every hour or after every major activity. If you wait until the end of the day to complete the form, you will probably forget some of the activities in the time slots. In addition, it

should be used for a minimum evaluation period of two weeks. I highly recommend that it be used for at least one month to encompass all of your standard tasks.

Updating this sheet every hour for two to four weeks will require some discipline. You may have to remind yourself every hour to update the sheet for a couple of days until it becomes routine. However, at the end of the evaluation period, you will gain new insights on how your time is spent. These new insights will help you better organize and manage your time. You may discover that you could delegate some tasks to one of the department heads which would lighten your work load and promote professional growth for your management team.

Use a new sheet every day. Jot down a key phrase or a few words that describe the activity for each period of the day. Retain the sheets for the evaluation period. At the end of the evaluation period, review the amount of time that you spend on the telephone, in meetings, writing reports, problem resolution, etc.

You will be amazed at how much time you spend on the telephone or on activities that may not be related to achieving your goals.

If you find that you are spending too much time on the telephone or that it is a constant interruption, you may

want to have the receptionist or voice mail handle your calls for an hour or two while you complete a complex task requiring concentration. By managing interruption, you will gain time blocks to complete your work in less time than

you would use with the continual interruptions.

You will begin to control your time and actually have more time for other matters that require your attention or contribute to achieving your management objectives.

### Is there a pattern here?

Also look for work habit trends. Do you get more done in the mornings or afternoons? This analysis may reveal that you are a strong producer in the morning, slow down after lunch and pick up again after three o'clock. Armed with this knowledge, you may want to schedule meetings or activities requiring prolonged concentration during your most productive periods.

Once you have successfully completed a time use evaluation period, you should use it again six months later for a couple of weeks and periodically after that. It will be a reminder to keep focused on your priorities and to make sure that you are managing your time instead of your time managing you.

This time analysis form can also be a useful management tool for your staff members. Sharing it with them will also give them the same time management controls that you have gained. If they are more efficient, the station's overall performance should improve. The form can also be used to justify hiring, reducing or

transferring staff.

You may discover that a group is under staffed. You may also uncover specific problem areas. For example, you may learn that the sales staff is spending too much time on the telephone, rather than in face-to-face meetings. Or you may learn that the program director is swamped with visits by record promoters and calls from jocks looking for jobs.

Review of a time analysis form can help the program director set aside one day of the week for record promoters, or a couple of hours a week to talk to potential new hires. Moreover, you will be able to tap each person's strength and help improve his/her productivity.

The bottom line is that this humble form can be used as an effective tool to manage your own time as well as help your staff manage their time. It can pinpoint unknown problems and justify the need for additional or reduced staff. Be aware that it cannot replace sound management judgement. However, it can provide reliable raw data for analysis to help guide decisions, improve your productivity and assist you in managing one of your most valuable resources—time.

□ □ □

*Sue Jones is a senior manager for Computer Data Corporation, Inc. in Rockville, MD. She can be reached at 703-323-0491.*

**We are often slaves to our schedules rushing from one meeting to the next task. At the end of the day we are dragging . . .**

## ATTENTION P.D.s

Schedule the best in "OLD-TIME RADIO" with

*When Radio Was . . .*

Hosted by ART FLEMING, original star of "JEOPARDY"

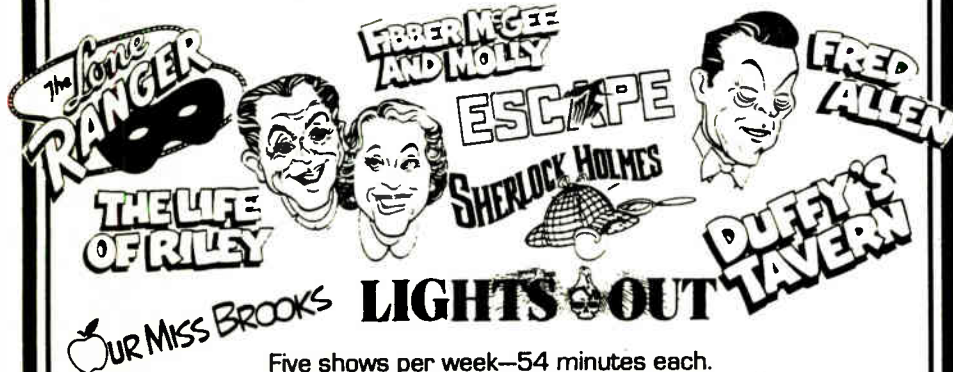

Five shows per week—54 minutes each.

**BARTER, NO CASH PAYMENTS!**

Delivered via Satellite (SATCOM).

For information and a free demo tape contact David West at

**DICK BRESCIA ASSOCIATES (201) 385-6566**

*When Radio Was* celebrates its 4th year on 100 stations.

Circle (107) On Reader Service Card

# SAVE MONEY

WHILE MEETING THE FCC JULY 1 STL DEADLINE WITH **MARTIFCC** APPROVED TRANSMITTERS.

COMPOSITE STL-15C	\$3500.00
MONOPHONIC STL-10	\$1645.00

Guaranteed compatible with your current STL system.

Ask about the \$250 rebate when you purchase a stand alone STL-15C Transmitter.

**MARTI Electronics, Inc.**

**PO Box 661**

**Cleburne TX 76033-0661**

Phone: (817) 645-9163 FAX: (817) 641-3869

Circle (184) On Reader Service Card

# Generate Non-Traditional Revenue

by Lucia Cobo

**WASHINGTON** In these days of rock videos and virtual reality, radio stations must take sharper aim at drawing in their target audiences and keeping the revenue stream on an upward slant.

Many of them are successfully employing promotions, event marketing, remotes, direct mail and even sophisticated bumper stickers to make their mark on both listeners and advertisers.

## Change in budgets

The last few years have witnessed a doubling or tripling of promotional and marketing budgets, whereas straight-out advertising budgets have increased only slightly, according to Broadcast Direct Marketing's Courtney Thompson. Add to that the increased degree of competition in the radio marketplace, and it just makes sense for stations to turn to alternate revenue sources, including promotional and event dollars.

"There is a demand for additional dollars at radio stations," Thompson said. "Non-cost-per-point and non-ratings-sensitive." "With many promotions," said Thompson, "You can make money on the promotion, bring in new listeners, keep established listeners tuned in and create a separate profit center for your station."

As examples he cited stations KIFM San Diego, KKSF San Francisco and WNUA Chicago. The three stations are printing custom magazines (designed by Broadcast

Direct Marketing) including contests, promotions or sweepstakes to bring people back to the station, and bring print advertisers to their radio stations.

But making these alternate sources generate revenue for you takes training, according to Thompson. Broadcast Direct offers full-day seminars along with complete turnkey packages. Said Thompson: "There is a void in the training area—not a lot of companies can train personnel on how to target these dollars."

He added, however, that the number of stations targeting these alternate sources is growing steadily.

## Easy to do

How to draw attention to your station at a busy fair or sporting event is the specialty of E-Z UP International. According to Marty Dotterweich, national sales manager, the industry has indeed come far in learning how to stand out in a crowd. "When we first started selling these, the tents were blank—the first stations used them for shade," said Dotterweich.

Gradually, he added, stations began requesting call letters and logos be added to the tent, as well as ordering the tents in station colors.

Said Dotterweich: "We've noticed it is a 'keeping up with the Joneses.' If one station has a fancy tent, other stations in the market immediately want to have one too." The company likes to get at least one customized unit into each of the top 25 markets

for that reason, he added.

Another change in how stations are using the tents said Dotterweich, is that they are now selling advertising on the canopy to station clients. E-Z UP can place the logos anywhere the client requests because it does all the silk-screening in house he said.

The company is celebrating its ten-year anniversary and recently opened an office in Europe.

## Direct approach

Combining expertise in broadcasting and direct marketing, Charles and Eric Mohr, owners of direct Response Traffic builders, have expanded their marketing services to include specialized turnkey direct mail for radio and television stations.

According to Charles Mohr, the recession has caused fundamental shifts in the consumer buying psychology. Consumers today are more prone to using coupons and shopping for generic brands. "What we offer a radio station," he said, "Is a consumer product that is in demand—across all demographic lines, people are using coupons."

The turnkey direct mail program, set up to be used by a station's sales force, has both a magazine and envelope format. The program can increase revenue and cash flow, or be used for tune in advertising, station promotion, value added sales or stand alone direct mail purchases. In addition, the program also attracts the newspaper advertiser as results can be quantified. Since direct mail is a pre-sold advertising medium, rev-

enue is received before the ads mail. Database marketing and customized solo direct mail programs are also available.

"In today's economy, businesses need to be smart, practical, and resourceful while trying to increase their market share and hold costs down," said Mohr. "What is going on is that as great a medium as radio is, it is always looking for value-added ideas. There is a potpourri of many different things a station can do to benefit itself and its clients."

## Not just a decal

Communications Graphics manufactures decal promotion budgets for radio stations. Rick Lawrance, president, sees more and more stations using bumper stickers as more than just giveaways.

Said Lawrance: "Bumper stickers are an integral part of radio station efforts at grassroots marketing. In many instances, the bumper sticker is the sole visual image of a station in its market."

Another reason stations with small or non-existent promotions can use bumper stickers effectively, according to Lawrance, is the fact that it is a self-liquidating method. "The effective integrating of sponsor and station can be done," he said. "For example, liner coupons provide that extra value for advertisers."

In addition, said Lawrance, the bumper sticker helps the station get visual impact. "For years, radio thought that only the audio was important. Now that they had to learn about the visual aspect, the quality of the art has gotten much better. It helps give a personality to the station as opposed to being just a billboard."

*It's Here . . .*

## THE NEW GENERATION OF FM TRANSMITTERS.

Throughout the years Continental has built the world's most reliable transmitters and other RF products. The new generation of three bay transmitters is no exception. This family of transmitters offers the broadcaster efficiency and excellent audio performance.

### Standard features include:

- A Solid-State IPA
- Front Panel Indicators and Breakers
- Internal Harmonic Filter
- Automatic Power Level Control
- "Exclusive Soft Start™"
- Totally Self Contained (except 35kW)

The 3 bay family of transmitters is available in power levels from 21.5kW to 70kW and comes with the 50 watt 802B exciter, tuned and tested on your frequency and ready for easy installation. Continental can outfit your facility with the best products in the industry.

**CONTACT CONTINENTAL FIRST**

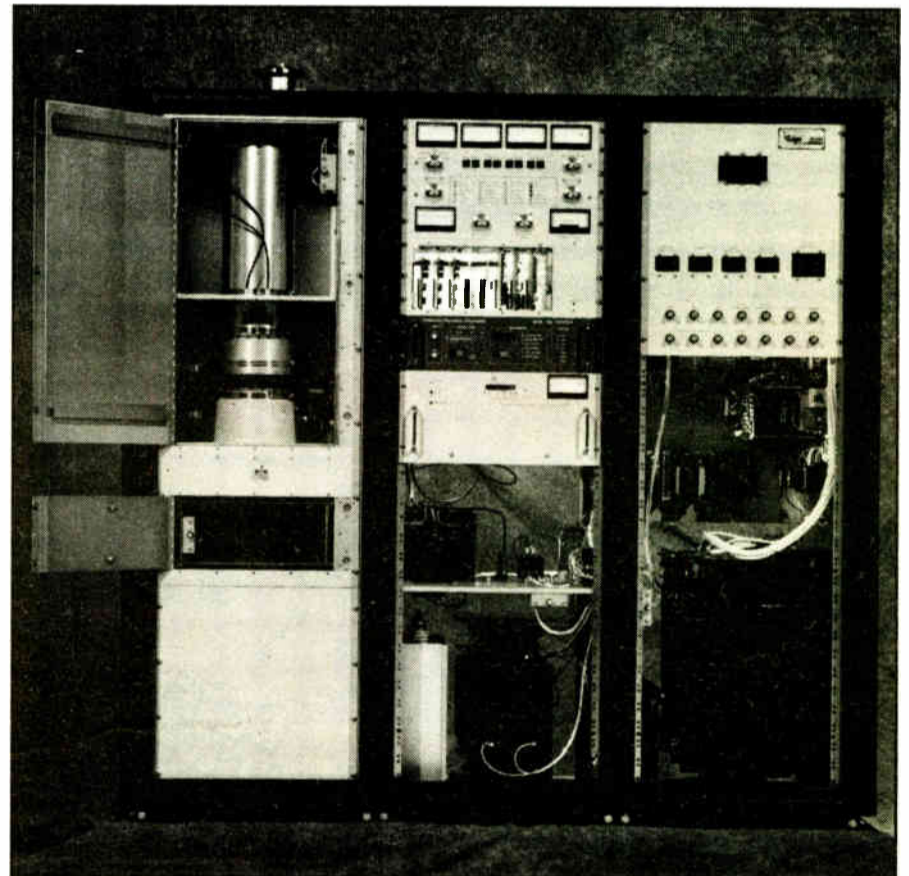

**Continental Electronics Corporation**

P.O. BOX 270879 DALLAS, TEXAS 75227-0879 214-381-7161 TELEX 73-398 FAX 214-381-4949



TECH TALK

# Latest in On-Going DAB Panel Talks

by Judith Gross

**NEW YORK** As Yogi Berra might have said, "It was deja vu all over again." Once again DAB proponents were lined up on the stage. Once again, it was the NAB's Engineering Conference annual DAB panel and once again I was trying to keep sleepy attendees interested after a full day of technical discussions, and get to the bottom of some unanswered questions on the now familiar subject.

But almost all of the faces were new and some of the systems were as well. Gone were American Digital Radio, Mercury Digital, Strother and Lincom. European researchers remained in the audience while Eureka-147 was represented by Clint Pinkham, of Thomson Consumer Electronics.

No less than two AT&T Systems were represented: Nikil Jayant spoke about progress with AT&T's system which will be submitted to the EIA Committee for its tests this spring and John Cioffi represented the Amati system, which will go before the committee as well.

The VOA's Don Messer was ready to answer my call for a rousing debate and Gannett's Paul Donahue represented a host of engineers involved in USA Digital's in-band, on-channel system for AM and FM.

The term IBOC was bandied about as an established part of the DAB lexicon. Satellite proponents, with the exception of VOA, which is developing a satellite DAB system with NASA, were absent, and Messer all but apologized for being one of the heathens in a terrestrial-sympathetic room of believers. And there was no DAB bus circling the Golden Nugget or cruising the Vegas strip.

**Two parallel tracks**

DAB (or DAR or DRB, depending on which committee you belong to) developments over the past year came in two

areas. As to systems, AT&T and Amati were more specific on what, in addition to the PAC compression algorithm, they were proposing: basically adjacent channel systems with perhaps some diversity antennas thrown in for good measure.

USA Digital showed a booth demo of FM DAB similar to one which we saw in New Orleans at last September's Radio Show. Big progress came in their AM DAB with analog and digital broadcasts on the same frequency this time: 1660 on the expanded AM band. And it sounded good.

But a mobile FM DAB demo was scrapped when some non-DAB electronics equipment sent spikes through the system,

destroying one of a kind ACT circuits. USA Digital engineers worked round the clock for the first three days of the show trying in vain to repair the damage.

**Starting the arguments**

The second shift took place so subtly that it went unnoticed by all but the closest DAB observers (or is that really "closet DAB groupies," as I'm sorry to admit I am?). And it's subtle enough to be generating more questions than it answers. This was the news that now it will be the NRSC who will have the say on what DAB system will become the U.S. standard. Oh the EIA will still press on with its DAR com-

mittee's timetable, but NRSC will begin its DAB work on a "parallel" track.

The first question of the DAB panel discussion was all mine. I wanted to know how this whole thing with two committees deciding on different systems will work. USA Digital is not even submitting its system to the EIA. And broadcasters have long since made their position on DAB vociferously known: it's IBOC or nothing. So the work of both the NRSC (a joint effort of the EIA and NAB) and the EIA on its own with respect to setting a U.S. DAB standard, would seem to be moot at best. Neither EIA subcommittee chairmen nor the NAB could shed light on this question. Confusion still reigns.

But another question, a more interesting one, was raised during the panel discussion  
continued on page 19 ▶

## Belly Up for the Remote Bar Fun

▶ continued from page 11

- Rock'em Sock'em Robots: These are lifesize metal objects that work very much like their toy counterparts;
- Human Bowling: The pins are huge and so are the bowling balls. One by one people get inside the ball and are rolled at the pins;
- Mountain Climbing Wall: It's a wall with knobs that you race up;
- Samurai Surfer: Stand on surf board and watch the television monitor throw waves at you. Try to stay on for points.

The prices for these experiences range from one to five thousand dollars. If you wish to rent, try an amusement rental company.

**Leave 'em hungry**

**Time Out:** Make your appearances relatively short. Very few stays in a bar should be more than two or three hours. The unusual activities shouldn't be around long enough for people to become bored. It's always great having to tear something down when it's still in demand. This means that the activity was popular and that the bar will want to pay you to come back.

**Don't do it for free:** I once worked for a station that gave away a night once a week to a bar just to get exposure. When the DJs showed up they were ignored by the workers and club jock. It was only after the owner started paying a

talent and promotional fee that the bar realized they had a stake in making it a successful night for all those involved.

Remember that most bars only hold a few hundred people. Also, generally only people that live or work near the establishment you're at will go there. These two factors leave out a lot of people in your listening audience.

What can the bar do for you? The bar should put up table tents, posters or flyers promoting your venture. They should also make announcements all week in the club. A little in-house promotion can make a difference.

If you have an interactive phone line make sure all the details about your bar events are on it. Include directions and the phone number. If you're not set up for this, make certain your receptionist has the information close by. The liner card in the control room should also always contain details for callers.

Signage and sound: Banners should be hung in all obvious places at least a half hour prior to the arrival of your talent. Your station or station tapes should be playing. Leave bumper stickers and any small handouts at the front door.

Make it free. If you can consistently make admission to your bar parties free, you will draw more people. Nothing draws a crowd like a crowd.

□□□

Mark Lapidus is promotion director for Group W's WCPT(AM)-WCXR(FM) Washington. He can be reached at 510 King Street, Alexandria, VA 22314.

## MICRO SOUND

### Digital Audio Workstations

**Delivering Your Expectations**

You expect the ultimate quality, precise editing and faster production that digital audio promises ... Meet MicroSound.

Now produce any audio project with true sonic transparency and noiseless performance in a fraction of the time! Make undetectable edits instantly, no matter how long your files; or undo-redo them any time, since your masters are untouched. Sync audio cues instantly to sample-precision, moving thousands unbound on unique *Floating-Tracks™*. *Disk-Layering™* allows up to 38 cues at any location, to be mixed and output to stereo or 4-tracks!

Assembled/tested AT-486 Workstations start under \$7,800; or add to your 386/486 computer for under \$3,700.

Contact MTU today for your free 24 page brochure to find out how fast MicroSound can meet your expectations.

*Quality digital audio since 1977*





(919) 870-0344  
Fax: (919) 870-7163



Micro Technology Unlimited  
156 Wind Chime Court  
Raleigh, NC, USA 27615



## A GREAT GIVEAWAY!

Roll-A-Sign™ disposable plastic banners are a great, cost-effective way to promote your station.

Indoors or out, Roll-A-Sign powers your message across and is an ideal giveaway for a concert, remote, etc. Co-op it with a sponsor and it more than pays for itself!

Depending on your logo's design, you'll get up to 338 banners on a 1,000' roll. . . just roll 'em off and cut.

Each banner is printed on high quality, sunstabilized plastic film, 4 or 6 mils thick, up to 36 inches wide. Fax us your logo and specifics on color separations, and we'll give you a free quote.

For any questions about quantities, sizes, imprints, colors, etc., call

## 1-800-231-2417

or FAX: 713-947-2053 or in Texas call collect 713-484-6892

Roll A Sign™ • Reef Industries, Inc. • P.O. Box 750245 • Houston, TX 77275-0245

## UPLINK

# Remote Possibilities for Affiliates

by Karl Baehr

**ALBUQUERQUE, N.M.** Remotes can be great revenue generators, but if you're a satellite affiliate how do you pull one off?

Satellite affiliates can successfully do quality remotes without a lot of expense or headaches. There are logistical considerations regarding timing, switching and, cuing that you must keep in mind. The importance of on air quality is always a predominant consideration, as is the quality of the person doing the remote. (Keep in mind that a personality that kicks butt in the studio may feel a bit

uncomfortable the first time a few hundred listeners are staring back at him!)

## Remote transmission

Let's talk about remote transmission. I will say (though engineers reading this might hate me for it) that I have heard quality telephone remotes. If you don't have the bucks for a remote transmitter, you can use a land line or cellular phone, but invest in hybrid equipment that will enhance the phone's performance on both ends of the remote.

Many companies provide frequency extenders, hybrids for conventional and cellular phones. Comrex makes the PLXMICRO for mobile phones. I've used the Gentner MICROTTEL 1 at several stations.

When doing a remote you will need to have a sharp board operator back in the studio. Take manual control of the satellite feed to control the network "stepping" on your local breaks. Get copies of the music logs from the network promos by the network air talent. "We'll be checking in with Larry Local live at the Texas State Fair next..."

The liners you produce for a remote can be very creative. I have used what I call "banter tracks" which are basically scripted, pre-produced "conversations" between the network and local talent much like you would receive with a comedy service. Using a tone trigger over the phone line to fire off the cart machine(s) back in the studio, these conversations do sound live and can be very effective.

Many listeners don't know until they're told that a station is a satellite station anyway. A true fact. Once they do know, to many it just doesn't matter. A good sounding station is a good sounding station.

## It's all in the timing

When doing a remote broadcast on a satellite affiliate you will need a good

digital timer as you are working within the confines of the network's windows. With a little creativity and a few dollars, your engineer should be able to rig up a timer that can be tone-triggered over the phone line.

Now if you don't have any local "remote-ready" talent, your network does. Every network I've talked to is glad to make its talent available for local promotions. This costs a bit more, but costs can be built into the remote package. This option can be very effective, particularly if you arrange to have the air talent in your market for a major event such as a state fair, race, sporting event. Here in Albuquerque we have the International Balloon Fiesta.

Remotes can be a great way to get your station out into the community and create visibility. They are good for the bottom line too. Regarding the fact that few if any know a station is satellite programmed, there is nothing wrong with calling in and recording several live remote breaks for playback. Again, as you are working within the network windows this may be preferable to actual live breaks, and besides, everyone else does it, right!?

## Something new

A few weeks ago I was contacted by Paul Moore, VP/Sales for "Radio One." Paul saw a recent *Uplink* column and wanted to introduce us to the new network, which at this writing is only 30 days old. He told me that "Radio One is the beginning of a true revolution (in satellite syndication)." After reviewing the material he sent me and talking with him about what Radio One is up to, I must tell you that these guys just might be on to something.

**RW:** Tell our readers a bit about who *Radio One* is, how long you've been around, what you offer formatically.

**Moore:** Radio One started about two years ago as a group of Rocky Mountain-based stations owned by Cliff Gardiner. We wanted to work the bugs out before we moved to a larger arena as what we are doing here is very involved and "high touch." The current effort is about a month old.

**RW:** Elaborate on "high touch."

**Moore:** In addition to the format which is live 24 hours and customized completely for your station, that is only the beginning of what we do. Radio One will also do your commercial production. We do your traffic. We do your billing. We prepare your accounts receivable. We monitor your transmitter. We even do your local news and weather.

**RW:** How?

**Moore:** We have a producer and air talent for every 15 affiliates' daypart. The air talent will actually record every break for every station during the music and feeds the breaks down the line for re-broadcast locally. We feel that one producer can handle four air personalities so we can grow the format a ways and still maintain an incredibly high degree of interaction and localization.

**RW:** You have one format now?

**Moore:** Yes. "The Mountain" is an album-oriented, music intensive format targeting adults 35 to 49 with a slight female skew.

**RW:** How do you accomplish all the other services while maintaining the high degree of localization? Take news for example.

**Moore:** Local news is provided by the local daily newspaper. We will contact them and make the arrangements. The local newspaper will fax us the top stories of the day every morning, and any subsequent developments. We record the news here, feed it to the local audisk for storage and playback. There are seven newscasts per day. We give the newspaper a billboard for their participation.

continued on page 35 ▶

## At Your Fingertips!

Find the information you need in Radio World's 1993 Directory.

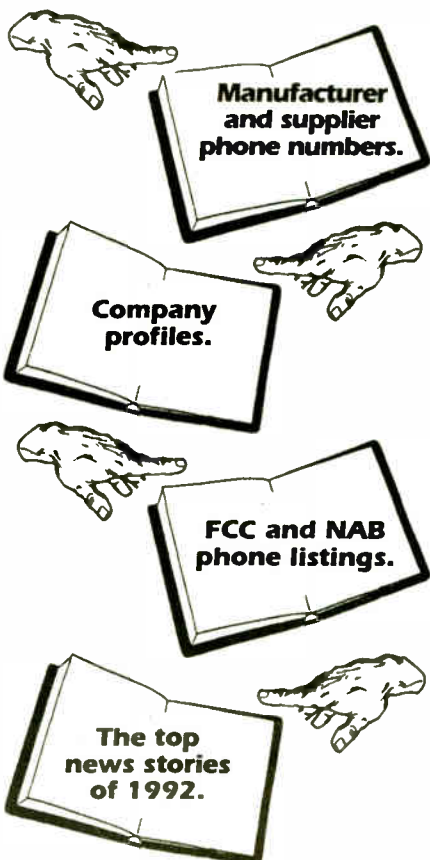

...And more.

We have a limited number available at \$14.95 each.

To order, call



1-800-336-3045

## THE SECRET'S OUT—DIGITAL FURNITURE

MODULAR  
FLEXIBILITY  
WITH A  
CUSTOM FIT

We Offer Six Elegant  
Lines of Studio Furniture

4153 BONITA STREET  
SPRING VALLEY, CA 91977  
PHONE 619/698-4658  
FAX 619/698-1268

**MURPHY**  
STUDIO FURNITURE

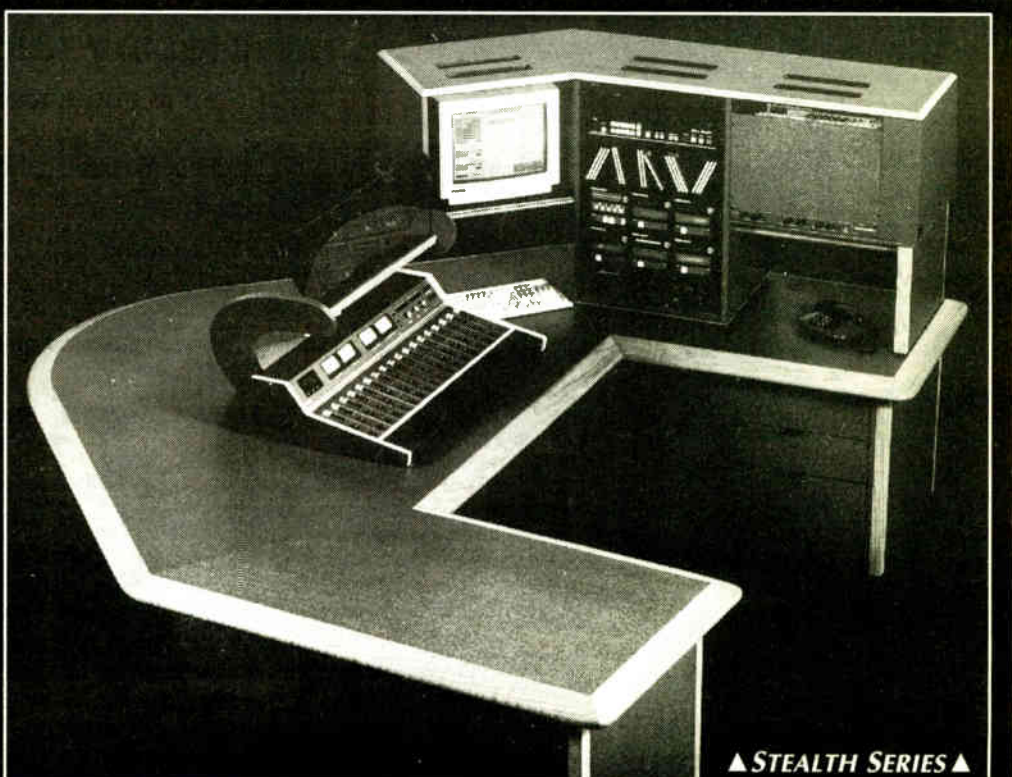

▲ STEALTH SERIES ▲

Circle (81) On Reader Service Card

# DAB Discussions to Last a Few More Years

► continued from page 17

by USA Digital's Donahue. Forgive me, Paul, for paraphrasing, but the gist of it was "Why would anyone even invest in another, non IBOC system, when IBOC is the only system acceptable to the radio industry and USA Digital is making such respectable progress?" Why indeed?

Jayant, from AT&T, patiently explained yet again how technically, it's still an open ballgame, up for grabs by all. Pinkham and Cioffi echoed the sentiment, putting their faith in the systems they represented. What if the USA Digital system can't meet broadcasters' expectations? What if the tests prove there's a better system, technically? What if the question of allocating new spectrum, yes, here, in the U.S., were addressed in a future international broadcasting conference?

No one came out and said it, of course, but basically the unasked question being thrown back at USA Digital is: what if you fail? And the equally silent answer was: Well of course Eureka, AT&T and Amati will be right there, ready to take your place as the designated technical messiah of radio's digital future.

In fact, Pinkham, though he was way too polite to ask it this way, indicated Eureka's own unasked question: Why mess with a "maybe" when there already is a system that's been proven to work that is being adopted by your nearest neighbors (Canada and maybe Mexico)?

## Back to the bottom line

My questions stayed with the practical side of the debate: "Why would anyone (currently, AT&T and Amati) even want to spend time and money developing a system that broadcasters oppose, especially when so many before them have gone (literally) broke doing just that?"

In the end, this is a question that remained unanswered—along with many others. Once again, politics intrudes on technology. And currently, in an economic climate seeing its first real boost in the past several years, radio station owners have the luxury of letting the DAB controversy burn itself out over a much longer timetable than originally anticipated, while they focus their attention firmly on making the industry—and their own bottom line—healthy again.

The EIA will press on with its committee tests; the NRSC will convene meetings and allow broadcasters their forum for reinforcing their IBOC stand; AT&T and Amati will develop their systems further, USA Digital will keep doing its tests and no doubt grace us with a mobile demo at the fall Radio Show and Eureka will sit quietly by in the U.S. while pushing to become an international DAB standard.

If IBOC is viable, it will be two to five years before DAB trickles into stations and five to 20 before it becomes widespread. If something other than IBOC is needed, push that timetable back at least another decade.

By then, we'll be firmly entrenched in the next millennium, the radio manufacturers will have had time to design new receivers, the FCC will have had a chance to rubber stamp what is already a de facto standard (whichever one it turns out to be) and DAB proponent panels at the NAB convention will have gone the way of the horse and buggy.

Maybe by then we'll even all agree on what to call it.

□ □ □

*Judith Gross works for Media/Scan, a New York City-based marketing firm specializing in broadcast and pro-audio technology. She can be reached at 212-929-6108.*

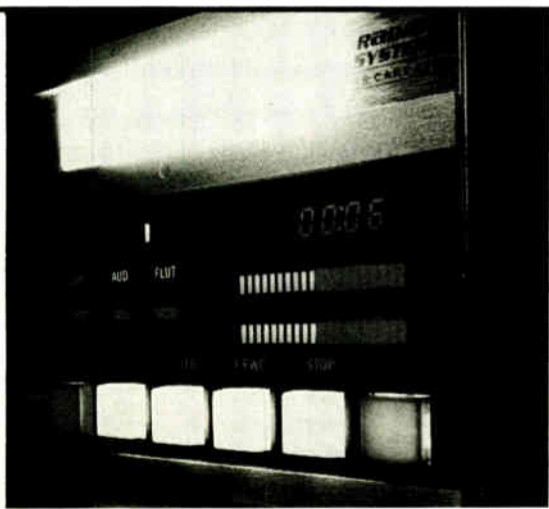

## Alive and well.

Some companies would like you to believe that the cart is dead.

But today, with an installed U.S. base of more than 100,000 machines, carts are in active use at more than 98% of all U.S. broadcast facilities.

So, if you depend on carts everyday, we just wanted you to know that we're a manufacturer who still believes in the format, and make the finest cart machines available.

The RS-2000 cart machine. It will make your carts sound like digital until the day it makes sense to go digital.

**RADIO SYSTEMS INC.**  
800/523-2133 or FAX 609/467-3044

Circle (104) On Reader Service Card

## BIG...RICH...FULL DIMENSION CONCERT SOUND

The CP2013 is the only composite processor with a fast, peak responding AGC. *Why?* Because most AGC amplifiers are too "envelope destructive" to be used this way.

### The Benefits?

- Incredible spatial effect due to enhanced L-R
- Eliminates excessive subsonic energy
- Much cleaner than conventional composite clippers
- 1.5dB louder, due to low second harmonic clipper, converts "would be" distortion into useful modulation.



COMPROC CP-2013

*Other features* include two composite outputs, and a new zero phase shift pilot feed-through circuit requiring no setup.

## BIG SOUND...MEANS BIG NUMBERS CALL NOW!!

**HNAT HINDES Inc**

42 Elaine St., Thompson CT 06277  
203-935-9066 or 203-935-9242  
FAX: 203-935-9919

Circle (143) On Reader Service Card

## TXL-110, TXL-210

Transmission Limiters

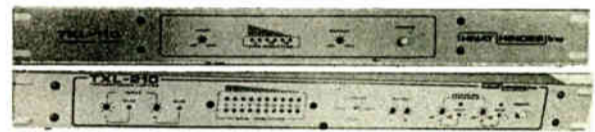

## ENVIRONMENTALLY SAFE... NO EAR POLLUTION... Just CLEAR, BIG DIMENSION SOUND.

Today's digital audio imposes a new requirement on broadcast transmission systems, particularly audio processors.

The TXL series Transmission Limiters are designed to preserve your program resource and deliver it intact to the transmission system, without the familiar processing residue that cost rating points.

The TXL series limiters are also safe to your FINANCIAL ENVIRONMENT... (No slick, multicolor full page ads to pay for).

CALL TODAY...For more on the TXL-110 & TXL-210 capabilities.

**HNAT HINDES Inc**

42 ELAINE ST., THOMPSON, CT 06277  
203-935-9066 / 9242 FAX 203-935-9919

Circle (27) On Reader Service Card

## ULTRAMOD®...UM2000 FM STEREO MODULATION SYSTEM



The **UM2000** is a complete FM processing and stereo generating system featuring:

- Dual band, stereo AGC and peak processors of exceptional clarity.
- Digitally synthesized stereo generator with separation exceeding 60dB at 1 KHz, and typically 55 dB at 15 KHz.
- Dual composite outputs for feeding main and auxiliary transmitters or STL's.
- Separate Pilot output for composite processor interfacing.

CALL TODAY!

**HNAT HINDES Inc**

42 Elaine St., Thompson CT 06277  
203-935-9066 or 203-935-9242  
FAX: 203-935-9919

—FOR BROADCASTERS WHO SPEND THEIR OWN MONEY—

Circle (211) On Reader Service Card

# STATION SERVICES

News and Services for Business, Programming and Sales

## New Racing Program Debuts

**LAS VEGAS** The Winning Line Inc. launched "The Weekly Racing Report," the company's second national sports radio property. "The Weekly Racing Report" is broadcast live from The Las Vegas Hilton SuperBook every Friday evening from 6 p.m. - 7 p.m., PT, 9 p.m. - 10 p.m. The show is rebroadcast Saturday mornings from 7 a.m. - 8 a.m., PT, 10 a.m. - 11 a.m., ET. The Hilton's SuperBook is the world's largest and most sophisticated Sports and Race Book.

The program will be co-hosted by two of the most respected names in the horse racing world. Michael Roxborough is president of the Las Vegas Sports Consultants, the official Triple Crown oddsmaker for The Daily Racing Form, and the world's leading sports oddsmaker. Roxy is a consultant to sports books in Nevada, Mexico, England, Australia and Europe. In addition, his lines are syndicated to more than 75 newspapers across America.

"The Weekly Racing Report" is on Satcom C-5, Transponder 19, Channel 6. The program will also be broadcast on Galaxy 2 Transponder Channel 85.1.

For information contact Kyle Heinrich at 206-285-5480; or circle **Reader Service 85**.

## CBS Hispanic Adds Programming

**NEW YORK** The CBS Hispanic Radio Network added a second regularly scheduled program to its lineup when it began airing "Hollywood Hoy," a two-minute, twice-daily look at the latest news from the entertainment capital of the world. The program features exclusive interviews and reports on films, music and television. Hosted by Amelia Macchiavello, affiliates will receive two different editions of the

broadcast each day.

For information, contact Sina DeVito at 212-975-3773; or circle **Reader Service 76**.

## NAB Plans Diversity Initiatives for Minorities

**WASHINGTON** The Resource Development Committee of the National Association of Broadcasters recently adopted a slate of initiatives to be implemented by its Department of Human Resource Development.

The efforts listed below were approved by the Committee for 1993: 1) A pilot regional Employment Clearinghouse Broadcast Career Seminar scheduled to be held in Atlanta, and possibly repeated in six other major cities; 2) A Minority Futures Symposium on challenges and opportunities facing the industry in the 1990s; 3) A revision of the department's booklet, Diversity in Broadcasting: Actions Toward Better Business," to include data and photos of the progress of minorities and women in talent and management positions in the top 50 markets, and 4) the production of a work place diversity video with assistance of WHMM-TV facilities, to be part of state broadcast association meeting presentations.

For information contact Dwight Ellis at the NAB at 202-429-5350; or circle **Reader Service 117**.

## NPR Salutes Ella Fitzgerald

**WASHINGTON** Jazz legend Ella Fitzgerald's life and artistry will be celebrated in two National Public Radio (NPR) specials scheduled for July.

The hour-long programs, honoring the "First Lady of Song" in her 75th year, are: "Lady Be Good," a documentary exploring Fitzgerald's artistry and musical achievements, and "A Celebration of

Ella," which features highlights from an All-Star 1993 Carnegie Hall tribute and an Ella Fitzgerald concert given in 1981. NPR is producing the programs for broadcast during the July 4 weekend.

For information, contact Quincy Johnson at 202-822-2312; or circle **Reader Service 219**.

## Unistar to Distribute The G. Gordon Liddy Show

**NEW YORK** Unistar Radio Networks, in its first collaboration with Infinity Broadcasting, will distribute The G. Gordon Liddy Show.

Liddy's debut year on Infinity-owned WJFK(FM) Washington, D.C. has been tremendously successful. Liddy was rated number one with Men 25-54 and number two with Adults 25-54, beating Rush Limbaugh in overlapping hours, M-F, noon to 2 p.m., in the Washington Metro and ADI Fall 1992 Arbitron.

Liddy's show includes studio guests, audience phone calls and his own frank style, resulting in a contemporary, live radio program that has drawn attention. Liddy has featured guests like former Secretary of Defense Dick Cheney, Senator Robert Dole, Reverend Jesse Jackson and talk show host Geraldo Rivera.

The G. Gordon Liddy Show is available live via satellite, weekdays 10 a.m. to 2 p.m., ET.

For information, contact Renee Casis at 212-373-4977; or circle **Reader Service 208**.

## Mutual Broadcasting Adds Pat Buchanan

**LOS ANGELES** Westwood One announced the introduction of conservative political personality Pat Buchanan to the Mutual Broadcasting System. "Pat Buchanan & Company," set to debut July 5, 1993, will air M-F, Noon-3 p.m., ET, includes a rotating list of liberal co-hosts with opposing points of view.

In contrast to other controversial radio talk shows, Pat Buchanan & Company will present both sides of the issues, with heated debates between Buchanan and his

co-hosts. Among those lined-up to confront Buchanan include Ben Wattenberg, a senior fellow at the American Enterprise Institute and the author of five books on politics and the electorate; Chris Matthews, nationally-syndicated columnist with the San Francisco Examiner and former top aide to "Tip" O'Neill, when he was Speaker of the House; Bob Beckel, one of Washington's leading political analysts who has worked in the White House, on Capitol Hill and led numerous political campaigns; and Juan Williams, a best-selling author on politics and political analyst/national correspondent for The Washington Post.

For information, contact Laurie Peters at 310-840-4383; or circle **Reader Service 146**.

## Radio's Past in New Show

**CHICAGO** Dick Brescia Associates offers its nationally syndicated old-time radio show, "When Radio Was," to stations interested in programming that creates devout listenership. Presently, "When Radio Was" boasts a weekly audience of one million listeners on more than 100 stations including WBBM Chicago, WWJ Detroit, KCMO Kansas City and KFYI Phoenix.

The program is heard five hours per week. Art Fleming, of Jeopardy fame, is the program's host, and provides listeners with nostalgic sounds of yesteryear. Listeners are reminded of the glorious Golden Age of radio with such classics as "The Lone Ranger," "The Shadow," "Sergeant Preston of the Yukon," "Lights Out," "Fibber McGee and Molly," the great "Gildersleeve," "Escape," "Duffy's Tavern," "The Life of Riley" and many others.

"When Radio Was" is a bartered program provided to interested stations on an exclusive per-market arrangement. The show contains twelve minutes of commercial time in which stations have six minutes of that time to sell. The program is available via satellite.

For information, contact David West of at 201-385-6566; or circle **Reader Service 129**.

## STUDIO SERVICES

### MUSIC SCHEDULING SOFTWARE

**New!** **HOT CLOCKS**  
scheduling system

Get **better** and  **fresher** rotations  
Buy out price only \$495.00

The basic Suresystem scheduler was \$125.00  
**Now just \$90.00**

Programming services available

- Music Logs (We can program the music for your station)
- Set-up and data entry for RCS Selector
- Hooks for auditorium tests

Call us today  
La Palma Broadcasting

1-800-RADIO-90

**427 SOUND EFFECTS**  
**\$89.00**

For a 5-CD set with a 30-day  
money-back guarantee.

*Take an extra \$10 off if you mention this ad!*

Send \$79 to Ghostwriters  
2412 Unity Ave. N., Dept. RW  
Minneapolis, MN 55422

For credit card orders call  
**(612) 522-6256**

### ATTENTION PROVIDERS!

Promote your services to **Radio World's** 21,000+ readers. Reach Radio Station and Recording Studio owners/managers and engineers with your message. For information on affordable advertising call **Simone** at **1-800-336-3045**.

**\$146,000+ In 3 Days**

In Lancaster-Palmdale, CA

**Custom jingles for your clients!**

**Let our jingles make money  
for your station... NOW!**

**RADIO CONCEPTS INC.®**

**(612) 656-9259 Fax: (612) 656-0626**

USAirplay

# When Technology Means Less Choice

by Charles Taylor

**WASHINGTON** When the "Grease" soundtrack was finally released on compact disc in the States last year, I must admit I was in line to buy it on the day of release.

Reviewing the familiar—albeit miniaturized—liner notes, I positioned the disc in the player, took a place on the sofa and commanded the music to start with a push of my remote.

Ah, the summer of 1978, before the adult realities of deadlines, rent or calories. My hair was even still curly.

There I was with school chum Sarah Sprinkle, scratching down the lyrics to all the songs (except the gooey "Beauty School Dropout"), then, with all the zest that adolescence induces, singing loud and long, occasionally even closing in on the right notes.

**Scratch, scratch**

The only thing missing from this modern day incarnation was the scratchy surface noise that was eventually carved into the vinyl by my turntable needle after many months of repeated playings.

On CD, it was crisp. It was vibrant. It was indeed delivery of the early 1980's promise that CDs will change the way we listen to music, always and for the rest of time.

That is, until the development of digital audio tape (DAT), the Philips Digital Compact Cassette (DCC) and Sony MiniDisc. Hmm. Let me see if I understand. Barely a decade into the technology that alleges permanent perfect keepsakes of our music while carrying us far into the future, manufacturers are pushing hard with the message that, yes, CDs are good, but wouldn't one, two or even three more mediums be as good or even better?

Evidence of a forward-thinking industry, quick to develop new technologies for the betterment of the audio marketplace? Or indication of a menacing trend where marginally better technologies are being pushed on a public that barely has time to make the transition from one technology before it is antiquated by another and retired from the racks?

**Dirty tricks**

I guess I'm skeptical after the dirty tricks manufacturers and vendors played on consumers to propel CD technology. Vinyl's downfall was forced in a number of ways. First, record companies enticed consumers with CD "bonus" tracks unavailable on vinyl or cassette. The less expensive versions contained nine or so songs, the discs sometimes two or three more tracks. Savvy marketing or bribery for CD holdouts?

Then, music manufacturers initiated strict vinyl return policies to record stores, forcing them to order vinyl conservatively and cautiously. Vinyl singles, meanwhile, were eradicated—not enough profit on 45s, manufacturers said. Ironically, instead of marketing CD singles, tracks were released on the inferior cassette single. Why? Record companies admitted that full-length CDs are where the money is. Why take sales away by offering singles?

Most music retailers greedily played along, recognizing that the new technology

offered fatter profits. Its less rewarding LP counterpart was moved to crowded racks in the back of the stores, and no longer placed on sale.

In short order, the industry heralded that CDs had triumphed over the format that stood tall as the standard for more than half a century. Record companies began releasing works from major artists on CD and cassette only, further forcing the saturation of the disc. Today, few mainstream titles are even released on vinyl.

Mind you, I don't argue the inherent advantages of compact disc technology. My "Grease" soundtrack offers greater

fidelity than its vinyl companion, it is capable of handling more minutes of music and it is easily cared for.

I'm talking about an issue of choice.

Most European nations have reached a point where CD is the preferred medium, but not at the expense of vinyl or cassette. All three, along with vinyl 45s, CD singles and the disgraceful cassette single, share space amid the racks. Choice. That is the responsibility of the industry.

**Ambitious technologies**

Which brings us back to the manufacturing giants' ambitious new technologies.

DAT, while bringing forth digital quality on tape, made analog cassettes immediately obsolete. For many reasons, the carrier never caught on as a medium for pre-recorded music. DCC is the latest attempt at updating tape technology and this time at least is compatible with the traditional Philips cassette. But as reported in a number of publications, including **RW**, it fails to offer full digital fidelity. The average analog tape decks offers admirable fidelity with Dolby technology and can be had for under \$150. DCC costs at least \$600.

The MiniDisc makes up for CD's single shortcoming—the inability to record. Sony apparently expects consumers to abandon their new CD players just for a technology that is more compact at five times the price. And don't forget blank

continued on page 30 ▶

## SEND YOUR AUDIO ACROSS THE STREET OR AROUND THE WORLD™

When you think digital audio, think **California Digital.**

We provide satellite/digital technology to make many options available at low cost.

**California Digital offers expertise in:**

- ▮ Digital Satellite Networks
- ▮ Remote Broadcasts
- ▮ Installation and Training
- ▮ Rugged Fly-away Systems
- ▮ Custom Ku Power Control Software
- ▮ System Design & Engineering
- ▮ FCC Licensing
- ▮ Equipment sales, leasing and financing
- ▮ Switch 56 & ISDN program distribution

COVER THE US WITH SATCOM K1: FULL TIME STEREO CHANNELS FROM \$1100/MONTH

Call for details on cost effective solutions:

**CALIFORNIA DIGITAL AUDIO**

West Coast Office (805) 523-2310 Fax (805) 523-0480  
Midwest Office (612) 631-5064 Fax (612) 631-5010

**MAKE MONEY BY CREATING A MUSIC PROGRAMMING NETWORK!**

Circle (200) On Reader Service Card

World Radio History

The advertisement is enclosed in a double-line border. At the top right, a satellite is shown with lines indicating its signal path to a globe of the Earth. A large diagonal banner across the center contains the text 'DIGITAL AUDIO'. At the bottom left, a ground station antenna is shown, labeled 'MUSICAM™'. To the right of the banner, a list of services is provided, followed by contact information for California Digital Audio, including office locations and phone/fax numbers. At the bottom, there is a call to action to 'MAKE MONEY BY CREATING A MUSIC PROGRAMMING NETWORK!' and a note about a reader service card.

# Who's running the ship?

**U**nattended operation is one way to keep your station profitable, but you still have to mind the store.

The acclaimed Burk Technology ARC-16 Remote Control System is the first step. You can control transmitter and studio from any phone.

But wait. There's more!



**I**ntroducing AutoPilot™ from Burk Technology.

AutoPilot is break-through computer software that makes automatic operation of your studio/transmitter facility a dream come true.

- Automatic power changes
- Automatic pattern changes
- Automatic site changes
- Automatic power trim
- Automatic fault recovery
- Automatic logging

Now your imagination is the only limit.

The new FCC fine schedule is imposing. Why risk a big penalty when AutoPilot can help you stay within the rules?

Call us at 508-433-8877  
or toll free at  
**1-800 255-8090**  
for more information  
and a FREE DEMO.

# BURK

TECHNOLOGY

Circle (141) On Reader Service Card

# DAB Equipment Cost-Estimate Study

► continued from page 1  
variations on the IBI system, including using channels other than adjacent ones, and allocating AM stations the FM-IBI channels.

Although an AM allocations could

which would reduce a station's costs, Pizzi said.

In a new band system, such as Eureka 147, a complete new transmission system will be required for a station, driving the hardware costs from \$66,000 to as

(acquiring land, etc.), estimated as high as \$300,000.

## Combining signals

Pizzi, however, pointed out that the current Eureka 147 project in Europe and Canada "employs a multiplex arrangement by which four or more (as many as six) program signals are combined in a single transmission system. Therefore, each station's cost of conversion is reduced by a factor of four or more (as much as six)."

Another variation on a new band sys-

**When program signals are combined in a single transmission system, each station's cost of conversion is reduced.**

tem is the "cellular approach," that would employ many low-powered co-channel transmitters within a market. This enhances coverage and reduces power requirements, but initial start-up costs would be higher, Pizzi said.

In other costs, Pizzi estimated that IBOC would likely incur the lowest operation and regulation costs. However, he added, receiver costs may be higher because of IBOC signal extraction complexity. At another session at NAB, \$1,000 was suggested as a likely price for first generation DAR receivers.

In addressing potential return on investment for stations, Pizzi noted that duopoly arrangements using digital transmission would be "progressive rather than regressive migration, in that the same number of players produce more services, rather than fewer players producing the same services."

Figure 1. Digital Audio Radio Transmission Hardware List & Approximate Costs

Item	IBOC(FM)	IBI	NB
Exciter	\$ 20,000	\$15,000	\$25,000
Transmitter	25,000	25,000	≥100,000
Combiner	5,000	25,000	
Transmission Line		(5,000)	30,000
Antenna		(10,000)	25,000
Monitor	5,000	5,000	10,000
STL/TSL & Remote Control	(≥5,000)	(≥5,000)	50,000
Tower			(≥300,000)
Installation	5,000	≥5,000	25,000
Per Station Factor	1x	1x	≤0.25x
<b>TOTALS (per station)</b>			
Lo	\$ 60,000	55,000	≤66,000
Hi	≥65,000	≥75,000	≥141,000
( )=possible expenses			

require a complete new transmission systems under this scheme (low power), "there remains the possibility that multiple AM stations might share such a system, or that an IBOC/IBI hybrid arrangement might exist (an FM uses its IBOC frequency and leases its adjacent channels to AM stations),"

much as \$141,000 (the high numbers are considered worst-case scenario, according to Pizzi). An exciter would cost about \$25,000 while a digital transmitter could cost as much as \$100,000. A transmission line and antenna could cost as much \$55,000. And an even bigger cost could be building a new tower site

## Turn Twisted Copper Pairs Into Gold.

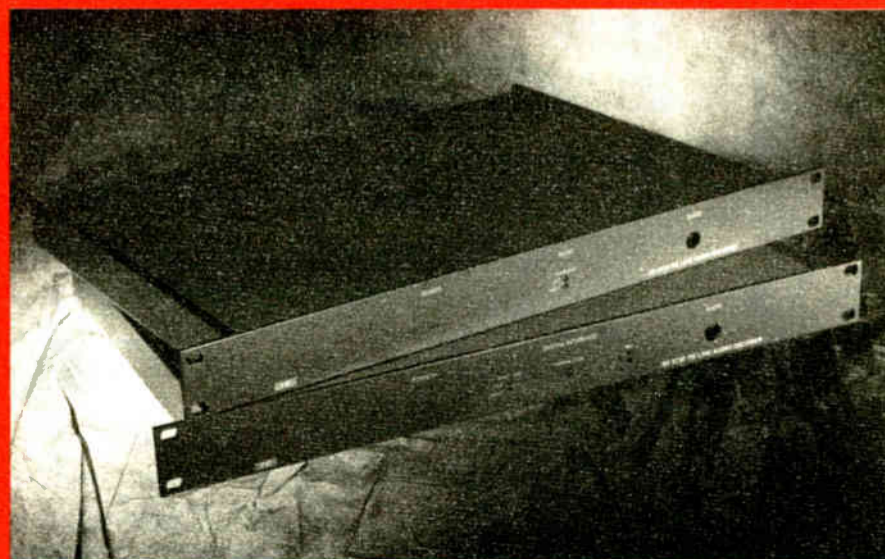

Just when you thought your bag of technical tricks was empty, RE America introduces the 15kHz Tie Line Audio Codec. Developed for 15kHz quality audio links, the RE8720/8730 (stereo or dual mono) and RE 8721/8731 (mono) provide a cost-effective alternative to expensive digital or equalized telco circuits by utilizing existing twisted copper pairs. The RE Tie Line products add new life to DC metallic pairs between your studio and transmitter.

### Tie Line Audio Advantages

- ▲ Install and forget.
- ▲ Less than 4ms total delay.
- ▲ Superior to mechanical equalization.
- ▲ Digitally pure sound.

### Tie Line Codec Applications

- ▲ Studio to transmitter links.
- ▲ Studio to microwave links.
- ▲ Studio to studio links.
- ▲ Satellite backhaul.
- ▲ Sports, RPU and many more.

**re**

RE AMERICA, INC.  
31029 Center Ridge Rd. ▲ Westlake, Ohio 44145  
Phone: (216) 871-7617 ▲ Fax: (216) 871-4303

Circle (88) On Reader Service Card



Starting  
under \$3,100

## Cost-Effective Quality

### The New Dynamax MX Series

## Modular Audio Console

- True modular design
- Ultra-reliable motherboard construction
- VCA mixer and monitor control
- Active balanced line inputs, transformer isolated mic inputs
- Active balanced main and monitor outputs
- Full monitoring/cueing facilities with VCA level control and active source selection
- Built-in cue amp with speaker and amplified stereo 8-ohm headphone output
- Remote start logic
- Count-up event timer
- Two input expansion switches standard
- Two inputs per module, mic/line or line/line - line inputs may be mono or stereo, consumer or professional format
- Four assignable outputs - two stereo plus two mono
- Available in 6, 8, 10 or 12 channel models
- Rotary or linear faders
- Separate audio and logic power supplies
- Sturdy, all-steel construction
- Durable Lexan overlay control surfaces
- All inputs/output connection via compact, captive screw barrier strips - no soldering, crimping or spade connectors necessary
- Excellent RF immunity

*Equipment Solutions To Keep You Number One*

**BSW**<sup>®</sup>

BROADCAST SUPPLY WORLDWIDE

7012 27th Street West Tacoma, Washington 98466

Toll Free 800-426-8434

Toll Free Fax 800-231-7055

Circle (127) On Reader Service Card

World Radio History

# DIGILINK

*...a revolution in radio studio technology .....*

## **THE DIGITAL AUDIO ADVANTAGE...**

Introduced in April of last year, Digilink is a digital audio workstation that saves your station money. There is no more routine maintenance, it has a 15 year average life, *and* you have total automation capability for nights... weekends... or whenever you need it. It comes complete in a 5 1/4" high, rack mounted cabinet that converts ordinary analog audio to CD quality digital audio which is stored on a computer hard drive. It does this just like you would store a business letter on your home computer. Digilink can then call up and play any digital audio file in milliseconds off its internal hard drive. Basically, you can think of Digilink as a huge multideck cart machine or "rotary cart player" where you can line up and play thousands of carts our audio cuts sequentially. A single Digilink can therefore replace all of your cart machines in production, On Air, or in automation.

## **Digilink is a perfect cart or reel machine replacement...**

Digilink is the perfect replacement for magnetic tape based cart or reel machines. With Digilink, you can replace your cart machines with CD quality digital audio that requires no calibration, no maintenance, and the media has a 15 year average life. You can replace your reel to reel machines, razor blades, and tape with fast, nondestructive, CD quality, on screen waveform editing. You can cue virtually instantaneously. Digilink even costs less than comparable analog cart or reel machines. Digilink is the perfect audio record and play system for professional radio broadcast applications.

## **Digilink performs ALL types of automation...**

With Digilink you can operate fully live or mix various automation types into your daily programming. You can store all of your audio on hard disk at an incredible price or you can use hard disk for only commercial material recording. Digilink has an internal audio switcher with machine logic control. Digilink therefore supports satellite automation, reel and DAT tape automation, CD automation, and full hard disk automation all out of one compact box. Because Digilink is a computer, you can print out a log of what you have scheduled to play or print out a log of what really did play. With Digilink, you can be live on the air with full CD quality audio or program the system and walk away forever. Digilink even interfaces with all major traffic and billing systems through a Digilink import-export routine.

## **Digilink is engineered and manufactured by Arrakis...**

Digilink is not simply a hardware package assembled from parts built by *other* computer manufacturers and run under our software. Arrakis is the *only* manufacturer to build nearly all parts of the digital system in-house. We build our own *Arrakis* DSP board, SCSI board, I-O board, switcher board, cabinet, and cabling. Because Arrakis builds the system and doesn't simply mark up someone else's hardware, Arrakis can offer you Digilink with broadcast features and performance unmatched by anyone *and* at a truly remarkable price !!!

2619 Midpoint Drive, Fort Collins, CO. 80525



..... at an incredible price. !!!!!

**SALE \$7,995**

under

**9,000**

for a COMPLETE 6 hour stereo system

whether you lease for under \$300 a month or buy, with Digilink you can literally make money by ...

- reducing maintenance,
- reducing staff demands,
- improving On Air sound,
- improving Production,  
*and improving all areas of your station performance !!!*



## FEATURES

- Simultaneous record- play !!!
- Uncompressed CD quality audio  
*or mix 2:1 or 4:1 compression*
- Use keyboard, mouse, trackball,  
or even a touchscreen
- Digital Waveform Editing
- Mix mono and stereo files
  
- Live Cart Machine replacement
- Reel to Reel machine replacement
- Satellite Automation
- Tape Based Automation
- CD Automation
- Hard Disk Based Automation
- Traffic and Billing Interface
- supports digital networks

## SPECIFICATIONS

*all tests performed at 1:1 compression*

### Digital Signal Processing System (DSP)

Sampling System- 16 bit linear PCM, 2 channels  
Sampling Rates- 44.1,32,22kHz, fixed filter on routing switcher  
Compression- 0,2,4...adaptive differential PCM

### Controller -

Floppy Disk- 3 1/2" 1.44M capacity, System Hard Disk- 40MB  
Printer Support- IBM compatible, parallel port

### Audio Performance- Digital Record playback

THD- .008%, Dynamic Range >85dB,  
Freq Response- (+)(-).5dB 10Hz-15kHz

### Physical Specifications

Dimensions- 19" Rack mounted- 19"W x 5 1/4" (3RU)H x 16"D  
Weight- 60lb's , Power- 110/220VAC, 50/60Hz, 100W

### Audio Performance- Routing Switcher

THD- .005% typ, S/N < 100dB below +4dBm  
Dynamic Range- >120dB,  
Freq. Response- (+)(-).1dB 20Hz-20kHz

**by ARRAKIS SYSTEMS inc.**

Voice (303) 224-2248, FAX (303) 493-1076

# PURE PROGRESS.

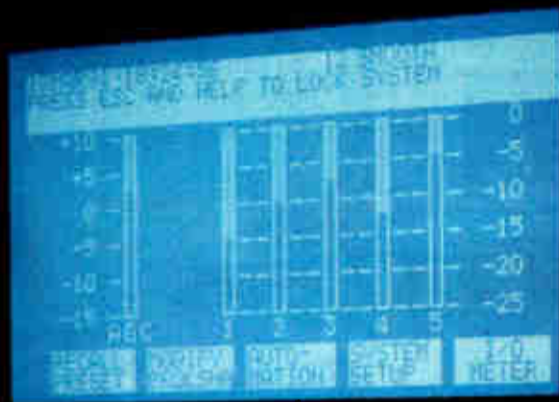

OPTIMOD ▶ FM

8200

POWER

## Stations Are Profiting From It.

FM stations around the world are finding more sophisticated ways to keep their listeners from cruising the dial. And OPTIMOD-FM 8200 has become a critical part of their strategy. Why? Because the 8200 is a technological breakthrough with bottom line impact. It lets you create a distinct, powerful sound that results in larger audiences, higher ratings and improved profitability.

## Digital Makes the Best Even Better.

Digital technology not only improves the quality of the signal—it makes the OPTIMOD-FM 8200 more programmable, more flexible and more user-friendly. And it can actually help keep capital equipment costs down because it allows stations to expand and upgrade their system

with software, rather than expensive hardware.

A case in point: all current 8200 owners will receive a new software upgrade free of charge.

Version 1.0's sonic and operational improvements meet broadcasters' ongoing demands for superior audio performance and increased control—like customized bass response and automatic switching of presets for dayparting.

## The New Standard.

The OPTIMOD-FM 8200 is now the new industry standard for digital audio processors. Call your dealer now for a hands-on evaluation of the 8200. In a market where stations live and die by the ratings, you can dominate the dial.

**OPTIMOD ▶ FM**  
D I G I T A L

**FEATURE-PACKED  
1.0 SOFTWARE**  
✓ Improved Sound  
✓ Greater Control  
**CUSTOMIZE Your  
Sound**

**orban**

a division of AKG Acoustics, Inc.

1525 Alvarado Street, San Leandro, CA 94577 USA

Phone: (1) 510/351-3500 Fax: (1) 510/351-0500

© 1993 AKG Acoustics, Inc. Orban and OPTIMOD are registered trademarks of AKG Acoustics, Inc. AKG is a registered trademark of Akustische u. Kino-Geräte Ges.m.b.H., Austria

Circle (46) On Reader Service Card

World Radio History

**INSIGHT ON RULES**

# Commission Checklist Plain and Useful

by Harold Hallikainen

**SAN LUIS OBISPO, Calif.** The number of resources available to help a station determine compliance with FCC rules is increasing. Besides the FCC AM and FM Self Inspection Reports, NAB has released a Radio Broadcasters' Inspection Checklist, and the FCC has released a new Broadcast Service Checklist.

The FCC checklist provides a good, plain-English description of what is expected to comply with various rules. It does not cover all rules, and, to a certain extent, is an interpretation of the rules.

**A few discrepancies**

The rules are the law; the checklist is not. The checklist provides a way for a station chief operator to quickly determine compliance with those areas of the rules that are frequently violated. I agree with all the statements made in this checklist, except for a few regarding remote control.

The checklist states: "The master control equipment must have fail-safe circuitry installed that turns off the transmitter if a corrective response to an out-of-tolerance condition is not received within five minutes."

This wording first showed up in the FCC "clarification" of the remote control rules, issued Sept. 12, 1988. However, both the checklist and the clarification seem to impose requirements beyond those contained in the rules. The remote control rules (73.1410) make no requirement for automatic limit checking or automatic shutdown. Such requirements are listed in the ATS rules (73.1500).

However, the ATS rules do not specify which parameters require monitoring and control. Further, the ATS rules require a shutdown in three minutes, as opposed to the five minutes specified in checklist

and the clarification.

I spoke at length with James McNally of the FCC (202-632-9660) on these discrepancies. He agreed that the current remote control rules do not require "fail-safe," limit checking or automatic shutdown. A portion of the ATS rules accidentally got into the remote control clarification. Since there was little inquiry by the public, the FCC never issued a corrected clarification.

**Operatorless stations**

It appears, McNally says, that the FCC is finally going to move on an item that has been on their agenda since 1990, a change in transmitter metering and control regulations.

The current rules require monitors and

**The checklist provides a good, plain-English description of what is expected.**

controls (either direct transmitter control or remote control) to be sufficiently close to the operator so the operator can observe deviations from normal indications from the routine duty position. An exception is made for extension metering immediately observable by the operator, but the controls are "down the hall."

Several stations have been cited (and I've received several phone calls) for having a master-control area where all remote control and monitoring equipment is located, but the operator is in a studio where this equipment is not visible. Should the proposed rule be adopted,

these master-control installations would be acceptable, and the need for extension metering would be eliminated.

However, in the three years this item has been sitting at the FCC, a lot has happened. Congress has since given the FCC the option to waive or modify the Communications Act requirement that broadcast stations have a licensed operator on duty. Late this year, it is expected that the FCC will issue a proceeding to propose allowing broadcast stations to run with no operator at all.

I would expect such rules to require some automation of transmitter monitoring (similar to the existing ATS regulations, but I would hope they would specify which parameters are important enough to require monitoring if the FCC is going to cite stations for insufficient monitoring capability) and the automation of EBS, as discussed in the EBS rulemaking issued earlier this year.

Automatic transmitter parameter monitoring is, of course, done in an effort to prevent interference. It is the one parameter that is most commonly monitored and probably has the least capability of causing interference. Most transmitters cannot operate much above the licensed power. However, it is very easy to over-modulate a transmitter, causing considerable interference to adjacent channels.

I see three important reasons for broad-

cast stations to have operators. Transmitter parameter monitoring and EBS alerting and emergency program transmission can be automated. But the FCC should be able to contact some responsible person to immediately shut down the station if it is causing interference. If there is no operator, who will the FCC contact?

In other respects the FCC's latest checklist appears to agree with the rules. I'd suggest using it to check your station.

**Availability**

The FCC's latest Broadcast Service Checklist (FOB-18) is available from your local FCC field office.

The NAB Radio Broadcasters' Inspection Checklist (L-9304) is available only to NAB Radio members. NAB Publications can be reached at 800-368-5644.

Those stations considering off-premises control may want to get a copy of "Walkaway" from Burk Technology (800-255-8090). This four-page brochure gives the basic FCC requirements for off-premises control.

I'll continue checking checklists next month with a detailed review of the NAB checklist.

□□□

*Harold Hallikainen is president of Hallikainen and Friends, a manufacturer of transmitter control and telemetry systems. He also teaches electronics at Cuesta College, San Luis Obispo, Calif., and is getting better at Contra dancing. He can be reached at 805-541-0200. He can also be reached on internet at ap621@cleveland.freenet.edu..pa.*

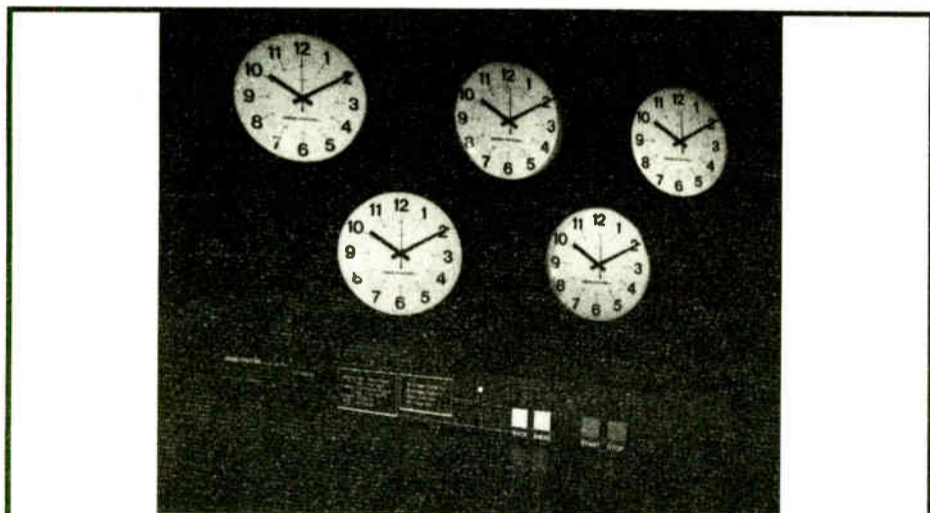

## Impulse Buy.

Up to 50 of our big, bright, economical analog clocks can be connected to the Radio Systems impulse clock driver for super accurate on-second timing throughout your facility.

- Low cost system • One second advance and hold
- Daylight Savings advance • External sync reference capable
- Internal crystal or line sync reference (TCXO time-base optional)
- Battery back up standard • New digital read-out available!

**RADIO SYSTEMS INC.**  
800/523-2133 or FAX 609/467-3044

Circle (9) On Reader Service Card

# THIS CONSOLE...

...LED A REVOLUTION by proving that a low-priced console could offer major market features and superb audio specifications.

...Comes in 6, 12, 18 and 24 channel models for any size studio.

...Is the famous RS-Series console from Radio Systems, Inc.

And is available for the first time from **BROADCASTERS GENERAL STORE.**

Call today for your price on broadcasting's best console value.

from **BROADCASTERS GENERAL STORE**  
(904) 622-7700 • FAX (904) 629-7000

Circle (137) On Reader Service Card

## OFFBEAT RADIO

# Duopolies Change Radio Moneymaking

by Dee McVicker

**AMARILLO, Tex.** What happens when you break the time-honored law of commercial radio that says stations on the same frequency band shall compete?

That's the question on everybody's mind as the spring Arbitron sweeps through Amarillo, Tex., where Westwind Communications implemented one of the first duopoly arrangements.

Ever since Westwind purchased Amarillo stations KPUR-AM-FM, a 5 kW daytime/1 kW nighttime AM and a 3 kW FM, there has been an unprecedented blur of activity and a new way of looking at station operation at KLSF-FM's studios on Rusk Street.

## Striking fast

Prior to the duopoly arrangement, 100 kW KLSF(FM) had been Westwind's only station in the Amarillo market. It ranked well among 25- to 44-year-old females with a Hot AC format.

Then, said Westwind General Manager Keith Adams, "An AM and FM combo went off the air in June (1992). About then the FCC changed the rules. I worked a deal to buy the combos and, as it turned out, I think we were one of the first duopoly deals that was filed and probably approved."

Westwind survived FCC revisions and waited out a long bureaucratic delay to purchase the stations under the new

duopoly rules, which now allows station owners to operate more than one station per service in a market.

"By the time the FCC decision was made that they were going to do some form of duopoly, it was just a matter of how things would shake down. But we knew that Amarillo, with as many signals as it had, would definitely be one of the markets," said Westwind's opera-

**Micro technology solved one problem. Each station fit into a chassis no larger than a dresser drawer.**

tions and program manager, Joe Geoffroy. The Amarillo market of around 160,000 currently has 18 commercial stations, he said.

Once the FCC gave its blessing, the radio business changed virtually overnight. Suddenly, programming requirements tripled along with engineering concerns, and station operation was no longer a simple matter of airing a single program from one studio.

There was now one studio facility and three stations, two of which could easily have been locked in a ratings battle under the old FCC rules, but now share

studio space. Adjustments needed to be made, not only to shoe-horn three radio stations into a one-station facility, but to make two FMs and an AM profitable in an increasingly saturated market.

## Getting a micro fit

Micro technology solved one problem. Westwind fit each station into a chassis no larger than a dresser drawer with per-

sonal computers.

Side-by-side in one studio, KLSF and KPUR-FM each pump out their respective programming from individual computer workstations, while KPUR(AM) programming is managed from another workstation just down the hall. All three computers, plus a production workstation, are tied together over a local-area network (LAN) through the Dalet automation system. The computers share a six-gigabyte hard drive, where liners and commercials are stored.

KLSF, said Geoffroy, "has always been a 25-to-44-year-old-positioned station,

and we didn't see any need to change that." The next decision was whether to pick up a KPUR-FM format to boost male audience or find a format complementary KLSF to increase Westwind's cumulative strength with women, 25 to 44.

"Our strategy on the two FMs was let's just go for a dominant women audience across the two FMs," Geoffroy said. On KPUR(AM), he said, "We think news/talk is growing with the 35-plus folks, but will predominantly be a 45- or 50-year-old-plus format, male or female. So that will strengthen our demographics story on up to 54."

KPUR and KPUR-FM (with an Oldies format) are both satellite driven. "We had to look at what we were prepared to do operationally, and one of our positions on operating a duopoly was maintaining expense," Geoffroy said.

Westwind has not had to hire additional sales personnel to increase advertising. "We're significantly ahead (in advertising billing) than when KLSF was a stand-alone," Geoffroy said.

Westwind has changed in other areas of its operation over the past few months. With digital now the prevailing technology, words such as keyboard, sound byte, and disk—once the exclusive language of musicians and radio personnel—have suddenly taken on new meaning.

Even the word "station" has a different meaning. Today at Westwind it can refer to one of three call signs or one of four PCs at the Rusk Street studios.

□□□

Dee McVicker is a regular contributor to RW and a freelance writer specializing in broadcasting. She can be reached at 602-545-7363.

# Sensational Sound Over Switched 56/ISDN

## Transmit 10 kHz Over a Single Digital Circuit!

CCS, the pioneer of digital audio codecs, proudly presents the CDQ1000, the only codec that lets you transmit up to 10 kHz of audio over a single switched 56 or ISDN line.

## Preserve Your Past Investments in Codecs!

The versatile CDQ1000 is fully compatible with G.722, 7.5 kHz codecs such as the CCS Micro56 and Micro66i. It also interoperates with the CCS CDQ2000 ISO MUSICAM<sup>®</sup> codec. You can now achieve universal compatibility with a single codec!

- Three modes of operation: 7.5, 8.2, or 10 kHz
- CCITT G.722 or enhanced MUSICAM compression
- Two-way mono transmission
- 56 kbps or 64 kbps data rate
- Both V.35 and X.21 digital interfaces

The CDQ1000, Crystal Clear Digital Audio™ at an affordable price.



CCS Audio Products  
33 West Main Street  
Holmdel, NJ 07733, USA  
(908)946-3800 FAX: (908)946-7167



CCS Europe GmbH  
Obere Hauptstraße 52  
D-8050 Freising  
49 8161 12222 FAX: 49 8161 12280



# PRODUCTS & SERVICES SHOWCASE

For more information on the products shown below, circle the appropriate Reader Service No.(s) on the enclosed Subscription/Reader Service card or contact the advertiser directly.

## S.C.M.S., Inc. Charlotte, N.C.

Low Prices – Experienced Staff  
New and Re-built R.F. and Audio

### This Month's Special

New and improved digital 4 track workstation. Double the storage time for the same low price of \$2,799.00 using DOS 6 compression. Call for details on the "STEALTH PRODUCER."

Toll-Free 800-438-6040

FAX 704-889-4540

READER SERVICE NO. 33

## ARE YOUR LIGHTS ON?

The FCC requires that towers be lighted in accordance with the provisions of the station license. The Commission specifies (Section 17.47) that licenses shall make an observation of the tower lights at least once every 24 hours either visually or by observing an automatic and properly maintained indicator. The indicator should register any failure or malfunction of the tower lights.

Obstruction Lamp Alarm Relay  
SCR490D

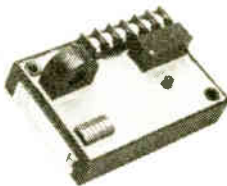

**SSAC inc**  
SOLID STATE TOWER LIGHTING CONTROLS

Senses Failed Obstruction Lights  
2 to 9 Steadily Burning Lamps can be Monitored

\$86.49

Universal Light Alarm Relay  
SCR430T



\$86.49

Senses Flashing Beacon or Obstruction Lights  
Switch Selectable Number, Voltage, and Wa-  
tage of Lamps

Shorted Flasher Alarm Relay  
SFA430T



\$74.89

Senses a Constantly ON Beacon  
Operates with SCR430T to Provide Complete  
Beacon Monitoring

Main Sales Office  
2342 S. Division Avenue  
Grand Rapids Michigan 49507



AUDIO  
BROADCAST  
GROUP

Southeastern Sales Office  
200 Fareway Drive Suite 2  
Smithfield North Carolina 27577

1-800-999-9281

1-800-369-7623

READER SERVICE NO. 177

## Zercom 25Hz Tone Processors

\$390

Zercom Corporation's dual 25Hz detector and dual program amplifier/25Hz notch filter accurately detects tones and removes them from programming.

One unit converts a remote controllable reel-to-reel machine into the equivalent of an Otari ARS-1000DC or Revox PR99 reproduce only machine. The other converts two mono reel-to-reel machines or one stereo machine.

Designed as a reel-to-reel playback interface for automation or live assist, some automation systems are using the 25Hz Tone Processor as a program amplifier. The 25Hz filter is only 6Hz wide at the 3 dB point, allowing good bass response of the audio. This is far better than the usual 50Hz high pass filter that removes ALL bass. Maximum output per channel is +17 dBm or +23 dBm with the active balance output option.

Some users are interfacing cassette machines with the 25Hz Tone Processor. A number of stations are using it as a 25Hz detector and filter on satellite networks, including the Beethoven net.

Call today for more information, including pricing.

**ZERCOM**

Box 84, Merrifield, MN 56465 • 218-765-3151

READER SERVICE NO. 151

## NEW! Composite Audio DA and Switcher!



### APPLICATIONS

- Switching Between Composite STL's
- Main/Alternate Processing Switching
- Feed Up to 3 Transmitters with Identical Audio
- SCA or SAP Generator Switching
- Non-Intrusive Composite Testing/Monitoring

### FEATURES

- 2 Input Switcher
- 3 Isolated Outputs
- Individual Level Control for Each Output
- Front Panel and Remote Control with Full Status
- Power Fail Memory with Bypass Mode
- Inputs Selectable for Balanced or Unbalanced Operation

**bdi** Broadcast Devices, Inc.  
5 Crestview Avenue  
Peekskill, NY 10566

Tel. (914) 737-5032 FAX: (914) 736-6916

READER SERVICE NO. 108



The CELLCAST RBS-400 1.8 offers complete portability and flexibility for remotes. Complete with a 4-channel mixer, frequency extender, cellular transceiver and landline capabilities, 600 ohm line out, and Vu meter. It is powered by 10 Ni-Cad rechargeable batteries, 12v adaptor, and AC power supply. 24 hour protection support standard.

Call Bridget  
Taylor today  
for our  
\$195.00  
2 week trial at



**1-800-852-1333**

READER SERVICE NO. 54

## DIGITAL ANTENNA MONITORS

In-Stock-Available for  
Immediate Delivery



Price US\$2400.00 2 Towers  
Will operate with any remote control equipment.



Price US\$1780.00 2 Towers  
For AM directionals with studio located at transmitter site.

These monitors are state-of-the-art instruments of unequalled accuracy (.5% or better on ratio and .5° or better on phase) and stability. With typical modulation the true ratio readout of these monitors is a factor of 10 more stable than instruments that measure normalized amplitude, and their phase readouts are rock solid. Phase sign is automatic, no extra operation. In addition to the analog DC outputs for remote control the Model CMR has a multiplexed BCD digital output which can be used to drive the Remote Indicator Model CMR-1. RF inputs have dual protection. Gas discharge tubes across the sample line terminations plus relay protection.

**GORMAN REDLICH MFG. CO.**

257 W. Union St. Athens, Ohio 45701  
Phone 614-593-3150 • FAX 614-592-3898

READER SERVICE NO. 31

DON'T  
GAMBLE  
WITH  
LIGHTNING!



TEN YEARS EXPERIENCE  
PROVIDING AFFORDABLE TOWER  
LIGHTNING PROTECTION TO  
THE BROADCAST INDUSTRY.

**Conan**  
Corporation

Write to us today for a FREE brochure!  
P.O. Box 2548, Farmington, N.M. 87499  
Call (505) 325-5336 FAX (505) 326-2337

READER SERVICE NO. 68

## DIELECTRIC COAXIAL LOADS



- Dry Loads 5-150 Watt
- Oil Filled 600-10,000 Watt
- Water Cooled 25-100 kW
- Heat Exchangers
- New for '93...High Power Calorimeter

CALL FOR OUR NEW CATALOG!

Dielectric Communications  
P.O. Box 949  
Raymond, Maine 04071

207-655-4555  
FAX 207-655-7120

READER SERVICE NO. 157

## SOUND YOUR BEST ON THE AIR!

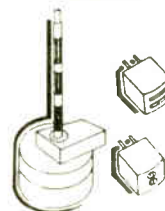

### CART MACHINE SERVICES:

**CART MOTORS REBUILT** to quiet flutter-free  
perfection-shafts resurfaced  
Single \$120.00 Triple \$140.00

**CART HEADS RELAPPED** guaranteed to  
perform like new

Same day turnaround

Replacement heads and motors available

### REEL TO REEL SERVICES:

**HEADS RELAPPED** and precise digital/optical

**ASSEMBLY ALIGNMENTS**

performed for maximum  
response & head life

**CAPISTAN & REEL MOTORS REBUILT**  
for MCI, OTARI and more.

For peak performance from your recording equipment, call  
The Audio Magnetic Professionals.

**AMP**  
SERVICES

224 Datura Street, Suite 614, West Palm Beach, FL 33401  
Call 1-800-826-0601 for "Same Day Service" in Florida (407) 659-4805  
Authorized Parts Dealers for: MCI • OTARI • TEAC/TASCAM

READER SERVICE NO. 23

## Q-TIPS

# Modulation War; Digital Escalation

by John "O" Shepler

**ROCKFORD, III.** My baptism into the mysterious world of audio processing involved a CBS Audimax/Volumax combination in the mid-70s. Sure, I'd seen Gates and RCA limiters sitting quietly in their racks before. They were there as protection against overmodulation fines. Nothing more or less.

These CBS boxes were different somehow. The manual actually explained how to go inside the Audimax to change a timing resistor. How curious this was.

Change a resistor and you can change your sound.

Not long after, I got my education in what the major-market engineers had been tinkering with for some time. They'd discovered, a little at a time, that one station could be made to sound dramatically better than another. The improvements were made with equalizers to boost the high frequencies lost in most AM receivers and by speeding up the dynamics of the processors to add power to the sound.

My own early experiments were

performed on a pair of Marti CA-40 wideband compressor/limiters and, later on, on one of the most innovative boxes of the time, the Dorrough 310 Discriminate Audio processor (DAP). It really didn't take too much. Simply reduce the size of the timing capacitor that sets the attack/recovery of the compression and all of a sudden the sound gets louder and denser.

## Early analog processing

I imagine that during those early days of the processing wars, hundreds of engineers around the country were removing tantalum and electrolytic timing caps and soldering in smaller ones. Surely there must have been a run on one to 100uf capacitors during that period.

The timing capacitor trick began to lose its impact as processors became more sophisticated and expensive. The timing controls were made with front-panel adjustments so that programmers could tweak to their heart's content. Actually, that was a blessing. It gets psychologically harder to put those side cutters into a \$10,000 box.

I'm sure there's still a lot of secret tinkering going on in the back rooms of well-healed stations searching for a way to rise above the pack, as well as at smaller stations with ambitious engineers and enough money to afford some extra resistors and caps.

For many people though, pushing the audio envelope has become a fading interest. The best analog processing systems offer such a large combination of adjustments that most are quite happy to settle for some variation of the factory suggestions.

Sure, you still have the option of mixing and matching boxes in hopes of stumbling on a fortunate combination that blows the doors off the competition. Then the other station will buy the same boxes and you're back to an even playing field. It's getting harder to sound louder or even better no matter

continued on page 35 ►

## Better Gear Should Mean More Choices

► continued from page 21

media, priced higher than some pre-recorded CDs. I just don't see it taking off on the consumer level.

Face it. Manufacturers are hoping to push consumers to buy as many prerecorded music carriers as possible. But by inundating the marketplace with scores of options that offer only vaguely distinct applications—and at the expense of the consummate sound quality of CD—I remain unconvinced that any of the new carriers are worth the hype.

So what does this mean for radio?

First, radio's success is in part dependent on the practices of the record buying public. The symbiotic relationship between initiating airplay of an artist and subsequently pushing his or her recordings is age old. Not offering that product on as many mediums as the public accesses cheats the efforts of radio to establish the stars of tomorrow.

As well, the popularization of music carriers has great impact on the radio studio of tomorrow. Around the world, the use of CD jukeboxes is growing rapidly. Will radio stations invest heavily in the technology, only to find that in five years, manufacturers have lost interest in lieu of a more lucrative carrier? As DAT continues to gain ground as a storage device for pro applications, will manufacturers abandon its further development for a more expensive, allegedly more advanced product?

Let technology excel, but not at the expense of choices that have not yet run their natural course. The forced abandonment of able technology is far from progress.



## Your Future Is Bright With Harris Allied.

A star is born. Meet Steve Keating, Harris Allied's Southern California regional sales manager. Steve is no stranger to the audio industry. He has been in broadcasting since 1966, has had extensive experience not only in professional audio and broadcast RF products, but also as an end user.

Steve will serve the area's professional audio and broadcast market from our newest facility located with the Broadcast Media Center, a full service agency for the electronic media community, in the CNN Building at 6430 Sunset Blvd., Suite 1150, Hollywood, CA 90028.

The Hollywood office, access-

ible by a toll-free telephone number and a fax, is on direct computer link with Harris Allied's product distribution center. This link provides up-to-the-moment placement and tracking of orders—most of which are shipped within 24 hours.

Visit our new Hollywood location where you'll find a product demonstration studio equipped with the latest digital storage and editing equipment and a variety of new professional broadcast and professional audio products. Call Steve to arrange your personal tour.

1-800-690-2828  
213-462-6622  
FAX 213-462-8468



**HARRIS ALLIED**

## SUBSCRIPTION/READER SERVICE FORM

**Radio World**

### FREE Subscription/Renewal Card

I would like to receive or continue receiving **Radio World**

FREE each month.  Yes  No

Signature \_\_\_\_\_ Date \_\_\_\_\_

Please print and include all information:

Name \_\_\_\_\_ Title \_\_\_\_\_

Company/Station \_\_\_\_\_

Address \_\_\_\_\_

City \_\_\_\_\_ State \_\_\_\_\_ ZIP \_\_\_\_\_

Business Telephone ( ) \_\_\_\_\_

Please circle only one entry for each category:

#### I. Type of Firm

- D. Combination AM/FM station F. Recording Studio  
A. Commercial AM station G. TV station/teleprod facility  
B. Commercial FM station H. Consultant/ind engineer  
C. Educational FM station I. Mfg, distributor or dealer  
E. Network/group owner J. Other \_\_\_\_\_

#### II. Job Function

- A. Ownership G. Sales manager  
B. General management E. News operations  
C. Engineering F. Other (specify) \_\_\_\_\_  
D. Programming/production \_\_\_\_\_

### Reader Service

June 9, 1993 Issue Use Until September 9, 1993

Please first fill out contact information at left. Then check each advertisement for corresponding number and circle below.

#### Purchasing Authority

1. Recommend 2. Specify 3. Approve

001 023 045 067 089 111 133 155 177 199

002 024 046 068 090 112 134 156 178 200

003 025 047 069 091 113 135 157 179 201

004 026 048 070 092 114 136 158 180 202

005 027 049 071 093 115 137 159 181 203

006 028 050 072 094 116 138 160 182 204

007 029 051 073 095 117 139 161 183 205

008 030 052 074 096 118 140 162 184 206

009 031 053 075 097 119 141 163 185 207

010 032 054 076 098 120 142 164 186 208

011 033 055 077 099 121 143 165 187 209

012 034 056 078 100 122 144 166 188 210

013 035 057 079 101 123 145 167 189 211

014 036 058 080 102 124 146 168 190 212

015 037 059 081 103 125 147 169 191 213

016 038 060 082 104 126 148 170 192 214

017 039 061 083 105 127 149 171 193 215

018 040 062 084 106 128 150 172 194 216

019 041 063 085 107 129 151 173 195 217

020 042 064 086 108 130 152 174 196 218

021 043 065 087 109 131 153 175 197 219

022 044 066 088 110 132 154 176 198 220

Copy & Mail to: Radio World, PO Box 1214, Falls Church, VA 22041, or FAX to: 703-998-2966

# PRODUCTS & SERVICES SHOWCASE

For more information on the products shown below, circle the appropriate Reader Service No.(s) on the enclosed Subscription/Reader Service card or contact the advertiser directly.

## WIRELESS IFB SYSTEM

Used by hundreds of TV stations for van-to-field cueing in ENG & SNG applications. Transmitter provides mix of program and instructions to rugged, pocket receivers.

- 100% duty cycle
- Wideband audio
- Excellent operating range



**COMREX®**

Comrex Corp., 65 Nonset Path, Acton MA 01720  
Tel: 1-800-237-1776 Fax: 508 635-0401

READER SERVICE NO. 16

## ALAN DICK & CO. (USA) INC. LDL COMMUNICATIONS INC.

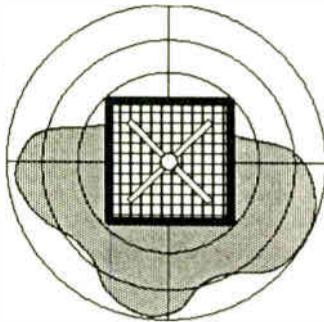

For your full turn-key or individual components needs... ADC/LDL supplies a full range of product and services for the FM broadcaster. RF transmission products include low power, side-mount antennas as well as high power, broadband, multi-channel antennas and combiners.

**LDL COMMUNICATIONS INC.**

14440 CHERRY LANE CT. #201  
LAUREL, MD 20707

301-498-2200 FAX: 301-498-7952

**ADC (USA) INC.**

9 CLINTON DRIVE, HOLLIS, NH 03049

603-598-4500 FAX: 603-598-4212

READER SERVICE NO. 8



## Econco REBUILT POWER TUBES



Approximately One Half  
the Cost of New

3,000 Hour Unconditional Guarantee  
Call for Our Price List

Econco 1318 Commerce Ave. Woodland, CA 95695  
Phone: 916-662-7553 Fax: 916-666-7760 Telex: 176756  
Toll Free: 800-532-6626 From Canada: 800-848-8841

READER SERVICE NO. 50

## Shape Up!

**Coverage.** Saturation. DBK contours. In FM broadcasting, the "bottom line" is always based on your pattern.

More than any other manufacturer, Shively has the experience and reputation for providing crucial pattern solutions for critical propagation problems. On any tower. At any power level. Remember, *it pays to be heard.*

A good pattern. The shape you need. Talk to your consultant. And contact us.

## Shively Labs

A Division of Howell Laboratories, Inc.

19 Harrison Road, Bridgton, ME 04009  
207-647-3327 FAX 207-647-8273

READER SERVICE NO. 98

## Simple-CD \$4,995.00!



**New CD based storage & hard disk automation system**  
New Simple-CD is a powerful digital hard disk system for basic CD music formats. Full live assist, sweep, overnight, weekend or full walk-away CD automation at an economy price.

- Interface for up to 32 Pioneer™ PD-M501 or PD-TM/2 CD playbacks in any combination.
- Simple-CD sounds great! CD-CD and CD to digital overlap, tight production and real time control included.
- Superb stereo digital sound from the premium apt-X™ digital audio card which is included.
- Computers are cheap! You supply 386 SX-25 or better computer, color monitor and the hard disk and we supply the intelligent Simple-CD software and audio cards.
- Cards & software install in your computer with no hassle. Just plug into your mixer or console.
- Interfaces available to CD-Music Log, EZ Log, Simple Log and Super Log and other Traffic and Billing and Music selector systems.
- Simple-CD is more powerful and provides better sound than UDS™, Pristine™ and Smartcaster™

**The Management**

1-800-334-7823 1-817-625-9761 FAX: 817-624-9741  
P.O. Box 1-36457 Ft. Worth, TX. 76136  
1600+ Stations - Our 13th year

READER SERVICE NO. 120

## RECORDABLE CDs

Convert from your old unreliable cart machines to Compact Discs

- INSTANT CUEING  
of station ID's and spots
- CONSERVE SPACE  
consolidate selected cuts
- ULTIMATE FIDELITY

AS LOW AS \$59.00 PER DISK!

Our system offers a unique partial recording capability. This means that a partially recorded CD can be removed and played on any standard CD player. As new program material becomes available it can be recorded on the same disk. Save money on discs while getting the flexibility and quality you need.

Third Story Recording  
5120 Walnut Street  
Philadelphia, PA 19139

1-800-497-DISK (3475)

READER SERVICE NO. 186

## NOW! A QUALITY AGILE BROADCAST SCPC AUDIO RECEIVER

AT AN AFFORDABLE PRICE!



## UNIVERSAL SCPC 300-C COMMERCIAL AUDIO RECEIVER

### SPECIFICATIONS

Frequency agile, C and Ku Band, stable microprocessor-controlled tuning, variable band widths, 3:1 and 2:1 companding built in. Transponder tuning, LNB supply, polarity control, tunes all SCPC frequencies 50 to 90 MHz, readout on LCD display, 50-channel memory, line output, de-emphasis select, muting system, phase lock loop for stability, LNB calibration set up, 2 frequency synthesizers, digital AFC and more.

**INTRODUCTORY PRICE: \$1345.00 plus S & H.**

**UNIVERSAL ELECTRONICS, INC.**

4555 GROVES RD., SUITE 13, COLUMBUS, OH 43232  
(614) 866-4605 FAX (614) 866-1201

READER SERVICE NO. 96

## The Best Audio Test Meter Made!

### Advantage Model 310

Precision Audio Signal And Noise Level Meter

Professional  
Price!

**\$399**



- Low THD/Hi RF Reject With Valley Audio's Trans-Amp™
- Lo-Noise Wideband Circuitry
- Large Dual Scale Meter
- Super-Accurate Filters
- Average, RMS Or Peak Det
- -100 dB to +30 dB Range
- Scope and Preamp Monitoring Outputs

Call For The  
Nearest Dealer:  
**1-800-800-4345**



Valley People  
Merriam, Kansas

READER SERVICE NO. 75

## Improve Your Voice!

Clear the cobwebs out of  
your mic signal path with the  
new Benchmark MP-3 Mic Preamp

- 1 dB noise figure
- THD = 0.005% (2 kHz at A=40 dB)
- Variable gain +26 to +65 dB
- Balanced output
- +48 V Phantom power input
- Jack mount anywhere!

**\$95**



Contact your pro audio dealer or call  
**BENCHMARK MEDIA SYSTEMS, INC.**  
800/262-4675 315/437-6300 FAX 315/437-8119

READER SERVICE NO. 45

# WORKBENCH

## Pens, Programs and Other Hidden NAB Gems

by John Bisset

**FALLS CHURCH, Va.** Part of the fun of an NAB Show is discovering the nuggets hidden away in the ten-by-ten booths. Of all the goodies I found at the 1993 show, my favorite was the TAB Safety Pen.

The pen and an accompanying video on TV, AM, and FM safety, are the Texas

Association of Broadcasters' way of putting safety first. TAB lost a general manager to electric shock last year. He put his hands inside what he thought was a dead rig while he was working on a transmitter.

This little pen will sense any voltage by glowing red. You don't need to break a circuit, pierce insulation or have current flowing to get an indication. Just hold it

close to the wire you want to test, and if the circuit is live, the tip will glow red.

The flat screwdriver-shaped tip will fit into three prong electrical outlets to indicate which prong is hot. You can also move the tip along a wire to spot a cable break. The tip will glow up to the point of the break.

This device is a must for every station engineer, since it will also detect the presence of RF. It costs less than \$25 and is a literal lifesaver. TAB picked up several group station endorsements, including CBS, Group W and Capital Cities. For more information on the TAB Safety Pen, circle **Reader Service Number 121**.

\*\*\*

Radio Design Labs, for several years the marketer of matchbox-sized related products, displayed its new Rack-Up Series. For a couple hundred dollars each, distribution and headphone amplifiers, a mini-mic/line mixer or remote VU metering panels can be purchased, then slipped into the unique rack mounting kit. Radio Design Labs has combined the "matchbox" concept with an EIA-standard rack mount, a space-saving, inexpensive problem solver. For more information, circle **Reader Service Number 74**.

\*\*\*

For years, Rules Service Company (RSC) has provided compilations of the FCC rules and regulations. Updates are issued every other month, and a year-long subscription to all broadcast parts is just \$205. There are two advantages to RSC's product. It's compact; the binder will fit nicely with all the software books you keep on your shelf.

\*\*\*

Radio Systems displayed a series of slave and master analog and digital clocks and timers, along with their consoles, cart machines, and RS-DAT machines. The timers and clocks come in a variety of sizes, for either wall, rack or console mounting. In keeping with their tradition of unique show treats, Radio Systems passed out Kit Kat candy bars in

continued on page 37 ►

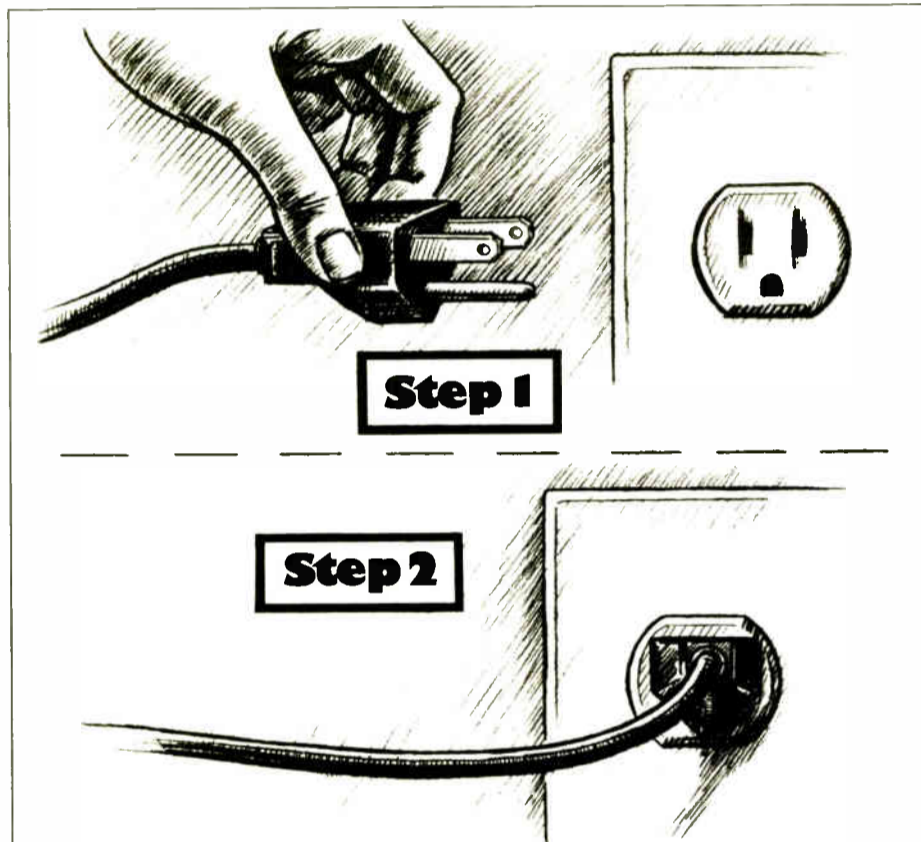

## How To Install Your Gates AM Transmitter.

Easy now, we know we're exaggerating. Barely. Because installing our Gates AM transmitter actually requires little more than connecting the antenna, AC power, and audio feed, and pressing the start button.

This field-proven, 100% solid state, low-maintenance transmitter delivers a strong, clean, reliable signal, thanks to our patented PPDm technology. The transmitter is available in mono or stereo, and in power

levels of 1, 2.5, and 5 kW.

The Gates AM transmitter's high performance shouldn't be a surprise. After all, it's a Harris, the leader in AM technology. We've been involved in AM longer than our domestic competition combined. Which makes Harris the easy solution for your next AM transmitter.

**217-222-8200**  
**Fax 217-224-1439**  
**Canada 800-268-6817**  
**Toronto 416-731-3697**

**HARRIS ALLIED**

©1993 Harris Corp.



**DO YOU KNOW YOUR MARKET? YOUR COMPETITION DOES!**

**DATAWORLD MAPS CAN**

Depict your coverage!  
 Market orient your sales people!  
 Target your ethnic/demographic markets!  
 Identify marginal signal areas!  
 Plot any special requirements!

**MAP OPTIONS**

- SHADOWING (TERRAIN SHIELDING)
- CONTOUR COVERAGE
- POPULATION DENSITY
- ZIP CODE BOUNDARIES
- RECEIVED SIGNAL LEVEL
- SPECIAL REQUIREMENTS

**dataworld**  
 A Service of DW, Inc.

(301) 652-8822

(800) 368-5754

"Doing things for successful FM translators"



**FM TECHNOLOGY ASSOCIATES, INC.**

Talk with Howard Enstrom, veteran broadcast consultant who, in the 70s switched to FM translators as a specialty.



**FMTA services: Feasibility studies, frequency searches, system design-engineering, FCC applications. Publisher of The SIGNAL SOURCE, bi-monthly newsletter all about FM translators. BEST EQUIPMENT PRICES.**

**FM TECHNOLOGY ASSOCIATES, INC.**

30925 Vista Vista  
 Mount Dora, FL 32757  
 (904) 383-3682 FAX (904) 383-4077

"Call me, I'm interested." Circle (72)

"Send me literature." Circle (118)

Circle (15) On Reader Service Card

Circle (145) On Reader Service Card



## FEED LINE

# Be Ready, AM Stereo Has Returned

by W.C. Alexander

**DALLAS** Things are looking up for AM stereo growth in the coming year or two.

The Japanese have selected Motorola's C-QUAM system as their national standard, which should increase the number of C-QUAM-capable receivers on the market. Now, the FCC is also on the verge of adopting C-QUAM as the U.S. AM stereo standard and at the same time just about insisting that all expanded-band stations broadcast in stereo. (Remember the Model I plan from MM 87-267 a few years back?)

With all of this just ahead, let's take another look at AM stereo—what it is, how it evolved, how to implement it and how much it costs.

## A history lesson

AM stereo grew slowly in this country beginning in about 1981, when the FCC made its "marketplace decision" (or, rather, decided not to decide). Five original proponent systems (Belar, Harris, Kahn, Magnavox and Motorola) were pared down to just two (Kahn and Motorola) shortly thereafter. Both systems had merits, technical and otherwise, but for several reasons (which I won't go into here), stations using the Motorola system grew; those using the Kahn system didn't.

At Motorola's last count, about 700 stations in the U.S. are transmitting in C-QUAM stereo. That's about 14 percent of all AM stations, not a bad figure, but considering it took 12 years to grow to that point, it's nothing to be too proud of as an industry.

Receivers have appeared and disappeared on the aftermarket, and have appeared and more-or-less stayed on the original equipment market. GM, Chrysler, Nissan and others offer C-QUAM receivers in their new car sound

system packages. Some of these are excellent, some are mediocre. Among others, Sony, Kraco and even Radio Shack have offered aftermarket AM stereo receivers, some of them multi-mode. Today, Motorola says, there are between 22 and 27 million C-QUAM capable receivers in the U.S.

## What does it take?

All parts of an AM station, from the production room to the transmitter, are affected by the decision to broadcast in stereo. How well the station will sound—both in stereo and in mono—depends on how much care is taken in the conversion.

Right up front, I'll tell you that making an AM station sound good in stereo is a lot more difficult than doing the same for an FM. True AM stereo involves more than simply purchasing an exciter and monitor.

First, all the audio sources must be changed to stereo. This means cart machines, cassette decks and reel tape machines. The mixing console must be stereo, as well as all distribution amps and audio processors downstream. This is true of both the control and production studios.

I have seen AM stations transmitting in stereo where the music was the only stereo source. Everything else was mono. The on-air sound was great, until a commercial came on. If I were an advertiser and heard that station in stereo, I would feel as if I were being cheated.

Operator training is one area often overlooked. I have walked into production studios in stereo stations (even FM stations) and seen the pan controls centered on left or right discrete inputs. That kills stereo separation.

On the creative side, there is a lot that can be done with two channels of audio to make a production more exciting and

pleasant. Production people often don't know how to do this or won't go to the trouble to learn. On the other extreme, they must be careful to avoid inappropriate "ping-pong" effects, where material is placed in one channel to the complete exclusion of the other. This is irritating to listen to in FM stereo, but on AM, it reduces the mono loudness by half.

Proper phasing of the channels is critical to AM stereo performance. This includes both gross (wiring) and fine (adjustment) phase. When wiring a studio for stereo, be sure that none of the channels are "flipped" or reversed in polarity. This will result in just about complete loss of audio in mono. Head azimuth, particularly in cart equipment, must be carefully maintained and regularly checked for phase alignment. A 90-degree phase error can result in a 3 dB loss at 10 kHz. In addition to sounding muddy, poor phase performance will result in increased L+R to L-R and L-R to L+R crosstalk. This destroys separation.

Channel level matching (left to right) also has an effect on crosstalk.

## A different process

The audio processing required for AM stereo operation is different from that required for FM, because of the nature of the C-QUAM modulation scheme. It uses a combination of amplitude modulation

(L+R) and phase modulation (L-R). These two modulation paths are independent of one another and processing is more effective if it is done in matrix form as well. This is easily achieved by matrixing the left and right into L+R and L-R before processing and then processing them as such.

This processing usually includes some form of single-channel limiting to prevent single-channel operation (left or right only) from robbing the mono signal of half its loudness. In addition to this, the unique requirements of the C-QUAM decoder make it necessary that the left and right channels be limited to -75 percent, where -100 percent represents full envelope modulation caused by a single channel input.

I have done some experiments myself with this and found that different radios react differently to heavy (> -75 percent) left or right channel modulation. My Sony radio seems to hold up pretty well, but the Realistic receiver sounded like @!#%.

If a typical FM processor is used to drive a C-QUAM exciter, you will be very unhappy with the results.

In the next couple of columns, we will cover methods for getting the stereo audio to the transmitter, transmitter modification for stereo, incidental phase modulation (IPM), exciter installation, equalization and group delay, monitoring and maintenance. Stay tuned.

□□□

*Cris Alexander is director of engineering for Crawford Broadcasting. He can be reached at Box 561307, Dallas 75356.*

## NEWTech '93

A MAJOR NEW COMMUNICATIONS INDUSTRY SHOW



Miami Beach, Florida September 28 - October 1, 1993  
Miami Beach Convention Center

Produced in conjunction with the RTNDA and SBE annual conventions

The first jointly produced exhibition of The Radio-Television News Directors Association and The Society of Broadcast Engineers

For information on Exposition space call: Eddie Barker, EBA Inc., 800-225-8183

For Convention information call: SBE, 317-253-0122 or RTNDA, 202-467-5200

Circle (214) On Reader Service Card

## ENGINEERS AROUND THE WORLD USE THE ...AT-51 AUDIO TEST SYSTEM... BECAUSE IT IS VERSATILE, RELIABLE, AND RUGGED...

### FOR MEASURING

- Harmonic Distortion
- Volts
- dB
- Wow and Flutter
- Stereo Phasing
- Signal +Noise/Noise Ratio
- Intermodulation Distortion
- Differential Gain in Stereo Channels



Model AT-51  
Audio Test System

Contact Us now for Complete Details and Descriptive Literature.

POTOMAC INSTRUMENTS

932 PHILADELPHIA AVE., SILVER SPRING, MD 20910  
(301)589-2662 FAX: (301)589-2665

Circle (180) On Reader Service Card

**BOTTOMLINE BROADCASTER**

# Simple, Time-Saving Printer Alarms

by Edwin Bukont

**GREENBELT, Md.** Printers have become common equipment throughout broadcast facilities. Often one person, who may have other duties, tends a multitude of printers. That person usually can't devote his/her full attention to the printers.

There is a simple alarm device to alert the printer attendant when something is received or if the printer has failed for some reason. The device may be customized to drive extension buzzers, warning lamps or even an auto-dialer to access someone's pager. All components are readily available at Radio Shack or possibly in your own workshop.

**Putting it together**

The device consists of three sections (Figure 1): a logic buffer to convert and isolate printer signals to a common alarm trigger; an alarm unit with timer and output devices, and controls and indicators. The logic interface connects to the alarm unit through Q2, a general purpose optocoupler.

In 'ready' mode, when the printer is functioning properly, a PNP transistor (Q1) keeps the opto turned on. If the interface becomes disconnected from the printer, if the printer fails or the printer's buzzer is activated, the opto turns off and this activates the NAND gate latch composed of IC-1a,b,c and the reset switch. The output of the latch drives the desired alarm indicator.

The logic interface uses two signals. A sample of the buzzer voltage and Pin 32, the "fault/off-line" tally of the Centronics connector. This line is normally high but

goes low if there is a system fault such as bad data, loss of paper or being off-line. This signal directly drives one input of NAND gate IC-2.

The buzzer is used because it commonly

printer's buzzer. This voltage is buffered by R9 and Q4 to drive the second input of NAND gate IC-2.

Both NAND inputs are high when the logic interfaces are at rest. Thus the

+5 Vdc is tapped at C37, a bypass cap on the motherboard. Return is to the motherboard ground.

When the opto is on, it keeps the output of inverter IC-1a high. This keeps the latch output low and relaxes the alarm relay (K1). When the opto turns off, IC-1a goes low and sets the latch which energizes the relay.

The latch is reset by pulsing low an input of IC-1c. However, the latch will not reset

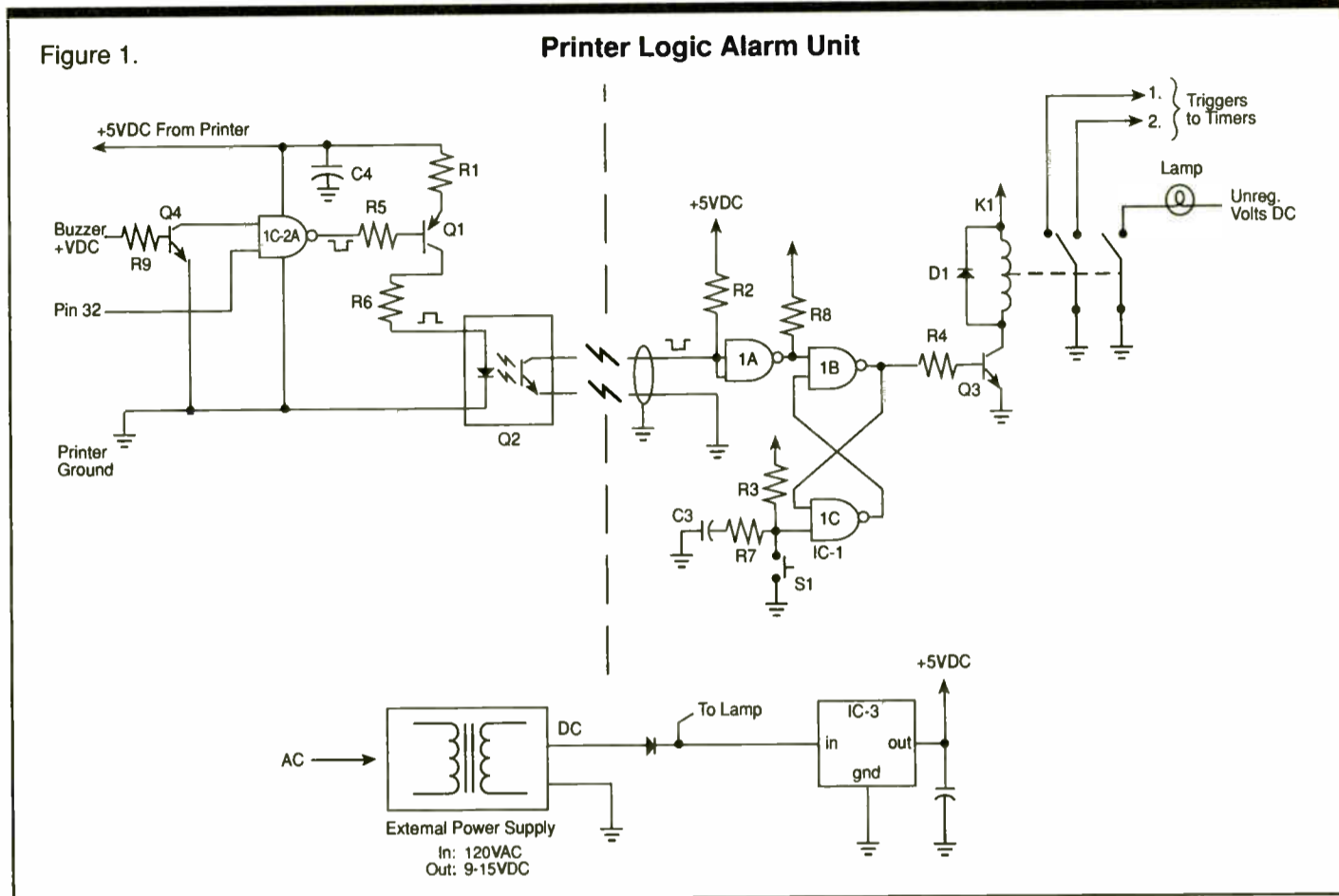

beeps to indicate failures or the beginning of printing. For the Epson FX-185 printer, I tapped the long lead of R77 which provides a switched (+) voltage to drive the

NAND gate output is normally low, which sinks Q1 and causes it to supply voltage to the opto. When either NAND input goes low, the output goes high and turns off the opto.

Because the buffer receives its supply voltage from the printer, a power failure also will turn the opto off. Power is tapped from within the Epson as follows:

if IC-1a remains low. Thus, the operator cannot reset the alarm without correcting the printer fault.

**Timer choices**

There are two timer schematics shown: a recycling timer that provides a delay, then operates an alarm, resets and

continued on page 36 ▶

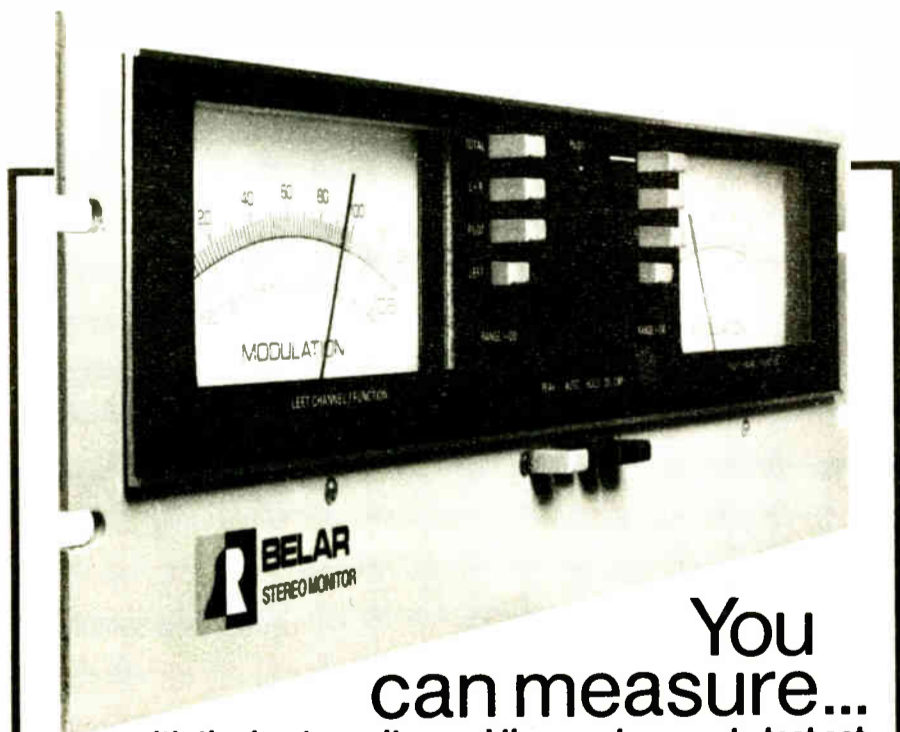

You can measure...

with the best monitor and the most accurate test set.

The FMM-2/FMS-2 series monitors provide an even greater degree of precision measurement than ever before... You can measure S/N below 90 dB, You can measure crosstalk below 85 dB, You can measure separations of better than 70 dB, You can measure frequency response to better than 0.25 dB, You can measure distortions to lower than 0.01%, and much more... Our uncluttered panels and autoranging voltmeters make these measurements a dream.

**BELAR** (215)687-5550  
**ELECTRONICS LABORATORY, INC.**  
 LANCASTER AVENUE AT DORSET, DEVON, PENNSYLVANIA 19333  
 Call or write for more information on Belar AM, FM, Stereo, SCA and TV monitors.

Circle (37) On Reader Service Card

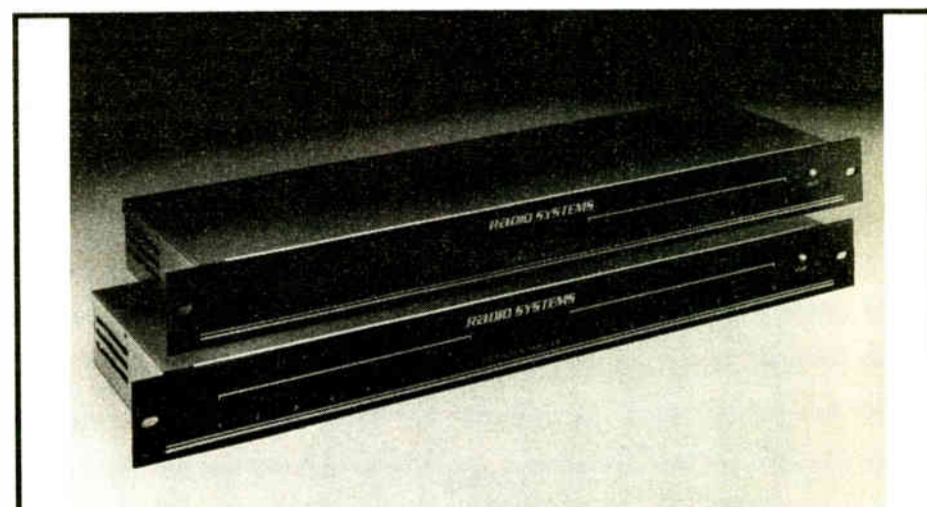

## What can you say about a DA?

Radio Systems distribution amplifiers are really no big deal.

Sure, the specifications are excellent and they are easy to install, thanks to rear panel barrier strips.

And, they are flexible with independent front panel level adjusts for each channel, balanced bridging inputs, and low impedance outputs.

OK, 1,800 are in service, most for over five years, so they are reliable.

Not to mention that they're inexpensive, and available in eight channel, stereo or mono models.

Come to think of it, there is a lot to say for a Radio Systems DA.

**RADIO SYSTEMS INC.**

800/523-2133 or FAX 609/467-3044

Circle (123) On Reader Service Card

# Digital Modulation War

► continued from page 30  
how much you spend.

So where's it all going? Digital, I think.

Digital signal processing for broadcast audio is really in its infancy because it still has one foot in the analog world. Digital processors you can buy today offer digitized versions of the best analog techniques: precision and repeatability, features that are easier to obtain once you get away from the tolerance limitations of analog components. They also offer some whizbang features such as clocks to change parameters for every-day part, liquid crystal metering and programming by floppy disk.

The most obvious linkage is to analog control board, tape equipment, and even CDs. They may be digitally recorded, but they come right back to the analog. When the source material stays completely digital from recording studio to home receiver, one constraint on digital audio processing will be broken.

A less obvious constraint is one that is self-imposed. The heritage of digital processors is the evolution of processing itself, from the tube-type RCA limiters, through improvements of the CBS boxes, and contenders such as UREI, Harris, two generations of Dorrrough DAPs, the Optimods, Gregg Labs, Inovonics, CRL, Aphex, MSI composite processing and countless others.

## Remotes for Satellite Stations too

► continued from page 18

Weather works the same way. We have in-house weather services we subscribe to. We then feed the local affiliates with the updated weather every hour.

**RW:** How about billing and accounts receivable?

**Moore:** Insertion orders are faxed from each affiliate daily. Our traffic managers schedule the orders. The commercials are produced here and fed down the line for storage and local playback. Billing is generated and can be mailed directly from here or sent to the affiliate for mailing locally if they want a local postmark. All money goes directly to the affiliate.

**RW:** So you are not only localizing each affiliate, but you are really pretty much reducing the responsibility of that affiliate to successfully selling the on air product.

That's about it, yes.

If you would like to know more about Radio One, contact Paul Moore directly at 303-949-4485. See you next time.

□ □ □

Karl Baehr is president of KBE "Broadcasting By Design" a radio consultancy that provides support services for satellite radio stations and produces the Actual Radio Measurement (ARM) electronic survey system. He can be reached at 505-828-0488; fax: 505-821-4226.

Jumping the chasm from analog to digital does little more than create really good versions of the best analog algorithms.

What's wrong with that? Only that analog technology was beginning to reach the point of diminishing returns anyway. The real limits to the growth of analog processing sophistication are the cost of the components and the increasing stack-up of error and noise as you cascade dozens or hundreds of op-amps and their passive components.

Digital is inherently free of these bonds. The critical part is in the conversion from A to D and back from D to A. In between, you are free to build nearly

infinite complexity, limited only by the cost of the processing horsepower and the leading edge of audio research.

### Digital directions

Digital will start to come into its own when the processing topologies look nothing like an Optimod or anything else yet seen. You won't be able to solder in a different timing capacitor. Maybe today you can find the equivalent of that timing cap buried deep within the DSP code. Perhaps a sharp engineer with a PC and a prom burner can even do the equivalent of soldering—enter a new cap with a few bytes of patched object code.

Eventually we could be seeing mathematical transforms that don't even relate to concepts like gain riding, compression, expansion, or even clipping.

Who's to say what psychoacoustic impact may be possible?

Does this mean the long-predicted end of the processing wars is finally at hand? On the contrary, the battleground is simply shifting from analog to digital, from hardware to software, from resistors and capacitors to mathematics.

Better keep an eye on your competition. That stranger with the beard and thick glasses could be a high priced digital audio consultant. He may even be carrying around the processing that will take them to number-one on a floppy disk in his front shirt pocket.

□ □ □

John Shepler is an engineering manager, writer, and longtime RW columnist. He can be reached at 5653 Weymouth Drive, Rockford, IL 61114 or on Prodigy Email as GJMS86A.

**the unity 2000i**  
the world's best sounding fm processor

**CUTTINGEDGE**

2101 SUPERIOR AVENUE, CLEVELAND, OHIO 44114 • TEL: (216) 241-3343 • FAX: (216) 241-4103

# Time Saving Printer Alarm Details

▶ continued from page 34

begins timing again; and a one-shot with delay that could operate an auto-dialer or other device if the printer is not reset in time.

The recycling Timer 1 (Figure 2) is muted by the alarm relay (K1) N.C. contact keeping Pin 6 low of IC-4 (a 556 dual timer). When K1 energizes, ground is removed from Pin 6 and the first timer begins charging. After the delay, the second timer pulses the output at Pin 9 for a short period. As drawn, there is a one-minute delay, the alarm sounds for five seconds and then recycles.

The one-shot Timer 2 (Figure 3) may be triggered directly by Q3 or by a contact of relay K1 to ground. Note that this is the opposite of how we triggered the recycling timer. The trigger is applied as shown to start the first half of a 556 dual timer, which provides a delay.

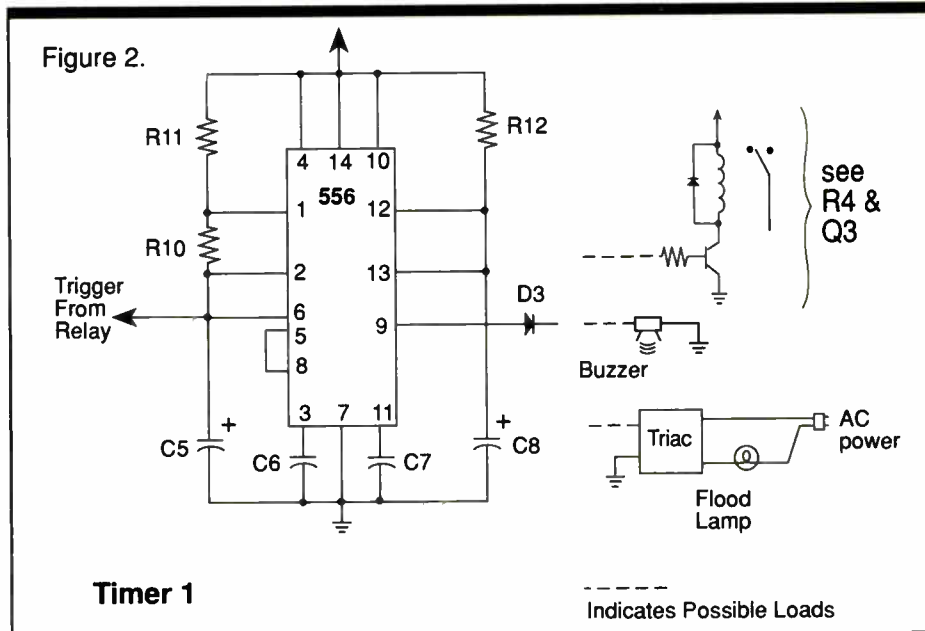

Timer 1

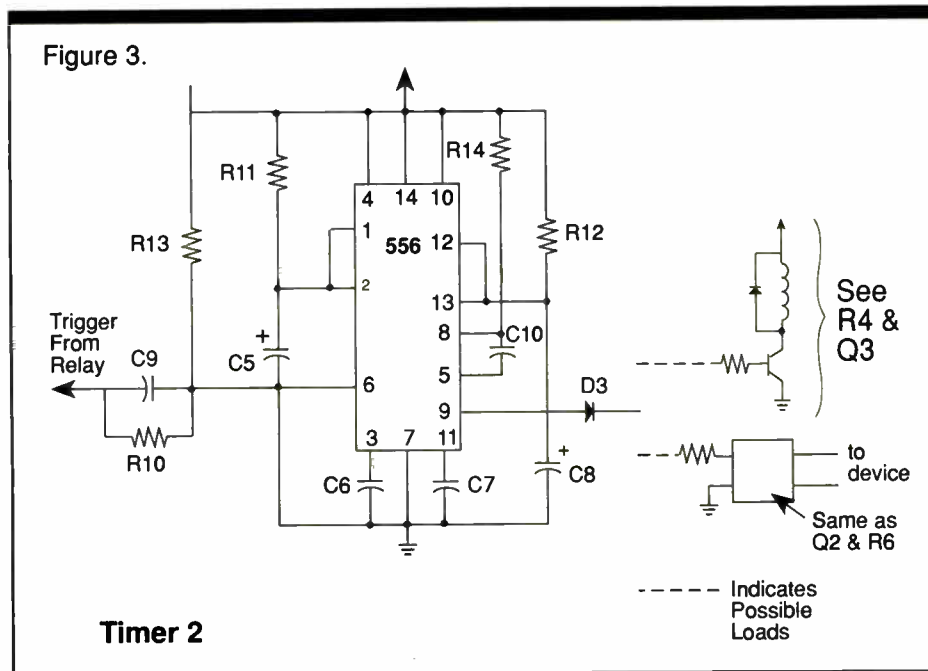

Timer 2

When the first timer resets, it triggers the second timer to fire a short duration 'pulse' output. This pulse might operate a relay or another optocoupler to trigger a remote control alarm, automation equipment, an auto-dialer or other device.

Power (+5 Vdc) for the alarm logic and timer circuits is supplied by IC-3. You can use a commercially available supply, just to be sure it can handle the drain of logic, lamps and relay coils. The original unit used unregulated +15 Vdc to power the indicator lamps and a +5 Vdc regulator.

### The recipe

Parts:-Resistors in ohms, 1/4 wt / caps are 15 wvdc except \*.

—Alarm unit (without timer 1 or 2):  
Q2=NTE3083 or any opto with a transistor, not triac, output; Q1=2N4126 (PNP);

continued on next page ▶

**EFFICIENT**  
**AM LINE**  
**SOLID STATE**  
**STEREO TRANSMITTERS**

○ C-QUAM™ AM stereo included

○ Patented high efficiency Class E power modules

○ 5 separate power levels meet all license requirements

○ Redundant switching power supplies

○ 1, 2.5, 5 and 10 kW models available

○ Star Combiner network provides uninterrupted operation

○ Built-in output matching network



**BROADCAST ELECTRONICS INC.**

4100 N. 24TH ST. P.O. BOX 3606  
QUINCY, IL 62305-3606 U.S.A.  
PHONE (217) 224-9600  
FAX (217) 224-9607  
TELEX 250142

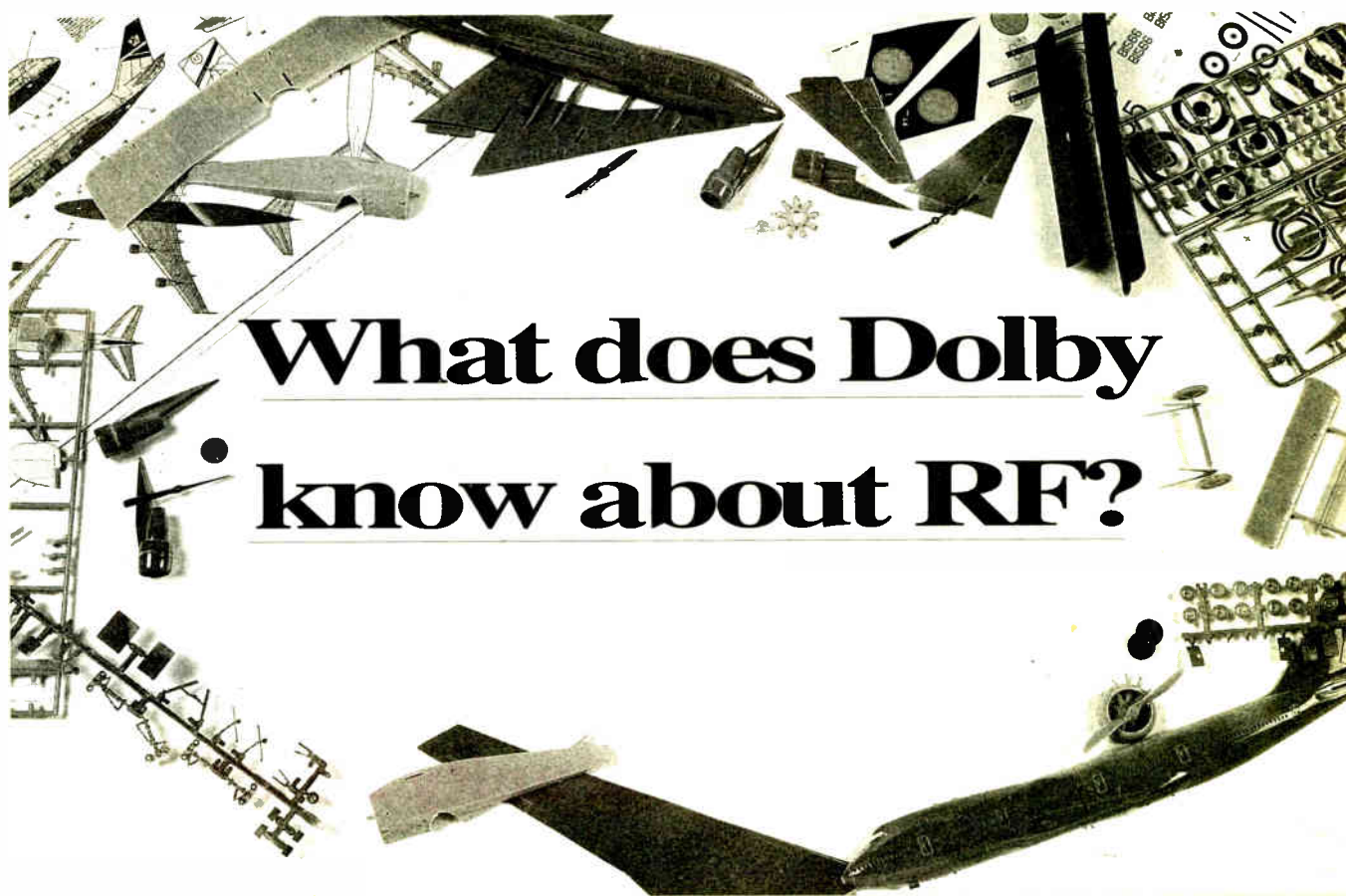

**What does Dolby know about RF?**

## ROOTS OF RADIO

# Fireside Chats Soothed the Nation

by James T. Wold

**MINNEAPOLIS** For those who recall the 1930s, the best-remembered radio voice carried an unforgettable resonance and assurance. It was a voice that instilled confidence when the nation had all but lost faith in itself, replacing fear and panic with equanimity. The nation was in the throes of the Great Depression.

## Building Easy Printer Alarm

► continued from previous page

Q3,4=2N4124 (NPN); IC-1=7400N (4X NAND); IC-2=LS00N (low I, 4X NAND); IC-3=MC780CT +5 Vdc regulator; R1,6=150; R5,9=10k; R4=1k; R2,3,8=2.2k; R7=10; C1=0.01uf; \*C2=1uf, 30 wvdc; C3,4=0.001uf; D1=1N4001; D2=1N4004; K1=5 Vdc DP/DT relay; S1=momentary SP/ST, N.O.; PS=15Vdc/650 ma supply or suitable for your loads; lamp=suitable lamp (1813 bayonet shown here).

—Timer 1 (recycling timer): R10=10k; R11=1.5m; R12=100k; C5,8=50uf; C6,7=0.05uf; D3=1N4001.

—Timer 2 (one-shot timer): R10=1m; R11=1.5m; R12=100k; R13,14=22k; C5,8=50uf; C6,7,10=0.05uf; C9=0.005uf; D3=1N4001.

□ □ □

*Edwin Bukont is the chief engineer at WPGC-AM-FM Morningside, Md. (Washington). He can be reached there at 301-441-3505, ext. 8213; address: 6301 Ivy Lane, Suite 810, Greenbelt, Md. 20770.*

Often, during the worst years of the depression, the consoling voice of President Franklin D. Roosevelt assured the nation that the government was doing all it could to solve the problems that confronted everyone.

Roosevelt would tell listeners about the programs that had been initiated to cope with the depression. He often ended with a reminder that the depression would soon be over and that people should sustain their courage.

But Roosevelt's skill went beyond just saying the right words. He showed the American people that he was a man they could identify with.

The first fireside chat was broadcast on March 12, 1933, just eight days after the 32nd president had been inaugurated.

Soon after arriving at the White House from the inaugural ceremony at the Capitol, FDR rolled his wheelchair into the Oval Office, where he sat quietly alone for a few moments in deep meditation.

He contemplated the nation's dire financial crisis brought on by an unprecedented rush to convert deposits into cash. Then he gave a mighty shout for his aides and instructed them to prepare an order closing all banks and to call for a special session of Congress. FDR's emergency banking bill, which undergirded the nation's financial system, was pushed through the House in 38 minutes.

But most Americans did not fully understand what the new President and Congress were doing about the crisis. FDR decided to go to the microphone to explain it all to a vast listening audience. That first fireside chat drew an estimated 60 million listeners, by far the highest rating any radio program to date had achieved.

"My friends," he intoned, and soon most Americans thought of the jut-jawed man at the helm as indeed their friend.

In that first chat, FDR spoke in language the uneducated could understand—why the grave financial crisis had

arisen and why, when he gave orders to the banks to re-open their doors, there would be no more need for panic withdrawals of cash.

"I assure you," he continued, "that it is far safer to keep your money in a bank than under a mattress. Confidence and courage are the essentials for our plan. You must have faith; you must not be stampeded by rumors. Together we cannot fail."

Some historians believe that radio speech, so intimate and reassuring, did more to restore confidence in the financial system than the new legislation itself.

While he was president, Herbert Hoover delivered a total of 95 radio addresses. But the first fireside chat was the first broadcast directly from the White House. For the next decade, millions listened regularly to FDR's voice and felt they were guests in the White House as they heard the President speak of mortal dangers and high hopes in both the darkest and the most dazzling hours of our times.

□ □ □

*James T. Wold is a free-lance writer based in Minnesota. He is author of Minnesota Microphones, published by Northstar Press. Wold can be reached at 1106 South Seventh St., Minneapolis, MN 55415.*

## WORKBENCH

► continued from page 32

a Radio Systems Consoie wrapper. For more information on Radio Systems products, circle **Reader Service Number 205**.

★ ★ ★

DGS Pro-Audio is the Gotham wire distributor here in the U.S. Gotham, a European company, displayed a new flexible audio cable, the GAC-2. Similar to other two-conductor shielded cables, the GAC-2 differs in that the foil shield is melted to the outer conductor plastic, for quick and easy stripping and wire

preparation. The extra step of cutting the foil after the outer protective jacket is removed is eliminated. For more information on this new cable, which, by the way, is carried by Mouser, circle **Reader Service Number 62**.

★ ★ ★

Clark Wire and Cable drew throngs to their booth with a new insulation displacement solderless XLR connector. This new Australian-made connector is invaluable for a remote box. Its special crimp-down design means the cable can't pull loose, and the solderless fea-

ture means wiring up XLR's might actually become fun. Susan Clark says she's having a hard time keeping these connectors in stock, because they're priced at regular XLR prices. This one's hot. For more information, circle **Reader Service Number 217**.

★ ★ ★

Studio Technology displayed a compact CD storage rack, 35 inches by 23.5 inches. The rack stores 155 CDs and costs under \$150.

RAM Broadcast Systems demonstrated their KTS-2000A "springless" heavy-duty mic booms. Removing the springs eliminates noise to microphones and insures a smooth arm movement in any direction. The arms look nicer too.

For information on the compact CD storage rack, circle **Reader Service Number 35**. For details on RAM's springless mike boom, circle **Reader Service Number 159**.

★ ★ ★

Interfacing consumer levels used to be rather a costly investment. Russ Friend and Associates put an end to the high cost of IHF-PRO interfaces with their CD100-X adapter amplifier, complete with adjustable levels, for just \$89. A stereo RCA cable is provided and the output is a barrier strip. For a spec sheet, circle **Reader Service Number 187**.

★ ★ ★

We all know the Otari MX-5050 as a popular audio reel-to-reel workhorse. Professional Audio Works demonstrated a new timecode modification for this and most other popular audio recorders. The modification includes a new head assembly capable of reading and writing time code. Retrofit kits are also available for Ampex ATRs, Studer and MCI/Sony machines.

Even if you're not into time code, you'll want a copy of the P.A.W. Bias Chart. This little card lists the correct amount of overbias for 3M, Ampex, AGFA and BASF tapes. For your free Bias Chart, circle **Reader Service Number 115**.

□ □ □

*John Bisset is a principal with Multiphase Consulting, a contract engineering and projects company. He can be reached at 703-764-0751.*

## As much as we know about audio.

With decades of experience in audio and psychoacoustics behind it, Dolby's DSTL<sup>®</sup> digital aural STL was destined to be the best-sounding system in the world. And it is. But the story doesn't end there. Using the most advanced RF technologies, the DSTL system achieves new heights of RF performance and reliability:

- **Increased fade margin.** Thanks to a highly sensitive receiver, the Dolby DSTL system outperforms analog and other digital STLs on long or obstructed paths, where dependable operation is a must.
- **Greater immunity to interference.** A wide RF dynamic range makes the Dolby DSTL system highly immune to adjacent channel and co-channel interference. Even powerful cellular and paging transmitters won't faze it, so your signal comes through loud and clear.
- **Superior spectrum efficiency.** With sophisticated modulation techniques and an ultralinear RF transmitter, two program and two auxiliary channels occupy a bandwidth of only 250 kHz (half that of ordinary composite STLs). That means clear skies for you and your frequency coordinator, particularly in congested markets.

Progressive RF technology plus digital sound quality add up to the highest-performance STL ever. Contact Dolby Laboratories or your authorized Dolby DSTL distributor to see how it flies.



Dolby Laboratories Inc. • 100 Potrero Avenue, San Francisco, CA 94103-4813 • Telephone 415-558-0200 • Facsimile 415-863-1373 • Telex 34409  
Dolby Laboratories Inc. • Wootton Bassett • Wiltshire SN4 8UJ • England • Telephone 0793 842100 • Facsimile 0793 842101 • Telex 44849  
Dolby, DSTL and the double-D symbol are trademarks of Dolby Laboratories Licensing Corporation ©1993 Dolby Laboratories Inc., S93/9720



# There are just a couple of things we can't supply to broadcasters... buildings and voice talents.

Call AEQ and you will find almost everything you need for your local radio station or for your international broadcast network.

Our talented engineers can provide you with Systems Engineering Design, state of the art equipment, technical advice and, most of all, the expertise obtained through the set up of over a hundred radio stations using our own designed equipment over the last ten years.

Do not hesitate. Choose somebody who knows. Choose AEQ.

AEQ MP-10 Portable Mixer.  
Allows program production and news report from anywhere with an available telephone line.

AEQ SYSTEL-3000 Multipoint Multiconference System.  
Allows full duplex simultaneous intercommunication of up to 9 people.  
Controlled via PC or through AEQ CR-01 remote control console.

AEQ TH-02 Digital Hybrid.  
The ultimate solution to talk show problems.

AEQ BC-2000 Broadcast Mixing Console.  
Complete Modular design. 18, 25 or 35 module versions.

- ❖ Power Amplifiers
- ❖ Digital Telephone Hybrids
- ❖ Frequency Line Extenders
- ❖ Distribution Amplifiers
- ❖ Broadcast Mixing Consoles
- ❖ Broadcast Portable Mixers
- ❖ Self Powered Monitors
- ❖ Line Amplifiers
- ❖ Line Equalizers
- ❖ "Turn-key" Projects
- ❖ ...and much more !

 **aeq**

C/ Rey Pastor, 36 Pol. Ind. Leganés 28914 - Leganés (Madrid) ESPAÑA Tel.: + 34 1 686 13 00 Fax: + 34 1 686 44 92  
AEQ-America 2211 South 48th Street, Suite H - Tempe, AZ USA 85282 Tel.: (602) 431-0334 Fax: (602) 431-0497

Circle (90) On Reader Service Card  
World Radio History

**ECLECTIC ENGINEER**

# Well-Modulated Radio An Unrealized Dream

by Barry Mishkind

**TUCSON, Ariz.** Looking back, I guess it must have been that super double fudge chocolate dessert creation we were served at dinner during the NAB show. We'd been up late, talking about the processing equipment shown on the floor.

At first, I was certain the phone had rung at 3 a.m. and my friend and fellow engineer Joe was on the other end saying it was essential I come to his transmitter site immediately.

Well, Joe's a good egg. He's helped me out many times during emergencies, so I felt I'd better get there as soon as possible.

**Enough is enough**

I was surprised to see the lot at Joe's station parked full. What could be wrong? Did the transmitter's high-voltage transformer explode? Was the antenna matching unit struck by lightning? What could bring out all these chief engineers at 3 a.m.?

All seemed calm near the tower base, so I figured it had to be a major failure in the control room. Probably it was the old console with the flaky power supply. It'd be a disaster if it

wasn't fixed by morning drive.

But there was no panic inside either. Every local chief engineer was in the conference room, drinking coffee or

cola, and chatting about engineering. Joe called for our attention. He'd been thinking about the discussion we'd had at the last radio engineers luncheon on the trends in audio processing.

The recent generation of digital audio processors seemed to produce ever greater "smash" and reduced dynamic range. Joe felt it was time to do something about the modulation wars that turn virtually every station in the market into broadcast square waves between 2.3 kHz and 2.8 kHz in a vain attempt to be the loudest signal on the band.

"Enough is enough," he said. "As professionals, we have to do something before the average time spent listening drops below three minutes."

Harold spoke up in agreement, citing a whole series of recent auto accidents, apparently caused by people distracted from road conditions while they tried to find a listenable station.

Mark felt the same way. His program director demanded so much processing that the alley behind his station was cluttered by the tops of waves which had been clipped in their new MegaDigiMod audio processor.

One by one each engineer agreed the modulation wars weren't doing anyone any good, and the aural signature of our collective craftsmanship was really no source of pride.

Still, none felt they could turn their processing down. Each said the PD would immediately start screaming the station was only half as loud as the competition unless the modulation monitors indicated

a constant 99 percent. Anything less, according to these programming gurus, was a wasted opportunity to grab more listeners as they tuned past the station.

Frustration within the group grew as the night progressed. Wasn't there anything that could reverse the trend to more and more smash?

**As professionals**

Joe laid out his plan: We'd all go directly to our respective stations, and at exactly 4:45 a.m., back off precisely 3 dB of clipping and 10 dB of compression from our audio chains. We'd recalibrate our modulation monitors so that they would look exactly the same to the programmers. Then we'd lock up, go home and relax in the knowledge that everyone would be putting out a cleaner signal. None of our program directors would get wind of our plan.

Chick thought we might even get some calls asking what we'd done to improve the sound of our stations. PDs from all over the country would call, trying to find out how we managed to be both clean and loud, so they could do it in their markets.

Maybe the NAB would give us an award, proclaiming we'd done a major service to the industry. Certainly we'd be in demand to consult the major chains.

We carried out Joe's plan with glory in our eyes. Not one program director noticed the difference in modulation levels. Sure enough, my boss called me into his office and told me how much his friends and clients liked our "new" clean sound. He asked me how I'd done it.

"Well, we did do a few things with the audio chain to clean up some problems," I said....

Buzzzzzz!—the alarm clock and another day.

It was odd how good I felt. Driving in, I thought I heard less distortion and breakup than normal. The plan is working. Maybe, if we could take just a few more dB of smash out, it would clean up the rest. I started noting several ideas as they came into my head.

I walked into the office and found a message to call Joe.

"Hi, guy," his cheerful voice came on the line. "I've got some good news."

"Great! Let me in on it," I replied.

"Okay, just thought you'd like to know that overnight we installed the new Multi-MegaDigiMod processor with the variable post squash tri-clipper circuit. We're now at least .25 dB hotter than you. Just try and catch up to us!"

Well, I had a dream.

□ □ □

Barry Mishkind, aka **RW's "Eclectic Engineer,"** hides out in Tucson, AZ. He can be reached at 2033 S. Augusta Place (85710). Electronic addresses: **BMISHKIND** on MCI Mail, or **barry@coyote.datalog.com** on Internet (also via CompuServe).



## WHY QEI?

**24 Hours.**



Our 24 hour service hotline number is 609-728-2020.

Call us toll free at 800-334-9154 for all the facts on QEI "New Reliables" FM transmitters from 1kw to 30 kw.

**Power Up.**



With our FMQ 3.5/5/10 kW or 20/30 kW FM transmitters, you can upgrade power in the field.

Call us toll free at 800-334-9154 for all the facts on QEI "New Reliables" FM transmitters from 1kw to 30 kw.

**No Extras.**



We never charge you extra for single phase power. Not on our FMQ 10000 or our FMQ 20000B—not even on our 30 kW FMQ 30000B.

Call us toll free at 800-334-9154 for all the facts on QEI "New Reliables" FM transmitters from 1kw to 30 kw.

**Less is More.**



All of QEI's FM transmitters have no plate blockers or sliding contacts.

Call us toll free at 800-334-9154 for all the facts on QEI "New Reliables" FM transmitters from 1kw to 30 kw.

**Free.**



Our FREE spares kits include every solid state component of the transmitter, exciter and remote control.

Call us toll free at 800-334-9154 for all the facts on QEI "New Reliables" FM transmitters from 1kw to 30 kw.

**The Longest.**



Our PA tube warranty is the longest in the business — 15,000 hours.

Call us toll free at 800-334-9154 for all the facts on QEI "New Reliables" FM transmitters from 1kw to 30 kw.

**Single Phase 30 kW.**



Our new FMQ 30000B is the only 30 kW transmitter available with a single phase power supply.

Call us toll free at 800-334-9154 for all the facts on QEI "New Reliables" FM transmitters from 1kw to 30 kw.

**Built-in Backup.**



QEI's constant 50 Ohm interstage impedance lets you bypass the IPA or PA in the unlikely event of a problem.

Call us toll free at 800-334-9154 for all the facts on QEI "New Reliables" FM transmitters from 1kw to 30 kw.

QEI CORPORATION  
ONE AIRPORT DRIVE • P.O. BOX 805 • WILLIAMSTOWN, N.J. 08094

24 HOUR SERVICE HOTLINE (609) 728-2020  
TEL (800) 334-9154 • FAX (609) 629-1751

**Q**UALITY • **E**NGINEERING • **I**NNOVATION

Circle (59) On Reader Service Card

# Radio World

## Broadcast Equipment Exchange

"Broadcast Equipment Exchange" accepts no responsibility for the condition of the equipment listed or for the specifics of transactions made between buyers and sellers.

**RADIO RESOURCES**  
1201 S. Sharp St.  
Baltimore, MD 21230  
**DO YOU HAVE EXCESS EQUIPMENT TO SELL?**  
Mail or fax us a list of what you have for sale, and we will help you turn your excess equipment into CASH...  
Some of the equipment items we need are:  
POTOMAC FIELD STRENGTH METERS  
MARTI VHF/UHF RPU EQUIPMENT  
MARTI STL EQUIPMENT  
MOSELEY STL EQUIPMENT  
ORBAN 8100A OPTIMOD  
If there is a piece of pre-owned equipment you are looking for give us a call, we can probably help you  
**THE INDUSTRY'S BEST NEW & PRE-OWNED EQUIPMENT DEALER**  
Ask for Bill, Steve or Chuck  
Voice: 1-800-54-RADIO  
FAX: 1-410-783-4635

Circle (132) On Reader Service Card  
**ACOUSTICS**

**STUDIOFOAM**  
SOUND ABSORBENT WEDGES  
TESTS 18% BETTER THAN SONEX!  
COSTS LESS! BETTER COLORS!  
**1-800-95-WEDGE**

### AMPLIFIERS

**Want to Sell**

LPB DA 1 16 distribution amp, new. J Gelo, J&H Music Programming, POB 1697, Marco Island FL 33969.

Crown D-75 amp, gd cond, \$300. J Parks, WCNX, River Rd, Middletown CT 06457. 203-347-2565.

BGW Pro 6000 stereo power amp, 100 watts per chnl, gd cond, \$225. A Gregory, 3003 20th St, San Francisco CA 94110. 415-285-1953.

Straight Wire Audio (2) DAs, \$150 ea; (2) Lauderdale Elects LEL DA-8 DAs, \$100 ea; (2) Ramko DA-6 BRV/Es, \$125 ea. M Guthrie, 813-855-5642.

RCA, Altec, Dynaco tube amps, sell of trade. Tracy Eaves, 615-821-6099 (evenings before 10PM EST).

Dynaco Stereo 70 tube power amp 35W/chnl, works, \$20. P Russell, Bowdoin College, Sills Hall, Brunswick ME 04011. 207-725-3066.

Leak stereo 50 point one preamp through line II FM tuner, all tubes near mint, \$3000. P Robillard, WYLD, 2228 Gravier St, New Orleans LA 70119. 504-581-1280.

### ANTENNAS & TOWERS

**Want to Sell**

Phasetek P600-204 current transformers, toroidal pickup units for antenna sampling system, brand new, \$450. T Newcomb, KAPY, Box 1290, Port Angeles WA 98362. 206-452-9228.

ERI CP-FM antenna, 2-bay tuned to 101.7 MHz, disco style, BO. K Block, KMAN, POB 1850, Manhattan KS 66500. 913-776-1850.

### FM - ANTENNAS

Designed and built for your frequency. Choose from 1 to 12 bays and five power levels. Financing available. Call Jimmie Joynt at S.W.R. **214-335-3425**

Andrew 3-1/8" rigid coax, 380', 13 yrs old, on tower & pressurized, \$200/20' section, you pay rigging & shipping. T Nelson, WCAL, St Olaf College, Northfield MN 55057. 507-646-3328.

Phelps Dodge 3 1/8" rigid coax line, 9-20' lengths; ERI FMH 12AC ant parts. T Worthmann, WJAG, 309 Braasch, Norfolk NE 68701. 402-371-0780.

ERI 37CP8 8 bay in storage, tuned to 107.3 FM, negotiable at around \$6000. K Reising, WRZQ, 825 Washington St, Columbus IN 47201. 812-379-1077.

Andrew A 10R 50507 coax, 1-5/8", (2) 275' rolls, \$8.75/ft. S Ross, WQFE, 733 N Green St, Brownsburg IN 46112. 317-852-9119.

Utility towers, (6) 400' w/antenna coupling units & six tower phasor, priced standing or on the ground, BO. G Proctor, WCRJ, 980 FM 1746, Woodville TX 75979. 409-429-3679.

Gates phasor 2 tower plus ATU's 5 kW 1480 DA-2. K Kuenzie, KFCE, 13E 11th, Washington MO 63090. 314-239-0209.

Shively A6810 2-bay high powered mdl tuned to 100.7, great cond, \$2500. M Bitner, WGWD, POB 919, Quincy FL 32353.

**FINALLY — Affordable Broadcast Products MADE 100% in the USA!**  
PLFM-100 obsolete exciter upgrade - \$229.95  
CSG-10 stereo generator w/comp clipper-\$349.95  
BIA-1 optmxd balanced interface - \$249.95  
\*FMT-15 15W FM xmtr - \$1,495  
\*FMT-15S stereo FMT-15 xmtr - \$1,895  
\*RTU-1 remote controlled tuner - \$495  
\*New products introduced at NAB  
**JT Communications**  
579 NE 44th Ave. Ocala FL 34470-1421  
904-236-0744 fax 904-236-5130

ERI FML-3E 3-bay, \$3K. R Miller, Miller Media Group, POB 169, Taylorville IL 62568. 217-824-3395.

Dielectric DCVS6B 6-bay FM CP antenna w/radomes, 8 yrs old, excel cond, tuned to 93.1 MHz, BO. R Cleveland, Radio One Ltd, 206 Rockwood Ave, Frederickton NB E3P 2M2, Canada.

Misc RF parts: (3) 15 A light chokes, (3) Delta TCT-2 xfms, (5) shunt assys w/ shunts, (15) 100 mfd@20 kv vacuum caps, (3) M-24-20 inductors, (1) M-23-15 inductors. M Martindale, KVON, 1124 Foster Rd, Napa CA 94558. 707-252-1440.

Transmission line parts, many Dielectric hard line reducers & elbows from 4-1/16" system. C Murray, KMGCE, 925 Country Club Rd #200, Eugene OR 97401. 503-484-9400.

Kintronics FMC-30 iso-coupler, 107.3 MHz, BO. G Proctor, WCRJ, 980 FM 1746, Woodville TX 75979. 409-429-3679.

268' solid galvanized steel FM or two-way tower, 18' face w/tops to 13", light kit, turn buckler, will hold ERI 3-bay or equiv, BO. M Casey, WKSX, Drawer 1, Johnston SC 29832. 803-275-4444.

ERI FML-3E 3-bay, \$3K. R Miller, Miller Media Group, POB 169, Taylorville IL 62568. 217-824-3395.

Patch bay, 24 position patch bay, pre wired terminal strips, BO. G Johnson, WLDY, POB 351, Ladysmith WI 54848. 715-532-5588.

Andrew A 10R 50507 coax, 1-5/8", (2) 275' rolls, \$8.75/ft. S Ross, WQFE, 733 N Green St, Brownsburg IN 46112. 317-852-9119.

268' solid galvanized steel FM or two-way tower, 18' face w/tops to 13", light kit, turn buckler, will hold ERI 3-bay or equiv, BO. M Casey, WKSX, Drawer 1, Johnston SC 29832. 803-275-4444.

Utility tower, 500', 36" face, new in 1982. Also 2-bay antenna tuned to 101.7. C Clinton, KSOX, 345 S 7th Raymondville TX 78580. 210-689-3333.

Gates phasor 2 tower plus ATU's 5 kW 1480 DA-2. K Kuenzie, KFCE, 13E 11th, Washington MO 63090. 314-239-0209.

Andrew HJ9-50 5" air line on spool w/connectors, 450' length, \$25/ft. Randy, WPJO, 505 Josephine St, Titusville FL 32796. 800-326-8890.

722' TV tower, 8' face, 43% guy radius, new Central w/warranty. Orig price \$321,000, avail. for \$150,000. Scott or Ray 812-853-0595.

**Want to Buy**

FM 103.3 any number bay, pref ERI, 140' cable w/conns & access; 100+ free-standing tower. 305-292-5009.

3-tower array phasor, 1290 kHz w/5000 W day/night pwr rating. D Wolfe, KMEN, 2001 Iowa Ave #200, Riverside CA 92507. 909-684-1991.

Band pass cavity filter, 10 kW or more. R Murphy. 602-855-1051.

Rohn 45G, need 5 sections. R Sewell, WORQ, 1075 Brookwood Dr, Green Bay WI 54304. 414-494-9010.

8-bay FM, low power on 103.3 & high power 8-bay, low freq. R Murphy, 602-855-1051.

Dielectric or Delta 4 port 3-1/8" coax switch in gd working cond; also need 3-1/8" to 1-5/8" EIA adaptor. H Kneller, WKII, 3151 Cooper St #56, Punta Gorda FL 33950. 813-639-1112.

Phasor, 5 tower, 5 kW. G McClintock, WNQM, 1300 WWCR Ave, Nashville TN 37218. 615-255-1300.

Lapp 9863 insulator for AM tower. K Broeffle, KUPL, 6400 SW Canyon Ct, Portland OR 97221. 503-297-3311.

Band pass cavity filter, 10 kW or more. R Murphy. 602-855-1051.

Phasor, 5 tower, 5 kW. G McClintock, WNQM, 1300 WWCR Ave, Nashville TN 37218. 615-255-1300.

### AUDIO PRODUCTION

**Want to Sell**

dbx 150 2 chnl NR unit, gd cond, \$100. A Gregory, 3003 20th St, San Francisco CA 94110. 415-285-1953.

### CASSETTES • CARTS • REELS

#### J & I AUDIO/VIDEO

A wholesaler in the Radio and Television market. Now running SPECIALS on audio and video:

BASF CASSETTES-AMPEX R-Rs  
AUDIOPAK, FIDELIPAC & ITC CARTS

For more information call Kris Elliot at 1-800-942-1711

or write to: J&I Audio/Video  
20899 Kelvin Pl.  
Woodland Hills, CA 91367

Circle (12) On Reader Service Card

Digidesign SoundTools 1 w/DAT I/O; Mac dig edit hardware & software, \$1475; Lexicon 224 dig reverb, \$1995/BO. R McMillen, Super Duper, 1634 SW Alder St, Portland OR 97205. 503-228-2222.

Rane SP15 5-band studio parametric EQ, \$330; Rane DC 24 2-chnl or stereo ganged dynamics simultaneous limit, compress & expand, \$330; Symetrix 511A single ended NR, \$395; Howetech phase Chaser, unused, BO; Sound Ideas sound effects libraries on CDs, BO; Acoustic System 6' 6" broadcast booth, \$5500. W Dooley, 818-798-9128.

Sparta TPA 7-1 (3), 25 W audio modules, new, \$45/ea or 3/\$100. D Peluso, KJUL, 2880 E Flamingo #E, Las Vegas NV 89121. 702-732-2200.

AKG 414 P48 like new, \$675; Dynaco 410, 400 W amp, \$400; dbx 1BX expander, \$135. W Gunn, 619-320-0728.

## STUDIO EQUIPMENT IMMEDIATE DELIVERY

- SIERRA AUTO SYS Audio Routing Switch
- BENCHMARK SYSTEM 1000
- YAMAHA YPDR 601 CD Recorder
- RANE SM82 / SP-15 / SM-26
- TASCAM 2 & 8 Trk Rcdr, CD & Cass Player
- SATELLITE DISHES . . . and MUCH MORE!

Call 617/267-8600 for complete configurations

Like New! • Sale or Lease

EQUIPMENT REMARKETING COMPANY • Boston, MA

Audio Digital TC-2 digital delay unit, new, no manual, \$790 prepaid UPS. D Peluso, KJUL, 2880 E Flamingo #E, Las Vegas NV 89121. 702-732-2200.

Used audio equipment including: Audiron-ics console, Orban 245 stereo synth, dbx 463X (2), 3M mincom 1/4" FT in console, Scully 280, Dynex 240, Orban 526A & 622B, Aphex 602, Auditronics PEQ 82, Scully 280 FT in console, 360 Systems programmable EQ, Lexicon 1200, UREI 964, Burwyn DNF 1500A, Kepex rk w/5 Gates & 1 limiter, Scully 280 4 trk 1/2", call for details, \$5950 takes all. N Funk, Rodel Audio, 1028 33rd St NW, Washington DC 20007. 202-338-0770.

MCI JH110A 2-trk in stand w/sound & vision rem/locator, \$1200; Orban 674A paragrahic stereo EQ, \$600; Foxtex 3070 comp/limiter, \$150; Foxtex 3180 reverb, \$50. W Gunn, 619-320-0728.

Prophet 600 synthesizer, \$450; Spectro Acoustics rack mount 200 W amp, \$150; Crown VFX2 electronic crossover, \$125. W Gunn, 619-320-0728.

SKL H/L/O variable filter (pair), \$200. W Gunn, 619-320-0728.

Roland SPH323 phasor, \$75; Rockman sustainer & stereo chorus/delay, \$350/both. W Gunn, 619-320-0728.

TT (Bantam) ADC patchbays, 144 pts, 1 rack sp, \$129; Tannoy HPB385A 15" coaxial monitor pair in cabinet, \$1750; Altec 436A tube compressors, Daven attn, both \$700. W Gunn, 619-320-0728.

**Want to Buy**

Any mic processor (2), gd cond. B Dickerson, WEAG, 1421 S Water St, Starke FL. 904-964-5001.

Fairchild 600 conac or 602 Conex high freq limiters. J Gangwer, 942 32nd St, Richmond CA 94804. 415-844-2363.

## WANTED:

Pultec EQ's; Fairchild, Teletronix, dbx, UREI, Sontec Limiters. Neumann, Telefunken, AKG and RCA mics. MacIntosh or Marantz Gear; Lang, Neve and API gear. Misc old tubes and guitars.

**DAN ALEXANDER AUDIO**

1340 Mission Street  
San Francisco, CA 94103  
(415) 252-7102  
FAX: (415) 864-7512

Ampex MX10 or MS 35 mixers. W Gunn, 619-320-0728.

## MERCENARY AUDIO

### WANTS TO BUY YOUR:

NEVE-SSL-TRIDENT-AMEK  
UREI-TELETRONIX-FAIRCHILD  
PULTEC-LANG-LEXICON  
UNIVERSAL AUDIO-NEUMANN  
AKG-TELEFUNKEN-AMS

ANYTHING THAT IS  
OF EXCEPTIONAL  
AUDIO QUALITY!

"this is not a problem"  
(508)543-0069 TEL  
(508)543-9670 FAX

## AVOID HEAVY FINES FOR EBS NONCOMPLIANCE!

### INTRODUCING THE NEW DAI-1 FROM SINE SYSTEMS



- Easily handles EBS requirements for "WALK AWAY" Operations
- Allows direct access to the air chain (discrete or composite)
- Remote broadcasts (no one at the station)

For more information about the DAI-1 or the Sine Systems Dial Up Remote Control, Call Your HE Sales Engineer today!

(804) 974-6466

FAX (804) 974-6450

Will work with your present remote control!



Circle (84) On Reader Service Card

## ITC REPAIR — REFURBISHMENT

Direct Factory Cartidge Machine Repair Service  
Upgrades or Refurbishment  
All Work Warranted

Call The ITC Technical Service Department  
Toll-Free at



(800) 447-0414  
(309) 828-1381



International Tapetronics Corporation  
2425 South Main Street  
Bloomington, IL 61704





### AUTOMATION EQUIP

#### Want to Sell

Systemation dig audio syst & traffic comp w/Darts software, \$9750. D Miller, WINA, POB 498, Charlottesville VA 22902. 804-977-3030.

MW Persons 3A prog for up to 4 sources, untd sequential rotation w/manual, \$200. R Chambers, Sierra Bdctg Corp, 3015 Old Johnstonville Rd, Susanville CA 96130. 916-257-2121.

Revox PR99's (4) PB units, like new w/rackmounts, \$1100 ea. E Gross, KEYZ, 410 E 6th St, Williston ND 58801. 701-572-5371.

Schafer 903 w/5 Carousels, 4 rks & docs, \$500. S Horner, KBBY, 6150 Olivas Pk Dr, Ventura CA 93002. 805-654-0573.

IGM automation w/2K memory, mon panel, clock, (3) 24 tray random select Carousels, wiring harness for 4 R-R's, spare parts, manuals, working when removed, \$1700 plus crating/shipping. M Fitzer, WKCX, POB 1546, Rome GA 30162. 706-291-9770.

Cetec 7000 Brain only, controlled R-R PB & Audiophile cart stacks, \$1600. C Knerr, KCNA, 139 SE J St, Grants Pass OR 97526. 503-474-7564.

Schafer 901 w/901 cntrl unit, (4) R-R's, 902 switch unit, (3) random select Carousels, cart PB, (4) rks, \$4500/BO. P Coates, KBZZ, POB 485, La Junta CO 81050. 719-384-5456.

IGM & EC w/3 24 tray Go-Carts, great cond, \$3995; IGM, EC w/4 24 tray SMC Carousel units that were factory refurbished, \$2995. C Murray, KMGE, 925 Country Club Rd #200, Eugene OR 97401. 503-484-9400.

Soundmag DPS-1, (3) 350 Carousels, (4) tone sensors, (2) dbl deck cart machines, stereo R/PB cart deck, new motor-hands, remote keyboard, local keyboard, Brain, (4) R-R PB, \$2000. M Casey, WKSX, Drawer 1, Johnston SC 29832. 803-275-4444.

SMC 350's (6) in gd cond, sell all or individually, \$350 ea. P Swint, KFSB, 2620 Dogwood Rd, Joplin MO 64801. 417-624-1310.

#### Want to Buy

Reels, carts, Brain's w/schematics, reasonably priced. R Bell, WRVB, 4314 Cherry Ct, Evansville IN 47714. 812-479-3377.

### BUSINESS OPPORTUNITIES

#### Want to Sell

**CCA is continuing to grow and expand its sales force and is looking for representatives to market well built and reliable CCA transmitters in exclusive sales territories.**

Reply in confidence to:  
Steve McElroy, VP-Sales  
CCA Electronics, Inc.  
PO Box 426  
360 Bohannon Road  
Fairburn, GA 30213

Two top quality music formats ready for partnership or sell outright, potential unlimited. J Gelo, J&H Music Program-ming, POB 1697, Marco Island FL 33969.

**For Sale: Sunbelt Contract Engineering Service**  
Established client base,  
11 yrs. successful operation, great owner/operator opportunity.  
Write for details to:  
Radio World, PO Box 1214,  
Falls Church, VA 22041  
Attn: Box #: 93-05-26-01 RW

### CART MACHINES

#### Want to Sell

ITC triple deck, 2 mono machs, one w/ automation tones, gd cond, \$750, one nds mtr/bearing, \$500. E Moody, KJEM, 216 N Main, Bentonville AK 72712. 501-273-9039.

Fidelipac CTR-112, clean, gd cond, stereo PB units (2), \$800 ea or \$1500/pair. P Bammerlin, WRQK, 4111 Martindale Rd, Canton OH 44705. 216-492-5630.

Spotmaster 2000 mono R/P cart machine, fair cond, \$400. J Parks, WCNX, River Rd, Middletown CT 06457. 203-347-2565.

ITC Delta I stereo cart machines, working. E Trevino, KBOR, POB 3407, Brownsville TX 78523. 210-544-1600.

Tapecaster 700P stereo, play, exc cond, \$350; ITC RP 329-0003, mono w/triple cue, exc cond, \$400. A Wes, KZPX, HCR 1 Box 286-D, Merrifield MN 56465. 218-765-3333.

#### CART MACHINES:

For Sale: \$395 & UP  
Repairs: \$100 per deck + parts  
Recondition: \$150 per deck + parts. Call Mark @ 619-598-3311

Spartamatic 800C R/P's (2), working cond w/manual, \$200 ea; Tapecaster 700 R/P w/bad motor w/manual, \$100/BO. M Fitzer, WKCX, POB 1546, Rome GA 30162. 706-291-9770.

ITC PD II R/P, mono, excel cond, \$500. D Johnson, MetroCities 381 Mansfield Ave Ste 500, Pittsburgh PA 15220. 412-928-0707.

Harris CC II mono R/P w/all tones refurbished, \$695. P Willey, WNAW, 466 Curran Hwy, N Adams MA 01247. 413-663-6567.

BE 1070RPS stereo R/P fast forward w/service manual, \$500. P Ferrand, Ferrand Comm, 65 Atherton Ave, Nashua NH 03060. 603-889-1067.

Fidelipac Dynamax CTR12PB (3), CTR14 R/PB (1), rack shelves (2), great cond \$4000 for set. S Bulman, First Take Recording, 16128 Orchard Grove Rd, Gaithersburg MD 20878. 301-963-7758.

Great Prices on original equipment tape heads for ITC, BE, Fidelipac, Otari, Tascam & others!

**IE HALL Electronics**  
(804) 974-6466 • FAX 6450

Many Premium line SP & WP players & recorders, call for info. C Murray, KMGE, 925 Country Club Rd #200, Eugene OR 97401. 503-484-9400.

Fidelipac CTR 90 gd cond, stereo, all tones, timer, etc, \$1200 or trade for prod equip. R Wells, KSRO, 1410 Neotomas Ave, Santa Rosa CA 95405. 707-545-3313.

Fidelipac Dynamax CTR112 stereo (5), perfect cond, \$1300 ea plus shipping. B Lord, Lord Bdctg, 13313 SE 208th, Kent WA 98042. 206-631-2374.

Tapecaster 700 RP stereo electronics, needs repair, transport fine, w/replacement transistors, \$65/BO. J Rudisill, Audio Independence, POB 746, Aptos CA 95001. 408-684-0605.

Audicord DL-PS (5) PB, stereo, \$400 ea; Audicord DL-RS, R/P, stereo, \$700; (6) Audicord E31R, E Series, mono PB, gd cond, \$200 ea/\$1000 all; ITC Delta, R/P, stereo, very gd cond, \$2200; ITC RP w/ mono, \$300, all 3 yrs old. C Knerr, KCNA, 139 SE J St, Grants Pass OR 97526.

Nortronics CH3-R sensor type tape heads (8), \$10/ea or 8/\$80 pre paid. D Peluso, KJUL, 2880 E Flamingo #E, Las Vegas NV 89121. 702-732-2200.

ITC 30 stereo w/single tone detector cue cards, good cond, heads recently replaced, \$750 ea. C Alexander, Crawford Bdctg, POB 561307, Dallas TX 75356. 214-445-1713.

ATC stereo R/P cart machines. A Zand, Villanova Univ, Villanova PA 19085. 215-645-4285.

Tapecaster RP-700 R/P, \$200; BE Tri deck, play only, \$950. R Chambers, KSUE, 3015 Johnstonville Rd, Susanville CA 96130. 916-257-2121.

BE 5300C tripledeck, stereo, PB, mint less than 50 hrs, BO. R Kaufman, Pams Prods, POB 462247, Garland TX 75046. 214-271-7625, after 3PM CDT.

#### Want to Buy

ITC RPD 3 tones, rk mnt ears. DJ Williams, Lincoln County Bdctr, 1103 Utah Ave, Libby MT 59923. 406-293-6234.

### CASSETTE & REEL-TO-REEL RECORDERS

### STUDER SERVICE SPECIALIST

Thousands Serviced • Unbeatable Rates  
Precision Capstan Resurfacing  
**Audio Advantage**  
Tel (615)742-3834 FAX (615)254-8826  
**PRICE-QUALITY-SERVICE**  
Let Us Prove It

#### Want to Sell

Technics RS1500 2 track, excel cond. J Gelo, J&H Music Programming, POB 1697, Marco Island FL 33969.

Revox PR99 (4) to use w/automation or live music on reel, 25 Hz detectors, excel cond, \$600/ea or BO. P Delaney, KQYB, Box 308, Spring Grove MN 55974. 507-498-5720.

Ampex 351 (3) full-trk, unmounted w/book, \$200 ea/BO; Magnecord PT-6 w/7 1/2 & 15 capstans, book, BO; ext arm for 10 1/2" reels on PT-6, BO. D Carver, KZBK, 107 S Main, Brookfield MO 64628.

Ampex AG440C mono R/P, like new cond, \$750. D Johnson, MetroCities, 381 Mansfield Ave, Ste 500, Pittsburgh PA 15220. 412-928-0707.

Teac 330-S, 2-trk; Teac A-3440, 4-trk; Teac A-4010, 2-trk. D Low, WUJM, 1 Carriage Ln Ste B-100, Charleston SC 29407.

Otari MK III-5050 8 trk, mint cond, low hrs, 1/2" tape, 7.5 & 15 ips, \$2200. C Lallo Jr, 465 W Anderson St, Hackensack NJ 07601.

ITC R-R (2) 7.5 ips w/tone detector, \$250 ea, clean/gd cond. F Willis, WKXH, POB K, Alma GA 31510. 912-632-0104.

Magnecorder PTH6 vintage recorder in working cond w/case, free, you pay shipping. A Mitchell, A Mitchell Productions, 8107 Yorktown Dr, Alexandria VA 22308. 703-768-6186.

Viking 78 tape decks, \$100 ea/BO; (1) Ampex 600 w/manual, \$200/BO; (2) ITC 750 tape decks in vgc, \$550 plus shipping. M Fitzer, WKCX, POB 1546, Rome GA 30162. 706-291-9770.

### EXPERT REVOX REPAIRS

Fast Turnarounds—Competitive Rates  
Rebuilt A77s, \$800  
Capstan shaft resurfacing, \$35.  
**JM TECHNICAL ARTS**  
30 Music Sq. W. #5  
Nashville, TN 37203 (615) 244-6892

Ampex 351 & 354 transport head assembly, several amps, need work or for parts. D Johnson, MetroCities, 381 Mansfield Ave, Ste 500, Pittsburgh PA 15220. 412-928-0707.

Otari ARS 1000 (4) interfaced to SMC automation equip, \$500 ea. P Swint, KFSB, 2620 Dogwood Rd, Joplin MO 64801. 417-624-1310.

**SCULLY TAPE RECORDERS**  
PARTS AND SERVICE  
**SEQUOIA ELECTRONICS**  
4646 Houndshaven Way  
San Jose, CA 95111  
(408) 363-1646

Telex Magnecord 1022 2-trk R/P & 4-track play with rack, good condition, \$250+s/h. A Wes, KZPX, HCR 1 Box 286-D, Merrifield MN 56465. 218-765-3333.

Crown CX824 with variable speed, sync, remote, never used, mint condition, \$1000; Scully 260B stereo mounted 1/4" head assembly with cables, new, \$250. D Kocher, Digital Sound Makers, 1901 Hanover Ave, Allentown PA 18103. 215-776-1455.

Ampex 440-C/7 (2), 5-15 ips 1/4" with Ampex roll around cabinets & remote controls, new erase, record & playback heads, excellent condition, \$1395 ea. Bill 313-242-2319, 8-4 in Mi.

Ampex 354 elects (2), fair cond, BO. R Meyers, Benchmark Comms, 4700 SW 75th Ave, Miami FL 33155. 305-264-5963.

Sony TC 650 R-R 7.5" 2-trk master, new heads/belts, very clean, \$300/BO; Scott DA 688 cass dubg deck, exc cond, \$65. M Stewart, M&M Studios, 5712 Parker Rd, Modesto CA 95357. 209-523-0956.

Crown SX-722 1/2-trk, stereo, clean, \$300. G Hultman, Hultman Media Svcs, 300 Limp Creek Rd, Grants Pass OR 97527. 503-474-6466.

Otari MX5050 B2-II immac, \$1610; MK3, gd cond, \$1000. R McMillen, Super Duper, 1634 SW Alder St, Portland OR 97205. 503-228-2222.

### CLEAN PATCH BAYS NO DOWN TIME



**VERTIGO BURNISHERS AND INJECTORS RESTORE ORIGINAL PERFORMANCE TO YOUR PATCH BAYS**  
**\$34.95 Ea.**  
**VERTIGO RECORDING SERVICES**  
12115 Magnolia Blvd. #116 818-907-5161  
North Hollywood, CA 91607 fax 818-784-3763

Scully 280 14" stereo machine & electronics, no console. K Kuenzie, KFXE, 13E 11th, Washington MO 63090. 314-239-0209.

## EMPLOYMENT

To place ads in this section, use the ActionGram form. To respond to box numbers write Radio World, PO Box 1214, Falls Church, VA 22041. Attn: \_\_\_\_\_

### POSITIONS WANTED

Experienced air personality seeks new challenge, prefer midwest, good voice & production, love appearances, credible, reliable, dependable, thorough knowledge of the business. Jack Reynolds, 414-242-4357.

Group hands-on field chf w/7 AMs & FMs seeks downsizing, smaller grp/few contract stations in NE OH. Curt, 216-645-6383.

Great voice, college grad dying to work any format, anywhere, love play by plays, Univ of IA Comms degree. K Fleming, 319-354-1540.

PT Broadcast Tech in ALBQ, NM.. 4+ years experience and seek potential FT BE career after current military service.. cannot relocate. Larry 505-260-0236.

General Manager for FL medium/large market, 29 years experience in sales, program, engineering, turnarounds/start ups, avail immediately. 813-849-3477.

Sales-oriented, computer-literate, production/promotion director with own equip seeks permanent home, will relocate, 15 years experience, call for demo tape. 208-467-6799.

Experienced air personality seeks overnight shift at Midwest Top 100, oldies/classic, rock/hot, AC/country/AOR/AC. Jack, 414-242-4357.

Voice/Production talent avail for small market stations, low, low rates, spots, sweepers & liners. Call or write for demo package. B Simonson, Box 206, Oshkemo MI 49077. 616-363-8561.

Ready to work hard in news/sports /talk radio, college station GM with experience in news, play-by-play, production, sales. Andy, 205-870-2877.

Former Owner/Manager seeks small market opportunity. Will accept sales position. Can do it all including announcing and sports play-by-play. Years of experience. Reply to: Radio World, POB 1214, Falls Church VA 22041. Attn Box #06-09-01RW.

Mama's Dead! David F. Diamond, major market talk show host.. "Diamond in the Rough".. a poor man's Rush Limbaugh, is ready to move now. 1-800-844-1841.

Sales, management, programming, marketing and engineering, expertise to successfully achieve turnaround for any station with good signal in decent market. 813-849-3477.

Would like to get back into sports, currently working at station in Illinois, May '92 grad, 3 years of play-by-play experience, 5 years total radio experience, will relocate. Derek, 618-667-6169.

### HELP WANTED

Seeking full-time radio main engineer with FCC general permit and two years experience. Send resumes to: Raleigh Rubanking, WHO/KLYF, 1801 Grand, Des Moines, IA 50309. EOE.

Production person needed for satellite automation system, new Hot AC FM station. Skill in using Digilink a plus. Located in middle Georgia market. Send resume, photo & air-check to D.L. Jones, 3017 Piedmont Rd #200, Atlanta GA 30305.

Engineer Wanted, Western Nebraska AM/AM/FM. Minimum 5 years experience RF, Audio, Computer. Knowledge of FCC Rules and regulations. Competitive salary, benefits. Send Resume to: Michael Tracy, POB 532, Scottsbluff, Nebraska 69363-0532.

**SKYWAVE CHICAGO**  
Seeks confident, high energy maintenance engineer with strong analog, digital, xmtr, d.a. and, yes, people skills. Current or former chief motivated by money and recognition? Enjoy challenge but hate routine? Accustomed to calling your own shots? Send us a resume for consideration to: Skywave Chicago, 2118 W Warner, Suite 2, Chicago, IL 60618.

General Manager, heavy experience in sales to operate 3 new FM AC stations in central Georgia. Send resume to D.L. Jones, 3017 Piedmont Rd #200, Atlanta GA 30305.

Midwest based tower manufacturer is looking for an experienced salesman. Our company is dynamic, growing, and dedicated to providing superior products. The successful candidate will possess a high degree of integrity and desire to succeed. Applicant must have a background in a communication field such as cellular, LMR, or broadcast. Competitive base, good benefits package, and excellent earnings potential. Reply with resume and cover letter to:  
**Box 5631, Austin TX 78763.**  
All replies kept in strict confidence.

Asstant engineer, WYNF FM. Applicant needs strong skills in audio, RF & remote broadcasting. 1-5 years experience, FCC licence or SBE certificate required. Send resume to Roswell Clark, WYNF FM, 9720 Executive Center Dr., St. Petersburg FL 33702.

### BROADCAST EMPLOYMENT WEEKLY

New professional positions in the broadcast industry available weekly from coast to coast and beyond to include U.S. territories. Stations report job announcements to us daily from all departments. Information is updated weekly & available to you fresh. No more "cold" calls and large phone bills to find out who's hiring. Call for more info.

**1-800-922-JOBS.**

"We take the hassle out of your career moves!" Local Better Business Bureau Participant!

## ABOUT OUR EMPLOYMENT SECTION

**HELP WANTED:** Any company or station can run "Help Wanted" ads for \$1.50/word or buy a display box for \$55/column inch. Payment must accompany insert, use your MasterCard or VISA; **there will be no invoicing.** Blind box numbers will be provided at an extra charge of \$10. Responses will be forwarded to listee, unopened, upon receipt. Call 800-336-3045 for details.

**POSITIONS WANTED:** Any individual can run a "Position Wanted" ad, FREE of charge (25 words max), and it will appear in the following 2 issues of Radio World. Contact information will be provided, but if a blind box number is required, there is a \$10 fee which must be paid with the listing (**there will be no invoicing**). Responses will be forwarded to the listee, unopened.

**Mail to: BROADCAST EQUIPMENT EXCHANGE**  
PO Box 1214, Falls Church, VA 22041  
Attn: Simone Mullins

### CASSETTES & R-R...WTS

Uher 5000 5" reel transcriber, spare parts, service manuals of Uher products, \$50/all plus UPS. E Davison, POB 7167, Springfield IL 62971-7167.

Tascam 58 8-trk, 1/2", very gd cond, low hrs, XLR in/out, conns for SMPTE lockup w/video, manual, 10 1/2" take-up, \$2000. T Carroll, In-House Prod, 456 9th St #20, Hoboken NJ 07030. 212-340-7519.

Otari MX5050 8-trk in custom console, demo, 1/2", \$2000; Otari 8-trk in Ruslang console, new, 1/2", \$2500; (3) Technics RSM-65, new, \$250 ea/BO; Sony TC-228 8-trk R/P, new, \$150/BO; Sony TC-777-4 1/4-trk, 1/4", mint cond, \$350. J Diamond, Blue Diamond, Box 102C Chubbick Rd RD 1, Canonsburg PA 15317. 412-746-3455.

**Ampex, ITC, Scully Reel-to-Reel Tape Recorder Spare Parts, Accessories Motor Remanufacturing.**

**VIF INTERNATIONAL**  
PO Box 1555  
Mtn View CA  
94042 U.S.A.

Inside USA: 1-800-848-4428  
Outside USA: 1-408-739-9740  
FAX: 1-408-739-0809

**Ampex Pro R-R**, (1) 350 & (3) 440. A Zand, Villanova Univ, Villanova PA 19085. 215-645-4285.

**Tascam ATR-60-4HS 4 trk**, 1/2" R-R, 15/30 ips, 2 yrs old in mint cond, \$2500. D Shaw, De Koch Music, 900 S Fifth St, Milwaukee WI 53201. 414-645-4464.

**Telex copier 1 & 2**, mono cass duplicator workhorse, factory refurbished, 1-3 copies, \$150. P Russell, Bowdoin College, Sills Hall, Brunswick ME 04011. 207-725-3066.

**Radio Systems DTC-1000 DAT** recorder, cosmetic ding on one corner, 6 mos old, \$995 plus shipping. B Lord, Lord Bldg, 13313 SE 208th, Kent WA 98042. 206-631-2374.

**Ampex MM1200 16 trk R-R/R/P**. Exc cond. Mark, 619-598-3311.

**MCI JH-110 2 trk w/new head stack**, excel cond, \$1500. K Harvey, KISC, E 300 Third Ave, Spokane WA 99202. 509-459-9800.

**Uher 5000 5" reel transcriber**, spare parts, service manuals of Uher products, \$50/all plus UPS. E Davison, POB 7167, Springfield IL 62971-7167.

**Ampex 350 mono R-R's (2)** with Inovonics electr, solid state rack mount units, \$300 ea; Ampex AG-350 mono R-R with solid state electr from Ampex, rack mount unit also, \$500. A Baker, Broadcast Production of America, 804 E 38th, Indianapolis IN 46205. 317-925-7371 or fax 317-924-5293.

**Sanyo stereo cassette**, belt broke but works good, \$20. W Dougherty Jr, WLD Recording Std, Music Valley, Rt 1, Mill Spring MO 63952. 314-998-2681.

**Ampex 350/440 transport & elects pts** some new, most used, in super cond, mtrs, hdstks, guides etc; pts for Scully 280s and complete Inovonics elects for 350s & 440s, all reasonably priced. M Gore, 54 Ney St, San Francisco CA 94112. 415-469-0136 noon to 5PM West Coast time.

**Fostex 80-8 8-track** with NR, new Ampex tape & metal reels, rem ctrl & foot switch, punch in rem w/original box & manual, nice cond, \$2300/BO. W Dougherty Jr, WLD Recording Std, Music Valley, Rt 1, Mill Spring MO 63952. 314-998-2681.

**Tascam ATR-60-4HS 4 trk**, 1/2" R-R, 15/30 ips, 2 yrs old in mint cond, \$2500. D Shaw, De Koch Music, 900 S Fifth St, Milwaukee WI 53201. 414-645-4464.

**Nakamichi 550 stereo recorder** with power supply, \$250; Tandberg 11, 3 speed, 7" reel, battery operated, \$100; Ampex 600/620 7.5 ips recorder, good condition, Best Offer. R Woolf, Audio & Recording Systems, 3986 Edidin Dr, Jacksonville FL 32211. 904-744-1661.

**Scully 280 14" stereo machine & electronics**, no console. K Kuenzie, KFKE, 13E 11th, Washington MO 63090. 314-239-0209.

**Otari MX5050** in gd cond w/rem, manual, ris, \$850/BO. J Rudisill, Audio Independence, POB 746, Aptos CA 95001. 408-684-0605.

**Teac 22-4 4-chnl 1/4" w/factory tech** manual, \$500. J Hunter, KBRE, Box 858, Cedar City UT 84720. 801-590-1277.

**Ampex Pro R-R**, (1) 350 & (3) 440. A Zand, Villanova Univ, Villanova PA 19085. 215-645-4285.

**ITC 750 w/tone detector (2)**, gd cond, \$250 ea. F Willis, WKXH, POB K, Alma GA 31510. 912-632-0104.

**3M M-79 Professional 2-trk** mastering machine in roll-around console, above meter bridge/NAB metal reels & hardcover manual, excel cond, \$1250. W Dougherty Jr, WLD Recording Std, Music Valley, Rt 1, Mill Spring MO 63952. 314-998-2681.

**Pentagon mono duplicator**, makes 1-3 copies from master VU meters, \$150. P Russell, Bowdoin College, Sills Hall, Brunswick ME 04011. 207-725-3066.

**Tascam 40-4 w/dbx & flight case**, \$950; Tascam 48 8 trk, excel for sync, \$2950. W Gunn, 619-320-0728.

**Revox PR-99 MK II 1/2 trk** stereo play units with 25 Hz sensor (4), new still in factory boxes, \$950 ea/FOB. D Peluso, KJUL, 2880 E Flamingo #E, Las Vegas NV 89121. 702-732-2200.

**Ampex MM 1100 16 trk 15/30 ips** in superb cond, hds almost unused cond, all elects have been checked out, has updates, counter, MDA fans, AC stabilizer card, mods, \$6000. M Gore, 54 Ney St, San Francisco CA 94112. 415-469-0136.

**Scully 270 14" PB**, 1 stereo plus 1 mono for pts, \$200/both; Ferrograph Super 7, 10", 3-7-15 ips, 2 trk, \$300. W Gunn, 619-320-0728.

**Tascam 32 2-trk & 38 8-trk**, like new, \$2000/both; Teac 3340 4-trk, 1/4" deck, \$375; Tascam 80-8 8-trk never really used/perf, \$1600. W Gunn, 619-320-0728.

**Ampex ATR800 mono**, like new, \$1200 & AG440-8 1" 8-trk; Otari 7800 1" 8-trk, \$2900. W Gunn, 619-320-0728.

**Otari Mark II-IV 1/2" 4-trk**, multi-trk, mint, less than 50 hrs, BO. R Kaufman, Pams Prods, POB 462247, Garland TX 75046. 214-271-7625, after 3PM CDT.

#### Want to Buy

**Audio & stop delay card** for an Otari ARS 1000 recorder, card #ASB-2. D Carr, WTHL, 2034 N Hwy 39, Somerset KY 42501. 606-679-6300.

**Ampex ATR102 15-30 ips 1/4" or 1/2"**, possible trade w/some cash. Bill, 313-242-2319, 8-4 in MI.

**Schematic/manual for Pioneer CTF-950** cassette deck, call w/asking price. CR Leasure, WTBO, POB 1644, Cumberland MD 21502. 301-722-6666.

**Tascam MU-40 meter bridge**. D Green, KTCU, POB 30793, Ft Worth TX 76129. 817-921-7630.

**Scully '100' recorders**, record/play amplifiers, 8, 16, 24 track heads. Sequoia Electronics, 4646 Houndshaven Way, San Jose CA 95111. 408-363-1646.

**Ampex ATR100 taperecorders** for parts. Circuit cards, heads, motors, machine parts, or electronic parts. Call 818-907-5161.

#### CD's/PLAYERS

#### Want to Sell

**Nikko NCD-600**, 60 disc player, will interface to IBM computer, new w/8 yr warranty, never used, will ship via UPS, \$850. Keith, ALI, 9 Roxbury St, Keene NH 03431. 603-352-8460.

**Denon DN-950FA CD cart player**, 6 mos old, \$725 plus shipping. B Lord, Lord Bldg, 13313 SE 208th, Kent WA 98042. 206-631-2374.

**Denon 950FA CD players**, working. E Trevino, KBOR, POB 3407, Brownsville TX 78523. 210-544-1600.

**Studer A725 (3)**, \$250 ea. K Rider, Unistar Radio Networks, 1675 Broadway, NUNY 10019. 212-373-4947.

#### Want to Buy

**CD library**, EZ listening or beautiful music, no reel or carts. R Potyka, KRXS, 1730 E Indigo, Mesa AZ 85203. 602-969-7707.

**Sony CDP-3000 CD players** in working condition vintage 1988 or later. Call Bill or John at CD Associates, 714-733-8580 or FAX 714-786-1486.

#### COMPUTERS

#### Want to Sell

**Tandy 1000HD computer** w/monochrome monitor & printer, \$300. J Hunter, KBRE, Box 858, Cedar City UT 84720. 801-590-1277.

**Superior Electric Stabaline computer** power conditioner, handles up to 4 computers, \$135 plus shipping. B Lord, Lord Bldg, 13313 SE 208th, Kent WA 98042. 206-631-2374.

#### CONSOLES

#### Want to Sell

**Tascam M216 16x4x2 bal/unb** recording/PA console, new condition with black nylon heavy padded case, \$875/BO. M Stewart, M&M Studios, 5712 Parker Rd, Modesto CA 95357. 209-523-0956.

**RECORDABLE CD and DAT**

**MEDIA and MACHINES**

**LOWEST PRICES!**

*Your New Digital Headquarters*

**LPB®**

28 Bacton Hill Rd. Frazer PA 19355  
215-644-1123 Tel. 215-644-8651 Fax

Grde (95) On Reader Service Card

**McCurdy SS8600** free standing custom stereo 12 channel, real time clock, digital timers, slide attenuators, echo foldback, etc, \$5900. P Willey, WJW, Church St, N Adams MA 01247. 413-663-3419.

**BE 5 chnl mono**, \$450; Shure M688 mic mixer, stereo, \$125; Shure M68RM reverb mic mixer, \$125. B Elliott, WRFX, 915 E 4th St, Charlotte NC 28204. 704-338-9970.

**Gately 16 x 8 custom audio carbd w/EQ** on every channel, 4 FX buss, quad monitoring, Canon connectors for line & mic inputs & outputs, \$1000. A Baker, Broadcast Productions of America, 804 E 38th, Indianapolis IN 46205. 317-925-7371 or fax 317-924-5293.

#### Want to Buy

**Gates Stereo Yard** wanted for parts, need not be working. D Hallow, KSTN, 2171 Ralph Ave, Stockton CA 95206. 209-948-5786.

**Stereo board**, 12 or more inputs. D Royer Sr, POB 3384, Kinston NC 28501. 919-523-5151.

#### DISCO & SOUND EQUIPMENT

#### Want to Sell

**DOD crossover**, 2-way stereo, 3-way mono, \$125. J Gardner, KZBK, 107 S Main, Brookfield MO 64628.

**Yamaha QX5 MDF-1 MIDI sequencer & disk drive**, \$200 both/\$125 ea. P Cibley, Cibley Music, 138 E 38th St, NY NY 10016. 212-986-2219.

**50 Years of Recording Equipment For Sale** — Choice items: Altec, W.E., Ampex, Others Will sell by lot or piece Price Negotiable 913-341-5665 or 816-931-8735

**Orban 674A stereo graphic parametric EQ**, \$750; UREI 539 1/3 oct EQ (4), \$395 ea; dbx 20/20 RTA/EQ as new, \$595. R McMillen, Super Duper Audio Duplicating, 1634 SW Alder St, Portland OR 97205. 503-228-2222.

**Dolby 301 A-type stereo**, discrete, \$500. W Gunn, 619-320-0728.

**MICOR VIDEO EQUIPMENT**

**PR&E BMX-II 8 stereo line**, 4 digitimer DT-4, 2 mic, studio mon, phone mix, mono out, dig clock **\$6,000**

**PR&E News Mixer 4 tape**, 1 mic, & 1 phone input **\$1,600**

**OTARI MX-5050 1/4" 2-track** **\$1,800**

**BE 3200ARP cart machine** **\$900**

**RADIO SYSTEMS 1x8 ADA** **\$175**

**This and more...CHICAGO 312 334 4300**

**Audionics 200 series blue face mods**, 1 mono line output, gd cond, \$125; (3) stereo line output, \$150 ea/\$475 all. M Guthrie, 813-855-5642.

**Gates SA-40 9 chnl tube type mono board**, worked fine when removed from service, complete w/manual, BO. D Burgeson, WDND, Box 119, Wilmington IL 60481. 815-458-2141.

**Spotmaster 5 BM 100 5 chnl dual mono**, vgc, \$700. J Arzuaga, WREI, Rd 2 KM 102.5, Quebradillas PR 00678. 809-825-2725.

**Shure M675 production master add-on mixer** for the M-67, \$100; Shure M-67 mixer, fair cond, \$150. J Parks, WCNX, River Rd, Middletown CT 06457. 203-347-2565.

**Cetec Centurion 12 channel consoles**, one good, one for parts, many extra parts & modules also available, \$1750. E Moody, KJEM, 216 N Main, Bentonville AR 72712. 501-273-9039.

**Ramko XL415 4 channel stereo** in very good condition, wired to punch blocks, with power supply & manual. M Martindale, KVON, 1124 Foster Rd, Napa CA 94558. 707-252-1440.

**Spotmaster 4 channel**, 8 input, good condition, \$200 plus shipping. F Willis, WKXH, POB K, Alma GA 31510. 912-632-0104.

**Autogram IC-10 10 channel stereo** with all mods & some active-balanced input modules, exc cond, \$2500. C Alexander, Crawford Bldg, POB 561307, Dallas TX 75356. 214-445-1713.

**PHONE: 703-998-7600 FAX: 703-998-2966**



Call Simone Mullins, Classified Ad Manager, to reserve space in the next issue. Use your credit card to pay, we now accept VISA and MASTERCARD.

## RadioWorld

5827 Columbia Pike, Ste 310 Falls Church, VA 22041

#### Select from these categories for best ad positioning:

- Acoustics
- Amplifiers
- Antennas & Towers & Cables
- Audio Production (Other)
- Automation Equip.
- Brokers
- Cameras (Video)
- Cart Machines
- Cassette & R-R Recorders
- CATV-MATV Equip.
- CD's
- CD Players
- Computers
- Consoles
- Disco-Pro Sound Equip.
- Financial Services
- Limiters
- Microphones
- Miscellaneous
- Monitors
- Movie Production Equip.
- Receivers & Transceivers
- Remote & Microwave Equip.
- Satellite
- Software
- Stations
- Stereo Generators
- Switchers (Video)
- Tapes, Carts & Reels
- Tax Deductible Equip
- Test Equipment
- Transmitters/Exciters
- Tubes
- Turntables
- TV Film Equip.
- Video Production Equip.
- Video Tape Recorders
- Positions Wanted
- Help Wanted

#### Display Rates for Classified Advertising Effective January 1, 1991

	1x	3x	6x	12x
1-9 col inch (per inch)	\$55	53	50	45
10-19 col inch (per inch)	50	48	45	40
Distributor Directory	90	85	80	75
Professional Card	60	55	50	45
Classified Line Ad		\$1.50 per word		
Blind Box Ad		\$10 additional		

To compute ad costs: Multiply the number of ad inches (columns x inches) by the desired rate schedule for your per unit cost. Example: a 3" ad at the 1x rate is \$165, at the 3x rate \$159, at the 6x rate \$150, at the 12x rate \$147, etc.

## DISTRIBUTOR DIRECTORY

The following distributors serving the broadcast industry would be glad to help you with any of your requirements.

... country, top 40, news, urban, talk, jazz, the classics, mixed bag ...

RADIO! The beat goes on!

### CROUSE-KIMZEY OF ANNAPOLIS

tops in broadcast equipment

1-800-955-6800  
ask for Kathleen

### CORNELL-DUBILIER MICA CAPACITORS

FROM STOCK

### JENNINGS VACUUM CAPACITORS

FROM STOCK

### JENNINGS VACUUM RELAYS

## SURCOM ASSOCIATES

2215 Faraday Ave., Suite A  
Carlsbad, California 92008  
(619) 438-4420

### DISCO & SOUND EQUIP...WTS

Sony C-37a mic, \$1250; (2) API 550a modules w/P.S., \$1500; EMT 140 ST reverb, \$3000; 2 ch Massenberg pre-amp, \$2000. Tony Campana. 313-553-4044.

Cerwin-Vega DM-1 disco mxr, high quality classic, no bells or whistles, \$125/BO. J Rudisill, Audio Independ-dence, POB 746, Aptos CA 95001. 408-684-0605.

Fostex 80-8 & 812 8-trk & 12-trk 2 rec console, rems, phantom pwr, peak hold, new Ampex tape & metal reel, manuals, all in orig boxes, exc cond, \$3950/BO. W Dougherty Jr, WLD Rec Std, Music Valley, Rt 1, Mill Spring MO 63952. 314-998-2681.

#### Want to Buy

Spectral processor, used, in excel cond w/manual; used Eventide effects gen in excel cond w/manual. Send info/price to: Heritage, POB 16, Boston MA 02167.

### FINANCIAL SERVICES

#### FINANCING ON ALL

#### RADIO EQUIPMENT

- Easy to qualify
- Fixed-rate, long-term leases
- Any new or used equipment & computers
- 100% financing, no down payment
- No financials required under \$50,000
- References available

Call Mark Wilson  
(800) 275-0185



Use Our Experience For Your Business

EQUIPMENT Financing, Lease Purchase Option. Need equipment for your radio, television or cable operation? New or Used. No down payment. Carpenter & Associates, Voice 501-868-5023 Fax 501-868-5401.

#### LIMITERS

#### Want to Sell

Harris Solid Statesman AGC, gd cond, \$150/BO; Gates Solid Statesman AGC, \$100/BO; RCA BA-6A w/manual, \$75. M Fitzner, WKCX, POB 1546, Rome GA 30162. 706-291-9770.

## SERVICES

#### REMOTE EQUIPMENT RENTALS

COMREX and GENTNER 1, 2 & 3-Line Extender Systems  
MARTI and TFT 450, 455 & 161 MHz RPU Systems  
SWITCHED-56 SYSTEMS  
Call or FAX Dwight Weller  
WELLER AUDIO-VISUAL ENGINEERING  
Phone: 410-252-8351 FAX: 252-4261

#### OBSTRUCTION LIGHTING

Beacons lights accessories  
FAX inquiries on your letterhead to:  
**ROHN** P.O. Box 2000 Peoria, Illinois 61656  
PH: (309) 697-4400  
FAX: (309) 697-5612

#### SPECIALIZING IN ERECTION, REPAIRING, PAINTING AND MAINTENANCE RADIO, TWO-WAY, T.V. TOWERS AND FLAG POLES

#### A STEEPLEJACK CO. PAINTING AND STEEPLEJACK CONTRACTORS

FULLY INSURED FOR YOUR PROTECTION  
DON HIGHLAY 3722 ROMA 713-462-6105 HOUSTON, TEXAS 77080

#### Tower Sales & Erection

Turnkey Site Development Installation & Maintenance AM/FM Broadcast, TV, Microwave Systems, Antennas & Towers  
**TOWERCOMM** Communications Specialists  
Ben Wall President 6017 Triangle Dr Raleigh, NC 27613 (919) 781-5496 Ger. Contr. Lic #5891 Fax (919) 781-6454

EV RE 27 (3), N/D, never used, still in cases, \$425 ea or all for \$1175. W Harris, WNPC, POB 189, Newport TN 37821. 615-623-8743.

Altec 639 (2), gd cond, \$450 ea; (2) RCA 77, gd cond, in use, \$900 ea. L Berel, On-Cue Recdg, POB 85042, Hollywood CA 90072. 800-726-9813.

Sony ECU 22 condenser mics (2), excel cond, \$350/pr. M Stewart, M&M Studios, 5712 Parker Rd, Modesto CA 95357. 209-523-0956.

AKG 202E two element mic, excel cond, \$120. D Kocher, Digital Sound Makers, 1901 Hanover Ave, Allentown PA 18103. 215-776-1455.

EV RE55 (2), exc cond in boxes & metal case, no clamps, \$340/pr. R Schneider, POB 80795, Springfield MA 01138.

Sennheiser M2002 binaural system w/dummy head, windscreens & JVC BN-5 binaural processor, \$350/BO. J Rudisill, Audio Independ-dence, POB 746, Aptos CA 95001. 408-684-0605.

RCA DX77 on orig floor stand w/3 wheels; RCA 4095A antique table-top mic stand; heavy duty accordion style mic arm w/base, BO. G Johnson, WLDY, POB 351, Ladysmith WI 54848. 715-532-5588.

AKG D-900 (2) dynamic shotgun mics, \$125 ea or \$225/both; (1) AKG N46E 2 mic AC power supply, \$50; Lectrosonic quad box, new, \$1175. E Toline, Audio Etc, 525 W Stratford Pl, Chicago IL 60657.

EV 676 supercardioid mics 3/\$200; EV RE10 mic, \$125. W Gunn. 619-320-0728.

Telefunken tube mic pre amps V-76, U-73 limiter's; RCA BA-21As, BA-1As; Altec tube mic-pres. Tracy Eaves, 615-821-6099 (evenings before 10PM EST).

Telefunken M921 dual (2-way, not front/back) nickel capsules, cardioid only, classic tube mic; Neumann KM84 pair, mint, \$1100. W Gunn. 619-320-0728.

Telefunken M-250, U-67, 221-A; Neumann U-67, KM-56, UM-57; RCA KV3A-10,0001, 44-BX, 77-DX, 8K-4, BK-5, 74-B, varicustics; Altec M-20, M-11, M-30 tube type mics. Trade or sale. Tracy Eaves, 615-821-6099 (evenings before 10PM EST).

#### Want to Buy

RCA BK-6B lavalier mic. D Dintenfuss, 7549 27th Ave NW, Seattle WA 98117. 206-784-4803.

Sennheiser 441 or Shure SM-81's in gd cond. W Dougherty Jr, WLD Recording Std, Music Valley, Rt 1, Mill Spring MO 63952. 314-998-2681.

CBS/NBC call-itr plate & antique floor mic stand for RCA 44 mic. M Harrington, POB 7619, Little Rock AR 72217. 501-223-9056.

Sennheiser K2U or K3U condenser mic power unit. E Davison, POB 7167, Springfield IL 62971-7167.

Any microphone processors (2), Symetrix, Valley, etc. B Dickerson, WEAG, 1421 S Water, Starke FL. 904-964-5001.

RCA 77DXa/44BXa ribbon, chrome/TV grey, gd cond, BO. R Kaulman, Pams Prods, POB 462247, Garland TX 75046. 214-271-7625, after 3PM CDT.

77-DX's, 44-BX's, KU-3A's On-Air lights. Top price paid. Fast response. Bill Bryant Mgmt, 2601 Hillsboro Rd, G12, Nashville TN 37212. 615-269-6131.

#### MISCELLANEOUS

#### Want to Sell

Lazy Susan wire cart rks, floor/table mds, several TT's w/preamp, tonearms, cartridges, Gates Stereo Statesman board (parts), BO. M Casey, WKXS, Drawer 1, Johnston SC 29832. 803-275-4444.

New 8 space grey carpet rack box w/front/rear panels, \$75. M Stewart, M&M Studios, 5712 Parker Rd, Modesto CA 95357. 209-523-0956.

Rack System, 12 VDC, 25 amp, regulated, adjustable from 10-14 VDC, \$125. J Parks, WCXN, River Rd, Middletown CT 06457. 203-347-2565.

Inventory Reduction Sale...over 500 item list. (Fax or Mail). Call Mark at 619-598-3311.

RTS Intercom PS-31 power supply, \$300; ADC audio patch bays, new, \$75. K O'Malley, WTAR/WLTY, 804-446-2731.

Retron Blowers for Elcom, Harris, CCA, CSI, McMorin, rebuilt & new. Goodrich Enterprises Inc. 11435 Manderson St Omaha, NE 68164 402 493 1886 FAX 402 493 6821

Anvil cases in various sizes w/rack rails. J Hunter, KBRE, Box 858, Cedar city UT 84720. 801-590-1277.

CSI Technologies 13F38405 5.2 microfarad, 15 KVDC oil capacitors, no PCB's, new, \$150. J Alexander, KMCL, POB 24, Notus ID 83656. 208-459-9047.

Powerstat 240 volt, 0-280 volt variable autotransformer, excel cond, \$400/BO. M Fitzner, WKCX, POB 1546, Rome GA 30162. 706-291-9770.

Mod-Tap, six 24-corrector telescopic patch fields for 19-inch rack mount, removed from svc, \$100/BO. M Starin, WGOT-TV, 457 Varney, Manchester NH 03120. 603-625-1165.

Onan 12.5JC-18R 12.5 kW standby generator, propane powered w/60 amp 3 phase transfer panel & all access, \$5000. J Hunter, KBRE, Box 858, Cedar City UT 84720. 801-590-1277.

Audio & RF tech manuals for Sparta equip, write for list. D Peluso, KJUL, 2880 E Flamingo #E, Las Vegas NV 89121. 702-732-2200.

JBL ceiling speakers, housing & volume controls (2), \$35 ea; Lil Miss Moffat 48V phantom power supply (2), \$22 ea; Broadcast Supply 6' equip mounting rails (2), \$20 ea, all items plus shipping. B Lord, Lord Bdctg, 13313 SE 208th, Kent WA 98042. 206-631-2374.

CLOSING UP SHOP. SELLING CHEAP!! Excel decks, amps, mixers, music & EFX libraries, 16" TT and 30's programs on 16" etc. Call for list: 708-739-0044.

Dummy loads, Bird air-cooled, oil filled 5 kW, 2.5 kW, 1 kW, 500 W. Goodrich Ent, 11435 Manderson St, Omaha NE 68164. 402-493-1886.

New up timers (2), 2" readouts, counts to 9:59 and resets, momentary closure resets unit to 0:00, \$65 postpaid. D Peluso, KJUL, 2880 E Flamingo #E, Las Vegas NV 89121. 702-732-2200.

Radio Sales training tapes on 16 VHS cass, 30 topics covered, station going non-profit, \$2000. R Trumbo, KNLF, POB 117, Quincy CA 95971. 1-800-397-4146.

WE SSA telephone speaker phone, \$50/BO plus UPS. E Davison, POB 7167, Springfield IL 62971-7167.

#### Want to Buy

Old Broadcasting Yearbooks wanted for research, the older the better. B Massey, WKYX, 360 Interstate N, Atlanta GA 30339.

Broadcast equip catalogs, literature, manuals, especially Collins Radio Company equip catalogs. J Stitzinger, 23800 Via Irana, Valencia CA 91355. 805-259-2011.

Radio transformers by Chicago, UTC, Triad, Peerless, Freed, Sola, send list. J Gangwer, 942 32nd St, Richmond CA 94804. 415-644-2363.

Jazz record collections, 10" LP/12" LP be-bop, swing, dixie, highest prices paid. B Rose, Program Recdgs, 228 East 10th, NYNY 10003. 212-674-3060.

#### MONITORS

#### Want to Sell

Belar FMM-1 & FMS-2 monitor, gd cond, \$2995/pair. C Murray, KMGE, 925 Country Club Rd #200, Eugene OR 97401. 503-484-9400.

## CONSULTANTS

#### W. LEE SIMMONS & ASSOC., INC.

BROADCAST TELECOMMUNICATIONS CONSULTANTS  
5 Gracefield Road  
Hilton Head Is., SC 29928  
1-800-277-5417  
803-785-4445  
FAX: 803-842-3371

#### Consulting Communications Engineers

- FCC Data Bases
- FCC Applications and Field Engineering
- Frequency Searches and Coordination
- AM-FM-CATV-ITFS-LPTV

**OWL ENGINEERING, INC.**  
1306 W. County Road. F, St. Paul, MN 55112  
(612)631-1338 "Member AFCCE"

#### MLJ

Moffet, Larson & Johnson, Inc.  
Consulting Telecommunications Engineers  
Two Skyline Place, Suite 800  
5203 Leesburg Pike  
Falls Church VA 22041  
(703) 824-5660  
FAX: 703-824-5672  
Member AFCCE

#### MULLANEY ENGINEERING, INC.

Consulting Engineers  
•Design & Optimization of AM Directional Arrays  
•Analysis for New Allocation, Site Relocation, And Upgrades AM-FM TV LPTV  
Wireless Cable (MDS/MDDS/ITFS/OFS)  
•Environmental Radiation Analysis  
•Field Work  
•Expert Testimony  
9049 Shady Grove Court  
Gaithersburg, MD 20877  
Phone: (301) 921-0115  
Fax: (301) 590-9757

#### Where In The World Are You?

Reach radio professionals worldwide by advertising in *Radio World's* international edition. Call Simone for more information.  
1-800-336-3045

#### T. Z. Sawyer Technical Consultants

AM-FM-TV-LPTV  
• FCC Applications & Exhibits  
• Experimental Authorizations  
• AM Directional Antennas  
• High Power Antenna Arrays  
• Frequency Studies  
• Class Upgrades  
• STL Applications  
• Station Inspections  
**1-800-255-2632**  
FAX: (301) 913-5799 • 6204 Highland Dr. • Chevy Chase, MD 20815

#### PC - SOFTWARE

AM FM TV Search Programs  
Contour Mapping-STL Paths  
RF HAZ-1990 POP Count  
FAA Tower-Draw Tower  
**Doug Vernier**  
Broadcast Consultant  
1600 Picturesque Dr  
Cedar Falls, IA 50613  
**800-743-DOUG**

#### EVANS ASSOCIATES

Consulting Communications Engineers  
TV • FM • AM • ITFS • Satellite  
FCC Applications, Design and Field Engineering  
Video/Data/Voice • Light Fiber & Microwave • Wide-Area Networks & STL's  
216 N. Green Bay Road  
Thienville, WI 53092  
(414) 242-6000 • FAX (414) 242-6045  
Member AFCCE

#### North America RF & Audio

**Mirkwood Engineering Services**  
Broadcast and Telecommunications Consultants  
Multidiscipline Engineering and Planning Firm including • Application & Allocation Services  
• Project, Engineering & Construction Management • Site Acquisition  
• Rural & Remote Site Installations  
• Field Service • Studio Design & Installation  
50 Park Ave. Claremont, NH 03743  
(603) 542-6764

**Don't Gamble with your advertising dollars.**  
Advertise in Radio World and reach 22,000+ subscribers.  
**Call Simone at 1-800-336-3045 today!**

Contact Radio World Newspaper for availabilities  
P.O. Box 1214 Falls Church VA 22041

1-800-336-3045



### MONITORS...WTS

Potomac Instruments AM-19 2 tower phase monitor, works but needs minor repair, clean, \$350 plus shipping; Gates/Harris AM mod mon, solid state, clean, \$200 plus shipping. B Elliott, WRFX, 915 E 4th St, Charlotte NC 28204. 704-338-9970.

#### Want to Buy

EBS system, encoder, decoder & AM rcvr, TFT or McMartin preferred. R Wells, KSRO, 1410 Neotomas Ave, Santa Rosa CA 95405. 707-545-3313.

Belar AMM2/3 mod monitors or others. G McClintock, WWCN/WNQM, 615-255-1377/1300.

McMartin (buy & sell) any model. C Goodrich, 11435 Manderson, Omaha NE 68164. 402-493-1886 or fax 402-493-6821.

### RECEIVERS & TRANSCIEVERS

#### Want to Sell

Attec 711A FM rcvr, early SS, selective, \$75 plus UPS. E Davison, POB 7167, Springfield IL 62971-7167.

DB 264 on 155.625 MHz, \$250+s/h; Motorola TOD6073A w/5.25 dB gain, 150-159 MHz freq, \$250+s/h; Cuschcraft BR-4, 42-50 MHz, \$60+s/h, all base stations. A Wes, KZPX, HCR 1 Box 286-D, Merrifield MN 56465. 218-765-3333.

### SCA RECEIVERS—ALL TYPES

Reading Service / Ethnic / Data Professional, Portable, Table

DAYTON INDUSTRIAL CORP. (Manufacturer) 4411 Bee Ridge Rd. #319 Sarasota, FL 34233 Tel: 813 378 5425 FAX: 3394

Sony SRF-A1 AM stereo walkman, new, quantities avail, \$89. C Fox, WOLF, 4853 Manor Hill Dr, Syracuse NY 13215. 315-468-0908.

Marti SCG-10 67 kHz subcarrier gen, SCG-10 39 kHz subcarrier gen, SCG-10 39 kHz sub carrier demod; AF1-55 67 kHz rcvr, 1 yr old; Marti CLA-40A amp. D Sorenson, SBC, 604 N Kiwanis, Sioux Falls SD 57104. 505-334-1117.

GE MPI 5 W VHF 2 chnl handheld, 136-150 MHz for meters no charger, \$50. P Russell, Bowdoin College, Sills Hall, Brunswick ME 04011. 207-725-3066.

**AM STEREO RECEIVERS**  
From \$34.95 Portable, Home, Auto  
**RRADCO**  
Phone/FAX 708-513-1386

Professional SCA demod card w/excel crosstalk rejection, \$20; Superadio III w/SCA, \$85, performance guaranteed. 1-800-944-0639.

### RECORDING SERVICES

CD 1-off copies from your DAT master. 48 hour turnaround. Integrated Digital Systems 310-478-4264 fax: 310-444-9224

### REMOTE & MICROWAVE EQUIPMENT

#### Want to Sell

Moseley TRC15 remote terminal & TR55A telemetry rcvr for STL system w/manuals & shipping, \$600. G Wise, WEKU, 102 Perkins Bldg, Richmond KY 40475. 606-622-1672.

Gentner SPH3A telephone interface, \$400. J Hunter, KBRE, Box 858, Cedar City UT 84720. 801-590-1277.

Marti RMC-30 w/30 functions, \$750. G Proctor, WCRJ, 980 FM 1746, Woodville TX 75979. 409-429-3679.

### COMREX RENTALS

1, 2 and 3-Line Extenders Switched 56 Systems Call Steve Kirsch for details Silver Lake Audio (516) 623-6114 FAX: 377-4423

Marti STL 10, 1991 system control w/4' dish & approx 700' coax, on 951.5. C Ratliffe, Rt 2, Box 178, Wadesboro NC 28170. 704-694-5040.

RCA BTR-11B remote control w/manual, working when removed, \$150/BO; (2) Marti M-30 BT remote pickup xmtrs, both on 161.76 w/manuals, \$450 ea; Raytheon RR-30 3-chnl remote amp w/manual, working, BO; RCA remote console, type BC-10A w/manual, gd cond, BO, prices do not include shipping. M Fitzer, WKCX, POB 1546, Rome GA 30162. 706-291-9770.

### RENTALS RENTALS RENTALS

#### COMREX 3-line extender

Frank Grundstein 215-642-0978 Audio/Video

Moseley PCL-303C STL system in gd cond, \$500. P Christensen, WIVY, 3101 University South, Jacksonville FL 32216. 904-646-0129.

Gates RDC-10 (3), 1 gd cond, 2 OK, 1 w/book, \$100/BO. D Carver, KZBK, 107 S Main, Brookfield MO 64628.

TFT 8800 STL, excel cond, spare, 2 RX, 2 TX w/TX combiner, meets 1993 specs, \$3500. R Potyka, KRXS, 1730 E Indigo, Mesa AZ 85203. 602-969-7707.

Moseley PCL-505 2 split-chnl xmtrs, (2) rcvrs & Decibel Products DB-8061-2B transmit combiner, working cond, \$2850. J Shadle, KPSN, 3719 N 32nd Ave, Phoenix AZ 85017. 602-279-5577.

Marti STL-10 mono STL xmtr & rcvr on 948.5 MHz, \$2000. J Callow, WAGN, 413 10th Ave, Menominee MI 49858. 906-863-1340.

Gentner EFT-3000 telephone line frequency extender (2), \$8250. D Becvar, KTIS, 3003 N Snelling Ave, St Paul MN 55113. 612-631-5047.

Moseley 303 (2) trans/ (2) receive. K Kuenzie, KFXE, 13E 11th, Washington MO 63090. 314-239-0209.

Complete broadcast facility, set up for talk, news & music, all late, high quality equip, 14' x 30', 2-axle mobile studio, less than 5 yrs old w/air-cond & restroom, ideal for emergency or export in any market. Nationwide Talk Radio, POB 68088, Oak Grove OR 97268. 503-774-0459.

1986 Winnebago LaSharo radio bdcg remote truck, ready to roll, cabinetry new, track lights, chairs, etc, \$12,000/BO. R Clark, WYFN, 9720 Executive Ctr Dr, St Petersburg FL 33702. 813-576-6090.

Burk Technology TC8, 3 yrs old, excel cond, \$1500. B Anderson, WTGY, POB 9, Charleston MS 38921. 601-647-5600.

Moseley TRC 15, 15 chnl remote control unit, gd working cond, no book, \$500/BO. L Nixon, Classic City Prod, 1094 Baxter St, Athens GA 30606. 706-613-6724.

Anixter-Mark 10' & 6' STL dishes grid style w/950 MHz feeds, call for price. J Hunter, KBRE, Box 858, Cedar City UT 84720. 801-590-1277.

Moseley TPT-2 STL transfer panel, gd cond, \$425. D Peluso, KJUL, 2880 E Flamingo #E, Las Vegas NV 89121. 702-732-2200.

15C PPP Raytheon color weather radar system mdi 4804C, 6' antenna, 50 mile range, VRM, EBL, plus many other features, \$3500. K Casey, 602-582-6550.

Wavetek 907AF, All mode signal generators (2), cover 7.0-12.4 GHz. Exc condition, with manual, \$1200 each, Douglas RF Devices (916) 688-5647.

#### Want to Buy

Marti RPT-15/similar 455 MHz. C Crouse, 814-837-9711.

Scala 960 mini-flectors STL antenna. K Kuenzie, KFXE, 13E 11th, Washington MO 63090. 314-239-0209.

Marti old tube remote pick-up xmtr or newer solid state xmtr & rcvr. G McClintock, WWCN/WNQM, 615-255-1377/1300.

Moseley, Marti, TFT, need STL xmtr & rcvr reasonably priced. R Bell, WRVB, 4314 Cherry Ct, Evansville IN 47714. 812-479-3377.

### SATELLITE EQUIPMENT

#### Want to Sell

Fairchild DCC card; McCurdy DIC-1; CO Magnetics time switch for Unistar hot country/adult rock, \$950. B Christie, Grande Radio Grp, POB 907, La Grande OR 97850.

## SATELLITE SAVINGS!

#### We buy & sell:

Fairchild DART 384 Scientific Atlanta Adcom 7550's

#### Unistar Rcvrs

#### 1806-24's

#### Sedat Cards

#### Microdyne

#### Great Tech

Support Before & After the Sale.

#### 90 Day

#### Guarantee

#### We Repair & Rebuild

#### Satellite Systems

(719) 634-6319

(Fax) 635-8151

Wegener 1806 Ku Band rcvr, 2 yrs old, excel cond, BO. J Hansen, WYRQ, 70 SE 1st Ave, Little Falls MN 56345. 612-632-2992.

Marcom/Prodelin 181-6 10' fiberglass dish, 8 bolt together sections, hand crank, \$350. B Dickerson, WEAG, 1421 S Water St, Starke FL. 904-964-5001.

Harris 6529 satellite rcvr (2), working, stereo, \$200 ea or \$400/all. Bud K, W4OAK, 4237 Airline Rd, Musk MI 49444. 616-733-4040.

7300 wideband BPSK rcvr, 7300 digital proc unit complete w/satellite dish, \$7000 cash. H Morgan, WHJM, 802 S Central Knoxville TN 37902. 615-546-4653.

### NEED A BACK-UP SCPC RECEIVER?

The fully-agile Universal SCPC 300-C Commercial SCPC

Broadcast Receiver can be tuned to any of your programming on CPC in one minute or less. The SCPC 300-C is frequency and transponder agile, all companding is built-in and selectable, microprocessor controlled, memory bank allows 3-second program change. All modem features, strand alone unit. An affordable quality SCPC receiver.

For full details and prices, SEE OUR AD IN THIS ISSUE and call Universal Electronics, Inc. at 614-866-4605.

Wegener 1608-II sat rcvr, needs some work, BO. C Knerr, KCNA, 139 SE J St, Grants Pass OR 97526. 503-474-7564.

#### Want to Buy

SEDAT 7.5 or 15 kHz satellite rcvr card for DAYNET. H Sell, KTRR, Box 727, Rolla MO 65401. 314-364-2525.

### STATIONS

#### Want to Sell

Mid-South Class A FM w/pending C2 (50 kW) upgrade, fully computerized digital automation system, on air one yr, great market acceptance, needs sales oriented owner-operator, \$250M, terms negotiable. 404-767-1840.

WFIC AM, Collinsville-Martinsville VA, 1000 watt Day, with/without real estate, will finance but prefer cash. Write or call Les Williams, 703-647-1530.

FM 99.1 commercial license avail, small Caribbean island, full studio & xmtr, package & manager/investor needed to start-up. Lou, Box 269, Anguilla WI. FAX 1-809-497-3770.

### MUST SELL

AM 500 Watt full time in central Ohio. Some terms, offers considered.

For info write to: Chamberlain, PO Box 69 Bellefontaine, OH 43311

AMs in Northern Maine (2), unique set-up, great first ownership for the right person, \$140,000. T Beardsley, WSJR, 6 10th Ave, Madawaska ME 04756. 207-728-4000.

1 kW FT AM in small single station market in South Central Virginia, \$125,000 includes building, serious cash inquiries only. WODI, 1230 Radio Rd, Brookneal VA 24528. 804-376-2288.

5kW day/29W nite w/new tower/ground system, w/4 acres in Jacksonville, FL metro market. Beautiful historic beach town. Best cash offer over \$200,000. Bill, 205-238-0281 or Mark, 205-236-6484.

#### Want to Buy

Qualified & exper announcer, mgr, engineer, salesman seeks AM or FM to buy w/no money down, owner financing, will consider GM also, if buy out possible in future. E Smith, POB 1341, Florence MS 39073-1341. 601-845-1920.

AM/FM/combo/CP, small/med mkt, pref southwest, off air/troubled OK, exper owner w/cash & equip. D Carver, KZBK, 107 S Main, Brookfield MO 64628.

Station in Southeast U.S., prefer SC, NC, GA, FL or TN, will consider all, down payment w/owner financ, reply in conf to: Radio, 104 Pearson Rd, Easley SC 29642.

FM or AM/FM combo in North Central Iowa or South Central Minnesota. G Hawley, 3708 240th St, Clear Lake IA 50428. 515-357-7870.

### STEREO GENERATORS

#### Want to Sell

McMartin BFM 1521 tested & guaranteed, also mono & stereo audio processors. Goodrich Ent, 11435 Manderson St, Omaha NE 68164. 402-493-1886.

#### Want to Buy

CCA SG-1E composite stereo gen for CCA FM-40E exciter, working or service-able cond OK, documentation required. C Dunnam, Linear Research Assoc, 5244 Perry City Rd, Trumansburg NY 14886. 607-387-3411 or fax 607-387-7806.

### TAPES/CARTS & REELS



**A&D**  
**Cart Rebuilding**  
Do Bad Carts Have Your Temperature Rising?

Let A&D clean, load & pack your carts. They'll be serviced within 10 working days! Guaranteed!

3706 Vold Ct. 715-635-7347  
Eau Claire WI 54701 Fax: 715-835-1151

#### Want to Sell

Airchecks of the 50's-60's-70's-80's, also some video airchecks of KOMA. B Eckart, Box 803, Mustang OK 73064.

100 7" w/1200' tape in mailers, \$1 ea/BO; (30) 5" w/600' tape in mailers, \$.75 ea/BO. D Carver, KZBK, 107 S Main, Brookfield MO 64628.

Fidelipac Mester carts, most 4 min long w/country songs recorded, \$300/all or \$.50 ea. KD Austin, KFXI, 1101 Hwy 81N, Marlow OK 73055. 405-658-9292.

Oldies/A.C. music library, approx 80 reels w/tones, \$350 plus shipping. F Willis, WKXH, POB K, Alma GA 31501. 912-632-0104.

Collection of Jazz 7" reels & LPs from 1920-1980, \$100 or will trade for Tascam or Teac 2-chnl cassette deck. D Pulwers, Dave's Price Audio Productions, 310 N Howard St #103, Alexandria VA 22304. 703-751-9346.

Fidelipac Gold Mastercarts, music lengths, \$1 ea; Gray, 300 carts, \$.25 ea, you pay shpg. E Moody, KJEM, 216 N Main, Bentonville AK 72712. 501-273-9039.

Mix format on Scotchcart II's, 3274 songs, 6 mos old, \$8950; Scotchcart II's, music sizes, some new, others 6 mos old, \$2-2.50 ea; Abco & Fidelipac wire cart racks, hold 50 & 25 carts ea, \$20 & 15 ea, plus shipping. B Lord, Lord Bdcg, 13313 SE 208th, Kent WA 98042. 206-631-2374.

Transcriptions, 16" including armed-forces radio shows & Hawaii Calling shows, trade for other transcripts or equip. R Wells, KSRO, 1410 Neotomas Ave, Santa Rosa CA 95405. 707-545-3313.

Pams Jingles ref tapes, 1951-1976, BO. R Kaufman, Pams Records, POB 462247, Garland TX 75046. 214-271-7625.

#### Want to Buy

Library desperately needs music from 40's-50's-60's-70's, records & tapes, ASAP. S Stevenson, POB 1288, Blaine WA 98231. 604-531-4576, leave msg.

Century 21, TM, Bonneville or other syndicated reel tapes, all formats, will consider CDs, complete sets only. R Simonson, Box 206, Oshtemo MI 49077. 616-363-8561.

Gold Discs 1 or all, radio CDs of all kinds. K Kuenzie, KFXE, 13E 11th, Washington MO 63090. 314-239-0209.

### TAX DEDUCT EQUIP

#### Want to Sell

Destitute high school radio station requires tax-deductible donation of 1 kW transmitter or amplifier or working exciter. B Long, WSTB Streetsboro High School, 1900 Annalane Dr, Streetsboro OH 44241. 216-626-4906.

Non comm educ FM station for blind & handicapped needs equipment from microphone to tower. Fred, Aaron Svcs, POB 181, Collinsville MS 39325. 601-626-7061.

Non-profit student broadcast program seeks old/used equip, any cond, will pay S&H. L Jackson, 616-445-8093.

Educational radio needs bdcg & std equip, legal & IRS recognized, will pay s/h & give receipt. Dr Newcomb, GRRN, 19130 Nelson-Parkman Rd, Garrettsville OH 44231. 216-643-4125.

### TEST EQUIPMENT

#### Want to Sell

Potomac AT-51 test set, excel cond w/transformers, \$2995. J McPhearson, Blue Ridge Bdcg, 14926 Ampstead Ct, Centreville VA 22020. 703-968-7492.

Heathkit IM-2420 freq counter, gd cond, w/manual, \$150/BO; HP 200C audio oscillator, gd cond, \$200/BO; RCA WO-91B scope w/manual, \$100/BO plus shipping; B&W 210 audio oscillator in vgc w/manual, \$100 plus shipping. M Fitzer, WKCX, POB 1546, Rome GA 30162. 706-291-9770.

General Radio 916 impedance bridge, \$300. T Nelson, WCAL, St Olaf College, Northfield MN 55057. 507-646-3328.

Westcom Hameg HM103-3 oscilloscope, \$270 plus shipping. B Lord, Lord Bdcg, 13313 SE 208th, Kent WA 98042. 206-631-2374.

# TRANSCOM CORP.

Serving the Broadcast Industry Since 1978

Fine Used AM & FM Transmitters and Also New Equipment

For the best deals on Celwave products, Andrew cable and Shively antennas.

- |                                  |                                |
|----------------------------------|--------------------------------|
| 1 kW FM 1978 Collins 831C2       | 2.5 kW AM 1982 CCA 2500D       |
| 2.5 kW FM 1978 CCA 2500R         | 2.5 kW AM 1976 McMartin BA2.5K |
| 3 kW FM 1975 CCA 3000D           | 5 kW AM 1977 RCA BTA 5L        |
| 3 kW FM 1974 Harris FM3H         |                                |
| 3.5 kW FM 1979 Syntronics SI-F-3 | 50 kW AM 1977 CCA AM50,000D    |
| 10 kW FM 1970 Collins 830F2      | 50 kW AM 1979 Harris MW50B     |
| 15 kW FM 1971 AEL 15KG           |                                |
| 25 kW FM 1981 Harris FM25K       |                                |
| 30 kW FM BE FM30                 |                                |

1077 Rydal Road #101  
Rydal PA 19046

800-441-8454 • 215-884-0888 • FAX No. 215-884-0738

Circle (111) On Reader Service Card

**MARATHON PRODUCTS COMPANY**  
Audio Cartridge Rebuilding Division

Rebuilding/reloading, like new, all brands, any length up to & including 3.5 minutes, \$1.75 ea. FOB out plant, 48 hrs delivery.

New NAB Marathon cartridges prices on request.  
35 Years professional experience!  
Lifetime member AES R.D. MYERS Sr.  
Manufacturers of Audio Devices, Continuous Tape Mag.

**69 Sandersdale Rd.  
Charlton, MA 01507**  
1-508-248-3157 or 1-508-853-0988

Circle (82) On Reader Service Card

**TEST EQUIPMENT...WTS**

ITT 1735D 17" oscilloscope w/manual, needs work but clean. BO. R Meyers, Benchmark Comm Corp, 4700 SW 75th Ave, Miami FL 33155. 305-264-2357.

Potomac AG-51/AA-51 test set in A-1 cond, \$2700 plus UPS. J Fernandez, Box 3047, Bayamon, P.R. 00960. 809-796-7281.

**We Have RENTAL EQUIPMENT available to SAVE YOU MONEY**

Spectrum Analyzer  
Potomac Field Strength Meters  
Impedance Bridges  
Receiver/Generator  
Audio Test Set

ALSO

Other Equipment Available

**RADIO RESOURCES**

Ask for STEVE, BILL or Chuck  
**1-800-54-RADIO**

Crown RTA-2 analyzer, \$1400; Klark-Teknik DN60 real time analyzer, \$1850. R McMillen, Super Duper Audio Duplicating, 1634 SW Alder St, Portland OR 97205. 503-228-2222.

**Want to Buy**

Manke M-1 wow & flutter meter in gd cond, top dollar pd. E Davison, POB 7167, Springfield IL 62791-7167.

Audio Precision, HP, Neutrik, Tek, Sound Tech or similar decent audio test gear. W Dooley 818-798-9128.

**TRANSMITTERS**

**Want to Sell**

Gates BC1G 1kW AM, needs mod xformer, \$750 plus shipping; (2) tower phasing units, full of inductors & caps, \$750 plus shipping, willing to part out phasor cabinet. B Elliott, WRFX, 915 E 4th St, Charlotte NC 28204. 704-338-9970.

Exciters: McMartin B-910 tuned and calibrated to your frequency, guaranteed: Mono, stereo, SCA, Goodrich Ent. Inc. 11435 Manderson St., Omaha, NE 68164. 402-493-1886 FAX: 402-493-6821

Sparta 610 250 W FM, \$500. S Homer, KBBY, 6150 Olivias Pk Dr, Ventura CA 93002. 805-654-0577.

ITA FM 10,000C, 10 kW, rebuilt, new tubes & sockets w/spares, ready to run. T Mohr, WCLS, POB 296, Oscoda MI 48750. 517-739-8180.

Continental 816R-2B 21.5 kW FM w/802A exciter tuned to 107.5 MHz, 2 yrs old, cash and/or cash plus trade for 2.5-5 kW FM xmtr. S Wallington, K-Love Radio, 2290 Airport Blvd, Santa Rosa CA 95403. 707-528-9236.

Collins 830H 1A 20 kW, 1967, 2 10 kW driver halves driven by IPA ctr cabinet, some spare parts, \$12,000 FOB our xmtr bldg. T Nelson, WCAL, St Olaf College, Northfield MN 55057. 507-646-3328.

Gates 20H, exc cond, \$15K. S Wodlinger, WIXI, 3337 Tamiami Trl N, Naples FL 33940. 813-262-1000.

Harris IG 1 kW AM, gd cond, \$4500; Harris Vanguard I, 1 kW AM, gd cond, \$2900; Robert Jones J-318 FM booster, 10 watts, \$2500; CSI exciter FM synthesized tuned from 88 to 108, 10/W gd cond same QEI 675 a few spare boards, \$550. J Arzuaga, WREI, Rd 2 KM 102.5, Quebradillas PR 00678. 809-625-2725.

Kintronics PS-1 AM low pwr w/2 pwr levels, pwr reduc for nighttime, \$1000. S Buchanan, WPRZ, POB 3220, Warrenton VA 22186. 703-349-1250.

Emcee HTU-100 TV tube-type translator, chnl 70 in/78 out, gd cond, \$800+s/h. A Wes, KZPX, HCR 1 Box 286-D, Merrifield MN 56465. 218-765-3333.

**NEW McMARTIN BF-5K**  
Lowest priced tube replacements

5500 W FM, broadband grounded grid output circuit, VSWR protection, excellent efficiency 75-80% automatic recycling & overload status. Fully remote controlled. FCC approved to 5500 watts.

**Goodrich Enterprises, Inc.**  
11435 Manderson Street  
Omaha, NE 68164  
402-493-1886  
FAX: 402-493-6821

Bauer 1 kW minor repair, \$2500. F Willis, WKXH, POB K, Alma GA 31510. 912-632-0104.

Gates FM5H 5 kW FM, rebuilt w/McMartin BFM8000 exciter, package \$16K. R Miller, Miller Media Group, POB 169, Taylorville IL 62568. 217-824-3395.

Collins 30K-4 dual chnl 2-30 MHz AM voice or key 300 W, gd cond, police or aviation xmtr, trade for stereo exciter/TE-3 or eqv. J Cunningham, KHKC, Rt 2 Box 113B, Stonewall OK 74871. 405-265-4496.

Gates BC-10P AM, used only as stand-by, \$10,000. G Proctor, WCRJ, 980 FM 1746, Woodville TX 75979. 409-429-3679.

Gates TE-3 FM exciter, stereo, SCA on 95.1 MHz, exc cond, \$350/BO plus UPS. L Van Prooyen, WGRD, B330 Myers Lk, Rockford MI 49341. 616-874-9242.

CSI T-3-F1 w/harmonic filter at 99.5 w/spare tubes, excel cond, \$7000/BO. R Hays, KRLB, 5800 Quick, Lubbock TX 79405. 806-745-5800.

McMartin BF-25K 10-25 kW FM xmtr, completely refurbished & tuned & tested to your freq, guaranteed; 1 kW AM xmtr. Goodrich Ent., 11435 Manderson St, Omaha NE 68164. 402-493-1886.

**FM - TRANSMITTERS**  
Factory new not used. Why buy a used Transmitter when you can own a new FM Transmitter for about the same cost? Call JIMMIE JOYNT at 214-335-3425.

RCA BT-1D 1 kW FM tuned to 104.3 MHz, w/Harris MX-15 exciter, recond but never used, \$8000 FOB Las Vegas NV. Harris exciter alone, \$2500 prepaid UPS. D Peluso, KJUL, 2880 E Flamingo #E, Las Vegas NV 89121. 702-732-2200.

Gates BC-5P/2, 5 kW AM, excel cond, \$5,000. G Proctor, WCRJ, 980 FM 1746, Woodville TX 75979. 409-429-3679.

Moseley 505-C xmtr/rcvr, factory type accepted, unit at Moseley, will ship recalibrated to your freq. C Murray, KMGE, 925 Country Club Rd #200, Eugene OR 97401. 503-484-9400.

Bendix TDD-5 30 W AM, new gov surplus, modified to cover your freq, tube type, 62 LBS, plate modulation, \$300. J Cunningham, KHKC, Rt 2 Box 113B, Stonewall OK 74871. 405-265-4496.

Harris FM 2.5K 2500 W, one owner, w/spare tube, spare blower, MS-15 exciter, \$10K. R Miller, Miller Media Group, POB 169, Taylorville IL 62568. 217-824-3395.

Collins 20V3, 1290 kHz, for use or parts, BO. G Erway, KKSJ, POB 40309, Santa Barbara CA 93140. 805-560-1290.

RCA BTF-1E2 1000 W FM w/stereo exciter type BTE-15A, solid state. John, 405-672-2593.



GCR-201 25 & 40 Amps, 17,000 Volts  
Features:  
1. Lowest priced RF contactor in the world.  
2. Large microswitches; powerful solenoids.  
3. 50% less moving parts than competition.

**GELECO:**  
Ph: (416) 421-5631  
Fax: (416) 421-3880

Harris MS15 technical manuals; MS15 exciter & modules, Vol 1 & 2, \$25 FOB USA Continent. E Davison, POB 7167, Springfield IL 62971-7167.

Schematics of any tube type cathode modulation AM bcd xmtrs from late '50s through '70s, up to \$30. J Cunningham, KHKC, Rt 2 Box 113B, Stonewall OK 74871. 405-265-4496.

Harris MW1A 1 kW solid state, gd cond, \$8500. B King, 1809 Lightsey, Austin TX 78704. 512-832-4061.

CSI exciter FM synthesized tuned from 68 to 108 10 w/gd cond, same QEI 675, a few spare boards, \$550. J Arzuaga, WREI, Rd 2 KM 102.5, Quebradillas PR 00678. 809-895-2725.

Harris IG 1 kW AM, gd cond, \$4500; Harris Vanguard I, 1 kW AM, gd cond, \$2900; Robert Jones J-318 FM booster, 10 W, \$2500. J Arzuaga, WREI, Rd 2 KM 102.5, Quebradillas PR 00678. 809-895-2725.

Continental/Bauer 1 kW AM, minor repairs, \$2500. F Willis, WKXH, POB K, Alma GA 31510. 912-632-0104.

Used & New Transmission Line, many sizes & lengths, many like new. 816-635-5959.

**Want to Buy**

Complete translator packages & SCA receivers. M McNiell, KNON, POB 710909, Dallas TX 75371. 214-823-1326.

**USED TV TRANSMITTERS,**  
antennas, cable, rigid line, etc.  
one watt to 110 kW.  
**BUY — SELL BROADCASTING SYSTEMS**  
602-582-6550  
FAX: 602-582-8229  
Kenneth Casey

Continental & 103.3 exciter, gd cond. 305-292-5009.

Any 250 W AM, no PCB's, on or near 1360 kHz, small stature & foot print desired, will consider all except junkers. C Rohde, KNRB, 121 NE Loop 820, Hurst TX 76053. 817-589-1100.

Harris MX-15 FM exciter, must be in good condition. G Sapiano, WLNG, POB 2000, Sag Harbor NY 11963. 516-725-0803.

Collins 820 F1 or other gd 10 kW AM xmtr. G McClintock, WNQM, 1300 WWCAR Ave, Nashville TN 37218. 615-255-1300.

Any FM 3 kW, needing repair OK. R Bell, WRVB, 4314 Cherry Ct, Evansville IN 47714. 812-479-3377.

Used 20 kW FM, 1980 or newer. W Wilson, KJTY, 1005 SW 10th Ave, Topeka KS 66604. 913-357-8888.

**Wanted Dead or Alive**  
FM Transmitters  
Any Age or Power  
414-482-2638

AM xmtrs including: Collins 20V Series, 300J, 500J & RCA BTA-500 or BTA-1, will arrange shipping for operational restorable units. G Lee, POB 5786, Beverly Hills CA 90209. 310-696-0177.

CCA 10A DS 10 W exciter, send info/description/price to Heritage, POB 16, Boston MA 02167.

5 kW stereo FM in gd working cond w/exciter. D Royer Sr, POB 3384, Kinston NC 28501. 919-523-5151.

McMartin AM/FM xmtr, any model, exciter or stereo modules. Goodrich Ent., 11435 Manderson, Omaha NE 68164. 402-493-1886.

**TUBES**

**Want to Sell**

**D and C Electronics Co.**  
Lowest Price on Tubes including:  
4-1000A/3-1000Z/  
8877/4CX250B/833A  
4-500/5-500/4-400/  
4CX 3500/5CX1500  
and much more!  
Factory Warranty!

**1-800-881-2374**  
**(904) 688-2374**

Se habla Español  
FAX: (904) 683-9595

Small tubes, amp, Rx & some small Tx, approx 500, all new in boxes, call or write for copy of inventory list, to be sold in large lots. BO. T Nelson, WCAL, St Olaf College, Northfield MN 55057. 507-646-3328.

**ECONCO**  
Quality Rebuilt Tubes  
Approximately 1/2 the Cost of New  
Call for Our Price List  
**800-532-6626**  
**916-662-7553**  
**FAX 916-666-7760**  
Circle (7) On Reader Service Card

Gates BC1G (2) 900 kHz vacuum crystals to plug-in octal socket, \$100 ea. R DuFault, Chesapeake Engineering, 1308 White Way, Laurel MD 20707. 410-792-0851.

**MIKE FORMAN ELECTRON TUBES**  
Solid State Replacement Rectifiers for 872 A Mercury Vapor Rectifiers.  
New: \$19.95 each.  
**510-530-8840 Fax: 510-530-0858**

**JOLIDA INC.**  
Annapolis Junction, MD  
CALL  
**1-800-783-2555**  
3CX1000A3, 3CX1500A7, 3-500G, 4CV100000C, 4CX1000A, 4CX1500B, 4CX1000D, 4CX250B, 4CX300A, 4CX35000C, 4CX350A, 4CX5000A, 4-400A, 4-400C, 572B, 6146B, PL328/TH328, PL347/TH347, 807, 813, 833A, 833C, and more...  
**CALL 1-800-783-2555**  
**JOLIDA INC.**  
Annapolis Junction, MD

**PETER DAHL CO.**  
*Save \$\$*

Heavy Duty Replacement Transformers, DC Filter chokes and capacitors for AM & FM transmitters manufactured by: AEL, CCA, CSI, COLLINS, CONTEL, CONTINENTAL, BAUER, GATES, GE, HARRIS, ITA, McMARTIN, RAYTHEON, RCA, SINGER, SINTRONIX, WILKINSON. Many other models also available.

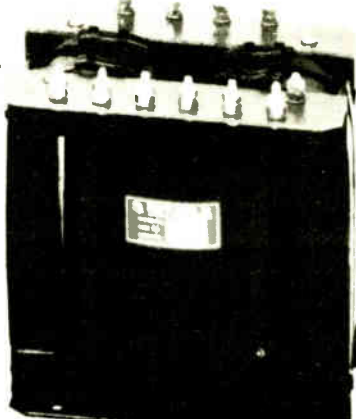

**FAST Delivery and FREE Technical Support.**

**5869 WAYCROSS AVENUE EL PASO, TEXAS 79924**  
(915) 751-2300 TELEX: 76-3861 PWDCO  
FAX: (915) 751-0768

Circle (202) On Reader Service Card

**FM BROADCASTERS!!**  
We can meet all your FM transmitter needs!!

**SOLID STATE**  
Amplifiers and transmitters are available at the popular levels of 25, 100, 300, 500, 1000, 1500, 2000, 2500, 3000, 4000 and 4500 watts. All units are broadbanded and designed for local and remote operation.

**ZERO BIAS GROUNDED GRID TRANSMITTERS**

**SINGLE TUBE—MEDIUM POWER**  
Offered at 1.5, 3.5, 5.5, 7.5 and 12KW. These transmitters include a broadbanded solid state IPA, which can be used as emergency transmitters and a single zero biased grounded grid triode in their PA.

**TWO TUBE—HIGH POWER**  
These transmitters utilize two grounded grid triodes and are available at standard outputs of 15, 22, 25, 30, 40 and 50KW.

*"The Transmitter People"*  
**Energy-Onix**  
752 Warren Street, Hudson, New York 12534  
(518) 828-1690 FAX (518) 828-8476  
A Wise Enterprise

Circle (73) On Reader Service Card

**TUBES...WTS**

**REBUILT ELECTRON TUBES**

Partial List: 6623, 23791, TH150, 6425F, 5604, 6696, 6697, 5681, 5682, 5671, 7804, 3CX10,000H3, 3CX20,000H3, 4CX5000A, 4CX35,000C

Worn out power tubes purchased

**Vacuum Tube Industries, Inc.**

1-800-528-5014  
508-584-4500 X75

4-1000A, 8877, 4CX250B, 4CX1500B, 4CX3000A & more. We carry large inventory all major brands, Eimac, Amperex, RCA, etc. Call Stew 1-800-842-1489.

**For the Best Price**

& 24 Hr service on transmitting tubes call 402 493 1886 day or night. FAX 402 493 6821.

**Want to Buy**

**TRANSMITTER TUBE REBUILDING**

**FREELAND PRODUCTS INC.**  
75412 HWY. 25  
Covington, Louisiana 70433  
U.S.A.

— Since 1940 —

1-504-893-1243

FAX: 1-504-892-7323

**TURNTABLES**

**Want to Sell**

Russco CueMaster TTs (2) in gd cond, \$100 ea; Russco TT w/no motor, \$50; Russco Studio Pro TT, \$100; (2) Russco Studio Pro TTs w/tonerarms, excel cond, lo hrs, \$200 ea, prices do not include shipping. M Fitzner, WKCX, POB 1546, Rome GA 30162. 706-291-9770.

QRK/Russco 12C TTs, excel cond, \$99. C Roberts/R Zorn, Mars Hill Bdcg, 4044 Makyes Rd, Syracuse NY 13215. 315-469-5051.

JVC 44-DD-5 quadrophonic disc demodulator, never used. \$125/BO. D Pulwers, Dave's Price audio Prod, 310 N Howard St, Ste 103, Alexandria VA 22304. 703-751-9346.

Stanton 310b phono preamp, low hrs, \$195. R McMillen, Super Duper, 1634 SW Alder St, Portland OR 97205. 503-228-2222.

Technics SL1200 MKII, very gd w/cartridge, \$325/BO. J Rudisill, Audio Independence, POB 746, Aptos CA 95001. 408-684-0605.

RTS-405 stereo TT preamp (2), \$190 ea plus shpg. B Lord, Lord Bdcg, 13313 SE 208th, Kent WA 98042. 206-631-2374.

Keith Monks record cleaner, \$650; Keith Monks anti-static Lp sleeves, never opened, \$24/box of 300. R McMillen, Super Duper Audio Duplicating, 1634 SW Alder St, Portland OR 97205. 503-228-2222.

**VIDEO TAPE RECORDERS**

**Want to Sell**

Sony VO-2610, 3/4" U-matic VTR, 2 audio chns, auto repeat, vgc, \$250. C Yengst, WAWZ, Zarephath NJ 08890. 908-469-0991.

## ACTION-GRAM

**Equipment Listings**

Radio World's Broadcast Equipment Exchange provides a FREE listing service for all broadcast and pro-sound end users. Simply send your listings to us, following the example below. Please indicate in which category you would like your listing to appear. Mail your listings to the address below. Thank you.

Please print and include all information:

Contact Name \_\_\_\_\_  
Title \_\_\_\_\_  
Company/Station \_\_\_\_\_  
Address \_\_\_\_\_  
City/State \_\_\_\_\_  
Zip Code \_\_\_\_\_  
Telephone: \_\_\_\_\_

I would like to receive or continue receiving

**Radio World FREE each month.**

Yes  No

Signature \_\_\_\_\_ Date \_\_\_\_\_

Please Circle only one entry for each category:

**I. Type of Firm**

- D. Combination AM/FM station F. Recording studio  
A. Commercial AM station G. TV station/teleprod facility  
B. Commercial FM station H. Consultant/ind engineer  
C. Educational FM station I. Mfg. distributor or dealer  
E. Network/group owner J. Other \_\_\_\_\_

**II. Job Function**

- A. Ownership G. Sales Manager  
B. General management E. News operations  
C. Engineering F. Other (specify) \_\_\_\_\_  
D. Programming/production \_\_\_\_\_

Brokers, dealers, manufacturers and other organizations who are not legitimate end users can participate in the Broadcast Equipment Exchange on a paid basis. Line ad listings & display advertising are available on a per word or per inch basis.

WTS  WTB  Category: \_\_\_\_\_  
Make: \_\_\_\_\_ Model: \_\_\_\_\_  
Brief Description: \_\_\_\_\_  
Price: \_\_\_\_\_

\*Closing for listings is the first and third Fridays for the next month's issue. All listings are run for 2 issues unless pressed for space or otherwise notified by listee.

**Broadcast Equipment Exchange**

Phone: 703-998-7600 PO Box 1214, Falls Church, VA USA 22041 FAX: 703-998-2966

## This Month's Crossword

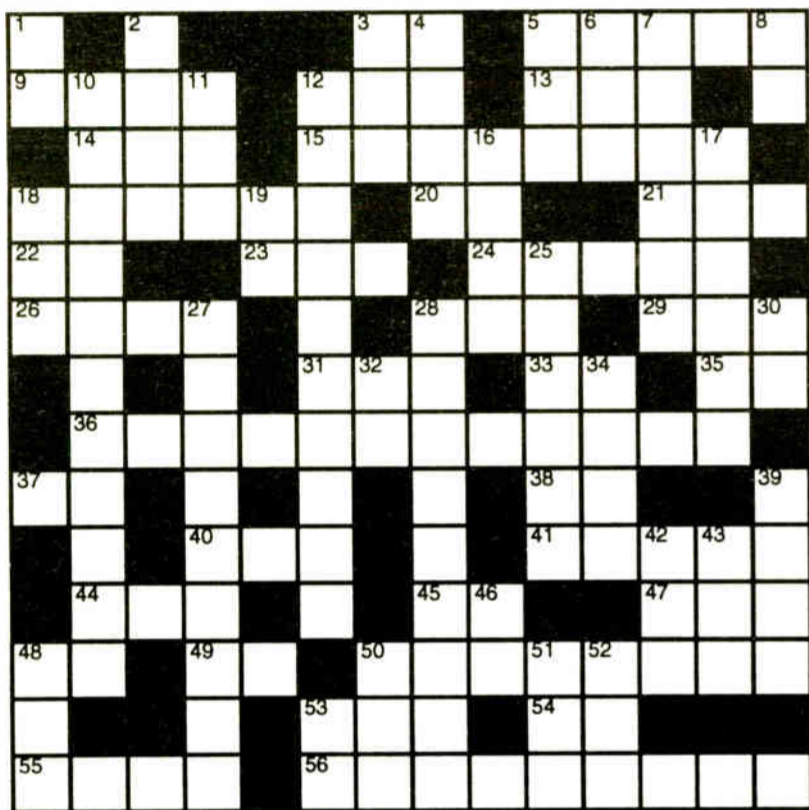

by Steve Walker

solution in next issue of RW

**ACROSS**

**DOWN**

1. Nighttime
5. Experiments
9. Fake
12. Force open
13. Johnson/Evinrude motor parent
14. Spark
15. Action/ \_\_\_\_\_
18. Kind of skiing
20. Time out
21. \_\_\_\_\_ goes the weasel
22. Prairie State
23. Clock maker
24. Computer communication device
26. Prima donna
28. Male/female name
29. Wind instrument
31. Golf term
33. American Samoa (abbr)
35. Distance receive
36. CD 10
37. Hello
38. Prefix meaning not
40. Poem
41. To be stingy
44. 6th sense
45. ITC Cart designation
47. 19th Greek letter
48. Upon
49. Prefix, from
50. Digital cart machine with built-in phone interface
53. Lion
54. One of Jack's giant's favorite words
55. Bird
56. Possession

1. Type of flip-flop
2. Cover
3. Prefix meaning before
4. "Perfect fit" RF components
5. Toddler
6. Type of interference (abbr.)
7. Expensive test sets
8. Secret Service
10. Expand\*Ability
11. Bought by Sony
12. Whirlwind Active Press Box
16. Unconscious state
17. Wanderers
18. Assistance
19. Cornhusker State
25. Tape decks
27. "True blue" carts
28. Portable One is made by Audio \_\_\_\_\_
30. Roman numeral XIX + I
32. Morning
34. Kitchen thing
39. Cowboy accessory
42. Communications company
43. \_\_\_\_\_ Tse-Tung
46. Movie rating
48. French Yes
50. Condensation
51. Flying with instruments
52. Help!
53. \_\_\_\_\_ and behold

# ADVERTISER INDEX

This listing is provided for the convenience of our readers. Radio World assumes no liability for inaccuracy.

Page No.	Advertiser	Reader Service No.	Page No.	Advertiser	Reader Service No.
38	AEQ	90	19	Hnat Hinds	143
29	AMP Services	23	19	Hnat Hinds	27
9	ATI	119	19	Hnat-Hinds	211
24,25	Arrakis	55	40	J & I	12
29	Audio Broadcast Group	177	31	LDL	8
8	Audio Precision	32	42	LPB	95
47	Audioarts Div. of Wheatstone Corp.	53	44	Marathon	82
2	Audioarts Div. of Wheatstone Corp.	26	15	Marti	184
34	Belar	37	17	Micro Technology Unlimited	142
31	Benchmark Media	45	18	Murphy Studio Furniture	81
29	Broadcast Devices	108	11	Myat	138
36	Broadcast Electronics	30	26	Orban/AKG/dbx	46
10	Broadcast Services	193	12,13	Otari	134
27	Broadcasters General Store	137	45	Peter Dahl Company	202
4	Burk Technology	94	32	Potomac Instruments	180
2	Burk Technology	141	39	QEI	59
7	CCA Electronics	161	22	RE America	88
21	California Digital	200	20	Radio Concepts	92
29	Cellcast Communication Products	54	40	Radio Resources	132
31	Comrex	16	15	Radio Spirits	107
3	Comrex	182	7	Radio Systems	97
16	Continental Electronics Corp.	51	10	Radio Systems	42
28	Corporate Computer System (CCS)	173	19	Radio Systems	104
29	Cortana	68	27	Radio Systems	9
35	Cutting Edge	40	34	Radio Systems	123
9	Dataworld	153	17	Reef Industries	39
32	Dataworld	15	3	Rodman Brown & Associates	78
29	Dielectric	157	29	S.C.M.S.	33
36,37	Dolby	102	33	SBE	214
31	Econco	50	31	Shively Labs	98
45	Econco	7	8	The Express Group	165
45	Energy Onix	73	31	The Management	120
32	FM Technology	145	31	Third Story Recording	186
14	Fidelipac	169	44	Transcom	111
23	Fidelipac	127	31	Universal Electronics	96
29	Gorman Redlich	31	31	Valley Audio Products	75
40	Hall Electronics	84	48	Wheatstone	164
1	Harris-Allied Broadcast Equipment	99	29	Zercom	151
6	Harris-Allied Broadcast Equipment	18,125			
30	Harris-Allied Broadcast Equipment	17,83			
32	Harris-Allied Broadcast Equipment	72,118			

Publisher .....Stevan B. Dana  
Associate Publisher .....Carmel King  
Marketing Consultant .....Al Leon  
Marketing Assistant .....Annette Deutscher  
Production Director .....Kim Lowe  
Production Manager .....Julianne Stone  
Production .....Vicky Baron, Lisa Lyons, Lisa Mamo  
Ad Coordinator .....Regan Deatherage  
Ad Coordination Manager .....Simone Mullins  
Circulation Director .....Tiana Hickman  
Circulation Manager .....Rebecca Seaborg  
Accounts Receivable .....Steve Berto

**Advertising Sales Representatives**

U.S. East: Skip Tash .....703-998-7600 Fax: 703-998-2966  
U.S. West: Dale Tucker .....916-721-3410 Fax: 916-729-0810  
International: Stevan B. Dana .....+1-703-998-7600 Fax: +1-998-2966  
Europe: Dario Calabrese .....+39-2-753-0274 Fax: +39-2-753-2697  
Japan: Eiji Yoshikawa .....+81-3-3327-2688 Fax: +81-3-3327-3010

Free Subscriptions are available upon request to professional broadcasting and audiovisual equipment users. For address changes, send current and new address to RW a month in advance at P.O. Box 1214, Falls Church, VA 22041. Unsolicited manuscripts are welcomed for review: send to the attention of the appropriate editor.

# Just R I G H T !

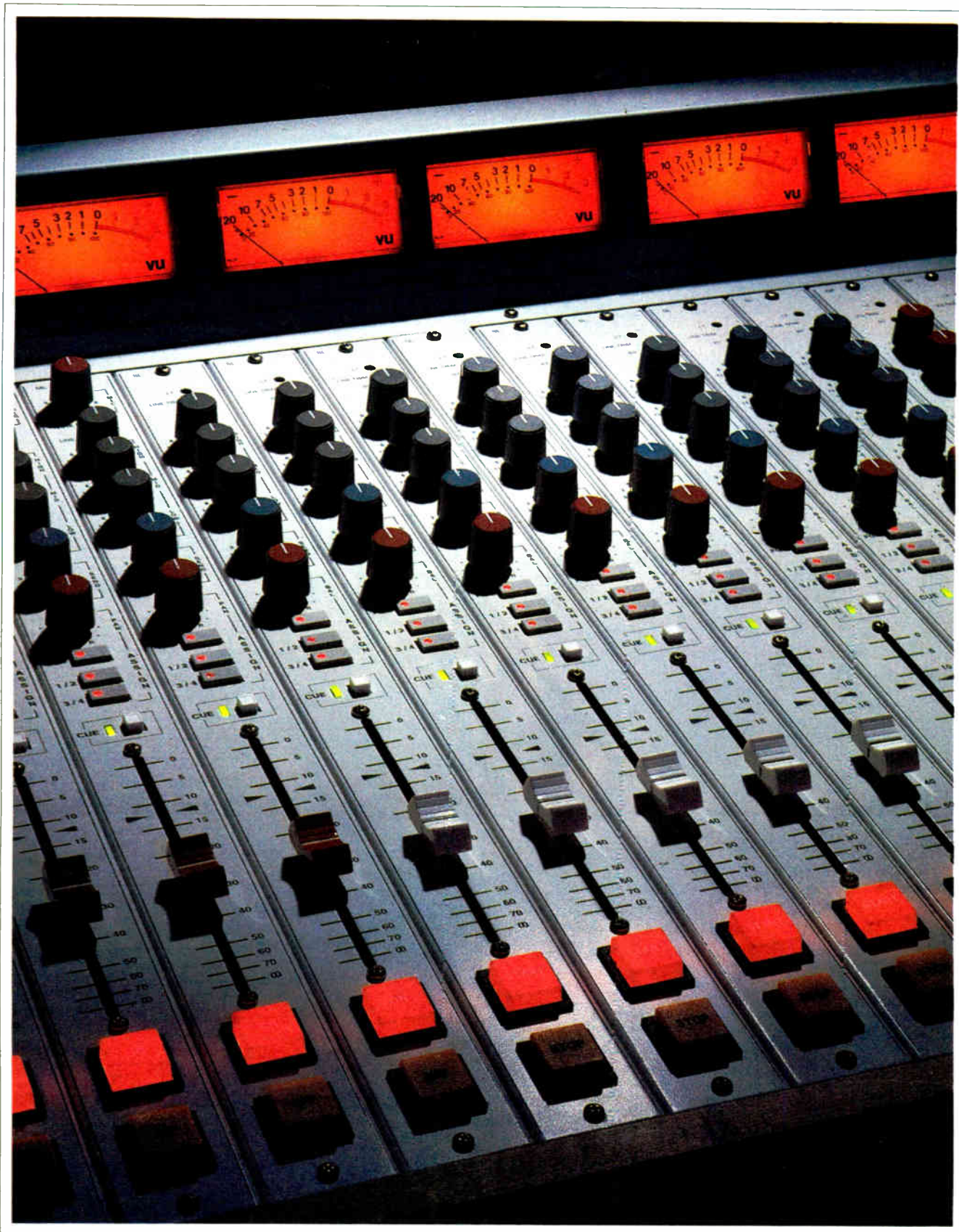

**MR-40**

**MULTI-TRACK PRODUCTION** doesn't have to be complicated. The MR-40 has just the features most stations are looking for: 4-track bus assign for your tape recorder; program assign so you can transfer direct to your 2-track—or go right on-air! It has machine Start/Stops just below the fader like an on-air console, but also includes a 3-band equalizer section so you can have the tone control that a normal radio console couldn't provide. It even has a stereo send bus that follows stereo channel balance controls—ever so important for today's stereo effects devices.

Mono modules have both mic and line inputs: mic for recording and line for track playbacks. Subgroup channels provide fader control for record levels and also have a second

track playback path for really quick sessions. And of course the MR-40 has an on-air type monitor section, complete with control room, headphone and studio outputs, plus all the necessary muting and tally functions you'd want. It even has a built-in cue speaker and power amplifier.

Small format doesn't mean we've cut corners either: all audio switches are gold contact; assign buttons are LED illuminated; all ICs are double burned-in, and all circuits are double-tested—we don't take any chances with reliability! The **MR-40** is a perfect blend of excellence in engineering and sensible size. It's just right for 4-track analog and digital work stations—it can even back up your on-air console! So contact Audioarts.

# Wheatstone Has It!

## Super Performance – Great Price!

**OUR NEW A-300 CONSOLE HAS ALL THE RIGHT STUFF:** Performance right at the limits of technology, the features you want, and a fresh clean look your clients will admire. It's got all the busses you'll need. It's got the crosstalk and bus off isolation you HAVE to have for LMAs and FM/AM combos. Its small footprint and low profile let you conserve valuable studio real estate. Its virtual audio bus™ architecture lets you place any module anywhere in the console—no dedicated slots!

Talent will love our easy-to-learn superphone module and the automated cue system that makes monitoring confusion-free. Our integrated intercom system lets them communicate with any other Wheatstone console or talent location—handsfree.

Your program director will really like the sound of this console: no VCA distortion—just flawless specs. And, because of its ultra-flexible architecture, it can be easily adapted to any format, anytime.

The A-300 has what engineers want: first class documentation, gold switches, gold connectors, a hinged meterbridge for easy re-lamping, straight-forward reliable logic technology, and the best I/O connection and tooling system in the industry.

The A-300 is the console that has followed the evolution of radio. Benefit from Wheatstone's experience and total commitment to your satisfaction. Contact us.



 Wheatstone® Corporation

**A-300**

7305 Performance Drive, Syracuse, NY, 13212 (tel 315-452-5000 / fax 315-452-0160)

Circle (164) On Reader Service Card  
World Radio History