

SBE Show a Success in St. Louis

by John Gatski

St. Louis MO Most vendors at the Society of Broadcast Engineers (SBE) show in St. Louis 4-7 October were pleased with the quality and turnout, but many remain uncertain about next year's show in Houston.

SBE President Brad Dick said St. Louis show was very successful with 23% percent higher (3727 vs. 3022) attendance

than last year's show in Kansas City, indicating a renewed strength in SBE that had waned following the 1988 Denver show.

Based on SBE attendance figures from St. Louis, there were 3727 total exhibitors and attendees. SBE's breakdown included 919 exhibitor passes (exhibit workers and their guests), 657 paid registration passes (those who were allowed on the exhibit floor and registered for the

Best For Less at AES

by Frank Beacham

Los Angeles CA It is reassuring to note that in this period of rising prices and economic uncertainty, there were some real bargains for radio stations in the exhibit hall at AES.

Remarkable innovation and proven technology at breakthrough low prices was scattered throughout the convention center hall among the pricier, cutting edge devices. From the radio production point of view, never has such capability and quality been available for such a low cost.

Take for instance multitrack analog recording. Tascam brought broadcast-

quality, 8-track recording to a new low price level at AES with the introduction of its Model 488 Portastudio. With a list price of \$1599 (most Tascam dealers offer substantial discounts), the new console offers Tascam's proven staggered head design 8-track cassette format with an integrated eight-mono and two-stereo input mixer.

The cassette spins at 3 3/4 IPS to offer a frequency response of 40 Hz to 16 KHz and an SNR of 95 dB with the unit's DBX II noise reduction system engaged. The 488 also offers a range of automation features. Tascam also showed its Model 688 MIDiStudio with an expanded mixer and

(continued on page 18)



Convention-goers had plenty to see at the AES show (left) in Los Angeles and the SBE's St. Louis gathering (above, below). Show coverage begins on page 11.



The New Dynamax® CTR 90 Series

Absolutely, positively the finest cartridge machine ever made by man. (And priced for Earthlings.)

Call Fidelipac or your Dynamax Dealer for information and pricing, including the introductory bonus offer.



DYNAMAX®
BROADCAST PRODUCTS BY FIDELIPAC™

Fidelipac Corporation
P.O. Box 808 • Moorestown, NJ 08057
TEL: (609) 235-3900 • FAX: (609) 235-7779

engineering sessions) and 2151 exhibits-only badges, which included the floor browsers and also paid registrant guests.

Positive feelings about SBE

In 1990, preregistration also increased by 20%, Dick noted. "This means that engineers are now budgeting in advance for our show," he said.

Exhibitor reactions were mostly positive to the St. Louis show, although they emphasized it was not a great show.

"It was a good show for the money and effort they put into it," CRL Market-

ing Manger William Ammons said. "It was bigger than Kansas City, but it wasn't anything earth-shattering."

Radio Systems Inc. came away from SBE "with some pretty good leads," according to salesman Garrett Conover.

"I think they did a great job in St. Louis," Harris-Allied National Marketing Manager Dave Burns said, who has lobbied SBE to keep the show in the central Midwest.

Coaxial Dynamics Advertising VP Robert Scott said the floor was busy dur-

(continued on page 15)

Mexico Adopts C-QUAM Standard

AM Stereo's Acceptance Grows Abroad; Motorola System Proves the Favorite

by John Gatski

Mexico City MEXICO With Mexico's recent adoption of Motorola C-QUAM AM stereo as the national standard, AM stereo is making progress in gaining acceptance beyond the US.

Mexico joined Brazil, Australia and Canada in the adoption of C-QUAM in September. Japan and England are evaluating

the AM stereo system for consideration as their official standard.

In the US, the FCC has declined to adopt an official AM stereo standard, but C-QUAM is considered the *de facto* standard by virtue of its acceptance.

Currently, 610 US AMs broadcast C-QUAM stereo with an additional 200 throughout the rest of the world, according

to Motorola.

AM stereo proponents are convinced that AM stereo would increase in the US if the government officially endorsed a standard. While the FCC maintains it will not endorse a specific standard, it is seeking comments on whether AM stereo should be a part of any measure to increase service and reduce interference.

Slow acceptance

"We're extremely pleased with the progress of AM stereo, al-

though it has not been as quick as we would like," Motorola Broadcast Equipment Manager Don Wilson said.

At least one American broadcasting manufacturer believes that the adoption of AM stereo abroad could be a boon to its sales.

Delta Electronics Marketing VP Joe Novak said the foreign AM stereo market, including Mexico, looks better than the US market right now.

And, he said, if Japan adopts C-QUAM, it could really open

the market, not only in that country, but worldwide, including the US.

Japan's major influence will be in receiver manufacturing because the country is the number-one producer of radio receivers, Novak explained.

Many industry analysts believe the lack of receivers has slowed AM stereo's penetration in the US. With more receivers available, more stations in the US may decide to convert to AM stereo, Novak said.

Paralleling the US

In addition to being the latest country to embrace C-QUAM, Mexico also officially adopted NRSC pre-emphasis guidelines for AM bandwidth reduction from 15 kHz to 10 kHz.

There are about 600 AM stations in Mexico, making it one of the top ten countries in numbers of AM stations, according to Motorola. Only one Mexican station, however, currently is broadcasting in AM stereo.

Motorola believes AM stereo's acceptance in Mexico will follow the same course as in the US.

"The stations that have money will do it in quick order," Wilson said. "Unfortunately, there are a lot of poorer stations."

In the US, conversion of a mono-broadcast AM station to stereo is estimated to cost at least \$15,000.

Motorola began trial C-QUAM AM stereo broadcasts in Mexico on test station XEQ (940 kHz) in July 1987. Commercial station, Radio MIL (1000 kHz), began broadcasting AM stereo in October 1989 and remains the only one at this time, Wilson said.

For information from Motorola, contact Don Wilson at 312-576-0554.

WE SURPRISED OURSELVES!



AUDIOARTS® A-50 RADIO CONSOLE!

We wanted to know if it really was possible to build a high quality low-cost radio console. We found the answer to be quite exciting! We've come out with the A-50 console and even given it its own trade name: AUDIOARTS. This console comes complete with machine control functions; individually programmable channel logic; program, audition and telephone outputs; control room and studio monitors; as well as headphone and cue power amplifiers. It's also designed so you can expand or add accessory modules as your needs grow.

The A-50 is cost effective through clever engineering and the latest advances in electronic assembly procedures. It was developed by the same design team that creates our other high end equipment. Its performance is light years beyond the competition.

Imagine the benefit that our major market experience can bring to your station. Take advantage of Wheatstone's expertise and reputation. Call us today for immediate action!

 Wheatstone Corporation

6720 V.I.P. Parkway, Syracuse, NY 13211 (TEL 315-455-7740 / FAX 315-454-8104)

INDEX

Crossing Swords with Pirates by Harold Hallikainen	22
Certifying RF Rule Compliance by Lex Felker	23
Laying a Foundation for DAB by Tom McGinley	24
Studying Radio History by George Riggins	28
Correct Combiner Chemistry by Bill Cordell	30
Tips to Make Radio Life Easier by Barry Mishkind	31
Dynamic EQ Smooths Sound by John Q Shepler	32
Running a Religious Remote by Bruce Bartlett	34
Workbench	37
A Data Compression Overview by Mel Lambert	38
Amplifier Class: A Family Affair by Ed Montgomery	39

NAB Montreux Plan Raises Ire

by Alan Carter

Washington DC The NAB has struck a nerve with manufacturers in the UK by announcing it will hold a radio-only show in Montreux, Switzerland, beginning in 1992.

From the UK manufacturers' point of view, according to several contacted and based on comments some of their US counterparts heard from distributors, a US group shouldn't be holding a show in Europe and Montreux, a site exhibitors don't like, could not have been a worse choice.

The show, the NAB/Montreux International Radio Conference and Exhibition, to be held in early June 1992, is a joint project between NAB and Montreux.

Questions abound

"I'm not quite sure what its (NAB's) role is in Europe other than a commercial one," said Solid State Logic Marketing Director Colin Pringle. He also said he doubted US manufacturers who exhibit in Europe would have advised NAB to go into Montreux.

Montreux is criticized because the only access is by train from Geneva, Switzerland, and hotel and convention facilities are not of the quality some exhibitors want.

But NAB Conventions and Exhibits Senior VP Rick Dobson maintained that

the problem is that "a very small group" of UK manufacturers interpreted the selection of Montreux as an endorsement of the Montreux Television Symposium over the International Broadcasting Conference (IBC).

Meeting with manufacturers at IBC in September in Brighton, England, Dobson said he tried dispel the concerns. He said he knew he would receive "some

move.

Said Wells, "I think he (Dobson) is naive, and you can quote me on that."

Neither Wells nor Pringle indicated their companies would exhibit at the radio show.

Not the best of times

Wells further questioned the logic of holding "another" trade show when

To make the issue more complicated, Dobson said the doubt from manufacturers about the NAB radio show also can be attributed to the IBC moving from Brighton to Amsterdam.

flak" going into the meeting.

"Personally, I feel this has become a very emotional issue and it is hard for the facts to be seen," Dobson said. "I told them, and they did not take kindly to that statement."

But Soundtracs Managing Director Todd Wells said opposition is from more than a small group of UK companies. Wells said members of the Professional Audio Exhibitors Group (PAEG) are against the show, and he also said PAEG-North America would issue a statement opposing NAB's

there is a worldwide economic downturn. "The timing of yet another audio show couldn't be worse. It's the wrong economic timing."

To make the issue more complicated, Dobson said the doubt from manufacturers about the NAB radio show also can be attributed to the IBC moving from Brighton to Amsterdam. "A lot of frustration has accumulated in the UK over IBC," he said.

Dobson said he told the manufacturers, whom he still expects to exhibit with NAB, that the show is radio only. "If NAB wanted to launch a TV show in Europe it would have launched a TV show in Europe," he said.

NAB wanted to provide an "educational venue for radio," Dobson said.

Dobson maintained there is no anti-American sentiment, although he said the issue was raised but quickly overshadowed when the "real" concern of the Montreux TV exhibit surfaced.

As for those who question why the "National" Association of Broadcasters is expanding to an international scope, Dobson said NAB wants to provide a venue for US manufacturers into the growing European market. Manufacturers represent about 50% of NAB's associate membership.

He also said US broadcasters can provide expertise to Europeans who are moving into commercial broadcasting.

NAB does not think the European radio show will distract from international attendance at the US spring convention or the US radio show.

"The radio show (in Europe) will only help NAB," Dobson said. "It is making the Europeans that much more aware of us as an organization."

Now DAT's Affordable!



Technics' SV-DA10 uses MASH A/D and D/A converter technology to offer DAT quality at a new low price. The shuttle search dial makes it possible to cue and review from 1/2 to 15 times normal tape speed while monitoring the audio. The post recording utilities include writing end markers, start ID's, program numbers, and skip ID's.

Manufacturer's list price is a mere \$995. Rack mount shelves and IHF-to-Pro interfaces are available with your SV-DA10 at special package pricing.

The SV-DA10 is one more way Bradley will help you go digital in the 1990's.



Where Service and Engineering Make the Difference

Circle 27 On Reader Service Card

Digital Quality Transmission

Broadcast Electronics' FM3.5B 3500 Watt FM Transmitter

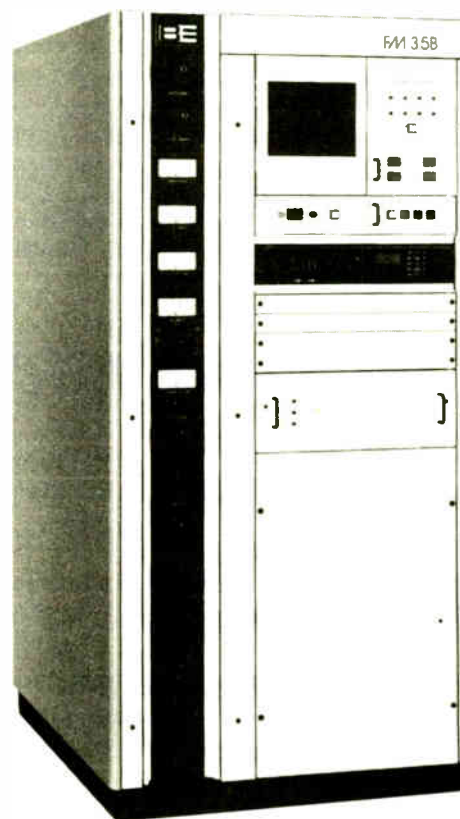

- **Guaranteed** 85 dB S/N.
- **New** World Standard FX 50 Exciter.
- **Built-in** synchronous AM noise test facility.
- **Patented** folded half-wave coaxial cavity eliminates plate blocking capacitor and sliding contacts.
- **Self contained** solid state broadband IPA in slide out drawer.
- **Complete** emergency RF patching.
- **Automatic** power control that maintains constant output power with proportional VSWR foldback protection.
- **Eight** individual meters.
- **Optional** microprocessor video display system (MVDS) with diagnostics.
- **Optional** PC Remote Control from MVDS.

The Model FM-3.5B single tube FM transmitter is the first choice for stations seeking the ultimate in audio performance.

BE BROADCAST
ELECTRONICS INC.

4100 N. 24th ST., P.O. BOX 3606, QUINCY, IL 62305, (217) 224-9600, TELEX: 250142, FAX: (217) 224-9607

Circle 11 On Reader Service Card

Show To Show: Call It a Wrap

by Judith Gross

Falls Church VA Just when you thought it was safe to look at a calendar ... I see there are only 150 days until the spring NAB show.

Don't want anybody to get the impression I'm all-showed-out; it was fun sitting in planes munching on those little bags of peanuts and all.

Let's see, there was a visit to the AES show in LA, city of sun, squeezed in there somewhere. I tend to think of it as "The Lost Weekend" because I got lost among the latest in fun audio toys.

Yep, just me and the purple-haired audio gurus with the satin jackets.

AES was a quiet show, by comparison to past years or maybe to years when it's held in Noo Yawk, where the rumbling of the subways adds reverb whether ya want it or not.

Actually, audio shows are getting quieter because the tapping on a keyboard is a lot less noisy than the scrubbing of a reel disk. In other words, computers are taking over.

Used to be every booth had a black box and a few dozen XLRs. Now you look around and see lotsa VDTs, in vivid color, no less.

There was a lot of chatter about 3-D

You can hear 3-D audio with one of the surround sound decoders on the market. Seems some folks who have them for their TVs have heard them decoding the radio, too.

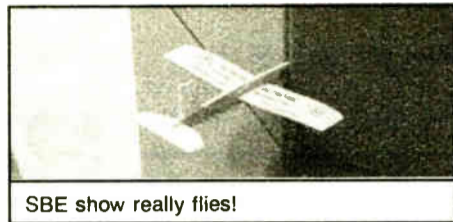

SBE show really flies!

It wasn't all work, however. Got a chance to visit with RW's West Coast reporter, Frank Beacham, who has a nifty little office where Columbia Pictures' lot was back in the golden days of the silver screen. You could feel the ghosts of Bogey and others when you walk around there.

Frank just finished producing a radio drama on "The Orangeburg Massacre," a tough moment in the history of the civil rights movement. You get chills listening to his recreation of the event. A whole slew of public radio stations have committed to airing it next February.

Also had a chance to visit that well-known Hollywood theater with its star-studded cement autographs. Did you know that John Wayne and John Travolta are right next to each other? Think there's a cosmic statement there?

☆☆☆

Over in St. Louis a few weeks later, the SBE had a healthy gathering of engineers come to see the latest the industry has to offer.

It was a good chance to chat with some old friends and get some nuts and bolts type info at the sessions.

There was enough traffic on the exhibit floor to keep everybody hopping—no pitching dimes this time around. But I did catch a few exhibitors flying these balsa wood planes, hitting unsuspecting booth sitters with them.

Nobody's saying this too loudly, but there's a fair amount of sentiment against moving the show to Houston

next year. Nothing personal against the fair Texas city (I don't want a lot of angry folks in ten-gallon hats and nasty-looking spurs at my door to argue the merits of Sam Houston's namesake).

The point is, is it central enough to draw the healthy crowd we saw the last two years in KC and St. Lou? I know the dollars are already committed, but let's ask a few tough questions here and see how we can make it a win-win for everybody.

After all, the exhibitors are footing the lion's share of the bill. It has to be worth their while to send crews and equipment cross country.

Maybe the fact that the show will be combined with the Texas Association of Broadcasters meeting will help.

MUSICAM algorithm, which compresses data down in a 6:1 ratio for the Eureka 147 DAB system.

First, Tony Masiello of CBS played tapes comparing compressed and uncompressed audio on a digital audio tape. Now, I know the audio golden ears always say they can hear the difference, but let's get real here.

Maybe one or two extraordinary humans and a handful of dogs could. But as one person present put it, "the audio purists will never be satisfied."

OK, it's subjective. OK, the psychoacoustics use an average. Actually, they set an average threshold of hearing and then skew conservative. Most folks couldn't hear it.

But especially amazing was a tape



But is it hot enough?

Anyway, session-wise, what turned out to be the most exciting and all-around informative session at the SBE show wasn't even an official session.

DAB was the hot topic and the occasion was the meeting of the Digital Radio Committee, now calling itself the Committee for Digital Radio Broadcasting, or CDRB (gee, this industry loves its acronyms!).

The committee, which wants the industry to know that it is open to all, featured two amazing presentations on compression technology, specifically the

Tony played of what gets thrown "into the old bit bucket" when they compress the audio. You can barely make out the rhythm of the music but it sounds like a raspy whisper.

Doesn't sound like it's a loss worth getting excited about, unless you happen to favor the sound of fingernails on chalkboard. OK, I'm being subjective here myself; high frequencies don't do a lot for me. I guess I even like the NRSC standard. But maybe you'll get a chance to hear it all sometime and judge for

(continued on next page)



audio. It's a tricky thing. Seems you have to be in the "sweet spot" a lot of the time or it just sounds like stereo. But the systems are out there.

And what's more, many radio stations are playing 3-D audio on-air, in the form of pre-produced spots. They're passing through what many consider the hottest thing in audio and they don't even know it.

Transmitter Control can be a Bear

You need to make sure you can stay on the air and stay legal. At the same time, you need to keep operating costs under control.

Choosing the right remote control system is the first step.

The ARC-16SA* from Burk Technology lets you control your transmitter from any phone. You can establish off-premises control points for unattended operation, or supervise non-technical operators by phone.

The annual savings can be thousands of dollars.

The ARC-16SA is part of a modular system. For full-time control, add a studio unit. Multi-site options make it easy to control several transmitter sites or even control studio equipment such as program automation.

Call now for your copy of our new catalog, then ask us to show you how we can improve your operation and your bottom line.

Call TOLL FREE
1-800 255-8090

BURK
TECHNOLOGY

7 Lomar Drive, Pepperell, MA, 01463 (508) 433-8877

Earwaves Wraps Up The Fall Trade Shows

(continued from previous page)
yourself. Then you tell me.

After Tony, we were fortunate enough to get a tutorial on compression technology, and some specifics of the MUSICAM algorithm, from Dr. L. W. Hinderks, who has worked with Bell Labs and others on such things and is, according to Tony, the only US licensee of MUSICAM. Larry is currently working with Corporate Computer Systems, which markets codec gear for ISDN and all.

Anyway, Larry managed not only to make the advanced technology understandable, but even entertaining.

He started by asking if anyone of the 60 or so present thought digital was dead. Not a hand went up. Satisfied that he was not preaching to a hostile group, the good Dr. continued.

Basically, it's all done with smoke and mirrors, but you knew that.

Seriously, it works in the frequency, not time domain. You digitize the signal, which adds a level of uniform noise. Quantizing it moves it below the level of the lowest frequency of the signal. When it's below the signal you can't hear it.

Then they use a lowpass filter in the low frequencies, a highpass filter in the highs. They move the noise level—in 32 sub-bands for the MUSICAM system—

until it's just under the signal. That's the minimum number of bits needed in each band. You can get rid of the rest.

The DSPs are looking at the sub-bands constantly—that's how fast they are. It's maybe 24 to 36 milliseconds of delay involved in the process.



Then comes the psychoacoustics. The experts have a hearing threshold—but remember they skew conservative. You can get rid of everything below the threshold. So we're losing bits, bit by bit, so to speak.

Next comes tonal masking. It's based on the way our ears hear. Seems we tend not to hear tones which are very, very close to those of the highest amplitudes. The experts create a model, or "masking skirt" defining where we actually hear a specific signal. It looks like a ribbon strung on uneven sized phone-poles. You can get rid of everything below the skirt.

The secret is to adjust the noise level to fall just under the psychoacoustic threshold at each of the 32 sub-bands. But basically, when you think about all the bits that have hit the "old bit bucket," it's mind-boggling. Bottom line from those in the know: If it isn't in there, you couldn't hear it anyway.

Whew! What a tutorial. We learned in 40 minutes what it took the Germans and French years to perfect. The Germans figured out the psychoacoustics but knew diddly about the sub-bands, or filters, part of the technology.

The French knew all about the filters but hadn't a clue about the psychoacoustics. They got together and the MUSICAM system is the result.

I have a feeling we'll be hearing a lot about all of this in the next few months and years to come.

The CDRB, by the way, has set a goal of exploring DAB technologies which could work on the existing FM band. So far I've heard of two, and you can read about them in stories in this issue.

One, developed by John Leonard and Gary Myers, called Power Multiplexing, lets a less powerful digital signal be put "under" the stronger analog one and makes use of a receiver's "capture effect" to get the desired signal.

The other, in development by Ted Schober of Radiotechniques, Bill Spurlin of Christian Science Monitor and Pete Moncure, makes use of the spacing in between FM stations and also unused TV frequencies for digital radio signals.

So far they're just theories, but it's a start.

You might say digital was the sleeper hot topic at all the shows this fall. Of course taking in all that information makes a weary show-goer mighty hun-

The SBE should be satisfied with the increasing momentum its fall convention has gathered. The return to St. Louis and the lack of scheduling conflicts between exhibits and sessions proved a successful combination.

This year attendance was up and exhibitors were generally happy with the quantity and quality of traffic in the exhibit hall.

Convention organizers also heeded the concerns of exhibitors and eliminated excessive exhibit hours for a portion of the weekend.

It would be good for the SBE to be able to build on the past two years' successes and work toward an even stronger show next year. But there are some important issues which need to be resolved if this is to happen.

The first is location. With many exhibitors unenthusiastic about the show's move to Houston and some saying outright that they will not exhibit there, the SBE and its show organizers need to take a second look.

One way to do this would be to poll exhibitors to ascertain the potential for success or disaster in Houston. SBE could avoid a repeat of its disappointing show in Denver two years ago by beginning to work on this problem now.

Even if a move to another venue is out of the question, by talking to potential exhibitors the SBE may find ways to make Houston a more attractive site than it now appears to be.

Two lesser problems concern the opening reception and the sessions offered. Many companies would like to see the opening day of the convention be more than a two-hour cocktail reception at day's end. The work involved for exhibitors in set-up and transportation may warrant a rethinking of this opening event.

As for the sessions, while they were well-attended and praised by attendees, SBE would be doing its members and the industry a greater service by including more on emerging technologies, such as DAB, which became a part of the discussions almost only by coincidence.

Many of the engineers who attend the SBE convention do not attend the larger, more costly shows and this fall gathering may be their only chance to keep abreast of the industry's rapid changes.

If SBE can address these remaining concerns and continue to encourage larger numbers of its members to attend by increasing its marketing efforts, the fall SBE show could rise to even greater heights of success.

—RW

Building A Better SBE

gry and thirsty.

So I just gotta ask the SBE (I mean they put it in their show brochure and all): What really did happen to Saturday's pizza and beer?

Heard a juicy tidbit? Spill your guts to Earwaves by faxing JG at 703-998-2966, writing to PO Box 1214, Falls Church VA 22041, or calling 703-998-7600. Who knows, you could win a coveted RW mug.

Radio World

Vol 14, No 21 November 7, 1990

Editor, Judith Gross

Associate Editor, Alex Zavistovich

News Editor, Alan Carter

Reporters, Charles Taylor, John Gatski

Benn Kobb, Frank Beacham/L.A.

Editorial Assistant, Marissa Friedman

Technical Advisor, Tom McGinley

Production Director, Kim Lowe

Chris Freter, Lisa Roach, Julianne Stone

Ad Production Coordinator, Jeanne Pearson

Regan Deatherage

Publisher, Stevan B. Dana

Associate Publishers, Arthur Constantine

Carmel King

Ad Coordination Manager, Simone Mullins

Circulation Manager, Tiana Hickman

Accounts Receivable, Valerie Mason

Advertising Sales Representatives:

East & Midwest, Art Constantine

800-336-3045, Fax: 703-998-2966

West Coast, Pat Macsata

415-786-2198, Fax: 415-786-2754

Radio World (ISSN: 0274-8541) is published semimonthly by Industrial Marketing Advisory Services, Inc., 5827 Columbia Pike, Suite 310, Falls Church, VA 22041. Phone: 703-998-7600, Fax: 703-998-2966.

Second-class postage rates is paid at Falls Church VA 22041 and additional mailing offices. POSTMASTER: Send 3579 forms and address changes to Radio World, P.O. Box 1214, Falls Church VA 22041. Copyright 1990 by Industrial Marketing Advisory Services, Inc. All rights reserved.

Free subscriptions are available upon request to professional broadcasting and audiovisual equipment users. For address changes, send current and new address to RW a month in advance at the above address. Unsolicited manuscripts are welcomed for review; send to the attention of the appropriate editor.

Next Issue
Radio World
November 21, 1990

FCC Shouldn't Sell Synchronous Short

by George Whitaker

Dallas TX In the current proposed rulemaking for AM improvement, I feel the FCC is failing to address one very significant possibility for making AM better able to compete in today's marketplace. That improvement is synchronous broadcasting.

GUEST EDITORIAL

Many AM stations find themselves in the same position as KSSA, in that they lose a large part of their market when they switch to nighttime power. In our case, we cannot hit Fort Worth and a large part of the Fort Worth suburbs from our Dallas transmitter site. This represents almost one million people that we would lose at night if we were not operating a synchronous transmitter in Fort Worth.

Since our Fort Worth synchronous operation began a few months ago, we have experienced significant growth in our listening audience and a commensurate increase in revenue.

Technically, the limitations imposed by the zones of interference are acceptable in light of the coverage gained. We are attempting to minimize the effect of the zone and currently are waiting on some

promised new equipment from Harris Corporation that will allow interlacing the audio from the two transmitters. This approach has some promise theoretically and we hope that the field tests will prove to be beneficial.

It is reasonable to assume that any synchronous transmitter granted would be of low power. In our case, 210 W gives very good coverage. Therefore, the amount of interference generated by these operations would be minimal. I am firmly convinced that the benefits far outweigh the limitations, and urge that such operations be authorized, at least on a "case by case" basis.

Just before the freeze on AM was announced, I had been contacted by three other stations in this area for information about our operation. All three of them, after examining our operation, indicated that they were going to apply for similar operation. The freeze, of course, put an end to their efforts.

Having experimented with synchronous operation, it is our conclusion that it is a viable option for keeping AM competitive. I am encouraging other AM stations with similar coverage problems to take a good look at the possibilities if synchronous transmission is allowed. And, I hope they will urge the FCC to include this in the AM improvement package.

■ ■ ■

George Whitaker is CE of KSSA-AM/FM and can be reached at 214-528-1600.

**GET IT
RIGHT**
FROM HARRIS ALLIED

THE BEST DEAL YOU'LL EVER WALK AWAY FROM

1

7 days of "walk away" time.

An automated broadcaster's dream? It's reality for AUDISK owners. AUDISK stores more than cart-based systems, and costs less. Your entire commercial inventory—plus PSAs, liners and IDs, and more—can be online at once. AUDISK's "smart audio" software will automatically play your liners and IDs in random rotation, substitute a PSA for a past-killdate commercial, switch ID calls in time with the satellite jocks, etc.

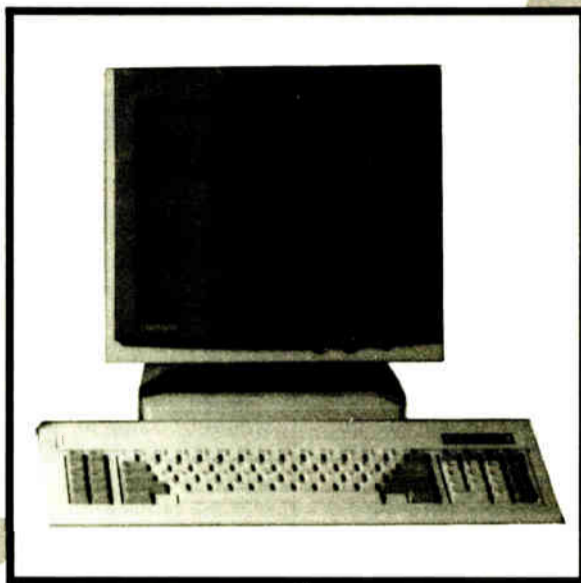

2

AUDISK delivers the promise of automated digital audio.

Until now, digital systems only gave you part of the automation solution. AUDISK does it all—digital automation and digital storage—in one compact, convenient, easy-to-use system. For satellite formats, live-assist or any combination, nothing's easier to use than AUDISK. Even a computer novice can manually schedule an entire weekend of commercial stopsets in under 15 minutes. Or use the optional traffic system software interface for even greater convenience.

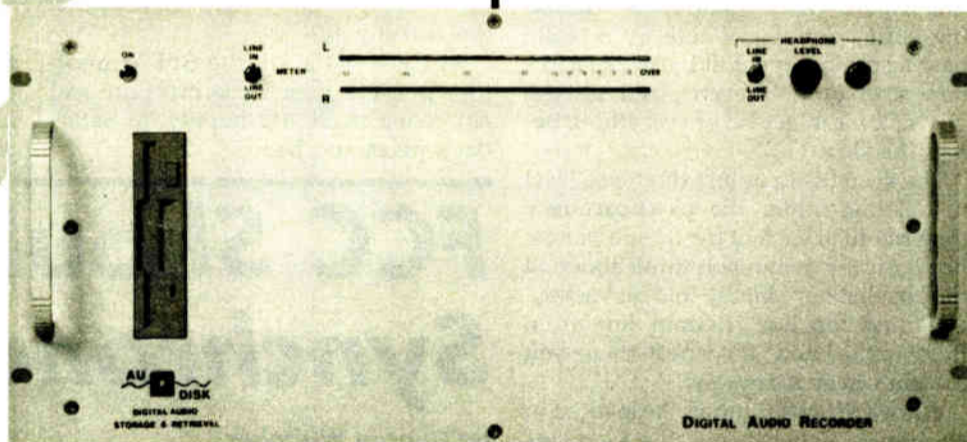

3

The first digital audio hard disk system that's as easy to own as it is to use.

The wait for an affordable digital audio hard disk system is over. AUDISK actually costs less than cart-based automation. And it's designed by radio people for radio people. So the balanced XLR inputs and outputs, standard remote contact closures, even the optional traffic system interface, all fit the systems you already have installed. AUDISK makes digital audio storage and automation easy in every way.



4

All the backup you could ever need.

In an emergency, AUDISK stands alone. With options like "disk mirroring" and fully redundant systems, you can walk away with total confidence. And AUDISK comes with another important kind of backup—the unmatched resources of Harris Allied Broadcast Equipment, including the service, installation support and custom configuration capabilities of Harris Allied Systems.

5

Take the first step.

Call your Harris Allied representative toll-free at 800-622-0022 for more information on the digital audio automation system that does it all, so you can walk away—AUDISK.

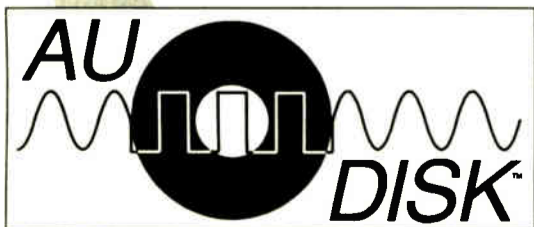

**HARRIS
ALLIED**
BROADCAST EQUIPMENT

800-622-0022
Canada 800-268-6817

STUDIO EQUIPMENT • HARRIS RF PRODUCTS • SATELLITE GEAR • TRADE-INS • TURNKEY SYSTEMS

© 1990 HARRIS/ALLIED

"Call me, I'm interested." Circle 33.

"Send me literature." Circle 116.

DAB NOI Prompts Joint Filing

Groups Urge FCC To Seek More Comment

by Charles Taylor

Washington DC More than 50 broadcasting groups are reviewing the draft of a joint filing on the FCC's broad-based notice of inquiry on digital audio broadcasting (DAB).

The Radio Operators Caucus, as it calls itself, is tagged in the comments as "an informal group of radio licensees operating in large markets throughout the United States." The filing was prepared by John Fiorini and Mark Van Bergh with the Washington law firm of Gardner Carton & Douglas, which represents Emmis Broadcasting.

Emmis Broadcasting President Steven Crane said the caucus, loosely formed

three or four years ago to monitor issues affecting the industry across the board, decided to initiate the joint filing during the NAB 1990 radio show in Boston in September.

New ground

"This is probably the first time the group has spoken out on a given issue," Crane said. "They (the FCC proposals) all result in a major restructuring of the radio broadcasting industry."

DAB will have a "profound implication" on radio broadcasting, he said. The integration of DAB into the market does not have to be controlled as much as it has to be "carefully thought through," Crane continued.

"There is no question that DAB will follow its evolutionary path and take its place in the broadcasting industry," he said.

In a draft of the filing, the group asked the Commission to recognize its Notice of Inquiry as a starting point in the information gathering process. It suggested that a second round of comments be solicited, perhaps following a further NOI "after interested parties have had time to study and better understand (DAB) and the issues it raises.

"It is still too early for anyone to have answers to the plethora of issues which the possible implementation of a (DAB) service involves," the draft filing stated.

Move cautiously

The filing also cautioned the FCC to proceed slowly with any decisions regarding transmission methods, digital algorithms, digital encoding, digital compression techniques or spectrum.

"The Commission will need to evaluate the potential benefits and costs of (DAB) as it seeks to determine whether there is a need for the service," the caucus wrote.

It also said that digital radio should not be regarded as a new service, but as a new transmission mode for an existing

service. "Essentially, (DAB) is the next generation of radio transmission technology which appears to offer enhanced capabilities for a service with a long and storied past."

The group stressed that DAB should not disrupt the existing radio broadcasting system.

Individual groups are expected to file comments in addition to the joint statement.

The FCC has extended to comment deadline from 12 October to 13 November, with reply comments extended from 13 November to 14 December. The issue is contained in Gen. Docket 90-357.

Nets Plan For Digital

by Alan Carter

New York NY CBS and Capital Cities/ABC radio networks will transmit programming to their collective more than 3000 affiliates in 20 kHz audio beginning in August 1991, setting the stage for a new digital era in radio.

With hardware developed by Scientific Atlanta (SA), the networks are upgrading satellite transmission capabilities in audio from 15 to 20 kHz and also increasing the number of channels per transponder from 20 to 60.

The project was guaranteed to go on line when CBS signed a 10-year agreement to lease space from ABC, which has a satellite contract with GE American Communications, according to CBS Technical Operations Director Tony Masiello. CBS's contract with GE runs out next year.

ABC also will lease space to other audio programmers, according to Radio Satellite Systems Director Bob Donnelly. Until this deal was set in motion, ABC consistently ran out of transponder space, he said.

"We've turned down business," Donnelly said. "We've lost money."

The project also allows for cost savings to the networks using it, Masiello explained, because it provides for more

channels per transponder.

The project represents an expansion of SA's Digital Audio Transmission Service (DATS). It will comply with parameters set by the two radio networks: CD-quality (20 kHz), plug-in compatibility with the present system and the ability to handle compression algorithms such

The project provides for more channels per transponder.

as the MUSICAM system which has been used for tests of DAB broadcasting with the Eureka 147 system.

It will also decode SA's own proprietary compression algorithm available through the company's upgrade of its DATS system, a new product SA calls SEDAT, introduced at Radio 1990.

The new satellite distribution system will allow a program supplier to transmit CD-quality audio, building one link necessary for DAB when it goes from radio station to consumer.

Until this project is set in place Masiello said, "No radio network is able to transmit CD quality."



For Excellence In Antennas

- A complete line of TV and FM Broadcast Antennas
- Modern 7,000 ft. test range facilities
- Innovative Engineering Careful construction
- Two Year Warranty on Product and Workmanship

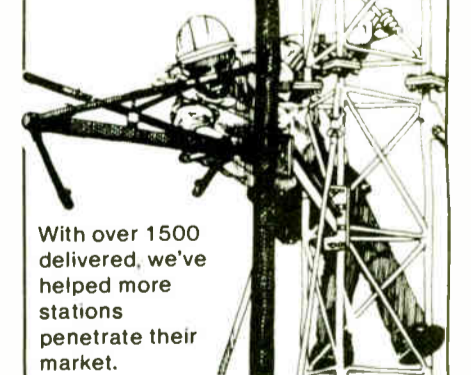

With over 1500 delivered, we've helped more stations penetrate their market.

FCC Directionals
Pattern Studies
Multi-Station Arrays
Full Scale Measurement

JAMPRO ANTENNAS, Inc.
6939 Power Inn Road
Sacramento, CA 95828
(916) 383-1177 TELEX 377321

Your Problem Solvers

from **ATI**

- Mike
- Line
- Phono
- Mixing
- Matching
- Metering
- Monitoring
- Processing
- Distribution
- Rack Mounting



AUDIO TECHNOLOGIES, INC.

328 W. Maple Ave., Horsham, PA 19044 • (215) 443-0330 • FAX (215) 443-0394



DAB Plan Takes American Slant

by Alan Carter

Haddon Heights NJ Claiming that the European-developed Eureka digital audio broadcasting (DAB) system will not integrate with radio stateside, three US broadcast engineers are working on a proposal with an American slant.

Radiotechniques President Ted Schober said he and co-developers Bill Spurlin, radio operations manager for The Christian Science Monitor, and Peter Moncure of RadioSoft are working on a proposal to operate DAB within existing FM spectrum.

FM spectrum exists in all markets for DAB "if you use the right system," Schober said. Under the plan, however, in the major markets, not all AM and FM stations on DAB will fit among with existing FMs, except by temporarily sharing TV channels 2-6.

Sharing spectrum

The group's digital shared spectrum technique would locate the DAB signal between the FM stations and some on unused TV band spectrum.

When DAB takes hold, the FM stations would be turned off to make more room for DAB stations. The DAB stations that temporarily operated on the TV band on currently unused channels would move back to the FM band.

Listeners, Schober said, would not be aware of the frequency move.

No interference would occur to the existing FM or TV stations if DAB is a low-power service and employs the group's shared spectrum techniques, he said.

No hardware has been developed, Schober said. But the system initially would use a Channel 6 low-power transmitter and an RF generating device that he described as "more like a computer than an exciter."

Schober noted several differences from the Eureka system that a US system must accomplish.

The essential differences, he maintained, are the need for an RF coding scheme that can share spectrum with other broadcasters and a source coding algorithm that he claims is twice as good as MUSICAM, at its present level of development. MUSICAM is Eureka's source coding algorithm.

More efficient algorithm

Without improvements over MUSICAM, Schober said it will be difficult to assign all existing AM and FM broadcasters a DAB channel.

An improved algorithm also would allow use of the telephone companies' Integrated Services Digital Networks (ISDN) to send CD-quality audio over phone lines. ISDN has a 64 kBits/s ca-

capacity. If the algorithm is improved from MUSICAM's current 128 kBits/s for a mono channel to 64 kBits/s, then two ISDN lines could carry the full stereo signal.

Similar algorithms exist for very high quality, but not quite CD quality, at still lower data rates, Schober said. These lower rate algorithms will permit even higher spectrum efficiency.

The proposal, Schober continued, also assigns audio channels to compensate for interfering stations, and the error rates for all channels are shared.

Schober, Spurlin and Moncure are forming a consortium of engineers and scientists from the industry and universities that would license the technology to manufacturers. Their work will include receiver development.

Power Multiplexing: DAB On the FM Band

by Judith Gross

San Jose CA The search for DAB systems which will be compatible with existing FM spectrum has opened a whole new area of research for engineers in the industry.

Two ideas have been put forth so far. One, from Ted Schober of Radiotechniques, uses spacing in between FM stations for low power digital signals (see related story).

Another idea has been developed by John Leonard and Glen Myers and makes use of a technology called Power Multiplexing.

Shared power

Under a plan developed by the two, a digital signal shares the power of an analog FM signal, taking up no further spectrum. In the past, technologies have allowed signals to multiplex in the frequency and time domain but not share power.

The digital signal would be much lower power than the analog, since digital transmission requires lower power levels to achieve the same coverage, would be

placed "under" the analog signal and fed to a station's antenna along with the analog signal through a combiner.

The "capture effect" in FM receivers would ignore the weaker digital one and only receive the stronger analog signal. A new receiver, developed by Myers, would be used to recover the digital signal and could also receive the current analog stereo signal.

The new demodulator Myers developed creates a replica of the stronger (analog) FM signal 180° out of phase with the original signal. Adding the two together in the receiver suppresses the analog signal and overcomes the capture effect, allowing the weaker (digital) signal to be recovered.

No disruption of service

Leonard emphasized that the most attractive feature about using power multiplexing for DAB is that, unlike Europe's Eureka 147 system, no new spectrum would be required. He said that the performance of such a system with respect to multipath interference needs to be determined in over-the-air tests.

He also noted that for the transmission of the digital signal, some compression algorithm—perhaps MUSICAM, which is used in the Eureka 147 system—would need to be used.

He also said that digital broadcasting via power multiplexing should be considered a new service offered by existing stations, with the existing FM station having full control of both digital and analog signals.

Leonard and Myers hope to interest stations in testing the technology and are also talking with receiver manufacturers. They are also discussing the technology with the Committee for Digital Radio Broadcasting, which has expressed an interest in exploring systems compatible with existing FM spectrum.

For more information, contact John Leonard at 408-729-3838.

PROOFS IMPROVED

FM and TV-BTSC AUDIO PROOF TESTING is reduced from hours to minutes with System One from Audio Precision... Automatic proofs run properly at constant deviation, plotting the required generator amplitude... and when finished, the results are stored in graphic form for your records.

SPLIT SITE proofs are simple with System One's available separate generator and analyzer configuration. With immediate capability to view and control both instruments, it's like being in two places at once.

THE REST OF THE TIME System One is the universal audio test set for maintaining any audio device or channel... STLs, consoles, carts, cassettes and RDATs, digital recorders and workstations... System One is the only product that can completely test both your analog and digital audio.

Call 800/231-7350 for our 36 page color catalog... and when you're ready our representative will arrange for an on-site demonstration.

Audio precision

P.O. Box 2209, Beaverton, OR 97075
503/627-0832, 800/231-7350
FAX: 503/641-9806
TELEX: 283957 AUDIO UR



AUDIO TRANSFORMERS SESCOM'S MI SERIES OF PROFESSIONAL QUALITY TRANSFORMERS



FEATURES:
BROAD FREQUENCY RESPONSE
 ± 1 dB 20-20KHz
LOW DISTORTION
30Hz LESS THAN .2%
AT FULL POWER
MAGNETIC-SHIELDING
ELECTRO-STATIC SHIELDING
BUILT TO THE HIGHEST STANDARDS

4000 VOLT INSULATION

4 POWER LEVELS

100% TESTED FOR PERFORMANCE

QUICK DELIVERY

AFFORDABLE

SEND FOR FREE CATALOG

SESCOM INC.

2100 WARD DR.
HENDERSON NV 89015 U.S.A.

702-565-3400, 800-634-3457, FAX 702-565-4828



POWER. PERFORMANCE. AND PROFIT.

What do you really need in a digital audio hard disk system? Simple operation, total creative control, a high level of recording and editing power, and lower cost?

Yes, Studer Dyaxis exactly.

The New Dyaxis 2 + 2. Now providing 4-channel simultaneous playback, Dyaxis is the ideal tool for production and post facilities where multichannel applications are required. New advanced features include overdub, multi-take record and programmable in/out, faster time-scaling, EQ and level change. (Original Dyaxis owners can upgrade!)

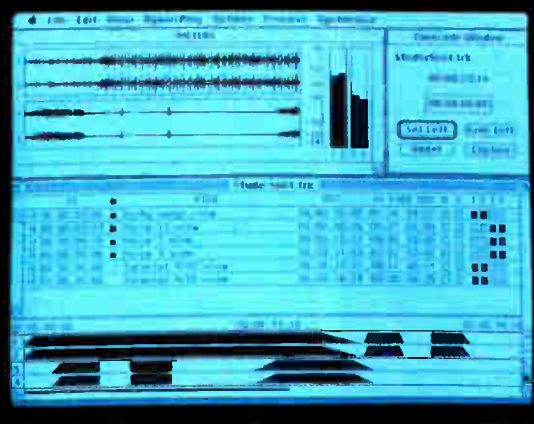

Synchronization Is Easy. With the System Synchronizer and Timecode option, Dyaxis (and Dyaxis 2 + 2) is a master of sample accurate timecode-based slave applications. With a click of the mouse, Dyaxis locks to SMPTE, EBU, VITC, video, and film tach.

Superb Audio Quality. Through Studer Editech Corporation's own proprietary A-D/D-A convertor implementation, anti-aliasing filter and analog circuit designs, Dyaxis has achieved a reputation for outstanding sound quality.

RDAT Backs Up More. Dyaxis' integrated data RDAT subsystem stores all soundfiles along with their precise editing instructions.

Digital Compatibility. Dyaxis communicates with and transcodes between all major digital audio formats such as DASH, AES-EBU, SPDIF, PD, SDIF, 601 and more.

Studer Dyaxis—Designed For You. Discover digital technology that's flexible, powerful and easy to use—all the right stuff at a price that might pleasantly surprise you. With Studer's legendary technical support and financial capabilities, Dyaxis is a sound investment in your future. Call us at 800-366-4900 for our free 12-page color brochure on Studer Dyaxis, or call any of our regional offices for an immediate demonstration.

Picture your sound. On Dyaxis.
From Studer, a name you can trust.

STUDER REVOX

Studer Revox America, Inc.
1425 Elm Hill Pike • Nashville, TN 37210
Tel: 615 254-5651 Fax: 615 256-7619
New York 212 255-4462 • Los Angeles 818 780-4234
Studer Revox Canada Ltd., Toronto 416 423-2831

STUDER DYAXIS 2+2.



HE SAID,



“You can write almost anything you want about this machine and put my name under it.” SO WE DID.

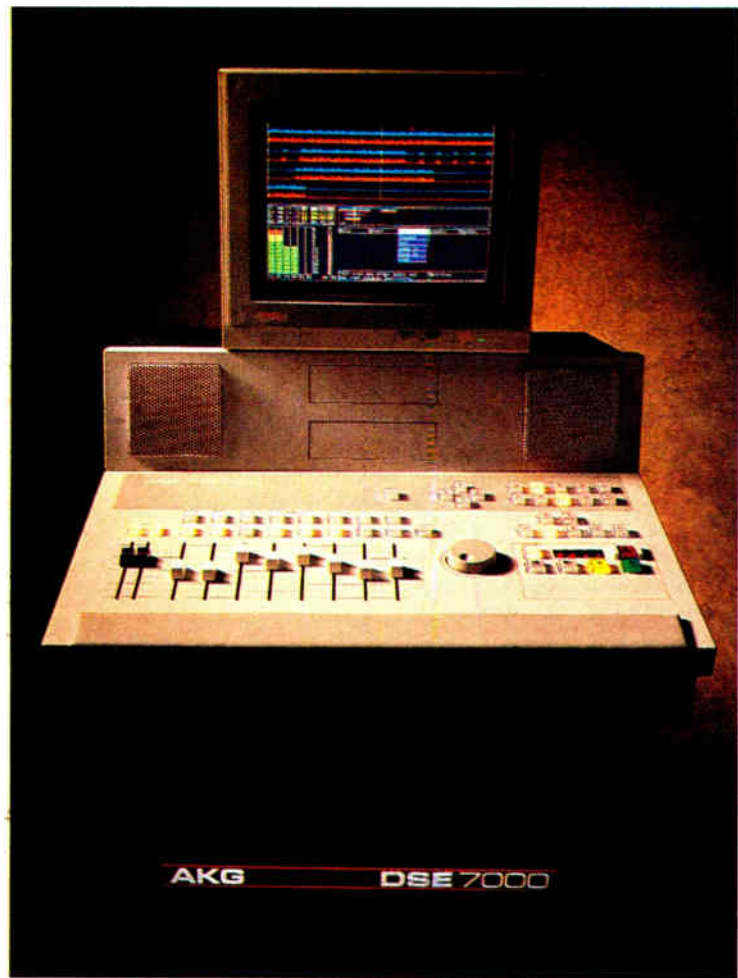

THE DIGITAL SOUND EDITOR. STATIONS FROM BOSTON TO SAN DIEGO ARE MAKING IT THE HOTTEST BOX IN RADIO.

Dan McCoy was the first production director in radio to use the DSE 7000, and he saw it revolutionize the way production is done at

WZOU-FM,



one of the top stations

in Boston. A spot that used to take an hour to produce now takes 20 minutes. Without tape.

Without razors. Without a single dB of generation loss. Even agency dubs now go right to the

DSE for levels, sound enhancement



and tags; then onto carts. Creativity has exploded, too. With the DSE's instant UNDO feature, the fear of trying new things is gone. You simply try another take, assemble a different edit, or test a new effect. If you don't like the results, UNDO it instantly. No wonder WZOU has

designed their production facility around the DSE.



And no wonder Dan McCoy calls

this machine “the most impressive thing that's ever happened to radio.” His words, not ours.



1525 ALVARADO STREET, SAN LEANDRO, CALIFORNIA 94577, USA, (415) 351-3500. FAX: (415) 351-0500



DSE 7000 • THE NEW SPEED OF SOUND™



Show Coverage

SBE Exhibitors Unveil Latest in Technology

by Alex Zavistovich

St. Louis MO A range of new and recently introduced broadcast-related equipment was on display at the SBE

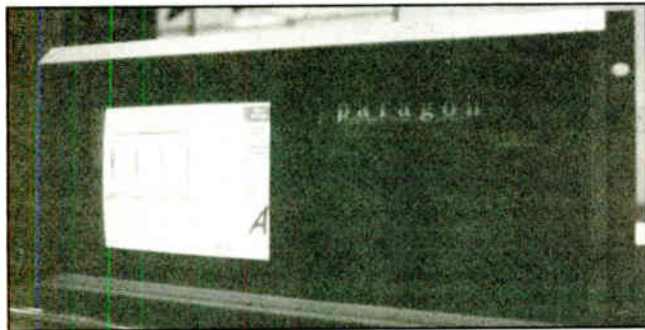

The Paragon, from Audio Animation, features digital signal processing accessed by touch screen.

convention. Several manufacturers used the event to debut products to the broadcasting community.

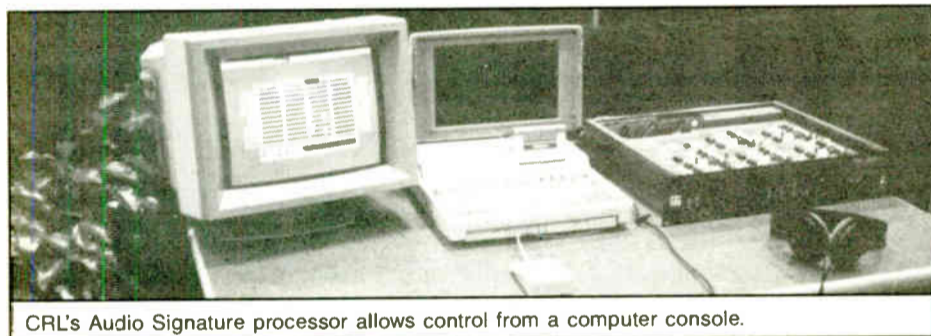

CRL's Audio Signature processor allows control from a computer console.

While not a debut showing at the SBE, the product which undeniably generated some of the greatest interest during the exhibit was the Paragon digital audio dynamics processor from Audio Animation, Inc. The Paragon, a fully digital audio transmission processor, is RAM-based and utilizes no clippers. Also, the



A line of routing equipment was on display from SAS.

unit uses touch-screen technology to control its functions.

A wide band compander, four-band compressor and four-band limiter are provided in the Paragon, all with control of attack times, release times, crossover frequencies and other functions. The device comes factory loaded with 35 presets, five for each major broadcasting format.

Other products also got their share of

attention, many of which were actual introductions at the SBE.

Introduced in prototype this past spring but now in production is CRL's Audio Signature processor. The unit enters the digital age by providing micro-processor control of processing parameters. Computer interface allows for control from a PC, with features such as mic presets which can be loaded into memory for future use.

Sierra Automated Systems introduced the ANC-8 alphanumeric control panel. The eight-character

ANC-8—the latest addition to the SAS 32000 series routing switcher and mixing system—allows source selection by

dialing up the actual source name.

Sources are displayed in alphabetical order on the ANC-8; rotating the "no

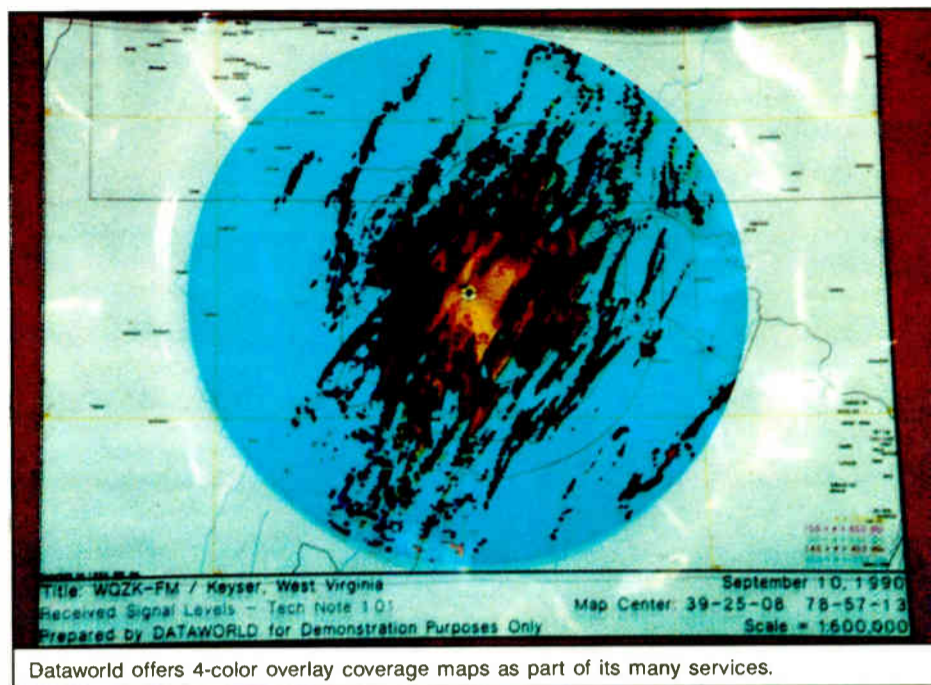

Dataworld offers 4-color overlay coverage maps as part of its many services.

end stops" shaft encoder eliminates the need for a cross referenced list of input number versus name. All remote ANC-8 panels receive alpha assignments, without interrupting or affecting the operation of the switching system.

New from Electronics Research, Inc. (ERI) was the Invisi-Shield, an electrically transparent ice shield that affords protection from falling ice, with no perceptible pattern distortion.

The Invisi-Shield can be mounted directly over each element, reducing the potential accumulation of radial ice. Its 300 psf load rating and 6'x4' size also provides a convenient work platform for the antenna over which it is mounted.

Marketed in the US by Redwood Marketing is a line of professional products

from Eela Audio of Holland. An introduction for that company in the States is the Reportophone® S20A, a portable telephoneline adapter combined with a two-input mixer for microphone and



ERI's Invisi-Shield is designed to reduce radial ice accumulation.

tape recorder.

Dedicated signal processing (equaliza-
(continued on page 15)



The VISION MOBILE STUDIO

Increase your
**MOBILITY,
VISIBILITY,
PROFITABILITY ...**

with a powerful, compact, fully equipped, easy to use mobile remote broadcasting studio, designed for your needs.

VISION MOBILE STUDIOS
VOYAGER RV CENTER, INC.
79 OLD PALATINE ROAD
WHEELING, ILLINOIS 60090
PHONE: 1-708-537-1770
FAX: 1-708-537-1899

Circle 40 On Reader Service Card



SATISFACTION GUARANTEED.

What's going on in the console business?

Last year, when we introduced the RS-Series consoles, our pricey competitors fought back by advertising that their consoles were "Designed — Then Priced", implying that for what our consoles cost, they couldn't be well made.

Then more than 250 broadcasters bought RS-Series consoles. And they all loved them. More than 38% bought another.

So this year the competition changed their ads. Now the headlines cry "We Surprised Ourselves", and sure enough, they go on to admit that it does seem possible to build a quality, mid-priced console.

So, while the competition scrambles to cheapen up their pricey consoles, we invite you to take advantage of our experience and reputation for real value.

Buy an RS-Series console and use it for up to 30 days. And if for any reason you're not 100% satisfied, send it back. We'll refund your money — in full.

Get a great console — at a great price — with absolutely no risk.

It's an offer we can afford to make, because we didn't re-engineer the affordable quality console — we invented it.

RADIO SYSTEMS INC.

110 High Hill Road □ P.O. Box 458 □ Bridgeport, NJ 08014-0458 □ 609/467-8000 □ 800/523-2133 □ FAX 609/467-3044

Pirates, PCBs and Processing

SBE Engineering Sessions Provided Lively Forum For Discussion of Radio's Most Pressing Problems

by George Riggins

St. Louis MO Under the Silver Arch, not the Golden Arches, gathered a fair number of technical people and manufacturers for the 1990 SBE National Convention.

At last count either four or five vendors cancelled at the last moment. They probably did not feel that the third or fourth trade show in the span of a few short weeks would bring anyone who had not been in Boston, Los Angeles or points in between.

The loss goes to the vendors who did not show. The attendance was good. As for those vendors who did show, the general consensus was that the floor traffic was excellent and the majority of the contacts were of quality.

Yes, there were the usual gripes about the coffee being worse than what is usually served at a truck stop. At least I did not hear any serious gripes about the convention on an overall basis.

It was interesting to listen to Wally Johnson recount some of the history of the industry in his part of one session. Hard to realize that FM as we know it today is only a little more than 40 years old. Yet, Edwin Armstrong tried to get the FM method of propagation going over 60 years ago. There are now more FM stations on the air than there are AM stations, 5756 FM vs. 4979 AM as of the last count.

Capturing pirates

One of the lighter but very serious presentations was on the problems of pirate radio. No part of the world is immune. Don Bishop of Mobile Radio Technology treated a very touchy subject with a bit of humor. This is a problem that can and does effect all of us in one way or another. It is in our own best interests to help identify and locate any pirate station that appears in any part of the RF spectrum.

On the serious side there were two subjects that need more attention: How to deal with any item within the station that can possibly contain PCBs and what is the future of audio processing and the NRSC standard in the coming digital age.

Kent Kroneman of KUED-TV, Salt Lake City, UT took those in attendance on a step by step journey through the proper disposal of PCB-containing capacitors and transformers. To say there is not a lot of paper work connected with this task is to make an understatement.

Kent outlined the problems and proce-

dures involved with the proper and legal disposal of toxic materials. Kent listed three basic steps to follow: Inventory the site, replace PCB-containing devices and properly dispose of the PCB-containing devices.

One other factor that Kent stressed was what working with other stations in the area will accomplish in reducing the costs to all who participate. Proper plan-

It is in our own best interests to help identify and locate any pirate station . . .

ning is the key to reducing the costs.

In the Salt Lake City area, most of the TV and FM stations located on the site with KUED-TV were able to work together in obtaining replacement parts, removing the suspect parts from service and then getting the contaminated parts removed from the site.

The first step in identifying suspected PCB containing parts is to contact the manufacturer of the transmitter—or other device—and ask the basic question, "do any of the capacitors or transformers used in model XYZ contain PCBs?" If the system manufacturer cannot answer the question, then the question must be addressed to the individual part manufacturer.

If the question cannot be answered in the negative, any oil-filled part must be considered as containing PCBs. After identifying all suspected parts, replacements must be obtained.

The problem with replacing PCB-containing parts is, there is a relatively short time span allowed for the parts to legally remain on the premises. PCB-

containing parts must be removed from the premises and disposed of within 30 days after removal from service. So, if there is to be a group effort to remove PCB containing devices from a remote site, close cooperation between all concerned is an absolute must.

For more detailed data contact Kent Kroneman at KUED-TV, Salt Lake City, UT, 801-581-6271.

Processing for night owls

The "night owl" session on processing was packed. The two-hour session was

ing does not make the steak better; in fact, the steak will probably be less than appealing when covered with the entire contents of a seasoning container.

Frank mentioned that he was a consultant to several stations, and was recommending that some of the stations drastically reduce the amount of processing used. The records (CDs) that were being played already had about 50 dB of processing added at the time of recording and no more processing (compression/limiting) was needed or desired.

Sandra Woodruff explained the reasons for installing the NRSC filter. Sandra commented that the real problem for NRSC was obtaining the cooperation of receiver manufacturers to build product to the NRSC Standards.

With heavy processing, all agreed—at least I think there was agreement—that the NRSC filter either eliminated all the "monkey chatter" or at least lowered the chatter to an acceptable level.

The open mic part of the session brought forth many interesting comments. Most of the comments will be held for further study on the subject. The most fascinating comment came from Bill Gilman: "Just say no!", meaning, say "no" to trying to correct all the programming and management problems by turning up the processing.

George Riggins is RW's Old Timer.

lively and animated. For those not in attendance, the panel was chaired by Bill Ammons of CRL. Joining Bill were Frank Foti of Cutting Edge, Bill Gilman of Gentner and Sandra Woodruff of KFWB, Los Angeles representing the NRSC portion of the controversy of processing.

Perhaps the most germane statement was made by Frank Foti to the effect that processing is being overused, abused and misused. Bill Gilman likened processing to seasoning a good steak. A little salt, pepper and steak sauce bring out the flavor. Adding a bottle of season-



Harris DX Series Digitally Modulated Solid State AM Transmitters

What makes DX Series transmitters the first choice of competitive AM broadcasters around the world? Simplicity, reliability, ruggedness—and significant performance breakthroughs in AM technology. No other AM transmitter offers all these DX Series features:

- Patented Digital Modulation delivers the strongest, cleanest AM signal yet: Over 135% positive peak capability, plus the lowest THD and IMD ever
- RF/AC ratio of 86% for lowest power costs of any AM transmitter
- ColorStat™ front panel signal flow diagram with red/green LEDs shows status at a glance
- Harris power supplies are designed for continuous duty operation with 100% sine wave modulation
- Modular construction with readily available FET output devices
- Bandpass filter and output matching network for effective lightning protection
- 100% solid state design totally eliminates tube replacement costs and reduces maintenance costs sharply
- Output impedance matching controls provide tuning flexibility for non-standard or changing loads

AM stations around the world have already discovered the competitive advantage of DX Series transmitters in 10, 25, 50 and 100 kW power levels*. Isn't it time you did too? Call Harris Allied today at 217-222-8200, Ext. 3408 for more information on digitally modulated DX Series AM transmitters.

* Contact us for applications to 500 kW and beyond.

HARRIS ALLIED

Harris Allied Broadcast Equipment
Radio RF Sales • P.O. Box 4290
Quincy, IL USA 62305-4290

© 1990 Harris Corporation

Circle 3 On Reader Service Card

Circle 37 On Reader Service Card

Circle 66 On Reader Service Card

Introducing

THE WIZARD™ from Belar

FM Digital Modulation Analyzer

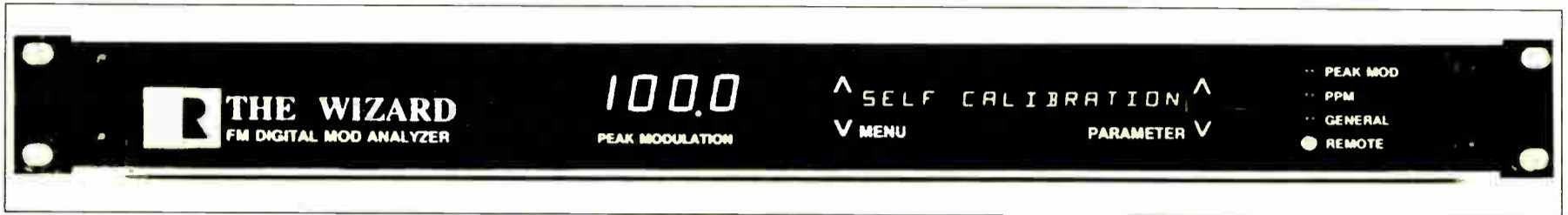

Belar, the world leader in RF test and measurement systems, brings you a new generation in FM modulation measurement. The WIZARD™ features include:

- Menu driven—16 character alphanumeric display
- Deviation in percent—0.1 or 1 percent increments
- Deviation in kHz—0.1 or 1 kHz increments
- Up to 0.1% accuracy—function of demodulator calibration
- Self calibration to external calibrating signal
- Pre-set peak mod—adjustable in 0.5% increments
- Pre-set PPM—adjustable from 0 to 100 PPM
- Variable peak hold time—adjustable in 0.5 second increments
- Peak weighting mode—time constants are menu selected
- Real time mode or past time mode
- Provision for pilot injection measurement from FMS-2
- Provision for pilot modulation measurement from FMS-2
- Provision for SCA injection measurement from SCM-2
- Silent sentry alarm—adjustable in time and threshold
- Will accept external alarms—such as off frequencies from FMM-4A
- Alarms read on menu—menu will cycle if two or more are present
- Modulation adjust on two ports—adjustable in 0.5% increments
- RS-232 port—provides computer graphs and remote operation
- Three level password protection—look only, change, and manager
- Either infinite window histogram or sliding window histogram
- Optional FM precision demodulator that will remotely self calibrate
- One rack height panel space—including precision demodulator

Sample PC Output

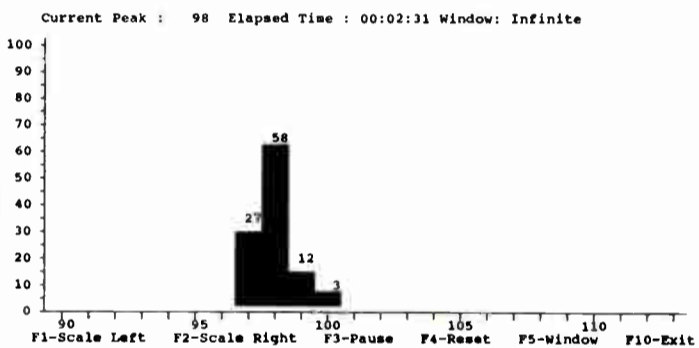
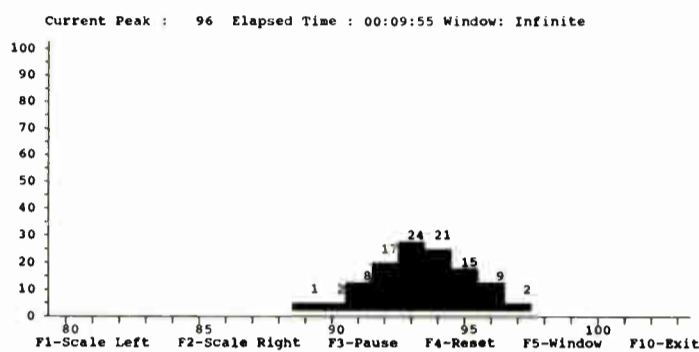

Communications Options Plot Help Exit

Elapsed Time : 00:04:12 Window : Infinite

F1-Scale Left F2-Scale Right F3-Pause F4-Reset F5-Window

Remote Display

Peak Modulation: [1] [0] [0] [0]

Peak Mod [100.0] PPM [10] Audio Fail

Menu: 75.0 - KHZ DEV

F6 - Menu Left F7 - Menu Right F8 - PARAM UP F9 - PARAM DOWN

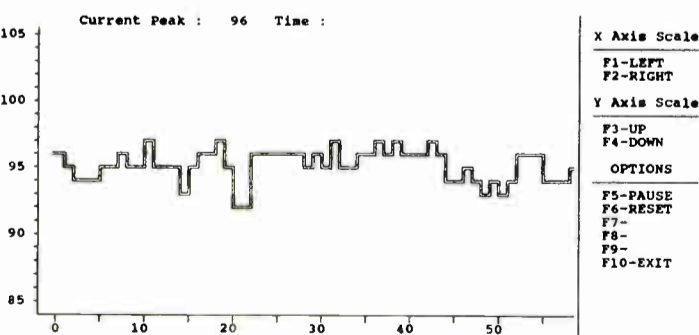

Sample Setup Menus

^ SELF CALIBRATION ^
V MENU PARAMETER V

^ SAVE CONFIG ^
V MENU PARAMETER V

^ BLANK - ON ^
V MENU PARAMETER V

^ TIME MODE - REAL ^
V MENU PARAMETER V

^ DEV 75.0 KHZ ^
V MENU PARAMETER V

^ HOLD 1.0 SEC ^
V MENU PARAMETER V

^ PEAK MOD 100.0 % ^
V MENU PARAMETER V

^ REMOTE - OFF ^
V MENU PARAMETER V

^ INFINITE - ON ^
V MENU PARAMETER V

^ PILOT INJ 9.0 % ^
V MENU PARAMETER V

^ SCA INJ 10.0 % ^
V MENU PARAMETER V

^ PK WEIGHT - OFF ^
V MENU PARAMETER V

^ RES- 1.0 PERCENT ^
V MENU PARAMETER V

^ PPM THRESH 10 ^
V MENU PARAMETER V

^ PPM COUNT 10 ^
V MENU PARAMETER V

^ SENTRY 10.0 % ^
V MENU PARAMETER V

^ SENTRY 30.0 SEC ^
V MENU PARAMETER V

^ MOD ADJ- 0.5 % ^
V MENU PARAMETER V

For details, price and delivery information, contact Belar or your authorized Belar dealer

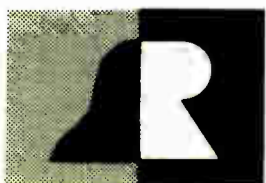

BELAR
ELECTRONICS LABORATORY, INC.

LANCASTER AVENUE AT DORSET, DEVON, PENNSYLVANIA 19333 • 215-687-5550 • FAX: 215-687-2686

Where Accuracy Counts ... Count on Belar

Convention Deemed Success

(continued from page 1)

ing the show, but the opening evening was too limited at two hours.

"We were pleased with the activity we had," Scott said. "I think it would be better if you had longer exhibiting hours on opening day."

Companies like St. Louis

QEI Senior VP Bill Hoelzel said SBE "wasn't quite as good as Radio 1990, but it was better than Kansas City last year."

Although relatively good marks were given to the St. Louis show, there was plenty of grumbling about the 1991 Houston show.

SBE's Dick acknowledged the exhibi-

tor concern. "I think it is fair to say that some of them came to St. Louis saying, 'we are not sure about Texas'" he said.

Only about 20-25 vendor representatives attended the 7 AM Saturday morning exhibitors meeting, according to SBE show manager Eddie Barker, of Eddie Barker Associates.

Although a few reportedly did sign up for booth space in Houston after the St. Louis show, many who usually sign up to get the best booth space early have not yet committed.

Undecided companies

"We decided to wait this time," Harris-Allied's Burns said. "There is a 90%

chance we are going to go to Houston."

Burns said the company is not thrilled with Houston because of its location, which will draw fewer people than St. Louis or Kansas City, he said.

"It works in the Midwest. Why monkey with it?" Burns said. "I think they (SBE) are going to have to do a selling job to get people enthusiastic about the 1991 show."

One bright spot for Houston, which could draw additional attendance, is the concurrent Texas Association of Broadcasters Show. It will be moved from San Antonio to Houston in 1991, Burns noted.

Other companies echoed Harris-Allied's reservations about moving the show from the Midwest. Until the 1988 show in Denver, the show had stayed in St. Louis.

Unappealing location

"I was very disappointed that it left St. Louis in the first place," QEI's Hoelzel said. "If we go to Houston, it probably will be with less," he added, citing increased transportation costs.

CRL's Ammons questioned whether there are enough engineers within driving range of Houston when compared to St. Louis.

"If you draw a 300-mile ring around Houston you basically have New Orleans, Dallas and San Antonio," he said.

But not all companies are willing to write off Houston so soon, according to comments made after the show.

"We haven't made up our minds about Houston, but we probably will go if that is where it is," ATI Inc. VP Ed Mullins said.

Continental's Director of Promotions and Advertising Steve Claterbaugh attended the Saturday exhibitor meeting and acknowledged there was some discontent about Houston at the meeting and on the show floor.

Products Paraded at SBE

(continued from page 11)

tion and compression) allows field reporters to send a clean noise-free signal back to the studio. The S20A also includes a pushbutton dialer, with a choice of tone or pulse. A built-in buzzer circuit provides contact with the studio.

Also new from Eela Audio is the S50, a portable, battery-powered stereo or two-channel mixer.

Harris Corporation also unveiled a new product—the HT 500 FM, a 500 W solid state FM transmitter, which comes in a portable shipping container. The unit includes standard automatic power control, proportional VSWR foldback, auto-restart in the event of AC failure and built-in direct remote control interface.

Fresh from its debut at the AES was the Portable One, from Audio Precision. This portable test set offers 12 basic measurements, selected with function buttons.

THD+N, IMD, amplitude, noise, two-channel level, real-time ratio, phase, wow and flutter, general load resistance, AC mains check, SINAD, frequency and

real-time crosstalk can all be measured with the unit, which weighs in at 17 lb. and comes with a retractable handle.

Premiered at the AES but having its first broadcast-specific demonstration at SBE was the Otari DDR-10 digital audio disk recorder and editor.

The DDR-10 is being marketed by Otari as a replacement for conventional two-track editing. It features SMPTE/EBU synchronization capability, AES/EBU and S/PDIF digital I/O and full editing capability in a non-destructive mode. Onboard DSP effects include equalization, stereo time compression and expansion, crossfades, mixing and merging.

Another comparatively new arrival on the broadcast scene was the Tracker from Radio Computing Services. A computer-based audio logging system, the Tracker uses proprietary compression technology to store up to 200 hours of audio information on a single DAT cassette.

The computerized logger is also equipped with a telephone interface that allows the system to be controlled from any remote location.



Stereo Play \$1875 List

BROADCAST SERVICES/EME

The Davis Communications Group, Inc.

The Preferred Source ... for all ITC products.

ITC Series 1 The last cart machine you'll ever buy...

An ITC Series 1 cart machine placed in service today will perform well into the next century. ITC has set the standard for long-term reliability, outstanding factory support and unsurpassed performance. We've priced the Series 1 to fit every budget.

Call today:

800/525-1037

Fishing For A Phone Number?

Catch it in the

1990 Radio World Annual

—The Industry Source for
Manufacturer, Supplier,
NAB and FCC Phone List-
ings, as well as Product
Information, Company
Profiles, Buyers Guide
Reprints, RW's 1989
Editorial Index, Reference
Material, and More...

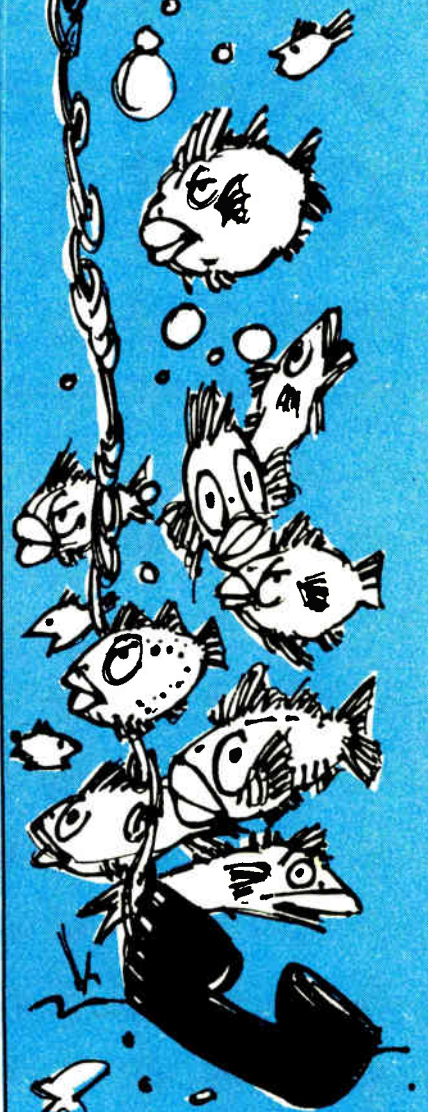

Send \$14.95 for each Annual to:

**RW 1990 Annual
P.O. Box 1214
Falls Church, VA 22041**

Audio Discoveries at the AES

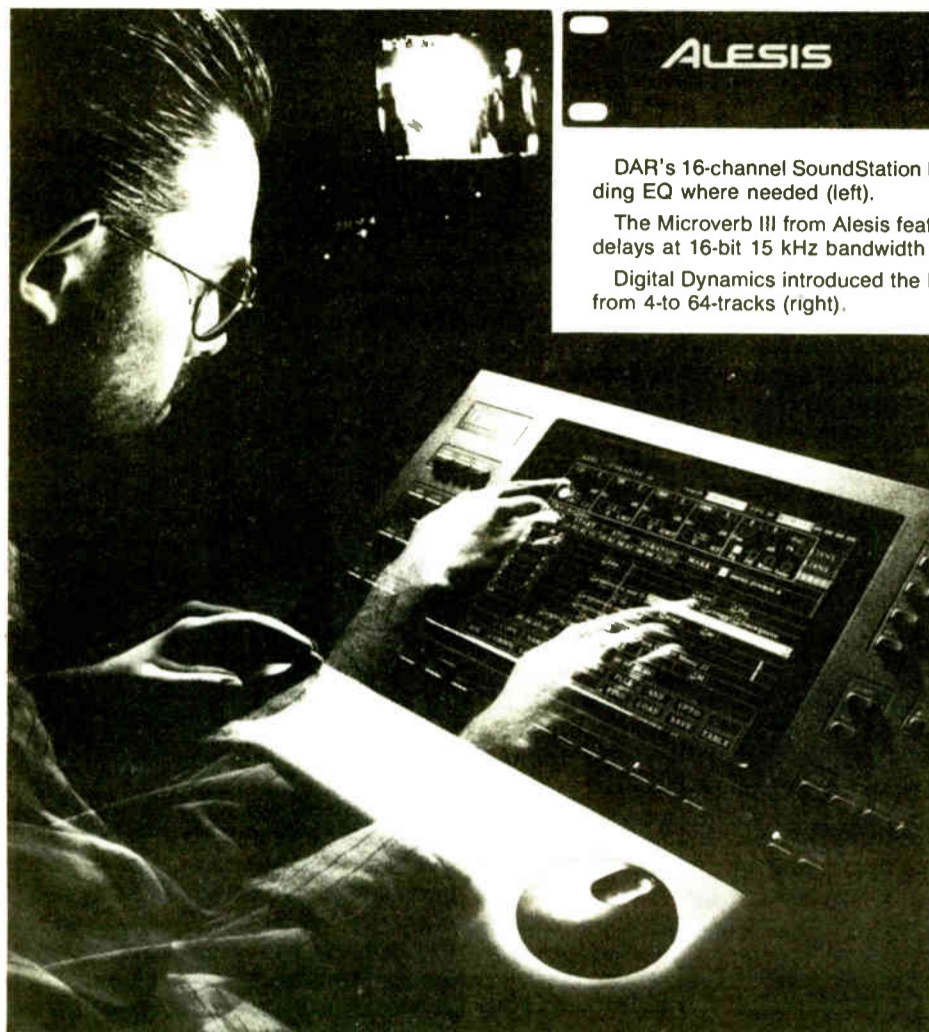

DAR's 16-channel SoundStation DSP has segmented editing for adding EQ where needed (left).

The Microverb III from Alesis features 256 programs of reverbs and delays at 16-bit 15 kHz bandwidth (above).

Digital Dynamics introduced the Pro Disk 464, a record/edit system from 4-to 64-tracks (right).

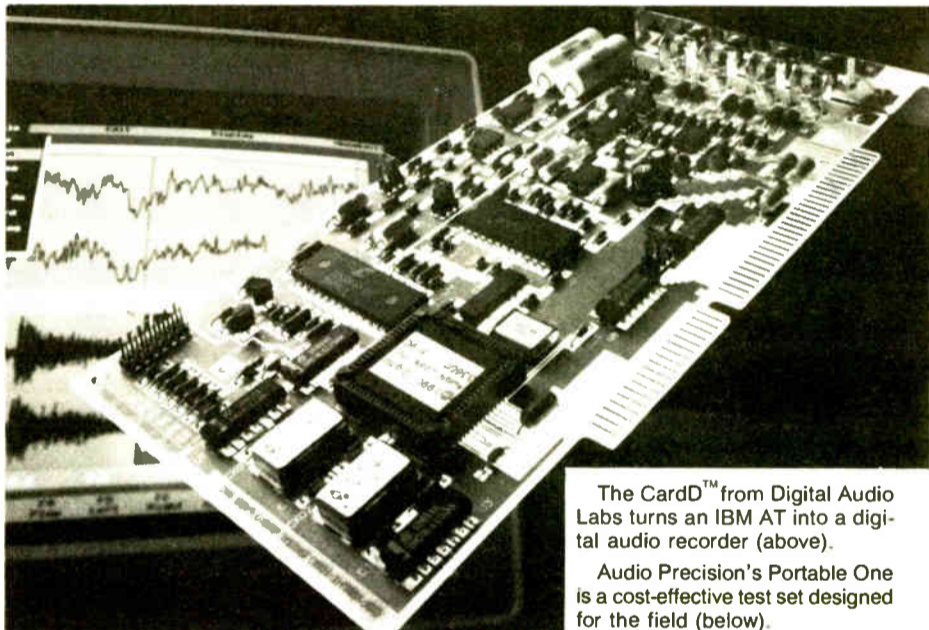
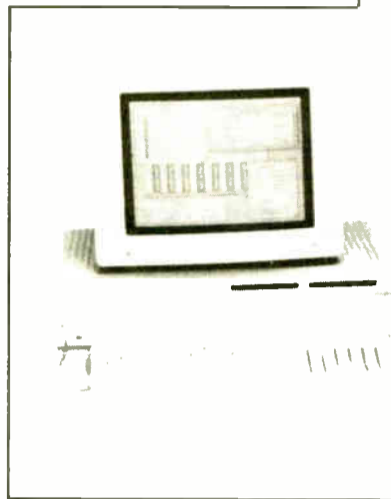
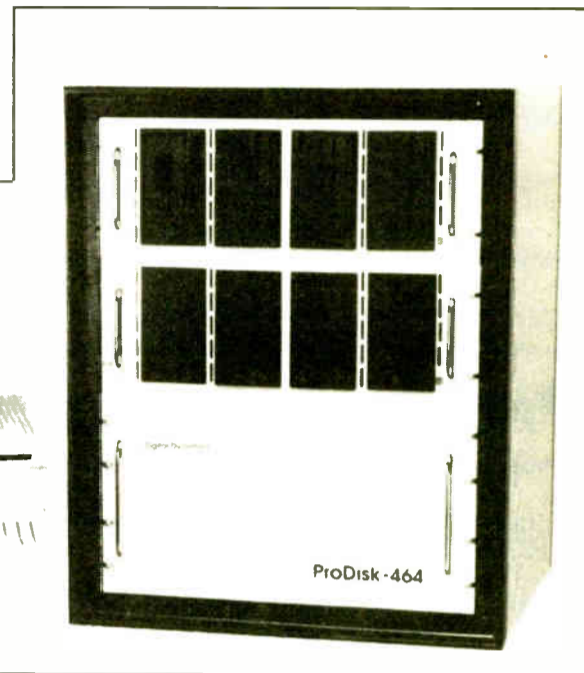

The CardD™ from Digital Audio Labs turns an IBM AT into a digital audio recorder (above).

Audio Precision's Portable One is a cost-effective test set designed for the field (below).

7.5kHz Dial up Audio

CCS' family of digital audio CODEC boxes gives you *Crystal Clear Digital Audio™* over switched 56/64kb dial phone lines, ISDN, DS0 fractional T1 or other digital facility. 56kb and 64kb dual speed capability is available for international service. Watch for our 15kHz audio on 56kb in December '90.

Crystal Clear Digital Audio™



The Complete RF Exposure Measurement System from Holaday Industries

Measure Both E and H fields

ANSI RF exposure standard requires measurement of both the electric and magnetic field.

Automatic Self-zero

Completely automatic self-zeroing eliminates drift, improves accuracy of readings.

Recognized by Federal Agencies

Evaluated and used by NIOSH, OSHA, EPA and CDRH, as well as state, local health departments and consulting engineers.

NBS Probe Design

Isotropic probe design originated by National Bureau of Standards.

Displays Time Average Reading

Real-Time display of the current six minute relates directly to the ANSI RF average exposure standard.

Call or write for more information on these reasonably priced systems. Rental systems also available.



HOLADAY INDUSTRIES, INC.
14825 Martin Drive
Eden Prairie, MN 55344
Telephone: (612) 934-4920
Telex: 29-0922 FAX: 612/934-3604



CORPORATE COMPUTER SYSTEMS Audio Products
33 West Main Street Holmdel, N.J. 07733
Phone (908)946-3800 FAX (908)946-7854

Who's Setting The Pace For FM Transmitter Technology?

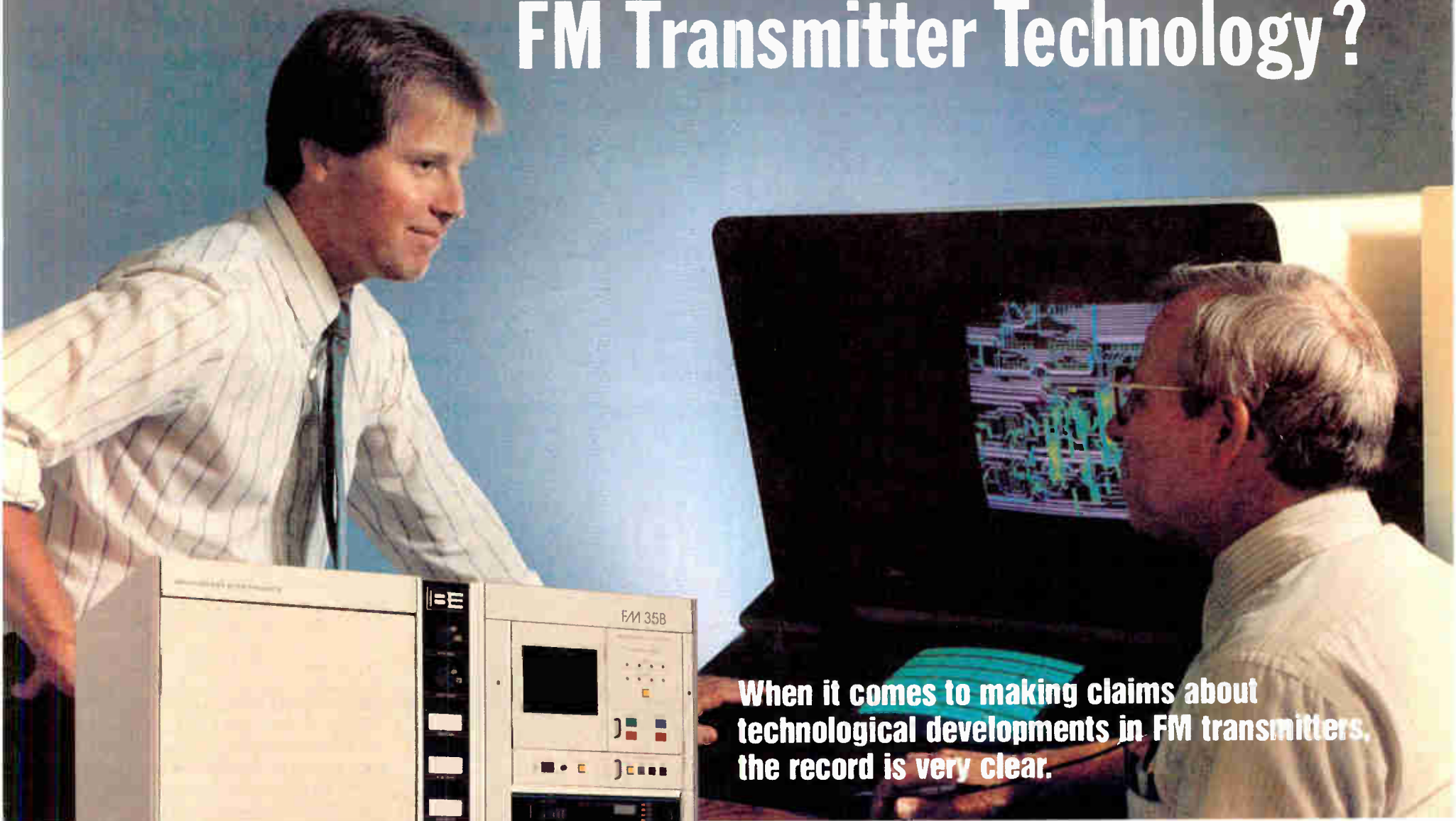

When it comes to making claims about technological developments in FM transmitters, the record is very clear.

Broadcast Electronics:

First to introduce a Proportional VSWR Foldback System.

First to introduce "PWM Automatic Power Control" with "Soft Start".

First to offer a built-in synchronous AM test port.

First to design a single tube high power 30kW FM Transmitter.

First to introduce a single tube 10kW FM Transmitter with a 4CX7500A tube.

First to introduce a single tube 3.5kW FM Transmitter with a 4CX3500A tube.

First to introduce a Microprocessor Video Diagnostic System.

First to offer built-in, PC based, transmitter remote control.

First to offer a standard synchronous FM booster option.

And, Broadcast Electronics again sets the world standard for FM Exciters with the new FX 50 which stands alone in audio performance with 93 dB S/N and .003% THD and IMD.

State of the Art Leadership

Stereo technology, only B.E. designs it all - AM, FM and TV stereo generators.

Broadcast Electronics is the only major FM transmitter manufacturer who designs and manufactures its own solid state intermediate power amplifier (IPA).

All products are backed by B.E.'s 24 hour parts and service and a strict quality assurance program.

The result of this commitment to state-of-the-art innovation is a complete line of RF products, designed to provide you with years of reliable service. Certainly it's clear who **is** setting the standards for FM transmitter technology!

Patented Innovations

Broadcast Electronics has the largest and most skilled engineering staff dedicated to the radio broadcast equipment industry. Significant FM transmitter design patents awarded to B.E.:

- Folded Half-wave Output Cavity, patented 1982.
- Internal Second Harmonic Suppressor, patented 1982.
- Broadband Input Impedance Matching Circuit, patented 1985.

Put our engineering expertise to work for you. Call (217) 224-9600 for the Broadcast Electronics Representative in your area.

BE [®] **BROADCAST
ELECTRONICS INC.**

4100 N. 24th ST., P.O. BOX 3606, QUINCY, IL 62305-3606 U.S.A., PHONE (217) 224-9600, TELEX 250142, FAX (217) 224-9607
Circle 142 On Reader Service Card

World Radio History

Bargains Mark AES

(continued from page 1)

built-in MIDI tape synchronizer, gapless auto punch in/out and an electronically switched signal routing system with memory. The transport includes a rotary shuttle control that provides precise tape cueing. The 688 carries a list price of \$3299.

"Most radio production rooms doing music tend to go to the 688 because they are using MIDI samplers and synchronizers," said Tascam's Don Tinen. "But for general production with microphones and traditional sound sources without MIDI, the 488 will sound the same."

Other differences: The 688 offers balanced mic inputs, the 488 does not. The 688 offers three-band EQ and the 488 controls just treble and bass. The 688 is capable of recording eight tracks simultaneously; the 488 can record four at a time. And the 688 is available now; the 488 will be available by Christmas.

Stereo mics

To enhance the stereo "image" of a radio station from music remotes to news, two American manufacturers have developed stereo microphones that set new low price standards for their class.

Though Crown and Shure each offer



The 89th AES convention drew engineers to Los Angeles, pursuing the latest in audio technology.

a different stereo miking technique, their microphones—each at under \$1000—offer ways for any radio station to economically produce high quality "true"

stereo broadcasts (as opposed to the panned pot variety).

Shure's entry into the stereo microphone market is the new VP88 coincident Mid-Side (M-S) microphone with a list price of \$995 (again, substantially discounted at the retail level). The VP88 uses a forward facing Mid capsule and perpendicular Side capsule plus a built-in stereo matrix "to provide wide, natural uncolored response for optimized stereo imaging," according to the company.

Crown demonstrated its Stereo Ambient Sampling System (SASS) microphone and issued a compact disc to demonstrate its capabilities. The mono-compatible, near-coincident SASS microphone—suitable for a wide range of broadcasting tasks—uses Crown's patented PZM technology.

SASS inventor Mike Billingsley, a Vermont sound producer, demonstrated the microphone in applications from music, to sound effects to dialogue recording and presented a technical paper on the microphone's capabilities to the AES. The SASS microphone, which lists for less than \$900, is available now from Crown International.

Low end workstations

Another area of interest for smaller radio stations is in the low end of the digital workstation market.

Sonic Solutions of San Francisco, known for its high-end Sonic System CD Premastering System and NoNoise noise reduction, announced the "Sonic Mini Editing System" with radio stations cited as a key target market. Priced at \$8750 (a complete system, including Macintosh II family computer and hard disk with capacity for more than 80 minutes of CD-quality stereo story, will cost a little more than \$20,000), the workstation is a two-track disk-based editing system in the 16-bit domain.

Available immediately, the Mini system offers seamless waveform editing, real-time edit playback and expansion with such options as background loading/unloading, multitrack editing, machine control, 20-bit editing, project management, varispeed and PQ editing. It also can be expanded to include the Sonic System Mixing Desk, NoNoise and the START Lab CD Maker. With the one shot CD maker, a radio station could create inexpensive in-house CDs.

Sonic Solutions joins companies such as Digidesign, Dyaxis, AKG and others who are aiming fast-developing low-end digital workstations at the radio market.

Though new price sheets reflected generally higher prices from top name precision manufacturers from Europe and Japan, there were many exceptions to the rule on the exhibit floor of this AES. In fact, never before has so much audio technology been as affordable as it is now in the fall of 1990.

When You Consider Remote Possibilities...



PLXmicro Frequency Extender/Encoder

Perfect complement to a cellular phone, transforming the sound to broadcast quality. Provides connections for microphone, tape and headphone. Compact size. Battery-operated. Full duplex operation.



Multiline Frequency Extender

The most sophisticated and easy-to-use frequency extender available. This versatile 1, 2, or 3 line system automatically dials, levels and equalizes your line at the push of a button. Incorporates Comrex unmatched noise reduction.

Consider Comrex. We're the people who pioneered the frequency extender and have set the standard in broadcast quality telephone transmission for nearly 30 years.

Comrex covers every remote possibility—in radio, television and teleconferencing. Comrex equipment is specified by networks and stations worldwide who understand the paybacks of Comrex dependability.

TH-1 Hybrid

Users say it's the "best hybrid we've ever worked with." Provides reliable broadband balance plus auto or manual answer, dual call start, adjustable ring count, caller mute and more.

TH-X Extender Hybrid

Picks up where the TH-1 Hybrid leaves off. Combines all of the TH-1 features with transmit/receive frequency extenders and automatic caller leveling. Ideal for use with the PLXmicro and cellular phone for two-way, on-air remotes.

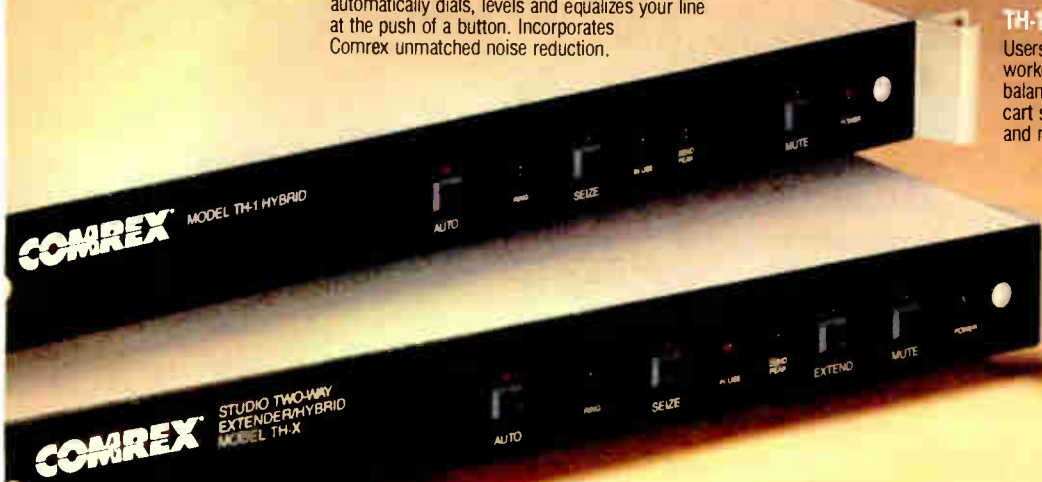

Call or write for more information including a free demo tape.

COMREX®

Comrex Corporation, 65 Nonsset Path, Acton, MA 01720
1-800-237-1776 / (508) 263-1800 / FAX: (508) 635-0401

Satisfaction is not a luxury.

When you've handled the tough situations and made them look easy. When you've built a solid record of excellence. That's the time to appreciate the satisfaction of real achievement. It's also the time to acknowledge the tools that helped you do the job a little better than it might have been done. For many of today's leading broadcast professionals, a BMX Series III on-air console is right on top of that list.

That's because Pacific Recorders engineers aren't satisfied with a console design unless it meets all of your requirements. The BMX III handles complex programming, acquisition and communication tasks simultaneously—and brings superb audio performance to all

of them. The exceptionally broad range of mainframe sizes and module types lets you configure the board for your particular applications. Yet the functional layout is always easy to understand and learn.

At PR&E, we build consoles for the long term. So while you will certainly be pleased with your purchase of a new BMX III, you're likely to be even more satisfied with each passing year. Which is one more reason so many station groups and networks specify BMX III on-air consoles—time after time.

For more detailed information on the many advantages of owning a BMX Series III on-air console, call PR&E direct at 619-438-3911.



This satisfied BMX III user is Herb Squire, Chief Engineer at WQXR-FM/AM, New York, N.Y.



**Pacific
Recorders &
Engineering Corp.**
2070 Las Palmas Dr.
Carlsbad, CA 92009
Tel 619-438-3911
Fax 619-438-9277

©Pacific Recorders & Engineering Corp.

3-D Audio: The Next Big Thing?

by Frank Beacham

Part I of II

Los Angeles CA Think of it as a very unique party with a memorable guest list. You are there with a couple of trendy dummies named "Fritz" and "Klaus," a team of distinguished aural scientists from around the globe, a sprinkling of genius-level computer wizards and some of the world's top rock'n'roll performers.

Welcome to the liveliest party in audio today: 3-D Sound.

The theme of the Audio Engineering Society (AES) meeting here 21-25 September was "Creating Illusions in Sound—The Fusion of Art, Technology and Imagination." It was an appropriate topic for the multimillion dollar smoke and mirrors world of 3-dimensional audio processing.

Not too far away

3-D audio is being perceived by a range of audio manufacturers—large and small—as "the next big thing" in audio.

Well-established companies such as Sony, Hughes, Roland and Shure have joined small boutique specialists such as Gamma Electronic Systems, Archer Communications, BBE Sound, Spatial Sound Inc., Modulation Sciences and Minim Electronics to develop that elusive product that will give consumers a more realistic listening experience than available with traditional stereo.

Many radio broadcasters, whether knowingly or not, are already transmitting programming utilizing one or more of these 3-D processes.

The Bedini Audio Spatial Environment (BASE) from Gamma Electronic Systems of Glendale, CA, a \$3000 black box, has already been used to process more than 200 music recordings, dozens of international radio commercials and 40 motion pictures.

BASE, invented by John Bedini, is described as a binaural template that processes traditional stereo sound so that it sounds as if it is not coming through a pair of speakers but from throughout the room.

BASE processors will be offered to radio stations within a year and will be reduced to a chip for inclusion in con-

Unlike BASE, which requires no decoding, Ambisonics requires the listener to purchase a special decoder and have a surround speaker system to fully enjoy the process. Non-decoded Ambisonics recordings sound like traditional stereo, according to a spokesman for Minim Electronics, a decoder manufacturer.

Shure Brothers, whose Stereosur-

round system has been previously used for television broadcasts, announced at AES the first compact disc release utilizing its system. *By Way of the World*, a Telarc jazz recording by The Spies, can be decoded by any radio receiver that utilizes a Dolby Surround Sound processor, which is compatible with the Shure system.

"This is an exceptional system and not just a gimmicky fad, like quad, for example. Stereosurround is

definitely here to stay," said Telarc Technical Services Coordinator Michael Bishop.

Not just TV

Joining the consumer processor market is Lexicon with its CP-1 Digital Audio Environment Processor. The CP-1—which can feed two to eight speakers—not only features decoding of Dolby surround sound with Pro Logic circuitry, but uses twelve remote control selectable computer programs to improve spatial acoustics from several listening sources.

Modulation Sciences is offering its StereoMaxx Spatial Image Enlarger to radio stations with the claim it "enhances and enlarges your music's stereo image



sumer radio receivers, said Sylvio J. Pennucci, director of business development for Gamma Electronics.

"We've already completed testing with a major radio conglomerate and feel BASE would probably eliminate a lot of processing used now in radio," he said. "The reason people EQ and do all these games and tricks is to make up for the inadequacy of stereo. Because we are binaural, we send a signal your brain more easily understands. You tend to listen to radio at a lower volume because you are getting all the information you need."

While many releases from Capitol Records, CBS/Sony, MCA and Polygram use BASE, the entire Nimbus record catalogue is encoded in a 3-D system called Ambisonics.

Your Next Four Band Audio Processor is the ...

Audio Signature™

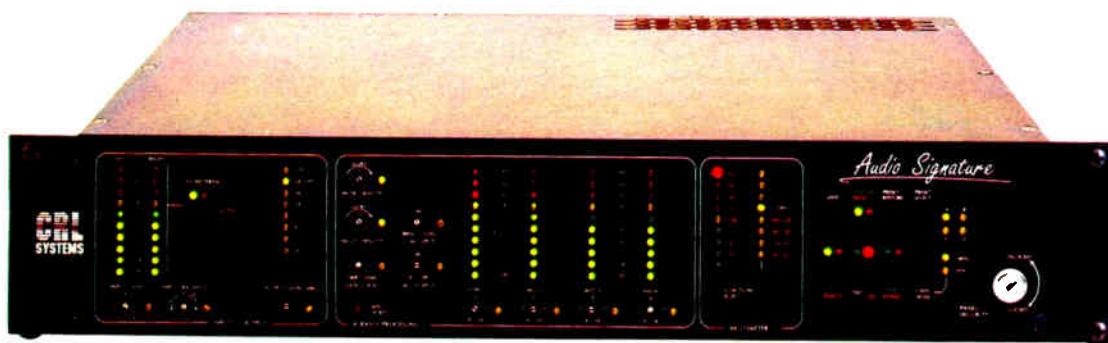

The CRL Audio Signature is a unique way to think of audio processing. Combine a powerful four band stereo compressor to an advanced microprocessor system. The result is a unit that lets you define the processing parameters that you want. Select the band split points—tailor the wide-band and multi-band density for your format. Boost or cut each band as you like. Created the sound that you want? Then store your design in one of four memory positions. Remote control? Dayparting?—You bet! Your PC and modem can control the Audio Signature from anywhere, anytime! The Audio Signature is a perfect replacement for older mono four band processors. Call or write CRL today—discover the power of the Audio Signature.

THE
PROFESSIONAL'S
CHOICE



Circuit Research Labs, Inc.
2522 West Geneva Drive
Tempe, Arizona 85282-3192 U.S.A.
(800) 535-7648 (602) 438-0888 FAX (602) 438-8227
Bulletin Board System (602) 438-0459

Audio Signature is a
trademark of Circuit
Research Labs, Inc.

for a dramatically bigger, fuller sound." The StereoMaxx, said Modulation Sciences, is compatible with any loudness processor and causes no phase, multipath or mono compatibility problems.

BBE Sound of Huntington Beach, CA, offers a \$200 consumer 3-D sound processor for home sound systems. Professional versions of the system are now being promoted for professional use by radio stations.

On the air

Chief Engineer Bob Leembruggen of LA's KTWV-FM has experimented on air with both the BASE and BBE processors. Though he refused to give a critical opinion of either device he is using neither on the air. "There is nothing you can put in your chain that will allow you to have less processing," he said.

Roland used the AES meeting to introduce its new Roland Sound Space processing system that enables a 3-D aural environment to be reproduced on a conventional two-speaker stereo system.

The system, which will sell in the \$40,000 range, is composed of two processors, binaural and transaural. The binaural processor converts the input signal into signals resembling the L/R signals of binaural recording, allowing the three-dimensional localization of a sound source to be manipulated as desired.

A separate transaural processor is used to eliminate aural crosstalk and provide spacious sound reproduction through a two-channel speaker system.

In a demo room at the Los Angeles Convention Center, Roland instructed listeners to sit in precisely positioned chairs. Effects heard from this "sweet spot" were dramatic but diminished substantially when the listener moved as little as a few inches away. Roland representatives acknowledged the narrow listening area and predicted a wider listening area for the system before its manufacture next year.

QSound, a 3-D system developed by Archer Communications, also is less effective beyond that sweet spot directly in front of the two speakers. "That is an ongoing development problem that we are working on," QSound inventor Dan Lowe told the *Los Angeles Times*.

QSound, a license-only technology, is applied to the sound mixing process and can be used to enhance all stereo formats from motion picture to broadcast. Polygram Records has a five-year agreement to use QSound on about 20 of its releases.

Hughes' Sound Retrieval System now is being marketed on high-end Sony television sets as the SRS 3-D sound feature. Hughes claims "the subtle restoration of certain frequencies in recorded audio can duplicate the way your ears locate sound" and with its SRS circuit "you don't have to stay in the 'sweet spot' created by delay arrays and surround-type matrices."

Another California company, Spatial Sound Inc., has introduced a \$3000 Spatial Sound Processor for a range of applications including theatre, live performances, film and video post production and stereo recording. The joystick-controlled SP-1 is a programmable multi-channel 3-D audio signal panner that allows the creation of sound movements in stereo and surround sound.

■ ■ ■
We'll meet Fritz, Klaus and some new stereo microphone technologies in Part 2 of this article in the next *Radio World*.

AKG's K 1000 Turns Heads at AES Show

by Frank Beacham

Los Angeles CA At virtually every AES show there's a new audio toy that "blows the socks off" of visitors. It's the new gadget everybody tells their friends about, and after a few hours of this word of mouth, a line forms for a demo.

This year's "Wow!" award has to go to AKG for its stunning new K 1000 Reference Listening System. Never before have so many people tried to justify spending \$895 for a pair of headphones.

Resembling extended bat ears when worn, AKG has developed a new design in which hinged earphones are angled away from the ears without actually touching them. The concept results in improved stereo imaging.

According to AKG, headphones are asked to reproduce signals intended for loudspeakers, where each ear can receive directional cues from two correctly positioned speakers. Conventional headphones negate the ability to localize these from shared cues.

The K 1000 headphone design provides for sufficient inter-aural cross-talk (sound from the left transducer received by the right ear, and vice



AKG's Dave Ogden models the company's K 1000 Reference Listening System headset.

versa) to produce the proper binaural experience.

The K 1000, AKG said, delivers an acoustically transparent and accurate stereo perspective with extended low frequency response. AES visitors apparently agreed, though their less technical responses ranged from "mind blowing," "outrageous," and "how could I ever justify buying these to my wife?"

For information, contact Dave Ogden at AKG Acoustics Inc.: 415-351-3500.

Madison at a Glance

Madison WI The 1990 Broadcasters' Clinic will be held 13-15 November at The University of Wisconsin-Madison. For further information or to register by phone, call 608-262-7942.

TUESDAY, 13 NOVEMBER

7:45 AM - Registration and continental breakfast

9:00 AM - **Broadcast Engineering Sessions.** Update of the FAA EMI Program; George Werl, Jr., Consulting Engineer, Edina MN

Advanced Communications for Broadcasters; Ameritech

Proposed Changes to the AM Rules; Don Markley, Consulting Engineer, Peoria IL

Noon - Luncheon

HDTV: The US Perspective; Wayne Luplow, Director of R/D, Zenith Systems, Glenview IL

2:00 PM - SEDAT: Spectrum Efficient Digital Audio Transmission Systems; Scientific Atlanta, Norcross GA

Using the Global Positioning System; Garrett Lysiak, President, Owl Engineering, St. Paul MN

3:30 PM - **Equipment Exhibits Open**

7:30 PM - **Engineering Forum** Moderators: Gary Mach and Ken Dixon

WEDNESDAY, 14 NOVEMBER

7:45 AM - Registration and continental breakfast

8:30 AM - **Broadcast Engineering Sessions.** An Introduction to Light Fiber for Broadcasters; Ralph Evans, P.E., Evans and Associates, Thiensville TN

STL/TSL Planning Considerations; Ron Yokes, Todd Communications, Minneapolis MN

Basic Considerations in Modern FM

Antenna Design; Robert Surette, Shively Labs, Bridgton ME

10:30 AM - **Equipment Exhibits Open**

2:30 PM - Loudness Problems and Why; Michael Dorrough, President, Dorrough Electronics, Woodland Hills CA

AM Stereo Maintenance; George Buchwald, Motorola

Some Interesting Field Test Results; John Bisset, Multi-Phase Consulting-Delta, Alexandria VA

MIDI in Radio Production; Bill Mullin, Pyramid Radio, South Holland IL

Field Experiences: Solutions through Measurement Techniques; Mark Persons, Persons Associates, Brainerd MN

7:30 PM - **Pizza-Engineering Forum and "Ask the FCC".** Moderators: Doug McDonnell and Ken Dixon

THURSDAY, 15 NOVEMBER

8:30 AM - **Broadcast Engineering Sessions** Local Area Network Computers for Broadcast Facilities; Chris Cain, Director of Engineering, WISC-TV, Madison WI

Transient Protection Systems; Bogdan Klobassa, Northern Technology, Spokane WA

Defining the North American Standard for Digital Audio for Broadcasting and an Update on Compatible HDTV; A. James Ebel, Consultant, Lincoln NE

2:00 PM - Broadcast Audio of the Future and HDTV: Video and Audio Considerations; Tom Keller, Broadcast Technology Partners, Bloomfield Hills MI

On the Cutting Edge of Technology; George Uibell, Abekas Video Systems, Redwood City CA

Video Cart-Systems Management; Rick Swiers, Sony Broadcast

Digital Routing and Switching; Steven Vigneaux, Sony Broadcast

The Perfect Match

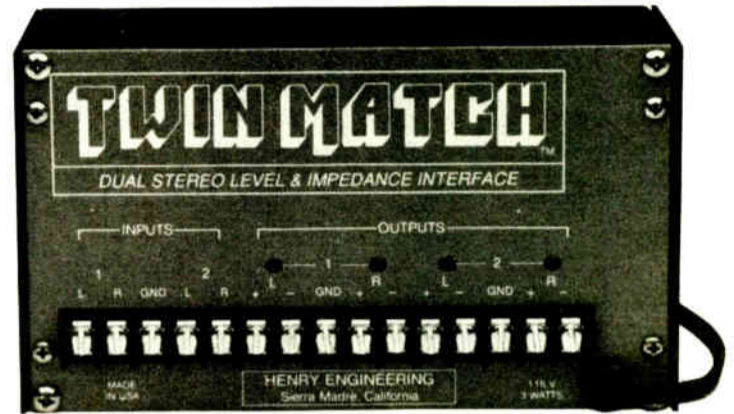

With BSW And Henry Engineering

Twinmatch is a new four channel level and impedance interface from Henry Engineering for matching -10dbv equipment to +4dbm professional gear. Similar to the popular Matchbox, the Twinmatch is a "one way" unit and provides the perfect match between a pair of stereo CD players or a 4-channel tape deck and your professional console.

As always, Hank has built this with great specs. Its DC-coupled active circuitry yields a frequency response from DC to 30 kHz, a signal to noise ratio of -85 dB, and only .008% distortion. Twinmatch is the same size and price as the Matchbox and is in stock at the factory for immediate shipment. Just call BSW Toll-Free and we'll have one on the way to you in no time.

Now doesn't that sound like a perfect match - a brand new problem solver from Henry Engineering available from another great problem solver - BSW.

BSW[®]

BROADCAST SUPPLY WEST

America's Full-Time Broadcast Supplier

1-800-426-8434

ORDERS • INFORMATION • SPECIFICATIONS
BSW • 7012 27th Street W • Tacoma, WA 98466 • FAX 206-565-8114

Crossing Swords with Pirates

by Harold Hallikainen

San Luis Obispo CA Reviewing the stack of information I recently received from the FCC, I found an interesting unlicensed station in Hawaii. This "public radio" group appears to have done just about everything right but get a station license.

The group was incorporated in Delaware in 1987, applying as a 501(c)(3) tax exempt organization with the IRS. The tax exempt purpose of the corporation was to "provide the public with quality listening entertainment and information." The area to be served by the sta-

tion was a "remote and sparsely populated district on the island of Hawaii." The area received no FM signals.

Putting out feelers

It appears that the station manager sent a letter to the FCC in Hawaii regarding starting an FM station in 1986. The letter asks how to start a low power (under 100 W) FM station. The FCC field office replied, in part, "Unfortunately, there are no provisions in our rules to operate the kind of station you propose."

Station licenses are only granted on allotted channels. One is free to petition

the Commission to allocate a channel to the community, the FCC explained. The reply also pointed out the minimum operating schedule and minimum operating power requirements.

Eventually, the station went on the air without the benefit of a station license. The equipment was purchased from a company that advertised in *Rolling Stone*. It consisted of a stereo generator, an exciter, a 10 W power amplifier and an omnidirectional antenna on a 20' pole.

The equipment supplier's catalog includes a disclaimer: "The plans and kits in this catalog are offered for your information only. You, as the purchaser and user, assume all legal and financial responsibility which results from the ultimate use of your purchase."

After about three years operation, a public relations firm called the FCC to find out the "ownership situation" of the station. When the FCC could not find any record of the station, the PR firm sent a copy of the station's "station profile," which provided details including its frequency, coverage, format, operating schedule, etc.

Fine ping-pong

The station was inspected by the FCC on 24 October 1989. On 26 October, the FCC issued a Notice of Apparent Liability for \$750 for willful violation of the Communications Act of 1934 by operating an unlicensed broadcast station.

On 30 October, the station advised the FCC that it was off the air and would remain so until it could obtain an NCE license. The station operator pointed out that, being the only receivable FM station in the area, it performed a public service. Further, the station did not have the assets required to pay the fine. For these reasons, it was requested the fine be reduced.

On 9 November, the FCC phoned the station with a compromise: Turn in the transmitter. The station operator said the other board members (remember, this is a corporation) wanted to hold on to the transmitter. The FCC then suggested each of the six board members pay \$50 (reducing the fine from \$750 to \$300).

The station operator said no, but he'd

like to discuss it with the other board members. He also said he'd like a court hearing. The FCC advised him that if he refused to pay, the forfeiture would go to court for the full \$750.

On 13 November, the station operator said the board felt they should not pay the \$300.

Escalation

On 14 November, the FCC issued a forfeiture order for \$750. The order details why the fine was not reduced. The FCC pointed out that discontinuance of a violation after notification to cease does not excuse the violation (in this case, unlicensed transmissions).

INSIGHT ON RULES

Further, the FCC records showed that the violation was done willfully, as the operator had full knowledge that a radio license was required to legally broadcast (the FCC still had the 1986 correspondence in which the operator asked how to get a license).

The FCC dismissed the community service justification by saying that the potential of unlicensed stations to cause interference to other radio users, the undermining of the FCC administrative procedures to properly obtain a license and the encouragement to other unlicensed operations far exceeds any community benefits provided.

The purpose of issuing a forfeiture, the FCC maintained, is to penalize in order to prevent future violations and to discourage other potential violators. If the violator could readily afford the forfeiture, it would not serve its purpose.

In telephone conversations, the FCC added, the station operator would not agree to a compromise, and the station did not provide any detailed financial information demonstrating that it could not afford the \$750 fine.

On 24 November, the station sent financial information (a bank statement) showing no account activity and an account balance of \$20. Based on this, on 30 November, the FCC reduced the fine to \$100, payable in two installments. The second payment was made 17 February 1990, closing the case.

(continued on page 28)

GET IT RIGHT
FROM HARRIS ALLIED

Q Do You Know These Guys?



A If Not, You Should.

These gentlemen are veteran, experienced broadcast personnel who are the "heart" of Harris Allied Equipment Exchange. Their experience is unparalleled. They BUY, SELL and TRADE used broadcast equipment and have been since the late 1960s.

We need to BUY used equipment to replace our inventory. Business is good and so our shelves are a bit bare. Have you checked under your benches...in the cabinets...in that store-room...up in the attic, etc.? What are you waiting for? Take a look around and let us know what you have and we'll try to make a deal with you.

We accept TRADE-INS on buys of new equipment and we SELL USED and NEW broadcast equipment (demos and scratch & dents). We also selectively BUY used radio equipment of various vintages.

Call on us any business working day. (That's Jim on your left and Chuck to your right.) They've been around for a long time and they know the business. You're guaranteed the best knowledgeable broadcast assistance the industry has to offer and you'll get the fairest price for your used equipment.

HARRIS ALLIED
EQUIPMENT EXCHANGE

317-962-1471

FAX 317-966-6321

635 SOUTH E ST. • P.O. BOX 1487 • RICHMOND, IN 47374

©HARRIS/ALLIED 1990

Live! . . . in concert!
ALL the Time

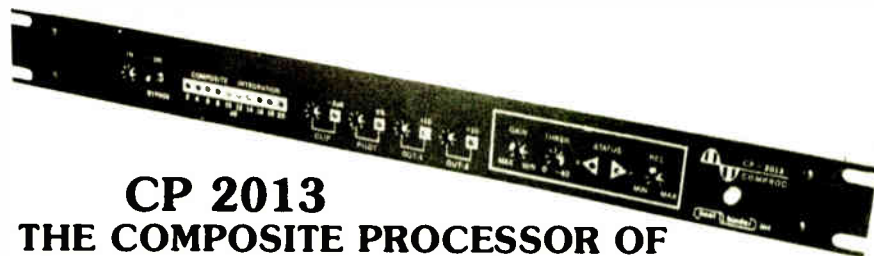

CP 2013
THE COMPOSITE PROCESSOR OF THE FUTURE HERE TODAY

- ★ Low second harmonic clipper — flat to 420KHz!
- ★ Separation exceeding 60 dB
- ★ Ultra smooth, fast acting AGC, builds stereo image without the grunge!
- ★ 1½ dB louder than any other composite clipper
- ★ Multiple outputs plus remote control

AVOID THE RUSH — CALL NOW

hnat hinders inc

42 Elaine Street • R.R. 1 • Thompson, Connecticut 06277 • (203) 935-9066 • (203) 935-9242

Certifying RF Rule Compliance

What the FCC Wants on Renewal Applications

by Lex Felker

Washington DC "Does my station comply with the FCC's radio frequency radiation requirements?" Radio broadcasters are asking this question because it is one that the Commission is asking them as part of the license renewal process.

Fortunately, many licensees' facilities already comply with the agency's guidelines. But the FCC expects applicants to do more than certify compliance. The agency requires applicants to prepare an explanation of why they comply.

New and modified broadcast applications have been scrutinized for compliance with the RF radiation guidelines since the FCC established these regs several years ago.

Compliance by other broadcasters, however, has only been considered when license renewal applications were filed. Because radio station license terms are now seven years, many licensees may only now be evaluating how well they conform with the RF radiation regulations.

The FCC's RF radiation rules

Pursuant to the National Environmental Policy Act (NEPA), the FCC adopted the American National Standards Institute's (ANSI) RF radiation limits in 1985. The rules require licensees to take whatever steps are necessary to prevent exposing workers and members of the general public to RF energy exceeding the ANSI criteria.

To assist licensees, the FCC has published charts and formulas that can be used to establish whether particular broadcast facilities produce excessive fields in regions where humans can

reasonably be expected to enter.

It turns out that many full service broadcast facilities will not produce excessive RF field strengths in areas frequented by humans. Because of the height and vertical radiation characteristics of FM broadcast antennas, for example, many stations do not produce excessive RF fields at ground level.

Furthermore, because of certain technical characteristics of AM stations, and higher limits for low frequency emissions, even the most powerful "standard broadcast" stations will only produce excessive field strengths within small areas relatively close to the antenna.

FELKER'S FORUM

In those instances where humans could theoretically be exposed to excessively large field strengths, access to the affected areas must be limited (by fencing off the region and posting warning signs, for example).

Sometimes a transmitting facility is located in a remote area the general public is not expected to visit. In these cases, access might be limited effectively by simply posting warning signs.

Employee protection

Licensees are responsible for preventing exposure to employees, as well. This requirement can be met by establishing work policies that prohibit access to the relevant areas while the facility is in operation or by minimizing exposure to very short periods of time (one or two minutes). In some cases (involving collocated studios, for example), shielding may be required to reduce RF radiation inside the office/studio complex to acceptable levels.

As straightforward as it is to apply the Commission's guidelines, licensees should use some common sense in evaluating their specific circumstances.

For example, an apartment or office building in close proximity to an FM station could pose a possible non-compliant situation despite the fact that excessive field strengths are not produced at ground level. Here, it may be necessary to conduct on-site field measurements if calculations indicate the existence of excessive field strengths.

Common antenna towers and antenna "farms" present a special case in which compliance may not always be established by a simple single station analysis.

The FCC expects that in these circumstances, the radiated fields of all relevant transmitting facilities are suited to establish those areas where excessive RF radiation exists.

What the FCC is looking for

The renewal application contains a question as to whether the proposal is a "major" action under NEPA. Among other things, this question is asking renewal applicants to certify that their facilities comply with the FCC's RF radiation guidelines.

Merely answering the question with a "no" is insufficient. The agency expects the renewal applicant to attach a brief statement (one or two paragraphs) which indicates why it is in compliance with these rules.

This explanation should impart the licensee's understanding of its obligation to prevent exposure to workers and members of the general public. The statement should also briefly describe the basis for the licensee's belief that it complies with the RF radiation regulations.

Follow this approach, and you should not have your renewal application "bounced" by the Commission. But be prepared to go through this exercise again—maybe even before the next renewal cycle.

ANSI has modified its exposure limits, and within the next year or so the FCC is expected to modify its rules to bring them into line with ANSI's. A description of these new criteria, and how their compliance may affect licensees, are topics I'll save for a future column.

■ ■ ■

Lex Felker is a technology/engineering consultant with the law firm of Wiley, Rein & Fielding, Washington, DC. He may be reached at 202-429-7000.

OMNIBRIDGER

PORTABLE LINE BRIDGING Headset Amplifier

- HIGH LEVEL LOW IMPEDANCE OUTPUT
- WIDE FREQUENCY RESPONSE - LOW DISTORTION
- WIDE INPUT LEVEL ACCOMMODATION
- A TRUE ISOLATED TRANSFORMER INPUT
- MULTIPLE INPUT AND OUTPUT CONNECTIONS
- SELECTABLE DC LINE TERMINATION FOR TELEPHONE CIRCUIT HOLD

AVAILABLE FROM STOCK

CIRCUIT DEVELOPMENT CO., INC.
50 20th ST. BROOKLYN, NY 11232 USA
TEL. (718) 768-4889 • FAX: (718) 768-3958
(800) 628-3461

Circle 136 On Reader Service Card

It's Not Just A Phase We're Going Through.

The tremendous success of the Tannoy PBM series of reference monitors is by no means coincidental. Since the introduction of the world renowned NFM-8 nearfield monitor, much time and effort has been spent on discerning the needs of the mixing engineer and the applied requirements of "playback monitors". The PBM Line exemplifies this commitment to excellence in reference studio monitoring. These compact loudspeakers sport robust poly cone mid-bass transducers utilizing efficient long-throw, high power voice coils. The low frequencies are carefully controlled by optimally tuned ports located on the rear of the loudspeakers. Hi frequencies are provided by Hi Power ferro fluid cooled polyamide dome tweeters which extend H.F. bandwidth beyond 20KHZ. The driver accommodation is knitted

together by means of a precision hardwired crossover unit, utilizing robust low loss components, and heavy-duty input terminals which will accept standard 3/4" spaced banana plugs and the majority of high quality, specialist audio cables. Transducers and crossover assemblies are neatly housed in a stylish, high density, partial wrap cabinet, specially designed to minimize unwanted cabinet resonance, and high frequency reflection. In summarizing, we have left the best feature of all for last "price versus performance."

TANNOY
Professional Products



TEC AWARD WINNER

TANNOY

Tannoy North America, Inc. 300 Gage Ave., Unit 1, Kitchener, Ont., Canada, N2M 2C8
Telephone (519) 745-1156 Telex 069-55328 Fax (519) 745-2384

World Radio History

Circle 35 On Reader Service Card

Laying a Foundation for DAB

by Tom McGinley

Greenbelt MD Given the feasibility of some form of DAB being implemented within the next six to eight years, contemplating the typical DAB air chain of the future might be helpful for long range planning.

First and foremost will be the need to convert to all-digital studios to take full advantage of DAB's benefits. Many stations are already well on their way towards that goal.

CD players and DAT machines are replacing vinyl turntables, cart tape decks and open reel machines as source

equipment at a steady pace. Very few stations in even the smallest markets are not playing at least part of their music from CD players directly.

Workstations here

Production people are already using digital audio work stations, such as the AKG DSE 7000, and they can hardly wait to be able to dub their commercials and promos directly to a digital disk recorder for playback on a compatible CD player in the control room.

Several digital cartridge type systems have recently appeared using magnetic media. The new 360 Systems DigiCart

uses Bernoulli disk drives borrowed from the computer industry.

For automated systems, mass storage on large hard disk drives such as with MacroMedia's Audisk is also available and will meet specific application needs.

Other systems make use of computer control for spots with material stored on hard disks. Whether such systems will enjoy widespread use in the near future is uncertain.

At a minimum, they will serve as a bridge technology to the eventual introduction of an erasable optical disk, fully compatible with CD players, probably within the next two to four years.

Analog consoles still perform

While digital audio mixing consoles are already available and in use by recording studios, their application in radio stations is not yet economic nor compelling.

Too many sources are still analog, requiring expensive A to D conversion. Another drawback to digital mixing is the fact that the 16 bit CD format limits the ultimate S/N ratio to 96 dB. The best analog consoles can achieve over 120 dB.

Nonetheless, keeping all mixing and routing functions in the digital domain will become the norm as more sources become digital and an industry standard for coding and sampling is established.

Digital audio processing equipment is already in widespread use. Digital signal compression, peak limiting, clipping and stereo generation appear to be almost ready with the introduction of Gentner's digital Prizm and Lazer, now in beta test.

Digital STL systems are here and continue to grow in popularity. Wireless systems such as the Marti or MA/Com are still limited to 23 GHz, because of the bandwidth restrictions at 950 MHz.

The greatest potential for digital STL growth probably exists with the telephone company. As more and more cit-

ies are "wired" with fiber optics, PCM systems such as QEI's CAT/Link will become a more logical choice, especially in larger markets.

RF horizon

Not much has happened at the RF end of radio in the way of digital development. Except for the exciter, not much really has to happen if the eventual DAB system adopted uses the existing FM channels.

Several years ago, a company called RF Digital Solutions introduced a design for a digitally synthesized FM exciter. That concept will likely appear in hardware form by at least one transmitter manufacturer in the next few years.

If the Eureka 147 system becomes the standard for DAB, RF systems will change dramatically. Because Eureka is a multiplexed spread spectrum technology, 14 to 16 stations will all share a common exciter, transmitter, and antenna system.

Small markets will only need one such facility, transmitting from the highest available existing site. Medium markets may need one main site, plus two or more lower power gap-filler sites.

Major markets may need more than one main site plus a series of gap-filler sites, depending on terrain.

Transmission facilities will either be owned by the group of stations, as many community antenna sites are now, or by one site owner who leases to each station, much like multiplexed two-way radio systems.

Transmitters will only need to be in the one kW range because of the unique multipath canceling characteristics of COFDM modulation.

It is obviously still too early to tell what form DAB will take.

No matter which system is chosen, those stations which have fully implemented digital based equipment from studio to transmitter will have a clear advantage in exploiting all the benefits of DAB.

■ ■ ■

Tom McGinley is Director of Engineering for Cook Inlet Radio Partners and Radio World's technical advisor.

LOCK THE DOORS, WALK AWAY, YOU'RE ON THE AIR...

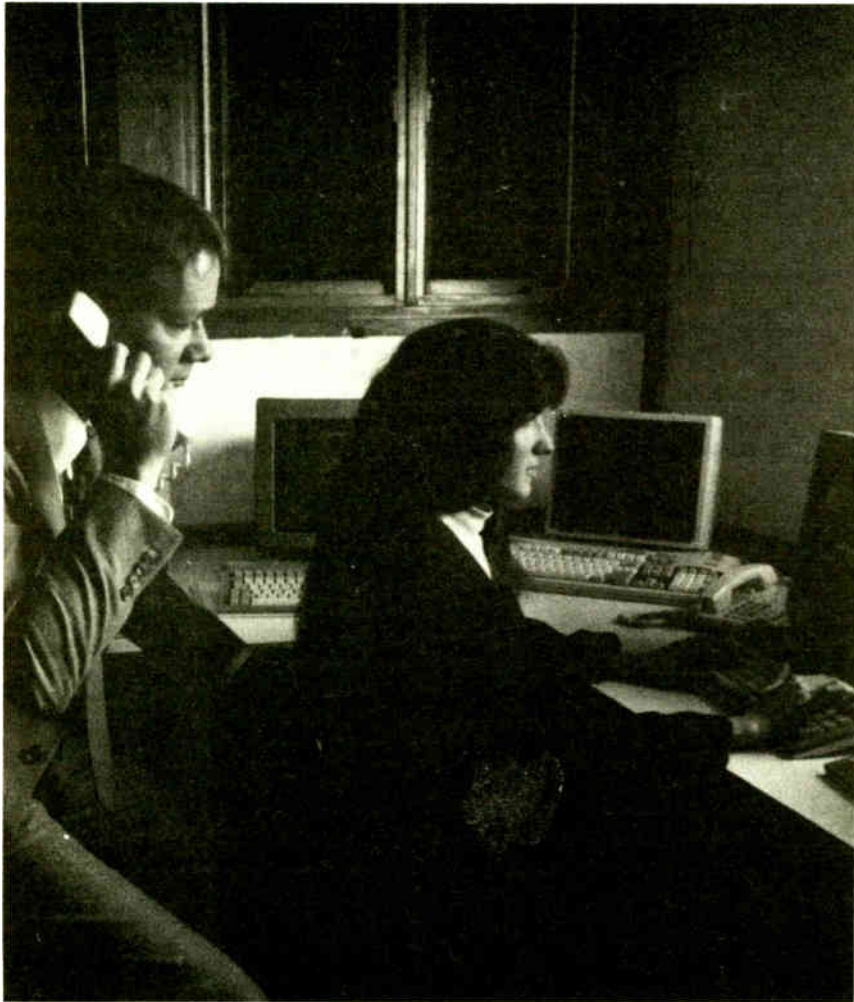

... Because We're On The Job

The National Supervisory Network is your duty operator 24 hours a day, seven days a week, providing:

■ FCC & FEMA Compliance for an Off-Premise Control Point ■ A Licensed, Trained, Experienced Operator on Duty ■ Transmitter Monitoring & Command ■ Emergency Broadcast System Monitoring & Command ■ Security & Fire Alarm Monitoring ■ Complete Operations Logs—Readings Every 30 Minutes ■ Trend Analysis Reports for Your Engineer ■ An On-Line Broadcast Data Base ■ Optional Private Data Sub-Networks for Station Groups ■ Optional CD Quality Digital Audio Sub-Networks

We supply the satellite and computer equipment for the basic data link as part of our regular service fee: \$1.20 per hour.

For Information

1 (800) 345-VSAT

NATIONAL OFF-PREMISE CONTROL

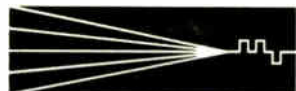

**NATIONAL
SUPERVISORY
NETWORK**

AVON, COLORADO

fm TRANSMITTERS FROM CONTINENTAL

- COMPACT AND EFFICIENT
- SOLID-STATE DRIVER
- EXCLUSIVE SOFT START™
- AUTOMATIC POWER CONTROL
- TOTALLY SELF CONTAINED
- TRANSTAT™ READY

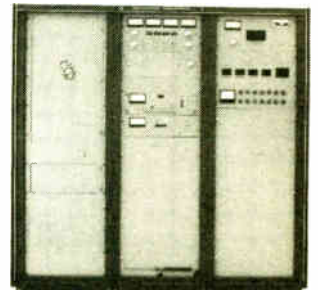

varian 

continental electronics division



P.O. Box 270879 Dallas, Texas 75227 • (214) 381-7161 FAX: (214) 381-4949

2061

WHY YOU SHOULD PAY MORE FOR LESS.

**New Name-
Same Great Cart!**
The ITC Cart II Cartridge, formerly ScotchCart® II

Less phase jitter caused by poorly tracking tape, because the naturally lubricated concave guides gently position the tape and allow the cartridge machine to perform critical guidance.

Less tape noise and signal loss with our 100% laser-inspected, high output, low noise tape which delivers better frequency response and keeps signal-to-noise ratio high, harmonic distortion low.

Less wow and flutter or stop cue overshoot, because there's no rotating hub to wear out, warp or rattle.

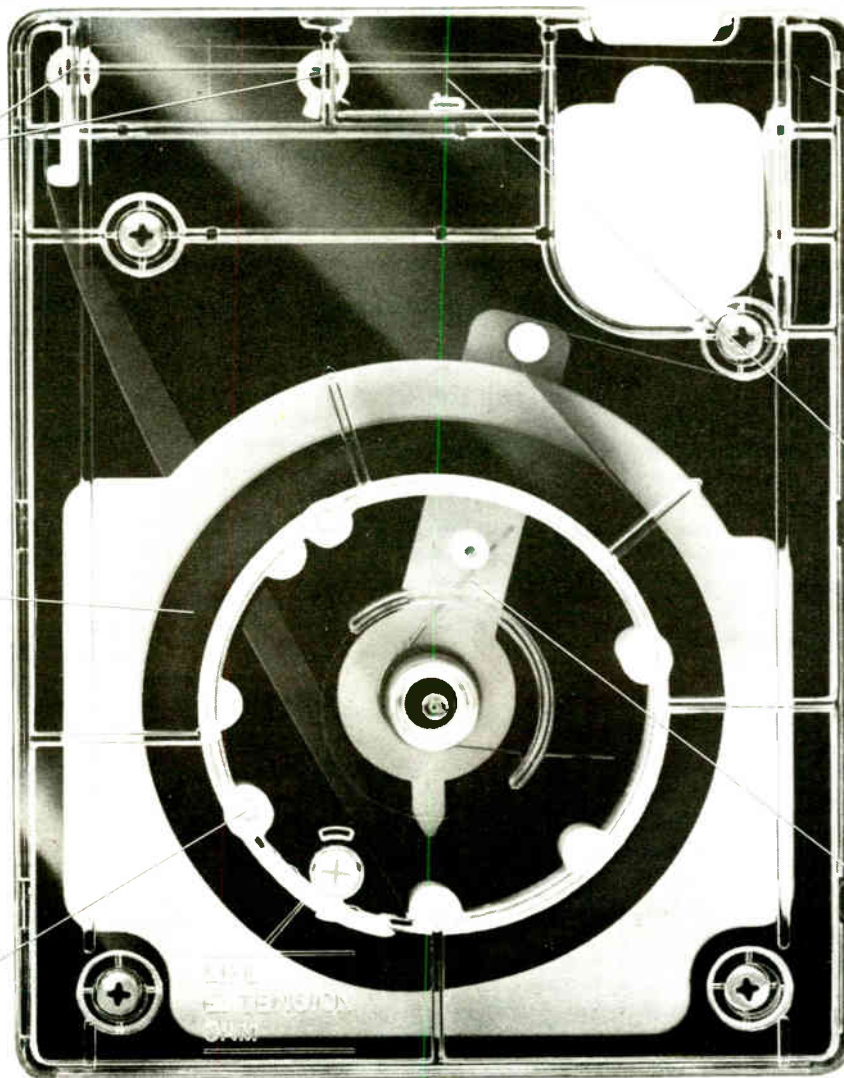

Less chance of the cartridge cracking or breaking, because the tough polycarbonate cover withstands repeated use and abuse.

Less head wear, tape steering and modulation noise, because there aren't any pressure pads to add friction.

Less chance of tape destruction, because our patented dynamic tension control system ensures proper tape-to-head contact, and provides constant tension to control looping and prevent twisting.

The ITC Cart II Cartridge, formerly ScotchCart® II

With broadcast cartridges, like everything else, you get what you pay for. With ITC Cart II cartridges, you get a revolutionary design that delivers trouble-free operation, superb sound quality and a life expectancy that's second to none.

We have renamed the cartridge due to trademark considerations, but only the name has changed, the cartridge and tape are the

same. New name, same great cartridge and performance.

For a complete listing of ITC Cart II dealers, call ITC toll-free at 800-447-0414 (in Illinois, call collect 309-828-1381.) Or write to ITC at P.O. Box 241, Bloomington, IL 61702-0241.

Because a cheaper cartridge may be more trouble than you can afford.

ScotchCart® II is a registered trademark of 3M

Circle 61 On Reader Service Card

World Radio History

NEW NEW NEW

SERIES CONSOLES

S – \$6,499 /18 CHANNELS – \$8,893



224-2248

FEATURES

- Totally Modular Console-Input modules, Output modules, Option modules
 - Ease of Service
 - Ease of Installation
 - Ease of Expansion
- Three Mainframe Sizes-8 channels, 18 channels, 28 channels
 - Full Metering
 - Timer on All models
 - Talkback to "2" studios
- Ultrahigh Quality Construction and design
 - Penny and Giles 3000 Series slide faders
 - VCA's
 - ITT Schadow switches
 - Gold connectors-IC's socketed-regulated power supply
- 3 Stereo Output Buses
- 2 Internal Mix-minus Buses for 'Telephone'
- Option Modules-D.A.'s, Mono Mixes, Remote Selectors, Etc.
- Comprehensive Logic system
 - Start and stop sources by isolated internal reed relays
 - Remote channel On and Off control with Tally lamps for turrets
 - Flashing OFF switches for cart machine status
 - Three muting buses for Control room and two studios
 - Timer reset selectable on each module
 - Monitor DIM function during cue and talkback

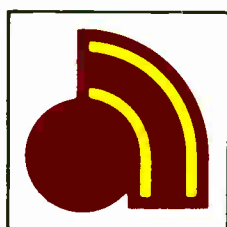

arrakis
SYSTEMS, INC.

**NEW
NEW
NEW
NEW
NEW**

NEW NEW NEW

Studying Radio History

by George Riggins

Long Beach CA The library at Thousand Oaks, CA dedicated a portion of its facilities to archiving old radio and TV scripts. I understand CBS donated the many scripts stored in the basement of Columbia Square in Hollywood to the library on 13 September 1990. I'll attempt to obtain more information as to what is available, and under what conditions.

Steve Cisler (9SX in 1925) wrote to share a few gems of broadcast trivia, collected over 65 years. Perhaps the best gem was the "FRC citing stations for not having flush toilets, or insisting that an engineer on the 'pot' be able to see all the meters from a close vantage point!" Wonder where the architect was able to place the item of convenience so the station was able to comply with the interpretation of the rules?

Another gem Steve mentioned was that "Cook Binaural records played with a two-headed pickup." The first stereo broadcast in San Francisco using the Cook Binaural system was KEAR-AM and KFKX-FM.

Wonder how many announcers were fired for raiding the station refrigerator and eating too much? It must have happened at least once because Steve mentioned the incident,

but failed to say which station. We will have more from Steve in the future.

The Mississippi muddle

In the last installment, we noted the demarcation line between the "W" and "K" call areas and the fact that Minnesota and Louisiana straddle



the Mississippi River. Minnesota seems to be the one with misplaced calls.

If one was to take the statement

that one could "immediately recognize an Atlantic or Pacific call" too seriously, he or she would go slightly bonkers when listening to many of the stations in Minnesota. When a city straddles the demarcation line, which prefix should be used?

Using the Mississippi River rather than the St. Croix River and the Minnesota-Wisconsin border was probably an arbitrary decision. It's likely no one considered that the Mississippi River runs between Minneapolis and St. Paul and then through several other cities in Minnesota.

In addition, do we follow the course of the river through the Bemidji area and then southwest to the source in Itasca (continued on next page)



When you need extra hands mixing audio, Shure's AMS can help.

Until recently, you needed outstanding hand-ear-eye coordination to mix audio in multiple-microphone broadcast situations.

Now there's a system that gives you broadcast-quality audio when you can't cover all the faders at once. It's the Shure Automatic Microphone System (AMS), featuring patented direction-sensitive gating.

The Shure AMS continuously compares audio signal levels from two matched unidirectional condenser microphone cartridges located back-to-back in each AMS microphone. The rear-facing cartridge monitors ambient sound, while the front-facing cartridge handles sound from the desired source. When the front cartridge output exceeds the rear cartridge output by 9 dB, the AMS mic channel gates on automatically in .004 seconds.

Because of this unique gating concept, an AMS microphone channel will only gate on

when addressed from within a 120-degree "window of acceptance" centered at the front of the microphone. AMS mics not addressed from within this angle remain off. So the number of open microphones is kept to a minimum automatically, with no need for manual control.

Since the Shure AMS automatically keeps track of the number of open microphones and adjusts the overall gain to compensate, your broadcast level stays constant as mics open and close, without troublesome gain-riding.

Direction-sensitive gating makes the



SHURE®

The Sound of the Professionals®... Worldwide.

Circle 47 On Reader Service Card

World Radio History

Shure AMS the best system to use in multiple-mic situations, from panel talk shows to game shows to hearings on Capitol Hill. More and more broadcast engineers are discovering the advantages of having broadcast-quality multiple-microphone



audio without the headaches of manual mixing or the time-consuming setup of so-called automatic mixers.

With AMS you not only get all the advantages of a truly automatic microphone system, you also get the broadcast-quality audio and reliability of Shure microphones.

For a comprehensive AMS literature packet, call us at 1-800-257-4873. For AMS technical support, call Michael Pettersen at 1-708-866-2512.

Pirates

(continued from page 22)

So, what unlicensed radio broadcasting is allowed? Many people assume anything is permitted if the transmitter power is under 100 mW. That is not the case.

What is permitted

Part 15.219 of the Rules allows unlicensed operation between 510 kHz and 1706 kHz if the final amplifier input power is 100 mW or under (excluding filament power) and the total of the antenna, transmission line and ground lead lengths is 3 m or less. (This is the current regulation that the old Knight Kit transmitter I built in fourth grade operated under; it cost \$12.95, had two 50C5s and a 12AX7. That transmitter replaced the old spark gap transmitter I'd built out of a toy buzzer.)

Part 15.221 authorizes "carrier current" transmission on an educational campus. This section, along with the section covering "tunnel radio" (real underground radio) pretty much put the conducted and radiation limits at the campus or tunnel boundary. Inside the campus or tunnel, the owner is pretty much free to do whatever, as long as it does not interfere with the protected contour of a licensed station.

Part 15.239 covers unlicensed operation in the FM broadcast band. Transmitters must be FCC certified. The radiated field is limited to 250 μ V/meter, measured 3 m from the radiator. There is no 100 mW exemption for operation in the FM band.

So, it appears that unless you own a campus or a tunnel, you're limited to use of that FCC certified "Mr. Microphone" without a station license.

Harold Hallikainen is president of Hallikainen and Friends, a manufacturer of transmitter control and telemetry systems. He also teaches electronics at Cuesta College, San Luis Obispo. He can be reached at 805-541-0200.

Gems of Yesteryear

(continued from previous page)

State Park? No matter what the thinking was, there are many calls in Minnesota that do not follow the original guidelines.

There are a few misplaced calls that have been issued so that an FM outlet could have the same prefix as the older AM call. That is understandable. In one or two cases the original call goes back to the early 1920s, before the east-west division.

The call WJYY-AM, Baxter—issued in 1987—goes along with WJYY-FM in Brainerd. WJYY-FM was issued in 1978, so the addition of the AM facility would not be out of line, since Brainerd is on the eastern shore of the river and probably has suburbs on the west bank. Brainerd has both "K" prefixes and "W" prefixes as does Duluth.

According to an AAA road map of Minnesota and the latest aeronautical chart, the city of Cloquet is located west of Duluth; Superior, WI is across St. Louis Bay to the east. Cloquet has two stations, one licensed in 1950 and the other in 1976, both with "W" prefix calls.

Duluth has both "K" and "W" prefix calls, and at least one, WEBC, was moved from Superior to Duluth between 1934 and 1936. WEBC was licensed to Superior, WI in 1934, and by the printing of the February 1937 issue of *White's Radio Log*, the city of license had been changed to Duluth.

Miles Abernathy, N5KOB of Austin, TX, says the old transmitter site of WOAI, San Antonio is now the location of the City Hall for the city of Selma, TX. The two-story white building of the mid-'50s with the single stick out back is long gone.

It seems to me that the WOAI building of the WWII era was a single-story white building that sat back from US 81 a couple of hundred feet. In 1944 and 1946, the site was at least five miles out in the country on the way north to Austin or points in between.

Remembrances of things past

When last we spoke with Al Smith, we left him just as he had started working at KMA in Shenandoah, IA. One of the comments Al made about going to work at KMA was that "people worked for very long hours at nearly all stations without overtime in those days."

About the facilities of KMA, Al noted, "They had a large auditorium studio complex where people could watch the entertainers—again, all live talent. The auditorium was used evenings for the showing of movies. KMA sold about everything imaginable on the air—nursery stock, chicks, oranges, tires, etc. They would literally sell box-car loads of merchandise over the air. They had a huge farm and small town audience.

"I had the morning shift at the studio or the transmitter. I used to help put the station on the air at 5:00 AM. For 1937 this was a very modern station. They had a portable control room in the big studio. Incidentally, one of the most popular programs was 'Country School' in the late afternoons. All the entertainers dressed up like school children, with recitations, comic skits, school antics and the like. The homemaker shows originated from the homemaker's home.

"KMA had a beautiful two-story building with an apartment upstairs for the

chief engineer. A 488' vertical antenna was fed from the new 5000 W RCA transmitter.

"I had an embarrassing experience at the transmitter. One day we had some visitors and I wanted to show how the transmitter would come back on the air automatically after an overload. Instead of momentarily dropping the plate voltage for the demonstration, I turned off the filament voltage. It took over two minutes for the transmitter to recycle and return to the air—not a good thing to tell the chief engineer about!

"I always remember the time one leg of the 488' self-supporting tower had to be jacked up to replace a huge insulator it rested on. A touchy situation after midnight. The insulator had a slight crack that moisture could enter and detune the antenna.

"Two operators were discharged (from KMA) in the spring of 1937. I was only out of work for about a week and went to work for KFAB-KFOR in Lincoln, NE.

Life in Lincoln

"KFAB-KFOR was a different type of operation. KFAB was a CBS affiliate and KFOR a Mutual network affiliate. Both stations had the same studios. Program switching for both stations was accomplished by one man in master control. Sometimes programs were also fed to KOIL in Omaha. This was accomplished by a pre-set system.

"There was some live talent. I remember we had an organ concert remote every noon on KFOR from the Lincoln Theatre, a multimicrophone church service on KFAB on Sunday from a local church, plus Nebraska football on KFAB. We also fed dance bands to the networks after 10:30 PM. This was a common practice for most network affiliates.

"KFAB and WGGM—the CBS station in Chicago—operated on the same frequency. At night interference would exist if both stations did not carry the same program from CBS and their carrier frequencies were not precisely the same, within a fraction of a cycle. The precise frequency relationship was obtained by feeding an audio tone from the WBBM transmitter via a telephone line to the KFAB transmitter which locked KFAB's transmitter carrier frequency to that of WBBM.

"This worked very well for CBS programming. Each station had 14 seconds for their station breaks out of the 30 second time. If WBBM had a local program at night, they paid KFAB to remain silent during that period.

"Later KFAB obtained the WJAG-Norfolk, NE frequency of 1110 kc by a deal giving Norfolk the lower 770 kc channel, which helped Norfolk daytime coverage, but WJAG had to be off the air at night. KFAB moved to Omaha and obtained 50,000 W of power on 1110 kc."

This brings Al up to October of 1937, when he decided it was time for a change. We will pick up with Al at KSCJ in Sioux City, IA next time.

■ ■ ■

George Riggins has experience in radio and electronics dating back to the 1930s. He is also a licensed ham operator and has had his own broadcast sales and service company, Riggins Electronic Sales, for over 20 years. He can be reached at 213-598-7007.

QEI QEI QEI QEI QEI QEI QEI QEI QEI QEI

WHY QEI?

24 Hours.



Our 24 hour service hotline number is 609-728-2020.

Call us toll free at 800-334-9154 for all the facts on QEI

"New Reliables" FM transmitters from 1kw to 30 kw.

Power Up.



With our FMQ 3.5/5/10 kW or 20/30 kW FM transmitters, you can upgrade power in the field.

Call us toll free at 800-334-9154 for all the facts on QEI "New Reliables" FM transmitters from 1kw to 30 kw.

No Extras.



We never charge you extra for single phase power. Not on our FMQ 10000 or our FMQ 20000B—not even on our 30 k FMQ 30000B.

Call us toll free at 800-334-9154 for all the facts on QEI "New Reliables"

FM transmitters from 1kw to 30 kw.

Less is More.



All of QEI's FM transmitters have no plate blockers or sliding contacts.

Call us toll free at 800-334-9154 for all the facts on QEI "New Reliables" FM transmitters from 1kw to 30 kw.

Free.



Our FREE spare kits include every solid state component of the transmitter, exciter and remote control.

Call us toll free at 800-334-9154 for all the facts on QEI "New Reliables" FM transmitters from 1kw to 30 kw.

The Longest.



Our PA tube warranty is the longest in the business — 15,000 hours.

Call us toll free at 800-334-9154 for all the facts on QEI "New Reliables" FM transmitters from 1kw to 30 kw.

Single Phase 30 kW.



Our new FMQ 30000B is the only 30 kW transmitter available with a single phase power supply.

Call us toll free at 800-334-9154 for all the facts on QEI "New Reliables" FM transmitters from 1kw to 30 kw.

Built-in Backup.



QEI's constant 50 Ohm interstage impedance lets you bypass the IPA or PA in the unlikely event of a problem.

Call us toll free at 800-334-9154 for all the facts on QEI "New Reliables" FM transmitters from 1kw to 30 kw.

QEI CORPORATION
ONE AIRPORT DRIVE • P.O. BOX D • WILLIAMSTOWN, N.J. 08094
TEL (800) 334-9154 • (609) 728-2020 • FAX (609) 629-1751

QUALITY • ENGINEERING • INNOVATION

Correct Combiner Chemistry

by Bill Cordell

Houston TX Every station would like to have its own tall tower and antenna facility. Every station would like to run a specific antenna gain and transmitter power. But due to financial and logisti-

whose chemistry got close, but not all ingredients fell into place. A good rule of thumb is: If four or more stations can go to a common site and agree on the antenna system, the facility will save the station owners money while at the same time providing them with very good

of caution begins to pay off.

The very flat areas of our country seem to allow higher gain antennas. Hilly terrain requires a medium type gain antenna system, while mountainous areas demand low gain antennas to try to force the signal into blocked and shadowed areas.

With one project in Houston, some stations wanted very high gain antennas and others wanted very low gain. After a detailed study of power limits on the antenna, transmission line and combining system, we limited the number of bays to twelve. This allowed each station to use 20 to 27 kW transmitters and keep the transmission line safety factor to a better than two-to-one margin.

I have worked with master and combined antennas from all of the antenna manufacturers. Regardless of the make or model of the antenna, it is imperative to have the antenna system placed on the full scale test range to know where the signal is really going. Typically, this cost to range test the antenna is approximately 10% of the cost of the antenna; that is a cheap price to guarantee your coverage pattern.

From theory to practice

Some combined facilities are not owned by the FM stations at all. In the case of the master antenna system installed on the WPMI tower between Pensacola and Mobile, the tower owner installed the entire master antenna and combiner system and is leasing space to FM users.

The facility was designed for six stations running between 22 and 25 kW TPO. This was determined by a consensus of the end users and a balance of antenna bays on the tower (to keep windloading to a minimum). There are now three stations on the facility, with a fourth station in the process of being installed.

The aforementioned system used a panel-type antenna. A panel antenna provides a good circular azimuthal pattern over a very wide bandwidth, but a ring type radiator or a spiral antenna also can be a good combined or master antenna. Bandwidth will be the limiting factor, but if frequencies are close, then a ring-type radiator with larger than normal feed lines can be used.

This is the case with the multistation

ring-type antenna that Clear Channel Communications installed on its 2000' tower between Beaumont and Houston, TX. The antenna VSWR met specifications, but the line was slugged to better the overall system VSWR.

The last word

When determining any possible new construction, upgrade or remodeling of FM transmitter facilities, give careful consideration to the use of combined and master antenna systems.

Depending on the size, height and

With combined facilities, the majority of the final antenna configurations are based on input from all parties involved.

cost of the tower (especially the cost), follow this rule of thumb: If three or more stations can combine and co-exist at one site, there will be cost savings. If a very large tower and combining system is required, then it typically takes four or more stations to make "financial sense."

No matter the size or configuration, it behooves the station engineer to consider all antenna and transmitter facility alternatives to improve the station and make good financial sense.

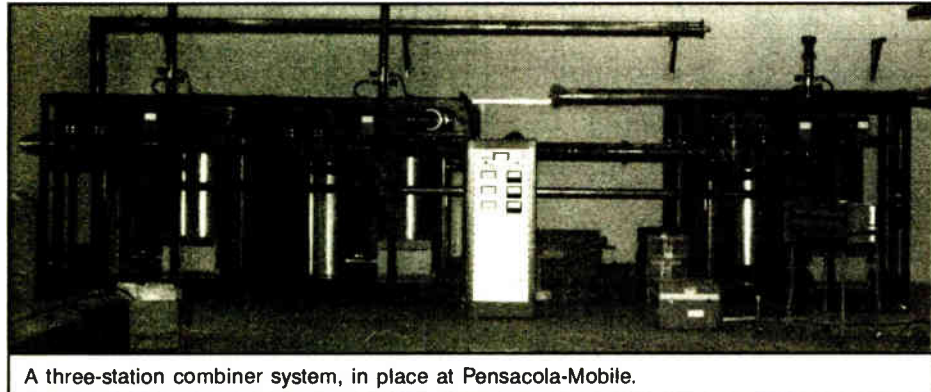

A three-station combiner system, in place at Pensacola-Mobile.

cal considerations, this is just not always possible. An alternative is moving to a combined FM facility.

A special chemistry is required, however, before station engineers and managers can take such a step. Stations must reconsider their philosophy regarding TPO and antenna gain, and everyone must do some compromising.

If a number of stations physically can move to a common site; if philosophies can be slightly modified to agree on a master antenna configuration; and if financial considerations show that the project can save money, then the chemistry is just right.

I have spoken with many groups

measured coverage.

With combined facilities, the majority of the final antenna configurations are based on input from all parties involved. The antenna system begins to form itself depending on antenna gain, size and number of transmission lines, available transmitters and total number of participants.

Safety first

When it comes to the average power and voltage breakdown of the transmission line, it is best to be conservative. I adhere to a two-to-one safety factor. When ambient temperatures reach more than 100° F and the VSWR increases (from other causes), that extra measure

CCA

Evolution.

CCA has delivered more than 3,000 Broadcast Transmitters over the past 25 years. For 25 years our designs have been refined and improved. The result is the Evolution of the world's most perfected, most tested, most reliable, Radio Transmitter.

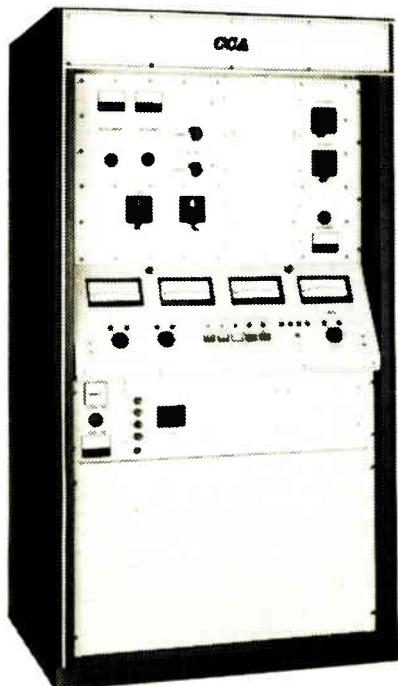

- * Grounded Grid Triode
- * Longest Tube Life
- * Auto Power Control
- * VSWR Power Foldback
- * Single Phase Optional

CCA Electronics, Inc.
P.O. Box 426
Fairburn, GA 30213
(404)964-3530 FAX (404)964-2222

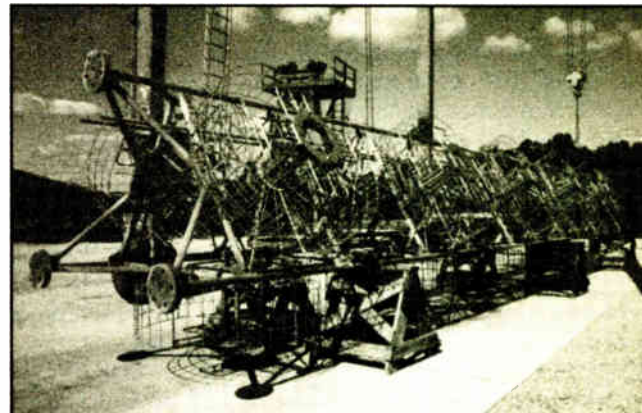

One of the author's projects, the Senior Road Tower Group's master antenna, lies awaiting analysis at the Harris test range.

Most of all, it takes input from station engineers, such as those gathering in the Dallas-Fort Worth area, to determine the best possible new master antenna and tall tower facility for use in each area. With each engineer seeking the best for each station, the best is usually attained for all.

Bill Cordell is a principal in Spectrum Engineering Co., and has worked on the design and installation of a dozen master and combined FM transmitting facilities in the US and Mexico. He can be reached at 713-438-3838.

custom CD reference discs

TRANSFER YOUR JINGLE PACKAGES, SPOTS, PROMOS, MUSIC LIBRARIES OR ANYTHING AUDIO TO QUALITY DIGITAL COMPACT DISCS IN ANY QUANTITY FROM ONE UP.



FOR INFORMATION AND PRICING:
FRANKFORD/WAYNE MASTERING LABS

1697 BROADWAY, NEW YORK, NY 10019
(212) 582-5473

Tips to Make Radio Life Easier

by Barry Mishkind

Tucson AZ Looking over my cluttered desk, your faithful columnist has a number of small items that need to be addressed. Some relate to feedback from previous articles, for which I'm always grateful.

For example, several persons have called regarding the articles on sound levels and OSHA requirements. There is real concern about how to balance the need to meet the standards without "spoiling the fun" of the air staff.

The basic information, for those of you that would like to have a copy, or are just masochistic enough to enjoy reading government regulations, is contained in OSHA Regulation 1910.95, which comes with appendices A through H. Your nearest OSHA office will be glad to provide a fuzzy photocopy.

While I can't report that every station for which I've worked immediately jumped on the bandwagon, many owners and managers are willing to take reasonable steps based on a reasoned approach.

ECLECTIC ENGINEER

If your station is reluctant to make suggested changes, perhaps this is one of those areas in which your state or local broadcasting association would be willing to get involved. Most are willing to consider anything of legal concern to members' stations.

Also, your local SBE chapter may be able to make a presentation to stations in the market as a professional broadcast engineering society. If other stations get involved, yours will be more easily convinced to do so as well.

Getting connected

Computer Bulletin Board Systems (BBSs) are another topic of great interest, and the growth of information available to broadcasters has quite literally exploded in the last year.

For instance, there are now no fewer than five major technical conferences available to users, just by dialing out via modem. And that is just technical conferences; there are others dealing with programming, news, talent, job hunting, Star Trek(!), and many more.

If you haven't seen the previous articles, we have been highlighting the different BBSs and services available. In the 26 September issue of RW, we presented a listing of many of the BBSs devoted wholly or partly to broadcasting. We are always ready to add any we've missed.

Of course there are many other places to get into the picture. All of the conferences run on a "network" of small BBSs, often run by hobbyists, not all of whom are broadcasters.

Once you connect onto a conference, you can ask if there is a local BBS that also carries the conference. Or, check with the local computer shop and ask about FidoNet or RelayNet, two of the national general purpose networks.

If you contact the local sysop, he or she will likely carry the conference(s) you

would like to see, especially if you offer a few dollars to cover his phone costs in getting the messages. But that's only common courtesy, isn't it?

The RelayNet (RIME) technical conference just started to roll in September, according to moderator Mike Callaghan of KIIS, Los Angeles. So everyone is new on there; feel free to join in.

MediaNet and SpectroNet are two more national conferences. And in DC there is a BBS that primarily caters to consultants and journalists. AirWaves, run by Bob Horvitz, deals with FCC and spectrum politics.

You might also let the programming staff and management staff know about the other conferences (or echos); there is a lot of sharing of information going on out there.

Of course, there is a double edge to this: If the PD gets hooked, you might find it harder to get on the modem yourself!

Speed, speed, I need more speed!

While thinking about computers and access to BBSs and other databases, one of the minor drawbacks has been the length of connection time it often re-

quires.

This is especially true if your modem is of the older variety: 1200 or (cough, choke, choke) 300 baud. It can seem that waiting for the uploads or downloads takes an eternity. In fact, at 1200 you can usually read text files faster than they are sent. At 300 baud, there's time to take a nap!

Moving up to 2400 baud can make a difference. Many modestly priced 2400 baud modems are available, often for around \$100 or so. At 2400 baud, you have to be quick to read the scrolling

(continued on page 35)

CAN WE TALK?!

W

hy waste time experimenting with the new UNPROVEN microphone processors on the market today, when the industry standard is waiting to perform for you?

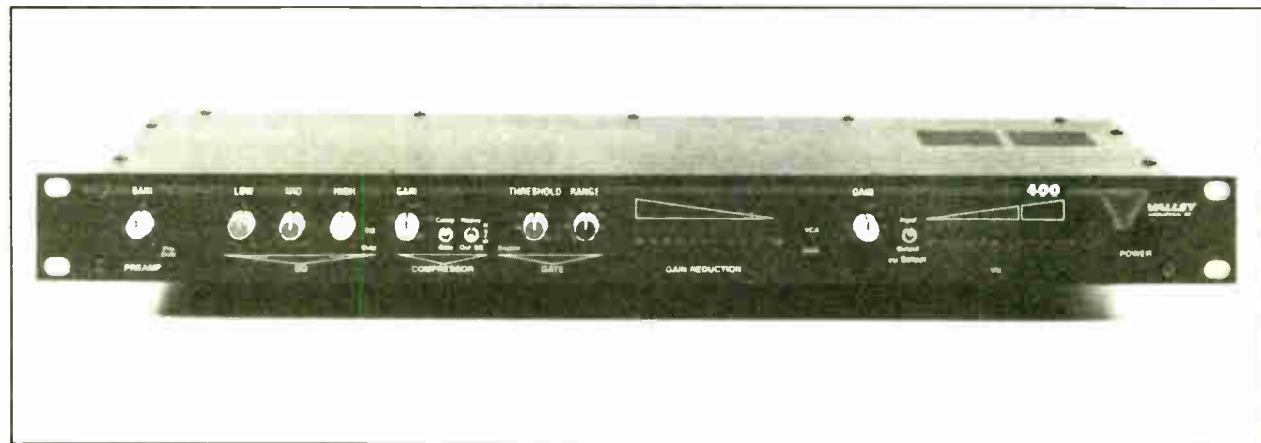

THE VALLEY 400
Microphone Processor

PROVEN...AND IN STOCK AT



BROADCASTERS GENERAL STORE

HOME OFFICE
2480 S.E. 52nd St.
Ocala, FL 32671
(904) 622-9058

REGIONAL OFFICE
746 Cypress Lane
Carol Stream, IL 60188
(708) 231-7120

REGIONAL OFFICE
1805 Kimberly Drive
Marietta, GA 30060
(404) 425-0630

REGIONAL OFFICE
1300 Ravenwood Dr.
Arlington, TX 76013
(817) 275-1380

INTRODUCING

RS CART 2000.

A great *new* cart machine.

With so many good cart machines on the market today, how do you make a new one better?

Begin by including every important cart machine feature: 3 cue tones, fast forward, XLR connectors, active phase correction, front panel azimuth adjust, LED VU and phase meters, full logic, remote control, and more. You'd have to buy every other machine available to assemble all these features.

Next, build it to last. That means long life heads, 1/2" thick deck plate, direct drive Nidec motor, massive toroidal power supply, newly designed positive cart hold-down and guidance systems, and precision head-block assembly.

Finally, distinguish it with features no other unit has. The RS-2000 is the first cart machine to offer flutter correction, splice finder, and timer on all models.

But features aren't important if the engineering isn't top-notch. The RS-2000 was created by industry-renowned design engineer Mike Sirkis. So this "new" machine carries more than a decade of cart machine experience.

One last note: since the RS-2000 is built, sold and supported exclusively by Radio Systems, it carries one more trademark—**VALUE**. Every RS-2000 model is very affordable.

Call toll-free today for details.

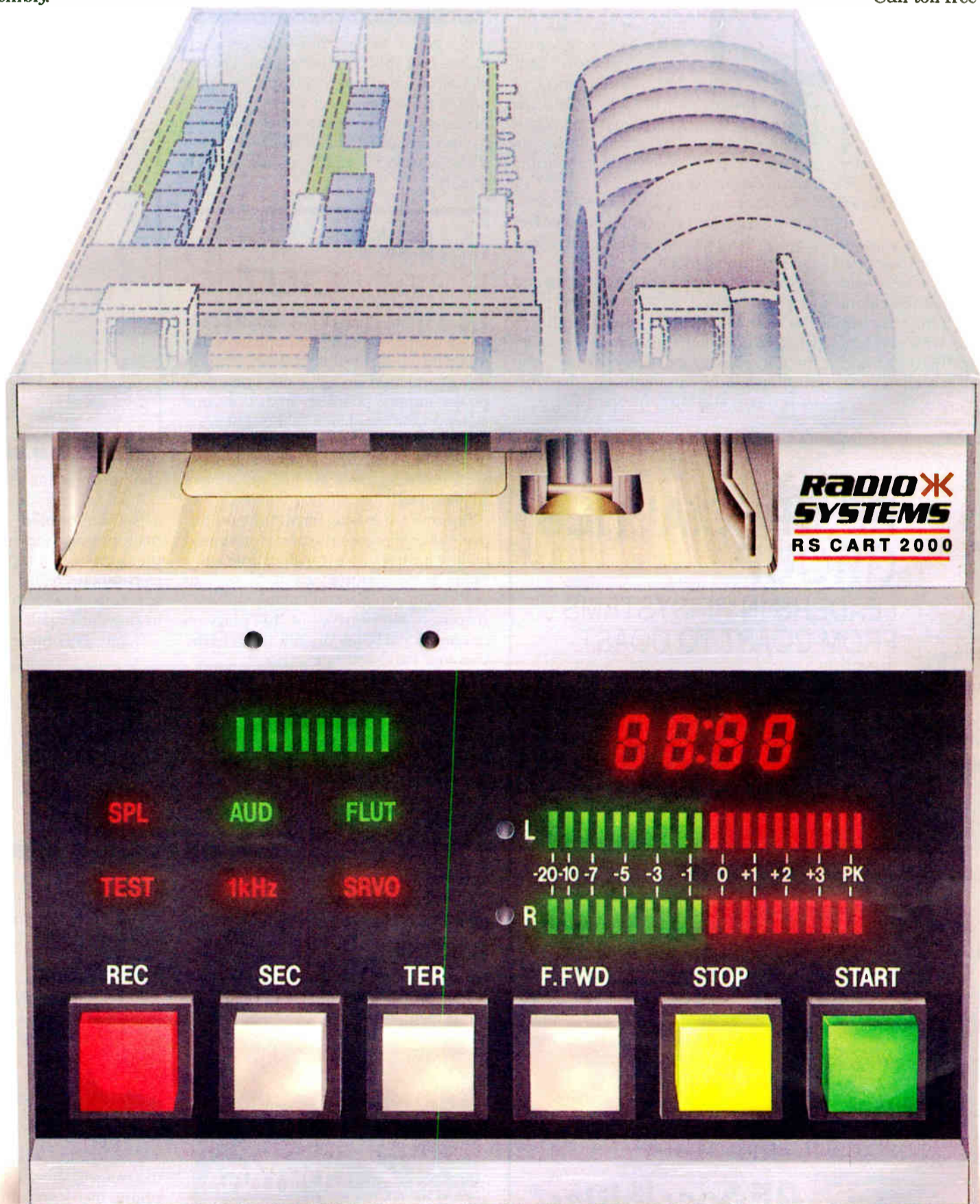

Running a Religious Remote

The Ins and Outs of Setting Up Equipment to Produce a Broadcast from a House of Worship

by Bruce Bartlett

Elkhart IN Your assignment: Do a remote broadcast from a house of worship, in stereo, and make it sound great. This

The easiest way to capture the service is to plug into the church's reinforcement mixer. Look for an output jack that is ahead of any graphic equalizer used to equalize the house speakers. If the church has a sound technician, you can ask him or her where to obtain such an output.

If this output is an XLR-type connector, plug a cable into that output and plug the other end into your mixer or recorder.

To avoid ground loops between your audio system and that

of the church, you need to isolate the grounds of the two systems. One way is to float (disconnect) the shield from pin 1 of one of your cable's XLR connectors (as shown in Figure 1).

Another way is to connect a 1:1 isolation transformer between the two mixers (Figure 2). This is necessary if either mixer is unbalanced.

Although tapping off the PA is fast and easy, the sound quality may be poor. You're stuck with the mics the church uses, which might be of mediocre quality. You're also at the mercy of the church audio person, who might do a bad mix or set gain staging improperly.

The only way to control the audio quality is to do it yourself: Mic everything and mix it with your own mixer. If you put two mics on each source—one for PA and one for broadcast—this will look cluttered.

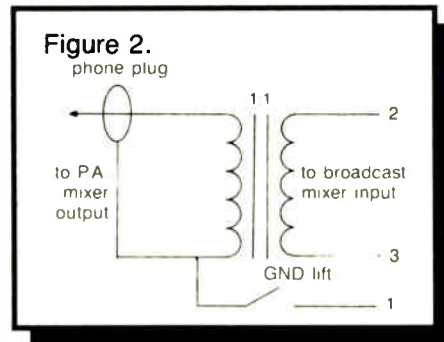

It's better to use one mic on each source and split each mic signal. That is, connect each mic to a microphone splitter (Figure 3); connect one split to the house mixer and connect the other split to your broadcast mixer. This works best if the church microphones are of high quality.

LINE OUT

Most splitters have a ground-lift switch on each input to prevent ground loops between the multiple audio systems. If you're using condenser mics that need phantom power, supply phantom from only one mixer on the input side of the split.

Now let's tackle the actual miking techniques for each sound source. Following are some suggested methods that have worked well.

Pastor. If the pastor stays at the pulpit, use either the gooseneck mic mounted on the pulpit, or a cardioid mic on a boom stand about 8" away. Be sure to put a foam pop filter on the microphone. Another alternative is to place a unidirectional boundary mic (such as the Crown PCC-160 or Shure SM-91) on top of the pulpit.

If the pastor wanders, use a clip-on lavalier microphone, either hard wired or into a transmitter. Be sure to use a belt clip or place the mic connector in the pocket to act as a cable strain relief.

With certain types of preaching, the preacher gets louder and louder as the sermon progresses. To prevent overload, you'll need to patch a compressor in line with the preacher's input channel.

Also, you'll probably need to set the input gain, input attenuation or pad on

the preacher's input channel to prevent input overload distortion.

I've heard many broadcasts where the preacher sounded distorted because the mic signal overloaded the mixer's mic preamp. I don't know whether this distortion is accepted as normal for this type of service, but it can be prevented if you want.

Choir. For permanent installations, you can hang two mics about 10' apart over the choir (Figure 4). Two mic manufacturers (Audio-Technica and Crown) offer miniature mics especially designed for choir miking; they are almost invisible in use.

If the mics are used for sound reinforcement, place them close to minimize feedback: about 1 1/2' in front of the front row of singers, and about 1 1/2' above the head height of the back row (Figure 4). If the mics are used only for recording or broadcast, you can place them a few feet farther to pick up room reverberation.

A temporary setup is to mount two cardioid mics on mic stands, either high up on boom arms or at full stand height

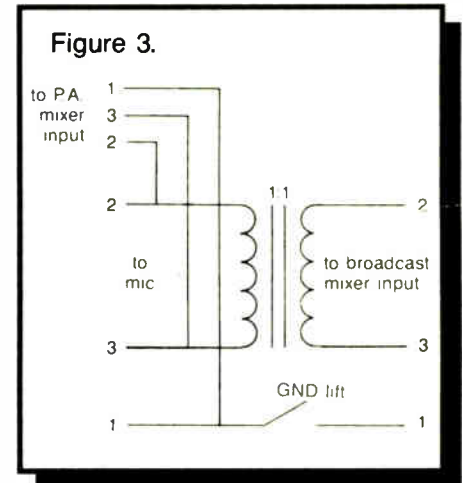

aiming up at the choir. A soloist or reader can be covered with a stand-mounted handheld cardioid microphone. You might want to compress the signal and roll off some lows to compensate for proximity effect. Be sure to place a foam pop filter on the mic to prevent breath pops.

Organ. Try one or two condenser mics

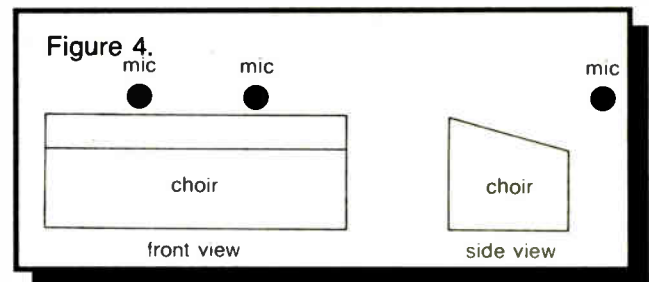

several feet from the organ pipes or organ loudspeaker. The mics should have an extended low-frequency response.

Cassette deck. This provides background music which you mix with the vocal mics. The cassette deck outputs connect to mixer line inputs. To split the signals to the PA and broadcast mixers, you'll need a Y-adaptor and isolation transformer (one per channel).

Altar table. Place a unidirectional boundary mic on the table. Some models come in white to blend with a white tablecloth.

Congregation. Hang a stereo mic over the congregation. Of course, this microphone feeds only the broadcast mixer.

Musical ensemble. Miking techniques for individual instruments were covered in previous *Line Out* articles.

Augmentation of the PA feed with

(continued on next page)

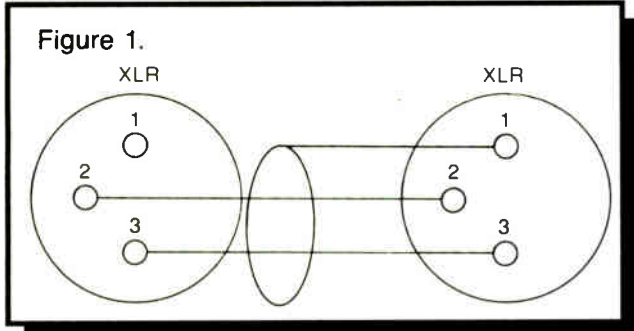

is a big job!

Unless you take a feed off the PA, you'll have many sources to mix—the pastor, choir, soloists, organ, cassette deck (for singers' background music), altar table, congregation and sometimes an entire musical ensemble.

Let's consider some effective ways to handle the situation. There are three basic approaches to this task: take a feed off the church's sound reinforcement mixer; mic and mix everything yourself; or augment the PA feed with some of your own mics (say, for the organ and congregation). We'll look at each of these approaches in detail.

RF SPECIALTIES GROUP

LEADERS IN RF SYSTEMS FROM COAST TO COAST

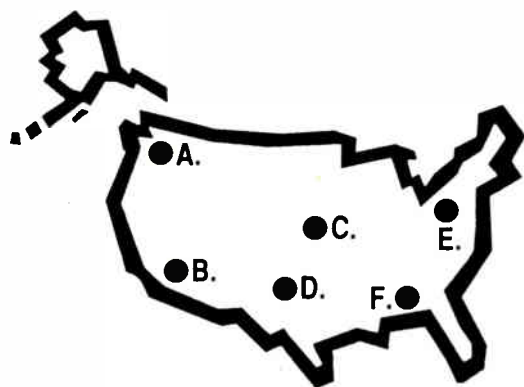

FOR ALL YOUR BROADCAST EQUIPMENT NEEDS, CALL THE SPECIALIST NEAR YOU

SYSTEM DESIGN

COMPETITIVE PRICING



A. RF Specialties of Washington, Inc.
19237 Aurora Avenue N.
Seattle, WA 98133
Phone (206) 546-6546
FAX (206) 546-2633
John Schneider

B. RF Specialties of California
3463 State Street, Suite 229
Santa Barbara, CA 93105
Phone (805) 682-9429
FAX (805) 682-5170
Sam Lane

C. RF Specialties of Missouri
R.R. #2, Box 152H
Kearney, MO 64060
Phone (816) 635-5959
FAX (816) 635-4508
Chris Kreger

D. RF Specialties of Texas
P.O. Box 7630
Amarillo, TX 79114
Phone (806) 372-4518
FAX (806) 373-8036
Don Jones & Tim Hawks

E. RF Specialties of Pennsylvania, Inc.
121 Conneaut Drive
Pittsburgh, PA 15239
Phone (412) 733-1994
FAX (412) 327-9336
Tom Monahan

F. RF Specialties of Florida
P.O. Box 397
Niceville, FL 32578
Phone (904) 678-8943
FAX (904) 729-2744
Bill Turney

Each Office is Independently Owned and Operated

Oh-Oh!

Call CORTANA

For Affordable Lightning Protection

505-325-5336

P.O. Box 2548, Farmington, N. M. 87499
FAX 505-326-2337

A Grab-Bag of Engineer's Hints

(continued from page 31)

messages. Using ZModem transfer protocol, I see transfer rates jump to about 225 characters per second (cps).

But the real speed boost, and a boon to those using long distance to connect, is the jump to 9600 baud modems.

Switching to warp drive

US Robotics (USR) makes a fine unit in this class. It is called the Courier HST dual standard. I've recently had the pleasure of using one and watching the files literally zip in and out of my computer.

The dual standard refers to the fact that, like AM stereo, for ex-

ample, there is no one standard for modems. USR covers two of the more common ones. Actually 95% of BBSs that run at 9600 baud use a protocol recognized by the Courier dual standard.

Transfer rates are not just improved by a factor of four. The faster modems utilize a number of compression and other techniques that lift the speed to 1700-2000 cps!

The RelayNet (RIME) technical conference just started to roll in September. . .

Since I've used this modem extensively to call BBSs all over the country, I can tell you that it has worked flawlessly. Even on weaker, low level modem audio, I got clean text and data transfer.

According to USR, this is in part due to using trellis coded modulation. If that sounds like techno-babble to you, just remember that it makes the system less vulnerable to line or impulse noise, reducing errors dramatically.

While we're now talking a lot

more money for the USR Courier than a 2400 baud modem, the savings on long distance can be dramatic. For instance, if you spend \$60 a month on long distance charges for connection time, a 9600 baud modem could chase that down 60-75% or more.

In other words, you might be able to pay for such a modem out of your long distance budget. And then you don't have to listen to any of those obnoxious long

distance company ads at all!

By the way, does anyone actually know the name of that bar in Fiji?

Who goes there?!

Even though we've not seen a huge wave of problems in the US, station security is going to be an important concern of the '90s, both at the studio as well as out at the transmitter sites.

While there are many stations

that to this day literally are open to any visitors, a significant number have already made policy changes and public access to the studios is now more restricted. Guards are on duty at a number of facilities.

Some major and medium market stations have become so concerned for the safety of their personnel that visitors feel they are approaching an armed camp.

Equipment and copper thefts

have also increased at transmitter sites, which are often unattended.

This column will next be taking an intensive look at the subject.

If you have had any noteworthy experiences or observations you'd be willing to share with others, please call or write and give me the information. If we can share our problems and solutions, everyone will benefit. Thanks!

■ ■ ■

Barry Mishkind, aka RW's "Eclectic Engineer," is a consultant and contract engineer in Tucson. He can be reached at 602-296-3797, or on FidoNet 1:300/11.

Don't Let The Sound Gremlins Derail You.



Those mischievous Sound Gremlins are always trying to create audio calamity. But the dbx® family of world standard compressor/limiters will give you the technical and musical muscle to fortify your sound. Our compressor/limiters will put punch in your voice processing, level out phone lines, maximize cart transfers and help you avoid those catastrophic overloads.

Kick the Sound Gremlins out of your signal with dbx's OverEasy® transition into compression, patented dbx VCAs and human-ear compatible true RMS detection.

From location to production to air, dbx has the products to suit your needs. Call your local dealer now to demo a dbx compressor/limiter. Then you'll know why our signal processors have been rated #1 in professional recording studios for the past four years.*

Don't wait. Catch the *dbx Express* now.

*In recording studios as reported in *Billboard's* 1988, 1989, 1990, 1991 U.S. Studio Equipment Brand Usage Surveys.

A division of
AKG Acoustics, Inc.
1525 Alvarado Street
San Leandro,
California 94577, USA
Tel: (1) 415/351-3500

INDUSTRY STANDARD
COMPRESSOR/LIMITERS • NOISE REDUCTION SYSTEMS • EQUALIZERS • MODULAR PROCESSORS

Religious Remotes

(continued from previous page)

your own mics is a common technique. The PA feed usually lacks the sound of the organ and the congregation. So you mix these, and mix their signals with the PA feed.

With some careful mic placement and mixer artistry, your broadcast of a worship service can be a blessing instead of a curse.

■ ■ ■

Bruce Bartlett is a microphone project engineer and technical writer with Crown International. He can be reached at 219-294-8000.

©1990 AKG® Acoustics, Inc.
dbx® and OverEasy® are registered trademarks of Carillon Electronics Corporation ©1989, 1990

Circle 125 On Reader Service Card

World Radio History

Built for Business.



The Revox PR99 MKIII Professional Recorder

The **PR99** means business and in today's high-pressure, competitive environment, your station can't settle for anything but the very best. Featuring advanced audio electronics, the PR99 MKIII professional recorder outlasts and outperforms all others. With its superior construction, this recorder was built for long-term dependability, easy maintenance and the highest quality audio. And our reputation for service and technical support remains unsurpassed in the industry.

Take note of these PR99 features: • a solid die-cast aluminum transport chassis and head block • record and playback heads built to the same tolerances as the heads for Studer multitracks

- easily accessible modular electronics for tough, reliable performance
- an Autolocator with digital counter in hours, minutes and seconds
- rack mounts standard.

With ease and versatility, this no-nonsense machine stands up to the rigors of daily station operations. Whether taping news call-ins, downlinking or uplinking satellite feeds, producing commercial spots or remote recording—whatever your station needs, the PR99 delivers!

For value and performance over the long haul, Play a Pro. The one built for business.

STUDER REVOX

Studer Revox America, Inc.
1425 Elm Hill Pike • Nashville, TN 37210 (615) 254-5651
New York (212) 255-4462 • Los Angeles (818) 780-4234
Studer Revox Ltd., Toronto (416) 423-2831

Call your Studer Revox Professional Products Dealer for more information about the complete line of Studer Revox Professional Products.

WORKBENCH

Transmitter Site Tips

by John Bisset

Falls Church VA This month, our *Workbench* column focuses on the transmitter site.

Low cost PSSA/PSA readings

If you've been trying to figure out an inexpensive way to make PSA/PSSA

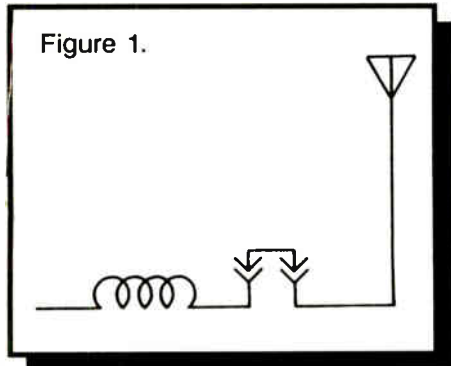

readings, or impedance bridge measurements without shutting off the transmitter, consider Tom King's suggestion for parallel J-plugs.

At the output of your ATU, install a

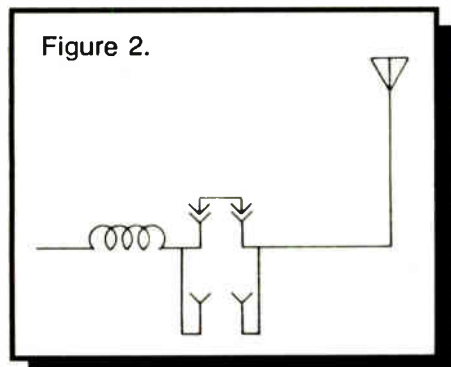

second J-plug jack in parallel. Insert your low power ammeter into one of the jacks, pull the shorting plug which is wired in parallel, read your current or make your bridge measurement, and re-insert the shorting plug when you are done.

Such a procedure cuts down on run-

ning back and forth from the transmitter building to the tower turning the rig off and on. Be sure to use caution poking around inside a live ATU—even if it is only 25 W! This procedure is obviously taboo for higher power levels. Not only do you have the shock hazard, but standing next to an open ATU may violate ANSI guidelines.

In addition to the J-plug hardware, Tom's company, Kintronic Labs, also sells the low power Delta meters and a more sophisticated Delta "Hot Jack" with make-before-break contacts. Call Tom in Bristol, TN for more information: 615-878-3141. By the way, Kintronics is also a supplier of Jennings vacuum capacitors, and they maintain a good stock of these components.

Tower grounding

If you've ever worked with ground screen at the base of a tower—either replacing it or patching it—you know how quickly a torch can disintegrate the thin copper screen if the flame is held in one place too long.

When either patching screen or joining two pieces of screen together, lay a piece of soft drawn copper wire along the seam and wrap the edges of the ground screen around it. Then, butt the patch or other end of the screen up to this seam and repeat the process.

Flux the seam with silver solder flux; solder it using a torch and silver solder. The result is a very neat and electrically sound seam.

By the way, if you are planning to do silver soldering, invest in a bottle of MAPP gas. This gas provides a much hotter flame than propane, making the bonding job less time consuming—especially when bonding onto something with a wide surface area like copper strap.

Use caution with this gas, however. When the ground screen starts to glow cherry red, you've left the flame on too

long. Any more heat and the screen will disintegrate!

RFR metering on a budget

After having his consultant make RFR measurements at his 50 kW DA, Merrill Pittman, CE at WANN-Annapolis, MD, was faced with a dilemma. His site was soon to be rebuilt, but he needed RFR compliance now.

Rather than invest in costly remote metering and weatherproof boxes, only to have them torn up in a few months, "Pitt" came upon a novel and cost-effective solution. At the local five and dime, he bought four small magnifying glasses. Four blocks of wood were drilled and served as mounting bases for the magnifiers.

One of these magnifiers was placed on the shelf of each tower's ATU, directly in front of his RF ammeter. Standing the required four feet away, the meter switch could be thrown with a wooden stick; the magnifying glass gave an excellent meter indication well out of the harmful RFR fields as determined by his consultant.

Maintenance on the RCA BTF-20E1

Ex-RCA specialist Gene Landau told of a routine maintenance tip for engineers who maintain RCA BTF-20E1 transmitters.

Inside the PA box are two parasitic absorption devices. These dipoles—one on

the front right and the other in the rear—consist of a resistor on the order of 70 ohms, fitted with cylindrical tubes on either end that form the dipole.

Each of these parasitic suppressors float within the cavity on two ceramic insulators. Over time, these resistors may either change value or short out altogether. Disastrous results can follow. Gene recommends checking these resistors periodically with an ohmmeter to avoid any problems.

If you want to discuss your RCA transmitter with Gene, he can be reached at Landau Radio in Alabama: 205-428-0146.

Workbench request for tips

I'd like to encourage you to look around your plant to see what you've built that could help someone else. We all know of those little insignificant projects that may appear to be "just common sense." However, we've also all been in the position where we can't see the forest for the trees.

If you'd like to discuss your idea before sending it, give me a call. Or FAX your suggestion to 703-998-2966. I look forward to talking with you!

■ ■ ■

John Bisset recently left Delta Electronics to join Multiphase Consulting, a company specializing in projects and contract engineering. He can be reached at 703-379-1665.

Computer Automation

A-Bus Low Cost Data Acquisition and Control

Measuring, Sensing, Switching and Governing.

A-Bus is a system for connecting equipment and sensors to a computer. From measuring voltage levels, to sensing switch closure, to activating relays, to controlling position, you can have complete computer control. A-Bus is designed to help you automate, whether it's an extensive remote application, or a simple repetitive chore.

When nothing else will do.

Sometimes you're presented with a unique problem, where the normal solution just doesn't fit. The A-Bus system was designed to be adaptable to whatever computer you have, expandable beyond your needs, and modular to fit your project exactly. This was required by a major radio station in San Francisco. Their remote transmitters were blocked by hills. A-Bus devices were connected to the repeaters atop the hills. The main studio could test and adjust the antennas for optimum performance.

The bottom line.

When budgets are tight, it's nice to know that the A-Bus was designed carefully to keep it affordable. This was very important to a small college radio station. They couldn't afford an expensive automation system, but inexperienced announcers required careful supervision to ensure FCC compliance. With the low-cost A-Bus system installed, the station manager had more time to spend on important tasks.

Support.

Alpha Products has produced thousands of systems, and they are being used by customers all over the world. Our recent customers include KSFO, KFRC, KBIA, WMJX, WBNX-TV, KETA-TV, and the Sun Radio Network. We are committed to reliability and customer satisfaction; our team of engineers stands ready to help you with any questions you might have. A-Bus components are stocked and available for immediate delivery.

A Sampling.

Relay Card, 8 SPST, 3A @120VAC: \$142. Fast 12-bit A/D, 8 analog inputs, 0-5V, 10µS conversion: \$179. Digital Input, 8 opto isolated: \$65. Touch-Tone decoder: \$87. TTL I/O, 24 lines: \$65. Also: Latched Input, Serial Multiplexing, D/A, Clock, Stepper Motor Control, etc.

Call for our Catalog
(800) 221-0916

ALPHA Products

242-Q West Avenue, Darien CT 06820 (203) 656-1806 (fax 203 656 0756)

Broadcast
furniture & systems.



AUDIO
broadcast group inc.

Call us today!

1-800-999-9281

Audio Broadcast Group, Inc.
2342 S. Divison Avenue Grand Rapids, MI 49507-3087
Phone (616) 452-1596 • FAX (616) 452-1652

After you've
seen the rest, get
the best!

- Over 150 systems delivered and installed.
- Outstanding workmanship.
- Stunning performance.
- Delivered on time, within a budget.

Ask for user's list.

A Data Compression Overview

by Mel Lambert

Part I of II

Studio City CA In response to some valuable feedback from **Radio World** readers, I have decided to devote the next pair of columns to providing a more detailed overview of the principles and techniques for digital audio data compression.

DIGITAL DOMAIN

For an increasing number of applications, including terrestrial and satellite transmissions (i.e. DAB), in addition to hard-disk/magneto-optical recording, a variety of innovative techniques are now available that significantly reduce the amount of spectrum and storage space required for CD-quality audio.

In a nutshell, these new techniques digitize an input waveform and delete redundant information to significantly reduce the number of bits needed to carry the necessary data. The data is then decoded at the receiving end without those deletions being audible.

Tipped off by phone

The phone companies have used compression techniques such as these for many years to increase the number of voice signals that can be carried per digitized transmission line. The radio community now has access to a number of devices that compress digital bitstreams to produce transmission and recording channels requiring between one-quarter and one-eighth the equivalent bandwidth of a conventional digital system.

Such techniques can be used to reduce the data rate of standard 16-bit PCM audio signals—with no subjective difference in sound quality—so that they can be carried over a 64, 96, 128 or 256 kbps (kbits per second) lines. (This is dependent upon the sampling frequency and data compression ratio.)

ISDN, fractional T-1 channels and the newly innovated switched 56-kbps links

are used to carry the data. And, by increasing the capacity of hard-disk and MO (magneto-optical) drives by a factor of four or eight, automated replay and random-access editing systems can provide enhanced on-line data storage per megabyte.

All data compression technologies rely on a variety of encode/decode algorithms that eliminate redundant information, without making it obvious that any acoustically relevant data has been deleted from the bitstream.

Just as our familiar FAX machines do not bother to send information that designates the white or blank areas on a page—lacking typed copy or hard-drawn graphics—it is also possible to compress a digitized audio signal so that it requires less time and/or transmission capacity to send it from source to destination.

Where it begins

Anyone who has examined music and speech spectra on an oscilloscope cannot have failed to notice two fundamental characteristics: The waveforms are reasonably periodic and repetitive in nature and the spectra are normally weighted towards the lower frequencies.

Starting with these two fundamental properties, we can devise schemes that examine the audio waveform in one of two ways, and then delete unwanted and unnecessary material from the bitstream. The input signal can be analyzed either within the Time or Temporal Domain—the familiar time/amplitude response—or within the Frequency Domain, by performing a Fourier Transform on the relevant waveform.

In essence, compression techniques based on temporal analysis will encode

periodic information in fewer bits than required by conventional 16-bit PCM systems (by coding level-change differences, rather than instantaneous levels measured every sampling period). Frequency-based analysis will allow bits to be assigned that designate the contents of important bands of information, particularly within the low-frequency region.

Let's now add to this objective analysis two fundamental subjective properties of human hearing: Loud signals, continuous tones and transients mask a broad range of lower-level signals centered around the primary masking frequency; and peak hearing sensitivity is centered around the

have resulted in the development of two main design approaches: sub-band ADPCM, which performs a complex time-domain analysis of the program material; and Transform Coding, which analyzes the signal in the frequency domain.

(Again it should be emphasized that neither of these techniques reduce the effective sampling frequency of the signals being carried. This both ensures complete compatibility with existing digital interfaces and transmission links, and also implies consistent bandwidth and frequency response.)

In transform encoding, which is used in the Dolby AC-2 system, ASPEC and others, an input is analyzed within the frequency domain as a series of narrow bands; the AC-2 encoder/decoder utilized some 256 narrow bands, while the ASPEC system is reported to be based

SUMMARY OF DIGITAL AUDIO DATA COMPRESSION SYSTEMS

System	Coding Principle	Number of Bands/Blocks	Bit Rates	Frequency Response	Bit Distrib.	Processing Delay	Auxiliary Data Capacity	Error Immunity	Hardware Implementation
APT apt-X 100	Sub-band Adaptive Differential Pulse Code Modulation (ADPCM)	4	Four bits per sample	Defined by sample rate.	Fixed	3.8 mS at Fs=32 kHz	8 kbps per channel at Fs=32 kHz	10E-4	ROM-masked AT&T DSP16 chip
ASPEC	Transform, with Overlapping Frequency Blocks	1024 (?)	128 kbps 96 kbps 64 kbps	20 kHz 20 kHz 20 kHz	Adaptive	80 mS 145 mS 167 mS	To be added to future versions	10E-4	Motorola 56000 DSP chip, plus external DRAM
ATAC	Transform, with Non-overlapping Frequency Blocks	1280 (?)	128 kbps 96 kbps 64 kbps	20 kHz 20 kHz 20 kHz	Adaptive	54 mS	Unknown	10E-4	Six-chip Encoder, and Two-chip Decoder, ASIC Implementation
CCITT G.722	Sub-band ADPCM	2	64 kbps	7 kHz	Fixed	1.4 mS	16 kbps	10E-4	Low complexity AT&T DSP16 and Motorola 56000 DSPs.
Dolby AC-2	Adaptive Transform with Overlapping Frequency Blocks	256	128 kbps	15 kHz	Adaptive	45 mS	1.2 kbps	10E-5	Motorola 56001 DSP chip, plus external DRAM (dynamic RAM).
MASCAM (earlier version of MUSICAM)	Sub-band ADPCM	24	128 kbps	15 kHz	Adaptive	Unknown	30 kbps (?)	10E-4	AT&T DSP32C DSP chip
MUSICAM	Sub-band ADPCM	32	128 kbps 96 kbps 64 kbps	20 kHz 20 kHz 20 kHz	Adaptive	19.84 mS 18.70 mS 18.51 mS Decode only	Unknown	10E-4	AT&T DSP32C DSP chip

1-2 kHz region. We can easily see that further redundancies in the audio waveforms can also be used to save valuable data bits during the encoding process.

By analyzing the primary high-level regions in a signal, a coding system can make intelligent estimates of the material being masked or hidden by the dominant tones or transients and then eliminate that data from the bitstream. And because the ear is less sensitive at medium to higher frequencies, in certain coding schemes such regions are allocated fewer bits.

As I pointed out in my September column, these two techniques of looking for redundant information within the audio waveform—or, more prosaically, looking for patterns that require fewer data bits to code unambiguously than conventional 16-bit digitized information—

on a series of 1024 bands.

Frequency bands in which information is masked by continuous tones or transients will be ignored by such systems, thereby enabling the compression algorithm to concentrate its bit allocation to the bands containing subjectively relevant information.

In addition, transform-based systems also utilize a system of pre-defined waveform patterns from an established "look-up" library of sound models, and send an identifier for the decoder to "resynthesize" the closest-fit library model.

Exploring ADPCM

Adaptive Differential Pulse Code Modulation (ADPCM) techniques use a combination of conventional linear PCM

(continued on page 40)

WHEN WORLD LEADERS SPEAK THE AVA MICROPHONE CLAMP IS ALWAYS FRONT AND CENTER



The legendary AVA Microphone Clamp is making history of its own all over the world. The finest, most secure and practical device for emergency in-the field audio hookup is available only from Audio-Visual Associates at our special discount price of just \$35.95. Call today for immediate delivery. Dealer inquiries welcome.

AV AUDIO-VISUAL ASSOCIATES INC.

6620 Virginia Manor Road • Beltsville Maryland 20705

Call Toll Free    1-800-543-0582



YOU TOLD US WHAT YOU WANTED...

We heard you!



FEATURES & BENEFITS

Remote Control • Emergency switching
Meaningful metering • Ease of setup
3 SCA/RDS inputs • Expandability
19kHz Pilot output • Provides RDS sync.
Composite processing • Maximized modulation

INTRODUCING
"Second Generation"
FM/FMX™
STEREO GENERATOR
MODEL 706

FMX™ Stereo transmission substantially increases noise-free stereo coverage area.

Inovonics, Inc.
(800)733-0552 FAX (408)458-0554

"Your Partners into the 90's
...and Beyond"

Amplifier Class: A Family Affair

This is the fifth in a 12-part series called Amplifier Fundamentals. Northern Virginia Community College will offer 1.2 CEUs (continuing education units) to registered students who successfully complete the course and an examination mailed at its conclusion.

Successful completion of the course and the final exam will also earn 1.3 professional credits toward recertification under the maintenance of certification provisions of the SBE Certification Program. To register, contact the Director of Continuing Education, Annandale Campus, 8333 Little River Turnpike, Annandale, VA 22003, or call 703-323-3159. The fee for the course is \$35.

by Ed Montgomery

Part V of XII

Annandale VA Amplifiers can be divided into two large families: small-signal amplifiers and large-signal amplifiers. Small-signal amplifiers are used to establish an electronic representation of

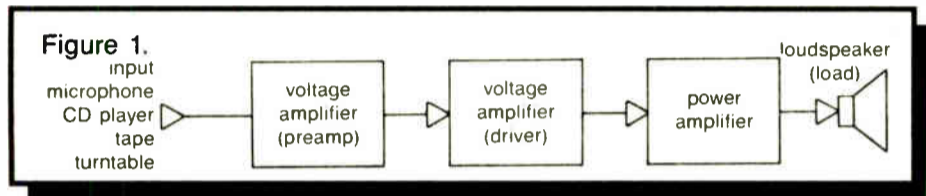

audio or light.

The electric current in the best microphone is a minute signal that could not be useful unless it were amplified to a desired level. Often this requires several stages of amplification.

The output of this amplifier could be a line level to feed a tape recorder input, transmitter or telephone line; it also could feed a large-signal amplifier, or power amplifier. The power amplifier will drive loudspeakers converting the electrical energy back into sound (or in the case of video, light).

Figure 1 is an illustration of a typical audio chain with the two voltage amplifiers being small-signal and the power amplifier driving the loudspeaker or load.

Most small-signal amplifiers are designed to be "single end" or employ only one transistor to amplify the signal. Often power amplifiers use two transistors or tubes to amplify their signal. This also brings amplifier classification into consideration. Amplifiers that have current flowing through them during the entire time they are operating are termed "Class A."

Figure 2 is an illustration of a sine wave with degree markings in every quadrant of its cycle. Class A amplifiers will draw current for the entire 360°. Class B amplifiers will only permit current to flow for 180° of the cycle; Class C amplifiers will permit current to flow for less than 180°. There is also a Class AB amplifier that permits current to flow more than 180° but less than 360°.

Amplifiers that conduct for less than 360° consume less power than those that are constantly operating, but they also introduce a considerable amount of distortion. Still, these amplifiers can

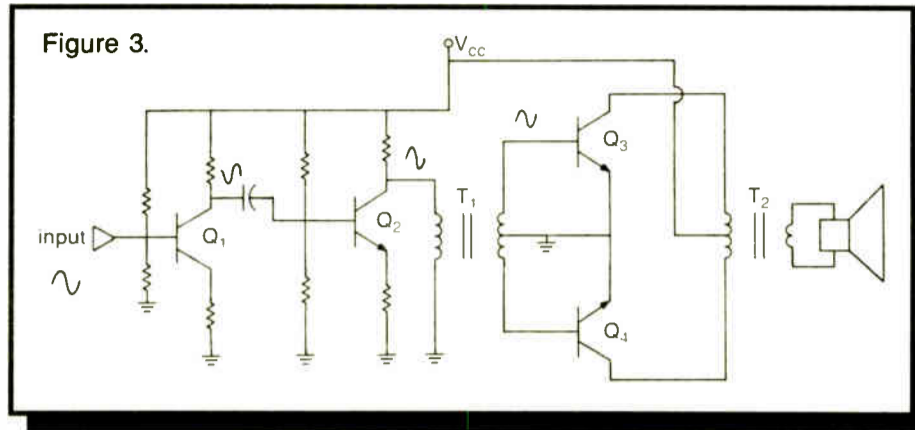

be useful.

Figure 3 is an illustration of the use of a Class A and Class B amplifier. Transistor Q₁ and Q₂ are single end, Class A small-signal amplifiers. The output of Q₂ is transformer coupled, through T₁ to transistors Q₃ and Q₄. This combination is known as a "push-pull" stage.

The two transistors are operated Class

from a single ended amplifier. This is easily done with a transformer or an amplifier operated as a phase inverter (as

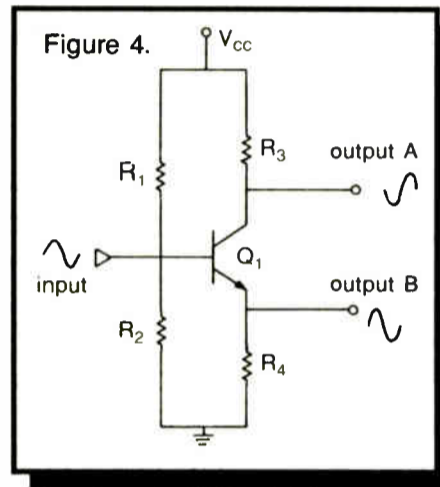

illustrated in Figure 4). This is a special type of amplifier where collector resistor R₃ and emitter resistor R₄ are chosen to have equal voltage drops with transistor Q₁ acting as an inverter.

Over the years several different designs have been developed for power amplifiers. Figure 5 is an illustration of a "split-secondary" or "totem pole"

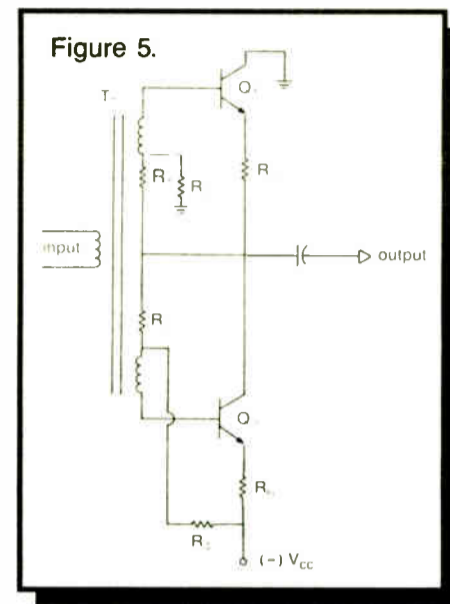

power amplifier.

Two identical power transistors are connected in series in this design. Transformer coupling splits the signal from previous stages so that the signal on the base of Q₁ is 180° out-of-phase with the signal on the base of Q₂. This amplifier design does not require a transformer to couple its output to another source.

(continued on page 40)

ATTENTION: AA-4 USERS

If you are comfortably standardized on the AA-4, you have a superb but less expensive option: the Audiomax 4000 cartridge is fully compatible but provides expanded headroom with improved high frequency response in a sturdier shell. Over 100,000 Audiomax cartridges are now in use. Manufactured by Fidelipac with satisfaction guaranteed.

SAVE 25%

NATIONAL AUDIO COMPANY

BOX 3657, GLENSTONE STA. / SPRINGFIELD, MO 65808 / 417-863-1925
FAX 417-863-7825

"Doing things for successful FM translators"



FM TECHNOLOGY ASSOCIATES, INC.

Talk with Howard Enstrom, veteran broadcast consultant who, in the 70s switched to FM translators as a specialty.



FMTA services: Feasibility studies, frequency searches, system design-engineering, FCC applications. Publisher of The SIGNAL SOURCE, bi-monthly newsletter all about FM translators. BEST EQUIPMENT PRICES.

FM TECHNOLOGY ASSOCIATES, INC.

30925 Vista Vista
Mount Dora, FL 32757
(904) 383-3682 FAX (904) 383-4077

Data Compression Explained

(continued from page 38)

and Adaptive Differential coding, which reduce the PCM bit rate by coding level differences between samples, rather than the absolute level of each sample.

According to the characteristics of the audio signal, ADPCM adapts the step size represented by each quantizing interval, to accommodate rapid changes in level caused by high frequencies or transients, thereby providing an overall reduction in bit rate.

Additional split-band techniques, such as sub-band coding, are used to take advantage of the spectral redundancies within the audio spectrum. As part of the

sub-band coding process, the signal is split into a number of independent bands, and the accuracy of the quantization is varied in each band according to the input-signal energy.

Critical regions of the audio spectrum can therefore be coded more accurately, with quantizing energy being biased towards the high sensitivity, low-frequency region. High-energy regions are also coded more accurately than in PCM techniques, which yield a lower coding noise platform.

Next time: Further details of data compression schemes, and a series of subjective criteria that can be applied

to systems to determine their "real-world" robustness in broadcast and recording applications.

Also, some personal comments regarding the recent series of ISO Evaluation Sessions held in Stockholm, and the

need for the US broadcasting community to become more actively involved in the standardization processes for coding schemes.

Mel Lambert has been intimately involved with the production and broadcast industries on both sides of the Atlantic for more than 12 years. Now principal of Media&Marketing, a consulting service for the professional audio industry, he can be reached at 818-753-9510.

Dynamic EQ Put to Work

(continued from page 32)

approach is to re-equalize troublesome songs in the production studio and then run a reasonable amount of multiband processing on everything.

Bad dubs actually may sound worse under dynamic equalization. The processor will struggle to put some high end where there is none. The result is a hissy high band modulated by whatever is leaking in from the mid channels.

The same is true for hum and rumble. Too much multiband processing will make these problems more noticeable. The price you pay for consistency is the need for increased vigilance over all your material.

A dynamic multiband processor is not exactly like a graphic equalizer. You adjust the equalizer until the sound is right and then dub the song through it. A multiband processor is more like having a production engineer constantly fiddling with the EQ settings as the song plays. This gives a different effect. With this processing, every song has the same amount of lows, mid-ranges, and highs.

Don't depend on robots to fix your audio problems. Solve the engineering

and production problems before going to auto-pilot.

First, get all levels set the same. Align all the tape equipment to match the standard alignment tape. Proof the boards and switchers to make sure every channel is flat and undistorted.

Next, review the music. A lot of inconsistency is caused by recording the music library over many years, on different brands of cart or tape, using different machines. Recording all your music consistently will smooth out many problems.

When re-recording, take note of problem songs. These are candidates for the re-production tricks mentioned earlier. Have a goal of making these tunes sound like the others.

Finally, apply a moderate amount of dynamic equalization in your processing chain. This provides the automatic fine tuning that keeps everything sounding just right for the listener.

John Shepler is an engineering manager, broadcast consultant, writer and regular RW columnist. He can be reached at 815-654-0145.

Amplifier Classification

(continued from page 39)

Figure 6 is an illustration of a "complementary symmetry" amplifier. This amplifier takes advantage of the fact that NPN and PNP transistors require signals

R_1 , D_1 and D_2 are designed to overcome "crossover" distortion. This occurs as the transistors approach their cut-off region. In fact, crossover distortion is a problem in most solid-state amplifiers, and requires most designs to be operated Class AB rather than Class B.

The complementary-symmetry amplifier requires exactly matched NPN and PNP transistors. Often this is difficult to achieve in power transistors but is much more accessible in voltage amplifiers. Quite often a complementary-symmetry amplifier has been used as a driver for a totem pole power amplifier.

Ed Montgomery currently is an electronics teacher in the Fairfax County school system. He has taught broadcast engineering at Northern Virginia Community College and worked as a broadcast engineer for several radio stations. He can be reached at 703-971-6881.

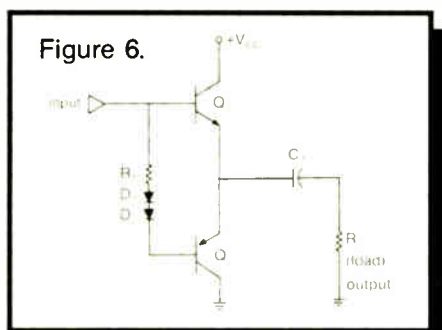

of opposite polarity to perform the same function. The NPN transistor Q_1 and PNP transistor Q_2 are in series with the base inputs connected in parallel.

GET IT RIGHT

FROM HARRIS ALLIED

New Definition of Excellence Comes to Subcarriers!

Meet the TECTAN Model 450

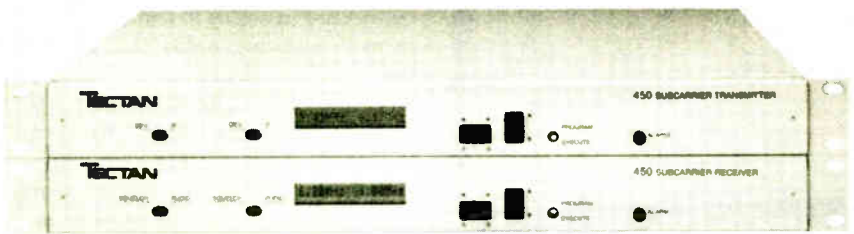

Model 450 Dual FM Subcarrier

The 450 is a frequency agile, synthesized FM subcarrier designed specifically for narrow band multi-channel applications and incorporates the latest noise reduction techniques, superior audio quality and unmatched flexibility for any situation where two or more audio circuits are required. Each unit contains two completely independent transmitters or receivers for stereo applications over terrestrial microwave, satellite or analog fiber optic facilities.

New Definition of Agile Comes to SCPC!

Meet the TECTAN Model 412

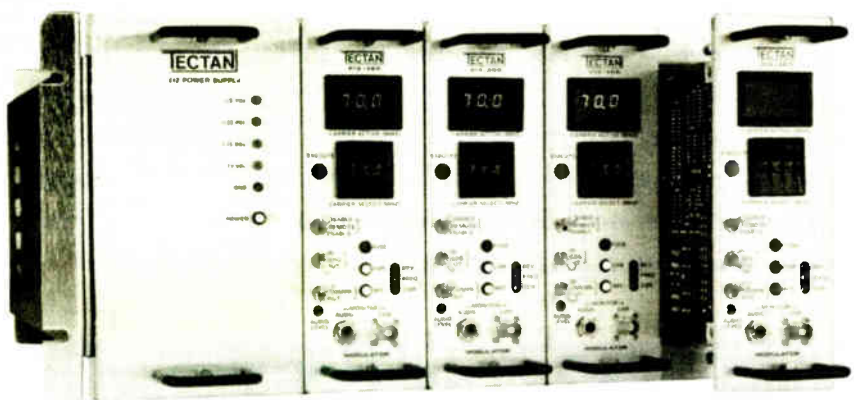

Model 412 Frequency Agile SCPC FM Terminal

This agile terminal unit is for satellite transmission and reception of high quality audio, voice or data. It allows direct access to satellite circuits from any location without combining with other channels.

Call for FULL details on these and other TECTAN products.

HARRIS ALLIED

SATELLITE EQUIPMENT

317-962-8596

FAX 317-962-8961

3712 NATIONAL RD. WEST • P.O. BOX 1487 • RICHMOND, IN 47375

©HARRIS/ALLIED 1990



AS-101 Audio Switcher

- Illuminated and legendable control buttons
- Instant or overlap switching
- Front panel accessible level controls
- Options include: RS-232 interface, remote control, relay-follow-switch outputs
- Network proven quality and reliability!

10 stereo in 1 stereo out

P.O. Box 1342 Bellingham, WA 98227
(206) 734-4323 (206) 676-4822 (FAX)

Conex Electro-Systems, Inc

Broadcast Equipment Exchange®

"Broadcast Equipment Exchange" accepts no responsibility for the condition of the equipment listed or for the specifics of transactions made between buyers and sellers.

AMPLIFIERS

Want to Sell

Dynakit PAS 2 tube preamp, excel, \$100; Dynakit SCA 35 tube amp, excel, \$150; Langevin mono tube amp, uses 4 GLG's, \$150; Pilot AA 904 tube mono, excel, \$100. Kremer Kraft, 301 SW 16th St, Ft Lauderdale FL 33315. 305-524-5652.

Spotmaster BETMS-200 solid state stereo TT preamp, \$150. A Garza, Foster Comm, 2824 Sherwood Way, San Angelo TX 76901. 915-949-2112.

Harris GTM-88R RF amp, 104.9 MHz, \$100. R Coleman, WGEN, Box 87, Geneseo IL 61254. 309-944-4633.

McIntosh MC-240 in excel cond, \$500. Z Masoomian, WQXR, 141 Park Ave, Arlington MA 02174.

Crown USA Power Line 19" rack mount w/handles, black level control L&R, balance of warranty applies. 120 W (2), will pay UPS, \$300 ea; Nikko Alpha 400 pwr amp, like new cond, balance of warranty applies, wall manuals & packing, \$260. C Keith, ALI, Box 313, Keene NH 03431. 603-352-8460.

Panasonic WA-750 120 W PA amp, 4 inputs, tone controls, master, VU meter, like new, \$100. P Russell, Bowdoin College, Sills Hall, Brunswick ME 04011. 207-725-3066.

Marantz PM500 stereo amp, \$250; Yamaha preamp C4, \$250. J Parsons, Parsons Recdg, 10375 Cannas, N Huntingdon PA 15642. 412-863-9590.

RCA BA-44, monitor amp, BA-48 line amp, never used, \$100 ea. R Humphrey, WLJ, 7 Parkway Cir, Pgh PA 15220. 412-922-9290.

Bogen 30 W RMS stereo integrated amp, tube type, BO. M Saady, First City Recd, 141-60 84th Rd, 3E, Briarwood NY 11435. 718-846-2062.

McIntosh 75 tube power amp w/manual, \$325. D Lundy, Lundy Tape Duplicators, Cumberland Gap Pkwy, Heidrick KY 40949. 606-546-6650.

Gates M5546A compressor expander amp, BO. A Terry, WODY, Box 545, Bassett VA 24055. 703-629-5900.

Ampex 601 amp, JBL speaker, heavy case, mint cond, \$100/BO. B Baker, Pinetucket Recdg, 747 Wire Rd, Auburn AL 36830. 205-826-0390.

Radio Systems PA-1 stereo phono preamps (2), \$125 ea. G Fullhart, WVKS, 4665 West Bancroft, Toledo OH 43615. 419-531-1681.

Want to Buy

WE 86, 124, 142 & others; McIntosh & Marantz tube amps, also wrecked amps w/missing parts, any cond. J Kreines, DeMott/Kreines Films, 5330 Kennedy, Millbrook AL 36054. 205-285-6179.

Tube amps & remote mixers incl RCA OP-6, OP-7, BA series & WE 22D remote mixer. B Davies, Virgo Prod, 5548 Elmer Ave, N Hollywood CA 91601. 818-761-9831.

WE, Westrex, Marantz tube amp catalogs, specs, ads relating to above items. D deForest, 7441 Wayne, Ste 10-D, Miami Beach FL 33141. 305-866-5401.

Scully '100' recorders, record/play amplifiers, 8, 16, 24 track heads. Sequoia Electronics, 1131 Virginia Ave, Campbell CA 95008. 408-866-8434.

ANTENNAS & TOWERS

Want to Sell

Jampro JSCP-5 antenna, 99.3 MHz w/mounting brackets, 1-5/8" EIA flange, on 300' tower, excel cond, buyer removes, \$1500. C Sigmon, WBZK, POB 398, York SC 29745. 803-684-4241.

World Tower 429' w/30"-24" face, 1.5 yrs old, solid leg, to Ohio code, w/lighting package, you remove plus \$15,000. B Carr, WRED, 1201 Fremont Pk, Woodville OH 43469. 419-837-9696.

Andrews 300' 1-5/8" coax, no known defects, on 300' tower, buyer removes, \$1800; also 300' 24" face guyed tower, 21 yrs old. Kept painted, gd cond, heavy material & heavy duty, buyer removes, \$9500. C Sigmon, WBZK, POB 398, York SC 29745. 803-684-4241.

Cortana folded unipole for AM upper skirt, \$500. A Garza, Foster Comm, 2824 Sherwood Way, San Angelo TX 76901. 915-949-2112.

Stainless 24" face 380' tower, complete lighting kit. M St Cyr, 3565 29th SE, Grand Rapids MI 49512. 616-949-8760.



FM ANTENNAS

Performance & Reliability
You Can Count On!

If Your Antenna Doesn't Perform, Neither Will Your Station!

Why buy a used antenna when you can own a new S.W.R. FM Antenna. All S.W.R. Antennas are factory built and tuned to your frequency. S.W.R. has a modern test range to completely test your antenna. Pattern optimization can assure you of your coverage area. All S.W.R. Antennas have a 5 year limited warranty.

4 POWER LEVELS TO CHOOSE FROM

- FM1** For Low Power FM Stations.
Up to 6 Bays. Power input up to 6 Kw.
- FM5** For Medium Power FM Stations.
Up to 12 Bays. Power input up to 15 Kw.
- FM10** For High Power FM Stations.
Up to 12 Bays. Power input up to 40 Kw.
- FMP20** Panel FM Antenna for Multi Station Operation. Power input up to 120 Kw.

For Complete Information & Pricing
Call Jimmie Joynt at 800/279-3326
J & L Associates • P.O. Box 25966
Colorado Springs, Colorado 80936
Ph. 719/528-5862 • 800/279-3326



Piord #24 440' solid tower, 5 yrs old, complete lightning kit. M St Cyr, 3565 29th SE, Grand Rapids MI 49512. 616-949-8760.

Harris FMA-4 hor 10 kW pwr in, all parts, gd cond, BO, will crate & ship. A Branch, KYAY, 2402 Woodridge, Decatur GA 30033. 404-325-7847.

Andrew 1861 reducer, 3-1/8" to 1-5/8", \$160; 1061A 90° elbow, 1-5/8" A-3-1/2", B-6", \$145; 1062A 90° elbow, 3-1/8", A & B 4-1/2", \$255; 75AN 7/8" to N, female, \$45; 23187 3-1/8" male to male, 9-1/2", \$140. D Agnes, WCLV, 26501 Emery Ind Pkwy, Warrensville OH 44128. 216-464-0900.

Rohn 180' self-supporting tower, standing but not in service, you remove, BO, E Histed, WONH, POB 1104, Honesdale PA 18431. 717-253-1616.

ERI single bay w/radome on 107.1, BO; Multirrons 160-220-1 RF contactor, BO. Z Hoffmaster, KTHS, Radio Ave, Berryville AR 72616. 501-521-0104.

Foam transmission line, 1-5/8", 400' section & 200' section, \$5ft FOB. D Dobrowski, WSSM, 1028 Braemoor, Downers Grove IL 60515. 708-963-3795.

ERI 8 bay Class C 98.5, single bay, various RF connectors. T Rusk, KUAR, 2801 S University, Little Rock AR 72204. 501-569-8485.

Shively 6813 NP 2 bay, 92.7 radomes, 1 yr old. E Santmyre, WWP, 12 N LaVale, LaVale MD 21502. 301-729-8876.

Shively 6813 2-bay, circularly polarized w/deicers & matching transformer. 5 yrs old, tuned to 90.7, \$2000. J McDermott, KCV, POB 800, Camdenton MO 65020. 314-346-2763.

Celwave CFM-LP2 face mount 2 bay on 100.1 w/domes, \$1200 plus shpg. M Heuberger, KTIG, POB 409, Peguot Lakes MN 56472.

Potomac AM 19 (204), 3 tower phase angle/loop current antenna monitor, w/6' phasor cabinet, complete w/tuning coils, freq 1360, \$2500. D Woodrome, KVL, 100 Spring Valley, Woodville TX 75979. 409-283-3734.

Anixter Mark 4' parabolic dish for 950 MHz band, pair w/hardware, \$800. D Schresser, WKFR, 4154 Jennings, Kalamazoo MI 49001. 616-344-0111.

Phelps-Dodge CFM HP-10 10 bay FM, circularly polarized, tuned to 105.9 MHz, 3-1/8" center fed w/3 point tuning, gd cond, you pay freight, \$6000/BO. M Sprysenski, WOCL, 2101 SR 434 Ste 305, Longwood FL 32779. 407-682-2121.

Utility 42" face 496' tower w/full lighting, excel cond, in Texas, you move, BO. P Parks, KLV, 27 Sawyer, Beaumont TX 77702. 409-838-3911.

Jampro JSCP-10 in excel cond, 9 yrs old, on 93.3 MHz, BO. P Parks, KYKR, POB 5488, Beaumont TX 77726. 409-838-3911.

Harris 2-bay CP FM tuned to 92.1, you ship, BO. G Perich, WVXR, POB 1, Jacksonville FL 32234. 904-259-2272.

Phelps Dodge 91318 hangers (20) for 3-1/8" rigid line; Interbay lines & misc parts for JSCP Jampro antenna; parts off of FMH12AC miter cut antenna, blocks, tees, interbays, arms, etc; (2) Andrew 78ARF connectors for 3" heliax; (2) Cablewave 738350 connector for 3" heliax. WJAG, 309 Braasch, Norfolk NE 68701. 402-371-0780.

Andrew 4" heliax, 480', 18 mos old, BO. P Parks, KYKR, POB 5488, Beaumont TX 77726. 409-838-3911.

Cablewave 250' 3.5" transmission line w/o connectors, (2) 550' 7/8" transmission line w/connectors, pressurized, Eddie, KCFX, 10800 Farley Ste 310, Overland Park KS 66210. 913-661-0101.

Andrew HF7-50A air dielectric heliax approx 326' w/87R gas pass & 87G gas barrier, last off reel, 2 yrs old, splice, on reel ready to ship, \$1850. D Kelly, KWPN, Box 84, W Point NE 68788. 402-372-5423.

FM ERI type G5CPS-2AE 2-bay rotoliller, 32 kW, complete w/shorting stub, input transformer, face mounts for Rohn 55-G tower, on 98.3 MHz, in excel cond, in storage, BO. T Baun, WFM, W172 N 7348 Shady Ln, Menomonee Falls WI 53151. 414-255-3100.

Cortana folded unipole, upper skirt. A Garza, Foster Comm, 2524 Sherwood Way, San Angelo TX 76901. 915-949-2112.

Jampro JA Series HP antenna system (4) 50 ohm bays using power divider, used on 94.5 MHz, gd back-up. C Murray, KMGE, 925 Country Club Rd, Eugene OR 97401. 503-484-9400.

Dielectric 4-1/16" rigid sections w/spring hangers, 4-1/16" field flanges, also some 3" rigid spring hangers. C Murray, KMGE, 925 Country Club Rd, Eugene OR 97401. 503-484-9400.

ERI FML-2 2-bay, one at 96.7 & one at 92.7. M Ripley, KOZE, Box 936, Lewiston ID 83501. 208-743-2502.

ERI G5CPS 10 bay, no deicers & 1° of beam tilt, tuned to 100.7 MHz, BO. Eddie, KCFX, 10800 Farley Ste 310, Overland Park KS 66210. 913-661-0101.

Phelps Dodge HFM-LP5 tuned to 89.5 MHz w/4 bays CFM, \$1500. D Karrs, KOPN, 915 E Broadway, Columbia MO 62201. 314-874-5676.

FM ANTENNAS

1 BAY	\$1,500
2 BAY	2,300
3 BAY	3,150
4 BAY	4,000

MORE BAYS AVAILABLE
All warranted, tuned
and tested

ARMSTRONG TRANSMITTER CORP.
5046 Smoral Road (315) 488-1269
Syracuse, NY FAX (315) 488-1365

Soft drawn uninsulated #10 copper wire, approx 2600', 2 full reels of 100' ea & (3) partials; 74' of 5/8" heliax; 141' of 5/8" heliax; 50' RG 8/U coax; various runs of 27 pair multicable shielded; punch blocks, jack panels & panduit. A Garza, Foster Comm, 2524 Sherwood Way, San Angelo TX 76901. 915-949-2112.

Jampro JSCP-8 93.3 MHz, broadband, will tune, recently on air w/480' of Andrew 4" heliax, coax is 18 mos old, 55 kW rating, both in excel cond, will sell separately, BO. P Parks, KYKR, POB 5488, Beaumont TX 77726. 409-838-3911.

Tower bracket, 1/4" x 1/8" for Rohn 25; (2) tower brackets. A Garza, Foster Comm, 2524 Sherwood Way, San Angelo TX 76901. 915-949-2112.

ERI G4-CPH-10 10 bay CP high power FM tuned to 96.1 MHz, w/500 W deicers, all functioning & mounting brackets, makes 100,000 W ERP H&V w/20 kW xmtr. C Murray, KMGE, 925 Country Club Rd, Eugene OR 97401. 503-484-9400.

Shively 6810 6 bay w/1.5 yr old deicer, BO. Eddie, KCFX, 10800 Farley Ste 310, Overland Park KS 66210. 913-661-0101.

Want to Buy

Circularly polarized 2-bay FM, tuned to 91.1 or close. W Wilson, KJTY, 2519 NW Topeka Ave, Topeka KS 66617. 913-357-8888.

One-bay circularly polarized antenna on 93.3 & 6-bay on 100.3. L Fuss, KOQZ, POB 159, Fayetteville GA 30214. 404-460-6159.

UHF TV bdct/translator antennas; Scala parapanels, any channel; Scala SL-8 chnl 19-23, 32-46, 60-64; Bogner B Series chnl 20-30, 31-42, 55-69 or Bogner LPS 1, 2 & 4; Thomas UHF panels any chnl. J Powley, 1536 Logan, Altoona PA 16602. 814-944-8571.

UHF TV translator antennas on old chnl 70-83 band; Scala SL-8 or parapanels; Bogner B4, B8, B16 or B24; Emcee DGA-10 corner reflectors. J Powley, 1536 Logan, Altoona PA 16602. 814-944-8571.

Shively 6813 or 6812 NP 2 bay, 104.5 w/radomes. E Santmyre, WWP, 12 N LaVale, LaVale MD 21502. 301-729-8876.

4 Bay tuned to 102.3, must be in excel cond. C Hargrave, KSPK, POB 1052, Walsenburg CO 81089. 719-738-3636.

Bogner B Series, UHF TV bdct/translator antennas, chnl 20-30, 43-54, 55-69, prefer B16U or B24U, can use B4U or B8U antennas, or Bogner LPS 1, 3 & 4, Thomas UHF panels on any UHF TV chnl. J Powley, 1536 Logan, Altoona PA 16602. 814-944-8571.

LPTV VHF & UHF antennas & transmission line, 1-3/8" & larger, 60'-600'. M Ernst, WBUD TV, 720 Fairhill Dr, Louisville KY 40207. 502-893-6656.

Rigid coax, 50 pieces of 20'-3'-1/8", Andrew or Celwave accepted, can fax info. E Anderson, WEAS, 912-234-7264 or fax: 912-233-7247.

FM 6-10 bay tuned or tunable to 90.5. M Schwarzbauer, Family Educ Bdctg, 1715 Michigan, Sturgeon Bay WI 54235. 414-743-6065.

AUDIO PRODUCTION

Want to Sell

KLH Burwen TNE 7000A & DNF 1201A transient noise eliminator & dynamic noise filter w/manuals, \$600/BO. D Christian, Pacific Lutheran Univ, 121st & Park Ave South, Tacoma WA 98447. 206-535-7265.

Studer Dyaxis digital editing system w/760 MB hard drive, DSP accelerator card & Macintosh II cx w/radius pivot monitor, less than 50 hrs use. T Jones, KNXR, 220 South Bdwy, Rochester MN 55904. 507-288-7700.

Yamaha SPX-90 digital effects unit, like new, \$475. Davis, MCP Studios, POB 521, Newberry SC 29108. 803-276-0639.

Boss RPS-10 digital pitch shifter/delay, excel cond, \$100. J Shade, WFAN, 34-12 36th, Astoria NY 11106. 718-706-7690.

Wegener SCPC satellite rcvr, 6-bay FM antenna tuned to 99.3 MHz, approx 280' of 3/125" air dielectric heliax transmission line, Gates stereo Producer audio console, mono Audimax & mono Volumax. B Herzog, WKPR, 3891 Waukau, Oshkosh WI 54903. 414-236-4242.

Altec 1567A (3), \$125 ea. J Parsons, Parsons Recdg, 10375 Cannas, N Huntingdon PA 15642. 412-863-9590.

dbx 119, \$50; SAE 5000A, \$100; Vector Research VQ-110A EQ 10 band, \$75. V Gray, GCA, 6840 Sterling, Raytown MO 64133. 816-358-8929.

CASSETTES - CARTS - REELS

J & I AUDIO/VIDEO

A wholesaler in the Radio and Television market.
Now running SPECIALS on audio and video:
BASF CASSETTES - AMPEX R-R's AUDIOPAK, FIDELIPAC & 3M CARTS
For more information call person-to-person collect:
Kris Elliot at 818-992-4288
or write to: **J&I Audio/Video**
20899 Kelvin Pl., Woodland Hills, CA 91367

Circle 96 on Reader Service Card

Henry Engineering Mix-Minus Plus, \$100/BO. G Fullhart, WVKS, 4665 West Bancroft, Toledo OH 43615. 419-531-1681.

Altec 9880A active filter, \$150. D Lundy, Lundy Tape Duplicators, Cumberland Gap Pkwy, Heidrick KY 40949. 606-546-6650.

Lang PEQ-2A (2) program EQ's, solid state, \$300 ea; Pultec HLF-3C filter set, passive, \$200; will sell all for \$700 plus shipping. D Glasser, Airshow Inc, 7021 Woodland, Springfield VA 22151. 703-642-9035.

Attention FM CP Holders!

We'll Build Your 3 kw Class A
For **LESS** Than \$100,000
GUARANTEED

We Include All This:

- * Up to 300 ft support tower with necessary Transmission Line and new 4-bay FM antenna
- * FM transmitter with solid state exciter and stereo generator
- * All necessary monitors and audio processing equipment
- * Equipment rack and digital remote control unit
- * A complete and fully equipped control room as well as a completely equipped 4-track production room

ALL you supply are transmitter building, & remodeled studio site..... We'll do the rest!

Similar savings on construction of B1, C3, C2, and C1 FM facilities, too.

CALL (512) 448-0058 Today For Complete Details

BROADCAST TRANSMISSION SYSTEMS
7008 Lock Lommond Austin, Texas 78749

Circle 31 on Reader Service Card

AUDIO . . . WTS

Sound Craftsmen TG-2209-600 EQ; (2) Ampex 351 R-R's; McMartin TBM-2500C FM RF amp; QRK 12C TT; Russco Cue Master TT; Collins 212Y remote amp; Gates M-5136 tube type 2 pot mixer; Ampex 4 pot tube type mic mixer; (2) Revox A77 R/P for parts; Marantz PMD 220 for parts; Technics SP-15 TT for parts; (3) mic swivel stands; BE cart rewriter; Rust remote control system. A Garza, Foster Comm, 2524 Sherwood Way, San Angelo TX 76901. 915-949-2112.

Pultec EQP1, EQD1A3, EQ4. M Block, Production Block, 2838 N Front, Harrisburg PA 17110. 717-233-4155.

Shure M688 stereo mixer w/rack mount, \$100; dbx 157 (2) side by side in rack mount, \$250; Omnicraft SP-1, needs work, \$50. R Branske, 5347 S Spaulding, Chicago IL 60632. 312-737-3303.

Want to Buy

**WANTED
DEAD OR ALIVE!
PULTEC EQ'S**

Fairchild & Teletronix Limiters; Neumann. Telefunken. AKG, RCA, & Schoeps microphones. Tube McIntosh or Marantz amps & pre-amps. Sontec, ITI, & Lang EQs. Neve or API equipment. Boxes of old tubes; Urei, Orban, United Audio. DBX, & other outboard gear. Ampex ATR102s or 104s. Parts for MCI JH110/114 recorders. Altec 604s/crossovers/Tannoy speakers. JBL 2231; Altec 288h drivers; Misc. equipment of all types.

Please Call:

Dan Alexander Audio
5935 Market St.
Oakland, CA 94608
1-(415) 644-2363
FAX: 1-415-652-4022

Tube limiters, compressors & EQ's, especially Fairchild 660 & 670, Teletronix LA2A & LA3A; Pultec EQs or NABECs; Lang EQs, Sontec & SPI EQs, etc; other vintage tube signal processing equip. J Kreines, DeMott/Kreines Films, 5330 Kennedy, Millbrook AL 36054. 205-285-6179.

AUTOMATION EQUIP

Want to Sell

IGM Go-Cart 24 (2), \$2500 ea; SMC 721 dual cart PB, \$500; SMC 710 cart PB, \$250, both SMC's in rack mount drawers. J Wenstrom, Wynne Bdcg, 503-882-4656.

Xtel AF-11R printer, working, \$75; Xtel AF-11R printer for parts, \$25; Otari ARS-1000 w/SMC card, \$800. M Persons, KLT/KFML, 70 N.E. 1st Ave, Little Falls MN 56345. 218-829-1326.

SMC w/DP-1 digital programmer, (6) racks, (6) SMC 350 mono Carousels, (2) SMC 721 dual mono cart decks, SMC 710 PB cart deck, (2) ARS-1000 stereo PB reels, (2) 750 ITC stereo PB reels, network back fill & join, system can accept up to 20 sources for total of 40 stereo inputs, (2) SMC 710 RP decks, one mono, one stereo, stereo deck needs work, automation has desk type brain, many spare cards, manuals, \$8700. G Smith, KORQ, 2449 S Tread Way, Abilene TX 79606. 915-672-5149.

Format Sentry FS-12B w/latest updates, remote control panel & wired for satellite of R-R, IBM compatible, computer included, IGM stereo Instacart, 48 trays, all in rack, on air, \$7500/BO. M Wilson, WGRK, POB 246, Greensburg KY 42742. 502-932-7402.

5025 BPC w/(4) Otari's, (4) Carousels, time gate, complete, BO. B Histed, WSIR, 665 Lake Howard Dr SW, Winter Haven FL 33880. 813-425-3411.

SMC automation system, complete w/2000 events, currently in use w/Satellite Music, avail 10/90, w/(4) Carousels, (4) reels & controller, works great, \$9500. Tony, FM97, POB 1465, Grand Island NE 68802. 308-381-3697.

SMC DP-1 intact wall boards, ideal for spare parts or for backup, w/pwr supply, BO. B Downs, KTSR, Box 3248, Bryan TX 77805. 409-846-1150.

SMC DS20-DP2 Brain, (6) Carousels stereo, (4) Otari ARS 1000 R-R's, in use, excel cond, \$12,500. P Swint, KIXQ, 2620 Dogwood Rd, Joplin MO 64301. 417-624-1310.

Schafer 903E stereo, spare parts, (4) Ampex AG440 stereo tape PB, (3) IGM 42 stereo Go-Carts, Xtel printer, (6) equip cabinets, gd cond, \$12,000. Blake, KJAX, POB 201-075, Stockton CA 95201. 209-948-5569.

Audiometrics AMCD5-1000 multi play CD players w/SMC automation controller, live assist CD playing system, gd cond wall schematics/manuals, BO. J Glass, WZOK, POB 6186, Rockford IL 61125. 815-399-2233.

IGM stereo Instacart 48 trays, Format Sentry interface, gd cond, on air, \$4000/BO. M Wilson, WGRK, POB 246, Greensburg KY 42743. 502-932-7402.

Sigma 301R2-24, datacels (7). B Hicks, KBAT, 3306 Andrews Hwy, Midland TX 79703. 915-697-7300.

Robojock CD-600 (4) will interface w/IBM for automation or live assist, like new, complete, \$1200. C Keith, ALI, Box 313, Keene NH 03431. 603-352-8460.

Satcue 400 switchers for Unistar formats by Colorado Magnetics (2), \$500 ea. H Widsten, KGNB, 1540 Loop 337 North, New Braunfels TX 78130. 512-625-7311.

Schafer 800T automation controller for parts, AG 440 PB, (2) Scully 270 PB, large rack, (2) Gates Criterion PB, all for \$800/BO. F Morton Jr, KMGZ, POB 7953, Lawton OK 73506. 405-536-9530.

SMC MSP-10 w/(2) stereo 452 bi-directional Carousels, (2) racks w/network card, SA-1 Silence Sence unit, almost new, will help buyer set up if within 75 mi of NW Florida, buyer pays shipping, \$10,000. Scott, 904-892-3158.

SMC DP-1, complete system, DP-1 programmer, AS-16 switcher, (5) 350 Carousels, (2) 710 cart machines, 721 dual cart machine, TS-25 dual sensor, remote control, \$5500. J Keane, KAPS, Box 70, Mt Vernon WA 98273. 206-424-7676.

SMC ESP2 incl (6) Otari ARS 100 R-R's, (2) 452 bi-directional stereo Carousels, (4) racks, control system, remote control w/CRT, dual play cart, printer, 2-1/2 yrs old, BO. L James, KYQG, POB 650, Wichita KS 67201. 316-265-1065.

Harris System 90 automation system including (5) ITC 750 R-R decks, stereo; SMC 24 bin Carousel, mono; (2) IGM 42 bin Go-Cart, stereo; IGM 78 bin Go-Cart, stereo; ITC 3D PB cart deck, stereo; logging encoder; Texas Instruments 700 ASR electr data terminal; (4) AMCO equip racks, recently rebuilt & upgraded, works great. WGER, 6165 Bay Rd, Saginaw MI 48604. 517-792-1063.

IGM EC system w/BAI monitor panel & (2) IGM stereo Instacart interface units, \$2500. S Bush, KTKK, 3595 S 1300 W, Salt Lake City UT 84119. 801-264-8250.

Want to Buy

Automation brain for limited duty, C Keith, ALI, Box 313, Keene NH 03431. 603-352-8460.

Complete automation system for use w/Satellite Music Network. D Thibodeaux, WHNK, 215 Centerville, Ste 351, Brentwood TN 37007. 615-737-9143.

Simple function automation Brain, advise via fax, 603-352-8461 as to specs, etc. C Keith, ALI, Box 313, Keene NH 03431.

Insta-Cart or Go-Cart machines, Mandel, KAMP, POB 1018, El Centro CA 92244. 619-352-2277.

Commercial insertion equip & cart machines, low to mid price range. M Ernst, WBUJ TV, 720 Fairhill Dr, Louisville KY 40207. 502-893-6656.

BE Sat 16-X interface card 908-6810 for Instacart, source cable 945-6433 for Instacart, source cable 945-8430 for Go-Cart, source cable 945-6462 for satellite SMN. L Maierholzer, WTGC, 101 Armory Blvd, Lewisburg PA 17837. 717-523-3271.

Manual for a Gates AMS-10, any info desperately needed, will pay per page fee on copies. A Branch, KYAY, 2402 Woodridge, Decatur GA 30033. 404-325-7847.

CAMERAS (VIDEO)

Want to Sell

Ikegami HL-79-E, Fujinon 14x9 lens w/2X extender, gd plumbicon tubes, camera in fine shape, \$12,000. R Yerema, World Video, 10625 Scripps Ranch Blvd, San Diego CA 92131. 619-695-1045.

Ikegami HL-79A in excel cond, Canon 13x1 lens, gd plumbicon tubes, \$5000; Ikegami HL-79DA in excel cond, Fujinon 14x9 lens, WT 2X extender, gd plumbicon tubes, \$7500. R Yerema, World Video, 10625 Scripps Ranch Blvd, San Diego CA 92131. 619-695-1045.

Sony 1610 single tube, color, aluminum case & access, like new, \$400. R Yerema, World Video, 10625 Scripps Ranch Blvd, San Diego CA 92131. 619-695-1045.

Sony Ero9100 Hi-8 industrial camcorder, 3 mos old, generates TC on address track internally, Uni-omni mic, extras, \$1500. S Weiss, 1st Generation Film/Video, 429 W Ohio, Chicago IL 60610. 312-661-3456.

Panasonic color CCD WVEX1, \$600. J Parsons, Parsons Recdg, 10375 Cannas, N Huntingdon PA 15642. 412-863-9590.

Sony BVW-30, w/Beta camcorder, Fujinon 14x9 lens w/2X extender, excel cond, \$10,000. R Yerema, World Video, 10625 Scripps Ranch Blvd, San Diego CA 92131. 619-695-1045.

Ikegami HL-95 w/14x9 lens w/2X extender, no recorder, very gd tubes, \$9000. R Yerema, World Video, 10625 Scripps Ranch Blvd, San Diego CA 92131. 619-695-1045.

Sony HVC-2200 3 tube color camera, electronic zoom, excel cond, low hrs, carrying case & manuals, \$150/BO. M Gehring, WKTU, Q-19 Redbank Run Apts, Woodbury NJ 08096. 609-384-1435.

Ikegami 730 retubed Canon 15:1, AC/batteries, case, manual, extender card, sharp, \$2800. Gene Sive Productions, 31844 Rancho Amigos, Bonsall CA 92003. 619-749-7662.

Hitachi KP-C100U color chip CCTV w/low time & white balance, \$125. P Russell, Bowdoin College, Hill Hall, Brunswick ME 04011. 207-725-3066.

Sony DXC 1640 tube camera w/case, \$700/BO; (2) RCA TK-630 w/CCU, BO; Sharp XC 700 w/case & access, shop manual, battery, pwr supply, overhauled w/one new tube, \$1800/BO. T Quinn, 408-475-0423.

Hitachi FP-C1 w/15x1, AC adapter, case, shooting cable, Anton Bauer charger, Sony VO-6800 w/Porta Brace & batteries, \$8500/BO; Panasonic AG-7400 w/Porta Brace, batteries, AC adapter, \$1700. A Pagan, Metrovision, POB 595013, Miami FL 33159. 305-828-9471.

Want to Buy

Old RCA, Dumont, GE, etc, tube type TV cameras; Phillips, Bendix, RCA, CBS, etc. early portable camera equipment. A Weiner, 14 Prospect, Yonkers NY 10705. 914-423-6638.

CART MACHINES

Want to Sell

Audi-Cord 31R, play, mono, \$500/BO; mdl 36R, play, stereo, \$600/BO; mdl SZ6R R/P, stereo, \$900/BO, all in gd cond. C Ibarra, KTAN, 2300 Busby Dr, Sierra Vista AZ 85235. 602-458-4313.

Sparta MC 104 PB's (4) ea plus spare in cabinet, w/spare pwr supply, 150 Hz & 8 kHz tones, \$700. L Beigel, On-Cue Record, POB 85042, Los Angeles CA 90072. 213-466-3595.

ITC stereo R/P, \$1200. J Wenstrom, Wynne Bdcg, 503-882-4656.

SMC 792 dual stereo deck, mounted in pull-out drawer, works well, \$450. B Downs, KTSR, Box 3248, Bryan TX 77805. 409-846-1150.

BE 5301 mono triple deck, circa 1977, working cond but needs top motor bearing, which is still avail from BE, \$500. B Bicoy, WMFO, POB 65, Medford MA 02153. 617-625-0800.

Tapecaster 700RPS, recently rebuilt, new parts, vgc, \$650. M Stephens, WAEC, 1465 Northside Dr, Atlanta GA 30318. 404-355-8600.

RCA RT-7B (6), (4) BA-7 record amps, 4-unit cabinet, gd-poor cond, BO/all or part. R Meyers, Benchmark Comm, 4700 SW 75th, Miami FL 33155. 305-264-5963.

Telex 36 cart deck, 4 trk play w/elect trk switching, rack mounting, all new, factory cartons, \$200. E Davison, 217-787-0800.

SMC 792 stereo R/P: A Garza, Foster Comm, 2524 Sherwood Way, San Angelo TX 76901. 915-949-2112.

BE 500-C (8) mono R/P: \$400 ea or \$2500/all. J Linn, WHKS, 62 N Main, Port Allegany PA 16743. 814-642-7004.

Audi-Cord A Series dual R/P w/dub feature, stereo, \$1250. E Douglas, KUNQ, POB 30, Houston MO 65483. 417-967-3353.

ITC 99A mono, excel cond, meets full factory spec, splice finds, bulk erases, does head alignment by microprocessor automatically, \$1200. E O'Donnell, WIBW, POB 119, Topeka KS 66601. 913-272-3456.

SMC 590 R/P: \$250; BE 2000 play for parts. WJAG, 309 Braasch, Norfolk NE 68701. 402-371-0780.

ITC PDII mono cart play decks (8), excel, \$400 ea; Spotmaster 500C mono cart recorder, \$200. M Persons, KKNL, Box 930, Aitkin MN 56431. 218-829-1326.

ITC RP Series (3), stereo, 3-tone, \$750/BO. G Fullhart, WVKS, 4665 West Bancroft, Toledo OH 43615. 419-531-1681.

Want to Buy

ITC Premium WP Series, mono, must have all three tones, in gd cond, w/rack ears preferred. D Williams, KKNL, Lincoln City Bdctrs, 1103 Utah, Libby MT 59923. 406-293-6234.

Collins dual tape, stereo, play, record, also manuals. J Panza, LL&S, POB 9847, Kansas City MO 64134. 816-763-9820.

ITC triple deck 3D's, mono or stereo, ITC record units, stereo. R Dymont, Group D, 8402 Lake Ave, Cincinnati OH 45236.

CASSETTE & REEL-TO-REEL RECORDERS

Want to Sell

Studer A820 1/4 2 trk, all hard & software updates, immaculate cond, no head wear, very low hrs w/remote, \$9500 plus shpg. R Cannata, Cantrax Recorders, 2119 Fidler, Long Beach CA 90815. 213-498-6492.

Telex Series 235 stereo tape duplicator system, 1 master w/complete spare & 4 slaves, in new cond, \$600. J Krepol, RNDL, 6147 Walker St, Philadelphia PA 19135. 215-624-1050.

Crown S/P logger for parts, \$25. C Sigmon, WBZK, POB 398, York SC 29745. 803-684-4241.

Stellavox SP-7 portable, similar to Nagra, 7-1/2, 15, 30 ips, 2-trk stereo, takes 10" reels, pilot tone for film sync, w/pwr supply, reel adaptors, manuals, carrying case, mint cond, \$1000/BO. B Watson, KSAK, Walnut CA. 714-946-6249.

SEE HOW LOW WE'LL GO!!
(On DENON CD Players)



For the Best DENON Deal Call



barrett associates, inc.
BROADCAST EQUIPMENT

(800) 748-5553

PHONE: 703-998-7600 FAX: 703-998-2966



Call Simone Mullins, Classified Ad Manager, to reserve space in the next issue. Use your credit card to pay, we now accept VISA and MASTERCARD.

RadioWorld®
5827 Columbia Pike, Ste 310
Falls Church, VA 22041

Ad deadlines are the first Friday of each month for the following month's issue

Select from these categories for best ad positioning:

- Help Wanted
- Positions Wanted
- Amplifiers
- Antennas & Towers & Cables
- Audio Production (Other)
- Automation Equip.
- Brokers
- Cameras (Video)
- Cart Machines
- Cassette & R-R Recorders
- CATV-MATV Equip.
- Consoles
- Computers
- Disco-Pro Sound Equip.
- Financial Services
- Limiters
- Microphones
- Miscellaneous
- Monitors
- Movie Production Equip.
- Receivers & Transceivers
- Remote & Microwave Equip.
- Stations
- Stereo Generators
- Switchers (Video)
- Tapes, Carts & Reels
- Test Equipment
- Transmitters
- Tubes
- Turntables
- TV Film Equip.
- Video Production Equip.
- Video Tape Recorders

Classified Advertising Rates Effective January 1, 1991

	1x	3x	6x	12x
1-9 col inch (per inch)	\$55	53	50	45
10-19 col inch (per inch)	50	48	45	40
Distributor Directory	90	85	80	75
Professional Card	60	55	50	45
Classified Line Ad	\$150 per word			
Blind Box Ad	\$10 additional			

To compute ad costs: Multiply the number of ad inches (columns x inches) by the desired rate schedule for your per unit cost. Example: a 3" ad at the 1x rate is \$165, at the 3x rate \$159, at the 6x rate \$150, at the 12x rate \$147, etc.

CASSETTE . . . WTS

Garner 2056 1 master, 5 slave, 1/4" stereo 60 ips, 7-1/2 or 10 reels, manual. D Agnes, WCLV. 26501 Emery Ind Pkwy, Warrensville OH 44128. 216-464-0900.

Ampex 350 1/4" transport w/original 350 electr, vgc. \$600. L Watson, WCDV, 227 E Forest Ln., Palatine IL 60067. 708-397-2525.

AKAI M 7SE older type R-R, works fine, one VU off scale, but does not affect operation, \$100. J Cunningham, KEOR, Rt 2 Box 113B, Stonewall OK 74871. 405-265-4496.

Magnecord 1022 stereo (2); (2) Magnecord 1021 mono, transports for parts on both these pairs, electronics OK; (4) Scully 270's for parts only, BO on any items. H Widsten, KGNB, 1540 Loop 337 North, New Braunfels TX 78130. 512-625-7311.

Roberts 997 stereo open reel recorder, tube type, cond unknown, \$35; Ampex 601 open reel recorder, tube type, cond unknown, w/manual, \$50; Ampex 601, no case, \$45. C Sigmon, WBZK, POB 398, York SC 29745. 803-684-4241.

ITC 750 PB (2), \$300 ea; ITC 750 PB for parts only, \$50. R Coleman, WGEN, Box 67, Geneseo IL 61254. 309-944-4633.

3M M56 8 chnl 1" tape pro-studio recorder w/full remote, sel-sync, Dolby A interface cables & new tape stock, \$2900; Audix MXT1000 8 chnl master mix down console, \$1500, or both for \$4000. J Krepol, RNDL, 6147 Walker St, Philadelphia PA 19135. 215-624-1050.

Ampex AG440-C in Ruslang console, 1/2 trk stereo, 7.5 & 15 ips, (2) Inovonics elects, excel cond, \$1500. R Barwig, Barwig Recdng, 5254 W Agatite, Chicago IL 60630. 312-283-2820.

Sony TC-580 1/4 trk stereo, 3 speeds, bi-directional R/P, new heads, excel cond in walnut cabinet, \$175 plus shpg. A LeFay, APL Prod., POB 371, Walnut CA 91788. 714-920-0175.

Stellavox SP 7 crystal sync recorder w/pwr supply, cables, case, (3) manuals & spares, like new, \$1800. Gene Sive Productions, 31844 Rancho Amigos, Bonsall CA 92003. 619-749-7662.

Scully 250 FT, 1/4" w/meter bridge & rolling cart, gd cond, \$1500/BO. N Cleary, Audio Innovators, 5001 Baum, Pgh PA 15213. 412-621-1950.

Auditronics AV123-4TS 1/4 trk; Inonics RR-2 2 trk, all in gd cond, BO/all or part. R Meyers, Benchmark Comm, 4700 SW 75th, Miami FL 33155. 305-264-5963.

Soundcriber audio logging recorder, fair cond. BO. R Meyers, Benchmark Comm, 4700 SW 75th, Miami FL 33155. 305-264-5963.

Ampex AG-440B 2 trk, 10.5" rack mount, vgc, \$700 plus shpg; Denon DH-510 prof 2 trk, 10.5" reels, 7.5 & 15 ips, excel cond, \$900. K Peckham, 5824 Danville, Madison WI 53719. 608-271-8763.

Tascam 38 8 trk, 3 yrs old, low hrs, perfect heads, w/remote, like new, \$1500. K Thomas, Rebel Recdng, POB 207, Atlantic Bch FL 32233. 904-388-7711.

Crown 700-SS vgc, stereo, will pay UPS to you, \$300. C Keith, ALI, Box 313, Keene NH 03431. 603-352-8460.

HEAD RECONDITIONING

Restore your worn heads to original (new) performance at a fraction of the replacement cost. Our laboratory services include:

- Digital/Optical & Electrical inspection
- Precision recontouring of heads
- Complete digital/optical alignment of assembly
- Exclusive "Audio Magnetic Head Test Report"™ & Data Sheets

We also carry a full line of replacement heads and parts. Our 25 years of experience and reputation are unmatched in the industry.



GMP MAGNETIC SCIENCES
249 Kennedy Road
P.O. Box 121 • Greendell, NJ 07839
Tel (201) 579-5773
Fax (201) 579-6021

Circle 53 on Reader Service Card

Tascam 8516 1" 16 trk w/dbx, stand & wired for synchronizer, \$5500 or possible trade. Funkenstein Recdng Std, 7811 La Cosa, Dallas TX 75248. 214-239-4075.

Gates ATC recorder, vgc; (3) Gates ATC tape decks, vgc. L Popp, 814-467-7894.

Scully 280 4 trk 1/2" in Ruslang console, late mdl w/motion sensing, spare cards & capstan motor, low hrs, gd cond, \$1400 plus shpg; Teac 2300X stereo 1/4 trk, 7" reels, excel cond, \$180. K Peckham, 5824 Danville, Madison WI 53719. 608-271-8763.

Teac A-3300 SX 2 trk master R/P, vgc. L Popp, 814-467-7894.

Otari MX-5650QXD 4 trk, 1/4", tape heads just lapped, vgc, buyer pays frt, \$850. B Petruzzi, Rouse St Prod, 13727 Sylvan Ste 11, Van Nuys CA 91401. 818-780-4572.

Teac 450 (2) stereo, new belts, heads, rebuilt motor, excel cond, \$135 ea or \$260/pr plus shpg. A LeFay, APL Prod, POB 371, Walnut CA 91788. 714-920-0175.

Scully 280B 4 trk 1/2", vgc. \$995/trade. G Liebisch, WPTF, POB 29521, Raleigh NC 27626. 919-876-0674.

3M M79 24 trk, 2" w/selectake one, vgc, w/meter overbridge & roll around console, \$9500. N Cleary, Audio Innovators, 5001 Baum, Pgh PA 15213. 412-621-1950.

CLEAN PATCH BAYS NO DOWN TIME



Please write for additional information and order form today.

VERTIGO BURNISHERS AND INJECTORS RESTORE ORIGINAL PERFORMANCE TO YOUR PATCH BAYS
\$34.95 Ea.

VERTIGO RECORDING SERVICES
12115 Magnolia Blvd. #116 818-907-5111
North Hollywood, CA 91607 FAX: 818-784-3763

Telex 1422 (2) 2 trk, \$350/both; Tapesonic 70 TRS 2 trk, \$350; Teac A3300 2T 2 trk, \$400; Teac A7030 portable, \$400; Teac tube type 505 stereo, \$300; Crown SS800 4 chnl tube, \$300; Sony TCC300, \$125; Akai 4000D, \$100; Akai X355, \$225; Wollensak 3M cassette 47C5, \$50; Viking 230 decks (3), \$200/all. J Parsons, Parsons Recdng, 10375 Cannas, N Huntingdon PA 15642. 412-863-9590.

RCA RT-21 mono w/cueing knob, w/manual, \$150. M Cramer, WGBA, 1391 N Road, Green Bay WI 54307. 414-494-2626.

Revox A77 MK III 1/4 trk stereo, 7.5 & 3.75 ips w/built-in pwr amps & speakers, vgc, just serviced, \$235 plus shpg. A LeFay, APL Prod, POB 371, Walnut CA 91788. 714-920-0175.

Reel hubs (2), \$20; Ampex mono AG 500 in working order wirecord amp, \$525; Emerson MM-314 transistorized w/speeds 15/16, 1-7/8, 3-3/4, 7-1/2 ips, gd working cond, \$45. S Dynes, Dynes Prod, Wheeling WV 26003. 304-233-8856.

Ampex 350 FT transports w/Inovonics solid state R/P elect & floor cabinets (2), \$500 ea. G Liebisch, WPTF, POB 29521, Raleigh NC 27626. 919-876-0674.

Magnecord 1024 stereo R/P (2), excel cond, \$100 ea; (2) Scully 270 chassis, misc parts, \$150/all. F Fess II, WLRB, POB 250, Macomb IL 61455. 309-833-5561.

Scully 280B stereo mounted on table w/wheels, amps, on rack, mint cond, working when removed from service, \$2000. L Pereira, Radio Ribatejo FM, POB 5334, Newark NJ 07105. 201-484-8574.

Crown SX-711 FT (2), \$100 ea; Telex Viking TD 235 stereo decks (2) 7-1/2, 7, 15 ips, \$150/pr; MCI JH 110 stereo 7-1/2, 15 & 30, roll around console, \$2800; Ampex AG 440-B FT, roll around console, \$850. D Lundy, Lundy Tape Duplicators, Cumberland Gap Pkwy, Heidrick KY 40949. 606-546-6650.

Revox A-77 (10) in various conditions, \$200 ea/\$1500 all; ITC ELS-IV bulk eraser/splice finder, \$400/BO. G Fullhart, WVKs, 4665 West Bancroft, Toledo OH 43615. 419-531-1681.

Record elect for ITC 750 R-R deck; mono record elect for ITC RP series cart deck. WGER, 6165 Bay Rd, Saginaw MI 48604. 517-792-1063.

Otari 5050BII in excel cond, \$1800. G Arroyo, WONO, 2483 John Young Pkwy, Orlando FL 32804. 407-293-0000.

Scully 280 FT (2), \$500 ea or \$800/both. J Linn, WHKS, 62 N Main, Port Allegany PA 16743. 814-642-7004.

Scully 270 2 trk stereo, R/P, works gd, \$500. WJAG, 309 Braasch, Norfolk NE 68701. 402-371-0780.

Sony CCP13A high speed cassette duplicator, 4 trk, 3 slaves, excel cond, \$750/BO. B Baker, Pinelucket Recdng, 747 Wire Rd, Auburn AL 36830. 205-826-0390.

Magnecord 1022 (2), stereo, elect OK, transports for parts; (2) Magnecord 1021, mono, elect OK, transports for parts; (4) Scully 270's, parts only, BO/all. H Widsten, KGNB, 1540 Loop 337 North, New Braunfels TX 78130. 512-625-7311.

Sony TC-277-4 4 chnl quad deck, needs work, \$40; Sony TC-650 3-head stereo 1/4" recorder, solenoid driver, \$100. P Russell, Bowdoin College, Sill Hall, Brunswick ME 04011. 207-725-3066.

Otari MX-5050 Mk III 1/2" Pro, 4 trk w/factory roll around floor stand, low hrs, mint cond, \$3400. K Stallings, SLP & Co, 19 West 36th, NY NY 10018.

Marantz PMD-221 portable mono 3-head, still under warranty, like new, \$195. J Ellingson, J Ellingson Voice, 913 Warwick Dr, Cedar Falls IA 50613. 319-277-8535.

Ampex 350 (2) in excel cond; Magnecord, solid state in own cabinet, excel cond; Gates rack mt cabinet; (2) Gates TT's; several old mdl RCA mics, BO. R Raines, Dixie Snd Stds, Rt 8 Box 491, Corinth MS 38834. 601-287-6783.

Want to Buy

Ampex MR-70 2 trk in gd original cond; Ampex NAB test tape, 15 ips; pair of RCA ribbon mics, D deForrest, 7441 Wayne, Ste 10-D, Miami Beach FL 33141. 305-866-5401.

MCI JH110B or C, 1/4" 1/2 trk stereo; Casio CFX-200 scientific calculator watch. B Umberger, WNLT, 51 S Main, Ste 957, Clearwater FL 34625. 813-446-0957.

Teac/Tascam 3440/80-8 remote controls, foot or console top operation. J McCallum, McCallum Recdng, 3311 E Bruce Randolph Ave, Denver CO 80205. 303-399-8548.

Metrotech 534A info and/or parts. A Allegra, Calvary Baptist, 1380 Valley Forge, Lansdale PA 19446. 215-368-4444.

Nagra IV-SD, non-sync stereo recorder, cash or trade. F Beacham, 213-462-2908.

Otari, MCI, Ampex, Studer or Scully 8 trk and/or 2 trk stereo. R Dymont, Group D, 8402 Lake Ave, Cincinnati OH 45236.

Carry case for Sony TCD-5M or TCD-5 Pro II portable recorders. R Schneider, POB 80795, Springfield MA 01138. 413-736-5853.

Inovonics 376 2 trk PB only elect. M Addey, Kaleb Sounds, 210 Riverside Dr, NY NY 10025. 212-865-3106.

Ampex ATR100 taperecorders for parts. Circuit cards, heads, motors, machine parts, or electronic parts. Call 818-907-5161.

MCI/Sony capstan & reel motors, any cond., recdng heads, most migs, machines, new, used. Relapped then sold. Amp Services, 224 Datura St No 614, W Palm Beach FL 33401. 800-826-0601, in FL 305-659-4805.

COMPUTERS

PCBoards

P-C-B ARTWORK MADE EASY!
create and revise your circuit artwork in a flash with PCBoards Software
For IBM's or Compatibles
LAYOUT — SCHEMATIC — AUTO-ROUTER
\$99.00 ea. Demo Pkg. \$10.00

PCBoards 2110 14th Ave. S.
Birmingham, AL 35205 (205) 933-1122

Circle 42 on Reader Service Card

Ampex MR-70 electr and/or transports for parts; Otari 4050-OM open reel mastering deck for high speed tape duplication. C Richardson, Richardson Recdng, 1938 Baltimore Annapolis Blvd, Annapolis MD 21401. 301-757-3733.

HE HALL

Electronics

THE BEST DEALS ON QUALITY REBUILT & BRAND NEW BROADCAST EQUIPMENT

We BUY & TRADE equipment too!
Please phone or send for our latest flyer.

10:00AM-6:00PM EST

804-974-6466 1305-F Seminole Trail
FAX 804-974-6450 Charlottesville, VA 22901

Circle 118 on Reader Service Card

CONSOLES

Want to Sell

ADM V1203, full EQ, 12x3 audio board, like new, compressor/limiters in master output chnl only lacking talkback module, fully loaded, computer interface, \$3000 plus shpg. S Sonnenblick, 305-891-3582.

RAMSA WRT820b
20x8x2
NEW IN BOX
FULL WARRANTY
\$5400.00 + shipping
Klay Anderson
801-466-3196

Sparta 3310 dual mono audio console, 10 rotary mixers, program, audition & cue outputs, vgc, \$850. R Beierle, KFYR-TV, POB 1738, Bismarck ND 58502. 701-255-5757.

Teac M-09 4 chnl mixing console, vgc, \$120. W Dougherty Jr, WLD Recording, Rt 1 Music Valley, Mill Spring MO 63952. 314-998-2377.

Tascam 312B 12x4x2, less than 20 hrs use, \$3000/BO. B Hansen, WFBM, 3055 S Fourth, Springfield IL 62703. 217-528-3033.

BE 8M20, 8 chnl mono, gd cond, \$450. H Widsten, KGNB, 1540 Loop 337 North, New Braunfels TX 78130. 512-625-7311.

Tapco C-12 portable, stereo, 12 in & 4 out w/manuals, \$1000/BO. D Christian, Pacific Lutheran Univ, 121st & Park Ave South, Tacoma WA 98447. 206-535-7265.

Yamaha PM 700 12x2x2 mixer & PM 400 8x2 mixer, both \$900; UREI 527A 27 band graphic EQ's (2), both \$700. J Krepol, RNDL, 6147 Walker St, Philadelphia PA 19135. 215-624-1050.

Gateway 80 solid state 8 chnl mono, sell or trade. L Fuss, KOOZ, POB 159, Fayetteville GA 30214. 404-460-6159.

RCA BC19A 4 chnl stereo, \$500. L Schrecongost Recdng, POB 1032, Indiana PA 15701. 412-349-5706.

McCurdy SS8550 series custom console, 1980, 12 faders, 3 program busses, timer & dual redundant pwr supply, dist amp outputs, second talent turret, mic on/off/headphone control. B Umberger, WNLT, 51 S Main Ste 957, Clearwater FL 34625. 813-446-0957.

Peavey MK3-16 portable, stereo, \$1000/BO; Quantum Audio Labs QM 1010 16/8 w/some documentation, avail in 10/90, \$2000/BO; Quantum Audio Labs QM 8 portable, stereo, w/manuals, \$500/BO. D Christian, Pacific Lutheran Univ, 121st & Park Ave South, Tacoma WA 98447. 206-535-7265.

RCA BC6B 10 chnl, 2 line console, tube type, fair cond, BO. L Watson, WCDV, 227 E Forest Ln, Palatine IL 60067. 708-997-2525.

BE 4-mixer mono console, \$500. R Coleman, WGEN, Box 67, Geneseo IL 61254. 309-944-4633.

Collins 212-M & 212-S, one mono, one stereo, lots of spare parts & manuals for both, BO. S Carter, WRKN, POB 145, Brandon MS 39043. 601-825-5045.

Teac Tascam 3, like new, 8x4x2, \$500. E Davison, 217-787-0800.

Gates Dualux II 8 chnl w/manual, gd cond, need only one new stereo pot to put in excel cond, \$800/BO pls shpg. C Ibarra, KTAN, 2300 Busby Dr, Sierra Vista AZ 85235. 602-458-4313.

S-I-S T40, 2 chnl parts only, trade for Ampex AG 350 transport parts. B Butler, WELE, 432 S Nova, Ormond Bch FL 32174. 904-677-4122.

Gates Producer w/new replacement pots, dual chnl w/q switch not installed, 4 chnl mono, could modify for stereo or mix minus, \$200. L Beigel, On-Cue Record, POB 85042, Los Angeles CA 90072. 213-466-3595.

Ramsa T820B 20/40 input, full metering, 18 mos old, like new, full EQ on ea chnl, 8/16 buss out, \$5000. R Thomas, Rebel Recdng, 5555 Radio Ln, Jacksonville FL 32205. 904-388-7711.

LPB 4 chnl mono, \$475. S Dynes, Dynes Prod, Wheeling WV 26003. 304-233-8856.

SPOTMASTER BROADCAST ELECTRONICS

—PARTS—
and Accessories

SEQUOIA ELECTRONICS

1131 Virginia Ave
Campbell CA 95008
(408) 866-8434

Sound Workshop Logex 8 16 chnl mixing board w/stand & shelf, BO. D Coffman, WSOR, 940 Tarpon, Ft Myers FL 33916. 813-334-1930.

Micro-Trak Sport III dial-up remote sports mixer, mixes 2 mics, line level & spotter mic, A/C or battery pwr, VU meter, (3) headphone outputs, compact, briefcase format, nice cond. B Fisher, KPOK, Box 477, Bowman ND 58623. 701-523-3883.

Ramsa 8118, 18 in 4 out, mint cond, \$1800. B Ranes, DIR, 32 E 57th, NY NY 10022. 212-371-6850.

Gateway 10 pot board, completely rebuilt. L Popp, 814-467-7894.

McCurdy SS8800 stereo 8 chnl 24 input w/furniture & patch bays, \$3000/BO. B Mitchell, WSYR, 500 Plum, Syracuse NY 13204. 315-472-9797.

Wheatstone Audioarts 8X w/24 input, excel cond, \$9500/BO. D Kocher, DLK Snd Stds, 1901 Hanover, Allentown PA 18103.

SSR 32x8 bi-amp recdng console, less than 1 yr old, \$9500 or possible trade. Funkenstein Recdng Std, 7811 La Cosa, Dallas TX 75248. 214-239-4075.

LPB Signature II S-20 10 chnl stereo, step attenuators w/manual, mint cond, \$2500. S Horner, KKUR, 255 W Stanley, Ventura CA 93003. 805-654-0577.

McCurdy SS8500 Series, 11 stereo faders, 11 machine controls, 4 program busses & meters, digital clock & up/down timer, 4 EQ chnl, XLR I/O wiring & numerous other deluxe features & controls, clean, \$4950. W Clark, 318 E Calhoun, Macomb IL 61455. 309-837-2244.

Peavy Mark III Series 12 chnl, stereo audio mixing board w/case, \$750. W Nauman, WLWJ, 400J Royal Commerce, Royal Palm Beach FL 33411. 407-793-5555.

Gates Gateway 8 chnl mono for parts, BO. E Douglas, KUNQ, POB 30, Houston MO 65483. 417-967-3353.

MOTORS REBUILT

All CART & MCI

We guarantee quiet, flutter free performance when we meticulously rebuild your motor.

Single Decks **\$150.00**

Triple Decks **\$175.00**

MCI CAPSTAN **\$400.00**

MCI REEL **\$200.00**

Metal shaft resurfacing on other motors available.

Audio Magnetic / Professionals



224 Datura Street, Suite 614
West Palm Beach, FL 33401
1 (800) 826-0601
In Florida (407) 659-4805

Authorized
OTARI, SONY, TEAC Parts Dealers

HEADS RELAPPED

All CART & MULTITRACK

You have started to notice a loss of high end, excessive oxide shedding, or possibly even visible signs of wear on your heads. You are now sacrificing your recording quality.

— We recommend our head relapping and assembly alignment services. For a fraction of replacement cost, we guarantee full performance restoration to factory specifications.

— Let us help you "Keep Ahead" in the industry.

Audio Magnetic / Professionals



224 Datura Street, Suite 614
West Palm Beach, FL 33401
1 (800) 826-0601
In Florida (407) 659-4805

Authorized
OTARI, SONY, TEAC Parts Dealers

Circle 127 on Reader Service Card

CONSOLE . . . WTB

BE 4M50 4 chnl mono board, excel cond, manual, \$250. P Russell, Bowdoin College, Sill Hall, Brunswick ME 04011. 207-725-3066.

Norcom Maxi-Tel 4 chnl telephone/remote mixer, rotary dial-up, (4) mic inputs, switchable to line level inputs, (4) headphone outputs, radio monitor in, record out, A/C or battery power. LED clock & timer, \$300. B Fisher, KPOK, 122 S Main, Bowman ND 58623. 701-523-3883.

Bauer 910 8 chnl mono, \$400; Bauer 912 5 chnl stereo, \$400. WJAG, 309 Braasch, Norfolk NE 68701. 402-371-0780.

Audio Interface Systems 8 pot mono dual chnl, one in excel cond & one for parts, \$500/BO. J Linn, WHKS, 62 N Main, Port Allegany PA 16743. 814-642-7004.

Dugan System automatic mic mixers (3) 6x1 auto or manual, 19" rack mount, \$125 ea. D Lundy, Lundy Tape Duplicators, Cumberland Gap Pkwy, Heidrick KY 40949. 606-546-6650.

Maxi-Tel remote sports console & Telex CS-75 Sportcaster headset w/mic, \$275. S Bush, KTKK, 3595 S 1300 W, Salt Lake City UT 84119. 801-264-8250.

McMartin B-500 5-chnl stereo, needs work, \$200/BO. G Fullhart, WVKK, 4665 West Bancroft, Toledo OH 43615. 419-531-1681.

BE 4BEM 50 Spotmaster, w/4 pots, mono solid state; Ramko SC-5M, 5 pot, mono solid state; Ramko DC 8M 8 pot stereo solid state; Collins 212 F-2 6 pot mono tube type. A Garza, Foster Comm, 2524 Sherwood Way, San Angelo TX 76901. 915-949-2112.

BE 8BES100 8 chnl, stereo mixer, spare cards/parts, gd cond, \$550. G Hill, KEWB, 1538 Market, Reading CA 96002. 916-243-5392.

BE 4S-5DA 4 chnl stereo mixer, 12 inputs, monitor, cue & headphones, amps w/manual, excel cond, \$550. G Hill, KEWB, 1538 Market, Reading CA 96002. 916-243-5392.

Broadcast Audio System 20, 12 stereo inputs, P&G faders, 7 band EQ on ea input, 3 stereo outputs, 3 remote inputs addtl on ea fader, ext redund pwr supplies, excel cond, 5 yrs old, \$8200. M Graziano, Cath Comm, 65 Elliot, Springfield MA 01105. 413-732-4546.

Want to Buy

API & Neve consoles, also API & Neve EQs, anything considered, especially API 550A & 550B's. J Kreines, DeMott/Kreines Films, 5330 Kennedy, Millbrook AL 36054. 205-285-6179.

Stereo console, 10 or 12 channel in gd cond, KGHT, 7515 Geyer Springs Rd, Little Rock AR 72209. 501-568-5448.

McCurdy SS8500 spare parts needed desperately, R Gates, KTLG, 1602 S Brownlee, Corpus Christie TX 78404. 512-882-4394.

API & Neve, also EQs, anything considered, especially need API 550A & 550B's. J Kreines, DeMott/Kreines Films, 5330 Kennedy, Millbrook AL 36054. 205-285-6179.

McCurdy 8500, 8600, 8550, 8650; Ward-Berk R1200, R2000; Audiotronics 110, 200 or 300; Harris M-90 or ADM stereo boards. R Dymont, Group D, 8402 Lake Ave, Cincinnati OH 45236.

DISCO & SOUND EQUIPMENT

Want to Sell

JBL 4312 L+R studio mix-down, 3 way monitors, real walnut, like new, balance of 5 yr warranty applies, we pay UPS, \$275 ea. C Keith, ALI, Box 313, Keene NH 03431. 603-352-8460.

JBL 4350 speakers, electrically perfect, need refinishing, new cones, diaphragms w/crossover, \$3200/BO; perfect pair Dynaco ST-70s/PAS-2 preamp, \$375; NAD2140 40 W/wh, mint, \$240. R Nelson, Tropical Bldgct, 14093 SW 142, Miami FL 33196.

JBL 4312 L+R monitors (6), like new, balance of warranty applies, wall packing, we pay UPS, \$275 ea. C Keith, ALI, Box 313, Keene NH 03431. 603-352-8480.

Community Light & Sound RS440 (1 pr) 4-way speakers w/Community VB790 bass bins, in Anvil cases, excel cond, \$1600. J Kreines, 5330 Kennedy Ave, Millbrook AL 36054. 205-285-6179.

Lexicon 200 reverb, mint cond, \$1800; Lexicon Prime Time II, mint cond, \$900; Sony PCM 701, mind cond, \$950. D Kocher, DLK Snd Sids, 1901 Hanover, Allentown PA 18103. 610-261-1111.

Altec Acoustica Voice passive filters, individual & rack mount on 1/3 octave centers, \$5-50. J McLane, 115 W Gutierrez, Santa Barbara CA 93101. 805-963-3941.

Yamaha NS-10 (4) w/remainder of warranty, (2) boxed, (2) open, \$320/pr. C Keith, ALI, Box 313, Keene NH 03431. 603-352-8460.

Westlake RB5M (2), 2 woofers, one mid, one tweeter, pr in vgc, \$1000/pr. B Ranes, DIR, 32 E 57th, NNYN 10022. 212-371-6850.

AKG The Tube, 2 mos old, \$1650; (2) Orban 642B para EQ's, \$650/ea. T Campana, Dan Yessian Music, 33117 Hamilton Ste 175, Farmington Hills MI 48334. 313-553-4044.

Community Light & Sound RS440 4-way speakers, pair, w/Community BV790 bass bins in Anvil cases, excel cond, \$1600 plus shpg. J Kreines, DeMott/Kreines Films, 5330 Kennedy, Millbrook AL 36054. 205-285-6179.

Sequential Circuits 6 trak, all original programs, Midi Arpeggio stacks, cables, excel cond, \$300/BO. N Brecher, Traxx, 192 Keltton, Brighton MA 02135. 617-739-9261.

Fisher MC 708 audio component system; Marantz TT; Audiotronics 132 multi-trk, multi-head large reel machine tape duplicator w/carrying case; xmtr breaker box, 200 VAC 200 A; (6) formica 7 wood turntable cut-outs for Technics SP-15 TT's. A Garza, Foster Comm, 2524 Sherwood Way, San Angelo TX 76901. 915-949-2112.

Eventide H969 Ultra Harmonizer w/warranty card, \$1750; (28) play stereo Scully tape heads, \$25 ea; several Magnecord Presto lapped play heads. S Russell, Russell Music, 60410 Klett Dr, Decatur MI 49045. 616-782-9258.

Mobile DJ system, top quality components w/JBL speakers, complete w/extensive library, SASE for complete list, \$11,000. American Music Formats, 15205 W Lynwood, New Berlin WI 53151. 414-784-5463.

Alesis or LXP-1 stereo digital reverb in gd shape for small recording studio. W Dougherty Jr, WLD Recording, Rt 1 Music Valley, Mill Spring MO 63952. After 5:30 PM. 314-998-2377.

Altec 604-E (pair) in excel cond only; also JBL Paragon wanted. D deForrest, Insight Prod, 7441 Wayne Ave Ste 10-B, Miami Beach FL 33141. 305-866-5401.

FINANCIAL SERVICES

EQUIPMENT FINANCING "LOANS BY PHONE"

- NO FINANCIALS REQUIRED FOR TRANSACTIONS UNDER \$35,000
- NEW OR USED EQUIPMENT
- \$2,000 to \$200,000
- NO DOWN PAYMENT
- SALE-LEASEBACK EQUIPMENT FOR WORKING CAPITAL

TO APPLY OR REQUEST ADDITIONAL INFORMATION CONTACT MARK WILSON

ENF EXCHANGE NATIONAL FUNDING (800) 342-2093 FAX: (214) 235-5452

LIMITERS

Want to Sell

CBS Volumax 410, \$80. B Umberger, WNLT, 51 S Main Ste 957, Clearwater FL 34625. 813-446-0957.

Aphex 700 studio Dominator, less than 20 hrs use. T Jones, KNXR, 220 South Bdw, Rochester MN 55904. 507-288-7700.

Radio Design Labs NRSC A, pre-emphasis & 10 kHz audio filter w/pwr supply & complete manual, \$200. B Fisher, KPOK, Box 477, Bowman ND 58623. 701-523-3883.

Orban/Texar/Kahn, 222A stereo spacial enhancer, slot 5 card to use w/Prisms, Power Side, complete system, BO. D Doughty, H&D Bdct Group, POB 781, Ulica NY 13503. 315-797-1330.

CBS Volumax/CBS Audimax III, rebuilt, \$250/pr. Gates Solid Statesman limiters (2), \$250/pr. H Widsten, KGNB, 1540 Loop 337 North, New Braunfels TX 78130. 512-625-7311.

CBS audiomax 3 compressor, \$80; CBS audiomax 3S, stereo, \$170; Collins 900-F1 FM SCA mon, \$50; Collins 900-C2 FM stereo mon, \$400; CBS DPE-450 dynamic presence EQ, \$80; Sola Line conditioner, 8.34 amps, mdl 6C128, B Umberger, WNLT, 51 S Main, Ste 957, Clearwater FL 34625. 813-446-0957.

CRL PMC 300A in excel cond, replacing w/newer unit, must sell. B Fisher, KPOK, Box 477, Bowman ND 58623. 701-523-3883.

Gentner RCF-1 replacement card #5 for Optimod 8100A when using Prisms, \$300. M Holderfield, WQOF, POB 1427, Dothan AL 36302. 205-792-1149.

Orban Optimod 8000A, gd cond, just removed from service, \$1600. A McEwing, WGLY, RR 1 Box 1040, Waterbury VT 05676. 802-244-5683.

Gates FM Top-Level, stereo, \$75. T O'Laughlin, O's Own Prod, Rt 1 Box 41, Barneveld WI 53507. 608-924-2001.

CRL PMC-300A peak mod controller, \$500. K Lane, KVRP, Box 1118, Haskell TX 79521. 817-864-8505.

CRL Systems FM4G incl SPP-800 stereo preparation processor, (2) SEP-400B's spectral energy processors, SMP-800 stereo mod processor & a SG-800 stereo gen, all in excel cond, 4 yrs old, \$4500. B Dickerson, WEAG, 1421 S Water, Starke FL 32091. 904-964-5001.

CRL SEP-800 audio processing w/book; Orban 674A stereo EQ w/book, all equip in gd cond, BO. L Crumpton, KZZB, POB 20495, Beaumont TX 77720. 409-833-0774.

CRL SMP 900 AM stereo audio processor w/NRSC-1 attachment, \$2500/BO, cash or money order. P Dale Ware, KUTY, Palmdale CA. 805-947-3107.

RCA BA-147 FM mono, \$200. G Liebisch, WPTF, POB 29521, Raleigh NC 27626. 919-876-0674.

UREI BL-40 spare circuit board, \$100. J McLane, 115 W Gutierrez, Santa Barbara CA 93101. 805-963-3941.

Valley People Gain Brain II (2) limiting amps, \$200 ea/BO/trade. J McLane, 115 W Gutierrez, Santa Barbara CA 93101. 805-963-3941.

Optimod 8000A limiter/stereo gen, all lyrics replaced recently & limiter section opamps upgraded to low noise FET types, works great, \$1500. M Heuberger, KTI, POB 409, Peguot Lakes MN 56472.

CRL PMC 300A, excel cond, \$400. S Manuel, WWJB, 55 W F1 Dade, Brooksville FL 39601. 904-796-7469.

UREI BL-40 Modulimiter, gd cond, w/manual, \$100/BO; CBS Volumax 4000A, working when removed, w/manual, \$75/BO. S Carter, WRKN, POB 145, Brandon MS 39043. 601-825-5045.

Gates FM Top-Level, excel cond, \$75; Lauderdale Electronics program lock, mono, excel cond, \$75. F Fess II, WLRB, POB 250, Macomb IL 61455. 309-833-5561.

Gentner RCF-1 replacement card #5 for Optimod 8100A when using Prisms, \$300. M Holderfield, WQOF, POB 1427, Dothan AL 36302. 205-792-1149.

UREI 530 9 band EQ, stereo, looks bad but works, \$50. F Fess II, WLRB, POB 250, Macomb IL 61455. 309-833-5561.

Radio Design Labs NRSC A w/pre-emphasis & 10 kHz audio filter w/pwr supply & manual, \$200; CRL PMC 300A, excel cond. B Fisher, KPOK, Box 477, Bowman ND 58623. 701-523-3883.

CRL SEP 400A & PMC 300, two each, excel cond, \$600 ea; Kahn stereo exciter w/pwr side tuned to 1140 kHz, excel cond. G Arroyo, WONQ, 2483 John Young Pkwy, Orlando FL 32804. 407-293-0000.

Dukane Medallion dynamic range limiter, chrome face 19" rack mount, +4 & +10 lim & gate, \$150. D Lundy, Lundy Tape Duplicators, Cumberland Gap Pkwy, Heidrick KY 40949. 606-546-6650.

CRL PMC 300A set-up w/Radio Design Labs NRSC 1 pre-emphasis & 10 kHz audio filter to meet NRSC 1 standards, complete manuals, \$750. B Fisher, KPOK, Box 477, Bowman ND 58623. 701-523-3883.

Aphex 102A type C dual chnl aural exciter, still under warranty \$170. J Ellingson, Ellingson Voice-Overs, 913 Warwick, Cedar Falls IA 50613. 319-277-8535.

UREI BL-40 Modulimiter (2), excel, \$300 ea. M Persons, KKN, Box 930, Aitkin MN 56431. 218-829-1326.

Marti CLA-40H compressor/limiter, \$100. E Douglas, KUNQ, POB 30, Houston MO 65483. 417-967-3353.

Collins 26U-1 peak limiter in gd cond. A Terry, WODY, Box 545, Bassett VA 24055. 703-629-5900.

Gates Solid Statesman AGC's (2), \$250/pr. H Widsten, KGNB, 1540 Loop 337 North, New Braunfels TX 78130. 512-625-7311.

Harris MSP-90 dual chnl AGC/compressor, \$800/BO. J Linn, WHKS, 62 N Main, Port Allegany PA 16743. 814-642-7004.

Optimod 8000A \$1495 & UP 414-482-2638

CBS Labs Audimax stereo limiter, 1 side chnl not working; Universal Audio BL-40 Modulimiter; Dorrough DAP 310 audio processor. A Garza, Foster Comm, 2524 Sherwood Way, San Angelo TX 76901. 915-949-2112.

Orban Optimod 8000A in excel cond, low hrs, used as backup, \$1200. L Maierhofer, WTGC, 101 Armory Blvd, Lewisburg PA 17837. 717-523-3271.

Aphex aural exciter type 3 2 chnl stereo single rack space, excel, \$175. B Fisher, KPOK, 122 S Main, Bowman ND 58623. 701-523-3883.

CRL APP-300A, BO; CRL PMC-300A, BO; Pacific Recorders Multi-Max audio compressor/limiter mdl MXIAM, BO; Auto-Jock for automation, \$1000. Mandel, KAMP, POB 1018, El Centro CA 92244. 619-352-2277 between 7-8 AM or 12-1 PM.

CRL PMC 300A peak mod controller, \$450. W Nauman, WLJL, 400J Royal Commerce, Royal Palm Beach FL 33411. 407-793-5555.

Want to Buy

Optimod 8100A (2). R Roberts, KPUP, 1188 Padre Dr, Salinas CA 93901. 408-758-5400.

Orban 8100, D Brooks, WCIC, 3263 Court St, Pekin IL 61554.

Fairchild 660 or 670, Teletronix LA2A, LA3, other tube compressors & limiters; & other vintage tube signal processing equip. J Kreines, 5330 Kennedy Ave, Millbrook AL 36054. 205-285-6179.

Dorrough DAP 310 w/serial nos. 500-1000. B Moenig, 77 Bayberry Ct, Glen Mills PA 19342. 215-558-1670.

Audio Prism, latest pair for stereo operation; Orban 8100A in gd/vgc. D Schaberg, WTHM, POB 21055, Lansing MI 48909. 517-393-1037.

Orban Optimod 8100A, M Cooney, Bdct Mgmt, 610 N Kiwanis, Sioux Falls SD 57104. 605-336-2706.

Tube limiters, compressors & EQs, especially Fairchild 660 & 670, Teletronix LA2A & LA3A; any Pultec EQs or NAVECS; Lang, Sontec & API EQs, etc; also other tube signal processing equip. J Kreines, DeMott/Kreines Films, 5330 Kennedy, Millbrook AL 36054. 205-285-6179.

Orban 8000A Optimod, gd cond, H Voss, WJLY, Rt 2, Ramsey IL 62080. 618-423-2635.

dbx 117 or 119 consumer stereo compressor in gd working cond. Glenn, 1105 Turtle Creek, Paso Robles CA 93446.

MICROPHONES

Want to Sell

AKG LBB super shotgun, perfect, belt pack PS, full case, response certification, fantastic pattern, \$480. L Watson, WCDV, 227 E Forest Ln, Palatine IL 60067. 708-397-2525.

RCA 44-A on original desk stand, vgc, \$575/BO; RCA 77DX on orig desk stand, \$500/BO; RCA 74 JRs (2), gd cond, need ribbons, \$150; EV RE 16, \$75; EV RE 55, excel, \$80. Kremer Kraft, 301 SW 16th St, Ft Lauderdale FL 33315. 305-524-5652.

EV RE-16 dynamic mics w/case & stand clip, excel cond, \$125/ea or \$225/pr. C Butler, Butler Bdct Srvc, 1775 Bartlett Ave, Orange Pk FL 32073. 904-264-8169.

Sennheiser MD-421 dynamic mics w/case & stand mount, mint cond, \$225/ea or \$400/pr. C Butler, Butler Bdct Srvc, 1775 Bartlett Ave, Orange Pk FL 32073. 904-264-8169.

AKG 451-Eb condenser mics w/case, wind-screen & stand clip, mint cond, \$250/ea or \$450/pr. C Butler, Butler Bdct Srvc, 1775 Bartlett Ave, Orange Pk FL 32073. 904-264-8169.

Shure SM-61's in vgc w/cases & windscreens, \$160/pr. W Dougherty Jr, WLD Recording, Rt 1 Music Valley, Mill Spring MO 63952. 314-998-2377.

Synchron AU7A, mint cond, w/custom pwr supply for 2 mics, w/documents. R Robinson, 203-269-4465.

RCA SV, works, want to trade for other gear; also F1, SCO2000, trade for Casio DA-2 DAT, T Hill, WBJC, 2901 Lib Hgts Ave, Baltimore MD 21215. 301-396-0404.

EV RE20, \$375. B Hansen, WFMB, 3055 S Fourth, Springfield IL 62703. 217-528-3033.

EV 1776 (2), (2) extra batteries, gd cond, \$100/both. R Swan, WROY, POB 400, Carmi IL 62821. 618-382-4161.

RCA 44BX, 74B, 77DX, Brush Sound Cell crystal; Eastern sound ribbon mdl 50, BO individually or for lot. P Weber, Weber Studio, 102 Southgate Blvd, Melbourne FL 32901. 407-724-9590.

Altec Bird Cage (2); WE 8 Ball; EV 647 vintage mics, BO. M Massey, WKHX, 360 Interstate N, Atlanta GA 30339. 404-955-0101.

Schoeps CMTS-501 coincident stereo mic, switchable multipattern capsules for M-S or X-Y stereo, new, \$1795; (2) Shure 300 bi-directional ribbons, new, \$165 ea; Schoeps MK-3 omni capsule, new, \$285. C Richardson, Richardson Recd, 1938 Baltimore Annapolis Blvd, Annapolis MD 21401. 301-757-3733.

Schoeps MK-8 bi-directional capsule, new, \$475; (2) Shure SM-18 surface mount mics, new, \$49 ea; Shure SM-89 shotgun mic, new, \$649. C Richardson, Richardson Recd, 1938 Baltimore Annapolis Blvd, Annapolis MD 21401. 301-757-3733.

Norelco D119CS/200, \$10; GE CB mic, \$10; Altec 570B, \$20; RCA BK-5B, \$200; RCA BK-1A (2), one has base, other has boom mount, \$25 ea; RCA shotgun mic, \$25. S Dynes, Dynes Prod, Wheeling WV 26003. 304-233-8856.

Microphones approx 30 from home studio incl AKG 414, \$350 ea, 451, \$200 ea, D-190, \$60, D-224, \$180, Sennheiser 441, \$275, 421, \$175, Shure SM-81, \$225 ea, SM-61, \$85, mdl 300, \$100, many others from EV, Beyers, Altec, Sony & Ramsa, call for complete list & prices. K Peckham, 5824 Danville Dr, Madison WI 53719. 608-271-8763.

Sennheiser ME80/K2U spot mic w/extra ME80 head, like new, \$275; MKE10-3 tie clip mic module, new, \$75. E Davison, 217-787-0800.

Altec 639 ribbon & dynamic classic, w/yoke & connectors complete, \$550. L Beigel, On-Cue Record, POB 85042, Los Angeles CA 90072. 800-726-9813.

HME professional VHF wireless mic system, System 85 mic, RX-722 rcvr & Excalibur carrying case, \$495. W Clark, 318 E Calhoun, Macomb IL 61455. 309-837-2244.

Ross RM-7HC/C, uni-directional perfect, cord w/1/4" plug, cover, N Brecher, Traxx, 192 Keltton, Brighton MA 02135. 617-739-9261.

EV 664, BO. E Douglas, KUNQ, POB 30, Houston MO 65483. 417-967-3353.

AKG C460B preamp w/CK-22LS cardioid & CK-4 figure eight capsules, \$550 plus shipping. D Glasser, Airshow Inc, 7021 Woodland, Springfield VA 22151.

MICROPHONES . . . WTB

Want to Buy

Vintage tube condenser mics, Neumann, Telefunken, Schoeps, AKG & classic ribbon mics, RCA 77s, 44s; Telefunken ELAM 250s or 251s, any cond; AKG C12s & C24s, any cond; Neumann U47, U48, M249B, KM56, U67, etc, any cond. J Kreines, Demott/Kreines Films, 5330 Kennedy Ave, Millbrook AL 36054. 205-285-6179.

Vintage mics by Altec, Neumann, Sony, RCA, etc. Kremer Kraft, 301 SW 16th St, Ft Lauderdale FL 33315. 305-524-5652.

RCA, Neuman, Schoeps, AKG, Telefunken & other makes of vintage mics, any cond or parts, stands & call letter plates, will buy or have mics to trade. R Van Dyke, Caffrey House, 2 Squires Ave, E Quogue NY 11942. 516-728-9835.

Telefunken ELAM 250 & 251; AKG C12/C12A, C24, C60; Neumann U47, U48, M49, M50, KM56, U64, U67, SM2, SM69, SM269, etc; also other pro condenser mics incl Neumann U87, U89, TLM170, RSM190, SM69 fet, U47 fet, AKG 412, 414; ribbon mics; also wrecked mics w/missing parts in any cond. J Kreines, DeMott/Kreines Films, 5330 Kennedy, Millbrook AL 36054. 205-285-6179.

Classic mics, EV, Telefunken, Neumann, etc, will trade. G Titcomb, Easy St Recdg, 2 Easy St, Woodbury CT 06798. 203-263-0785.

Original RCA 77-DX mic desk stand; also need pattern ID plate for back w/2 screws. C Lund, Cycle Sound & Video, 167 Madison, Waterbury CT 06706. 203-756-7761.

Neumann Z40, Z140, Z240 matrix transformers. E Kelly, Mobile Master, POB 61, Glenelg MD 21737. 301-596-9101.

RCA 44's, 77's, WE & other ribbon mics, working or not. B Davies, Virgo Prod, 5548 Elmer Ave, N Hollywood CA 91601. 818-761-9831.

RCA 44 or 77 velocity mics, complete & functional only, send details, price. D deForrest, Insight Prod, 7441 Wayne Ave Ste 10-B, Miami Beach FL 33141. 305-866-5401.

Four threaded lower collars, pipe thread & compression springs & rings for RCA 74-B mics. C Lund, Cycle Sound & Video, 167 Madison, Waterbury CT 06706. 203-756-7761.

Neumann SM 69 or SM 69fet, p'efet SM 69fet w/NS69 power supply/remote control, satin finish, no swivels, will trade Neumann TLM 170. E Kelly, Mobile Master, POB 61, Glenelg MD 21737. 301-596-9101.

Will buy or trade for RCA 4A condenser mike no major missing parts please. J Webb, 15117 Hamlin, Van Nuys CA 91411. 818-769-6738.

MISCELLANEOUS

Want to Sell

Connecticut readers: tag sale 9/22-23/90 for a Gates Stereo Steteman, Klipsch Cornwalls, RCA mono cart R/PS, Phase Linear amps & much more, send SASE for complete list & directions. Doc Rock Productions, 3700 Durham Rd, Guilford CT 06437.

1975 Coachmen 22' camping trailer converted to mobile unit, tandem axle, (2) TT's, console, internal & external sockets, AM/FM monitor, heatpump, range, refrigerator, \$2750. C Sigmon, WBZK, POB 398, York SC 29745. 803-684-4241.

Extel AH11R solid state printers (2), vj working cond, standard size paper, approx 25 new spool ribbons & all power cords, sold separately or together. A Wasilewski, KMWX, POB 1460, Yakima WA 98907. 509-248-1460.

Kato 50 kW 3 phase generator, Perkins diesel engine w/50 gallon day tank, less than 50 hrs running time, \$20,000/BO or trade for 25 or 35 kW FM xmtr. P Parks, KYKR, 27 Sawyer, Beaumont TX 77703. 409-838-3911.

Pelco VS508H 8-position sequential CCTV switcher, new, original packing, \$600/BO. A Allegra, Calvary Baptist Church, 1380 Valley Forge, Lansdale PA 19446. 215-368-4444.

Tandy Mdl II computer, keyboard, 3-drive expansion bay, \$400. C Sigmon, WBZK, POB 398, York SC 29745. 803-684-4241.

Extel AH/PIIR teleprinter, like new cond w/stand, BO. J Anderson, WKCO, 2192 Hwy 72 East, Corinth MS 38834. 601-286-6451.

TIE E300C 13 line TT phone w/schematics, new, \$50; TIE E100C 5 line key phone 1A2 type, rotary, new w/schematics, \$30. E Davison, 217-787-0800.

WE modern style portable magneto phones (2), \$100/pr; wall phone, red, single number dialer, new, \$50. E Davison, 217-787-0800.

Executone Equity-1 telephone key system, 30 phones, KSU's, KTU's, etc, \$1800. A Allegra, Calvary Baptist, 1380 Valley Forge, Lansdale PA 19446. 215-368-4444.

TIE/GTE 60012G office telephone system, 4 incoming w/7 stations & KSU, \$2500. J Brown, Joyner Comm, 2000 Regency Pkwy Ste 450, Cary NC 27512. 919-469-8383.

WE 111C repeat coils, \$25 ea; 120H, \$15 ea; 23A 5 kHz EQ, \$25. E Davison, 217-787-0800.

FREE 56-PG CATALOG

Complete line of audio modules and accessories for all engineered sound & broadcast applications



MODULAR AUDIO PRODUCTS
1-800-333-7697
1-516-345-3100
FAX 516-345-3106
DIV. OF MODULAR DEVICES INC
1 RONED RD • SHIRLEY NY 11967

Circle 91 on Reader Service Card

UMC 40 H-85 cart motor, cap 1.5 MFD, 117 V, 60 Hz phase 1, 25 W, 600 rpm, hysteresis synchronous cart motor, \$125; patch bay, \$75; Spotmaster TPI-A cart winder, \$200; ADC patch cord, stereo (2), \$10 ea. S Dynes, Dynes Prod, Wheeling WV 26003. 304-233-8856.

Switchcraft 1/4" balanced patch bays, some normalled, \$60 ea; West Penn 291 2 conductor shielded cable, all or part of 1800, new, 8¢/ft. B Petruzzi, Rouse St Prod, 13727 Sylvan Ste 11, Van Nuys CA 91401. 818-780-4572.

Ampex motor for an Ampex R-R hyst syn 77, cont VF-5.0 PH1, 0.4 Amp, 60 Hz, 117 V, \$45; ADC PJ 22 patch cord wire assembly, stereo, \$10; Weston 308 amp meters (2), \$5 ea; table mount gooseneck, \$15; EV 1-666, \$10. S Dynes, Dynes Prod, Wheeling WV 26003. 304-233-8856.

CPT 8520 word processor w/monitor, (2) built-in 8" disk drives, keyboard, program & utility disks, (5) extra disks, user's manual, letter quality printer, (5) extra print wheels, muffler hood w/fan for printer, \$350/BO. R Woolfenden, WFAX, 18322 Cabin Rd, Triangle VA 22172. 703-221-2742.

Rotron Blowers for Elcom, CCA, CSI, McMartin, rebuilt & new. Goodrich Enterprises Inc., 11435 Manderson St., Omaha, NE 68164. 402 493 1886 FAX 402 331 0638

IGM & Teletype PAL encoding system, FSK, complete w/teletype 33 printer/reader & manuals, working cond, recently removed from service, BO. D Gander, KDUZ, Box 10, Hutchinson MN 55350. 612-587-2140.

Audion Proxima 6 rare near-field lower monitor (2), excel cond, without EQ or subwoofer module, will include EQ schematic, \$395/BO plus UPS. V Gray, CCA, 6840 Sterling, Raytown MO 64133. 816-358-8929.

TM Master plan library; also misc radio & office equip from station that has gone out of business. L Popp, 814-467-7894.

Onan 75 kW propane type, 3-phase w/transfer panel, BO. Eddie, KCFX, 10800 Farley Ste 310, Overland Park KS 66210. 913-661-0101.

Kato 50 kW 3 phase AC generator, 151 A at 208-240 V, supercharged diesel engine w/less than 150 hrs operation, spare voltage regulator, \$12,000. P Parks, KYKR, POB 5488, Beaumont TX 77726. 409-838-3911.

Extel AH11R printer for parts or repair, \$30; Hygain scanner, works gd, \$30. WJAG, 309 Braasch, Norfolk NE 68701. 402-371-0780.

Ruslang RL-500 tape transport, blk/woodgrain finish wcasters, \$100. P Parks, KLV1, 27 Sawyer, Beaumont TX 77702. 409-838-3911.

Andrew dehydrator, BO. Eddie, KCFX, 10800 Farley Ste 310, Overland Park KS 66210. 913-661-0101.

Vaco modems (2) units for sending data on telco dial up lines. C Murray, KMG E, 925 Country Club Rd, Eugene OR 97401. 503-484-9400.

Extel 1 AF 11 R printer w/stand & book; GE AP printer; Smith Corona 101 universal tractor feed. A Garza, Foster Comm, 2524 Sherwood Way, San Angelo TX 76901. 915-949-2112.

Harmon-Kardon mixers, new DPR7; Meissner mixer five inputs-battery; Cannon plugs, 3 prong, male & female; 40 new tubes & resistors cheap; Lafayette TE22 audio gen; Sencore transistor & diode tester; manuals for Ampex, Puftec, Altec & others. Mr. Oliver 212-874-7660 in afternoons.

Grampian cutter heads, 1D feedback (tandberg); patch bays (4) 24 inputs single, also patch cords; Daven 600 ohms attenuators (silent) (8) excel; Presto 6N cutter lead screws; Editorial blocks for recorders 1/2"; EV 12TRX speakers (2) & cabinets. Mr. Oliver, 212-874-7660 in afternoons.

Want to Buy

Blind & paralyzed young man would like donations of any receiver or word processor, call or write. R Les, 5909 W 6th St, Apt 1, Los Angeles CA 90036. 213-938-5347.

Early WWII vintage radar equip, complete systems and or pieces. A Weiner, 14 Prospect Dr, Yonkers NY 10705. 914-423-6638.

Equip necessary for construction of upgrade to 5 kW AM daytime directional on 1380 KHz including Continental/Harris 5 kW xmtr, 5 kW 2-tower phasing unit in cabinet & antenna tuning units, 180° guyed tower, 16-20" face, (2) tower phase monitor, Delta CPB-1 common point bridge, Delta OIB-1 operating impedance bridge, 5 or 10 kW AM dummy load, (2) Delta TCA-10 & TCA-20 RF ammeters w/current transformers, etc, if you have any of the equip needed for this upgrade call between 8:30AM & 10PM, leave name, number, equip description & asking price. 512-696-5615.

WE, Altec, RCA speakers; old mics, tube mixers, consoles, limiters, amps, 16" transcriptions, on-air lights, blank recdg discs, bcdt/recdg catalogs, magazines, manuals, mic flags. R Van Dyke, Caffrey House, 2 Squires Ave, E Quogue NY 11942. 516-728-9835.

AM-RF around 1400 kHz, EBS decoder, plug in mods for Gatesway II mono console. Bill, 904-678-8943.

Jazz record collections, 10" LP 1/2" LP bebop, swing, dixie, highest prices paid. B Rose, Program Recdgs, 228 East 10th, NNYN 10003. 212-674-3060.

MONITORS

Want to Sell

Harris FT-80 FM mod mon, 104.9 MHz, \$450; Harris FS-80 FM stereo mon, 104.9 MHz, \$450. R Coleman, WGEN, Box 67, Geneseo IL 61254. 309-944-4633.

McMartin TBM-3500 FM, cond unknown, \$50; Gates GTM-88F freq, cond unknown, \$125. C Sigmon, WBZK, POB 398, York SC 29745. 803-684-4241.

TFT 730A SCA subcarrier mod mon, \$900/BO. D Lerner, 115 W 23rd, NNYN 10011. 212-463-0798.

Modulation Sciences Mod-Minder, used 2-3 hrs, complete w/software, BO. H Plumlee, WGAP, POB 4939, Maryville TN 37802. 615-983-4310.

Belar SCM-1 SCA mod mon, 92 kHz, excel. M Persons, KTLF/KFML, 70 N.E. 1st Ave, Little Falls MN 56345. 218-829-1326.

QEI 675T200 RF & SWR monitor & PA voltage & amp monitor, fwd & rev SWR switch, 19" rack mount, 3" high, translator & up to 200 W use, \$125. S Lawson, KAK Prod, 928 Hyland, Santa Rosa CA 95404. 707-528-4055.

ITC CART II
(Formerly Scotch Cart II)



Call Us For The Best Prices On The Best Cart!

HE HALL Electronics
(804) 974-6466

General Radio Type 1931-A was operational when removed. BO. A Terry, WODY, Box 545, Bassett VA 24055. 703-629-5900.

FM mod mon, stereo in gd working cond. R Lark, WXCE, Box 1260, Amery WI 54001. 715-268-7185.

Want to Buy

Any older McMartin mod monitors. C Goodrich, 11435 Manderson, Omaha NE 68164. 402-493-1886.

MOVIE PROD EQUIP

Want to Sell

Nagra III internal xtal, rolloff filter, Sennheiser 805 w/KAT 15, leather case, ATN pwr supply, excel cond, \$1350; & new Bell & Howell 70 DR w/Anvil case, 1" Comsat, instructions, \$325. J Kreines, 5330 Kennedy Ave, Millbrook AL 36054. 205-285-6179.

Nagra III, internal xtal, roll-off filter, Sennheiser 805 w/KAT 15, leather case, ATN pwr supply, excel cond, \$1350; New Bell & Howell 70 DR w/Anvil case, 1" Comsat, instructions, \$325. J Kreines, DeMott/Kreines Films, 5330 Kennedy, Millbrook AL 36054. 205-285-6179.

Want to Buy

Mitchell 35 & 16mm cameras & accessories, other professional 16/35mm cameras, incl Arri-flex, Aaton, CP, etc; optical printers, Research Products 1000, 1001, & Acme & Oxberry; cine lab equipment; upright Moviolas, especially 35mm. Westrex 35mm; optical recorders, & RCA & Maurer optical recorders; CP16s any condition; good cine optics (Zeiss, Ultra-T, Angenieux, Cooke, etc); also need Zeiss 9.5mm Distagon, reasonable, need not be mechanically mint. J Kreines, DeMott/Kreines Films, 5330 Kennedy Ave, Millbrook AL 36054. 205-285-6179.

Film cameras & accessories, especially Arri-flex, Bolex & Eclair, also film sound items, Nagra & Stellavox recorders, reasonably priced editing & lighting equip. H Biller, 108 Hamilton, Silver Spring MD 20901. 301-565-2798.

EMPLOYMENT

To place ads in this section, use the ActionGram form. To respond to box numbers, write Radio World, PO Box 1214, Falls Church, VA 22041, Attn:

POSITIONS WANTED

News reporter in mkt 192 seeks move up, 2 yrs exper in AC/News talk, strong anchor skills, conversational, East Coast but will consider. Matt, 919-452-1133.

Bdct eng would like to do repair & new work, FM only in NW Virginia area, 25 yrs w/FM sta's. V Pat, Box 232, Weyers Cave VA 24486.

Radio Vet w/22 yrs exper, seeks on-air w/C&W or AC in South Georgia, gd references. B Rachels, 516 Colton, Thomasville GA 31792.

Eleven year pro seeking work in Midwest'n, solid background in news, sports (P-B-P) & programming. Sam, 218-894-3395.

Looking for PT engineering work in the greater Mobile AL area. C Strozier, 205-928-9406.

Sports anchor/PBP w/16 yrs exper in small mkt seeks position in medium or major mkt in Texas, sports pro. D Blanton, 817-665-0765.

Audio engineer w/4 yrs exper seeking position in Eastern Ohio or Western PA, serious inquiries only. M Anderson, 412-847-0111.

Dedicated pro seeking air/MD position, country & proud of it, will consider all offers. Bryan, 904-478-5321.

Dedicated announcer, 7 yrs exper seeks medium/large market challenge, creative, prefer oldies/classic, AC, jazz, also interested in music/promotions/production director position, relocateable. Phil, 6773 Mara Ave 29, Pains CA 92277. 619-367-7371.

Energetic, reliable PD/AT seeks position, AM/FM oldies/classic rock in Southern coastal/FL region. Todd, 919-455-2202/6000.

Experienced & reliable sportscaster/announcer seeks sports director position in IA, IL, or WI, football, basketball, baseball PBP, production, will relocate. Robert, 319-652-6640 or 319-242-1252.

Engineer/Newsman/GM w/20 yrs exper in all areas of radio, seeks Florida position, gd references. Bill, 803-245-4902 (PM) 245-2411 (days).

Entry level position w/community based AM or FM bdct, prefer family minded station, willing to learn your way of doing things, some prior exper. Looking for rural area, CO, WY, NC, KY, WV, but open. Steve, 1240 Riverbreeze Blvd, Ormond Bch FL 32176. 904-441-6956.

CE w/big production voice & over 15 yrs of hands-on eng exper, seeks position w/production in a competitive top 100 market. G Morgan, 704-563-8676.

Program/Announcer, worked South FL major markets, 5 yrs on air, 20 yrs related, creative voices, prod skills, Gospel stations included, all formats, markets, open relocate correct offer, owner chain, create own niche, will program Gospel. V Harris, 305-758-3732.

GM w/26 yrs exper, looking for NE small market. K Watts, POB 152, Big Flats NY 14814. 607-562-7522.

Operations director/PD, knowledgeable about all facets of radio, 20 yrs exper, oldies, country, AC or newstalk formats preferred. Stacy Richardson, 918-835-2777.

FCC licensed engineer, 29 yrs exper seeking contract work, studio/xmtr design, construction, maint. D Parrish, 813-772-5875.

Have a construction permit? I will get you on the air...construction/hiring/training air & sales staff/programming. Will do programming changes for existing stations. Ritchey Communications, 512-828-9252.

HELP WANTED

Chief Engineer for Shamrock Communications Maryland AM/FM. Applicants should have strong organizational skills. SBE Certification desired. Send resume to Mark Timpany, WQFM, 606 West Wisconsin Ave, Milwaukee WI 53203. EOE.

BROADCAST AUDIO SALES, CONSOLES
Expanding sales team looking for self motivated individual. Engineer/technician experience in operation/architecture of audio consoles a must. Sales ability, computer operation, and knowledge of manufacturing helpful. Broadcast knowledge required. Send resume to: WHEATSTONE CORPORATION, 6720 VIP Parkway, Dept. E, Syracuse NY 13211 (No calls, please)

Metroplex Robinson Communications, Inc. is seeking a qualified technical director for WUFW/WXBX, Buffalo. Strong studio construction & transmitter maintenance skills a must. Minimum 5 years broadcast technical experience & SBE certification required. Contact Dennis Sloatman at 407-298-5510 or send resume to: Metroplex Communications, Inc., 2001-N Mercy Dr, Orlando FL 32808. Equal Opportunity Employer.

Chief Technician. Studio, audio, RF, modern AM daytimer, new FM, automation, satellite, RPU's, two-way repeater. Benefits. WTGC/WUNOS POB 592, Lewisburg PA 17837. 717-523-3271.

EMPLOYMENT SECTION

HELP WANTED: Any company or station can run "Help Wanted" ads at the flat rate of \$25 per listing per month (25 words max). Payment must accompany insert; there will be no invoicing. Blind box numbers will be provided at an extra charge of \$5. Responses will be forwarded to listee, unopened, upon receipt. Call 800-336-3045 for display rates.

POSITIONS WANTED: Any individual can run a "Position Wanted" ad, FREE of charge (25 words max), and it will appear in the following 3 issues of Radio World. Contact information will be provided, but if a box number is required, there is a \$5 fee which must be paid with the listing (there will be no invoicing). Responses will be forwarded to the listee, unopened.



Mail To: BROADCAST EQUIPMENT EXCHANGE
PO Box 1214, Falls Church, VA 22041



WE'RE BUYING!
INTERESTED???

Then call Jim or Chuck
@ 317-962-1471 @
ALLIED EQUIPMENT EXCHANGE

BUY We selectively buy used radio equipment
SELL We sell used and new radio equipment
TRADE We take trade-ins for used and new radio equipment

Allied has served broadcaster needs since the 60s! Our veteran broadcasting salesmen will "horse trade" with you—give them a try today!

HARRIS ALLIED EQUIPMENT EXCHANGE
317-962-1471

CONSULTANTS

EVANS ASSOCIATES
Consulting Communications Engineers

FCC Applications, Design & Field Engineering
Broadcast Engineering Software

216 N. Green Bay Rd.
Thiensville, WI 53092

(414) 242-6000
Member AFCCE

W. LEE SIMMONS & ASSOC., INC.

BROADCAST TELECOMMUNICATIONS CONSULTANTS

1036 William Hilton Pkwy
Ste 200F
Hilton Head Is., SC 29928

(803) 785-4445

SOFTWARE
FM CHANNEL SEARCH

FM Database pool
MSDOS
EGA Graphics-Color
Broadcast Technical Consulting

V Doug Vernier
Broadcast Consultant
1600 Picturesque Drive
Cedar Falls, IA 50613
319-266-8402

MAGRILL ENGINEERING
Radio Engineering Consultants

FCC Applications • Upgrades
Pre-purchase evaluations
Station planning & Design
Turnkey systems • Field service

Experienced, Economical & Fast

(904) 591-3005

Barry Magrill P.O. Box 1010
President Fairfield, FL
Member IEEE 32634

Rp Communications
Robert Cham
Telecommunications

FCC Application Preparation
Custom Audio Console
Design & Modification
Digital & Analog Recording
& Broadcast Facilities Design
High Quality Field Recording

77 1/2 Intervale Ave.
Burlington, VT 05401

802-862-7447

NEW

**WE NOW ACCEPT
VISA &
MASTERCARD**



new station construction field service AM directionals

RON KROB
broadcast technical consultant

4910 Four Star Court
Fort Collins, CO 80524 303 484 2704

RADIO SYSTEMS ENGINEERING

FCC Applications • Design
• Installation • Field Service

Experienced & Affordable

4289 Roanridge
Las Vegas, Nevada 89120

**24 Hr: (702) 454-2085
FAX: 702-458-2787**

Moffet, Larson & Johnson, Inc.
Consulting Telecommunications Engineers

Two Skyline Place
5203 Leesburg Pike # 800
Falls Church VA 22041

703-824-5660
800-523-3117

Member AFCCE

THIS SPACE AVAILABLE

Call Simone Mullins
at 1-800-336-3045

AVIATION CONSULTANTS

- FAA Obstruction Analysis
- FM EMI Evaluations
- Expert Witness Service
- Tower Marking & Lighting

WALTER WULFF & Assoc.
(404) 881-6786
P.O. Box 77028
Atlanta, GA 30357

MEYER GOTTESMAN
Broadcast consultant/engineer

FM, TV and LPTV applications. Frequency studies, transmitter field service, etc. We go anywhere! Former CE Boston, Houston, Miami and Ft. Lauderdale. Former HARRIS transmitter field engineer.

3377 Solano Ave., #312
Napa, CA 94558

Tel: (415) 221-2000 (anytime)
FAX (415) 387-2425 (days)

Consulting Communications Engineers

- FCC Data Bases
- FCC Applications and Field Engineering
- Frequency Searches and Coordination
- AM-FM-CATV-ITFS-LPTV

OWL ENGINEERING, INC.

1306 W. County Road, F,
St. Paul, MN 55112
(612)631-1338 "Member AFCCE"

Huntsville Antenna Engineering

There is hope for AM radio!
AM station unipole antennas with circular polarization & beam tilt. Broadband your present AM tower Series R shunt fed.

205-353-9232 205-353-6747

Kenneth Casey
Consulting Radio Engineer

GOODRICH enterprises, inc.
Parts and technical service for all MCMARTIN TRANSMITTERS, CONSOLES EXCITERS, RECEIVERS TRANSMITTER AND INDUSTRIAL TUBES.

11435 Manderson St.
Omaha, Nebraska 68164 U.S.A.

PH:010-1-402-493-1886 FAX:010-1-402-331-0638
TELEX: 940103 WUPUBTLX BSN

DISPLAY YOUR CONSULTANT'S CARD HERE AND BE SEEN BY OVER 21,000 READERS

SERVICES

FM TRANSMITTERS
3.5, 12, 20, 25KW
\$24,000 TO \$46,000

FM-AM Transmitter Installation
Maintenance and Field Service

BROADCAST EQUIPMENT
REFURBISHED & REPAIRED

BROADCAST TECHNICAL CONSULTANT

TELO TECHNOLOGY
Stanwood, WA. 98292
206-387-3558

FCC's Engineering
AM, FM and TV Data Bases for your PC

Call today to request a free sample

Communications Data Services

6105 E Arlington Blvd
Falls Church VA 22044
(703) 534-0034

Steven L. Delay
AM/FM Broadcast Field Service

International & Domestic

Ground Systems	Field Intensity Measure
Broadcast Studios	Turnkey Transmitting Facilities
Construction	AM Directionals
Microwave	Purchase Evaluations

RR1-236 Pawnee, IL 62558
24 HR. 217-498-7339
FAX 217-498-8197

CLOUD NINE BBS

300 to 19200 Baud
N-8-1
Multi-Node System

(713) 855-4382

FCC Information
On-Line Call Sign Search
On-Line Engineering Formulas
Messages, Conferences, Files, Doors

THIS SPACE AVAILABLE

Call Simone Mullins
at 1-800-336-3045

BROADCASTING & ELECTRONIC SERVICES LABS
PO BOX 178
NEWTON, UT 84327
801-563-3088

BROADCAST EQUIPMENT
REFURBISHED & REPAIRED
AUDIO, VIDEO, RF, DIGITAL

15 YRS EXPERIENCE

SPECIALIZING IN ERECTION, REPAIRING, PAINTING AND MAINTENANCE RADIO, TWO-WAY, T.V. TOWERS AND FLAG POLES

A STEEPLJACK CO.
PAINTING AND STEEPLJACK CONTRACTORS

FULLY INSURED FOR YOUR PROTECTION

DON HIGHLEY 3722 ROMA
713-462-6105 HOUSTON, TEXAS 77080

THIS SPACE AVAILABLE

Call Simone Mullins
at 1-800-336-3045

MIRKWOOD ENGINEERING

Rural & Remote Site
Field Engineering

50 Park Ave.
Claremont, NH 03743

603/542-6784

T & W

Tower/Antenna
Erection • Maintenance
• 24 Hr. Emergency Service •

Hurlock, MD
301-376-3555

TENCO TOWER

Lic. No. 357096

Installation & Maintenance of
Broadcast & Communications
Towers & Antennas

Donald J. Tenna

(916) 362-6846
(916) 638-8833
FAX: (916) 638-8858

9723 Folsom Blvd. Suite A
Sacramento, CA, U.S.A. 95827

PARAMOUNT
COMMUNICATION • SYSTEMS

INSTALLATION AND SERVICE OF BROADCAST ANTENNA SYSTEMS/TOWER MAINTENANCE & ERECTION

WESTMONT, NJ (609) 869-0222

WIDEST & FINEST CHOICE OF PRODUCTION MUSIC & SFX

PROMUSIC

Call For Our Free Demo & Information On
BROADCAST Plus
Annual Rates.

1-800-322-7879

RF Components

Field phasing
modifications
and installation

Call Dave Gorman
215-249-9662
POB 401
Dublin PA 18917

THIS SPACE AVAILABLE

Call Simone Mullins
at 1-800-336-3045

CONTACT RADIO WORLD NEWSPAPER FOR AVAILABILITIES.

P.O. Box 1214 • Falls Church VA • 22041

1-800-336-3045

World Radio History



MOVIE . . . WTB

Mitchell 35 & 16mm cameras & access, other prof 16/35 mm cameras, incl Arriflex, Aaton, CP, etc; optical printers, esp Research Products 1000, 1001, Acme & Oxberry; Cine lab equip incl ultrasonic cleaner; small to medium size 16 or 16/35mm processing machines; upright Moviolas, especially 35mm; Westrex 35mm optical recorders, RCA & Maurer optical recorders; CP16s any cond; Steenbecks; gd cine optics; Zeiss 9.5mm Distagon, will consider any film equip. J Kreines, DeMot/Kreines Films, 5330 Kennedy, Millbrook AL 36054. 205-285-6179.

RECEIVERS & TRANSCEIVERS

Want to Sell

Motorola Micor FM 2-way transceiver less accessories, mdl T43RXA1900AA, 162-174 MHz, 12 VDC, \$150. B Dickerson, WEAG, 1421 S Water, Starke FL 32091. 904-964-5001.

GE Phoenix SX & GE MPI handheld, hand-held charger stand & belt case, one has mobile mike & one has base mike, dual freq, 460-470 UHF, \$1600/BO. T Trotzer, KGY, POB 1249, Olympia WA 98507. 206-943-1240.

AM STEREO RECEIVERS
Portable, Home/Studio, Auto
RRADO GROUP
708-843-8481

Two-way radio, hand-held & mobile UHF radios for shows or remotes, can put on your freq, Icom, Motorola, GE, some fancy, some simple, from \$175. R Nelson, Tropical Bdcg, 14093 SW 142, Miami FL 33192.

Dynakit FM-3 tube tuner, \$100; Pilot 380 tube stereo tuner, \$90; MacIntosh MR71 stereo tube tuner in Panico case, near mint cond, \$400; Knight KN 2560 tube CB, excel, \$75; Gonsset communicator III orig manual & bill of sale, nice works, \$65. Kremer Kraft, 301 SW 16th St, Ft Lauderdale FL 33315. 305-524-5652.

Hammarlund VHF transceiver, 35 W, cond unknown, \$50. C Sigmon, WBZK, POB 398, York SC 29745. 803-684-4241.

Swan 240 rcvr for SSB, covers 75, 40 & 20 meter band power of 200 W, complete w/DC mobile & AC pwr w/Hustler mast, spring & resonators, for 40 & 20 meters, \$175/BO. T Spencer, WODY, Box 545, Bassett VA 24055. 703-629-2509.

Scientific Atlantic decoder 7300 wideband BPSK rcvr, excel cond. L Popp, 814-467-7894.

High quality micro-miniature 67 kHz SCA decoder, about 1" square, prewired & ready to install, \$15. D Jackway, 5742 Fairoak, Springfield MO 65810. 417-881-1846.

Motorola VHF radios, one 15 W Moxby base PL, one 15 W Mocom 35 busy, (3) HT210 5 W handhelds w/chargers, PL, like new, \$100 ea. P Russell, Bowdoin College, Sills Hall, Brunswick ME 04011. 207-725-3066.

Bogen TP200 digital tuner, AM/FM mono/stereo, new, \$200; Bogen TP50 mono AM/FM tuner, new, \$100; 450 MHz mobile RF amp, TPL mdl UD-6AC-7, 1-15 W, \$100. E Davison, 217-787-0800.

Motorola two-way system, not working, BO. E Doubias, KUNQ, POB 30, Houston MO 65483. 417-967-3353.

McMartin TR-66A SCA rcvr. WGER, 6165 Bay Rd, Saginaw MI 48604. 517-792-1063.

Kenwood TH-21 1 W 2 meter hand-held w/service manual, \$25. P Russell, Bowdoin College, Sill Hall, Brunswick ME 04011. 207-725-3066.

Want to Buy

Fairchild Dart 384 satellite receiver w/15 kHz card & down converter. P Reilly, KGRC, POB 1017, Hannibal MO 63401. 314-221-2221.

REMOTE & MICROWAVE EQUIP

Want to Sell

Rust 108-1C & 108-0C studio & transmitter remote control units w/manuals, \$500. A Garza, Foster Comm, 2824 Sherwood Way, San Angelo TX 76901. 915-949-2112.

**(2) Gentner SPH3A
(1) Gentner SPH3
(3) Gentner Hybrid Coupler
Good Condition
\$1500/all
Klay Anderson
801-466-3196**

Marti RMC-2AX dial up type remote control unit, works w/phone line or SCA, complete studio/xmtr units w/manual, \$495. J Moore, KENO, Box 388, Roswell NM 88201. 505-625-2098.

Wilbur 7-30-357/367 35' heavy duty telescoping mast w/12 V compressor, braces for rear bumper installation, video showing mounting & operation avail, all in gd cond, \$3000. B Peretic, WYED TV, 919-553-1700.

Wegener 1806-03 Ku-Band downlink incl dish, excel cond, BO. J Bartels, KANO, 100 E Main, Anoka MN 55303.

**- NEW AND USED -
Satellite Receive Only
ANTENNAS
PLUS! Receivers/Demodulators**

- Wegener
- Fairchild
- Harris
- Scientific-Atlanta
- Microdyne
- Avcom
- Prodelin

**For ALL Network Affiliations
WE BUY • SELL • TRADE
Flexible Lease Financing!
TELCOM GROUP INTL
PH. (505)883-4737 FAX (505)889-0078
OVERNIGHT DELIVERY AVAILABLE**

Microdyne/Scientific Atlanta 5 meters satellite receive antenna (3), one w/dual feed, one w/two simulast dual feeds & one SIA Cassegrain dual feed, \$1000/BO. M Comer, Box 1285, Colonial Beach VA 22443. 804-224-9711.

Symetrix TI-101 (2) telephone interface/hybrids, like new, \$450/both or \$250 ea. M Holderfield, WOOF, POB 1427, Dothan AL 36302. 205-792-1149.

Burk TC-8 remote control w/dialup & voice (2), wire modem, excel cond, 1 yr old, \$2000/BO. M Black, WEOS, Hobart College, Geneva NY 11436. 315-781-3456.

Harris 6550 satellite rcvr chassis w/PS & down converter, no demod cards, mint cond, \$400. H Widsten, KGNB, 1540 Loop 337 North, New Braunfels TX 78130. 512-625-7311.

ABC Network decoder, excel cond, \$200; interface for Revox deck for auto rec w/above, \$100. M Black, WEOS, Hobart College, Geneva NY 11436. 315-781-3456.

Anderson satellite switcher, works w/any satellite music network format, like new cond, \$200. B Hearst, WWCH, POB 688, Clarion PA 16214. 814-226-8600.

Tel-E-Mote Darks 60 remote phone, \$35. S Dynes, Dynes Prod, Wheeling WV 26003. 304-233-8856.

Symetrix TI-101 (2) telephone interface/hybrids, like new, \$450/both or \$250/ea. M Holderfield, WOOF, POB 1427, Dothan AL 36302. 205-792-1149.

Wegener gear for Transtar/Unistar oldies chnl, will work for AM only & Format 41 w/minor changes, \$3500/BO. M Wilson, WGRK, POB 246, Greensburg KY 42742. 502-932-7402.

Symetrix TI-101 telephone interface, new, BO. H Plumlee, WGAP, POB 4939, Maryville TN 37802. 615-983-4310.

ABC Network tone decoder, \$200. M Holderfield, WOOF, POB 1427, Dothan AL 36302. 205-792-1149.

Burk Technology TC8 remote control system w/radio modem uplink & telemetry return, perfect cond, \$1800. Mary Clites, WCBC, POB 1290, Cumberland MD 21502. 301-724-5000.

Marti SGC-10 92 kHz SCA gen, excel; Marti R30-150 RPU rcvr, \$200. M Persons, KLTF/KFML, 70 N.E. 1st Ave, Little Falls MN 56345. 218-829-1326.

Comrex LXT, LXR, TCB single line extender package, \$4500. J Gennaro, WFHR, Box 8022, WI Rapids WI 54495. 715-424-1300.

Wegener 1606 sat rcvr for SMN Star station, 1606-10 down converter, 1606-01 wideband demod, 1645 & 1646 tone decoders, 1605-03 pwr supply, 1601 main frame, \$1500. J Macke, KRBS, POB 5180, Roseburg OR 97470. 503-672-6641.

Moseley TRC-15 system for studio & xmtr, excel cond; 10 channel master satellite dish, vgc. L Popp, 814-467-7894.

LAUX satellite system w/(2) 8705 audio terminals, LNA LC0106, 70 MHz downconverter, (2) runs of 25-30' ea of RG/59 U coax, 9' parabolic dish for 4 GHz, w/books. A Garza, Foster Comm, 2524 Sherwood Way, San Angelo TX 76901. 915-949-2112.

Moseley PCL 505/C type approved, stereo composite, tuned to 949.500 MHz, set, BO; Moseley PCL 505/C type approved, stereo composite, tuned to 951.5 MHz, set, BO. Eddie, KCFX, 10800 Farley Ste 310, Overland Park KS 66210. 913-661-0101.

Terracom TCM-7 TV microwave link on 13 GHz, \$4900. T Hopkins, Cape Fear Enter, Rt 1, Box 269-A, Faison NC 28341. 919-594-0172.

Marti, RPT-25P & R-50450 UHF remote pickup xmtr & rcvr, setup for telemetry operation, \$995. W Clark, 318 E Calhoun, Macomb IL 61455. 309-837-2244.

Scientific Atlanta 7300 & 7325 digital audio rcvr & processor unit w/1 dual 15 kHz & 1 voice cue decoder, like new, \$5950. W Clark, 318 E Calhoun, Macomb IL 61455. 309-837-2244.

Modulation Assoc ASAT freq agile SCPC satellite rcvr, \$1200. S Bush, KTKK, 3595 S 1300 W, Salt Lake City UT 84119. 801-264-8250.

Marti RR30/150 receiver tuned to 161.70 MHz, \$450. E Douglas, KUNQ, POB 30, Houston MO 65483. 417-967-3353.

Marti STL-8 STL xmtrs & rcvrs. WGER, 6165 Bay Rd, Saginaw MI 48604. 517-792-1063.

Micro Controls PTS-10C composite STL systems, 949.0 MHz, excel, \$2000. M Persons, KKIN, Box 930, Aitkin MN 56431. 218-829-1326.

Anixter Mark STL dish, 8', 6', 4' & mini reflector, call for details, BO. Eddie, KCFX, 10800 Farley Ste 310, Overland Park KS 66210. 913-661-0101.

Silver Lake Audio
now has available for rental:
3-LINE COMREX
2-LINE COMREX • PORTABLE DAT
plus much more at reasonable rates!
Call Steve for details
(516) 623-6114

Want to Buy

Any FSR, Gentner, Telos, telephone hybrid coupler, gd quality, donations acknowledged. A Allegra, Calvary Baptist Church, 1360 Valley Forge, Lansdale PA 19446. 215-368-4444.

Satellite uplinks, modulator, HPA, 2° compliant antenna, prefer K-band. U George, U.G. Satellite TV, 314 W 52 St, NY NY 10019. 212-677-2200.

Rust Series F mdl RI-108 needed for parts, any cond. J Goeman, KJAM, 1015 Eagan, Madison SD 57042. 605-256-4514.

Marti VHF RPU freq close to 161.70 otherwise any will do, could use xmtr & rcvr. J Boswell, 205-222-8849.

75 kHz dual audio card for Fairchild/Comtech Dart 384 digital satellite rcvr, or will trade 15 kHz card for same. S Bush, KTKK, 3595 S 1300 W, Salt Lake City UT 84119. 801-264-8250.

Ku-band TV satellite uplink, MPA, exciter, etc, truck unnecessary. U George, Satellite TV, 314 W 52nd, NY NY 10019. 212-677-2200.

STATIONS

Want to Sell

AM daytimers (2), WFIC, Collinsville-Martinsville VA, 1 kW & WPUV, Pulaski VA, 5 kW, includes real estate, owner financing. L Williams, Rt 1 Box 314, Wirtz VA 24184. 703-647-1530.

Combo AM/FM & stand alone FM stereo, Class A, some financing avail to qualified buyer, real estate included, \$925,000. G Shurden, 601-843-4091.

BROKER

**AM AND FM RADIO STATIONS
HAVE BUYERS AND SELLERS
FINANCIAL PACKAGE AVAILABLE**

1-813-747-7373

**ALL INFORMATION
CONFIDENTIAL**

Upper Midwest FT AM w/FM possibility, owner financing, gd stable medium market, must be financially qualified before any information is released. 1-404-460-6159.

AM and/or FM radio stations for sale in central Arkansas or will sell percent to active working partner. Vivian, 501-420-1525 or 501-568-5448.

FM Class A Oklahoma single market, nearly new equip, long lease on studio & xmtr tower needs owner-operator & sales exper, less than \$100,000 to qualified w/low down, \$99,500. Joyce Erway, KRMK, Cordell OK 73632. 407-283-6871.

Investors for new FM stations in Midwest & West Coast, must have minimum of \$50,000 cash investment. Dale, 1-715-836-9476.

**SOUTHEAST UHF-TV with additional income property—\$3,200,000; AM/FM middle Georgia incl. Real Estate—\$215,000. Call for comprehensive prospectus on these and other broadcast properties. Let us assist you in investing your media properties.
THE JESSE NEAL BROWDER CO. INC.
404-928-7906
BROADCAST BROKERS APPRAISERS**

Class A FM w/CP to upgrade to 50,000 W, located half way between Jackson & Nashville TN, near the Loretta Lynn Dude Ranch, must sell immed due to health reasons, \$200,000, terms avail to exper bdctr w/gd credit & bank ref, serious inquiries only. B Coleman Jr, WIST, POB 460, Lobelville TN 37097.

Want to Buy

Private investor will fund new stations or acquisition of existing stations, must show gd potential debt or equity investment. M Ernst, WBUD TV, 720 Fairhill Dr, Louisville KY 40207. 502-893-6656.

Looking to buy w/nothing down, also consider becoming GM for equity & future ownership. L Haber, POB 136, Woburn MA 01801. 617-246-5634.

WANTED
Silent AM or FM Stations
CP's or Turnarounds
Brokerage, Management,
Financing, & Equipment
Available
414-482-1959

CP's, turn arounds & dark stations. L Fuss, KOOZ, POB 159, Fayetteville GA 30214. 404-460-6159.

LPTV or small market AM, dark or troubled OK, owner financing w/little or no down. B Turner, 1000 E Third, Del Rio TX 78840.

AM, FM or LPTV problem stations, turn arounds, daytimers, dark, etc, send complete details w/price & terms. J Powley, 1536 Logan, Altoona PA 16602. 814-944-8571.

AM or FM, Midwest-California-Nevada only, owner financing, small down. D Ganske, 1-715-832-0691.

Joplin MO super A FM, \$290,000 firm. D Stubblefield, 417-781-1100.

FM or AM/FM, previous ownership & turnaround expert, looking for owner-financed turnaround in MW or South, successful husband/wife team. B Kramer, American Forces Network-Europe, APO New York 09757.

AM, FM or TV, problem stations, turnarounds, daytimers, dark, etc, bdctr seeking new challenge, send complete details w/price & terms. J Powley, 1536 Logan Ave, Altoona PA 16602. 814-944-8571.

AM or FM, little or nothing down, prefer Southeast, consider any, 20 yrs exper. J Dalton, 703 N Webster, Taylorville IL 62568. 217-824-7342.

Small AM or FM station for sale or take over in US w/small down or complete buyout, dark stations given equal consideration, trying to turn into family operation. S Neumann, 1240 Riverbreeze Blvd, Ormond Beach FL 32176. 904-441-6958.

Exper owner seeks new TV stations, troubled or dark & CP's, full power & low power, outright sale or joint venture. M Ernst, WBUD TV, 720 Fairhill Dr, Louisville KY 40207. 502-893-6656.

AM or FM, dark or troubled OK, owner financing w/little or no down. E.M., POB 652, Mishawaka IN 46544.

STEREO GENERATORS

Want to Sell

Moseley SCG-9 stereo gen, \$500. R Coleman, WGEN, Box 67, Geneseo IL 61254. 309-944-4633.

SWITCHERS (VIDEO)

Want to Sell

Echolab SE-2 w/keyer, matte, \$600/BO. R Jensen, MPI Productions, 5812 21st St, Racine WI 53906. 414-632-3131.

TAPES, CARTS & REELS

Want to Sell

Metal reels & boxes, (28) 14" in perfect cond, \$140. H Widsten, KGNB, 1540 Loop 337 North, New Braunfels TX 78130. 512-625-7311.

Nortronics 9125, 9102, 9103 (2) complete sets, play, record, erase, mono for Ampex 350-351, new. D Agnes, WCLV, 26501 Emery Ind Pkwy, Warrensville OH 44128. 216-464-0900.

Easy Listening music library, new, 113 instrumental, 86 vocal, \$1000; Beautiful music library, older, 129 vocal/instrumental, \$200. R Coleman, WGEN, Box 67, Geneseo IL 61254. 309-944-4633.

Fidelipac carts (580), all lengths & conds, extra shells & parts, tape in gd to poor cond, most shells are usable, gray carts, \$500/all. H Widsten, KGNB, 1540 Loop 337 North, New Braunfels TX 78130. 512-625-7311.

Complete nostalgia/big band format w/2780 stereo cuts on 129 metal reels of Ampex 406, includes 10 reels of big band era Christmas music, comes w/extensive reel sheets, artist, title separation schedules, runs on (3) 10.5 machines, in perfect cond, \$30/reel or trade for equip. S Callahan, WFTI, 1120 Pinellas Bayway, Tierra Verde FL 33715. 813-866-3544.

AC vocal CD library, great variety of artists, many are Greatest Hits albums; new NAC instrumental CD library, light jazz & new age artists, sold as libraries not individual discs, half price. Nancy Grubbs, KAT-G, 3910 IH 35 South, Ste 300, Austin TX 78704. 512-448-0947 or fax 512-440-0947 for lists.

**A&D
Cartridge Rebuilding
Service**
We clean, load & pack. Serviced within 10 work days! Work guaranteed!
**3380 Bakely Ave., Eau Claire, WI 54701
(715) 835-7347**

Video cassettes, (100) 3/4", various lengths, \$3 ea/BO. D Staats, WRZZ, POB 1346, Parkersburg WV 26102. 304-863-3319.

Fidelipac gray cart shells (170) w/complete cart except tape & pressure pad, \$1.25 ea or \$200/all. S Dynes, Dynes Prod, Wheeling WV 26003. 304-233-8856.

Easy listening music, 250 reels in vgc, no dupes, \$10 ea; production library w/SFX, mostly unopened, \$250. J Wenstrom, Wynne Bdcg, 503-882-4656.

Scotchcart Big Band/Nostalgia, complete, stereo, 1500 units plus software to rotate, \$7500/BO. W Schroeger, WRCH, Radio Park, Farmington CT 06034. 203-678-9100.

Metal reels, 14" (28) in boxes, perfect cond, \$140. H Widsten, KGNB, 1540 Loop 337 North, New Braunfels TX 78130. 512-625-7311.

Fidelipac carts (600), all lengths, extra shells & parts, gray carts, \$500/all. H Widsten, KGNB, 1540 Loop 337 North, New Braunfels TX 78130. 512-625-7311.

Complete library of movies & cartoons, 265+ titles, all on VHS tape, \$175 plus shipping. D Dobrowolski, WSSM TV, POB 9089, Downers Grove IL 60515. 708-963-3795.

Want to Buy

Blank, small hole recording discs, 10" & smaller, used in 1940's & 50's, aluminum, glass or cardboard base OK. T Edwards, KOZY, Box 597, Grand Rapids MN 55744. 218-326-3446.

Sound effects CD library, call w/list & price. L Beigel, On-Cue Record, POB 85042, Los Angeles CA 90072. 800-726-9813.

45 RPM records from the 50's & 60's, major label records stored in sleeves in vgc, small label records considered on case by case basis, entire libraries bought. B Berry, Karavan Bdcg Svc, 13 Montgomery Pl, Conroe TX 77384. 409-273-2801.

Old bdcg transcriptions, RCA Thesaurus, red label, circa 1935-6. Joe Green Marimba orch, standard radio 12 or 16", Gene Assin Trio, circa 1933-4. R McDonald, 5231 Horson, Mission KS 66202. 713-722-2677.

Jingles used by NBC affiliates for the News and Information Service format in early 70's, usually supplied on (2) 7" reels. R Meyers, Benchmark Comm, 4700 SW 75 Ave, Miami FL 33155. 305-995-1717.

**RAMKO DC-5RA
5 POT RACK MOUNT
DUAL MONO CONSOLE**



**Completely Rebuilt
90 Day Warranty
Great for News & Remotes**

**HE HALL
Electronics
(804) 974-6466**

Capps or other hot stylus kit for Presto 80-G recording lathe; Van Epps R-D-2 instruction manual/information needed to set-up, gd photo copy OK. C Lund, Cycle Sound & Video, 167 Madison, Waterbury CT 06706. 203-756-7761.

NAB alignment tape, 15 ips. D deForrest, In-sight Prod, 7441 Wayne Ave Ste 10-B, Miami Beach FL 33141. 305-866-5401.

RCA, Presto disc record

TRANSMITTERS! TRANSMITTERS! TRANSMITTERS!

AT LAST!

Quality Rebuilt AM & FM Transmitters Delivered, Matched To Your Antenna, and Placed On The Air. And, For No More Than You'd Pay For a Transmitter In Pieces From The Other Guys.

When you buy a BTS transmitter, we deliver it on our company truck. We place it in your transmitter building. And, the *very best* transmitter engineer in America places it on the air for you. When we're finished, you know how it will sound because it's On the Air. No other way of buying a used transmitter makes sense. Overseas and Alaskan/Hawaiian services are available, too!

We'll take your old transmitter and other broadcast gear in trade!

Complete turnkey station construction available!

Broadcast Transmission Systems
7008 Lock Lommand Austin, Texas 78749
(512) 448 - 0058

Circle 58 on Reader Service Card

Tek 380 WF vectorscope, NTSC monitor, never used, \$3500. R Ose, 317 S Butterfield, Libertyville IL 60045. 312-856-2620.

Sound Technology AN-1 stereo simulator, \$350. M Persons, KKIN, Box 930, Aitkin MN 56431. 218-829-1326.

Tek 1410 NTSC test gen w/modules, \$2900; Tek 529 waveform monitor, \$325. T Hopkins, Cape Fear Enter, Rt 1 Box 269-A, Faison NC 28341. 919-594-0172.

HP 3550B test set incl HP audio oscillator, HP patch panel & HP DB meter, excel cond, \$500. G Arroyo, WONO, 2483 John Young Pkwy, Orlando FL 32804. 407-293-0000.

Sencore VA62 signal gen/analyzer w/VC-63 video head test accessory, \$2600. L Teffeteller, KPCC, 1570 E Colorado, Pasadena CA 91106. 818-578-7132.

HP 654A test oscillator & 334A distortion analyzer, both w/fresh calibration, \$1700/both. B Hildebrand, Computraffic, 8604 Hedgebur, St Louis MO 63114. 314-427-2727.

Tek 504 oscilloscope, vgc, strong tube, \$300/BO. B Baker, Pinetucket Recdng, 747 Wire Rd, Auburn AL 36830. 205-826-0390.

Nems-Clarke Type 120E field intensity meter in gd cond. M Ripley, KOZE, Box 936, Lewiston ID 83501. 208-743-2502.

Want to Buy

Complete board A3, reciprocal amp for HP 8690B sweeper; also want 8698B & 8699B plug-ins. Herb, CFQC TV, 216 First Ave N, Saskatoon, Sask S7K 3W3, Canada. 306-249-1656.

TRANSMITTERS

Want to Sell

Jetronic USN-TDD-5 25 W AM set to your freq, gd cond, w/book & cabinet, ready to use, \$450. J Cunningham, KEOR, Rt 2 Box 113B, Stonewall OK 74871. 405-265-4496.

MARTI STL-8's
Discreet \$1995
414-482-2638

Collins 1000 W 20V3 in excel cond, on air at 980 kHz, w/manual, \$5100. C Sigmon, WBZK, POB 398, York SC 29745. 803-684-4241.

RCA BTF-5D 5 kW FM xmtr tuned to 94.9 MHz, less exciter, working when removed as auxiliary xmtr. M St Cyr, 3565 29th SE, Grand Rapids MI 49512. 616-949-8760.

Harris/Gates TE1 exciter, great cond, w/SCA gen, \$650. A McEwing, WGLY, RR1 Box 1040, Waterbury VT 05676. 802-244-5683.

LEASING AVAILABLE ON USED TRANSMITTERS
AMERICAN BROADCAST FINANCIAL CORPORATION
414-482-2638

Sintronics SJ-A-IS 1 kW solid state AM, worked when removed 4 yrs ago, spare parts, boards, manuals, BO. B Bowin, WBCC, POB 789, Bucyrus OH 44820. 419-468-2326.

1 W dual output translators (2) plus 10 element Yagi antennas, gives ERP of 16 W in 2 directions, \$2500 ea. J Landon, WCOO, 501 N Goodlette C-204, Naples FL 33940. 813-434-5557.

Continental 802A exciter, like new; McMartin B910 exciter w/stereo gen & SCA gen, low price; Moseley MRC-1600 remote control, new w/full warranty, priced at cost; Shively 6810, 8-bay w/heaters, mid-band. (816) 635-5959.

8E FM 3.5A w/FX-30 exciter, upgrading to C2, will remove 9/90. B Bailey, KJEF, POB 1248, Jennings LA 70546. 318-824-2934.

BE FM3.5A APC for FM 3.5A xmtr, tested but unused, new cond, \$1000/BO. R Ripley, RNI, 41-22 149th Pl, Flushing NY 11355. 718-961-6463.

Johnson Thunderbolt, classic tube 1 kW linear exciter, all tubes, gd cosmetics, \$600/BO. Kremer Kraft, 301 SW 16th St, Ft Lauderdale FL 33315. 305-524-5652.

Harris 1976 FM 2.5 H3 2500 W FM w/TE-3 exciter w/stereo gen, spare driver tube, new, (2) finals, \$8000. R Parker, WTAZ, 332 Detroit, Morton IL 61550. 309-263-0102.

Harris STX-18 AM stereo exciter, Harris STM-18 AM stereo monitor, both operating true C-QUAM system, excel cond. B Bailey, KJEF, POB 1248, Jennings LA 70546. 318-824-2934.

ARMSTRONG TRANSMITTER

FINEST REBUILT TRANSMITTERS

We're the leading re-manufacturer of transmitters worldwide.

Transmitters are available:

- Tuned & Tested on YOUR Frequency
- Guaranteed and Installed
- Completely Re-manufactured
- Expedited Service Available

Trade-Ins gladly accepted - **WE DELIVER!**
See your choice in transmitters WORKING in our huge new showroom BEFORE you take it home!



**NO ONE ELSE OFFERS YOU THIS!
SEE & TEST IT ALL YOU WANT!**

ARMSTRONG TRANSMITTER CORP.

5046 Smoral Road Syracuse NY 13031
Phone 315-488-1269 FAX 315-488-1365

Circle 101 on Reader Service Card

TEST EQUIPMENT . . . WTS

Cushman CE-5 service monitor, 512 MHz AM/FM w/deviator & wideband preselector plug ins, mint, \$1050; Ballentine 500 MHz freq counter, 0.1-10 sec gate, \$125; Davis 7208, 600 MHz freq counter, \$100; Tek RTM 502, new, \$265. R Nelson, Tropical Bdcg, 14093 SW 142, Miami FL 33192.

HP 205AG audio osc & HP 330B dist anal, tube type, \$125/both; Daven type 6E transmission set, \$50. M Cramer, WGBA, 1291 N Road, Green Bay WI 54307. 414-494-2626.

Tektronix 520 vectorscope, strong tube, rackmount, recent recalibration, \$900. G Sive, Video Connection, 31844 Rancho Amigos, Bonsall CA 92003. 619-749-7662.

Gold Line Loft TS-1 audio test set, osc, counter, dB meter, like new, \$150. E Davison, 135 N Illinois, Springfield IL 62702.

B&K 820 digital capacitance meter, vgc, \$125. J Wenstrom, Wynne Bdcg, 503-882-4656.

Tektronix 1L30 spectrum analyzer plug-in, 1.0-10.4 GHz, 105 dBm sensitivity at 20 kHz dispersion, for Tektronix 530, 540 & 550 series oscilloscopes, also incl a Narda micro-line coaxial directional coupler mdl 22836 w/20 dB down pickoff, \$800. B Dickerson, WEAG, 1421 S Water, Starke FL 32091. 904-964-5001.

TEST EQUIPMENT

Why Buy When You Can Rent?
POTOMAC, DELTA, BIRD.
Other Equipment Available
Call For Rates and Availability

RADIO RESOURCES

1-800-54-RADIO
1-800-547-2346
301-783-0737

Conar 255-2 solid state oscilloscope, hor/vert inputs, Z-axis input, 14 sweep speeds, 11 voltage ranges, int/ext/line trig, w/manual & schematics, \$200. S Mattingly, WWWO, 5216 Bradburn, Muncie IN 47304. 317-289-9500.

HP 400D VTVM, like new, \$100. F Fess II, WLRB, POB 250, Macomb IL 61455. 309-833-5561.

Tek 475-A scope w/manual, probes, stand, excel cond. C Richardson, Richardson Recdng, 1938 Baltimore Annapolis Blvd, Annapolis MD 21401. 301-757-3733.

FINEST REBUILT TRANSMITTERS

FM TRANSMITTERS

1 kW	Gates	FM1B
1 kW	ITA	1000B
1 kW	RCA	BTF1D
1 kW	Collins	B30D1
1 kW	RCA	BTF1E
1 kW	Harris	FM 1H
2.5kW	Collins	B31D1
2.5kW	Continental	B14R2
3 kW	RCA	BTF 3E
3 kW	G.E.	3KW
3.5kW	B.E.	3.5A
3.5kW	McMartin	BF 3.5K
5 kW	RCA	BTF-5D
5 kW	RCA	BTF-5E
10 kW	RCA	BTF10D
10 kW	Gates	FM10B
10 kW	Harris	FM 10H
20 kW	CCA	20,000E
20 kW	Collins	B31G1
20 kW	RCA	BTF-20E1
25 kW	Wilkinson	25000
25 kW	McMartin	BF25K
25 kW	Harris	FM-25K
30 kW	McMartin	BF30K

AM TRANSMITTERS

250W	RCA	250GL
1 kW	Gates	BC1F
1 kW	Gates	BC1T
1 kW	Gates	BC1J
1 kW	CCA	1000D
1 kW	Collins	20V2
1 kW	Collins	B20D1
1 kW	McMartin	BF-1K
1 kW	Harris	MW-1A
1 kW	Bauer	707
1 kW	Gates	BC-1G
5 kW	Gates	BC5E
5 kW	RCA	BTA5T
5 kW	Collins	21E
5 kW	RCA	BTA-5L
5 kW	Harris	BC-5H
5 kW	Wilkinson	5000E
5 kW	Collins	B20E/F
5 kW	Gates	BC-5P2
10 kW	RCA	BTA10H
10 kW	Harris	BC-10H
50 kW	RCA	50G
50 kW	GE/Canada	50KW
50 kW	Continental	317B

ARMSTRONG TRANSMITTERS
5046 Smoral Road
Syracuse, NY
(315) 488-1269
FAX (315) 488-1365

LPB AM-30/TCU-30 30 W on 830 kHz w/coupler for carrier current, excel cond, \$700/BO. S Neumann, Neu-Comm, 1240 Riverbreeze Blvd, Ormond Beach FL 32176. 904-441-6956.



High performance at affordable prices.

- New front panel programmable composite STL's.
- New directly programmable FM composite receivers
- New options for synchronous boosters and translators
- New FM exciters, transmitters, amplifiers: 2W to 30kW
- Same old price, quality service and reliability

Bext, Inc.

739 Fifth Avenue.
San Diego, CA 92101
619-239-8462
Telex 229882 Fax 619-239-8474

Circle 70 on Reader Service Card

Bird Termaline 8745-677 20 kW water cooled dummy load w/3-1/8" EIA flange, \$750. G Liebisch, WPTF, POB 29521, Raleigh NC 27626. 919-876-0674.

TTC XL1FM2 FM translator, dual 1 W amp, (2) Scala antennas & cables, BO. G Thomas, WMSI, 1375 Beasley Rd, Jackson MS 39206. 801-982-1062.

Gates FM-250-C tuned to 92.1 MHz, used as back-up, working when removed in 7/90, exciter not included, operates on single 4CX-250B tube, buyer to pick-up or pay for shipping, BO. T Murray, WROJ, 100 W 9th St, Ste 306, Rochester IN 46975.

Collins 20V2 1 kW AM, exceptionally clean, wired for remote w/remote equip, \$3500. K Crosthwait, WTNN, 13206 Buttermilk, Knoxville TN 37932. 615-531-2297.

McMartin 2.5 kW AM, vgc. L Popp, 814-467-7894.

Elcom Bauer 15 W exciter, 6 mos old, will tune to your freq, \$2500/BO. V Michael, WHTO, 575A Montgomery Pk, S Williamsport PA 17701. 717-323-8200.

TRANSCOM CORP.

Fine Used AM & FM Transmitters, and Also New Equipment

For the best deals on Celwave products, Andrew cable, Shively & Comark antennas.

1978	CCA 2500R, 2.5 kW FM	1986	Cont. 314R1, 1 kW AM
1975	Harris FM5H3, 5 kW FM	1974	Harris BC1H1, 1 kW AM
1983	Wilkinson 10000E, 10 kW FM	1981	McMartin BA2.5K, 2.5 kW AM
1980	Harris FM10K, 10 kW FM	1979	Harris MW5A, 5 kW AM
1972	CCA 20,000DS, 20 kW FM	1966	Cont. 315B, 5 kW AM
1973	RCA BTF 20E1, 20 kW FM	1980	McMartin BA5K, 5 kW AM
1972	Harris/Gates FM20H3, 20 kW FM	1972	CCA AM5000D, 5 kW AM
1983	Wilc. 25000E, 25 kW FM	1967	Gates BC5P2, 5 kW AM
1976	CCA AM 50,000D, 50 kW AM	1972	RCA BTA 10U, 10 kW AM

201 Old York Rd. • York Plaza Ste 207
Jenkintown PA 19046
215-884-0888 • FAX No. 215-884-0738

PETER DAHL CO.

Save \$\$

Heavy Duty Replacement Transformers, DC Filter chokes and capacitors for AM & FM transmitters manufactured by: AEL, CCA, CSI, COLLINS, CONTEL, CONTINENTAL, BAUER, GATES, GE, HARRIS, ITA, McMARTIN, RAYTHEON, RCA, SINGER, SINTRONIX, WILKINSON. Many other models also available.

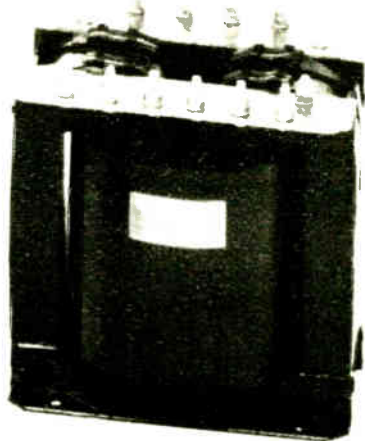

FAST Delivery and FREE Technical Support.



5869 WAYCROSS AVENUE EL PASO, TEXAS 79924
(915) 751-2300 TELEX: 76-3861 PWDCO
FAX: (915) 751-0768

Circle 149 on Reader Service Card

TRANSMITTERS ... WTS

Gates BC250-T 250 W tube type w/6(8) 8008, (16) 810, (10) 807 tubes, Kintronics RF switcher, manual, all parts replaced w/Harris factory parts, works, tuned to 1190 kHz, BO. M Casey, WKSX, Drawer I, Johnston SC 29832. 803-275-4444.

Harris TE-3 exciter in excel rebuilt cond, 8-90 w/composite input, \$950 plus shpg, 55 lb. G Garcia, KPEZ, 3001 Lake Austin Blvd Ste 400, Austin TX 78703. 512-478-6900.

Emcee TTS-20 (2) 20 W TV xmtrs in the 2 GHz region w/RCA color TV modulators, excel cond, BO. P Parks, KLVJ, 27 Sawyer, Beaumont TX 77702. 409-838-3911.

Continental 816R3 25 kW, gd cond, tuned to 100.7 MHz, less exciter, BO. Eddie, KCFX, 10800 Farley Ste 310, Overland Park KS 66210. 913-661-0101.

Harris/Gates BC 1H 250/500/1000 W, very clean, excel cond, tuned for 900 kHz, BO; Collins 500A-1 presently being used as auxiliary, 250/500 W, BO. A Terry, WODY, Box 545, Bassett VA 24055. 703-629-5900.

Best has some show units at sale price. Full 2 yr warranty, like new. Exciters, amplifiers, STL's. First come first served only. Call for details. Best, 619-239-8462.

Want to Buy

Low power AM, 250-300 W, rack mount, for standby, will consider BC250GY. J David, KMPL, POB 907, Sikeston MS 63801. 314-471-1520.

AM 250-500 W for auxiliary use, anything but basket cases considered. J McAulay, KITH, 21810 Hwy 18, Apple Valley CA 92307. 619-247-1111.

WANTED

AM and FM Transmitters, all powers. Finders fee for locators. DON'T take the chance of not being paid, sell to the oldest broadcast supply house in Latin America.

GUARANTEE RADIO SUPPLY CO.

1314 Iturbide LAREDO, TX 78040
(512) 722-3233
(512) 727-8458 (fax)

RCA TTU-1B or TTU-2A UHF TV xmtrs for parts; GE TT-24-A 100 W or TT-20-A 1 kW UHF TV xmr for parts; RCA instruction manuals for TTU-10A UHF TV xmr. J Powley, 1536 Logan, Altoona PA 16602. 814-944-8571.

Late mdl 1 kW AM wanted, no junk. L Fuss, KOOZ, POB 159, Fayetteville GA 30214. 404-460-6159.

UHF & VHF TV translators, 10-100 W will consider old UHF band 70-83 equip: low band 2-6 VHF TV xmr, 100 W to 11 kW. J Powley, 1536 Logan, Altoona PA 16602. 814-944-8571.

Solid state 1 kW needed ASAP. K Sleeman, KTOB, 12 E Washington, Petaluma CA 94952. 707-763-1505.

Gates BC500G modulation transformer in gd cond, reasonably priced. B Estes, W3HN, POB 1309, Bryson City NC 28213. 704-488-2682.

RCA TTU-2A UHF TV xmr for parts; GE TT-24-A, 100 W or TT-20-A, 1 kW UHF TV xmr for parts. J Powley, 1536 Logan, Altoona PA 16602. 814-944-8571.

Single phase, 10K FM, 102.3, must be in excel cond, C Hargrave, KSPK, POB 1052, Walsenburg CO 81089.

USED TV TRANSMITTERS, antennas, cable, rigid line, etc. one watt to 110 kW. Fair market price paid. Turnkey handling.

BROADCASTING SYSTEMS

602-582-6550
FAX: 602-582-8229
Kenneth Casey

Shortwave, high or low pwr. G McClintock, WWCW, 4647 Old Hydes Ferry Pk, Nashville TN 37218. 615-255-1300.

Low power FCC approved under Part 15 xmr or leaky wire RF system for talking billboards, AM or FM quantities OK. B Baker, Pinetucket Recd, 747 Wire Rd, Auburn AL 36830. 205-826-0390.

TOP DOLLAR

For Your Old Transmitter, STL or Exciter! Call for a quote We arrange quick dismantling & removal PCB's? No Problem Call Us. **ARMSTRONG TRANSMITTER CORP.** 5046 Smoral Rd Syracuse, NY (315) 488-1269 FAX (315) 488-1365

AM, 5 kW, no PCB's. J Roach, KARY, Box 1310, Prosser WA 99350. 509-786-1310.

FM 5 or 10 kW in gd working cond. R Lark, WXCX, Box 1260, Amery WI 54001. 715-268-7185.

Any FM greater than 5 kW CW power wanted not for over air use at reasonable price. D Randall, 321 Sandbank, Cheshire CT 06410. 203-272-6774.

2-5 kW, can fax info. E Anderson, WEAS, 912-234-7264 or fax: 912-233-7247.

LPTV 10-100 W VHF, 100 W-2 kW UHF. M Ernst, WBUD TV, 729 Fairhill Dr, Louisville KY 40207. 502-893-6656.

Harris or Continental 1984 or later prefer solid state, for 50 kW AM station, can fax info. K Faulkner, WGUN, 404-939-8258 or fax: 404-939-0795.

McMartin AM/FM xmr, any model, exciter or stereo modules. Goodrich Ent., 11435 Manderson, Omaha NE 68164 402-493-1886.

McMartin older B-910 FM exciter. C Goodrich, 11435 Manderson, Omaha NE 68164. 402-493-1886.

RCA 6181 & 8501 & GE GL-6163 used as final in RCA & GE UHF TV xmtrs. J Powley, 1536 Logan, Altoona PA 16602. 814-944-8571.

BROADCASTING EQUIPMENT "AM, FM, TV"

All powers and conditions. We dismantle and pick up. **TRANSMITTERS STUDIOS STL I.B.S.** International Broadcast Supply 1771 N. Powerline Road, Pompano Beach, FL 33069 Tel. 305-977-9111 FAX. 305-977-0488

TUBES

Want to Sell

3B28, \$10; 575A, \$30; 813, \$40; 837, \$20, others, all new. R Humphrey, WLTI, 7 Parkway Cir, Pittsburgh PA 15220. 412-921-8254.

Reliable electron tubes. BETHPAGE ASSOC.

507 Superior Ave. Newport Beach CA 92663 714-722-6733 FAX: 714-722-6508

Eimac 4-250, new in boxes, \$100 ea. P Deets, WFHR, Box 8022, WI Rapids WI 54495. 715-424-1300.

For the Best Prices & 24 Hr service on transmitting tubes call 402 493 1886 day or night. FAX 402 331 0638. TELEX 940103 WU PUB TLX BSN

Tubes including 12AT14A/AX7's, 6AL5, 6H6, 6S17, & 1612's plus more. R Bickle, KOAK, POB 465, Redoak IA 51566. 712-623-2584.

3CX1500A7, 4CX5000A, 6146B, 4CX2508, 4CX3000A & more. We carry large inventory all major brands, Eimac, Ampere, RCA, etc. Call Stew 1-800-842-1489.

ECONCO

Quality Rebuilt Tubes Approximately 1/2 the Cost of New

Call for Our Price List **800-532-6626 916-662-7553** FAX 916-666-7760

ELECTRON TUBES

Partial List: 6623, 23791, TH150, 6425F, 5604, 6696, 6697, 5681, 5682, 5671, 7804, 3CX10, 000H3, 3CX20, 000H3, 4CX5000A, 4CX35, 000C

Vacuum Tube Industries, Inc.

1-800-528-5014

Want to Buy

European receiving tubes, EL3N, HM309, EBF-2, EF9, EF43 & others, also buying multiband European auto radios by Telefunken, Becker, Blaupunkt, W Wilkes, Box 103, Brisbane, PA 16620. 814-378-8526.

TUBE REBUILDING

FREELAND PRODUCTS

Since 1940 **SAVE ABOUT 50%** —We buy dud tubes— **800-624-7626 504-893-1243 FAX 504-892-7323**

RCA 6181 & 8501 & GE GL-6183, used as final in RCA & GE UHF TV xmtrs. J Powley, 1536 Logan, Altoona PA 16602. 814-944-8571.

REBUILT ELECTRON TUBES

Partial List: 6623, 23791, TH150, 6425F, 5604, 6696, 6697, 5681, 5682, 5671, 7804, 3CX10, 000H3, 3CX20, 000H3, 4CX5000A, 4CX35, 000C

Vacuum Tube Industries, Inc.

1-800-528-5014

TURNTABLES

Want to Sell

Harris CB1201 TT's (2) w/arms & cartridges, \$25 ea. R Coleman, WGEN, Box 67, Geneseo IL 61254. 309-944-4633.

Russco Studio Pro B (2), excel new idler wheels, \$150/ea; Rek-O-Kut G-2 new old sock, \$100; Grey viscous damped 12" arm, \$35. Kremer Kraft, 301 SW 16th St, Ft Lauderdale FL 33315. 305-524-5652.

Gates CP-77 12" TT w/Gates stereo preamp w/manual, \$75. M Cramer, WGBA, 1291 N Road, Green Bay WI 54307. 414-494-2626.

Harris CB 1201 prof bnd TT's, (2) 3 speeds, in excel working cond, \$50 ea; Audio Technica ATP-N2 replacement stylus tapered cantilever elliptical 4 x .7 mil diamond (2), \$10 ea; Audio Technica ATP-N2 replacement stylus tapered cantilever spherical 0.6 mil diamond, \$10; RCA 8707242 tone arm, \$45. S Dynes, Dynes Prod, Wheeling WV 26003. 304-233-6856.

Presto 6N cutter, \$300; Gray tone arm, \$50. J Parsons, Parsons Recd, 10375 Cannas, N Huntingdon PA 15642. 412-863-9590.

Turntable, 16", \$25. WJAG, 309 Braasch, Norfolk NE 68701. 402-371-0780.

Want to Buy

Presto 80-G & 92-B service info, on lathe & amp, photo copies OK. C Lund, Cycle Sound, 167 Madison St, Waterbury CT 06706. After 5:30 PM. 203-756-7761.

Shure, Rek-O-Kut, etc. 16" in gd cond w/shell. J Panza, LL&S, POB 9847, Kansas City MO 64134. 816-763-9820.

Technics SLP1500 MK II, K Thomas, WQIK, 5555 Radio Ln, Jacksonville FL 32205. 904-388-7711.

TV FILM EQUIP

Want to Sell

Arri 16 BL Apec auto exposure 12-120, 1-400 magazine matt box, pwr zoom, battery, cables, crystal motor lens, rebuilt, sharp, quiet, \$4200. Gene Sive Productions, 31844 Rancho Amigos, Bonsall CA 92003. 619-749-7662.

VIDEO PROD EQUIP

Want to Sell

Microtime 1020 TBC, all manuals, excel cond, \$1500. D Lahey, Pathfinder, 17094 McGuffie, Salinas CA 93907. 408-663-5192.

Otari EC-201 portable hand-held SMPTE time code reader, \$250. P Cibley, Cibley Music, 138 E 38th, NNYN 10016. 212-986-2219.

Grass Valley 1400 prod switcher w/options, works, gd cond, \$1500; Convergence 201 editor w/2 interfaces, (2) Sony 5800 or BVU interfaces features edit list, auto tag, split edit, etc, \$1800. R Yerema, World Video, 10625 Scripps Ranch Blvd, San Diego CA 92131. 619-695-1045.

Channelmatic NSS-4 share switcher & Channelmatic Lii' MoneyMaker, BO. D Staats, WRZZ, POB 1346, Parkersburg WV 26102. 304-863-3319.

JVC 8250 editor, only 150 hrs, mint cond, 3/4" U-matic, \$2850 firm. J Jones, RBY Studios, 920 Main St N, Southbury CT 06488. 203-264-3666.

Bosch Compositor, dual chnl character gen, 2 keyboards, graphics compose console, election return package works, gd cond, \$2000. R Yerema, World Video, 10625 Scripps Ranch Blvd, San Diego CA 92131. 619-695-1045.

Quanta Select 7 character gen, works gd, many different fonts, dual disk drive, 16-64 points, crawl, roll many features, \$950. R Yerema, World Video, 10625 Scripps Ranch Blvd, San Diego CA 92131. 619-695-1045.

Video Media Z6000, Z6006 editor keyboard & switcher box, \$250; Convergence TR-100 editing time code reader, \$800. R Yerema, World Video, 10625 Scripps Ranch Blvd, San Diego CA 92131. 619-695-1045.

Studio animation, audio & visual equip incl color monitors (2), Panasonic camera w/lights, digitizer, beta players & recorders, GV 386 computer, complete cubcomp system & all attendant software necessary, incl new AT&T TOPAS Software, to do any animation, painting or 3-D work currently technologically feasible for either industrial or commercial work. L Tavel, 2839 Lafayette Rd, Indianapolis IN 46222. 317-924-1300.

Panasonic WJ4600 special effects gen, excel cond, \$350/BO. B Baker, Pinetucket Recd, 747 Wire Rd, Auburn AL 36830. 205-826-0390.

Microtime 1020 TBC w/manual for 3/4 or 1", works great, \$1400. Dave, Pathfinder Prod, 17094 McGuffie, Salinas CA 93907. 408-663-5192.

Conrac 5222/RS25 reference monitors, NTSC 525 line, 60 Hz, large screen, several, \$400/BO or will trade for film equip. H Biller, 108 Hamilton, Silver Spring MD 20901. 301-565-2798.

Sony BCR-4, telecine adapter, high resolution unipler for film to video transfer, gd cond, \$50; Froehlich 190-300 stereo video control center, interconnect (3) VCRs & (4) audio sources, lighted passive switcher, audio volume control, replace patch panel w/routing switcher, \$50. W Watrous, Watrous Video, 739 S Orange, Sarasota FL 34236. 813-366-3316.

Panasonic VY 922 special effects gen, BO. D Lundy, Lundy Tape Duplicators, Cumberland Gap Pkwy, Heidrick KY 40949. 606-546-6850.

Quanta 7A character gen w/shop manual, \$2500/BO; Sony MX20 8 trk audio mixer, \$700; Sony RM555 multi recorder remote control, \$400/BO; Tek RM529 waveform mon, \$750; Fuji lens N10x10, \$250/BO; Videomecia Z-6000C edit controller, \$1000/BO; RCA telecine system w/(2) 16mm projectors & TK 27 camera, BO; 3M image enhancer w/R-B-G outputs, \$700/BO; JVC S-62 tube color camera, \$400/BO; Sony DXC 1610 tube camera w/case, \$700/BO; (2) RCA TK-630 cameras w/CCU, BO; numerous JVC CR 4400 3/4" portapaks, \$400-\$1000. T Quinn. 408-475-0423.

Paltex Abner ABR-1A A/B roll editor w/CRT display, time code, cables for JVC 6600/8250, will work w/600/850, \$2750/BO. R Jensen, MPI Productions, 5812 21st St, Racine WI 53906. 414-632-3131.

Want to Buy

Early RCA, Dumont, GE color & B&W monitors. A Weiner, 14 Prospect Dr, Yonkers NY 10705. 914-423-6638.

VIDEO TAPE RECORDERS

Want to Sell

JVC CR4400U 3/4 port recorders (4) w/access, \$800 ea/BO; (3) Sony RM-430 edit controllers, \$500/BO; JVC BR-6400U VHS recorder, \$1500/BO. T Quinn, Monte Vista Std, 208 Cherry, Capitola CA 95010. 408-475-0423.

Ampex VR 1200 C (2), \$1000 ea. L Schrecongost Recd, POB 1032, Indiana PA 15701. 412-349-5706.

Ampex 1200B 2" quad (2) to trade plus big box of manuals & spares for RCA TP-66 film chain projector, Mid-Atlantic area please. P Badger, WVES, Box 104, Birdsneat VA 23307. 804-442-4037.



FIRST FOR ALL YOUR FM NEEDS:

- Exceptional FM Exciter Performance
- Advanced Line of 1kW to 8kW Total Solid State FM Transmitters
- Full Line of FM Transmitters from 150 Watt to 50kW to Meet All Your FM Needs
- Excellent Financing Available

TTC
813-684-7724

Gates BC1J, gd looking rig, fls light, never usec the plates, BO. R Gray, WSUB, 200 Ft Hill Rd, Groton CT 06340. 203-446-1980.

Elcom-Bauer 680 FM exciter, like new cond, w/manual, \$2395/BC. D Phillips, KTCN, POB 372, E Springs AR 72632. 501-253-6101.

Collins 310Z-2 exciter, 94.3 MHz, excel, \$4000; QEI 7775 AT'S System, excel, \$500. M Persons, KKIN, Box 930, Aitkin MN 56431. 218-829-1326.

FM Transmitters

- 20 kw 1978 Collins 831-G2 1973 RCA BTF-20E1
- 5 kw 1969 Harris FM 5H
- 1 kw 1967 Collins 830D 1969 CCA 1000D

PMA Marketing
414-482-2638

Gates M6095 10 W exciter, \$200/BO. J Linn, WHKS, 621 N Main. Port Allegany PA 16743. 814-642-7004.

Kahn STS-1 stereo exciter w/pwr side, tuned to 1140 kHz, excel cond, \$2600; Collins 20V tuned to 1090 kHz in gd cond, \$1500. G Arroyo, WQNC, 2483 John Young Pkwy, Orlando FL 32804. 407-293-0000.

Ampex 1" VR-7500X R/P; Ampex 1" VP-4900C play only; Ampex 1" R/P for parts, all look very gd, stored several years, \$500/BO. B Perry, Ainsley Comm, 1520 Market, Little Rock AR 72211. 501-221-1380.

JVC CR6600U 3 1/4" recorder, feeder deck for JVC edit system, low hrs, nice shape, new drum, \$950. J Kreines, 5330 Kennedy Ave, Millbrook AL 36054. 205-285-6179.

JVC CR6600U 3 1/4", source deck for JVC edit system, 300 hrs, nice cond, \$950. J Kreines, DeMott/Kreines Films, 5330 Kennedy, Millbrook AL 36054. 205-285-6179.

Panasonic WV6400, \$900; Panasonic 8420, \$450, both in great cond, portables w/cases, batts & AC chargers. RSB, TP5 Video, POB 1233, Edison NJ 08818. 201-287-3626.

JVC BR8600 VHS editor, \$1300; JVC BR6400 VHS recorder/source, \$600. Gene Sive Productions, 31744 Rancho Amigos, Bonsall CA 92003. 619-749-7662.

Sony BVU-110 bdct portable VTR w/time code, case, \$695 ea; BVU-50 bdct VTR, \$295 w/case; BVU-200 3 1/4" editors, \$695 ea; VO-2600 VTR's, \$395 ea; Sony MX-20 mixers, \$195 ea. U George, U.G. Satellite TV, 314 W 52 St, Nyny 10019. 212-677-2200.

Sony VO 5600 3 1/4" recorder, \$795; Panasonic NV 9100A player, \$340. B Cooke, GBC Electronics, 125 Birch, Blountville TN 37617. 615-323-2976.

JVC 5550 3/4" player (2), mint cond, 150 hrs, ideal for A/B roll system, \$1650 ea. J Jones, RBY Studios, 920 Main St N, Southbury CT 06488. 203-264-3666.

Panasonic 8950 slo-motion dynamic tracking 1/2" VHS VCR w/tuner, mint cond, \$900. RSB, TP5 Video, POB 1233, Edison NJ 08818. 201-287-3626.

Panasonic AG7500 SVHS R/P (3), Panasonic AG-A750 & NV-A505 edit controllers, Panasonic NV-J500 multi VTR switcher/controller, brand new cond w/under 120 hrs on VTRs, all books, packaging, boxes & etc avail, can be sold on individual or package basis. A Zand, Villanova University, Villanova PA 19085. 215-645-4285.

Sony edit systems, VO5850, VO5800, RM440, \$6000/BO; VO2860, 2260, RM 430, \$2300/BO; RM400 controller, \$200; RM430 controller, \$400, other misc equip. T Quinn. 408-475-0423.

RCA TCR-100 & spare parts w/manuals & spare heads: (1000) 2" RCA carts, BO. J Becknell, WCSC, POB 186, Chas SC 29402. 803-723-8371.

JVC CP5000U 3 1/4" U-matic player, remote plus approx 30 KCS tapes, great cond, \$575. B Hines, IPS Inc, Rd 1 Box 413A, Export PA 15632. 412-468-4115.

RCA video heads & spare parts, call for list. J Becknell, WCSC, POB 186, Chas SC 29402. 803-723-8371.

Sony VO-5850 editing systems w/Convergence controllers, U-matic, gd cond, \$3000 ea; Sony BVU-110 portable U-matics w/time code, \$600 ea; Sony BVU-50 port recorders, \$295 ea; Sony BVU-200, \$700 ea. U George, Satellite TV, 314 W 52nd, NY NY 10019. 212-677-2200.

RCA TR-70 2" R-R VTR, BO. J Becknell, WCSC, POB 186, Chas SC 29402. 803-723-8371.

Sony VO-2600 3 1/4", \$500; Sony VO-2610 3 1/4", \$550; Sony VO-5800 3 1/4", \$2500; Sony BVU-110 3 1/4" portable, \$2150. R Jensen, MPI Productions, 5812 21st St, Racine WI 53906. 414-632-3131.

JVC BR6200U portable VHS recorder, 2 chnl audio, insert editing, audio mixing, wireless remote, (3) NBP1 Nicads, AC/charger, custom case, \$675. B Hines, IPS Inc, Rd 1 Box 413A, Export PA 15632. 412-468-4115.

Panasonic NV-9100A, 3 1/4" player, needs work, \$150; NV-C15 5' extension cables (2), new, \$10 ea; NV-U134 RF converter, \$35. R Branska, 5347 S Spaulding, Chicago IL 60632. 312-737-3303.

Want to Buy

Early Ampex slow motion recorder. A Weiner, 14 Prospect Dr, Yonkers NY 10705. 914-423-6638.

ADVERTISER INDEX

This listing is provided solely for the convenience of our readers. Radio World assumes no liability for inaccuracy.

Page No.	Advertiser	Reader Service No.	Page No.	Advertiser	Reader Service No.	Page No.	Advertiser	Reader Service No.
10	AKG/Orban	-	23	Circuit Devmnt	136	7	Jampro	45
6	Allied Broadcast	33, 116	18	Comrex	56	39	National Audio	5
22	Allied Broadcast	14, 106	40	Conex	49	24	Nat'l Supervisory Network	22
32	Allied Broadcast	9, 78	24	Continental Elec.	93	19	Pacific R & E	86
40	Allied Broadcast	110, 119	16	Corp. Computer	51	29	QEI	20
37	Alpha Products	10	34	Cortana	13	12	Radio Systems	108
26-27	Arrakis Systems	122	20	CRL	99	33	Radio Systems	100
7	ATI	8	13	Dataworld	37	34	RF Specialties	103
37	Audio Bdct Grp	63	35	dbx	125	8	Sescom	12
8	Audio Precision	75	1	Fidelipac	15	28	Shure	47
38	Audio Visual	67	39	FM Technology	44	9	Studer Revox	111
14	Belar	121	30	Frankford Wayne	18	36	Studer Revox	151
3	Bradley Broadcast	27	13	Harris	66	23	Summit Audio	3
3	Bdct Electronics	11	22	Hnat Hindes	114	11	Voyager Mobile	40
17	Bdct Electronics	142	16	Holiday Industries	77	2	Wheatstone	81
15	Bdct Services	131	38	Inovonics	148	51	Wheatstone	73
31	Bdcters Gen'l Store	145	25	ITC	61	52	Wheatstone	38
21	BSW	23						
4	Burk Technology	124						
30	CCA Electronics	139						

Advertising Sales Representatives:

East Coast, Art Constantine: 800-336-3045 Fax: 703-998-2966
 Midwest, Art Constantine: 800-336-3045 Fax: 703-998-2966
 West Coast, Pat Macsata: 415-786-2198 Fax: 415-786-2754

ACTION-GRAM

Equipment Listings

Radio World's Broadcast Equipment Exchange provides a FREE listing service for all broadcast and pro-sound end users. Simply send your listings to us, following the example below. Please indicate in which category you would like your listing to appear. Mail your listings to the address below. Thank you.

Please print and include all information:
 Contact Name: _____
 Title _____
 Company/Station _____
 Address: _____
 City _____ State _____ Zip _____
 Phone Number: _____
 Brokers, dealers, manufacturers and other organizations who are not legitimate end users can participate in the Broadcast Equipment Exchange on a **paid** basis. Listings are available on a \$25/25 word basis. Call 1-800-336-3045 for details and complete display rates.

I would like to receive or continue receiving **Radio World FREE** each month. YES NO

Signature _____ Date _____
 Please circle only one entry for each category:

I. Type of Firm

D. Combination AM/FM station F. Recording studio
 A. Commercial AM station G. TV station/teleprod facility
 B. Commercial FM station H. Consultant/ind engineer
 C. Educational FM station I. Mfg, distributor or dealer
 E. Network/group owner J. Other _____

II. Job Function

A. Ownership D. Programming/production
 B. General management E. News operations
 C. Engineering F. Other _____

WTS: WTB: Category: _____
 Make: _____ Model #: _____
 Brief Description: _____

 Price: _____

WTS: WTB: Category: _____
 Make: _____ Model #: _____
 Brief Description: _____

 Price: _____

WTS: WTB: Category: _____
 Make: _____ Model #: _____
 Brief Description: _____

 Price: _____

WTS: WTB: Category: _____
 Make: _____ Model #: _____
 Brief Description: _____

 Price: _____

WTS: WTB: Category: _____
 Make: _____ Model #: _____
 Brief Description: _____

 Price: _____

WTS: WTB: Category: _____
 Make: _____ Model #: _____
 Brief Description: _____

 Price: _____

*Closing for listings is the first Friday of the previous month. All listings are run for 3 months unless otherwise notified.

Broadcast Equipment Exchange

PO Box 1214 Falls Church VA 22041

703-998-7600

FAX: 703-998-2966



It's Handled!

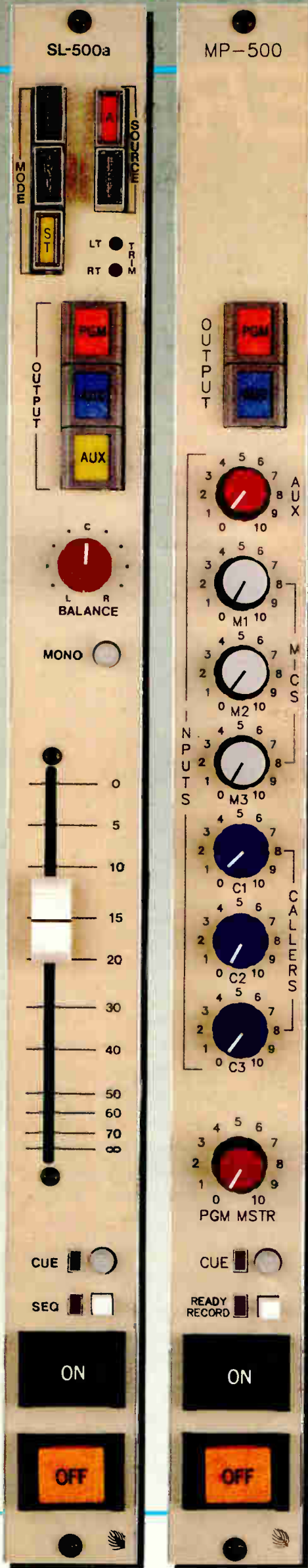

Customize your A-500 Console with Wheatstone's powerful accessory modules! We've handled auto-sequencing, telephone call-ins, and intercom requirements. Our auto-sequencing line input will take the rush out of back-to-back carts. Our multiphone module can handle 3 callers, 3 mics and reel-to-reel machine control all at once. Our new 8-station intercom module will link up all your studios and talent positions...

AUTO-SEQUENCING: The SL-500as input module allows the DJ to automatically sequence through a pre-loaded bank of cart or CD machines. All audio and machine control functions are handled by the module's logic circuitry. When the first ON switch is pressed, that module's associated machine automatically starts to play; when it has finished the channel is turned OFF, the next programmed module is turned ON, and its machine starts to play. Dead air and missed spots can be a thing of the past with this sequence function.

TELEPHONE/TALK SHOW: The MP-500 multiphone module offers a totally new way of handling telephone talkshow functions. Operation is simple: when the announcer wishes to do a phone segment he simply activates the MP-500 module and all mute, level, combining, and machine control functions are handled automatically. The MP-500 permits conferencing between 3 callers and 3 microphones, and provides separate multitrack tape feeds for various mic/caller signal combinations, permitting simple track punch-ins to replace razor and tape edits. This module eliminates complicated announcer set-ups, miscalls, and feedback problems.

COMMUNICATIONS: The ICM-500 module is part of a completely integrated intercom system; a family of modules available for all Wheatstone broadcast and production consoles. It even includes a rackmount version for your equipment room or remote hook-ups. It allows direct communication between 8 locations in your facility. Your intercom needs are handled by simply plugging in this module set.

TAKE ADVANTAGE of our expertise and reputation. Call Wheatstone. Let our application engineers handle your toughest requirements.



 **Wheatstone® Corporation**

6720 V.I.P. Parkway, Syracuse, NY 13211 (tel 315-455-7740/fax 315-454-8104)

Circle 73 On Reader Service Card

World Radio History

Something Very Good Just Got **BETTER!**



A-32EX On-Air Console

Finally engineers confined to tight budgets can choose a console that won't compromise station reliability or signal integrity. After all, the A-32 is a Wheatstone console. It borrows from the componentry and design of our larger A-500 consoles, currently installed in major markets all over the country, from frontline independents to national networks.

Our new A-32EX is even better, with ample expansion room for additional inputs and a powerful family of accessory modules, including our new MP-32 talkshow module (that neatly interfaces multiple hybrids, tape recorders, announcer mics and studio-to-caller feeds), our ICM-32 six station intercom module (letting you communicate with other console locations and announce studios), and our SC-20 studio module (to provide comprehensive studio monitor, automatic muting, and talkback functions), plus multiple line selector and machine control modules, and a complete family of studio turret components.

The A-32EX console features modular construction, a fully regulated rackmount power supply, logic follow, full machine control and of course, an all-gold contact interface system. It has two mic channels and fourteen stereo line modules, each with A/B source select and Program/Audition bus assign, plus Cue switches on the line modules. Standard features include Program and Audition VU meters, digital timer, and a monitor module for control room and headphone functions. The console is also available in a smaller version (the A-20) with two mic channels and eight stereo line input modules.

The A-32EX is a perfect choice for stations planning an upgrade in signal quality and control room image. It's also a natural choice for the newsroom. So profit from Wheatstone's experience and reputation—call us today for immediate action!

 Wheatstone Corporation

6720 V.I.P. Parkway, Syracuse, NY 13211 (TEL 315-455-7740 / FAX 315-454-8104)

World Radio History
Circle 38 On Reader Service Card