

MARCH 1982

# SOUND & COMMUNICATIONS



# EVM™ by Electro-Voice

## The low-frequency loudspeaker

Electro-Voice EVM™ Series II loudspeakers represent the ultimate in maximum efficiency, low-frequency speaker design. Years of experience, testing and refinement have resulted in a series of loudspeakers that are ideally suited for professional high-level, high-quality musical instrument and sound reinforcement systems.

Series II speakers incorporate many unique and innovative refinements that result in a loudspeaker that combines incredibly high power handling capability, efficiency and mechanical durability. All EVM's are conservatively rated at 200 continuous watts per EIA Standard RS-426A. This procedure is substantially more stringent than the more common continuous or "RMS" sine wave test, because it provides not only a 200-watt long-term stress (heat) but also duplicates mechanically demanding short duration program peaks of up to 800 watts which can destroy speaker cones and suspension parts.

EVM's are the ideal speaker for vented and horn-type enclosures. They are also featured in Electro-Voice's TL line of optimally-vented low-frequency systems. TL enclosure builder's plans are also available for custom construction, and each EVM data sheet contains the Thiele/Small parameters which allow you to predict the large and small signal performance in vented boxes.

For these and other reasons, not the least of which is an unmatched record of reliability, EVM's have been universally accepted by sound consultants, contractors and touring sound companies. When specifying a low-frequency loudspeaker, there really is no other choice. EVM — by Electro-Voice.



600 Cecil Street, Buchanan, Michigan 49107

In Canada

Electro-Voice, Div. of Gulton Industries (Canada) Ltd.  
145 Herbert St., Gananoque, Ontario K7G 2V1.



# SEEBURG SATELLITE MUSIC

## Great Sounding Profitability

Resolve your background music delivery problems with simple, economical satellite transmission — unmatched in 24 hour quality and uninterrupted profitability.

Your most difficult customers will thrill to SEEBURG'S unsurpassed LIFESTYLE MUSIC, the modern format that always sounds Fresh — Not Canned!

The public agrees that we have created the finest music library ever assembled, today's naturally upbeat sounds that people REALLY want to hear, instead of the old "snooze music" that has bored them too long.

And your constantly updated LIFESTYLE sounds come direct from our studios, totally uninterrupted, toally trouble free, totally hands off, and totally profitable.

You can enjoy very economical distributor fees and other great marketing opportunities with Seeburg's fast-growing fresh music distribution systems.

Call today Toll Free:

1-800-334-1561

1-919-834-0833



# SEEBURG MUSIC

**It's Sound Business!**  
711 Hillsborough Street,  
Raleigh, N.C. 27605

# SOUND & COMMUNICATIONS

devoted to the professional and business interests of independent contractors, dealers and distributors of private communications systems, employing audio, radio and telephone circuits, in mixes of interconnect/intercom, sound distribution/reinforcement, 1-way/2-way radio paging and life-safety/security systems; in industrial, commercial, institutional and government applications.

MARCH 1982, VOLUME 27, NUMBER 11

Founded 1955

## ARTICLES

- 12 Conference Communications
- 16 Calculating Sound System Performance  
by Thomas G. Bouliane
- 22 Long-Distance Resale & the Hospitality Industry  
by Kenneth Casner
- 38 Managing Phone Costs  
by Charles Viau
- 40 Profile: Kinetic Kelly
- 48 Mobile Radio Servicing—Part 6  
by Leo G. Sands
- 58 Florida Sound Show
- 66 Vibrating Fire Alarm

## DEPARTMENTS

- |    |                                       |            |  |
|----|---------------------------------------|------------|--|
| 4  | Late Lines                            | 52         | National Sound & Communications<br>Conference Update |
| 42 | New Products<br>Intercom/Interconnect | 54         | New Products   |
| 46 | Tip & Ring                            | 65         | The Societies Page                                   |
| 68 |                                       | Classified |  |

---

This month's cover: a conference in session, using the Sony Communication System. See story Page 12.

---

combining SOUND MERCHANDISING & MODERN COMMUNICATIONS  
© SOUND PUBLISHING COMPANY, INC., 1982

Reprint of any part of contents without permission forbidden.

Titles Registered in the U.S. Patent Office.

Sound & Communications (U.S. P.S. 943-140) is published by Sound Publishing Company, Inc., 156 E. 37th St., N.Y., N.Y. 10016. 212-685-3480.

President J.J. Brookman; Treasurer, R.F. Brookman, Secretaries, J.E.B. Lapidus, W.F. Brookman.

Subscription rates: U.S. — 3 years \$37.50, 1 year \$15.00. Canada and Mexico — 3 years \$48.00, 1 year \$18.00. Foreign and South America — 1 year \$25.00.

Controlled circulation postage paid at Easton, Pennsylvania 18042.

Postmaster: If undeliverable notify on Form 3579 address correction.

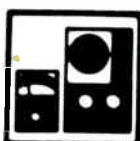

# ADVERTISERS

Bob Amos & Associates .....	68
Anixter .....	57
Atlas Sound .....	47
Audio Environments Inc. ....	34-35
AVA Electronics Corp. ....	68
BGM International .....	68
Bose Corporation .....	51
C&M Products Ltd. ....	68
Cabletronix .....	68
Calrad Electronic Products .....	53
David Clark Company .....	50
Communitron Corp. ....	59
Direct Systems Company .....	67
Dukane Corp., Communications Systems Div. .	Cover 3
Edcor .....	64
Electro-Voice .....	Cover 2
Electronic Industry Show Corporation .....	61
Fanon .....	62
Florence Corp. ....	52
Hall Engineering .....	68
Ideal Wire Products Inc. ....	68
ITT/DESD .....	29
Lexicon, Inc. ....	19
MacKenzie Laboratories, Inc. ....	65
McGohan Electronics, Inc. ....	68
Monroe Electronics, Inc. ....	30
Montgomery Mfg. Co. ....	68
Opamp Labs Inc. ....	68
Quam-Nichols Company .....	15
Renkus-Heinz, Inc. ....	53
Ring Communications, Inc. ....	33
San/Bar Corporation .....	37
Saxton Products, Inc. ....	63
Seeburg Music .....	1, 39
Shure Brothers Inc. ....	6, 17, Cover 4
Signal Cable Company .....	8
Sony Corp. of America .....	21
Sound Products/3M .....	14, 22
Southwest Utilities Inc. ....	31
Spectra Sonics .....	10-11
Talk-A-Phone .....	46
Tape-Athon .....	32
TekTone Sound & Signal Mfg. ....	36
Tele-Path Industries, Inc. ....	27
Telex Communications, Inc./Turner .....	41
Tei-Tron Systems Div., Radio Manufacturers, Inc. ..	14
Toa Electronics, Inc. ....	7, 23
Trutone Electronics, Inc. ....	67
University Sound .....	49
UREI .....	5
Wanlass Industries Inc. ....	66
Yamaha .....	9

# STAFF

**publisher & editor**  
**JEROME J. BROOKMAN**

**managing editor**  
**HERB FRANK**

**contributing editors**

**GEORGE LEON**  
Field Editor

**DOUGLAS J. GREEN**  
Telephony

**DANIEL GREEN**  
Electroacoustics

**ALBERT PETERSON**  
Washington Bureau

**national advertising  
sales manager**  
**JILL BROOKMAN**

**business manager**  
**RHODA F. BROOKMAN**  
**LEAH SPECTOR**

**production manager**  
**MARIE PONZO**

**circulation director**  
**J. ERAN**  
**FLORENCE LEVESQUE**  
**ADREA JACOBS**

**reader service**  
**MILENA M. KREPINSKY**

**sales offices**

**EAST COAST & MIDWEST**

156 E. 37th St.  
New York, N.Y. 10016  
(212) 685-3480

**WEST COAST**

**JOBSON, JORDAN,  
HARRISON & SCHULZ, INC.**  
119 W. Bellevue Drive  
Pasadena, CA 91105  
(213) 796-9200

**ENGLAND**

**E.G. RIVERA**  
**RIVERA MARKETING**  
7 Mayfield Road  
Royal Tunbridge Wells  
Kent TN4 8ES  
England Tel: 0892-42574

**JAPAN**

**NISHIHATA ASSOC. INC.**  
Doshomachi Bldg.  
31, 4-chome Doshomachi  
Higashi-ku, Osaka, 541  
Japan Tel: (06) 227-1380

**Circulation audited by  
Verified Audit Circulation Corp.**



# LATE LINES

On January 8, 1982, Charles L. Brown, chairman of AT&T and William F. Baxter, a Reagan Administration appointee as Assistant Attorney General/Anti-Trust Division, Justice Department, jointly announced that they had settled the 7-year anti-trust suit.

After 129 days of court sessions, the government had dropped the charges. The action has not met with the approval of Judge Harold Greene, who has been hearing the case since June 21, 1978. All during the trial, Judge Greene had informed members of his court that this case was not going to become another IBM.

To accelerate the deliberations, Judge Greene employed innovative and sometimes controversial techniques. One cited by the "Legal Times" was his "stipulation" of large amounts of evidence to be considered during the trial. Both sides were ordered to write out in detail what they intended to prove and what evidence and witnesses they would offer. The parties then reviewed each other's statements for accuracy. What was still in dispute would be considered at the trial.

It was during the trial that William F. Baxter, the government's anti-trust chief, declared during an interview that he "would litigate this case to the eyeballs," to get a favorable decision.

While the anti-trust action was in progress in Washington, AT&T was attending Federal Court in Newark, N.J., seeking to have the 1956 Consent Decree obviated. They convinced Judge Vincent Biunno, of the United States District Court, Newark, that from the date of the decree to the present, many technological and economical changes had been wrought, and that the Consent Decree should be modified.

The Newark court held that the government's proposed anti-trust settlement with AT&T is "fully supported by the dramatically changed circumstances" in the communications industry and reflected "a carefully considered and undoubtedly wise business decision," Judge Biunno said.

In a 9-page opinion on a Justice Department motion to transfer custody of the 1956 case to another federal court in Washington, D.C., Judge Biunno said that the settlement was "in the general public interest."

As part of its motion to transfer the 1956 case, involving AT&T and its manufacturing arm, Western Electric, the Justice Department told the court that it would comply with the disclosure provisions of the federal law known as the Tunney Act.

The Tunney Act provides that the government disclose the terms of a proposed settlement 60 days before it is to take effect, along with a statement on its economic impact. Competitors would be allowed to participate in hearings before the court decided whether the settlement was in the public interest.

This brought a rising howl from many competitors, their complaint being capsulized in the statement made by William McGowan/MCI chairman, who said in Washington that although AT&T was "willing to have a Tunney Act hearing in front of Judge Greene," the procedure "doesn't give the other parties the same rights as if it was a hearing on the settlement of the trial



The UREI power amplifiers are designed to extend UREI quality from our low level signal processing all the way through to our exclusive Time Align™ studio monitors.

## The New UREI Power Amplifiers

Careful evaluation of competitive power amplifiers indicates that while in some cases adequate reliability has been achieved, audible performance is often marginal.

The UREI 6000 Series amplifiers offer the knowledgeable professional the reliability he demands *and* the sound-quality he deserves.

Exceptionally large power supplies and exceedingly high speed, high current circuitry combine to produce low-end punch and high-end sparkle which is unexcelled in professional power amps. Moderate use of negative feedback results in fast recovery from transient overloads and avoids excessive high order harmonic distortion when the amplifier is driven into clipping.

### The Model 6500 Listening Amplifier

Two totally independent plug-in channels, removable from the front panel.

each with its own power supply and continuously variable cooling fan. Exclusive Conductor Compensation™ corrects for wire loss and transducer related load anomalies, resulting in absolutely accurate waveforms at the speaker terminals. 275 Watts per channel into 8 ohms, 600 Watts per channel into 2 ohms. Standard rack mount, 7" high.

### The Model 6300 Dual Channel Power Amplifier

225 Watts per channel into 8 ohms, 380 Watts per channel into 4 ohms. 5 1/4" rack space!

### The Model 6250 Dual Channel Power Amplifier

150 Watts per channel into 8 ohms, 200 Watts per channel into 4 ohms. 3 1/2" rack space!

### The Model 6150 Dual Channel Power Amplifier

80 Watts per channel into 8 ohms, 80 Watts per channel into 4 ohms. 1 3/4" rack space!!

Audition the UREI Power Amplifiers at your professional sound dealer and discover how good a reliable amplifier can sound.

From One Pro to Another—trust all your toughest signal processing needs to UREI.

\*Time-Align is a Trademark of E.M. Long Assoc., Oakland, CA. All referenced Trademarks are property of, or licensed by United Recording Electronics Industries, a URC Company.



UREI

From One Pro To Another

United Recording Electronics Industries

8460 San Fernando Road, Sun Valley, California 91352 (213) 767-1000 Telex 65-1389 UREI SNVY

Worldwide: Gotham Export Corporation, New York; Canada: Gould Marketing, Mcntreal H4T 1E5

See your professional audio products dealer for full technical information.

© UREI 1981

## cure the 10 most common nuisances in PA instantly



**fact:** These 10 problem solvers in your toolbox are like 10 new tricks up your sleeve. Or 10 hours of saved time. Or money in the bank. They make molehills out of troubleshooting mountains, without soldering, or splicing, or internal equipment modifications.

### Problem: Solution:

<b>Input Overload</b>	<b>A15AS</b> Microphone Attenuator—prevents overload.
<b>Phasing</b>	<b>A15PRS</b> Phase Reverser for balanced lines.
<b>Low-Frequency Noise</b>	<b>A15HP</b> High Pass Filter—reduces low-frequency noises and proximity effect.
<b>High-Frequency Noise</b>	<b>A15LP</b> Low Pass Filter—reduces objectionable high-frequency noises.
<b>Lack of Presence</b>	<b>A15PA</b> Presence Adapter—adds intelligibility and brilliance.
<b>Sibilance</b>	<b>A15RS</b> Response Shaper—sibilance filtering, plus flattened response.
<b>Line Level to Mic Input</b>	<b>A15LA</b> Line Input Adapter—converts balanced low-impedance mic input to line level input.
<b>Matching/Bridging/Isolating</b>	<b>A15BT</b> Bridging Transformer—matches balanced or unbalanced devices of different impedances.
<b>Trouble-shooting</b>	<b>A15TG</b> Tone Generator—700 Hz signal helps check levels, connections, mixer inputs, and cables.
<b>Microphone Impedance Matching</b>	<b>A95 and A97</b> Series Line Transformers—make it possible to connect low-impedance lines to mid- and high-impedance inputs (or vice-versa.)



**The Sound of the Professionals®**  

Send for the brochure, AL280F  
 Shure Brothers Inc., 222 Hartrey Ave.,  
 Evanston, IL 60204.

In Canada: A. C. Sirmmonds & Sons Limited  
 Manufacturers of high fidelity components,  
 microphones, sound systems and  
 related circuitry.

now going on in Washington." McGowan said that AT&T was "trying to do this as a modification of the 1956 Consent Decree, which only dealt with Western Electric, rather than as a settlement of the Washington trial under Judge Greene, which has to do with the entire industry."

McGowan said he "and about 100 others" would file a petition seeking a Tunney Act hearing on Judge Greene's case.

A.G.W. Biddle, president of the Computer & Communications Industry Association, maintained that the parties to the settlement "have clearly tried to circumvent the legal authority of the Tunney Act ... (and) ... technically there is no way for people to fight it."

The Newark court action—and that of the AT&T and Justice Department attorneys—prompted Judge Greene to say that by filing the proposed settlement in Newark as only an amendment to the 1956 Consent Decree, the two sides—intentionally or not—may have circumvented a federal law that requires a 60-day period for public comment. "I think that law applies," he said. He argued that the settlement should have been filed in his District Court as well as the Newark court. Judge Greene said he was convinced that the parties, contrary to their protestations that Judge Biunno's action surprised them, had framed the settlement as a technical amendment to the 1956 Consent Decree so it could be handled in Newark and remain free of the Tunney Act's provisions.

In declaring that he would keep the case open for the allowable 60 days under the Tunney Act, Judge Greene declared, "This case is too important to the public interest to have it dropped in so haphazard a fashion." Repeatedly, Judge Greene brought out the fact that Judge Biunno had not seen the huge volume of evidence about Bell and the government's complaint that was presented before the Washington court during the trial. "After all, what have we been doing here for the past 11 months?" he asked.

Exactly what has been going on during the 11 months the anti-trust case has consumed?

—a lot of planning by AT&T, looking toward the day when Baby Bell would roll its carriage of goodies through the deregulated side of the business;

—a lot of head-holding by the more than 100 competitors of AT&T, guessing what the future holds for each of them as an operating company, and for the industry at large, now toe-to-toe with Ma Bell and its hefty clone, Baby Bell, in the competitive marketplace created by the Carterfone Decision of 1968, and the FCC Computer Inquiry II Decision of 1980.

—and a lot of backing and fulminating by assorted members of the one hundred competitors. For example:

- Many of AT&T's customers, competitors and regulators complain that details of the divestiture plan may be more important than the 13-page settlement, which sets out the principles to be followed in shedding the local companies. But, said an independent communications equipment supplier, "only AT&T knows the game plan, and it's the game plan that counts."

- Sen. Robert Packwood (R/Ore)—the primary sponsor of the telecommunications legislation which the Senate passed by a 90-to-4 vote last year—believes that the settlement removes the prospect of long-distance fees subsidizing local telephone rates. The settlement would force AT&T to divest its local telephone companies.

- A pair of Washington Post staff writers predicted, soon after the anti-trust case "settlement," that "legislators, regulators and other policy makers will debate and most likely refine the structure of the telecommunications industry left in the wake... of the settlement. Although industry officials say the settlement will result in fairer dealings among the local phone companies and all other telephone firms, many also acknowledge that the newly constituted AT&T, although smaller, may be an even more formidable giant."

- Christopher Mines, an analyst at the Boston Yankee Group (a research and consulting concern), commenting to the Wall Street Journal, said, "We think business (phone) rates will go up 100% over the next two years... increases will vary from state to state." The Yankee Group also



# HOW TO SEE A PROFIT IN THE RELIGIOUS MARKET. THE COMPACT TOA MODEL RX-31C MIXING CONSOLE.

They're all over the place. From the big city to the rural recesses of America. And no doubt, many of them are your best customers. Or should be. They're the small churches, synagogues and various houses of worship that need a cost-effective and dependable solution to spreading the word; an affordable sound system controller that gets the message across to the fold without emptying the collection plate—a way to communicate the words and music clearly without garbling missives and slurring sermons.

Introducing the TOA Model RX-31C Church Mixer.

The perfect eight by one, tabletop or rack mounting mixer that can be spec'd into the smallest chapel on the stingiest budget.

Engineered with the same reliability and quality performance that is the hallmark of the TOA 900 Series P.A. Amplifiers, the RX-31C ("C" for church, get it?) is compact and loaded with the practical, useful features that you need for the church job. Like: effective, five section peaking equalization and built-in high and low pass filters; on each input,

mic/line and trim control, channel on/off, phantom power for condensers from a heavy-duty power supply, headphone monitoring, and L.E.D. peak indicators for accurate level control. The 31C is fully transformer isolated on both the in's n' outs which are on XLR's. From a nominal +4 to a max of +24 dBm you get performance for any pulpit: 20 Hz to 20 kHz, +0.0-2.5 dB; less than 0.05% THD (+4 dBm @ 1 kHz); and a quiet -132 dBm E.I.N. on hum and noise: to keep the hum out; of the hymn. To keep the control setting sacred, an optional attractive cover can be easily fitted over the top panel. To feed a tape machine there's an individual Record Out from the Line feed. Literally, everything you need to convert the tired, worn-out junk and go on your own crusade to go after the new business that's out there waiting for you.

Start with a TOA RX-31C mixer, but don't forget that you've got all the modular TOA 900 Series P.A. components to go with it. The RX-31C has been engineered to be an additional, integral component to an entire 900 Series P.A. system. No

matter which way you turn, TOA has a way for you to get wholly involved in the religious market.

And see a profit.

Call us for all the details. You just got the word.



*Crafted in Japan.  
Proven in the States.*



TOA Electronics, Inc.  
1023 Grandview Drive South San Francisco, CA 94080  
(415) 588-2538 Telex: 331-332

© 1981, TOA Electronics

**A new concept  
in cable  
that saves up to  
75% of total  
costs... with  
no need for  
conduit...**



## **SIGNA/CLAD<sup>®</sup>**

**The safe, versatile and economical wiring system! Available in both U/L "MC" types for up to 600 volt use as well as for low voltage applications.**

SIGNA/CLAD installations can be made in air plenums, hoistways, shafts and other situations where conduit would be required to contain wiring. SIGNA/CLAD—a completely new, extruded, ductile aluminum sheathed cable packaged on continuous length reels of 500, 1000 and 2000 ft. And, you can easily form and shape the lengths *by hand!*

### **Quick and easy installation saves time and production costs!**

On an installed basis, SIGNA/CLAD can save up to 75% of total costs as compared to wiring in conduit. It completely eliminates cost of conduit and couplers and dramatically reduces labor cost. Installed much like conventional cable, SIGNA/CLAD can be secured with the same type of fasteners used with EMT or NM cable. SIGNA/CLAD can be terminated in outlet or junction boxes with 1/2", 3/4" or 1" holes using fittings for type ALS cable.

For extra fast information and service call: Toll Free 800-323-9355. In Illinois, call 473-2200.

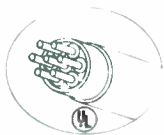

**SIGNAL  
CABLE COMPANY**

A division of  
Electrical Conductors, Inc.  
2325 Davis Street  
North Chicago, Illinois 60064

© 1979 Electrical Conductors, Inc.

Write today for your free SIGNA/CLAD catalog that shows our complete product line, with and without the SIGNA/CLAD features.

surmises that businesses usually get hit hardest when phone rates go up. State utility regulators "view residential customers as their constituents and overcharge business customers," Mines said.

• The National Association of Regulatory Commissioners (NARUC), soon after the settlement, filed a motion to intervene in the anti-trust suit against AT&T, decrying the Justice Department's attempt to dismiss the suit after AT&T agreed, among other things, to divest itself of its 22 operating companies. District Judge Harold Greene refused to allow the dismissal to be filed, stating that the parties had in fact agreed to the entry of a Consent Decree in the case pending before him. In effect, the Judge will review the Consent Decree, and NARUC wants to participate in the review.

NARUC, citing the statutory responsibilities of the state commissions to act in the interests of telephone subscribers, asserted that "the potential for impact upon ratepayers would be immense and perhaps unparalleled in regulatory history." NARUC further asserted that the agreement and AT&T's subsequent implementation plan could, in practical effect, impair the state commissions' legal authority to regulate telecommunications with respective states.

Edward F. Burke, NARUC president and chairman of the Rhode Island Public Utilities Commission, said "It has not been possible to fully evaluate the implications of the proposed settlement, nor did we anticipate the divestiture of the 22 operating companies. We have, therefore, taken the precaution of moving to seek intervention to protect the role of the state commissions and the interests of the ratepayers of all of the United States."

NARUC declared that a related area of concern was the inherent conflict of interest between AT&T and the 22 newly independent local operating companies which would be created by the divestiture. State regulators have expressed apprehension about the effect which the conflict of interest would have upon the evaluation of assets to be transferred. In addition, the state commissioners fear that the agreement could result in encroachment upon state jurisdiction over intrastate telephone rates and service—which, they predict, can rise by as much as 200 to 300%.

U.S. Independent Telephone Association (USITA) is also concerned, according to Jack Harrington, USITA's director of government relations, who reports that its members (1428 independent telcos) are growing increasingly worried that the policy of settlement "can slop over to us." Many firms are concerned about the future of long-distance service and facilities. Some of the long-distance facilities AT&T uses are owned by the independents. As a result, the companies want to be assured that these facilities will continue to be used, and that the companies will continue to be paid for their use after the divestiture plan is implemented.

MCI Telecommunications Corp. chairman William McGowan said that the divestiture of AT&T's local operating companies "is positive and what MCI has been seeking for a long time." MCI would bitterly oppose, asserted McGowan, the establishment by AT&T of a single holding company to run the new local operating firms. "Letting these companies band together could have as ill an effect on long-distance competition as Bell's structure does today." (AT&T floated a "balloon" in a recent statement to the press that just such a "holding company," to direct the 22 companies they would divest, would be organized.)

It is too early to discern the establishing of "structure" and operations by the various elements in telecommunications services—regulated and unregulated. AT&T will require at least six months to a year to put in place a program that has been incubating within their high management offices... a program that will be acceptable to the court, that squares with the new communications act now being written by the House Subcommittee on Communications, chaired by Rep. Timothy Wirth. He has promised to bring in a bill with much tighter reins over AT&T.

There is yet another overseer to the bill and the settlement by AT&T and the Anti-Trust Division of the Justice Department, and that is the House Judiciary Committee chaired by Rep. Peter Rodino. He is reported to be much concerned over protection of the public interest.

In a phrase... regulation of the telecommunications industry is in turmoil.



The new advanced-design S5115HT speaker system.

## EVERYTHING YOU HEAR IS TRUE.

Introducing the S5115HT 3-way, self-contained speaker system. A system with features that are one step ahead of the others.

Features like loudness combined with accuracy. The kind of sharp definition and precise transient response vital for modern keyboards and the demanding standards of live sound reinforcement.

And the convenience of a built-in passive crossover, plus the ability to accommodate the bi- or tri-amplification needs of today's sound systems.

And a system so complete and rugged that it can't be beat. Or beat up. Whether putting in thousands of miles on the road, or turning out sound night after night in the same spot.

The S5115HT. Because the truth is, you need tomorrow's speaker system today.

Visit your Yamaha dealer or write us for more information. Yamaha, Box 6600, Buena Park, CA 90622. In Canada, Yamaha Canada Music Ltd., 135 Milner Ave., Scarb., Ont. M1S 3R1.

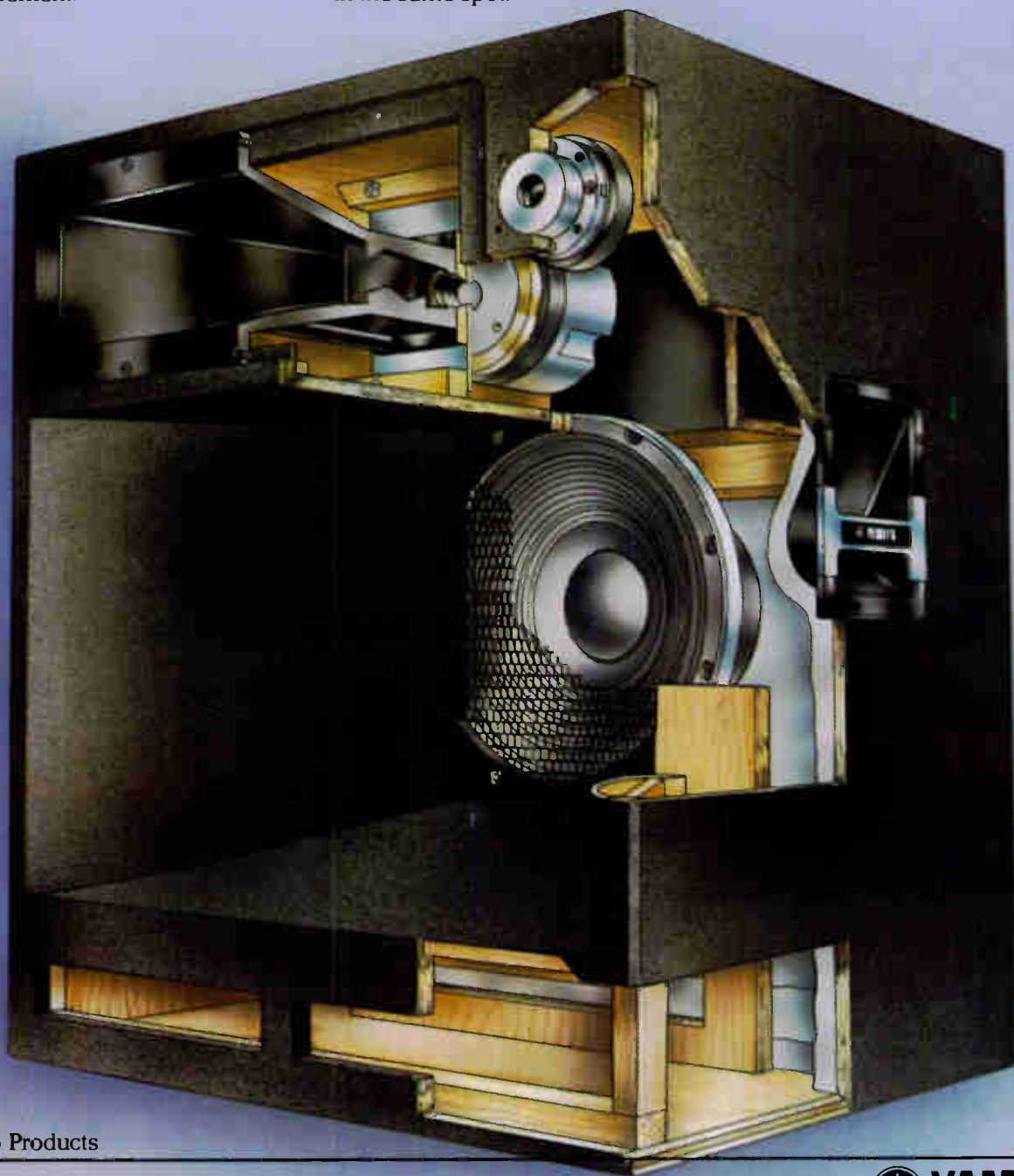

Combo Products

THE WAY IT WILL BE.

 **YAMAHA**



# Spectra Sonics has the answers to important contractor questions.

*The Sound Contractor of the 1980's is entering a new era of limited budgets and increased sound system requirements. To remain competitive will require exceptional audio product performance, at reduced initial and operating costs.*

## Unequaled Performance and Innovative Design for nearly two decades

Since 1963, Spectra Sonics has developed and produced professional audio products that are the first by any measure or standard. As the originator of the modular audio amplification concept, SPECTRA SONICS has accumulated more experience in this realm than any other audio amplifier manufacturer. From the largest performing arts centers, to schools, churches, and municipal sound systems, SPECTRA SONICS audio products continue to perform with an unequaled level of performance, reliability and serviceability.

## Immediate Product Delivery

For over seventeen years, the complete line of SPECTRA SONICS audio products have been delivered immediately in an "off the shelf manner."

## 24 Hour Repair Capability

During this same period of time, processing and shipment of repaired products were, and continue to be, completed within 24 hours or less.

## Cost Effective Design

For the majority of sound system requirements, the cost per watt for SPECTRA SONICS model 701 modular power amplifiers is far below any other conventional or modular power amplifier system.

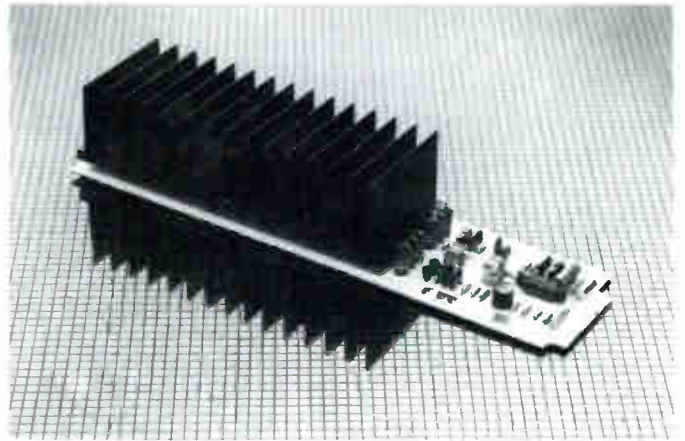

## The Model 701 Modular Power Amplification System

The Model 701 power amplification system is the result of over ten years of modular power amplifier design and operational experience. The performance, reliability, versatility and serviceability far exceeds any other conventional or modular type system. With the simple addition of the Model 505 electronic filter, the 701 system may be used in a bi-amplified or tri-amplified configuration.



## The Model 3100 Self-Powered Portable Speaker System

The Model 3100 is the solution to a number of sound system requirements, permanent or portable. The system is capable of delivering 113dB at four feet. At this sound pressure level, battery operation can be expected to extend beyond 10 hours, (program material). The 3100 contains a power amplifier, microphone mixer (low z), line amplifier, loudspeakers, as well as batteries and recharger. Weighing just 38 pounds, the 3100 may be easily utilized in a vertical or horizontal configuration. The 3100 operates on either 120 VAC (240 VAC optional), or self-contained batteries.

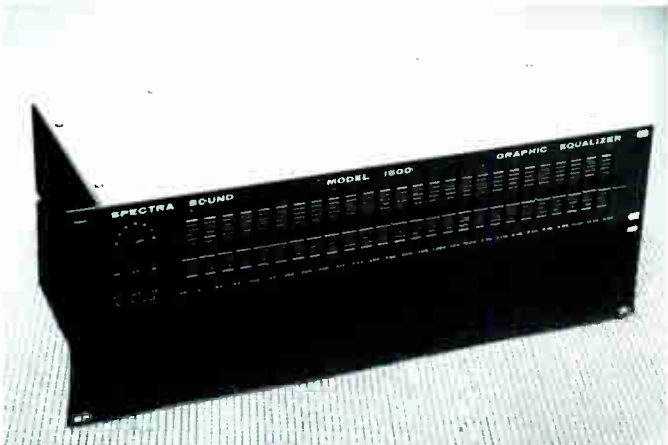

### The Model 1000B and the Model 1500 Graphic Equalization Systems

The Model 1000B and the Model 1500 are unequalled in graphic equalizer performance, reliability, and versatility. Each unit has unmeasurable distortion below .0018% (20Hz to 20kHz, + 18dBv), and the lowest noise of any equalization system, 104dB below + 4dBv, unweighted. Both equalizers feature a switchable boost/cut range, infrasonic filter, and complete system bypass.

Spectra Sound is a wholly owned subsidiary of Spectra Sonics

### For Further Information:

*Spectra Sonics manufactures over seventy professional audio products for every sound system requirement. For further information on the full product line, contact:*

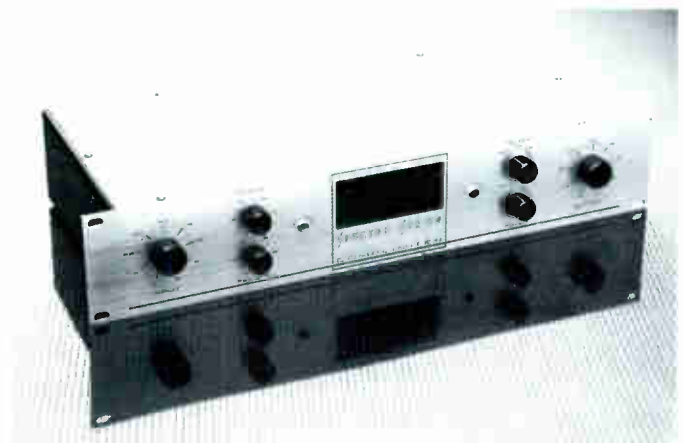

### The Model 610 Complimeter™

The Model 610 Complimeter™ is the only compressor/limiter that functions as a peak limiter and volume compressor, independently, or simultaneously. The Model 610 far exceeds the performance of any conventional compressor/limiters with respect to attack time, variable compression ratios, as well as the lowest distortion and noise.



### The Model 1100 Line/Microphone Mixer

The Model 1100 is a compact rack mount mixer designed for use in sound reinforcement, studio, and broadcast applications. The low noise and distortion of the Model 1100 is unequalled by any other rack mount mixer available to the industry. The unit will accept six line or microphone inputs and provide a monaural and independent monitor output. All inputs and the monaural output of the Model 1100 are transformer isolated.

# SPECTRA SONICS

LEADER IN ADVANCED TECHNOLOGY



3750 AIRPORT ROAD OGDEN, UTAH 84403 801-392-7531

# Conference Communications

**S**CS—the Sony Communication System—is a compact, portable and highly versatile tool for conference situations. Capable of making possible simultaneous interpretation into six languages,

the system is suitable for international conferences, conventions, panel discussions, receptions, meetings, lectures, guided tours, etc.

Simple to install and easy to





handle, the system is designed to fit in castered carrying cases. It adapts automatically to local power sources throughout the world.

Elements of the SCS are available as components, in various configurations, depending on the specific requirements of the user. Featuring both wireless and wired components, the system can be specified according to requirements for conferences in single languages or multiple languages utilizing simultaneous interpretation. The system is built for maximum automation. Most functions are centrally controlled, so that operation by the participants can be reduced to a minimum. This central control in many cases means that fewer on-site technicians will be necessary, thus reducing labor costs involved in conferences.

Inductive loop transmission utilized in the wireless system provides stability, reliability, and good tonal quality. The wired system has equally fine tonal quality and, like the wireless system, incorporates sophisticated Automatic Gain Control circuits to counteract the feedback found in multi-microphone situations. AGC creates uniform volumes, regardless of how loudly or softly the participants speak, and assures fatigue-free communications.

#### The Wired System

The system's control unit, the SX-5000, is capable of operating a chairman's unit and 59 delegates' units (accommodating up to 119 delegates), as well as ten interpreters' units.

Interpreters use the SX-6600 unit, monitoring either the floor language or an interpreted language, should relay interpretation be required. The translated output can be bussed to any one of the six system channels for flexibility in set-up. Complete duplication of all facilities allows two interpreters to alternate from the same booth.

Delegates' units, the SX-3600s, are serially connected, avoiding cable tangles and allowing foolproof two-way communication between participants. Each SX-3600 is designed for use by two delegates.

The chairman's unit, the SX-4600, is similar to the delegates' units and has the additional



Top to bottom: the SX-1310A, SX-6300 and SX-2600 wireless units.

#### SX 5000-Wired System

- 12-pin connectors are employed for all connections.
- The SX-5000 embodies a howling suppressor circuit. In actual application, this circuit eliminates acoustic feedback and, at the same time, cuts the speaker output of those units placed on both sides of one whose microphone is live.
- When more than five people try to speak at one time, an automatic control circuit built into the SX-5000 mutes the output from the SX-3600 (delegates' units) microphones for those people and transmits a chime sound instead. On a priority signal from the SX-4600 (chairman's unit) the SX-5000 also turns off all the delegates' microphones so that only the chairman can speak before the conference.

#### SX-2600 Wireless Receiver

- Automatic Gain Control circuit is incorporated to cope with variations of field strength. The level difference is a mere 3 db in the range from 100 to 130 dBu V/m.
- A taped record of the conference can be made by connecting an optional tape recorder to the recording output jack of the SX-2600.
- The transmitter operates on three carrier frequencies which are oscillated by a phase-locked loop circuit incorporating quartz for high accuracy. The SX-1310 comes in two versions, according to carrier frequencies. Type "A" operates on higher frequencies, corresponding to channels 1, 2 and 3. Type "B" operates on lower frequencies, corresponding to channel 4, 5 and 6. By using one of each version, a maximum of 6 channels can be operated simultaneously.

## Pardon Me . . . But Your Hotel's On Fire.

Hotel fires are no joke. They can be deadly. With the new Tel-Tron FSB Smoke Detector System hotel guests are always safe.



This new system continuously powers and tests all detectors; signals location of any malfunction; sounds alarm and signals location of smoke.

So call us instead of the Fire Department.

Dealer Inquiries Invited  
Phone (904) 255-1921  
800-874-5622

**Tel-Tron**

Tel-Tron Products of Excellence  
Tel-Tron Systems Division  
Radio Manufacturers, Inc.  
220 Fentress Blvd.  
Daytona Beach, Fl. 32014

## For your Business Music Customers



- Background/foreground
- Original artists
- Rent or purchase

Dealer inquiries invited.

Write or phone: 612-733-0447

Sound Products/3M  
3M Center  
St. Paul, MN 55144

3M hears you...

**3M**



Top to bottom: the SX-5000, SX-6600, SX-4600 and SX-3600 wired SCS components.

feature of a priority switch to override delegates.

### The Wireless System

Accommodating the floor microphone, the wireless transmitter is central to the wireless system. The SX-1310 A or B offers three independent channels which can be combined for six-channel operation. Through use of the tuning dial and meters, optimum transmission through various antenna lengths can be accomplished.

The wireless receiver, the SX-2600, is pocket-size, and battery-powered for up to 120 hours use.

The interpreter's unit, the SX-6300, monitors floor or interpreted lan-

guages. Output can be switch-selected to any one of three channels. With this multi-channel configuration, an interpreter can work on bi-directional translation or interpretation into a third language without changing booths. Complete duplication of facilities allows two interpreters to alternate from the same booth.

### System Combinations

The wireless and wired systems may be easily combined for panel discussions or symposiums by specialists of different nationalities. Typically, the participants will use the wired units, while the press, observers and audience use the wireless units. □

# Don't be chicken about buying the best baffle assemblies...Quam!

You can't get a good omelette if you don't start with a good egg. And Quam's not just clucking when we say that you can't get a good baffle assembly if you don't start with a top-grade speaker. After all, which came first—the speaker or the ceiling baffle?

Quam's speaker assemblies—with speaker, transformer, and ceiling baffle mounted, ready for installation—are your most practical choice—because it makes sense to buy your assemblies from the most experienced manufacturer of the most important element—Quam!

Quam starts you off with a choice of 10 different 8" speakers, covering a variety of p.a., background music and related sound system applications, to handle virtually any performance, installation or price requirement.

Yoke it to any of five matching transformers, then top it off with either of two white baffles—steel or plastic. Scramble the elements eggs-actly the way you like; the result will be a complete assembly that won't lay an egg when it comes to convenience, flexibility, and speaker quality.

And here's some news that'll have you sunny side up: there's no charge for the assembly; you pay only the price of the components themselves!

When you're choosing baffle assemblies—don't have egg on your face. Rely on the most eggs-perienced manufacturer—Quam.

## Quam-Nichols Company

234 E. Marquette Rd. • Chicago, IL 60637  
(312) 488-5800

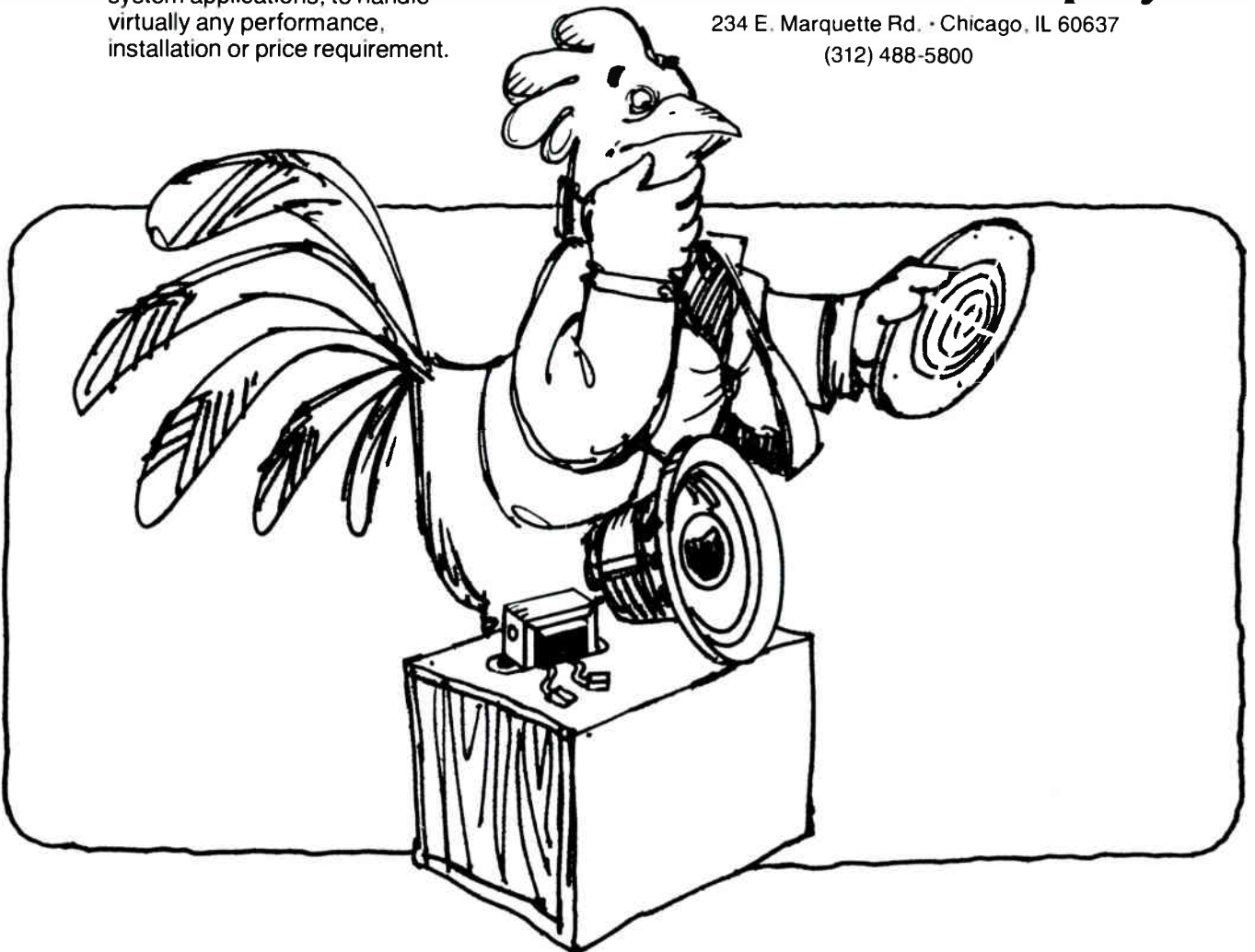

## Quam: the sound decision



# CALCULATING SOUND SYSTEM PERFORMANCE

by Thomas G. Bouliane

This article presents a program, written for hand-held programmable calculators, which employs readily available base data and computes the most relevant performance criteria for supplied sound reinforcement equipment in a given acoustic space. A technique is also presented wherein the effects of occupancy may be used to establish the minimum occupancy required to render a sound system effective in a setting which otherwise would be unsatisfactory when empty.

**E**lectroacoustic practitioners have applied mathematical models to the phenomena comprising their field for several decades. These mathematical analyses have been refined and expanded upon over the years, resulting in improved understanding of the influences on sound system performance. It is possible today to predict in advance of a sound system installation the projected performance of that installation with sufficient accuracy to permit written guarantees in the commercial marketplace.

Until recently, the mathematical procedures required for accurate prediction were very time consuming and thus did not lend themselves to daily application. The introduction of sophisticated and cost-effective computing equipment, however, has eliminated this obstacle and has placed a very powerful analytic tool within the **General Description**

The program is written in Reverse

Polish Notation (RPN), the language of Hewlett-Packard calculators. Sufficient information is provided, however, to permit ready translation into any available language. This information includes a step-by-step program listing with marginal notes defining operational procedures and the applicable formulae, a flow diagram highlighting conditional branches, a listing of storage registers with definitions of terms, and a listing of all formulae employed. The program as written may be directly entered in Hewlett-Packard's Model 41C programmable calculator for immediate use.

The program employs English units throughout. Appropriate constant substitutions are available in the literature for the conversion of this program for metric operation.

### Basic Data Required

The elementary data required include the volume of the space in question (V), the interior surface area of the space (S), the distance of the talker to the furthest listener ( $D_0$ ), the distance of the system's loudspeaker to the nearest open microphone ( $D_1$ ), the distance of the loudspeaker to the furthest listener ( $D_2$ ), either or both the talker-to-microphone distance ( $D_s$ ) and the equivalent acoustic distance (EAD)\*, the average room height (Rm. Ht.), and the number of open microphones (NOM).

The program also requires certain information which varies by frequency. The frequencies of interest are those octave bands ranging from 125 Hz to 4 kHz. The information required includes either the room's reverberation time in seconds ( $RT_{60}$ ) or the room's total absorptivity (Sa) in Sabine units, the number of loudspeakers (N) operating into the space, the four-foot/one-watt sen-

sitivity of these loudspeakers, the directivity factor (Q) of the loudspeakers, the average sound pressure levels required, and the amplifier power available in watts.

Once the information is entered, the program will compute and display:

- Reverberation time ( $RT_{60}$ ), if it isn't already known;
- Average absorptivity ( $\bar{a}$ ) in Norris-Eyring units per square foot;
- Total absorptivity (Sa) in Norris-Eyring units;
- Minimum directivity factor (Q) of the loudspeaker(s) required to achieve  $AL_{cons} = 15\%$ ;
- Critical distance ( $D_c$ ) for the loudspeaker(s) selected;
- Articulation loss of consonants ( $AL_{cons}$ ) of the system with the selected loudspeaker(s);
- Needed acoustic gain (NAG) of the system;
- Potential acoustic gain (PAG) available;
- Electrical power required (EPR) to achieve the average SPL selected; and
- Average sound pressure level achievable with the selected loudspeaker(s) and the available amplifier power.

### Loudspeaker Q vs. Articulation Loss of Consonants

Upon displaying the minimum loudspeaker Q required to achieve

\*Equivalent acoustic distance: That maximum distance in the space at which a listener perceives an unamplified talker with sufficient loudness and with an adequate ratio of direct vs. reflected sound to establish acceptable intelligibility. Used as a performance goal for the installed sound system.

# Shure makes the mixer to fit the need.



## Need a deluxe broadcast remote mixer?

The M267 is ideal for live broadcasts of sports, conventions, other remotes.

- Built-in limiter prevents overload distortion
- Mic/Line Capability on each input and output

## Want professional mixer features at minimum cost?

The M67 is the most popular model for remote broadcast and production work.

- AC or battery operation
- Transformer balanced inputs and outputs

## Want to expand your sound system?

The M268 is great as an independent mixer or for adding inputs to existing sound systems.

- Built-in simplex power for condenser microphones
- Quieter operation than competing models

## Need a low cost, versatile PA mixer?

The lightweight, portable M68 is a great buy as a basic mixer.

## What if input levels vary?

The SE30 is the only combination mixer/gated compressor unit with an adjustable response rate that prevents "pumping."

- Automatic gain riding keeps levels constant
- Lowers background music automatically in paging systems

## Need an 8-channel mixer, but short on space?

The SR109 is popular in large hotel paging systems, as well as small post-production rooms.

- 8 channels with bass and treble tone controls
- Built-in limiter

Write for our free circuitry catalog.



**The Sound of the Professionals®**

Shure Brothers Inc., Dept. 67  
222 Hartrey Ave., Evanston, IL 60204  
In Canada: A. C. Simmonds & Sons Limited

Manufacturer of high fidelity components, microphones, loudspeakers, sound systems and related circuitry.

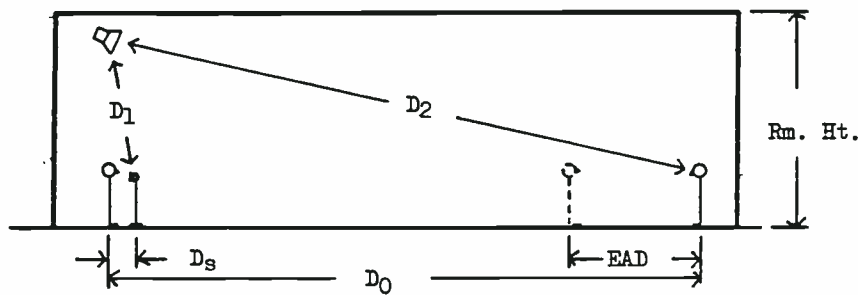

Distance designations for central loudspeaker designs.

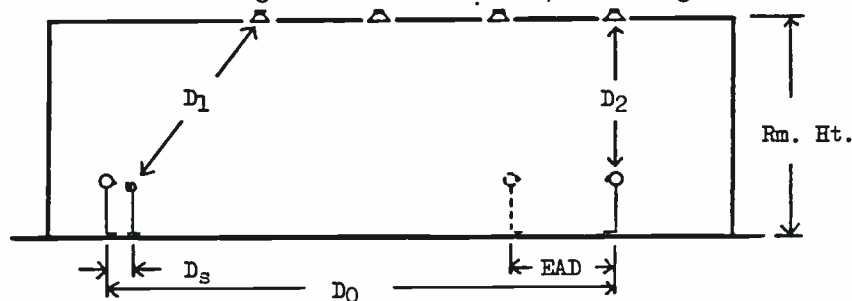

Distance designations for distributed loudspeaker designs.

The operator enters that value and continues through the data collection process. During this stage, the operator will be asked for values of  $D_s$  and EAD. He may either enter the values he has selected or enter zero for an unknown. He will also be asked if the room's reverberation time is known (RT60 KNOWN?). If it is, he enters any number other than zero to signify a "yes" reply; if it is not known, he enters a zero to indicate a "no" response.

Depending upon his reply to this inquiry, the program will next prompt for the reverberation time in the octave band of interest (RT60=? ) or for the total absorptivity in Sabine units for that octave band ( $S_a:S_{ab}=?$ ). The program will then compute and display the average absorptivity per square foot of surface area in Norris-Eyring units ( $a:N-E=?$ ) and the total absorptivity in Norris-Eyring units ( $S_a:N-E=?$ ).

The next item to appear is an operator prompt for the number of loudspeakers operating into the space in the octave band of interest (NO. SPKRS.=?). This figure is the ratio of total loudspeakers to that number covering the listener at  $D_2$ . Upon receiving that figure, the program then computes and displays the minimum loudspeaker Q required for  $AL_{cons} = 15\%$  (MIN. Q=?). When the program is advanced by the operator, he is then asked for the Q value of the loudspeaker(s) he wishes to test (Q AVAIL.=?). The program then computes and displays the values for critical distance ( $D_c=?$ ) and articulation loss of consonants (%AL=?) for that loudspeaker choice. If the resulting  $AL_{cons}$  figure is greater than 15%, the program will ask the operator if he wishes to test another Q value (NEW Q=?). He may either enter a new value for Q or enter zero to signify a "no" response. If a new value is entered, the program will recompute and display revised value for  $D_c$  and  $AL_{cons}$ .

If the operator elects to remain with the original Q value, the program will then prompt him for the frequency band in which he is working (FREQUENCY=?). The operator then enters an octave band center frequency ranging from 125 through 4,000. Should the operator

$AL_{cons} = 15\%$ , the program will prompt the operator for the Q value of the selected loudspeaker(s). Once the value is entered, the program will compute and display the  $AL_{cons}$  available for the loudspeaker choice. Should the resulting  $AL_{cons}$  be greater than 15%, the program will prompt the operator for a revised Q value. The operator may then alter his selection and the program will compute and display the  $AL_{cons}$  figure for the revised Q value.

### Occupancy as Added Absorption

If the operator elects to remain with the original Q value, the program will proceed to compute and display the minimum number of occupants required in the space to achieve  $AL_{cons} = 15\%$  with the selected loudspeaker(s). The program then prompts the operator for the number of occupants he wishes to test. Upon entry of that figure, the program then recomputes values for  $\bar{a}$ ,  $S_a$ ,  $RT_{60}$ ,  $D_c$ , and  $AL_{cons}$  for the new condition of occupancy.

### Maximum $D_c$ and Minimum EAD

The operator may have elected, during the entry of the initial data, to omit values for the talker-to-microphone distance ( $D_s$ ) or the equivalent acoustic distance (EAD). If this was the case, the program will also compute and display:

The maximum  $D_c$  permissible with the given EAD; or

The minimum EAD achievable

with the given  $D_s$ .

In each of these instances, the program will prompt the operator for the value of the missing item, then calculate and display the system's needed acoustic gain (NAG) and potential acoustic gain (PAG).

### Varying $D_c$ and EAD for Improved PAG vs. NAG

Should the system's PAG be less than its NAG, the program will prompt the operator for revised  $D_s$  and EAD values. Once entered, the program will compute and display NAG and PAG for the new condition.

### Amplifier Power and the SPL Available

Finally, once the program computes and displays the electrical power required to achieve the desired average SPL level, it prompts the operator for the amplifier power available. When entered, the program computes and displays the average SPL attainable with that power. Should this value be less than that desired, the program will prompt the operator for a revised amplifier power figure. It will recompute SPL levels for the revised power figure(s) until the resulting SPL equals or is greater than that desired.

Once accomplished, the program will prompt the operator for the  $RT_{60}$  or the  $S_a$  for the next octave band of interest. The program then recycles in its entirety.

### Operation Guide

The program begins by prompting



# Lexicon Has a Delay System for Every Application and Budget

## The Lexicon Model 91 Delay System

We've taken our sophisticated big-system Model 102 PCM technology and packaged it for small budgets — churches, schools and colleges, community auditoriums and similar installations.

And, we've done it without compromising on Lexicon quality or resorting to delta modulation techniques.

Our modestly priced Model 91 has features that have made the 122 the choice for many of the world's greatest concert halls and studios. You get ultra low (less than .08%) noise and distortion...dynamic range greater than 90dB...0 to 120ms delay, adjustable in 7.5ms increments...5-level LED headroom indicator... automatic audio by-pass for zero delay or emergencies... plus other advanced Delta-T performance extras.

And, like all Lexicon systems, the Model 91 digital delay is conservatively designed and modular for fast, easy, on-the-spot maintenance. There's nothing like it in its price range.

## Model 92 System

Another modestly priced Lexicon system with "concert hall quality" features! Gives you all the superb performance of the Model 91 — plus two delay outputs instead of one. The Model 92 is also an excellent choice for sound studios where a quality delay is required for doubling or echo pre-delay.

## Prime Time Model 93 Delay/Processor/Mixer

Specifically designed for studios and entertainers the Model 93 combines flexibility and versatility heretofore unavailable in any system anywhere. Included are two time delay outputs independently adjustable from 0 to 256ms... complete mixing for delay and reverb processing... integral VCO for vibrato, doppler pitch shift, flanging and similar special effects... long delay (up to 2 seconds) special effects... and numerous other advanced capabilities. Features 90dB dynamic range, with less than 0.08% distortion at all delay settings.

## Model 122 Series

The ultimate in sound quality. Stereo and Mono models for studios and sound reinforcement with 15 kHz bandwidth and 1 to 5 outputs. Options include VCO, remote controls and Extension Chassis for very large systems. Full modularity and computer quality construction insure system flexibility and high reliability, proven in more than a thousand installations world-wide.



Big project or small, the job's done right when it's done with a Lexicon digital delay system. Write for full information.

# Lexicon

Lexicon, Inc., 60 Turner Street, Waltham, MA 02154 (617) 891-6790  
Export: Gotham Export Corporation, New York, NY

World Radio History

enter an inappropriate figure at this stage, the program will prompt him to RE-ENTER a proper value. Once a valid figure is entered, the program will then compute and display the minimum number of occupants required to fill the space in order to achieve  $AL_{cons} = 15\%$  with the loudspeaker Q being tested (MIN. OCC =). The next operator prompt is for the value of occupancy the operator wishes to test (NO. OCC. =?). The operator then enters the occupancy figure and the program computes and displays revised figures for Sa:N - E,  $\bar{a}$ :N - E,  $RT_{60}$ ,  $D_c$ , and  $AL_{cons}$ . If the revised  $AL_{cons}$  figure remains less than 15%, the program will again ask the operator if he wishes to test another Q value. He may enter a new value for Q at the point and the calculations resulting from this figure will be based upon absorptivity values for the state of occupancy he earlier defined. If he elects to remain with the original Q value, the resulting MIN. OCC. figure will be for that number of additional occupants required to establish  $AL_{cons} = 15\%$ .

Once an articulation loss figure of 15% or less is achieved, the program will proceed to compute and display values for needed acoustic gain (NAG) and potential acoustic gain (PAG). If either the value of  $D_s$  or EAD had been omitted during the entry of the initial data, the program will compute and display the maximum value of  $D_s$  (MAX. DS =) or the minimum value of EAD (MIN. EAD =) permissible for PAG = NAG. Once this figure is displayed, the program prompts the operator for a chosen value for the missing item: (CHOSEN DS =?) or (CHOSEN EAD =?). The program completes its computation of NAG and PAG upon

receiving the chosen value and displays the respective figures. Should PAG be less than NAG, the program will display that fact (PAG < NAG) and prompt the operator for a revised  $D_s$  or EAD figures. As with the  $AL_{cons}$  and Q computations described above, the program will compute and display new values for NAG and PAG upon the entry of revised  $D_s$  or EAD values.

The next operator prompt is for the average sound pressure level desired of the system at  $D_2$  (DESIRED SPL?). Upon entry of that value, the program prompts the operator for the four-foot/one-watt sensitivity figure of the loudspeaker(s) operating into the octave band of interest. The program then computes and displays the electrical power required to achieve that sound pressure level (EPR =). The program then prompts the operator for the amplifier power available to drive the loudspeaker(s) (W. AVAIL. =?). Once entered, the program computes and displays the average sound pressure level achievable with that amplifier power (AVAIL. SPL =). If this value is less than that desired, the program will prompt the operator for a new power figure (W. AVAIL. =?). The program will continue to compute and display revised SPL figures until adequate amplifier power is supplied.

This completes a full cycle of the program. Once adequate SPL is established, the program will return to the beginning of the process and request either the reverberation time ( $RT_{60} = ?$ ) or the absorptivity (Sa:SAB. =?) for the next octave band of interest. The program then continues through the cycle again until the operator gathers all the required data.

*Mr. Bouliane studied physics and engineering at the University of Buffalo and began his career in audio engineering with Seneca Sound Inc., then the Altec contractor for Western New York State. He was responsible for the sales and engineering of non-entertainment reinforcement systems and became a Synergetic Audio Concepts graduate while with that firm.*

*He is presently with Audio Contractors Inc., the Altec contractor succeeding Seneca Sound, where he specializes in electroacoustic applications. He is a member of the Audio Engineering Society and his work can be heard at The Chautauqua Institution, the State University of New York at Buffalo, and at several other Western New York State sites.*

## Application Notes

The program tests the space in question for a statistically valid reverberation field as defined by Davis<sup>1</sup> in each frequency band of interest. The operator is automatically cautioned in the event that the statistical foundation for the application of these calculations is weakened. The program also uses the Norris-Eyring family of equations<sup>2</sup> throughout.

The program calculates the electrical power required (EPR) and the sound pressure levels resulting from a given amplifier power figure on the basis of average program levels. These figures assume a requirement for a 10-dB "headroom margin" above the average level. When entering the desired SPL figure, the operator should be aware that this is an average level and that the 10-dB headroom margin is accounted for. The EPR and SPL AVAIL. figures resulting from the calculations are also average levels and peak values will be 10 dB higher than shown. □

*Information in this article is taken from a paper presented at the 70th Convention of the Audio Engineering Society, October 30-November 2, 1981, New York. Reprinted with permission.*

## Acknowledgements

*The author wishes to acknowledge the contributions of Don and Carolyn Davis. Their labors, through Synergetic Audio Concepts, represent a diverse and comprehensive source of information in the electroacoustic field. All the formulae and variations used in this program can be found in their book Sound System Engineering, a required text for all serious sound system designers. Bill Raventos of Ivie Electronics, Ray Rayburn of Rayburn Electronics, and Glen Ballou of United Technologies also deserve my thanks for arousing my interest and involvement.*

## References

- (1) Don Davis, "Uses, Abuses and Misuses of the Critical Distance Concept," Syn-Aud-Con Tech Topic, Vol. 7, No. 12, p. 1 (Summer, 1980).
- (2) Don and Carolyn Davis, Sound System Engineering (Howard W. Sams, Indianapolis, 1975), p. 64.



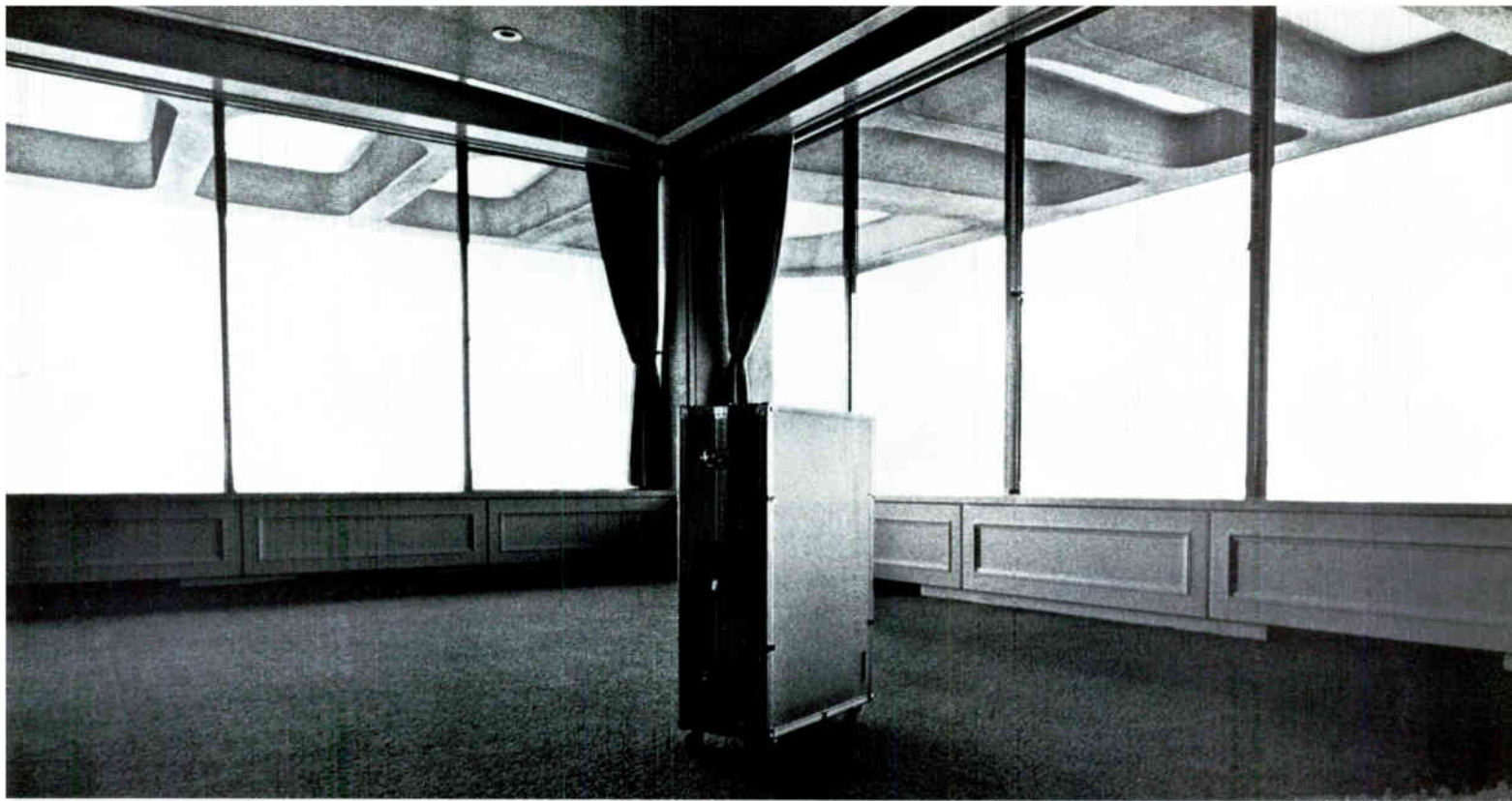

# IN 30 MINUTES YOU CAN TURN THIS SUITCASE INTO AN INTERNATIONAL CONFERENCE CENTER.



Believe it or not, packed inside this small suitcase is enough interpretation equipment to allow up to 50 people to communicate in multiple languages—simultaneously. And its set-up time, whether for panel discussions, conventions, receptions, meetings, lectures, or even full-blown international conferences, is a mere one-half hour.

No, Sony hasn't gone into the suitcase business, although we'd be happy to tell you where to find them, but what we are selling is the remarkable Sony Communication System inside.

Built around the suggestions of experienced interpreters working directly with the engineering staff at Sony, it's the most dependable, the most flexible, the easiest to handle, the simplest to install (actually adapting to any local power supply anywhere in the world), and therefore it's the most practical communications system you can buy.

To find out exactly where to buy it, or to simply find out more information about the compact Sony Communication System, write to Sony, Professional Audio Division, 9 W. 57th St., New York, NY 10019, or call Robert Hecht (212) 371-5800 or John Phelan (213) 537-4300.

**SONY.**  
Professional Audio



# Long-Distance Resale & the Hospitality Industry

by Kenneth Casner

The idea that a hotel is entitled to compensation covering the expense of providing phone service isn't new. Since 1945, AT&T has authorized operating companies to pay them a 15% commission on interstate long distance for acting as telco's collection agent. That's about 50 cents a call for being a bookkeeper, auditor, public relations rep and semi-public utility. Manually adding taxes and surcharges to HOBIC slips before posting them to the room folio; accounting for wrong

room numbers and writing credits to guests who claim they didn't make a call; and maintaining a PABX system with the people to operate and service it—it's always been a losing proposition. But those were the rules.

Well, the rules have changed. On December 28th, 1980, the FCC published Report and Order 80.54, "...Policies Concerning Resale..." Placing a guest's long distance calls via Direct Distance Dialing (DDD) or WATS became an alternative to using HOBIC. Then, how to charge for the service became a problem. That's because until recently considerable speculation existed over the definition of the term "resale." In an earlier decision, FCC Docket 20097, it was defined as the product of "...a flexible, specialized common carrier which purchases... facilities at discount rates and offers them (at a profit) to the small user." But this requires a license (FCC 214) and the filing of a tariff.

To avoid the regulatory issue became the common goal of the AH&MA and the Commission. On June 26th, 1981, the FCC published a Public Notice to clarify its position on resale and the hospitality industry.

According to this statement, the term "resale" and its inherent restrictions no longer applied if the income from service was related to compensating for overhead expense rather than creating a net profit. At the same time, AT&T announced that the 15% was to be discontinued after the first of the year (since extended through 1982).

## Starting Your New Business

Congratulations! You're about to break the umbilical cord, providing guest phone service on your own

hook. And like any other business you've been involved in, success depends on your ability to compete. That presents a problem when your only competition is also your only supplier—especially when the phone company sets its own prices and makes its own rules.

If you're never thought of the phone company as a rival for your guests' business, consider the following: over 50% of your potential gross sales is already siphoned off in the form of credit card (now "Calling Card"), third-party billings, reverse charges, person-to-person and international calls. And if you're aware of AT&T's most recent rate request, you know that they are trying to make Calling Card service more attractive by reducing its cost over charge-to-room calls by 73%. That's stiff competition!

Add to that the potential of a new tariff on WATS and DDD, increasing the cost of monthly service by \$200 a line in a resale environment. That request has been with the Commission for some time now. Then there are the Supplemental Common Carriers (MCI, Sprint, ITT, Western Union, etc.) who are courting the business traveler with dial-up discount long distance services. A problem, yes, with many solutions. A few are outlined in this article.

## The Way It's Always Been

Rather than use trade names, we've divided available equipment into general categories by function. As a base to work from, the first

Mr. Casner is V.P., Marketing, for TDX Systems.

For business  
and industry...

a proven intracom  
Communications System



- Fast food
- Retail Stores
- Manufacturers

Distributor inquiries invited.  
Write or phone: 612-733-0447

Sound Products/3M  
3M Center  
St. Paul, MN 55144

3M hears you...

**3M**

# EXES INTERCOM SYSTEMS FROM TOA: THE FEATURES, QUALITY, PRODUCT RANGE AND PROFIT YOU CAN SPEC' INTO ANY JOB.

With a TOA intercom, you can stay in touch with the entire market.

Never before has the need for fast, reliable and efficient communications in business, industry, education and the medical field been more in the forefront for the sound contractor. From the small office to the large facility, there's a demand for independent communications systems that are compact, feature-laden, expandable and affordable. And that's where the complete TOA line of EXES systems comes in.

To satisfy any requirement, in any price range, you can specify an EXES system with total confidence, knowing that you've chosen the most advanced, easiest to install and most profitable intercom on the market. There's three basic systems to choose from: 16 station up to many hundreds, all electronic and microprocessor-controlled from centrally switched ex-

changes (we invented this innovative technology six years ago). Operational formats are duplex, "hands-free" through master and sub-stations in desk and wall mount configurations including portable handset capability.

Best of all, an EXES system won't haunt you after its simple installation; regardless of the size of the system, operational costs and maintenance are always minimal. Future expansion with the modular design of all EXES systems (including tie line requirements) is something to look forward to, not have nightmares about.

With EXES you get a wealth of features that everyone wants including contractor and user-programmable functions, eavesdropping privacy protection, PA access, dial-access switching and much more. When it comes to quality, you've got us wired too: voice recognition is excellent

with switching speed in the microsecond range. There's no feedback due to special engineering of the acoustical chambering and frequency response characteristics.

Not only is a TOA EXES intercom a dynamic and evolutionary system that can grow with any client's requirement; it's available from stock too — with complete technical back-up and installation/operation software that makes your life easier, not more complicated.

Call us now to find out how you can stay in touch with the entire market, and make a profit while you're at it. We'll send you complete details on EXES, the affordable solution to the most complex intercom system you can dream up.



*Crafted in Japan  
Proven in the States.*

**TOA Electronics, Inc.**

1023 Grandview Drive  
S. San Francisco, CA 94080  
(415) 588-2538 Telex: 331-332



© 1981, TOA Electronics

diagram (A) represents how it's always been done. Administrative and local guest calls are sent via dial "9" trunks. Local call charges are usually generated at the telco central office and returned to the hotel as electrical pulses accumulated on electro-mechanical message meters. Long distance is handled via HOBIC, dial "8," and directed to a special central office, where an operator interrupts each call with a request for the caller's room number. Charges are returned via a phone call to the hotel's attendant, or over a data circuit to a teletype machine.

### Four Ways to Beat the System

The second diagram (B) details the least complex method of getting into business. It's also the least expensive, least complicated, and as a result offers the least protection from the inevitable...change. A dialed-digit scanner is attached, in your equipment room, to the two wires connecting your phone system to the instrument in each guest room. These connections are referred to as "tip and ring" because they describe their use in the scheme of a PABX's electrical function. As each call is made, the scanner passes information on the numbers dialed to an on-site information processor. The processor times each call and on completion presents the equivalent of a HOBIC slip, with taxes and surcharges already figured.

To facilitate the use of DDD, the phone company has made a new type of HOBIC service available. When installed, calls that are prefixed by a "1" go directly to the DDD network without operator intervention. Charges are made at the DDD rate and are presented in a monthly bill, just as are calls made on local dial "9" lines. "O+" calls still go to the operator. The teletype must be retained for receiving call charges attached to "011" international and for other occasions when a guest charges to the room.

The problems attached to this solution are easy to spot, the first connected with the methodology itself. Since the system isn't integrated electrically with your PABX, failures mean no call ticket. But the calls still go DDD and you pay for them until the repair man gets there.

The next choice (C) adds a new element to the essentially "passive"

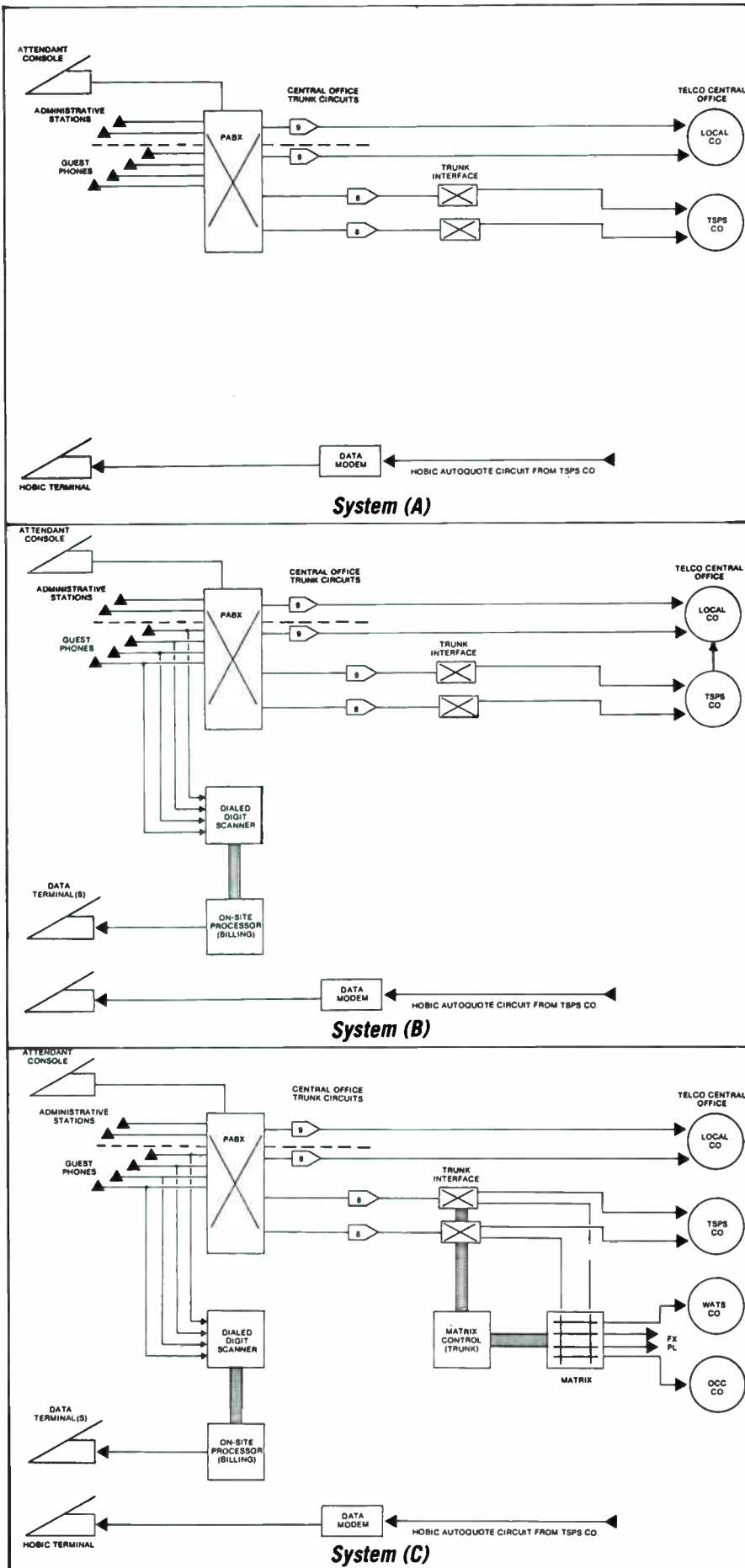



# When a business calls for a better phone system



## customize with KeyPak.™

For any business that's growing, a phone system that streamlines communications is essential.

That's why Tele-Path's KeyPak™ System is made to suit any customer, large or small. So you can give them the features they need in their phones. And help them build for the future.

**Build all-new communications. Or modernize existing systems.**

Perhaps a customer needs only basic intercom capability. KeyPak keeps it simple for them and you.

Or maybe more complex features are in order. From Handsfree TalkBack to Automatic Privacy, Busy Override to Toll Restriction, KeyPak supplies the features-- made to order.

Our unique modular approach to telephone systems allows customized expansion with exactly-- and only--



the options your customers need.

In fact, KeyPak is so versatile, it can be used to enhance an existing 1A2 Key System, or serve as the core of an all-new system you create.

KeyPak is profitable for your customers and for you. Because it brings them back to you for future expansion.

For all the advantages of KeyPak, get in touch with Tele-Path Industries today

and let us key you in.

### Some of KeyPak's most popular options are:

- Handsfree TalkBack®**  
With a call announcing such as our TalkBack Phone II, you listen and reply over the speaker without holding a receiver.
- Internal and External Paging**  
Use your phone to reach employees

Check No. 7 on Reader Service Card

fast. Over their TalkBack or a public address system.

- Off-Hook Busy, Camp-On Busy, and Busy Override**

Gives intercom caller a busy signal when phone is off-hook; lets call get through when line is free. Override lets priority intercom calls get through to busy stations.

- Off-Premise Stations**

Connects other company locations over the intercom.

- Trunk Add-On® and Transfer**

Lets you put through outside calls to off-premise company locations. Calls can then be transferred to other stations or back to the receptionist.

- Through-Dialing to Other Locations**

Tie lines can link offices across town or across the country.



2760 Mary Linda Ave., N.E.  
Roanoke, VA 24012 (703) 982-8844

# Intercom/Interconnect

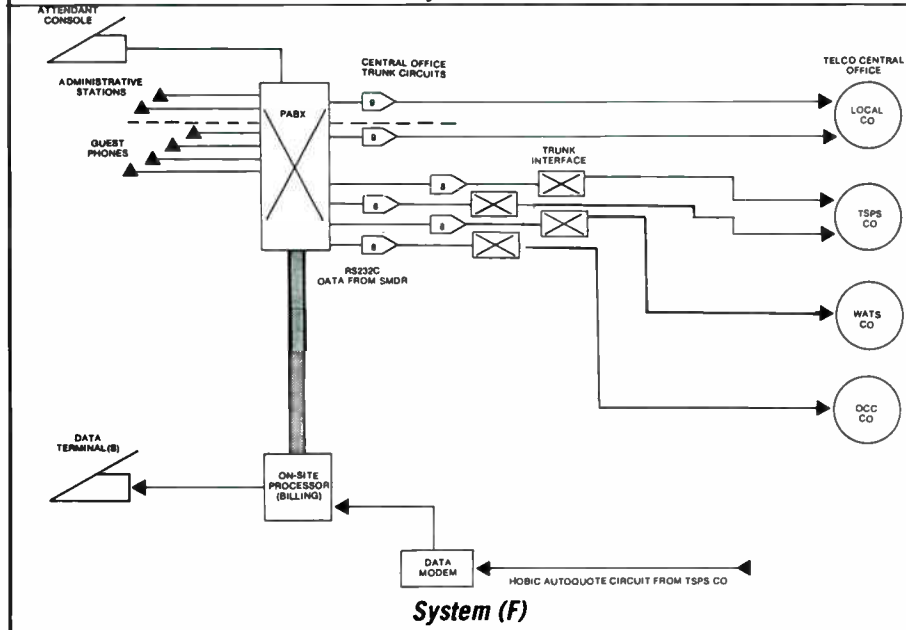
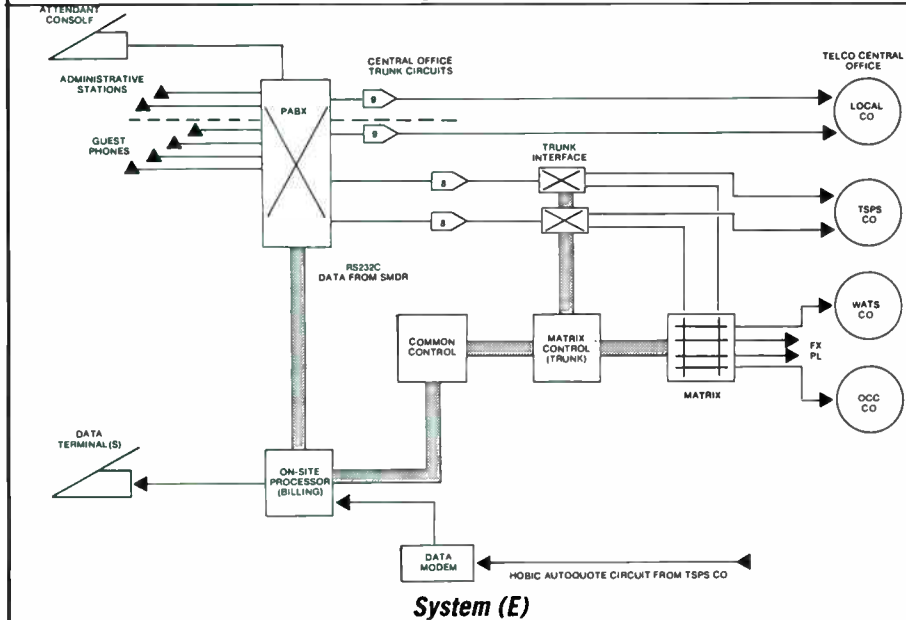
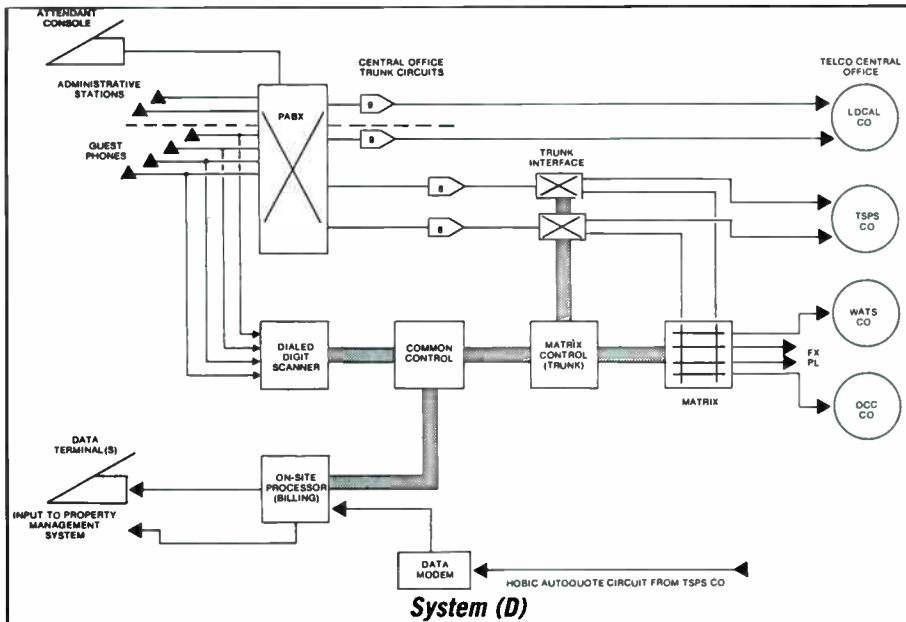

situation described in B, routing, or least-cost call routing. A dialing mechanism is inserted (interfaced) between the output of the PABX dial "8" trunks and a variety of facilities (including DDD and HOBIC) that can be used to process calls. This system may be as uncomplicated as is necessary to send all "1+" calls to a dial-up carrier, or as complex as necessary to analyze the digits dialed and make a choice between dial-up carrier, intra- and interstate WATS.

In the industry we refer to this combination of elements as an "active" system. Active, but in this diagram not interactive. And problems similar to the passive setup still exist.

System (D) represents the ultimate, the fully integrated-active system. First shown in this diagram is the coupling of HOBIC to the on-site processor and the availability of a property management (front-desk system) computer link. What makes this system different, though, is the common control concept used. In simpler terms, its right hand always knows what its left hand is doing. If a trunk fails to function, the program may be arranged to re-route calls over an alternate facility. Diagnostic notices may be issued through the terminal to alert the maintenance man before a problem becomes serious. Most important, calls can be sent via HOBIC temporarily, with no loss to the property and no inconvenience to its guests.

System (E) shows how the expense of one costly element in an active-integrated unit is eliminated. In this case, call detail output from the SMDR port of a smart PABX is used to replace the Dialed Digit Scanner. This approach can save about 40% on the cost of an installation. The added cost of SMDR, when purchased with a new PABX, is generally less than a thousand dollars, considerably less than the Scanner.

Finally, System (F) eliminates the need for any peripheral component save the on-site processor. It uses the combination of SMDR and Least-Cost Routing functions found in many of the more sophisticated computer PABXs available. The PABX monitors the digits dialed by a guest and sends the call over the least costly facility available to it. SMDR information is sent on com-



# ITT JUST REINVENTED INTERCOMMUNICATIONS. AGAIN.

ITT loves invention. That's why we're a world leader in duplex intercom systems.

Our revolutionary micro-processor-based Time Expander™ system set new standards for the industry by combining unmatched features, flexibility and economy. Providing unmatched sales and profits for our distributors—all in the same package.

Now, we've done it again.

**A small miracle called Minicom® II.** What the Time Expander does for your larger customers, Minicom II does for the vast majority of your market: 8-64 stations. **With a breakthrough pricing advantage below 24 lines!**

In a micro-sized cabinet that measures barely 15¾" x 27½" x 12", this advanced software-controlled microprocessor system lets you offer your customers **over a dozen standard features without rewiring, predesignation or preprogramming.** All, on compact 2-pair wiring with the fastest, most fool-proof installation on the market.

**Efficiency. And cost effectiveness.** Direct dialing... hands-free conversation... camp-on... paging with meet-me... are just some of the 'standard' features that give us the edge in intercom technology. To give you the edge in sales.

Plus our exclusive combination of hands-free speed with full-duplex on handset-to-handset

calls. Extremely versatile call, transfer and forwarding abilities. And that's not all.

As part of our ELS intercom family, the system also offers sophisticated capabilities that make it ideal for school and hospital use. Exciting options like background music, dialed in or out at each extension. And much, much more!

**No compromises.** It's this simple: we just invented a whole new group of prospects for you.

Because with ITT, smaller customers don't have to settle for pared-down features. And you don't have to settle for reduced margins. (Line-by-line, instrument-by-instrument, nothing even comes close!)

For more information on our distributor program, contact Ron Stone, President, (212) 839-0500.

**ITT** DESD

One World Trade Center, Suite 8927  
New York, NY 10048





pletion of the call to the on-site processor for billing. There are even rumors of a new generation of PABXs that can handle the billing internally.

## Conclusion

Just as corporate discounts and convenient locations are good selling points, a property's reasonable long distance charges can be worth advertising. The decision on what system to buy should be weighted as much by marketing considerations as technical. Many of the available systems are modular. They may be installed as passive today and reasonably upgraded to integrated-active when necessary. Any decision must take into account the prospect of purchasing an entire new PABX.

Chances are you've already calculated the gross on selling DDD calls at Operator-Assisted rates. It looks good on paper, practical, until AT&T modifies the Operator-Assisted tariff, or makes Calling Card service available at no extra charge. Then what? That's why the ability to use

alternatives to DDD like WATS and competing common carriers like MCI and Sprint are important in the near future.

The fact is that any property may improve its P&L statement in the area of guest long distance without an inordinately large capital investment. Many suppliers are quite willing to finance installations out of the increased revenues generated by their systems. It would pay to speak to several before making a decision. We hope that the information presented in this article will serve to make that decision easier.



## Information Processing

Since more than 1,100 hotels and motels already have computer systems in use or on order, the acceptance of hotel data processing already has a stable base. The list of vendors who are marketing those systems is less stable.

During 1981, 17 vendors entered the hotel data processing market

with new systems. During the same period, 13 vendors of hotel data processing systems restructured, merged, sold out, or simply faded from the competitive scene. That leaves American hotel properties with a choice of 28 hotel data processing systems, with four others in advanced stages of development.

That volatility is not all bad, since the seasoned survivors have steadily improved their systems, and the newcomers have learned from the mistakes of the dropouts. Some of the best systems of a few years ago would be totally non-competitive in the present market.

Continued improvement of available systems is likely in 1982. Hotel operators are becoming more sophisticated in their use of data processing, and therefore are becoming more demanding.

Changes in hotel data processing are likely to be evolutionary rather than revolutionary, but 1982 will hopefully see advances in these areas:

1. Improvement of some of the back-office applications, often the weakest part of the vendors' systems. Too often they have adapted a general accounting package, without making sufficient modifications to meet the specialized requirements of the lodging industry.
2. Expansion of some of the systems to meet the requirements of larger properties more effectively. There are still surprisingly few systems which handle effectively the data processing requirements of hotels of more than 700 rooms.
3. The first releases of lower-cost micro-computer versions of present systems, aimed at making those systems cost-justifiable for properties of 100 rooms.
4. Extension of the capability of some of the computer systems to interface with the telephone equipment, energy management systems, fire safety, or security systems. Too few of the present systems have yet developed their potential in multi-discipline technology.
5. Development of phone-call accounting packages and exten-

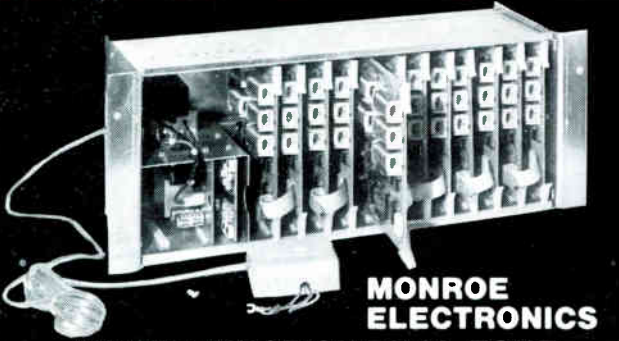

**MONROE ELECTRONICS**  
**MULTI-FUNCTION DUAL-TONE TELEPHONE REMOTE CONTROL RECEIVER SYSTEMS**

Single function or expandable systems respond to DTMF codes to provide latching or momentary relay outputs. Verification and status information is conveyed by audible tones.

- Magnetically latching or momentary relay outputs.
- Responds to DTMF codes from standard dial-up telephone.
- Microwave or radio link audio input.
- Operates from 24 VDC or 117 VAC.
- Expandable up to 60 relay outputs.

**\$1,825**

**OPTIONAL:** contact status monitor with alarm, voltage limit status monitor with alarm and auto dialer.

**ALSO AVAILABLE:** Radio-telephone interconnect systems, FSK Remote Monitor and alarm systems.

Write for brochure on Tone Signal Products

**M E** **MONROE ELECTRONICS, INC.**  
224 Housel Avenue, Lyndonville, NY 14098  
Phone: (716) 765-2254

# CUTTING COST Isn't The Only Reason You'll Like Our Line Status Monitor.



The LSM 2000, Line Status Monitor, expands the capabilities of your PABX system by utilizing the most modern and efficient features available. At the same time it eliminates the need for costly key telephone sets and still provides the functional equivalent to Key Systems.

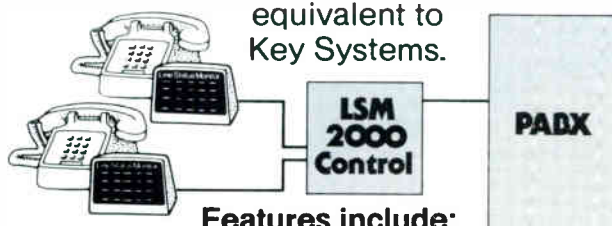

Features include:

- Busy Station** — When a telephone in the group is in use, the associated LED is on steady.
- Idle Station** — LED is dark when telephone hand set is in place.
- Ringing Station** — LED associated with ringing station flashes on and off in con-

junction with an alert tone until station is answered or call is abandoned.

**20 Station Group** — The LSM 2000 may be used with groups from one to twenty.

**Multiple Location** — Same station monitoring may be accomplished at more than one location or several groups of same and/or different stations may be accomplished from one control unit.

**The LSM 2000 for improved efficiency and reduced expense.**



**Southwest  
Utilities** INC

1301 CORNELL PKWY  
SUITE 800  
OKLAHOMA CITY, OK 73108

For more information call 405•946-1200

sions of present computer systems. This will permit at least two vendors of hotel data processing systems to offer phone-call accounting without the need for an extra microprocessor.

6. Expansion of at least two of the present computer systems to permit them to receive reservations information directly from central reservations system. At least one of those systems will also be able to receive reservations, via the AIRINC network, from several hundred airline and travel agent terminals.
7. Development of an automatic check-out terminal, activated by any of the major credit cards. The new terminal would make it unnecessary for card-carrying guests to wait in line at the cashier's station.

*reprinted with permission from Hotel & Resort Industry/December 1981; written by Larry Chervenak/president, Chervenak, Keane & Company.*

## SYSTEM AND PRODUCT SUPPLIERS FOR HOBIC

### OEM Suppliers/Retailers

Sykes Datatronics Inc.  
Datapoint Corporation  
Com-Dev  
Linatel Systems  
Telephone Management Systems  
Roim Corporation

### Manufacturers Selling Direct

Telesphere International  
Northern Telecom  
International Systems Inc.  
Homisco Inc.  
Micro Plaza Inc.  
Tri-Tech Systems  
Shure Communications  
Bitel International Corp.  
Hotac  
Alston-Conrac  
NPS Teletrak  
TDX Systems

### Retailers

Telecommunications Facilities Management  
Marmon Group

For a historical resume of government regulatory action in the field of telephony, see page 36.

## MESSAGE INSERTING SYSTEM

Designed to insert messages in a background music system using an SCA tuner, phone line or tape transport, this system automatically fades music out, inserts message (up to 12 per hour) and then fades music in. Messages may be recorded by a local store manager, or professionally produced for a store chain.

## MESSENGER II



The Messenger II consists of a Model CR-4500 cassette tape player and a model TU-60 control unit housed in a rugged metal package with walnut trim.

**Call Toll Free, except from California... (800) 421-1029**

**Tape-Athlon**

502 South Isis Avenue, Inglewood, California 90301 • (213) 776-6933



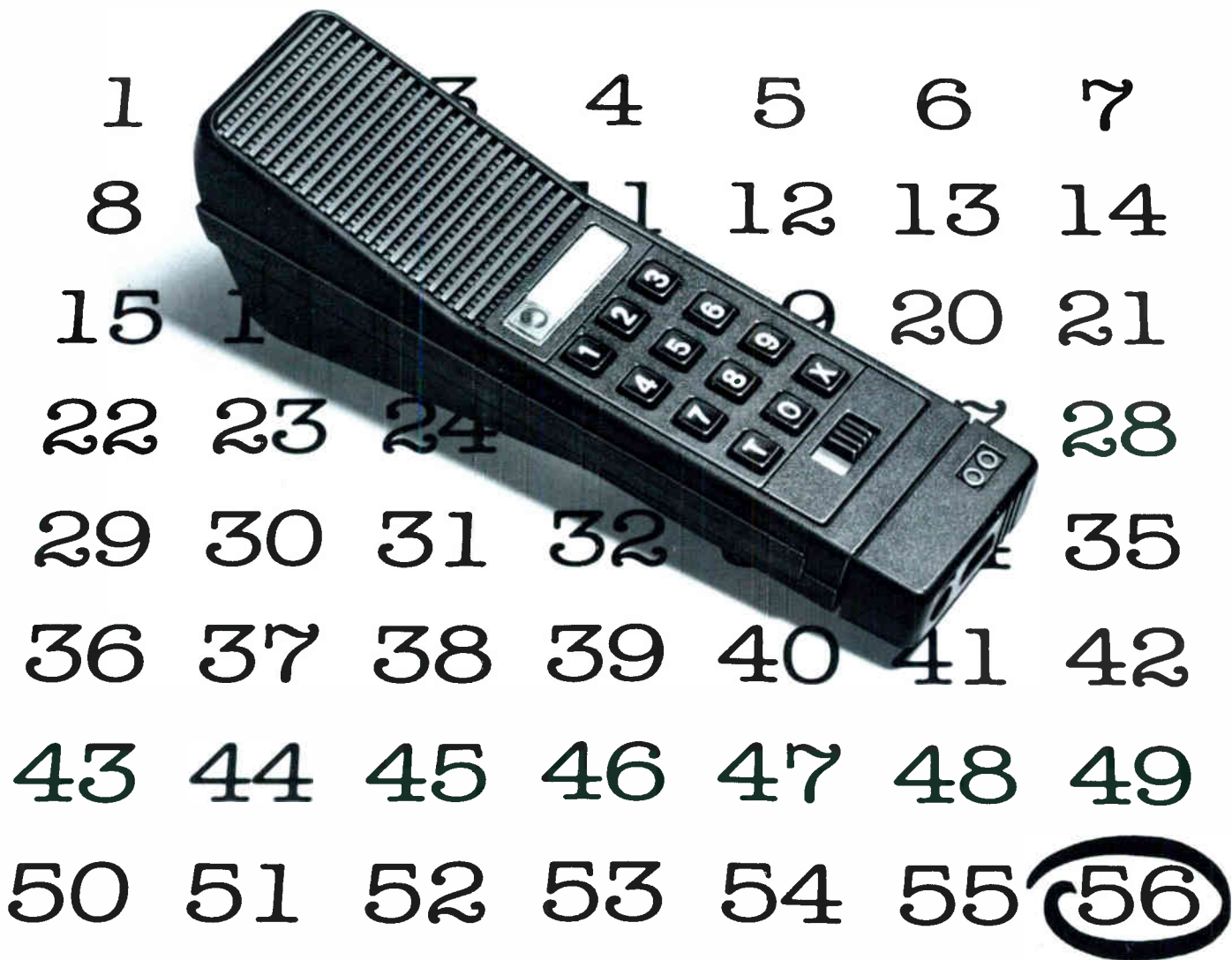

# A new way to play the numbers and win big.

**New Mini-Tridex intercom opens doors wide for dealers among smaller companies that couldn't afford a Tridex before.**

Sure our microprocessor-controlled Tridex intercom for up to 5,000 stations is super. But a lot of smaller companies felt they couldn't afford it. The numbers weren't right for them. That is, until now.

Because now Ring is introducing its new microprocessor-controlled Mini-Tridex (CB900) for up to 56 stations *at a price that's virtually irresistible!*

Suddenly even small companies are prospects for this incredible hands-free intercom. With features like group hunting, conferencing, automatic callback on busy lines, priority call and more, it's an easy package to sell.

Dealers will now find the Ring-Master line even more competitive than before. Besides the new Mini-Tridex they can offer customers our famed Ring-Master Tridex for 30 to 5,000 stations; the advanced Modulex for 5 to 70 stations; and the handsome Simplex for 2 to 20 stations.

These profitable systems require little service, are easy to install and are backed by Ring-Master's

internationally-respected quality control and technical support.

We've got the winning numbers. Find out how to deal yourself in by calling 516-293-6700 or mailing the coupon. Ring Communications, Inc., 35 Pinelawn Road, Melville, NY 11747.



**Ring Communications, Inc.**

35 Pinelawn Rd., Melville, NY 11747

Yes! I'm interested in discussing an exclusive Ring-Master dealership. Contact me right away.

NAME \_\_\_\_\_

TITLE \_\_\_\_\_

COMPANY \_\_\_\_\_

ADDRESS \_\_\_\_\_

CITY \_\_\_\_\_ STATE \_\_\_\_\_ ZIP \_\_\_\_\_

TELEPHONE \_\_\_\_\_

Here's how our dealers sales are growing.

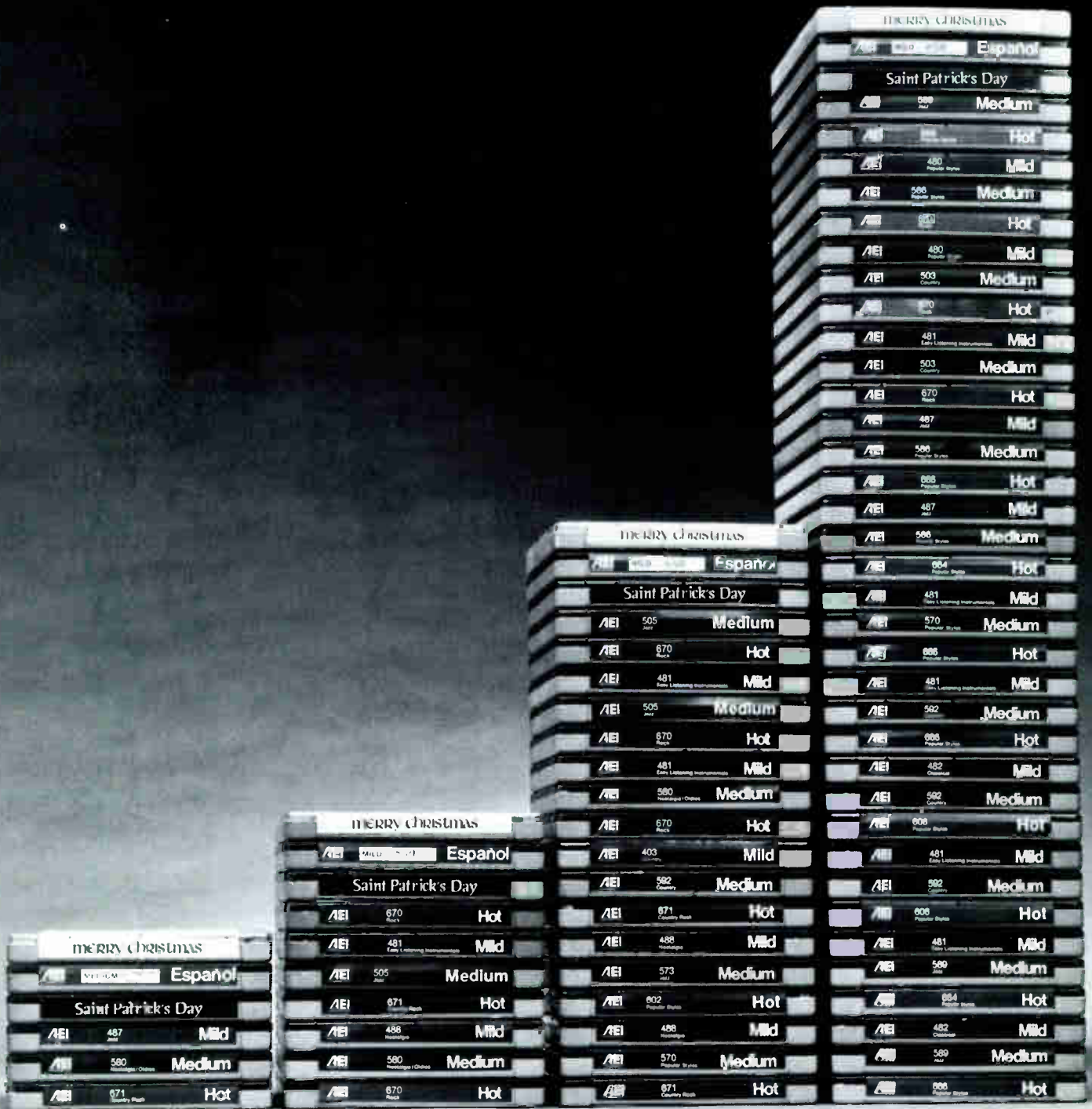

1978  
30% UP

1979  
66% UP

1980  
92% UP

1981  
91% UP

# OUR TAPES ARE BREAKING RECORDS.

Our Foreground music system has become a solid hit all over the country.

You might say we're number one with a bullet in restaurants, shops, hotels, and stores everywhere. Because our music helps customers stay longer and spend more.

That has resulted in record-breaking sales for our dealers nationwide. Record-breaking profits, too.

Part of the reason is our system of providing leads.

In most cases, our national sales staff can hand a new dealer a captive audience of local prospects.

You make the calls, sell the system, and reap the rewards.

Also, when we sign up a new national account—a restaurant chain, for example—you'll get the business from that chain's stores in your territory. In the form of equipment sales and music service residuals.

So your end of the deal becomes as simple as cashing a monthly check.

## THIS MACHINE CAN MAKE YOUR BANK ACCOUNT SING.

It's the Paragon VI. The industry standard for commercial playback units.



Rugged, reliable, with exceptionally high fidelity, it's the backbone of the AEI system. And we've teamed it up with the largest catalog of recording artists and songs on the market. We can offer prospects literally thousands of musical options.

So it's easy to see why AEI attracts more

Foreground music customers than anyone else.

## OUR INCENTIVES WILL BE MUSIC TO YOUR EARS.

Our sales incentives can be as simple as cash, or as exotic as Hawaii. But they're all generous, and frequent.

Because we believe in working hard. And passing along the rewards to people who make good things happen.

So if you think programmed music systems are within the selling skills of your sales team, join our team.

And get set for a record-breaking year yourself. For complete details, call David Bell at 206-329-1400 or write AEI.



FOREGROUND MUSIC  
AUDIO ENVIRONMENTS INC. 619 East Pine Street, Seattle, WA 98122



WE HAVE  
WHAT YOU  
NEED  
AT  
**TekTone**

COME SEE US AT

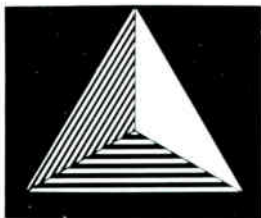

**EDS '82**

ELECTRONIC DISTRIBUTION  
SHOW AND CONFERENCE  
APRIL 29, APRIL 30, MAY 1  
NEW ORLEANS, LOUISIANA

**BOOTH D5**  
featuring

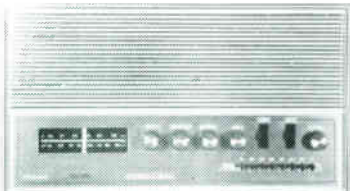

**EK-804 AM/FM**  
**MASTER STATION**

- Room to room communication from any inside or patio station.
- Communication with door stations with automatic reply.
- Master has selective calling capability with automatic hands free reply from inside stations.
- Inside/patio stations can be monitored.
- Stations may be turned off for full privacy.
- Auxilliary input provided.
- Optional add-on intruder alarm available.

**TekTone**  
SOUND & SIGNAL MFG.  
1331 S. Killian Drive  
Lake Park, Florida 33403  
(305) 844 2383  
Speed Your Order—Call It In Toll Free  
(800) 327 8466  
TLX # 513438

**Background on FCC Decisions**

The phenomenal growth of business communications may be attributed to advancements in switching and transmission technology at a time when government deregulation encouraged competition. The result is a blossoming industry in long-line microwave and satellite networks—Specialized Common Carriers (SCC)—who now provide alternative long distance voice and data services on a nationwide basis.

The Federal Communications Commission chipped away at the AT&T monopoly for nearly a quarter century to achieve its goal. During this time several important rulings helped create the foundation for this progress.

**1968—The Carterfone Decision:** By allowing the Carterfone device, a two-way radio patch to the telephone network, the FCC made possible private car-to-telephone communications. This was the first "foreign attachment" ruling and cleared the way for non-public utilities to market phones, PBXs and other "interconnected" equipment. AT&T still provided protection, via "interfaces" required to prevent (in their opinion) potential harm to the public network.

**1969—The MCI Decision:** MCI (formerly Microwave Communications Inc.) was licensed to construct and operate a multi-hop interstate radio link between St. Louis and Chicago and lease private-line service to business in direct competition with AT&T long-lines.

**1971—Specialized Common Carrier:** The MCI decision was extended to include other independent carriers on a nationwide basis. Bell was ordered to provide local links between the independents and their customers. Later in 1974, SCCs were authorized to hook their private lines into the local exchange networks, making available alternate dial-up long distance services to subscribers from any telephone in the utility network.

**1971—Computer Inquiry I:** Public Utilities were franchised to provide unregulated computer services through wholly owned but separate subsidiaries. AT&T, however, was still excluded under the terms of its 1956 Consent Decree.

**1972—Domestic Satellite:** To encourage competition, the FCC invited non-AT&T applications to provide telecommunications services via satellite. Treating satellites as "microwave links in the sky" they expanded the Specialized Common Carrier's ability to compete.

**1975—Subscriber Equipment Registration Program:** The need for renting interface devices (PCA) from AT&T ended. Establishment of a certification program for phone instruments gave manufacturers of interconnect equipment a major boost.

**1976—FCC Docket 20097:** Tariff restrictions prohibiting the sharing and resale of interstate private line services were found unlawful. The FCC ordered that all interstate carriers change their tariffs to reflect the Commission's new policies and allow unlimited resale.

**1977—Execunet:** The courts reversed the FCC stand on Docket 20097. The SCCs (MCI, ITT, Southern Pacific, WU, etc.) had to temporarily stop selling new customers dial-up long-distance phone service on their microwave and satellite networks.

**1978—Expanded Registration:** The 1975 program was extended to include multi-line phone equipment and PABXs.

**1980—Computer Inquiry II:** The FCC ordered total deregulation by March 1, 1982 of all terminal equipment and enhanced transmission services. *If implemented*, this ruling allows AT&T to provide unregulated services and sell equipment through a separated subsidiary. The decision is now being challenged.

**1981—Resale and Sharing (80.54):** The FCC authorized unlimited resale and sharing of interstate phone services, including MTS and WATS. Resellers, SCCs and Network Sharing Groups, including hotels, can now buy long-distance services at volume discounts and retail them to consumers (and guests).

# Easy does it.

For 12 years we've been the industry leader in key system line card design and reliability. Now we have the most complete line of key system packages. So, make it easy on yourself. Get the whole system from us.

## Easy to afford.

San/Bar's small key systems are economical because you can pick and choose the features you want without having to pay for features you can't use. For example, most systems cost about \$125 to \$140 per station including advanced intercom features and a choice of multi-button telephones.

## Easy to install.

Our compact, lightweight systems are modular and self-contained in an easy to install wall mount design. Most models utilize the same type of UL approved power supply, ringing generator and interrupter to simplify installation and maintenance. All systems are FCC registered and agency installation agreements are available.

## Easy to maintain.

Like all San/Bar products, the key systems carry the famous extra San/Bar warranty and the solid-state design with built-in quality means efficient reliable service.

## Easy to modify.

San/Bar key systems can be expanded or changed which makes them perfect for a growing customer. The modular building-block design lets you change or add a variety of features to customize each system.

We have seven basic systems including the highly featured SB6640 key system:

**SB6640** - Up to 8 CO/PBX lines - Up to 20 stations of rotary and/or tone intercom, including call announcing and hands free answer back. Zone and all call paging is also available as well as many other options and features.

**SB6620** - 3 lines - 10 station intercom.

**SB6610** - 5 lines - 10 station intercom.

**SB6630** - 6 lines - no internal intercom.

**SB6680** - 6 lines - voice announcing, soft paging and background music.

**SB6615** — 14/29 line — 8/48 station multi-path intercom.

San/Bar key systems are becoming the standard of the industry and can include our exciting variety of special features:

- Music-on-hold
- FM receiver for music
- Off premise extensions
- Add-on-conference
- Paging access
- Zone paging
- Background music
- Call announcing with hands free answer back
- Call forwarding
- Programmable station toll restriction
- Touch pad dialing for rotary systems
- Delayed ring and message waiting
- Hot-line/private-line signaling
- Station privacy

For more information, contact our Marketing Department at **1-800-527-4837**.

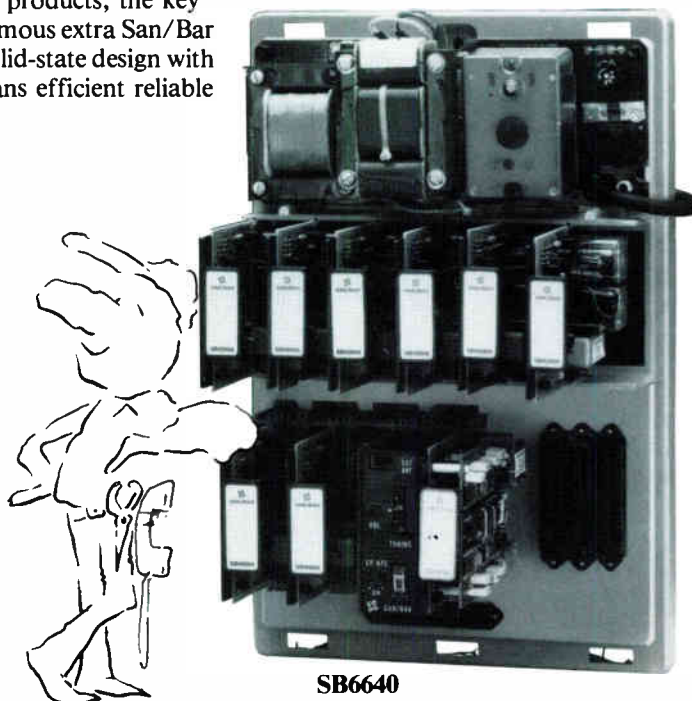

**SB6640**



Serving the Telephone Industry  
Since 1962

## SAN/BAR

San/Bar Corporation  
Business Systems Division  
2405 South Shiloh Road  
Garland, TX 75041  
Phone: 214-840-2710  
Toll Free: 1-800-527-4837

Business Systems Division  
Telephone Service Center  
Transmission Systems Division  
Breakfree Division

Corporate Offices:  
9999 Muirlands Blvd.  
Irvine, CA. 92714

*Our line cards have made us a leader in the field for years...now we're taking the lead in key systems*

# Managing Phone Costs

by Charles Viau

It's not surprising that most people take a good look each month at their home phone bills before sending off a check to the local Bell Telephone Company. Although phone costs may not have risen as significantly as other products and services, it's still an outlay that one likes to control.

Home phone costs may be high, but imagine what a phone bill is like for corporate offices at Macy's, Dunkin' Donuts and the like. Imagine approving a \$50,000/month phone bill, authorizing it as correct and releasing payment.

Communications Analysis Corp. realized the effort involved for a telecommunications manager, office manager, or finance officer to validate phone costs and keep them under control. So, in 1979, the corporation was formed, software development began, and their first customers were put on-line. By 1980, the company opened its own computer center using a PDP1150 and today its customer base has more than tripled.

Not only is the number of customers increasing, but the size of the companies CAC is processing for is also increasing. Recent clients are companies where the telecommunications department serves more than 2000 telephone users. Telecommunications managers can either purchase software to do their own processing, or contract with CAC to have the processing done at CAC's processing center.

Last summer, CAC announced the development of MOSTE. MOSTE (Management of System Telephone Expenses) is proprietary licensed software which will provide comprehensive telecommunications management reports that record and summarize calls made from a telephone switch. It will allow the

user to define his telephone usage and provides a tool for telephone-use management and telephone-cost management.

This information is organized in a pyramid-like fashion by extension, and is summarized by department, division, and company. Precise costs are assigned to each call, allowing a manager to accurately allocate costs to specific departments or for client bill-back; this means user accountability. It also means verification of local Telco billing is feasible. One is also able to identify telephone system abuse and misuse by quantifying non-business calls.

MOSTE provides real-time management capability of the telephone traffic data with network/traffic analysis reports, in an easy-to-read format. It is an aid to every telecommunications and DP manager in facilities planning and network design/management, presenting statistics in such a manner that they are understandable by both non-technical and technical-oriented telecommunications managers.

MOSTE is IBM compatible; a DEC compatible version is being completed. The software package is fully documented and is supported by source code for reports. Performance-critical portions are implemented in assembly language, and reports are processed using COBOL. MOSTE provides flexible, on-line inquiry, and complete report-program generation. Documentation includes detailed instructions for installation, a codebook for text data files, and a comprehensive user's guide. Ongoing maintenance and support of the package will be available to reflect rate, tariff, and central office changes.

To summarize, managers can use these reports to:

- reduce phone costs,
- reconfigure the voice-communications network,
- provide the most efficient service at the lowest cost,
- allows allocating costs to vari-

ous departments in the company,

- identify and reduce non-business calls.

The process works like this: a collection device is connected to the main telephone switch and a record is made of each and every phone call. Once a month this mag-tape, floppy disc, etc., is sent to CAC for processing. CAC, in return, sends a set of reports to the client, which enables a manager to analyze telephone usage and reduce telephone costs.

Jerry Stokes at *Bolt, Beranek & Newman* has been doing business with CAC since 1979 and says, "Within BBN, we have different divisions that act almost as separate companies. We use CAC's reports to redistribute costs to these departments...no phone is free. It's as if the employees rent their phones from our department, which is responsible for the telephone system. You just can't throw phones out to the people in the company and not have control. Our ultimate concern is cost-effectiveness, and the reports help us achieve that goal."

CAC has recently acquired *Kendall Corporation* as a new customer and will handle the processing of their telephone records somewhat differently than for *Bolt, Beranek & Newman*. *Kendall's* voice communication network is made up of four nodes, located in Boston, Augusta, Walpole, and at an Illinois plant. Rather than send a tape to CAC monthly, CAC will poll these four locations. John Eldridge at *Kendall* says, "We will utilize the reporting process to get a breakdown on trunk activity. Accumulating this data in step-stone fashion, we will have reports by department and division within a location, and then incorporate that into a corporate summary. We have devised an unusual pricing scheme and will charge back each department for network use, in addition to the calls. We are excited about the reports and the fact that we can recover all associated telephone costs." □

*Mr. Viau is Programming Director for Communications Analysis Corp., Framingham, Mass.*



# Changing Couldn't Be Easier

because the **SEEBURG MTN-10**  
background/foreground music system couldn't  
be simpler or better!

If you're listening to any other commercial sound system now, listen to this . . .

In a snap, you can create the perfect mood for your hotel, restaurant, club, retail store, office or plant with the most convenient AND lowest price on-premise music system available.

Our MTN's tape cartridge conveniently snaps on and off its base in seconds for easy operation. But since that's not your biggest headache . . . we've also built the system's playback head directly into each tape cartridge.

This means that every 90 days, when your fresh 14 to 20 hours of premium Seeburg music arrive, you just send back the potential head worries found in other equipment (gummed-up head and dragging tape) that are caused by heavy use.

Your listeners will enjoy the high-fidelity sounds offered in our 25 distinctive music categories (you choose the best for your needs) as much as you'll enjoy MTN's maintenance-free performance.

The MTN-10 also features:

- a built-in 20 watt amplifier
- automatic muting on *paging mike input*.
- ability to drive up to 40 speakers and be directly connected into any existing speaker system.

If you've never owned a background music system, why not investigate our trouble-free MTN-10 system? We think you'll change your mind and get one — of ours!

Distributorships still open. 90% of our MTN-10's are sold as replacements for costly outmoded systems.

Call toll free today:

**1-800-334-1561**

**SEEBURG MUSIC — It's Sound Business**

711 Hillsborough Street • Raleigh, NC 27605 • 1-800-334-1561 • 1-919-834-0833

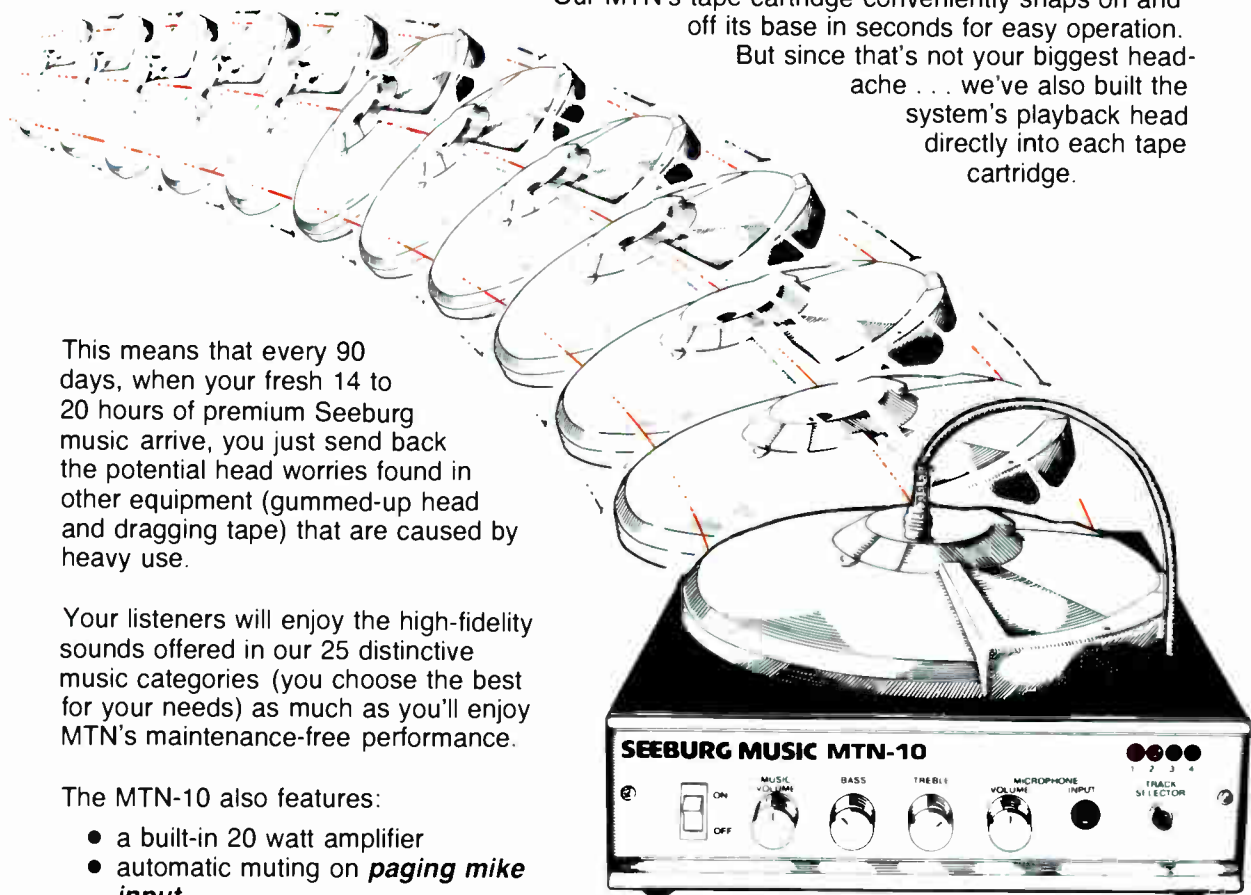

# Profile: Kinetic Kelly

**T**homas L. Kelly, Jr. is a youthful 44, speaking in bursts of staccato sentences as he talked about the success of his company. He is president of TIE/Communications, Inc., an interconnect company that has rolled up impressive gains for several years, gains far larger than the interconnect industry has shown in general. Kelly is kinetic... there is a constant swirl of activity in and about his desk. His manner is that of a man who has much to say and much to do, and does not have the time for all he has to accomplish.



Kelly has an impressive background in sales and engineering. One cannot doubt his salesmanship, the force and speed of his thoughts; his engineering is less obvious, but his record leaves no doubt that he must be equally capable in that direction.

Both his salesmanship and his engineering stand him in good stead in his present position. Kelly had been engaged in engineering first as a college student at Lehigh University, then in the Navy from 1959 to 1962. From there he went to AT&T, performing a variety of sales jobs. AT&T has been the alma mater for many people now engaged in the interconnect industry, in management, as well as for engineers and technicians. After three years with Ma Bell, Kelly became president of PTC, a telephone consulting firm. When the company was formed in 1971, he became president of TIE.

TIE has an edge over many firms

engaged in the private telephone sector; they design many of their systems, with the manufacturing being done here or in Japan. The equipment, produced exclusively following their own in-house designs, has many advantages in such a highly competitive industry, an industry that has eliminated many early competitors.

At the end of the first year of operations, TIE's sales amounted to \$450,000. By the end of 1981—only 10 years later—sales were estimated to total approximately \$125 million.

Sales figures for the past two years are impressive: The first quarter for 1981, as compared to the same period for 1980, showed a gain of 139 percent (from \$10,210,000 to \$24,443,000); the second quarter posted an even greater gain—183 percent (\$13,210,000 increased to \$27,437,000). The third quarter was the smallest gain (still a very substantial one) of 133 percent (\$16,579,000 to \$38,604,000).

Sales for the nine months ending September 30, 1980 were \$39,998,000, while for the same period in 1981 the sales amounted to \$100,484,000, a gain of 151 percent.

Net income for the first quarter showed gains of 284 percent for 1981 over 1980; 336 percent for the second quarter; 185 percent of the third quarter. At the time of this writing, the final quarter was not yet in. This is all the more remarkable when skyrocketing inflation and a recession are taking huge bites out of the country's economy.

In early 1981, TIE signed a \$15-million one-year renewable agreement with General Telephone/Automatic Electric, Inc. Kelly pointed out, "The decision of GTE to market TIE products proves the technological acceptance and cost advantages of the TIE family of key systems."

To what does Kelly attribute TIE's success? He answered, "We've been leading the field in the development

and design of small capacity key-phones. In 1978 we introduced microprocessor-based digitally-controlled keyphones. In 1980 we decided to focus on the design, manufacturing and marketing of small to medium business systems, as well as residential systems, to the national and international markets. We discovered in 1977 that the technology of telecommunications stood at the point where 98 percent of all equipment was electro-mechanical." He went on to predict that by the end of '82, 95 percent of all telecom systems will be microprocessor-based, capable of making the phone more than just an instrument transmitting a two-way conversation.

TIE employs a staff of over 60 engineers and technicians to design, develop and field test products now using digitally-controlled technology. The products contain sufficient flexibility in their design to allow them to interface with single-line telephones. Apart from their inherent flexibility, they also become more cost effective for the end-user.

He then jumped to another facet of the subject, "We have brought out 20 small business communications systems with less than 50 extensions."

Asked what he considered a medium-size business system, he said that these are systems under 200 extensions. He switched—a proper description for a man whose life is inextricably bound up in telephony—to another subject: "We're going after the residential trade, three to twenty extensions, with three lines and eight phones."

There was a brief interruption while he was reminded that he was expected to go into a luncheon meeting. He turned back to another subject: "In another 18 months, we'll bring out eight *new* (he stressed the word) systems. We're keeping up with all that's new in present technology."

On another tangent, Tom Kelly

remarked: "The business today is in stand-alone keyphones. There's approximately 3.1 million stand-alone systems in the U.S. That's a \$1.3 billion-market." And there was no doubt that TIE intends to tap such a lucrative market. Kelly was emphatic: "We captured 10 percent of that market in sales already and five percent in installations. We installed one million in the U.S. We have nine different systems with varied sizes—21 in all." With a note of pride he added, "We are the Maserati of home phone equipment." According to Kelly's estimate, there's a \$5-billion market for such phones and the peripherals.

Asked to whom he sells, he replied, "We sell to four groups of people. First are the interconnect dealers; second, independent telcos; then, supply companies, including dealers in sound equipment; the last one, and the one we're now going after, is the international market."

He added, underlining his point, "We went after the Canadian market. After one year we had \$6 million in sales. The reason...?"

He rushed to answer his own question, "TIE equipment is competitively priced, with the best quality obtainable. We provide sales, good service and engineering back-up services—and operational support."

Customers of interconnect systems years ago had complained, with good cause—in those days—that if their phone supplier or installer went out of business, they were in a quandry when they needed service and parts. When we brought up his point, Kelly answered, "With every telephone system we issue a letter that promises alternate contractors to provide continued service in the rare case that the original contractor goes out of business. We also stock every part for phones going back ten years."

As a sideline, it is worth mentioning that now the interconnect companies are very careful to choose contractors and suppliers who are adequately financed and able to guarantee continued service for the life of the service contract and even beyond.

Kelly's parting statement was typical: "We expect to increase our business by 60 percent for 1982."

□

# Gooseneck Paging?



# Turner has More!

Turner gooseneck paging microphones are available in seven different models. Each model has features that make it uniquely suited to specific installation requirements. A minimum amount of electronic modification is needed because Turner has engineered its products to meet virtually all gooseneck applications. There is a quality Turner gooseneck paging microphone with features to meet the following application requirements:

- Low Impedance • High Impedance • Zone Paging • Noise Cancelling • Normally Open Switching • Normally Shorted in off Position • Press-to-Talk Switch • No Switch.

And, that's only the beginning. Turner has 18 other paging microphones in desk top, handheld and wall mount versions as well as a full line of sound reinforcement microphones. Turner *does* have more, and now, with the additional product development strength of Telex Communications, Inc., there will be even more to come.

## Quality Products for The Audio Professional



# TELEX® TURNER®

TELEX COMMUNICATIONS, INC.

9600 ALDRICH AVE. SO., MINNEAPOLIS, MN 55420 U.S.A.  
EUROPE: 22, rue de la Legion-d'Honneur, 93200 St. Denis, France



## NEW PRODUCTS

### CORDLESS PHONE

The "Code-A-Phone" boasts full duplex operation with clear transmission and reception. The powerful transmitters can reach as far as 700 feet or more, depending on local operating conditions. The special key code privacy system, with 512 codes per channel (operator adjustable), prevents any handset from using the base station unless it is set to the same code. The unit comes with a rechargeable NiCad battery pack and a two-way charging system. Features include base-to-handset paging, automatic redial, amplifier and variable volume control for the hard-of-hearing, and multiple handset operation. The system is available in pulse tone, making it compatible with both touchtone and rotary dialing.



For more information write 147 on the inquiry card. Or write: Cybernet International, Inc., 7 Powder Horn Dr., Warren, N.J. 07060.

### AUDIO MESSAGES

The Search 400 system provides high fidelity audio messages which are randomly accessible at high speeds. The unit can be used alone, or it can be easily interfaced with most popular microcomputers, or any microprocessor-based system, to allow fully automated control.



The system is capable of either four-track mono or two-track stereo. Up to 400 messages of varying lengths can be recorded, with a maximum capacity of almost 8 hours. Typical access time is only a few seconds, and up to 4 messages can be accessed instantaneously. The system is composed of a Phi-Deck cassette transport, electronic control boards, a keypad for manual use, indicator lights and numerical readout of the tape position address, and a self-contained power supply. The entire unit is self-contained in a small cabinet. The front control panel contains the keypad, location number display, stereo volume controls, and switch for the selection of certain automatic features. A rotary switch allows manual track selection for use with the keypad, or microprocessor control. The independent motors allow extremely rapid and highly controlled tape movement.

For more information write 148 on the inquiry card. Or write: Triple I, Inc., 4605 North Stiles, Oklahoma City, OK 73154.

### PHONE SYSTEM

Engineered for cost-effective communications in smaller organizations, the microprocessor-controlled MAX-824 system may be ordered equipped for 6, 12, 18, or 24 telephone stations with 12 talking paths—4 private intercom lines and dial access to 8 Central Office lines. The dual-mode system may be utilized in small business or hotel/motel applications. Either mode is selected by a single switch, with system features optimized for efficiency in the selected operational mode. An optional attendant's console provides additional features for streamlining call supervision and call routing functions. The simple two-wire system requires only a single pair to each station for operation, and works from standard single-line instruments.



For more information write 149 on the inquiry card. Or write: Melco Labs, 14408 NE 20th, Bellevue, WA 98009.

## VOICE STORAGE

A modular voice storage subsystem, VoiceStor, is easily integrated with PBX and key telephone systems, advanced office communication systems, teleprocessing systems, and radio communication systems, providing capabilities for voice store and forward, advanced calling, and voice prompting. The system relies on a recording of an actual voice for its vocabulary and phrases, therefore the systems in which it is incorporated respond in natural, human tones, complete with the variations in timing and inflection which are absent from synthesized vocabulary generators.



The vocabulary is stored in "live" memory. Changes in stored words and phrases, and in the voice used, are easily made on-site with no special equipment or set-up requirements. The range of storage options available includes: 100 to 200 seconds of onboard RAM for simple voice prompting and short-term voice storage applications; digital tape cassette for permanent backup of standard vocabularies; and three-disk subsystems which can be configured to provide from four to eighty hours of vocabulary, phrase, and message storage. The system's flexibility readily permits expansion from eight to thirty-two simultaneous input/output transactions, and storing of up to 24,000 messages, phrases or words. Multiple microprocessors handle all input/output control, voice conversion, and memory management functions. Proprietary logic optimizes the use of available memory space and eliminates dead periods in the recorded and reproduced audio. VoiceStor is simple to inter-

face to virtually any microprocessor or minicomputer-based system using a byte-wide bus or to mainframe systems through either of two standard RS-232C serial input/output ports. System commands are provided for record and playback of individual words, recorded or assembled phrases, and entire messages. Other commands provide for erasing, repeating, and initiating a self-diagnostic program. The subsystem mounts easily in a standard nineteen-inch rack for ready assembly into host systems and is offered with a variety of options to minimize system integration efforts. All external connections are made directly to terminations provided on the printed circuit backplane.



□ For more information write 150 on the inquiry card. Or write: Voicestek Corp., 15 Soldiers Field Pl., Brighton, MA 02135.

## TELEPATCHERS

The 10/20-series Telepatchers are all amplified, nine-line units which provide call forwarding or conferencing with disconnect supervision on all types of telephone lines.



These lines can be trunks, FX lines, tie lines, WATS, etc. Units can be grouped together for larger con-

ferences. The 10/20 allows other calls to be received or initiated on the same telephone while a conference call is in progress. Parties with tone dials can recall attendant by pressing the "0" Operator button. Amplified to compensate for bridging loss, the 10/20 Telepatcher is FCC-registered.

□ For more information write 151 on the inquiry card. Or write: Telephonic Equipment Corp., 17401 Armstrong Ave., Irvine, Cal. 92714.

## SELECTOR

The TA-8 Super-Selector is a pushbutton device which automatically controls the lights on most key systems, dispensing with the need for electronic light controls built into single-line phone products and accessories when attached to multi-line phones. The unit eliminates ringing, flashing lights and false hold problems caused by devices without A+A<sup>1</sup> control after line seizure. Working on lines 1 through 5 on multi-line phones, the Super-Selector may be easily installed with standard 25-pair connectors. No power is necessary, and the device may be moved and reused any time.

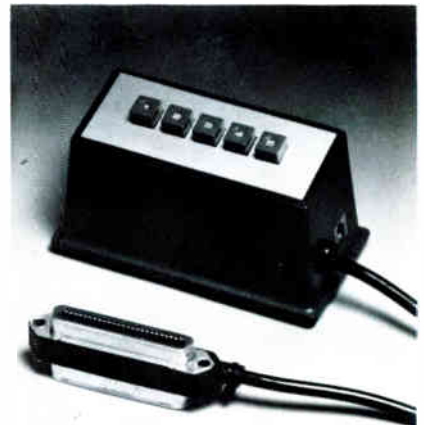

Each line can be accessed at the push of a button. Supplied with a 6-foot cable, the TA-8 is particularly useful for cordless telephones, amplifiers, dialers, answering machines, computers and facsimile equipment.

□ For more information, write 152 on the inquiry card. Or write: TT Systems Corp., 9 East 37th St., New York, N.Y. 10016.

## TIP & RING

TIE/COMMUNICATIONS, SHELTON, CT, HAS ENTERED INTO A \$45-MILLION AGREEMENT TO SUPPLY EXECUTONE INC. with a family of exclusively designed electronic key systems over a 3-year period. The agreement allows Executone to manufacture these systems under a royalty-paying license and after minimum sales quotas are met, TIE and Executone are contemplating sharing in the manufacture and supply of these products.

SOUTHEASTERN COMMUNICATIONS SERVICES, INC., ATLANTA, GA, HAS BECOME AN AUTHORIZED DISTRIBUTOR FOR NEC TELEPHONES, INC., serving the North Georgia-East Tennessee area. The interconnect company, established in April 1980, serves over 70 end-users, with more than 2500 equipment lines in its service base.

—TELESCIENCES, INC./MOORESTOWN, NJ, SAYS IT HAS REACHED AN ORAL AGREEMENT IN PRINCIPLE WITH AT&T THAT WOULD PROVIDE FOR AT&T'S PURCHASE OF \$300 MILLION OF ITS PRODUCTS over the next eight years. The agreement, which takes effect early in 1982, represents settlement of a previously reported civil suit in which Telesciences charged AT&T and its units with monopolizing the telecommunications equipment market. The suit, filed in the U.S. District Court, Washington, D.C., in September 1980, claimed that AT&T "monopolized, attempted to monopolize, unlawfully combined and conspired to monopolize and restrain trade" in developing and servicing telecommunications equipment. Telesciences' president termed the settlement "fair... (and that it) satisfies all parties." AT&T would make an advance payment of \$40 million, providing Telesciences the opportunity to nearly triple the business it does with the Bell System.

THE HILTON COMMUNICATIONS NETWORK AND THE ROBERT WOLD COMPANY, IN JOINT VENTURE, HAVE INTRODUCED A NATIONWIDE SATELLITE VIDEOCONFERENCING SERVICE providing end-to-end production and transmission of broadcast-quality closed-circuit, custom-designed television events in Hilton Hotels.

According to Barron Hilton, chairman and president of the hotel corporation, the new service is "open for business immediately," and is the first in the hotel industry to offer a single-source, turnkey package, including program design, production, satellite transmission and reception, large screen projection, conference and sleeping room accommodations, catering and a full range of hotel amenities.

The Robert Wold Company, which pioneered the use of domestic satellites for commercial television program distribution, has been producing and transmitting videoconferences independently for the past three years.

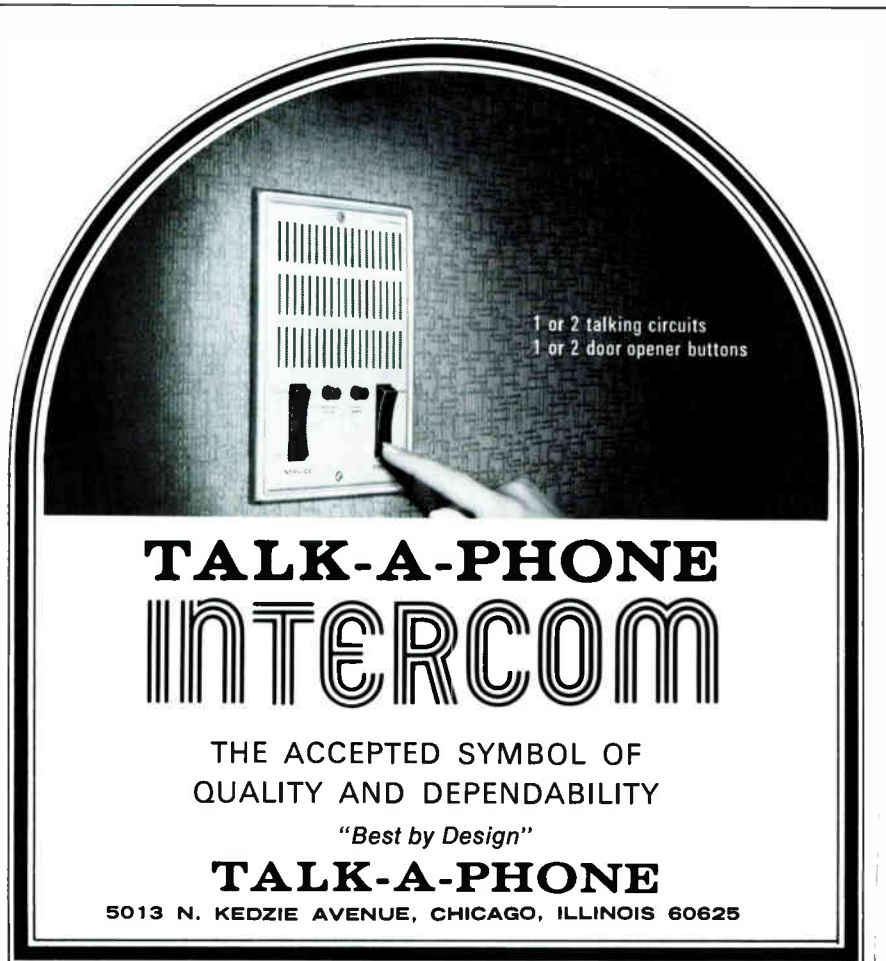

1 or 2 talking circuits  
1 or 2 door opener buttons

# TALK-A-PHONE INTERCOM

THE ACCEPTED SYMBOL OF  
QUALITY AND DEPENDABILITY

*"Best by Design"*

## TALK-A-PHONE

5013 N. KEDZIE AVENUE, CHICAGO, ILLINOIS 60625

—CENTEL BUSINESS SYSTEMS/CHICAGO (UNIT OF CENTRAL TELEPHONE & UTILITIES) HAS ACQUIRED, FOR AN UNDISCLOSED PRICE, THE ASSETS AND OPERATIONS OF GENERAL COMMUNICATIONS & ELECTRONICS, INC., a Nashville-based interconnect firm that distributes Rolm, GTE, Stromberg-Carlson, Wescom and ITT telephone equipment. General Communications & Electronics (GC&E) had 1980 sales of \$5.6 million. It has a total installed base of 21,000 stations and 200 customers. The interconnect firm was founded 10 years ago, employs 75 people, and maintains offices in Chattanooga, Memphis and Knoxville, Tenn.

Centel Business Systems has 56 offices in more than 20 states. It serves more than 5000 customers with an installed base of almost 215,000 lines. It had sales of \$100 million for the 12 months ending September 1980. Centel Business Systems was created by the parent company last year to consolidate its nationwide competitive telephone



equipment activities into one organization.

Centel said that its plans call for GC&E to operate as part of its Fisk Division, based in Houston, TX. GC&E president Michael W. Tune will report to John Hinkel, president of Fisk. Hinkel reports to James A. Lovell, group vice-president of Centel Business Systems.

—AT&T ATTORNEYS ARE SEEKING A DISMISSAL OF A \$3-BILLION ANTI-TRUST SUIT BROUGHT IN WASHINGTON, D.C. AGAINST THE BELL SYSTEM BY MCI COMMUNICATIONS CORP. The suit is similar to a case tried in Chicago last year that resulted in a record \$1.8-billion verdict against AT&T.

The Washington, D.C. suit, assigned to U.S. District Judge John Garrett Penn, covers MCI allegations against AT&T since 1975, while the Chicago case cut off at that point.

In both cases, MCI charges AT&T with illegally monopolizing the long distance telephone business.

In oral arguments dismissing the second case, AT&T attorneys have declared that the second suit "goes to the heart of this country's judicial system." If the second case is tried, there is "no reason it (MCI) cannot do it again two years from now in another court."

An attorney for MCI said that even the resolution of the Chicago suit, now before the appeals court, "could not in any way preclude action in the Washington, DC. case." The judge did not say when he would rule on AT&T's motion to dismiss the suit.

The complex court battles between the two companies date back to March 1974, when MCI filed its suit in Chicago. MCI decided the following year to seek damages only for the period ending with April 1975. But on April 30, 1979, MCI filed a second anti-trust suit against AT&T and against the nation's independent telephone companies, charging anti-competitive acts since May 1975.

Meanwhile, the Chicago suit continued, and in June 1980 a jury awarded MCI \$1.8 billion in damages. AT&T has appealed the decision to the Court of Appeals for the Seventh Circuit, and both companies await a decision from the three-member panel.

# "PAGING SPEAKERS THAT LET YOU TALK BACK"

Whenever you use ATLAS SOUND environment-resistant loudspeakers within your sound or intercom system, you can add an extra dimension to paging, signalling or telephone communications.



#### AP-Series

The world's most appreciated indoor/outdoor loudspeakers, 15 or 30 Watts. Choice of 8 or 45 Ohms, or built-in Vari-Tap control-center for line matching. Sensitivity as microphone: -20 dBm.



#### SC-Series

Economy and reliability with superior intelligibility, 15 or 30 Watts. Weatherproof construction. High impact plastic bell. 4, 8 and 45 Ohms models. Sensitivity as microphone: -21 dBm (Ref.: 1k Hz., 10 dynes/cm<sup>2</sup>).



#### VT-Series

Functional dependability with the advantage of minimum size, 15 Watts. U. L.-listed, vandal resistant and weatherproof. Ambient temperature range from 150°F to -30°F. Sensitivity as microphone: -26 dBm.



ATLAS SOUND,  
DIVISION OF AMERICAN TRADING  
AND PRODUCTION CORPORATION,  
10 POMEROY ROAD, PARSIPPANY, NJ 07054  
(201) 887-7800

84

# Mobile Radio Servicing

## Part 6

by Leo G. Sands

### Facilities— Continued

#### Monitor Receivers

Invaluable in the shop is a multi-bank fm scanner-monitor receiver equipped with crystals or programmed for all of the channels normally encountered. One such is shown in Fig. 6-1. Using such a receiver, you can quickly determine if a transmitter is generating a signal and if it modulates.

#### Control Heads

When servicing trunk-mounted mobile units, you should have appropriate control heads available for use on the bench, so that you will

Table A. Coaxial Connector Equivalents

Military	Amphenol	Gold Line	Decibel	Andrew	Calectro	Radio Shack
M-358	83-1T	GL-271	11304	10805-4		278-198
M-359A	83-58	GL-272				278-199
PL-258	83-1J	GL-227	11303		F3-124	258-1369
PL-259	83-1SP	GL-228	11301		F3-120	278-205
SO-239	83-1R	GL-210			F3-123	278-201
SO-239A	83-798					
UG-83			11309			
UG-146			11308			
UG-175/U	83-185	GL-173	11302		F3-121	278-206
UG-298/U			11307			
UG-1185	83-112		11305			
UG-1186			11306			
			11320	44AP		
			11321	44AU		
			11322	44AW		
			11323	44AN		
			11324	44AZ		
			11330	45AP		
			11331	45AU		
			11332	45AW		
			11333	45AN		
			11334	45AZ		
			11355	45AR		

not have to remove the one in the vehicle.

Also, you should have power cables and an assortment of coaxial jumper cables equipped with all of the types of connectors you will encounter. Table A lists coaxial connector equivalents by the type numbers used by various manufacturers and suppliers.

A handy device to have on hand is a "signal sniffer," which consists of a pickup coil connected to a coaxial cable and plug, as shown in Fig. 6-2. It can be used to measure receiver local-oscillator frequencies and other frequencies with a frequency counter by placing the pickup coil around or near the appropriate coil.

#### Timesaver Tester

The GC Electronics Probe IV is a general-purpose continuity, voltage, and polarity tester. It does not have a meter. Instead, it has an LED



Figure 6-1. The Realistic PRO-200 programmable scanner. Photo courtesy of Radio Shack, a Division of Tandy Corp.

# There is a Difference Horns and Drivers are not all alike

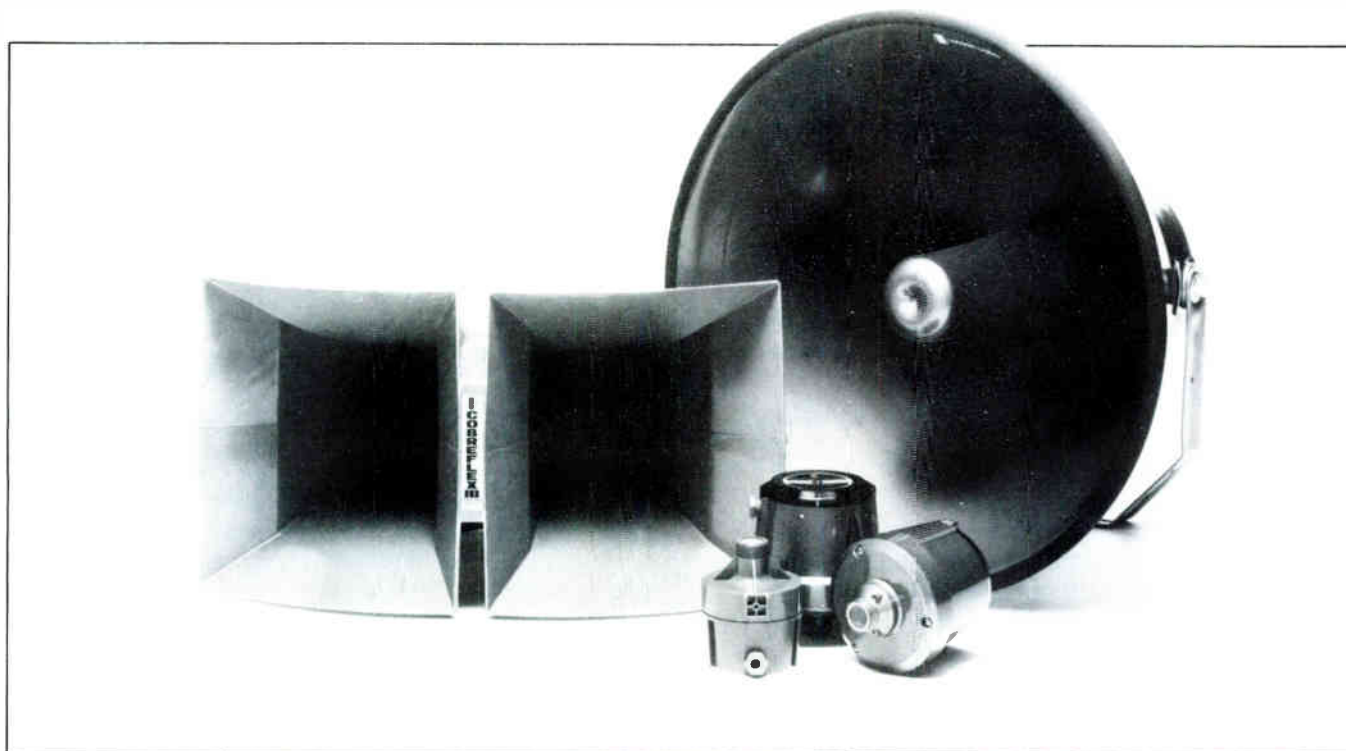

## University Sound proves it with new concepts for today's market

Whether designing a new sound system or updating an old one, our new one-inch throat horns and drivers are your natural choice.

Their larger voice coils and diaphragms work harder and longer. The new ID40C and ID60C one-inch throat drivers (8 ohm and transformer models) have screw-driver selectable taps for both wattage and 25/70 volt selection. They are completely sealed for protection from any environment and have a built-in BX connector. Covered with an acrylic finish which will not crack or chalk, they are easily and quickly field serviced. The new medium powered 30-watt

drivers (ID30C8, ID30C16, and ID30CT) feature one-inch throats and are adaptable to all University Sound horns.

Of critical importance in updating an existing system is the compatibility of all one-inch throat units with the older three-quarter-inch models. Matched with all the new one-inch throat LH-1 and COBREFLEX® III horns, you will have increased efficiency and reduced distortion.

This horn and driver combination has a predictable response over a controlled dispersion angle. A first in the Commercial Sound field!

The COBREFLEX III ensures a flat response over 100-degrees horizontal in the speech range with excellent available response both above and below. Where narrow, controlled dispersion is a design factor, the LH-1 is a true 40-degree horn for use in short, medium, and long throw applications. The response is flat throughout the speech range but has usable response from 100 to 20,000 cycles.

Both horns are available with completely documented specifications. What you design is what you get.

For further information see your University Sound representative or write direct to:



**UNIVERSITY SOUND®**  
ALTEC LANSING SOUND PRODUCTS  
1515 South Manchester Avenue  
Anaheim, California 92803



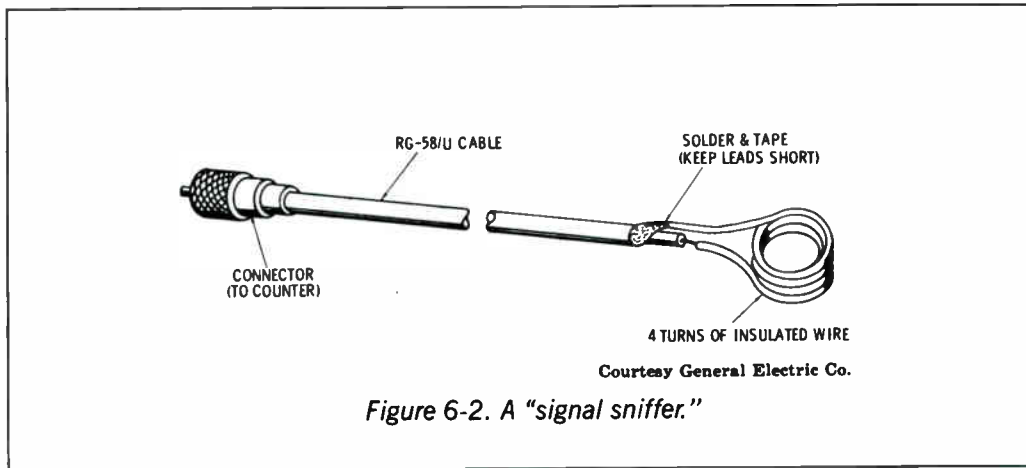

Figure 6-2. A "signal sniffer."

(light-emitting diode) that lights or does not light, indicating a "yes" or "no" answer. The Probe IV will indicate the presence of ac or dc voltage from 3 to 600 volts. When the Probe IV is used as a continuity checker, its LED will glow when the circuit resistance is less than 50 ohms.

It can be used for determining if a vehicle has a negative or positive

ground system. As a continuity checker, it can be used in lieu of an ohmmeter or a test lamp for checking mobile-antenna grounding and coaxial-cable integrity. And for bench troubleshooting, it can be used to check for the presence of operating voltages higher than 3 volts.

*to be continued*

## Series 3100 . . . Series 3200 . . . Series 3400 Communication Systems To Fit Every Need

**Series 3100** . . . Designed for fixed or permanent application. Each component separate — power supply — amplifier — headset stations — impedance control, etc.

**Series 3200** . . . The ultimate in flexible communication systems. Fixed, portable or semi-portable. Offers signaling, paging, director's override, auxiliary input.

**Series 3400** . . . Portable, self-contained. Comes ready to connect and operate. Built sturdy for rugged applications.

All Communication Systems are designed for use with our **Noise Attenuating Headsets**.

Call or write for FREE brochure and name of local dealer.

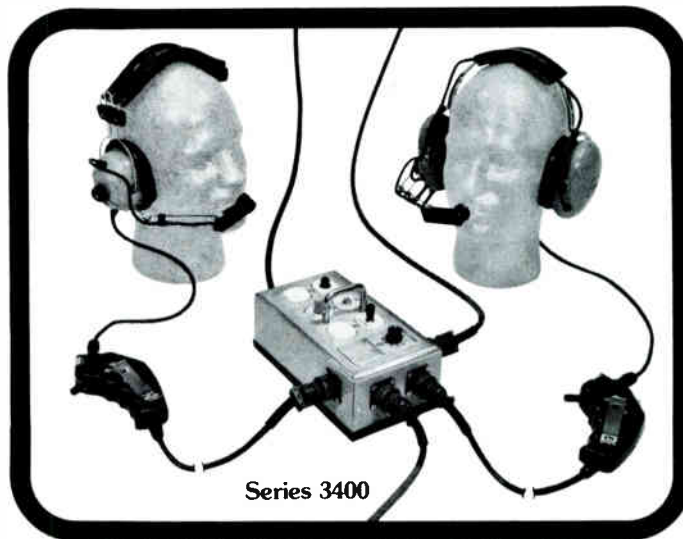

"the quiet people"

**David Clark COMPANY**  
INCORPORATED

370 Franklin St., Worcester, MA 01604 (617) 756-6216

Western Regional Office — Los Angeles, CA (213) 776-4571  
Distributed in Canada by Levitt Safety Ltd.  
Distributed in Australia by Sureguard Safety PTY. LTD.

---

# ***Bose<sup>®</sup> wants to give you the business.***

---

Bose Corporation is now seeking applications from sound contractors in selected areas interested in joining our limited network of authorized dealers. Qualifying contractors will participate in the design and engineering of audio systems incorporating Bose's advanced sound reinforcement technology—backed by a comprehensive package of marketing and technical support.

Our line of professional products includes the Model 802 Loudspeaker System, an advanced design combining smooth spectral response, uniform dispersion and high power handling capacity in an exceptionally compact, easy-to-install enclosure. And we're about to introduce an entirely new series of innovative products that will make the lifelike sound of Bose available to more customers than ever before.

Bose Pro Products have the performance, appearance and price it takes to please your clients and build your profits. Send in the coupon today, and find out how Bose can give you the business you've been looking for.

Bose Corporation  
The Mountain, Dept. SC  
Framingham, MA 01701

- Please send me the Bose Professional Products Catalog and your technical data.
- Please have your representative contact me.

Name: \_\_\_\_\_

Firm: \_\_\_\_\_

Street: \_\_\_\_\_

City: \_\_\_\_\_

State: \_\_\_\_\_ Zip: \_\_\_\_\_

Telephone: (    ) \_\_\_\_\_

***BOSE***<sup>®</sup>

Better sound through research.

# NATIONAL SOUND & COMMUNICATIONS CONFERENCE UPDATE

The National Sound and Communications Association has announced its detailed agenda for the National Sound and Electronic Systems Conference, to be held in conjunction with the 1982 Electronic Distribution Show and Conference in New Orleans. The agenda with conference sessions at the New Orleans Marriott and trade exhibits at the New Orleans Hilton as part of EDS '82, features management programs to help participants create effective business organizations, new market sessions to help guide businesses to important growth areas, and technical sessions to

keep sound and electronic system contractors abreast of the state of the art.

The program will begin on Thursday, April 29, with "Building through Diversification." Sessions begin at 8 a.m., with Francis C. Rebedeau, NSCA executive secretary, leading a program covering strategic planning. Rebedeau will provide the guidelines participants will need to look objectively at their operations and at the new markets available, providing a framework from which participants can develop a plan that will make the two mesh.

Following will be "New Business

Opportunities for the Sound and Electronics Systems Contractor." In these sessions, conducted from 8:25 to 9:40 a.m. and repeated at 9:45 to 10:50 a.m., leading contractors will keynote discussions on how to enter specific markets. The sessions and their leaders are: Life Safety, John Pieroth, Signal Communications, Seattle; Access Control/Security, Noel Palm, Douglas Roach Communications, Los Angeles; Health Care Systems, Harold Lander, Signal Communications, Seattle; Sound Masking, Bud McKinney, Lloyd F. McKinney Associates, Hayward, California; Theater Sound, Mitch Simmons, SunDome, Phoenix; Conference Room/Board-Room/Table Amplification Systems, Bob Lin, COMCO Systems, Inc., Long Island City, New York; Church Sound Systems, Ed Burquez, Sound Engineering Service, Birmingham, Alabama; and Foreground Music, Mark Torrence, Yesco Foreground Music, Seattle.

The Friday, April 30, session, "Managing for Growth," begins with a financial management workshop. This session will focus on the special financial problems—and the sometimes unique solutions—contractors face and will permit the exchange of techniques and procedures with fellow contractors. The session runs from 8 to 8:45 a.m.

Following the workshop, at 8:45 a.m., will be "People Management," led by Rebedeau and Robert F. Ancha, Ancha Electronics, Elk Grove Village, Illinois, NSCA president. The program will begin with Rebedeau discussing the modern methods of motivation and how to identify motivators and demotivators within an organization. Ancha will follow with a discussion of how to attract and keep people with well designed incentive programs.

The day's Conference program continues with a 10 a.m. session on "Satellites and the Contractor." This program will examine the phenomenal growth of the satellite and earth station market, and will help contractors determine where they fit into this emerging marketplace.

Following the Friday programs will

## CONDOMINIUM APARTMENT COMMUNICATION SYSTEMS

Florence offers a complete range of apartment communications systems. No matter how large or small, Florence has a system to fit your requirements. For complete information, please call or write us in Chicago.

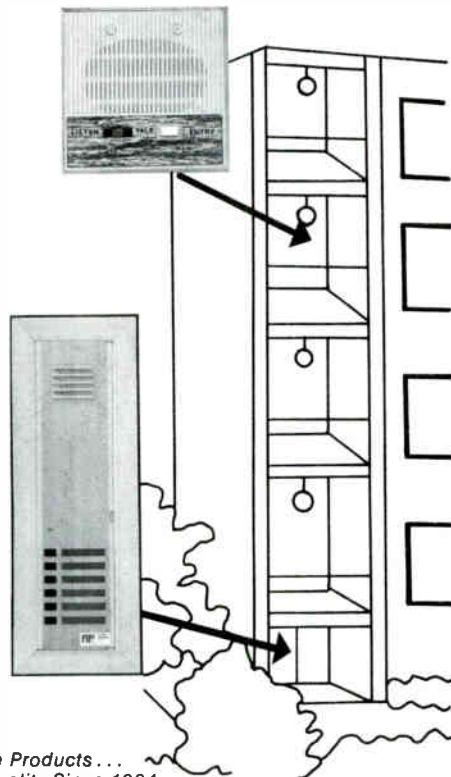

Always ask for Florence Products . . .  
Famous for Handcrafted Quality Since 1934

**FLORENCE CORPORATION**

2101 N. ELSTON AVE., CHICAGO, IL 60614 312/384-3310



be a meeting of the National Sound and Communications Association. Both current members and prospective members attending the National Sound and Electronic Systems Conference are invited to attend.

The Saturday, May 1, program, "Supersound at the Superdome," is a program concentrating on domed stadia sound system design and installation, utilizing the Superdome as a working classroom.

The program begins at 8 a.m. with Joel Lewitz, Paoletti/Lewitz/Associates, San Francisco, sharing his experience in domed stadia sound systems in general, and his first-hand knowledge of the Superdome system. A tour of the Superdome will follow at 8:45 a.m. After the two-hour tour, at 10:45 a.m., a question and answer session will be conducted at the Superdome.

Each afternoon of the Conference has been reserved for contractors to tour the EDS '82 exhibits at the New Orleans Hilton. In addition to some 75 manufacturers of sound and electronics systems products, attendees will have the opportunity to view the products of 200 additional manufacturers of electronic products.

Contractors registering prior to April 1 will be able to take advantage of an early-bird discount for the National Sound and Electronic Systems Conference. For NSCA members and sponsors, the cost of the three-day program is \$85. One-day admission is \$45. After April 1, the cost for the three-day program will be \$100, with a one-day admission costing \$60. Non-members may take advantage of early-bird costs of \$110 for the three-day program and \$65 for a one-day admission. After April 1, the cost will be \$125 for the three-day program, and \$80 for a one-day admission.

The non-member surcharge will be credited to the contractor's dues if the company joins the National Sound and Communications Association prior to June 15, 1982.

To register for the National Sound and Electronic Systems Conference, or to obtain further information on the event, contact Francis C. Rebedeau, Executive Secretary, National Sound and Communications Association, 5105 Tollview Drive, Rolling Meadows, IL 60008. Telephone: 312/577-8350.



setting new standards for excellence and value in Sound

## RENKUS-HEINZ PROFESSIONAL EXTENDED RANGE COMPRESSION DRIVER



Durable under conditions where others fail . . . designed to deliver unsurpassed sound quality . . .

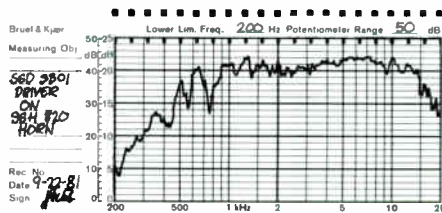

FREQUENCY RESPONSE 4" ON AXIS IN LISTENING ROOM

**ABSOLUTELY UNIQUE:** No other 2" throat driver offers such a combination of extended frequency range, power-handling capacity and natural sound clarity. Compact size and affordable price clinch the superiority of this driver—it's the ideal choice for all high-power 2-way speaker systems.

ASK YOUR DEALER FOR A DEMO OR WRITE US



**RENKUS-HEINZ, INC.** • DRIVERS • HORNS • SPEAKER SYSTEMS  
17851AB Sky Park Circle • Irvine CA 92714 • (714) 540-3154

## Introducing the New Calrad 40-watt Public Address Music Amplifier with AM/FM tuner

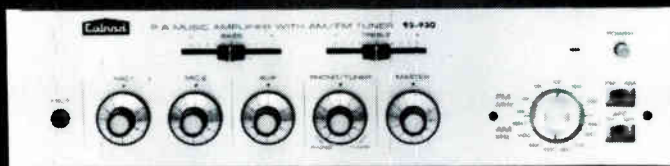

the latest electronic engineering techniques are featured in this truly up-to-date P.A. amplifier with its clean, uncluttered control panel for more efficient operation!

### TECHNICAL SPECIFICATIONS

<b>AMPLIFIER SECTION</b>		<b>TUNER SECTION (at TUNER OUTPUT)</b>	
Power Output .....	40 watts	Frequency Range .....	AM: 535-1605kHz
Frequency Response .....	50 Hz - 17.5kHz, +1dB, -3dB	FM: 88-108MHz	
Hum and Noise		Sensitivity .....	AM: 500µV for 20dB quieting
MIC Input .....	55dB below rated output	Distortion .....	FM: 4µV for 30dB quieting
AUX Input .....	70dB below rated output	AM: 1.5%, MOD 30% 400Hz	
PHONO Input .....	65dB below rated output	FM: 0.8%, MOD 100% 400Hz	
Sensitivity		<b>MISCELLANEOUS</b>	
MIC Input .....	0.8mV/600 ohms	Power Requirement .....	120VAC/60Hz
AUX Input .....	2mV/50 kohms	Dimensions .....	14-19/32" x 3-23/32" x 8-9/32"
PHONO Input .....	150mV	Weight .....	10.8 lbs
Outputs .....	4, 8, 16 ohms 12.5V (3.9 ohms), 25V (15.6 ohms), 70V (122.5 ohms)		
Inputs .....	2 MIC (low-impedance), 1 MIC (high impedance), 1 AUX (high impedance, high level), 1 PHONO (for magnetic PHONO)		
Muting Level .....	-30dB		



**ENGINEERED ELECTRONIC PRODUCTS**  
819 N. HIGHLAND AVE., LOS ANGELES, CA 90038  
(213) 465-2131

# NEW PRODUCTS

## POWER MODULE

To provide emergency telephone service in case of a local power failure, Model PFT-5 is a module that automatically transfers five C.O. trunks from the EPABX to designated instruments, upon power loss. Under EPABX failure conditions, the unit may be manually switched for uninterrupted service. FCC-registered, the device is compatible with all EPABX and EKSU systems, and is simple to install with a standard 25-pair connector. It requires a 24-VDC power supply.

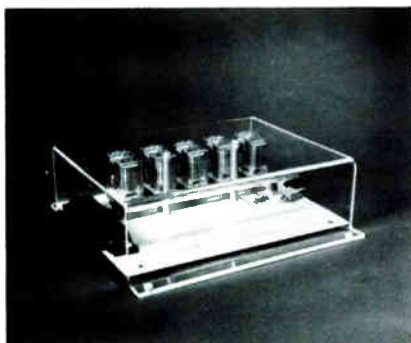

□ For more information write 153 on the inquiry card. Or write: Detroit Communications Corp., 3280 W. Fourteen Mile Rd., Royal Oak, Mich. 48073.

## CABLE

Unshielded, multi-conductor Control and Audio Cable has cabled, stranded tinned copper conductors.



Designed for audio, communication, control and instrumentation systems, the cable has colored-coded polyvinylchloride insulation with jackets of overall grey polyvinylchloride. Characteristics include a voltage rating of either 150 or 300 V, and a temperature range of 60 or 80° C, depending on the particular UL style number. The cable is resistant to acids, alkalis, oils, moisture, solvents and fungus.

□ For information write 154 on the inquiry card. Or write: Dearborn Wire & Cable Co., 9299 Evenhouse Ave., Rosemont, Ill. 60018.

## BACKGROUND MUSIC



"Easy Jazz" offers over 150 hit recordings by jazz greats of yesterday and today, for background music applications. Instrumental standards are by Duke Ellington, Count Basie, Oscar Peterson, and others, while vocal selections include Sarah Vaughan and Ella Fitzgerald. The choices were made through popularity surveys conducted by Billboard magazine. A wide selection of other types of background music is also included in this Cantata music library.

□ For more information write 165 on the inquiry card. Or write: 3M Sound Products, P.O. Box 33600, St. Paul, Minn. 55133.

## SOUND MONITOR

Designed to measure industrial background noise levels automatically, the SM-1 is a 100-db dynamic range digital sound level monitor. It provides reliable, unattended noise measurement and eliminates the manual and subjective methods that accompany most conventional sound-monitoring systems. Equipped with a wide viewing angle, remote microphone and windscreens, the unit is easy to set up and can be operated by non-technical personnel. A built-in threshold sound-level selector can be set to any predetermined limit. Once the level is set, the system automatically measures and digitally displays ambient sound. When the noise level exceeds the threshold, a warning light and flag signal are activated. The flag signal can be interfaced to other devices and used for such applica-

tions as lighting warning signs or flashers, turning machines or operations equipment on or off, and for controlling levels of speakers or amplifiers in specific situations. The SM-1 is effective in any situation where it is imperative to monitor environmental or occupational background noise: for product labeling, test monitoring, by OEMs as ancillary equipment for a variety of product applications, in plants and factories as an area monitor, and as an audiometric background noise measurement instrument. A wide range of supportive equipment is available.



□ For more information write 155 on the inquiry card. Or write: Instrument Development Corp., 67 Leuming St., S. Hackensack, N.J. 07606.

## WAVEFORM ANALYZER

The SC61 waveform analyzer combines a scope, a digital VM and a frequency counter. Used as a scope, the instrument can analyze waveforms in CCTV equipment, sound system amplifiers, etc. The scope works up to 100 MHz; a scaler will extend the digital frequency counter range to 600 MHz.

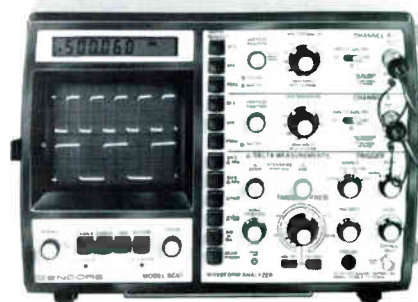

The unit may be used in the automatic mode, enabling the user to measure DC voltage, AC voltage peak-to-peak, and frequency, by pushing a button. The versatile analyzer will also measure any portion of a waveform instantly.

□ For more information write 156 on the inquiry card. Or write: Sencore, 3200 Sencore Drive, Sioux Falls, S.D. 57107.



## PRODUCTION SWITCHER

A computer-controlled production switcher, Model SE/3, features transition-centered architecture and unusual programming flexibility. The unit's powerful, built-in microcomputer replaces most of the digital logic found in other switchers, and controls all switching and effects. It provides for the programming, storage and instant re-creation of any desired sequence of patterns, pictures and transitions. The integral solid-state memory can store up to 600 shots. With the power of the computer a variety of new, improved production techniques are available. The switcher has 12 inputs, including black and background. Two-and-a-half separate pattern generators and three mix/effects amplifiers can simultaneously air five different sources and three wipe patterns, without lock-outs. Special effects include quad splits, re-entrant effects and "soft take." All effects, controls and programming functions are accessible at the front panel.

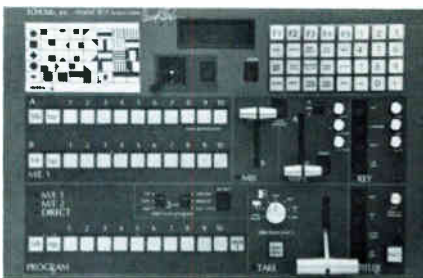

□ For more information write 157 on the inquiry card. Or write: ECHO-lab Inc., 175 Bedford St., Burlington, Mass. 01803.

## PAGING

Microprocessor-based, the Life Safety System is an instant two-way voice communication/paging system with the optional feature of being an early warning detection and reporting system in the event of fire. The system is primarily designed for use in high-rise office buildings, hotels, motels or any

other facility where 24-hour supervision is available to monitor a central control panel. Individual emergency speaker/receiver units can be installed inside present telephone equipment, flush-mounted wall or free standing units. When a button is pushed on the emergency unit, a signal is displayed at the central control station. When the signal is acknowledged, instant two-way voice communication becomes available, hands-free at the emergency unit, thus providing assistance in the event of severe illness, intruders, or any other emergency.



From the central control panel, instant paging can be initiated into any area of a building. Should the need ever arise, orderly and prompt evacuation can be achieved from a single room, floor, wing or the entire building. Individual smoke detectors can be connected into the system and, when activated, a signal will be displayed at the central control station, thus providing early warning detection and reporting in the event of fire. The central control panel meets code requirements for an annunciator panel, as fire officials can visually determine all areas that may be heavily charged with smoke. Other features include the ability to monitor unoccupied areas for vandalism or theft. Should a line short-out, melt or be severed, a lighted signal will appear on the control panel and will remain lit until corrected. The spare pair of wires in the present telephone system provides easy installation of the Life Safety Communication/Paging System.

□ For more information write 158 on the inquiry card. Or write: Life Safety Systems, Inc., 1301 Cornell Parkway, Oklahoma City, Okla. 73108.

## WIRELESS INTERCOM

Model T-50/2B base stations provide full duplex intercommunication between a director, producer, etc., wearing an FM wireless headphone, and sound equipment, camera or lighting operators, who use hard-wired intercom systems.



Within a 150-yard range, the system offers clear 2-way voice communication without wires. Each system includes a transmitting and receiving base station, and a wireless intercom headphone.

□ For more information write 166 on the inquiry card. Or write: R—Columbia Products Co., Inc., 2008 St. Johns Ave., Highland Park, Ill. 60035.

## SPEAKERS

The SMS 1582 Stage Monitor and the FRS 1582 Full-Range Speaker System are both rated at 200 watts.



Both models have special exponential horns and 2-inch throat high-frequency compression drivers. Professional-quality 15-inch low-frequency speakers are used. The compact, rugged systems are carpeted; they may be used in passive or bi-amp modes.

□ For more information write 159 on the inquiry card. Or write: Renkus-Heinz, Inc., 17851 AB Sky Park Circle, Irvine, Cal. 92714.



# ESTIMATING

means the difference between a Sound Contractor's Profit and Loss.

The Sound & Communications

## HANDBOOK ON ESTIMATING

guides you through all the steps: costs of materials, labor, taxes, insurance, utilities, etc., and explains the accounting techniques that lead to PROFITS.

The Handbook includes sample forms, layout sheets, material on wire and conduit, and room acoustics. The Sound Contractor, or anyone handling electrical/electronic/mechanical operations, must become an accountant when creating an estimate. This Handbook provides the practical, cost-accounting data you need to achieve that dual identity.

At only \$15.50 per copy—with leatherette cover, spiral binding—the HANDBOOK is inexpensive enough to place a copy on the Estimator's desk, the Sales Manager's desk, the construction crew supervisor's desk, and, of course, the bookkeeper's desk.

There are quantity discount prices starting at 5 books per order. Ask for details.

Complete the coupon. Enclose your check or money order - or credit card number FOR YOUR COPY TODAY!

Sound Publishing Co., Inc.  
156 East 37th St., NY, NY 10016  
Send me \_\_\_\_\_ book(s) at \$15.50 per copy.  
NY residents add 8¼% sales tax.

Enclosed find check/money order for \$ \_\_\_\_\_ in payment.

Name \_\_\_\_\_

Street No. \_\_\_\_\_

City \_\_\_\_\_

State \_\_\_\_\_ Zip \_\_\_\_\_

Visa       Master Charge

No. \_\_\_\_\_

## WIRE STRIPPER

The K-7-B Wire Stripper and Twister has a special design which allows for straight-thru-center stripping, making for unlimited strip length on all wire sizes 8-28 AWG.

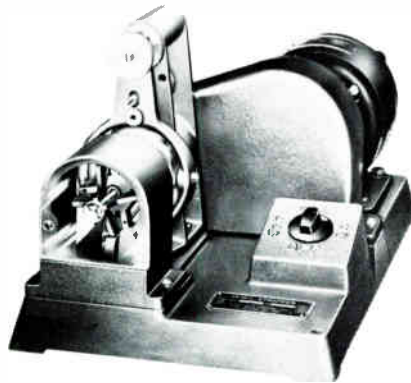

Four tungsten carbide tipped blades insure a clean strip of either film type or extruded insulation, including PVC, PTFE and fiberglass. The blades are controlled by a footpedal which frees hands to work the wire and adjust for different sizes of wire, while the machine is running. A reversible motor on the unit prolongs blade life and also neatly twists together the individual strands of stranded conductor while stripping. Compact and lightweight, the machine is simple to operate. An optional rolling stand is available.

For more information write 160 on the inquiry card. Or write: The Eraser Co., Inc., P.O. Box 4961, Syracuse, N.Y. 13221.

## CONTROLLER

The LynTec Programmable Audio Controller is designed for noise masking and timed audio level applications. It provides timed level control of up to seven channels of audio. The output level may be user programmed to rise and fall at specific starting times. The rate of rise and fall are also programmable. All programming controls are on the front panel. A "Standby Battery Cover" conceals the supervisory programming controls to discourage tampering. Typical applications include lowering masking noise level slowly in the early evening and raising it again in the morning, before the normal work day begins, or reducing the background music

and paging in an airport gate area at 11 P.M. A "Day-of-Week Inhibit" function allows holding the level low on low usage days, such as weekends. The internal quartz clock has standby battery backup to assure timekeeping integrity when the AC power fails. A pulse load battery tester checks the battery once a day, to verify battery condition and alarms at 75% battery discharge. An optional dual pink/white noise source board provides two channels of 0 dBm RMS level noise output for programmed masking noise use.

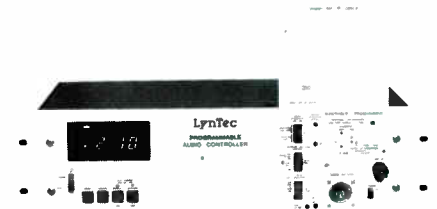

For more information write 161 on the inquiry card. Or write: Technical Visuals, 7030 Grandview, Merriam, Kans. 66204.

## MIC CABLES

Available in lengths of 10, 18, 25 and 50 feet, the AT8303 Series of microphone cables have XLR/A3F connectors at one end and XLR/A3M connectors at the other. Another type, the AT8302, is 16½ feet long and has an XLR/A3F connector at one end and a standard phone plug at the other. Model AT8305 is a 20-foot cable assembly tailored for the user who must adapt instantly to low or high-impedance usage. It has an XLR/A3F connector at one end and a Lo-Hi Z transformer connector with phone plug at the other. Many of the units offer a choice of colors.



For more information write 162 on the inquiry card. Or write: Audio-Technica U.S., Inc., 1221 Commerce Drive, Stow, Ohio 44224.

## AMPLIFIER



The PAT-120 public address amplifier, rated at 120 watts, may be used on 117 or 220 VAC. It includes a headphone jack for monitoring, fused AC line, fused output protection, and inputs for mics-tuner-phonos-tape decks, etc. The unit comes in a dark gray cabinet with a black panel with white accents. The slide controls include Mic-1, Mic-2, Master Volume, Bass, Treble, Aux (fader), and Power on/off. Frequency response is 50 to 20,000 Hz. Output impedance is 4, 8 or 16 ohms, 25 and 70-volt line.

□ For more information write 163 on the inquiry card. Or write: Components Specialties, Inc., Speco Div., 1172 Rte. 109, Lindenhurst, N.Y. 11757.

## BASS SPEAKER

Using a true exponential horn to provide high acoustic output at low distortion, the MR-102 Mid-Bass Reproducer is particularly suited for concert sound reinforcement, movie houses, theaters and discos. The special displacement plug main-



tains a true exponential expansion rate throughout the horn's critical throat region, and eliminates the distortion, heard as harshness or "honkiness," that plagues many horn-based systems. The plug also allows a reduction in throat size that increases efficiency by some 3 to 4 dB, and also blocks any spurious high frequency spikes from the driver's dust cap from entering the horn. Meant for use in the 200 Hz to 1200 Hz range, the MR-102's -3 dB

points are 150 Hz and 1500 Hz, and it delivers 107 dB SPL at one meter and one watt input, when loaded with a 12-inch driver. This choice of driver and crossover points relieves the neighboring mid-range compression driver of much of its workload, and reduces or eliminates mid-range driver failures in most systems. The driver used in the Mid-Bass Reproducer is damped with special compounds, to reduce break-up modes above piston range, and to eliminate the high-Q spikes present in most available 12" drivers. The driver's conservative thermal design allows continuous sine wave operation with 150 watts in-

put, and 300 watts with program input. The MR-102 is packaged in 18-ply-to-the-inch laminated birch hardwood for mechanical ruggedness in the field, as well as freedom from resonances. All cabinet voids are filled with anti-resonance foam. Features include recessed carrying handles, steel corner reinforcements, scuff and water-resistant polyurethane finish, perforated steel grille over the driver, and dual 1/4" phone and banana jack connectors.

□ For information write 164 on the inquiry card. Or write: Eastern Acoustic Works, 59 Fountain St., Framingham, Mass. 01701.

**Attention:  
TVRO/MATV  
INSTALLERS.**

**Protect  
your investment.**

**Cable TV is at 400 MHz.**

**Is your  
MATV system ready?**

**ANIXTER**  
PRUZAN

**is the answer.**

**We have it all!**

**TVRO/MATV/MDS/STV**

**CALL HOT LINE TOLL FREE**

**800-323-9640**

# Florida Sound Show

There is no gainsaying the advantages enjoyed by exhibitors and attendees when "the factory moves to the field."

The Florida Sound Show—January 6,7,8,1982—is an every-other-year event, conducted by Bill Bencsik Associates, with participating support from manufacturers, represented by their independent sales rep organizations.

The organization and planning evidenced by Bill Bencsik and his colleagues have positioned this independent sales organization, covering all of Florida and Puerto Rico, as a front-runner among his clientele, numbering among them Disney World, Sea World and other leisure parks, in addition to sound contractors, wholesalers and broadcasting stations.

Participating manufacturers declared, in their responses to a brief survey, that such a product showing generated a higher ratio of sales than many other shows, including national events in Las Vegas, Atlanta, New Orleans and other "central" locations. The reasons, they observed, are two-fold: (a) the Florida Sound Show delivered a controlled audience—meaning that every attendee was an interested customer/prospect, of a higher order of technical comprehension. Too, more time could be devoted to that customer/prospect without the interruptions that occur on the floor or in the booth of a national show. And (b) the cost per square foot of exhibit space, plus the cost of transportation of men, product and catalog literature, proved much lower than at a national show.

The every-other-year Florida Sound Show attracts several hundred attendees, from most of the state. They are, for the most part, the men responsible for the purchase, installation and maintenance of sound distribution/reinforcement systems in leisure parks; plus security system contractors and suppliers of intercom systems within hotels and motels and the plants engaged in light manufacturing. There is a smattering of miscellaneous sound system business

people, incorporating musical instrument dealers, recording studio people and "engineers" with municipalities.

It is an audience that has been cultivated by Bill Bencsik through a build-up process that involves eight weeks of preparation. The timing runs as follows:

Eight weeks prior to "show time," the first letter and questionnaire is mailed to a list of over 400 names—people who've been called upon for business, and people who've attended at least one Florida Sound Show.

Five weeks before "show time," there is a follow-up letter, with a questionnaire, advising the recipient that he did not respond to the first solicitation. Surely he is interested in seeing "what's new" in those areas of his expertise which will enhance his body of information about product and product application. Too, there is an open-house dinner party during the three-day exhibit "on the house."

Two weeks before "show time" there is a telephone blitzkrieg to the stragglers. Then the organization of all of the information delivered from the questionnaire is transferred to an overall "Operations Board." Each attendee, as he registers, is handed his "program"—he has been assigned an hour and place of meeting with the manufacturer, between 9 AM and 4:30 PM. He is allotted a full hour to meet with the prime supplier's sales people, technical

people or principals.

Thus, the manufacturer knows with whom he is meeting each hour of the day, while the attendee is aware of his dates throughout the 3-day showing.

Each participating manufacturer, if he so chooses, may conduct a technical seminar—a product presentation wherein the maker and the marketer exchange information: the marketer/user in this case bringing his experiences to the maker, and the maker interpolating his professional engineering answers to questions.

A hop-scotching survey revealed that the manufacturer found these sessions of inestimable value. He was hearing from the field, from the technician or salesperson intimately bound up with the product and its problems. He found this much more satisfactory, as a firsthand piece of information, than a second-hand report from the independent sales rep.

Can Bill Bencsik measure the increase in sales through the advent of the Florida Sound Show? Bencsik's answer was a philosophical one—he did not view the sound show as a vehicle for immediate money-making. He saw the meeting as an extension of his organization and the firms he represented, building product knowledge, strengthening friendships and underscoring the motto that "all business is local." The participating manufacturers obviously support Bencsik and his organization, for each Sound Show has seen an increase in

## Florida Sound Show participating manufacturers

Acoustone  
Argos Products Company, Inc.  
Auth Electric Co., Inc.  
Communications Co.  
Control  
Eastern Acoustic Works  
Lexicon, Inc.  
MacKenzie Laboratories, Inc.  
McMartin Industries, Inc.  
Soundolier  
Tape-Athon Corp.  
TEAC/Tascam  
Telex Communications, Inc.  
University Sound  
West Penn Wire Corp.  
White Instruments, Inc.





Front row, from left, Tracy Meyer, Janet Bencsik, Linda Bemer; rear, Larry Meyer & Bill Bencsik, all of Bencsik Associates

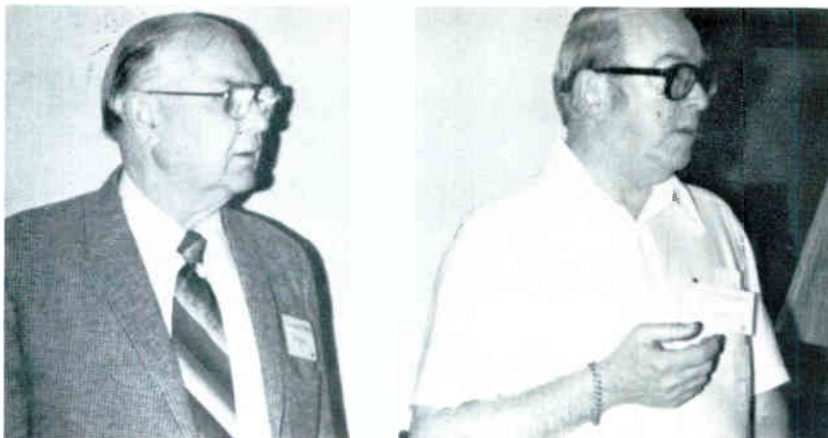

From left, Jerome Tanner, Don MacLaughlin, Argos Products



From left, Bob Felz, Harmony Music; Jerry Wade, Telex; Andy Grives, Harmony Music; seated, Bob Pearl, Melody Music

Ultrasonic  
**DRIVE-THRU**

**Communictron Corp.**

P.O. Box 1099  
Hutchinson, Kansas  
67501  
WATS No. 800-835-2256

**EXCLUSIVE  
DISTRIBUTION**

**For Details Call**





Jeffrey Ehrlich, Loft Professional Products



Emory Straus, White Instruments



Don Meren, Telex Communications



Ken Berger, Eastern Acoustic Works

their number.

The participating manufacturer's dollar outlay is a minimal contribution to Bencsik to cover the rental of the seminar hall; their bigger dollar outlay is for the motel room, serving as exhibit booth, and sleeping quarters.

This year's show attracted archi-

itects and consulting engineers, all first-time visitors. Bencsik has found them exercising more and more influence over component selection to perform the dedicated services included within blueprint designs. Too, Bencsik attributes a steadily rising sales curve for specialized audio products through the

years to the attention he has given these professionals—a rise he estimates to be somewhere between 50 and 100 percent.

Bencsik Associates represent manufacturers of speakers, signal processing equipment, microphones, wire and cable, security systems and intercom systems. □



# JOIN YOUR INDUSTRY AT THE THIRD NATIONAL SOUND AND ELECTRONIC SYSTEMS CONFERENCE

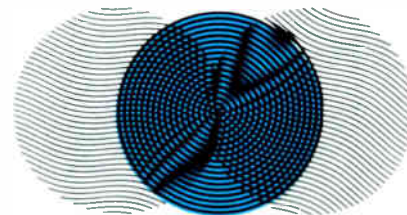

DESIGNED TO GIVE SOUND CONTRACTORS A FORUM  
FOR THE EXCHANGE OF IDEAS AND INFORMATION

**THURSDAY, FRIDAY, SATURDAY**  
**APRIL 29, 30, MAY 1**  
**NEW ORLEANS, LOUISIANA**  
**NEW ORLEANS HILTON**  
**AND MARRIOTT HOTELS**

**MANAGEMENT AND MARKETING SEMINARS**  
**TECHNICAL SESSIONS AND PRODUCT MEETINGS**  
**PRODUCT EXHIBITS AND SUPPLIER CONFERENCES**



(In conjunction with the 1982 Electronic Distribution Show and Conference)

#### INTENDED FOR:

SOUND CONTRACTORS  
ELECTRONIC SYSTEMS  
INSTALLERS  
MANUFACTURERS  
SALES  
REPRESENTATIVES

#### PRODUCT EXHIBITS:

AMPLIFIERS	WIRE AND CABLE
BACKGROUND MUSIC SYSTEMS	CONNECTORS
INTERCOMS	CABINETS
MICROPHONES	INSTRUMENTS AND TEST EQUIPMENT
SPEAKERS	AND OTHER RELATED EQUIPMENT
TELEPHONE AND INTERCONNECT DEVICES	AND ACCESSORIES
SECURITY SYSTEMS	

#### SESSIONS ON:

SYSTEMS DESIGN  
MANAGEMENT &  
MARKETING  
NEW BUSINESS  
OPPORTUNITIES  
QUESTION AND ANSWER  
OPPORTUNITIES WITH  
INDUSTRY EXPERTS

#### PRODUCT SALES MEETINGS:

MANUFACTURER SALES  
MEETINGS FOR SOUND AND  
ELECTRONIC SYSTEMS  
CONTRACTORS

For complete information contact:



ELECTRONIC INDUSTRY  
SHOW CORPORATION  
222 South Riverside Plaza  
Suite 1606  
Chicago, IL 60606  
Telephone: (312) 648-1140

Please send badge application and registration forms to:

Name \_\_\_\_\_

Title \_\_\_\_\_

Company \_\_\_\_\_

Street Address \_\_\_\_\_

City, State, Zip \_\_\_\_\_





Geoff Keleher, MacKenzie Labs



Blair Hunnicutt, Tape-Athon



Lee Tate, Tape-Athon Corp.



**FANON PRESENTS**

The newest value in  
**ECONOMY PUBLIC ADDRESS AMPLIFIERS**

Ask your distributor to show you our new models, PAA-15 (15 WATT)  
and PAA-35 (35 WATT) Public Address Amplifiers

**FANON**® BLAZING NEW TRAILS IN ELECTRONICS  
SINCE 1949

15300 SAN FERNANDO MISSION BLVD. MISSION HILLS, CA 91345  
TEL:(213) 365-2531 TELEX: 182884 FANON USA MSHI



Pete Jordan, Communications Co.

*Sound & Communications*



Chuck Watts, Comtrol Corp.



George Backer, Acoustone



Bill Mohrhoff, TEAC/Tascam

# **CABLE WIRE**

**SAXTON: A PRIME MANUFACTURER OF ALL TYPES OF WIRE & CABLE. STANDARD ITEMS ARE AVAILABLE FOR IMMEDIATE SHIPMENT FROM OUR LARGE WAREHOUSE INVENTORY.**

- COAXIAL CABLES—Military, Commercial, CATV  
RG 62 A/U, RG 59/U, RG 58/U, RG 213/U
- FIRE ALARM—POWER LIMITED  
NEC Art. 800, Class Fire & Smoke, Teflon

- UL & CSA HOOK-UP WIRES—AWM,MTW,THHN
- CUSTOM CABLES TO ORDER

- BELDEN & ALPHA EQUIVALENTS
- POWER LIMITED CABLES  
NEC Article 725 & Article 760

- MULTI-CONDUCTOR CABLES—  
Shielded & Unshielded  
All types of constructions, Belden & Alpha Equivalents
- COMPUTER, POS & DATA CABLES

- SECURITY & ALARM WIRE & CABLE
- TELEPHONE CORDAGE

CALL TOLL FREE 800-431-2774 FOR PRICES AND NAME OF YOUR NEAREST DISTRIBUTOR

# **Saxton PRODUCTS, INC.**

215 N. Rt. 303 Congers, N.Y. 10920  
(914)268-6846 NY (212)933-6262 CA.(213)926-5596

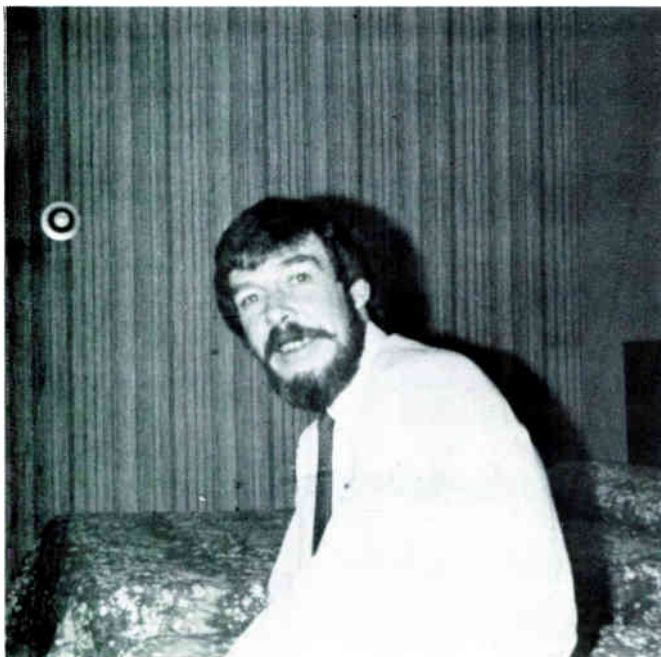

Keith Worsley, Lexicon, Inc.



Lou Valente, West Penn Wire

## The ED/COR Advantage-

Tomorrows Technology  
Today



### AM 400 AUTOMATIC MICROPHONE MIXER THE AFFORDABLE ONE

4 Lo Z inputs — expandable to 28  
 Individual mic input gain control  
 Individual "trigger" sensitivity control  
 Individual gain control — allows adjustable muting  
 State of the art CMOS logic circuitry  
 Logic output for speaker or similar control

Complete elimination of first word cut-off  
 LED indicators for active channel indication  
 Balanced output mic or line level-Switchable  
 Unbalanced output available. Both outputs can be used simultaneously

Free standing or rack mountable — 1 3/4" rack space.  
 Rapid repair/maintenance via connectors and jumper strips.  
 Meets and exceeds competitive performance at far less cost.

Call 800-854-0259 for complete information.

Wireless Microphones    Headphone Amplifiers    Automatic Microphone Mixers  
 Mixer Amplifiers    Power Amplifiers    Preamplifiers    Multiplex Snake

16782 HALE AVENUE    IRVINE, CALIFORNIA 92714    (714) 556-2740



Charles Round, University Sound



Alan Schwartz, Auth Electric



## THE SOCIETIES PAGE

**Electronic Representatives Association (ERA)** and the National Sound and Communications Association (NSCA) will offer Technical Seminars on Emerging Markets for Sound and Electronic Installers on March 30th and 31st at the La Guardia Marriott Hotel, NYC.

Moderators at the seminars will present practical approaches to life-safety/fire protection, sound masking, satellite TV and CCTV surveillance. The line-up of speakers was announced by Joel H. Schwartz, chairman of the Sound, Signal and Security (SSS) Division, New York Chapter ERA, and coordinator of the seminar.

The seminars are divided into four sessions, with two sessions scheduled each day from 9 a.m. to 12 p.m. and 2 p.m. to 5 p.m. A free lunch, with a keynote speaker, will be offered to seminar attendees on each day between the hours of 12 noon and 2 p.m.

Seminar topics include: Session I: Introduction to Life-Safety/Fire Protection; Session II: Introduction to Satellite TV Reception; Session III: Introduction to Sound Masking; and Session IV: Introduction to CCTV Surveillance Systems.

Speakers scheduled for each session are: Session I: Burt D. Myers, president, B.D.M. Consulting, Inc., independent consultants. Myers is a former Deputy Chief Inspector and Principal Electrical Inspector for the New York City Fire Department. Session II: Thomas C. Christy, applications engineer for Earth Stations, Blonder-Tongue Laboratories. Session III: Dr. William Wokoun, president, B.W. Research Laboratories, Inc., a research and consulting firm using psychological techniques to solve human factors and communications problems. Wokoun is also chairman of Muzak Corporation's Board of Scientific Advisors. Session IV: Bob DeGennaro and Oscar Kraut. DeGennaro is president, Video Surveillance Corporation, a member of the Board of Directors of the Metropolitan Burglar Alarm Association of New York, and a contributing editor to S.D.M. magazine. Kraut is vice-president,

marketing and sales, Stylist Systems Corporation, and was formerly a sales executive with several major CCTV manufacturers.

Registration for the seminars is on a first-come, first-served basis. Costs are: \$40 for one person, one session; \$60 for one person, two sessions, one day; \$80 for one

person, one session each day; \$100 for one person, three sessions; \$120 for one person, four sessions. Registration fees include all applicable materials. Additional attendees from the same company can register at a 10% discount after the first person registers at the full fee.

For further information, including pre-registration materials and session outlines, contact Joel H. Schwartz, L-C-A Sales Co., 76 Main Street, Tuckahoe, NY 10707, or call 914/961-4700 or 212/585-1645.

# For life-safety messages, nothing beats the human voice.

The human voice. Time and again, studies have shown that nothing communicates better—or has a more calming effect—than a carefully phrased vocal message.

MacKenzie Laboratories offers a complete line of proven, highly reliable message-repeater systems designed to provide such vital pre-recorded announcements instantly and automatically, even from remote locations.

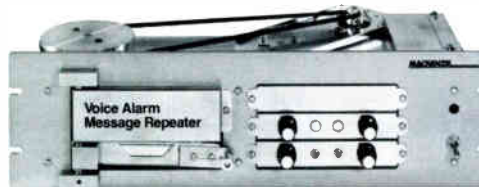

MacKenzie message-repeater systems are ideal for all the following life-safety applications:

**Voice Alarm and Warning**—Messages which alert people about impending emergencies such as tornados, hurricanes, gas leaks or other potentially life-threatening situations.

**Voice Evacuation**—A combination of pre-recorded and live instructions for evacuating a building in an emergency.

**Fireman's Return**—An announcement explaining that an elevator car is returning to the ground floor during an emergency and reassuring passengers there is "no cause for alarm."

**Code Blue**—A coded hospital message which alerts emergency personnel that a cardiac arrest or some other situation requiring immediate attention is occurring at a specific location.

**Emergency Message System**—A combination of pre-recorded, selectable messages interfaced with a building's automatic alarm system, Code Blue annunciator or environmental monitoring system.

All MacKenzie systems are available with microprocessor-based memories and priority-sequence controllers to handle multiple and simultaneous messages. For details about specific applications, call MacKenzie toll-free at 800-423-4147.

**MACKENZIE** MacKenzie Laboratories, Inc.

5507 Peck Road, Arcadia, California 91006, (213) 579-0440

# Vibrating Fire Alarm

**A** fire alarm system for hearing-impaired students, faculty and staff members at Winthrop College, Rock Hill, S.C., has won Winthrop a \$5,000 national award for innovative cost reduction.

The \$5,000 prize represents third place among 160 entries in the National Association of College and University Business Officers/U.S. Steel Foundation Cost Reduction Incentive Awards Program for 1981. The competition was open to the nation's 3,100 institutions of higher education.

The Winthrop system employs



individual paging devices for hearing-impaired members of the cam-

pus community to wear whenever they are on college grounds. Similar in appearance to the beeping pagers worn by physicians and other professionals, the Winthrop pagers vibrate for 30 seconds when any fire alarm on campus is activated.

The fire alarm system for deaf people most often used by institutions utilizes flashing signal lights. Winthrop would have spent at least \$147,000 to install a flashing light system, which contrasts with the \$7,000 cost of the vibrating pager system, according to Winthrop Resident Construction Engineer Steve

## “ven-tril-o-quism

n. A method of producing vocal sounds so that they seem to originate in a source other than the speaker.” *American Heritage*

### ONCE AN ART

### WITH US A SCIENCE

ROBOTS

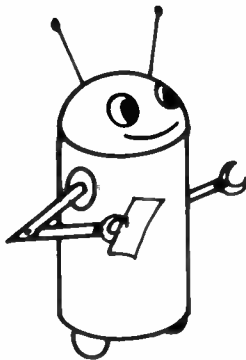

LECTERNS

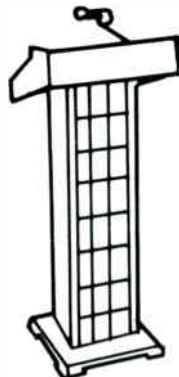

PORTABLE PA SYSTEMS

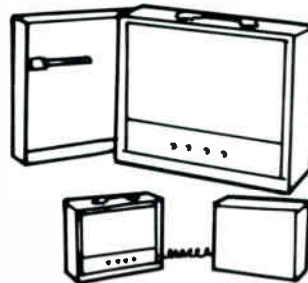

INTERCOMS



**WISSCO**

A DIVISION OF WANLASS INDUSTRIES, INC.

1599 Superior Ave. A-1 • Costa Mesa, CA 92627

Toll Free (800) 854-6280 • (714) 645-1281 • (415) 777-4533

Warren, who developed the system. "We didn't invent anything—the components were standard radio communication equipment already in existence," Warren said. "There was no new technology, just a new application.

"It just beats the heck out of the alternative, and we saved almost one percent of Winthrop's total annual budget," Warren added.

The inspiration for the paging system came in a line of a technical journal. Warren remembers reading about "the fascinating possibilities of a Dick Tracy vibrating watch" used to signal danger to people with hearing impairments.

"There were discussions in trade magazines for some time that there had to be a better way than flashing lights," (to warn hearing-impaired people in case of fire) Warren said.

"It turned into a headache of a paper chase, with some electronics people swearing it wouldn't work, others promising us it could, and then shipping errors and other order delays."

The vibrating pager system has many advantages over flashing lights, according to Warren. More than 1,550 lights would be needed in Winthrop's 31 buildings where a hearing-impaired student, faculty or staff member might conceivably be at any time of the day or night. Also, smoke from a fire could obscure the light signals and the intense heat generated in a building fire could destroy the wiring to the signal lights.

The financial benefits of the vibrating pagers over flashing lights earned the \$5,000 prize for Winthrop. Warren estimated the initial investment total for the pagers at \$7,040. Flashing lights, he said, would cost Winthrop \$147,250 "at the extremely conservative end."

Annual maintenance for the pagers is about \$400, compared with over \$4,000 for the lights, Warren said.

The college bought five of the pagers initially. They will be used as individuals with hearing impairments are identified among the current 5,040 students and 660 employees.

If more than five persons need the fire alarm pagers, Warren said the college can buy them at about \$350 apiece. The system can accommodate an infinite number of pagers. □

## STILL UNEQUALED

... and proven so in  
side-by-side demonstrations



It's been two years that you've been seeing this ad. Edstan is still the leader, and still looking for dealers. Many areas lack representation.

An Edstan dealer is a communications specialty contractor, who serves one or more hospitals. Most of our systems were sold by dealers. Only one has sold more than one system.

Here's what we do for you:

- (1) engage in a national sales campaign to produce leads;
- (2) provide factory involvement in demos, installations and maintenance;
- (3) cite 30-plus satisfied hospital users;
- (4) provide continuous improvements in Edstan II.

Announcement next month of EDSTAN JUNIOR!

Call me, Dave Verner, for a complete information package. Toll free 800-423-4765.

Edstan II marketed nationally by DIRECT SYSTEMS COMPANY, a Div. of Time and Sound Company, 12115 Rivera Rd., Whittier, CA 90606

Visit our booth at the Electronic Distribution Show & Conference in New Orleans, April 29 through May 1.

# RAYMER

## Model RPM—Audio Voltage and Power Meter (hand held)

- Visually indicates voltage across 25V and 70V speaker lines from .4V to 100V.
- Visually indicates wattage applied to speaker voice coils from 25mW to 1000W.
- Eliminates errors found in meter movement by showing read-outs on 10 light emitting diodes calibrated in 3 db increments.
- Supplied with audible monitor.
- Includes low battery shut-off.
- Supplied with standard 9V battery, belt clip, and pair of test leads.

### TECHNICAL SPECIFICATIONS

VOLTAGE SCALES	10V Range .450 to 10V 100V Range 4.50 to 100V
FREQUENCY RESPONSE	50 Hz to 500 KHz ±1.5 dB.
OVERALL DIMENSIONS	2 1/4" wide — 1" deep — 7" long
WEIGHT	12 oz. (Including Battery)

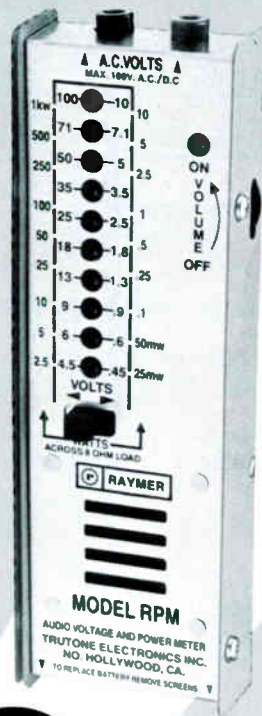

See Your Distributor or Contact  
**TRUTONE ELECTRONICS INC.**

7315 Fulton Ave., No. Hollywood, CA 91605 • Phone (213) 764-3434  
(213) 875-0423

Distributed in Canada by . . .  
ENGINEERED SOUND SYSTEMS • 3078 Jarrow Avenue • Mississauga, Ontario



## The Receiver



### MODEL MS-72R — 7 WATT FM PAGING RECEIVER

Features sensitive reception of FM Broadcast for background music and selectable microphone or auxiliary paging sources, with precedence, all in a compact 3 1/2" x 8 1/2" x 9" size cabinet.

- FM Sens. is 1.25 microvolt for 30 db S+N/N ratio (at 300 ohms).
- Power output is 7 watts into 8 ohms, balanced 25 V., or 70 V lines.
- Frequency response for music 50 HZ to 15KHZ with less than 1/4% distortion.
- Special mic page response is 250 to 2500HZ.
- Mic input sens. is 0.7 MV at 200 ohms with RFI filter.
- Aux. input sens. is 100 MV at 50K ohms.

Front panel has lighted 5 1/2" slide rule dial. Controls include tuning, page level, music level, tone, AFC/MUTE and Power ON/OFF.

All connections on rear panel are screw type except the Aux. input is phono type. Also on rear, a page source selector switch and power circuit breaker are provided.

## McGohan Electronics, Inc.



1033 Fairway Drive  
Bensenville, Ill. 60106  
312-595-2342

## CLOCK AND PROGRAM SYSTEMS by MONTGOMERY

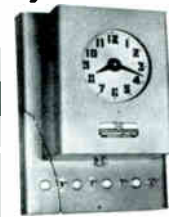

**NEW! MULTI-CIRCUIT** — Provides complete automatic operation of 1 to 5 separate schedules on 1 to 5 groups of signals. Signals adjust from 2 to 25 seconds. Calendar switch regulates automatic operation. Clock and program mechanism set by turning hands. Special signals, by push-buttons, do not disturb automatic operation. 12 or 24 hour model.  
Write MONTGOMERY MFG. CO., Owensville, Ind. 47665

## cabltronix

Cable for electronics, sound, intercom, interconnect, fire/burglar alarm, control, signal, nurse call, apartment house, and computers.

Hardware: AMP connectors; boots; bridging clips; "B" connectors; Dennison and Tyton tie wraps; Arrow staplers and staples; screws; plastic anchors; electrical/packing/masking tapes; and Cyanoacrylate adhesives.

366 Washington Street  
P.O. Box 3003 • Newburgh, NY 12550  
(914) 565-7570 • (212) 597-3691

# CLASSIFIED

Classified listings are accepted up to the 1st of the month preceding publication. Rate — \$47.00 per column inch. Check with order.

## LINE STATUS INDICATOR

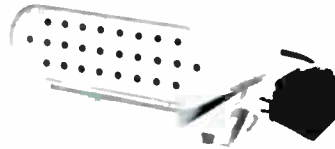

The call pickup indicator works with any standard PBX on 25-pair cable (up to 24 lines) or 50-pair cable (up to 48 lines). LEDs indicate both busy and ringing lines with audible tone signal for ringing lines. Own power supply uses 110-V outlet. Complete engineering and specs/ dealer prices from:

C&M PRODUCTS LTD., 111 French Ave.  
Braintree, Mass. 02184. 617-848-2750



Lorun Street, Tewksbury, Mass. 01876

Tel. (617) 851-4541

Manufacturers of quality sound & communications cable.  
Stock & price list mailed on request

### FREE 32pg Catalog & 50 Audio/Video Applic.



8-in/2-out, 12-in/4-out, 16-in/4-out  
Video & Audio Dist Amps. TV Audio & Recd Prod Consoles  
OPAMP LABS INC (213) 934-3566  
1033 N Sycamore Av LOS ANGELES CA, 90038

### Background Music for SCA-CATV-Telephone BGM INTERNATIONAL

A Division of  
**F. T. C. BREWER COMPANY**  
P.O. Box 8057  
Pensacola, Florida 32505  
904 433-7932

## MATCHING TRANSFORMERS

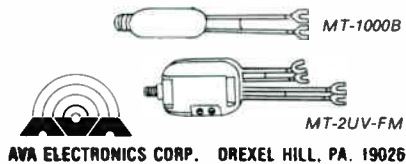

AVA ELECTRONICS CORP. OREXEL HILL, PA. 19026



### ACOUSTIC TEST INSTRUMENTS USE TO ADJUST EQUALIZERS, OPTIMIZE SPEAKER PLACEMENT, ETC.

Complete Test Set	\$449
Calibrated Sound Level Meter	\$199
Fractional Octave Pink Noise Generator	\$339
Handbook on Acoustic Testing	\$10

Free broch HALL ENGINEERING Dept CS  
P O Box 506, Martinsville NJ 08836  
(201) 647-0377

## BOB AMOS & ASSOCIATES



We are Specialists for CCTV, Telephone Products, Broadcast Products & Engineering Sound Contractors  
P. O. BOX 3247, IRVING, TEXAS 75061  
214-827-8232  
214-252-1161

Outstanding career opportunity for sales person with proven record in background music/communications business. We operate MUZAK franchise and Altec Sound Company in Corpus Christi, Texas (metro population of 450,000). The City is in the center of the Energy Belt and growing very rapidly. Position offers dynamic earning potential, great living conditions, and opportunity for management. Please send resume of past performance and experience to: Bill Balthrope, 214 Tower Life Building, San Antonio, Texas 78205.

Technician/installer wanted for the design, fabrication and installation of sound and intercom systems for an established Altec Sound System Contractor. Must be experienced with sound products and have the ability to perform first quality shop and field work. Only experienced persons need apply. Excellent future opportunity for the capable person. Contact or send resume to:

Gus J. Matty  
Lier Sound Company  
633 North D Street  
San Bernardino, Ca. 92401  
Phone 714-884-8243

### INVESTOR-PARTNER

Interconnect-Intercom Established and growing. Enjoy living and working in Southern California.

Unitel West, Inc.  
Call Jerry Gross (213) 245-8588

### MOVE TO THE SUNBELT

Needed—Telephone Installers experienced on 1A2 Key, Electronic Key, & Electronic PBX. Good pay for the right persons. Call: Southwest Utilities, Inc., Okla. City, OK 405-946-1200.

### FOR SALE

Sound Contracting Company. Active in sound, intercom, fire alarm, MATV. Current bookings in excess of \$500,000. Owner wishes to retire. Contact Rex Lee, Jr. 904-673-2500.

# Clear, Crisp Sound!

Clear, crisp sound is based on exceptional loudspeakers...and so was Dukane Corporation.

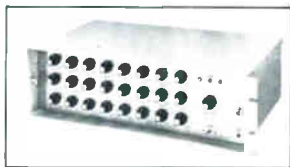

Dukane offers a complete line of professional sound equipment.

Loudspeakers were our first product, and are still a major part of our business. Our line includes speakers and horns for every application. All share one common value...

the ability to project with uniform coverage and minimum distortion. Through the years, our technology has developed a full line of communications products. We provide sound systems used in major public facilities, stores and

plants, schools and healthcare facilities. Every Dukane component, whether in a public address, intercom or sound masking system, is backed by more than 50 years of expertise. Every installation is supported by an extensive world-wide dealer and

service organization.



A variety of amplifiers, preamplifiers and mixers are available.

We'd like you to have more information on the full range of Dukane sound product and design capabilities. Attach your business card to this ad and send for free information.



**DUKANE** 

DUKANE CORPORATION/COMMUNICATIONS SYSTEMS DIVISION/ST. CHARLES, ILLINOIS 60174 312/584-2300

# Key tools of your trade...



## ...under one cover

Getting bids is never easy. And in these money-conscious times it's tougher than ever. Shure can help. We offer a wide selection of special purpose microphones for special installation requirements. And as you've come to know, Shure microphones not only sound great but are built to withstand the abuse of real world punishment, installation after installation, time after time.

Each of these microphones offers built-in ruggedness and reliability, and is designed to give you the optimum performance in every circumstance, whether it is:

- paging in areas of high background noise (Model 450);
- gooseneck mounting for podiums, pulpits, lecterns or cashier windows (Models 561, 562, 572G and 515SBG);
- lavalier microphones for audio-visual work (SM11, Models 570 and 570S);
- unobtrusive sound reinforcement on church altars (SM18W) and in conference rooms (SM18B) . . . or whatever demands the job may make.

For all the facts on Shure's full line of special purpose microphones, fill out and return the coupon below for your FREE copy of our new 72 page catalog describing over 150 microphones. No matter what your client's needs, there's a Shure microphone that will help you do the job better. When it comes to special purpose microphones, we wrote the book.

PLEASE PRINT

Yes, send me your new Full Line Microphone/Circuitry Catalog, AL700. (Outside the U.S., enclose \$2.00 for postage and handling.)

Name \_\_\_\_\_

Address \_\_\_\_\_

City \_\_\_\_\_ State \_\_\_\_\_ Zip \_\_\_\_\_



# SHURE®

The Sound of the Professionals®

Shure Brothers Inc., Dept. 63, 222 Hartrey Ave., Evanston, IL 60204  
In Canada: A.C. Simmonds & Sons Limited

Manufacturer of high fidelity components, microphones, loudspeakers, sound systems and related circuitry.