

Stereo Review® Presents

Display until December 26, 1989 \$3.95

STEREO®

BUYERS' GUIDE 1990

MORE THAN 3,000 HI-FI COMPONENTS

How to Buy a Stereo System

Features, Specs, and Prices of Receivers, Speakers, CD Players, Cassette Decks, Amplifiers, Accessories, Tape, and More



State-of-the-Art Components

Polk Fluid-Coupled Subwoofers

Used in most of the Polk home speakers, the fluid-coupled subwoofer system realizes the advantages of both small and large woofers at the same time. Small woofers are faster, have better midrange response, and wider dispersion. Large woofers move more air and thus produce louder, deeper bass. In the Polk system, the small bass midrange drivers hydraulically and elastically transfer low frequency energy below 60 Hz to the large, low-resonance sub-woofer. The result is remarkably deep, powerful, clear and detailed bass.

Polk Isophase Crossover System

A speaker's crossover acts much like the conductor of an orchestra. It tells each driver when and how loud to play. Even the best drivers would sound bad if poorly matched and blended together by an inexpensive crossover. Hidden from view, many manufacturers will skimp on the quality of their crossovers, resulting in poor overall sonic performance. Polk recognizes the vital importance of a system's crossover and spares no effort or expense in designing and building this critical component. Expensive air-core pure copper coils are used to insure wide dynamic range and excellent sound quality at every volume level. Precision resistors and capacitors are also used to maintain perfect driver blending and the lowest possible distortion.

“Polk Builds State-of-the-Art Components For Lifelike Sound, Quality and Reliability.”

Consistently Superior Technology Results in Better Sound.

Exclusive Trilaminare-Polymer Drivers

Polk drivers are unique and superior in performance and reliability. Rather than accepting the sonic compromises of one cone material, we laminate three complimentary cone materials together to achieve a level of performance unmatched by simple paper or plastic cones. The basic lightweight and strong fiber cone is first laminated with a space-age polymer that stiffens the material to prevent distortion; a second polymer is then added to eliminate resonance and coloration through visco-elastic damping. Polk drivers also use costly butyl rubber surrounds for more accurate cone movement and deeper bass response, and to prevent the deterioration experienced over time with foam surrounds. The result is a driver that faithfully reproduces the timbre of every musical instrument and voice while maintaining every subtle detail of the composition. Your Polk speakers will sound great year after year, after year.

We Build Our Own Component Parts

The sound quality of a loudspeaker is ultimately determined by the quality and consistency of its component parts and the ability of the designer to successfully combine those parts to achieve a coherent, seamless and balanced musical presentation. A brilliant design concept is easily ruined by the use of inferior parts and inadequate cabinet construction. Recognizing this, Polk's engineers insist on designing, building and testing components in our own factories. As an owner of Polk loudspeakers, you have our guarantee that your speakers conform to Matthew Polk's singular vision of musical accuracy, consistency and reliability.

Polk's SafetyGuard Tweeter Protection Device (not pictured)

This distortion-free circuit instantaneously shuts down the tweeter(s) when the speaker is overdriven. And unlike crude fuses, Polk's SafetyGuard is fast, effective and self resetting.

Polk's Exclusive Tweeter Design

Every detail of Polk's exclusive tweeter design has been critically engineered to insure the listener the ultimate in high-frequency performance. The voice coil is precision wound with high-conductivity coated wire for more extended high frequency response. The ultra light polyamide dome is extremely fast for superior transient response. It allows the listener to perceive even the most subtle detail and texture in the music. This remarkable soft dome also smooths and eliminates annoying resonances and peaks thereby avoiding the shrillness and edgy sound of hard-dome designs. The small diameter dome shape and a specially contoured minimum diffraction faceplate provide wide dispersion insuring that you will enjoy full fidelity and well-balanced sound throughout your listening room.

Additionally, Polk's newest and most advanced design, the SL3000 trilaminare tweeter, is available on the limited production SRS1.2 tl and SRS 2.3 tl loudspeaker systems. Although this tweeter can only be produced in limited quantities, it represents a new standard of engineering excellence in component design. For those interested in receiving more detailed information on the technology used in this design, please contact us for a copy of our "white paper" on engineering achievements incorporated in the SL3000 tweeter.

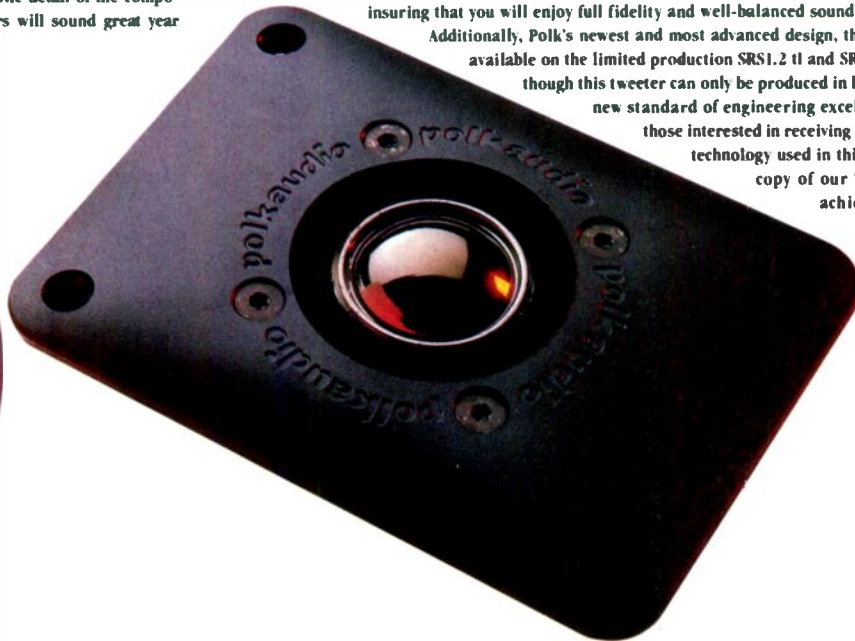



Take Ten

Introducing the
new ten disc
CD Changer,
another industry
first* from Ford.

Now you can enjoy hours of continuous music without having to load, unload, or store your compact discs while you drive.

This new state-of-the-art system uses interchangeable ten disc magazines in a changer unit that is stored safe and secure in the trunk of your car. And a full-function remote control allows the selection of any track on any disc

at the touch of a button.

The new ten disc CD Changer is compatible with any Ford, Mercury or Lincoln equipped with the optional Ford High Level Audio or Ford JBL Audio system. See your local Ford or Lincoln-Mercury dealer for details.

The new ten disc CD Changer from Ford. We're sure you'll rate it a "perfect 10."

*First optional dealer-installed CD Changer available from a U.S. automobile manufacturer.



AUDIO SYSTEMS
The Sound of Quality

STEREO

BUYERS' GUIDE 1990



FEATURES

System Quest	6
<i>By Ian G. Masters</i>	
Music Everywhere	16
<i>By Rich Warren</i>	

PRODUCT LISTINGS

Receivers	30
Power Amplifiers	44
Preamplifiers	60
Integrated Amplifiers	76
Tuners	84
Compact Disc Players	90
Cassette Decks	116
Open-Reel Tape Decks	126
Turntables	127
Cartridges & Tonearms	132
Speakers	140
Headphones	205
Signal Processors	214
Accessories	221
Pocket Stereo	242
Blank Tape	246
Audio Glossary	250
Directory of Manufacturers	258

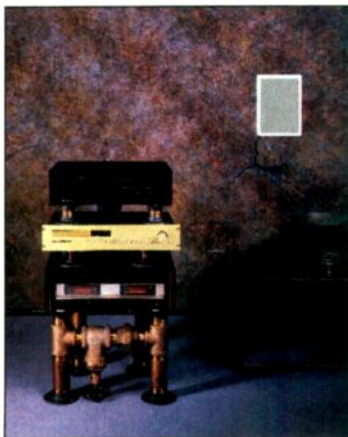

Cover components (counterclockwise from top right):

Boston Acoustics Model 360 speaker
(listing on page 156);

Aiwa FD-1000 cassette deck (listing on page 116);

Conrad-Johnson DF1 preamplifier/CD player
(listing on page 91);

Pioneer M-91 amplifier (listing on page 53).

Cover photograph: Robert Lorenz

Table and bowl courtesy of Modern Age.
Shelving is not commercially available.

Stereo Review®'s STEREO BUYERS' GUIDE 1990

WILLIAM WOLFE Editor

LOREN FALLS Art Director

BOB ANKOSKO Senior Editors
WILLIAM GOLDMAN

MIKE METTLER Associate Editor

MICHAEL CUFFE Database Coordinator

CHRIS GIANCOLA Editorial Assistant

LAURA SUTCLIFFE Assistant Art Director

BARBARA AIKEN Project Coordinator

SUE LLEWELLYN Design Consultant

LOUISE BOUNDAS Editorial Director

MICHAEL SMOLEN Executive Editor

WINSTON A. JOHNSON
Vice President and Publisher

ADVERTISING

Advertising Director: Nick Matarazzo
212-719-6035

National Sales Manager: Charles L. P. Watson
212-719-6038

Consulting Director: Richard J. Halpern
212-719-6025

Account Manager: Sharon Dube
212-719-6037

Corporate Account Manager: Tom McMahon
212-719-6025

Assistant to the Publisher: Nadine L. Goody
Classified Advertising: 800-445-6066

Midwestern Managers: Arnold S. Hoffman,
Jeffrey M. Plaster 312-679-1100

Western Managers: Bob Meth,
Paula Borgida Mayeri, 213-739-5130

Tokyo Office: Iwai Trading Co., Ltd.
603 Ginza Sky Heights Building, 18-13,
Ginza 7-Chome, Chuo-Ku, Tokyo, Japan 104
Japan Representative: J.S. Yagi
Telephone: 03-545-3908

Production Director: Karen L. Rosen
Production Manager: Michele Lee

STEREO REVIEW PRESENTS IS
PUBLISHED BY DIAMANDIS
COMMUNICATIONS INC.

President and CEO: Peter G. Diamandis
Executive Vice President: Robert F. Spillane
Senior Vice President, Finance, and CFO:
Arthur Sukul

Senior Vice President, Manufacturing &
Distribution: Murray Romer

Senior Vice President, Operations &
Administration: Robert J. Granata

Vice President, Controller: David Pecker
Vice President, General Counsel:
Catherine Flickinger

Vice President, Circulation, Leon Rosenfield;
Vice President, Communications, Phyllis
Crawley Gates; Vice President, Marketing,
Anthony F. Incalcaterra; Vice President, Research,
Bruce Gershfield; Senior Vice President, Sales,
James A. Frahm.

Stereo Review Presents is published four times
a year by Diamandis Communications Inc.,
a wholly-owned subsidiary of Hachette
Publications, Inc., 1515 Broadway, New York,
NY 10036.

COPYRIGHT 1989 BY DIAMANDIS PUB-
LICATIONS INC. ALL RIGHTS RESERVED.

PERMISSIONS: Material in this publication
may not be reproduced in any form without
permission. Requests for permission should be
directed to: The Editor, Stereo Review,
Diamandis Communications Inc., 1515
Broadway, New York, NY 10036.

The Orchestra.



The Conductor.

You're looking at something unusual in the audio spectrum: a series of high-end components and an integrated remote that truly work in concert. Introducing the Mitsubishi E-5200 audio system. A system designed so that the amp, tuner/preamp, graphic equalizer, dual cassette deck, CD changer and speakers on the left are under total and complete control by the programmable remote on the right. In fact, we call it a "responding" remote, because unlike other remotes ours features an LCD that not only shows you what the system is actually doing but also confirms that the tuner/preamp has executed your commands. So you and your orchestra are always in perfect harmony.



The LCD readout is instantly updated with a signal from the tuner/preamp giving you a complete visual report at all times.

Program your 5-disc CD changer with digital optical output and 4X oversampling.

You have control of 360 degrees of Dolby Surround™ sound. Because you can adjust the volume of two 4-watt speakers with laminated drivers up front plus the two speakers in the rear.

You can even make adjustments to your seven-band graphic equalizer.

Turn on a 150-watt-per-channel amplifier.

Have complete control of a dual auto-reverse cassette deck featuring Dolby B, C, HX Pro and full logic controls.

It's also compatible with all Mitsubishi video products so you can program your VCR here.

© 1989 Mitsubishi Electric Sales America, Inc. Dolby, Dolby Surround and HX Pro are trademarks of Dolby Laboratories Licensing Corp. *150 watts per channel minimum RMS 16 ohm channels driven into 8 ohms from 20Hz-20kHz with no more than 0.05% total harmonic distortion. For the name of your authorized dealer call (800) 527-8888 ext. 245.

MITSUBISHI ELECTRONICS
TECHNICALLY, ANYTHING IS POSSIBLE

CIRCLE NO. 20 ON READER SERVICE CARD

SYSTEM QUEST

How to buy just what you need—without busting your budget

Serious business, audio. Take a look around any hi-fi store and check out the expressions of the customers: The concentration and earnestness are almost audible. But isn't audio an entertainment medium? Isn't it supposed to be fun? Sure, but it's the *use* of the equipment that's entertaining. The initial purchase can be an intimidating process, at least for most of us. The sheer number of components available, and the variations among them, can make the purchase of a system daunting even for a seasoned audiophile. For the beginner, making choices is that much more difficult.

But it's not impossible. You could, of course, simply put yourself in the hands of an audio salesperson and buy whatever he recommends, assuming the price is right. Even easier would be to purchase a complete one-brand system. Both options would probably give you pretty good sound, and you *might* even end up with a system perfectly suited to your listen-

BY IAN G. MASTERS

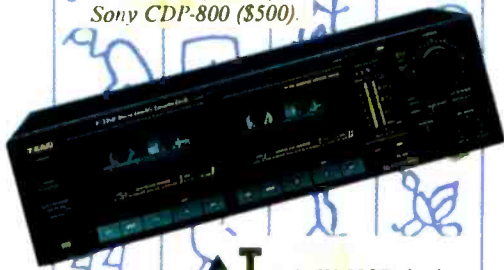

PHOTO BY MARK WEISS; STYLING COURTESY OF AUSTIN PRODUCTIONS INC.





System Quest components (preceding pages): Revox Duetto (\$1,095), Yamaha RX-1130Ti (\$1,199), Sony CDP-800 (\$500).



Teac's W-550R dual-well cassette deck offers Dolby HX Pro, Dolby B and Dolby C noise reduction, high-speed dubbing, continuous play, and auto-reverse. Price: \$400.

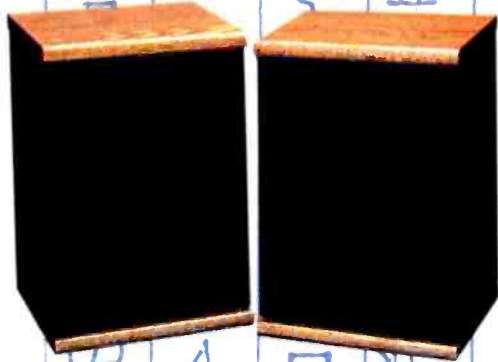

Acoustic Research's STC 666 satellite/subwoofer system features a tuned dual-cavity subwoofer enclosure (not shown) and a pair of two-way bookshelf speakers. System price: \$580.



Denon's DR-125 receiver delivers 30 watts per channel and features a CD-direct switch, five inputs, sixteen AM/FM station presets, and a variable loudness/equalization control. Price: \$300.

ing habits and requirements. But that's not likely; the reason there are so many different configurations of hi-fi gear is that no two users' needs are precisely the same, and audio manufacturers are only too happy to provide a bewildering array of equipment in the hope that one or more of their models will suit you. In addition, one of the pleasures of buying something as complex as a stereo system is knowing afterwards that it was your own creation, particularly since a good one usually represents a fairly major investment.

What Do You Need?

Of the thousands of audio components available, there are probably only a handful that are ideal for you, ones that do everything you require but are not burdened with a lot of expensive features you'll never use. The trick is to eliminate all of the models that are definitely unsuitable. Before you can do that, however, you must determine exactly what it is your equipment will have to do—and what it won't. From there, you can get a very good idea of the components you'll need. Bear in mind that any stereo setup is a group of interrelated devices; each one must offer the functions you need and be compatible with the others in the system.

The first thing you need to do is to sketch out the basic design of your system. Will it be a conventional two-channel stereo, or will you want surround-sound capability (which utilizes four or more channels)? Will it be used strictly for listening to music, or will it include video equipment as well? Will it be used just for playback, or will some form of tape recording be required? Will you want to listen to it in one room only or in several locations? The answers to these questions will determine to a large extent what equipment you should consider.

Another early decision involves determining what sort of source material you will want to use. Until recently, a turntable that played vinyl discs was virtually standard, but now you may consider it an option. If you are starting from scratch, you may well decide to buy all of your music in the form of cassettes or compact discs, dispensing entirely with conventional LP's. On the other hand, if you have a library of vinyl, you will need a turntable.

One more thing to consider is FM

radio capability. Most of us spend a fair amount of time listening to broadcast music and so require some sort of tuner. Over the years, most audio buyers have built their systems around receivers, which combine FM and AM capacity with the system's main control functions and power amplification on a single chassis. This may be ideal for you from the point of view of performance as well as convenience, but in some circumstances it may be inadequate. If, for instance, you intend to tune in distant stations or your tuner is plagued by multipath distortion, you may need something more elaborate than the tuner sections provided by most receivers; you may have to buy a stand-alone tuner. On the other hand, if the FM coverage in your area is minimal or nonexistent, or if you simply don't intend to use your stereo system for radio listening, there's little point in spending money on FM capability; you may want to look at an integrated amplifier, which is similar to a receiver but without the tuner circuitry.

The most critical thing to decide before you start shopping is the sort of power/speaker combination you will require. The speakers you choose will determine how your system sounds, so throughout the selection process most of your effort should be directed at the choice of these vital components. That, in turn, will dictate your power requirements.

Speakers make up the most crowded corner of audio. Hundreds of models are available, all of them different but all promising hi-fi sound. Choosing the right ones is never easy, but at this stage you need only consider such basic requirements as the appropriate size for your listening room—there's little point in even considering some mammoth multidriver system, for example, if you live in a studio apartment. Give some thought as well to the appearance of the speakers you are contemplating: Some of them have a way of dominating the rooms they occupy, and while this may not matter to you, you probably won't be the only person who has to look at them.

You may wish to use more than a conventional two-speaker stereo arrangement, of course, and this will affect not only the choice of speakers but of electronics as well. For

surround-sound or ambience enhancement, you will require not only the appropriate decoder but also a power amplifier with enough channels to drive all of the speakers or a sufficient number of separate amplifiers. If, on the other hand, you plan to use extra speakers to extend coverage or for listening in another room, you will have to select an amplifier that can handle the extra current drain—not all amps are happy driving more than one pair of speakers, even if they provide front-panel switching for it. In any event, if you do plan to use multiple speakers, make sure their impedance specification, which measures how well they respond to the electrical power delivered by an amp, is at least 8 ohms; speakers with 4 or 2 ohms are harder to drive.

The speakers you eventually select will have to be powered either by a separate power amplifier or by the amp section of a combined unit such as a receiver or integrated amplifier. The most important thing to consider with an amplifier is its output power, or how many watts it will put out cleanly. Your decision will depend on a number of factors involving the speakers you choose, the physical nature of your listening room, the sort of music you listen to, and how you listen to it.

Speakers vary widely in their sensitivity, or the amount of acoustic power they put out for a given amount of incoming electricity delivered by the amplifier. If you choose very insensitive speakers, you may have to compensate by buying a larger amplifier; depending on the circumstances, this might mean you have to look at separate electronic components rather than combined ones, since receivers and integrated amplifiers rarely offer truly high power output. If your room is unusually large or acoustically "dead" (with thick carpets, overstuffed furniture, and heavy curtains, all of which absorb sound), you will require more power than if the room is small or acoustically "live." If you like to listen to your music at very high volume levels, you also will have to provide adequate power reserves. And if your taste runs to rock music, which is often heavily compressed during the production process, you'll need more sustained power capability than if you listen to less aggressive material. As a general rule, you

should buy as many watts as you can afford, but this won't be vitally important if your speakers are very sensitive. Most buyers eventually choose smallish speakers, however, and the usual tradeoff is sensitivity.

Cost considerations are extremely important in purchasing any system, of course. It is possible to obtain respectable sound for a few hundred dollars these days—or you could drop tens of thousands. With audio, the relationship between price and quality is a fairly tenuous one, however; paying a lot of money for your system does not guarantee quality performance. Decide what you can afford, and fit the system to your budget. That may mean holding off on the second cassette deck or waiting to add surround sound, but you should be able to put together a good basic system for a modest outlay. Don't be too rigid in your budgeting, however; if you fall in love with an item that falls outside your price range, allow for flexibility to indulge your taste.

What's Out There?

Once you've decided what type of system you want and how much you're willing to pay for it, it's time to do some research. Find out what products are on the market and what will fit your needs. If you can learn something about how things work, and hence how to read the specifications most manufacturers provide, so much the better.

Audio magazines like STEREO REVIEW are obviously a good place to start. Read the product reviews, the advertisements, and any other references to specific pieces of equipment to get an idea of what's out there. This will probably have to take place over a period of time, as no one issue of a single magazine does more than scratch the surface of the products that are available. A trip to the library to browse through back issues may be in order, but don't bother going too far back, as many manufacturers tend to have a fairly high turnover of models; about a year or so should do it.

Listings of products, such as those found in this guide, can be particularly useful, as they cover virtually everything that's out there along with detailed specifications and suggested retail prices. These prices may vary from what you will actually have to pay, however, since many dealers offer significant discounts.



▲ **J**VC's RX-401BK receiver delivers 50 watts x 2 and features a seven-band graphic equalizer with five presets, Dolby Surround circuitry, and forty AM/FM station presets. Price: \$380.



▲ **P**olk's SDA three-dimensional imaging technology is the cornerstone of the SDA SRS 2.3tl speaker system. Power handling is 750 watts. Price: \$1,250 each.



▲ **H**arman Kardon's HD7600 CD player employs a bit-stream D/A converter, which is said to improve low-level linearity. Features include optical and coaxial digital outputs, a music calendar, intro scan, autospace, and a twenty-seven-key remote control. Price: \$599.



▲ Linn's Axis turntable employs a sophisticated electronic drive system to reduce motor noise and vibration. The belt-drive turntable is operated manually and comes with Linn's LVX tonearm. Price: \$795.



▲ Infinity's Kappa 7 is a three-way system with a 12-inch woofer, 3-inch Polydome k midrange, and EMIT k tweeter. Power handling is 200 watts rms. Price: \$1,398 a pair.



▲ Philips' CD 880 CD player features the Favorite Track Selection system, which memorizes up to 785 tracks. The unit incorporates dual 16-bit D/A converters, a four-time oversampling digital filter, and optical and coaxial digital outputs. Price: \$749.

either during sale periods or all the time. Still, the prices listed will give you a rough idea of basic price ranges and the comparative cost between components. You should be able to narrow your choices considerably at this stage, choosing those models that do what you require and aren't too expensive.

When you develop a short list of appropriate equipment, it will be worth your while to find out which of your choices are available locally. Unless you live in a major urban center, you will probably find that certain brands are not carried by nearby dealers. You could always order them by mail or go somewhere where they are available, of course, but it's usually more convenient to do your shopping close to home and—preferably—in a single store. (A retailer is more likely to give you a price break if he sells you the whole system.)

One good starting point when tracking down a retailer is to look through the Yellow Pages; most dealers advertise there, and most list the brands they carry. Be aware, however, that retailers pick up and drop brands fairly frequently, so some listings may be out of date. Phone or visit the store to confirm what's available.

A further form of research is just to ask questions. If you are not knowledgeable about hi-fi equipment when you start your search, you probably know someone who is. Most audio fans have very definite views on products and brands and are only too willing to share them. Such opinions should be taken with a smidgen of salt, but they are valuable nonetheless, particularly if the person you consult recommends something he himself has purchased and is happy with. You may also ask friends if they know of a good retailer in your area.

Pounding the Pavement

Now comes the time to look at some potential purchases. Take an afternoon (or several) to wander through the local audio stores; the more you do this, the better your view of what's going on in the audio market will be, both in terms of the products available—which may not necessarily correspond to the ones you have read about—and the prices you are likely to pay.

Don't be afraid to ask questions of the salespeople. Not only are you

a potential customer and therefore worth their time, but many of them are also audiophiles who *love* to talk about audio. Give them a break, though, and do it when they're not too busy—few salespeople are likely to be thrilled at providing basic audio information when the shop is full of people who are actually buying. (Saturdays are generally bad days for asking lots of questions.)

It's a good idea to pick up as much product literature as you can during this preliminary trek. Most retailers have racks with brochures, reprints of product reviews, and so forth. Manufacturers' literature can be more detailed than what you will have read in the magazines, so you should eventually try to get a brochure for every piece of equipment you are seriously considering. If the dealer doesn't have any material on a certain model, drop a line to the product's manufacturer or distributor. Most will be glad to send you information.

Unless you are *absolutely* sure you know what you want at this stage, don't buy anything. Understandably, a salesperson will try to convince you to do so, so you may have to muster every ounce of sales resistance you can—but if you really want to make the right choice, hold off for a bit.

Choosing the right dealer is as important as choosing the right equipment. In your preliminary walk through the stores, therefore, one of your main tasks should be to select the one where you will make your final purchase. One reason you may pick a particular dealer is that you simply like the salesperson there more than the others. This is valid up to a point, as it is his job to make you happy, and if he accomplishes this in the initial stages, you are likely to get good service from him thereafter. But you shouldn't pick a dealer *only* because you like the salesperson. However nice he may be, if he doesn't sell the products you are interested in, you may well end up with a system that falls short of what you want. Of course, he may suggest alternative components that are just as good, and that's fine as long as you know they really are comparable.

The shop's pricing policy is obviously of very great importance as well. A single piece of equipment can vary widely in price from store to store, and it is to your advantage

"They Were Designed To Play Music And Make It Sound Like Music..."

This They Do Very Well, In A Most Unobtrusive Way, At A Bargain Price... It's Hard To Imagine Going Wrong With Ensemble!"

*Julian Hirsch
Stereo Review, Sept. '88*

Cambridge SoundWorks has created Ensemble,[™] a speaker system that can provide the sound once reserved for the best speakers under laboratory conditions. It virtually disappears in your room. And because we market it directly, Ensemble costs hundreds less than it would in stores.

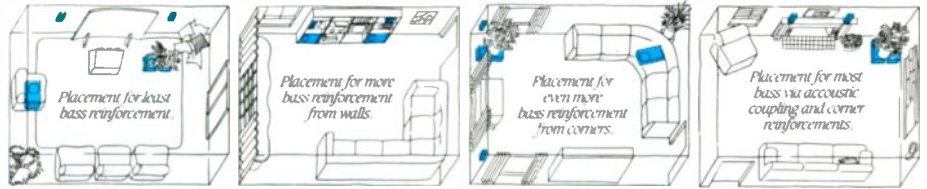

You can put Ensemble's low-frequency units exactly where they should go for superb bass. You can't do this with conventional speakers because you have to be concerned about the upper frequencies coming from the same enclosures as the low ones.

Ensemble, on the other hand, *takes advantage* of your room's acoustics. The ear can't tell where bass comes from, which is why Ensemble's bass units can be tucked out of the way—on the floor, atop bookshelves, or under furniture. The satellites can be hung directly on the wall, or placed on windowsills or shelves. No bulky speakers dominate your living space, yet Ensemble reproduces the deep bass that no mini speakers can.

Not all the differences are as obvious as our two subwoofers.

Unlike seemingly similar three-piece systems Ensemble uses premium quality components for maximum power handling, individual crossovers that allow several wiring options and cabinets

At only \$499*—complete with all hardware and 100' of speaker cable—Ensemble is *the* value on today's speaker market.

**Call 1-800-AKA-HIFI[†]
(1-800-252-4434)**

Our toll-free number will connect you to a Cambridge SoundWorks audio expert. He or she will answer all your questions, take your order and arrange surface shipment via UPS. Your Cambridge SoundWorks audio expert will continue as your personal contact with us. We think you'll like this new way of doing business.

[†]In Canada, call 1-800-525-4434. Audio experts are on duty Mon.-Sat., 9AM-10PM, Sun., 9AM-6PM Eastern Time. Fax #: 617-332-9229.

Henry Kloss, creator of the dominant speaker models of the '50s (Acoustic Research), '60s (KLH), and '70s (Advent), brings you Ensemble, a genuinely new kind of speaker system for the '90s, available only factory direct from Cambridge SoundWorks.

The best sound comes in four small packages.

Ensemble consists of four speaker units. Two compact low-frequency speakers reproduce the deep bass, while two small satellite units reproduce the rest of the music, making it possible to reproduce just the right amount of energy in each part of the musical range without turning your listening room into a stereo showroom.

Your listening room works with Ensemble, not against it.

No matter how well a speaker performs, at home the listening room takes over. If you put a conventional speaker where the room can help the low bass, it may hinder the upper ranges, or vice-versa.

What Henry Kloss tells his friends

Every time I came out with a new speaker at AR, KLH, or Advent, my friends would ask me, "Henry, is it worth the extra money for me to trade up?" And every time I would answer, "No, what you've already got is still good enough."

But today, with the introduction of Ensemble, I tell them, "Perhaps now is the time to give your old speakers to the children."

Ensemble is a Trademark of Cambridge SoundWorks, Inc.



Unlike seemingly similar satellite systems which use a single large subwoofer, Ensemble uses two separate, compact bass units. They fit more gracefully into your living environment, and help minimize the effects of the listening room's standing waves.

ruggedly constructed for proper acoustical performance. We even gold-plate all connectors to prevent corrosion. An even bigger difference is how we sell it...

Thousands agree: the best showroom is your living room.

We make it possible to audition Ensemble the *right* way—in your own home. In fact, Ensemble is sold *only* by Cambridge SoundWorks directly from the factory. Listen for hours without a salesman hovering nearby. If after 30 days you're not happy, return Ensemble for a full refund.

CAMBRIDGE SOUNDWORKS

Suite 142, 154 California St., Newton, MA 02158

- Send more information and test reports.
 - Send Ensemble risk-free for 30 days, for \$499*
 - Send an Ensemble Gift Certificate for \$499*
- I'm paying by Check MC Visa AmEx

Acct. Number _____ Exp. _____

Signature _____

Name _____

Address _____

City _____ State _____ Zip _____

Phone (Area Code) _____ Number _____

FOR IMMEDIATE SERVICE: 1-800-AKA-HIFI

We ship worldwide, including APO & FPO.

MA residents add 5% sales tax.

*Plus freight (\$7-\$25). Delivery time usually 2-7 days.



to get the best deal you can. But bear in mind that the tradeoff is usually in service—an extremely low price is attractive until you find out that the dealer who offers it is unable or unwilling to give you any information on it or to repair it if it breaks. It's usually worth a little extra cash to deal with a shop that will be responsible for the equipment.

Many dealers offer some sort of return policy if you find your system unsatisfactory when you get it home. Others offer extended warranties to supplement those offered by the manufacturers. Such services are usually reflected in the prices charged, but on balance this is probably good insurance.

The Crunch: Buying It

However much you may have read, discussed, and thought about your system in advance, the final decisions will almost inevitably be made in the dealer's showroom. Unless you are positive that only *one* particular set of components will satisfy you, what you actually buy will be determined by a combination of your knowledge, the salesperson's persuasiveness, and your reaction to the actual equipment when you finally get your hands on it. Be patient—the buying process *can* be enjoyable.

The first step is to pick your speakers. Your best guides in this area are your own ears—if you like the way a speaker sounds, it will be good for you no matter what its price tag says. You have to listen correctly, however. There are many circumstances in which good speakers can be made to sound bad, and bad ones can sound better than they really are.

For a fair and useful comparison, you should audition speakers in a room the approximate size of your own listening room, and the speakers should be in about the same position there as they will be at home; the competing pairs should also be auditioned side by side. The sound a speaker produces is to a very large extent affected by its acoustical environment.

The competing speakers should also be playing at precisely the same level. Tiny differences in volume—ones that are not obvious—tend to favor the louder pair, even though it may not be as good in absolute terms. Check with the dealer to make sure that levels have been

equalized before you even begin listening. It's also wise to take along some of your own recordings when you audition speakers. Every dealer has material that he uses for demonstration purposes, but if you aren't familiar with it, you have no point of reference. You should bring two or three of your own records, tapes, or CD's encompassing different types of music into every audio store you visit. If you use LP's for this purpose, consider buying fresh copies for the demonstration—the small investment in duplicating records you already own can pay dividends by freeing the demo from the distraction of past abuse.

The important thing with speakers is to do a lot of listening. Subtle differences take time to become apparent, but once you have identified a characteristic you dislike you will never be able to ignore it; it's much better to discover it in the dealer's listening room than after you get the speakers home.

Once you have a pretty good idea of the speakers you want, you can turn to the rest of the system. Start with the amplifier: Make sure it has enough power for the speakers and the way you intend to use them. Good dealers can give you guidance as to what this means in terms of watts; as we've mentioned, buy more than he recommends if you can. If your power needs are fairly modest, you should be able to satisfy them with a receiver or integrated amplifier. This is an attractive solution for most of us, as it tends to save money, leaving more cash available for the rest of the system. On the other hand, high power demands usually require separate amplifiers and other freestanding electronic components. In such a case, it's wiser to accept the situation and pay the premium; too little power is likely to result in distortion and may even cause damage to your equipment.

Only when you have settled on the amp/speaker combination should you buy input devices: CD players, cassette decks, and so forth. To a large extent, you can choose among these components by the features they offer and their prices, as there are no longer *huge* differences in performance within these categories of components. Look at the controls, since these components offer many different features. Buy just what you need and no

more, as extra goodies will inevitably cost more. If the amplifier and speakers have come close to stretching your budget, you may choose to buy only one source component at this time, leaving the purchase of extra ones till your cash flow improves. If you do this, make sure that your system's controls, whether on a receiver, integrated amplifier, or separate preamplifier, have flexibility for later expansion.

Reserve a portion of your budget for some accessories. If you include a turntable in your system, a few dollars for a good record-cleaning system is a vital addition. Similarly, methods to clean CD's and the heads in a cassette deck are worthwhile additions. And make sure you have enough wire to hook everything together. Virtually all components come with connecting cables, but they may not be long enough or of high enough quality for your setup. In particular, you will almost certainly have to buy speaker wires, so be aware at the outset how much cable you will require, remembering that longer lengths require heavier-gauge wire to preserve the integrity of the music signal. As a rule, you should buy at least 12-gauge wire.

ONCE YOU HAVE SELECTED YOUR equipment and taken it home, you should set it up as soon as you can to make sure everything works as it should. This includes making sure that nothing is broken, of course, but more important is determining how the system sounds. There is no sure way to predict whether the speakers that sounded so good in the store will perform as well in the unique environment of your own home. If they sound awful, exchange them immediately—few dealers are likely to be sympathetic if you have used your equipment for months before bringing it back. If all's well, send in the warranty cards and stash the equipment cartons somewhere out of the way—you'll need them if you ever move or have to send something in for repair.

Then enjoy! Buying stereo equipment can be a time-consuming process, and one fraught with questions and uncertainties. But once you have gone through the steps, you should have a system perfectly suited to your music-listening needs, and that's certainly a goal worth spending some time to reach. □



The Definition of Excellence. In Sight and Sound.

Introducing Proton's new big screen 31" monitor/receiver with Apex Aural Exciter.[®]

Proton has always set the industry standard for breathtaking video performance. And our big new 31" picture follows in that tradition. But this time, the picture isn't all we've expanded.

By incorporating the Apex Aural Exciter circuitry, we've achieved a new level of audio clarity and transparency. So harmonics are restored, highs more natural, and vocals more vivid. And, at the touch of a button, our Expander provides vastly superior stereo imaging.

With our SD-1000 Enhanced Surround Decoder, your enjoyment will be even greater. This Apex innovation starts where Dolby[®] leaves off, creating an expanded listening area that wraps you in pure listening pleasure.

Unmatched by many professional systems, the Dolby compatible SD-1000 offers dynamic surround sound from any stereo source.

We took the industry's best and brightest picture. And added the most advanced sound. Proton. The new definition of excellence.

For a free brochure and the Proton retailer nearest you, call (800) 772-0172. In California, (800) 428-1006. Or write to 5630 Cerritos Ave., Cypress, CA 90630.

PROTON[®]
CLEARLY THE BEST



The CDV 488 plays all six disc formats:
3-inch, 5-inch CD, 5-inch CDV, 8-inch/
12-inch CD-LDs and the 8-inch LD single.



AudioVideo

PHILIPS CDV488. THE FINEST EXPRESSION IN DIGITAL SIGHT AND SOUND.



When Philips invented laser videodisc technology, we envisioned uncompromised video performance. The CDV488 is the result of this philosophy.

In fact, according to *High Fidelity*, it achieves "...a level of performance that cannot be bested in any significant regard by any competitive product..."

The CDV488 provides 300% sharper color fidelity than any consumer videotape, including Super VHS. And Philips' proprietary wide bandwidth CCD comb filter with S-video output enhances color detail and color accuracy even further.

It also produces a remarkable 420+ lines of horizontal picture resolution—greater than many broadcast video recorders.

The universal remote allows you access to digital performance features like rock-solid still frames, single-frame

advance and crisp slow motion on all videodisc formats. Add to this the jog shuttle that gives you the freedom to operate these effects from your armchair, and you begin to see why the CDV488 offers a home video alternative to the picture quality and special effects found in professional studios.

Remarkably, its high standards in digital video are matched by its specifications in audio. It features the latest Philips Select Grade TDA-1541-A SI dual D/A Converter System, widely regarded as the premier D/A conversion technology available today.

From the company that created compact disc, now comes the CDV488. For those who insist upon the finest expression of digital sight as well as sound.

Call 1-800-223-7772 for your nearest Philips audio/video specialist, to audition this outstanding CDV player.

WORLD-CLASS TECHNOLOGY. EUROPEAN EXCELLENCE.



PHILIPS

CIRCLE NO. 23 ON READER SERVICE CARD

MUSIC EVERYWHERE

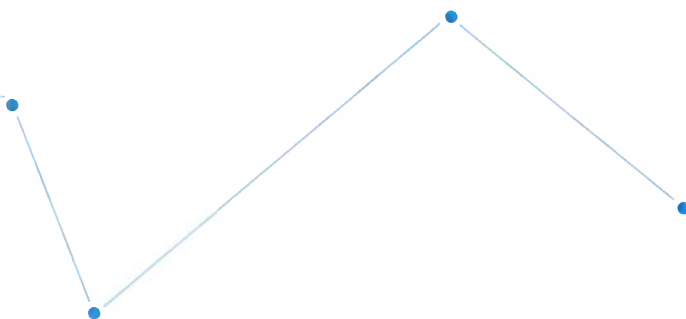

IN his book *Music in Every Room*, John Krich describes checking into a hotel advertising music in every room. Only after being shown to his humble accommodations does he discover the meaning of that promise: A table radio in the hotel's courtyard blares 24 hours a day. The closest thing to remote control is invoking a mute function by closing the window.

Too many people endure a similar whole-house music system. When they want music in the kitchen or bedroom, they turn up the stereo system in the living room. Of course, changing from CD player to tuner, or changing stations on the tuner, means traipsing across the house.

America's fitness craze exhausts itself at the front door. Cross the threshold into your home and you want convenience. What this country needs is a bracket to secure an audio/video remote control to the handlebars of an Exercycle. More than that, America wants remote-controlled music in every room.

Since the dawn of high fidelity people have fished wires through walls to extend the coverage of their sound systems. Tube amplifiers, with their massive, multi-impedance output transformers, could power several sets of speakers. Solid-state amplifiers, with their often less-stable direct-coupled outputs, were limited to a couple of pairs of speakers. You could place a pair of speakers in every room, but you'd only hear music in two rooms at the same time. Even if you went to the effort of installing an amplifier in every room, the only thing you would control remotely in each room was the volume.

Unlike the hotel in Krich's book, Bang & Olufsen, Revox, Luxman, Soundstream, Audiophile Systems, and others now promise, and deliver, high-fidelity music in every room of your home—and with remote control. This pleasure costs considerably more than a table radio, but it also means you'll never *need* another table radio.

Every room can be a
listening room
with a sophisticated
whole-house
remote-control system.

BY RICH WARREN

Bang & Olufsen prides itself on style. A complete B&O system would look great in every room, but the expense adds up rapidly, so the Danish company engineered a way to provide sound throughout the house without putting a system in every room. It fashioned its Master Control Link (MCL) and Beolink long before the idea of whole-house systems became fashionable.

First B&O solved the problem of amplifier loading by modifying the amplifier circuitry of its receivers. The only penalty of connecting additional speakers was a drop in level, and recently B&O solved that problem with its add-on 30-watt-per-channel MCL 2P power amplifiers, designed to be hidden in every remote room as a part of the Beolink system.

The Beolink controller operates all Beosystem 6500 components, the Beocenter 9500 integrated one-piece system, and B&O's new video components. Beolink will also operate future B&O components as well as its new lighting modules, tiny black boxes that control house lighting from the Beolink 1000 remote. The modules can be programmed to "remember" various connections, such as dimming the lights in a room when you touch the TV button on the remote.

Wiring connects infrared sensors in each room with the central B&O Master Control Link 2AV. The system can be wired in a hub-and-spoke or daisy-chain configuration. The handheld Beolink 1000 remote terminal can communicate with the MCL 2AV through any infrared sensor. The MCL 2AV controls audio and video sources in up to sixteen





While a complete Bang & Olufsen system in every room of your house would be a treat, the Beolink system allows you to control selected audio and video components, or just a pair of speakers, in any room through the main system using remote infrared sensors and the handheld Beolink 1000 terminal (right).



different rooms, and the Beolink 1000's thirty-eight buttons operate every feature.

The beauty of the B&O Master Control Link system stems from its two-way digital technology, which permits "smart" responses to commands. With optional MCL amplifiers, additional rooms can have their own B&O CD players or cassette decks controlled by the Beolink 1000. Thus, the main system can be playing in some rooms while local components fill other rooms with sound. You can even dispense with the additional amplifiers by using B&O's powered loudspeakers, such as the Beolab Penta and the new Beolab 3000 and 5000 flat wall speakers. With the introduction of new video components, B&O now provides video switching as well through the MCL 2AV. A useful feature is the ability to use the TV speakers as remote speakers for the audio system without turning on the TV and, conversely, to pipe TV sound through the audio system.

Revox calls its B209 bus system the "Easyline." It permits both multiple sourcing, with different source programs from the main system playing in different rooms, and local sourcing, where each room has its own source of music. The speakers and local components need not be made by Revox, and the local components can also feed programs into the main system.

Switches on the Revox B209 module can be used to designate certain rooms for listening only. That way children can be prevented from operating the main system while still having control of the local volume. And to avoid accidental interruption of tape recording, the system can be set to block commands until the recording finishes.

Revox transmits both audio and control signals via a single cable from the connector box at the main system to "T-adaptors" in each room. These adaptors split the signal for feeds to additional rooms. Remote locations must have amplifiers and speakers or powered loudspeakers, plus a 15-volt power supply for the B209 module.

The Revox B203 Timer Controller connects Revox Series 200 components with any MS-DOS personal computer. With the B203 and its matching B205 remote-control module, you can totally automate your audio system. Using the optional software package you can eas-

Fresh air and wide-open spaces.

Introducing the first tuner/preamplifier that includes Carver's remarkable sonic enhancements.

We didn't invent the preamplifier/tuner combination. We just gave it what it's always needed:

Fresh air—A remarkable FM tuning system that virtually eliminates station noise and multipath interference.

Wide open spaces—The ability to recreate 3-dimensional sonic reality with your existing speakers.

Asymmetrical Charge-Coupled FM Detector. At the touch of a button on the CT-Seven's burnished face plate, multipath distortion, interference and distant station noise are dramatically reduced. Yet stereo separation, space, depth and ambience are not only retained, but seemingly enhanced by the lack of background noise. Choose 6 FM and 6 AM presets by remote control or scan the broadcast band in auto or manual mode. You may even discover "new" stations which were previously unlistenable!

Sonic Holography® Generator. The CT-Seven is capable of redefining your perception of music by recreating the multi-dimensional sound stage of a live performance. According to some of America's top reviewers, Sonic Holography® "... seems to open a curtain and reveal a deployment of musical forces extending behind, between and beyond the speakers. The effect strains

credibility." And you can create it from any stereo sound source. With your existing speakers.

Useful features and remote control. The CT-Seven includes an ultra-low noise phono stage pre-preamplifier for both moving magnet and moving coil cartridges plus dual tape monitors, CD input and AUX for video sound. Instead of distortion-inducing electronics, the CT-Seven's remote volume control is motorized for smooth control and smoother sound quality.

The CT-Seven's powerful partners. Only Carver gives you four perfectly matched power amplifier choices each using Carver's cool-running Magnetic Field Technology which dispenses with bulky power supplies and power-wasting external heat sinks... yet which is so rugged it's used in the world's largest touring professional sound systems.

Fresh air, wide open spaces and serious power at your Carver dealer. Switch between the CT-Seven and the most expensive tuner in the room to hear Asymmetrical Charge-Coupled FM Detection work its magic. Turn up the volume to live performance sound levels and discover the impact of true dynamic headroom.

And then get ready for another pleasant experience when you discover just how affordable performance like this can be.



CARVER

POWERFUL

MUSICAL

ACCURATE

Carver Corporation, P.O. Box 1237, Lynnwood, WA 98046
For more information or the dealer nearest you, call 1-800-443-CAVR

Distributed in Canada by EVOLUTION AUDIO INC.



The Luxman TP-117 preamplifier/tuner (above) has five external-sensor inputs to enable two-zone operation in up to ten different rooms; it comes with two hand held remotes.

With Mitsubishi's Home Automation System (right), you've got complete control over your audio/video equipment, security and energy devices, and appliances.

Revox's B203 Timer Controller and B205 remote control (below) interface with MS-DOS personal computers for automated control over Revox 200 Series components.

Linn's X-Tend System (bottom) is an infrared link that can relay remote-control signals from room to room to components hidden from sight.



ily program virtually every function of your audio system. If you plan an intimate dinner party, for instance, you can program the music in advance, before your date arrives, to foster the mood for later in the evening. The system will switch between sources and vary the listening level at specified times. You'll still need to dim the lights manually.

Somewhere between the extremes of sophisticated multiroom systems lies a series of Luxman components centered around the Model TP-117, which combines two preamplifiers, a tuner, and a remote-control center in a single chassis. The TP-117 can be combined with Luxman source components and any number of Luxman RC-501 remote infrared sensors, RC-502 remote signal converters, RC-503 infrared remote-control repeaters, and RC-504 external infrared emitters. The system is also compatible with other manufacturers' source equipment.

Soundstream, until recently best known for its automobile sound systems, drives home its reputation with the System-1 "Simul-Source" multiroom remote-control network. The system consists of the C-1 audio/video preamp, DA-1 power amp, T-1 tuner, R-1 universal remote control, and BD-1 remote sensor. With the full system, you can simultaneously feed any of seven audio and video components connected to the C-1 to as many as six different locations, or you can feed up to six different programs to different rooms. You can also add speakers in additional rooms, but without the control flexibility. You can listen to the main system in any room outfitted with remote sensors and amplifiers through your choice of speakers.

For example, Soundstream suggests that you could watch and listen to a videodisc on a large-screen TV set in the den, where the main system is located, while simultaneously playing FM music in the living room, a VCR through a TV set in the master bedroom, a CD in the second bedroom, a cassette in the dining room, and a different tape on the patio. Soundstream emphasizes that all of the source components can be different brands. The R-1 remote can learn nearly any company's infrared command signals.

Audio Design Associates (ADA) of White Plains, New York, markets primarily to the custom installer, so it's unlikely that you'll see much of

California Audio Labs introduces the new ICON CD Player

*From the company that builds the
worldwide reference standard
in CD Players.*

California Audio Labs has set the standard in CD player performance for years. Now, at an affordable \$695 the new ICON joins the most successful family of high end CD players made. Featuring 8 times oversampling and 18 bit D/A converters, the ICON is made in America to exacting standards. Our new linear drive laser and 24 bit digital filter add quality and performance far beyond expectations.



*At California
Audio Labs,
exceptional
sound quality
is a tradition.
The ICON brings
CAL performance
to a new level
of affordability*

California Audio Labs
7231 Garden Grove Blvd. Suites E&F
Garden Grove, CA 92641
(714) 894-9747 Fax (714) 894-6706

the company's equipment on your local dealer's shelf. ADA designs only multiroom systems with audio and video switching. For example, the System 818 consists of the DSP-8 digital switching preamp, the MRA-808 multiroom power amp, the CPC-1 Central Program Controller, the ASU-10 AC-power switching unit, an MC-1600 remote control or MC-1700 deluxe controls for each room, and the appropriate wiring. Larger and smaller systems are also available. You choose the audio sources that feed the system. ADA offers its own tuner, equalizer, and series of power amplifiers for the main and remote systems, but any brand of source component will work. The remote locations need only speakers and remote terminals since the master multichannel amplifier provides the power.

The ADA IMC-85 Integrated Media Controller goes a step further by combining all cable and audio/video signals to your VCR's, monitors, and TV sets. It can switch up to eight audio/video inputs to any of eight audio/video outputs as well as three cable inputs to any of five cable outputs. The remote controls may be either hard-wired wall units or table-top models. They control source selection, transport functions, volume, tone, and on/off switching for the remote speakers and the main system power. All eight sources can be operated simultaneously.



AUDIOPHILE SYSTEMS, located in Indianapolis and best known for U.S. distribution of Linn products, has designed a simple, functional system called "X-Tend." It's an infrared extender that transmits commands back to the main system from other locations in the home. It works in conjunction with the Linn LK-1 preamp and matching power amp. Because the LK-1 includes an isolated tape-out function, you can listen to one source in the main listening room and a different source at one or several remote locations. Each remote location requires its own integrated amplifier and speakers. Any integrated amplifier will suffice, and using an integrated amp permits independent manual adjustment of tone and balance in each room.

Any brand of source components can be connected to the Linn preamp as long as they can be con-

trolled with an infrared remote. Audiophile Systems recommends purchasing a universal remote control that can learn the commands for the LK-1 and the source components you've chosen. It suggests the magnificently versatile but infuriatingly complex Core CL-9 (assuming you can get someone knowledgeable to program it).

Mitsubishi also makes the Core CL-9 the centerpiece of its audio/video remote-control system, which is only part of its larger home-automation system. Mitsubishi designed a custom interface between touch-tone telephones and the CL-9, and a telephone is used to control many of the functions of its system. You can call from anywhere in the world to program your VCR or to turn on the stereo system at 2 a.m. in order to drive your neighbors crazy or fool the local burglar into thinking you're home.

As currently designed, the Mitsubishi home-automation system doesn't offer speaker switching between rooms. You'll need to wire each room for sound in addition to the wiring for the home-automation system. Mitsubishi is investigating including whole-house audio/video switching in its future systems. In any case, you won't need to carry around a remote for the rooms you do wire since the audio (and video) can be controlled from any touch-tone phone.

Bose has attacked sound in every room from an acoustical standpoint. While most companies devoted their attention to the intricacies of remote control, Bose concentrated on sonics. The Bose Acoustimass Built-In Music System is based on the AM-5 three-piece speaker system, which uses two pairs of tiny cubical satellite speakers for the mid and high frequencies and a unique box for the bass. The diminutive, easily hidden Acoustimass bass module provides extended bass to supplement the unobtrusive satellite speakers, which can be mounted on a wall or shelf with a bracket or installed on a lighting track. Bose determines the optimal position of these speakers for each installation with a special computer program. A hidden amplifier powers each system. For places where the bass module is impractical, Bose offers its 102-S/E and 102-FB "background" speaker systems.

A flush, wall-mounted take-off on

the electronics in Bose's Acoustic Wave Music System forms the center of the system. It includes a tuner and a Sony D-15 CD player, but you can also select your existing audio system as a source. Bose intends to provide a more versatile, multifunction whole-house remote control for the system in the near future. For now, users must be satisfied with hard-wired independent volume controls in each room. The Bose Acoustimass Music System can be installed in older homes, but it is marketed mainly to builders of new homes and remodelers; the biggest obstacle to retrofitting older homes is that wires must be snaked through walls.



IN Japan, Misawa Homes, famous for its high-quality, even luxurious prefabricated homes, has designed an advanced home-automation system that includes hidden speakers in the walls of most rooms. Misawa provides a rudimentary audio system with the speakers, but people who want to upgrade have to buy B&O components, since that is the only brand of equipment compatible with the Misawa system.

All of the systems discussed here require some degree of professional installation. Fishing wires through walls demands not only competence but finesse. In many areas it also means hiring a licensed electrician to comply with building and fire codes. For music everywhere, your best bet is a good audio/video dealer who specializes in custom installation. Once you've destroyed a few feet of dry wall, you'll agree.

Having music at your fingertips, wherever you may be, yields almost indescribable pleasure, similar to what you probably felt when you connected your first stereo component system. Someday in the future, complete home-automation systems will connect and control all our electronic equipment and appliances. You can enjoy the essence of such a whole-house system today with these audio and audio/video systems. Not only are they better than a single radio in a courtyard, but they're more convenient and less expensive than a component system in every room. □

Rich Warren is audio columnist for the Chicago Tribune.



LUXMAN

AT HOME IN THE 90'S



Home Entertainment in the 90's. . .

Several trends have emerged from the 80's:

- *The overall cost of owning a home in the United States has continued to soar.*
- *The admission price of concerts, movies and sporting events has continued to escalate.*
- *And, the performance quality and operating convenience of home audio and video components has dramatically improved.*

Entering the 90's these three factors will combine to fuel an increasing enthusiasm to entertain "at home." Simply stated, it has become more practical and more desirable to invest in high quality audio/video systems that deliver a whole new dimension in "home entertainment." With the proper combination of audio and video components, you can:

- *Enjoy music as if you were attending a "live" concert.*
- *Experience films like you do in a movie theatre.*
- *Observe sporting events as if you were at the stadium.*

Virtually every type of "live" entertainment can be faithfully reproduced in the home of the 90's, providing you design a system tailored to your individual needs.

Luxman Home Audio Components. . .

There are two basic elements of a home entertainment system:

Picture - Several manufacturers concentrate on improving picture quality with advanced technology in the area of large-screen televisions, Laserdisc video players, V.C.R's, and soon, high-definition picture screens.

Sound - Luxman audio components satisfy the "sonic requirements of each system and deliver the emotional impact of the original performance.

Every component is carefully designed to meet three performance criteria:

Sonic Realism - All efforts are made to reproduce music with all of the warmth and transparency of the original source.

Ease of Operation - Each component is designed for optimum convenience, both on the control panel and on the remote handpiece.

Long-Term Reliability - Every model incorporates proven circuit designs and exhaustive quality evaluations to provide uncompromising durability.

The trend towards high-quality home entertainment systems is a focal point in the 90's, and the audio components are the heart of each system. That's why Luxman is *at home in the 90's*.

Luxman at home in the 90's

... in every room

The Luxman remote controlled receivers (R-115, R-117) and preamplifier (TP-117) include a handpiece that operates all Luxman CD players and cassette decks, eliminating the need for multiple remotes. And these system control centers are equipped to feed information to any part of the house, enabling multiple-room enjoyment of both audio and video sources.

For example, a remote sensor eye (RC-501) can be installed in another part of the house, allowing you to run speaker wires to an extra pair of speakers and operate the entire system in that room.

This eliminates the need for another complete audio system in that listening area. And with a relatively simple procedure for running cable through the house, you can ultimately carry your handpiece into any room and turn the main system on and off, adjust volume, change radio stations, fast forward a compact disc, and more.

... and in every wall

The S-505 loudspeakers bring true high-fidelity sound to any wall or ceiling installation. Designed primarily for home entertainment rooms, S-505 loudspeakers are also moisture resistant and work well in the higher humidity of a kitchen, bathroom ... any place where in-wall speakers are desired. The grille accommodates the RC-501 sensor eye for easy "hidden" installation and can be painted to match any environment.

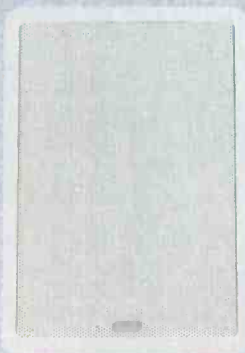

S-505 Wall Mount Loudspeakers w/hidden sensor eye



Each room in your home can connect to the main system with S-505 speakers, eliminating the need for another audio system in that room.

... introducing "multi-zone" remote

For the ultimate multi-room installation, the TP-117 "multi-zone" preamplifier adds the extra convenience of independent source select.

Most multiple room combinations have a limitation: The source selected in one room must be fed to all rooms simultaneously.

"Independent source select" means that you can listen to a compact disc in the bedroom, while someone else plays the radio in the living room, independent of each other.

With the proper connections, the video signal coming from the main system can also travel down the same cables

used for basic "multi-room" installation. This enables remote televisions to receive the video signals from the main V.C.R. or Laserdisc player.

With a command repeater (RC-503), the handpiece of each video component can "talk" to the remote eyes, enabling complete remote operation at each location.

Whether used for music only, or integrated with a video system, Luxman components offer convenience, flexibility, and the most accurate sonic reproduction available today.



RC-503 Command Repeater



The TP-117 "multi-zone" preamplifier can feed all audio or video sources to any room for total independent operation.

Receiver Technology

Luxman receivers are carefully designed to deliver the purity and warmth of the original source, plus the high dynamic power necessary to drive any speaker load.

- **Purity and Musical Warmth** – Conventional receivers measure well in standard laboratory tests, but tend to alter the overall harmonic structure of the original musical instruments. Luxman receivers incorporate a voltage-driven amplification configuration that faithfully reproduces the harmonics of the original source.
- **High Dynamic Power** – Luxman receivers also incorporate massive power supplies with high energy reserves to ensure distortion-free transients into a variety of speaker loads.
- **Long-Term Reliability** – High-speed, high-current Darlington output transistors, large heat sink assemblies, and over-sized power transformers combine to ensure long-term reliability.



R-117 AM/FM Stereo Receiver (160 Watts/Ch.)



R-115 AM/FM Stereo Receiver (70 Watts/Ch.)



R-113 AM/FM Stereo Receiver (35 Watts/Ch.)

Recommended Applications

	R-117	R-115	R-113
Dynamic Power Per Channel (2 Ohms)	700 W	270 W	100 W
Max. Size of Listening Room	Large	Med → Large	Medium
Recommended Speaker Efficiency	Low → High	Med → High	High
No. of Audio Sources	Up to 6	Up to 6	Up to 6
No. of Video Sources	3 Audio/ Video	2 Audio/ Video	2 Audio Only
Remote Control Capability	Full System	Full System	N/A
Multiple Room Expandability	Yes	Yes	N/A

Separate Components

For over 60 years, Luxman "Separate" components have won numerous awards for their innovative circuit designs and sonic superiority. The latest generation of Luxman Separates further advance the "state-of-the-art" in terms of performance and flexibility.



TP-117 Multi-Zone Remote Preamp (Built-In Tuner)



M-117 Voltage-Driven Power Amplifier (200 Watts/Ch.)



M-113 Voltage-Driven Power Amplifier (50 Watts/Ch.)

The **TP-117** is a tuner/preamplifier in a class of its own. As a master control center, it accommodates most sophisticated audio/video applications.

With two separate, high-quality preamplifiers combined into one chassis, the TP-117 allows multiple-room remote operation, independent from the main system.

This unique design enables separate control over source, volume, and power in each connected zone. The TP-117 also provides five external sensor inputs to enable "two-zone" operation in up to ten rooms.

Last but not least, the sonic quality of the TP-117 rivals the finest tuners and preamplifiers in the world, thus making it an excellent value for single-room systems as well.

The **M-117** power amplifier is a "no-frills" black box with enormous power and minimal distortion. Designed for the most difficult speaker loads, the M-117 measures an incredible 820 watts per channel (dynamic power – 2 ohms) and yields a memorable, seductive sound that surpasses all competitive models.

The **M-113** is a smaller version of the reference model M-117. Rated at 180 watts per channel (dynamic power – 2 ohms), this power amplifier is perfect for less demanding speakers in a main system and is often recommended in multi-room combinations for each remote pair of speakers.

Compact Disc Technology

Luxman CD players are carefully designed to convert digital signals so precisely, that they are indistinguishable from the original source. Several innovative technologies are utilized in all models.

- **Precision-molded Laser Housings** never warp and increase the light-output of the laser pick-up. This improved readability provides a more accurate tracking of the compact disc.
- **Error Concealment** "interpolates" missing data when the laser cannot read the CD correctly due to scratches or dirt. This eliminates digital mistakes and creates a more accurate reconstruction of the analog waveforms.
- **STAR Circuit Topology** provides independent circuit paths to all parts on the circuit board. This eliminates low-level distortion and improves low-level resolution.



D-105u Compact Disc Player ("Brid" Tube Circuitry)



DC-113 6-Disc CD Changer (Single Play Capability)



DZ-112 Compact Disc Player (18 Bit-8X Oversampling)



DZ-111 Compact Disc Player (16 Bit-4X Oversampling)

Compact Disc Player Features

	D-105u	DC-113	DZ-112	DZ-111
High Speed D/A Converters	Dual 18-Bit	Dual 16-Bit	Dual 18-Bit	Dual 16-Bit
Oversampling	8X	8X	8X	4X
Digital Outputs	Optical/Coax	Coax	Coax	Coax
Motor Driven Remote Volume	Yes	—	Yes	—
Computer Controlled Volume Fader	Yes	—	Yes	—
Edit Function	Yes	—	Yes	—
Serial Remote	Yes	Yes	Yes	Yes
"Brid" Tube Technology	Yes	—	—	—
No. of Discs	Single	6 + 1	Single	Single

Cassette Decks

In the tradition of Luxman "Ultimate Fidelity" components, all cassette recorders incorporate sophisticated technologies like Duo-Beta, STAR Circuitry, Hexalam Heads and HX-PRO for optimum sonic accuracy. Each model is designed for a specific application.



K-110W "Dual Well" Auto-Reverse Cassette Deck (HX-PRO)



K-110 Auto-Rev., Bi-Directional Record Cassette (HX-PRO)



K-112 3 Head, Double Dolby Cassette Deck (HX-PRO)



K-111 2 Head, Full Logic Cassette Deck (HX-PRO)

The **K-110W** offers the ultimate record/playback convenience while maintaining excellent sonic reproduction. This "double" auto-reverse transport allows high-speed duplication, simultaneous playback of two tapes, and dual deck programmability.

The **K-110** features a single auto-reverse transport with bi-directional record capability. This cassette deck is a simplified version of the K-110W with no compromise in recording quality. The K-110 also includes stereo microphone inputs for convenient "live" recording.

The **K-112** is a three-head, double Dolby configuration that allows monitoring of the "just-recorded" signal, while the recording is being made. This cassette deck is specially designed with a superb "single-direction" transport to ensure professional-grade recording.

The **K-111** is a 2-head version of the K-112 for excellent recording at a more affordable price. A high-quality, full logic transport and twin motor drive system maintains Luxman's reputation for sonic accuracy and durability.

Luxman is one of the most sophisticated and technically advanced audio product lines on the market today. With more than sixty years of experience in designing and producing audio products, we have made a number of innovative technological achievements. The end result is an international reputation for home audio components with musical warmth and transparency.

Luxman is committed to providing the highest quality product, but this is only a part of our total commitment. Every effort is made to ensure that our product will give valued customers the highest level of satisfaction for many years to come. That is why *all* Luxman home audio components are backed by the longest full-line warranty in the industry: 5 years parts and labor.

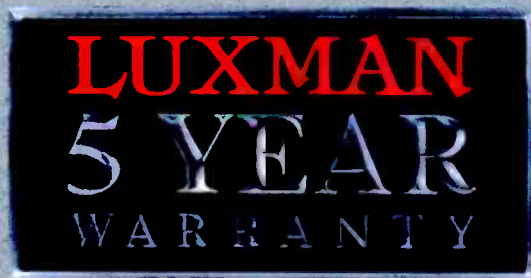

You will also find that the retailers that carry Luxman parallel this commitment to offer only the finest products with complete customer service. Should you need assistance or service on a Luxman component, just contact your local Luxman dealer.

For additional information on these and other Luxman components, or the authorized dealer nearest you:

CALL
1-800-4-LUXMAN

S * T * E * R * E * O BUYERS' GUIDE



In the following 219 pages, you will find detailed information on current stereo components and accessories. Listings include features, performance specifications, and prices.

The listings are divided into component categories and ordered alphabetically by manufacturer. Within each manufacturer's section, components appear in descending order of price.

Features and specifications have been supplied by the manufacturers, and they have not been verified by STEREO REVIEW lab tests.

We advise you not to base purchasing decisions on specs alone.

Note that all prices listed in this guide are manufacturers' suggested retail, or list, prices. Actual selling prices vary from dealer to dealer.

For more information about products mentioned in this guide, contact an authorized dealer or the manufacturer. Manufacturers' addresses and telephone numbers are listed in the directory that begins on page 258. A glossary of commonly used terms and abbreviations begins on page 250.

RECEIVERS

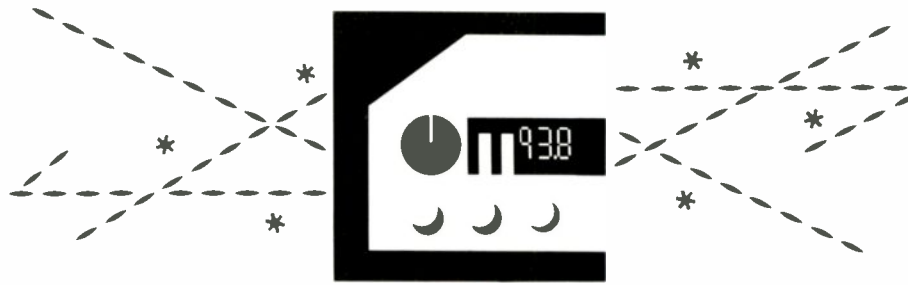

ACOUSTIC RESEARCH

X-07 70-W/ch Receiver

Receiver with infrared remote to control power, volume, tuning, input selection, and AR CD-player functions. Features audio and video dubbing; close-tolerance metal-film resistors and film capacitors; concealed bass, midrange, treble, balance, loudness, mono, tape, VCR, tuning, and speaker-switching controls; 8 AM/8 FM station presets; gold-plated phono inputs. Inputs for MM phono; MC phono; tape; AUX; CD player; video sound source; VCR 1; VCR 2; optional remote. Amp section: 70 continuous average W/ch from 20-20,000 Hz into 8 ohms with less than 0.03% THD, 80 W into 4 ohms; S/N 100 dBA. Tuner section: FM section 50-dB quieting sens stereo 40 μ V (37.2 dBf); FM S/N (at 65 dBf) 75 dB stereo, 80 dB mono; THD stereo 0.3%; capture ratio 1.0 dB; AM rejection 60 dB; alt-ch sel 70 dB. 3 $\frac{1}{4}$ x 17 x 15 $\frac{1}{2}$ in; 25 lb, 2 oz. \$770

RC-03. Remote control for the above. \$25

a/d/s/

R4 70-W/ch Receiver

Features alphanumeric display on front panel indicating input source or received radio station. Digital-synthesis tuner with 30 memory presets for AM or FM stations; digital volume and tone controls; optional remote control; RS-232 port allows control through personal computer; optional remote capable of multi-room control. Amp section: 70 W/ch into 8/4 ohms, <0.07% THD; FR 20-20,000 Hz +0, -0.5 dB. Tuner section: IHF sens 26 dBf stereo; signal strength for 50-dB quieting 35 dBf stereo; capture ratio 1.5 dB; alt-ch sel 65 dB; max S/N 75 dB mono, 70 dB stereo. 2 $\frac{3}{4}$ x 17 $\frac{1}{2}$ x 14 $\frac{3}{4}$ in; 23 lb. \$1,000

RC1 Unified Remote. For use with the above and other a/d/s/ components. \$150

AUDIOCON BY ELEKTROAKUSTIK

R-2000AC 120-W/ch Receiver

AM/FM receiver with full-function remote. Features inputs for CD, DAT, tape deck, MM, MC. Amplifier section: 120 W/ch cont avg into 8 ohms; FR 4-300,000 Hz; THD 0.004%. Tuner section: stereo separation >41 dB; S/N 75 dB (mono), 73 dB (stereo). 17 $\frac{1}{8}$ x 5 $\frac{7}{8}$ x 15 $\frac{1}{4}$ in; 52 $\frac{3}{4}$ lb. \$3,200

BANG & OLUFSEN

Beomaster 5500 50-W/ch Receiver

Includes Master Control Panel remote control; presets for 20 AM/FM stations; Auto Power Handling Control; double-acting auto gain control in FM; volume, bass, treble, and balance controlled from knob on MCP remote; works with other Beosystem 5500 components for multiroom remote control; direct selection of any AM/FM station by frequency; station search; silver and black finish. Amp section: FR 20-20,000 Hz, \pm 1.5 dB; THD <0.09%; S/N 80 dB. FM tuner section: 50-dB quieting sens 40 dBf stereo; FR 20-15,000 Hz, \pm 1.0 dB; S/N 65 dBf; capture ratio 1.7 dB. 16 $\frac{1}{2}$ x 3 x 12 $\frac{3}{4}$ in; 19 lb, 3 oz. \$2,150

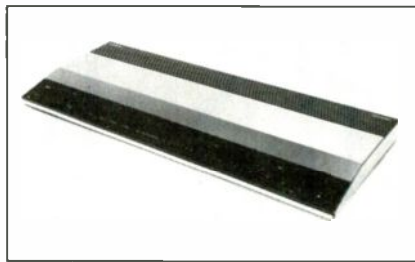

Bang & Olufsen Beomaster 4500

Beomaster 4500 20-W/ch Receiver

Remote controlled with Beolink 1000 terminal; digital tuner with 20 AM/FM presets; multiroom capability; optional wall-mounting brackets; programmable volume and tone levels; programmable inputs; integrates with B&O video products. Black and silver finish. Amp section: FR 20-20,000 Hz, \pm 1.5 dB; THD <0.1%; S/N >77 dB. FM tuner 50-dB quieting sens 19 dBf mono, 40 dBf stereo; FR 20-15,000 Hz, \pm 1.0 dB; S/N 65 dBf; cap ratio 1.7 dB. 24 $\frac{3}{8}$ x 2 $\frac{3}{4}$ x 9 $\frac{3}{8}$ in; 15 lb, 6 oz. \$1,098

CARRERA

CR-2530 30-W/ch Receiver

AM/FM receiver with headphone jack with level control. Amp section: FR 20-20,000 Hz; THD 0.25%. Tuner section: 38 dBf stereo; cap ratio 1.7; alt-ch sel 58 dB. 13 lb. \$200

CR-2300 25-W/ch Receiver

AM/FM receiver with headphone jack with level control. Amp section: FR 40-20,000 Hz; THD 0.5%. Tuner section: 41 dBf stereo; cap ratio 2; alt-ch sel 50 dB. 12 $\frac{1}{2}$ lb. \$150

CARVER

HR-752 100-W/ch Surround-Sound Receiver

AM/FM receiver with wireless remote and Sonic Holography. Features asymmetrical charge-coupled FM detection circuit; magnetic-field power amplifier section. A/B speaker outputs; B-speaker-system matrix surround-sound synthesizer, 20 AM/FM presets with preset scan; 5 audio inputs; CD direct; motorized volume control; 3-band tone controls; dual tape monitors with dubbing; pre/main outputs. 100 W/ch; 4.7 dB dynamic headroom; 0.5% THD; 85 dB MM phono S/N; 1.5 dB cap ratio; 0.2% FM stereo THD; 52 dB alt-ch sel; 78 dB stereo FM S/N. 35 lb. \$650

HR-722 60-W/ch Receiver

AM/FM receiver with wireless remote and Sonic Holography. Features asymmetrical charge-coupled FM detection circuit; magnetic-field power amplifier section. 20 AM/FM presets with preset scan; 5 audio inputs; CD direct; motorized volume control; A/B speaker outputs; 3-band tone controls; dual tape monitors with dubbing. 60 W/ch; 4.7 dB dynamic headroom; 0.5% THD; 85 dB MM phono S/N; 1.5 dB cap ratio; 0.2% FM stereo THD; 52 dB alt-ch sel; 78 dB

FM S/N. 35 lb. \$550

DENON

DRA-1025R 120-W/ch Receiver

AM/FM receiver with remote control. Features inputs for turntable, 2 tape decks, CD player, and VCR; pre-out main jacks; 5-way speaker terminals; 16 station tuner preset; FL display; preset FM scan; variable loudness EQ; simulcast copy function; simulated stereo circuit. 120 W/ch into 8 ohms; THD 0.006% -3 dB; IM 0.005%; FR 20-50,000 Hz \pm 1 $\frac{1}{2}$ dB; S/N 110 dB. 6 $\frac{3}{8}$ x 17 $\frac{1}{8}$ x 15 $\frac{1}{2}$ in; 26 $\frac{1}{2}$ lb. \$1,000

DRA-825R. Similar to above, 90 W/ch \$800

DRA-625R 65-W/ch Receiver

AM/FM receiver with integral system remote control. Features liquid-cooled heat sinks; variable loudness EQ; 1-touch source selection; pre-out jacks; 3-way speaker terminals; 16-station random preset memory tuning; auto scanning; last-channel-tuned memory. THD 0.0095%; IM 0.025%; FR 20-50,000 Hz \pm 1.5 dB; S/N: phono 88 dB, FM 82 dB, CD/tuner/tape 98 dB. 5 $\frac{3}{8}$ x 17 $\frac{1}{8}$ x 13 $\frac{3}{4}$ in; 21 lb. \$550

DRA-425R. Similar to above, 50 W/ch \$450

DRA-325R 40-W/ch Receiver

Class A amplifier with integral system remote control. Features electronic input switching; non-switching amp. 16-station preset tuning; auto seek; variable loudness control; last-channel memory; A/V in/out \$350

DRA-25 30-W/ch Receiver

Features straight amplification design; liquid-cooled heat-sink; microprocessor-assisted tuning system. CD direct switch; variable loudness EQ; 16-station presets; FL display; auto-scan; up/down manual tuning; last-channel-tuned memory. Amp section: 30 W/ch min rms into 8 ohms; FR 20-20,000 Hz; THD <0.05%. Tuner section: 50 dB quieting sens 23 μ V (stereo); capture ratio 1.5 dB; AM suppression 50 dB. \$300

FISHER

RS627B 100-W/ch Receiver

AM/FM receiver with Class AII circuitry. Features quartz PLL synthesis tuner; 24 station presets; FM mute; source direct switch; CD record switch; remote-controlled motorized volume control; 5-band graphic equalizer. Includes 38-function wireless remote control. 100 W/ch min rms into 8 ohms; FR 20-20,000 Hz; THD <0.05%; S/N 55 dB. 17 $\frac{3}{8}$ x 5 $\frac{3}{4}$ x 10 $\frac{3}{4}$ in; 20 lb. \$500

RS625B 120-W/ch Receiver

AM/FM receiver with 38-function wireless remote control. Features 5-band graphic equalizer; motorized volume control; 24 AM/FM station presets; autoscanning; FM muting; loudness switch; FL display. 120 W/ch rms into 8 ohms; FR 20-20,000 Hz; THD <0.09%. \$450

RS615B 60-W/ch Receiver

AM/FM receiver with 37-function wireless remote control. Features 5-band graphic equalizer; motor

RECEIVERS

ized volume control; 24 AM/FM station presets; autoseek tuning; FM muting; loudness switch; FL display. 60 W/ch rms into 8 ohms; FR 20-20,000 Hz; THD<0.09% \$350

RS605B 40-W/ch Receiver

Features 5-band graphic equalizer; 24 AM/FM station presets; autoseek tuning; FM muting; loudness switch; FL display. 40 W/ch rms into 8 ohms; FR 20-20,000 Hz; THD<0.09% \$250

HARMAN KARDON

hk990 Vxi 90-W/ch Receiver

AM/FM receiver with digital-synthesis quartz-locked tuning and remote. Features high-current/high-voltage design; Active-Tracking tuner circuitry. 6 AM/12FM presets; seek tuning; LED signal-strength meter; two tape monitors; two A/V monitors; interactive video switching; high-level CD inputs; external processor jacks; MC head amp; subsonic filter; mono and loudness buttons; tape-copy selector. Amp: 90 W/ch cont avg into 8 ohms from 20-20,000 Hz with <0.08% THD; S/N 98 dB (CD, video). Tuner: 50-dB quieting sens 36 dB; AM rej 55 dB; cap ratio 1.0 dB; adj-ch sel 30 dB; alt-ch sel 80 dB \$1,099

hk880 Vxi 60-W/ch Receiver

AM/FM receiver with digital-synthesis quartz-locked tuning and remote control. Features high-current/high-voltage design. 6 AM/12 FM presets; seek tuning; LED signal-strength meter; two A/V tape monitors; interactive video switching; high-level CD inputs; external processor jacks; subsonic filter; mono and loudness buttons; tape copy selector. Amp section: 60 W/ch cont avg into 8 ohms from 20-20,000 Hz with <0.08% THD; S/N 98 dB (CD, video). Tuner section: 50-dB quieting sens 36 dB; AM rej 55 dB; cap ratio 1.0 dB; adj-ch sel 5 dB; alt-ch sel 70 dB. 17 $\frac{3}{8}$ x 5 $\frac{1}{4}$ x 14 $\frac{1}{2}$ in; 22 lb. \$799

hk550 Vxi 45-W/ch Receiver

AM/FM receiver with digital-synthesis quartz-locked tuning. Features high-current/high-voltage design. 6 AM/12 FM presets; seek tuning; two tape monitors; CD, video, and high-level aux inputs; loudness button. Amp section: 45 W/ch cont avg into 8 ohms from 20-20,000 Hz with <0.09% THD; S/N 98 dB (CD, video). Tuner section: 50-dB quieting sens 37 dB; AM rej 55 dB; cap ratio 1.0 dB; adj-ch sel 5 dB; alt-ch sel 70 dB. 17 $\frac{3}{8}$ x 4 x 14 $\frac{1}{2}$ in; 15 lb. \$499

hk440 Vxi 30-W/ch Receiver

AM/FM receiver with digital-synthesis quartz-locked tuning. Features high current/high voltage design. 6 AM/12FM presets; seek tuning; two tape monitors; high-level CD and video inputs; loudness button. Amp section: 30 W/ch cont avg into 8 ohms from 20-20,000 Hz with <0.09% THD; S/N 98 dB (CD, video). Tuner section: 50-dB quieting sens 37 dB; AM rej 55 dB; cap ratio 1.0 dB; adj-ch sel 5 dB; alt-ch sel 70 dB. 17 $\frac{3}{8}$ x 4 x 14 $\frac{1}{2}$ in; 14 lb. \$399

hk330 Vi 25-W/ch Receiver

AM/FM receiver with digital-synthesis quartz-locked tuning. 6 AM/12 FM presets; select tuning; two tape monitors; high-level CD and video inputs; loudness button. Amp section: 25 W/ch cont avg into 8 ohms from 20-20,000 Hz with <0.09% THD; S/N 98 dB (CD, video). Tuner section: 50-dB quieting sens 38.2 dB; AM rej 45 dB; cap ratio 1.5 dB; adj-ch sel 5 dB; alt-ch sel 70 dB. 17 $\frac{3}{8}$ x 4 x 14 $\frac{1}{2}$ in; 12.5 lb. \$299

JVC

RX1010VTN 120-W/ch A/V Receiver

AM/FM receiver featuring Dolby Pro-Logic with adjustable digital delay. Features 3 video inputs; digital tuning with 40 presets; auto memory; 7-band graphic EQ; MC and MM phono inputs; FL display; programmable A/V remote with LCD. 120 W/ch at THD 0.007% into 8 ohms; 360 W/ch into 2 ohms \$1500

RX901VBK 100-W/ch A/V Receiver. Same as above with 48-key programmable remote. 100 W/ch at THD 0.007% into 8 ohms; 300 W/ch into 2 ohms . . . \$950

RX801VBK 100-W/ch Surround Sound Receiver

AM/FM receiver with digital Dolby Surround. Features 2 video inputs; digital tuning with 40 tuner presets; auto memory; 7-band graphic EQ; 2 pr of speaker connections; FL display; programmable A/V remote with 48 keys \$630

RX701VBK 80-W/ch Surround Sound Receiver. Same as above with 80 W/ch \$540

RX501BK 65-W/ch Receiver

AM/FM receiver with matrix surround sound. Features digital tuning with 40 presets; auto memory; 7-band graphic EQ; 2 pr of speaker connections; LCD display; full function A/V remote \$430

RX401BK 50-W/ch Receiver. Same as above with 50 W/ch \$380

RX301BK 40-W/ch Receiver

AM/FM receiver with matrix surround sound. Features digital tuning with 40 presets; auto memory; 2 pr of speaker connections; LCD display; A/V remote \$270

KENWOOD

KR-V9010 130-W/ch A/V Receiver

A/V receiver with 130 W/ch front and 20 W/ch rear. 7-band graphic EQ/spectrum analyzer, and video dubbing. Features Dolby Pro-Logic circuitry with Normal/Wide/Phantom modes, test-tone, center channel, and rear preouts; Theater/Hall surround-sound modes. Adjustable digital delay; programmable remote control; S-VHS connector; 4 video inputs; 20 AM/FM station/name presets; 10 EQ presets; on-screen display capability; digital input. FR (line to speaker) 10-200,000 Hz +0, -3 dB; THD 0.008%; S/N 100 dB. 50-dB quieting sens 37.2 dB stereo; AM rej 62 dB; capture ratio 1.0 dB; sel 55 dB at 400 Hz. 17 $\frac{1}{4}$ x 6 $\frac{1}{4}$ x 16 $\frac{1}{2}$ in; 32.3 lb \$850

KR-V8010 100-W/ch A/V Receiver

A/V receiver with 100 W/ch front and 20 W/ch rear. 7-band graphic EQ, and video dubbing. Features Dolby Surround, Theater-Hall surround-sound modes. Remote control; 3 video inputs; rear preouts; 20 AM/FM station/name presets; 10 EQ presets; EQ recording switch; digital input. FR (line to speaker) 10-200,000 Hz +0, -3 dB; THD 0.008%; S/N 100 dB. 50-dB quieting sens 37.2 dB stereo; AM rej 62 dB; capture ratio 1.0 dB; sel 55 dB at 400 Hz. 17 $\frac{1}{4}$ x 6 $\frac{1}{4}$ x 16 $\frac{1}{2}$ in; 27.5 lb. \$650

KR-V7010 80-W/ch A/V Receiver

A/V receiver with 80 W/ch front and 10 W/ch rear. 7-band graphic EQ/spectrum analyzer, and video dubbing. Features Dolby Surround and digital-delay modes. 2 video inputs; rear preouts; 20 AM/FM station/name presets; 10 EQ presets; EQ recording switch. Includes remote control. FR (line to speaker) 10-200,000 Hz +0, -3 dB; THD 0.008%; S/N 100 dB. 50-dB quieting sensitivity 37.2 dB stereo; AM rejection 57 dB; capture ratio 1.2 dB; selectivity 53 dB at 400 Hz. 17 $\frac{1}{4}$ x 5 $\frac{1}{4}$ x 12 $\frac{1}{2}$ in; 18.1 lb. \$499

KR-V6010 70-W/ch A/V Receiver

A/V receiver with 70 W/ch front and 5 W/ch rear. 5-band graphic EQ, and video dubbing. Features Dolby Surround and digital-delay modes. Remote control; 2 video inputs; 10 AM/FM station/name presets. FR (line to speaker) 10-70,000 Hz +0, -3 dB; THD 0.009%; S/N 100 dB. 50-dB quieting sens 41.2 dB stereo; AM rej 70 dB; capture ratio 1.2 dB; sel 53 dB at 400 Hz. 17 $\frac{1}{4}$ x 5 $\frac{1}{4}$ x 11 $\frac{1}{8}$ in; 15.9 lb. \$399

KR-A5010 60-W/ch Receiver

Receiver with 60 W/ch and 5-band graphic EQ. Features electronic input selectors, remote control; 10 AM/FM station/name presets; 2 video-sound inputs. FR (line to speaker) 10-70,000 Hz +0, -3 dB;

THD 0.3%; S/N 100 dB. 50-dB quieting sens 41.2 dB stereo; AM rej 70 dB; capture ratio 1.2 dB; sel 53 dB at 400 Hz. 17 $\frac{1}{4}$ x 5 $\frac{1}{4}$ x 11 $\frac{1}{8}$ in; 13.2 lb. \$299

KR-A4010 45-W/ch Receiver

Receiver with 45 W/ch and 20 AM/FM station presets. Features electronic input selectors; preset scan; auto and manual tuning; video sound and CD/aux inputs. FR (line to speaker) 10-70,000 Hz +0, -3 dB; THD 0.3%; S/N 95 dB. 50-dB quieting sens 41.2 dB stereo; AM rej 70 dB; capture ratio 1.2 dB; sel 53 dB at 400 Hz. 17 $\frac{1}{4}$ x 5 $\frac{1}{4}$ x 11 $\frac{3}{4}$ in; 11.7 lb \$249

LUXMAN

All receivers carry a 5-year parts and labor warranty.

R-117 160-W/ch AM/FM Receiver

Receiver with full-function system remote control. Features low-impedance drive capability; triple-shielded power transformer; 5-varactor, dual-gate MOSFET FM front end; Duo-Beta dual feedback-loop amp circuitry; STAR circuit topology to reduce noise and distortion. 20 AM/FM station presets; cable FM fine tuning (25 kHz steps); CD-direct, 3 video, MM/MC-phono inputs; 3-position loudness compensation; signal-strength/multipath indicators; subsonic filter; FM IF-bandwidth selector; pre-out/main-in and signal-processor jacks. Amp section: 160 W/ch from 20-20,000 Hz into 8 ohms with 0.03% THD; S/N: MC 70 dB, MM 88 dB. CD/tape/video 100 dB; IM 0.03%. FM section: 50-dB quieting sens 36.6 dB (stereo); cap ratio 1.5 dB; alt-ch sel 75 dB (narrow IF). AM section: S/N 50 dB. 17 $\frac{1}{4}$ x 5 $\frac{1}{2}$ x 16 $\frac{3}{4}$ in; 35 lb \$1,200

R-115. Similar to above except 75 W/ch; 2 video inputs; no MC phono input. S/N: phono 88 dB, CD/tape/video 98 dB. 25.5 lb \$850

R-113. Similar to above except 35 W/ch and no remote control. THD 0.08% \$480

McINTOSH

MAC 4360V 100-W/ch Receiver

Features MPX filter; 6 AM/FM station presets; signal-strength indicator; LED display of station frequency; 1 unswitched outlet; loudness control; 1, 2, and 1+2 speaker selector; 5-band equalizer; scan; headphone jack. Includes remote control. Amp: THD 0.02%; IM 0.02%; FR 20-20,000 Hz +0, -0.5 dB; SN 100 dBA. Tuner: S/N 75 dB stereo; FR 20-15,000 Hz +0, -1.0 dB stereo; THD 0.08% at 1,000 Hz. 18 $\frac{1}{2}$ x 6 x 14 in; 34 lb, 8 oz \$2,995

MAC 4280 75-W/ch Receiver

Features MPX filter; 5 AM/FM station presets; signal-strength indicator; LED display of station frequency; Power Guard circuit; 1 unswitched outlet; loudness control; 1, 2, and 1+2 speaker selector; 3-band equalizer; scan; headphone jack. Amplifier section: total harmonic distortion 0.03%; intermodulation distortion 0.03%; frequency response 20-20,000 Hz +0, -0.5 dB; 100 dBA. Tuner section: signal-to-noise ratio 75 dB stereo; frequency response 20-15,000 Hz, \pm 0.5 dB stereo; total harmonic distortion 0.1% at 1,000 Hz. 18 $\frac{1}{4}$ x 5 $\frac{1}{4}$ x 15 $\frac{1}{2}$ in; 25 lb \$1,995

MAC 4275. Similar to the above; without remote control. \$1,798

MARANTZ

SR3600BI. 120-W/ch Receiver

Receiver with Dolby Surround Sound. Features remote control; 40 AM/FM presets; preset scan; VCR-to-VCR dubbing; 3-band tone control; speaker A/B switch; center channel output \$879

SR3500BI. 110-W/ch Receiver

Receiver with 40 AM/FM station presets. Features remote control; preset scan; VCR-to-VCR dubbing; 3 band tone control; speaker A/B switch; cable FM input; MM/MC phono input selector; matrix sound \$749

RECEIVERS

TA-100 100-W/ch Receiver

AM/FM receiver with 16 presets. Features remote control; 5-band EQ; inputs for MM, phono, tape, CD, 2 video sources; VCR-to-VCR dubbing; 100 W/ch; 0.1% THD. 16 $\frac{1}{2}$ x 5 $\frac{7}{8}$ x 12 $\frac{1}{2}$ in; 23.7 lb \$500

SR3300BL 35-W/ch Receiver

Receiver with 32 AM/FM presets. Features VCR-to-VCR dubbing; 3-band tone control; speaker A/B switch; audio/video integration; matrix sound \$449

SR-560 45-W/ch Receiver

Features 16 preset digital tuning; 7-band EQ; inputs for MM phono, tape, CD, 2 video sources; VCR-to-VCR dubbing; 0.3% THD; sens 11.2 dBf IHF. 16 $\frac{1}{2}$ x 3 $\frac{3}{8}$ x 10 in; 11.9 lb \$250

RS2253CB 50-W/ch Receiver

Features surround-sound capability; uniphase circuit design; remote control \$250

RS 2252CB 25-W/ch Receiver

Features relay speaker switching; ultra low noise phono/FM circuitry; remote control \$200

Century Collection

RS 3559 125-W/ch A/V Receiver

AM/FM receiver with five independent amplifiers and 64-key remote. Features thermal tunnel heat sink; oversized industrial power transformer; Dolby Surround; 6-sector alphanumeric information center; CD direct; 10-channel multi-scan AM/FM memory; 30 station presets; 3 video inputs. \$1,000

RS 3557 100-W/ch A/V Receiver

AM/FM receiver with four independent amplifiers and 44-key remote. Features oversized industrial power transformer; Dolby Surround; alphanumeric information center; 10-channel FM memory; 30 station presets; 3 video inputs. \$700

RS 3555 50-W/ch Receiver

AM/FM receiver with four independent amplifiers and 36-key remote. Features oversized industrial power transformer; CD direct; 2-color alphanumeric information center; station character generator. \$500

MITSUBISHI

M-AV1 125-W/ch Surround Sound A/V Receiver

4-channel AM/FM receiver with Dolby Surround and matrix circuitry. Features 125 W/ch front and 25 W/ch rear. Remote control; motorized-volume, bass, and treble controls; tone defeat; audio mute; preamp loudness; subsonic/high-cut filters; rec selector; on-screen displays of all functions; adjustable LCD display; 16 FM presets with scan; FM muting; headphone jack; 4 audio/video, 3 audio inputs; 1 video, 2 audio, and monitor outputs; pre-amp loop. 125 W/ch min rms into 8 ohms from 20-20,000 Hz; THD 0.05% \$1,200

M-AV2 80-W/ch Surround Sound A/V Receiver

4-channel AM/FM receiver with Dolby Surround and matrix circuitry. Features 80 W/ch front and 20 W/ch rear. Remote control; motorized-volume, bass and treble controls; tone defeat; audio mute; preamp loudness; subsonic/high-cut filters; rec selector; 16 FM presets with scan and menu switching; FM muting; on-screen display of all functions; adjustable LCD; headphone jack; 4 audio/video, 3 audio outputs; 1 video output; monitor outputs; pre-amp loop. 80-W/ch min rms into 8 ohms from 20-20,000 Hz; THD 0.05% \$1,000

M-AV3. Similar to above except no rec selector, menu switching of tuner presets, on-screen display, and adjustable LCD. \$800

NAD

7600 Monitor Series 150-W/ch Receiver

Bridgeable AM/FM stereo receiver with power envelope circuitry. Features high-current output stage;

high-resolution phono preamp; MC pre-preamp; close tracking soft-clipping circuitry. Bass EQ; semi-parametric tone controls; wide/narrow IF mode; speaker impedance selector. 150 W/ch rms; +4 dB dynamic headroom. Includes wireless remote control with motor-driven volume. Rack mountable. \$1,599

7400 Monitor Series 100-W/ch Receiver

Bridgeable AM/FM stereo receiver with power envelope circuitry. Features soft-clipping circuit. 14 random AM/FM pre-sets; MM/MC switch on discrete 4 transistor phono preamp; semi-parametric tone controls; bass EQ; pre-amp out/main in. 100 W/ch rms; +5.7 dB dynamic headroom. Includes remote control with motor-driven volume. Rack mountable. \$999

7100 Monitor Series 50-W/ch Receiver

Bridgeable AM/FM stereo receiver with power envelope circuitry. Features soft-clipping circuit. 14 random AM/FM pre-sets; MM/MC switch on discrete 4 transistor phono preamp; bass EQ; pre-amp out/main in. 50 W/ch rms; +6 dB dynamic headroom. Rack mountable. \$749

7240PE 40-W/ch Receiver

AM/FM receiver featuring soft-clipping circuit; high-current output stage; low-noise phono pre-amp. Speaker imp selector; bass EQ. 40 W/ch rms; +6 dB dynamic headroom \$499

7225PE 20-W/ch Receiver

AM/FM receiver featuring power envelope circuitry; soft-clipping circuitry. Preamp out/main in; bass EQ; 5-way speaker binding posts. 20 W/ch rms; +4.4 dB dynamic headroom \$329

7020e 20-W/ch Receiver

AM/FM receiver featuring soft-clipping circuit; high-current output stage. Bass EQ. 20 W/ch rms; +2.5 dB dynamic headroom \$279

NAKAMICHI

TA-4A 100-W/ch A/V Receiver

Features Stasis power amplifiers (two internal amplifiers for hi/low impedance source). Multi-regulated isolated-ground power supply; four high-Q twin-varicap diode tuner; FET differential preamp. Tone, variable loudness and mute controls; MM/MC phono preamp with defeatable subsonic filter; quartz PLL tuner with 10 presets; 5 audio and 3 video inputs; system remote control with multi-room expansion capability. Amp section: 100 W/ch cont avg into 8 ohms (135 W/ch max); FR 20-20,000 Hz \pm 0.5 dB; THD < 0.1% at 20-20,000 Hz; S/N > 100dB. Tuner section: 50-dB quieting sens 37.5 dBf stereo; cap ratio 2.0 dB; alt-ch sel 65 dB, \pm 400,000 Hz. 17 x 5 x 14 $\frac{1}{2}$ in; 33 lb. \$1,295

TA-3A 75-W/ch A/V Receiver. Similar to above but 75 W/ch; lacks remote multi-room expansion capability; 4 audio and 3 video inputs; 17 x 4 x 14 $\frac{1}{2}$ in; 24 lb, 4 oz. \$895

TA-2A 50-W/ch Receiver. Similar to above but 50 W/ch; 4 audio and 1 video inputs; 17 x 4 x 14 $\frac{1}{2}$ in; 18 lb, 15 oz. \$595

TA-1A 35 W/ch Receiver. Similar to above but 35 W/ch; lacks Stasis circuitry and system remote control. 3 audio and 1 video inputs; 17 x 4 x 10 $\frac{1}{2}$ in; 13 lb, 4 oz. \$349

NEC

AVR-1010 100-W/ch A/V Receiver

AM/FM receiver with built-in Dolby and matrix surround-sound processors. Features unified remote control with LCD readout that can operate other NEC audio and video components; four built-in power amps (one for each front and rear ch); quartz-PLL digital-synthesis tuning; 16 AM/FM station presets; preset scan; FM mute; selectable wide/narrow IF bandwidth; 3 volume level/channel balance presets;

computer-controlled volume and input selection; audio mute; a master volume control; front/rear volume control; front-left, front-right, rear-left, and rear-right volume controls; rear and front bass/treble controls; digital delay; headphone jack; tape monitor; mono output. Inputs for phono, CD player, tape deck, aux, TV, and VCR. Tuner section: FM usable sens 10.8 dBf (0.95 μ V); FM S/N 74 dB stereo. Amp section: 100 W/ch into 8 ohms from 20-20,000 Hz with 0.02% THD (front), 50 W/ch into 8 ohms (rear). 17 x 5 $\frac{1}{2}$ x 17 in; 35 lb \$899

AVR-710 70-W/ch A/V Receiver

AM/FM receiver with built-in Dolby and matrix surround-sound processors. Features unified remote control that can operate other NEC audio and video components; four built-in power amps (one for each front and rear ch); quartz-PLL digital-synthesis tuning; 16 AM/FM station presets; preset scan; FM mute; 3 volume level/channel balance presets; computer-controlled volume and input selection; audio mute; a master volume control; front/rear volume control; front-left, front-right, rear-left, and rear-right volume controls; rear and front bass/treble controls. Inputs for phono, CD player, tape deck, aux, TV, and VCR. Tuner section: FM usable sens 13.2 dBf (2.5 μ V); FM S/N 72 dB stereo. Amp section: 70 W/ch into 8 ohms from 20-20,000 Hz with 0.02% THD (front), 35 W/ch into 8 ohms (rear). 17 x 5 $\frac{1}{2}$ x 17 in; 33 lb \$699

R-510 50-W/ch A/V Receiver

Remote-controlled AM/FM receiver with 16 AM/FM station presets. 50 W/ch into 8 ohms with 0.02% THD. \$499

NIKKO AUDIO

R-550 55-W/ch A/V Receiver

AM/FM receiver with Class AB power amplifier. Features video image dubbing; automatic record out; optional rack mounting ears. Amplifier section: FR 5-100,000 Hz at 1 W; THD < 0.06%; S/N 95 dB. Tuner section: 50-dB quieting sens 37.2 dBf stereo; capture ratio 2.0 dB; alternate-channel selectivity 75.8 dB. 17 $\frac{1}{2}$ x 5 $\frac{1}{8}$ x 13; 32 lb \$500

R-400. Identical to R-550 except for 40 W/ch, processor feature, and single direction video dubbing. \$350

ONKYO

TX-SV7 40-W/ch Surround Sound A/V Receiver

Audio/video AM/FM receiver with 40 W/ch front and 20 W/ch rear. Features MTS decoder for stereo TV broadcasts; processor with Dolby, matrix, hall surround-sound effects, and simulated stereo. Universal remote control that operates a variety of different brand audio and video components; 36 AM/FM station presets; FM mute; 4 speaker terminals; bass, treble, and balance controls; pre-out/main-in jacks; 2 video, 4 audio inputs. \$1,000

TX-860 80-W/ch Receiver

Receiver with discrete output circuitry and low-impedance drive capability. Features AM/FM tuner with 4-mode APR (Automatic Precision Reception) system; distant/local, IF bandwidth (wide/narrow), hi-blend (on/off), and stereo/mono. Video dubbing; 20 station presets with battery-free backup; Selective Tone Control with 50-Hz boost; digital input; simulated-stereo processor; stereo image, dynamic bass expander modes; sleep timer; RI remote compatible. Controller included. 80 W/ch min rms into 8 ohms; dynamic power 185 W/ch into 2 ohms \$500

TX-860NI. Same as above except RC-AV20M programmable remote control replaces audio-only controller \$550

TX-840 60-W/ch Receiver

Receiver with discrete output circuitry and low-impedance drive capability. Features AM/FM tuner with 3-mode APR (Automatic Precision Reception) system; IF bandwidth (wide/narrow), hi-blend (on/

off), and stereo/mono. Video dubbing; 20 station presets with battery-free backup; Selective Tone Control with 50-Hz boost; digital input; simulated-stereo processor; sleep timer; RI remote compatible. Controller included. 60 W/ch min rms into 8 ohms; dynamic power 155 W/ch into 2 ohms \$380
TX-840M. Same as above except RC-AV20M programmable remote control replaces audio-only controller \$430

Integra Series

Integra TX-890 125-W/Ch Receiver

Receiver with discrete output circuitry and low-impedance drive capability. Features FM tuner with 5-mode APR (Automatic Precision Reception) system to optimize reception: A/B antenna, RF (distant/local), IF bandwidth (wide/narrow/S-narrow), hi-blend (on/off), and stereo/mono; dual FM antenna inputs. 20 station presets with battery-free backup; cable FM fine tuning (25 kHz steps); dynamic bass expander; Selective Tone Control with 50-Hz boost; digital input; MM/MC phono inputs; simulated-stereo processor; video dubbing; alternate audio dubbing; rec out selector; sleep timer; pre-out/main-in jacks; RI remote compatible. Controller and side panels included. 125 W/ch min rms into 8 ohms; dynamic power 380 W/ch into 2 ohms \$820
Integra TX-890M. Same as above except RC-AV20M programmable remote control replaces audio-only controller \$880

Integra TX-870 105-W/ch Receiver

Receiver with discrete output circuitry and low-impedance drive capability. Features AM/FM tuner with 4-mode APR (Automatic Precision Reception) system; distant/local, IF bandwidth (wide/narrow), hi-blend (on/off), and stereo/mono. 20 station presets with battery-free backup; Selective Tone Control with 50-Hz boost; cable FM fine tuning (25 kHz steps); digital input; simulated-stereo processor; video dubbing; alternate audio dubbing; sleep timer; pre-out/main-in jacks; RI remote compatible. Controller included. 105 W/ch min rms into 8 ohms; dynamic power 310 W/ch into 2 ohms \$680
Integra TX-870M. Same as above except RC-AV20M programmable remote control replaces audio-only controller \$740

PARASOUND

R/HD Receiver Series

Both Parasound R/HD receivers feature CMOS electronic logic switching; high current/high speed discrete outputs; high speed linear phono gain stage; preamplifier output jacks; LED function indicators; CD and video inputs; A/B speaker pairs, separately switched; mono mode select; headphone jack.

R/HD-600 60-W/ch Receiver

Features 16 station presets. 8 AM/8 FM; variable loudness contour; 2-tape monitors; relay protection; FR 20-20,000 Hz ± 1 dB; THD <0.2%; IM <0.2%; dynamic headroom 1.5 dB; S/N 90 dB line. 78 dB phono; phono overload 220 mV; preamp output 0.775 V. 17/4 x 4 x 11/4 in. \$400

R/HD-300 30-W/ch Receiver

Features 12 station presets. 6 AM/6 FM; switchable loudness contour; single tape monitor; FR 20,000 Hz ± 1 dB; THD <0.2%; IM <0.2%; dynamic headroom 1.5 dB; S/N 90 dB line. 78 dB phono; phono overload 220 mV; preamp output 0.775 V. 17/4 x 3 x 9/4 in. \$300

PHILIPS

FR 980 4-Ch A/V Receiver

4-ch A/V receiver with Dolby Surround. Features surround mode switch with matrix, spatial, stereo, mono; digital synthesis AM/FM tuner with 19 presets; 7-band graphic EQ with programmable acoustic memory; motor-driven rotary volume control for

CD-BOX™, TAPE-BOX™ & VHS-BOX™

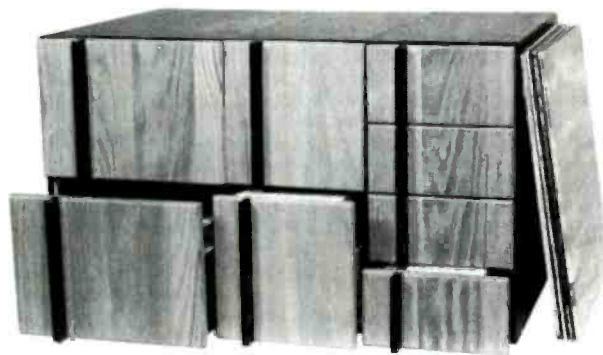

Introducing
Maple
\$49.95 & \$59.95

The CD-BOX, TAPE-BOX, and VHS-BOX are stand alone units. They fit in the space intended for LPs in audio-video furniture and shelves. The solid hardwood drawer faces suit any decor. Maple units offer the quality and efficiency of our original BOXES at a lower price. CD-BOX stores 60 discs in two drawers, with dividers. Holds multi-CD albums. TAPE-BOX, four drawers, hold 64 audio and 8mm cassettes or 48 VHS-Cs. CD & TAPE : w 6 3/8", h 12 3/4", d 14 3/4" VHS-BOX holds 24 VHS or Beta cassettes in two drawers. w 9", h 12 3/4", d 14 3/4"

To order call 800-247-2018.

CD-BOX & TAPE-BOX	
Maple	\$49.95
Light & Dark Oak	64.95
Black Lacquer & Walnut	69.95
Teak	79.95
VHS-BOX	
Maple	\$59.95
Light & Dark Oak	74.95
Black Lacquer & Walnut	79.95
Teak	89.95
Ship UPS per unit, in cont. US.	\$5.00
<i>30 day money-back satisfaction guarantee.</i>	

Designed and manufactured in the USA
 By Hills Products Inc. 603-464-3999
 PO Box 1015, Hillsboro, NH 03244



CIRCLE NO. 70 ON READER SERVICE CARD

Transport Yourself.

The IRS 690 cordless headphone system.

Escape to a deeply personal world of sonic pleasure. The Beyerdynamic IRS 690 system. With the warmth and intimacy that is distinctively Beyer. Advanced infrared technology for cordless, 360-degree movement without static or interference. And the same diffuse-field design as the CT 99C's—the world's most critically-acclaimed dynamic headphones—for superior imaging and startling accuracy.

Let the IRS 690 system transport you. Experience them at your local Beyer headphone dealer.



Ecstasy in Audio

beyerdynamic

Beyerdynamic 5-05 Burns Avenue, Hickville, NY 11801 Tel. (516) 935-8000 Fax (516) 935-8018

CIRCLE NO. 51 ON READER SERVICE CARD

RECEIVERS

both channels; video split screen with video noise reduction; record selector with parallel recording capability; MM or MC phono settings; ambient control switch; 9 audio inputs; 4 audio outputs; 4 video inputs; 3 video outputs; AM and FM antennas; headphone jack; function display; pre-set scanning function for AM/FM tuner; re-modulator output jack for optional re-modulator. Includes 50-key universal A/V remote with LCD display, 125 W/ch (front); 15 W/ch (rear); S/N 75 dB; THD 0.1%. 4 3/8 x 16 7/8 x 15 1/4 in; 35 lb \$999

FR 880 4-Ch A/V Receiver

4-ch A/V receiver with Dolby Surround. Features surround mode switch with matrix, spatial, stereo, mono; digital-synthesis AM/FM tuner with 19 presets; motor-driven rotary volume control for both channels; 9 audio inputs; 4 audio outputs; 4 video inputs; 3 video outputs; AM and FM antennas; headphone jack; function display; preset scanning function for AM/FM tuner; re-modulator output jack for optional re-modulator. Includes 44-key universal A/V remote with LCD display, 75 W/ch (front); 15 W/ch (rear); signal-to-noise ratio 75 dB; total harmonic distortion 0.1%. 4 3/8 x 16 7/8 x 15 1/4 in; 25 lb \$649

FR-780 70-W/ch A/V Receiver

Features motorized volume control; 19 programmable station presets; alpha text mode display; separate bass EQ function; A/V tape-to-tape dubbing. Includes wireless remote control. 70 W/ch min rms into 8 ohms; FR 20-20,000 Hz; THD < 0.05%. \$549

PIONEER

VSX-9500S 125-W/ch A/V Receiver

A/V receiver with Dolby Pro Logic Surround processor and digital delay. Features type II non-switching amp rated at 125 W/ch front, 30 W/ch rear; motor-driven volume control; 5 audio inputs; video adaptor loop; 5 video inputs; stadium sound; simulated surround sound; FL display; programmable remote control; video enhancer with split-screen monitoring; VCR noise filter; 5-position remote-operated acoustic tonal setting memory; pre-outs and main input terminals; 30 AM/FM presets; memory scan; manual, automatic, and direct-access tuning; HITS (Hyper Intelligent Tuning System) enables memory display by radio call letters and categories \$1,050

VSX-7500S 125-W/ch A/V Receiver

A/V receiver with Dolby Surround processor. Features type II non-switching amp rated at 125 W/ch front, 30 W/ch rear; programmable remote; 6 video inputs; 5 audio inputs; video adaptor loop; simulated stereo; split-screen video enhancer; video recording enhancer; VCR noise filter; 30 AM/FM presets; auto dimmer; 60/30-minute sleep timer \$900

VSX-7500 125-W/ch A/V Receiver

A/V receiver with Dolby Surround processor and digital delay. Features type III non-switching amp rated at 125 W/ch front, 30 W/ch rear; 5 audio inputs; video adaptor loop; 5 video inputs; stadium sound; simulated surround sound; FL display; programmable remote control; video enhancer with split-screen monitoring; VCR noise filter; 5-position remote-operated acoustic tonal setting memory; pre-outs and main input terminals; 30 AM/FM presets; memory scan; manual, automatic, and direct-access tuning \$760

VSX-5400 100-W/ch A/V Receiver

A/V receiver with Dolby Pro Logic Surround processor and digital delay. Features type II non-switching amp rated at 100 W/ch front, 15 W/ch rear; 4 audio inputs; 3 video inputs; stadium sound; simulated surround sound; FL display; 30 AM/FM presets; video enhancer with split-screen monitoring. Includes programmable remote control \$650

VSX-3300 80-W/ch A/V Receiver

A/V receiver with Dolby Pro Logic Surround proces-

sor, digital delay, and remote control. Features type III non-switching amp rated at 80 W/ch; 3 audio inputs; 2 video inputs; 5-band graphic EQ; FL display; programmable remote control; 24 AM/FM presets \$445
VSX-3300. As above with normal Pioneer SR remote control \$395

SX-2300 60-W/ch Receiver

Receiver with quartz-synthesis tuning and 60 W/ch. Features speaker matrix sound; simulated stereo for mono sources; 24 AM/FM presets; memory scan; auto tuning; 5-band graphic EQ; A/B speaker selector; FL display; microcomputer control; 5 audio inputs. Imp 8 ohms; frequency response 20-20,000 Hz; total harmonic distortion 0.07% \$250

SX-1300 40-W/ch Receiver

Receiver with quartz-synthesis tuning and 40 W/ch. Features 24 AM/FM presets; memory scan; auto tuning; 5-band graphic EQ; A/B speaker selector; FL display; microcomputer control; 5 audio inputs. Imp 8 ohms; frequency response 20-20,000 Hz; total harmonic distortion 0.07% \$210

PROTON

AV-646 60-W/ch A/V Receiver

Receiver with Dynamic Power on Demand circuitry. Features Aphex Aural Exciter circuitry; Schotz II tuner; remote control; 18 FM and 9 AM presets; rotary tuning; PLL synthesis; 2-color LCD display. Amplifier section: 60 W/ch into 8 ohms; frequency response 20-20,000 Hz \pm 3 dB; total harmonic distortion 0.02% at rated power. Tuner section: 50-dB quieting sens 32 μ V mono, 30 μ V stereo; cap ratio 10 dB; AM rej 65 dB. 8 1/2 x 4 3/8 x 15 1/8; 15.5 lb \$900

D940 40-W/ch A/V Receiver

Receiver with Dynamic Power on Demand (DPD) circuitry and Schotz NR. Features 4-gang FM front end; 2-gang AM front end; selectable phono section for MM and MC phono; speaker EQ; separate low-noise MC amp; active volume control; infrasonic filter. Inputs for MM, MC phono; phono 2; tape; aux; extra aux; CD; video sound source. Amp section: 40 continuous average W/ch from 20-20,000 Hz with less than 0.02% THD into 8 ohms; dynamic headroom 6 dB; IHF IM 0.008%; FR 20-20,000 Hz \pm 0.2 dB. FM section: alt-ch sel 55 dB; adj-ch sel 90 dB; 50-dB quieting sens 33.2 dBf stereo; S/N 70 dB stereo; THD stereo 0.2%; sep 45 dB at 1,000 Hz; capture ratio 1.5 dB. 16 1/2 x 4 x 10 1/8 in; 20 lb \$489

AV-300 AM/FM 30-W/ch Receiver

Digital-synthesis stereo receiver. Features Schotz PLL detector; optional remote control. Inputs for MM phono, tape, aux, video sound source. 30 continuous average W/ch from 20-20,000 Hz with < 0.02% THD into 8 ohms; includes Dynamic Power on Demand which boosts dynamic power to 120 W (8 ohms) with 6 dB dynamic headroom; IHF IM 0.015%; frequency response 17-35,000 Hz \pm 1 dB. FM section: 50-dB quieting sens, stereo, 2.8 μ V; max S/N, A-wtd, stereo 70 dB; THD stereo 0.2%; sep 50 dB at 1,000 Hz; capture ratio 1.5 dB. AM section: sens 300 μ V/m. 16 1/2 x 3 3/4 x 9 3/8 in; 20 lb \$459

REALISTIC

AV-900 A/V Receiver with TV Tuner

Receives VHF TV broadcasts (decodes MTS stereo and SAP), UHF broadcasts, cable-TV channels, 140-channel TV tuner; surround-sound decoder; digital-synthesis tuner. Wireless remote control (needs 2 AAA batteries); video signal processing and dubbing; stores 4 pairs of cable/FM channels; RF output on channel 3 or 4; baseband output for monitors. Inputs for phono, tape, CD player, two VCR's. 35 W/ch into 8 ohms \$600

STA-2700 100-W/ch Receiver

Receiver with quartz tuning; 6 AM and 6 FM presets; and search tuning. Features MPX blend; FM muting;

high filter; infrasonic filter; overload and overheating protection. Digital frequency display; 5-part LED signal-strength meter; 2-part dual output power meters; 2-way tape dubbing and 2-deck monitoring; loudness control. Remote requires 2 AA batteries. 100 W/ch into 8 ohms \$500

STA-2380 60-W/ch Receiver

Receiver with 6 AM and 6 FM presets. Up/down scan, lock; dual 7-step output meter MPX blend; high filter. Drives 2 pairs of speakers; headphone jack; 5-segment fluorescent signal-strength meter; 2 AC outlets. Inputs for MM phono; tape; tape 2; aux; CD player. Amp section: 60 W/ch into 8 ohms, 98 W into 4 ohms; S/N 84 dB phono 100 dB aux. FM section: 50-dB quieting sens stereo 32 dBf (40 μ V); S/N 70 dB (stereo); capture ratio 1 dB; AM rej 50 dB; alt-ch sel 70 dB \$400

STA-117 30-W/ch Receiver

6 AM/6 FM presets; 75-/300-ohm AM/FM antennas; quartz digital tuning; feather-touch manual or auto tuning; 3-LED signal-strength meter; loudness control; subsonic filter. Inputs for MM phono; tape; aux; CD player. Amp section: 30 W/ch into 8 ohms; S/N 84 dB phono; FM section: 50-dB quieting sens stereo 32 dBf (40 μ V); signal-to-noise ratio 60 dBA (stereo); capture ratio 1.5 dB; separation 40 dB; FM tuner AM rejection 50 dB; alt-ch sel 50 dB \$280

STA-785 50-W/ch Receiver

Quartz digital tuning; search up or down; feather-touch controls; 6 AM/6 FM presets; FM muting; 5-LED signal-strength meter; loudness control. Inputs for MM phono; tape; aux; CD player. Amp section: 50 W/ch into 8 ohms. FM section: capture ratio 2 dB; FR 40-20,000; S/N 56 dB, 67 aux; AM rej 45 dB; alt-ch sel 50 dB \$200

STA-130 22-W/ch Receiver

PLL tuning; loudness button; FM muting; drives 2 pairs of speakers; stereo/mono switch; bass, treble, volume, balance controls; overheating and overload protection. 5-LED output power meter; Inputs for MM phono; tape; aux; CD player. Amp section: 22 W/ch into 8 ohms. FM section: capture ratio 3 dB; alt-ch sel 50 dB \$160

STA-19 5-W/ch Mini Receiver

Inputs for AM/FM phono, tape. Features Auto-Magic fine tuning; jack for mini headphones; jack for mini cassette players; EQ switch; loudness control. Walnut vinyl finish over metal case. 5 W/ch into 8 ohms; S/N 70 dB phono, 72 aux; IHF sens 22.3 dBf; sep at 1,000 Hz 35 dB \$130

REVOX

B285 70-W/ch Receiver

AM/FM stereo receiver with two microprocessors for control of input sensitivities, output levels, and operating functions. Features alphanumeric multi-mode LCD display; 29 AM or FM presets; level and reception mode (mono/stereo, blend) separately programmable for each preset station; programmable volume limit; -20 dB mute button; subsonic filter; loudness contour; programmable output levels for A and B speaker pairs; comprehensive speaker protection circuits; serial data bus for external control devices; wireless infrared remote control (transmitter optional). Inputs for phono, tape, CD player, tape 2. Amp section: frequency response 20-20,000 +0, -0.3 dB; total harmonic distortion 0.005% (1,000 Hz, 90 W, 4 ohm); dynamic headroom 2.5 dB; S/N 96 dB line, 80 dB phono. FM section: 50-dB quieting sens 15.2 dBf mono, 36.8 dBf stereo; alt ch sel 96 dB; S/N 78 dB; capture ratio 0.8 dB. AM section: S/N 60 dB. 17 3/4 x 6 x 13 in; 33 lb \$2,500

ROTEL

RX855 50-W/ch A/V Receiver

AM/FM receiver with dual-mono power supply.

DENON PRECISION AUDIO COMPONENT/INTEGRATED STEREO AMPLIFIER PMA-1520



WHAT MAKES ONE AUDIO BRAND SOUND BETTER.

RECEIVERS actually combine a separate amplifier and tuner onto a single chassis. So one clue to a receiver's sound quality is the quality of the separates technology it incorporates.

At Denon, the new DRA-1025 and DRA-825 Receivers have the same Optical Class A circuitry that graces Denon separate amplifiers. Developed through statistical research into the playback requirements of CDs, this circuit makes the legendary sound of true Class A mode a practical reality. These receivers also benefit from the same Pure Current power supply that gives our separates superb transient response.

Every Denon receiver features thick, anodized aluminum front panels and discrete output transistors. Selected models offer Denon's Integral System (IS) remote control.

DRA-1025



This unwavering consistency is a prime example of Design Integrity, the Denon philosophy that encompasses our eight decades of mastery in every link of the music reproduction chain.

It's simply easier to make audio components sound more like music when you know what music sounds like.

DENON

DESIGN INTEGRITY



Denon America, Inc., 222 New Road, Parsippany, NJ 07054 (201) 575-7810
Denon Canada, Inc., 171 Denison Street, Markham, Ont. L3R 1B5 Canada
CIRCLE NO. 27 ON READER SERVICE CARD

RECEIVERS

Features direct signal paths; 8 AM and 8 FM presets; inputs for MM and MC phono, CD, tuner, video, tape 1, tape 2. Amp section: 50 W/ch into 8 ohms; FR 20-20,000 Hz; THD <0.03%; S/N 102 dB. Tuner section: 50-dB quieting sens 37.2 dBf stereo, 15.2 dBf mono; cap ratio 1.0 dB. 17 x 4 3/4 x 13 1/2 in; 25 lb. . . . \$549

RX850A 30-W/ch Receiver

AM/FM receiver with 16 station presets. Features protection circuitry; remote mounted switches; hard-wired direct speaker terminals; direct signal paths; inputs for MM/MC phono, CD, tuner, video/aux, tape. Amp section: 30 W/ch into 8 ohms; FR 20-20,000 Hz \pm 3 dB; THD <0.3%; S/N 95 dB. Tuner section: 50-dB quieting sens 37.2 dBf stereo, 15.2 dBf mono; cap ratio 1.0 dB. 17 1/2 x 2 3/4 x 13 in; 26 lb. . . . \$399

RX845 30-W/ch Receiver

Quartz-synthesized AM/FM receiver with 8 AM and 8 FM presets. Features main/remote speaker switch; inputs for phono, CD, tuner, video, tape. Amp section: 30 W/ch into 8 ohms; FR 10-45,000 Hz \pm 0.5 dB, -3 dB; THD 0.05%; S/N 90 dB. Tuner section: cap ratio 1.5 dB; alt-ch sel 60 dB. 17 1/2 x 3 3/8 x 12 in \$299

SAE

R-102 50 W/ch Receiver

AM/FM stereo receiver with an on-board computer to eliminate dependency between front-panel layout and audio circuits. Features alphanumeric and digital readouts for input functions, tone, volume, balance settings, station frequency and tuner memories; 3 digital tone memories; tuner memory scan; phono power amplifier. 50 W/ch at 0.025% THD. . . . \$499

SANSUI

RZ-7000 70-W/ch A/V Receiver

AM/FM receiver with quartz-PLL synthesizer tuner and 5-band graphic EQ with 5 factory-set patterns. Features 3 extra-large heatsinks; low-impedance capability; 30 random station presets; preset scan; station call memory; memory for 30 user-set patterns for tuner, and 5 other user-set patterns; VCR and cassette dubbing capability; connections for AM loop and indoor/outdoor FM antennas; inputs for CD, phono, tape, VCR-1, VCR-2/VDP, and processor; outputs for headphones, A, B, and A+B speakers; motorized volume control; pale-blue FL display. Includes 36-key multi-function integrated system remote control. Amp: 70 W/ch into 8 ohms; THD <0.02%; S/N 76 dB. Tuner: FM usable sens 11.2 dBf mono; S/N 70 dB; THD <0.2%. 5 x 17 x 13 1/4 in; 22 lb. Matte-black finish. . . . \$570

RZ-5000 60-W/ch A/V Receiver

AM/FM receiver with quartz-PLL synthesizer tuner and 30 random station presets. Features preset scan; station call memory; extra-large heatsink; low-impedance capability; VCR and cassette dubbing capability; connections for AM loop and indoor/outdoor FM antennas; inputs for CD, phono, tape, VCR-1, VCR-2/VDP, and processor; outputs for headphones, A, B, and A+B speakers; motorized volume control; pale-blue FL display. Includes 36-key multi-function integrated system remote control. Amp: 60 W/ch into 8 ohms; THD <0.05%; S/N 76 dB. Tuner: FM usable sens 11.2 dBf mono; S/N 70 dB; THD <0.25%. 5 x 17 x 13 1/4 in; 21 lb. Matte-black finish. . . . \$430

RZ-3000 50-W/ch A/V Receiver

AM/FM receiver with quartz-PLL synthesizer tuner and 30 random station presets. Features preset scan; station call memory; extra-large heatsink; low-impedance capability; VCR and cassette dubbing capability; connections for AM loop and indoor/outdoor FM antennas; inputs for CD, phono, tape-1, tape-2/monitor, and VCR/VDP; outputs for A, B, and A+B speakers; motorized volume control; pale-blue FL display; headphone jack. Includes 20-key multi-function integrated system remote control. Amp: 50 W/ch into 8 ohms; THD <0.09%; S/N 76 dB. Tuner:

FM usable sens 11.2 dBf mono; S/N 70 dB; THD <0.3%. 5 x 17 x 13 1/4 in; 21 lb. Matte-black finish. . . . \$365

RZ-1000 32-W/ch A/V Receiver

AM/FM receiver with quartz-PLL synthesizer tuner and 30 random station presets. Features preset scan; station call memory; extra-large heatsink; low-impedance capability; connections for AM loop and indoor/outdoor FM antennas; inputs for CD, phono, tape-1, tape-2/monitor, and VCR/VDP; outputs for A, B, and A+B speakers; pale-blue FL display; headphone jack. Amp: 32 W/ch into 8 ohms; THD <0.09%; S/N 75 dB. Tuner: FM usable sens 11.2 dBf mono; S/N 70 dB; THD <0.3%. 5 x 17 x 13 1/4 in; 14.5 lb. Matte-black finish. . . . \$285

SCOTT

STA1510 Integrated Amp With Tuner

Separate integrated amp and tuner sold together. Features wireless remote control; 7-band graphic equalizer; gold-plated input jacks. Inputs for MM phono, tape, CD/DAT, video sound source; LED power meters; digital station readout. Amp section: 150 W/ch into 8 ohms. FM section 50 dB quieting sens stereo 10 μ V (25 dBf); max S/N 65 dB. . . . \$550
STA1010. As above, 110 W/ch. . . . \$450

RS500 AM/FM Receiver

Receiver with remote control. Features 7-band graphic equalizer; electronic volume control; power meter; loudness control; high filter; 8 AM/8 FM station presets. Inputs for MM phono, tape, CD/DAT, video sound source. Amp section: 50 W/ch into 8 ohms. FM section: usable sens 5 μ V (19.2 dBf). . . . \$250

RS250 AM/FM Receiver

Quartz digital-synthesizer tuning section; power-output meter; high filter; presets for 8 AM/8 FM stations. Inputs for MM phono; tape; CD/DAT. Amp section: 25 W/ch into 8 ohms. FM section: usable sens 5 μ V (19.2). . . . \$150

SHARP

SA-R55AV 55-W/ch A/V Receiver

Receiver with RCA type video input terminal and monitor output. Features 34-key infrared remote control; 30 presets (20 FM/10 AM); matrix surround sound; bass boost; 5-band graphic equalizer; LCD frequency display. 55 W/ch from 20-20,000 Hz; THD 0.08%. 17 x 4.94 x 11 in. . . . \$380

SHERWOOD

RV-1340R 100 W/ch Surround-Sound A/V Receiver

4-ch A/V receiver with Dolby Surround. Features dual-gate MOSFET; quartz-locked computerized tuning. 5-band graphic EQ; 2 video inputs; video enhancer; direct switch; 30 station presets; preset scan; auto tuning; tape monitor; headphone jack. Includes full-function infrared wireless remote control. Amp section: (rear) W/ch into 8 ohms (front), 20 W/ch into 8 ohms (rear); FR 20-20,000 Hz; THD 0.04%; IMD 0.04%; S/N 79 dBA (phono), 100 dBA (aux). Tuner section: usable sens 11.2 dBf; 50 dB quieting sens 19.2 dBf (stereo), 14.8 dBf (mono); THD 0.15% (mono), 0.25% (stereo); 50 dB stereo sep at 1,000 Hz; alt-ch sel 70 dB. 5 x 17 3/8 x 15 in. . . . \$499

RA-1240R 70-W/ch Surround-Sound A/V Receiver

A/V receiver with Surround sound. Features dual-gate MOSFET; quartz-locked computerized tuning. 5-band graphic EQ; 30 preset stations; video sound input; preset scan; auto tuning; tape monitor; headphone jack. Includes full-function infrared wireless remote control. Amp section: 70 W/ch into 8 ohms; FR 20-20,000 Hz; THD <0.08%; IMD 0.05%; S/N 75 dBA (phono), 95 dBA (aux). Tuner section: Usable sens 11.2 dBf; 50-dB quieting sensitivity 19.2 dBf (mono), 39.2 dBf (stereo); total harmonic distortion 0.2% (mono); stereo sep at 1,000 Hz 45 dB; frequency

response 10-15,000 Hz; cap ratio 2 dB; alt ch sel 60 dB. 5 x 17 3/8 x 15 in. . . . \$329

RA-1145R 50-W/ch Surround-Sound A/V Receiver

A/V receiver with Surround sound. Features dual gate MOSFET front end; quartz PLL synthesized tuning system. Loudness control; 30 station presets; video sound input; motor-driven analog volume control; digital display. Includes multi-function Digi-Link remote system. Amp section: 50 W/ch into 8 ohms; FR 20-20,000 Hz; THD 0.09%; S/N 75 dBA (phono), 95 dBA (aux); damping factor 60 dB; IMD 0.07%. Tuner section: usable sens 11.2 dBf; FR 10-15,000 Hz; stereo sep at 1,000 Hz 45 dB; cap ratio 2 dB. . . . \$269

RA-1142 50-W/ch Surround-Sound A/V Receiver

Features digital synthesizer tuner; 24 station presets; video inputs; headphone jack. Amp section: THD 0.05%; FR 40-20,000 Hz; S/N 75 dB (MM). Tuner section: usable sens 11.2 dBf; 50-dB quieting sens 19.2 dBf (mono), 39.2 dBf (stereo); cap ratio 2 dB; THD at 1,000 Hz 0.2% (mono), 0.4% (stereo); alt ch sel 60 dB; S/N 75 dB (mono), 68 (stereo); ch sep at 1,000 Hz 45 dB. . . . \$199

RA-1140 25-W/ch Surround-Sound A/V Receiver

A/V receiver with surround sound. Features dual gate MOSFET front end; quartz-locked computerized tuning. Video sound input; digital readout; LED peak power indicators; loudness control; 24 station presets; auto tuning; tape monitor; headphone jack. 25 W/ch into 8 ohms; FR 40-20,000 Hz; THD <0.05%; IMD 0.3%; S/N 75 dBA (phono), 95 dBA (aux). Tuner section: usable sens 11.2 dBf; 50-dB quieting sensitivity 19.2 dBf (mono), 39.2 dBf (stereo); THD 0.2% (mono); stereo sep at 1,000 Hz 45 dB; FR 10-15,000 Hz; cap ratio 2 dB; alt ch sel 60 dB. 4 1/2 x 17 x 15 in. . . . \$149

SONY

STR-D2010 130-W/ch Receiver

AM/FM receiver with digital signal processing and programmable remote control. Features digital parametric equalizer; Dolby Surround processor with digital delay and digital noise reduction; tuner EQ link; index tuning; direct comparator tuning with direct access tuning; 3 video inputs with 5-video capability; built-in demonstration mode. Tuner section: S/N 84 dB mono, 78 dB stereo; THD 0.2% mono, 0.4% stereo; sel 60 dB; sep 45 dB (at 1,000 Hz). 17 x 5 1/2 x 14 in; 26 lb. 7 oz. . . . \$1,100

STR-AV1010 120-W/ch A/V Receiver

Audio/video receiver with programmable remote control. Features 120 W/ch into 8 ohms; tuner EQ link; Dolby Surround-sound processor with digital delay and digital noise reduction; dynamic bass feedback; 7-band electronic graphic equalizer; spectrum analyzer display; index tuning. Tuner section: S/N 84 dB mono, 78 dB stereo; THD 0.2% mono, 0.4% stereo; sel 60 dB; sep (at 1,000 Hz) 45 dB. 17 x 5 1/2 x 13 3/8 in; 21 lb. 3 oz. . . . \$700

STR-AV910 100-W/ch A/V Receiver

Audio/video receiver with remote control. Features 100 W/ch into 8 ohms; Dolby Surround-sound processor with digital delay; 7-band electronic graphic equalizer; spectrum analyzer display; index tuning; direct comparator tuning with direct access tuning; tuner EQ link; dynamic bass feedback. Tuner section: S/N 80 dB mono, 74 dB stereo; THD 0.3% mono, 0.5% stereo; sel 60 dB; sep (at 1,000 Hz) 45 dB. 17 x 5 1/4 x 13 3/8 in; 21 lb. . . . \$480

STR-AV710 55-W/ch A/V Receiver

Audio/video receiver with remote control. Features 55 W/ch into 8 ohms; matrix surround sound; index tuning; direct comparator tuning with direct access tuning; tuner EQ link; dynamic bass feedback; 5-band electronic graphic equalizer; spectrum analyzer display. Tuner section: S/N 80 dB mono, 74 dB stereo; THD 0.3% mono, 0.5% stereo; selectivity



C R A F T S M A N S H I P

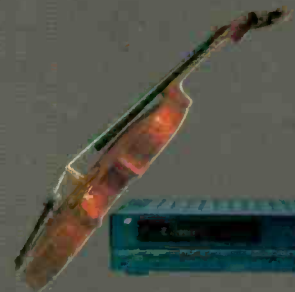

T H E D I S T I N G U I S H E D R Z - S E R I E S F R O M S A N S U I

SANSUI ELECTRONICS CORPORATION P.O. Box 625, 1250 Valley Brook Avenue Lyndhurst, New Jersey 07071, (201) 460-9710

In Canada: Vantage Electronics Corp., Richmond, B.C. (604) 276-9898

CIRCLE NO. 99 ON READER SERVICE CARD

Are you CD-literate?

Do you know

- why CDs sound better than LPs?
- the fundamentals of digital audio?
- how information is encoded and stored on CDs?
- how oversampling chip sets improve performance?
- how optical pickups are used for playback?
- how discs are manufactured?
- how to choose a CD player and detect a defective disc?

Ken Pohlmann's new book contains virtually everything you need to know about this revolutionary technology. Written with the clarity, expertise, and humor that has made Ken Pohlmann a favorite among *Stereo Review* readers, this book is the only source for people who are serious about CD technology and its applications.

The Compact Disc A Handbook of Theory and Use



by Ken Pohlmann
Stereo Review Contributing Editor

"This book is an invaluable source for anyone—layman and professional alike—who wants to be fully informed about the medium that is revolutionizing the consumer electronics industry."

Michael Smolen
Stereo Review Executive Editor

Order this book and enclose payment—we'll pay postage and mail it within 24 hours!

 _____ Yes! Send me _____ copies @
 \$29.95 each for a total of \$ _____.
 (WI and CA residents add sales tax.)
 My check for full payment is enclosed.

Name _____

Address _____

City _____

State _____ Zip _____

Send to:
 A-R Editions, Inc.
 801 Deming Way, Box P
 Madison, WI 53717
 (608) 836-9000

RECEIVERS

60 dB; separation (at 1,000 Hz) 45 dB. 17 x 5 1/2 x 11 1/2 in; 14 lb, 13 oz \$350

STR-AV310 40-W/ch A/V Receiver

Audio/video receiver with remote control. Features 40 W/ch into 8 ohms; digital synthesis tuner; direct access tuning; auto scan tuning. Tuner section: S/N 80 dB mono, 74 dB stereo; THD 0.3% mono, 0.5% stereo; sel 60 dB; sep (at 1,000 Hz) 45 dB \$240
 STR-AV210. Same as above, without remote. \$210

Sony Elite Receiver Series

STR-GX10ES 150-W/ch A/V Receiver

Audio/video receiver with programmable remote. Features 150 W/ch cont into 8 ohms, 20-20,000 Hz, with 0.007% THD; spontaneous twin drive power supply design; copper-plated G-Chassis design constructed with non-metallic compound; separate power supplies for system control and audio circuit stages; audio/video switching capability (3 video sources); video and tape dubbing capability; S-video terminals; defeatable subsonic filter; 3-band, low noise, high-gain negative feedback type tone controls; source direct switch; quartz frequency-synthesizer tuning; wave optimized digital stereo decoder; 20 station presets. Tuner section: S/N 84 dB; THD .08%; sel 90 dB; sep (at 1,000 Hz) 60 dB \$1,200

STR-GX9ES 130-W/ch A/V Receiver

Audio/video receiver with programmable remote control. Features 130 W/ch continuous into 8 ohms, 20-20,000 Hz, with 0.008% THD; spontaneous twin drive power supply design; G-Chassis design constructed with non-metallic compound; separated power supplies for system control and audio circuit stages; audio/video switching capability (3 video sources); video and tape dubbing capability; S-video terminals; defeatable subsonic filter; 3-band, low noise, high-gain negative feedback type tone controls; source direct switch; quartz frequency-synthesis tuning; wave optimized digital stereo decoder; 20 station presets. Tuner section: S/N 84 dB; THD .08%; sel 90 dB; sep (at 1,000 Hz) 60 dB \$1,000

STR-GX7ESII 120-W/ch A/V Receiver

Audio/video receiver with programmable Remote Commander. Features 120 W/ch continuous into 8 ohms, 20-20,000 Hz, with 0.008% THD; spontaneous twin drive power supply design; G-chassis design constructed with non-metallic compound; separate power transformers for the system control and audio circuitry; audio/video switching capability (3 video sources); S-video terminals; low-noise, negative-feedback type tone controls; source direct switch; quartz frequency-synthesis tuning; 20 station presets. Tuner section: S/N 76 dB; THD .2%; sel 65 dB; sep (at 1,000 Hz) 50 dB \$750

STR-GX6ESII 100-W/ch A/V Receiver

Features 100 W/ch cont into 8 ohms, 20-20,000 Hz, with 0.03% THD; spontaneous twin drive power supply design; separate power transformers for the system control and audio circuitry; audio/video switching capability (2 video sources); low-noise, negative-feedback type tone controls; source direct switch; quartz frequency-synthesis tuning; 20 station presets. Includes programmable remote control. Tuner: S/N 76 dB; THD 0.2%; sel 65 dB; sep (at 1,000 Hz) 50 dB \$600

STR-GX5ESII 80-W/ch A/V Receiver

Features 80 W/ch cont into 8 ohms, 20-20,000 Hz, with 0.08% THD; spontaneous twin drive power supply design; separate power transformers for the system control and audio circuitry; A/V switching capability; source direct switch; adaptor input/output; 30 station presets. Includes remote control. Tuner section: S/N 74 dB; THD 0.5%; sel 60 dB; sep (at 1,000 Hz) 45 dB \$500

STR-GX4ESII 50-W/ch A/V Receiver

Features 50 W/ch cont into 8 ohms, 20-20,000 Hz,

with 0.08% THD; spontaneous twin drive power supply design; separate power transformers for the system control and audio circuitry; high-current discrete output transistors; A/V switching capability; adaptor input/output; 30 station presets. Includes remote control. Tuner section: S/N 74 dB; THD 0.5%; sel 60 dB; sep (at 1,000 Hz) 45 dB \$380

TEAC

AG-75 75-W/ch A/V Receiver

AM/FM receiver with quartz PLL synthesized tuning. Features high-current discrete circuit. Matrix surround; rec selector; variable loudness control; CD direct; motorized volume; CD/VCR and Tape/DAT input terminals; 16-station memory; auto tuning; stereo/mono switch; FL display. Includes 28-key wireless remote control. Amp section: 75 W/ch rms into 8 ohms; FR 40-20,000 Hz; THD 0.05%; S/N 80 dB (phono), 92 dB (CD/aux, tuner, tape). FM tuner section: usable sens 11.2 dBf (mono); AM rej 55 dB; cap ratio 2 dB; image rej 47 dB; THD at 1,000 Hz 0.2% (mono), 0.5% (stereo); stereo sep at 1,000 Hz 40 dB; S/N 78 dB (mono), 72 dB (stereo). \$400

AG-55 55-W/ch Receiver

AM/FM receiver with 7-band graphic EQ with ± 10 dB boost/cut. Features Quartz synthesized PLL tuner. LED power meters; CD, aux and TV/VCR inputs; high cut filter and bass boost EQ switch; dual speaker terminals; 8 AM/FM random access station memory; auto station search; LED frequency display. Amp section: 55 W/ch min continuous rms into 8 ohms; FR 20-20,000 Hz; THD 0.5%; S/N 70 dB (phono). Tuner section: FM usable sens 11.2 dBf (mono); image rejection 45 dB; THD at 1,000 Hz 0.25% (mono), 0.5% (stereo); stereo sep 40 dB \$300

TECHNICS

SA-R530 100-W/ch A/V Receiver

A/V receiver with quartz digital tuner and Dolby-Surround processor. Features rear-mounted thermally triggered fan; 7-band graphic EQ/spectrum analyzer with 5 factory preset curves and 5 user assignable curve memories; 24 preset channel memory; auto-simulcast tuning; motor-driven volume control; 3 A/V inputs; 6 audio inputs; video output for monitor; full-function FL display; 6 digital A/V surround modes including Dolby and stereophex simulated stereo. Includes 96-key intelligent remote control. 100 W/ch into 8 ohms; THD < 0.007%; FR 20-20,000 Hz \$695

SA-R477 100-W/ch Class-A A/V Receiver

A/V receiver with quartz synthesizer tuner, Dolby Surround, digital delay circuit, and 7-band graphic EQ. Features 2-color FL display; 4 audio inputs; 2 VCR inputs; internal cooling fan; preamp out; main-amp in; A+B speaker terminals; loudness switch. Includes 45-key A/V remote control. Amp section (front ch): 100 W/ch min rms into 8 ohms; THD 0.008%; FR 20-20,000 Hz; S/N 70 dB. (Rear ch) 5 W/ch into 8 ohms; THD 0.8% at 1,000 Hz. FM tuner section: sens 11.2 dBf; 50 dB quieting sens 20.2 dBf (mono), 40.2 dBf (stereo); THD 0.2% (mono), 0.3% (stereo); S/N 75 dB (mono), 70 dB (stereo); FR 20-15,000 Hz +1/-2 dB; alt-ch sel 65 dB; cap ratio 1.0 dB; AM rej 50 dB; stereo sep 40 dB (at 1,000 Hz), 30 dB (10,000 Hz). 17 x 5 1/2 x 11 1/2 in; 18.1 lb \$530

SA-R377 80-W/ch Class-A A/V Receiver

A/V receiver with quartz synthesizer tuner and 7-band graphic EQ/spectrum analyzer. Features internal cooling fan. 2-color FL display; remote-controllable rotary type volume; 4 audio inputs; 2 VCR inputs; preamp out; main-amp in; A+B speaker terminals; loudness switch. Includes 42-key A/V remote control. Amp section: 80 W/ch min rms into 8 ohms; THD 0.008%; FR 20-20,000 Hz; S/N 70 dB. FM tuner section: sens 11.2 dBf; 50 dB quieting sens 20.2 dBf (mono), 40.2 dBf (stereo); THD 0.2% (mono), 0.3% (stereo); S/N 75 dB (mono), 70 dB (stereo); FR 20-15,000 Hz +1/-2 dB \$380

All good things come to those who wait.



Finally. A that reproduces not just bits a

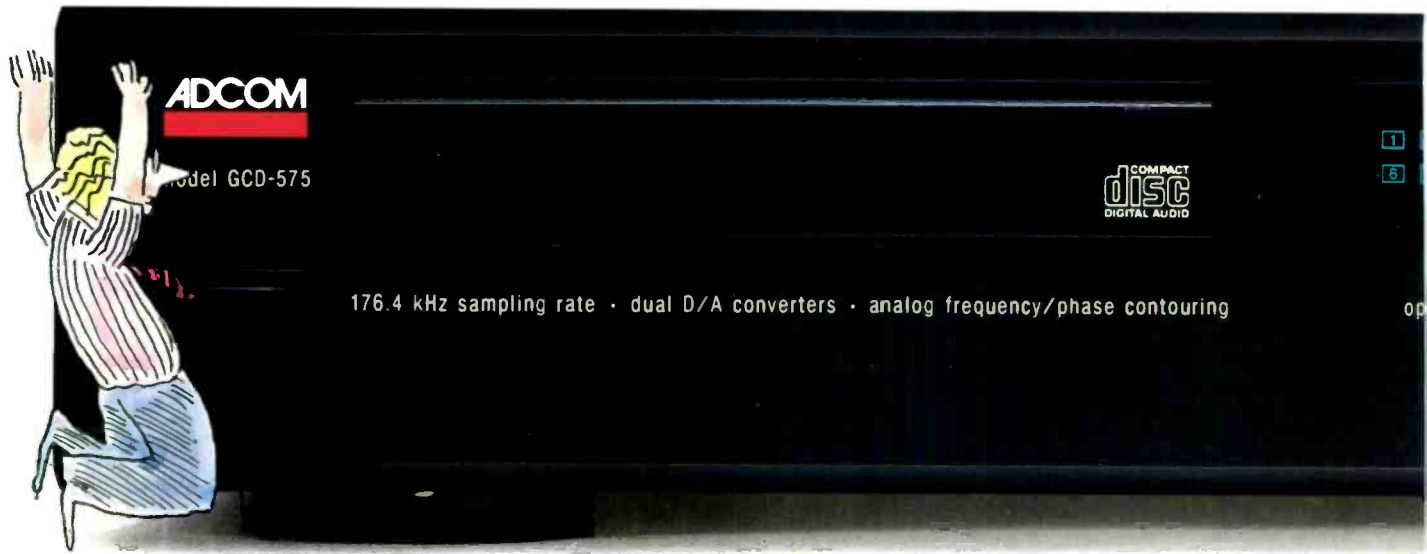

Adcom's new GCD-575 Compact Disc Player has been worth waiting for. Now there's a CD player with analog audio circuits as technically advanced as its digital stages.

Since the human ear can only appreciate musical sounds in their analog format, Adcom began with the objective of producing the first affordable CD player whose direct-coupled audio output would deliver the long anticipated technical benefits of digital sound.

Class "A" Makes A Difference

Designers and engineers usually use Class "A" audio circuits where price is no object. In its purest form, Class "A" offers a highly sophisticated level of audio amplification, often demanded by those who can distinguish outstanding sonic performance from the merely average. Adcom's GCD-575 employs a no-compromise, Class "A" analog audio amplifier section which provides superior resolution by more clearly defining low-level information.

CD player all of the music, and bytes of it.



This higher resolution makes an audibly dramatic difference in the musicality of CD reproduction. To achieve this result, the analog audio circuits in the GCD-575 were based on the same proprietary high speed linear amplifiers used in Adcom's GFP-555 preamplifier, universally recognized for its outstanding musical integrity.

No other CD player at any price uses these superb audio components.

Digital Sound At Its Best

Adcom's selectable analog frequency/phase contour circuit enhances the musicality of CD's which have been poorly mixed, or digitally over equalized. Subtly contoured by the AFPC, many of these CDs become more listenable, with much of the fatiguing harshness and "glare" reduced. In addition, the stereo image and sound stage becomes more focused allowing for a more natural sonic presentation.

(Over please)

The Adcom GCD-575

Details You Can Hear

Importantly, Adcom's CD player is designed with a low output impedance (100 Ohms) so that it can operate up to its maximum capability with a wide variety of associated equipment. It is not only compatible with virtually all input stages of amplifiers, preamplifiers, tuner/preamplifiers, etc., but also permits the use of longer interconnecting audio cables, when required, with minimal signal deterioration.

Additionally the GCD-575 is supplied with a high quality, low-loss audio cable to prevent the sonic smear that conventional audio cables tend to cause. The use of this special cable and the 100 Ohm output impedance permits the GCD-575 to be used with Adcom's SLC-505 passive straight line controller. If no other source equipment will be used, the variable output (front panel controlled) can be used directly into your power amplifier, bypassing the preamplifier circuits normally required by other CD players.

A multi-winding power transformer, connected to three separate tightly regulated power supplies for the audio, digital and display circuitry, insures isolation of the different functions and optimal operation of each without interference.

The four special heavy feet installed on the GCD-575 are reversible metal castings. On one side, the flat surface insures a wide contact area. The reverse side is cast with built-in "Iso-points" which, when used in a three-foot configuration, operates as a "tripod" support system.

A special polarity-inverting switch permits you to reverse the normal positive polarity to negative (inverted) polarity. This corrects playback of CDs in which the polarity was incorrectly recorded (inverted), or for use in systems in which one of the components causes a reversal of correct polarity.



Full Function Remote Control

Specifications

Frequency Response: 5Hz - 20kHz, +0.1, -0.5dB

Signal-to-noise Ratio: 105dB

Dynamic Range: 98dB

THD: 0.0025%

IMD (70Hz difference): @ 5kHz
0.00018%

Channel Separation (1kHz): 95dB

Interchannel Phase Shift:
@ 20kHz Less than 1.8°

Output Impedance: Fixed 100Ω/
Variable 100Ω/Digital 75Ω

Output Level: Fixed 2.5V RMS
Variable Greater Than 4.5V RMS
Digital 0.5V peak-to-peak

Sampling Rate: 176.4kHz

Quantized Bits: 16-bit linear

Power: 120VAC/60Hz
(Available in 220/240V, 50Hz)

Dimensions: 17" (430mm)W ×
11-1/4" (285mm)D ×
3-7/16" (87mm)H

Weight: 12 lbs. (5.5 kg.)

Optional: Model RM-3 rack mount
adaptors. Available with white front
panel.

*Specifications subject to change
without notice.*

More Features For Better Value

Other features include a full function remote-control system with random access track capability; low group-delay digital and analog filters; triple-beam laser format; a direct digital output; playback of 3-inch discs without an adaptor; and a very-high-quality headphone output.

The GCD-575's advanced facilities include:

- Programming of up to 24 tracks
- Programming of any phrase
- Audible fast forward and reverse
- Adjustable introscan
- Auto search

Display functions include:

- Elapsed time on track or disc
- Time remaining on track or disc
- Programmed tracks
- Track being played
- Number of tracks up to 20

Why Should You Listen To Us?

Over the years, Adcom has earned a reputation for delivering superb performance at a modest price. The GCD-575 keeps faith with this tradition.

Once again, Adcom clears an innovative path through the jungle of confusing claims about "digital" sound, and provides a logical and direct path to musical purity.

If you've been waiting for a CD player which faithfully reproduces all of the music, not just bits and bytes of it, you'll want to visit your nearest authorized Adcom dealer right now... because while it may be true that all good things come to those who wait, you've waited long enough for a CD player this good.

ADCOM[®]
fine stereo components

11 Elkins Road, East Brunswick, NJ 08816
U.S.A. (201) 390-1130

Distributed in Canada by PRO ACOUSTICS INC.
Pointe Claire, Quebec H9R 4X5

CIRCLE NO. 61 ON READER SERVICE CARD

RECEIVERS

SA-R2777 60-W/ch A/V Receiver

AM/FM quartz synthesis tuner with 7-band graphic EQ. Features internal cooling fan, 2-color FL display; 24-ch preset memory; remote-controllable rotary type volume; 4 audio inputs; 2 video inputs; A+B speaker terminals; loudness switch. Includes 32-key A/V remote control. Amp section: 60 W/ch min rms into 8 ohms; THD 0.05%; FR 20-20,000 Hz; S/N 70 dB. FM tuner section: sens 11.2 dBf; 50-dB quieting sens 20.2 dBf (mono), 40.2 dBf (stereo); THD 0.2% (mono), 0.3% (stereo); S/N 75 dB (mono), 70 dB (stereo); FR 20-15,000 Hz +1/-2 dB; alt-ch sel 65 dB; cap ratio 1.0 dB; AM rej 50 dB; stereo sep 40 dB (at 1,000 Hz), 30 dB (10,000 Hz), 17 x 4 1/2 x 11 7/8 in; 15.6 lb. \$330

SA-R177 40-W/ch Receiver

AM/FM quartz synthesis tuner with 5-band graphic EQ. Features 2-color FL display; 24-ch preset memory; remote-controllable rotary type volume; 5 input facilities; A+B speaker terminals; loudness switch. Includes 32-key remote control. Amp section: 40 W/ch min rms into 8 ohms; THD 0.3%; FR 40-20,000 Hz; S/N 68 dB (phono), 70 dB (other sources). FM tuner section: sens 11.2 dBf; 50-dB quieting sens 20.2 dBf (mono), 40.2 dBf (stereo); THD 0.2% (mono), 0.3% (stereo); S/N 75 dB (mono), 70 dB (stereo); FR 20-15,000 Hz +1/-2 dB; alt-ch sel 65 dB; cap ratio 1.0 dB; AM rej 50 dB; stereo sep 40 dB (at 1,000 Hz), 30 dB (10,000 Hz), 17 x 4 1/2 x 11 7/8 in; 13.1 lb. \$280

VECTOR RESEARCH

VRX-9200R 120-W/ch Surround Sound Receiver

Features 8 discrete output transistors; Dolby Surround; quartz synthesis tuning, 4 x 40 W pre-out/main-in jacks; video signal routing; A/V processing loop; video monitor output; dedicated CD input; 20 station presets; preset scan; mono/stereo switch; motorized rotary volume control; A/B RF antenna inputs; FM autoscans; 2 tape monitors with dubbing in either direction; 2 A/V monitors with dubbing; MC head amp; high and subsonic filters; parallel speaker switching; surround level, front/rear balance; remote control. Amp: FR 10-50,000 Hz; THD 0.03%; IM 0.03%; damping factor 120. Tuner: 50-dB quieting 14.6 dBf mono, 35.5 dBf stereo; cap ratio 1 dB; alt-ch sel 65 dB. 17 x 5 1/2 x 15 1/2 in; 26 lb. \$850

VRX-8200R 110-W/ch Surround Sound Receiver

Features 8 discrete output transistors. Pre-out/main-in jacks; video signal routing; A/V processing loop; video monitor output; dedicated CD input; quartz-synthesis tuning; 20 station presets; preset scan; mono/stereo switch; A/B RF antenna inputs; FM autoscans; 2 tape monitors with bi-directional dubbing; MC head amp; high and subsonic filters; parallel speaker switching; motorized rotary volume control; remote. Amp: FR 10-50,000 Hz; THD 0.03%; IM 0.03%; damping 120. Tuner: 50-dB quieting sens 14.6 dBf mono, 35.5 dBf stereo; cap ratio 1 dB; alt-ch sel 65 dB. 17 x 5 1/2 x 15 1/2 in; 24 lb. \$660

VRX-6200R 65-W/ch A/V Surround Sound Receiver

Features 8 discrete output transistors. Pre-out/main-in jacks; video signal routing; A/V processing loop; video monitor output; dedicated CD input; quartz-synthesis tuning; 16 station presets; mono/stereo switch; RF antenna inputs; FM autoscans; 2 tape monitors with dubbing; loudness contour; parallel speaker switching; motorized rotary volume control; remote control. Amp: FR 10-50,000 Hz; THD 0.05%; IM 0.05%; damping factor 120. Tuner: 50-dB quieting sens 14.6 dBf mono, 36.2 dBf stereo; cap ratio 1.2 dB; alt ch sel 60 dB. 17 x 4 1/2 x 13 1/2 in; 20 lb. \$450

VRX-5200R 50-W/ch A/V Surround Sound Receiver

Features 8 discrete output transistors; quartz synthesis tuning. 20 random AM/FM presets; dedicated CD inputs; A/V processing loop; 2 switched/unswitched outlets; separate FM mute and mono; video monitor out; rotary volume control with LED; pre-out main-in jack; video signal routing; 75-ohm connector; AM/FM autoscans. Amp: THD 0.07%; IM 0.07%; FR 10-50,000

Hz. Tuner: 50-dB quieting sens 15.6 dBf mono, 37.6 dBf stereo; cap ratio 1.3 dB; alt ch sel 60 dB. 17 x 4 1/2 x 13 1/2 in; 17 lb. \$370

VRX-3600R 40-W/ch A/V Surround Sound Receiver

Features 8 discrete output transistors; quartz synthesis tuning. 20 random AM/FM presets; dedicated CD inputs; A/V processing loop; 2 switched/unswitched outlets; separate FM mute and mono; video monitor out; rotary volume control with LED; pre-out main-in jack; video signal routing; 75-ohm connector; AM/FM autoscans. Amp: THD 0.08%; IM 0.08%; FR 10-50,000 Hz. Tuner: 50-dB quieting sens 15.6 dBf mono, 37.6 dBf stereo; alt-ch sel 58 dB. 17 x 4 1/2 x 13 1/2 in; 15 lb. \$320

VRX-2700 30-W/ch A/V Receiver

Features 8 discrete output transistors; quartz synthesis tuning. 20 random AM/FM presets; dedicated CD inputs; A/V processing loop; 2 switched/unswitched outlets; separate FM mute and mono; video monitor out; rotary volume control with LED; pre-out main-in jack; video signal routing; 75-ohm connector; AM/FM autoscans. Amp: THD 0.09%; IM 0.09%; FR 10-50,000 Hz. Tuner: 50-dB quieting 17.2 dBf mono, 38.7 dBf stereo; cap ratio 1.5 dB; alt-ch sel 58 dB. 17 x 4 1/2 x 13 1/2 in; 13 lb. \$220

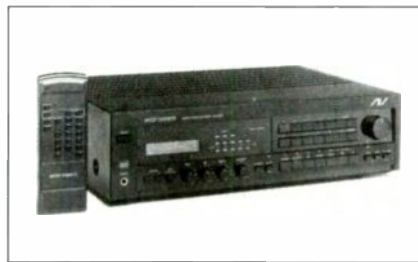

Vector Research VRX-5200R

YAMAHA

RX-1130Ti A/V Receiver

4-ch AM/FM A/V receiver with 5-mode surround including Dolby, natural, hall, simulated stereo, live and continuously variable delay time (10 ms to 30 ms). Features computer servo lock tuning system; 24-segment signal-strength meter; high dynamic power low-impedance drive capability; 8 audio, 3 video inputs; rear level control; front/rear pre-main coupling terminals; banana plug compatible speaker connection terminals; center defeat bass, mid, and treble controls; 8-position rec out selector; 16-station random access preset tuning with multi-status memory; sleep timer; continuously variable loudness; motor driven volume control with LED indicator. Includes learning capable multi-function remote control with RS integrated system remote control pre-programmed. Front ch: 125 W/ch min rms into 8 ohms; FR 20-20,000 Hz; THD 0.015%. Rear ch: 30 W/ch into 8 ohms at 1,000 Hz; THD 0.08%. Titanium finish; 37 lb. \$1,199

RX-1100L 125-W/ch A/V Receiver

AM/FM receiver with RS integrated system remote control. Features digital tuner; absolute linear amplification; high dynamic power; low-impedance drive capability; 16-station random access preset tuning; digital fine tuning; continuously variable loudness control; dual tape monitor inputs; pre-main coupling terminals; 3 video source inputs; audio and video rec out selectors; video enhancer with level and detail control; switching for 3 pairs of speakers; LED indicator on volume knob. 125 W/ch min rms into 8 ohms; FR 20-20,000 Hz; THD < 0.015%. Black finish; 30 lb. \$999

RX-930Ti 4-Ch A/V Receiver

4-ch AM/FM receiver with 3-mode surround sound including Dolby, natural, and simulated surround. Features direct PLL IF count synthesis tuning; 16-

station random access preset tuning with multi-status memory; 12-segment signal-strength meter; center defeat bass, and treble controls; rear level control; 8-position rec out selector; front/rear pre-main coupling terminals; high dynamic power low-impedance drive capability; 8 audio, 3 video inputs; motor-driven volume control with LED indicator; sleep timer; continuously variable loudness. Includes learning capable multi-function remote control with RS integrated system remote control pre-programmed. Front ch: 85 W/ch min rms into 8 ohms; FR 20-20,000 Hz; THD < 0.15%. Rear ch: 25 W/ch into 8 ohms at 1,000 Hz; THD 0.08%. Titanium finish; 26 lb. \$849
RX-930. As above, black \$849

RX-830Ti 4-Ch A/V Receiver

4-ch AM/FM receiver with 3-mode surround sound including Dolby, natural, and simulated surround. Features rear-level control; direct PLL IF count synthesis tuning; 16-station random access preset tuning with multi-status memory; 12-segment signal-strength meter; 6-position rec out selector; 6 audio, 2 video inputs; high dynamic power low-impedance drive capability; motor driven volume control with LED indicator; sleep timer; center defeat bass, and treble controls; continuously variable loudness. Includes learning capable multi-function remote control with RS integrated system remote control pre-programmed. Front ch: 70 W/ch min rms into 8 ohms; FR 20-20,000 Hz; THD < 0.015%. Rear ch: 15 W/ch into 8 ohms at 1,000 Hz; THD 0.1%. Titanium finish; 20 lb. \$599
RX-830. As above, black \$599

RX-730 70-W/ch A/V Receiver

AM/FM receiver with RS integrated system remote control. Features high dynamic power low-impedance drive capability; digital tuner; 16-station random access preset tuning; continuously variable loudness; 2 video source inputs; tone bypass switch; CD-direct switch; 12 segment signal-quality meter; high-gain AM loop antenna; 6 position rec out selector; sleep timer; A+B speaker selector; LED indicator on motorized volume control; pre-main coupler. 70 W/ch min rms into 8 ohms; FR 20-20,000 Hz; THD < 0.02%. Black; 15.5 lb. \$499

RX-530 50-W/ch Receiver

AM/FM receiver RS integrated system remote control. Features high dynamic power low-impedance drive capability; digital tuner; 16-station random access preset tuning; continuously variable loudness; 6 position rec out selector; sleep timer; A+B speaker selector; CD-direct switch; 12 segment signal-quality meter; high-gain AM loop antenna; bass extension switch; tape-to-tape dubbing. 50 W/ch min rms into 8 ohms; FR 20-20,000 Hz; THD < 0.02%. Black; 13 lb. \$399

RX-330 40-W/ch Receiver

Features digital tuner; 16-station random access preset tuning; 5-segment signal-strength meter; high-gain AM loop antenna; high dynamic power low-impedance drive capability; A+B speaker selector; CD-direct switch; continuously variable loudness. 40 W/ch min rms into 8 ohms; Frequency response 20-20,000 Hz; total harmonic distortion < 0.04%. Black; 13 lb. \$299



Yamaha RX 930

POWER • AMPLIFIERS

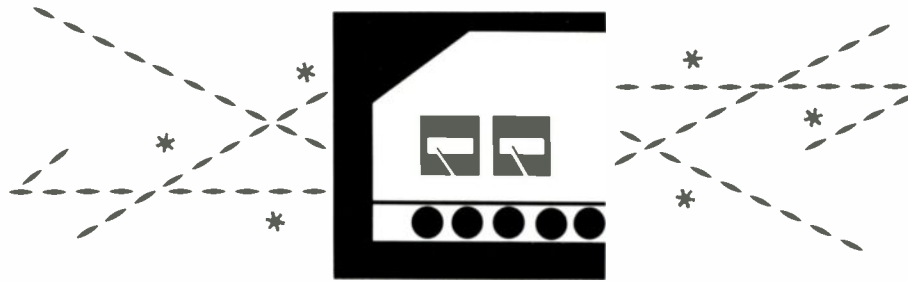

ACCUPHASE BY MADRIGAL

P-800 400-W/ch Amplifier

Features two sets of 7 parallel push-pull transistor pairs for the output stage; two separate power supplies for L/R channel; cascode differential push-pull input stage; MOSFET cascode push-pull and cascode push-pull drive stage; capable of driving 400 W into 2 ohms, 600 W into 1 ohm. Power meter; 40,000 ohm balanced input, 20,000 ohm unbalanced phono jack; mounting provision for cooling fans. FR 20-20,000 Hz, ± 0 dB; THD 0.01%; S/N 125 dBA; IM 0.003%; damping factor 200 at 50 Hz. 19 x 9 $\frac{3}{8}$ x 19 $\frac{1}{4}$ in; 103 lb, 13 oz. \$12,500

M-1000 1000-W Mono Amplifier

Two separate power units with push-pull drive in bridged connection; each power unit employs 14 parallel push-pull pairs of wide-band transistors; low imp drive of 1,600 W into 1 ohm, 1,100 W into 2 ohms; cascode push-pull and MOSFET drive stage. Digital power meter; 40-kilohm balanced input; 20 kilohm unbalanced phono jack; mounting provisions for cooling fans. Frequency response 20-20,000 Hz, ± 0 dB; THD 0.01%; signal-to-noise ratio 125 dBA; IM 0.003%; damping factor 200. 19 x 9 $\frac{3}{8}$ x 19 $\frac{1}{4}$ in; 103 lb, 13 oz. \$12,000

P-500 250-W/ch Amplifier

Stereo amplifier with power meters. Bridge connection allows 1,000 W mono into 4 ohms, 500 W/ch into 2 ohms. 250 W/ch into 8 ohms. 19 x 8 $\frac{3}{8}$ x 17 $\frac{1}{2}$ in; 73 lb, 11 oz. \$8,600

P-300V 180-W/ch Amplifier

Features power meters. 180 W/ch into 8 ohms; bridgeable for 500 W into 8 ohms. 300 W into 2 ohms. 17 $\frac{1}{2}$ x 6 $\frac{3}{8}$ x 14 $\frac{3}{4}$ in; 50 lb, 10 oz. \$6,000

P-102 50-W/ch Amplifier

Features two all-stage push-pull power unit in bridged configuration. Class A MOSFET push-pull output stage; cascode push-pull differential input stage; twin mono construction using two mono amplifiers and two separate power supplies for L/R channels; direct-coupled amplifier with DC servo configuration; capable of driving 80 W into 4 ohms and 70 W into 2 ohms. Power meter; 40,000 ohm balanced input and 20,000 ohm unbalanced phono jack. FR 20-20,000 Hz ± 0 , -2; THD <0.01%; S/N 120 dBA; IM 0.003%; damping factor 70. 18 $\frac{3}{4}$ x 6 $\frac{3}{8}$ x 16 in; 48 lb, 6 oz. \$4,400

ACOUSTIC RESEARCH

P-10 150-W/ch Amplifier

Transient (IHF dynamic) power capability of 1,200 W/ch in 2 ohms, 800 W into 4 ohms, and 400 into 8 ohms. 150 continuous average W/ch from 20-20,000 Hz into 8 ohms with no more than 0.3% THD 200 W into 4 ohms; 200- μ sec dynamic power 300 W; dynamic headroom 4.3 dB; S/N 95 dB; slew rate 30 V/ μ s; IM 0.03%. 4 $\frac{1}{2}$ x 17 x 14 $\frac{1}{2}$ in. \$849

A-07 70-W/ch Amplifier

Features switchable side-chain feedback tone control.

filters and provision for moving magnet and moving-coil cartridges. Remote controllable when linked to the T-06/R tuner. Frequency response 15-20,000 Hz, -0.3 dB; THD 0.03%; signal-to-noise ratio 100 dBA; IM 0.03%; damping factor 100; 17 $\frac{1}{4}$ x 3 $\frac{1}{2}$ x 10 $\frac{1}{2}$ in; 25 lb, 2 oz. \$500
A-05. Similar to the above except 40 W/ch. . . . \$400
A-03. Similar to the above except 30 W/ch. . . . \$300
RC-03. Remote control for the A-07 \$25

ADA

PBA-500 800-W Mono Amplifier

Subwoofer amplifier with continuously variable level, frequency, and bandwidth controls. Features toroidal power transformer; 20 segment LED output meter; fan cooled; front panel switch and fuse. 800 W bridged mono from 20-200 Hz with no more than 0.05% THD into 8 ohms; 1200 W into 4 ohms; slew rate 10 V/ μ sec; IM 0.08%. 19 x 7 $\frac{1}{2}$ x 12 $\frac{1}{2}$ in; 49 lb. \$2,520

PT-200 60-W/ch Amplifier

Dual-mono power amp capable of driving 1 ohm loads. Features dual toroidal power transformers; 44-segment triangular LED output meters with peak indication; front panel power switches, indicators, fuses; stepped attenuator gain controls; soft clipping circuit; fan cooled; standard EIA rack-mountable. 60 W/ch cont avg from 20-20,000 Hz with no more than 0.06% THD into 8 ohms; 110 W into 4 ohms; S/N 102 dB; slew rate 12 V/ μ sec; IM 0.15%. 19 x 3 $\frac{1}{2}$ x 16 $\frac{1}{2}$ in; 28 lb. \$2,395

PF-300 200-W/ch Amplifier

MOSFET power amplifier capable of driving $\frac{1}{2}$ -ohm loads continuously. Features dual mono design with independent toroidal transformers; front panel power switches, indicators and fuses; fan cooled. 200 W/ch from 20-20,000 Hz with no more than 0.05% THD into 8 ohms; 300 W into 4 ohms; slew rate 10 V/ μ sec; IM 0.08%. 19 x 7 x 15 $\frac{1}{2}$ in; 48 lb. \$1,695

PF-300 100-W/ch Amplifier

MOSFET power amplifier capable of driving $\frac{1}{2}$ -ohm loads continuously. Features front panel power switches, indicators and fuses; dual mono design with independent toroidal transformers. 100 W/ch from 20-20,000 Hz with no more than 0.09% THD into 8 ohms; 160 W/ch into 4 ohms; slew rate 15 V/ μ sec; IM 0.07%. 19 x 5 $\frac{1}{4}$ x 15 $\frac{1}{2}$ in; 37 lb. \$1,695

PBA-150 100-W/ch Mono Amplifier

Subwoofer amplifier with continuously variable adjustable level, frequency, and bandwidth controls. Features front panel power switch, indicator, fuse; fan cooled; standard EIA rack-mountable; 20-segment LED output meter. 100 W/ch cont avg from 20-200 Hz; THD <0.06% into 8 ohms; 125 watts into 4 ohms; S/N 101 dB; slew rate 10 V/ μ sec; IM 0.07%. 19 x 5 $\frac{1}{4}$ x 12 $\frac{1}{2}$ in; 20 lb. \$1,495

PF-200 60-W/ch Amplifier

MOSFET power amplifier capable of driving 1-ohm loads. Features 4-segment LED output meters; front-panel power switch; indicator and fuse; toroidal

power transformer; fan cooled; standard EIA rack-mountable. 60 W/ch cont avg from 20-20,000 Hz with no more than 0.07% THD into 8 ohms; 110 watts into 4 ohms; S/N 95 dB; slew rate 10 V/ μ sec; IM 0.07%. 19 x 5 $\frac{1}{4}$ x 15 $\frac{1}{2}$ in; 25 lb. \$1,295

PT-50 25-W/ch Amplifier

Compact amplifier capable of handling 2 ohm loads. Features 10-segment LED output meters; rear panel power fuse; front panel gain controls; toroidal power transformer; fan cooled; standard EIA rack-mountable. 25 W/ch continuous average from 20-20,000 Hz with no more than 0.02% total harmonic distortion into 8 ohms; 40 watts into 4 ohms; S/N 104 dB; IM 0.04%. 19 x 1 $\frac{3}{4}$ x 11 $\frac{1}{2}$ in; 8 lb. \$950

ADCOM

GFA-555 200-W/ch Amplifier

Able to drive 1-ohm loads. Features low-negative-feedback design; constant damping factor; toroidal transformer; instantaneous distortion alert when distortion produced higher than 1% at speaker outputs; direct-coupled design. 200 W/ch into 8 ohms; 350 W/ch into 4 ohms; THD <0.09% and IM <0.05%; constant damping factor >100 20-20,000 Hz. \$750
GFA-555W. As above with white front panel. . . . \$800
GFA-555S. With silver front panel. \$800
RM-7. Optional rack-mount adaptors for GFA-555. \$20/pr
RM-7W. As RM-7 in white. \$25/pr
RM-7S. As RM-7 in silver. \$25/pr

GFA-545 100-W/ch Amplifier

Able to drive 1-ohm load. Features low-negative-feedback design; constant damping factor; toroidal transformer; instantaneous distortion alert when distortion produced higher than 1% at speaker outputs; direct-coupled design. 100 W/ch into 8 ohms. THD <0.09%, 150 W/ch into 4 ohms; IM 0.008%. 5 $\frac{1}{2}$ x 17 x 12 $\frac{1}{2}$ in; 25 lbs. \$500
GFA-545W. As above with white front panel. . . . \$550
GFA-545S. With silver front panel. \$550
RM-5. Optional rack-mount adaptors for GFA-545 series. \$20/pr
RM-5W. As RM-5 in white. \$25/pr
RM-5S. As RM-5 in silver. \$25/pr

GFA-535 60-W/ch Amplifier

Able to drive 1-ohm load. Features low-negative-feedback design; constant damping factor; hookup for 2 sets of speakers; instantaneous distortion alert when distortion products higher than 1% at speaker outputs; direct-coupled design; separate power transformers for each ch. THD <0.09%, 100 W/ch into 4 ohms; IM 0.008%. 3 $\frac{1}{4}$ x 17 x 12 $\frac{1}{2}$ in. . . . \$300
GFA-535W. As above with white front panel. . . . \$350
GFA-535S. With silver front panel. \$350
GFA-535L. Same as GFA-535 with addition of flush-mounted gain controls for each channel. Ideal for use in surround-sound application. \$370
RM-3. Optional rack-mount adaptors for GFA-545. \$20/pr
RM-3W. As RM-3 in white. \$25/pr
RM-3S. As RM-3 in silver. \$25/pr

POWER • AMPLIFIERS

a/d/s/

PA4 150-W/ch Amplifier

Features all discrete transistors; polypropylene capacitors; metal-film resistors; 10 bipolar output devices per ch; open-loop bandwidth of <100 MHz to avoid rate limiting and stability with complex speaker loads; toroidal transformers for low noise and high current. Drives 2 pairs of speakers; power and speakers switched from a/d/s/ CC4 control center or R4 receiver; clipping LED's. 150 W/ch into 4 or 8 ohms. <0.05% THD; bridgeable to 250 W in mono. FR 20-20,000 Hz +0,-0.2 dB; S/N >110 dBA at 1,000 Hz; dynamic headroom >1.5 dB; damping factor >100, 4 ohms; slew rate >30 V/ μ s. 2 $\frac{3}{4}$ x 17 $\frac{1}{2}$ x 14 $\frac{3}{4}$ in; 27 lb. \$900

AUDIO BY VAN ALSTINE

Transcendence 200-W/ch Amplifier

Hybrid power amplifier with MOSFET's. Features low-imp drive capability. 200 W/ch into 8 ohms; THD<0.01%; 17 x 14 $\frac{1}{2}$ x 7 $\frac{1}{2}$ in; 38 lb \$1,995

Model 280D 160-W/ch Amplifier

Features low-impedance drive capability. 160 W/ch into 8 ohms; 0.01% THD. 17 x 10 x 5 in; 28 lb. \$775

Model 240D 120-W/ch Amplifier

Full-complementary power MOSFET amplifier. Features precision metal resistors; precision film capacitors; high-voltage, high-current semiconductors. 120 W/ch into 8 ohms; THD<0.01%. 13 x 14 x 7 in; 27 lb. \$550

AUDIO RESEARCH

M300 MkII 300-W Hybrid Mono Amplifier

Hybrid design with FET (for front end) and vacuum tubes (in output stage); cross-coupled circuit; front-panel replaceable line and screen voltage fuses with LED indicators; 2 integral low-noise cooling fans (switchable for "Hi" or "Lo"); standby switch for warmup or interruptions; auto muting for silent shutdown; gold-plated inputs connect ground before hot; output taps for 1, 2, 4, or 8 ohms; front and rear handles. 300 min W cont avg from 16-25,000 Hz with <0.051% THD into 8 ohms; power at clipping 330 W; FR 10-60,000 Hz -3 dB; S/N 90 dB; slew rate 25 V/ μ sec; 10 $\frac{1}{2}$ x 19 x 16 in; 110 lb \$5,495

Classic 150 Hybrid 140-W Mono Amplifier

Hybrid mono power amplifier with matched FET in front end and vacuum tubes in triode configuration in output. Features tube protection circuit; cross-coupled circuit. Standby switch; auto muting; balanced output. 140 min W cont avg into 1-2-4-8 ohms from FR 7-100,000 Hz -3dB. \$4,995

D-125 Hybrid 120-W/ch Amplifier

Stereo hybrid power amp rated at 120 W into 4-8-16 ohms. Input stage FET-based; output stage with 2 "quad" banks of 6550 power output tubes; self monitoring circuits; tube saver circuit; internal fan cooling; automatic muting at shutdown; 8 $\frac{3}{4}$ x 19 x 16 $\frac{1}{2}$ in; 84 lb. \$4,450

Classic 60 Hybrid 60-W/ch Amplifier

Stereo hybrid power amplifier with matched FET in front end and vacuum tubes operating in triode configuration in output. Features auto IX balance servo circuit; driver balance servo; automatic bias correction adjusts for incoming line voltage. Low noise fan; front-panel fusing for line and screen. 60 min W/ch cont avg from FR 12-40,000 Hz -3 dB. 7 x 19 x 15 $\frac{3}{4}$ in; 63 lb \$3,295

Classic 30 Hybrid 30-W/ch Amplifier

Stereo hybrid power amplifier with matched FET in front end and vacuum tubes operating in triode configuration in output. Features auto IX balance servo circuit; automatic bias correction adjusts for incoming line voltage. Front-panel fusing for line and

screen. 30 min W/ch cont avg from FR 15-50,000 Hz -3 dB. 7 x 19 x 14 $\frac{1}{2}$ in; 46 lb. \$2,295

B & K COMPONENTS

Sonata Series

Pro-600 250-W/ch Dual-Mono Amplifier

Dual-mono power amplifier with 200 W/ch cont avg into 8 ohms and 350 W/ch cont avg into 4 ohms. Features Class A pre-driver circuitry driving a class AB MOSFET output stage; Toroidal transformers; digital audio compatibility; balanced inputs. FR 1-100,000 Hz; THD <0.09% at 1,000 Hz; S/N 95 dB; IM 0.09%; slew rate 24V/ μ sec; damping factor 600; dynamic headroom 1.1 dB \$1,698

Pro-600 250-W/ch Dual-Mono Amplifier. Same as above without balanced inputs \$1,498

M-200 200-W Mono Amplifier

Mono amplifier with 200 W into 8 ohms and 400 W into 4 ohms. Features Class A pre-driver circuitry driving a class AB MOSFET output stage; Toroidal transformers; digital audio compatibility; balanced inputs. FR 1-100,000 Hz; THD <0.09% at 1,000 Hz; S/N 95 dB; IM 0.09%; slew rate 25V/ μ sec; damping factor 1000; dynamic headroom 1.4 dB \$1,098

Pro-200 200-W Mono Amplifier. Same as above without balanced inputs \$898

Pro-600 250-W/ch Amplifier

High-power amplifier with fan-cooled driver stage. 250 continuous average W/ch from 20-20,000 Hz with no more than 2% distortion into 8 ohms, 400 W into 4 ohms; FR 1-100,000 Hz \pm 3 dB; S/N 95 dB; dynamic headroom 0.1 dB; slew rate 24 V/ μ sec; IM 0.09%; bridgeable to 800 W. \$1,298

EX-442 200-W/ch Dual-Mono Amplifier

Dual-mono power amplifier with gold-plated input and output connectors. 200 continuous average W/ch; FR 5-45,000 Hz \pm 3 dB; S/N 95 dB; dynamic headroom 0.5 dB; slew rate 14 V/ μ sec; IM 0.09%; 300 W into 4 ohms; 42-ampere peak-to-peak current capability. 6 x 19 x 15 in; 35 lb. \$895

ST-202 Plus 200-W/ch Amplifier

Power amplifier designed to deliver high wattage to speakers. 200 continuous average W/ch from 20-20,000 Hz with < 0.09% THD into 8 ohms; dynamic headroom 1.8 dB; S/N 95 dB; slew rate 12 V/ μ sec; IM 0.09%. 6 x 19 x 15 in; 30 lb. \$698

ST-202 150-W/ch Amplifier

Power amplifier with gold-plated connectors for driving 8- and 4-ohm loads. 150 continuous W/ch from 20-20,000 Hz with no more than 0.09% THD into 8 ohms; frequency response 5-45,000 Hz \pm 3 dB; signal-to-noise ratio 95 dB; dynamic headroom 1.5 dB; slew rate 11 V/ μ sec; IM 0.09%; 200 W into 4 ohms. 6 x 19 x 15 in; 25 lb \$648

ST-140 Class A 150-W Amplifier

Power amplifier with Class A design up to output stage. 150 cont avg W from 20-20,000 Hz with <0.09% THD into 8 ohms; 200 W into 4 ohms; FR 5-45,000 Hz \pm 3 dB; signal-to-noise ratio 95 dB; dynamic headroom 1.5 dB; slew rate 11 v/ μ sec; IM 0.09%. \$498

ST-140 Class A 105-W/ch Amplifier

Power amplifier with Class A design up to output stage. 105 continuous average W/ch from 20-20,000 Hz with no more than 0.09% THD into 8 ohms, 100 W into 4 ohms; frequency response 5-45,000 Hz \pm 3 dB; signal-to-noise ratio 90 dB; dynamic headroom 1.4 dB; slew rate 11 V/ μ sec; IM 0.09%. \$498

BEDINI

BA-803 200-W/ch Amplifier

Solid-state stereo amplifier. 200 W/ch rms into 8

ohms and 400 W/ch rms into 4 ohms; THD<0.15% 8 ohms rated power; IM<1%; FR 20-20,000 Hz; S/N 105-dB; dynamic headroom 3 dB; damping factor 500 min; slew rate 55 V/ μ sec. 7 $\frac{1}{2}$ x 19 x 18 $\frac{3}{4}$ in; 50 lb. \$2,500

BA-802. As above. 150 W/ch rms into 8 ohms; 300 W/ch rms into 4 ohm \$1,900

BA-801. Similar to above. 100 W/ch rms into 8 ohms; 140 W/ch rms into 4 ohms \$1,400

BELLES RESEARCH

450 200-W/ch Amplifier

Solid-state power amplifier with dual complementary bipolar transistor circuitry and power MOSFET. All components are mounted on a single circuit board. Features Van den Hul cable wiring; high-quality capacitors and resistors; toroidal power transformer. 200 W/ch cont from 20-20,000 Hz with <0.01% THD into 8 ohms; FR 0.2-60,000 Hz \pm 3 dB into 8 ohms; damping factor >200. 3-year warranty. 10 x 17 x 13 in; 55 lb. \$1,595

150 100-W/ch Amplifier

Solid-state power amp with dual complementary bipolar transistor circuitry, and power MOSFET. All components are mounted on a single circuit-board. Features van den Hul silver mono-crystal wiring; high-quality capacitors and resistors; toroidal power transformer. 100 W/ch cont from 20-20,000 Hz with <0.09% THD and IM into 8 ohms; damping factor >175. 3-year warranty. Dimensions: 7 x 17 x 8 $\frac{1}{2}$ in; 22 lb \$649

BERNING

EA-2101 100-W/ch Tube Amplifier

All-triode stereo vacuum-tube power amp. Features high-frequency resonant regulated power supply; Shutdown protection for low-line brown-out and improper bias conditions on tubes. 100 W/ch continuous from 20-20,000 Hz with <2% THD into 8 ohms; four output transformer output winding per channel. FR 10-60,000 Hz. \pm 1.5 dB; S/N 100 dB. 5 $\frac{1}{4}$ x 19 x 19 in; 40 lb. \$3,500

BOULDER AMPLIFIERS

Boulder 500 150-W/ch Amplifier

150-W output with two stage amplification and adjustable output levels. Toroidal power transformer; shielded power cord; protection circuitry with visual indicators for short circuit, IX input offset, thermal warning and thermal offset. LED meter at -40, -20, -6 dB; clip LED indicators for + and - voltage or current; removable rack-mount ears; screw-on feet; gold-plated connectors (3-pin input D3F, RCA phono, 5-way output); rear-panel switch-selectable input modes and multiple connectors; recessed panel controls. 150 W/ch into 8 ohms, 250 W/ch into 4 ohms, 500 mono into 8 ohms; FR 20-20,000 Hz; total harmonic distortion .005%; slew rate 35 V/ μ sec stereo. 70 V/ μ sec mono; imp 10,000 ohms; peak current 50 amperes. 17 x 5 $\frac{1}{4}$ x 15 $\frac{1}{2}$ in; 51 lb \$3,695

International version for 100/120/220/240 V AC. 50/60 Hz. \$3,995

Boulder 500AE 150-W/ch Amplifier

Similar to above, balanced output levels, no LED indicators \$2,995

International version for 100/120/220/240 V AC. 50/60 Hz. \$3,295

Boulder 250AE 75-W/ch Amplifier

Balanced input stereo amplifier with clip detection circuitry. Features two-stage amplification, and ground referencing at the preamplifier. 75 W/ch into 8 ohms, 125 W/ch into 4 ohms, 250 mono into 8 ohms; FR 20 - 20,000 Hz; total harmonic distortion .005%; slew rate 25 V/ μ sec stereo, 50 V/ μ sec mono; imp 10,000 ohms; peak current 30 amps. 17 x 5 $\frac{1}{4}$ x 15 $\frac{1}{4}$ in; 30 lb. \$1,995

International version for 100/120/220/240 V AC. 50/

POWER • AMPLIFIERS

60 Hz..... \$2,195

BRYSTON

6B 500-W/ch Amplifier

Mono power amp with 1,000 W into 4 ohms with avg current of 22 amps; 1,000 W into 1 ohm with 35 amps average; ground lift switch; 500 W/ch cont from 20-20,000 Hz; THD 0.005%; S/N 105 dB; slew rate 60 V/ μ sec; IM 0.005%; 5 $\frac{3}{4}$ x 19 x 12 in; 55 lbs. \$1,895

4B 250-W/ch Amplifier

Class-AB power amp with bridging switch. Features 1,500-sq-in heat-sink area; regulated power supply to all voltage gain stages; ch sep back to line cord; red LED clipping indicator. Output power 200 W/ch, 800 W bridged into 8 ohms; FR 20-20,000 Hz; THD 0.01%; IM 0.01%; slew rate 60 V/ μ sec; power bandwidth 1-100,000 Hz; damping factor 500 at 20 Hz, 8 ohms. 5 $\frac{1}{4}$ x 19 x 13 $\frac{1}{2}$ in. \$1,695
3B. Similar to 4B except 100 W/ch, 400 W bridged; input sens/imp 1 V/50k ohms; 500-sq-in. heat-sink area; 9 in D. \$1,095
2B. Similar to 3B except 50 W/ch, 200 W bridged; input sens/imp 0.75 V/50k ohms; 250-sq-in. heat-sink area; 3 $\frac{1}{2}$ x 19 x 10 in. \$650

CAMBRIDGE AUDIO

A250 250-W Mono Amplifier

Separate power amplifier with power-on switch only. 250 W into 8 ohms; peak 45 amps; S/N > 100 dB; THD 0.5%. \$1,800/pr

A100 100-W/ch Amplifier

Stereo power amplifier with power-on switch only. FR 5-50,000 Hz < 1 dB; 100 W/ch into 8 ohms; S/N > 100 dB; THD 0.5%. 2 $\frac{1}{2}$ x 17 $\frac{1}{2}$ x 11-in.; 21 lb. \$699

A50 60-W/ch Amplifier

Separate power amplifier with power-on switch only. Can be connected for bridge mono operation by rear-panel switch. 60 W/ch into 8 ohms; mono 150 W into 8 ohms (clipping at 200 W); peak current capability of 35 amps; S/N > 100 dB; THD > 0.5%. \$579

CARVER

Silver Seven 375-W Tube Amplifier

Mono amplifier with fully balanced circuit topology. Features 14 KT-88 power-output tubes; A-450 Ultra Linear output transformers with oxygen-free primary leads and pure silver secondaries; Wonder Cap capacitors; Van den Hul silver interconnects; pure silver internal wiring with Wonder Solder; polished granite anti-vibration base with Simms aluminum machined transformer end bells; 1, 4, 8-ohm taps. 375 W into 8 ohms; 20-20,000 Hz with THD < 0.5%; peak current output 35 amps; FR 1.5 Hz to 100,000 Hz \pm 0 dB. 150 lb. \$8,750

Silver Seven-t 575-W Mono Amplifier

Solid-state mono power amplifier with Transfer Function Calibration. Features magnetic-field power amplifier design; analog power meter. 575 W into 8 ohms; 900 W into 4 ohms; 1000 W into 2 ohms; THD 0.5%; slew rate 300 V/ μ sec; input impedance 100,000. 16 lb. \$899

TFM-45 375-W/ch Amplifier

Stereo magnetic-field amplifier with Transfer Function Calibration. Features voltage into 2, 4, 8 ohms; analog power meters. 375 W/ch into 8 ohms; 500 W/ch into 4 ohms; 1000 W/ch bridged mono; THD 0.5%; slew rate 180 V/ μ sec; input impedance 100,000. 20 lb. \$899
TFM-42 375-W/ch Amplifier. Same as above with LED "ladder" power meter. \$839

AV-64 Amplifier

Two stereo 3-/4-ch magnetic field power amplifiers in one chassis for surround sound, satellite subwoofer systems, add-on subwoofers and multi-room applica-

tions. Features built-in 18 dB/octave electronic crossover with turnover point at 75 Hz. Rear panel trim level controls. 4 x 60 W into 8 ohms, or 2 x 60 + 180 W mono subwoofer output; THD 0.15%; FR 3-36,000 Hz -3 dB; input impedance 10,000. 14 lb \$760

TFM-25 225-W/ch Amplifier

Stereo magnetic-field amplifier with Transfer Function Calibration. Features voltage into 2, 4, 8 ohms; analog power meters. 225 W/ch into 8 ohms; 350 W/ch into 4 ohms; 350 W bridged mono; total harmonic distortion 0.5%; slew rate 180 V/ μ sec; input imp 100,000. 20 lb. \$650
TFM-25 225 W/ch Power Amplifier. Same as above without power meter. \$580

CELLO

7000-00 200-W/ch Mono Amplifier Set

Features 2 mono amps which employs 8 driver transistors and forty 250-W output devices per amplifier; 2 mono dual choke input design power supplies; two electrically conductive heat-sink tunnels cooled by two fans per chassis. \$16,000

Encore 60-W/ch Amplifier

Comprised of two mono amplifiers in independent chassis. Features dual choke power supply; copper, nickel-plated heat sink; 40 output devices per channel. Can be separated into two mono amplifiers (mono kit required). \$6,000

CITIZEN

PAF-330 25-W/ch Amplifier

Stereo amplifier with class A operation. 25 W/ch cont; FR 40-20,000 Hz; THD 0.5%; S/N 85 dB. 2 $\frac{3}{8}$ x 6 $\frac{1}{8}$ x 10 $\frac{1}{4}$; 7 $\frac{3}{4}$ lb. \$165

CLASSE AUDIO

All Classe Audio power amplifiers drive 2 channels and are bridgeable.

DR-3-VIIC 45-W/ch Amplifier

Amplifier featuring pure Class A output. Bandwidth 20-20,000 Hz; THD 0.01%; sens 800 mV; 45 W/ch into 8 ohms; dynamic headroom 8 dB; 300 W into 4 ohms, bridged. 102 lb. \$4,500

DR-9 100-W/ch Amplifier

Power amplifier featuring Class AB output. Balanced inputs/outputs; bandwidth 20-20,000 Hz; THD 0.01%; sens 1000 mV; 100 W/ch into 8 ohms; dynamic headroom 6 dB; imp 1 ohm; 800 W into 4 ohms, bridged. 64 lb. \$3,500

DR-3B 25-W/ch Amplifier

Power amplifier featuring pure Class A output. Bandwidth 20-20,000 Hz; THD 0.01%; sens 800 mV; 25 W/ch into 8 ohms; dynamic headroom 7 dB; 200 W into 4 ohms, bridged. 72 lb. \$3,200

DR-8 70-W/ch Amplifier

Power amplifier featuring Class AB output. THD 0.01%; sens 900 mV; 70 W/ch into 8 ohms; dynamic headroom 5 dB; imp 1 ohm; 550 W into 4 ohms, bridged. \$2,400

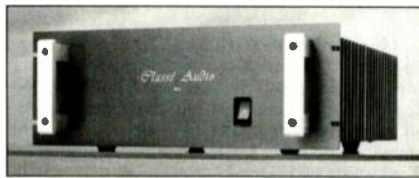

Classe Audio DR-9

CONRAD-JOHNSON

Premier One B 150-W/ch Amplifier

Low-noise parts in circuitry; LED bias indicators. 150

W/ch into 4, 8, or 16 ohms; S/N 90 dB. \$5,750

VFT 200 200-W/ch Hybrid Amplifier

Hybrid stereo amplifier with zero-feed back design. Features tube driver with MOSFET output stage. 125 lb. \$4,995

MV100 90-W Mono Tube Amplifier

Low-imp power supplies and extensive use of polystyrene capacitors; LED bias indicators. 90 W into 8 ohms; signal-to-noise ratio 94 dB; 9 x 19 x 20 $\frac{1}{2}$ in.; 90 lb. \$3,750

MV50. Similar to above, 45-W into 8 ohms; S/N 94 dB; 40 lbs. \$1,685

CROWN

PSA-2 265-W/ch Amplifier

265 W/ch into 8 ohms; 520 W/ch into 16 ohms or 760 W/ch into 8 ohms mono; four second/instantaneous turn-on; aluminum chassis; mono/stereo slide switch; frequency response 20-20,000 Hz \pm 0.1 dB; total harmonic distortion < 0.002%; intermodulation distortion 0.01%; slew rate > 30 volts/ μ sec; damping factor > 700; draws 90 watts or less when idle. 19 x 7 x 14 $\frac{1}{4}$ in. \$1,995

Macro-Tech 1200 295-W/ch Amplifier

295 W/ch into 8 ohms; 555 W/ch into 16 ohms or 790 W/ch into 8 ohms mono; four second turn-on; mono/stereo switch; LED power indicator; steel chassis; frequency response 20-20,000 Hz \pm 0.1 dB; THD < 0.05%; IM < 0.05%; slew rate > 13 volts/ μ sec; damping factor > 1,000; draws 60 watts or less on idle. 19 x 3 $\frac{1}{2}$ x 16 in; 44.6 lb. \$1,565

Macro-Tech 600 215-W/ch Amplifier

215 W/ch into 8 ohms; 395 W/ch into 16 ohms or 510 W/ch into 8 ohms mono; four second turn-on; pushbutton power switch; mono/stereo switch; LED power indicator; steel chassis; frequency response 20-20,000 Hz \pm 0.1 dB; IM < 0.05%; slew rate > 13 volts/ μ sec; damping factor > 1,000; draws 60 watts or less when idle. 19 x 3 $\frac{1}{2}$ x 16 in; 39 $\frac{1}{2}$ lb. \$1,295

Micro-Tech 1200 295-W/ch Amplifier

295 W/ch into 8 ohms; 555 W/ch into 16 ohms or 790 W/ch into 8 ohms mono; power rocker switch; mono/stereo switch; LED power indicator; steel chassis; FR 20-20,000 Hz \pm 0.1 dB; THD < 0.05%; IM < 0.05%; slew rate > 13 volts/ μ sec; damping factor > 1,000; draws 60 watts or less when idle. 19 x 3 $\frac{1}{2}$ x 16 in; 40 $\frac{1}{2}$ lb. \$1,295

DC-300A II 165-W/ch Amplifier

165 W/ch into 8 ohms; 340 watts into 16 ohms or 545 watts into 8 ohms mono; instantaneous turn-on with minimum thump and no program delay; independent input level controls; power switch with pilot light; mono-stereo switch; LED indicators; all-aluminum chassis; frequency response 0-20,000 Hz \pm 0.1 dB; total harmonic distortion < 0.001% from 20-400 Hz; IM < 0.05%; slew rate 8 volts/ μ sec; draws 40 watts or less when idle. \$1,095

PS-400 165-W/ch Amplifier

165 W/ch into 8 ohms; 360 W/ch into 16 ohms or 520 W/ch into 8 ohms mono; four second turn-on; independent input-level controls; mono/stereo slide switch; 2 LED signal-presence indicators; all-aluminum chassis; frequency response 0-20,000 Hz \pm 0.1 dB; THD < 0.001% from 20-400 Hz; IM < 0.05%; slew rate 16 volts/ μ sec; draws 40 watts or less when idle. 19 x 7 x 10 $\frac{1}{8}$ in; 55 lb. \$1,019

Micro-Tech 600 215-W/ch Amplifier

215 W/ch into 8 ohms; 395 W/ch into 16 ohms or 510 W/ch into 8 ohms mono; power rocker switch; mono/stereo switch; LED power indicator; steel chassis; frequency response 20-20,000 Hz \pm 0.1 dB; total harmonic distortion < 0.05%; IM < 0.05%; slew rate > 13 volts/ μ sec; damping factor > 1,000; draws 60 watts or less on idle. \$995

POWER • AMPLIFIERS

PS-200 95-W/ch Amplifier

95 W/ch into 8 ohms; 190 watts into 16 ohms or 280 watts into 8 ohm mono; four-second turn-on; push-button power switch; input-level controls; mono/stereo slide switch; 2 LED signal presence indicators; all-aluminum chassis; FR 0-20,000 Hz ± 0.1 dB; THD $<0.01\%$ from 20-400 Hz; IM $<0.05\%$; slew rate 16 volts/ μ sec; draws 40 watts or less when idle. 19 x 5 $\frac{1}{4}$ x 10 $\frac{1}{2}$ in; 25 lb. \$829

D-75 35-W/ch Amplifier

35 W/ch into 8 ohms; 95 watts into 8 ohms mono; <110 dB hum and noise in the range 20-20,000 Hz; instantaneous turn-on with minimum thump and no program delay; two input-level controls; power switch; mono/stereo switch; 2 signal-presence indicators; 1 power indicator; ground link; FR 20-20,000 Hz at 1 watt into 8 ohms (stereo); IM $<0.05\%$; slew rate 6 volts/ μ sec; ± 15 watts power consumption when idle. 19 x 9 x 13 $\frac{1}{2}$ in; 10 lb. \$524

DBSYSTEMS

DB-6A 40-W/ch Amplifier

Stereo power amplifier able to drive 1-ohm loads. Features 12-dB/octave infrasonic filter; peak-clipping LED's; electronic clamp. Output power 40 W/ch continuous into 8 ohms from 20-20,000 Hz at 0.003% THD; THD 0.0008% at 1,000 Hz; IM $<0.002\%$; FR 20-40,000 Hz $+0/-1$ dB; input sens/imp 1 V/50 kilohms; S/N 112 dB at 1 V A-wtd; slew rate 15 V/ μ s; damping factor >400 . 20-1,000 Hz. 4 $\frac{7}{8}$ x 16 x 12 $\frac{3}{4}$ in. \$795

DB-6A-M. Similar to DB-6A except bridged mono amp at 140 W continuous with 0.008% THD; slew rate 30V/ μ sec. \$795

19-in rack adaptor \$55

Mono version of DB-6A to DB-6A-M \$39

DB-6A-M(2). Similar to DB-6A-M except pair of mono amplifiers \$1,545

Updates and Modifications

DB-6A. Modification increases power supply capacitance to 126,000 μ F \$200

Power Supply Increase. Triples power supply capacitance to 42,000 μ F for cleaner clipping. Gold-plated binding posts and jacks; warranty extension to 2 years \$160

Stereo-to-Mono Conversion. Conversion from 40 W stereo amplifier to 140-W mono amplifier. \$39

dbx

BX-3MkII 400 W/ch Amplifier

Configurable 2-/3-/4-channel power amplifier able to power 8 speakers at one time. Features DC configuration with a dual-FET input stage; separate volume controls for each channel. Power output into 2 channels; 400 W/ch into 8 ohms. 125 W/ch and 400 W into third channel with subwoofer output; 125 W/4 ch; 0.003% THD. Dark-cherrywood side panels \$1,299

DENNESEN ELECTROSTATICS

Antares II 75-W/ch Amplifier

75 W/ch into 8 ohms. MOSFET power amp. Frequency response 10-100,000 Hz ± 1 dB; THD $<0.1\%$; signal-to-noise ratio 90 dB; IM 0.1%; slew rate 30 V/ μ sec; 5 $\frac{1}{4}$ x 19 x 8-in; 30 lb \$595

Orion. As above. 150 W mono \$1,500

DENON

POA-2400 200-W/ch Class A Amplifier

Stereo amplifier with Denon optical design and twin pure current supply. Features high-speed protection circuits. Bar-line multi display; self diagnostic function. 200 W/ch into 8 ohms; THD $<0.01\%$; IM $<0.002\%$; frequency response 1-300,000 Hz $+0/-3$ dB at 1,000 Hz; signal-to-noise ratio 123 dB. 7 $\frac{1}{2}$ x 17 $\frac{1}{2}$ x 16 $\frac{1}{2}$ in; 38.5 lb. \$750

POA-6600A 250-W Mono Amplifier

Mono power amplifier with Dual Super Non-NFB circuit for high-speed signal transmission. Features pure current power supply; separate power supply block chassis; high-speed reset-type protection circuit. Cannon type balance input connector; conventional RCA input jack with selector switch; front-panel level control; extra-large speaker terminals; peak indicators; remote power on/off switching from DAP-5500/2500 or PRA-1200 preamps. 250 W min rms into 8 ohms; FR 20-20,000 Hz; THD $<0.02\%$; IM 0.002%; S/N 123 dB; slew rate ± 500 V/ μ sec. \$750

POA-4400. Similar to above with 150 W. \$500

POA-800 50-W/ch Amplifier

Bridgeable stereo amplifier with discrete MOSFET output transistors. Features 3-way speaker terminals; peak-signal indicator; remote power control from Denon preamps. 50 W/ch into 8 ohms; 120 W into 8 ohms (bridged); THD $<0.05\%$ \$320

DISCRETE TECHNOLOGY

LSIIa 140-W Mono Amplifier

Mono amplifier with dual tracking, thermal coupled matched front-end transistors. Features cascode voltage section; 1% metal-film resistors; polystyrene and polypropylene capacitors. Power rating 140 W rms into 8 ohms; FR 20-20,000 Hz; THD $<0.05\%$; S/N 100 dB below 10 W output; IM $<0.05\%$ using SMPTE method at any power level up to 140 W into 8 ohms; slew rate 60 v/ms; damping factor 200 at 50 Hz; dynamic headroom 4.2 dB at 8 ohms. \$3,000/pr

LSIIa 140-W/ch Amplifier

Stereo amplifier with dual tracking, thermal coupled matched front-end transistors. Features cascode voltage section; 1% metal-film resistors; polystyrene and polypropylene capacitors; distech platinum interconnect cable. Power rating 140 W/ch rms into 8 ohms from 20-20,000 Hz $>0.09\%$ THD; FR 3-100,000 Hz -3 dB; S/N 90 dB below 10 W output; IM $<0.09\%$ using SMPTE method at any power level up to 140 W into 8 ohms; slew rate 45 v/ms; damping factor 100 at 50 Hz; dynamic headroom 3.2 dB at 8 ohms. \$1,250

ECLER

Model 83-PAM1800 270-W/ch Amplifier

MOSFET amplifier with 400 W/ch into 4 ohms; 270 W/ch into 8 ohms; 800 W/ch mono. FR 10-50,000 Hz; THD $<0.05\%$; S/N 105 dB. 32 lb \$1,943

Model 83-PAM1500 160-W/ch Amplifier

MOSFET amplifier with 250 W/ch into 4 ohms; 160 W/ch into 8 ohms; 500 W/ch mono. FR 10-20,000 Hz; THD $<0.05\%$; S/N 105 dB. 28 lb \$1,598

Model 83-PAC200 100-W/ch Amplifier

Power amplifier with 150 W/ch into 4 ohms; 100 W/ch into 8 ohms; 300 W/ch mono. FR 7-50,000 Hz; THD $<0.05\%$; S/N 105 dB. 19 lb \$822

ELECTROCOMPANET BY MUSIC AND SOUND IMPORTS

Amplifier Amplifiers

All Electrocompaniet power amps are Class AB, DC servo controlled, and feature thermal shutoff safety filter in output stage.

250. Inverts phase. 250 W/ch into 8 ohms; 480 W/ch into 4 ohms; FR 0-100,000 Hz; THD 0.003%. 45 lb. Approx \$3,995

100. Does not invert phase. 100 W/ch into 8 ohms; 180 W/ch into 4 ohms; FR 0-100,000 Hz; THD 0.003%. 40 lb. Approx \$2,195

FORTE AUDIO BY THRESHOLD

Model 1a 50-W/ch Amplifier

Dual-channel, non-inverting power amp using FET/bipolar front-end topology and operating in pure Class A throughout front-end and power output

stages. Input stage is direct coupled and biased with regulated constant-current sources. Output stage employs 20 high-speed power devices and uses no active protection circuits. Does not impose a fuse or isolation inductor at the output and maintains constant damping over the full frequency band. Gold-plated input and output connectors. Glass-epoxy circuit boards. Custom toroidal power transformer. Rated power 50 W/ch at 0.1% THD into 8 ohms; FR 20-20,000 Hz; bandwidth -3 dB points of 7 and 100,000 Hz; slew rate 40 V/msec; imp 75,000 ohms. 19 x 7 x 11 in; 36 lb \$1,100

Model 3 200-W/ch Amplifier

Similar to Model 1a except higher power with output stage operating in high-bias Class AB. Rated power 200 W/ch at 0.01% THD into 8 ohms; FR 20-20,000 Hz; bandwidth -3 dB points of 7 and 100,000 Hz; slew rate 40 V/msec; imp 75,000 ohms. 19 x 7 x 11 in; 36 lb \$1,100

FOSGATE-AUDIONICS

T-100 Tri-Channel 75-W x 3 Amplifier

Amplifier designed for use with surround audio systems. Features discrete full complementary circuit. Input level control; defeatable bass filter. 75 W/ch into 8 ohms; 120 W/ch into 4 ohms; THD and IM $<0.2\%$; FR ± 1 dB from 20-20,000 Hz. 17 $\frac{1}{4}$ x 2 $\frac{3}{4}$ x 12 in; 17 lb. \$599

S-100 75-W/ch Amplifier

Stereo amplifier with discrete full complementary circuit. Features input level; defeatable bass filter. 75 W/ch into 8 ohms; 120 W/ch into 4 ohms; THD and IM $<0.02\%$; FR ± 1 dB from 20-20,000 Hz. 17 $\frac{1}{4}$ x 12 in; 14 lb. \$499

M-100 75-W Mono Amplifier

Mono amplifier with full discrete complementary circuit. Features input level; defeatable bass filter. 75 W into 8 ohms; 140 W into 4 ohms; total harmonic distortion and IM $<0.02\%$ at rated output from 20-20,000 Hz; FR 20-20,000 Hz ± 1 dB. 17 $\frac{1}{4}$ x 2 $\frac{3}{4}$ x 12 in; 14 lb. \$399

M-60 MkII 35-W Mono Amplifier

Mono amplifier designed for use in A/V system with discrete full complementary circuit. Features input level control; designed for center ch amplification in surround audio systems. 60 W at 4 ohms; 35 W at 8 ohms; THD and IM less than 0.20% at rated output from 20-20,000 Hz; FR ± 1 dB from 20-20,000 Hz. 8 $\frac{1}{2}$ x 2 $\frac{3}{4}$ x 7 $\frac{1}{2}$; 6 lb. \$199

HAFLER

XL-600 305-W/ch Amplifier

Excelinear near-zero-phase-shift circuit with J-FET double differential push-pull cascoded 'tube-like' input and current-mirroring 2nd stage. 16 MOSFET outputs; direct coupled; stable into all loads; high capacitance (72,000 mfd); Excelinear speaker-tweaking adjustment; gold inputs and outputs; mono bridging switch; variable speed DC fan cooling. 305 W/ch into 8 ohms with $<0.05\%$ THD, 20-20,000 Hz; $<0.04\%$ IM from 1-305 W; 450 W/ch into 4 ohms; 900 W mono into 8 ohms; input sens 2.4 volts for 305 W @ 8 ohms; FR 10-50,000 Hz ± 0.1 dB; signal-to-noise ratio >100 dB @ 305 W; slew rate 100 V/ μ s; damping factor >200 at 1,000 Hz. 19 x 7 x 13 in; 51 lb. \$1,195

DH-500 255-W/ch Amplifier

Features MOSFET's on compact, enclosed, multi-speed-fan cooled heat sink. Fuses and relay protect speakers against turn-on thumps or DC shifts; self-protective capability of the MOSFET's eliminates need for amp protection; optional bridging kit to obtain 800 W mono. FR 5-50,000 Hz -0.5 dB; S/N >100 dB; THD 0.0015% at 1,000 Hz; slew rate 40 V/ μ s; damping factor 350 at 1,000 Hz; IM $<0.007\%$. 17 x 7 $\frac{1}{4}$ x 11 in; 45 lb. Factory assembled \$749

Listen to the Technics Mica CX Speaker Series at one of these fine stores:

ALABAMA • Mobile — Hooper
ALASKA • Anchorage — Magnum Electronics
ARIZONA • Yuma — Kukuk's Stereo
ARKANSAS • Blytheville — Mr. Audio • Fayetteville — Stereo One • Texarkana — Tape Village
CALIFORNIA • Berkeley — Uncle Ralphs • Carlsbad • Chula Vista • Escondido • La Mesa • San Diego — Jacks Sound Centers • Fairfield — Del Mars • Los Angeles — Cosmos • San Jose — Quement • Santa Ana — Main St. Electronics
COLORADO • Aspen — Henry's Stereo • Glenwood Springs — Music Box
FLORIDA • Delray Beach — Good Life • Fort Walton Beach — Audio International • Key West — Audio International • Miami — World of Sound • Tampa — Good Life
IDAHO • Boise — All American Audio • Boise — Sound Pro • Lewiston — Steiners
ILLINOIS • Chicago — Hi Fi Hutch • Effingham — Crossroads Electronics • Farmington — World Wide TV
KANSAS • Garden City — Team Electronics
KENTUCKY • St. Matthews — Wilder Electronics
MAINE • Augusta — Pomerleau's • Bangor — The Sound Source
MASSACHUSETTS • New Bedford — Audiometrics • Worcester — O'Coin's
MICHIGAN • Allen Park — World Wide TV • Brighton — World Wide TV • Petoskey — Puff's of Petoskey • Rochester Hills — Video Systems • Waterford — World Wide TV
MINNESOTA • Duluth — Mel's • Mankato — Team Electronics • Winona — Amalgamated Audio
MISSISSIPPI • Jackson — Hooper • Meridian — Hooper • Pascagoula — Hooper
MISSOURI • Jefferson City — Audio Magic • Osage Beach — Phone Station • Popular Bluff — American Hi Fi • Springfield — Harvey's Home Entertainment • St. Louis — Quality Sight and Sound
MONTANA • Bozeman — Sound Pro
NEBRASKA • Norfolk — Mid City Stereo • North Platte — Monte's Sound Systems • Scottsbluff — Panhandle
NEW HAMPSHIRE • Walpole — Real to Reel
NEW JERSEY • East Hanover — Tops • Edison — Tops • Secaucus — Tops • Totowa — Sim-O-Rama
NEW MEXICO • Albuquerque — Baillos
NEW YORK • Albany — Hippo's • Canandaigua — Hathorne's • Corning, Elmira & Ithaca — Chemung Electronics
NORTH CAROLINA • Burlington • Eden • Greensboro • High Point • Lexington • Salisbury • Winston Salem — Ed Kelly's
NORTH DAKOTA • Grand Forks — Team Electronics • Minot — Team Electronics • Williston — Stereo West
OHIO • Cincinnati — ICB Audio • Fairview Park — Wellman & Griffith, Inc. • Mentor — Mentor TV, Inc. • Royalton — Phil Reddish Supply, Inc. • Toledo — Stereo One
OREGON • Portland — Brownell Sound
PENNSYLVANIA • Berwyn — Soundex Electronics • Ephrata — Galens of Ephrata • Erie — Studio One • Greenburg — Stereo Shop • Hazelton — Jannen Systems • Johnstown — East Hills TV & Sporting • Leighton — Lasermedia • Pottsville — Pamco Enterprises • Smithfield — Recrees' Warehouse • State College — Hi Fi, Inc. • Willow Grove — Soundex Electronics
SOUTH CAROLINA • Columbia — Norton's
SOUTH DAKOTA • Rapid City — Team Electronics • Sioux Falls — Gourley's Pro Audio
TENNESSEE • Memphis — Modern Music • Nashville — Electronic Express
TEXAS • Austin — A&B TV • Corpus Christi — Audio Video Designs • Houston — Applebaum & Company • Lufkin — Sound Center of Lufkin
UTAH • Salt Lake City — Gadgets
VERMONT • Williston — Consumer's Showcase
VIRGINIA • Charlottesville — Audio World Limited • Collinsville — Bryant Radio Supply • Roanoke — Lee Harman & Sons, Inc. • Stafford — QRC Electronics • Virginia Beach — FX • Winchester — Sound City
WASHINGTON • Bellingham — Video Depot
WISCONSIN • Janesville — Team Electronics of Janesville • Madison — Phillips • Wausau — Sound World of Wausau
WYOMING • Casper — Jeff's Electronics

Technics

One Panasonic Way, Secaucus, NJ 07094

POWER • AMPLIFIERS

DH-500 Kit \$700
DH-501. Sculpted non-rack panel \$50
DH-502. Bridging kit \$40
DH-551. Flat rack panel with handles \$50

XI-280 145-W/ch Amplifier

J-FET double differential input and 12 MOSFET output. Excelsior speaker tweaking adjustment; gold inputs; mono bridging switch; speaker protection fuses. 200 W/ch into 4 ohms. 400 W/ch mono into 8 ohms. FR 10-50,000 Hz ± 0.1 dB; total harmonic distortion $< 0.05\%$; IM $< 0.04\%$; signal-to-noise ratio > 100 dB; slew rate 75 V/ μ s; damping factor 300 at 1,000 Hz. 17 x 5 1/2 x 10 1/2 in; 27 lb; assembled \$675
Kit \$600
XI-281. Sculpted rack panel w/handles \$60
XI-282. Sculpted non-rack mount panel \$45
XI-285. Flat rack panel \$35

DH 120 60-W/ch Amplifier

Features four lateral MOSFET outputs. L/R channel level controls, stereo/mono switch, aux speaker outputs which feed a matrix signal for ambience effects. Bridgeable to mono 125 W into 8 ohm. Frequency response 10-40,000 Hz ± 0 , -0.5 dB; THD $< 0.002\%$; signal-to-noise ratio > 100 dB; damping factor 100 at 1,000 Hz; slew rate 30 V/ μ s. 17 x 3 1/4 x 9 in; 18 lb; assembled \$349
Kit \$325
DH-122. Sculpted non-rack panel \$45
DH-121. Flat rack panel \$35

SE 120 65-W/ch Amplifier

Features MOSFET output devices. Stereo/mono bridging switch and gold input connectors. 75 W/ch into 4 ohms; THD $< 0.008\%$ \$325

HARMAN KARDON

Citation Twenty-Two 200-W/ch Amplifier

Amplifier with selectable high-current and high-voltage output. Features dual-voltage design; dual power transformers; gold-plated input jacks and speaker terminals; eight 130 W/ch power transistors per channel. Clipping indicators; LED power meters; anodized brushed aluminum blue/black finish with rubber trim. 200 W/ch into 8 ohms from 20-20,000 Hz with $< 0.08\%$ THD; S/N 100 dB (at 1 W); slew rate 160 V/ μ sec; damping factor 120; current capability ± 120 amps. Bridged power 400 W into 8 ohms from 20-20,000 Hz with $< 0.12\%$. Dimensions: 17 1/2 x 6 1/8 x 15 3/4 in; 45 lb \$1,149

Twenty-Four. Similar to above except 100 W/ch; current capability ± 60 amps; four 130 W/ch power transistors per ch; damping factor 75; 33 lb \$699

HEATH

AAW-2500 100-W/ch Amplifier

Stereo power amplifier with four dual polarity power supplies and a protection circuit to shield speakers from turn-on transients and prevent short circuit by muting audio when a > 2 ohms load is placed across speaker terminals. Features toroidal power transformer; high-grade capacitors; High instantaneous current capability HCC 60 amps. 100 W/ch continuous into 8 ohms; FR 0.1-170,000 Hz; THD $< 0.06\%$; S/N 98 dB. 17 1/2 x 4 x 13 3/4 in; 30 lb \$499
AA-2500. Unassembled kit; 33 lb \$449

HEYBROOK BY D'ASCANIO AUDIO

P-3 100 W/ch Amplifier

Hand-assembled power amp with toroidal transformer capable of 30-amp output. Features circuits designed with close-tolerance, high-quality components. Thick aluminum chassis acts as a heat sink over entire surface, equalizing temp within the case and maintaining a stable relationship between internal components. 100 continuous average W/ch from 20-20,000 Hz into 8 ohms with no more than 0.05%

THD. 120 W into 4 ohms; S/N 60 dB; IM 0.05%; instantaneous peak current ± 30 amps. 17 x 4 x 12 in; 18 lb \$898

HITACHI

HMA120AVSW 120-W/ch Amplifier

Features A, B, A + B speaker switching; 10-LED power meter. 120 W/ch into 8 ohms; FR 20-20,000 Hz; THD 0.08%; S/N 118 dB. Rosewood caps. \$280

INTEGRA BY dBTRITON AUDIO SYSTEMS

MF120 120-W/ch Monoblock Amplifier

Features MOSFET amplification; silver soldered connections; 300 W power supply; 120 W/ch into 8 ohms; imp 100 k. 7 1/2 x 4 x 12 3/4; 32 lb \$3,000

JRM

Power Tower Amplifier

4-ch power amplifier with all polypropylene capacitors. Features complementary/symmetry all-cascode Class AB design; no V-I limiting; power fail; high-temperature protection. 12-step LED readout per ch. 500 W/ch x 2. 250 W/ch x 2 rms into 2 ohms; slew rate ± 80 V/ μ sec; S/N 98 dB; total harmonic distortion 0.02%; power bandwidth 0.6-75,000 Hz. 24 1/2 x 16 x 14 1/2 in; 75 lb \$2,500

Power Tower/B Amplifier

As above with each ch bridged (8 ampere modules total); imp 4 ohms. 95 lb \$3,100

KENWOOD

Basic-M2A 220-W/ch Amplifier

Features low-impedance drive capability; 616-W/ch into 2 ohms. Full circuit protection via thermostat-controlled fan cooling. FL peak-power meters with selectable peak-hold and 2 hold times; gold-plated inputs; headphone jack; power indicator; muting relay. 220 W/ch min rms into 8 ohms; frequency response 20-20,000 Hz; THD 0.004%; S/N 120 dB; damping factor 1,000 (at 50 Hz). 17 1/4 x 6 1/4 x 14 3/4; 34.1 lb \$679

Basic M1D 125-W/ch Amplifier

Features Voltage Interface Gate (VIG) to maintain fidelity during power-supply fluctuations, and low-impedance drive capability; 310 W/ch into 2 ohms. Full circuit protection. FL peak-power meters; power indicator; headphone jack; muting relay. 125 W/ch min rms into 8 ohms; FR 20-20,000 Hz; THD 0.008%; S/N 120 dB; damping factor 1,000 (at 50 Hz). 17 1/4 x 5 3/4 x 13 1/4; 21.6 lb \$429

KINERGETICS

KBA-202 Gold Series 250-W Class-A Mono Amp

Features 1-kVA toroidal transformer with 42,000 μ F capacitor in power supply; military-grade circuit boards; patented hysteresis distortion cancelling circuit. 250 W into 8 ohms; headroom 3 dB; input imp 100,000 ohms; slew rate 65 V/ μ sec; power bandwidth 1-100,000 Hz; voltage gain 30 (absolute). 19 x 16 x 5 in; 30 lb \$2,250/pr

KBA-75 Gold Series 75-W/ch Class-A Amplifier

Features 1-kVA power supply; dual-coil toroidal transformer; auto servo-controlled DC offset adjustment; high-power output transistors with wide linear region; hysteresis-distortion cancelling circuit. 75 W/ch into 8 ohms; headroom 3 dB; input imp 100,000 ohms; slew rate 65 V/ μ sec; voltage gain 20 (absolute); power bandwidth 1-300,000 Hz \$1,495

KLYNE AUDIO ARTS

SKN 120 120-W Dual-Mono Amplifier

Dual-mono power amplifier with balanced and unbalanced inputs. Features solid-state construction; separate power supplies for each channel; high-



THE FIRST ROCK GROUP THAT ACTUALLY IMPROVES THE SOUND OF OUR SPEAKERS.



One of the most advanced speakers on the face of the earth is made from the face of the earth.

Presenting the Technics CX Speaker Series. A remarkable 3-way speaker system made from one of nature's most unique sound conductors: mica.

In fact, mica has just the right characteristics for a speaker. It's lightweight yet extremely rigid, 1.5 times more rigid than titanium. Which means no matter what type of music you listen to, our mica speakers can reproduce it with amazing clarity.

More specifically, the pure mica dia-

phragm tweeter and midrange driver cones provide incredible accuracy. And the composite mica/pulp woofer not only delivers a deep, rich bass but helps eliminate the distortion that can accompany it.

What's more, the CX series is available in a bookshelf and two floor-standing models. The latter uses a linear compliance Passive Radiator in the rear of the cabinet to further improve low frequency re-

production and total efficiency.

So, if you appreciate a brilliantly clean sound, listen to the Technics CX Series.

We don't think you've ever heard rock sound like this before.



Technics Mica CX Series

Technics
The science of sound

POWER • AMPLIFIERS

current complementary bipolar outputs; Class A/AB. 120 W into 8 ohms; FR 0.5-200,000 Hz. 17 x 4¾ x 18½ in; 45 lb. Approx. \$4,000

LAZARUS ELECTRONICS

HL-1A 50-W/ch Hybrid Amplifier

Pure (not sliding scale) Class A tube MOSFET hybrid power amp may be operated as a fully differential mono amp or as a stereo amp. May be configured (by dealer) as either Class A or Class A/B. 625 W toroidal transformer. 100 W into 4 ohms; bridgeable to mono 200 W into 8 ohms; dynamic headroom 3 dB; S/N 80 dB; IM 0.2%. 19 x 3½ x 16½ in; 35 lb. . . . \$3,840/pr

Model 50/50 50-W/ch Amplifier

Pure Class A amplifier. 50 W into 8 ohms; 100 W into 4 ohms; 200 W into 2 ohms. Wire both channels in parallel for 400 W into 1 ohm, monobloc . . . \$1920

Model 200/200 200-W/ch Dual Hybrid Amplifier

Features vacuum tubes in the driver stage with MOSFET in the final output stage; separate transformer and TX voltage regulator for MOSFET and tube stages; zero negative feedback. 350 watts into 4 ohms; sens 600 mV; input impedance 47,000 Hz; 35 lb. \$1,750

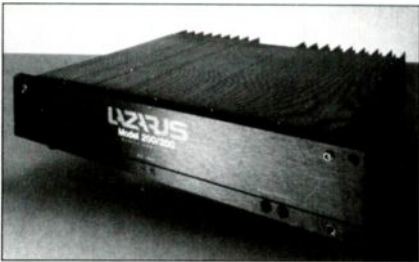

Lazarus Model 200/200

LEXICON

525 105-W/ch Amplifier

Amplifier with 5-channel discrete circuitry. Features Class A, AB, and MOSFET in output stages. 105 W/ch; THD <0.1%; slew rate 11 V/μsec; headroom 1.5 dB. 38 lb. \$1,295

LINN PRODUCTS

LK280 80-W/ch Amplifier

80 continuous average W/ch from 20-20,000 Hz; companion to LK1 preamp. 3 x 12¾ x 10½-in; 19 lb. \$1,495

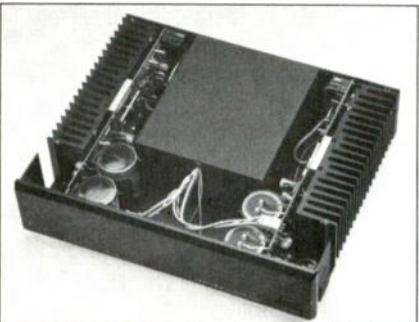

Linn LK-280

LUXMAN

ML-117 200-W/Ch Amplifier

Bridgeable amplifier with low-impedance drive capability. Features dual-FET per channel input stage; high-current bipolar output transistors; Duo-Beta dual feedback-loop circuitry to widen bandwidth and improve transient response; STAR circuit topology to reduce noise and distortion; high-energy power

supply. Peak-clip indicators; gold-plated speaker binding posts and input terminals; variable and fixed inputs. 200 W/ch from 20-20,000 Hz into 8 ohms; dynamic power 820 W/ch into 2 ohms; 550 W/ch into 4 ohms. 300 W/ch into 8 ohms; bridged output 700 W; THD 0.03% at rated power; signal-to-noise ratio 120 dB; intermodulation distortion 0.007%; slew rate 20 V/μsec; damping factor 130 (50 Hz, 8 ohms). 17¼ x 6½ x 17½ in; 52 lb. \$1,250

ML-113 50-W/ch Amplifier

Amplifier with low-impedance drive capability. Features dual-FET per channel input stage; high-current bipolar output transistors; Duo-Beta dual feedback-loop circuitry to widen bandwidth and improve transient response; STAR circuit topology to reduce noise and distortion; high-energy power supply. Peak-clip indicators; gold-plated input terminals; 5-way speaker terminals; adjustable input sens. 50 W/ch from 20-20,000 Hz into 8 ohms; dynamic power 180 W/ch into 2 ohms; 140 W/ch into 4 ohms. 90 W/ch into 8 ohms; bridged output 700 W; THD 0.03% at rated power; signal-to-noise ratio 116 dB; intermodulation distortion 0.005%; slew rate 15 V/μsec; damping factor 100 (50 Hz, 8 ohms). 17¼ x 5¾ x 14½ in; 19 lb. \$600

McINTOSH

MC-2500 500-W/ch Amplifier

Features Sentry Monitoring circuit which constantly monitors the signal to the output transistors to protect them from damage; bridgeable to 1,000 W mono; Left and right channel gain control; speaker on/off switch; peak-reading, peak-locking power meters; meter range selector; headphone jack. Power output: 500 W/ch both channels driven from 20-20,000 Hz with less than 0.02% THD; IM <0.02% if instantaneous peak power output is less than 1,000 W/ch both channels driven; FR 20-20,000 Hz +0, -0.25 dB; S/N 95 dB; damping factor >30; input imp 50,000 ohms; input sens switchable, 0.75 or 2.5 V (level control provided for higher input voltages). Power Guard: THD not to exceed 2% with up to 20 dB overdrive at 1 kHz. Standard 19-in rack mounting; 17 x 10 x 17 in; 129 lb. \$3,495

MC-7200 200-W/ch Amplifier

Features Power Guard circuitry to eliminate amplifier clipping due to overdrive; Sentry Monitor circuit constantly monitors the output signal and instantly reacts to prevent overload of the output transistors; thermal shut-down; turn-on delay; direct current failure protection; power line transient surge protection; bridgeable to 600 W mono. Peak responding power output meter; meter hold control; L/R gain control. Frequency response 20-20,000 Hz +0, -0.25 dB; total harmonic distortion 0.005%; S/N 105 dBA; IM 0.005%; damping factor >200. 14¾ x 5¼ x 15¾ in; 53 lb. \$2,595

MC-7270 270-W/ch Amplifier

Features autotransformer; left and right channel gain control; bridgeable to 540 W mono. Peak-reading, peak-locking power meters; meter selector. Power output: 270 W/ch both channels driven from 20-20,000 Hz with less than 0.02% THD; IM <0.02% if instantaneous peak power output is less than 600 W/ch both channels driven; FR 20-20,000 Hz +0/-0.25 dB; damping factor >30; input impedance 20,000 ohms; input sensitivity switchable, 0.75 or 2.5 V (level control provided for higher input voltages). Power Guard: THD <2% with up to 20 dB overdrive at 1 kHz. 16¼ x 7¾ x 14½ in; 82 lb. \$2,295

MC-754 100-W/ch Amplifier

Features Power Guard to eliminate amplifier clipping due to overdrive; digital sonic overload corrector to prevent the amplifier from exceeding an average of 0.3% distortion for overload stresses up to 10 dB; bridgeable to 200 W mono. Frequency response 20-20,000 Hz +0, -0.25 dB; THD 0.02%; signal-to-noise ratio 110 dB; IM 0.02%; damping

factor >90. 13¾ x 9¾ x 5½ in; 21 lb. \$995



McIntosh MC-754

MARK LEVINSON BY MADRIGAL

No. 20.5 100-W Mono Amplifier

Class-A highly biased mono amp with fully regulated power to all audio stages; internal spike and surge suppression; RF filtering of raw AC from outlet to reduce noise; separated positive and negative supply rails each with their own toroidal power transformer, full-wave bridge rectification, and filter capacitors to prevent cross modulation between rails; electronic regulation to refine power used by signal-carrying circuits; 3 high-current devices to drive output stage; electronic protection against abuse; all gain stages controlled at clipping; balanced inputs with Camac connectors; Neutrik XLR connector; internal switching to adjust for operation at 90-240 V AC; 100 W into 8 ohms, 200 W into 4 ohms. 17½ x 8¾ x 22 in; 90 lb. Faceplate available in 19-in width \$5,750

No. 23 100-W/ch Dual-Mono Amplifier

2 separate mono amps in single chassis; AC mains filtering; film capacitors; surge limiting; 2 power supplies for each L/R channel; oxygen-free copper bars supply output stage with +84-V DC rails; triple bypassing; output supply capacitance of 146,000 μfarads and 2-1.2 KVA transformers produce 240 joules of stored energy; full-wave bridge rectifier; independent tracking for + and - rails; only bipolar devices in gain stages; inverting input for full balanced connection; 50-kilohm imp through audio bandwidth; output stage operates in class AB; controlled clipping; external line and internal fuses; thermal sensors. 100 W/ch into 8 ohms, 200 into 4, 350 into 2; gain 26 dB; damping factor >700 (50 Hz ref to 8 ohms). \$4,975

No. 27 100-W/ch Dual-Mono Amplifier

Chassis contains two completely separate monaural amplifiers; raw AC current filtered by two separate circuits to remove unwanted frequency and to reduce transformer core saturation and mechanical hum; surge limiting circuit; 729 VA toroidal transformer in each channel; two separate power supplies for each channel; audio signal is processed through two Class A cascaded voltage gain stages and three current gain stages; cascaded differential input stage; class AB output stage. Camac connector or three-pin Neutrik XLR connector input. 200 W into 4 ohms, 350 W into 2 ohms; sens 141 mV; voltage gain 26 dB. Face plate also available in 19-in width \$3,495

ML-11 50-W/ch Amplifier

All discrete circuitry; Class-A operation in voltage gain and driver stages; Class AB2 operation in output

The listings are based on data provided by the manufacturers. For more product information, contact an authorized dealer or the manufacturer directly. Manufacturers' addresses and phone numbers are listed in the directory beginning on page 258.

More For My Money

I'd always thought you needed big speakers to get good sound. So every couple of years, some department store would have a sale and I would buy the biggest speakers I could find for the money. Then I moved across the country to take a new job. I left my old speakers behind. I was sure they wouldn't fit in my new apartment and I was ready for new ones anyway.

After the move, I went shopping for new speakers at a specialty hi-fi store near my apartment. I told the salesman to show me something under \$500. He took me into a room full of all kinds and sizes of speakers.

The first speakers he demonstrated were fantastic. The bass was big and tight. The stereo image was beautiful. Surely it was the biggest pair in the room.

"I don't have the room for those big speakers," I said. "And besides, I'm sure I can't afford them."

He stopped the demonstration to show me a KLIPSCH® kg², a compact and elegant model. "Yeah, this is more my size," I said, "let's hear a pair of these."

"You just did," he said.

I bought those kg²s. I paid a lot less than I had planned. And, believe me, I got a lot more for my money.

For your nearest KLIPSCH dealer, look in the Yellow Pages or call toll free, 1-800-223-3527.

 **klipsch**[®]
A LEGEND IN SOUND.™

P.O. BOX 688 • HOPE, ARKANSAS USA 71801

CIRCLE NO. 2 ON READER SERVICE CARD

POWER • AMPLIFIERS

stage. Power supply of 320 VA toroidal power transformer, 2 12-ampere bridge rectifiers, 4 10,000 μ F filter capacitors, for separate rectification and 20 joules of energy storage for each ch. Six 200 W, 15 ampere power transistors per ch enable ML-11, when pulsed, to develop 25 volts peak, at peak currents up to 12.5 amperes (312.5 W peak) per ch. Optional externally programmable voltage-limiting circuit reduces voltage output to protect speakers; gold-plated binding posts for output connections and Camac input connectors; hand-brushed black anodized front plintoe. 50 W/ch into 8 ohms, 100 W/ch into 4 ohms, 140 W into 8 ohms bridged. 8 $\frac{3}{4}$ x 19 x 12 in.; 25 lb. \$2,100

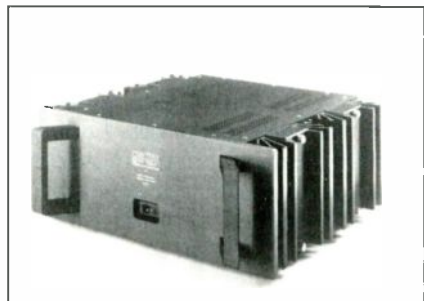

Mark Levinson Model 27

MELOS AUDIO

Modern Triode 400-W Mono Amplifier

Mono power amplifier with toroidal output transformers. Features Class AB output, 400 W cont avg into 8 ohms, 400 W cont avg into 4 ohms; FR 20-20,000 Hz at full power; dynamic headroom 3 dB \$4,500
Modern Triode 200. As above with 200 W cont avg into 8 ohms and 200 W cont avg into 4 ohms \$2,995

TM-100 ST 90-W/ch Amplifier

Stereo amplifier with toroidal output transformer. Features Class AB output, 90 W/ch cont avg into 8 ohms, 90 W/ch cont avg into 4 ohms; FR 20-20,000 Hz at full power; dynamic headroom 3 dB . \$1,995

TM-90 ST 80-W/ch Amplifier

Stereo power amplifier with toroidal power transformer, regulated power supplies using tubes and transistors. Wide bandwidth output transformers; triple triode driver tubes; LED indicators. 80 W/ch; THD <0.5%; FR 8-45,000 Hz \pm 1.5 dB; S/N 85 dB; sens at rated power 1.5 V. 17 $\frac{1}{2}$ x 7 $\frac{1}{2}$ x 13 $\frac{1}{2}$ in.; 50 lb \$1,595

MERIDIAN BY MADRIGAL

205 Model 100-W Amplifier

Class AA mono amplifier with toroidal high current power supply. Features full complimentary circuit design; "music sense" which turns on amplifier when music is detected. 10 W into 8 ohms. 4 x 6 $\frac{1}{4}$ x 14 in ea; 13 lb ea \$1,790/pr

MOTIF BY CONRAD JOHNSON

Motif MS200 200-W/ch Amplifier

With MOSFET output stage; extensive use of large-value polystyrene capacitors. 200 continuous average W/ch from 20-20,000 Hz with no more than 0.1%

THD into 8 ohms; FR 20-20,000 Hz \pm 0.10 dB; S/N 100 dB; 7 x 19 x 18 $\frac{1}{2}$ in.; 45 lbs. \$5,000
MS100. As above with 100 W/ch. \$3,250
MS50. Similar to MS200 except 50 W/ch \$2,350

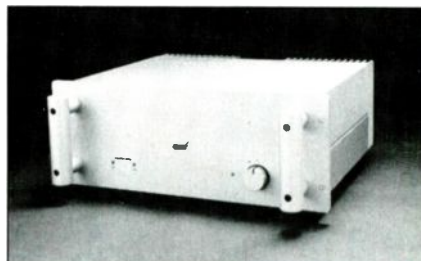

Motif MS100

NAD

2600A Monitor Series 150-W/ch Amplifier

Bridgeable amplifier with power envelope circuitry. Features high voltage; high-current capacity; close tracking soft clipping circuit. Speaker impedance selector; input level controls; normal/lab inputs. 150 W/ch rms; +4 dB dynamic headroom. Rack mountable \$799

2400 Monitor Series 100-W/ch Amplifier

Bridgeable amplifier with power envelope circuitry. Features soft clipping circuit. Input level controls; normal/lab inputs. 100 W/ch rms; +5.7 dB dynamic headroom. Rack mountable \$599

2100 Monitor Series 50-W/ch Amplifier

Bridgeable amplifier with power envelope circuitry. Features soft clipping circuit. Input level controls; normal/lab inputs; A, B, A+B speaker switching. 50 W/ch rms; +6 dB dynamic headroom. Rack mountable \$399



NAD 2600A

NAKAMICHI

PA-7AH 225-W/ch Amplifier

Features Stasis topology; utilizes two internal amplifiers for high- and low-impedance sources. 700-W toroidal power transformer; bridge rectifiers; electrolytic filters; 18 transistors per ch; Rib Framework chassis. 225 continuous average W/ch from 20-20,000 Hz with no greater than 0.05% THD into 8 ohms; 340 max W/ch into 8 ohms; FR 20-20,000 Hz +0, -0.2 dB; S/N >120 dB; damping factor >60; dynamic headroom 1.7 dB; power bandwidth 5-50,000 Hz (8 ohms, 112.5 W, 0.05% THD). 17 $\frac{3}{8}$ x 7 $\frac{7}{8}$ x 16 $\frac{1}{8}$ in; 62 lb, 13 oz \$2,195
PA-5AH. Similar to above but 150 W/ch. 17 $\frac{7}{8}$ x 6 $\frac{1}{2}$ x 16 $\frac{1}{8}$ in; 47 lb, 6 oz \$1,550



Nakamichi PA-7AH

NEC

Renaissance Series

MS-50 50-W Mono Amplifier

Single-channel power amp with 3 switch-selected inputs. Features variable-frequency low- and high-cut filters; vibration-free construction; large FL power meter; separate circuit construction; industrial-grade twin-crossbar relays with gold-plated contacts; sculptured brass terminals; heavy-duty speaker terminals. Rated power output 50 W into 8 ohms from 20-20,000 Hz with 0.004% THD, 100 W into 4 ohms with 0.006% THD; dynamic power 240 W into 2 ohms, direct input; frequency response 5-300,000 Hz; signal-to-noise ratio >115 dB (direct input). 8.3 x 4.7 x 15 in; 18 lb \$375

AV-210 20-W/ch A/V Surround Sound Amplifier

Amplifier integrates Dolby B and hall surround sound with digital delay circuitry. 15-key wireless remote control; 3 memory presets for volume and balance; headphone jack; input volume/balance control; surround level indicator. Frequency response 20-20,000 Hz; THD 0.3%; delay time 20 msec. 17 x 3 $\frac{1}{4}$ x 7 $\frac{1}{8}$ in; 9 lb \$299

NHT

VA-1 20-W/ch A/V Amplifier

Designed to accept audio signals from stereo TV's and drive stereo speakers. Features Class AB output; balanced line- and high-level inputs; stereo speaker outs; power and volume switches. Delivers 20-W/ch cont avg into 8 ohms, 30-watts per channel continuous average into 4 ohms from 20-25,000 Hz with 0.01% total harmonic distortion. High gloss black cabinet. 3 $\frac{1}{2}$ x 17 x 8 $\frac{3}{4}$ in; 7 lb \$150

NIKKO AUDIO

Alpha-2000 330-W/ch Amplifier

Amplifier with XLR cannon connectors for direct connections with mixing boards and to eliminate noise generating converters. Features horizontal back-lit meters; gold-plated terminals; 4-way protection circuits that shut down amplifier when heat, shorting, clipping, and stray DC problems occur. Frequency response 5-100,000 Hz +0 dB, -0.5 dB; total harmonic distortion 0.001% at rated power at 1,000 Hz; signal-to-noise ratio 120 dB; damping factor 200; dynamic headroom 1.8 dB. 19 x 7 $\frac{3}{8}$ x 18 $\frac{1}{8}$ in; 57 $\frac{1}{4}$ lb \$1,800

Alpha-800 250-W/ch Power Amplifier. As above with frequency response 5-100,000 Hz +0 dB, -2 dB; THD 0.005% at rated power at 1,000 Hz; signal-to-noise ratio 118 dB; damping factor 155; dynamic headroom 1.21 dB. 19 x 7 $\frac{3}{8}$ x 18 $\frac{1}{8}$; 50 $\frac{3}{4}$ lb . \$1,300

Alpha-600 180-W/ch Amplifier

Amplifier with Class AB circuits. Features magnetic flux-ring; anoxic-copper coils. Frequency response 5-100,000 \pm 0 dB; THD 0.004% at rated power at 1,000 Hz; signal-to-noise ratio 110 dB; damping factor 100; dynamic headroom 1.6 dB. 18 $\frac{3}{8}$ x 5 $\frac{1}{2}$ x 14 $\frac{1}{8}$ in; 30 $\frac{3}{8}$ lb \$760

Alpha-400 120-W/ch Amplifier. As above with THD 0.002% at rated power at 1,000 Hz; signal-to-noise ratio 115 dB; damping factor 50; dynamic headroom 1.0 dB. 18 $\frac{3}{8}$ x 5 $\frac{1}{2}$ x 14 $\frac{1}{8}$ in; 28 $\frac{1}{2}$ lb \$550

NUMARK

SA2200 225-W/ch Amplifier

Bridgeable stereo amplifier with dual self-resetting thermal breakers. Features LED clipping indicators and power switch circuit breaker with indicator light. 375 W/ch cont avg into 4 ohms; 225 W/ch cont avg into 8 ohms; 725 W/ch mono into 8 ohms; frequency response 20-20,000 Hz \pm 0.25 dB; total harmonic distortion < 0.05%; signal-to-noise ratio 105 dB; intermodulation distortion .02%; slew rate 50 V/ μ sec; damping factor 220. 5 $\frac{1}{4}$ x 19 x 15; 32 lb \$900

The listings are based on data provided by the manufacturers. For more product information, contact an authorized dealer or the manufacturer directly. Manufacturers' addresses and phone numbers are listed in the directory beginning on page 258.

POWER • AMPLIFIERS

ONIX BY MUSIC HALL

OA601 60-W/ch Amplifier
Stereo amplifier, 60 W/ch \$1,845

OA401 40-W/ch Amplifier
Stereo amplifier, 40 W/ch \$1,050

ONKYO

M-5160 150-W/ch Amplifier
Amplifier with Delta power supply and A/B speaker selector. 150-W/ch min rms into 8 ohms, frequency response 20-20,000 Hz; total harmonic distortion 0.09%; signal-to-noise ratio 100 dB; intermodulation distortion 0.09%; damping factor 40. 17 $\frac{1}{8}$ x 6 $\frac{1}{8}$ x 11 $\frac{1}{4}$ in; 21 lb. \$360

Integra Series

Grand Integra M-510 300-W/ch Amplifier
Dual-mono power amp with 1 ohm impedance drive capability. Features power supply with Real-Phase transformer to eliminate current fluctuations; high-current capability; 3 separate power supplies (left, right, aux for lights, meters etc.). Calibrated power meters w/ accuracy to 1 dB; adjustable meter sens. 300 W/ch min rms into 8 ohms; frequency response 20-20,000 Hz; total harmonic distortion 0.005%; signal-to-noise ratio 120 dB; intermodulation distortion 0.003%. 400 W/ch into 8 ohms; 500 W/ch into 4 ohms. Dynamic power 750 W/ch into 4 ohms, 1,300 W/ch into 2 ohms, 2,100 W/ch into 1 ohm. 20 x 10 $\frac{1}{2}$ x 21 in; 165 lb. \$4,500

Grand Integra M-508 200-W/ch Amplifier
Dual-mono power amp with low-impedance drive capability. Features Linear Switching power supply with Real-Phase transformer to eliminate current fluctuations; high-current capability. Calibrated high-speed power meters; peak-power meters; variable inputs with left/right channel level controls. 200 W/ch min rms into 8 ohms; frequency response 20-20,000 Hz; total harmonic distortion 0.003%; signal-to-noise ratio 120 dB; intermodulation distortion 0.003%; damping factor 140. Dynamic power 460 W/ch into 4 ohms, 685 W/ch into 2 ohms, 860 W/ch into 1 ohm. 18 $\frac{1}{4}$ x 7 $\frac{1}{4}$ x 16 $\frac{3}{4}$ in; 55 lb. \$1,200

Integra M-504 165-W/ch Amplifier
Dual-mono power amp with low-impedance drive capability. Features Linear Switching power supply with Real-Phase transformer to eliminate current fluctuations; high current capability. High-speed peak-power meters; heavy-duty speaker terminals. 165 W/ch min rms into 8 ohms; frequency response 20-20,000 Hz; total harmonic distortion 0.003%; signal-to-noise ratio 120 dB; intermodulation distortion 0.003%; damping factor 140. Dynamic power 350 W/ch into 4 ohms, 530 W/ch into 2 ohms. 18 $\frac{1}{4}$ x 7 $\frac{1}{4}$ x 16 $\frac{3}{8}$ in; 46 lb. \$830
CW-M504. Wood sidepanels for above \$85

Integra M-502 140-W/ch Amplifier
Dual-mono power amp with low-impedance drive capability. Features Linear Switching power supply; 4-way speaker selector. 140 W/ch min rms into 8 ohms; frequency response 20-20,000 Hz; total harmonic distortion 0.005%; signal-to-noise ratio 120 dB; IM 0.004%; damping factor 140. Dynamic power 290 W/ch into 4 ohms, 425 W/ch into 2 ohms. 17 $\frac{1}{8}$ x 7 $\frac{1}{4}$ x 16 $\frac{1}{2}$ in; 41 lb. \$650



Onkyo M-508

PARASOUND

HCA2200 200-W/ch Amplifier
High-current discrete amplifier. Features 24 output devices; 1,000 V toroidal transformer; bridgeable to 500 W mono. Gold-plated input jacks; 5-way terminals. frequency response 5-100,000 Hz; dynamic headroom 1.5 dB \$895

HCA-80011 90-W/ch Amplifier
High-current discrete amplifier. Features 60-MHz outputs; gold-deposited 36,000 μ F electrolytic capacitors; mono bridging with rear-panel switch; gold-plated RCA jacks; $\frac{1}{4}$ -in phone jack; 5-way terminals; front panel level controls; speaker A/B terminals; headphone jack; relay protection 19-in rack mountable. Frequency response 20-20,000 Hz \pm 0.5 dB; total harmonic distortion <0.1%; signal-to-noise ratio > 104 dB; intermodulation distortion <0.1%; damping factor >120. 17 $\frac{1}{4}$ x 3 $\frac{3}{4}$ x 11 $\frac{3}{4}$ in ... \$395

HCA-500 45-W/ch Amplifier
High-current discrete amplifier. Features no integrated circuits; oversized power transformer; RCA jacks; $\frac{1}{4}$ -in phone jacks; 5-way terminals; front panel level controls; relay protection indicator; 19-in rack mountable. Frequency response 20-20,000 Hz \pm 0.5 dB; total harmonic distortion <0.25% signal-to-noise ratio > 100 dB; IM <0.2%; damping factor >85. 17 $\frac{1}{4}$ x 3 $\frac{3}{4}$ x 11 $\frac{3}{4}$ in. \$285

PIONEER

Elite M-91 200-W/ch Amplifier
Features honeycomb heat sink; film condenser; regulated power supply; CD-direct input; 200 W/ch into 8 ohms; frequency response 20-20,000 Hz; total harmonic distortion 0.003% \$1,300

VSA-1000 100-W/ch Amplifier
100 W/ch cont avg from 20-20,000 Hz into 8 ohms with no more than 0.005% total harmonic distortion. 16 $\frac{1}{2}$ x 6 $\frac{1}{8}$ x 16 $\frac{1}{2}$ in. \$1,000

A-757 Amplifier
120 W/ch cont avg from 20-20,000 Hz into 8 ohms with no more than 0.003% total harmonic distortion. 16 $\frac{1}{2}$ x 6 $\frac{3}{4}$ x 18 $\frac{3}{4}$ in. \$750



Pioneer Elite M-91

PROTON

D1200 100-W/ch Amplifier
Stereo amplifier with Dynamic Power on Demand (DPD) to deliver as much as 1,500 W/ch (2 ohms) at peak demand, with 6 dB headroom. Features one-touch bridging and wide-range power-output meters. 16 $\frac{1}{2}$ x 4 $\frac{1}{4}$ x 9 $\frac{3}{4}$ in; 33 lb \$699

AA-1150 50-W/ch Amplifier
Dual-mono amplifier with Dynamic Power on Demand (DPD) to deliver up to 450 W/ch at peak demand, with 7 dB headroom. Features separate power supplies/ch; dual peak-level power meters; LED DPD indicator; protection circuitry; gold-plated connectors; high-current capacity; power switch. Signal-to-noise ratio 115 dB; total harmonic distortion 0.02%; intermodulation distortion 0.02%; damping factor >150. 19 x 4 $\frac{1}{4}$ x 14 $\frac{1}{2}$ in; 25.3 lb ... \$499

PS AUDIO

200C X 200-W/ch Amplifier
Stereo amplifier with Class AB outputs. Features large 5-way binding posts; gold-plated input jacks. 200 W/ch into 8 ohms, 400 W/ch into 4 ohms; total harmonic distortion 0.02%; signal-to-noise ratio -100 dB; slew rate 250 V/ μ sec; damping factor 200. 19 x 6 x 19 in; 69.9 lb \$1,950

100C 120-W/ch Amplifier
Stereo amplifier with Class AB outputs. Features 5-way binding posts; gold-plated input jacks. 120 W/ch into 8 ohms, 200 W/ch into 4 ohms; total harmonic distortion 0.02%; signal-to-noise ratio -100 dB; slew rate 250 V/ μ sec; damping factor 200. 19 x 6 x 15 in; 35 lb. \$1,195

QUAD

Model 606 140-W/ch Amplifier
Power amp with feed-forward error correction (current dumping) combines clarity of Class A operation with efficiency of Class B. Protection circuitry uses a sensor on AC-input side of power supply to integrate current over time. No fuses or relays located in signal path; total harmonic distortion (continuous sine wave in 8 ohm resistive load any level up to 130 W) <0.01% at 20 Hz, <0.01% at 1,000 Hz, <0.03% at 20,000 Hz; frequency response 20-20,000 Hz -0.25 dB. 12 $\frac{3}{4}$ x 5 $\frac{1}{2}$ x 9 $\frac{1}{2}$ in; 27 lb. \$1,295

Model 306 60-W/ch Amplifier
Power amp with feed-forward error correction (current dumping) combines clarity of class A operation with efficiency of class B. Protection circuitry uses a sensor on AC input side of power supply to integrate current over time. No fuses or relays located in signal path. total harmonic distortion (continuous sine wave in 8 ohm resistive load any level up to 50 W) <0.01% at 20 Hz, <0.01% at 1,000 Hz, <0.03% at 20,000 Hz; frequency response 20-20,000 Hz -0.25 dB. 12 $\frac{3}{4}$ x 2 $\frac{3}{4}$ x 8 $\frac{1}{4}$ in; 11 lb. \$695

QUICKSILVER AUDIO

60-W Mono Tube Amplifier
Hand-wired, tube-type amplifier using no transistors or circuit boards. 60 continuous average W from 20-20,000 Hz into 8 or 4 ohms. Can drive 0.5 ohm loads. 30 lb; 9 $\frac{1}{4}$ x 6 x 14 $\frac{3}{8}$ in. \$925

REVOX

B242-S 200-W/ch Amplifier
High-output power amp capable of driving loads from 2-8 ohms at rated levels. Features dual independent power supplies; IX voltage control; electronic short-circuit protection; temperature sensor to activate fan cooling; auto on/off switching responds to signal from preamp; 4/8 ohm speaker output switch; LED bar-graph output meter; heavy-duty output connectors. 200 continuous average W/ch from 20-20,000 Hz with no more than 0.03% total harmonic distortion, 300 W into 4 ohms; frequency response 20-20,000 Hz \pm 0, -0.3 dB; dynamic headroom 2.5 dB into 8 ohms; signal-to-noise ratio 117 dB unbalanced, 114 dB balanced; damping factor 200 (1 kHz 8 ohms); sep 80 dB at 1,000 Hz. Dimensions: 17 $\frac{3}{4}$ x 6 x 14 $\frac{1}{4}$ in; 37.5 lb. \$3,500
B242. As above, different cosmetics \$3,000

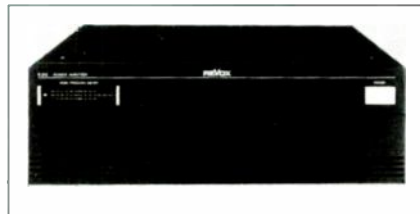

Revox B242

POWER • AMPLIFIERS

ROTEL

RB870BX 100-W/ch Amplifier

100 W/ch stereo amplifier bridgeable with RA870 (integrated amp) for 300 watts mono. Frequency response 4-100,000 Hz +0.5 dB, -3.0 dB; total harmonic distortion <0.03% from 20-20,000 Hz; signal-to-noise ratio 110 dB; intermodulation distortion <0.03%; damping factor 180. 17½ x 4¾ x 13¾; 20 lb \$499

RB850 50-W/ch Amplifier

50 W/ch into 8 ohms bridgeable to 150 W mono. Frequency response 4-100,000 Hz +0.5 dB, -3.0 dB; total harmonic distortion <0.03%; signal-to-noise ratio 110 dB; IM <0.05%; damping factor 180. 17½ x 3¾ x 12¾ in; 19 lb \$299



Rotel RB870BX

ROWLAND RESEARCH

Model 5 150-W/ch Amplifier

Solid-state power amp with FET front-end circuitry and bipolar outputs. Features direct-coupled zero-negative-feedback circuitry; separate power supplies; toroidal power transformer with 164,000-microfarad total capacitance; remote AC power switching; internal universal voltage switch; balanced or unbalanced inputs standard with XLR connector; adjustable input imp; Class A operation to over 35 watts; 150 W/300 W/475 W rms into 8/4/2 ohms; total harmonic distortion <0.03%, 1,000 Hz, 20 W; slew rate 75 V/μs; damping factor >175. 20-20,000 Hz. 19 x 8¾ x 24 in; 128 lb \$5,500

Model 7 350-W Mono Amplifier

Solid-state mono power amp with FET front-end circuitry and bipolar outputs. Features direct-coupled zero-negative-feedback circuitry to eliminate all capacitors and inductors from signal path; separate power supplies for front-end circuitry; toroidal power supplies with 132,000-microfarad capacitance for over 500 joules of energy; remote AC power switching; internal voltage switching (100V-240V AC). Balanced or unbalanced inputs standard with XLR connector. Adjustable input imp for optimum input cable termination 350 W/700 W/1100 W rms into 8/4/2 ohms. Class A operation to over 50 watts; total harmonic distortion <0.015%, 1,000 Hz, 20W; slew rate 50 V/μs; damping factor >300. 20-20,000 Hz; 19 x 8¾ x 24 in; 160 lb ea. \$4,900

Model 1 60-W/ch Amplifier

Features differential mode and single-ended inputs for a maximum preamplifier compatibility, single gain stage with no negative feedback; single-stage differential FET circuitry utilizing no input, coupling or compensation capacitors; 600 VA toroidal transformer to power 24 150W bipolar output transistors; 60 W/120 W/215 W rms into 8/4/2 ohms. bridgeable to produce over 220 W into 8 ohms; total harmonic distortion <0.25%, 1,000 Hz, 20 W; slew rate 70 V/μs; damping factor >200. 20-20,000 Hz. 17 x 5¾ x 15 in; 72 lb \$2,950

Model 3 100-W Mono Amplifier

Solid-state power amp with bipolar outputs with FET inputs. Features direct-coupled zero-negative-feedback circuitry; separate power supplies for front-end; toroidal power transformer stable to 1 ohm; remote power switching; balanced or unbalanced inputs standard; adjustable input imp; 100 W/200 W/320 W

rms into 8/4/2 ohms; THD <0.03%, 1,000 Hz, 20 W; slew rate 45 V/μs; damping factor >120. 20-20,000 Hz. 15¼ x 5¼ x 14 in; 72 lb \$2,275

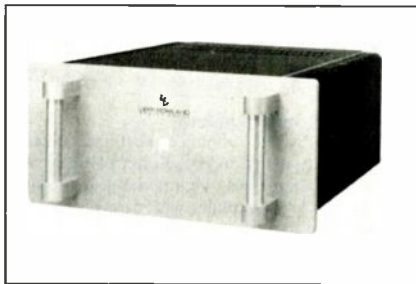

Rowland Model 5

SAE

X10A 100-W/ch Amplifier

Class A stereo amplifier. Features gold-plated connectors; toroidal transformer; LED power meters; anodized gray finish; wide/narrow band inputs. 100 continuous average W/ch from 20-20,000 Hz with no more than 0.025% total harmonic distortion into 8 ohms; frequency response 20-20,000 Hz ±0 dB; signal-to-noise ratio 110 dB; slew rate 20 amps/μs; dynamic headroom 1.2 dB; IM 0.02%. 19 x 3½ x 12½ in; 28 lb \$900

A502 200-W/ch Amplifier

Stereo amplifier with automatic bridging circuit. Features dual-speaker system switching; peak and average LED power display; rack mountable. 200 cont avg W/ch from 20-20,000 Hz with no more than 0.025% total harmonic distortion into 8 ohms; 600 W mono operation; frequency response 20-20,000 Hz ±0 dB; S/N 110 dB; dynamic headroom 1.2 dB; IM 0.025%. 19 x 5¼ x 14 in; 48 lb \$799

A202 100-W/ch Amplifier

Stereo amplifier with balanced, discrete outputs. Features dual-speaker switching; peak; average level LED display; rack mountable. 100 cont avg W/ch from 20-20,000 Hz with no more than 0.025% total harmonic distortion into 8 ohms; frequency response 20-20,000 Hz ±0 dB; signal-to-noise ratio 110 dB; dynamic headroom 1.2 dB; IMD 0.025%. 19 x 3½ x 14 in; 31 lb \$499

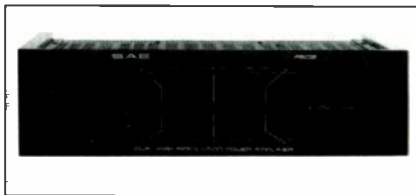

SAE A502

SANSUI

B-2102MOS 110-W/ch Amplifier

Features diamond differential circuit with a cascode configuration; X-balanced circuitry; MOSFET's; rapid switching speed; pure copper insulators; low output impedance. 5 pair of inputs (3 variable, 2 fixed); speaker A, B. 110 W/ch min rms into 8 ohms; total harmonic distortion < 0.008%; frequency response 1x-300,000 Hz +0/-3 dB; signal-to-noise ratio >110 dB; damping factor 100 at 8 ohms; slew rate ±150 V/μsec; rise time 0.5 μsec. 17¾ x 6¾ x 18¾ in; 77 lb. Black-matte finish \$3,750

B-2102 200-W/ch Amplifier

200 W/ch min rms into 8 ohms; FR 20-20,000 Hz; total harmonic distortion 0.003%; IM <0.003%; damping factor 100 into 8 ohms; slew rate ±350 V/μsec; signal-to-noise ratio 115 dB; ch sep 100 dB. 17 x 6¾ x 16¼ in; 39 lb \$1,200

B-3000 120-W/ch Amplifier

Features DC servo circuit; separate heat sinks for left and right channels; short detection; zero voltage detection; thermal detection. 2 power meters; range control; headphone jack; outputs for 2 speaker systems. 120 W/ch into 8 ohms; frequency response 20-20,000 Hz; total harmonic distortion 0.05%; IM 0.01%; signal-to-noise ratio 120 dB \$260

B-1000 75-W/ch Amplifier

Features DC servo circuit; separate heat sinks for left and right channels; short detection; zero voltage detection. 2 power meters; range control; headphone jack; outputs for 2 speaker systems. 120 W/ch into 8 ohms; frequency response 20-20,000 Hz; total harmonic distortion 0.05%; IM 0.01%; signal-to-noise ratio 120 dB \$210

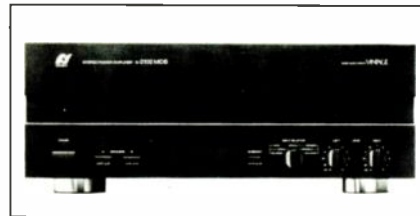

Sansui B-2102MOS

SHERWOOD

AM-7040 200-W/ch Amplifier

Amplifier with high-speed MOSFET output stage with high-instantaneous-current capacity. Features complete relay protection; independent left and right power transformers; variable and fixed inputs; complementary symmetry input stage with matched transistor pairs; overload protection; heavy gauge conductors. Power-level indicator; video sound input; loudness control. 200 W/ch min rms into 8 ohms; frequency response 20-20,000 Hz; total harmonic distortion < 0.025%; IMD 0.015%; damping factor 170 dB; S/N 125 dBA; ch sep at 1,000 Hz 70 dB. 6¾ x 17¾ x 15¾ in \$699

SONOGRAPHE BY CONRAD-JOHNSON

SA120 120-W/ch Amplifier

Features MOSFET output stage; 120 W/ch into 8 ohms; signal-to-noise ratio 100 dB; 5¾ x 18 x 12 in. . \$895

SONY

Elite Series

TA-N77ES 270-W/ch Amplifier

Features spontaneous twin-drive power supply; low-impedance drive capability; mono operation at 580 W into 8 ohms from 20-20,000 Hz with 0.007% total harmonic distortion; chimney-style heatsinks; fixed and variable inputs 2 independent protection circuits; peak-level power meters; 2 sets of speaker terminals. 270 W continuous into 4 ohms, 20-20,000 Hz with 0.006% THD; damping factor 100; slew rate 150V/μsec, 300V/μsec (inside) \$1,200

TA-N110 45-W/ch Amplifier

Features 45 W/ch into 8 ohms from 20-20,000 Hz with 0.08% total harmonic distortion; 3 built-in

The listings are based on data provided by the manufacturers. For more product information, contact an authorized dealer or the manufacturer directly. Manufacturers' addresses and phone numbers are listed in the directory beginning on page 258.

A unique sonic signature from Acoustat.
 Remarkable sound, but then so is the price.
 For under \$1000 your listening pleasure
 can begin this fall.

SPECTRA

ACOUSTAT

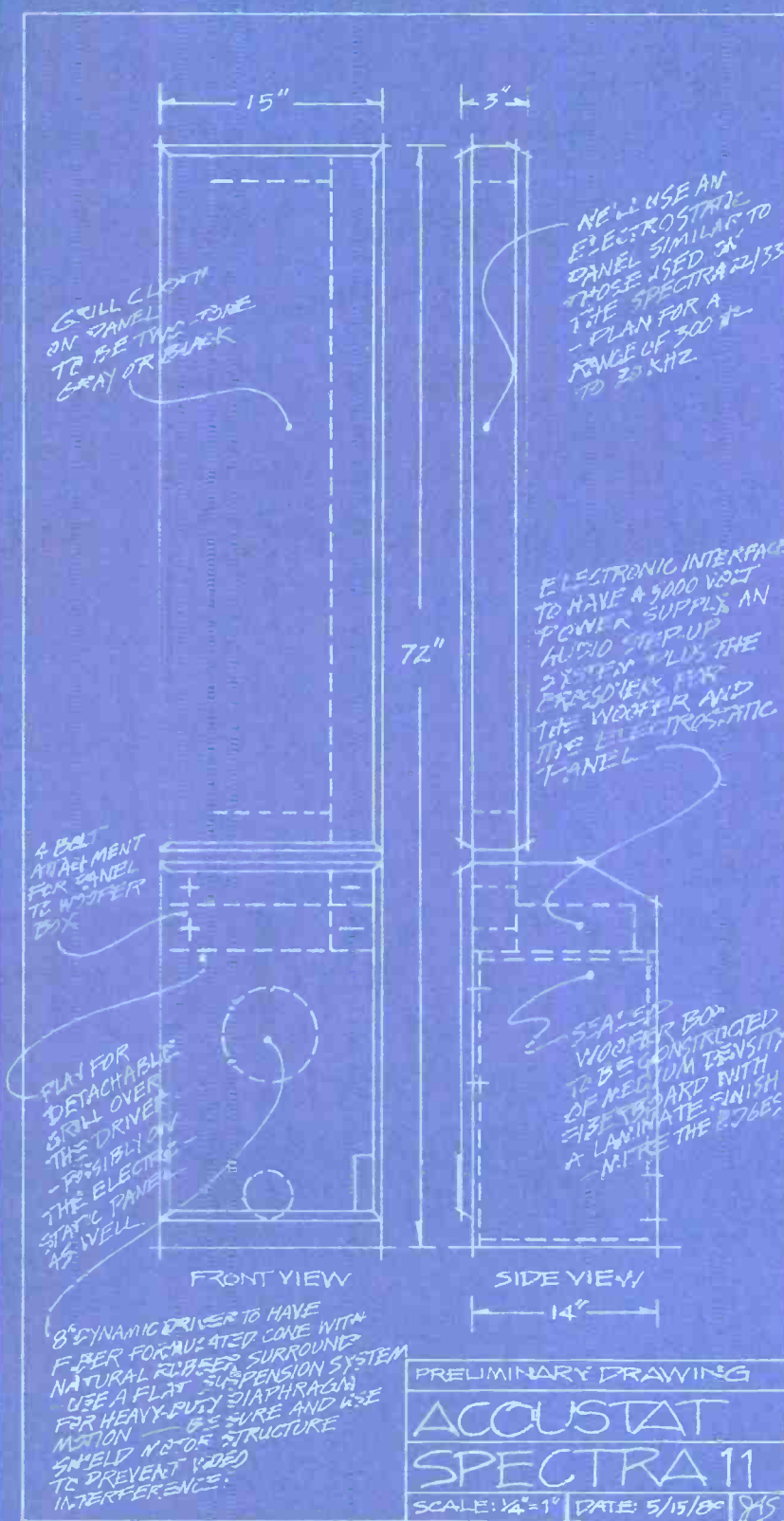

ACOUSTAT
 A division of Rockford Corporation
 Tempe, Arizona 85283
 For the dealer nearest you call 1-800-366-1619

“It is so clearly superior to past amplifiers in the low- to mid-priced range—not to mention most amplifiers two to three times its price—that I can unhesitatingly recommend it for even the most demanding high end system.”

Anthony Cordesman

stereophile

volume 8, no. 4

ADCOM GFA-555

High Power, High Current.

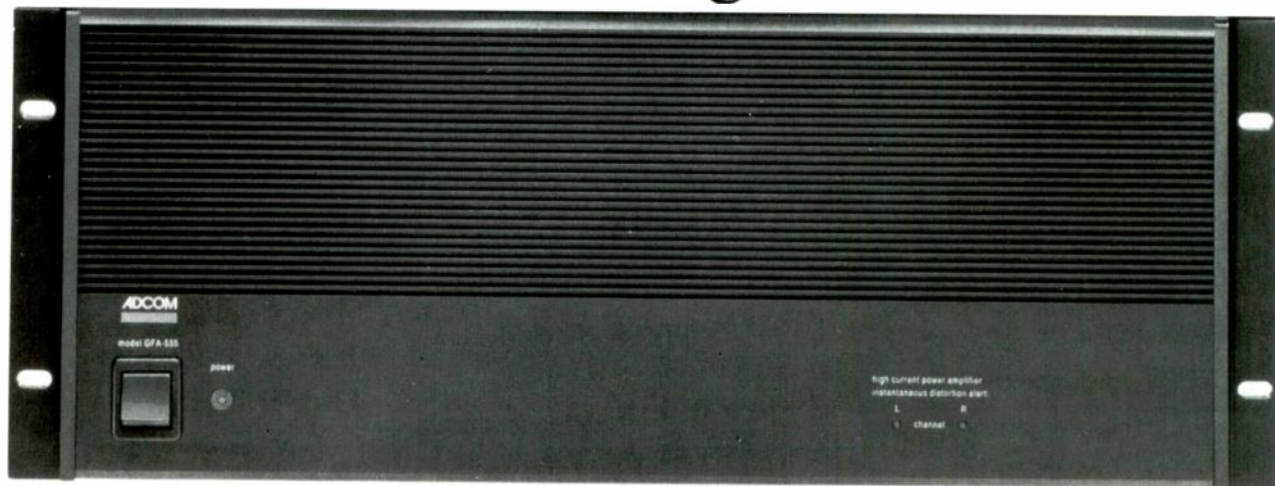

The complete review:

A BEST-BUY BREAKTHROUGH OR THE START OF A NEW WAVE?

I am reluctant to call any given transistor power amp a "best buy" or breakthrough. From my talks with designers and other audiophiles, it is clear that the state of the art in power amplifiers is about to change. From where I stand, the Adcom GFA-555 is the first sample of this new wave. It is so clearly superior to past amplifiers in the low- to mid-priced range—not to mention most amplifiers two to three times its price—that I can unhesitatingly recommend it for even the most demanding high end system.

The GFA-555 does everything well, and most things exceptionally well. It provides superb, well-controlled bass with far better speaker load tolerance than most amps. Its midrange and treble are remarkably low in coloration. There is no hint of hardness, and none of the loss of inner detail common to transistor amplifiers.

"The Adcom's soundstage is sufficiently superior that even those who claim all power amplifiers sound alike might hear the difference."

With the exception of the Krells, I have never heard a more detailed, natural, and extended upper four octaves in a transistor amp. The Adcom may even be a legitimate rival to the Krell; it's brighter and more dynamic, and somewhat more open. And, like the Krell, it gives the impression, on really good material, that the amplifier simply isn't there, on really good material. Nor is the Adcom romantic or sweet, like New York Audio's new Moscodes. Rather, it offers natural upper octave detail that the latter miss. Other amplifiers have similar upper octave performance, but I unhesitatingly recommend the Adcom over the very stiff competition from Tandberg and Threshold.

The Adcoms' soundstage is sufficiently superior that even those who claim all power amplifiers sound alike might hear the difference. It comes very close to the better tube power amplifiers in providing detailed, stable, realistic imaging with natural depth. It is not an Audio Research D-250, but is extraordinarily holographic—I suspect almost embarrassingly so. This kind of soundstage has previously cost at least \$2000.

I am also highly impressed with this amplifier's dynamics. Once again, it is not going to survive a one-on-one with the Audio Research D-250 or Conrad Johnson Premier Fives, but it rivals any transistor power amplifier in its power class that I have heard—including high-powered receivers or amps with trick power supplies—at any price. It provides these dynamics into virtually any load without bloat, restriction of sound, or change in timbre. For all the nonsense published by most manufacturers about driving complex loads, this amplifier actually delivers.

The Adcom does not lose sweetness and detail as its power goes up. I am normally leery of transistor amplifiers rated much above 100 watts; they too often blur detail and harmonic information, and this sonic price tag is far more costly than the added power is worth. This does not happen with the Adcom unless the distortion lights are blinking, and they only blink when the amp is delivering well over its rated 200 watts per channel (8 ohms) or 325 watts (4 ohms). By comparison, once-outstanding high power amplifiers like the Hafler DH-500 now sound annoyingly veiled.

With a minor dealer modification, you can even drive 1 ohm loads like the Scintilla. I can't measure whether the Adcom delivers its rated 800 watts per channel into 2 ohms, or 20 amps peak, but I can tell you that it does a superb job of driving this superb speaker. Anything in its price range (or even close) generally changes timbre and degenerates when driving the Scintilla at 1 ohm.

"For all the nonsense published by most manufacturers about driving complex loads, this amplifier actually delivers."

I'm going to have to say a few words about its technology before I give Adcom a swelled head. You'll be happy to note that the manufacturer claims for the GFA-555 a simple gain path, a 700 watt toroidal transformer, a well-regulated high current power supply, new ultra-stable bias circuitry, direct coupling, no current limiting, and no output inductor. More substantively, its harmonic shape mixes suitable yinyang while avoiding the curse of pyramidology. This, of course, means that it weighs 34 pounds, has simple rack-mount black styling, pilot lights, warning lights (to indicate distortion levels above 1%), and measures exactly 7 $\frac{1}{16}$ " by 12 $\frac{1}{4}$ " by 19".

More pragmatically, the technical specifications are significant in that they represent reasonable bandwidth (4-150,000 Hz), damping (150-200), gain (27 dB), and noise (-106 dB). Of these, only the noise specification is outstanding. No attempt is made to beat distortion records: .09% THD at rated power into 8 ohms, and .25% into 4. I have heard so many power amplifiers with infinitely (well, an order of magnitude) better specifications sound so much worse; this may be the amplifier whose sound could convince *Stereo Review*, *High Fidelity*, etc. that their present measurements are virtually worthless.

I suspect that the Adcom is going to force many designers in the \$1000-1500 range to either make radical improvements in their products over the next six months, or look at the possibility of retiring from competition. This is a "must" amplifier to audition before you spring for anything close in

"I suspect that the Adcom is going to force many designers in the \$1000-1500 range to either make radical improvements in their products... or look at the possibility of retiring from competition."

price. If the Adcom is simply the first of a whole wave of good amplifiers, it will help revitalize the high end for the average audiophile, and force most manufacturers into more reasonable pricing. Now, Adcom, if you can only come up with a preamp as good!

AHC

ADCOM[®]

fine stereo components

11 Elkins Road, East Brunswick, NJ 08816
U.S.A. (201) 390-1130
Distributed in Canada by: PRO ACOUSTICS INC.
Pointe Claire, Quebec H9R 4X5

Manufacturer's note: Approximate retail prices listed in order of mention in review:

Adcom GFA-555	\$ 750
Krell	2300-7500
N.Y. Audio Moscode	900-1600
Tandberg	1000-2000
Threshold	1490-3150
Audio Research D-250 (MK II)	6000
Conrad Johnson Premier 5 (pair)	6000
"high powered receivers"	?
"amps with trick power supplies"	?
Hafler DH-500	850

POWER • AMPLIFIERS

digital delay modes; variable delay times; built-in video switching capability; input attenuator; 3-way input switch; 2 sets of speaker terminals. 100 W continuous into 8 ohms, 20-20,000 Hz with 0.08% total harmonic distortion. \$300

SOUNDCRAFTSMEN

A5002 250-W/ch Amplifier

Power amplifier with Class H Vari-Proportional circuitry and autobuffer for continuous operation into 2 ohms, 4 ohms, and 8 ohms. Features auto crowbar-protection circuit for output protection without current limiting; 20 LED/channel indicators; front-panel switching for 2 pairs of speakers; clipping indicators; input level controls. Output power 250 watts per channel into 8 ohms, 375 watts per channel into 4 ohms continuous rms, 20-20,000 Hz at <0.09% total harmonic distortion; signal-to-noise ratio >105 dB; slew rate >50 V/ μ s; TIM <0.02%; dynamic headroom >2 dB. \$949

Pro-Power Four 205-W/ch Amplifier

Ultra-high-current MOSFET power amp with dual 20-segment LED clipping indicators. 2-pair speaker switching. 205 continuous average W/ch from 20-20,000 Hz into 8 ohms with no more than 0.05% total harmonic distortion. 300 W/ch into 4 ohms, 450 W/ch into 2 ohms; signal-to-noise ratio 105 dB; slew rate 40 V/ μ s; intermodulation distortion 0.05%. 19 x 5 1/4 x 11 in; 28 lb. \$849

Pro-Power Three. As above without level controls and LED meters. \$749

Pro-Reference Two 100-W/ch Amplifier

MOSFET stereo power amp with 20-LED power meters. Features switching for 2 pairs of speakers; clipping indicators; brushed aluminum with charcoal finish rack-mount front panel. Output power 100 W/ch into 8 ohms, 200 W/ch into 4 ohms, continuous rms, 20-20,000 Hz at <0.05% total harmonic distortion; signal-to-noise ratio >105 dB; damping factor 200. \$699

Pro-Reference One. Same as above without LED meters. \$599

PCR800 205-W/ch Amplifier

Phase-control-regulation MOSFET stereo power amp. 205 W/ch continuous rms; 20-20,000 Hz into 8 ohms; total harmonic distortion 0.05%; signal-to-noise ratio >105 dB; 18 lb; 8 1/4 x 5 x 12 in. \$539

Pro-Power One Amplifier. Same as above except high current circuitry added for 300 W/ch at 4 ohm; 450 W/ch at 2 ohm. \$579

SOUNDSTREAM

DA-1 200-W/ch Amplifier

System 1 component features fully discrete Darlington transistor circuitry to minimize need for current limiting; bridgeable to 600 W mono into 8 ohms. Drives up to 4 pairs of speakers simultaneously; dual front-panel overload indicators; optional RSS-2 speaker selectors can be used singly or daisy-chained, allowing up to 4 pairs of speakers to be controlled by the R-1 remote. Frequency response 20-20,000 Hz \pm 0.1 dB; signal-to-noise ratio >110 dBA; total harmonic distortion <0.1%; slew rate >35 V/ μ sec. 17 x 5 7/8 x 14 in; 35 lb. \$1,195

SPECTRASCAN

BPA-101B 100-W/ch Amplifier

Stereo amplifier with proprietary nested, multiple feedback loops. Features DC-coupling with highly regulated power supply; protection circuit; L/R ch clipping indicator. 100 W/ch into 8 ohms, 174 W/ch into 4 ohms; switchable to bridge operation for 350 W mono into 8 ohms frequency response 2-120,000 Hz; total harmonic distortion 0.07%; signal-to-noise ratio 98 dB; intermodulation distortion 0.07%; Slew rate 40 V/ μ sec; damping factor 200. 5 1/4 x 19 x 14 in; 40 lb. \$1,895

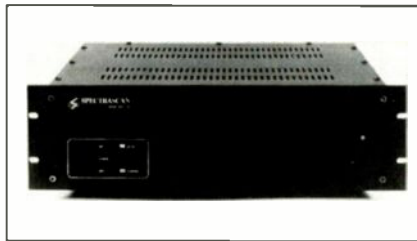

Spectrascan BPA-101B

SUMIKO

BA1 85 W/ch Amplifier

Dual mono amplifier with Class A operation. 85 W/ch into 8 ohms; 170 W/ch into 4 ohms; frequency response 20-20,000; total harmonic distortion 0.09%; imp 0.5 ohms; dynamic headroom 2.2 dB. 47 lb. \$6,000

BA2 70-W/ch Amplifier

Dual mono amplifier with Class A operation. 70 W/ch into 8 ohms; 140 W/ch into 4 ohms; frequency response 20-20,000; total harmonic distortion 0.09%; imp 1 ohms; dynamic headroom 2 dB. 27 lb \$3,000

BA3 50-W/ch Amplifier

Amplifier with 50 W/ch into 8 ohms; 90 W/ch into 4 ohms; frequency response 20-20,000; total harmonic distortion < 0.1%; dynamic headroom 2 dB \$1,800

SUMO

Andromeda II 200-W/ch Amplifier

Class AB MOSFET amp, fully balanced from input to output. Operates as a pure Class A amplifier except at the Class AB output stage. 400 W/ch into 4 ohms; THD 0.05% into 8 ohms, 0.1% into 4 ohms; IM 0.05%; rise time 2 μ sec; slew rate 115 V/ μ sec; damping factor >500. 19 x 7 x 16 3/4 in; 55 lb \$1,499

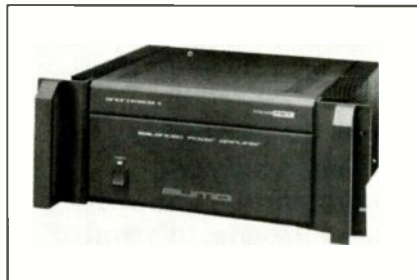

Sumo Andromeda II

The Nine Plus 65-W/ch Amplifier

Class A power amp without any active bias circuits or thermal tracking networks. Features balanced-bridge configuration; push-pull quadrature feedback circuits; discrete Darlington output stage; direct-coupled circuitry from input to output. Power output 65 W/ch into 8 ohms from 20-20,000 Hz with <0.1% total harmonic distortion; 120 W/ch into 4 ohms from 20-20,000 Hz with <0.2% total harmonic distortion; intermodulation distortion 0.05% from 0.25 W to rated output; input sensitivity for rated output 1.0 V rms; damping factor >150. 19 x 8 3/4 x 7 in. \$1,299

Polaris 100-W/ch Amplifier

Class AB amp that operates in Class A except at the Class AB output stage. MOSFET output devices. 175 W/ch into 4 ohms; total harmonic distortion 0.05% into 8 ohms, 0.1% into 4 ohms; intermodulation distortion 0.05%; rise time 2 μ sec; input imp 47,000 ohms; damping factor >500. 19 x 5 1/4 x 8 3/4 in \$749

Ulysses 60-W/ch Amplifier

Class AB MOSFET amp. Proprietary linearizing circuit

pure Class A gain stage; bridgeable to 180 W mono into 8 ohms. 60 W/ch into 8 ohms; FR 20-20,000 Hz; total harmonic distortion <0.05%; intermodulation distortion < 0.05%; input imp 47,000 ohms; damping factor >500; slew rate 85 V/ μ sec; rise time <2 μ sec. 19 x 13 x 3 1/2 in; 25 lb. \$549

SUPERPHON

Maxx 80B 40-W/ch Amplifier

Solid-state amp with MOSFET input and large signal gain stages. MOSFET outputs. 250 W toroidal power transformer. 80 W/ch into 4 ohms. Bridges to 160 W into 8 ohms, 250 W into 4 ohms. 40,000 μ F storage capacitance. Frequency response DC-100,000 Hz; input imp 50,000 ohms; damping factor >200. 6 1/2 x 6 x 9 in; 12 lb. \$499

TECHNICS

SE-A100 170-W/ch Amplifier

Features 1 voltage and 1 current amplifier per ch; Class AA bridge circuitry; massive power supply; 3 transformers (left-ch current amp, right-ch current amp, L/R voltage amps) using 1:1:1 windings; 91,200- μ F filtering; magnetic isolation; vibration damping. 170 W/ch into 8 ohms; dynamic headroom 0.7 dB. 17 x 8 1/4 x 18 3/4 in; 70 lb. \$1,900

SE-A5MK2 150-W/ch Amplifier

Features computer drive to neutralize transient crossover distortion; parallel 3-stage Darlington output; power-linear circuit to compensate for speaker imp variation; power-output meters. 150 W/ch into 8 ohms; frequency response DC-150,000 Hz \pm 0/-3 dB; intermodulation distortion 0.002%; damping factor 100. 17 x 7 x 16 3/4 in; 40.6 lb. \$1,100

SE-M100 115-W/ch Amplifier

Power amplifier with 8x-oversampling digital filter and four 20-bit D/A converters. Features digital-direct drive with unity gain power amp circuit; twin-mono construction. Optical and coaxial digital outputs. Amp section: 115 W/ch min rms into 8 ohms; total harmonic distortion 0.005%; frequency response 20-20,000 Hz; damping factor 110; signal-to-noise ratio 98 dB. Digital section: total harmonic distortion 0.005% at 1,000 Hz; signal-to-noise ratio 100 dB; frequency response 2-20,000 Hz \pm 0.3 dB. 17 x 6 1/4 x 15 1/2 in; 35.2 lb. \$1,100

THRESHOLD

SA/12e Stasis 275-W Mono Amplifier

Noninverting complimentary-symmetry mono amp with J-FET in front-end signal path and proprietary STASIS output stage; binary topology in pure Class A voltage amp connected directly to the loudspeaker load and operated in conjunction with a high-ampere current mirror also operated in pure Class A; output stage bias accuracy is maintained through Threshold's proprietary optical-bias technology. DC-coupled front-end gain stages are biased for Class A operation at all signal levels; subject to cascode shielding and two stages of current regulation; power supply; two 1,200 watt toroidal transformers. 250,000 μ F capacitance, 62,000 μ F of front-end decoupling; output stage: 64 high-speed, 250 watt, 200 volt, 20 ampere rated devices. Input imp are switchable between 50,000 ohms unbalanced through RCA connectors and 600 ohms balanced through locking XLR connectors; thermal protection circuitry. 275 watts pure Class A operation 20-20,000 Hz into 8 ohms, @ 0.1% distortion; bandwidth direct current to 3 dB @ 100,000 Hz; slew rate 50 V/ μ s; current capability 70 amps cont, 200 amps peak; noise <100 dB; output imp <0.03 ohm at 20-20,000 Hz. 19 x 8 3/4 x 27; 120 lb. \$7,200

S/1600e Stasis 800-W Mono Amp

As SA/12e except: Higher power; very high bias Class AB allowing circuitry for pure class A operation to 20% of rated power. Power supply: two 1,200 W

POWER • AMPLIFIERS

toroidal transformers, 250,000 μ F capacitance, 62,000 μ F front-end decoupling. Output stage 64 high-speed 250 W, 200 V, 20 amp rated devices, 800 W/ch into 8 ohms 20-20,000 Hz at @ 0.1% distortion; slew rate 100 V/ μ S, current capability 35 amps cont, 200 amps peak; output imp <0.05 ohm at 20-20,000 Hz. 19 x 8 $\frac{3}{4}$ x 27 in; 120 lb \$7,200

SA/4e Stasis 100-W/ch Amplifier

As SA/6e except dual channel and power supply with two 800 W toroidal transformers, 186,000 μ F capacitance, 31,000 μ F front-end decoupling/ch. Output stage 24 high-speed 250 W, 200 V, 20 amp rated devices/ch, 100 W pure class A/ch, 20-20,000 Hz both ch, driven into 8 ohms @ 0.1% distortion; current capability 35 amps/ch cont, 120 amps/ch peak. 19 x 8 $\frac{3}{4}$ x 23 $\frac{3}{4}$ in; 97 lb \$5,900

S/550e Stasis 250-W/ch Amplifier

As S/1600e except dual channel and power supply with two 800 W toroidal transformers, 186,000 μ F capacitance, 31,000 μ F front-end decoupling/ch. Output stage 24 high-speed 250 W, 200 V, 20 amp rated devices/ch, 250 W/ch, 20-20,000 Hz both ch, driven into 8 ohms @ 0.1% distortion; slew rate 50 V/ μ S; current capability 30 amp/ch cont, 100 amp/ch peak; output imp <0.03 ohm at 20-20,000 Hz. 19 x 8 $\frac{3}{4}$ x 23 $\frac{3}{4}$ in; 97 lb \$5,900

SA/10e Stasis 175-W Mono Amplifier

As SA/12e except lower power and power supply with single 1,200 W toroidal transformer, 186,000 μ F capacitance, 62,000 μ F of front-end decoupling. Output stage: 44 high-speed 250 W, 200 V, 20 amp rated devices, 175 W pure class A operation 20-20,000 Hz into 8 ohms @ 0.1% distortion; current capability 60 amps cont, 200 amps peak. 19 x 8 $\frac{3}{4}$ x 17 $\frac{1}{4}$ in; 79 lb \$4,800

S/450e Stasis 200-W/ch Amplifier

As S/550e except lower power and power supply with single 1,200 W toroidal transformer, 186,000 μ F capacitance, 31,000 μ F front-end decoupling/ch. Output stage: 22 high-speed 250 W, 200 V, 20 amp rated devices/ch, 200 W/ch 20-20,000 Hz both ch driven into 8 ohms @ 0.1% distortion; current capability 30 amps/ch cont, 120 amps/ch peak. 19 x 8 $\frac{3}{4}$ x 17 $\frac{1}{4}$ in; 79 lb \$4,800

SA/1 Stasis 160-W Mono Amplifier

As SA/12e except lower power and not DC coupled; no front-end specific power supply decoupling. Power supply: single 1,000 W toroidal transformer, 120,000 μ F capacitance; output stage: 40 high-speed 250 W, 200 V, 20 amp rated devices, 75,000 ohms unbalanced input capability; standard five-way output terminal assemblies; illuminated peak-level output meter, 160 W 20-20,000 Hz into 8 ohms @ 0.15% distortion; current capability 40 amps cont, 150 amps peak. Dimensions: 19 x 8 $\frac{3}{4}$ x 17 $\frac{1}{4}$ in. Weight: 79 lb \$4,400

S/500 Stasis 250-W/ch Amplifier

As S/1600e except lower power and dual channel and not DC coupled; no front-end specified decoupling. Power supply: single 1,000 W toroidal transformer, 120,000 μ F capacitance. Output stage: 20 high-speed 250 W, 200 V, 20 amp rated devices/ch, 250 W/ch 20-20,000 Hz both ch driven into 8 ohms @ 0.15% distortion; bandwidth -3 dB @ 7 and 100,000 Hz; current capability 12 amps/ch cont, 100 amps/ch peak. Dimensions: 19 x 8 $\frac{3}{4}$ x 17 $\frac{1}{4}$ in. Weight: 79 lb \$4,200

SA/6e Stasis 125-W Mono Amplifier

As SA/10e except lower power and power supply with single 800 W toroidal transformer, 124,000 μ F capacitance; 1,900 μ F of front-end decoupling. Output stage: 28 high-speed 250 W, 200 V, 20 amp rated devices, 125 W pure Class A operation 20-20,000 Hz into 8 ohms @ 0.1% distortion; current capability 50 amps cont, 135 amps peak. 19 x 8 $\frac{3}{4}$ x 13 $\frac{1}{4}$ in; 56 lb \$3,600

SA/3.9e STASIS 60-W/ch Class A Amplifier

As SA/4e except lower power and power supply with single 800 W toroidal transformer, 124,000 μ F capacitance, 950 μ F front-end decoupling/ch. Output stage: 14 high-speed 250 W, 200 V, 20 amp rated devices/ch, 60 W pure Class A operation 20-20,000 Hz driven into 8 ohms @ 0.1% distortion; current capability 30 amps/ch cont, 95 amps/ch peak. 19 x 8 $\frac{3}{4}$ x 13 $\frac{1}{4}$ in; 56 lb \$3,600

S/350e Stasis 150-W/ch Amplifier

As S/450e except lower power and power supply with single 800 W toroidal transformer, 124,000 μ F capacitance, 950 μ F front-end decoupling/ch. Output stage: 14 high-speed 250 W, 200 V, 20 amp rated devices/ch, 150 W/ch 20-20,000 Hz both ch driven into 8 ohms @ 0.1% distortion; current capability 25 amps/ch cont, 100 amps/ch peak. 19 x 8 $\frac{3}{4}$ x 13 $\frac{1}{4}$ in; 56 lb \$3,600

SA/2 Stasis 100-W Mono Amplifier

As SA/1 except lower power and no peak-level meter. Power supply: single 700 W toroidal transformer, 60,000 μ F capacitance. Output stage: 28 high-speed 250 W, 200 V, 20 amp rated devices, 100 W 20-20,000 Hz into 8 ohms @ 0.15% distortion; current capability 30 amps cont, 100 amps peak. 19 x 8 $\frac{3}{4}$ x 13 $\frac{1}{4}$ in; 56 lb \$3,150

SA/3 Stasis 50-W/ch Amplifier

As SA/2 except dual channel and power supply with single 700 W toroidal transformer, 60,000 μ F capacitance. Output stage: 14 high-speed 250 W, 200 V, 20 amp rated devices, 50 W/ch 20-20,000 Hz into 8 ohms @ 0.15% distortion; current capability 16 amps/ch cont, 80 amps/ch peak. 19 x 8 $\frac{3}{4}$ x 13 $\frac{1}{4}$ in; 56 lb \$3,150

S/300 Stasis 150-W/ch Amplifier

As S/500 except lower power and power supply with single 700 W toroidal transformer, 30,000 μ F capacitance. Output stage: 8 high-speed 250 W, 200 V, 20 amp rated devices/ch, 150 W/ch 20-20,000 Hz both ch driven into 8 ohms @ 0.15% distortion; current capability 10 amps/ch cont, 80 amps/ch peak. 19 x 8 $\frac{3}{4}$ x 13 $\frac{1}{4}$ in; 56 lb \$3,150

S/200 Stasis 100-W/ch Amplifier

As S/300 except lower power and power supply with single 400 W toroidal transformer, 30,000 μ F capacitance. Output stage: 8 high-speed 250 W, 200 V, 20 amp rated devices/ch, 100 W/ch 20-20,000 Hz both ch driven into 8 ohms @ 0.15%; current capability 8 amps/ch cont, 50 amps/ch peak. 19 x 8 $\frac{3}{4}$ x 9 $\frac{1}{4}$ in; 44 lb \$2,100

VECTOR RESEARCH

VA-1450 75-W/ch Amplifier

Features high-current design, 8-output transistors; dual transformers; bridgeable to 200 W mono; phase inverted line-out; 100 continuous average W/ch 20-20,000 Hz <0.08% total harmonic distortion into 4 ohms; frequency response 10-40,000 Hz \pm 1 dB; dynamic headroom 2.5 dB; 1HF intermodulation distortion 0.08% Dimensions: 17 x 3 x 12 in. Weight: 21 lb \$349

WINGATE AUDIO

2000A 100-W/ch Power Amplifier

Dual-mono construction amplifier with 100% MOSFET. Features MOSFET regulated power; toroidal power transformer; ultra-wide bandwidth, 100 continuous average W/ch from 20-20,000 Hz with no more than 0.5% total harmonic distortion into 8 ohms; frequency response 0.1-250,000 Hz \pm 0. -3 dB; signal-to-noise ratio >100 dB; dynamic headroom 1.6 dB; slew rate 100 V/ μ sec; intermodulation distortion 0.5%; gain 30 dB; input imp 25,000 ohms. 22 x 19 x 8 $\frac{3}{4}$ in; 67 lbs. \$3,900
4000A, 200 W/ch dual-mono Class A, same performance as 2000A except 200 W \$4,600

WRIGHT AUDIO

P-75 35-W/ch Tube Amplifier

Stereo amplifier with all point-to-point hand wiring. 35 W/ch; input imp 470,000 ohms; output imp 4 and 8 ohms; 16 ohms available by special order. 16 x 10 x 14 in; 40 lb \$850

YAMAHA

MX-10000 250-W/ch Amplifier

Power amplifier with dual-amp Class A operation. Features hyperbolic converting non-switching circuitry; power MOSFET's. High-precision analog dB scale peak-level meter, 250 watts per channel minimum rms into 8 ohms; frequency response 20-20,000 Hz; THD < 0.0005%. Titanium gray with high luster walnut end panels; 120 lb \$7,000

MX-1000U 250-W/ch Amplifier

Power amplifier with hyperbolic conversion amplification circuit. Features A+B+C speaker switching; 26-segment LED power-level meters; independent left and right level control; 4-digit numerical power-output display; LED meter and digital peak-hold display; meter display load selectors; compatible with banana plugs. 260 watts per channel into 8 ohms; FR 20-20,000 Hz; THD < 0.003%. 600,000 μ F x 2 power-supply capacity \$1,199

MX-800U 170-W/ch Amplifier

Power amplifier with hyperbolic conversion amplification circuit. Features A+B+C speaker switching; 26-segment LED power-level meters; independent left and right level control; meter display load selectors; compatible with banana plugs. 170 watts per channel into 8 ohms; FR 20-20,000 Hz; THD < 0.003%. 600,000 μ F x 2 power supply capacity \$849

MX-55/Ti 35-W/ch x4 Amplifier

Features independent left and right channel power supplies; vibration-resistant chassis construction. 70 W/ch x 2 into 8 ohms; frequency response 20-20,000 Hz; total harmonic distortion 0.003%. 35 W/ch x 4 into 8 ohms; frequency response 20-20,000 Hz; total harmonic distortion 0.005%. Ch sep 110 dB (2 ch), 90 dB (4 ch); 26 lb. Titanium finish. \$599
MX-55, As above, black \$599

MX-600U 135-W/ch Amplifier

Power amp with hyperbolic conversion amplification circuit. 135 W/ch into 8 ohms; frequency response 20-20,000 Hz; total harmonic distortion < 0.003%. Features A+B speaker switching; 12-segment LED power-level meters; independent L/R level control; compatible with banana plugs. 600,000 μ F x 2 power supply capacity \$529

A10Ti 50 W/ch Amplifier

50 W/ch min rms into 8 ohms; dynamic power 100 W/ch into 6 ohms. Titanium finish, 20 lb \$500
A10, As above, black \$500

MX-35/Ti 20-W/ch x4 Amplifier

Features independent level control. 40 W/ch min rms x 2 into 8 ohms; frequency response 20-20,000 Hz; total harmonic distortion 0.05%. 20 W/ch min rms x 4 into 8 ohms; frequency response 20-20,000 Hz; total harmonic distortion 0.07%; 13 lb. Titanium finish. \$299
MX-35, As above, black \$299

The listings are based on data provided by the manufacturers. For more product information, contact an authorized dealer or the manufacturer directly. Manufacturers' addresses and phone numbers are listed in the directory beginning on page 258.

PREAMPLIFIERS

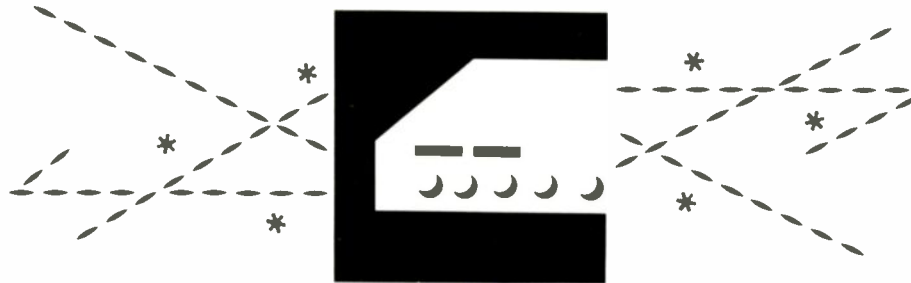

ACCUPHASE BY MADRIGAL

C2801. Preamplifier

All-stage Class A push-pull arrangement and DC servo-controlled direct-coupled unit amps and signal paths. Built-in head amp for MC cartridges; separate power transformers for each ch (+26 dB or +32 dB); MC input-imp selector switch; separate R and L input-level control; 2-stage selectable loudness compensation. Phono input 2 mV, phono (head amp on): 0.1 mV/0.5mV selectable; line/tuner input 126 mV; rated output 2 V; line/tuner S/N 110 dB; phono S/N 85 dB; phono S/N (head amp on) 72 dB \$11,750

C270 Preamplifier

Cascode push-pull circuits on all stages; separately regulated power supply for each gain stage in each ch; fully balanced input and output for CD player; 10 inputs; selectable loudness compensation. Inputs for MM phono; tape; tape 2; CD player; CD player/balanced; tuner; 4 line-level sources. S/N 92 dB; 34.5 lb \$8,250

C200V Preamplifier

Preamp and control center with 11 inputs; separate tone controls for each ch with selectable turnover frequencies; some inputs and outputs accessible from front panel. Inputs for MM phono, MC phono, tape, tape 2, tape 3; aux, phono 2, phono 3, CD player, tuner; line 2; line 3. Max output 8.0 V; MM phono sens 0.5 mV for 0.5-V output at 1,000 Hz; MM phono input overload level 300 mV; 30 lb \$6,000

C-202 Preamplifier

Features four separate cascode Class A push-pull amplifiers for L/R channel and CD/line; 8 inputs with one balanced and two unbalanced sets of outputs for the CD section; logic control relay signal path; separate power transformer windings and rectifier circuits for L/R channels and separate voltage regulators for each amplifier unit. FR 20-20,000 Hz +0, -0.2 dB; THD 0.005%; S/N 110 dBA. 18 3/4 x 5 3/8 x 14 3/4 in; 24.2 lb \$4,100

ADCOM

GFP-555 Preamplifier

Features two-sided copper-plated circuit board for low noise and hum; switchable phono-input capacitance; switchable gain on phono input; tape dubbing; separate headphone amp; 2 sets of outputs (AC coupled, DC coupled); signal-processor loop; 5 pairs of high-level inputs. Can record from one input while listening to another input. Inputs for MM phono; MC phono; tape; tape 2; CD player; tuner; video. FR DC-400,000 Hz ±0.5 dB; THD 0.005%; MM phono sens 0.4 mV for 0.5-V output at 1,000 Hz; sens for line-level inputs 40 mV. 17 x 3 3/4 x 12 3/4 in \$500
GFP-555W. As above with white front panel . . . \$575
GFP-555S. With silver front panel \$575

GTP-500 Preamplifier/Tuner

Preamplifier with built-in tuner. Wireless remote control included. Remote sensors available for remote control from different rooms. Preamp section features inputs for MM phono; tape; tape 2; CD

player; tuner. Tuner section features quartz-referenced digitally synthesized tuning; auto up and down scan; 8 AM/FM presets; 5-LED signal-strength display; high-blend circuit; 2 sets of outputs (AC coupled, DC coupled). Preamp: S/N phono A-wtd 85 dB; IM 0.0015%. Tuner: sens 36.5 dBf stereo; THD 0.09% stereo at 1,000 Hz; S/N 75 dB stereo; sep tuner 52 dB at 1,000 Hz. 17 x 3 3/4 x 12 3/4 in \$550
GTP-500W. As above with white front panel . . . \$625
GTP-500S. With silver front panel \$625

GTP-400 Preamplifier/Tuner

Preamplifier with built-in tuner. Phono stages operate in full Class A operation; RIAA equalization circuit is use in high-output moving-coil or MM phono cartridges. Separate recording selector allows listening to one source while recording another; feedback tone control; eight FM stations and eight AM stations memory. Preamp section: THD <0.01%; IM 0.005%; FR 20-20,000 Hz, ±0.1 dB; S/N: phono 80 dB, line >95 dB. Tuner section: -50 dB quieting mono 13.5 dBf, stereo 37 dBf; HF sens mono 11 dBf; cap ratio 1.7 dB; THD stereo 0.1% at 1,000 Hz; S/N mono 80, stereo 75 dB; FR 30-15,000 Hz, ±0.5 dB. 17 x 3 3/4 x 12 3/4 in; 15 lb \$350
GTP-400W. As above with white front panel . \$400

Accessories

RM-3. Optional rack-mount adaptors for GFP-555 and GTP-500 \$20/pr
RM-3W. RM-3 in white \$25/pr
RM-3S. RM-3 in silver \$25/pr
XR-500. Optional remote sensor for GTP-500 . \$90

AUDIO BY VAN ALSTINE

Transcendence Preamplifier

Features compound hybrid construction; toroidal power transformer; regulated power supply. RIAA phono inputs; 2 sets of tape inputs with tape-to-tape monitoring; 3 sets of line-level inputs for digital and analog sources; volume/balance controls; separate bass and treble controls for each channel; 2 pairs of audio outputs; amp-driven headphone jack. Power bandwidth >800,000 Hz; 200 W rated speaker selector switch. 13 1/2 x 12 1/2 x 4 1/2 in; 11 lb . . \$1,195

FET Three Plus Preamplifier

Features audio circuits which use fast FET op-amps with hybrid current amps. Dual phono, dual tape and two additional high-level inputs; tape-to-tape monitoring; volume/balance controls; bass and treble controls; 2 audio outputs; headphone jack. THD <0.003%. Available at lower price in simpler chassis. 17 x 9 x 3 in; 13 lb \$795

Super Pas Three Tube Preamplifier

Features volume/balance controls; RIAA equalization; phono and 3 or 5 line-level inputs; tape monitoring capability. 13 1/2 x 9 x 4 1/2 in; 9 lb. Factory wired \$595
Kit \$200

FET Three Preamplifier

Features linear fast FET op-amp circuits; matched

phono circuits. Tight-tracking volume/balance controls; balanced tone controls; tuner, tape, and aux inputs; 2 switched AC outlets. 13 1/2 x 8 1/2 x 3 in; 7 lb \$340

AUDIO DESIGN ASSOCIATES

ADP-8 Preamplifier

Preamplifier with 8-input capability. Features 5 stereo source inputs; 3 stereo tape inputs; 1 stereo signal-processor loop input; input imp <47k ohms; max input level ±8 volts; 3 main outputs; 3 tape outputs; 1 processor loop output; volume, balance, bass, mid, treble, and source selection controls; 1 switched outlet. Output imp >100 ohms; max output level ±12 volts; frequency response 20-20,000 Hz ±0.25 dB; total harmonic distortion 0.05%; signal-to-noise ratio -85 dB. Dimensions: 3 1/2 x 19 x 13 1/2 in. Weight 9 lb \$995



Audio Research SP-9 MkII

AUDIO RESEARCH

SP-15 Hybrid Preamplifier

Hybrid stereo preamplifier with FET's and 3 vacuum tubes. Features second chassis with toroidal power transformer; 7 inputs including MM/MC, tapes 1 and 2, CD, tuner, video, aux; auto muting; manual muting; bypass control; absolute phase switch; gain and attenuation controls; 7 sets of outputs; front panel MC impedance selector. Frequency response 0.1->200,000 Hz -3 dB; total harmonic distortion 0.005% at 2V rms; signal-to-noise ratio 110 dB; max 80V rms output; phono overload 350 mV rms at 1,000 Hz. 5 1/4 x 19 x 10 1/4 in; 29 lb \$5,995

SP-14 Hybrid Preamplifier

Hybrid stereo preamplifier with FET's and vacuum tubes. Features shielded toroidal power transformer; 7 inputs; auto muting; manual muting; bypass control; gain and attenuation controls; allows recording of one input while listening to another; internally adjustable phono impedance and capacitance. FR <1-200,000 Hz -3dB; total harmonic distortion 0.01% at 2 V rms; signal-to-noise ratio 100 dB; max 50 V rms output; phono overload 200 mV rms at 1000 Hz. \$2,995

SP-9 MkII Hybrid Preamplifier

On-board power supply; auto mute circuit for warmup, voltage drop; switchable muting; 2 tape inputs, 2 tape outputs; 2-position tape-monitor switching; gold-plated input/output jacks connect ground before hot, disconnect hot before ground; shielded toroidal power transformer; internally adjustable phono-section imp; 2 6DJ8 vacuum tubes (1-

PREAMPLIFIERS

in phono stage, 1-in line stage); compatible with many MC cartridges. FR (high level, ± 0.5 dB) 5-50,000 Hz; magnetic phono, ± 0.3 dB of RIAA, 30-40,000 Hz; max output 2 V rms; distortion $< 0.01\%$ at 2 V rms out; input imp 50k ohms (all high level); phono 47k ohms (changeable)..... \$1,795

B & K COMPONENTS

Sonata Series MC-101 Preamplifier

MM/MC switchable preamp. 2 tape loops; 2 tone controls; MM sens .8 mV; MM S/N80 dB; MC S/N80 dB; FR 1-150,000 Hz -0 , $+0.5$ dB; THD .02%; Tiffany connectors; balanced output..... \$1,098
Sonata Series MC-101 Preamplifier. Same as above without balanced output..... \$898

Pro-10MC Preamplifier

Preamp with built-in MC stage. Inputs for MM phono, MC phono, tape, aux, CD player, tuner. FR 1-100,000 Hz ± 3 dB; max output 6 V; THD 0.01%; IM 0.01% IHF; MM phono sens 0.5 mV for 0.5-V output at 1,000 Hz; MM phono input overload level 100 mV, line-level sens 45 mV. 3 1/2 x 19 x 10 in; 12 lb..... \$648

Pro-10 Preamplifier

Preamp gold-plated connectors for positive contact and reliability. Inputs for MM phono, tape, aux, CD player, video, tuner. FR 1-100,000 Hz ± 3 dB; max output 6 V; THD 0.01%; IM 0.01% IHF; MM phono sens 0.5 mV for 0.5-V output at 1,000 Hz; MM phono input overload level 100 mV, line-level sens 45 mV. 3 1/2 x 19 x 10 in; 12 lb..... \$598

Pro-5 Preamplifier

Preamp features 5 high-level inputs; 1 phono stage with 59 dB gain; balance, volume, bass, treble controls; gold-plated RCA connectors; moving-coil capacity. Inputs for MM phono, tape, aux, CD player, tuner, video. FR 1-100,000 Hz ± 3 dB; S/N 100 dB; MM phono sens 0.7 mV for 0.5-V output at 1,000 Hz; MM phono input overload level 105 mV at 1,000 Hz; sens for line-level inputs 63 mV..... \$398

BEDINI

BC-800 Preamplifier

Flat preamp with inputs for 2 tape decks, CD, DAT, tuner, and phono. Volume and balance controls. FR 1-110,000 Hz $+0$, -3 dB; THD $< 0.1\%$; IM $< 0.03\%$; RIAA phono deviation 10-30,000 Hz ± 0.25 dB; S/N phono to rec out -100 dB/line to pre out -110 dB..... \$1,750

BC-866 Preamplifier

Class A flat preamp with inputs for phono, tuner, tape, CD, aux. Balance and volume controls. FR 1-110,000 Hz $+0$, -3 dB; THD $< 0.15\%$; IM $< 0.05\%$; RIAA phono deviation 20-25,000 Hz $\pm .25$ dB; S/N phono to rec out -90 dB/line to pre out -100 dB..... \$800

BELLES RESEARCH

BELLES 55 Preamplifier

Stereo preamplifier with complementary circuitry and Class A power MOSFET outputs. Features phono section with internal DIP switch for MM and MC cartridges; 2 settings for gain; 2 settings for cartridge loading. External high-energy power supply with DIN connector in rear. 5 inputs; monitor 1; monitor 2; volume; balance; subsonic filter. FR 10-100,000 Hz ± 3 dB..... \$649

BERNING

TF-12 Preamplifier

Dual-mono tube preamp with differential triode design. Features digitally controlled switching matrix (1-dB steps over 80-dB range) for volume and balance functions to avoid colorations; LED dot-matrix displays relative levels of both channels in dB's; high-frequency resonant power supply; wireless remote

control of volume, balance, and mute; high-gain line section (32 dB). Inputs for MM phono; MC phono; tape; AUX; CD player; tuner; video. Frequency response 5-100,000 Hz, ± 3 dB; MM phono sens 0.38 mV for 0.5-V output at 1,000 Hz; sens for line-level inputs 32 mV..... \$2,950

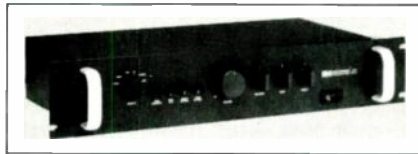

B&K Pro-5

BOULDER AMPLIFIERS

Modular Preamp System Components

The components listed below are sold separately, and in systems. Each module has gold-plated connectors, uses common power supply, and measures 4 1/4 x 3 1/2 x 1 1/4 in.

MS11 Phono Preamp

Module performs RIAA EQ and gain adjust. MC and MM inputs; optional input for low-level MC's has 20-dB gain; triple F switchable Bessel 3-pole low-cut filter at 10, 20, or 30 Hz; max gain 60 dB; RCA inputs standard, 3-pin optional; unbalanced RCA outputs; solid-state balanced output. FR 20-20,000 Hz; THD .0025%..... \$989

MS10. As above, no Bessel filter..... \$849

MS01 Power Supply, 100-240 vac 50/60 Hz, powers 4 modules..... \$599

MS21. Selector-switch module with inputs for phono, CD, tuner, tape 1 and 2, aux; dubs between decks..... \$449

SSMC Solid-State MC Input. Bridging with 20-dB gain..... \$489

SSBO Solid-State Balanced Output. Inverting stages for balanced output..... \$299

MS32 Output Controller Module. Features buffered inputs, volume, and balance controls, stereo/mono switch, individual channel polarity switches, mute (-20 dB)..... \$1,249

Boulder Ultimate Preamplifier

Features components MS01, MS11, MS21, MS32; mounted in one dual frame, and two single frames..... \$4,795

Boulder Complete Preamplifier

Features components MS01, MS10, MS21, MS31; mounted in one quad frame..... \$2,895

Boulder Line Preamplifier

Features components MS01, MS31; mounted in a dual frame..... \$1,395

CAMBRIDGE AUDIO

C50 Preamplifier

Stereo preamplifier with connections for 4 input sources plus tape. Features segmented passive RIAA EQ. Passive tone controls with tone bypass switch and two outputs, one being a passive direct output after the volume control and the other a normal output; MM or MC switchable phono inputs with discrete circuitry. THD 0.005%. Sold only as a combination with the A50 power amp, combination price, \$999

C100 Preamplifier

Preamp with inputs for MM/MC phono (switchable), tape, tape 2. Features dubbing capabilities; straight-line design. FR flat within 0.1 db 20-80,000 Hz; THD 0.005% from 20-20,000 Hz; max output 12 V; MM input 2.6 mV at 47,000 ohms; MC input 0.3 mV at 47,000 ohms; S/N MM 82 dB, line 96 dB..... \$698

CARVER

C-19 Hybrid Reference Preamplifier

Stereo preamplifier with 5 inputs including MM and MC phono and CD direct. Features 6DJ8 tubes;

Wonder Caps; wide circuit traces; no IC's in the primary signal path. Dual external processor loops; dual tape monitor loops with dubbing; Spectral Tilt overall frequency balance EQ; individual 1/R tone controls with variable turnover; headphone output with speaker defeat switch; subsonic filter; absolute phase switch. FR 1-60,000 Hz -0.3 dB; THD 0.07%; MM phono sens 1.5 mV; MM phono S/N 86 dB; MC phono S/N; max output 7 V, 12 lb..... \$1,199

CT-17 Preamplifier/Tuner

Combination Asymmetrical Charge Coupled Detection AM/FM tuner and Sonic Holography preamplifier with remote. Preamplifier features Dolby Pro Logic 5-ch surround-sound processor with rear volume, hall and stadium ambient effects; 7 inputs including CD direct, 2 video sound; simulated-stereo synthesis for mono video; 3-way tone controls; dual tape monitors; high-cut filter; remote with separate input/record selector and extra remote volume control for room-to-room capability. Tuner features 20 AM/FM presets with preset scan; stereo/mono; auto/manual controls. Preamplifier section: Frequency response 1-60,000 Hz ± 0.3 dB; THD 0.01%; max output 7 V. Tuner section: stereo quieting sens 36.1 dBf; stereo sens 20.1 dBf; stereo cap ratio 1.4 dB; AM suppression 73 dB; alt-ch sel 58 dB; FM stereo THD 0.02%; stereo S/N 79 dB, 16 lb..... \$800

C-16 Sonic Holography Preamplifier

Preamplifier with Sonic Hologram Generator. Features 5 inputs including MM and MC phono; dual external processor loops; dual tape monitor loops with dubbing. Spectral Tilt overall frequency balance EQ; individual 1/R tone controls with variable turnover; headphone output with speaker defeat switch. FR 1-60,000 Hz -0.3 dB; THD 0.01%; max output 7 V, 6 lb..... \$730



Carver C-19

C-11 Sonic Holography Preamplifier

Preamplifier with Sonic Hologram Generator. Features video sound Preognition circuit; 5 inputs including MM and MC phono; external processor loop; dual tape monitor loops with dubbing. Individual 1/R tone controls with variable turnover; loudness EQ; headphone output with speaker defeat switch; subsonic filter; adjustable MM phono capacitance. FR 1-60,000 Hz -0.3 dB; THD 0.05%; max output 7 V, 6 lb..... \$580

CELLO

1003-00 Encore Preamp

Features universal phono section; gain 36 dB, 46 dB, 60 dB; loading 49k, 10k/220 pF, 1k/0.2 pF; balanced line input (optional); 8 single-ended line inputs; buffered tape outputs; balanced line out; plus 2 single-ended line outputs; choke-input power supply; phase switch; 2 tape monitors; with phono..... \$8,000
 Without phono..... \$7,500
Encore Phono Modules..... \$800/pr

Audio Suite

Open-architecture mainframe accepts up to 10 slide-in vertical modules for phono, tape, CD, video, DAT, and tuner inputs; houses pro modules including mic preamp/mixers, tape head recording and mastering amplification, digital-to-analog converters, monitor amps for headphones or speakers. Can control multi-amps and multi-media systems.

P101. MC phono input module..... \$3,500
 P301. Output module..... \$3,200

PREAMPLIFIERS

1002. Mainframe chassis	\$1,800
P100. MM phono input module	\$2,000
P201. CD input module	\$2,500
P201. DAT input module	\$2,500
P201. Digital processor input module	\$2,500
P100. High-gain MM phono input module	\$2,000
B301. Output module	\$1,800
P200. Tape input module	\$1,500
P200. CD input module	\$1,500
P200. Tuner input module	\$1,500
P200. Aux input module	\$1,500
P200. Video input module	\$1,500
P200. DAT input module	\$1,500
B100. MM phono input module	\$1,500
B100. MC phono input module	\$1,500
B200. RCA line input module	\$800

Accessories

Blank bay assembly	\$75
Blank front plates	\$50
Blank rear plates	\$25

Master Power Supply

120 V AC	\$2,400
----------	---------

CLASSE AUDIO

DR-7 Preamplifier

Preamplifier features balanced inputs/outputs; dual chassis; 5-transformer power supply; 2 tape & processor loops; MC input. FR 20-20,000 Hz ± 0.2 dB; max output 8 V; THD 0.01%; sens 50 mV; MM and MC S/N 80 dB. \$4,995

DR-6 Preamplifier

Preamplifier features balanced outputs; polarity inverter; direct phono bypass; separate power supply. FR 20-20,000 Hz ± 0.2 dB; max output 8 V; THD 0.01%; MM and MC S/N 80 dB. \$3,000

DR-5 Preamplifier

Preamplifier features balanced inputs/outputs; MC input; direct phono bypass; regular or balanced output stages; 1 tape; polarity inverter optional. FR 20-20,000 Hz ± 0.2 dB; max output 8 V; THD 0.01%; sens 50 mV; MM and MC S/N 80 dB. \$1,995

clear audio

Harmony Phono Preamplifier

Preamplifier mounts directly to any MC phono cartridge or headshell with 1-in wires. Features RIAA EQ; power supply, gain stage box with volume control, wiring harness. FR 0-100 ± 3 dB; THD 0.01%; S/N 80 dB; max output 8 V; 7 g. \$2,850

CONRAD-JOHNSON

Premier Seven Preamplifier

Vacuum-tube preamp with FR 2-100,000 Hz and 0.25% THD. Two tape processor loops and moving coil input. \$7,850

PV9 Tube Preamplifier

With low-noise precision metal-film resistors; polystyrene capacitors in audio circuitry; facilities for 2 tape recorders; 2-way dubbing; phono, tuner, AUX inputs; 2 amp outputs; front-panel mute control. FR 20-20,000 Hz ± 0.25 dB phono; S/N 70 dB below 10 mV phono, 84 dB below 2.5 V output high level; THD and IM 0.05%; gain 40 dB phono, 29 dB high level; max output 25 V; phono overload 500 mV at 1 kHz; 4 3/4 x 14 x 11 3/4 in. \$2,950

PV8 Tube Preamplifier

With cathode follower outputs and solid-state voltage regulator designed for minimal AC imp; regulated filament supplies virtually eliminate infrasonic noise resulting from AC line fluctuations. Features 1% tolerance, mil-spec deposited tin-oxide audio circuit resistors; audio circuit capacitors are polystyrene dielectric; volume control tracks within 0.5 dB; auto

muting at turn-on, turn-off; 2 tape-recorder loops with 2-way dubbing; 5-function mode switch; precision tracking volume control. Max output 40 V rms; FR 2-100,000 Hz; <0.5% THD and IMD; hum and noise (20-20,000 Hz); phono 72 dB below 10 mV input, high level 84 dB below 2.5 V output; output imp <200 ohms; 10 x 16 x 3 3/4 in.; 15 lb. \$1,685

PV10 Tube Preamplifier

Stereo preamplifier with zero-feedback circuits in both line and phono stages. Features 2 triode amplifiers separated by a passive RIAA EQ network; five vacuum tubes; discrete regulated power supply with polypropylene and polystyrene capacitors. Phono plus five line inputs; 1 tape loop; balance bypass switch. >.1% THD or IM; hum and noise (20-20,000 Hz); phono 72 dB below 10 mV input, line stage 84 dB below 2.5 V output; output imp <500 ohms. 16 x 3 3/4 x 11; 12 lb. \$995



Conrad-Johnson PV10

CONVERGENT AUDIO TECHNOLOGY

SI-1 Preamplifier

Preamplifier with all vacuum-tube design. Features twelve separate regulators, one for each stage; adjustable loading; external power supply; switched metal film resistors for volume and balance controls. Inputs for MM phono; MC phono; tape; aux; CD; tuner; video. FR 0.1-1 MHz ± 3 dB; S/N 90 dB; THD 0.0005%; MM phono sens 0.125 mV for 0.5 V output at 1,000 Hz; MM phono input overload level 250 mV at 1,000 Hz; sens for line-level inputs 25 mV. 19 x 5 1/4 x 12 1/2, external power 11 1/2 x 4 1/2 x 6; 28 lb. \$4,500

COUNTERPOINT

SA-11 Line-Level Tube Preamplifier

Full-featured line-level control center includes industrial-grade stepper motors to control 2 custom-built 41-position attenuators. Features full vacuum-tube power supply and audio circuitry; wireless handheld remote control; Isolinear design for max isolation and linearity. Inputs for tape; tape 2; aux; CD player; tuner; video. FR 1.5-70,000 Hz; THD 0.02% max; S/N 82 dB at 500 mV, 1,000 Hz; 17 x 7 3/8 x 20 in; 55 lb. \$5,795

SA-9 Tube Phono Preamplifier/Equalizer

Full-vacuum-tube phono-cartridge preamplification and equalization system with independent MC and MM circuits. Isolinear design for max isolation and extreme linearity. Input for MM and MC phono. FR 1-180,000 Hz, ± 3 dB; THD <0.1% at 2V rms output level. 19 x 4 1/2 x 14 1/2 in; 20 lb. \$4,395

SA-5000 Preamplifier

Tube/solid-state preamp which uses tubes for all major audio amplification. Separate chassis regulated tube power supply. Absolute phase control; buffered out enable/disable; Inputs for MM phono, MC phono (17 dB user adjustable J-FET gain stage), tape, tape 2, aux, CD, tuner. FR 4-60,000 Hz, ± 0.1 dB; THD 0.01%; 19 x 4 1/2 x 12 3/8 in; 39 lb. \$2,995

SA-3000 Preamplifier. Similar to above. FR 8-40,000 Hz, ± 0.1 dB; 19 x 4 1/2 x 12 3/8 in; 22 lb. \$1,895

SA-2 Tube Preamplifier

Features two 6DJ8 vacuum tubes per channel. Utilizes four tubes as rectifier, pass device, reference voltage and error amplifier. Bias control for adjusting operating point of the audio tube; inputs for MC

phono. FR 0.5-350,000 Hz; THD variable as a function of bias control; S/N 93 dBA; 19 x 2 x 11 3/4 in; 16 lb. \$1,145

SA-1000 Preamplifier

Features three-tube hybrid circuitry. Preamp with inputs for MM/MC phono, tape, CD player, tuner. FR 2-170,000 Hz, ± 0.1 dB; THD 0.065%; S/N 83 dBA at 10-500,000 Hz; 19 x 4 1/2 x 12 3/8 in; 20 lb. \$835

CROWN

PSI-2 Preamplifier

Features seven inputs; seven second turn-on; power switch; tape 1 and 2 monitor switch; treble and bass controls; output balance control; loudness switch; black polyester vinyl coated aluminum with black splatter coated steel; aluminum chassis; FR 10-50,000 Hz ± 0.25 dB; THD <0.0025% at rated output; 19 x 1 3/4 x 11 1/2 in; 11 lb. \$695

DB SYSTEMS

DBR-15B & 2A Preamplifier System

Rack-mount precision preamplifier with power supply. Features combination of DB-1B and DB-5 in a 19-in rack unit; tone control; auxiliary cable included. \$985
With oak cabinet \$1,135

DB-1A & 2A Preamplifier System

Stereo preamplifier with separate DB-2A regulated power supply. Features gold-plated jacks; Alps 80 dB tracking volume control. THD $\pm 0.0008\%$, 20-20,000 Hz; IM $\pm 0.001\%$; FR phono 10-40,000 Hz ± 0.07 dB, high-level 2-50,000 Hz $+0/-1$ dB; S/N A-wtd 89 dB phono, 90 dB line; filters: low-cut flat, 20 Hz, 36 Hz at 6 dB/octave phono only, high-cut flat, 5 kHz, 10,000 Hz at 6 dB/octave; output imp 1 kilohm; max output voltage 6 V into 10 kilohms/3,000 pF; input sens for 1 V output; phono 2 mV into 50,000 ohms/100 pF, high-level 120 mV into 50 kilohms. 3-year warranty extension. 8 1/2 x 7 x 3 1/4 in. \$495

DB-1B & 2A. DB-1A with low-noise high-level stage (-94 dB ref 1 V). Features reduced crosstalk; gold-plated jacks; tight tracking volume control; solid-oak cabinet with hand-rubbed tung-oil finish. 12 x 3 3/8 x 7 in. \$700

DBR-1B. Same as DB-1B except mounted on 19-in rack. Includes DB-2 A power supply. \$645

DB-1A-HL & DB-2A. Preamplifier similar to DB-1A with 5 high-level inputs and no phono section. Features Alps 80 dB tracking volume control; gold-plated jacks. FR 1-250,000 Hz ± 3 dB; S/N 92 dB; THD 0.0006%; sens for line-level inputs 120 mV. 3-year warranty extension. \$375

DB-1B-HL & DB-2A. Preamplifier similar to DB-1A-HL with lower noise (-94 dB ref 1 V); Features reduced crosstalk; gold-plated jacks; tight tracking volume control; loudness-compensation switch; and solid oak cabinet with hand-rubbed tung-oil finish. \$530

Updates and Modifications

DB-1 & DB-2 to DB-1A & DB-2A

Improved RIAA (0.04 dB); complete retest. Upgrade includes gold-plated phono input jacks and diamond-cut solid-aluminum knobs. \$70

DB-1A to DB-1B

Includes new lower-noise high-level stage, Alps 80 dB tracking volume control, 6 dB better ch sep, all gold-plated jacks, solid oak cabinet with new front panel and warranty extension to 3 years. \$200
Same as above with selected 55 dB tracking volume control. \$155
Install Alps 80 dB volume control on DB-1A, DB-1A-HL, or DB-1B. \$65
Install gold-plated jacks on DB-1A. \$40

DB-2A. Features lower output impedance, 12 dB less ripple and a soft turn-on circuit. \$15

American Acoustics®

No other loudspeaker offers these advanced features and a 10-year warranty.

From the initial research and development to finished product, we're dedicated to providing the very best in sound to our listener.

For instance, our new Dual Source Format Loudspeakers, a stunning culmination of technical excellence and pure auditory emotion by people who love music just like you do. Features like dual bass transducers for high level bass clarity. Symmetric rear port apertures for quick bass reflex at near zero distortion. Geometric baffle cover configuration that minimizes sound diffraction and improves high frequency dispersion. Midrange driver positioning (above the tweeter) for improved time arrival over the entire sound spectrum. Discrete high-slope crossovers for smooth frequency transition.

And, like all American Acoustics Loudspeakers, an industry-leading 10-year warranty! A full decade of listening confidence. Because we're confident about what goes into every American Acoustics product. Superior componentry, advanced materials and construction techniques along with quality conscious, old-fashioned American craftsmanship.

Whether you choose the exciting new DS-Series, our popular D-Series, or our value-priced AAL Series, you'll hear the pride. Today, tomorrow, and for years to come.



DS Format Series

American Acoustics
One Mitek Plaza
Winslow, IL 61089

LISTENING FOR THE FUTURE

CIRCLE NO. 35 ON READER SERVICE CARD

For the dealer nearest you please call 1-800-223-5266
When calling, please refer to number 10977

PREAMPLIFIERS

dbx

CX-3MKII Preamplifier

Preamplifier operates as a control center for a video or audio system with 2, 3, 4, channels. Features isolated audio and video circuits; Dolby Surround sound circuitry; MM/MC; matrix; hall; record output selector; simulated stereo for mono soundtracks; 2 tape decks, 2 video decks, CD, tuner, video disc inputs; remote \$799

DENNESEN ELECTROSTATIC

JC-80 Preamp

Dual mono preamplifier with MM and MC phono inputs, tape 1, tape 2, aux. Features all FET, DC-coupled; no interstage coupling caps; feedback input stage; passive RIAA; each stage separately regulated; invertible phase. FR 1-15,000 Hz ± 0.1 dB; THD 0.005%; max output 20 V; IM 0.005%; 19 x 1 3/4 x 12 in; 10 lb \$2,250 ea

Sirius Preamp

Straight-line preamp with split passive RIAA and FET input. Inputs for MM phono, tape, tape 2, aux. FR 5-100,000 Hz ± 0.1 dB; THD 0.01%; max output 10 V; IM 0.01%; sens for line level inputs 125 μ V. 19 x 2 x 8 in; 7 lb \$489
Sirius II. Dual mono; external power supply \$650

DENON

DAP-5500 Preamp

Preamplifier with 4x oversampling D/A converter. Digital section features 4 D/A push-pull Super Linear Converter system; separate digital and analog chassis; 3 digital inputs (one optical, 2 coaxial); coaxial digital tape-monitor loop; optical isolators; D/A converter output jacks. Audio section features Unity Gain Interface amplifier; Cannon-type input/output; 2 RCA line-in; 1 RCA line out; front-panel mounted RCA input/output jacks; two tape-monitor loops; source-direct switch; separate power supplies for digital and analog sections; nonresonant, vibration-resistant chassis. 5 1/4 x 17 1/8 x 15 in \$1,500

DAP-2500 Preamp

Stereo preamplifier with 4x oversampling D/A converters. Digital section features 4 push-pull Super linear converter system; 2 digital inputs (1 optical, 1 coaxial); coaxial digital tape monitor loop; optical isolators; D/A converter output jacks. Audio section features Unity Gain Interface amplifier; Cannon-type balanced outputs; 2 tape-monitor loops; source direct switch; MM/MC preamplifier; 2 video inputs; 1 video output. Includes Denon Integral System remote control for full-system remote and remote power control for connected Denon power amps \$1,000

PRA-1500 Preamp

Stereo preamplifier with MM and MC phono inputs. Features Unity Gain Interface amplifier, 2 tape-monitor loops; source-direct mode; balanced output connections; 2 video inputs; 1 video output; mono wideband and subwoofer outputs. Includes Denon Integral System remote control for full-system remote and remote power control for connected Denon power amps \$500

PRA-1200 Preamp

Stereo preamplifier with video inputs and switching facility. Features headphone amplifier, 8 audio inputs; variable loudness control; MM and MC phono. S/N 105 dB; S/N MC 79 dB, MM 96 dB; FR 1-300,000 Hz ± 0.2 dB/-3 dB; THD < 0.003%; 4 7/8 x 17 1/8 x 11 1/2 in \$475

DISCRETE TECHNOLOGY

Pro-Reference Preamp

Solid-state preamplifier with high-current supply. Features aluminum rack-mountable enclosure; de-

signed to be matched with one of 3 different amplifier modules; direct-coupled circuit; volume and power controls; switchable cartridge loading; switchable gain; Distech cable; modular construction; low impedance main outputs. With MC amplifier... \$2,995
With phono amplifier module..... \$2,495
With line amplifier module..... \$1,895

ELECTROCOMPANET BY MUSIC AND SOUND IMPORTS

Electrocompaniet preamplifiers feature FR 5-100,000 Hz ± 0.5 dB; max output 15 V; MM phono S/N 84 dB; high-level sens 100 mV; no tone controls; balance and volume only; MM input imp 47 kilohms; external power supply.

EC-1 Preamp. Includes MC, MM phono, 2 tape processor loops, tuner and inverts phase. Approx..... \$2,095
EC-1A. As above except no MC phono and no phase inverting. Approx..... \$1,795

EXPRESSIVE TECHNOLOGIES

SU-1 Phono Preamp

Step-up transformer for MC cartridges. FR 0.7-150,000 Hz ± 0.5 dB; S/N 100 dB; gain 28 dB fixed; phono overload 1000 mV. 5 3/8 x 19 x 8 1/4 in; 35 lb \$2,500

FORTE AUDIO BY THRESHOLD

Model 2 Preamp

Dual-channel, non-inverting hybrid topology, low-noise, matched integrated gain devices enhanced with discrete pure Class A biasing, active constant-current sourcing, and imp buffering. Accepts input from high- and low-output MC and MM cartridges; 4 high-level sources and tape recorder. Record/monitor facilities for recorder allow listening to one source while recording another; internal selection of resistive and capacitive cartridge loading; selectable cartridge gain of +40, 50, 60 dB. External power supply in separate chassis; gold-plated signal connectors; glass-epoxy circuit boards. THD < 0.02% at 3 V; noise < -100 dBA referenced to 1 V input; gain ± 20 dB; input imp 25,000 ohm; output imp 470 ohms. 19 x 1 3/4 x 7 in \$990

HAFLER

Iris Preamplifier

Infrared remote integrated system with pure FET Class A design utilizing c-MOS switching and a passive fiber-optic volume/balance control. 5 high level inputs, two tape inputs; external-processor loop, and patented MM/MC phono stage; outputs: record 1, record 2, external-processor out. line; knob control remote. FR 20-20,000 Hz ± 0.1 dB; THD 0.005% line, 0.002% MM, 0.009% MC; S/N MM - 87 dBA, MC - 80 dBA, 94 dBA line; 17 x 3 x 8 1/2 in; 9 lb \$800
Without remote \$650

DH-110 Preamplifier

Preamplifier operates all discrete devices (no integrated circuits in signal path) in full symmetry format. Controls: volume, balance, bass, treble, input selector, phono selector, monitor selector, mono/stereo, high-pass filter; external-processor loop, tone control engage. Features rack-mounting capability; single active circuit board; step-action volume control; integral muting circuit; 2 pairs of audio outputs; low-imp power supply; full power bandwidth to 200,000 Hz; 2 phono, tuner, aux, 2 tape deck, external-processor inputs; 2 tape (buffered), 2 line, external-processor outputs; headphone jack. THD < 0.0006% at 1,000 Hz, 3 V rms; phono input FR 20-20,000 Hz ± 0 , -0.25 dB; S/N weighted 87 dB; rated output 3 V rms, 4-210,000 Hz; THD < 0.001% 20-20,000 Hz; 17 x 3 x 8 1/2 in; 10 lb; Assembled... \$500
Kit \$450

DH-100 Preamplifier 2

Preamp with RIAA EQ utilizing 1%-tolerance compo-

nents; low-imp power supply; power-on delay circuit; Inputs for MM phono, tape, aux, tuner. Features volume, balance, treble, bass, tape monitor, power controls; 2 switched outlets. FR 20-20,000 Hz ± 0.25 dB; max output 8 V; THD < 0.005%; IM below residual noise of current test instruments; MM phono sens 10 mV for 0.5-V output; 13 1/2 x 3 x 9 in; 7 lb. Assembled..... \$215
Kit..... \$200

SE-100 Preamp

Preamplifier with all-discrete JFET devices in the signal path; low impedance power supply; power-on delay circuit; optional MM/MC high gain; tape loop features J-FET buffering. Volume, balance, bass, treble, tone defeat switch; headphone input; inputs: tuner, CD, video, aux/phono, and tape; outputs: tape out, 2 line. 17 x 3 x 8 1/2 in; 9 lb \$275
Optional MM/MC phono board \$125



Hafler Iris

HARMAN KARDON

Citation Twenty-Five Preamplifier

Preamplifier with remote control. Features passive equalization in open-loop mode; moving-coil head amp with resistance trim; moving-magnet capacitance trim. Inputs for CD, A/V1, A/V2, tape 1, tape 2, VCR 1, VCR 2, and phono; high-cut filter; subsonic filter; switchable bass and treble turnover; tone defeat; mono switch; headphone jack. FR 0.25-250,000 Hz ± 0 , -3 dB (aux @ 0.5 V output); THD 0.002% (aux @ 1 V output); slew rate 120 V/ μ sec; rise time 1.4 μ sec; S/N 91 dB (CD, video input); RIAA EQ (20-20,000 Hz) ± 0.2 dB; \$899

Citation Twenty-One Preamplifier

Preamplifier with fully discrete circuitry. Features low negative feedback; active/passive symmetrical RIAA EQ. Inputs for CD, CD-direct, video sound, tuner, phono, 2 tape decks; gold-plated jacks; mono switch; low-noise transistors; discrete MC head amp; subsonic filter (6-dB/octave, -3 dB @ 15 Hz); phase-correct loudness (+10 dB @ 50 Hz, +3 dB @ 250 Hz); 10-dB bass and treble boost/cut; tone defeat. Max output 10 V \$629



Harman Kardon Citation Twenty-One

HEATH

APW-2510 Preamplifier

Stereo preamplifier with dual RIAA equalization circuitry. Features MM/MC switch; subsonic and high cut filters; tape copy selector for dubbing between two tape decks or recording from another input; tone defeat; switchable bass and treble turnover frequencies; 6 inputs. Frequency response 0.1-180,000 Hz; THD 0.006%; signal-to-noise ratio 83 dB MM phono, 80 dB MC phono, 92 dB aux, 92 dB tape. 17 1/2 x 4 x 13 3/4 in; 16 lb \$399
AP-2150, Unassembled kit; 19 lb \$349



REALISTIC®

The CD Player for the Changing Times

America's biggest name in audio presents a better way to enjoy the best in sound—the Realistic compact disc changer. You can load up to six discs in its magazine and enjoy hours of superb digital stereo. Or, program up to 32 selections from the discs to play in any sequence. Either way, you can pause, replay, program and search, using the wireless remote control.

The large LED display simplifies remote operation. Manual and automatic search make it easy to find selections.

This high-performance changer has a Tri-Spot laser pickup system for accurate tracking. Two-times oversampling

provides super sound. And Radio Shack carries extra magazines so you can protect all of your CDs and have them loaded and ready for play.

Come in and try the Realistic CD-6000. It's affordably priced at only 359.95 and available today.

Exclusively at

Radio Shack®
The Technology Store™

A DIVISION OF TANDY CORPORATION

Price applies at participating Radio Shack stores and dealers.

FREE 184-Page Radio Shack Catalog! Write Dept. 135-04, 300 One Tandy Center, Fort Worth, TX 76102

PREAMPLIFIERS

HEYBROOK BY D'ASCANIO AUDIO

C-3 Preamp

Hand-assembled preamplifier features special circuitry for CD input to prevent overloading; aluminum chassis; rear-panel power switch. Inputs for moving-magnet and moving-coil phono, tape, aux, CD player, tuner, and video. Frequency response 10-50,000 Hz \pm 3 dB; MM phono sens 85 mV for 0.5-V output at 1,000 Hz; line-level sens 160 mV. 17 x 3 x 13 in; 8 lb \$698

HITACHI

HPT120AVSW AM/FM Tuner/Preamp

AM/FM tuner/preamp with quartz digital-synthesis tuner. Features 20 AM/FM presets; audio inputs for phono, CD, tape; video inputs for TV, VCR, videodisc player; electronic volume and balance controls; 5-band graphic EQ; video-signal enhancer. Includes unified infrared remote control with LCD display. Rosewood end caps \$450

INTEGRA AUDIO BY dBTRITTON AUDIO SYSTEMS

Integra Reference Preamplifier

Dual mono design, with 3 inputs for phono and 2 auxiliary jacks. Features logic switching circuitry. Dual- or quad-wired gold-plated switches; separate volume controls per channel; switchable tape and main outputs; external power supply. 15 x 4 x 6 1/4 in; 32 lb/pr \$7,500

Integra TP1 Preamplifier

Two-stage stereo preamplifier with 3 inputs. Features separate volume controls per channel; logic switching circuitry. Switchable tape and main outputs; separate volume controls per channel; external power supply. 15 x 4 x 6 1/4 in; 10 lb \$3,000/pr

JRM

JRM Preamplifier

Stereo preamplifier with MM and MC phono inputs. Features all polypropylene capacitors; electromechanical devices gold-plated; 2-stage RIAA \pm 0.1 dB conformity. Separate input select for main, record and out; inputs for tuner, 2 tapes, aux; 18 dB infrasonic filter; 10 W/ch headphone amplifier. 10 V max output; S/N MM 87 dB, MC 76 dB; slew rate \pm 13 V/ μ sec; THD 0.01%; FR 0-50,000 Hz -1 dB. 2 3/4 x 8 1/2 x 19 in \$450

KENWOOD

Basic-C2 Preamplifier

Preamplifier with MM/MC phono and impedance selectors. Features phono EQ amplifier with single negative feedback loop; super-coupled volume control for low noise; 4-way filter system. 2-way tape dubbing with monitoring; source (rec out) tape selector; 2 aux/video inputs; loudness switch; mono/stereo switch; headphone jack with level control; LED indicators. FR 1-350,000 Hz +0, -3 dB; THD 0.001% @ 1 V; S/N 110 dB (main), 94 dB (MM), 70 dB (MC). 17 1/4 x 3 x 12 1/2 in; 9.9 lb \$329

KINERGETICS

KPA-2 Preamplifier

Line preamplifier with patented hysteresis distortion cancelling circuits. Features dual mono with 2 toroidal transformers; 1 processor loop; servo loop to eliminate DC offset; no capacitors in signal path. 7 audio inputs; 1 tape output; 1 positive and 1 inverted output. Slew rate 60 V/ μ sec; voltage gain 13 dB. 19 x 3 3/4 x 12 1/2 in; 12 lb \$895

KPA-2 Phono Preamplifier

Add-on to the KPA-2 line preamp. Dedicated to phono-cartridge gain applications. Features military-

grade class epoxy circuit boards; patented hysteresis distortion cancelling circuits. MM/MC capability; gain and cartridge loading; adjustability with internal dip switch \$395

KLYNE AUDIO ARTS

SK-5A Preamplifier

Full-function stereo preamplifier with control to invert absolute phase. Features balanced differential outputs. Inputs for tuner; CD/aux; tape; MM/MC phono. Output imp 600 ohms; input imp phono 0-47,000 ohms. 2 1/2 x 19 x 12 1/2 in; 12 lb \$3,250
SK-4A. As above, straight-line version without line amps, phase inversion, and mode switches. \$2,450
 With optional line amps installed \$2,695

System Six Preamplifier Series

6LX. Full-function stereo preamplifier with 6 high-level inputs and optional user installable phono boards. Features external power supply; independent listen and record circuitry; inputs for phono/aux; CD; tape 1; tape 2; video/aux. Output imp 300 ohms; input imp phono 0-47,000 ohms. 2 1/2 x 19 x 11 1/2 in; 10 lb \$1,850
6L. Similar to 6LX without external power supply \$1,550
6PZ. Similar to 6LX with low-noise phono board for MC cartridges \$950
6PX. Similar to 6LX with reference phono board for MC cartridges \$895
6P. Similar to 6LX with plug-in phono board featuring adjustable gain \$595

LAZARUS

Balanced Deluxe Hybrid Preamplifier

Features balanced differential circuitry; two separate chassis and power supply for the balanced differential circuitry; hybrid circuitry features tubes and FETs; phono stage for low-output moving-coil cartridge. Six inputs; volume control with balance attenuators; AC power/standby switching; auto muting function; six-position record selector; XLR output connectors; Tiffany jacks for the phono inputs, CD inputs and main outputs. Sens 0.2 mV; input overload (phono) 100 mV; input overload (line) 25 V; noise -85 dB at 2 mV input; output imp 10 ohm \$1,985

Balanced Classic Hybrid Preamplifier

Features balanced differential circuitry; two separate chassis and power supply for the balanced differential circuitry; hybrid circuitry features tubes and FETs. Six inputs; volume control with balance attenuators; AC power/standby switching; auto muting function; six-position record selector; XLR output connectors; Tiffany jacks for the phono inputs, CD inputs and main outputs. Sens 2.0 mV; input overload (phono) 600 mV; input overload (line) 25 V; noise -85 dB at 2 mV input; output imp 10 ohm \$1,695

Cascade Deluxe Hybrid Preamplifier

Hybrid preamplifier with vacuum tubes and FET's. Features MC input; 6 inputs; full switching capability; auto muting; front-panel mute; power switching; tiffany connectors for phono, CD and main outputs; slim line chassis; black, fully anodized aluminum chassis; switchable phono loading. Output overload 75 V; line input overload 25 V; phono overload 300 mV; sens 0.2 mV; noise -85 dB at 2 mV input; output imp 600 ohm \$1,200

Cascade Classic Tube Preamplifier

Vacuum tube preamp. Features 6 inputs; auto muting; front panel mute and power switching; other features similar to the above. Output overload 75 V; line input overload 25 V; phono overload 300 mV; sens 1.5 mV; noise -80 dB at 2 mV input; output imp 600 ohms \$950

Cascade Basic Tube Preamplifier

Tube preamp with inputs for MM phono; tape; tuner.

FR 10-32,000 Hz \pm 3 dB; S/N 90 dB; THD 1.2%; MM phono sens 1.5 mV for 0.5-V output at 1,000 Hz; MM phono input overload level >250 mV at 1,000 Hz; sens for line-level inputs 50 mV. 19 x 1 1/8 x 1 1/8 in; 8 lb \$650

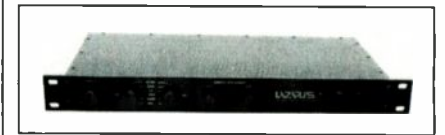

Lazarus Cascade Classic

LINN PRODUCTS

LK1 Preamplifier

Stereo microprocessor preamplifier with independently adjustable input-level matching. Features keyboard lockout; all switching and level adjustments electronic on board; remote control. Inputs for MM and MC phono; tape; tape 2; aux; tuner. 3 x 10 1/2 x 10 1/2 in; 9 lb \$1,050

LUXMAN

TP-117 Preamplifier/Tuner/Remote Controller

Dual preamps in one chassis provide independent source selection and volume control for two sets of components. Features RF TV modulator; separate regulated power supply; AM/FM tuner with computerized tuning and 4-stage FM front end. 20 AM/FM station presets with auto-seek tuning; cable FM fine tuning (25 kHz steps); motor-driven volume controls with auto preset; multifunction remote control; pre-out/signal processor jacks; video switching with buffer amplifiers; CD-direct input. Amp section: FR 20-20,000 Hz \pm 0.5 dB; THD 0.006%; S/N 86 dB (phono), 96 dB (CD/tape/video). FM section: 50-dB quieting sens 38 dBf (stereo); cap ratio 1.5 dB; alt-ch sel 68 dB. AM section: S/N 50 dB. 17 1/4 x 4 3/8 x 13 in; 11.4 lb \$1,250

LE-109 Phono Preamplifier

Features MC/MM inputs; variable gain and impedance switches; MC straight circuit; subsonic filter; 3-step attenuator selector. FR 20-20,000 Hz \pm 0.3 dB; THD 0.005% (2 V @ 1,000 Hz); S/N 100 dB. 17 1/4 x 2 1/2 x 12 1/4 in; 10 lb \$500

McINTOSH

C-34V A/V Preamplifier

A/V control center with Comander system for controlling sources' dynamic range. Features inputs for laser, tape 1-3, VCR 1 and 2, TV, tuner, and phono; 3 switched, 2 unswitched outlets in rear; provision for 2 sets of speakers; record and listen selectors; 5-band equalizer. Preamp section: FR 20-20,000 Hz +0, -0.5 dB; THD <0.01%; S/N phono 90 dBA, high level 100 dB. Monitor amplifier section: 20 W/ch with 0.01% max total harmonic distortion; FR 20-20,000 Hz +0, -0.2 dB; signal-to-noise ratio 100 dBA. Dimensions: 16 1/8 x 5 1/2 x 13 in; 26 lb \$2,195

C-35 A/V Preamplifier

Features a pair of cascoded FET's to operate the inputs switching system; nine inputs for compact disc, laser disc, TV, tuner, phono, aux 1, aux 2, VCR/T1, VCR/T2; tape-monitor switches for two audio tape recorders; loudness control; five-band equalizer; headphone jack. FR 20-20,000 Hz +0, -0.5 dB; THD <0.007%; S/N phono 90 dB, high level 105 dB. 16 1/8 x 5 1/2 x 13 in; 16 lb, 8 oz \$1,995

MARK LEVINSON BY MADRIGAL

No 26 Phono Preamplifier

High-gain preamplifier with matrix-style DC switching. Features relay hermetically sealed bifurcated contacts of silver with gold plating; 6-line level inputs; CD; tuner; aux-1; phono/aux-2; tapes 1 and 2; 2 tape inputs; non-buffered tape outputs; absolute

*“If the PS•3 speakers were sold like magic elixirs, I would have bought a case!”**



Introducing the unique new PS•3 speaker system.

With every two-piece stereo speaker system you must resolve two quandaries: 1) where will it sound best, and 2) where will it fit? Often these are different and conflicting places in your listening room. Even worse, the best place for bass response is rarely ideal for stereo imaging.

“The PS•3 satellites sound smooth and natural.”

The new Design Acoustics PS•3 Micro-Monitor™ three-piece design offers a versatile answer to these dilemmas. Simply place the two tiny Point Source™ oak veneer satellites exactly where they create the best stereo image. Small and handsome, they fit almost anywhere without compromise.



“The woofer continues the smooth work...”

Then locate the bass module wherever it creates the smoothest, deepest bass...even out of sight. Again, without sonic compromise. The result is far better imaging and wider, flatter response than you can hear from any comparable two-enclosure system. And the PS•3 looks and sounds great no matter the shape or size of your room.

“...you can tune the bass...without affecting the midrange or treble balance.”

The new PS•3 has many more advantages that make it the ideal system for your home. Don't choose any speaker system without first hearing and seeing the new PS•3. Visit a Design Acoustics dealer near you. Write for brochure and dealer list today.

*All quotes by noted audio critic Rich Warren, Chicago Tribune, May 12, 1989

DA DESIGN[®] ACOUSTICS
An Audio-Technica Company
1225 Commerce Drive, Stow, OH 44224 • (216) 686-2600

PREAMPLIFIERS

phase of main outputs or stereo/mono operation selection on front panel; independently switchable gain for each channel; internal gain adjustment provided through PC mount switches for each channel providing gain of 6, 12, 18 at the unbalanced output or 12, 18, or 24 dB at the balanced output; custom-made Penny and Giles conductive plastic volume potentiometer; dual monaural design with separate circuitry for each channel; PLS-226 chassis contains 3-power supplies, 2 provide unregulated DC current for 2 audio channels and 3rd separately rectifies and filters circuit-supplies power to relay control circuit; two toroidal transformers; Faraday shields reduce AC line coupled noise; 9 gold-plated contacts for connecting cable; pos, neg, and ground for each audio channel; 4 discrete, independent regulators; 3-pin Neutrik XLR connectors; all aluminum chassis. Output imp 40 ohms; line input imp 14,000 ohms; phono input imp MC 825 ohms, MM 47,000 ohms; line gain: single-ended 6/12/18 dB, balanced 12/18/24 dB; phono gain: MM 38/44 dB, MC 58/64 dB. Preamp: 17 1/2 x 23 1/4 x 13 1/4 in; PLS-226 7 1/2 x 2 1/4 x 13 1/4 in; 32 lb. \$4,995
No 26. w/Low-Gain Phono. Same as above but with low gain phono. \$4,920
No 26. No Phono. Same as above but without phono. \$4,220

ML10A Preamplifier

Simplified version of L-series circuitry in single-circuit-board configuration. All audio circuitry completely discrete and operates in Class A. Inputs for 2 line sources, monitors tape deck, phono section for virtually any cartridge. Camac connectors. Line section provides up to 22 dB of gain with typical distortion of 0.004% THD and 0.004% and typical S/N of 95 dB unwtid below 2 V reference. Phono section offers selectable gain of 42, 53 or 63 dB. Six internal switches and gold-plated loading sockets allow infinite cartridge-loading capability. Typical distortion for phono circuit 0.014% total harmonic distortion and 0.005% IM and S/N typically -72 dB. Internal power supply with high-speed push-pull regulator; biased for Class A; load regulation of 0.05%; wide-band noise output 23 V; 7 or 17 dB line gain. Hand-brushed black anodized finish. 19 x 2 1/4 x 10 1/8 in. \$3,325

ML-12A Preamplifier

For use with ML-11 power amp, or with other power amp if used with PLS-124 power supply (see below). Inputs for MM phono, MC phono, tape, aux, tuner. Phono section accepts any cartridge, gain 42, 53, or 63 dB and gold-plated sockets for precise cartridge loading. Line-level section gain 4, 9, 13, or 17 dB to match amps, speakers, sources. Gold-plated Camac connectors for inputs and outputs and separate level controls for each section. Hand-engraved black anodized front panel. Phono S/N 75 dB unwtid at 63 dB gain; THD 0.006% and IM 0.004%; SMPTE at 6 V output; S/N <92 dB below 1 V ref; 19 x 2 1/4 x 9 3/4 in. \$1,600
PLS-124. Optional power supply with separate rectification and filtering for each ch. Ripple 40 mV before regulation in ML-12A. \$455

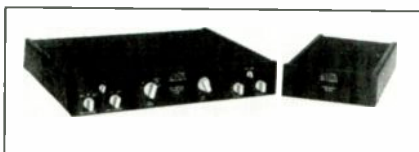

Mark Levinson No. 26

MELOS AUDIO

MA-222B Hybrid Preamplifier

Dual-mono construction preamplifier with dual toroidal transformers. Features 2 heavy aluminium chassis; zero feedback circuitry; 10 regulated power supplies; heavy gold plated connectors; inputs for 2-

CDs, phono, tuner, 2-aux; 2 tape monitor loops; 3 main outputs; phase reversal switch. Phono gain 65 dB; FR 2-300,000 Hz \pm 1 dB; THD 0.07%; imp 20 ohms; max overall gain 85 dB. \$3,395

CD-T/B Tube Preamplifier

Preamplifier with Melos CD-TII/B CD player for made systems using CD as the primary music source. Heavy aluminum chassis; toroidal transformer; Tiffany connectors; CD input, tuner, video aux, aux phono; tape monitor loop; 2 main outputs; remote. FR 20-20,000 \pm 0.2 dB; THD 0.07%; S/N 90 dB \$1,595

GK1 + 1 Tube Preamplifier

Vacuum tube preamplifier with remote power supply and stepped attenuators. Features each amplification stage powered by one of the 9 regulated power supplies; passive RIAA EQ; auto-muting circuit protection. 3 selectable MC and MM phono section; FR 2-300,000 Hz \pm 1 dB; THD 0.07%; 20- 20,000 Hz; S/N 65-85 dB (phono/sensitivity dependent). 19 x 3 1/2 x 13 1/4 in; 15 lb (preamp); 17 1/8 x 3 3/8 x 6 in; 10 lb (power supply) \$1,395

MA-111 Hybrid Preamplifier

Hybrid preamplifier with heavy aluminum chassis and external toroidal power supply. FR 2-300,000 Hz 1 dB; THD 0.07%; max gain 67 dB; line gain 27 dB \$1,195

MA-110 Hybrid Preamplifier

Hybrid preamplifier with 1 processor loop. FR 2-300,000 Hz \pm 1 dB; THD 0.07%; max output 22V. \$995

MERIDIAN BY MADRIGAL

Model 201 Preamplifier

Features 6 inputs; tape-to-tape dubbing for 2 decks; full source monitoring capabilities; 64-step volume control; user-programmable mute level and volume offset between sources; MM/MC inputs. Can be externally controlled as a part of the Meridian Multiroom system. Includes remote control. 4 x 6 1/4 x 12 1/4 in; 10 lb. \$1,090
Model 202 Multiroom Preamplifier. As above, with 2 independent outputs for Meridian Multiroom systems. Each preamplifier can independently choose and distribute any of 6 inputs at its own volume. 4 x 6 1/4 x 12 1/4 in; 11 lb. \$1,390

MODSQUAD

Line-Drive AGT Preamplifier

Passive system control center for line-level sources; advanced grounding topology (AGT) with star-center grounding throughout; non-ferrous, non-magnetic chassis. Five line-level inputs and two tape loops; two main outputs wired in parallel for bi-amplification; front panel input selector with mute position, volume and balance controls; switchable chassis shielding. FR 1x-200,000 Hz +0, -3 dB; THD 0.0001%; input imp 8200; output imp variable; ch sep 86 dB. 16 1/2 x 2 1/2 x 10 3/4 in; 3 lb. \$1,095
Standard. Same as above, except different interior component \$595



Mod Squad Phono Drive

Phono Drive Preamplifier

Solid-state hybrid circuit combining JFET, bipolar, and MOSFET transistors; direct coupled circuitry with proprietary 1x servo control; star-center grounding and star-feed power lines; nonferrous, nonmagnetic

chassis. MM and MC cartridges inputs; front-panel-selectable loading for MC input plus internal, user-definable loading option; volume and balance control; direct output. Frequency response 5-110,000 Hz +0, -3 dB; THD 0.001%; signal-to-noise ratio 88 dBA (MM), 60 dBA (MC); output imp 60 ohms; input imp 45,000 ohms (MM), selectable (MC). 16 1/2 x 2 1/2 x 10 3/4 in; 7 lb. \$1,295

MOTIF BY CONRAD-JOHNSON

MC7 Dual-Mono Preamplifier

Dual-mono all-FET preamp with remote power supply. Features precision-matched FET for ch-to-ch balance; exclusive use of polystyrene capacitors throughout audio circuits and power supply regulators. Inputs for MM/MC, tape, tuner. FR 5-100,000 Hz \pm 0.5 dB; max output 10 V; THD 0.1%; IM 0.1% IHF; MM phono sens 0.35 mV for 0.5-V output at 1,000 Hz; MM phono input overload level 150 mV, sensitivity for line-level inputs 50 mV; 3 1/2 x 19 x 12-in.; 15 lbs \$3,500

MC8 Preamplifier

Similar to MC7 except stereo with internal power supply. Inputs for MM/MC; tape; tape 2; CD player; tuner. FR 5-100,000 Hz \pm 3 dB; THD 0.1%; MM phono sens 0.35 mV for 0.5-V output at 1,000 Hz; sens for line-level inputs 50 mV; MM phono input overload level 150 mV at 1,000 Hz. 3 1/2 x 19 x 12-in.; 15 lbs \$2,250

MC9 Stereo Preamplifier. Line only preamp \$1,295

NAD

1700 Monitor Series Preamplifier/Tuner

Features external processor loop. IF wide/narrow; 14 AM/FM random presets; motor-driven volume control; semi-parametric tone controls; bass EQ; 2-way tape dubbing. Stereo sep 50-dB; S/N >80 dB. Includes remote control. Rack mountable \$799

1300 Monitor Series Preamplifier

High-resolution phono preamp. Features MC preamp; external processor loop; infrasonic filter. Bass EQ; null switch; semi-parametric tone controls (bass switchable to 50, 100, 250 Hz, treble switchable to 3,000, 6,000, or 12,000 Hz; \pm 12 dB boost/cut); 2-way tape dubbing. Max output 12V. Rack mountable \$399

1240 Preamplifier

Discrete transistor phono preamplifier. Features switchable 12-dB/octave infrasonic filter; high-current headphone amp; cartridge capacitance loading. Bass equalizer; 2 outputs; MM/MC, compact disc player, tuner, tape, video, and aux 1 and 2 inputs; \pm 7 dB boost/cut at 10,000 Hz; \pm 10 dB boost/cut at 50 Hz \$249



NAD 1700

NAKAMICHI

CA-7A Preamplifier

Preamp with full-system wireless remote control of Nakamichi series 7 or 5 components. Features total isolation of digital and analog sections; isolated ground technology; acoustical fine-tuning system; motor-driven volume control; inputs for MM and MC phono, 2 tape, 2 aux, tuner, CD; 2 outputs; multi-room remote control with RS-7 remote sensor. Frequency response 1-100,000 Hz +0, -3 dB; signal-to-noise ratio >94 dBA; total harmonic distortion <0.002% at 20-20,000 Hz; 17 1/8 x 3 1/4 x 12 1/4 in; 15 lb, 4 oz. \$2,595

PREAMPLIFIERS

CA-5A11 Preamplifier

Features 5 high-level inputs; phono input; copies between 2 tape decks in either direction; recording deck monitors copying procedure; all inputs and 2-sets of output terminals are gold-plated; remote power connector optional (SPC-1 power strip); MM- or MC-cartridge phono input; output level; bass; balance; treble; low-noise FETs; bipolar transistors; multi-regulated isolated ground power supply; S/N >95 dBA; THD <0.002% at 20-20,000 Hz; FR 1-100,000 Hz +0, -3 dB; 17 $\frac{1}{2}$ x 2 $\frac{1}{2}$ x 11 $\frac{1}{4}$ in; 11 lb, 4 oz. \$1,095

NIKKO AUDIO

Beta 600 Preamplifier

Stereo preamplifier with two-band parametric equalizer with variable level, variable bandwidth, and selectable frequency turnover controls. Features CD direct circuit isolated from other analog circuitry; 2-output terminals; gold-plated pin jacks; 2 record-out selectors; mechanical switches; MM/MC selector. THD 0.002%; S/N 100 dB; channel sep Hz 76 dB at 1,000 Hz; FR 5-100,000 Hz +0 dB, -1 dB. 19-in rack mountable with black diecast aluminum front plates. \$600

Beta 400 Preamplifier. As above with FR 5-100,000 +0 dB, -2 dB. \$440

NOVA

CPA-100A Preamplifier

All-discrete, all J-FET preamplifier with option for MC amplifier. Inputs for MM, MC phono; tape; tuner; CD player. Max output 12 V; THD 0.01%; IMD 0.01%; MM phono sens 2.5 mV for 0.5 V output at 1,000 Hz; MM phono input overload level 250 mV; phono gain 34 or 40 dB switchable; line-level sens 98 mV. Black finish with oak side panels. 19 x 4 x 9 $\frac{1}{2}$ in; 14 lb. \$1,995

PPA-202. J-FET MC head-amp card plugs into CPA-100A. Features selectable input imp; 3 gain settings; MC phono input. High-overload capability allows greater than 1 V rms undistorted output. FR 0.05-1.5 MHz \pm 3 dB; S/N 71 dB; THD 0.01%. 6 $\frac{3}{4}$ x 3 x 1 $\frac{1}{2}$ in; 1 lb. \$300

NUMARK

PE100 Preamplifier/Graphic Equalizer

Stereo preamplifier with MM and MC inputs. Features MOSFET circuitry; six inputs (phono/2, tuner, CD, tape 1/2). 10-band graphic EQ per ch; center frequencies at 30, 60, 120, 240, 480, 960, 1920, 3840, 7680, 15360 Hz. FR 10-100,000 Hz; THD .008%; S/N 84 dB. 18 x 4 x 10 $\frac{1}{2}$; 11 $\frac{1}{2}$ lb. \$500

ONIX AUDIO by MUSIC HALL

OA-24 Preamplifier

Must be used with SOAP-2 power supply. Features 5 inputs and remote control. \$1,245

ONKYO

P-3160 Preamplifier

Preamplifier featuring Selective Tone Control with 50-Hz boost. CD direct input; simulated stereo circuitry; motorized volume control; 7 inputs; front-panel VCR jacks. FR 15-30,000 Hz \pm 1 dB; THD 0.009% (tuner, CD); S/N 92 dB (MM). 17 $\frac{1}{8}$ x 4 $\frac{1}{4}$ x 10 $\frac{1}{2}$ in; 8 lb. \$270

Integra Series

Grand Integra P-308 Preamplifier

Preamp with independent, magnetically-shielded power supplies for each amplification block. Features short signal-path routing; subsonic feedback loop to cancel IX components; signal in-phase filters to reduce common-mode noise. Defeatable tone controls; switchable Contra-Bass control; high-cut sloping filter position on treble control; 8 inputs including MM/MC phono jacks and 2 front-panel jacks for

portable components; dual record-output selector. FR 0.8-170,000 Hz +0, -3 dB; THD 0.0005% (CD); S/N 101 dB (CD). Wood side panels included. 18 $\frac{1}{4}$ x 4 x 15 $\frac{1}{8}$ in; 19 lb. \$660

Integra P-304 Preamplifier

Preamp with independent, magnetically-shielded power supplies for each amplification block. Features Delta power supply with Real-Phase transformer. Dual record-output selector; adjustable phono gain and load imp; 8 inputs including MM/MC phono jacks. FR 0.8-170,000 Hz +0, -3 dB; total harmonic distortion 0.0005% (tuner, CD); S/N 92 dB (MM). 18 $\frac{1}{4}$ x 4 x 15 $\frac{1}{8}$ in; 17 lb. \$530

PARASOUND

P/FET-900 Class A Preamplifier

FET Class A preamplifier. Features FET discrete transistors; electronic logic switching; polypropylene capacitors; regulated power supply; gold-plated jacks; muting relay; variable loudness contour; 10-amp power switch; 3-AC outlets; mono switch; 2-tape monitors; 2-direction dubbing; separate CD. Video inputs; FR 10-80,000 Hz \pm 0.5 dB; THD <.005%; IM <0.005%; S/N 95 dB high. 80 dB phono; 17 $\frac{1}{4}$ x 2 $\frac{1}{2}$ x 9 $\frac{1}{2}$ in. \$395

P/HP750 Preamplifier

Features C-MOS switching for inputs, tape; variable loudness contour; high and low filters; tape dubbing. FR 5-65,000 Hz; THD 0.006%; IM 0.006%; S/N 92 dB; phono overload 200 mV; output sens 8.5 V. \$235

PIONEER

C-90 A/V Preamplifier

Features wireless remote control; motorized rotary volume control. 5 audio inputs; 5 video inputs (3 input/outputs, 2 input only); 3 different power supplies; copper-plated chassis; 2 video outputs; recording selector/tape-dubbing switch; subsonic and high/low filters; loudness, muting, and tone controls; video enhancer (detail, sharpness, and noise cancel). 9 x 21.7 x 19 in. \$900

PROTON

1100 Preamplifier

Stereo preamplifier with separate MC phono input. Features built-in headphone amp; bass EQ switch; listen/record selector; high-level pre-out 18 V. FR 20-20,000 \pm 2 dB; THD 0.003% (20-20,000 Hz, 2 V output). 16 $\frac{1}{2}$ x 2 $\frac{1}{2}$ x 13 in. \$399

AP-1000 Preamplifier

Stereo preamplifier with separate record and listen selectors. Features bass, presence, and treble controls with bypass circuitry; dual-mono construction with separate power supplies for both channels; two discrete preamplifiers; phono preamp section with FETs; selectable input capacitance for MM cartridges; multiple gain levels for MC cartridges; bass EQ switch; inputs for phono, tuner, CD, video, tape 1, tape 2; headphone jack. FR 20-20,000 Hz \pm 2 dB; THD 0.003%; IMD 0.003%; video S/N 103 dB; tape play S/N 103 dB; MM phono S/N 91 dB; MC phono S/N 70 dB. 16 $\frac{1}{2}$ x 3 $\frac{3}{4}$ x 13 $\frac{1}{2}$ in; 14.3 lb. \$259

PS AUDIO

5.5 Preamplifier

Full-function preamplifier with all MOSFET circuitry. Features dual-mono power regulation; extra-large transformer; MM and MC phono sections; 5 gain selections for phono cartridge; cartridge loading; high-level bypass; remote power supply. THD <0.01%; IMD <0.01%; MM noise -82 dB; MC noise -78 dB. 19 x 2 $\frac{1}{4}$ x 12 $\frac{1}{2}$ in; 15 lb. \$1,195

4.6 Preamplifier

Full-function preamplifier with MM and MC phono sections. Features 5 gain selections for phono car-

tridge; ca-tridge loading; high-level bypass; remote power supply. THD <0.01%; IMD <0.01%; MM noise -82 dB; MC noise -78 dB. 19 x 2 $\frac{1}{4}$ x 8 $\frac{1}{2}$ in; 15 lb. \$699

QUAD

Quad 44 Control Unit

Preamp/control system with lift/step bass control to boost low-frequency output of small speakers, attenuate bass output when operating as filter to give 5 dB drop at 2 frequencies; \pm 2 dB tilt control that shifts tonal balance; variable filter slope control at 5,000, 7,000, 100,000 Hz; all tone controls have defeat positions. balance/mono switch; radio, aux, disc, tape 1, tape 2 input selectors with optional microphone or MC phono inputs available. Input sens/imp 1 mV at 35 mV in/47,000 ohms phono, 100 mV at 5 V in/39,000 ohms tape, 1,000,000 ohms radio and aux; FR 30-20,000 Hz \pm 0.5 dB phono RIAA, 30-20,000 Hz -0, +1 dB; high-level distortion 0.02%; residual noise -104 dBA; 8 x 2 $\frac{1}{2}$ x 5 $\frac{1}{8}$ in. \$995

Quad 34 Control Unit

Preamp control unit with tilt control; bass control; inputs for disc, tape, tuner, aux; 3 push-button filters; bass lift and step. Distortion worst case any input 0.5%. Residual noise A-wtd volume control at minimum -105 dB; FR \pm 0.3 dB any input except phono, FR phono RIAA \pm 0.5 dB. \$795

QUICKSILVER AUDIO

Preamplifier

Preamplifier with on/off power switch. Bandwidth 1-650,000 Hz; max input 30 V rms from 20-20,000 Hz; max output 65 V rms from 20-20,000 Hz, 3 year warranty on parts and labor. 17 x 10 x 4 $\frac{1}{2}$ in; 21 lb. \$1,495

REVOX

B252 Preamplifier

Microprocessor-controlled preamp with input sensitivities programmable into nonvolatile memory and infrared remote control. Inputs for MM phono; MC phono; tuner; tape; tape 2; AUX; phono 2; CD player; external equalizer. FR 20-20,000 Hz +0, -0.2 dB; THD <0.01%; S/N 96 dB (line input), 75 dB (phono input); MM phono sens 1.6-23 mV for 5-mV output; sens for line-level inputs 160 mV to 2.3 V. 17 $\frac{3}{4}$ x 6 x 13 in; 15 lb, 7 oz. \$1,750

ROTEL

RTC850 Tuner/Preamplifier

Tuner preamplifier with dual gate MOSFETS in tuner front end. Features 16 AM/FM station presets; direct signal paths; inputs for MM/MC, CD, tape, and video; full function remote; motorized volume control. Tuner section: 50-dB quieting sens, mono 14.8 dBf, stereo 37.2 dBf; AM rej 58 dB; cap ratio 1.0 dB; S/N 75 dB stereo, 80 dB mono; alt-ch sel 70 dB. Preamplifier section: FR 20-20,000 Hz \pm 0.2 dB; total harmonic distortion <0.004%; signal-to-noise ratio 100 dB. 17 $\frac{1}{2}$ x 3 $\frac{3}{8}$ x 13 $\frac{1}{8}$ in; 12 lb. \$499

RC870BX Preamplifier

Stereo preamplifier with MM and MC phono inputs. Features toroidal transformer; 4 electrolytic capacitors; metal film resistors; metal layer capacitors; direct CD input with its own level control; tape dubbing; video dubbing; inputs for phono, CD, tuner, tape 1, tape 2, AV/aux 1, AV/aux 2. FR 20-20,000 Hz \pm 0.2 dB; THD <0.004%; S/N 95 dB. 17 $\frac{1}{2}$ x 2 $\frac{1}{2}$ x 12 $\frac{1}{4}$; 10 lb. \$399

RC850 Preamplifier

Stereo preamplifier with MM and MC phono inputs. Features OP amplifier stages in phono EQ; tone defeat switch; inputs phono, CD, tuner, tape 1, tape 2, AV/aux 1, AV/aux 2. FR 20-20,000 Hz \pm 0.2 dB; THD <0.004%; S/N 95 dB. 17 $\frac{1}{2}$ x 2 $\frac{1}{2}$ x 10 $\frac{1}{2}$; 8 lb. \$249

PREAMPLIFIERS

ROWLAND RESEARCH

Coherence One Preamplifier

Solid-state FET preamp with companion regulated power supply. Accepts all MM and MC cartridges directly. Direct-coupled design from input to output. Split-passive RIAA EQ. Provides inputs for 1 phono and 3 high-level inputs. Tape-rec outputs selectable from any input. Features phase reversal and full muting from front panel; separate R/L-ch balance controls; master volume; balanced outputs standard; outputs mute upon powerup or error. Phono stage: gain 40-50-60 dB; THD+noise <0.04% at 1,000 Hz. Line stage: gain 20 dB; FR 0.2-500,000 Hz -3dB; THD+noise <0.015% at 1,000 Hz \$3,950

SAE

P102 Preamplifier

Computer direct-line preamplifier with 3 digital tone memories, electronic volume and balance controls. Features sequential audio muting for cross-fading between input sources. Inputs for MM phono, MC phono, tape, tape 2, aux, phono 2, CD player, tuner, external processor. FR 20-20,000 Hz \pm 0.5 dB; THD 0.025%; IM 0.025% IHF; max output 7.5 V; MM phono sens 160 mV for 0.5-V output at 1,000 Hz; MM phono input overload level 240 mV. \$449

SANSUI

C-2102 Preamplifier

Features direct-coupled line amp; subsonic filter; phono, CD, tuner, line, and tape/DAT 1, 2, 3 inputs/outputs; rec and cartridge selectors (MC, high MC, MM). THD 0.003%; FR 20-20,000 \pm 0.2 dB (phono); S/N 88 dB (MM phono), 70 dB (MC phono), 110 dB (other sources) \$750

C-1000 Preamplifier

Preamplifier with full-function remote. Features multiple audio inputs; 2 video inputs; motor-driven volume control; delay-line video enhancer; monitor output; keyboard instrument input; variable loudness; mute. Preamp output 1,000 mV/1.5 kilohms; FR 10-100,000 Hz. 17 x 3 $\frac{3}{8}$ x 9 $\frac{1}{2}$ in; 7.1 lb. \$190

SHERWOOD

AP-7020 Hybrid Preamplifier

Features discrete pure complementary flat amplifier; switchable MM/MC phono gain amplifier; active high and subsonic filter. Loudness switch; crossover frequency for subwoofer; gold-plated phono jacks; switchable tone control turn-over frequency; direct switch (tone bypass); rec-out selector switch; 2 sets of pre-amp output jack; external processor in/out jack; muting switch; balanced in/out; 3 tape and processor loops; 2 tone controls. FR 20-150,000 Hz +0.5/-3 dB; THD 0.005%; S/N 80 dB (MM), 75 dB (MC) 17 $\frac{1}{2}$ x 4 $\frac{1}{2}$ x 11 in \$359

SONOGRAPHIE BY CONRAD JOHNSON

SC1 FET Preamplifier

All-FET preamplifier with matched-FET polypropylene and polystyrene capacitors for all audio circuits; discrete power-supply regulation; inputs for phono, tuner, CD, video, tape 1 and 2. FR 5-100,000 Hz \pm 0.5 dB; max output 10 V; THD 0.1%; IM 0.1%; phono

overload 150 mV; 3.5 x 18 x 12 in \$595

SONY

Elite Series

TA-E77ESD Preamplifier

Preamplifier with built-in D/A section featuring 4x-oversampling filter and dual D/A converters. Features 91-key programmable remote control; full A/V switching capability; S-video and composite video terminals; source direct switch; passive tone control; independent record/out selector; adaptor terminals; phono input selection. Intermodulation distortion 0.001%; total harmonic distortion 0.001%; separation > 90 dB; frequency response 5-20,000 Hz \pm 0.5 dB \$1,000

SOUNDCRAFTSMEN

DX 4200 Preamplifier/Equalizer

Combination preamp/equalizer with digital audio and video inputs. Features in/out balancing to 0.1 dB; phono preamp has variable cartridge loading (50-800 pF, 100/47,000 ohm) adjustable \pm 20 dB gain moving coil or moving magnet cartridge inputs; 3-way tape dubbing; 2 external signal-processor loops; conventional line outputs plus separate autobridge line outputs for auto mono bridging of most amps; EQ signal-to-noise ration 114 dB; passive-coil filters with 15 dB boost or cut for each octave; differential/comparator circuitry for true 0.1 dB unity-gain equalizer balancing; 19-in rack-mount front panel; includes frequency spectrum analyzer test record and instant reset Computone charts. Dimensions: 9 x 5 $\frac{1}{4}$ x 11 in. \$749

DX4000. Same as DX4200 without graphic equalizer but with 3 external signal-processor loops. Dimensions: 19 x 3 $\frac{1}{2}$ x 11 in \$439

Pro-Control Preamplifier

Digital C-MOS. Features five tape monitors for audio or video tape, CD, tuner, and phono inputs. Two signal processor loops, subsonic filter, and direct mode to bypass all processing. Headphone jack, autobridge circuit to triple amplifier output. Frequency response 20-20,000 Hz \pm 0.1 dB; total harmonic distortion <0.005%; signal-to-noise ratio: phono 97 dB, high-level 116 dB. Rack mount front panel. Dimensions: 19 x 3 $\frac{1}{2}$ x 10 $\frac{1}{2}$ in \$699

Pro-Control Three Preamplifier. Same as above, 2 tape monitors and 1 loop. \$549

Pro-PT Two Preamplifier/Tuner

Combination tuner/preamplifier features C-MOS digital switching for phono, CD, tuner, video/audio, two tape monitors with dubbing; variable loudness control; high and low filters. FR 10-80,000 Hz \pm 0.5 dB; THD <0.005%; S/N 95 dB high, 80 dB phono. Tuner section: FM sens 10.3 dBf; cap ratio 1.2 dB ... \$449

DX3000-17 Preamplifier

Features C-MOS digital switching for phono, CD, tuner, video/audio, two tape monitors with dubbing; variable loudness control; high and low filters. FR 10-80,000 Hz \pm 0.5 dB; signal-to-noise ratio 95 dB high, 80 dB phono; total harmonic distortion <0.005%. 17 x 2 $\frac{3}{4}$ x 9 $\frac{1}{2}$ in. \$279

SOUNDSTREAM

C-1 A/V Preamplifier

System 1 component; dual mono Class A circuitry features discrete component signal path; each remote-controlled component has a separate power supply for audio and switching circuits to minimize noise in the audio signal; unique digital switching circuitry links Soundstream products. Audio/video dubbing: disc-to-tape or tape-to-tape; separate record and listen circuitry permits simultaneous recording and listening or viewing; audio connections include phono/aux, tape 1, tape 2, CD, tuner; audio/video functions include VCR 1, VCR 2, videodisc, TV (output

only); optional accessories: plug-in dual mono phono preamp cards, remote-controlled AC power strip, and infrared remote; includes R-L remote control; Controls all functions of the C-1, T-1, and DA-1, or control 11 separate components, 8K byte memory directs operation of all components, 6 addition unassigned user-selectable functions. Frequency response 20-20,000 Hz \pm 0.1 dB; total harmonic distortion <0.05%; signal-to-noise ratio > 100 dBA; input impedance 30,000 ohms; input sensitivity <100mV for 0.5V out. 17 x 3 $\frac{3}{8}$ x 11 $\frac{1}{2}$ in; 15 lb \$1,495

SPECTRASCAN

LCA-10-MC Preamplifier

Stereo preamplifier with high-gain, high-voltage input buffer-amplifier to eliminate cartridge interaction. Features dual-head amplifiers; toroidal power transformer; dual line outputs; switchable input cap for moving-magnet input; separate source and record switches; low-noise moving-coil head amp; input for moving-magnet, CD, video, tuner, tape 1 and 2, 2 sets of outputs. Frequency response 3-250,000 Hz; total harmonic distortion line amp 0.05% from 20-20,000 Hz; intermodulation distortion 0.05%; signal-to-noise ratio 100 dB; sensitivity 100 mV for 1.0 V

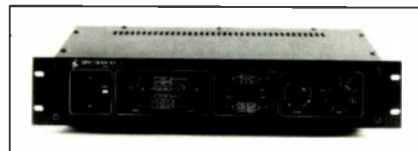

Spectrascan LCA-10

output. 3 $\frac{3}{4}$ x 19 x 9 $\frac{1}{2}$ in; 17 lb \$1,969
Without head amplifier \$1,569

STANTON

310B Phono Preamp/Equalizer

Designed to correctly interface all Stanton-selected magnetic cartridges for optimum playback of records and calibration of audio systems. Features universal mounting brackets; selection of flat or NAB curves; switchable rumble filter; individual gain adjust; capacitive-cartridge loading trim. Can be used in balanced and unbalanced modes and in-phase and out-of-phase mix of L/R ch for mono reproduction of older records. RCA phono jacks (input), 5-terminal barrier strip (output). Output source imp 5 ohms, designed for loads 150 ohms or higher; frequency response \pm 0.5 dB from 20-20,000 Hz in Flat or NAB positions; total harmonic distortion -0.05% at 20 dBm; ch sep 60 dB min 20-15,000 Hz \$280

SUMIKO

YBA1 Preamplifier

Dual mono preamplifier with MC/MC phono inputs. Features selectable polarity inversion. FR 5-400,000 Hz \pm 0.2 dB; THD 0.05%; S/N 90 dB \$5,500

YBA2. As above, without polarity switch ... \$3,000

YBA3 Preamplifier

Preamplifier with moving magnet phono input and optional moving coil input. FR 5-400,000 Hz \pm 0.2 dB; THD 0.05%; S/N 83 dB \$1,800

SUMO

ATHENA Preamplifier

Stereo preamp with built-in moving-coil head amp. Features discrete circuitry utilizing 1% metal-film resistors and metallized polypropylene capacitors; gold-plated input/output jacks; separate record/mode select functions; linear-phase subsonic filter; high-level bypass; laser-trimmed volume control. FR 20-20,000 Hz \pm 0.1 dB; THD/intermodulation distortion <0.01% below 18 V output; S/N (moving coil) 80 dBA, (moving magnet) 85 dBA, high-level 100 dB. 19 x 1 $\frac{1}{4}$ x 8 $\frac{3}{4}$ in. \$729

The listings are based on data provided by the manufacturers. For more product information, contact an authorized dealer or the manufacturer directly. Manufacturers' addresses and phone numbers are listed in the directory beginning on page 258.

If getting everything you've ever dreamed about in a receiver has been just, well, a dream, this message could prove to be most valuable. Because the RV-1340R Audio Video Remote Receiver is the finest Sherwood has ever built. With tighter engineering tolerances and more high performance features than any other component in its price range.

Behind its double-thick brushed aluminum front-end are two discrete amplifiers and Dolby® surround sound circuitry. One amp sends 100 watts per channel to the front speakers. While the second delivers a full 20 watts per channel to the rear. So you can turn on your Sherwood and turn your living room into a home theater experience.

The unit is designed with MOS-FET components and fully complementary circuitry. Plus video dubbing with adjustable video enhancement. And with Sherwood's DIGI-LINK unified wireless remote, you'll put an entire Sherwood system at your command.

To put the RV-1340R to the test, visit your Sherwood dealer for a thorough demonstration. And discover a receiver you can look up to that's within your reach.



MOST VALUABLE RECEIVER.



 **Sherwood®**
LIVE PERFORMANCE SOUND™

13845 ARTESIA BLVD. CERRITOS, CA 90701 • IN CANADA: NORESKO CANADA INC., TORONTO, ONTARIO © 1989 INKEL CORPORATION.
Dolby is a trademark of Dolby Laboratories Licensing Corporation.

CIRCLE NO. 33 ON READER SERVICE CARD

“In its price category, the Adcom GFA-535 is not only an excellent choice; it’s the only choice.”

Sam Tellig, The Audio Cheapskate

stereophile

Vol. 10 No. November 1987

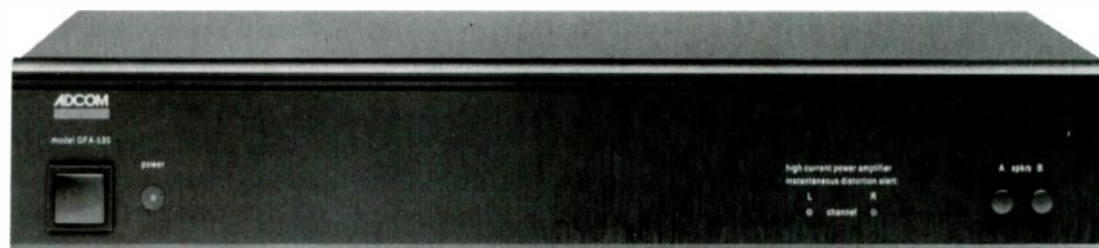

Adcom GFA-535 power amplifier.

The complete report:

Sometimes products are too cheap for their own good, and people don't take them seriously: the Superphon Revelation Basic Dual Mono preamp, Rega RB300 arm, AR ES-1 turntable, Shure V15-V MR cartridge, and the B&K ST-140 power amp. They can't be any good because they cost so little, right?

Wrong, of course.

Adcom appears to be having the same problem with their \$299.95 GFA-535 amp. Credibility.

Now if this amplifier were imported from England and sold for \$599.95, then maybe it would be taken seriously. And highly praised, no doubt.

For the baby Adcom is one of the finest solid-state amps I have heard. No, not the best; I'm not sure what *is* the best. But it's an amplifier that is so good for so little money as to be practically a gift.

Actually, when Rob Ain from Adcom called, I was about as enthusiastic about the GFA-535 as you were before you finish reading this piece. But Rob insisted, "You've gotta hear this amp."

He brought it over the next day, along with the GFP-555 preamp (\$499.95), and we put both pieces into the rest of the system: a Shure Ultra 500 in a Rega RB300 arm on an AR ES-1 table, with Quad ESL-63 speakers on Arcici stands. Then we chatted for a half hour or so while the electronics warmed up.

And then, simultaneously, the two of us decided to shut up and listen.

"I've never heard the Quad ESL-63 sound better," Rob said. Of course, he was hardly an impartial observer, but the sound was extraordinarily clean, detailed, and musical. If it wasn't the best sound I have ever heard from Quads, it was pretty close.

This humble \$300 amplifier was driving a pair of very revealing \$3000 speakers and giving a very good account of itself. (We listened first to some Goran Sollscher classical guitar.)

"So how come this product isn't flying off the dealers' shelves?" I asked Rob.

"I don't know. Everyone wants the GFA-555 with 200 watts per channel. Including people who don't need it."

"Does the GFA-555 sound any better?" I asked.

"It's our aim to have all our amps sound pretty much the same. You pay more money, you get more power."

Rob pointed out that while the GFA-535 is rated at 60Wpc, it puts out more like 80. And while I did not do any measurements, my experience with other amps tells me Rob's right. I suppose Adcom doesn't want to steal sales from its GFA-545, rated at 100Wpc and selling for \$200 more.

After a couple of hours, Rob left, grinning from ear to ear, and I later sat down to listen alone. True, when I tried certain Telarcs and pushed hard I could get the amplifier to clip—two LEDs quickly light up (very useful). But the Quads were running out of the ability to use the power anyway. My first impressions

were confirmed: the GFA-535 is one of the best amplifiers around for driving Quads. Spondor SP-1s, too.

Suddenly, it hit me what this meant. Conventional wisdom had been dealt a severe blow. You know, the old saw that you should never power a good pair of speakers with a

“The GFA-535 reminds me of...amplifiers that sell...for about three and five times the price.”

cheap amplifier. Here was a cheap amp—one of the cheapest on the market—that sounded good with Quads, Spondors, later Vandersteens. Probably Thiels, too—at least the CS1. What it means is you can stretch your speaker budget a bit and get the speakers you really want, then economize by buying an Adcom GFA-535 for \$299.95. True, you may be a little power shy, but probably not much. And to say the least, the GFA-535 would make a decent interim amp.

What does the GFA-535 sound like? (You thought I'd forget that part, right?) Well, this is one of the most neutral amps I've heard.

“...the baby Adcom is one of the finest solid-state amps I have heard...so good for so little money as to be practically a gift.”

While it doesn't sound particularly tubelike, it avoids the typical transistor nasties through the midrange and into the treble. I wouldn't call it sweet—there's no euphonic coloring—but it isn't cold or sterile. What it is, is smooth. And detailed. Far more detailed than I would ever imagine a \$300 amplifier could be. The GFA-535 reminds me of the Eagle 2A and PS Audio 200C, amplifiers that sell, respectively, for about three and five times the price. Of course, they have more power. And they *are* more detailed. The point is, the Adcom comes close. Very close.

The bass, like everything else, is neutral, certainly not fat and overdone. But it's here where

you notice that this amp is not a powerhouse. You just don't get the solidity and extension you get with a very powerful (and expensive) solid-state amp. Nor do you get the breadth and depth of soundstage that you often find with a very powerful amp. The Adcom GFA-535 sounds a wee bit small, which it is.

My only criticism, and it's more of a quibble, is that the speaker connectors are non-standard and unique (so far as I know). You insert bared speaker wire into a hole and twist the connector tight a quarter turn. Most speaker cables will fit, but some will not. Certainly MIT won't. Neither will the best Kimber, the kind with eight clumps of strands. The less costly four-clump Kimber will, and proved an excellent choice. My sample amp was quiet—

“This amplifier is so good and so cheap that I think any CD owner who buys an integrated amp is nuts.”

no hum—and ran cool. There are selectors for two sets of speakers. And the 535 looks nice.

And talk about economy: If you're not into LPs anymore, you could buy a Mod Squad, dbx, or Old Colony line-level switching box—or possibly a B&K Pro 5 preamp, with its switchable line amp section (only \$350), or the Adcom SLC-505 passive preamp (\$150)—and run it with a CD player. In fact, if you are into CD only (no tape, no tuner, no phono), you could buy a CD player with a variable volume output and run it directly into the Adcom. This amplifier is so good and so cheap that I think any CD owner who buys an integrated amp is nuts.

In its price category, the Adcom GFA-535 is not only an excellent choice; it's the only choice. The real question is whether you should buy one even if \$299.95 is much *less* than you planned to spend for an amp—*ie*, whether you should put the money into a better CD player or pair of speakers instead.

ADCOM[®]
line stereo components

11 Elkins Road, East Brunswick, NJ 08816
U.S.A. (201) 390-1130 Distributed in Canada by:
PRO ACOUSTICS INC. Pointe Claire, Quebec H9R 4X5

PREAMPLIFIERS

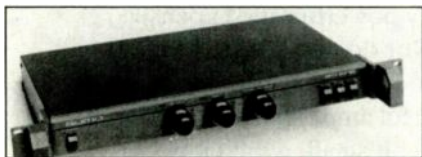

Sumo Athena

SUPERPHON

Revelation II Preamplifier

MOSFET preamp with J-FET phono, MOSFET current sourcing. Voltage regulated through 10 shunt regulators, adjustable bias setting for output stage. Input for 1 phono, 4 high-level inputs plus 2 complete tape loops; full muting from panel with automatic muting for line surge/drop protection. Frequency response 2-175,000 Hz; THD >0.5 at 3 V rms; signal-to-noise ratio 95 dB (line), 77 dB (phono); max output 5 V rms; 150 mV MM phono overload; MM phono input imp 47,000 ohms; phono gain 37 dB; line gain 20 dB \$799

C.D. Maxx Preamplifier

Active line-stage preamplifier with passive option. Class A MOSFET solid-state circuit with MOSFET current sourcing; voltage regulated by 6 shunt regulators. Inputs for 3 high level, 1 tape loop, 1 dubbing out, 2 pairs main outputs; full muting from top panel; optional gain. FR 2-200,000 Hz; THD >0.5 at 2 V rms; S/N >95 dB; input imp 10,000 ohms; output imp 600 ohms; gain 14 dB; max output 3 V rms \$399

TECHNICS

SU-A200 A/V Preamplifier

Features Class AA circuitry; active servo power supply; inputs for MM/MC phono, tape 1 and tape 2/VCR, aux; phono 2, CD player, tuner, and video (AV 1). Switches video signals from A/V inputs as well as audio signals from 8 inputs with video output for monitor. FR 0.5-180,000 Hz +0/-3 dB. 17 x 5 x 14 1/4 in; 20 lb. \$1,200

SU-A6MK2 Preamplifier

Stereo DC preamplifier with infrasonic filter. Features shelving tone controls; selectable turnover frequencies; audio muting; inputs for MM/MC phono, tape 3, tape 2, aux 2, phono 2, CD player, tuner, computer, VCR, DAT recorder, TV. Max output 8 V. 17 x 3 7/8 x 14 1/4 in. \$800

SU-A40 Preamplifier

Features Class AA phono EQ amp; output amp circuits; high-speed capacitors with electrolyte; active servo power supply; OFC wiring. 6-position input and recording selector; tape 3 monitor/ext for another tape deck or signal processor; MM/MC phono selector; tone defeat switch; subsonic filter; loudness switch; stereo/mono switch; muting switch. THD 0.009% (MM), 0.01% (MC), 0.006% (other sources); S/N 79 dB (MM), 74 dB (MC), 91 dB (other sources); frequency response 30-15,000 Hz ±0.2 dB (phono), 20-20,000 Hz +0/-0.1 dB (other sources); ch sep 50 dB (aux, at 1,000 Hz). 17 x 4 1/8 x 11 3/8 in; 8.8 lb \$330

THRESHOLD

Model FET Ten/Hi Preamplifier

Dual-ch, high-level noninverting field-effect transistor preamp dedicated specifically to line-level signal applications. Accepts 5 high-level sources and 2 tape decks with full flexibility in record/monitor signal routing. External power supply in separate chassis. Input J-FETs operated in parallel, doubling transconductance and lowering noise and distortion. Secondary gain stages use cascaded MOSFETs to suppress voltage fluctuations, allowing low distortion even when driving loads less than 500 ohms. Circuit boards are military-grade glass-epoxy with gold-over-nickel-over-copper-plated paths. Gold-plated con-

nectors with Teflon insulation. Precision metal-film and wirewound resistors are used throughout. Bandwidth response 1.5 Hz and 125,000 Hz at -3 dB points; THD 0.01% at 3 V rms from 20-20,000 Hz into 1,000-ohm load; crosstalk no greater than -75 dB at 20,000 Hz with 1,000-ohm source; noise no greater than -110 dBA referenced to 1 V input; input imp 25,000 ohms, nominal; output imp 100 ohms. Controls for program source selector; record signal routing; monitor signal selection; mode; balance; audio level. 19 x 13 1/4 x 6 1/2 in. \$2,500

Model FET Nine Preamplifier

Dual-ch noninverting field-effect transistor preamp. Accepts inputs from high- and low-level MC, MM, or other velocity-output characteristic phono cartridges, 3 high-level sources, and 2 tape decks with full flexibility in record/monitor signal routing. Cartridge section uses single gain-variable preamplification stage for moving-coil and moving-magnet cartridges. Cartridge loading selected by internal DIP switch assemblies. Signal-path topologies and power-regulation circuits derived from FET Ten research. External power supply in separate chassis. Circuit boards are military-grade glass-epoxy with gold-over-nickel-over-copper-plated paths. Gold-plated connectors with Teflon insulation. Precision metal-film and wirewound resistors are used throughout. Frequency response bandwidth 1.5 Hz and 125,000 Hz at -3 dB points; total harmonic distortion 0.01% at 3 V rms from 20-20,000 Hz into 10,000-ohm load; high-level input imp 25,000 ohms, nominal; output imp 100 ohms. Controls for program source selector; record signal routing; monitor signal selection; ch balance; audio level. 19 x 13 1/4 x 6 1/2 in. \$1,950

Model FET Ten/Pc Preamplifier

Dual-ch noninverting field-effect transistor preamp dedicated specifically to phono-cartridge gain applications. Accepts inputs from high- and low-level moving-coil, moving-magnet or other velocity-output characteristic phono cartridges and provides RIAA equalized output suitable for preamp high-level inputs. Single gain-variable high-performance stage provides signal increase required by different cartridge types. Combination of active low-frequency and active and passive high-frequency equalization make up RIAA equalization. Up to 16 different cartridge-loading characteristics may be user selected with internal DIP switch assemblies. External power supply in separate chassis. Circuit boards are military-grade glass-epoxy with gold-over-nickel-over-copper-plated paths. Gold-plated connectors with Teflon insulation. Precision metal-film and wirewound resistors are used throughout. Crosstalk no greater than -70 dB at 20,000 Hz with 1,000-ohm source; output imp 420 ohms. 19 x 13 1/4 x 6 1/2 in. \$1,650

WINGATE AUDIO

660 Preamplifier

Preamplifier with 100% FET. Features MOSFET regulated power; toroidal power transformer; ultra-wide bandwidth; selectable phono input imp. Frequency response 0.1-250,000 Hz +0, -3 dB; 20 V output with no more than 0.05% total harmonic distortion; intermodulation distortion <0.05%; moving-magnet phono overload 400 mV; moving-magnet phono signal-to-noise ratio >100 dB; moving-magnet phono signal-to-noise ratio >80 dB \$1,695

990 A/V Preamplifier

Same performance as the 660 plus separate audio and video switching; remote control \$1,995

WRIGHT AUDIO

SP-1 Tube Preamplifier

Preamplifier with dual monaural vacuum tube rectification and signal path circuitry. Features choke-filtered rectifiers; polystyrene and polypropylene capacitors; metal-film resistors in signal path; point-to-point hand wiring throughout; inputs for phono,

CD, tuner, tape, video, spare 1; mono mode; L/R mute; external loop; tape monitor. 16 x 7 x 13; 23 lb. \$685

YAMAHA

CX-10000 Preamplifier with D/A Converter

Digital preamplifier with hi-bit 4-times oversampling digital filter and digital-to-analog converter. Features digital direct input/output; integrated surround-sound processor; parametric equalizer; 16 memory presets combining surround-sound processor and/or parametric equalizer. Includes wireless remote control; Titanium finish with high luster walnut side panels. 65 lb \$7,500

HX-10000 Phono Preamplifier

Phono preamp with 2 independent moving-coil head amplifiers. Titanium finish with high luster walnut side panels. 20 lb \$2,500

CX-2000 A/V Preamplifier with D/A Converter

Digital preamplifier with 8-times-oversampling, 18-bit digital filter and hi-bit twin digital-to-analog converters. Features auto sampling frequency switching; hi-bit direct output; 4 video inputs; 4 digital inputs; 1 optical and 2 coaxial digital audio rec outputs; 10 analog audio inputs; continuously variable loudness control; 5 audio and 2 video rec outs; 12 position rec out selector; source-direct switch; provisions for simultaneous A/V recording on 2 VCR's; 6-position moving-magnet or moving-coil cartridge load selector. Titanium finish with wood side panels. 33 lb \$1,499

CX-1000U A/V Preamplifier with D/A Converter

Digital preamplifier with built-in 18-bit, 8-times-oversampling digital filter and hi-bit twin digital-to-analog converters. Features 4 digital (coaxial and optical) audio inputs and 4 video inputs; continuously variable loudness control; 5 audio rec outputs and 2 video rec outputs; 12-position rec out selector; provisions for simultaneous A/V recording on two VCR's; 1 optical, 2 coaxial digital audio rec outputs; auto sampling-frequency switching; 6-position moving-magnet or moving-coil phono cartridge load selector; source-direct switch; audio mute. Includes RS integrated system remote control. Black; 28 lb \$1,199

CX-800U A/V Preamplifier

Preamplifier with 8 audio and 3 video inputs. Features 4 audio and 2 video rec outputs; 9-position rec out selector; provision for simultaneous A/V recording on two VCR's; source-direct switch; phase invert switch; continuously variable loudness control; 6-position moving-magnet and moving-coil cartridge load selector; bass and treble controls; subsonic filter. Includes RS integrated system remote control. Black; 15 lb. \$699

AVC-70Ti A/V Surround-Sound Preamplifier

A/V preamplifier with 4-mode digital surround including Dolby Surround. Features 4-position digital delay (15, 20, 25, 30 ms); 10 audio and 5 video inputs; 2 S-VHS inputs and 2 outputs; video monitor outputs; A/V inputs for camcorder; 2 sets of front channel outputs and 1 set of rear channel outputs; bass, midrange, treble, and balance controls; bass extension; separate rear channels volume control; 10 position rec out selector; motorized master volume control; Includes learning-capable 37-key multi-function remote control and RS integrated system remote control. Titanium finish; 13 lb \$529
AVC-70. As above, black. \$529

CX-600U A/V Preamplifier

Preamplifier with 6 audio and 2 video inputs. Features 2 audio and 1 video rec output; 6-position rec out selector; source-direct switch; continuously variable loudness control; moving-magnet and moving-coil cartridge switch; bass, treble, and midrange controls; subsonic filter. Includes RS integrated system remote control. Black; 12 lb \$449

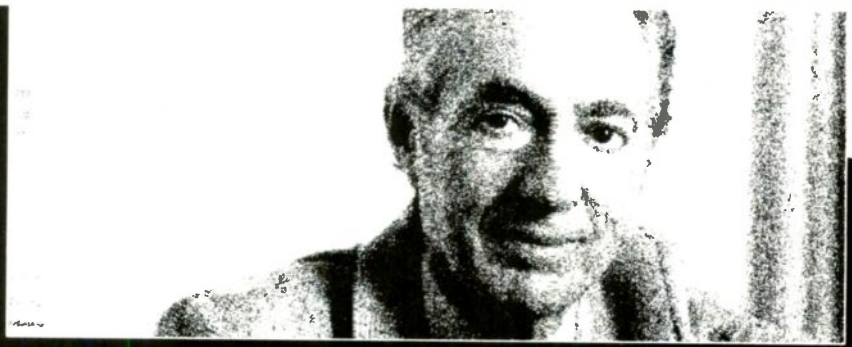

—Leonard Feather, Celebrated Jazz Critic for the L.A. Times, Washington Post News Service and Author of many books including "The Jazz Years—Earwitness to an Era."

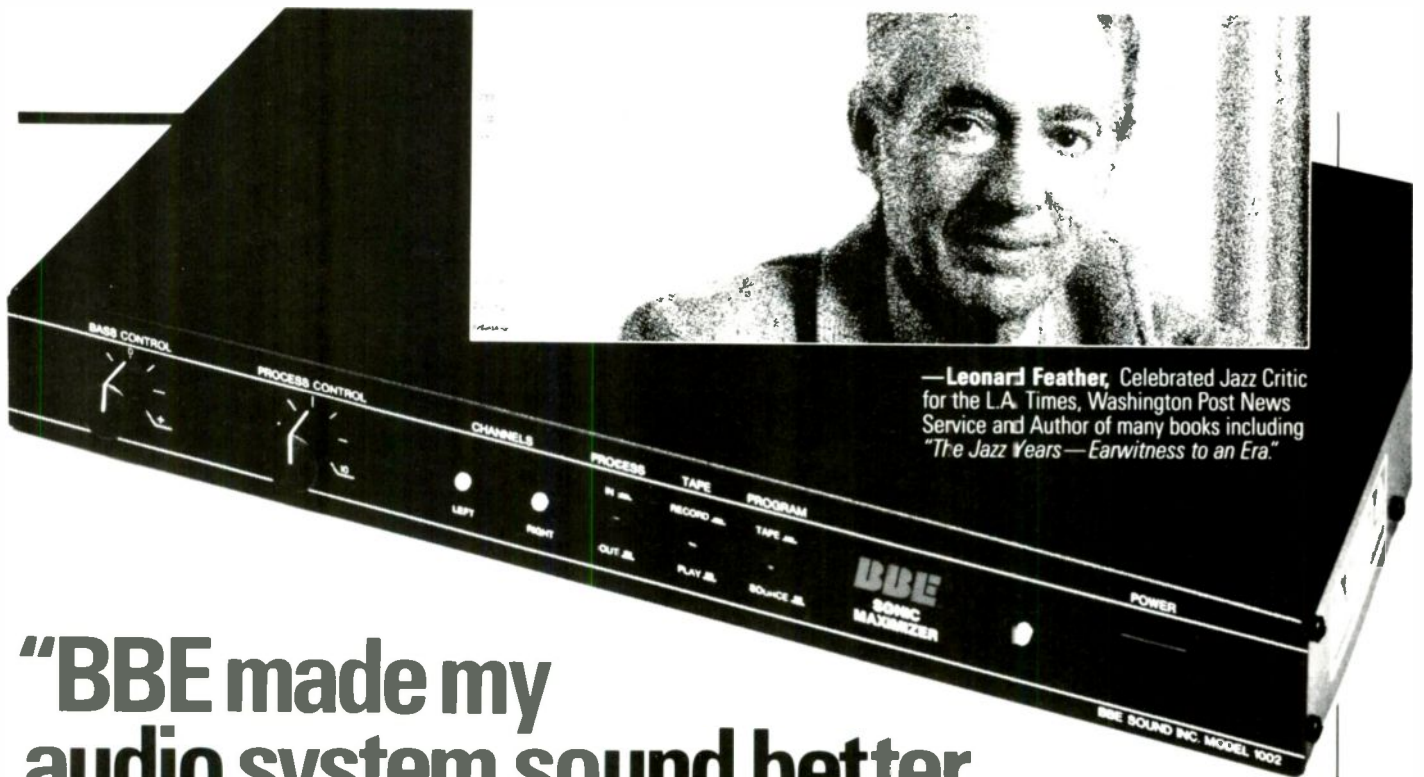

"BBE made my audio system sound better than I ever dreamed possible!"

"Listening to music has been my vocation and avocation for a lifetime. I've spent countless hours sitting in front of bandstands while some of the world's greatest musicians mesmerized me with their artistry.

"Listening to recorded music, of course, falls short of the delights of listening to a live performance. I was therefore skeptical when told that BBE could make a dramatic improvement to virtually all audio systems and I had to hear it for myself.

"I was amazed at how much better the BBE 1002 made my music system sound! There was a presence, a *being there* sense of excitement. The rich textures of the instrumental sounds, the subtle nuances and details in the music come through with clarity and authenticity.

"BBE is clearly one of the most important advances in the electronic reproduction of music to come along in my lifetime. Bravo, BBE! Encore!"

The Great Professional Music Magazines Love BBE

"The difference in processed audio and non-processed audio is like the difference between high-fidelity speakers with and without pillows placed in front of them."

—Radio World

"There was no doubt the BBE processor added more spatial quality, more transients and more clean highs. This is the first black box that actually helped make my

music sound the way that I *knew* it should. The effect is shattering!"

—Music Technology

BBE Really Fits In

Measuring 16½" x 9" x 1¾", BBE fits perfectly into your audio rack. Then just plug it into your wall socket and standard tape loop.

Full Money-Back Guarantee

If you're not completely satisfied with the BBE 1002, return it within 30 days. We'll refund your money. No questions asked.

Full Warranty

All BBE products are backed by a full year's warranty on all parts and labor—and by our reputation for innovation and leadership in the audio and electronics industries.

Easy to Order

It's as easy as one, two, or three.

1. Call us. Toll free. 1-800-233-8346. In California, 1-800-558-3963.
2. Or, complete and send us the coupon at right.
3. Or, if you're in New York, New Jersey, Connecticut, Pennsylvania, Delaware, Maryland, District of Columbia, Atlanta, Houston, New Orleans, Birmingham, Miami or Dallas, pick up your BBE 1002 in any **MACY's** audio department.

BBE[™] Sound Inc.

5500 Bolsa Ave., Suite 245, Huntington Beach, CA 92649, (714) 897-6766. (800) 233-8346. In California, (800) 558-3963. In Canada, contact Daymen Audio, 3241 Kennedy Road, #22, Scarborough, Ontario M1V2J9 or call (416) 298-9644. BBE is a trademark of BBE Sound, Inc.

Send me _____ BBE 1002 unit(s) at \$189 each. (U.S. currency only. California residents add applicable tax. Price includes UPS ground shipping charges. For UPS overnight: shipping, add \$18. For UPS 2nd day shipping, add \$8.50. Canadian residents: please write or call for additional information.)

Enclosed is a check for \$ _____
Or please charge to my:
 Visa MasterCard
 American Express

Card #

Exp. Date _____

Signature _____

Name (print) _____

Address _____

City/State/Zip _____

Area Code/Phone No. (To facilitate shipping)

5500 Bolsa Ave., Suite 245, Huntington Beach, CA 92649, (714) 897-6766. (800) 233-8346. In California, (800) 558-3963.

SRBG

INTEGRATED • AMPLIFIERS

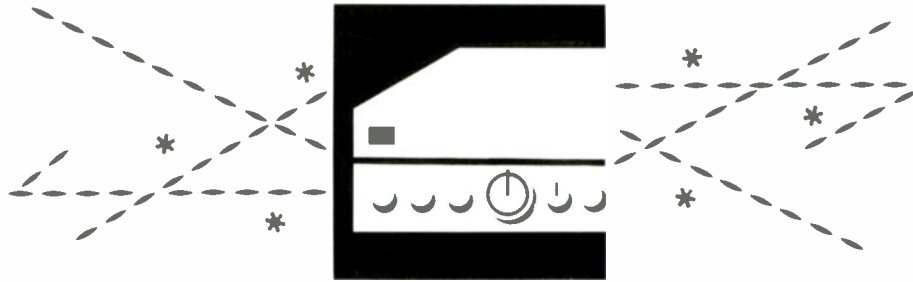

ACCUPHASE BY MADRIGAL

E-305 130-W/ch Integrated Amplifier

Features 3-parallel push-pull output stage employing MOSFET devices; direct-coupled IC servo design; separate power supply and voltage regulators for preamplifier and power amplifier; phono stage for all MC and MM cartridges; logic relay control for signal path. 8 unbalanced inputs and balanced CD and line inputs; tone control; peak output meter; subsonic filter. Frequency response 20-20,000 Hz ± 0.2 dB; THD 0.02%; signal-to-noise ratio 123 dBA; IM 0.01%; damping factor 100. 18 $\frac{3}{4}$ x 6 $\frac{3}{4}$ x 14 $\frac{3}{4}$ in.; 45 lb. 2 oz. \$4,700

E-302 120-W/ch Integrated Amplifier

3-position loudness compensation and power meters. Inputs for MM phono; MC phono; tape; tape 2; phono 2; CD player; 3 line inputs. S/N 120 dB; MM phono sens 0.22 mV for 0.5 V output at 1,000 Hz; sens for line-level inputs 7.1 mV; 120 W/ch into 8 ohms; 180 W/ch into 4 ohms. 17 $\frac{1}{2}$ x 5 $\frac{3}{4}$ x 14 $\frac{3}{4}$ in.; 35 lb. 10 oz. \$3,200

E-205 80-W/ch Integrated Amplifier

Parallel push-pull output stage driven by MOSFET devices; direct-coupled circuitry with IC servo; high-gain equalizer; MC input imp selector; 9 inputs; turnover selector switch; tape monitor and dubbing switches; subsonic filter; outputs for 2 pairs of speakers; mono switch. Inputs for MM phono; MC phono; tape; tape 2; CD player; tuner; 3 line-level inputs. Champagne-gold or black-anodized finish. 80 W/ch into 8 ohms; 100 W/ch into 4 ohms. 17 $\frac{1}{2}$ x 5 $\frac{3}{4}$ x 14 $\frac{1}{2}$ in.; 30 lb. 12 oz. \$2,275

ARCAM

Delta 90 70-W/ch Integrated Amplifier

Features toroidal power transformer. Aluminum casing; MM/MC, CD, tuner, 2 tape rec inputs; independent listen and rec controls; mono switch; headphone input. 70 W/ch into 8 ohms; THD 0.02% at 1,000 Hz. 17 x 11 $\frac{3}{8}$ x 3 $\frac{1}{2}$ in.; 18 lb. Black \$750

Delta 60 50-W/ch Integrated Amplifier

Features 200 VA toroidal power transformer and separately regulated MC pre-preamplifier. MM, CD, tuner, 2 tape rec inputs; tape monitoring; mono switch; twin loudspeaker outlets; headphone input. 50 W/ch into 8 ohms; FR 20-20,000 Hz; THD 0.02% at 1,000 Hz. 17 x 11 $\frac{3}{8}$ x 3 $\frac{1}{2}$ in.; 15 lb. Black. \$600

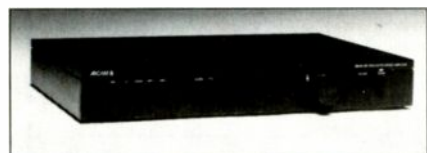

Arcam Delta 60

Alpha2 30-W/ch Integrated Amplifier

Features toroidal power transformer. Aluminum chassis; CD, MM/MC, tuner, and tape rec inputs; full monitoring; headphone input. 30 W/ch into 8 ohms;

FR 20-20,000 Hz; THD 0.02% at 1,000 Hz. 17 x 9 x 3 $\frac{3}{8}$ in.; 10 lb. Charcoal \$350

AUDIO BY VAN ALSTINE

CA-150 Plus 75-W/ch Integrated Amplifier

Stereo integrated amplifier with Van Alstine FT Three Plus hybrid preamplifier circuitry. Features 240D full complementary power MOSFET amp circuits driven from high-current toroidal power transformer; 2-stage power supply with isolated regulated preamp sections. Volume/balance controls; phono, CD, and tuner inputs; dual tape-to-tape monitoring and dubbing capability; drives two pairs of speakers simultaneously or separately; headphone jack. 75 W/ch into 8 ohms; THD <0.01%. 13 $\frac{1}{2}$ x 12 $\frac{1}{2}$ x 4 $\frac{1}{2}$ in.; 15 lb. \$795

AUDIOCON BY ELEKTROAKUSTIK

PA-2000 AC 120-W/ch Integrated Amplifier

Integrated amplifier featuring special circuitry that adjusts to the ambient space of any listening environment. Features full-function remote; inputs for CD, DAT, tape; moving-magnet, moving-coil. 120 W/ch into 8 ohms; frequency response 3-300,000 Hz; total harmonic distortion 0.004 percent; slew rate 100 V/ μ sec; damping factor >400. 17 $\frac{1}{8}$ x 5 $\frac{7}{8}$ x 15 $\frac{1}{4}$ in.; 48 lb. \$2,800

PA-1000 110-W/ch Integrated Amplifier

Integrated amplifier with symmetrical output to connect active speakers or additional amplifiers. Features 8 signal sources; independent record; ambient space adjustment function. 110 W/ch into 8 ohms; Frequency response 3-300,000 Hz; total harmonic distortion 0.005%; slew rate 100 V/ μ sec; damping factor >300. 17 $\frac{1}{8}$ x 5 $\frac{7}{8}$ x 15 $\frac{1}{4}$ in.; 48 lb. \$2,000

AUDIO DESIGN ASSOCIATES

MRA-808 40-W/ch Amplifier

Contains 8 integrated amplifier modules. Features each module with digitally controlled volume, bass and treble. 40 W/ch cont from 20-20,000 Hz into 8 ohms with no more than 0.03% THD; 60 W/ch into 4 ohms; slew rate 10 V/ μ sec; IM 0.02%. 19 x 12 $\frac{1}{2}$ x 14 $\frac{1}{2}$ in.; 50 lb. \$8,295

DC-A-40 40-W/ch Integrated Amplifier

Amplifier with inputs for MM phono, tape, tape 2, AUX, CD player, tuner. Features electronic digital volume control; separate phono preamplifier. 40 continuous average W/ch from 20-20,000 Hz with no more than 0.06% THD into 8 ohms; 50 W into 4 ohms; FR 20-20,000 Hz ± 3 dB; THD 0.06%. 19 x 3 $\frac{1}{2}$ x 12 in.; 6lb. \$950

AUDIO DYNAMICS

CA-2000F 100-W/ch Integrated Amplifier

Features CD-direct switch; infrasonic filter; CD, tuner, AUX, and 2 tape inputs; two phono preamps; separate low-noise Class A moving-coil preamp;

dubbing capability; separate power-supply regulators; CD and phono jacks are gold-plated; wireless universal remote control for Audio Dynamics products. Frequency response 20-20,000 Hz, ± 0.5 dB; signal-to-noise ratio MM phono 76 dB, line 83 dB; THD <0.1%; ch sep 65 dB at 1,000 Hz; damping factor 100 at 50 Hz; slew rate 50 V/ μ sec. 17 x 4 x 14 $\frac{3}{8}$ in.; 22 lb. \$799

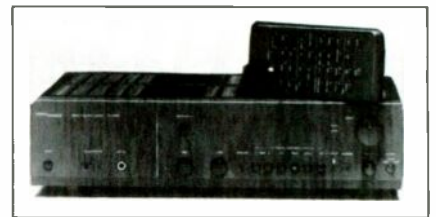

Audio Dynamics CA-2000F

CAMBRIDGE AUDIO

P70 70-W/ch Integrated Amplifier

Stereo amplifier with tone controls and direct/tone switch \$699

P50 100-W/ch Intergrated Amplifier

Stereo amplifier with passive segmented equalization on MM and MC inputs. Features tone on/off switch. Power output 50 W/ch into 8 ohms; total harmonic distortion 0.05% \$449

P25 100-W/ch Integrated Amplifier

Stereo amplifier with passive segmented phono section. Features large toroidal input transformer; MC/MM switchable inputs. 25 W/ch; THD 0.05%; S/N MM 80 dB, MC 73 dB, line 80 dB. 2 $\frac{1}{2}$ x 17 $\frac{1}{2}$ x 11-in.; 17 lb. \$349

CREEK AUDIO BY MUSIC HALL

5050 80-W/ch Integrated Amplifier

80 W/ch. Multifunction amplifier with inputs for MM and MC phono, video, CD, tuner, 2 tape-to-tape in and outs. Features preamplifier out/preamplifier in; tape monitor; tape-to-tape dubbing; active/passive tone controls, 4-speaker switching (A, A and B, B). Amp also bridgeable to mono unit to provide 2 mono amps. 200 W/mono amp. \$950

4040/S2 40-W/ch Integrated Amplifier

Amplifier with inputs for MM phono, CD, tuner, tape in and out. 40 W/ch into 8 ohms \$450
4140/S2. Similar to above but with 45-65 W/ch; MC switch; increased sens and gain. \$550



Creek Audio 5050

INTEGRATED • AMPLIFIERS

DENON

AVC-2000 75-W/ch A/V Integrated Amplifier

Features Dolby Pro Logic decoder with 5 amplifier channels (stereo front and rear, mono center channel); line-level preamplifier outputs; hall and stadium ambience-enhancement effects; sharpness/detail video enhancement; adjustable rear-channel delay time (15-30 msec); 17 audio inputs for phono (MM), CD, tuner, aux, 3 audio tape decks, 3 VCR's; 2 VDP's; TV. Includes learning remote which controls other audio components. 75 W/ch into 2 ohms (front), 20 W/ch into 2 ohms (rear), 20 W/ch into 1 ohm (center); FR 20-20,000 Hz +0, -1 dB; THD 0.009% at 1,000 Hz; S/N CD 83.2 dBA, phono 75.5 dBA; sens CD 18.5 mV, phono 0.35 mV. 17 1/8 x 6 1/4 x 15 3/4 in. \$1,000

PMA-1520 130-W/ch Integrated Amp

Optical Class A integrated amplifier with 4 push-pull super linear D/A converters and 4x-oversampling digital filter. Features pure-current power supply; compatibility with low-impedance speakers; digital multi-interface decoder. 7 sets of audio inputs; CD-direct switch provides shortest CD signal path. 130 W/ch into 8 ohms; FR 20-20,000 Hz; THD 0.005%; S/N aux 107 dB, MM 95 dB, MC 77 dB. 17 1/8 x 6 1/4 x 15 3/4 in. \$1,000

PMA-920. Similar to PMA-1520, 115 W/ch, No CD-direct switch or D/A converters \$600

PMA-720. Similar to PMA-920, 90 W/ch \$450

PMA-520. Similar to PMA-720, 70 W/ch \$350

AVC-700 55-W/ch A/V Integrated Amplifier

Features Dolby Pro Logic decoder with 4 amplifier channels; line-level preamplifier outputs; hall ambience-enhancement effects; adjustable rear-channel delay time (15-30 msec); 10 audio inputs. Includes remote control. 55 W/ch into 2 ohms (front), 18 W/ch into 2 ohms (rear); FR 20-20,000 Hz +0, -1 dB; THD 0.009% at 1,000 Hz; S/N CD 83.2 dBA, phono 75.5 dBA; sens CD 18.5 mV, phono 0.35 mV. 17 1/8 x 5 3/8 x 13 3/4 in. \$600

PMA-320 60-W/ch Integrated Amplifier

Stereo integrated amplifier with CD-direct switch. Features high-speed power transistors; dual current power supply; toroidal power transformer; electronic signal switching. 7 audio inputs; speaker selector switch; 3-way speaker terminals. 60 W/ch into 8 ohms; FR 20-20,000 Hz; THD <0.05%. \$300

PMA-250 25-W/ch Integrated Amplifier

Stereo integrated amplifier with CD-direct switch. Features high-speed power transistors. Inputs for phono, CD, tuner, aux, tape monitor; dual-concentric volume controls; headphone jack; large speaker terminals. 25 W/ch min rms into 8 ohms; FR 20-20,000 Hz; THD < 0.08%; IM 0.03%. \$250

DUAL

PA5060 60-W/ch Integrated Amplifier

60-W/ch integrated amplifier with high-current output capability and MC phono input. Black \$400

PA5030 30-W/ch Integrated Amplifier

30-W/ch integrated amplifier with high-current output capability and MC phono input. Black \$300

ELECTROCOMPANET BY MUSIC AND SOUND IMPORTS

EC-100 100-W/ch Integrated Amplifier

Amp with 100 W/ch into 8 ohms, 180 W/ch into 4 ohms; FR 0-100,000 Hz; THD 0.003%, 30 lb. \$1,495

HARMAN KARDON

HE6900 170-W/ch Integrated Amplifier

High-voltage/high-current integrated amplifier with discrete components in signal path. Features electronic front-panel function switches that control analog switches at rear inputs to create short signal

paths; selectable power-supply voltage; Interactive A/V switching; active/passive phono section; MM/MC phono inputs; 2-way tape copy; 2 VCR/tape monitors; rec out selector; tone defeat; mono switch; subsonic and high-cut filters; separate preamp-out/main-in jacks. 170 W/ch from 20-20,000 Hz into 4/8 ohms with <0.08% THD; S/N 80/76 dB (MM/MC); slew rate 280 V/μsec; damping factor 70; negative feedback 12 dB; high-current capability ±90 amp \$1,299

HE6800. Same as above except 120 W/ch. High-current capability ±70 amp. \$949

HE6600 90-W/ch Integrated Amplifier

High-voltage/high-current integrated amplifier with discrete components in signal path. Features selectable power-supply voltage; active/passive phono section; MM/MC phono inputs; 2-way tape copy; rec out selector; tone defeat; mono switch; subsonic and high-cut filters; separate preamp-out/main-in jacks. 90 W/ch from 20-20,000 Hz into 4/8 ohms with <0.08% THD; S/N 80/76 dB (MM/MC); slew rate 180 V/μsec; damping factor 65; negative feedback 12 dB; high-current capability ±50 amp \$699

HE6500 70-W/ch Integrated Amplifier

High-voltage/high-current integrated amplifier with discrete components in signal path. Features selectable power-supply voltage; active/passive phono section; MM/MC phono inputs; mono switch; 2 tape monitors; external processing loop; subsonic filter. 70 W/ch from 20-20,000 Hz into 8 ohms with <0.09% THD; S/N 80/76 dB (MM/MC); slew rate 90 V/μsec; damping factor 65; negative feedback 20 dB; high-current capability ±40 amp \$549

HE6200 45-W/ch Integrated Amplifier

High-voltage/high-current integrated amplifier with discrete components in signal path. Features selectable power-supply voltage. Active/passive phono section; loudness-contour switch; 2 tape monitors. 45-W/ch from 20-20,000 Hz into 8 ohms with <0.09% THD; S/N 80 dB (phono); slew rate 90 V/μsec; damping factor 60; negative feedback 20 dB; high-current capability ±30 amp \$349

HE6100 30-W/ch Integrated Amplifier

High-voltage/high-current integrated amplifier with discrete components in signal path. Features active/passive phono section; loudness-contour switch; 2 tape monitors. 30-W/ch from 20-20,000 Hz into 8 ohms with <0.09% THD; S/N 78 dB (phono); slew rate 90 V/μsec; damping factor 60; negative feedback 20 dB; high-current capability ±22 amp. \$249

HITACHI

HA-007SW 65-W/ch Integrated Amplifier

Integrated stereo amplifier with MOSFET's. Features pure drive circuit. Switchable inputs for Video I and 2, phono, CD, tuner, VDP, and tape; subsonic filter; A, B, A + B speaker switching; loudness; tone control. Rosewood end caps. 65 W/ch min rms into 8 ohms; FR 20-20,000 Hz; THD <0.05%. \$470

JVC

AXZ911BK 100-W/ch Integrated Amplifier

Digital stereo amp with Pure-A circuitry for Class-A operation. Features D/A converter with 4x-oversampling filter; separate layout for digital and analog circuits; gold-plated terminals; 3 digital connections: 1 optical, 1 coaxial, 1 input/output for DAT; high-gain phono EQ for MM/MC cartridges; bass-response control; wireless remote. 100 W/ch into 8 ohms from 20-20,000 Hz with <0.003% THD. \$1,100

AXZ10101N 100-W/ch Integrated Amplifier

Digital stereo amplifier with Pure-A circuitry for Class-A operation. Features built-in 18-bit D/A converter with 8x oversampling and K2 interface; separate digital and analog circuits; gold-plated terminals; 3 digital connections; high-gain phono EQ for MM/MC cartridges; bass-response control; wireless

remote. 100 W/ch into 8 ohms; FR 20-20,000 Hz; THD <0.004% \$1,100

KENWOOD

KA-V7000 105-W/ch A/V Integrated Amplifier

Features Dolby Pro-Logic, Theater, Stadium, and Synthetic Surround effects. Dolby Pro-Logic has normal/wide/phantom modes, test tone, center channel, subwoofer and rear preouts; Voltage Interface Gate (VIG); digital input; adjustable delay; 3 surround-sound memory presets; video dubbing; 6 video and 6 audio inputs; programmable remote control; S-VHS inputs and outputs; built-in visual enhancer with 3 memory presets; on-screen display capability. 105 W/ch min rms into 8 ohms (front), 20 W/ch (rear); FR 20-20,000 Hz; THD 0.05%; S/N 100 dB; IM 0.01%. \$999

KA-V1000R 80-W/ch A/V Integrated Amplifier

Features Dolby Surround, Theater, and Stadium surround effects; digital input; programmable remote control; 6 audio and 6 video inputs; S-VHS inputs and outputs; built-in visual enhancer with 3 memory presets; on-screen display capability. 80 W/ch min rms into 8 ohms (front), 20 W/ch (rear); FR 20-20,000 Hz; THD 0.02%; S/N 100 dB; IM 0.02%. \$849

KA-880D 100-W/ch Integrated Amplifier

Features low-impedance drive capability; 265 W/ch dynamic power output into 2 ohms. Voltage Interface Gate (VIG) maintains fidelity during power-supply fluctuations. Digital input; 3 tape inputs; 2-way dubbing with tape-monitor switch; dual rec-out selector; MM/MC cartridge selector; -30 dB muting; loudness switch; subsonic filter. 100 W/ch min rms into 8 ohms; FR 20-20,000 Hz; THD 0.008%; S/N 108 dB; IM 0.008%. \$429

Spectrum Series

KA-128 125-W/ch Integrated Amplifier

Integrated amplifier featuring 7-band graphic EQ with 5 memory presets. Full circuit protection; EQ recording capability. Digital input; bidirectional tape dubbing; 5 audio, 2 video-sound inputs; headphone jack; remote control. 125 W/ch min rms into 8 ohms; FR 20-20,000 Hz; THD 0.05%. \$349

KA-88 100-W/ch Integrated Amplifier

Integrated amplifier featuring 7-band graphic EQ, 7-point LED power meters; bi-directional tape dubbing; 2 video-sound inputs. 100 W/ch min rms into 8 ohms; FR 20-20,000 Hz; THD 0.09%. \$279

LINN PRODUCTS

Intek 50-W/ch Amplifier

Amplifier with MM and MC phono inputs. Features separate play and record paths; switchable speaker outputs; power amplifier driven headphone output. 50 W/ch into 8 ohms. \$995

LUXMAN

LV-117 110-W/ch Integrated Amplifier

Digital-direct integrated amplifier with dual 16-bit D/A converters and 4x-oversampling filter. Features low-impedance drive capability; 3 differential HI input and predriver stages per channel; dual-paralleled power transistor output stages; Duo-Beta dual feedback-loop to widen bandwidth and improve transient response; STAR circuit topology to reduce noise and distortion. Line-straight switch for all source inputs; video switching; signal processor/pre-out jacks; optical and coaxial digital inputs. 110-W/ch cont avg from 20-20,000 Hz into 8 ohms; dynamic output 300-W/ch into 2 ohms, 250-W/ch into 4 ohms; 160-W/ch into 8 ohms; THD 0.05%; S/N 97 dB (line-straight); IM 0.02%; slew rate 12 V/μsec; damping factor 50 (50 Hz, 8 ohms) \$1,200

LV-113. Similar to LV-117 except 65 W/ch; no MC phono inputs. Dynamic output 190 W/ch into 2 ohms, 150 W/ch into 4 ohms; 90 W/ch into 8 ohms;

INTEGRATED • AMPLIFIERS

S/N 84 dB (phono), 96 dB (other analog inputs) slew rate 20 V/μsec; damping factor 30 (50 Hz, 8 ohms). 17¼ x 5¾ x 15 in; 21.6 lb \$750

LV-105U 80-W/ch Hybrid Integrated Amp
Integrated amplifier combining J-FET's, twin-triode vacuum tubes, and high-current MOSFET output devices. Features Duo-Beta dual feedback-loop amp circuitry to widen bandwidth and improve transient response; STAR circuit topology to reduce noise and distortion; pre-heat mode, CD-straight button; optical and coaxial digital outputs; tape and video dubbing; rec-out selector; MM/MC phono inputs; signal processor jacks. 80-W/ch cont avg from 20-20,000 Hz into 8 ohms; THD 0.25%; dynamic power 170-W/ch into 2 ohms, 140-W/ch into 4 ohms; signal-to-noise ratio 90 dB (MM), 70 dB (MC), 96 dB (CD)/tuner/tape/video; IM 0.03%. 17¼ x 5¼ x 13¾ in; 25 lb \$1,000

LV-112 55-W/ch Integrated Amplifier
Integrated amplifier with discrete driver/power-amp stages and bipolar output devices. Features low-impedance drive capability; high-energy power supply; Duo-Beta dual feedback-loop to widen bandwidth and improve transient response; STAR circuit topology to reduce noise and distortion. Line-straight, subsonic filter switches; 6 inputs including front-panel aux-input; DAT/tape select/dubbing, DAT/tape monitor, loudness compensation buttons. 55-W/ch cont avg from 20-20,000 Hz into 8 ohms; dynamic output 150-W/ch into 2 ohms, 120-W/ch into 4 ohms; 80-W/ch into 8 ohms; THD 0.05%; S/N 84 dB (MM phono), 95 dB (other analog inputs); IM 0.02%; slew rate 20 V/μsec; damping factor 30 (50 Hz, 8 ohms). 17¼ x 5¾ x 14¾ in; 20 lb \$550

LV-111. Similar to LV-112 except 40-W/ch; 4 inputs. Dynamic output 90-W/ch into 2 ohms, 60-W/ch into 4 ohms; 60-W/ch into 8 ohms; S/N 82 dB (phono); slew rate 15 V/μsec; damping factor 25 (50 Hz, 8 ohms). 17¼ x 4¾ x 11 in; 14 lb \$350

MARANTZ

PM-94G 140-W/ch Integrated Amplifier
140-W/ch integrated amp features Quarter-A design; AVSS (Automatic Voltage Supply Shift); matched complementary MOSFET output devices in triple push-pull circuit; CD/phono direct switch; tone defeat switch; toroidal power transformer; ceramic damped capacitors; copper-plated chassis; separate monitor/dubbing selectors for 2 tape decks plus VCR; built-in MC step-up transformer; switches for mono mode, subsonic filter, muting, speakers on/off; total harmonic distortion 0.01%; rose-gold with rosewood side panels \$3,000

PM-94BL. As above with black finish \$2,800

PM-94G 100-W/ch Integrated Amplifier
100-W/ch integrated amp features Quarter-A design; AVSS (Automatic Voltage Supply Shift); matched complementary MOSFET output devices; CD/phono direct switch; tone-defeat switch; ceramic damped capacitors; copper-plated chassis; separate monitor/dubbing selectors for 2 tape decks plus VCR; built-in MC step-up transformer; switches for mono mode, subsonic filter, muting, speakers on/off; THD 0.015%; black with rosewood side panels \$1,360

PM-74DBL 105-W/ch Integrated Amplifier
105 W/ch black integrated amp features Quarter-A design; AVSS (Automatic Voltage Supply Shift); CD/phono direct switch; tone defeat switch; ceramic damped capacitors; copper-plated chassis; separate monitor/dubbing selectors for 2 tape decks; tone defeat; switches for mono mode, subsonic filter, muting, speakers on/off; IM 0.03%; total harmonic distortion 0.03%. 8¼ x 19½ x 16½ in; 23.1 lb \$699

PM-65AVBL 65-W/ch Integrated Amplifier
65-W/ch integrated amp features CD/phono direct switch; 3 monitor loops; 4 position record out; video switching; 20-20,000 Hz bandwidth; total harmonic

distortion 0.03%; IM 0.03%. 5¾ x 16¾ x 14¾ in; 22 lb \$499

PM-25BL 30-W/ch Integrated Amplifier
30-W/ch integrated amp features CD/phono direct switch; independent heat sinks; 20-20,000 Hz bandwidth; THD 0.1%; IM 0.03%. \$299

McINTOSH

MA-6200 75-W/ch Integrated Amplifier
Features 100 W/ch into 4 ohms. 42 lb \$1,795

MISSION ELECTRONICS

Cyrus II 60-W/ch Integrated Amp
Stereo amplifier with high peak current delivery. Features nonmagnetic, precision-fabricated die-cast alloy case and chassis; metal-film resistors; polypropylene capacitors; polystyrene capacitors; separate listen and record selectors; inputs for CD, tuner, hi-fi, video, tape recorder, and MM and MC phono cartridges; direct-connected, front-panel-mounted headphone socket without loudspeaker switching; drives any loudspeaker load; fully compatible. 60 W/ch; FR 20-20,000 Hz; THD 0.003% at 1,000 Hz into 8 ohms; S/N 83 dB; slew rate 10 V/μsec; damping factor 100. Available in matte black and nextel gray. 8½ x 3 x 13½ in; 11 lb \$799

Cyrus PSX External Power Supply. Optional power supply for Cyrus II integrated amplifier. Features VA custom toroidal transformer; 4 x 15,000 μF Cyrus Sliit-foil capacitors; electrically-transparent, die-cast magnesium chassis. Available in matte black and nextel gray. 8½ x 3 x 13½ in; 19 lb \$699

Cyrus I 30-W/ch Integrated Amplifier
Stereo amplifier with high current delivery. Features electrically-transparent magnesium die-cast integral chassis and heat sink; aluminum alloy die-cast from and cover; close-tolerance metal-film resistors and polyester capacitors; separate record-out control for all inputs; inputs for CD, tuner, hi-fi, video, tape recorder, and both MM and MC phono cartridges; direct connected, front panel mounted headphone socket without loudspeaker switching; fine-adjustment balance control for all inputs. 30 W/ch; FR 20-20,000 Hz; THD 0.003% at 1,000 Hz into 8 ohms; slew rate 10 V/μsec; damping factor 100. Available in matte black and nextel gray. 8½ x 3 x 13½ in; 15 lb \$499

NAD

3400 Monitor Series 100-W/ch Integrated Amplifier
Bridgeable stereo amplifier with power envelope circuitry. Features soft clipping circuitry. Preamp out/main in; semi-parametric tone controls; bass equalizer. Includes full-function remote control. 100 watts/channel rms; +5.7 dB dynamic headroom. Rack mountable \$799

3240PE 40-W/ch Integrated Amplifier
Features power envelope circuitry; soft clipping circuitry; high current, Bass EQ; speaker impedance selector. 40 W/ch rms; +6 dB dynamic headroom \$399



NAD 3400

3225PE 25-W/ch Integrated Amplifier
Features power envelope; soft clipping circuitry; discrete 4 transistor phono preamp. Preamp out/main amp in. 25 W/ch rms; +4 dB dynamic headroom \$249

NEC

AVA-505 222-W/ch Integrated Amplifier
Integrated amplifier designed for dynamic surround-sound and Dolby Pro-Logic. Features 3- or 5-channel amplification; high dynamic power (222 W total); all IC construction; separate volume controls for front, surround, and center; built-in speaker protection relay. 5-channel amplification: 30 W x 4 and 60 W x 1 (center). 3-channel BTL-mode amplification: 60 W x 3; 0.03% THD; S/N 90 dB. 17 x 4¼ x 13¾ in; 20 lb, 5 oz \$449

NIKKO AUDIO

IA-600 120-W/ch Integrated Amplifier
Integrated amplifier that permits any source to be routed to all 4 outputs and allow the listening to one source while recording from another. Features Class AB circuitry; gold-plated input jacks; anoxic copper coils; magnetic flux ring; RCA connectors for pre-out and main-in; subsonic filter; inputs for CD, tuner, phono, aux, tape 1 and 2, video 1 and 2, signal processor, CD direct. 10 MM or MC selectors, 20-dB muting; stereo/mono switch; bass, treble and balance knobs are back lit. 1.76 dB headroom; 5-60,000 Hz power bandwidth; THD .003% dB; S/N 94 dB; FR 5-100,000 Hz +0/-1.5 dB \$660

IA-400. Similar to IA-600 but 80 W/ch FTC at 8 ohms; power band width 10-70 kHz \$530

ONIX AUDIO BY MUSIC HALL

OA21 50-W/ch Integrated Amplifier
Amplifier with inputs for MM or MC phono, tape, CD player, tuner. Features 300 VA toroidal input transformer; 20,000 μF capacitors; MM or MC board. 50 W/ch into 8 ohms; slew rate 150 V/μsec; FR 15-40,000 ± 3 dB. 15 x 3 x 9 in; 11 lb \$750

OA20 35-W/ch Integrated Amplifier
Integrated amplifier with inputs for MM, CD player, tuner, and tape. 35 W/ch \$389

ONKYO

A-RV400 100-W/ch A/V Integrated Amplifier
Integrated A/V amplifier featuring discrete output circuitry and switching power supply. Selective Tone Control with 50-Hz boost; 3 video inputs; source-direct mode to bypass preamp section; simulated-stereo switch for video soundtracks; FL panel display. 100 W/ch min rms into 8 ohms; FR 20-20,000 Hz; THD 0.08%; S/N 102 dB (CD); IM 0.08%; damping factor 40; dynamic power 190-W/ch into 4 ohms. 17¼ x 5¾ x 11¼ in; 20 lb \$400

A-RV400M. Same as above except RC-AV20M programmable remote control replaces audio-only controller \$450

A-8200 60-W/ch Integrated Amplifier
Integrated amplifier featuring low-impedance discrete outputs and switching power supply. Source-direct mode to bypass preamp section; Selective Tone Control control with 50-Hz boost; 7 inputs including MM/MC; multi-function remote control. 60 W/ch min rms into 8 ohms; frequency response 20-20,000 Hz; THD 0.06%; signal-to-noise ratio 102 dB (CD); IM 0.06%; damping factor 40; dynamic power 135-W/ch into 2 ohms. 17¼ x 5¾ x 11¼ in; 15.9 lb \$320

Integra Series

Grand Integra A-G10 135-W/ch Integrated Amp
Integrated amplifier with dual 18-bit linear D/A converters, and 8x oversampling digital filter. Features oversized power-supply block to drive low-impedance loads; proprietary Opto-Drive D/A converters and current converter in differential amp stage; dual-mono design with separate analog and digital power supplies; high-speed switching power supply with 8 split chemical capacitors per channel.

We're making a big deal out of practically nothing.

The most difficult job for a compact disc player is to reproduce low amplitude signals. Fortunately, Yamaha has created a remarkable CD player that rises to the occasion.

The CDX-1120 reproduces those low amplitude signals that until now, have been distorted or lost in the noise generated by the digital-to-analog conversion process in most CD players.

Allowing you to distinguish the subtle variations between, say, both an oboe and clarinet softly playing middle C.

As well as enjoy improved ambiance, revealing the acoustic characteristics where the performance took place.

And superior imaging, clarifying the placement of each instrument in an orchestra.

All worthy reasons to take a good, soft listen to our remarkable new CDX-1120. Only then, can you truly appreciate Yamaha's Super Hi-Bit Technology.

Yamaha's exclusive Super Hi-Bit System utilizes the additional information generated by our 20-bit digital filter to more accurately

reproduce the low amplitude signals coming from the disc.

To achieve this superior sound definition, Yamaha uses four 18-bit D/A converters, each with an exclusive 4-bit Floating System to boost linearity to 22-bits.

Delivering four times greater resolution of low amplitude signals than even fixed 20-bit D/A converter systems.

What's more, Yamaha's exclusive Super Hi-Bit DAC Direct Output provides phase accuracy so close to the original recording, it's unprecedented in the industry.

The CDX-1120 also features Digital DeEmphasis and Digital Volume Control to give the best possible signal output -- uncompromised by analog components.

To fully appreciate the phenomenal CDX-1120, pay a visit to your local Yamaha dealer.

Once you hear it for yourself, the advantages will come across loud -- and soft -- and clear.



A full-function remote lets you control everything. With 21-track random access programming, 5-way repeat play and more.

YAMAHA[®]



INTEGRATED • AMPLIFIERS

Optical and coaxial digital inputs; source-direct mode; remote control with phase-reverse button. 130 W/ch cont avg into 8 ohms; dynamic power output 420 W/ch into 2 ohms. Wood side panels... \$3,000

A-8800 100-W/ch Integrated Amplifier

Integrated amplifier with dual 18-bit linear D/A converters, 4x oversampling digital filter. Features oversized power-supply block to drive low-impedance loads; proprietary Opto-Drive D/A converters and current converter in differential amp stage; discrete output section; high-speed switching power supply with split chemical-capacitors. Optical and coaxial digital inputs; 10 inputs; pre-out/main-in terminals. 100 W/ch min rms into 8 ohms; FR 20-20,000 Hz; THD 0.008%; S/N 107 dB (CD); IM 0.005%; damping factor 100; dynamic power 310 W/ch into 2 ohms. 17 1/8 x 6 1/2 x 15 1/2 in; 32 lb... \$850

A-8700 105-W/ch Integrated Amplifier

Integrated amplifier with Anti-Electromagnetic Interference (AEI) transformer. Features low-impedance discrete outputs; switching power supply with tri-terminal regulators; proprietary Opto-Drive current converter in differential amp stage; shielded four-block design; Super Servo power and equalizer stages. Source-direct mode to bypass preamp section; MM/MC inputs; switchable subsonic filter. 105 W/ch min rms into 8 ohms; FR 20-20,000 Hz; THD 0.008%; S/N 107 dB (CD); IM 0.005%; damping factor 150; dynamic power 305 W/ch into 2 ohms. 17 1/8 x 6 1/8 x 15 1/8 in; 29.7 lb... \$530

A-8500 80-W/ch Integrated Amplifier

Integrated amplifier with low-impedance discrete outputs. Features switching power supply with tri-terminal regulators; proprietary Opto-Drive current converter in differential amp stage; shielded four-block design; Super Servo power and equalizer stages. Source-direct mode to bypass preamp section; MM/MC inputs; 4-position rec selector. 80 W/ch min rms into 8 ohms; FR 20-20,000 Hz; THD 0.008%; S/N 107 dB (CD); IM 0.005%; damping factor 150; dynamic power 224-W/ch into 2 ohms. 17 1/8 x 6 1/8 x 15 1/8 in; 27.5 lb... \$420



Onkyo A-R1400

PARASOUND

C/HD650 65-W/ch Integrated Amplifier

High-current-discrete control amplifier. Features variable loudness contour; bass, treble turnover selectors; C-MOS switching for input, record out; 2 tape monitors; tone defeat; preamp output jacks; speaker A,B selector. FR 20-40,000 Hz; THD <0.1%; IM <0.1%; S/N 90 dB; dynamic headroom 1.5 dB; damping factor >120; phono overload 200 mV. 17 1/4 x 4 x 11 1/4 in... \$330

C/HD350 35-W/ch Integrated Amplifier

High-current-discrete control amplifier. Features variable loudness contour; C-MOS switching for input, record out; 2 tape monitors; tone defeat; preamp output jacks; speaker A,B selector. FR 20-40,000 Hz; THD <0.15%; IM <0.15%; S/N 90 dB; dynamic headroom 1.5 dB; damping factor >105; phono overload 185 mV. 17 1/4 x 3 x 9 3/4 in... \$220

PHILIPS

FA 960 100-W/ch Integrated Amplifier

Integrated amp with high current/low impedance drive capability. Features dynamic power supplies and heat sinks for each channel; high accuracy phono

amplifier for either MC or MM cartridges; muting/protection circuit. CD direct and 6 other inputs; rec selector for parallel recording; tone-defeat key to bypass bass and treble controls; gold-plated terminals for CD direct and phono inputs; EQ curve to IEC standard; active tone control; parallel, selectable loudspeaker outputs for each channel; source and tape selected display; metal cabinet; headphone jack; gold-plated speaker relays; loudness and mono switches; 2 tape monitors; tape copy keys; slide balance control; bipolar push-pull output stages. 100 W/ch into 8 ohms at 1,000 Hz; THD 0.008%; IM 0.03%; frequency response 18-70,000 Hz \pm 1.0 dB (line inputs); FR 40-20,000 Hz \pm 0.5 dB (phono input); S/N 106 dB (CD Direct). 5 3/4 x 16 1/2 x 13 1/4 in... \$549

FA 860 65-W/ch Integrated Amplifier

Integrated amp with high current/low impedance drive capability. Features separate power supplies and heat sinks; phono amplifier for either MC or MM cartridge; muting/protection circuit. 4-gang volume control; CD direct and 6 other inputs; gold-plated terminals for CD direct and phono input; EQ curve to IEM standard; active tone control; parallel, selectable loudspeaker outputs for each channel; source and tape selected display; metal cabinet; headphone jack; gold-plated speaker relays; loudness and mono switches; 2 tape monitors; tape copy keys; slide balance control; bipolar push-pull output stages. 65 W/ch into 8 ohms; THD 0.008%; IM 0.03%; FR 18-70,000 Hz \pm 1.0 dB (linear inputs); FR 40-20,000 Hz \pm 1.0 dB (equalized inputs); S/N 106 dB (CD direct). 4 1/2 x 16 1/2 x 13 in... \$439

PIONEER

Elite A-91D 120-W/ch Integrated Amplifier

Features digital circuit for CD's; line-direct switch; nonswitching type III circuit; separate voltage- and current-amplifying stages; 2 high-capacity, magnetically-shielded transformers; independent digital conversion circuitry; dual D/A converters; 4x-oversampling digital filter; analog low-pass filter; five digital inputs (two optical); three digital outputs (one optical). 120 W/ch cont avg min rms into 8 ohms. FR 20-20,000 Hz; THD <0.003%... \$1,600

A-757 100-W/ch Integrated Amplifier

Nonswitching integrated amplifier with separate voltage- and output-amplifying stages. Features line direct switch, honeycomb chassis, insulators, and heat sink; separate circuit blocks; nonswitching type III circuit; direct connection II; 8 inputs. 100 W/ch cont avg into 8 ohms; FR 20-20,000 Hz; THD 0.003%. 16 1/2 x 6 3/8 x 1 1/8 in; 43 lb... \$750

A-335 40-W/ch Integrated Amplifier

Features CD direct switch; honeycomb chassis and heat sink; 6-position record selector; connections for two pair of speaker systems. 40 W/ch cont avg into 8 ohms; FR 20-20,000 Hz; THD 0.02%. 16 1/8 x 4 7/8 x 13 3/4 in; 15 lb, 7 oz... \$250

PROTON

AM-656 60-W/ch Integrated Amplifier

Features Dynamic on Demand Power circuitry; Aphex Aural Exciter circuitry; tone-bypass control; motorized volume control; 2-color LCD display; remote capability. FR 20-20,000 Hz \pm 0.3 dB; THD 0.02%; IM 0.01%; damping factor >150; dynamic headroom 6 dB. 18 1/2 x 3 3/8 x 15 1/8 in; 26.6 lb... \$700

D540 40-W/ch Integrated Amplifier

High-current, high-dynamic-power amplifier with Dynamic Power On Demand (DPD) circuitry. Features phono section with MC and MM phono selections; active volume control; anti-clipping circuit. 40 continuous W/ch from 20-20,000 Hz; FR 20-20,000 Hz \pm 0.2 dB; S/N 85 dB (unweighted), 105 dB (A-wtd); dynamic headroom 6 dB; dynamic power rating: 11H 20 ms at 8 ohms is 160 W, 4 ohms 280 W, 2 ohms 380 W; 100 ms duration 8 ohms is 150 W, 4

ohms 220 W, 2 ohms 230 W; 200 ms 8 ohms is 150 W, 4 ohms 190 W, 2 ohms 200 W. 16 1/2 x 3 1/2 x 12 1/2 in; 19.14 lb... \$319

AM-300 30-W/ch Integrated Amplifier

Integrated amplifier with Dynamic Power On Demand (DPD) circuitry. Features low-imp drive capability; remote control; low-noise MC amp; selectable MC/MM input. 30 W/ch into 8 ohms; THD 0.01%; damping factor 90 dB; dynamic headroom 6 dB; line input sens 150 mV; line input imp 47k ohms/220 pF; phono input sens MM/MC 2.5/0.25 mV; phono input imp MM/MC 47k ohm/100 ohm; crosstalk at 1,000 Hz is 75 dB; S/N 100 dB for tape and video... \$289

AM-200 20-W/ch Integrated Amplifier

Features low-impedance drive capability; bass EQ; selectable phono preamp load capacitance for any moving-magnet cartridge; cassette deck loop. 20 W/ch into 8 ohms; frequency response 20-20,000 Hz \pm 0.2 dB; total harmonic distortion 0.15%; signal-to-noise ratio 102 dB; IM 0.15%; damping factor >150. Dimensions: 16 1/2 x 3 x 10 in; 11.4 lb... \$249

REALISTIC

SA-150 Mini Amplifier

Inputs for tuner, tape deck, turntable. Mono/stereo button; tone control; headphone jack. Walnut-grain vinyl finish. 9 x 2 1/2 x 6 in... \$60

SA-10 Mini Amplifier

Inputs for ceramic phono, tuner, tape deck. Mono/stereo button; tone control; 1/R volume control. 8 x 3 1/4 x 5 1/2 in... \$30

REVOX

B250-S 150-W/ch Integrated Amplifier

Preamp section has 2 separate circuits for simultaneous listening and recording from 2 different sources. 6 inputs for tuner; tape 1 and 2, aux, CD and phono MM (moving coil input as an option). Each input level adjustable and can be stored in non-volatile memory. Optional video-switcher provides 4 video inputs (2 VCR, videodisc, TV) for both sound and picture, controlled via the B208 hand-held I.R. remote; Bright FL display varies in intensity with ambient light. 150 W/ch into 4 ohms; THD <0.015%; MM phono signal-to-noise ratio 80 dB. 17 3/4 x 4 1/4 x 13 in; 13 lb... \$2,500
B150. Similar to B250-S. 90 W/ch (ω) 4 ohms \$1,275



Revox B150

ROTEL

RA840BX3 50-W/ch Integrated Amplifier

50 W/ch amplifier with triple differential Class A front end. Features 3 gain stages in front end; protection circuitry; direct-signal paths; hard-wired speaker terminal; direct close tolerance selected components; inputs for MC/MM, CD, tuner, AV/aux, tape. Frequency response 20-20,000 Hz \pm 0.2 dB; total harmonic distortion <0.3%; signal-to-noise ratio 95 dB; IM <0.3%; damping factor 100. 17 1/2 x 3 3/8 x 13 1/8 in; 16 lb... \$399

RA820BX3 30-W/ch Integrated Amplifier

Amplifier with triple-differential Class A front end. Features protection circuitry; direct-signal paths; inputs for MC/MM, CD, tuner, AV/aux, tape. FR 20-20,000 Hz \pm 0.2 dB; THD <0.3%; S/N 93 dB; IM <0.3%; damping factor 100. 17 1/2 x 3 3/8 x 13 1/8 in; 16 lb... \$299

DON'T STOP THE MUSIC



Enjoy 12 discs, non-stop with Hitachi's DA-C70SW CD Player. It has a unique twin 6-disc magazine loading system so you can play 12 hours of uninterrupted music, whenever you wish to. You can hear your music in any order you prefer. This Hitachi's programming options let you set it...and, forget it! Should you change your mind, just change the discs in one magazine while the other plays. Choose one of three playback modes. Long Play for 12 discs in order, non-stop. Single Play, for 1 disc at a time. Program Play lets you pick up to 32 selections from all 12 discs to play in any order. Each mode comes with Random Play for more variation. The 41-key remote makes operation easy.

All the music's yours...
from Hitachi!



 **HITACHI**
A World Leader in Technology

We Make Entertainment Come Alive!

CIRCLE NO. 83 ON READER SERVICE CARD

INTEGRATED • AMPLIFIERS

SAE

1102 60-W/ch Integrated Amplifier

Amplifier with on-board computer to eliminate dependency between front-panel control switches and audio circuits. Features high-current power-amp stage; peak/average LED power display; 2-way tape copy; external loop; MM and MC phono inputs; 3 programmable digital tone memories; sequential audio muting (fade out/in when switching inputs); all controls are grouped together by function with alphanumeric and digital LED display for input functions, tone settings and volume level. 60 W/ch; max THD from 20 Hz-20,000 Hz 0.025% at full rated power both ch driven. \$499

SANSUI

AU-X911DG 100-W/ch Integrated Amplifier

Integrated amp with LDCS 1-bit D/A converter. Features independent circuitry for the left and right amplifiers; Alpha X-balanced and super feedforward circuits; direct-access rotary switching at the point of input; motor-driven remote switching; separate digital and analog transformers. Digital-direct and source-direct operation; separate record selector; 5 pair of gold-plated analog inputs; 4 pair of gold-plated digital inputs; record selector; subsonic filter; loudness; speaker A, B, A+B. 100 W/ch min rms into 8 ohms; FR 10-20,000 Hz; THD 0.005%. 17 x 6 1/2 x 17 3/4 in.; 40 lb. \$1,250

AU-X711 100-W/ch Integrated Amplifier

Features Alpha X-balanced circuitry; cascode-connected differential FET input design; digital-direct input; source-direct input; loudness switch; subsonic filter; independent record selector; 10 gold-plated inputs; speaker A, B. 100 W/ch min rms into 8 ohms; FR 10-20,000 Hz; THD 0.003%; S/N 88 dB (MM), 70 dB (MC), 110 dB (CD, tuner, tape); damping factor (at 8 ohms) 150; slew rate 180 V/μsec; rise time 0.6 μsec. 17 x 6 3/8 x 17 3/8 in. \$975

AU-X701 100-W/ch Integrated Amplifier

Features Alpha X-balanced circuit; high-capacity transformer; source-direct connection; independent rec selector; high-gain phono EQ for MM and MC cartridges; muting switch; loudness switch; subsonic filter; speaker A, B. 100 W/ch min rms into 8 ohms; FR 20-20,000 Hz; THD <0.005%; damping factor (at 8 ohms) 80; slew rate; ±180 V/μsec; rise time 0.6 μsec; S/N 110 dB (CD), 88 dB (MM), 70 dB (MC). 17 3/4 x 6 1/2 x 17 3/8 in.; 37.7 lb. \$775

AU-X611AV 80-W/ch Integrated Amplifier

Features low-impedance drive capability; high gain phono EQ; motor driven volume control; video inputs; signal processor loop; source-direct switch; separate transformer coil windings; rec selector; gold-plated headphone output. 80 W/ch min rms into 8 ohms; FR 20-20,000 Hz; THD <0.008%; damping factor (at 8 ohms) 100; S/N 87 dB (MM), 75 dB (MC), 95 dB (all other sources). Includes remote control. 17 x 6 3/8 x 17 3/8 in.; 24.3 lb. \$750

AU-X501 80-W/ch Integrated Amplifier

Features low-impedance drive capability; high gain phono EQ; high capacity transformer; source-direct switch; independent rec selector; subsonic filter; loudness switch; speaker A, B. 80 W/ch min rms into 8 ohms; FR 20-20,000 Hz; total harmonic distortion <0.005%; damping factor (at 8 ohms) 100; S/N 110 dB (CD), 83 dB (MM), 70 dB (MC). 17 3/4 x 5 3/8 x 14 5/8 in.; 23.8 lb. \$450

AU-X301i 65-W/ch Integrated Amplifier

Features low-impedance drive capability; high-gain phono EQ for MM and MC cartridges; stabilized ground circuit; record selector; subsonic filter. 65 W/ch min rms into 8 ohms; frequency response 20-20,000 Hz; THD 0.05%; signal-to-noise ratio 80 dB (MM), 65 dB (MC), 105 dB (CD, tape). 17 x 5 3/8 x 12 1/4 in.; 20.9 lb. Matte black finish \$350

A-2000 50-W/ch Integrated Amplifier

Features speaker A, B; 6 inputs; inputs for DAT, VCR, and a processor; variable loudness control; mic mixing. Includes full-function remote control. 50 W/ch into 8 ohms; THD 0.07%; FR 20-20,000 Hz. 17 x 5 x 9 3/8 in.; 12.6 lb. \$280

A-1000 30-W/ch Integrated Amplifier

Features 6 inputs; inputs for DAT, VCR, and a processor; variable loudness control; high filter. 30 W/ch min rms into 8 ohms; THD 0.07%; FR 40-20,000 Hz. 17 x 5 x 9 3/8 in.; 9 1/2 lb. \$200

SHARP

Optonica SM-A75 35 Watts x 4 A/V Integrated Amplifier

Features 11 surround effects; 3 user-programmable modes; 35 watts x 4; 2 monitor output controls; FL display; Super Bass; A/V cross playback; wireless remote control; adjustable time delay; adjustable feedback level; dubbing selection; 9 audio inputs/5 video inputs; 3 audio outputs/4 video outputs. S/N 89 dB (75 dB phono); IM 0.8%; CD FR 15-30,000 Hz (front), 15-17,000 Hz (rear). \$600

SHERWOOD

AI-1210R 100-W/ch Integrated Amplifier

Features surround sound; low-noise phono amplifier; subsonic filter. Video sound input; loudness control; direct switch; headphone input jack; peak-power indicator; mute switch. Includes full-function wireless remote control. 100 W/ch; IM 0.04%; S/N 79 dB; frequency response 8-70,000 Hz. 5 1/8 x 17 3/8 x 13 in. \$349

AI-1110 50-W/ch Integrated Amplifier

Features surround sound; low-noise phono amplifier. Video sound input; loudness control; rotary-type volume control; direct switch. 50 W/ch; IM 0.1%; S/N 75 dB; frequency response 8-60,000 Hz. 3 3/8 x 17 3/8 x 8 7/8 in. \$169

SONY

TA-F700ES 105-W/ch Integrated Amplifier

Features nonmagnetic G-chassis construction; spontaneous twin-drive power supply; super legato linear circuitry; source-direct switch to route input signal directly to volume control; passive tone-control circuitry with selectable bass and treble turnover frequencies; defeatable subsonic filter; inputs for 3 tape decks with dubbing capabilities, MM/MC phono, CD player, tuner, and aux signal; independent record output selector for taping one signal while listening to another; A-B, A+B speaker switching. 105 continuous W/ch into 8 ohms with 0.004% THD. 140 W/ch into 4 ohms with 0.008% THD. \$700

TA-F500ES 80-W/ch Integrated Amplifier

Features nonmagnetic G-chassis construction; spontaneous twin-drive power supply; super legato linear circuitry; source-direct switch to route input signal directly to volume control; passive tone-control circuitry; defeatable subsonic filter; inputs for 3 tape decks (2 video); MM/MC phono, CD player, tuner, and aux signal; independent record output selector for taping one signal while listening to another; A-B, A+B speaker switching. 80 continuous W/ch into 8 ohms with 0.006% THD. 100 W/ch into 4 ohms with 0.01 THD. 17 x 5.75 x 14.75 in.; 29 lb. \$500

SOUNDSTREAM

RA-100 50-W/ch Remote-Room Amplifier

Bridgeable to 100 W mono. Features include built-in remote electronic volume, balance, system on/off, bass and treble, and master level controls, variable line outputs; input for a local audio source. Wall-mounting brackets included. Frequency response 20-20,000 Hz; signal-to-noise ratio >95 dB; THD <0.1%. 9 x 12 x 1 1/8 in.; 5 lb. \$650

TECHNICS

SU-V90D 100-W/ch Integrated Amplifier

Digital integrated amplifier with D/A converter and Class AA circuitry. Features four 18-Bit D/A converters; 4x-oversampling digital filter; auto switching between sampling frequencies; subsonic filter. Optical/coaxial digital inputs; loudness control; muting; direct digital operation mode. Amp section: 100 W/Ch into 8 ohms; THD 0.003%; FR 20-20,000 Hz; damping factor 60. Digital section: THD 0.003% at 1,000 Hz; S/N 110 dB; FR 20-20,000 Hz ±0.3 dB. Preamp section: FR 30-15,000 Hz (phono), 20-20,000 Hz +0/-0.1 dB (other sources); S/N 79 dB (MM), 74 dB (MC), 91 dB (other sources). \$1,050

SU-AV55 50-W/ch A/V Integrated Amplifier

A/V integrated amplifier with Dolby Surround-sound. Features digital low-bass synthesis with level control; S-VHS input/output terminals; 3 A/V inputs; 7 audio inputs; video out and S-VHS video out; FL display; stereoplex simulated stereo. Includes wireless remote control. Front section: 50 W/ch into 8 ohms; FR 20-20,000 Hz; total harmonic distortion <0.02%. Rear: 10 W/ch into 8 ohms; FR 20-20,000 Hz; THD <0.09%. \$800

SU-V660 90-W/ch Integrated Amplifier

Stereo integrated amplifier with Class AA circuitry. Features high-speed capacitors with electrolyte; heavy-duty power supply; large aluminum heat sinks; active servo power supply. Power amp direct input; MM/MC cartridge input; 6-position multiple input facilities; A/B speaker terminals; tone-defeat switch; loudness switch; stereo/mono mode switch. Amp section: 90 W/ch min rms into 8 ohms; FR 20-20,000 Hz; THD 0.007%; damping factor 80. Preamp section: FR 30-15,000 Hz ±0.8 dB (phono), 20-20,000 Hz +0/-0.2 dB (other sources); S/N 76 dB (MM), 72 dB (MC), 80 dB (other sources). \$380

SU-V460 50-W/ch Integrated Amplifier

Stereo integrated amplifier with Class AA circuitry. Features high-speed capacitors with electrolyte; heavy-duty power supply; large aluminum heat sinks. Power amp direct input; 6-position multiple input facilities; A/B speaker terminals; tone-defeat switch; loudness switch; stereo/mono mode switch. Amp section: 50 W/ch min rms into 8 ohms; FR 20-20,000 Hz; THD 0.007%; damping factor 60. Preamp section: FR 30-15,000 Hz ±0.8 dB (phono), 20-20,000 Hz +0/-0.2 dB (other sources); S/N 76 dB (MM), 81 dB (other sources). \$300

TOSHIBA

NB-1000 125-W/ch Integrated Amplifier

Amplifier with A/V digital surround-sound processor and controller. Features 10 audio inputs; 4 video inputs; numerous A/V cross-play options; inputs include 2 tape decks, 2 VCR's, CD player, DAT deck, television; remote control; 12 digital sound effects including concert hall, night club, cathedral, stadium, and theater. 125 W/ch stereo, 50 W/ch Dolby Surround. \$949

WRIGHT AUDIO

Stereo 75 35-W/ch Tube Integrated Amplifier

Stereo amplifier with all point-to-point hand wiring. Features all polypropylene and polystyrene capacitors; metal-film resistors; inputs for CD, tuner, tape, video, spare 1 and spare 2; mono mode; L/R mute; external loop; tape monitor. 35 W/ch; input imp 220,000 ohms; output imp 4 and 8 ohms; 16 ohms by special order. 16 x 10 x 16 in.; 43 lb. \$985

YAMAHA

AX-900U 130-W/ch Integrated Amplifier

Integrated amplifier with independent preamp/power amp configuration. Features absolute linear amplification; high dynamic power; low-impedance drive

capability. Continuously variable loudness control; preamp in/main amp out terminals; dual rec-out selectors. 130 W/ch min rms into 8 ohms; FR 20-20,000 Hz; THD<0.005%. Black; 42 lb. \$749-

AVX-100Ti 65-W/ch A/V Integrated Amplifier
Master A/V amplifier with 10 audio and 6 video inputs. Features S-VHS terminals; switchable 4 channel (65 W/ch front, 14 W/ch rear) or 3 channel (65 W/ch front, 28 W center channel out) operation. Bass, midrange, treble, stereo balance and bass extension tone controls; separate rear or center channel volume control; 8-mode digital surround processor with continuously variable delay including Dolby Surround; video enhancer; independent rec out selection of video and audio signals; 3-mode superimpose video monitoring; title editing; master volume control. Includes integrated system remote control. Titanium finish; 23 lb. \$699
AVX-100U. As above, black \$699

AX-700U 110-W/ch Integrated Amplifier
Features absolute linear amplification; high dynamic power; low-impedance drive capability. CD-direct position; continuously variable loudness control; rec-out selector; accessory output loop; 3 tape inputs. 110 W/ch min rms into 8 ohms; FR 20-20,000 Hz; THD<0.005%. Black; 29 lb. \$599

AVC-50 45-W/ch A/V Integrated Amplifier
Integrated amplifier with built-in surround-sound decoder. Features 5 surround modes including Dolby Surround. 10 audio and 4 video inputs; built-in video enhancer with continuously variable sharpness, detail, and level control; bass extension control; continuously variable delay time control. 45 W/ch (front), 45 W/ch (rear) min rms into 8 ohms; FR 20,20,000 Hz; THD<0.05%. Includes RS integrated system remote control. Black; 18 lb. \$599

AVC-30U 100-W/ch A/V Integrated Amplifier
Integrated amplifier with built-in surround-sound decoder. Features pre-main coupling loop. Audio and video input source selection; independent rec out selection of audio and video sources. 100 W/ch (front), 20 W/ch (rear) into 8 ohms; FR 20-20,000 Hz; THD<0.05%. Includes RS integrated system remote control. Black; 26 lb. \$469

AX-630Ti 85-W/ch Integrated Amplifier
Integrated amplifier with active servo technology. Features high dynamic power; low impedance drive capability; high capacity electrolytic capacitors; independent power supply for the preamp and power amp; MC cartridge head amp; accessory output loop (line level). Continuously variable loudness control; 6 audio source inputs; OFC wire; CD direct switch; 6 position rec out selector; center defeat bass and treble controls; switchable subsonic filter; banana-plug compatible speaker terminals. 85 W/ch min rms into 8 ohms; FR 20-20,000 Hz; THD<0.01%. Titanium finish; 20 lb. \$449
AX-630. As above, black \$449

AX-430 55-W/ch Integrated Amplifier
Integrated amplifier with high dynamic power and low-impedance drive capability. Features MC cartridge head amp. CD-direct switch; continuously variable loudness control; 6 audio source inputs; tape copy selector; independent A/B speaker selection; center defeat bass and treble controls; banana-plug compatible speaker terminals. 55 W/ch min rms into 8 ohms; FR 20-20,000 Hz; THD<0.15%. Black; 18 lb. \$299



Yamaha AV-630



HUNGRY METAL

TDK's new MA cassettes have a voracious appetite for musical energy. Thanks to the awesome magnetic properties of their ultra-fine, ultra-dense Finavinx metal particles, they can consume (and store) massive quantities of the most powerful digital sources.

Considering the high frequency MOL'S (Maximum Output Levels) inherent in today's digital music, a tape must have extremely high coercivity and remanence to perfectly reproduce it. And MA's ultra-refined Finavinx, which contains nearly twice the magnetizable ions of normal and high position tapes, provides these two characteristics in a major way.

Compared to TDK's previous MA, an exceptional tape in its own right, new MA achieves a high frequency MOL (10 kHz) of 0 dB — an improvement of +3 dB! Combine this with an exceptional low bias noise of -58.0 dB, and you get a high frequency dynamic range improvement of 4.5 dB!

New MA's revolutionary particles also assure enduring storage and stable performance, thanks to TDK's special surface treatment. And to enhance these superb characteristics, the anti-resonance SP-AR mechanism drastically reduces modulation noise.

So, it's no wonder why audio perfectionists who demand perfect reproduction select MA. It's even available in 110 minute lengths, which will accommodate two CDs. Due to TDK's unique combination of smooth, durable base film and special coating technology, long term reliability is finally possible in this length.

Of course, new MA is also available in 46 and 90 minute lengths. Now, exactly how hungry are you for metal?



TUNERS

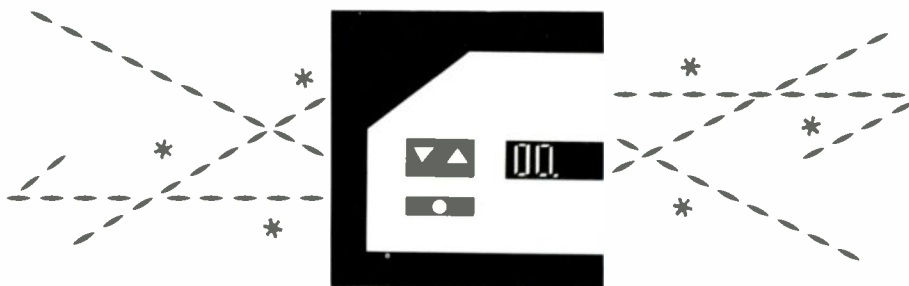

ACCUPHASE BY MADRIGAL

T-106 AM/FM Tuner

Quartz-locked synthesis; 14-station random memory; pulse tuning; double-tuned front end; FM stereo demodulator; AM synchronous detector; signal-strength meter; peak-modulation meter; MPX filter; sel switch; muting switch. FM section: 50-dB quieting sens mono 17 dBf, stereo 17 dBf; S/N 83 dB stereo, 79 dB mono (at 80 dBf A-wtd); FR 10-60,000 Hz $\pm 0.0, 0.5$ dB; capture ratio 1.5 dB; sep 50 dB at 1,000 Hz; AM sup 80 dB at 65 dBf. AM section: sens 20 μ V/m at 20 dB S/N; 17 1/2 x 5 x 1 1/2 in \$2,750

T-107 FM Tuner

Electronic tuning; 12-station random memory; auto sweep for FM reception; double-tuned front end to reject interference and IM; differential-gain linear FM detector; IF filters with flat group-delay characteristics; resonator-controlled stereo demodulator; multipath and signal-strength meter; MPX filter; muting switch; champagne-gold or anodized-black finishes. FM section: 50-dB quieting sens 17 dBf; S/N stereo 85 dB; FR 10-16,000 Hz. ± 3 dB; capture ratio 1.5 dB; sep 50 dB at 1,000 Hz; AM sup 80 dB; adj-ch rej 30 dB. 17 1/2 x 4 3/8 x 1 1/2 in; 12.8 lb \$1,800

ACOUSTIC RESEARCH

T-06/R AM/FM Tuner

Features a built-in infrared receiver which can be linked to the A-07 and/or RD-06. FM section: 50 dB quieting sens. mono 14.6 dBf, stereo 37.2 dBf; AM rej 60 dB; cap ratio 1.5 dB; S/N 78 dB mono, 73 dB stereo (at 65 dBf A-wtd); FR 30-15,000 Hz. ± 1.0 dB; sep 45 dB. AM section: S/N 50 dB. 17 1/4 x 3 1/2 x 10 3/8 in; 13.5 lb \$400

T-06 AM/FM Tuner. Same as above, without remote control facility \$330
RC-03. Remote control for the T-06/R \$25

ADCOM

GFT-555 AM/FM Tuner

Features quartz-referenced digital-synthesis tuning; auto up/down scan; instant-recall preset tuning; fluorescent digital-frequency display; 8 AM/FM presets; 5-LED signal-strength display; switchable high-blend circuit; mono/mute switch; tuning accuracy of 0.00025%. THD stereo 0.07% at 1,000 Hz; 50-dB quieting sens stereo 35.5 dBf; S/N 78 dB stereo; FR 30-15,000 Hz ± 3 dB; capture ratio 1.5 dB; sep 53 dB at 1,000 Hz; AM suppression 70 dB. 17 x 3 3/4 x 1 1/2 in \$500
GFP-555W. As above with white front panel \$550
GFI-555S. With silver front panel \$550

a/d/s/

CC4 AM/FM Tuner/Preamp

Features microprocessor operating system for remote-control operation, digital volume and tone controls, and alphanumeric display. Remote IR receiver capability for multi-room remote control; RS-232 port for control by personal computer; digital-synthesis tuning with 30 AM or FM stations;

optional remote control via RC1. Preamp section: max output > 7 V rms into 10,000 ohms/1,000 μ F; volume and balance control range 80 dB in 1-dB steps; bass and treble control range ± 10 dB in 2-dB steps; low bass 0 to +6 dB in 1-dB steps. FM section: sens < 13 dBf mono; 50-dB quieting sens < 40 dBf stereo; capture ratio < 1.5 dB; sel > 65 dB; spurious rejection > 100 dB; stereo S/N > 70 dB; sep at 1,000 Hz > 47 dB. AM section: sens for 6-dB S/N < 10 μ V; IF rejection > 50 dB; S/N 44 dB. 2 3/4 x 17 1/2 x 1 1/4 in; 15 lb \$850
RC1 Unified Remote Control. For use with the above and other a/d/s/ components \$150

Atelier T2 AM/FM Tuner

AM/FM synthesized tuner with 16 station presets and auto FM search tuning. Features flywheel manual tuning; fine-tuning control; switchable muting; high-blend control; LED frequency display; center tuning plus signal-strength displays; AC outlets. FM usable sens mono 1.0 μ V (11.0 dBf) stereo 5.5 μ V (26.1 dBf); stereo 50-dB quieting sens 15 μ V (34.8 dBf); S/N mono > 70 dB, stereo > 65 dB; FR 10-14,500 Hz. ± 0.1 dB; ch sep > 38 dB at 10,000 Hz; capture ratio < 1.8 dB; AM quieting sens < 5 μ V for 6 dB S/N; image rejection > 55 dB; S/N (with 1,000-Hz 5-mV signal) > 44 dB; 2 3/4 x 17 1/2 x 1 1/4 in; 13.2 lb \$539

ARCAM

Delta 80 AM/FM Tuner

Analog tuner with digital frequency display and 6 AM/FM presets. Features flywheel-assisted rotary knob; 3-color FM tuning indicator and logarithmically-scaled signal strength meter; automatic frequency control (AFC) switch; mono switch. FM section: sens 1.4 μ V; tuning range 87.5-108 MHz; stereo S/N 70 dB; stereo S/N 68 dB; cap ratio 1.5 dB. AM section: MW, 5300-16,000, LW, 1,600-2,700 Hz; signal-to-noise ratio 50 dB ref 30% modulation. 17 x 10 3/8 x 2 3/8 in; 10 lb. Black \$600

Alpha 2 AM/FM Tuner

Features birdie filter single glass-fiber Printed Circuit Board. MW/LW reception; automatic-frequency-control (AFC) switch; mono switch; red LED beacon; rotary flywheel tuning control with analog tuning scale. FM section: sens 1.4 μ V; stereo S/N 68 dB; FR 20-12,000 Hz ± 0.5 dB, -2 dB at 15,000 Hz; ch sep at 1,000 Hz > 40 dB; cap ratio 1.5 dB; alt-ch sel > 60 dB; AM suppression > 50 dB. AM section: MW, 5300-16,000, LW, 1,600-2,700 Hz; signal-to-noise ratio 50 dB reference 30% modulation. 17 x 9 x 3 3/8 in; 5 lb. Charcoal finish \$330

AUDIO BY VAN ALSTINE

Transcendence Series Two FM Tuner

FM tuner with discrete audio stage. Features isolated active output circuits; all metal-film resistors and capacitors; Class A current-sourced predrivers; separate shunt-regulated and filtered power supply. Electronic signal seeking; digital readout; 5 nonvolatile station presets; mono/stereo switching; variable tuning with between step capability. 17 x 9 x 3 in; 10 lb \$825

FET Three FM Tuner

FM tuner with Overload-Immune FET integrated circuitry in the audio stages. Features film coupling capacitors; optimized power supply decoupling circuits. Electronic signal-seeking; tuning; digital readout; nonvolatile station presets; mono-stereo switching; variable tuning; headphone jack. 17 x 9 x 3 in; 9 lb \$525

AUDIOCON BY TA ELEKTROAKUSTIK

T-1000AC AM/FM Tuner

Quartz-synthesis tuner with microprocessor control. Features 2 switchable and adjustable antenna inputs; displays current station, compares its program to other transmitters and provides for switching over to a station with the same program but with a stronger signal; remote. Distortion factor at 40,000 Hz 0.1% mono, 0.2% stereo; ch sep 70 dB; FR 6-15,000 Hz ± 6 dB \$1,200

AUDIO DESIGN ASSOCIATES

FM-600A FM Tuner

Analog FM tuner with 6 presets and digital frequency readout. Features servo-lock circuitry; 15-pole IF filter; AFC tuning; muting; stereo-blend noise filter; stereo/mono mode all front panel switchable; signal strength/multipath LED meter; rear-panel left- and right- output-level controls; standard EIA rack-mountable. FM section: FM usable sens stereo 1.9 mV; 50-dB quieting sens stereo 2.7 mV; THD 0.15% at 1,000 Hz; S/N 65 dB; FR 15-15,000 Hz ± 3 dB; capture ratio 1.9 dB; sep 47 dB at 1,000 Hz; adjacent-ch rejection 90 dB. 19 x 5 1/4 x 1 1/2 in; 12 lb \$2,395

AUDIO DYNAMICS

T2000E AM/FM Tuner

Programmable AM/FM tuner. Features remote-control capability; Schotz noise reduction; interference rejection; 10 AM/10 FM station presets. 50-dB quieting sens: mono 16.2 dBf, stereo 40 dBf; S/N: FM 70 dB, AM 40 dB; FR 20-15,000 Hz. ± 1 dB; alt-ch sel 67 dB. $\pm 400,000$ Hz; capture ratio 1.5 dB. 17 x 2 1/8 x 1 2/8 in \$349

CAMBRIDGE AUDIO

T50 AM/FM Tuner

Analog tuner with FM and two AM wavebands. Features dual MOSFET tuning head; dual FM demodulator with linear IF strip; pilot tone cancelling stereo decoder; linear-phase birdie filter \$399

CARVER

TX-11b AM/FM Tuner

Digital-quartz-synthesized tuner with asymmetrical charge coupled FM detector circuit to reduce multipath distortion. Features AM stereo section with separation 35 dB and S/N 77 dB. LED signal-strength meter; 13 random AM/FM presets; wide/narrow bandwidth selector; indoor AM/FM antenna included. Stereo sens 16.3 dB IHF; cap ratio 1.0 dB; AM suppression 75 dB; stereo alt-ch sel 110 dB; stereo

TUNERS

THD 0.02% at 1,000 Hz; stereo signal-to-noise ratio 82 dB. 11 lb. \$750

TX-12 AM/FM Tuner

Quartz-synthesis tuner with asymmetrical charge coupled FM detector circuit to reduce multipath distortion. Features 20 random AM/FM presets with preset scan; analog signal-strength meter; wireless remote; indoor AM/FM antenna included. Stereo sens 18.6 dBf IHF; cap ratio 1.45 dB; AM suppression 72 dB; alt-ch sel 60 dB; THD 0.02% in stereo at 1,000 Hz; stereo S/N 76 dB. 10 lb. \$400

TX-10 AM/FM Tuner

Digital quartz-synthesis tuner with asymmetrical charge coupled FM detector circuit. 20 random AM/FM presets with preset scan; digital signal-strength meter; wide/narrow bandwidth selector; indoor AM/FM antenna included. Stereo sens 23.5 dBf IHF; cap ratio 1.6 dB; AM suppression 72 dB; alt-ch sel 58 dB; stereo THD 0.2% at 1,000 Hz; stereo S/N 74 dB. 9 lb. \$230

CREEK AUDIO BY MUSIC HALL

T40 FM Tuner

FM tuner with auto mute. Features AFC, local/DX; narrow/wide switching. \$475



Creek Audio T40

DAVIDSON-ROTH

Day Sequerra FM Broadcast Monitor

Features spectrum analyzer, audio vector oscilloscope; FM tuning with 1-KHz accuracy, multipath display; RF frequency counter. Fully balanced, dual differential RF signal path with FET circuitry. Modified Travis-Smith detector for flat frequency response over 1.2 MHz deviation bandwidth. 7 3/8 x 19 1/2 x 16-in cabinet version; 7 x 19 x 15 1/4-in rackmount version; 45 lb. \$12,800

Day Sequerra FM Studio Tuner

Analog with FM tuner with 1,000 Hz tuning accuracy to preserve ch separation. Features multiple IF processors with variable Q circuits; selectable IF bandwidths for adjacent-ch selectivity; dual-mono servos with balanced outputs; absolute phase and phase compensation circuitry. 35 lb. \$3,300

dbx

TX-3MkII AM/FM Tuner

Tuner with Schotz NR for superior reception in difficult conditions. Features 8 AM and 8 FM presets; auto hi-blend eliminates excessive noise; seek. FR 20-15,000 Hz \pm 0.35 dB; 0.07% THD \$599

DENON

TU-800 AM/FM Tuner

Features twin-drive PLL circuits; digital-synthesis tuning; low-impedance output. 3-step IF bandwidth selection; 30-station random preset memory; MPX/NR switch; auto-scan tuning; manual tuning; step manual tuning; last-channel-tuned memory; FL display. FM 50 dB quieting sens 20 μ V (37.2 dBf) stereo, 1.6 μ V (15.3 dBf) mono; S/N 96 dB mono, 86 dB stereo; capture ratio 1.2 dB; AM sup 70 dB. 3 1/2 x 17 1/8 x 12 1/8 in. \$500

TU-550 AM/FM Tuner

Features digital-synthesis tuning. 2-step IF bandwidth selection; 20-station random preset memory; MPX filter; auto-scan tuning; quick manual tuning;

manual step tuning; last channel memory; FL display. Low imp of approximately 600 ohms; FM section: sens 0.9 μ V (10.2 dBf); THD stereo 0.15%, mono 0.08%; S/N stereo 78 dB, mono 84 dB; FR 20-15,000 Hz \pm 0.5/-1.0 dB; stereo sep 45 dB at 1,000 Hz. AM sens 18 μ V. 17 1/8 x 2 3/8 x 11 1/2 in; 6.8 lb. \$300

TU-460 AM/FM Tuner

Quartz-lock digital tuner with 30 station presets. Features last-channel tuned memory; auto-scan tuning; quick manual tuning; manual step tuning; RF attenuator switching. Includes Denon Integral System remote control for control from Denon IS receivers, preamps, and A/V amps. FM 50 dB quieting sens 38.5 dBf stereo, 15.3 dBf mono; S/N 82 dB mono, 78 dB stereo; cap ratio 1.5 dB; sep 45 dB at 1,000 Hz \$240

TU-450 AM/FM Tuner

Quartz-locked digital tuner with 16-station presets. Features digital-synthesis tuning. MPX/NR switch; auto-scan tuning; quick manual tuning; manual step tuning; last-channel memory. FM 50 dB quieting sens 23.1 μ V (38.5 dBf) stereo, 3.1 μ V (21.2 dBf) mono; S/N 80 dB mono, 76 dB stereo; cap ratio 1.5 dB; AM sup 50 dB. 2 3/4 x 17 1/8 x 9 3/8 in \$225

DUAL

CT5040 AM/FM Tuner

High-performance AM/FM tuner features digital-synthesis tuning and 40 AM/FM station presets. Black \$250

HAFLER

Iris FM Tuner

Digital-synthesis PLL tuning system. 3 dual-gate MOSFET; 5 tuned front end circuits; triple-tuned RF stage; auto DX; Hafler handshake system. 5 station memory; auto-search; digital readout; allows remote operation with Iris preamp. usable sens 11.3 dBf; 50-dB quieting sens 17.2 dBf mono, 37.2 dBf stereo; THD 0.1% mono, 0.18% stereo; cap ratio 1.5 dB; alt ch sep 60 dB; S/N 72 dB mono, 68 dB stereo. 17 x 3 x 8 1/2 in; 9 lb. \$450

DH-330 FM Tuner

Quartz-controlled tuner provides exact station selection with a digital-synthesis tuning system. Features multipath distortion and noise-sensing circuit; 5-station memory; autosearch; digital readout; nonvolatile memory; 3 dual-gate MOSFETs; 5 tuned front-end circuits; triple-tuned RF stage volume control and separate output on front panel for taping or headphones; kit is comprised of 4 fully assembled, tested, and aligned circuit boards which plug together. Usable sens 11.3 dBf; 50-dB quieting sens mono 15.3 dBf, stereo 36.5 dBf; dist. at 1,000 Hz, 100% modulation mono 0.1%, stereo 0.18%; capture ratio 1.5 dB; alternate ch sel 60 dB; sep 45 db at 1,000 Hz; 35 dB at 10,000 Hz; S/N, mono, 72 dB, stereo, 68 dB. 17 x 3 x 8 1/2 in; 9 lb. Assembled \$425
Kit. \$400

SE-130 AM/FM Tuner

Digital-synthesis PLL tuning system. 14 station preset-7 AM/7 FM; auto seek/scan. 17 x 3 x 8 1/2 in. \$300

HARMAN KARDON

Citation Twenty-Three AM/FM Tuner

Digital-synthesis quartz-locked tuner with Active-Tracking high-selectivity (Hi Q) circuit. Features 16 AM/FM presets; seek and manual tuning; mono and mute buttons; LCD readout; analog fine-tuning; fly-wheel-stabilized tuning knob; remote control; anodized brushed aluminum blue/black finish with molded rubber trim; heavy-gauge metal chassis. FM specs (w/ Hi Q): 50-dB quieting sens 40.4 dBf (stereo); AM rej 70 dB; capture ratio 1.75 dB; alternate-channel selectivity 75 dB; adjacent-channel selectivity 30 dB; S/N 75 dB (stereo); stereo separation 35 dB @ 1,000

Hz. AM section: S/N 55 dB. 17 3/8 x 2 3/4 x 14 1/8 in; 15 lb \$699

TU920 AM/FM Tuner

Digital-synthesis quartz-locked tuner with Active-Tracking high-selectivity (Hi Q) circuit. Features 16 AM/FM presets; muting; 2-way seek; manual up/down tuning; 5-LED signal-strength meter; tuned indicator; metal chassis. Available in black or champagne. FM specs (w/ Hi Q): 50-dB quieting sens 37.3 dBf (stereo); AM rej 55 dB; cap ratio 2.0 dB; alt-ch sel 75 dB; adj-ch sel 30 dB; S/N 74 dB (stereo); stereo sep 50 dB @ 1,000 Hz. AM section: S/N 53 dB. 17 3/8 x 2 3/4 x 14 1/8 in; 10 lb \$399

TU911A. Similar to above except lacks Active Tracking circuitry. 3-LED signal-strength meter. FM specs: 50-dB quieting sensitivity 37 dBf (stereo); AM rej 55 dB; cap ratio 1.3 dB; alt-ch sel 60 dB; adj-ch sel 5 dB; S/N 74 dB (stereo); stereo sep 50 dB @ 1,000 Hz \$299

TU909 AM/FM Tuner

Digital-synthesis quartz-locked tuner. Features 6 AM/12 FM presets; seek and manual tuning; black-out LCD; tuned/stereo indicators; black metal chassis. FM specs: 50-dB quieting sens 38.2 dBf (stereo); AM rej 45 dB; cap ratio 1.5 dB; alt-ch sel 70 dB; adj-ch sel 5 dB; S/N 72 dB (stereo); stereo sep 45 dB @ 1,000 Hz. AM section: signal-to-noise ratio 53 dB. 17 3/8 x 2 3/4 x 14 1/8 in; 10 lb. \$229

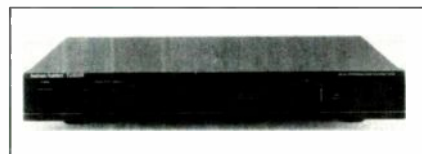

Harman Kardon TU909

HEATH

AJW-2520 AM/FM Tuner

Quartz-locked tuner with 16 AM or FM presets. Station memory retained up to one week after power failure. Features Low Group Delay I.F. (Intermediate Frequency) section; 3-segment LED signal-strength meter; muting; manual up/down tuning; bidirectional tuning; tuned indicator. FM section: 50-dB quieting sens, mono 37 dBf; cap ratio 1.3 dB; signal-to-noise ratio 74 dB stereo, 82 dB mono. 17 1/2 x 2 3/4 x 14 1/4 in; 10 lb. \$249
AJ-2520. Unassembled kit \$229

HITACHI

FT-007SW AM/FM Tuner

AM/FM quartz digital-synthesis tuner with 2-pole birdy filters. Features auto-quieting control function; RF/IF band switching; field condition computer system; 16 AM/FM station presets; FL AM/FM signal locked indicator; high-gain AM loop antenna. Rose-wood end caps \$400

JVC

FX1010TN AM/FM Tuner

Computer-controlled quartz-PLL digital-synthesis tuner with Opticalink system for reduced digital noise. Features 40 AM/40 FM station presets; auto memory; preset scan; variable stop level; dB signal-strength indicator; 6-column alphanumeric display; 2 antenna inputs; program memory and monitor for recording off the air unattended; record calibration signal generator; titanium finish \$480
FX1100BK. Same as above in black. \$470

KENWOOD

KT-990D AM/FM Tuner

Quartz-synthesis AM/FM tuner with Direct Linear Loop Detector (DLLD) to preserve dynamic range. Features Direct Linear Reception Circuit (DLRC) to

TUNERS

reduce digital noise; Direct Pure Decoder (DPD) to increase stereo separation; pentacle power supply; digital rotary tuning. 20 station presets; auto quieting control; manual/auto FM/IF bandwidth selectors; RF selector; rec calibrator; 3-station timer programming. FM: 50-dB quieting sens 38.8 dBf stereo; AM rej 76 dB; capture ratio 1.0 dB; alt-ch sel 60 dB. AM: sel 30 dB. 17¼ x 3 x 13 in; 8.8 lb. \$375

KT-880D AM/FM Tuner

Quartz-synthesis tuner with Direct Linear Reception Circuit (DLRC) to reduce digital noise. Pentacle power supply. 20 station presets; wide/narrow FM/IF bandwidth selectors; FL display; FM auto muting. FM: 50-dB quieting sens 38.8 dBf stereo; AM rej 76 dB; capture ratio 1.0 dB; alt-ch sel 60 dB. AM: sel 25 dB. 17¼ x 3 x 12¼ in; 7.7 lb. \$269

Spectrum Series

KT-88 AM/FM Tuner

Quartz-synthesis AM/FM tuner with programmable 2-event, 60-min sleep timer. Features 20 station presets, 12 with station name; preset scan. FM: 50-dB quieting sens 41.2 dBf stereo; AM rej 75 dB; capture ratio 1.2 dB; alt-ch sel 50 dB. AM: sel 25 dB. 17¼ x 3 x 10½ in; 6.8 lb. \$169

KINERGETICS

KBT-1 AM/FM Tuner

AM/FM tuner designed to correct for hysteresis errors in electronics of broadcast station (adjustable correction). Features circuit designed to compensate for components used in broadcast station's electronics; remote power supply; digital-synthesis tuning. 5 AM, 5 FM presets; scan tuning; selectable IF bandwidth; inputs for 300- and 75-ohm antennas. FM specs: 50-dB quieting sens 36.0 dBf (stereo); THD 0.05% (wide), 0.10% (narrow) at 1,000 Hz; S/N 75 dB (mono), 70 dB (stereo); ch sep 40 dB (wide), 45 dB (narrow); cap ratio 1.5 dB; alt-ch sel 70 dB (narrow), 50 dB (wide); image rej 75 dB. Black or silver anodized brushed aluminum. \$795

LUXMAN

All tuners carry Luxman's 5-year parts-and-labor warranty.

T-117 AM/FM Tuner

Digital-synthesis tuner with twin FM detectors; high S/N pulse-count detector for strong signals and PLL detector for weak signals. Features computer-analyzed tuning system that continuously samples radio signal-levels to optimize reception; dual-gate MOSFET front-end circuitry. 24 AM/FM presets; selectable FM/IF bandwidth; record-calibration button; cable FM fine tuning (25 kHz increments); unattended program recording; timer-program button; auto-seek/manual tuning button with indicator; IF wide/narrow indicators. FM section: 50-dB quieting sens 36 dBf; AM rej 70 dB; cap ratio 1.5 dB; alt-ch sel 80 dB (narrow); S/N 78 dB (stereo). AM section: S/N 48 dB. 17¼ x 2½ x 12¼ in; 10 lb. \$600

T-111 AM/FM Tuner

Digital-synthesis tuner with computer-analyzed tuning system that continuously samples radio signal-levels to optimize reception. Features 20 AM/FM presets; memory scan; cable FM fine tuning (25 kHz increments); unattended program recording; auto-seek/stereo mute button with indicator. FM section: 50-dB quieting sens 38 dBf; AM rej 68 dB; cap ratio 1.3 dB; alt-ch sel 60 dB; S/N 70 dB (stereo). AM section: S/N 52 dB. 17¼ x 2¾ x 8¾ in; 5.1 lb. \$300

MAGNUM DYNALAB

Etude FM Tuner

Features analog tuning; isolated power supply switching; dual AGC stage monitors. Digital display; high-/low-level audio outputs; auto-blend circuit with

manual defeat; panel meters for continuous monitoring of RF signal input, multipath interference level, and center tune condition; stereo/mono switch; noise-activated muting system with manual defeat; switchable wide/narrow IF bandwidth. Usable sens 10.3 dBf (mono), 11.2 dBf (stereo); 50-dB quieting sens 13.2 dBf (mono), 34.0 dBf (stereo); cap ratio <1.5 dB; alt ch >70 dB (wide), >80 dB (narrow); adj ch 12.0 dB (wide), adj ch 30.0 dB (narrow); stereo sep 60.0 dB; AM rejection -70 dB. 19 x 13 x 3½ in; 14 lb. \$1,195

FT-101 FM Tuner

Features MOSFET front end; group-delay ceramic filtering; analog tuning; sequential blend circuit adjusts stereo separation automatically. Switchable wide/narrow IF bandwidth; noise-activated muting system with manual defeat; stereo/mono switching; manual auto frequency control switching; panel meters for continuous monitoring of RF signal input, multipath interference level, and center tune condition; rotary tuning. Usable sens 10.3 dBf (mono), 11.2 dBf (stereo); 50-dB quieting sens 13.2 dBf (mono), 34.0 dBf (stereo); cap ratio 1.5 dB; alt ch 55.0 dB (wide), 75.0 dB (narrow); adj ch 6.0 dB (wide), 20.0 dB (narrow); stereo sep 60.0 dB; AM rej -70 dB. 19 x 13 x 3¾ in; 12lb. Optional remote control. Black, champagne gold, or brushed silver. \$698

FT-11 FM Tuner

Features IF amplification; MPX decoding circuitry; group delay circuitry; analog tuning; sequential blend circuit adjusts stereo separation automatically. 3-programmable station presets; rotary flywheel tuning; stereo/mono switch; noise-activated muting system with manual defeat; panel meters for continuous monitoring of RF signal input and center tune condition. Usable sens 12.1 dBf (mono); 50-dB quieting sens 35.3 dBf (stereo); stereo sep 50.0 dB; cap ratio 1.5 dB; alt ch 50.0 dB; adj-ch rej 6.0 dB; AM rej 70.0 dB. 17 x 2½ x 7 in; 10 lb. \$449

MARANTZ

ST 54 AM/FM Tuner

Quartz-locked digital-synthesis tuner. Features 24-station preset memory (16 FM/8 AM plus bandwidth setting for each preset); retains memory for 2 weeks without AC or battery; switchable wide/narrow bandwidth. \$780

ST 54 CG AM/FM Tuner

Features dual-gate MOSFET/analog priority; wide/narrow if bandwidth sw; 16 AM/FM presets. Gold color with rosewood side panels. \$500
ST 54 BI. As above, black with rosewood side panels. \$420

ST 35 BI AM/FM Tuner

Features dual-gate MOSFET front end; 16 AM/FM presets; LED signal meter. \$300

McINTOSH

MIR-7082 AM/FM Tuner

AM/FM tuner with Signal Locked Loop tuning system. Features electronic memory for 7 AM and 7 FM stations; digital frequency readout; DMOS-FET RF amplifier; double-balanced mixer; PLL MPX decoder; audio-output suppression circuits for 19 kHz and 38 kHz carrier; LED tuning meter; electronically regulated power supply; internal audio processor; memory search; wide-band AM; remote control interface. FM section: sensitivity mono 13 dBf (1.3 V) for 30 dB of quieting; signal strength for 50 dB of quieting. 18/36 dBf mono/stereo; capture ratio 1.5 dB; IM 0.08% from 20-15,000 Hz with 100% modulation or less; alt ch sel 55 dB; sep 50 dB at 1 kHz; FM suppression 60 dB; image rejection 90 dB. AM section: sensitivity 35 V; signal-to-noise ratio 55 dB IHF. 65 dB at 100% modulation; total harmonic distortion 0.2% at 30% modulation; sel 40 dB IHF; IF response 90 dB. 16 x 5½ x 13 in. \$1,499

MERIDIAN

204 FM Tuner/Timer

FM tuner with quartz synthesis tuner and 18 preset memories. Features built-in timer compatible with entire Meridian system; battery backup. Search/step tuning in 50 kHz steps; numerical signal-strength meter; sliding separation stereo decoder that maintains 50 dB min signal-to-noise ratio on weak signals. Can be controlled by Multiroom system. Dimensions: 4 x 6¼ x 12¼ in. Weight: 10 lb. \$1,090

MISSION ELECTRONICS

Cyrus AM/FM Tuner

Digital-synthesis, quartz-PLL tuner with 59 AM and 59 FM presets. Features magnesium diecast chassis; aluminum diecast cover and front; toroidal transformer. Full-function remote; programmable 15 dB volume control; display shut down; direct station accessing; scan; handset disable; 2-mode operation; automatic storing; flip and browse facility. 8½ x 3½ x 13½ in. \$649

NAD

Model 4300 Monitor Series AM/FM Tuner

Features digital frequency synthesis tuning; 8 AM/FM presets; IF wide/narrow; FM NR. Stereo separation 55 dB; selectivity 80 dB; image rej 120 dB; S/N >80 dB. Rack mountable. \$499

Model 4225 AM/FM Tuner

Features ultralinear IF filters; switchable blend circuit. 14 AM/FM presets. S/N 75 dB. \$249

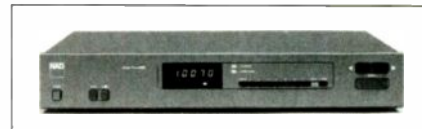

NAD Model 4225

NAKAMICHI

ST-7 AM/FM Tuner

Tuner with Schotz noise reduction. Features 5-segment signal/multipath meter; PLL circuitry; 16 station presets; output level controls (R + L independent). FM IHF sens mono 1.7 µV (10 dBf), stereo 3.9 µV (17 dBf); FM usable sens mono 1.7 µV (10 dBf), stereo 3.9 µV (17 dBf); 50-dB quieting sens mono 2.7 µV (14 dBf), stereo 14 µV (28 dBf); THD stereo 0.08%, mono 0.06% at 1,000 Hz; S/N 76 dB stereo, 80 dB mono; FR 20-15,000 Hz, ±1 dB; capture ratio 1.9 dB; sep 55 dB at 1,000 Hz; AM suppression better than 60 dB; alt-ch rejection >60 dB. 17¾ x 2½ x 11¾ in; 10.3 lb. \$795

NIKKO AUDIO

Gamma-600 AM/FM Tuner

Tuner with IF detection changing circuitry to assure minimum tuning deviation. Features MPX hold circuitry; oversized display; ceramic filter; differential IF amplifier circuitry. Variable high blend; memory can; stereo muting switch; IF band selector. 50 dB quieting sens. mono 13.5 dBf, stereo 38.2 dBf; AM rej 70 dB; cap ratio, wide 1.0 dB, narrow 2.0 dB; alt-ch sel, wide 40 dB, narrow 80 dB; S/N 79 dB stereo, 86 dB mono; FR 30-15,000 Hz ± 1 dB. 19 x 3¾ x 13¾ in; 9¼ lb. \$440
Gamma 400. Similar to above. 17¾ x 3¾ x 13¾ in. \$420

ONKYO

T-4000 AM/FM Tuner

Tuner with scan up/down tuning and 20 AM/FM station presets. Features FL display; battery-free memory backup; built-in AM loop antenna; sleep

“...one of the most convenient-to-use preamps around... it is a fundamentally musical performer at an affordable price.”

John Atkinson/Stereophile Vol. 12 No. 6 June 1989



The IRIS System. Hafler's continuing commitment to uncompromised musical sound reproduction and exceptional value.

The IRIS Preamp circuitry replicates the smooth sound of vacuum tubes while maintaining the very low noise and high dynamics of transistors.

The IRIS Remote is intentionally easy to use. The rotary knobs control volume and balance with an accuracy, convenience and feel that is unique to Hafler.



The IRIS FM Tuner is a perfect complement to the Hafler system. It combines precise quartz controlled tuning with infrared remote control and a clearly legible display. That makes finding and enjoying your favorite stations a pleasure.

The IRIS CD Player, due this fall, completes an intensive engineering effort to create a new level of superior performance at an "affordable price."

For the dealer nearest you call 1-800-366-1619.

Hafler
A DIVISION OF ROCKFORD CORPORATION

"The Affordable High-End"



TUNERS

timer function with Onkyo P-3160 preamp; R1 remote compatibility. FM: 50-dB quieting sens 36.1 dBf (stereo); cap ratio 1.5 dB; sel 55 dB (DIN); S/N 66 dB (stereo); stereo sep 40 dB (ω 1,000 Hz). AM: signal-to-noise ratio 40 dB. Dimensions: 17 $\frac{1}{8}$ x 2 $\frac{1}{8}$ x 10 $\frac{1}{2}$ in. Weight 5.7 lb. \$200

Integra Series

Grand Integra T-G10 FM Tuner

FM tuner with 5-mode APR (Automatic Precision Reception) system that can be operated automatically or manually to optimize reception: A/B antenna. RF (distant/local). IF bandwidth (wide/narrow/S-narrow). hi-blend (on/off). and stereo/mono. Battery-free memory backup; high sensitivity and selectivity; chassis damping. Dual antenna inputs; 20 station presets with scan; cable FM fine tuning; timer preset programming; R1 remote compatible. Controller included. Wood side panels. \$850

Grand Integra T-9090II FM Tuner

FM tuner with dual-mode PLL circuit and SFR (Sonic Filter Circuit) to improve tuning accuracy. Features same APR reception system offered in T-G10 tuner; power-supply filter. Dual antenna inputs; 31-key remote control; 20 station presets with scan; auto strong-station memory; multi-function digital display; digital signal-strength readout; timer preset programming; adjustable output-level; cable FM fine tuning. Wood side panels. 50-dB quieting sens 37.2 dBf (stereo); cap ratio 1.0 dB; S/N 85 dB (stereo); stereo sep 55 dB (ω 1,000 Hz). 18 $\frac{1}{4}$ x 4 x 15 $\frac{1}{4}$ in; 18.7 lb. \$750

Integra T-4087 AM/FM Tuner

AM/FM tuner with 4-mode APR (Automatic Precision Reception) system: distant/local, IF bandwidth (wide/narrow), hi-blend (on/off), and stereo/mono; all modes except distant/local can be overridden. Features PLL demodulator; separate power supplies/ground wiring for all major sections; RF amp with dual-gate MOSFET. 5-segment signal-strength indicator; 20 AM/FM station presets with scan; battery-free memory backup. Black finish. FM: 50-dB quieting sens 36 dBf (stereo); cap ratio 1.0 dB; signal-to-noise ratio 77 dB (stereo); stereo sep 45 dB (ω 1,000 Hz). AM: signal-to-noise ratio 40 dB. 17 $\frac{1}{8}$ x 3 x 14 $\frac{3}{4}$ in; 9.5 lb. \$420

Integra T-4500 AM/FM Tuner

AM/FM tuner with 3-mode APR (Automatic Precision Reception) system: IF bandwidth (wide/narrow), hi-blend (on/off), and stereo/mono; all modes can be overridden. Features RF section with 5 varactor diodes. Antenna attenuator switch; local/distant switch; 8-segment signal-strength indicator; 40 AM/FM station presets with "classified memory" scan; battery-free memory backup; R1 remote compatible. FM: 50-dB quieting sens 36.1 dBf (stereo); cap ratio 1.3 dB; signal-to-noise ratio 73 dB (stereo); stereo sep 45 dB (ω 1,000 Hz). AM: signal-to-noise ratio 40 dB. 17 $\frac{1}{8}$ x 3 $\frac{3}{8}$ x 14 $\frac{1}{2}$ in; 8.8 lb. \$320



Onkyo Integra T-4500

PARASOUND

T/DQ-260 AM/FM Tuner

Quartz-referenced, digital-synthesis tuner features 16 presets, 8 AM/8 FM; scan/manual tuning; mono mode switch; PLL tuning; regulated power supply. 50-dB quieting sensitivity 37.7 dBf; alt ch sel 66 dB; total harmonic distortion <0.05% mono, <0.1% stereo; frequency response 20-15,000 Hz \pm 0.5 dB; capture ratio 1.2 dB. 17 $\frac{1}{4}$ x 2 $\frac{1}{2}$ x 9 $\frac{1}{2}$ in. \$285

PIONEER

Elite F-91 AM/FM Tuner

Digital-synthesis AM/FM tuner. Features ARTS (Active Real-Time Tracing System) with active IF filter; digital decoding; 4-ganged tuning capacitor; MOSFET circuit; 24 AM/FM station presets; 3-position muting level; remote compatible; honeycomb chassis. THD 0.02%; alt ch sel 85 dB; S/N 92 dB. \$600

F-656 AM/FM Tuner

FM section: 50-dB quieting sens. mono 15.9 dBf, stereo 37.3 dBf; cap ratio 1.0 dB; S/N (at 80 dBf) mono, 86 dB, stereo, 81 dB; FR 20-15,000 Hz. +0.4, -1 dB. 16 $\frac{1}{2}$ x 3 $\frac{3}{8}$ x 12 $\frac{1}{2}$ in. \$325

F-445 AM/FM Tuner

FM section: 50-dB quieting sens, 18dBf mono, 36.2 dBf stereo; S/N mono 80 dB, stereo, 78 dB; FR 30-15,000 Hz. +1, -1 dB. 16 $\frac{1}{2}$ x 3 $\frac{3}{8}$ x 12 $\frac{1}{2}$ in. \$210

PROTON

AT-670 AM/FM Tuner

PLL synthesis AM/FM tuner with Schotz II tuning. Features rotary knob; 2-color display; 18 FM and 9 AM presets; remote capability, 50-dB sens 32- μ V mono, 30- μ V stereo; AM rejection 65 dB; cap ratio 1.0 dB; S/N 83 dB mono, 74 dB stereo. 18 $\frac{1}{2}$ x 4 $\frac{3}{8}$ x 15 $\frac{1}{8}$ in; 15.5 lb. \$400

440 AM/FM Tuner

Schotz AM/FM tuner with Schotz Noise Reduction. Features digital station readout; 12 station presets; memory backup holds station settings for 2 weeks when unplugged; adjustable rear-panel output level. FM section: 50-dB quieting sens mono (15.3 dBf), stereo (33.2 dBf); AM sup 60 dB; capture ratio 1.5 dB; sep 45 dB at 1,000 Hz; FM usable sens mono 1.8 μ V (10.3 dBf); THD stereo 0.2%, mono 0.05% at 1,000 Hz; S/N 70 dB stereo, 75 dB mono; FR 20-20,000 Hz \pm 0.2 dB; alt-ch rej 55 dB; adj-ch rej 90 dB. AM section: sens 300 μ V with built-in antenna. 16 $\frac{1}{2}$ x 2 $\frac{1}{2}$ x 9 $\frac{3}{4}$ in. 15 lb. \$269

AT-300 AM/FM Tuner

PLL AM/FM stereo tuner with Schotz noise reduction and remote-control option. Features 20 station presets; search & scan. FM sens 1.9 μ V and 50 dB quieting sens (stereo) is 3.5 dB; THD 65 dBf 0.1%; S/N 75 dB; sep 50 dB \$229

AT-200 AM/FM Tuner

AM/FM stereo tuner with dual-mode tuning system. Features search tuning; manual tuning; 12-position touchbutton-activated memory for 6 AM/6 FM station presets; phase-locked-loop frequency synthesis tuning; 5-number digital readout; stereo LED indicator; mono/stereo selector; signal-strength indicator. Usable sens 1.8 μ V; capture ratio 1.5 dB; alt ch sel 65 dB; stereo sep (at 1 kHz) 45 dB; THD 0.2%; S/N 74 dB stereo; IF rejection 90 dB. 16 $\frac{1}{2}$ x 2 $\frac{1}{2}$ x 10 in; 7.5 lb. \$209

QUAD

FM4 FM Tuner

FM stereo tuner designed to be used with Quad 44 preamp. Features 8 pushbuttons to store/recall station presets, tuning knob, power switch; bar-graph meter to indicate signal strength, center-channel tuning; dedicated microprocessor that recalls desired station from memory, tunes it, automatically sets muting, automatic-frequency-control levels. Stations stored in memory remain there for up to 5 years, even with power disconnected. Available in grey. Mono/stereo 50-dB quieting sens 2.7/25 μ V; mono/stereo signal-to-noise ratio 76/70 dBA at 1 kHz. 1 mV; mono/stereo distortion 0.05%/0.10% stereo; capture ratio 2.5 dB; sel 53 dB; image/IF rejection 80/100 dB; frequency response 20-15,000 Hz \pm 0.1 dB; crosstalk 40 dB at 1 kHz; pilot-tone suppression 60 dB; deemphasis switchable 50/75 μ sec; 8 x 1 $\frac{1}{8}$ x 5 $\frac{1}{8}$ in; 6 lb, 1 oz \$695

REALISTIC

TM-150 AM/FM Mini Tuner

PLL tuning; stereo/mono switch; FM stereo LED; illuminated tuning dial; built-in AM and FM antennas; terminals for external antenna. 9 x 2 $\frac{1}{2}$ x 6 in. . . \$60

REVOX

B260-S FM-Tuner

FM stereo tuner stores 60 preset stations with reception modes in non-volatile memory, allows user to arrange stored stations into separate groups for scanning. Maximum S/N >80 dB; THD 0.07%; alternate-channel selectivity; FR 20-15,000 Hz \pm 0.5 dB; 17 $\frac{1}{4}$ x 4 $\frac{1}{4}$ x 13 in; 15.5 lb. \$2,500

B160 FM-Tuner. Similar to B260-S but stores up to 30 preset stations \$990

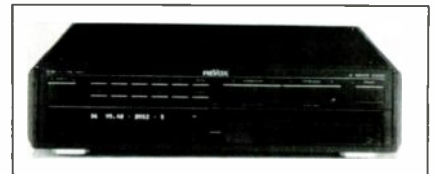

Revox B260-S

ROTEL

RT870 AM/FM Tuner

Quartz-PLL tuner with 16 AM or FM presets. Features 4 regulated power supplies; active filter networks; shielded dual gate MOSFET front end; FM noise filter selector. 50-dB quieting sens 37.2 dBf stereo, 14.8 dBf mono; AM rej 58 dB; cap ratio 1.0 dB; alt-ch sel 60 dB wide, 80 dB narrow; S/N 75 dB stereo, 80 dB mono; FR 30-15,000 \pm 0.5 dB; sep 48 dB at 1,000 Hz. 17 $\frac{1}{2}$ x 2 $\frac{5}{8}$ x 12 $\frac{1}{2}$ in; 8.5 lb. \$399

RT850A AM/FM Tuner

Quartz-synthesis tuner with microprocessor circuitry. Features dual-gate MOSFET front-end; 6 AM/6 FM presets, manual and autoscans tuning. FM section: usable sens mono 2 μ V (11.2 dBf), 50-dB quieting sens mono 3 μ V (14.6 dBf), stereo 40 μ V (37.2 dBf); THD stereo 0.2%, mono 0.08% at 1,000 Hz; S/N 73 dB stereo, 75 dB mono; FR 30-15,000 Hz \pm 0.2 dB; capture ratio 1.0 dB; sep 48 dB at 1,000 Hz; AM suppression 58 dB; AM section: sens 300 μ V/m; S/N 50 dB. 2 $\frac{1}{2}$ x 17 x 11 $\frac{1}{2}$ in; 8.5 lb. \$299

RT830A AM/FM Tuner

AM/FM analog tuner with LED indicators for signal strength. FM section: usable sens mono 2 μ V (11.2 dBf), 50-dB quieting sens mono 3.5 μ V (16 dBf), stereo 50 μ V (39.4 dBf); total harmonic distortion stereo 0.6%, mono 0.3% at 1,000 Hz; signal-to-noise ratio 65 dB stereo, 70 dB mono; FR 35-13,000 Hz \pm 1.5 dB; capture ratio 2 dB; sep 38 dB at 1,000 Hz; AM suppression 62 dB; AM section: sens 300 μ V/m; S/N 45 dB. 2 $\frac{1}{2}$ x 17 x 12 $\frac{1}{2}$ in; 6.8 lb. \$199

SAE

T102 AM/FM Tuner

Computer direct-line digital tuner with 16 station presets. Features auto and manual tuning; IF narrow; high blend. FM section: 50-dB quieting sens 34 μ V; cap ratio 1.2 dB; alt-ch rejection -100 dB narrow; adj-ch rejection -15 dB narrow; IIF sens stereo 4.1 μ V; THD stereo 0.08% at 1,000 Hz; S/N 70 dB stereo; FR 30-18,000 Hz \pm 1, -2 dB; sep 55 dB at 1,000 Hz. 19 x 3 $\frac{1}{2}$ x 12 $\frac{1}{2}$ in. \$349

SANSUI

TU-X711 AM/FM Tuner

Quartz PLL synthesis tuner with Super Linear Digital decoder. Features R1-mode selector; IF-bandwidth selector; record calibrator; 2 separate antenna inputs; 30 random presets and a numeric keypad for instant

TUNERS

station recall; preset scan. Usable sensitivity 10.8 dBf; 50 dB quieting sensitivity 16.2 dBf (mono); total harmonic distortion at 85 dBf < 0.009% (mono), 0.02% (stereo); signal-to-noise ratio 98 dB (mono), 91 dB (stereo); alternate channel selectivity 60 dB (wide), 75 dB (narrow). Dimensions: 17 3/4 x 3 7/8 x 12 1/2 in. Weight: 11.2 lb. Black finish \$625

TU-X701 AM/FM Tuner

Vintage series tuner with 30 AM/FM station presets. Features numeric keypad for recall; programming 2 station frequencies for unattended recording; memory scan; RF mode selection; IF bandwidth selection; record calibrator; FM noise canceler; mode switch. Usable sensitivity 38.0 dBf (stereo); total harmonic distortion 0.0095% (stereo); signal-to-noise ratio 98 dB; IF response (at 84 MHz) 110 dB. Dimensions: 17 3/4 x 3 7/8 x 11 7/8 in. Weight: 10.4 lb. \$550

TU-X501 AM/FM Tuner

Quartz PLL digital synthesis tuner with 30 AM/FM station presets. Features numeric keypad for instant recall; memory scan; IF band selector; FM noise canceler; auto/manual tuning; FL display. FM section: frequency response 20-15,000 Hz \pm 0.5dB; 50-dB quieting sensitivity 16.0 dBf (mono), 36.0 dBf (stereo); signal-to-noise ratio 86 dB (mono), 80 dB (stereo); total harmonic distortion 0.05% (mono), 0.06% (stereo); alternate channel selectivity at 500 Hz - 50 dB (wide), 75 dB (narrow). Dimensions: 17 3/4 x 3 3/4 x 11 1/2 in. \$350

TU-X301i AM/FM Tuner

Quartz PLL digital synthesis tuner with 30 AM/FM station presets. Features numeric keypad for instant recall; 5-sec preset station scan; pale blue indicators. FM section: 50-dB quieting sensitivity 18.0 dBf (mono), 38.0 dBf (stereo); signal-to-noise ratio 79 dB (mono), 73 dB (stereo); total harmonic distortion 0.1% (mono), 0.15% (stereo). Dimensions: 17 x 2 3/4 x 10 1/4 in. Weight: 6.2 lb. Black-matte finish \$250

T-900SW AM/FM Tuner

Analog tuner with FM muting and 3-LED signal-strength meter. FM section: 17.0 dBf (stereo), 10.8 dBf (mono); signal-to-noise ratio (at 65 dBf) 75 dB. Dimensions: 17 x 3 3/4 x 9 1/4 in. Weight: 5.5 lb. \$175

T-1000 AM/FM Tuner

AM/FM stereo tuner with quartz-PLL synthesis tuning. Features 16 station presets; high-blend circuitry; 2 FM tuning modes, 1 for strong signals, 1 for weak signals. 50 dB quieting sensitivity 16.5 dBf; signal-to-noise ratio 75 dB; capture ratio 1.5 dB. Dimensions: 3 3/4 x 17 x 9 in. Weight: 6 lb. \$145



Sansui TU-X-501

SHERWOOD

TD-7010R AM/FM Tuner

Quartz PLL synthesis tuning system. Features 3 pairs of IF ceramic filters; MOSFET front end. Digi-Link remote system; digital display; auto/manual scan; 30 station presets; preset scan switch; 10-segment signal-strength meter; hi-blend switch; FM mute switch; AM bar antenna. Usable sensitivity 9.8 dBf; 50 dB quieting sensitivity 36.1 dBf (stereo), 19.2 dBf (mono); frequency response 10-15 Hz \pm 3 dB; total harmonic distortion 0.25% (stereo), 0.15% (mono); 50 dB stereo sep at 1,000 Hz; capture ratio 1.5 dB; alternate-channel selectivity 70 dB. Dimensions: 3 3/4 x 17 3/8 x 8 3/4 in. \$200

TD-1120 AM/FM Tuner

Quartz PLL synthesis tuning system. Features MOSFET front end. Digital display; 24 station presets; auto-

tuning; AM loop antenna. Usable sensitivity 11.2 dBf; 50 dB quieting sensitivity 39.2 dBf; total harmonic distortion 0.4%; stereo sep 45 dB at 1,000 Hz; frequency response 10-15 Hz \pm 3 dB; capture ratio 2 dB; alternate-channel selectivity 60 dB. Dimensions: 3 3/4 x 17 3/8 x 8 3/4 in. \$150

SONY

Elite Series

ST-S730ES AM/FM Tuner

Features radial power-supply design; automatic microprocessor exclusion circuit master clock; SST super sound tracking; WOLF wave optimized IF system; WODD wave optimized direct detector; WODSD wave optimized digital stereo decoder; direct comparator circuitry. signal-to-noise ratio 92 dB stereo, 100 dB mono; total harmonic distortion 0.0075% stereo, 0.004% mono; sensitivity 10.3 dBf/0.9 μ V; selectivity (at 400 kHz) 70 dB; sep (at 1 kHz) 70 dB. Dimensions: 3 3/4 x 18 1/2 x 14 3/4 in. Weight: 12 lb, 6 oz \$550

SOUNDCRAFTSMEN

Pro-Tuner Four AM/FM Tuner

Digital quartz-PLL tuner with 16 station presets, 5-digit station readout, auto-scan tuning, and active high-blend filter. 19-in rack-mount front panel. IHF sensitivity 1.6 μ V; signal-to-noise ratio 75 dB; distortion 0.08%. Dimensions: 19 x 2 3/8 x 12 in. \$379

SOUNDSTREAM



Sony ST-S730ES

T-1 AM/FM Tuner

System 1 component features full frequency defeatable blend circuit to reduce stereo background noise by 9 dB; knob moves in 50,000 Hz steps for tuning off frequency stations; separate audio and switching power supplies. Flywheel-assisted manual tuning knob for fine reception adjustment; 16 presets and complete station search; strength indicator; R-I remote accesses major tuner functions. 50-dB quieting sensitivity 14.8 dBf; AM rejection 60 dB; capture ratio 1.5 dB; alternate channel selectivity 65 dB; signal-to-noise ratio > 82 dB mono; > 79 dB stereo; total harmonic distortion at 6,000 Hz: 0.12% mono; 0.2% stereo. AM section: sensitivity, 20 dB signal-to-noise ratio 30% modulation 10 mV; max quieting, 30% modulation 50 dB; total harmonic distortion at 1,000 Hz 0.5%. Dimensions: 17 x 3 3/4 x 11 1/2 in. Weight: 15 lb. \$795

SUMO

Aurora AM/FM Tuner

Digital synthesis AM/FM tuner with rotary tuning. Features auto seek forward/reverse; 8 presets for both AM/FM; tunes FM in 1/4 increments (50,000 Hz spacing), allowing fine tuning; dynamic impulse noise reduction system; linear-phase IF filters. Auto seek forward/reverse; 8 preset for both AM/FM; gold-plated output jacks. 50-dB quieting mono 16 dBf, stereo 34 dBf; usable sensitivity 11 dBf mono; alternate-channel selectivity 75 dB; capture ratio 1.0 dB; signal-to-noise ratio mono 85 dB, stereo 82 dB. Dimensions: 19 x 8 3/4 x 1 3/4 in. \$729

TECHNICS

ST-G70 AM/FM Tuner

Stereo tuner with 39 AM/FM station presets. Features

class AA circuitry; IC twin quartz circuitry; IC linear switching MPX filter; auto IF-bandwidth selection; twin tuner design. 10-key random access; auto-scan; FM signal-strength display \$380

ST-G460 AM/FM Tuner

Quartz-synthesis tuner with 39 AM/FM station presets. Features IC circuit construction; IC linear switching MPX filter; advanced FM front-end circuitry; 19,000 Hz pilot signal auto canceller; wide-band quadrature detector. Multi-function FL display; auto-scan tuning and auto memory; FM-mode switch (auto/mono). FM specs: sensitivity 10.8 dBf; 50 dB quieting sensitivity 18.1 dBf (mono), 38.1 dBf (stereo); total harmonic distortion 0.05% (mono), 0.1% (stereo); signal-to-noise ratio 80 dB (mono), 73 dB (stereo); frequency response 4-18,000 Hz +0.5/-1.5 dB; alternate-channel selectivity 65 dB; cap ratio 1.0 dB; image rej 55 dB; AM rej 55 dB; stereo sep 50 dB (at 1,000 Hz), 40 dB (at 10,000 Hz) \$240

TOSHIBA

ST-5528 AM/FM Tuner

Features 16 presets; digital display; preset memory recall; preset scan; automatic digital tuning lock-in for each available station; system remote control \$170

YAMAHA

TX-2000 AM/FM Tuner

AM/FM tuner with 24 station presets. Features computer servo lock tuning; digital fine tuning; multi-status station memory; two-mode station display; RS remote control compatibility; four tuning modes; two position IF-mode selector. Includes remote control. Titanium finish with side panels. Channel selectivity 90 dB. \$749

TX-1000i AM/FM Tuner

Digital AM/FM stereo tuner with computer-servo-lock tuning. Features absolute linear phase IF amplifier "Alpha" circuitry. Digital fine tuning; 2-position IF-mode selector; 4 tuning modes; antenna-selector switch; 24-station random access memory presets; multi-status memory; 4-letter station name display; 24-segment signal-quality meter; remote control; RS optical integrated system remote compatible. Channel selectivity 90 dB. Weight: 14 lb. \$549

TX-900U AM/FM Tuner

AM/FM tuner with 20-station presets. Features integrated system remote compatibility; digital fine tuning; 3-position auto/manual IF-mode selector; 4-way station memory; high blend; integrated multi-function LCD display. Black finish. Weight: 9 lb. \$399

TX-530Ti AM/FM Tuner

AM/FM tuner with PLL IF count synthesis tuning. Features 20 station presets; 4-way multi-status station memory; high blend switch; 24 segment signal quality meter; 2 position IF-mode selector with indicators; low impedance, high gain AM loop antenna; auto search and manual tuning; RS remote control compatibility. Titanium finish. 9 lb. \$329
TX-530. As above, black \$329

TX-330Ti AM/FM Tuner

PLL synthesis tuner with 16 station presets. Features 3-way multi-status station memory; 5-segment signal-quality meter; low impedance, high gain AM loop antenna; auto search and manual tuning; RS remote control compatibility. Titanium finish \$249
TX-330. As above, black \$249



Yamaha TX-330

COMPACT · DISC · PLAYERS

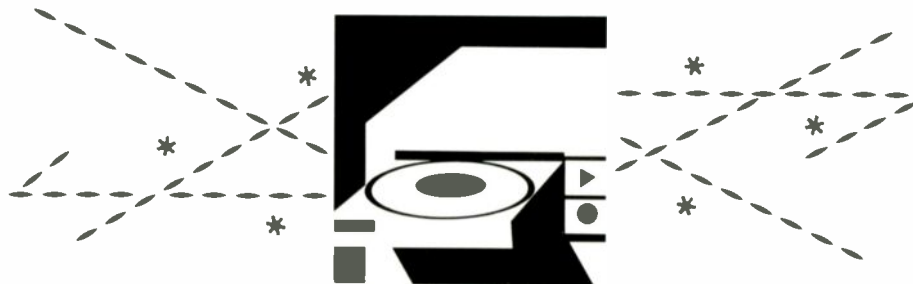

ACCUPHASE BY MADRIGAL

DP-80L/DC-811. Dual-Chassis CD Player
CD player employing master clock principle; linear-motor-driven laser pickup with 8-bit microprocessor said to access any track in less than 1 second; non-resonant mechanism construction with aluminum diecast frame and floating suspension. Digital processor with employed 20-bit discrete D/A converter; separate 20-bit 8x-oversampling digital filter for each channel; GIC 3-pole Butterworth type active filter; 21 optoisolators in each channel; three sampling frequencies; 6 inputs (3 optical, 3 coaxial); noise shaper and deemphasis circuitry; direct-coupled output stage with 0-dB-gain buffer; two unbalanced and one balanced outputs; RC-2 remote control. Frequency response 4-20,000 Hz, ± 0.3 dB; THD 0.002%; signal-to-noise ratio 120 dB; ch sep 112 dB; sampling frequencies 32,000/44,100/48,000 Hz. CD player: 18 $\frac{3}{4}$ x 5 $\frac{3}{8}$ x 14 $\frac{3}{4}$ in; 33 lb, 2 oz. Digital processor: 18 $\frac{3}{4}$ x 5 $\frac{3}{8}$ x 14 $\frac{3}{4}$ in; 35 lb, 2 oz. \$13,000

DP-70 CD Player

Play, track search, pause on front panel; number keypad, stop, repeat (all, 1, phrase), index search, display (track and index or time), scan, and output-level controls behind panel; fixed and variable RCA outputs; XLR balanced output; 75-ohm coaxial cable output; optional wide-band optical-fiber output; digital output pins; track selection in <1 sec with linear motor; 4x-oversampling (176.4 kHz) digital filters; discrete D/A converter; 5-pole GIC Butterworth low-pass filters; isolating optocouplers; independent power supply for digital and analog circuits; 4 optocouplers input digital data, latch clock deglitches signal to D/A converter; direct-coupled 0-dB-gain buffer amp as output stage with push-pull 1x servo direct coupling; metal shielding; passive elements and buffer amp in de-emphasis circuit; ceramic composite resin floating mounting; legs lathed from pure brass bar; hairline-finish golden panel and natural persimmon sideboard. Frequency response 4-20,000 Hz, ± 0.3 dB; THD 0.002%; signal-to-noise ratio 115 dB; ch sep 110 dB; 18 $\frac{3}{4}$ x 5 $\frac{3}{8}$ x 14 $\frac{3}{4}$ in; 46 lb, 6 oz. \$7,600

ACOUSTIC RESEARCH

CD-06 CD Player

16-bit, 4x oversampling CD player. Computer-driven laser swing arm; dual D/A converters (analog circuitry employs a Gaussian filter for elimination of filter delay); random-access programming of up to 20 tracks in any order; scanning, play, pause and volume control can be performed by remote control. Fixed level and remote variable audio outputs as well as separate digital output. Frequency response 4-20,000 Hz, ± 0.5 dB; total harmonic distortion 0.007%; signal-to-noise ratio 105 dB; ch sep 92 dB. 17 $\frac{1}{4}$ x 3 $\frac{3}{8}$ x 9 $\frac{7}{8}$ in; 12 lb, 6 oz. \$500
RC-03. Remote control for the above. \$25

ADCOM

GCD-575 CD Player

Dual digital-to-analog, 4x oversampling, 16-bit linear

converters. Selectable analog frequency/phase contouring circuitry; fixed and variable outputs; 3-beam laser; plays 3-in CD's. Programs up to 24 tracks in any sequence; repeats disc, track, program, or any selected sequence or phrase; audible fast scan and fast forward. Displays simultaneously total tracks up to 20. Timer display. Remote transmitter. Frequency response 5-20,000 Hz ± 0.1 , -0.5 dB; S/N 105 dB; THD 0.0025%; ch sep 95 dB; IM (SMPTE) 0.00018%; 17 x 3 $\frac{1}{2}$ x 11 $\frac{1}{4}$ in; 12 lb; black \$600
GCD-575. White front panel. \$650

a/d/s/

Atelier CD4 CD Player

Features 16-bit 2x oversampling D/A converters; 3-beam laser; multiple power supplies to isolate digital and analog stages for minimum interaction and noise generation; servo-laser intensity system switches focus intensity depending on quality of disc to maximize performance; brick-wall digital filter works in conjunction with advanced multiple-pole low-pass filter; error correction uses variable-size window. Programming of 16 tracks in random order; repeat disc, track, phrase, or program; random access by time within a track; access by index point; audible fast search; displays elapsed time from track start, remaining time to disc end, track/program selection number, index, program in memory; optional remote control via RC1. FR 20-20,000 Hz, ± 0.25 dB; THD <0.01%, 20-20,000 Hz, 0 dB; S/N >102 dB, 1,000 Hz, 0 dB; ch sep >86 dB, 20-20,000 Hz. \$850
RC1 Unified Remote Control. For use with the above and other a/d/s/ components \$150

AIWA

XC-005 CD Player

8x oversampling and 18-bit D/A converter. 3-beam laser, compatible with CD-3 without adaptor. 30-second peak search, or real-time peak search during playback; memo file for 116 discs stores 10 characters/file, playback program, peak level; wireless remote 20-key track selection; 30-selection random programmable memory; index search; auto blank; time counter; optical and coaxial digital output; headphone jack with volume control. FR 4-20,000 Hz ± 0.3 dB; THD 0.0025%; S/N 110 dB; ch sep 100 dB. 17 x 4 $\frac{3}{8}$ x 14; 11.5 lb. \$550
XC-004. Similar to above, 4x oversampling; no memo files; 20-selection random programmable memory. Frequency response 20 - 20,000 Hz ± 0.5 dB; THD 0.004%; S/N 96 dB; ch sep 90 dB. 17 x 4 $\frac{3}{8}$ x 14; 11 lb \$440
XC-002. As above, wireless remote 10 key track selection; no headphone volume control \$300



Aiwa XC-005

ANALOGIC DESIGN GROUP

NXa Series Vacuum Tube Hybrid CD Player

CD player with 4x oversampling; 16 bit processing; 2 D/A converters. Hybrid analog stages; vacuum tubes for active filtering and final outputs; isolated power supply and transport damping. 20-track programming; track skip; 3-speed audible fast search; repeat disc-track-program; cues by track and index; display indicates current track number, elapsed time of current track. Includes wireless remote control. Frequency response 10-20,000 Hz ± 0.5 dB; S/N 100 dB; THD 0.09% at 0 dB. 3 $\frac{1}{2}$ x 19 x 11 in. \$1,495

NXa Series FET Hybrid CD Player

CD player with 4x oversampling; 2 D/A converters; 16 bit processing. Features hybrid analog stage; FET output/analog filtering circuitry; direct coupled 1x servos; decoupled/isolated analog and digital power supply stages. Track skip; 3-speed audible track search; repeat disc-track-program; display indicates current track number, elapsed time of current track; infrared remote control. Frequency response 17-19,000 Hz ± 0.75 dB; S/N 102 dB A-wtd; THD 0.01%. 3 $\frac{3}{4}$ x 17 x 11 in. \$1,095

ARCAM

Delta 170 CD Transport

For use with outboard D/A converter. Features a fully-floating diecast single-beam laser mechanism mounted on a damped sandwich construction aluminum chassis; full 64K adaptive-error correction; master oscillator with a separate dedicated transformer and power supply that is optically isolated from the servo and microprocessor circuitry. Includes full-function remote. \$1,295

Delta 70 CD Player

CD player with dual 16-bit D/A converters and 4x oversampling. Features 20-track programming; 3-speed search; track skip; direct/variable audio outputs; headphone jack; digital output. FR 10-10,000 ± 0.1 dB; S/N 105 dB; dynamic range 96 dB. 17 x 10 $\frac{3}{8}$ x 3 $\frac{1}{2}$ in; 14 lb. Black \$1,000
Remote \$100

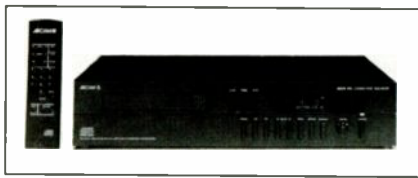

Arcam Delta 170

AUDIO BY VAN ALSTINE

Transcendence FET-Valve CD Player

Drawer-loading CD player with 4x oversampling and dual 16-bit D/A converters. Features Class-A compound hybrid vacuum tube and power MOSFET filter driver circuits; toroidal power transformer; regulated heater supply; exact-channel phase-gain tracking.

COMPACT • DISC • PLAYERS

Features 20-track programming; repeat; shuffle play; time and track display; 3-speed music search with cueing; CD-single compatibility; wireless remote control. 16½ x 11 x 3 in; 12 lb \$1,195

FET-Three-Plus CD Player

Drawer-loading CD player with 4x oversampling and dual 16-bit digital-to-analog converters. Features custom hybrid module output stages and film coupling capacitors; filter drivers with ½-amp current drive at 200 V/μsec; exact channel phase-gain tracking. 20-track (and index number) programming; repeat; skip forward/back; time/track display. Infra-red remote control optional. Dimensions: 16½ x 11½ x 3 in; 9 lb. \$550

FET-Three CD Player

Drawer-loading CD player with 4x oversampling and dual 16-bit D/A converters. Features fast (30 V/μsec) overload immune integrated circuit audio stages, and film-coupling capacitors; exact channel phase-gain tracking. 20-track (and index number) programming; repeat; skip forward/back; time/track display. Infra-red remote control optional. 16½ x 11½ x 3 in; 9 lb. \$350

AUDIO DYNAMICS

CD-2000F CD Player

Slide-drawer-loading CD player with full-function remote control and advanced error-processing circuitry. Features 3-beam laser pickup; 16-track random programming; 16-bit D/A converter with 4x-oversampling digital filter; CD-single compatible. 16-track programmability. Frequency response 10-20,000 Hz, ±0.5 dB; total-harmonic distortion 0.005% at 1,000 Hz; dynamic range 96 dB; ch sep 90 dB; signal-to-noise ratio 96 dBA. 17 x 2 x 12¾ in; 8 lb. 3 oz. \$399

CD-1000F CD Player

Slide-drawer-loading CD player with full-function remote control and advanced error-processing circuitry. Features random 16-track programming; 16-bit linear D/A converter; skip forward; skip back; fast forward; fast reverse; repeat track, disc, or program; 7-pole (7th-order) analog filtering; 3-beam laser. Displays current track number, elapsed time of current track, remaining time on disc, and program on disc, and program in memory. Frequency response 20-20,000 Hz, ±0.5 dB; total harmonic distortion 0.005%; signal-to-noise ratio 96 dBA. 17 x 3½ x 11½ in; 10 lb, 9 oz. \$249

BANG & OLUFSEN

Beogram 5500 CD Player

Integrates with Beosystem 5500. 16-bit 4x-oversampling; Bessel elliptical analog filter; 2 D/A converters; separate power supplies for digital and analog sections; digital output. Programs 20 tracks; adds time of programmed tracks; displays time remaining on disc; skip forward and back; 3-speed forward and reverse; direct access by track number; intro scan; auto space; controlled by Master Control Panel (comes with Beomaster 5500 receiver). Black and silver finish. Frequency response 3-20,000 Hz, ±0.3 dB; signal-to-noise ratio 110 dBA; dynamic range >96 dB; total harmonic distortion <0.003%; ch sep >96 dB at 1,000 Hz. Dimensions: 16½ x 3 x 12¾ in. Weight: 14 lb, 2 oz. \$1,100

Beogram 4500 CD Player

Integrates with Beosystem 4500 for full remote control. 16-bit 4x oversampling; Bessel elliptical analog filter; 2 D/A converters; separate power supplies for digital and analog sections. Skip forward and back; direct access by track number; plays 3-in CD without an adaptor. Black and silver finish. Frequency response 3-20,000 Hz, ±0.3 dB; signal-to-noise ratio 110 dBA; total harmonic distortion 0.0025%; ch sep >101 dB; dynamic range >96 dB. 16½ x 3 x 12¼ in; 9 lb, 14 oz. \$800

CALIFORNIA AUDIO LABS

California Audio Labs CD players are made in the United States.

Tempest MKIII CD Player

8x oversampling and 18-bit D/A converter with full-function remote. Features dual chassis; all-tube analog section; DC coupled; (C.A.L.) linear-drive transport with glass optics; phase reversal switch \$4,500

Aria MKIII CD Player

18-bit D/A converter with a tube hybrid circuit in the analog section. Features fiber optics in the data path; DC coupled; (C.A.L.) linear-drive transport with glass optics; full-function remote \$1,995

Tercet MKIII CD Player

8x oversampling and 18-bit D/A converter with discrete circuits instead of op amps. Features solid state technology; DC coupled; (C.A.L.) linear-drive transport with glass optics; full function remote \$1,295

Icon CD Player

8x oversampling and 18-bit D/A converter with full function remote with 10-key direct access. Features (C.A.L.) linear-drive transport with glass optics. Frequency response 20-20,000 Hz +0 dB, -0.5 dB; THD 0.003% \$695

CAMBRIDGE AUDIO

CD2 CD Player

16x oversampling and 16-bit D/A converter. Features 64k of error correction; no analog stages. THD 0.0025%; dynamic range >100 dB \$1,750

CARVER

TL-3300 CD Player

8x oversampling and dual 18-bit D/A converter with Digital Time Lens circuitry for AAD CD's to restore original ambient effects. Features 22-track programming with dedicated keypads on remote and panel; 3-in CD capability; 3-way repeat; skip and scan functions; remote compatible with Carver receivers. FR 5-20,000 Hz ±0.2 dB; 0.002% THD at 1,000 Hz; 100 dB S/N; 90 dB ch sep; 100 dB dynamic range. 8 lb. \$700

TL-3200 CD Player

8x oversampling and dual 16-bit D/A converter with Digital Time Lens circuitry for AAD CD's to restore original ambient effects. Features 32-track programming with dedicated remote keypad; remote volume control; shuffle play with delete option; intro-scan; 3-in CD capability. 3-way repeat; skip and 2-speed scan functions; remote compatible with Carver receivers. FR 2-20,000 Hz ±0.2 dB; 0.005% THD at 1,000 Hz; 100 dB S/N; 90 dB ch sep; 100 dB dynamic range. 8.5 lb. \$550

TL-3100 CD Player

4x oversampling and 16-bit D/A converter with 5th order analog filters. Features Digital Time Lens circuitry for AAD CD's to restore original ambient effects. 16-track programming with dedicated remote keypad; 3-way repeat; skip and scan functions; remote compatible with Carver receivers. Frequency response 2-20,000 Hz ±0.2 dB; 0.005% THD at 1,000 Hz; 96 dB signal-to-noise ratio; 80 dB ch sep; 100 dB dynamic range. 7 lb. \$350

CARRERA

CD Changer

CD-7500 CD Changer

4x oversampling, 16-bit D/A converter, 6 disc capacity. Features fixed line outputs, and headphone jack; shows elapsed time for disc and track. 32 program-

mable selections; repeat disc, track and program. Frequency response 20-20,000 Hz ±0.5 dB; THD .009%; signal-to-noise ratio 96 dB. 13 lb. \$450

CD Player

CD-3200 CD Player

2x oversampling, 16-bit D/A converter. Features fixed line outputs, and headphone jack; shows elapsed time for disc start. Repeat disc, track and phrase. Frequency response 20-20,000 Hz ±0.5 dB; THD .01%; S/N 95 dB. 9 lb. \$200

CITIZEN

Portable CD System

CBM 5000LT

Portable CD player, cassette player/recorder and AM/FM tuner with 2x oversampling. Features 30-selection programmable memory; 3-beam laser; accepts 3-in CD's without adaptor. CD: FR 8-20,000 Hz; THD 0.3%; S/N 85 dB; Tape: FR 125-8,000 Hz; S/N 55 dB; W&F 0.18%. 14½ x 3 x 10 in; 5¼ lb. \$350

Portable CD Players

CBM-3000 Portable CD Player

Portable CD player with 2x oversampling and 16-bit D/A converter. Optional FM transmitter and remote control keypad. Features 3-beam laser; anti-shock circuit; headphone jack; line-out jack; DC power input; remote jack for optional remote. 16-track random access programming; track skip, fast forward, headphone volume; intro scan/A-B; memory enter/repeat; memory/keylock; LCD shows total number of tracks, total playing time of disc, track in play, elapsed playing time, and A-B repeat. Frequency response 20-20,000 Hz; S/N 92 dB. 5 x 1½ x 6½ in; less than 3 lb. \$330

CBM-50-CP Portable CD Player

Portable CD player with 2x oversampling; 16-bit D/A converter, clear see-through case. Features 3-beam laser; receives 5- or 3-in discs; anti-shock mechanism. Controls for play/pause, stop, forward/backward skip, repeat and hold. FR 20-20,000 Hz; THD 0.07%; S/N 92 dB. 5 x 1¼ x 5½ in; 7½ lb. \$246

CBM-2200 Portable CD Player

Portable CD player with 2x oversampling; 16-bit D/A converter anti-shock circuit that pauses after shock, then automatically resumes play at point on disc where disrupted. Features 16-track random programming; 3-beam laser; memory clear; memory back-up; skip forward/back; repeat track; auto shut-off; headphone jack with adjustable audio level; inputs/outputs for DC plug, headphone jack; line-out jack; AC adaptor/charger; earbuds; carrying belt; patch cord; rechargeable battery pack. Frequency response 20-20,000 Hz; THD 0.07% at 1,000 Hz; S/N 92 dB. 5½ x 5½ x 1½ in; 1 lb. \$245

CBM-777 Portable CD Player

Portable CD player with 2x oversampling digital filter; 3-beam laser; 13 bit D/A converter; functions include play/pause, stop, forward/reverse, skip, fast forward/reverse, repeat, headphone volume, power; AC adaptor; FR 20-20,000 Hz; THD 0.08%; S/N 80 dB; 5½ x 6¾ x 1¾ in. \$169

CONRAD-JOHNSON

DF1 CD Player/Preamplifier

CD player with preamplifier and digital filtering. CD player features noise-shaping circuitry that yields 16-bit resolution; dual D/A converters. Preamplifier features discrete FET analog circuits with discrete regulated DC power supplies; level control; aux and tape inputs; tape output. CD player: output 1.1 V; FR 5-19,000 Hz ±0.5 dB; hum and noise better than 85dB below 1.0 V; THD <0.25% at rated output. Preamplifier: gain 26 dB; max output 5V;

LIMITED EDITION CD
Free With Purchase Of Any
Car CD Player Or Home 6-Disc
Multi-CD Player By 12/31/89.

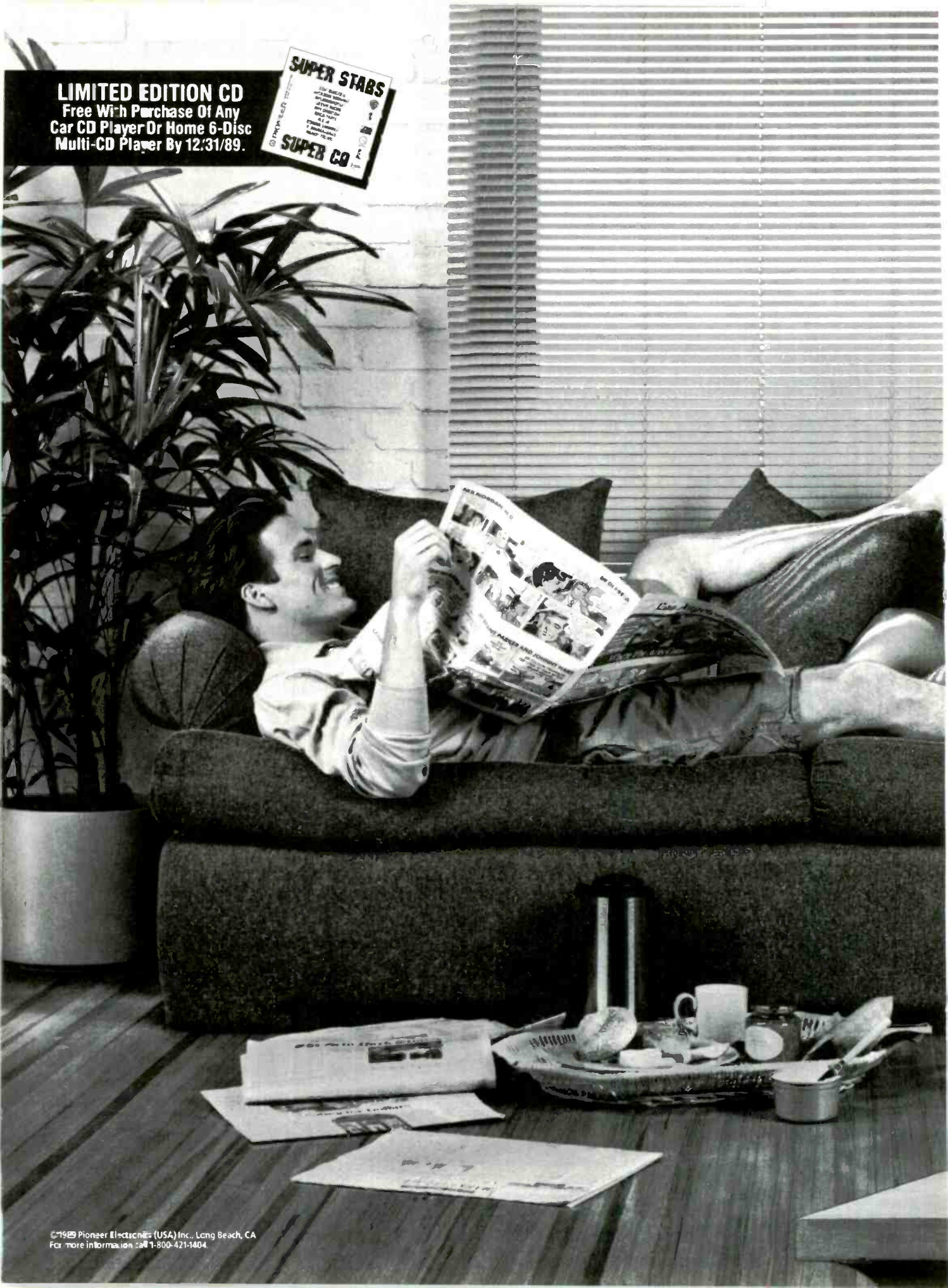

Sunday morning. Time to kick back, get comfortable, and perfect the art of doing absolutely nothing. The ideal companion? Pioneer's new PD-M710 six-disc CD player. Now you can enjoy up to six hours of your favorite music without lifting a finger.

The secret is Pioneer's innovative six-disc magazine format. It works in both Pioneer home and car multi-play systems and allows you to catalog and store your favorite CD's. And it even features Non-Repeating Random Play, which is like having your own computerized disc jockey.

All of which means you can spend less time changing your music and more time enjoying it. But don't wait for the weekend.

PIONEER

We Bring The Revolution Home.

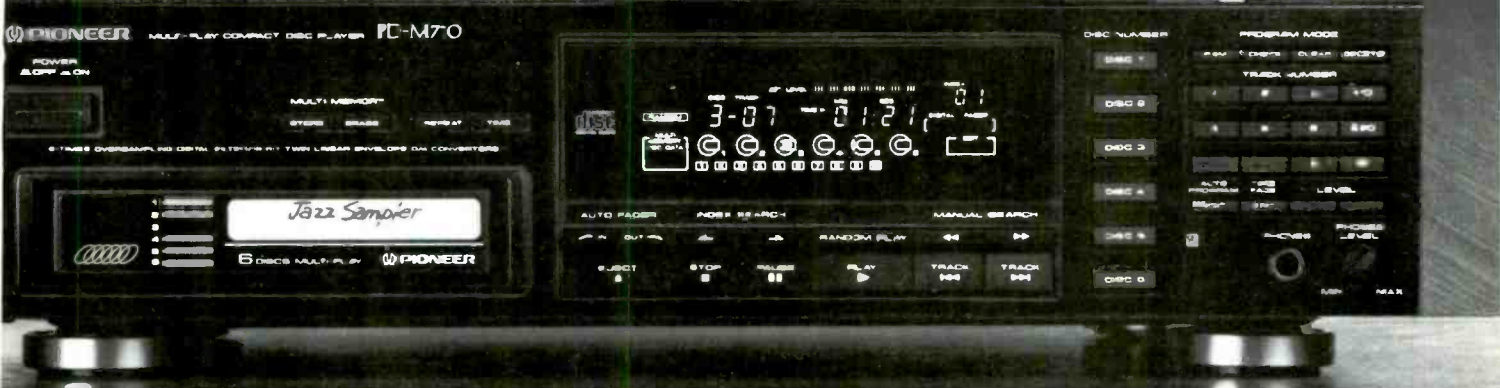

COMPACT · DISC · PLAYERS

frequency response 5->100,000 Hz; hum and noise better than 82 dB below 1.0V output; THD >0.25% at rated output. 2-year limited warranty. 19 x 3 3/4 x 12 in; 19 lb \$1,385

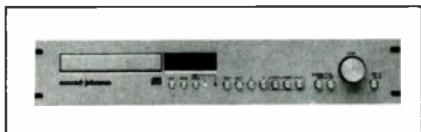

Conrad Johnson CD Player/Line Preamp

CROWN

CD-70 CD Player

3-beam laser pickup. Dual-mode track repeat; headphone jack. AC operation only. \$200

Portable CD Systems

CD-600 Portable CD System

CD player with 3-beam laser pickup; AM/FM tuner; dual cassette decks. Features 16-program memory; repeat all tracks or one; pause control; high speed dubbing; autoreverse; built-in mic; headphone jack; timer and remote. AC or 8 D batteries. 24 x 8 x 9 in; 13 3/8 lb. \$399
CD-500. As above, with 3-in CD adaptor; no timer; no remote. 28 x 5 x 7 in. \$360
CD-270. As above with 3 band graphic EQ; single cassette; no adaptor. 22 x 6 1/2 x 6 1/2 in. \$360
CD-300. As above, with skip function; balance control. 22 x 6 x 6 in; 8 3/8 lb \$326
CD-250. As above, no random program, skip function, balance control, graphic EQ. \$300

Portable CD Player

CD-10 Portable CD Player

CD player with 3-beam laser pickup. Features auto-power-off; battery indicator. Skip, pause, search, and random play functions; headphone jack. Comes with AC adaptor or rechargeable battery. 3 3/4 x 1 1/2 x 3 7/8 in; 0.63 lb. \$419

DENON

DCD-3520 CD Player

8x oversampling and dual 20-bit super-linear D/A converters. Features MSB; LC-OFC analog filter; optical isolator; 5-independent power supplies; separate digital and analog circuits; bulk molding compound pickup chassis; digital-output terminal; optical digital output terminal. Headphone jack; 20-track random programming; 10-key direct selection; index search; time search; repeat function; auto space; timer play; remote control; emphasis display; 8-digit FL display \$1,500

DCD-1520 CD Player

8x oversampling and dual 20-bit super linear D/A converters. Features MSB; OFC analog filters; optical isolation between digital and analog stages; pickup chassis made of non-resonant bulk molding compound; dual-construction chassis. Optical and coaxial digital outputs; 20-track programmability with normal and program random play; remote volume control; headphone jack with level control; direct track access; index/time search; 3-way repeat; auto space/edit; timer play; 8-digit FL display with music calendar; direct play of 3-in CD's. Includes Denon Integral System remote control for control from Denon IS receivers and preamps. FR 2-20,000 Hz \pm 0.2 dB; S/N 115 dB \$750

CDC-1420 CD Player

8x oversampling and dual 20-bit super linear D/A converters. Features MSB; OFC analog filters; optical isolation between digital and analog stages; isolated pickup chassis. Optical and coaxial digital outputs; 20-track programmability with normal and program random play; remote volume control; headphone

jack with level control; direct track access; index search; 3-way repeat; auto space/edit; timer play; 8-digit FL display with music calendar; direct play of 3-in CD's. Includes Denon Integral System remote control for control from Denon IS receivers and preamps. FR 2-20,000 Hz \pm 0.2 dB; signal-to-noise ratio 108 dB \$600

DCD-920 CD Player

8x oversampling and dual 20-bit super-linear D/A converters. Features pickup with floating suspension. Variable analog output; auto edit; auto space; 20 selection music calendar; compatible with 3-in CD's; 2 modes of random playback; program random play; display track number, playing time, total tracks, total playing time, total remaining time, and index number. Includes remote control. FR 2-20,000 Hz; S/N 106 dB; total harmonic distortion 0.0035%. 4 x 17 1/8 x 12 3/8 \$499

DCD-820 CD Player

20-bit, 8x oversampling digital filter and dual 16-bit super-linear D/A converters. Features MSB; noise shaping; active analog filters; isolated pickup-up chassis. Coaxial digital output; 20-track programmability with normal and program random play; remote volume control; headphone jack with level control; direct track access; index search; 3-way repeat; auto space/edit; timer play; 8-digit FL display with music calendar; direct play of 3-in CD's. Includes Denon Integral System remote control for control from Denon IS receivers and preamps. Frequency response 2-20,000 Hz \pm 0.2 dB; signal-to-noise ratio 102 dB. \$400

DCD-620 CD Player

20-bit, 8x oversampling digital filter and dual 16-bit super-linear D/A converters. Features MSB; noise shaping; active analog filters; isolated pickup-up chassis. 20-track programmability with normal and program random play; headphone jack with level control; direct track access; 2-way repeat; auto space/edit; timer play; 6-digit FL display with music calendar; direct play of 3-in CD's. Includes Denon Integral System remote control for control from Denon IS receivers and preamps. FR 2-20,000 Hz \pm 0.2 dB; S/N 100 dB \$300

DCD-520 CD Player

4x oversampling and dual 16-bit super-linear D/A converters. Features MSB; isolated pickup-up chassis. Coaxial digital output; 20-track programmability; headphone jack; direct track access from 10-key remote; auto space; 6-digit FL display; direct play of 3-in CD's. FR 2-20,000 Hz \pm 0.2 dB; signal-to-noise ratio 98 dB \$250

CD Changers

DCM-777 CD Changer

6-disc magazine with 8x oversampling and dual 20-bit super linear D/A converters. Features MSB; optical isolation between digital and analog stages; isolated pickup-up chassis. Optical and coaxial digital outputs; 32-selection programmability with normal, program, and disc sequential random play; remote volume control; headphone jack with level control; direct track access; 3-way repeat functions; timer play; 7-digit FL display. Includes Denon Integral System remote control for control from Denon IS receivers and preamps. Optional magazines for 3-in CD's. FR 2-20,000 Hz \pm 0.2 dB; signal-to-noise ratio 103 dB \$700

DCM-555II CD Changer

6-disc magazine CD changer with 4x oversampling. Features super linear real-time D/A converters. 32-selection program play; continuous playback of all 6 discs; full random play; program random play; disc sequential random play. Includes full function remote control. FR 2-20,000 Hz; S/N 98 dB; total harmonic distortion 0.004%. 4 1/2 x 17 1/8 x 14 1/8; 13.25 lb. \$550

Portable CD Player

DGP-100 CD Player

8x oversampling and dual 16-bit super linear D/A converters. Features shock-mounted pickup chassis; 32-track programmability; headphone and line output jacks; repeat modes; LCD display; direct play of 3-in CD's. Includes soft carrying case, stereo connecting cable, and rechargeable battery. Optional second battery for 4 hrs of playing time. FR 2-20,000 Hz \pm 0.2 dB; S/N 90 dB \$399

DISCRETE TECHNOLOGY

LSI MKV Signature CD Player

4x oversampling and two 16-bit D/A converters. Features 3 power supplies: 1 main inboard supply operates the digital and transport circuitry assemblies. 2 main outboard power supplies operate L/R ch analog circuitry; 2 fixed analog outputs; 1 fixed analog input; 3 Powerbridge III AC line cables; programmable remote. Frequency response 2-20,000 Hz; THD 0.001% at 1,000 Hz; S/N better than 103 dB. 16 1/2 x 4 1/8 x 14 1/4 in; 35 lb \$4,000

LSI MKV CD Player

4x oversampling and two 16-bit D/A converters. Features 3 power supplies: 1 main inboard supply operates the digital circuitry. 2 main outboard power supplies operate L/R ch analog outputs; 3 Powerbridge III AC line cables; digital output jack; headphone output jack. Includes programmable remote. Frequency response 20-20,000 Hz; THD 0.001% from 20-20,000 Hz; signal-to-noise ratio 103 dB from 20-20,000 Hz. 16 1/2 x 3 3/4 x 11 in; 20 lb \$3,500

LS I Mark III CD Player

Front-loading CD player with remote-controlled programming. Features FTS; digital output and headphone jacks; dual 16-bit D/A converters; 4x-oversampling digital filter; CIRC; 1-beam laser; frequency response 20-20,000 Hz; dynamic range 120 dB; S/N 100 dB; ch sep 100 dB; THD .003%; IM .0033%. 16.5 x 3.2 x 11.03 in; 6.8 lb. \$1,195

LS I Mark IV. As above with external power supply \$1,495

DUAL

CD 5070 CD Player

CD player with 3-beam pickup and 2x-oversampling digital filter. Features 16-bit D/A converter; gold-plated connectors; 16-track random-access programming; 12-function remote; headphone jack with adjustable level. Frequency response 5-20,000 Hz; total harmonic distortion 0.006%; dynamic range >95 dB; signal-to-noise ratio 94 dB (A wtd). 18 1/8 x 12 1/8 x 3 3/8 in; 10.5 lb \$450

EMERSON

AC2503 Portable CD System

Programmable CD player with AM/FM radio and cassette recorder with CD output jacks. Features 2-way speaker system; 3-in CD compatible; built-in condenser mic.. 20-track programming; 5-band graphic EQ; LCD shows track number, elapsed time, program number. 22 x 7 x 8 in \$280

FISHER

CD Changer

DAC199B CD Changer

5-disc capacity with 8x oversampling, 18-bit digital filter and dual 16-bit D/A converters. Features 32-selection programmability; 31-function wireless remote; selection memory and title file memory; 3-in CD compatibility; random play; intro scan; scan, skip, repeat functions; headphone jack with volume control. signal-to-noise ratio > 90 dB; ch sep> 80 dB; total harmonic distortion < 0.07% at 1,000 Hz. 17 3/8 x 5 3/8 x 11 7/8 in; 12.1 lb. Black \$400

COMPACT • DISC • PLAYERS

CD Players

AD752 CD Player

8x oversampling 18-bit digital filter and dual 16-bit D/A converters. Features 20-selection programmability; 1/all repeat; editing button; scan/search; 3-in CD compatibility. Includes 25-function wireless remote. Signal-to-noise ratio > 90 dB; ch sep > 80 dB; total harmonic distortion < 0.07% at 1,000 Hz. 17 $\frac{3}{8}$ x 3 $\frac{3}{8}$ x 11 in; 8.4 lb \$320

AD751 CD Player

8x oversampling 18-bit digital filter and dual 16-bit D/A converters. Features 20-selection memory; introscan; indexing; random play; 3-in CD compatibility. Includes 6-function wireless remote. Signal-to-noise ratio > 90 dB; ch sep > 80 dB; total harmonic distortion < 0.07% at 1,000 Hz. 17 $\frac{3}{8}$ x 3 $\frac{3}{8}$ x 10 $\frac{3}{8}$ in; 8.4 lb \$300

CD Portable Systems

PHD850 Portable CD System

Portable CD system with 19-function remote control. Features 25-selection programmability; surround sound; double cassette deck with high-speed dubbing; autoreverse in deck 1 and 2; full logic controls; Dolby NR; detachable 3-way bass reflex speakers; 4-band graphic EQ; 3- and 5-in CD compatibility; quartz clock/timer; right and left rec indicators; AC/DC operation. \$800

PHD815 Portable CD System

Portable CD system with AM/FM PLL digital synthesis stereo tuner. Features detachable 2-way speaker system; double cassette recorder with autoreverse; high-speed 1-touch synchro dubbing; surround-sound circuitry; Dolby NR; 16-selection programmability; 5-band graphic EQ; quartz digital clock and timer; 3- and 5-in CD compatibility; CD output jacks; AC/DC operation. \$460

PHD800 Portable CD System

Portable CD system with double cassette recorder and autoreverse. Features detachable 2-way speaker system; AM/FM stereo tuner; high-speed 1-touch synchro dubbing; surround-sound circuitry; 16-selection programmability; 4-band graphic EQ; 3- and 5-in CD compatibility; CD output jacks; AC/DC operation. \$400

PHD700 Portable CD System

Portable CD system with surround-sound circuitry. Features detachable 2-way speaker system; AM/FM stereo tuner; single cassette recorder; 16-selection programmability; 3-band graphic EQ; 3- and 5-in CD compatibility; CD output jacks; AC/DC operation. \$350

GOLDSTAR

GCD-64R CD Player

CD player with 3-beam laser pickup and linear-skating loading mechanism. Features full-function remote control; 20-track programming; shuffle play; music search; auto repeat; headphone jack; display showing elapsed/total time, track number, repeat and memory. \$300

PCD-N7 Portable CD System

Self-contained AM/FM radio, cassette recorder, and CD player. Features 2 full-range speakers; 16-track CD programming; 3-in CD compatibility; CD-out and headphone jacks. Operates on AC or DC power. \$250

GCD-613 CD Player

CD player featuring 9-track programming; repeat disc/program; forward/reverse scan; total/elapsed time, track number display. Frequency response 5-20,000 Hz \pm 1.5 dB; THD 0.03%; dynamic range 90 dB; S/N 90 dB (@ 1,000 Hz). 13 $\frac{1}{2}$ x 3 $\frac{1}{2}$ x 11 in; 8.8 lb \$210

HARMAN KARDON

HD7600 CD Player

CD player with pulse-width modulated bit-stream D/A converter operating @ 33.8 MHz to improve linearity and low-level accuracy. Features 3rd-order analog filter to improve S/N; discrete-component buffer stage, differential amp, and low-pass filter; separate transport, analog, and digital power supplies; 3-beam laser pickup; optical and coaxial digital input/output. 27-key remote control with intro scan and autospace; music calendar; A/B repeat; audible 2-speed cue and review; output-level controls; fixed and variable analog outputs; headphone jack. Frequency response 4-20,000 Hz \pm 3 dB; THD 0.003%; S/N 106 dB; dynamic range 96 dB; ch sep 95 dB; overall linearity within 0.02 dB @ -90 dB. \$599

HD7500. Same as above without optical and coaxial digital input/output \$449

HD7400 CD Player

4x oversampling and dual 18-bit D/A converters. Features sample-and-hold processor; discrete analog-output section; direct coupling from D/A to audio output jacks; separate transport, analog, and digital power supplies; 3-beam laser pickup. 36-track programming; audible 2-speed cue and review; display shows track/program number and elapsed time or total number of tracks, total time, and time remaining; 19-key remote. Frequency response 4-20,000 Hz \pm 0.02 dB; THD 0.008%; S/N 100 dB; dynamic range 96 dB; ch sep 88 dB. \$349

HD7300. Same as above w/out remote control \$299

HEATH

ADW-2530 CD Player

CD player with 3-beam laser optical head and discrete analog output section. Features sample-and-hold processor; 36-track programmable memory; 2-speed audible cue and review; track and index search; 10-function wireless remote. Frequency response 4-20,000 Hz, \pm 0.5 dB; THD 0.03%; S/N 103 dB; ch sep 83 dB. 17 $\frac{1}{2}$ x 3 $\frac{3}{8}$ x 10 in; 11 lb. \$349

HITACHI

CD Players

DA007SW CD Player

Features digital filter; separate digital and analog circuitry; 3-beam laser pickup; anti-vibration floating mechanism. 10-key direct random access on remote and main unit; 15 program random playback; index search; headphone volume control. Includes remote control. Aluminum finish. Rosewood ends. Dynamic range 95 dB; THD 0.003%; S/N 95 dB \$320

DA8200SW CD Player

Features oversampling digital filter; 3-beam laser pickup; vibration-free floating suspension; 24-program track search system; random play; 4-way repeat; FL display. Includes remote control. Rosewood end caps. \$280

DA6500 CD Player

Features floating suspension system; 24-program random memory; random play; skip search; 4-way repeat; scan automatically samples the first 10 seconds of each track; index search; 2-speed manual search \$170

DA7000 CD Player

Features floating suspension system; 24-program random memory; skip search; 4-way repeat; index search; 2-speed manual search; timer play. \$170

CD Changers

DAC-70SW CD Changer

Twin cartridge CD changer with 2 six-disc magazines. Features oversampling digital filter. Direct program remote with volume; independent maga-

zine/disc exchange; 32-program random memory track search; direct, random, scanner, and repeat play; skip/manual search; real time counter; track time counter; programmable timer; sleep timer; resume play standby; clock. Rosewood end caps. Dynamic range 95 dB; total harmonic distortion 0.004%. \$550

JVC

CD Players

XLZ555BK CD Player

CD player with 4x oversampling, dual D/A converters, and 3-beam laser pickup. Features optical/coaxial digital outputs; double-floating independent suspension system; optical noise reduction; 2 analog outputs. Random-access programming of up to 32 tracks; random play; disc/track title indication; 3-in CD compatibility; auto/multi-disc editing key; 5-way repeat with A/B; index play; skip; search; auto/manual search; remote control with volume control and numeric keypad; intro scan; headphone jack with adjustable level; fluorescent display; disc title memory. \$490

XLZ444BK CD Player

CD player with 4x oversampling, dual D/A converters, and 3-beam laser pickup. Features coaxial digital output; Opticalink noise reduction; independent suspension system. 32-track random-access programming; random play; 3-in CD capability; auto-editing key; auto/manual search; headphone jack with adjustable level; FL display; remote control with numeric keypad; intro scan; 5-way repeat with A/B \$330

XLV222BK CD Player

CD player with auto/manual editing key. Features multi-function FL display; 3-beam laser pickup; independent suspension system; repeat track, disc, and program; auto/manual search; headphone jack; double-oversampling digital filter; 3-in CD capability; 32-track random-access programming. \$255

CD Changers

XL1600BK CD Changer

CD changer with 6-disc magazine section and auto-loading single-play drawer. Features magazine/disc title indication with message and program memory; repeat all tracks, single track, and programmed tracks; random play; auto/manual search; multi-function FL display; timer play; 3-beam laser pickup; independent suspension system; remote control with numeric keypad; 32-track programming; headphone jack; 2x-oversampling digital filter \$560

XL1400BK CD Changer

CD changer with 6-disc capacity and wireless remote control. Features 3-beam laser pickup; 2x-oversampling digital filter; independent suspension system; 32-track random-access programming; random play; repeat all program, and track; random play; auto/manual search; multi-function FL display; 6-disc magazine \$430

XL1300BK. As above, no remote control. \$380

Portable CD Systems

PC-X300 Portable CD System

Combination CD player with double cassette deck. CD section features 20-track program play; synchro start recording; 3-in CD compatibility. Cassette features synchro start high-speed dubbing; relay play; Dolby B NR; metal compatibility. Other features: powered subwoofer; 15 FM and 5 AM presets with multi-color display; 5-band graphic equalizer; detachable speakers with 4-in cones. 3.5 W/ch min rms into 8 ohms from 300-15,000 Hz, and for subwoofer 12 watts min rms into 4 ohms from 50-150 Hz, both with <10% total harmonic distortion; AC/DC power source. 26 $\frac{1}{2}$ x 9 $\frac{3}{8}$ x 9 $\frac{3}{8}$ in; 18.3 lb \$550

COMPACT • DISC • PLAYERS

PC-X200 Portable CD System

Similar to above with single-well deck and subwoofer with 9 watts min rms into 4 ohms from 30-180 Hz, with <10% THD. \$400

RC-X510 Portable CD System

Combination CD player with double cassette deck. CD section features 20-track program play; synchro start recording; 3-in CD compatibility. Cassette features synchro start high-speed dubbing; relay play; metal compatibility; 1-touch recording. Other features: powered subwoofer; AM/FM tuner; 3-band graphic EQ. 2.0 W/ch min rms into 6 ohms from 300-15,000 Hz, and for subwoofer 6 watts min rms into 8 ohms from 60-150 Hz both with <10% total harmonic distortion. \$330

RC-X3 Portable CD System

Combination CD player, AM/FM stereo tuner, double autoreverse cassette deck, amplification, and speakers. Features CD synchro-start recording; continuous record; high-speed tape-to-tape dubbing; two 4 $\frac{3}{4}$ -in full-range speakers; 3-beam laser pickup; 22-track random-access programming; repeat play; intro scan; search; mic and headphone outputs; automatic record level with variable monitor. \$330



JVC PC-X200

KENWOOD

All Kenwood CD players and changers except models DP-M98 and DP-48, feature the Digital Pulse Axis Control (DPAC) system to reduce jitter.

CD Players

DP-8010 CD Player

8x oversampling and dual 18-bit D/A converters. Laser pickup features linear motor mechanism with low center of gravity; optical and coaxial digital outputs; multi-point vibration insulation; remote control with volume; random track memory; 20-track direct access. Frequency response 4-20,000 Hz; signal-to-noise ratio 112 dB; total harmonic distortion >0.0015% @ 1,000 Hz. 17 $\frac{1}{4}$ x 4 $\frac{3}{4}$ x 14 $\frac{1}{2}$ in; 21.2 lb. \$650

DP-7010 CD Player

8x oversampling and dual 18-bit D/A converters. Features optical and coaxial digital outputs; multi-point vibration insulation; remote control with volume; random track memory; 20-track direct access. Frequency response 4-20,000 Hz; S/N 108 dB; total harmonic distortion > 0.0025% @ 1,000 Hz. 17 $\frac{1}{4}$ x 4 $\frac{3}{4}$ x 12 $\frac{1}{2}$ in; 13 lb. \$449

DP-3010 CD Player

8x oversampling and dual 16-bit D/A converters. Features computerized CD editing; remote control; random play; 20-track direct access; headphone output with volume control. Frequency response 10-20,000 Hz \pm 1 dB; S/N 100 dB; total harmonic distortion > 0.007% @ 1,000 Hz. 17 $\frac{1}{4}$ x 4 $\frac{1}{2}$ x 10 $\frac{1}{4}$ in; 8.4 lb. \$349

DP-2010 CD Player

4x oversampling and dual 16-bit D/A converters. Features remote control; random track memory; random play; 10-track direct access; headphone output. Frequency response 10-20,000 Hz \pm 1 dB; S/N 100 dB; THD >0.008% @ 1,000 Hz. 17 $\frac{1}{4}$ x 4 $\frac{1}{2}$ x 10 $\frac{1}{4}$ in; 8.4 lb. \$279

CP-1510 CD Player

4x oversampling and dual 16-bit D/A converters. Features remote control; random play; 10-track direct access; headphone output. Frequency response 10-20,000 Hz \pm 1 dB; S/N 100 dB; THD >0.008% @ 1,000 Hz. 17 $\frac{1}{4}$ x 4 $\frac{1}{2}$ x 10 $\frac{1}{4}$ in; 8.4 lb. \$249

CD Changers

DP-M6010 CD Changer

8x oversampling, dual 16-bit D/A converters, and 6-disc magazine/single CD tray. Features computerized CD editing; one-touch disc selection; remote control; random play; 10-track direct access; FL display with music calendar and disc indicator. Frequency response 10-20,000 Hz \pm 1 dB; S/N 102 dB; THD >0.006% @ 1,000 Hz. 17 $\frac{1}{4}$ x 4 $\frac{3}{4}$ x 13 $\frac{7}{8}$ in; 15 lb. \$449

DP-M4010 CD Changer

4x oversampling, dual 16-bit D/A converters, and 6-disc magazine. Features one-touch disc selection; remote control; random play; FL display with music calendar and disc indicator. Frequency response 10-20,000 Hz \pm 1 dB; S/N 98 dB; THD >0.007% @ 1,000 Hz. 17 $\frac{1}{4}$ x 4 $\frac{1}{2}$ x 13 $\frac{1}{2}$ in; 5.5 lb. \$349

DP-48 CD Player

4x oversampling and dual 16-bit D/A converters. Features 20-track programming; timer playback; FL display. \$199

Portables CD Players

DPC-80 Portable CD Player

4x oversampling, digital output, and remote control. Features 24-track programming, search; skip/repeat; 4-hr operation with rechargeable battery. FR 20-20,000 Hz \pm 1 dB; S/N 90 dB; THD >0.01% @ 1,000 Hz. 5 $\frac{1}{8}$ x 1 $\frac{1}{8}$ x 5 $\frac{7}{8}$ in; 0.88 lb. \$449

DPC-60 Portable CD Player

2x oversampling and remote control. Features track/disc repeat; illuminated play key. Frequency response 20-20,000 Hz \pm 1 dB; S/N 90 dB; THD >0.08% @ 1,000 Hz. 5 $\frac{1}{4}$ x 1 $\frac{3}{8}$ x 6 $\frac{1}{8}$ in; 0.88 lb. \$299

Spectrum Series

DP-M98 CD Changer

4x oversampling, dual 16-bit D/A converters, and 6-disc magazine. Features 32-track programming; 10-track direct access; audible track search; repeat track/disc; timer playback. \$329



Kenwood DP-M6010

KINERGETICS

KCD-40 Gold Series CD Player

8x oversampling digital filter, 4 D/A converters, and 1-beam laser pickup. Features spring-isolated transport; patented hysteresis distortion cancelling circuit; no capacitors in signal path; servo loop used for eliminating DC offset. Program memory from 226 discs; volume and balance controls; 19-in rack mount. 19 x 3 $\frac{3}{4}$ x 12 $\frac{3}{8}$ in; 15 lb. \$1,995
KCD-20BR. As above, dual D/A converters and 4x oversampling. \$1,195

KRELL

MD-1 CD Player

Top-loading CD turntable with custom-designed toroidal transformers and 2-stage regulation limit.

Features Philips single-beam CDM-3 swing arm motor drive mechanism and glass lens; 4-point suspension with solid-aluminum components and base play; optical and coaxial outputs. \$4,000



Krell MD-1

LUXMAN

All CD players and changers have input and output jacks for Luxman's integrated-system remote control and carry a 5-year parts and labor warranty.

D-105U Hybrid CD Player

8x oversampling and dual 18-bit D/A converters. Features BRID hybrid-circuit design using twin-triode vacuum tube amplification in analog output stages; Duo-Beta dual feedback-loop amp circuitry to widen bandwidth and improve transient response; optical and coaxial digital outputs; metal chassis and component shielding; high-mass magnetic disc clamp; 3-beam laser pickup. 32-track programming; random play; auto edit/fade-out for CD taping; auto scan/pause; timer/power-off memory; 9-key remote control. FR 5-20,000 Hz, \pm 1 dB; THD 0.05%; S/N 105 dB; dynamic range 92 dB; ch sep @ 1,000 Hz 90 dB. 17 $\frac{1}{4}$ x 5 $\frac{1}{2}$ x 13 $\frac{1}{2}$ in; 18.7 lb. \$1,200

DC-113 CD Changer

8x oversampling, dual 16-bit D/A converters, 6-disc magazine, and single-CD tray. \$680

D-113D CD Player without D/A Converter

CD player with no D/A or analog circuitry. Designed for use with digital-direct amplifiers. Features optical and coaxial digital outputs; 3-beam laser pickup; high-density magnetic disc clamp. 16-track programming; 10-key direct access; 9-key remote control; fast-scan, skip, pause, and repeat buttons; multi-function display. Performance specifications depend on amplifier used. 17 $\frac{1}{4}$ x 3 $\frac{3}{8}$ x 12 $\frac{3}{8}$ in; 9.7 lb. \$550

DZ-112 CD Player

8x oversampling and dual 18-bit D/A converters. Features Duo-Beta dual feedback-loop amp circuitry to widen bandwidth and improve transient response; coaxial digital output; metal chassis and component shielding; high-mass magnetic disc clamp; 3-beam laser pickup. 32-track programming; random play; auto edit/fade-out for CD taping; auto scan/pause; timer/power-off memory; 9-key remote control. Frequency response 5-20,000 Hz, \pm 0.5 dB; THD 0.005%; S/N 106 dB; dynamic range 96 dB; ch sep @ 1,000 Hz 100 dB. 17 $\frac{1}{4}$ x 3 $\frac{3}{8}$ x 12 $\frac{1}{4}$ in; 10 lb. \$500



Luxman DZ-111

DZ-111 CD Player

4x oversampling and dual 16-bit D/A converters. Features Duo-Beta dual feedback-loop amp circuitry to widen bandwidth and improve transient response; coaxial digital output; metal chassis and component shielding; high-mass magnetic disc clamp; 3-beam laser pickup. 32-track programming; random play;

A REAL WORLD GUIDE TO CD PLAYER TECHNOLOGY



ONKYO[®]

A Real World Guide to CD Player Technology

Introduction

In theory, Compact Disc technology is surprisingly simple.

A disc stores information in the form of 16 bit digital words (16 consecutive "0s" or "1s"). This information can be reproduced through conversion of those 16 bits into what is called the analog domain by using a device called a digital-to-analog (D/A) converter. An output filter then removes unwanted ultrasonic frequencies inherently produced by the digital process.

However, the engineering methods now used to accomplish these tasks require sophisticated devices called digital filters in addition to the D/A converters mentioned above. As is unfortunately typical of most new technology, explanations of both operation and their significance have created substantial misconceptions. Onkyo thinks it is time to clear the air, and we have prepared this practical guide to

digital technology so you'll be equipped to survive the digital jungle!

We think you'll find the following information useful, relevant, and even enjoyable.

We'll explain the operation of digital filters: what they do, what various digital word lengths really mean, and why a CD player with "18 Bit" on the front panel may not be an 18 bit player at all!

We'll also cover the little understood but critically important concept of LINEARITY in the D/A conversion process and finish with some words of caution for those of you who may think that the recently introduced 1-bit conversion systems herald a new digital dawn.

A few words about the CD format and sampled waveforms

The Compact Disc format specifies that audio data be stored on the disc at the rate of 44,100 16-bit words for every second of music. And that's only for one channel! In addition to the musical information, other data relating to arcane subjects like EFM demodulation, synchronization, error correction codes, etc., adds to the constant flow of information off the disc. In fact, the optical pickup of every CD player reads data from a disc at an almost unbelievable rate of 4.3218 million bits per second!

In a perfect world, it should be relatively simple to convert each channel to an analog audio signal, to be amplified and applied to loudspeakers. However, the digital world is not perfect, despite what you might have heard.

Two important obstacles must be addressed by the CD player's circuitry.

First, D/A converters are not perfect. Only a perfect 16-bit converter could completely reproduce the 16-bit audio data and the laws of physics, at least as we now understand them, dictate that such converters cannot exist. Thus, truly accurate conversion is a painstaking process and care must be taken to provide as accurate

a conversion as possible. As we shall see, this may include use of individually calibrated linear 18-bit converters.

Secondly, sampled analog signals, such as those present at the output of a D/A converter, contain a large amount of ultrasonic information generated by the digital process itself. This extraneous high frequency data, definitely not part of the original audio signal, is potentially harmful to other high fidelity components and must be suppressed in some way before the signal passes "downstream."

Where does this unwanted information come from? The following will give you a good conceptual understanding:

Digital recording begins with a process called "sampling," in which the original musical waveform

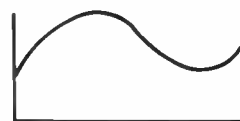

Analog waveform

is divided, or sampled, many times a second. (This

process is remarkably similar to cutting a loaf of bread into many individual slices.) In the case of a CD, each channel of the stereo musical signal is sampled, or divided, 44,100 times each second. That's what a "sampling rate" of 44.1kHz really means.

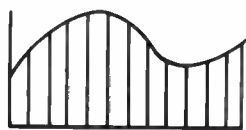

Sampling

Each "slice" of music, then, becomes a separate entity, which can be easily handled by the digital process. The result looks something like this ---

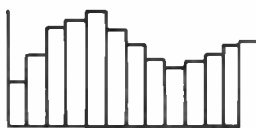

Samples

The next step is called "quantization," and involves assigning a numerical value to each of these samples. Quantizing simply substitutes 16 "0s" and "1s" (called a digital "word") in a very precise order corresponding to the original measured value of each sample. Think of weighing each slice of bread on a scale and writing the result in a notebook.

Unfortunately, the quantization process is only an approximation and is much like the quandary you would face if your slice of bread weighed 1.26 ounces but you were told to put it in either a "1 ounce" or "1.5 ounce" wrapper. Specifically, the CD standard allows for 65,536 different quantization possibilities but not every sample precisely "fits" where the digital system says it should. The resulting differences generate "quantization noise," which manifests itself as the spurious high frequency information mentioned above.

A closer look reveals the identity of these high frequency noise bands. They are images of the original audio signal repeated at multiples of the sampling frequency.

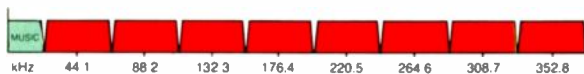

 = Unwanted Quantization Noise Images

In the case of the CD format, these quantization noise bands are centered at 88.2 kHz, 132.3 kHz, 176.4 kHz,

220.5 kHz, etc. This occurs in any digital audio product and is a natural consequence of using sampled waveforms. Even though these frequencies are well above the highest humanly audible frequency, they could interfere with an analog tape recording by "beating" against a bias oscillator, or affect stereo radio transmission. In addition, they could cause harmful instability (called oscillation) in an amplifier or even burn out the tweeter in a loudspeaker system.

First generation CD players

Basic CD Player

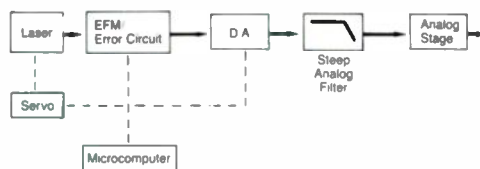

used a "brickwall" analog filter after the D/A converter to eliminate these frequencies. Although very effective in removing the unwanted noise bands before they could potentially cause damage, these very abrupt filters were not very kind to the music as it passed through.

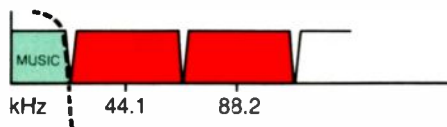

Besides being bulky and expensive to build, these filters drift with age, and they have a negative affect on audio quality because of subtle variations on frequency response and not-so-subtle effects on the phase relationships of higher musical frequencies.

To combat this problem, later generation players employed a digital filter in addition to the analog filters.

Oversampling CD Player

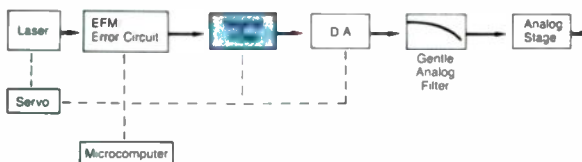

Although digital filters perform a similar function, they operate in the digital domain instead of the analog domain and this has led to a number of widespread misconceptions.

The truth about Digital Filtering and Oversampling

As we've seen, all sampled waveforms contain extraneous high frequency information called quantization noise bands or images. Although these can be removed from the final analog waveform with just an analog filter, there is a more clever way—a supplemental digital filter.

A digital filter is a fast but not very versatile computer. It takes the stream of digital words from the CD and calculates additional digital words which it inserts between the original ones from the disc. The filter does this through what is really an elementary series of high speed multiplications and additions—precisely the kind of relatively mindless number crunching that computers are good at.

This high speed creation of new digital words is called "oversampling" because the filter creates additional digital words, or samples, where none existed before.

If this drawing represents the digitized samples from the disc—



then this represents the result of a "2 times oversampling" digital filter which produces twice as many samples as existed originally.



A 4 times oversampling filter, twice as fast as a 2 times design, produces samples as follows.



A digital filter, then, processes audio data while still in digital form before it is reconstructed as an analog waveform. The major advantage is that the digital filter's computation shifts the unwanted noise bands higher in frequency and consequently further away from the music. As you can see from the following drawing

2x Oversampling Digital Filter

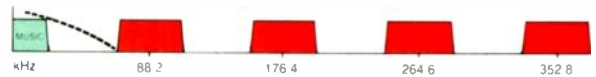

4x Oversampling Digital Filter



8x Oversampling Digital Filter



the faster the filter's operating speed, the further away the noise bands will be and progressively less radical analog filters are required to protect the rest of the high fidelity system from the potentially harmful effects of the quantization noise bands.

Thus, the real burden of filtration shifts from the analog domain to the digital domain, where it can be done more easily, more accurately, and with little or none of the sonic problems associated with steep slope analog filters.

Some common misconceptions about Digital Filters

Unquestionably, digital filters represent a great improvement over the use of analog filters alone. However, their performance must be kept in perspective, and the extent of their advantages understood.

A digital filter solves the problem of noise bands by fooling Mother Nature. **However, a digital filter does not, in theory, affect the audio signal at all, either in terms of its accuracy or fidelity. A good digital filter strives to leave the audio data unaffected.**

The idea that a so-called 18-bit digital filter alone represents an advantage is a misconception. In fact,

the computations performed in every digital filter generate words of perhaps 28 bits or more. As long as the internal calculations are accurate, and a sufficient number of bits is retained after each calculation, **the number of bits output from the filter is not relevant to the fidelity of the output signal. The fact that some manufacturers advertise, for example, 18-bit digital filtering is in itself a meaningless claim.** What is relevant is how those bits are employed AFTER the filter.

D/A conversion architectures

Linear 18 Bit Conversion

As already noted, a 16-bit D/A converter cannot perfectly reproduce the 16-bit audio data from a Compact Disc. Inevitable conversion losses always result in something less than 16 bits of information returning to the analog domain. As explained in an earlier Onkyo white paper, there are several very real advantages in using 18-bit D/A converters to reproduce 16-bit data from a CD. **A linear 18-bit converter can provide a much more accurate reproduction of those 16 bits, hence providing measurably lower noise and distortion in the audio signal.**

Pseudo 18 Bit Methods and Their Limitations

Some manufacturers seek the same benefit through pseudo 18-bit methods. For example, they might use bit switching through a 16-bit D/A converter, or use parallel 16-bit D/A converters. While workable, such designs usually introduce problems. A major hurdle, for example, in a bit-switching system is the high speed analog level adjustment that accompanies the digital bit shifting. These rapid level switches can produce audible glitches or other unwanted anomalies that are totally avoided by true linear 18-bit D/A conversion.

A Comment On 20-Bit Designs

A seemingly logical question must be asked: if 18-bit conversion offers real advantages over 16-bit, doesn't 20-bit offer similar advantages over 18? The answer, surprisingly, is no.

To fully understand this, remember that every compact disc carries information in the form of 16 bit words and that the job of ANY D/A converter is to convert that digital information as accurately as possible. 18-bit conversion, as already described, addresses real world limitations of 16-bit converters **but 20-bit conversion provides no demonstrable benefits because of flaws in its current implementation.**

Right now, no integrated circuit manufacturer supplies a linear 20-bit D/A converter for use in CD players. This lack, caused by several very difficult design and manufacturing considerations, has led some companies to combine 16-bit and 4-bit IC converters, or 18-bit ICs and separate 2-bit discrete circuits, in a so-called 20-bit conversion scheme. However, temperature differences between the two converters often preclude accurate synchronization. In addition, the circuit used to sum the outputs of the different converters adds unnecessary complexity to an already strained design.

D/A conversion (cont.)

20-bit designs do offer a theoretical improvement in signal-to-noise performance, possibly 12 dB better than linear 18-bit conversion designs. But this must be balanced by the fact that ultimate performance depends not on the capabilities of the players but rather on the inflexible 16-bit limitations of the discs themselves. In other words, this theoretical improvement is of little practical value.

As of this writing, 20-bit conversion appears to be more of a marketing statement than an engineering accomplishment. However, the arrival of fully integrated linear 20-bit conversion ICs may well warrant a reconsideration of this opinion in the future.

The real question—D/A conversion linearity

D/A converter accuracy is even more important than the number of bits processed by the D/A converter. **Conversion Accuracy, also known as Linearity, really determines the fidelity of the audio signal.**

A D/A linearity test measures the converter's ability to reproduce various analog signals, particularly less intense ones like soft musical passages, that directly reflect the value of the digital word from the disc. Any deviation, or nonlinearity, results in harmonic distortion in the audio signal.

For example, when a bit changes from 1 to 0, the analog output must decrease exactly by a proportional amount. Of course, the amount that the analog voltage changes depends on which bit has changed. That's because each bit has a different influence on the analog signal. The most significant bit (MSB) accounts for a change in fully half of the analog signal's amplitude, while the least significant bit (LSB) in an 18-bit word represents a very minor amplitude change of less than four parts in a million!

Most good D/A chips include a means to calibrate the converter. This allows the manufacturer to compensate for minor differences between chips that might otherwise cause variations in sound quality.

Some D/A chips offer calibration of the MSB only, while others offer calibration of the four most significant

bits. Because these most significant bits steer the converter's output, proper calibration greatly improves overall accuracy.

This accuracy is most significant at low levels (e.g. quiet musical passages), usually below -60 dB. These non-linearities can easily be heard; for example, an industry standard test disc produced by CBS contains a "fade to silence" test tone. Poor D/A linearity is plainly audible as a pronounced variation in the desired steady decrease in loudness as the tone is being played. Similar problems arise with music but the effects are more subtle because music's constantly changing dynamics tend to mask some of the unwanted variations.

However, although chip designers realize the importance of calibration, apparently some CD player manufacturers do not. Some CD players are not even designed to make use of the calibration pins on the D/A converter chip. Perhaps even worse are the well-documented instances where, despite provision for calibration, some players evidence no attempt at adjustment; during production the calibration is often overlooked or set incorrectly. Many researchers and audio critics have found cases of calibration trim pots simply set in the middle of their adjustment range—a very suspicious alignment.

Linearity measurements

Although the audible effects of non-linearity may be somewhat subtle to some listeners, the results of poorly calibrated D/A converters are plain to see.

The following graphs, all containing information about the accuracy of various D/A converters, were plotted on a sophisticated computer-driven test instrument that shows any inaccuracies as a deviation from an ideal "straight line" response.

For example, the figure below shows a CD player with inaccurate conversion, particularly at levels lower than -60 dB where both channels begin to show considerable nonlinearity.

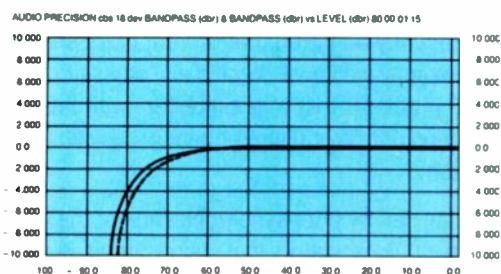

As you can see, a -70 dB signal reproduces at an amplitude of -71 dB, and a -80 dB signal at -84 dB. At -90 dB the nonlinearity is even more considerable. Clearly, this expansion of low level dynamics can alter critical background or ambient sounds that affect our perception of the acoustic environment in which the music was recorded.

The next figure shows another CD player with a different kind of nonlinear output.

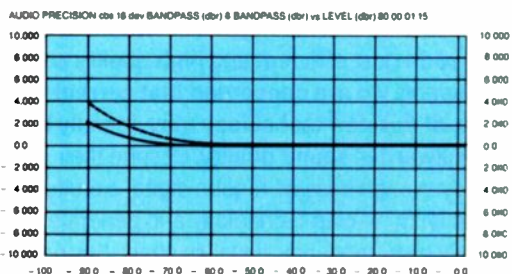

Here, a -70 dB signal reproduces at -69 dB, a -80 dB signal at -79 dB or -78 dB (depending on the channel), and a -90 dB signal at -88 dB or -86 dB (again, depending on the channel). This non-linearity results in compression of low level information. Again, the affect could be audible.

The following figure shows a CD player with extreme nonlinearity problems.

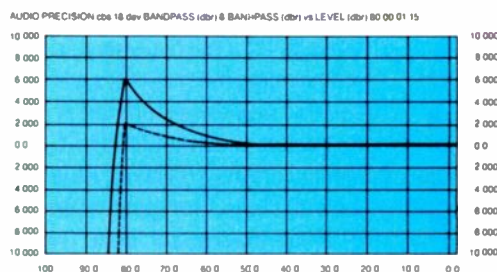

Here, the D/A converter compresses the output signal through -80 dB, then suddenly expands it in a radical manner. Any low level audio waveform reproduces in a highly nonlinear fashion. The resulting distortion could greatly detract from the overall fidelity of music reproduction.

From this, we can easily see that unless the manufacturer is willing to purchase high quality converters and adjust them during production, the results can be highly unpredictable and unsatisfactory. On the other hand, when good converters are individually calibrated using the MSB adjustment described above, the results can be impressive.

For example, the next figure shows the output of a highly linear 18-bit CD player. Although there is a small error at the very low signal level of -90 dB, it is barely measurable and is not audible.

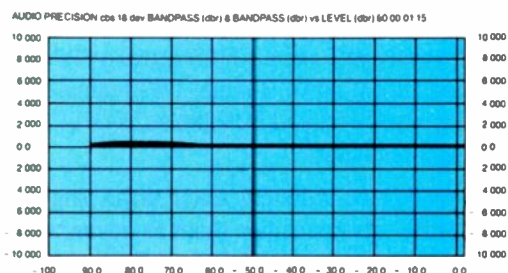

The secret, then, is careful D/A converter selection, and calibration of individual converters in each player. By adjusting the four most significant bits, or the MSB itself, linearity can be greatly improved. Tests show that this also improves the fidelity of the audio signal.

Clearly, the number of bits in a D/A converter is usually not the most relevant measure of its quality. In fact, it is a somewhat artificial way of determining conversion quality. Certainly, an 18-bit converter would be preferable to a 16-bit model, but only if the D/A converter is of high quality and properly calibrated. A poor 18-bit converter can be considerably inferior to a good 16-bit converter. As we have seen, it is adjustment for maximum linearity that most influences the bottom line—measured and audible performance.

The new One-Bit architectures

Several equipment manufacturers are now proclaiming performance advantages for a relatively new "single bit" approach to D/A conversion. Indeed, there are several differences between this new design and the more mature conversion architectures that tend to support some of the less fanciful claims. **However, as is often the case with all new designs, first generation efforts often fall far short of the theoretical ideal. This is indeed the case here.**

First, a short recap is needed to understand what has and, perhaps more importantly, what has not been said about single-bit designs.

The mainstay of virtually all digital audio products is the so-called parallel conversion of audio data words, whether 16- or 18-bits. And for good reason. This architecture has proven to be highly successful. As we have seen, extremely accurate conversion results from careful D/A design and calibration. However, these D/A converters are expensive and the labor intensive calibration procedures add to the manufacturing cost. **Understandably, some manufacturers have been unwilling to expend this effort, and have developed alternative conversion systems which are less complex and thus less expensive than conventional designs.**

Two different approaches have emerged so far: MASH (Multi Stage Noise Shaping) and "bit streaming." Both methods convert sampled data to an analog waveform using only one bit. MASH uses a PWM (Pulse Width Modulation) signal, whereas bit streaming technology uses a related PDM (Pulse Density Modulation) technique.

The high level of publicity about these single-bit designs attempts to position them as advances to existing conversion technologies. Unfortunately, it conveniently neglects some very real problems which may have a significant effect on the sound quality of CD players using this approach. Bluntly put, today's one-bit designs are examples of inexpensive and immature technologies masquerading as solutions to problems which have already been solved.

One-bit designs claim theoretically perfect conversion linearity at very low signal levels. But, as we have already seen, conventional multi-bit converters offer performance very near this theoretical ideal. However, calibrated multi-bit designs do not suffer from some of the problems unique to the current generation single-bit architectures.

One problem is that single-bit processing is inherently "dirtier" than multi-bit designs in that the

quantization noise bands are potentially more intrusive. A technique called "noise shaping" uses highly sophisticated computations called algorithms to alter the noise spectrum of the signal. However, these algorithms are part of a rapidly emerging branch of applied mathematics and are not as well understood as some would have us believe. **In fact, proper implementation is difficult because of the complexity and high data rate of the algorithm's computation, but is absolutely crucial to successful one-bit operation. Without proper noise shaping, one-bit methods are far inferior to parallel methods.**

As an example of this somewhat unsettled situation, consider this: one of the leading developers of one-bit designs recently admitted that current noise shaping techniques may well pose significant "parasitic coupling" problems that might interfere with the natural reproduction of mid or high frequency musical information.

Jitter, caused by poor synchronization of the various reference clock oscillators in a digital circuit, is also of great concern. Current multi-bit methods divide the signal's amplitude into parts for conversion. One-bit methods divide the signal in time. Although this may seem an obscure point, many engineers are still not satisfied that most conventional designs have fully dealt with the audible effects of clock speed variations. The higher operating speed of one-bit designs raises this question to a new level of importance in that any time-axis variations introduced by clock jitter or other noise are of a proportionately larger magnitude. **In short, jitter could disastrously disrupt a one-bit system.**

Although we firmly believe that one-bit architectures offer exciting possibilities and one day may provide cost efficient and high quality audio reproduction, we are concerned that current versions of this new technology may actually be a step backward in sound quality. Despite their efficiency, one-bit designs require digital circuits which push the limits of chip technology and generate an extremely high frequency signal. In short, this new technology has already revealed problems of its own. High quality 18-bit converters with proper calibration already offer essentially perfect linearity without the teething problems outlined above.

Right now, the single biggest advantage of one-bit designs is that they are cheaper to produce! Onkyo does not feel that the consumer is well served by playing the role of guinea pig for the sake of manufacturing economies.

Conclusion

Despite all the hype, a few simple facts are all that's needed to evaluate CD player technology.

1) The oversampling rate in a digital filter determines the placement of the quantization noise images. The higher the oversampling rate, the higher the placement, and hence the less critical the analog filter.

2) The number of bits in a digital filter per se is not important, as long as sufficient accuracy is maintained.

3) The greater the bit structure in a D/A converter, the greater the opportunity for higher conversion accuracy of the 16 bits of audio signal from the CD. However, the accuracy of any converter, whether 16 or 18 bits, hinges on the precision of its calibration. This can be easily determined by measuring D/A linearity.

However the accuracy of any converter, whether 16 or 18 bits, hinges on the precision of its calibration. This can be easily determined by measuring D/A linearity.

4) So-called 1-bit systems have been developed, but their success is still not determined. One thing is clear: a well-calibrated 18-bit D/A conversion system can provide near-perfect reproduction of a digital audio signal. Onkyo believes that the design and calibration used in its players with either 16- or 18-bit converters approaches this ideal performance without encountering problems unique to one-bit architectures.

References

The following list is by no means complete but it does represent a good starting place for anyone who wants to understand the complexity of today's, and tomorrow's, world of digital audio.

Joel M. Halbert and Mark A. Shill: "An 18-Bit D/A Converter for High Performance Digital Audio Applications." AES (Audio Engineering Society) Preprint, New York, October, 1987.

Stanley P. Lipshitz and John Vanderkooy: "Are D/A Converters Getting Worse?" AES (Audio Engineering Society) Preprint, Paris, March, 1988.

Ken C. Pohlmann: *The Compact Disc: A Handbook of Theory and Use*. A-R Editions, 1989.

Ken C. Pohlmann: *Principles of Digital Audio*, Howard W. Sams, 1989.

Ken C. Pohlmann, "Eighteen Bit Conversion," *Audio Magazine*, October, 1987.

David Ranada: "The Two-Bit Difference," *High Fidelity* magazine, January, 1988.

John Vanderkooy and Stanley P. Lipshitz: "Resolution Below the Least Significant Bit in Digital Audio Systems With Dither," *Journal of the Audio Engineering Society*, March, 1984.

ONKYO®

Onkyo USA Corporation
200 Williams Drive, Ramsey, NJ 07446 201-825-7950

COMPACT · DISC · PLAYERS

auto scan/pause; timer play; 9-key remote control. Frequency response 5-20,000 Hz, ± 0.5 dB; total harmonic distortion 0.005%; signal-to-noise ratio 106 dB; dynamic range 96 dB; ch sep @ 1,000 Hz 100 dB. 17 $\frac{1}{4}$ x 3 $\frac{3}{8}$ x 12 $\frac{1}{4}$ in; 10 lb \$350

MADRIGAL

Proceed CD Player

Burr-Brown 18-bit D/A converters featuring very fast settling, glitch-free current output; 8-times oversampling digital filter; two master power supplies feed into eleven distributed power supplies are electronically regulated; employs Philips CDM1 MkII transport mechanism, cast aluminum base plate. Hall-effect motor; separate transformer used for the digital and analog section to minimize grounding noise. Audio and balanced output; wireless remote control. Frequency response 10-20,000 Hz ± 0 , -0.2 dB; total harmonic distortion 0.004%; signal-to-noise ratio 105 dB; ch sep 120 dB; IM 0.006%. \$1650



McIntosh MCD 7007

MAGNAVOX

CD Players

CDB492 CD Player

Features dual 16-bit digital-to-analog converters; random play; 3-in CD compatibility; 20-track memory programming; repeat play; next/previous track skip; 3-speed music search with cueing; headphone jack; 4-digit LED display. Includes 9-function remote control. \$180
CDB490. As above, no remote control. \$170

CD Combi Players

CDV485 CD Combi Player

Plays 3- and 5-in CD's, 5-in CDV's, 8- and 12-in videodiscs. Features 4x oversampling; dual 16-bit D/A converters; digital output; 5-mode repeat; random play for audio discs; 20 chapter/track programming; CX noise reduction; favorite track selection (audio discs). Includes 38-button remote control \$800
CDV484. As above, 37-button remote and no favorite track selection \$750

CDV474 CD Combi Player

Remote-controlled combination player for CD's, CDV's, and videodiscs. Audio features: auto ID of disc type; programmability. Video features: fast/slow motion; reverse play; freeze frame; random access \$799

CD Changer

CDB496 CD Changer

Features 6-disc changer; 30-track memory programming; repeat play; random play; next/previous track skip; 3-track memory; 3-speed music search with cueing; 5-digit LCD display. Includes 11-function remote control. Optional single-disc magazine and 6-disc magazine for 3-in CD's \$300

MARANTZ

CD-94 CD Player

CD player with 4x oversampling and dual 16-bit converters. Features digital outputs with optically coupled link to optional CDA-94 separate D/A converter; favorite track selection memorizes over

200 disc programs; shuffle play; random-track programming; intro scan; three independent power supplies for digital, analog, and mechanical sections; wireless remote with full programming capabilities; black rosewood side panels \$1,700
CD-94G. As above with rose-gold finish and rosewood side-panels \$1,800

CD 3577 CD Player

CD player with dual D/A converters. Features 20-track music calendar; synchro dubbing capability; coaxial digital output; timer; 27-key remote control; 3-in and 5-in CD compatible. Frequency response 4-20,000 Hz; THD 0.005%; signal-to-noise ratio 100 dB \$450

CD-40 CD Player

Features 16-track programming; 16-bit D/A converter; 2x oversampling; forward/reverse search/skip; repeat play; track/index display; THD 0.07%; S/N 90 dB; 3 x 16 $\frac{1}{2}$ x 10 $\frac{1}{2}$ in; 7.7 lb \$300

CD 2472 CB CD Player

Features 16-track random access programming; unitary-triplex laser system; digisonic circuit; remote control. \$230

CD Changers

DC 3587 CD Changer

5-disc top-loading CD changer with 4x oversampling and dual 16-bit D/A converters. Features high resolution digital filter; biaspheric glass lens in unitary laser; linear motor transport; 20-step random access programming; repeat; random play; 2-color FL display; 25-key remote. Frequency response 2-20,000 Hz; total harmonic distortion 0.05%; signal-to-noise ratio 95 dB \$380

CDC320BL CD Changer

Features wireless remote control; 6-disc magazine; 15-track programmable; 3-beam laser. 3 $\frac{1}{4}$ x 16 $\frac{1}{2}$ x 11 $\frac{1}{8}$ in; 11.2 lb \$369

DC 2482 CB CD Changer

6-disc capable. Features multiplex transport; 3-beam laser pickup; remote control \$330

MCINTOSH

MCD 7007 CD Player

Features 16-bit D/A converters with 4x oversampling; D/A converter chip incorporates separate converters for L/R channels, eliminates multiplexing and delay time between channels; anti-jamming motorized front-loading tray. Programability directly from a short scan of each track; three-speed search; remote control; damaged disc/mute error correction indicator; digital output jack; headphone jack with volume control. Frequency response 20-20,000 Hz ± 0 , -0.3 dB; total harmonic distortion 0.0012% at 1,000 Hz; S/N 107 dB; ch sep 102 dB at 1,000 Hz. 16 $\frac{1}{8}$ x 5 $\frac{1}{2}$ x 13 in; 18 lb \$1,995

MELOS AUDIO

CD-T II CD Player

8x oversampling, 18-bit dual-chassis player. Features analog filtering; toroidal transformer and regulated power supplies contained in aluminum chassis; gold-plated connector; full function CD remote control. Frequency response 20-20,000 Hz ± 0.2 dB; THD 0.07%; S/N (A-wid.) 90 dB; Output 1.25 V rms; 100 ohm output imp \$1,595

MERIDIAN

207 CD Player/Preamplifier

16-bit 2-unit CD player with 3-input preamplifier. Features 4x oversampling; passive analog filter; high-mass suspended transport; physical and electrical isolation between all critical circuits. 64-step volume control; display of track, index, track/disc time, disc remaining time, and volume number; indicators for

phase, EQ, mute, and errors. Includes remote control of all CD and preamp functions. Optional phono input for MM/MC cartridges. Each unit measures: 4 x 6 $\frac{1}{4}$ x 12 $\frac{1}{4}$ in; 22 lb \$1,990

206 CD Player

16-bit 2-unit CD player with 4x oversampling. The units are linked and provide physical and electrical isolation between transport, power supply, and digital and analog electronics. Features single processor; passive analog filter. Next/previous track and index; continue button which restarts CD to last location; display of track, index, track/disc time, disc remaining time; optical and coaxial digital outputs. 4 x 12 $\frac{1}{2}$ x 12 in; 20 lb \$1,690

MISSION ELECTRONICS

Cyrus PCM II CD Player

4x oversampling, dual 16-bit D/A converters with post-DAC filter. Features 5 separate internal power supplies for analog and digital circuits; analog stages can be driven externally by optional Cyrus PSX power supply; digital output with 100-ohm removable loading plug. 29 function remote with display shut down; absolute phase inversion; low loss 60 x 1 dB stepped volume control; 20 track random programming with recall; 3-speed search; 3-mode time display; scan; program; direct track access; index selection. Frequency response 20-20,000 Hz; S/N 96 dB; total harmonic distortion 0.003% at 0 dB. 17 x 3 $\frac{1}{4}$ x 12 in; 14 lb \$999

MITSUBISHI

CD Players

DP-311R CD Player

4x oversampling and dual 16-bit D/A converters. Features 3-beam laser pickup. 36-track random-access programming; one-touch skip; forward/reverse search; repeat; wireless remote control .. \$599

M-C5100 CD Player

8x oversampling and dual 18-bit D/A converters. Features single master-clock frequency for all digital circuits; anti-resonant chassis; Photo Direct amplifier IC. Optical and coaxial digital outputs; auto editing; music calendar; displays disc contents \$550

DP-212R CD Player

2x oversampling player featuring 3-beam laser pickup. 36-track random-access programming; 2-speed forward/reverse search; index search; repeat play; headphone jack; wireless remote. \$249

CD Changer

M-C4100 CD Changer

2x oversampling, dual 16-bit D/A converters, and 5-disc tray. Features single master-clock frequency for all digital circuits; anti-resonant chassis. 20-track programming; audible scan; introscan; random play; 3-in disc compatibility; headphone jack with level control; remote control \$499

MOD SQUAD

Prism CD Player

Drawer-loading CD player with Philips 16-bit digital processing. Features internal disc damping system; 4x oversampling; wireless infrared remote control; digital data and clock lines timed for current synchronization and minimal jitter; fast settling, current summing amplifier stage; proprietary zero-feedback voltage regulators for analog section and for DA converter voltage reference; all direct-coupled circuitry; DC servo amplifier. 20-track random programming; repeats disc, track, program, and phrase (A-B repeat); digital time-domain alignment; fixed line outputs; output level 4 V rms; digital outputs. Frequency response 0.1-20,000 Hz, ± 0.05 dB; S/N 110 dB; THD 0.02%; 8 lb \$1,495

COMPACT • DISC • PLAYERS

NAD

CD Players

5300 Monitor Series CD Player

4x-oversampling digital filter, dual discrete D/A converters, and 3-beam laser pickup. Features ambience circuit. Serial digital output; error display; skip/scan forward and back; displays track number and elapsed/remaining time; repeat; programmability. Includes wireless remote control with volume control. \$899

5100 Monitor Series CD Player

Features 16-bit D/A conversion; 4x oversampling; dynamic range circuit; 8 separate analog, digital, and mechanical power supplies. Variable and fixed outputs; normal and delete mode programming. Includes remote control with volume control. Rack mountable. \$499

5340 CD Player

Features 16-bit D/A conversion; 8x-oversampling 18-bit digital filter. Serial digital output; variable and fixed outputs. Includes remote control with volume control. \$399

5325 CD Player

Features 16-bit D/A conversion; 4x-oversampling 18-bit digital filter; pulse width modulation circuitry. Includes remote control. Linearity 1 dB at 90°. \$299

CD Changer

5170 Monitor Series CD Changer

CD changer with 6-disc magazine and single play drawer. Features 16 bit D/A conversion; 4x oversampling. Multiple play; serial digital output; intro scan; random play of all discs; 32-track programmable memory. Includes remote control with volume control. Rack mountable. \$699



NAD 5340

NAKAMICHI

CD Players

OMS-7AII CD Player

Drawer-loading CD player. Features 3-beam laser; 4x-oversampling digital filter; dual 16-bit, glitch-free D/A converters. Programming of 24 tracks in random order; display of current track number, elapsed time of current track, remaining time on disc, program stored in memory; sound audible during fast forward and fast reverse; skip forward; skip back; fast forward; fast reverse; cancel; repeat disc, program; cue by track number, index number; 7-function remote control; headphone jack with adjustable level. Max line output 2 V; headphone output 35 mW; total harmonic distortion at 1,000 Hz 0.0025%; S/N > 104 dBA; ch sep > 100 dB; Frequency response 5-20,000 Hz, ± 0.5 dB. 17 1/8 x 3 7/8 x 12 1/2 in; 16 lb, 5 oz. \$1,995
OMS-5AII. Similar to OMS-7AII without remote and programming functions. \$1,650

CDP-2A CD Player

Mid-level CD player featuring 16-bit 4x oversampling with digital filtering; dual D/A converters; third order Bessel analog filter; multi-regulated isolated-ground power supplies. 24-memory programming function; wireless remote control with 24-key transmitter; headphone jack with level control; 3-beam laser pickup; frequency response 20-20,000 Hz ± 0.5, -1.0 dB; signal-to-noise ratio > 100 dBA total harmonic distortion 0.0025% at 1,000 Hz. 16 7/8 x 2 7/8 x

10 1/8 in; 11 lb, 4 oz. \$549

OMS-1A CD Player

Features 16-bit D/A conversion; 2x-oversampling digital filtering with 5th-order active analog filter; dual-mono analog circuits; independent digital and analog power supplies; 3-beam laser pickup with astigmatism detection; high-precision servo; synchronized digital timing; floating disc drive with precision centering. 15-track program memory; wireless remote control; bidirectional skip search; dual-speed cueing; repeat play; frequency response 5-20,000 Hz; S/N > 96 dBA; THD 0.007% at 1,000 Hz; ch sep > 88 dB. 16 7/8 x 2 7/8 x 10 1/8 in; 8 lb, 3 oz. . . . \$329

CD Changers

CDC-4A CD Changer

6-disc changer with single-disc tray. Features 8x oversampling; dual 16-bit D/A converters; 3-beam laser; 3rd-order high-cutoff Bessel output filters; multi-winding multi-regulated power supply with isolated ground topology; floating disc-drive mechanism; coaxial digital output; fixed and variable analog outputs. 50-program memory; memory/time data backup; 3-way random play of programmed selections; headphone output with adjustable level; gold-plated output and headphone jacks. Includes RM-4CDC 37-key wireless remote. FR 5-20,000 Hz, ± 0.5 dB; S/N > 103 dBA; THD 0.002% at 1,000 Hz. 17 x 4 x 13 3/8 in; 15 lb, 10 oz. \$1,195

CDC-3A CD Changer

6-disc changer with single-disc tray. Features quadruple-oversampling; dual 16-bit D/A converters; 3-beam laser; 3rd-order high-cutoff Bessel output filters; multi-winding multi-regulated power supply with isolated ground topology; floating disc-drive mechanism; coaxial digital output. 50-program memory; memory/time data backup; 3-way random play. Includes RM-3CDC 32-key wireless remote. Frequency response 5-20,000 Hz, ± 0.5 dB; S/N > 102 dBA; THD 0.0025% at 1,000 Hz. 17 x 4 x 13 3/8 in; 13 lb, 4 oz. \$795

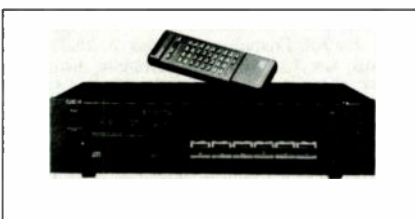

Nakamichi CDC-4A

NEC

Renaissance Series

CD-830 CD Player

Features 16x transversal filtering circuit; four unipolar D/A converters; digital servo-tracking system; optical D/A coupling; A/D separate power supplies; digital output. Disk/tape edit function; auto/manual edit; digital auto fade out; auto space; tape remaining time indication; 24-track random programming; 3-way repeat; variable intro scan; random play; 2-speed search; wireless remote control and headphone output with volume control. Frequency response 5-20,000 Hz, ± 0.5 dB; signal-to-noise ratio 105 dB; total harmonic distortion 0.0025% at 1,000 Hz; ch sep 103 dB at 1,000 Hz. Dimensions: 17 x 4 3/8 x 13 in. Weight: 25 lb, 6 oz. \$999

CD-730 CD Player

Features 16x transversal filtering circuit; four unipolar, 16 bit D/A converter; optical D/A coupling; A/D separate power supplies; two digital output. plays 3-in CD without an adaptor; auto/manual edit; digital auto fade out; auto space; 24-track random program-

ming; 3-way repeat; variable intro scan; 2-speed search; random play; headphone output with volume control; wireless remote control. Frequency response 5-20,000 Hz, ± 0.5 dB; S/N 105 dB; THD 0.0025% at 1,000 Hz; ch sep 103 dB at 1,000 Hz. 17 x 4 3/8 x 12 in; 12 lb, 6 oz. \$399

CD-630 CD Player

Features 8x transversal filtering circuit; two unipolar, 8 bit D/A converter; optical D/A coupling; A/D separate power supplies; digital output. plays 3-in CD without an adaptor; auto/manual edit; auto space; 24-track random programming; 3-way repeat; variable intro scan; 2-speed search; random play; headphone output with volume control; wireless remote control. Frequency response 5-20,000 Hz, ± 0.5 dB; S/N 105 dB; total harmonic distortion 0.0025% at 1,000 Hz; ch sep 100 dB at 1,000 Hz. 17 x 4 3/8 x 12 in; 11 lb, 15 oz. \$299

CD-530 CD Player

Features 4x oversampling; digital filter; dual D/A converters. 24-track random programming; two-way repeat function; wireless remote control. \$229

NIKKO AUDIO

CD-400 CD Player

CD player with 6-function wireless remote. Features 3-beam laser pickup; from mounted headphone jack with headphone volume control; 16 random program memory; indexing; 4-way search system; program repeat. S/N 105 dB. \$300

NUMARK

CD9000 CD Player

Disc cartridge loading CD player with 16-bit D/A converter. Features auto/manual eject; change pitch and key by ± 10%; 10 program memory; repeat program. Frequency response 20-20,000 Hz; signal-to-noise ratio 80 dB. 19 x 5 3/8 x 12; 18 1/2 lb. . . . \$3,000

ONKYO

All CD players and CD changers are compatible with Onkyo's RI integrated-system remote control.

DX-3500 CD Player

8x oversampling, dual 16-bit Opto-Drive digital-to-analog converters. Features 3-beam laser pickup; opto-coupling. 20-track random music calendar; 10-key direct play; shuffle/timer play; 3-in CD compatibility; optical and coaxial digital outputs; remote control. \$420

DX-2700 CD Player

18-bit 8x oversampling, dual 16-bit D/A converters with individual MSB calibration. Features 3-beam laser pickup; opto-coupling. 20-track programming with editing capability; 3-mode random music calendar; 10-key direct play; 3 repeat modes; 3-in CD compatibility; optical and coaxial digital outputs; remote control. \$350

DX-1700 CD Player

18-bit 8x oversampling, dual 16-bit digital-to-analog converters with individual MSB calibration. Features 3-beam laser pickup. 20-track programming with editing capability; 3-mode random music calendar; 3 repeat modes; 3-in CD compatibility; remote control. \$300

DX-1500 CD Player

2x oversampling, 16-bit D/A converter. Features 3-beam laser pickup. 16-track programming with editing capability; 3-mode display with random-track sequencing. \$250

CD Changers

DX-C500 CD Changer

18-bit 8x oversampling, dual 16-bit D/A converters

COMPACT · DISC · PLAYERS

with individual MSB calibration, and 6-disc magazine. Features Opto-Coupling; 3-beam laser pickup. 40-track programming with editing capability; Music File memory for up to 340 discs; 3-mode random music calendar; 4 repeat modes; 10-key direct play; 3-in CD compatibility; remote control \$530

DX-C-300 CD Changer

18-bit 8x oversampling, dual 16-bit D/A converters with individual MSB calibration, and 6-disc magazine. Features 3-beam laser pickup. 40-track programming with editing capability; 3-mode random music calendar; 4 repeat modes; 3-in CD compatibility; remote control \$430

Integra Series

Grand Integra DX-G10 CD Player

8x oversampling, dual 18-bit Opto-Drive D/A converters with absolute level and 4 MSB calibration. Features five-element opto-coupling; cast-steel anti-vibration chassis; high-speed linear-motor laser transport; 3rd-order GIC-type analog output filters; separate transformers for digital and analog stages. Variable-speed disc scan and cue; 4-mode repeat; 16-track programming; 10-key direct play; time-search function; phase-reverse switch; coaxial and optical digital outputs; fixed and variable analog outputs; variable intensity display; full-function remote control. \$2,500

Integra DX-7500 CD Player

8x oversampling, dual 18-bit Opto-Drive D/A converters with 4MSB calibration. Features opto-coupling; separate power transformers for digital and analog stages; 3rd-order GIC-type analog output filters; Poly-Sorb spacers for vibration damping. 20-track random music calendar; shuffle/timer play; optical and coaxial digital outputs; fixed and variable analog outputs; remote control \$700

Integra DX-5500 CD Player

4x oversampling, dual 18-bit Opto-Drive D/A converters. Features opto-coupling; separate power transformers for digital and analog stages; 3rd-order GIC-type analog output filters; Poly-Sorb spacers for vibration damping. 20-track random music calendar; shuffle/timer play; optical and coaxial digital outputs; fixed and variable analog outputs; remote control. \$600

PANASONIC

SL-P3800C CD Changer

4x-oversampling, dual 16-bit D/A converters, and 6-disc magazine. Features high-speed linear access system. Direct access system; 36-track programming; skip and search; 2-way random play; independent disc selection; multifunction 10-key remote control. \$380

SL-NP11 Portable CD Player

4x oversampling, 16-bit D/A converter. Features direct-drive motor. Auto power-off; 18-track programming; resume-play mode; multifunction, 1-key wired remote control; LCD display; battery indicator; AC adapter; 2 rechargeable AA batteries. Carrying case, strap, and stereo cord included \$350

RX-DS30 Portable CD System

AM/FM cassette recorder with CD player. Features XBS bass-boost system; soft-touch logic controls; edit-pause. CD section: 36-track programming; 12-key direct access programming. Tape section: autoreverse; auto rec-level and tape selectors. Tuner section: 12 AM, 12 FM presets. LCD display; clock/timer; AC-in, aux-in, CD-out, external mic, and headphone jacks \$320

SC-SLPS352 CD Player

4x oversampling and dual D/A converters. Features high-speed linear access system; large insulation feet. Music matrix; 20-track programming; skip and

search; track/disc/program repeat; FL display; 3-in CD compability; auto cue; multi-function time mode \$230

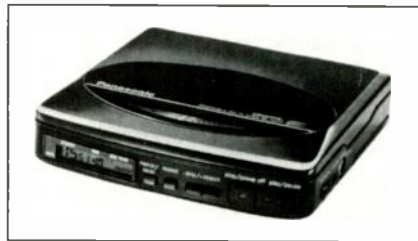

Panasonic SL-NP11

PARASOUND

D/VF-900 CD Player

Variable high-frequency focus-adjust CD player. Features 2x oversampling; digital filtering; triple-beam laser; double-shock mounting; full-feature wireless remote control; gold-plated jacks; 15-selection programming; repeat all/track/ any start-stop points; regulated power supply; high-speed audible search; headphone jack level control; Frequency response 5-20,000 Hz; S/N 99 dBA; total harmonic distortion <0/005% at 1,000 Hz; ch sep >86 dB. 17¼ x 3½ x 12 in \$335

PHILIPS

CD Players

1.HH1000 CD Transport/Converter

2-piece system with CD transport and D/A converter. D/A converter and digital filter features 4x oversampling and 16-bit D/A converter with select-grade TDA-1541 "AS-1" chips. Transport features Philips' CDM-1 mechanism made of diecast aluminum alloy and a single-beam laser pickup. Other features: favorite-track selection; single-disc tray; 20-track programmable memory; 4-way repeat; disc/track time display; headphone jack with level control; digital output; optical output; copper-plated alloy castings. Includes universal C/D/learn, full-function remote control. Frequency response 20-20,000 Hz ±0.1 dB; S/N 101 dB; total harmonic distortion 0.0015%. 62 lb \$4,000

960 CD Player

4x oversampling, 16-bit D/A converter. Features single-beam pickup; optical coupler; diecast aluminum nonmagnetic main- and subchassis. Favorite-track selection; fast track access; copy pause; 2-motor front-loading drawer; keypad track selection; 20-track random-access programming; information display; search forward/reverse keys with 3-speed search; repeat key; scan key. Includes infrared full-function remote control. FR 2-20,000 Hz; S/N >105 dB; dynamic range >96 dB; ch sep 105 dB; THD 0.0015%. 4 x 16¾ x 15¾ in; 21.1 lb \$949

CD-60 CD Player

4x oversampling, dual 16-bit D/A converters. Features Philips' exclusive Radialinear drive mechanism; motorized volume control; digital audio output terminal; optical digital output terminal; headphone jack with volume control; favorite-track selection; auto music scan. Includes full-function remote control \$429

CD-50 CD Player

4x oversampling, dual 16-bit D/A converters. Features Philips' Radialinear high precision transport. Favorite-track selection; random music playback; auto music search preview \$329

CD Changer

875 CD Changer

Six-disc changer with single-disc tray, 4x oversam-

pling, and 16-bit D/A converter. Features aluminum-front, metal chassis. 40-track programming with calendar-type display; favorite track selection; shuffle play; A-B repeat; scan-play remote volume control; headphone jack with volume control. Includes LCD remote. Optional six-disc magazine for 3-in CD's \$499

Combi-Players

CDV488 CD Combi Player

Plays 3- and 5-in CD's, 5-in CDV's, 8- and 12-in videodiscs. Features 4x-oversampling digital filter; dual 16-bit D/A converters; high-resolution video circuitry with chrominance and luminance; favorite track selection; 20 audio track or video chapter programming; gold-plated video input; optical and coaxial digital audio outputs; C/N NR; S-type video output connector. Includes full-function A/V learn remote control with LCD. Frequency response 20-20,000 Hz ±0.1 dB; S/N >100 dB; ch sep >96 dB at 1,000 Hz; THD >0.007% \$1,300

CDV-487 CD Combi Player

Plays 3- and 5-in CD's, 5-in CDV's, 8- and 12-in LD's. Features Philips' exclusive high-resolution chroma/luma processor; TDA-1541-A "S1" D/A converter; SAA-7220 P/B selected digital filter; blue FL display; 10-key pad; favorite track selection; 20 audio track or video chapter programming; headphone jack with volume control; digital audio output terminal. Includes remote control. \$949

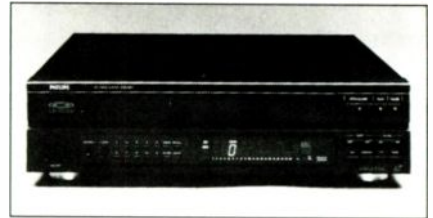

Philips CDV-487

PIONEER

CD Players

Elite PD-91 CD Player

CD player with 8x-oversampling digital filter and dual 18-bit D/A converters. Features 3rd-order low-pass analog Butterworth filter; laser pickup with integral buffer amplifier; 24-track random-access programming; music window search; random play; digital fader with variable fading time; auto program edit; time edit; digital output jacks; coaxial and optical outputs; headphone jack with adjustable level; FL display; 4 separate power supplies; laminated iron plate coated with polyacetal and copper-plated honeycomb plates; coil springs with rubber dampers to support subchassis \$1,400

Elite PD-71 CD Player

CD player with 8x-oversampling digital filter and dual 18-bit D/A converters. Features fluorescent display; 24-track random access programming; random play; direct wire connections; bi-polar power transformer; multi-floating system; remote control. \$850

PD-7300 CD Player

Frequency response 4-20,000 Hz; signal-to-noise ratio 106 dB; ch sep 100 dB. 16¾ x 4¾ x 12¾ in \$550

PD-6300 CD Player

Frequency response 4-20,000 Hz; signal-to-noise ratio 104 dB; ch sep 100 dB. 16¾ x 3¾ x 12¾ in \$390

PD-T503 Dual-Tray CD Player

Double-disc CD player; can remove one disc while other is playing. Features honeycomb chassis; magnetic-clamp disc stabilizer; non-repeating random

COMPACT · DISC · PLAYERS

play; 24-track programming; 3-way repeat; timer start; dual 15-track music calendars; status memory; 3-in CD compatible; remote control; headphone output with volume control \$330

PD-T403 Dual-Tray CD Player

Double-disc CD player; can remove one disc while other is playing. Features 4x oversampling; dual D/A converter; honeycomb chassis; magnetic-clamp disc stabilizer; 24-track non-repeating random play; 2-disc random and relay play; 3-way repeat; timer start; 3-in CD compatible; remote control \$300

PD-T303 Dual-Tray CD Player

Double-disc CD player; can remove one disc while other is playing. Features 4x oversampling; dual D/A converters; honeycomb chassis; magnetic-clamp disc stabilizer; 24-track non-repeating random play; 2-disc random and relay play; 3-way repeat; timer start; 3-in CD compatible; remote control \$280

PD-4350 CD Player

Compatible with 3-in CD's. Features 4x oversampling; 18-bit digital filter; magnetic-clamp disc stabilizer; honeycomb chassis; random play; 20-track random programming; programmable pause; repeat; 6-digit FL display; remote control. Frequency response 4-20,000 Hz; and S/N 102 dB; ch sep 95 dB. 16 $\frac{3}{4}$ x 3 $\frac{3}{4}$ x 12 $\frac{3}{4}$ in. \$270
PD-4300 CD Player. Same as above, without remote control. \$250

Changers and Combi-Players

CLD-91 Combi Player

Compatible with 3- and 5-inch CD's, 8- and 12-inch videodiscs, and CDV's. Features 18-bit D/A converter; dual centering; jog and shuttle dial; visual/track intro scan; direct chapter and track search; FL display; remote control \$2,000

PD-M710 CD Changer

Magazine-type CD changer with 6-disc capacity and remote control. Can play CD-3's with optional magazine. Features 8x oversampling; dual D/A converters; magnetic clamp disc stabilizer; 40-track non-repeating random play; multi-memory for up to 20 magazines; 15-track calendar; index search; status memory; time-fade editing; four-way repeat; digital level control; random play; delete play; headphone output jack with volume control. \$650

PD-M610 CD Changer

Magazine-type CD changer with 6-disc capacity and remote control. Features 8x oversampling; dual D/A converters; disc stabilizer; 32-track non-repeating random play; delete play \$480

PD-M510 CD Changer

Magazine-type CD changer with 6-disc capacity and remote control. Features 4x oversampling; dual D/A converters; honeycomb chassis; 32-track programming; 4-way repeat; non-repeating random play; 3-inch CD magazine optional. \$390

PD-M410 CD Changer

Magazine-type CD changer with 6-disc capacity and remote control compatibility. Features 4x oversampling; dual D/A converters; honeycomb chassis; 32-track programming; 4-way repeat; non-repeating random play; 3-inch CD magazine optional. \$365

PROTON

AC-620 CD Player

Dual-16 bit D/A converters and programming capabilities. Frequency response 20-20,000 Hz \pm 0.3 dB; THD 0.003%; S/N 100 dB. 18 $\frac{1}{2}$ x 3 $\frac{3}{4}$ x 15 $\frac{3}{4}$ in; 17.2 lb \$700

AC-300 CD Player

4x oversampling with wireless remote control. Features one-beam laser pickup; Cross Interleave Reed Solomon Code (CIRC) error correction; 20-track

programmable memory; 3-speed music search; precise audible cueing at two lower speeds, real-time digital display of total tracks, total playing time, track number, and elapsed time of each track; repeat disc, track, and program; headphone jack with adjustable level. Frequency response 20-20,000 Hz \pm 3 dB; dynamic range 96 dB; S/N 96 dB; ch sep (at 1 kHz) 94 dB; THD (at 1 kHz) 0.003%; IM 0.003%. 16 $\frac{1}{2}$ x 3 $\frac{3}{4}$ x 11 $\frac{1}{4}$ in; 7.9 lb \$399

QUASAR

CD Player

CD8949 CD Player

CD player with 4x-oversampling digital filter and dual 16-bit D/A converters. Features 20-step random access programming; edit guide; high-speed linear access; skip/search/repeat; compatible with 3-in and 5-in CD's; remote control capable. Frequency response 2-20,000 Hz, \pm 1 dB; S/N 96 dB; THD 0.05%. 16 $\frac{3}{4}$ x 3 $\frac{3}{4}$ x 10 $\frac{3}{4}$ in; 7.9 lb \$200

CD Changer

CD8989 CD Changer

4x-oversampling digital filter. 16-bit D/A converter. 5-disc top-loading rotary design CD player. Features repeat play; random play; 25-key remote control with 10-key direct access and 10-key programming; 2-color FL disc and programming display; linear motor; dual aspheric glass lens. Frequency response 2-20,000 Hz \pm 1 dB; signal-to-noise ratio 96 dB; total harmonic distortion 0.05%. 16 $\frac{3}{4}$ x 3 $\frac{3}{4}$ x 14 $\frac{1}{4}$ in; 8.6 lb \$330

Portable CD Components

GX89CD Portable CD Boombox

Portable CD boombox with 4x oversampling and dual digital-to-analog converters. Features multi-information LCD display; bass boost; 36-step random access programming; 12-key direct access; skip/search/repeat; autoreverse; clock/timer; 12 AM/12 FM preset memory. Uses 10 D batteries. 26 $\frac{1}{4}$ x 7 $\frac{3}{8}$ x 8 $\frac{1}{2}$ in; 12.2 oz \$300

CD8959 Portable CD Player

Portable CD player with 4x oversampling and dual D/A converters. Features bass boost; dual aspheric glass lens; 1-key remote; resume play; random play; LCD information display; 18-track random access programming; repeat; skip/search; memory/recall; 3-in and 5-in CD compatible. Uses 2 AA batteries. Includes carphones; rechargeable NiCd AA batteries; AC adaptor/charger. Frequency response 20-20,000 Hz \pm 0.5, -1.5 dB; S/N 96 dB. 5 x 1 $\frac{3}{8}$ x 5 $\frac{3}{4}$ in; 11.2 oz \$250

REALISTIC

CD-6000 CD Player

CD changer with: 2x oversampling. Plays up to 6 discs automatically; 32 tracks; 3-beam laser; 3-way repeat; remote control; dual-mode LED display; autosearch; bi-directional audible search \$360

CD-1600 CD Player

CD player with 3-beam laser features skip forward and back; floating disc tray. 2-speed search forward and reverse; programs 16 tracks; 3-way repeat; index search; repeat tracks; music calendar to show program contents; wireless remote needs 2 AA batteries \$250

CD-1700 CD Player

CD player with 2x oversampling and 3-beam laser. Features remote control; auto search; 2-speed scan forward and back; 8-digit LCD readout; repeat programmed selections or entire disc. Frequency response 5-20,000 Hz \pm 10 dB; total harmonic distortion 0.05%; signal-to-noise ratio 90 dB. 11 x 3 x 13 $\frac{1}{4}$ in \$230

CD-2400 CD Player

CD player with 3-beam laser features floating disc tray; 4-digit fluorescent display; 15 track programmable; repeats track, program, disc; scan forward and reverse; bi-directional auto search; 3-way repeat of programmed selections, entire disc or single selection \$200

REVOX

B226-S CD Player

Drawer-loading CD player with Revox system-remote compatibility. Features 4x oversampling 16-bit dual D/A converters; display shows track number, time remaining, time elapsed for both track and disc; fixed and variable outputs; 2-digital outputs; 19-step programming by track/index access from 1-99; audible forward/reverse search; locate function; headphone jack with adjustable level; FR 20-20,000 Hz \pm 0.1 dB; S/N > 100 dB; THD < 0.005%; ch sep > 90 dB; 17 $\frac{3}{4}$ x 4 $\frac{1}{4}$ x 13 in; 18 lb, 11 oz \$1,895
B126 CD Player. As above, cosmetic differences \$1,275

ROTEL

RCD-855 CD Player

4x-oversampling, dual 16-bit D/A converters. Features digital filter; standard line output and digital output; servo processor circuits; remote control; shuffle play; scan; repeat; 3 speed search; automatic CD ROM switch; CD-3 compatibility. Frequency response 20-20,000; THD + noise 0.0025% at 1,000 Hz; S/N 100 dB. 17 $\frac{1}{2}$ x 3 $\frac{3}{4}$ x 13 $\frac{3}{4}$ in; 15.4 lb .. \$349

SAE

D102 CD Player

4x-oversampling and 16-bit D/A converter with error corrector. Features 1-beam laser; LED readout for track, time mode, error alert, and repeat. Random access function for 20 tracks; cueing function; bi-directional, 3-speed audible search modes; previous/next track; 12-function infrared remote control. FR 20-20,000 Hz \pm 0.3 dB; THD 0.006%; S/N > 100 dB. 19 x 3 $\frac{1}{2}$ x 13 in; 20 lb \$599

SAMSUNG

CD Players

CD-22R CD Player

2x oversampling and 16-bit linear D/A converter. Features 15-function remote; 16-track programming; CD-3 capability; slide volume control; track selector; track/index and time display. Frequency response 20-20,000 Hz \pm 0.6 dB; S/N > 95 dB. 16 $\frac{1}{2}$ x 3 $\frac{1}{4}$ x 11 $\frac{3}{8}$; 9.1 lb \$250

CD-17 CD Player

2x oversampling and 16-bit linear D/A converter. Features 3-beam laser pickup; 16 track programming; CD-3 capability; search; skip functions; track/index and time display. Frequency response 20-20,000 Hz \pm 1 dB; S/N > 85dB. 13 $\frac{3}{4}$ x 3 $\frac{1}{2}$ x 11 $\frac{3}{8}$; 7.3 lb. .. \$200

Portable CD Systems

RCD-800 Portable CD System

Portable CD system with 2x oversampling, AM/FM radio, double cassette deck, detachable speakers. CD

The listings are based on data provided by the manufacturers. For more product information, contact an authorized dealer or the manufacturer directly. Manufacturers' addresses and phone numbers are listed in the directory beginning on page 258.

COMPACT • DISC • PLAYERS

features 3-beam laser pickup; 16-track programming; CD-3 capability. Other features: FM stereo tuner; high-speed dubbing; synchro-record and continuous play; Dolby B NR; metal tape capability; 3-band graphic EQ; stereo headphone jack. 4.5 W/ch rms at 10% THD. 25¼ x 10 x 8½ in; 13.2 lb. \$370

RCD-2500 Portable CD System

Portable CD system with 2x oversampling, AM/FM radio, double cassette deck, speakers. CD features 3-beam laser pick-up; 16-track programming; CD-3 capability. Other features: digital tuning; 5 AM and 10 FM presets; memory scan; high-speed dubbing; synchro-record and continuous play; Dolby B NR; metal tape capability. 3-band graphic EQ. 4 W/ch rms at 10% THD. 26¾ x 8¾ x 6¾ in; 12.1 lb. \$370

RCD-2000 Portable CD System

Portable CD system with 2x oversampling, AM/FM radio, autoreverse cassette deck, speakers. CD features 16-track 3-beam laser pickup; 16-track programming; repeat control; skip/search control. Other features: FM-stereo LED indicator; continuous play; Dolby B NR; metal-tape capability; 5-band graphic EQ; beat cut switch; 12-V DC car adapter. 4 W/ch rms at 10% THD. 24 x 8½ x 6¾ in; 9.4 lb. \$350

RCD-1500 Portable CD System

Portable CD system with 2x oversampling, AM/FM radio, double cassette deck, speakers. CD features 3-beam laser pickup; 16-track programming; CD-3 capability. Other features: FM-stereo LED indicator; high-speed dubbing; synchro-record and continuous play; one-touch record; 3-band graphic EQ. 4 W/ch rms at 10% THD. 26¾ x 7¾ x 6¾ in; 12.1 lb. \$330

RCD-950 Portable CD System

Portable CD system with 2x oversampling, AM/FM radio, cassette deck, speakers. CD features 3-beam laser pick-up; 16-track programming; CD-3 capability. Other features digital tuning with memory scan; 10 FM and 5 AM presets; synchro-dubbing CD-to-tape; one-touch record; metal-tape capability; 3-band graphic EQ. 4 W/ch rms at 10% THD. 23 x 6¾ x 6½ in; 8.4 lb. \$300

RCD-900 Portable CD System

Portable CD system with 2x oversampling, AM/FM radio, cassette deck, speakers. CD features 3-beam laser pick-up; 16-track programming; CD-3 capability. Other features: FM-stereo LED indicator; synchro-dubbing CD to tape; one-touch record; metal-tape capability; variable tone control; loudness control. 4 W/ch rms at 10% THD. 23 x 6¼ x 6½; 8.4 lb. \$260

SANSUI

CD Players

CD-X711 CD Player

Features 4 of Sansui's exclusive LDCS 1-bit D/A converters with third-order noise shaping. Features FL display shutoff switch to eliminate any excess electronic noise; free-floating suspension made up of 4 oil-damped coiled-spring insulators; 1 optical and 1 coaxial digital output; 20-track random programming; 20-track program calendar; random play; variable-time music scan; auto spacing; 4-way repeat; auto music program search; timer start; index search. Includes full-featured remote control. Frequency response DC-200,000 Hz ±0.3 dB; THD 0.003% at 1,000 Hz; S/N 103 dB. 17 x 5 x 15¼ in; 22 lb. Black finish \$1,100

CD-X501i CD Player

4x-oversampling digital filter and twin D/A converters. Features digital output; FL display; 20-track random programming; random play; 4-way repeat; variable time music scan; Dynamic Servo System; master clock; flux-free chassis. THD 0.003% at 1,000 Hz; Frequency response 4-20,000 Hz; dynamic range >97 dB; S/N >106 dB. 3¾ x 17¾ x 12½ in. Black finish \$600

CD-X311 CD Player

Features 4 of Sansui's exclusive LDCS 1-bit D/A converters with third-order noise shaping. Features FL display shutoff switch to eliminate any excess electronic noise; 4-sec space between programs; program edit; time edit that will automatically scan the disc being copied and select music matching the selected time; headphone output with volume control; 20-track music calendar; 10-key direct selector/programmer; auto music program search; music scan; coaxial digital output. Includes 28-key wireless remote control. Frequency response 4-20,000 Hz; signal-to-noise ratio 100 dB; total harmonic distortion 0.006% at 1,000 Hz. Dimensions: 17 x 4 x 11 in. Weight: 12 lb. \$500

CD-X301i CD Player

2x-oversampling digital filter with twin D/A converters. Features FL display; 20-track random programming; random play; 4-way repeat; Dynamic Servo System; master clock; Frequency response 4-20,000 Hz; dynamic range >96 dB; THD 0.003% at 1,000 Hz. 3¾ x 17 x 11½ in. \$330

CD-V1000 CD Player

Features 2x-oversampling digital filter; 24-track random programming; 3-way repeat; synchronized operation with some Sansui tape decks; multifunction LED display for total time, elapsed time, and time remaining on disc. Frequency response 5-20,000 Hz; dynamic range 95 dB; total harmonic distortion 0.003% at 1 kHz; output voltage 2 V. 3¾ x 17 x 11 in; 10.8 lb. \$320

CD-X105 CD Player

Features 3-beam laser pickup; 20-track programmability; 3-mode repeat; auto spacing; random play; remote control. Frequency response 20-20,000 Hz; signal-to-noise ratio 90dB; THD 0.03% at 1,000 Hz. 17 x 3¾ x 11 in; 7.7 lb. \$260

CD Changer

CD-X510M CD Changer

2x oversampling, dual D/A converters, two 6-disc magazines, and a single-play tray. 3-in CD compatibility; random programming; variable music/intro scan; 3 repeat modes; remote control. Frequency response 5-20,000 Hz; dynamic range >95 dB; S/N 100 dB; THD 0.004% at 1,000 Hz. 5¾ x 17 x 12¾ in. \$630

SANYO

CD Player

CP860 CD Player

2x-oversampling digital filter and 3-beam laser pick-up. Features 3-in CD compatibility; 16-track programmability; skip; search; repeat program; calendar display. Includes 16-key wireless remote control. Frequency response 5-20,000 Hz; THD 0.03%; signal-to-noise ratio 90 dB at 1,000 Hz; ch sep 90 dB at 1,000 Hz. \$170
CP820. As above, no remote or calendar display \$160

CD Changers

CPM900 CD Changer

CD changer with 10 disc magazine and 3-beam laser pickup. Features capacity for six full-size CD's and four 3-in CD's; 32 selection programmability; 10-key touch programming; random play; repeat function; intro scan; forward/reverse search and skip; LCD multi-function display; real time counter; headphone jack with level control. Frequency response 5-20,000 Hz; total harmonic distortion 0.03%; S/N 103 dB at 1,000 Hz. \$280

Portable CD Systems

MCD950 Portable Dual CD System

CD system with 2 CD drawers, powered extended

bass sound system with passive radiator, and AM/FM stereo. Features surround-sound circuitry. Carbon-fiber speakers; 3-band graphic EQ. Dual CD section: 30-selection programmability; CD to tape edit recording with synchro start; continuous CD play; 3-in CD compatibility; skip, search, and repeat; 10-key remote CD operation. Dual cassette section: built-in clock with alarm; autoreverse playback/recording (deck B), autoreverse playback (deck A); auto music select system (deck A); high-speed dubbing; continuous play; continuous play; synchro start dubbing; Dolby noise reduction. Includes 32-key remote control. CD Specs: Frequency response 20-20,000 Hz; dynamic range 90 dB at 1,000 Hz; ch sep 80 dB at 1,000 Hz. \$800

MCD650K Portable CD System

Portable CD system with top-loading horizontal CD tray, double cassette recorder, and AM/FM stereo. Features surround-sound circuitry. Carbon-fiber speakers; 4-band radio. High-speed dubbing; 20-selection programmability; CD edit recording; built-in clock and timer with alarm; autoreverse; 3-in CD compatibility. Includes rechargeable battery pack and AC line cord. Frequency response 20-20,000 Hz; dynamic range 85 dB at 1,000 Hz; ch sep 70 dB at 1,000 Hz. \$500

MCD550K Portable CD System

Portable CD system with AM/FM stereo cassette recorder and remote control. Features surround-sound circuitry; carbon-fiber speakers. CD section: 16-selection programmability; intro scan; repeat; random play; 3-in CD compatibility. Cassette section: autoreverse recording and playback; auto music select system; built-in quartz clock and timer. Includes AC cord. Frequency response 20-20,000 Hz; dynamic range 88 dB at 1,000 Hz; ch sep 70 dB at 1,000 Hz. \$370

MCD450K Portable CD System

Portable CD system with top-loading horizontal CD tray, cassette recorder, and 4-band radio. Features surround-sound circuitry; carbon-fiber speakers; powered extended bass sound system; CD section: 16-selection programming; 1-touch synchro-start dubbing from CD to tape; 2-way CD repeat; 3-in CD compatibility. Includes AC cord. Frequency response 20-20,000 Hz; dynamic range 85 dB at 1,000 Hz; ch sep 70 dB at 1,000 Hz. \$250

SCOTT

DA990 CD Player

CD player with 2x oversampling and 16-bit D/A converter with digital filtering. Features 3-beam laser; switchable analog filter. 24-key wireless remote; programs 30 tracks in any order; calendar-type program selection. THD 0.01%. 17½ x 3¾ x 10 in; 11 lb. \$330

DA1000 Dual-Tray CD Player

CD player with 2 drawers. Features 23-key wireless remote control; 32-track random programming; skip search; index search; 2-speed manual search; 3-way repeat playback; CD-3 capability. 17½ x 4¾ x 11¾ in; 13 lb. \$300

DA980 CD Player

CD player with 3-beam laser and digital filter plus third order analog filter. Features 15-track random programming; 21-key remote; two speed manual search; index search; 3-way repeat playback; CD-3 capability. 17½ x 3¾ x 11½; 9 lb. \$250
DA952. As above without remote control \$200

SHARP

CD Players

DX-R830 CD Player

CD player with 8x-oversampling; dual D/A converters; FL multi display with music schedule; 3-beam

COMPACT • DISC • PLAYERS

laser pickup; 10-key direct program; search up/down; auto program search; auto program-locate device; repeat; digital time counter and mode indicator; infrared remote control with 10 keys \$410

DX-R820 CD Player

CD player with 8x oversampling; dual digital-to-analog converters; LCD multi display; 3-beam laser pickup; cue/review; auto program search; auto program locate device; repeat; digital time counter and mode indicator; infrared remote control with 10 keys \$340

DX-R790 CD Player

CD player with 20-track random-access programming; 10-key direct program; 2x-oversampling digital filter; FL multi display with music schedule; 3-beam laser pickup; search up/down; auto program search; repeat; digital time counter and mode indicator; infrared remote control with 10 keys \$300

DX-R770 CD Player

CD player with 20-track random-access programming; 2x-oversampling digital filter; 3-beam laser pickup; LCD multi display; cue/review; automatic program search; repeat; digital time counter and mode indicator; infrared remote control with 10 keys \$270

DX-670 CD Player. Same as above, without remote \$230

CD Changer

DX-C5000 CD Changer

Magazine-type compact disc changer with 6-disc capability. Features 32-track random-access programming; memory backup function; single and all repeat function; 2x-oversampling digital filter; FL display; APSS (Auto Program Search System); monitor search; cushioned floating mechanism; remote control. \$460

Portable CD Systems

Optonica CDX-17 Portable CD System

Portable CD player/double cassette deck/AM/FM stereo. Tuner: 10 AM/20 FM station presets; signal-to-noise ratio 60 dB stereo; alt ch sel 55 dB. CD: 2x-oversampling digital filter; 3-beam pickup; 20-track APMS random programming; random play; repeat play; continuous play; frequency response 20-20,000 Hz \pm 1 dB; signal-to-noise ratio $>$ 90 dB. Cassette: full-logic controls; double autoreverse; one capstan; wow and flutter 0.19% wrms; signal-to-noise ratio 62 dB Dolby B. Other features: Dolby B noise reduction; X-Bass sound; 20 W/ch amplifier; 35-key wireless remote control; 2 tripod-mountable speakers with frequency response 70-20,000 Hz; matrix surround sound capability; digital clock timer; 4-band graphic equalizer \$1,000

CD-X9 Portable CD System

Portable CD player/double cassette deck/AM/FM stereo. Features Dolby B NR; automatic programmable music selector, 20 programs for CD; auto program search system; infrared remote control; 2 x 5-band graphic equalizer; built-in clock/timer; dynamic VU meter; synchronous dubbing; continuous playback; high-speed dubbing. CD: Frequency response 20-20,000 Hz; wow and flutter $<$ 0.001%. Tape: Frequency response 50-15,000 Hz; signal-to-noise ratio 55 dB. tape 1, 50 dB. tape 2; wow and flutter 0.25 \$729

WQ-CD83 Portable CD Changer System

Portable 2-disc capacity CD changer/double cassette deck/AM/FM stereo. CD: 16-bit digital filter; 3-beam pickup; 24-track APMS random programming; random play; repeat play; continuous play; frequency response 20-20,000 Hz. Cassette: full-logic controls; high-speed dubbing; double autoreverse; one capstan; wow and flutter 0.15% wrms; signal-to-noise ratio 60 dB Dolby B. Other features: Dolby B noise

reduction; X-Bass sound; 3 amplifiers; wireless remote control; 2 speakers; super woofer; matrix surround-sound capability; clock timer; 4-band graphic equalizer with LCD spectrum analyzer; APSS \$700

WF-CD77 Portable CD System

Portable CD player/double cassette deck/AM/FM stereo. CD: wireless remote control; 16-bit digital filter; 3-beam pickup; 20-track random programming; random play; repeat play; continuous play. Cassette: full-logic controls; high-speed dubbing; double autoreverse; one capstan. Other features: Dolby noise reduction; 2 2-way speakers; clock timer; 4-band graphic equalizer; APSS \$630



Sharp Optonica WQ-CD83

SHERWOOD

CD-1182R CD Player

8x oversampling with 16-bit digital-to-analog converter. Features 16-track programmability; random play; disc/track elapsed-time display; 4-way repeat; headphone jack with level control; Digi-Link remote control. Frequency response 2-20,000 Hz \pm 0.5 dB; signal-to-noise ratio $>$ 95 dB; total harmonic distortion 0.004%. 11 lb \$299

CD-1160R CD Player

2x oversampling, 16-bit digital-to-analog converter, and 3-beam laser pickup. Features motorized touch-sensitive disc loading. Digi-Link remote capability; 20-track programming; multi-function LCD display; auto-space function for making auto-search recordings; 4-way repeat; random play. Frequency response 20-20,000 Hz \pm 0.5 dB; signal-to-noise ratio $>$ 90 dB; total harmonic distortion $<$ 0.005%. 2 $\frac{1}{2}$ x 17 $\frac{3}{8}$ x 10 $\frac{1}{4}$ in \$249

CD-1180C CD Player

8x oversampling and 16-bit digital-to-analog converter. Features 16-track programmability; random play; disc/track elapsed-time display; 4-way repeat; headphone jack with level control. Digi-Link remote compatible. Frequency response 2-20,000 Hz \pm 0.5 dB; signal-to-noise ratio $>$ 95 dB; total harmonic distortion 0.004%. 10.7 lb \$269

CD-1060C CD Player

4x oversampling and 16-bit digital-to-analog converter. Features 16-track programmability; disc/track elapsed-time display; 4-way repeat; headphone jack. Digi-link remote compatible. Frequency response 2-20,000 Hz \pm 0.5 dB; signal-to-noise ratio $>$ 93 dB; total harmonic distortion 0.07%. 10.7 lb \$229



Sherwood CDM-1260R

CD Changer

CDM-1260R CD Changer

6-disc CD changer with 4x oversampling and 16-bit digital-to-analog converter. 32-track programming; disc/track elapsed-time display; 4-way repeat; remote control. frequency response 20-20,000 Hz \pm 0.5 dB; signal-to-noise ratio 91 dB; total harmonic distortion 0.001%. \$349

SONOGRAPHE BY CONRAD-JOHNSON

SD-1B CD Player

Drawer-loading CD player with discrete FET audio circuits and power supplies designed by Conrad-Johnson. Features programming of 20 tracks in any order; skip forward; skip back; fast forward; fast reverse; repeat disc; program; headphone jack; digital filtering; dual digital-to-analog converters; sound audible during fast scan. Cues by track and index number. 4x oversampling at 176.4 kHz. Displays current track number, program in memory; elapsed time of current track. 3.75 x 18 x 12-in.; 8.5 lb \$795

SONY

CD Players

CDP-970 CD Player

CD player with remote. Features Unilinear converter/digital filter; dual digital-to-analog converters; envelope differential detection system; noise shaping; 5 power supply stages; aspheric optical pickup; 16-bit digital filter with 4x oversampling; 20-key direct music selector and delete shuffle play capability; 20-selection music calendar; Custom File; variable line output; optical outputs; CD-3 capability \$500

CDP-770 CD Player

Features 18-bit 8x-oversampling digital filter; dual 16-bit digital-to-analog converters; noise shaping; optical digital output; 20-key direct access; servo stabilizer circuit; 20-track musical calendar; shuffle play; repeat play; search; program edit; full function remote control. 17 x 3 $\frac{3}{4}$ x 10 $\frac{1}{2}$ in; 7 lb, 5 oz .. \$350

CDP-670 CD Player

Features 48-bit 8x-oversampling digital filter; dual 16-bit digital-to-analog converters; noise shaping; servo stabilizer circuit; optical digital output; 16-track music calendar; shuffle play; repeat play; search; full function remote. 17 x 3 $\frac{3}{4}$ x 10 $\frac{1}{2}$ in; 7 lb, 12 oz \$295

CDP-470 CD Player

Features 4x-oversampling digital filter; dual 16-bit digital-to-analog converters; servo stabilizer circuit; 16-track music calendar; shuffle play; repeat play; search; program edit; full function remote control. 17 x 3 $\frac{3}{4}$ x 10 $\frac{1}{2}$ in; 7 lb, 12 oz \$240

CDP-270 CD Player

Features 4x-oversampling digital filter; dual 16-bit digital-to-analog converters; servo stabilizer circuit; 15-track music calendar; shuffle play; repeat play; search; program edit; remote control capable. 17 x 3 $\frac{3}{4}$ x 10 $\frac{1}{2}$ in; 7 lb, 12 oz \$225

ES Series

CDP-R1 CD Player and DAS-R1 D/A Converter

CD player with twin optical link between the two components. Features 45-bit 8x-oversampling digital filter; noise shaping; 4 16-bit digital-to-analog converters; optical and coaxial digital outputs; servo stabilizer circuit; frame and beam construction; linear motor; aluminum diecast optical transport base; left/right twin-mono circuit configuration; multiple stage power supply; Custom File; 20-key direct access remote control; 20-selection random music sensor; high-speed search; index search; shuffle play; delete option; 5 repeat modes. Player: 18 $\frac{1}{2}$ x 5 x 16 $\frac{1}{4}$ in; 37 lb, 7 oz. Converter: 18 $\frac{1}{2}$ x 5 x 16 $\frac{1}{4}$ in; 37 lb, 7 oz \$8,000

CDP-X7ESD CD Player

CD player with digital sync. Features 45-bit 8x-oversampling digital filter; noise shaping; dual 18-bit linear digital-to-analog converters; optical and coaxial digital outputs; balanced outputs; servo stabilizer circuit; frame and beam construction; linear motor;

**"I'LL JUST
BRACE MYSELF
WITH THE
STEERING WHEEL"**



Who are you trying to fool?
There's no way a steering wheel
can stop you from slamming into a
dashboard. Only a safety belt can.
Stop making excuses and start
buckling your safety belt.

**YOU COULD LEARN A LOT
FROM A DUMMY.
BUCKLE YOUR SAFETY BELT.**

A Public Service Message   U.S. Department
of Transportation

COMPACT • DISC • PLAYERS

discrete left and right twin-mono circuit; multiple-stage power supply; twenty-selection random music sensor; high-speed search; index search; six repeat modes; shuffle play; delete option; music calendar. Includes 20-key remote control. Dimensions: 18 $\frac{3}{8}$ x 5 x 14 $\frac{7}{8}$ in. Weight: 37 lb. 8 oz. \$2,000

CDP-608ESD CD Player

CD player with digital sync. Features 45-bit 8x-oversampling digital filter; noise shaping; dual 18-bit linear digital-to-analog converters; optical and coaxial digital outputs; servo stabilizer circuit; frame and beam construction; linear motor; left/right twin-mono circuit configuration; Custom File; 20-key direct access remote control; 20-selection random music sensor; automatic music sensor; high-speed search; index search; 6 repeat modes; shuffle play; delete option; music calendar. 18 $\frac{3}{8}$ x 5 x 14 $\frac{7}{8}$ in; 25 lb. 6 oz. \$900

CDP-508ESD CD Player

Compact disc player with digital sync. Features 45-bit 8-times-oversampling digital filter; noise shaping; dual 18-bit linear digital-to-analog converters; optical digital outputs; servo stabilizer circuit; monococque chassis; linear motor; left and right twin-mono circuit configuration; Custom File; 20-selection random music sensor; automatic music sensor; high-speed search; index search; five repeat modes; shuffle play; delete option; music calendar. Includes 20-key direct access remote control. Dimensions: 18 $\frac{3}{8}$ x 4 $\frac{3}{8}$ x 13 $\frac{1}{2}$ in. Weight: 14 lb. 5 oz. \$550

CDP-208ESD CD Player

CD player with 18-bit 8x-oversampling digital filter; noise shaping; dual 16-bit linear digital-to-analog converters; optical digital outputs; servo stabilizer circuit; monococque chassis; 20-key direct access remote control; 20-selection random music sensor; automatic music sensor; high-speed search; 5 repeat modes; shuffle play; program edit; music calendar. 17 x 4 x 10 $\frac{7}{8}$ in; 9 lb. 1 oz. \$380

CD Changers

CDP-C800 CD Changer

5-disc carousel CD changer with DiscJockey cartridge-loading system. Features 18-bit 8x-oversampling digital filter; dual 18-bit digital-to-analog converters; noise shaping; servo stabilizer circuit; optical digital output; variable line output; Custom File; 5 + 10 key direct access playback; music calendar display; shuffle play; repeat play; search; 32-track programming; full function remote control. 17 x 5 x 15 $\frac{1}{4}$ in; 13 lb. 4 oz. \$500

CDP-C900 CD Changer

Ten-disc magazine compact disc changer with DiscJockey cartridge-loading system. Same magazine can be used in car compact disc changers. Features 18-bit 8-times-oversampling digital filter; dual 16-bit digital-to-analog converters; noise shaping; servo stabilizer circuit; optical digital output; ten-key direct access playback; shuffle play; repeat play; search; 32-track programming; full function remote control. Dimensions: 17 x 4 $\frac{3}{8}$ x 14 $\frac{3}{8}$ in. Weight: 14 lb. 2 oz. \$470

CDP-C700 CD Changer

5-disc carousel CD changer. Features 18-bit 8x-oversampling digital filter; dual 16-bit digital-to-analog converters; noise shaping; servo stabilizer circuit; Custom File; shuffle play; repeat play; search; 32-track programming; full function remote control. 17 x 5 x 15 $\frac{1}{4}$ in; 11 lb. 15 oz. \$400

CDP-C500 CD Changer

5-disc carousel CD changer with DiscJockey cartridge-loading system. Features 4x-oversampling digital filter; dual 16-bit digital-to-analog converters; servo stabilizer circuit; shuffle play; repeat play; search; 32-track programming; remote control. 17 x 4 $\frac{3}{8}$ x 15 $\frac{1}{4}$ in; 10 lb. 13 oz. \$330

CDP-C400. As above, remote compatible \$300

ES Series Changers

CDP-C15ESD CD Changer

10-disc magazine CD changer with DiscJockey cartridge-loading system. Features 18-bit 8x-oversampling digital filter; dual 18-bit linear digital-to-analog converters; optical and coaxial digital outputs; error prediction logic; t/R twin mono circuit configuration; multi-stage power supply; Custom File; 10-disc/10-track direct access remote control; 60-selection random music sensor, automatic music sensor; high-speed search; shuffle play; 4 repeat modes. 18 $\frac{3}{8}$ x 4 $\frac{3}{8}$ x 14 $\frac{3}{8}$ in; 14 lb. 9 oz. \$800

CDP-C9ESD CD Changer

10-disc magazine CD changer with DiscJockey cartridge-loading system. Features 18-bit 8x-oversampling digital filter; noise shaping; dual 18-bit linear digital-to-analog converters; optical digital outputs; servo stabilizer circuit; 10-disc/10-track direct access remote control; 32-selection random music sensor, automatic music sensor; shuffle play; 4 repeat modes; music calendar. Dimensions: 17 x 4 $\frac{3}{8}$ x 14 $\frac{3}{8}$ in. Weight 14 lb. 2 oz. \$500

CDP-C8ESD CD Changer

5-disc carousel CD changer. Features 18-bit 8x-oversampling digital filter; noise shaping; dual 18-bit linear digital-to-analog converters; optical digital outputs; servo stabilizer circuit; monococque chassis; Custom File; 5-disc/10-track direct access remote control; 32-selection random music sensor, automatic music sensor; shuffle play; 5 repeat modes; music calendar. 18 $\frac{3}{8}$ x 5 x 15 $\frac{1}{4}$ in.; 15 lb. 7 oz. \$500

CDP-C7ESD CD Changer

5-disc carousel CD changer with remote control. Features 4x-oversampling 16-bit digital filter; dual digital-to-analog converters; Custom File; 16-selection music calendar; shuffle play; timer switch; variable line output; disc select and output-level controls. \$480

Portable CD Components

CFD-DW83 Portable CD System

Portable CD player with AM/FM tuner and dual cassette deck. Features record and playback; autoreverse; cue and review; Sony Mega Bass; automatic music sensor; search; random music sensor; repeat play; dual 4-in 2-way speakers; 3-band graphic equalizer; digital clock; timer; stereo headphone and CD output jacks; input jack; 2-way power supply. Includes AC power cord. Uses 8 D batteries. 25 $\frac{3}{8}$ x 8 $\frac{3}{8}$ x 9 in; 18 lb. 5 oz. \$400

D-25 Portable CD Player

With 4x oversampling and 16-bit digital-to-analog converter. Features 22-track random music programming; 5-way repeat; music search; key hold switch; LCD display. Includes remote, stereo headphones, adaptor, rechargeable battery, line-out cord, carrying case, and strap \$360

CFD-D73 Portable CD System

Portable CD player with AM/FM tuner and cassette deck. Features cassette recording and playback; autoreverse; Sony Mega Bass; automatic music sensor; search; random music sensor; repeat play; dual 4-in speakers; three-band graphic equalizer; digital clock; timer; stereo headphone and CD output jacks; input jack; 2-way power supply. Includes AC power cord. Uses 8 D batteries. 24 $\frac{3}{4}$ x 6 $\frac{3}{4}$ x 7 $\frac{7}{8}$ in; 15 lb. 12 oz. \$350

CFD-454 Portable CD System

Portable CD player with AM/FM tuner and cassette deck. Features cassette recording and playback; automatic music sensor; shuffle play; repeat play; cue and review; 5-band graphic equalizer; detachable 2-way speakers; stereo headphone and CD output

COMPACT • DISC • PLAYERS

jacks; input jack. Includes AC power cord. Uses 8 D batteries. 26 $\frac{3}{8}$ x 11 $\frac{3}{8}$ x 7 $\frac{1}{2}$ in; 16 lb. 12 oz. . . . \$320

D-T4 Portable CD Player

Portable CD player with AM/FM tuner. Features Unilinear converter/digital filter; single aspheric-lens laser pickup; auto-tracking recovery system; BP-3 rechargeable battery; random music sensor 16-track programming; four repeat modes including 1, all, A/B, and shuffle; remote control via RM-DM1K remote control; multi-function back-lit LCD including battery-strength indicator; local/D/A switch. Comes with AC power adaptor, line-out cord, carrying case, and strap \$320

D-4. As above without tuner. \$260

D-88 Portable CD Player

Designed for 3-in CD's, compatible with 5-in CD's. Features Unilinear converter/digital filter; single aspheric lens laser pickup; auto-tracking recovery system; high-speed music search; shuffle play; 3-way repeat; BP-2 rechargeable battery; optional remote control; LCD shows track number and repeat mode. Includes AC adaptor, rechargeable battery pack, stereo mini plug, and carrying bag \$280

CFD-60 Portable CD System

Portable CD player with AM/FM tuner and cassette deck. Features search; repeat play; cue and review on cassette deck; dual 4-in speakers; headphone and CD output jacks. Includes AC power cord. Uses 8 D batteries. 23 $\frac{3}{4}$ x 7 x 7 $\frac{3}{4}$ in; 10 lb 2 oz. \$250

D-9 Portable CD Player

Bass-boosted for deeper bass sounds with 2x oversampling and 16-bit digital-to-analog converter. Features 22-track random music sampling; 5-way repeat; music search; wireless remote; key-hold switch; back-lit LCD display; auto-tracking recovery. Includes AC adaptor, rechargeable battery, line-out cord, carrying case, and strap \$250

D-2 Portable CD Player

With 2x oversampling and 16-bit linear converter. Features 3-way repeat; high-speed music search; key-hold switch; LCD display showing track number and elapsed time. Includes AC adaptor, line-out cord, and carry belt. \$220

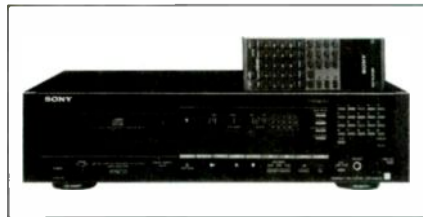

Sony CDP-608ESD

SOUNDCRAFTSMEN

CD750 CD Player

CD player with differential/compander circuitry. Features high dynamic range; optional tening; spectral gradient circuit; both circuits bypassable; indexing; digital filter; all-metal chassis; audible scan; random; passage-repeat; 3-beam laser; full function infrared remote; oversampling; multi-function fluorescent display; headphone jack; gold-plated output jacks; shock-resistant disc-handling \$599

SOUNDESIGN

Portables

4955 Portable CD System

Front-loading CD player, dual cassette deck, and AM/FM radio with 2-way stereo speakers and extra bass sound (XBS). CD section: 3-beam laser pickup; 16-song random access memory; LCD display for track number, total time, time remaining, program num-

ber, pause and repeat. Dual cassette deck; high-/normal-speed dubbing; continuous play. Other features: 3-band graphic EQ; PLL MPX circuitry; headphone jack; line in/out and external mic jack. Includes AC cord. Also works with DC adaptor (not included) and D batteries. 24 $\frac{1}{2}$ x 8 x 6 in. Black finish. \$230

4928 Portable CD Player

Battery-operated top-loading portable CD player with 3-beam laser pickup, 16-program random access memory, and built-in battery charger. Features repeat; music search; 6-digit LED display showing track number and time elapsed; low-battery indicator. Includes AC adaptor, 2 $\frac{1}{2}$ -ft line output cord, headphones, and carrying case with a shoulder strap. 5 $\frac{1}{4}$ x 1 $\frac{1}{2}$ x 6 $\frac{3}{8}$ in. Black \$200

SYLVANIA

CD Player

CD1490 CD Player

CD player with dual 16-bit digital-to-analog converters. Features CDM4 laser scanning assembly; touch-to-close disc tray; 20-track memory programming; 4-digit LED display; next/previous track skip; 3-speed music search with cueing; shuffle play; repeat play; 3-in CD compatibility; stereo headphone jack. Frequency response 2-20,000 Hz \pm 0.5 dB; signal-to-noise ratio >90 dB; ch sep 93 dB at 1,000 Hz; total harmonic distortion <0.02% at 1,000 Hz. 16 $\frac{1}{2}$ x 3 x 11 in \$150

CD Changer

CD1494 CD Changer

CD changer with 6-disc magazine and dual 16-bit digital-to-analog converters. Features auto changer; 30-track memory programming; 5-digit LCD display; next/previous track skip; 3-speed music search with cueing; shuffle play; repeat play; stereo headphone jack. Frequency response 2-20,000 Hz \pm 0.5 dB; signal-to-noise ratio >90 dB; ch sep 93 dB at 1,000 Hz; total harmonic distortion <0.02% at 1,000 Hz. 16 $\frac{1}{2}$ x 3 $\frac{3}{4}$ x 12 $\frac{1}{2}$ in. \$250

SYMPHONIC BY FUNAI

CD 3000A CD Changer

16-bit digital-to-analog converter and 6-disc Pioneer-style cartridges. Features 3-beam laser pickup; wireless remote control; 32-track random programming; repeat track, disc, and program; search function; elapsed time display. \$399

CD 2000A CD Player

16-bit digital-to-analog converter with 15-track random programming. Features 3-beam pickup; CD-3 capability; feather-touch controls; programmable repeat function; amber elapsed-time display LCD; headphone jack with adjustable level; wireless remote control. \$249

TEAC

CD Players

P-1 CD Transport and D-1 D/A Converter

Transport features: 3-beam linear tracking system; vibration-free rigid disc clamping system; heavy-duty $\frac{3}{4}$ -in aluminum front panel; large capacity power supply; direct search; 40-selection random programming; 4-way repeat; time display; floating suspension laser mechanism; disc tray variable speed control; vibration damping; variable brightness control. digital-to-analog converter features: 18-bit, 4x oversampling digital filter; twin digital-to-analog converters; 4th-order analog filter; MOSFET analog circuits; ZD circuitry; auto sampling frequency switching (30,000-50,000 Hz); 3 coaxial and 1 optical inputs; 2-box double bottom chassis; noiseless digital muting system; remote-controlled, motor-driven output vol-

ume. Includes wireless remote control. digital-to-analog converter specs: signal-to-noise ratio 100 dB; total harmonic distortion <0.0015% at 1,000 Hz; ch sep >100 dB; frequency response 0-20,000 Hz; Transport: 8 $\frac{7}{8}$ x 5 $\frac{3}{8}$ x 16 $\frac{1}{2}$ in; 24.25 lb. Digital-to-analog converter: 8 $\frac{7}{8}$ x 5 $\frac{3}{8}$ x 16 $\frac{1}{2}$ in; 25 $\frac{1}{4}$ lb \$5,995

PD-480 CD Player

8-times-oversampling and dual digital-to-analog converters. Features 20-selection random memory programming; three-way repeat; program delete; ten-key pad on front panel, memory program calendar; auto space; multi-function eight-digit fluorescent LCD display. Includes 30-key full function remote control. Frequency response 2-20,000 Hz \pm 0.5 dB; signal-to-noise ratio >100 dB; total harmonic distortion 0.008%; channel separation >98 dB. Dimensions: 17 $\frac{1}{8}$ x 3 $\frac{1}{2}$ x 11 $\frac{1}{8}$ in. Weight: 8.4 lb. \$400

PD-440 CD Player

4x oversampling and dual digital-to-analog converters. Features 20-selection random memory programming; 3-way repeat; auto space; multi-function 8-digit LCD display. Includes 16-key remote control. FR 2-20,000 Hz \pm 0.5 dB; signal-to-noise ratio > 90 dB; THD 0.008%; ch sep >88 dB. 17 $\frac{1}{8}$ x 3 $\frac{1}{2}$ x 11 $\frac{3}{8}$ in; 8.4 lb. \$280

PD-165 CD Player

16-bit digital-to-analog converter and three-beam laser pickup. Features 16-selection random memory programming; two-way repeat; four-digit LED display; three-inch CD compatibility. FR 5-20,000 Hz \pm 1 dB; S/N 90 dB; THD 0.005% at 1,000 Hz; channel separation 80 dB at 1,000 Hz. 17 $\frac{1}{8}$ x 3 $\frac{3}{8}$ x 10 $\frac{1}{8}$ in; 7 lb. \$250

CD Changer

PD-700M CD Changer

Six-disc compact disc changer with 4-times-oversampling, dual digital-to-analog converters, and three-beam laser pickup. Features 32-track multi-disc random playback; multi-function fluorescent display; three-way repeat; front-loading disc cartridge. Includes ten-key remote control. Frequency response 5-20,000 Hz \pm 1 dB; signal-to-noise ratio 93 dB; total harmonic distortion 0.01% at 1,000 Hz. Dimensions: 17 $\frac{1}{8}$ x 4 x 13 $\frac{1}{4}$ in. Weight: 11.4 lb. \$499

TECHNICS

CD Players

SL-P1300 CD Player

8-times-oversampling digital filter and four 18-bit digital-to-analog converters. Features separate digital and analog power supplies; Class AA sample-and-hold circuitry; high-speed linear-motor access system. 10-button keypad; auto-cue; A/B repeat; \pm 8% pitch control; optical and coaxial digital outputs; 2-speed search dial; audible pause; rocker switch for mixing; cueing by direct CD time code; balanced outputs; skip keys; 2-speed audible search; repeat track, disc, and program; headphone jack with adjustable level; line out via unbalanced (phono) pin connectors; subcode output; full-function fluorescent display; cue search. Includes remote control. Dimensions: 6 $\frac{3}{4}$ x 16 $\frac{1}{8}$ x 14 $\frac{7}{8}$ in \$1,800

SL-P1200 Disco CD Player

CD player for discos or production cues to any point within track. Features dual high-speed digital-to-analog converters; 2x-oversampling digital filter; 9th-order low-pass analog filter; 1-beam laser; high-speed Linear Motor Access Rocker control for momentary advance or retard. Quartz-locked pitch control (\pm 8%); 2-speed cueing; rear-panel remote jack for mixer; auto cue to first note of desired track; FL display; locates track start in <1 sec; subcode output; skip forward; skip back; fast forward/reverse; audible sound during fast scan; repeat track, disc, program; 20-track programming; headphone jack with adjust-

COMPACT • DISC • PLAYERS

able level; cues by track number, index number, time, track, time, and program displays. Includes infrared remote control. 17 x 7 x 15 in; 22 lb. \$1,500

SL-P999 CD Player

Four 20-bit D/A converters and 8x-oversampling digital filter. Features Class AA circuitry; discrete low-noise active servo power supply; anti-vibration/resonance multi-layer chassis construction; high-speed linear motor access system; dual aspheric glass lens. 32-track random access programming; skip and index skip; 20-key direct-access system; auto cue; auto space; optical digital output; sample-and-hold noise suppression; edit guide; random play; search play; window search; peak-level search; FL display; timer play; 3-in CD compatibility. Includes 43-key remote control. Frequency response 2-20,000 Hz \pm 0.3 dB; signal-to-noise ratio 113 dB; THD 0.0013%. 17 x 5 x 13 $\frac{3}{8}$ in; 13.2 lb. \$600

SL-P770 CD Player

4x-oversampling digital filter and four 18-bit D/A converters. Features separate digital and analog power supplies; OFC wiring; high-speed linear-motor access system. Optical and electrical digital outputs; auto-cue; signal output meters; full-function FL display; linear matrix track and programming indicator; 20-key direct access; random play; headphone jack with adjustable level; disc window; 2-speed audible search; peak-level search for taping; CD edit; music scan; A/B repeat; track repeat; dimmer switch; gold-plated output jacks; 32-track programming; timer play. Includes remote control. \$580

SL-P555 CD Player

4x-oversampling digital filter and four 18-bit D/A converters. Features Class AA circuitry; anti-resonance/vibration construction; high-speed linear-motor access system. Peak-level search; edit guide; optical digital output; search play; cueing search; random play; 32-track random access programming; FL display; skip and index skip; repeat; A-B repeat; 10-key direct access system; auto cue; music scan; 3-in CD compatibility; headphone jack with volume control; timer play. Includes 31-key remote control. Frequency response 2-20,000 Hz \pm 0.3 dB; S/N 100 dB; THD 0.0035%. 17 x 4 $\frac{1}{2}$ x 13 $\frac{1}{8}$ in. \$410

SL-P222 CD Player

4x-oversampling digital filter and four 18-bit D/A converters. Features high-speed linear motor access system; dual aspheric glass lens; 20-track random access programming with 10-key control panel; random play; skip forward/reverse; repeat; A-B repeat; 10-key direct access; auto cue; music scan; edit guide; optical digital output; 2-color multi-function display; 3-in CD compatibility; headphone jack with volume control. Includes 31-key remote control. Frequency response 2-20,000 Hz \pm 0.5 dB; signal-to-noise ratio 96 dB; THD 0.005%. 17 x 3 $\frac{3}{8}$ x 11 in; 7.9 lb. \$290

SL-P102 CD Player

4x-oversampling digital filter and dual 16-bit D/A converters. Features high-speed linear motor access system; dual aspheric glass lens; Edit guide with synchro editing; 20-track random access programming; skip forward/reverse; auto cue; 3-in CD compatibility; headphone jack with volume control; multi-function FL display. Includes 23-key remote control with 10-key pad; remote control compatible with several Technics receivers. Frequency response 2-20,000 Hz \pm 1 dB; signal-to-noise ratio 96 dB; total harmonic distortion 0.05%. 17 x 3 $\frac{3}{8}$ x 11 in; 7.9 lb. \$220

CD Changer

SL-PC20 CD Changer

5-disc CD changer with revolving disc platform. Features 4x oversampling digital filter; dual 16-bit D/A converters. Sequential play; 20-step random access programming; direct-disc access; repeat; ran-

dom play; 2-color FL display. Includes 25-key wireless remote control. Frequency response 2-20,000 Hz \pm 1 dB; signal-to-noise ratio 96 dB; THD 0.05%. 17 x 3 $\frac{3}{4}$ x 14 $\frac{1}{4}$ in; 8.6 lb. \$330

Portable CD Players

SL-XP6 Portable CD Player

Compact, lightweight portable compact disc player with normal, resume, and random play modes. Features skip keys; memory key; 18-step random-access programming; play; stop; 4x-oversampling digital filter; AC adaptor; auto power off after 5 minutes in stop mode; headphone jack with adjustable level; repeat; search; line-out jack; LCD display. 1 x 5 x 5 in; 13.4 oz. \$380

SL-XP2 Portable CD Player

4x-oversampling digital filter and dual 16-bit D/A converters. Features dual aspheric glass lens; direct-drive spindle motor. XBS extra bass system; resume play; random play; LCD display; 18-track random access programming; auto power off; repeat key; skip/search keys; memory recall key; line out terminal; 3-in CD compatibility. Powered by internal NiCd rechargeable batteries or AA batteries. Includes multi-function single-key remote control, earphones, rechargeable NiCd AA batteries, AC adaptor/recharger. signal-to-noise ratio 88 dB. 5 x 1 $\frac{3}{8}$ x 5 $\frac{3}{4}$ in; 13.8 oz. \$220

TOSHIBA

CD Players

XR-9459 CD Player

4x oversampling and digital surround sound. Features 3-beam laser pick-up; rechargeable battery; wireless remote; 16-track programming; headphone jack with volume; wired remote; carry case. . . . \$450

XR-9037 CD Player

2x oversampling and remote control with volume. Features digital peak search; 20-program random memory; digital filter. . . . \$450

XR-9018 CD Player

2x oversampling and 16-track random programming. Features 3-beam laser pickup; quick-program-selector up/down key; automatic repeat capability; LCD with track, lap, and remaining time; fast forward and reverse; integrated system remote capability; headphone jack with adjustable level. . . . \$279
XR-9028. As above, includes 10-key remote control. . . . \$329

CD Changers

XR-9057 CD Changer

CD changer with 6-disc capacity and single-play drawer. Features 2x oversampling; 3-beam laser pickup; 32-track random programming; 32-key wireless remote control; intro scan; random play; 9-digit multi-function display; cumulative time display; 10x audible search; fast forward and reverse; integrated system remote capability. . . . \$499

XR-9058. As above with integrated system remote. . . . \$499

Portable CD Players

XR-9458 Portable CD Player

Portable CD player with wireless/wired remote control. Features 3-beam laser pickup; 16-program random memory with repeat; headphone jack with adjustable level; LCD of track, lap, and remaining time; CD-3 capability. . . . \$426

XR-9437 Portable CD Player

Compact CD player with AM/FM stereo, 9 FM/5 AM presets; 3 beam laser pick-up; 16-program random memory w/repeat; quick-program select; uses 4 AA batteries or rechargeable NiCd. . . . \$400

Portable CD Systems

RT-8089 Portable CD System

Portable CD player with built-in dual cassette deck, tuner, and speakers. CD section features 16-track programming; search and skip; CD line output. Cassette section features AM/FM stereo. Deck features autoreverse. . . . \$480

RT-8088 Portable CD System

Portable CD player with built-in cassette deck, tuner, and speakers. CD section features 20-program random memory; CD-double-speed recording system; CD auto-recording system; 20-song music calendar and integrated digital time counter; intro scan; auto spacing; random play; auto sleep. Cassette section features autoreverse; manual reverse; 3-band graphic equalizer. . . . \$400

RT-8069 Portable CD System

Portable CD player with built-in cassette, tuner, and speakers. CD section features 16-track programming; CD-line output. Deck features microphone jack; input line; recorder; tape bias switch. 3-band graphic EQ; balance control. . . . \$320

VECTOR RESEARCH

VCD-420R CD Player

Features 4x oversampling, dual D/A converters; digital filter. Music calendar; CD-3 compatible; 5-way repeat; shuffle play; 28-function remote control. Frequency response 20-20,000 Hz \pm 0.5 dB; S/N > 100 dB; THD < 0.004%; ch sep > 90 dB; dynamic range > 95 dB. 17 x 3 $\frac{3}{4}$ x 12 in; 9 lb, 15 oz. . . . \$350

VCD-410R CD Player

Features 8x oversampling, dual 18-bit D/A converters; digital filter. CD-3 compatible; 4-way repeat; 15 function remote control. Frequency response 20-20,000 Hz \pm 0.5 dB; S/N > 100 dB; THD > 0.004%; ch sep > 90 dB; dynamic range > 95 dB. 17 x 3 $\frac{3}{4}$ x 12 in; 9 lb, 15 oz. . . . \$270

CD Changer

VCD-610R CD Changer

CD changer with 4x oversampling, dual D/A converters, and 6-disc capacity. Shuffle play; audible cue & review; 4-way repeat; 18-function remote control. Frequency response 20-20,000 Hz \pm 0.5 dB; S/N > 96 dB; THD < 0.009%; ch sep > 86 dB; dynamic range > 92 dB. 17 x 4 $\frac{1}{2}$ x 12 $\frac{1}{2}$ in; 13 lb. . . . \$400



Vector Research VCD-420R

YAMAHA

CD Players

CDX-10000 CD Player

Limited centennial edition CD player with 4x oversampling, hi-bit D/A converter, and wireless remote. Features high-speed linear motor; internal photo-optical coupling; heavy-duty chassis. 20-bit digital volume control; output-level control; digital-out; 24-track direct access play; random play; headphone jack; gold-plated terminals. Titanium grey with walnut end panels. 69 lb. . . . \$3,000

CDX-2020 CD Player

Hi-bit 8x-oversampling digital filter and 4 hi-bit, MSB

COMPACT • DISC • PLAYERS

digital-to-analog converters; this produces 22-bit linearity. Features hi-bit switchable direct output; digital de-emphasis circuitry; current isolation system; shunt-regulated power supplies and independent transformers; microcomputer controlled 2-way servo system; heavy-duty chassis with pinpoint damping system; high-speed linear motor; floating suspension system; glass lens 3-beam laser pickup with built-in head amplifier in high-precision die-cast aluminum chassis. 20-bit digital volume control; optical and coaxial digital output connectors; 3-in CD compatibility; 5-way repeat play; 24 track random access programmable play; direct track access; 3-way music search; index search; calendar display; random play; gold-plated terminals; RS integrated system remote control compatibility. Includes 46-key wireless remote control. Titanium finish with wood side panels. 39 lb \$1,499
CDX-1120Ti. As above, no wood side panels. 28 lb \$1,199

CDX-920Ti CD Player

Hi-bit 8x oversampling 18-bit digital filter and twin hi-bit D/A converters which produce 22-bit linearity. Features hi-bit switchable direct output; digital de-emphasis circuitry; current isolation system; microcomputer controlled 2-way servo system; heavy-duty chassis with ballpoint damping system; glass lens 3-beam laser pickup with built-in head amplifier in high-precision diecast aluminum chassis. 20-bit digital volume control; optical and coaxial digital output connectors; auto/manual tape edit program; 3-in CD compatibility; 5-way repeat play; 24 track random access programmable play; direct track access; 3-way music search; index search; calendar display; random play; gold-plated terminals; RS integrated system remote control compatibility. Includes 47-key wireless remote control. Titanium finish. 22 lb ... \$699
CDX-920. As above, black. \$699

CDX-820Ti CD Player

Hi-bit 8x oversampling 18-bit digital filter and twin hi-bit D/A converters. Features hi-bit switchable direct output; current isolation system; microcomputer controlled 2-way servo system; glass lens 3-beam laser pickup with built-in head amplifier in high-precision diecast aluminum chassis. Coaxial digital output; auto/manual tape edit program; 3-in CD compatibility; 5-way repeat play; 24 track random access programmable play; index search; calendar display; 4-mode program (random, tape edit, delete, manual); 8-digit multi-function fluorescent display; headphone jack with level control; anti-resonance, anti-vibration design; RS integrated system remote control compatibility. Includes 45-key wireless remote control. Titanium finish. 15 pound \$599
CDX-820. As above, black. \$599

CDX-720 CD Player

Hi-bit 8x oversampling 18-bit digital filter and twin 18-bit D/A converters. Features hi-bit switchable direct output; microcomputer controlled 2-way servo system; glass lens 3-beam laser pickup with built-in head amplifier in high-precision diecast aluminum chassis. Optical and coaxial digital output connectors; 4-way repeat play; 24 track random play; 3-in CD compatibility; auto/manual tape edit program; 3-mode program (random, tape edit, manual); intros-can; calendar display; 6-digit multi-function LCD; headphone jack with level control; RS integrated system remote control compatibility. Includes 25-key wireless remote control. Black; 13 lb \$429

CDX-520 CD Player

Hi-bit 8x oversampling 18-bit digital filter and twin 16-bit D/A converters. Features hi-bit switchable direct output; microcomputer controlled 2-way servo system; glass lens 3-beam laser pickup with built-in head amplifier in high-precision diecast aluminum chassis. Coaxial digital output; 4-way repeat play; 24 track random play; 3-in CD compatibility; auto/manual tape edit program; 3-mode program (ran-

dom, tape edit, manual); index search; intros-can; calendar display; 6-digit multi-function LCD; headphone jack with level control; RS integrated system remote control compatibility. Includes 25-key wireless remote control. Black; 13 lb \$329

CDX-420 CD Player

Double-resolution 16-bit digital filter and twin high-speed 16-bit D/A converters. Features microcomputer controlled 2-way servo system; glass lens 3-beam laser pickup with built-in head amplifier in high-precision diecast aluminum chassis. 4-way repeat play; 24 track random play; 3-in CD compatibility; auto/manual tape edit program; 3-mode program (random, tape edit, manual); three-way music search; calendar display; six-digit multi-function LCD; headphone jack; direct track access. Black; 13 lb. ... \$279

CD Changers/Combi Players

CDV-1600Ti Combi Player

8x oversampling and 18-bit twin D/A converters. Plays 3- and 5-in CD's, 8- and 12-in discs, and 5-in CDV's. Features 15-chapter/track random programming capability; separate A/V power supplies; OFC wire; gold-plated output terminals; optical digital output; 4-way repeat; FL display; index search. Includes wireless remote control with RS integrated remote control compatibility. Video section: resolution 425 lines. Audio: Frequency response 5-20,000 Hz \pm 3 dB; total harmonic distortion 0.0035% at 1,000 Hz; ch sep 100 dB at 1,000 Hz; signal-to-noise ratio 110 dB. 17 $\frac{1}{8}$ x 4 $\frac{3}{8}$ x 16 in; 19.4 lb. Titanium finish \$899
CDV-1600. As above, black finish \$899

CDV-1100 Combi Player

8x oversampling and 18-bit twin D/A converters. Plays 3- and 5-in CD's, 8- and 12-in video discs, and 5-in CDV's. Features 10-speed forward/reverse playback of videotapes; 4-way repeat. Includes 31-key remote control unit with RS integrated remote control compatibility. Video section: resolution 425 lines. Audio: Frequency response 5-20,000 Hz \pm 3 dB; total harmonic distortion 0.005% at 1,000 Hz; ch sep 97 dB at 1,000 Hz; signal-to-noise ratio 108 dB. 17 $\frac{1}{8}$ x 4 $\frac{3}{8}$ x 15 $\frac{1}{2}$ in; 17.6 lb. Available in Titanium and black finish \$699

CDC-610U CD Changer

CD changer with 10-disc magazine. Features 18-bit, 4x-oversampling digital filter; D/A converter; three-beam laser pickup; microcomputer-controlled 2-way servo system; 3rd-order low-pass analog filter. 36-track random access programming; memory play; random play; disc scan; music scan; three-way repeat; index search; headphone jack with adjustable level. Includes wireless remote control. Black; 20 lb. \$599

CDC-500 CD Changer

CD changer with 6-disc magazine and 1-disc tray. Features 4x-oversampling digital filter; 3-beam laser pickup. 32-track random access programmability; random play; intro scan; coaxial digital output; 6-key direct-disc access; 10-key direct track access; 2-way repeat play (1 disc or all discs); headphone jack with level control; RS integrated system remote control compatibility. Includes 32-key wireless remote control. Black; 15.5 lb \$499

The listings are based on data provided by the manufacturers. For more product information, contact an authorized dealer or the manufacturer directly. Manufacturers' addresses and phone numbers are listed in the directory beginning on page 258.

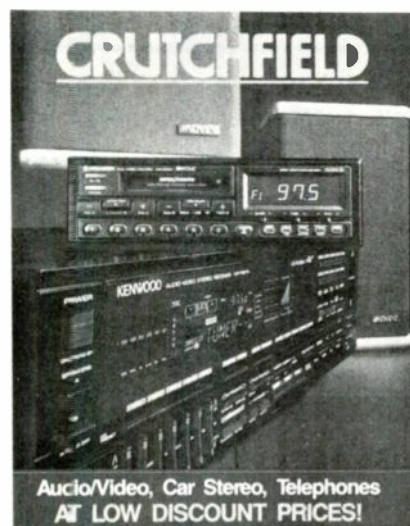

You'll find the most helpful shopping information in the 116 page Crutchfield catalog.

FREE Stereo Catalog

Refer to the Crutchfield catalog before buying your next car stereo, home stereo, or video product:

- 116 pages of helpful articles, consumer tips, charts, and installation guides.
- Color photos, complete descriptions and technical specifications on hundreds of the finest brand name products.

You get more value shopping Crutchfield:

- Toll-free product advice, ordering, and customer service.
- 24 hour shipping.
- Absolute satisfaction guaranteed.
- Full 30-day return privileges.
- Discount prices on Sony, Pioneer, JVC, Jensen, Proton, Advent, Clarion, Kenwood, AR, Infinity, Bose, and many more!

Call or send this coupon now for your FREE Catalog

800-336-5566

Be sure to mention *Stereo Review* when calling

Name _____

Address _____ Apt # _____

City _____ State _____ Zip _____

Optional: Do you have space in your home that you use as an office? Yes No

CRUTCHFIELD

1 Crutchfield Park, Dept. SR, Charlottesville, VA 22906

CASSETTE • DECKS

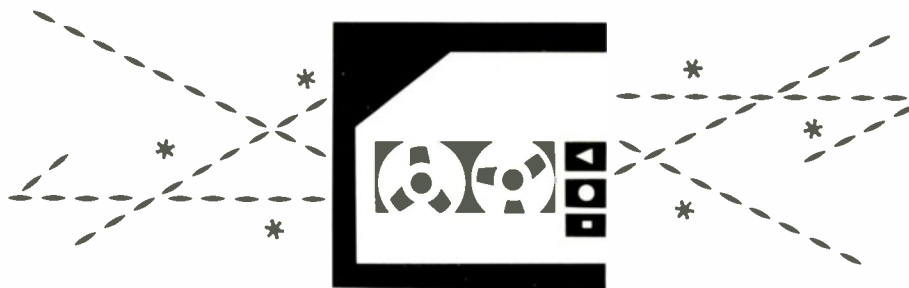

ACOUSTIC RESEARCH

RD-06 Cassette Deck

Features Dolby B, C, and HX-Pro. Brushless direct drive DC-servo motor; rec/play sendust-core head; ferrite-core erase head. Bias-adjustment function; rec balance function; optional remote control. S/N Dolby B 64 dB, Dolby C 73 dB, Dolby out 55 dB; wow and flutter 0.2% DIN; FR 30-20,000 Hz, ± 3 dB (metal tape). 17 x 4 $\frac{3}{8}$ x 13 in; 12 lb, 5 oz. . . . \$500
RC-03. Remote control for the above. . . . \$25

a/d/s/

C4 3-Head Cassette Deck

Microprocessor-controlled Dolby B/C/HX Pro cassette deck. Quartz-controlled-PLL capstan motor drive in die-cast metal chassis. Digital recording-level and balance controls; full status displays; remote controlled through a/d/s/ R4 receiver or CC4 tuner/preamp; auto bias/EQ for all tape types; memorizes adjustable bias and level settings for each tape type; displays elapsed or remaining time; record and play timer; auto repeat; music search; mic/line mixing; adjustable headphone output; LED rec-level meters; rec-level range 80 dB in 1-dB steps. Speed deviation <0.5%; w&F <0.04% wtd rms; FR 20-20,000 Hz, ± 2 dB; S/N Dolby C, metal tape >74 dBA with Dolby C (optional outboard NR system extends S/N to >93 dBA). 2 $\frac{3}{4}$ x 17 $\frac{1}{2}$ x 14 $\frac{3}{4}$ in; 22 lb. . . . \$1,250

Atelier C3 2-Speed Cassette Deck

Records and plays at 1.88 ips (standard speed) and 3.75 ips (double speed); Dolby B/C; 3 head, 2 motor; quartz-PLL direct-drive-capstan multiple-pole outer-rotor motor. Repeat function; mic/line mixing; music search; memory stop/play; LED meters; headphone jack; remote controlled through a/d/s/ R4 receiver or CC4 tuner/preamp. w&F 0.04% wrms; FR 20-20,000 Hz, ± 2 dB; S/N (A-wtd, all tape types) no NR >58 dBA, Dolby B >66 dBA, Dolby C >74 dBA. 2 $\frac{3}{4}$ x 17 $\frac{1}{2}$ x 14 $\frac{3}{4}$ in; 19 lb, 10 oz. . . . \$850

AIWA

AD-WX909 Double Cassette Deck

3-head double deck featuring Dolby HX Pro (deck 2); Dolby B & C (both decks). ADMS (auto demagnetizing system); IC logic controls; independent digital tape counters; bias fine adjustment for CrO₂/normal-bias tape ($\pm 20\%$); auto tape/source monitor selector; gold-plated CD inputs and LINE/CD front-panel selector. High-speed dubbing; continuous playback. FR 10-17,000 (normal bias), 10-19,000 (high bias), 10-20,000 (metal); S/N Dolby C 80 dB; w&F 0.0055% deck 1, 0.028% deck. 4 $\frac{3}{8}$ x 17 x 11 $\frac{3}{4}$ in; 14 $\frac{1}{2}$ lb \$900

AD-F1000 3-Head Cassette Deck

Cassette deck incorporating Super DX recording rec/playback heads. Dolby HX Pro, B, C, and dbx NR, CD/DAT inputs; switchable MPX filter; fluorescent display and electronic tape-counter with memory rewind and repeat; auto tape and rec-mute selectors; and record/play timer standby. FR 20-18,000 Hz (metal); S/N ratio 95 dB (dbx, metal tape); w&F 0.025%. 17 x 5 $\frac{3}{8}$ x 17; 18 lb. . . . \$880

AD-WX999 Double Cassette Deck

Double cassette deck featuring playback and recording in both decks. Dolby B, C NR and HX Pro. Remote control, bias fine adjustor ($\pm 20\%$), tape counters for each deck, rec/play timer standby. Frequency response 20-18,000 Hz; S/N 65 dB; w&F .055%. 17 x 5 $\frac{1}{2}$ x 12 $\frac{3}{8}$; 12 lb. . . . \$600
AD-WX888. As above, no remote, deck 1 playback only. . . . \$470
AD-WX777. As AD-WX888, no Dolby HX Pro \$370

AD-F780 3-Head Cassette Deck

Cassette deck incorporating Super DX recording rec/playback heads. Dolby HX Pro; Dolby B, and C NR. IC logic controls with cue and review; fluorescent display and electronic tape counter with memory rewind and repeat; switchable MPX filter; auto tape and rec-mute selectors; FR 20-20,000 Hz (metal); S/N Dolby C 78 dB; w&F 0.035%. . . . \$500

AD-WX808 Double Cassette Deck

Autoreverse double deck with Dolby HX Pro and Dolby B & C. Features amorphous head; blank-skip continuous playback; double-speed playback; IC logic controls; digital tape-counter; auto rec mute; rec/timer standby. Frequency response 20-17,000 Hz (normal bias), 20-19,000 Hz (high bias), 20-20,000 Hz (metal); S/N Dolby C; 78 dB, Dolby B; 65 dB; w&F 0.055%. 5 x 17 x 12 $\frac{3}{8}$ in; 11 lb. . . . \$500

AD-WX707 Double Cassette Deck

Autoreverse double deck with Dolby B & C. Features bias fine-tuning; continuous playback; IC logic controls; high-speed dubbing; auto rec mute; auto tape-selector; rec/play timer standby (deck 2). Frequency response 20-16,000 Hz (normal bias), 20-17,000 Hz (high bias), 20-18,000 (metal); S/N; Dolby C 78 dB, Dolby B 65 dB. 5 x 17 x 12 $\frac{3}{8}$ in; 11 lb. . . . \$350

AD-R40 2-Head Cassette Deck

2-head autoreverse cassette deck with bi-directional auto rewind. Dolby HX Pro, B, C NR. FR 20-18,000 Hz (metal); W&F 0.065%; S/N Dolby C 78 dB. \$230
AD-S37. As above without autoreverse or bi-directional auto rewind. . . . \$200

AD-WX505 Double Cassette Deck

Double cassette deck featuring Dolby C NR. Double-speed dubbing; continuous playback; auto tape-selector. Rec/play timer standby. FR 20-17,000 Hz (metal); S/N Dolby C 78 dB; w&F 0.09%. . . . \$180
AD-S27. As above, no double cassette. . . . \$140

BANG & OLUFSEN

Beocord 5500 Autoreverse Cassette Deck

Automated recording; auto azimuth adjust; auto Dolby B and C NR for play; auto and manual rec level; programs 23 tracks; HX Pro headroom extension; tape loads in motorized drawer; black and silver; remote controlled by Master Control Panel. Black and silver finish. w&F <0.09% wrms; speed deviation $\pm 1.5\%$; frequency response (chrome) 30-18,000 Hz, ± 3 dB; signal-to-noise ratio with chrome tape >65 dB Dolby B, >74 dB Dolby C. 16 $\frac{1}{2}$ x 3 x 12 $\frac{3}{4}$ in; 18 lb, 7 oz. . . . \$1,100

Beocord 4500 Autoreverse Cassette Deck

Integrates with Beosystem 4500 for full remote control. Dolby B and HX Pro; autobias control. Sensi-touch controls; auto search. FR (chrome) 30-18,000 Hz, ± 3 dB; w&F <0.09% wrms; S/N (Metal) Dolby B 66 dB. 16 $\frac{1}{2}$ x 2 $\frac{3}{4}$ x 9 $\frac{1}{2}$ in. . . . \$800

CAMBRIDGE AUDIO

CT-100 Cassette Deck. . . . \$499

CARRERA

CX-3250 Double Cassette Deck

Dual-well cassette deck with Dolby B NR. Features 3 preset bias/EQ positions; peak level indicators; 2 mic inputs. FR 40-14,000 ± 3 dB; S/N 52 dB; w&F 0.08%. . . . \$150

DENON

DRM-800 3-Head Cassette Deck

3-head cassette deck with Dolby HX Pro and Dolby B & C NR. Dual capstan, computer-controlled 3-motor silent mechanism; non-slip reel drive; amorphous alloy SF combination head; dual power supply. Full auto stop; rec balance control; fine bias adjustment; peak-hold FL meters; rec return mode; auto space; real time counter; output level control; headphone jack. Denon IS remote allows control from Denon IS receivers. FR 20-20,000 Hz ± 3 dB with metal tape; w&F 0.038%; S/N >75 dB (Dolby C). . . . \$500
DRM-700. As above, FR 25-20,000 Hz with metal tape; w&F 0.045%; S/N >73 dB (Dolby C). . . . \$400

DR-N34HX 3-Head Cassette Deck

3-head cassette deck with Dolby HX Pro and Dolby B & C NR. Features dual-capstan transport; full-logic control transport; computer-controlled silent mechanism; non-slip reel drive; SF combination head; dual power supply. Wireless remote control; manual bias fine-tuning; full auto-stop; MPX-filter switch; 4-digit tape counter with memory stop; FL peak-level meter; balance control; rec pause/mute; auto-space; one-touch rec/standby; output-level control; headphone jack. Includes Denon Integral System remote control. FR 25-20,000 Hz ± 3 dB with metal tape; w&F 0.045% wrms; S/N >75 dB (Dolby C). . . . \$500

DRR-680 Cassette Deck

Autoreverse deck with Dolby HX Pro and Dolby B & C NR. Features computer-controlled 2-motor transport; non-slip reel drive; amorphous alloy combination head; dual power supply. Full auto stop; rec balance control; fine bias adjustment; peak-reading FL level meters; auto space; output level control; headphone jack. Includes Denon Integral System remote control. Frequency response 20-19,000 Hz ± 3 dB with metal tape; w&F 0.06%; S/N >74 dB (Dolby C). . . . \$400

DRW-750 Double Cassette Deck

Double cassette deck with Dolby HX Pro and Dolby B & C NR. Features double non-slip reel drive; 2 motor transports with computer-controlled full-logic operation; SF heads; dual power supply; 2x normal high-

CASSETTE • DECKS

speed dubbing. Full auto stop; rec balance control; fine bias adjustment; peak-reading FL level meters; auto space; output-level control; headphone jack. Includes Denon Integral System remote control. Frequency response 20-18,000 Hz \pm 3 dB with metal tape; w&F 0.06%; S/N > 74 dB (Dolby C) \$400

DRM-600 Cassette Deck

Cassette deck with Dolby HX Pro and Dolby B & C NR. Features computer-controlled 2-motor transport; non-slip reel drive; amorphous alloy SF head; dual power supply. Full auto stop; rec balance control; fine bias adjustment; peak-reading FL level meters; auto space; real-time counter; output level control; headphone jack. Includes Denon Integral System remote control. FR 20-20,000 Hz \pm 3 dB with metal tape; w&F 0.055%; S/N > 74 dB (Dolby C) \$350

DRM-500 Cassette Deck

Cassette deck with Dolby HX Pro and Dolby B & C NR. Features computer-controlled 2-motor transport; non-slip reel drive; SF head; dual power supply. Full auto stop; rec balance control; fine bias adjustment; peak-reading FL level meters; rec return mode; auto space; 3-digit counter; headphone jack. Includes Denon Integral System remote control. Frequency response 25-18,000 Hz \pm 3 dB with metal tape; w&F 0.055%; S/N > 74 dB (Dolby C) \$275

DRM-400 Cassette Deck

Cassette deck with Dolby B & C NR. Features computer-controlled 2-motor transport; SF head; Full auto stop; rec balance control; fine bias adjustment; peak-reading FL level meters; rec return mode; auto space; 3-digit counter; headphone jack. Includes Denon Integral System remote control. Frequency response 25-18,000 Hz \pm 3 dB with metal tape; w&F 0.057%; S/N > 73 dB (Dolby C) \$240

DUAL

CC5050 3-Head Cassette Deck

Three-head stereo cassette deck with Dolby B and C NR. Frequency response 20-19kHz \pm 3 dB (metal). Black \$499

CC-5850 2-Head Cassette Deck

Stereo cassette deck with 2 motors. Features Dolby B and C NR. \$450

FISHER

CR-W905B 3-Head Double Cassette Deck

Double cassette deck with double autoreverse and Dolby B and C NR. Features switchable MPX filter. Full-logic controls; metal-tape capability; high-speed 1-touch dubbing; sequential playback; intro-scan; blank skip; digital tape counter. Includes 30-function wireless remote control. w&F 0.06% wrms; S/N 62 dB Dolby B; Frequency response 40-15,000 Hz \pm 3 dB CrO₂. 17 $\frac{3}{8}$ x 5 $\frac{3}{8}$ x 10 $\frac{3}{4}$ in; 11.9 lb. Black \$350

CR-W880B 3-Head Double Cassette Deck

Double cassette deck with autoreverse. Features 2 full-logic autoreverse cassette mechanisms (1 record/play, 1 play only). Metal tape capability; ASF (Auto Search Function); Dolby B NR; sequential play; high-speed synchro dubbing; 5-LED rec meters; auto tape selector; timer standby; headphone jack. \$300

CR-W780B 3-Head Double Cassette Deck

Double cassette deck with autoreverse. Features 2 autoreverse cassette mechanisms (1 record/play, 1 play only); MPX filter. Metal-tape capability; Dolby B NR; high-speed synchro dubbing; 5-LED rec meters; auto tape selector on deck 1; timer standby; mechanical tape counter; headphone jack. w&F 0.15% wrms; S/N 61 dB Dolby B; FR 40-15,000 Hz \pm 3 dB CrO₂. 17 $\frac{3}{8}$ x 4 $\frac{7}{8}$ x 10 $\frac{3}{4}$ in; 9.3 lb. Black \$260

CR-W680B 3-Head Double Cassette Deck

Double cassette deck with autoreverse. Features 2 cassette mechanisms. Metal tape capability; Dolby B

NR; high-speed synchro dubbing; 5-LED rec meters; auto tape selector on deck 1; timer standby; mechanical tape counter; headphone jack. w&F 0.15% wrms; S/N 61 dB Dolby B; Frequency response 50-14,000 Hz \pm 3 dB CrO₂. 17 $\frac{3}{8}$ x 5 $\frac{3}{8}$ x 11 in; 8.5 lb. Black . \$150

HARMAN KARDON

CD491 3-Head Cassette Deck

Cassette deck with direct-drive dual-capstan transport, Dolby B, C, and HX Pro. Features 3 heads; 2 motors; logic controls. Bias tone-generator/fine-trim control; autospacer; music search; output-level control; memory stop/play; weighted peak-hold LED meters; mic inputs; mic/line mixing; headphone jack; rec mute. Timer compatible. Frequency response (all tape) 20-24,000 Hz \pm 3 dB; S/N (A-wtd. high-bias tape); no NR 58 dB, Dolby B 66 dB, Dolby C 75 dB; w&F 0.025% wrms. 17 $\frac{3}{8}$ x 14 $\frac{3}{4}$ x 13 $\frac{1}{2}$ in; 14.3 lb \$1,099

TD392 3-Head Cassette Deck

Cassette deck with Dolby B, C, and HX Pro. Features 3 heads including sendust rec head and ferrite play head; 1 motor; logic controls. Bias tone-generator/fine-trim control. output-level control; memory stop/play; weighted LED meters; headphone jack; rec mute. Frequency response (all tape) 20-22,000 Hz \pm 3 dB; S/N (A-wtd. high-bias tape); no NR 57 dB, Dolby B 65 dB, Dolby C 73 dB; w&F 0.05% wrms. 17 $\frac{3}{8}$ x 14 $\frac{3}{4}$ x 13 $\frac{1}{8}$ in; 12.8 lb \$799

CD302 2-Head Cassette Deck

Cassette deck with Dolby B, C, and HX Pro. Features 3 heads including sendust rec/play head. 1 motor; logic controls. Bias fine-trim control; output-level control; defeatable MPX filter; headphone jack; rec mute. Frequency response (all tape) 20-20,000 Hz \pm 3 dB; S/N (A-wtd. high-bias tape); no NR 57 dB, Dolby B 65 dB, Dolby C 73 dB; w&F 0.05% wrms. 17 $\frac{3}{8}$ x 14 $\frac{3}{4}$ x 10 $\frac{1}{4}$ in; 12.8 lb \$499

TD262 2-Head Cassette Deck

Cassette deck with Dolby B, C, and HX Pro. Features 2 heads including amorphous rec/play head; logic controls. Bias fine-trim control; 7-LED peak-level meter; defeatable MPX filter; metal tape compatibility; rec mute. Same specs and dimensions as TD302. 10 lb \$399

TD212 2-Head Cassette Deck

Cassette deck with Dolby B, and C. Features 2 heads including hard-permalloy rec/play head; logic controls. Bias fine-trim control; 6-LED peak-level meter; defeatable MPX filter; metal tape compatibility; rec mute. Same specs and dimensions as TD302. 10 lb \$299

HEATH

ACW-2540 2-Head Cassette Deck

Single cassette deck with Dolby B, C, and HX Pro. Features 7-segment LED peak metering system; amorphous tape head. record mute; memory search; MPX filter; solenoid transport. Frequency response 20-20,000 Hz, +/- 3 dB; THD 1%; S/N no NR 57 dB, Dolby B 65 dB, Dolby C 73 dB; ch sep 45 dB; w&F 0.05%. 17 $\frac{1}{2}$ x 4 $\frac{3}{4}$ x 10 $\frac{1}{4}$ in; 12 lb \$349

HITACHI

DW99 Double Cassette Deck

Autoreverse cassette deck with Dolby B and C NR. Features feather touch IC logic microprocessor; high-speed dubbing; long play; scanplay; skip; auto rec; mute; peak hold; timer rec and play. \$400

JVC

TDV1010TN 3-Head Cassette Deck

Remote cassette deck with double-Dolby B, C, and HX Pro. Features closed loop dual capstan with direct-drive motor; full logic transport; 210,000 Hz

high bias circuit; MPX filter; half-shell stabilizer. Bias control and record-level calibration; auto tape selector; FL digital peak-metering; music scan; auto rec mute \$700

TDV711EK 3-Head Cassette Deck

Computer-controlled cassette deck with 2-motor full-logic mechanism. Features monitor-capable discrete 3-head configuration; SA head for record; amorphous head for play; closed-loop dual-capstan drive with direct-drive motor; 2 direct inputs; OFC plating on circuit boards; separate circuit construction; DC configured amps on separate PC boards; low-imp voltage-tracking regulated power supply; high-rigidity chassis. Dolby HX Pro; Dolby B and C NR; MPX filter; FL digital peak display; level meters and digital counter; auto rec mute; music scan; timer start; auto tape selector; headphone jack with adjustable level; bias control; gold-plated terminals \$620

TDR621EK 3-Head Cassette Deck

Cassette deck with Dolby HX Pro and Dolby B and C NR. Features MPX filter; full-logic mechanism; 2 direct inputs; closed-loop dual capstan drive; fluorescent digital peak; auto rec mute; music scan; timer start; auto tape selector; headphone jack with adjustable level \$510

TDW9013K Double Cassette Deck

Quick reverse autoreverse double cassette deck with full-logic transport. Featuring high-speed editing with synchro-dubbing; Dolby B and C NR and HX Pro; auto tape selector; FL peak meter; music scan; full-function remote; timer start \$480

TDW8013K Double Cassette Deck

Autoreverse double cassette deck with full-logic transport. Features high-speed editing with synchro-dubbing; Dolby B and C NR auto tape selector; music scan; timer start \$360

TDW501 Double Cassette Deck

Autoreverse double cassette deck with full-logic transport. Featuring high-speed editing with synchro-dubbing; Dolby B and C NR; auto tape selector; music scan, mic inputs, pitch controls; timer start. . . \$310

TDR421EK 3-Head Cassette Deck

Cassette deck with Dolby B, C, NR and HX Pro. Features quick autoreverse; full-logic transport; FL peak metering; auto rec mute; auto tape selector \$290

TDW3013K Double Cassette Deck

Double cassette deck with full-logic transport. Features autoreverse in 1 well; high-speed editing with synchro-dubbing; Dolby B and C NR; auto tape selector \$260

TDX321BK Cassette Deck

Cassette deck with Dolby B and C NR and HX Pro. Features full-logic transport; auto rec mute; auto tape selector \$240

TDW2013K Double Cassette Deck

Double cassette deck with full-logic transport. Features high-speed editing with synchro-dubbing; Dolby B and C NR; auto tape selector \$200

KENWOOD

KX-W8000 Double Cassette Deck

Dual-well autoreverse cassette deck with Dolby B, C, and HX Pro. Features full-logic controls; 2-motors; 2-head tape drives; hard-permalloy rec/play heads; double-gap ferrite erase heads. Bi-directional rec/playback in both wells; peak-level meter; auto bias-adjustment (deck B); high-speed dubbing; 16-program search; index scan (deck A); blank skip; auto rec-mute. Frequency response 30-14,000 Hz \pm 3 dB (normal tape), 30-15,000 Hz \pm 3 dB (high-bias and metal tape); signal-to-noise ratio (normal tape); no noise reduction 57 dB, Dolby B 65 dB, Dolby C 72 dB; total harmonic distortion < 0.6% @ 1,000 Hz

CASSETTE • DECKS

(normal tape); wow and flutter 0.08% wrms. 17¼ x 5 x 10½ in; 11.9 lb \$429

KX-W6010 Double Cassette Deck

Dual-well autoreverse cassette deck with Dolby B and C. Features full-logic controls; 2-motors; 2-head rec/playback tape drive; hard-permalloy rec/play head; double-gap ferrite erase head. Rec/playback in deck B only; peak-level meter; auto bias-adjustment (deck B); high-speed dubbing; 16-program search; index scan (deck A); blank skip; auto rec-mute. Frequency response 30-14,000 Hz ± 3 dB (normal), 30-15,000 Hz ± 3 dB (high-bias), 30-16,000 Hz ± 3 dB (metal); signal-to-noise ratio (normal tape): no noise reduction 57 dB, Dolby B 65 dB, Dolby C 72 dB; total harmonic distortion < 0.6% @ 1,000 Hz (normal tape); wow and flutter 0.08% wrms. 17¼ x 5 x 10½ in; 11 lb \$329

KX-W3510 2-Head Cassette Deck

Autoreverse cassette deck with Dolby B and C. Features hard-permalloy rec/play head; double-gap ferrite erase head. Peak-level meter; auto bias-adjustment; 16-program search; index scan; blank search. Frequency response 30-15,000 Hz ± 3 dB (normal tape), 30-16,000 Hz ± 3 dB (high-bias tape), 30-17,000 Hz ± 3 dB (metal tape); S/N (metal tape): no NR 59 dB, Dolby B 68 dB, Dolby C 74 dB; total harmonic distortion < 0.5% @ 1,000 Hz (normal tape); wow and flutter 0.08% wrms. 17¼ x 5 x 12½ in; 10.6 lb \$299

Spectrum Series

KX-68W Double Cassette Deck

Dual-well autoreverse cassette deck with Dolby B. Features full-logic controls; 2-motors; 3 heads; hard-permalloy rec/play heads; double-gap ferrite erase head. Rec/playback in deck B only; peak-level meter; high-speed dubbing; program search; index scan; auto tape selector. Frequency response 30-14,000 Hz ± 3 dB (normal tape), 30-15,000 Hz ± 3 dB (high-bias and metal tape); S/N (normal tape): no NR 57 dB, Dolby B 65 dB; THD < 0.6% @ 1,000 Hz (normal tape); W&F 0.08% wrms. 17¼ x 4¾ x 10½ in; 10.8 lb \$279

KX-58W Double Cassette Deck

Dual-well autoreverse cassette deck with Dolby B. Features full-logic controls; 2-motors; 3 heads; hard-permalloy rec/play heads; double-gap ferrite erase head. Rec/playback in deck B only; peak-level meter; high-speed dubbing; program search; index scan; auto tape selector. Frequency response 30-14,000 Hz ± 3 dB (normal tape), 30-15,000 Hz ± 3 dB (high-bias and metal tape); S/N (normal tape): no NR 56 dB, Dolby B 64 dB; THD < 0.9% @ 1,000 Hz (normal tape); W&F 0.15% wrms. 17¼ x 4¾ x 10½ in; 8.8 lb \$229

KX-48C 2-Head Cassette Deck

Autoreverse cassette deck with Dolby B and C. Features full-logic controls; 1-motor; 2 heads; hard-permalloy rec/play head; double-gap ferrite erase head. Rec/playback in deck B only; peak-level meter; high-speed dubbing; program search; index scan; auto tape selector. Frequency response 30-14,000 Hz ± 3 dB (normal tape), 30-15,000 Hz ± 3 dB (high-bias and metal tape); S/N (normal tape): no NR 56 dB, Dolby B 64 dB, Dolby C 72 dB; total harmonic distortion < 0.9% @ 1,000 Hz (normal tape); wow and flutter 0.15% wrms. 17¼ x 4¾ x 10½ in; 8.2 lb \$179



Kenwood KX-W8010

LUXMAN

All cassette decks carry a 5-year parts-and-labor warranty.

K-112 3-Head Cassette Deck

Cassette deck with Dolby B, C, and HX Pro. Features Hexalam 3-head assembly; 2-motor, single-capstan transport; logic-controls; Duo-Beta dual feedback-loop amp circuitry. Tape monitoring; auto space; 4-digit electronic tape counter with memory; output/rec-level, fine-bias, rec balance controls; system remote control jacks. Frequency response 20-21,000 Hz ± 3 dB (metal tape), 20-20,000 Hz ± 3 dB (high-bias tape), 20-19,000 Hz ± 3 dB (normal-bias tape); S/N (high-bias tape): no noise reduction 55 db, Dolby B 64 dB, Dolby C 72 dB; wow and flutter 0.05% wrms. 17¼ x 4¼ x 12½ in; 9.5 lb \$600

K-105 2-Head Cassette Deck

Autoreverse cassette deck with Dolby B/C and dbx. Features 2-head rotating tape assembly; 3-motor, dual-capstan transport; logic-controls; Duo-Beta dual feedback-loop amp circuitry. Music search, intro scan, blank search/skip; auto rec pause; auto space; master volume, rec-balance controls; peak-level indicator. Frequency response 20-18,000 Hz ± 3 dB (metal tape), 20-16,000 Hz ± 3 dB (high-bias tape), 20-15,000 Hz ± 3 dB (normal-bias tape); S/N (metal tape): no noise reduction 60 dB, Dolby B 67 dB, Dolby C 71 dB, dbx 90 dB; wow and flutter 0.05% wrms. 17¼ x 4½ x 12 in; 10 lb \$600

K-110W Double Cassette Deck

Dual-well cassette deck with autoreverse in both decks and Dolby B, C, and HX Pro. Features high-speed dubbing; simultaneous playback of 2 tapes; dual-deck relay play \$580

K-110 Cassette Deck

Autoreverse cassette deck with Dolby B, C, and HX Pro. Features bi-directional recording; logic controls \$480

K-111 2-Head Cassette Deck

Cassette deck with Dolby B, C, HX Pro. Features Hexalam 2-head assembly with motor-driven cam; 2-motor, single-capstan transport; logic-controls; Duo-Beta dual feedback-loop amp circuitry. Rec-level control; L/R mic and system remote control jacks. Frequency response 30-18,000 Hz ± 3 dB (metal tape), 30-17,000 Hz ± 3 dB (high-bias tape), 30-16,000 Hz ± 3 dB (normal-bias tape); S/N (high-bias tape): no NR 55 db, Dolby B 63 dB, Dolby C 70 dB; W&F 0.06% wrms. 17¼ x 4¼ x 10½ in; 7.7 lb. . \$380

MARANTZ

DT84 Digital Audio Tape Deck

DAT deck with wireless remote control. Features 48 kHz sampling-frequency recording; 44.1/48 kHz sampling frequency play; quadruple oversampling; subcode post recording; 30-track random-program play; cue/review; 2-way repeat; auto rewind/auto replay; Frequency response 5-20,000 Hz; S/N 96 dB; THD 0.01% \$1,900

SD-55 Cassette Deck

2-head cassette deck with dual motor and micro-processor control. Features Dolby B and C NR; variable bias fine tune control; auto tape type sensor; rec mute; memory tape counter w/auto stop; MPX filter \$780

SD565 Double Cassette Deck

Double cassette deck with autoreverse, record, and playback for both transports. Features 15-song quick music search; auto tape selector; high-speed dubbing; mixing; auto rec mute; Dolby B and C NR; 2 heads; 2 motors; memory stop/play; LED meters; soft-touch controls; mic inputs; headphone jack; W&F 0.05% wrms; Frequency response 35-15,500 Hz; signal-to-noise ratio 65 dB. Dimensions: 4 x 16½ x 10¼ in.

Weight: 11.9 lb \$429

DL 3507 Cassette Deck

Single cassette deck with Dolby B, C, and HX Pro. Features two sets of permalloy recording heads; ferrite erase heads; dual constant-current drive amplifier; 20-track bidirectional automatic music search; auto biasing; synchro record capable with CD player. FR 20-20,000 Hz; W&F 0.6%; S/N 74 dB. \$380

SD 385BL Double Cassette Deck

Double cassette deck with Dolby B and C NR. Features autoreverse; high-speed dubbing; quick music search \$299
SD 285BL. Same as above, w/out autoreverse \$250

SD160 Double Cassette Deck

Features Dolby B NR; high-speed dubbing; mic input, LED meters; Frequency response 40-13,000 Hz; signal-to-noise ratio 64 dB; wow and flutter 0.08%. 4¾ x 16½ x 7¼ in; 8.4 lb \$170

DA 2452CB Double Cassette Deck

Double cassette deck with autoreverse on play deck only. Features Dolby B NR; high-speed dubbing; auto tape selector with LED \$170

MITSUBISHI

MT-5100 Double Cassette Deck

Dual-well autoreverse cassette deck with Dolby B and C. Features high-speed synchronous dubbing; full-logic controls; continuous playback of 2 cassettes. Music search; repeat; blank skip; auto mute; auto bias calibration; remote control \$400

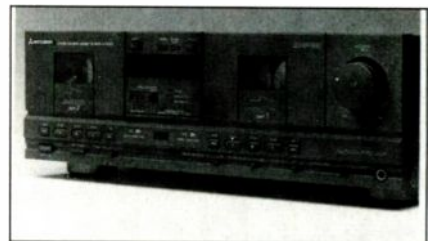

Mitsubishi MT-5100

NAD

6300 Monitor Series 3-Head Cassette Deck

3-head, 3-motor cassette deck with Dolby B and C NR. Features full logic transport; Dolby HX Pro; Dyncq range expansion; Car processor to boost level of soft passages 20 dB. NAD/Dolby-developed Play Trim which optimizes high frequency playback characteristics; fine bias tuning. Speed accuracy ± 1%; W&F 0.03% wrms; Frequency response 30-19,000 ± 3 dB. Includes wireless remote control. Rack mountable \$899

6100 Monitor Series Cassette Deck

Features Dolby B and Dolby C NR; Dolby HX Pro; Dyncq range expansion; full logic transport; CAR circuitry. NAD/Dolby-developed Play Trim which optimizes high frequency playback characteristics; fine bias adjustment. Includes remote control. Rack mountable \$499



NAD 6100

6340 Cassette Deck

Features Dolby B and Dolby C NR; Dolby HX Pro; Dyncq range expansion; full logic transport; Car

CASSETTE • DECKS

circuitry. Fine bias adjustment \$399

6325 Cassette Deck

Features Dolby B and Dolby C NR; full logic transport; Car circuitry. Compatible with normal, chrome, and metal tape \$249

NAKAMICHI

Model 1000 DAT Recorder

Features F.A.S.T. (Fast Access Stationary Tape Guide Transport) mechanism; 4-head design for off-tape monitoring; microprocessor-controlled direct-drive reel motors. Full indexing and high-speed program search; digital fader; model 1000r wireless remote controller. Sampling frequencies: 48,000 Hz (rec/play), 44,100 Hz (play), 32,000 Hz (rec/play); drum rotation: 2,000 rpm (rec/play); tape speed: 0.32 ips; digital input: 75 ohms coaxial/optical (switchable); digital output: 75 ohms coaxial/optical; coaxial and optical cable included. 17 $\frac{3}{8}$ x 5 $\frac{1}{4}$ x 14 $\frac{1}{8}$ in; 35 lb, 4 oz \$5,400

Model 1000p Outboard Digital Processor. For above; features 8x oversampling, 20-bit calibrated D/A converters; 16-bit auto-calibrated A/D converter; 2x oversampling digital filter. See "Signal Processors" for more details \$4,600

Dragon 3-Head Cassette Deck

Microprocessor-controlled, autoreverse cassette deck with Dolby B and C. Features auto azimuth correction system; dual-gap ferrite/sendust erase head; asymmetrical diffused-resonance transport; Super Linear Torque direct-drive motors; auto-retracting slot guides; tape-pad lifter; auto tape-slack reducing mechanism. Rec-level and bias-calibration controls with 2-tone oscillator; separate tape and EQ switches for ZX, SX, and EX cassettes; direct-coupled recording and playback amplifiers; 2-speed cueing; 2-speed master fader; auto rec pause; left, right, master input levels-control; output level-control; rec mute; high-output headphone jack; defeatable infrasonic filter; 4-digit LED electronic counter with memory stop and repeat; optional remote control via RM-20. Wow and flutter 0.019% wrms; Frequency response 20-22,000 Hz, ± 3 dB with ZX tape; signal-to-noise ratio Dolby B/C 66/72 dB (A = wtd, ZX tape at 400 Hz, 0dB); sep/crosstalk 37/60 dB at 1,000 Hz, 0 dB; input sens/imp 50 mV/50 kilohms line; output level/imp 1 V/2.2 kilohms line, 45 mW/8 ohm headphones; 17 $\frac{3}{8}$ x 5 $\frac{1}{2}$ x 11 $\frac{3}{8}$ in; 21 lb. \$2,295

RM-20 Remote Control Unit. For use with the above \$50

CR 7A 3-Head Cassette Deck

Cassette deck with asymmetrical diffused-resonance dual-capstan transport. Features 3 motors; auto bias/EQ; Dolby B; Dolby C; manual azimuth adjust; elapsed-time counter; remaining-time counter. Output-level control; memory stop/play; LED meters; soft-touch controls; headphone jack; rec mute; wireless remote; auto & manual tape/equalizer selection; auto fade; auto repeat. Wow and flutter 0.027% wrms; Frequency response, ferric 18-21,000 Hz, ± 3 dB; signal-to-noise ratio (A-wtd), metal 66 dB, Dolby B 72 dB; line-input sens for 0-dB reading 50 mV; line-output level with 0-dB indication 1,000 mV. 17 $\frac{3}{8}$ x 5 $\frac{1}{2}$ x 12 in; 19 lb, 13 oz \$1,695

RX-505 3-Head Cassette Deck

Cassette deck with unidirectional autoreverse to eliminate bidirectional azimuth error. Mechanism turns cassette over at end of side during record or playback. Features asymmetrical dual-capstan closed-loop transport; auto fade (20 secs before end of tape); Dolby B and C; DC servo motors. Auto record pause; LED peak-level meters reading from -40 to +10 dB; dual-speed master fader; punch-in recording; memory stop/play; soft-touch controls; Optional remote control via RM-15. Wow and flutter <0.04% wrms; Frequency response 20-20,000 Hz, ± 3 dB all tape types; S/N Dolby C and metal tape >70 dB; THD <0.9% with ZX tape; line-input sens for 0-dB reading

50 mV; line-output level with 0-dB indication 1,000

mV; 17 $\frac{3}{8}$ x 5 $\frac{3}{8}$ x 11 $\frac{3}{8}$ in; 22 lb \$1,395

RM-15 Remote Control Unit. For use with the above \$50

RX-202. Similar to RX-505 with 2 heads. w&F <0.06% wrms. 17 $\frac{3}{8}$ x 5 $\frac{3}{8}$ x 10 in; 19 lb, 13 oz \$795

CR 5A 3-Head Cassette Deck

Cassette deck with asymmetrical diffused-resonance dual-capstan transport. Features 3 motors; Dolby B, Dolby C. Bias fine tuning; output-level control; memory stop/play; LED meters; soft-touch controls; headphone jack. rec mute; auto repeat; dual speed-master fader control; independent L/R; optional remote control via RM-5. w&F 0.027% wrms; Frequency response, ferric 18-21,000 Hz, ± 3 dB; S/N (all A-wtd) Dolby B 66 dB, Dolby C 72 dB; line-input sens for 0-dB reading 50 mV; line-output level with 0-dB indication 1,000 mV. 17 $\frac{3}{8}$ x 5 $\frac{1}{2}$ x 12 in; 18 lb, 2 oz \$1,095

RM-5 Remote Control Unit. For use with the above \$50

CR-4A 3-Head Cassette Deck

Features asymmetrical dual-capstan direct-drive transport with FC-servo, brushless, slotless, coreless direct-drive capstan motor; DC motor mechanism; manual bias & level calibration; built-in test signals; Dolby B/C. Independent tape and EQ selection; 13-segment, 50-dB peak-level meters. one-touch rec/pause; 4-digit LED counter with memory stop and auto repeat; calibration; concentric record level & balance control; output level; gold-plated input, output, and headphone jacks; OFC wiring and copper-plated chassis; optional remote control via RM-5. w&F < $\pm 0.048\%$; frequency response 20-20,000 Hz, ± 3 dB; S/N Dolby C 72 dB THD <0.8%; sep > 37 dB; 17 x 4 x 10 $\frac{1}{2}$ in 13 lb \$995

RM-5 Remote Control Unit. For use with the above \$50

CR-3A 3-Head Cassette Deck

Features asymmetrical dual-capstan transport; Dolby B/C. Independent tape & EQ selection; bias fine tune; DC servo motor; DC motor mechanism; 13-segment 50-dB peak-level meters. 4-digit LED counter with memory stop and auto repeat; rec mute; Dolby, source/tape, rec mute, stop, play, pause and record indicators; concentric rec-level and balance controls; output level control; gold-plated input/output jacks; headphone jack; optional remote control via RM-5. w&F $\pm 0.06\%$; frequency response 20-20,000 Hz, ± 3 dB; signal-to-noise ratio Dolby-C NR >72 dB; total harmonic distortion <0.9%; sep >37 dB; 17 x 4 x 10 $\frac{1}{2}$ in; 12 lb, 13 oz \$795

RM-5 Remote Control Unit. For use with the above \$50

CR-2A 2-Head Cassette Deck

Features microprocessor-controlled silent-mechanism transport; DC-servo motor; Dolby B/C with defeatable MPX filter; bias fine tune; independent tape and EQ selection; 37-dB peak-level meters. 4-digit LED counter; memory stop; auto repeat; timer rec/play; rec mute; concentric record level and balance controls; output-level control; headphone jack; optional remote control via RM-5. wow and flutter < $\pm 0.11\%$; frequency response 20-20,000 Hz; S/N Dolby-C NR >70 dB; THD < 1.0%; sep > 36 dB; 17 x 4 x 10 $\frac{1}{2}$ in; 11 lb, 14 oz \$495

RM-5 Remote Control Unit. For use with the above \$50

CR-1A 2-Head Cassette Deck

Features microprocessor-controlled silent-mechanism transport; DC-servo motor; Dolby B/C; defeatable MPX filter; independent tape and EQ selection; 37-dB peak-level meters. 3-digit mechanical counter; memory stop; auto repeat; timer rec/play; concentric record-level and balance controls; headphone jack. w&F < $\pm 0.11\%$; FR 20-20,000 Hz; S/N Dolby-C NR >70 dB; THD <1.0%; sep >36 dB; 17 x 4 x 10 $\frac{1}{2}$ in; 11 lb, 14 oz \$395

NIKKO AUDIO

D-600 3-Head Cassette Deck

Cassette deck with Dolby B, C, and HX Pro. Features bipolar power supply; direct-coupled circuitry; twin-moto IC-logic transport control; hard Permalloy record/playback head; MPX filter; electronic tape counter with index and tape-run-time modes; 2 color L/R peak-level meters; bias fine-tuning control; record mute with auto spacer; master recording level control with L/R ch preset controls; automatic tape type selection. Frequency response 20-21,000 Hz (metal), 20-20,000 Hz (high bias), 20-19,000 Hz (normal); signal-to-noise ratio (A-wtd) no NR 60 dB, Dolby B 70 dB, Dolby C 80 dB; w&F 0.006%. 17 $\frac{3}{8}$ x 4 $\frac{7}{8}$ x 10 $\frac{3}{8}$ in; 11 lb. \$600

D-400. As above with 2 heads. Frequency response 20-19,000 Hz (metal), 20-18,000 Hz (high bias), 20-17,000 Hz (normal); signal-to-noise ratio (A-wtd) no NR 59 dB, Dolby B 69 dB, Dolby C 74 dB; wow and flutter 0.006%. Dimensions: 17 $\frac{3}{8}$ x 4 $\frac{7}{8}$ x 10 $\frac{3}{8}$ in. Weight: 11 lb \$500

ONKYO

Integra TA-2090 3-Head Cassette Deck

Computer-controlled cassette deck with Dolby B, C, HX Pro, and dbx. Features 3 heads; 3 motors; auto bias/EQ; dual capstans; bias fine tuning; direct drive; sendust heads; MPX filter. Elapsed-time counter; remaining-time counter; music search; output-level control; memory stop/play; mike input; headphone jack; rec mute; record calibration controls; 2-color peak hold meter. Remote control and side panels optional. Frequency response 25-17,000 Hz ± 3 dB (normal-bias tape), 25-19,000 Hz ± 3 dB (high-bias tape), 25-21,000 Hz ± 3 dB (metal tape); S/N (metal tape); no NR 60 dB, Dolby B 70 dB, Dolby C 80 dB, dbx 87 dB; w&F 0.02% wrms. 17 $\frac{3}{8}$ x 4 x 15 $\frac{1}{2}$ in; 20 lb. \$950

CW-20. Optional woodgrain side panels for TA-2090. \$60/pr

TA-2800 3-Head Cassette Deck

Computer-controlled cassette deck with Dolby B, C, and HX Pro. Features 3 heads; 3-motors; dual capstans; auto bias; record calibration. Real-time counter; switchable MPX filter; RI remote compatible. Frequency response 20-21,000 Hz (metal tape); S/N 58 dB (metal tape, no Dolby); w&F 0.035% wrms. 17 $\frac{3}{8}$ x 5 $\frac{1}{8}$ x 14 $\frac{1}{8}$ in; 14 lb \$650

TA-RW490 Double Cassette Deck

Dual-well autoreverse cassette deck with Dolby B, C, and HX Pro. Features rec/playback, music search, and autoreverse in both wells. High-speed and real-time dubbing; continuous recording; 2 real-time tape counters; headphone jack; mike input. Remote control optional \$630

TA-RW470 Double Cassette Deck

Dual-well autoreverse cassette deck with Dolby B and C. Features 2 motors. Real-time tape counter; standard and high-speed dubbing; continuous play; AMCS (Automatic Music Control System); RI remote compatible. \$500

TA-2600 3-Head Cassette Deck

Computer-controlled cassette deck with Dolby B, C, and HX Pro. Features auto bias. Real-time counter; switchable MPX filter; forward AMCS (Automatic Music Control System); RI remote compatible. Frequency response 20-20,000 Hz (metal tape); signal-to-noise ratio 58 dB (metal tape, no Dolby); w&F 0.045% wrms. Dimensions: 17 $\frac{3}{8}$ x 5 $\frac{1}{8}$ x 14 $\frac{1}{8}$ in. Weight: 13 lb \$480

TA-R300 2-Head Cassette Deck

Computer-controlled autoreverse cassette deck with Dolby B, C, and HX Pro. Features auto bias/tape selector. Electronic tape counter; switchable MPX filter; FL display; auto space; rec mute; dual mode (block/full) repeat; forward AMCS (Automatic Mu-

CASSETTE • DECKS

sic Control System); R1 remote control included. Frequency response 30-18,000 Hz \pm 3 dB (metal tape), 30-17,000 Hz \pm 3 dB (high-bias tape), 30-16,000 \pm 3 dB (normal-bias tape); S/N 58 dB (metal tape, no Dolby); wow and flutter 0.07% wrms. 17 $\frac{1}{8}$ x 4 $\frac{1}{8}$ x 10 $\frac{1}{4}$ in; 10 lb. \$360

TA-RW400 Double Cassette Deck

Dual-well computer controlled cassette deck with Dolby B, C noise reduction and HX Pro. Features autoreverse in both wells; 2-motor tape transports; auto bias/tape selector. Recording in deck B only; normal and high-speed dubbing; continuous play; auto space; rec mute; 8-segment LED level meter; R1 remote compatible. Frequency response 30-16,000 Hz \pm 3 dB (metal tape), 30-15,000 Hz \pm 3 dB (high-bias tape), 30-14,000 \pm 3 dB (normal-bias tape); signal-to-noise ratio 58 dB (metal tape, no Dolby); wow and flutter 0.07% wrms. 17 $\frac{1}{8}$ x 4 $\frac{1}{2}$ x 13 $\frac{1}{8}$ in; 10.6 lb. \$340

TA-2200 2-Head Cassette Deck

Computer-controlled cassette deck with Dolby B, C noise reduction and Hx Pro. Features 2 heads; 2 motors; full-logic transport; auto bias/tape selector. Electronic tape counter; fluorescent display; switchable multiplex filter; forward AMCS (Automatic Music Control System); auto space; rec mute; dual mode (block/full) repeat; R1 remote compatible. Frequency response 30-18,000 Hz \pm 3 dB (metal tape), 30-17,000 Hz \pm 3 dB (high-bias tape), 30-16,000 \pm 3 dB (normal-bias tape); signal-to-noise ratio 58 dB (metal tape, no Dolby); wow and flutter 0.07% wrms. 17 $\frac{1}{8}$ x 4 $\frac{1}{8}$ x 10 $\frac{1}{4}$ in; 10 lb. \$330

TA-R200 Cassette Deck

Computer-controlled autoreverse cassette deck with Dolby B, C, and HX Pro. Features auto bias/tape selector. Auto space; rec mute; dual mode (block/full) repeat; R1 remote compatible. \$260

TA-2000 Cassette Deck

Computer-controlled cassette deck with Dolby B, C, and Hx Pro. Features full-logic transport; auto bias/tape selector. Auto space; rec mute; dual mode (block/full) repeat; R1 remote compatible. \$230



Onkyo TA-R200

PARASOUND

D/HX-600 Cassette Deck

Features Dolby B and Dolby C noise reduction; Dolby HX Pro headroom extension; sendust-alloy head; LED peak and peak storage meters; Play Trim; polystyrene capacitors; hand-selected parts; single IC servomotor; soft-touch controls. Signal-to-noise ratio 75 dB with metal tape and Dolby C; 17 $\frac{1}{8}$ x 4 $\frac{1}{2}$ x 11 in; 12 lb. \$360

PHILIPS

FC-60 3-Head Cassette Deck

3-head cassette deck with Dolby B and C NR. Features Dolby HX Pro; electronic real-time counter; alpha text mode display; digital peak-level display with peak memory function; fine bias adjustment; rec calibration controls. Compatible with Philips RC-5 remote control. \$549

FC 567 Double Cassette Deck

Double cassette deck with Dolby B and C NR. Features digitally controlled electronic autoreverse; auto 2-way recording for both decks; ability to record

or play up to 3 hours of continuous music; normal and high-speed dubbing; mono mic mixing capabilities; Quick Music Search (QMS) for fast skipping of up to 15 tracks; memo key operates in conjunction with QMS to program 16 tracks in any order; LED bar indicates peak levels for left and right channels; slide record-level controls left and right channels; microprocessor controls; precision ground capstans and pressure rollers; full auto stop; 3-digit tape counter with reset; auto tape selection operates when tape is inserted (with normal, metal and chrome tape); timer switch allows play/record with external timer control; tape direction and mode indicators; MPX filter; Autospace Record Mute inserts 4-second pause between tracks; front panel microphone and headphone inputs. Dual DC-servo motors; speed tolerance 1.5%. Wow and flutter 0.04% wrms; frequency response 30-18,000 Hz. Dimensions: 4 x 16 $\frac{7}{8}$ x 10 $\frac{3}{8}$ in. Weight: 11.7 lb. \$479

FC-50 Cassette Deck

2-head cassette deck with Dolby B and C NR. Features Dolby HX Pro; dynamically balanced cast-alloy flywheel/capstan mechanism; hard-permalloy head; electronic real-time counter; alpha text mode display; digital peak-level display with peak-level memory function; fine bias adjustment; QMS quick music search; auto music scan; blank skip; timer rec/playback. Compatible with Philips RC-5 remote control. \$379

FC-40 Cassette Deck

2-head cassette deck with Dolby B and C NR. Features Dolby HX Pro; feather-touch computer controlled logic transport; switchable MPX filter; auto tape type selector; fine bias adjustment. Compatible with Philips RC-5 remote control. \$299



Philips FC-60

PIONEER

Elite CT-91 3-Head Cassette Deck

Cassette deck with Dolby B, C, and HX Pro. Features full-logic controls; 3 heads; 2 motors; 3 power supplies; bias fine tuning; anti-vibration design; dual-capstan; amorphous head; FL display; system remote compatible; electronic real-time tape counter; power eject auto monitor; frequency response 20-23,000 Hz; signal-to-noise ratio 60 dB; wow and flutter 0.022%. 5 $\frac{1}{4}$ x 16 $\frac{5}{8}$ x 14 $\frac{1}{8}$ in; 21 lb. 3 oz. \$950

CT-W910R Double Cassette Deck

Dual autoreverse cassette decks with Dolby B and C NR and HX Pro. Features 2 heads; 2 motors; high-speed dubbing; synchronous start; 15 selection music search; blank search; blank skip; automatic tape selector; remote control capability. Frequency response 18-18,000 Hz; signal-to-noise ratio 58 dB; wow and flutter 0.055%. Dimensions: 16 $\frac{3}{8}$ x 5 $\frac{1}{4}$ x 12 $\frac{1}{2}$ in. Weight: 13 lb. 4 oz. \$650

CT-S705 3-Head Cassette Deck

Single cassette deck with Dolby B and C NR. Frequency response 20-20,000 Hz; S/N 58 dB; W&F 0.05%. 16 $\frac{3}{8}$ x 5 $\frac{1}{4}$ x 12 $\frac{3}{4}$ in; 13 lb. \$480

CT-W710R Double Cassette Deck

Dual autoreverse cassette decks with Dolby B and C noise reduction and HX Pro. Features high-speed dubbing; electronic real-time tape counter; 15 selection music search; blank skip; blank search; automatic record mute; automatic tape selector. Frequency

response 25-17,000 Hz; signal-to-noise ratio 57 dB; wow and flutter 0.055%. 16 $\frac{3}{8}$ x 4 $\frac{3}{8}$ x 12 $\frac{1}{2}$ in; 11 lb. 11 oz. \$450

CT-S605 2-Head Cassette Deck

Single cassette deck with Dolby B and C NR and HX Pro. Frequency response 25-17,000 Hz; signal-to-noise ratio 58 dB; wow and flutter 0.055%. 16 $\frac{3}{8}$ x 5 $\frac{1}{8}$ x 12 $\frac{3}{4}$ in; 11 lb. \$375

CT-W600R Double Cassette Deck

Dual cassette deck with Dolby B and C NR. Features playback on transport 1 and recording or playback on transport 2. Frequency response 25-17,000 Hz; signal-to-noise ratio 57 dB; W&F 0.055%. 16 $\frac{3}{8}$ x 4 $\frac{3}{8}$ x 12 $\frac{1}{2}$ in; 11 lb. \$360

CT-W510 Double Cassette Deck

Dual cassette deck with Dolby B and C noise reduction. Features playback on transport 1 and recording or playback on transport 2; high-speed dubbing; relay play; 15-selection music search. Frequency response 25-16,000 Hz; signal-to-noise ratio 56 dB; wow and flutter 0.06%. 16 $\frac{3}{8}$ x 4 $\frac{3}{8}$ x 12 $\frac{1}{2}$ in; 11 lb. \$310

CT-W500 Double Cassette Deck

Cassette deck with Dolby B and C noise reduction. Features playback on transport 1 and recording or playback on transport 2; relay play; Pioneer cassette stabilizer system; independent operation keys for each deck; remote control compatibility; blank search; blank skip; automatic recording mute. \$310

CT-S405 2-Head Cassette Deck

Single cassette deck with Dolby B and C NR and HX Pro. Frequency response 25-16,500 Hz; signal-to-noise ratio 57 dB; W&F 0.075%. 16 $\frac{3}{8}$ x 4 $\frac{3}{8}$ x 10 $\frac{3}{4}$ in; 9 lb. 4 oz. \$230

CT-W310 Double Cassette Deck

Cassette deck with Dolby B and C NR. Features playback on transport 1 and recording or playback on transport 2; five-segment LED level indicator; SR control with pause; tape counter; automatic tape selector. Frequency response 35-16,000 Hz; signal-to-noise ratio 56 dB; W&F 0.13%. 16 $\frac{3}{8}$ x 4 $\frac{3}{4}$ x 10 $\frac{3}{8}$ in; 8 lb 10 oz. \$225

CT-W300 Double Cassette Deck

Cassette deck with Dolby B and C NR. Features playback on transport 1 and recording or playback on transport 2; relay play; Pioneer cassette stabilizer system; independent operation keys for each deck; remote control compatibility. \$225

CT-S305 2-Head Cassette Deck

Single cassette deck with Dolby B and C noise reduction. Frequency response 25-16,500 Hz; signal-to-noise ratio 57 dB; W&F 0.075%. 16 $\frac{3}{8}$ x 4 $\frac{3}{4}$ x 10 $\frac{3}{4}$ in; 9 lb. 4 oz. \$200



Pioneer CT-W910R

PROTON

AD-630 Cassette Deck

Autoreverse cassette deck with Dolby B, C, and dbx NR. Features 3-motor IC logic mechanism; real-time counter; 2-color LCD display; MPX filter; 20 song programming; remote capability. Frequency response 30-17,000 Hz \pm 3 dB (normal), 30-18,000 Hz \pm 3 dB (high bias), 30-19,000 Hz \pm 3 dB (metal); S/N no NR 50 dB, Dolby B 60 dB, Dolby C 70 dB (normal tape); wow and flutter 0.03%. 18 $\frac{1}{2}$ x 3 $\frac{7}{8}$ x 15 $\frac{1}{8}$ in; 18.7 lb. \$800

CASSETTE • DECKS

REALISTIC

SCT-84 Double Cassette Deck

Double cassette deck with Dolby B and C NR; synchro-start dubbing. Features bias control and autoreverse. High-bias tape FR 20-15,000 Hz \pm 3 dB; wow and flutter 0.06% wrms; total harmonic distortion 1%. 15 x 17 x 12 1/2 in. \$180

SCT-74 Double Cassette Deck

Dolby B and Dolby C; high-speed dubbing; compatible with normal, high-bias, metal tapes; LED's for power and recording; mic inputs; headphone jack. High bias frequency response 60-12,000 Hz \pm 3dB; wow and flutter 0.12% wrms. \$180

SCT-46 Double Cassette Deck

Dolby B; 2 heads; high-speed dubbing; headphone and mic jacks; synchro-start; continuous play; 2-color LED level meters; permalloy rec/play head. High-bias tape frequency response 30-15,000 Hz \pm 3 dB; signal-to-noise ratio 66 dBA with metal tape and Dolby B; wow and flutter 0.1% wrms. \$150

SCP-32 Cassette Deck

Single cassette deck with autoreverse and Dolby B noise reduction. Metal/high-bias selector switch. 3 3/8 x 8 1/4 x 5 5/8 in. \$100

SCP-31 Cassette Deck As above, no Dolby B; no autoreverse. \$50

8-Track Cartridge Player

TR-169 8-Track Cartridge Player

Stereo 8-track player; auto or manual program change; output-level control; program LED's. 4 x 10 x 7 in. \$50

REVOX

B215-S 3-Head Cassette Deck

Cassette deck with 3 microprocessors for control of bias, level, EQ, transport, and real-time counter. Features 3 heads, Dolby HX Pro, Dolby B & C; 4 motors; digital storage of bias, level, EQ settings for 6 tape formulations; manual or auto record-level setting; diecast transport chassis; azimuth-stable pivoting headblock; 2 programmable locate buttons; loop mode; auto start-of-record locate. Counter computes elapsed time on partially wound tapes. Wow and flutter 0.1% wrms; frequency response ferric 30-18,000 Hz \pm 3 dB, high bias and metal 30-20,000 Hz \pm 3 dB; signal-to-noise ratio (A-wtd) ferric: 55 dB no noise reduction, 64 dB Dolby B, 70 dB Dolby C, high bias; 57 dB no noise reduction, 65 dB Dolby B, 72 dB Dolby C, metal; 58 dB no noise reduction, 66 dB Dolby B, 72 dB Dolby C; line-input sens for 0-dB reading 50 mV; line output level with 0-dB indication 775 mV; 17 3/4 x 6 x 13 in; 20 lb. \$2,800

B215. As above, cosmetic differences. \$2,300



Revox B215-S

ROTEL

RD865 2-Head Cassette Deck

Cassette deck with Dolby B, C, and HX Pro. Features 2 high-torque DC motors; soft-touch full-logic controls; remote; automatic tape bias and equalization; memory and repeat functions; FL bar graph meters; record mute. Frequency response 30-18,000 Hz \pm 3 dB (normal), 30-19,000 Hz \pm 3 dB (high bias), 30-

20,000 Hz \pm 3 dB (metal); signal-to-noise ratio Dolby B 64 dB, Dolby C 73 dB. Wow and flutter 0.035%. 17 1/2 x 4 1/2 x 12 in; 11.5 lb. \$449

RD855 2-Head Cassette Deck

Cassette deck with Dolby B and C NR. Features 2 high-torque DC motors; soft-touch full-logic controls; remote; automatic tape bias and equalization; memory and repeat functions. Frequency response 30-18,000 Hz \pm 3 dB (normal), 30-19,000 Hz \pm 3 dB (high bias), 30-20,000 Hz \pm 3 dB (metal); signal-to-noise ratio Dolby B 64 dB, Dolby C 73 dB; wow and flutter 0.035%. 17 1/2 x 4 1/2 x 12 in; 11.5 lb. \$349

RD845 2-Head Cassette Deck

Features Dolby B and C NR. Features high-torque motor. FR 30-18 000 Hz \pm 3 dB (metal). \$249

SAE

C102 2-Head Cassette Deck

Full-logic microprocessor cassette deck with Dolby B and C noise reduction. Features tape transport encased in electronic sliding drawer; 2 motors; elapsed-time counter; remaining-time counter; LED meters; sendust heads. Music search; blank skip; manual azimuth adjust; memory stop/play; rec mute. Frequency response 20-20,000 Hz for all tape types; signal-to-noise ratio (high bias): 55 dB no noise reduction, 65 dB Dolby B, 74 dB Dolby C; wow and flutter 0.06% wrms. 19 x 3 1/2 x 14 in; 18 lb. \$499



SAE C102

SANSUI

D-X701 3-Head Cassette Deck

2-motor, dual capstan cassette deck with full-logic controls and Dolby B and C noise reduction. Features individual record and playback DC amplifiers; fine-bias adjustment; headphone jack with adjustable level; auto-monitor; memory stop; 15-track auto music program search; FL display. Frequency response 30-20,000 Hz; wow and flutter 0.035% wrms; signal-to-noise ratio 60 dB. \$700

D-X301R Cassette Deck

Cassette deck with full-logic controls and computerized dual-function control. Features Dolby B and C noise reduction; Dolby HX Pro; auto bias adjustment; rec/play timer; Sansui integrated system remote capability; record cancel; music scan; headphone jack with adjustable level; memory stop; 20-track auto music program search. Frequency response 20-19,000 Hz; wow and flutter 0.5% wrms; signal-to-noise ratio 72 dB (Dolby C). \$390

D-3000WR Double Cassette Deck

High-speed dubbing autoreverse deck with Dolby B and C noise reduction. Features LED meters for each channel; full logic, soft-touch controls; auto music program search; rec mute. Wow and flutter 0.09% wrms; Frequency response 20-17,000 Hz (metal); signal-to-noise ratio 72 dB (Dolby C, metal), 64 dB (Dolby B). 17 x 5 x 9 in; 9.9 lb. \$380

D-X301i Cassette Deck

Cassette deck with Dolby B and C noise reduction. Features Dolby HX Pro; computerized dual function control; auto music program search; bidirectional music scan; 2 repeat modes; fine bias adjustment; switchable MPX filter; auto rec mute; full logic controls; timer rec/playback; peak meters; electronic tape counter. Remote interface with other Sansui components. Frequency response 30-20,000 Hz \pm 3

dB; signal-to-noise ratio 75 dB (Dolby C); wow and flutter 0.05% wrms. 17 x 5 x 11 3/4 in; 10 lb. Black finish. \$350

D-1000W Double Cassette Deck

Double cassette deck with high-speed dubbing and Dolby B and C noise reduction. Features 2 full-logic, computer-controlled transports; manual level controls; auto music program search. Wow and flutter 0.09% wrms; frequency response 20-17,000 Hz (metal); signal-to-noise ratio 74 dB (metal). \$310

D-900W Double Cassette Deck

Features normal/high speed dubbing; auto music program search; Dolby B noise reduction. Wow and flutter 0.2% wrms; frequency response 40-15,000 Hz; signal-to-noise ratio 63 dB (Dolby B, metal tape). 17 x 5 x 9 in; 8 lb. \$240

D-550WR Double Cassette Deck

Double cassette deck with autoreverse on the playback deck and Dolby B noise reduction. Features relay play; auto level control; high-speed dubbing; tape type selector. \$230



Sansui D-X301i

SANYO

RDW589 Double Cassette Deck

3-head double cassette deck with 4-track high speed dubbing which is twice as fast as normal high-speed dubbing. Features Dolby B and C noise reduction; power loading; continuous playback; metal tape capability; 5-segment LED peak-level meters; 3-digit tape counter; full auto-stop mechanism. Wow and flutter 0.06% wrms; FR 40-15,000 Hz (CrO₂); signal-to-noise ratio 65 dB (metal). 16 1/2 x 4 3/8 x 8 in. \$170

RDW489 Double Cassette Deck

3-head autoreverse double cassette deck with Dolby B and C noise reduction. Features synchronized 1-touch high-speed dubbing; power loading; continuous playback; metal tape capability; 5-segment LED peak level meters; 3-digit tape counter; full auto stop mechanism. Wow and flutter 0.08% wrms; frequency response 40-15,000 Hz (CrO₂); signal-to-noise ratio 65 dB (metal). 16 1/2 x 5 x 7 7/8 in. \$150

RDW59 Double Cassette Deck

Features Dolby noise reduction; continuous playback; high-speed dubbing; synchronous dubbing; metal-tape capability; dual level meters; auto-stop; soft-touch transport controls; 3-digit tape counter; headphone jack. \$130

RDW389 Double Cassette Deck

3-head double cassette deck with Dolby B and C noise reduction. Features synchronized 1-touch high-speed dubbing; continuous playback; metal tape capability; 5-segment LED peak-level meters; 3-digit tape counter; full auto stop mechanism. Wow and flutter

The listings are based on data provided by the manufacturers. For more product information, contact an authorized dealer or the manufacturer directly. Manufacturers' addresses and phone numbers are listed in the directory beginning on page 258.

TOTAL HARMONIC DISTORTION

...AT LAST! THE FUNNIEST RODRIGUES CARTOONS FROM THE PAST TWO DECADES OF STEREO REVIEW HAVE FINALLY BEEN COLLECTED IN BOOK FORM...



Yes, now you can own **TOTAL HARMONIC DISTORTION** by Charles Rodrigues!

This handsome, 128-page paperback—with 118 classic cartoons, a foreword by William Livingstone, and an illustrated autobiographical sketch by Rodrigues himself—is only \$7.95. Enjoy your favorites again, catch the gems you missed, and share the laughs with friends!

Makes a great gift!
Get two copies for the full stereo effect!

TO ORDER: Send check or money order for \$7.95 per copy, plus \$1.50 for postage & handling to:

Perfectbound Press
Suite 4118A
1120 Ave. of the Americas
New York, NY 10036

Type or print mailing address with order. New York State residents add 6% sales tax per copy. Outside U.S.: add \$1.75 postage & handling for first copy and 50¢ for each additional copy (U.S. bank funds only). Allow six to eight weeks for U.S. delivery, longer outside U.S.

CASSETTE • DECKS

0.08% wrms; frequency response 40-15,000 Hz (CrO₂); signal-to-noise ratio 65 dB (metal). 16½ x 5 x 7¾ in. \$100

RDW41A Double Cassette Deck

2-head deck features synchro dubbing; continuous playback; Dolby noise reduction; metal-tape capability; soft-eject doors; 5-segment LED level meters, 3-digit tape counter; auto stop. Wow and flutter 0.08% wrms; frequency response 60-13,000 Hz (chrome); S/N (metal). 16½ x 5 x 8 in. \$80

SHERWOOD

DS-7000R 3-Head Cassette Deck

3-head cassette deck with Dolby B and C NR. Features microprocessor supervised, full-logic control. Fine bias control; digital readout; auto tape selector; separate left/right record level adjustment; output level control; mic and headphone jacks; 13-segment rec level indicators; rec mute button; timer switch; 2-line input jacks with record cross fader. Frequency response 30-18,000 Hz; signal-to-noise ratio 75 dB; ch sep at 1 kHz 40 dB; wow and flutter 0.05%. 5 x 17¾ x 11 in. \$469

DD-1230R Double Cassette Deck

Double cassette deck with autoreverse and Dolby B and C noise reduction. Features microprocessor supervised, full-logic control. Digital tape counter; normal/high speed dubbing; bi-directional auto music search; auto tape selector; fully synchronized 1-touch dubbing; relay play with alternate playback deck; rec mute button; separate rec level and balance control; 13-segment rec level indicators; timer-record and start; illuminated tape run direction indicators; air-dampened soft eject cassette doors. Frequency response 30-16,000 Hz; signal-to-noise ratio 75 dB; ch sep at 1,000 Hz 40 dB; wow and flutter 0.12%. 4¾ x 17¾ x 8¾ in. \$299

DS-1630R Cassette Deck

Cassette deck with auto reverse and Dolby B and C noise reduction. Features microprocessor supervised, full-logic control. Digital readout; auto tape selector; 2-line input jacks with record cross fader; auto music search system; 3 playback modes; mic and headphone jacks; rec level and balance controls; output level control; 12-segment rec level indicators; rec mute button; air-dampened soft eject cassette door; timer switch. Frequency response 30-18,000 Hz; signal-to-noise ratio 75 dB; ch sep at 1,000 Hz 40 dB; wow and flutter 0.09%. 5 x 17¾ x 11 in. \$289

DS-1135C Cassette Deck

Features Dolby HX Pro; Dolby B and C noise reduction; average/peak level indicators; elapsed time indicator; 1 mic input. Frequency response 30-16,500 Hz ± 6 dB; wow and flutter 0.08%; signal-to-noise ratio 72 dB. Digi-Link remote compatible. 9 lb. \$199

DD-1130 Double Cassette Deck

Features Dolby B and C noise reduction; high-speed dubbing; synchronized dubbing; relay play; continuous play; normal, chrome, and metal tape settings; adjustable recording level; three-digit tape counter; LED recording level indicators; air-dampened soft eject cassette doors. Frequency response 30-16,000 Hz; signal-to-noise ratio 73 dB; channel separation at 1,000 Hz 37 dB; wow and flutter 0.2%. Dimensions: 4¾ x 17¾ x 8¾ in. \$159

DD-1032C Double Cassette Deck

Features average/peak level indicators and elapsed time counter. Frequency response 30-15,500 ± 6 dB; wow and flutter 0.15%; signal-to-noise ratio 65 dB; Dolby B noise reduction. Remote compatible. 7.7 lb. \$140

DD-1030 Double Cassette Deck

Features Dolby B noise reduction; relay/continuous play; normal/high-speed dubbing; average/peak level

indicators; elapsed time counter. Frequency response 30-15,000 Hz ± 6 dB; signal-to-noise ratio 64 dB; ch sep at 1,000 Hz 37 dB; wow and flutter 0.2%. \$139

SONY

TC-WR810 Double Cassette Deck

Double cassette deck with Dolby HX Pro. Features B and C noise reduction; double autoreverse; dual/simultaneous record; high-speed dubbing; MPX filter; automatic music sensor; relay play; remote capable. FR 30-17,000 Hz; w&F 0.09%; signal-to-noise ratio 58 dB. 17 x 4.75 x 11 in; 10 lb, 6 oz. \$500

TC-WR710 Double Cassette Deck

Double cassette deck with Dolby HX Pro. Features Dolby B and C noise reduction; double autoreverse; high-speed dubbing; automatic music sensor; replay play; remote capable. Frequency response 30-15,000 Hz; wow and flutter 0.09%; signal-to-noise ratio 58 dB. 17 x 4¾ x 11 in; 9 lb, 8 oz. \$350

TC-WR610 Double Cassette Deck

Double cassette decks with Dolby B and C noise reduction. Features double autoreverse; relay play; high-speed dubbing; automatic music sensor; remote capable. Frequency response 30-15,000 Hz; wow and flutter 0.09%; signal-to-noise ratio 58 dB. 17 x 4¾ x 11 in; 9 lb, 8 oz. \$315

TC-WR510 Double Cassette Deck

Double cassette deck with Dolby B and C noise reduction. Features double autoreverse; high-speed dubbing; remote capable. Frequency response 30-15,000 Hz; wow and flutter 0.12%; signal-to-noise ratio 58 dB. 17 x 4¾ x 11¼ in; 8 lb, 3 oz. \$245

TC-RX410 Cassette Deck

Single cassette deck with Dolby HX Pro. Features Dolby B and C noise reduction; autoreverse; microphone inputs; remote capable. Frequency response 30-15,000 Hz; wow and flutter 0.09%; signal-to-noise ratio 58 dB. 17 x 4¾ x 11¼ in; 8 lb, 10 oz. \$240

TC-W310 Double Cassette Deck

Double cassette deck with Dolby B and C noise reduction. Features high-speed dubbing. Frequency response 30-15,000 Hz; wow and flutter 0.12%; signal-to-noise ratio 58 dB. 17 x 4¾ x 11¼ in; 7 lb, 8 oz. \$190

TC-FX110 Cassette Deck

Single cassette deck with Dolby B and C noise reduction. Frequency response 30-15,000 Hz; wow and flutter 0.12%; signal-to-noise ratio 58 dB. 17 x 4¾ x 11¼ in; 7 lb, 12 oz. \$130

Sony Elite Cassette Deck Series

TC-K730ES 3-Head Cassette Deck

Three-head cassette deck with a mid-ship drive system that separates the control circuitry from the audio circuits leaving the tape transport mechanism in the mid-ship portion of the chassis. Features LC-OFC laser amorphous heads; Dolby B and C noise reduction; closed-loop dual capstan transport; quartz-lock direct drive 3-motor design; linear counter; record level calibration; variable bias; automatic tape type; MPX filter switch; auto play; auto space/record mute; timer record/playback, wow and flutter 0.025%; Frequency response 20-21,000 Hz ± 3 dB; signal-to-noise ratio 60 dB (73 dB, Type-IV tape). 18½ x 5 x 13¾ in; 20 lb, 15 oz. \$850

TC-WR11ES Double Cassette Deck

Double cassette deck with twin/sequential recording. Features 4-motor (2 per transport) design with feather-touch controls; autoreverse; high-speed dubbing; Dolby B and C noise reduction on both decks; relay play; auto pause; linear real-time counter; automatic music sensor; blank skip; automatic tape type selection; remote control; 210 kHz super bias. Wow and flutter 0.05%; frequency response 20-

CASSETTE • DECKS

20,000 Hz \pm 3 dB; signal-to-noise ratio 59 dB (72 dB, Type-IV tape). 17 x 5 $\frac{1}{2}$ x 3 $\frac{3}{4}$ in; 10 lb \$800

TC-WR10ES Double Cassette Deck

Double cassette deck with twin/sequential recording. Features high-speed dubbing; autoreverse; relay play; laser-amorphous heads; Dolby HX Pro B and C noise reduction; multiplex filter switch; linear counter; automatic music sensor; automatic tape type; auto space/record mute; blank skip; timer record/playback. Wow and flutter 0.09%; frequency response 20-20,000 Hz \pm 3 dB; signal-to-noise ratio 58 dB (71 dB, Type-IV tape). Dimensions: 17 x 4 $\frac{3}{4}$ x 10 $\frac{1}{2}$ in. Weight: 10 lb. 5 oz. \$550

TC-K630ES 3-Head Cassette Deck

Three-head cassette deck. Features LC-OFC laser amorphous heads; Dolby HX Pro; Dolby B and C noise reduction; two-motor transport; linear tape counter; variable bias adjustment; automatic tape type; multiplex filter switch; automatic play; automatic space/record mute; timer record/playback; blank skip; music scan. Wow and flutter 0.05%; frequency response 20-21,000 Hz \pm 3 dB; signal-to-noise ratio 59 dB (72 dB, Type-IV tape). Dimensions: 17 x 4 $\frac{3}{4}$ x 13 $\frac{1}{2}$ in. Weight: 11 lb. 7 oz. \$450

TC-WR8ES Double Cassette Deck

Double cassette deck with relay play. Features high-speed dubbing; autoreverse; laser-amorphous heads; Dolby HX Pro; Dolby B and C NR; MPX filter switch; linear counter; automatic music sensor; automatic tape type; auto play; auto space/record mute; blank skip; timer record/playback. Wow & flutter 0.09%; frequency response 20-20,000 Hz \pm 3 dB; signal-to-noise ratio 58 dB (71 dB, Type-IV tape). Dimensions: 17 x 4 $\frac{3}{4}$ x 10 $\frac{1}{2}$ in. Weight: 10 lb. 5 oz. \$430

TC-RX55ES Cassette Deck

Autoreverse cassette deck. Features LC-OFC laser amorphous heads; Dolby HX Pro headroom extension; Dolby B and C noise reduction; electronic digital counter; automatic tape type; multiplex filter switch; automatic play; automatic space/record mute; timer record/playback; high-speed cue and review. Wow & flutter 0.09%; frequency response 20-20,000 Hz \pm 3 dB; signal-to-noise ratio 58 dB (71 dB, Type-IV tape). Dimensions: 17 x 4 $\frac{3}{4}$ x 11 $\frac{1}{2}$ in. weight: 8 lb. 9 oz. \$300

TEAC

R-919X 4-Head Cassette Deck

4-head cassette deck with Dolby HX Pro, double dbx, and Dolby B and C NR. Features 3-motor IC-logic transport control silent mechanism; double acculign rotating head system; hysteresis tension servo control system; bi-polar power supply and DC configuration circuit; autoreverse/repeat; multi-function FI display; electronic tape index counter with tape run time mode; 2-color L/R peak program level meter; fine bias adjustment; computational program search; computational direct selection; intro check; blank scan; memory play/stop; block repeat; auto monitor; master rec level control; output level control; MPX filter; timer rec/playback capability. Optional wooden side panels. Includes full-function wireless remote control. Wow & flutter 0.029% wrms; frequency response 25-20,000 Hz \pm 3 dB (metal); signal-to-noise ratio 80 dB at 1,000 Hz (Dolby C). Dimensions: 17 $\frac{1}{8}$ x 4 $\frac{7}{8}$ x 10 $\frac{1}{4}$ in. Weight: 13.25 lb. \$830

The listings are based on data provided by the manufacturers. For more product information, contact an authorized dealer or the manufacturer directly. Manufacturers' addresses and phone numbers are listed in the directory beginning on page 258.

W-990RX Double Cassette Deck

Double cassette deck with bi-directional double deck continuous rec/playback and parallel recording. Features 3-motor IC-logic control mechanism; bi-polar power supply and DC configuration circuit; dbx and Dolby B and C noise reduction; sync reverse capability; 1-touch high-speed and normal speed dubbing; intro check memory dubbing system; random memory program dubbing; reverse edit function; editing dubbing; cobalt amorphous LC-OFC rec/play head; multifunction FI display; independent electronic counter for decks I and II; 2-color L/R peak program level meter; computer program search; computational direct selection; intro check; blank scan; timer rec/playback; auto tape select; rec mute with auto spacer; headphone jack. Includes full-function wireless remote control. Wow and flutter 0.045% wrms; frequency response 30-19,000 Hz \pm 3 dB; signal-to-noise ratio 78 dB at 1,000 Hz (Dolby C) \$800

V-970X 3-Head Cassette Deck

3-head cassette deck with Dolby HX Pro, double dbx, and Dolby B and C noise reduction. Features 3-motor IC-logic transport control silent mechanism; closed-loop dual capstan drive; independently micro-aligned rec and play head with cobalt amorphous LC-OFC winding; hysteresis tension servo control system; bi-polar power supply and DC configuration circuit; multifunction FI display; electronic tape index counter with tape run time mode; 2-color L/R peak program level meter; fine bias adjustment; L/R level control; computer program search; computational direct selection; intro check; blank scan; memory play/stop function; block repeat; auto monitor; master rec level; output level control; MPX filter; timer rec/playback capability. Wooden side panels optional. Includes full-function wireless remote control. Wow and flutter 0.028% wrms; frequency response 25-20,000 Hz \pm 3 dB (metal); signal-to-noise ratio 80 dB at 1,000 Hz (Dolby C) \$800

R-616X Cassette Deck

Autoreverse cassette deck with Dolby HX Pro, dbx, and Dolby B, and C noise reduction. Features bi-directional rec/play autoreverse; repeat; IC logic controls; 15-program random memory play; block repeat; 1-touch recording; fine bias adjustment; rec mute with auto spacer; auto tape selector; MPX filter switch; timer/play standby function; independent record levels. W&F 0.05% wrms; FR 25-20,000 Hz (metal); S/N 90 dB (dbx in over 1 kHz). 11 lb. . \$500

V-670 3 Head Cassette Deck

Features Dolby HX Pro and Dolby B and C NR; fine bias adjustment; rec mute with auto-spacer; auto-tape selector; electronic tape counter with index and tape-run time modes; master rec level control with left and right channel preset; 2-color L/R program level meters; multi-function FI display \$450
V-570. Similar to above, 2 head \$350

W-550R Double Cassette Deck

Cassette deck with 2-motor IC-logic control mechanism. Features Dolby HX Pro; Dolby B and C NR; bi-polar power supply; quick autoreverse; blank scan; sync reverse; hard permalloy heads; 2-color LED meter; rec mute; auto tape selector; headphone jack; 1-touch high-speed/normal dubbing; continuous play; timer rec/play. System remote capable. W&F 0.07% wrms; frequency response 30-18,000 Hz (chrome); signal-to-noise ratio 69 dB at 5,000 Hz (Dolby B) . . . \$400

R-540 Cassette Deck

Autoreverse cassette deck with Dolby HX Pro and Dolby B and C NR. Features 2-motor IC-logic control mechanism; bi-polar power supply; hard permalloy heads; 2-color LED meter; rec mute; auto tape selector; headphone jack; timer rec/play. System remote capable. W&F 0.07% wrms; FR 30-18,000 Hz (chrome); S/N 69 dB at 5,000 Hz (Dolby B) . . . \$290
W-450R Double Cassette Deck

Autoreverse double cassette deck with Dolby HX Pro and Dolby B and C noise reduction. Features

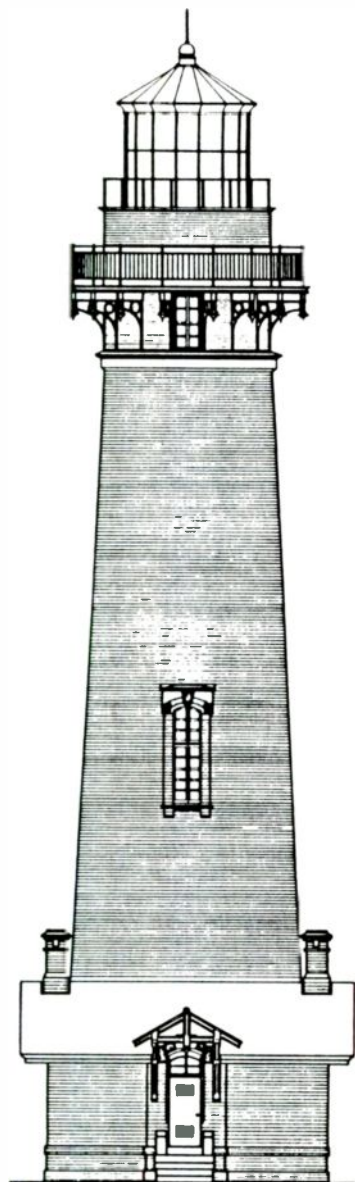

PIGEON POINT LIGHTHOUSE, SAN MATEO COUNTY, CA

PRESERVATION PLAN ON IT

Planning on restoring a house, saving a landmark, reviving your neighborhood?

Gain a wealth of experience and help preserve our historic and architectural heritage. Join the National Trust for Historic Preservation.

Make preservation a blueprint for the future.

Write:

National Trust
for Historic Preservation
Department PA
1785 Massachusetts Ave., N.W.
Washington, D.C. 20036

CASSETTE • DECKS

continuous playback and bi-directional recording in deck II; sync reverse capability; sync dubbing capability; 1 program skip function in deck II; auto-tape selector. Wow and flutter 0.05% wrms; FR 30-17,000 Hz (metal); signal-to-noise ratio 70 dB (Dolby C). 4 7/8 x 17 1/8 x 10 3/4 in. 10.1 lb. \$290
R-455 CHX. Similar to above, no double deck \$220
V-285-CHX. Similar to above, no autoreverse \$150

W-470 Double Cassette Deck

Double cassette deck with Dolby B and C NR. Features IC-logic control mechanism; bipolar power supply; hard-permalloy heads; intro check; skip play; 2-color LED meter; rec mute; auto tape selector; headphone jack; timer rec/play; 1-touch high-speed/normal dubbing; continuous play. System remote capable. Wow and flutter 0.07% wrms; frequency response 30-17,000 Hz (chrome); signal-to-noise ratio 69 dB at 5,000 Hz (Dolby B). 17 1/8 x 5 x 11 1/2 in; 10.5 lb. \$250

R-445 Cassette Deck

Autoreverse cassette deck with bi-directional rec/play. Features Dolby B and C noise reduction; accurate rotating head reverse system; 1-program skip function; repeat; 2-color LED meter; rec mute; headphone jack. Wow and flutter 0.06% wrms; frequency response 30-17,000 Hz (chrome); signal-to-noise ratio 65 dB at 5,000 Hz (Dolby B). 17 1/8 x 4 7/8 x 8 1/2 in; 6.6 lb. \$210

W-370C Double Cassette Deck

Double cassette deck with continuous playback from deck I to deck II. Features normal/high-speed dubbing; Dolby B and C noise reduction; fine bias adjustment; 2-color LED meter; direct function mechanism; full auto stop mechanism; auto tape-type selector; 3-digit mechanical tape counter; metal tape compatibility. Wow and flutter 0.095% wrms; frequency response 30-15,000 Hz (chrome); signal-to-noise ratio 65 dB at 5,000 Hz (Dolby B). 17 1/8 x 4 3/4 x 8 1/2 in; 7 lb. \$200

V-480 Cassette Deck

Cassette deck with IC-logic control mechanism and bi-polar power supply. Features hard permalloy heads; Dolby HX Pro; Dolby B and C noise reduction; fine bias adjustment; 2-color LED meter; rec mute; auto tape-type selector; headphone jack; timer rec/play. System remote compatible. Wow and flutter 0.07% wrms; frequency response 30-17,000 Hz (chrome); signal-to-noise ratio 69 dB at 5,000 Hz (Dolby B). Dimensions: 17 1/8 x 5 x 11 1/2 in. Weight: 9.9 lb. \$200

W-350 Double Cassette Deck

Double cassette deck with double-deck continuous playback from deck II to deck I. Features normal/high-speed dubbing; Dolby B noise reduction; 2-color LED meter; direct function mechanism; full auto stop mechanism; auto tape-type select; 3-digit mechanical tape counter; metal tape compatibility. Wow and flutter 0.095% wrms; frequency response 30-15,000 Hz (chrome); signal-to-noise ratio 65 dB at 5,000 Hz (Dolby B). 17 1/8 x 4 3/4 x 8 1/2 in; 7 lb. \$170

V-270C Cassette Deck

Cassette deck with Dolby B and C noise reduction. Features fine bias adjustment; direct function mechanism; full auto stop mechanism; metal tape compatibility; 3-position tape selector; 2-color LED meter; 1-touch recording; 3-digit mechanical tape counter. Wow and flutter 0.095% wrms; frequency response 30-15,000 Hz (chrome); signal-to-noise ratio 65 dB at 5,000 Hz (Dolby B). 17 1/8 x 4 3/4 x 8 1/2 in; 6.4 lb. \$140

V-250 Cassette Deck

Features Dolby B noise reduction; direct function mechanism; auto stop mechanism. Metal capability; 3-position tape selector; 1-touch recording. Wow and flutter 0.09% wrms; frequency response 30-18,000 Hz (metal); signal-to-noise ratio 65 dB (Dolby B). 4 3/4 x 17 1/8 x 8 1/2 in; 6.4 lb. \$120

TECHNICS

RS-B905 3-Head Cassette Deck

Features closed loop dual capstan transport; 2-motor transport; dbx; Dolby HX Pro; Dolby B and C NR; FL display; fine bias adjustment; record calibration tone generator; MPX filter; auto rec-mute; headphone jack with adjustable level \$620

RS-TR555 Double Cassette Deck

Double cassette deck with dbx, Dolby HX Pro, and Dolby B and C noise response. Features 2-motor transport; full-logic control feather-touch operation; dual range FL peak-level meters; metal compatibility; double quick-reverse; double quick rec/play; simultaneous parallel recording; 3-hr series recording; 24-hr series playback; high-speed editing; synchro start/stop and rec mute; dual electronic tape counters; remote control capability; CD synchro editing with selected Technics CD players; music select; auto tape select; L/R independent rec level controls; timer rec/playback capability; headphone jack. Brushed aluminum front panel. Wow and flutter 0.07% wrms; frequency response 20-18,000 Hz (chrome); signal-to-noise ratio 66 dB (Dolby B, chrome). 17 x 5 3/8 x 11 3/8 in; 12.1 lb. \$440

RS-B605 3-Head Cassette Deck

Features 2-motor transport; dbx; Dolby HX Pro; Dolby B and C NR; FL display; fine bias adjustment; auto rec-mute \$360

RS-TR355 Double Cassette Deck

Double autoreverse cassette deck with Dolby HX Pro headroom extension, Dolby B and C noise reduction. Features full-logic control feather-touch operation; dual range FL peak-level meters; 2-speed DC servo motors; metal tape compatibility; 24-hr series playback; high-speed editing; synchro start/stop and auto rec mute; CD synchro editing; dual electronic tape counters; full remote control capability; auto tape select; cue and review; L/R independent rec-level controls; timer rec/playback capability; headphone jack. Brushed aluminum front panel. Wow and flutter 0.1% wrms; frequency response 20-18,000 Hz (chrome); signal-to-noise ratio 66 dB (Dolby B, chrome). 17 x 5 3/8 x 11 3/8 in; 10.6 lb. \$330

RS-TR255 Double Cassette Deck

Double autoreverse cassette deck with Dolby B and C NR. Features 2-speed DC servo motors; 2-color LED peak-level meters; metal tape compatibility; full-logic control feather-touch operation; 18-hr series playback; high-speed editing; synchro start/stop and auto rec mute; CD synchro editing; remote control compatibility; auto tape select; cue and review; L/R independent rec-level controls; 3-digit tape counter; timer rec/playback capability; headphone jack. Wow and flutter 0.1% wrms; frequency response 20-16,000 Hz (chrome); signal-to-noise ratio 66 dB (Dolby B, chrome). 17 x 5 3/8 x 11 3/8 in; 10.6 lb. \$230

RS-TR155 Double Cassette Deck

Double autoreverse cassette deck with Dolby B noise reduction. Features full-logic control feather-touch operation; 2-color LED peak-level meters; 2-speed DC servo motors; metal compatibility; 18-hr series playback; high-speed editing; synchro start/stop and auto rec mute; CD synchro editing; remote control capability; auto tape select; cue and review; L/R independent rec level controls; 3-digit tape counter; timer rec/playback capability; headphone jack. Wow and flutter 0.1% wrms; frequency response 20-16,000 Hz (chrome); signal-to-noise ratio 66 dB (Dolby B, chrome). 17 x 5 3/8 x 11 3/8 in; 10.6 lb. \$210

TOSHIBA

PC-5858 Double Cassette Deck

Double cassette deck with high-speed dubbing. Features IC logic design; Dolby B and C NR; continuous play between decks; continuous record between decks; quick search selection; repeat function. \$399

UHER of AMERICA

CR 1601 3-Head Portable Cassette Deck

Compact front-loading portable cassette recorder with monitor facility featuring 8 hours record time and built-in voice actuating system. Features 2 motors; direct drive; dual capstans; manual azimuth adjust; elapsed-time counter; output-level control; bias fine tuning; memory stop/play; LED meters; soft-touch controls; mike inputs; headphone jack; rec mute; 3 tape speeds: 1.88 ips, 0.94 ips and .16 ips with ALC. Frequency response 20-19,000 Hz (ferric) ± 3 dB; wow and flutter <2% wrms. 9 1/4 x 2 1/4 x 7 1/4 in; 5 lb. \$1,799

CR 1600 3-Head Portable Cassette Deck

Compact front-loading, fully electronic, auto-reverse, record/playback stereo cassette recorder with Dolby B noise reduction. Features 8 hours record time with a built-in voice activation system; 2-motors; 4-tracks; A/V input capability; switchable ALC with 2-time constants; separate channel record level meters; 1 7/8 and 1 1/2 ips; remote soft-touch solenoid controls with built-in speaker; operates on dry cell, 12-V car battery, or 110/220 V AC. Frequency response 30-16,000 Hz; wow and flutter ± 1%. 9 x 2 1/4 x 7 1/4 in; 5.75 lb. \$1,799

Accessories

F-423 Diapilot

Self-contained unit for synchronized tape control operation of automatic slide projector for use with Uher open-reel and cassette decks. DIN plug connector \$260

Z-135 Power Supply/Charger

Power supply/charger unit for Uher cassette recorders \$107

VECTOR RESEARCH

VCX-450 Cassette Deck

Cassette deck with Dolby B and C noise reduction. Features logic controlled transport; autoreverse mechanism. Multiskip music search; bi-directional play/record; L/R channel mic input; metal tape capability. Frequency response 30-17,000 Hz ± 3 dB normal, 30-17,000 Hz ± 3 dB high bias, 30-18,000 Hz ± 3 dB metal; signal-to-noise ratio Dolby B 67 dB; Dolby C 75 dB; wow and flutter 0.05% wrms. 17 x 4 1/2 x 11 1/4 in; 11 lb, 8 oz. \$400

VCX-255 Cassette Deck

Cassette deck with Dolby B and C noise reduction. Features logic controlled transport; fine bias adjustment. L/R channel mic input; record-balance control; metal tape capability. Frequency response 30-17,000 Hz ± 3 dB normal, 30-17,000 Hz ± 3 dB high bias, 30-18,000 Hz ± 3 dB metal; signal-to-noise ratio Dolby B 67 dB; Dolby C 75 dB; wow and flutter 0.05% wrms. Dimensions: 17 x 4 1/2 x 11 1/4 in. Weight: 11 lb, 8 oz. \$180

VCX-325 Double Cassette Deck

Double cassette deck with Dolby B noise reduction. Features 2-speed dubbing; synchro-start dubbing; continuous play; power-assist transport controls; mic inputs; manual dubbing/recording level; metal-tape capability. FR 40-13,000 Hz ± 3 dB normal, 40-14,000 Hz ± 3 dB high bias, 40-15,000 Hz ± 3 dB metal; signal-to-noise ratio 63 dB (Dolby B); wow and flutter 0.08% wrms. 17 1/4 x 4 1/2 x 10 in; 8 lb, 8 oz \$160

YAMAHA

KX-1200Ti 3-Head Cassette Deck

3-head cassette deck with 28-key wireless remote control. Features double dbx dynamic expansion; double Dolby B and C noise reduction; closed-loop dual-capstan tape transport; ORBIT system with optical balance tuning indicator; Dolby HX Pro headroom extension; amorphous head; full-logic

CASSETTE • DECKS

control; optimum recording-level indicator; RS integrated system remote compatibility. Titanium finish; 22 lb \$749
KX-1200U. As above, black \$749

KX-W900Ti Double Cassette Deck

Double cassette deck with autoreverse. Features amorphous recording and playback heads; play, record, and autoreverse on both decks; relay play and record; Dolby B and C noise reduction and Dolby HX Pro; high-speed dubbing; auto dubbing; skip dubbing; random program dubbing; manual dubbing; cross-Dolby dubbing; simultaneous independent recording; 44-key wireless remote control; random program play on both decks; music search on both decks; intro scan; record return; auto record mute; blank skip; auto tape selection; 4-digit electronic linear tape counter; 13-segment peak level meters on both decks; remaining time indicator. Titanium finish; 18 lb \$699
KX-W900U. As above, black \$699

KX-R700Ti Cassette Deck

Cassette deck with autoreverse record and playback. Features full-logic, 3-motor tape transport; amorphous record/play head; dbx, Dolby B, C, and Dolby HX Pro; MPX filter; super bias. Electronic record volume control; optimum record-level indicator; power eject and close; remaining tape time display; auto fade in/out; auto tape selector; rec return; bidirectional intro scan; 9-selection random program play; music search; programmable timer/clock; linear real-time counter; blank skip; 0-memory; auto rec mute; memory stop; integrated system remote compatibility. Includes 39-key wireless remote control. Titanium finish; 14 lb \$579
KX-R700U. As above, black \$579

KX-800U 3-Head Cassette Deck

3-head cassette deck with double dbx dynamic range expansion. Features Dolby B and C noise reduction; ORBIT optical balance tuning system; three motors; Dolby HX Pro; multiplex filter; amorphous heads. Master fader; linear time counter; 12-segment peak-level meter; integrated system remote compatibility; optimum record-level indicator; random program play; intro scan; music search; repeat; record return; auto rec mute; auto tape selector; memory stop; headphone jack with adjustable level. Includes 28-key wireless remote control. signal-to-noise ratio 69 dB Dolby B, 77 dB Dolby C; 90 dB dbx; Frequency response 20-22,000 Hz \pm 3 dB. 14 lb \$569

KX-W602Ti Double Cassette Deck

Cassette deck with autoreverse rec and playback on both decks. Features full-logic 2-motor transport in each deck; amorphous rec/play heads; Dolby B and C NR; Dolby HX Pro headroom extension (deck A); 13-segment peak-level meter; 4-digit linear counter; manual, normal, and high-speed dubbing; auto dubbing; skip dubbing; random program dubbing; remaining time display; relay play allows up to 24 hrs of continuous play; relay rec; 9-selection random program play; bidirectional intro scan; MPX filter; RS integrated system remote control compatibility. Includes 31-key wireless remote control. Titanium finish; 13 lb \$519
KX-W602. As above, black \$519

KX-630Ti 3-Head Cassette Deck

3-head cassette deck with double Dolby B and C noise reduction. Features Dolby HX Pro headroom extension; hard permalloy rec head; amorphous play head; double-gap ferrite erase head; 13-segment LCD peak level meter; LCD linear time counter; master fader; MPX filter; high-speed fast forward/rewind; remaining time indicator; random program optimum rec level indicator; bidirectional intro scan; manual bias adjustment \pm 20% play; play trim; auto tape selector; auto rec mute; rec return; memory stop; output volume control; headphone output with level control; music search; repeat; RS integrated system remote control compatibility. Includes 28-key wire-

less remote control. Titanium finish; 13 lb ... \$469
KX-630. As above, black \$469

KX-W302U Double Cassette Deck

Autoreverse double cassette deck with play in both directions, record in one. Features amorphous rec/play head; Dolby B and C noise reduction; MPX filter; Dolby HX Pro; full-logic operation. One-touch dubbing at normal and high speed; relay play; auto tape selector; auto record mute; music search; integrated remote compatibility. Optional remote control. 12 lb \$449

K-640B Cassette Deck

Autoreverse cassette deck with RS integrated system remote compatibility. Features amorphous head; Dolby B, C, HX Pro, and dbx. Auto fade; remaining time; introscan. Black; 16 lb \$449

KX500U Cassette Deck

3-motor cassette deck with Dolby B and C NR and Dolby HX Pro. Features MPX filter. Manual bias adjustment \pm 20%; master fader; 12-segment peak level meter; integrated system remote compatibility; play trim; random program play; bidirectional intro scan; music search; repeat; record return; auto rec mute; auto tape selector. Includes 27-key wireless remote control. 13 lb \$399

KX-W202U Double Cassette Deck

Double cassette deck with full one-way operation dual mechanism. Features hard-permalloy rec/play head; Dolby B and C NR; MPX filter. 1-touch dubbing at normal and high speed; relay play; music search; record return; auto record mute; auto tape selector; integrated system remote compatibility. Optional remote control. 11 lb \$349

KX-R430 Cassette Deck

Autoreverse cassette deck with Dolby B and C noise reduction. Features amorphous head; bidirectional intro scan; Dolby HX Pro headroom extension; 2 heads; 2 motors; music search; full, single, and phrase repeat; rec return; auto rec mute; auto tape selector; timer rec and play; headphone jack; 7-segment LED peak-level meter; MPX filter; blank skip; manual bias adjustment \pm 20%; integrated system remote compatibility. Includes 11-key wireless remote. Black. 11 lb \$349

KX-300U Cassette Deck

Cassette deck with Dolby B and C noise reduction. Features 2 motors; Dolby HX Pro; multiplex filter. Manual bias adjustment \pm 20%; 7-segment peak level meter; integrated system remote compatibility; play trim; bidirectional intro scan; music search; repeat; record return; auto rec mute; auto tape selector. Includes 10-key wireless remote control. Weight: 11 lb \$299

KX-230 Cassette Deck

Cassette deck with Dolby B and C noise reduction. Features hard-permalloy head; 2-motor transport; full logic control; bidirectional intro scan, full repeat and phrase repeat; Dolby HX Pro headroom extension; auto tape selector; rec return; auto rec mute; 7-segment peak level meter; MPX filter; manual bias adjustment \pm 20%; timer rec/play; headphone jack; RS integrated system remote compatibility. Optional RS-K3 remote control. Black. 11 lb \$269

KX-130 Cassette Deck

Cassette deck with Dolby B and C noise reduction. Features hard-permalloy head; 1 motor transport; full logic control; 6-segment peak-level meter; auto tape type selection; rec mute/return; separate left and right level control; headphone jack. Black. 11 lb \$219

Accessories

RS-kW-5. Infrared remote control for all RS integrated system compatible cassette decks \$50
RMA-K20. Rack mount adaptor for KX-1200U \$18

Are you CD-literate?

Do you know

- why CDs sound better than LPs?
- the fundamentals of digital audio?
- how information is encoded and stored on CDs?
- how oversampling chip sets improve performance?
- how optical pickups are used for playback?
- how discs are manufactured?
- how to choose a CD player and detect a defective disc?

Ken Pohlmann's new book contains virtually everything you need to know about this revolutionary technology. Written with the clarity, expertise, and humor that has made Ken Pohlmann a favorite among *Stereo Review* readers, this book is the only source for people who are serious about CD technology and its applications.

The Compact Disc A Handbook of Theory and Use



by Ken Pohlmann
Stereo Review Contributing Editor

"This book is an invaluable source for anyone—layman and professional alike—who wants to be fully informed about the medium that is revolutionizing the consumer electronics industry."

Michael Smolen
Stereo Review Executive Editor

Order this book and enclose payment—we'll pay postage and mail it within 24 hours!

 _____ Yes! Send me _____ copies @
 \$29.95 each for a total of \$ _____.
 (WI and CA residents add sales tax.)
 My check for full payment is enclosed.

Name _____

Address _____

City _____

State _____ Zip _____

Send to:
A-R Editions, Inc.
 801 Deming Way, Box P
 Madison, WI 53717
 (608) 836-9000

OPEN-REEL • TAPE • DECKS

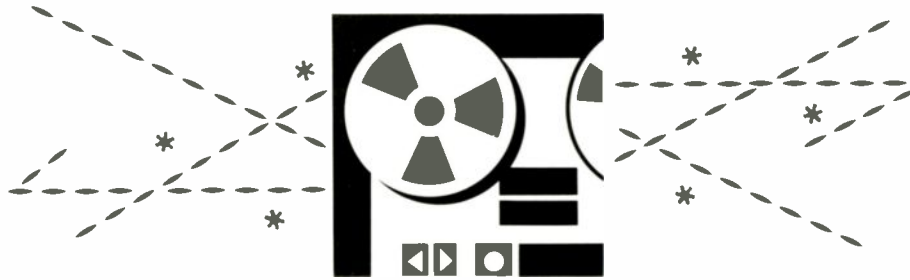

FOSTEX

E-22 Open-Reel Tape Deck

3-channel stereo master recorder/reproducer open-reel tape deck. Features half-track stereo on 1/2-inch tape with a third, center channel for SMPTE time code or other cueing data; gapless punch-in/punch-out; spot erase; microprocessor-controlled transport; XLR balanced inputs/outputs and phono inputs/outputs \$3,995

E-2 Open-Reel Tape Deck

2-channel stereo master recorder/reproducer open-reel tape deck. Features standard half-track stereo on 3/4-inch tape with a third, center channel for SMPTE time code or other cueing data; gapless punch-in/punch-out; spot erase; microprocessor-controlled transport; XLR balanced inputs/outputs and phono inputs/outputs \$3,750

M-20 Open-Reel Tape Deck

2-track recorder/reproducer open-reel tape deck featuring standard half-track stereo format; 7-inch reel size; 15 ips tape speed; 3/4-inch tape width. Frequency response 40-20,000 Hz \$1,500

REVOX

B77 MK II Open-Reel Tape Deck

Open-reel tape deck featuring two speeds (3.75 ips and 7.5 ips); 10 1/2-in reel capacity; front-panel variable-speed control $\pm 10\%$; integrated-drive-logic computer-type push-point function keys; built-in tape cutter, dual VU meters with peak-level indicators; separate left/right record and input controls; tape monitor switch; provision for remote control of all functions and electric timer operation; connectors for remote control of variable tape speed, and slide projector or crossfade unit. Frequency response 30-16,000 Hz ± 2 , -3 dB at 3.75 ips, 30-20,000 Hz at 7.5 ips; wow & flutter no more than 0.1% at 3.75 ips, no more than 0.08% at 7.5 ips; signal-to-noise ratio > 64 dB at 3.75 ips, > 67 dB at 7.5 ips; mic input level/imp 0.15 mV/2,200 ohms (low position, 50-600 ohm mikes), 2.8 mV/110,000 ohms (high, 20,000 ohm mikes). Available in high-speed, low-speed, super low-speed, two and four track versions. Dimensions: 16 1/4 x 17 3/4 x 8 1/2 in. Weight: 37 lb, 8 oz. \$2,450



Revox B77 MK II

TEAC

X-2000M Open-Reel Mastering Deck

Two speed (15 and 7.5 ips) 2-track, 3-head open-reel tape deck. Features dbx 1 NR; 10 1/2-in reel capacity; direct-drive motor. Pitch control; EE tape capability; full logic feather-touch controls; tape/source monitoring; fine bias adjustment; real-time counter; mic/line mixing; mic attenuator; separate L/R input-level controls; rec mute; timer function. Optional remote control. Frequency response 40-33,000 Hz (7.5 ips), 40-40,000 Hz (15 ips); wow & flutter 0.02%/0.03% wrms at 15/7.5 ips; signal-to-noise ratio 100 dB (dbx), 17 1/8 x 17 x 10 1/2 in; 46 lb. \$2,235

X-2000RBI, Open-Reel Tape Deck

Two-speed (7.5 and 3.75 ips) 4-track, 2-channel tape deck with dbx 1 NR and 10 1/2-in reel capacity. Features 6 heads for bi-directional 3-head function; cobalt amorphous heads; 3-motor transport; LSI full logic control; tension servo control; motion sensing; dual capstan closed-loop transport; pitch control; auto search functions; EE tape switch; fine bias adjustment; mic/line mixing; real-time counter. Optional remote control. FR 40-33,000 Hz ± 3 dB (7.5 ips); w&F 0.03% wrms (7.5 ips); S/N 100 dB (dbx), 17 x 18 x 10 1/2 in; 46.3 lb. \$2,069
X-2000R. As above, silver finish. \$2,055

X-2000 Open-Reel Tape Deck

Two-speed (7.5 and 3.75 ips) 4-track, 2-channel tape deck with dbx 1 NR and 10 1/2-in reel capacity. Features 3 cobalt amorphous heads; 3-motor transport; LSI full logic control; tension servo control; motion sensing; dual capstan closed-loop transport; pitch control; auto search functions; EE tape switch; fine bias adjustment; mic/line mixing; real-time counter; mute with adjustable auto space; cue control; spooling mode. Optional remote control. FR 40-33,000 Hz ± 3 dB (7.5 ips); w&F 0.03% wrms (7.5 ips); S/N 100 dB (dbx), 17 x 18 x 10 1/2 in; 46.3 lb. \$1,950

X300R Open-Reel Tape Deck

3-head, 3-motor system with 7.5 ips speed. Features bi-directional playback; autoreverse; auto repeat; light-touch transport controls; mic/line mixing; rec mute; independent left and right output controls; tape/source monitor selector; 3-mode tape selector; timer start; front-panel mic and headphone jacks. FR 40-30,000 Hz ± 3 dB (7.5 ips); w&F 0.04% wrms (7.5 ips); S/N 65 dB with THD 3%. 16 1/2 x 12 7/8 x 9 1/8 in; 33.07 lb. \$1,280
X300. As above, no bidirectional playback, autoreverse, or auto repeat. \$1,145

UHER

1200 Report Monitor Open-Reel Deck

Synchro full-track tape deck with neo pilot. Features 4 heads; built-in monitor speaker; switchable roll-off filter; optional beep generator; pilot frequency device for picture-sync recording. Tape speed 7.5 ips; frequency response 40-16,000 Hz ± 3 dB; signal-to-noise ratio 62 dB; w&F 0.15% wrms. 28 1/2 x 10 x 23 1/2 in; 8.36 lb. \$5,049

6000 Report Universal Tape Recorder

Four-speed (3.75, 1.88, 0.94, 0.47 ips) tape recorder. Records up to 24 hours on 1 tape. Designed for monitoring, court reporting, surveillance. Features four motors; 5-in reel capacity; built-in dynamic noise reduction; switchable auto level control; electronic tape tension control; switchable loudspeaker; tape counter; audio/video input jack. 11 x 3 1/2 x 9 in; 8 lbs \$2,150

Report-Monitor Series Tape Recorders

Report-Monitor decks feature 3 heads, LED function indicators, integrated power supply, fully electronic amplifier switching, battery or .AC operation, tape-tension regulators, die-cast aluminum casings. All models can be used in portable or stationary applications. Speeds 7.5, 3.75, 1.88, 0.94 ips.

4400 Report Monitor, 4-track stereo. \$1,779
4200 Report Monitor, 2-track stereo. \$1,779
4000 Report Monitor AV, Half-track monaural \$1,665



Uher 4200 2-Track

Accessories

F-423 Diapilot

Self-contained unit for synchronized tape control operation of automatic slide projector for use with Uher open-reel and cassette decks \$260

F413 Acoustic Stop/Start Switch

Acoustic activated. For use with Uher decks. . . \$139

Z-125A Power Supply

Power supply and charger for Uher Monitor series decks. \$130

The listings are based on data provided by the manufacturers. For more product information, contact an authorized dealer or the manufacturer directly. Manufacturers' addresses and phone numbers are listed in the directory beginning on page 258.

TURNTABLES



ACOUSTIC RESEARCH

ES-1 Manual Turntable

Manual belt-drive turntable with 24-pole synchronous motor. Features 33 and 45 rpm speeds, w&f 0.04% wrms; rumble - 78 dB; effective tonearm mass without cartridge 14.5 g; effective tonearm length 229 mm; max tracking error 2.6°. 7 x 18 $\frac{1}{8}$ x 15 $\frac{1}{4}$ in (dustcover down); 18 lb. Natural cherry, with tonearm \$725
Natural cherry, without tonearm \$550

EB-101 Manual Turntable

Manual belt-drive pivoted-arm turntable with fully isolated 3-point suspension. Arm and platter on subchassis formed by pressed-steel T-bar spring-suspended and damped at 3 points. 33 $\frac{1}{3}$ and 45 rpm. Features 12-pole synchronous motor (500 rpm at 50 Hz, 600 rpm at 60 Hz); 3.9 lb platter; detachable carbon-fiber headshell with clamping screw on arm; base finished in oiled walnut veneer, w&f 0.05% DIN; rumble - 72 dB DIN; effective tonearm mass without cartridge 12 g; cartridge weight range 3-9 g; effective tonearm length 229 mm; overhang 16 mm; vertical and horizontal friction <100 mg; 7 x 18 $\frac{1}{4}$ x 15 $\frac{1}{4}$ in (dustcover down); 13 lb, 8 oz \$500



Acoustic Research ES-1

a/d/s/

Atelier P4 Automatic Turntable

Features quartz-crystal-controlled direct drive; pivoted arm; ultra-low-mass tonearm; 33 $\frac{1}{3}$ and 45 rpm; variable speed control with strobe; holds platter and tonearm on a subchassis that floats on 4 tuned mounts. Optional remote control if connected to a/d/s/ R4 receiver or CC4 tuner/preamp. w&f \pm 0.025% wrms, \pm 0.035% DIN; rumble -75 dB DIN B, 53 dB DIN A; effective tonearm length 8.69"; max tracking error 2.2°. \$600

BANG & OLUFSEN

Beogram 5500 Automatic Turntable

Short tangential tonearm; 33 and 45 rpm; silver and black; remote controlled by B&O Master Control Panel; repeats play up to 7 times; leaf-spring suspension; compatible with B&O Microcross cartridges; auto record-size sensing; auto interior light. Black and silver finish. Wow & flutter no more than 0.06% DIN, \pm 0.03% wrms; tracking error no more than \pm 0.05%; DIN-weighted rumble >80 dB; 16 $\frac{1}{2}$ x 3 x 12 $\frac{3}{4}$ in; 11 lb, 12 oz \$499

Beogram 4500 Automatic Turntable

Integrates with Beosystem 4500 for full remote control; built-in phono preamp; 3-point leaf-spring suspension; tangential tracking; accepts B&O MMC1-5 cartridges. Black and silver finish, w&f 0.06%; DIN weighted rumble >80 dB. 16 $\frac{1}{2}$ x 3 x 12 $\frac{3}{4}$ in; 11 lb, 11 oz \$499

Beogram 9000 Automatic Turntable

Turntable with tangential tracking tonearm; 33 $\frac{1}{3}$ and 45 rpm; Optimum Pivot Point tonearm suspension; 3-point leaf-spring and pendulum suspension system; integrated low-mass tonearm/cartridge combination; accepts all B&O MMC1-5 cartridges; servo-controlled DC motor. Wow & flutter <0.03% wrms. 16 $\frac{1}{2}$ x 3 x 12 $\frac{3}{4}$ in; 11 lb, 12 oz \$450

Beogram TX-2 Automatic Turntable

Tangential-tracking, belt-drive turntable; 33 and 45 rpm; fixed headshell. Recommended tracking force 1-1.5 g; wow & flutter 0.03% DIN; rumble - 80 dB. Dimensions: 16 $\frac{1}{2}$ x 3 x 12 $\frac{3}{4}$ in; 11 pounds, 10 ounces \$399

Beogram RX-2 Automatic Turntable

Belt-drive turntable with pendulum-suspended chassis and straight pivoting tonearm; 33 and 45 rpm; fixed headshell. Recommended tracking force 1-1.5 g; w&f 0.035% DIN; rumble - 75 dB; 16 $\frac{1}{2}$ x 2 $\frac{1}{2}$ x 18 in; 13 lb, 3 oz \$299

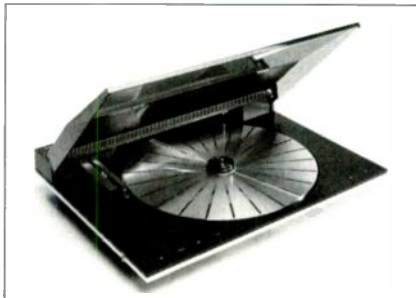

Bang & Olufsen Beogram 4500

CARRERA

LT-120 Automatic Turntable

Belt-drive turntable with linear tonearm. Features fixed mount cartridge; two speeds (33 $\frac{1}{3}$, 45), w&f 0.05%; rumble 69 dB; recommended tracking force 1 $\frac{1}{4}$ -3g \$170

CT-1155 Semiautomatic Turntable

Belt-drive turntable with pivoted tonearm. Features P-mount cartridge; two speeds (33 $\frac{1}{3}$, 45), w&f 0.07%; rumble 65 dB; recommended tracking force 1 $\frac{1}{4}$ -3g \$100

DENON

All Denon turntables employ servo speed control and are noncontact, microprocessor controlled. Motor servo by magnetic speed detection.

DP-591 Semiautomatic Turntable

Features massive wood base with isolation; 5.5-lb platter with high-torque direct-drive AC motor. Lift only \$695

DP-47F Semiautomatic Turntable

Features dynamic servo tracer; flat-twin direct drive design; fully-automatic locate function; thick wood base \$450

DP-23F Automatic Turntable

Full-size automatic turntable with dynamic servo tracer. Black \$275

DP-7F Automatic Turntable

P-mount; automatic turntable with dynamic servo tracer. Black \$200

DUAL BY ORTOFON

CS 7000 Semiautomatic Turntable

Belt-drive turntable with 24k gold-plated finish. Features Optimum Pivot gyroscopic gimbal tonearm system; carbon-fiber headshell; metal feet; full-floating subchassis; resonance-damped die-cast aluminum platter; auto stop; 33 $\frac{1}{3}$, 45, or 78 rpm play speeds, w&f <0.025%; S/N 80 dB. 17 $\frac{1}{2}$ x 5 $\frac{1}{4}$ x 15 $\frac{1}{4}$ in; 25 lb \$875

CS5000 Semiautomatic Turntable

Belt-drive turntable with hall-effect motor and 4-point full-floating suspension system. Features quartz-monitored 3-speed electronic control; optimum-pivot tonearm design; acoustic mat; cueing lever; 33 $\frac{1}{3}$, 45, and 78 rpm. w&f 0.015% wrms; rumble <56 dB DIN unwt'd. Available with black or walnut wood base \$500

CS505-3 Semiautomatic Turntable

Belt-drive, heavy mass platter, and acoustic mat. Features floating chassis design; variable pitch; carbon-fiber headshell on ULM tonearm. Walnut or black wood base \$360

CS455 Automatic Turntable

Belt-drive automatic turntable with four-point suspension. Features adjustable tracking force; detachable $\frac{1}{2}$ -inch headshell; floating sub-chassis; viscosity-damped cueing device. Wooden base with a black satin finish \$300

CS450. Same as above except semi-automatic turntable \$270

CS431 Semiautomatic Turntable

Belt-drive semiautomatic turntable with four-point suspension. Features low mass tonearm; headshell with $\frac{1}{2}$ -in mounting; floating sub-chassis; viscosity-damped cueing device; wooden base in black satin finish \$219

CS410. Same as above with cartridge \$179

HEYBROOK BY D'ASCANIO AUDIO

TT-3 Series II Manual Turntable

Hand-assembled belt-drive 33 $\frac{1}{3}$ and 45 rpm arm-

TURNTABLES

less manual turntable with removable armboard. Features on-board electronic power supply; low-speed synchronous motor to drive large 2-piece platter; adjustable 3-point spring-suspension subchassis of cast aluminum; laminated armboard; large wood base. Finished in real walnut or gloss black. Wow & flutter <0.1% DIN peak wtd; rumble -73 dB wtd DIN-B. Dimensions: 6¼ x 17½ x 14¼ in; 26 lb \$898

JVC

ALFQ555BK Automatic Turntable

Direct-drive turntable with coreless DC servo direct-drive motor. Features automatic record size and speed selector; low-mass straight tonearm; high-stability cabinet support system; large insulators; arm cueing control; double-servo quartz control; illuminated strobe on platter perimeter; plug-in cartridge connector \$240

ALF353BK Automatic Turntable

Turntable with automatic record size and speed selector. Features DC servo motor; arm cueing control; plug-in cartridge connector system; low-mass straight tonearm \$175

ALA151BK Semiautomatic Turntable

Semiautomatic turntable with automatic tonearm return. Features DC-servo motor; arm cueing control; low-mass straight tonearm; plug-in cartridge connector \$100

KENWOOD

KD-5010 Automatic Turntable

Automatic quartz PLL direct-drive turntable with plug-in phono cartridge. 33½ and 45rpm; straight tonearm. Wow & flutter no more than 0.05%; rumble 75 dB (DIN-weighted); effective tonearm length 8¾ in; tracking error 0-3°. Cartridge: frequency response 20-20,000 Hz; output voltage 2.5 mV. 17¼ x 5 x 14½ in; 10.8 lb \$249

Spectrum Series

KD-68FC Linear-Tracking Turntable

Automatic linear-tracking turntable. Features belt-drive operation; includes cartridge \$200

KD-48FC Automatic Turntable

Automatic belt-drive turntable. T4P cartridge included \$119

KD-38R Semiautomatic Turntable

Auto-return belt-drive turntable. T4P cartridge included \$79

LINN PRODUCTS

LP12 Manual Turntable

Belt-drive 33½-rpm turntable with manual tonearm; 24-pole synchronous motor; 12-in zinc-aluminum alloy die-cast platter with felt mat; hardened tool-steel spindle; adjustable 3-point spring-suspension subchassis; heavy-gauge stainless-steel base plate; solid hardwood base; optional 45-rpm adapter. Wow & flutter 0.04% wrms; rumble -60 dB unwt; speed accuracy ±0.04%. Dimensions: 5½ x 17½ x 14 in \$1,165



Linn Axis

Axis Manual Turntable

Belt-drive manual turntable with pivoted arm. Plays 33½-rpm LP's and 45-rpm singles. Speed accuracy 0.1%; wow & flutter 0.05%; rumble -75 dB DIN; effective tonearm length 284 mm; 16 lbs \$795

Basik Turntable

Two-speed turntable with tonearm \$495

MARANTZ

TT-285CTBI Automatic Turntable

Belt-drive fully automatic turntable features linear tracking; P-mount cartridge \$279

TT 275CTBI Semiautomatic Turntable

DC-servo direct-drive semiautomatic turntable with P-mount cartridge \$199

TT-185CTBI Semiautomatic Turntable

Belt-drive turntable features semiautomatic DC-servo motor; damped cueing; P-mount cartridge; straight low-mass tonearm; front panel controls. 3¾ x 16½ x 13½ in; 9.5 lb \$139

TT-2462CB Semiautomatic Turntable

Belt-drive turntable features semiautomatic DC-servo motor; P-mount cartridge \$90

NUMARK

TT3000 Manual Turntable

Direct-drive DC motor with S-shaped, 4-way ball bearing tonearm. 17 ¼ x 5½ x 14½; 27 lb \$880

TT1600 Manual Turntable

Direct-drive DC motor with S-shaped, static balanced tonearm. Features 2 speed (33 and 45 rpm) quartz lock and lock defeat switch; pitch control slider; headshell with light. w&F 0.007% wrms; rumble 56 dB; tracking force 0-6 g; tonearm effective length 9 in. 17 ¼ x 5 x 14½; 26 lb \$709

TT1400 Manual Turntable

Direct-drive DC motor with S-shaped, static balanced tonearm. 17 ¼ x 5½ x 14½; 22 lb \$500

ONKYO

CP-1500F Automatic Turntable

Direct-drive, quartz-servo turntable with 2 speeds. Features straight tonearm; Triple-Stage Isolation system; diecast aluminum platter. Front panel controls; RI remote compatible. \$259

CP-1200A Semiautomatic Turntable

Direct-drive, quartz-servo turntable with Triple-Stage Isolation system, and diecast aluminum platter. Features front-panel controls. Smoked dust cover \$130

Integra Series

Integra CP-1057FB Automatic Turntable

Computer-controlled, direct-drive turntable with quartz-locked PLL motor. Features single-band stroboscope for 33½ and 45 rpm speeds; Triple-Stage Isolation system with shock-absorbent feet, floating chassis, and dense cabinet; separate tonearm motor; gimbal tonearm support; Polysorb record mat and cabinet feet; gold-hued, diecast aluminum platter. Front-panel controls; anti-skating mechanism with dial control; 2-speed search; repeat play; remote-control connector. Black finish. Wow and flutter 0.023% wrms; signal-to-noise ratio 80 dB (DIN B); max tracking error +3°, -1°; effective tonearm length 8 7/8 in \$360

ORACLE AUDIO

Premiere Mark IV Manual Turntable

Belt-drive turntable without tonearm. Remote control power drive module, 33½ and 45 rpm; variable-

speed control; strobe; high-torque AC motor; adjustable spring-suspension system; record-coupling system; tone arm cartridge protractor, strobe disc included. 20 x 6½ x 15 in; 33 lb \$2,995
Gold Plated. Premiere Mark III aluminum and 24k gold plating. 43 lb \$3,495

Delphi MK IV Manual Turntable

Belt-drive turntable without tonearm. Available in dual speed (33½ and 45 rpm) and single speed (33½ rpm only); hi-torque AC motor; adjustable spring-suspension system; record-coupling system; tonearm/cartridge protractor and strobe disc included. 19 x 6 x 14½ in; 28 lb. Dual speed \$1,895
Single speed \$1,595
Delphi Aluminum. Aluminum/24k gold plating. Dual speed \$2,395
Single speed \$2,095
Delphi Black. 24k gold plating. Dual speed \$2,595
Single speed \$2,295

Alexandria Mark III Manual Turntable

Belt-drive turntable without tonearm. Features 33½ and 45 rpm; hi-torque AC motor; adjustable spring-suspension system; record-coupling system. Black piano finish. 19¼ x 6 x 14¾ in \$1,195

Paris Turntable

Belt-drive turntable without tonearm. Features 33½ and 45 rpm play speeds; AC type motor; tri-point suspension. White finish. 15 lb \$550

PIONEER

Elite PL-90 Automatic Turntable

Direct-drive turntable with coreless, quartz PLL DC servo motor with stable hanging rotor. Features straight tonearm made of aluminum and ceramics; 33½ and 45 rpm play speeds; 14¾-inch platter. w&F 0.018%. 8½ x 23½ x 17 in \$950

PL-910 Automatic Turntable

Belt-drive turntable with DC servo-motor. Features statically balanced linear tracking tonearm with DRA; 33½ and 45 rpm play speeds; 0.6 mm diamond stylus. Wow & flutter 0.06%. 16½ x 4 x 14 in; 6.2 lb \$400

PL-L550 Automatic Turntable

Direct-drive turntable with stable hanging rotor. Features dynamic resonance absorber; T4P-mount plug-in cartridge connector; linear tracking; 8-times repeat. Wow & flutter 0.025%. 16½ x 4¼ x 14¾ in; 10.5 lb \$270

PL-670(BK) Automatic Turntable

Direct-drive turntable with stable hanging rotor. Features dynamic resonance absorber; T4P P-mount cartridge adaptor; Polymer Graphite straight tonearm; automatic disc-size selector. w&F 0.025%. 4¾ x 16¾ x 14¾ in \$175

PL-600 Automatic Turntable

Belt-drive turntable with DC servo-motor. Features statically balanced straight tonearm; 33½ and 45 rpm play speeds; MM type cartridge; 0.6 mm diamond stylus. Wow & flutter 0.06%. 16½ x 3¾ x 14 in; 6.2 lb \$140

REALISTIC

IAB-2200 Automatic Turntable

Linear-tracking turntable with Realistic/Audio-Technica dual-magnet P-mount cartridge. Features straight tonearm; strobe; variable speed control (33½ and 45 rpm); repeat button. w&F 0.065% wrms; rumble 62 dB DIN; effective tonearm length 132 mm \$150

IAB-89 Turntable with Phono Preamp

Semiautomatic turntable with switchable stereo pre-amplifier for compatibility with moving-magnet inputs, ceramic phono inputs, or high-level tape or

Now there's a better way to orchestrate your autosound.



**SAVE 15% on
CAR STEREO REVIEW...
new from the
Editors of Stereo Review!**

Musicians: N.Y. Chamber Orchestra

Until now, it always took a lot of time and effort to ensure "living room" sound from your car stereo. That's why the Editors of *Stereo Review* are proud to introduce *Car Stereo Review*—the ultimate guide to ultimate autosound!

This is the world's *first* and *only* regular publication dedicated to the pursuit of high-quality autosound. Each issue will be packed with how-to articles for buying, installing, and maintaining auto-sound equipment—so you can get more pure enjoyment from your car stereo than you thought possible.

Whether you're purchasing your first car stereo system or upgrading your present one, you'll want to check out our product reviews of all the latest autosound components. Our Equipment Test Reports make it easy for you to select the right components for your needs and your budget.

And our exclusive Road Tests feature users' evaluations of various installations under real driving conditions.

You'll also find money-saving shopping tips, expert advice for choosing an installer (or doing it yourself), car stereo security tips, CD and tape reviews—and fresh, updated listings of car stereo products, so you can compare features, specs and prices.

Here, then, is everything you need to know about car stereo, written by the *Stereo Review* experts who are in the know. Subscribe today and receive special Charter Subscriber rates: just \$14.98 for six big issues. That's a 15% savings off the annual newsstand cost!



CHARTER SUBSCRIPTION SAVINGS CERTIFICATE

CAR STEREO REVIEW

P.O. Box 57316, Boulder, CO 80322-7316

YES, show me the better way to guarantee the sound quality of my car stereo! Please enter my one-year Charter Subscription to *Car Stereo Review*, and send me six issues for only \$14.98. That's 15% off the annual newsstand cost of \$17.70!

8H72

CHECK ONE:

Payment enclosed. Bill me later.

Mr. _____
Mrs. _____
Ms. _____
(please print full name)

Address _____ Apt. _____

City _____

State _____ Zip _____

Outside the U.S. add \$6.00 for additional postage. Please allow 60 to 90 days for delivery of first issue.

TURNTABLES

aux inputs. Features Realistic/Audio-Technica cartridge; straight tonearm; belt drive; neon strobe. Pitch control; damped cueing; rubber mat; auto changer stacks 4 records; 45 adaptor; 33 $\frac{1}{3}$ and 45 rpm. Rumble -55 dB; wow & flutter <0.1%. \$90

LAB 450 Semiautomatic Turntable

Direct-drive with Realistic/Shure MM cartridge. Features neon strobe; straight tonearm; damped cueing. Front-panel controls; 33 $\frac{1}{3}$ and 45 rpm; adjustable antiskating; rubber mat; 45 adaptor. Rumble -65 dB; w&f <0.05%. \$80

REVOLVER BY MUSIC HALL

Revolver Turntable

Split-plinth belt-drive turntable with plinth and platter of medium-density fibreboard and self-damping material. Features AC synchronous motor with 2-speed stepped pulley; ethylene propylene drive belt; 3 molded non-adjustable feet. Includes Precision Instant Grip clamp, Starmat, lubricating oil; Revolver tonearm. Redwood high-gloss finish. \$595
Black-ash veneer \$545

Revolver Rebel Turntable

Includes tonearm and cartridge. Black-satin finish \$399

REVOX

B291 Automatic Turntable

Quartz-controlled direct-drive turntable with patented Revox Linatrack system. Features short linear-tracking tonearm; pitch control regulation of $\pm 9.9\%$ in precise 0.1% steps, with LED display showing the variation; P-mount cartridge adaptor; channel balance; automatic start; front-panel-mounted controls. wow and flutter <0.05%; rumble >50 dB (DIN 45539 A), >52 dB (DIN45539 A with 20 Hz high-pass filter), >72 dB (DIN 45539 B); tracking error <0.5%; tracking force 8-20 mN. 17 $\frac{3}{4}$ x 5 $\frac{3}{8}$ x 15 $\frac{1}{2}$ in; 20 lb \$1,500

SANSUI

P-2000 Automatic Turntable

Cartridge stylus 0.6 mil diamond. Features IX servo motor; 1-touch start/stop. Remote control compatibility. Signal-to-noise ratio 72 dB. 17 x 4 $\frac{3}{8}$ x 14 in; 7.3 lb. \$180

P-900E Semiautomatic Turntable

Belt-drive turntable with low-mass straight tonearm. Features auto return and power on/stop; cue; cut; pitch control and stroboscope. No cartridge. w&f <0.1% wrms; S/N >72 dB. 3 $\frac{3}{8}$ x 16 $\frac{1}{2}$ x 13 in; 8.8 lb. \$90

SCOTT

PS70C Semiautomatic Turntable

Semiautomatic belt-drive turntable with low-mass P-mount tonearm. Features frequency-governed IX motor; strobe light; pitch control; fully damped cueing; shock absorbing feet; auto return and shutoff; hinged, adjustable dustcover. 16 $\frac{1}{2}$ x 13 x 4 $\frac{3}{8}$ in; 7 $\frac{1}{2}$ lb. \$100

PS60C Same as PS70C except 16 $\frac{1}{2}$ x 3 $\frac{3}{4}$ x 13. \$90

PS60 Same as PS60C without cartridge. \$80

SHERWOOD

PF-1170R Automatic Turntable

Direct-drive turntable featuring IX servo motor and pitch control with strobe. Features front-panel operating controls; fully automatic start, stop, and return; repeat; die-cast alloy platter; 45 rpm center adaptor; 2-speeds. Max tracking error +2.6°, -1°; w&f 0.06%. 4 $\frac{1}{2}$ x 17 $\frac{3}{8}$ x 15 in \$159

PM-1270 Automatic Turntable

Belt-drive turntable with straight-line tonearm sys-

tem. Features 2-speeds; auto stop; die-cast alloy platter; pitch control with strobe; cueing control; straight-line tubular static balanced tonearm. Max tracking error +2.6°, -1°; w&f 0.08%. 3 x 13 x 9 in. \$149

SONOGRAPHIE BY CONRAD JOHNSON

SG-3A Manual Turntable

Belt-drive turntable with Sumiko tonearm. Tuned suspension, resonance-free polymer platter. Wow and flutter <0.02% wrms; rumble -65 dB; Dimensions: 6.75 x 18.25 x 14.5-in (dustcover down). Weight: 23 lbs. \$795
SG-3. Same as above without tonearm \$595

SONY

PS-FL7II Automatic Turntable

Front-loading linear-tracking automatic turntable. Features direct drive, PLL quartz-lock operation; P-mount compatibility; 33 $\frac{1}{3}$ and 45 rpm; remote control capability, stackable top. Wow and flutter 0.03%; S/N 75 dB; effective tonearm length 3-in; max tracking error $\pm 0.1^\circ$; Dimensions: 17 x 3 $\frac{7}{8}$ x 15 $\frac{1}{8}$ in. Weight: 16 lb \$350

PS-IX520 Automatic Turntable

Fully automatic linear-tracking turntable. Features direct drive, PLL quartz-lock operation; P-mount compatibility. 33 $\frac{1}{3}$ and 45 rpm; gel-filled feet; remote control capable. w&f 0.035%; S/N 75 dB; effective tonearm length 3 inches; max tracking error $\pm 0.1^\circ$. 17 x 3 $\frac{3}{8}$ x 14 $\frac{3}{8}$ in; 11 lb. \$270

PS-IX430 Automatic Turntable

Belt-drive P-mount turntable with pivoted arm. Features 33 $\frac{1}{3}$ and 45 rpm, cueing lever, anti-resonance base, disc size selector, remote control capability. w&f 0.046%; rumble 70 dB. 17 x 4 $\frac{1}{2}$ x 14 in (dustcover down); 9 lb. \$180

SOTA INDUSTRIES

Cosmos Turntable

Belt-drive turntable with 12 lb platter on 22 lb subassembly. Features inverted Sapphire bearing, 4-point corner weights and matching 4-spring design; regulated IX-drive, fully damped, fully isolated motor; vacuum hold-down; rigid arm support; one-piece-design platter block; motor hard-mounted to subassembly. Comes with vacuum, reflex clamp, electronic flywheel, and deluxe tone arm board. w&f 0.03 wrms; rumble -88.2 dB; speed accuracy $\pm 0.2\%$; speed adjustment 5%. 20 $\frac{1}{4}$ x 16 $\frac{1}{2}$ x 7 $\frac{1}{2}$ in. Gloss matrix \$4,000
High-gloss black \$4,500

Deluxe Star Sapphire III Turntable

Manual 2-speed belt-drive turntable with variable speed control and strobe. Features heavyweight (22 lb) sub-assembly for maximum isolation; exclusive inverted bearing with sapphire disc; single piece (11 lb) platter, rim drive; vacuum hold-down system; low-level pressure, continuous through play, adjustable vacuum; acrylic vacuum supermat; all-wood top; speed control panel; heavy-duty dustcover with oak finish. w&f 0.03 wrms; rumble -88.2 dB; speed accuracy $\pm 0.2\%$; speed adjustment 5%. 20 $\frac{1}{4}$ x 16 $\frac{1}{2}$ x 7 $\frac{1}{2}$ in; 44 lb; oak finish \$1,600
African rosewood, Black wood \$1,750
Ebony, Brazilian rosewood, Cocobola rosewood \$1,900
Black-satin finish \$2,000

Deluxe Sapphire III Turntable

Turntable with inverted Sapphire bearing. Features 12-lb platter on 22-lb subassembly; 4-point corner weights and matching 4-spring design; regulated IX-drive, fully damped, fully isolated motor. w&f 0.03 wrms; rumble -88.2 dB; speed accuracy $\pm 0.2\%$; speed adjustment 5%. 20 $\frac{1}{4}$ x 16 $\frac{1}{2}$ x 7 $\frac{1}{2}$ in. Oak

finish \$1,295
African rosewood, Black wood \$1,395

Options

Vacuum Conversion Kit. For Sapphire model; same vacuum system, same features as on Star available as an upgrade for any Sapphire made \$695
Electronic Flywheel. A/c line conditioner for the Sapphire and Star turntables only. Isolates and regulates motor/drive from all outside interference (voltage shifts, EMI, RFI, hash) \$300
Series III Upgrades. New platter or motor or sub-assembly \$250/ea
All three upgrades \$700
Vacuum Acrylic Supermat. For Star or vacuum Sapphire. Designed for optimal coupling, matched impedance, extreme damping \$150
Reflex Clamp. Couples record to platter (in conjunction with Supermat) with reflex action. One part grabs spindle while the second motion presses record against mat. Simple level action; aluminum casting; decoupled from record with foam \$135
Aluminum Arm Board. For SME, ET-2, Linn. The Arm, Premier FT-3, MMT, and MMT-VTA turntables \$90

SYSTEMDEK

Model IV E Turntable

Belt-drive turntable with 33 $\frac{1}{3}$ and 45 rpm; pivoted tone-arm; anti-skate adjustment; fixed cartridge mount. Wow & flutter 0.06%; rumble -78 dB; speed inaccuracy $\pm 0.01\%$; speed adjustment range $\pm 2\%$; cable capacitance 300 pF. Dimensions: 19 $\frac{1}{2}$ x 6 x 15 $\frac{3}{4}$ in \$899

Model II X E Turntable

Belt drive turntable with 33 $\frac{1}{3}$ and 45 rpm; pivoted tone-arm; anti-skate adjustment; fixed cartridge mount. Wow & flutter 0.08%; rumble -78 dB; speed inaccuracy $\pm 0.01\%$; speed adjustment range $\pm 2\%$; cable capacitance 300 pF. Dimensions: 18 $\frac{1}{2}$ x 5 $\frac{3}{8}$ x 14 $\frac{3}{8}$ in. \$659

Model II X Turntable

Belt drive turntable with 33 $\frac{1}{3}$ and 45 rpm; pivoted tonearm; anti-skate adjustment; fixed cartridge mount. Wow & flutter 0.08%; rumble -78 dB; speed inaccuracy $\pm 0.15\%$; speed adjustment range $\pm 2\%$; cable capacitance 300 pF. Dimensions: 18 $\frac{3}{4}$ x 5 $\frac{1}{2}$ x 14 $\frac{1}{2}$ in \$559

TECHNICS

SL-1200MKII Manual Disco Turntable

Direct-drive quartz-controlled manual turntable with 33 $\frac{1}{3}$ - and 45-rpm speed control. Features gimbal-suspended tonearm with height adjustment; brushless IX motor; $\pm 8\%$ quartz-locked pitch control; quick start and stop; pop-up stylus light; aluminum die cast cabinet; anti-resonant viscoelastic main base. Wow & flutter 0.025%. \$530

SL-MA1 Automatic Turntable

Direct-drive turntable with P-mount cartridge and phase-locked loop quartz lock. 33 $\frac{1}{3}$ and 45 rpm speed control; wow & flutter 0.012% wrms; rumble -80 dB; effective tonearm length 230 mm; max tracking error +0°32' (inner groove), +2°32' (outer groove). Dimensions: 17 $\frac{1}{4}$ x 6 $\frac{3}{4}$ x 16 in (dustcover down). Weight: 19.8 lb. \$490

SL-J33 Automatic Turntable

Automatic direct-drive linear tracking turntable with P-mount cartridge. Allows up to 8 tracks to be played in any order. Indicates number of tracks on album side and which track is playing. Features programmable phase-locked loop quartz-lock front-panel feather-touch controls; cueing; auto stylus muting. Remote controlled through some Technics receivers. 33 $\frac{1}{3}$ and 45 rpm; wow & flutter 0.012%; rumble -78 dB; effective tonearm length

TURNTABLES

105 mm; max tracking error $\pm 0.1^\circ$. 12 $\frac{1}{4}$ x 4 x 12 $\frac{1}{4}$ in (dustcover down); 9 lb. \$250

SL-QD33 Automatic Turntable

Direct-drive turntable with P-mount cartridge. Features 2 motors; quartz lock; ultra-low-speed brushless DC motor for platter drive; pivoting arm; end-of-disc detection; electronic feather-touch front-panel controls. Remote control compatible through some Technics receivers. 33 $\frac{1}{3}$ and 45 rpm; strobe. Wow & flutter 0.012% wrms; rumble -78 dB; effective tonearm mass 7.5g, length 230 mm; max tracking error $\pm 2^\circ$. 17 x 4 $\frac{1}{2}$ x 14 $\frac{1}{4}$ in (dustcover down); 10 lb. \$200

SL-L20 Automatic Turntable

Belt-drive linear-tracking turntable with P-mount cartridge. Features front-panel soft-touch controls; cueing; 2-speed search; auto disc-size/speed detection to prevent tonearm from lowering on empty mat. Remote-control compatible through some Technics receivers. 33 $\frac{1}{3}$ and 45 rpm; w&F 0.045% wrms; rumble -70 dB; effective tonearm length 105 mm; max tracking error $\pm 0.1^\circ$. 17 x 3 $\frac{3}{4}$ x 13 $\frac{3}{4}$ in (dustcover down); 8 lb. \$190

SL-QD22 Semiautomatic Turntable

Direct-drive turntable with 2 motors and P-mount cartridge. Features PLL quartz lock; ultra-low-speed DC brushless motor. End-of-disc detection; pivoting arm; strobe; front-panel electronic feather-touch controls. 33 $\frac{1}{3}$ and 45 rpm; w&F 0.012% wrms; rumble -78 dB; effective tonearm mass 7.5g, length 230 mm; max tracking error $\pm 2^\circ$. 17 x 4 $\frac{1}{2}$ x 14 $\frac{1}{4}$ in (dustcover down); 10 lb. \$160

SL-BD22 Semiautomatic Turntable

Belt-drive turntable with aluminum die cast gimbal pivot and highly rigid lightweight aluminum tonearm. Features P-mount cartridge; vibration-isolation base; front-panel cueing control; pivoted arm. 33 $\frac{1}{3}$ and 45 rpm. w&F 0.45% wrms; rumble -70 dB (DIN B); effective tonearm mass 7.5g, length 230 mm; max tracking error $\pm 2^\circ$. 17 x 4 $\frac{1}{2}$ x 14 $\frac{1}{4}$ in (dustcover down); 8 lb. \$140

SL-BD20 Semiautomatic Turntable

Belt-drive turntable with DC servo motor and P-mount cartridge connector system. Features highly sensitive gimbal suspension tonearm; vibration absorbing base; front-panel operation; hinged detachable dustcover; 45 rpm adaptor. Turntable: 33 $\frac{1}{3}$ and 45 rpm; w&F 0.045% wrms $\pm 0.06\%$; rumble -70 dB. Tonearm: tracking error angle $+0^\circ 32'$ (inner groove), $+2^\circ 32'$ (outer groove); effective mass 13.5g; tracking force 1.25g; cartridge weight 6g. 17 x 3 $\frac{3}{8}$ x 14 $\frac{3}{4}$ in; 7.9 lb. \$120

Turntables without Tonearms

SP-10MK3 Turntable

Quartz-synthesis direct-drive turntable with high torque for full speed in 30° of rotation. Features electronic, mechanical braking for speed change in 0.3 sec; high-precision integral rotor-platter quartz motor; quartz-locked pitch control (0.1% steps to $\pm 9.9\%$ all speeds); separate power supply in remote-control unit with numeric LED speed, pitch displays; soft-touch switches (start/stop duplicated on turntable). 33/45/78-rpm; w&F 0.015% wrms $\pm 0.001\%$. 14 $\frac{1}{4}$ x 14 $\frac{1}{4}$ x 4 $\frac{1}{2}$ in. Turntable weight: 40 lb. Power supply/control unit: 13.2 lb. \$2,700

SP-10MK2A Turntable

Quartz-synthesis direct-drive turntable with high torque for full speed in 25° of rotation. Features electronic, mechanical braking for speed change in 0.3 sec; separate power supply. Includes remote-control unit. 33/45/78-rpm; w&F 0.025% wrms $\pm 0.035\%$; rumble -70 dB (DIN B); speed drift within $\pm 0.002\%$. 14 $\frac{1}{2}$ x 14 $\frac{1}{2}$ x 4 in; 20.9 lb. \$1,400

SH-10B7. Optional base \$950

SP-15 Turntable

Quartz-synthesis direct-drive turntable that reaches full speed in 0.4 sec (40° of rotation) and stops in 0.4 sec (40° of rotation) at 33 $\frac{1}{3}$ rpm. Features $\pm 9.9\%$ quartz-locked pitch control. 33/45/78-rpm w&F 0.025% wrms; rumble 56 dB (DIN A), 78 dB (DIN B) \$900

SP-25. Similar to SP-15, no 78-rpm speed. $\pm 6\%$ pitch control \$570

SH-15B2. Heavy acoustic rubber base with simulated wood for SP-25 and SP-15 \$500

SH-15B3. Similar to SH-15B2, heavy acoustic rubber base only \$500

THORENS BY EPI

All Thorens turntables are belt-driven, single-play units with straight tubular tonearms for maximum rigidity; gimbal suspension; antiskate control; 9.12-in effective tonearm length; tracking error $<0.18^\circ/\text{cm}$ ($<0.46^\circ/\text{in.}$).

TD 520 Semiautomatic Turntable

Belt-drive with automatic tonearm lift, motor shut-off. Features 33 $\frac{1}{3}$, 45, 78 rpm; electronic speed selection; $\pm 6\%$ pitch control; stroboscope; velocity-sensing auto shut-off trigger; frictionless magnetic antiskating; twin solid-core chassis and 3-point leaf-spring suspension. w&F 0.035%; rumble -72 dB unwt'd \$1,100

TD 521. Same as above without tonearm .. \$1,000

TD 320 Semiautomatic Turntable

Belt-drive 33 $\frac{1}{3}$ and 45rpm turntable with solid-core chassis. Features 16-pole synchronous motor; twin solid-core chassis and 3-point leaf-spring suspension; friction-free velocity sensing auto shut-off triggering. w&F 0.35%, rumble -52 dB unwt'd, -72 dB wtd; 6 $\frac{1}{4}$ x 17 $\frac{3}{8}$ x 13 $\frac{1}{8}$ in. \$600

TD 321. Armless version of TD-320 \$500

TD 318 Semiautomatic Turntable

Belt-drive 33 $\frac{1}{3}$ and 45 rpm turntable with 16-pole synchronous motor. Features twin solid-core chassis; 3-point leaf-spring suspension; frictionless velocity-sensing auto shut-off trigger. Wow & flutter 0.04%; rumble -50 dB unwt'd, -70 dB unweighted; 6 x 17 x 14-in \$450

TD 316. Manual turntable similar to TD 318 without auto lift and shut off \$350

TD 280 Semiautomatic Turntable

Belt-drive 33 $\frac{1}{3}$ and 45 rpm with 24-pole synchronous motor. Features 1-piece solid-core chassis and spring damping elements in feet; frictionless velocity-sensing auto shut-off trigger. Wow & flutter 0.045%; rumble -48 dB unwt'd, -70 dB wtd; 5.3 x 17 x 14-in \$275

TOSHIBA

SR-5638 Automatic Turntable

Automatic, belt-driven turntable. Features front-panel cueing; power select; speed select; T4P magnetic cartridge; 45 and 33 $\frac{1}{3}$ rpm play speeds \$129

VECTOR RESEARCH

VT-320 Automatic Turntable

2-speed, belt-drive fully automatic turntable features platter drive DC servo motor; Platter 11 $\frac{3}{8}$ -in diam, die-cast; speed 33 $\frac{1}{3}$ and 45 rpm; linear-tracking tonearm w/cartridge; automatically switched record size, manual override. 15-track programming; random and access play; tonearm muting. Wow & flutter 0.05 wrms; S/N >65 dB (DIN B). 16 $\frac{1}{2}$ x 3 $\frac{3}{8}$ x 14 $\frac{1}{8}$ in; 9 lb \$200

VT-185 Semiautomatic Turntable

Features quick-start/high torque DC-servo motor; traditional plug-in head-shell with standard $\frac{1}{2}$ -in mounting centers; front-panel controls; aluminum-

alloy platter; auto-return and shut-off; auto-start function; separate pitch controls for 33 and 45 rpm ($\pm 3\%$); st-robe. Wow & flutter 0.05% wrms; S/N 68 dB (DIN B). 17 $\frac{1}{2}$ x 4 $\frac{1}{2}$ x 14 $\frac{1}{8}$ in; 11.5 lb \$190

VT-155 Semiautomatic Turntable

Features DC-servo motor; P-mount cartridge compatibility; front-panel controls; aluminum-alloy platter; auto-return and shut-off; pitch control stroboscope. Wow & flutter 0.07% wrms; signal-to-noise ratio 65 dB (DIN B). 17 x 3 $\frac{3}{8}$ x 13 in; 8 lb, 12 oz \$96



Vector Research VT-320

WELL TEMPERED LAB

Well-Tempered Arm and Table

Belt-drive turntable with Fountainhead base and platter. Features separate damping and azimuth controls and adjustments for vertical-tracking, antiskating, and tracking-force. 19 x 15 $\frac{1}{2}$ x 7 in; 43 lb \$1,795

Well-Tempered Table \$1,075

Well-Tempered Arm \$825

Dustcover \$100

The Well-Tempered Record Player

Belt-drive turntable with fluid-damped arm. Features three-layer board base construction; arm with vertical tracking adjustment and azimuth; 0-clearance damped turntable bearing; 0-clearance damped arm bearing; isolated, damped motor assembly ... \$895

Well-Tempered Record Player Arm \$525

Well-Tempered Record Player Table \$460

Dustcover \$100

YAMAHA

TT-500U Automatic Turntable

Direct-drive turntable with RS integrated remote system compatibility. Features straight tonearm design; resonance absorbing turntable mat; disc clamper. Black; 15 lb \$269

TT-400U Automatic Turntable

Belt-drive turntable with RS integrated remote system compatibility. Features straight tonearm design; resonance absorbing turntable mat; disc clamper. Black; 15 lb \$199

P-90M Automatic Turntable

Fully automatic, belt driven turntable with DC servo motor. Includes cartridge. Remote controllable by MRX-90M \$170

TT-300U Semiautomatic Turntable

Belt-drive semiautomatic turntable with straight tonearm design. Features resonance absorbing turntable mat; EP adaptor. Black; 10 lb \$159

The listings are based on data provided by the manufacturers. For more product information, contact an authorized dealer or the manufacturer directly. Manufacturers' addresses and phone numbers are listed in the directory beginning on page 258.

CARTRIDGES & TONEARMS



ADCOM

SXC-van den Hul Moving-Coil Phono Cartridge
High-output MC cartridge with tubular sapphire cantilever and Van den Hul stylus. Features 3.5-micron contact radius; vertical groove extended to 85 microns; aluminum cantilever; crosscoil armature. Output 2.3 mV at 5 cm/s; frequency response 20-20,000 Hz +3, -0 dB; tracking force 1.8 g; square-wave rise time 7 ms; channel separation 20 dB at 200-20,000 Hz; 4.7 g \$500

XC-MRH Moving-Coil Phono Cartridge
High-output moving-coil cartridge with nude-mounted square-shank stylus. Features thin-walled aluminum cantilever; crosscoil armature. Output 2.3 mV at 5 cm/s; frequency response 20-20,000 Hz, ± 1 dB; channel separation 28 dB at 1,000 Hz; tracking force 1.8 g; effective tip mass 0.35 mg; 0.15 mil x 3.0 mil scanning radius; 4.7 g \$360

XC-LTH Moving-Coil Phono Cartridge
High-output MC cartridge with Line-Trace stylus, thin-wall aluminum cantilever, crosscoil armature. Output 2.3 mV at 5 cm/sec; FR 20-20,000 Hz, ± 1 dB; ch sep 28 dB at 1,000 Hz; tracking force 1.8 g; effective tip mass 0.35 mg; weight 4.7 g \$290

HC-vdH II Moving-Coil Phono Cartridge
High-output MC cartridge with Van den Hul stylus. Features thin-wall aluminum cantilever; crosscoil armature. Output 2.3 mV at 5 cm/s; FR 20-15,000 Hz +1.5, -1 dB, 20-20,000 Hz +2.5, -1 dB; ch balance within 1.5 dB; tracking force 2 g; effective tip mass 0.35 mg; 4.7g \$250
HC-E II. Similar to HC-VDH II except with elliptical stylus. \$160

AKG ACOUSTICS

P100LE Phono Cartridge
Hand-made cartridge using the patented transverse-suspension, tapered beryllium cantilever. Features Analog-six stylus; adjustable vertical tracking angle; 5-year warranty; limited edition. Moving-iron cartridge. \$1,000
P100LE-vdH. Same as P100LE except stylus is a van den Hull II type \$1,000

Super Nova P8ES Phono Cartridge
Moving iron cartridge with patented transversal suspension system and van den Hul II replaceable diamond stylus. Features printout of FR/crosstalk curve; carbon-fiber stylus brush; screwdriver. Output 2.8 mV at 3.54 cm/sec; FR 10-28,000 Hz, ± 1 dB; sep 30 dB at 1,000 Hz; tracking force range 1-1.5 g; cartridge weight 3.5 g \$450

P-25S Phono Cartridge
Induced-magnet cartridge with patented transverse-suspension system, cylindrical/magnet design. Features printout of FR/crosstalk curve; carbon-fiber stylus brush; screwdriver; antiresonance compound. Output 2.7 mV at 3.54 cm/sec rms; frequency response 10-28,000 Hz; sep ± 1 dB; tracking-force range 0.75-1.25 g \$250

P-15S Phono Cartridge

Induced-magnet cartridge with patented transverse-suspension system, cylindrical magnet. Features printout of FR/crosstalk curve; carbon-fiber stylus brush; antiresonance compound. Output 3.4 mV rms at 3.54 cm/sec; FR 10-23,000 Hz; sep ± 1.5 dB; tracking force 1.0-1.5 g; elliptical diamond stylus (mass 0.018 mg); 3.5 g \$175

P10 Phono Cartridge

Designed for broadcast and disco; built-in stylus guard prevents damage during use. Output 5.8 mV at 3.54 cm/sec; FR 20-20,000 Hz, ± 2 dB; sep 25 dB at 1,000 Hz; tracking force range 2.5-4.5 g; cartridge weight 3.5 g \$130

P-10S Phono Cartridge

Induced-magnet cartridge with patented transverse-suspension cylindrical magnet. Features carbon-fiber stylus brush; antiresonance compound. Output 5.8 mV rms at 3.54 cm/sec; FR 20-20,000 Hz; sep ± 2 dB; tracking force 1.25-2.0 g; elliptical diamond stylus (mass 0.25 mg); 3.5 g \$125

P-5ED Phono Cartridge

Induced-magnet cartridge with patented transverse-suspension cylindrical magnet. Features compatibility with automatic turntables, record changers; elliptical diamond stylus. Output 5.8 mV rms at 3.54 cm/sec; FR 20-20,000 Hz; sep ± 2 dB; tracking force 1.5-2.0 g \$80

P4 Phono Cartridge

Standard 0.5-in-mount cartridge designed for heavy/medium-heavy tonearms. Frequency response 20-20,000 Hz; sep 20 dB at 1,000 Hz; tracking force 1.5 g; cartridge weight 3.5 g \$50
P4DP. As above except standard TP4 mount. . . \$50

ARCAM

Cartridges

The following applies to all cartridges: tracking weight 1.6-2 g; output 4 mV at 5 cm/sec; FR 20-20,000 Hz; standard weight 6 g, magnesium weight 6.3 g. Available in both magnesium- and plastic-bodied formats. Black finish.

P77Mg Cartridge. Profiled stylus \$150
E77Mg Cartridge. Elliptical stylus \$120
C77Mg Cartridge. Conical stylus \$80

Stylus Replacements

PN7. \$90
EN7. \$60
CN7. \$25

Loading Modules

ULM/M. Moving magnet. \$25
ULM/C. Moving coil \$25

AUDIO BY VAN ALSTINE

Longhorn Z Phono Cartridge

Internally damped and externally stabilized phono cartridge. FR 10-60,000 Hz; sep 30 dB; output 4 mV; tracking force 1.5 g \$99

AUDIO-TECHNICA

All cartridges feature a dual MM design.

ATML170 Phono Cartridge

Phono cartridge with square-shank nude-mounted stylus. Features paratoroidal PCCC coils. Output 4.0mV; tracking force 1.25 + 3 dB; frequency response 5-40,000; channel separation 31 dB at 1,000 Hz; weight 7.0 g \$345

AT140ML Phono Cartridge

Phono cartridge with square-shank nude-mounted stylus. Features paratoroidal oxygen-free copper coils. Output 5.0 mV; tracking force 0.8-1.6 g; FR 5-32,000; channel separation 30 dB at 1,000 Hz; weight 6.4 g \$195

AT130E/T Phono Cartridge

Phono cartridge with biradial nude-mounted stylus. Features 0.2 x 0.7 mil stylus; paratoroidal oxygen free-copper coils. Output 5.0 mV; tracking force 0.8-1.8 g; FR 10-30,000 Hz; channel separation 30 dB at 1,000 Hz; weight 6.4 g \$135

AT125LC/T Phono Cartridge

Phono cartridge with linear-contact titanium-bonded stylus. Features paratoroidal oxygen-free copper coils. Output 5.0 mV; tracking force 1.0-1.8 g; FR 10-28,000 Hz; channel separation 29 dB at 1,000 Hz; weight 6.4 g \$150

AT120E/T Phono Cartridge

Phono cartridge with titanium-bonded stylus. Features 0.3 x 0.7 mil stylus; oxygen-free copper coils. Output 5.0 mV; tracking force 1.0-1.8 g; FR 15-25,000; channel separation 29 dB at 1,000 Hz; weight 6.4 g \$95

AT110E Phono Cartridge

Phono cartridge with a bonded biradial stylus. Features 0.4 x 0.6 mil stylus; oxygen-free copper coils. Output 4.5 mV; tracking force 1.0-2.0 g; FR 20-22,000; channel separation 29 dB at 1,000 Hz; weight 7.0 g \$70

AT105 Phono Cartridge

Phono cartridge with a bonded uniradial stylus. Features 0.6 mil stylus; oxygen-free copper coils. Output 4.5 mV; tracking force 1.5-2.5 g; FR 20-20,000; channel separation 26 dB at 1,000 Hz; weight 7.0 g \$55

P-Mounted Series

AT152MLP Phono Cartridge

Phono cartridge with square-shank nude-mounted stylus. Features paratoroidal oxygen-free copper coils. Output 5.0 mV; tracking force 1.0-1.5 g; FR 5-35,000 Hz; channel sep 31 dB at 1,000 Hz. \$250

AT231EP Phono Cartridge

Phono cartridge with linear-contact bonded stylus. Output 5.0 mV; tracking force 1.0-1.5 grams; frequency response 10-30,000 Hz; channel separation 31 dB at 1,000 Hz \$195

CARTRIDGES & TONEARMS

AT132EP Phono Cartridge

Phono cartridge with biradial, nude-mounted stylus. Features 0.2 x 0.7 mil stylus; paratoroidal oxygen-free copper coils. Output 5.0 mV; tracking force 1.0-1.5 g; FR 10-30,000 Hz; channel separation 30 dB at 1,000 Hz \$150

AT221EP Phono Cartridge

Phono cartridge with biradial nude-mounted square-shank stylus. Features 0.2 x 0.7 mil stylus. Output 5.0 mV; tracking force 1.0-1.5 grams; frequency response 10-28,000 Hz; channel separation 31 dB at 1,000 Hz \$135

AT216EP Phono Cartridge

Phono cartridge with biradial nude-mounted stylus. Features 0.3 x 0.7 mil stylus. Output 5.0 mV; tracking force 1.0-1.5 g; FR 15-27,000 Hz; channel separation 29 dB at 1,000 Hz \$100

AT211EP Phono Cartridge

Phono cartridge with biradial bonded stylus. Features 0.4 x 0.7 mil stylus. Output 5.0 mV; tracking force 1.0-1.5 g; FR 15-25,000 Hz; channel separation 29 dB at 1,000 Hz \$75

AT201EP Phono Cartridge

Phono cartridge with biradial bonded stylus. Features 0.4 x 0.7 mil stylus. Output 5.0 mV; tracking force 1.0-1.5 g; FR 20-25,000; channel separation 26 dB at 1,000 Hz \$65

AT201P Phono Cartridge

Phono cartridge with unradial bonded stylus. Features 0.6 mil stylus. Output 5.0 mV; tracking force 1.0-1.5 g; FR 20-22,000 Hz; channel separation 26 dB at 1,000 Hz \$55

AUDIOQUEST

Phono Cartridges

AQ 7000 Moving-Coil Phono Cartridge

High-output moving-coil phono cartridge with single layer coil. Features a flat and round compound to produce no internal standing weight; prevents audio resonance; line contact; tracking force 1.9 grams; 0.3 mV. Cartridge weight 9.5 grams \$1,295

AQ B-200MH Moving-Coil Phono Cartridge

High-output moving-coil phono cartridge. Features machined-aluminum sandwich body; hollow boron cantilever; micro ridge; available with 1.6- or 0.5-mV output \$850

AQ 404I-MH Moving-Coil Phono Cartridge

High-output MC cartridge utilizes 15-micron wire for coils. Features aluminum body; nonresonant cast metal; hollow-boron cantilever; line contact; available with 1.6- or 0.5-mV output \$550

AQ MC-5 Moving-Coil Phono Cartridge

High-output 2.5-mV MC cartridge with line-contact stylus; non-resonant polymer body; FR 20-30,000 Hz; aluminum cantilever \$325

AQ MC-4 Moving-Coil Phono Cartridge

High-output 2.5-mV moving-coil phono cartridge with elliptical stylus. Features direct phono input; compliance 10; nonresonant polymer body; frequency response 20-20,000 Hertz; aluminum cantilever \$250

AQ MC-3 Moving-Coil Phono Cartridge

Dynamic high-output 3- μ V MC cartridge with elliptical stylus. Features nonresonant polymer body; compliance 8; tracks 2 g; FR 20-20,000 Hz; aluminum cantilever \$150

AQ M-1 Phono Cartridge

Induced magnetic cartridge with elliptical stylus. Features compliance 25; FR 20-20,000 Hz; tracks 1.5 g \$95

Tonearms

AQ PT-5+ Tonearm

Straight tonearm with wire from unbroken copper strands. An integral damper to prevent vibration. Features precision arm bearings; aluminum/polyolefin structure; nondetachable headshell; adjustable viscous damping at the pivot point. Pivot-to-stylus length 229 mm \$425

AQ PT-5. As above, high-purity copper wire. . \$350

BANG & OLUFSEN

MMC Series Phono Cartridges

All MMC cartridges feature armature mounted perpendicularly to the cantilever; crystal sapphire cantilever; multiradial diamond; four high-output, low-imp coils wound on cores of very low permeability aligned in perfect symmetry with the magnet.

MMC-1. Diamond contact line 0.1 x 0.1 mm sq.; stylus bonding nude; cantilever sapphire tube; recommended tracking force 10 mN/1 gram; FR 20-20,000 Hz, ± 1 dB; 1.6 g \$490

MMC-2. Diamond contact line 0.12 x 0.12 mm sq.; stylus bonding nude; cantilever sapphire tube; recommended tracking force 10 mN/1 g; FR 20-20,000 Hz, ± 1.5 dB; 1.6 g \$325

MMC-3. Diamond elliptical 0.15 x 0.15 mm sq.; stylus bonding nude; cantilever tapered aluminum tube; recommended tracking force 10 mN/1 g; FR 20-20,000 Hz, ± 2 dB; 1.6 g \$215

MMC-4. Diamond elliptical 0.20 mm round; stylus bonding titanium; cantilever tapered aluminum tube; recommended tracking force 12 mN/1.2 g; FR 20-20,000 Hz, ± 2.5 dB; 1.6 g \$125

MMC-5. Diamond elliptical 0.25 mm round; stylus bonding titanium; cantilever tapered aluminum tube; recommended tracking force 15 mN/1.5 g; FR 20-20,000 Hz, ± 3 dB; 1.6 g \$70

CELLO

Chorale Moving-Coil Cartridge

Aluminum-alloy cantilever; elliptical stylus; 13 g \$900

CLEARAUDIO

Phono Cartridges

Insider Moving-Coil Phono Cartridge

Moving-coil phono cartridge with hyper-elliptical stylus. Features hand-polished, gold plated surface. Output 0.7 mV at 5 cm/sec; FR 10-110 Hz; ch sep 45 dB at 1,000 Hz, tracking force 1.8-2.2 g. Cartridge weight 11.5 g \$5,350

Replacement stylus \$2,700

Prädikat Moving-Coil Phono Cartridge

MC cartridge with hyper-elliptical stylus. Output 0.6 V at 5 cm/sec; FR 10-75 Hz; ch sep 40 dB at 1,000 Hz; tracking force 1.8-2.2 g. Weight 5.5 g \$1,650

Replacement stylus \$850

Signature Moving-Coil Phono Cartridge. Similar to above, rhodium plated. FR 10-70 Hz. Cartridge weight 9 g \$1,495

Replacement stylus \$800

Veritas-S Moving-Coil Phono Cartridge

Moving-coil phono cartridge with hyper-elliptical stylus. Features lead alloy body. FR 10-60 Hz; ch sep 35 dB at 1,000 Hz; tracking force 1.8-2.2 g. Cartridge weight 13.5 g \$1,295

Replacement stylus \$650

Delta STD. Similar to Delta-S, original alloy; ch sep 30 dB at 1,000 Hz. Cartridge weight 4.5 g \$695

Replacement stylus \$350

Gamma STD. Similar to Gamma-S, original alloy. Cartridge weight 4.5 g \$495

Replacement stylus \$250

DENNESEN ELECTROSTATICS

ABI-1-1 Tonearm

Air-bearing lateral-tracking tonearm includes air pump. Entire arm tube removable. Stylus overhang 0 mm; overall length and effective length user adjustable. 1.5 lb (with pump) \$2,000

DENON

DI-1000 Moving-Coil Phono Cartridge

Output 0.2 mV at 50 mm/sec; FR 20-110,000 Hz; sep 30 dB at 1,000 Hz; tracking-force range 0.8 \pm 0.1 g. Cartridge weight 6 g \$859

DI-305 Moving-Coil Phono Cartridge

Features twin-radius; boron cantilever. Output 0.2 mV at 50 mm/sec; FR 20-75,000 Hz; sep 28 dB at 1,000 Hz; tracking-force range 1.2 \pm 0.2 g. Cartridge weight 5.8 g \$559

DI-304 Moving-Coil Phono Cartridge

Moving-coil phono cartridge features boron cantilever; high compliance \$395

DI-302 Moving-Coil Phono Cartridge

Features boron cantilever. Output 0.25 mV at 50 mm/sec; FR 28-70,000 Hz; separation 28 dB at 1,000 Hz; tracking-force range 1.4 \pm 0.2 grams. Cartridge weight 6 g \$260

DI-301 Moving-Coil Phono Cartridge

Output 0.3 mV at 50 mm/sec; FR 20-60,000 Hz; sep 28 dB at 1,000 Hz; tracking-force range 1.4 \pm 0.2 g. Cartridge weight 4.7 g \$160

DI-160 Moving-Coil Phono Cartridge

Output 1.6 mV at 50 mm/sec; FR 20-50,000 Hz; sep 28 dB at 1,000 Hz; tracking-force range 1.6 \pm 0.3 g. Cartridge weight 4.8 g \$115

DI-110 Moving-Coil Phono Cartridge

Output 1.6 mV at 50 mm per seconds; FR 20-45,000 Hz; sep 25 dB at 1,000 Hz; tracking-force range 1.80 \pm 0.30 grams. Weight: 4.8 g \$85

DIGITRAC BY ORTOFON

300SE Phono Cartridge

Variable magnetic-shunt cartridge with aluminum cantilever and nude fine-line diamond stylus. Output 4 mV at 5 cm/sec; FR 20-30,000 Hz; sep 24 dB at 1,000 Hz; high compliance 35 μ m/mN; tracking force range 1-1.5 g; cartridge weight 6 g \$200

200 NE Phono Cartridge

Variable magnetic-shunt cartridge with aluminum cantilever and elliptical nude diamond stylus. Output 4 mV at 5 cm/sec; FR 20-25,000 Hz; sep 22 dB at 1,000 Hz; high compliance 30 μ m/mN; tracking force range 1.25-1.75 g; cartridge weight 6 g \$140

EMINENT TECHNOLOGY

Model 2 Straight Tonearm

Straight-line-tracking, air-bearing tonearm with adjustable VTA/SRA over an arc while playing record. Features airpump; adjustable height; interchangeable arm tube with preset geometry; decoupled counterweight in horizontal plane; interchangeable preset counterweights; headshell and tonearm manufactured as 1 piece. Tracking-force range 0-5 g; effective mass 5-20 g vertical, 20-30 g horizontal.

CARTRIDGES & TONEARMS

Overall length 290 mm; effective length 180 mm; total mass 400 g \$950

EPOCH BY STANTON

Epoch II Series Model HZ9S Cartridge

MM cartridge with Stereohedron II stylus. Output 0.8 mV; FR 10-25,000 Hz; sep 35 dB at 1,000 Hz, 22 dB at 10,000 Hz; tracking-force 0.75-1.5 g. Cartridge weight 4 g \$250

LZ9S Phono Cartridge

Includes Stereohedron II stylus. Output 0.04 mV; FR 10-50,000 Hz, individually calibrated to 20,000 Hz; sep 35 dB at 1,000 Hz, 22 dB at 10,000 Hz; tracking force 0.75-1.5. Weight 3.8 g \$250

HZ8S Phono Cartridge

Includes Stereohedron II stylus. Output 0.8 mV; frequency response 10-20,000 Hz; separation 35 dB at 1,000 Hz, 22 dB at 10,000 Hz; tracking force 0.75-1.5. Weight 4 grams \$190

LZ8S Phono Cartridge

Includes Stereohedron II stylus. Output 0.04 mV; FR 10-20,000 Hz; sep 35 dB at 1,000 Hz, 22 dB at 10,000 Hz; tracking force 0.75-1.5. Weight 3.8 g \$190

HZ7S Phono Cartridge

Includes Stereohedron II stylus. Output 0.8 mV; FR 10-20,000 Hz; sep 30 dB at 1,000 Hz, 15 dB at 10,000 Hz; tracking 0.75-1.25. Weight 4 g \$120

HZ6E Phono Cartridge

Includes elliptical stylus. Output 0.8 mV; FR 10-20,000 Hz; sep 30 dB at 1,000 Hz, 15 dB at 10,000 Hz; tracking force 0.75-1.25. Weight 4 g \$95

GRADO

Joseph Grado Signature Series

MCZ Phono Cartridge

MM cartridge with hybrid design and 4 separate magnetic gaps around cantilever. Features compatibility with light-to-medium-mass tonearms and standard 47,000-ohm MM inputs; user-replaceable stylus. Output 1.5 mV; resonance 8-12 Hz; torsional resonance approximately 25,000 Hz; resistance 70 ohms; inductance 9 mH \$300

8M2 Phono Cartridge

MM cartridge with user-replaceable stylus. Features compatibility with standard 47,000-ohm MM inputs. Output 3.5 mV; electrical resistance 475 ohms; inductance 45 mH \$200

Professional Series

Designed for high output and stability under severe use; for broadcast, in changers, or arms that will not track at 1 g. Recommended tracking force 2-3 g. Output 4 mV at 3.54 cm/sec (45); sep 20 dB 10-20,000 Hz.

ZCE+. Specially-selected units; elliptical diamond stylus \$45
ZTE+. Elliptical diamond stylus \$30

Specifications for all models below: 0.5-in mounting centers (or optional P-mount for some); input load 47,000 ohms; inductance 45 millihenries; DC resistance 475 ohms; pickup weight 5 g.

Super Flux-Bridger Series

With 0.5-in or P-mount. Recommended tracking force 0.75-2 g. Output 4 mV at 3.54 cm/sec (45); sep 25 dB 10-30,000 Hz.

Z2+. True Ellipsoid stylus \$265
Z1+. True Ellipsoid stylus \$180
Z+. Grado diamond stylus \$130
ZF1+. Grado diamond stylus \$110
ZF2+. Elliptical diamond stylus \$86
ZF3E+. Elliptical diamond stylus \$69

Flux-Bridger Series

0.5-in or P-mount; elliptical diamond stylus; Recommended tracking force 1-2 g. Output 4 mV at 3.54 cm/sec (45); sep 20 dB 10-30,000 Hz.

ZCE+1. \$55
ZTE+1. \$25

Replacement Styli

For standard 0.5-in and P-mount cartridges; spherical styli for 78-rpm records \$4 additional.

Z2+ /S \$10
Z1+ /S \$75
Z+ /S \$55
ZF1+ /S \$45
ZF2+ /S \$36
ZF3E+ /S \$33
ZCE+ /S \$30
ZCE+ /S \$28
ZTE+ /S \$21
ZTE+ /S \$17

HEYBROOK BY D'ASCANIO AUDIO

The Heybrook Tonearm

Pivoted-tracking magnesium-tube straight tonearm with adjustable vertical tracking angle and fixed headshell. Statically balanced with fixed headshell and locking counterweight. Tracking-force range 0-3 g; overall length 11 3/8 in \$549

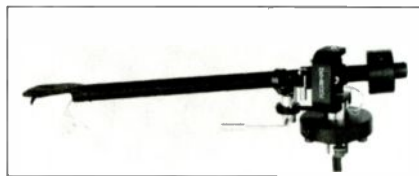

The Heybrook Tonearm

LINN PRODUCTS

Troika Moving-Coil Phono Cartridge

Elliptical stylus; body milled from solid aluminum; 3 mounting screws; flying-lead cartridge tags eliminate 1 connector. FR 20-20,000 Hz \pm 1 dB; sep > 30 dB at 1,000 Hz; tracking force 1.5-1.7 g; ch bal at 1,000 Hz within 1 dB; recommended load 470 ohms; tracking angle 20° \$1,750
Replacement stylus \$1,167

Karma Moving-Coil Phono Cartridge

Elliptical stylus; body milled from solid aluminum. FR 20-20,000 Hz \pm 1 dB; sep 30 dB at 1,000 Hz; tracking force 1.5-1.7g; cartridge weight 5.7g; ch bal within 1 dB at 1,000 Hz; tracking angle 20°. \$1,225
Replacement stylus \$817

Asaka Moving-Coil Phono Cartridge

Elliptical stylus; body milled from solid aluminum. Output 0.2 mV; FR 10-50,000 Hz \pm 3 dB; sep 27 dB at 1,000 Hz; tracking force 1.5-1.9g; cartridge weight 5.7 g; vertical tracking angle 20° \$795
Replacement stylus \$530

K-18 Phono Cartridge

Elliptical stylus; bolt-in user-replaceable stylus assembly; aluminum body \$450

K-9 Phono Cartridge

Elliptical stylus; aluminum cantilever. FR 20-20,000 Hz \pm 2 dB; sep 25 dB at 1,000 Hz; tracking force 1.5-1.9 grams; vertical tracking angle 20° \$275
Replacement stylus \$165

K-5 Phono Cartridge

Elliptical stylus FR 20-20,000 Hz \pm 2 dB; tracking force 1.7 g \$150
Replacement stylus \$90

Basik Phono Cartridge

Spherical stylus. FR 20-20,000 Hz \pm 2 dB; ch sep 25

dB at 1,000 Hz; tracking force 1.8 g; cartridge weight 6 g \$75

Tonearms

Ekos Tonearm

Tonearm featuring individually graded and matched bearings; bidirectional damped cueing; assembled with advanced adhesives \$1,995

Ittok LV-II Tonearm

Tonearm with 11.5-in overall length, 9-in stylus-pivot distance, damped cueing mechanism. Features radial ball bearings. Effective mass 12 g; total cable capacitance 100 pF; cartridge weight range 3-12 g \$1,095

Akito Tonearm

Tonearm with large-diameter arm tube; assembled with advanced adhesives \$395

Basik Plus Tonearm

Straight statically balanced tonearm with fixed aluminum headshell and decoupled counterweight. Tracking-force range 0-3 g calibrated to 0.1 g; effective mass 11 g; stylus overhang 18 mm; overall length 284 mm; effective length 230 mm. Includes Basik cartridge \$295



Linn K-18

MADRIGAL

Carnegie Two Moving-Coil Phono Cartridge

Features cantilever with ultra low mass. 0.28-mm diam. solid boron rod; square nude diamond 0.12 x 0.12 mm; machined aluminum alloy, internally damped. Frequency response 10-50,000 Hz; imp 20 ohms; channel balance > 1.0 dB; channel separation > 35 dB at 1,000 Hz and 25 dB at 10,000 Hz; open circuit output voltage 0.35 mV at 1,000 Hz at 5 cm/sec; perpendicular tracking angle 22 \pm 2 degrees; micro-edge line contact 4 x 80 microns. Weight: 9 oz. \$850

MONSTER CABLE

Sigma Genesis 2000 Moving-Coil Cartridge

Induced symmetrical-field-canceling circuitry; unique symmetrical coil construction; diamond carbon-coated boron cantilever with "air response" cantilever damper and MicroRidge MK II stylus \$1,250

Alpha Genesis 1000 Mk II Moving-Coil Cartridge

Low output; diamond-sputtered cantilever; phase-corrected coils \$800
Alpha Genesis 500. Step-down version of Alpha Genesis 1000 Mk II \$500

MUSIC HALL

Bullet Phono Cartridge

Highly modified Audio-Technica cartridge with elliptical stylus \$125

NAGAOKA

MP 50s Phono Cartridge

MM phono cartridge with impact aluminum frame. Nude super-elliptical stylus, sapphire pipe cantilever. FR 20-28,000 Hz; output voltage 2.5 mV (5cm/sec) @

CARTRIDGES & TONEARMS

1,000 Hz; ch sep >27 dB @ 1,000 Hz; stylus pressure 1.1-1.5 g; cartridge weight 9 g \$330
N50 MP. Replacement styli \$200

MP 30 Phono Cartridge

MM phono cartridge with impact aluminum frame. 0.4 x 0.7 mil elliptical stylus; Boron cantilever. FR 20-25,000 Hz; output voltage 3 mV (5 cm/sec) @ 1,000 Hz; ch sep >25 dB @ 1,000 Hz; stylus pressure 1.3-1.8 g; cartridge weight 9 g \$220
N30 MP. Replacement styli \$125

MP 11 Phono Cartridge

Magnetodynamic phono cartridge with UT58 Boron taper pipe cantilever. 0.4 x 0.7 mil elliptical block diamond stylus. FR 20-23,000 Hz; output voltage 4.0 mV (5 cm/sec) @ 1,000 Hz; ch sep >25 dB @ 1,000 Hz; stylus pressure 1.8-2.3 g; cartridge weight 6.8 g \$150
N11 MP Boron. Replacement styli \$85

MP 11 Gold. Similar to above with A5052 duralumin, plated cantilever. Stylus pressure 1.7-2.3 g; cartridge weight 7.9 g \$110
N11MP Gold. Replacement styli \$65

MP 11 Phono Cartridge

Phono cartridge with samarium-cobalt magnet. 0.3 x 0.7 mil elliptical diamond stylus. FR 20-20,000 Hz; output voltage 5 mV (5 cm/sec) @ 1,000 Hz; ch sep >23 dB @ 1,000 Hz; stylus pressure 1.8-2.3 g; cartridge weight 6.8 g \$80
N11 MP. Replacement styli \$55

MP 10 Phono Cartridge

MM phono cartridge with A5052 duralumin cantilever. 0.5 mil conical diamond stylus; FR 20-20,000 Hz; output voltage 5 mV (5 cm/sec) @ 1,000 Hz; channel separation >22 dB; stylus pressure 2.0-2.5 g; cartridge weight 6.8 g \$60
N10 MP. Replacement styli \$35

MP03. Bulk Budget cartridge, elliptical stylus. \$40
NNC-P. Same as above, P-mount \$40

ORTOFON

Ortophase Moving-Coil Phono Cartridges

MC3000. MC cartridge with low-mass (0.25 mg) moving system. Features proprietary Ortofon Fg Replicant 100 stylus mounted on a rigid aluminum conical cantilever; carbon-fiber armature wound with pure silver coils and a neodymium permanent magnet. Aluminum oxide, ceramic cartridge housing with Moh scale hardness factor of 9. Output voltage at 1,000 Hz 5cm/sec 0.1 mV; ch sep at 1,000 Hz >25dB; frequency response 5-90,000 Hz +4 -1dB; tracking ability at 315 Hz at recommended tracking force >80 µm; weight 9.5 g \$1,000
MC30 MKII. MC cartridge with extruded aluminum body, carbon-fiber support system, and silver coil windings. Stylus replicant 80. Output 0.25 mV at 1000 cm/sec; FR 20-40,000 Hz; sep >25 dB at 1,000 Hz; tracking ability at recommended tracking force 90 µm; weight 9 g \$600
MC20 Super. MC cartridge with extruded aluminum body. Features Van den Hul stylus; carbon-fiber support system. Output 0.25 mV at 1,000 cm/sec; FR 15-40,000 Hz; sep >25 dB at 1,000 Hz; tracking-force range 1.5-1.9 g; cartridge weight 9 g \$300
MC10 Super. MC stereo phono cartridge with elliptical nude stylus. Vertical tracking angle 20X, output 0.25 mV at 1 kHz, 5 cm/sec; FR 20-20,000 Hz ± 1 dB; tracking force 1.5 g; 7 g \$100

High-Output Moving-Coil Cartridges

X5MC. High-output MC cartridge for direct connection to MM phono input. Features Fg type 2 nude diamond stylus. High-output/low-moving mass achieved through focused magnetic field and only 230 coil windings per pole piece. Output 2 mV at 5 cm/sec. FR 15-40,000 Hz +4 -1.5 dB; sep >25 dB at 1,000 Hz, weight 4.1 g \$300

X3-MC. High-output MC cartridge connects directly to MM-phono input. Features focused magnetic field for high output with low-moving mass (230 coil windings per pole piece) and nude fine-line diamond. Output 2 mV at 5 cm/sec; FR 20-40,000 Hz +4, -1.5 dB; sep >25 dB at 1,000 Hz; tracking-force range 1.8-2.2 g; cartridge weight 4.1 g; vertical tracking angle 23X \$200
X3-MCP. P-mount version of X3-MC \$200
X1-MC. High-output MC cartridge with low-moving mass, aluminum cantilever, and elliptical diamond. Output 2 mV at 5 cm/sec; FR 20-30,000 Hz +4, -1.5 dB; sep >22 dB at 1,000 Hz; tracking-force range 1.75-2.2 g; cartridge weight 4.1 g; vertical tracking angle 23X \$100
X1-MCP. P-mount version of X1-MC \$100

Diamond Collection 500 Series

Model 540. MM cartridge utilizing proprietary slotted-pole pin construction for improved high frequency response. Patented locking stylus guard to secure stylus to cartridge body avoiding unwanted resonances. Square-shank nude diamond Fg type 1. Output at 3mV at 1 kHz per 5 cm/sec. FR 20-28kHz +4, -1 dB; sep >25 dB; tracking force range from 1-1.5g; weight 5 g 300
530. Similar to 540 except uses square-shank nude fine-line diamond. FR 20-25,000 Hz \$225
520. Similar to 530 except uses a square-shank nude elliptical diamond. sep 23dB; frequency response 20-23,000 Hz \$150

Optimum-Mass Phono Cartridges

OM-40 Gold. Variable-magnet-shunt cartridge with individually calibrated Van den Hul stylus. Output 3.5 mV at 1,000 cm/sec; FR 20-30,000 Hz; sep 25-1,000 dB at 1,000 Hz; tracking-force range 1-1.5 g; cartridge weight 5 or 2.5 g \$300
OM-30. Low-mass variable-magnet-shunt phono cartridge. Features plastic cartridge body for rigidity and low weight; copper coils; nude fine-line diamond stylus; tracking force 1.25 grams; frequency response 20-27,000 Hz; output voltage at 1,000 Hz (5 cm/sec) 3.5 mV; wt 2.5 grams; channel separation at 1,000 Hz >25 dB \$225
OMP-30. P-Mount version of OM-30 cartridge; 6 g \$225
OM-20. Similar to OM-30 except for a more rectangular nude elliptical diamond stylus; designed for medium-weight tonearms; FR 20-22,000 Hz; output voltage at 1,000 Hz (5cm/sec) 4 mV \$175
OMP-20. P-Mount version of OM-20 cartridge; 6 g \$175
OM-10. Similar to OM-20 except for a heavier stylus tip; designed for use with heavier tonearms; tracking force 1.5 gram; FR 20-20,000 Hz; output voltage at 1,000 Hz (5 cm/sec) 4 mV; ch sep at 1,000 Hz 22 dB \$95
OMP-10. P-Mount version of OM-10 cartridge; 6 g \$95
OM-5E. Similar to OM-10 except for heavier stylus tip; for use with heavier tonearms. Tracking force 1-5 g; FR 20-20,000 Hz \$65
OMP-5E. P-Mount version of OM-5E \$65

Pro Series

Concorde Pro Kit. MM cartridge kit with one Concorde integrated pro body and two spherical pro styli. FR 20-20,000 Hz; output 5 mV at 1,000 Hz 5 cm/sec; sep/balance at 1kHz 20/2dB; weight 16 g \$100
OM Pro-Kit. MM-cartridge kit with one OM Pro body and 2 pro styli. Features spherical stylus and aluminum cantilever. Output 5 mV at 5 cm/sec; FR 20-18,000 Hz ± 3 dB; sep 20 dB at 1,000 Hz; tracking-force range 3-5 g; cartridge weight 5 g \$50
Stylus Pro. Replacement stylus for above OM Pro Kit \$30

300 Series

320U. Universal P-mount with 1/2-in mount adaptor, moving magnet generating principal. Square shank nude elliptical diamond. FR 20-22,000 Hz; output 5 mV at 5 cm/sec; sep 24 dB \$129

310U. Similar to 320U except has highly-polished elliptical diamond stylus. FR 20-20,000 Hz \$89
305E. Similar to 310U except has an elliptical diamond stylus. sep 23 dB \$60

Universal Series

TM20U. Variable-magnetic-shunt cartridge with square-shank nude elliptical diamond and universal mount. Output 4 mV at 1 kHz, 5 cm/sec; frequency response 20-25,000 Hz; bal/sep. 1.5/25 dB; weight 6 g \$129
TM14U. Stereo cartridge with elliptical diamond stylus and universal mount. FR 20-20,000 Hz; output 4.5 mV; sep/balance 25/1.5 dB at 1 kHz; equivalent stylus tip mass 0.5 mg; recommended load 47k ohms/200 pF; tracking force 1.25 g \$89
TM7U. Cartridge with elliptical diamond stylus and universal mount. FR 20-20,000 Hz; output 5 mV at 1 kHz, 5 cm/sec; sep/balance 22/2 dB at 1 kHz; tracking force 1.25 g; equivalent tip mass 0.5 mg; recommended load 47 kilohms/200 pF \$60

FF15XE MkII. Variable magnetic shunt cartridge with 8-µm elliptical diamond stylus tip. Output 3.2 mV at 1 kHz, 1 cm/sec; FR 20-20,000 Hz; balance/sep 2 dB/20 dB at 1 kHz; compliance 20 µm/mN (horizontal, vertical); tracking-force range 1.5-3 g; 5 g \$50

PICKERING

XLZ/7500S Phono Cartridge

Cartridge with nude Stereohedron diamond stylus tip. Sens 0.06 mV/cm/sec ± 2 dB; FR 10-50,000 Hz; sep 35 dB; tracking force 0.5-1.5 g; includes Dustamatic brush; replacement stylus D7500 \$275

XSV/5000 Phono Cartridge

Cartridge with nude Stereohedron diamond stylus tip. Output 3.8 mV; FR 10-50,000 Hz; tracking force 0.5-1.5 g; sep 35 dB; includes Dustamatic brush. Replacement stylus D5000 \$275
XSV/4000. Similar to XSV/5000 except FR 10-36,000 Hz; tracking force .75-1.5 g; replacement stylus D5000 \$200

XV-15/1200 Phono Cartridge

Output 4.4mV at 5.5 cm/sec; FR 10-30,000Hz; 0.2 x 0.7-mil elliptical stylus; tracking force 0.75-1.25g; sep 35 dB; features Dustamatic brush; replacement stylus D1200 \$170

XV-15/757S Cartridge

Stereohedron stylus, output 4.4 mV; tracking force 0.75-1.5 g; FR 10-25,000 Hz; replacement stylus D757S \$140

XSV/3000 Phono Cartridge

Output 5 mV at 5.5 cm/sec; FR 10-30,000Hz; Stereohedron stylus tip; tracking force 0.75-1.5 g; sep 35 dB; features Dustamatic brush; replacement stylus D3000 \$130

XV-15/625E Phono Cartridge

Output 4.4 mV at 5.5 cm/sec; FR 10-25,000 Hz; 0.3 x 0.7-mil elliptical stylus; tracking force 0.75-1.5 g; sep 35 dB; features Dustamatic brush; replacement stylus \$110

XV-15/625DJ Phono Cartridge

Designed for disco use. Output 0.8 mV/cm/sec; sep 30 dB; tracking force 1-4 g; 0.3 x 0.7-mil elliptical stylus \$82

XV-15/400E Phono Cartridge

Output 5.5 mV at 5.5 cm/sec; FR 10-25,000 Hz; 0.4 x 0.7-mil elliptical stylus; tracking force .75-1.25 g; sep 35 dB; features Dustamatic brush; replacement stylus D400 \$95

XV-15/150DJ Phono Cartridge

Extra-high-output (8 mV) cartridge; designed for amateur and home DJs. FR 10-20,000 Hz; ch sep 28

CARTRIDGES & TONEARMS

dB; stylus tip 0.7 mil spherical; tracking force 2-4 g; replacement stylus D150DJ..... \$79

P-Mount Phono Cartridges

TLZ/7500S. High-performance low-imp cartridge with 4-coil, high-energy samarium-cobalt magnet. Nude Stereohedron stylus; output 0.06 mV/cm/sec; tracking force .75-1.5 g; FR 10-50,000 Hz..... \$275
XSP/4004. Stereohedron stylus. Output 3.8mV; tracking .75-1.5 g; FR 10-36,000 Hz..... \$200
XSP/3003. Stereohedron series P-mount cartridge with output 3.3 mV. FR 10-30,000 Hz; tracking force .75-1.5 g, ±.25 g..... \$130
TL-4S. 4-coil induced magnet. Stereohedron stylus. Output 4.4 mV, tracking force .75-1.5 g. FR 10-25,000 Hz..... \$170
TL-3S. Stereohedron stylus. Output 4.4 mV; tracking .75-1.5 g; FR 10-25,000 Hz..... \$140
TL-2S. Stereohedron stylus. Output 4.4 mV; tracking .75-1.5 g; FR 10-22,000 Hz..... \$110
TL-2E. Elliptical stylus. Output 4.4 mV; tracking .75-1.5 g; FR 10-22,000 Hz..... \$95
TL-1. Standard P-mount, 2-coil moving magnet. Tracking .75-1.5 g. Elliptical stylus. FR 10-20,000 Hz, output 4.4 mV..... \$37
TL625DJ. P-mount cartridge. FR 20-20,000Hz, output 4.4 mV, tracking force 3.5-4 g. Replacement stylus DJL..... \$82
TLE Type 2. Elliptical stylus. Output 3.0 mV; tracking force .75-1.5 g; FR 10-22,000 Hz..... \$60
TLE. Elliptical stylus. Output 4.4 mV; tracking force .75-1.5 g; FR 10-20,000 Hz..... \$55

V-15/Series II-S. Stereohedron stylus, frequency response 10-25,000 Hz, output 3.5 mV. Replacement stylus DSR-S..... \$88
V-15/Series II-EE. Elliptical stylus, frequency response 10-20,000 Hz, output 3.5 mV. Replacement stylus DSR-EE..... \$55
V-15/Series II-E. Elliptical stylus, frequency response 10-18,000 Hz, output 3.5 mV. Replacement stylus DSR-E..... \$50

V15-DJ Phono Cartridge

Spherical cartridge (standard .5-in mount); nominal Output 4.4mV; tracking force 2-5 g; wt. 5.5 g... \$43

PIONEER

PC-295T Induced-Magnet Phono Cartridge

T4P P-mount cartridge. FR 10-33,000 Hz; output voltage 2.5 mV; tracking force 1.25 g..... \$80
 PN-295T. Replacement stylus for PC-295T..... \$35

PC-300T Induced-Magnet Phono Cartridge

T4P P-mount cartridge. FR 10-33,000 Hz; output voltage 2.5 mV; tracking force 1.25 g..... \$80
 PN-300T. Replacement stylus for PC-300T..... \$30

PC-290T Induced-Magnet Phono Cartridge

T4P P-mount cartridge. FR 10-33,000 Hz; output voltage 2.5 mV; tracking force 1.25 g..... \$70
 PN-290T. Replacement stylus for PC-290T..... \$30

PC-5MC Moving-Coil Phono Cartridge

High-output MC cartridge. FR 10-32,000 Hz; output voltage 2 mV; tracking force 1.7-2.3 g..... \$54
 PN-5MC. Replacement stylus for PC-5MC..... \$32

PC-250T Phono Cartridge

T4P P-mount cartridge. FR 10-30,000 Hz; output voltage 2.5 mV; tracking force 1-1.5 g..... \$50
 PN-250T. Replacement stylus for PC-250T..... \$20

REALISTIC

V15 Realistic/Shure Phono Cartridge

Cartridge features dynamic stabilizer; viscous damping for tracking of warped record. Tracking force 1¼-1¾ g; FR 5-30,000 Hz..... \$80

RXT6 Realistic/Shure Phono Cartridge

Telescope stylus with dynamic stabilizer. P-mount

adaptor and installation kit. Tracking force 1¼-1¾ g..... \$50

RXP3 Realistic/Shure Phono Cartridge

P-mount; elliptical diamond stylus; tracking force 1¼ g..... \$30

R47XT Realistic/Shure Phono Cartridge

Elliptical diamond stylus (10 x 18 microns); tracking force 1¾-2¼ g; sep 20 dB..... \$27

RS500DJ Realistic/Stanton Phono Cartridge

Pro Series cartridge features back-cues and scratch mixes; tracking force 2½ g..... \$30
RS00DJ. Replacement stylus..... \$20

RX1500 Phono Cartridge

Dual-magnet cartridge with diamond elliptical stylus; tracking force 1-1½ g..... \$30

R25XT Realistic/Shure Phono Cartridge

Elliptical diamond stylus (10 x 18 microns); tracking force 2½-3½ g..... \$20

Styli

R8X. Diamond stylus for R1000, Shure M90, M75, T-2 series..... \$25
RT1500. Diamond elliptical stylus for RX1500, Audio-Technica AT-102P, 102, 112, 122EP cartridges; tracking force 1-1.5 g..... \$20
RS3P. Diamond stylus for RXP3 and Shure M92E, M99E, M104E..... \$19.95
RS50E. Diamond elliptical stylus for ADC, QLM34 MK III, P32, K5E cartridges..... \$19.95
R5X. Diamond stylus for R47, Shure M70 and M75 series..... \$17.95
R3X. Diamond stylus for R25, Shure M71 and M75ECS series..... \$16.95
42-2772. Diamond conical stylus..... \$15
DAT-2. Diamond conical stylus for Pickering V15/AT-1/2, KLH, similar cartridges..... \$12
ATN-771E. Diamond elliptical stylus for Audio-Technica AT-70/71/71E..... \$11
RSK8C. Diamond conical stylus for QLM30 and ADC K series cartridges..... \$11
PS-203. Diamond stylus for Clarinette 14/15/16 and 13-1117/1118..... \$6

REVOLVER BY MUSIC HALL

Revolver Straight Tonearm

Statically balanced pivoted direct-coupled tonearm with zero free-play-adjusted precision ball races. Features decoupled counterweight. Tracking force 2-10 grams calibrated to 0.1 grams; effective mass 7 grams; offset angle 23.5°; stylus overhang 18 mm. Overall length 285 mm; effective length 228 mm; 393 grams..... \$200

Revolver Super Tonearm

Similar geometry to Revolver Straight Tonearm but incorporates larger zero free-play bearings, alloy arm tube..... \$450

SHURE

ULTRA 500

All of V15 type V-MR (see below) plus other features. Total effective mass 0.165 mg; dynamic vertical stylus compliance at 10 Hz 20 µm/dyne; output at 1,000 Hz; 5 cm/sec peak velocity; 3.2 mV..... \$400

V15 Phono Cartridge

MM cartridge with improved low-distortion Micro-Ridge stylus tip and Microwall beryllium stylus shank for increased trackability. Features viscous-damped Dynamic Stabilizer and Side-Guard stylus protection system; includes Duo-Point Alignment Gauge and computer performance printout. Output 3.2 mV at 1,000 Hz (5 cm/sec peak velocity); frequency response 10-28,000 Hz; sep 25 dB or greater at 1,000 Hz; tracking force 1.0 g; replacement stylus VN5MR..... \$297

V15 Type V-B Phono Cartridge

MM cartridge with exclusive hyperelliptical tip, Microwall beryllium stylus shank, dynamic stabilizer and Side-Guard stylus protection system. Includes individual computer performance printout. Output 3.2 mV at 1 kHz (5 cm/sec peak velocity); FR 10-28,000 Hz; sep 25 dB or greater at 1,000 Hz; tracking force 1.0 g; replacement stylus VN5HE; VN5MR upgrade..... \$237

V15 Type V-P Phono Cartridge

Specifically designed for ultimate performance in P-mount tonearms. Features hyperelliptical tip; microwall beryllium stylus shank; computer performance printout. Same specs as V15 type V-B. Replacement stylus VN5P..... \$221

VST V Moving-Magnet Phono Cartridge

MM cartridge. Features microwall/beryllium stylus shank; hyperelliptical stylus tip; telescoped stylus shank; dynamic stabilizer; Side-Guard stylus protection system. FR 10-35,000 Hz; trackability at 10,000 Hz 72 cm/sec; ch sep at 1,000 Hz 25 dB..... \$170

M111HE Phono Cartridge

Features telescoped stylus shank, hyperelliptical tip, dynamic stabilizer, Side-Guard stylus protection system; rigid, low-mass converter allows mounting to either conventional 0.5-in-mount tonearms or most P-mount tonearms; output 5.0 mV at 1 kHz (5 cm/sec peak velocity); FR 20-20,000 Hz; sep 25 dB at 1 kHz; tracking force 1.25 g. Replacement stylus N111HE..... \$146

M110HE Phono Cartridge

Features telescoped stylus shank, hyperelliptical tip, and Side-Guard stylus protection system; rigid, low-mass converter allows mounting to either conventional 0.5-in-mount tonearms or all P-mount tonearms; same specs as M111HE. Replacement stylus N110HE..... \$119

M105E Phono Cartridge

Features 0.2 x 0.7 mil elliptical tip and thin-walled, reinforced aluminum shank. Features Destaticizer brush to clean dust from record grooves and remove static electricity from record surface, side-guard stylus protection system helps prevent accidental stylus damage. Fits most P-mount tonearms and includes rigid 0.5-in-mount converter. Output 5.0 mV at 1 kHz (5 cm/sec peak velocity); FR 20-20,000 Hz; sep 25 dB at 1 kHz; tracking force 1.25 g. Replacement stylus N105E..... \$108

VST III Phono Cartridge

MM cartridge. Features microwall/beryllium stylus shank; hyperelliptical stylus tip; telescoped stylus shank; dynamic stabilizer; Side-Guard stylus protection system. FR 10-20,000 Hz; trackability at 10,000 Hz 56 cm/sec; ch sep at 1,000 Hz 25 dB..... \$100
VST III-P. As above. P-mount..... \$90

M104E Phono Cartridge

Cartridge with 0.2 x 0.7-mil elliptical stylus tip and tubular heat-treated aluminum stylus shank. P-mount compatible and includes rigid 0.5-in-mount converter. Output 5.0 mV at 1 kHz (5 cm/sec peak velocity); FR 20-20,000 Hz; sep 25 dB; tracking force 1.25 g. Replacement stylus N104E..... \$76

SC39EJ Phono Cartridge

Features biradial stylus; Side-Guard stylus protection system; output voltage 4 mV; FR 20-20,000 Hz; ch bal within 2 dB; ch sep 20 dB at 1,000 Hz; tracking force 1.5-3 dB; beige stylus grip..... \$76
SC39B. As above, spherical stylus; green stylus grip..... \$68

M55E Moving-Magnet Phono Cartridge

MM cartridge. Output 6.2 mV at 5 cm/sec peak velocity (1 kHz); FR 20-20,000 Hz; tracking force 0.75-2 g; sep 20 dB (1 kHz); 0.2 x 0.7-mil biradial (elliptical) stylus; replacement stylus N55E..... \$71

CARTRIDGES & TONEARMS

M44E Phono Cartridge

MM cartridge. Output 9.5 mV at 5 cm/sec peak velocity (1 kHz); FR 20-20,000 Hz; tracking force 1.75-4 g; sep 20 dB (1 kHz); 0.4 x 0.7-mil biradial (elliptical) stylus; replacement stylus N44E . . . \$62

M44G Phono Cartridge

Features flip-down stylus-guard; 15-micron spherical stylus tip. Tracking force ¾-1¼ grams; FR 20-20,000 Hz; ch bal within 2 dB; ch sep at 1,000 Hz 20 dB; output 6.2 mV . . . \$57

M44C Phono Cartridge

Features flip-down stylus-guard; 15-micron spherical stylus tip. Tracking force 3-5 grams; FR 20-20,000 Hz; ch bal within 2 dB; ch sep at 1,000 Hz 20 dB; output 6.2 mV . . . \$55

M447 Phono Cartridge

Features flip-down stylus-guard; 15-micron spherical stylus tip. Tracking force 1½-3 grams; FR 20-20,000 Hz; ch bal within 2 dB; ch sep at 1,000 Hz 20 dB; output 6.2 mV . . . \$55

M199E Phono Cartridge

Heat-treated tubular aluminum stylus shank and 0.2 x 0.7 mil elliptical stylus tip. P-mount compatible; fits conventional 0.5-in-mount tonearms with rigid converter. Output 5.0 mV at 1 kHz (5 cm/sec peak velocity); FR 20-20,000 Hz; sep 20 dB at 1 kHz; tracking force 1.25 g. Replacement stylus N99E \$54

SC35C Phono Cartridge

Features spherical stylus; light blue stylus grip; output voltage 5 mV; frequency response 20-20,000 Hz; channel balance within 2 dB; channel separation 20 dB at 1,000 Hz; tracking force 4-5 grams . . . \$49

M192E Phono Cartridge

Heat-treated tubular aluminum stylus shank and 0.4 x 0.7 mil elliptical stylus tip. P-mount compatible and fits conventional 0.5-in-mount tonearms with rigid converter. Output 5.0 mV at 1 kHz (5 cm/sec peak velocity); frequency response 20-18,000 Hz; separation 20 dB at 1,000 Hz; tracking force 1.25 g. Replacement stylus N92E . . . \$33

SIGNET

OC9 Moving-Coil Phono Cartridge

Features 0.2 x 0.7 mil bi-radial nude diamond stylus; gold-plated beryllium cantilever; POCO coils; Output 0.4 mV at 1,000 Hz, 5cm/sec; FR 15-50,000 Hz; tracking force range 1.25-1.75 g; cartridge weight 7.8 g. . . . \$395

AM Analog Master Series

AM150s Phono Cartridge

Standard mount, Twin-flux design featuring POCO wire; gold-plated beryllium cantilever; square-shank MicroLine stylus. FR 5-37,000 Hz; output 5.0 mV at 1,000 Hz, 5 cm/sec; tracking force range 0.8-1.8 g. Cartridge weight 6 g. . . . \$350

AM140s Phono Cartridge

Standard mount, Twin-flux design featuring POCO wire; tapered beryllium cantilever; nude straight line contact stylus. FR 5-35,000 Hz; output 5.0 mV at 1,000 Hz, 5 cm/sec; tracking force range 0.8-1.6 g. Cartridge weight 6 g. . . . \$275

AM130s Phono Cartridge

Standard mount, Twin-flux design featuring POCO wire; thin-wall alloy tapered cantilever; 0.3 x 0.7 nude elliptical stylus. FR 5-30,000 Hz; output 5.0 mV at 1,000 Hz, 5 cm/sec; tracking force range 0.8-1.6 g. Cartridge weight 6 g. . . . \$225

AM20s Phono Cartridge

Standard mount, Twin-flux design featuring POCO wire; thin-wall alloy tapered cantilever; 0.3 x 0.7 nude elliptical stylus. FR 10-30,000 Hz; output 5.0 mV at

1,000 Hz, 5 cm/sec; tracking force range 0.9-1.9 g. Cartridge weight 6 g. . . . \$195
AM20p, P-mount version of above . . . \$195

AM110s Phono Cartridge

Standard mount, Twin-flux design featuring POCO wire; thin-wall aluminum cantilever; 0.3 x 0.7 mil miniature nude elliptical diamond stylus. FR 15-25,000 Hz; output 5.0 mV at 1,000 Hz, 5 cm/sec; tracking force range 1.3-2.3 g. Cartridge weight 6 g. . . . \$125
AM110p, P-mount version of above . . . \$125

MK Micro-Coil Series

MK120He Moving-Coil Phono Cartridge

High-output design features user-replaceable stylus with 0.2 x 0.7 mil nude square-shank diamond. Output 2 mV at 5 cm/sec; FR 15-30,000 Hz; sep 29 dB at 1,000 Hz, 20 dB at 10,000 Hz; tracking-force range 1.2-1.8 g; cartridge weight 5 g . . . \$200

MK55e Moving-Coil Phono Cartridge

Low mass; dual moving MicroCoil design; user-replaceable stylus with 0.3 x 0.7 mil nude mounted diamond. Output 0.5 mV at 5 cm/sec; FR 20-28,000 Hz; sep 28 dB at 1,000 Hz, 18 dB at 10,000 Hz; tracking-force range 1.2-1.8 g; cartridge weight 4.2 g. . . . \$150

Standard Series

Standard 107 Phono Cartridge

Universal mount, linear contact stylus. Output 3.0 mV at 1,000 Hz; sep 31 dB at 1,00 Hz; FR 10-30,000 Hz; tracking force 1.6 g . . . \$150

Standard 105 Phono Cartridge

Universal mount, 0.3 x 0.7 mil elliptical stylus; output 5.0 mV at 1,000 Hz at 5 cm/sec; sep 29 dB at 1,000 Hz; tracking force 1.6 g . . . \$110

Standard 103 Phono Cartridge

Universal mount, 0.4 x 0.7 mil elliptical stylus; output 5.0 mV at 1,000 Hz at 5 cm/sec; frequency response 15-25,000 Hz; separation 29 dB at 1,000 Hz; tracking force 1.6 g. . . . \$90

Standard 101 Phono Cartridge

Universal mount; 0.6 mil stylus; output 5.0 mV at 1,000 Hz at 5 cm/sec; FR 20-20,000 Hz; sep 24 dB at 1,000 Hz; tracking force 1.6 g . . . \$60

Standard 100 Phono Cartridge

0.5-in mount; 0.4 x 0.7 mil elliptical stylus; output 4.2 mV at 1,000 Hz at 5 cm/sec; FR 20-22,000 Hz; sep 22 dB at 1,000 Hz; tracking force range 1.5-2.5 g. . . \$60

SOUTHERBY CLEARAUDIO

Tonearms

Triquartz I

Linear, cueing tonearm has changeable wand. Features adjustable vertical tracking angle, quartz rod in tracking assembly. Tracking force 0.5-3 g; overall length 10-in; 2-in pivot-stylus distance; 1-20 g cartridge weight range. . . . \$1,295

STANTON

Collector's Series

Model 100 Phono Cartridge

Rare-earth cartridge with Stereohedron II diamond stylus. FR up to 50,000 Hz . . . \$300

Calibration Series

9811-Z Mk II Phono Cartridge

Low-imp cartridge, fully calibrated for exact precision with nude Stereohedron diamond stylus. Includes mounted "longhair" brush. Output 0.06 mV/

cm/sec 22 dB; FR 10-50,000 Hz; sep 35 dB; tracking force 1 g ± .25 g. Weight 5.5 g. . . . \$250

9811HZ Mk II Phono Cartridge

High-imp stereo cartridge with nude Stereohedron diamond stylus, fully calibrated. Includes mounted "longhair" brush. Output 0.7 mV/cm/sec; FR 10-50,000 Hz; sep 35 dB at 1 kHz; tracking force 1 g ± .25. Weight 5.5 g. . . . \$250

881S Mk II Phono Cartridge

Nude Stereohedron stylus replacement stylus for D81S, D810 for mono LPs and D827 for 78s. Features white brush; white with silver handle. Output 0.9 mV/cm/sec; FR 10-25,000 Hz (individually calibrated to 20,000 Hz); balance/sep (1 kHz) ± 1 dB/35 dB; tracking force 0.75-1.25 g. Weight with brush 5.7 g . . . \$180

681EEE Mk II-S Phono Cartridge

Induced-magnet cartridge with Stereohedron II stylus shape. Features dynamically improved cantilever assembly. Output 0.7 mV/cm/sec; frequency response 10-22,000 Hz; separation 35 dB at 1,000 Hz; tracking force 1 gram ± .25. Cartridge weight 6.3 grams. . . . \$120

High-Performance P-Mounts

I-847S P Mount Cartridge

P-mount cartridge with Stereohedron stylus. Replacement stylus for D84S. Output 0.7 mV/cm/sec; frequency response 10-36,000 Hz; separation 35 dB; tracking 0.75-1.5 grams. Cartridge weight 5.9 grams. . . . \$198

Stereo Standard P-Mount Series

I-747S Plug-In Cartridge

Features Stereohedron stylus. Replacement stylus D747S. Output 0.9 mV/cm/sec; FR 10-25,000 Hz; sep 35 dB; tracking force 0.75-1.5 g. Cartridge weight 5.7 g. . . . \$138

I-737S Phono Cartridge

Plug-in phono cartridge with Stereohedron stylus. Replacement stylus D73S. Output 0.9 mV/cm/sec; frequency response 10-22,000 Hz; channel separation 35 dB; tracking force 0.75-1.5 grams; channel balance 2 dB. Weight 5.7 grams . . . \$110

I-737E Plug-In Cartridge

Elliptical stylus, 0.3 x 0.7 mil. Replacement stylus D73E. Output 0.9 mV/cm/sec; FR 10-22,000 Hz; sep 35 dB; tracking .75-1.5 g; ch balance 2 dB. Weight 5.7 g. . . . \$93

I-727E P-Mount Cartridge

Plug-in cartridge with 0.4 x 0.7-mil elliptical stylus. Replacement stylus D727E. Output 0.8 mV/cm/sec; FR 10-25,000 Hz; sep 32 dB; tracking force 0.75-1.5 grams. . . . \$90

I-725E P-Mount Cartridge

Cartridge with elliptical stylus. Replacement stylus D71E. Output 0.8 mV/cm/sec; FR 10-22,000 Hz; tracking force 0.75-1.5 g; sep 28 dB; ch balance <2 dB. Weight 5.7 g. . . . \$66

I-720EE P-Mount Cartridge

Elliptical stylus 0.3 x 0.7 mil. Replacement stylus D71EE. Output 0.8 mV/cm/sec; FR 10-20,000 Hz; ch sep 28 dB; tracking 0.75-1.5 g; ch balance 2 dB. Weight 5.7 g . . . \$58

Professional Disco Series

890A1 Phono Cartridge

Cartridge with 0.7 spherical stylus tip and 4-coil body. Made specifically for backcueing, scratch mixing, and slip cueing. Comes with extra stylus. Output 0.76 mV/cm/sec; FR 20-20,000 Hz; bal/sep ± 2/30 dB at 1,000 Hz. . . . \$125

CARTRIDGES & TONEARMS

680SL Phono Cartridge

Cartridge with nude Stereohedron stylus tip and brush. Output 1.1 mV/cm/sec; FR 20-20,000 Hz; balance/sep 2/30 dB; tracking force 3-6 g with brush; load resistance 47,000 ohms; load capacitance 275 pF. Weight 5.5 g. \$109

L680EL Phono Cartridge

For P-mount tonearms; automatically compensates for higher tracking forces. Includes fluorescent-coated stylus. Replacement stylus D6800EL. Output 1.1 mV/cm/sec; FR 20-18,000 Hz; sep 30 dB at 1,000 Hz; tracking force 3.5-4 g. Weight 8.4 g. \$106

680EL Phono Cartridge

0.4 x 0.7 mil elliptical diamond stylus. Replacement stylus D6800EL. Comes with extra stylus. Output 0.82 mV/cm/sec; FR 20-18,000 Hz; balance/sep $\pm 2/30$ dB (1 kHz); tracking force 2-5 g; load imp 47,000 ohms; load capacitance 275 pF. Weight 5.5 g. \$106
680EL-MP. A matched pair of 680EL cartridges factory tested to have the same output levels, ch sep and FR. For 2-turntable setups \$149

681SE Phono Cartridge

0.4 x 0.7 mil elliptical stylus; self-supporting (1 g) brush; replacement stylus D6800SE, D6810 for LPs, D6827 for 78s. Output 1 mV/cm/sec; FR 10-10,000 Hz ± 0.5 dB; balance/sep ± 2 dB/35 dB (1 kHz); tracking force 2-4 g; 10,000 Hz to 20,000 Hz, individually calibrated; load imp 47,000 ohms; load capacitance 275 pF; weight 5.5 g. \$110

680AL Phono Cartridge

0.7 mil spherical stylus tip; comes with extra stylus. Replacement stylus D6800AL. Output 1.1 mV/cm/sec; FR 20-18,000 Hz ± 2 dB; bal/sep $\pm 2/30$ dB (1 kHz); tracking force 2-5 g; load resistance 47,000 ohms; load capacitance 275 pF. Weight 5.5 g. \$90

L500AL Phono Cartridge

P-mount MM cartridge automatically compensates for higher tracking forces required for disco use. Comes with fluorescent-coated stylus; replacement stylus D57PAL. Output 1.0 mV/cm/sec; FR 20-17,000 Hz; sep 28 dB at 1,000 Hz; tracking force 3.5-4 g. Cartridge weight 8.5 g. \$57
500EL. Similar to above except output replacement stylus D5100EL; frequency response 20-18,000 Hz; separation 30 dB at 1,000 Hz; tracking force 2-5 grams. Cartridge weight 5 grams. \$63

500AL Phono Cartridge

0.7 mil spherical stylus. replacement stylus D5107AL. Output 1.0 mV/cm/sec; FR 20-17,000 Hz ± 2 dB; bal/sep $\pm 2/28$ dB (1 kHz); tracking force 3-7 g; load resistance 47,000 ohms; load capacitance 275 pF. Weight 5 g. \$58
500AL-MP. A matched pair of 500AL cartridges factory tested to have the same output level, ch sep and FR. For dual-turntable set-ups \$122

Stereo Standard Series (with "Longhair" Brush)

680EE Phono Cartridge

0.3 x 0.7 mil elliptical diamond stylus D680. Output 0.82 mV/cm/sec; FR 20-20,000 Hz; balance/sep ± 2 dB/35 dB (1 kHz); tracking force 0.75-1.5 g; load imp 47,000 ohms; load capacitance 275 pF. \$83

Broadcast Series, Mark II

500EE Mk II Phono Cartridge

0.3 x 0.7 mil elliptical diamond stylus; replacement stylus D50EE Mk II. Output 1 mV/cm/sec ± 2 dB; FR 10-20,000 Hz; balance/sep $\pm 2/35$ dB (1 kHz); tracking force 0.75-1.5 g. \$60

500E Mk II Phono Cartridge

0.4 x 0.7 mil elliptical diamond stylus; replacement stylus D50E Mk II. Output 1 mV/cm/sec ± 2 dB; FR 10-22,000 Hz; balance/sep $\pm 2/35$ dB (1 kHz); tracking force 1-2 g. Weight 5.5 g. \$55

500A Mk II Phono Cartridge

0.7 mil spherical diamond stylus; replacement stylus D50A Mk II. Output 1 mV/cm/sec ± 2 dB; FR 10-20,000 Hz; balance/sep $\pm 2/35$ dB (1 kHz); tracking force 1-2 g. Weight 5.5 g. \$38



Stanton 890AL

SUMIKO

Kiseki Series

Lapis Lazuli Moving-Coil Phono Cartridge

MC cartridge with hyper-elliptical stylus, made of lapis lazuli. Diamond cantilever. Output 0.4 mV. Cartridge weight 11 g. \$5,600

Agaat Ruby Moving-Coil Phono Cartridge

MC cartridge with hyper-elliptical stylus. Ruby cantilever. Output 0.4 mV; FR 20-50,000 Hz; ch sep 30 dB; tracking force 2 g. Cartridge weight 11 g. \$1,250
Purple Heart Sapphire. As above, sapphire cantilever; sendust armature. Cartridge weight 7.5 g. \$975
Blue Gold. As above, aluminum body; boron overlay cantilever. Cartridge weight 11 g. \$600

Virtuoso Series

Virtuoso DTi Moving-Coil Phono Cartridge

MC cartridge with diamond-titanium cantilever. Van den Hul stylus. Output 1.8 mV; FR 15-32,000 Hz; tracking force 1.8-2.2 g. Cartridge weight 7.5 g. \$1,200
Virtuoso Boron. As above, boron cantilever. \$850

Alchemist Series

Alchemist III SvdH Moving-Coil Phono Cartridge

MC cartridge with samarium-cobalt magnet; zinc body; sapphire rod cantilever and van den Hul stylus. Output 1.8 mV; FR 10-60,000 Hz; ch sep 30 dB; tracking force 1.8-2.2 g. Cartridge wt. 6.7 g. \$495
Alchemist IIB. As above, boron cantilever. FR 15-32,000 Hz; ch sep 35 dB \$475

Alchemist IAT Moving-Coil Phono Cartridge

MC cartridge with aluminum/magnesium cantilever and elliptical stylus. FR 20-40,000 Hz; ch sep 25; tracking force 1.5-2.1 g. Cartridge weight 6.7 g. \$300

Grace Series

Grace F9 Phono Cartridge

MM cartridge with elliptical stylus. Ruby cantilever. Output 2.6 mV; FR 10-60,000 Hz; ch sep 30 dB; tracking force 1.8-2.2 g. Cartridge weight 6.3 g. \$235
Grace F9F. Classic. As above, aluminum cantilever. Output 3.75 mV; FR 10-47,000 Hz; cartridge weight 6 g. \$250

Talisman Series

Talisman SvdH Moving-Coil Phono Cartridge

MC cartridge with van den Hul stylus. Sapphire-tube cantilever. Output 0.26 mV; FR 10-60,000 Hz; ch sep 30 dB; tracking force 1.8-2.2 g. Cartridge weight 6.3 g. \$235

Talisman BvdII. As above, boron cantilever. FR 10-50,000 Hz; tracking force 1.5-2.1 g. \$195
Talisman AT. Similar to above, aluminum/magnesium cantilever and elliptical stylus. Output 0.20 mV; FR 20-40,000 Hz; ch sep 25 dB \$225

Sumiko Blue Point Moving-Coil Phono Cartridge

MC cartridge with elliptical stylus. Standard or P-mount. Output 3 mV; FR 15-35,000 Hz; ch sep 32 dB; tracking force 1.25-1.7 g. Cartridge wt. 5.9 g. \$125

Pearl Phono Cartridge

MM cartridge with elliptical stylus. Output 5 mV; FR 12-30,000 Hz; ch sep 30 dB; tracking force 1.5-2.0 g. Cartridge weight 6 g. \$75

Black Pearl Phono Cartridge

MM cartridge with elliptical stylus. Output 5 mV; FR 18-27,000 Hz; ch sep 28 dB; tracking force 1.5-2.0 g. Cartridge weight 6 g. \$50

Oyster Phono Cartridge

MM cartridge with spherical stylus. Output 4 mV; FR 30-20,000 Hz; ch sep 25 dB; tracking force 1.5-2.5 g. Cartridge weight 5.3 g. \$30

Tonearms

Each of the tonearms have cueing, anti-skating adjustment, and vertical tracking angle adjustment.

SME Series V Straight Tonearm

Pivoted tonearm with 1-piece magnesium casting from headshell to rear of counterweight rails. Features captive ball-race bearings; all silver wiring. Tracking force 0-3g; effective mass 11g; effective length 9 $\frac{1}{2}$ in; overall length 11 $\frac{1}{2}$ in \$2,250
Series IV. Similar to Series V except ABEC-3 bearings; static balanced vertical tracking; manually adjusted arm height. \$1,500

SME 309 Tonearm

Pivoted tonearm with fixed cartridge mount. Tracking force 0-3 g; effective length 9 $\frac{1}{2}$ in; overall length 11 $\frac{1}{2}$ in \$950

Premier FT-4. Pivoted tonearm with fixed mount

features azimuth adjustable damped tube; VTA lift base; silver wiring. Tracking force 0-3 g; effective length 9 $\frac{1}{2}$ in; overall length 12 in \$550
Premier FT-3K. As above, no VTA lift base, off-wire \$395

Premier MMT. Pivoted tonearm with removable shell mount.

Features adjustable azimuth. Tracking force 0-3 g; effective length 9 $\frac{1}{2}$ in; overall length 12 in. \$290

SYSTEMDEK

TA-1 Tonearm

Pivoted tonearm with fixed cartridge mount. Cueing, anti-skate, adjustable vertical tracking angle, pivot-stylus distance 11 $\frac{1}{4}$ in. Tracking force 1-3 g; cartridge weight range 3-10 g; cable capacitance 300 pF; mounting hole diameter 1-0.5 in \$200

TECHNICS

EPC-205CMK4 Phono Cartridge

Ultra-low-mass-cantilever P-mount cartridge with 0.2 x 0.7 mil elliptical nude diamond and neodymium magnet. Output 2.5 mV at 5 cm/sec; sep 25 dB at 1,000 Hz; tracking force 1.25 g ± 0.25 g; cartridge weight 6 g; effective moving mass 0.019 mg \$250
EPC-205CMK4. Regular mounting \$280

EPC-P310 MCMK2 Moving-Coil Phono Cartridge

0.2 x 0.7 nude diamond stylus and ultra-low-mass cantilever. Features neodymium magnet; coreless twin ring coils. Output 1.2 mV at 5 cm/sec; sep 25 dB at 1,000; tracking force 1.25 g ± 0.25 g; cartridge weight 6 g; 0.139 mg boron cantilever \$200

CARTRIDGES & TONEARMS

EPC-P550 Phono Cartridge

Output 2.5 mV at 5 cm/sec; sep 25 dB at 1,000 Hz; tracking force range 2.5 g ± 0.25 g; cartridge weight 6 g \$140

EPC-P540 Phono Cartridge

Output 2.5 mV cm/sec; sep 25 dB at 1,000 Hz; tracking force 1.25 ± 0.25 grams; cartridge weight 6 grams \$110

EPC-P530 Phono Cartridge

Output 2.5 mV at 5 cm/sec; sep 25 dB at 1 kHz; tracking force 1.25 ± 0.25 grams; cartridge weight 6 grams \$80

Tonearm

EPA 250 S-Shaped Tonearm

Dynamically balanced tonearm with decoupled counterweight. Tracking force range 0-2 g; effective mass 14 g; stylus overhang 15 mm; overall length 343 mm; effective length 250 mm; tracking error +1°6' (inner groove), +2°6' (outer groove) \$800

VANDENHUL

Moving-Coil Phono Cartridges

The generator, suspension, super-hardened boron cantilever, and stylus are designed by A.J. van den Hul and appear in the following cartridges. Aluminum housing has reference lines for adjustments and each cartridge comes with a 2-point alignment gauge and a spirit-level balance to adjust azimuth; mounting holes are threaded for quick set up.

MC-Two Moving-Coil Phono Cartridge

Does not need an MC preamp. Output 2mV; tracking 1-1.3g \$1,475

MC-One Moving-Coil Phono Cartridge

For use with high-performance preamps. Receives more precision tuning than the MC-10 and the cantilever of the MC-One returns to its original position after excursion faster than the MC-10; fast action/reaction between stylus/record groove. Output 0.6mV; tracking force 1.3-1.5g \$1,075 Available in 47 kilohm \$1,175

MC-10 Moving-Coil Phono Cartridge

For use with a moderate output preamp. Output 0.5mV; tracking force 1.3-1.5g \$775 Available in 47 kilohm \$875

Retipping and Upgrading

Available for all of the above \$389-\$1,088

VECTOR RESEARCH

VPM-105 Phono Cartridge

Diamond stylus; dual moving-magnet; low mass; pre-mounted in VT185 head shell \$60

VPM-103 Phono Cartridge

Diamond stylus; dual moving-magnet; low mass; plug-in P-mount T4P \$50

YAMAHA

MC-100 Moving-Coil Phono Cartridge

Features cross-matrix air-core moving-coil system;

The listings are based on data provided by the manufacturers. For more product information, contact an authorized dealer or the manufacturer directly. Manufacturers' addresses and phone numbers are listed in the directory beginning on page 258.

pure beryllium tapered tubular cantilever; distinctive metal housing for high magnetic flux density; original equalizing damper; high-energy samarium cobalt magnet. 0.5 lb. \$300

MC-501 Moving-Coil Phono Cartridge

Moving-coil phono cartridge with cross-matrix system. Features aluminum-tapered tubular cantilever; Low Temperature Dependency (LTD) equalizing damper; sendust core; resonance-free one-piece housing. Weight: 0.5 lb \$150

MC-10 Low/High Output MC Phono Cartridge

Features cross-matrix moving-coil system; aluminum-tapered tubular cantilever; original equalizing damper; metal housing assembly; one point suspension. 0.5 lb \$120

MC-21 MC/MM Phono Cartridge

Features MC/MM phono input compatibility; cross-matrix moving-coil system; aluminum tapered tubular cantilever; original equalizing damper; resonance free one-piece housing. 0.5 lb \$70

Illinois audio

12 E. DELAWARE PLACE • CHICAGO, IL 60611

(312) 664-0020 • SAVE MONEY, TIME AND FREIGHT ON FAMOUS BRAND STEREO EQUIPMENT • 800-624-8042



JVC RX-701VBK Surround Sound Receiver

- AM FM Stereo Digital Receiver • 160 Watts (80+2) • Dolby Surround Sound
- Built In Synthesizer Tuner • 40 Memory Presets • 7 Band EQ • 2 PR Sp-Quad Connections

CALL FOR PRICE



JVC XLM701BK CD Multi-Changer

- 6 • 1 CD Changer Player • Remote Control • Random Access Program up to 32 steps • 18 bit DAC • 4x oversampling • Digital Filter

CALL FOR PRICE



TECHNICS SLP300 Multi-Disc CD Changer

- Programmable 6-Disc Changer • Player • 36 Step Random Access Program • Quadruple Oversampling Digital Filter • High Resolution Laser Pick-Up

List \$329.95 SALE: \$229.95



TEAC AD-4 CD Player / Cassette Deck Combo

- Remote Control of CD player and cassette deck • 16-track random program dubbing and play • Dolby B & C • Auto reverse rec. play • Synchro start dubbing

List \$599.95 SALE: \$275.00



TEAC V-285CHX Stereo Cassette Deck

- Dolby B & C & HX PRO NR • Bias Free Tuning • Full Auto Stop Mech • Metal Tap Comp. Pat. • 3 Pos. Tape Select • 3 Digt. Tape Counter

List \$149.95 SALE: \$99.95



TECHNICS SLP999 Remote Controlled CD Player with the works!

- 20 bit • 32 Track programmable 1 ty • 8x over-sampling • 4 DACs • Peak level control • A/B Repeat Auto Level • 3 CD capable • Edit guide • Music Scan

CALL FOR PRICE



TECHNICS SL-PC20 Rotary Compact Disc Changer

- Change discs during play with top loading 5-disc • rotary design • Completely program mable • repeat and random play for 5 discs • Multi-function 25 key wireless remote control • Quadruple oversampling • 20 step random access programming

CALL FOR PRICE



SHARP DX-770 Compact Disc Digital Audio Player

- 3 Beam laser pick-up • Random access programmable memory—up to 20 selection • Cue & Review • Remote Control

List \$269.95 SALE: \$139.95

BLANK AUDIO TAPE

MAXELL XLII-100—100 minutes perfect for CD recording • Improved performance hi bias 10 for \$24.95

TDK SAX 90—Super Avilyn High Bias 10 for \$20.99

SONY UX-PRO—Top of the line cassettes • Ultimate hi bias 10 for \$24.89

TDK SA76—Super high resolution • Super avilyn • Anti-Resonance 10 for \$17.95

MAXELL XL-II590—Extended range hi bias cassette 10 for \$23.95

MAXELL MX-90—Perfect for digital recordings—Metal particle 10 for \$28.95

PHONO CARTRIDGES

SHURE M110HE—High fidelity high trackability P Mount cartridge \$36.50

AUDIO TECHNICA AT-132EP—High performance P Mount cartridge \$59.95

SHURE V15-VMR—Micro ridge standard mount cartridge \$129.95

STEREO HEADPHONES

SONY MDR CD-6—Adjustable closed-ear digital ready \$79.00

SENNHEISER HD480—Digital • Open Air Design • CD Perfect List \$99.00 Sale: \$69.95

KOSS SST-7—The best Open air light comfortable digital ready \$44.95



16 YEARS OF MEETING THE NATION'S STEREO NEEDS WITH THE ABSOLUTE BEST PRICES ON TOP NAME NATIONAL BRANDS Call Mon. thru Sat. 10 to 5 (312) 664-0020 • 1 (800) 624-8042

Prices in this ad are for mail-order only. Freight charges not included in prices. All merchandise shipped brand new, factory fresh with full warranty. Not responsible for typographical errors.



— Send for Free Price List! —

Name _____
Address _____
City _____ State _____ Zip _____
Phone (_____) _____

*NOTE This is just a partial listing of extensive inventory. please call for quotes on additional items or fill out and return the attached price list request!

SPEAKERS



ACOUSTAT

Spectra Series

Spectra 66 Electrostatic Speaker

Speaker utilizing six electrostatic elements and Symmetric Pair Electrically Curved Transducer (SPECTRA); each speaker contains a narrow-line source sector operating at all frequencies, adjacent sectors handle midrange and low frequencies, and the remaining panel area reproduces bass only. Power handling >100 W/ch; nom imp 4 ohms. Dark oak finish and black, beige, charcoal gray, or light gray grille; natural oak or black oak finish at additional cost. 33¼ x 94 x 17 in. \$5,500/pr

Spectra 44 Electrostatic Speaker

Speaker utilizing six electrostatic elements and Symmetric Pair Electrically Curved Transducer (SPECTRA); each speaker contains a narrow-line source sector operating at all frequencies, adjacent sectors handle midrange and low frequencies, and the remaining panel area reproduces bass only. Recommended amplifier power >100 W/ch; nom imp 4 ohms. Dark oak finish and black, beige, charcoal gray, or light gray grille. Also natural oak or black oak finish at additional cost. Dimensions: 23 x 94 x 17 in. \$3,300/pr

Spectra 33 Electrostatic Speaker

Speaker utilizing electrostatic elements and Symmetric Pair Electrically Curved Transducer (SPECTRA); each speaker contains a narrow-line source sector operating at all frequencies, adjacent sectors handle midrange and low frequencies, and the remaining panel area reproduces bass only. Compatible with the SPW-1 woofer, crossover at 100 Hz. Recommended amplifier power >100 W/ch; nom imp 4 ohms. Dark oak finish and black, beige, or gray grille; natural oak or black oak finish at additional cost. 33¼ x 66 x 17 in. \$2,250/pr

Spectra 22 Electrostatic Speaker

Speaker utilizing electrostatic elements and Symmetric Pair Electrically Curved Transducer (SPECTRA); each speaker contains a narrow-line source sector operating at all frequencies, adjacent sectors handle midrange and low frequencies, and the remaining panel area reproduces bass only. Compatible with the SPW-1 woofer, crossover at 100 Hz. Recommended power >100 W/ch; nom imp 4 ohms. Dark oak finish and black, beige, or gray grille; natural oak or black oak finish at additional cost. 23 x 66 x 17 in. \$1,850/pr

SPW-1 Spectra Woofer 1

Passive woofer designed for use with Spectra 22/33. Utilizes four 6½-in side firing woofers (2 per channel) in a ported enclosure; 100 Hz crossover; fuses and switch allowing optional bi-amplification with electronic crossovers. Power handling >100 W/ch; nom imp 12 ohms. 23 x 20 x 17 in. \$600 ea

Spectra Systems

Spectra 33 + SPW1. See above \$2,850
Spectra 22 + SPW1. See above \$2,450

Optional finish. Light oak or black oak bases for the above. \$75

Medallion Series

Model 1+1 Electrostatic Speaker

Full-range electrostatic speaker features coherent line source array. Recommended amplifier power >100 watts/channel; nominal impedance 4 ohms. Teak laminate finish and black, gray, or beige grille, optional finishes at additional cost. Dimensions: 16 x 94 x 17 in. \$1,750/pr

Model 1 Electrostatic Speaker

Electrostatic speaker utilizes a 10-in dual voice coil floor-firing woofer for extended low frequency. Recommended amplifier power >100 watts/channel; nominal impedance 4 ohms. Teak laminate finish and black, gray, or beige grille, optional finishes at additional cost. Dimensions: electrostatic speaker - 16 x 72 x 17 in, woofer cube - 18½ x 20¾ x 18½ in. \$2,450/pr

Optional finish. Walnut, oak, rosewood, and gloss black laminate for the above. \$75

ACOUSTIC INTERFACE

All Acoustic Interface speakers have a 15-year limited warranty.

Sound Prism 3-Way Powered Speaker

Vented-horn speaker with 24 x 52-in compression woofer, 13 x 22-in horn midrange, 7¼ x 3-in horn tweeter, built-in triamplification (1,500 W/woofer, 300 W/midrange, 100 W/tweeter). Features infrared or fiber-optic transmitter from preamplifier to speaker; ultra-fast tweeter transient overload protection; over-voltage, over-current, thermal overload, clipped and DC signal protection. Midrange, tweeter level controls; oiled walnut or oak. FR 10-20,000 Hz ± 1 dB; sens 105 dB SPL/W/m; .09% THD at 100 dB from 10-20,000 Hz; crossovers 550 and 5,000 Hz; imp 8 ohms; 80 x 27 x 36 in; 500 lb ea \$30,000/pr

Sound Portal 3-Way Speaker

Vented-horn speaker with 24 x 32-in compression woofer, 19 x 7-in horn midrange, 5 x 5-in horn tweeter. Features ultra-fast tweeter transient overload protection; midrange, tweeter-level controls; oiled walnut or oak cabinet. FR 15-20,000 Hz ± 2.5 dB; 0.1% THD at 100 dB from 15-20,000 Hz; crossovers 800 and 5,000 Hz; sens 101 dB SPL/W/m; min power 15 W; imp 8 ohms; 60 x 25½ x 24 in; 175 lb ea. \$10,000/pr

Studio Reference 3-Way Speaker

Vented speaker with 12-in woofer, 15 x 4-in horn midrange; 5¼ x 2-in horn tweeter. Features ultra-fast tweeter transient overload protection; midrange, tweeter-level controls; oiled walnut or oak cabinet; black cloth grille. Frequency response 22-20,000 Hz ± 2.5 dB; 0.3% total harmonic distortion at 100 dB from 22-20,000 Hz; crossovers 880 and 5,000 Hz; sensitivity 98 dB SPL/W/m; min power 15 W; imp 8 ohms; 48 x 18½ x 16 in; 102 lb ea \$3,180/pr

Tremor Subwoofer

Vented subwoofer with 2 woofers in separate subenclosures. Features oiled walnut or oak cabinet; black cloth grille. FR 29-200 Hz ± 2.5 dB; 1% THD at 100 dB; sens 96 dB SPL/W/m; min power 15 W; imp 8 ohms; 27 x 63½ x 16 in; 150 lb \$1,090 ea
With 800 W/ch x 2 internal amplification \$1,790 ea

Professional Series II 3-Way Speaker

Vented speaker with 12-in woofer, 2-in dome midrange; 1-in dome tweeter. Features midrange and tweeter controls; oiled walnut or oak cabinet; black cloth grille. FR 29-20,000 Hz ± 2.5 dB; 1% THD at 100 dB from 29-20,000 Hz; crossovers 800 and 6,600 Hz; sens 95 dB SPL/W/m; min power 15 W; imp 8 ohms; 36 x 18½ x 16 in; 80 lb ea \$1,780/pr

Transcendent 2-Way Speaker

Vented speaker with 12-in woofer, 1¼-in dome midrange/tweeter. Features midrange, tweeter-level controls; oiled walnut or oak cabinet; black cloth grille. FR 38-20,000 Hz ± 2.5 dB; 1% THD at 100 dB from 38-20,000 Hz; crossover 1,900 Hz; sens 94 dB SPL/W/m; min power 15 W; imp 8 ohms; 24 x 16 x 14½ in; 51 lb ea \$980/pr

Intimate 2-Way Speaker

Acoustic-suspension speaker with 10-in woofer, 1-in dome tweeter. Tweeter level control; oiled walnut or oak cabinet; black cloth grille. FR 49-20,000 Hz ± 2.5 dB; 2% THD at 100 dB from 49-20,000 Hz; crossover 5,000 Hz; sens 93 dB SPL/W/m; min power 15 W; imp 8 ohms; 19 x 12 x 12 in; 29 lb ea \$580/pr

Shadow 2-Way Speaker

Acoustic-suspension speaker with 8-in woofer, 1-in dome tweeter. Features cylindrical cabinet covered with black cloth grille. FR 69-20,000 Hz ± 2.5 dB; 2% THD at 100 dB from 69-20,000 Hz; crossover 5,000 Hz; sens 91 dB SPL/W/m; min power 15 W; imp 8 ohms; 24½ high x 8¾ in diameter \$380/pr

Angstrom 2-Way Speaker

Acoustic-suspension speaker with 6½-in woofer, 1-in dome tweeter. Features charcoal enamel cabinet; black cloth grille. FR 78-20,000 Hz ± 2.5 dB; 2% THD at 100 dB from 78-20,000 Hz; crossover 5,000 Hz; sens 90 dB SPL/W/m; min power 15 W; imp 8 ohms. 12¾ x 7½ x 6½ in; 9 lb/ea; walnut or oak \$350/pr
Charcoal-enamel finish \$250/pr

ACOUSTIC RESEARCH

TSW-A Series

All TSW-A series speakers feature drivers in a vertical array with Acoustic Blanket for precise stereo imaging and polypropylene woofer and midrange drivers.

TSW 910-A 4-Way Speaker

Floor-standing acoustic-suspension column speaker with Tetra-Helix tweeter mounting plate. Features two 12-in woofers (one front-firing, one rear-firing); 8-in lower-midrange driver; two 6½-in midranges; 1-in titanium-dome liquid-cooled tweeter with acoustic lens; split crossover network. Power range 35-400 W; imp 4 ohms; FR 28-32,000 Hz. -3 dB; crossover

SPEAKERS

point 200, 550, 5,500 Hz; sens 90 dB with 2.83 V rms input at 1 meter on axis. Solid walnut or oak top and bottom with cloth-covered and black-vinyl-veneer cabinet and black cloth grille. 52 $\frac{3}{4}$ x 15 $\frac{3}{4}$ x 18 $\frac{1}{2}$ in; 140 lb \$2,200/pr

TSW 810-A 3-Way Speaker

Floor-standing acoustic-suspension column speaker with Tetra-Helix tweeter mounting plate. Features two 10-in woofers (one front-firing, one rear-firing); two 6 $\frac{1}{2}$ -in midranges; 1-in titanium-dome liquid-cooled tweeter with acoustic lens; split crossover network. Power range 25-250 W; imp 4 ohms; FR 33-32,000 Hz, -3 dB; crossover point 350, 4,000 Hz; sens 90 dB with 2.83 V rms input at 1 meter on axis. Solid walnut or oak top and bottom with cloth-covered and black-vinyl-veneer cabinet and black cloth grille. 42 $\frac{3}{4}$ x 15 $\frac{3}{4}$ x 18 $\frac{1}{2}$ in; 95 lb .. \$1,700/pr

TSW 710-A 3-Way Speaker

Floor-standing acoustic-suspension column speaker with Tetra-Helix tweeter mounting plate. Features two 8-in filled polypropylene cone long-throw woofers; 6 $\frac{1}{2}$ -in filled polypropylene cone midrange in its own subenclosure; $\frac{3}{4}$ -in titanium-dome liquid-cooled tweeter. Power range 15-175 W; imp 4 ohms; FR 40-40,000 Hz, -3 dB; crossover point 250, 5,000 Hz; sens 90 dB SPL with a 2.83 V rms drive level input at 1 meter on axis. Solid American hardwood top and bottom (walnut or oak) with black-vinyl-veneer cabinet and black cloth space frame grille. 38 $\frac{1}{2}$ x 14 $\frac{3}{8}$ x 13 $\frac{3}{8}$ in; 46 lb \$1,300/pr

TSW 610-A 3-Way Speaker

Floor-standing acoustic-suspension speaker with Tetra-Helix tweeter mounting plate. Features 12-in woofer; 6 $\frac{1}{2}$ -in midrange; $\frac{3}{4}$ -in titanium-dome liquid-cooled tweeter with acoustic lens. Power range 15-175 W; imp 4 ohms; FR 40-40,000 Hz, -3 dB; sens 90 dB with 2.83 V rms input at 1 meter on axis. Solid walnut or oak top and bottom with black-vinyl-veneer cabinet and black cloth grille. 32 $\frac{3}{8}$ x 14 x 13 $\frac{3}{4}$ in; 57 lb \$1,000/pr

TSW 510-A 3-Way Speaker

Floor-standing acoustic-suspension speaker with Tetra-Helix tweeter mounting plate. Features 10-in woofer; 6 $\frac{1}{2}$ -in midrange; $\frac{3}{4}$ -in titanium-dome liquid-cooled tweeter with acoustic lens. Power range 15-150 W; imp 4 ohms; FR 44-40,000 Hz, -3 dB; sens 90 dB with 2.83 V rms input at 1 meter on axis. Solid walnut or oak top and bottom with black-vinyl-veneer cabinet and black cloth grille. 30 $\frac{3}{8}$ x 14 x 13 $\frac{3}{4}$ in; 49 lb \$800/pr

TSW 415-A 3-Way Speaker

Floor-standing acoustic-suspension speaker. Features two 8-in polypropylene woofers and a $\frac{3}{4}$ -in nitrogen-fired titanium dome liquid-cooled tweeter. Power handling 15-150 W; imp 6 ohms; FR 44-40,000 Hz, -3 dB; sens 90.5 dB SPL; crossover point 150, 3,800 Hz. Top and bottom with black-vinyl-veneer cabinet and black cloth grille. 29 $\frac{1}{2}$ x 12 $\frac{3}{8}$ x 11 $\frac{3}{4}$ in; 31 lb, 8 oz \$720/pr

TSW 410-A 3-Way Bookshelf Speaker

Bookshelf acoustic-suspension speaker with Tetra-Helix tweeter mounting plate. Features 8-in woofer; 6 $\frac{1}{2}$ -in midrange; $\frac{3}{4}$ -in titanium-dome liquid-cooled tweeter with acoustic lens. Power range 10-100 W; imp 4 ohms; FR 46-40,000 Hz, -3 dB; sens 89 dB with 2.83 V rms input at 1 meter on axis. Solid walnut or oak top and bottom with black-vinyl-veneer cabinet and black cloth grille. 24 $\frac{1}{2}$ x 12 $\frac{1}{4}$ x 11 $\frac{3}{4}$ in; 30 lb, 8 oz \$600/pr

TSW 315-A 3-Way Bookshelf Speaker

Bookshelf acoustic-suspension speaker with Tetra-Helix tweeter mounting plate. Features 6 $\frac{1}{2}$ -in woofer; 6 $\frac{1}{2}$ -in woofer/midrange; $\frac{3}{4}$ -in titanium-dome liquid-cooled tweeter with Tetra-Helix mounting plate. Power range 10-100 W; imp 4 ohms; FR 48-40,000 Hz, -3 dB; crossover point 450, 3,800 Hz; sens 89 dB

with 2.83 V rms input at 1 meter on axis. Solid walnut or oak top and bottom with black-vinyl-veneer cabinet and black cloth grille. 22 $\frac{1}{2}$ x 12 $\frac{1}{4}$ x 11 $\frac{3}{4}$ in; 30 lb, 8 oz \$550/pr

TSW 310-A 2-Way Speaker

Acoustic-suspension speaker with Tetra-Helix tweeter mounting plate. Features 10-in woofer; $\frac{3}{4}$ -in titanium-dome liquid-cooled tweeter with acoustic lens. Power range 10-100 W; imp 6 ohms; FR 45-40,000 Hz, -3 dB; sens 90 dB with 2.83 V rms input at 1 meter on axis. Solid walnut or oak top and bottom with black-vinyl-veneer cabinet and black cloth grille. 27 $\frac{3}{4}$ x 12 $\frac{1}{4}$ x 11 $\frac{3}{4}$ in; 35 lb, 8 oz \$540/pr

TSW 215-A 3-Way Bookshelf Speaker

Bookshelf acoustic-suspension speaker. Features two $\frac{5}{8}$ -in-polypropylene woofer and a $\frac{3}{4}$ -in nitrogen-fired titanium-dome liquid-cooled tweeter. Power handling 10-75 W; imp 6 ohms; FR 72-40,000 Hz, -3 dB; sens 88 dB SPL; crossover point 5,000 Hz. Hardwood top and bottom (oak or walnut) with black-vinyl-veneer cabinet and black cloth grille. 20 x 9 $\frac{7}{8}$ x 8 $\frac{3}{8}$ in; 17 lb \$430/pr

TSW 115P 2-Way Powered Speakers

Fully self-contained powered speakers with shielded drive units for video system capability. Features 4-in filled polypropylene cone acoustic-suspension woofer with electronic bass extension equalization. $\frac{3}{4}$ -in titanium-dome liquid-cooled shielded tweeter with Tetra-Helix mounting plate. Power on/off LED power on indicator; volume control; input/output panel with two DIN plug for audio output to accessory speaker, and stereo receptacle for audio input. Solid walnut or oak top and bottom with black-vinyl-veneer cabinet and black cloth grille. 10 $\frac{1}{2}$ x 7 x 6 $\frac{7}{8}$ in; 11 lb \$400/pr

TSW 210-A 2-Way Speaker

Bookshelf acoustic-suspension speaker with Tetra-Helix tweeter mounting plate. Features 8-in woofer; $\frac{3}{4}$ -in titanium-dome liquid-cooled tweeter with acoustic lens. Power range 10-100 W; imp 8 ohms; FR 54-40,000 Hz, -3 dB; sens 87 dB with 2.83 V rms input at 1 meter on axis. Solid walnut or oak top and bottom with black vinyl-veneer cabinet and black cloth grille. 17 $\frac{3}{8}$ x 9 $\frac{3}{4}$ x 8 $\frac{3}{8}$ in; 15 lb, 5 oz .. \$380/pr

TSW 110-A 2-Way Speaker

Bookshelf acoustic-suspension speaker with Tetra-Helix tweeter mounting plate. Features 6 $\frac{1}{2}$ -in woofer; $\frac{3}{4}$ -in titanium-dome liquid-cooled tweeter with acoustic lens. Power range 10-75 W; imp 8 ohms; FR 68-40,000 Hz, -3 dB; sens 88 dB with 2.83 V rms input at 1 meter on axis. Solid walnut or oak top and bottom with black-vinyl-veneer cabinet and black cloth grille. 15 x 9 $\frac{3}{4}$ x 8 $\frac{3}{8}$ in; 14 lb \$280/pr

Spirit Series

Model 162 3-Way Speaker

Acoustic-suspension, three-way with dual coupled woofer. Features carbon-loaded polypropylene woofer and 1-in treated-cloth dome liquid-cooled tweeter; Dual-density baffle; laminated iron-core chokes crossover to minimize distortion and DC resistance; frameless grille; walnut or black-ash woodgrain vinyl finish. Power handling 10-175 W; FR 45-22,000 Hz, -3 dB; sens 91 dB; imp 4 ohms. 36 $\frac{3}{8}$ x 9 $\frac{3}{8}$ x 13 $\frac{3}{8}$ in; 43 lb, 5 oz \$1,200/pr

Model 142 3-Way Speaker

Features carbon-loaded polypropylene woofer and liquid-cooled tweeter; direct-coupled woofer and mid/woofer; dual-density baffle; frameless grille; acoustic-suspension enclosure. Walnut or black-ash woodgrain vinyl finish. Power handling 10-100 W; FR 52-25,000 Hz, -3 dB; sens 90 dB; imp 4 ohms. 25 $\frac{3}{8}$ x 9 $\frac{7}{8}$ x 11 in; 23 lb, 5 oz \$800/pr

Model 132 2-Way Speaker

Features carbon-loaded polypropylene woofer and

1-in treated-cloth dome liquid-cooled tweeter; direct-coupled woofer; dual-density baffle; frameless grille; acoustic-suspension enclosure. Walnut or black-ash woodgrain vinyl finish. Power handling 10-100 W; frequency response 55-22,000 Hz, -3 dB; sensitivity 90 dB; impedance 8 ohms. 17 $\frac{1}{2}$ x 9 $\frac{3}{8}$ x 10 in; 15 lb, 14 oz \$500/pr

Model 122 2-Way Speaker

Features carbon-loaded polypropylene woofer and liquid-cooled tweeter; direct-coupled woofer; dual-density baffle; frameless grille; acoustic-suspension enclosure. Walnut or black-ash woodgrain vinyl finish. Power handling 10-80 W; FR 62-25,000 Hz, -3 dB; sens 90 dB; imp 8 ohms. 15 $\frac{3}{8}$ x 7 $\frac{1}{2}$ x 8 $\frac{3}{4}$ in; 11 lb, 4 oz \$349/pr

Model 112 2-Way Speaker

Features treated paper woofer and liquid-cooled tweeter; direct-coupled woofer; dual-density baffle; frameless grille; acoustic-suspension enclosure. Walnut or black-ash woodgrain vinyl finish. Power handling 10-60 W; frequency response 65-25,000 Hz, -3 dB; sensitivity 90 dB; impedance 8 ohms. 14 x 7 $\frac{1}{2}$ x 7 $\frac{3}{8}$ in; 9 lb, 4 oz \$289/pr

Partners Series

Pro Partners 2-Way Bookshelf Speaker

Power bookshelf acoustic-suspension speaker. Features a 8-in polypropylene woofer and a 1 $\frac{1}{4}$ -in liquid-cooled cone tweeter. AC/DC inputs; power on/off LED power-on indicator; concentric rotary volume control; 3.5-mm stereo receptacle for audio input; two-pin DIN plug for audio output to passive speaker. Black-vinyl-veneer finish, black cloth grille. 17 lb \$470/pr

Powered Partner 2-Way Powered Speaker

Acoustic-suspension bookshelf speaker with shielded drivers for use with TV and personal stereo systems. Features built-in equalized amp; on/off switch; volume and tone controls; AC/DC inputs; 4-in long-throw woofer; 1 in liquid-cooled tweeter. Can be placed on top or near TV, hung on a pole, mounted on wall, or clamped to a shelf with optional clamps. 15 W continuous with < 1% THD; FR 50-25,000 Hz, \pm 3 dB; crossover point 5,000 Hz. Black aluminum finish. Triangular; 6 x 10 $\frac{1}{2}$ x 7 $\frac{3}{8}$ in; 7 lb ea. \$400/pr

Rock Partner 2-Way Speaker

Acoustic-suspension floor-standing or bookshelf speaker with 8-in long-throw woofer and 1 $\frac{1}{4}$ -in liquid-cooled cone tweeter. Triangular shaped with versatile mounting options. FR 65-22,000 Hz, \pm 3 dB; max power 100 W rms; sens 88 dB SPL/W/m; crossover point 4,000 Hz; imp 8 ohms. Black-vinyl-veneer. 14 $\frac{3}{4}$ x 9 $\frac{1}{2}$ x 8 $\frac{3}{4}$ in; 15 lb ea \$300/pr

Environmental Partner 2-Way Speaker

Weather-resistant acoustic-suspension speaker with triangular shape for versatile mounting options. Features 4-in long-throw polypropylene woofer; 1-in liquid-cooled polymer cone tweeter. Power range 7-75 W; imp 6 ohms; FR 95-25,000 Hz, \pm 3 dB; sens 88 dB SPL/W/m. Diecast aluminum case and endcap. 6 x 10 $\frac{1}{2}$ x 7 $\frac{3}{8}$ in; 6 lb ea \$300/pr

Active Partners 2-Way Speaker

Self-contained powered 2-way speaker system with shielded drive units and versatile mounting system. Features 4-in long-throw woofer and liquid-cooled 2-in tweeter; AC/DC power supply included. Amp power 24 W; FR 60-20,000 Hz; crossover point 5,000 Hz. 5 lb \$270/pr

Fun Partners 2-Way Speaker

Features a 4-in polypropylene woofer and 1-in liquid-cooled polymer cone tweeter. Plastic case; cloth grille available in assorted colors. Power handling 7-75 W; frequency response 90-25,000 Hz, -3 dB, sens 91 dB SPL 1 meter for 2.83 V rms input on cabinet axis; crossover point 4,000 Hz; imp 4 ohms. 4 lb \$200/pr

SPEAKERS

Additional Products

STC 666 Subwoofer/Satellite System

New STC (Series Tuned Cavity) system. The STC subwoofer is small enough to be hidden leaving only the satellites visible. AR's proprietary enclosure uses two tuned cavities in a series configuration. Uses a newly developed set of enclosure parameters to eliminate unwanted high frequencies that would allow the ear to pinpoint the position of the subwoofer. The first cavity works to increase efficiency of the loudspeaker in the bass frequencies and minimizes distortion by limiting woofer excursion near resonance. The second cavity acts as a high-frequency output from the two 6-in woofers. The satellites feature a black cabinet with a choice of oak or walnut wood trim. Satellites have shielded drivers for use in video systems \$580/system

ARIMS 2-Way Miniature Speaker

Acoustic-suspension speaker with rigid deep-drawn aluminum cabinet. Threaded inserts on rear allow multiple mounting options. 4-in cone woofer; 1-in dome tweeter. Frequency response 95-25,000 Hz, ± 3 dB; power range 7-75 W; sensitivity 95 dB SPL/W/m; impedance 4 ohms. Satin black finish. Dimensions: 7 $\frac{3}{4}$ x 4 $\frac{3}{4}$ x 4 $\frac{3}{4}$ in; 4 lb, 8 oz. \$280/pr

ADC

Soundshaper 3025 Subwoofer/Satellite System

2-way model 3010 bookshelf size speaker and model 3015 subwoofer. Model 3010 features 4-in woofer and 1/2-in dome tweeter; ferrofluid-cooled tweeter; wall-mounted bracket. FR 85-24,000 Hz ± 3 dB; sens 88 dB ± 1 dB SPL W/m; imp 6 ohms; power handling 50 W rms, 150 W max; crossover point 5000 Hz. Model 3015 subwoofer features 8-inch bass enhancement. FR 41-165 Hz ± 3 dB; sens 88 dB ± 1 dB SPL W/m; imp 4 ohms $\pm 10\%$; power handling 50 W rms, 150 W max; crossover point 110 Hz. Satellites 11 x 7 5/8 in, 5 1/2 lb; subwoofer 11 x 7 1/2 x 17 in, 15 1/2 lb. \$500
Soundshaper 3010 2-Way Speaker. Satellite pair from above listing \$270
Soundshaper 3015 Subwoofer. Subwoofer from model 3025 system \$230

a/d/s/

Monitor Series

M15 3-Way Speaker

Vertically aligned "unison" drivers (two 10-in woofers and 5 1/4-in midrange in separate subenclosure, 1-in dome tweeter); woofers near floor, midrange at top, to control boundary effects; copolymer diaphragms; 4th-order (24 dB per octave) Linkwitz-Riley crossovers at 200 and 2,000 Hz; stainless-steel voice-coil former; magnetic cooling fluid in midrange and tweeter for high power handling and dynamic linearity; frameless perforated-steel grilles; walnut veneer or black finish. Power handling 300 W max; FR 26-22,000 Hz, ± 3 dB; sens 87 dB SPL/W/m; imp 4 ohms. 47 1/4 x 11 1/2 x 15 3/4 in; 110 lb. \$2,600/pr
M12. Similar to M15 except 8 1/2-in woofers. Power handling 250 W max; FR 34-22,000 Hz, ± 3 dB; sens 87 dB SPL/W/m; 43 1/4 x 10 1/2 x 14 1/4 in; 83 lb \$1,600/pr
M9. Similar to M12 except 1 1/2-in midrange and one 8 1/2-in woofer; crossover at 700 Hz and 6,000 Hz. Power handling 150 W max FR 38-22,000 Hz, ± 3 dB. 33 3/4 x 11 1/2 x 13 in; 40 lb. \$1,100/pr

Compact Monitor Series

CM7 3-Way Speaker

Features 7 3/4-in woofer, 1 1/2-in dome midrange, 1-in dome tweeter; copolymer diaphragms; 4th-order Linkwitz-Riley crossovers at 700 and 2,000 Hz; voice-coil formers of stainless steel for woofer and Kapton for midrange and tweeter; magnetic cooling fluid in midrange and tweeter for high power handling and dynamic linearity; enclosure molded from polymer resin filled with metallic mineral for

high density and inertness; frameless perforated steel grille; black or white finish. Power handling 150 W max; FR 40-20,000 Hz, ± 3 dB; sens 87 dB SPL/W/m; imp 4 ohms; 16 3/8 x 8 3/4 x 10 7/8 in; 38 lb. \$1,400/pr
CM6. Similar to CM7 except 2-way, with 6-in woofer and 1-in tweeter; power handling 100 W max; 2,000-Hz crossover. FR 50-22,000 Hz, ± 3 dB; 12 3/4 x 7 1/4 x 8 7/8 in; 22 lb. \$900/pr
CM5. Similar to CM6 except 5-in woofer. Power handling 75 W max; FR 65-22,000 Hz, ± 3 dB; sens 86 dB SPL/W/m; 9 3/4 x 5 3/4 x 6 7/8 in; 14 lb. \$650/pr

1.9e 3-Way Bookshelf Speaker

Vertically aligned "unison" drivers (8 1/2-in Stiffite woofer, 1 1/2-in midrange and 1-in soft-copolymer dome tweeter); woofer is driven by wet wound, two layer, oxygen-free copper voice coil wound on stainless-steel former; tweeter is driven by oxygen-free copper voice coil wound on Kapton former, high magnetic cooling fluid for efficient thermal transfer; Linkwitz-Riley crossover at 2,000 Hz. Glass fiber damping, acoustic suspension enclosure with diffraction-corrected front baffle and flush driver mounting construction; black fabric ABS grille; walnut veneer or matte black laminate finish. Power handling 125 W max; frequency response 38-22,000 Hz, ± 3 dB; sens 92 dB SPL/W/m; imp 4 ohms; 21 3/8 x 11 3/8 x 10 1/4 in; 40 lb. \$800/pr

1.8e 2-Way Bookshelf Speaker. Similar to above, lacks midrange driver. Walnut or matte-black laminate finish. Power handling 125 W max; FR 44-22,000 Hz, ± 3 dB; sens 91 dB SPL/W/m; imp 4 ohms; 19 3/4 x 11 3/8 x 10 1/4 in; 25 lb. \$600/pr

1.7e 2-Way Bookshelf Speaker. Similar to above except 7 3/4-in woofer, Matte-black finish. Power handling 100 W max; FR 46-22,000 Hz, ± 3 dB; sens 89 dB SPL/W/m; imp 4 ohms; 17 1/8 x 10 x 9 1/8 in; 19 lb. \$500/pr

Miniature Speakers

Model 300CC 2-Way Speaker

5 1/4-in long-excursion acoustic-suspension Stiffite woofer, 1-in soft-dome tweeter. Features aluminum enclosure (black textured urethane with convex-steel grille). Available on special order in 6 custom colors with matching grilles and brackets (black, light grey, dark grey, beige, mocha, white). Power handling 75 W max; FR 75-20,000 Hz, ± 3 dB; crossover 2,500 Hz with 12 dB/octave slope; sens 88 dB SPL/W/m; imp 4 ohms. 8 3/8 x 5 7/8 x 5 3/4 in. \$430/pr

Model 200CC 2-Way Acoustic-Suspension Speaker

4-in long-excursion woofer, 1-in soft-dome tweeter; brushed-aluminum enclosure (textured urethane with convex-steel grille). Available on special order in six custom colors with matching grilles and brackets (black, light grey, dark grey, beige, mocha, white). Power handling 50 W max; frequency response 95-20,000 Hz, ± 3 dB; crossover 2,500 Hz with 12 dB/octave slope; sens 86 dB SPL/W/m; imp 4 ohms. 6 7/8 x 4 1/4 x 4 3/4 in. \$330/pr

Subwoofer Systems

SWS Powered Subwoofer

12-in subwoofer features an electronic crossover network and a dedicated 350-W bass amplifier. Linkwitz-Riley crossover with adjustable crossover points; built-in level control allows the output to be matched to the satellite speakers. \$1,000

SW4 Subwoofer

10-in subwoofer designed to extended the range of a/d/s/ Compact Monitors. Passive bandpass filtering circuitry; dual tuned enclosure \$600

SW2 Subwoofer. Similar as above. Designed to fit between floor or ceiling. \$400

ADVENT

The Advent Maestro 3-Way Speaker

Acoustic-suspension floor-standing speaker with 10-

in black cone and surround woofer, 2-in mica-filled black polypropylene-dome midrange in subenclosure, and 1-in ferrofluid-filled soft-dome tweeter. Features solid-pecan top and base with beveled edges, anti-diffraction baffle cover, and grille with rounded side edges. Power range 150-750 watts rms; frequency response 40-23,000 Hz ± 2.5 dB; sensitivity 90 dB SPL/W/m; impedance 6 ohms. 33 1/4 x 16 x 9 3/4 in; 50 lb. \$700/pr

The Advent Legacy 2-Way Speaker

Acoustic-suspension floor-standing speaker with 10-in high-excursion cone woofer with aluminum-coil form; 1-in ferrofluid-filled soft-dome tweeter. Features solid-pecan top and base with wraparound grille. Min power 100 W rms; FR 42-23,000 Hz ± 3 dB; sens 88 dB SPL/W/m; imp 8 ohms. Black texture vinyl finish over dense fiberboard. 28 1/4 x 16 x 9 3/4 in; 46 1/2 lb. \$399/pr

Mini-Advent System

Complete compact size subwoofer system which includes the Mini Advent (below) two 5 1/4-in high-excursion woofers, two 5 1/4-in high-excursion midranges, and two 1/2-in polycarbonate ferrofluid-filled tweeters. Power handling 55 W rms, 165 W peak; FR 60-21,000 Hz ± 3 dB; imp 6 ohms. 7 x 12 x 6 1/2 in; 11 lb. \$180/ea
Total Subwoofer System with Mini Advent... \$380

Advent Prodigy Tower 2-Way Speaker

Floor-standing speaker with 8-in high excursion woofer and 3/4-in polyamide ferrofluid-filled tweeter. Min power 75 W rms. Finished in an oiled solid pecan wood top and base. 28 1/2 x 10 x 8 3/4 in; 25 1/4 lb. \$350/pr

Advent Prodigy II 2-Way Bookshelf Speaker

Bookshelf or floor-standing speaker with 8-in high-excursion woofer and 3/4-in polyimide ferrofluid-cooled soft-dome tweeter. Features solid pecan end-caps. Power handling 75 W rms; FR 45-23,000 Hz ± 3 dB. \$350/pr

Advent Baby II 2-Way Bookshelf Speaker

Bookshelf speaker with 6 1/2-in woofer and 1/2-in polycarbonate ferrofluid-filled hard dome tweeter. Min power 50 W rms; FR 60-21,000 Hz ± 3 dB; imp 6 ohms. Cabinet with oiled solid wood top with black texture vinyl over dense fiberboard. 16 1/2 x 11 x 6 1/4 in; 13 lb. \$250/pr

Mini Advent 2-Way Speaker

Compact-size speaker with 5 1/4-in high-excursion woofer and 1/2-in polycarbonate ferrofluid-filled tweeter. Min power 40 W rms; FR 110-21,000 Hz ± 3 dB; imp 6 ohms. Oiled solid pecan wood top with black foamed polystyrene cabinet. 11 x 6 1/2 x 5 1/8 in; 10 lb. \$200/pr

Indoor/Outdoor Mini Advent 2-Way Speaker

Compact-size weather-resistant speaker with 5 1/4-in high-excursion woofer and 1/2-in polycarbonate ferrofluid cooled tweeter. Compatible with Mini-Advent brackets and subwoofer. Power handling 40 W rms; FR 110-21,000 Hz ± 3 dB. Black molded cabinet. \$200/pr

AIWA

SC-B10 Powered Speakers

Bass reflex design bookshelf speaker. BBE high-EQ control system; independent volume control; flexible angle mounting; magnetic shielding; RCA jacks; 20-m cord. 15 W output; 8 x 5 x 7 in; 5 lb. \$250 ea

ET-700 Speaker

Features 3 drivers in one bookshelf enclosure: a 3 1/2-in driver flanked by two 3 1/8-in drivers. Volume control; magnetic shielding; 6-ft connection cord RCA to mini stereo plug; flexible angle mounting; auto power off. 10 W output; 12 x 5 x 7 1/2 in; 10 lb. \$150 ea

SPEAKERS

ALLISON ACOUSTICS

Prices may be slightly higher in some areas.

IC-20 Image-Control Speaker

Triangular acoustic-suspension tower speaker with 1 side facing wall, 1 side facing in, 1 facing out; each side facing away from wall has 10-in woofer, two 3½-in convex midranges, two 1-in convex tweeters; relative balance of mids and tweeters on each panel may be adjusted by remote control or with switch on rear to direct more sound in (for precise imaging with more direct and less reflected sound), out (for open and spacious ambience with more reflected and less direct sound), left, right, or centered (for equal amplitude at off-center listening positions); level of each panel has 3 possible settings; LED's on center of speaker display setting; inside woofer pointed into cabinet, outside woofer pointing out; separate inputs for woofers and for mids and tweeters for easy bi-amping; auto-resetting resistors in each crossover; cabinet panels ¾-in-1¼-in thick, braced front-to-back and between panels; interior damped with glass fiber; passive parallel half-section crossovers at 350 and 3,750 Hz; Oak, walnut, or black. FR -3 dB at 28.5 Hz, -8 dB at 21 Hz; imp 6 ohms nominal, 8 average, 5 min; power range 30-400 W/ch; sens 87 dB SPL/2.83 V/m; 48 x 21 x 12 in; 100 lb \$5,200/pr

CD9 3-Way Speaker

Stabilized-radiation-loading speaker with 10-in woofer, 3½-in convex-diaphragm midrange, 1-in convex-diaphragm tweeter, designed for placement against single wall. LC half-section crossover network; switches to select system acoustic power response (flat to concert-hall balance slope); walnut or oak-veneer cabinet with hand-rubbed lacquer finish; steel base. FR down 3 dB at 35.5 Hz; crossovers 350 and 3,750 Hz; imp 4 ohms; efficiency 0.7% at floor/wall intersection; power range 30-200 W; 37½ x 12½ x 10½ in \$1,300/pr

CD8 3-Way Speaker

Stabilized-radiation-loading speaker with 8-in woofer, 3½-in convex-diaphragm midrange, 1-in convex-diaphragm tweeter. LC half-section crossover network with switches to select acoustic response from flat to concert-hall slope. Walnut or oak-veneer cabinet with hand-rubbed lacquer finish. Crossover frequencies 450 and 3,750 Hz; efficiency 0.7%; power range 30-200 W; response -3 dB at 39 Hz; 28¾ x 10½ x 10½ in \$950/pr

CD7 2-Way Speaker

Stabilized-radiation-loading speaker with 8-in woofer, 1-in convex-diaphragm tweeter, designed for placement against single wall. LC crossover network with premium chokes, computer-grade capacitors; walnut or oak-veneer cabinet with hand-rubbed lacquer finish. Crossover 2,000 Hz; response -3 dB at 41 Hz; imp 4 ohms; power range 15-150 W; 26½ x 9¾ x 9¾ in \$600/pr
CD6. Same as CD7 except for wall or shelf mounting; FR -3 dB at 46.5 Hz; 11¼ x 11¼ x 11¼ in \$460/pr

MS-205 Subwoofer/Satellite System

Acoustic-suspension system with two satellites with 4-in long-throw woofer, 1-in convex-diaphragm tweeter and one separate bass unit with 8-in woofer and 1½-in dual-winding voice coil. Impedance 4 ohms nom, 3.5 min; low frequency performance -3 dB at 55 Hz; sens 90 dB SPL/2.83 V/m; suggested amplifier power 10-100 W/ch; crossover points at 150 Hz, 2,500 Hz. Satellites 10 x 5 x 5¼ in; woofer 11¼ in \$500/system

AL Series

All AL Series speakers come with a 5-year warranty and the Allison Power Guard circuit, which shuts down the system to prevent thermal failure.

AL-130 3-Way Speaker

Acoustic-suspension speaker with two 8-in push-pull

woofers, 3½-in midrange, 1-in convex-diaphragm tweeter. Power handling up to 200 W with clipping 10% of the time; sens 90 dB SPL/2.83 V/m; imp 4 ohms; crossover points at 100 Hz, 450 Hz, and 4,000 Hz; suggested amplifier power 15-200 W. 37¾ x 12½ x 14¾ in; 57 lb. Oak, walnut; black woodgrain vinyl \$1,100/pr

AL-125 3-Way Speaker

Acoustic-suspension speaker with two 6-in push-pull woofers, 3½-in midrange, 1-in convex-diaphragm tweeter. Power handling up to 200 W with clipping 10% of the time; sens 90 dB SPL/2.83 V/m; imp 4 ohms; crossover points at 100 Hz, 450 Hz, and 4,000 Hz; suggested amplifier power 15-200 W/ch. 30¾ x 11¼ x 11½ in; 40 lb. Oak, walnut, black woodgrain vinyl \$900/pr

AL-120 2-Way Speaker

Acoustic-suspension speaker with two 6-in woofers, 1-in convex-diaphragm tweeter. Power handling 200 W clipping 10% of the time; sens 90 dB SPL/2.83 V/m; imp 4 ohms; crossover points at 100 Hz and 2,000 Hz; suggested amplifier power 15-200 W/ch. 23¾ x 11¼ x 11½ in; 33.2 lb. Oak, walnut, black woodgrain vinyl \$600/pr

AL-115 2-Way Speaker

Acoustic-suspension speaker with 8-in woofer and 1-in convex-diaphragm tweeter. Power handling 150 W clipping 10% of the time; sensitivity 90 dB SPL/2.83 V/m; imp 4 ohms; crossover point 2,000 Hz; suggested amplifier power 15-150 W/ch. Dimensions: 20 x 11¼ x 10 in. Weight: 22 lb. Oak, walnut, black woodgrain vinyl \$440/pr

AL-110 2-Way Speaker

Acoustic-suspension speaker with 6-in woofer and 1-in convex-diaphragm tweeter. Power handling 105 W clipping 10% of the time; sens 90 dB SPL/2.83 V/m; imp 4 ohms; crossover point 2,000 Hz; suggested amplifier power 15-150 W/ch. 15¾ x 9½ x 9 in; 16 lb. Oak, walnut, black wood grain vinyl \$340

AL-105 2-Way Speaker

Acoustic-suspension speaker with 6-in woofer and 1-in copolymer-dome tweeter. Power handling 150 W clipping 10% of the time; sens 90 dB SPL/2.83 V/m; imp 4 ohms; crossover point 2,500 Hz; suggested amplifier power 15-150 W/ch. 14¾ x 9½ x 8¼ in; 13 lb. Oak, walnut, black wood grain vinyl \$240

Compact Speakers

Mini 2P Powered Speaker

Mini speaker with 4-in long throw woofer and 1-in dome tweeter. LC type crossover operating at 2,000 Hz. Sens 90 dB SPL/2.83 V/m. Power range 5-50 W; imp 6 ohms. 7¼ x 4¾ x 4¾-in; \$359 set
Mini 2. Similar to above except not powered. Power handling 5-50 W/ch; imp 6 ohms \$198/pr

Mini 2 SW Subwoofer

Less than 1 cubic foot compact subwoofer with 8-in woofer and two complete crossover networks operating at 150 Hz. Sens 90 dB SPL/2.83 V/m; power handling 10-100 W; imp 4 ohms. 11¼ x 11¼ x 11¼ in \$289/ea

Wall Brackets for Mini 2 and 2P \$50/pr

ALTECLANSING

Bias 550 5-Way Powered Speaker System

Six speaker, floor-standing system with two 10-in carbon-fiber subwoofers, 8-in carbon-fiber woofer, 6-in carbon-fiber upper midrange coupler, diamond-coated polyimide 2-in upper midrange, and 1-in tweeter. Power handling (five way powered system), subwoofer 250 W 4 ohms, woofer 125 W 8 ohms, midrange 125 W 8 ohms, upper midrange 125 W 8 ohms, tweeter 75 W, 8 ohms; 5-way Butterworth crossover system; all drivers are enclosed in their

own acoustic-suspension enclosures; active EQ with remote; swiveling mid and high freq drivers swivel. FR 20-22,000 Hz ± 2 dB; sens 90 dB SPL/W/m; imp 22,000 ohms; crossover points 80, 450, 150, 1500, and 4,500 Hz. 71 x 19 x 24 in \$12,000/pr

Model 512 4-Way Powered Speaker

Acoustic-suspension floor-standing speaker with two 10-in woven carbon-fiber woofers, 6½ mid-bass of the same material, 2-in midrange with polyimide/diamond coat, and 1-in tweeter. Features control panel on top of speaker for built-in triamplifier; automatic on/off switch. FR 20-22,000 Hz ± 3 dB; amplification 250 W into 4 ohms, 75 W into 8 ohms, 75 W into 8 ohms; sens 90 dB SPL/W/m; imp 22,000 ohms. 57 x 13 x 13½ in; 120 lb/ea \$4,000/pr

Model 511 4-Way Speaker

Acoustic-suspension speaker with two 10-in long-throw woven carbon-fiber woofers, 6½-in woven carbon-fiber mid-bass, 2-in polyimide/diamond coated dome midrange, and 1-in diamond-coated dome tweeter with ferrofluid cooling. Features single/bi/tri/quad amplifier capability. FR 24-20,000 Hz ± 3 dB; sens 92 dB SPL/W/m; power handling cont 150 W, max 300 W. 57 x 13 x 13½ in; 110 lb \$3,000/pr

Model 510 3-Way Speaker

Acoustic-suspension speaker with bi-amp capability and adjustable crossover with two 10-in carbon-fiber woofers, 2-in midrange, 1-in dome tweeter, each with polyimide vacuum-deposited titanium. Power range 150 W nom, 300 W max; sens 93 dB SPL/W/m; imp 4 ohm; 46 x 12 x 13½ in \$1,600/pr

Model 508 3-Way Speaker

Acoustic-suspension tower speaker with two 8-in woven carbon-fiber cones, 2-in midrange, 1-in tweeter, each with polyimide vacuum-deposited titanium housed in walnut veneer pressed-wood cabinet. FR 40-20,000 Hz ± 3 dB; sens 90.5 dB SPL/W/m; power handling 125 W nom, 250 W max; imp 4 ohm; 40 x 10.5 x 11 in \$1,100/pr

Model 505 3-Way Speaker

Acoustic-suspension speaker with 10-in long-throw woofer with a woven carbon-fiber cone, 3½-in midrange of the same material, 1-in polyimide titanium tweeter with ferrofluidic cooling. FR 35-20,000 Hz ± 3 dB; sens 92 dB SPL/W/m; power handling 100 W nom, 200 W max. Genuine walnut veneer or black finish. 34 x 12 x 13¾ in ... \$850/pr

PSW-10 Subwoofer

Powered by a 100 W amplifier designed for 10-in carbon-fiber woofer. FR 26-150 Hz ± 3dB. Input imp line 7,000 ohms; 17½ x 17½ x 17½ in \$850/pr

305 3-Way Speaker

Acoustic-suspension with 10-in carbon-fiber woofer; 2-in midrange; 1-in tweeter. Power range 125 W nom, 250 W max; sens 93 dB SPL/W/m; imp 8 ohm; 27 x 14.5 x 12-in \$800/pr

Model 205 3-way Speaker

Acoustic suspension speaker with 8-in carbon-fiber woofer, 2-in midrange and 1-in polyimide/titanium tweeter. Power handling 75 W nom - 150 W max; sens 91 dB SPL/W/m; imp 6 ohm 22 x 12 x 9 in \$600/pr

Model 105 2-Way Bookshelf Speaker

2-way acoustic-suspension speaker with 6-in carbon-fiber woofer and 1-in polyimide/titanium tweeter. FR 50-20,000 Hz ± 3 dB; power range 50 W nom-100 W max; sens 91 dB SPL/W/m; imp 6 ohm; 17 x 9½ x 8½ in \$375/pr

Model 95 3-Way Speaker

Acoustic-suspension speaker with 8-in carbon-filled polypropylene woofer; 4-in midrange; 20-mm polyimide-dome tweeter. FR 35-22,000 Hz; power handling 75 W nom-150 W max; sens 92 dB SPL/W/m; 22 x 12 x 9 in \$300/pr

SPEAKERS

Model 85 2-Way Bookshelf Speaker

Acoustic-suspension speaker with 6½-in carbon-filled polypropylene woofer; 20-mm polyimide-dome tweeter. FR 35-22,000 Hz; power handling 50 W nom. 100 W max; sens 92 dB SPL; 17 x 9½ x 8½ in. \$200/pr

Model 55 2-Way Indoor/Outdoor Speaker

Compact indoor/outdoor speaker. 2-way acoustic suspension with 4-in carbon-fiber woofer reinforced with epoxy and a 20-mm polyimide-dome tweeter. FR 85-20,000 Hz ± 3 dB power range 40 W nom. 80 W max; imp 4 ohm; 9¾ x 7 x 5½ in. \$250/pr



Altec Lansing Model 550

AMBRIA BY PARASOUND

S-2000 Subwoofer/Satellite System

5-piece subwoofer/satellite system. Features subwoofer with 6 drivers; 4 satellite 2-way speakers (for pole, wall, ceiling mount with Ambria fixtures); black or white; subwoofer hand-rubbed piano-grade lacquer. Frequency response 28-22,000 ± 3 dB; sensitivity 92 dB; impedance >4 ohms with up to 10 satellites; subwoofer 12 x 12 x 46 in. \$1,750/system
S-1000. Similar to S-2000 except 3 pieces; subwoofer obelisk has 4 drivers; 2 satellite speakers. FR 35-22,000 ± 3 dB; imp >4 ohms with up to 6 satellites. Subwoofer 9 x 9 x 35 in. \$900/system
S-100. Extra satellite speakers for S-1000 and S-2000 systems. Black or white \$335/pr
S-100F. In-wall version of S100. Black or white finish. \$315/pr

S-150 2-Way Speaker

Molded enclosure; level control; black or white. FR 70-22,000 Hz ± 3 dB; sens 92 dB \$495/pr

C-300 In-Wall Speaker

Features 6-in polypropylene woofer and a 1-in soft-dome tweeter. Power handling 60 W cont; FR 45-20,000 Hz ± 3 dB; sens 90 dB SPL/W/m; imp 8 ohms. 8½ x 12 x 3¾ in. \$370/pr

C-200 In-Wall Speaker

Features 5½-in polypropylene woofer and a ¾-in dome tweeter. Power handling 50 W cont; FR 60-20,000 Hz ± 3 dB; sens 89 dB SPL/W/m; imp 4 ohms. 7½ x 11 x 2¾ in. \$240/pr

AMERICAN ACOUSTICS

DS Series

DS 1212 3-Way Speaker

Bass-reflex speaker with two 12-in woofer, 6½-in ferrofluid-sealed midranges, 1-in soft-dome tweeter. Power handling 275 W rms; FR 23-22,000 Hz; sens 95 dB SPL/W/m; imp 4 ohms. 15½ x 44 x 17¾

in. \$1,000/pr

DS 1010 3-Way Speaker

Bass-reflex speaker with two 10-in woofers, 5-in ferrofluid-sealed midrange, and 1-in soft-dome tweeter. Power handling 200 W rms; FR 34-22,000 Hz; sens 94 dB SPL/W/m; imp 4 ohms. 14 x 37¼ x 14¾ in. \$750/pr

DS 88 2-Way Speaker

Bass-reflex speaker with two 8-in woofers and 1-in soft-dome tweeter. Power handling 125 W rms; FR 38-22,000 Hz; sens 93 dB SPL/W/m; imp 4 ohms. 12 x 26¼ x 12¾ in. \$500/pr

DS 66 2-Way Speaker

Bass-reflex speaker with two 6½-in woofers and 1-in soft dome tweeter. Power handling 85 W rms; FR 42-22,000 Hz; sens 93 dB SPL/W/m; imp 4 ohms. 10½ x 21½ x 10¾ in. \$300/pr

D Series

D9550E 5-Way Speaker

12-in polymer foam surround woofer, two 5-in sealed-back ferrofluid-cooled midranges; 1-soft-dome polymer tweeter; 3-in cone tweeter. Power handling 205 W rms; FR 32-22,000 Hz; sens 99.5 dB W/m; imp 8 ohm; crossover at 600 Hz. Warm oak or black-ash finish. 40¾ x 15 x 14½ in. \$880/pr

D8550E 3-Way Speaker

Vented speaker with 15-in polymer coated woofer, 5-in sealed-back ferrofluid-cooled midrange, and a soft-dome polymer ferrofluid-cooled tweeter. Power handling 205 W/rms; FR 37-22,000 Hz; sens 98.5 dB SPL imp 4/8 ohm; crossover frequency 700 Hz, 5,000 Hz. 30¾ x 18½ x 14½ in. \$750/pr

D5550E 4-Way Speaker

Vented speaker with 15-in polymer-coated woofer, 5-in sealed-back ferrofluid-cooled midrange, soft-dome polymer ferrofluid tweeter, 3-in dome ferrofluid cooled tweeter. Power handling 120 W rms; FR 43-22,000 Hz; sens 96.5 dB W/m; imp 4/8 ohm; crossover frequency 1,700 Hz, 6,000 Hz. 27 x 15½ x 10¼ in. \$520/pr

D4550E 3-Way Speaker

Vented speaker with 10-in polymer woofer, 5-in sealed-back ferrofluid-cooled midrange, soft-dome ferrofluid-cooled tweeter. Power handling 80 W rms; FR 45-22,000 Hz; sens 95.5 dB W/m; imp 4/8 ohm. 24 x 15 x 10 in. \$420/pr

D3550E 2-Way Bookshelf Speaker

Vented speaker with 8-in polymer woofer, polymer ferrofluid-cooled and damped soft-dome tweeter. Power handling 45 W rms; FR 60-22,000 Hz; sens 94.5 dB W/m; imp 4/8/ ohm. 18½ x 11¼ x 8 in. \$280/pr

D2550E 2-Way Bookshelf Speaker

Vented bookshelf speaker with 6½-in polymer woofer, polymer ferrofluid-cooled soft-dome tweeter. Power handling 40 W rms; FR 65-22,000 Hz; sens 91.5 dB W/m; imp 4/8 ohm. 12¾ x 9¾ x 7 in. \$230 ea

AAL Series

All AAL series speakers have a 10-year warranty.

AAL 154 4-Way Speaker

Vented speaker with 15-in fiber-cone woofer, 4-in and 3-in ferrofluid-sealed midranges, and a 3¾-in round horn-loaded quartz tweeter. Power handling 125 W rms; FR 40-20,000 Hz; sens 92 dB SPL/W/m; imp 4 ohms. 18½ x 29 x 15 in. \$500/pr

AAL 124 4-Way Speaker

Vented speaker with 12-in fiber-cone woofer, 4-in and 3-in ferrofluid-sealed midranges, and a 3¾-in round horn-loaded quartz. Power handling 100 W rms; FR 50-20,000 Hz; sens 90 dB SPL/W/m; imp 4 ohms. 15½ x 27 x 10¾ in. \$400/pr

AAL 103 3-Way Speaker

Vented speaker with 10-in fiber-cone woofer, 4-in cone ferrofluid-sealed midrange, and a 3¾-in round horn-loaded quartz tweeter. Power handling 75 W rms; FR 55-20,000 Hz; sens 91.5 dB SPL/W/m; imp 4 ohms. 15 x 24 x 10½ in. \$360/pr

AAL 83 3-Way Bookshelf Speaker

Vented bookshelf speaker with 8-in fiber-cone woofer, 3-in cone ferrofluid-sealed midrange, 3¾-in round horn-loaded tweeter. Power handling 50 W rms; FR 75-20,000 Hz; sens 92 dB SPL/W/m; imp 4 ohms. 11¼ x 18½ x 8½ in. \$230/pr

AAL 62 2-Way Bookshelf Speaker

Vented bookshelf speaker with 6½-in fiber-cone woofer and 3¾-in round horn-loaded tweeter. Power handling 38 W rms; FR 90-20,000 Hz; sens 90 dB SPL/W/m; imp 4 ohms. 9½ x 12¾ x 7½ in. \$200/pr

ANALOG ONE

Audio Mirrors Subwoofer/Satellite System

A 3-speaker set with controller, using 2 Monitor 2-D speakers and a dipole subwoofer. Specifications of controller not available \$3,800

Monitor One 3-Way Speaker

28-mm liquid-cooled dome tweeters in a floor standing speaker. 3-in midrange voice coils with hexagonal windings. Power handling 180 W cont. \$1,800/pr

Monitor 3-DF. 3-way speaker with focal tweeter \$1,180/pr

Monitor 3-D. As above, no tweeter. \$1,150/pr

Monitor 2-DF. 2-way speaker with focal tweeter. \$980/pr

Monitor 2-D. As above, no tweeter. \$950/pr

DS-80 Dipole Subwoofer

12-in driver. Crossover at 80 Hz. Additional specifications not available \$1,025/pr

DS-100. As above, crossover at 100 Hz. \$1,015/pr

DS-120. As above, crossover at 120 Hz. \$1,000/pr

ANGSTROM ASSOCIATES

Reflexion 3-Way Speaker

Floor-standing 3-way tuned port speaker with 1-in polyamide dome tweeter, twin 8-in polymer-loaded polypropylene low/mid frequency drivers with butyl suspension. FR 35-20,000 Hz, ± 2 dB; power handling 7-200 W; crossover point 250 Hz, 2,000 Hz; sens 95 dB SPL/2.83 vrms @ 1M; nominal imp 6 ohms; 31½ x 10½ x 12½ in; 120 lb/pr \$995/pr w/stands

Reference 2-Way Speaker

Tuned port speaker with 1-in ferrofluid cooled cloth dome tweeter; 8-in polymer-loaded polypropylene woofer with butyl suspension. FR 37-20,000 Hz, ± 2 dB; power handling 10-150 W; crossover at 2,500 Hz; sens 90 dB SPL/2.83 vrms @ 1M; nominal imp 8 ohms; 24¼ x 10½ x 12½ in. \$795/pr w/stands

New Image 2-Way Speaker

2-way tuned port design with 1-in ferrofluid-cooled cloth dome tweeter, 8-in polymer-loaded polypropylene woofer with neoprene suspension. Frequency response 37-20,000 Hz, ± 2 dB; power handling 12-100 watts; crossover point 2,500 Hz; sensitivity 89 dB super-long-play/2.83 V/m; impedance 8 ohms; 12½ x 10½ x 12½ in; 70 lb/pr \$550/pr
New Image. With stands \$595/pr

Radix Series

Radix 500 3-Way Speaker

3-way, tuned port speaker with twin low/mid drivers of 8-in polymer-loaded polypropylene with butyl suspension, 1-in hi-temp voice coil, with aluminum former, 1-in polyamide ferrofluid-cooled dome tweeter. FR 40-20,000 Hz, ± 2dB; sens 94 dB SPL 2.83 vrms @ 1M; power handling 7-150 watts; crossover

PINNACLE®

Specialists in Compact Speakers



MODEL PN5+
DIGITAL DISC COMPATIBLE
DAT COMPATIBLE

“At lower levels the sound character of the PN5+ system was amazingly close to that of our reference speakers, which cost nearly twenty times as much!...Quite remarkable...!”

Stereo Review Magazine January 1988

Pinnacle's entire product focus is on **quality compact speakers**. We concentrate our efforts to make the best small speakers on the market. And we do. Pinnacle engineers have developed our exclusive patented Diaduct™ port design. We strategically angle the port deep inside the cabinet to allow enough length for proper tuning. The result is surprisingly deep tight bass

from a small enclosure. In fact, the sound character of Pinnacle compact speakers is often mistaken for that of much larger more costly speakers. You will enjoy a full bodied musical experience from speakers as small as one foot high. Pinnacle delivers full spectrum sound in a compact format. Priced from \$139/pair at audio dealers nationally.

CALL OR WRITE FOR INFORMATION

PINNACLE®

Patented Compact Loudspeakers

517 ROUTE 111, HAUPPAUGE, NY 11788
(516) 360-9410

PINNACLE® SPEAKERS
DESIGNED AND MANUFACTURED
IN THE U.S.A.

CIRCLE NO. 24 ON READER SERVICE CARD

© Copyright 1988 Inter-Ego Systems, Inc.
Pinnacle® is a registered trademark of Inter-Ego Systems, Inc.

SPEAKERS

point 2,500 Hz; imp 6 ohms. 4 1/2 x 9 1/2 x 9 3/8 in; 110 lb/pr \$900/pr

Radix 400 3-Way Speaker

3-way, tuned port speaker with twin low/mid drivers of 4-in polymer-loaded polypropylene with butyl suspension, 1-in hi-temp voice coil, with aluminum former, 1-in polyamide ferrofluid-cooled dome tweeter. FR 40-20,000 Hz, ±2dB; sens 93 dB SPL 2.83 V/m; power handling 10-100 W; crossover point 2,500 Hz; imp 6 ohms. 37 1/2 x 8 1/2 x 9 3/8 in; 75 lb/pr \$725/pr

Radix 300 2-Way Bookshelf Speaker

2-way, tuned port speaker with 8-in polymer-loaded polypropylene midbass driver with butyl suspension, 1-in hi-temp voice coil with aluminum former, 1-in fabric-dome tweeter. FR 45-20 Hz, ±2dB; sens 91 dB SPL 2.83 V/m; power handling 12-85 W; crossover point 2,500 Hz; imp 8 ohms. 24 1/2 x 9 1/2 x 9 3/8 in; 55 lb/pr \$525/pr

Radix 200 2-Way Bookshelf Speaker

2-way, tuned port speaker with 8-in polymer loaded polypropylene midbass driver with butyl suspension, 1-in hi-temp voice coil with aluminum former, 3/4-in polyimide dome tweeter. FR 50-20,000 Hz, ±2 dB; sens 89 dB SPL 2.83 V/m; power handling 15-70 W; crossover point 2,800 Hz; imp 8 ohms. 18 3/4 x 8 1/2 x 9 3/8 in; 36 lb/pr \$400/pr

APOGEE ACOUSTICS

Diva 3-Way Ribbon Speaker

Full-range ribbon speaker with adjustable seamless crossover. Features trapezoidal woofer ribbon; separate midrange and tweeter ribbons. Anthracite, taupe or custom finishes. Frequency response 30-25,000 Hz; impedance 4 ohms. Dimensions: 73 x 31 x 3 in; 150 lb ea \$8,250/pr
Dedicated Active Crossover. For Diva, Duetta and Caliper Speakers. Offers capability to be used with balanced amps or single-ended amps. LED display indicates levels of woofers and midrange/tweeter \$3,995

Scintilla Full-Range Ribbon Speaker

Full-range ribbon speaker with internal seamless crossover. Features trapezoidal woofer ribbon; integrated, coalescent midrange/tweeter ribbon that utilizes filed magnetic and electromagnetic constraints. Custom finishes. FR 30-20,000 Hz; imp 4 or 1 ohms. 57 x 30 x 3 1/2 in; 140 lb ea \$4,395/pr

Duetta Signature 2-Way Ribbon Speaker

Midsize 2-way full-range ribbon speaker. Utilizes ribbon transducers for both midrange/tweeter and woofer; trapezoidal woofer ribbon; combination midrange/tweeter ribbon; internal seamless crossovers. Anthracite, taupe or custom finishes. Frequency response 30-20,000 Hz; imp 4 ohms. 58 x 26 x 3 in; 115 lbs ea \$3,750/pr

Caliper Signature 2-Way Ribbon Speaker

Midsize 2-way full-range ribbon speaker. Features trapezoidal woofer ribbon; narrow-canted combination midrange/tweeter ribbon; seamless crossover circuitry. Anthracite, taupe or custom finishes. Frequency response 30-20,000 Hz; imp 3 ohms. 48 x 24 x 2 in; 70 lb ea \$2,745/pr

Stage I 2-Way Ribbon Speaker

2-way full-range ribbon speaker. Features trapezoidal woofer ribbon; combination midrange/tweeter ribbon; internal seamless crossover. Taupe or black with mahogany trim. FR 35-20,000 Hz; imp 3 ohms. 36 x 26 x 2 in; 40 lb ea \$1,995/pr

ARCAM

One+ 2-Way Speakers

Reflex-loaded cabinets with medite front baffles. Features genuine wood veneers; polymer coned midbass drivers; proprietary dome tweeters. Element

crossovers may be biwired using separate cable runs from the amplifier to the bass/midrange and treble sections to improve imaging. FR 35-20,000 Hz; 100 W power handling; imp 8 ohms. Optional walnut or black finish. 10 1/8 x 12 1/2 x 20 1/4 in \$800

Two+ 2-Way Speaker

Reflex-loaded cabinets with medite front baffles. Features genuine wood veneers; polymer coned midbass drivers; proprietary dome tweeters. Element crossover may be biwired using separate cable runs from the amplifier to the bass/midrange and treble sections to improve imaging. FR 42-20,000 Hz; 70 W power handling; imp 8 ohms. Optional walnut or black finish. 8 3/4 x 11 x 14 1/8 in \$600

Three+ 2-Way Speakers

Reflex-loaded cabinets with medite front baffles. Features vinyl veneers; polymer coned proprietary dome tweeters; 8-element crossover. FR 47-20,000 Hz; 50 W power handling; imp 8 ohms. Optional walnut or black finish. 7 1/8 x 10 3/8 x 13 1/2 in ... \$350

ATC LOUDSPEAKER TECHNOLOGY

SCM-400 3-Way Speaker

Four 12-in cone woofers, 3-in soft-dome midrange. Sens 94 dB/W/m, separate 3-way 24 dB/oct active crossover with adjustable phase, gain, crossover frequencies, and employs momentary gain reduction \$9,000/pr
SCM-500. Similar to above except two 15-in cone woofers \$8,000/pr
SCM-200. Similar to above except two 12-in cone woofers \$7,000/pr

SCM-50 3-Way Speaker

Bass-reflex floor-standing near-field studio control monitors with drivers employing soft domes, short voice coils in long magnetic gaps, high-flux density, dual suspensions, and cast frames for low distortion and high SPL. Features 9-in cone woofer; 3-in soft-dome midrange; 1-in dome tweeter; min power 50 W rms; max power 500 W rms; sens 85 dB SPL/W/m; imp 8 ohms. Oak and walnut, mahogany standard finishes. 28 x 12 x 16 in; 85 lb ea \$6,000/pr
SCM-50A. Similar to SCM50 except contains 3-way modified active crossover with phase correction driving 3 amps (200-W bass, 100-W mid, 50-W highs). Overload protection by active FET momentary gain reduction plus tweeter thermal protection by light distinguishing resistor (LDR). Well-balanced continuous SPL of 111 dB with 10 dB transient headroom. 28 x 12 x 16 in; 95 lb ea \$9,000/pr
SCM-100. Similar to SCM50 except 12-in cone woofer. Sens 88 dB SPL/W/m; max cont SPL 115 dB plus transient headroom; FR 50-16,000 Hz, ±2 dB at 115 dB. 16 x 33 x 19 in; 115 lb ea \$8,000/pr
SCM-100A. Similar to SCM50A except 12-in cone woofer, maximum continuous SPL 115 dB plus transient headroom. Dimensions: 16 x 33 x 19 in; 125 lb ea \$11,000/pr

AUDIO CONCEPTS

All Audio Concepts speakers are in kit form. Full kits include everything needed to make a speaker. All speaker drivers are from a variety of manufacturers worldwide. Refer to the 1989 Audio Concepts catalogue for more specific details.

Orion 3-way Speaker

Hybrid 12-in woofer. Power range up to 250 W rms; FR 35-20,000 Hz, ±3 dB; sens 89 dB W/m. 56 x 13 1/2 x 13 in \$1,200/pr

Super Titan 3-Way Speaker

Floor-standing speaker with 2 12-in woofers. Dome tweeter and 1 midrange. Power range up to 300 watts rms; frequency response 30-20,000 Hz, ±3 dB; sensitivity 92.5 dB watts per meter. 36 1/2 x 17 x 16 1/2 in \$1,100/pr

Pulse Subwoofer

Dual 10-in subwoofer. Power range up to 200 W rms; FR 34-400 Hz, ±3 dB; sens 87 dB W/m. 18 x 14 1/2 x 17 in \$450 ea

Sapphire 2-Way Speaker

Hybrid 7-in woofer. Power range up to 125 W rms; FR 65-20,000 Hz, ±3 dB; sens 90 dB W/m. 36 x 13 x 12 1/2 in \$850/pr

Saturn Subwoofer

Dual hybrid 12-in subwoofer. Power range up to 200 W rms; FR 22-200 Hz, ±3 dB; sens 88 dB W/m. 44 x 13 x 12 1/2 in \$640/pr

M2 3-Way Speaker

Aperiodic 12-in woofer. Power range up to 200 W rms; FR 30-20,000 Hz, ±3 dB; sens 89.5 dB W/m. 36 x 14 1/4 x 11 3/8 in \$600/pr

G2 3-Way Speaker

Aperiodic 10-in woofer. Power range up to 200 W rms; FR 36-20,000 Hz, ±3 dB; sens 89 dB W/m. 28 x 14 x 13 in \$470/pr

Compact Monitor 2-Way Speaker

Aperiodic 7-in woofer. Power range up to 125 W rms. FR 43-20,000 Hz, ±3 dB; sens 87 dB W/m. 16 x 10 x 8 in \$420/pr

Laser 3-Way Speaker

Sealed dual 8-in woofers. Power range up to 150 W rms; FR 48-20,000 Hz, ±3 dB; sens 93 dB W/m. 35 x 10 x 12 1/2 in \$440/pr

JR 2-Way Wall Speaker

7-in woofer. Power range up to 100 W rms; FR 55-20,000 Hz, ±3 dB; sens 89 dB W/m. 16 x 10 x 2 3/4 in \$300/pr

C2 2-Way Speaker

Sealed 8-in woofer. Power range up to 100 W rms; FR 48-20,000 Hz, ±3 dB; sens 90 dB W/m. 19 x 12 x 10 1/2 in \$270/pr

S2 2-Way Speaker

7-in woofer. Power range up to 100 W rms; FR 65-20,000 Hz, ±3 dB; sens 88 dB W/m. 10 x 16 x 8 in \$220/pr

AUDIOSOURCE

LS-Twelve 2-Way Speaker

Floor-standing/bookshelf speaker with 6 1/2-in polypropylene woofer and 1-in soft-dome ferrofluid-cooled tweeter. FR 40-20,000 Hz; sens 93 dB SPL/W/m; imp 4 ohms; power handling 90 W; crossover frequency 3,000 Hz. Available in oak walnut, veneer, black or white enamel over high-density particle board with metal grill; 8 3/8 x 22 7/8 x 7 7/8 in; 17 lb, 8 oz \$360/pr

LS-Eleven 3-Way Shielded Speaker

Compact acoustic-suspension speaker with two 4-in polypropylene woofers and 1-in ferrofluid-cooled soft-dome tweeter. Video shielding for hi-fi video applications. FR 60-20,000 Hz; sens 89 dB SPL/W/m; imp 4 ohms; power handling 80 W; crossover frequency 600/3,000 Hz. Available in oak or walnut veneer, or black or white enamel over high density particle board with metal grill. 5 x 14 1/2 x 5 3/4 in; 8 lb, 10 oz \$230/pr

LS-One 2-Way Shielded Speaker

Acoustic-suspension speaker with 4-in polypropylene woofer, 1-in ferrofluid cooled soft dome tweeter. Video shielding for hi-fi video application. Frequency response 100-20,000 Hz; power handling 40 watts; impedance 4 ohms; sensitivity 87 dB SPL/W/m; crossover 2,500 Hz. Black cast-aluminum enclosure with metal grille, available in walnut, oak, black metal or weather-tight finishes; 4 1/2 x 7 1/8 x 4 1/2 in; 5 lb, 8 oz \$200/pr

SPEAKERS

AXIOM AUDIO

AX 5 2-Way Speaker

Dual-enclosure speaker with 10- and 5-in woofers, and 1-in dome tweeter. FR 29-22,000 Hz \pm 2 dB; sens 87 dB; imp 6 ohms; crossover at 3,000 Hz. Dark, natural, or black oak finish with black knit grille. 12 x 36 x 12 in; 80 lb/pr \$1,699/pr

AX Sub Center-Channel 4-Way Speaker

Subwoofer and center channel speaker with two 10- and one 5-in woofer, and 1-in dome tweeter. FR 29-22,000 Hz \pm 3 dB; sens 87 dB; imp 6 ohms; crossover at 120, 250, and 3,000 Hz. Dark, natural, or black, oak finish with black knit grille. 33 x 15 x 16 in; 90 lb/ea. \$1,449/ea

AX Sub 2-Way Speaker

Subwoofer with two 10-in woofers and active crossover. FR 29-120 (or 250) Hz \pm 3 dB; sens 87 dB; imp 6 ohms; crossover at 120 or 250 Hz. Dark, natural, or black oak finish with black knit grille. 33 x 15 x 16 in; 80 lb/ea. \$1,099/ea

AX 3 2-Way Speaker

Dual-enclosure speaker with 8- and 5-in woofer, and 1-in dome tweeter. FR 36-22,000 Hz \pm 2 dB; sens 88 dB; imp 6 ohms; crossover at 3,000 Hz. Dark, natural, or black oak finish with black knit grille. 10 x 36 x 10 in; 66 lb/pr \$849/pr

AX 1 2-Way Speaker

Tuned port speaker with 5-in woofer, and 1-in dome tweeter. FR 70-22,000 Hz \pm 2 dB; sens 87 dB; imp 6 ohms; crossover at 3,000 Hz. Dark, natural, or black oak finish with black knit grille. 6 x 11 x 6 in; 30 lb/pr. \$599/pr

AX 2 2-Way Speaker

Tuned port speaker with 8-in woofer, and 1-in dome tweeter. FR 40-22,000 Hz \pm 2 dB; sens 89 dB; imp 8 ohms; crossover at 3,200 Hz. Dark, natural, or black oak finish with black knit grille. 10 x 24 x 10 in; 50 lb/pr. \$559/pr

AX 2 2-Way Bookshelf Speaker

Tuned port speaker with 8-in woofer, and 1-in dome tweeter. FR 43-22,000 Hz \pm 2 dB; sens 89 dB; imp 8 ohms; crossover at 3,200 Hz. Dark, natural, or black oak finish with black knit grille. 10 x 19 x 10 in; 44 lb/pr. \$429/pr

AX 1.5 In-Wall 2-Way Speaker

Wall-mounted speaker with 6 1/2-in woofer, and 3/4-in dome tweeter. FR 45-22,000 Hz \pm 2 dB; sens 89 dB; imp 8 ohms; crossover at 3,500 Hz. Black knit grille. 19 x 14 x 1 in; 16 lb/pr \$339/pr

AX 1.5 2-Way Speaker

Tuned port speaker with 6 1/2-in woofer, and 3/4-in dome tweeter. FR 45-22,000 Hz \pm 2 dB; sens 89 dB; imp 8 ohms; crossover at 3,500 Hz. Dark, natural, or black oak finish with black knit grille. 8 x 19 x 8 in; 36 lb/pr \$339/pr

AX 1.5 Bookshelf Speaker

Tuned port speaker with 6 1/2-in woofer, and 3/4-in dome tweeter. FR 50-22,000 Hz \pm 2 dB; sens 89 dB; imp 8 ohms; crossover at 3,500 Hz. Dark, natural, or black oak finish with black knit grille. 8 x 15 x 8 in; 30 lb/pr \$299/pr

BANG & OLUFSEN

Beolab Penta II 3-Way Powered Speaker

Powered 5-sided bass-reflex floor-standing speaker with 150 W amplifier in each cabinet. Features four 5-in woofers, four 3-in midranges, one 1-in dome tweeter (vertically aligned); dynamic clipping attenuator for protection. 3-position bass-level switch; auto turn on and off when use with Beosystem 5500; digital display shows source, volume, recording, status, overload. Finished in brushed stainless steel

with black grille. Speaker section: power handling 150 W cont; FR 40-20,000 Hz +4, -8 dB; sens 92 dB SPL/W/m; crossover frequency 700/5000 Hz; imp 8 ohms. Amp section: FR 20-20,000 Hz; THD <0.015%; damping factor 150; S/N >100 dB. 5 x 65 x 5 3/8 in; 53 lb/ea \$3,295/pr

Beovox Penta 3-Way Speaker

Five-sided bass reflex speaker. Features four 5-in woofers, four 3-in midranges, one 1-in dome tweeter (vertically aligned). Finished in brushed stainless steel with black grille. FR 40-20,000 Hz +4, -8 dB. 5" x 59" x 5 3/8 in; 37 lb. 8 oz/ea \$2,200/pr

Beolab 5000 Wall-Hanging Powered Speaker

Bass-reflex 2-way speaker with 55 W amplifier in each cabinet. Features two 5-in woofers and one 1-in dome tweeter. Automatic bass-level switching; auto turn on and off when used with B&O Beolink system; digital display shows source, volume, recording status. Finished in brushed stainless steel and blue or gray grille cloth. Speaker section: power handling 60 W cont; FR 60-20,000 Hz +4, -8 dB; sens 89 dB SPL/W/m; imp 8 ohms; crossover frequency 3,500 Hz. Amp section: FR 20-20,000 Hz; THD <0.1%; S/N >97 dBA. 17 3/4 x 39 3/4 x 3 in; 33 lb. 8 oz/ea. \$2,095/pr

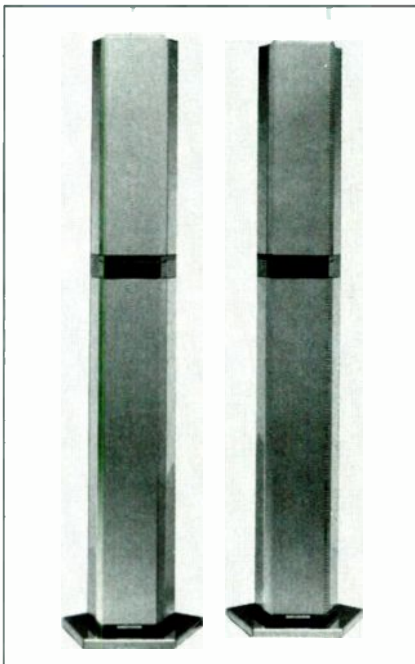

Bang & Olufsen Beovox Penta

Beolab 3000 2-Way Wall-Hanging Powered Speaker

Bass-reflex speaker with 55-W amplifier in each cabinet. Features one 5-in woofer and one 1-in dome tweeter. Automatic bass-level switching; auto turn on and off when use with B&O Beolink system; digital display shows source, volume, recording status. Finished in brushed stainless steel and blue or gray grille cloth. Speaker section: power handling 45 W cont; FR 75-20,000 Hz; sens 87 dB SPL/W/m; crossover frequency 3,500 Hz; imp 8 ohms. Amp section: FR 20-20,000 Hz; THD <0.1%; S/N >97 dBA. 17 3/4 x 21 1/4 x 3 in; 20 lb/ea. \$1,695/pr

RI 140 3-Way Speaker

Floor-standing bass-reflex speaker with two 6 1/2-in woofers, 5-in midrange, 1-in dome tweeter in gray plastic enclosure with black grille. FR 40-20,000 Hz +4, -8 dB; sens 93 dB SPL/W/m; power handling 140 W cont; imp 8 ohms; crossover frequency 800/3,000 Hz. 28 x 20 x 9 1/2 in; 33 lb/ea. \$990/pr

RI 60.2 2-Way Speaker

Floor-standing speaker with 1-in dome tweeter, two

5-in cone woofers, tuned port; charcoal black finish. Frequency response 45-20,000 Hz +4, -8 dB; power handling 60 W cont; sens 93 dB SPL/W/m; imp 8 ohms; crossover frequency 2,500 Hz. 21 1/4 x 16 x 7 in; 19 lb. 10 oz/ea \$550/pr

RI 35 2-Way Bookshelf Speaker

Bass-reflex bookshelf speaker. Features 5-in woofer; 3/4-in tweeter. Power handling 35 W cont; FR 48-20,000 Hz +4, -8 dB; imp 8 ohms; sens 92 dB SPL/W/m; crossover frequency 3,500 Hz; bitumen blocks on inside of curved backplate; thermoplastic cabinet. 15 3/4 x 12 1/2 x 5 in; 7 lb. 13 oz/ea. \$380/pr

Beovox CX100 Bookshelf Speaker

Black, white, grey, or brushed-aluminum bookshelf box speaker with two 4-in woofers, 1-in dome tweeter. Power range 10-110 W; sens 89 dB SPL/W/m; imp 6 ohms; 4 x 12 x 8 in; 13 lb. 8 oz. \$380/pr

Beovox CX50. Black finish; 8 lb/ea. \$280/pr

B&W LOUDSPEAKERS

Matrix 801 Series 2 Speaker

Floor-standing 6th-order Butterworth vented system with vertically aligned drivers to minimize time delays. Features a 12-in polymer cone bass, 5 3/8-in Kevlar cone midrange and a 1-in metal-dome high frequency. Electronic bass-alignment filter. Walnut or black-ash finishes. Power handling 600 W. FR 20-20,000 Hz, \pm 2 dB; sens 87 dB (2.83V, 1 m); crossover point 380 and 3,000 Hz; imp 8 ohms. 39 3/4 x 17 x 22 in; 110 lb ea. \$5,000/pr

Natural Oak, white finish \$5,500/pr

STAV 801. Stand for Matrix 801 Series 2. \$200/pr

801 Hood. Hood for 801 (black or brown). \$300/pr

Matrix 802 Series 2 3-Way Speaker

Floor-standing 6th-order Butterworth vented system with vertically aligned drivers. Features two 8-in polymer cone bass, one 5-in Kevlar cone midrange, one 1-in metal-dome high frequency; electronic-bass alignment filter. Walnut or black-ash finishes; power 500 W; FR 27-20,000 Hz, \pm 2 dB; sens 90 dB (2.83V, 1 m); crossover point 400 and 3,000 Hz; imp 8 ohms. 11 3/4 x 41 x 14 1/2 in; 70 lb. \$3,600/pr

Natural oak, white finish. \$3,750/pr

CM2 Matrix Mini 2-Way Speaker

Floor-standing 4th-order Butterworth vented system consisting of CMI head unit crossing over at 150 Hz into subwoofer section forming the stand. B&W matrix enclosure is employed in both stand and head module. overload protection circuit. Column finish in black, white, nextel grey, walnut. Power handling 200 W; imp > 4 ohms. 39 1/4 x 6 3/8 x 8 1/2 in; base width 10 x 9 1/2 in d. \$1,750/pr

CM2-SW Subwoofer Col. Similar to CM2 without the high-frequency driver \$1,050/pr

CM-WB. Wall-mounting bracket for the CM2 and the CM2-SW. \$40/pr

Matrix Series 2 Speakers

All Matrix speakers feature electronic-time-delay overload protection, homopolymer polypropylene bass/mid drivers, and ferrofluid-cooled tweeters. Matrix enclosure: a honeycomb structure of interlocking, perforated cross members bonded to the outer walls and filled with acoustic foam for low-resonance operation.

Matrix 3

Floor-standing speaker with two 8-in cone woofers (one for lower bass and other for midbass frequencies); 1-in polyimide tweeter; heavy magnet assemblies in mid/bass drivers (5 lbs ea). Walnut, black ash finishes. No upper power limit due to overload protection; frequency response 70-25,000 Hz, \pm 2 dB; sensitivity 90 dB SPL/W/m; imp 4 ohms. 35 3/4 x 10 1/4 x 16 in; 64 lb. \$2,500/pr

Natural oak finish \$2,850/pr

Matrix 2

Bookshelf speaker with 8-in cone woofer; 1-in polyi-

The SRS Series



SRS 2.3 II

"The sound is superbly balanced and totally effortless." Stereo Review Magazine

“Matthew Polk’s SRS Speakers Bring You the Ultimate Listening Experience”

“Spectacular... it is quite an experience.” *Stereo Review Magazine*

The Joy of Owning the Ultimate Dream Speakers

Music lovers who are privileged to own a pair of SRS's will share in Matthew Polk's dream every time they sit down and enjoy the spine-tingling excitement of listening to their favorite music. Demonstrating them to admiring friends ultimately increases their pride-of-ownership. “Awesome” is the word most often used to describe the sound of an SRS system. They are capable of playing at live concert levels for long periods of time, with a surprising lack of effort and without producing ear-fatigue.

The bass response can literally move your body any time the music requires it, yet they perfectly reproduce all of the subtle nuances of a string quartet and are just as enjoyable at a low volume level as when played loud. Music and ambience surround the listener in an almost 360-degree panorama of sonic splendor that is, in the words of High Fidelity magazine, “Mind-boggling... Astounding... Flabbergasting.” But words alone cannot possibly describe the experience of listening to these ultimate speaker systems, you simply must hear them.

SRS 1.2 tl

Two time Audio Video Grand Prix Winner

The ultimate expression of Polk technology, this limited production flagship model sets the industry standards for imaging, detail, dynamic range, and bass reproduction.

SRS 2.3 tl

Audio Video Grand Prix Winner

This scaled-down version of the SRS 1.2 tl incorporates all of flagship's design innovations without significantly compromising its awesome performance.

Polk Audio's SRS: The Quest for Perfection

The goal of Matthew Polk's Signature Reference System (SRS) speakers is to bring an unparalleled level of life-like musical reproduction to your home. Perfect musical reproduction, long the dream of every speaker designer, is approached so closely by Matthew Polk's SRS's that it will seem as if the musicians are performing right in your listening room. This stunning achievement combines technology and creative insight to bring you a listening experience that you will never forget.

1. Patented SDA True Stereo Technology — The first and only speaker systems to maintain full stereo separation all the way from the source to your ears. (see pg. 9 for a more complete description). SRS speakers seem to disappear as musical images fill your listening room and seem to immerse you in a fully three-dimensional soundfield of startling realism.

2. Multiple Driver Arrays — The use of multiple drivers allows each separate element to work less hard and lowers distortion even at live concert levels. Power handling is increased to 1,000 watts per channel, providing a seemingly limitless dynamic range.

3. Time-Compensated Driver Alignment — Time-coherent driver placement insures that the entire spectrum of sounds reaches your ears at the same time. The sound is better focused, balanced and less fatiguing.

4. Wavelength Optimized Line-Source — Vertical driver arrays focus the sound waves into the room in a way which greatly reduces floor and ceiling reflections. Progressive reduction of the acoustical length of the arrays maintains constant vertical dispersion and eliminates “comb” filtering effects that limit other multiple driver systems. The result is extraordinary clarity and detail, great flexibility in room placement and precise stereo imaging from virtually any place in the room.

5. Planar 15" subwoofer — SRS bass performance is breathtaking. The use of small active drivers (eight in the SRS 1.2 tl, six in the SRS 2.3 tl) coupled to a huge sub-bass radiator achieves a bass response that is extraordinarily tight, fast (no boominess), deep and distortion free. In fact, the distortion at 25 Hz is lower than that of many audiophile-quality tube amplifiers.

6. Bi-amp Capability — The optional use of separate amplifiers for the high and low frequencies further improves clarity, lowers distortion and increases dynamic range.

7. Hand-Crafted Limited Production — The one-at-a-time attention that goes into the production of every Polk SRS speaker system means that your pair will sound and look as good as Matthew Polk's own.

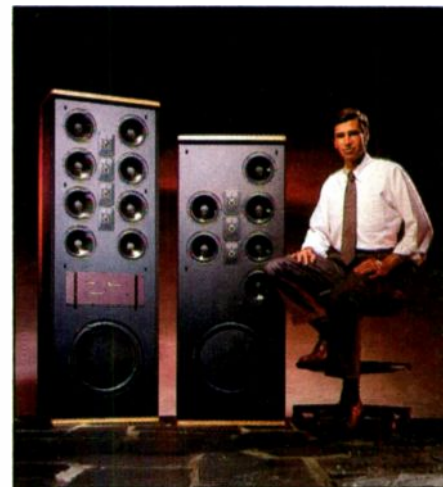

Matthew Polk with the ultimate expressions of loudspeaker technology: The SRS 1.2 tl and SRS 2.3 tl.

The SDA Series



SDA 2B

"They have the ability to make your previous favorite speaker sound almost second rate."

Stereo Review Magazine

“Polk’s Revolutionary True Stereo SDAs Always Sound Better Than Conventional Speakers”

“Mindboggling...Astounding...Flabbergasting” High Fidelity Magazine

SDA 1C

Audio Video Grand Prix Winner

This floor standing model uses SRS vertical line-source technology in an attractively slim, tower configuration, offering tremendous impact and amazing stereo imaging with a minimum use of floor space.

SDA 1C Studio

Same configuration as the SDA 1C but in a vinyl clad cabinet.

SDA 2B

Audio Video Grand Prix Winner

The SDA 2B represents an incredible value which combines spectacular SDA performance with a remarkably affordable price. High Fidelity said listening to the SDA 2B is “an amazing experience.”

SDA 2B Studio

Same configuration as the SDA 2B but in a vinyl clad cabinet.

SDA CRS +

Audio Video Grand Prix Winner

The SDA Compact Reference System is the worlds’ best sounding small speaker and can be either bookshelf or stand mounted. Stereo Review called the CRS “an impressive achievement.” No other small speaker offers such a compact package of high technology and performance.



Polk Audio’s Grand Prix Award winning SDA Series speakers. Pictured left to right, SDA 1C, SDA 2B and SDA CRS +.

A Fundamental Advance in Loudspeaker Design

Polk’s patented SDA technology is the most fundamental advance in loudspeaker design in twenty years. High Fidelity magazine said of the SDA design, “Polk reinvents the loudspeaker...startling evidence of the industry’s essential creative vitality.” Rolling Stone Magazine agreed when they wrote, “They truly represent a breakthrough.” The Polk SDA’s are the world’s only “True Stereo” speakers, that is, the only speakers which are specifically designed to realize the full sonic potential of every stereophonic recording.

The SDA Difference

In order to maximize performance, stereo separation is carefully maintained in all audio components. However, with conventional loudspeakers both ears hear both speakers and the two channels are mixed together before they ever reach your ears. Because stereo separation is not maintained all the way to your ears, much of the sense of spaciousness and sonic realism of the original recording is lost. The soundstage is only as wide as the distance between the speakers and sonic images are rendered flat and small.

Polk SDA speakers are the first true stereo speakers and are able to maintain perfect stereo separation all the way from the source to your ears. By acoustically isolating the two stereo channels, each ear hears only the correct stereo channel; the left ear hears left channel, and the right ear hears right channel. Recordings literally come alive in your listening room. Musical images are reproduced with incredible clarity and pinpoint accuracy. You are surrounded by a stunning three-dimensional sound stage that extends from wall-to-wall, and also wraps around you. Only with Polk Audio SDA loudspeakers can you hear all of the spaciousness and life-like imaging of the original performance.

How SDA Technology Works

Conventional speakers allow both of your ears to hear both the left and right channels at the same time. This is called “Interaural Crosstalk Distortion.” This crosstalk distortion could be prevented by building a wall between your speakers right up to your nose, so that each of your ears would hear only the speaker on one side of the wall. SDA speakers cancel this distortion, but in a much more comfortable, elegant, and highly accurate fashion. Each SDA speaker reproduces a signal that is the exact opposite of the undesirable crosstalk signal. This cancellation signal is timed to arrive at your ear at precisely the same time as the undesirable crosstalk signal. When these two signals combine, they naturally and acoustically cancel each other. What remains is one correct stereo channel delivered to each ear. In this way SDA speakers allow you to hear stereo performances the way they were meant to be heard.

The SDA Advantage

Only Polk’s patented SDA loudspeakers let you hear all of the information and spatial realism that is on the original recording. Conventional speakers restrict what you hear due to their failure to maintain complete stereo separation. Stereo Review magazine said that with SDA speakers: “The result is always better than would be achieved with conventional speakers.” Hear the SDA advantage for yourself.

The RTA Series



"They provide smooth, fast and incredibly well detailed sound."

“Polk’s RTA Tower Loudspeakers Combine Legendary Polk Performance with Contemporary Style.”

Big speaker performance with an efficient use of space.

RTA 11t

The RTA 11t is the finest conventional (non-SDA) speaker that Polk Audio manufactures. Its extremely high power handling (250 watts) and high efficiency (90dB) provide remarkable dynamic range from both large and small amplifiers. The RTA 11t utilizes the same technologically advanced fluid-coupled subwoofer design found in Polk’s flagship model. Dual 8” sub-bass radiators are coupled to two 6½” mid/bass drivers, resulting in a fast, powerful, deep, and ultra-accurate bass response, without the boomy, undetailed sound of large woofer systems.

RTA 8t

In a slightly smaller package, the RTA 8t offers the same driver complement as the larger, more expensive RTA 11t, and thus shares its benefits of superior imaging, musicality, and detail.

Both Polk RTA series loudspeakers achieve the extremely rare combination of good looks and state-of-the-art performance. The tall, elegantly slender and deep “tower” design cabinets allow for substantial internal volume for high efficiency and powerful bass, but only require less than one square foot of floor space! The small baffle surface area around each driver minimizes diffraction (sonic reflections), thereby insuring outstanding imaging and low coloration.

Positioning the 1” silver-coil dome tweeter between the two 6½” trilaminate polymer bass/midrange drivers achieves what is called “coincident radiation.” This means that both the mid- and high-frequencies appear to radiate from the same place on the baffle resulting in perfect blending at the critical crossover point. (See illustration, below).

Polk RTA speakers have an uncanny ability to perfectly reproduce the human voice, pianos, guitars, and every other instrument whose faithful reproduction demands superlative midrange and high-frequency performance. Bass and percussion instruments are accurately reproduced with full visceral power and realism, without the heaviness, boominess, or lack of detail that plague lesser designs.

The discriminating listener who seeks state-of-the-art performance and design will find the quintessential combination of both in Polk’s RTA series loudspeakers.

THE PRINCIPLES OF COINCIDENT RADIATION

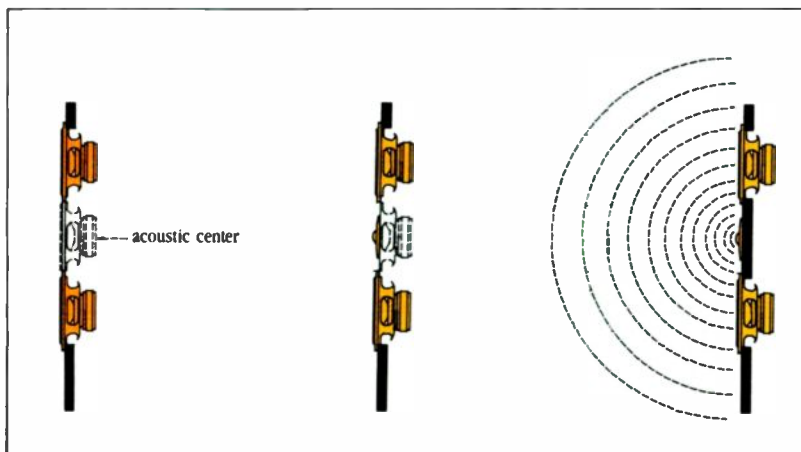

The perceived source of sound of two identical drivers is centered in the area between them.

In the Polk RTA loudspeaker, the tweeter is positioned at the acoustic center of the drivers.

Drivers and tweeter appear to operate together as an ideal point source resulting in precise imaging, uniform dispersion and startling midrange accuracy.



Polk Audio's RTA 8t and RTA 11t High Performance Tower Speakers

The Monitor Series



Monitor 10B

"The best high performance speaker value on the market today." Off The Record

“Polk’s Remarkable Monitors Redefine Incredible Sound/Affordable Price”

“At their price, they’re simply a steal” Audiogram Magazine

Monitor 10B

One of the world’s best sounding loudspeakers, and in the words of Audiogram magazine, “At the price they are simply a steal.” The Polk 10B utilizes dual trilaminate polymer drivers, a 1” dome tweeter coupled with a built-in subwoofer for accurate bass response and superior high frequency clarity.

Monitor 7C

Basically a smaller, less expensive version of the Monitor 10B. By offering superlative performance whether mounted on a shelf or a speaker stand, the 7C is a highly versatile addition to any audio system. How good does it sound? Audio Alternative magazine said, “It is amazing.”

Monitor 5B

Similar in design and performance to the Monitor 7C, however it utilizes an 8” subwoofer (rather than 10”) and is more compact. The 5B represents one of the best values of the entire Monitor Series.

Monitor 5Jr. +

Called the best sounding speaker of its price in the world regardless of size. It achieves life-like three-dimensional imaging which 10 years ago was not available in any bookshelf speaker at any price.

Monitor 4.5

Shares most of the high technology components and rewarding musical performance of the larger Polk speakers at a surprisingly low price. A critically tuned bass duct insures high efficiency and great bass performance despite its convenient compact design.

Monitor 4A

Identical to the 4.5 in a smaller cabinet. Audio critic Lawrence Johnson called it, “an all around star of great magnitude.” The 4A’s affordable price means that no matter how small your budget, you can afford the incredible sound of Polk!

Matthew Polk’s Vision: Superior Sound for Everyone

Polk Audio is an American company that was founded in 1972 by three Johns Hopkins University graduates who were fanatical audiophiles with a common vision. They believed that it was possible to make speakers that performed as well as the most exotic and expensive systems at a fraction of the price. Starting with only \$200, they began by designing and manufacturing the Monitor Series loudspeakers. The Monitor Series combined the advantages of American high technology and durability with European styling and refinement. Over the years an unending stream of rave reviews, industry awards, and thousands of enthusiastic Polk customers have established the Monitor Series as the choice for those looking for both incredible sound and an affordable price. There is no better value in audio equipment today than a Polk Monitor series loudspeaker.

Uncompromising Standards at Every Price

A limited budget does not mean a limited ability to appreciate fantastic sounding music. That’s why we put our best engineering efforts and only the finest materials into every Polk product regardless of price.

Every Polk Monitor Series speaker uses the same trilaminate polymer cone technology as the flagship SDA-SRS 1.2. Every Polk Monitor utilizes a 1” polymer dome tweeter, and most use exactly the same tweeter found in the SRS 1.2. All Polk Monitors employ costly multi-component crossover networks and ¾” thick high density, non-resonant cabinets. Pick up a Polk Monitor 4A, then pick up a comparably priced but larger speaker from a different manufacturer. You’ll notice that the Polk is heavier, more solidly built and sports a superior fit and finish. Now compare the sound. We are sure you’ll agree with Musician magazine, which said Polk Monitors are: “Vastly superior to the competition.”



Matthew Polk with his incredible sounding affordably priced Monitor Series loudspeakers. Front row (L to R) Monitor 5Jr. +, Monitor 4A, Monitor 4.5, Monitor 5B Back row (L to R) Monitor 10B, Monitor 7C

The Thrilling Sound of Polk Monitors

Polk Monitors achieve open, boxless, three-dimensional imaging surpassed only by the SDA’s. Their silky smooth frequency response assures natural, non-fatiguing, easy to listen to sound, while their fast transient response results in music that is reproduced with life-like clarity and detail. In addition, dynamic bass performance, ultra-wide dispersion, high efficiency and high power handling are all hallmarks of Monitor Series performance

There is a Polk Monitor Perfect for You

Each time you advance through the six Monitor Series models, you’ll immediately hear a remarkable improvement in efficiency, bass response, and output volume. They are designed so that a smaller Polk played in a small room will sound nearly identical to a larger Polk played in a large room. A larger Polk in a small room will, of course, play that much louder with even better bass. No matter what price range fits your budget, there is a spectacular Polk Monitor Series speaker waiting to fulfill your sonic dreams.

SPEAKERS

BOSTON ACOUSTICS

mid-dome tweeter. Walnut and black ash finishes. No upper power limit due to overload protection; FR 80-25,000 Hz, ± 2 dB; sens 87 dB SPL/W/m; imp 4 ohms. 23½ x 10¼ x 12¼ in; 35 lbs \$1,600/pr
Natural oak finish \$1,750/pr
STAV Mat 2 Series 2. Stand for Mat 2 Series 2 speakers \$250/pr

Matrix 1

Bookshelf speaker with 6-in cone woofer, 1-in polyimide-dome tweeter. Walnut and black ash finishes. No upper power limit due to overload protection; FR 80-25,000 Hz, ± 2 dB; sens 85 dB SPL/W/m; imp 4 ohms. 16 x 9 x 12¼ in; 35 lbs \$1,200/pr
Natural oak finish \$1,300/pr
STAV Mat 1 Series 2. Stand for Mat 1 Series 2 speakers \$250/pr

Digital Monitor Series

DM580 2-Way Speaker

Two 8-in bass/midrange with composite short-fiber cone, 1-in coil on hi-temp former. One 1-in aluminum-dome tweeter. Simulated veneers of walnut or black ash finishes. FR 38-30,000, -6 dB; Sens 91 dB, 2.83 V/m; imp 8 ohm; 34¾ x 9¼ x 16 in; 40 lb, 11 oz. \$900/pr
STAV 580. Black mounting base for DM580 \$60/pr

CM1 Matrix Mini 2-Way Speaker

Bookshelf model, molded DMC (fiberglass polyester composite) low-density matrix enclosure with 5-in Kevlar bass driver and new TA301 metal-dome tweeter. White, black or nextel grey finishes. Power handling 200 W max; FR 90-20,000 Hz, ± 2 dB; imp 8 ohms. 9¾ x 6¾ x 8¾ in; 11 lb ea \$750/pr

DM570 2-Way Speaker

One bass/midrange with composite short-fiber cone, 1-in coil on hi-temp former. One 1-in aluminum-dome tweeter. Simulated veneers of walnut or black ash finishes. FR 45-30,000 Hz, -6 dB; sens 91 dB, 2.83 V/m; imp 8 ohm; 25 x 9¼ x 11¾ in; 23 lb, 11 oz. \$650/pr
STAV 500. Stand for DM570 \$75/pr

DM560 2-Way Speaker

One bass/midrange with composite short-fiber cone, 1-in coil on hi-temp former. One 1-in aluminum-dome tweeter. Simulated veneers of walnut or black ash finishes. FR 65-30,000 Hz, ± 2.5 dB; sens 90 dB, 2.83 V/m; imp 8 ohm; 19¼ x 9¼ x 11¾ in \$550/pr
STAV 500. Stand for DM560 \$75/pr

LM-1 2-Way Speaker

2-way mini speaker with colored nextel finishes and protection against overload. 4-in woofer; switchable to 8 or 4 ohms. For home and car use. Beige finishes. Min power 10 W; 4-in woofer, ¾ tweeter... \$558/pr
LM-1/PM. Panel-mount version \$500/pr

DM550 2-Way Speaker

One 6¾-in bass/midrange with composite short-fiber cone, 1-in coil on hi-temp former, one 1-in aluminum-dome tweeter. Simulated veneer of walnut or black-ash. FR 70-20,000 Hz, ± 2.5 dB; sens 87 dB, 2.83 V/m; 13¾ x 8¼ x 9¾ in; 12 lb \$400/pr

Acoustitone Subwoofer

Features two 6-in woofer; coupled; rear: bass reflex, front: helmhole resonator. Butterworth band pass; fourth order bass rolloff. Simulated black-ash finish. Power handling 200 W max; FR 22-100 Hz, -3 dB. 21¼ x 13½ x 9¼ in; 27 lb, 8 oz \$350 ea

BIB

Point-4 2-way Speaker

Features 4-in woofer and 2½ tweeter in a 8-in sealed enclosure. Swivel mounting brackets and hardware included. Power handling 50 W; FR 45-20,000 Hz; sens 85.5 dB; imp 4 ohms; crossover point 4,000 Hz. 8 x 4½ x 5 in; 5 lb, 11 oz \$130/pr

T Series

T1000 Series II 3-Way Speaker

Floor-standing acoustic-suspension speaker with 2 active 8-in copolymer-cone woofers, 6½-in copolymer-cone midrange in an internal subenclosure, and 1-in CFT5 ferrofluid-cooled tweeter. Features tapered-grille design to eliminate sonic diffraction; tall slender enclosure for minimum floor space; genuine walnut veneers, black-ash vinyl, woodgrain vinyl. Power range 15-150 W rms; FR 46-20,000 Hz ± 3 dB; sens 87 dB SPL/W/m; imp 8 ohms; crossover frequencies 250 and 2,500 Hz. 10¼ x 42½ x 12¾ in. Wood veneer \$1,200/pr
Vinyl \$1,000/pr

T930 3-Way Speaker

Floor-standing acoustic suspension speaker with 10-in copolymer cone woofer, 6½-in copolymer cone midrange, and 1-in CFT5 dome tweeter. Features genuine walnut veneer, hand finished on 5 sides, woodgrain vinyl, and black-ash vinyl. Power range 15-150 W/ch rms; FR 40-20,000 Hz ± 3 dB; sens 90 dB SPL/W/m; imp 8 ohms; crossovers at 250 and 2,500 Hz. 10½ x 36¾ x 12 in \$800/pr
Vinyl \$700/pr

T830 3-Way Speaker

Floor-standing acoustic-suspension speaker with 8-in copolymer-cone woofer, 3½-in copolymer-cone midrange, and 1-in dome tweeter. Features woodgrain vinyl and black-ash finishes. Power range 15-100 W rms; FR 45-20,000 Hz ± 3 dB; sens 88 dB SPL/W/m; imp 8 ohms; crossover frequencies 800 and 4,000 Hz. 9¾ x 32½ x 10 in \$500/pr

Designer Series

All Designer speakers are intended for flush mounting in walls or ceilings and come packaged ready to install. Each speaker has a matte-white finish that can be painted to match room decor and a water-resistant design. Includes mounting hardware; optional brackets available for installation in new construction. Prices depend on installation costs.

SW-10 Powered Subwoofer

10-in subwoofer in a compact vented enclosure. System features internal 100 watt amplifier with electronic crossover. Auto-on, auto-off; black-ash vinyl finish. Low frequency: 34 Hz -3 dB; 24 dB/octave high filter at 95 Hz. 11¼ x 13½ x 7¼ in \$600

Model 360 2-Way In-Wall Speaker

Flush-mount speaker with 6½-inch copolymer-cone woofer and 1-inch CFT4 ferrofluid-cooled soft-dome tweeter. Woofer is specially designed to provide full bass without needing a special enclosure. Power range 5-60 watts rms; frequency response 58-20,000 Hz ± 2 dB; impedance 8 ohms; sensitivity 90 dB SPL/W/m. 12 x 8¾ in; mounting depth 3¼ inches \$450/pr

Model 350 2-Way In-Wall Speaker

Flush-mount speaker with 5¼-in copolymer woofer and 1-in CFT4 ferrofluid-cooled soft-dome tweeter. Power range 5-50 W rms; FR 68-20,000 Hz ± 2 dB; imp 4 ohms. 9½ x 6¾ in; mounting depth 2.63 in \$400/pr

PowerVent 12 Subwoofer

Subwoofer has two bass drivers and uses a combination of sealed and vented chambers for greater efficiency. Features auto-on, auto-off; black-ash finish. FR 46-150 Hz; imp 8 ohms; sens 87 dB SPL/W/m; power range 15-100 W rms. 16½ x 13½ x 7¼ in \$350

Model 325 2-Way In-Wall Speaker

Compact flush-mount speaker with 5¼-in woofer and in-line mounted ¾-in cone tweeter. Matte-white finish with matte-white steel perforated grille. FR 70-20,000 Hz ± 3 dB; power range 5-25 W rms; imp 4 ohms \$250/pr

Model 305 2-Way Speaker

Compact 5¼ dual-cone full-range loudspeaker. Matte-white finish with matte-white steel perforated grille. Frequency response 70-16,000 Hz ± 3 dB; impedance 4 ohms \$175/pr

A Series

SubSat Six Subwoofer/Satellite System

Three-piece system with 2 small satellite speakers and 1 compact subwoofer. Each satellite features a ¾-in ferrofluid-cooled tweeter and a 4-in midrange with copolymer diaphragm. Subwoofer features two bass drivers with both sealed and vented chambers. Power range 15-150 W rms; frequency response 46-20,000 Hz ± 3 dB; imp 8 ohms; sensitivity 87 dB SPL/W/m. Satellite 5 x 8 x 4 in; Subwoofer 16½ x 13½ x 7¼ in \$600/system

A120 2-Way Speaker

Bookshelf speaker in vented enclosure with 10-in passive radiator, 6-in midrange, 1-in CFT 3 ferrofluid-cooled dome tweeter. Features tapered grille design to eliminate sonic diffraction; woodgrain and black-ash vinyl finishes. FR 39-20,000 Hz ± 3 dB; imp 8 ohms; sens 87 dB SPL/W/m; power range 15-75 W rms. 24½ x 9¾ x 12½ in \$420/pr

A100 Series III 2-Way Speaker

Acoustic-suspension speaker with 10-in copolymer-cone woofer and 1-in CFT5 ferrofluid-cooled soft-dome tweeter. Power range 15-75 W rms; FR 39-20,000 Hz ± 3 dB; crossover at 2,000 Hz; sens 90 dB SPL/W/m. Woodgrain vinyl finish with tapered charcoal grille. Includes black pedestal base. 32½ (including base) x 16 x 8¾ in \$420/pr

A70 Series II 2-Way Speaker

Acoustic-suspension bookshelf speaker with 8-in copolymer-cone woofer and 1-in CFT5 ferrofluid-cooled soft-dome tweeter. Power range 15-75 W rms; frequency response 45-20,000 Hz ± 3 dB; crossover at 2,500 Hz; sensitivity 90 dB SPL/W/m; imp 8 ohms. Woodgrain vinyl finish with charcoal grille. 23 x 12½ x 8¾ in \$320/pr

A60 Series II 2-Way Speaker

Acoustic-suspension speaker with 8-in copolymer-cone woofer and 1-in soft-dome ferrofluid-cooled tweeter. Power range 15-75 W rms; FR 52-20,000 Hz ± 3 dB; crossover at 3,000 Hz; sens 90 dB SPL/W/m; imp 8 ohms. Woodgrain vinyl finish with charcoal grille or matte-black vinyl finish with back grille. 18¼ x 11¼ x 7¾ in \$240/pr

A40V Series II 2-Way Shielded Speaker

Acoustic-suspension 2-way bookshelf speaker with 6½-in copolymer-cone woofer and ¾-in ferrofluid-cooled tweeter. Features MagnaGuard magnetic shielding to allow placement near a TV or video monitor. Power range 5-50 W rms; FR 65-20,000 Hz ± 3 dB; crossover 3,500 Hz; sens 90 dB SPL/W/m; imp 8 ohms. Matte-black finish with black grille. 13½ x 8¼ x 7¼ in \$190/pr

A40 Series II 2-Way Speaker

Bookshelf acoustic-suspension speaker with 6½-in copolymer-cone woofer and 0.75-in ferrofluid-cooled tweeter. Power range 5-50 W rms; FR 65-20,000 Hz ± 3 dB; sens 89 dB SPL/W/m; imp 8 ohms. Woodgrain vinyl with charcoal grille or matte-black vinyl with black grille. 8¼ x 13½ x 7¼ in \$180/pr

BOSE

01 Series

Model 901 Series VI Speaker

Direct/Reflecting acoustic-matrix speaker with active EQ and 8 rear-facing, 1 front-facing 4½-in full-range drivers. Features pentagon-shaped cabinet with multi-cell injection-molded core panels of hardwood veneer and walnut finish; active equalizer

SPEAKERS

with fixed EQ; midbass and midtreble shelf control; tape monitor switch; five-year warranty. Power handling unlimited; imp 8 ohms; dynamic range 106 dB. Equalizer: 13 x 2 3/4 x 4 7/8 in. Speaker: 21 x 12 3/4 x 13 in; 35 lb/ea. Price includes EQ \$1,499/pr

Model 601 Series III 3-Way Speaker

Floor-standing Direct/Reflecting speaker system with all tweeters and one woofer mounted above main enclosure in free-space-array configuration for lifelike stereo imaging. Features two 8-in Digital Dynamic Range cone woofers; four 3-in cone tweeters; subport enclosure system with slotted port. Hardwood veneer with walnut finish; five-year warranty. Crossover points at 1,500 and 2,500 Hz; power handling 400 W max rms; imp 8 ohms. 12 1/2 x 30 x 12 1/2 in; 45 lb/ea \$999/pr

Model 501 Series IV 3-Way Speaker

Floor-standing Direct/Reflecting speaker system with two 3-in tweeters mounted in free-space-array and a 10-in long-excursion woofer. Teak-grain vinyl veneer finish; five-year warranty. Power handling 200 W max rms; crossover points 1,500 and 2,500 Hz; imp 8 ohms. 25 x 16 x 14 in; 40 lb/ea. Sold only in stereo pairs \$699/pr

Model 401 3-Way Speaker

Floor-standing Direct/reflecting speaker system with two 6 1/2-in woofers and a 2-in magnetic liquid-cooled tweeter. Features Stereo Space array design; column-design enclosure; thermal-system protection circuit. Vinyl veneer with walnut or black finish; five-year warranty. Power handling 200 W max rms; nominal imp 4 ohms. 12 x 12 x 30 in; 31 lb/ea \$599/pr

Model 301 Series II 3-Way Speaker

Direct/Reflecting ported bookshelf speaker system with 8-in woofer, two 3-in tweeters in Free Space Array. Features dual-frequency crossover to allow woofer and tweeter to operate simultaneously over nearly a full octave; tweeter-protection circuit. Particle-board cabinet with walnut-grain or black vinyl veneer finish; five-year warranty. Power handling 150 W max rms; crossover points 1,500 and 2,500 Hz; impedance 8 ohms; 17 x 10 1/2 x 9 1/2 in; 18 lb, 8 oz ea. Sold only in stereo pairs \$399/pr

Model 201 Series II 3-Way Speaker

Direct/Reflecting bookshelf speaker with Free Field tweeter. Features dual-frequency crossover network; 6-in woofer; 2-in tweeter; auto tweeter protection. Available in rosewood vinyl-veneer finish; five-year warranty. Power handling 120 W max rms; crossover points 1,500 and 2,500 Hz; imp 8 ohms; 14 1/2 x 7 3/4 x 9 in; 19 lb/ea \$269/pr

Model 101 Indoor/Outdoor 1-Way Speaker

Indoor/outdoor ported speaker. Features high-impact polystyrene cabinet for environmental applications; 4 1/2-in full-range driver. Optional multi-purpose mounting arms and brackets available at extra cost; finished in black or white with white, blue, red, or green grilles. Power handling 60 W max rms; imp 4 ohms. 9 x 6 x 5 in; 10 lb/pr \$219/pr

.2 Series

Model 10.2 3-Way Speaker

Floor-standing ported speaker with an 8-in midrange driver, two 2-in tweeters and an 8-in subwoofer. Features Acoustimass system technology; Stereo Everywhere; Stereo Targeting; automatic system protection; Syncom II computer quality control. Hardwood veneer finish; five-year warranty. Power handling 180 W max rms; sens 88 dB; imp 8 ohms. 38 3/4 x 11 3/4 x 11 3/4 in; 46 lb/ea \$1,299/pr

Model 6.2 2-Way Speaker

Bookshelf speaker with controlled-dispersion-pattern design with Direct/Reflecting speaker technology. Features 8-in woofer; two 3-in tweeters; Stereo Targeting system; dual-chamber sub-ported bass

venting system, interactive crossover network. Hardwood veneer with teak finish; five-year warranty. Power handling 200 W max rms; imp 4 ohms. 20 x 10 x 9 3/8 in; 19 lb, 8 oz ea. Optional speaker stand (AS-1) available at extra cost \$599/pr

Model 4.2 2-Way Speaker

Compact bookshelf speaker with Direct/Reflecting speaker technology. Features 8-in woofer; 2 1/2-in axial-mounted tweeter; Stereo Targeting system; dual-chamber bass venting system with slot-port exit; auto tweeter protection circuit. Vinyl veneer with teak finish; five-year warranty. Power handling 150 W max rms; imp 8 ohms. 18 x 9 1/2 x 10 in; 15 lb/ea. Optional speaker stand (AS-1) available at extra cost \$399/pr

Model 2.2 2-Way Speaker

Compact bookshelf speaker with Direct/Reflecting speaker technology. Features 6-in long-excursion woofer; 2-in magnetic-fluid-cooled tweeter; slot-port bass tuning system; Teak vinyl finish; five-year warranty. Power handling 150 W; imp 8 ohms. 9 7/8 x 14 3/4 x 7 1/2 in; 12 lb/ea \$269/pr

Acoustimass Series

AM-5 Acoustimass Subwoofer/Satellite System

Compact modular system with Acoustimass bass module and Direct/Reflecting cube speaker arrays. Each array features 2 separate cube enclosures that can be adjusted for direct or reflecting configuration. The bass module has two 6 1/2-in drivers and a patented Acoustimass enclosure. Features positive-temperature coefficient resistor to compress overloading input signals. Scratch-resistant black satin finish for the acoustimass module, black polymer finish for the cube speaker arrays; five-year warranty. Power handling 100 W max rms. Cube speaker array: 3 1/2-in per side plus grille. Bass module: 12 x 20 x 8 in; 33 lb \$799

Acoustimass SE-5 Subwoofer/Satellite System

Compact modular system with Acoustimass bass module and Stereo Targeting arrays. Each array includes two 2 1/2-in magnetically shielded wide-range drivers in a black enclosure. Bass module has two 6-in subs that fire into 2 internal chambers. Features positive temperature coefficient protection circuit; high positive current coefficient resistor; Scratch-resistant black satin finish, black polymer finish for the stereo targeting arrays; five-year warranty. Power handling 100 W max rms; imp 6 ohms. Array: 8 1/4 x 4 7/8 x 3 3/8 in. Bass module: 7 3/8 x 12 3/8 x 20 1/4 in; 33 lb \$799

Acoustimass 3 Subwoofer/Satellite System

Acoustimass bass module and two magnetically shield cube enclosures. Features a 5 1/4-in woofer and two 2 1/2-in wide-range transducer to operate in a range above 200 Hz. Black finish; optional accessories include wall/ceiling mount brackets. Power handling 100 W max. Cube enclosure: 4 1/2 x 3 1/2 x 4 1/2 in, bass module: 14 x 8 x 8 in \$599

Free-style 1-Way Speaker System

European-styled compact speaker system with Bose patented curved and flared port design. Features a 4 1/2-in full range driver with a copper pole piece to handle the extreme high frequency and high power handling. Black or red finish. Power handling 120 W max. 9 1/2 x 5 1/2 x 6 in \$339

RoomMate II Portable Powered Speaker

Pair of speakers with built-in stereo amp to accept output of pocket stereo and portable CD player through audio cable. AC/DC compatible. 4 1/2-in full-range driver with helical voice coils in each speaker. Features 2-stage active equalization network; distortion-limiting circuitry; dual-channel power amp. Power supply 25 W transformer; Fibreglas-reinforced injected styrene cabinet. Sens 102 dB. 6 1/4 x 2 3/4 x 4 1/4 in; 10 lb. Black finish \$339/pr

Power Case. Includes rechargeable battery, charger, travel bag, car adapter \$219.95
 TB-II, Travel Bag \$99.95
 Car Adaptor \$19.95
 WB-10, Wall Brackets \$24.95/pr
 MIMA-4, Mounting Arms \$59.95/pr
 WC-5, Wall/Ceiling Brackets \$59.95/pr

Video RoomMate Powered Speaker

Bass-reflex bookshelf speaker for use with any VCR, TV, monitor, or LaserDisc player. Features 4 1/2-in fully shielded full-range helical-voice-coil driver; fully shielded electronic amplification/active equalization system; dual-tuned ports; 6-ft RCA cable; volume control; mono 4-connector. Grey enclosures with black baffle and silver/grey grille. 6 x 9 x 6 in; 11 lb, 9 oz \$339/pr

BSM

Series 12 MKII 4-Way Speaker

Floor-standing passive-radiator speaker with 12-in polypropylene-cone passive radiator, 12-in polypropylene cone woofer, 4-in cone midrange, and 2-in cone tweeter. Features circuit overload protection. FR 30-20,000 Hz ± 3 dB; min power 15 W rms; max power 100 W rms; sens 94 dB SPL/W/m; imp 4/8 ohms. Ebony woodgrain finish. 15 x 41 x 11 in; 37 lb \$399/pr

Series 7 MKV 3-Way Speaker

Floor-standing acoustic-suspension speaker with 12-in polypropylene cone woofer, 4-in cone midrange, and 2-in cone tweeter. Features circuit overload protection. FR 30-20,000 Hz ± 3 dB; min power 15 W rms; max power 100 W rms; sens 94 dB SPL/W/m; imp 4/8 ohms. Ebony woodgrain finish. 15 x 27 x 11 in; 28.5 lb \$299/pr

Series 4 MKV 3-Way Speaker

Floor-standing acoustic-suspension speaker with 10-in polypropylene cone woofer, 3-in cone midrange, and 1-in cone tweeter. Features circuit overload protection. FR 40-20,000 Hz ± 3 dB; min power 15 W rms; max power 65 W rms; sens 92 dB SPL/W/m; imp 4/8 ohms. Ebony woodgrain finish. 14 x 24 x 10 in; 18.5 lb \$249/pr

Series 3 MKV 3-Way Speaker

Acoustic-suspension speaker with 8-in polypropylene cone woofer, 3-in cone midrange, and 2-in cone tweeter. Features circuit overload protection. FR 48-20,000 Hz ± 3 dB; min power 15 W rms; max power 50 W rms; sens 92 dB SPL/W/m; imp 4/8 ohms. Ebony woodgrain finish. 11 x 24 x 8 in; 16 lb \$199/pr

Series 1 2-Way Bass-Reflex Speaker

Floor-standing speaker with 8-in polypropylene cone and 2-in cone tweeter. Features circuit overload protection. FR 48-20,000 Hz ± 3 dB; power range 15-50 W rms; sens 92 dB SPL/W/m; imp 4/8 ohms. Ebony woodgrain finish. 11 x 24 x 8 in \$149/pr

CAMBRIDGE PHYSICS CORP.

G-66 II 3-Way Speaker

Two 8-in woofers, 3-in dome midrange, 1-in dome tweeter. FR 26-22,500 Hz; sens 92.5 dB; crossover at 450, and 4,000 Hz. 44 x 18 x 12 in; 90 lb. . \$900 ea

G-33 II 2-Way Speaker

One 10-in and one 8-in woofer, 1-in dome tweeter. FR 36-22,500 Hz; sens 91 dB; imp 6 ohms; crossover at 1,500 Hz. 29 1/2 x 16 x 9; 34 lbs \$550/pr

G-11 II 2-Way Speaker

8-in woofer, 1-in dome tweeter. Power handling 15-100 W; FR 44-22,500 Hz; sensitivity 90 dB; impedance 6 ohms; crossover at 1,500 Hz. 19 1/2 x 12 x 8 1/2 in; 20 lb \$350/pr

G-7 II 2-Way Speaker

6 1/2-in woofer, 3/4-in dome tweeter. Power handling

SPEAKERS

10-60 W; FR 60-20,000 Hz; sensitivity 90 dB; impedance 6 ohms; crossover at 2,500 Hz. 16 x 12 x 6 in.; 15 lb. \$260/pr

CAMBRIDGE SOUNDWORKS

Ensemble by Henry Kloss Subwoofer/Satellite

Full speaker system consisting of 2 subwoofers and 2 satellite units. Each satellite features 3/2-in ferrofluid-cooled cone midrange (170 Hz to 2,300 Hz), and 1 3/4-in direct radiator with an integral 3/8-in ferrofluid-cooled dome tweeter (2,300 Hz to 20,000 Hz); cabinet is high-density particle board finished in dark gray Nextel; metal grilles. Each low-frequency unit features 8-in long-throw acoustic-suspension driver; cabinet is made of high-density particle board with internal bracing, and is finished in black high-pressure laminate with metal grilles. Nom imp 6 ohms; power range 25-100 W. Subwoofer: 12 x 21 x 4 1/2 in. Satellite: 5 1/2 x 8 x 4 in. \$499

Ambiance by Henry Kloss 2-Way Speaker

Acoustic-suspension speaker with 6 1/2-in long-throw woofer and a 1-in ferrofluid-cooled tweeter. Crossover at 1,800 Hz; sens 83 dB SPL/W/m; nom imp 8 ohms; min power 15 W/ch. Available in Nextel; solid oak; or primed for painting. 7 x 11 x 5 1/2 in Nextel or primer. \$109 ea
Solid oak. \$129 ea

CANTON

Active Speakers

CA 30 3-Way Powered Speaker

Quad-amplified floor-standing speaker with a differential amp and motional feedback system for each driver section (120 W woofer, 100 W midrange, 100 W tweeter). Features four 10 1/8-in cone woofers; 8-in cone woofer; 1 1/2-in metal-dome midrange; 1-in aluminum/manganese dome tweeter; Darlington output stage for amps; auto on/off stabilized dual mains supply; electronically controlled protection circuitry; Bass, midrange and treble level control. FR 20-30,000 Hz, ± 3 dB; crossover frequency 220/1600/4500 Hz; bandwidth 3-140,000 Hz; s/n 100 dB. Black-ash or matte-mahogany finish. 15 x 66 1/2 x 16 1/2 in; 275 lb. \$16,500/pr

CA 20 4-Way Powered Speaker

Quad-amplified floor-standing speaker with a differential amp and motional feedback system for each driver section (120 W woofer, 100 W midrange, 100 W tweeter). Features two 10-in cone woofers; 8-in cone woofer; 1 1/2-in metal-dome midrange; 1-in aluminum/manganese dome tweeter; Darlington output stage for amps; auto on/off stabilized dual mains supply; electronically controlled protection circuitry. Bass, midrange and treble level control. FR 20-30,000 Hz, ± 3 dB; bandwidth 3-140,000 Hz; s/n 100 dB; crossover frequency 220/1600/4500 Hz. Black-ash or matte-mahogany finish. 13 3/8 x 48 3/8 x 12 3/8 in; 175 lb. \$10,000/pr
Gloss black, white, mahogany, or custom \$12,000/pr

CA 15 3-Way Powered Speaker

Tri-amplified floor-standing speaker with electronic signal correction of all drivers. Features 10-in long-throw woofer; 5-in midrange; 1-in aluminum/manganese dome tweeter; crossover frequencies 350/3,500 Hz; 3 separate 100-W amplifiers for bass, midrange and treble; bass and treble level control. FR 20-30,000 Hz, ± 3 dB; THD < 0.03%. s/n 100 dB; crossover frequency 350/3500 Hz. Black-ash or matte-mahogany finish. 12 1/4 x 35 3/8 x 12 3/8 in. \$6,500/pr
Gloss black or white. \$7,000/pr

Floor-Standing Speakers

CT 120 4-Way Speaker

Bass-reflex speaker features 12-in woofer; 8-in bass/midrange; 1 1/2-in midrange; 1-in aluminum/manganese dome tweeter. Power handling 200 W continu-

ous/350 W peak; imp 4 ohms; FR 18-30,000 Hz; sens 95.2 dB SPL/W/m; crossover frequencies 250/1,100/4,600 Hz. Black and white ash, matte mahogany, oak or walnut finish. 14 1/4 x 47 1/4 x 15 in; 110 lb, 4 oz. \$5,000/pr
Gloss finishes, custom. \$6,250/pr

CT 100 4-Way Speaker

Bass-reflex speaker features 10-in woofer; 6-in bass/midrange; 1 1/2-in midrange; 1-in aluminum/manganese-dome tweeter. Power handling 180 W continuous/300 W peak; imp 4 ohms; FR 24-30,000 Hz; sens 94.8 dB SPL/W/m; crossover frequencies 250/1,100/4,600 Hz. Black and white ash, matte mahogany, oak or walnut finish. 12 3/8 x 41 1/4 x 13 3/8 in; 79 lb, 6 oz. \$3,500/pr
Gloss finishes, custom. \$4,500/pr

CT 90 3-Way Speaker

Bass-reflex speaker features 10-in woofer; 5-in midrange; 1-in aluminum/manganese-dome tweeter. Power handling 150 W continuous/250 W peak; imp 4 ohms; FR 24-30,000 Hz; sens 93.4 dB SPL/W/m; crossover frequencies 450/4,000 Hz. Black and white ash, matte mahogany, oak or walnut finish. 12 1/4 x 35 1/2 x 12 3/8 in; 53 lb. \$2,400/pr
Gloss finishes, custom. \$3,250/pr

CT 80 3-Way Speaker

Bass-reflex speaker features 8 1/2-in woofer; 5-in midrange; 1-in aluminum/manganese-dome tweeter. Power handling 100 W continuous/150 W peak; imp 4 ohms; FR 24-30,000 Hz; sens 93.4 dB SPL/W/m; crossover frequencies 450/4,000 Hz. Black and white ash, matte mahogany, oak or walnut finish. 11 x 22 3/8 x 11 1/4 in; 41 lb, 14 oz. \$1,650/pr
Gloss finishes, custom. \$2,250/pr

Fonum 600 3-Way Speaker

Bass-reflex speaker features 9-in woofer, 1 1/2-in fabric dome midrange and a 3/4-in fabric-dome tweeter. Black grille. Power handling 90/130 W; imp 4 ohms; FR 30-26,000 Hz; crossover frequency 900/5000 Hz. black ash finish. 10 1/4 x 31 1/2 x 11 in. \$995/pr

Bookshelf Speakers

Karat 60 3-Way Bookshelf Speaker

Bass-reflex speaker featuring 10-in woofer; 5-in midrange; 1-in aluminum/manganese-dome tweeter. Power handling 100 W continuous/150 W peak; imp 4 ohms; FR 24-30,000 Hz; sens 93.9 dB SPL/W/m; crossover frequency 450/4,000 Hz. Oak, walnut, mahogany, white or black finish. 12 3/8 x 22 3/8 x 12 3/8 in; 36 lb, 6 oz. \$1,590/pr
I.F 500. Speaker stand for Karat 60. \$350/pr
FG 200. Speaker stand for Karat 60. \$200/pr

Karat 40 3-Way Bookshelf Speaker

Bass-reflex speaker featuring 9-in woofer; 5-in midrange; 1-in aluminum/manganese-dome tweeter. Power handling 90 W continuous/130 W peak; imp 4 ohms; FR 24-30,000 Hz; sens 92.6 dB SPL/W/m; crossover frequency 450/4,000 Hz. Oak, walnut, mahogany, white or black finish. 10 3/8 x 20 1/8 x 10 3/8 in; 28 lb, 11 oz. \$1,290/pr
I.F 500. Speaker stand for Karat 40. \$350/pr

Karat 30 2-Way Bookshelf Speaker

Bass-reflex speaker featuring 9-in woofer; 1-in aluminum/manganese-dome tweeter. Power handling 80 W continuous/110 watts peak; impedance 4 ohms; frequency response 30-30,000 Hz; sensitivity 92.2 dB SPL/W/m; crossover frequency 2,000 Hz. Oak, walnut, mahogany, white or black finish. 10 3/8 x 17 x 10 3/8 in; 22 lb. \$890/pr
CF 70. Speaker stand for Karat 30. \$250/pr

Fonum 400 3-Way Bookshelf Speaker

Bass-reflex speaker features 9-in woofer, 1 1/8-in fabric dome midrange and a 3/4-in fabric-dome tweeter. Black grille. Power handling 70/110 watts; impedance 8 ohms; frequency response 35-26,000 Hz;

crossover frequency 900/5000 Hz. Black ash finish. 10 1/4 x 18 1/8 x 9 3/4 in. \$749/pr

Karat 20 2-Way Bookshelf Speaker

Bass-reflex speaker featuring 8-in woofer; 1-in aluminum/manganese-dome tweeter. Power handling 50 W continuous/80 W peak; imp 4 ohms. FR 36-30,000 Hz; sens 91.9 dB SPL/W/m; crossover frequency 2,500 Hz. Oak, walnut, mahogany, white or black finish. 8 3/8 x 13 3/8 x 7 7/8 in; 12 lb, 2 oz. \$690/pr
CF 70. Speaker stand for Karat 20. \$250/pr

Fonum 300 2-Way Bookshelf Speaker

Bass-reflex speaker features 8-in woofer, 1-in fabric-dome tweeter. Black grille. Power handling 50/80 W; imp 8 ohms; frequency response 38-26,000 Hz; crossover frequency 2500 Hz. Black ash finish. 8 3/4 x 13 3/4 x 7 7/8 in. \$495/pr

Mini Speakers

InWall 9 2-Way Speaker

Features 9-in woofer and 1-in aluminum/manganese dome tweeter. White grille. Power handling 80/110 W; imp 4 ohms. 10 1/4 x 10 1/4 x 3 1/4 in. \$600/pr
Framing kit (for new construction). \$30/pr

GL 300 F 2-Way Speaker

Speaker acoustically tuned for wall mounting. Features 1-in dome tweeter (fabric); long-throw 6 3/8-in cone woofer cone. Enclosure surfaces black or white; grille of perforated steel plate; color to match enclosure; permafix spring clamps; 5-m connecting cable; removable grille. imp 4 ohms; power handling 40/60 W; FR 48-30,000 Hz; crossover at 1,700 Hz; sens 87.3 dB SPL/W/m. 8 3/8 x 13 3/8 x 3 1/8 in; 7 lb, 11 oz. \$500/pr
With walnut finish. \$550/pr

GL 260 2-Way Speaker

Speaker with 6 3/8-in woofer, 1-in dome tweeter. Features wall-mounting suitability; perforated metal grille. FR 42-30,000 Hz; crossover 1,700 Hz; power handling 45/70 W; sens 87.3 dB SPL/W/m; imp 4 ohms. White or black finish. 7 1/8 x 10 1/2 x 4 3/4 in; 7 lb, 8 oz. \$490/pr
CF 70. Speaker stand for GL 260. \$250/pr
Cantomount 1. "L" shaped mounting bracket for GL 260. \$30/pr
Cantomount 2. Ball-joint mounting bracket for GL 260. \$50/pr

HC 100 2-Way Speaker

Bookshelf speaker with 4 3/8-in cone woofer, 1-in dome tweeter. Features Permafix spring clamps; 5-m connecting cable; one-point mounting fixture; removable grille. FR 48-30,000 Hz; power 35/60 W; imp 4 ohms; sens 87.2 dB SPL/W/m. Black, white or bronze finish. 7 1/2 x 4 3/4 x 5 3/4 in; 4 lb. \$340/pr

Plus S 2-Way Speaker

Speaker suitable as satellite in connection with Canton Plus Beta and Plus C subwoofers. Features 4 3/8-in cone woofer; 1-in dome tweeter; flush wall mount; removable grille. FR 45-30,000 Hz; power handling 40/70 W; sens 87.2 dB SPL/W/m; imp 4 ohms. Black, white or brown finish. 4 3/4 x 8 x 4 in; 5 lb. \$340/pr
Walnut finish. \$495/pr
CF 70. Speaker stand for Plus S. \$250/pr
Cantomount 2. Ball-joint mounting bracket for Plus S. \$50/pr
Cantomount 1. "L" shaped mounting bracket for Plus S. \$30/pr

Subwoofers

Plus Beta Powered Subwoofer

Floor-standing bi-amplified woofer system containing amplification for satellites and subwoofer. Features 12 3/8-in cone woofer; signal-correction circuit; thermal overload; short-circuit protection; bass level control; adjustable crossover; adjustable input sens;

The Infinite Slope Series

The patented technology available only in JSEng. speakers, combined with advanced aspects of enclosure design and component construction make the Infinite Slope speaker series a source of unlimited dimensionality, incredible accuracy and unmatched musicality.



JS ENGINEERING

The "Infinite Slope Series" available at better audio dealers.
519 East Middle Turnpike Manchester, CT (203) 643-2160

Manufactured under license by Modafert Acoustical Labs Pat #4771466,4403112

CIRCLE NO. 15 ON READER SERVICE CARD

SPEAKERS

auto on/off; terminals and switching for up to 4 satellite speakers. FR 20-70/90/120 Hz, ± 3 dB; amp output power 140 W ea; THD and $<0.1\%$. Black, white, or walnut finish. 13 $\frac{3}{8}$ x 15 $\frac{1}{8}$ x 15 in; 41 lb, 14 oz. \$2,000 ea

Plus C Subwoofer

Compact passive 12 $\frac{3}{4}$ -in cone subwoofer for use in connection with satellites such as Canton Plus S. FR 22-120 Hz; power handling 75(2x) W; sens 89.9 dB SPL/W/m; imp 4 ohms. Black, white or walnut finish. 14 $\frac{3}{4}$ x 13 $\frac{3}{8}$ x 13 $\frac{3}{4}$ in; 26 lb, 4 oz. \$575 ea

CARTER-CRAFT

40-432 Powered Mini Speaker System

Speaker with DC in 4.5 V (3-C batteries - ea.). Features hook-up cables with 3.5 mm phone plug. Black with silver trim. 4 x 5 x 4 in. \$36/pr

40-434 Mini-Tower Powered Speaker System

Speaker with built-in amplifier 1.5 W. Features 4 speakers; AC adapter jack; DC-6 V (4-C batteries); hook-up cables with 3.5 mm phone plug. Black. 2 $\frac{1}{2}$ x 6 $\frac{1}{2}$ x 3 $\frac{3}{8}$ in. \$28/pr

40-428 "Pick-Pocket" Folding Speaker System

Folding speakers for mini stereo systems. Features 2-in stereo cable; suede-cloth carrying case. 4 x 2 $\frac{1}{2}$ in folded size; 1 lb. \$22/pr

CARVER

The Amazing Loudspeaker, Platinum Edition

1 $\frac{1}{2}$ -in-thick planar design speaker with 60-in full-range ribbon driver and integral subwoofer section consisting of 4 long-throw 12-in cone woofers. FR 23-40,000 Hz - 3 dB; sens 89 dB; max SPL 121 dBA; power handling 800 W. Available in piano-lacquer black and genuine oak finishes. 30 x 66 x 10 in (at base); 110 lb/ea. \$2,195/pr

The Amazing Loudspeaker, Silver Edition

1 $\frac{1}{2}$ -in-thick planar design speaker with 40-in full range ribbon driver and integral subwoofer section consisting of 3 long-throw 12-in cone woofers. FR 23-40,000 Hz - 3 dB; sens 89 dB; max SPL 119 dBA; power handling 600 W. Available in piano-lacquer black and genuine oak finishes. 22 x 54 x 10 in (at base); 75 lb/ea. \$1,795/pr

CELESTION

SL700 2-Way Speaker

Sealed-box design speaker with metal-dome tweeter and 2-part roll surround on the woofer. Features Aerolam cabinet of 12-liter volume. Power handling 120 W. With integral stand. \$3,000/pr

System 6000 Subwoofer

Double dipole low-frequency array with two 12-in long-throw units in each of the 2 systems. Features electronic section with crossover and EQ; variable gain and extension controls. \$2,700/pr

SL600 Si 2-Way Speaker

Speaker with metal-dome tweeter and a 6-in plastic bass unit. Features cabinet made from Aerolam, an aluminum honeycomb construction. \$2,000/pr

SL12 Si 3-Way Speaker

Speaker with metal-dome tweeter, 6-in bass/midrange, 6-in woofer. Features cabinet with a complete figure-8 bracing; bass units with separate enclosures. \$1,500/pr

DL12 Series 2 2-Way Speaker

Floor-standing speaker with two 8-in woofers and 1-in pure-titanium tweeter. Features Transfer Bass Loading enclosure. \$1000/pr

SL6 Si 2-Way Speaker

Speaker with one piece metal-dome tweeter and 6-in

plastic bass unit. Features figure-8 bass cabinet bracing and fully locked rear panel; gold-plated connectors. \$950/pr

DL10 Series 2 3-Way Speaker

Bass-reflex speaker with 10-in woofer, 6-in midrange, 1 $\frac{1}{4}$ -in aluminum-dome tweeter. Features separate midrange enclosure. \$929/pr

DL8 Series 2 2-Way Speaker

Sealed-cabinet, stand-mountable speaker with 8-in celoprene cone woofer and 1-in metal tweeter. Uses a figure-8 cabinet brace. Available in simulated American walnut or black finishes. \$540/pr

DL6 Series 2 2-Way Speaker

Sealed-box, stand-mountable speaker with 8-in woofer and 1-in metal-dome tweeter. Available in simulated American walnut and black finishes. \$430/pr

DL4 Series 2 2-Way Speaker

Sealed-box, bookshelf speaker with 6-in woofer and 1-in metal-dome tweeter. \$330/pr

Celestion 3 2-Way Speaker

Bookshelf speaker with 5-in woofer and 1-in pure-titanium tweeter. \$250/pr

CELLO

Amati 3-Way Speaker

Compact speaker for wall, shelf, or stand mounting. Features four tweeters, four midranges, and one woofer housed in a braced cabinet; tweeter, midrange, and woofer crossover are separate for tri-wiring, but can be bussed together for 2-wire connection. sens 90 dB at 2.83 V; imp 4 ohms, 2 ohms above 5,000 Hz. oak finish. 27 x 20 x 10 in. \$3,500/pr

CERCA

All Cerca speakers are omni directional and are housed in ceramic vase enclosures. All speakers feature a 5-year warranty on all electronic components.

Victoria 200 3-Way Speaker

Floor-standing speaker with 8-in cobex woofer, 5-in polypropylene midrange, and 1-in metal-dome tweeter. Features bi-ampable gold-plated, binding posts; 12 element hard-wired crossover. Power range 20-220 W; FR 36-20,000 Hz ± 3 dB; sens 86 dB SPL/W/m; crossover points at 400 and 2,500 Hz. Antique glaze with gray or brown glaze decoration. 35 $\frac{3}{4}$ x 13 $\frac{3}{4}$ in; 33 lb. \$2,200/pr

Victoria 120 3-Way Speaker

Floor-standing speaker with 6 $\frac{1}{2}$ -in cobex woofer, 5-in polypropylene midrange, and 1-in metal-dome tweeter. Features bi-ampable, gold-plated binding posts; 12 element hard-wired crossover. Power range 20-180 W; FR 41-20,000 Hz ± 3 dB; sens 86 dB SPL/W/m; crossover points at 500 and 2,500 Hz. Antique glaze with gray or brown glaze decoration. 33 $\frac{1}{2}$ x 12 $\frac{3}{8}$ in; 22 lb. \$1,700/pr

Classic 120 3-Way Speaker

Floor-standing speaker with 6 $\frac{1}{2}$ -in cobex woofer, 5-in polypropylene midrange, 1-in metal-dome tweeter. Features bi-ampable, gold-plated binding posts; 12 element hard-wired crossover. Power range 20-180 W; FR 42-20,000 Hz ± 3 dB; sens 86 dB SPL/W/m; crossover pts at 500 and 2,500 Hz. Lead free glazes in black, gray, and silky white. 34 $\frac{1}{2}$ x 13 $\frac{3}{8}$ in \$1,700/pr

Hi-150 Subwoofer/Satellite System

System includes Hi-150 subwoofer and Hi-150 satellite. Power range 20-220 W; FR 34-20,000 Hz; sens 86 dB SPL/W/m; crossover points 500 and 2,500 Hz. \$1,000/system

Hi-150 Subwoofer

Subwoofer with two 10-in polypropylene bass speak-

ers housed in one enclosure. Crossover frequency at 500 Hz. 18 x 14 $\frac{1}{4}$ in. \$600 ea

Hi-150 2-Way Satellite System

2-way system with 5-in polypropylene midrange and 1-in metal-dome tweeter. Frequency response 500-20,000 Hz. 12 $\frac{1}{2}$ x 11 in. \$400/pr

CERWIN-VEGA

Digital Series

D-9 3-Way Speaker

3-way, 4-driver, floor-standing speaker with 15-in woofer, dual 6-in midrange and 1-in tweeter. Features Helmholz/Theile enclosure fabricated from high-density pressed board with woodgrain vinyl finish and brown stretch grille. Power range 5-350 W; FR 29-20,000 Hz; sens 101 dB; imp 4 ohms; crossover frequencies 500 and 3,500 Hz; 18 x 35 $\frac{1}{2}$ x 17 $\frac{1}{4}$ in; 85 lb. \$1,050/pr

D-7 3-Way Speaker

3-way tower speaker with 12-in woofer, dual 6-in cone distributed midrange driver in large chamber, 1-in horn tweeter. Features circuit protection; midrange, tweeter-level controls. Max power 200 W; FR 25-20,000 Hz ± 3 dB; crossovers 500 and 3,500 Hz; sens 98 dB SPL/W/m; imp 8 ohms. \$870/pr

D-5 3-Way Speaker

Floor/shelf 3-way speaker with 12-in woofer, 6-in cone midrange, 1-in horn tweeter. Features circuit protection; tweeter level controls. Max power 150 W; frequency response 32-20,000 Hz ± 3 dB; crossovers 700 and 3,500 Hz; sensitivity 96 dB SPL/W/m; impedance 8 ohms. \$660/pr

D-3 3-Way Speaker

3-way shelf speaker with 10-in woofer, 6-in cone midrange, 1-in horn tweeter. Features circuit protection; midrange, tweeter level controls; FR 30-20,000 Hz ± 3 dB; crossovers 700 and 3.5 kHz; sens 94 dB SPL/W/m; imp 8 ohms; finished in hickory woodgrain vinyl w/brown stretch cloth grille. \$580/pr

D-2 2-Way Speaker

2-way speaker system with 10-in woofer in a cast aluminum frame and 1-in voice coil horn. Features high-frequency protection circuit breaker; direct-radiating vented enclosure. Power handling 5-125 W; FR 30-20,000 Hz; sens 94 dB; imp 8 ohms; crossover frequency 3,000 Hz. Hickory woodgrain vinyl finish with brown stretch cloth grille. 23 $\frac{1}{2}$ x 14 x 10 in; 38 lb. \$440/pr

D-1 2-Way Speaker

2-way system with an 8-in woofer and 1-in voice-coil high frequency horn. Features resettable high-frequency-protection circuit breaker; vented cabinet; FR 30-20,000 Hz; power min/max 5/100 W; sens 92 dB W/m; 8 ohms imp; crossover frequency 3,000 Hz; Hickory woodgrain vinyl with cloth grille. 20 x 11 x 10 in; 49 lb/pr. \$340/pr

SW-12B Subwoofer

Vented direct radiating subwoofer compatible with most 4/8 ohm speakers. Features 12-in floor facing woofer built on a diecast aluminum frame with 7 lb magnet. Power range 5-125 W; sens 92 dB W/m. Woodgrain vinyl veneer finish. 13 $\frac{3}{4}$ x 25 $\frac{1}{2}$ x 16 $\frac{1}{4}$ in; 48 lb. \$320/ea

AT Series

AT-15 3-Way Speaker

3-way bass-reflex speaker includes two fuse protection. Features 15-in woofer; 2 5-in midranges; dome tweeter. Power 5-400 W; sens 102 dB SPL/W/m; imp 4 ohms; 36 $\frac{1}{2}$ x 19 x 18 $\frac{1}{2}$ in; 85 lb. \$1,080/pr

AT-12 3-Way Speaker

Similar to above with 12-in woofer; 1 5-in midrange.

fi·del'ə·tī

1. Tonal fidelity ensures the faithful reproduction of the exact timbre of each specific musical sound.
2. Spatial fidelity ensures the accurate recreation of the positions and "feel" of instruments in three dimensional space.
3. Transient fidelity ensures the clarity of subtle musical detail and nuances necessary for a sense of reality.
4. Dynamic fidelity ensures the preservation of musical contrasts that are crucial to musical enjoyment.

THIEL Coherent Source®



Loudspeakers preserve the time and phase information of music, providing more complete musical performance than conventional speakers. This time and phase accuracy, along with cabinets designed to greatly reduce diffraction and enclosure resonances, provides unsurpassed spatial fidelity.

Instruments are correctly placed in their originally recorded positions; the sound stage is wide, extending even beyond the speakers, and remains stable in space regardless of listener position.

Accurate imaging, along with the extreme tonal accuracy provided by very uniform frequency response, and the exceptional clarity achieved by very rigid cabinets, sophisticated drivers and high quality electrical components together provide loudspeakers that deliver complete musical fidelity. We invite you to audition them with the music you love most.

"The CS3.5 is the finest, most accurate loudspeaker I've had the pleasure of reviewing ...one amazing loudspeaker."

—Bruce Bartlett, *High Performance Review* April 1988

"The Thiel 3.5 is a true standard for dynamic speakers. An extraordinarily musical speaker."

—Bebo Morani, *AUDIO Review, Italy* April 1987

"The Thiel CS3.5 is a remarkable loudspeaker. It offers exceptional imaging, both laterally and in terms of depth."

—*Audio Ideas* 1987

"... musically, the CS2 is outstanding ... The imaging and depth are ... exceptional."

—Anthony H. Cordesman, *Stereophile* Vol.8 No.6

"After the first couple of minutes, we had no doubt that the CS2s were exceptional speakers."

—Julian Hirsch, *Stereo Review* January 1986

"The CS2 provides incredible stereo imaging with stunning depth. This is the speaker of choice for the music lover in search of a true rendition of timbres and dynamics."

—*Revue Du Son, France* June 1987

"This [CS1.2] loudspeaker excels in so many areas that it is hard to find significant criticisms to make ... truly a remarkable product."

—Karl Eransford, *Hi Fi Heretic* number 10

"You might hope for this caliber of sound from a speaker selling for upwards of \$2,000 ... it [CS1.2] is worth hearing even if you have no plans to buy a speaker."

—Julian Hirsch, *Stereo Review* January 1989

"It's most unusual to get this much sonic precision at this low a price," [CS1.2]

—Larry Archibald, *Stereophile* January 1989

Suggested prices: CS1.2 \$1090, CS2 \$1650, CS3.5 \$2450, CS5 \$9200. Call or write for product information, reviews and the name of your nearest dealer

THIEL • 1042 Nandino Boulevard • Lexington, Kentucky 40511 • 606-254-9427

CIRCLE NO. 39 ON READER SERVICE CARD

SPEAKERS

Power handling 5-200 W; sens 97 dB W/m; imp 6 ohms; 30 x 16 x 14 in; 55 lb \$690/pr

AT-10 3-Way Speaker

Similar to above with 10-in woofer; internal self-resetting circuit breaker. Power handling capacity 5-150 W; sens 95 dB; imp 6 ohms. 28½ x 14 x 13½ in; 40 lb \$620/pr

Sat-6 Subwoofer/Satellite System

6½-in 2-way satellites, with a 10-in dual voice-coil bass driver. CT3 dome tweeter; 6½-in cone midrange. Power handling 200 W; FR 40-20,000 Hz; sens 96 dB; imp 8 ohms. Woodgrain vinyl, fabric grilles. Satellites 9½ x 12¾ x 8½ in, woofer 17 x 17 x 17 in \$599

AT-8 2-Way Speaker

2-way version of above with 8-in woofer, dome tweeter. Power handling 5-100 W; sens 94 dB; imp 6 ohms. 21 x 12 x 10 in; 26 lb \$410/pr

SE Series

380SE 3-Way Speaker

Floor-standing bass-reflex speaker with 15-in cone woofer. Features two 7-in cone midranges; 1-in VC elliptical tweeter. Power handling 5-405 W; FR 29-20,000 Hz ± 3 dB; sens 102 dB SPL/W/m; imp 4 ohms. Finished in black vinyl. 36 x 17½ x 19½ in; 90 lb \$1,080/pr

300SE 3-Way Speaker

Floor-standing bass reflex speaker with 12-in cone woofer. Features 7-in cone midrange; 1-in VC horn-loaded elliptical dome tweeter. Power handling 5-255 W; FR 25-20,000 Hz ± 3 dB; sens 98 dB SPL/W/m; imp 6 ohms. Finished in black vinyl. 32 x 14½ x 16¼ in; 65 lb \$900/pr

280SE 3-Way Speaker

Floor-standing bass-reflex speaker with 12-in cone woofer. Features 6-in cone midrange; 1-in VC horn-loaded elliptical dome tweeter. Power handling 5-155 W; FR 32-20,000 Hz ± 3 dB; sens 96 dB SPL/W/m; imp 6 ohms. Finished in black vinyl. 25½ x 14½ x 11½ in; 45 lb \$690/pr

250SE 3-Way Speaker

Floor-standing bass-reflex passive speaker with 10-in cone woofer. Features Hemholtz Thiele enclosure with sound-absorbent baffle; circuit breaker protection; 6-in cone midrange; 1-in VC horn-loaded elliptical dome tweeter. Power handling 5-125 W; FR 32-20,000 Hz ± 3 dB; sens 95 dB SPL/W/m; imp 6 ohms; Finished in black vinyl. 28 x 12½ x 11½ in; 41 lb \$600/pr

240SE 2-Way Bookshelf Speaker

Bookshelf bass-reflex speaker with 10-in cone woofer. Features 1-in VC horn-loaded elliptical dome tweeter. Power handling 5-125 W; FR 32-20,000 Hz ± 3 dB; imp 6 ohms. 25 x 12½ x 11½ in; 36 lb \$470/pr

200SE 2-Way Bookshelf Speaker

Features 8-in woofer; 1-in tweeter; vented tuned, direct radiating design. Power handling 5-100 W; FR 32-20,000 Hz ± 3 dB; imp 6 ohms. 22 x 10½ x 12¼ in \$410/pr

CHAPMAN SOUND

T9 4-Way Speaker

Air-suspension speaker comes standard in bi-wired, bi-ampable configuration with two 10-in poly laminate cone woofers, 6½-in poly laminate cone midrange, 5-in poly laminate cone midrange, and 1-in dome tweeter. FR 25-20,000 Hz ± 3 dB; min power 50 W rms; max power 500 W rms; sens 88 dB SPL/W/m; imp 2 ohms. Oak finish. 22 x 45 x 14 in; 150 lbs ea. \$3,300/pr

T7 3-Way Speaker

Air-suspension speaker available bi-wired and bi-

amp with 10-in poly laminate cone woofer, 5-in poly laminate cone midrange, and 1-in dome tweeter. FR 30-20,000 Hz ± 3 dB; min power 50 W rms; max power 200 W continuous, 500 W peak; sens 86 dB SPL/W/m; imp 4 ohms. Oak finish with black grille; 14 x 39 x 11 in; 75 lbs ea. \$1,495/pr

CITIZEN

3D System Powered Speaker

Satellite system with two remote speakers and a subwoofer. 20 W/ch \$155

SSP 303A Powered Speaker

3-in stereo speakers. 5 W/ch \$75

ASP 777

3-in speakers available in white or black. 2½ W/ch \$60

CLEMENTS

RT-7 2-Way Speaker

Floorstanding speakers with 8-in copolymer-polypropylene cone woofer and 7-in direct-inductance planar-ribbon midrange. Features compression-line bass loading; first order bass slope; oxygen-free copper cable. FR 28-25,000 Hz ± 3 dB; sens 87 dB SPL/W/m; imp 7 ohm; min power 20 W; crossover frequency at 1,575 Hz. Available in rosewood, oak, and zebrawood veneer. 48 x 10 x 19 in .. \$2,595/pr

RB-8.0 2-Way Speakers

Speakers feature 8-in polypropylene cone woofer and 7-in direct-inductance planar-ribbon mid-range. Features compression-line bass loading; frequency-tilt control. 200 W/ch; FR 32-40,000 Hz ± 3 dB; sens 88 dB/W/m; max power rating 200 W; imp 6.5 ohms; crossover frequency at 1,575 Hz. High density fibre wood with oak veneer and walnut. 26 x 13½ x 15½ in \$1,600/pr

RB-6.5 2-Way Speakers

Speakers with 6½-in high power polypropylene cone woofer and 7-in direct-inductance planar-ribbon mid-range. Features compression-line bass loading; frequency-tilt control. FR 38-40,000 Hz ± 3 dB; sens 80 dB/W/m; max power rating 150 W; imp 6.5 ohm; compression line bass loading; crossover frequency at 1,575 Hz. High density fiber wood with oak veneer. 24½ x 13½ x 13¼ in \$1,200/pr

Little d's 2-Way Speaker

Speaker system with 5¼-in polypropylene cone woofer and 5-in direct-inductance planar-ribbon midrange. Features compression-line bass loading; third-order woofer slope. FR 42-25,000 Hz ± 3 dB; sens 88 dB SPL/W/m; imp 6 ohms; max power rating 100 W; crossover frequency at 2,000 Hz. ¾-in resin impregnated plastic mold with perforated plastic grille-cloth covered; splatter black, white, gray, red, or black \$850/pr

DAHLQUIST

DQ-20 3-Way Speaker

Vertical-phase-array speaker intended for floor placement with 10-in cone woofer, 8¾-in cone midrange, ¾-in dome tweeter. Min power 70 W rms; imp 4 ohms. Oak with black or white grille \$2,000/pr

DQ-12 3-Way Speaker

Vertical-phase-array speaker with long-throw 8-in woofer, 5-in cone midrange, and 1-in aligned-fiber dome tweeter. Features woofer operating in sealed enclosure and midrange operating in aperiodic cylinder. Min power 40 W rms; imp 8 ohms. Black grille \$1,200/pr

M Series

M-909 3-Way Speaker

Floor-standing speaker with dual cast-frame woofer,

5-in midrange, and 1-in dome tweeter. Features quasi-phase array; genuine wood enclosure, spaced grill with solid wood trim, flocked anti-diffraction baffle. Sens 92 dB; power range 20-250 W; FR 30-24,000 Hz. 39¼ x 13½ x 10½ in \$1,500/pr

M-907 3-Way Speaker

Acoustic-suspension speaker with 10-in woofer, 5-in midrange, 1-in dome tweeter, damped enclosure. Sens 88 dB; power range 40-150 W; FR 30-24,000 Hz. Real-wood walnut enclosure, spaced grille with solid walnut trim. 28 x 14½ x 12½ in \$1,000/pr

M-905 2-Way Speaker

Front-firing tuned-port speaker with cast frame 8-in woofer and 1-in dome tweeter. Sens 91 dB; power range 20 W min to 125 W max; imp 8 ohm. Real wood walnut or oak enclosure, spaced grille with solid walnut trim. 24 x 13½ x 12 in \$680/pr

M-905L 2-Way Speaker

Front-firing tuned-port speaker with cast-frame 8-in woofer and 1-in dome-tweeter. Sens 91 dB; power range 20 W min to 125 W max; imp 8 ohms. Black woodgrain laminate enclosure with grille. 24 x 13½ x 12 in \$580/pr

M-903 2-Way Speaker

Front-firing tuned-port with 6½-in cast-frame woofer; 1-in dome tweeter. Features 5-way binding posts; accepts banana plugs. Nominal imp 8 ohms; power range 20-70 W; FR 48-24,000 Hz; sens 90 dB. Available in black or oak woodgrain laminate. 17 x 8½ x 10½ in; 16 lb \$450

Accessories

ST-9 Speaker Stand

Nonresonant floor stand for Dahlquist M series speakers; provides rigid mounting, 3.5° upward tilt; matte black finish; capacity; 100 lb. 11¼ x 14 x 12 in; 7.5 lb \$100/pr

DANA AUDIO

Model 1 Bookshelf Speaker

Acoustic-suspension speaker with 6½-in woofer, ¾-in titanium tweeter. Features gold binding posts. Power handling 80 W cont; FR 83-20,000 Hz ± 3 dB; imp 8 ohms; crossover at 3,150 Hz. Finished in black, scratch-resistant vinyl. Three-year warranty. 8¾ x 14¾ x 7½ in \$155/pr

dB PLUS

All speakers have 1-in dome tweeter, walnut vinyl finish, black knit grilles, and nominal impedance of 8 ohms, minimum 4 ohms.

Model 1212 3-Way Speaker

Floor-standing bass-reflex speaker with two 12-in viscous-damped cone woofers; 6½-in cone midrange. Power handling 10-200 W; FR 23-22,000 Hz ± 3 dB; sens 103 dB SPL/W/m. 36 ¾ x 12 ¼ x 11 ½ in; 54 lbs \$1,200/pr

Model 1010 2-Way Speaker

Floor-standing bass-reflex speaker with two 10-in viscous-damped cone woofers. Power handling 20-150 W; FR 25-22,000 Hz ± 3 dB; sens 100 dB SPL/W/m; 36¾ x 12¼ x 11½ in; 45 lb \$850/pr

Model 990 2-Way Speaker

Floor-standing passive-radiator speaker with 10-in viscous-damped cone woofer. Power handling 10-100 W; FR 30-22,000 Hz ± 3 dB; sens 98 dB SPL/W/m; 32¾ x 12¼ x 11½ in; 37 lb \$600/pr

Model 880 2-Way Speaker

Bass-reflex speaker with 10-in viscous-damped cone woofer. Power handling 10-100 W; FR 35-22,000 Hz ± 3 dB; sens 96 dB SPL/W/m; 24 x 12 x 11½ in; 29 lb \$500/pr



fundamentally extraordinary.

Acclaimed by the leading high end publication, the Precise Monitor 10 has built an enviable reputation for its honesty, clarity and extraordinary orchestral fundamentals.

There's an entire family of Precise loudspeakers that embodies these same qualities. Designed by noted engineer Keith Johnson with the express purpose of bringing the high end experience to a greater number of enthusiasts.

Audition Precise speakers, the affordable reference systems, today. For the name of your nearest Precise dealer, call 1-800-553-4355, and enter code 41228 when asked.

Precise

Acoustic Laboratories

Suite B 200 Williams Drive Ramsey NJ 07446

CIRCLE NO. 26 ON READER SERVICE CARD

SPEAKERS

Model 440 2-Way Speaker

Bass-reflex bookshelf speaker with 6½-in polypropylene cone woofer. Power requirements 10-80 W; FR 45-22,000 Hz ± 3 dB; sens 94 dB SPL/W/m; 16 x 9½ x 9¼ in; 16 lb. \$360/pr

dbx

All dbx speakers feature a limited 5-year warranty.

Soundfield 50 5-Way Speaker

Two vented, floor-standing enclosures each with 10-in woofer, 6½-in midrange, 4-in upper midrange, and 3 wide-dispersion ½-in tweeters. Phased arrangement produces both measurably flat response (34-20,000 Hz ± 2.5 dB) and consistent stereo imaging throughout room. Sens 91 dB SPL/2.83 V/m; imp 4 ohms nominal, 2.5 ohms min; power range 40-400 W; phased-arranged crossover 200 Hz, 800 Hz, 3,150 Hz, main axis. Walnut or black base and top with matching grilles \$2,000/pr

Soundfield 150 3-Way Speaker

Vented, floor-standing speaker with 10-in woofer; 4½-in midrange; 2½-in tweeters. Features phased-arrangement; 360° imaging; wrap-around speaker grilles. FR 39-20,000 Hz ± 3 dB; sens 91 dB; nom imp 4 ohms; power range 30-250 W/ch; 20½ x 16 x 39½ in; 60 lb. Available in charcoal grey/black or beige/walnut \$1,500/pr

Soundfield 1500 3-Way Speaker

Vented, floor-standing speaker with 8-in woofer; 4½-in midrange; 2½-in tweeters. Features phased-arrangement; 360° imaging; wrap-around speaker grilles. FR 44-20,000 Hz ± 3 dB; sens 92 dB; nom imp 4 ohms; power range 30-250 W/ch. 16 x 14 x 33 in; 35 lb. Available in charcoal grey/black or beige/walnut \$1,000/pr

Soundfield 2500 3-Way Speaker

Vented, floor-standing speaker with 6½-in woofer; 2½-in midrange; two ½-in tweeters. Features phased-arrangement; 360° imaging; wrap-around speaker grilles. FR 49-20,000 Hz; sens 90 dB; nom imp 6 ohms; power range 25-150 W/ch at 4 ohms. 12 x 8 x 29 in; 21 lb. Available in charcoal grey/black or beige/walnut \$580/pr

SPF 5000 3-Way Bookshelf Speaker

Bookshelf speakers with 6½-in woofer, 2½-in fluid-cooled midrange, two fluid-cooled ½-in tweeters. Features phased arrangement. FR 65-20,000 Hz; sens 89 dB; nom imp 6 ohms; power range 30-150 W/ch at 4 ohms. 15½ x 11¾ x 7¾ in; 13 lb. In black or walnut \$450/pr

DCM

Time Window 3-Way Speaker

Folded transmission-line speaker with 8-in cone woofer, 6½-in cone midrange, and 2¾-in soft-plastic-dome tweeters. Features time-coherent point source for more accurate off-axis sound reproduction. Adjustable high- and middle-frequency energy output, narrow to wide image spatial control; also utilizes acoustic antidiffraction lenses. FR 24-20,000 Hz; min power 10 W, max power 200 W; sens 90 dB; imp 8 ohms. Dark oak with dark brown fabric. 16¼ x 39¼ x 12¾-in; 45 lb. \$1,499/pr

Time Frame TF1000 3-Way Speaker

Tapered transmission-line speaker with 8-in woofer, 4-in midrange driver, ¾-in soft plastic-dome tweeter. Features acoustic antidiffraction lens; transmission line termination. Max power rating 50 W rms pink noise continuous/300 W peak program; 8 ohm imp; sens 91 dB W/m. 49 x 19½ x 8 in; 49 lb. . . \$1,099/pr

Time Window 1A 2-Way Speaker

Hybrid transmission-line speaker intended for floor placement with two 6½-in cone woofers with acoustic lens; 2¾-in soft plastic-dome tweeter with acoustic

lens. Features wide-angle sound distribution; pinpoint imaging properties; with cylindrical back and triangular-prism front; optimized for min time-dispersion error. Min power 10 W, max power 200 W; sens 91 dB; imp 8 ohms; dark oak with dark brown fabric. 15 x 36 x 11¾ in; 32 lb. . . . \$949/pr

Time Frame TF700 3-Way Speaker

Floor-standing folded and tapered transmission-line speaker with 8-in cone woofer, 4-in cone midrange, and ¾-in dome tweeter. FR 34-20,000 Hz ± 3 dB; min power 20 W rms; max power 250 W; sens 90 dB SPL/W/m; imp 8 ohms. 45 x 18 x 7 in. \$849/pr

Time Frame TF500 2-Way Speaker

Mirror-imaged floor-standing loudspeaker with 6½-in cone woofer; ¾-in soft-plastic-dome tweeter with acoustic lens. Features folded, tapered transmission-line bass loading. FR 34-20,000 Hz; power range 10-100 W; sens 90 dB SPL/W/m; imp 8 ohms. Dark oak finish with dark brown fabric grille. 17 x 41 x 6¾ in; 42 lb \$649/pr

Time Frame TF350 Shielded 2-Way Speaker

Floor-standing transmission-line speaker with 6½-in magnetically-shielded cone woofer and a ¾-in dome tweeter. Features an acoustic antidiffraction lens. FR 42-20,000 Hz ± 3 dB; power range 10-100 W rms; sens 89 dB SPL/W/m; imp 8 ohms. Dark brown with brown cloth finish. 37 x 15 x 7 in; 31 lb. . . \$499/pr

FullTime Bass System

Two transmission line cabinets each with one 6½-in woofer. Max power handling 50 W rms, 150 W peak; FR 50-150 Hz; imp 8 ohms nom; sens 91 dB SPL/W/m. 30¾ x 10¼ x 10¼ in; 19 lb ea \$429/pr

Time Frame TF275 2-Way Speaker

Floor-standing coaxially mounted speaker with 6½-in cone woofer and ¾-in dome tweeter. FR 50-20,000 Hz ± 3 dB; min power 10 W rms; max power 50 W rms; sens 91 dB SPL/W/m; imp 8 ohms. Dark oak with dark brown grille. 34 x 13 x 6 in. . . . \$399/pr

TimePiece 2-Way Speaker

Floor-standing speaker with 6½-in cone woofer and ¾-in dome tweeter. Power handling 15 W rms, peak 100 W; FR 60-20,000 Hz; suggested amplifier power 10-80 W; sens 90 dB SPL/W/m; imp 8 ohms nom. 16 x 7¾ x 7¾ in; 12.5 lb ea \$299/pr

HalfTime 2-Way Speaker

Floor-standing, acoustic suspension speaker with 6½-in woofer and ¾-in dome tweeter. Features antidiffraction lens. FR 90-20,000 Hz; sens 90 dB SPL/W/m; suggested amplifier power 10-80 W; imp 8 ohms min. 9¾ x 8 x 8 in \$249/pr

DELAWARE ACOUSTICS

DELAC S10w 3-Piece Speaker System

Two S10 satellites (without bass equalization), matching subwoofer. Passive 6 dB/octave crossover at 120 Hz. Power handling 25-150 W; FR 35-20,000 Hz 3 dB. Subwoofer 14 x 10 x 14 in. \$1,295/system

DELAC S10e Speaker

Floor-standing speaker with two 4½-in woofers, ¾-in ferrofluid-cooled dome tweeter. Features passive line-level bass correction circuit. Power handling 15-80 W; FR 60-20,000 ± 3 dB; crossover at 4,500 Hz; sens 85 dB; imp 4 ohms. 2-year limited warranty. 5 x 40 x 3 in \$1,095/pr

DELAC S8w 3-Piece Speaker System

Two S8 satellites (without bass equalization), matching subwoofer. Passive 6 dB/octave crossover at 120 Hz. Power handling 25-100 W; FR 35-20,000 Hz 3 dB. Subwoofer 14 x 10 x 14 in. \$945/system

DELAC S8e Speaker

Switchable stand/wall-mount speaker with 4½-in woofer, 3¾-in tweeter. Features connections for bi-

wiring, or bi-amping; passive bass EQ. Power handling 15-50 W; FR 70-20,000 Hz ± 3 dB; sens 85 dB; imp 8 ohms; crossover at 3,000 Hz \$745/pr

DENNESEN ELECTROSTATICS

Dennesen Nine 3-Way Speaker

Floor-standing bass-reflex/electrostatic hybrid speaker with 8-in bextrene woofer; 6½-in midrange; six 3-in electrostatic tweeters. Phase corrected and time aligned. Includes electronic crossover for bi-amping in stereo. Power handling 50-200 W; FR 20-35,000 Hz ± 3 dB; sens 89 dB SPL/W/m; imp 8 ohms. Oiled walnut finish. 35 x 11 x 15 in; 60 lb \$1,800/pr

DESIGN ACOUSTICS

DA 360 Outdoor 2-Way Speaker

Omnidirectional all-weather speaker. Features rust-proof heavy-duty plastic enclosures; dual driver system; white finish; mounted from any angle or pipe mounted from bottom \$240/pr

Point Source Series

PS-3 Subwoofer/Satellite System

Consists of 2 oak veneer satellites and a slot-loaded bass module. Satellite has ¾-in polycarbonate dome tweeter and 3½-in mid-range. Bass module has two downfiring 6½-in high-compliance, long-throw woofers. Crossovers are housed in each cabinet with frequencies at 200 Hz and 3000 Hz. Sens 88 dB SPL/W/m; FR 50-20,000 Hz; power handling 20-100 W \$600/system

PS-10 3-Way Bookshelf Speaker

Acoustic-suspension 3-way speaker with downward-firing 10-in long-throw woofer, 5-in midwoofer, 1-in soft-dome tweeter. Features tweeter-level control; mirror-image driver placement; acoustically treated baffle; walnut-vinyl finish; brown cloth grille. FR 48-20,000 Hz; crossovers 190 and 2,000 Hz; sens 90 dB SPL/W/m; power range 15-200 W; imp 8 ohms; 14 x 13½ x 11 in \$520/pr

PS-8b 2-Way Bookshelf Speaker

Acoustic-suspension speaker. Features 8-in woofer; 1-in soft-dome tweeter; mirror-image drivers; acoustically treated baffle; crossover at 2,000 Hz; FR 50-20,000 Hz; sens 90 dB SPL/W/m; power range 15-200 W; 9½ x 13 x 11½ in. . . . \$370/pr

PS-6V Shielded Bookshelf Speaker

Acoustic-suspension speaker. Features 6½-in woofer; ½-in soft-dome tweeter; mirror-image driver placement; acoustically treated baffle; magnetically shielded for use with video monitors. FR 50-20,000 Hz; power range 10-100 W; sens 88 dB SPL/W/m; imp 8 ohms; black/gray grille; 8 x 12 x 11½ in. \$280/pr

PS-6 2-Way Bookshelf Speaker

Two-way design features 6-in woofer; ½-in soft-dome tweeter; FR 50-20,000 Hz; sens 88 dB SPL/W/m; power range 15-100 W; 11½ x 12 x 8.12 in; 12 lb. \$260/pr

DESKTOP LOUDSPEAKER SYSTEMS

DLS-3x Intimate Satellite/Subwoofer System

4-piece satellite speaker system. 2 DM-2x satellites with 3¼-in cone woofer, ¾-in dome tweeter, ½-in supertweeter; 2 subwoofers house 2 7-in drivers and 2 8-in passive radiators. Power handling 20-200 W; FR 38-30,000 Hz ± 3 dB; sens 87½ dB SPL/W/m; imp 4 ohms. Black or walnut finish. \$2,399/system

DLS-2 Intimate Satellite/Subwoofer System

4-piece satellite speaker system. 2 DM-1 satellites with 3¼-in cone woofer, ¾-in dome tweeter; 2 BMW-2 subwoofers house 6½-in cone driver and 2 6½-in passive radiators. Power handling 20-250 W; FR 39-19,000 Hz ± 3 dB; sens 87 dB SPL/W/m; imp 4½

SPEAKERS

ohms. Black or walnut finish. Satellites 7½ x 4½ x 3½ in; subs 12½ x 10 x 8½ in; 38 lb. \$899/system

DLS-1A Intimate Satellite/Subwoofer System

3-piece speaker system. 2 full-range DM-1 satellites with ¾-in cone woofer, 7/8-in dome tweeter; 1 small BMW-1 subwoofer with 6½-in cone driver. Power handling 20-325 W; FR 54-18,000 Hz ± 3 dB; sens 86 dB SPL/W/m; imp 4½ ohms. Walnut, golden oak, or teak finish; satellites 7½ x 4½ x 3½ in; subwoofer 16 x 5½ x 8 in; 28 lb. \$649/system

BMW-2 Intimate Subwoofer

Floor-standing subwoofer with 6½-in cone driver, 2 8-in passive radiators. Power handling 20-150 W; FR 39-175 Hz ± 3 dB; sens 86 dB SPL/W/m; imp 5 ohms. Black finish. 9 x 9 x 9 in; 10 lb. \$525/pr

DM-1 Intimate 2-Way Bookshelf Speaker

Bookshelf speaker with ¾-in cone woofer, 7/8-in dome tweeter. Power handling 20-125 W; FR 175-18,000 Hz ± 3 dB; sens 85 dB SPL/W/m; imp 8 ohms. Walnut, golden oak, or black finish. 7½ x 4½ x 3½ in; 4.5 lb. \$300/pr

S-1 Speaker Stand

For use with wide-screen TV, stereo TV or audio system. Phase aligned; flat black finish; invisible wiring track. 8 x 17 x 8 in; 2.2 lb. \$70/pr

EMINENT TECHNOLOGY

LFT-III Planar Doublet Speaker

Single-diaphragm Linear Field Transducer; diaphragm remains within constant magnetic-flux field over entire displacement range; push-pull operation; soft-foil/mylar diaphragm with very thin traces and narrow gaps between each trace driven directly by amplifier; recommended placement at least 3 ft from rear wall; diaphragm area 580-in; peak-to-peak displacement 0.4-in. FR 35-40,000 Hz ± 4 dB; power range 100-250 W; sens 83 dB SPL/2.83 V/m; max sens 106 dB SPL/W/m; imp 4 ohms. 54 x 27 x 1¾ in; 90 lb ea. \$3,250/pr

LFT-VI Planar Doublet Speaker

Single-diaphragm Linear Field Transducer; diaphragm remains within constant magnetic-flux field over entire displacement range; push-pull operation; soft-foil/mylar diaphragm with very thin traces and narrow gaps between each trace driven directly by amplifier; recommended placement at least 2 ft from rear wall; diaphragm area 410-in; peak-to-peak displacement 0.3-in. FR 38-20,000 ± 4 dB; power range 100-250 W; sens 83 dB SPL/W/m; imp 6 ohms. 78 x 18 x 2 in; 75 lb ea. \$2,900/pr

LFT-IV Planar Doublet Speaker

Single-diaphragm Linear Field Transducer; diaphragm remains within constant magnetic-flux field over entire displacement range; push-pull operation; soft-foil/mylar diaphragm with very thin traces and narrow gaps between each trace driven directly by amplifier; recommended placement at least 2 ft from rear wall; diaphragm area 270-in; peak-to-peak displacement 0.3-in. FR 45-20,000 Hz ± 4 dB; power range 100-250 W; sens 78 dB SPL/W/m; imp 8 ohms. 60 x 18 x 12 in; 55 lb ea. \$1,850/pr

ENERGY

Reference Connoisseur 2-Way Speaker

2-way bass-reflex speakers, matched 0.12 dB left and right. 7-in polypropylene cone woofer with PVC-stitched suspension; 1½-in dual hyperdome tweeter. Power range 20-200 W; FR 25-20,000 Hz ± 1½ dB off axis; sens 89 dB; imp 8 ohms. 35½ x 11 x 14 in; 80 lb. Prices vary depending on finish; 6 matched wood veneers available. \$1,600-\$3,300/pr

Reference 2-Way Speaker

Bass-reflex front-port monitors matched within 0.12 dB left and right. 7-in polypropylene cone woofer

with PVC-stitched suspension; 1½-in dual hyperdome tweeter; includes stands; black vinyl veneer finish. power range 20-200 W; FR 34-20,000 Hz ± 1½ dB off axis; sens 89 dB; imp 8 ohms. 24¾ x 10½ x 12 in; 34 lbs. \$1,200/pr

Pro Monitor 2-Way Speaker

Bass-reflex speakers matched 0.5 dB left and right. 7-in polypropylene cone woofer with PVC-stitched suspension; 1½-in dual hyperdome tweeter. Walnut-grain vinyl, black, and oak finishes with black sag-resistant fabric grilles; includes stands. Power handling 20-200 W; frequency response 28-20,000 Hz ± 1½ dB off axis; sensitivity 89 dB; impedance 8 ohm. 24¾ x 10½ x 12 in; 34 lbs. \$900/pr

ESM-1s 2-Way Speaker

Bass-reflex speaker pair with 8-in woofer; 1 in ferrofluid-dome tweeter; phase-corrected crossover at 2,000 Hz; walnut or black ash vinyl. power range 1½-120 W; FR 30-22,000 Hz ± 3 dB; sens 86 dB; imp 8 ohms; 24 x 10½ x 11 in; 35 lb each. \$500/pr
ESM-2s. Similar to above, recommended power range from 12-100 W; FR 40-22,000 Hz. 23 x 11 x 11 in; 24 lb ea. \$400/pr
ESM-3. Similar to above, power range 10-80 W; FR 45-22,000 Hz; 20 x 10 x 9 in; 20 lb each. \$330/pr
ESM-4. Similar to above, 6½ in woofer; ¾ in dome tweeter. Power range 10-80 W; FR 60-20,000 Hz ± 3dB; 14 x 10 x 10 in; 11 lb ea. \$230/pr

EPICURE

All EPI speakers have wood-veneer cabinets with narrow front baffles and non-parallel side walls to minimize diffraction and internal standing waves. The grilles are covered with gray cloth. The tweeters have damped polycarbonate domes and 1-in voice coils. The bass and midrange drivers have mineral-filled polypropylene cones which are formed with non-concentric pattern to increase rigidity and reduce structural resonances.

Episure Model 1 System 4-Way Speaker

System consists of Model 1 speakers and a Speaker Placement Equalizer (SPEQ). Floor-standing speakers have an electronically reinforced 8-in woofer in a vented cabinet, an 8-in midbass in an isolated chamber. Two 4-in midranges and a 1-in tweeter are mounted in a separate narrow baffle cabinet. The special air mass loaded cabinet vent is integrated into the cabinet base. Internally wired with Monster Cable. FR 32-20,000 Hz ± 3 dB; crossovers at 160, 500 and 2,500 Hz; recommended amplifier power 20-200 W; imp 6 ohm. 42¾ x 12 x 13 in. \$1,400

Episure Model 2 4-Way Speaker

Floor-standing speaker with an 8-in woofer in a vented cabinet, 8-in mid-woofer in an isolated chamber, 4-in midrange and 1-in tweeter. The air mass loaded cabinet is integrated into the cabinet base. Internally wired with Monster Cable. FR 38-20,000 Hz ± 3 dB; crossovers at 190, 500 and 2,500 Hz; recommended amplifier power 10-175 W; imp 6 ohm. 35¼ x 12 x 13 in. \$900/pr

Episure Model 3 3-Way Speaker

Floor-standing speaker with an 8-in woofer in a vented cabinet, a 4-in midrange and a 1-in tweeter. The air mass loaded cabinet is integrated into the cabinet base. FR 42-20,000 Hz ± 3 dB; crossovers at 500, 2,500 Hz; recommended power 10-150 W; imp 6 ohm. 30 x 12 x 13 in. \$700/pr

Episure Model 4 2-Way Speaker

Bookshelf speaker with an 8-in woofer in a vented cabinet and a 1-in tweeter. The flared cabinet vent is integrated into the cabinet base. FR 48-20,000 Hz ± 3 dB; crossover at 2,000 Hz; recommended power 10-100 W; imp 8 ohm. 20 x 11¾ x 12 in. \$450/pr

Episure Model 5 2-Way Speaker

Bookshelf speaker with a 6-in woofer in a vented

cabinet and a 1-in tweeter. The flared cabinet vent is integrated into the cabinet base. FR 55-20,000 Hz ± 3 dB; crossover at 2,000 Hz; recommended power 10-75 W; imp 8 ohm. 16 x 10 x 10½ in. \$350/pr
Episure Model 5V 2-Way Speaker. Same as above but with vinyl veneered cabinet. \$300/pr

EPOS BY MUSIC HALL

ES 14 Speaker

Speaker with 8-in custom-made woofer and custom-made aluminum tweeters. Features no crossover but roll-off from woofer at 2,000 Hz. Black ash or walnut veneer. 19½ x 8 x 11½ in. \$1,195/pr
Matching Stands. \$220/pr
Optional grilles. \$40/pr

ESS

AMT Series

AMT-Monitor Speaker

Floor-standing passive radiator speaker with 21½ x 21½-in Heil air-motion transformer with mylar articulated diaphragm. Features 12-in cone passive rad; 12-in cone woofer. Power handling 35-400 W; FR 35-23,000 Hz ± 3 dB; sens 91 dB SPL/W/m; imp 6 ohms. Oiled walnut finish. 18½ x 41 x 12 in; 82 lb. \$1,140/pr

AMT 1D 2-Way Speaker

Floor-standing passive-radiator 2-way speaker with 12-in polypropylene woofer, 12-in passive radiator. Features 21½ x 21½-in Heil air-motion transformer with mylar articulated diaphragm; brilliance controls; Maximum power handling 400 watts; frequency response 35-23,000 Hz ± 3 dB; crossover 800 Hz; impedance 6 ohms; sensitivity 91 dB SPL/W/m. Oiled-walnut finish; black-brown grille. Dimensions: 35¼ x 16¼ x 16¼ in. Weight: 85 lb. \$1,040/pr

Mini Monitor 620 Bookshelf Speaker

Two-way mini bookshelf speaker. Features dynamic 5¼-in long excursion woofer; 1¼-in dome tweeter; 5-in passive radiator. Power handling 10-60 W; FR 60-20,000 Hz ± 4 dB; sens 87 dB SPL/W/m; imp 8 ohms. Oiled walnut veneer finish. 7 x 12 x 7½ in; 16½ lb/pr. \$160/pr

Performance Series

PS-1220 3-Way Speaker

Floor-standing passive radiator speaker with 12-inch woofer. Heil air-motion transformer tweeter with 10½ x 10½-inch radiating area, 4-inch midrange with hi-temp voice coil. Power handling 10-200 watts; frequency response 28-23,000 Hz ± 1 dB; sensitivity 93 dB SPL/W/m; impedance 4 ohms. Solid walnut finish. Dimensions: 14¼ x 12 x 34 inch. Weight: 65 pounds. \$420/pr

PS-1020 2-Way Speaker

Floor-standing passive-radiator speaker system with 12-in woofer. Heil air-motion transformer tweeter-midrange. 10½ x 10½-inch radiating area. Power handling 10-150 watts; frequency response 28-23,000 Hz ± 1 dB; sensitivity 93 dB SPL/W/m; impedance 4 ohms. Solid walnut finish. Dimensions: 14 x 13 x 25 in. Weight: 44 lb. \$370/pr

The listings are based on data provided by the manufacturers. For more product information, contact an authorized dealer or the manufacturer directly. Manufacturers' addresses and phone numbers are listed in the directory beginning on page 258.

An earful of n

Looking at them, you'd never suspect that graphite, kapton, polypropylene and neodymium are all that musical.

But polypropylene, when it's injection-molded and reinforced with radially-aligned graphite fibers in our IMG woofer, becomes Stanley Clarke's battering ram bass.

Graphite, in the form of thousands of tiny, hollow spheres in our Polyspherite™ dome midrange, sounds exactly like Kenny G's alto sax on fire.

And kapton, stretched into a micro-thin diaphragm and suspended between powerful neodymium magnets in our EMIT *k* tweeter, is the steam rising from Jeff Hamilton's cymbals.

All these disparate materials, in the hands of our speaker designers, are transformed into the most positive proof that the State of the Art has taken a significant step forward.

Introducing the new RS Series.

These six speakers embody everything we know about the physics of transforming exotic plastics and rare-earth metals into music.

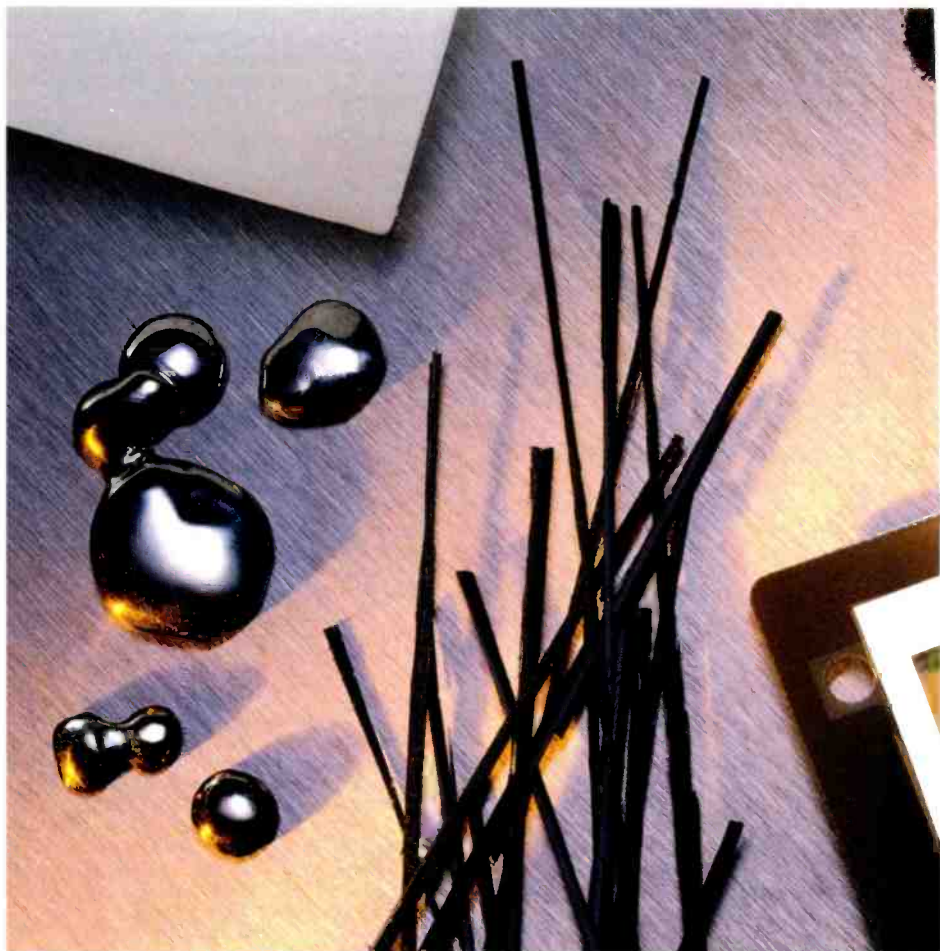

Their drivers are unlike any you've seen or heard before. Drivers we had to invent because there were none this musically accurate before.

Their very cabinet profiles are shaped by our understanding of the behavior of soundwaves.

And their grilles display the mobius emblem that has adorned the most critically acclaimed speakers in the world.

For the audiophile in all of us.

Yet, for all its state-of-the-art engineering, exotic, space-age speaker materials, and extreme sonic accuracy, the RS Series wasn't created for the money-is-no-object audiophile.

Its price range of only \$85 to \$530 per speaker puts the RS Series well within the reach of most people who,

ew technology.

frankly, don't even care about our use of photo-etched aluminum voice coils and Monster Cable® internal wiring. Because it's only the music that really matters.

For all these reasons—musical, technical and economic—we invite you to bring a favorite record or CD to your Infinity dealer and hear it as you've never heard it. Through the new Infinity RS speakers.

We promise you all the passion and excitement you can handle.

Which, since you're as hooked on music as we are, is exactly what you deserve.

 **Infinity**

We get you back to what it's all about. Music.



©1989, Infinity Systems, Inc., 9409 Owensmouth Avenue, Chatsworth, CA 91311. (818) 709-9400. **H A** Harman International Company.

CIRCLE NO. 19 ON READER SERVICE CARD

SPEAKERS

PS-920 2-Way Bookshelf Speaker

Passive radiator speaker system with 8-in woofer, Heil air-motion transformer tweeter-midrange with 10 $\frac{3}{4}$ x 10 $\frac{3}{4}$ -in radiating area. Power handling 5-100 W; FR 38-23,000 Hz \pm 1 dB; sens 91 dB SPL/W/m; imp 4 ohm. Solid walnut finish. 11 $\frac{1}{2}$ x 22 x 11 in; 37 lb. \$306/pr

PS-820 2-Way Bookshelf Speaker

Passive radiator speaker with 6-in woofer, Heil air-motion transformer tweeter-midrange with 10 $\frac{3}{4}$ x 10 $\frac{3}{4}$ -in radiating area. Power handling 5-125 W; FR 42-23,000 Hz \pm 1 dB; sens 89 dB SPL/W/m; imp 4 ohm. Solid walnut finish. 9 $\frac{1}{2}$ x 17 $\frac{3}{4}$ x 9 $\frac{1}{2}$ in; 54 lb. \$306/pr

FISHER

STV-440M 3-Way Shielded Speaker

Bass-reflex with 15-in woofer, 5-in ferrofluid midrange, 3-in ferrofluid tweeter. Magnetic-field compensated. 150 W/ch rms into 8 ohms; sens 93 dB SPL/W/m; FR 38-20,000 Hz. Baldwin oak vinyl veneer finish. 17 $\frac{7}{8}$ x 38 $\frac{3}{4}$ x 12 $\frac{7}{8}$ in. \$600/pr

STV-430M 3-Way Shielded Speaker

3-way floor-standing bass-reflex speaker with 15-in woofer, 4-in ferrofluid midrange, 3-in ferrofluid tweeter. Magnetic-field compensated. Power handling 100 W/ch rms into 8 ohms; sens 92 dB SPL/W/m; FR 40-20,000 Hz. Baldwin oak vinyl veneer finish. 17 $\frac{7}{8}$ x 36 x 12 $\frac{7}{8}$ in. \$400/pr

STV-420M 3-Way Shielded Speaker

3-way floor-standing bass-reflex speaker with 12-in woofer, 4-in ferrofluid midrange, 2-in ferrofluid tweeter. Magnetic-field compensated. Power handling 100 W/ch rms into 8 ohms; sens 91 dB SPL/W/m; FR 45-20,000 Hz. Baldwin oak vinyl veneer finish. 14 $\frac{3}{8}$ x 29 $\frac{3}{4}$ x 12 $\frac{7}{8}$ in. \$320/pr

STV-410M 3-Way Shielded Speaker

Bass-reflex with 10-in woofer, 4-in midrange, 3-in tweeter. Magnetic-field compensated. 60 W/ch rms into 8 ohms; sens 90 dB SPL/W/m; FR 50-20,000 Hz. Baldwin oak vinyl veneer finish. 12 $\frac{3}{8}$ x 25 $\frac{3}{4}$ x 10 $\frac{7}{8}$ in. \$200/pr

WS-460B 2-Way Speaker

Air-suspension speaker with 6 $\frac{1}{2}$ -in woofer and 3-in tweeter. 30 W/ch rms into 8 ohms; sens 90 dB SPL/W/m; FR 75-15,000 Hz. Baldwin oak vinyl veneer finish. 12 x 9 $\frac{3}{8}$ x 9 $\frac{3}{8}$ in; 10 lb. \$160/pr
WS-462. As above, black. \$160/pr

FOCUS SPEAKER SYSTEMS

High-Definition Tower 2-Way Speaker

2-way staggered-transmission-line speaker with 1 $\frac{1}{4}$ -in inverted-Kevlar dome tweeter with 3-lb magnet; two 8-in woofers. Features 3 phase-aligned drivers; lead-lined cabinet; cabinet made of 14-layer epoxy-pulp sleeve; internal bracing; rounded baffle; sub-enclosure for tweeter; solid-oak bases, tops, side rails; 1st-order crossover at 1,000 Hz; crossover components matched to better than 1% tolerances; adjustable and removable spiking system. FR 35-20,000 \pm 2 dB; group delay better than \pm 0.2 msec; nominal imp 4 ohms, min imp 3.2 ohms; sens 92 dB SPL/W/m; power range 30-200 W/ch. 14 x 64 x 16 $\frac{1}{2}$ in; 115 lb. \$2,950/pr

High-Definition 2-Way Speaker

Floor-standing speakers 8-in woofer, 1 $\frac{1}{4}$ -in tweeter. Features cabinets constructed from 14-layer Pox-Pulp sleeve braced inside, wrapped with $\frac{1}{4}$ -in foam on outside and capped with solid-oak end pieces; phase-aligned drivers in separate sub-enclosures to improve imaging; adjustable and removable spiking system directly couples speakers to any type of floor. FR 32-20,000 Hz \pm 2 dB; sens 89 dB SPL/W/m; imp 8 ohms; amp power 30-200 W/ch. 47 x 12 x 12 in. \$1,450/pr

Model .7 High-Definition Monitor 2-Way Speaker

Contoured-port speaker with 8-in woofer and 1-in dome tweeter. Features computer-matched time-alignment; Pox-Pulp internally braced cabinet; hard-wired crossovers. FR 37-19,000 Hz \pm 2 dB; nominal imp 8 ohms; power range 30-150 W/ch; sens 90 dB SPL/W/m. 12 x 28 x 12 in; 37 lb. \$880/pr
Matching Stands. \$195/pr

Model .5 High-Definition Monitor 2-Way Speaker

Bookshelf speaker with Pox-Pulp cabinet; 8-in woofer; 1-in dome tweeter. FR 45-20,000 Hz \pm 3 dB; nominal imp 8 ohms, min imp 4.8 ohms; power range 30-150 W/ch; sens 90 dB SPL/W/m; 12 x 19 x 12 in; 27 lb. \$650/pr

FOSGATE-AUDIONICS

Architectural Speakers

AS-802 2-Way In-Wall Speaker

Sealed, flush-mount speaker with 8-in polypropylene woofer and 1-in ferrofluid-coupled soft-dome tweeter. Designed for center channel and full system application. Features 18 dB/octave crossover with air-core inductor; 250 V low-loss film capacitors. Variable tweeter control. FR 40-22,000 Hz; imp 8 ohms; sens 89 dB SPL/W/m. \$995/pr
DS-802. In-room version of AS-802. Available in black lacquered oak, natural oak, or walnut. 10 $\frac{1}{2}$ x 19 x 12 in; 25 lb. \$695/pr

LF-212 Subwoofer

Subwoofer with dual-voice coil 12-in polypropylene woofer. Features direct input or crossover; internal crossover for use with AS-602, AS-802, or DS-802. FR 22 Hz; imp 4 ohms. 20 x 18 x 18 in; 48 lb. \$595

AS-602 2-Way Speaker

Flush-mount speaker with 6 $\frac{1}{4}$ -in polypropylene woofer/midrange and 1-in soft-dome tweeter. Designed for main, surround and extension audio applications; compatible with LF-212 subwoofer system. Features 12 dB/octave crossover with air-core inductors; automatic reset tweeter protection circuitry. FR 75-22,000 Hz; power range 10-100 W. 8 $\frac{1}{2}$ x 12 x 2 $\frac{3}{4}$ in. \$425/pr

AS-502 2-Way Speaker

Flush-mount speaker with 5 $\frac{1}{4}$ -in polypropylene woofer/midrange with $\frac{3}{4}$ -in mylar-dome tweeter. Designed for surround audio and extension audio applications. Features weather resistant design; first order crossover. FR 85-18,000 Hz; power range 10-75 W. 7 $\frac{1}{2}$ x 11 x 2 $\frac{1}{2}$ in. \$295/pr

FOSTEX

H-3 2-Way Speaker

Bookshelf speaker system with patented regular phase (RP) tweeter which operates in piston motion and two 8-in woofers. 30 x 11 x 10 in. \$499

H-2 2-Way Speaker

Bookshelf speaker system with patented regular phase (RP) tweeter which operates in piston motion and 8-in woofer. 21 $\frac{1}{2}$ x 9 $\frac{1}{2}$ x 9 in. \$399

H-1 2-Way Speaker

Bookshelf speaker system with patented regular phase (RP) tweeter which operates in piston motion and 6-in woofer. 16 $\frac{1}{2}$ x 8 x 7 in. \$299

FRIED PRODUCTS

D/2 Subwoofer

Dual-channel transmission-line subwoofers in a new column design with 8-in woofer. Features normal input for use with Fried satellite speakers; bi-amp input for use with other satellites; fuse protection. FR 28 Hz at \pm 3 dB; power range 20-200 W. 10 $\frac{1}{2}$ x 36 x 15 $\frac{1}{2}$ in. \$2,500
As above in kit form \$650

O/4 Subwoofer Kit. Similar to D/2; 10-in woofer with FR 23 Hz \pm 3 dB. 13 $\frac{1}{2}$ x 36 x 23 in. \$750

G/3 3-Way Speaker

Floor-standing transmission-line speaker with 10-in polypropylene-duocone woofer; 6 $\frac{1}{2}$ -in midrange; $\frac{3}{4}$ -in dome tweeter. Features series crossover networks and duocone drivers; full-free-flow transmission-line loading of midrange and aperiodic-design principles for linearity and dynamic range. FR 23-22,000 Hz \pm 3 dB; power range 10-200 W rms; sens 91 dB SPL/W/m; imp 8 ohms. Walnut and oak finishes. 16 x 44 x 18 in; 100 lb. \$2,400/pr

C/3-L 2-Way Speaker

Full-transmission-line-loaded speaker with 6 $\frac{1}{2}$ -in duocone woofer; $\frac{3}{4}$ -in dome tweeter. For use alone or as a satellite. Features series networks; pyramid shape. FR 60-22,000 Hz \pm 3 dB; power range 10-250 W rms; sens 91 dB SPL/W/m; imp 8 ohms. 10 $\frac{1}{2}$ x 13 $\frac{1}{2}$ x 15 $\frac{1}{2}$ in; 20 lb. \$1,450/pr assembled
C/3-L Kit. As above except as a kit \$450/pr

Studio IV 2-Way Speaker

"Flow-resistance" floor-standing speaker with 8-in duocone woofer; 2-in duocone midrange; 1 $\frac{3}{4}$ -in dome tweeter. Features series networks. FR 26-22,000 Hz \pm 3 dB; power range 10-1,000 W; sens 91 dB SPL/W/m; imp 8 ohms. Walnut finish. 12 x 39 x 18 in; 75 lb. \$1,400/pr

R/4 3-Way Speaker

Column loudspeaker with 10-in polypropylene woofer with vented pole piece; 5 $\frac{1}{4}$ -in polypropylene midrange cone with vented pole piece; 1-in dome tweeter with ferrofluid damping. Features built-in tilt back pedestal with line loading for midrange and line-tunnel loading for bass. FR 32-20,000 Hz \pm 3 dB power range 25-100 W/ch; sens 90 dB; imp 8 ohms. 32 x 12 x 10 $\frac{1}{2}$ in; 35 lb ea. \$995/pr

A/3 2-Way Speaker

Speaker with 8-in polypropylene woofer, 1-in soft-dome tweeter. Features edge-on free-flow filters; line tunnel. FR 45-20,000 Hz \pm 3 dB; power range 25-100 W; imp 8 ohms; crossover frequency 2,000 Hz; sens 89 dB SPL/W/m. 23 x 13 x 10 $\frac{1}{2}$ in. \$650/pr

Q/3 2-Way Speaker

Speaker with 8-in polypropylene woofer; dome tweeter. Features edge-on free-flow filters; circuit-breaker. FR 45-20,000 Hz; power range 20-100 W. Walnut or black-ash finish. 20 x 13 x 10 $\frac{1}{2}$ in. \$440/pr

Beta 2-Way Bookshelf Speaker

Bookshelf speaker with 6 $\frac{1}{2}$ -in polypropylene woofer; composite tweeter with 2-in cone and $\frac{3}{8}$ -in dome. Features polypropylene cones and linear crossovers; series filter crossover; distributed bass-loading free-flow filter system. Walnut or black-ash finish. 13 $\frac{1}{2}$ x 8 x 8 in. \$325/pr

Duo Subwoofer

"Flow-resistance" floor-standing subwoofer with 10-in cone woofer. Features dual-voice-coil polypropylene driver. FR 30-100 Hz \pm 3 dB; power range 20-200 W; sens 90 dB SPL/W/m; imp 8 ohms. Walnut or black-ash finish. \$330 ea

GOLDSOUND

All Gold Sound speakers are kits comprised of JBL speaker components and crossovers, grille material, damping, and 18 pages of plans and instructions.

Model#14 4-Way Speaker Kit

Brown vented-enclosure speaker system with 18-in woofer, 10-in cone mid-bass, titanium-driver mid-horn, and biradial-horn tweeter separate midrange and tweeter controls. Features level controls for top 3 drivers. FR 28-21,000 Hz \pm 3 dB; sens 95 dB; min power 5 W; crossover pts 200, 1,200 at 5,000 Hz; optional oiled walnut. 46 x 29 x 19 in. \$2,499/pr

SPEAKERS

Model 2018 4-Way Speaker Kit

Brown vented-enclosure speaker system with 18-in woofer, 8-in cone midbass, 5-in midrange driver, and titanium-dome tweeter. Features level controls for top 3 drivers. FR 28-21,000 Hz \pm 3 dB; sens 95 dB; min power 5 W; crossover frequencies 400, 1,400 at 5,000 Hz; imp 8 ohms. Optional oiled walnut. 46 x 29 x 19 in. \$1,776/pr

Model 2005 4-Way Speaker Kit

Speaker with 15-in woofer, 8-in midbass, 5-in midrange and 1-in titanium-dome tweeter. Features level controls for top 3 drivers. FR 28-21,000 Hz \pm 3 dB; sens 95 dB SPL/W/m; power range 5-300 W rms; crossover points at 400, 1,400, and 5,000 Hz; imp 8 ohms; dispersion 60 degrees horizontal and vertical to 20,000 Hz. \$1,429/pr
With 44 x 18 x 14-in cabinets. \$1,919

Model 11 3-Way Speaker Kit

Speaker with 15-in woofer, 7 $\frac{1}{2}$ -in European midrange, JBL biradial horn tweeter. Features level controls for upper drivers. FR 28-21,000 Hz \pm 3 dB; sens 93 dB SPL/W/m; power range 5-300 W rms; crossover points at 300 and 5,000 Hz; imp 8 ohms; dispersion 100 degrees horizontal and vertical at 20,000 Hz. \$1,129/pr
With 44 x 18 x 14-in cabinets. \$1,619

Model 10 3-Way Speaker Kit

Brown vented-enclosure speaker system with 15-in woofer, 7 $\frac{1}{2}$ -in European midrange, 1-in JBL titanium-dome tweeter. FR 28-25,000 Hz \pm 3 dB; sens 93 dB SPL/W/m; power range 5-300 W rms; crossover points at 300 and 5,000 Hz; imp 8 ohms. \$929/pr
With 44 x 18 x 14-in cabinets. \$1,419/pr

Model 9 4-Way Speaker Kit

Speaker with two 15-in cast-frame woofers, 7 $\frac{1}{2}$ -in European cast-frame midrange, and exponential-horn tweeter. FR 28-25,000 Hz \pm 3 dB; sens 98 dB SPL/W/m; power range 5-600 W rms; crossover points at 60, 200, and 4,000 Hz; imp 4 or 8 ohms. 46 x 29 x 19 in. \$899/pr

Model 7 4-Way Speaker Kit

Speaker with two 12-in polypropylene woofers, two 6 $\frac{1}{2}$ -in European cast-frame midrange, European 1-in dome tweeter. Features tweeter in a symmetrical array with the tweeter at the acoustic center. FR 35-25,000 Hz \pm dB; sens 95 dB SPL/W/m; power range 5-400 W rms; crossover points at 50, 200, and 4,000 Hz; imp 4 or 8 ohms. \$799/pr
With 44 x 18 x 14-in cabinet. \$1,289/pr

Model 6 4-Way Speaker Kit

Speaker with two 8-in polypropylene woofers, two 5 $\frac{1}{4}$ -in polypropylene midranges, and European 1-in linen-dome ferrofluid-cooled tweeter. Features tweeter in a symmetrical array with the tweeter at the acoustic center. FR 32-30,000 Hz \pm 3 dB; sens 93 SPL/W/m; power range 5-200 W rms; crossover points at 60, 200, and 3,000 Hz; imp 4 or 8 ohms. \$499/pr
With 37 x 14 x 11-in cabinet. \$849/pr

Model 5 4-Way Speaker Kit

Speaker with 15-in cast-frame dual-voice coil woofer, 7 $\frac{1}{2}$ -in European cast midrange, and 1-in dome tweeter. FR 32-25,000 Hz \pm 3 dB; sens 95 dB SPL/W/m; power range 5-300 W rms; crossover pts at 60, 200, 4,000 Hz; imp 4 or 8 ohms. \$499/pr
With 44 x 18 x 14 in cabinets. \$989/pr

Model 4 4-Way Speaker Kit

Speaker with 12-in polypropylene dual-voice coil woofer, two 6 $\frac{1}{2}$ -in polypropylene midrange and European 1-in ferrofluid-cooled dome tweeter. Features tweeter in symmetrical array with the tweeter at the acoustic center. FR 35-25,000 Hz \pm 3 dB; sens 93 SPL/W/m; power range 5-200 W rms; crossover points at 70, 200, and 4,000 Hz; imp 4 or 8 ohms. \$399/pr
With 37 x 14 x 11-in cabinets. \$749/pr

Subwoofer Kits

Compound Load Subwoofer Kit

Two 18-in JBL subwoofer. FR 23-200 \pm 3 dB; sens 92 dB SPL/W/m; power range 40-1,200 W rms; imp 8 ohms. \$749 ea
With 24-dB adjustable crossover. \$1,129 ea

Compound Load Subwoofer Kit

Two 15-in JBL subwoofers. FR 23-200 Hz \pm 3 dB; sens 90 dB SPL/W/m; power range 40-600 W rms; imp 8 ohms. \$479 ea
With 24-dB active crossover. \$859 ea
With 44 x 18 x 14-in cabinet. \$249 extra

Subwoofer Kit

18-in JBL subwoofer. FR 28-200 Hz \pm 3 dB; sens 95 dB SPL/W/m; power range 20-600 W rms; imp 8 ohms. \$399 ea
With 24-dB adjustable crossover. \$779 ea

Compound Load Subwoofer Kit

Two 15-in subwoofers with 150 Hz passive crossover. FR 24-200 Hz \pm 3 dB; sens 92 dB SPL/W/m; pwr range 40-600 W rms; imp 4 or 8 ohms. \$399 ea
With 44 x 18 x 14-in cabinet. \$678 ea

Compound Load Subwoofer Kit

Two 12-in subwoofers. Features 150 Hz passive crossover. FR 25-200 Hz \pm 3 dB; sens 90 dB SPL/W/m; power range 40-400 W rms; imp 4 or 8 ohms. \$319 ea
With 18 x 18 x 16-in cabinet. \$449 ea

Model 3 3-Way Speaker Kit

Speaker with 12-in polypropylene woofer, 5 $\frac{1}{4}$ -in polypropylene midrange, and 1-in dome tweeter. FR 39-25,000 Hz \pm 3 dB; sens 93 SPL/W/m; power range 5-200 W rms; crossover points at 80, 200, and 4,000 Hz; imp 4 or 8 ohms. \$299/pr
With 25 x 14 x 11-in cabinets. \$499/pr

Subwoofer Kit

15-in JBL subwoofer. FR 29-200 Hz \pm 3 dB; sens 93 dB SPL/W/m; power range 20-300 W rms; imp 8 ohms. \$259 ea
With 24-dB active crossover. \$639 ea
44 x 18 x 14-in cabinet. \$249 ea

Subwoofer Kit

Cast dual-voice coil 15-in subwoofer. Features 150 Hz passive crossover. FR 32-200 Hz \pm 3 dB; sens 95 dB SPL/W/m; power range 20-300 W rms; imp 4 or 8 ohms. \$249 ea
With 44 x 18 x 14-in cabinet. \$498 ea

Model 2 4-Way Speaker Kit

Speaker with 8-in polypropylene woofer, 4 $\frac{1}{2}$ -in midrange, and ferrofluid-cooled dome tweeter. FR 45-25,000 Hz \pm 3 dB; sens 92 dB SPL/W/m; power range 5-100 W rms; crossover points at 90, 300, and 6,000 Hz; imp 4 or 8 ohms. \$218/pr
With 19 x 12 x 10-in cabinets. \$348

Subwoofer Kit

Dual-voice coil 12-in subwoofer. Features 150 Hz passive crossover. FR 32-200 Hz \pm 3 dB; sens 93 dB SPL/W/m; power range 20-200 W rms; imp 4 or 8 ohms. \$199 ea
With 18 x 18 x 16-in cabinet. \$299 ea

Model 1 2-Way Speaker Kit

Speaker with 10-in European bextrene woofer and 1-in ferrofluid-cooled linen-dome tweeter. FR 48-20,000 Hz \pm 3 dB; sens 93 dB SPL/W/m; power range 5-60 W rms; crossover point at 3,000; imp 8 ohms. \$149/pr
With 25 x 14 x 11-in cabinets. \$359/pr

Model .6 2-Way Speaker Kit

Sealed 2-way speaker with 6 $\frac{1}{2}$ -in polypropylene woofer and 1-in European ferrofluid-cooled linen-dome tweeter. FR 58-20,000 Hz \pm 3 dB; sens 92 dB

SPL/W/m; power range 5-60 W rms; crossover point at 3,000 Hz; imp 4 or 8 ohms. \$98/pr
With 16 x 10 x 8 in cabinets. \$198/pr

Model .2 2-Way Speaker Kit

Sealed speaker with 5 $\frac{1}{4}$ -in polypropylene woofer and 3 $\frac{1}{4}$ -in European ferrofluid-cooled dome tweeter. FR 68-20,000 Hz \pm dB; sens 91 dB SPL/W/m; power 5-60 W rms; crossover at 3,000 Hz; imp 4 or 8 ohms. \$79/pr
With 12 x 8 x 7-in cabinets. \$149

In-The-Wall Installation Series

All Gold Sound In-The-Wall speakers are flush-mount with water-resistant polypropylene cones and white grilles.

844 In-Wall Subwoofer

8-in subwoofer with a 40-oz magnet. FR 32-2,000 Hz; sens 92 dB SPL/W/m; power range 20-150 W rms; imp 4 ohms. Includes grilles. \$134 ea
848 In-Wall Subwoofer. As above. 8 ohms. \$139 ea

8AC 2-Way In-Wall Speaker

Speaker with 8-in woofer and 2-in polypropylene ferrofluid-cooled dome tweeter. FR 32-20,000 Hz \pm 3 dB; sens 92 dB SPL/W/m; power range 5-100 W rms; crossover at 3,000 Hz; imp 4 or 8 ohms; 60 degree dispersion \pm 3 dB to 15,000 Hz. \$134 ea

824 In-Wall Subwoofer

8-in subwoofer with 20-oz magnet. Features dual voice coil: that allow one 824 be a subwoofer for two smaller speakers. FR 32-2,000 Hz \pm 3 dB; sens 92 dB SPL/W/m; power range 20-100 W rms; imp 4 ohm/voice coil. Includes grilles. \$99 ea
828 In-Wall Subwoofer. As above. 8 ohms. \$99 ea

8C 2-Way In-Wall Speaker

Speaker with 8-in woofer and 1 $\frac{1}{4}$ -in ferrofluid-cooled polymid-cone tweeter. FR 40-25,000 Hz \pm 3 dB; sens 92 dB SPL/W/m; power range 5-70 W rms; crossover at 4,000 Hz; imp 4 or 8 ohms; 60 degree dispersion \pm 3 dB to 16,000 Hz. Including grilles. \$99 ea

GOODMANS OF ENGLAND

High Impact Monitor Series

H.I.M. 880 3-Way Speaker

Bass-reflex speaker with 15-in woofer, 8-in midrange and 1-in soft-dome tweeter. Features an infinite baffle; separate level controls for the woofer and midrange. Min pwr 10 W; FR 30-20,000 \pm 5 dB; sens 100 dB SPL/W/m; imp 8 ohms; crossover pts at 500 and 4,000 Hz. Black finish. 40 x 18 x 17 in. \$1,149/pr

H.I.M. 440 3-Way Speaker

Bass-reflex speaker with 12-in woofer, 4-in midrange, and 1-in tweeter. Features an infinite baffle; separate level controls for the midrange and tweeter. Min power 10 W; FR 30-20,000 Hz; sens 98 dB SPL/W/m; imp 8 ohms; crossover points at 1,000 and 4,000 Hz. Black finish. 35 x 15 x 17 in; 66 lb/ea. \$749/pr

H.I.M. 220 2-Way Speaker

Bass-reflex speaker with 10-in woofer and 1-in soft-dome tweeter. Features level controls for the tweeter. Min power 10 W; FR 40-20,000 Hz; sens 98 dB SPL/W/m; imp 8 ohms; crossover point at 4,000 Hz. Black finish. 30 x 13 x 16 in; 44 lb/ea. \$549/pr

H.I.M. 110 2-Way Speaker

Bass-reflex speaker with 8-in woofer and 1-in soft-dome tweeter. Features level controls for the tweeter. Min power 10 W; FR 45-20,000 Hz; sens 98 dB SPL/W/m; imp 8 ohms; crossover point at 4,000 Hz. Black finish. 20 x 10 x 12 in; 24 lb/ea. \$449/pr

The Maxim Collection

The Maxamp Remote 2-Way Powered Speaker

Bass-reflex. 25 W powered speaker with 5-in woofer and 3 $\frac{1}{4}$ -in dome tweeter. FR 65-20,000 Hz; sens 86 dB SPL/W/m; imp 8 ohms. Black. 10 x 7 x 7 in. \$475/pr

SPEAKERS

The Maxamp 2-Way Powered Speaker

Bass-reflex, 25 W powered speaker with 5-in woofer and 3/4-in dome tweeter. FR 65-20,000 Hz; sens 86 dB SPL/W/m; imp 8 ohms. Black finish. 10 x 7 x 7 in; 18 lb/pr \$325

The Maxim 2-Way Speaker

Bass-reflex speaker with 5-in woofer and 3/4-in dome tweeter. Min power 15 W; FR 65-20,000 Hz; sens 86 dB SPL/W/m; imp 8 ohms. Black finish. 10 x 7 x 7 in; 18 lb/pr \$245

B-Max Subwoofer

Subwoofer with two 6-in drivers. FR 30-150 Hz; impedance 8 ohms; crossover 150 Hz. 24 x 8 x 9 in; 22 lb/ea \$225/ea

Bookshelf Monitor Series

M5 2-Way Bookshelf Speaker

Bass-reflex speaker with 8-in woofer and 3/4-in polyimide-dome tweeter. Min power 15 W; sens 88 dB SPL/W/m; impedance 8 ohms. 16 x 10 x 8 in; 28 lb/pr \$299/pr

M3 2-Way Bookshelf Speaker

Bass-reflex speaker with 5 1/2-in woofer and 3/4-in polyimide-dome tweeter. Min power 15 W; sens 88 dB; imp 8 ohms. 15 x 9 x 7 in; 22 lb/pr \$239/pr

M1 2-Way Bookshelf Speaker

Bass-reflex speaker with 5-in and 3/4-in polyamide-dome tweeter. Min power 15 W; sens 86 dB SPL/W/m; imp 8 ohms. 10 x 8 x 7 in; 18 lb/pr \$179

GUSS ENTERPRISES

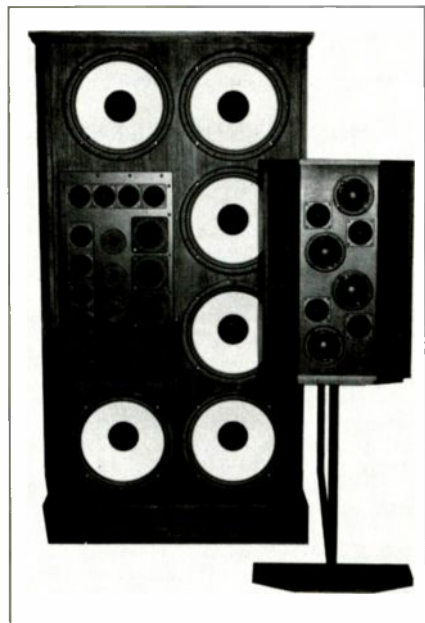

Guss Enterprises System 1

Custom Monitor

Speaker system with 204 drivers in 8 enclosures; twenty-four 15-in woofers; forty-eight 5-in midranges; thirty-two 1-in tweeters; 100 custom piezos. Power range 100-900 W rms. 4 cabinets 30 x 72 x 20 in; 4 cabinets 22 x 72 x 16 in. \$100,000/system

System 1-Guss Monitor Speaker

The Wall of Sound. 102 drivers in 4 enclosures. Features twelve 15-in cone woofers; twenty-four 5-in dome dual-diaphragm midranges; sixteen 1-in dome tweeters; 50 custom piezoelectric supertweeters. Controls include midrange; tweeter; rear-ambience; satellite. Frequency response 15-30,000 Hz \pm 3 dB; power

range 30-600 W; sens 92 dB SPL/W/m; imp 6 ohms. Walnut oak. 30 x 72 x 20 in and 22 x 72 x 16 in \$50,000/system

System 2-Symphony Speaker System

Floor-standing speaker system with 26 drivers in 4 enclosures and 3-D Focus control. Features four 5-in cone woofers; six 5-in dome dual-diaphragm midranges; four 1-in dome tweeters; 12 custom piezoelectric supertweeters. Controls include midrange; tweeter; rear-ambience; satellite. FR 20-30,000 Hz \pm 3 dB; power handling 30-300 W; sensitivity 92 dB SPL/W/m; impedance 4 ohms. Walnut and oak finishes. 2 cabinets 22 x 54 x 20 in and 8 x 25 x 8 in; 165 lb, 12 lb \$15,000/system

System 3-Concerto Speaker System

Floor-standing speaker system with 22 drivers in 4 enclosures. Features four 12-in cone woofers; six 5-in dome dual-diaphragm midranges; four 1-in dome tweeters; 8 custom piezoelectric supertweeters. Controls include midrange; tweeter; rear-ambience; and satellite. FR 30-30,000 Hz \pm 3 dB; power range 30-300 W; sens 92 dB SPL/W/m; imp 4 ohms. Walnut and oak finishes. 2 cabinets 22 x 54 x 20 and 28 x 25 x 8 in; 150 lb, 12 lb \$9,000/system

System 4-Sonata Speaker

Floor-standing speaker system with 12 drivers in 4 enclosures. Features two 12-in woofers; two 5-in dome dual-diaphragm midranges; 6 custom piezoelectric supertweeters. Controls for midrange; tweeter; satellite. Frequency response 30-30,000 Hz \pm 4 dB; power handling 30-200 watts; sensitivity 90 dB SPL/W/m; impedance 8 ohms. Walnut and oak; 17 x 28 x 15 in and 6 x 6 x 12 \$4,000/system

HAFLER

Model 400 3-Way Speaker

Floor-standing speaker with tuned transmission line design; mirror image array consisting of 1-in soft dome tweeter, two 6 1/2-in midrange woofers, and a 8-in rear mounted woofer; sloping baffle; rear mounted ports; pedestal base. Gold 5-way input jacks; spike feet included. FR 30-20,000 Hz; sens 92 dB SPL/W/m; nom imp 8 ohm; min power 20 W/ch. Dark oak veneer w/black grille. 10 1/2 x 40 3/4 x 12 in; 58 lb/ea \$1,100/pr

Model 300 2-Way Speaker

Floor-standing speaker with tuned transmission line design; mirror image array consisting of 1-in soft dome tweeter, and two 6 1/2-in midrange woofers; sloping baffle; rear mounted port; pedestal base. Gold 5-way input jacks; spike feet included. FR 35-20,000 Hz; sens 91 dB SPL/W/m; nom imp 8 ohm; min power 20 W/ch. Dark oak veneer w/black grille. 9 1/2 x 36 x 11 1/2 in; 45 lb ea \$795/pr

Model 200 2-Way Bookshelf Speaker

Features mirror image array with 1-in soft dome tweeter, and a 6 1/2-in midrange woofer; sloping front baffle; rear mounyed port. Gold 5-way input jacks. FR 50-20,000 Hz; sens 88 dB SPL/W/m; nom imp 4 ohm; min power 20 W/ch. Dark oak veneer w/black grille. 8 1/2 x 10 1/4 x 14 1/4 in. \$450/pr

HARTLEY PRODUCTS

The Reference 4-Way Speaker

Floor-standing speaker with 24-in superwoofer, 10-in midrange, two 7-in tweeters. Crossovers at 125, 3,000, 8,000 Hz; FR 16-25,000 Hz; power range 25-300 W; imp 5-8 ohms. Wood cabinet with removable knit grille. 50 1/4 x 36 x 24 in. \$5,195/pr

The Concertmaster 4-Way Speaker

Floor-standing speaker with 18-in woofer, 10-in midrange, two 7-in tweeters. Crossovers at 125, 3,000, 8,000 Hz; FR 16-25,000 Hz; power range 25-300 W; imp 5-8 ohms. Wood cabinet with removable black grille. 41 1/2 x 29 x 18 in \$3,995/pr

SPL-1 Speaker System

Includes 2 SW-10 bass modules, ST-4 phasor arrays, tilt stands for SW-10, aluminum adjustable stands for ST-4, mounting screws, stereo crossover, Allen key. ST-4 with polar-aligned phaser with phaser-array supertweeter. Imp 8 ohms; power range 15-150 W rms. System: FR 25-25,000 Hz \pm 3 dB. All parts have hand-rubbed walnut veneers; black knit grilles. 12 x 5 x 5 in \$1,999/system

The Reference Mini-Tower 2-Way Speaker

Floor-standing speaker with two 6 1/2-in thermoplastic woofers and 1-in hybrid dome tweeter. Crossover 3,100 Hz; power range 5-150 W; imp 4 ohms; FR 32-25,000 Hz. Oak veneered cabinet with removable knit grille. 32 1/2 x 11 1/2 x 12 in \$660/pr

Subwoofers

All Hartley subwoofer cabinets are constructed with walnut veneers and internally lined with a 3/4-in thick cellulose wadding material.

SW-24 Subwoofer

Subwoofer with infinite-type enclosure. Power range 25-300 W; imp 5 ohms; FR 16 Hz \pm 3 dB. 36 x 50 1/4 x 22 in; 250 lb \$1295

SW-18 Subwoofer

Subwoofer with infinite enclosure. Power range 25-300 W; imp 5 ohms; FR 16 Hz \pm 4 dB. 29 x 41 1/2 x 18 in; 150 lb \$990

SW-10 Subwoofer

Subwoofer with air-column enclosure. Power range 15-100 W; imp 6 ohms; FR 25 Hz \pm 3 dB. 18 x 24 x 18 in; 70 lb \$525

HEATH

Heath/JBL ASW-1230 3-Way Speaker

Ported speaker with 12-in Aquaplas woofer, 5-in high-polymer midrange, and 1-in pure titanium diaphragm tweeter. FR 60-20,000 Hz, -3 dB; sens 91 dB; impedance 8 ohms; crossover points 800 and 4,000 Hz. Walnut veneer finish. 14 x 40 x 10 1/2 in; 58 lb \$399 ea
AS-1230, Unassembled kit \$349 ea

Heath/JBL ASW-1082 2-Way Bookshelf Speaker

Ported bookshelf speaker with 1-in high-polymer woofer and 1-in pure titanium diaphragm tweeter. FR 80-20,000 Hz, -3 dB; sens 90 dB; imp 8 ohms; crossover at 3,000 Hz. Walnut vinyl veneer finish. 13 1/4 x 23 x 9 in; 28 lb \$160 ea
AS-1082, Unassembled kit; 29 lb \$130 ea

ASW-24 Surround-Sound Speaker

Ported surround-sound speakers with 4-in driver. FR 18-40,000 Hz, \pm 0.5 dB, front; THD 0.05% front, 0.38% surround. 6 3/4 x 9 x 4 1/4 in \$50/pr

HEYBROOK BY D'ASCANIO AUDIO

All Heybrook speakers come with a limited 5-year warranty.

HB-3 3-Way Speaker

Hand-assembled acoustic-suspension speaker with 10-in doped-cone woofer; 4 1/2-in doped-cone midrange and 3/4-in soft-dome tweeter; removable rear panel for bi- and tri-amping; real walnut or black-ash finish. FR 35-20,000 Hz \pm 3 dB; power range 15-200 W. 25 x 13 3/8 x 11 3/8 in; 46 lb \$1,598/pr

HB-200 2-Way Speaker

Dual-reflex-tuned speaker with 6 1/2-in woofer and metal-dome tweeter. Black ash or walnut finish. FR 34-22,000 Hz; sens 88 dB; nom imp 8 ohms; power range 15-100 W. 18 x 11 x 9 in \$999/pr

HB-150 2-Way Speaker

Dual-reflex-tuned speaker with 6 1/2-in woofer and

*P*repare to be swept away.

By upscale speaker performance of remarkable value. By sonic accuracy with stunning dynamics and superb imaging.

Even more by impressive efficiency and astounding bass output. By a powerful principle called "venturi." Harnessing the force of sound energy to achieve surprising depth and impact. All in a sleek mini-tower architecture of uncommon integrity and unexpected detail.



The result is performance quite surprising for the size. And extraordinary for the price.

Hear and see what you've been waiting for, now at selected audio specialty stores. Or write us for the brochure and name of your nearest Venturi dealer. B-I-C America, 895-E, Hampshire Road, Stow, Ohio 44224.

Distributed exclusively in Canada by Linear Marketing Corporation, 2197 Dunwin Drive, Mississauga, Ontario L5L 1K2



Venturi™
Speaker Systems by B-I-C America

SPEAKERS

metal-dome tweeter. Black-ash or walnut finish. FR 40-22,000 Hz; sens 88 dB; nom imp 6 ohms; power range 15-100 W. 16 x 9 x 9 in. \$799/pr

HB-100 2-Way Speaker

Infinite-baffle speaker with 8-in woofer and metal-dome tweeter. Features black or woodgrain finish. FR 50-20,000 Hz; sens 89 dB; nom imp 8 ohms; power range 15-100 W. 19 x 11 x 10 in. \$599/pr

HB-1 2-Way Speaker

Hand-assembled acoustic-suspension bookshelf speaker with 8-in doped-cone woofer; 1-in dome tweeter. Features removable rear panel for biamping; walnut vinyl or gloss-black finish. Frequency response 42-20,000 Hz \pm 3 dB; impedance 8 ohms; power handling 10-75 watts; sensitivity 89 dB SPL/W/m. 18 $\frac{3}{4}$ x 11 $\frac{1}{2}$ x 9 $\frac{1}{4}$ in; 19 lb. \$429/pr

Point Seven 2-Way Speaker

Infinite-baffle speaker with 6 $\frac{1}{2}$ -in woofer and metal-dome tweeter. Features black finish. FR 45-24,000 Hz; sens 87 dB; nom imp 6 ohms; power range 15-75 W; 16 x 9 x 9 in. \$429/pr

Point Five 2-Way Speaker

Hand-assembled infinite-baffle bookshelf speaker with 6 $\frac{1}{2}$ -in doped-cone woofer; $\frac{3}{4}$ -in dome tweeter; structurally-rigid cabinet; black finish. FR 50-20,000 Hz \pm 3 dB; power range 15-75 W; sens 87 dB; nom imp 6 ohms. 14 x 9 x 9 in. \$299/pr

HITACHI

HSW50 3-Way Speaker

3-way slimline acoustic-suspension speaker with 8-in woofer, 5-in midrange, and $\frac{3}{4}$ -in dome tweeter. Power handling 70 W. Matte-black finish. 30 x 9 $\frac{3}{8}$ x 9 $\frac{3}{8}$ in. \$500/pr

HSA3051 3-Way Speaker

3-way bass-reflex speaker with 10-in woofer, 3-in midrange, and 2-in tweeter. Features circuit breaker. Custom-designed wood cabinet; detachable cloth grille. Power handling 60 W. \$300/pr

HS40 2-Way Bookshelf Speaker

2-way acoustic-suspension speaker with 6 $\frac{1}{2}$ -in woofer and $\frac{1}{2}$ -in half-dome polycarbonate tweeter. Power handling 50 W. Matte-black finish. Dimensions: 14 $\frac{3}{8}$ x 8 $\frac{3}{4}$ x 9 $\frac{1}{2}$ in. \$290/pr

HSA2029 2-Way Speaker

2-way bass-reflex speaker with 8-in woofer and 2-in tweeter. Features custom-designed wood cabinet. Power handling 45 W. \$200/pr

IMAGE

All speakers have nominal impedances of 6 ohms (minimum impedance of 4 ohms) and black grilles.

Concept 200 2-Way Speaker

Ported speaker with two 6 $\frac{1}{2}$ -in woofers; $\frac{3}{4}$ -in damped hyperbolic cotton-dome tweeter; crossover at 2,100 Hz; Italian black-walnut vinyl. Power range 35-200 W; FR 30-23,000 Hz \pm 2 dB; sens 87 dB SPL/W/m. 43 x 10 x 15 in; 66 lb each. \$1,000/pr

Concept 100 2-Way Speaker

Ported speaker with 6 $\frac{1}{2}$ -in woofer; $\frac{3}{4}$ -in damped hyperbolic cotton-dome tweeter; crossover at 2,100 Hz; Italian black walnut vinyl. Power range 35-100 W; FR 45-23,000 Hz \pm 2 dB; sens 87 dB SPL/W/m. 16 x 9 x 11 in; 23 lb each. \$650/pr

Reference Two 2-Way Speaker

Ported speaker with 8-in polypropylene damped woofer; 1-in polyester soft-dome tweeter; crossover at 2,100 Hz; lagos-hickory vinyl. Power range 20-100 W; frequency response 35-20,000 Hz \pm 3 dB; sensitivity 88 dB SPL/W/m. 24 x 11 x 12 in; 31 lb each. \$450/pr

Reference One 2-Way Speaker

Ported speaker with 8-in polypropylene damped woofer; $\frac{3}{4}$ -in polyester soft-dome tweeter; crossover at 2,500 Hz; lagos hickory vinyl. Power range 20-100 W; FR 40-20,000 Hz \pm 3 dB; sens 89 dB SPL/W/m. 19 x 10 x 9 in; 20 lb each. \$350/pr

Reference .5 2-Way Speaker

Ported speaker with 6 $\frac{1}{2}$ -in polypropylene damped woofer; $\frac{3}{4}$ -in polyester soft-dome tweeter; crossover at 2,500 Hz; lagos hickory vinyl. Power range 20-75 W; FR 45-20,000 Hz \pm 3.5 dB; sens 87 dB SPL/W/m. 16 x 10 x 9 in; 15 lb each. \$260/pr

INFINITY

IRS Series

IRS Series V Reference 3-Way Speaker

Modular 4-piece 3-way floor-standing speaker. Features 2 woofer modules with six 12-in woofers in feedback loop of servo amp (two 2,000-W woofer amps); 2 midrange/tweeter modules with 12-dipole midrange drivers; 36 tweeters in dipole line-source array (24 front/12 rear-facing); bass variable low-pass filters; low-pass variable damping; woofer level controls; selectable input imp midrange/tweeter amp control; woofer phase switch; servo bass on/off circuit; Monster Cable for all internal wiring. FR 15-45,000 Hz, \pm 2 dB; crossovers frequency 70/4,500 Hz, 60-120 Hz at main control unit woofer/midrange, 5,000 Hz midrange/tweeter; midrange/tweeter amp input range 100-500 W/ch; imp 4 ohms; oiled and "Grand Piano" Brazilian rosewood finish; 100-ft cable for hookup of midrange/tweeter to midrange/tweeter amp. Woofer modules: 20 $\frac{3}{4}$ x 90 x 28 $\frac{3}{4}$ in; midrange/tweeter modules: 47 x 90 x 17 in; base footprint: 38 x 12 in; 1,500 lb. \$50,000/system

IRS Beta 5-Way Speaker

Includes (per side) four 12-in woofers with servo-controlled polypropylene/graphite fiber injection molded cones; 2 upper bass/midrange (70 Hz-60,000 Hz) planar push-pull drivers which act as a dipole; low-mass EMIT with neodymium magnets for upper midrange; low mass/neodymium EMIT's from IRS V (in a dipole configuration) for the lower treble; SEMIT (a smaller aperture EMIT) which extends response beyond 44 kHz. The system operates in a bi-amp mode and includes the IRS V servo control unit; active and passive crossover control. Monster Cable for all internal wiring. Power handling 75-300 W cont (mid/tweeter), 150-500 W cont (Bass); imp 4 ohms; FR 15-45,000 Hz, \pm 2 dB; crossover frequency 100/750/4,500/10,000 Hz. Woofer module: 16 $\frac{1}{2}$ x 64 $\frac{3}{4}$ x 14 $\frac{1}{2}$ in; mid/tweeter module: 17 x 64 $\frac{3}{4}$ x 1 in; base footprint: 18 x 17 in; 215 lb. \$11,950/system

IRS Gamma. As above, 2 woofers and 1 midbass, accelerometer, and servo system. \$6,950/system

IRS Delta. Similar to Gamma with accelerometer; can be updated to Gamma with addition of servo system (below). \$5,500/system

IRS Servo Control Unit. \$1,450

Kappa Series

9 Kappa Reference Standard 5-Way Speaker

Features two 12-in cast frame L/C tuned woofers; SEMIT K supertweeter; rear-firing EMIT K tweeter; 3-in polydome rear radiator; polygraph K composite polypropylene/graphite 5-in mid-bass dome; 3-in edgewound polydome K midrange; internal crossovers; bi-ampable. Monster Cable for all internal wiring. Oak solids and veneer with high-density particle board with a furniture-grade lacquer finish. FR 29-45,000 Hz, \pm 3 dB; crossover frequencies 80, 800, and 4,500 Hz; power rating 60-340 W/rms; sens 89 dB SPL/W/m; imp 4-6 ohms. 21 $\frac{1}{2}$ x 59 $\frac{1}{2}$ x 8 in. \$2,898/pr

8 Kappa Reference Standard 4-Way Speaker

Similar to 9 Kappa without supertweeter and radiator, and 1 woofer. Monster Cable for all internal

wiring. FR 33-45,000 Hz, \pm 3 dB; power rating 50-250 W/rms; sens 89 dB SPL/W/m; imp 4-6 ohms. 20 $\frac{1}{2}$ x 47 $\frac{1}{2}$ x 8 in. \$1,998/pr

7 Kappa Reference Standard 3-Way Speaker

Similar to 8 Kappa with 12-in woofer, 3-in polydome K midrange, and EMIT K tweeter. Monster Cable for all internal wiring. Power rating 40-200 W rms; imp 4-6 ohms; FR 37-45,000 Hz, \pm 3 dB; crossover frequency 800/4,500 Hz; sens 88 dB SPL/W/m. 17 x 37 x 12 in. \$1,398/pr

6 Kappa Reference Standard 3-Way Speaker

Monitor-size design similar to 7 Kappa except the woofer is 10-in. Monster Cable for all internal wiring. Power rating 30-150 W/rms; imp 4-6 ohms; frequency response 39-45,000 Hz, \pm 3 dB; sens 88 dB SPL/W/m; crossover frequency 800/4,500 Hz. 15 x 25 x 10 $\frac{1}{2}$ in. \$998/pr

Kappa Oak Pedestal Base. Pedestal base for 6 Kappa Reference Standard speaker. \$129/pr

5 Kappa Reference Standard 2-Way Speaker

Bookshelf speaker featuring a 6 $\frac{1}{2}$ -in graphite woofer and EMIT k tweeter. Monster Cable for all internal wiring. Power handling 20-100 W rms; FR 49-45,000 Hz, \pm 3 dB; sens 87 dB SPL/W/m; imp 4 ohms; crossover frequency 4,500 Hz. Oak hardwood solids and veneers. 10 $\frac{1}{2}$ x 17 x 9 in. \$798/pr

SM Series

SM 150 3-Way Speaker

Floor-standing bass-reflex speaker with 15-in cone woofer, two 4 $\frac{1}{2}$ -in midranges, and 1-in polycell dome tweeter. Power handling 300 W; FR 29-27,000 Hz, \pm 3 dB; sens 101 dB SPL/W/m; imp 8 ohms; crossover frequency 500/5,500 Hz. Rosewood vinyl finish. 19 x 39 $\frac{1}{2}$ x 12 $\frac{1}{2}$ in. \$1,118/pr

SM 120 3-Way Speaker

Floor-standing bass-reflex speaker with front-mounted high- and mid-level controls. Features 12-in cone woofer; 4 $\frac{1}{2}$ -in cone midrange; 1-in polycell-dome tweeter. Power handling 200 W; FR 32-27,000 Hz; sens 98 dB SPL/W/m; imp 8 ohms; crossover frequency 750/5,500 Hz. Rosewood vinyl finish. 15 $\frac{3}{4}$ x 33 $\frac{1}{4}$ x 12 $\frac{1}{2}$ in. \$798/pr

SM 100 2-Way Speaker

Floor-standing bass-reflex speaker with 10-in cone woofer and 1-in polycell-dome tweeter. Power handling 150 W; sens 98 dB SPL/W/m; imp 8 ohms; crossover frequency 2,500 Hz. Rosewood vinyl finish. 14 x 29 $\frac{1}{2}$ x 12 $\frac{1}{2}$ in. \$558/pr

SM 80 2-Way Speaker

Bookshelf speaker features 8-in polypropylene coated woofer and polycell tweeter. Power handling 125 W; FR to 27,000 Hz; sens 98 dB SPL/W/m; imp 8 ohms. Rosewood or Walnut vinyl finish. 11 $\frac{1}{4}$ x 18 x 10 $\frac{1}{2}$ in. \$438/pr

RS Series

RS 6001 3-Way Speaker

Floor standing speaker features two 8-in graphite woofers, 2-in polyspherite midrange, and EMIT k tweeter; crossover network. Power handling 200 W cont; FR 42-45,000 Hz, \pm 3 dB; sens 89 dB SPL/W/m; imp 6 ohms; crossover frequency 600/4,200 Hz. Chatsworth oak vinyl or black oak vinyl. 11 $\frac{1}{2}$ x 37 x 9 $\frac{3}{8}$ in. \$1,058/pr

RS 5001. Similar to above, single 8-in woofer; power handling 125 W cont. \$738/pr

RS 4001 3-Way Speaker

Features 8-in graphite woofer, 2-in polyspherite midrange, and a $\frac{3}{4}$ -in polyspherite tweeter. Power handling 125 W; FR 44-22,000 Hz, \pm 3 dB; sens 89 dB SPL/W/m; imp 6 ohms; crossover frequency 600/4,000 Hz. Chatsworth oak vinyl or black oak vinyl. 11 $\frac{1}{2}$ x 22 $\frac{1}{2}$ x 9 $\frac{3}{8}$ in. \$538/pr

SPEAKERS

RS 3001 2-Way Speaker

Features 8-in graphite woofer and a 3/4-in polyspherite tweeter. Power handling 100 W cont; FR 45-22,000 Hz, ± 3 dB; sens 89 dB SPL/W/m; imp 6 ohms; crossover frequency 4,000 Hz. Chatsworth oak vinyl or black-oak vinyl. 11 1/2 x 20 3/4 x 9 3/8 in. . . . \$398/pr

RS 2001 2-Way Speaker

Features 6 1/2-in graphite woofer and a 3/4-in polyspherite tweeter. Power handling 75 W cont; FR 55-22,000 Hz, ± 3 dB; sens 89 dB SPL/W/m; imp 6 ohms; crossover frequency 4,800 Hz. Chatsworth oak vinyl or black-oak vinyl. 8 1/2 x 14 1/4 x 7 1/4 in. . . . \$238/pr

RS 1001 2-Way Speaker

Features 4 1/2-in graphite woofer and a 1/2-in polyspherite tweeter. Power handling 50 W cont; FR 70-22,000 Hz, ± 3 dB; sens 89 dB SPL/W/m; imp 6 ohms; crossover frequency 4,500 Hz. Chatsworth oak vinyl or black-oak vinyl. 7 1/2 x 12 3/4 x 6 3/8 in. . . . \$170/pr

RS Powered Subwoofer

Features 10-in graphite woofer; 100 W servo-driven amplifier. Crossover frequency control; switchable passive high-pass satellite filter; bass response down to 30 Hz. . . . \$600 ea

Environmental Reference Standard Series

ERS 800 2-Way In-Wall Speaker

Features 8-in graphite woofer and EMIT k tweeter. independent tweeter control. . . . \$600/pr

ERS 600 2-Way In-Wall Speaker

Features 6-in graphite woofer and Polyspherite tweeter. independent tweeter control. . . . \$350/pr

ERS 500 2-Way In-Wall Speaker

Features 5 1/4-in coaxial speaker. . . . \$275/pr

Modulus System

Modulus 2-Way Bookshelf/Wall-Mount Speaker

Modulus speakers can be used as bookshelf speakers, wall-mounted speakers, pedestal-mounted system, or a satellite/subwoofer system. Features a 5 1/4-in graphite woofer and EMIT tweeter. Triangular "iso-tip" feet; wall bracket/self-damping isolation mounting plate. . . . \$1,000/sys

Pedestal. 25-in pedestal for the Modulus speaker system. . . . \$300/pr

Modulus Powered Subwoofer

Integrates with Modulus system. Features 12-in graphite woofer; 200 W servo-driven amplifier; separate subwoofer control box includes variable low-frequency cut-off, 2-position rumble filter, low-frequency-level control, absolute phase switch, and an active high-pass satellite control. Bass response extends down to 22 Hz. . . . \$1,700 ea

INTERNATIONAL COMPONENTS

BHP-1062 2-Way Speaker

2-way mini speaker with 5 1/4-in long-throw aluminum voice coil woofer with 30-oz magnet and 1-in soft-dome tweeter with 15-oz magnet. Features circuit breaker protection; electronic crossover network. Recessed, quick-connect speaker terminals; black, snap-on, open weave grilles. FR 50-21,000 Hz; imp 8 ohm. Simulated walnut wood enclosures. . . . \$139/pr

MS-500AV Powered Speaker

Pocket-sized acoustic-suspension speaker with power booster for mini-stereo cassette players and recorders. Uses 4 penlite batteries or 1x 6V power supply, not included. . . . \$32/pr

JAMO

S-100 2-Way Speaker

2-way speaker with 1-in dome tweeter. FR 45-20,000

Hz; crossover frequency 3,500 Hz; imp 8 ohms. 8 3/4 x 10 1/4 x 8 3/4 in; 8 lb. . . . \$298/pr

S-3 Outdoor 2-Way Satellite Speaker

2-way speaker that is water resistant; 2-in cone. FR 80-20,000 Hz; crossover frequency 4,500 Hz; imp 8 ohms. 10 1/4 x 8 x 8 1/4 in; 3 lb. . . . \$238/pr

S-3 Satellite. As above, non-water resistant \$198/pr

S-60 2-Way Speaker

2-way speaker with 2-in cone. FR 70-20,000 Hz; crossover frequency 3,000 Hz; imp 6 ohms. 6 1/4 x 7 3/4 x 7 in; 4 lb. . . . \$198/pr

Concert Series

Concert VII 3-Way Speaker

3-way speaker with 1-in dome tweeter. FR 24-23,000 Hz ± 3 dB; impedance 8 ohms. 11 x 36 x 12 in; 62 lb. . . . \$1,698/pr

Concert V 3-Way Speaker

3-way bass reflex speaker with 6 1/2-in woofer and 1-in dome tweeter. Continuous power 110 W; peak power 160 W; sens 93 dB SPL/W/m; FR 30-22,000 Hz ± 3 dB; crossover frequencies 150/3,500 Hz; imp 6 ohms; overload protection; 24K gold-plated binding posts. Mahogany or stained black ash. 31 1/2 x 14 x 11 in; 42 lb. . . . \$1,198/pr

Concert II 2-Way Bookshelf Speaker

2-way bass-reflex speaker with 6 1/2-in woofer and 1-in dome tweeter. Continuous power 80 watts; peak power 120 watts; sensitivity 91 dB SPL/W/m; frequency response 40-20,000 Hz ± 3 dB; crossover frequency 2,000 Hz; impedance 8 ohms; overload protection; 24 gold-plated binding posts. Mahogany or stained black ash. 16 x 9 1/2 x 10 in; 20 lb \$750/pr

Professional Series

All Jamo Professional Series 3-way speakers are bass reflex and incorporate Jamo's proprietary Controlled Dispersion treble array of multiple horn-mounted tweeters. All Professional Series speakers feature ALR connection sockets and screwed terminals for large cables; removable wire-mesh grilles; black finish; reinforced corners, and a self-locking fixture for easy stacking.

Professional 400. Features 15-in woofer; 5-in horn midrange; 5-1-in horn tweeters. Peak power 560 W; continuous power 400 W; sens 95 dB SPL/W/m; FR 25-20,000 Hz ± 3 dB; crossover frequencies 900 and 4,000 Hz; imp 8 ohms; max SPL 121 dB. 35 1/2 x 20 1/2 x 16 3/4; 93 lb. . . . \$1,800/pr

Professional 300. Features 12-in woofer; 5-in horn midrange; three-1-in horn tweeters. Peak power 420 W; continuous power 300 W; sens 94 dB SPL/W/m; FR 30-20,000 Hz ± 3 dB; crossover frequencies 1,000 and 5,000 Hz; imp 8 ohms; max SPL 118 dB. 29 1/2 x 17 1/2 x 13 3/8; 57 lb. . . . \$1,200/pr

Professional 200. Features 10-in woofer; 5-in horn midrange; 1-in horn tweeter. Peak power 280 W; continuous power 200 W; sens 93 dB SPL/W/m; FR 35-20,000 Hz ± 3 dB; crossover frequencies 1,200 and 6,000 Hz; imp 8 ohms; max SPL 116 dB. 25 3/8 x 14 3/4 x 11 1/2; 42 lb. . . . \$800/pr

SW-60/S-60 Subwoofer System

FR 25-65/150 Hz; imp 47 kohm. 13 x 15 1/2 x 13 in; 26 1/2 lb. . . . \$799

SW-60. Without S-60. . . . \$599

Classic Series

CL-30 3-Way Speaker

3-way speaker with 1-in dome tweeter. FR 40-20,000 Hz; sens 92 dB; imp 8 ohms. 10 3/4 x 33 1/4 x 10 1/4 in; 29 lb. . . . \$598/pr

CL-20 2-Way Speaker

2-way speaker with 1-in dome tweeter. FR 35-20,000 Hz; sens 92.5 dB; imp 8 ohms. 10 3/4 x 18 1/4 x 10 1/4 in; 18 lb. . . . \$398/pr

Art 2-Way Wall Speaker

2-way, flat panel, wall-hanging loudspeaker which works as full-range or satellite unit. Features 5-in woofer, 1-in dome tweeter; peak power 90 W; continuous power 60 W; sens 88 dB/W/m; FR 40-20,000 Hz, ± 3 dB; crossover frequencies 3,000 Hz; imp 8 ohms; overload protection. Neutral-black and white lacquer finishes. 13 3/4 x 15 3/4 x 3 1/2 in; 10.6 lb. . . . \$500/pr

Magic Series

SW-3 Subwoofer System

Features 4-in midrange and includes S-3 satellites. FR 35-20,000 Hz; crossover frequency 200/4,500 Hz; imp 8 ohms. 13 3/8 x 8 x 19 in; 29 lb. . . . \$499

SW-3. Without S-3 satellites. . . . \$349

Magic 14 3-Way Speakers

3-way bass-reflex system with 10-in woofer, 3 1/2-in midrange, and 1-in dome tweeter. Max power 200 W; FR 40-20,000 Hz; crossover frequencies 1,200/1,400 Hz; imp 8 ohms; 20 3/4 x 12 x 8 3/8 in. . . . \$499/pr

Magic 10 3-Way Speakers

3-way bass reflex system with 8-in woofer, 3 1/4-in midrange and 1-in dome tweeter. Max power 140 W; FR 43-20,000 Hz; crossover frequencies 1,500/4,000 Hz; imp 8 ohms; 18 3/4 x 11 x 8 3/8 in. . . . \$399/pr

Magic 8 3-Way Speakers

3-way bass reflex system with 6 1/2-in woofer, 2-in midrange and 1-in dome tweeter. Max power 120 W; FR 47-20,000 Hz; crossover frequencies 1,500/5,000 Hz; imp 8 ohms; 16 3/8 x 9 3/8 x 8 3/8 in. . . . \$299/pr

Magic 6 3-Way Speakers

3-way bass reflex system with 5-in woofer, 2-in midrange, and 3/4-in tweeter. Max power 90 W; FR 55-20,000 Hz; crossover frequencies 4000/8000 Hz; imp 8 ohms; 12 x 7 1/2 x 8 3/8 in. . . . \$199/pr

Compact Line Series

C120 3-Way Bookshelf Speaker

Bass-reflex speaker with 8-in dual-magnet woofer, 5-in midrange, and 1-in dome tweeter. FR 38-20,000 Hz ± 3 dB; peak power 140 W; continuous power 120 W; sens 92 dB SPL/W/m; crossover frequencies 1,200 and 5,000 Hz; imp 8 ohms. Black or white finish. 16 1/2 x 10 1/4 x 8 3/4; 14.3 lb. . . . \$338/pr

C90 3-Way Bookshelf Speaker

Bass-reflex speaker with 8-in cone woofer, 3 1/4-in cone midrange and 1-in dome tweeter. FR 40-20,000 Hz ± 3 dB; peak power 120 W; continuous power 90 W; sens 91.6 dB SPL/W/m; crossover frequencies 1,200 and 4,000 Hz; imp 8 ohms. Black or white finish. 14 1/2 x 9 x 8 3/4 in; 11 lb. . . . \$278/pr

C70 2-Way Bookshelf Speaker

Bass-reflex speaker with 6 1/2-in woofer and 1-in dome tweeter. FR 45-20,000 Hz ± 3 dB; peak power 90 W; continuous power 70 W; sens 90 dB SPL/W/m; crossover frequency 2,500 Hz; imp 8 ohms. Black or white finish. 12 x 7 1/2 x 8 3/4; 8.4 lb. . . . \$198/pr

C60 2-Way Bookshelf Speaker

Bass-reflex speaker with 4-in cone woofer and 2-in cone tweeter. FR 70-20,000 Hz ± 3 dB; peak power 60 W; continuous power 50 W; sens 89 dB SPL/W/m; crossover frequency 2,600 Hz; imp 4 ohms. Black finish; 6 1/2 x 4 x 6 3/4 in; 2.9 lb. . . . \$159/pr

JBL

Ti Series

Model 250 Ti 4-Way Speaker

14-in woofer, 8-in lower midrange, 5-in polypropylene midrange, and 1-in titanium-diaphragm tweeter. Mirrored-image symmetrical-field geometry magnetic structure. Power 400 W cont; imp 8

INTRODUCING OHM'S FULL

At Last.

Speakers designed for the way you listen to music.

Speakers that provide a fully-balanced, 3-dimensional stereo image no matter where you sit or stand in the room. Speakers that deliver exceptional overall sound reproduction. Speakers you can afford.

Speakers you'll love.

THE CONCEPT

Instruments recorded left stay left...

We started with a basic premise: most people don't (or at least don't want to) sit glued to one spot for hours just to listen to their favorite music.

Yet for years, these same people have accepted the tyranny of the "sweet spot." Move a little to the left or right and the stereo balance is destroyed. Move even more and you might as well not have stereo at all. It's been one of the most persistent and troublesome barriers standing between listeners and their music.

We've eliminated it.

Ohm FRS Series
\$450 to \$1,400 per pair



ROOM STEREO™

THE TECHNIQUE

We've engineered the output at the highest frequencies to be louder along an axis pointing diagonally across the listening area and softer directly in front of the speaker. The technique is called "Controlled Directivity" (see illustration). The results are simply spectacular as a perfectly balanced, 3-dimensional stereo image fills the entire room.

In addition, we use time and phase aligned drivers to ensure that first-arrival sounds reach each ear simultaneously, without any confusing out-of-phase sounds.

Our speakers are also designed to respect the low and mid frequency tonal characteristics of each and every real-world source, resulting in extremely sharp, accurate imaging.

No other speakers available today incorporate all three of these essential techniques. That's why only Ohm speakers can create a true, 3-dimensional sound stage throughout a room.

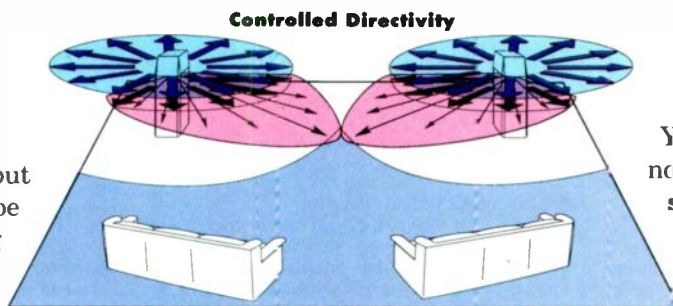

Balanced 3D Stereo Image Enjoyed Throughout The Room

THE TECHNOLOGY

Here is just some of the proven, advanced technology you'll find in our Full Room Stereo speakers:



Coherent Audio Monitors
\$300 to \$575 a pair



Ohm Sound Cylinders
\$650 to \$1,200 a pair



Ohm XO Series
\$750 to \$7,100 a pair

■ High performance, Ferrofluid-cooled tweeters mounted off the main baffle board to eliminate distortion.

■ A patented Sub-Bass Activator Circuit that enhances the already deep bass response of the acoustically coupled sub-woofer while also reducing bass distortion.

■ Patented Coherent Line Source (CLS) drivers that use the inverted cone configuration proven best for producing the controlled directivity essential for Full Room Stereo.

You expect the best technology from Ohm. We make sure you get it.

THE OHM LINE

From the new, compact FRS 5 to the top-of-the-line Walsh 5, the Ohm speakers pictured on these pages offer a selection designed to deliver the performance you want at a price you can afford.

Unbeatable quality and value ideally suited to the way you live and listen: that's Ohm.

THE COMMITMENT

For over 18 years, Ohm Acoustics, Inc. has dedicated itself to making Full Room Stereo

and 3-dimensional sound a reality. Only such dedication could have created technology this unique, a line of speakers this impressive, and sound reproduction that is as close to the real world as you can possibly get.

...those recorded right, stay right. No matter where you move in the room.



241 Taaffe Place, Brooklyn, NY 11205

You'll find Ohm products at the following locations:

ABC Warehouse, FEDCO, Hammond Electronics, Highland Super Stores, McDuff Electronics, Macy's (Northeast), Sight in Sound, Video Concepts, West Coast Sound and many selected independent dealers. Call 718-783-1111 for other locations.

SPEAKERS

ohms; crossovers 400, 1,400, and 5,200 Hz; sens 90 dB SPL/W/m. Burmese teak finish. 22½ x 52 x 14¼ in; 126 lb ea. \$4,798/pr

Model 240 Ti 3-Way Speaker

Floor-standing speaker with 14-in woofer, polypropylene midrange, and ultra-low-mass pure-titanium-diaphragm tweeter. Features symmetrical field geometry magnetic structure. Power handling 300 W cont; imp 8 ohms; crossover 900 Hz, 4,000 Hz; sens 89 dB SPL/W/m. Burmese teak; 18 x 36¾ x 12 in; 85 lb ea. \$1,198/pr

Model 120 Ti 3-Way Speaker

Features 12-in woofer; polypropylene midrange; ultra-low-mass pure-titanium-diaphragm tweeter; symmetrical field geometry magnetic structure. Power handling 250 W cont; imp 8 ohms; crossovers 900 and 4,000 Hz; sens 89 dB SPL/W/m. Burmese teak; 14½ x 24½ x 11 in; 54 lb ea. \$1,398/pr

Model 18 Ti 2-Way Speaker

Features 6½-in polypropylene woofer; pure-titanium-diaphragm tweeter; symmetrical field geometry magnetic structure. Power 200 W cont; imp 8 ohms; crossover 3,000 Hz; sens 88 dB SPL/W/m. Burmese teak; 9¾ x 14¾ x 7¼ in; 17 lb, 8 oz ea. \$758/pr

LT Series

L100t3 3-Way Speaker

Floor-standing speaker with 12-in aquaplas-laminate woofer, 5-in high-polymer-laminate midrange, and 1-in pure-titanium-diaphragm tweeter. Power handling 400 W cont; FR 35-27,000 Hz; crossovers 800 and 4,500 Hz; sens 91 dB SPL/W/m; imp 8 ohms. Oak or walnut veneer finish. 14½ x 36¼ x 15¾ in; 58 lb/ea. \$1,398/pr

L80t3 3-Way Speaker

Floor-standing speaker with 10-in aquaplas-laminate woofer; 5-in polymer-laminate midrange; 1-in pure-titanium-diaphragm tweeter. Power handling 300 W cont; FR 40-27,000 Hz; crossovers 800 and 4,500 Hz; sens 90 dB SPL/W/m; imp 8 ohms. Oak or walnut veneer finish. 12¾ x 32 x 14¼ in; 44 lb ea \$1,098/pr

L40t3 2-Way Bookshelf Speaker

Features 8-in polymer-laminate woofer and 1-in pure-titanium dome tweeter. Power handling 250 W cont; FR 45-27,000 Hz; sens 88 dB SPL/W/m; imp 8 ohms; crossover frequency 2,500 Hz. Oak or walnut veneer finish. 11¼ x 21 x 9¾ in; 24 lb ea. \$798/pr

L20t3 2-Way Bookshelf Speaker

Features 6½-in filled-polypropylene woofer and 1-in pure-titanium-diaphragm tweeter. Power handling: 100 watts continuous; frequency response 55-27,000 Hz; crossover 3,000 Hz; sensitivity 88 dB SPL/W/m; impedance 8 ohms. Oak or walnut veneer finish. 9¼ x 15½ x 8¼ in; 14 lb ea. \$598/pr

Signature Series

S-2 2-Way Speaker

Pedestal speaker with 8-in high-polymer-laminate woofer and four ¾-in titanium-laminate tweeters. Features omnidirectional enclosure; woofer fires upward; ported enclosure; hidden terminals. Power handling 100 W; FR 40-20,000 Hz; Imp 8 ohms; sens 88 dB SPL/W/m; crossover frequency 3,000 Hz. 10 x 40 x 10 in; 40 lb ea. \$1,100/pr

Pro VIII 2-Way Shielded Speaker

Wall-mount speaker with 1-in titanium-dome tweeter, 6½-in high-polymer-laminate woofer; spatial identification dividing network; optional wall and ceiling-mounting hardware; magnetically shielded. Power handling 120 W cont; sens 90 dB SPL/W/m; FR 55-27,000 Hz; imp 6 ohms; crossover 3,000 Hz. 9½ x 15 x 9 in; 26 lb \$429/pr
MTC-51. Wall-mounting system for Pro VIII 2-way speakers. \$195/pr

S-4 2-Way Wall-Mount Speaker

Features 1-in titanium dome tweeter and 6½-in high-polymer-laminate woofer. Features flush-mounting capability; can be used with S-1 subwoofer. Power handling 100 W cont; imp 8 ohms; sens 88 dB SPL/W/m; FR 125-22,000 Hz; 100 W max power. 8¾ x 12 x 3¾ in; 16 lb \$299/pr

Pro III 2-Way Speaker

A/V monitor with 1-in titanium-dome tweeter, 5-in high-polymer mid/low driver, and high-spatial-identification dividing network. Features magnetic shielding; die-cast enclosure material; polypropylene structural foam. Power handling 100 W max; sens 87 dB SPL/W/m. 6¼ x 9½ x 5¾ in \$289/pr
MTC-2. Wall/Ceiling Mount System. Allows Pro III to be mounted on any rigid surface while permitting the speaker to be aimed in almost any direction. Includes MTC-1. \$65 ea

S-3 2-Way Wall-Mount Speaker

Features 1-in titanium-dome tweeter and 5¼-in polymer-laminate woofer. Flush-mounting capability; can be used with S-1 subwoofer. Power handling 100 W cont; imp 8 ohms; sens 86 dB SPL/W/m; FR 125-22,000 Hz. 7¼ x 10½ x 3¾ in; 14 lb \$249/pr

LX Series

LX55 3-Way Speaker

Floor-standing speaker with 10-in high-polymer-laminate woofer, 5-in high-polymer-laminate midrange and 1-in pure-titanium dome tweeter. Power handling 200 W cont; FR 40-20,000 Hz; sens 92 dB SPL/W/m; imp 8 ohms; crossover frequency 800/4,000 Hz. Walnut or black finish. 13¾ x 26¼ x 12 in; 62 lb ea \$798/pr

LX44 3-Way Speaker

Floor standing speaker with 8-in high polymer laminate woofer, 5-in high-polymer-laminate midrange and 1-in titanium dome tweeter. Power handling 150 W cont; FR 45-20,000 Hz; sens 91 dB SPL/W/m; imp 8 ohms; crossover frequency 800/4,000 Hz. Walnut or black finish. 11¾ x 23½ x 12 in; 33 lb ea. \$558/pr

LX22 2-Way Bookshelf Speaker

Features 6½-in high-polymer-laminate woofer and 1-in titanium dome tweeter. Power handling 125 W cont; FR 50-20,000 Hz; sens 90 dB SPL/W/m; imp 8 ohms; crossover frequency 3,000 Hz. Walnut or black finish. 10 x 15¾ x 8¾ in; 42 lb ea. \$358/pr

JBL series

JBL4800 3-Way Speaker

Floor-standing speaker with 10-in high-polymer-laminate woofer, 5-in high-polymer-laminate midrange and ½-in titanium dome tweeter. Power handling 150 W cont; FR 50-23,000 Hz; sens 89 dB SPL/W/m; imp 8 ohms; crossover frequency 800/4,500 Hz. Oak. 11 x 32 x 9½ in; 36 lb ea \$698/pr

JBL3800 3-Way Speaker

Floor-standing speaker with 8-in high-polymer-laminate woofer, 5-in high-polymer-laminate midrange and ½-in titanium dome tweeter. Power handling 150 W cont; FR 50-23,000 Hz; sens 89 dB SPL/W/m; imp 8 ohms; crossover frequency 800/4,500 Hz. Oak. 11 x 32 x 9½ in; 29 lb ea \$558/pr

JBL2800 2-Way Bookshelf Speaker

Features 8-in high-polymer-laminate woofer and a ½-in pure-titanium dome tweeter. Power handling 125 W cont; FR 55-23,000 Hz; sens 89 dB SPL/W/m; imp 8 ohms; crossover frequency 2,500 Hz. Oak finish. 11 x 22½ x 9½ in; 20 lb ea. \$338/pr

JBL2600 2-Way Bookshelf Speaker

Features 6½-in high-polymer-laminate woofer and ½-in pure-titanium dome tweeter. Power handling 100 W cont; FR 60-23,000 Hz; sens 89 dB SPL/W/m;

imp 8 ohms; crossover frequency 3,000 Hz. Oak finish. 9 x 17 x 8¾ in; 12 lb ea \$238/pr

JBL2500 2-Way Bookshelf Speaker

Features 5¼-in high-polymer-laminate woofer and ½-in pure-titanium dome tweeter. Power handling 80 W cont; FR 90-23,000 Hz; sens 88 dB SPL/W/m; imp 8 ohms; crossover frequency 3,000 Hz. Oak finish. 7¼ x 12 x 6¾ in; 8 lb ea. \$178/pr

Subwoofers

B460 Subwoofer

Bass system consists of JBL Model 2245H 18-in driver mounted in vented enclosure of 8 cubic feet. The combination is third-order quasi-Butterworth. Features die-cast aluminum frame; integrally stiffened cone with foam surround; edge-wound voice coil with 4-in diameter and nearly 1 in long; individually machined magnetic pole piece and back plate; cone coated with aquaplas damping formulation for optimum mass and density; large high-flux symmetrical-field-geometry magnetic structure in drivers to reduce second-harmonic distortion; density-compressed wood enclosure; 1 in thick and heavily braced. Min recommended power 200 W; impedance 8 ohms; crossovers 63 Hz (external crossover); sens 94 dB SPL/W/m; magnetic assembly weight 20 lb; 38¼ x 24¾ x 24¼ in; shipping weight 125 lb, 8 oz. \$1,999

B-380 Subwoofer

Bass system with 15-in bass driver and 4-in ribbon-wire voice coil in a vented alignment. Features hand-crafted oiled American black walnut veneer cabinet; bi-amp option with BX63A; max recommended power 600 W; crossover frequency 63 Hz; sens 90 dB SPL/W/m; 27½ x 20¾ x 17 in \$899

BX63A Dividing-Summing Network. Electronic dividing-summing network designed to match characteristics of JBL B380 and B460 subwoofers. Features active low-pass filter with crossover frequency continually adjustable from 63 to 125 Hz. Passive high-pass will bridge stereo amp to provide single-ch drive. Provides proper voltage drive for JBL B380 or B460 subwoofers, adjustable imp compensation for different amps. S/N 95 dB; THD 0.01%; max outputs 18 dBV (10,000 ohm output load); IM 0.01% SMPTE . . . \$375

S-1 Pedestal Subwoofer

Pedestal subwoofer for use with JBL signature series wall-mount speakers. Features 8-in downward-firing high-polymer-laminate woofer; dual voice coil; external passive crossover network; ported enclosure; 4 pairs of speaker terminals. Imp 8 ohms; sens 88 dB SPL/W/m; FR 40-20,000 Hz; 100 W max power. Available in walnut veneer, black lacquer, white lacquer, and rosewood vinyl. 10 x 33½ x 10 in; 38 lb . . . \$500

JENSEN

Model 3150 Concert Series 3-Way Speaker

Speaker with 15-in woofer, 5-in midrange, and 3-in cone tweeter. FR 33-21,000 Hz; imp 8 ohms. 32 x 18½ x 11½ in \$350/pr

Model 3120 3-Way Speaker

Features 12-in cone woofer, 5-in midrange, and 3-in tweeter. FR 48-21,000 Hz; max power 150 W, 60 W continuous; imp 8 ohms. 29 x 15½ x 10½ in; 30 lb \$280/pr
Model 3121. As above in oak finish. \$280/pr

Model 3100 3-Way Speaker

Features 10-in cone woofer, 5-in midrange, and 3-in tweeter. FR 43-21; max power 125 W peak, 50 W continuous; imp 8 ohms. 20 x 13 x 10½ in; 24 lb \$220/pr

Model 2650 2-Way Bookshelf Speaker

Bookshelf speaker with 6½-in woofer and 3-in

Investing in sound? Here's how to make it pay off.



Great buys—at a great buy: SAVE UP TO 77%!

Stereo Review is written for people who want to make smart buying decisions. We'll help you find the right stereo equipment—the *first* time you buy—and show you how to use it the right way. Because *sound information* is the key to getting an audio system that gives you what you really want.

We test over 70 stereo products in all price ranges each year. *Stereo Review's* product evaluations tell you how the components sound... identify unique features... compare models to others in the same price bracket. We warn you about design quirks, distortion, potential problems. We make the components suffer—so you don't have to.

You'll appreciate our straightforward explanations of audio technology. Telling you how to get more out of your equipment. Announcing important breakthroughs. Clueing you in on professional maintenance tips. The kind of inexpensive know-how that can make a million-dollar difference in how your system sounds.

Even if you already have the perfect system, you'll value *Stereo Review's* record reviews. An average of 30 a month, in all categories of music. They'll insure that your system's power isn't wasted on inferior recordings. **Use this coupon to subscribe to *Stereo Review* at UP TO 77% OFF. It's one of the best sound investments you'll ever make!**

Stereo Review

P.O. Box 55627
Boulder, CO 80322-5627

YES! I want superior stereo sound. Please enter my subscription to *Stereo Review* for the term checked below:

- One year (12 issues) \$6.97
 Two years (24 issues) \$13.94
 Three years (36 issues) \$20.97

CHECK ONE: Payment enclosed. Bill me later.

Mr.
Mrs.
Ms. _____ 8H71
(please print full name)

Address _____

City _____

State _____ Zip _____

Annual newsstand cost is \$30.5. The full one-year subscription price is \$13.94.

Foreign postage: Add \$5 a year for Canada, \$8 a year payment in U.S. currency must accompany order for other countries outside U.S. and possessions. Please allow 30 to 60 days for delivery of first issue.

SPEAKERS

cane tweeter. FR 55-21,000 Hz; 50 W cont rms. Barton hickory cabinet finish \$150 ea

JPW LOUDSPEAKERS

AP3 2-Way Speaker

Infinite-baffle speaker with 8-in doped-paper-cone woofer and 3/4-in soft-plastic dome tweeter with ferrofluid damping. Features wiring for bi-amp capabilities. FR 55-20,000 Hz \pm 3 dB; min power 10 W rms; max power 100 W rms; sens 100 dB SPL/W/m; imp 8 ohms. Available in walnut, black ash, blonde ash or teak finishes. 10 1/4 x 20 1/2 x 11 1/2 in; 53 3/8 lb/pr \$549/pr

AP2 2-Way Speaker

Infinite-baffle speaker with 8-in doped-paper-cone woofer and 3/4-in soft-plastic dome tweeter with ferrofluid damping. Features wiring for bi-amp capabilities. Frequency response 60-20,000 Hz \pm 3 dB; min power 10 W rms; max power 80 W rms; sens 80 dB SPL/W/m; imp 8 ohms. Available in walnut, black, blonde ash and teak finishes. 10 1/4 x 17 1/4 x 10 1/4 in; 42 3/8 lb/pr \$399/pr

P1 2-Way Speaker

Floor-standing infinite-baffle speaker with 8-in doped-paper-cone woofer and 3/4-in soft-plastic dome tweeter with ferrofluid damping. FR 65-20,000 Hz \pm 3 dB; min power 10 W rms; max power 70 W rms; sens 90 dB SPL/W/m; imp 8 ohms. Available in walnut and black finishes. 10 1/4 x 17 1/4 x 10 1/4 in; 33 1/2 lb/pr \$349/pr

JRM

Monitor Powered Subwoofer/Satellite System

Powered 3-piece system with 4-way stereo configuration. Subwoofer has two 12-in polypropylene drivers; Satellite has three 6 1/2-in polypropylene midbass, 3-in polypropylene midrange, and two piezo-horn tweeters. Subwoofer features 7-way mono bass electronic crossover with 7 level controls; 7 amplifier modules at 350 W rms into 2 ohms. Satellite features time-align drivers; protect mechanism. FR 18-20,000 Hz. Optional cabinet finish and grille \$2,500 4-piece system with dual subwoofer/electronics \$3,300 12 V DC, 21,000 Hz power supply option. \$75

Transparency Satellite Tower 3-Way Speaker

Sealed, vertical-line-source speaker with six 6 1/2-in polypropylene midbass, 3 x 27-in diffraction-horn midrange; 1 7/8-in horn-tweeter. Features user-adjustable time-align driver; uniform 140 degree horizontal dispersion. Requires external crossover and subwoofer. FR 20-20,000 Hz; min amplifier power 1 at 200 W, 2 at 50 W. Optional finish and grille. 66 x 16 x 8 in \$1,300 ea HLS Pro Satellite. As above, horizontal-line-source with six 10-in midbass, larger midrange drivers, and two tweeters \$2,000 ea

Transparency Subwoofer S18B

QB3 vented subwoofer with 18-in woofer. FR 27-250,000 Hz \pm 1.5 dB; 94 SPL/W/m; min amp power 200 W; nominal imp 8 ohms. Optional finish, optional grille color and material. 36 x 25 x 24 in; 175 lb \$700 ea

Transparency Subwoofer S18B-6

B6 vented subwoofer features 18-in woofer. FR 20-250,000 Hz \pm 1.5 dB; 94 SPL/W/m; min amp power 200 W; nominal imp 8 ohms. Optional finish, optional grille color and material. 36 x 25 x 24 in; 175 lb \$700 ea

Transparency Subwoofer S15A

QB3 vented subwoofer features 15-in woofer. FR 27-300,000 Hz \pm 1.5 dB; 91 SPL/W/m; min amp power 200 W; nominal imp 8 ohms. Optional finish, optional grille color and material. 36 x 23 x 16 in; 130 lb \$550 ea

Transparency Subwoofer S15A-6

B6 vented subwoofer features 15-in woofer. FR 20-300,000 Hz \pm 1.5 dB; 91 SPL/W/m; min amp power 200 W; nominal imp 8 ohms. Optional finish, optional grille color and material. 36 x 23 x 16 in; 130 lb \$550 ea

Transparency Subwoofer D15A

C4 vented subwoofer features two 15-in woofers. FR 18-300,000 Hz \pm 1.5 dB; 89 SPL/W/m; min amp power 200 W; nominal imp 2/4/8 ohms. Optional finish, optional grille color and material. 48 x 34 x 24 in; 200 lb \$550 ea

Transparency Subwoofer S18A

B4 vented subwoofer features 18-in woofer. FR 25-250,000 Hz \pm 1.5 dB; 95 SPL/W/m; min amp power 200 W; nominal imp 2/4/8 ohms. Optional finish, optional grille color and material. 36 x 30 x 24 in; 175 lb \$500 ea

Transparency Subwoofer D12A

QB3 vented subwoofer features two 12-in woofers. FR 27-450,000 Hz \pm 1.5 dB; 88 SPL/W/m; min amp power 200 W; nominal imp 2/4/8 ohms. Optional finish, optional grille color and material. 36 x 23 x 18 in; 150 lb \$450 ea

Transparency Subwoofer D12A-6

B6 vented subwoofer features two 12-in woofers. FR 18-450,000 Hz \pm 1.5 dB; 88 SPL/W/m; min amp power 200 W; nominal imp 2/4/8 ohms. Optional finish, optional grille color and material. 36 x 23 x 18 in; 150 lb \$450 ea

J.S. ENGINEERING

Model 4 4-Way Speaker

Floor-standing speaker with two 10-in cone woofers, 7-in cone midrange, 2-in dome upper midrange, 7/8-in dome tweeter. Features complex rounded trapezoidal shape; patented phase shift bass loading and Infinite Slope crossover; front and side of speakers angled 8°; uniform horizontal output to 90° off axis. Imp 8 ohms. 48 1/2 x 19 x 22(bottom) in; 16 x 6 1/2(top) in; 150 lb. Walnut, oak, black oak \$4,500/pr

Infinite Slope Model 1.8A 3-Way Speaker

Phase-shift bass-loading speaker with 8-in and 10-in cone woofers 6-in, cone midrange, and 1-in dome tweeter. FR 35-20,000 Hz \pm 3 dB; minimum power 20 W rms, max power 300 W rms; sens 90 dB SPL/W/m; imp 8 ohms. Oak, walnut, black gloss. 16 x 38 x 16 in; 100 lb \$1,795/pr

Infinite Slope Model 1 2-Way Speaker

Sealed floor-standing speaker with 7-in and 8-in cone woofer and 1-in dome tweeter. Features Infinite Slope crossover; patented phase shift bass loading; front of speaker angled 15 degrees. Available in oak, walnut, black gloss. FR 40-20,000 Hz \pm 2 dB; power range 10-150 W; imp 8 ohms; sens 90 dB SPL/W/m. 13 x 29 x 14 1/2 in; 55lb \$1,095/pr Model 2A. Similar to the Model 1, except has 12-in and 10-in cone woofers, 6 1/2-in cone and 2-in dome midranges, and 1-in dome tweeter. Front of speaker is angled at 8 degrees. FR 25-24,000 Hz \pm 2 dB; power handling 50-350 W; sensitivity 90 dB SPL/W/m; impedance 8 ohms, 47 x 18 x 16 in at bottom, 11 in at top; 150 lb \$2,495/pr

Infinite Slope Model .8 2-Way Speaker

Floor standing speaker with two 8-in cone woofers and 1-in dome tweeter. Features patented phase-shift bass loading and Infinite Slope crossover. Imp 8 ohms. Walnut, oak, black-lacquer finish .. \$899/pr

Infinite Slope Model .6 2-Way Speaker

Floor-standing ported speaker with 8-in cone woofer; 1-in dome tweeter. Features Infinite Slope crossover 100 dB octave. FR 40-20,000 Hz \pm 3 dB; power range 5-150 W; sens 91 dB SPL/W/m; imp 8 ohms. walnut, oak, black lacquer. 11 x 23 x 13 in; 35 lb .. \$599/pr

Subwoofer

Subwoofer with 12-in driver with 2 voice coils. FR 30-60 Hz; sens 90 dB. Available in oak and walnut. 18 x 18 x 16 in; 50 lb \$495 ea

JVC

SX911WD 3-Way Speaker

Floor-standing speaker with 12-in cross-carbon woofer; 4 1/2-in cross-carbon midrange; 1.2-in amorphous-diamond coated tweeter. Features 3-part crossover network; low-resonance/-vibration diecast aluminum speaker frames; high-density particle-board enclosure; round-cornered front baffle. 300 W max power handling. \$720 ea

SX-A6 4-Way Speaker

Floor-standing with 9 1/4-in x 13 3/4-in passive radiator; 8-in cone woofer; 1 1/4-in soft-dome midrange; 1-in soft-dome tweeter. Features two 3-in ambience enhancement drivers in rear; self-resetting protection circuit for more tweeter power handling. LED overload indicator. FR 25-23,000 Hz \pm 3 dB; power handling capacity 150 W/240 W (music); sens 89 dB SPL/W/m; imp 6 ohms. Wood finish. 15 3/8 x 31 7/8 x 10 1/4 in; 38.6 lb \$500/pr

SX-A3 2-Way Shielded Bookshelf Speaker

Passive-radiator speaker with 8-in x 12-in passive radiator; 8-in cone woofer; 1-in soft-dome tweeter. Features self-resetting protection circuit for more tweeter power handling. LED overload indicator; magnetically shielded for both audio and video use. FR 35-23,000 Hz \pm 3 dB; power handling capacity 130 W/200 W (music); sens 88 dB SPL/W/m; imp 6 ohms. Wood finish. 13 1/2 x 24 1/2 x 11 1/4 in. . \$400/pr

SPX5WD Floor-Standing Speaker

Floor-standing speaker with one full-range 5-in driver. Features column design \$180/pr

KEF

Reference Series

Model 107 3-Way Speaker

Floor-standing coupled-cavity bass-loading speaker uses 2 woofers operating into a resonant chamber vented at top of enclosure to combine sensitivity of bass reflex with accuracy and bass-extension of acoustic suspension. Features two 10-in cone woofers; 4-in polypropylene-cone midrange; 1-in ferrofluid-cooled soft-dome tweeter; pivoting midrange/tweeter head assembly with individual contoured enclosures for minimum diffraction, reduced off-axis coloration, and optimum stereo imaging; hybrid crossover network with built-in passive crossover and outboard active bass EQ with controls for contour, damping, and extension. Conjugate load-matched passive crossover presents amp with uniform imp at all frequencies. Power handling 300 W cont; FR 20-20,000 Hz, \pm 2 dB; sens 90 dB SPL/W/m; imp 4 ohms. Walnut, black-ash, or rosewood finish. 13 x 46 x 17 3/8 in; 99 lb ea \$4,800/pr

Model 104/2 3-Way Speaker

Floor-standing speaker with cone woofers vertically aligned, coupled-cavity bass loading technique, chassis-less drivers, conjugate load matching. Two 8-in cone woofers, two 4 1/2-in cone midranges and 1-in ferrofluid-cooled dome tweeter. Power handling 200 W max; FR 35-20,000 Hz, \pm 2 dB; sens 92 dB SPL/W/m; imp 4 ohms; 11 x 35 1/2 x 16 3/8 in; 70 lb, 8 oz. Walnut, rosewood or black ash \$2,200/pr 104/2 KUBE. Active bass EQ with controls for contour and extension \$200

Model 103/3 3-Way Speaker

Bookshelf coupled-cavity bass-loading speaker with woofer operating into a resonant chamber vented at bottom of enclosure to combine sensitivity of bass reflex with accuracy and bass-extension of acoustic suspension. Features 8-in cone woofer; 6-in polypro-

SPEAKERS

pylene-cone midrange; 1-in ferrofluid-cooled soft-dome tweeter; hybrid crossover network with built-in passive crossover and outboard active bass EQ with controls for contour and extension. Conjugate load-matched passive crossover presents amp with uniform imp at all frequencies. Power handling 200 W max; FR 50-20,000 Hz, ± 2 dB; sens 92 dB SPL/W/m; imp 4 ohms. Walnut, black-ash, or rosewood finish. Includes feet for shelf mounting. 10 $\frac{3}{8}$ x 22 $\frac{3}{8}$ x 12 $\frac{1}{2}$ in; 37 lb, 8 oz ea. . . . \$1,490/pr
KS103/3. Optional floor stands for free-standing placement \$109/pr

Model 102 2-Way Bookshelf Speaker

Features 6-in polypropylene-cone woofer and 1-in ferrofluid-cooled soft-dome tweeter; hybrid crossover network with built-in passive crossover and outboard active bass EQ with controls for contour and extension. Conjugate load-matched passive crossover presents amp with uniform imp at all frequencies. Power handling 200 W cont; FR 65-20,000 Hz, ± 2 dB; sens 92 dB SPL/W/m; imp 4 ohms. Walnut, black-ash, or rosewood finish. Dimensions: 8 $\frac{1}{4}$ x 13 x 10 $\frac{1}{4}$ in; 15 lb/ea. \$890/pr
ULS20. Optional floor stands for Model 102 bookshelf speaker. \$125/pr

C Series

All C-series speakers feature polymer woofer diaphragms; fluid cooling on tweeters; gold-plated input terminals. Terminals accept heavy-gauge wire, 4mm banana plugs, and dual banana plugs on $\frac{3}{4}$ -in centers.

C95 3-Way Speaker

Floor-standing speaker features KEF Uni-Q 2-way driver; 8-in woofer and 1-in polymer-dome tweeter; coupled cavity bass loading; 8-in unit mounted vertically inside cabinet is loaded at the front by a tuned cavity; conjugate load matching; separate set of connecting terminals allows to bi-amplify driving the bass unit separately. Power handling 250 W cont; frequency response 50-20,000 Hz; sensitivity 90 dB SPL/W/m; impedance 4 ohms. Grain-match real walnut or black ash finish. 9 $\frac{3}{4}$ x 34 $\frac{3}{8}$ x 12 $\frac{3}{8}$ in; 41 lb, 10 oz ea. \$1,290/pr

C75 3-Way Speaker

Floor-standing loudspeaker just over $\frac{1}{2}$ a square foot; uses the same KEF Uni-Q driver as C95; second 8-in bass unit on matching diecast chassis; sealed enclosure. Power handling 150 W cont; FR 57-20,000 Hz, ± 3 dB; sens 91 dB SPL/W/m; imp 4 ohms. Simulated walnut or simulated black ash finish. 9 $\frac{3}{4}$ x 28 $\frac{3}{8}$ x 10 $\frac{1}{8}$ in; 28 lb, 7 oz ea. \$750/pr

C55 3-Way Speaker

Small enough for bookshelf or free standing. Features KEF Uni-Q driver with polymer cone 8-in passive radiator which extends bass to 48 Hz - 6 dB and a $\frac{3}{4}$ -in polymer-dome tweeter. Passive radiator enclosure; clip-on injection moulded grille made to minimize 'tunnel' effects. Power handling 150 W cont; FR 60-20,000 Hz, ± 3 dB; sens 90 dB SPL/W/m; imp 4 ohms. Simulated walnut or simulated black ash finish. 9 $\frac{3}{4}$ x 18 $\frac{3}{8}$ x 10 $\frac{1}{8}$ in; 15 lb, 13 oz ea. \$550/pr

C35 2-Way Bookshelf Speaker

Features KEF Uni-Q driver with 8-in polymer woofer and $\frac{3}{4}$ -in polymer-dome tweeter; can be placed upright or on its side with no effect on horizontal dispersion; sealed enclosure. Power handling 150 W cont; FR 64-20,000 Hz, ± 3 dB; sens 88 dB SPL/W/m; imp 4 ohms. Simulated walnut or simulated black ash finish. 9 $\frac{3}{4}$ x 14 $\frac{3}{4}$ x 8 $\frac{1}{8}$ in; 10 lb, 10 oz ea. \$440/pr

C25 2-Way Bookshelf Speaker

Features B160, a 6 $\frac{1}{2}$ -in cone driver with lightweight polymer diaphragm; $\frac{3}{4}$ -in dome tweeter; sealed enclosure. Power handling 110 W cont; FR 65-20,000 Hz, ± 3 dB; sens 87 dB SPL/W/m; imp 4 ohms. Simulated walnut or simulated black ash. 8 $\frac{1}{8}$ x 13 $\frac{3}{8}$ x 6 $\frac{7}{8}$ in; 9 lb ea. \$330/pr

CR15 2-Way Bookshelf Speaker

Features 5-in polymer cone bass unit with diecast chassis and $\frac{3}{4}$ -in metal-dome tweeter. Gold-plated terminals; sealed enclosure. Power handling 80 W; FR 68-20,000 Hz, ± 3 dB; sens 85 dB SPL/W/m; imp 4 ohms. Simulated walnut or simulated black ash. 7 $\frac{1}{8}$ x 10 $\frac{3}{8}$ x 5 $\frac{7}{8}$ in; 7 lb ea. \$240/pr

Custom Series

Models are designed for seamless integration into any listening environment. Speakers are finished in white and can be painted to match any decor. Grilles can be covered with cloth.

CR250SW In-Wall Subwoofer

Features 10-in subwoofer extends bass response of CR200 or CR160 by 1 octave. Power handling 150 W cont; FR 32-150 Hz, ± 2 dB; sens 90 dB SPL/W/m; imp 4 ohms. 13 x 13 x 3 $\frac{3}{4}$ in. Price not including installation \$550

CR200F 2-Way In-Wall Speaker

Features 8-in bass driver mounted to 1-in soft-dome tweeter with fluid cooling; self-resetting tweeter protection circuit; power handling 100 watts continuous; frequency response 55-22,000 Hz, ± 2 dB; sensitivity 90 dB SPL/W/m; impedance 4 ohms. 13 x 10 x 3 $\frac{1}{2}$ in. Price not including installation \$450/pr

CR160S 2-Way In-Wall Speaker

Features 6 $\frac{1}{2}$ -in Uni-Q woofer with coincident, coplanar $\frac{3}{4}$ -in soft-dome tweeter employing Ne-Fe-B magnet; uniform radiation pattern and wide dispersion any all directions. Power handling 70 W cont; FR 60-17,000 Hz, ± 2 dB; sens 88 dB SPL/W/m; imp 4 ohms. 8 $\frac{3}{4}$ -in square frame. Price not including installation \$400/pr
CR160R. As above, except round frame . . . \$400/pr

KENWOOD

LS-P9100 4-Way Speaker

Floor-standing 5-speaker system with 17-in passive radiator. Features 10 $\frac{1}{2}$ -in polypropylene woofer; 4-in polypropylene midrange; 1 $\frac{1}{4}$ -in flat-leaf-diaphragm supertweeter; 2 cone tweeters; crossover network. Max power handling 250 W; FR 20-48,000 Hz; sens 91 dB/W/m; imp 8 ohms; crossover points: 900, 5,500, 10,000 Hz. Simulated woodgrain finish. 17 $\frac{1}{4}$ x 44 $\frac{1}{2}$ x 13 $\frac{1}{4}$ in; 62 lb ea. \$700/pr

LS-P5100 4-Way Speaker

Floor-standing 4-speaker system with 13-in passive radiator. Features 8 $\frac{1}{2}$ -in polypropylene woofer; 4-in polypropylene midrange; 1 $\frac{1}{4}$ -in flat-leaf-diaphragm supertweeter; 2 cone tweeters; crossover network. Max power handling 150 W; FR 25-48,000 Hz; sens 90 dB/W/m; imp 8 ohms; crossover points: 800, 5,000, 10,000 Hz. Simulated woodgrain finish. 14 $\frac{1}{2}$ x 35 $\frac{1}{2}$ x 10 $\frac{3}{4}$ in; 40 lb ea. \$470/pr

Spectrum Series

LSK-703 3-Way Bookshelf Speaker

Acoustic-suspension enclosure with 12-in woofer; 4 $\frac{1}{4}$ -in midrange; 2-in tweeter. Max power handling 160 W; FR 40-20,000 Hz; sens 91 dB/W/m; crossover points 2,000, 5,000 Hz; imp 8 ohms. Simulated teak finish. 14 $\frac{1}{8}$ x 26 $\frac{3}{4}$ x 10 $\frac{1}{4}$ in; 25.4 lb ea. . . . \$285/pr

LSK-503 3-Way Bookshelf Speaker

Acoustic-suspension enclosure with 10-in woofer; 4 $\frac{1}{4}$ -in midrange; 2-in tweeter. Max power handling 130 W; FR 45-20,000 Hz; sens 90 dB/W/m; crossover points 2,000, 5,000 Hz; imp 8 ohms. Simulated light teak finish. 14 x 24 $\frac{1}{8}$ x 10 $\frac{1}{2}$ in; 22 lb ea. . . . \$220/pr

LSK-303 2-Way Bookshelf Speaker

Acoustic-suspension enclosure with 8-in woofer; 2-in tweeter. Max power handling 100 W; FR 50-20,000 Hz; sens 90 dB/W/m; crossover point 5,000 Hz; imp 8 ohms. Simulated light teak finish. 12 $\frac{1}{8}$ x 22 $\frac{1}{8}$ x 8 in; 15.4 lb ea. \$145/pr

LSK-05S Rear Surround Speaker

Full-range speaker for rear-channel sound. Features bass-reflex, wedge-shaped enclosure; 4 x 6-in dual-cone driver. Max power handling 40 W; FR 80-20,000 Hz; sens 90 dB/W/m; imp 8 ohms. Simulated light-teak finish. 7 $\frac{3}{4}$ x 10 $\frac{7}{8}$ x 5 $\frac{3}{4}$ in; 3.1 lb ea. . . . \$69/pr

LSK-01S Rear Surround Speaker

Full-range speaker for rear-channel sound. Features acoustic-suspension enclosure; 4-in driver. Max power handling 20 W; FR 100-20,000 Hz; sens 91 dB/W/m; imp 8 ohms. Simulated light-teak finish. 5 $\frac{1}{2}$ x 7 $\frac{1}{2}$ x 4 $\frac{3}{4}$ in; 2.6 lb ea. \$49/pr

KEYSTONE

Thunder 18-Way Speaker

Contains fifteen 5 $\frac{1}{4}$ -in magnesium silicate filled polypropylene woofers and 3 Motorola dual element tweeters. The shape of the cabinet is like a pyramid and can be moved around on its casters. Cabinet is carved from $\frac{3}{4}$ -in marble-like Corian by DuPont. Light or dark finish. Black, azure, rose, yellow, pearl, or white grilles. Factory-delivered and set up. Lifetime guarantee. Power handling 50-500 W; impedance 7/8 ohms min; 75 lb/ea. \$2,995/pr

KINDEL AUDIO

MQLS Modular System

The MQLS Modular System consists of either the MQLS-1 or MQLS-2 speaker fixed to the top of the MQLS Subwoofer.

MQLS-1 Modular Speaker

Full-range speaker with four 6 $\frac{1}{2}$ -in mid-woofers and 1-in soft-dome tweeter. Features centered tweeter configuration in which all four mid-woofers operate through the upper bass, then the uppermost and lowest woofers are rolled off by the crossover; the two center woofers have a 3rd-order crossover to the tweeter. 8 $\frac{1}{2}$ x 34 x 14 $\frac{1}{4}$ in; 48 lb. \$1,700/pr

MQLS-2 Modular Speaker

Similar to MQLS-1 but with two 6 $\frac{1}{2}$ -in woofers, two 4-in midranges, 1 $\frac{1}{2}$ -in dome mid-tweeter, and 2 $\frac{1}{2}$ x $\frac{1}{2}$ -in ribbon supertweeter. \$1,425/pr

MQLS Subwoofer

Two vented and compression-loaded subwoofers with 10-in woofers in Bandpass-type enclosures. 16 x 23 x 18 in; 57 lb. \$1,125

P-105 2-Way Speaker

Speaker with 8-in polypropylene woofer with dual voice coil and 1-in soft-dome tweeter. Features crossover at 250 Hz which rolls off one woofer voice coil winding; conventional crossover at 2,500 Hz (first order) to tweeter; sealed box for bass. FR 40-20,000 Hz ± 2.5 dB; imp 4 ohms; minimum power 20 W. 20 x 10 x 9 in. \$495/pr

P-55 2-Way Speaker

Speaker with 6-in polypropylene woofer and 1-in dome tweeter. Features a sealed box bass. FR 55-20,000 Hz ± 2.5 dB; crossover at 3,000 Hz; imp 8 ohms; minimum power 20 W. Black-gloss finish. 14 x 8 x 8 in. \$299/pr

The Purist Series

Purist I.T 2-Way Speaker

Floor-standing speaker using a 2 pi/4 pi configuration with two 6 $\frac{1}{2}$ -in polypropylene cone woofers and 1-in dome tweeter. Features bass loading via an 8-in passive radiator in a loaded-line configuration. FR 35-20,000 Hz ± 2 dB; imp 4 ohms. 13 x 43 x 6 $\frac{1}{2}$ in; 60 lb. \$895/pr

KINERGETICS

SW-100 Subwoofer System

The subwoofer cabinet contains two 10-in long-throw

SPEAKERS

woofers and is constructed of high-density fiberboard. The system includes the SW-200 150-W/ch passive amplifier/crossover which includes a patented compound circuit using polypropylene film capacitors; crossover pt 100 Hz. Oak, walnut, or black finish \$1,532
SW-200 Amplifier. 5 x 17 $\frac{1}{4}$ x 10 in; 20 lb. . . . \$754
SW-100 Subwoofer. FR -3 dB at 17 Hz; efficiency 95 dB; SPL 113 dB at 30 Hz, 1 meter. 24 x 11 x 16 in; 50 lb. . . . \$439

SW-100.5 Subwoofer System. As above, one 10-in long-throw woofer per cabinet and mono amplifier \$1,094
SW-100.5 Amplifier. 5 x 17 $\frac{1}{4}$ x 10 in; 20 lb. . . . \$554
SW-100.5 Subwoofer. FR -3 dB at 17 Hz; efficiency 92 dB; SPL 107 dB at 30 Hz, 1 meter. 12 x 11 x 16 in; 25 lb. . . . \$220

KINETIC AUDIO

Titan/Trapezium 6-Way Speaker

Floor-standing ported speaker with 12-in polypropylene-cone subwoofer, 12-in polypropylene-cone woofer, 6 $\frac{1}{2}$ -in polypropylene cone mid/woofer, 2-in textile-dome tweeter, 1 $\frac{1}{8}$ -in synthetic-dome tweeter, $\frac{3}{4}$ -in synthetic-dome supertweeter. Features interconnecting harness of color-coded high-performance speaker cables; 5-way heavy-duty binding posts; linear-phased driver arrangement in mirror-image pairs. Front-mounted fuse and noninductive level controls. Crossover points 60, 90, 500, Hz; FR 12-22,000 Hz \pm 1.5 dB; min power 35 W, max power 250 W; sens 90 dB SPL/W/m; imp 4 or 8 ohms. Mirror-matched high-grade walnut veneer; black grille with non-resonant frame. Grilles, stands, and casters included. 18 x 60 x 22 in; 245 lb. . . . \$5,000/pr

Trapezium 5-Way Speaker

Ported speaker with 12-in polypropylene-cone woofer, 6 $\frac{1}{2}$ -in polypropylene-cone mid-range, 2-in textile-dome tweeter, 1 $\frac{1}{8}$ -in synthetic-dome tweeter, $\frac{3}{4}$ -in synthetic-dome supertweeter (tweeters have magnetic-fluid cooling/damping). Features interconnecting harness of color-coded high-performance speaker cables; 5-way heavy-duty binding posts. Linear-phased driver arrangement in mirror-image pairs; front-mounted fuse and noninductive level controls. Crossover points at 90, 500, 3,000, 7,000 Hz; FR 12-22,000 Hz \pm 1.0 dB; min power 45 W, max 200 W; sens 90 dB SPL/W/m; imp 6 ohms. Mirror-matched high-grade walnut veneer. Black grille with non-resonant frame. Includes grilles, stands, and casters. 16 x 60 x 20 in; 205 lb. . . . \$4,000/pr

Labyrinth 4-Way Speaker

Floor-standing ported speaker with 12-in polypropylene-cone woofer, 6 $\frac{1}{2}$ -in polypropylene-cone mid-range, 2-in textile-dome tweeter, 1 $\frac{1}{8}$ -in synthetic-dome tweeter (both tweeters have magnetic-liquid cooling/damping). Features interconnecting harness of color-coded high-performance speaker cables; 5-way heavy-duty binding posts. Linear-phased driver arrangement in mirror-image pairs; front-mounted fuse and noninductive level controls. Crossover points 90, 500, 3,000 Hz; FR 16-22,000 Hz \pm 1.5 dB; min power 35 W, max 200 W; sens 91 dB SPL/W/m; imp 6 ohms. Mirror-matched high-grade walnut veneer. Black grille with nonresonant frame. Includes grilles, stands, and casters. 16 x 48 x 18 in; 185 lb. . . . \$3,000/pr

Trapezoid 4-Way Speaker

Floor-standing, ported speaker with 12-in polypropylene-cone woofer, 6 $\frac{1}{2}$ -in polypropylene-cone mid-range, 1 $\frac{1}{8}$ -in synthetic-dome tweeter with magnetic-liquid cooling/damping, $\frac{3}{4}$ -in synthetic-dome supertweeter with magnetic-liquid cooling/damping. Features interconnecting harness of color-coded high-performance speaker cables; 5-way heavy-duty binding posts. Linear-phased driver arrangement in mirror-image pairs; front-mounted fuse and noninductive level controls. Crossover points 90, 2,000,

7,000 Hz; FR 18-22,000 Hz \pm 1.5 dB; min power 20 W, max 200 W; sens 92 dB SPL/W/m; imp 8 ohms; Mirror-matched high-grade walnut veneer. Black grille with non-resonant frame. 16 x 40 x 14 in; 115 lb. . . . \$2,000/pr

Stat Monitor 3-Way Speaker

Floor-standing or large-shelf, ported speaker with 12-in polypropylene-cone woofer, 6 $\frac{1}{2}$ -in polypropylene-cone midrange, 1 $\frac{1}{8}$ -in synthetic-dome tweeter with magnetic-liquid cooling/damping. Features interconnecting harness of color-coded high-performance speaker cables; 5-way heavy-duty binding posts; linear-phased driver arrangement in mirror-image pairs. Front-mounted fuse and noninductive level controls. Crossover points 90, 2,000 Hz; FR 18-22,000 Hz \pm 1.5 dB; min power 15 W, max 200 W; sens 93 dB SPL/W/m; imp 8 ohms; Mirror-matched high-grade walnut veneer. Black grille with nonresonant frame. 14 $\frac{1}{2}$ x 26 x 14 in; 95 lb. . . . \$1,000/pr



Kinetic Audio Titan/Trapezium

Stat Miniature Monitor 2-Way Speaker

Ported speaker with 6 $\frac{1}{2}$ -in polypropylene-cone woofer; 1 $\frac{1}{8}$ -in synthetic-dome tweeter with magnetic-liquid cooling/damping. Features interconnecting harness of color-coded high-performance speaker cables; 5-way heavy-duty binding posts linear-phased driver arrangement in mirror-image pairs. Front-mounted fuse and noninductive level controls. Crossover point 2,000 Hz; FR 38-22,000 Hz \pm 2 dB; min power 5 W, max 150 W; sens 93 dB SPL/W/m; imp 8 ohms; Mirror-matched high-grade walnut veneer. Black grille with nonresonant frame. 9 x 15 x 9 in; 30 lb. . . . \$700/pr

Subwoofers

Trapezoid Subwoofer

Floor-standing subwoofer with 12-in polypropylene-cone driver. Features built-in 180-Hz passive crossover; separate direct-to-woofer terminals; may be used with electronic crossover or optional low-loss 4-point passive crossover/low-pass filter, in mirror-image pairs; interconnecting harness of color-coded high-performance speaker cables; 5-way heavy-duty binding posts. FR 16-2,000 Hz \pm 1.5 dB; min power 25 W, max 350 W; sens 92 dB SPL/W/m; imp 8 ohms; Mirror-matched high-grade walnut veneer. Black grille with nonresonant frame. 16 x 40 x 14 in; 95 lb. . . . \$600/pr

Stat Subwoofer

Ported subwoofer with 12-in polypropylene cone driver. Features built-in 180-Hz crossover; separate direct-to-woofer terminals; interconnecting harness of color-coded high-performance speaker cables; 5-

way heavy-duty binding posts. FR 18-2,000 Hz \pm 2 dB; min power 15 W, max 350 W; sens 93 dB SPL/W/m; imp 8 ohms; Mirror-matched high-grade walnut veneer; black grille with nonresonant frame. 14 $\frac{1}{2}$ x 26 x 14 in; 85 lb. . . . \$450/pr

KIRKSAETER

Monitor Tower 140 4-Way Speaker

Acoustic-suspension speaker with two 10-in active long-excursion polypropylene woofers acting as a subwoofer, 4 $\frac{1}{2}$ -in coated cone upper bass/lower midrange, 2-in soft-metal dome midrange, and $\frac{3}{4}$ -in titanium-dome tweeter with ferrofluid. Power handling 10-250 W; sens 93 dB SPL/W/m; FR 20-32,000 Hz; imp 4-8 ohms. 11 $\frac{3}{8}$ x 11 $\frac{3}{8}$ x 42 in; 53 lb. 4 wood finishes . . . \$2,299/pr

Monitor Tower 140 3-Way Speaker

Acoustic-suspension speaker with a 10-in long-excursion polypropylene woofer, 5-in polypropylene midrange in an acoustic-sealed aluminum chamber, and $\frac{3}{4}$ -in titanium-dome tweeter with ferrofluid. Power handling 10-140 W; sens 92 dB SPL/W/m; imp 4-8 ohms; FR 22-32,000 Hz. 11 $\frac{3}{8}$ x 11 $\frac{3}{8}$ x 37 $\frac{1}{8}$ in; 44 lb. 4 wood finishes . . . \$1,499/pr

Monitor 141 3-Way Bookshelf Speaker

Acoustic-suspension speaker with a 10-in long-excursion polypropylene woofer, 5-in polypropylene midrange in an acoustic-sealed aluminum chamber, and $\frac{3}{4}$ -in titanium-dome tweeter with ferrofluid. Power handling 10-140 W; sens 93 dB SPL/W/m; imp 4-8 ohms; FR 25-32,000 Hz. 13 x 10 $\frac{3}{4}$ x 21 $\frac{3}{4}$ in; 30 lb. 4 wood finishes . . . \$1,249/pr

Monitor 121 3-Way Bookshelf Speaker

Acoustic-speaker with an 8 $\frac{1}{2}$ -in long-excursion woofer, acoustic-sealed 4 $\frac{1}{2}$ -in polypropylene midrange with ferrofluid, and $\frac{3}{4}$ -in titanium-dome tweeter with ferrofluid. Power handling 10-120 W; frequency response 28-32,000 Hz; sensitivity 92 dB SPL/W/m; imp 4-8 ohms. 11 $\frac{1}{2}$ x 9 $\frac{7}{8}$ x 20 $\frac{3}{8}$ in; 24 lb. 4 wood finishes . . . \$999/pr

Tower Amadeus 200 3-Way Speaker

Acoustic-suspension speaker with two active 8 $\frac{1}{2}$ -in long-excursion polypropylene woofers, acoustic-sealed 4 $\frac{1}{2}$ -in polypropylene midrange with ferrofluid, and $\frac{3}{4}$ -in titanium-dome tweeter with ferrofluid. Made of high-density fiberboard. Power handling 10-200 W; sens 92 dB SPL/W/m; imp 4-8 ohms; FR 27-30,000 Hz. 11 x 13 x 42 in; 40 lb. Black-oak, walnut, dark-oak finishes . . . \$999/pr

Tower Amadeus 120 3-Way Speaker

Acoustic-suspension speaker with an 8 $\frac{1}{2}$ -in long-excursion polypropylene woofer, acoustic-sealed 4 $\frac{1}{2}$ -in polypropylene midrange with ferrofluid, and $\frac{3}{4}$ -in titanium-dome tweeter with ferrofluid. Made of high-density fiberboard. Power handling 10-120 W; sens 91 dB SPL/W/m; imp 4-8 ohms; FR 28-30,000 Hz. 9 $\frac{3}{4}$ x 9 $\frac{3}{4}$ x 33 in; 30 lb. Black-oak, walnut, dark-oak finishes . . . \$799/pr

Omega Satellite/Subwoofer System

Includes 2 lacquered acoustic-suspension speakers each with a 5 $\frac{1}{2}$ -in polypropylene woofer/midrange and 2 polypropylene 2 $\frac{1}{2}$ -in tweeters, and a ported subwoofer with two 7-in polypropylene lower bass drivers (made of fiberboard). Power handling 20-100 W; sens 89 dB SPL/W/m. Subwoofer frequency range 40-180 Hz, satellites 180-20,000 Hz. Satellites 5 $\frac{1}{8}$ x 8 $\frac{3}{4}$ x 3 $\frac{3}{8}$ in; 4 lb/ea. Subwoofer 11 $\frac{3}{8}$ x 19 x 8 $\frac{3}{4}$ in; 21 lb. Black or white finish. . . . \$799/system

Concept 120 3-Way Bookshelf Speaker

Ported enclosure speaker with an 8 $\frac{1}{2}$ -in long-excursion polypropylene woofer, 4 $\frac{1}{2}$ -in polypropylene acoustic-sealed midrange with ferrofluid, and $\frac{3}{4}$ -in titanium-dome tweeter with ferrofluid. Made of high-density fiberboard with front panels of solid wood, black oak, walnut, or antique oak. Power handling

MAGNEPLANARS®

Top Choice of Tough Customers

FROM STEREOPHILE, VOL.12, NO.1 (JAN, 1989)

the stereophile readership survey

TOP 30 LOUDSPEAKER BRANDS

Brand name

Percentage
of Stereophile
readership
owning brand

Percentage of
speaker owners
that would not buy
the product
if they had it
to do over again.

Magnepan

6.9%

1%

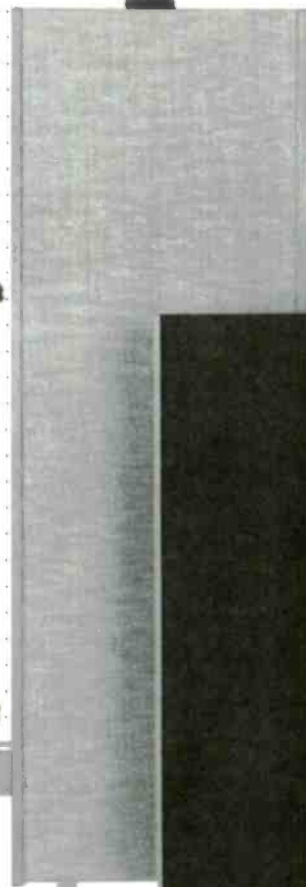

MAGNEPAN 1645 Ninth St., White Bear Lake, MN 55110

CIRCLE NO. 10 ON READER SERVICE CARD

SPEAKERS

10-120 W; sens 91 dB SPL/W/m; imp 4-8 ohms. 10 $\frac{3}{4}$ x 10 $\frac{1}{2}$ x 20 $\frac{1}{2}$ in; 24 lb. \$699/pr

Satellite I 2-Way Bookshelf Speaker

Bookshelf ported enclosure speaker with a 4 $\frac{1}{2}$ -in coated cone woofer and 1-in rubber-suspended titanium-dome upper midrange/tweeter. Power handling 10-100 W; sens 89 dB SPL/W/m; FR 68-32,000 Hz. 5 $\frac{1}{2}$ x 9 $\frac{7}{8}$ x 7 $\frac{1}{8}$ in; 9 lb. \$649/pr

HiTeck Manhattan 3 3-Way Bookshelf Speaker

Satellite ported enclosure speaker with an 8 $\frac{1}{2}$ -in long-excursion polypropylene woofer, acoustic-sealed 4 $\frac{1}{2}$ -in polypropylene midrange with ferrofluid, and $\frac{3}{4}$ -in titanium-dome tweeter with ferrofluid. High-density fiberboard with black oak, walnut, or antique finishes. Power handling 10-120 W; FR 38-22,000 Hz; sen 91 dB SPL/W/m. 9 $\frac{3}{8}$ x 15 $\frac{3}{8}$ x 11 $\frac{1}{2}$ in; 16 lb \$649/pr

Concept 100 2-Way Bookshelf Speaker

Ported enclosure speaker with a 7-in long-excursion polypropylene woofer and 1-in textile-dome tweeter. High-class fiberboard with front trim panels of black oak, walnut, or antique oak. Power handling 10-100 W; sens 90 dB SPL/W/m; imp 4-8 ohms; FR 29-22,000 Hz. 8 $\frac{3}{8}$ x 10 $\frac{3}{8}$ x 17 $\frac{1}{8}$ in; 19 lb. \$599/pr

HiTeck Manhattan 2 2-Way Bookshelf Speaker

Satellite ported enclosure speaker with a 7-in long-excursion polypropylene woofer and 1-in textile-dome tweeter. Made of high-density fiberboard. Power handling 10-100 W; sens 90 dB SPL/W/m; FR 40-22,000 Hz. 8 x 12 $\frac{3}{8}$ x 11 $\frac{1}{2}$ in; 14 lb. Black-oak, walnut, or antique-oak finishes. \$499/pr

KLH

Professional Reference Series

All Professional Reference Series speakers come with vented cabinets, push terminals that accept large-diameter wire and banana plugs, oak grain vinyl finish, high-density board cabinet, and a 5-year limited warranty.

Model 7700 3-Way Speaker

Tuned-port speaker with 12-in copolymer/fiber woofer, 4-in midrange, and 1-in dome tweeter. Features 12-in passive radiator. Power 5-175 W rms; FR 22-22,000 Hz \pm 6 dB; sens 92 dB SPL/W/m; imp 8 ohms; crossover pts 900 and 3,500 Hz. . . . \$578/pr

Model 7500 3-Way Speaker

Tuned-port speaker with 12-in copolymer/fiber woofer, 4-in midrange, and 1-in soft-dome tweeter. Power range 5-150 W rms; FR 24-22,000 Hz \pm 6 dB; sens 91 dB SPL/W/m; imp 8 ohms; crossover points 900 and 3,500 Hz. 15 $\frac{1}{4}$ x 31 $\frac{1}{4}$ x 10 in. . . . \$478/pr

Model 7200 2-Way Shielded Bookshelf Speaker

Tuned-port speaker with 8-in polypropylene woofer and 1-in dome tweeter. Features shielded magnets for positioning next to a TV without disrupting the picture. Power range 5-95 W rms; FR 40-22,000 Hz \pm 6 dB; sens 90 dB SPL/W/m; imp 8 ohms; crossover point 3,500 Hz. 11 $\frac{3}{4}$ x 19 $\frac{1}{2}$ x 11 $\frac{3}{8}$ in. . . . \$398/pr

Model 7100 2-Way Shielded Bookshelf Speaker

Tuned-port speaker with 6 $\frac{1}{2}$ -in polypropylene woofer and 1-in dome tweeter. Features shielded magnets for positioning next to a TV without disrupting the picture. Power range 5-65 W rms; FR 50-22,000 Hz \pm 6 dB; sens 89 dB SPL/W/m; imp 8 ohms; crossover point 3,500 Hz. 9 x 16 $\frac{1}{2}$ x 9 $\frac{3}{8}$ in. . . . \$278/pr

1000 Series

All 1000 series speakers come with vented cabinets, push terminals that accept large-diameter wire and banana plugs, oak grain vinyl finish, high-density board cabinet, and a 5-year limited warranty.

AV-5000 3-Way Speaker

Tower speaker with 12-in copolymer/fiber woofer, 4-in hemi-dome midrange, and a Motorola pieza

electric horn tweeter. Power range 3-180 W rms; FR 20-30,000 Hz \pm 6 dB; sens 94 dB SPL/W/m; imp 8 ohms; crossover points 900 and 4,000 Hz. $\frac{3}{8}$ -in Oak finish. 15 $\frac{1}{4}$ x 42 $\frac{3}{4}$ x 10 $\frac{3}{4}$ in. \$598/pr

AV-4000 3-Way Speaker

Tuned-port speaker with 12-in copolymer/fiber woofer, 4-in hemi-dome midrange, and a Motorola piezoelectric horn tweeter. Power range 3-160 W rms; FR 24-30,000 Hz \pm 6 dB; sens 93 dB SPL/W/m; imp 8 ohms; crossover points 900 and 4,000 Hz. $\frac{3}{8}$ -in oak finish. 15 $\frac{1}{2}$ x 29 $\frac{3}{4}$ x 10 $\frac{3}{4}$ in. \$498/pr

AV-3000 2-Way Shielded Bookshelf Speaker

Tuned-port bookshelf speaker with 8-in polypropylene shielded-magnet woofer and a 3 $\frac{1}{2}$ -in ferrofluid cooled tweeter. Power range 5-75 W rms; FR 40-22,000 Hz \pm 6 dB; sens 91 dB SPL/W/m; imp 8 ohms; crossover point 4,000 Hz. $\frac{3}{8}$ -in oak finish. 9 x 15 $\frac{1}{2}$ x 9 $\frac{3}{8}$ in. \$398/pr

AV-2000 2-Way Shielded Bookshelf Speaker

Tuned-port bookshelf speaker with 6 $\frac{1}{2}$ -in polypropylene shielded-magnet woofer and a 3-in ferrofluid cooled tweeter. Power range 5-65 W rms; FR 50-22,000 Hz \pm 6 dB; sens 89 dB SPL/W/m; imp 8 ohms; crossover point 4,000 Hz. $\frac{3}{8}$ -in Michigan oak finish. 9 x 15 $\frac{1}{2}$ x 9 $\frac{3}{8}$ in. \$258/pr

500 Series

All 500 series speakers come with vented cabinets, push terminals that accept large-diameter wire and banana plugs, oak-grain vinyl finish, high-density board cabinet, and a 5-year limited warranty.

T312D 3-Way Speaker

Tower speaker with 12-in copolymer/fiber woofer, 4-in hemi-dome midrange, 1-in cooled soft-dome tweeter. Features 12-in polymer passive radiator. Power handling 3-175 watts; frequency response 20-22,000 Hz \pm 6 dB; sensitivity 96 dB SPL/W/m; impedance 8 ohms; crossover points 900 and 4,000 Hz. 15 x 43 x 10 in. \$598/pr

1203D 3-Way Speaker

Tuned-port speaker with 12-in copolymer/fiber woofer, 4-in hemi-dome midrange, 1-in soft-dome tweeter. Pwr range 3-150 W; FR 24-22,000 Hz \pm 6 dB; sens 94 dB SPL/W/m; imp 8 ohms; crossover points 900 and 4,000 Hz. 15 $\frac{1}{4}$ x 31 $\frac{1}{4}$ x 10 in. . . . \$498/pr

Model 802 2-Way Shielded Speaker

Tuned-port speaker with 8-in polypropylene woofer and a 3-in ferrofluid-cooled tweeter. Features shielded magnets for positioning next to a TV without disrupting the picture. Power range 5-95 W rms; FR 40-22,000 Hz \pm 6 dB; sens 92 dB SPL/W/m; imp 8 ohms crossover point at 4,000 Hz. 11 $\frac{3}{4}$ x 19 $\frac{1}{2}$ x 11 $\frac{3}{8}$ in. \$398/pr

Model 602 2-Way Speaker

Tuned-port speaker with 6 $\frac{1}{2}$ -in polypropylene woofer and 3-in ferrofluid-cooled tweeter. Features shielded magnets for positioning next to a TV without disrupting the picture. Power range 8-65 W rms; FR 50-22,000 Hz \pm 6 dB; sens 90 dB SPL/W/m; imp 8 ohms; crossover point at 4,000 Hz. 9 x 16 $\frac{1}{2}$ x 9 $\frac{3}{8}$ in. \$258/pr

Legend Series

All Legend Series speakers come with polymer-coated drivers, push terminals that accept large-diameter wire and banana plugs, oak grain finish, and 5-year limited warranties.

Model 1900 3-Way Speaker

Tuned-port speaker with 15-in woofer, 5 $\frac{1}{4}$ -in midrange, and a 3-in tweeter. Power range 5-125 W rms; FR 35-23,000 Hz \pm 8 dB; sens 93 dB SPL/W/m; imp 8 ohms; crossover points 700 and 4,000 Hz. Oak vinyl finish. 33 x 19 $\frac{1}{4}$ x 12 $\frac{3}{4}$ in. \$518/pr

Model 1700 3-Way Speaker

Tuned-port speaker with 12-in woofer, 5 $\frac{1}{4}$ -in mid-

range, and a 3-in tweeter. Power range 5-110 W rms; frequency response 38-22,000 Hz \pm 8 dB; sensitivity 92 dB SPL/W/m; impedance 8 ohms; crossover points 900 and 4,000 Hz. Oak vinyl finish. 43 x 15 $\frac{1}{4}$ x 10 $\frac{3}{4}$ in. \$478/pr

Model 1500 3-Way Speaker

Tuned-port speaker with 12-in woofer, 5 $\frac{1}{4}$ -in midrange, and 3-in tweeter. Power range 5-85 W rms; frequency response 42-22,000 Hz \pm 8 dB; sensitivity 91 dB SPL/W/m; impedance 8 ohms; crossover points 900 and 4,000 Hz. Oak vinyl finish. 31 x 15 $\frac{1}{4}$ x 10 $\frac{3}{4}$ in. \$438/pr

Model 1400 3-Way Speaker

Tuned-port speaker with 10-in woofer, 5 $\frac{1}{4}$ -in midrange, and a 3-in tweeter. Power range 5-70 W rms; FR 49-22,000 Hz \pm 9 dB; sens 90 dB SPL/W/m; imp 8 ohms; crossover points 900 and 1,400 Hz. Oak vinyl finish. 27 x 13 $\frac{3}{4}$ x 10 $\frac{3}{4}$ in. \$378/pr

Model 1100 2-Way Speaker

Tuned-port speaker with 8-in woofer and 3-in tweeter. Power 5-50 W rms; FR 55-22,000 \pm 9 dB; sens 89 dB SPL/W/m; imp 8 ohms; crossover point 4,000 Hz. Oak vinyl finish. 22 x 11 $\frac{3}{4}$ x 8 $\frac{1}{4}$ in. \$258/pr

KLIPSCH

Klipschorn 3-Way Speaker

Fully horn-loaded floor standing speaker features K-33-E woofer, K-55-M midrange and K-77-M tweeter. Power handling 100 W cont; FR 35-17,000 Hz. \pm 3 dB; sens 104 dB SPL/W/m; imp 8 ohms. 31 $\frac{1}{4}$ x 52 x 28 $\frac{1}{2}$ in; 167 lb. Priced depending on finish, from approx. \$3,198/pr

Belle Klipsch 3-Way Speaker

Fully horn-loaded floor-standing utilizing same drive components as Klipschorn. Power handling 100 W cont; FR 45-17,000 Hz. \pm 5 dB; sens 104 dB SPL/W/m; imp 8 ohms. 30 $\frac{1}{4}$ x 35 $\frac{3}{8}$ x 18 $\frac{3}{4}$ in. Available in exotic woods. Priced depending on finish, from approx. \$2,598/pr

I.a Scala. Fully horn-loaded 3-way speaker similar to Belle Klipsch but available only in natural birch, stained birch, or black finishes. Specs same as Belle Klipsch. 23 $\frac{3}{4}$ x 35 $\frac{1}{2}$ x 24 $\frac{1}{2}$ in. Priced depending on finish, from approx. \$1,706/pr

Cornwall II 3-Way Speaker

Floor-standing speaker featuring 15-in woofer (K-34-E), horn-loaded compression midrange (K-57-K) and tweeter (K-79-K). Vented enclosure; optional riser base. Power handling 100 W cont; FR 38-20,000 Hz. 3 dB; sens 100 dB SPL/W/m; power handling 100 W; imp 8 ohms. Available in exotic wood. 25 $\frac{1}{4}$ x 35 $\frac{3}{4}$ x 15 $\frac{1}{2}$ in; 90 lb ea. Priced depending on finish, from approx. \$1,638/pr

Chorus 3-Way Speaker

Floor-standing speaker featuring 15-in woofer (K-48-E), horn-loaded compression drivers for midrange (K-57-K) and tweeter (K-79-K). Vented box enclosure; built-in riser base. Power handling 100 W cont.; FR 45-20,000 Hz. \pm 3 dB; sens 101 dB SPL/W/m; imp 8 ohms. Walnut, oak or exotic woods finish. 18 $\frac{1}{2}$ x 39 x 15 $\frac{1}{2}$ in; 89 lb ea. Priced according to finish, from approx. \$1,490/pr

Forte 3-Way Speaker

Floor-standing speaker featuring horn-loaded compression drivers for midrange (K-53-K) and tweeter (K-75-K); 12-in woofer (K-23); 12-in passive radiator (KD-13) mounted on rear of cabinet. Vented box enclosure; built-in riser base. Power handling 100 W cont; FR 32-20,000, \pm 3 dB; sens 98 dB SPL/W/m; imp 8 ohms. Available in exotic woods. 16 $\frac{1}{2}$ x 35 $\frac{3}{8}$ x 12 in; 56 lb ea. Priced according to finish, from approx. \$1,180/pr

Heresy II 3-Way Speaker

Features 12-in woofer (K-24-K), horn-loaded com-



Can you think of any rock and roll song that actually sounds better at a low volume?

(Well, okay, maybe *Sugar, Sugar* by the Archies).

Simply, for most of us, great rock and roll is best when it's played loud. And clear.

Which is precisely where we come in. At Cerwin-Vega, we build loudspeakers so you, and your neighbors, can hear everything from booming

bass to guitars gently weeping.

In fact, our three series of loudspeakers (the AT, SE, and D-Series) can reproduce bass all the way down to a throbbing 30 Hertz. And all the way up to 28,000 Hertz.

There are 6 models in our high-tech SE Series (above). Cerwin-Vega AT-Series loudspeakers (left) are available in 4 models.

What's more, every Cerwin-Vega speaker can run on as little as 5 watts. On the other hand, our 15" models can handle up to 400 watts of continuous power.

And reach a volume level of 127 very loud decibels.

Of course, in this magazine, every speaker sounds exactly the same. Silent.

So we suggest you take your favorite discs to your favorite store and ask to listen to Cerwin-Vega speakers.

Tell them you'd just like to hear the sound of a little live ammunition.

Cerwin-Vega!

For more information please write or call Cerwin-Vega: 555 East Easy St., Simi Valley, CA 93065 805-584-9332
Cerwin-Vega Canada: 2360 Midland Ave., Scarborough, Ontario M1S4A9 Cerwin-Vega Europe: Grynderupvej 12, P.O. Box 40, DK-9610 Norager, Denmark



Cerwin-Vega D-Series loudspeakers are available in 5 models. From the 8"1/2-way D-1 to the 15"13-way D-9.

If rock and roll is rebellion, this is live ammunition.

SPEAKERS

passive midrange (K-53-K) and tweeter (K-76-K). Sealed enclosure. Power handling 100 W continuous; FR 50-20,000 Hz, ± 3 dB; sensitivity 96 dB SPL/W/m; impedance 8 ohms. Available in exotic woods. 15 $\frac{1}{2}$ x 21 $\frac{3}{8}$ x 13 $\frac{3}{4}$ in; 37 lb ea. Priced depending on finish, from approximately \$882/pr

Kg² 2-Way Speaker

Floor-standing speaker with 12-in rear-mounted passive radiator (KD-12), two 8-in polymer-cone woofers (K-8), and horn-loaded tweeter (K-74). Vented box enclosure; built-in riser base. Power handling 100 W cont; FR 38-20,000 Hz, ± 3 dB; sens 94 dB SPL/W/m; imp 6 ohms. Oak or walnut finish. 15 $\frac{3}{4}$ x 24 $\frac{1}{4}$ x 10 $\frac{3}{4}$ in; 40 lb ea. From approx \$598/pr

Kg² 2-Way Speaker

Features rear-mounted passive radiator (KD-10), 8-in polymer woofer (K-9-K) and a horn tweeter (K-72). Vented box enclosure. Power handling 65 W cont; FR 35-20,000 Hz, ± 3 dB; sens 90 $\frac{1}{2}$ dB SPL/W/m; imp 4 ohms; crossover frequency 1,800 Hz. Oak or walnut veneer finish. 13 $\frac{1}{4}$ x 18 $\frac{7}{8}$ x 11 $\frac{1}{2}$ in; 28 lb ea. From approx..... \$420/pr

KOSS

M/100 Plus Powered Speaker

Built-in 20-watt amp allows amplification from the headphone jack of TV, portable tape, or CD player. FR 50-30,000 Hz; S/N 80 dB; THD < 5% (ω : 1 kHz); 4 ohm imp. 27 lb/pr \$260/pr

M/90 Plus 2-Way Speaker

Features two 4 $\frac{1}{2}$ -in woofers and 1-in dome tweeter. FR 50-30,000 Hz; sens 88 dB SPL/W/m; 4-6 ohm imp; max power 20 W continuous, 100 W peak. 12 $\frac{7}{8}$ x 5 $\frac{1}{4}$ x 5 $\frac{1}{2}$ in; 30 lb/pr..... \$220/pr

Dynamite M/80 Plus Speaker

Acoustic-suspension bookshelf speaker with automatic circuit breaker to guard against speaker damage. Features dual-active 4 $\frac{1}{2}$ -in woofers, 1-in dome tweeter. FR 50-30,000 Hz ± 3 dB; min power 10 W/rms; max power 100 music; imp 6 ohms. 5 $\frac{1}{4}$ x 12 x 5 $\frac{1}{4}$ in; 8 lb..... \$180/pr

M/60 Plus 2-Way Speaker

Features 1-in dome tweeter; 4 $\frac{1}{2}$ -in woofer. FR 100-30,000 Hz; sens 84 SPL/W/m; imp 8 ohms nom. 6 ohms min; power range 15-75 W music. 4 $\frac{3}{4}$ x 4 $\frac{3}{4}$ x 5 $\frac{1}{2}$ in..... \$135/pr

LASER SPEAKERS BY LASER AUDIO

Laser Signature Reference 1200 2-Way Speaker

Floor-standing speaker with bottom-firing sub-woofer, 12-in sub-bass, 8-in midbass, dome tweeter. Features circuit-overload protection FR 22-20,000 Hz ± 3 dB; min power 25 W rms; max power 200 W rms; sens 97 dB. High-luster black finish with oak burl top and bottom. 34 $\frac{3}{4}$ x 15 $\frac{1}{4}$ x 15 $\frac{1}{2}$ in \$750 ea

Laser Signature Reference 1000 2-Way Speaker

Floor-standing speaker with bottom-firing sub-woofer, 10-in sub-bass, 6 $\frac{1}{2}$ -in midbass, and dome tweeter. Features circuit-overload protection. FR 25-20,000 Hz ± 3 dB; min power 25 W rms; max power 150 W rms; sens 97 dB. High-luster black finish with solid oak burl top and bottom. 35 $\frac{3}{4}$ x 13 $\frac{1}{4}$ x 15 $\frac{1}{2}$ in..... \$600 ea

FXT-8 MKVII 2-Way Speaker

Bookshelf bass-reflex speaker with 8-in bass and dome tweeter. Features circuit-overload protection. FR 35-20,000 Hz ± 3 dB; min power 35 W rms; max power 125 W rms; sens 92 dB. High-luster black finish. 19 x 10 x 11 in \$250 ea

FXT-6 2-Way Speaker

Bookshelf bass-reflex speaker with 6 $\frac{1}{2}$ -in bass and dome tweeter. Circuit-overload protection. FR 40-

20,000 Hz ± 3 dB; min power 35 W rms; max power 100 W rms; sens 91 dB. High-luster black finish. 15 x 8 x 10 in \$200 ea

LAZER-TECH SPEAKERS

L112 Tower Monitor 3-Way Speaker

Speaker with 12-in polypropylene woofer, 4 $\frac{1}{2}$ -in extended-range driver, 1-in soft-dome tweeter. Features separate isolation chambers for bass and midrange drivers; extensive internal bracing; 18" sloped-front sound plane; twin rear-firing tuned ports; 3-way computer-matched crossover network. FR 32-25,000 Hz; imp 8 ohm; sens 93 dB SPL/W/m; crossover 700 & 4,000 Hz; power handling 10-250 W. Rosewood or teak finish with removable black grilles. 90 lb ea..... \$1,395/pr

L110. As above with 10-in polypropylene bass driver. 68 lb \$1,195/pr

LP8 3-Way Speaker

46-in tall twin-ported 3-way panel system with two 8-in translucent cone bass drivers with 30 oz magnet; 4 $\frac{1}{2}$ -in extended-range driver, two 1-in soft-dome tweeter. Features separate midrange, bass and tweeter isolation chambers; 3-way computer designed crossover network; fuse protection circuit; black removable grilles; input connections for cable. FR 30-25,000 Hz; imp 8 ohm; Sens 93 dB. Oak, teak, rosewood, walnut, white rosewood or black formica finish. 28 x 19 $\frac{1}{2}$ x 5 $\frac{1}{2}$ in; 55 lb \$1,250/pr

LP8A. A short, wide version of the LP8. Has no rear-mount horn but rather two 1-in soft dome tweeters on the front sound panel; slightly sloped stand; all other features are same as LP8. 28 x 19 $\frac{1}{2}$ x 5 $\frac{1}{2}$ in; 55 lb..... \$1,195/pr

LENOXX

SP-200 Mini Pocket-Stereo Speakers

Passive speaker system. Features metal mesh grille; Alnico drivers. 3 $\frac{1}{2}$ x 2 $\frac{1}{2}$ x 1 $\frac{3}{4}$ in..... \$15/pr

LINN PRODUCTS

DMS Isobarik 3-Way Speaker

Isobarik-loading 3-way floor-standing speaker with 12-in, 9-in woofers, 5-in midrange, two 3 $\frac{1}{2}$ -in dome tweeters. Can be triamped. FR 25-20,000 Hz ± 1.5 dB; crossovers at 375 and 3 kHz; instantaneous dynamic range 54 dB; imp 4 ohms; power range 50-500 W; 30 x 15 x 16 $\frac{1}{2}$ in..... \$5,385/pr

Kaber 2-Way Speaker

Floor-standing tower speaker with two 5-in woofers and 3 $\frac{1}{2}$ -in tweeter. Woofers operate at different enclosure resonance and crossover points. Can be tri-wired, or passively tri-amped. Includes integral base



Linn Nexus LS 250

stand. Walnut or black ash finish \$1,995/pr

S.A.R.A. Isobarik 2-Way Speaker

Isobarik-loading 2-way bookshelf speaker with two 8-in woofers, 3 $\frac{1}{2}$ -in dome tweeter. Cast structural foam housing. FR 36-20,000 Hz ± 2 dB; imp 4 ohms; 17 x 13 x 10 in \$1,795/pr

Nexus LS 250 2-Way Loudspeaker

Ported 2-way system, 8-in carbon-loaded polypropylene woofer, 3 $\frac{1}{2}$ -in soft-dome tweeter. Molded front baffle and port of structural foam polymer. Built-in 14-in pedestal stand. 4th order Linkwitz-Riley crossover, phase aligned, at 2,500 Hz. Frameless grill cloth stretches over baffle. Can be bi-wired, sens 88 dB SPL/W/m. 10 x 22 x 12 in..... \$1,095-\$1,295/pr

Helix 2-Way Speaker

Bookshelf or floor mounting, ported speaker with 8-in woofer and 3 $\frac{1}{2}$ -in dome tweeter. Can be bi-wired or passively bi-amped. 20 x 10 x 11 in. Simulated black ash finish..... \$795/pr

K.A.N. 2-Way Speaker

Acoustic-suspension bookshelf speaker with 5-in woofer, 3 $\frac{1}{2}$ -in dome tweeter. FR 70-20,000 Hz ± 3 dB; imp 8 ohms; 12 x 7 $\frac{1}{2}$ x 6 $\frac{1}{2}$ -in \$785/pr

Index 2-Way Speaker

Acoustic-suspension speaker for floor or bookshelf. 8-in KEF B200 cone woofer; 1-in dome tweeter; cabinet of full 3 $\frac{1}{4}$ -in high-density particle board; 50-strand 20-amp cable. FR 60-20,000 Hz ± 3 dB; power range 15-50 W; sens 87 dB SPL/W/m; imp 8 ohms. 17 x 11 x 8-in; 17 lb; black woodgrain..... \$595/pr

LUXMAN

S-505 2-Way In-Wall Speaker

Flush-mount system designed for custom installation in walls or ceilings. Features 8-in woofer with long-throw 1 $\frac{1}{2}$ -in voice coil and graphite/polypropylene cone; 1-in soft-dome tweeter with auto-resetting overload protector. Tweeter-level control; mounting provision for optional RC-501 remote control sensor; integral clamps and mounting brackets. FR 50-22,000 Hz ± 2.5 dB; sens 89 dB SPL/W/m; nom imp 8 ohms. Outside frame: 14 $\frac{1}{2}$ x 10 $\frac{1}{2}$ x 3 $\frac{3}{16}$ in \$500

RC-501. Remote sensor..... \$100

PB-81. Pair of rough-in brackets..... \$70

MG-81A. Pair of speaker grilles..... \$30

MG-81B. Pair of speaker grilles with opening for remote sensor..... \$30

MAGNEPAN

Magneplanar Tympani-IVa 3-Way Speaker

Combination planar-magnetic and ribbon tweeter with bi-amplification option. FR 30-40,000 Hz ± 3 dB; power handling 300 W max; sens 87 dB SPL/W/m; imp 4 ohms bass, 3 ohms midrange/tweeter; crossover frequency 400/3,000 Hz. Off-white, black, or brown panel with oak trim; bass section: 1254 sq. in planar magnetic, midrange section: 168 sq. in planar magnetic, tweeter section: 1 $\frac{1}{4}$ x 55 x 0.0001-0.00015 in; 260 lb/pr \$3,800/pr

Magneplanar MG-IIIa 3-Way Speaker

Combination planar-magnetic and ribbon tweeter with bi-amp option. FR 37-40,000 Hz ± 3 dB; power handling 200 W max; sens 85 dB SPL/W/m; imp 4 ohms bass, 3.4 ohms midrange/tweeter; crossover pts 500/3,000 Hz. Off-white, black, or brown panel with oak trim; bass section: 620 sq. in planar magnetic, midrange section: 170 sq. in planar magnetic, tweeter section: 1 $\frac{1}{4}$ x 55 x 0.0001-0.00015 in \$2,195/pr

Magneplanar MG 2.5/R 2-Way Speaker

Combination planar-magnetic and ribbon tweeter. FR 37-40,000 Hz ± 3 dB; power handling 200 W max; sens 84 dB SPL/W/m; imp 5 ohms; crossover frequency 800 Hz. Off-white, black, or brown panel with oak trim; bass section: 609 sq. in planar magnetic,



ONLY ONE COMPACT SPEAKER SYSTEM CAN COMPETE WITH GLENMONITOR BLOCKHEADS . . .



. . . GLENMONITOR CUBITS

At times, the competition is extremely tough. Fortunately for us, GlenMonitor is the only competition. After all, if it weren't for our Cubits, our Blockheads would be the only compact speaker system worth listening to.

The power and precision of our Blockheads and Cubits allows them to compete with the best large scale home speaker systems. And with their unique design and finishes they are also the only contenders for the best looking speakers.

Because at GlenMonitor we want our speakers to look as great as they sound—don't you?

So while other companies are busy shouting about how good they are why don't you hear how good a compact speaker system can sound. Hear GlenMonitor Cubits and Blockheads, and start listening for the whisper between the shouts. For more information about GlenMonitor's Cubits, Blockheads and their complete home line, contact GlenMonitor USA (518) 398-5077.

GLENMONITOR USA



SPEAKERS

midrange/tweeter section: 9 sq. in. planar magnetic; 22 x 71 x 2 in.; 110 lb/pr \$1,695/pr

Magneplanar MG1.4 2-Way Speaker

Floor-standing 2-way speaker with planar magnetic woofer and tweeter. Features oak side rails; off white fabric grille. Power handling 200 W cont; FR 40-18,000 Hz, ± 3 dB; crossover frequency 1,000 Hz; sens 87 dB SPL/W/m; imp 5 ohms purely resistance. 22 x 60 x 2 in. \$980/pr

Magneplanar SMGa 2-Way Speaker

Full-range speaker with 0.5-mil diaphragm driven by Magneplanar magnetic field. Power handling 100 W cont; FR 50-18,000 Hz ± 4 dB; sens 85 dB SPL/W/m; imp 4 ohms; crossover 2,400 Hz. Bass/midrange section: 370 sq. in. tweeter section: 58 sq. in.; 19 $\frac{1}{4}$ x 48 $\frac{3}{4}$ x 1 $\frac{3}{4}$ in.; 60 lb/pr \$495/pr

MARANTZ

SP 1515 3-Way Speaker

Ported, floor-standing speaker with 15-in woofer; 5-in ferrofluid cone midrange; 3-in ferrofluid cone tweeter; sculptured furniture-style cabinet. Max power 165 W; sens 92 dB SPL/W/m; imp 8 ohms. Bartonwood vinyl finish. 18 x 32 $\frac{1}{2}$ x 16 $\frac{1}{2}$ in; 47 lb. \$400/pr

SP 1200 3-Way Speaker

Ported, floor-standing speaker with 12-in woofer; 4-in ferrofluid cone midrange; 3-in ferrofluid cone tweeter. Max power 165 W; sens 90 dB SPL/W/m; imp 8 ohms. Bartonwood vinyl finish. 15 x 29 $\frac{1}{2}$ x 11 $\frac{1}{2}$ in; 32 lb. \$300/pr

SP 1000 3-Way Speaker

Ported speaker features 10-in woofer; 4-in ferrofluid cone midrange; 3-in ferrofluid cone tweeter. Max power 130 W; sens 89 dB SPL/W/m; impedance 8 ohms. Bartonwood vinyl finish. 13 x 27 x 11 in; 25 lb. \$240/pr

SP 800 3-Way Speaker

Ported speaker features 8-in woofer; 4-in ferrofluid cone midrange; 2-in ferrofluid cone tweeter. Max power 60 W; sens 89 dB SPL/W/m; impedance 8 ohms. Bartonwood vinyl finish. 13 x 26 x 8 $\frac{1}{2}$ in; 15 lb. \$150/pr

SP208 2-Way Speaker

Ported, 2-way speaker system with 8-in woofer and 2-in tweeter. Max power 50 W; sens 90 dB SPL/W/m; imp 8 ohms. Oak vinyl finish. 10 $\frac{3}{4}$ x 18 $\frac{3}{4}$ x 8 $\frac{3}{4}$ in; 10 $\frac{1}{2}$ lb. \$120/pr

MARTIN-LOGAN

The Statement Electrostatic Speaker System

Floor-standing system consisting of 2 visually-transparent curvilinear electrostatic panels used in conjunction with two woofer towers and blended by an electronic crossover. Each electrostatic element measures 3 x 6 in and is curved and housed in a massive frame; each woofer tower houses four 12-in woofers mounted in individually sealed anti-resonant chambers; dual-mono crossover consists of four separate chassis; 2 chassis contain power supplies; 2 chassis contain crossover using a proprietary discrete Class-A differential FET buffer topology and pure-current source voltage regulation system; can play at volumes up to 120 dB. Power handling 1,000 W cont; FR 16-25,000 Hz, ± 1.5 dB; sens 93 dB SPL/W/m; imp 6 ohms. Electrostatic section: 39 $\frac{1}{2}$ x 84 x 6 in. Woofer towers: 15 x 84 x 30 in. Available in a variety of finishes. System weighs 1 ton \$40,000

The Monolith II Hybrid Electrostatic Speaker

Floor-standing curvilinear electrostatic panel speaker mounted atop a tuned subwoofer box. Designed for wide dispersion without the use of delay lines of lenses. Constant voltage crossover provides phase coherency. Features 2-ft x 4-ft electrostatic cell for

100-24,000 Hz and a 12-in polypropylene-cone subwoofer with 2-in voice coil that is down 3 dB at 16 Hz. Power handling 500 W cont; FR 28-24,000 Hz, ± 2 dB; sens 90 dB SPL/W/m; imp 8 ohms. Available in a variety of finishes. 25 x 75 x 13 $\frac{1}{2}$ in. \$5,500/pr

The CLS II Electrostatic Speaker

Floor-standing curved electrostatic speaker. Features wide-dispersion format for full-range reproduction; 2-ft x 4-ft electrostatic cell to reproduce all frequencies from 50-22,000 Hz; 30 degrees seamless horizontal dispersion; 4-ft line-source vertical; arc-free diaphragm; see-through appearance. Power handling 150 W cont; FR 50-22,000 Hz, ± 2 dB; sens 85 dB SPL/W/m; imp 6 ohms. Available in a variety of finishes. 26 x 48 x 2 in; 75 lb ea. \$3,500/pr

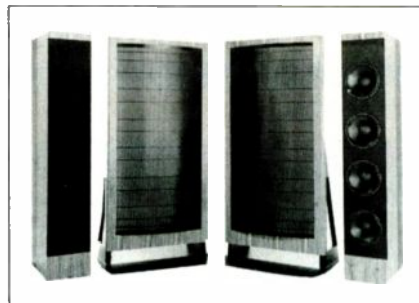

Martin-Logan The Statement

The Sequel II Hybrid Electrostatic Speaker

Floor-standing electrostatic/subwoofer system. Features visually transparent electrostatic transducer that operates from 200-24,000 Hz; 30° seamless horizontal dispersion in a vertical line-source format; 1-ft x 4-ft electrostatic cell; super-low-mass 10-in subwoofer in a tuned chamber with a matrix voice coil to create linear field in large excursion modes. Power handling 300 W cont; FR 26-24,000 Hz ± 3 dB; sens 89 dB SPL/W/m; imp 6 ohms. Oak and black finish. 14 $\frac{1}{2}$ x 74 x 13 $\frac{1}{2}$ in; 110 lb ea. \$2,500/pr

MBQUART

Quart Aera 3-Way Powered Speaker

Floor standing, 3-way tri-amplified powered speaker; 3 power amps: 70, 70, 140 W/ch. Features pulsating-sphere high frequency driver utilizing magnetostriction, 2-in aluminum dome midrange and 10-in diecast woofer with butyl surround. FR 28-50,000 Hz; sens 280 W; crossover pts 700/5,000 Hz. Piano varnish black or white. 13 x 48 x 16 in. \$20,000

MB 980S 3-Way Speaker

Floor-standing, acoustic-suspension column speakers. Features 1-in titanium-dome with ferrofluid tweeter; 2-in aluminum-dome midrange; two 8-in butyl suspension, long-throw woofers; Power handling 160 W cont; FR 34-32,000 Hz; sens 88 dB SPL/W/m; crossover frequencies 350/500/2,900 Hz; imp 4 ohms. 11 x 39 $\frac{1}{2}$ x 11 in; 57 lb 3 oz ea. Genuine walnut or oak, white or grey laquer. (special finishes at extra cost). \$2,399/pr

MB 650S 3-Way Speaker

3-way acoustic-suspension column loudspeakers. Features 1-in multilayered, compressed wood; ceramic magnets; fluid cooled tweeter; computer optimized bass response; 1-in titanium-dome tweeter; 2-in supronyl dome midrange; 8-in butyl suspension, long-throw woofer; power handling 100 W cont; FR 39-32,000 Hz; sens 88 dB/W/m; crossover frequency 400/2,900 Hz; imp 4 ohms. 10 $\frac{3}{4}$ x 33 $\frac{3}{4}$ x 10 $\frac{1}{4}$ in; 38 lb 10 oz ea. Genuine walnut or oak, white, black or gray laquer \$1,499/pr

MB 350S 2-Way Speaker

Bass reflex speakers feature 8-in woofer; 1-in titanium-dome tweeter. Power handling 80 W cont; FR 38-32,000 Hz; sens 89 dB SPL/W/m; crossover frequency

1500 Hz; imp 4 ohm; 10 $\frac{1}{4}$ x 32 x 11 in; 40 lb ea. Black, white, oak, walnut, cherry, rosewood, mahogany, pine finishes \$999/pr

MB 310 Subwoofer

Subwoofer features 12-in woofer; FR 25-100 Hz; sens 87 dB SPL/W/m; min. amp power 50 W; crossover frequency 100 Hz; 16 x 19 x 15 in; 40 lb. Walnut, oak, matte lacquer black or white finishes \$849

MB 390 3-Way Bookshelf Speaker

Acoustic-suspension speaker. Features 1-in titanium-dome tweeter; 4-in butyl suspension midrange; 10-in butyl suspension, long-throw woofer. Power handling 130 watts continuous; frequency response 40-32,000 Hz; sensitivity 88 dB SPL/W/m; impedance 4 ohms; crossover frequencies 400/1,800 Hz. 12 x 20 $\frac{1}{2}$ x 12 in; 28 lb 10 oz ea. Genuine walnut or oak, matte lacquer white or black finishes \$899/pr

MB 280 2-Way Bookshelf Speaker

Acoustic-suspension speaker. Features 1-in titanium-dome tweeter; 8-in butyl suspension, long-throw woofer; Power handling 80 W cont; FR 50-32,000 Hz; sens 88 dB SPL/W/m; imp 4 ohms; crossover frequency 1,500 Hz. 10 $\frac{1}{2}$ x 17 $\frac{1}{4}$ x 10 $\frac{1}{4}$ in; 22 lb ea. Genuine walnut or oak, white or black lacquer finishes \$579/pr

MB 220 2-Way Bookshelf Speaker

Acoustic-suspension speaker. Features 1-in titanium-dome tweeter; 6 $\frac{1}{2}$ -in butyl suspension, long-throw woofer; power handling 60 W cont; FR 60-32,000 Hz; sens 87 dB SPL/W/m; crossover frequency 1,500 Hz; imp 4 ohms. 9 x 12 x 8 in; 11 lb ea. Genuine walnut or oak, matte lacquer black or white finishes. \$479/pr

McINTOSH

XRT 22 3-Way Speaker System

2-piece speaker consisting of a bass cabinet containing two 12-in woofers and an 8-in midrange, and a tweeter column containing 23 1-in tweeters. Bass cabinet: 25 $\frac{3}{4}$ x 40 $\frac{3}{4}$ x 12 $\frac{3}{4}$ in; tweeter column: 10 $\frac{1}{2}$ x 79 $\frac{1}{2}$ x 1 $\frac{1}{2}$ in; 258 lb. Oak finish \$8,000/pr Walnut finish \$8,500/pr CS 22. Stands for XRT 22 tweeter column. Walnut or oak. 37 lb \$600/pr

XRT 18 3-Way Speaker System

2-piece speaker consisting of a bass cabinet containing a 12-in woofer and 6-in midrange and a high-frequency column frame containing sixteen 1-in dome tweeters. Features 3-ampere fast acting fuse for woofer and midrange and a 1.25-ampere fuse for tweeters. Cabinet constructed of 48-pound density fiber board with walnut veneer exteriors. FR 20-20,000 Hz; sens 86 dB SPL/W/m; max power 150 W continuous program power, 500 W peak; min power 30 W; imp 8 ohms; crossover frequencies 350 and 1,500 Hz. Bass cabinet: 17 $\frac{1}{2}$ x 27 $\frac{1}{4}$ x 11 $\frac{3}{4}$ in. tweeter column: 10 $\frac{1}{2}$ x 57 $\frac{1}{4}$ x 1 $\frac{1}{2}$ in; 108 lb \$4,500/pr CS 18. Stands for XRT 18 tweeter column. Oak or walnut. 47 lb. \$600/pr

XR 1052 4-Way Speaker

Features 10-in woofer with copper voice coil; 5-in midrange isolated from woofer; 1-in dome tweeter with copper-wire voice coil centered and suspended with custom surround; 15-in passive radiator with accurately adjusted moving mass; built-in crossover with points at 55, 450, and 1,300 Hz; cabinet made of high density particle board; imp 8 ohms. FR 30-20,000 Hz; power handling 250 W max. Walnut finish. 16 x 47 $\frac{1}{2}$ x 11 $\frac{1}{2}$ in; 94 lb \$2,504/pr

XD 717 3-Way Speaker

3-way speaker with 12-in woofer, 6 $\frac{1}{2}$ -in midrange, and 1-in dome tweeter. Sens 87 dB SPL/W/m; power handling 100 W max; imp 8 ohms; crossover frequencies 350 and 1,000 Hz. Cabinet constructed of $\frac{3}{4}$ -in high-density particle board with internal bracing and airtight assembly. Walnut veneer protected by hand-rubbed lacquer finish \$1,598/pr

SPEAKERS

XD 715 3-Way Speaker

Floor-standing speaker with 10-in woofer, 5-in midrange, and 1-in dome tweeter. FR 20-20,000 Hz; sens 87 dB SPL/W/m; power handling 100 W max; min power 30 W; imp 8 ohms; crossover frequencies 350 and 1,000 Hz. Cabinet constructed of 3/4-in high-density particle board with internal bracing and airtight assembly covered by a walnut veneer. 14 3/4 x 30 1/4 x 10 in; 43 lb \$1,198/pr

XL 10 3-Way Speaker

Features 1-in dome tweeter, 8-in woofer, and a 10-in controlled-mass passive radiator. Tweeter is protected by an 0.6-amp fuse. Power handling 100 W max; imp 8 ohms; FR 45-20,000 Hz; sens 89 dB SPL/W/m; crossover frequency 90 and 1,000 Hz. Walnut finish. 14 1/4 x 25 x 7 1/2 in; 27 lb, 8 oz \$858/pr

XL 1W Subwoofer

Dual-voice-coil subwoofer designed to complement and extend performance of McIntosh XL 1 speaker. Features 12-in woofer; two 1.5-ampere fast-acting fuses; walnut veneer cabinet protected by an oil-like multi-coat hand-rubbed lacquer finish. FR 20-150 Hz; sens 85 dB SPL/W/m; power handling 100 W max; min power 30 W; crossover frequency 90 Hz. 17 1/2 x 27 1/4 x 11 3/4 in; 62 lb \$549 ea

XL 1 2-Way Compact Speaker

Bookshelf speaker with 6-in woofer, 1-in dome tweeter, and 1,000 Hz crossover network. Features 0.6-ampere fast-acting fuse. FR 70-20,000 Hz; max power handling 80 W max; min power 30 W; imp 8 ohms; sens 85 dB SPL/W/m. Constructed of 3/4-in high-density particle board with internal bracing. Walnut finish. 8 1/4 x 12 7/8 x 7 in \$525/pr

McNEILL ENGINEERING

Keystone 3D Pyramid Speaker

3-dimensional 360 degree dispersion speaker with fifteen 5-in air-pumping talc-filled poly woofers and 3 titanium-composite soft-dome ferrofluid cooled tweeters. Features pyramid-shaped Corian construction; live rubber surrounds; colored keyed grille covers; low-friction casters; acoustic room coupler. Price includes delivery and room equalization. Power handling 400+ W. 28 x 28 in \$2,999/pr

12C 2-Way Speaker

Air-suspension speaker with 12-in woofer and titanium-coated soft-dome ferrofluid cooled tweeter. Features internally-braced and ribbed cabinet; internally-braced woofer; 5-way gold binding posts; 12-gauge soldered internal wiring; choice of solid Corian construction colors; choice of grille colors. Power handling 150 W. 17 x 26 x 15 in \$1,899/pr

8C 2-Way Speaker

Air-suspension speaker with 8 1/2-in Audex TPX woofer with phase plug and titanium-coated soft-dome ferrofluid cooled tweeter. Features norsorex rubber surround; choice of 7-layer cross-grained plywood or Corian construction; internally ribbed and braced cabinet; 12-gauge soldered internal wiring; 5-way gold binding posts. Real wood finish with choice of grille colors. Power handling 100 W cont \$1,199/pr

8W 2-Way Speaker. As above with plywood only construction; black grille. 12 x 21 x 10 in. . . \$959/pr

6W 2-Way Speaker

Air-suspension speaker with 6 1/2-in Audax long-throw woofer and titanium-dome ferrofluid cooled tweeter. Features live rubber surround; dense particle board with oak veneer; internally-braced cabinet; 5-way gold binding posts. 14-gauge all soldered internal wiring. Power handling 50 W \$699/pr

MERIDIAN

M100 3-Way Powered Speaker

Tri-amplified loudspeaker with integral amplifica-

tion 3-way design using multiple drive units and passive radiator. Contains four 5-in woofers, two 5-in midrange drivers, one 1-in ferrofluid damped soft dome tweeter. Features balanced or unbalanced input; "music sense" auto turn-on system. Power handling 280 W; FR 34-20,000 Hz; max output 113 dB SPL. 39 3/4 x 13 3/4 x 18 1/2 in; 100 lb ea. Rosewood, walnut, or black ash \$6,990/pr

D600 3-Way Powered Speaker

Tri-amplified vented-box active loudspeaker with 6 1/2-in woofer, 6 1/2-in bass/midrange, and 1-in metal-dome tweeter. Features select between digital and analog inputs; 2 analog, 2 digital, and 1 digital/optical input. Display gives information about source and volume number, and when connected to Meridian 200 series components, also shows CD track number and FM preset number and frequency. Includes infrared remote control that controls D600 loudspeakers and other Meridian components. Remote unit controls frequency shaping and tilt controls to optimize loudspeaker response. 70 W x 3; FR 36-20,000 Hz; SPL 110 dB. 35 1/2 x 8 1/4 x 11 3/8 in; 70 lb ea. Rosewood, walnut, or black ash \$5,490/pr

M60. As above, single analog output and no display or remote control. 60 lb \$3,900/pr

M2011 2-Way Powered Speaker

Bi-amplified vented-box active loudspeaker with twin 70-W internal amplifiers, two 5-in bextreme cone midbass drivers and 1-in metal-dome tweeter. Features electronic crossover; balanced/unbalanced inputs; "music sense" circuit that automatically turns on system upon receipt of music. SPL 109 dB; FR 40-20,000 Hz. Walnut or black ash \$2,990/pr

M3011 2-Way Powered Speaker

Bi-amplified vented-box active loudspeaker with twin 70-W internal amplifiers, 6 1/2-in midbass driver and 1-in metal-dome tweeter. Features PVI surround; balanced/unbalanced inputs; "music sense" circuit that automatically turns on system upon receipt of music. FR 40-20,000 Hz; SPL 106 dB. Walnut or black \$1,990/pr

MIRAGE

All speakers are ported; nominal imp 6 ohms (min 4); black knit grilles; dome tweeters with crossover point of 2,200 Hz.

M1 3-Way Speaker

Floor-standing speaker with two 8-in polypropylene woofers (1 front 1 rear) with 38-oz magnets crossing over to two 4-in cone midranges (1 front, 1 rear) at 300 Hz; 2 1/4 in soft-dome tweeters (1 front, 1 rear); black lacquer, white, or oak finish. Power range 100-400 W; FR 20-22,000 Hz \pm 3 dB; sens 86 dB SPL/W/m; imp 6 ohms; 60 x 19 1/2 x 9 in; 120 lb ea \$5,000/pr

Model 760 2-Way Speakers

Bass-reflex speaker with two 8-in carbon-filled polypropylene midbass units with butyl surround; crossover pt 2,200 Hz; 1-in ferrofluid-cooled soft-dome tweeter. Black vinyl or walnut finish. Power range 30-200 W; FR 30-20,000 Hz \pm 3 dB; sens 89 dB SPL/W/m; imp. 6 ohms; 37 x 11 x 14 in; 62 lb ea . . . \$1,000/pr

Model 460 2-Way Speaker

8-in woofer; 1-in dome tweeter; black vinyl or walnut finish. Power range 15-120 W; FR 35-20,000 Hz \pm 3 dB; sens 88 dB SPL/W/m; 25 x 10 x 11 in; 32 lb ea. \$600/pr

Model 360 2-Way Speaker

8-in woofer; 1/4-in tweeter; black vinyl or walnut finish. Power range 15-100 W; frequency response 45-20,000 Hz \pm 3 dB; sens 88 dB SPL/W/m; 20 x 10 x 9 in; 20 lb ea \$400/pr

Model 260 2-Way Speaker

6 1/2-in woofer; 3/4-in tweeter; black vinyl or walnut finish. Power range 15-70 W; FR 50-20,000 Hz \pm 3

dB; sens 88 dB SPL/W/m; power range 15-70 W; 15 x 9 x 9 in; 14 lb ea. \$260/pr

MISSION ELECTRONICS

Mission 767 3-Way Powered Speaker

Tower speaker with two powered 8 1/4-in mineral-loaded homopolymer coned woofers, two 6 1/2-in mineral-loaded polypropylene midbass coned drivers, 1-in dome super-elliptical imp transformer tweeter. Features low-frequency active filter; low-frequency; high-current power amplifier; passive midrange and upper bass crossover; 1-in medium-density fiber board cabinet with rounded corners; 3 separate internal enclosures; 5-way binding posts; controls for low-frequency roll off and contour; bi-amping and bi-wiring capability. Power handling 200 W rms; FR 20-20,000 Hz \pm 3 dB; sens 91 dB SPL/W/m; imp 8 ohms. 11 3/8 x 55 1/8 x 16 3/8 in; 220 lb ea \$3,999/pr

Mission 765 2-Way Speaker

Reflex speaker with two 8-in polypropylene midbass drivers and 1-in super elliptical imp transformer tweeter with ferrofluid cooling. Features bass-reflex loading; flared spikes; full time alignment; flared, tuned port; 5-way terminal posts. Power handling 200 W rms; FR 40-20,000 Hz \pm 3 dB; nom imp 4 ohms; crossover point at 3,200 Hz. Available in natural walnut and black ash wood veneers. 10 1/4 x 37 3/8 x 13 3/8; 50.6 lb ea \$1,299/pr

Mission 764 2-Way Speaker

Reflex speaker with 8 1/4-in mineral-loaded homopolymer midbass driver and 1-in dome super elliptical imp transformer tweeter with ferrofluid cooling. Features bass-reflex loading; flared tuned port; bi-amping and bi-wiring connectors; 5-way terminal posts. Power handling 200 W rms; FR 38-20,000 Hz \pm 3 dB; nom imp 8 ohms; crossover frequency 3,200 Hz. Available in natural walnut and black ash wood veneers. 9 7/8 x 33 7/8 x 13 1/4 in; 44 lb ea \$999/pr

Cyrus 782 2-Way Speaker

Sealed speaker with two 6 1/2-in mineral-loaded polypropylene midbass drivers and 3/4-in ferrofluid-cooled fabric dome tweeter. Features flared reflexport; 1-in medium-density fiber board; floor spikes; 5-way binding posts; bi-amping and bi-wiring. Power handling 25-150 W rms; FR 49-20,000 Hz \pm 3 dB; sens 91.5 dB SPL/W/m; nom imp 4 ohms; crossover frequency 3,200 Hz. Available in walnut, black ash, and rosewood finishes. 10 x 20 3/4 x 13 in; 31 lb/ea. \$799/pr

Mission 763 2-Way Speaker

Reflex speaker with 8-in polypropylene midbass driver and 3/4-in ferrofluid-cooled fabric dome tweeter. Features bass-reflex loading; flared tuned port; 3/4-in medium density fiber board; removable carpet-piercing spikes; 5-way binding post; bi-amping and bi-wiring posts. Power handling 150 W rms; FR 42-20,000 Hz \pm 3 dB; sens 89 dB SPL/W/m; nom imp 8 ohm; crossover frequency 3,200 Hz. Simulated rosewood, walnut, and black-ash veneers. 9 7/8 x 30 1/4 x 13 1/4 in; 35 lb ea \$599/pr

Cyrus 781 2-Way Speaker

Reflex speaker with 6 1/2-in mineral-loaded polymer midbass driver and 3/4-in ferrofluid-cooled fabric-dome tweeter. Features 3/4-in medium-density fiber board; 5-way post; bi-amping and bi-wiring; flared tuned-port. Power handling 25-100 W; FR 47-20,000 Hz; sens 90.5 dB SPL/W/m; nom imp 6 ohms; crossover point 3,500 Hz. Available in walnut and black ash finishes. 9 x 17 x 11 in; 20 lb ea. . \$499/pr

Mission 762 2-Way Bookshelf Speaker

Reflex speaker with 8-in plastiflex midbass driver and 3/4-in ferrofluid-cooled fabric-dome tweeter. Features 3/4-in medium-density fiber board; reflex bass loading; flared, tuned port; 5-way binding posts. Power handling 125 W rms; FR 50-20,000 Hz \pm 3 dB; sens 93.5 dB SPL/W/m; imp 8 ohms; crossover

SPEAKERS

point 4,300 Hz. Available in simulated walnut and black ash veneers. Dimensions: 9 $\frac{7}{8}$ x 16 $\frac{3}{8}$ x 11 $\frac{1}{8}$ in. Weight: 21 lb ea \$399/pr

Mission 761 2-Way Bookshelf Speaker

2-way speaker with 6 $\frac{1}{2}$ -in midbass driver and $\frac{3}{4}$ -in ferrofluid-cooled soft-dome tweeter. Features $\frac{3}{4}$ -in visco elastically-damped transverse-folded cabinet; 5-way binding posts. Power handling 100 W rms; FR 58-20,000 Hz \pm 3 dB; sens 89 dB SPL/W/m; nom imp 6 ohms; crossover point 4,200 Hz. Simulated black ash veneer. Dimensions: 8 $\frac{1}{4}$ x 15 x 8 $\frac{3}{8}$ in. Weight: 13 lb ea. \$249/pr

MITSUBISHI

M-S5100 3-Way Speaker

Floor-standing 3-way system featuring 12-in high-polymer laminate woofer, 5-in high-polymer laminate midrange, and 1-in titanium-dome tweeter. Power handling: 150 W cont, 600 W peak; FR 35-27,000 Hz \pm 6 dB. \$1,100/pr

M-S52G 2-Way Surround-Sound Speaker

Speaker system for rear-channel applications featuring 4-in woofer and 2-in tweeter. Mounting brackets included \$150/pr

M&K

MX-1000CC Center-Channel Powered Subwoofer

Center-channel speaker with two 5-in polypropylene midranges and three 1-in soft-dome tweeter and powered subwoofer with two 21-in drivers. Designed for surround-sound systems. Features two speaker inputs for center channel; independent level control for bass; upper roll-off frequency adjuster. Subwoofer specs similar to the MX-1000. \$1,995

MX-2000 Powered Subwoofer

Powered subwoofer with two 12-in push-pull drivers. Features 300 W cont amplifier; separate continuously variable upper roll-off frequency adjuster. FR 20-125 Hz \pm 3 dB; imp preamplifier input 15,000 ohms, power amplifier input 600 ohms. 18 $\frac{3}{8}$ x 23 x 25 $\frac{1}{2}$ in; 105 lb \$1,695

MX-1000 Pedestal Powered Subwoofer

Magnetic-shunt powered pedestal acoustic-suspension with two 12-in drivers. Magnetic design and pedestal shape allow use as stand for large monitor TV's. 26 x 28 x 22 in; 115 lb \$1,495

S-100 2-Way Satellite Speaker

Satellite speaker with two 5-in polypropylene midranges and three 1-in soft-dome tweeters. Features two back-panel switches to adjust midrange and treble. Satin Graphite Lacquer finish \$895
Glass Bead black finish \$795/pr
Video shielding add \$125/pr

Satellite 1B 2-Way Speaker

2-way acoustic-suspension speaker with two 5-in polypropylene woofers and two 1-in soft-dome tweeters. Features 36 tonal balances through midrange; tweeter character switches. FR 70-22,000 Hz \pm 3 dB; power range 7 $\frac{1}{2}$ -400 W; impedance 4 ohms. Walnut or oak finish with black grille. Dimensions: 21 x 7 $\frac{3}{4}$ x 7 $\frac{3}{8}$ in. Weight: 19 lb. \$725/pr

Satellite 2B 2-Way Speaker

Acoustic-suspension speaker with 6 $\frac{1}{2}$ -in polypropylene woofer and 1-in soft-dome tweeter. Features selector for 36 tonal balances; midrange, treble character switches. FR 65-20,000 Hz \pm 3 dB; power range 15-100 W. Walnut or oak finish with black grille. 10 $\frac{1}{2}$ x 6 $\frac{1}{2}$ x 7 in; 9 lb. \$550/pr

SX-4 2-Way Satellite Speaker

Acoustic-suspension speaker with two 5-in woofers and two 1-in soft-dome tweeters. Features selector for 4 tonal balances via multiple inputs. FR 70-20,000 Hz \pm 3 dB. Black vinyl finish \$495/pr

Satellite 3B 2-Way Speaker

Acoustic-suspension speaker with 5-in polypropylene woofer and 1-in soft-dome tweeter. Features selector for 4 tonal balances via multiple inputs. FR 100-20,000 Hz \pm 3 dB; power range 15-100 W. 10 $\frac{1}{2}$ x 7 x 6 $\frac{1}{2}$ in; 9 lb. Black finish, black grilles. \$395/pr
Walnut veneer with black grilles. \$450/pr

SX-7 2-Way Satellite Speaker

Bookshelf, acoustic-suspension speaker with 4-in paper-cone midrange; $\frac{3}{4}$ -in soft-dome tweeter. Features cast-aluminum box with perforated metal grille; circuit-breaker protection. FR 100-20,000 Hz \pm 3 dB; power range 5-100 W; sens 87 dB SPL/W/m; imp 4 ohms. Black finish. 4 $\frac{1}{2}$ x 7 $\frac{3}{8}$ x 4 $\frac{1}{2}$ in; 6 lb. \$240/pr

Subwoofers

V1B Subwoofer

Internally amplified subwoofer with 12-in polypropylene driver. Features preamplifier, power amplifier inputs; active filtering at 24 dB/octave with adjustable roll-off point. FR 18-125 Hz \pm 3 dB. Walnut or oak finish with black grille. 18 $\frac{3}{4}$ x 17 $\frac{3}{4}$ x 15 $\frac{3}{4}$ in; 50 lb. \$850 ea
V2B. Similar to V1B, less powerful. 43 lb. \$695 ea
V3B. Similar to V2B, less powerful and black painted enclosure. 17 $\frac{1}{2}$ x 17 $\frac{1}{2}$ x 14 $\frac{1}{2}$ in; 43 lb. \$595 ea

VX-4 Subwoofer

Internally amplified subwoofer with 12-in driver. Features adjustable low-pass filter. FR 40-125 \pm 3 dB; 50 W cont. Black vinyl finish \$440 ea

VX-7 Subwoofer

Acoustic-suspension subwoofer with specially designed 50-W amplifier and 8-in woofer. FR 50-80 Hz \pm 3 dB; max power 50 W internally amplified. Black finish. 10 x 11 $\frac{3}{4}$ x 9 $\frac{1}{2}$ in; 25 lb \$360 ea

MONITOR AUDIO

Monitor Gold Series

MA1800 Gold 2-Way Speaker

Floor-standing, double-ported speaker with two 6-in polypropylene woofers and 1-in gold metal-dome tweeter. Features "balanced flow" design; internal cabinet allows for sand filling. FR 30-30,000 Hz \pm 3 dB; imp 8 ohms; sens 89 dB SPL/W/m; power range 20-300 W. Black ash, oak, walnut, rosewood finishes. 15 x 46 x 12 in. \$3,600/pr

MA1200 Gold 2-Way Speaker

Floor-standing, ported-cabinet speaker with 6-in polypropylene woofer and 1-in gold metal-dome tweeter. Internal cabinet allows for sand filling. FR 35-30,000 Hz \pm 3 dB; imp 8 ohms; sens 89 dB SPL/W/m; power range 15-200 W. Black ash, oak, walnut, rosewood finishes. 8 x 36 x 10 in. \$2,250/pr

MA952 Gold 2-Way Speaker

Floor-standing, tuned cabinet speaker with two 6-in polypropylene woofers and 1-in gold metal-dome tweeter. Features infinite baffle. FR 45-30,000 Hz \pm 3 dB; imp 8 ohms; sens 89 dB SPL/W/m; power range 15-120 W. Black ash, Kenya black, oak, walnut finishes. 9 x 31 x 13 in. \$1,750/pr

MA852 Gold 2-Way Speaker

Floor-standing speaker with 8-in polypropylene woofer and 1-in gold metal-dome tweeter. Features internally braced cabinet; infinite baffle. FR 50-30,000 Hz \pm 3 dB; imp 8 ohms; sens 89 dB SPL/W/m; power range 15-120 W. Black ash, Kenya black, oak, walnut finishes. 10 x 18 x 11 in. \$1,350/pr

R452/MD 2-Way Speaker

Tuned port speakers with 8-in doped-paper woofer and 1-in aluminum-dome tweeter. Features heavy cabinets with $\frac{3}{4}$ -in thick panel construction; inside of cabinets is veneered. FR 50-20,000 Hz \pm 3 dB; imp 8 ohm; sens 91 dB/W/m; power range 15-150 W.

Walnut, black ash, or oak finish. 25 $\frac{1}{4}$ x 10 x 12 $\frac{1}{2}$ in; 66 lb \$1,199/pr

R352/MD 2-Way Speaker

Reflex speakers with 8-in woofer and $\frac{3}{4}$ -in metal-dome tweeter. Feature foam-lined cabinet. FR 50-20,000 Hz \pm 3 dB; imp 8 ohm; sens 91 dB/W/m; power range 15-120 W. Walnut, oak, black ash finish. 25 $\frac{1}{4}$ x 10 x 12 $\frac{1}{2}$ in; 57 lb. \$899/pr

R300/MD 2-Way Speaker

Sealed-box speakers with 8-in doped-woofer and $\frac{3}{4}$ -in metal-dome tweeter. Features cabinets veneered inside and out. Frequency response 50-20,000 Hz \pm 3 dB; imp 8 ohm; sens 90 dB/W/m; amp power 15-100 W. Walnut, black ash, or oak finish. 18 $\frac{1}{2}$ x 10 x 12 $\frac{1}{2}$ in; 44 lb. \$699/pr

R100 2-Way Speaker

Sealed-enclosure speakers with 8-in woofer and 1-in soft-dome tweeter. FR 60-20,000 Hz \pm 3 dB; imp 8 ohm; sens 89 dB/W/m; amp power 15-60 W. Black ash or walnut. 15 $\frac{3}{4}$ x 10 x 7 in; 25 lb 5 oz. \$349/pr

Speaker Stands

MA-30. Fits R100, R252, R300/MD, MA 852 Gold speakers. In black ash, walnut, oak, or Kenya black \$189/pr
In rosewood, mahogany, or teak \$269/pr
MA-40. Fits R352/MD and R452/MD. In black ash, walnut, oak, or Kenya black \$189/pr
In rosewood, mahogany, or teak \$269/pr
MA Metal Stand. Fits Monitor 7 and Monitor 9 speakers. Features spiked top and bottom. Comes in black finish only. \$179/pr

MORDAUNT-SHORT

System 442 3-Way Speaker

Reflex speaker with two 7-in woofers and a 1-in titanium-dome tweeter. Power range 40-300; FR 50-20,000 Hz \pm 5 dB; sens 87 dB SPL/W/m; imp 6 ohms; crossover points at 250 and 5,000 Hz. Black ash, mahogany, walnut or light ash finishes. 37 x 10 x 15 in; 55 lb/ea \$2,900/pr

MS 3.50 2-Way Speaker

Transmission-line speaker with 8-in woofer and 1-in aluminum-dome tweeter. Min power 15 W; FR 45-22,000 Hz \pm 5 dB; sens 90 dB SPL/W/m; imp 8 ohms; crossover point at 4,000 Hz. Black ash finish. 35 x 9 x 15 in; 40 lb/ea. \$899/pr

MS 3.40 2-Way Speaker

Reflex speaker with 8-in woofer and 1-in aluminum-dome tweeter. Min power 15 W; FR 50-22,000 Hz \pm 5 dB; sens 90 dB SPL/W/m; imp 8 ohms; crossover 4,000 Hz. Black ash finish. 23 x 9 x 15 in. \$549/pr

MS 3.30 2-Way Speaker

Reflex speaker with 8-in woofer and 1-in aluminum-dome tweeter. Min power 15 W; FR 60-22 Hz \pm 5 dB; sens 90 dB SPL/W/m; imp 8 ohms; crossover point 4,000 Hz. Black ash finish. 18 x 9 x 11 in; 18 lb/ea. \$429/pr

MS 3.20 2-Way Speaker

Reflex speaker with 5-in woofer and $\frac{3}{4}$ -in aluminum-dome tweeter. Min power 15 W; FR 70-22,000 Hz \pm 5 dB; sens 88 dB SPL/W/m; imp 8 ohms; crossover pt 5,000 Hz. Black ash finish. 14 x 7 x 8 in. \$329/pr

MS 3.10 2-Way Speaker

Reflex speaker with 5-in woofer and $\frac{3}{4}$ -in aluminum-dome tweeter. Min power 15 W; FR 75-20,000 Hz \pm 5 dB; sens 88 dB SPL/W/m; imp 8 ohms; crossover at 5,000 Hz. Black ash finish. 11 x 7 x 8 in. \$229/pr

Gold Series

MS300G 2-Way Speaker

Sealed speaker with two 6 $\frac{1}{2}$ -in woofer/midranges

SPEAKERS

and a 3/8-in ferrofluid-cooled and damped titanium-dome/cone tweeter. Features a 3/8-in high-density board cabinet with full circumference brace. Power range 30-150 W; FR 70-20,000 Hz -3 dB; sens 89 dB SPL/W/m; imp 8 ohms; crossover point at 5,000 Hz. Mahogany, black ash, or walnut finishes. 9 x 21 1/2 x 9 3/4 in; 19.1 lb ea. \$725/pr
MS500G..... \$975/pr

MS100G 2-Way Speaker

Sealed speaker with 6 1/2-in woofer/midranges and a 3/8-in ferrofluid-cooled and damped titanium-dome/cone tweeter. Features a 3/8-in high-density board cabinet with full circumference brace. Power range 20-80 W; FR 77-20,000 Hz -3 dB; sens 87 dB SPL/W/m; imp 8 ohms; crossover point at 5,000 Hz. 9 x 13 x 8 in; 10 lb ea. \$425/pr

Series 2

All Series 2 speakers come with a 5-year warranty and Positec overload-protection system.

MS55Ti 2-Way Speaker

Sealed speaker with two 7 1/4-in woofer/midranges and a 3/4-in ferrofluid-cooled and damped titanium-dome/cone tweeter. Features a 3/8-in high-density-board cabinet with full-circumference brace. Power range 25-150 W; FR 50-20,000 Hz -3 dB; sens 90 dB SPL/W/m; imp 8 ohms; crossover at 4,000 Hz. Black ash/walnut finishes. 10 3/8 x 32 3/4 x 11 3/4 in; 34.4 lb/pr. \$769/pr

MS45Ti 2-Way Speaker

Sealed speaker with two 7 1/4-in woofer/midranges and a 3/4-in ferrofluid-cooled and damped titanium-dome/cone tweeter. Features a 3/8-in high-density board cabinet with full circumference brace. Power range 25-150 W; FR 55-20,000 Hz -3 dB; sens 90 dB SPL/W/m; imp 8 ohms; crossover point at 4,000 Hz. Black ash or walnut finishes. 10 3/8 x 25 1/4 x 11 3/4 in; 47 1/2 lb/pr. \$569/pr

MS35Ti 2-Way Speaker

Reflex-loaded speaker with 7 1/4-in woofer/midrange and a 3/4-in ferrofluid-cooled and damped titanium-dome/cone tweeter. Features a 3/8-in high-density board cabinet with full circumference brace. Power range 30-100 watts; FR 55-20,000 Hz -3 dB; sens 88 dB SPL/W/m; imp 8 ohms; crossover point at 4,000 Hz. 10 3/8 x 19 1/2 x 11 in; 37.4 lb/pr. \$389/pr

MS25Ti 2-Way Speaker

Sealed speaker with 7 1/4-in woofer/midrange and a 3/4-in ferrofluid-cooled and damped titanium-dome/cone tweeter. Features a 3/8-in high-density board cabinet with full circumference brace. Power range 25-75 W; FR 70-20,000 Hz -3 dB; sens 87 dB SPL/W/m; imp 8 ohms; crossover point 4,000 Hz. Black ash or walnut finishes. 10 3/8 in x 16 x 9 3/4 in; 29 lb/pr. \$389/pr

MS15 2-Way Speaker

Sealed compact speaker with 6 1/2-in woofer/midrange and a 3/8-in ferrofluid-cooled and damped synthetic-dome/cone tweeter. Features a 3/8-in high-density board cabinet with full circumference brace. Power range 20-60 W; FR 75-20,000 Hz -3 dB; sens 87 dB SPL/W/m; imp 8 ohms; crossover point at 5,000 Hz. Black ash finish. 9 x 13 x 6 1/2 in. \$279/pr

MS10 2-Way Speaker

Rear-reflex loaded speaker with 5 1/2-in woofer/midrange and a 3/8-in ferrofluid-cooled and damped synthetic-dome/cone tweeter. Features a 3/8-in high-density-board cabinet with full-circumference brace. Power range 10-5 W; frequency response 75-20,000 Hz -3 dB; sens 86 dB SPL/W/m; imp 8 ohms; crossover point at 5,000 Hz. Black-ash finish. 7 3/4 x 11 3/8 x 7 1/4 in; 7 1/4 lb/ea. \$229/pr

Integral Stands

IS 1. For MS10, MS25Ti, and MS100G. \$119

IS 2. For MS25Ti, MS35Ti, and MS300. \$109
 IS 3. For MS45Ti. \$99

MOREL ACOUSTICS

Duet 2-Way Speaker

Speaker with 6-in woofer and 1 1/8-in ferrofluid cooled soft-dome tweeter. Features the Hexatech technique winding (aluminum wire, wound hexagonally) in tweeter; double-magnet woofer also using the Hexatech voice coil. Power handling 150 W rms; frequency response 40-22,000 Hz ± 2 dB. Dimensions: 8 x 15 x 12 in. Weight: 20 lb. \$995/pr

MILP-403-II 3-Way Speaker

Ported floor-standing speaker with 9-in free-edge paper-cone woofer, 3-in dome midrange, and 1 1/8-in dome tweeter. Power range 10-125 W rms; FR 38-25,000 Hz ± 3 dB; sens 88 dB SPL/W/m; imp 4-8 ohms. Finished in walnut, teak, or black. 21 x 12 x 10 in; 26 lb. \$795/pr

MPL-203 2-Way Speaker

Linear-phase speaker with 6-in woofer and 1 1/8-in ferrofluid-cooled soft-dome tweeter. Features sealed cabinet; woofer with double magnet, 3-in voice coil woofer. Power handling 150 W; FR 45-28,000 Hz ± 3 dB. Walnut, red walnut, teak, or black finish. 8 x 16 x 9 1/2 in; 18 lb. \$695/pr

MPL-307 2-Way Speaker

Speaker with two 9-in woofers and a 1 1/8-in dome tweeter. Power handling 200 W; FR 33-25,000 Hz ± 3 dB. Walnut veneer. 13 x 23 x 12 in; 32 lb. \$540/pr

MILP-202 II Bookshelf Speaker

Acoustic-suspension linear-phase bookshelf speaker. Power range 10-150 W rms; FR 60-28,000 Hz ± 3 dB; sens 89 dB SPL/W/m; imp 4-6 ohms. Available in walnut, teak, or black. 8 x 13 x 10 in. \$445/pr

CR-7 2-Way Speaker

Acoustic-suspension bookshelf speaker with 6-in treated paper-cone woofer with metal grille and a 1-in soft-dome tweeter with metal grille to eliminate internal standing waves and improve dispersion and flatness of frequency response. Features an asymmetrical cabinet design; available in mirrored pairs. Power range 20-200 W rms; FR 70-25,000 Hz ± 3 dB; sens 90 dB SPL/W/m; imp 4-8 ohms. Black finish. 11 x 7 1/2 x 4 3/4 x 7 in; 10 lb ea. \$498/pr

MILP-201 2-Way Speaker

Acoustic-suspension bookshelf speaker with 9-in free-edge paper-cone woofer and a 1 1/8-in dome tweeter. Power range 10-100 W rms; FR 48-20,000 Hz ± 3 dB; sens 89 dB SPL/W/m; imp 8 ohms. Walnut finish. 10 x 16 x 10 in. \$395/pr

Speaker Accessories

B-7 Mounting Bracket. Mounting bracket for CR-7. \$40

ST-2 Floor Stands. 4-in black wooden stands. \$30

MUSIC AND SOUND IMPORTS

Mas 925 III 3-Way Speaker

Floor-standing speaker with 10-in polypropylene-cone passive radiator, 8-in polypropylene-cone woofer, 1 3/4-in textile-dome tweeter, and 3/4-in textile-dome tweeter. FR 30-18,000 Hz ± 3 dB; power range 25-150 W; sens 91 dB SPL/W/m; imp 8 ohms. Natural oak, dark oak veneer finishes. 23 1/2 x 11 1/8 x 11 1/8 in; 39 lb. \$799/pr

NEAR

CS-410CL Concert Grand 3-Way Speaker

Four B-199B woofers, 2 B-209B midranges, and 8 tweeters in an array. Power range 60-350; imp 8 ohms. Classic style cabinet. 52 x 36 x 19 in. \$6,990/pr
 CS-410M. Same as CS-410CL except Moorish style cabinet. \$6,990/pr

CS-310B. Same as CS-410CL except with matte walnut enclosure. \$6,490/pr

Symphony No. 1 CS-4000 CL 3-Way Speaker

Speaker with 2 woofers, a 6 1/2-in midrange and eight 2-in tweeters in an array. Features an infinite baffle. Max power 250 W; imp 8 ohms; crossover points at 400 and 2,500 Hz. Classic styling. 44 1/2 x 26 1/4 x 15 1/8 in. \$3,499/pr
 CS-4000M. Same as CS-4000 CL with Moorish styling. \$3,499/pr
 CS-4000A. Same as CS-4000 CL with walnut enclosure. \$3,099/pr

Concerto V CS-302 M 3-Way Speaker

3-way speaker with 12-in woofer, 6-in midrange, and two 2-in tweeters. Features an infinite baffle. Maximum power handling 150 watts; impedance 8 ohms; crossover points at 400 and 2,500 Hz. Walnut finish. Dimensions: 28 x 26 x 15 in. \$1,600/pr

CS-300M 2-Way Speaker

Same as CS-302 M but 2-way with upgrade to 302M available. Walnut finish. \$1,100/pr

NEAR Series Speakers

All NEAR series speakers are covered by a 10-year warranty; the cabinets are covered by a 2-year warranty.

NEAR-80 4-Way Speaker

4-way floor-standing speaker with 12-in multiple-fiber woofer, 6-in metal-alloy midrange, 2-in upper-midrange, and 3/4-in dome tweeter. Features infinite-baffle enclosure. Power handling 20-250 watts; FR 33-22,000 Hz ± 3 dB; crossover points at 400, 2,500, and 12,000 Hz. Dimensions: 15 1/2 x 41 x 12 3/4 in. Weight: 69 lb. \$1,480/pr

NEAR-70 3-Way Speaker

Floor-standing speaker with 12-in multiple-fiber woofer, 6-in metal-alloy midrange, and 1-in dome tweeter. Features an infinite-baffle enclosure. Power range 20-200 W; FR 33-22,000 Hz ± 3 dB; crossover points at 400 and 3,000 Hz. 15 1/2 x 41 x 12 3/4 in; 67 lb. \$1,280/pr

NEAR-50 3-Way Speaker

3-way tuned-port, floor-standing speaker with 8-in metal-cone woofer; 2-in upper-midrange; and 3/4-in metal-dome tweeter. Power handling 20-150 watts; FR 38-22,000 Hz ± 3 dB; crossover points at 2,500 and 12,000 Hz. Dark oak finish. Dimensions: 10 1/2 x 36 3/4 x 11 1/4 in. Weight: 40 lb. \$920/pr

NEAR-60 3-Way Speaker

Ported speaker with 12-in woofer, 4-in metal-alloy midrange, and a 1-in soft-dome tweeter. Power range 25-100 W; FR 35-22,000 Hz ± 3 dB; imp 8 ohms; crossover points at 800 and 3,000 Hz. Vinyl. 15 1/4 x 27 x 11 in; 48 lb. \$799/pr
 Dark oak. \$920/pr

NEAR-40M 2-Way Speaker

Tuned-port, floor-standing speaker with 8-in metal-cone woofer and 1-in metal-dome tweeter. Power range 20-150 W; FR 32-28,000 Hz ± 2dB; crossover point at 2,500 Hz. Dark oak finish. 10 1/2 x 34 3/4 x 11 1/4 in; 36 lb. \$799/pr

NEAR-20 3-Way Speaker

Ported speaker with two 8-in polypropylene-cone woofers and 3/4-in dome tweeter. Power range 25-75 W; FR 38-23,000 Hz ± 3 dB; imp 8 ohms; crossover points at 500 and 3,000 Hz. Dark oak or vinyl. 10 x 34 x 10 1/4 in; 38 lb. \$560/pr

NEAR-10 2-Way Speaker

Ported speaker with 8-in polypropylene-cone woofer and a 3/4-in soft-dome tweeter. Power range 25-75 W; FR 38-23,000 Hz ± 2.5 dB; imp 8 ohms; crossover point at 3,500 Hz. Dark oak or vinyl. 10 1/4 x 20 x 10 in; 17 lb. \$330/pr

SPEAKERS

A.E.S. Series Speakers

A.E.S. 2.0 2-Way Speaker

Outdoor speaker with 8-in metal-alloy-cone woofer and a 2-in metal-cone tweeter. Power range 25-150 W; frequency response 40-18,000 Hz; imp 8 ohms; crossover point at 2,500 Hz. Fiberglass-resin finish. 13 x 20 x 12 in; 24 lb. \$660/pr

A.E.S. 1.5 2-Way Speaker

Outdoor speaker with 6-in metal-alloy-cone woofer and 2-in metal-cone tweeter \$460/pr

A.E.S. 1.0 Outdoor Speaker

Outdoor speaker with 6-in metal-alloy-cone full-range driver \$360/pr

NEC

SW-400 Powered Sub/Full-Range System

Magnetically-shielded speaker system with powered subwoofer and full-range speaker system. Features bass-reflex, 12-in subwoofer with built-in 60-W power amp; low-pass filter; 4-in full-range speaker; 3-level turnover switch. FR 20-20,000 Hz. 23 $\frac{3}{4}$ x 19 $\frac{1}{2}$ x 15 $\frac{3}{8}$ in; 64 lb. \$599/system
SW-300B. Similar to the SW-400 without the two full-range speakers \$349 ea

RS-4.1 2-Way Shielded Speaker

Features a 4-in midrange and 1-in dome tweeter. Magnetically shielded. Power handling 50 W/\$225/pr

NHT

Model Two 3-Way Speaker

Sealed speaker features two 6 $\frac{1}{2}$ -in woofers, 6 $\frac{1}{2}$ -in midrange, 1-in dome tweeter; angled front baffle; video shielding. FR 40-22,000 Hz \pm 3 dB; nom imp 8 ohms; min power 35 watts. Black, white, or oak finish; black or white grilles. 37 x 7 x 12 in; 45 lb ea. \$850/pr

Model One 2-Way Speaker

Sealed speaker features 6 $\frac{1}{2}$ -in woofer, 1-in dome tweeter; angled front baffle; video shielding. Frequency response 63-22,000 Hz \pm 3 dB; nom imp 8 ohms; min power 20 watts. Black or white and grille. 12 x 7 x 10 in; 11 lb ea. \$350/pr

Model Zero 2-Way Speaker

Sealed speaker features 4 $\frac{1}{2}$ -in woofers, 1-in dome tweeter; angled front baffle; video shielding. Frequency response 85-21,000 Hz \pm 3 dB; nom imp 8 ohms; min power 15 watts. Black finish and grille. 9 x 6 x 5 in; 5 $\frac{1}{4}$ lb ea. \$200/pr

Model SW-1 Subwoofer

Sealed speaker with dual 6 $\frac{1}{2}$ -in woofers. FR 40-100 Hz \pm 3 dB; nom imp 8 ohms; min power 35 watts. Black, white, or oak finish; black or white grilles. 19 x 8 x 12 in; 27 lb ea. \$250

NILES AUDIO

Model 300 2-Way In-Wall Speaker

Speaker with 8-in polypropylene woofer with rubber edge and 1-in soft-dome tweeter. Features slide switch crossover. Min power 10 W/ch; FR 40-20,000 Hz \pm 3 dB; sens 89 dB SPL/W/m; imp 8 ohms; crossover point 2,500 Hz. Pearl-white finish and grille cover. 14 $\frac{1}{4}$ x 10 $\frac{1}{4}$ x 3 $\frac{3}{8}$ in; 12 lb/pr. \$460/pr

Model 200 2-Way In-Wall Speaker

Speaker with 6 $\frac{1}{2}$ -in polypropylene woofer with rubber edge and 1-in soft-dome tweeter. Features assignable jumper on crossover. Min power 10 W/ch; FR 55-20,000 Hz \pm 3 dB; sens 88 dB SPL/W/m; imp 8 ohms; crossover point at 2,800 Hz. Pearl-white finish and grille cover. 11 $\frac{3}{4}$ x 8 $\frac{3}{4}$ x 3 $\frac{1}{2}$ in; 9 lb/pr \$330/pr

Model 100 2-Way In-Wall Speaker

Speaker with 6 $\frac{1}{2}$ -in polypropylene woofer with treated foam edge and 1-in dome tweeter. Features

assignable jumper on crossover. Min power 15 W/ch; FR 55-20,000 Hz \pm 3 dB; sensitivity 87 dB SPL/W/m; impedance 8 ohms; crossover point 4,000 Hz. Pearl-white finish and grille. Dimensions: 11 $\frac{3}{4}$ x 8 $\frac{3}{4}$ x 3 $\frac{3}{8}$ in. Weight: 6.5 lb/pr. \$220/pr

NOVAK

MR 7 2-Way Bookshelf Speaker

Bookshelf speaker with 7-in Kevlar woofer and 1-in kevlar inverted-dome tweeter. Features polypropylene capacitors; air-core inductors; internal bracing. Power range 10-250 W; frequency response 48-22,000 Hz \pm 3 dB; sensitivity 90.5 dB SPL/W/m. Walnut finish. 39 lb. \$1090/pr

Model 2X 2-Way Speaker

Speaker with 6 $\frac{1}{2}$ -in plastic-cone woofer and ferrofluid cooled dome tweeter. Features 4th-order Butterworth loading; 1st-order crossover with mylar capacitors; non-diffraction baffle; non-allergenic anti-static black foam grille. Power range 5-75 W; FR 44-24,000 Hz \pm 3 dB; sens 91 dB SPL/W/m \$400/pr
 Black laminate \$449/pr

NUMARK

PM 330C 3-Way Powered Speaker

3-way speaker with Class D amplifier and 15-in woofer; titanium horn midrange and ring radial tweeter. Power handling 225 W cont; FR 35-18,000 Hz \pm 3 dB; sens 102 dB; crossover points 2,200 and 8,000 Hz. Finished in gray carpet. 21 x 33 x 16 in; 67 lb. \$1,100 ea

E340C 3-Way Speaker

3-way speaker; slotted-port design. 90-oz magnet and 3-in voice coil in woofer; titanium midrange; phenolic diaphragm tweeter. 300 W cont. Carpet covered. 42 x 24 x 19 in; 80 lb. \$990 ea

M Series

M1515F 3-Way Speaker

3-way speaker with two 15-in woofers; horn midrange and horn tweeter. Power handling 400 W cont; FR 29-18,000 Hz; sens 101 dB; imp 4 ohms; crossover points 2,200 and 8,000 Hz. Carpet covered, with castors. 24 x 47 x 18 in; 91 lb \$895 ea

M330C 3-Way Speaker

3-way bass reflex speaker with 15-in woofer; horn midrange and horn tweeter. Power handling 200 W cont; FR 39-18,000 Hz; sens 102 dB; imp 8 ohms; crossover points 2,200 and 8,000 Hz. Carpet covered. 21 x 33 $\frac{1}{2}$ x 16 in; 59 lb \$550 ea

M215C 2-Way Speaker

2-way speaker with 15-in woofer; compression midrange with horn flare. Power 200 watts continuous; frequency response 45-17,000 Hz; sens 103 dB; imp 8 ohms; crossover 2,000 Hz. Carpet covered. 18 $\frac{1}{4}$ x 29 x 17 in; 49 lb. \$450 ea

D20C 2-Way Speaker

2-way speaker with 6 $\frac{1}{2}$ -in woofer; tweeter. Power handling 75 watts continuous; frequency response 45-18,000 Hz \pm 3 dB; sensitivity 91 dB; impedance 8 ohms; crossover 2,000 Hz. Carpet covered. 11 $\frac{1}{4}$ x 15 $\frac{1}{4}$ x 10 $\frac{1}{2}$ in; 23 lb. \$250 ea

OHM ACOUSTICS

Walsh 5 Vented Speaker

Features coherent-line source (CLS) Walsh driver; 3 controls for lows, perspective (midrange), and highs, each with 3 positions; gold-plated 5-way binding posts; gold internal connectors; Monster Cable internal wiring. Power handling 500 W cont; FR 25-25,000 Hz \pm 4 dB; imp 4 ohms. Available in walnut, oak and rosewood finishes or teak/white/black lacquer. 95 lbs; 17 $\frac{1}{2}$ x 17 $\frac{1}{2}$ in at bottom tapering to 15 x 15 in at top; 43 in tall; 95 lb ea. \$5,800/pr

XO Line

4XO Inverted-Cone Speaker

Bass-reflex speaker features inverted coherent-line source (CLS) conical surface driver; gold-plated 5-way binding posts; gold internal connectors; lead-lined cabinet; Monster Cable internal wiring; casters; ferrofluid cooled; protection circuits; Standard finish walnut and oak, available in Scandinavian rosewood, black, or white lacquer. Power handling 500 W cont; FR 32-23,000 Hz \pm 4 dB; imp 8 ohms. 15 $\frac{1}{2}$ x 40 x 15 $\frac{1}{2}$ in, at base \$2,250/pr

3XO Inverted-Cone Speaker

Bass-reflex speaker features CLS inverted conical surface driver; press-connector inputs accept banana plugs or up to 12-gauge wire; lead-lined cabinet; casters; ferrofluid cooled; protection circuits. Standard finish walnut and oak, available in Scandinavian rosewood, black, or white lacquer. Power handling 200 W cont; FR 36-22,000 Hz \pm 4 dB; imp 8 ohms. 13 $\frac{1}{2}$ x 36 x 13 $\frac{1}{2}$ in, at base. \$1,500/pr

2XO Inverted-Cone Speaker

Bass-reflex speaker features coherent line source (CLS) inverted conical surface driver; press-connector inputs accept banana plugs or up to 12-gauge wire; sub-bass activator; ferrofluid cooled; protection circuits. Standard finish walnut and oak, available in Scandinavian rosewood, black, or white lacquer. Power handling 120 W cont; FR 44-21,000 Hz \pm 4 dB; imp 8 ohms. 11 $\frac{1}{2}$ x 32 $\frac{1}{2}$ x 11 $\frac{1}{2}$ in \$1,000/pr

1XO Inverted-Cone Speaker

Bass-reflex speaker features inverted conical surface driver; press-connector inputs accept banana plugs or up to 12-gauge wire; ferrofluid cooled; protection circuit. circular metal grille. Walnut finish. FR 48-20,000 Hz \pm 4 dB; power range 10-90 W; imp 8 ohms. 32 $\frac{1}{2}$ x 11 $\frac{1}{2}$ x 11 $\frac{1}{2}$ in, at base tapering to 9 $\frac{1}{4}$ x 9 $\frac{1}{4}$ in, at top; 24 lb. \$750/pr

Full Room Stereo Line

FRS 15 Inverted-Cone Speaker

Features inverted-cone, coherent line source (CLS) driver; ferrofluid-cooled driver and protective circuits; bass-reflex enclosure is heavily-braced and lead-lined; sub-bass activator; 5-way binding posts. Power handling 500 W peak; FR 30-22,000 Hz \pm 4 dB; sens 91 dB SPL/W/m; imp 8 ohms. Finished in oak vinyl veneer. 11 $\frac{3}{4}$ x 54 x 11 $\frac{3}{4}$ in. \$1,400/pr

FRS 11 Inverted-Cone Speaker

Features inverted-cone, coherent line source (CLS) driver; ferrofluid cooled driver and protective circuits; bass reflex enclosure is heavily-braced and lead-lined; sub-bass activator; 5-way binding posts. Power handling 250 W peak; FR 35-22,000 Hz \pm 4 dB; imp 8 ohms. Finished in oak vinyl veneer \$1,100/pr

FRS 9 2-Way Speaker

Features corner-mounted tweeter, 8-in woofer and rear-mounted 12-in passive radiator; ferrofluid cooled driver; sub-bass activator; 5-way binding posts; protection circuits. Power handling 225 W peak; FR 36-20,000 Hz \pm 4 dB; imp 8 ohms. Finished in oak vinyl veneer. 11 $\frac{3}{4}$ x 35 $\frac{1}{4}$ x 11 $\frac{1}{4}$ in \$800/pr

FRS 7 2-Way Speaker

Features corner-mounted tweeter, 6-in woofer and rear-mounted 10-in passive radiator; ferrofluid cooled driver; sub-bass activator; 5-way posts; protection circuits. Power handling 175 W peak; FR 40-20,000 Hz \pm 4 dB; sens 91 dB SPL/W/m; imp 8 ohms. Finished in oak vinyl veneer. \$650/pr

FRS 5 2-Way Bookshelf Speaker

Features corner-mounted tweeter and 6-in woofer; ferrofluid driver; sub-bass activator; 5-way binding post; protection circuits. Power handling 125 W peak; FR 48-20,000 Hz \pm 4 dB; imp 8 ohms. Finished in oak vinyl veneer. 11 $\frac{3}{4}$ x 11 $\frac{3}{4}$ x 11 $\frac{3}{4}$ in \$450/pr

SPEAKERS

Sound Cylinders Line

SCT+ Inverted Cone Speaker

Features inverted-cone, coherent line source (CLS) controlled-directionality driver; ferrofluid cooled drivers; protection circuits; 5-way post. Power handling 225 W peak; FR 37-20,000 Hz \pm 4 dB; sens 91 dB SPL/W/m; imp 8 ohms. Finished in Scandinavian light oak, New England walnut and black matador vinyl veneer. 11 $\frac{3}{4}$ x 42 x 11 $\frac{3}{4}$ in. \$1,100/pr

SCT Inverted Cone Speaker

Features inverted-cone, coherent line source (CLS) controlled-directionality driver; ferrofluid cooled drivers; protection circuits; 5-way post. Power handling 175 W peak; FR 40-20,000 Hz \pm 4 dB; sens 91 dB SPL/W/m; imp 8 ohms. Finished in Scandinavian light oak, New England walnut and black matador vinyl veneer. 11 $\frac{3}{4}$ x 36 $\frac{1}{2}$ x 11 $\frac{3}{4}$ in. \$850/pr

SCS Inverted Cone Speaker

Features inverted-cone, coherent line source (CLS) controlled-directionality driver; ferrofluid cooled drivers; protection circuits; 5-way post. Power handling 125 W peak; FR 44-20,000 Hz \pm 4 dB; sens 90 dB SPL/W/m; imp 8 ohms. Finished in Scandinavian light oak, New England walnut and black matador vinyl veneer. 11 $\frac{3}{4}$ x 31 $\frac{1}{2}$ x 11 $\frac{3}{4}$ in. \$650/pr

Pro Series

Pro 250 Sound Cylinder Loudspeaker

Cylindrical speakers with black matador standard finish with optional real wood veneers of teak, oak, rosewood and walnut. Features lead lining; Monster Cable wirings; Power handling 250 W cont; FR 35-20,000 Hz; sens 91 dB; imp 8 ohm. 45 $\frac{1}{2}$ -in h x 11 $\frac{1}{2}$ -in diameter. \$1,200/pr

Pro 200. Similar to Pro 250 but power handling 200 W cont; FR 39-20,000 Hz; sens 91 dB; imp 8 ohm. 39-in h x 11 $\frac{1}{2}$ -in diameter. \$950/pr

Pro 150. Similar to Pro 250 but power handling 150 W cont; FR 42-20,000 Hz; sens 91 dB; imp 8 ohm. 34 $\frac{1}{2}$ -in h x 11 $\frac{1}{2}$ -in diameter. \$750/pr

Pro 42 2-Way Bookshelf Speaker

Features rotatable egg-shaped tweeter; $\frac{3}{4}$ -in ferrofluid cooled polycarbonate tweeter, 8-in woofer and 12-in passive radiator. Power handling 300 W peak; FR 32-20,000 Hz \pm 4 dB; sens 90 dB SPL/W/m; imp 8 ohms. 14 x 25 $\frac{1}{4}$ x 11 in. \$530/pr

Pro 32 2-Way Bookshelf Speaker

Features rotatable egg-shaped tweeter; $\frac{3}{4}$ -in ferrofluid cooled polycarbonate tweeter, 6-in woofer and 10-in passive radiator. Power handling 175 W peak; FR 39-20,000 Hz \pm 4 dB; sens 90 dB SPL/W/m; imp 8 ohms. 12 $\frac{7}{8}$ x 22 $\frac{1}{4}$ x 11 in. \$430/pr

Pro 16 2-Way Bookshelf Speaker

Features rotatable egg-shaped tweeter; $\frac{3}{4}$ -in cooled polycarbonate tweeter, 6-in woofer in vented enclosure. Power handling 125 W peak; FR 46-20,000 Hz \pm 4 dB; sens 89 dB SPL/W/m; imp 8 ohms. 9 x 17 $\frac{1}{4}$ x 11 in. \$330/pr

Coherent Audio Monitors Series

CAM 42 SBA 2-Way Bookshelf Speaker

Two-way bookshelf speaker. Features rotatable egg shaped $\frac{3}{4}$ -in polycarbonate dome tweeter system; 8-in polypropylene woofer; ferrofluid-cooled tweeter; 12-in passive radiator and ohm's patented sub-bass-activator; Power handling 300 watts peak; FR 39-20,000 Hz \pm 4 dB; sensitivity 90 dB SPL/W/m; impedance 8 ohms. Brushed bronze vinyl finish. 14 $\frac{3}{4}$ x 11 x 26 $\frac{1}{2}$ in. \$575/pr

CAM 32 SBA 2-Way Bookshelf Speaker

Two-way bookshelf speaker. Features rotatable egg shaped $\frac{3}{4}$ -in polycarbonate-dome tweeter system; polyswitch circuit breakers; protection circuits; 6 $\frac{1}{2}$ -in woofer; 10-in passive radiator; and patented sub-bass

activator. Power handling 175 W peak; FR 39-20,000 Hz \pm 4 dB; sens 90 dB; imp 8 ohms. Brushed bronze vinyl. 12 $\frac{3}{4}$ x 11 x 22 $\frac{1}{4}$ in. \$450/pr

CAM 16 SBA 2-Way Bookshelf Speaker

Two-way vented speaker. Features rotatable egg shaped tweeter system mounted on top of cabinet and adjustable; bevelled cabinet; frameless grilles; 6 $\frac{1}{2}$ -in woofer; Power handling 125 W peak; FR 46-20,000 Hz \pm 4 dB; sens 89 dB; imp 8 ohms. Brushed bronze vinyl. 9 x 11 x 17 $\frac{1}{4}$ in. \$300/pr

ONKYO

S-91 4-Way Speaker

Bass-reflex system with 12-in polypropylene woofer, 5-in midrange, 1-in ferrofluid-cooled polycarbonate dome tweeter, and $\frac{1}{2}$ -in dome supertweeter. Features auto overload protection. Max power 150 W; FR 32-22,000 Hz; sens 93 dB SPL/W/m; imp 8 ohms. Oak veneer. 15 $\frac{7}{8}$ x 39 $\frac{3}{4}$ x 10 $\frac{1}{8}$ in; 40 lb. \$480/pr

S-51. Same as above except simulated-oak vinyl finish. 16 x 40 x 8 $\frac{3}{8}$ in; 35 lb. \$340/pr

S-11 3-Way Speaker

Bass-reflex system with 12-in polypropylene woofer, 5-in midrange, and 1-in ferrofluid-cooled polycarbonate-dome tweeter. Features tuned port; auto overload protection. Power handling 120 W max; FR 36-20,000 Hz; sens 91 dB SPL/W/m; imp 8 ohms. Simulated-oak vinyl finish. 14 x 36 x 9 $\frac{3}{8}$ in; 31 lb. \$260/pr

OWI

2300 2-Way Weather-Resistant Speaker

Wall/ceiling-mount, weatherized flat-wave system with 5 x 5-in dynapleat woofer, 1 $\frac{1}{2}$ -in dyna-ribbon tweeter. Features woofer with strontium magnet. Power handling 30 W rms, 60 W max; FR 50-20,000 Hz; sens 85 dB SPL/W/m; imp 4 ohms; crossover point 5,000 Hz. Available in ivory or black. 9 x 9 x 1 $\frac{1}{2}$ in; 2.6 lb ea. \$320/pr

OWI-503 3-Way Weather-Resistant Speaker

High-fidelity loudspeakers. Features $\frac{5}{4}$ -in woofer; 2-in tweeter; 1-in tweeter; 10-oz magnet. Power handling 60 W rms, 120 W max; FR 60-22,000 Hz; sens 93 dB SPL/W/m; imp 8 ohm; crossover points 6,000 and 9,000 Hz. Aluminum diecast; black or cream. 6 $\frac{3}{4}$ x 10 x 6 in; 7 lb ea. \$275/pr

Thinly II Model 2301 Wall/Ceiling Speaker

Wall/ceiling, flush mount loudspeaker with $\frac{5}{2}$ -in Honeycomb-Ring speaker; 8 $\frac{1}{2}$ -oz strontium magnet. Power handling 30 W rms, 60 W max; FR 65-20,000 Hz; sens 90 dB SPL/W/m; imp 6 ohm. Black or ivory. 9 x 9 x 1 $\frac{3}{4}$ in; 2.4 lb. \$250/pr

OWI-900 Weather-Resistant Subwoofer

Weatherized subwoofer with $\frac{5}{4}$ -in speaker and 10-oz magnet. Power handling 30 W rms, 60 W max; FR 40-450 Hz; imp 8 ohms; sens 93 dB SPL/W/m; crossover frequency 430 Hz. Aluminum diecast; black. 10 x 6 $\frac{3}{4}$ x 6 in; 7 lb ea. \$199

OWI-203 3-Way Weather-Resistant Speaker

Mini-loudspeakers featuring 4-in polypropylene woofer, 2-in mylar tweeter, and $\frac{1}{2}$ -in mylar tweeter; 10-oz strontium magnet. Power handling 50 W rms; 100 W max; FR 90-22,000 Hz; imp 8 ohm; sens 92 dB SPL/W/m; crossover frequencies 6,000 and 9,000 Hz. Aluminum diecast; autumn grey, black, or cream. 7 x 4 $\frac{1}{2}$ x 4 in; 5 $\frac{1}{2}$ lb ea. \$159/pr

OWI-202 2-Way Weather-Resistant Speaker

Mini-loudspeakers featuring 4-in polypropylene woofer, 2-in mylar tweeter, 10-oz strontium magnet. Power handling 40 watts rms, 80 watts maximum; frequency response 90-20,000 Hz; nom imp 8 ohms; sensitivity 92 dB SPL/W/m; crossover frequency 6,000 Hz. Aluminum diecast; autumn grey, black, or cream. 7 x 4 $\frac{1}{2}$ x 4 in; 4.41 lb. \$139/pr

PARASOUND

Sub/Sat One Subwoofer/Satellite System

System combines BPI-480 and the CPI440bi. Features two 8-in subwoofers, two 4-in midbass, and two 1-in dome tweeter with acoustic blanket. Power handling 100 watts continuous; FR 35-20,000 Hz \pm 3 dB; sensitivity 89 dB SPL/W/m; impedance 4 ohms. Black oak grain finish. Subwoofer 18 x 14 $\frac{3}{4}$ x 11 $\frac{1}{2}$ in; satellites 6 x 9 x 6 $\frac{1}{2}$ in. \$465

AW-S390 Weather Resistant Subwoofer

Diecast enclosure system with weather-resistant parts. Features two $\frac{5}{4}$ -in carbon-fiber reinforced polypropylene subwoofer; 12 dB/oct. crossover; mounting brackets included. Power handling 100 W cont; FR 44-130 Hz \pm 3 dB; sens 90 dB/W/m; impedance 4 ohms; crossover frequency 130 Hz. White finish. 6 $\frac{1}{2}$ x 9 x 6 $\frac{1}{2}$ in. \$325/pr

AMW-380 2-Way Weather Resistant Speaker

Diecast enclosure system with weather-resistant parts. Features $\frac{5}{4}$ -in carbon-fiber reinforced polypropylene woofer, 1-in dome tweeter; 12 dB/oct. crossover; mounting brackets included. Power handling 80 W cont; FR 48-20,000 Hz \pm 3 dB; sens 90 dB/W/m; imp 4 ohms; crossover frequency 2,600 Hz. White finish. 6 $\frac{1}{2}$ x 9 x 6 $\frac{1}{2}$ in. \$325/pr

AWS-280 2-Way Weather Resistant Speaker

2-way ported speaker designed to function outdoors year-round. 5-in polypropylene cone woofer, labyrinth bass loading, 1 $\frac{1}{2}$ -in polypropylene cone tweeter; 6 dB/oct crossover. High-density particle-board beige enclosure with molded outer shell and mounting hooks. Power handling 60 watts continuous; frequency response 55-20,000 Hz \pm 4 dB; sensitivity 88 dB SPL/W/m; impedance 4 ohms; crossover frequency 3,300 Hz. 6 $\frac{1}{2}$ x 10 $\frac{1}{2}$ x 7 in; 11 lb. \$255/pr

CPI-440bi 2-Way Speaker

Features 4-in high-compliance carbon-fiber-reinforced polypropylene cone woofer and 1-in ferrofluid-damped soft-dome tweeter with acoustic blanket. Nondiffraction cabinet; 1st-order network with polypropylene capacitor; 4th-order vented design. Power handling 55 watts continuous; frequency response 70-22,000 Hz \pm 4 dB; THD 1%; imp 4 ohms; sensitivity 88 dB SPL/W/m. Simulated black oak finish. 5 $\frac{7}{8}$ x 9 x 6 $\frac{1}{2}$ in. \$210/pr

AWM-360 2-Way Speaker

Features carbon-fiber reinforced polypropylene woofer cones, ferrofluid damped dome tweeter in a diecast enclosure; 12 dB/oct crossover. Mounting brackets included. Power handling 70 W cont; FR 75-20,000 Hz \pm 3 dB; sens 87 dB SPL/W/m; imp 4 ohms. 4 $\frac{3}{8}$ x 7 $\frac{1}{8}$ x 4 $\frac{3}{8}$ in. \$200/pr

PHASE TECHNOLOGY

Phase Coherent Series

PC-1000Ho 3-Way Speaker

Floor-standing passive-radiator speaker with 10-in solid-piston radiator, 8-in solid-piston woofer, $\frac{5}{4}$ -in solid-piston midrange, 1-in soft-dome tweeter. Accepts banana plugs. Power handling 25-200 W rms; FR 25-20,000 Hz \pm 3 dB; sens 91 dB SPL/W/m; imp 4 ohms; crossover points 200 and 2,000 Hz. Walnut and dark oak veneer finishes. 15 $\frac{1}{2}$ x 38 x 8 $\frac{1}{2}$ in; 70 lb ea. \$1,400/pr

PC-800Ho 3-Way Speaker

Floor-standing acoustic-suspension phase-coherent speaker, 10-in flat solid-piston woofer, $\frac{5}{4}$ -in flat solid-piston midrange, 1-in soft-dome tweeter. Features removable mini-diffraction grille; genuine wood veneer; speaker protection. Accepts banana plugs. Power 25-150 W rms; FR 30-20,000 Hz \pm 3 dB; sens 91 dB SPL/W/m; imp 4 ohms; crossover points 200 and 2,000 Hz. Walnut or dark-oak veneer finishes. 15 x 34 $\frac{3}{4}$ x 8 in; 57 lb ea. \$990/pr

SPEAKERS

PC-600Ho 2-Way Speaker

Floor-standing acoustic-suspension phase-coherent speaker with 8-in solid-piston woofer, 1-in soft-dome tweeter. Features removable mini-diffraction grille; genuine wood veneer; speaker protection. Accepts banana plugs. Power handling 25-125 W rms; frequency response 35-20,000 Hz \pm 3 dB; sens 91 dB SPL/W/m; imp 4 ohms; crossover point 1,400 Hz. Walnut or dark-oak veneer finishes. 12 x 31 $\frac{1}{4}$ x 8 in; 42 lb/ea. \$620/pr

PC-60 2-Way Speaker

Bookshelf acoustic-suspension phase-coherent speaker with 6-in solid-piston woofer and 1-in soft-dome tweeter. Accepts banana plugs. Power range 15-100 W; FR 55-20,000 Hz \pm 3 dB; sens 87 dB SPL/W/m; imp 4 ohms. Walnut, stained-oak, and light-oak finishes. 8 x 13 $\frac{1}{2}$ x 8 in; 15 lb. \$480/pr

PC-40 2-Way Speaker

Bookshelf acoustic-suspension phase-coherent speaker with 5 $\frac{1}{4}$ -in solid-piston woofer; 1-in soft-dome tweeter. Accepts banana plugs. Power range 15-80 W; FR 70-20,000 Hz \pm 3 dB; sens 89 dB SPL/W/m; imp 4 ohms. Walnut, stained-oak, and light-oak finishes. 6 $\frac{1}{2}$ x 9 $\frac{3}{4}$ x 5 $\frac{1}{4}$ in; 10 lb. \$380/pr

Euro Series

730-ES 3-Way Tower Speaker

Tower speaker with 10-in bass/midrange driver, 5 $\frac{1}{4}$ -in cone midrange, 1-in ferrofluid-cooled soft-dome tweeter. Features asymmetrically mounted tweeter and midrange. Power handling 120 watts; frequency response 36-20,000 Hz \pm 3 dB; sensitivity 93 dB SPL/W/m; nominal impedance 8 ohms; crossover points at 250 and 3,000 Hz. Black-ash or dark-oak vinyl veneer. 34 x 12 $\frac{1}{2}$ x 10 $\frac{3}{4}$ in. \$630/pr

530-ES 2-Way Bookshelf Speaker

Bookshelf speaker with 10-in bass/midrange and 1-in ferrofluid-cooled soft-dome tweeter. Features asymmetrically mounted tweeter. Power handling 100 watts; frequency response 40-20,000 Hz \pm 3 dB; sensitivity 93 dB SPL/W/m; nominal impedance 8 ohms; crossover point 2,200 Hz. Black-ash or dark-oak vinyl veneer. 22 $\frac{1}{2}$ x 13 x 10 $\frac{3}{4}$ in. \$420/pr

435-ES 2-Way Bookshelf Speaker

Bookshelf speaker with 8-in bass/midrange and 1-in ferrofluid-cooled soft-dome tweeter. Features asymmetrically mounted tweeter. Power handling 80 watts; frequency response 45-20,000 Hz \pm 3 dB; sensitivity 92 dB SPL/W/m; nominal impedance 8 ohms; crossover point 2,500 Hz. Black-ash or dark-oak vinyl veneer. 22 $\frac{1}{2}$ x 12 x 10 $\frac{3}{4}$ in. \$300/pr

Subwoofer/Satellite Systems

PC-60/50 Subwoofer/Satellite System

3-piece satellite/subwoofer system consists of PC60 satellite and PC50 subwoofer. Power handling 25-150 watts; frequency response 30-20,000 \pm 3 dB; sensitivity 87.5 dB SPL/W/m; impedance 8 ohms; crossover point 150 and 1,200 Hz. \$830/system

PC-40/50 Subwoofer/Satellite System

3-piece system consists of PC40 satellite and PC50 subwoofer. Power handling 15-100 W rms; FR 30-20,000 Hz \pm 3 dB; sens 89 dB SPL/W/m; imp 8 ohms; crossover points 150 and 1,500 Hz. \$710/system

Subwoofer

PC-50 Subwoofer

Down-firing floor-loaded acoustic-suspension subwoofer with 10-in solid-piston woofer. Features polypropylene bypass capacitors; internal passive crossover for use with satellite speakers; feet extenders for heavy carpeting. Power range 25-200 W; FR 30-150 Hz \pm 3 dB; power range 25-200 W; sens 87 dB SPL/W/m; imp 8 ohms. Walnut, light-oak, stained-oak finish. 13 x 14 x 15 in; 33 lb. \$350 ea

PINNACLE

All Pinnacle shelf speakers feature a 7-year parts and labor warranty.

PN 8+ 2-Way Bookshelf Speaker

Acoustic-suspension bookshelf speaker with dual patented front-mounted Diaduct ports, 8-in black polypropylene woofer, and 1-in high gloss polymer, double-chamber, liquid-cooled dome tweeter. Power handling 10-125 W rms cont, 375 W peak; FR 30-21,000 Hz; sens 90 dB SPL/W/m; imp 6 ohms; crossover points 1,000 and 6,000 Hz. Black-oak veneer with contrasting solid oak wood trim. 19 $\frac{1}{2}$ x 11 $\frac{1}{2}$ x 11 $\frac{3}{8}$ in; 35 lb/pr. \$399/pr

PN 7+ 2-Way Bookshelf Speaker

Vented bookshelf speaker with dual patented front-mounted Diaduct ports, 6 $\frac{1}{2}$ -in black polypropylene woofer and a 1-in polymer-dome, liquid-cooled tweeter. Power handling 10-80 W rms cont, 240 W peak; FR 38-21,000 Hz; sens 91 dB SPL/W/m; imp 6 ohms; crossover frequency 3,300 Hz. Black-oak veneer with contrasting solid oak wood trim. 15 $\frac{1}{8}$ x 9 $\frac{1}{4}$ x 8 $\frac{3}{8}$ in; 35 lb/pr. \$309/pr

PN 6+ 2-Way Bookshelf Speaker

Bookshelf speaker with front-mounted Diaduct-port design, 6 $\frac{1}{2}$ -in polypropylene woofer; 3 $\frac{1}{4}$ -in ferrofluid dome tweeter. Power handling 10-70 W rms cont, peak 210 W; FR 40-21,000 Hz; sens 90 dB SPL/W/m; imp 6 ohms; crossover frequency 4,500 Hz. Oak accent finish. 15 $\frac{1}{8}$ x 9 $\frac{1}{4}$ x 6 $\frac{7}{8}$ in; 25 lb/pr. \$239/pr

Sub + Subwoofer

Tuned-passive subwoofer with patented Diaduct port, two 6 $\frac{1}{2}$ -in down-firing woofers. Features rigidly braced, partitioned enclosure with non-parallel internal walls; switchable first-order crossover; compatibility with 4-8 ohm bookshelf speakers. Power handling 100 W rms, 2 year warranty. 13 $\frac{3}{8}$ x 19 $\frac{1}{2}$ x 11 $\frac{1}{2}$ in. \$229/ea

PN 5+ 2-Way Speaker

Bookshelf speaker with Diaduct-port design, 5 $\frac{1}{4}$ -in polypropylene-cone woofer; 3 $\frac{1}{4}$ -in polycarbonate ferrofluid tweeter. Power handling 10-50 W rms cont; 150 W peak; FR 50-21,000 Hz; sens SPL/W/m 86 dB; imp 6 ohms; crossover frequency 5,000 Hz. 11 $\frac{1}{4}$ x 6 $\frac{3}{4}$ x 6 $\frac{7}{8}$ in; 17 lb/pr. \$179/pr

PN 2+ 2-Way Mini-Speaker

Mini-speaker with patented Diaduct-port design, 4-in cone woofer, 3 $\frac{1}{4}$ -in polycarbonate ferrofluid tweeter. Power handling 5-40 W rms cont, peak 120 W; FR 65-21,000 Hz; sens 86 dB SPL/W/m; imp 6 ohms; crossover frequency 5,500 Hz. Black-oak vinyl veneer finish. 10 $\frac{3}{4}$ x 6 $\frac{1}{4}$ x 6 $\frac{5}{8}$ in; 14 lb/pr. \$139/pr

PIONEER

Elite TZ-9 Speaker

Integrated twin-bass drive system with horizontally opposite-mounted twin woofers. Features ceramic graphite diaphragm in dome midrange and dome tweeter. \$2,000 ea

Elite TZ-7 Speaker

Features ceramic carbon dome tweeters; integrated twin-bass drive system with horizontally opposite-mounted twin woofers. \$1,800/pr

CS-V910 3-Way Speaker

Magnetically-shielded 3-way speaker. Features 12-in cone woofer; 4 $\frac{3}{4}$ -in titanium-dome midrange; 1-in titanium-dome tweeter; aluminum diecast frame in woofer and midrange; round-cornered baffle. FR 25-30,000 Hz; imp 6 ohms; sens 90 dB SPL/W/m; 150 W max power handling. Dark oak veneer finish. 35 $\frac{3}{4}$ x 16 $\frac{1}{8}$ x 15 $\frac{1}{8}$ in; 75 lb. \$1,040/pr

S-T500 Speaker

Features ceramic-carbon diaphragm; vertical twin-

bass drive system with horizontally opposite-mounted twin woofers; large core inductors. \$1000/pr

Elite DSS-F6 3-Way Speaker

Features 7 $\frac{7}{8}$ -in polymer-graphite-cone woofer; 2 $\frac{7}{8}$ -in boron-cone midrange; beryllium ribbon tweeter; mirror-image driver alignment; Pioneer's LDMC (Linear Drive Magnetic Circuit), EBD (Electronic Bass Drive), and DRS (Dynamic Response Suspension). Nominal imp 6 ohms; sens 91 dB SPL/W/m; max power 120 W. Sold only in mirror-image pairs. 18 $\frac{1}{2}$ x 10 $\frac{3}{8}$ x 9 $\frac{3}{8}$ in. \$700/pr

S-T300 Speaker

Features ceramic carbon diaphragm; vertical twin-bass drive system. \$700/pr

S-W1000 Subwoofer

Can be switched to produce center-channel speaker output for surround-sound system. Features 12-in woofer; switchable power amplifier. Subwoofer only: FR 20-140 Hz; 70 W power output; imp 6 ohms; THD 5%. Subwoofer and center channel amplifier: FR 70 Hz; 30 W at 6 ohms; THD 5%. Center channel only: FR 20-20,000 Hz; 25 W at 6 ohms; THD 1%. Rounded corner black cabinets. \$500

CS-C300 Center-Channel Speaker. Complements above; 7 $\frac{1}{2}$ -in cone woofer; 2 $\frac{1}{2}$ -in cone tweeter. FR 50-20,000 Hz; 60 W power handling. \$70 ea

S-T100 Speaker

Features ceramic carbon diaphragm; vertical twin-bass drive system design. \$500/pr

CS-G401W 3-Way Speaker

3-way bass-reflex speaker. Features 15 $\frac{3}{4}$ -in woofer; 4 $\frac{3}{4}$ -in midrange; 2 $\frac{1}{2}$ -in tweeter; imp 6 ohms; FR 30-20,000 Hz; 150 W max power handling; sens 92 dB SPL/W/m; walnut grain vinyl finish. 29 $\frac{1}{8}$ x 17 $\frac{3}{8}$ x 11 $\frac{5}{8}$ in; 36 lb, 5 oz. \$360/pr

CS-VX110 2-Way Speaker

Magnetically-shielded speaker for A/V use. Features 7-in woofer; 2 $\frac{1}{2}$ -in tweeter; FR 50-20,000 Hz; imp 8 ohms; sens 90 dB SPL/W/m; 60 W max power handling; dark oak veneer finish. 13 $\frac{3}{4}$ x 9 $\frac{3}{8}$ x 7 $\frac{3}{8}$ in; 9 lb, 15 oz. \$320/pr

CS-G301WAI 3-Way Speaker

Bass-reflex bookshelf speaker with 12-in woofer, 4 $\frac{3}{4}$ -in midrange, and 2 $\frac{1}{2}$ -in tweeter. Imp 6 ohms; sens 91.5 dB SPL/W/m; max power 120 W. Walnut-grain vinyl finish. 26 $\frac{1}{2}$ x 15 x 13 in. \$280/pr

CS-G201WAI 3-Way Speaker

Bass-reflex bookshelf speaker with 10-in woofer, 3-in midrange, and 2 $\frac{1}{2}$ -in tweeter. Imp 6 ohms; sens 90 dB SPL/W/m; max power 100 W. Walnut-grain vinyl finish. 24 x 13 $\frac{3}{4}$ x 11 $\frac{1}{8}$ in. \$210/pr

CS-G101WAI 2-Way Speaker

Sealed-box bookshelf speaker with 10-in woofer and 2 $\frac{1}{2}$ -in tweeter. Imp 6 ohms; sens 90 dB SPL/W/m; max power 50 W. Walnut-grain vinyl finish. 22 $\frac{3}{8}$ x 13 x 7 $\frac{7}{8}$ in. \$150/pr

S-X7 Full-Range Speaker

Compact bass-reflex speaker designed for surround-sound applications. Features 3 $\frac{1}{2}$ -in driver; sens selector switch; black vinyl finish. Imp 16 ohms; sens 90 dB SPL/W/m; max power 30 W. 5 $\frac{3}{8}$ x 7 $\frac{1}{2}$ x 4 $\frac{1}{2}$ in. \$130/pr

CS-X5 Surround-Sound Speaker

Speaker for surround-sound applications. Features 4-in full-cone driver; impedance 8 ohms; 30 watts maximum power handling; sensitivity 90 dB SPL/W/m. 7 $\frac{1}{2}$ x 5 $\frac{1}{2}$ x 5 in; 3 lb. \$60/pr

POLK AUDIO

SDS-400 2-Way Surround-Sound Speaker

Compact speaker system features 6 $\frac{1}{2}$ -in trilaminare

SPEAKERS

polymer bass/midrange driver and 1-in ferrofluid cooled dome tweeter. 4 position dimensional blend control. Power 100 W cont; FR 55-20,000 Hz; nom imp 6 ohms. 8½ x 14½ x 7¾ in; 16 lb . . . \$300/pr

SDA Series

SDA-SRS 1.2tl Signature Reference 3-Way Speaker
Incorporates Polk's proprietary Stereo Dimension Array technology for 3-dimensional imaging. Features 15-in planar sub-bass radiator; eight 6½-in trilaminate polymer bass/midrange drivers; four SL3000 1-in trilaminate polymer dome tweeters. FR 10-26,000 Hz; power handling 1,000 W cont; imp 6 ohms. Oiled oak, and walnut finish. 21 x 63½ x 13½ in; 185 lb \$3,400/pr

SDA-SRS 2.3tl Signature Reference 3-Way Speaker
Floor-standing smaller-version SRS 1.2tl. Features Polk's proprietary Stereo Dimension Array technology for 3-dimensional imaging. Features 15-in planar sub-bass radiator; six 6½-in trilaminate polymer bass/midrange drivers; three SL3000 1-in trilaminate polymer dome tweeters. Power handling 750 W cont; FR 12-26,000 Hz; nom imp 6 ohms. Oiled oak or walnut finish. 20¾ x 55 x 13½ in; 155 lb \$2,500/pr

SDA-1C 3-Way Speaker

Floor-standing speaker. Features four 6½-in trilaminate polymer bass/midrange drivers; two 1-in silver-coil polymer-dome tweeters; 12-in planar sub-bass radiator. Power handling 500 W cont; FR 15-26,000 Hz; nom imp 6 ohms. Oiled walnut or oak cabinet. Black studio version at lower cost. 16½ x 43½ x 12 in; 95 lb \$1,800/pr

SDA-2B 3-Way Speaker

Similar to SDA-1B except two 6½-in trilaminate polymer bass/midrange drivers; 1-in silver-coil polymer-dome tweeters; 12-in planar sub-bass radiator. Power handling 350 W cont; FR 20-26,000 Hz; nom imp 6 ohms. Oiled walnut or oak cabinet. Black studio version at lower cost. 16½ x 39½ x 12 in; 87 lb \$1,200/pr

SDA-CRS+ 3-Way Bookshelf Speaker

Features SDA technology for lifelike three-dimensional imaging with 10-in sub-bass radiator, two 6½-in trilaminate polymer bass/midrange drivers, and 1-in polymer-dome tweeter. Power handling 200 W cont; FR 25-26,000 Hz; nom imp 6 ohms. Black ash, walnut or oak vinyl finish. Genuine walnut or oak veneer finish available at extra cost. 12¾ x 20 x 10½ in; 36 lb \$900/pr

RTA Series

RTA 11t Monitor 3-Way Speaker

Real-Time-Array speakers with two 8-in low-resonance subwoofer, two 6½-in trilaminate polymer bass/midrange drivers, and 1-in polymer-dome tweeter. Power handling 350 W cont; FR 22-26,000 Hz; nom imp 6 ohms. Black-ash, walnut, and oak vinyl finish. Genuine walnut and oak veneer finish available at extra cost. 10½ x 39 x 14½; 58 lb \$950/pr

RTA 8t Monitor 3-Way Speaker

Real-Time-Array floor-standing speaker with two 6½-in trilaminate polymer bass/midrange drivers, and 1-in silver-coil polymer-dome tweeter. Power handling 250 W cont; FR 30-26,000 Hz; nom imp 6 ohms. Black-ash, walnut, and oak vinyl finish. Genuine walnut and oak veneer finish available at extra cost. 16 x 28 x 9¼ in; 48 lb \$650/pr

Monitor Series

Monitor 10B 3-Way Speaker

Sub-bass radiator/sealed floor-standing speaker with 10-in fluid-coupled subwoofer, two 6½-in trilaminate polymer bass/midrange drivers, and 1-in polymer dome tweeter. Power handling 250 W cont; FR 25-26,000 Hz; nom imp 6 ohms. Black-ash, walnut, and

oak vinyl finish. Genuine walnut and oak finish available at extra cost. 16 x 28 x 11½ in . . . \$740/pr

Monitor 7C 3-Way Speaker

Sub-bass radiator/sealed bookshelf speaker with 10-in fluid coupled subwoofer. 6½-in trilaminate polymer bass/midrange driver, and 1-in polymer dome tweeter. Power handling 150 W cont; FR 25-26,000 Hz; nom imp 6 ohms. 14 x 24 x 9¼ in \$580/pr

Monitor 5B 3-Way Speaker

Similar to 7C; features 1-in silver-coil dome tweeter, 6½-in trilaminate polymer bass/midrange driver, and 8-in fluid coupled subwoofer. Power handling 125 W cont; FR 30-26,000 Hz; nom imp 6 ohms. 10½ x 21½ x 8½ in; 26 lb \$450/pr

Monitor 5 Jr. + 3-Way Bookshelf Speaker

Features 1-in silver-coil dome tweeter, 6½-in trilaminate polymer bass/midrange driver, and 8-in fluid coupled subwoofer. Power handling 125 W cont; FR 30-26,000 Hz; nom imp 6 ohms. Black-ash, walnut, and oak vinyl finish. 17 x 9 x 8¾ in . . . \$370/pr

Monitor 4.5 2-Way Bookshelf Speaker

Features 6½-in trilaminate polymer bass/midrange driver and 1-in ferrofluid-cooled dome tweeter; isophase crossover; terminated transmission duct that loads bass/midrange driver into deep-bass range. Power handling 100 W cont; FR 30-25,000 Hz; nom imp 6 ohms. 9 x 17 x 8¾ in; 22 lb \$260/pr

Monitor 4A 2-Way Bookshelf Speaker

Features 6½-in trilaminate polymer bass/midrange driver and 1-in ferrofluid-cooled dome tweeter; isophase crossover; terminated transmission duct that loads bass/midrange driver into deep-bass range. Power handling 100 W cont; FR 55-20,000 Hz; nom imp 6 ohms. 8½ x 14½ x 7¾ in; 16 lb \$220/pr

In-Wall Speaker

AB-800 Architectural Reference 2-Way Speaker

In-wall speaker features two 6½-in trilaminate polymer bass/midrange driver, and 1-in silver-coil polymer-dome tweeter. Power handling 150 W cont; FR 28-26,000 Hz; nom imp 6 ohms. Off-white finish. 6¼ x 15½ x 3 in \$550/pr

AB-700 Architectural Reference 2-Way Speaker

In-wall speaker features 6½-in trilaminate polymer bass/midrange driver, and 1-in silver-coil polymer dome-tweeter. Power handling 125 W cont; FR 30-26,000 Hz; nom imp 6 ohms. Off-white finish. 6¼ x 9¾ x 3 in \$400/pr

PRECISE ACOUSTIC LABORATORIES

Monitor 10 3-Way Speaker

Bass-reflex speaker with 10-in woofer, 6½-in midrange, and 1-in soft-dome tweeter. Features tuned-port design. FR 20-35,000 Hz; power handling 250 W max. Natural-oak-veneer finish. . . . \$1,600/pr

Monitor 9 2-Way Speaker

Floor-standing speaker with 8-in woofer, 1-in tweeter, and 10-in passive radiator. Power handling 150 W max; sens 91 dB SPL/W/m; imp 6 ohms. . . \$700/pr

Monitor 7 Speaker 2-Way Speaker

Bass-reflex speaker with 8-in woofer and 1-in tweeter. FR 28-35,000 Hz; power handling 100 W max; sens 91 dB SPL/W/m; imp 6 ohms. . . . \$500/pr

Monitor 5 2-Way Speaker

Bass-reflex speaker with 8-in woofer and 1-in dome tweeter. Features 9-element crossover. FR 32-45,000 Hz; power handling 80 W max. . . . \$400/pr

Monitor 3 2-Way Speaker

Bass-reflex speaker with 6½-in woofer and 1-in tweeter. . . . \$300/pr



Precise Acoustic Laboratories Monitor 10

PSB SPEAKERS BY LINCOLNWOOD

Stratus Tower 2-Way Speaker

2-way speaker with 8-in woofer with focused magnetic gap and cloth-dome tweeter. Power handling 30-200 W; crossover at 1,800 Hz; FR 40-20,000 ± 1.5 dB; sens 91 dB; imp 6 ohms. Light/dark oak, or black wood finishes. . . . \$1,500/pr

CS 260 2-Way Speaker

2-way speaker with dual 6-in polypropylene woofers and 1-in treated cloth-dome tweeter. FR 40-20,000 Hz ± 1.5 dB. Black or dark oak finish. . . . \$1,000/pr

CS 180W 2-Way Speaker

2-way speaker with 8-in polypropylene woofer and 1-in treated cloth-dome tweeter. FR 40-20,000 Hz ± 1.5 dB. Black or dark oak finish. . . . \$800/pr
CS 180V. As above, black or brown finish. \$700/pr

Subwoofer 1

Contains two 8-in extra-long-throw woofers with aluminum voice coils and a tuned port. Woofers may be combined for mono. Subwoofer optimized for 50MKII speakers; may be used with 30MKII or other speakers with sens 86-92 dB SPL/W/m. Stereo crossover network at 100 Hz rolls off frequencies going to satellite speakers at 6 dB/octave. Power handling 30-200 W rms; system resonance 26 Hz; sens 88 dB SPL/W/m; 22 x 22 x 22 in; 90 lb. Brown or black finish. . . . \$700

50 MKII 2-Way Speaker

2-way speaker with 8-in polypropylene cast basket woofer and 1-in textile-dome tweeter. Rated impedance 6 ohms. Black or brown finish. . . . \$500/pr

40 MKII 2-Way Speaker

2-way speaker with 8-in polypropylene woofer and ¾-in textile-dome tweeter. Rated impedance 6 ohms. Black or brown finish. . . . \$400/pr

30 MKII 2-Way Speaker

2-way speaker with 6½-in polypropylene woofer and ¾-in textile dome tweeter. Rated impedance 6 ohms. black or brown finish. . . . \$300/pr

20 MKII 2-Way Speaker

2-way speaker with 6½-in woofer and ½-in polydome tweeter. Imp 6 ohms. Black or brown finish \$200/pr

QUAD

ESL-63 US Monitor Electrostatic Speaker

Full-range electrostatic double speaker with dipole source. Features 2 protection circuits. Power han-

SPEAKERS

ding 150 W; sensitivity 86 dB SPL/W/m; impedance 8 ohms; axis band limits -6 dB at 35 Hz, third-order, -6 dB at 20,000 Hz. Black finish. 28 x 36 x 11 in; 46.5 lb. \$3,995/pr
ESL-63 Pro. Professional version with carrying handles \$4,400/pr

REALISTIC

Nominal imp of all Realistic speakers is 8 ohms.

Mach Two 3-Way Speaker

Vented ferrofluid-cooled speaker with 15-in woofer, 5-in cone midrange, 4-in dual-radial superhorn tweeter. Level controls for midrange and tweeter. Max power 160 W; sens 94 dB SPL/W/m \$512/pr

Nova 15 Speaker

Vented speaker with 2½-in tweeter. Max power 60 W; Walnut-veneer finish. 19 x 16¾ x 7½ in. . . \$160/pr

MC-1800 2-Way Speaker

Acoustic-suspension, bookshelf speaker with 8-in woofer and 2½-in tweeter. FR 70-20,000 Hz ± 3 dB; max power 50 W rms; imp 8 ohms. \$120/pr

MC-800 2-Way Bookshelf Speaker

6½-in woofer; 2½-in cone tweeter. Features push-on speaker terminals. Max power 40 W. Removable cloth grille. 13½ x 8¾ x 5½ in. \$90/pr

Model 40-165 Mini Speaker

2½-in square drivers features attached cable with mini plug. Max power 1 W; 3¾ x 3 x 1¾ in. \$20/pr

Model 40-155 Mini Speaker

Single enclosure with two 1½-in drivers with mini plug. 3¾ x 3¼ x 1¼ in. \$10/pr

Optimus Speakers

Model 1000 3-Way Speaker

Floor-standing bass-reflex tuned-port speaker with 15-in woofer, 5-in midrange, 3-in tweeter. FR 50-20,000 Hz ± 3 dB; max power 100 W rms; sens 92 dB SPL/W/m; imp 8 ohms. Oiled-walnut finish. 17½ x 31½ x 11½ in; 44 lb. \$400/pr

Model 900 3-Way Speaker

Floor-standing bass-reflex tuned-port speaker with 12-in woofer, 4-in midrange, 2½-in ferrofluid tweeter. FR 50-20,000 Hz ± 3 dB; max power 100 W rms; sens 90 dB SPL/W/m; imp 8 ohms. Oiled-walnut finish. 14 x 29¾ x 10¾ in; 33 lb. \$320/pr

Model 650 3-Way Speaker

Bass-reflex speaker; 12-in woofer; 4-in midrange; 2½ cone; 100 W; sens 91 dB \$240/pr

Minimus Speakers

Model 0.9 2-Way Speaker

5-band equalizer; 5 W/ch; 5-in woofer; 1½-in tweeter. \$200/pr

Model 7W Speaker

4-in woofer; 1-in soft-dome tweeter and spring terminals. Max power 40 W \$120/pr

Model 7 Speaker

Diecast metal enclosure; long-excursion 4-in woofer; 1-in soft-dome tweeter; crossover; hanger slots and recessed spring connectors for wall mounting. Max power 40 W; 7 x 4½ x 4½ in. \$100/pr

Model 25 Speaker

5-in long-throw woofer; 2½-in tweeter. Max power 40 W. Walnut veneer. 11 x 6¼ x 4½ in. \$70/pr

Model 0.6 Powered Speaker

Powered speakers feature 2½-in drivers. Powered by 8 C batteries. Includes case, strap, cable. 5¾ in high. \$50/pr

Model 18 Speaker

4-in driver; spring terminals. Walnut vinyl finish. 9½ x 5¾ x 4¾ in. \$48/pr

Model 3.5 Speaker

Molded enclosure with steel grille; spring terminals. Max power 15 W; 5¾ x 3¾ x 3 in. \$44/pr

Model 2.5 Speaker

4-in driver. Max power 10 W. Walnut vinyl finish. 6¾ x 5 x 3 in. \$36/pr

Model 3 Speaker

5-in driver. Max power 7 W. Walnut vinyl finish. 10 x 8½ x 5½ in. \$30/pr

Model 0.3 Speaker

Cube speaker with 3-in driver. Max power 7 W. Walnut veneer. 4 x 4 x 3½ in. \$28/pr

Supertweeters

Dynamic. FR to 40,000 Hz; mounts in or outside speaker cabinet; max power 50 W; 4-in H. \$22

Piezo. FR to 27,000 Hz. Max power 75 W; sens 96 dB SPL/W/m. \$13

Accessories

Mounting Brackets. For models 7W and 7S \$15.95/pr

Mounting Brackets. For Model 3.5. \$10.95/pr

RECOTON

Wireless 100 Powered Speaker System

System consisting of transmitter and 2 powered speakers enabling listening to stereo in any room in house. Transmitter plugs into any audio component or AC outlet, speakers plug into that room's AC outlet. Features 4½-in full-range driver; volume control; FR 60-15,000 Hz; sep 90 dB; S/N 80 dB; 12 W/ch amp. Available in black and white. \$270

SS53-Amplified Speakers

Speakers for portables \$25/pr

REEL TO REAL DESIGNS

Legacy-Signature 4-Way Speaker

Features 10-in and 8-in polypropylene woofers, 6½-in polypropylene midwoofer, 1¼-in metallized midrange, and a samarium-cobalt ribbon super-tweeter. Slot-loaded subwoofer section with double-magnet structure; dual pairs of Tiffany binding posts; bi-ampable; hand-tuned crossover; 5 chamber cabinet braced to 1½-in wall thickness. Power handling 45-400 W; FR 20-30,000 Hz ± 2 dB; sens 91.5 dB SPL/W/m; imp 4 to 8 ohms; crossover points 120, 2,200, and 8,500 Hz. Oiled oak, walnut, rosewood or black lacquer finish \$1,696/pr

Legacy Dual 12 Subwoofer

Dual channel subwoofer with independent carbon-filled polypropylene 12-in bass driver. Features 6th order alignment; variable crossover frequency and slope. Power handling 30-500 W; FR 16-100 Hz ± 2 dB; sens 91.5 dB SPL/W/m; imp 4 ohms/ch; crossover at 55 or 95. Oiled oak, walnut, rosewood or gloss black lacquer finish \$748 ea

Legacy-2 PLUS 3-Way Speaker

Features 10-in polypropylene woofer; 6½-in polypropylene midrange; 1-in polyimide ferrofluid cooled dome tweeter. Gold Tiffany binding posts. Power handling 30-200 W; FR 28-22,000 Hz ± 2 dB; sens 90.5 dB SPL/W/m; imp 6 ohms; crossover points 180 and 2,800 Hz. Oiled oak, walnut, rosewood or black lacquer finish \$1,196/pr

Legacy Dual 10 Subwoofer

Dual-channel subwoofer with independent 10-in bass drivers. Features assisted 4th-order alignment; variable crossover frequency and slope. Power handling 30-400 W; FR 22-120 Hz ± 2 dB; sens 91 dB SPL/W/

m; impedance 8 ohms; crossover point 55 or 95 Hz. Oiled oak, walnut, rosewood or gloss black lacquer finish \$548 ea

Legacy-3 3-Way Speaker

Speaker with 8-in polypropylene woofer, 6½-in cast-frame midbass, and 1-in ferrofluid-cooled dome tweeter. Features double-reflex bass alignment; gold Tiffany binding posts. Power handling 30-200 W; FR 34-22,000 Hz ± 2 dB; sens 91.5 dB SPL/W/m; imp 4 ohms; crossover points 200 and 2,800 Hz. Hand-rubbed oak, walnut, rosewood or gloss black lacquer finish. \$896/pr

Legacy-Super 2-Way Speaker

Bookshelf speaker with two 6½-in polypropylene midwoofers, 1-in aluminum ferrofluid cooled tweeter. Features gold Tiffany binding posts; fuse protection. Power handling 30-200 W; FR 38-22,000 Hz ± 2 dB; sens 94.5 dB SPL/W/m; imp 4 ohms; crossover point at 2,000 Hz. Oiled oak, walnut, rosewood or gloss black lacquer finish \$750/pr
 Optional T-braced stands with spiked hardwood base \$120/pr

Legacy 2-Way Satellite Speaker

Bookshelf speaker with 6½-in polypropylene woofer and 1-in aluminum-dome tweeter. Features braced cabinet stuffed with polyester fiber; gold Tiffany binding posts. Power handling 30-150 W; FR 40-22,000 Hz ± 2 dB; sens 90 dB SPL/W/m; imp 8 ohms; crossover point at 2,800 Hz. Oiled oak, walnut, rosewood or gloss black lacquer finish \$548/pr
 Optional T-braced stands with spiked hardwood bases \$120/pr

Legacy Mini-Monitor 2-Way Speaker

Compact speaker with 5¼-in bextrene midbass and 1-in aluminum-dome tweeter. Features gold Tiffany binding posts. Power handling 30-125 W; FR 59-22,000 Hz ± 2 dB; sens 90 dB SPL/W/m; imp 4 ohms; crossover point at 2,200 Hz. Available in oiled oak, walnut, rosewood, or gloss black. 16 lb ea. \$448/pr
 Optional T-braced stands with spiked hardwood bases \$120/pr

REVOX

Agora B MK II Powered Speaker

Floor-standing tri-amplified active ported speaker incorporating three 100 W amps with active dividing networks in each enclosure. Designed to be driven from preamp or direct from high-level sources such as CD player. Features push-pull dual woofer design with one woofer facing into enclosure to eliminate even-order harmonic distortion. Two 9-in cone woofers; 4¾-in cone midrange; ¾-in titanium-dome tweeter. Low-frequency amp utilizes feedback to compensate for back-EMF. Also features 4-step bass and treble controls; bass blend switch; auto power on/off. FR 30-21,000 Hz ± 3 dB; sens 110 dB SPL/W/m; real walnut veneer finish with brown grille or polished ebony finish with black grille \$5,000/pr
 Black lacquer finish \$5,900/pr

Power Cube Powered Speaker

Incorporating 2 additional amplifiers to power any suitable pair of satellite speakers. Features 12¼-in woofer, 150 W amp for bass speakers; two 100-W amps for use with satellites. Can be connected to outputs of either a preamp or amp. FR 35-22,000 Hz -3 dB; sens 100 dB SPL/W/m. Black or white matte finish. 15½ x 14½ x 16¼ in; 42 lb. \$1,600/ea

Duetto Speaker

Single-enclosure speaker with two sets of three drivers mounted on either side of wedge shape enclosure. May be used with Power Cube or Piccolo Bass. Features two 4-in midranges; 1-in dome tweeter. Frequency response 90-22,000 Hz; sens 89 dB SPL/W/m; nominal impedance 4 ohms. Black lacquer finish. 14 x 14 x 14 in \$1,095
 Black or white matte finish \$795

SPEAKERS

Piccolo Satellite/Subwoofer System

Satellite speakers may be used with or without companion subwoofer. Satellites feature 4¼-in mid range driver; ¾-in dome tweeter. Subwoofer features 10¼-in subwoofer. Power handling 70 W cont; frequency response 48-22,000 Hz ± 3 dB; sensitivity 86 dB SPL/W/m; imp 4 ohms; black finish. Satellite: 5.5 x 8.75 x 5.75 in, 5 lb, 8 oz. Subwoofer: 15.25 x 14.25 x 14.5 in, 32 lb

Satellites..... \$390/pr
Subwoofer..... \$450 ea

RH LABS

SB-3X Powered Subwoofer

Powered subwoofer with 150-W amplifier and 12-in driver. Features continuously variable 40-120 Hz 18 dB/octave electronic crossover; phase reversal control. 23 x 20 x 20 in..... \$1,400

SB-4X Powered Subwoofer

Powered subwoofer with 100-W amplifier and 10-in driver. Features continuously variable 40-120 Hz 18 dB/octave electronic crossover; phase reversal control. 16¼ x 19½ x 16 in..... \$900

RICH ACOUSTIC LABS

MT88 3-Way Speaker

Speaker with two 8-in poly-cone woofers, 1-in soft-dome tweeter. FR 31-20,000 ± 3 dB; crossovers at 60 and 2,700 Hz; power range 10-250 W; nom imp 4 ohms; oak or walnut finishes; sens 91 dB SPL/W/m. 32½ x 10½ x 11¼ in..... \$799/pr

Model 8 2-Way Speaker

Speaker with 8-in poly-cone woofer, 1-in soft-dome tweeter. FR 34-20,000 ± 3 dB; crossover at 2,500 Hz; power range 10-200 W; nom imp 8 ohms; oak or walnut finishes; sens 90 dB SPL/W/m..... \$499/pr

Model 6 2-Way Speaker

Speaker with 6½-in poly-cone woofer, 1 ¾-in soft-dome tweeter. FR 38-20,000 ± 3 dB; crossover at 2,700 Hz; power range 10-150 W; nom imp 8 ohms; oak or walnut finishes; sens 90 dB SPL/W/m. 20½ x 8¾ x 9¼ in..... \$399/pr

ROCKUSTICS

All Rockustic speakers have a natural-look stone enclosure. Rockustic speakers are water- and weather-resistant for outdoor applications and feature positive, negative, and ground connection terminals.

Stonehenge 3-Way Outdoor Speaker

3-way speaker with 8-in woofer, 5½-in midrange, and 1-in dome tweeter. FR 54-18,500 Hz ± 3 dB; power handling 150 W; imp 4 ohms; sens 90 dB SPL/W/m. 85 lb..... \$1,500/pr

Hillside 3-Way Outdoor Speaker

3-way speaker with 8-in woofer, 5½-in midrange, and 1-in dome tweeter. FR 54-18,500 Hz ± 3 dB; power handling 150 W; imp 4 ohms; sens 90 dB SPL/W/m. 120 lb..... \$1,500/pr

Rocky Jr 2-Way Outdoor Speaker

2-Way speaker with 6½-in long-throw polypropylene-cone woofer, 1-in soft-dome ferrofluid-cooled tweeter, and third-order crossover (3,000 Hz). FR 58-18,500 Hz ± 2½ dB; imp 5 ohms nominal, 3.7 ohms min; sens 90 dB SPL/W/m..... \$700/pr

ROGERS

All speakers come with a 5-year warranty. Cones are polypropylene and tweeters are metal dome unless otherwise specified.

PM150a 2-Way Reflex Speaker

Features bi-wireable crossover network. Power handling 200 W; imp 8 ohms; FR 40-16,000 Hz ± 3 dB;

sens 92 dB SPL/W/m. 30 x 18 x 15½ in; 78 lb. Walnut, teak, or black..... \$3,495/pr

LS5/9 2-Way Speaker

Power handling 100 W; FR 50-16,000 Hz ± 3 dB; imp 8 ohms; sens 87 dB SPL/W/m. 18¾ x 11 x 10¾ in; 38 lb. Walnut, teak, or black..... \$2,595/pr

Studio 1a 2-Way Speaker

Features aluminum-dome tweeter and bi-wireable crossover. Power handling 220 W; FR 45-20,000 Hz ± 3 dB; imp 8 ohms; sens 89 dB SPL/W/m. 25 x 12 x 12 in; 40 lb. Walnut, teak, or black..... \$1,399/pr

LS7t 2-Way Speaker

Features titanium-dome tweeter and bi-wireable crossover. Power handling 200 W; FR 55-22,000 Hz ± 2 dB; imp 8 ohms; sens 88 dB SPL/W/m. 22 x 10¾ x 11 in; 38 lb. Walnut, teak, or black..... \$949/pr

LS6a 2-Way Speaker

Features bi-wireable crossover. Power handling 150 W; FR 50-20,000 Hz ± 2 dB; imp 8 ohms; sens 89 dB SPL/W/m. 20 x 10¾ x 11 in; 45 lb. Walnut, teak, or black..... \$699/pr

LS3/5a 2-Way Bookshelf Speaker

Power handling 75 W; FR 70-20,000 Hz ± 3 dB; imp 11 ohms; sens 82.5 dB SPL/W/m. 11¾ x 7½ x 6¾ in; 25 lb. Walnut, teak, or black..... \$649/pr

LS4a 2-Way Bookshelf Speaker

Power handling 100 W; FR 55-20,000 Hz ± 2 dB; imp 8 ohms; sens 88 dB SPL/W/m. 17 x 10 x 9¾ in. Black/walnut vinyl..... \$549/pr

LS2a 2-Way Bookshelf Speaker

Power handling 100 W; FR 60-20,000 Hz ± 2 dB; imp 8 ohms; sens 87 dB SPL/W/m; 29 lb. 14 x 9 x 8 in. Black/walnut vinyl..... \$399/pr

Speaker Stands

All stands are supplied with fully-adjustable, carpet-piercing spikes.

S40. For use with the Studio 1a, LS6a, and LS7t speakers. 40 lb. Black..... \$129

S55. For use with the LS2a and the LS3/5a speakers. 35 lb. Black..... \$129

S59. For use with the LS5/9 and the LS4a speakers. 44 lb. Black..... \$129

SANSUI

Vintage SP-100i 2-Way Shielded Speaker

2-way magnetically-shielded bass-reflex speaker. Features 8¼-in filament carbon woofer with twin magnets; 1-in titanium-diaphragm tweeter with diamond plating; ½-in diecast aluminum tweeter base; isolated crossover network. Both speakers have cylindrical frames. Tweeter's flange plate is attached to cork sheet. FR 40-30,000 Hz; crossover at 1,500 Hz; sens 88 dB SPL/W/m; imp 6 ohms; max power handling 120 W. 17¾ x 11 x 13½ in; 41.9 lb. Titanium finish..... \$1,800/pr

SP-X5U 3-Way Speaker

6½-in low woofer, 5¼-in midbass with a carbon-filled polypropylene cone with butyl rubber surround and an aluminum diecast frame, and a 1-in liquid-cooled tweeter with a silk diaphragm dome. Features rounded baffle edges; gold-plated 5-way binding posts. FR 45-23,000 Hz ± 3 dB; power handling 75 W/ch rms; sens 88 dB SPL/W/m; imp 6 ohms; crossover freq at 350 and 7,000 Hz. 37½ x 11½ x 11½ in. Oak or black wood-grain finish..... \$500/pr

SP-X3U 3-Way Speaker

Acoustic-suspension 3-way speaker. Features 10-in carbon-filled polypropylene woofer with butyl rubber surround; 5-in carbon-filled polypropylene midrange cone; ¾-in ferrofluid-cooled dome tweeter; silicone carbon-oxide-core coil crossover network; gold-plat-

ed 5-way binding posts. FR 35-23,000 Hz ± 3 dB; max power handling 250 W; imp 8 ohms. 21¼ x 14 x 10¾ in; 17 lb. Oak cabinets..... \$400/pr

SW-S7.7U 3-Way Subwoofer/Satellite System

2 SP-XO 7U acoustic-suspension satellites and 1 SP-W7U tunable acoustic post subwoofer. The subwoofer (SP-W7U) is a 6½-in twin drive mechanism mounted in a cabinet with a tuneable port. The 5-in midrange in the satellites has a carbon-filled polypropylene cone. The satellite tweeter is a ½-in ferrofluid cooled polycarbonate soft-dome. Power handling 60 W/ch rms into 6 ohms; FR 55-22,000 Hz; sens 88 dB SPL/W/m. Crossover frequencies at 200 and 6,000 Hz. Satellites: oak grain or black wood grain. 7 x 11¾ x 7½ in; 10 lb. Subwoofer: black textured finish. 19 x 9¾ x 11¾ in; 26 lb..... \$380/system

SP-X2U 2-Way Speaker

Acoustic-suspension 2-way speaker. Features 8-in carbon-filled polypropylene woofer with butyl rubber surround; ¾-in ferrofluid-cooled dome tweeter; silicone carbon-oxide-core coil crossover network; gold-plated 5-way binding posts; rounded cabinet baffles. FR 40-23,000 Hz ± 3 dB; max power handling 200 W; imp 8 ohms. 21¼ x 11¾ x 10¾ in; 28 lb. Oak cabinets..... \$300/pr

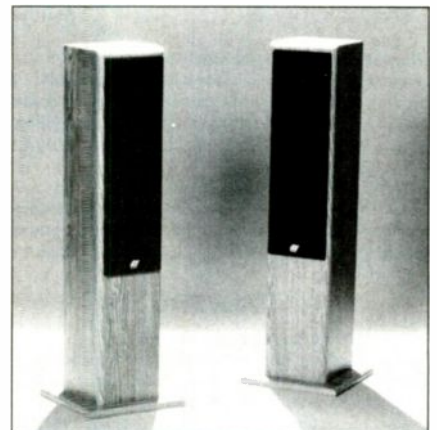

Sansui SP-X5U

SP-X1U 2-Way Speaker

Acoustic-suspension 2-way speaker. Features 6½-in carbon-filled polypropylene woofer with butyl rubber surround; ½-in ferrofluid-cooled dome tweeter; silicone carbon-oxide-core coil crossover network; nickel-plated 5-way binding posts; rounded cabinet baffles. FR 50-22,000 Hz ± 3 dB; max power handling 150 W; imp 8 ohms. 14½ x 9½ x 9½ in; 17 lb. Oak cabinets..... \$220/pr

SCOTT

Model 10.3a 3-Way Bookshelf Speaker

Acoustic-suspension speaker with 10-in woofer; ferrofluid-cooled 4½-in midrange; 1¾-in center-mounted ferrofluid-cooled tweeter; hickory vinyl finish. FR 45-20,000 ± 4 dB; power range 10-100 W rms; sens 92 dB SPL/W/m; imp 8 ohms; 23¼ x 12½ x 8¾ in; 20 lb ea..... \$520/pr

Model 8.2a 2-Way Bookshelf Speaker

Acoustic-suspension speaker with 8-in woofer; 1¾-in ferrofluid-cooled tweeter; hickory vinyl finish. FR 55-20,000 Hz ± 4 dB; power range 5-70 W rms; sens 92 dB SPL/W/m; Dimensions: 18 x 10¾ x 7½ in; 12 ea..... \$320/pr

AS-1B 2-Way Bookshelf Speaker

Acoustic-suspension speaker with 6½-in woofer; 1-in textile soft-dome tweeter. Features passive tweeter protection; air-core crossover coils. 3-way binding posts; oak vinyl finish. FR 55-22,000 Hz ± 4 dB;

SPEAKERS

power range 15-120 watts rms; sensitivity 90 dB SPL/W/m; impedance 4 ohms. 15 x 8 $\frac{3}{8}$ x 7 $\frac{1}{2}$ in; 14 lb each. \$300/pr

S12T6/S12T6K Speaker

Floor-standing 3-way 6-driver system with 12-inch woofer, two 4 $\frac{1}{2}$ -inch ferrofluid-cooled midranges (1 front, 1 top), three 1 $\frac{3}{4}$ -inch ferrofluid-cooled tweeters (1 front, 2 top). Oak vinyl finish. Frequency response 45-20,000 \pm 4 dB; power range 15-175 watts rms; sensitivity 92 dB SPL/W/m. 31 $\frac{3}{8}$ x 16 $\frac{3}{8}$ x 11 in; 37 lb each. \$250 each

S10T5. Similar to S12T6 except 10-in woofer; 5-driver system with maximum power of 150 watts each. \$200 ea

S123 3-Way Speaker

3-way acoustic-suspension speaker with 12-inch woofer, 4 $\frac{1}{2}$ -in ferrofluid-cooled midrange, and 1 $\frac{3}{4}$ -inch ferrofluid-cooled tweeter. Frequency response 45-20,000 Hz \pm 4 dB; power handling 10-150 watts rms; sensitivity 92 dB SPL/W/m. Dimensions: 31 $\frac{3}{8}$ x 16 $\frac{3}{8}$ x 11 in; 33.5 lb each. \$230/pr

Model 6.2a 2-Way Bookshelf Speaker

Acoustic-suspension speakers with 6 $\frac{1}{2}$ -inch woofer; 1 $\frac{3}{4}$ -in ferrofluid-cooled tweeter. Hickory vinyl finish. Frequency response 60-18,000 Hz \pm 4 dB; power range 5-60 watts rms; sensitivity 90 dB SPL/W/m. 15 x 8 $\frac{7}{8}$ x 7 $\frac{1}{2}$ in; 9 lb each. \$160/pr

Model P38B 3-Way Bookshelf Speaker

Acoustic-suspension speaker with 8-inch woofer; 2-inch midrange; 2-inch tweeter. Frequency response 50-19,000 Hz; 75 watts maximum power handling. 11 x 21 $\frac{1}{4}$ x 8 $\frac{1}{2}$ in; 14 lb each. \$140/pr

SP28B 2-Way Bookshelf Speaker

Features 8-inch woofer; 3-inch tweeter; frequency response 50-19,000 Hz; 40 W maximum power handling. 11 x 18 x 8 $\frac{1}{4}$ in \$120/pr

SEATTLE SOUND

P.S. 1 Triamplified Speaker System

Triamplified satellite/subwoofer system in self-contained high-density fiberboard enclosure with 6 $\frac{1}{2}$ -inch polypropylene cone woofer and $\frac{3}{4}$ -inch ferrofluid-cooled polyamide soft-dome tweeter. Features 4-subenclosure design; 4th-order Linkwitz-Reilly-type crossover at 150 Hz and 100-W amplifier for satellites; 2 separate subwoofer enclosures. Frequency response 20-20,000 Hz; THD <0.05%. 39 x 13 $\frac{1}{2}$ x 16 $\frac{1}{2}$ in. \$3,500/system

SW1 Subwoofer

Mirror Image Stereo Subwoofer System that includes two discrete subwoofers, each with its own tuned enclosure, and crossover. Features two asymmetrical chambers each with its own mono crossover and 8-inch woofer; 5-way binding posts \$899 each

M Series

All M Series speakers incorporate narrow, time-aligned front boards, propylene drivers, aluminum voice-coil bobbins, ferrofluid-cooled polyimide-dome tweeters, high-density enclosures, third-order crossovers, heavy-duty five-way binding posts, and fourth-order tuned-port enclosures. They are available with black oak vinyl, real walnut veneer, and high-gloss finishes. All prices given are with black-oak vinyl finishes.

M5 3-Way Speaker

Features 8-inch subwoofer, 6 $\frac{1}{2}$ -inch woofer and 1-inch tweeter. Power handling 175 watts maximum; frequency response 34-21,000 Hz; sensitivity 93 dB sound-pressure-level/W/m; nominal impedance 8 ohms; crossovers at 180 and 2,500 Hz. 31 x 11 x 13 in; 47 lb \$1,199/pr

M4 2-Way Speaker

Features 8-inch woofer and $\frac{3}{4}$ -inch tweeter. Power

handling 100 watts maximum; frequency response 36-21,000 Hz; sensitivity 92 dB SPL/W/m; nominal impedance 8 ohms; crossover at 2,500 Hz. 28 $\frac{1}{4}$ x 10 x 12 in; 39 lb \$899/pr

M3 2-Way Speaker

Features 6 $\frac{1}{2}$ -inch woofer and $\frac{3}{4}$ -inch tweeter. Power handling 100 watts maximum; frequency response 42-21,000 Hz; sensitivity 91 dB SPL/W/m; nominal impedance 8 ohms; crossover at 2,500 Hz. 20 $\frac{1}{2}$ x 8 x 10 in; 23 lb \$599/pr

M2 2-Way Speaker

Features 5 $\frac{1}{4}$ -inch woofer and $\frac{3}{4}$ -inch tweeter. Power handling 75 watts maximum; FR 50-21,000 Hz; sens 89 dB SPL/W/m; nom imp 8 ohms; crossover at 2,500 Hz. 13 x 7 x 8 $\frac{1}{2}$ in; 13 lb \$499/pr

C.I. Series

C.I.4 2-Way Speaker

Custom-installed, free-standing speaker with 8-inch woofer and $\frac{3}{4}$ -inch tweeter. Features 3rd-order symmetrical crossover; 4th-order tuned port enclosure. Power handling 100 watts maximum; frequency response 36-21,000 Hz; sensitivity 92 dB SPL/W/m; nominal impedance 8 ohms; crossover at 2,500 Hz. 22 x 14 x 9 in \$1,800/pr

C.I.3 2-Way Speaker

Custom-installed, free-standing speaker with 6 $\frac{1}{2}$ -inch woofer and $\frac{3}{4}$ -inch tweeter. Features 3rd order symmetrical crossover; 4th order tuned port enclosure. Power handling 100 watts maximum; frequency response 42-21,000 Hz; sensitivity 91 dB SPL/W/m; nominal impedance 8 ohms; crossover at 2,500 Hz. 22 x 10 $\frac{1}{4}$ x 7 in. \$1,200/pr

C.I.2 2-Way Speaker

Custom-installed, free-standing speaker with 5 $\frac{1}{4}$ -inch woofer and $\frac{3}{4}$ -inch tweeter. Features 3rd order symmetrical crossover; 4th order tuned port enclosure. Power handling 75 watts maximum; frequency response 50-21,000 Hz; sensitivity 89 dB SPL/W/m; nominal impedance 8 ohms; crossover at 2,500 Hz. 15 x 14 x 3 $\frac{1}{2}$ in. \$1,000/pr

SHAHINIAN ACOUSTICS

Diapason Module Speaker

Asymmetric-prism with four 5 $\frac{1}{4}$ -inch curved polycone rubber-edge drivers and tweeters six $\frac{3}{8}$ -inch W-shaped titanium domes. Features 1-inch aluminum voice coil; 20-oz ceramic magnet; unequal rakes in each direction made of 13-ply Finland birch; 2 optional input filter choices or direct by-pass for bi-amp use filters; 2 optional roll-off filters to facilitate exact matching or by-pass; teased lamb's wool damping. Frequency response 125-22,000 Hz - 3 dB; power handling 250 watts average. Brown, black beige, bone, double-knit polyester grille options. 35 lb \$4,500/pr

Obelisk 3-Way Speaker

3-way folded double-prism 50-inch hybrid transmission line speaker with 8-inch asymmetrically placed high-temperature voice-coil poly woofer, 10-inch mass-loaded-membrane viscous damped polypropylene passive radiator, two 1 $\frac{3}{8}$ -inch cambric ultra light exposed dome midranges, four $\frac{3}{8}$ -inch W-shaped polyimide-dome tweeters. Minimum power handling 50 watts; maximum power handling 500 watts; impedance 4 ohms nominal. Walnut and Oak standard finishes. Optional finishes available. Dimensions: 29 x 14 $\frac{1}{2}$ x 12 $\frac{1}{2}$ in; 55 lb \$2,050/pr

ARC 3-Way Speaker

Vertical transmission-line speaker with 8-inch high-temperature voice coil polypropylene woofer; 10-inch mass-loaded-membrane viscous-damped passive radiator; 1 $\frac{3}{8}$ -inch cambric ultra-light exposed dome midrange, and 1-inch titanium super-tweeter. Features time-aligned phase-correct driver place-

ment. Minimum power 30 watts; maximum power 350 watts; impedance 4 ohms nominal. Natural, medium or dark oak finish on $\frac{3}{4}$ -inch fiberboard. 27 $\frac{1}{2}$ x 14 x 9 $\frac{1}{4}$ in; 42 lb \$1,200/pr

L.YRE 2-Way Speaker

Forward-firing speaker with 8-inch high-temp voice coil poly-woofer, 1-inch titanium-deposit poly dome super-tweeter, and 10-inch passive radiator. Frequency response 30-18,000 Hz - 3 dB. Dark or light oak veneer; 23 $\frac{1}{2}$ x 11 $\frac{1}{4}$ x 11 $\frac{1}{4}$ in; 43 lb \$950/pr

ELF 2-Way Speaker

Forward-firing small monitor with tuned-damped vent enclosure, 5 $\frac{1}{4}$ -inch polypropylene woofer with rubber edge, 1-inch polypropylene-dome tweeter. Frequency response 55-18,000Hz - 3 dB; minimum power 25 watts; maximum power 150 watts; impedance 6 ohms nominal. Natural medium or dark oak finish. 12 $\frac{1}{2}$ x 6 $\frac{3}{8}$ x 7 $\frac{1}{4}$ in; 26 lb/pr \$450/pr

Subwoofer

Double Eagle Stereo Subwoofer

Stereo subwoofer in one enclosure with acoustically separated channels with two 8-inch polypropylene rubber-edged high-temperature voice-coil woofers and two 10-inch mass-loaded-membrane viscous-damped polypropylene passive radiators. Frequency response 26-1,000 Hz - 3 dB; maximum power short duration peaks 1,000 watts; impedance 6 ohms nominal/ch; crossover 18 dB per octave at 140 Hz. Walnut finish on Finland Birch. Optional finishes available. 30 x 23 x 14 in; 105 lb \$1,150 each

SHURE



Shure HTS50LRS

HTS50CF Center-Channel Speaker System

Acoustic suspension speaker for use as center front speaker in surround system setup with two 6 $\frac{1}{2}$ -inch woofers and 1-inch dome tweeter. Features curved polymer diaphragm; magnetically shielded, polypropylene drivers; fluid-cooled, fused tweeter. Frequency response 55-18,000 Hz; sensitivity 88 dB SPL/W/m; impedance 5.6 ohms. Walnut-veneer finish; molded plastic grille. 20 x 13 $\frac{1}{2}$ x 8 $\frac{3}{8}$ in; 37 lb . \$750

HTS50SW Subwoofer

Subwoofer for use in surround system setup with heavy damped cone, shielded double magnet structure, and 12-inch transducer. Features curved polymer diaphragm; polypropylene drivers. Frequency response 33-80 Hz; sensitivity 91 dB SPL/W/m; impedance 8 ohms. Walnut veneer finish. 18 x 23 x 14 in; 65 lb \$625

HTS50LRS Surround-Sound Speaker

Acoustic suspension speaker for use as front left,

SPEAKERS

right, and/or surround speaker in surround system setup with 6½-inch woofer and 1-inch dome tweeter. Features curved polymer diaphragm; magnetically shielded, polypropylene drivers; fluid-cooled, fused tweeter. Frequency response 60-18,000 Hz; sensitivity 85 dB SPL/W/m; impedance 5.6 ohms. Walnut-veneer finish; molded plastic grille. 13½ x 10 x 8¾ in; 24.2 lb. \$500

SIGNET

SL280 2-Way Speaker

Features 8-inch polypropylene woofer with rubber surround and injection-molded magnesium frame; 1-in ferrofluid-cooled aluminum dome tweeter; vented enclosure; bi-wired option. Power handling 150 watts continuous; FR 40-25,000 Hz; sens 87 dB SPL/W/m; imp 8 ohms; crossover frequency 3,000 Hz. Oak veneer. 9¾ x 25 x 12¾ in; 37 lb. \$850/pr

SL260 2-Way Speaker

Features 6-inch polypropylene woofer with rubber surround and injection-molded magnesium frame; ¾-inch ferrofluid-cooled aluminum dome tweeter; vented enclosure; bi-wired option. Power handling 125 watts continuous; frequency response 50-25,000 Hz; sensitivity 86 dB SPL/W/m; impedance 8 ohms; crossover frequency 4,000 Hz. Oak veneer. 8¼ x 15½ x 12¾ in; 23 lb. \$850/pr

SL230 3-way Subwoofer/Satellite System

Satellite contains a 3½-inch injection-molded midrange driver and a ¾-inch ferrofluid-cooled dome tweeter; subwoofer utilizes two down-firing, slot-loaded 6-inch drivers. Power handling 100 watts continuous; frequency response 50-20,000 Hz; sensitivity 88 dB SPL/W/m; crossover frequency 200/3,000 Hz. Satellites are finished in oak veneer and the subwoofer in black vinyl. Satellites: 4¾ x 8¼ x 4¾ in, subwoofer: 13 x 21 x 6¾ in; 35 lb/system \$700/system

SNELL ACOUSTICS

Type A-III 4-Way Speaker

Floor-standing acoustic-suspension speaker with curved baffle to eliminate diffraction, mechanically isolated midrange enclosure, floor-loaded woofer, and rear-loaded supertweeter for accurate room response. Hand-adjustment of crossover values for specific drivers assures acoustic performance virtually identical to reference speaker. Features 12-inch high-power long-excursion mass-loaded mechanically-isolated cone woofer; 5-inch mechanically-isolated cone midrange; 1-inch individually adjusted controlled-dispersion dome tweeter; ¾-inch low-mass ferrofluid-cooled dome supertweeter. Dual gold-plated inputs allow bi-wiring or bi-amping with or without electronic crossover. Power handling 250 watts rms; frequency response 24-26,000 Hz ± 3 dB, 38-18,000 Hz ± 1 dB; nominal impedance 8 ohms; crossover frequency 275/2,700/10,000 Hz. Hand-sanded, hand-rubbed matching oak, dark oak, walnut, or black-finished veneers. 23½ x 50¾ x 14 in; 160 lb each. \$4,680/pr

Type C-II 3-Way Speaker

Floor-standing bass reflex speaker system. Features 10-inch long-throw woofer; 5-inch midrange; 1-inch treated-cloth ferrofluid-cooled dome tweeter; ¾-inch switchable rear tweeter; 4th-order 24 dB/octave filters; bi-wirable or bi-ampable. Power handling 250 watts rms; frequency response 34-22,000 Hz ± 3 dB; sensitivity 88.5 dB SPL/W/m; nominal impedance 8 ohms; crossover frequency 275/2,700 Hz. Hand-sanded, hand-rubbed matching oak, dark oak, walnut, or black-finished veneers. 14½ x 46 x 11¾ in; 95 lb each. \$1,890/pr

Type E/III 2-Way Speaker

Floor-standing bass-reflex speaker with 8-inch polymer-treated woofer, 1-inch soft-dome tweeter, and ultra-low-mass ¾-inch ferrofluid-cooled rear-loaded dome supertweeter designed for flat early-arrival of

sound and accuracy of listening-room response. Hand-adjusted crossover for specific drivers assures acoustic performance virtually identical to reference speaker. Dual gold-plated inputs allow bi-wiring or bi-amping. Features rear-loaded port for optimum low-frequency room loading. Power handling 150 watts rms; frequency response 39-20,000 Hz ± 1.75 dB; sensitivity 91 dB SPL/W/m; nom imp 6 ohms; crossover frequency 2,700 Hz. Hand-sanded, hand-rubbed matching oak, dark oak, walnut, and black-finish veneer. 13 x 35 x 11 in; 50 lb/ea. . . . \$990/pr

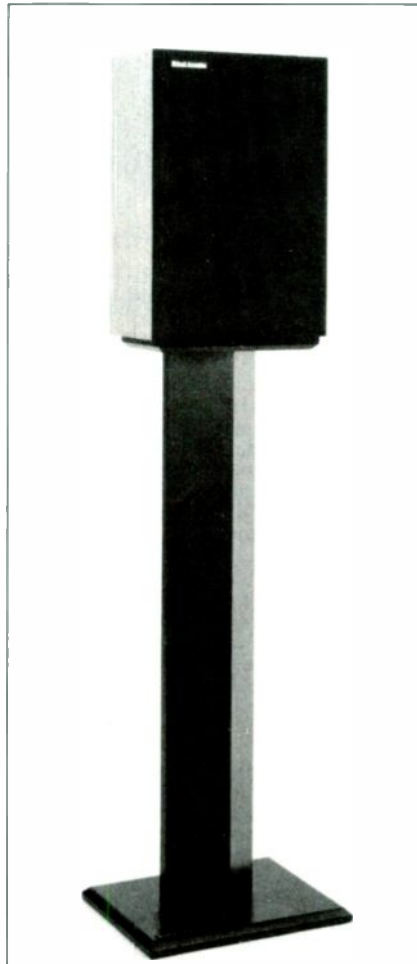

Snell Acoustics Type Q

Type Q 2-Way Speaker

2-way bookshelf speaker designed for stand placement. Each speaker is individually adjusted to match a reference speaker within a fraction of a dB. Features 6½-inch polypropylene cone woofer; 1-inch rear-firing textile-dome tweeter and a ¾-inch rear-firing tweeter; flush grille to eliminate diffraction. Power handling 150 watts rms; frequency response 75-20,000 Hz ± 3 dB; sensitivity 86 dB SPL/W/m; nominal imp 8 ohms; crossover frequency 2,200 Hz. Oak, dark oak, walnut, or black-finished veneers. 10½ x 15½ x 6¾; 23 lb, 8 oz each. \$780/pr

Type Q Stand. Speaker stand designed for use with Type Q speakers. Bolts directly to Type Q's. Can be mass-loaded with sand or lead and incorporate spikes on the bottom. Each stand provides for the bolting of a Type Q speaker directly to the stand. Black-finished veneer. 32 inch high; 20 lb/pr. \$120/pr

Type J/III 2-Way Speaker

Bookshelf bass-reflex speaker designed to maximize accuracy of early arrival sound and listening room response. Hand-adjustment of crossover values for specific drivers assures acoustic performance virtual-

ly identical to reference speaker. Features 8-inch polymer-treated curvilinear cone woofer; 1-inch soft-dome tweeter; dual gold-plated inputs for optional bi-wiring and bi-amping. Power handling 150 watts rms; frequency response 49-20,000 Hz ± 2 dB; sensitivity 91 dB SPL/W/m; nominal impedance 6 ohms; crossover frequency 2,700 Hz. Oak, dark oak, walnut, and black-finished veneer. 13 x 23 x 10 in; 35 lb each. \$650/pr

Type J Stand. Speaker stand designed for use with Type J speakers. Can be mass-loaded with sand or lead and incorporate spikes on the bottom. Black-finished veneer. 15 lb/pr. \$98/pr

Type K-II 2-Way Speaker

Bookshelf acoustic-suspension speaker with 8-inch polypropylene cone woofer and ¾-inch ferrofluid cooled soft-dome tweeter. Hand-adjusted crossover values for specific drivers assures acoustic performance virtually identical to reference speaker. Dual inputs for optional bi-wiring or bi-amping. Power handling 100 watts rms; frequency response 70-20,000 Hz ± 2 dB; sensitivity 90 dB SPL/W/m; nominal impedance 8 ohms; crossover frequency 2,700 Hz. Oak, dark oak, walnut, or black-finish veneer. 11 x 18 x 9 in; 26 lb each. \$465/pr

Type K Stand. Speaker stand designed for use with Type K speakers. Can be mass-loaded with sand or lead and incorporate spikes on the bottom. Black veneer. 15 lb. \$98/pr

SONANCE

All Sonance speakers are flush-mount in-wall type.

IV 2-Way Speaker

Speaker with 8-inch polypropylene cone woofer and 1-in polycarbonate dome tweeter. Features woofer with butyl rubber surround and special compliant dust cap; tweeter with acoustic chamber and bored pole piece; crossover with solid capacitors, polypropylene by-passes, and heavy-gauge chokes. Power handling 5-100 watts; frequency response 35-22,000 Hz ± 2 dB; sensitivity 90 dB SPL/W/m; nominal impedance 8 ohms; crossover point at 2,500 Hz. Available in white with cloth or metal grille. 16 x 9 x 3½ in; 11 lb. \$650/pr

PSW2 Subwoofer

Subwoofer with 2-channel dual-voice coil 8-inch driver. Features crossover with 3 position level control. Frequency response 20-125 ± 3 dB; sensitivity 87 dB SPL/W/m; nominal impedance 6 ohms; crossover 125 Hz. White with cloth or metal grilles. 16 x 9 x 3½ in; 14 lb. \$450 ea

III MkII 2-Way Speaker

Speaker with 6½-inch polypropylene cone woofer and 1-inch soft dome tweeter. Features woofer with treated urethane surround and protective screens on basket windows; tweeter with two positions: flat and +2.5 dB; crossover with solid dielectric capacitors, air core choke on HP, and ferrite core on LP circuit. Power handling 5-75 watts; frequency response 45-20,000 Hz ± 2 dB; sensitivity 89 dB SPL/W/m; nom imp 8 ohms; crossover point 2,500 Hz. Available in white with cloth or metal grilles. 16 x 9 x 3½ in; 9 lb. \$375/pr

M130 2-Way Speaker

Speaker with 4-inch polypropylene cone woofer and 1-in polycarbonate, ferrofluid-damped proprietary dome tweeter. Power handling 5-75 watts; frequency response 70-20,000 Hz ± 2 dB; sensitivity 86 dB SPL/W/m; nominal impedance 8 ohms; crossover point at 4,500 Hz. Available in white with metal or cloth grille. 9¼ x 6½ x 2½ in. \$300/pr

II MkII 2-Way Speaker

Speaker with 6½-inch polypropylene cone woofer and 1-inch polycarbonate proprietary tweeter. Features woofer with urethane surround and protective screens on basket windows. Power handling 5-50

SPEAKERS

watts; frequency response 55-20,000 Hz \pm 2 dB; sensitivity 90 dB SPL/W/m; nominal impedance 8 ohms; crossover point at 3,500 Hz. Available in white with cloth or metal grille. 12 x 9 x 3 in.; 8 lb \$245/pr

IA 2-Way Speaker

Speaker with 6½-inch polypropylene core woofer and 2-in cone tweeter. Power handling 3-35 watts; frequency response 85-12,000 Hz \pm 5 dB; sensitivity 88 dB SPL/W/m; nominal impedance 8 ohms; crossover point at 3,000 Hz. Available in white with white cloth or metal grille. 12 x 9 x 3 in.; 8 lb \$190/pr

Flush-Mount In-Wall Subwoofer System

ASW1 Powered Subwoofer

Subwoofer module for use with dedicated circuitry in VCA1 amplifier with 8-inch cast frame dual voice coil driver. Features doped pulp cone with a butyl surround; selectable 50, 75, 100 Hz crossover. Frequency response 20-100 \pm 2 dB; sensitivity 87 dB SPL/W/m; nominal impedance 8 ohms. White with cloth or metal grille. 16 x 9 x 3½ in.; 15 lb \$260
VCA1 Remote Control 60 W/ch Amplifier. 3-channel integrated amplifier for ASW1 subwoofer. Features active bass-boost circuitry; amplifier protection system; 3 selectable roll-off frequencies. 60 watts/ch into 8 ohms with 0.05% total harmonic distortion. 100 watts/ch into 4 ohms with 0.05% total harmonic distortion; frequency response 20-20,000 at rated power +0 dB, -0.2 dB; intermodulation distortion 0.025% at 1 watt to rated power. Dimensions: 16¾ x 3½ x 13¾ in. Weight: 30 lb \$1,239

SONOGRAPHE BY CONRAD-JOHNSON

SW 1000 Stereo Subwoofer

2 side-firing magnetically shielded 10-inch woofers in golden oak cabinet. FR 25-110 Hz \pm 2 dB; power range 10-200 watts; sensitivity 90 dB SPL/W/m; impedance 8 ohms; 19½ x 36 x 18 in. \$849 each
SW 500. Same as SW 1000 except mono. with single 10-inch woofer; 19½ x 18 x 18 in. \$595 each
SL 21 Mini-Monitor Satellite Speaker
 Vented; 6½-inch polypropylene woofer; 1-inch dome tweeter; golden oak cabinet with brown grille. Frequency response 52-20,000 Hz \pm 2 dB; power range 10-80 watts; sensitivity 90 dB SPL/W/m; impedance 8 ohms; 14½ x 10½ x 10½ in. \$695/pr

SONY

APM-66ES 3-Way Speaker

Bass-reflex speaker with APM (Accurate Pistonic Motion) driver technology that incorporates a light, rigid, flat-diaphragm design. Features 66 sq-inch APM woofer; 7.4 sq-inch APM midrange; 1.4 sq-inch APM tweeter; built-in circuit breaker for tweeter protection; heavy-duty cabinet construction with rounded edges. Includes speaker cord. Frequency response 30-30,000 Hz; sensitivity 89 dB SPL/W/m; power capacity 100 watts nominal, 200 W peak; 15 x 26 x 14¾ in. \$1,100/pr

APM-22ES 2-Way Speaker

Bass-reflex speaker with APM (Accurate Pistonic Motion) driver technology that incorporates a light, rigid, flat-diaphragm design. Features 45 sq-inch APM woofer; 1.4 sq-inch APM tweeter; built-in circuit breaker for tweeter protection; heavy-duty cabinet construction with rounded edges. Includes speaker cord. Frequency response 40-20,000 Hz; sensitivity 88 dB SPL/W/m; power capacity 80 watts nominal; 11½ x 20¾ x 12¾ in. \$500/pr

SA-W30 Powered Subwoofer

Powered bass-reflex subwoofer with turn over frequency selector. Features built-in 60-W amp; 12-in woofer; 19½ x 19 x 15¾ in. \$450

SRS-77G Portable Powered Speaker

For Walkman, Discman players. Water-resistant;

built-in amp; volume control; amp bypass. \$200/pr

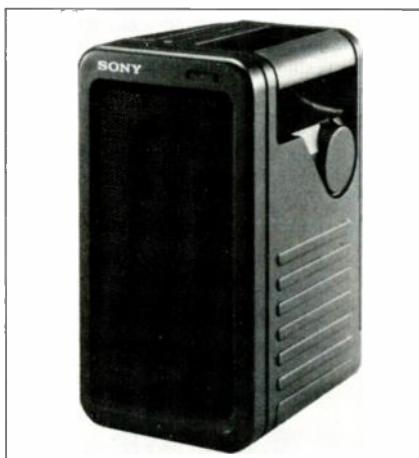

Sony SRS-77G

SOTA INDUSTRIES

Panorama 2-Way Speaker

Time-Domain speaker with 7-inch woofer; 1-inch hard-dome tweeter. Features bass extension of 45 Hz \pm 3 dB; truncated pyramid enclosure; 1¼-inch walls; hard/soft structural damping on woofers. Maximum power handling 150 watts/ch; frequency response 45-22,000 Hz \pm 3 dB; sensitivity 90 dB SPL/W/m; nominal impedance 6 ohms; crossover at 3,200 Hz. 12 x 18 x 6 in.; 35 lb. Oak or cherry \$1,595
 Brazilian rosewood, ebony \$1,895
 Blackwood \$1,795

Vista 2-Way Bookshelf Speaker

Balanced port speaker with 7-inch Kevlar-cone mid-band drivers and ¾-inch titanium-coated tweeter. Features braced cabinet. Power range 25-200 watts; frequency response 50-30,000 Hz \pm 3 dB; sensitivity 87 dB SPL/W/m; impedance 7-8 ohms. Available in golden oak or black \$950/pr

SOUND DYNAMICS

Model 1500 2-Way Speaker

Computer-tuned bass-reflex, pair with matched parts. 1-inch horn-loaded soft-dome tweeter with free-floating dome suspension; 15-inch woofer with high-gauss linear forced motor and epoxy potting; walnut grain vinyl; base attached. Power handling 20-250 watts; frequency response 25-22,000 Hz \pm 3 dB; sensitivity 102 dB SPL/W/m; impedance 8 ohms. 34 ¾ x 18 x 16 in.; 90 lb each. \$1,100/pr

Model 700 2-Way Speaker

Computer-tuned bass-reflex pair with matched parts. 1 in horn-loaded soft-dome tweeter with free-floating suspension; 12-inch woofer with high-gauss linear forced motor and epoxy potting; black ash vinyl veneer. Power handling 15-200 watts; frequency response 30-22,000 Hz \pm 3 dB; sensitivity 101 dB SPL/W/m; impedance 8 ohms. 27¾ x 14¾ x 12 in.; 45 lbs each \$750/pr

Model 500 2-Way Speaker

Computer-tuned bass-reflex pair with matched parts. 1-inch horn-loaded soft-dome tweeter with free-floating suspension; 10-inch high-gauss plastic-coated woofer black ash vinyl veneer. Power handling 10-200W; frequency response 34-23,000 Hz \pm 3 dB; sensitivity 98.5 dB SPL/W/m; maximum power 200 watts; impedance 8 ohms. 23½ x 12 x 11¾ in.; 38 lbs each \$550/pr

Model 100S Mk II 2-Way Bookshelf Speaker

Bass reflex speaker with 6½-inch polypropylene cone woofer and 1-inch dome tweeter; black ash vinyl veneer. Power range 10-70 watts; frequency response

50-20,000 Hz \pm 3 dB; sensitivity 93 dB sound-pressure-level/watts/meter; imp 8 ohms; 16 x 9½ x 9½ in.; 20 lb. \$260/pr

SPICA

Angelus 2-Way Speaker

2-way mirror-imaged speaker system with 8-inch plastic cone bass/mid driver and 1-inch soft-dome tweeter. Features computer optimized crossover; built-in adjustable spikes. Frequency response 35-17,500 Hz \pm 3 dB (90-15,000 Hz \pm 1.5 dB); recommended power 50-200 watts; nominal impedance 8 ohms; crossover 3,400 Hz (-6 dB). Walnut or oak finishes. Dimensions: 21 x 46 x 10¼ in. Weight: 57 lb each. \$1,295/pr

TC-50 2-Way Bookshelf Speaker

2-way acoustic-suspension bookshelf speaker with 6-inch cone woofer and 1-inch dome tweeter. Features triangular shape allowing system to be within 15° of absolute phase from 350-5,000 Hz. Frequency response 58-16,500 Hz \pm 3 dB; power handling 25-50 watts, 100 watts peak; sensitivity 83 dB SPL/W/m; impedance 4 ohms. Available in oak, walnut or black finishes. Dimensions: 13 x 15½ x 11¾ in. Weight: 21 lb each. \$600/pr

SPL

Each speaker has a dome tweeter, nominal impedance of 8 ohms (minimum impedance of 6 ohms), an black-ash vinyl finish with black knit grill

Model 4000 2-Way Speaker

Bass-reflex speaker with two 10-inch woofers; 1-inch tweeter; crossover at 2,200 Hz. Power range 20-150 W; frequency response 25-22,000 Hz \pm 3 dB; sensitivity 98 dB SPL/W/m. 43 x 13 x 15 in.; 65 lb each. \$1,000/pr

Model 3000 2-Way Speaker

Bass-reflex speaker with two 8-inch woofers; 1-inch tweeter; crossover at 2,200 Hz. Power range 15-125 W; frequency response 30-22,000 Hz \pm 3 dB; sensitivity 96.6 dB SPL/W/m. 37 x 12 x 15 in.; 52 lb each. \$750/pr

Model 2000 2-Way Speaker

Passive-radiator speaker with 8-inch woofer; 1-inch tweeter; crossover at 2,200 Hz. Power range 10-100 watts; frequency response 35-22,000 Hz \pm 3 dB; sensitivity 95 dB SPL/W/m. 33 x 12 x 9 in.; 33 lb each. \$500/pr

Model 1000 2-Way Speaker

Bass-reflex speaker with two 5¼-inch woofers; ¾-inch tweeter; crossover at 3,000 Hz. Power range 10-100 W; FR 40-20,000 Hz \pm 3 dB; sensitivity 90 dB SPL/W/m. 21 x 10 x 12 in.; 21 lb each. \$350/pr

SUMO

Aria Planar Speaker

Floor-standing panel speaker. Full-range, dipole, single-element, point-source design; utilizes tensioned mylar as the membrane; patents-pending design; no crossover components; no equalization; no delay lines. Power handling 200 watts continuous average; frequency response 40-20,000 Hz \pm 3 dB; sensitivity 86 dB SPL/W/m; nominal impedance 4 ohms. Medite construction. Dimensions: 30 x 60 x 3½ in. Weight 65 lb \$3,000/pr

Samson Bass-Reflex Subwoofer

Floor-standing subwoofer with 15-inch composite-cone woofer, 18.5-lb magnet assembly, 4-inch edgewound copper voice coil; symmetrical magnetic-field motor structure. Solid 1-inch butcher-block oak top. Frequency response 20-120 Hz \pm 1 dB; power handling 1,000 watts continuous; sensitivity 91 dB SPL/W/m; impedance 8 ohms. 29 x 22 x 19 in.; 140 lb. \$749 each

SPEAKERS

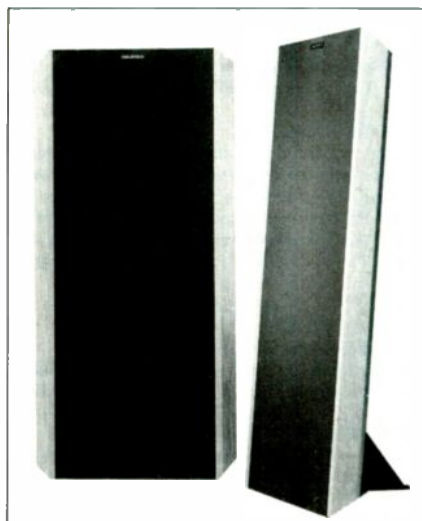

Sumo Aria

SYMDEX

Epsilon Signature 3-Way Speaker

Vented speaker with 10-inch neoflex cone woofer, 7-inch dual voice-coil neoflex midrange, and 1-inch aluminum ferrofluid-cooled dome tweeter. Features cabinets of medium-density fiber; cross-bracing; internal borosilicate ceramic coating; polypropylene capacitors; internal wire of Symdex Omega cable; computer matched within 0.5 dB. Power range 30-250 watts; frequency response 25-20,000 Hz; sensitivity 88 dB SPL/W/m; impedance 8 ohms; crossover points 100 and 2,300 Hz. Available in oak or black lacquer formica. 13 x 48 1/2 x 13 in. \$3,000/pr

Gamma Signature 2-Way Speaker

Vented speaker with 7-inch dual voice-coil neoflex cone woofer and 1-inch aluminum ferrofluid-cooled dome tweeter. Features cabinets of medium-density fiber; cross-bracing; internal borosilicate ceramic coating; polypropylene capacitors; internal wire of Symdex Omega cable; computer matched within 0.5 dB. Power range 30-150 watts; frequency response 45-20,000 Hz; sensitivity 88 dB SPL/W/m; impedance 8 ohms; crossover point at 2,300 Hz. Available in oak or black lacquer formica. 10 x 44 x 6 in; 40 lb each. \$1,600/pr

SYNTHESIS BY CONRAD-JOHNSON

Reference Speaker System

Five-piece speaker system with two subwoofer columns (each with two 10-inch woofers), two midrange/high-frequency units (with 7-inch midranges, 1-inch dome tweeters, leaf supertweeter); golden oak finish with radiused solid-hardwood edges; active electronic crossover supplied. Frequency response 22-32,000 Hz \pm 2 dB; power handling 10-250 watts; sensitivity 91 dB sound pressure level/W/m; nominal impedance 8 ohms. Dimensions: subwoofer columns 69 x 14 x 14 inches; satellite speakers 44 x 10 x 10 inches \$6,800/system

LM 310 3-Way Speaker

10-inch woofer; 7-inch midrange; 1-inch dome tweeter. Light or dark oak cabinet with radiused solid hardwood edges. Frequency response 25-20,000 Hz \pm 2 dB; power range 10-200 watts; sensitivity 91 dB SPL/W/m; impedance 8 ohms; 45 1/2 x 13 3/4 x 14 1/2 in.; 70 lb \$3,250/pr

LM 260 2-Way Speaker

Ported: 8-inch polypropylene woofer; 1-inch dome tweeter. Light or dark oak cabinet with radiused solid-hardwood edges. Frequency response 41-

20,000 Hz \pm 2 dB; power range 10-100 watts; sensitivity 91 dB SPL/W/m; impedance 8 ohms; 39 1/2 x 12 x 11 in.; 50 lb. \$1,695/pr

LM 210 2-Way Speaker

Ported speaker with 6 1/2-inch polypropylene woofer; 1-inch dome tweeter. Light or dark oak cabinet with radiused solid-hardwood edges. Frequency response 46-20,000 Hz \pm 2 dB; power range 10-80 watts; sensitivity 90 dB SPL/W/m; impedance 8 ohms; 33 1/2 x 10 1/2 x 10 1/2 in. \$1,195/pr

CM 205 2-Way Bookshelf Speaker. Same as above, with frequency response 54-20,000 \pm 3 dB. 10 x 10 1/2 x 16 in; 20 lb. \$1,195/pr

TA ELEKTROAKUSTIK

TMR-220 5-Way Speaker

Transmission-line speaker. Power handling 220 watts continuous average; frequency response 15-45,000 Hz; sensitivity 89 dB SPL/W/m; impedance 5 ohms; crossover points at 150, 1,000, 5,000 and 20,000 Hz. Standard finish black oak. 16 1/2 x 63 x 20 1/2 in; 165 lb. \$11,000/pr

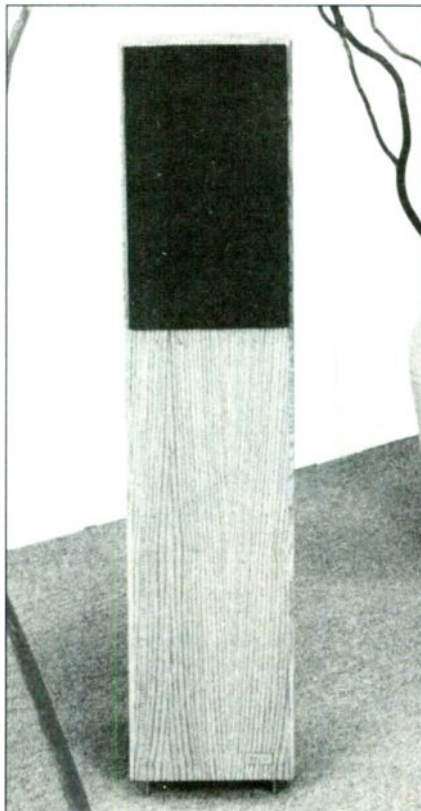

Taddeo Domestic Monitor One

TMR-160 4-Way Speaker

Transmission-line speaker. Power handling 180 watts continuous average; FR 18-35,000 Hz; sens 85 dB SPL/W/m; imp 5 ohms; crossover points at 200, 1,000 and 6,000 Hz. Standard finish natural oak. 16 x 48 x 18 1/2 in; 121 lb \$4,500/pr

TMR-80 3-Way Speaker

Transmission-line speaker. Power handling 140 watts continuous average; FR 25-35,000 Hz; sens 88 dB SPL/W/m; imp 5 ohms; crossover points at 900 and 5,000 Hz. Standard finish natural walnut. 11 1/2 x 35 1/2 x 13 1/2 in; 55 lb \$2,000/pr

P-30 3-Way Bookshelf Speaker

Tuned-port speaker with 10 3/8-inch woofer, 4 3/8-inch midrange, and 1-inch tweeter. Maximum power handling 160 watts; FR 20-30,000 Hz; crossover

points 350 and 3,000 Hz. Standard finish natural oak. 12 x 22 x 12 1/2 in; 37 1/2 lb \$1,700/pr

TMR-120 4-Way Speaker

Transmission-line speaker. Power handling 160 watts continuous average; FR 22-35,000 Hz; sens 86 dB SPL/W/m; imp 5 ohms; crossover points at 200, 900 and 4,000 Hz. Standard finish natural oak. 13 1/2 x 41 x 15 3/4 in; 81 1/2 lb \$1,500/pr

TMR-60 3-Way Speaker

Transmission-line speaker. Power handling 120 average continuous; frequency response 30-30,000 Hz; sensitivity 88 dB SPL/W/m; impedance 5 ohms; crossover points at 700 and 3,500. Standard finish mahogany. 10 x 30 1/2 x 11 1/2 in; 37 1/2 lb. \$1,500/pr

P-20 3-Way Bookshelf Speaker

Tuned-port speaker with 8 3/8-inch woofer, 4-inch midrange, 1-inch ferrofluid diaphragm tweeter. Maximum power 140 watts; frequency response 25-30,000 Hz; impedance 5 ohms; crossover points at 350 and 3,000 Hz. Standard finish mahogany. 10 1/2 x 19 1/2 x 11 in; 26 1/2 lb \$1,200/pr

P-10 2-Way Bookshelf Speaker

Tuned-port speaker with 7 3/8-inch woofer and 1-inch ferrofluid-diaphragm tweeter. Maximum power 110 watts; frequency response 30-30,000 Hz; impedance 5 ohms; crossover point at 1,500 Hz. Standard finish dark oak. 10 x 15 x 10 in; 20 lb. \$900/pr

PP-140 3-Way Speaker

Bass-reflex speaker. Power handling 90 watts continuous average; frequency response 30-25,000 Hz; sensitivity 90 dB SPL/W/m; impedance 4 ohms; crossover points at 600 and 5,000 Hz. Standard finish black oak. 11 x 20 1/2 x 10 1/2 in; 27 lb \$700/pr
PP-140S. As above, tower speaker. 10 1/2 x 33 1/2 x 10 1/2 in. \$800/pr

PP-120 3-Way Speaker

Bass-reflex speaker. Power handling 80 watts continuous average; frequency response 30-25,000 Hz; sensitivity 88 dB SPL/W/m; impedance 4 ohms; crossover points at 700 and 5,000 Hz. Standard finish black oak. 10 x 17 1/2 x 9 in; 22 lb \$500/pr
PP-120S. As above, tower speaker. 10 1/2 x 30 1/2 x 9 1/2 in. \$600/pr

PP-80 3-Way Speaker

Bass-reflex speaker. Power handling 60 watts continuous average; frequency response 33-25,000 Hz; sensitivity 92 dB SPL/W/m; impedance 4 ohms; crossover points at 2,000 and 7,000 Hz. Standard finish black oak. 9 1/2 x 15 1/2 x 8 1/2 in; 19 lb . . . \$300/pr

TADDEO

Domestic Monitor One 2-Way Speaker

Reflex speaker with 6-inch polypropylene-cone woofer and 1-inch ferrofluid cooled soft-dome tweeter. Features crossover with 1st order slope; all wiring is discrete and uses heavy gauge audiophile wire; all connections are hand soldered with silver solder; 5-way binding posts. Power range 20-100 watts rms; frequency response 44-22,000 \pm 3 dB; sensitivity 92 dB SPL/W/m; nominal impedance 8 ohms; crossover point 2,000 Hz. 9 x 40 1/2 x 10 3/4 in; 47 lb . . . \$849/pr

TANNOY

Prestige Series

Westminster 3-Way Speaker

Floor-standing dual-concentric speaker with Sync-Source Time Alignment; compound horn enclosure; 15-inch cone woofer; 2-inch compression-horn tweeter. Power handling 200 watts rms; frequency response 18-20,000 Hz \pm 2 dB; sensitivity 96 dB SPL/W/m; impedance 8 ohms; crossover frequency 300/1,000 Hz. Walnut finish. 25 3/4 x 37 1/2 x 15 3/4 in; 253 lb, 9 oz each. \$9,495/pr

SPEAKERS

RHR 2-Way Speaker

Floor-standing dual concentric high-compliance speaker with Sync-Source Time Alignment. Features rear folded-horn rectangular exponential section; direct-radiating front section; 250 watts maximum power handling; sensitivity 92 dB SPL/W/m; nominal impedance 8 ohms; frequency response 35-20,000 Hz \pm 4 dB; hard-wired passive crossover at 1,000 Hz. Walnut finish. 27 $\frac{3}{8}$ x 48 $\frac{7}{8}$ x 22 $\frac{3}{4}$ in; 165 lb, 5 oz each. \$8,995/pr

Guy R. Fountain Memory 2-Way Speaker

Floor-standing dual-concentric speaker with Sync-Source Time Alignment; quadruple-ducted-port enclosure; 15-inch cone woofer; 2-inch compression-horn tweeter. Power handling 200 watts rms; frequency response 29-20,000 Hz \pm 3 dB; sensitivity 95 dB SPL/W/m; nominal impedance 8 ohms; crossover frequency 1,000 Hz. Walnut finish. 31 x 43 x 19 in; 136 lb each. \$5,995/pr

Edinburgh 2-Way Speaker

Floor-standing dual-concentric speaker with Sync-Source Time alignment; distributed port reflex enclosure; 12-inch cone woofer; 2-inch compression horn tweeter. Power handling 180 watts rms; frequency response 30-20,000 Hz \pm 3 dB; sensitivity 92 dB SPL/W/m; impedance 8 ohms; crossover frequency 1,200 Hz. Walnut finish. 25 $\frac{1}{2}$ x 40 x 16 $\frac{1}{2}$ in; 97 lb each. \$4,995/pr

Stirling 2-Way Speaker

Floor-standing dual-concentric speaker with Sync-Source Time Alignment; dual variable-distributed enclosure; 10-inch cone woofer; 2-inch compression-horn tweeter. Power handling 150 watts rms; frequency response 35-20,000 Hz \pm 3 dB; sensitivity 93 dB SPL/W/m; impedance 8 ohms; crossover frequency 1,200 Hz. Walnut finish. 20 $\frac{1}{2}$ x 33 $\frac{1}{2}$ x 15 in; 48 lb, 8 oz each. \$3,995/pr

Series 90

DC3000 3-Way Speaker

Floor-standing speaker with coupling spikes. Features 8-inch dual concentric DMT driver; 8-inch bass unit, driven below 400 Hz; slotted-port system. Bi-wired, gold terminals; cross-braced driver and cabinet; wired with van den Hul cable. Power handling 175 watts rms; frequency response 30-25,000 Hz \pm 3 dB; sensitivity 92 dB SPL/W/m; nominal 6 ohms; crossover frequency 400/2,300 Hz. Black-ash or rosewood veneers. 6 $\frac{1}{2}$ x 22 $\frac{3}{4}$ x 7 $\frac{1}{2}$ in; 58 lb, 14 oz ea. \$1,900/pr

J95 3-Way Speaker

Floor-standing speaker with coupling spikes. Features 8-inch polyolefin co-polymer bass driver, 8-inch polyolefin co-polymer bass/mid driver, driven below 400 Hz, and a 1-inch DMT aluminum-dome tweeter. Bi-wired, gold terminals; closed box system; cross braced driver and cabinet; van den Hul cable. Power handling 125 watts rms; frequency response 30-20,000 Hz \pm 3 dB; sensitivity 90 dB SPL/W/m; nominal impedance 8 ohms; crossover frequency 400/3,000 Hz. Black-ash or rosewood veneers. 6 $\frac{1}{2}$ x 22 $\frac{3}{4}$ x 7 $\frac{1}{2}$ in; 52 lb each. \$1,500/pr

DC2000 3-Way Speaker

Floor-standing speaker with coupling spikes. Features 8-inch dual concentric DMT driver; 8-inch bass unit, driven below 400 Hz; closed box system. Bi-wired, gold terminals; cross-braced driver and cabinet. Power handling 150 watts rms; frequency response 44-25,000 Hz \pm 3 dB; sensitivity 92 dB SPL/W/m; nominal 6 ohms; crossover frequency 400/2,300 Hz. Black-ash veneers. 6 $\frac{1}{2}$ x 17 $\frac{7}{8}$ x 6 $\frac{3}{8}$ in; 43 lb, 14 oz each. \$1,300/pr

J30 2-Way Speaker

Floor-standing speaker with coupling spikes. Features 8-inch polyolefin co-polymer bass driver, 8-inch polyolefin co-polymer Auxiliary Bass Radiator

(ABR), and 1-inch DMT aluminum-dome tweeter; closed box system. Bi-wired, gold terminal; cross-braced drivers and cabinet; wired with van den Hul cable. Power handling 110 watts rms; frequency response 40-20,000 Hz \pm 3 dB; sensitivity 90 dB SPL/W/m; nominal impedance 8 ohms; crossover frequency 3,000 Hz. Black-ash or rosewood finish. 6 $\frac{1}{2}$ x 17 $\frac{7}{8}$ x 6 $\frac{3}{8}$ in; 34 lb, 13 oz each. \$1,075/pr

M20 2-Way Speaker

Floor-standing speaker with 8-inch polyolefin copolymer bass driver, and 1-inch DMT aluminum-dome tweeter; ducted-port system. Bi-wired, gold terminals; cross braced drivers and cabinet; wired with van den Hul cable. Power handling 100 watts rms; frequency response 48-20,000 Hz \pm 3 dB; sensitivity 89 dB SPL/W/m; nominal impedance 8 ohms; crossover frequency 3,000 Hz. Black-ash or rosewood veneers. 6 $\frac{1}{4}$ x 12 $\frac{3}{8}$ x 5 $\frac{1}{8}$ in; 18 lb, 8 oz each. \$900/pr

DC1000 2-Way Speaker

Features 8-inch dual concentric DMT driver; single port source; rigidly braced driver; ducted-port system. Bi-wired, gold terminals. Power handling 120 W rms; frequency response 48-25,000 Hz \pm 3 dB; sensitivity 90 dB SPL/W/m; nominal impedance 8 ohms; crossover frequency 2,300 Hz. Black-ash or rosewood finish. 6 $\frac{1}{4}$ x 12 $\frac{3}{8}$ x 5 $\frac{1}{8}$ in; 17 lb, 14 oz each. \$800/pr

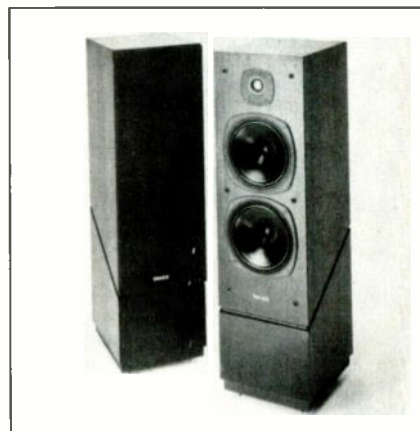

Tannoy J95

M15 2-Way Speaker

Features 8-inch polyolefin co-polymer bass driver, and 1-inch DMT aluminum-dome tweeter; ducted-port system. Bi-wired. Power handling 100 watts rms; frequency response 48-20,000 Hz \pm 3 dB; sensitivity 89 dB SPL/W/m; nominal impedance 8 ohms; crossover frequency 3,000 Hz. Black-ash or rosewood finish. 6 $\frac{1}{4}$ x 12 $\frac{3}{8}$ x 5 $\frac{1}{8}$ in; 15 lb, 7 oz/ea. \$650/pr

E11 2-Way Speaker

Features 6 $\frac{1}{2}$ -inch polyolefin co-polymer bass driver, and 1-inch DMT aluminum-dome tweeter; ducted-port system. Bi-wired. Power handling 90 watts rms; 20,000 Hz \pm 3 dB; sensitivity 88 dB SPL/W/m; nominal impedance 8 ohms; crossover frequency 3,000 Hz. Black-ash finish. 5 $\frac{1}{4}$ x 9 $\frac{3}{4}$ x 5 $\frac{1}{8}$ in; 10 lb, 8 oz each. \$425/pr

Comet Series

C-10 2-Way Speaker

Features 10-inch polycone woofer; 1-inch dome tweeter; high-density particle-board cabinet. Power handling 125 watts rms; frequency response 47-20,000 Hz \pm 3 dB; nominal impedance 8 ohms; sensitivity 91 dB SPL/W/m; crossover frequency 2,300 Hz. 12 x 24 x 11 $\frac{1}{2}$ in; 27 lb each. \$569/pr

C-8 2-Way Speaker

Features 8-inch polycone woofer; 1-inch dome tweeter;

high-density particle-board cabinet. Power handling 100 watts rms; frequency response 55-20,000 Hz \pm 3 dB; nominal impedance 8 ohms; sensitivity 90 dB SPL/W/m; crossover frequency 2,400 Hz. 10 $\frac{1}{4}$ x 19 x 9 in; 17 lb, 8 oz each. \$459/pr

C-6 2-Way Speaker

Features 6 $\frac{1}{2}$ -inch polycone woofer; $\frac{3}{4}$ -inch dome tweeter; high-density particle-board cabinet. Power handling 100 watts rms; frequency response 59-20,000 Hz; nominal impedance 8 ohms; sensitivity 87 dB SPL/W/m; crossover frequency 2,600 Hz. 8 x 11 $\frac{1}{8}$ x 8 $\frac{1}{2}$ in; 10 lb each. \$349/pr

TC AUDIO

1A Subwoofer/Satellite System

System with Sub1A subwoofer and Sat 1A satellites. Includes S28 stands. \$997

TC 55 3-Way Tower Speaker

Speaker with 10-inch flaired-neck copolymer-resin-cone woofer, 5-inch treated midrange, and 1-inch liquid-cooled dome tweeter. Features 10-inch subwoofer radiator. Power range 15-200 watts rms; frequency response 30-20,000 Hz \pm 3 dB; sensitivity 91 dB SPL/W/m; impedance 4 ohms. Real-oak cabinets. 13 x 32 x 13 $\frac{3}{4}$ in. \$718/pr

TC 35 3-Way Speaker

3-way floor-standing speaker with 8-inch flaired-neck copolymer-resin-cone woofer, 5-inch treated midrange, and 1-inch liquid-cooled dome tweeter. Power handling 15-200 watts rms; frequency response 44-20,000 Hz \pm 3 dB; sensitivity 91 dB SPL/W/m; impedance 4 ohms. Real-oak cabinets. Dimensions: 12 x 24 x 10 in. \$558/pr

Sat 1A Satellite System

Two satellites with two 5-inch treated midranges and 1-in liquid-cooled dome tweeter. Power handling 20-200 watts rms; frequency response 175-20,000 Hz \pm 3 dB; sensitivity 93 dB SPL/W/m; impedance 4 ohms. Dimensions: 6 x 16 x 5 $\frac{1}{4}$ in. \$499

TC 30 2-Way Bookshelf Speaker

Bookshelf speaker with 8-inch flaired-neck copolymer-resin-cone woofer and 1-inch liquid-cooled dome tweeter. Power range 15-150 watts rms; frequency response 53-20,000 Hz \pm 3 dB; sensitivity 92 dB SPL/W/m; impedance 4 ohms. Real-oak cabinets. 11 $\frac{1}{8}$ x 15 $\frac{7}{8}$ x 9 $\frac{1}{2}$ in. \$429/pr

Sub 1A Subwoofer

Subwoofer with 10-inch flaired-neck copolymer-resin-woofer and 10-inch subwoofer radiator. Power range 20-200 watts rms; frequency response 32-175 Hz \pm 3 dB; sensitivity 93 dB SPL/W/m; impedance 4 ohms. 17 $\frac{1}{2}$ x 16 x 17 $\frac{1}{2}$ \$399 each

TC 15 2-Way Bookshelf Speaker

Bookshelf speaker with 6 $\frac{1}{2}$ -inch flaired-neck copolymer-resin-cone woofer and 2 $\frac{1}{2}$ -inch tweeter. Power range 10-100 watts rms; frequency response 58-19,000 Hz \pm 3 dB; sensitivity 92 dB SPL/W/m; impedance 4 ohms. Real-oak cabinets. 10 x 12 x 7 in. \$279/pr

TCS 10 2-Way Bookshelf Speaker

Bookshelf speaker with 5 $\frac{1}{4}$ -inch polymer woofer and 2 $\frac{1}{2}$ -inch liquid-cooled tweeter. Power range 10-75 watts rms; frequency response 65-19,000 Hz \pm 3 dB; sensitivity 93 dB SPL/W/m; impedance 4 ohms. Finished in textured black. Includes brackets for wall-mounting. 11 $\frac{3}{8}$ x 6 $\frac{3}{8}$ x 8 $\frac{3}{8}$ in. \$229/pr

Speaker Stands

S28, 28-inch high oak pedestals for SAT 1A, TC 15 or TC 30. \$99
S15, 15-inch high oak pedestals for TC 15, or TC 30. \$59
SSAO, Angled stands for TC 30 or TC 35. \$39

SPEAKERS

TDL

Reference Standard 4-Way Speaker

Floor-standing, dual transmission-line bass, 6-sided speakers. Feature two 6-inch mid-range units loaded by their own transmission-line; two 12-inch x 8-inch woofers; two 1-inch tweeters mounted symmetrically in-line around the central 3/4-inch super-tweeter; two sets of input terminals for bass and mid and upper frequencies. Frequency response 16-35,000 Hz; minimum power 50 watts; nominal impedance 8 ohms; sensitivity 87 dB/W/m; crossover frequency 200/3,500/13,000 Hz. Black or walnut finish. 14 x 30 3/8 x 12 3/8 in.; 154 lb; 6 oz each. \$6,995/pr

Monitor 4-Way Speaker

Floor-standing, transmission-line speakers. Features full transmission-line loading around 12-inch x 8-inch bi-radial woofer; solid polystyrene diaphragm with glass-fibre reinforcing; midrange unit 6-inch doped polymer cone; 1-inch magnesium-alloy metal-dome tweeters; 3/4-inch chemical-dome ferrofluid controlled super-tweeter; magnets have vented poles; 2-pairs of input terminals for bass frequencies and for mid & high frequencies. Frequency response 18-35,000 Hz; minimum power 40 watts; nominal impedance 8 ohms; sensitivity 87 dB SPL/W/m; crossover frequency 300/3,500/13,000 Hz. Walnut with gold trim and brown grille, or black with silver trim and black grille. 7 1/2 x 29 3/8 x 11 3/4 in.; 103 lb, 10 oz ea. \$4,595/pr

Studio 3 2-Way Speaker

Transmission-line speakers. Feature two doped Cobex cone, 8-inch vented pole woofers; 1-inch magnesium alloy, suspended metal-dome, ferrofluid tweeter with separate rear chamber. Frequency response 20-20,000 Hz; minimum power 30 watts; nominal impedance 8 ohms; sensitivity 87 dB/W/m; crossover frequency 3,000 Hz. Walnut or black finish. 7 1/2 x 24 3/8 x 10 3/8 in.; 59 lb, 9 oz each. \$1,995/pr
Studio 2. Similar to Studio 3 except 1 Cobex cone woofer; frequency response 24-20,000 Hz; 6 3/4 x 22 1/8 x 9 3/8 in.; 44 lb, 9 oz each. \$1,545/pr
Studio 1. Similar to Studio 2, 6 3/4-inch bass/midrange unit. Frequency response 28-20,000 Hz; sensitivity 86 dB SPL/W/m. 5 7/8 x 18 1/8 x 8 3/8 in. \$1,445/pr

Super Compact 2-Way Speaker

Reflex system speakers. Feature 8 1/4-inch doped Cobex cone, vented pole woofer; 1-inch magnesium alloy metal-dome tweeters with separate rear chamber. Frequency response 28-20,000 Hz; minimum power 25 watts; nominal impedance 8 ohms; sensitivity 87 dB/W/m; crossover frequency 3,000 Hz. Walnut or black finish. 6 3/4 x 12 1/2 x 7 3/4 in.; 52 lb, 13 oz/pr. \$1,095/pr
Compac Compact 2-Way Speaker. Similar to Super compact loudspeakers except 6 3/4-inch doped Cobex cone woofers; frequency response 30-20,000 Hz; minimum power 20 watts; sensitivity 86 dB/W/m; 5 3/4 x 11 x 7 1/8 in.; 44 lb, 2 oz/pr. \$935/pr

TEAC

ST-X5 3-Way Speaker

3-way floor-standing acoustic-suspension speaker with 10-inch polypropylene, carbon-filled cone woofer, 5-inch polypropylene, carbon-filled cone midrange, and 3/4-inch titanium dome ferrofluid-cooled tweeter. Power handling 90 watts; impedance 6 ohms; SPL 90 dB/W/m; crossover frequencies at 1,200 and 6,000 Hz; frequency response 45-22,000 Hz ± 3 dB. 13 1/4 x 29 1/2 x 8 1/4 in.; 29 lb. \$480/pr

ST-X3 2-Way Bookshelf Speaker

2-way acoustic-suspension speaker with 8-inch polypropylene, carbon-filled cone woofer and 3/4-inch titanium-dome ferrofluid-cooled tweeter. Power handling 65 watts; nominal impedance 6 ohms; SPL 89 dB/W/m; crossover frequency 1,500 Hz; frequency response 55-22,000 Hz ± 3 dB. Dimensions: 11 1/2 x 19 1/2 x 7 1/2 in. Weight: 16 lb. \$320/pr

ST-X1 2-Way Bookshelf Speaker

2-way acoustic-suspension speaker with 6 1/2-inch polypropylene, carbon-filled cone woofer and 3/4-inch titanium dome ferrofluid-cooled tweeter. Power handling 40 watts; impedance 6 ohms; SPL 89 dB/W/m; crossover frequency 2,000 Hz; FR 60-22,000 Hz ± 3 dB. 10 x 14 1/2 x 7 in.; 10 lb. \$230/pr

TECHNICS

SB-RX50 2-Way Bookshelf Speaker

2-way bass-reflex speaker with 9 1/2-inch flat-diaphragm woofer and coaxial 1 1/8-inch flat-diaphragm tweeter. Power handling 160 watts; frequency response 30-48,000 Hz at 16 dB below average level; sensitivity 87 dB SPL/W/m; impedance 6 ohms. 11 1/8 x 18 3/8 x 11 1/8 in.; 36.4 lb. Wood finish. \$1,220/pr

SB-CX700 3-Way Speaker

3-way speaker with composite Mica cone-type 12-inch woofer, pure Mica cone-type 4-inch midrange, pure Mica 1-inch dome tweeter, and 13-inch cone-type passive radiator. Features rigid non-diffractive cabinet; vertical in-line speaker unit alignment; tweeter attenuator; auto reset thermal relay protection for the tweeter. Power handling 200 watts, 100 watts DIN; sensitivity 90 dB SPL/W/m; frequency response 25-45,000 Hz (at 16 dB below average level); impedance 6 ohms; crossover frequencies 400 Hz and 3,500 Hz. Dimensions: 14 3/8 x 35 1/2 x 12 1/4 in. Weight: 51.8 lb. \$700/pr

SB-CX500 3-Way Speaker

3-way speaker with composite Mica cone-type 10-inch woofer, pure Mica cone-type 4-inch midrange, pure Mica 1-inch dome tweeter, and 11-inch cone-type passive radiator. Features vertical in-line speaker unit alignment. Power handling 150 watts, 75 watts DIN; sensitivity 89 dB SPL/W/m; frequency response 28-45,000 Hz (at 16 dB below average level); impedance 6 ohms; crossover frequencies 500 Hz and 3,500 Hz. 12 3/8 x 32 1/4 x 12 1/4 in.; 37 lb. \$600/pr

SB-RX30 2-Way Bookshelf Speaker

Bass-reflex speaker with 9-inch flat-diaphragm woofer and 1 1/8-inch flat-diaphragm coaxial tweeter. Features magnetic shielding for placement near TV's. Power 120 watts; frequency response 44-30,000 Hz at 16 dB below average level; sensitivity 88 dB SPL/W/m; impedance 6 ohms. 10 3/8 x 15 x 9 in.; 16.5 lb. Wood finish. \$550/pr

SB-CX300 2-Way Speaker

Bass-reflex speaker with 8-inch composite Mica cone-type woofer and 1-inch pure Mica cone-type dome tweeter. Features in-line speaker unit alignment. Power handling 120 watts, 60 watts DIN; sensitivity 88 dB SPL/W/m; frequency response 38-45,000 Hz (at 16 dB below average level); impedance 6 ohms; crossover frequency 1,500 Hz. 10 3/8 x 18 1/2 x 10 in.; 17.2 lb. \$400/pr

SB-L96 3-Way Speaker

Bass-reflex speaker with 15-inch cone woofer, 4-inch cone midrange, and 1/2-inch diffuser-equipped cone tweeter. Features linear-phase design for waveform fidelity; aluminum bobbins and heat-resistant voice coils for high power handling; non-resonant fabric dust caps. Power handling 200 watts; frequency response 32-22,000 Hz at 16 dB below average level; sensitivity 93 dB SPL/W/m; impedance 8 ohms. 17 3/4 x 31 3/8 x 12 7/8 in.; 35.9 lb. Simulated woodgrain finish. \$340/pr

SB-C250 2-Way Speaker

2-way compact speaker with 7-inch crystallized Mica polypropylene-diaphragm cone woofer and 1-inch dome tweeter. Power handling 100 watts. 9 1/8 x 14 3/8 x 8 in. \$340/pr

SB-L76 3-Way Speaker

Bass-reflex speaker with 12-inch woofer, 4-inch midrange, and 2 1/8-inch tweeter. Features aluminum

bobbins and heat-resistant voice coils for high power handling; non-resonant-fabric dust caps. Power 150 watts; frequency response 33-22,000 Hz at 16 dB below average level; sensitivity 92 dB SPL/W/m; impedance 8 ohms. 14 1/4 x 27 1/8 x 12 7/8 in.; 23.8 lb. Simulated woodgrain finish. \$260/pr

SB-L56 3-Way Speaker

Bass-reflex speaker with 10-inch cone woofer, 4-inch cone midrange, 2 1/8-inch cone tweeter. Power 120 watts; frequency response 37-22,000 Hz at 16 dB below average level; sensitivity 92 dB SPL/W/m; impedance 8 ohms. 12 3/4 x 25 3/8 x 10 3/8 in.; 18.7 lb. Simulated woodgrain finish. \$200/pr

SB-L36 2-Way Speaker

Bass-reflex speaker with 10-inch cone woofer and 2 1/8-inch cone tweeter. Power 100 watts; frequency response 42-22,000 Hz at 16 dB below average level; sensitivity 92 dB SPL/W/m; impedance 8 ohms. 12 3/4 x 25 3/8 x 9 in.; 16.3 lb. Simulated woodgrain finish. \$130/pr

Micro Series

SB-F2MK2 2-Way Speaker

Sealed-box speaker in die-cast metal enclosure with 5 1/2-inch honeycomb disc woofer and 1 1/4-inch honeycomb disc tweeter. Features switchable 4/8-ohm impedance; resettable thermal relay protection; internal shielding; linear-phase design; protective metal grilles. Tripod mountable. Power handling 100 watts, 50 watts DIN; frequency response 55-33,000 Hz ± 5; sensitivity 88 dB SPL/W/m; impedance 4/8 ohms. 6 1/4 x 10 x 6 3/4 in.; 11 lb. \$390/pr

SB-F1MK2 2-Way Speaker

Sealed-box speaker in diecast metal enclosure with 4 3/4-inch woofer and 1 1/8-inch tweeter. Features switchable 4/8-ohm impedance; resettable thermal relay protection; internal shielding; protective metal grille; linear-phase design. Tripod mountable. Power handling 80 W music, 40 watts DIN; frequency response 65-33,000 Hz ± 5 dB; sensitivity 86 dB SPL/W/m. 5 1/4 x 8 1/2 x 5 3/8 in.; 6.4 lb. \$320/pr

SB-S20 2-Way Bookshelf Speaker

2-way acoustic suspension bookshelf speaker with 4-inch woofer and 1 1/2-inch tweeter. Impedance 8 ohms. \$100/pr

TEI ELECTRONICS

SL280 2-Way Speaker

Floor-standing speaker with 8-inch polypropylene woofer; 1-inch ferrofluid-cooled aluminum-dome tweeter. Features air-core conductors and OFC wire. Power handling 20-150 watts; frequency response 40-25,000 Hz; sensitivity 87 dB; impedance 8 ohms; crossover point 3,000 Hz. Oak-veneer finish. 9 3/4 x 25 x 12 7/8 in.; 37 lb. \$850/pr

SL260 2-Way Speaker

Floor-standing speaker with 6-inch polypropylene woofer; 3/4-inch ferrofluid-cooled aluminum-dome tweeter. Features air-core conductors and OFC wire. Power handling 20-125 watts; frequency response 50-25,000 Hz; sensitivity 86 dB; impedance 8 ohms; crossover point 4,000 Hz. Oak-veneer finish. 8 1/8 x 15 1/2 x 12 7/8 in.; 23 lb. \$600/pr

The listings are based on data provided by the manufacturers. For more product information, contact an authorized dealer or the manufacturer directly. Manufacturers' addresses and phone numbers are listed in the directory beginning on page 258.

SPEAKERS

SL230 Subwoofer/Satellite System

Satellites contain 3/2-inch midrange and 3/4-inch ferrofluid-cooled titanium dome tweeter. Subwoofer contains two down-firing 6-inch drivers. Features satellite protection circuits. Power handling 100 watts; frequency response 50-20,000 Hz; sensitivity 88 dB; impedance 8 ohms; crossover point 200, 3,000 Hz. Satellites have oak-veneer finish; subwoofer finished in black vinyl. Weight 35 lb \$600/pr

THIEL

CS 5 Coherent Source 5-Way Speaker

Floor-standing speaker incorporates the coherent source design utilizing a sloping baffle and electronic correction to achieve proper time alignment and a synthesized first-order acoustic crossover system. Three 8-inch woofer, 5-inch midrange driver, 2-inch upper midrange metal-dome driver, and a tweeter; three-dimensional marble/polymer composite casting baffle; driver diaphragms are made of either aluminum Kevlar or Kevlar/foam sandwich. Power handling 400 watts rms; frequency response 20-22,000 Hz ± 1 dB; sensitivity 87 dB SPL/W/m; impedance 2 ohms. Teak, gloss-black laminate, rosewood, walnut or oak finish. 13 x 64 x 17 in; 180 lb each \$9,700

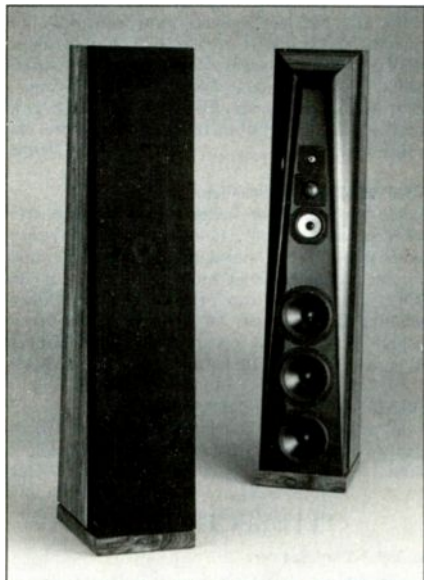

Thiel CS 5

CS 3.5 Coherent Source 3-Way Speaker

Floor-standing electronic-bass-equalized speaker with 10-inch cone woofer, 4-inch cone midrange, and 1-inch dome tweeter. Features complete time coherence by sloping baffle; complete phase coherence by synthesized first-order crossover system; 3-dimensional sculpted anti-diffraction baffle; electronic bass system; magnetic distortion-reducing drivers; cast-magnesium driver chassis; polypropylene crossover capacitors; 30-mm thick cabinet panels; real wood veneer. Power handling 250 watts rms; frequency response 23-20,000 Hz ± 2 dB; sensitivity 89 dB SPL/W/m; impedance 4 ohms. Teak, oak, walnut, black, rosewood finishes. Dimensions: 13 x 42 x 13 in. Weight: 75 lb each \$2,450/pr

CS 2 Coherent Source 3-Way Speaker

Floor-standing ported speaker with 8-inch cone woofer, 3-inch cone midrange, and 1-inch dome tweeter. Completely time and phase coherent. Time coherence achieved with sloping baffle; phase coherence achieved with synthesized first-order crossover networks. Features anti-diffraction grille; cast magnesium driver baskets; polypropylene crossover capacitors. Power handling 250 watts rms; frequency response 38-20,000 Hz ± 2 dB; sensitivity 87 dB SPL/

W/m; impedance 6 ohms. Oak, walnut, black, rosewood, teak finishes. 12 x 39 x 12 in; 62 lb each \$1,650/pr

CS 1.2 Coherent Source 2-Way Speaker

2-way floor-standing speaker with sloping baffle. Features metal dome tweeter. Woofer features cast magnesium chassis; polypropylene diaphragm; sculpted speaker grille; Power handling 150 watts rms; frequency response 52-18,000 Hz ± 2 dB; sensitivity 87 dB sound pressure level/W/m; impedance 8 ohms; heavy internal bracing. Finished with teak, walnut, oak, rosewood, or black laminate. Dimensions: 11 x 37 x 11 in. Weight: 47 lb each \$1,090

TRIAD DESIGN

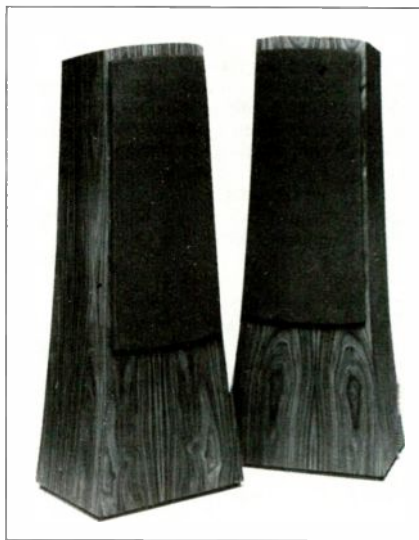

Triad System 10

System Ten 3-Way Speaker

Features 10-inch paper cone woofer with patent pending 1/2-in voice coil/magnet assembly, 4-inch paper-cone midrange with patent-pending voice coil/magnet assembly, and 1-inch paper-dome tweeter with patent-pending voice coil/magnet assembly. Power handling 300 watts continuous; FR 36-18,000 Hz ± 2 dB; sensitivity 89 dB SPL/W/m; nom imp 8 ohms; crossover frequency 900/4,400 Hz. Light oak, medium oak, walnut veneer, black or white finish. Rosewood, teak, zebrawood and other exotic veneer available at extra cost \$2,500/pr

System Four Woofer/Satellite system

System consisting of System Four Satellite units and System Four Woofer units. Designed for floor placement with satellites on top of the woofers. Features 1-in ferrofluid-cooled dome tweeter and 8-inch polypropylene cone woofer for each satellite, two 8-inch polypropylene cone woofer for each woofer system with a built-in 100 watts (into 4 ohms) amplifier. Satellites system: power handling 100 watts continuous; frequency response 70-18,000 Hz ± 3 dB; sensitivity 90 dB SPL/W/m; impedance 8 ohms; crossover frequency 2,000 Hz. Woofer system: frequency response 39-110 Hz ± 3 dB; input impedance of speaker level 1,000 ohms; input impedance of line level 47,000 ohms; magnetic shielding available at extra cost. Light oak, medium oak, walnut veneer, black, or white finish; rosewood, teak, zebrawood. Satellite: 11 x 18 x 10 in. Woofer system: 14 1/2 x 14 x 13 in \$1,400/system
System Four Satellites \$550/pr
System Four Woofer \$425 each

System Seven Woofer/Satellite System

System consisting of System Seven Satellite units and

System Seven Woofer unit. Features 1-inch ferrofluid cooled dome tweeter and 5-inch cast basket, treated paper-cone midrange for each satellite. 12-inch polypropylene-cone woofer for the woofer system with a built-in 70 watts (into 8 ohms) amplifier. Satellites system: power handling 100 watts continuous; frequency response 140-20,000 Hz ± 2 dB; sensitivity 88 dB SPL/W/m; impedance 8 ohms; crossover frequency 2,500 Hz. Woofer system: frequency response 28-110 Hz ± 3 dB; input impedance of speaker level 1,000 ohms; input impedance of line level 47,000 ohms. Light-oak, medium-oak, walnut veneer, black, white, red, yellow, blue or green finish; rosewood, teak, zebrawood and other exotic veneer available at extra cost. Satellite: 5 1/2 x 10 x 5 1/2 in. Woofer system: 13 x 13 x 13 in. \$900/system
System Seven Satellites \$450/pr
System Seven Woofer \$450 each
System Seven Stands, 28 in high. Spike feet. Black or white finish \$100/pr

System Six Woofer/Satellite System

System consisting of System Six Satellite units and System Six Woofer unit. Features 3/4-inch ferrofluid cooled mylar dome tweeter and 3/2-inch treated paper-cone midrange for each satellite, 8-inch polypropylene-cone woofer for the woofer system with a built-in 70 W (into 8 ohms) amplifier. Satellites system: power handling 70 watts continuous; frequency response 165-20,000 Hz ± 2 dB; sensitivity 89 dB SPL/W/m; impedance 8 ohms; crossover frequency 3,200 Hz. Woofer system: frequency response 40-140 Hz ± 3 dB; input impedance of speaker level 1,000 ohms; input impedance of line level 47,000 ohms. Light-oak, medium-oak, walnut veneer, black, white, red, yellow, blue or green finish; rosewood, teak, zebrawood and other exotic veneer available at extra cost. Satellite: 4 x 7 x 4 in. Woofer system: 10 1/4 x 10 1/4 x 10 1/4 in \$600/system
System Six Satellites \$300/pr
System Six Woofer \$300 each
System Six Stands, 27 in high. Spike feet. Black or white finish \$70/pr

In-Wall Speaker

System Seven In-Wall Woofer/Satellite System

System consisting of In-wall System Seven Satellite units and In-wall System Seven Woofer unit. Features 1-inch ferrofluid-cooled, fabric-dome tweeter, 5-inch cast basket, treated paper-cone midrange for the satellite, 12-inch polypropylene-cone woofer with a built-in 70 watts amplifier for the woofer unit. Satellite: power handling 100 watts continuous; frequency response 120-20,000 Hz; sensitivity 89 dB SPL/W/m; nom impedance 6 ohms; crossover frequency 2,500 Hz. Woofer: frequency response 38-120 Hz ± 3 dB; nom impedance 8 ohm. Satellite unit: 7 1/4 x 10 3/4 x 4 in. Woofer unit: 14 1/4 x 19 7/8 x 6 in \$900/system
System Seven In-Wall Woofer \$450

System Six In-Wall Woofer/Satellite System

System consisting of In-wall System Six Satellite units and In-wall System Six Woofer unit. Features 3/4-inch ferrofluid-cooled mylar-dome tweeter, 3/2-inch treated paper-cone midrange for the satellite, 8-inch polypropylene-cone woofer with a built-in 70 watts amplifier for the woofer unit. Satellite: power handling 50 watts continuous; frequency response 160-20,000 Hz; sensitivity 89 dB SPL/W/m; nom impedance 6 ohms; crossover frequency 3,200 Hz. Woofer: frequency response 42-160 Hz ± 3 dB; nom impedance 8 ohm. Satellite unit: 5 3/4 x 7 3/4 x 4 in. Woofer unit: 14 1/4 x 14 1/4 x 4 in \$600/system
System Six In-Wall Woofer \$300

VECTOR RESEARCH

All Vector Research speakers feature anti-resonant one-piece woofer baskets; mid- and high-frequency drivers with ferrofluid damping; soft-dome tweeters; bass-reflex design; 8-ohm impedance; light-oak finish.

SPEAKERS

VSP-124 4-Way Speaker

Features 12-inch woofer; 5-inch midrange; 1-inch tweeter; 12-inch passive radiator. Power handling 250 watts continuous; sensitivity 92 dB SPL/W/m. 14½ x 39¼ x 12½ in; 47 lb ea. \$520/pr

VSP-123 3-Way Speaker

Features 12-inch woofer; 5-inch midrange; 1-inch tweeter. Pwr range 250 watts continuous; sens 92 dB SPL/W/m. 14½ x 27½ x 11½ in. \$400/pr

VSP-102 2-Way Speaker

Features 10-inch woofer; 1-inch tweeter. Power range 120 watts continuous; sensitivity 90 dB SPL/W/m. 13 x 27 x 11 in. \$300/pr

VSP-82 2-Way Speaker

Features 8-inch woofer; 2-inch tweeter. Power range 60 watts continuous; sensitivity 89 dB SPL/W/m. 10¾ x 18¾ x 8¾ in; 15 lb each \$160/pr

VELODYNE ACOUSTICS

ULD-18 Powered Subwoofer

Floor-standing subwoofer with servo-controlled long-throw 18-inch driver with ¾-inch peak-to-peak linear travel; 400-W amplifier. Level control to match subwoofer output to satellite speaker output. frequency response 15-85 Hz ± 3 dB; crossover at 85 Hz. Walnut, oak, or black finish. Cabinet: 23 x 31 x 22 in; amp: 17 x 3½ x 11 in \$2,595

ULD-15. As ULD-18 but with 15-inch driver and 17 x 22 x 18 in cabinet. output capability 109 dB at 32 Hz \$1,795

ULD-12 Powered Subwoofer

12-inch servo-controlled down-firing driver with 100-W rms Class B amplifier. Passive crossover at 85 Hz. Line- or speaker-level connection; subsonic filter -3 dB at 15 Hz; frequency response 18-85 Hz ± 3 dB. Walnut, oak veneer, or black finish. Cabinet: 16 x 17 x 21 in; controller 8 x 1½ x 6 in; 32 lb \$1,195

Servo 1200 Powered Subwoofer

Powered subwoofer features integrated class A/B amp; 12-inch woofer. Passive crossover at 85 Hz; active crossover adjustable from 60 Hz to 100 Hz. Power handling 100 watts continuous; frequency response 25-100 Hz; THD < .5%. Black finish. 2 year warranty. 18¼ x 16 ¼ x 18¼; 60 lb. \$895

Servo 1200 Powered Subwoofer

Powered subwoofer features integrated Class A/B amp; 12- and 10-inch drivers. Passive crossover. power handling 100 W cont; FR 25-100 Hz; THD < .5%; crossover at 45 Hz. Black, vinyl wood-grain finish. 18¼ x 16 ¼ x 18¼; 40 lb. \$645

Passive Crossover/Bypass

High-pass crossover with bypass capabilities for ULD-18 ULD-15. 7 x 1½ x 6 in \$195

VENTURI BY BIC AMERICA

All Venturi speakers are vented. They have horizontal cross-bracing, gold 5-way binding posts, 5-year warranty, and are offered in medium-oak and black finishes.

Venturi V830 3-Way Speaker

Speaker with 8-inch carbon-impregnated polypropylene woofer, 6-inch cast-frame polycarbonate midrange, and a 1-inch ferrofluid cooled poly laminate soft-dome tweeter. Features a segmented cabinet with 1½-inch high-density dividing plate; spikes for floor coupling. Power handling 30-250 watts; frequency response 40-22,000 Hz ± 3 dB; sensitivity 91 dB SPL/W/m; impedance 8 ohms; crossover points 1,000 and 5,000 Hz. 10¼ x 40 x 11½ in; 45 lb each \$799/pr

Venturi 630 3-Way Speaker

Speaker with 6-inch woofer, 6-inch polycarbon mid-

range, and 1-inch poly laminate soft-dome tweeter. Power handling 20-150 watts; frequency response 49-22,000 Hz ± 3 dB; sensitivity 90 dB SPL/W/m; impedance 6 ohms; crossover points 1,500 and 5,000 Hz. 9 x 34 x 11 in; 37 lb each \$599/pr

Venturi V820 2-Way Speaker

Speaker with 8-inch woofer and 1-inch poly laminate soft-dome tweeter. Power handling 20-150 watts; frequency response 40-22,000 Hz ± 3 dB; sensitivity 91 dB SPL/W/m; impedance 8 ohms; crossover point at 2,500 Hz. 10 x 27 x 12 in; 29 lb/ea. \$439/pr

Venturi V620 2-Way Speaker

Speaker with 6-inch woofer and ¾-inch poly laminate soft-dome tweeter. Power handling 20-100 watts; frequency response 49-20,000 Hz ± 3 dB; sensitivity 90 dB SPL/W/m; impedance 8 ohms; crossover point 3,000 Hz. 9 x 23 x 11 in; 24 lb/ea. \$329/pr

Venturi V62 2-Way Bookshelf Speaker

Bookshelf speaker with 6-inch woofer and ¾-inch poly laminate tweeter. Min power 20 watts; frequency response 52-20,000 Hz ± 3 dB; sensitivity 90 dB SPL/W/m; impedance 8 ohms; crossover 4,000 Hz. 9 x 14 x 9 in; 14 lb each \$199/pr

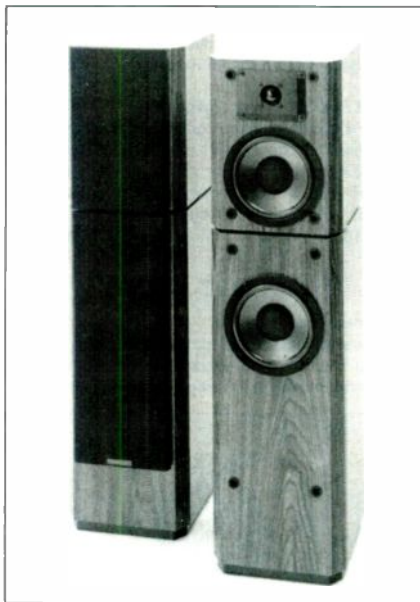

Venturi V830

WHARFEDALE

Coleridge 2-Way Speaker

Features 8-inch mineral filled homogenous of polypropylene 2 (MFHP 2) woofer in two moving coil in alloy housing. 1-inch titanium-dome in alloy housing; cast-aluminum chassis; sandwich mounted bass units; down firing flared reflex port. Gold plated 4-way speaker terminal with bi-wiring option. Power handling 100 watts continuous; frequency response 45-20,000 Hz; sensitivity 89 dB SPL/W/m; nom impedance 8 ohm. Black ash and real wood veneers. 10 x 18¾ x 10½ in \$1,400/pr

Precision Series

All Precision Series woofers are made of mineral-filled polypropylene.

Model 512.2 4-Way Speaker

Features two 8-inch woofers, 4-inch midrange woofer, and ¾-inch metal-dome tweeter; tuned-port enclosure. Power handling 150 watts continuous. frequency response 30-22,000 Hz ± 3 dB; sensitivity 90 dB SPL/W/m; crossovers at 1,000 and 5,000 Hz; nom impedance 8 ohms. Mahogany or black-ash veneer. 11 x 35 x 11 in; 53 lb, 14 oz each \$1,900/pr

Model 510.2 3-Way Speaker

Features 8-inch woofer, 4-inch midrange woofer, and ¾-inch metal-dome tweeter; tuned-port enclosure. Power handling 100 watts continuous; frequency response 35-22,000 Hz ± 3 dB; sensitivity 90 dB SPL/W/m; crossovers at 1,000 and 5,000 Hz; nom impedance 4 ohms. Mahogany veneer or black finish. 11 x 24 x 11 in; 30 lb, 13 oz each \$1,400/pr

Model 507.2 2-Way Speaker

Features 8-inch woofer, and ¾-inch metal-dome tweeter; tuned-port enclosure. Power handling 100 watts continuous; frequency response 40-22,000 Hz ± 3 dB; sensitivity 90 dB SPL/W/m; crossover at 5,000 Hz; nominal impedance 8 ohms; Mahogany veneer or black finish. Dimensions: 10 x 19 x 11 in; 22 lb, 8 oz each. \$940/pr

Model 505.2 2-Way Speaker

Features 8-inch woofer, and ¾-inch metal-dome tweeter; acoustic suspension enclosure. Power handling 100 watts continuous; frequency response 42-22,000 Hz ± 3 dB; sensitivity 87 dB SPL/W/m; crossover at 5,000 Hz; nom impedance 8 ohms. Black finish. 10 x 17 x 9 in; 12 lb each \$560/pr

Model 504.2 2-Way Speaker

Features 4-inch woofer, and ¾-inch metal-dome tweeter; tuned-port enclosure. Power handling 100 watts continuous; frequency response 48-22,000 Hz ± 3 dB; sensitivity 86 dB SPL/W/m; crossover at 3,500 Hz; nom impedance 8 ohms; Mahogany veneer or black finish. 7 x 11 x 8 in; 10 lb each \$400/pr

Delta Series

Delta 90 3-Way Speaker

Features 10-inch woofer, and 4-inch cone midrange, and ¾-inch polyimide, soft-dome tweeter; tuned-port enclosure. Power handling 100 watts continuous; frequency response 35-20,000 Hz ± 3 dB; sensitivity 89 dB SPL/W/m; crossovers at 1,000 and 5,000 Hz; nom impedance 8 ohms. Black oak vinyl finish. 12 x 27 x 9 in; 33 lb each \$700/pr



Wharfedale Coleridge

Delta 70 2-Way Speaker

Features 8-inch woofer, and ¾-inch polyimide, soft-dome tweeter; tuned-port enclosure. Power handling 100 watts continuous; frequency response 40-20,000 Hz ± 3 dB; sensitivity 89 dB SPL/W/m; crossover at 3,500 Hz; nom impedance 8 ohms. Black oak vinyl finish. 11 x 21 x 8 in; 16 lb, 8 oz each \$450/pr

Delta 50 2-Way Speaker

Features 8-inch woofer, and ¾-inch polyimide, soft-dome tweeter; infinite-baffle design. Power handling 100 W; frequency response 45-20,000 Hz ± 3 dB;

A Major Event In The History Of Phased Array Speaker Systems.



The DQ12

is a new Phased Array™ system which provides the open window on the soundstage for which Dahlquist is famous. Images come to life with a vivid, three dimensional feel that truly suggests live sound sources.

The design provides for extremely accurate voice band reproduction by paying special attention to the shape of the mid-top end baffle. In addition, millions of electrostatically aligned fibers adjacent to the tweeter diaphragm control high frequency diffraction at the source.

The mid range system consists of a low distortion, low mass laminate cone operating in an aperiodic loading structure. This provides optimal cone loading and controlled dipolar radiation for accurate depth of field reproduction.

The DQ12 provides the emotional involvement with music, so important for long term satisfaction and enjoyment.



Threaded spiked feet for increased image stability & transparency



Isolated mid-top end baffle for reduced coloration & optimal time alignment

Specifications

Design Type	Woofer Diam.	Midrange Diam.	Tweeter Diam.	Frequency Response
Inf Baffle	8 Inch	5 Inch	1 Inch	35-20 kHz

Recommended Min Amp Power	Crossover Frequencies	Impedance	Dim.
40 Watts	400, 3500	8 nominal 5 min	42" x 16 x 9

Finish: Black With Black Cloth Weight: 42 lbs

Suggested Retail: \$1200/Pair

DAHLQUIST

601 Old Willels Path, Hauppauge, NY 11788
Tel: 516-234-5757 Fax: 516-234-5781

CIRCLE NO. 7 ON READER SERVICE CARD

SPEAKERS

sensitivity 89 dB SPL/W/m; crossover at 5,000 Hz; nom impedance 8 ohms. Black-oak vinyl finish. 10 x 18 x 8 in; 13 lb. 3 oz each \$350/pr

Delta 30 2-Way Speaker

Features 6½-inch woofer, and ¾-inch polyimide, soft-dome tweeter; tuned-port enclosure. Power handling 75 watts continuous; frequency response 45-20,000 Hz ±3 dB; sensitivity 89 dB SPL/W/m; crossover at 5,000 Hz; nom impedance 8 ohms. Black-oak vinyl finish. 8 x 15 x 6 in; 8 lb. 13 oz each \$270/pr

Diamond Series

Ritz Diamond 2-Way Speaker

Features 6½-inch woofer, and ¾-inch polyimide, soft-dome tweeter; tuned-port enclosure. Power handling 100 watts continuous; frequency response 40-22,000 Hz ±3 dB; sensitivity 90 dB SPL/W/m; crossover at 5,000 Hz; impedance 8 ohms. Black-oak vinyl finish. 9 x 14 x 8 in; 17 lb. 10 oz each \$450/pr

Active Diamond Plus 2-Way Speaker

Features 4½-inch woofer, and ¾-inch tweeter; built-in 20-W amp with 3rd-generation monolithic devices; tuned-port enclosure; 5th-order crossover. On/off switch; volume control. frequency response 50-20,000 Hz; crossover frequency 3,500 Hz. Black-oak vinyl finish. 7 x 9 x 8 in; 18 lb each \$350/pr

Diamond MK III 2-Way Speaker

Features 4½-inch woofer, and ¾-inch tweeter; fifth-order crossover; tuned-port enclosure. Power handling 100 watts continuous; frequency response 50-20,000 Hz; 86 dB SPL/W/m; impedance 8 ohms. Black oak vinyl finish. Dimensions: 7 x 9 x 8 in. Weight: 15 lb, 8 oz/ea \$300/pr

WOLCOTT AUDIO

MDF Omnisphere Speaker

Floor-standing bass-reflex speaker uses a single point source of sound with a spherical dispersing surface and four 6½ in polypropylene-cone, butyl-surround

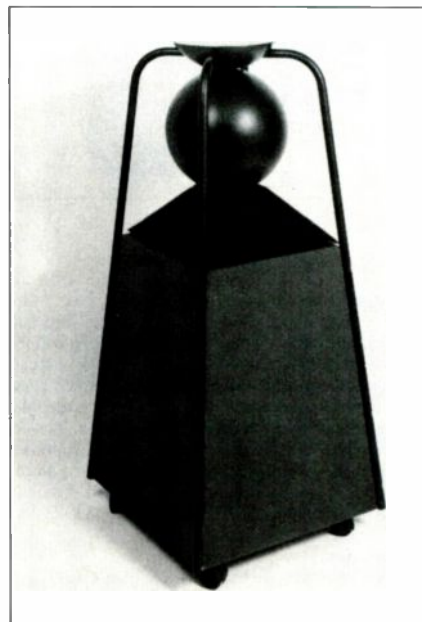

woofers; 1½-inch soft-dome tweeter. Features a vertically aligned tweeter driving the space between opposing, closely spaced 6-inch radius sphere and semisphere forms a radial horn which along with 4 quadrant pyramid-mounted woofer/midrange drivers produces single-point-source omnidirectional dispersion; auto electronic tweeter protection. Power

range 20-250 watts rms; frequency response 30-20,000 Hz ±3 dB sensitivity 90 dB SPL/W/m; impedance 6 ohms. Unit on casters with floor-loaded ports. Oak-veneer finish. 21 (at base) x 49 x 21 (at base); 110 lb \$4,500/pr MDH. Same as MDF except high-gloss black lacquer finish \$4,500/pr

YAMAHA

Monitor Speakers

NS-1 2-Way Speaker

2-way acoustic-suspension speaker with aluminum, nickel, cobalt magnets used in both woofer and tweeter. 6¼-inch mica impregnated polypropylene woofer and 1¼-inch soft, resin-coated, cotton-dome tweeter. Features magnetic shielding; tweeter-level control. Polyurethane coated natural birch cabinet. Power handling 60 watts \$998/pr

NS-10M 2-Way Bookshelf Speaker

Bookshelf speaker with 7-inch singlesheet white-cone woofer. 1¾-inch soft-dome tweeter, acoustic-suspension enclosure, high-efficiency max-sound-dispersion design. Power handling 100 watts; sensitivity 90 dB SPL/W/m. 8½ x 15 x 7¾ in; 30 lb \$398/pr

Active-Servo Speakers

ST-SF90 5-Way Bookshelf Speaker

5-way active-servo speaker for shelf or wall-mounting. Consists of four 4-inch drivers and one 1-inch polydome tweeter. Includes curved metal shelf stands. Depth dimension: 2¾ in \$900/pr

S1 2-Way Speaker

2-way field-isolation system with 6-inch polypropylene multirange driver and 1-inch soft-dome tweeter. Frequency response 28-20,000 Hz. Black... \$700/pr

ST-SV90 2-Way Bookshelf Speaker

2-way verticle active-servo bookshelf speaker with 4¾-inch polypropylene cone and 1-inch soft-dome tweeter. Features magnetic shielding. Weight: 22 lb \$450/pr

Subwoofers

NS-W10 Subwoofer

Woofer system with 8-inch woofer and built-in 60-watt/ch amplifier. Features double-magnet magnetic shielding; 2 section enclosure. Frequency response 80-120 Hz; switchable low-pass filter (18 dB/octave); volume control. 34 lb. \$718/pr

NS-W2 Subwoofer

Features 10-inch woofer; built-in 40-watt amplifier with volume control; magnetic shielding. 17¾ x 14 x 12¾ in; 32 lb. \$578/pr

FFT Series

NS-A7.7 2-Way Speaker

2-way speaker with 7-inch woofer mica polypropylene cone. Features ¾-inch linear phase soft-dome tweeter; crossover with polypropylene capacitors; FFT computer design. \$218/pr

Surround-Sound Speakers

NS-A95 2-Way Surround Sound Speaker

2-way acoustic-suspension surround/effects speaker with 4½-inch long-throw woofer and 2-inch wide-dispersion cone tweeter. Includes mounting bracket and speaker wire. Power handling 5 watts min, 30 watts max; impedance 4 ohms; sensitivity 91 dB SPL/W/m. 9 x 9 x 3½ in. Black. 4.4 lb. \$70/pr NS-A90. As above, white \$70/pr

NS-E90 Surround Speaker

Cosmetically matched to AVS-90M surround-sound amplifier. 9 lb. \$80/pr

HEADPHONES

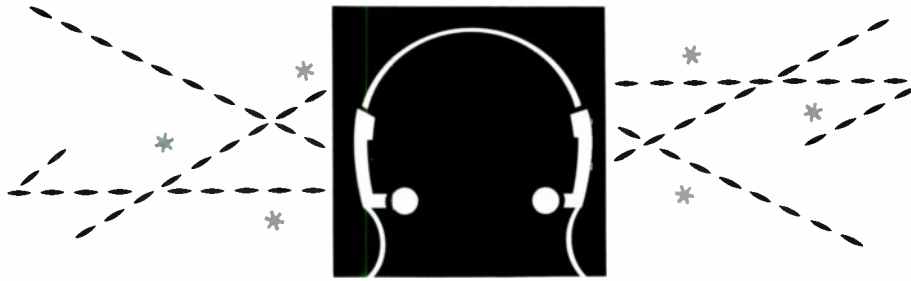

AIWA

HP-X80 Headphones

Closed-type headphones with coiled cord. Samarium-cobalt drivers, 1 $\frac{1}{2}$ -in carbon-disk flat-diaphragms. 180° turn ear pad. 24K gold-plated plug and plug adaptor \$95
HP-X50. As above, double-dome 1 $\frac{1}{2}$ -in driver units. Straight cord \$70
HP-X30. As above, fixed ear pad \$50

HP-A550 Open-Air Headphones

1 $\frac{1}{2}$ -in-diameter double-dome driver units, $\frac{4}{5}$ -in length bass resonator ducts, copper-clad aluminum wire voice coils, 24K gold-plated plug and plug adaptor. Double-enclosed earpad \$33
HP-A350. As above, no double-enclosed earpad \$27

HP-V250 Open-Air Headphones

Walkman-type headphones with 1 $\frac{1}{2}$ -in-diameter driver units. Copper-clad aluminum wire. Double-folding headband, includes plug adaptor \$17
HP-A150. As above, headband does not fold .. \$12

HP-V88 Earphones

Ear-bud type headphones. Samarium-cobalt drivers, double-dome diaphragms, 2 $\frac{3}{8}$ -in bass resonator ducts. 24K gold-plated plug and plug adaptor. Cord-winding carrying case \$80
HP-V57. As above with 1 $\frac{1}{2}$ -in resonator ducts, no plug adaptor. In-line volume control \$35
HP-V53. As above, no volume control \$28
HP-V25. As above, $\frac{3}{8}$ -in diameter speaker. 3 pairs of earpads \$22
HP-V12. As above, no case \$12

AKG ACOUSTICS

K340 Headphones

Two-way electrostatic/dynamic headphones with fixed-charge electrostatic transducer/dynamic moving-coil transducer and passive diaphragms in each earcup. Connects directly to headphone jack of receiver or amplifier or across speaker output terminals. Frequency response 15-25,000 Hz; SPL 117 dB at 0.1% total harmonic distortion; nominal impedance 400 ohms; maximum continuous input 200 mW/channel at 117 dB SPL; includes 10-ft 4-conductor cables with 3-conductor $\frac{1}{4}$ -inch stereo phone plug. Weight: 13 $\frac{1}{2}$ oz less cable \$235

K280 Headphones

Features parabolic-type, dual-transducer design in each earcup; low imp electrical circuit; matches 4-75 ohm outputs. Includes 9 $\frac{3}{4}$ -ft cable, standard stereo-telephone plug. 8 $\frac{3}{4}$ oz \$195

K260 Open-Air Headphones

Open-air, circumaural stereo headphone with dynamic MC transducers. Matches 4-600 ohm outputs. 10-ft cable; standard stereo plug; 9 $\frac{1}{4}$ oz \$170

K240 DF Headphones

Designed with a flat frequency response based on European requirements for reference monitor headphones. FR 20-20,000 Hz ± 2 dB; max input 11 V;

Matches 4-600 ohm outputs; max SPL 95 dB at <0.3% THD; With 8 $\frac{1}{4}$ -ft cable and standard stereo phone plug; 8 $\frac{1}{2}$ oz \$150

K240M Headphones

Free-field stereo headphones; dynamic MC transducer and 6 passive radiators in each circumaural cup. FR 15-20,000 Hz; imp 600 ohms; max SPL 119 dB at 0.3% THD; supplied with 10-ft 4-conductor cable and $\frac{1}{4}$ -in phone plug; 7 $\frac{7}{8}$ oz \$150

K145S Electrostatic Headphones

Two-way semi-open electrostatic headphones. FR 25-24,000 Hz, ± 3 dB; imp 150 ohms; phone connector; 10-ft. long cord; 6 oz \$110

K-141M Headphones

Semi-open stereo dynamic pro monitoring headphones with MC transducers. FR 20-20,000 Hz; max SPL 120 dB at 0.5% THD. imp matches 4-600 ohms; 10-ft 4-conductor cable and standard 3-conductor stereo phone plug; 6 $\frac{7}{8}$ oz \$100

K135S Headphones

Semi-open dynamic headphones. FR 25-18,000 Hz, ± 3 dB; imp 150 ohms; phone connector; 5 $\frac{1}{2}$ oz.; cord 10 ft. long \$80

K130 Headphones

Supra-aural stereo headphones with dynamic MC transducers. FR 20-20,000 Hz; max SPL 119 dB; imp 200 ohms at 0.7% THD; 10-ft 4-conductor cable with 3-conductor stereo phone plug; 4 oz \$70

K55 Headphones

CAD/CAM designed supra-aural stereo headphone with wire-headband construction. Matches 4-150 ohm outputs. Comes with 9 $\frac{3}{4}$ -ft cable; combination standard/mini stereo phone plugs. 3 $\frac{1}{4}$ oz. \$50
K21TV. As above with cable-mounted control box for left/right level adjustment, stereo/mono switch, and dual-channel mode for SAP broadcasts \$60

K45 Headphones

Ultra-lightweight supra-aural stereo headphones with dynamic MC transducers. FR 30-18,000 Hz; max SPL 117 dB at 0.9% THD; matches 4-200 ohm outputs; 10-ft 4-conductor cable; combination standard/mini stereo phone plug; 2 $\frac{3}{4}$ oz \$60

K-2 Mini Headphones

2 MC dynamic transducers; adjustable earcups with washable cushions; matches 4-200 ohm outputs; 9-ft cable; combination standard/mini stereo phone plug; 3 $\frac{1}{4}$ oz. \$45

ALARON (RHAPSODY)

RY-251 Headphones

Samarium cobalt drivers; compact headphone buds; coil-up storage and carrying case; standard stereo jack and mini-plug adaptor. FR 12-24,000 Hz; sens 108 dB SPL/W/m; imp 18 ohms at 1 KHz; cord length 4-ft \$15

RY-252 Headphones

Samarium cobalt; adjustable and folding headband;

standard stereo plug and mini-plug adaptor. FR 16-22,000 Hz \$15

RY-245 Headphones

Headphones for use with portable and home stereos includes $\frac{1}{4}$ -in stereo adaptor plug; 3 $\frac{1}{2}$ -mm mono adaptor plug; 2 extra sets of earpads. \$10
RY-242. As above without accessories \$5

AUDIO-TECHNICA

Sound Guard Series

SG750CD. Full-size, closed-back headphones with full-range, 40-mm mylar drivers; FR 20-20,000 Hz; $\frac{1}{4}$ -in phone-plug connector; 4.7 oz \$50

SG600CD. Mid-size, with closed back. Full-range 40-mm mylar drivers; FR 20-20,000; mini-plug with $\frac{1}{4}$ -in adaptor. 2.8 oz \$40

SG450. "Turbo" stereophones. Bass-vent design; fully adjustable headband; FR 20-20,000 Hz; mini connector with $\frac{1}{4}$ -in adaptor; 0.5 oz \$30

SG430. Micro earbuds with full-range drivers; FR 35-20,000 Hz; mini connector with $\frac{1}{4}$ -in adaptor and extra earpiece covers. 0.3 oz \$25

SG410. Ultra-lightweight mini headphones with polymer dome drivers; FR 40-20,000 Hz; mini connector with $\frac{1}{4}$ -in adaptor; 1.0 oz \$15

ATH910 Headphones

Closed-back headphone with 44-mm samarium-cobalt drivers and oxygen-free copper cable. $\frac{1}{4}$ -in plug. FR 20-22,000 Hz; cord length 9.8 ft; imp 4-16 ohms; sens 100 dB SPL/m/W; 7.2 oz. \$100

ATH909 Headphones

Open-back headphone with 44-mm samarium-cobalt drivers and oxygen-free copper cable. FR 20-20,000 Hz; cord length 9.8 ft; $\frac{1}{4}$ -in plug; imp 4-16 ohms; sens 100 dB SPL/m/W; 6.9 oz \$80

ATH908 Headphones

Open-back headphone with 44-mm samarium-cobalt drivers. FR 20-20,000 Hz; cord length 9.8 ft; $\frac{1}{4}$ -in plug; imp 4-16 ohms; sens 100 dB SPL/m/W; 7.2 oz \$70

AP1400 Headphones

Open-back headphones. Imp 4-16 ohms; FR 20-22,000 Hz; sens 105 dB SPL/W/m; $\frac{1}{4}$ -in phone plug; 10-ft cable; 5.5 oz \$60

AP1300 Headphones

Closed-back headphones. Imp 4-16 ohms; FR 20-20,000 Hz; sens 108 dB SPL/W/m; $\frac{1}{4}$ -in phone plug; 10-ft cable; 5.4 oz \$50

AP1200 Headphones

Open-back headphones. Imp 4-16 ohms; FR 20-20,000 Hz; sens 90 dB SPL/W/m; $\frac{1}{4}$ -in phone plug; 6-ft cable; 3.3 oz \$40

AP1000 Earphones

"Over the ear" hanging earbud. Frequency response 100-15,000 Hz; cord length 4 feet; mini plug. Includes carrying case. 1 oz \$25

HEADPHONES

AZDEN

DM90 Headphones

Features oversized 40-mm drivers; samarium-cobalt magnets; 16-micron polymer and copper-clad aluminum voice coils; gold-plated mini plug; gold-plated adaptor plug for standard jacks. FR 4-26,000 Hz; max input 800 mW; sens 105 dB/mW \$100
DM-70. Similar to above. FR 4-24,000 Hz; max input 500 mW; sens 103 dB/mW \$80

DSR-48 Headphones

Features oversized polymer drivers; gold-plated mini-plug with gold-plug adaptor. FR 15-24,000 Hz; max input 100 mW; sens 97 dB/mW \$70

DSR-18 Headphones

Full-size headphone with coiled cord and gold-plated mini plug with gold-plug adaptor. FR 15-22,000 Hz; max input 200 mW; sens 103 dB/mW \$70

DSR-12 Headphones

Full-size headphone with 1/4-in plug. FR 20-20,000 Hz; max input 100 mW; sens 105 dB/mW \$60

DSR-88 Earphones

In-ear design with samarium cobalt magnets; gold-plated mini-plug with gold adaptor. FR 18-20,000 Hz; max input 100 mW; sens 104 dB/mW \$50

DSR-42 Headphones

Less than 4 oz; mini plug. FR 30-20,000 Hz; max input 100 mW; sens 102 dB/mW \$40

BANG & OLUFSEN

Form 1 Headphones

Dynamic, semi-open headphones. Features lightweight self-adjusting earpads with tension relief pads to remove pressure from ear. FR 20-20,000 Hz, ± 3 dB; imp 35 ohms; mini & phone connector. . . \$120

Form 2 Open-Air Headphones

Dynamic, open headphone. Features lightweight self-adjusting earpads; mini & phone connector. FR 20-20,000 Hz, ± 3 dB; imp 30 ohms \$60

BEYER DYNAMIC

IRS 690 Wireless Headphone System

Wireless infrared headphone system comprised of the DT 690 headphones, IS 690 infrared transmitter and LG-690 power supply. Built-in rechargeable 9V battery, mono-stereo switch, built-in volume control. FR 20-20,000 Hz \$399

DT 48A Headphones

Audiometric-calibration, standard-reference headphones for acoustic measurements. FR 16-20,000 Hz; max power 200 mW; imp 5 ohms. \$320

DT 48 Headphones

Features removable/replaceable ear cushions and 10-ft coiled cable. FR 16-20,000 Hz ± 2 dB; imp 200 ohms; sens 105 dB SPL with 1-mW input at 1,000 Hz; max power 96.8 mW; phone plug; 14 oz without cord. \$300

DT 109 Headphones with Microphone

Headphones with dynamic boom microphone for use in live and remote broadcasting. Features rugged modular construction, available with straight or coiled 10-ft cord in numerous mic and headphone impedances, comfortable for extended wearing. FR 30-20,000 Hz ± 3 dB; imp 400 ohms; sens 94 dB SPL with 1-mW input at 1,000 Hz; max power 1,000 mW; phone plug; 14 1/2 oz with cord. \$232

DT 880 Headphones

Semi-open circumaural headphones with rare-earth magnets. FR 5-25,000 Hz ± 3 dB; imp 600 ohms; sens 94 dB SPL with 1-mW input of 1,000 Hz; max power 100 mW; phone plug; 10-ft cord length \$169

DT 880 Studio. Studio version of the DT 880 for when extremely wide frequency response and long wearing comfort is required. FR 5-35,000 Hz ± 3 dB; all other specs same as DT 880. \$229

DT 990 Headphones

Circumaural stereo headphones with very large, low-mass-diaphragm design. Frequency response equalized to diffuse soundfield method. FR 5-35,000 Hz ± 3 dB; imp 600 ohms; max power 100 mW; sens 96 dB at 1 mV/ch at 1,000 Hz. Includes 1/2-in connector. 8 oz \$209
DT 990 PRO. As above, with heavy-duty construction \$259

DT 108 Headphones with Microphone

Combination single-muff headphone with dynamic boom microphone for live and remote broadcasting. Features rugged modular construction, straight or coiled cord with numerous mic and headphone impedances, designed for extended wearing. FR 30-20,000 Hz ± 3 dB; imp 400 ohms standard; sens 94 dB SPL with 1-mW input at 1,000 Hz; max power 1,000 mW; phone plug; cord length 10-ft coiled or straight; 10.75 oz with cord \$193

DT 770 Headphones

Circumaural stereo headphones with bass-reflex system to improve accuracy and detail of low frequencies. Closed design isolates ambient noise. Frequency response equalized to diffuse soundfield method. Features very large, low-mass-diaphragm design. FR 15-30,000 Hz ± 3 dB; imp 600 ohms; max power 100 mW; sens 96 dB at 1 mV/ch at 1,000 Hz. Includes 1/2-in connector. 9 oz \$189
DT 770 PRO. As above, with heavy-duty construction \$239

DT 100 Headphones

Recording-studio monitor headphones for production and post-production. Features detachable straight or coiled 10-ft cord; available in numerous impedances, modular construction. FR 30-20,000 Hz ± 3 dB; imp 400 ohms; sens 94 dB SPL with 1-mW input at 1,000 Hz; max power 1,000 mW; phone plug; 12 1/2 oz with cord \$172

DT 96A Multi-Purpose Headphones

Headphones used in interpreting installations at conferences and conventions, listening libraries and language labs. Can be used with or without circumaural ear cushions. Features detachable straight or coiled 10-ft cord. Frequency response 30-17,000 Hz ± 3 dB; imp 400 ohms; sens 94 dB SPL with 1-mW input of 1,000 Hz; max power 360 mW; phone plug; 4 oz without cord \$140

DT 102 Single-Muff Headphones

Headphones for broadcast, recording and disco cueing. Features detachable straight or coiled 10-ft cord; available in numerous impedances; modular construction. FR 30-20,000 Hz ± 3 dB; imp 400 ohms; sens 94 dB SPL with 1-mW input at 1,000 Hz; max power 1,000 mW; phone plug; 9 oz without cord. \$115

DT 550 Headphones

Headphones with semi-open, circumaural design. Lightweight, adjustable suspension, 10-ft coiled cord. FR 10-22,000 Hz ± 3 dB; imp 600 ohms; sens 95 dB SPL with 1-mW input at 1,000 Hz; max power 100 mW; phone plug; 7 oz without cord \$145

DT 220 Headphones

Headphones with extremely lightweight, closed design; wide-band drivers; soft circumaural ear cushions. FR 20-20,000 Hz ± 3 dB; imp 400 ohms; sens 102 dB SPL with 1-mW input at 1,000 Hz; max power 100 mW; phone plug; 10 oz without cord \$129

DT 330 MK II Headphones

Semi-open circumaural headphone with rare-earth magnets. FR 15-18,000 Hz ± 3 dB; imp 40 ohms; sens

85 dB SPL with 1-mW input at 1,000 Hz; max power 100 mW; phone plug; cord length 10 ft; 6.75 oz without cord \$89
DT 340TV. As above with 22-ft cable and built-in independent L/R volume control for use with video \$85

DT 320 MK II Headphones

Headphones with semi-open, circumaural design. FR 20-20,000 Hz ± 3 dB; imp 40 ohms; sens 88 dB SPL with 1-mW input at 1,000 Hz; max power 100 mW; mini-connector; 1/2-in phone plug adapter; 10-ft cord length; 3 3/4 oz without cord \$75

DT 303TV Headphones

Lightweight headphones with built-in independent L/R volume controls for use with video \$69

DT 325 Headphones

Designed as a portable tape- or CD-player headphone. FR 20-20,000 Hz; imp 40 ohm; mini-connector with 1/2-in phone adaptor \$65

CARTER-CRAFT

Model 40-416 Mini Headphones

Dynamic headphones features rare-earth magnets with 7-ft cord. Features adjustable headband; soft ear pads. Includes mini and 1/4-in connectors. FR 20-30,000 Hz ± 3 dB; imp 38 ohms. 1.25 oz \$36

Model 40-414 Mini Headphones

Mini-stereo headphones with adjustable foam earpieces. Features 36-mm samarium-cobalt magnets and mylar cones; rotary volume/balance controls; stereo plug with adapter. Imp 32 ohms; max power 100 mW. 2 oz. Black \$27

Model 40-411 Mini Headphones

Features rare-earth magnets with 5-ft cord. Features adjustable headband; soft earpads. Includes mini and 1/4-in connectors. FR 30-20,000 Hz ± 3 dB; imp 32 ohms. 12 oz \$19

Model 40-421 Open-Air Headphones

Dynamic, open-air mini headphones with 5-ft cord and foam earpads. Folds up to store in cassette-sized case (included). Mini connector. 10 oz \$11

Model 40-417 Open-Air Headphones

Dynamic, open-air headphones with 5-ft cord and mini connector. FR 20-20,000 Hz ± 3 dB; imp 32 ohms. 1.5 oz \$11

Model 40-425 Earphones

In-ear-type headphones feature 6-ft cord and molded strain reliefs. Includes mini connector. Imp 8 ohms; max power 300 mW. \$8

Replacement Foam Earpads

Replacement earpads for Carter-Craft headphones

40-405. For 40-399 headphones, 2-pairs. \$2.45
 40-407. For 40-417 headphones \$1.65/pr
 40-409. For use with 40-411 and 40-416 headphones. \$2.15/pr

DENON

AH-D900 Headphones

Features titanium 40-mm diaphragm; samarium-cobalt magnet. Low-resonance plastic housings; soft, oval ear pads; reversible ear cup. FR 3-31,000 Hz; sens 106 dB/mW; max input 1,200 mW; imp 32 ohms. 7.7 oz. \$140
AH-D700. Similar to above, diaphragm is high-polymer film. Input 1,000 mW \$120

AH-D500 Headphones

Features high-polymer-film 40-mm diaphragm; samarium-cobalt magnet. Low-resonance housings; OFC voice coils. FR 4-28,000 Hz; sens 105 dB/mW; imp 32 ohms. 5.25 oz \$80

HEADPHONES

AH-D300. Similar to above, voice coil is copper-clad aluminum wire. \$70

AH-C30 Earphones

Features 15-mm diaphragms; samarium-cobalt magnets. Carrying case has built-in cord reel and storage for headphones and plug. FR 18-22,000 Hz; sens 106 dB/mW; imp 16 ohms. \$35

AH-C6. Similar to above, FR 16-22,000 Hz. \$25

FOSTEX

T20 Studio Headphones

Closed-ear headphones with regular-phase system in planar polyester ribbon drivers (diaphragm suspended between opposing pole magnet assemblies). Deposited spiral voice coil; oversize ear pads; adjustable headband; anisotropic ferrite magnets; diaphragm 1 $\frac{3}{8}$ in; all parts and assemblies secured by screws. Imp 50 ohms; sens 98 dB SPL/W/m; max input 200 mW; max output 119 dB with 200 mW; FR 30-40,000 Hz; 10.6 oz. \$130

T-20. As above with sens 96 dB SPL/W/m and FR 50-30,000 Hz. \$89

HEATH

TE-400 Headphones

Closed-back headphones with titanium elements. Features in-line volume/balance control; full-length coiled cord; $\frac{1}{4}$ -in plug. FR 20-30,000 Hz. 1 lb. \$70

TE-200 Open-Air Headphones

Open-air headphones with titanium elements. Features in-line volume/balance control; full-length coiled cord; $\frac{1}{4}$ -in plug. FR 20-20,000 Hz. 2 lb. \$60

HDP-1396 Headphones

8-ohm headphones with 2 $\frac{1}{4}$ -in speakers, individual volume controls, and 10-in cord. FR 40-15,000 Hz. 2 lb. \$15

INTERNATIONAL COMPONENTS

SHP-600 Headphones

Professional headphones featuring samarium-cobalt magnets and mylar-cone diaphragm. \$31

SHP-400V Headphones

Ultra-slim professional headphones with 6-ft coiled cord and $\frac{1}{4}$ -in phone plug. Features individual left/right volume controls. Brushed black aluminum earcups with chrome trim; leather padded cushions and adjustable headband. FR 20-21,000 Hz; 40-mm mylar-con drivers; max input power 0.5 W; 8 oz. \$25

SHP-500 Headphones

Ultra-slim headphones with 6-ft coiled cord and $\frac{1}{4}$ -in phone plug. Features brushed black aluminum earcups with chrome trim; leather padded cushions and adjustable headband. FR 18-22,000 Hz; 40-mm mylar-con drivers; max input power 0.5 W; 7 oz. \$22

SHP-300 Headphones

Professional featherlight mini folding headphones. Features samarium-cobalt drivers; $\frac{1}{4}$ -in stereo adaptor. Sens 101 dB/W/m (at 1,000 Hz); FR 20-19,900 Hz; imp 4-32 ohms. \$15

SHP-65 Headphones

Mini, superlight, headphones with 13-mm mylar speakers. FR 20-20,000 Hz. Extra earpads. \$8

SHP-55 Earphones

Open-air, lightweight, bud-type earphones. FR 20-20,000 Hz; imp 32 ohm. \$6

JVC

HAD990 Headphones

Features large-diameter driver units with samarium cobalt magnets. \$150

HAD770 Headphones

Features high-sensitivity coils made from copper-clad aluminum wire. \$120

HASU7 Headphones

Surround-sound headphones. Features 2 separate drivers in each earcup; front/rear separation; 2 independent plugs; moving coil. \$90

HAD600 Headphones

Headphones with gold-plated plug, adaptor and 3-m cord. Features moving-coil driver. FR 5-26,000 Hz. Weight with cord 5.6 oz. \$59.95

HAD500 Headphones

Headphones with gold-plated plug, adaptor and 3-m cord. Features moving-coil driver. FR 10-23,000 Hz. Weight with cord 5.3 oz. \$44.95

HACD7 Headphones

Lightweight headphones with gold-plated plug, adaptor and 3-m cord. Features moving-coil driver. FR 15-22,000 Hz. Weight with cord 2.9 oz. \$39.95

HAD300 Headphones

Headphones with moving-coil driver and 3-m cord. Includes $\frac{1}{4}$ -in and 3.5 mm adaptors. FR 20-20,000 Hz. Weight with cord 4.2 oz. \$24.95

KENWOOD

KH-500 Foldable Headphones

Open-air headphones with fold-up headband. \$30

KH-D9 Earphones

Lightweight earbud headphones with detachable, fold-up headband. \$20

KOSS

JCK/300 Cordless Headphone

Battery-powered infrared cordless stereo with transmitter and modulator. FR 20-20,000 Hz; left carrier frequency, 95,000 Hz, right 250,000 Hz; deemphasis, 50 μ s. \$275

Pro/450 Headphone

Studio and professional stereo featuring unique dual-element driver and neodymium magnet. FR 10-30,000 Hz. \$175

JCK/200-S Cordless Headphones

Dynamic circumaural cordless headphones equipped with transmitter and AC adaptor. FR 20-20,000 Hz \pm 3 dB. \$160

SST/10 Headphones

Designed for digital A/V equipment. Sens 0.36 V rms at 100 dB SPL. \$120

Pro/99 Headphone

Studio stereo with voice coil and diaphragm. Features anisotropic ferrite magnet. Frequency response 10-20,000 Hz; sensitivity 96 dB SPL/mW; impedance 100 ohms. 10.8 oz. \$99

Pro/4AA Headphone

For home and professional use. Features oversized 1-in voice coil. FR 10-22,000 Hz. \$99

Pro/4X Plus Headphones

Dual-element design combines rare-earth magnet with piezoelectric element. FR 10-40,000 Hz \pm 3 dB. \$90

TNT/88 Headphone

Dynamic stereo with closed circumaural design and titanium nitride diaphragm. Features gold plug and adapter. FR 15-30,000 Hz; sens 94.5 dB SPL/mW; imp 60 ohms. \$90

Pro/75 Headphone

Features 4-layer voice coil. FR 10-20,000 Hz. \$75

Pro/4AAA Plus Headphones

Features large voice coils; oversized diaphragm. FR 10-22,000 Hz \pm 3 dB. \$70

TNT/77 Headphone

Dynamic open-air stereo with titanium nitride diaphragm with adjustable temporal pad design. Features gold plug and adapter. FR 15-20,000 Hz; sens 91.5 dB SPL/mW; imp 60 ohms. \$70

PortaPro Headphones

Supra-aural folding headphones for high-end portable or home use. Features exclusive Comfort Zone multi-pivoting earcup adjustments. Mini plug and $\frac{1}{4}$ -in phone plug; cord length 5 ft. 2 $\frac{1}{2}$ oz w/cord. \$50

TNT/66 Headphone

Dynamic headphone with closed circumaural design with titanium-nitride diaphragm. Features gold plug and adapter. FR 20-20,000 Hz; sens 93.5 dB SPL/mW; imp 60 ohms. \$50

HV/1A Plus Headphones

High-velocity headphones with low-mass Decilite drivers for 15-30,000 Hz FR \pm 3 dB. Distortion 0.5% at 100 dB SPL; sens 0.9 V rms for 100 dB SPL. Acoustical-sponge ear cushions; extendable headband with self-adjusting pivoting yokes, soft padded vinyl cover; 10-ft cord; 10.1 oz. \$50

Porta/Pro Jr. Headphones

THD < 0.2% @ 100 dB SPL 1 kHz. \$40

K40LC Plus Headphones

Features dual balance controls; volume control. Rated at 100 ohms and 104 dB SPL W/m input. \$40

SST/5 Headphones

Dynamic headphones with closed circumaural design. Features adjustable leather headband and foam-filled ear cushions. FR 20-20,000 Hz \pm 3 dB. \$40

K6X Plus Headphones

Lightweight headphones. 100 dB SPL; imp 100 ohms; 6.3 oz. \$32

SST/4 Headphones

FR 20-20,000 Hz \pm 3 dB; imp 35 ohms; sens 100 dB; 6.3 oz. \$32

CS/2 Earphone

In-the-ear micro stereo. Features gold plug and adapter; matte black carrying case. THD < 1% \$30

CS/1 Earphone

White earbud. Features gold plug and adapter; protective spool carrying case. THD < 1% \$30

TD/50 Headphone

Hear-through headphones with 8-ft cord for stereo, VCR, or TV. Features self-adjusting slide bars; washable cushions; mini-mono adaptor; spare cushions. FR 18-20,000 Hz; imp 100 ohms. \$25

TD/60 Headphone

Lightweight home or portable closed circumaural design headphones. Features pivoting earcups; pivoting earplates; adjustable headband. Frequency response 18-20,000 Hz. \$20

TD/40 Headphone

Portable supra-aural headphones. Features volume and balance controls; screw-on adapter. FR 20-20,000 Hz; imp 32 ohms. 2.34 oz. \$20

CR/9 Earphone

Sidewinder design in-the-ear micro stereo. Features collapsible headband. Total harmonic distortion < 1% \$20

TD/30 Headphone

Adjustable headband; pivoting earcups; spare cushions; $\frac{1}{4}$ in adapter; imp 32 ohms. 1.9 oz. \$16

HEADPHONES

CR/8 Headphone

Lightweight sidewinder micro stereophone. Features adjustable headband. Total harmonic distortion <1% \$15

CR/7 Earphone

Sidewinder earbud design. Features detachable headband. THD<1% \$15

CR/6 Earphone

In-the-ear micro stereophone. Features wind-up spool carrying case. THD<1% \$12

TD/20 Headphone

Pivoting earcups: 1/4 in adapter. 1 3/4 oz \$10

LENOXX

CD-700 Headphones

Headphones with dynamic samarium-cobalt speaker elements. Features 1/4-in adapter. FR 20-20,000. 2 oz. \$20

Model 876 Foldable Headphones

Micro in-ear or over-ear headphones. Features Alnico alloy magnets; mini-mono plug for TV; 1/4-in plug; fully adjustable headband. FR 100-15,000 Hz .. \$10

Model 884 Headphones

Lightweight headphones with 4-ft cord. Features mylar diaphragms; 1/4-in adapter; fully adjustable headband. FR 100-15,000 Hz. 0.75 oz. \$8

Model 883 Earphones

In-ear, lightweight headphones that fit all personal portable stereos. Features dynamic mylar diaphragms; roll-up storage case. 0.5 oz \$8

MEMOREX BY MEMTEK

EDM-770 Headphones

FR 5-30,000 Hz; sens 107 dB SPL/W/m; imp 70 ohms \$120

PSS-100 Headphones

Headphones with 4 speaker elements and 25-ft cord. Features 2 gold-plated headphone jacks; front ch to be plugged into receiver and rear ch to be plugged into adapter box. \$100

EDM-550 Headphones

FR 5-25,000 Hz; sens 102 dB SPL/W/m; imp 60 ohms \$85

EDM-330 Headphones

FR 15-22,000 Hz; sens 102 dB SPL/W/m; imp 40 ohms \$60

EDM-110 Headphones

FR 5-25,000 Hz; sens 100 dB SPL/W/m; imp 25 ohms \$50

SLS-9 Headphones

Designer-styling available in arctic white, champagne, and metallic charcoal. FR 20-20,000 Hz; sens 96 dB SPL/W/m; imp 32 ohms \$30

DL-100 Headphones

FR 18-22,000 Hz; sens 102 dB SPL/W/m; imp 32 ohms \$20

Sonic-Lite Headphones

SL-88 Earphones

In-ear headphones with samarium-cobalt magnets. Features contoured shape; gold-plated connectors; mini-connector and mini-to-1/4-in adapter. FR 20-20,000 Hz \pm 3 dB; imp 16 ohms; max power 30 mW; sens 106 dB at 1 mV/ch at 1,000 Hz. 2 oz \$15

SL-90 Headphones

Headphones with samarium-cobalt magnets. Features gold-plated connectors; mini-connector and

mini-to-1/4-in adapter. FR 20-20,000 Hz \pm 3 dB; imp 32 ohms; max power 100 mW; sens 100 dB at 1 mV/ch at 1,000 Hz. 0.5 oz \$15

SL-60 Headphones

Lightweight headphones with adjustable headband. Features soft ear cushions; 45-in cord; mini plug; mini-to-1/4-in adapter. FR 50-18,000 Hz \pm 3; imp 32 ohms; max power 100 mW; sens 92 dB at 1 mV/ch at 1,000 Hz. 1.75 oz \$10

SL-40 Headphones

Lightweight headphones with adjustable headband. Features flexible pivot earpiece mounts; 45-in cord; mini plug; mini-to-1/4-in adapter. FR 50-16,000 Hz \pm 3 dB; imp 32 ohms; max power 50 mW; sens 80 dB at 1 mV/ch at 1,000 Hz. 1.5 oz. \$5

NAKAMICHI

SP-7 Headphones

Lightweight stereo headphone utilizing 25-micron thick polyester film with 40.5-mm diameter and 18.3-mm voice coil. FR 20-20,000 Hz; imp 45 ohms; max power 100 mW; 10-ft cable; standard 1/4-in phone plug. \$80

NUMARK

FLS-200 Open-Air Headphones

Open-air headphones with 10-ft cord. Features volume control on cord; samarium-cobalt drivers; 1/4-in plug; mini adaptor; extra earpads. Frequency response 20-25,000 Hz; sensitivity 100 dB; imp 20 ohms. 1 1/2 oz \$30

FLS-100 Open-Air Headphones

Open-air headphones with 10-ft cord. Samarium-cobalt drivers; 1/4-in plug; mini adaptor; extra earpads. FR 20-20,000 Hz; sens 98 dB; imp 32 ohms \$25

DH45SVT Headphones

Closed-back headphones with 10-ft cord. Features slide volume and tone controls for both channels. FR 20-19,000 Hz \$22

FLS-30B Open-Air Headphones

Folding headphones with 7-ft cord. FR 20-20,000 Hz; sens 98 dB; imp 32 ohms. \$20

HV100 Headphones

Closed-back headphones with 8-ft cord. FR 20-20,000; imp 32 ohms. 6 oz \$18

FLS-310 Headphones

Open-air headphones with 4 1/4-ft cord. Frequency response 20-22,000 Hz; sensitivity 100 dB; impedance 20 ohms. 1 3/8 oz \$17

ORA ELECTRONICS

Studio Spec Brand

GHT100 Earphones

In-ear headphones gold-plated stereo plug. . . . \$9.95

GH16RP Earphones

Lightweight in-ear earphones with case. Available in variety of colors \$5

GH11G Headphones

Lightweight, compact headphones with gold-plated plug and 27-mm ferrite drivers. \$3.60

PANASONIC

EAH-X250 Headphones

Closed-back, 2-way headphones with 1 3/4-in dome woofers and 1 1/4-in dome tweeters. Features neodymium woofer magnets; 10-ft cord; 1/4-in stereo plug; mini stereo-plug adapter. Frequency response 2-30,000 Hz; sensitivity 106 dB; impedance 55 ohms @ 1,000 Hz. 10.6 oz \$180

EAH-X150 Headphones

Closed-back headphones with 1 1/2-in dome drivers. Features polyethylene naphthalate diaphragms; neodymium magnets; 10-ft cord; 1/4-in stereo plug; mini stereo-plug adapter. FR 5-35,000 Hz; sens 107 dB; imp 63 ohms @ 1,000 Hz. 4.8 oz \$130

EAH-X120 Headphones

Closed-back headphones with 1 1/2-in dome drivers. Features polyethylene naphthalate diaphragms; neodymium magnets; 10-ft cord; mini stereo plug; 1/4-in stereo plug; mini stereo-plug adapter. FR 8-33,000 Hz; sensitivity 107 dB; impedance 45 ohms @ 1,000 Hz. 4.6 oz. \$95

EAH-X80 Headphones

Closed-back headphones with 1 1/2-in dome drivers. Features rare earth magnets; polyethylene naphthalate diaphragms; 10-ft cord; 1/4-in stereo plug; mini stereo-plug adapter. FR 8-30,000 Hz; sens 105 dB; imp 45 ohms @ 1,000 Hz. 4.4 oz \$55

EAH-S24 Open-Air Headphones

Headphones with adjustable headband. Features 4-ft cord; mini stereo plug; 1/4-in-plug adapter. Sens 100 dB; imp 32 ohms @ 1,000 Hz. \$20

EAH-Z9 Earphones

Lightweight earphones with folding headband and removable speaker units. Features 3 1/2-ft cord; mini stereo plug. FR 30-20,000 Hz; sens 102 dB; imp 16 ohms @ 1,000 Hz. 0.7 oz. \$18

EAH-S14 Open-Air Headphones

Features adjustable headband; 4-ft cord; mini stereo plug; 1/4-in-plug adapter. Sens 98 dB; imp 32 ohms @ 1,000 Hz. 2 oz \$13

PICKERING

CD-5 Headphones

Lightweight headphones with dynamic high-velocity element with polyester film diaphragm and samarium-cobalt magnets. Frequency response 20-20,000 Hz; sensitivity 110 dB SPL/W/m; 7 1/2-ft single side entry cord with gold plated stereo plug and mini stereo adaptor. \$79.95

CD-4 Headphones

Lightweight headphone with 7 1/2-ft cord and gold plated plug. FR 20-20,000 Hz; sens 110 dB SPL/W/m. \$66

PC2+2 Earphones

Features dual samarium-cobalt magnet drivers (2 per bud); 1/4-in gold-plated adaptor plug and roll-up storage-case. Imp 35 ohms at 1,000 Hz; sens 106 dB SPL/mW at 1,000Hz; FR 10-25,000 Hz; max input 50 mW; 4 ft cord; 12 g \$60

CD-2 Headphones

Headphone for digital or analog playback. Features samarium-cobalt drivers; lightweight. FR 20-20,000 Hz; 7 1/2 ft cord with standard stereo plug; Y type 4-conductor cord \$50

Featherfone 108 Earphones

Features volume control. FR 20-20,000 Hz; sens 105 dB SPL 0.25V at 1,000 Hz for each channel \$45

CD-1 Headphones

Intermediate size elliptical shaped headphones. Frequency response 20-20,000 Hz; sensitivity 105 dB; 7-ft Y cord with gold plated mini stereo plug and standard stereo adaptor \$35

OA-99P Earphones

Earphones with 5-ft cord with mini stereo plug and mini 1/4-in stereo adapter. FR 20-20,000 Hz; sens 105 dB SPL/W/m. \$30

Featherfone 104 Earphones

For in-ear wearing. FR 20-20,000 Hz; sens 98 dB \$30

Even If Your Best Friend Breaks Them, We'll Repair Or Replace Them.



Koss Stereophones have become world-renowned for two things: outstanding sound and extraordinary durability. But nobody's perfect. That's why Koss is pleased to present something literally unheard of in the audio business.

Introducing the industry's first lifetime warranty. From now on, if any pair of Koss Stereophones should ever fail for any reason, we'll repair or replace them. No questions asked. From the smallest portable model right up through Koss' infrared Kordless™ systems.

And that's something to think about the next time you're in the market for a pair of phones. After all, it'd be a shame for a broken pair of stereophones to break up a good friendship.

For more information and the name of your nearest dealer, call toll free: 1-800-USA-KOSS. Or write: Koss Stereophones, 4129 North Port Washington Road, Milwaukee, WI 53212.

KOSS
stereophones

Koss'No-Questions-Asked Limited Lifetime Warranty.

CIRCLE NO. 16 ON READER SERVICE CARD

HEADPHONES

Featherfone 102. Similar to Model 104 except sens is 92 dB. \$25

OA-88 Headphones

Headphones that can be used for headband or in-ear wear. High-velocity samarium-cobalt drivers; ultra-lightweight adjustable headband with replaceable foam cushions. FR 20-20,000 Hz; distortion <0.5% at 100 dB SPL; imp 32 ohms at 1,000 Hz; sens 98 dB SPL with 1-mW input at 1,000 Hz; max power 0.05 mW; mini stereo plug; 4-ft cord; 1/2 oz without cord. . . \$25

PC 100 Earphones

Features extra pair of ear cushions; 1/4-in gold plated plug; roll-up storage case; imp 35 ohms at 1,000 Hz; sens 100 dB at 1 mW at 1,000 Hz; FR response 20-20,000 Hz; 4-ft cord; max input 50 mW. 1/4 oz. . \$20

OA-66P Earphones

Features strontium-ferrite magnets; ultra-lightweight adjustable headband with replaceable polyurethane foam ear cushions. FR 20-20,000 Hz; distortion <0.5%; imp 32 ohms; sens 92 dB SPL with 1-mW input at 1,000 Hz; mini plug; 1/4-in adaptor plug; 1 1/8 oz without cord \$15

OA-44 Open-Air Headphones

Lightweight headphone features open-air design. FR 20-18,000 Hz; distortion <1/2%; sens >90 dB SPL/W/m; input imp 32 ohms; max power 100 mW. . \$3.95

PIONEER

SE-M90 Headphones

Midsize stereo headphones with 32-ohm nom impedance. Features ceramic titanium diaphragm; 1,000 mW max power input per channel; FR 3-50,000 Hz; 16-ft, 5-inch connection cord; 9 oz \$125

SE-M70 Headphones

Stereo headphones with 32-ohm nom impedance. Features ceramic titanium diaphragm; 1,000 mW max power input per channel; FR 3-50,000 Hz; 16-ft, 5-inch connection cord; 9 oz \$100

SE-72 Headphones

Stereo headphones with 1.9 g samarium-cobalt magnet drivers; 1 3/8-in polyethylene diaphragm . . . \$75

SE-M50 Headphones

Stereo headphones with 32-ohm nom impedance. Features ceramic titanium diaphragm; 1,000 mW max power input per channel; FR 3-50,000 Hz; 16-ft, 5-inch connection cord; 8.1 oz \$70

SE-205 Headphones

Rounded-cup style stereo headphones with 10-ohm nom imp. Features 500 mW max power input per ch; FR 20-20,000 Hz; 8-ft, 2-in cord; 1 lb \$45

SE-52 Headphones

Stereo headphones with 0.55 g samarium-cobalt magnet driver; 1.2 in polyethylene diaphragm. . \$45

SE-32 Headphones

Stereo headphones with 3.6 g ferrite-magnet driver; 1 3/8-in polyethylene diaphragm \$35

REALISTIC

PRO-60 Headphones

Variable-density ear cushions with 10-ft coiled cord. Includes 1/4-in phone plug. THD <0.5%; <8 oz. . \$50

LV-10 Headphones

Vented-back headphones with 2-in drivers and 10-ft coiled cord. Features foam earpieces; soft vinyl-covered headband with self-adjusting yokes; THD 0.5%; imp 4-16 ohms; 1/4-in plug \$40

Nova-65 Headphones

Side-mounted controls for volume and balance; 10-ft cord; foam-filled ear cushions; padded headband; 1/4-

in plug. \$35

Nova-55 Headphones

Samarium-cobalt magnets; mini plug. FR 20-20,000 Hz \pm 3 dB; imp 3.2-600 ohms; max power 5 V. 3 oz. \$30

Nova-40 Headphones

Stereo headphones with 3/2-in drivers and 10-ft coiled cord. Imp 4-16 ohms; soft-cushion earcups; padded adjustable headband; 1/4-in plug \$25

Nova-45 Headphones

1/4-in plug adaptor and rare-earth magnets and 6 1/2-ft cord. FR 20-20,000 Hz \pm 10 dB; imp 32 ohms; max power 40 mW. 3.3 oz. \$25

Nova-52 Folding Headphones

Rare-earth magnets, 6 1/2-ft cord with 1/8-in mini-plug. 3 oz \$20

Nova-16. Similar to Nova-10 except has separate Glide Path level controls. \$20

Nova-10 Headphones

2-in drivers; adjustable vinyl headband with cushioned earpads. 6 1/2-ft cord, 1/4-in plug \$16

Nova-37 Headphones

Folding headband; samarium-cobalt magnets; mini plug \$16

Nova-35 Headphones

Micro stereo headphones with foam earpads, adjustable headband, 5-ft cord with 1/8-in plug. 3 oz . . \$14

Nova-33 Headphones

Portable headphones with 4-ft cord. Foam ear cushions and 1/8-in plug. 1 1/4 oz \$11

Nova-36 Headphones

Fold-up headphones with foam pads; flexible 4-ft, 2-oz cord with 1/8-in mini plug \$8

Nova-34 Headphones

Imp 32 ohms; FR 40-20,000 Hz \pm 3 dB; max power 100 mW; mini plug; 4-ft cord; 3 oz \$6

RECOTON

Stereo 108 Earphones

Lightweight, stereo earbuds. Features cassette-shell container. Available in orange, green, blue, pink, yellow, and red. \$9.49

SANSUI

SS-155 Headphones

Isolation-free dynamic stereo headphones with 2-m cord, around-the-ear design, and 1 1/2-in drivers. Imp 100 ohms at 1,000 Hz; FR 20-20,000 Hz; max input power 500 mW; sens 104 dB/W/m at 500 Hz. 4.8 oz without cord. \$55

SS-133 Headphones

Isolation-free around-the-ear stereo headphones with 2-m cord and 1 1/2-in drivers. Imp 60 ohms; FR 20-20,000 Hz; max input power 500 mW; sens 104 dB/W/m. 4.4 oz without cord \$35

SENNHEISER

HD 540 Gold Open-Air Headphone

Limited edition top-of-the-line open-air design 10-foot stranded-steel cable with a 24-karat gold 1/4-inch stereo plug. Matte black design. Frequency response 16-25,000 Hz; sensitivity 94 dB SPL/W/m; total harmonic distortion <0.4%; impedance 600 ohms. 8 7/8 oz. \$349

HDI 234 HiDyn Wireless Headphone

Features separate volume slide controls for L/R channel; three-position switch for stereo, mono

channel 1 and mono channel 2. HiDyn noise reduction system. Notch-adjustable headband. FR 20-20,000 Hz. \$275

SI 234. Transmitter for the HDI 234. 12 infrared diodes and overmodulation display. Compatible with any hifi unit and stereo TV via the universal plug connector PX-1. FR 20-20,000 Hz. \$295

HD 540 Open-Air Headphones

Open-air dynamic headphones with integral acoustical silk dampening diaphragm. FR 16-25,000 Hz; sens 94 dB SPL/W/m; THD <0.4%; imp 600 ohms. 8 7/8 oz. \$199

HD 250 Headphones

Closed cushion headphone with resonance free transmission. FR 16-25,000 Hz; sens 94 dB SPL/W/m; THD <0.2%; imp 600 ohms. 8 7/8 oz. \$199

HDI/SI 405 Wireless Headphones

Headphones with separate transmitter that plugs into headphone jack of any receiver or amp for wireless transmission. Features individual volume controls; rechargeable battery. FR 50-8,000 Hz. \$169

SI 405. Transmitter for the HDI/SI 405. FR 40-12,000 Hz \$169

HD 520 Open-Air Headphones

Features a neodyme-ferrous magnet structure and a open-air housing design to prevent standing waves. FR 18-22,000 Hz; sens 94 dB SPL/W/m; THD <0.3%; imp 600 ohms. 7 1/2 oz \$149

HD 480 Open-Air Headphones

Open-air design headphones can be used with portables and home equipment. Features neodymium iron magnets; cushioned headband; 10-ft steel-stranded cable; 1/4-in phone adapter. FR 18-22,000 Hz; sens 94 dB SPL/W/m; THD <1%; imp 70 ohms. all components are user replaceable. 4 3/4 oz \$99

HD 450 Headphones

Headphone can be used for portable as well as home equipment. Features neodymium iron magnets; 10-ft stranded-steel cable; 1/4-in adapter; FR 20-20,000 Hz; sens 94 dB SPL/W/m; THD <1%; imp 70 ohms. Components are user replaceable. 4 3/4 oz \$79

HD 50 Mini Headphones

All user-replaceable parts. FR 20-20,000 Hz, 4-ft cable w/mini to 1/4-in phone plug adaptor. FR 20-20,000 Hz; sens 94 dB SPL/W/m; THD 1%; imp 42 ohms. 1 3/8 oz. \$79

PD 100 Mini Headphones

All user-replaceable parts. 3-ft cable w/ mini to 1/4-in phone plug adaptor. FR 20-18,000 Hz; sens 94 dB SPL/W/m; THD 1%; imp 42 ohms. 1 3/8 oz \$59

HD 30 Mini Headphones

All user replaceable parts including ear cushions and cable. Features 1/4-in stereo phone adapter; 4 ft cable. FR 50-17,000 Hz; sens 96 dB SPL/W/m; THD 1.3%; imp 32 ohms. 1 1/2 oz \$39

SENTRY INDUSTRIES

SENTW850 Headphones

Features 7-ft shielded cord with 1/8-in right angle stereo plug; 1/4-in adaptor for home use; single cord design; 1 3/8-in samarium-cobalt speakers; FR 20-20,000 Hz \pm 3 dB; sens 105 dB; imp 32 ohms. . \$26

SENH0780 Headphones

Features rotary volume/balance controls; 6-ft shielded cord with 1/8-in right angle stereo plug; 1/4-in stereo adaptor screw type for home use; 1 3/8-in samarium-cobalt magnet with mylar cone; FR 30-30,000 Hz \pm 3 dB; sens 97 dB; imp 28 ohms \$19

SENH0680 Headphones

Features 7 ft. shielded cord with 1/8-in stereo plug; 1/4-in adaptor for home use; single wire connection; 1-in

HEADPHONES

samarium-cobalt drivers; FR 18-20,000 Hz \pm 3 dB; sens 100 dB; imp 32 ohms. \$17

SENH0160 Headphones

Features 4-ft shielded cord with $\frac{1}{4}$ -in stereo plug; $\frac{1}{4}$ -in adaptor for home use; replacement earpads; 1-in drivers; FR 20-20,000 Hz \pm 3 dB; sens 92 dB; imp 16 ohms. \$13

SIGNET

TK44 Headphones

Electret-condenser headphones with adaptor box, low-mass diaphragm; double headband system; LED overload indicator; 8-ft OFC cord. FR 10-22,500 Hz \pm 3 dB; matching imp 4-16 ohms; sens 100 dB at 1 V/ch at 1,000 Hz. \$300

EP700 Open-Air Headphones

Features circumaural design; samarium-cobalt magnets; 10-ft OFC cord. FR 20-23,000 Hz; matching imp 4-16 ohms. $7\frac{1}{2}$ oz. \$150

EP500 Headphones

Closed-back headphones with circumaural design. Features samarium-cobalt magnets; OFC voice coil. Leather-like earpads; 10-ft cord. FR 20-22,000 Hz; matching imp 4-16 ohms. $7\frac{1}{2}$ oz. \$125

EP400 Headphones

Features samarium-cobalt magnets; high-compliance dome diaphragm; OFC voice coil of 40 micron silver/copper wire; double-headband system; dual-swivel earpads; 10-ft cord. FR 20-22,000 Hz; matching imp 4-16 ohms. $5\frac{1}{2}$ oz. \$100

EP350 Headphones

Features samarium-cobalt magnets. Mini-plug with phono plug adapter. FR 20-25,000 Hz; matching imp 4-16 ohms. \$80

EP300 Headphones

Features samarium-cobalt magnets; double headband system; high-polymer film element; 10-ft cord; FR 20-20,000 Hz; matching imp 4-16 ohms. 6 oz. \$55

EP100 Headphones

Features high-polymer film elements; samarium-cobalt magnets; 6-ft cord with mini-plug and $\frac{1}{4}$ -in phone plug adapter; FR 20-20,000 Hz; matching imp 4-16 ohms. $1\frac{3}{4}$ oz. \$30

SONY

MDR-R10 Headphones

Digital reference headphones made from bio-cellulose diaphragm and Japanese Zelkova wood. Features Greek sheepskin earpads. Available through special order only. \$4,000

MDR-CD999 Headphones

Circumaural design. \$250

MDR-IF5K Headphones

Cordless headphones using Hi-Band infrared technology. Features built in NiCd battery and arc-shaped transmitter/recharger. Includes AC power adaptor; mini/phone plug adaptor; stereo RCA/mini adaptor. \$200

MDR-CD6 Headphones

Supra-aural headphones with sealed-ear design; 30-mm dome driver unit; spring-loaded soft-touch elliptical earpads; independent left/right side click-sliders; stereo Unimatch plug; gold-coated double-layer high-molecule film diaphragm and copper-clad aluminum voice coil. Imp 45 ohms at 1,000 Hz; sens 110 dB/mW; rated power 0.1 W; power handling 0.5 W; FR 2-25,000 Hz; cord length 9.8 ft; 3.9 oz. . . . \$120

MDR-M66. As above with less bass response. . . . \$95

MDR-V7 Headphones

Closed-ear monitor headphones with 40-mm driver

unit; gold-plated Unimatch plug. FR 5-30,000 Hz; sens 106 dB 1 mV/ch; imp 63 ohms. 8 oz. . . . \$120

MDR-V6 Headphones

Closed-ear-type monitor headphones with folding-type compact headband; 40-mm driver unit; oval earpads; stereo Unimatch plug; OFC litz cord. Imp 63 ohms; sens 106 dB/mW; rated power 0.3 W; power handling 1 W; FR 5-30,000 Hz. \$100

MDR-V5 Headphones

Closed-ear headphones with 30-mm driver unit; gold-plated Unimatch plug. FR 10-26,000 Hz; sens 104 dB 1 mV/ch. imp 45 ohms. 5.8 oz. \$100

MDR-V4 Headphones

Closed-ear-type monitor headphones with rugged folding headband; 30-mm driver unit; one-sided cord; stereo Unimatch plug; OFC litz cord. Imp 45 ohms; sens 104 dB/mW; rated power 0.1 W; power handling capacity 0.5W; FR 10-25,000 Hz. Includes case. \$80

MDR-V2. Similar in design to MDR-V4. \$50

MDR-V1. Similar in design to MDR-V4. \$30

MDR-E484 Earphones

In-the-ear headphones with Sony Acoustic Twin Turbo Circuit; Unimatch plug; reel-type case. FR 10-30,000 Hz; sens 108 dB 1 mV/ch; imp 18 ohms. 2 oz. \$80

MDR-S505 Open-Air Headphones

Large-size open-air-type headphones with volume and tone controls; large-size earpads; 30-mm dome drive units; one-sided cord; stereo Unimatch plug. Imp 45 ohms; sens 104 dB/mW; rated power 0.04 W; power handling 0.1 W; FR 15-24,000 Hz; 9-ft, 10-in cord; 2.1 oz. \$70

MDR-A60 Earphones

Vertical in-the-ear-type headphones with Sony's Acoustic Turbo-Circuit for power bass and smooth high frequencies; 16-mm sapphire driver units; natural-form bio-tech curved headband design with 3-point folding mechanism; OFC litz wire; stereo Unimatch plug. Impedance 18 ohms at 1,000 Hz; sensitivity 108 dB/mW; rated power 0.03 watts; power handling 0.05 watts; frequency response 10-25,000 Hz; cord length 47.2-in; 0.7 oz. \$70

MDR-M33A Headphones

Features soft-touch elliptical earpads; one-sided cord; stereo Unimatch plug; 23-mm dome driver unit. Imp 25 ohms at 1,000 Hz; sens 100 dB/mW; rated power 0.05 W; power handling 0.1 W; FR 15-14,000 Hz; cord length 9.8 ft; 1.7 oz. \$60

MDR-M22 Headphones

With Unimatch plug and one-sided cord. FR 15-24,000 Hz; sens 100 dB 1 mV/ch; imp 25 ohms. 1.7 oz. \$60

MDR-S303 Open-Air Headphones

Large-size open-air-type headphones with large-size earpads; 30-mm dome drive units; one-sided cord; stereo Unimatch plug. Imp 45 ohms; sens 104 dB/mW; rated power 0.04 W; power handling 0.1 W; FR 15-22,000 Hz; cord length 9 ft, 10 in; 1.9 oz. \$50

MDR-E464 Earphones

In-the-ear-type headphones with gold-plated L-shaped mini plug; Sony's Acoustic TurboCircuit. Imp 13.5 ohms at 1,000 Hz; sens 104 dB/mW; FR 18-22,000 Hz; cord length 39 $\frac{1}{2}$ in; 0.17 oz. \$40

MDR-62 Open-Air Headphones

Open-air-type headphones with 30-mm drivers; Sony Acoustic Turbo Circuitry; Unimatch plug. FR 14-24,000 Hz; sens 104 dB 1 mV/ch; imp 45 ohms \$40

MDR-S101 Open-Air Headphones

Large-size open-air-type headphones with 23-mm dome driver units; large-size earpads; stereo Uni-

match plug adaptor. Imp 32 ohms; sens 98 dB/mW; rated power 0.04 W; power handling 0.1 W; FR 20-20,000 Hz; cord length 6.5 ft; 1.9 oz. \$30

MDR-32 Open-Air Headphones

Open-air headphones with 23-mm drivers; Sony Acoustic Turbo Circuitry; Unimatch plug. FR 16-22,000 Hz; sens 100 dB 1 mV/ch; imp 25 ohms \$30

MDR-S101MKII Open-Air Headphones

Open-air type headphones with 23-mm dome driver units; Unimatch plug. FR 20-20,000 Hz; sens 98 dB 1 mV/Ch; imp 32 ohms. 1.9 oz. \$30

MDR-A15L Earphones

Water-resistant in-the-ear headphones with mini plug. FR 18-22,000 Hz; sens 104 dB 1 mV/ch; imp 16 ohms. 0.5 oz. \$25

MDR-E225 Headphones

Water-resistant headphones with neck-chain cord; mini plug; carrying case. FR 18-22,000 Hz; sens 104 dB 1 mV/ch; imp 16 ohms. 0.18 oz. \$25

MDR-022 Headphones

Lightweight with plug and adaptor. FR 20-20,000 Hz; sens 98 dB 1 mV/ch; imp 32 ohms. 1.1 oz. . . . \$23

MDR-E434 Earphones

In-the-ear headphones with mini plug and carrying case; Sony Acoustic Twin Turbo Circuit. FR 16-22,000 Hz; sens 104 dB 1 mV/ch; imp 16 ohms. 0.2 oz. \$20

MDR-P1 Open-Air Headphones

Open-air type headphones with 23-mm driver units; Unimatch plug. FR 20-20,000 Hz; sens 96 dB 1 mV/ch; imp 32 ohms. 3.2 oz. \$20

MDR-012 Headphones

Lightweight with plug and adaptor. FR 20-20,000 Hz; sens 98 dB 1 mV/ch; imp 32 ohms. 0.9 oz. . . \$14.95

MDR-E424 Earphones

In-the-ear headphones with mini plug and carrying case. FR 20-20,000 Hz; sens 104 dB 1 mV/ch; imp 16 ohms. 0.18 oz. \$15

MDR-006L Headphones

Lightweight with mini plug. FR 30-17,000 Hz; sens 96 dB 1 mV/ch; imp 32 ohms. 1 oz. \$9.95

MDR-E414 Earphones

In-the-ear headphones with mini plug. Frequency response 20-20,000 Hz; sensitivity 104 dB 1 mV/ch; impedance 16 ohms. Weight: 0.4 oz. \$9.95

MDR-W05L Earphones

Lightweight in-the-ear headphones with 13.5 mm driver unit; Sony Acoustic Twin Turbo Circuit; mini plug. FR 18-22,000 Hz; sens 104 dB 1 mV/ch; imp 16 ohms. 0.42 oz. \$9.95

MDR-006 Headphones

Lightweight with plug and adaptor. FR 30-17,000 Hz; sens 96 dB 1 mV/ch; imp 32 ohms. 1 oz. . . . \$7.95

STANTON

SRS-265 Headphones

Audiophile/professional headphones with deluxe dynamic driver. Patented independently suspended earcup design for wearer comfort; $\frac{1}{4}$ -in plug. FR 5-22,000 Hz; sens 96 dB SPL/W/m; imp 100 ohms; max input 100 mW; THD <0.5% at 1,000 Hz. 8.6 oz. \$135

45M/MC DJ Headphones

Single-sided closed-ear design with 12-ft dual-straight cord and two $\frac{1}{4}$ -in plugs. Features adjustable metal headband; 200 ohm unidirectional mic mounted on headphone. FR 20-18,000 Hz; sens 96 dB at 0.7 V; imp 400 ohms. Mic specs: FR 25-12,000 Hz; sens 1.2 mV/Pa at 1,000 Hz/m. \$125

HEADPHONES

SRS-245 Headphones

Semi-enclosed with deluxe dynamic driver and 10-ft flat 4-conductor cord with 1/4-in plug. Features adjustable ratchet-type headband. FR 10-22,000 Hz; sens 94 dB SPL/W/m; imp 100 ohms; max input 100 mW; THD <0.5% at 1,000 Hz. \$110

ST-10 Headphones

Closed-back headphones with 7-ft "Y"-type flat-ribbon cord and gold-plated stereo mini plug. Features dual-driver design: 1/4-in gold-plated adaptor; FR 10-20,000 Hz; sens 98 dB SPL/W/m; imp 50 ohms. \$110

SRS-225 Headphones

Semi-enclosed headphone with high-velocity MC driver and 10-ft cord with 1/4-in plug. Features adjustable ratchet-type headband. FR 10-22,000 Hz; sens 94 dB SPL/W/m; imp 100 ohms; max input 100 mW; THD <0.5% at 1,000 Hz. \$80

ST-Surround Headphones

Headphone with surround and stereo sound. FR 20-20,000 Hz; sens 103 dB SPL/W/m; imp 50/32 ohms (surround/stereo). \$70

SRS-215 Headphones

Semi-enclosed headphone with high-velocity MC driver, 10-ft cord with mini stereo plug and 1/4-in adaptor. Features adjustable headband. FR 20-22,000 Hz; sens 98 dB SPL/W/m; imp 50 ohms; THD <0.5% at 1,000 Hz. \$60

ST-5 Headphones

Closed-back headphone with 7 1/2-ft cord and 1/4-in stereo plug. Features mylar drivers. FR 20-20,000 Hz; sens 100 dB SPL/W/m; imp 35 ohms. \$59.95

35M/11B Open-Air Headphones

Single-cup headphone with headband intended for disco use. Features high-velocity driver; samarium-cobalt magnet; 1/4-in connector. FR 20-20,000 Hz \pm 3 dB; sens 110 dB SPL/W/m/ch; imp 100 ohms; max power 1/4 W. \$55

35M/SR DJ Headphone

Shoulder-rest single-cup headphone for DJ use. Features samarium-cobalt magnet. FR 20-22,000 Hz; imp 100 ohms; max input 1/4 W. 3.8 oz. \$50

ST-3 Headphones

Full-range, isolated stereo headphones. 2-in high-velocity drivers, samarium-cobalt magnets, mini to 1/4-in adaptor. FR 20-20,000 Hz <3 dB; imp 32 ohms; sens 112 dB SPL/W/m/ch; max power 100 mW. \$40

ST-3.5 Headphones

7 1/2-ft "Y" cord and 1/4-in stereo plug. FR 20-20,000 Hz; sens 103 dB SPL/W/m; imp 35 ohms. \$40

1S-4 Earphones

Lightweight headphone with 3-ft cord, stereo 90 plug and 1/4-in adaptor. Features rare-earth magnet drivers; FR 20-20,000 Hz; sens 102 dB SPL/W/m; imp 32 ohms. \$35

ST-2 Headphones

Headphones with 1 1/2-in drivers, adjustable headband; 7.5-ft 4-conductor cord, 1/4-in to mini adaptor. FR 20-20,000 Hz; sens 100 dB SPL/W/m/ch at 1,000 Hz; imp 32 ohms; max power 100 mW. \$30

ST-1 Headphones

Home/portable headphones with 1 3/8-in drivers; adjustable headband; 7 1/2-ft 4-conductor cord, 1/4-in stereo plug. FR 25-20,000 Hz <3 dB; sens 110 dB SPL/W/m/ch at 1,000 Hz; imp 32 ohms; max power 100 mW; THD <0.5% at 110 dB. \$25

STAX

SR-Lambda + SRM-T1 Amplified Headphone

Includes an amplifier and a carspeaker. SRM-T1 is a

2-stage driver unit incorporates dual FET's and twin 6FQ7/6CG7 triode output tubes; the carspeaker's transducing diaphragm is 1 micron thick; 8-ft pure crystal ohno-continuous cast cord. SR-Lambda: FR 7-41,000 Hz; imp 129,000 Hz at 10,000 Hz; sens 101 dB/100V rms at 1,000 Hz. SRM-T1: FR 1X-20,000 Hz \pm 1 dB; gain 60 dB; THD 0.02% at 1,000 Hz. \$2,000

SR-Lambda/SRM-1 Mk2 Amplified Headphones

Panoramic-imaging professional carspeaker system with Class-A direct-drive amp. Connects to pre-out or record outputs. FR 1X-20,000 Hz \pm 1 dB; imp 50,000 ohms; sens 102 dB SPL with 1-mW input of 1,000 Hz; min power 0.00005 mW; special connector; cord length 7 ft; 15.1 oz with cord. \$1,200

SRE-16 Extension Cord. Five-meter cord for SR-Lambda. \$100

SR-Lambda/SRD-7 Electrostatic Headphone

Panoramic-imaging professional electrostatic earspeaker system with energizing adaptor that connects to amp outputs. Features circumaural design. FR 8-20,000 Hz \pm 1 dB; imp 8 ohms; sens 102 dB SPL with 1 W input of 1,000 Hz; max power 10,000 mW; cord length 7 ft; 15.1 oz with cord. \$750

SR-Lambda Electrostatic Headphones

Panoramic-imaging electrostatic carspeaker system with energizing adapter. FR 8-35,000 Hz \pm 2 dB; imp 8 ohms; sens 102 dB SPL with 1-mW input of 1,000 Hz; max power 10,000 mW; special connector; cord length 7 ft; 15.1 oz with cord. \$600

SR-Gamma Electrostatic Headphones

Circumambient imaging electrostatic carspeakers system with energizing adapter. FR 10-35,000 Hz; sens 102 dB/100 V rms; max output 109 dB. . . . \$400

SR-5/NB Electrostatic Headphones

Electrostatic carspeaker system with energizing adapter. FR 25-25,000 Hz \pm 2 dB; imp 8 ohms; sens 97 dB SPL with 1-mW input of 1,000 Hz; max power 10,000 mW; special connector; cord length 7 ft; 13.9 oz with cord. \$350

SR-84 Lambda Jr. Pro Headphones

Electret carspeaker system with energizing adapter. FR 20-20,000 Hz \pm 2 dB; imp 8 ohms; sens 95 dB SPL with 1-mW input of 1,000 Hz; max power 10,000 mW; special connector; cord length 7 ft; 7.5 oz with cord. \$300

SR-34 Pro Headphones

Electret carspeaker system with energizing adapter. FR 25-20,000 Hz \pm 2 dB; imp 8 ohms; sens 95 dB SPL with 1-mW input of 1,000 Hz; max power 10,000 mW; special connector; cord length 7 ft; 8 oz with cord. \$200

Accessories

SRD-P Adaptor for STAX Pro-Headphones

Portable adaptor for Professional Series Electrostatic headphones. To be connected to preamp outputs or directly to output of portable CD player or tape player. Operates on batteries or AC power, variable gain control; FR 20-25,000 Hz. \$300

SRD-X Adaptor for Stax Headphones

Portable adaptor that allows Stax electrostatic and electret carspeakers to be connected to a headphone jack. Operates on batteries or AC power adaptor. Features variable gain control. FR 25-25,000 Hz \pm 3 dB; imp 300 ohms; max power 0.03 mW. \$200

SRE-15/N Extension Cord

5-meter extension cord for all Stax earspeakers. \$40

TEAC

HP-402 Headphones

Deluxe lightweight stereo headphones with soft vinyl foam cushions. Imp 38 ohms. Includes 1/4-in plug

adaptor. \$35

HP-302 Mini Headphones

Samarium-cobalt magnet. Imp 32 ohms. Includes 1/4-in plug adaptor and 2 extra earpads. \$26

HP-308 Headphones

Lightweight headphones with 1/4-in plug adaptor and 2 extra earpads. Imp 32 ohms. \$25

HP-206 Headphones

Lightweight headphones with samarium-cobalt magnet and volume control. Includes 1/4-in plug adaptor and 2 extra earpads. Imp 32 ohms. \$22

TECHNICS

EAH-X15 Headphones

Features flat-disc diaphragm; copper-clad voice coils; samarium-cobalt magnets; stereo mini-plug; standard stereo headphone adaptor. \$120

EAH-T6 Headphones

Compact, lightweight headphones with stereo mini plug and standard headphone plug adaptor. Frequency response 20-20,000 Hz \pm 3 dB; impedance 40 ohms at 1,000 Hz; maximum power 100 mW. Weight: 1.25 oz. \$40

TEI ELECTRONICS

TK44 Headphones

Condenser headphones with 8-ft cord. Features LED overload-indicator. FR 10-25,000 Hz. \$300

EP700 Open-Air Headphones

Features samarium-cobalt magnets; OFC voice coil. FR 20-23,000 Hz. \$150
EP500. Similar to above, closed-back; FR 20-22,000 Hz. \$125

EP400 Headphones

MC headphones with samarium-cobalt magnets. Features swivel earpads. FR 20-22,000 Hz. \$100

EP350 Headphones

MC headphones with samarium-cobalt magnets. Gold-plated mini-plug with phono plug adaptor. FR 20-25,000 Hz. \$80

EP300 Headphones

MC headphones with samarium-cobalt magnets. Swivel earpads; 1/4-in phono plug and plug adaptor. FR 20-22,000 Hz. \$55

EP100 Open-Air Headphones

Features samarium-cobalt magnets; gold-plated mini-plug with 1/4-in adaptor. FR 20-20,000 Hz. . . . \$30

UHER AMERICA

W765A Headphones

Half-open design stereo headphones with 3 m cable. Features automatic strap adjustment; gimballed earcups. FR 16-20,000 Hz; SPL 94 dB SPL/W/m; imp 600 ohms; nom loading capacity 200 mW; THD 1.0%. 330 g. \$92

W 766A Headphones

Lightweight headphones with 8-ft coiled cord. Features lightweight, adjustable headband. Frequency response 20-20,000 Hz; impedance 200 ohms at 1,000 Hz. 2.2 oz. \$92

YAMAHA

YHD-1 Headphones

Foldable orthodynamic headphones. Features mini connector; phone connector. FR 20-20,000 Hz \pm 3 dB; imp 125 ohms; max power 1,000 mW; SPL 100 dB/mW (109 dB/V); \$80

YHD-2. Similar to above, except 97 dB/mW. . . . \$60

YHD-3. Similar to above, except 97 dB/mW. . . . \$40

Sennheiser Headphones

Excellence Needs No Explanation.

To learn more about the Sennheiser excellence in design and engineering,
please call or write.

 **SENNHEISER®**

6 Vista Drive, P.O. Box 987
Old Lyme, CT 06371
Tel # 203-434-9190 FAX # 203-434-1759

MICROPHONES • HEADPHONES • BOOM SETS • RF WIRELESS • INFRA-RED TECHNOLOGY

Manufacturing Plant: D-3002 Wedemark, Federal Republic of Germany

CIRCLE NO. 31 ON READER SERVICE CARD

SIGNAL · PROCESSORS

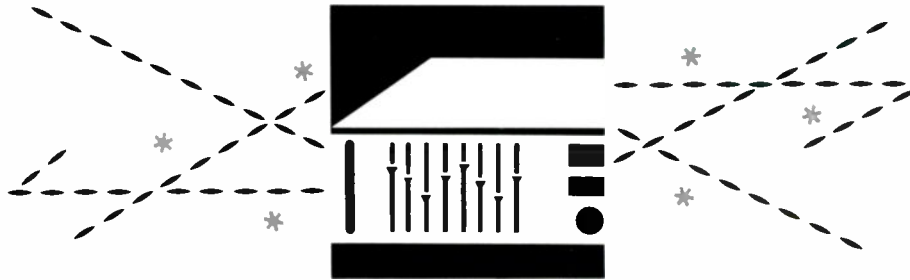

ACCUPHASE BY MADRIGAL

G-18 33-Band Graphic Equalizer

Third-octave stereo graphic equalizer with separate power supply for each ch; fully balanced inputs and outputs; 66 individual filter amps, each with discrete components and operating with constant Q throughout their range of 4.3; champagne-gold or black-anodized finish. Signal-to-noise ratio 110 dB. 17½ x 6½ x 14¾ in; 26 lb, 6 oz. \$5,450

F15L Electronic Crossover

For stereo bi- or tri-amplification; plug-in boards select crossover frequencies and slopes; 0.5 dB-per-step level controls from 0 dB to 20.5 dB for passbands. Signal-to-noise ratio 100 dB; 17½ x 4¾ x 14¾ in; 18 lb, 5 oz. \$4,200

ACE AUDIO

6500-SF Active Crossover

Designed to operate with any pair of stereo subwoofers to provide extra bass below 100 Hz. Features built-in subsonic filter (18 dB/octave below 15 Hz); twin level controls; Bessel filters provide optimum slope and improved group delay; any frequency available from 40-200 Hz; slope 12 dB/octave, distortion typically 0.002% at 2 V output; includes 1 plug-in frequency module. \$200
6500-DSB. Similar to model 6500-SF but without subsonic filter. \$175

6000-SF Active Crossover

Designed for bi- or tri-amplification. Features built-in subsonic filter (18 dB/octave below 15 Hz) plug-in frequency module; built-in power supply; 15 crossover frequencies, 200-10,000 Hz at 12-dB/octave; 2 tweeter level controls. THD and IM 0.002%; input imp 220 kohms; output imp 100 ohms; hum and noise <90 dB; 6 x 4¾ x 2¼ in. \$200
6000. As above without subsonic filter. \$175

6000-6 Active Crossover

Designed for optimum transient performance at any crossover frequency; passes perfect square waves. With 1 frequency module (interchangeable), 6 dB/octave slope, dual level controls. Distortion 0.002%; noise -95 dB; 2¼ x 6 x 4¾ in. \$194

ADC

SS-525X 12-Band EQ/Real-Time Analyzer

Automatic computerized 12-band system/room EQ with channels separate or together. Features real-time spectrum analyzer; dbx technology; remote control; precision 2-dB settings; switchable 18-dB/octave infrasonic (subsonic) filter; microcomputer with 4 memories for storing user-created EQ curves; switchable FL display; electronic rocker-switch frequency controls; left- and right-ch attenuation; 2 tape monitors; 2-way dubbing; EQ record; built-in pink-noise generator; ±13 dB control range. Includes calibrated electret-condenser mike. \$600

SS-325X 12-Band EQ/Real-Time Analyzer

12-band-per-ch equalizer/real-time analyzer with 5

memories for storing user-selected EQ curves. Features microphone; pink-noise generator; stepped EQ controls; narrow-band bass sliders; infrasonic filter; 2-way dubbing; center frequencies at 25, 40, 63, 100, 160, 500, 1,000, 2,000, 4,000, 8,000, and 16,000 Hz. \$400

SS-310 10-Band EQ/Real-Time Analyzer

Slim-line 10-band EQ with real-time analyzer sensitivity control and display. Features 18 dB subsonic filter; ±15 dB control range; pink noise generator and microphone; EQ record; EQ defeat; tape monitors, 2-way dubbing. \$220

SS-300SL 10-Band EQ/Real-Time Analyzer

Slim-line 10-band equalizer/real-time analyzer with microphone and pink-noise test signal for fine tuning speakers and room response. Features ±15-dB control range; large FL display; lighted EQ sliders; step infrasonic (subsonic) filters; 2 tape monitors; 2-way dubbing; center frequencies at 32, 63, 125, 250, 500, 1,000, 2,000, 4,000, 8,000, and 16,000 Hz. \$200

SS110 10-Band Equalizer. Same as above without microphone and pink-noise test. \$150

SS-100SL 10-Band Equalizer

Slim-line 10-band EQ with ±15 dB control range. Features FL RTA display; 18-dB/octave infrasonic (subsonic) filter; EQ record. \$140

SS-90 10-Band EQ/Analyzer

Slim-line 10-band with LED spectrum analyzer. Features EQ defeat; EQ record; tape monitor. ±15 dB control range; FR 20-20,000 Hz ±3 dB; THD 0.03%. \$100

APHEX SYSTEMS

103A Type C Aural Exciter

Used to enhance recordings, broadcasts, and sound systems, recreates and restores missing harmonics. Bandwidth 10-100,000 Hz, ±0.5 dB; noise -96 dBV; total harmonic distortion <0.01%; operating level -10 to +4 dBm; max in/out level +21 dBm; with racks (19-in wide). 1¾ x 17 x 6 in; 4lb, 8 oz. \$299

ARCAM

Arcam Delta D/A Converter

Features 4x oversampling; 16-bit dual D/A converters; motors; servos; displays; microprocessors; shared power supplies. Absolute phase-reversal switch; gold-plated phono sockets. 17 x 10¾ x 2¾ in; 11 lb. Black. \$650
Black Box 2. As above, dealer may install an optical input to the Delta Black Box. Features auto switching from 44.1-to-48kHz for DAT players. \$800

AUDIO CONTROL

C-101 Series Two 9-Band/EQ/Analyzer

Features 9-band stereo graphic equalizer, 101-LED spectrum analyzer display. Center frequencies at 32, 60, 120, 480, 960, 1,920, 3,840, 7,680, 15,500 Hz; ±15 dB boost/cut range. -1 dB subsonic rolloff at 25 Hz, -3 dB rolloff at 20 Hz, -21 dB rolloff at 10 Hz;

phase correlation circuit. Selectable peak-reading modes (fast/slow); horizontal L1D's indicate SPL; switchable calibration levels from 2 dB to 4 dB. Variable input sens; auto mic/line input switching; pink-noise generator; 18 dB/octave subsonic filter; frequency response 3-100,000 Hz ±0.75 dB; distortion 0.009%; signal-to-noise ratio 116 dB; input/output impedance 100k/150 ohms. Dimensions: 6½ x 19 x 3½ in. \$429

Richter Scale III Equalizer/Analyzer/Crossover

Combines 6-band half-octave bass equalizer, warble tone analyzer, programmable Linkwitz-Riley 24-dB/octave electronic crossover. Center frequencies at 22.5, 31.5, 45, 63, 90 and 125 Hz; ±12 dB boost/cut range. Low-frequency (12 dB/octave at 200 Hz) summing circuit for rumble reduction; stereo warble

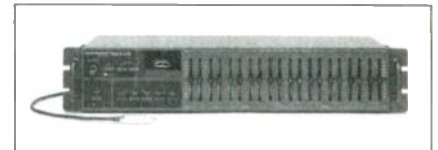

Audio Control Ten Plus Series Two

tone source adjustable to each center band via rotary knob; -20 to +6 dB lighted meter registering mic input; 18 dB/octave infrasonic filter; source/tape monitoring; mono and inverted mono outputs for bridging; gold jacks. Frequency response 3-100,000 Hz ±1 dB; total harmonic distortion 0.005%; input imp 100,000 ohms; output imp 150 ohms, signal-to-noise ratio 120 dB. \$349

Ten Plus Series Two 10-Band Equalizer

Stereo 10-band equalizer; LED indicators in slide controls and warble tone analyzer. Features video sound input and switching; 18 dB/octave infrasonic filter; tape EQ with flashing LED warning indicator; calibrated mike with response curve; sound-pressure meter. FR 3-100,000 Hz ±1 dB; THD 0.07%; S/N 120 dB. \$329

Phase-Coupled Activator/Crossover

Detects and digitally reconstructs fundamental musical frequencies attenuated in the recording processes. Patented circuitry discriminates between sound sources. 18 dB/oct subsonic filter; 18 dB/oct crossover output level. Programmable electronic crossover; in/out switch; tape monitor; sensitivity adjustment; rack mount. FR 5-100,000 Hz ±3 dB; S/N 118 dB; THD 0.005%; IM 0.01%. 2¾ x 17 x 8½ in. \$259

Ten Series Two 10-Band Graphic Equalizer

Stereo graphic equalizer with video/sound input and switching. Center frequencies 31.5, 63, 125, 250, 500, 1k, 2k, 4k, 8k, 16k Hz; boost/cut range max 12 dB; 18 dB/octave infrasonic filter. Features L1D's in slide controls; flashing L1D to indicate when in tape EQ mode. FR 3-100,000 Hz ±1 dB; THD 0.005%; S/N 120 dB, 5-yr warranty. 17 x 3¼ x 7¼ in; 9 lbs; \$229

Octave Equalizer

Equalizer with paired-octave slider controls; tape

SIGNAL PROCESSORS

record EQ. 18 dB/octave subsonic filter. FR 3-100,000 Hz ± 1 dB; S/N 118 dB; THD 0.008%. 2 1/2 x 17 x 6 in; 6 lbs. \$159

AUDIO DESIGN ASSOCIATES

EQ-5 5-Band Graphic Equalizer

Two channel, 5-band equalizer with unity gain controls. Features bypass switch; power switch and indicator; external DC power supply; compact design; standard EIA rack-mountable. Frequencies 37, 109, 675, 1,300, 15,900 Hz; frequency response 20-20,000 Hz ± 3 dB; S/N 85 dB THD 0.05%. 19 x 1 3/4 x 5 1/2 in; 2 lb. \$695

AUDIO RESEARCH

EC-21 Electronic Vacuum-Tube Crossover

Low-frequency, passive high-frequency electronic crossover; features individual low-ch level controls; 9-dB max gain; auto warm-up muting; fixed frequency capacitor kits available. Input imp 100 kilohms; THD 0.003%; outputs match Audio Research power amps; 19 x 6 x 5 1/4 in. \$995

AUDIOSOURCE

EQ-Ten Graphic EQ/Analyzer

12-band-per-channel touch controls. 32-function wireless remote control; pink-noise generator and calibrated electret condenser mic. Self-contained microcomputer programmed to calculate listening room acoustics and adjust the unit's equalization curve. 4 memory frequency response curves. 2 tape connections; dubbing 1-2 and 2-1 with or without EQ; LED display left and right channel's; 12 LED indicators for spectrum analyzer. FR 5-120,000 Hz, ± 1 dB; THD 0.008% at 1V output; control center points 25, 40, 63, 100, 160, 250, 500 Hz/1K, 2K, 4K, 8K, 16kHz, ± 1 dB. 16 1/2 x 3 1/2 x 8 3/4 in; 7 lb, 11 oz. \$430
EQ-Nine. Similar to above, no remote control \$300

SS-One/II Surround-Sound Processor

Dolby-surround processor with variable surround sound effects and built-in 30 W rear-ch amp. Features variable time delay; LED audio-level indicators; preamp outputs; synthesis and matrix stereo/surround for non-Dolby-encoded software; 100, 10,000 Hz boost circuits. FR 20-20,000 Hz, ± 3 dB; S/N 85 dB. 16 1/2 x 2 x 9 1/4 in; 6 lb, 10 oz. \$200
SS-Two. Similar to above with no remote. \$250

AV-Four A/V Selector/Processor

Synthesized surround sound with built-in 15-W/ch amp, 7-band graphic EQ with spectrum analyzer, 5 video/stereo audio inputs, RF in and out. Features DNR; antenna switching, RF modulator. FR 20-20,000 Hz, ± 3 dB; S/N > 80 dB. 16 1/2 x 2 1/4 x 10 in; 8 lb, 13 oz. \$170

AV-Three A/V Selector/Processor

Audio/video fader, enhancer, color, and hue control for 5 video/stereo inputs and outputs. Features spectrum analyzer display; RF in and out; RF modulator; DNR; stereo synthesizer; antenna switching. FR 20-20,000 Hz, ± 3 dB; S/N > 80 dB; chroma phase 45%; chroma level 200%; enhancer 0-9 dB. 16 1/2 x 2 1/4 x 10 in; 6 lb, 11 oz. \$200

EQ-Eight/II Graphic Equalizer

10-band equalizer with 90-LED spectrum display. Features LED's on slide controls; control range ± 12 dB; audio inputs plus second set of inputs for video audio or other high-output source; EQ rec switch; EQ defeat; tape monitor switch. FR 5-100,000 Hz, ± 1 dB; S/N - 80 dB; THD 0.03%. 5 lb; 16 1/2 x 2 3/8 x 7 1/8 in; 5 lb. \$160

CAMBRIDGE AUDIO

DAC 2 D/A Converter

Converter with all demodulating circuitry, digital filtering, and digital-to-analog conversion system for

any compact disc player with a data output. Features a version of the 32-bit, 16-times oversampling system developed by Cambridge. Inputs for two CD players and two DAT players; digital polarity inversion is offered; volume control; discrete Class A headphone amplifier. \$1,099

CARVER

H-9AV Sonic Hologram Generator

Adds lifelike space and dimension to music and video soundtracks. Features Vocal Zoom circuitry, which enhances dialogue centering and audibility; for use with any preamplifier, receiver or integrated amplifier; includes additional L-R and L+R outputs for advanced home video theater installations. THD 0.01%; FR 5-60,000 Hz -0.3 dB; S/N 100 dB. \$300

ECS-U Speaker-Enhancement System

Signal-processor system with Sonic Hologram Generator, High Frequency Trim equalization. Bass "Q" equalization, Gündree Perspective presence equalization and Sub Bass Restoration circuitry. Connects in tape monitor or outboard processor loop of any receiver, preamplifier, or integrated amplifier. THD 0.01%; frequency response 5-60,000 Hz -0.3 dB; signal-to-noise ratio 100 dB. \$300

CELLO

The Audio Palette

Features Class A discrete circuitry; comprised of 48 discrete amplifiers (1 for each frequency); nine 59-notch rotary controls. Center frequencies at 15, 120, 500, 2,000, 5,000, 25,000 Hz; max boost or cut 12 dB; sep input controls for L and R; controls for absolute phase (right 180°, left 180°, 0°, 180°), EQ (out, in, blend), monitor/center (+10 to <-40 dB), and output level (+10 to <-40 dB). \$10,500

Master Power Supply

For the Audio Palette. 120 V AC. \$2,400

CERWIN-VEGA

DB-10B Bass Turbocharger

1 band bass equalizer with subsonic filter below 20 Hz. Features switchable 5/10 dB of bass boost in the range 30-45 Hz; tape monitor connections; effect indicator. THD < 0.025%; rated output 2 V rms; 7 x 14 1/4 x 2 in; 27 oz. \$59

DB SYSTEMS

DB-3-36 In-Phase Crossover

In-phase crossover with power supply. Features high and low outputs always in phase; diode-protected inputs. THD < 0.0008%; input imp 90,000 ohms; output imp 1,400 ohms max; rated output 3 V into 10,000 ohms with 3-V input. \$565

DB-3 2-Way Active Crossover

Fixed frequency active crossovers 6 or 12 dB. Features separate power supply; screwdriver adjustable level controls on outputs. Frequency response 10-100,000 Hz ± 3 dB; signal-to-noise ratio 100 dB; total harmonic distortion 0.003%. Dimensions: 8 1/2 x 3 1/4 x 7 in. Weight: 2.5 lb. \$292
3-way 18 dB \$539
2-way 18 dB \$384
2-way 100 Hz, 18 dB \$322
DB-2A, Power Supply \$85
DBP-1, Auxiliary Cable. \$18

DB-3-24 In-Phase Crossover

24 dB/octave crossover minimizes irregularity in radiation pattern through crossover region. High and low-pass outputs always in phase with each other, 6 dB down at crossover frequency. Requires DB-2A power supply or DBP-1 cable. User specifies frequency. Available in 2-way only. \$490
DB-3-24-100, Standard version of above, set at 100 Hz, with additional common bass \$405

DB-5 Tone Control

Tone controls with 3 high- and 3 low-break frequencies; low-frequency boost switch and outputs for sum and difference signals. FR 10-100,000 Hz ± 3 dB; signal-to-noise ratio 96 dB; THD 0.0008%; IM 0.001%. Requires DB-2A power supply or DBP-1 aux cable if used with existing DB Systems equipment. 8 1/2 x 3 1/4 x 7 in; 2.8 lb. \$380
DB-5AU, Similar to DB-5 with oak cabinet and gold jacks \$465

DB-7 Phase Inverter

Phase inverter and bridging adaptor with supersonic and subsonic filters (18 dB). FR 10-100,000 Hz ± 3 dB; S/N 109 dB; THD 0.003%; IM 0.003%. Requires DB-2A power supply or DBP-1 aux cable if used with existing DB Systems equipment. 6 1/4 x 2 1/4 x 4 1/2 in; 1 lb. \$195

dbx

3BX-DS Dynamic-Range Controller

Controller expands dynamic range of almost any source by 50% and cuts tape hiss, rumble hum, record, and CD noise. Features 3-band individually-controlled expansion/compression level; ambience control. 0 to -50% (2:1) compression; impact restoration gain of 0 to +10% dB each band; dynamic range > 107 dB; 0.15% THD; FR 20-20,000 Hz \$499
1BX-DS Dynamic Range Controller. Same as above without individually controlled 3-band expansion/compression \$279

120X-DS Subharmonic Synthesizer

Synthesizer returns bass lost in recording and can be used as an electric crossover so a subwoofer can be added to your system. Features sampling of all bass frequencies from 54-110 Hz and synthesis corresponding frequencies at 1 octave lower. 4 separate controls adjust bass at any frequency. 0.05% THD; +9 dB subharmonic synthesis; 50-200 Hz adjustable crossover frequency \$299

SNR-1 Single-Ended Noise Reduction System

Single-ended noise reduction system reduces hiss noise from program sources from 20-40 dB. Features variable frequency signal-pass device to eliminate high-frequency noise, surface noise, tape hiss, and background noise; two-way closed-system with no prior encoding required; noise reduction level control with LED meter; variable cutoff frequency; source/tape switch; pre/post and bypass switches. 105 dB dynamic range; 0.1% total harmonic distortion \$279

DENON

DE-70B 12-Band Graphic Equalizer

Features separate rec out and input selectors; 3-position monitor switch; adjustable rate level. FR 10-200,000 Hz +0/-2.5 dB; THD 0.0003% at 1,000 Hz \$500
ACA-36, Wood side panels for DE-70B. \$30

ECLER

Model 83-FAP24 Active Crossover

Four/three way programmable active filter with selectable slope 12 or 18 dB/octave. Balanced inputs; indicator display of selected frequency. FR 10-50,000 Hz, 7 lb. \$923
Model 83-FAP2 2-Way Active Crossover. As above, for 2-way. \$675

Model 83-QEM102 Equalizer

2 x 10-band octave constant Q EQ has lighted gain adjustment controls, with green LED's. FR 20-20,000 Hz; THD < .05%. 5 lb. \$588

FISHER

ASR-875 Surround-Sound System

Surround system includes CAV-875 surround-sound processor/amplifier with wireless remote control and

SIGNAL • PROCESSORS

WS-460 surround speakers. Processor features Dolby Surround processing; simulated, hall, and stadium surround effects, switchable 10, 20, 30, 40, or 50 ms delay; 4 sets stereo video inputs; 2 sets stereo video outputs; 1 aux input; 1 tape monitor; 24-function remote control. Each speaker features a 6½-in woofer and a 3-in tweeter. 30 W/ch into 8 ohms; FR 20-20,000 Hz; THD < 0.5%. \$399

FOSGATE-AUDIONICS

DSM-3610 Pro Plus Surround Processor

High-separation surround processor with proprietary ProPlus logic circuitry. Features remote control; subwoofer output; side-channel outputs; left front, center front, right front, and left/right surround channels; ultra-low-noise variable time delay; bass EQ circuitry; operating modes for Dolby Surround and high-separation enhancement of regular stereo music sources; 4 A/V input; tape monitor. FR 2-300,000 Hz ± 1 dB. 17¼ x 2¾ x 12 in; 12 lb \$1,429

DSM-3608. Similar to 3610 without side channel outputs and A/V switching; includes 40 W/ch surround amplifier \$999

DSM-3606. Similar to 3608, without variable time delay and infrared remote control. \$629



Fosgate-Audionics DSM-3608

GOLDSOUND

30M8 30-Band Spectrum Analyzer

Portable ½ octave, 30-band real-time spectrum analyzer with 8 measurement memories. Features LED monitor to measure 25-20,000 Hz FR from 32 to 128 dB; flat, A and C weighting; line and mic input; calibrated, omni, detachable microphone with internal 12 V rechargeable battery and external recharger. \$649

Pink noise generator \$79

High SPL model measures 52-153 dB \$849

GS424 EQ Active Crossover

Rack-mount unit with black anodized aluminum front panels and smoked plexiglass security covers. Features 4-ch bi-amp; fixed bass EQ; subsonic filter; stereo output; variable frequency setting; 12 high-pass, low-pass, and midrange controls; Linkwitz-Reilly filters. S/N 102 dB; THD 0.02%; input 0.75 V \$484

GS424 Active Crossover

Rack-mount unit with black anodized aluminum front panels and smoked plexiglass security covers. Features 4-channel bi-amp; stereo output; variable frequency setting; 12 high-pass, low-pass, and midrange controls; Linkwitz-Reilly filters. Signal-to-noise ratio 102 dB; total harmonic distortion 0.02%; input 0.75 V \$424

GS224 EQ Active Crossover

Rack-mount unit with black anodized aluminum front panels and smoked plexiglass security covers. Features fixed bass equalization; subsonic filter; stereo output; variable frequency setting; 6 high-pass and low-pass controls; Linkwitz-Reilly filters. S/N 102 dB; THD 0.002%; input level 0.75 V; 24 dB slope \$384

GS224 Active Crossover

Rack-mount unit with black anodized aluminum front panels and smoked plexiglass security covers. Features stereo output; variable frequency setting; 6 high-pass and low-pass controls; Linkwitz-Reilly filters. S/N 102 dB; THD 0.002%; input level 0.75 V; 24 dB slope \$324

HARMAN KARDON

EQ8 10-Band Graphic Equalizer

Graphic equalizer with continuously variable subsonic filter (5-30 Hz, 6-dB/oct). Center frequencies for each channel at 31.5, 63, 125, 250, 500, 1,000, 2,000, 4,000, 8,000, 16,000 Hz; ± 12 dB boost/cut range. Features separate L/R input controls and overload LED's; tape monitor; EQ defeat/rec. FR 5-140,000 Hz, +0, -3 dB; THD 0.02%; S/N 105 dB. 17¾ x 4 x 13¾ in; 12 lb \$329

HEATH

AD-2550 Surround-Sound Processor

Surround-sound processor with six audio outputs and two stereo inputs. Features Dolby Surround, music surround, and mono enhance modes; 20-W amplifier; one-step adjustment; Dolby B NR. FR 18-40,000 Hz ± 0.5 dB; THD 0.05%, front, 0.38%, surround. 17 x 2¾ x 8½ in; 12 lb \$200

HITACHI

HGE77SW 10-Band EQ/Spectrum Analyzer

Stereo graphic EQ with FL spectrum analyzer. Features EQ on/off switch; EQ rec on/off; tape monitor; LED for each level control. THD 0.05%; FR 20-20,000 Hz; S/N 96 dBA. Rosewood end caps \$270

INTERNATIONAL COMPONENTS

VSP3600 A/V Surround Processor/Decoder

A/V surround processor/decoder with built-in 10 W surround amplifier and dynamic NR. Features surround compatible matrix decoding circuitry. Variable time delay; stereo synthesizer/expander; surround output jack; master volume control; tape output jacks; input-level indicators; gold-plated connectors. Up to 40 dB front-to-rear sep \$207

VSP2400 A/V Surround Processor/Decoder

Hooks up to main front-channel amp and rear-channel amp to provide surround processing. Features 10µsec time delay; input level LED indicators; gold-plated connectors. Up to 60 dB front-to-rear separation \$113

VSS1800 A/V Surround Simulator

Compatible with any solid-state Amplifier; extracts simulated surround ambience from any stereo source, and requires only an additional pair of rear speakers and speaker wire. Features surround-level control; noise eliminator. 6 x 2½ x 4¾ in \$35

JRM

PEM Preamplifier/Equalizer/Mixer

Stereo disco mixer made up of JRM preamplifier and remote unit with separate cross-fade for master and cue bus. Features 3 phono, 3 tape, 3 aux, 2 mic, tuner, bus expander; defeat mic record; 3-band A/B pre-EQ; 6-band master EQ; 4-band monitor EQ; 2-band mic and headphone EQ; 10-step bi-modal LED readout; individually buffered outputs: 3 tapes, 2 main, 2 monitor, 2 mono, 2 headphone jacks. 13 x 18 x 3 in \$1,300

Model 3BPB/X8 Active Crossover

Crossover with user selectable 2, 3, 4-way stereo. Features 18 dB/octave crossover slopes; all polypropylene capacitors; electromechanical devices gold-plated; infra- and ultra-sonic filters; independent high-, low-pass frequency selection; plug-in modules frequency setting; stereo/mono subwoofer outputs; 8 level controls. S/N ratio 94 dB; THD 0.01%. 2¾ x 7½ x 19 in \$750/pr

Low frequency module (2nd-order inverse high-pass filter) \$25

Model 3BPB/X4 Active Crossover

As above with 2-way stereo. 2¾ x 7½ x 13 in \$450

Remote Unit Equalizer

EA with 6 bands/ch and separate L/R controls. Features gyrator circuits; 2% polypropylene capacitors; electromechanical devices gold-plated; continually variable loudness range -35 dB; switched resistor EQ and balance controls; unity gain control. Requires JRM preamplifier or 3BPB crossover as base unit. S/N 98 dB; THD 0.01%; FR 4-50,000 Hz -3 dB. 5 x 9½ x 1½ in. \$350

JVC

XPA1000BK Acoustics Processor

Acoustics processor for accurate recreation of original spatiality. Features LSI for digital signal processing; digital processing using 16-bit quantization and 48 kHz sampling; 4x-oversampling D/A converter; 64x-oversampling A/D converter; direct digital inputs and outputs (optical and coaxial); 20 programmed sound-field patterns; 20 user-programmable sound-field patterns; compensation for ambience of listening room and source program; 4/6-ch system configuration selectable; motor-driven remote-controlled with volume control; FL display; multi-function remote control \$1,200

XPA1010TN. Same as above in black \$1,200

SEAM770BK 7-Band Graphic Equalizer

Electronic 7-band graphic equalizer with wireless remote control. Features 7 frequency equalizer controls per channel; 6 user preset equalizations; 6 programmed preset equalizations; computer-controlled electronic equalization. Remote control functions include adjusting frequency response; recalling a preset equalization; memorizing of user-programmed EQ curves; adjusting volume; fade-muting sound; initiating preset scan; selecting transfer, reverse, or flat response \$400

SUA400 A/V Surround-Sound Processor

A/V surround processor with wireless remote and front and rear volume controls. Features Dolby Surround; hall; simulated surround; left-right calibration and delay-time controls. Built-in power amp with 10 W/ch driven into 8 ohms from 40-20,000 Hz with no more than 0.5 THD. Headphone jack \$305

SUA30 A/V Surround-Sound Processor

Surround-sound processor with three surround effects including Dolby Surround, hall surround, and simulated surround. Features built-in amplifier; left/right calibration and delay-time controls; volume control for rear speakers; preamplifier-level output for external power amplifier; headphone jack for surround sound headphones. Power output: 10 W/ch into 8 ohms from 40-20,000 Hz with no more than 0.5% THD \$235

KENWOOD

GE-1100 12-Band Graphic EQ/Analyzer

Graphic equalizer with 12-band spectrum analyzer, built-in reverb. Center frequencies for each channel at 16, 32, 64, 125, 250, 500, 1,000, 2,000, 4,000, 8,000, 16,000, 32,000 Hz; ± 12 dB boost/cut range; L/R or L + R display selector; LED slide controls; time delay and depth controls; two tape monitors with bidirectional dubbing and monitoring; normal/reverse EQ selector; -6 dB attenuator. FR 10-50,000 Hz +0, -1 dB; THD 0.005%; S/N 105 dB. 17¾ x 6½ x 13¾ in; 13.6 lb \$449

GE-5010 7-Band Graphic EQ/Analyzer

Graphic equalizer featuring 7-band spectrum analyzer, 10-curve memory, and two FL displays. Center frequencies for each channel at 60, 150, 400, 1,000, 2,400, 6,000, 15,000 Hz with switchable ± 6 and ± 12 dB boost/cut range. FR 10-100,000 Hz +1, -3 dB; THD 0.006% @ 1,000 Hz; S/N 100 dB. 17¾ x 3½ x 10¾ in; 8.5 lb \$249

SS-78 A/V Surround Processor

Features Dolby Surround/Theater/Hall effects; ad-

SIGNAL • PROCESSORS

justable front/rear delay time; 15 W/ch amp for rear speakers; FL display; 2-way video dubbing; tape-monitor switch. FR 40-6,000 Hz \pm 3 dB (Dolby); S/N 62 dB @ 1,000 Hz. 17 $\frac{1}{2}$ x 2 $\frac{1}{2}$ x 10 $\frac{1}{2}$ in.; 7.7 lb \$249

Spectrum Series

GE-48 7-Band Graphic Equalizer

Center frequencies for each channel at 60, 150, 400, 1,000, 2,400, 6,000, 15,000 Hz; \pm 10 dB boost/cut range. Features EQ on/off switch; tape/source selector with LED indicators. FR 10-35,000 Hz \pm 0.5, -3 dB; S/N; THD 0.006% @ 1,000 Hz \$99

KINETIC AUDIO

3-Point Crossover/Level Control

Monophonic passive crossover/level control system that keeps low frequencies from entering miniature monitor and satellite speaker systems. Can be built into Kinetic speakers. Features mid-high-pass filter; crossover level control; converts 4- to 8-ohm load. Crossovers 65, 90, 180 Hz \$150

4-Point Low-Pass/Crossover

Monophonic passive crossover to be used with subwoofer for filtering out unwanted midrange and high frequencies. Can be built into Kinetic subwoofers. Crossover points are 60, 90, 180, and 350 Hz; imp 6-8 ohms. 4 x 15 x 10 in.; 15 lb \$150

KRELL DIGITAL

SBP-64X 18-Bit D/A Converter

Krell's digital proprietary "waveform replicator" with 4 Motorola DSP-56001 digital signal processors (2/ch) providing 64x oversampling. Features dual 18-bit D/A converters operating in parallel; separate outboard power supplies for the digital, analog, and D/A converter circuits. Single-ended and balanced outputs; auto selection of input frequency for 32, 44.1, and 48 kHz. Dynamic range > 300 dB; S/N 110 dBA \$8,950

SBP-16X 18-Bit D/A Converter

Krell's digital proprietary "waveform replicator" with 2 Motorola DSP-56001 digital signal processors providing 16x oversampling. Features dual 18-bit D/A converters operating in parallel; separate outboard power supplies for both the digital and analog circuits. Auto selection of input frequency for 32, 44.1, and 48 kHz. Dynamic range > 300 dB; S/N 100 dBA \$3,200

LEXICON

CP-1 Digital Environment Processor

Digital processor with auto azimuth error correction for Dolby Surround. Features ambience extraction; ambience synthesis; reverb; 32-character alphanumeric display; 12-segment headroom display; 2 backlit mute indicators. S/N 85 dB; imp 50 kilohm input, 500 ohm output. 17 x 2 $\frac{1}{2}$ x 12 $\frac{1}{2}$ in.; 11 lb \$1,295

CP-2 Digital Surround Processor

Digital processor with auto azimuth and auto input balance. Features music logic; 6 outputs; remote control; 16-bit D/A converters; polypropylene capacitors; 13 backlit status indicators; 12-segment parameter display. S/N 85 dB; imp 50 kilohm input, 500 ohm output. 17 x 2 x 12 in.; 11 lb \$995

LT SOUND

CLX-2 Compressor/Limiter/Expander

Features stereo and independent compression or limiting; de-emphasis circuit; noise gating; keyed expansion/gating; knee-type compression switchable in/out; external modulation jacks for tremolo and panning effects (requires external oscillator). Frequency response 20-40,000 Hz \pm 5 dB; THD < 0.003%; S/N > -90 dB; dynamic range > 115 dB; max input +25 dB \$895

RV-2 Stereo Reverberation Unit

Reverb unit compatible with any send/receive bus level. Features the sound of two different plates and an acoustic chamber simultaneously in stereo; microplate reverb with FR > 18,000 Hz; electronically adjustable decay; 90 dB reverb dynamic range. FR 2-40,000 Hz \pm 5 dB, reverb 20-18,500 Hz \pm 2 dB; input imp 47 K unbalanced; S/N > 90 dB. 19 x 1 $\frac{3}{4}$ x 7 $\frac{1}{4}$ in. \$895

Tape Noise Reduction Units

All noise-reduction units are compatible with the dbx NR system and any open-reel tape deck, have a user adjustable level from -10 to +4 dB, have simultaneous encode/decode, are rack-mountable, and are available in hardwired versions. S/N > -90 dBm; FR 20-20,000 Hz \pm .75 dB; THD < 0.15% at 1,000 Hz.

NR-8, 8-channel version \$795
NR-4, 4-channel version \$475
NR-2, 2-channel version \$275

PEQ-2 Dual 4-Band Parametric Equalizer

4-band parametric EQ with 2 control frequencies at 25-3,000 Hz, and one each at 85-13,000 and 125-20,000 Hz. Features output capable of driving 600 ohm loads; phone or RCA jacks; optional peak-dip or shelving response on upper and lower bands. FR 20-20,000 Hz \pm .5 dB, 2.2-100,000 Hz \pm 1 dB; S/N > 90 dB; slew rate 13 V/ μ sec. 19 x 3 $\frac{1}{2}$ x 7 $\frac{1}{8}$ in. \$595
PEQ-1. As above, single-channel version, no low-frequency rumble filter \$349

SL-2 Stereo Limiter

Features 2 channels; compression and expansion noise gate capability; compressor and expander work simultaneously; de-emphasis circuit; stereo or independent control available with front panel switch. S/N > 90 dB; FR 20-20,000 Hz \pm .5 dB; THD < 0.03%; slew rate 13 V/ μ sec. 19 x 1 $\frac{3}{4}$ x 7 $\frac{1}{4}$ in. \$395

ECU-2 Electronic Crossover

Electronic crossover capable of stereo bi-amping and stereo tri-amping. Features phase inversion switches; high slew rate Bi-FET integrated circuits; switchable 1.5 Hz or 30 Hz rumble filter; low crossover point 75-1,100 Hz; mid/high crossover point 75-1,100 Hz in 1x range, and 750-11,000 Hz in 10x range. S/N > 90 dB; THD < 0.007%; IM < 0.003%; filter slope 12 dB/octave. 19 x 2 x 7 $\frac{1}{4}$ in. \$295

LUXMAN

F-105 Surround-Sound Processor/Amp

Surround sound processor with 25 W/ch amplifier for rear speaker applications. Features Dolby Surround, time-delay surround with adjustable 10-35 ms delay, matrix-surround, and simulated stereo modes. Rear bass/treble/balance/volume, center-channel controls; master volume level indicator; muting, audio/video dubbing buttons/indicators; unified remote control. Amp section: 25 W/ch cont avg from 20-20,000 Hz into 8 ohms; total harmonic distortion 0.05%; signal-to-noise ratio 64 dB (20 msec time-delay). 17 $\frac{1}{4}$ x 3 x 11 $\frac{1}{8}$ in.; 13 lb \$600

G-111 10-Band Graphic Equalizer

Graphic equalizer with 10-band spectrum-analyzer display. Center frequencies for each channel at 31, 62, 125, 250, 500, 1,000, 2,000, 4,000, 8,000, and 16,000 Hz; \pm 12 dB boost/cut range. Features Duo-Beta dual feedback-loop amp circuitry to widen bandwidth and improve transient response. Display-level control; tape-1/tape-2 indicators; pre-equalized recording button; tape monitor and dubbing buttons. FR (all controls @ 0-dB) 7-100,000 Hz -1 dB; THD (all inputs) 0.0035%; S/N 112 dB. 17 $\frac{1}{4}$ x 3 x 9 $\frac{1}{4}$ in.; 6.6 lb \$250

McINTOSH

MQ 107 Custom Equalizer

Features 14 programmable filters, 7 per channel. 9 lb, 8 oz \$500

MQ 104 Custom Equalizer

Features 8 programmable filters, 4 per ch \$500

MARANTZ

CDA-94 Outboard D/A Converter

Used with CD players and other digital components providing digital output. When used with Marantz CD94, eliminates ground loops, contact rectification; accepts 2 wired digital inputs with additional input and output connectors for DAT tape deck; automatically selects correct sampling rate for DAT deck; fixed and variable line outputs, adjustable headphone level and balanced XLR-3 outputs for broadcast and professional applications. \$1,700

EQ 551 10-Band Graphic Equalizer

10-band EQ with separate controls for left and right channels and equalized tape output. Calibrated mic included. FR 20-40,000 Hz \pm 3 dB; THD 0.005%; S/N 80 dB. 2 x 16 $\frac{1}{2}$ x 7 $\frac{1}{8}$ in.; 6 lb \$250

SQ 2294CB Surround-Sound Processor

Features independent front and rear equalizers; 2 x 25 W built-in rear amp \$230

EQ 2293CB 10-Band Graphic Equalizer

10-band graphic equalizer with tape monitor and defeat SW; uniphase low distortion \$150

EQ 130 10-Band Graphic Equalizer

10-band graphic equalizer with separate controls for each channel. 2 $\frac{1}{2}$ x 16 $\frac{1}{2}$ x 8 in.; 5 $\frac{1}{2}$ lb \$130

EQ 2292CB 7-Band Graphic Equalizer

7-band graphic equalizer with tape monitor; low noise circuit design. \$100

MARK LEVINSON

LNC-2 Electronic Crossover

Modular system for frequency division of line-level signals; 4 active filters (2 high pass, 2 low pass); on/off switch for each high- and low-pass filter, internal stereo/mono switch and Camac connectors; hand-brushed and black anodized finish; 18 dB/octave slopes, optional 6 dB or 12 dB slopes for 3-way stereo operation; output level of each frequency response controlled by 10-turn locking potentiometer on front panel. Total harmonic distortion 0.002%; wideband noise < 102 dBV unwt'd; accuracy within 5% of specified crossover point; PLS-151 separate power supply load regulation 0.05%; wideband noise output 18 μ V. LNC-2 dimensions: 2 $\frac{1}{4}$ x 19 x 7 $\frac{1}{8}$ in. PLS-151 dimensions: 4 $\frac{3}{8}$ x 4 x 10 $\frac{1}{8}$ in.; 12 lb \$3,500

MELOS AUDIO

Analog/Digital Processor

Two-chassis tube analog/digital processor with "theater" design. Features digital processor with 8x oversampling and 18-bit D/A converter; analog and digital output filter; fixed line outputs. FR 20-20,000 \pm 0.2 dB; S/N 90 dB; THD 0.07% \$2,300

MEMOREX BY MEMTEK

DSS-100 Dolby Surround-Sound System

Home theater system with DS-10 amplifier and a pair of Memorex Series 10 speakers. Includes audio patch cables and speaker wire \$250

The listings are based on data provided by the manufacturers. For more product information, contact an authorized dealer or the manufacturer directly. Manufacturers' addresses and phone numbers are listed in the directory beginning on page 258.

SIGNAL • PROCESSORS

DS-10 Surround-Sound Decoder

Decoder reproduces Dolby Surround. Features 20 watts/channel through user's two rear speakers, or can be used as a stand-alone audio amplifier providing 5 W/ch to front and rear speakers; choice between Dolby Surround or stereo mode for non-surround encoded stereo programs; input balance control; front/rear balance. Flat black finish with gold lettering. \$130

Cordless Headphone Adaptor

Infrared transmitter beams any audio source to a special receiver module that can accept all mini-plug headphones. \$70

NAKAMICHI

Model 1000p Digital Audio Processor

Features 8x oversampling, 20-bit calibrated D/A converters; 16-bit auto-calibrated A/D converter; 2x oversampling digital filter; digital glitch cancellation circuitry; 2-speed twin-PLL digital audio interface; dual-deck capability. 32-segment digital level meter; digital muting circuitry; headphone jack; phono loudness control; audio cables included. D/A converter section: sampling frequencies 48,000/44,100/32,000 Hz; FR 5-20,000 Hz, ± 0.5 dB; S/N > 106 dB; dynamic range > 100 dB; THD 0.0005% at 1,000 Hz; ch sep > 106 dB. A/D converter section: sampling frequency 48,000 Hz; FR 5-22,000 Hz, ± 0.5 dB; S/N > 95 dB; dynamic range > 95 dB; THD 0.001% at 1,000 Hz; ch sep > 85 dB. 17 $\frac{1}{8}$ x 5 $\frac{1}{4}$ x 14 $\frac{3}{8}$ in.; 38 lb, 9 oz. \$4,600

NEC

PLD-910 Dolby Pro-Logic Decoder

Features L/R independent dual 16-bit digital delay circuit (1.0 μ sec-94 μ sec/0.1m step); Dolby Pro-Logic Surround; Creation Surround; 41-key wireless remote control; quadruple-oversampling digital filter; built-in test-tone generator. FIP indicator; input/output terminals; noise sequencer; Analog section: FR 10-100,000 Hz, -3dB; THD < 0.005%; S/N > 100 dBA. Digital section: FR 10-20,000 Hz, ± 1 dB; THD < 0.008%; S/N > 90 dBA. 17 x 3 $\frac{3}{8}$ x 13 $\frac{3}{8}$ in.; 17 lb, 6 oz. \$999

PLA-710 Dolby Pro-Logic Decoder

Features three-channel amplifier (F/R 30W x 2, Center 60W x 1). Adjustable digital delay; sound and recording selector; over input indicator; motorized master volume; on-screen adjustable function. \$699

PLD-710 Dolby Pro-Logic Decoder

Features L/R independent digital delay adjustment, recording selector, input level control and a test-tone generator; on-screen adjustable function; I/O terminals; S-terminal \$599

PLD-310 Dolby Pro-Logic Decoder

Active surround decoder featuring 4-channel sound encoded in video software and routes it to the left, right, center, and surround channels. Digital delay time 20 μ sec; built-in test tone generator. selectable center channel modes; 24-key wireless remote control. Analog section: FR 16-40,000 Hz, -2 dB; THD 0.01%; S/N 100 dB. Digital section: FR 10-70,000 Hz, -3 dB; THD 0.4%; S/N 70 dB. 17 x 2 x 13 $\frac{3}{8}$ in.; 12 lb, 13 oz. \$449

Renaissance Series

AVD-700E Surround-Sound Processor

Remote-controlled 16-bit digital-delay surround-sound processor with Dolby, hail, matrix, and creation surround circuits. Features inputs for up to 10 video and 5 audio sources; mix-and-match of any video with any audio source; master level control; reset button to set all volume levels to -40 dB without affecting any presets; volume indicators that indicate display levels of front and surround sound channel by channel. Analog section: FR 10-100,000

Hz, +0, -3 dB; S/N 100 dB; THD 0.005%. Digital section: FR 10-20,000 Hz +5, -1 dB; THD 0.02% 17 x 3 $\frac{3}{8}$ x 13 $\frac{3}{8}$ in.; 16 lb, 2 oz. \$729

AVX-910 Surround-Sound-Switcher Processor

A/V switcher with surround sound. Features inputs for CD, tuner, two aux, tape, two A/V, two S-video; outputs for tape and S-video, S-monitor, S-record; digital NR; digital memory. FR 5-100,000 Hz, +0, -3 dB; 17 x 3 $\frac{3}{8}$ x 13 $\frac{3}{8}$ in.; 15 lb, 15 oz. \$699

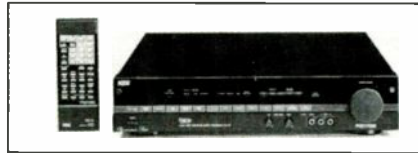

NEC PLD-710

NIKKO AUDIO

EQ-950 10-Band Equalizer/Analyzer

Graphic equalizer/spectrum analyzer with a spectrum display of separate or combined L/R equalizer settings. Features pink-noise generator; mic for EQ slope; EQ bypass; source selector; tape in/out. Center frequencies 31.5, 63, 125, 500, 1,000, 2,000, 4,000, 8,000, 16,000 Hz. \$329

NUMARK

NR-400 Noise-Reduction Processor

Noise reduction unit for audio tape through expansion. Features record and playback dials for level calibration; power; tape; aux and bypass buttons. FR 10-30,000 Hz; sens 58 mV; imp 47 ohms. 17 x 1 $\frac{3}{4}$ x 7 $\frac{1}{2}$; 10 lb. \$340

ONKYO

EQ-240 7-Band Graphic Equalizer

Graphic equalizer with 7 bands for each channel and spectrum analyzer display to show combined levels. Center frequencies at 64, 160, 400, 1,000, 2,500, 6,300, and 16,000 Hz; ± 10 dB boost/cut range. Features LED level controls; EQ-bypass and monitor/tape-source switches. Total harmonic distortion 0.01%; signal-to-noise ratio 100 dB. 17 $\frac{1}{8}$ x 2 $\frac{3}{4}$ x 10 $\frac{1}{8}$ in.; 6.4 lb. \$240

EQ-140 7-Band Graphic Equalizer

Graphic equalizer with 7 bands for each channel. Center frequencies at 63, 160, 400, 1,000, 2,500, 6,300, and 16,000 Hz; ± 10 dB boost/cut range. Features EQ-bypass and tape monitor switches; LED level controls. THD 0.01%; S/N 100 dB. 17 $\frac{1}{8}$ x 2 $\frac{3}{8}$ x 10 in.; 5.3 lb. \$150

Integra Series

Integra EQ-540 12-Band Graphic Equalizer

Graphic equalizer with 12 bands for each channel and test-tone generator. Center frequencies at 16, 32, 64, 125, 250, 500, 1,000, 2,000, 4,000, 8,000, 16,000, 32,000 Hz; switchable ± 12 or ± 6 dB boost/cut range. Features LED level controls; fixed and stepped-sweep test-tone modes; peak-hold mode; calibration microphone; FL display with frequency readout; input attenuator. Total harmonic distortion 0.01%; signal-to-noise ratio 100 dB. 17 $\frac{1}{8}$ x 3 $\frac{1}{2}$ x 14 $\frac{3}{8}$ in.; 10 lb. \$400

Integra EQ-35 12-Band Graphic Equalizer

Graphic equalizer with 12 bands for each channel and test-tone generator. Center frequencies at 16, 32, 64, 125, 500, 1,000, 2,000, 4,000, 8,000, 16,000, and 32,000 Hz; switchable ± 12 dB or ± 6 dB boost/cut range. Features LED level controls; signal generator for all center frequencies except 16 and 32,000 Hz; step or sweep test-tone modes; operation mode display; Delta power supply. Black finish. THD 0.01%; S/N 100 dB. \$330

PHILIPS

DAC 960 D/A Converter

D/A converter optically coupled to digital filters. Features 3 separate power supplies with 3 individual transformers; copper heat sinks; ceramic power capacitors; outputs with 2-stage muting; die-cast chassis. DAT compatibility; optical digital input with supplied fiber-optic cable; phase-inverter control; shock-absorbing feet; headphone amplifier with volume control. Frequency response 2-20,000 Hz; amplitude linearity ± 0.01 dB; signal-to-noise ratio > 101 dB; dynamic range > 96 dB; channel separation > 100 dB at 1,000 Hz; total harmonic distortion < 0.0015% at 1,000 Hz; intermodulation distortion -90 dB (at maximum output level). Dimensions: 3 $\frac{1}{2}$ x 16 $\frac{1}{8}$ x 13 $\frac{1}{4}$ in. Weight: 18.7 lb. \$949

RV-450 Surround-Sound Amplifier

Features Dolby Pro Logic processor with digital audio delay; 2 center-channel modes (normal for TV speakers and wide range for full-range speakers); switchable center channel outputs to discrete or phantom modes; input calibration controls that match the decoder to the source; matrix and hall surround modes; test-tone generator; 2 sets of surround outputs; master system volume control with adjustable center; surround volume controls; individual left and right input volume controls. 15 W/ch into 8 ohms. \$379

PIONEER

VSP-555 Surround-Sound Processor

Digital surround-sound processor with built-in amplifier and remote control. Features Dolby, stadium, and simulated surround modes; digital delay; audio/video switching and connections; 38 watts/ch amplifier at 8 ohms from 30-7,000 Hz with < 5% total harmonic distortion. \$375

GR-777 10-Band Graphic Equalizer

10-band graphic EQ with boost/cut of ± 10 dB and remote control. Features center frequencies of 32, 63, 125, 250, 500, 1,000, 2,000, 4,000, 8,000, and 16,000 Hz; 10-band spectrum analyzer; 5 programmable EQ patterns; 5 resident EQ patterns. \$370

EX-9000 Dynamic Range Expander

Features dynamic-range expansion; noise-reduction effect; FL level indicator; input-level control; tape monitor switch; black finish. Center frequencies 50, 500, 5,000 Hz; attack time 4.7 ms; release time 2.7 ms/6.8 ms switchable. 2 $\frac{3}{8}$ x 16 $\frac{1}{2}$ x 3 $\frac{3}{8}$ in. \$270

GR-555 7-Band Graphic Equalizer

7-band graphic EQ with boost/cut of ± 10 dB. Features center frequencies of 60, 150, 400, 1,000, 2,400, 6,000, and 15,000 Hz; 7-band spectrum analyzer; tape monitor. \$225

SR-60 Reverberation Amplifier

Features solid-state circuit; reverb, echo, and duet effects; visual display; tape monitor; black finish. Reverb time 0-3 seconds; delay time 100 ms (duet). 3 $\frac{3}{8}$ x 16 $\frac{1}{2}$ x 13 $\frac{3}{8}$ in. \$225

GR-470 7-Band Graphic Equalizer

7-band graphic equalizer with slide controls and LED indicators. Black finish. Center frequencies at 60, 150, 400, 1,000, 2,400, 6,000, and 15,000 Hz. 2 $\frac{3}{8}$ x 16 $\frac{1}{2}$ x 8 $\frac{3}{4}$ in. \$120

REALISTIC

31-2020 10-Band Equalizer/Analyzer

10-band/ch EQ with spectrum analyzer; IMX spatial expander; tape I and 2 in/out. S/N 95 dB. 16 $\frac{1}{4}$ x 2 $\frac{3}{8}$ x 8 $\frac{1}{2}$ in.; 6 lb. \$130

31-2018 10-Band Graphic Equalizer

10-band/ch EQ with IMX spatial expander. S/N 95 dB. 13 $\frac{3}{4}$ x 2 $\frac{1}{2}$ x 5 $\frac{3}{4}$ in. \$80

SIGNAL • PROCESSORS

ROGERS

AF510 Mono Electronic Crossover. Black . . . \$599

SAE

E102 10-Band Equalizer

Graphic equalizer with a real-time analyzer and pink-noise generator circuit. Features tape EQ; bar graph spectrum analyzer LED display. Tape monitor; bypass of EQ function; individual L/R ch contour analysis adjustment of display; defeatable illuminated sliders. 19 x 3½ x 13 in. \$499

SANSUI

DS-77 A/V Surround-Sound Processor

Provides amplification for rear channel and center front for A/V sound. Features super bass synthesizer; peak attacker; simulated stereo; built-in amp delay memories. Decodes specially encoded video tapes. FR 20-20,000 Hz ± 3 dB; THD 0.09%; delay time theater and hall 20 m/sec; 10 W/ch for rear speaker drive. 17 x 3 x 9½ in; 8.6 lb \$400

RA-1000 BBD Reverb Amplifier

Features 2 cassette inputs; bidirectional dubbing facilities; twin mic mixing facilities with separate volume controls for duet effect; color display of reverb effect. Reverb time: echo 0-4.5 sec, dual 30-200 m/sec. THD 0.025%. 17 x 4½ x 10¾ in; 3.7 lb \$300

SE-3000 10-Band Graphic Equalizer

10-band graphic equalizer with real-time spectrum analyzer. Center frequencies from 32-16,000 Hz; ± 12 dB boost/cut. Features line, tape, and CD/aux inputs. THD 0.008%; S/N 110 dB. 4½ x 17 x 8¾ in; 6.8 lb \$290

SE-2000 7-Band Graphic Equalizer

Center frequencies at 60, 150, 400, 1,000, 2,400, 6,000, 15,000 Hz; ± 12 dB boost/cut. Features EQ on/off switch. THD 0.03%; S/N 95 dB. 17 x 3¾ x 8¾ in; 5.5 lb \$120

SE-1000 7-Band Graphic Equalizer

Center frequencies at 60, 150, 400, 1,000, 2,400, 6,000, 15,000 Hz; ± 12 dB boost/cut; THD 0.03%; S/N 75 dB; 3¾ x 17 x 8¾ in; 4.9 lb \$90

SCOTT

EQ400 10-Band Graphic Equalizer

10 bands per ch; spectrum analyzer; center frequencies at 31.5, 63, 125, 250, 500, 1,000, 2,000, 4,000, 8,000, 16,000 Hz; ± 10 dB boost/cut range; delay circuit variable up to 20 msec; tape-monitor circuit; EQ rec switch. 17½ x 3¾ x 7¾ in. \$150

SHERWOOD



Sherwood ES-1280

ES-1280 20-W/ch Surround-Sound Amplifier

Features Ambisonics; Dolby surround; delay time 15-30 µsec; 4 hall/room simulations; stereo simulation. THD 0.3%; S/N 86 dB \$229

EQ-1330 9-Band Graphic Equalizer

Features ± 12 dB boost/cut; tape monitor; variable center frequencies. THD 0.025%; S/N 95 dB . . . \$129

SHURE

Shure HTS5300 Acra-Vector Logic Decoder

Dolby Surround audio processor. Acra-Vector Logic

decoder and variable digital time delay (memory doubled, 5-12 dB quieter than Shure HTS5200). Features Acoustic Space Generator; built-in Precision Test Generator; image analyzer display; refined remote; gold connectors and cables \$1,250

Shure HTS50SPA Signal-Processing Amplifier

Direct link between decoder and speaker. Features baffle diffraction; speaker driver modes for each channel; dynamic excursion protection; bass-extension capability; matched crossover components; thermal and short circuit protection, auto reset; 6 output transistors per channel; toroidal transformer; bridgeable for double power single channel mode; gold-plated connectors. \$1,250

Shure HTS60RX Remote Extender

Separate infrared-sensor-eye package for use with HTS5300 when decoder is installed in concealed location. 1 x 2¾ x 3¾ in \$99

SONOGAPHE BY CONRAD-JOHNSON

SX1 Active Crossover

Electronic crossover consists of 24 dB/octave low-pass and 12 dB/octave high-pass filters set at 110 Hz. Features high-pass filter with FET design; polystyrene and polypropylene capacitors with metal-film resistors. Custom filters can be ordered. Outputs high-pass, low-pass, mono low-pass, all-pass. 3¾ x 12 x 18½ in; 11 lb. \$495

SONY

Elite Series

SDP-777ES Digital Surround-Sound Processor

Combines digital delay circuitry with Dolby HX Pro-Logic decoding. Features 16-bit quantization digital processing; switch-selectable speaker configuration; built-in pink noise generator; matrix delay mode; hall delay mode; stereo simulator delay mode; built-in video switching capability; audio outputs; remote control. \$850

SOUND CONCEPTS

SSD550 Ambience Restoration/Surround System

Surround-sound and ambience-restoration system. Matrix decoder derives accurate rear channel from surround-sound films and video sources. Takes stereo inputs and provides two front and two rear-channel outputs with stereo delay for music or surround decoding plus delay for video. Features stereo audio delay system; continuous delay variation 5-100 msec; continuous reverb variation 0-100%; high-frequency rolloff from -3 to +6 dB; front mix level 0-100%; rear level 0-100%; 50- or 100-msec delay range; rear output delay or quad direct; front output direct or delay mix; input front or quad rear; input imp 60 kilohms min; output imp 300 ohms max; FR 20-10,000 Hz +1, -3 dB with 5 msec delay, zero dB high-frequency rolloff; dynamic range 90 dB min, S/N 85 dB min, 90 dB wtd; 1% max distortion at 1,000 Hz, 1 Vrms. 3½ x 15½ x 9 in \$869

IR2100 Image Restoration System

System expands stereo image beyond confines of space between speakers to reproduce sonic image presented to recording microphones. Features speaker/listener angle continuously adjustable 20-100°; continuous adjustment of perimeter to central sound level balance; master volume control; connects in tape loop or between preamplifier and power amplifier; handheld with 15-ft remote cable. S/N 80 dB; distortion 0.1% max. 6 x 3 x 1½ in. \$300
IR2200. Non-remote version of IR2100 with perimeter to central sound level brilliance control; connects in tape loop; has provisions for tape recorder, capability to record expanded image. S/N 80 dB; distortion 0.1% max. 7 x 2 x 4 in. Factory assembled \$189

KIR-1. Kit. \$95

VSP-1 Stereo Synthesizer

Provides interface to stereo system, creates spacious, realistic simulated stereo from mono sources. Features 10-band harmonically related frequency divisions. S/N 80 dB; distortion 0.2% max. 2 x 7 x 4 in. Factory wired \$159
KVSP-1. Kit. \$90

SX-80 Peak Expander/CX Decoder

Adds 20 dB of dynamic range to CX-encoded records and videodiscs, 6-9 dB of upward expansion to nonencoded sources; connects into tape loop, provides recorder connections. Features tri-color LED for 0 VU calibration with standard record supplied. S/N 80 dB; maximum THD 0.1%. 2 x 7 x 4 in. Factory assembled \$119
KSX-1. Kit \$76

SOUNDCRAFTSMEN

AE2000 10-Band Real-Time Analyzer/Equalizer

Stereo 10-band graphic equalizer with Differential/Comparator analyzer/equalizer circuitry, pink-noise generator. Features 100-LED (10-octave) real-time display with adjustable decay rate; mike preamp; input for analysis of 3-head tape deck, other signal processor; Auto-scan mode; brushed-aluminum front panel; hardwood side panels. Center frequencies 32, 64, 125, 250, 500, 1,000, 2,000, 4,000, 8,000, 16,000 Hz; boost/cut range ± 15 dB; display accuracy 0.1 dB; FR 20-20,000 Hz ± 0.1 dB; THD and IM <0.01% at 2 V; S/N 114 dB at max output; mic preamp input imp 2,000 ohms \$849

Pro-EQ 44 21-Band Graphic Equalizer

Stereo EQ with 21 bands/ch. Differential/Comparator true unity gain circuitry; digital C-MOS switching for tape monitor, EQ tape record, and EQ defeat; center frequencies are at ½ octaves below 1,000 Hz and ½ octaves above 1,000 Hz; center frequencies are standard ISO; filter controls are ± 15 dB. THD >0.01%; S/N 114 dB. 19 x 3½ x 11 in. \$549

DC 2215 10-Band Differential/Comparator EQ

Stereo 10-band equalizer with differential/comparator true-unity-gain circuitry for input to output balancing accuracy to within 0.1 dB. Equalizer filter circuits use precision wire-wound passive-coil inductors for high gain, low noise and distortion. Front-panel controls include tape monitor, LED defeat/EQ defeat and EQ tape record; boost/cut range ± 15 dB. Includes frequency spectrum analyzer test record, computer charts, cables. Front panel is rack mount, brushed aluminum with charcoal finish. THD and IM 0.01% at 2 V; S/N 114 dB at 10 V. \$449

Pro-EQ 22 10-Band Equalizer

Stereo 10-band equalizer features differential/comparator true unity gain circuitry and digital C-MOS switching for monitor, tape record and EQ defeat; filter controls are ± 15 dB. THD <0.01%; S/N 114 dB. 19 x 3½ x 11 in. \$349

SSI PRODUCTS

Surround System 4500

Dolby Surround decoder with proprietary-steering Dynamic Logic circuit. Features dual center channel and subwoofer outputs; 2 pair of surround

The listings are based on data provided by the manufacturers. For more product information, contact an authorized dealer or the manufacturer directly. Manufacturers' addresses and phone numbers are listed in the directory beginning on page 258.

SIGNAL • PROCESSORS

outputs; AC switched outlet; surround indicator; four A/V inputs; trim pots to balance external amplifiers; adjustable center-channel balance control; 3 position center channel distribution; 4 modes of surround. Front and rear sep 65 dB; L/R sep 70 dB; frequency response 18-50,000 Hz \pm 0.5 dB; total harmonic distortion 0.03% from 20-20,000 Hz. Available in rack mount. 19 x 3 1/4 x 13; 13.5 lb \$799

Surround-Sound System 4000 III

Dolby Surround decoder with built in 45 W/ch amplifier and remote control. Features dynamic logic; four audio/video inputs; two video outputs; front to rear balance; volume control for A/V system; variable delay; three surround modes; muting; center channel and subwoofer outputs; switchable rear/center channel amplification; auto Dolby B NR. THD front channels 0.03%. Dolby Surround 0.25%; music surround 0.35%; FR front channels +0.5 dB, 18-50,000 Hz. 3 1/4 x 17 x 13 in; 14.2 lb \$699

System 1000 Surround Sound. Similar to above with 20 W/ch amplifier and no remote control; 2 3/4 x 17 x 8 1/2 in \$199

Cinema 500 Surround Sound. Same as 1000 with two speakers included \$249

SUMO

Deiliah 2-Way Active Crossover

Features front-panel user-selectable frequencies and slopes; 12-dB/octave high-pass slope; 12- or 18-dB/octave switchable low-pass filter with level control; stereo and mono low-pass outputs with built-in bridging circuitry; independent low-/high-pass frequency controls. FR 5-200,000 Hz \pm 3 dB; THD < 0.007%; input imp 50,000 ohms; output imp < 100 ohms; high- and low-pass frequencies 50, 63, 80, 100, 120 Hz with bypass. 19 x 1 3/4 x 10 in; 10 lb ... \$549

TEAC

EQA-22 10-Band Graphic Equalizer

Stereo 10-band EQ with full monitoring capability during recording. Center frequencies at 30, 60, 120, 250, 500, 1,000, 2,000, 4,000, 8,000, 16,000 Hz; \pm 12 dB boost/cut. Features 2 tape inputs with dubbing facility; switchable EQ defeat; pre/post EQ switch; multi-color spectrum display \$170

EQA-6 10-Band Graphic Equalizer

Stereo 10-band EQ with switchable EQ defeat. Center frequencies 30, 60, 120, 250, 500, 1,000, 2,000, 4,000, 8,000, 16,000 Hz; \pm 12 dB boost/cut. Features tape monitor; LED's on all slide knobs. 17 1/8 x 2 3/8 x 7 7/8 in; 6 3/8 lb \$120

1EQA-3 10-Band Graphic Equalizer

Stereo 10-band EQ with switchable EQ defeat and tape monitor. Center frequencies 30, 60, 120, 250, 500, 1,000, 2,000, 4,000, 8,000, 16,000 Hz; \pm 12 dB boost/cut. 17 1/8 x 2 3/8 x 7 7/8 in; 6 3/8 lb \$100

TECHNICS

SH-8066 12-Band Graphic Equalizer

Direct-touch 12-band stereo graphic equalizer sets EQ curves according to line traced on front panel by fingertip. Remembers 8 preset curves; EQ plus function; auto EQ compensates for system frequency response and room acoustics. Signal-to-noise ratio 107 dB. 17 x 4 3/8 x 10 in; 8.4 lb \$600

SH-8058 7-Band Graphic EQ/Analyzer

7-band stereo graphic EQ with 3 user-assignable preset memories. Center frequencies at 63, 160, 400, 1,000, 2,500, 6,300, 16,000 Hz. Features one 7-band spectrum analyzer per channel; tape-output EQ; tape monitor \$220

SH-8038 7-Band Graphic Equalizer

7-band stereo graphic EQ with tape-output EQ. Features LED display on tip of each control; reverse curve switch; tape monitor \$120

SH-8017 7-Band Graphic Equalizer

Center frequencies at 63, 160, 400, 1,000, 2,500, 6,300, 16,000 Hz; \pm 12 dB boost/cut. Features low-noise operational amp; slide controls with LED indicators; calibrated decibel scale; source/tape switch. Frequency response 20-20,000 Hz -3 dB; total harmonic distortion 0.005%; signal-to-noise ratio 110 dBA. 17 x 3 x 7 3/8 in; 4 lb \$90

THRESHOLD

Model PCX Active Crossover

Dual-ch. dual-passband electronic crossover with 17 user-selectable crossover points between the range of 75 to 1,602 Hz (750 to 16,020 Hz available on special order). Computer modeling and optimization of filter circuit design allows 18-dB/octave slopes that will sum flat within a few % without phase inversion. Separate high- and low-pass filter outputs for each ch may be independently level adjusted with front panel controls. Bridged-mono operation possible with normal and inverted summed mono low-pass filter outputs. 2 PCX may be used in tandem for tri-amplication. Uses fully discrete, direct-coupled J-FET, MOSFET, and bipolar devices. External power supply in separate chassis. Military-grade, glass-epoxy circuit boards with gold-over-nickel-over-copper plated paths. Gold-plated signal connectors with Teflon insulation. FR low-pass filter TX to cutoff slope initiation, high-pass filter cutoff slope entry to 100,000 Hz; THD no greater than 0.01% from 20-20,000 Hz; input imp 20,000 ohms; output imp 1,500 ohms, nominal. 1 3/4 x 19 x 6 1/2 in \$1,600

VECTOR RESEARCH

VQ-125 10-Band Graphic Equalizer

10-band graphic EQ with spectrum analyzer and pink-noise generator. Features independent left/right EQ controls; 2 tape monitors; dubbing direction selector; rec EQ; 2 line inputs; peak-hold display; subsonic filter; input sens switch. Center frequencies: 32, 64, 125, 250, 500, 1,000, 2,000, 4,000, 8,000, 16,000 Hz; boost/cut range \pm 12 dB; S/N 109 dB; THD 0.009%. 17 x 4 x 9 1/2 in; 10 lb, 8 oz \$250

VQ-115 10-Band Graphic Equalizer

10-band graphic EQ with master level with peak LED indicator. Features independent left/right EQ controls; tape monitor; EQ-defeat switch. Center frequencies: 32, 64, 125, 250, 500, 1,000, 2,000, 4,000, 8,000, 16,000 Hz; boost/cut range \pm 12 dB; S/N 109 dB; THD 0.009%. 17 x 4 x 9 1/2 in; 9 lb, 8 oz \$130

YAMAHA

DSP-3000 Surround-Sound Processor

Surround-sound processor with hi-bit 4x-oversampling 18-bit digital filter and twin hi-bit D/A converters. Features built-in pink noise generator. 20 preset acoustic surround modes, including Dolby surround; 35 variations, including many U.S. concert halls, etc; 20 user-programmable memory modes; 5 variable parameter adjustments per mode or variation; up to 10-channel output capability; direct digital input (32 kHz, 44.1 kHz, 48 kHz); master volume control; on-screen display; adjustable front to rear balance and effect signal level; effect mute; main mute. Includes full-function remote control. Titanium finish. 22 lb \$1,899

DSP-100Ti Surround-Sound Processor

Features 12 preset acoustic surround modes including 6-ch Dolby surround; 12 user-programmable memory modes; built-in test-tone generator; motor-driven master volume control with red LED; superimposition with choice of 9 background colors in the absence of external video signal; separate front/rear effect level controls; 5 variable parameter adjustments per mode or variation; subwoofer output (200 Hz); full band mono output. Includes 30-key wireless remote control. Titanium finish. 11 lb \$699

DSP-100U. As above, black \$699

DSR-100 Pro/Ti Surround-Sound Processor

Surround-sound processor with DSP interface for Yamaha DSP models. Features Dolby Surround pro logic circuitry; built-in pink-noise generator. Digital delay control of 20 or 30 μ sec; input balance control; center mode switch; remote control; master volume control; tape monitor switch. Titanium finish; 11 lb \$599

DSR-100 Pro. As above, black \$599

EQ-1100U 10-Band Graphic Equalizer

Graphic equalizer with automatic room EQ. Features \pm 12 dB boost/cut; pink noise generator; 10-band spectrum analyzer; independent left and right channel controls; 3 EQ factory-preset memories; 4 EQ user-preset memories; electret condenser microphone; EQ recording capability. Includes 18-key wireless remote control. Black; 11 lb \$599

RMA-G60. Rack mount adaptor for EQ-1100U \$18

EQ-630Ti 10-Band Graphic EQ/Analyzer

Features \pm 12 dB boost/cut; independent left and right channels; 8 EQ curve memories; multifunction LCD display; peak hold; EQ reverse mode switch; rocker-type EQ controls; tape monitor switch; EQ rec capability; RS integrated system remote control compatibility. Includes 17-key wireless remote control. Titanium finish; 10 lb \$469

EQ-630. As above, black \$469

AVS-90M Surround-Sound Processor/Amplifier

Features 4 position video rec out selector; video enhancer; detail/video level; rec-monitor switching; front panel inputs; Dolby Surround; digital surround; S-VHS video switching; 3 audio inputs; remote controllable by MRX-90M. 11 lb \$400

EQ-500U 10-Band Graphic EQ/Analyzer

Features \pm 12 dB boost/cut; pink-noise generator; independent left and right channel controls; FL display; meter level adjustment; electret condenser mic; EQ recording capability. Black; 9 lb \$399

SR-50B Surround-Sound Processor/Amplifier

Features 5 surround modes including Dolby surround; adjustable time delay (5-30 ms); bass extension; A-B speaker switching. 25 W/ch min rms into 8 ohms; FR 20-20,000 Hz; THD < 0.01%. 13 lb ... \$349

EQ-32 10-Band Graphic EQ/Analyzer

Features \pm 12 dB boost/cut; independent left and right channel controls; FL display; meter level adjustment; EQ recording capability. Black; 11 lb \$299

EQ-330 10-Band Graphic Equalizer

Features \pm 12 dB boost/cut; independent L/R channel EQ; output-level control with power indicator; tape monitor with EQ rec function; EQ on/defeat switch; LED illuminated EQ slide controls. Black; 6.6 lb \$179

GE-30B 10-Band Graphic Equalizer

Graphic equalizer with independent L/R channel EQ with side-by-side controls. Center frequencies at 30, 60, 120, 240, 480, 1,000, 2,000, 4,000, 8,000, 16,000 Hz; \pm 12 dB boost/cut. Features independent L/R output level control; subsonic filter; EQ on/defeat switch; tape monitor with EQ rec. S/N 105 dB; FR 10-35,000 Hz \pm 0.5 dB. 17 1/8 x 4 x 9 1/8 in; 6.3 lb ... \$169

GE-20B 10-Band Graphic Equalizer

Graphic equalizer with independent L/R channel EQ with side-by-side controls. Center frequencies at 30, 60, 120, 240, 480, 1,000, 2,000, 4,000, 8,000, 16,000 Hz; \pm 12 dB boost/cut. Features independent L/R output level control; EQ on/defeat switch; tape monitor with EQ rec. S/N 105 dB; FR 10-35,000 Hz \pm 0.5 dB. 17 1/8 x 4 x 9 1/8 in; 6.2 lb \$149

LA-1 Level Attenuator

Improves S/N of effect channels output by approximately 9 dB. Connects between speaker output terminals of amp/receiver and the surround-sound processor's main inputs. 1 lb \$30

ACCESSORIES

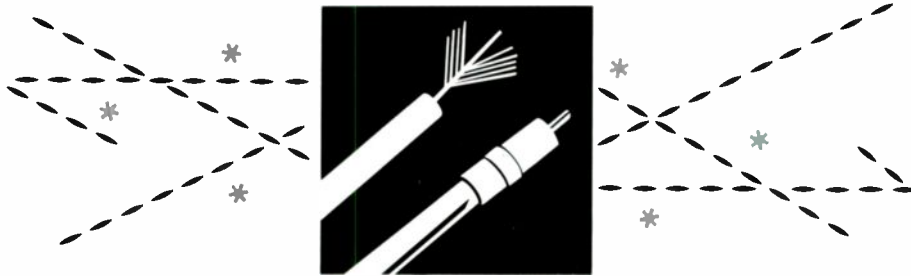

ACE AUDIO

4100-X-24b Infrasonic/Ultrasonic Filter

Active filter designed to eliminate infrasonic (turntable and record) noise and ultrasonic (RF, high-frequency noise, etc.) interference. Infrasonic rate 24 dB/octave below 20 Hz; ultrasonic section rate 12 dB/octave above 20,000 Hz. Distortion 0.002% at 2 V output \$142

4000-X-24 Super Infrasonic Filter

Combined active Bessel and passive filter sections provide low phase shift and an ultra-sharp cutoff (24 dB/octave); removes all infrasonic disturbances; individually hand-calibrated. Distortion 0.002%; response <3 dB at 20 Hz (24 dB/octave) \$132

4100 Infrasonic/Ultrasonic Filter

Active filter with infrasonic section rolloff 18 dB/octave below 20 Hz; ultrasonic section rolloff 12 dB/octave beyond 20,000 Hz; IM 0.002% typical, 20-20,000 Hz \$108

4000b Subsonic Filter

Low-frequency filter with 4 rear-panel connectors providing 18 dB/octave rolloff at 20 Hz or below, <3 dB. For use with direct-coupled receivers, amps, and/or subwoofers. IM 0.01% at 1 V output; input impedance 47 kilohms; output imp 150 ohms; min output load 10 kilohms; hum and noise <86 dB; 6 x 4 3/4 x 2 1/4 in \$98

3900 Ground Lliminator

Designed to break up ground-loop faults in connecting cables, thus reducing hum; employs passive circuitry \$21
Kit \$16

ACOUSTIC SCIENCES

Tube-Trap Acoustic Systems

Tube traps are cylinders that have sound-absorption and diffusion properties; they're used to control wall and corner reflections and room resonances.

Sets

Each set has two free-standing columns with bases. Dimensions are given as diameter x height.

11 in x 6 ft, trap set	\$819
T x 6 ft, (two stacked) trap set	\$724
9 in x 6 ft, trap set	\$614
16 in x 5 ft, 1/2 round trap set	\$599
16 in x 5 ft, 1/4 round trap set	\$390
11 in x 5 ft, 1/2 round trap set	\$384
9 in x 5 ft, 1/2 round trap set	\$307

Components

16 in x 38 in, supertrap	\$363
16 x 3 ft, trap	\$284
16 in x 5 ft, 1/2 round trap	\$281
11 in x 38 in, supertrap	\$237
16 in x 5 ft, 1/4 round trap	\$197
11 in x 3 ft, trap	\$186
11 in x 5 ft, 1/2 round trap	\$176
9 in x 5 ft, 1/2 round trap	\$139
9 in x 3 ft, trap	\$138

Systems

This section contains ceiling grids and acoustic tiles that are designed to be track mounted.

16 1/2-in round	\$51/ft
16 1/2-in round	\$39/ft
16 1/4-in round	\$35/ft
16-in track trap	\$32/ft
11 1/2-in round	\$32/ft
11 1/2-in round	\$26/ft
9 1/2-in round	\$25/ft
11-in track trap	\$21/ft
2 1/2-in window trap for vertical blinds	\$20/sq ft

ADCOM

GFS-3 Speaker Selector

Handles up to 3 pairs of speakers with built-in load protection for low-imp loads; headphone output; Twist 'n' Lock speaker connectors for heavy-gauge speaker wire. Can be used with amps rated up to 200 W/ch, 7 x 2 3/4 x 5 1/4 in \$99.95
GFS-6. Similar to above except handles up to 6 pairs of speakers \$159.95
GFS-6W. As GFS-6 with white front panel \$209.95
GFS-6S. With silver front panel \$209.95
RM-3. Rack-mount adaptors for GFS-6. \$20/pr
RM-3W. RM-3 in white \$25/pr
RM-3S. RM-3 in silver \$25/pr

GFS-4. Gold plated, brass 5-way binding posts, glass fiber epoxy printed circuit board. Oxygen free copper internal jumpers made with #12 AWG stranded cable. Handles 4 pair of speakers; black \$150
GFS-4. White \$200

SLC-505 Straight-Line Controller

A/V switch box with inputs for 2 videocassette recorders (with dubbing capability), aux tape, DAT tuner, and compact disc. Level and balance switch; single master circuit board with copper plating; ground screw; black \$160
SLC-505. White \$290

ACE-515 Line Enhancer

7 AC inputs, 2 switched 3 prong 1,500 watts maximum, 1 unswitched 3 prong 300 watts maximum, 4 unswitched 2 prong 300 watts maximum. Protection reset circuitry. Output amplifiers 10 amps max per pole continuous, accessories 2.5 amps max continuous; black \$180
ACE-515. White \$230

a/d/s/

B3 Storage Module

Stackable wooden cube divided into 3 sections by 2 vertical dividers. Tambour door in front slides up into top of unit. Each section holds about 33-LP's (about 99 total per unit). With optional 12-slot trays, each section holds 24 compact discs (72 total per unit) or 36 cassettes (108 total per unit). Single unit can hold 33 LP's in 1 section, 24 CD's in second, and 36 cassettes in third. Length and width matches measurements of Atelier components. Black and white \$249.00
B4. As B3; open front; adjustable shelf. \$169.00

AIWA

HCC-1000 Cassette Deck Cleaning System

Wet cleaning system for cassette decks. \$10

HCD-2000 Compact Disc Cleaning System

Wet cleaning system for CD players. \$17

ALLSOP

7500 DAT Cleaning System. Wet/dry system, cleans heads and tape path, deluxe storage case \$29.95

74000 Deluxe Cassette Deck Cleaner. Wet system, cleans heads, capstan, and pinch roller. Auto reverse, refill kit included; deluxe carrying pouch \$19.95
73000. Same as above with stand \$11.95

6500 Camcorder Cleaner. 8mm-camcorder cleaner with wet/dry system, patented ribbon \$14.95
6900. Same as above for VHS-C camcorders \$14.95

6100 VHS Cleaner. Cleans heads, tape path, and tape drive; wet/dry system; patented ribbon \$14.95

51000 CD Cleaner. Radial cleaning, lint free cotton pads, special solution, gear-driven rotation \$14.95

55000 Orbitrac Record Cleaning. System rotates from record's center hole/spindle, uses lint-free cotton pads and special solution \$9.95

60000 VHS Cleaner. Cleans heads, tape path, and tape drive; wet/dry system patented ribbon \$9.95
71300 Cassette Deck Cleaner. Wet system. Cleans heads, capstan, pinch roller; autoreverse \$7.95

70000 Cassette Deck Cleaner. Wet system. Cleans heads, capstan, and pinch roller; autoreverse. \$5.95

ANNIS

Demagnetizers and Magnetometers

The following products register the magnetism in recorder components and demagnetize them when necessary. The kits include the Han-D-Mag, a pocket magnetometer, a clip-on extension probe, a set of steel strips, and instructions.

K25/220 II. Deluxe Kit. Thin, long probe; for 220 V \$97
K20/220TL Standard Kit \$65
Han-D-Mag Only \$45

K25/115TL Deluxe Kit. Thin, long probe; for 115 V \$94
K20/115TL Standard Kit \$62
Han-D-Mag Only \$42

K25/220TS Deluxe Kit. Thin, short probe; for 220 V \$90
K20/220TS Standard Kit \$58
Han-D-Mag Only \$38

K25/115TS Deluxe Kit. Thin, short probe; for 115 V \$87

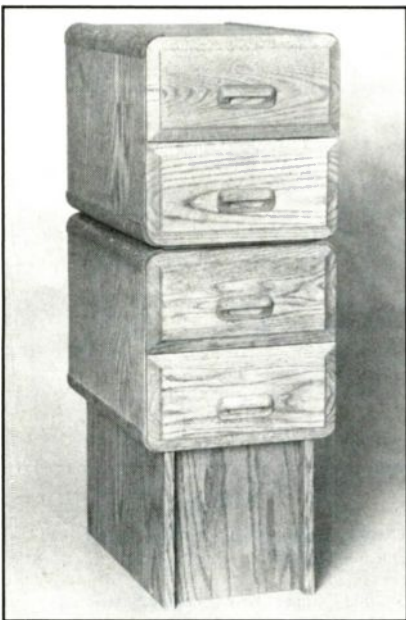

*** NEW ***

from

**SPECIALTY
WOODWORKS**

MediaPhile 200

The Media Storage System For Media Lovers Of All Kinds.

- Store 200 CDs in an incredible 2.5 cubic feet.
- Movable drawer partitions can be configured for CDs, videos or cassettes.
- Each drawer holds 100 CDs or 23 videos or 99 cassettes.
- **STACKABLE!!!**
- Store 800 CDs in a 15" x 22.75" floorspace!
- DataPhile 1000 available for 3.5" and 5.25" computer disks.
- Natural, Medium, Dark, Black Oak or Walnut.
- Silky Smooth full extension drawer slides.
- Optional pedestal stand (shown above) available.
- Optional Keyed Lock available.
- Ship Via UPS.
- Suggested Retail Price \$299.00

Call (904) 725-6951

for free color literature and the name of a dealer near you.

Remember our classy line, too.

**SPECIALTY
WOODWORKS**

7211 Pottsborg Dr./Jacksonville, FL 32216



ACCESSORIES

K20/115TS Standard Kit..... \$55
Han-D-Mag Only..... \$35

K25/220-L Deluxe Kit. Long probe for 220 V... \$93
K20/220-L Standard Kit..... \$61
Han-D-Mag Only..... \$41

K25/115-L Deluxe Kit. 4¼-in long probe; for 115 V..... \$90
K20/115-L Standard Kit..... \$58
Han-D-Mag Only..... \$38

K25/220-S Deluxe Kit. Short probe for 220 V... \$86
K20/220-S Standard Kit..... \$54
Han-D-Mag Only..... \$34

K25/115-S Deluxe Kit. Short 2¼-in probe; for 115 V..... \$83
K20/115-S Standard Kit..... \$51
Han-D-Mag Only..... \$31

Add-Ons

25/5. Range 5 Gauss..... \$49
20/5. Range 5 Gauss..... \$16.50
Clip-On Extension Probe..... \$3.50
Set of Steel Strips..... \$2

APATURE BY ACR

Speaker Wire

SP-518 Speaker Cable
Seven wire rope, 12-gauge, 21 pF per foot... \$1/ft
SP-134. Same as above, 16-gauge..... \$.50/ft
SP-87. 18-gauge wire..... \$.25/ft

Auto Quad. 4-conductor ribbon wire, 2 and 2 configuration..... \$1/ft
CL-2-16 Installation Wire. For use with class 2 circuits.
4-Conductor..... \$1.25/ft
2-Conductor..... \$.60/ft
Auto Primary. 8-gauge wire with heat, gas, and oil resistant jacket..... \$1/ft

Interconnect Cables

Black Beauty Digital. 8-conductor silver wire with teflon dielectric; shielded with drain wire... \$5/ft
Audio Video 30 Strand. OFC copper with air dielectric, 19.2 pF..... \$2/ft
Auto Connect. Coaxial cable with polyethylene dielectric; with shielding..... \$1.5/ft
Audio Video 19 Strand. As above, without shielding..... \$1/ft

ARCAM

DIN Connectors

High-definition DIN-to-phono and DIN-to-DIN connectors..... \$14.95

AUDIO DESIGN ASSOCIATES

System Basics

Switching systems for multiroom applications. Includes remote controls that enables system use from several areas.

System 88. Covers 8 rooms. Features room on/off; system off; volume; balance; one-button 8-source selection; one function control per source; LED readout..... \$7,665
System 48. Covers 4 rooms. Features room on/off; volume up/down; bass; treble; 8-source selector; one function control per source; LED readout; direct source access..... \$6,546
System 100. Covers 8 rooms. Features room on/off; system off; volume; balance; 2-source selection; one function control per source; LED readout; expandable to another zone..... \$4,920
System 1. Covers 8 rooms. Features room on/off; system off; volume; balance; one-source selection; one source function control; LED readout; expandable to another zone..... \$3,227

ISO-2 Line-Level Isolation Amplifier

Active, differential unity-gain amplifier with differential input with ground isolation between the RCA inputs and outputs. Can be used to eliminate audible hum due to ground loops and it is capable of driving long line-level wire runs. 2 x 3 x 4 in..... \$299

CCS-2 Speaker Source Selector

Current-controlled speaker source selector. AC current sensing device that provides a switched outlet and allows a pair of speakers to be used with two amplifiers..... \$299

ACS-2. Alternating current-controlled version of CCS-2 selector..... \$169

ACC-1M Low-Voltage AC Controller

Power switching device for AC sources. Provides low-voltage control of AC power. Features 2 grounded receptacles; 2 control inputs. Capable of allowing separate systems to share a common component; provides switched AC power for remote applications; AC relay..... \$269

LLS-2 Line-Level Audio Switcher

Audio switching device which features two stereo line-level inputs and one stereo output. Allows separate systems to share a component, can be used to switch input to an amplifier from a multi-room system to a local one, and can be used to add a seventh source to a six input preamplifier. 24 V input. 2-in x 3-in x 4-in..... \$269

AUDIO-TECHNICA

AT605 Audio Insulator System

Vibration-damping feet for use under speakers or turntables to prevent acoustic feedback; individually adjustable height. Supplied in set of 4, with bubble level..... \$35.95

AT6015 TechniClean

Audiophile record maintenance system cleans record surface and reduces static..... \$25.95
AT613. TechniClean record-cleaner replacement fluid. Removes dust, dirt, and oily fingerprints without promoting static. 60 cc..... \$4.50

AT609 Headshell Wire Set

Upgrades original headshell wiring. Set of 4 color-coded wires made of silver litz wire with gold-plated connectors..... \$12

AT607 Stylus Cleaning Formula

Cleaning solution dissolves foreign material on stylus without harming known stylus adhesives; in bottle with stylus brush..... \$4.95

AC-TP4 Terminal Pins

Set of 4 gold-plated terminal pins with color-coded insulators..... \$2.99

AC-TP4 Spade Lugs

Set of 4 gold-plated spade lugs with color-coded insulators..... \$2.99

Vital Link Cable Series

AT620 Super Conductivity Cable Set
Litz wire construction with double shielding and gold-plated connectors; for low imp and max rejection of RF interference; set of 2..... \$35.95

Full-Audio-Transfer Speaker Cable

Speaker cable made from oxygen-free copper. Available in large-diameter and extra-heavy-diameter gauges.

AXD-50. 50 ft; extra-heavy diameter; stereo pair; spooled..... \$43.95
AXD-30. As above, 30 ft..... \$28.50
A1.D-50. 50 ft; large diameter; stereo pair; spooled..... \$17.50
A1.D-30. As above, 30 ft..... \$11.50
AXD-500. As AXD-50, 500 ft..... \$.80/ft
A1.D-500. As A1.D-50, 500 ft..... \$.34/ft

ACCESSORIES

Full Audio Transfer Interconnects

Features oxygen-free copper; potted terminations; gold-plating.
 AC122-A2, 2-in, 2-out, RCA, 2 meters. . . . \$15.95
 AC122-A1, As above, 1 meter. . . . \$11.95

Audio/Video Cables

Cables feature oxygen-free copper, potted terminations, and gold-plated connectors. Video cables feature a foil shield and gold-plated connectors.

AC233-AV2, 3-in, 3-out RCA; 2 m video and stereo audio. . . . \$22
 AC223-AV2, 2-in, 3-out RCA; 2 m video and Y audio. . . . \$20
 AC222-AV2, 2-in, 2-out RCA; 2 m video and mono audio. . . . \$18
 AC211-V3, Single video, 3 m. . . . \$16
 AC222-AV1, 2-in, 2-out RCA; 1 m video and mono audio. . . . \$14
 AC211-V1, Single video, 1 m. . . . \$12

AUDIOQUEST

AQ Sorbothane Big Feet

Set of four 2½-in-diameter, 1-in-high sorbothane feet to absorb vibrations. . . . \$40

AQ Sorbothane Record Mat

¼-in thick sorbothane record mat absorbs vibrations from the vinyl. . . . \$39

AQ Sorbothane CD Feet

Four 2-in-diameter, ¾-in-high sorbothane feet. . . \$25

AQ Record Brush

Over one million conductive carbon fibers small enough to enter the groove of the record. . . . \$15

CD-60 CD Stabilizer Rings

Set of 60 adhesive rings designed to stabilize compact discs and prevent distortion from error-correction circuitry. Includes locator device for proper placement on discs. . . . \$9

CD-30 CD Stabilizer Rings

Same as above, set of 30. . . . \$35

CD-6 CD Stabilizer Rings

Same as CD-60, set of 6. . . . \$9

AudioQuiet Sound Paneling

Fiberglass panel covered in fabric. Any size up to 5 x 10 ft; 45 fabrics available. . . . \$80/panel; \$8/sq ft

Interconnecting Cable

Lapis Hyperlitz. Unbroken copper strands separated by teflon strands wrapped around a solid teflon core; teflon insulation around center conductor; light-blue polyvinyl-chloride jacket; gold-plated RCA plugs. 6-meter pair. . . . \$1,895
 Same as above, 1-meter pair. . . . \$395

Emerald Hyperlitz. Unbroken copper strands separated by polypropylene wrapped around a polypropylene core; teflon and polypropylene insulation around center conductor; green poly-vinyl-chloride jacket; gold-plated RCA plugs. 6-meter pair. . . \$695
 Same as above, 1-meter pair. . . . \$195

Quartz Hyperlitz. Unbroken copper strands with teflon insulation; black PVC jacket; gold-plated RCA plugs. 6-meter pair. . . . \$435
 Same as above, 1-meter pair. . . . \$135

Ruby. Unbroken copper strands with polypropylene insulation; red PVC jacket; gold-plated RCA plugs. 6-meter pair. . . . \$205
 Same as above, 1-meter pair. . . . \$85

Topaz. Oxygen-free copper strands with polypropylene insulation; brown PVC jacket; gold-plated RCA plugs. 6-meter pair. . . . \$95
 Same as above, 1-meter pair. . . . \$45

DriveWire One Interconnect Cables

Double-shielded coaxial interconnect cable with polypropylene insulation around center conductor; OFC strands; gold-plated RCA plugs. 6-m pair. . \$60
 Same as above, 1-meter pair. . . . \$35

Speaker Cable

Clear Hyperlitz. 12 unbroken-OFC strands separated by polypropylene rods around a polyethylene core; teflon over the conductor. . . \$50/ft (+\$95/pr. prep)
Green Hyperlitz. As above, but with six OFC strands. . . . \$25/ft (+\$95/pr. prep)

Cobalt Hyperlitz. 6 OFC strands separated by polypropylene rods around a polyethylene core with teflon over the conductor. . . \$15/ft (+\$75/pr. prep)

Midnight. 4 large surface-only oxygen-free copper strands in a helical array. . . \$6/ft (+\$50/pr. prep)

Blue. Uses 2 large surface-only oxygen-free-copper strands, spiraled together with fillers; blue-satin jacket. . . . \$2.50/ft (+\$40/pr. prep)

Type 4. Uses 4 conductors with 19 strands of oxygen-free copper; polypropylene insulation. . . . \$1.50/ft

Type 2. Uses 2 conductors with 26 strands of oxygen-free copper; polypropylene insulation. . . . \$0.95/ft

AUDIO RESEARCH

EC-21 Electronic Crossover

Vacuum-tube, 2-way electronic crossover (passive top) with auto-muting. . . . \$995

RMV-3 Rack-Mount Ventilator

Passive convection unit to allow air flow to dissipate heat. For all Audio Research units. . . . \$150

RFP-1 Rack-Mount Filler Panel

Available in 3½-in, 5¼-in, 7-in, or 10½-in heights \$79
 RFP. Rack filler panel, 1¾ (no handles). . . . \$49

218. EC-21 18 dB capacitor kit (specify frequency). . . . \$21

216. EC-21 6 dB capacitor kit (specify frequency) \$15

Wire Products by Audio Research range in sizes from .5 - 9 meters

LitzLink Interconnects. 3-meter unshielded. . . \$230
 shielded. . . . \$275
SGL Speaker Cables. 3-meter. . . . \$219
LitzLine Speaker Cable. 3-meter. . . . \$555

AUDIOSOURCE

LIC-1 CD Laser Lens Cleaner

Digitally encoded CD with built-in, man-made, carbon-fiber-impregnated cleaning brush. . . \$29.95

BASF

Ferro Extra I Cassette Case

Cushioned, fully-lined vinyl case holds 10 cassettes. Ferro Extra I is housed in a protective shell specifically designed for sound on the move, and can withstand temperature extremes from -22°F to 185°F. . . \$9.95

BELDEN WIRE AND CABLE

All connectors and adaptors are made by Neutrik, USA, Inc and feature screwless composition; 3-prong internal strain relief; expanding exterior boot; O-ring design.

3-Contact Right Angle Female XLR Connectors

8X1.RFBG. Gold-plated; black chrome. . . . \$9.43
 8X1.RFNS. Silver contacts; nickel-plated. . . \$9.03

XLR Adaptors

9ADTFF1. Female to female. . . . \$8.87
 9ADTMM1. Male to male. . . . \$7.93

9ADTFM1. Female to male. . . . \$7.93

3-Contact Right Angle Male XLR Connectors

8X1.RMBG. Gold-plated; black chrome. . . . \$8.67
 8X1.RMNS. Silver contacts; nickel-plated. . . \$8.34

3-Contact Female XLR Connectors

9X1.RFHD. Silver contacts; nickel/rubber-boot shell; heavy duty. . . . \$7.82
 9X1.RFBG. Gold-plated; black chrome. . . . \$3.87
 9X1.RFNS. Silver contacts; nickel-plated. . . \$2.00

3-Contact Male XLR Connectors

9X1.RMHD. Gold-plated; stainless shell; heavy duty. . . . \$7.60
 9X1.RMBQ. Gold-plated; black chrome. . . . \$3.45
 9X1.RMNS. Silver contacts; nickel-plated. . . \$2.34

Quarter-Inch Phone Plugs

9PBB001. Longframe; 3 contacts; black powder coated. . . . \$6.22
 9PBR001. Longframe; 3 contacts; red powder coated. . . . \$6.22
 9PQ30NS. 3 contacts; nickel-plated. . . . \$3.34
 9PQ30BG. 3 contacts; black chrome. . . . \$3.34
 9PQ20BG. 2 contacts; black chrome. . . . \$3.01
 9PQ20NS. 2 contacts; nickel-plated. . . . \$2.86

3-Contact Female XLR Receptacles

9RCPFBQ. Gold-plated; black chrome. . . . \$4.34
 9RCPFNS. Silver contacts; nickel-plated. . . \$3.33

3-Contact Male XLR Receptacles

9RCPMBQ. Gold-plated; black chrome. . . . \$3.72
 9RCPMNS. Silver contacts; nickel-plated. . . \$3.16



Belden 8X1.RFNS

BENNINGTON HART

CD Accessories

1550. Radial CD cleaner system. Includes scientifically formulated, nontoxic cleaning fluid; throw-away, nonabrasive cleaning pads; disc holder in storage case. . . . \$12.99
 1553. Replacement nontoxic CD cleaning fluid and throw-away cleaning pads for 1550 system. . . \$4.99
 1570. 20-CD flip-file plastic storage system. . . \$4.99
 1560. CD 1 ft.-lock storage case. Pops up CD as case opens; locks/unlocks CD automatically when case is closed/opened. 2 plastic cases. . . . \$3.99
 1565. 3-in CD adaptor. Includes 2. . . . \$2.99

Cassette Deck Care and Maintenance

1155 Cleaner II System. Automatically cleans heads, capstan, and pinch rollers in 1 operation while rotating 360°. Includes cleaning cassette; case; fluid; 5 non-abrasive soft replaceable cleaning tips. . . \$8.99
 1158 Cleaner II Refill Kit. Scientifically-formulated replacement fluid and 4 sets of nonabrasive cleaning tips for 1155 system. . . . \$3.99
 1150. Nonabrasive, wet/dry cassette cleaning system. Includes cleaning cassette and fluid. . . . \$3.99

BIB

A-616 CD Cleaner

CD cleaner features molded disc tray; chamois-

FREE CATALOGUE



**AMPS & TUNERS
ACCESSORIES
CASSETTE DECKS
CD PLAYERS
RECEIVERS
SPEAKERS
TURNTABLES &
CARTRIDGES...all at
DISCOUNT
PRICES**

CALL TOLL-FREE
1-800-426-6027
In New York 1-718-417-3737
OR WRITE
J&R MUSIC WORLD, Dept. SBG1089
59-50 Queens-Midtown Expressway, Maspeth, NY 11378

NAME _____

ADDRESS _____

QTY _____ STATE _____ ZIP _____

ACCESSORIES

covered cleaning pad/wheel; cleaning fluid; CD eject lever; chamois cleaning brush \$16.95
A-616RP. Replacement cleaning pad and fluid for A-616. \$6.95

A-625 Cassette Deck Cleaner
Automatic gear-driven cleaner. Oscillating center section cleans and polishes the audio head, while cleaning pads engage the capstan and pinch rollers. Kit includes a dust free storage album and a bottle of cleaning fluid \$14.95

A-636 CD Care System
Includes CD cleaning fluid, chamois leather cleaner, CD polish and polishing cloths \$12.95

A-640 CD Polish Applicator
Pre-measured CD polish applicator; treats up to 500 CD's \$12.95

A-621 Portable CD Storage Album
Holds six disc in individual dust-free compartments \$12.95

A-632 Audio Cassette Care System
Includes head cleaner, a bottle of cleaning fluid and tools to remove harmful contaminants \$12.95

A-634 Record and Stylus Care System
Includes a carbon fibre anti-static record brush, special designed brush and stylus cleaning fluid \$12.95

A-611 CD Storage Module
Strong practical CD storage unit holds up to 20 CD's in their jewel boxes. Fingertip touch release system automatically ejects selected CD for easy removal. Interlocking modules can be expanded vertically or horizontally. Molded of strong ABS plastic. Wall or shelf mounting. Two modules included \$9.95

A-629 Cassette Deck Cleaner
With demagnetizer \$9.95

A-635 CD Polish
Cleans and polishes compact and laser discs; removes light scratches from the disc's coating and applies anti-static protection \$7.95

A-612-A Disposable Tape Head Cleaner
Disposable audio head cleaner for all types of cassette players. Nonabrasive cleaning fluid applied by push-button cleans entire tape path. Use twice (once each side) then dispose \$1.99

THE BOOTHE COMPANY

Sweatband Headphones
Sweatband with in-ear type headphones. Features inside pocket \$16

BOULDER AMPLIFIERS

Balanced Cables
Gold-plated 3-pin male to 3-pin female.
CB75. 75 ft \$279/pr
CB35. 35 ft \$179/pr
CB12. 12 ft \$129/pr
CB6. 6 ft \$109/pr

Speaker Cables
For use with Boulder power amps only. Also available with gold spade connectors on one or both ends.
CS25. 25 ft, banana, coaxial \$199/pr
CS12. 12 ft, banana, coaxial \$121/pr
CS06. 6 ft, stacking banana both ends, coaxial \$85/pr
NS01. Terminator pair for use at speaker \$39

Audio Interconnect Cables
Gold-plated RCA-type phono; for general interconnection.

CA06. 6-foot \$99
CA03. 3-foot \$84
CA01. 8-inch \$69

Preamplifier Power Cables
Boulder Terminator
Speaker-cable termination network provides termination imp for frequencies where speaker cable must be treated as transmission line. Designed to eliminate reflections back down the speaker cable into amp for improved clarity \$69/pr

CP02. Short power cable (1 needed for each module) \$59
CP06. Long power cable (1 needed for remote phono preamp) \$49

3-pin connectors. For unbalanced feet to balanced input (in addition to RCA connections) \$44

Preamplifier Housings
MF04. Mainframe houses 4 preamp modules. Full rack size with removable rack-mount ears \$219
MF02. Mainframe houses 2 preamp modules. Half rack size \$179
MF01. Mainframe houses 1 preamp module. . \$159
MS00. Blank module panel for covering unused slots \$69

BRETFORD MANUFACTURING

5579 Americana A/V Entertainment Center
Features height-adjustable roll-out, removable, and fixed shelves; full-length glass doors with wood trim. The upper portion of the video section accommodates monitors or televisions up to 27-in wide. Lower storage area contains wire-formed dividers; hand-rubbed lacquer finish; slotted back panel for cable management. Available in dark/medium/new-black oak. 49 3/4 x 46 x 19 in; 175 lb \$484

5577 Americana Audio Cabinet
Features height-adjustable roll-out, removable, and fixed shelves; full-length glass doors with wood trim. Lower storage area contains wire-formed dividers; hand-rubbed lacquer finish; hidden casters; slotted back panel for cable management. Available in dark/medium-black oak. 23 x 47 x 17 in; 88 lb \$281

BRYSTON

.4B Switch Box
High-level switching with gain/balance control. Features 4 inputs (CD player, tuner, tape, aux); 1 tape loop. 9 lb; 13 1/2 x 19 x 9 in. \$595

Switch Boxes
No active components; designed for high-current applications.
4-Way. With headphone jack \$199
3-Way. With headphone jack \$199
2-Way. With headphone jack \$130

TF-1 MC Cartridge Step-Up Transformer
Designed to provide sufficient voltage to any preamplifier from low-output MC cartridges. 2 x 3 x 4-in. \$500

10B Electronic Crossover
Front-panel switching for control of filter settings, rolloff frequency, and slope. Low pass (and mid-range) level settings are 1 dB increments over a ± 5 dB range. All amplification buffer and filter stages are discrete. All passive filter components are 1% metal-film resistors and polystyrene capacitors. Available in either fully balanced (in and out) or unbalanced.
Balanced \$1,195
Unbalanced \$1,000

BUFF STUFF

CD Saver
Compact disc restorer eliminates audible pops

ACCESSORIES

and clicks caused by light scuffs and scratches on CD's and laser videodiscs. 30-milliliter bottle of formula is harmless to plastic coating on CD's is good for dozens of applications . . . \$9.95

BUSH INDUSTRIES

Jamestown Collection

Units feature golden brown oak finish, solid-oak dentil molding, raised panel doors and drawers, soft-shaped pilasters, and brass hardware.

- AV786.** A/V center. Features 2 storage drawers; 4 shelves; tempered-glass doors. 50 $\frac{3}{8}$ x 53 x 20 $\frac{1}{4}$ in. \$380
AV773. A/V center. Features adjustable shelf; enclosed storage space; 2 drawers. 60 x 50 $\frac{1}{2}$ 16 $\frac{1}{4}$ in. \$350
AV763. A/V center. Features 4-shelf component area; tempered-glass doors; enclosed storage area. 48 $\frac{1}{4}$ x 53 x 16 $\frac{3}{8}$ in. \$280
A666. Audio cabinet. Features one fixed, three adjustable component shelves; tempered-glass doors; casters. 47 $\frac{1}{2}$ x 22 $\frac{1}{4}$ x 16 $\frac{3}{8}$ in. \$170

Furniture Systems Series

With rounded corners, soft-shaped tops, fully radiused shelf fronts with decorative accent lines. Library Oak finish, full-length solid-oak door pulls, cord openings in rear, 72 in.

- L139WS.** Wood and glass doors; middle doors open 180° for TV viewing; 30 x 19 $\frac{3}{8}$ in. \$270
L132WS. Audio cabinet with wood and glass doors; 20 x 19 $\frac{3}{8}$ in. \$220
L134WS. Open shelving above wood doors; 30 x 19 $\frac{3}{8}$ in. \$200
L124WS. Wood doors; 15 $\frac{3}{8}$ in. \$170
L121WS. Wood doors; 15 $\frac{3}{8}$ in. \$150
L123WS. Open shelving; 15 $\frac{3}{8}$ in. \$150

AV1375 Home Entertainment Center

Audio/video home entertainment center with 25 x 27-in television compartment; adjustable VCR shelf; glass-enclosed storage with adjustable shelf; 20 $\frac{1}{4}$ -in glass-enclosed audio area with 3 adjustable shelves; silk-screen pattern on glass doors with wood frames. Solid oak and oak laminates with multistep lacquered finish. Rounded edges; soft shapes. Dimensions: 49 $\frac{1}{2}$ x 47 $\frac{3}{8}$ x 19 inches. 180 lb \$400

AV774 Room Divider/Entertainment Center

2 drawers below TV compartment; 4 adjustable bottom doors; wooden door handles; rounded edges on frame; shelving; drawers and doors. Library-oak finish. Cords run through center partition. 49 x 69 $\frac{1}{2}$ x 15 $\frac{1}{2}$ in; 180 lb. \$260

AV760 A/V Center

TV compartment for 26-in or 19-in TV; safety-tempered glass door; 3 adjustable shelves; enclosed space for accessories; pedestal base; adjustable shelf above TV compartment. Library-oak finish. Soft-shaped tops and rounded edges. 47 $\frac{3}{8}$ x 47 $\frac{1}{4}$ x 15 $\frac{1}{2}$ in; 145 lb \$230

B0829 Armoire A/V Center

Designed for bedroom. Features rear-cord access; 1 set of double doors; can also be used for clothing; Lakewood Oak finish; wood handles with brass end caps. 59 x 30 x 20 $\frac{3}{8}$ in. \$280

A1365 Audio Cabinet

22-in interior glass-enclosed facade with silk-screen pattern and wood frames; 2 adjustable interior shelves; hand-stained and chiseled accent lines; rounded edges and soft-shaped design. Solid oak and oak laminates with multi-step lacquered finish. 23 $\frac{1}{2}$ x 42 $\frac{1}{4}$ x 16 $\frac{1}{2}$ in; 78 lb. \$200

AV757 A/V Center

A/V entertainment center. Features space for several audio components, a VCR and TV; tempered-glass doors; enclosed storage area. 43 $\frac{3}{4}$ x 47 $\frac{1}{4}$ x 15 $\frac{3}{8}$ in. \$180

A641 Audio Cabinet

Safety-tempered glass door; 2 adjustable shelves; soft-shaped lift top; 2-wheel casters. Library-oak finish. 18 $\frac{3}{8}$ x 38 $\frac{3}{8}$ x 17 $\frac{1}{2}$ in; 58 lb. \$120

Artisan Plus Series

These cabinets feature rounded edges, and those with glass doors have silk-screen accents. Fastening parts are pre-installed, and panels fit together to be tightened with a screwdriver.

AV1320 Home Entertainment Center

Features glass doors; compact disc flip-storage space; adjustable VCR shelf; three adjustable shelves; and drawer for audio accessories. Has room for twenty-in and most twentyseven-in television sets. 48 $\frac{1}{2}$ x 51 x 19 in. \$450

A1312 Audio Cabinet

Features glass doors; CD disc flip-storage space; 2 adjustable shelves; and drawer for accessories. 42 $\frac{1}{4}$ x 23 $\frac{1}{2}$ x 16 $\frac{1}{2}$ in. \$250

Presidential Collection

These cabinets feature rounded edges, and are available in light or dark oak veneer. Fastening parts are pre-installed, and panels fit together to be tightened with a screwdriver.

AV2210 Entertainment Center

Features CD disc flip-storage space; adjustable pull-out shelf for turntable or disc player; 3 adjustable component shelves; drawer for accessories; recessed doors cover TV; 2 tempered glass doors cover component shelves. Fits 20-in and most 27-in TV sets. 49 $\frac{1}{4}$ x 52 $\frac{1}{2}$ x 20 $\frac{3}{8}$ in. \$600
AV2410. As above, dark oak. \$600

AV2212 Audio Cabinet

Features CD flip-storage space; pull-out shelf for audio components; two adjustable interior shelves; glass doors. 45 x 21 $\frac{1}{4}$ x 16 $\frac{3}{8}$ in. \$300
AV2412. As above, dark oak. \$300

Innovations Collection

AV0410 Entertainment Center

Features tempered, tinted glass doors; four-door storage space; VCR shelf; three adjustable interior shelves. Fits 20-in and most 27-in TVs. Black finish. 48 $\frac{1}{4}$ x 47 $\frac{1}{4}$ x 15 $\frac{3}{8}$ in. \$300
AV0810. Similar to above, finished in light-oak veneer \$290

A0412 Audio Cabinet

Features pull-out shelf and 3 adjustable interior shelves; tempered, tinted glass doors. Black finish. 41 $\frac{3}{8}$ x 21 $\frac{1}{4}$ x 16 $\frac{3}{8}$ in. \$200
A0812. Similar to above, finished in light-oak veneer \$190

V0806 Media Cabinet

Storage cabinet with doors has space for audio and video cassettes. Features flip-storage rack for CD's; shelves on interior of doors. Finished in light-oak veneer. 32 x 23 x 15 $\frac{3}{8}$ in. \$180

CANTON

CF-1 Speaker feet

Set of 8 adjustable acoustic decoupling feet for a pair of speakers \$125/set

Connect Series Switchboxes

Connect 50. Handles one to four pairs of speakers; DIN and phono jack; headphone outputs. Features volume controls for adjusting channels 2 and 4; connection to output of amplifiers, receivers; DIN speaker jacks. \$125
Connect 20. Switchbox for 1-3 tape decks or 2 decks and 1 high-level signal source. Features left/right regulators to reduce signal levels before recording; 5-

pole DIN jacks \$80
Connect 10. Similar to Connect 20 except designed for 1-3 pairs speaker switching. Features standard DIN speaker jacks \$70

Cantosweep

Record-care brush with antistatic carbon bristles. Removes static charges, dirt particles from grooves before play \$30

Cantolink Speaker Cable

Model 60. Premium-quality 60-millimeter speaker cable \$2.74/ft
Model 40. Premium-quality 40-millimeter speaker cable \$1.52/ft
Model 25. Premium-quality 25-millimeter speaker cable \$1.07/ft
Model 15. Premium-quality 15-millimeter speaker cable \$0.88/ft

CARVER

MCt Moving-Coil Transformer

Matches low output of moving-coil cartridge to standard moving-magnet phono stage. Selector switch for 3.9, 39, 110 ohms for virtually any moving-coil cartridge. Gain 24 dB; 1.5 lb \$225

Z-1 Wide-Band Z Coupler

Impedance-matching device enables Carver Magnetic Field power amplifier to be used with receiver or integrated amplifier. Receiver or integrated amp outputs drive power amp through Z-1 coupler, which presents an optimum non-inductive load to the amp in the receiver or integrated amplifier \$49

CARRY DISC BY MUSIC & SOUND IMPORTS

Carry Disc CD Holder

Holds 14 CD's in a quick open-and-close carrying case with a protective inner lining of soft velour \$15.95

Carry Disc II. Same as above but designed for use with 3-in CDs. \$15.95

CARTER-CRAFT

60-437 CD Carry-All

Hold 6 CD's without cases. Storage plates fan when case is opened with the slide button. Black, hinged case \$20.49

60-409 CD Cleaning Kit

Includes cleaning solution \$19.95

60-355G Stereo-to-Stereo Dubbing Kit

Use for dubbing from stereo VCR to stereo VCR. Features coded plugs for correct input/output; strain reliefs; 6-ft cable \$19.10

60-357G Stereo-to-Mono Dubbing Kit

Use for dubbing from stereo VCR to mono VCR. Features coded plugs for correct input/output; strain reliefs; 6-ft cables \$18.39

60-416 CD Storage Case

Auto eject and add-on unit holds 5 compact discs. Stackable modular design allows expansion of storage system. \$13.65

The listings are based on data provided by the manufacturers. For more product information, contact an authorized dealer or the manufacturer directly. Manufacturers' addresses and phone numbers are listed in the directory beginning on page 258.

ACCESSORIES

60-436-3 3-in CD Adapter

3-in CD adapter permits playing of 3-in CD's on regular CD equipment. Grooves permit secure fastening of the 3-in. 3-Pack. . . . \$9.90
Single. . . . \$3.80

60-435 CD Storage Case

Holds 20 CD's in cases. Permits fast viewing of front, backsides or spine of disc case \$5.50

60-434-3 Lift Lock DeLuxe CD Storage Case

Pops up disc as case opens. Center lock will unlock/lock CD automatically when case is opened/closed. 3-Pack. . . . \$5.45
Single. . . . \$2.20

Soft-Touch Cassette Storage Cases

Storage cases eject tapes by touching drawer front.

40-218. Stores 12 tapes \$40.45
40-217. Auto unit padded all around for safety, impact, heat resistant. Holds 6 cassettes. . . . \$35.65
40-216. Expandable unit holds 6 tapes and is expanded by purchasing additional units. . . . \$21.35

60-419 CD Converter

Converts automotive sound system to digital sound with cassette adaptor. Plugs into portable CD output/headphone jack and adaptor inserts into auto cassette player \$24.75

34-155 AC Adapter

U.L.-approved AC/DC adapter for 1.5-, 3-, 4.5-, 6-, 7.5-, 9-, and 12-V battery-operated components. Features universal 5-way plug. Includes built-in reversing feature. 1.5 lb. . . . \$12
34-157. As above with 300/100 mA conversion switch \$10.95

40-158 Tape-Care Kit

Features chemical cleaners and lubricants for heads, guides, and capstans. For use with auto and home tape decks. Includes 1 bottle each of cleaner and lubricant, a supply of swab-style Kleen Stix, and a specially treated cloth \$7.55

40-130-C Cassette Head Cleaner/Demagnetizer

Cordless cassette head cleaner and demagnetizer removes dirt and residual magnetism without use of any current. For home/auto cassette decks . . . \$4.90

40-126 Cassette Head Cleaner

Includes cleaning fluid. . . . \$4.10

60-415 Jewel Box

Clear, hinged jewel case for CD storage . . . \$2.60
60-415-3. Jewel case 3-pack. . . . \$5.45

Speaker Wire

2-conductor, 24-, 20-, or 18-gauge wire for hookup to 8-ohm speakers. Features clear-plastic insulation.

32-150. 25-ft length, 24 gauge \$2.60
32-152. 50-ft length, 24 gauge \$4.05
32-154. 100-ft length, 24 gauge \$6.15
32-155. 1,000-ft length, 24 gauge. . . . \$52
32-156. 50-ft length, 20 gauge \$5.75
32-158. 100-ft length, 20 gauge \$10.95
32-159. 50-ft length, 18 gauge \$7.94
32-157. 100-ft length, 18 gauge \$15.10

Connection Cables

Dual, color-coded stereo cable with RCA phono plugs on all ends.

60-342G. 12-ft gold-plated plugs \$6.65
60-340G. 6-ft gold-plated plugs \$5.20
38-143. 12-ft \$4.60
38-142. 6-ft \$3.25
38-141. 3-ft \$2.55

CASE LOGIC

Solid-Oak Racks

Designed to hold cassettes, CD's, and videotapes in combination.

DCD-250. Five-level rack holds 250 CD's . . . \$100
DCD-150. Three-level rack holds 150 CD's . . . \$60
DCD-36. Two-level rack holds 36 video tapes. . \$50

Oak CD Cabinets

For CD storage

OCD-120. Holds 120 discs \$75
OCD-100. Holds 100 discs \$60
OCD-90. Holds 90 discs \$65
OCD-60. Holds 60 discs \$50
OCD-50. Holds 50 discs \$40
OCD-30. Holds 30 discs \$35

Tape Cabinets

Available in horizontal or stacked construction.

OC-60. Holds 60 cassettes. . . . \$35

Leather cases for CD's and cassettes.

LCD-30. For 30 CD's \$90
LCD-15. For 15 CD's \$60
L-30. For 30 cassettes \$80
L-20. For 20 cassettes \$60
L-15. For 15 cassettes \$40

Leatherette Cases

MVCD-30 Holds 30 CD's \$25
MVP-30 Holds 30 cassettes. . . . \$20

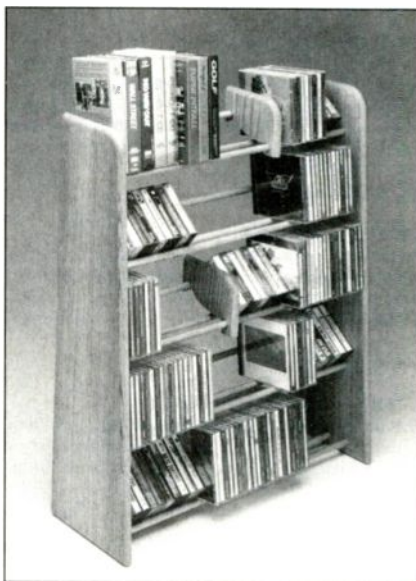

Case Logic DCD-250

Nylon Cassette Carrying Cases

Cases have foam padding and plastic trays; available in black, blue, grey, red, electric blue, teal.

CL-120. Holds 120 tapes \$40
CL-60. Holds 60 tapes \$25
PSC-30. Holds 30 tapes; zippered pocket. . . \$18.95
CP-30. Holds 30 tapes; zippered pocket. . . \$16.95
CLS-30. Holds 30 tapes. . . . \$14.95
CP-20. Holds 20 tapes \$12.95
CL-20. Holds 20 tapes; zippered pocket. . . \$11.95
CL-15. Holds 15 tapes \$9.95
CL-10. Holds 10 tapes \$6.95

Nylon CD Carrying Cases

Construction and color selection same as cassette version above.

CD-60. Holds 60 discs \$36
FSCD-30. Holds 30 discs; zippered pocket . . \$25
CD-30. Holds 30 discs. . . . \$20
CD-15. Holds 15 discs; pocket \$14.95
CD-8. Holds 8 discs \$6.95

CELLO

Speaker Stands

Granite \$6,000/pr

Cables

20-in Speaker Harness Cables \$250/ea

Adaptors

Fischer-CAMAC. (M-M, M-F, F-F, F-M) . . \$80/ea
Fischer-RCA. (M-M, M-F, F-F, F-M) . . . \$80/ea

Cello Strings Connectors

Fischer-Fischer. (M-F); available in 1-10 m . . . \$170-\$620
Fischer-XLR. (M-F, F-M); available in 1-10 m . . \$160-\$610
XLR-XLR. (M-F); avail in 1-10 m . . . \$150-\$600
XLR-RCA. (M-M, F-M); avail 1-10 m . . . \$140-\$590
Fischer-RCA. (M-M, F-M); available in 1-10 m . . \$150-\$600
RCA-RCA. (M-F); available in 1-10 m. . \$130-\$580

clearaudio

Champion-Clamp

Constructed of duraluminum and brass. . . . \$150

Clearconnect RCA Connector

Beryllium/copper connector. Male center pin has 14 point contact, outer ground has >50 \$40

CLIK CASE BY OUTER CIRCLE PRODUCTS

C-36 Cassette Case

Cassette case holds 36 tapes. Made from polypropylene-ene; available in 10 colors \$15
C-16. As above, holds 16 tapes \$9



Click Case CD Case

Click CD Case

Weather-resistant case to hold 16 CD's. Features angled display; available in black or gray . . \$13.50

CROWN INTERNATIONAL

Plug In Panel Accessories

Several optional modules are available. The following list is not intended to be all inclusive but a representative sampling.

PIP-FMX

Plug-in panel with female-to-male XLR balanced bridging daisy chains (interconnects) the amplifier inputs. Features one low-pass and one high-pass filter. Dimensions: 6 $\frac{3}{8}$ x 1 $\frac{7}{8}$ x 3 $\frac{3}{8}$ in. Weight 8 $\frac{1}{2}$ oz. . . . \$25

PIP-NOV

Mono crossover/filter features multiple formats such as bi-amping, tri-amping with 12 dB or 18 dB/octave high/low-pass filters. 6 $\frac{3}{8}$ x 1 $\frac{7}{8}$ x 3 $\frac{3}{8}$ in. . . . \$95

PIP-FXT

Balanced-to-balanced transformer isolated input from source to amplifier. Features plug-in panel with female XLR's and 1:1 transformers; center taps of transformers oriented to accommodate jumpers; one low-pass and one high-pass filter. 6 $\frac{3}{8}$ x 1 $\frac{7}{8}$ x 3 $\frac{3}{8}$ in; 8 $\frac{1}{2}$ oz. . . . \$65

PIP-CLP

Overload detector features two female XLR type

ACCESSORIES

connectors; compressor range 13 dB nominal; input imp 20k ohms balanced; FR 20-20,000 Hz \pm 0.2 dB \$75

CUSTOM WOODWORK & DESIGN

All Woodmore cabinets are hand-crafted of select hardwood solids and veneers. Available in natural oak, dark oak, natural American walnut, and black oak, with matching shelves. Prices vary with finish. Cabinets can be grouped or stacked to make complete entertainment centers.

Magic Lowboy Audio Cabinet

Concealed audio cabinet rises to user height by remote control. Fully enclosed. Max height 53-in; closed, measures 47 $\frac{1}{4}$ x 34 x 19 in. . . \$2,550-\$2,800

Woodmore Glass-Lid Audio Cabinet

2 adjustable shelves; feather-light hinged lid; casters. 24 x 42 x 19 in. \$505-\$615

Woodmore Lowboy Audio Cabinet

4 adjustable shelves; casters. 47 $\frac{1}{4}$ x 30 x 19 in. \$455-\$565

Woodmore Record Cabinet

4 adjustable shelves; wood-veneer back; stacking accessory. 47 $\frac{1}{4}$ x 42 x 14 in. \$450-\$565

Woodmore Audio Cabinet

3 adjustable shelves; casters. 24 x 42 x 19 in. \$380-\$490

Woodmore Entertainment Table

Finished on all 4 sides; with wood base. 47 $\frac{1}{4}$ x 16 x 19 in. \$370-\$460

Woodmore Smallboy Audio Cabinet

2 adjustable shelves; casters. 47 $\frac{1}{4}$ x 21 x 19 in. \$365-\$455

30-Inch Woodmore Audio Cabinet

2 adjustable shelves; casters. 24 x 30 x 19 in. \$300-\$380

21-Inch Woodmore Audio Cabinet

1 adjustable shelf; casters. 24 x 21 x 19 in. \$250-\$310

Woodmore Doors

Rollwood. Veneered razor-sliced slats on wood track \$165

Wood Doors. Concealed European hinges and solid-wood pulls \$110

Glass Doors. With chrome, black, or gold hardware. \$50

Drop Leaf. For 21-in Woodmore or Woodmore Smallboy. \$70

Outlet Strips and Boxes

8-Outlet Strip. Filter and spike protector. \$145

2-Outlet Box. Indicator lamps. \$65

Woodmore Speaker Stands

Available in 9, 15 and 30 in, with adjustable spiked levelers \$80-\$100

Storage Drawers

LD-Drawer. Holds open-reel tapes or file folders. 22 $\frac{1}{2}$ x 11 $\frac{1}{4}$ in. \$125

29 x 11 $\frac{1}{4}$ in. \$160

MD-Drawer. Holds up to 120 DAT's, 36 VHS or Beta tapes. 22 $\frac{1}{2}$ x 7 $\frac{3}{8}$ in. \$120

29 x 7 $\frac{3}{8}$ in. \$150

SD-Drawer. Holds up to 108 DAT's, 90 cassettes. 22 $\frac{1}{2}$ x 5 in. \$110

29 x 5 in. \$125

Stacking Rails and Bases
Wood accessories for stacking units into wall sys-

tems; with leveler brackets and adjustable levelers; rails $\frac{3}{4}$ -in high; bases 1 $\frac{1}{4}$ -in high. \$24-\$145

Rack Mount

Wood rails, metal channels, hardware to mount 5 units \$95-\$105

Slide-out Shelf. 2 $\frac{1}{2}$ -in; extends 10-in \$85-\$95

Wood Back. Custom slotted at additional cost \$36-\$65

Cabinet Lights. Matching wood rails; cord switch; $\frac{3}{4}$ -in high. \$45-\$47

DBSYSTEMS

DB-4B Moving-Coil Pre-Preamplifier

MC-cartridge pre-preamplifier with low-noise cascode amps, diode-protected inputs. Features internal low/medium/high gain switch. THD 0.0008%; 20-20,000 Hz at 1 V; noise -86 dB at 1 mV; FR 10-100,000 Hz +0/-0.1 dB; input/output imp 9 kilohms, 2,000 pF/220 ohms; max load 10 kilohms, 3,000 pF, internally adjustable gain/sens/overload dB/40 \pm V/45 mV high \$205

With DBP-4 coupler and DB-2A power supply \$275

DBP-12X Audio Cable

10-meter length of low-capacitance (400 pF) stereo interconnect cable, terminated with premium DBP-13PX gold plugs. \$95

1-meter length \$49

DBP-11 Phono Capacitance Switch Box

Features front-panel-switchable 100-400-pF loading for 2 MM phono cartridges. Open position is provided. Phono jacks, plugs are gold plated \$79.95

DBP-11MC. Similar to DBP-11 but with resistive instead of capacitive values. Includes 5 ohm load \$79.95

DBP-2J/5 Passive Switch Box

Switching module with 10 input and 2 output jacks. Can be used for switching 5 turntables, tape recorders, amps, signal processors, etc. Allows for selectable cartridge loading when used with DBP-6 or 6MC. A-B comparisons possible with 2 Y-adaptors. Can be used for switching baseband video (not ch 3 or 4) \$69.95

DBP-2JAU/5. Same as DBP-2J except jacks are gold plated \$89.95

Optional Alps volume control installed in switch box additional \$40

DBP-6 Phono Equalization Kit

Permits adding 100-400 pF of capacitance to phono input of any preamp or receiver. Consists of 2 Y adaptors, set of gold-plated phono plugs with polystyrene capacitors wired to give 100, 150, 200, 300, 400 pF. Resistive load (1%) included for experimenting with MC cartridges plus pair of empty plugs for making custom values. \$36.95

DBP-6MC. Similar to DBP-6 except for MC cartridges. Loads are 1% 10-, 20-, 50-, 100-, 200-metal-film resistors. Two empty plugs included. . . . \$36.95

Gold-Plated Connectors

DBP-13JR. $\frac{3}{8}$ -in gold-plated phono jacks (8 pk) \$29.95

DBP-13PM. Gold-plated phono plugs, 4 red, 4 black \$29.95

DBP-9AU. Banana plugs, 8 gold-plated, solderless. \$24.50

DBP-13PX. Phono plugs (2 pk) \$19.95

DBP-13P. Phono plugs (8 pk) \$17.95

DBP-9P. Dual banana plugs (2 pk) \$17.95

DBP-9J. Dual banana jacks (2 pk) \$17.95

DBP-13J. $\frac{1}{4}$ -in gold-plated phono jacks (8 pk) \$15.95

DBP-15. Y-adaptors (2 pk) \$12.95

DBP-16. 12 dB input attenuators \$12.95

DBP-17. Phono coupler (2 pk) \$12.95

DBP-14. Spade lugs (8 pk) \$5.95

DBP-9H. Banana handles, 4 red, 4 black. \$3.50

DBP-10 Phono Alignment Protractor

Accurately measures lateral tracking error of mounted phono cartridges to within 0.25". Instructions provided to optimize geometry, set correct overhang for minimum error and distortion, useful when checking vertical tracking angle. Comes with carrying case \$24.95

DBP-CK Cramolin Audio Kit

Contact cleaning system. Dissolves and prevents oxide formation. Reduces noise \$19.95

DBP-VSF Voltage Spike Protector

Plug-in power line adaptor limits voltage surges that can damage solid-state components \$14.95

DBP-SC Souther Clever Clamp

Lightweight clear record clamp. 23 g \$15

Update and Modification Availability

DB-4B. Improvement includes 5 dB more gain, 4 dB less noise, and gold-plated phono jacks \$160

Gain increased by 3 dB and 2 dB less noise. . . . \$28

DB-6. Improvement triples power supply capacitance to 42,000 μ F for cleaner clipping. Gold-plated binding posts and jacks; warranty extension to 2 years \$160

dbx

Model 400XG Program Route Selector

Rack-mountable powered switching box has inputs and outputs for 3 sound processors, 1 noise reduction unit, 3 tape decks. Dubbing can be interrupted by sound processors and/or encode/decode side of noise reduction unit. Illuminated pushbuttons show program route \$299

DENNESEN ELECTROSTATICS

Pivotram

Locates proper spot to drill tonearm mounting hole in. Made of aircraft aluminum. 1 lb. \$100

Sound Tractor

Phono-cartridge alignment protractor gives distance and offset angle for pivots in one step. Made of aircraft aluminum. 1 lb; 12 x 2 x 3 in. \$100

Same unit made of plastic. \$35

Polaris FM Antenna

Indoor FM antenna. Passive, includes coax cable and balance. 1 lb; 18 x 2 x 2 in. \$40

DENON

RC-RX IR System Remote Control

Enables any IR remote-controlled audio or video equipment to be operated from remote locations. The basic system includes the RC-616 retransmitter/power supply, RC-617S stand-alone sensor, and RC-618 subtransmitter with 100 feet of cable. Other pieces are optional. \$200

RC-617W. Wall-mount sensor \$40

RC-617S. Stand-alone sensor \$40

RC-618. Subtransmitter. \$20

RC-605 Programmable Remote Control

130 programmable keys shared by two programs. Also stores signals of other remote controls. . . . \$120

AMC-12 CD Cleaner System

Uses liquid and a soft, nonabrasive pad. \$25

D.G. INDUSTRIES

Compact Disc Storage

Stackable plexiglass compact discs tray. Features storage of 29 compact discs; tilts discs for easy reading of titles. \$29.95

ACCESSORIES

DISCRETE TECHNOLOGY

The Lug

High-performance lug for use with speaker cables. Features construction with oxygen-free long-molecular copper plate with conductivity-enhancing alloy; 35° angle; color coding. . . . \$7

Diamond Reference Speaker Cable

Uses 8 individual cables made of both multi-gauge and multi-stranded silver-plated oxygen-free copper conductors per speaker; teflon insulation; with oxygen-free spade lug.

12-ft.	\$1,750
10-ft.	\$1,500
8-ft.	\$1,250
6-ft.	\$1,000

Platinum-Plus Speaker Cable

Uses 7 individual cables for each speaker; features spiral twist; protective braided tubing; silver-plated oxygen-free copper conductors; assembled by hand; minimum of 30 amperes DC current handling capability.

10-ft.	\$875
8-ft.	\$755
6-ft.	\$650

Dreadnaught Speaker Cables

Made with pure silver-plated, oxygen-free copper wire. Each cable consists of two cables with a total of 20 multigauge individually-insulated solid conductors.

10-ft.	\$460
8-ft.	\$395
6-ft.	\$315
4-ft.	\$225

Power Bridge AC Line Cable

Filters broad-band RF from being fed back into the AC lines and then into other components. 20 silver-plated oxygen-free conductors; PVC jacket; 2-prong male plug.

Power Bridge II 8-ft.	\$200
Power Bridge II 6-ft.	\$170

Diamond Interconnect

Made with four multistranded oxygen-free copper conductors per tube and two teflon tubes per cable with an external pure-silver shield wire.

2.5-m.	\$390
2-m.	\$360
1.5-m.	\$330
1-m.	\$300
0.5-m.	\$270

Platinum Interconnect

Made with pure silver, multistranded, braided shield and pure silver-plated oxygen-free copper inner conductors.

10-m.	\$420
6-m.	\$300
4-m.	\$240
3-m.	\$210
2.5-m.	\$195
2-m.	\$180
1.5-m.	\$165
1-m.	\$150
0.5-m.	\$135

312C Speaker Cable

Phase-aligned multigauge speaker cable. Features silver-plated copper inner conductor; dielectric teflon insulation; spiral twist.

15-ft.	\$260
12-ft.	\$225
10-ft.	\$200
8-ft.	\$175
6-ft.	\$150
4-ft.	\$125

Balanced-Line Silver Plus Interconnect

Phase-aligned multigauge interconnect. Features silver-plated copper inner conductor; dielectric teflon

insulation; spiral twist; full-foil shield; heavy PVC outer jacket.

10-m.	\$350.50
9-m.	\$325.50
8-m.	\$300.50
7-m.	\$275.50
6-m.	\$250.50
5-m.	\$225.50
4-m.	\$200.50
3-m.	\$175.50
2.5-m.	\$162.50
2-m.	\$150.50
1.5-m.	\$137.50
1-m.	\$125.50
0.5-m.	\$112.50

Balanced-Line Blue Interconnect

Phase-aligned multigauge interconnect. Features silver-plated copper inner conductor; dielectric insulation; drain line; spiral twist; full-foil shield; heavy PVC outer jacket.

10-m.	\$219.50
9-m.	\$191.50
8-m.	\$180.50
7-m.	\$167.50
6-m.	\$154.50
5-m.	\$141.50
4-m.	\$128.50
3-m.	\$111.50
2.5-m.	\$107.50
2-m.	\$101.50
1.5-m.	\$95.50
1-m.	\$89.50
0.5-m.	\$83.50

Bass Alignment Filters for B&W Speakers

For use with B&W 801/802 speakers. Filters with 1% metal-film resistors and polystyrene capacitors. Features PowerBridge II AC line noise.

Mono alignment filter	\$1600
Stereo alignment filter	\$950

Replacement Terminal Plates for B&W Speakers

For use with B&W 801/802 speakers. 2 gold-screened, anodized-aluminum with large oxygen-free, five-way binding posts.

Replacement plates	\$200/pr
------------------------------	----------

DISCWASHER

DiscKit Record Care

Contains D4+ record-care system, Zerostat antistatic instrument, SC-2 stylus-care system housed in DiscOrganizer. . . . \$59.95

Zerostat-3

Antistatic instrument neutralizes static charges on virtually any surface; works without coating by showering surface with millions of positive and negative ions. . . . \$29.95

Discset

Provides essentials of record, and stylus care; includes D4+ record-care system, SC-2 Stylus Care System in milled walnut base . . . \$24.95

Discwasher Compact Disc Cleaner

Includes a CD cleaning unit, CD-1 cleaning fluid, cleaning pad grooming brush and replacement cleaning pad. 14 oz . . . \$19.95
 CD-1, 6-oz. fluid refill . . . \$10.95
 CD-1, 1 oz fluid refill . . . \$3.95
 CD cleaner replacement pads. . . \$4.95

CD Storage System

Lightweight, durable unit stores up to 20 CD's in their jewel boxes. Designed to allow user to flip through CD's stored in unit. Can be wall mounted. 6 x 2 x 14³/₄-in . . . \$19.95

D4+ Record Care System

Safe record-cleaning system designed to remove contaminants without reducing record fidelity. Con-

sists of D4+ fluid that lifts, suspends contaminants; soft-fiber pad with hand-milled walnut handle to remove debris and dry record; DC-1 pad-cleaner brush. . . . \$16.50
 16 oz replacement fluid . . . \$16.95
 6 oz replacement fluid . . . \$9.95
 1.25 oz replacement fluid . . . \$2.50

CD Storage Unit

Holds 10 CD's	\$12.95
Holds 5 CD's	\$8.95

SC-2 Stylus Cleaner System

Includes scientifically safe cleaning fluid, precision nylon-fiber brush designed to safely remove stylus contamination. Brush has attached stylus-inspection magnifying mirror . . . \$8.50
 SC-2 refill fluid . . . \$2.50

D'Stat II Mat

Turntable mat reduces static charges on contact, provides cushion to reduce sonic, mechanical feedback between record and turntable platter. . . \$8.50

CD Replacement Jewel Boxes, 2 pack . . . \$3.99

V.R.P. Record Sleeves

Scratch-free record liner sleeves that prevent static charge buildup during record storage and removal from sleeve. Super-smooth surface will not ooze plastic additives onto record; package of 10. . \$3.50

Cables

Gold-Ens Speaker Cables

30-ft length speaker cable with oxygen-free copper. Features clear, PVC-jacket; polarized and color-coded connector ends.

14 gauge	\$29.95
16 gauge	\$18.95

Gold-Ens A/V Cables

Perfectionist cables for audio, video; provide ultra-low capacitance with heavy gold-plated connections with molded nylon insulating sleeves.

2-meter triple strand	\$23.95
1-meter triple strand	\$21.95
5-meter double strand	\$19.95
4-meter double strand	\$17.95
2-meter double strand	\$15.95
1-meter double strand	\$13.95
0.5-meter double strand.	\$12.95

Gold-Ens Connector Cable

Double-strand RCA-style cable with gold-plated ends and pure-copper conductors. Available in both 2 and 3 strand sets from 1/2 m to 5 m . . . \$12.95-\$23.95

Tape Recording Accessories

D'Mag Cassette Deck Demagnetizer

Demagnetizes tape heads, capstans, and entire tape path. Requires no batteries or power cords . \$19.95

Discwasher Tape Deck Care Set

Includes Perfect Path Cassette Head Cleaner and C.P.R. Capstan Pinch Roller Cleaner. . . \$12.95

System II Cassette Tape Care

Combination head and capstan, pinch-roller cleaner for cleaning and maintaining all home and car cassette players. Nonabrasive dry fiber matrix tape safely removes dust and oxide buildups on heads and along entire tape path. Capstan, pinch-roller cleaner with an advanceable fiber-grid surface and specially formulated fluid removes tackiness and contamination from capstan and pinch-roller assembly to prevent jammed and eaten tapes. With carrying case. 4 x 2 1/2 x 0 1/2 in . . . \$11.95
 System II, As above without carrying case . \$11.95

C.P.R. Capstan/Pinch-Roller Cleaner

"Positive Drive" cleaning system for cassette decks

ACCESSORIES

designed to safely scrub pinch rollers, capstans with advancable cleaning fabric and harmless fluid \$8.95
0.34-oz. C.P.R. fluid refill \$1.95

Cassette Storage Case (6-unit)

Constructed of rugged, water-resistant vinyl. Clear window lid and Velcro-style clasp. \$7.95
12 unit. \$14.95

Perfect Path Cassette Head Cleaner

Nonabrasive dry system for audio cassette decks designed to remove oxides, and gummy residue along tape path and on tape heads \$5.95

D.W. ELECTROCHEMICALS

Stabilant 22 Liquid Semiconductor

Liquid that is initially nonconductive but under an electrical field or between metal contacts becomes conductive. Features good lubricating properties. Improves distortion and S/N figures.

100 ml concentrate. \$551
50 ml concentrate. \$310
100 ml dilute \$138
100 ml 22S (100 ml container with 20 ml. Concentrate for customer-added solvent use). \$137
15 ml concentrate. \$102
50 ml dilute \$76
15 ml dilute (service kit) \$36

ELECTRONIC SPECIALISTS

ISO-17 Power Isolator

Spike and surge suppression, background power-line-NR. Four isolated channels. 5-yr warranty \$280
ISO-18. As above, two isolated channels. \$238

ESOTERIC AUDIO

Speaker Connectors

T-Lok Speaker Connectors

Does not require crimping tools; 24K gold plating; colorband polarity identification. Available in single banana or dual banana construction. \$22/pr

Inter-Lok Speaker Connectors

Does not require crimping tools; 24K gold plating; interchangeable tip for banana, and bi-pin design. For wire gauge sizes 11-15 AWG \$25/4 pack
Inter-Lok XL. As above, for gauge 5-8 AWG. 4 pack. \$32

Ultra-Cable Series Speaker Cables

Premier

Expanded twin symmetry 5-wire network. 1,200 strands oxygen-free-copper \$2/ft

Signature

Expanded twin symmetry 5-wire network. 600 strands oxygen-free-copper \$1.10/ft

Reference

Standard twin symmetry 5-wire network. 520 strands pure grade copper. \$.85/ft

Interconnect Cable



Esoteric Audio Inter-Lok Connectors

Technology 3

Oxygen-free-copper windings, with teflon, free-air, and air-cellular polypropylene dielectrics. 24 karat gold plated locking RCA connectors. ... \$100/1m pr

Technology 2

250 strand enamel litz center conductor. Oxygen-free-copper windings, 5-wire network. Teflon, free-air, and air-cellular polypropylene dielectrics. 24K gold plated locking RCA connectors. ... \$100/1m pr

Ultra-Path 2+2

8 AWG with 1,200 strands oxygen-free-copper in polyethylene \$4/1m pr

EXPRESSIVE TECHNOLOGIES

IC-1 Interconnect

Balanced component interconnect features cable grounding system \$345/2 ft pr; \$70/add ft

GENEVA

Reel Tabs

Precut adhesive-backed Mylar or metal tabs for tape splicing, editing. Designed for use with Geneva splicing equipment.

1/4-in Mylar Reel Tabs

QM-531. 1,000/pkg \$112
QM-526. 200/pkg. \$23
QM-521. 50/pkg. \$7.56



Geneva Group PF-215

Cassette Mylar Reel Tabs

QM-524. 50/pkg. \$9.22
QM-522. 50/pkg. \$6.68

PF-215 High-Performance Bulk Tape Eraser

Tape eraser for S-VHS, Type IV metal tape and 8 mm. 2,800-gauss strength \$90

VCR-205 Audio/Video Demagnetizer

Removes residual magnetism from heads and tape path parts. Features 2900-gauss field intensity; vinyl covered probe won't harm heads. 9.25 oz \$50

PF-412 Auto-Stop CD Cleaner

Wet-type CD cleaner with 20 sec. cleaning cycle. Features chamois-type cleaning pad; straight-line cleaning pattern; Discsafe Fluid Spray. Batteries in AC adaption not included. Uses 4 AA batteries. . \$40

Tape-Splicing Blocks

Specially grooved to hold tape firmly during splicing. Features 2 deep slits for straight, diagonal cuts. Supplied with double-backed adhesive for mounting without drilling; stainless-steel cutter. 5/8 x 1 x 3/8 in.

PF-311. For 1/4-in tapes \$32
PF-312. For cassette tapes. \$32

PF-400 Compact Disc Storage Albums

LP-size storage unit for CD's. Each holds 4 CD's in clear plastic carrying case. 3-pack; holds 12 CD's total. \$14.95

PF-570 Deluxe Tape Deck Kit

Audio head cleaner with pinch roller cleaner/revitalizer. Features 100% pure TF head cleaning solution; safe for high-end system tape decks and can be used with QM-505 \$12.99

QM-505 Cellular Foam Swabs

Package of 25 swabs, for cleaning audio, videotape decks \$9.40

PF-116 Tape & Head Cleaner

Aerosol spray cleaner with extension tube to reach recessed parts. Safe for audio, video decks. 16-oz can. \$9.09

Stores CD Storage File

Drawer storage device with brake to keep drawers from falling out. Features 90 degree lid holder; labels easily viewed; each unit can be fitted together to form expanding storage system. Matte black finish \$8.50 each

PF-562 Audio Cassette Head Cleaner

Cleans heads and tape path components in 5 sec. Features gold-colored metal hubs; nonabrasive cleaning tape; alcohol cleaning solution; standard cassette housing. 3.25 oz \$7.99

PF-425 Disc Wipes

For cleaning CD's. Each package contains 70 pre-moistened, nonabrasive cleaning cloths containing Discsafe cleaning solution \$6.99

QM-108 Tape/Head Cleaner

Liquid tape and head cleaner in 8-oz can. \$6.10

QM-103 Tape/Head Cleaner

Aerosol tape and head cleaner blasts loose oxides, dirt. Supplied with extension tube \$6

PF-120 Audio/Video Splicing Kit

For editing and repairing audio cassettes, VHS and Beta videocassettes; splicing tape for 36 audio or 24 video splices; leader tape for audio cassette, VHS, Beta; with instructions. \$5.99

QM-102 Tape Head Cleaner

Liquid cleaner in 2-oz bottle. Leaves no residue; can be used on capstans, pinch rollers. \$4.99

QM-122. Same as QM-102 but in 1.7-oz spill-proof bottle. \$4.20

PF-105 Mini Super Blast

Removes dust and dirt from hard-to-reach areas. 1.5-oz can \$3.53

PF-870 Double RCA Jack

Connects RCA cables together in series for extra length \$2.99

PF-860 RCA Jack-to-Mini Plug

For connecting pocket stereos (or anything with mini jack) to stereo system (or anything with RCA inputs). \$2.99

PF-115 Electronic Cable Ties

20 reusable ties; each 5-in; with pop locks; trimmable with scissors \$2.29

GUSDORF

Model 5945 Audio Cabinet

Audio cabinet featuring autumn oak moisture/scratch-resistant finish; lift-up top; 3 shelves; push-to-open tempered safety-glass doors. 43 1/2 x 19 x 15 3/8 in. \$230

Model 4440 Formula Speaker Enclosures

Speaker enclosures featuring dark-oak finish and adjustable shelf to accommodate speakers up to 39 x 19 1/2 x 2 1/4 in. Matches Model 4450 entertainment center \$210/pr
Model 5900. Similar to above except in light oak with solid-wood trim; matches Model 5950 entertainment center and Model 5945 audio rack. Holds speakers up to 38 1/2 x 2 1/4 x 14 in. \$240/pr
Model 6640. Similar to Model 5900; matches Model 6550 entertainment center. Holds speakers up to 38 x 19 1/2 x 14 in. \$180/pr

ACCESSORIES

Model 3370 Black Audio Cabinet

Ready-to-assemble cabinet featuring chrome trim; tempered safety-glass doors with magnetic catches; lift-up top for turntable; concealed casters for easy mobility; two adjustable shelves. Tools, assembly hardware, and instructions included. Dimensions: 39 x 19 x 18 in. \$159

Model 3375. Similar to above except in oak . . \$149

Model 4445 Golden-Oak Audio Cabinet

Cabinet featuring bronze-tone trim and hardware; rounded corners and molding; smoked tempered safety-glass doors with magnetic catches; 3 adjustable shelves; record dividers. Instructions and assembly tools included. 20½ x 48½ x 19 in; inside width 15½ in. \$149.95

4447. Same as above with ebony finish . . . \$149

HEYBROOK BY D'ASCANIO AUDIO

TPS Power Supply

Two-way electronic speed switcher with voltage line stabilizer and filter. For use with the Heybrook turntable or others using synchronous motors. 2 x 4½ x 9 in; 4 lb. \$249

HBS-3 Speaker Stand

Loudspeaker stand designed for stable, rigid support. 4 adjustable pointed spoke feet top and bottom. 13¾ x 10 x 11¾ in; 18 lb \$139/pr

HBS-1. Similar to HBS-3 except 18-in tall . \$179/pr

HBS-PS. 20-in speaker stand \$129/pr

WB-2 Wall-Mounted Speaker Stand

Wall-mounted loudspeaker stand. Features facilities for bolts; black finish; 9 x 9 inch mounting area for speaker; 9 x 8-inch wall-mounting area . . . \$100

HI-PRO-TECH

Identadisc H.D. CD Protector

System for impressing identifying marks on CD's. Features warning labels for CD boxes; warning labels for car windows and CD players; registration in national reporting system; toll-free number . . . \$90

Identadisc. As above, for smaller collections . . \$50

INNOVATIVE CONCEPTS

ProView CD File

CD multiple-stack, side-by-side, or vertical, file system. Holds up to 18 CD's in a vertical library; touch-release mechanism; highly durable plastic with black satin gloss finish \$9.95

INTERNATIONAL COMPONENTS

Audio-Video Cables

Low capacitance, double-shielded, double-insulated flexible cables. Feature RF interference rejection; clear PVC outer jacket. 24K gold-plated connectors; stranded center conductors.

A-VC1012G. RCA to RCA 12-ft cable \$25

A-VC1006G. RCA to RCA 6-ft cable \$17.24

A-VC1003G. RCA to RCA 3-ft cable \$13.10

A-VC1112G. Quick "F" to Quick "F" 12-ft cable \$25.00

A-VC1106G. Quick "F" to Quick "F" 6-ft . . . \$17.24

A-VC1103G. Quick "F" to Quick "F" 3-ft . . . \$13.10

Double RCA to RCA Patch Cables

Extra heavy-duty gold end double RCA to RCA patch cables

A-VC812G. 12-ft cable \$14.42

A-VC806G. 6-ft cable \$12.16

A-VC803G. 3-ft cable \$10.16

A-HEC25 Headphone Extension Cable

Black 25-ft coiled cable. Molded plug and jack with stress relief \$5.84

A-VC806GE Double RCA to RCA Patch Cable

Economy gold-end double RCA to RCA 6-ft patch cable separate video and audio cables \$5.84

Speaker Cable

A-SW1850. Polarity-coded, clear 50-ft spool; 18 gauge \$7.50

A-SW2450. 50-ft clear, polarity coded speaker wire; 24 gauge \$3.05

A-SW2425. As above, 25 feet \$1.99

A-SW25B. 25-ft RCA-to-RCA speaker cable. 24 gauge \$2.45

A-SW12B. As above, 12 feet \$1.85

A-SW25A. RCA plug to RCA jack; 25-ft speaker extension cable \$2.45

JVC

CXM75 CD Magazine

Additional 6-disc magazines for JVC CD changers \$20

XCMI3 CD Magazine

3-in 6-disc magazine for JVC CD changer . . . \$20

KALIMAR

CD Storage Units

490 CD Pop Out Cabinet. Pressing tab above selection makes disc pop out of slot. Teak. Holds 30 CD's \$72

515 CD Library. Teak with three levels and two disc organizers. Holds 120 CD's \$60

501 CD Stack Up Cabinet. Teak stackable unit with carrying handle. Holds 44 CD's, accommodates 4 double jewel boxes \$55

480 Pop Out Cabinet. Pressing tab above selection makes disc pop out of slot. Teak. Holds 20 CD's \$49

493 Stack Up Cabinet. Teak stackable unit with carrying handle. Holds 30 CD's \$43

466 CD Roll-Top Cabinet. Teak with roll-top. Holds 28 CD's \$38

540 CD Selector. Teak flip-through. Holds 40 CD's \$19.95

502 Roundabout Accessory. Allows rotation of 501 unit \$14.50

503 CD Unit. Asian oak CD holder, stackable and connectable. Holds 10 CD's \$12.95

Cassette Storage Units

467 Cassette Carousel. Teak with tambour doors, turntable on ball bearings. Holds 24 cassettes . . \$73

479 Cassette Pop Out Cabinet. Pressing tab above selection makes cassette pop out of slot. Teak. Holds 30 cassettes \$56

473 Cassette Cabinet. Teak roll-top, three rows. Holds 45 cassettes \$47

478 Cassette Pop Out Cabinet. Pressing tab above selection makes cassette pop out of slot. Teak. Holds 15 cassettes \$31

421 Cassette Cabinet. Teak roll-top. Holds 15 cassettes \$27

422 Cassette Cabinet. Teak roll-top with two rows. Holds 30 cassettes \$40

KENWOOD

RC-100 Programmable Remote Control

Universal wireless remote with control keys for Kenwood audio components and TV monitors. Features memory mode to learn commands from other manufacturer's remote controls; 58 programmable keys \$99

CDM-608 CD-Single Magazine

6-disc magazine for Kenwood CD changers; for 3-in CD singles only \$30

CDM-600. As above, for 5-in CD's \$20 each

KINETIC AUDIO

Cabinets

Furniture-styled equipment/record/tape cabinets.

Can be stacked; adjustable-height shelves or rack rails; walnut veneer over particle-board side panels.

EC-XL. 48 x 21 x 18 in. Deluxe unit with plexiglas door and black dual-wheel casters \$500

EC-L. 48 x 21 x 18 in \$300

EC-M. 38 x 21 x 14 in \$200

EC-S. 24 x 21 x 14 in. \$150

Speaker Stands

Straight or tilted speaker stands with dual-angle up/down capability and flat black satin finish.

S-L. Large \$200/pr

S-M. Medium \$150/pr

S-S. Small \$125/pr

Stereo Amplifier/Line-Level Control

For bi- and multi-amping and other amplifier level adjustments. Features 10,000, 25,000, 50,000 ohm imps; phono jacks; connectors; mounting hardware \$150

Stereo Amplifier/Speaker Selector

Switches 2 stereo amplifiers into single pair of speakers or 2 pairs of speakers from single stereo amplifier \$150

KLYNE AUDIO ARTS

SK-2A Pre-Preamplifier

Pre-preamplifier for low output MC cartridges. Features high resolution design; adjustable high-frequency contour. Gain 24 dB; bandwidth 800-350,000 Hz; output imp 600 ohms \$750

KOSS

Portable Stereo Speakers

Mini speakers designed to plug into headphone jack of a portable stereo system.

KSC/8000. Dual-amplified speakers. 2-250 mW/ch. 8.9 oz (w/o battery) \$25/pr

KSC/5000. Mylar-covered diaphragm driver and amplified power booster \$16/pr

KSC/50. Features dual full-range transducers. 3.2 oz. \$10/pr

LASERLINE BY CREATIVE POINT

CD-4800W Compact Disc Storage unit

Holds up to 48 CD's. Securing release mechanism locks disc in slot and releases disc cartridge at a touch. Genuine oak-finish cabinet \$60

CD-4800B. Same as above in black finish . . . \$50

AC-5400W. Same as above for storage of 54 cassettes \$50

AC-5400B. Same as 5400W in black finish . . . \$40

CD-2400 Compact Disc Storage Unit

Holds up to 24 CD's. Securing release mechanism locks disc in slot and releases disc cartridge at a touch. Made of impact-resistant plastic. Modular design for adding additional units. 4.9 x 18¾ x 6¾-in . . . \$30

CD-1200. Same as CD-2400 except holds up to 12 CD's. 4 x 12¾ x 6¾ in \$19.95

CD-800. Same as CD-2400 except holds up to 8 CD's. 4¾ x 6¾ x 6¾ in. \$9.95

AC-1800 Cassette Storage Unit

Holds 18 cassettes; impact-resistant, high-grade plastic; cassettes lock in place; stackable; nonskid feet; hinged door. 5¾ x 16¾ x 5¾ in; 2.42 lb. . . . \$19.95

LEBO

Voyager series nylon carry cases are water resistant and are suitable to carry a variety of personal accessories. Features include zippered openings; padded construction; adjustable straps. Various colors are available.

33260 Leather Tex Voyager

Two-sided, soft carry case for 60 boxed or 96 unboxed cassettes; personal accessory pocket, de-

ACCESSORIES

tachable adjustable shoulder strap and handle; removable inner tray; black imitation leather. . . . \$36

25248 Jumbo Voyager

Nylon carry case for up to 48 CD's or personal accessories; can also store portable CD player and most camcorders; removable inner divider; two large zippered side pockets; detachable adjustable shoulder strap; red, black, victoria blue, grey \$34

34230 Leather Tex Voyager

Soft carry case for 30 regular or 15 double CD's. Features removable velcro inner divider; outside zippered pocket; adjustable shoulder strap with shoulder guard. Black imitation leather \$24

33230 Leather Tex Voyager

Soft carry case for 30 boxed or 48 unboxed cassettes; large accessory pocket; detachable, adjustable shoulder strap and handle; removable inner tray; black imitation leather. \$26

20030 First-Class Voyager

For 30 boxed or 48 unboxed cassettes, with large personal accessory pocket, removable tray, detachable, padded shoulder strap, handle, color coordinated hardware; red, black, silver grey, blue \$23

21230 Custom Lite Voyager

For 30 boxed or 48 unboxed cassettes, with large personal accessory pocket, removable tray; red, black, silver grey, victorian blue \$18.95
21220. Same as above for 20 boxed or 32 unboxed cassettes \$15.75

25212. For 12 regular or 6 twin box CD's with outside personal accessory pocket and detachable shoulder strap; interior Velcro compartment divider. . \$13.25

25006. For 6 regular or 3 twin boxed CD's, detachable shoulder strap and belt loop \$9.50

21010. For 10 cassettes or personal accessories, detachable shoulder strap and belt loop; red black, silver grey, victorian blue \$7.95

Storage Cabinets

58120 Oak Storage Unit

Oak storage unit for 120 regular CD's or 60 twin CD's. Features horizontal viewing for easy selection. Solid oak with hand-rubbed finish \$67

58860 Oak Storage Cabinet

Oak roll-top cabinet for 60 CD's. Features solid-oak and oak veneer with hand-rubbed finish \$67

58900 Oak Storage Cabinet

Oak roll-top cabinet holds 51 audio cassettes. Features solid-oak and oak veneer with hand-rubbed finish. \$56

58090 Oak Storage Unit

Oak storage unit holds 90 regular CD's or 45 twin CD's. Features horizontal viewing for easy selection. Solid-oak with hand-rubbed finish \$56
58060. As above oak storage unit for 60 CD's or 30 twin CD's \$45

58290 Oak Storage Unit

Oak storage unit holds 90 audio cassettes. Features horizontal viewing. Solid-oak with hand-rubbed finish \$45

LESLIE DAME ENTERPRISES

CD Storage Units

CD-260A CD Storage Unit. Solid-oak combination CD, Videocassette storage unit. Holds 260 CD's or 160 audio cassettes in any combination. Holds 20 video cassettes on top tier \$80
23096 CD Storage Rack. Oak-grain-finish CD rack holds up to 96 CD's. Stackable \$50
23860 CD Storage Unit. Solid-teak unit with tambour door, holds 60 CD's \$50

CD-232 CD Storage Unit. Deluxe solid oak wood, handcrafted finish, stackable, lazy-Susan construction. Turns completely around. Holds 32 CD's. \$42
CD-236 CD Storage Unit. Deluxe handcrafted solid-oak, stackable to 72 pieces, holds 36 CD's. . . . \$40
CD-48 CD Storage Unit. Solid hardwood construction CD storage unit. Holds 48 CD's. Stained and lacquered finish \$37

23064 CD Storage Rack. Oak-grain finish rack holds up to 64 single CD's or 32 twin box CD's. Stackable \$37
23760 CD Storage Rack. Solid-teak rack holds up to 60 CD's \$34

CD-20 Deluxe CD Case. CD carrying case holds 20 CD's. Leatherette cover with matching hardware and felt interior \$28

23836 CD Storage Unit. Solid Teak unit with roll top; holds 36 CD's \$28

CD-24 CD Storage Unit. CD storage unit of solid hardwood construction. Handcrafted, stained, and lacquer walnut finish. Holds 24 CD's vertically \$25

CD-60 CD Storage Unit. 3-drawer deluxe walnut woodgrain finished cabinet holds 60 CD's. . . . \$25



Lebo 34230 Leather Tex Voyager

CD-48E Storage Unit. CD storage unit of plywood construction. Holds 48 CD's vertically. \$22
CD-40 CD Storage Unit. 2-drawer, deluxe walnut woodgrain finished cabinet holds 40 CD's. . \$17.95
CD-24E CD Storage Unit. Vertical CD storage unit; plywood construction. Holds 24 CD's \$12.95

CD-10 CD Storage Unit. CD storage unit holds 10 CD's; 4 sides interlocking design; wall/shelf mounting or free standing \$3.95
CD-12 CD Storage Unit. Dual CD storage unit holds 12 CD's or 6 doubles; 4-sided interlocking plastic modular design; wall/shelf mounting or free standing. \$3.95

CD-10 CD Storage Unit. CD storage unit holds 10 CD's; 4 sides interlocking design; wall/shelf mounting or free standing \$3.95

CD-12 CD Storage Unit. Dual CD storage unit holds 12 CD's or 6 doubles; 4-sided interlocking plastic modular design; wall/shelf mounting or free standing. \$3.95

CD-10 CD Storage Unit. CD storage unit holds 10 CD's; 4 sides interlocking design; wall/shelf mounting or free standing \$3.95

CD-12 CD Storage Unit. Dual CD storage unit holds 12 CD's or 6 doubles; 4-sided interlocking plastic modular design; wall/shelf mounting or free standing. \$3.95

Cassette Storage Units

TA-248 Cassette Storage Rack. Solid-oak wood storage rack holds 48 audio cassettes \$40
82045 Cassette Storage Unit. Solid-teak storage unit with roll top holds up to 48 audio cassettes. . . \$36
82100 Cassette Storage Rack. Solid-teak storage rack holds 100 cassettes. \$36

TA-72 Cassette Wall Rack. Wood cassette wall rack with individual tape compartments holds 72 audio cassettes \$32

TA-136 Attache Cassette Case. Attache style cassette case of wood construction with black leatherette finish and key locks holds 36 cassettes. . . . \$29

TA-48 Cassette Wall Rack. Wood-finish cassette wall rack with individual tape compartment holds 48 audio cassettes \$25

TA-660 Vinyl Cassette Case. Padded vinyl cassette case holds 60 cassettes. \$13.95
HI-30C Audio Storage Cabinet. Audio storage cabinet holds 30 audio cassette tapes \$21

HI-42C Audio Storage Cabinet. Holds 42 audio cassette tapes \$12.95

TA-630 Vinyl Cassette Case. Padded vinyl cassette case holds 30 cassettes. \$8.95
TA-624 Vinyl Cassette Case. Padded vinyl cassette case holds 24 cassettes. \$7.95

TA-612 Vinyl Cassette Case. Padded vinyl cassette case holds 12 cassettes \$4.99
MRC-2 Magnetic Record Cleaning Brush . . . \$1.99

MAXELL

Demagnetizer

HE-44. Electronic demagnetizer \$30

Head Cleaners

R-CL. DAT head cleaner. \$12.99

HC-401. Wet head cleaner \$6.99

RCT. Dry head cleaner \$3.59

Cassette Boxes

P-Case. 3 empty cassette boxes. \$1.49

CD Cases

CD case. 2 empty CD boxes \$1.79

Metal Reel

MR-7. 7-in metal reel \$7.99

McINTOSH

CR 7 Infrared Remote Control System

Expandable remote system receiver designed to function with most McIntosh components. Features area-specific volume adjustment; AC power activation; source selection; tuner station select; full compact disc player operation; preamp select; mute. 8 lb \$849

CR 8. Remote area controller. Module for expanding remote capability to another location. \$678

R 626. Tape recorder interface \$499

R 623. Remote area volume control \$295

SCR 2. Speaker control relay (C 34V) \$200

SCR 3. Speaker control relay (C 31V/C 35). . . \$200

R 612. Power relay \$195

R 624. C 31V interface with CR 7/CR 8 remote control system \$195

R 603. Adaptor panel (CR 7/CR 8) \$155

R 606. Multiple sensor adaptor \$145

R 617. Cable: 2nd tuner for CR 8. \$79

IIR 7. Hand-held transmitter for CR 7 & CR 8. \$65

R 607. Switch box mount remote sensor \$42

R 620. Cable: Activate MR 80/MR 500/MAC 4200 Scan. \$14.50

Cabinets

L 62. Hand-rubbed, polished walnut-veneer cabinet for units with a 5 $\frac{1}{8}$ -in high front panel. 16 lb . \$140

L 60. Hand-rubbed, polished walnut-veneer cabinet, for compact components. 11 lb. \$119

I 52. Walnut-veneer cabinet for units with a 5 $\frac{1}{8}$ -in high front panel. 16 lb \$89

I 54. Walnut-veneer cabinet for units with a 7 $\frac{1}{8}$ -in high front panel. 17 lb \$89

I 50. Walnut-veneer cabinet, compact components. 11 lb \$69

R 662. Adapters to permit mounting XRT 18 tweeter columns on CS18 stands. 6 lb \$17.25 each

MEMOREX BY MEMTEX

CP8 Universal Remote Control

Learns functions of 8 remote controls. Features sequencing operation that performs multiple remote commands with one touch; time/day-of-week clock; booster for more powerful signal; backlit LCD display for night use \$79

Electronic Cassette Demagnetizer

Battery-powered head demagnetizing system. Eliminates residual magnetism to keep recordings free of noise and distortion. Works in less than 1 sec on any deck. \$24.99

Auto Lighter DC Power Adapter

Power battery-operated radio, tape player, or personal portable through car lighter socket. Features 6 plug types; 5 voltages; 2 polarities. \$14.99

CD Cleaner

Cleans CD's; restores uniform disc reflectivity. Includes cleaning solution; pad; bristle brush; storage case \$14.99

ACCESSORIES

Double-Pair Stereo Cable

Features 4 coaxial cables in one; stranded pure-copper conductors; color-coded RCA phono-type plugs; gold-plated; maximum signal transfer; interference-free reception. . . . \$11.99

Deluxe Speaker Cable

Premium speaker cable upgrades system. Features 16-gauge heavy-duty cable; 19 strand pure copper conductors; high conductivity. . . . \$11.99

Safeguard Voltage Spike Protector

Guards against brief high-voltage spikes that may occur in AC power lines. Works in any standard 110-120-V AC outlet. . . . \$7.99

Audio Patch Cables

Features gold plating for maximum signal transfer; low capacitance, heavy shielding for truest sound; 95% braided copper shielding for high frequency response and low distortion. 6 foot length. . . \$6.99

CD Player Dustcover

Vinyl CD player dustcover with clear front panel. Available in medium (14 x 12.5 x 3 in) and large (18 x 14 x 3 in) sizes. . . . \$5.99

Graphite Filament Record Cleaner

Cleans and neutralizes static electricity. Features thorough cleaning through electrically conductive graphite microbristles that fully reach into the bottom of record grooves. . . . \$5.99

CD Organizer

Storage unit with independent storage slots holds up to 12 CD's in vertical position; twin pack. . . \$4.99

CD Storage Case

High-quality dust-proof replacement storage case for individual CD's; standard jewel-box design; twin pack. . . . \$2.99

FM Dipole Antenna

Features folded dipole design length-tuned to optimum wavelength for FM radio band; no wire stripping necessary. . . . \$1.99

3-Pack Audio Albums

Design allows tape end in or out for hassle-free storage; cassette protection for home or car. . \$1.59

Tape and Record-Care Products

X-CD. Cassette head cleaner/demagnetizer. . \$6.99
Record care kit. . . . \$5.99
Cassette cleaning Kit. . . . \$2.99
Record cleaner. . . . \$2.99
Record cleaning fluid. . . . \$2.69
Cassette head cleaner. . . . \$1.89

Headphone Accessories

Infrared Cordless Headphone Adaptor. AC powered transmitter and battery-powered receiver provides cordless reception for any pair of mini-plugged headphones. . . . \$70

Headphone Extension. 20-ft lightweight stereo headphone extension cable. . . . \$5.99
Y-Adapter. Dual-headphone adapter. . . . \$2.99
Mono Adapter. Mono adapter for stereo headphones. . . . \$1.99

MISSION ELECTRONICS

Cyrus Loudspeaker Stand

Rigid, 3-column, steel tubular stand. Features carpet-piercing spikes; optional short-coned upward-facing top-plate spikes. Match with 781 and 782 speaker systems. Textured matte-black finish. . . . \$199

Mission Designer Loudspeaker Stand

Rigid "Z" shaped, steel tubular stand with carpet-piercing spike. Match with 761 and 762 speaker systems. Satin black finish. . . . \$149/pr

Isoplat Isolation Platform

¾-inch mounting depth isolation platform for compact disc players and power amplifiers. Features steel-cup sorbothane feet. Platform is finished in nextel gray. . . . \$79/ea

Cyrus Speaker Cable

0.95 mm solid-core oxygen-free copper cable with directional polypropylene and polyurethane insulation. . . . \$3/ft

Mission Speaker Cable

690 strand oxygen-free copper cable with directional polypropylene insulation. . . . \$2/ft

MIT

Speaker Cable

750 CVT Speaker Cable

45-ft. . . . \$5,400
40-ft. . . . \$5,000
35-ft. . . . \$4,600
30-ft. . . . \$4,200
25-ft. . . . \$3,800
20-ft. . . . \$3,400
15-ft. . . . \$3,000
12-ft. . . . \$2,800
10-ft. . . . \$2,600
8-ft. . . . \$2,400

MI-750E Speaker Cable

30-ft. . . . \$2,465/pr
25-ft. . . . \$2,080/pr
20-ft. . . . \$1,695/pr
15-ft. . . . \$1,375/pr
12-ft. . . . \$1,125/pr
10-ft. . . . \$960/pr
8-ft. . . . \$795/pr

MI-750SG Shotgun Series

25-ft. . . . \$2,105/pr
20-ft. . . . \$1,940/pr
15-ft. . . . \$1,425/pr
12-ft. . . . \$1,230/pr
10-ft. . . . \$1,095/pr
8-ft. . . . \$965/pr
SG term. . . . \$350/pr

Music Hose Speaker Cable

30-ft. . . . \$1,320/pr
25-ft. . . . \$1,120/pr
20-ft. . . . \$940/pr
15-ft. . . . \$725/pr
12-ft. . . . \$610/pr
10-ft. . . . \$535/pr
8-ft. . . . \$450/pr
Wbt banana/wbt banana. . . . \$392
Spade/wbt banana. . . . \$196
Bi-wire jumpers on cable speaker end. . . \$140

PC-Squared PC-18 Speaker Cable

20-ft. . . . \$315/pr
15-ft. . . . \$245/pr
12-ft. . . . \$205/pr
10-ft. . . . \$180/pr
8-ft. . . . \$150/pr
6-ft. . . . \$125/pr
Bulk. . . . \$6.75/ft
Cust term bananas. . . . \$82/pr
Cust term spades or pins. . . . \$42/pr
Banana Term. . . . \$40/pr

Zaphord Speaker Cable

20-ft. . . . \$195/pr
15-ft. . . . \$155/pr
12-ft. . . . \$130/pr
10-ft. . . . \$115/pr
8-ft. . . . \$98/pr
Bulk. . . . \$3.95/ft
Bananas on both ends. . . . \$69
Spades or pins bananas. . . . \$52
Spades or pins on both ends. . . . \$35

Interconnect Cable

MI-330SG Shotgun Interconnect Cable

50-ft. . . . \$3,730/pr
45-ft. . . . \$3,095/pr
40-ft. . . . \$3,030/pr
35-ft. . . . \$2,410/pr
30-ft. . . . \$2,185/pr
25-ft. . . . \$2,130/pr
20-ft. . . . \$1,495/pr
15-ft. . . . \$1,385/pr
10-ft. . . . \$1,270/pr
2-m. . . . \$670/pr
1.5-m. . . . \$570/pr
1-m. . . . \$490/pr
0.5-m. . . . \$460/pr

330SG500SG CVT Interconnect Cable

35-ft. . . . \$3,075
30-ft. . . . \$2,835
25-ft. . . . \$2,790
20-ft. . . . \$2,165
15-ft. . . . \$2,040
3-m. . . . \$1,920
2-m. . . . \$1,300
1.5-m. . . . \$1,200
1-m. . . . \$1,100

MI-330/MI-500 Interconnect Cable

25 ft. . . . \$730/pr
20-ft. . . . \$600/pr
15-ft. . . . \$470/pr
10-ft. . . . \$340/pr
2-m. . . . \$245/pr
1.5-m. . . . \$200/pr
1-m. . . . \$160/pr
0.5-m. . . . \$125/pr
RCA's. . . . \$30/pr

ZAPchord Interconnect Cable

25-ft. . . . \$180/pr
20-ft. . . . \$150/pr
15-ft. . . . \$120/pr
10-ft. . . . \$90/pr
2-m. . . . \$70/pr
1.5-m. . . . \$60/pr
1-m. . . . \$50/pr
0.5-m. . . . \$45/pr

PC-Squared PC-2 Interconnect Cable

1.5-m tonearm. . . . \$115
2-m. . . . \$108/pr
1-m tonearm. . . . \$95
1.5-m. . . . \$89/pr
1-m. . . . \$70/pr
0.5-m. . . . \$55/pr
Bulk. . . . \$5.89/ft
RCA's. . . . \$10/pr

Connectors

WBT Bananas Load & Source. . . . \$350
Fischers-Amp End MH. . . . \$170/pr
Tonearm box. . . . \$150
Tonearm DIN/Flex/CAMAC. . . . \$130/pr
RCA > XLR. . . . \$110/pr
CAMAC/CAMAC. . . . \$110/pr
Tonearm DIN/Flex/WBT. . . . \$97/pr
WBA RCA/CAMAC. . . . \$85/pr
Tonearm DIN/Flex/RCA. . . . \$75/pr
WBA RCA. . . . \$62/pr
RCA/CAMAC. . . . \$55/pr
XLR > XLR. . . . \$55/pr
Flex Section. . . . \$35/pr

MITSUBISHI

M-W5100 A/V Cabinet

Cabinet for Home Theater series components featuring contemporary styling and dark-gray vinyl finish; hideaway glass door; adjustable shelves; hinged-top. Matches size and cosmetics of Mitsubishi CS-3103R/MB-103 and CS-3504R/MB-504 TV's. . . . \$500

ACCESSORIES

M&K

LP-1S Passive Electronic High-Pass Filter

Line-level electronic high-pass filter for bi-amping with M&K subwoofers. Available in 8½-in front panel or 19-in rack mount. 100 Hz crossover point at 18 dB/octave. With bypass switch \$325
Without bypass switch \$300

Satellite Speaker Stand

Stand for M&K satellite speakers. Allows for permanent attachment of satellite to stand. Walnut/oak veneers, black finishes \$95/pr

VF-100 High-Pass Filter

High-pass filter with inputs, high-pass outputs for the main amplifier, and high-pass outputs for the subwoofer's preamplifier level inputs. Available in versions for power amplifiers with imp < 37,500 ohms, imp 37,500-75,000 ohms, and imp > 75,000 ohms. 6 dB/octave filter slope < 100 Hz \$75

M.M. NEWMAN

Heli-Tube. Spirally cut, industrial grade, expandable, black polyethylene cable wrap applies like tape to protect/organize wires. ¼-in. ⅜-in. ½-in sizes for bundles up to 4-in dia; 8 ft lengths; ½-in \$2.25
⅜-in \$1.60
¼-in \$1.45

MODSQUAD

Tonearm Junction

Interface for connecting tonearm to phono electronics \$150

Y Connector

Increase output of a component; bi-amp or tape dubbing application \$35

Tiptoes Cartridge Coupler \$15

Cartridge Clip Kit

Includes beryllium copper cartridge clips and heat shrinks. \$10

Tiptoes

Component platforms made of machined aluminum cones. Used to provide mechanical grounding between the component and the surface beneath it.

Tall Tiptoes. For under speakers, 1½-in. . . \$7 each
Short Tiptoes. For under components, ½-in \$5 each

MOGAMI WIRE PRODUCTS

NEGLEX Quad Interconnect Cables

2534, 22 gauge. 4- 20 x 24 O.D. 0.236-in . . \$0.70/ft
2893, 24 gauge. 4- 30 x 26 O.D. 0.189-in . . \$0.55/ft

MONSTER CABLE

CD SoundRing

CD vibration stabilizer mounts on outer edge of CD. High-density material provides necessary weight and dampening needed to stabilize CD. Fits all players and comes with centering device.

50 Rings \$50
12 Rings \$14.95
1 Ring Sampler \$1.50

Interconnect Cable

M1000 Interconnect Cable

Total Phase Aligned Bandwidth Balanced design; dual conductors and 3 wire networks; MicroFiber; M-Terminator connectors. Precut.

6-m pr \$500
2-m pr \$250
1.5-m pr \$210
1-m pr \$175
0.5-m pr \$120
From Spool \$10/ft

Interlink Reference II Interconnect Cable

Features 3-wire multiple-gauge network for each conductor. Thick core wire designed for frequencies below 300 Hz; 4 medium conductors intended for midrange, hair-thin woven stranded wires made for 700+ Hz; w/turbin connector.

6-m pr \$290
2-m pr \$130
1.5-m pr \$110
1-m pr \$85
0.5-m pr \$75

Interlink 500 Interconnect Cable

Precision Bandwidth Balanced construction; dual conductors with MicroFiber; designer colors. Precut.

6-m \$180
2-m pr \$75
1-m pr \$50
0.5-m pr \$40
From spool \$4/ft

Interlink 400 Interconnect Cable

Same Bandwidth Balanced design as Interlink Reference; Microfiber technology; unterminated

6-m pr \$88
5-m pr \$75
2-m pr \$45
1.5-m pr \$40
1-m pr \$35
0.5-m pr \$30
From spool \$1.25/ft

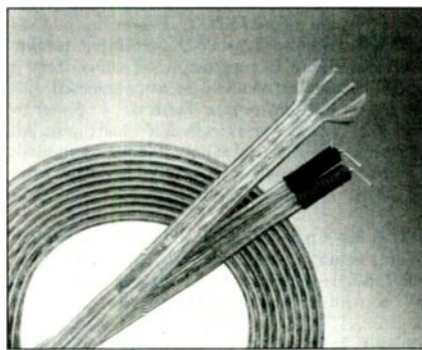

Monster Cable's "New Monster Cable"

Interlink CD Cable

Interconnect cable for CD players designed to increase performance and sound quality

6-m pr \$76
2-m pr \$40
1-m pr \$30
From spool \$1.50/ft

Interlink 301 Interconnect Cable

High-resolution, precision-stranded, noise-shielding, special-winding configurations, remote turn-on lead; protects against noise interference. For use with car, truck, van, or RV vehicle sound system.

5-m pr \$48
3-m pr \$35
1.5-m pr \$25
1-m pr \$23
From spool \$1/ft

Genesis Lightspeed Tonearm interconnect

For connecting cartridge to preamp \$175

Speaker Cable

M1 Speaker Cable

MicroFiber dielectric insulation designed to eliminate intertransient noise reduce transient interference, intended to preserve power and dynamics; primary and secondary grouped networks; carrying case.

With X-Terminators
9-m pr \$650
7½-m pr \$550
4½-m pr \$400

From spool \$9/ft
With M-Spades
9-m pr \$600
7½-m pr \$500
4½-m pr \$325

Powerline II Plus Speaker Cable

Powerline II Plus speaker cable is a bass control conductor for even distribution of magnetic fields; directly addresses magnetic behavior of audio signals; time aligned audio signal.

7½-m pr \$200
4½-m pr \$150

Powerline II Speaker Cable

Time Coherent winding designed to eliminate phase inaccuracies, align highs and lows for improved frequency response.

Unterminated. \$3.75/ft

Powerline III Speaker Cable

Smaller version of Powerline II.

Unterminated. \$2/ft

New Monster Cable Speaker Cable

Features Amplitude Balanced Multi-Network Conductor Technology; utilizes multi-gauged conductors for more linear sound throughout the entire audible range and a special winding configuration to help maintain signal integrity; separate high and low conductor networks for bi-wiring or bi-amping; terminated with OmniFlex angled 24 K gold pin connectors.

15-m pr \$129
9-m pr \$80
6-m pr \$50
4½ pr \$40
3-m pr \$35
From spool \$1.25/ft

Original Monster Cable Speaker Cable

Improved version of original Monster Cable with new strand configuration designed for midrange clarity, faster transient response, and extended low and high frequency response. Precut, with universal gold pin ends with lock-notch.

15-m pr \$100
9-m pr \$65
6-m pr \$45
4½-m pr \$35
From spool \$1/ft

Superflex Speaker Wire

High-purity copper speaker wire with flexible Dura-flex insulation; dividing web between the two conductors. Same stranding configuration as Monster Cable but fewer strands of wire.

7½-m pr \$45
4½-m pr \$28
3-m pr \$22
From spool \$0.50/ft

Connectors

Gold Pin Connectors

For push-pin terminal connections; features Monster's exclusive Lock-Notch for a no-pullout connection; 24K gold plated.

M series-4 pr pack \$10/pk
4 pr pack \$6/pk
125 pr bulk pack \$1/pr

Angled Gold Pin

Patent-pending 60-degree angle reduces stress between pin and cable; Lock-Notch design; OmniFlex connector.

M. series-4 pr pack \$12/pk
Regular-4 pr pk \$8/pk
Mini-4 pr pk \$8/pk
M. series-125 pr bulk \$2/pr
Regular-125 pr bulk \$1.50/pr
Mini-125 pr bulk \$1.50/pr

ACCESSORIES

Gold Spade Connectors

M. series-4 pr pk	\$20/pk
Regular-4 pr pk	\$10/pk
Mini-4 pr pk	\$8/pk
M. series-50 pr bulk pk	\$5/pr
Regular-125 pr bulk pk	\$2/pr
Mini-125 pr bulk pk	\$1.50/pr

Monster Tips

Banana connector features nine beryllium-copper leaf springs. 24K gold plated.

M. series-2 pr pk	\$14/pk
Regular-2 pr pk	\$12/pk
Mini-2 pr pk	\$12/pk
M. series-50 pr bulk pk	\$7/pr
Regular-50 pr bulk pk	\$6/pr
Mini-50 pr bulk pk	\$6/pr

Precision Gold Banana Connectors

Patented solid-shaft design; expanding shaft construction.

Component series connector-2 pr pk	\$100/pk
X-Terminator-2 pr pk	\$60/pk
Component series connector-24 pr bulk pk	\$50/pr
Powerconnect 2-2 pr pk	\$34/pk
X-Terminator-24 pr bulk pk	\$30/pr
Powerconnect 2-24 pr bulk pk	\$17/pr

Phonolink Precision Turbine Cut RCA Connectors

M-Terminator T connector-fits Interlink M1000 Mk 2; Phonolink reference 2T-fits Interlink reference 2; Phonolink 500 T connector-fit Interlink 500; Phonolink 400 T-fits Interlink 400, Interlink CD.

M-Terminator T connector-2 pr pk	\$70/pk
Phonolink reference T-2 pr pk	\$50/pk
M-Terminator T Connector-24 pr pk	\$35/pr
Phonolink 500 T-2 pr pk	\$30/pk
Phonolink 400 T-2 pr pk	\$28/pk
Phonolink reference T-50 pr pk	\$25/pr
Phonolink 500 T-50 pr bulk pk	\$15/pr
Phonolink 400 T-50 pr bulk pk	\$14/pr

Phonolink Precision Gold RCA Connectors

Phonolink 300 connector-fits Interlink 300, Interlink 301, and Interlink CD; Phonolink 2a connector-fits Interlink 2.

Phonolink 2a-2 pr pk	\$34/pk
Phonolink 300-2 pr pk	\$16/pk
Phonolink 300-50 pr bulk pk	\$8/pr

Phonolink Right Angle Turbine RCA Connector

Fits Interlink 500, Interlink 400, Interlink 300.

1 pair pack	\$20/pk
25 pr bulk pk	\$20/pr

Y Adaptor

Male-to-two female RCA Y-Adaptor; 24k gold plated. 12 pr bulk pk

12 pr bulk pk	\$12/pr
---------------	---------

Right Angle RCA Adaptor

Male-to-female RCA adaptor with 90 degree angled bend; 24k gold plated.

12 pr bulk pk	\$12/pr
---------------	---------

Crimp Rings

M. series-100 pieces pk	\$0.20/pk
Regular-100 pieces pk	\$0.10/pk

Cable Pants

M1-25 pr pk	\$2/pr
Powerline 2 Plus-25 pr pk	\$1/pr
Powerline 3 Plus-25 pr pk	\$1/pr

NAKAMICHI

CM-300 Electret Condenser Microphone

Electret condenser microphone with interchangeable pickup capsules

\$250	
CM-100 Electret Condenser Microphone. An economical version of the above	\$150

MX-100 Microphone Mixer

Features 3/4-in mic inputs.

PS-100 Power Supply

Produces 10 volts DC for MX-100, other Nakamichi blackbox series components; can power up to 6 components

\$128	
DM-10 Head Demagnetizer	\$38.50

SF-10 Subsonic Filters

Compact passive filters operate at line level to remove turntable rumble and other infrasonics caused by record warps and tonearm/cartridge resonances. Provides 6 dB/octave filter, down 10 dB at 10 Hz. May be used at tape output or amp tape-input jacks

\$15/pr

NILES AUDIO

Speaker Selection Systems

Connects up to 4 pairs of speakers to a receiver and plays any or all pairs simultaneously. Accommodates heavy gauge speaker cables. Features imp protection switch; separate L+R ch grounds. Handles 200 W/ch; genuine walnut side panels; rack-mount brackets optional.

MSA-10. Enables play of up to 10 pairs of 4, 6, or 8 ohm speakers off of any stereo amp. Features high-power-imp matching transformers; logic circuitry; 10 front-panel controls; rear connector accepts up to 14-gauge speaker wire; separate L+R ch grounds for use with bridged amps. Power handling 250 W/ch. Walnut side panels standard, rack-mount ears optional. 17 x 3 1/2 x 6 in; 12 lb.

\$550	
MSA-6R. Remote-controlled, 6-position speaker switching system to turn on or off either from a central location or remotely by using optional wall controls in different rooms. Turns on AC power to main system as well speakers in individual rooms. All 6 locations can be played at once. Maintains nominal 8-ohm load on amplifier no matter how many pairs are played. 19 x 5 1/4 x 12 1/8 in; 16 lb	\$599

SVC-4. For 4 pairs of speakers. Features individual volume controls; connection for second amp; auto-transformers; separate L+R ch ground connections for use with bridged amps. 11 1/8 x 4 3/8 x 5 1/4 in; 8 lb.

\$280	
SVC-4W. Same as SVC-4 except designed to be flush mounter into a wall. Preconstructed and retrofit versions available.	\$325

SVC-2. For 2 pairs of speakers. Individual volume controls; autotransformers.

\$150	
SPS-1. Accommodates up to 14-gauge speaker wire and power handling capacity up to 100 W/ch. Genuine walnut side panels.	\$80
Rack mounts.	\$15

HDS-6 Speaker Switcher

Enables play of up to 6 pairs of speakers. Accommodates up to 8 gauge wire; power handling 250 W/ch; headphone jack; works with any type of amplifier.

\$200	
HDS-4. Same as above but for 4 pairs of speakers	\$150

CPM-31 Patching Matrix

6 x 6 patching matrix to connect tape decks, equalizers, and NR units. Allows a component's output to be fed to another component's input. Passive unit with RCA jacks on rear. 9 x 4 x 8 3/4 in; 6 lb.

\$180

ADA-6 Audio Distribution Amplifier

Stereo line-level audio distribution amplifier. A single input can be distributed to 6 destinations with no degradation of original signal.

\$140	
IRP-1 Power Supply	\$140

Power supply for infrared repeater system

SV-5 Auxiliary Selector

Expands auxiliary input to accommodate up to five different sources such as CD, tape deck, tuner;

passive volume attenuator enables to adjust volume of each sound source

\$90

TSB-3 Tape Deck Switch Box

Record, playback and dub can be chosen from any of three tape decks. Patching performed by turning knobs. Features RCA phono jacks; optional rack-mount ears and walnut end panels. 7 1/8 x 2 3/8 x 5 3/8 in; 2 lb.

\$80

IRR-1 & IRC-1 Infrared Receiver

Wall-mount infrared receiver. When connected to IRP-1 and IRC-1 enables you to control almost any infrared remote control component; up to 30 IRR-1 units can be connected to the IRP-1 power supply.

IRR-1	\$70
IRC-1	\$20

SCW-1 Volume Control

Wall-mounted stereo volume controls for remote speakers. Use of autotransformers instead of L-pads.

\$48	
SVC-1. Table-top speaker volume control for remote speakers. Volume adjustment independent from main speakers. Uses autoformer volume control instead of L-pad.	\$75

SCW-2HP. High-power version of SCW-1. Uses high-power autoformer instead of L-pads. Power handling 15 W/ch. 4 1/2 x 4 1/2 x 2 1/2 in; 2 lbs.

\$70	
SCW-2A. Similar to SCW-1 but has selector switch for 2 different amplifier inputs	\$66

SCW-2. Similar to SCW-1 with stereo headphone jack

\$66

DPS-1 Amplifier/Speaker A-B Selector

Permits either of 2 amps to be played into a single pair of speakers, or a single amplifier to play into either of 2 pairs of speakers. Features high-power A-B selector switch box; handles 300 W/ch; rear panel connector for up to 14 gauge speaker cable or high definition wire pin connector

\$65

AXP-1 Auxiliary Input Selector

5-input, 1-output stereo selector box for 5 line-level signal sources. Allows selection by turning a knob. 5 1/8 x 2 1/2 x 5 1/8 in; 1 lb

\$55

PS-1 Phono A-B Switcher

Connects 2 turntables to a receiver with only one phono input. Features L+R ch grounds; switches both the hots and the grounds for total isolation; RCA phono connectors. 4 3/4 x 1 7/8 x 4 in; 0.5 lb.

\$50

DPS-1W Amplifier/Speaker Selector

Wall-mount high-power A-B selector. Used to share a common pair of loudspeakers with 2 different sound sources

\$50

LVW-1 Volume Attenuator

Wall-mount line-level attenuator. When used with preamplifier and power amplifier it enables placement of volume control on the wall

\$48

SJ-1 Wall-Mount Connector

Wall-mount plate containing two 5-way binding posts for speaker connections. Designed to mount on wall similar to electrical outlet plate. Available in bone, brass, stainless steel, and white. 2 3/4 x 4 1/2 in.

\$6.30

NITTY GRITTY

Mini-Pro MK 2 Record Cleaner

Semi-professional-type record cleaner designed for consumer use. Wets, scrubs, and vacuums both sides of record simultaneously. Cleans record of all dust, grease, and static charge. Features large oak cabinet; strong vacuum motor; quieter operation. 10 x 17 x 10 in.

\$700	
Hybrid 2. Same as above except cleans one side at a time. Built-in hinged dustcover and adaptor for cleaning compact discs.	\$610

2.5 Fi. Similar to Hybrid 2 without dust cover or CD cleaning.

\$500

ACCESSORIES

1.5 Fi. Similar to 2.5 Fi except no solid oak cabinet. \$440
 Model 1.0. Similar to above except manual. . . \$270

ONKYO

RC-AV20M Universal Remote Control

Can be programmed to operate a variety of different brand audio/video components. Features 100 programmable functions; full control of more than 10 components; audio and video operation modes. Pre-programmed with Onkyo RI command codes. . \$100

RC-AV10M Universal Remote Control

Can be programmed to operate a variety of different brand audio/video components. Features 55 programmable functions; full control of more than 6 components; audio and video operation modes. Pre-programmed with Onkyo RI command codes. . \$80

ORA ELECTRONICS

Studio Spec Brand

SDX1 Stereo TV Decoder

Decodes stereo TV audio signal for use with home audio/stereo equipment. Features switch for stereo/mono/SAP; separate ch. 3; MPX selector switch; stereo L/R audio outputs. \$99.95

CDA-1 CD Car Adaptor

Equipped with 2-cable sets: one connects a CD or cassette player output to the adaptors input, the other connects the adaptors 9-volt output to power external players. Complete with mounting hardware. . . \$40

CD-2 Compact Disc Cleaner

Self-contained compact disc cleaning kit includes cleaning brush, chamois pad, cleaning base/box, and 1.5 oz of compact disc cleaning solution in pump-spray bottle. \$13

CD-S10 CD Holder. Stores 10 CD's in a package design. \$12.95

CD-908 CD Storage Case

Storage case holds 6 CD's in soft, protective sleeves for easy carrying with no damage. \$10.95

CD-4. Individual CD storage boxes, clear plastic jewel box design. 2 per package. \$4

MK-116. Audio head maintenance kit includes felt, brush, and mirror probes, replacement felt pads, and head cleaning solution. \$4

ATC-DC-113. Dual-capstan audio cassette head cleaner. Wet-type specially designed to clean entire tape path in dual-capstan or autoreverse cassette decks. \$4

ATC-112. Wet-type, audio cassette head cleaner. \$3

Oxygen-Free Copper Cables

Cable with titanium-silence connectors.

OFT-228STV. For audio and video. . . \$57.95/2 m

OFT-220ST. For audio. \$53.95/2 m

OFT-585TV. For audio and video. . . \$49.95/0.5 m

OFT-55ST. For audio. \$43.95/0.5 m

ORTOFON

RC-015 Stylus Cleaner

Electronic stylus cleaner with tuned oscillator vibrates all contaminants off the stylus assembly. Includes 20-ml bottle of stylus-cleaning fluid; magnification mirror. \$34.95

CC-021 Cassette Maintenance Kit

Includes autoreverse cassette cleaner and electronic head demagnetizer. \$29.95

RC-014 Electronic Static Eliminator

Ion gun with trigger control bombards record surface with static-neutralizing ion particles. \$21.95

CD-040 Compact Disc Maintenance Kit

Includes cleaning cloth, cleaning spray, lens cleaner, in album storage box with padded cleaning surface. \$19.95
 CD-042. Replacement spray for CD-040. . . \$6.50

RC-013 Record-Care Kit

Includes walnut record brush with one-way pile; record cleaning solution to remove dirt and eliminate static; stylus cleaner. \$16.95
 RC-011. Replacement fluid for RC-013. . . \$4.95

CC-020 Autoreverse Cassette Cleaner

Wet-type cleaning cassette cleans all tape heads, capstans, and pinch-rollers in autoreverse cassette decks in 30 sec. Includes cleaning solution and replacement pads. \$12.95

CD-041 Component Isolators

Includes 8 absorbing feet with self-stick backing to eliminate vibration on all type components. . \$9.95

RC-010 Carbon-Fiber Brush

Record cleaner with polished carbon fibers to remove dirt from record grooves while built-in copper-wire grounding system eliminates static build-up. . \$9.95

RC-016 Disc Coupler

Designed to couple the record to the platter for increased bass response and improved imaging. Includes 2 center hubs to fit most center spindles. \$9.95

RC-018 Alignment Tool

Phono cartridge alignment tool features mirrored surface with two-point alignment system and center spindle cutout. \$4.95

RC-012 Stylus Cleaner

Cleaning fluid removes residue from stylus. Includes fluid and applicator brush. \$3.49

RC-009. Stylus pressure gauge. \$2.95

O'SULLIVAN

Model 79680 Entertainment Center

Solid-oak frames with marshall-oak laminate finish. Features clear tempered glass doors; 3 adjustable or removable component shelves; VCR shelf provided for smaller TV's and VCR combo; twin oak drawers for accessories; casters. 45 x 49 1/8 x 20 3/4 in. . . . \$350

Model 79030 Entertainment Center

Finish in glossy black formica high-pressure laminate. Features tempered clear glass doors; 2 adjustable shelves; pull-out turntable shelf; double doors for storage area with cast-metal door pulls. 47 x 48 1/4 x 15 1/4 in. \$320

Model 79799 Entertainment Center

Finished in walnut laminates. Features 2 adjustable or removable component shelves; glass tempered door; accommodates 31-in color monitors. 55 3/8 x 48 7/8 x 19 3/4 in. \$280

Model 79438 Entertainment Center

Finished in registry oak. Features 4 tempered clear glass doors with brass finish hardware; two adjustable component shelves; storage area with adjustable/removable shelf; drawer with an open storage area. Overall dimensions: 71 x 48 3/4 x 14 3/4 in. TV 27 1/2 x 29 x 14 3/4 in. \$270

Model 79480 Entertainment Center

Finished in registry oak laminates. Features rounded-edged design and sculptured rails with brass finish accents; tempered clear glass door protects adjustable/removable component shelves; bottom drawers are with brass finished drawer and with wood-grain laminate inserts. 43 3/4 x 49 x 15 3/8 in. \$220

Model 79782 Entertainment Center

Finished in Radford oak laminate. Features full-

length framed tempered glass door; 4 component shelves, 3 of which are adjustable or removable; twin panel doors; period brass finish hardware; large TV area; VCR shelf; dentil moulding; sculptured top shelf. 47 3/4 x 48 1/4 x 16 7/8 in. \$220

Model 79738 Entertainment Center

Finished in Radford oak laminate. Features 4 glass doors; 2 adjustable or removable component shelves; large shelf for accessories; large TV shelf; storage area behind panel door; period brass finish hardware; sculptured top shelf; dentil moulding. 49 1/4 x 72 1/8 x 16 in. \$220

Model 79227 Entertainment Center

Finished in colonial oak laminates. Features tempered clear glass doors protecting a top storage area; 2 adjustable/removable component shelves and twin doors with solid-wood pulls; TV area accepts most monitors. Overall 71 x 14 3/4 x 54 3/8 in; TV area: 27 1/2 x 14 3/4 x 30 in. \$200

Model 79980 Entertainment Center

Colonial oak laminate finish with adjustable VCR shelf; large TV area and adjustable component shelving; clear tempered glass door; twin double doors for storage area below. 47 1/4 x 48 1/8 x 15 1/2 in. . . . \$170

Model 79718 Entertainment Center

Finished in Radford oak laminate. Features large TV area; 4 adjustable shelves; glass door; brass finish hardware; twin panel doors; dentil moulding; sculptured top shelf. 48 x 42 1/2 x 15 3/4 in. \$160

Model 79538 Entertainment Center

Finished in colonial oak laminate. Features 2 tempered glass doors; an adjustable or removable component shelf; large TV shelf; storage area behind door; solid wood door pull; shelves for books. 48 3/4 x 66 1/2 x 15 in. \$150

Model 79581 Entertainment Center

Finished in colonial oak laminates. Features 2 tempered glass doors; TV shelf; twin doors with solid wood door pulls; adjustable or removable component shelf. 49 1/4 x 41 7/8 x 15 3/4 in. \$120

PARSEC

ARC AM/FM Antenna

Features patent-pending circuitry combines GASFET and JFFT amplification with electronic tuning and bandwidth selection. FM reception is omnidirectional; AM reception is highly directional to increase signal capture. Designed for use in either rack or free-standing installations. \$149.95

The 1S-4 Indoor FM Antenna

Features GASFET (gallium arsenide field effect transistor). Displays omnidirectional characteristics when placed in a vertical position; displays directional characteristics when placed in a horizontal position. \$49.95

FM Antenna/Booster

Designed to be free-standing and is omnidirectional when vertical and directional when horizontal. Features Schott MOSFET amplifier; variable output gain to maximize signal strength and tuner "quieting" when receiving weak stations and to eliminate tuner saturation when receiving strong stations. . . \$29.95

Scratch Out

Removes dirt, dust, fingerprints, and other oily residues from CD players. Reduces surface blemishes and scratches which cause playback malfunctions. \$9.95

PHANTOM ACOUSTICS BY THRESHOLD

The Shadow

Active system for controlling objectionable low frequen-

ACCESSORIES

cy room characteristics. It incorporates an electronic/acoustic servo design; two separate and independent suppression modules, each module consist of a sensing condenser microphone, servo electronics, and an acoustic transducer; each column's modules has its own external supply. Available in pairs for usual placement in the two room corners at the rear of the loudspeakers. Suppression factor 90% energy reduction @ 50 Hz; suppression bandwidth 30-200 Hz. 83½ in h, dia: 9½ in, base dia: 15 in; 45 lb/ea. \$1,790/pr

PHILIPS

AK9133GY01 "Smart One" Remote Control
Can be programmed for learning an unlimited number of features from other remote control units from almost any infrared remote TV, CD player, VCR, or audio system. At the touch of a button, the "Smart One" prompts you through the learning program and tells you when you have made an error. Controls up to 3 different infrared remote-controlled products at one time and has a back-up power source which preserves the memory in the event of battery failure \$80

EM-2200 Multi-Room Remote Control
For use with Philips products equipped with RC-5 jacks. Provides an additional infrared remote "eye" that picks up the Philips RC-5 remote control commands and relays them through a cable to Philips A/V equipment. Components can be located in another room or in a cabinet. \$69

PINE CONE

CD Cabinet
Solid teakwood cabinet. Holds 60 CD's; front panels roll completely open; stands alone or hangs on the wall with built-in metal brackets. 18 x 12¼ x 8½ in; 11 lb \$60

PIONEER

BSS-F1 Bodysonic Surround-Sound Chair
Swiveling black leather chair designed for surround-sound applications. Features 3¼-in diaphragm stereo speakers in headrest; dynamic damper bass drive unit mounted in seat; remote control mounted under seat; RCA jack; headphone jack. 40 x 38 x 38 in. \$2,000

CU-AV100 Smart Remote Control
Remote controls all Pioneer components on the system remote network. Features learning capability; 225-command capacity; 68 keys; 3 slide switches; 30-60 minute memory backup for changing batteries \$125
CU-AV70. As above with 65 keys, 70-command capacity. \$85

JA-RF5 RF Modulator
Radio frequency modulator that converts composite (baseband) video to radio frequencies so that video from an audio/video system can be viewed on a television without a video input. Features selectable output frequency; video/television switch for VHF antenna loop-through; 5-pin DIN connector and "F"-type for video in/television out. For use with Pioneer VSX-series audio/video receivers \$50

JD-M200 6-Disc Magazine
Additional 6-disc magazine for use with any Pioneer CD changer. Includes a complete set of labels and hard plastic storage sleeve. Available in 5-piece master carton \$10 ea
JD-M108. As above for CD-3's \$10

POLYDEX

CV-90 Speaker Cable
3 solid-core conductors with oxygen-free copper isolated and shielded individually. Entire cable includes low- and high-frequency shielding. \$13/ft

CV-50 Speaker Cable
6 solid-core conductors bound in triples, laid side-by-side, with oxygen-free copper \$4/ft

Modulation Cable
4 solid-core conductors of oxygen-free copper isolated and shielded individually. The entire cable includes low- and high-frequency shielding. \$3.50/ft

CV-30 Speaker Cable
4 isolated solid-core conductors, spiral wound, with oxygen-free copper \$3/ft

CV-20 Speaker Cable
2 spiral-wound-core conductors of oxygen-free copper \$1.50/ft

PS AUDIO

Digital Link Digital-to-Analog Converter
Outboard D/A processor with 8x oversampling and 18-bit Burr-Brown D/A converter. Features all plug-in modules; coaxial and HP fiber-optic inputs; data link outputs with no subcode information available through rear mounted CATV connector. Digital dither available as option \$1,195

REALISTIC

Hickory-Grained Audio Cabinet
Full-length tempered glass doors; hinged top; 3 adjustable shelves; storage space for LP's and tapes; metal supports; heavy-duty swiveling casters; unassembled; hickory-grained vinyl finish. \$120

Tape Control Center
Connects to tape-monitor loop to allow use of three tape decks for monitoring, recording, and dubbing; with illustrated manual \$24.95

Micro Head Cleaner
Nonabrasive tape in microcassette-type shell cleans tape path of microcassette machines \$2.99

Mini and Micro Tape Tray
Holds 12 minicassettes or microcassettes; smoke-tinted cover. \$2.49

Tape Recorder Maintenance
Lighted Demagnetizer. 3.5 in; for all tape decks \$13.95
Universal Demagnetizer. For all tape decks; 2 angled tips \$9.95
Cassette Head Demagnetizer. In cassette shell; works in 1 sec; with battery \$9.95
Demagnetizer/Cleaning Kit. Demagnetizer cassette, probe, mirror, solution, cloth \$5.95
Cleaner Cassette. Felt pads clean heads, pinch roller, capstan; with 0.5 oz of fluid \$3.99
8-Track Cleaner. Cleans heads and capstan rollers; nonabrasive \$3.59
Head-Cleaning Kit. With 6-dram bottle of Freon TF solvent and 6 foam swabs \$2.69
Pro-Style Solvent. Freon dissolves dirt and oxides on heads; 2 oz \$2.39
Head-Cleaning Spray. Removes dirt and oxide without residue. \$1.99
Cleaning Swabs. Reusable lintless foam; 10 pack \$1.95
Cassette Head Cleaner. Nonabrasive tape in cassette shell. \$1.89
Recorder Cleaning Kit. 2 1.25-oz bottles of cleaner and lubricant; 10 swabs \$1.89
Cassette Head Cleaner. Removes oxide from head and capstan; with fluid \$1.89
Cleaning Cloths. To clean tapes and equipment dustcovers; 4 pack \$1.79
Cleaning Sticks. Cotton-tipped 6-in wood sticks; 100 pack \$1.29
Head-Cleaner Solution. Cleans heads, tape guides, capstans, metal parts; 2 oz. \$0.99
"Nonslip" Solvent. Reduces slipping of idler wheels, belts, etc.; fast drying; won't harm rubber \$0.99

Cassette Accessories
Tape Splicer. Chrome cut/trim lever; with splicing tape and instructions \$6.49
Index Cards. Fits standard cassette boxes; 20 pack \$1.19
Tape Housing. With 24-in leader tape and instructions \$1.19
Cassette Boxes. Hinged; clear plastic; 3 pack. \$1.19
Index Labels. Adhesive; 6 each of red, yellow, blue, green; total 24 \$0.99
Molded Mailers. Meets first-class postal regulations; 3 pack \$0.89
Budget Mailers. Cardboard boxes with labels; meets first-class postal regulations; 6 pack \$0.79
Open-Reel Accessories
7-Inch plastic tape reel \$1.39
5-Inch plastic tape reel \$0.99

General Tape Accessories
Bulk Eraser. For all tape except metal and videotape \$17.95
Editing Block. Aluminum splicer for all tape sizes with 90x and 45x cutting guides; with blade and mounting strip \$3.99
Foot Switch. Remote-control on/off switch for typing from dictation; submini plug. \$3.49
Universal Splicer. Dual guides; levers secure tape; with blade and instructions. \$1.99
Phone Pickup. Suction cup attaches to handset; ¼-in mini plug; may be incompatible with electronic phones. \$1.99
Sensing Tape. Metallic tape stops or reverses recorders with contact or photosensitive systems; 100-in roll. \$1.99
Leader Tape. 7/32 x 200-in roll \$0.99
Splicing Tape. 100-in roll; ¼ in, ⅜ in, or ½ in widths \$0.79

RECOTON

Beammaster FM-100 Antenna
Powered omnidirectional FM antenna. Features obelisk shape; vertical or horizontal positioning; built-in amplifier; adjustable from 0-25 dB; can boost signals up to 125 times. \$54.95

CD-23 CD Mounting Bracket
Mounting bracket for portable compact disc players when used in cars. Features cushioned shock-absorbing platform; easy installation; unit can be mounted on-dash, under-dash, or on a center console; has adjustable top and side brackets; fits all portable compact disc players \$19.95

CD-3 3-Inch CD Adaptor Ring
Adaptor for playing 3-inch CD singles in standard-size or table-top players. Sold in pairs \$3.79/pr

REVOX

B209 Easyline Infrared Multi-Room Remote
Multi-room remote system controls volume, treble, bass, and balance of loudspeakers individually in each room. While one source plays in main listening area, different music source from main system can play simultaneously in remote rooms. Allows connection of independent music source in each remote room; system requires power amp, speakers and B209 module in each remote room. \$995

B208 Hand-Held Infrared Remote
Specifically designed to work with new generation of Revox units but can be used on all Revox remote controllable components. Keypad has over 55 functions \$160

RUSSOUND/FMP

Sound Distribution
SC-12
Sound distribution center for twelve stereo speakers and transformer \$425

ACCESSORIES

RD-4 Speaker Control

Switchbox for controlling 4 stereo speakers. Combination power switch, volume control and transformer. Features individually programmable outputs; automatic impedance protection; 4 ohm speaker protection; 100 watts per channel max power handling; separate left and right grounds. 17 x 5 x 2 1/8 in. \$259.95

AV-4 Audio/Video Switcher

Accommodates up to 4 VCR's or 3 VCR's and one A/V processor. Features passive operation; separate audio and video switching; dubbing, editing, and processing capability; compatible with all VCR's. 17 x 3 x 1 3/4 in. \$250

SDA-4 Sound Distribution Center

For 4 stereo speakers with transformer and volume control. \$249

MM-6 Sound Distribution Center

For 6 speakers with transformer switch \$190

Tape Recorder Selector Systems

MA-5 Matrix Recorder/Processor Audio Switch

Allows connection of up to 4 tape recorders and processors; can make three copies of a tape, or four copies of an external source. Dimensions: 3 1/2 x 1 3/4 x 7 3/4 in. \$90

VC-1 Remote Speaker Control

Volume control for 1 pair of speakers; portable; 10-position rotary switch; 10-autostep transformer. 6 x 3 1/2 x 3 in. \$75

AX-6 Input Source Selector

Auxiliary input source selector to add up to 6 inputs \$50

Speaker Selector Systems

HP-4. High power programmable speaker selector switch \$159
 PS-4. 4 programmable speaker selector \$109
 SWB-4G. 4 speaker selector with gold selector switch \$99
 SB-4. Deluxe 4 speaker selector switch \$79
 SB-3E. 3 speaker selector switch with earphones \$75
 SB-3. 3 speaker selector switch \$72

Line Transformers

ALT-2 Wall-Mount Stereo Volume Control

Features mechanically-shielded box; plate; knob. Depth < 2 ft. \$49
 ALT-1. As ALT-2 without plate and knob. \$45
 ALT-2M. As ALT-2. mono. \$33
 ALT-1M. As ALT-2. mono without plate and knob \$28

Attenuators

A70-2. 70 V, 20 W stereo attenuator with plate and knob \$53
 A25-2. 25 V, 20 W stereo attenuator with plate and knob \$52
 A25-1. 25 V, 20 W stereo attenuator without plate and knob. \$49
 A70-1. 70 V, 20 W stereo attenuator without plate and knob. \$49
 A70-2M. 70 V, 20 W mono attenuator with plate and knob \$39
 A25-2M. 25 V, 20 W mono attenuator with plate and knob \$37
 A70-1M. 70 V, 20 W mono attenuator without plate and knob. \$33
 A25-1M. 25 V, 20 W mono attenuator without plate and knob. \$31

Transformers

MT-25V. 25 V matching transformer. \$11.75

MT-70V. 70 V matching transformer. \$11.75
 IO-1B. Input output wall mount plate with 4 gold binding posts \$21
 IO-1A. Input output wall mount plate with 2 gold binding posts \$18
 SD-8. 1000 Rack Frame \$40

SANSUI

IR-1000U Remote Multi-Room Remote

Allows you to operate the main audio or video system from anywhere in the house using the system's regular remote. Infrared sender is affixed to the top or bottom of the main equipment in line with the main unit's remote sensor. Uses hardwire to transmit the signal. Includes receptor for installation at the remote location; infrared sender; 50 feet of wire; 9V power supply \$60

SENTRY INDUSTRIES

SENAUD42 Cassette Cabinet

Deluxe woodgrain finish with four-cushioned feet protect surfaces; each drawer holds fourteen tapes or an aggregate of 42 cassette tapes; can be stacked; master carton volume 3 3/8 cubic feet. Weight 37 lb \$15

SENHO5088 Mini-Speaker System

Two mini-speaker system fits all personal stereos; wedge style increases bass response. Includes 3 ft. cord with 1/8-in stereo connector. Dimensions: 4 3/8 x 3 x 2 3/8 in \$13

SENAUD33 Promotional Cabinet

Deluxe woodgrain finish with cushioned feet to protect surfaces; each drawer holds 11 tapes with boxes or 16 tapes without boxes; can be stacked; master carton 4 cubic feet; 40 lb \$11

SENA30WD Audio Cassette Deck

Deluxe woodgrain finish with dividers to hold tapes securely; wall mounting; can hold 30 cassette tapes; master carton 3 1/2 cubic feet; 53 lb \$9.95

SERVICE MANUFACTURING

Hardware Carrying Cases

Model 3300 Pocket Stereo Carrying Case

Shock protected case for most popular personal stereos or ten boxed audio cassettes; "En Garde" patchwork leather. Black and brown \$20

FP-1 Pocket Stereo/Cassette Waist Pack

Shock-protected adjustable waist pack for pocket stereos, cassettes, and accessories. Blue, black, red, or gray Regency nylon \$18
 FP-2. Same as above with outside change pocket \$22

CD206 Portable CD Player Carrying Case

Nylon case for most portable compact disc players with battery pack and ten compact discs \$13
 CD1606. Same as above in "Outback" burlap. Black, blue, and oyster \$16
 CD2206. Same as CD206 in "Doeskin" Ultra-Vinyl. Black \$17

WM-4 Pocket Stereo Waist Pack

Shock-protected adjustable waist pack for pocket stereos. Made of Regency nylon \$10

SC-1 Universal Carrying Case

Padded black-vinyl universal carry case for scanners, walkie-talkies, and portable telephones \$9

CD Carrying Cases

CD132 32-Disc Carrying Case

Gray flannel-like case for 32 single or 16 double CD's; individual compartments \$30
 CD2233. Same as above in "Doeskin" Ultra-Vinyl. Black \$38
 CD1632. Same as CD132 in "outback" burlap. Black,

blue, and oyster \$35
 CD133. Same as CD132 in leather-like vinyl. \$28
 CD118 18-Disc Carrying Case
 Gray flannel-like case for eighteen single or nine double compact discs; individual compartments \$25
 CD2219. Same as above in "Doeskin" Ultra-Vinyl. Black \$29
 CD1618. Same as CD118 in "Outback" burlap. Black, blue, and oyster \$27
 CD119. Same as CD118 in deluxe leather-like vinyl. \$21

CD216 16-Disc Carrying Case

Regency-nylon carrying case for 16 single or 8 double CD's; individual compartments. Black, gray, and blue \$20
 CD3316. Same as above in leather. Black and brown \$37
 CD2216. Same as CD216 in "Doeskin" Ultra-Vinyl. Black \$24
 CD1616. Same as CD216 in "Outback" burlap. Black, blue, and oyster \$22

CDW-1 6-Disc Carrying Case

Regency nylon wallet for 6 CD's; individual pockets without jewel boxes; velcro mounting strips included. \$12

Cassette Carrying Cases

Model 1860 60-Cassette Soft Carrying Case

Double-sided carrying case with plastic inserts for 60 boxed or 120 unboxed audio cassettes; Regency nylon. Blue and black \$30
 2040. Similar to above; padded vinyl library case. Tan, gray, black \$22
 2060. Similar to Model 2040; double-sided, high-tech design. Black, blue, maroon \$20

Model 1824 30-Cassette Soft Carrying Case

Shock protected dual-purpose case in flannel-like material for 30 boxed or 60 unboxed audio cassettes; expandable front accessory pocket. Gray and Denim \$25
 3303. Similar to above except in "En Garde" patchwork leather; holds 48 unboxed audio cassettes. Black and brown. \$38
 2233. Similar Model 1824 except double-zipper case in "Doeskin" Ultra-Vinyl; holds 48 unboxed cassettes. Black \$32
 1823. Similar to Model 1824 except holds 48 unboxed cassettes; plastic insert \$29
 1834. Same as Model 1824 in leather-like vinyl. Black \$26
 1804. Similar to Model 1824 except in padded nylon. Black, blue, red, and gray \$21
 1803. Similar to Model 1824 except for plastic inserts \$19

Model 2042 24-Cassette Attache Carrying Case

Padded vinyl attache case for 24 boxed or 48 unboxed audio cassettes. Tan, gray, black \$14
 2022. Same as above in Denim-look vinyl. Acid wash or stone wash \$14
 2061. Similar to above. Black, blue, maroon \$13

The listings are based on data provided by the manufacturers. For more product information, contact an authorized dealer or the manufacturer directly. Manufacturers' addresses and phone numbers are listed in the directory beginning on page 258.

ACCESSORIES

Model 1822 12-Cassette Soft Carrying Case

Shock-protected dual-purpose carry case in flannel-like material for 12 boxed or 24 unboxed audio cassettes. Expandable front accessory pocket. Gray and Denim \$19
 2232. Similar to above except double-zipper. Black \$23
 1832. Same as Model 1822 in leather-like vinyl \$20
 1802. Similar to Model 1822 except in padded gray nylon \$14
 2063. Similar to Model 1822 except in padded vinyl. Black, blue, maroon \$10
 2045. Similar to above except designer style. Tan, gray, black \$11
 2025. Same as above in denim-look vinyl. Acid wash or stone wash \$11

Model 1906A 6-Cassette Wallet

Padded Regency-nylon wallet for 6 cassettes; separate compartments. Blue, black, red, and gray \$12

Model 1800 10-Cassette Pouch

Shock-protected nylon pouch for 10 audio cassettes and/or most pocket stereos; adjustable shoulder strap doubles as a waist belt. Blue, gray, and red \$9

Shock Protected Burlap Series

Model 1660 60-Cassette Carrying Case

Double-sided case with plastic inserts for 60 boxed or 96 unboxed audio cassettes \$35

Model 1623 30-Cassette Carrying Case

Dual-purpose case for 30 boxed or 48 unboxed audio cassettes; double zipper \$28
 1604. Similar to above except holds 60 unboxed cassettes \$23
 1603. Similar to Model 1623 except has plastic inserts and single zipper \$21

Model 1622 12-Cassette Carrying Case

Dual-purpose carrying case for 12 boxed or 24 unboxed audio cassettes \$20
 1602. Similar to above \$15

Model 1600 Pocket Stereo Carrying Case

Holds most pocket stereos or 10 boxed audio cassettes \$10

SHURE

M64A Preamplifier

Fixed-gain stereo preamp with switch-selected phono, tape EQ; for use with unequalized amp inputs, mic's, as buffer amp in "flat" position; on-off switch; two phono jack inputs; 120 V AC 50/60 Hz, 5 W \$102

TTR-117 Test Record

Test record for testing cartridge response... \$16.50

SFG-2 Stylus Force Gauge

Allows precise setting of optimum stylus force for maximum trackability and sharply reduced wear on records and stylus tip \$9.25

SIGNET

Speaker Stands

ST-280. Contoured wood col upright, steel top plate, black lacquer base, spike feet, 18-in high .. \$179/pr
 ST-280. As above, 27-in high \$179/pr
 ST-230. All-steel stands, black enamel finish, 37-in high \$75/pr

Cleaners

SK315. Auto CD cleaning system. Combines wet and dry cleaning automatically. After timed wet cycle, pad retracts and chamois-type pad dries, buffs disc. Includes cleaning fluid and 4 AA batteries \$65
 SK305. Electronic stylus cleaner \$40
 SK-310. Record-cleaning system with low-residue cleaning and humidifying solution, convenient stor-

age base. Unidirectional brush reduces static charges on vinyl record surface \$30
 SK309/500. 500-ml bottle of cleaning agent for SK310 \$30
 SK302. Contact cleaner/restorer with 3-way action. Removes oxidation, leaves protective coating to slow-down future oxidation, serves as a contact enhancer. Tools allow thorough cleaning of plugs and jacks. For both audio and video components .. \$25
 SK312. Compact disc cleaner. Features soft leather chamois for surface dust and cleaning solution with optical quality cleaning cloths for tougher dirt .. \$25
 AC315. Power supply for SK315 \$20
 SK307. Audio cassette cleaner tape. Features Phillips-type cassette with alternating wet/dry cleaning system and cleaning fluid \$15
 SK316. Replacement fluid and pads for SK315 cleaning system \$15/set
 SK301. Liquid stylus cleaning formula \$6
 SK306. Replacement fluid for SK305 \$5
 SK309. Replacement fluid for SK310 and other record-cleaning systems to reduce residues \$5

Cables

MITU. Interconnect cable featuring PCCOC pure copper continuous cast conductor; high-density PCCOC braided shield; gold-plated solid brass RCA connectors; 6-ft pr \$150
 3-ft pr \$125
 1 1/2-ft pr \$100
 MIA-30. MLA cable preterminated with gold-plated pins. 30-ft pr \$73
 MIA-20. Same as above; 20 ft \$50
 MIA-15. Same as above; 15 ft \$39
 MIA-10. Same as above; 10 ft \$10
 MTP. Interconnect cable featuring PCCOC pure copper continuous cast conductor; OFC braided shield; gold-plated RCA connectors; 6-ft pr \$85
 3-ft pr \$70
 1 1/2-ft pr \$60
 VK412. OFC stereo audio/video cable; gold-plated RCA to RCA; 3.0 meter \$65
 2.0 meter \$60
 1.0 meter \$55
 MTA. Interconnect cable featuring OFC conductors and braided shield; gold-plated RCA connectors; 6-ft pr \$57
 3-ft pr \$45
 1 1/2-ft pr \$40
 MTS. Interconnect cable featuring OFC conductors; gold-plated RCA connectors; braided shield; 12-ft pr \$46
 6-ft pr \$34
 3-ft pr \$28
 1 1/2-ft pr \$25
 VK410. Audio/video interconnect cable. Features multistrand wide-bandwidth center conductor surrounded by as thick-foam dielectric for low capacitance and extended high-frequency response. 2 shields of dense copper braid and conductive polypropylene layers insures. Gold-plated male-to-male RCA connectors. Available in 1- and 3-meter lengths \$30-40
 VK411. As VK410 with gold-plated Quick-F to Quick-F connectors. 1- and 3-meter lengths. \$30-40
 MLS-20. MLS cable preterminated with gold-plated pins. 20-ft pr \$34
 MLS-15. Same as above; 15 ft \$27
 MLS-10. Same as above; 10 ft \$20
 MTC-2. Gold-plated RCA phono plug \$25
 MTCB-2. Gold-plated banana connectors; 2-pr/packs \$25
 MILCP-2. Gold-plated pin connectors; 2-pr/packs \$25
 MLCB-2. Gold-plated spade connectors; 2-pr/packs \$25
 VK212. Economy OFC stereo audio/video cable; gold plated RCA connectors; 3.0 meter \$30
 2.0 meter \$25
 1.0 meter \$20
 SK485. LC-OFC headshell wire set \$15
 VK421. Gold plated RCA to RCA barrel connector \$7
 VK422. Gold plated F to F barrel connector \$7
 VK423. Gold plated female RCA to male F connec-

tor \$6
 MLIU-250. Speaker cable utilizes PCCOC pure copper continuous cast conductors; individually insulated dual-gauge design \$5/ft
 GB50. Gold-plated banana plugs; w/red/black insulators \$2 ea
 MIA-500. Speaker cable features multiple strand construction, OFC conductor \$1.15/ft
 GS200. Gold-plated spade lugs; w/red/black insulators \$50 ea
 GP200. Gold-plated terminal pins; w/red/black insulators \$50 ea
 MLS-1000. Speaker cable features multiple strand construction; OFC \$35/ft
 H118. 18 gauge speaker wire \$1.66/ft

SONANCE

SDS4 Speaker Distribution System

Connects 4 pairs of speakers to one receiver or amplifier. Features separate left and right ground returns; push-push self-cleaning redundant contacts. Power handling 400 W (8 ohms), 200 W (4 ohms) \$180

VC50B Volume Control

Volume control using dual autoformers. Features modular construction; strip terminal connectors mounted on a printed circuit board. Can handle up to 50 W amplifiers \$99

ABB1 Box-Style Speaker Switcher

Speaker switcher can handle either on/off switching of a pair of speakers or select sources. Features high-capacity, single push-button contacts. Power handling 200 W \$75

VC50 In-Wall Stereo Volume Control

In-wall 50-W stereo volume control mounts in a standard switch plate or a P-ring. Features alignment capabilities; non-shorting wafer switch; single gang P-ring or open-back box mounting with standard light switch plates. FR 20-20,000 Hz -2 dB; attenuation -31.5 dB; -3 dB/step, 10 steps. Wall plate and knobs available in white, ivory, brown, brass .. \$55
 VC100. As above with 100 W power. 0 to -1.2 dB THD \$65

ABW1 In-Wall Source Switch

Can be used as either on/off switch or speaker switcher. Features separately switched 1/R ground circuits push-push type; self cleaning switch. Function: stereo 4 pole, double throw. Power handling 200 W. Mounting requires single gang P-ring or open-back box mounting with standard light switch wall plates. Wall plates and buttons come in white, ivory, brass, and brown \$26.50

Audio Terminal

Designed as connection points for conventional enclosed speaker systems while maintaining a basic in-wall signal distribution system. Features direct entry, screw clenching, gold-plated 5-way binding posts. Available in Leviton white, brown, ivory, brass, and stainless steel finishes.

AT12. Single-gang, 2-post wall plate for a single speaker \$59.30
 AT8. Single-gang, 4-post wall plate for a pair of speakers \$42.80
 AT4. Double-gang, 8-post wall plate for two pairs of speakers \$24
 AT2. Double-gang, 12-post wall plate for 3 pairs of speakers \$15

SONEX BY ILLBRUCK

SONEX Acoustic Foam

Sound-absorbing foam sheets used to control room acoustics by absorbing peak frequencies caused by standing waves, resonances, slap echoes, etc. Anechoic-type wedge shapes trap and diffuse sound.
 Juniors. 2-in-thick 24-in x 24-in sheets, 4 sheet box \$54

ACCESSORIES

SONRISE

XYLophile A/V Furniture

XYLophile is a modular furniture system available in 4 heights: 32, 48, 64, and 77 in and 2 widths: 23 and 31 in. Made of oak and walnut veneers and solid hardwood components. Options include drawers, slide-out shelves, TV swivel.

P64. Audio/video/audio	\$2,675
P48. Audio/video	\$1,630
P32. Audio/video	\$1,250
P64. Audio	\$675
P48. Audio	\$530

All cabinets come with a choice of walnut, oak (medium, light, or dark stain)

SG-11A Swivel Audio Cassette Holder

Dual-sided swivel audio cassette holder for 48 tapes. 14 $\frac{7}{8}$ x 10 x 6 $\frac{3}{4}$ in \$70

SG-11AL Stacking Audio Cassette Holder

Holds 40 tapes horizontally, each on its own shelf. 13 $\frac{7}{8}$ x 19 $\frac{3}{8}$ x 3 $\frac{3}{4}$ in \$70

SG-11DL Stacking CD Holder

One-sided unit holds 40 discs horizontally, each on its own shelf. 9 x 21 $\frac{1}{2}$ x 6 in \$70

SG-11LP Stacking Holder

Stacking holder for laser videodiscs or LP's. Holds 75 discs or LP's vertically. Choice of highgloss black, white, or grey lacquer. 14 $\frac{1}{2}$ x 14 $\frac{1}{2}$ x 13 in \$70

SG-11D Swivel CD Holder

Dual-sided holder stores 40 discs horizontally, each on its own shelf; may be ordered without the swivel for stacking purposes. 10 x 11 $\frac{1}{4}$ x 11 $\frac{1}{4}$ in \$70

SG-D1 Stacking CD Holder

Holds 45 single compact discs vertically, or a mix of single, double and triple discs; choice of high gloss black, white, or grey lacquer. 9 x 21 $\frac{1}{2}$ x 6 in ... \$50

All audio systems have 1-in shelves, fixed shelf at 13 $\frac{1}{2}$ -in with fins to accommodate LP's, and hidden casters. Comes in a choice of walnut, oak, silkwood, rosewood, highgloss black/white/gray lacquer.

E-1 Dawning Audio Cabinet

Audio cabinet with 3-adjustable shelves; 1 fixed-shelf; exterior height of 49 in. \$392

SM-2 Morning Star Audio Cabinet

Audio cabinet with 2 adjustable shelves. 1 fixed shelf; exterior height of 42 $\frac{1}{2}$ in \$360

SA-1 First Light Audio Cabinet

Audio cabinet with adjustable shelf and fixed shelf exterior height 34 $\frac{1}{2}$ in \$312

SONY

AVH-555ES Source Selector

Audio/video source selector \$450

XP-CD7 CD Cleaner

Automatic cleaner for compact discs \$59.95

Portable CD Accessories

SRS-150. Self-powered portable speakers	\$190/pr
RM-DM1K. Remote control and receiver	\$49.95
CPM-100P. Car mounting plate	\$49.95
BCBP2. 1-hr rechargeable battery pack for BP2 rechargeable battery	\$39.95
BP100. Rechargeable battery for models D10, DT10, D15	\$39.95
CPM-100P. Mounting plate with velcro pads and DC adaptor	\$37.95
CPM-100A. Mounting metal arm for CPM-100P	\$34.95
DCC-120. Car-battery cord	\$36.50
CPA-1. Car cassette adaptor allows hookup of a	

portable CD player to a car head unit	\$29.95
RMDM12. Wired remote control for portable CD players	\$24.95
CK-CD6. Carrying case designed for portable CD players	\$19.95
BPC 700K. Rechargeable battery pack for portable cassette players	\$14.95
ACD6M. AC adaptor	\$14.95
BP-3. Rechargeable battery for models D3, DT3, D4, DT4	\$14.95
BP-2. Rechargeable battery for models D15, D9, D88; 3 hrs charge, 2 hrs play	\$14.95
CK-CD01. Soft carrying case for portable CD players	\$12.95
EBP-3. 4 AA battery holder for models DT4, DT3, D4, D3	\$5.95

SOUND RUNNER

Oxygen-Free Speak Cables

Cables are unplated, high-density copper-strand cables. Uses 2 nonadjacent wires for the plus side and the other 2 wires for the negative side.

8108. 8 gauge; stranding 133 x 29	\$1.50/ft
8416. 13 gauge quad; 4-105 x 36	\$1.19/ft
8110. 10 gauge; stranding 238 x 34	\$0.99/ft
8112. 12 gauge; stranding 168 x 34; teflon version available	\$0.69/ft
8116. 16 gauge; stranding 67 x 34; teflon version available	\$0.49/ft

SOUNDESIGN

WC301AK Audio Cabinet

Oak-grain cabinet that houses a complete audio system. Has room for three components and a turntable on the unit's adjustable shelves. Features double glass doors with magnetic push latches; enclosed storage area at the bottom of the cabinet; back panel with openings for routing cables. Dimensions: 48 x 20 x 18 in. \$70

SOUNDSTREAM

SN-1 Simul-Source

The SN-1 allows the user to simultaneously access any of the C-1 preamp's available audio/video playback components in as many as 5 individual source zones (rooms). frequency response 20-20,000 Hz; signal-to-noise ratio >95 dB; total harmonic distortion 0.005%. \$995

RSS-2 Remote Speaker Selector

Allows 2 pairs of speakers to be connected to the RA-100 and the DA-1 amplifier. Two RSS-2's can be joined together to allow remote control switching of up to 4 pairs of speakers. Heavy duty terminal block connectors accepts up to 8 gauge wire; mounting brackets included \$125

BD-1 Remote Sensor

The BD-1 transmits infrared signals from a remote listening location, via multi-conductor cable, to either the C-1 preamp or the SN-1 Simul-Source network. Available in standard single-gang Decora style wall plate, table top box model, or ceiling mount remote eye \$120

RPS-6 Remote Power Strip

Allows up to 6 components to be switched on and off from the C-1 preamplifier and R-1 remote control \$75

Interconnect Cable

SL-1 Silver Teflon Interconnect Cable

Utilizes two silver coated, 22 AWG fine stranded center conductors or 99.96% oxygen-free copper; nitrogen filled teflon dielectric coating; 24K gold plated RCA connectors.

2-m	\$60/pr
1-m	\$40/pr
0.5-m	\$36/pr
Bulk	\$2/ft

DL-1 Dual Audio Cable

Features oxygen-free pre copper with a multiple fine-strand center conductor; polyethylene dielectric coating; PVC jacket; 24K gold-plated RCA connectors.

5-m	\$60/pr
2-m	\$40/pr
1.5-m	\$36/pr
1-m	\$30/pr
0.5-m	\$27.50/pr
Bulk	\$1.25/ft

Speaker Cable

SP-1 Speaker Cable

Four 14-gauge multi-stranded conductors of OFHC copper with polyethylene dielectric; four conductor topology allows for single cable bi-wiring.

SP-1	\$3/ft
------	--------

Speaker 120 Speaker Wire

12-gauge speaker wire	\$0.75/ft
-----------------------	-----------

Speaker 160 Speaker Wire

16-gauge speaker wire	\$0.40/ft
-----------------------	-----------

SPECIALTY WOODWORKS

Video Cabinets

All cabinets have glass doors and 8 slide-out shelves for audio cassettes, video cassettes, and CDs.

144VC Video Cabinet. In natural, medium or dark oak	\$530
In walnut or black oak	\$615
72VC Video Cabinet. In natural, medium or dark oak	\$339
In walnut or black oak	\$375

CD Cabinets

All cabinets have angled horizontal slots, glass doors, and an optional light kit.

264 CD Cabinet. In natural, medium, or dark oak	\$499
In walnut or black oak	\$595
Light kit	\$40
132 CD Cabinet. In natural, medium, or dark oak	\$330
In walnut or black oak	\$355

CD Racks

All racks are solid hardwoods with angled horizontal slots and have 3 slots for double CD's.

75 CD Rack. 20 x 20 $\frac{1}{2}$ x 6 in. In natural, medium or dark oak	\$85
In walnut or black oak	\$100
48 CD Rack. 20 x 16 x 6 in. In natural, medium or dark oak	\$66
In walnut or black oak	\$82
30 CD Rack. 20 x 10 $\frac{1}{2}$ x 6 in. In natural, medium or dark oak	\$54
In walnut or black oak	\$69

STANTON

RC5-Plus Record Cleaner

Kit contains cleaning fluid with antistatic ingredient. Comes with polarized brush, conductive handle. Cleans 300 record sides \$17

8-oz refill	\$10
RC4 8-oz refill	\$9
RC4 replacement applicator pad	\$9
2-oz refill	\$6
RC4 2-oz refill	\$4
1-oz stylus cleaning fluid	\$3
ARC-5 Carbon-Fiber Brush. Manufactured from aerospace high-elasticity carbon fiber. Removes dust particles and static charges	\$15
SC4 Mini Stylus-Cleaning Kit	\$8

STRAIGHT WIRE

Interconnect Cables

Maestro. Symmetrical coaxial design; microporous Teflon dielectric; and compression-fit phono plugs.

ACCESSORIES

Pearlescent polymer fiber braid covered with clear jacket. \$269/meter pr
Add'l meter pr length \$164
T.M.I. Similar to the Maestro with half as many strand; individually insulated conductors; microporous Teflon dielectric; polyurethane jacket; solid Teflon plug insulator; compression-fit plugs. Royal blue jacket \$145/meter pr
Add'l meter pr length \$55
L.S.I. Individually insulated OFHC conductors; sintered Teflon dielectric; gold plated phone plugs with spring-tension flange. Gray jacket. \$88/meter pr
Add'l meter pr length \$28
Laser-Link. Contains polymer-coated copper strands; polypropylene dielectric; gold plate phono plugs; can be use for balanced and unbalanced applications. Turquoise jacket. \$49/meter pr
Add'l meter pr length \$20
Flexconnect. Concentric tubular OFC conductors; coaxial geometry; microporous Teflon dielectric; gold plated phono plugs. Burgundy jacket \$35/meter pr
Add'l meter pr length \$14

Speaker Cables

Maestro. 384 individually insulated, ultra-high purity copper strands (9 gauge per polarity). Symmetrical coaxial design with microporous Teflon dielectric. Pearlescent polymer-fiber braided layer with clear PVC outer jacket. Additional \$80 for preparation charge \$30/ft
TMC. 96 individually insulated strands per polarity (10 gauge per polarity) combined in a symmetrical coaxial design with solid Teflon dielectric; intricate braid for full shielding coverage. Clear jacket. Add \$50 for preparation charge for gold spades or pins. \$10/ft
Music Ribbon-32. 32 OFC conductors; polypropylene jacket; 9 gauge per polarity; resistance/1,000 ft 0.858 ohms; current rating 50 amps. Tan or white color jacket; 1.9 in wide x .06 in thick. Add \$25 for preparation charge \$5/ft
Music Ribbon-16. 16 oxygen-free-copper conductors; polypropylene jacket; 12 gauge; resistance/1,000 ft 1.716 ohms; current rating 25 amps; choice of jacket colors. \$2.50/ft
Music Ribbon-8. OFC conductors; PVC jacket; 15 gauge; resistance/1,000 ft 1.365 ohms; 70 in w x 0.82 in thick \$1.25/ft
Pro-12. Concentric tubular 12 gauge wire; Teflon dielectric; polyethylene jacket \$3.50/ft
WaveGuide 8. OFC conductors insulated with white and gray polypropylene, spiraled into a helical array to minimize phase shift; 12 gauge per polarity. Clear PVC jacket. Add \$20 for preparation charge \$3.50/ft
WaveGuide 4. 4 polypropylene insulated OFC conductors (13 gauge) in an electrically optimized helical array. Add \$15 for preparation charge \$1.75/ft
WaveGuide 2. One white and one gray 12 gauge OFC polypropylene covered conductor composed of OFC strands. Covered with a clear PVC jacket. Add \$10 for preparation charge \$1/ft

TALWAR

Audio Cabinets

All Talwar audio cabinets are hand-finished wood and fitted with solid-brass hardware. Feature 1-in solid hardwood sides; structurally reinforced joints; tempered and beveled glass; 8-receptacle power supply with overcurrent protection; air columns; wire management system with wells for interconnects; removable back; heavy-duty piano casters; full extension drawer for tapes and accessories; adjustable shelves. Custom-made units with different dimensions, marble tops, and exotic wood available
K-270 Low-boy, 3-sections, solid red oak, 3 adjustable shelves. 70 1/2 x 30 x 20 in; 375 lb \$6,060
W-270. Solid walnut \$8,020
M-270. Solid mahogany \$7,230
C-270. Solid cherry \$6,850
K-420 Standard Unit. Solid red oak, 3 adjustable shelves. 24 x 48 x 20 in; 140 lb \$2,170

W-420. Solid walnut \$2,870
M-420. Solid mahogany \$2,580
C-420. Solid cherry \$2,450
K-320 Standard Unit. Solid red oak, 2 adjustable shelves. 24 x 36 x 20 in; 120 lb \$1,990
W-320. Solid walnut \$2,640
M-320. Solid mahogany \$2,380
C-320. Solid cherry \$2,260
K-220 Standard Unit. Solid red oak, 1 adjustable shelf. 24 x 30 x 20 in; 100 lb \$1,900
W-220. Solid walnut \$2,510
M-220. Solid mahogany \$2,260
C-220. Solid cherry \$2,140

SVC-1 Vibration Isolator

Isolation base with air springs to decouple turntable from airborne and structure-borne vibrations. Features one 2 1/4 x 20 1/4 x 1 1/2 in polished granite supported by air mounts. Requires bicycle pump or compressor to pump air into unit. Resonant frequency 2.9 Hz; max loads 200 lb. 24 1/2 x 3 1/2 x 20 1/4 in; 95 lb \$1,610

PIE-2 Power-Line Filter

Eliminates distortion caused by equipment interaction as well as power line noise and hash. Functions as a safety device for excessive voltage spikes and can be plugged between affected component and outlet. Features active-tracking circuits making it insensitive to load imp. Allows users to plug any combination of components with no side effects. \$750

SN-1 Static Neutralizer

Eliminates electrostatically-charged air particles that cause dust and debris accumulation on records. Generates positive and negative ions simultaneously. Operates continuously while record is playing. Fits onto turntable platform or clips onto dustcover. Power consumption 0.5 W; discharges 5,000 V to safe levels (<100 V) within 2 sec. 6 x 1 1/2 x 1 1/2 in . . . \$397

FVS-1 Fan Ventilation System

Features rack-mountable panel; 1 fan; filter; vibration isolator; all mounting hardware. Noise level 26 dBA; air flow 45 CFM. Black anodized steel panel. 19 x 6 x 2 in; 4 lb. \$183
Additional fan and vibration isolation \$67

Cabinet Lights

30-in long interior light \$182
22-in long interior light \$125

Additional Shelves and Drawers

6 1/2-in-deep drawer for CDs, video tapes \$180
Glass shelf. 16 x 20 x 1/2 in. \$110
Play-free sliders for turntables. \$139
4-in-deep drawer for cassettes, accessories . . . \$129
Wood shelf. 16 x 20 x 3/4 in \$84

Front Panel Remote Switch

Allows control of the power strip to be turned on and off from the front panel of the cabinet using a heavy-duty relay \$168

Cabinet Accessories

Rack Mounting Angles
48 in with hardware for 10 components. \$139
36 in with hardware for 8 components. \$106
24 in with hardware for 5 components. \$69

GB-12 Grounding Bus Bar

High purity copper bus bar eliminates hum induced by ground loops. Mounts into cabinet side. Includes hardware for 2 components. 1 x 12 x 1/4 in; 2 lb; 12 in long \$77

TANNOY

Loudspeaker Stands

These stands are ribbed for strength and feature floor-coupling spikes and an extruded aluminum upright separate channel for cable; suitable for blu-tack or upward spikes.

TS500. 24 in. \$220/pr
TS400. 18 in. \$210/pr
TS250. 12 in. \$200/pr

TANTRUM TRADING

LCD-48. Lacquered-wood CD storage unit; holds 48 CDs \$60

LC-36. Lacquered-wood cassette storage unit; holds 36 cassettes \$50

C-42. Wire cassette organizer with a pull-out drawer; holds 42 cassettes \$25

WCR-42. Wire free-standing/wall-mountable cassette rack; holds 42 cassettes \$14.99

CD-15. Vinyl case with see-through window; holds 15 CDs \$9.99

FRM-1. Album/laser disc display frame \$9.99

SP-3 Sacpac. 3-piece nylon belted sports pack \$9.95

C-11. Vinyl universal case with see-through window; holds 11 cassettes. \$6.99

CD-12. Stackable CD bricks; holds 12 CDs . . . \$4.99

AHC-3. Audio cassette head cleaner \$1.99

TDK

HD-30 Cassette Head Demagnetizer

Features red LED, continuous audible tone will be activated while in operating mode, and a beeper signifies operation termination \$25

RCL-11. Dry-type DAT head cleaner. \$15

HCW-01. Wet-type audio cassette head cleaner . \$9

MCL-11. Dry-type microcassette head cleaner \$3.99

HCL-11. Dry-type cassette deck head cleaner . . . \$2

TECHNICS

SH-R700 Intelligent A/V Remote Control

Features LCD; programmability; displays for CD, TV, VCR, and audio equipment; for table-top or handheld operation \$230

SH-F101 Indoor Active Tuned FM Wing Antenna

Compact dipole for reception in strong signal areas. Features auto electronic tuning circuit; high gain; manual tuning knob; diecast base; figure-8 pattern. Relative gain -2 db; half-power angle 90°; output imp 75 ohm; standing-wave ratio 1.2 or less; power source 1x 18 V. 16 7/8 x 6 3/8 x 4 1/2; 1.9 lb \$130

SH-S1 Tripod Stand

Tripod stand for SB-F1 and SB-F2 speakers . . . \$50

SH-S2. Angle mount for SB-F1 and SB-F2 speakers \$40

SH-S3. Suspension chain, bracket for SB-F2 speaker \$30

SH-90S Universal/P-Mount Headshell Adapter

Combination headshell/adaptor allows use of P-mount cartridges in universal-headshell arms . . \$30

TEI ELECTRONICS

Speaker Stands

ST-280. Wood column upright; steel top plate; black lacquer base; 18-in high \$179/pr

ST-260. As above, 27-in high \$179/pr

ST-230 All steel construction; black enamel finish; 37-in high \$75/pr

Model 79-VF2200 \$51.50

Model 79-VF2500 \$45.50

Model 79-VF3000 Speaker may be tilted backward on the stand \$44.85

Model 79-VF2000 Speaker may be tilted backward on the stand \$38

ACCESSORIES

Speaker Mounts

Model 79-DUO220

Clamping bracket for motional feedback speakers. Speakers can be rotated horizontally \$37

Model 79-BEK100

Mounting allows speaker to be adjusted horizontally and vertically. For speakers up to 55 lb \$26

Model 79-MINOR50. As above, for speakers up to 11 lb \$26

TERK

9800 Series Powered Indoor Antenna

FM antenna with Schotz low-noise amplifier. Features patented Gamma-loop element for directional and omnidirectional reception as well as superior multipath and noise rejection. Amplifier 38 dB gain; 110 V or 220 V. Lifetime limited warranty. Available in black, white, or gray. 5 x 1 in \$85

9600 Series "Pi" Powered Indoor FM Antenna

FM disc-shaped antenna with Schotz low-noise amplifier. Features patented Gamma-loop element for directional and omnidirectional reception as well as superior multipath and noise rejection; 360-degree range. Imp 75 ohm adaptable to 300 ohm with matching transformer (included); operating band 88-108 MHz; amplifier gain 30 dB; twin-tone modulation distortion <0.1% at 100 mV; 110 V or 220 V. Lifetime limited warranty. White or gray. 5 x 1 in \$80

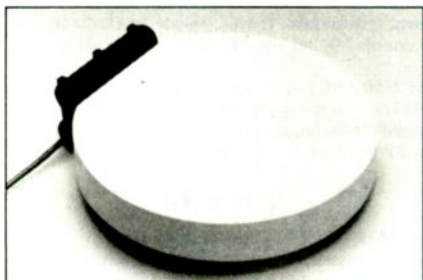

Terk 9600 Series "Pi"

9300 Series Powered Indoor FM Antenna

FM tower-shaped antenna. Features directional or omnidirectional applications; 360-degree range. Imp 75 ohm adaptable to 300 ohm with matching transformer (included); operating band 88-108 MHz; amplifier gain adjustable 0 to 25 dB; twin-tone modulation distortion <1.0% at 100 mV; 110 V or 22 V. Black. Base: 3 x 4 1/4, Height: 17 1/4 in \$40

2000 Series FM+ Indoor Antenna

5-in square antenna fits on any shelf. Features unidirectional and omnidirectional applications; 360-degree range. Imp 75 ohm adaptable to 300 ohm with matching transformer (included); operating band 88-108 MHz. 5 1/2 x 1 1/4 in \$19.95

THORSEN (GC ELECTRONICS)

Amplified UHF/VHF/FM Indoor Antenna

Cleans up TV and FM stereo signals. Features adjustable gain control. 75-ohm cable output \$50

Audio System Selector

Allows for switching of up to 4 stereo audio input sources to one audio output. RCA connections. \$32

Superlink II Connectors

For terminating high-performance interconnect cables. Features gold-plating; color coded bands \$9.99

Auto-Action Cassette Head Cleaner

Head cleaner with with cotton-tipped assemblies that swing left, right, and rotates in 360 degrees... \$8.99

Superlink Connectors

Connectors with gold-plated phono pin plugs. Fea-

tures aluminum-alloy connector shell; available in platinum, black, red, and gold..... \$8.89

TRACKMATE

TM 351 CD Cleaner

Cleans CD's inside the disc storage case to protect the label/mirror side of the CD. Employs a Kodak developed cleaning solution. Features a patented, nonabrasive brush geared for effective radial cleaning \$19.95

TM 451 Record Cleaner

Dual-brush record cleaner removes dust, oils, and static electricity. Includes a stylus cleaner .. \$19.95

TM161 Cassette Cleaner/Demagnetizer

Features cleaning-solution pen; cleaner/demagnetizer; jewelbox storage case \$14.95

TM301 CD Shield

Used to protect the recorded label side of the CD from permanent damage. Contains 10 shields and free CD case \$14.95

TM 151 Cassette Deck Cleaner

Audio cassette deck cleaner features Trackmate brushes designed to clean above, below, and on the tape path, to reach the capstan, tape head, and pinchwheels \$9.95

TREE DIMENSIONS

CD-250 Cassette-CD-Video Storage Unit

Capacity for 260 CD's, 160 cassettes, or 19 videos. Solid-oak hand-rubbed oil finish. 36 x 23 1/2 x 9 in \$90
Black matte \$100

Speaker Standards Adjustable Support System

3-in to 24-in adjustable speaker stands. Includes spikes for carpet and rubber isolation pads. Solid oak with honey oak or black matte lacquer finishes \$90/pr

CD-130 Cassette-CD-Video Storage Unit

Solid-oak hand-rubbed oil-finish cabinet. Capacity for 130 CD's, 80 cassettes, or 17 videos. 17 1/4 x 20 x 6 1/2 in; 7.5 lb \$50
Black Matte \$60

CD-80 Cassette-CD-Video Storage Cabinet

Solid-oak hand-rubbed finish. Capacity for 88 CD's, 53 cassettes, or 17 videos. 1 removable sliding divider panel included. 20 x 11 x 6 1/2 in \$40

V-75 Cassette-CD-Video Storage Unit

Cabinet with capacity for 208 CD's, 128 cassettes, or 80 videos. 23 1/4 x 35 x 8 1/2 in. Honey oak \$85
Matte black \$95

V-30 Cassette-CD-Video Storage Unit

Solid-oak hand-rubbed oil-finish cabinet. Capacity for 88 CD's, 54 cassettes, or 34 videos; 17.25 x 20 x 6 1/2 in; 7 lb. \$40
Black matte \$45
V-15. Same as above. Capacity for 44 CD's, 27 cassettes, or 17 videos; 8 x 20 x 6 1/2 in \$19.95

VAMPIRE WIRE

The cables in this group use oxygen-free copper and are jacketed in 105° PVC insulation.

Speaker Cable

2100C Speakerline \$1.95/ft
820C Speakerline. 12-gauge \$0.95/ft
210C Speakerline. 16-gauge \$0.55/ft
Baby Bat. 18-gauge \$0.20/ft

Interconnect

CC Interconnect. 20-gauge wire, terminated with male RCA connector \$19.95 m pr

The cables in this group are made of van den Hul matched-crystal (MC) copper.

Speaker Cable

SCS-2. Teflon-insulated speaker cable, 665 copper strands \$120/ft
SCS-6. Teflon-insulated speaker cable, 133 strands of copper \$49/ft
D-352. 12-gauge, 296 strands \$6.95/ft
CS-122. 12-gauge, 19 strands/conductor .. \$3.50/ft

Interconnects

MC Silver. Coaxial interconnect cable; 19-strand center conductor \$1,300 m pr
MC Gold. 7-strand conductor \$400 m pr
Thunderline. Balanced interconnect; 19 strands/conductor \$225 m pr
D 102 MK II. Balanced interconnect; 7 strands/conductor \$100 m pr
D 300 MK II. Coaxial, 22-gauge \$50 m pr

D-502 Tonearm Cable. 7 strands matched-copper wire. Terminated in RCA male and standard female DIN \$110

VECTOR RESEARCH

VRC-125 Universal Remote Control

Programmable remote control; audio/video functions; 102 functions \$100

WEBER WORKS BY THRESHOLD

Weber Wire

Ribbon loudspeaker cable employs a distributed impedance tri-wire relationship (Weber-Weave). 10-gauge wire with impedances set at ratios of 1, 1.41, and 1.73; made of 684 individual strands of oxygen-free copper coated with a pure silver skin. Current capacity of 100 amps RMS, 500 amps peak. Available in 3 lengths; longer custom lengths can be supplied on special order. 20 ft pair \$1,350
12 ft pair \$890
8 ft pair \$650

WHARFEDALE

Speaker Stands

SPS-700. 27 1/2 in high \$70
SPS-300. 12 in high \$50

YALE AUDIO

"Set-It-To-Here" Position Markers

Adhesive vinyl appliques indicate where controls should be set. Includes straight and curved arrows; arrows pointing to lines; pointing hands; switches; buttons in, buttons out. Useful for tone controls, equalizer sliders, tape-monitor buttons, processing loops, etc. Black, red, or white \$6.49

YAMAHA

SLC-10 Equipment Rack

Black metal, fits all standard 19-in rack mount components. Features rack or shelf mounting (4 shelves provided). 77 lb. \$549

SPS-A1 Speaker Stands

For NS-1. Features dark wood finish \$199/pr

The listings are based on data provided by the manufacturers. For more product information, contact an authorized dealer or the manufacturer directly. Manufacturers' addresses and phone numbers are listed in the directory beginning on page 258.

POCKET · STEREO

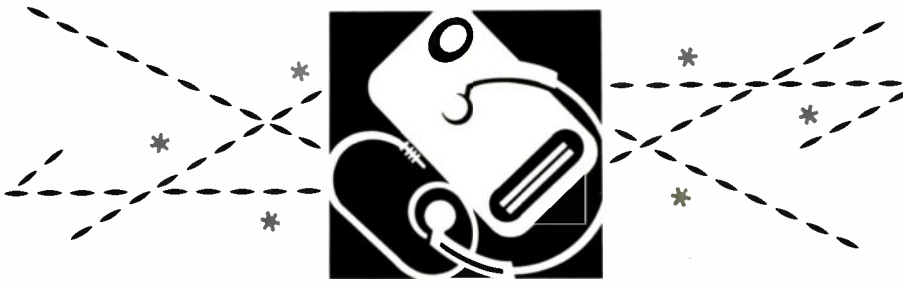

AIWA

HS-PX900A Cassette Player

Portable cassette player with 6-function wire remote. Dolby B/C, selectable autoreverse; bi-azimuth head adjustment; metal/normal tape selector, 15-minute charge. Powered by insertable lead-acid battery; AC adaptor; 2 AAA batteries. 3 x 4 3/8 x 1 1/8; 6.3 oz \$290
HS-PX700A. As above, 1-hour charge \$280

HS-J900 Portable AM/FM Cassette Player

Portable AM/FM cassette player with 5-station preset in each band, battery backup. Record capability; stereo mic; Dolby B; selectable autoreverse; digital LCD; time function; 15 minute charge. 3 1/4 x 4 3/8 x 1 1/4; 7.3 oz. \$290
HS-T900. As above, without record capability and stereo mic \$260

HS-J800 Portable Cassette Player

Recording capability with detachable one-point stereo mic. One-hour charge, includes AC adaptor/charger and a lead rechargeable battery for up to three hours playing time. Features built-in clock and AM/FM tuner with LCD display; autoreverse; Dolby B; metal and normal tape selection; includes battery case, carrying case, and headphones \$270
HS-T800. As above, without recording capabilities \$250

HS-J380 Portable Cassette Player

AM/FM recording cassette player with built-in clock and AM/FM tuner and LCD display. Cassette unit with autoreverse; Dolby B; metal/normal tape selection. Includes headphones, belt clip, and stereo mic. \$185
HS-T380. As above without recording capabilities \$160

HS-P202A Portable Cassette Player

Portable cassette player with selectable autoreverse. Dolby B; metal tape selector; one hour recharge. Runs on AC adaptor, 2-AAA batteries. 3 1/2 x 4 3/8 x 1 in. \$140

HS-T370 Portable AM/FM Cassette Player

AM/FM cassette player with three tone controls. Dolby B; metal/normal tape selection; anti-rolling tape mechanism. Compatible with rechargeable NiCd batteries, comes with headphones. 3 3/8 x 4 3/8 x 1 1/2 in; 9.4 oz. \$120
HS-G370. As above, no radio \$80

HS-T280 Portable AM/FM Cassette Player

AM/FM cassette player with LCD display and five station memory preset tuner. Features Dolby B; metal/normal tape selection; anti-rolling tape mechanism. Compatible with rechargeable NiCd batteries, comes with headphones and belt clip. Available in black or white finish \$120

HR-SO1MKII Portable AM/FM Cassette Player
 Features folding headphones; second headphone jack. Uses 2 AA batteries. 4.6 oz \$85

HS-T220 Portable AM/FM Cassette Player
 AM/FM autoreverse cassette player with selectable

continuous autoreverse. Separate bass and treble controls; 30-minute recharge; Dolby B noise reduction. Runs on AC adaptor or 2 AA batteries. 3 3/4 x 5 3/8 x 1 3/8; 9 oz \$85
HS-T210. As above, no Dolby B, no bass and treble controls \$75
HS-T110. As HS-T220, no autoreverse \$75
HS-T100. As above, no Dolby B, no bass and treble controls \$65

HR-S50 Portable AM/FM Radio

AM/FM tuner with LCD display. 5 station memory presets for each band; folding headband. Runs on 2 AAA batteries. \$80

HR-S20 Portable AM/FM Radio

AM/FM tuner with folding headband. Runs on 1 AAA battery. 2.9 oz. \$45

HS-P12 Portable Cassette Player

Portable cassette player features anti-rolling drive mechanism; metal tape selector; auto stop; belt hanger. Available in black (HS-P12B), white (P-12A), or burgundy red wine (P-12R) \$40

ALARON (RHAPSODY)

RY-378 Portable AM/FM Cassette Player

Cassette pocket stereo with AM/FM tuner. Features auto-stop; stop, FF, play cassette operation; belt clip; volume control; stereo headphone. Uses 3 AA batteries. 6 3/8 x 3 1/2 x 1 3/8 in \$24

RY-280 Solar Portable AM/FM Radio

Portable AM/FM radio with solar cells which recharge built-in Ni-Cad battery. Includes folding lightweight headphones; adjustable elastic arm band; portable clip. Dimensions: 3 1/2 x 1 3/8 x 3/4 in \$24

RY-275 Portable AM/FM Radio

Includes folding headphones; adjustable elastic arm band; transparent pouch for all-weather use. 3 3/4 x 1 1/4 x 3/8 in \$24

RY-278 Portable AM/FM Radio

Portable AM/FM-multiplex featherweight headphone radio with adjustable headband that folds up for storage. Features foam-padded earpieces; LED stereo indicator; in-out jack; doubles to connect with other personal or home stereos (connecting cables not included); operates on 2 AA batteries (not included) \$17

RY-269 Portable Cassette Player

Features slide volume control; stereo headphone; high-impact case. Uses 2 AA batteries. 4 1/4 x 3 1/4 x 1 3/8 in \$14.95

CITIZEN

CW-1R Cassette Player

Pocket cassette player with autoreverse. Runs on 2 AA batteries or 3V DC. Headphones and belt hook included. 4 1/2 x 3 x 1 1/8 in; 7 1/4 oz. \$44

CW-X2 Cassette Player As above with bass boost control. \$44

EMERSON

CRR100CS AM/FM Cassette/Recorder

Built-in condenser mic; record directly from tuner; DC power 3 V. Includes belt clip; stereo headphones. Operates on two AA batteries (not included). 5 1/2 x 3 1/2 x 1 3/8 in \$60

AC212 AM/FM Cassette Player

Pocket AM/FM cassette player with 3-band EQ and autoreverse. Features fast-forward; rewind. Runs on 2 AA batteries or 3V DC. 5 1/2 x 3 1/2 x 1 3/8 in \$55

AC2106 AM/FM Cassette Player

Pocket AM/FM cassette player with 3-band EQ. Features fast-forward; rewind; FM stereo LED indicator. Runs on 2AA batteries or 3V DC. 3 1/2 x 5 x 1 3/8 in \$45

AC2100 AM/FM Cassette Player

Pocket AM/FM cassette player with fast-forward. FM stereo LED indicator; belt clip. Runs on 2 AA batteries or 3V DC. 3 1/2 x 5 x 1 3/8 in \$35

HITACHI

CP-203R AM/FM Cassette Recorder

AM/FM cassette recorder with 1-touch recording. Features auto stop and cue/review; built-in mic; in-ear headphones. FR 60-10,000 Hz; w&F<0.35%. 3 1/2 x 5 1/2 x 1 1/2 in; 12 oz. \$75

CP-202R AM/FM Cassette Player

Mini-size stereo cassette player. Features auto stop; locking fast-forward and rewind \$45

JVC

CX-F40 AM/FM Cassette Player

Pocket AM/FM cassette player with synthesized tuning and 10 presets. Features anti-roll mechanism; Dolby B NR; digital clock; 4-track fixed head; metal and chrome playback; battery recharger circuit; 4-element graphic EQ; headphones. \$120

CX-F35 AM/FM Cassette Player

Features autoreverse mechanism and 3-element graphic EQ. Features anti-roll mechanism; Dolby B noise reduction; 4-track fixed head; metal and chrome playback; battery recharger circuit; headphones. \$90

CX-F30 AM/FM Cassette Player

Features autoreverse; 5-element graphic EQ; anti-roll mechanism; Dolby B noise reduction; 4-track fixed head; metal and chrome playback. Includes headphones. \$70

CX-F20 AM/FM Cassette Player

Features autoreverse; 3-element graphic EQ; anti-roll mechanism; metal and chrome playback; 4-track fixed head. Includes headphones \$60

KENWOOD

CP-C7 Cassette Player

Autoreverse cassette player with built-in rechargeable

POCKET • STEREO

ble battery and 12½ hr playing time. Features amorphous tape head; full-logic control. Dolby B and C NR; earphones; remote control. FR 40-18,000 (normal, high-bias, metal tape). Includes battery charger; AC adaptor; soft carrying case. 2¾ x 4¼ x 1 in; 6.8 oz (with rechargeable battery)..... \$249

LENOXX

897 AM/FM Cassette Player

Pocket AM/FM cassette player with maxi-bass switch. Features built-in belt clip; headphones; adjustable carrying strap..... \$69

935 AM/FM Cassette Player with 3-Band EQ

Personal cassette player features slide-rule tuner and 3-band equalizer. Features lightweight, adjustable headphones; auto stop; removable belt clip. Uses 2 AA batteries..... \$39

900 AM/FM Cassette Player

AM/FM stereo portable receiver with built-in stereo cassette player. Features lightweight, adjustable headphones; removable belt clip; auto stop; slide-rule tuner; Stereo headphone jack; DC input jack; FM stereo muting switch. Uses 2 AA batteries. 6 x 3½ x 1½ in..... \$29

PANASONIC

RQ-V505 AM/FM Cassette Player

Pocket AM/FM cassette player with autoreverse, remote control; and XBS bass-boost system. Features ultra-compact size; Dolby; rechargeable battery system with charger; anti-rolling mechanism; open-air headphones; metal-tape compatibility; auto stop; soft-touch fast-forward and rewind controls; carrying case. Operates on rechargeable battery or one AA battery..... \$180
RP-BP105. Rechargeable battery for above..... \$15

RQ-V340 AM/FM Cassette Player

Pocket AM/FM cassette player with autoreverse, 3-band EQ, and XBS bass-boost system. Features Dolby; rechargeable NiCd battery system with charger; open-air headphones; anti-rolling mechanism; auto stop; soft-touch fast-forward and rewind controls; local/DX and reverse-direction selectors; detachable belt clip; DC-in and headphone jacks. Operates on NiCd or one AA battery..... \$150

RQ-V320 AM/FM Cassette Player

Pocket AM/FM cassette player with autoreverse, 3-band EQ, and Dolby. Features open-air headphones; anti-rolling mechanism; auto stop; soft-touch fast-forward and rewind controls; local/DX, metal/high-bias/normal-bias tape, and reverse-direction selectors; FM stereo LED indicator; detachable belt clip; DC-in and headphone jacks. Operates on one AA battery..... \$105

RQ-V175 AM/FM Cassette Player

Pocket AM/FM cassette player with autoreverse, 3-band EQ, and XBS bass-boost system. Features Dolby; open-air headphones; anti-rolling mechanism; fast-forward and rewind; local/DX, metal/high-bias/normal-bias tape, and reverse-direction selectors; FM stereo LED indicator; detachable belt clip; DC-in and headphone jacks. Operates on 2 AA batteries..... \$105

RQ-A70 AM/FM Cassette Recorder

Pocket AM/FM cassette recorder with built-in condenser mic, sound-level equalizer, and built-in speaker. Features one-touch recording; pause, cue, and review; fast playback; rechargeable NiCd battery; open-air headphones; auto stop; local/DX selector; LED tape/battery indicator; detachable belt clip; DC-in, external mic, and headphone jacks. Operates on NiCd or 2 AA batteries..... \$105

RQ-V170 AM/FM Cassette Player

Pocket AM/FM cassette player with autoreverse, 3-

band EQ, and Dolby. Features open-air headphones; anti-rolling mechanism; fast-forward and rewind; local/DX, metal/high-bias/normal-bias tape, and reverse-direction selectors; FM stereo LED indicator; detachable belt clip; DC-in and headphone jacks. Operates on 2 AA batteries..... \$85

RQ-A60 AM/FM Cassette Recorder

Pocket AM/FM cassette recorder with built-in condenser mic and one-touch recording. Features pause, cue, and review; open-air headphones; auto stop; DX/local selector; LED tape/battery indicator; detachable belt clip; DC-in, external mic, and headphone jacks. Operates on 2 AA batteries..... \$80

RQ-V155 AM/FM Cassette Player

Pocket AM/FM cassette player with autoreverse, 3-band EQ, and XBS bass-boost system. Features open-air headphones; anti-rolling mechanism, fast-forward and rewind; local/DX and reverse-direction selectors; FM stereo LED indicator; detachable belt clip; DC-in and headphone jacks. Operates on 2 AA batteries..... \$75

RQ-V150 AM/FM Cassette Player

Pocket AM/FM cassette player with autoreverse and 3-band EQ. Features open-air headphones; anti-rolling mechanism; fast-forward and rewind; local/DX, metal/high-bias/normal-bias tape, and reverse-direction selectors; FM stereo LED indicator; detachable belt clip; DC-in and headphone jacks. Operates on 2 AA batteries..... \$60

RQ-V55 AM/FM Cassette Player

Pocket AM/FM cassette player with XBS bass-boost system. Features open-air headphones; auto-stop; fast-forward and rewind; local/DX selector; FM stereo LED indicator; detachable belt clip; DC-in and headphone jacks. Operates on 2 AA batteries..... \$55

RX-SA64 AM/FM Cassette Player

Pocket AM/FM cassette player with 48-hour playback time. Features built-in roll-up stereo earphones; auto-stop; fast-forward and rewind; local/DX FM sens selector; FM stereo LED indicator; headphone jack. Operates on 2 C-size batteries 4¾ x 3¾ x 1½ in; 11 oz..... \$50

RF-H6 AM/FM Headphone Radio

AM/FM radio built into collapsible open-air headphones. Features stereo/mono, local/DX selectors; rotary volume and tuning controls; detachable FM wire antenna. Operates on one AAA battery. 3 oz \$43

RQ-V50 AM/FM Cassette Player

Pocket AM/FM cassette player with open-air headphones. Features fast-forward and rewind; auto stop; local/DX selector; FM stereo LED indicator; detachable belt clip; DC-in and headphone jacks. Operates on 2 AA batteries..... \$40

RF-H2 FM Headphone Radio

FM radio built into lightweight open-air headphones. Features stereo/mono, local/DX selectors. Operates on one AAA battery. 2 oz..... \$33
RF-H2RD. Same as above in red..... \$33

QUASAR

GX3699 AM/FM Cassette Player

Pocket AM/FM cassette player with one-touch recording and condenser microphone. Features cue and review; auto-stop and pause; local/DX selector; lightweight headphones; detachable belt clip. Uses 2 AA batteries. 4 x 5 x 1¾ in; 7.1 oz..... \$70

GX3689 AM/FM Cassette Player

Pocket AM/FM cassette player with bass boost and autoreverse. Features 3-band graphic equalizer; anti-rolling mechanism; local/DX selector; LED FM stereo indicator; bass-boost ready headphones; detachable belt clip. Uses 2 AA batteries. 3¼ x 5 x 1½ in; 9.2 oz..... \$70

GX3679. As above, no bass boost..... \$55

GX3669 AM/FM Cassette Player

Pocket AM/FM cassette player with autostop. Features LED FM stereo indicator; local/DX selector; lightweight headphones; detachable belt clip. Uses 2 AA batteries. 3¼ x 5 x 2 in; 7.1 oz..... \$35

REALISTIC

SCP-27 AM/FM Cassette Player

Pocket AM/FM cassette player with Dolby B NR. Metal/normal tape selector; low-battery LED; belt clip. Runs on 2 AA batteries, or AC/DC adaptor. 4¾ x 3¾ x 1½ in..... \$100

SCP-25 AM/FM Cassette Player

Pocket AM/FM cassette player with Dolby B NR. Features selectable autoreverse; separate volume controls belt clip. Runs on 2 AA batteries, or AC/DC adaptor. 5½ x 3¾ x 1½ in..... \$80

SCP-19 Cassette Player

Pocket cassette player features Dolby B NR; autoreverse; EQ switch. LED's for tape direction; belt clip. Runs on 2 AA batteries. 4¾ x 3½ x 1½ in..... \$60

SCP-24 AM/FM Cassette Player

L/R volume controls; FM stereo/battery LED; detachable belt clip; auto stop. Runs on 3 AA batteries. 5¾ x 3¾ x 1½ in..... \$40

SCP-26 Cassette Player

Weatherproof housing; belt clip. Runs on 2 AA batteries. 4¾ x 4 x 1¾ in..... \$30

SCP-20 Cassette Player

Equalizer boosts or cuts bands centered at 100, 1,000, and 10,000 Hz; auto stop; LED for batteries; detachable belt clip. Runs on 2 AA batteries. 4½ x 3¼ x 1½ in..... \$30

SAMSUNG

MY-A1 AM/FM Cassette Player

Pocket AM/FM cassette player with 3-band graphic EQ and autoreverse. Features continuous play; Dolby B NR; metal tape capability; lightweight headphones; battery/AC adaptor. Runs on 2 AA batteries. 4¾ x 3¾ x 1¼ in; 9.2 oz..... \$80

MY-Q5 AM/FM Cassette Player

Pocket AM/FM cassette player with 3-band graphic EQ. Features auto-stop tape mechanism; lightweight headphones. Runs on 2 AA batteries. 5¼ x 3¾ x 1¾ in; 9.2 oz..... \$50

SANSUI

EM-P2 Portable Cassette Player/Mixer/Amp

Designed for musicians and vocalists. Features play; stop; rewind/review; fast-forward/cue; tape/tone selector; volume; headphone jack accepts plugs from musical instruments; stereo line-out jack; built-in mic; echo control; ± 15% pitch control..... \$175

SANYO

MGR95R AM/FM Cassette Player

AM/FM tuner/cassette player with autoreverse. Features recording from detachable stereo mic or from either radio band; EBSS (Extended Bass Sound System). 3¼ x 4½ x 1¾ in; 9.1 oz..... \$90

MGR90 AM/FM Cassette Player

AM/FM stereo cassette player with 12 station presets. Features LCD multi-function display; digital tuner; 3-band graphic EQ auto/manual tuning; locking fast-forward/reverse button; adjustable headphones; AC/DC operation. 3¾ x 5½ x 1¾ in; 1.1 lb..... \$80

MGR85D AM/FM Cassette Player

AM/FM tuner/cassette player with autoreverse. Features Dolby NR; 3-band EQ; cue and review; rechar-

POCKET • STEREO

geable \$70

MGP40R Portable Cassette Recorder

Recorder/cassette player with built-in piezo speaker. Features detachable condenser microphone; electronic pause control; adjustable headphones; AC/DC operation. 3½ x 4½ x 1½ in.; 1.1 lb. \$60

MGR84RG AM/FM Cassette Player

AM/FM tuner/cassette player. Features 3-band graphic equalizer; auto stop; stereo headphones; FM stereo indicator; detachable belt clip; rechargeable AA-size batteries; AC charger. Dimensions: 3¾ x 5½ x 1½ in. Weight: 8.8 oz. \$55
MGR84. As above, no batteries or charger \$50

MGP34RG AM/FM Cassette Player

AM/FM tuner/cassette player. Features 3-band graphic EQ; adjustable headphones; locking fast-forward; detachable belt clip; 2 rechargeable AA-size NiCd batteries; AC charger. 3¼ x 4¾ x 1½ in.; 6.7 oz. \$30
MGP34. As above, no batteries or charger \$40

MGR78 AM/FM Cassette Player

AM/FM cassette player with 3-band graphic EQ. Features 4-button control; auto stop mechanism; detachable belt clip; AC/DC operation; adjustable headphones. 5¾ x 3¾ x 1¾ in.; 1.1 lb. \$30

MGR63 AM/FM Cassette Player

Features 3-button transport controls; locking fast-forward; FM stereo indicator; auto stop mechanism; detachable belt clip; adjustable headphones; AC/DC operation. 3¾ x 5½ x 1½ in.; 8.4 oz. \$30

RP90 AM/FM Radio

One-piece AM/FM stereo headphone radio. Features folding headband; thumbwheel volume and tuning controls; telescopic rod antenna. Red, black, and yellow. 3½ x 7 x 2½ in.; 3.7 oz. \$25

RP42 AM/FM Radio

Portable radio with headphones. Features thumbwheel tuning; rear-mounted clip; separate rotary controls; 3-position band switch. Operates on a single AAA battery. 2 x 3½ x ¾ in.; 2 oz. Dark grey, yellow, or red burgundy. 2 x 3½ x 5¾ in.; 2 oz. \$18

MGP23 Cassette Player

Features auto stop mechanism; locking fast-forward; adjustable headphones; detachable belt clip; AC/DC operation. 3¾ x 4¾ x 1¾ in.; 6.3 oz. \$15

SHARP

JC-568 AM/FM Cassette Player

With stereo synthesis tuner. Features 5 AM/5 FM presets; autoreverse; Dolby B NR; 3-band graphic equalizer; anti-rolling mechanism; lightweight headphones; detachable belt clip. Uses 2 AA batteries. 3½ x 4¾ x 1½ in. \$150

JC-K15G Cassette Player

Ultra-mini-size cassette player with Dolby B noise reduction. Features autoreverse; bass-boost system; metal-tape capability; headphones; LED power indicator. \$130

JC-534 AM/FM Cassette Player

Mini-size unit with autoreverse. Features X-Bass; Dolby B NR; 3-band graphic equalizer; anti-rolling mechanism; AM/FM stereo radio; LED battery-strength indicator; detachable belt clip; headphones. 3½ x 4¾ x 1½ in.; 8.8 oz. \$110

JC-R88 AM/FM Cassette Player

Pocket AM/FM stereo radio and cassette player. Features autoreverse; 3-band graphic equalizer; anti-rolling mechanism. Available in black, blue, red, and yellow. \$90

JC-528 AM/FM Cassette Player

Compact-size stereo radio and cassette player with

Dolby noise reduction. Features autoreverse; 3-band graphic equalizer; direction switch; reverse mode selector; power/battery LED indicator; lightweight headphones and detachable belt clip. Uses 2 AA batteries. 3¾ x 4¾ x 1¾ in.; 9 oz. \$90
JC-518. Same as above, without Dolby noise reduction. \$80

JC-R88 AM/FM Cassette Player

Rechargeable stereo radio and cassette player. Features autoreverse; 3-band graphic equalizer; anti-rolling mechanism; power/battery LED indicator; lightweight headphones; detachable belt clip. Available in black, blue, red, and silver. 3½ x 4¾ x 1¾ in.; 8.5 oz. \$90

JC-508 AM/FM Cassette Player

Features autoreverse; anti-rolling mechanism; FM-stereo LED indicator; lightweight headphones; belt clip. Uses 2 AA batteries. 3½ x 5¾ x 1½ in.; 11.29 oz. \$60

JC-508 AM/FM Cassette Player

Features autoreverse; lockable FF/REW controls; anti-rolling mechanism; LED FM-stereo indicator; lightweight headphones; belt clip. Available in black or red. \$50

JC-130 AM/FM Cassette Player

Features locking fast-forward control; FM-stereo LED indicator; lightweight headphones; belt clip. Uses 2 AA batteries. 3½ x 5½ x 1½ in. \$35

SONY

WM-D6C Cassette Player

Features record and play modes; Dolby B and C noise reduction; disc quartz-lock drive system; stereo mini microphone jack; anti-rolling mechanism; 3-way power supply. Includes headphones, case, and connection cord. Uses 4 AA batteries. 6¾ x 1½ x 3¾ in.; 1 lb, 7 oz. \$400

WM-F701C AM/FM Cassette Player

Features Sony Mega Bass, to enhance low range; Dolby B and C noise reduction; digital synthesis tuning; 10 random station presets; autoreverse; mode selector; direction selector; NiCd rechargeable battery; earpiece style headphones. Includes battery and charger, battery case, plug adaptor, and carry pouch. Uses 1 AA battery. \$280

WM-AF605 AM/FM Cassette Player

Features Sony Mega Bass; digital synthesis tuning; 10 random station presets; channel seek; autoreverse; mode selector; direction selector; NiCd battery and charger. Includes earpiece headphones. 3 x 4½ x 1 in.; 7¾ oz. \$270

WM-D3 Cassette Recorder

Features record and play modes; Dolby B noise reduction; one-point stereo microphone; 5-segment LED peak-level meter; pause; 3-way power supply. Includes case, connection cord, strap, and headphones. Uses 2 AA batteries. \$270

WM-F200MK3 AM/FM Cassette Recorder

Features record and play modes; Sony Mega Bass; Dolby B noise reduction; one-point stereo microphone; autoreverse; mode selector; direction selector; local/DX switch, NiCd rechargeable battery and charger. Includes headphones, battery case, and case. Uses 1 AA battery. \$250

WM-701C Cassette Player

Features Sony Mega Bass; Dolby B and C NR; autoreverse; direction selector; mode selector; NiCd rechargeable battery; Includes headphones, battery and charger, carry pouch, and mini headphone adaptor jack. Uses 1 AA battery. \$220

WM-AF79 AM/FM Cassette Player

Features Sony Mega Bass; Dolby B noise reduction;

water-resistant design; autoreverse. Includes headphones. Uses 2 AA batteries. 4 x 4¾ x ¾ in.; 13.4 oz. \$160

WM-AF604 AM/FM Cassette Player

Features autoreverse; mode selector; Sony Mega Bass; NiCd rechargeable battery; earpiece headphones. Includes battery charger and belt clip. Uses 2 AA batteries. 2¾ x 4¼ x 1 in.; 7.6 oz. \$150

WM-AF67 AM/FM Cassette Player

Features 1-point stereo microphone; Sony Mega Bass; Dolby B noise reduction; autoreverse; 3 FM station presets; LED indicators for battery strength. Includes headphones and belt clip. Uses 2 AA batteries. 3½ x 4¾ x 1½ in.; 9 oz. \$145

WM-F73 AM/FM Cassette Player

Features autoreverse; Dolby B noise reduction; water-resistant design; belt drive system; anti-rolling mechanism; AM/FM tuner; local/distant switch; three-way power supply. Includes headphones and belt clip. Uses 2 AA batteries. 3½ x 5½ x 1¾ in.; 11.2 oz. \$120

WM-AF64 AM/FM Cassette Player

Features preset tuning; Dolby B noise reduction; autoreverse; belt-drive system; anti-rolling mechanism; AM mono and FM stereo reception; local/DX switch. Comes with belt-clip. 4¾ x 3½ x 1½ in.; 8.7 oz. \$100

WM-AF62 AM/FM Cassette Player

Features digital synthesis tuning; 10 random station presets; channel seek; clock and alarm; autoreverse; mode selector; direction selector. Comes with headphones and belt clip. 3¾ x 4¾ x 1¾ in.; 9 oz. \$100

WM-A602 Cassette Player

Features Sony Mega Bass; Dolby B noise reduction; autoreverse; mode selector; direction selector; supplied NiCd rechargeable battery and charger; earpiece headphones. Uses 1 AA battery. 3 x 4¼ x ¾ in.; 6½ oz. \$100

WM-AF59 AM/FM Cassette Player

Features autoreverse; mode selector; direction selector; water-resistant design; two headphone jacks. Includes headphones and belt clip. 3¾ x 5 x 1¾ in.; 11.9 oz. \$90

WM-AF57 AM/FM Cassette Player

Features Sony Mega Bass to enhance low range, autoreverse, mode selector, direction selector, Dolby B noise reduction, local/DX switch. Includes headphones and belt clip. Uses 2 AA batteries. 3¾ x 5 x 1¾ in.; 8.1 oz. \$80

WM-F46 AM/FM Cassette Player

Features record and play modes; stereo mini microphone jack; belt drive system; AM/FM tuner; local/DX switch; 3-way power supply. Includes headphones and belt clip. Uses 2 AA batteries. 3½ x 5½ x 1½ in.; 12.3 oz. \$80

WM-AF58 AM/FM Cassette Player

Features water resistant design; play mode; solar-powered clock and stopwatch. Includes mini headphones and belt clip. Dimensions: 5¾ x 4¾ x 1¾ in. Weight: 12 oz. \$80

WM-AF54 AM/FM Cassette Player

Features water-resistant design; play mode; two headphone jacks. Includes headphones and belt clip. 4 x 5½ x 2 in.; 12.36 oz. \$75

WM-AF50 AM/FM Cassette Player

Features Sony Mega Bass; autoreverse; mode/direction selector; local/DX switch. Includes headphones and belt clip. Uses 2 AA batteries. \$65

WM-A53 Cassette Player

Features autoreverse; mode selector; direction selec-

POCKET • STEREO

tor; headphones. Includes belt clip. Uses 2 AA batteries. 3 7/8 x 5 x 1 1/8 in; 11.3 oz. \$65

WM-A52 Cassette Player

Features solar clock and calculator; play mode; belt-drive system; headphones. Comes with belt clip. 5 1/2 x 4 x 1 1/8 in; 11.3 oz. \$63

SRF-75 AM/FM Radio

Includes Sony Mega Bass; water-resistant design. Includes headphones and belt clip. Uses 2 AAA batteries. 2 3/8 x 4 1/4 x 7/8 in; 3.5 oz. \$60

WM-AF48 AM/FM Cassette Player

Features autoreverse, mode selector, direction selector, local/DX switch. Includes headphones and belt clip. Uses 2 AA rechargeable batteries. 3 3/8 x 5 x 1 3/8 in; 8 oz. \$58

SRF-M50 FM Headphone Radio

Features synthesis FM stereo; water-resistant design; LCD tuning display. Uses 2 AA batteries. 6.5 oz. \$55

WM-AF28 AM/FM Cassette Player

Features rechargeable battery; belt-drive system; AM mono and FM stereo reception; local/DX switch. Comes with belt-clip, battery, and charger. 3 1/2 x 5 1/4 x 1 1/4 in; 8 oz. \$53

WM-AF44 AM/FM Cassette Player

Bass-boost to enhance low range. Features automatic shutoff and local/DX switch. Includes headphones and belt clip. Uses 2 AA batteries. 3 1/2 x 5 3/8 x 1 3/8 in; 8 oz. \$50

WM-AF29 AM/FM Cassette Player

Features automatic shutoff and local/DX switch. Includes headphones, rechargeable battery and charger, and belt clip. Uses 2 AA batteries. 3 1/2 x 5 3/8 x 1 3/8 in; 8 oz. \$50

SRF-M40W AM/FM Radio

Features PLL-synthesis tuner; 7 AM/7 FM station presets; AM mono and FM stereo reception; local/DX switch. Comes with belt-clip. Uses 2 AA batteries. 3 1/4 x 3 1/4 x 1 1/8 in; 6 oz. \$50

SRF-R7 Headphone Radio

Features AM/FM tuner and local/DX switch. Uses 2 AAA batteries. 5 oz. \$40

WM-AF23 AM/FM Cassette Player

Features automatic shutoff and local/DX switch. Includes headphones and belt clip. Uses 2 AA batteries. 3 1/2 x 5 3/8 x 1 1/2 in; 8 oz. \$40

WM-A26 Cassette Player

Features autoreverse. With headphones and belt clip. Uses 2 AA batteries. 3 3/8 x 4 3/8 x 1 3/8 in; 7.8 oz. \$40

WM-A18 Cassette Player

Features play mode; belt-drive system. Comes with belt clip, battery, and charger. 4 3/4 x 3 1/2 x 1 1/4 in; 7.2 oz. \$40

SRF-8 AM/FM Radio

Features water-resistant design; AM/FM LED indicator. Includes headphones and armband. Uses 2 AAA batteries. 2 3/8 x 4 3/8 x 1 1/4 in; 3 1/2 oz. \$40

SRF-R5 AM/FM Headphone Radio

Features local/distant switch. Uses 1 AA battery. 6 oz. \$35

SRF-4 AM/FM Radio

AM/FM radio with water-resistant design and local/DX switch. Includes headphones and holder. Uses 2 AA batteries. 2 1/4 x 4 1/4 x 7/8 in; 3 3/8 oz. \$33

SRF-60 AM/FM Radio

Features Sony Mega Bass; local/DX switch. Includes headphones and belt clip. Uses 2 AAA batteries. 2 3/4 x 4 1/2 x 1 in; 3.9 oz. \$30

SRF-FM2 Headphone Radio

FM-only radio with local/DX switch. Uses 2 AA batteries. 3.6 oz. \$30

WM-A12 Cassette Player

Includes headphones and belt clip. Uses 2 AA batteries. 3 1/2 x 4 7/8 x 1 7/8 in; 7 oz. \$28

SRF-FM1 FM Headphone Radio

FM-only radio features local/DX switch. Uses 1 AA battery. 5.6 oz. \$28

SRF-29 AM/FM Radio

Features local/DX switch. Includes headphones and belt clip. Uses 2 AAA batteries. 2 3/8 x 4 1/8 x 1 1/4 in; 3 oz. \$20

TOSHIBA

KT-4088 AM/FM Cassette Player

AM/FM cassette player with Super Bass. Features autoreverse; wired remote control; Dolby B NR; music quick-start system; earbuds \$230

DT-4088 AM/FM Cassette Player

AM/FM cassette player with wired remote control and autoreverse. Features Dolby B noise reduction; logic control; metal-tape switch; earphones. Uses 1 AA battery. \$230

KT-4978 Cassette Player

Cassette player with Super Bass. Features autoreverse; Dolby B NR; full IC logic wired remote control; anti-rolling mechanism; earbuds with case; uses 1 AA battery. \$190

KT-4078 AM/FM Cassette Player

AM/FM cassette player with autoreverse. Features wired remote control; Dolby B NR; music quick-start system; earbuds \$190

KT-4188 Cassette Player

Mini-size pocket cassette player. Features Super Bass; autoreverse; Dolby B NR; full IC logic wired remote control; anti-rolling mechanism; earbuds with case; uses on AA battery \$180

KT-4868 AM/FM Cassette Player

AM/FM cassette player with autoreverse. Features AC charger; Dolby B noise reduction; headphones; up/down channel selector; 3-band graphic equalizer; carrying cradle \$180

KT-4968 Cassette Player

Mini-size pocket cassette player. Features Dolby B NR; autoreverse; anti-rolling mechanism; earbuds; uses on AA. \$170

KT-4568 AM/FM Cassette Player

AM/FM cassette player. autoreverse. Features digital tuning; Dolby B NR; headphones; up/down channel selector; 3-band graphic EQ; carrying cradle \$170

KT-4549 AM/FM Cassette Player

AM/FM cassette player with digital synthesis tuning and autoreverse. Features 10 presets; 3-band graphic EQ; Dolby B NR; clock and alarm functions; earphones. \$170

KT-4178 Cassette Player

Features wired remote; autoreverse; Dolby B NR; IC logic control; anti-rolling mechanism. Includes earphones and case. Uses 1 AA battery \$170

KT-4087 AM/FM Cassette Recorder

Built in mic for rec; 3 band graphic EQ; autoreverse; Dolby B NR; AM/FM tuner \$160

KT-4058 AM/FM Cassette Recorder

Pocket AM/FM cassette player with detachable stereo mic and Dolby B noise reduction. Features 3-band graphic equalizer; autoreverse; pause switch; headphones. \$160

KT-4168 Cassette Player

Pocket cassette player with autoreverse and Dolby B NR. Features anti-rolling mechanism; metal-tape switch; earphones. Uses 1 AA battery \$150

KT-4059 AM/FM Cassette Recorder

AM/FM cassette player with built-in microphone and autoreverse. Features three-band graphic EQ; anti-rolling mechanism; tape-bias selector; headphones. \$140

KT-4548 AM/FM Cassette Player

Features digital synthesized tuning, 3-band graphic EQ; autoreverse; Dolby B NR; clock and alarm functions; headphones \$130

KT-4848 AM/FM Cassette Player

AM/FM cassette player with three-band graphic equalizer. Features autoreverse; Dolby B noise reduction; headphones; carrying cradle; rechargeable NiCd \$120

KT-4538 AM/FM Cassette Player

AM/FM cassette player digital tuning. Features autoreverse; Dolby B NR; headphones; up/down channel selector; 3-band graphic EQ; carrying cradle; 10 random presets. \$110

KT-4529 AM/FM Radio

Digital quartz-synthesis AM/FM stereo radio with 10 presets. Features clock and alarm; 3-band graphic EQ; earphones \$100

KT-4049 AM/FM Cassette Player

AM/FM cassette player with autoreverse. Features Dolby B noise reduction; 3-band graphic equalizer; anti-rolling mechanism; 3-band graphic EQ. Includes headphones and belt clip. \$90

RP-33 AM/FM Radio

Ultra-small AM/FM radio with earphones. \$80

RP-2068 Headphone Radio

1-piece design headphone/AM/FM radio. Digital tuning with 10 AM 5 FM preset stations; clock and alarm functions \$80

KT-4038 AM/FM Cassette Player

AM/FM cassette player with autoreverse. Features headphones; 3-band graphic EQ; belt clip; anti-rolling mechanism \$80

KT-4039 AM/FM Cassette Player

Pocket AM/FM cassette player with autoreverse. Features anti-roll mechanism; tape-bias selector; headphones. \$80

RP-2046 FM Radio

Ultra-small FM stereo radio with stereo/mono switch. Includes earphones. \$70

RP-2059 AM/FM Radio

AM/FM radio quartz-synthesis tuner. Features 10 presets; clock and alarm; FM stereo/mono switch; headphones included; battery back-up for synthesis tuning \$70

KT-4029 AM/FM Cassette Player

AM/FM cassette player with 3-band graphic EQ. Features headphones; belt clip; EQ \$60

KT-4019 AM/FM Cassette Player

AM/FM cassette player. Features headphones; auto shutoff; belt clip \$50

RP-2038 Headphone Radio

1-piece design headphone AM/FM radio. Features telescoping rod antenna; collapsible. Uses 2 AAA batteries. 4.2 oz \$50

KT-4029 FM Radio

Features 3-band graphic EQ; FM stereo indicator; headphones; belt clip \$40

BLANK • TAPE

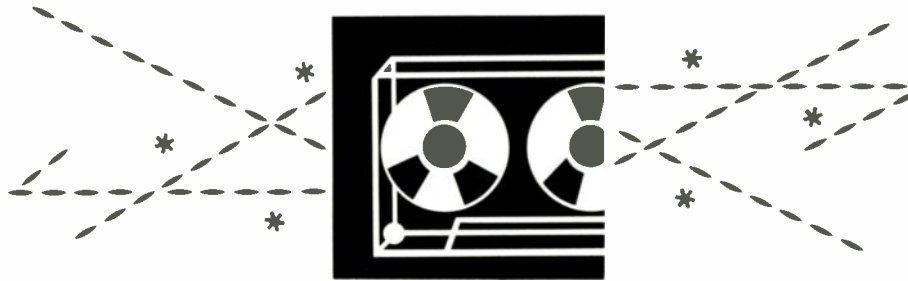

BASF

Digital Audio Tapes

Ultra-fine metallic pigment developed for helical-scan recording.

DAT C120, 120 min	\$11.99
DAT C90, 90 min	\$10.99
DAT C60, 60 min	\$9.99

Metal Maxima IV Cassettes

Metal-particle formulation with high-performance cassette mechanism.

C120, 120 min	\$6.49
---------------------	--------

Chrome Maxima II Cassettes

High-density chrome formulation with high-performance cassette mechanism.

C90, 90 min	\$4.29
C60, 60 min	\$3.29

Chrome Extra II Cassettes

Pure chrome formulation with high-performance cassette mechanism.

C90, 90 min	\$2.99
C60, 60 min	\$2.69

Ferro Maxima I Cassettes

Dual-layered and "micro-coated" with proprietary megadum iron oxide. Provides MOL of almost 4 dB.

C-90, 90 min	\$2.89
C-60, 60 min	\$2.59

Ferro Super I Cassettes

Iron-oxide formulation high-frequency sensitivity for extended frequency response.

C90, 90 min	\$2.54
C60, 60 min	\$1.94

Ferro Extra I Cassettes

Iron-oxide formulation with extended signal-to-noise ratio over the entire frequency range.

C90, 90 min	\$1.69
C60, 60 min	\$1.49

DENON

All Denon cassettes feature lifetime warranty and head-cleaning leader.

High-Density Series

HDM Metal Cassettes

High-stability pure-metal tape formulation uses high-density dispersion technology that yields a residual magnetic flux density of over 3,500 Gauss and a coercivity of 1,200 Oersted.

HDM-100, 100 min	\$5.99
HDM-90, 90 min	\$5.50

HDM-75, 75 min	\$4.99
HDM-60, 60 min	\$4.50

HD8 Metal Cassettes

High-density metal-particle formula uses New High Technorom magnetic pigment to increase residual flux density to 3,000 Gauss yielding an MOL of -4.5 dB at 10 kHz.

HD8-100, 100 min	\$4.99
HD8-90, 90 min	\$4.75
HD8-75, 75 min	\$4.25
HD8-60, 60 min	\$3.75

HD7 High-Bias Cassettes

Type-II formulation with extended high-frequency response and low noise. Residual flux density 1,850 Gauss, MOL -6.5 dB at 10 kHz.

HD7-90, 90 min	\$4.00
HD7-75, 75 min	\$3.50
HD7-60, 60 min	\$3.00

HD6 High-Bias Cassettes

Type-II formulation with extended high-frequency response. Residual flux density 1,700 Gauss, MOL -5.7 dB at 10 kHz.

HD6-100, 100 min	\$3.50
HD6-90, 90 min	\$3.25
HD6-75, 75 min	\$2.75
HD6-60, 60 min	\$2.50

DX Series

DX4 Ferric Normal Cassettes

Type-I formulation with extended FR. Residual flux density 2,000 Gauss, MOL -5.0 dB at 10 kHz.

DX4-90, 90 min	\$4.00
DX4-60, 60 min	\$3.00

DX1 Ferric Normal Cassettes

Low-noise high-output Type-I cassette with high sensitivity and high MOL -7.5 dB at 10 kHz.

DX1-90, 90 min	\$2.25
DX1-60, 60 min	\$1.75

DIC



DIC 120XR

R-DAT Cassettes

Digital audio tapes in a range of lengths are fabricated with densely-packed, ultra fine-grained magnetic metal particles to provide distortion-free sound reproduction.

120XR, 120 min	\$13
90XR, 90 min	\$11
60XR, 60 min	\$10
46XR, 46 min	\$9
30XR, 30 min	\$8
15XR, 15 min	\$6

FUJI

Digital Audio Tape

Super-Fine Metallix ultra-fine metal magnetic particle formulation. For DAT decks.

DAT (R-120), 120 min	\$12.95
DAT (R-90), 90 min	\$11.95
DAT (R-60), 60 min	\$10.95

FR Metal Series Cassettes

Metal tape with 70µsec EQ.

FR (C-90), 90 min	\$5.99
FR (C-60), 60 min	\$5.49

FR-II PRO Series Cassettes

High-bias tape featuring a temperature-resistant cassette shell.

FR-II Pro (C-90), 90 min	\$4.99
FR-II Pro (C-74), 74 min	\$4.79
FR-II Pro (C-60), 60 min	\$4.49

FR-IIx Series Cassettes

High-bias tape with 70-µsec EQ.

FR-IIx (C-90), 90 min	\$3.99
FR-IIx (C-74), 74 min	\$3.79
FR-IIx (C-60), 60 min	\$3.49

DR-II Series Cassettes

High-bias tape with 70-µsec EQ.

DR-II (C-90), 90 min	\$2.99
DR-II (C-60), 60 min	\$2.49

DR-I Series Cassettes

Normal-bias tape with 120-µsec EQ.

DR-I (C-90), 90 min	\$1.99
DR-I (C-60), 60 min	\$1.49

GENERAL ELECTRIC

All GE tapes carry a lifetime warranty.

GE-HO Series

Normal-bias low-noise tape.

5-pack, 90 min	\$4.49
2-pack, 90 min	\$1.49
2-pack, 60 min	\$1.29

BLANK • TAPE

GE-HFX Series

Normal-bias ferric-oxide tape.

2-pack, 90 min	\$1.79
2-pack, 60 min	\$1.59

GE-HBX Series

High-bias cobalt tape.

2-pack, 90 min	\$3.49
----------------------	--------

JVC

F Series

<i>XFIV, Metal tape. Equalization 70 μs.</i>	
C-90	\$4.50
<i>AFII, High-bias tape (CrO₂). Equalization 70 μs.</i>	
C-90	\$2.60
C-60	\$2.35
<i>AFI, Normal-bias tape. Equalization 120 μs.</i>	
C-90	\$2.20
C-60	\$1.80

G1 Normal-Bias Cassette Tape

Coercivity 370 Oe.

C-90, 90 min	\$1.60
C-60, 60 min	\$1.30

LORAN

Pro-DAT Cassettes

Also manufactured to custom lengths with 10-piece order.

Pro-DAT, 120-min	\$10.50
Pro-DAT, 60-min	\$7.50
Pro-DAT, 30-min	\$6
Pro-DAT, 10-min	\$5
Pro-DAT, 5-min	\$4.75

ESQ Series

High bias; extended high-frequency response; polycarbonate shell.

ESQ-90, 90 min	\$4.99
----------------------	--------

High-Bias Series

High bias; extended high frequency response; polycarbonate shell; cobalt-doped magnetic formulation.

HB-90, 90 min	\$3.99
HB-60, 60 min	\$3.49
HB-46, 46 min	\$2.99

MAXELL

Digital Audio Tape

Digital audio tape with Ceramic-Armor metal-particle formulation.

R-120DM, 120 min	\$14.99
R-90DM, 90 min	\$12.99
R-60DM, 60 min	\$10.99
R-46DM, 46 min	\$8.99

MX Metal Cassettes

Metal bias/EQ.

MX-100, 100 min	\$5.99
MX-90, 90 min	\$5.29
MX-60, 60 min	\$4.39

XLII-S Epitaxial Cassettes

High-level bias; 70-μsec EQ.

XLII-S100, 100 min	\$4.99
XLII-S90, 90 min	\$4.39
XLII-S60, 60 min	\$3.59

XL-II Epitaxial Cassettes

Chrome type; high-level bias; 70-μsec EQ.

C-100, 100 min	\$4.39
C-90, 90 min	\$3.99
C-60, 60 min	\$3.29
C-46, 46 min	\$3.29

UD-II Epitaxial Cassettes

High-level bias; 70-μsec EQ.

C-90, 90 min	\$3.29
C-60, 60 min	\$2.49
C-46, 46 min	\$2.49

XLI-S Epitaxial Cassettes

Normal bias; 120-μsec EQ.

XLI-S90, 90 min	\$4.39
XLI-S60, 60 min	\$3.59

UD-II Epitaxial Cassettes

Normal bias; 120-μsec EQ.

C-90, 90 min	\$3.29
C-60, 60 min	\$2.49
C-46, 46 min	\$2.49

Normal-Bias Cassettes

UR-120, 120 min	\$2.79
UR-90, 90 min	\$1.79
UR-46, 46 min	\$1.49
UR-60, 60 min	\$1.49



Maxell MX-100

Open-Reel Tapes

XLI Back-Coated Open-Reel Tapes

XLI 35-180B, 3,600 ft, 10½-in reel	\$35.79
XLI 35-90B, 1,800 ft, 7-in reel	\$12.79

Ultra-Dynamic Open-Reel Tapes

UD35-180, 3,600 ft, 10½-in reel	\$28.39
UD35-90, 1,800 ft, 7-in reel	\$9.19

MEMOREX BY MEMTEK

CDX II High-Bias Cassettes

Metal tape for High bias (Type II) setting, 70-μsec setting.

C-90	\$4.79
------------	--------

HBX II High-Bias Cassettes

High-performance ferric/cobalt tape for use at high-bias 70-μsec setting.

HBX II, High bias C-90	\$3.69
HBX II, (Type II) C-60	\$2.79

HBS II High-Bias Cassettes

Premium tape for high bias 70 μ sec EQ position.

HBS II, High bias C-100	\$2.59
HBS II, High bias C-90	\$2.29
HBS II, (Type II) C-76	\$1.99
HBS II, (Type II) C-60	\$1.79

MRX I Normal-Bias Cassettes

Normal-bias tape. Full lifetime warranty. High-visibility, clear shell.

C-90	\$2.29
C-60	\$1.79

dbx Normal-Bias Cassettes

Normal-bias tapes for all general-purpose voice or music recording. Features high-visibility clear shell.

C-120	\$1.99
C-90	\$1.49
C-60	\$1.19
C-46	\$1.10

NAKAMICHI

ZX Reference Cassette Tapes

Metalloy (metal-particle) formulation for recording on metal-compatible decks only; features ultra-high coercivity and retentivity for improved distortion and MOL; 70-μsec EQ.

ZX-C90, 90 min	\$10
----------------------	------

SX II Reference Cassette Tapes

Double-coated ionized cobalt and ferric-oxide formulation. CrO₂ bias and EQ (70 μsec).

SXII-C90, 90 min	\$8.90
------------------------	--------

SX Reference Cassette Tapes

Single-coated ionized cobalt and ferric-oxide formulation; high coercivity permits use of CrO₂ bias and EQ (70 μsec) for 4 to 5 dB increase in S/N ratio.

SX-C90, 90 min	\$6.50
----------------------	--------

EX II Reference Cassette Tapes

Reference cassette tapes with single-coated ferric-cobalt formulation; same bias and EQ (120 μsec) as EX tape; extra-low noise, high output.

EXII-C90, 90 min	\$6
------------------------	-----

REALISTIC

Cassette Tape

Prices may vary according to quantity purchased, with lower prices for larger quantities.

MIV Type IV Metal Cassette Tape

Fine-grain metal particles; 5-screw housing; hinged storage box.

MIV-90, 90 min	\$4.89
MIV-60, 60 min	\$4.19

MII Metal Type II High-Bias Tape

Metal tape for recording and playback with Type II bias and EQ; head-cleaning leader; hinged storage box.

MII-90, 90 min	\$3.98
MII-60, 60 min	\$3.42

IID III-Definition Chrome-Equivalent

For recording and playback with high-bias Type II bias and EQ; head-cleaning leader; hinged storage box; index card.

IID-90, 90 min	\$3
IID-60, 60 min	\$2.44

XR Type I Premium Ferric Tape

Hinged storage box with index card.

XR-120, 120 min	\$3.49
XR-90, 90 min	\$2.65
XR-60, 60 min	\$1.95
XR-45, 45 min	\$1.81

LN Low-Noise Type I Standard Ferric

Hinged storage box with index card.

LN-120, 120 min	\$2.44
LN-90, 90 min	\$1.95
LN-60, 60 min	\$1.39
LN-30, 30 min	\$1.11

BLANK • TAPE

Concertape Type I Cassettes

C-120, 3-pack; ea 120 min.....	\$4.49
C-90, 3-pack; ea 90 min.....	\$3.23
C-60, 3-pack; ea 60 min.....	\$2.33
C-30, 3-pack; ea 30 min.....	\$1.79
C-90, Single; 90 min.....	\$1.25
C-60, Single; 60 min.....	\$0.88

Open-Reel Tape

Supertape premium polyester base tape.

5-in reel; 900 ft; 1.0 mil; 1-9 tapes.....	\$3.99 ea
5-in reel; 900 ft; 1.0 mil; 10+ tapes.....	\$3.19 ea
7-in reel; 1,200 ft; 1.5 mil; 1-9 tapes.....	\$5.99 ea
7-in reel; 1,200 ft; 1.5 mil; 10+ tapes.....	\$4.79 ea
7-in reel; 1,800 ft; 1.0 mil; 1-9 tapes.....	\$6.99 ea
7-in reel; 1,800 ft; 1.0 mil; 10+ tapes.....	\$5.59 ea
7-in reel; 3,600 ft; 0.5 mil; 1-9 tapes.....	\$12.99 ea
7-in reel; 3,600 ft; 0.5 mil; 10+ tapes.....	\$10.39 ea
Concertape, Polyester Base, 7-in reel; 1,800 ft; 1.0 mil.....	\$2.99 ea

8-Track Cartridges

Low noise polyester base tape; 40 min.

1-11 cartridges.....	\$2.59 ea
12-24 cartridges.....	\$2.33 ea
25-49 cartridges.....	\$2.07 ea
50+ cartridges.....	\$1.81 ea

Low noise polyester base tape; 80 min.

1-11 cartridges.....	\$3.39 ea
12-24 cartridges.....	\$3.05 ea
25-49 cartridges.....	\$2.71 ea
50+ cartridges.....	\$2.37 ea

RECOTON

Gold Series

Low noise; normal bias; sold in 10 packs.

XR-90, 90 min.....	\$13.99/pk
--------------------	------------

SX Series

Sold in 2 packs.

SA-90, 90 min.....	\$4.49/pk
--------------------	-----------

SONY

ES Metal Cassette

Type-IV position (70 μ sec EQ).

ES-90, 90 min.....	\$9.99
--------------------	--------

UX Series Cassettes

Type-II position (70 μ sec EQ).

UX-Pro, C-90.....	\$7.99
UX-Pro, C-60.....	\$5.99
UX-ES, C-90.....	\$5.49
UX-ES, C-60.....	\$3.99
UX-S, C-90.....	\$3.99
UX, C-90.....	\$3.29
UX-S, C-60.....	\$2.99
UX, C-60.....	\$2.49

HF-S Series Cassettes

Type-I position (normal bias, 120 microsecond equalization).

HF-S 90, 90 min.....	\$2.69
HF-S 60, 60 min.....	\$1.99

HF Series Cassettes

Type-I (normal bias, 120- μ sec EQ).

HF 120, 120 min.....	\$2.99
HF 90, 90 min.....	\$2.29
HF 60, 60 min.....	\$1.79

HF 46, 46 min.....	\$1.49
--------------------	--------

TDK

MA-XG Metal-Alloy (Type IV) Cassette Tape

Metal bias cassette tape; 70 μ sec EQ; 3-layer RS-II vibration-damping mechanism to eliminate sympathetic vibrations.

MA-XG 90, 90 min.....	\$9.25
MA-XG 60, 60 min.....	\$7

MA-X Metal-Alloy (Type IV) Cassette Tape

Metal bias; 70- μ sec EQ; 2-layer plastic mechanism; improved Finavinx formulation designed for higher output level and wider dynamic range.

MA-X 90, 90 min.....	\$5
MA-X 60, 60 min.....	\$4.25
MA-X 46, 46 min.....	\$4.25

MA Metal-Alloy (Type IV) Cassette Tape

Metal bias; 70- μ sec EQ; unified two-layer shell.

MA-110, 110 min.....	\$5.25
MA-90, 90 min.....	\$5
MA-60, 60 min.....	\$3.50

SA-XG High-Bias (Type I) Cassette Tape

RS-II cassette mechanism; Super Avilyn formulation.

SA-XG 90, 90 min.....	\$8.75
SA-XG 60, 60 min.....	\$6.50

SA-X High-Bias (Type II) Cassette Tape

Dual-layer anti-resonance mechanism; dual-coated Super-Avilyn formulation; 70- μ sec EQ.

SA-X 90, 90 min.....	\$3.50
SA-X 60, 60 min.....	\$3
SA-X 46, 46 min.....	\$3

SA High-Bias (Type II) Cassette Tape

Low-resonance two-layer cassette mechanism.

SA 100, 100 min.....	\$4
SA 90, 90 min.....	\$3
SA 76, 76 min.....	\$2.75
SA 60, 60 min.....	\$2.50
SA 46, 46 min.....	\$2.50

SD High-Bias (Type II) Cassette Tape

Low-resonance cassette shell. 70- μ sec EQ.

SD 90, 90 min.....	\$2.50
SD 60, 60 min.....	\$2.25
SD 46, 46 min.....	\$2.25

AR-X Normal-Bias (Type I) Cassette Tape

Dual-coated Avilyn formulation; two-layer, low-resonance cassette shell. 120- μ sec EQ.

AR-X 90, 90 min.....	\$3
AR-X 60, 60 min.....	\$2.50

AR Normal-Bias (Type I) Cassette Tape

NP Ferric magnetic particles; low-resonance multi-face joint shell. 120- μ sec EQ.

AR-100, 100 min.....	\$3.50
AR-90, 90 min.....	\$2.75
AR-60, 60 min.....	\$2.50

AD Normal-Bias (Type I) Cassette Tape

Linear ferric-oxide particles; low-resonance multi-face joint shell. 120- μ sec EQ.

AD-90, 90 min.....	\$2.50
AD-60, 60 min.....	\$2.50

D Cassette Tape

Normal bias; 120-sec EQ; precision mechanism.

D-120, 120 min.....	\$2.50
D-90, 90 min.....	\$2

D-60, 60 min.....	\$1.75
D-46, 46 min.....	\$1.60
D-30, 30 min.....	\$1.50

DA Digital Audio Tape Cassettes

Super Finavinx pure-metal particle formulation digital audio cassette tape with TDC (Three Dimensional Compound) binder.

DA-R120, 120 min.....	\$14
DA-R90, 90 min.....	\$12
DA-R60, 60 min.....	\$10

3M

Black Watch Series

Metal Audio Cassette Tape

4040, 100 min.....	\$9
4040, 76 min.....	\$7

High-Bias Audio Tape

2020, 100 min.....	\$6
2020, 76 min.....	\$4

DAT Cassette

7707 (DT-120), 120 min.....	\$20
-----------------------------	------

Open-Reel Studio Mastering Tape

227 (1.0 mil), 3,600 ft.....	\$25
226 (1.5 mil), 2,500 ft.....	\$20
227 (1.0 mil), 1,800 ft.....	\$15
226 (1.5 mil), 1,200 ft.....	\$10

VISA BY INTERWORLD ELECTRONICS INC.

UCX-II-S High-Tech Turbo

High-bias cassette tape with ultra-refined chromium dioxide coating and special housing.

90 min.....	\$7.49
60 min.....	\$5.99

UCX-II High-Tech Turbo

High-bias cassette tape.

90 min.....	\$6.99
60 min.....	\$5.99

UFX-I High-Tech Turbo

Ferric cassette tape with clear housing.

90 min.....	\$5.99
60 min.....	\$4.49

CX-II Professional Tape

High-bias cassette tape.

90 min.....	\$6.99
60 min.....	\$5.49

FDX-I Professional Tape

Ferric cassette tape.

90 min.....	\$5.99
60 min.....	\$4.49

Extra Performance II Tape

High-bias cassette tape.

90 min.....	\$5.49
60 min.....	\$4.29

High Performance I Tape

Ferric cassette tape with iron dioxide coating.

90 min.....	\$3.99
60 min.....	\$2.99

8mm HI-BAND CAMCORDERS

HI-FI STEREO CAMCORDERS



- AUTHORIZED DEALER for:**
- CANON
 - GE
 - HITACHI
 - JVC
 - KYOCERA
 - MINOLTA
 - PANASONIC
 - OLYMPUS
 - RCA
 - RICOH
 - YASHICA
 - MUCH MORE!

MOST POPULAR FEATURES —

- SUPER VHS 8:1 ZOOM w/FLYING ERASE HEAD **\$1099**
INCLUDES ALL ACCESSORIES
- SUPER VHS FULL SIZE TIME/DATE 8x ZOOM **\$1299**
w/ DIGITAL EFFECTS
- 8mm SPECIAL EFFECTS 420 PIX. SLOW MO. **\$950**
HI-FI. 1:2000 SHUT

- VHS-C 6:1 ZOOM 5 LUX FLY ERASE **\$599**
- 8mm 4 LUX ERASE HI-FI SOUND **\$749**
- VHS FULL-SIZE CAM TIME/DATE 6:1 ZOOM **\$699**
- VHS FULL-SIZE CAM TIME/DATE 1 ZOOM **\$850**
- VHS 8:1 ZOOM FLY ERASE w/CH GEN **\$950**
w/BUILT-IN LIGHT **\$998**

**INCLUDES
— ALL —
ACCESSORIES**

BEST VALUE:

- PANASONIC PV530
- PANASONIC PV520
- CANON H460
- OLYMPUS VXS405KU
- CANON E808
- RCA CC320
- JVC GRS707
- JVC GR60U
- CANON A1
- RICOH R800H

SUPER PRICE REDUCTIONS:

- MINOLTA 881
- CANON E708
- HITACHI VM5200
- RCA CC310
- GE GE9825
- RICOH R850
- CANON E44C
- CANON E80
- JVC GRS77
- PV460

SUPER VHS CAMCORDERS



JVC GRS707

**VCR's - VHS & BETA
8mm**



- PANASONIC 4 HD VHS **\$359**
w/FLY ERASE HD
- QUASAR 4+2 HD Hi-Fi ST MTS **\$349**
- SUPER VHS Hi-Fi MTS **\$469**
- 4+2 SUPER VHS Hi-Fi MTS **\$649**
SUPER & FLY ERASE
- 4+2 SUPER VHS Hi-Fi MTS **\$899**
DIGITAL w/FLY ERASE
- VHS RECORDER **\$200**
- BETA DECK **\$275**
- AC/DC VHS PLAYER **\$198**
- 8mm & STEREO PCM Hi-Fi PORT. **\$599**
- 8mm PLAYER **\$349**

**SPECIAL EFFECT
& CHARACTER GEN.
EDITING PROCESSOR**



- NEWMARK VIDEO MIX JVC **\$350**
- GEN LOCK JKS55 **Call**
- NEWMARK VAM2003 Digital Dissolv. **Call**
- SANSUI VX99 **Call**
- AZDEN or NADY Wireless Mics
- SONY SBV1000 SELECTOR VIDEO (Professional MULTI-VIDEO IN & OUT)

**SUN PAK
VIDEO
LIGHT**



- CV150 **\$88** • C/300 **\$99.00**
- NP77 **\$68** • P3120 8mm SONY **\$650**
- SUPER VHS TAPE (T120) **\$10.00**

**TV's
20" REMOTE
COLOR TV
MTS STEREO
\$299**

- 40" PNP HI-RESOLUTION **\$1695**
STEREO
- SUPER VHS 30" TV **\$995**

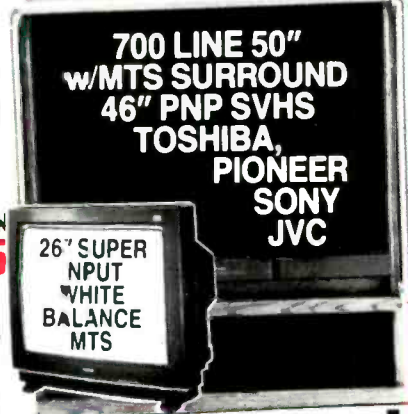

**700 LINE 50"
w/MTS SURROUND
46" PNP SVHS
TOSHIBA,
PIONEER
SONY
JVC**

AUDIO HI-FI RECEIVERS



LASER DISC COMPACT DISC

**CAR STEREO
— CALL TOLL FREE —
& RADAR DETECTORS**



FAX MACHINES

- TOSHIBA 3300 **\$739**
 - TOSHIBA 3700 **\$1049**
- CALL FOR OTHER MODELS AVAILABLE:
**CANON • SHARP
PANASONIC**

FOR MORE INFO, Call: (201) 696-6531

WE WILL MATCH OR BEAT ANY LEGITIMATE PRICE
Please call only for brand names seen in this ad.

Call Toll-Free: **1 (800) 444-6300**
Orders: **1 (800) 247-4654**

We ship within 24 hours. All prices quoted included manufacturer's standard accessories & U.S. Warranty. All units are factory sealed. Shipping & handling extra. Not responsible for typographical errors. S&H non-refundable.



AUDIO GLOSSARY

Note: Words in italics are defined elsewhere in the glossary.

AC (alternating current): The current available from the power outlets in American homes; it alternates direction sixty times a second.

acoustic-suspension: A type of *infinite-baffle speaker* that uses the air pressure inside a sealed speaker box to control driver motion.

AM (amplitude modulation): A *band of radio frequencies* that carries information by changing the strength of the *signal*. Most AM broadcasts are in *mono*, but many stations are adding equipment to broadcast *stereo* AM programs. You must have an *AM-stereo tuner* to receive them in stereo.

AM rejection (AM rej): A measurement of a *tuner's* ability to suppress changes in a *signal's* amplitude caused by *multipath* and other types of interference; higher figures are better.

amplifier: A separate component, or a section built into an integrated component, that strengthens the electrical *signal* (increases its amplitude). A *power amplifier* must be connected to a *preamplifier* (or "control amplifier") to switch and process the sound. An *integrated amplifier* combines power-amplifier and preamplifier functions in the same unit; a *receiver* adds an *AM/FM tuner* to that configuration.

analog: Type of audio component or recording medium that operates with *signals* whose waveforms are directly analogous to the sounds they represent; see *digital*.

antenna: A metallic wire or rod that receives radio or television broadcast *signals* over the air and sends them to a *tuner* for processing.

automatic turntable: One that sets the *stylus* onto a *record* to begin play and removes it at the end of play without the user having to touch the tonearm.

autoreverse: A feature of some *cassette decks* that allows them to play or record both sides of a *cassette* without the user having to turn it over manually.

AUX (auxiliary): An input jack found on some *receivers*, *integrated amplifiers*, and *preamplifiers* that can be used to connect *source* components such as a *CD player* but not *turntables*, which require special *phono* inputs.

azimuth: The angle between the actual recorded information and the edge of the audio tape. While the azimuth angle is theoretically set at 90 degrees, azimuth often varies from one tape deck to another.

balance: A control found on some *receivers*, *integrated amplifiers*, and *preamplifiers* that changes the relative *volume* of the left and right *channels*.

band: A particular segment of a *frequency spectrum*. For example, a *graphic equalizer* may divide the audio frequency spectrum into ten bands, with one control to adjust the relative volume of each band. The *AM* and *FM* bands are distinct parts of the *RF (radio frequency)* spectrum.

bass: The lower *frequencies* in the audio spectrum, such as those produced by a string bass or bass guitar. An instrument producing bass tones vibrates air more slowly than one producing *treble* tones.

bass reflex: A type of *speaker* system that has an opening, called a *vent* or *port*, in its enclosure so that the sounds produced by the backward motion of the bass *driver(s)* reinforce those produced by their forward motion, which come out of the front.

belt drive: A method of rotating the platter of a *turntable* by means of a belt that connects the turntable's motor to the platter.

bias: A very high-frequency *signal*

added to an audio signal being recorded on tape to reduce *distortion*. Type I (normal or ferric) tape requires less bias than Type II (chrome or chrome-equivalent) or Type IV (metal) tape.

cantilever: The rod or tube in a *phono cartridge* that supports the *stylus* and transfers its motion to the cartridge's signal-generating elements.

capstan: A rotating shaft in a tape recorder that pulls the tape across the *heads*. The tape usually travels between the capstan and the pinch-roller. A dual-capstan machine has two capstans; see *closed-loop*.

capture ratio: An important *specification* for an *FM tuner*, it indicates the minimum ratio between the strengths of two *FM signals* at the same *frequency* that enables the tuner to suppress the weaker signal by 30 *dB*. Smaller numbers indicate better performance.

cardioid: A heart-shaped polar response of a *microphone* that is sensitive to sounds arriving from the front and sides.

cartridge (phono cartridge): A small component mounted on the end of the *tonearm* in a *turntable*; it holds the *stylus*, which vibrates in the *record groove*. The cartridge converts the vibrations into a changing electrical current, or audio *signal*.

cassette: A kind of magnetic-tape cartridge containing two reels.

cassette deck: An *analog* component that uses standard-size audio *cassettes* for recording and playback; also known as a tape deck. Audio *signals* are recorded onto, or played back from, the magnetic tape contained in the cassette; see *heads*.

CD (compact disc): A 4.8-inch plastic-coated, metalized disc that stores up to 80 minutes of *digitally* recorded music. The non recordable disc contains microscopic pits that are read by

an optical laser pickup in a *compact disc player*. Each pit contains digitally encoded audio information.

CD (compact disc) player: A *digital* audio component based on the *PCM* recording system that plays back *compact discs*. Unlike *turntables*, which play back *vinyl records*, a CD player has no *stylus* and therefore makes no contact with the disc. Rather, a laser mechanism optically reads information contained on the CD.

CD-3 (CD single): A 3-inch *CD* that stores twenty minutes of *digitally* recorded music; akin to the 45-rpm single.

CD video (CDV): A *compact disc* that combines up to twenty minutes of *digital* audio with approximately five minutes of video. CDV's are gold-colored to distinguish them from silver-colored, audio-only CD's.

channel: A distinct path for an audio signal. *Stereo* signals consist of two channels, left and right, which are sent to left and right *speakers* (or headphones), respectively (see *separation*). A *surround-sound* system adds one or more additional channels, usually for the rear. *Mono* (or *monophonic*) signals have only one channel.

closed-loop: A drive system used in tape decks in which the tape is pulled by dual *capstans*, one on either side of the *heads*, so the part of the tape being played or recorded is held taut and fully isolated from the hubs.

compliance: A measurement of how easily the *stylus* of a *phono cartridge* can be moved by the grooves of a *record*. A high-compliance cartridge has a more flexible stylus than a low-compliance cartridge.

crossover (crossover network): A circuit that divides lower-frequency sounds from higher-frequency ones. A crossover is used in a *speaker* that has more than one *driver*. In a two-way speaker system, the crossover sends the low frequencies to the *woofer* and the high frequencies to the *tweeter*. Crossovers are also available as separate components.

crossover frequency (crossover point): In a *crossover network*, the frequency at which audio signals are divided so they can be routed to the appropriate

driver (low frequencies to a *woofer* and high frequencies to a *tweeter*, for example).

damping: The application of mechanical resistance, such as a rubber or silicone material, to the *cantilever* pivot of a *phono cartridge* to reduce the amplitude of a resonance; also applied in *speakers*.

DAT (digital audio tape): A *cassette* that is about half the size of a standard audio cassette. The cassette shell houses a reel of magnetic tape that contains *digitally* encoded audio information.

DAT (digital audio tape) deck: A *digital* recording/playback component that is based on the *PCM* recording system. Digitally encoded audio information is recorded onto, and retrieved from, magnetic tape. DAT recorders use a transport mechanism similar to ones found in VCR's.

dB (decibel): The common unit used to measure the *volume* of sound or an electrical signal that represents sound (also called loudness or amplitude). The decibel is a logarithmic ratio of two power levels. When *sound-pressure level (SPL)* is measured in decibels, for example, a whisper is about 40 dB and a jet engine about 120 dB. The decibel scale is logarithmic, meaning that an increase of 10 dB represents a tenfold increase in power: it takes ten times as much energy to produce an SPL of 80 dB as one of 70 dB, even though 80 dB is subjectively only twice as loud as 70 dB. Doubling the power raises the SPL by about 3 dB; cutting the power in half reduces the volume about 3 dB. Doubling or halving the volume results in an SPL change of about 10 dB.

dBf: One *decibel* referred to a standard power level of one femtowatt (one quadrillionth of a *watt*).

dbx: Ordinarily, a *noise-reduction* system—more precisely known as dbx II—developed by the dbx company and used in some *cassette decks*. This system reduces the *dynamic range* of the audio signal during recording, making the soft parts of the music louder and the loud parts softer. During playback, the processing is reversed, restoring the original dynamic range and reducing the *noise* added by the tape. The dbx I system is

used in professional studio tape recorders. Another type of dbx noise reduction is used in the *MTS* stereo-TV broadcasting system.

DC (direct current): Electricity that flows in one direction only; see *AC* (*alternating current*).

de-emphasis: A form of *equalization* used in *FM tuners* that is complementary to a pre-emphasis used in transmission. The purpose is to improve the overall *S/N* (*signal-to-noise ratio*), while maintaining a uniform *frequency response*. Some *compact discs* also are processed with a *frequency pre-emphasis*; these discs automatically engage de-emphasis circuits in the player.

defeat: To bypass a *signal-processing* feature, removing it entirely from the circuit. *Tone controls* are sometimes accompanied by a tone-defeat switch, which enables the user to eliminate their effects without changing their settings, allowing easy comparisons of the sound with and without tone-control modifications.

digital: A digit is a number, and digital components use numbers in some way. A *digital tuner*, for example, may only use numbers on its front-panel display or it may use digital-synthesis tuning circuits for improved reception. *Compact discs* contain a pattern representing a series of binary numbers (strings of ones and zeros); a *CD player* converts these numbers into a continuously changing current that represents the sound of the master recording. *Digital audio tape (DAT)* recorders turn *analog* input signals into binary numbers and record these on tape; for playback, the numbers are read from the tape and converted into an analog signal.

dipole: A type of *speaker* that radiates as much sound from its rear as from its front but with opposite polarity.

dipole antenna: A type of *antenna* that receives radio broadcasts from two directions. A T-shaped, folded dipole antenna is often supplied when you buy a *tuner* or *receiver*.

direct-drive: A method of rotating a *turntable* platter by using the motor shaft as the platter spindle.

dispersion: The spread of a *speaker's*

high-frequency output, measured in degrees.

distortion: An unwanted alteration in an audio signal; also see *THD* (total harmonic distortion), *noise*, and *IM* (intermodulation distortion).

dither: Very low-level noise added to a signal being digitized to reduce the high-order distortion caused by quantizing very low-level audio signals. See *quantization*.

Dolby B and Dolby C: Noise-reduction (NR) systems designed and licensed by Dolby Laboratories for use in consumer tape recorders. These encode/decode systems work by making high-frequency sounds softer during recording and louder during playback. Dolby C is more effective than Dolby B, but Dolby B is more common.

Dolby HX Pro: A special circuit for tape recorders—the HX stands for headroom extension—that lowers the amount of bias added during recording when the signal being recorded already has a lot of high frequencies. This allows high frequencies to be recorded at higher levels with less distortion.

Dolby Surround: A system developed for movie theaters, now available in some signal processors, preamplifiers, integrated amplifiers, and receivers, that adds two more audio channels (center-front and rear) to the ordinary stereo channels. To derive the extra channels, a decoder adds the left- and right-channel signals together for the center-front channel and subtracts them from each other for the rear channel, usually sent to two rear speakers.

driver: Any individual speaker within a system, such as a woofer or tweeter.

dubbing: The process of making a recording of another recording. A dubbing cassette deck can record from one tape in one transport to another in a second transport. Dubbing can be done with two single-transport decks or one dual-transport deck.

dynamic range: The difference, in decibels (dB), between the softest and the loudest possible sounds that a component can produce. Higher ratings are better because they indicate that the component can more accu-

rately reproduce the full dynamics of recorded music played through it.

effective mass: A measurement of how a tonearm resists motion. Tonearms must move freely to follow the groove of a record, and lighter tonearms usually perform this task better than heavy ones.

efficiency: The percentage of the electrical input power to a speaker that is converted to acoustic energy. Usually specified for speakers, an efficiency measurement can be helpful when matching an amplifier to a particular speaker. Speaker efficiency can range from a fraction of 1 percent to as much as 10 percent or more. Note that efficiency indicates nothing about sound quality, only quantity of acoustic energy for a given input power.

electrostatic: Speakers and headphones that produce sound by moving a flat diaphragm suspended in a high-voltage electrical field.

elliptical stylus: A stylus whose cross section, as seen from above, is an ellipse placed across the record groove. This type of stylus traces the finer high-frequency modulations of a record groove more accurately than a spherical stylus.

EQ (equalization): The process of changing the relative volume levels of different segments of the audio frequency spectrum to compensate for losses or distortion at some stage of recording or reproduction. For instance, the output from speakers can be equalized to compensate for room acoustics. Phono signals require a specific type of playback equalization because of the equalization built into the process of cutting a record.

equalizer: A component, or part of a component, that is used to equalize (see EQ) an audio signal received from a source component by dividing the signal into various separately adjustable bands. The most common type is the graphic equalizer, whose sliding controls make a rough graph of the selected frequency changes.

expander: A device used to restore natural dynamic range. This is achieved by counteracting the compression of dynamic range that occurs when recordings are made and when a signal is broadcast.

50-dB quieting sensitivity: A tuner spec measuring the level of an incoming stereo or mono FM signal that's required to produce a background-noise level of -50 dB; lower figures are better.

filter: A circuit that removes or attenuates a specific part of an audio signal. A subsonic (or infrasonic) filter removes low frequencies. Some cassette decks have MPX filters to remove the 19,000-Hz stereo pilot tone from FM broadcasts. Tone controls and equalizers are adjustable filters.

flutter: A wavering sound caused by abrupt changes in the speed of electro-mechanical components such as turntables and cassette decks. Expressed as a percentage of variation from the correct speed, flutter measurements are combined with wow measurements in a single wow-and-flutter (W&F) spec. Lower figures are better.

FM (frequency modulation): A type of radio broadcasting that carries audio information by changing the frequency of the broadcast signal. An FM station with a center frequency of 88.1 MHz will actually broadcast a signal that changes from slightly less than 88.1 MHz to slightly more according to the waveform being broadcast.

frequency: How often something vibrates or changes. Sounds are vibrations and can be represented by electrical signals that change at different rates; a low-pitched sound is represented by a slowly changing current, a high-pitched sound by a quickly changing current. Frequency is measured in cycles per second, or hertz (abbreviated Hz). Most people can hear notes as low as 20 Hz and as high as 15,000 or 20,000 Hz. In radio, frequency refers to the wavelength of the carrier signal of the station, such as 88.1 MHz for an FM station or 1,010 kHz for an AM station.

frequency balance: The relative volume of different segments of the audio frequency range, from bass to treble.

frequency response: This important specification indicates how evenly a component reproduces different frequencies. A typical spec might be 20 to 20,000 Hz \pm 3 dB, which means that the component will reproduce sounds as low as 20 Hz and as high as 20,000 Hz, and all those in between, not more

than 3 dB too loud or too soft. If a frequency-response specification does not include a tolerance (the plus-or-minus decibel figure), it is essentially meaningless.

graphic equalizer: see *equalizer*.

head amp: see *MC (moving-coil)*.

heads: The parts of a tape deck that impose a magnetic pattern on a tape (for recording) or detect one that is already there (playback). Most audio decks also have another head for erasing tapes, or randomizing the magnetic pattern on the tape so that a new one can be recorded. The heads of *analog* recorders are stationary, but those of *digital audio tape (DAT)* decks rotate like the helical heads in VCR's.

HX Pro: see *Dolby HX Pro*.

Hz (hertz): The standard unit of *frequency*, named after the German physicist Heinrich Hertz. Measurements in hertz represent cycles per second—that is, changes away from a basic state and back again. In audio, the basic state is defined either as ordinary air pressure (without sound) or its electrical equivalent (a zero-level *signal*).

IF (intermediate frequency) rejection: The ability of a superheterodyne *AM* or *FM* tuner's IF circuits to reject external interference at the intermediate *frequency*.

image rejection: The ability of a *tuner* to ignore *signals* removed from the desired *frequency* by twice the intermediate *frequency* (10.7 *MHz* in home *FM* receivers, 455 *kHz* in home *AM* receivers).

IM (intermodulation distortion): When a two-tone test *signal* is used, distortion components appear at *frequencies* that are sums and differences of multiples of the input *frequencies*. Their magnitude is expressed as IM, which is more distressing to the ear than *THD (total harmonic distortion)*. As with all types of distortion, lower figures are better.

impedance (imp): Measurement, in *ohms*, of the total opposition (resistance and reactance) that a component has to electrical power; usually found in discussions of speakers.

infinite-baffle: A type of *speaker* where the back wave produced by the *driver* is prevented from interfering with the front wave, usually by placing the driver in a sealed enclosure. See *acoustic-suspension*.

infrared: A part of the electromagnetic spectrum that is invisible to the human eye. Infrared *frequencies* are used by wireless remote controls to send *signals* to the components they control.

integrated amplifier: A component that performs the functions of both a *preamplifier* and a *power amplifier*.

isolation: The separation between a structure and everything surrounding it; usually in reference to *turntable tonearms* and platters.

kHz (kilohertz): 1,000 *Hz*.

LaserDisc: Pioneer's trademark for a laser-read videodisc system. (Other videodisc formats are no longer available in the U.S.) LaserDisc players are similar to *CD (compact disc) players*; combination units that play both kinds of discs as well as *CD videos* are available.

LCD (liquid-crystal display): A type of electronic readout that does not generate its own light and, therefore, uses very little power.

LED (light-emitting diode): An electronic readout that produces light; used as indicators on components.

linear-tracking tonearm: A type of *tonearm* that moves in a straight line across the radius of a record; see *pivoted tonearm*.

logic: In *cassette decks*, the ability to switch from one transport function, such as fast forward, to another, such as rewind, without first pressing the stop button; doing this in decks without logic controls can damage the tape. In a *surround-sound* system, logic circuits are used to process encoded *signals*.

loudness compensation: A form of *equalization* that progressively emphasizes low *frequencies* (and sometimes high *frequencies*) as *volume* is reduced. Loudness-compensation circuits, which appear in some *preamplifiers* and *receivers*, compensate for the

human ear's loss of *sensitivity* as the sound level decreases.

magnetic cartridge: A *phono cartridge* that generates an audio *signal* from the relative motions of a magnetic field and a coil or coils. The output is proportionate to the velocity of the *stylus* motion. See *MC (moving coil)* and *MM (moving magnet)*.

matrix: Circuits in *surround-sound* processors that can synthesize a rear *channel* for ambience even if the original recording consists only of left and right *stereo* channels.

MC (moving-coil): A type of *phono cartridge* in which the magnets are stationary and the coils where the *signal* is generated move in response to the motions of the *stylus* in the record groove. Some MC cartridges produce very little current, and their output must be amplified to standard levels by a "head amp" or *pre-preamplifier* before further processing by a *phono-preamplifier* section.

MHz (megahertz): One million *Hz*.

microphone: An electroacoustic pick-up device that converts acoustical energy—such as live music or a voice—into an electrical *signal* that is essentially equivalent in shape and amplitude to the acoustical input.

midbass: The segment of the audio *frequency* spectrum covering sounds produced in the upper *bass* and lower *midrange* region; special midbass *drivers* can be used to reproduce these frequencies.

midrange: The segment of the audio *frequency* spectrum between the *bass* and *treble* frequencies. The midrange includes most voices and the fundamental tones produced by most musical instruments. Midrange *drivers* reproduce sounds in this frequency range.

MM (moving magnet): The most common type of phonograph *cartridge*. A moving-magnet cartridge has magnets attached to the interior end of its *cantilever*. The *stylus* motion causes these magnets to move near coils of wire, generating an electric current representing the audio *signal*.

mono (or monophonic): An audio *signal* in which all the information is

combined in one *channel*; also, a component that handles only one channel, such as a mono *amplifier* (used in pairs for *stereo* programs).

MPX (multiplex): A method of combining two or more *signals* into one. Some tape decks have an *MPX filter* that removes the 19,000 Hz pilot tone from *stereo FM* broadcasts.

MTS (multichannel television sound): The encode/decode system devised by Zenith and dbx for *stereo TV* broadcasting in the United States. An MTS decoder, which may be built into an audio or video component, receives *stereo* broadcasts and produces *stereo signals* from them. See *SAP*.

multipath: A condition that occurs when a broadcast radio *signal* reaches the *antenna* over two or more paths of different lengths. The result is interference that causes *distortion* and a loss of *stereo channel separation*.

mV (millivolt): One thousandth of a volt.

μs (microsecond): One millionth of a second.

μV (microvolt): One millionth of a volt.

noise: An unwanted part of a processed *signal* that is not related to the original signal. Audio noise usually sounds like hiss.

NR (noise reduction): A system designed to reduce the *noise* added to an *audio signal* during recording. See *dbx* and *Dolby*.

ohm: The basic unit of *impedance*.

output level: A measure of how strong a *signal* produced by a component is, usually in relation to the strength of the signal put into it.

oversampling: A *digital filtering* technique used in some *compact disc players*. The 44.1-kHz *signal* from the *CD* is sampled at some multiple of that *frequency* (usually two or four times), which raises the frequencies of any spurious *signals* created by the *digital* recording process well above the audio range. The spurious signals are then removed by an *analog filter* with a gentle slope, which is said to cause fewer phase irregularities than

the sharp-cutoff filter required when oversampling isn't used.

passive radiator: An unpowered *speaker* assembly that is placed in the *port* of a vented enclosure system to produce a more uniform sound wave. Also called a "drone cone" or "slave cone."

PCM (pulse-code modulation): A system of recording that encodes an *audio signal* in a series of binary numbers (ones and zeros). *Compact disc players*, *digital audio tape (DAT) decks*, and *digital signal processors* all use PCM encoding.

peak indicator: Usually a flashing *LED* on a tape recorder that indicates when transient *signal* levels have exceeded the recorder's ability to handle them without *distortion*; a supplement to *recording-level meters*.

peak-reading meter: A *recording-level meter* that rises rapidly and declines at a moderate speed so the user can judge the levels of transient peak waveforms.

phono: Abbreviation for "phonograph"; refers to the low-level *signals* produced by a *phono cartridge* and to the phono input where a *turntable* is connected to a *preamplifier*, *integrated amplifier*, or *receiver*. Phono inputs use *RCA connectors*, sometimes called phono plugs.

piezoelectric (cartridge): A *phono cartridge* with a ceramic, crystal, or electret generating element that produces electricity when bent, twisted, or stressed. The cartridge's *output*, which can be fairly high, is proportionate to the amplitude of the *stylus* motion, rather than *stylus* velocity. See *magnetic cartridge*.

piezoelectric speaker: A speaker principle used in some *tweeters* that employs a ceramic element which expands or bends when fed a signal voltage. This deflection generates sound.

pivoted tonearm: The most common type of *tonearm*, it swivels on a fixed point so that the *cartridge* it holds can track the *record groove* from edge to center along a shallow arc. See *linear-tracking tonearm*.

PLL (phase-locked loop): A type of

tuner circuit that improves reception of radio broadcasts by locking the received *frequency* to a synthesized reference frequency, which is usually generated by a quartz crystal.

P-mount: A standardized type of *phono cartridge* that plugs into a specific kind of *tonearm*; it requires no adjustment or calibration.

port: An opening in a *bass-reflex* speaker system that allows the sound wave from the back of a *driver* to reinforce the sound wave from the front, also called a vent.

power amplifier: A component that takes the *audio signal* from a *preamplifier* and makes it strong enough to drive *speakers*.

preamplifier: A component that switches and processes *audio signals* from source components. Typically, preamplifiers amplify only the low-level *phono* signals from *turntables* (more precisely, from *phono cartridges*), raising them to the same level as signals from other source components (called "line level") and applying the necessary *RIAA equalization*.

preset: On a *tuner* or *receiver*, a memory position where the *frequency* of a selected radio station can be entered for instant recall.

programming: The process of entering in instructions for a component to carry out at a later time. For instance, many *compact disc players* can be programmed to play selected tracks in any order.

quantization: In a *digital audio signal*, the number of possible values available to represent various levels of amplitude. In a *CD (compact disc)* system, the resolution of the quantization is 16 bits, which means that each sample can have any value between zero and 65,535. Higher figures are better because they allow for more accuracy. See *sampling frequency*.

quartz-synthesis: See *PLL*.

random access: The ability to go directly to the beginning of a song, track, or program without having to scan the intervening material; the process is usually initiated using numbered buttons on a component's front panel or remote control.

RCA connector: The most common kind of connector for home audio systems, using small, one-pin *phono* plugs. The cables usually come in pairs, with the right *channel* marked in red and the left channel in black, gray, or white.

receiver: An audio component that performs three basic functions: receiving radio broadcasts, switching and processing audio *signals*, and amplifying the selected signal so it can drive *speakers*.

record: A 12-inch vinyl disc, also known as an LP or long-playing record, with intricate grooves that contain analog audio information. By vibrating in these grooves, the *stylus* of a *phono cartridge* converts mechanical information into a usable audio *signal* that can be amplified and sent to a pair of *speakers*. Seven-inch vinyl discs are called 45-rpm records, or singles.

recording-level meter: An indicator on a tape recorder that displays the signal levels being recorded onto tape from moment to moment; used to set proper recording levels.

RF (radio-frequency): The very high-frequency *signals* used to broadcast radio programs.

RFI (radio-frequency interference): Noise created in audio systems by interference from strong, nearby radio broadcasts.

RIAA: The Recording Industry Association of America, which has set standards for the equalization used on phonograph records. Every record has reduced *bass* and boosted *treble*, and these characteristics must be compensated for during playback by the *phono preamplifier*.

ribbon speaker: A form of high-frequency *driver* using a light ribbon suspended in a magnetic field that generates sound when current is passed through it.

rms (root mean square): A common method of averaging power measurements.

rpm: Revolutions per minute.

rumble: A measurement of how much motor noise is transmitted through a

turntable to the *cartridge*. Lower figures are better.

sampling frequency (or rate): In digital audio, the number of times a signal is sampled each second. The standard sampling rate for the *CD (compact disc)* format is 44.1 *kHz*, which means each second of sound is encoded by 44,100 numbers for each channel. Higher sampling rates are better because they can record higher frequencies.

SAP (separate audio program): A separate *mono channel* that is broadcast along with the two *stereo* channels in the *MTS* system for stereo TV. The *SAP* channel can be used for various purposes, such as providing an alternative soundtrack in a language different from that used on the primary channels.

saturation: A condition that occurs when an audio tape becomes fully magnetized and an increase in *signal* input level does not produce a corresponding increase in recorded level. Saturation also can occur in the magnetic structure of the tape *heads*.

scan: A *tuner* feature used to move quickly from one broadcast station to another, stopping on each *frequency* for a few seconds so the user can sample it. On *compact disc players*, the scan feature is used to move around quickly within a track, much like fast forward on a tape deck.

selectivity (sel): A *specification* that tells how well a *tuner* or *receiver* can differentiate between the selected broadcast *channel* and other stations using nearby *frequencies*. Adjacent-channel selectivity (adj-ch sel) measures rejection of signals from stations broadcasting on either side of the selected station; alternate-channel selectivity (alt-ch sel) measures rejection of signals from stations two channels away from the desired one. Higher numbers are better for both of these specifications.

semiautomatic turntable: A kind that lifts the *tonearm* from the *record* automatically at the end of a side; the *stylus* must be set onto the record by hand, however.

sensitivity (sens): A measurement used for *speakers* that tells how much sound is produced 1 meter away from

the speaker with an input of 2.83 volts (1 *watt* into 8 *ohms*). Higher numbers are better.

separation: The difference, measured in *decibels (dB)*, between the left and right *channels* of an audio *signal*, indicating the amount of leakage between channels in a component. Higher figures are better.

servo control: A technique that forces the speed or position of a moving device into conformity with a desired speed or position. The speed of a servo-controlled *turntable* is established by a precision voltage or *frequency* standard to which it is compared. Automatic adjustments are made to minimize differences and ensure the correct *rpm*.

signal: An electrical current that is modulated (changed) to represent audio information.

S/N (signal-to-noise ratio): Measured in *decibels (dB)*, the difference in level between the loudest possible *signal* a component can produce and its residual *noise*. Higher figures are better.

source: The program *signal* that is being recorded or played back. Components (*turntables*, *cassette decks*, *compact disc players*, etc.) provide program signals either by playing a recorded program (*LP's*, *tapes*, *CD's*) or receiving a broadcast program (*tuners* and *receivers*).

specification (spec): A numerical measurement of a component's performance as provided by the manufacturer.

speaker (or loudspeaker): A component—typically conical in shape—that accepts audio *signals* from a *receiver* or *amplifier* and converts them into sound waves. Also called a *driver*.

spherical stylus: A *stylus* whose shape is conical; typically used in cheaper *cartridges*. The downward-facing point of the cone, which vibrates in the *record* groove, is rounded to a specified radius of curvature. See *elliptical*.

SPL (sound-pressure level): A measurement of acoustic energy, usually encountered in the *sensitivity* rating of a *speaker*. See *dB*.

stereo: The use of at least two separate *channels* (signal paths) to create the illusion that music is being produced in the space between, and even beyond, a pair of *speakers*.

stylus: The needle-shaped material, usually diamond, at the end of the *cantilever* of a *phono cartridge*; it vibrates in record grooves, providing the cartridge with the energy needed to produce audio *signals*.

subwoofer: A separate *speaker* designed to reproduce only *bass frequencies*. Subwoofer systems sometimes contain an *amplifier* and *crossover*.

supertweeter: A *tweeter* used to reproduce only extremely high *frequencies*; usually found in four- or five-way *speaker* systems.

surround sound: See *Dolby Surround*.

tape monitor: A switch on a tape recorder that allows the user to listen to a tape as it is being recorded to insure proper recording; also may allow external *signal* processors to be used.

THD (total harmonic distortion): The percentage of an audio *signal* that consists of harmonics, or multiples of the fundamental *frequencies*. These harmonics are introduced by an *amplifier* or other component in its handling of the original signal. Lower figures are better.

tonearm: The cylindrical rod on a *turntable* that supports the *phono cartridge*. See *pivoted tonearm* and *linear-tracking tonearm*.

tracking: The ability of a *CD player* or *phono cartridge* to follow the pattern recorded on a *CD* or vinyl *record*.

tracking error: In playing a *record*, the *tonearm* should hold the *cartridge* as perpendicular to the record's surface as possible. Tracking error is expressed as the number of degrees away from perpendicular.

tracking force: The pressure of a *stylus* on a *record*, measured in grams.

transport: The parts of a tape deck that move the tape, including the motor(s), hubs, *capstan*(s), pinch-roller(s), and other mechanisms. In a *CD player* or *turntable*, the transport

system rotates the *CD* or *record*.

treble: The upper part of the audio spectrum; see *bass* and *midrange*.

tuner: A component that receives radio *signals* from an *antenna* and allows the user to select a station.

turntable: Also known as a *phonograph* or *record player*, a turntable rotates vinyl records; see *cartridge* and *stylus*.

tweeter: A driver in a *speaker* system that is designed to reproduce *treble* sounds (high *frequencies*).

two-way, three-way: Refers to the number of *frequency* bands a *speaker* system's *output* is divided into. A two-way system has a *woofer* and a *tweeter*; a three-way system adds a *midrange* speaker to that configuration.

usable sensitivity: The minimum level of *mono* input *signal* required for a *tuner* to produce a satisfactory output

signal, one with no more than 3 percent combined *noise* and *distortion*; lower figures are better.

volume: Usually expressed in *decibels* (dB), the strength of a sound wave or audio *signal*.

W/ch (watts per channel): A *specification* that indicates how much power an *amplifier* or *receiver* will deliver to each of a pair of *speakers*.

W&F (wow-and-flutter): A *specification* indicating the speed accuracy of mechanical components such as *turntables* and *cassette decks*. Lower figures are better. See *wow* and *flutter*.

woofer: A driver in a *speaker* system designed to reproduce the low, or *bass*, part of the audio *frequency* spectrum.

wow: A measurement of slow speed variations; usually combined with *flutter*, a measurement of fast speed variations. Lower figures are better.

ABBREVIATIONS

AC—alternating current	Electronic Engineers	μ —micro (one millionth)
A/D—analogue to digital	IF—intermediate frequency	NAB—National Association of Broadcasters
AFC—automatic frequency control	IHF—Institute of High Fidelity	nWb—nano Weber
alt-ch—alternate channel amplifier	IM—intermodulation (distortion)	NR—noise reduction
CD—compact disc	imp—impedance	PCM—pulse-code modulation
CIRC—cross interleave Reed-Solomon code	ips—inches per second	pF—picofarads
CrO ₂ —chromium dioxide	k—one thousand	PLL—phase-locked loop
D/A—digital to analog	kHz—kilohertz (one thousand cycles per second)	P-P—peak-to-peak, push pull
DAT—digital audio tape	LCD—liquid-crystal display	RF—radio frequency
dB—decibel	LED—light-emitting diode	RIAA—Recording Industry Association of America
dBf—decibel femtowatt	L/R—left/right	rms—root mean square
DC—direct current	LSI—large-scale integrated (circuit)	RPM—revolutions per minute
EE—extra efficiency	Mb/sec—megabits per second	sel—selectivity
EFM—eight-to-fourteen modulation	MC—moving coil	sens—sensitivity
EIA—Electronic Industries Association	MM—moving magnet	sep—separation
EIAJ—Electronic Industries Association of Japan	MNOS—metallic nitrogen-oxide semiconductor	SMPTE—Society of Motion Picture and Television Engineers
EQ—equalization	MOL—maximum output level	S/N—signal-to-noise ratio
F—farad	MOSFET—metal-oxide semiconductor FET	SPL—sound-pressure level
FeCr—ferrichrome	MPX—multiplex	THD—total harmonic distortion
FET—field-effect transistor	MSB—most significant bit	TIM—transient intermodulation
FR—frequency response	m—meter (as in SPL/W/m)	V—volt(s)
g—gram(s)	m—milli (one thousandth, as in msec)	VU—volume unit
HD—harmonic distortion	mH—millihenry	W—watt(s)
HX—headroom extension	mm—millimeter	W&F—wow and flutter
Hz—hertz (cycles per second)	ms—millisecond	Wb—Weber
IC—integrated circuit	mV—millivolt	wrms—weighted root mean square
IEC—International Electrotechnical Commission	mW—milliwatt	wtd—weighted
IEEE—Institute of Electrical		

WDS

"A CUT ABOVE THE REST"

DISCONTSIN EST. 1954
STEREO
 2417 W. Badger Road
 Madison, WI 53713
 1-800-271-6889
 SOME ITEMS CLOSEOUTS

VHS



JVC HRD620 ... SPECIAL
 Oak-Cut DA-4 Head System

JVC HRD520 ... SPECIAL
 Dual Screen Programming

SONY SLV50 ... SPECIAL
 DAA Head, PIP, Flying Erase

VHS MTS HIFI ... \$349
 SPECIAL PURCHASE



CANON A1 ... SPECIAL
 HiBit 8 mm

SONY CCD70 ... SPECIAL
 Call for Sony Camcorders

JVC GR35 ... SPECIAL
 Best VHS-C Camcorder

HITACHI VM5200 ... SPECIAL
 Audio Monitor, 6X Zoom

CAMCORDER



SONY D2 ... \$159
 Sony Quality

SONY D160 ... CALL
 Home and Car Discman

SONY D25 ... CALL
 Mega Bass Circuit

TOSHIBA XR9458 ... \$249
 Wired + Wireless Remote

SONY D9 ... \$194
 Mega Bass Circuit



SHARP GFC055 ... \$228
 Detachable Speakers

JVC PCV300 ... SPECIAL
 BEST CD Portable

SHARP WFC077 ... \$389
 Wireless Remote Dual Decks

SONY D454 ... \$239
 5 Band EO with AMS

JVC RCX3 ... SPECIAL
 Dubbing Cassette Decks



SAE D102 ... \$289
 4X Oversampling, Remote

JVC XLM701 ... SPECIAL
 6 + 1 Stacker, Best Buy

10 DISC STACKER ... \$379
 32 Track Programming

JVC XL2611 ... SPECIAL
 18 Bit, 4X, Digital Outputs

JVC XLV211 ... SPECIAL
 Dual 18 Bit, 4X, 3 Inch Rebay



PIONEER CLD1070 ... \$499
 Combination CD Player

JVC XLM401 ... CALL
 6 Disc Stacker

MAGNAVOX CD3000 SPECIAL
 6 Disc, 4X, and Dual D/A's

TEAC PD700 ... \$249
 6 Disc, 4X, Dual D/A's

JVC XLM300 ... SPECIAL
 6 Disc Stacker



JVC RX701 ... SPECIAL
 70 Wts/Ch REC

SAE A202 ... \$229
 100 Wt/Ch AMP

SAE P102 ... \$239
 Computer Direct Line PREAMP

SAE A502 ... \$389
 200 Wt/Ch AMP

SAE T102 ... \$174
 Computer Direct Line Tuner

SHERWOOD S2770H ... \$225
 74 Wts/Ch REC

JVC RX501 ... SPECIAL
 60 Wt/Ch REC

JVC RX801 ... SPECIAL
 100 Wt/Ch REC

JVC RX901 ... SPECIAL
 120 Wt/Ch REC

PROTON 940 ... SPECIAL
 DPD Circuitry REC

CASSETTE DECKS



SAE C102 ... \$249
 2 Motor, Dolby B + C

TEAC V670X ... \$259
 3-Head, Dolby B/C/HX PRO

JVC TDV711 ... SPECIAL
 3-Head, Dolby B/C/HX PRO

TEAC V285CHX ... \$97
 Dolby B/C/HX PRO

JVC TDR421 ... CALL
 Dolby B/C/HX Pro, A/R

JVC TDW801 ... SPECIAL
 Dubbing Auto Reverse REC/PLAY

TEAC V570X ... \$189
 Dolby B/C/HX PRO

TEAC W660 ... \$297
 Dubbing Auto Reverse REC/PLAY

JVC UDW501 ... SPECIAL
 Dolby B/C with Auto Reverse

JVC TDV621 ... SPECIAL
 3-Head, Dolby B/C/HX PRO

REC/AMP/PREAMP



ALPHASONIC PMA2050 ... CALL
 50 Wts/Ch, 100 Wts Mono

CLARION SE9350 ... \$87.99
 6 X 9 Three Way

JVC CSX6936 ... SPECIAL
 135 Wts., 6 X 9 Three Way

HYLE KP6940 ... SPECIAL
 High Power 6 X 9 Two Way

PYLE P201 ... SPECIAL
 The Pounder - Box Speaker

CAR SPEAKERS/AMPS



CELESTION DL10 II ... SPECIAL
 One of the Best Bright 10" 3-Ways

CELESTION DL12 II ... SPECIAL
 Floor Standing Tower

RECOTON 100's ... \$189 set
 Wireless Add-on Speakers

CELESTION DL8 II ... SPECIAL
 British 8" 2-Way Bookshelf

Design Acc PS-30 ... \$399
 Subwoofer System

CAR STEREO



SHERWOOD CRD350 ... \$179
 DIN with Dolby B/C

CLARION 8671 ... \$199
 Removable DIN, A/R

CLARION 8730 ... \$189
 DIN, Dolby, Radio/Tape Switch

JVC KSR490 ... SPECIAL
 Removable Din, A/R

CLARION 5630 ... SPECIAL
 AM/FM CD Player

CAR STEREO



CLARION 8302 SPECIAL
 12FM/6AM, A/R, Scan

JVC KSBX1010 SPECIAL
 High Power, Dolby, CD Input

CLARION 9700 ... \$199
 High Power, Dolby, A/R

SHERWOOD CRD210 ... \$149
 Dolby B/C, CD Inputs

CLARION 9770 ... \$239
 Removable DIN, Dolby

MISCELLANEOUS



KOSS JCK300S ... \$199
 Wireless Headphones

JVC PCV77 ... SPECIAL
 Portable Boom Box

CASIO WIZARD SPECIAL
 Pocket Computer

SONY MDRV6 ... \$72
 Professional Headphones

MAXELL MX90 \$29.95 cs
 Metal Audio Tapes

MISCELLANEOUS



SONY MDR1FSK ... \$165
 Wireless Headphones

DUAL CS5000 ... SPECIAL
 Walnut Base Turntable

UNIDEN RD9 ... \$115
 Radar Detector

SONY WMF100III ... \$119
 Walkman

AUDIOSOURCE SS2 \$189
 Dolby Surround with Remote

TV'S



SONY XBR SERIES SPECIAL
 We Carry Most Models

JVC AV3587 ... SPECIAL
 BEST 35" TV Made

PIONEER SDP502 ... SPECIAL
 50" Projection TV

JVC AV2759 ... SPECIAL
 BEST 27" Made

JVC C1329 ... SPECIAL
 13" Monitor/Receiver

SUPER VHS



JVC HRS8000 ... SPECIAL
 Digital Special Effects

JVC HRS5000 ... SPECIAL
 Special Effects Playback, HiFi

HITACHI VT3800A ... SPECIAL
 5+2 Head MTS HiFi

TOSHIBA SV970 SPECIAL
 Full Digital Effects, HQ PRO

SPECIALS ON 1990 MODELS
 GE, RCA, HITACHI, JVC, + MORE

WDS Rated #1 for SERVICE and PRICE

Guaranteed Low Price 10-Day Return

★ We get the BEST volume discounts
 ★ LOW OVERHEAD—To sell at best discounts
 ★ We shop the competition to ensure the best price

Buyer Protection Plan—FREE

★ Returns accepted within 10 days (must be called in for prior authorization). Products must be in original condition. Returns subject to restocking fee. Shipping and handling not refundable.

★ 30-DAY GUARANTEED NO LEMON
 ★ EVERY PRODUCT BRAND NEW—FULL WARRANTY

1-800-356-9514

IF YOU FIND A BETTER PRICE — CALL US



PHONE HOURS
 M-F 8 a.m. - 8 p.m.
 SAT 8 a.m. - 5:30 p.m.
 SUN 11 a.m. - 5 p.m.
 Central Time Zone

CALL US TOLL FREE
 • For expert recommendations
 • For product information
 • TO ORDER PRODUCT

DIRECTORY OF MANUFACTURERS

Accuphase (see Madrigal)

Ace Audio

532 5th St.
East Northport, NY 11731
(516) 757-8990

Acoustat

613 S. Rockford Dr.
Tempe, AZ 85281
(602) 967-3565

Acoustic Interface

Box 6632
Santa Barbara, CA 93160
(805) 964-0247

Acoustic Research

330 Turnpike St.
Canton, MA 02021
(617) 821-2300

Acoustic Sciences

385 Lawrence, P.O. Box 1189
Eugene, OR 97440
(503) 343-9727

ACR

125 Warner St., Groton, CT 06340
(203) 868-1652

ADA (See Audio Design Assoc.)

ADC

707 E. Evelyn Ave.
Sunnyvale, CA 94086
(408) 720-9800

Adcom

11 Elkins Rd.
East Brunswick, NJ 08816
(201) 390-1130

a/d/s/

One Progress Way
Wilmington, MA 01887
(508) 658-5100

Advent

25 Tri-State Int'l Office Center Ste. 400
Lincolnshire, IL 60069
(800) 323-0707

Aiwa

35 Oxford Dr.
Moonachie, NJ 07074
(201) 440-5220

AKG Acoustics

77 Selleck St., Stamford, CT 06902
(203) 348-2121

Alaron

185 Park St., P.O. Box 550
Troy, MI 48099
(313) 585-8400

Allison Acoustics

1590 Concord Ave.
Framingham, MA 01701
(617) 237-2670

Allsop

4201 Meridian St., P.O. Box 23
Bellingham, WA 98227
(800) 426-4303

Altec Lansing

Rt. 6 & Rt. 209
Milford, PA 18337
(717) 296-4434

Ambria (see Parasound)

American Acoustics

One Mitek Plaza
Winslow, IL 61089
(815) 367-3000

Analog One

Box 7202, St. Paul, MN 55107
(612) 649-0632

Analogic Design Group

Box 6227, High Point, NC 27262
(919) 884-7394

Angstrom Associates

290 Larkin St., Buffalo, NY 14220
(800) 387-8193

R.B. Annis

1101 N. Delaware St.
Indianapolis, IN 46202
(317) 637-9282

Apature (see ACR)

Aphex Systems

11068 Randall St.
Sun Valley, CA 91352
(818) 767-2929

Apogee Acoustics

35 York Ave., Randolph, MA 02368
(617) 963-0124

Arcam

Box 381
Highland Lakes, NJ 07422
(201) 764-8958

ATC Loudspeaker Tech.

231 Elwood Dr.
Rochester, NY 14616
(716) 865-9938

Audio By Van Alstine

2202 River Hills Dr.
Burnsville, MN 55337
(612) 890-3517

Audio Concepts

901 S. Fourth St., La Crosse, WI 54601
(608) 784-4570

Audio Control

22313 70th Ave. West
Mountlake Terrace, WA 98043
(206) 775-8461

Audio Design Associates (ADA)

602-610 Mamaroneck Ave.
White Plains, NY 10605
(914) 949-9595

Audio Products International

3641 McNicoll Ave.
Scarborough, Ontario, Canada
M1X 1G5
(416) 321-1800

Audio Research

6801 Shingle Creek Parkway
Minneapolis, MN 55430
(612) 566-7570

Audio-Technica

1221 Commerce Dr.
Stow, OH 44224
(216) 686-2600

Audiocon (see T + A Elektroakustik)

Audi-Quest/LiveWire

Box 3060
San Clemente, CA 92672
(714) 498-2770

AudioSource

1327 N. Carolan Ave.
Burlingame, CA 94010
(415) 348-8114

Axiom Audio

Box 82, Hwy. #60
Dwight, Ont. CAN, POA 1
(705) 635-2222

Azden

147 New Hyde Park Rd.
Franklin Square, NY 11010
(516) 328-7500

B&K Components

1971 Abbott Rd.
Lackawanna, NY 14218
(716) 822-8488

B&W of America

Box 653
Buffalo, NY 14240
(416) 751-4520

Bang & Olufsen

1150 Feehanville Dr.
Mount Prospect, IL 60056
(312) 299-9380

BASF

Crosby Dr.
Bedford, MA 01730
(617) 271-4000

Bedini

13410 Sayre St.
Sylmar, CA 91342
(818) 367-7922

Belden

Box 1980
Richmond, IN 47375
(800) 235-3364

Belles Research

1237 E. Main St.
Rochester, NY 14609
(716) 482-8850

Bennington Hart

427-3 Amherst, Ste. 423
Nashua, NH 03061
(603) 886-9554

Berning

11007 Candlelight Lane
Potomac, MD 20854
(301) 299-8970

Beyer Dynamic

5-05 Burns Ave.
Hicksville, NY 11801
(516) 935-8000

Bib

10497 Centennial Rd.
Littleton, CO 80127
(303) 972-0410

BIC America

895-E Hampshire Rd.
Stow, OH 44224
(216) 928-8392

The Boothe Company

P.O. Box 6184
Honolulu, HI 96818
(808) 422-8764

Bose

The Mountain
Framingham, MA 01701
(508) 879-7330

Boston Acoustics

70 Broadway
Lynnfield, MA 01940
(617) 592-9000

Boulder Amplifiers

4850 Sterling Dr.
Boulder, CO 80301
(303) 449-8220

Bretford

9715 Soreng Ave.
Schiller Park, IL 60176
(312) 678-2545

Bryston

57 Westmore Dr.,
Rexdale, Ontario, Canada
M9V 3Y6,
(416) 764-1800

BSM (see Laser Speakers)

Buff Staff

P.O. Box 43128
Upper Montclair, NJ 07043
(201) 509-9355

Bush

One Mason Dr.
Jamestown, NY 14702
(716) 665-2000

California Audio Labs

7231 Garden Cove Blvd., Ste. #E and F
Garden Cove, CA 92641
(714) 894-9747

Cambridge Audio
89 Doug Brown Way
Holliston, MA 01746
(617) 429-6706

Cambridge Physics
Fisk Mill Complex, Box 192
Marlboro, NH 03455
(603) 352-7163

Cambridge Soundworks
154 California St.
Newton, MA 02158
(800) 252-4434

Canton
915 Washington Ave. South
Minneapolis, MN 55415
(612) 333-1150

Carrera
1230 Calle Suerte
Camarillo, CA 93010
(805) 987-1312

Carry Disc
(see Music & Sound Imports)

Carter Craft
Box 5185
Rockford, IL 61125
(815) 963-2100

Carver
P.O. Box 1237
Lynnwood, WA 98046
(206) 775-1202

Case Logic
6930 Winchester Cir.
Boulder, CO 80301
(800) 447-4848

Celestion
89 Doug Brown Way
Holliston, MA 01746
(508) 429-6706

Cello
315 Peck St.
New Haven, CT 06513
(203) 865-1237

Cerca
5830 S. Triangle Dr.
Commerce, CA 90040
(213) 721-1168

Cerwin-Vega
555 E. Easy St.
Simi Valley, CA 93065
(805) 584-9332

Chapman Sound
Box 18123
Seattle, WA 98118
(206) 526-8647

Citizen
2020 Santa Monica Blvd., Suite 410
Los Angeles, CA 90064
(213) 550-0961

Classe Audio
9414 Cote de Liesse Rd.
Lachine, Quebec, Canada
H8T 1A1
(514) 636-6384

clearaudio
P.O. Box 7028
Westlake Village, CA 91359
(818) 889-9828

Clements
76th St. Clair Ave. W. 4th Fl.
Toronto, Ontario, Canada
M4V 1N2;
(416) 967-1622

Clik Case (see Outer Circle Products)

Conrad-Johnson
2800R Dorr Ave.
Fairfax, VA 22031
(703) 698-8581

Convergent Audio Technology
24 Falcon Dr.
West Henrietta, NY 14586
(716) 359-2700

Counterpoint
2610 Commerce Dr.
Vista, CA 92083
(619) 598-9090

Creative Point
4045 Clipper Ct.
Fremont, CA 94538
(415) 659-8222

Creek (see Music Hall)

Crown
19300 S. Susana Rd.
Compton, CA 90221
(213) 639-5055

Crown International
1718 West Mishawaka Rd.
Elkhart, IN 46517
(219) 294-8000

Custom Woodwork & Design
5200 West 73rd St.
Bedford Park, IL 60638
(312) 563-1745

D'Ascanio Audio
11450 Overseas Highway
Marathon, FL 33050
(305) 743-7130

Dahlquist
601 Old Willets Path
Hauppauge, NY 11788
(516) 234-5757

Dana Audio
Box 1
Austin, TX 78767
(512) 251-7701

Davidson-Roth
Box 95707
Hoffman Estates, IL 60195
(312) 843-1797

dB Plus
135 Torbay Rd., Markham
Ontario, Canada, L3R 1G7
(416) 475-0050

DB Systems
Box 460
Rindge Center, NH 03461
(603) 899-5121

dBritton Audio Systems
3 West 22 Ave.
Vancouver, BC, Canada
V5Y 2E9
(604) 874-5277

dbx
707 Evelyn Ave.
Sunnyvale, CA 94086
(408) 720-9800

DCM
670 Airport Blvd.
Ann Arbor, MI 48108
(313) 994-8481

Delaware Acoustics
Box 54
Newark, DE 19711
(302) 652-8578

Dennesen Electrostatics
715 Hale St.
Beverly, MA 01915
(508) 927-2521

Denon
222 New Rd.
Parsippany, NJ 07054
(201) 575-7810

Design Acoustics
1225 Commerce Dr.
Stow, OH 44224
(216) 686-2600

Desktop Loudspeaker Systems
Downtown Underground #549
3150 Mercier St.
Kansas City, MO 64111
(816) 231-1983

D.G. Industries
7740 Lemona Ave.
Van Nuys, CA 91405
(818) 787-0311

DIC Digital
2 University Plaza
Hackensack, NJ 07601
(201) 487-4605

Digitrac (see Ortofon)

Discrete Technology
3395 Long Beach Rd.
Oceanside, NY 11572
(516) 764-1121

Discwasher
4310 Transworld Rd.
Schiller Park, IL 60176
(312) 678-9600

Dual (see Ortofon)

D.W. Electrochemical
9005 Leslie St., Unit 106
Richmond Hill, Ont., Canada
L4B 1G7;
(416) 889-1522

Electrocompaniet
(see Music & Sound Imports)

Electronic Specialists
171 South Main St.
Natick, MA 01760
(508) 655-1532

Emerson
One Emerson Lane
North Bergen, NJ 07047
(201) 854-6600

Eminent Technology
225 East Palmer St.
Tallahassee, FL 32301
(904) 575-5655

Energy
135 Torbay Rd., Markham
Ontario Canada, L3R 1
(416) 475-0050

Epicure Products (EPI)
25 Hale St.
Newburyport, MA 01950
(508) 462-1000

Epoch (see Stanton)

Epos (see Music Hall)

Esoteric Audio
R.R. 3, Box 262
Winder, GA 30680
(404) 867-6300

ESS
2575 El Presidio St.
Long Beach, CA 90810
(213) 537-2037

Expressive Technologies
Box 46161
Bedford, OH 44146
(508) 429-8911

Fisher
21350 Lassen St. Box 2329
Chatsworth, CA 91311
(818) 998-7322

Focus Speaker Systems
1101 East Seconic St.
Dayton, OH 45403
(513) 222-3946

Forte Audio (see Threshold)

Fosgate-Audionics
Box 70
Heber City, UT 84032
(801) 654-4046

Fostex
15431 Blackburn Ave.
Norwalk, CA 90650
(213) 921-1112

Fried
7616 City Line Ave.
Philadelphia, PA 19151
(215) 473-7474

Fuji
555 Taxter Rd.
Elmsford, NY 10523
(914) 789-8100

Funai
100 North St.
Teterboro, NJ 07608
(201) 288-2606

GC Electronics
P.O. Box 1209
Rockford, IL 61105
(815) 968-9661

General Electric
P.O. Box 1976
Indianapolis, IN 46206
(317) 267-5000

Geneva
9909 South Shore Dr.
Plymouth, MN 55441
(612) 546-5620

Gold Sound
P.O. Box 141
Englewood, CO 80151
(303) 761-5310

GoldStar
1050 Wall St. West
Lyndhurst, NJ 07071
(201) 460-8870

Goodmans of England
1225 17th St., Ste. 1430
Denver, CO 80202
(303) 293-9737

Grado
4617 Seventh Ave.
Brooklyn, NY 11220
(212) 435-5340

Gusdorf
11440 Lackland Rd.
St. Louis, MO 63146
(314) 567-5249

Guss Enterprises
215 West 92nd St.
New York, NY 10025
(212) 580-7401

Hafler
613 S. Rockford Dr.
Tempe, AZ 85281
(602) 967-3565

Harman Kardon
240 Crossways Park West
Woodbury, NY 11797
(516) 496-3400

Hartley Products
1200 North 23rd St., Suite 105
Wilmington, NC 28405
(919) 763-7422

Heath
Hilltop Rd.
St. Joseph, MI 49085
(616) 982-5642

Heybrook (see D'Asconio)

Hi-Pro-Tech
Box 1357
Lansdale, PA 19446
(215) 822-2114

Hitachi
401 West Artesia Blvd.
Compton, CA 90220
(213) 537-8383

Illbruck
5155 E. River Rd., NE, Suite 413
Minneapolis, MN 55421
(612) 521-3555

Image
3641 McNicoll Ave.
Scarborough, Ontario, Canada
M1X 1G5
(416) 321-1800

Infinity
9409 Owensmouth Ave.
Chatsworth, CA 91311
(818) 709-9400

Innovative Concepts
1705 Junction Ct., Ste. 160
San Jose, CA 95112
(408) 436-1777

Integra (see dBritton)

International Components
105 Maxess Rd.
Melville, NY 11747
(516) 293-1500

Interworld Electronics
3095 N.W. 77th Ave.
Miami, FL 33122
(800) 333-0665

Jamo
425 Huehl Rd., Bldg 3A
Northbrook, IL 60062
(312) 498-4648

JBL
240 Crossways Park West
Woodbury, NY 11797
(516) 496-3400

Jensen
4136 N. United Parkway
Schiller Park, IL 60176
(312) 671-5680

JPW Loudspeakers
4632 Crossroads Dr.
Liverpool, NY 13088
(315) 451-5721

JRM
3716 Broadway NE
Knoxville, TN 37917
(615) 688-6501

J.S. Engineering
519 East Middle Turnpike
Manchester, CT 06040
(203) 643-2160

JVC
41 Slater Dr.
Elmwood Park, NJ 07407
(201) 794-3900

Kalimar
622 Goddard Ave.
Chesterfield, MO 63005
(800) 325-4099

KEF
14120-K Sullyfield Circle
Chantilly, VA 22021
(703) 818-3028

Kenwood
Box 22745
Long Beach, CA 90801
(213) 639-9000

Keystone
417 Temple Rd.
Monaca, PA 15061
(412) 375-9203

Kindel Audio
32992 Calle Perfecto
San Juan Capistrano, CA 92675
(714) 661-7321

Kinergetics
6029 Reseda Blvd.
Tarzana, CA 91356
(818) 345-2851

Kinetic Audio
Box 31075
Chicago, IL 60631
(312) 625-9322

Kirksaeter
4648 Evansdale Rd.
Woodbridge, VA 22193
(703) 680-5548

KLH
11131 Dora St., P.O. Box 1085
Sun Valley, CA 91352
(213) 875-0480

Klipsch
Box 688
Hope, AR 71801
(501) 777-6751

Klyne Audio Arts
828 7th Ave. S.E.
Olympia, WA 98501
(206) 943-5420

Koss
4129 N. Port Washington Ave.
Milwaukee, WI 53212
(414) 964-5000

Krell Digital
20 North Plains Industrial Rd. Ste. 12
Wallingford, CT 06492
(203) 294-1213

Laser Speakers
1140 8th Line Unit 15 Oakville
Ontario, Canada
L6H 2R4
(416) 842-2850

Laserline (see Creative Point)

The Last Factory
2015 Research Dr.
Livermore, CA 94550
(415) 449-9449

Lazarus
8130 Coldwater Canyon
North Hollywood, CA 91605
(818) 982-6477

Lazer-Tech Speakers
W. 522 Regina Dr.
Spokane, WA 99218
(509) 467-9369

Lebo/Peerless
60 West St.
Bloomfield, NJ 07003
(201) 429-8600

Lenox
140 43rd St.
Brooklyn, NY 11232
(718) 499-4005

Leslie Dame Enterprises
111-20 73rd Ave.
Forest Hills, NY 11375
(718) 261-4919

Lexicon
100 Beaver St., Waltham, MA 02154
(617) 891-6790

Linn Products
18720 Oxhard St.
Tarzana, CA 91356
(818) 708-8131

Loran
10-48 Clark St., Warren, PA 16365
(800) 633-0455

LT Sound
7980 LT Parkway
Lithonia, GA 30058
(404) 482-4724

Luxman
Box 2859
Torrance, CA 90509
(800) 421-2284

Madrigal
Box 781
Middletown, CT 06457
(203) 346-0896

Magnavox
1 Philips Dr.,
Box 14810
Knoxville, TN 37914
(615) 521-4316

Magnepan
1645 Ninth St.
White Bear Lake, MN 55110
(612) 426-1645

Magnum Dynalab
255 Great Arrow Ave.
Buffalo, NY 14207
(716) 873-9475

M&K
10391 Jefferson Blvd.
Culver City, CA 90232
(213) 204-2854

Marantz
20525 Nordhoff St.
Chatsworth, CA 91311
(818) 998-9333

Mark Levinson (see Madrigal)

Martin-Logan
Box 741,
2001 Delaware St.
Lawrence, KS 66044
(913) 749-0133

Maxell
22-08 Rte. 208 S.
Fair Lawn, NJ 07410
(201) 794-5900

MB Quart
25 Walpole Park South
Walpole, MA 02081
(508) 668-8973

McIntosh
2 Chambers St.
Binghamton, NY 13903
(607) 723-3512

McNeill
417 Temple Rd.
Monaca, PA 15061
(412) 375-9203

Melos Audio
723 Bound Brook Rd.
Dunellen, NJ 08812
(201) 968-8771

Memorex (see Memtek)

Memtek
Box 901021
Fort Worth, TX 76101
(817) 878-6700

Meridian
14120-K Sullyfield Circle
Chantilly, VA 22021
(703) 818-3028

Mirage
135 Torbay Rd.
Markham, Ontario, Canada
L3R 1G7
(416) 475-0050

Mission Electronics
440 Discovery Park, 3700 Gilmore Way
Burnaby, BC, Canada
V5G 4M1
(416) 673-3777

MIT (Musical Interface Technology)
Rt. 202, Box 117
Hollis, ME 04042
(207) 929-4553

Mitsubishi
5757 Plaza Dr., Box 6007
Cypress, CA 90630
(714) 220-2500

MM Newman
24 Tioha Way, P.O. Box 615
Marblehead, MA 01945
(617) 631-7100

Mod Squad
542 N. Highway 101
Leucadia, CA 92024
(619) 436-7666

Mogami
Box 2027
Culver City, CA 90230
(213) 390-6608

Monitor Audio
Box 1355
Buffalo, NY 14205
(416) 831-4741

Monster Cable
101 Townsend St.
San Francisco, CA 94107
(415) 777-1355

Mordaunt-Short
1225 17th St., Suite 1430
Denver, CO 80202
(303) 293-9737

Morel Acoustics
414 Harvard St.
Brookline, MA 02146
(617) 277-6663

Motif (see Conrad-Johnson)

Music & Sound Imports
30 Snowflake Rd.
Huntingdon Valley, PA 19006
(215) 357-7858

Music Hall
108 Station Rd.
Great Neck, NY 11023
(516) 487-3663

NAD
575 University Ave.
Norwood, MA 02062
(617) 762-0202

Nagaoka
210 8th St.
Lewiston, NY 14092
(800) 387-8193

Nakamichi
19701 S. Vermont Ave.
Torrance, CA 90502
(213) 538-8150

NEAR
1450 Hanover Ave.
Meriden, CT 06450
(203) 630-3400

NEC
1255 Michael Dr.
Wood Dale, IL 60191
(312) 860-9500

NHT
537 Stone Rd., Suite E
Benicia, CA 94510
(707) 747-0151

Nikko
5830 S. Triangle Dr.
Commerce, CA 90040
(213) 721-1168

Niles Audio
12331 SW 130th St.
Miami, FL 33186
(305) 238-4373

Nitty Gritty
4650 Arrow Highway, #F4
Montclair, CA 91763
(714) 625-5525

Nova
Box 25488
Los Angeles, CA 90025
(213) 477-7491

Novak
Merritts Island Road
Pine Island, NY 10969
(914) 258-4363

Numark
503 Newfield Ave., Raritan Ctr
Edison, NJ 08837
(201) 225-3222

O'Sullivan
1900 Gulf St.
Lamar, MO 64759
(417) 682-3322

Ohm Acoustics
241 Taaffe Pl.
Brooklyn, NY 11205
(718) 783-1111

Onkyo
200 Williams Dr.
Ramsey, NJ 07446
(201) 826-7950

Onix (see Music Hall)

Ora Electronics
9410 Owensmouth Ave.
Chatsworth, CA 91311
(818) 772-2700

Oracle
505 Boul Industrial
Sherbrooke P. Quebec, Canada
J1L 1X7
(819) 566-5566

Ortofon
122 Dupont St.
Plainview, NY 11803
(516) 349-9180

Outer Circle Products
Box 3667
Chicago, IL 60654
(312) 266-8820

Owi
1160 Mahalo Place
Compton, CA 90220
(800) 638-1694

Panasonic
One Panasonic Way
Secaucus, NJ 07094
(201) 348-7000

Parasound
950 Battery St.
San Francisco, CA 94111
(415) 397-7100

Parsec
400 W. Ninth St., Ste. 303
Wilmington, DE 19801
(302) 651-9189

Phantom Acoustics (see Threshold)

Phase Technology
6400 Youngerman Circle
Jacksonville, FL 32244
(904) 777-0700

Philips
1 Philips Dr., P.O. Box 14810
Knoxville, TN 37914
(615) 521-4316

Pickering
101 Sunnywide Blvd.
Plainview, NY 11803
(516) 349-0200

Pine Cone
Blake Building, Box 1378
Gilroy, CA 95021
(408) 842-7511

Pinnacle
517 Route 111
Hauppauge, NY 11788
(516) 360-9410

Pioneer
2265 E. 220th St.
Long Beach, CA 90810
(213) 835-6177

Polk Audio
5601 Metro Dr.
Baltimore, MD 21215
(301) 358-3600

Polydax Speaker
10 Upton Dr.
Wilmington, MA 01887
(508) 658-0700

Precise Acoustic Laboratories
200 Williams Dr., Suite B
Ramsey, NJ 07446
(201) 934-1335

Proton
5630 Cerritos Ave.
Cypress, CA 90630
(714) 952-8282

PS Audio
4145 Santa Fe Rd., #2
San Luis Obispo, CA 93401
(805) 543-6655

PSB (see NAD)

Quad
14120-K Sullyfield Circle
Chantilly, VA 22021
(703) 631-8618

Quasar
1325 Pratt Blvd.
Elk Grove Village, IL 60007
(312) 228-6366

Quicksilver Audio
4119 Coronado
Stockton, CA 95204
(209) 462-7711

Realistic
1700 One Tandy Center
Fort Worth, TX 76102
(817) 390-8330

Recoton
46-23 Crane St.,
Long Island City, NY 11101
(718) 392-6442

Reel to Real Designs
3021 Sangamon Ave.
Springfield, IL 62702
(800) 283-4644

Revolver (see Music Hall)

Revox
1425 Elm Hill Pike
Nashville, TN 37210
(615) 254-5651

RH Labs
6844 SW 60th Ave.
Portland, OR 97219
(503) 245-8666

Rhapsody (see Alaron)

Rich Acoustic Labs
3 Cleveland St.
Headland, AL 36345
(205) 693-5082

Rockustics
720F Billings St.
Aurora, CO 80011
(303) 363-6161

Rogers
64 Rambling Rd.
East Amherst, NY 14051
(201) 764-8479

Rotel
Box 653
Buffalo, NY 14240
(416) 751-4525

Rowland Research
Box 7231
Colorado Springs, CO 80933
(719) 473-1181

Russound/FMP
10 Forbes Rd.
Newmarket, NH 03857
(603) 659-5170

SAE
1502 Gage Rd.
Montebello, CA 90640
(213) 726-9999

Samsung
301 Mayhill St.
Saddle Brook, NJ 07662
(201) 587-9600

Sansui
1250 Valley Brook Ave
Lyndhurst, NJ 07071
(201) 460-9710

Sanyo
21350 Lassen St.
Chatsworth, CA 91311
(818) 998-7322

Scott
5601 Westside Ave.
North Bergen, NJ 07047
(201) 662-2000

Seattle Sound
Box 30028
Seattle, WA 98103
(206) 624-4038

Sennheiser
6 Vista Dr., Box 987
Old Lyme, CT 06371
(203) 434-9190

Sentry
252C Lake Ave.
Yonkers, NY 10701
(914) 968-0180

Service Manufacturing
River St.
Hasting-on-Hudson, NY 10706
(914) 478-4000

Shahinian Acoustics
33 A&B Cedarhurst Ave.
Medford, NY 11763
(516) 736-0033

Sharp
Sharp Plaza
Mahwah, NJ 07430
(201) 529-8200

Sherwood
14830 Alondra Bl.
La Mirada, CA 90638
(800) 962-3203

Shure
222 Hartrey Ave.
Evanston, IL 60202
(312) 866-2532

Signet
4701 Hudson Dr.
Stow, OH 44224
(216) 688-9400

Snell Acoustics
143 Essex St.
Haverhill, MA 01832
(508) 373-6114

Sonance
32992 Calle Perfecto
San Juan Capistrano, CA 92675
(714) 661-7558

Sonex (see Illbruck)

Sonographe (see Conrad-Johnson)

Sonrise
13622 NE 20th, Suite F
Bellevue, WA 98005
(206) 641-1900

Sony
Sony Dr.
Park Ridge, NJ 07656
(201) 930-7669

Sota
Box 7075
Berkeley, CA 94707
(415) 527-1649

Sound Concepts
27 Newell Rd.
Brookline, MA 02146
(619) 566-0110

Sound Dynamics
135 Torbay Rd., Markam
Ontario, Canada, L3R 1G7
(416) 475-0050

Sound Runner
Box 2027
Culver City, CA 90230
(213) 390-6608

Soundcraftsmen
2200 S. Ritchey St.
Santa Ana, CA 92705
(714) 556-6191

Soundesign
400 Plaza Two
Jersey City, NJ 07311
(201) 434-1050

Soundstream
120 Blue Ravine Rd.
Folsom, CA 95630
(916) 351-1288

Souther (see clearaudio)

Specialty Woodworks
7211 Pottsburg Dr.
Jacksonville, FL 32216
(904) 725-6951

Spectrascan
1110A Elkton Dr.
Colorado Springs, CO 80907
(303) 599-9254

Spica
3425 Bryn Mawr N.E.
Albuquerque, NM 87107
(505) 883-6120

SPL
135 Torbay Rd., Markham
Ontario, Canada, L3R 1
(416) 475-0050

SSI Products
400 S. Date Ave.
Alhambra, CA 91803
(818) 282-9419

Stanton
101 Sunnyside Blvd.
Plainview, NY 11803
(516) 349-0235

Stax
940 East Dominguez Ste. G
Carson, CA 90746
(213) 538-5878

Straight Wire
1909 Harrison St., #208
Hollywood, FL 33020
(305) 925-2470

Sumiko
Box 5046
Berkeley, CA 94705
(415) 843-4500

Sumo
21300 Superior St.
Chatsworth, CA 91311
(818) 407-2426

Superphon
1035 Conger, #3
Eugene, OR 97402
(503) 345-4226

Sylvania
1-40 & Straw Plains Pike
Knoxville, TN 37914
(615) 521-4316

Symdex
Box 359
Gloucester, MA 01930
(508) 281-4447

Symphonic (see Funai)

Synthesis (see Conrad-Johnson)

Systemdek
Box 1049
Hightstown, NJ 08520
(609) 448-7752

T + A Elektroakustik
6525 E. 82nd St., Suite 115
Indianapolis, IN 46250
(317) 255-0112

Taddeo
2604 Elmwood Ave.,
Suite 105
Rochester, NY 14618
(716) 244-6027

Talwar
75 Peters Rd.
Bloomfield, CT 06002
(203) 242-2433

Tannoy
300 Gage Ave.
Kitchener, Ontario, Canada
N2M 2C8
(519) 745-2364

Tantrum Trading
5816 Lankershim Blvd.
North Hollywood, CA 91601
(818) 762-1783

TC Audio
Box 59
Thurston, OR 97482
(503) 726-2027

TDK
12 Harbor Park Dr.
Port Washington, NY 11050
(516) 625-0100

TDL
652 Glenbrook Rd.
Stamford, CT 06906
(203) 324-7269

TEAC
7733 Telegraph Road
Montebello, CA 90640
(213) 726-0303

Technics
One Panasonic Way
Secaucus, NJ 07094
(201) 348-7000

TEI Electronics
570 W. 18th St.
Hialeah, FL 33010
(800) 327-8811

Terk
56 Harrison St.
New Rochelle, NY 10801
(914) 633-4448

Thiel
1042 Nandino Blvd.
Lexington, KY 40511
(606) 254-9427

Thorens (see Epicure)

Thorsen (see GC Electronics)

3M/Black Watch
One Appletree Sqr.,
Suite 1031
Bloomington, MN 55425
(612) 854-0845

3M/Scotch
3M Center
St. Paul, MN 55144
(612) 738-2770

Threshold
12919 Earhart Ave.
Auburn, CA 95603
(916) 888-0600

Toshiba
82 Totowa Rd.
Wayne, NJ 07470
(201) 628-8000

Trackmate
IDA Enterprise Centre,
East Wall Rd Dublin 3., Ireland
(617) 353-1143

Tree Dimensions
Box 609
Boone, NC 28607
(704) 262-0220

Triad Design
490 NE 219th
Troutdale, OR 97060
(503) 666-3666

Uher of America
7067 Vineland Ave.
North Hollywood, CA 91605
(818) 764-1120

Vampire Wire
14932 N. Florida Ave.
Tampa, FL 33612
(813) 961-3319

van den Hul
Rt. 202, Box 117
Hollis, ME 04042
(207) 929-4553

Vector Research
1230 Calle Suerte
Camarillo, CA 93010
(805) 987-1312

Velodyne Acoustics
1746 Junction Ave.
San Jose, CA 95112
(408) 436-0688

Venturi (see BIC America)

Visa (see Interworld Electronics)

Weber Works (see Threshold)

Well Tempered Labs
3108 McKinley Way
Costa Mesa, CA 92626
(714) 549-9878

Wharfedale
1230 Calle Suerte
Camarillo, CA 93010
(805) 987-1312

Wingate Audio
20 Sunnyside,
Suite A, Box 194
Mill Valley, CA 94941
(415) 381-5018

Wolcott Audio
2250 N. Bigelow Ave.
Simi, CA 93065
(805) 527-8842

Wright Audio
308 N. New St.
Staunton, VA 24401
(703) 886-4307

Yale Audio
2702 Azelee St., Tampa, FL 33609
(813) 876-6789

Yamaha
6722 Orangethorpe Ave.
Buena Park, CA 90620
(714) 522-9105

BACK TO SOUND CITY "dbx"

dbx 1 BX-DS
Dynamic-Range Controller
dbx 120X-DS
Subharmonic Synthesizer
ALSO AVAILABLE - SPEAKERS FROM dbx
CALL FOR PRICE

SUPER VHS

MITSUBISHI HSU71 S-VHS MTS HI-FI
JVC HRS8000U Top-Of-The-Line
"Best Made"
TOSHIBA SV930 4-HEAD S-VHS DIGITAL
and many more...

CALL FOR PRICE

SHARP QTCD25
AM/FM/CASSETTE/CD
JVC PCX300 PORTABLE
"Best Made"

TERK FM ANTENNAS
PI9600
FM8500

PROTON CLEARLY THE BEST

440 DIGITAL TUNER
1100 STEREO PREAMPLIFIER
D1200 STEREO POWER AMPLIFIER

Sound CITY

PROTON VT2905 RECEIVER/MONITOR

THE SYSTEM

NOTHING ELSE COMES REMOTELY CLOSE

"Special" Call FAX

MURATA M1600
AVAILABLE: SHARP, PANASONIC, MURATA

*Available in 220 volts

MINOLTA 881
8mm - 8X Zoom
Auto Focus - 4 Lux
SHARP VLL80U
Flying Erase Heads
SPECIAL PRICE
JVC, OLYMPUS, GE, CANON, RCA, PHILIPS

ALL MODELS AVAILABLE

THE FINEST IN HOME AUDIO CAR STEREO & VIDEO EQUIPMENT

- ALPINE
- ADS
- ADVENT
- AKG
- ALTEC LANSING
- AUDIO SOURCE
- AUDIO CONTROL
- BANG & OLUFSEN
- CARVER
- CERMIN VEGA
- CWD
- DCM
- DBX
- DEVON
- HARLER
- INFINITY
- KENWOOD
- KICKER
- MITSUBISHI
- MONSTER CABLE
- PARADIGM
- ONKYO
- ORION
- PHILIPS
- PINNACLE
- POLK (Car)
- PROTON
- LUXMAN
- SAE
- SANSUI
- SONANCE
- SONY
- SOUND CRAFTSMEN
- SOUNDSTREAM
- STAX
- TOSHIBA
- TRIAD
- YAMAHA
- GLEN MONITORS

Sound CITY
Meadtown Shopping Center
Kinnelon, N.J. 07405
(201) 838-3444

Some brand names not available mail order.

RANE, SENNHEISER, AKG, A-T, dbx, Fostex. SONY TAPE. LOFTECH, TRIPP-LITE. ELMO TeleCines, LOWEL, Chinon, BOGEN, Hi8. CARPENTER/GHP, BOX 1321, MEADVILLE, PA 16335-0821.

LOWEST PRICES
On over 150 brands
Car - Home - Video
For Specials List—800-233-8375
Audio Unlimited

HIGH QUALITY BRANDS—Car, Home, Video including esoteric. Audio Unlimited, 1203D Adams Ave., La Grande, Oregon 97850. (503) 963-5731.

SINGERS!
REMOVE VOCALS
FROM RECORDS AND CDs!

SING WITH THE WORLD'S BEST BANDS!
An Unlimited supply of Backgrounds from standard stereo records! Record with your voice or perform live with the backgrounds. Used In Professional Performance yet connects easily to a home component stereo. This unique product is manufactured and sold Exclusively by LT Sound - Not sold through dealers. Call or write for a Free Brochure and Demo Record.
LT Sound, Dept. SBG, 7980 LT Parkway
Lithonia, GA 30058 (404) 482-4724
Manufactured and Sold Exclusively by LT Sound
24 HOUR PHONE DEMO LINE: (404) 482-2485

LOUDSPEAKER COMPONENTS—KITS. Eton, Dynaudio, Focal, Eclipse. Catalog \$1. Meniscus 2442 28th st. S.W. Wyoming, MI 49509 (616) 534-9121.

AUDIOPHILES:
NO RISK AUDITIONINGS!
MODIFICATIONS TO B&K COMPONENTS
JSE INFINITE SLOPE SPICH ET FRIED B&K ELECTROCOMPANET KINERGETICS LEXICON SONY ES AUDIOQUEST KINGER KABLE, MONSTER CABLE SONANCE NILES AUDIO TRIPP LITE
SHIPPING PREPAID CREDIT CARDS ACCEPTED
CALL FOR MORE INFORMATION
SOUND UNLIMITED Est. 1959
169 Church St. Bristol, CT 06010 (203) 584-0131

CALL US LAST

WE WILL
BEAT ANY PRICE
PRINTED IN THIS MAGAZINE ON
AUDIO & CAR STEREO

The SOUND Approach
6067 Jericho Tpke., Commack, NY 11725
FAST DELIVERY (516) 499-7680
FULL WARRANTY

HIGH-END LOUDSPEAKER systems, speaker kits and the widest selection of raw drivers from the world's finest manufacturers. For beginners and audiophiles. Free catalog. A&S SPEAKERS, 3170 23rd St., San Francisco, CA 94110. 3(415) 641-4573

ANNOUNCEMENTS

STEREO BUYING GUIDE PROGRAM! Enter price and specifications, program prints out ratings. IBM or compatibles. Specify disk size. \$19.95 + \$1.75 P&H (TX + 6%). 2,300-unit data base: \$6.00. GAELRIC SOFTWARE, P.O. Box 22393, Houston, TX 77227-2393. 713-772-6949.

TAPES

PURE CHROME BASF CASSETTES AT DISCOUNT PRICES. C-10 TO C-100. CLEAR SHELLS. CLASSIC CASSETTES. 1-(800)-777-8939.

COMPACT DISCS

CD TRADE NETWORK, S3/DISC, WRITE: COMPACT DISC EXCHANGE, 1006 NOE STREET, SAN FRANCISCO, CA 94114.

CD-BINDER and other compact disc storage solutions. Call 1-800-992-8262 or write for FREE CATALOG. Univenture, Inc., Dept. SR, Box 570, Dublin, Ohio 43017.

LASER VIDEO DISCS

LASER SPECIALTY STORE. Since 1980. 10% OFF Retail. All Discs. Discounts on Players. THE LASER IMAGE (303) 586-5056.

WANTED TO BUY

WE NEED QUALITY COLLECTIONS
"TOP DOLLAR PAID" for—
LP's, Compact Discs and cassettes:
Classical, Rock, Jazz, Audiophile, more.
USA's LARGEST USED AND COLLECTOR SHOP
PRINCETON RECORD EXCHANGE
20 TULANE STREET PRINCETON, NJ 08542
(609) 921-0881

EQUIPMENT

WE SELL SECOND HAND HIGH QUALITY AUDIO VIDEO MONEY BACK GUARANTEE!
Send Name and Address for FREE MONTHLY INVENTORY
ROSS STEREO
2423 Morena Blvd. San Diego, CA 92110
(619) 275-3632

INSTRUCTION

FREE CATALOG. Institute of Audio/Video Engineering. 1831 Hyperion (SR), Hollywood, CA 90027. RECORDING SCHOOL. (800) 551-8877, (213) 666-2380. Approved for International Students. Member of NATTS.

ATTENTION CLASSIFIED ADVERTISERS

The CLASSIFIED MAGNET attracts prime prospects for your mail order products and services.
Reach the readers (proven buyers) of this and other DCI Magazine titles through low cost Marketplace Classified advertising.
To place your ads, or for further information (including rates, ad styles, sizes and multi-title discounts), call Lois Price Toll-Free at:
(800) 445-6066

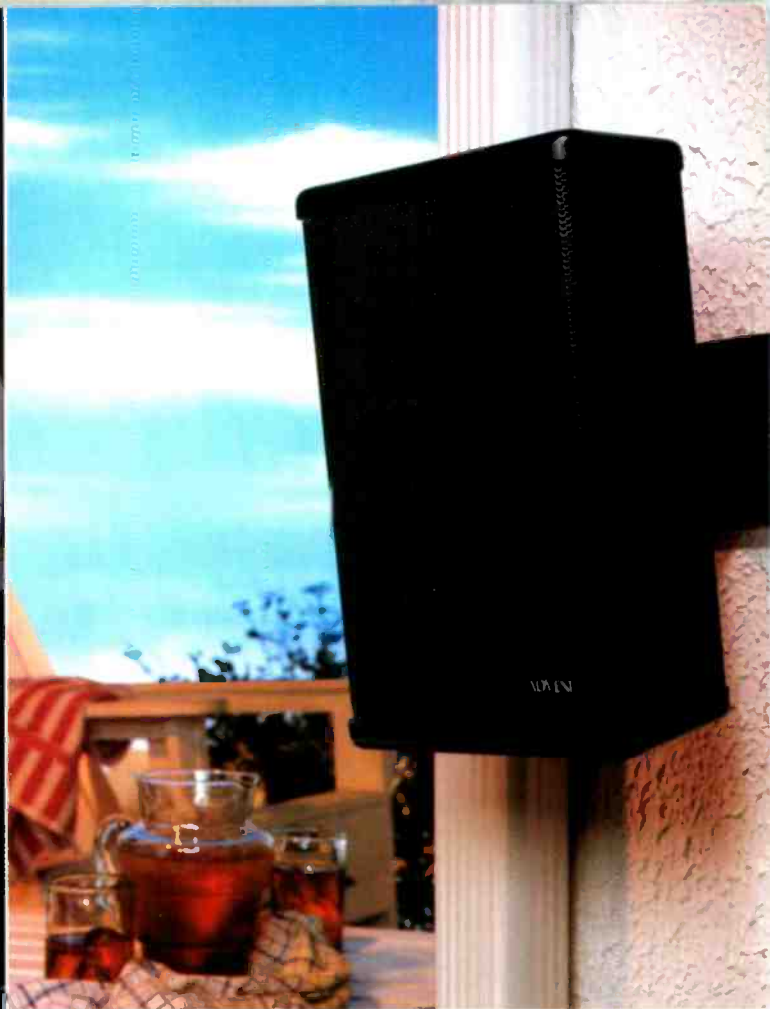
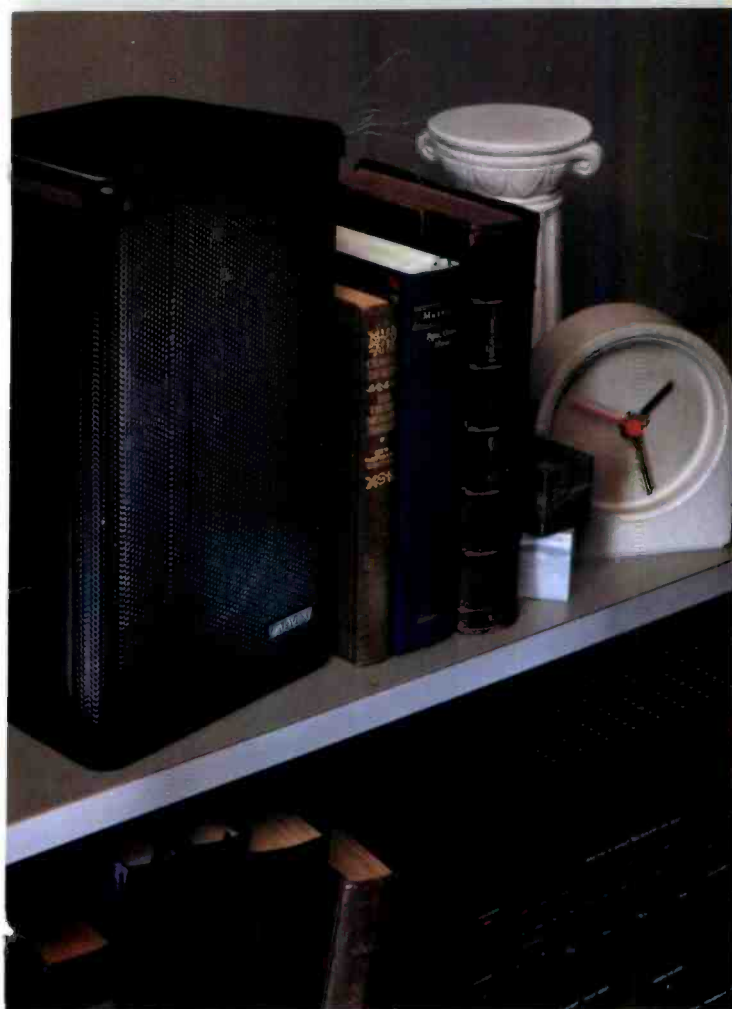

INTRODUCING PROOF THAT WE KNOW ACCURATE SOUND INSIDE AND OUT.

PRESENTING THE NEW INDOOR/OUTDOOR MINI ADVENT LOUDSPEAKERS.

Now you can hear the traditionally natural Advent® sound in a totally different environment. Outside.

Because our new Indoor/Outdoor Mini loudspeakers are resistant to water, humidity, heat and cold, the sound from your speakers will be accurate, even when the weatherman is not.

Plus, they've been designed with the same type of features that have made the Advent sound a legend indoors. Including 5¼" long throw polypropylene woofers. Polycarbonate hard dome tweeters.

And 120 watts peak power. (165, when connected to our Mini Subwoofer.) They sound terrific by themselves or completing a surround sound system.

Wrap it all up in sleek, black Eurostyle cabinets that go just about anywhere (especially when using our optional wall and ceiling mounts), and you have a pair of speakers that will definitely get you out of the house more often.

To hear our Indoor/Outdoor Mini loudspeakers, or any of the fine line of Advents (including the new Prodigy II), just step inside your nearest Advent dealer.



ADVENT®

Sound as it was meant to be heard.

© 1988 International Jensen Inc.
Advent is a registered trademark of International Jensen Inc.

T

TUNERS TUNE MORE...



The New Terk π^2 FM Antenna

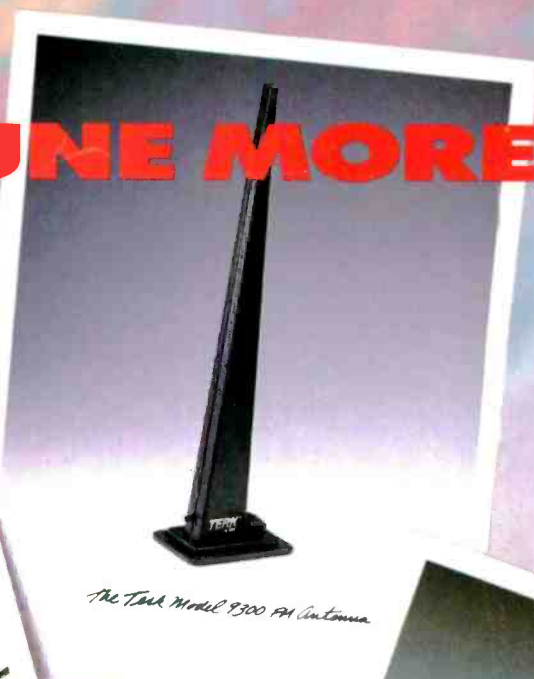

The Terk Model 9300 FM Antenna



The Terk FM+ Antenna

RECEIVERS RECEIVE MORE

The breakthrough FM antenna designs from Terk Technologies reduce FM noise, improve signal strength, and increase the number and quality of FM stations that you receive.

Now Terk FM antennas feature even greater improvements. The new Reference Standard π^2 , featuring a Schotz low-noise amplifier, has an adjustable gain control and offers an unparalleled 38 dB of gain. π^2 relies on the highly-acclaimed, patented Gamma Loop element for exceptional directional and omnidirectional reception, as well as superior multipath and noise rejection. Find out why Audio Magazine reviewer Len Feldman commented, "A truly amazing product."

Another outstanding innovation is the compact Terk FM+ antenna, based on the same Gamma Loop technology and offering the greatest signal improvements for the

least investment. You may also choose the Terk Classic Tower Model 9300 utilizing an adjustable gain that lets you correct for weak or strong stations.

Even today's high-performance receivers and tuners need extra help. Hear just how good your receiver or tuner can sound.

TERK

TERK Technologies New Rochelle, N.Y. 10801

π^2 , FM+, and Gamma Loop are trademarks of Terk Technologies. U.S. Patent #4,801,944 and patents pending.