



TELEVISION



EXPLAINED



BY W. E. MILLER

M.A. (Cantab). M.Brit.I.R.E.

EDITOR OF "THE WIRELESS & ELECTRICAL TRADER"



SECOND EDITION



**AERIAL TECHNIQUE · CIRCUITS
ANALYSED · RECEIVER OPERATION**

3/6
NET



Speakers & Components

**CONSISTENTLY SPECIFIED BY
EVERY LEADING DESIGNER**

**STENTORIAN
EXTENSION
SPEAKERS**

•

**F A C T O R Y
S P E A K E R S**

•

T R A N S F O R M E R S

•

V A L V E H O L D E R S

•

S W I T C H E S

•

C H O K E S

•

T R A N S F O R M E R S

Service Universal Output
Transformer

Miniature Service Universal
Output Transformer

Service Intervalve Transformer

**DETAILS AND PRICES
GLADLY SENT
ON APPLICATION**

WHITELEY ELECTRICAL RADIO CO. LTD., MANSFIELD, NOTTS.



The G.E.C. 9" diameter cathode ray tube 6501 is intended for high quality television reception, and is magnetically focused and deflected. The screen fluorescence is white. The tube end is made by a special moulding technique, which produces a screen face nearly flat, and more constant in production than is normally possible with bulbs made by the usual blowing technique. A picture size of approximately 200 x 160 mms. is obtainable with slight masking of the edges and corners. The bulb is made of high insulating glass giving a minimum of screen charging effects. The electrode gun is designed to give a high picture brightness, with excellent definition for a relatively small voltage drive to the modulator. Detailed technical data sheet available on request.

 PHOTO CELLS	 CATHODE RAY TUBES	 VALVES
--	--	---

The General Electric Co., Ltd., Magnet House, Kingsway, W.C.2.

The New COSSOR

1035

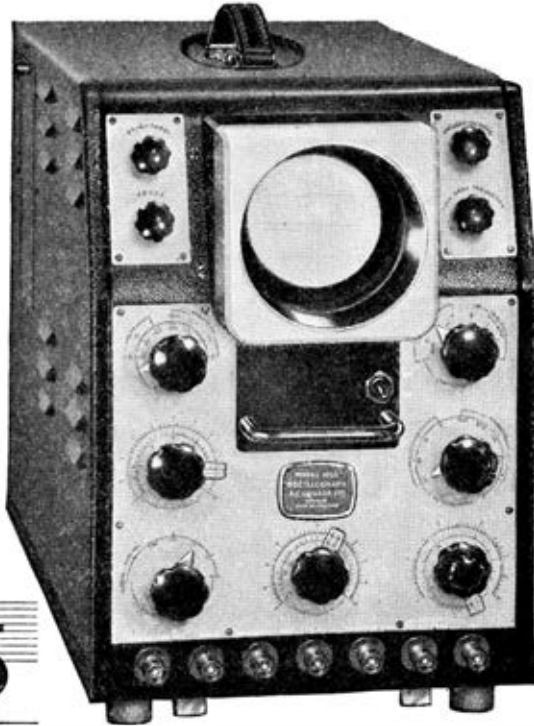

DOUBLE BEAM OSCILLOGRAPH

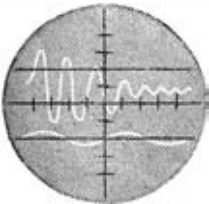

*Further details obtainable
on application to:—*

A. C. COSSOR LTD., INSTRUMENT DEPT., Highbury, N.5

CI/6

On the SPOT



WITH

EKCO

TELEVISION

Of course you want a television receiver! Who doesn't? You want to be "on the spot", like the rest of us. But you want technical excellence allied to beauty of cabinet; you want a competent installation and after-sales service; you want the assurance of fine quality and reliability. You want *EKCO* Television. See your Ekco dealer — seeing's believing!

E. K. COLE LIMITED • EKCO WORKS • SOUTHEND-ON-SEA

Best by a long sight!

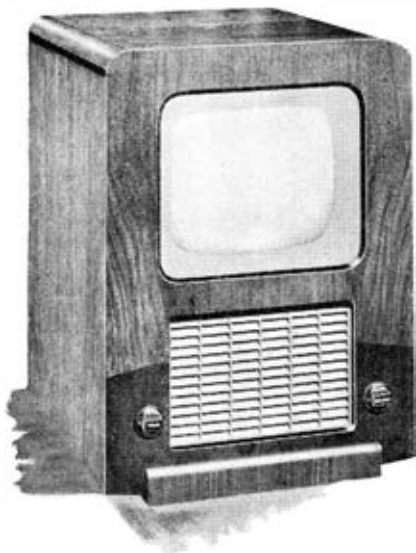

Model VT50A. 67 Guineas, plus Purchase Tax.

Unrivalled clarity of reception distinguishes Marconiphone Model VT50A in the field of modern television : its 10 in. diameter Emiscope Tube gives fine variations in tonal graduation.

Careful attention to circuit detail has resulted in a highly stable circuit needing the absolute minimum of adjustment during normal use. Two controls only—a combined volume-on-off switch, and one for brightness—appear on the front. Auxiliary controls, needing very occasional adjustment are grouped together on a panel at the rear. Noise and picture interference limiters provide a high degree of freedom from aural and visual interference with programmes.

MARCONIPHONE

TELEVISION—*the REAL Thing!*

THE MARCONIPHONE COMPANY LIMITED, HAYES, MIDDLESEX

M.52A

TELEVISION EXPLAINED

Aerial Technique: Circuits Analysed:
Receiver Operation

W. E. MILLER

M.A.(Cantab.), M.Brit.I.R.E.

Editor of "The Wireless & Electrical Trader"

Illustrated with 46 diagrams and 12 photographs

Second Edition



Published by

THE TRADER PUBLISHING CO., LTD.

Distributed by

ILIFFE & SONS, LTD.

LONDON, BIRMINGHAM, COVENTRY, MANCHESTER AND GLASGOW

*Published for "The Wireless & Electrical Trader" by The Trader
Publishing Co., Ltd., and distributed by Hiffe & Sons, Ltd., Dorset
House, Stamford Street, London, S.E.1.*

First Published 1947
Second Edition 1948

*This book conforms completely with the authorised
economy standards*

*Made and printed in Great Britain at The Ebor Press
by William Sessions Ltd., York*

(Bks 362/83561)

Contents

<i>Chapter</i>		<i>Page</i>
	PREFACE	4
I	AERIALS. Dipoles, Feeders, Reflectors, Interference	5
2	THE SIGNAL. Sequential and Interlaced Scanning; Transmitted Waveform; Band-width Occupied	9
3	THE RECEIVER. Main Units Required; Super-het and Tuned Radio Frequency Circuits	13
4	THE RECEIVER (<i>continued</i>). R.F. Amplifier and Frequency Changer Circuits	16
5	THE RECEIVER (<i>continued</i>). I.F. Amplifier Stages	21
6	THE RECEIVER (<i>continued</i>). Demodulator and Video Frequency Amplifier Stages; D.C. Restoration	23
7	THE RECEIVER (<i>continued</i>). Separation of the Synchronizing Pulses	27
8	THE CATHODE-RAY TUBE. Principles of Magnetic Type; Focusing and Deflection	31
9	SCANNING UNITS. Production of Saw-tooth Waveform with Gas Relay and "Hard"-valve Circuits	35
10	DEFLECTION AMPLIFIERS. Electrostatic and Electromagnetic Types	40
11	POWER SUPPLIES. For Electromagnetic and Electrostatic Tubes	42
12	RECEIVER INSTALLATION AND OPERATION. Location of the Set; Initial Adjustment of the Controls	46
	PICTURE FAULTS ILLUSTRATED	50, 51
	INDEX	52

Preface

TO coincide with the re-opening of the B.B.C. Television Service in June, 1946, it was decided to publish a series of articles on television receiving circuits in *The Wireless & Electrical Trader* with a view to helping radio dealers and service engineers to pick up the threads again after a hiatus of nearly seven years.

The series was, in fact, published as a "Television Refresher Course," and it soon became apparent that its issue in more permanent form was desirable. This book is the result, the chief changes being in the title, and in the addition of certain extra matter. Preparation of a second edition has provided the opportunity of adding information on the latest developments in circuits for the E.H.T. supply to the cathode ray tube.

The main part of the book, dealing with television receiver circuits, follows closely on the lines of "Radio Circuits," by the same author, who believes that the beginner will more easily follow the intricacies of a circuit if it is first split up into reasonably self-contained sections.

It has been necessary, in writing of television circuits, to assume a knowledge of ordinary radio receiving circuits, but anyone needing to brush up his knowledge of these is referred to the companion volume, "Radio Circuits," mentioned above.

Although the subject matter of "Television Explained" was originally intended for radio dealers and service engineers, it is felt that this book will also be of assistance to students and others interested in learning something of how television receivers work.

The final chapter on installation and operation is an addition to the original series of articles, and the author is indebted to the Philco Radio and Television Corporation of Great Britain, Ltd., for permission to reproduce the photographs on pages 50 and 51.

W. E. MILLER

*Dorset House,
Stamford Street,
London, S.E.1*

1948

TELEVISION EXPLAINED

1—Aerials

DIPOLES, FEEDERS, REFLECTORS, INTERFERENCE

NO apology is offered for commencing a book on television receiving circuits with a chapter on television aerials, since the aerial forms an important part of a television receiver, and its design, construction and siting are all more critical than in the case of the average aerial used with an ordinary broadcast receiver.

First of all, it may be said that the television aerial differs from the ordinary broadcast receiving aerial in that it is self-tuned to the frequency of the incoming signals. While it is quite possible in districts of high signal strength to receive television on an ordinary aerial, or even a short length of wire, this is not an efficient arrangement, and would be quite unsatisfactory in regions of low or even moderate signal strength.

Furthermore, the ordinary type of aerial may in any case result in poor picture quality (due to multiple images caused by reflections), and it does not permit one to reduce interference in the manner which can be employed in the conventional television aerial.

The simplest resonant or tuned television aerial consists of a wire or rod whose length bears a certain relation to the wavelength to be received. Since the B.B.C. television signals from Alexandra Palace are transmitted on a band around 7 metres (45 Mc/s), it is usual to employ a "half-wave" aerial, which is not only efficient, but is of a convenient length. Such an aerial consists of a straight wire or rod about half a wavelength long, which for 7 metres is 3.5 metres or about 11 ft.

Since the B.B.C. signals are vertically polarized by being transmitted from a vertical radiator, it is necessary for our receiving aerial to be mounted vertically for best results. In America, with a horizontally polarized transmission, the receiving aerials have to be horizontal.

If the half-wave aerial rod is mounted vertically, a standing wave is produced in it by the signal in such a way that there is zero current, but maximum voltage, at each end, and maximum current (zero voltage) at the centre. This is indicated in Fig 1. In order to transfer the energy picked up by the aerial to the receiver, a "feeder" must be connected between the two, and this must be of a special type. It is usual to connect the feeder to the point of maximum current in the aerial, that is, in the case of a half-wave type, to the centre.

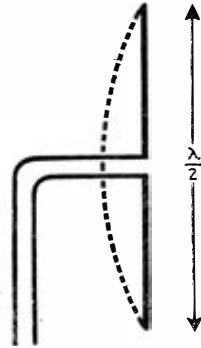

Fig. 1—Diagram of the half-wave dipole aerial largely used for television reception. The two halves are connected to the two leads of the feeder. The dotted line shows the current distribution in the aerial, with a maximum at the centre

The connection is made by breaking the half-wave aerial at its centre, and connecting each portion to one of the twin feeder wires. It is most important that the impedance of the feeder is fairly accurately matched to the impedance of the aerial, otherwise the maximum transfer of energy does not take place, and reflections giving multiple images may be set up.

The impedance at the centre of a half-wave aerial is 70-80 ohms, and this, therefore, must be the characteristic impedance of the feeder, unless the added

Television Explained

complication of a matching transformer is introduced. While a high impedance feeder could be made from two air-spaced wires accurately separated over the whole of their length, the construction of such a feeder for the comparatively low impedance of, say, 80 ohms is not practicable. Instead, two parallel spaced wires embedded in rubber or plastic material are used; alternatively, the co-axial type of feeder is employed, this having a central wire surrounded by a tubular metallic braiding forming the other conductor, the two being separated by solid, or partly air and partly solid, dielectric. Two typical sections of feeders are shown in Fig. 2.

While it is possible to connect a feeder at one end of the half-wave aerial (which is then in one length), the impedance here is high, and special matching arrangements are necessary.

One form of aerial using a continuous half-wave rod has connections made to it by rods attached to two high impedance points spaced accurately from the centre of the aerial rod. These connecting rods act as supports, and they converge so that the ends remote from the aerial rod are close together, and are connected to the primary of a matching transformer, which is so designed that an ordinary 80 ohm feeder may be connected to the secondary.

The total length of the television aerial is actually not exceedingly critical, since in any case, owing to the fact that vision and sound are transmitted on different frequencies, some compromise has to be made. Some manufacturers make their aerials to resonate at the vision frequency (45 Mc/s), while others choose a frequency at some value between 45 Mc/s and 41.5 Mc/s, the television sound frequency. This accounts for slight differences which may be found between the lengths of various makes of aerial.

The "electrical length" of an aerial of the rod type is greater than its physical

length by about 5 per cent, so the aerial rods are made about 95 per cent of the theoretical calculated length. For a 45 Mc/s half-wave aerial the length will be about 10 ft 5 in. The distance between the two halves of the dipole at the centre where the feeder is attached should be small, not much greater than 1 in.

With an unscreened twin feeder, one wire is connected to each half of the dipole; in the case of a co-axial feeder it is usual to connect the centre wire to the upper half of the aerial and the outer metallic casing to the lower half. In some cases the co-axial feeder is connected via a transformer at the centre of the aerial, this permitting the two halves of the aerial to be accurately balanced to earth. However, except in special circumstances this is not essential.

Equally, at the receiver end, the feeder has to be matched to the input circuits, and though some manufacturers specify twin feeder and others the co-axial type, in practice it will usually be found that either type can be employed with any set with little or no noticeable difference.

So far only the simple half-wave dipole has been mentioned; where space is restricted use is sometimes made of "folded" or "compressed" dipoles, the object of which is to make an aerial resonating at 45 Mc/s, but occupying less physical space than the normal type. Various shapes are employed for this purpose, but the principle is the same, and so is the method of connection to the receiver.

In localities where signal strength is not great, and interference levels are high, better results than those given by the simple dipole can be obtained by the addition of a reflector. This consists of a rod or wire, also about half a wavelength long, mounted vertically behind the dipole, and usually a quarter of a wavelength behind it.

The effect of the reflector is to reinforce the pick-up of the aerial in the forward direction and reduce it in the backward direction, from which it follows that the combination is to a certain extent directional, whereas, of course, the simple dipole picks up equally in all directions. Fig. 3 illustrates the type of polar diagram obtained by adding a reflector spaced by a quarter wavelength from the half wave dipole aerial.

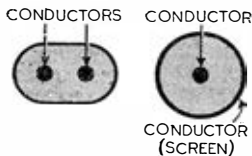

Fig. 2—Sections of typical feeders. Left, the ordinary twin-wire type; right the coaxial type

Aerials

The forward directivity of the dipole with reflector is not critical, but the property can be used to give an appreciable increase in signal strength in the forward direction. Behind the aerial the directivity is more critical, and it can be used to decrease the pick-up of unwanted noise, such as that produced by car ignition systems, particularly if they emanate from a well-defined source.

For maximum signal strength the aerial proper must face the transmitting station with the reflector behind it so arranged that a line drawn through reflector and aerial, if continued, would pass through the transmitter. However, since the alignment is not critical it sometimes pays to align for minimum interference, rather than maximum signal.

The length of the reflector rod (which is not split, and is not in electrical connection with the aerial or anything else) is usually about 3 per cent less than the calculated length for half a wavelength; it is thus slightly longer than the aerial which is 5 per cent less.

The distance between aerial and reflector may be a quarter of a wavelength, that is about 5 ft 6 in; it is not critical, and different spacings are sometimes used. However, since the presence of the reflector affects the impedance at the centre of the dipole aerial, mis-matching may occur with an 80 ohm feeder if the reflector is brought too close to the aerial.

It is possible, by making certain alterations to the lengths of the rods, and to the spacing between aerial and reflector, to affect the response curve of the aerial system. If the best definition of the television picture is to be secured, the aerial system, no less than the receiving circuits, must be capable of accepting the full band-width of the transmitted signal. By making the aerial rod shorter than the calculated value, and the reflector rod longer, and reducing the spacing, it has been found possible to secure a "double-humped" response whose effect is to increase considerably the band-width accepted by the aerial system. The diameter of the aerial rod also affects the response curve, the larger the diameter, the broader being the response.

Wherever possible the dipole with reflector should be used, in preference to a simple dipole, not necessarily to increase

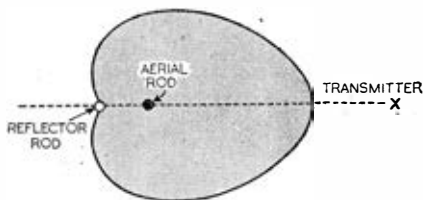

Fig. 3—Polar diagram of a dipole with reflector, showing increased pick-up in front of the aerial and reduced pick-up at the rear

signal strength, but to increase the signal to noise ratio.

As far as the siting of the aerial is concerned, there is often not a great deal of choice, but it is usually the case that the higher the aerial the better the signal and the less the electrical interference.

It is not essential, in the case of a television aerial, to site it so that the length of the feeder is the minimum possible. Within reason, the length of the feeder is not important, since the losses in feeder cable of good quality are very low. It is much better, therefore, to place the aerial in the most advantageous position, even if the length of the feeder is thereby increased.

It has already been explained that matching of the feeder cable to the centre of a half-wave dipole aerial is achieved by the use of special twin wire or co-axial cable having a characteristic impedance of 70-80 ohms, and other types of feeder should not be employed unless a suitable matching transformer is used. In any case, ordinary twisted flex is unsatisfactory.

At the receiver end, matching of the television feeder is provided for by the manufacturer of the receiver, and no special precautions need be taken here, except to see that the maker's instructions are followed, and that proper connecting plugs are used. On no account should the two wires of a twin feeder be splayed out for considerable lengths; only the minimum length necessary should be opened out for the fitting of the plugs.

The reason for the importance of correct matching is that it ensures the maximum transfer of energy to the receiver. Incorrect matching may mean that part of the signal is reflected back from the point where the mis-match

Television Explained

occurs. If this is at the receiver input sockets, for instance, the reflected part of the signal may return to the aerial, where it is reflected back again, and a portion of it may enter the receiver circuits in addition to the signal proper. There is obviously a time lag between the original signal and the reflected one, and the lag will depend on the distance the reflected signal has travelled, that is, on the length of the feeder.

The effect on the receiver is that the reflected signal produces an image which is displaced to the right of the normal image (because the cathode ray spot travels from left to right when building up the picture line by line). The amount

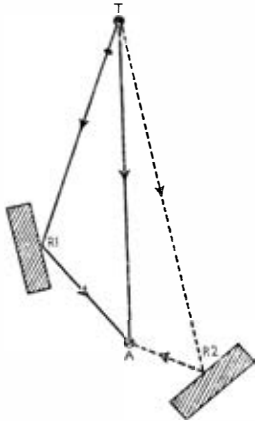

Fig. 4 — Diagram (not to scale), showing how external reflections occur. T is the transmitter, A the receiving aerial, and R1, R2 reflecting bodies

of displacement depends on the time lag between the normal and reflected signal, and it is possible to calculate the displacement for a given time lag, and hence for a given length of feeder. It can be said that with a feeder less than 100 ft long the effect of the reflection, if present, will be negligible. With longer feeders, if mismatched, one gets blurring of the image, or, as the length increases, a recognizable displaced image separated more and more from the true image.

With severe mis-matching, multiple reflections may occur, giving a whole series of displaced images, equidistant

from each other, and gradually tailing off in intensity.

If internal reflections in the feeder system do occur, the reflected image is fainter than the true one, but nevertheless it may be very troublesome, and must generally be eliminated by proper feeder matching.

There is another form of reflection, external to the aerial system, which can produce similar displaced images. These external reflections often result in considerable displacement due to the greater distances involved.

The diagram in Fig. 4 (not to scale) illustrates how simple external reflections occur. T represents the television transmitter, A the receiving aerial, and R1 and R2 are bodies, such as buildings or hills, which act as reflectors to the signal. The direct wave, TA, is picked up by the aerial normally, while an indirect wave, say TR1, is reflected by R1 and travels in the line R1A, being also picked up by the aerial, though it arrives later than the direct wave.

The time lag obviously depends on the difference in length between the total indirect path TR1, R1A, and the direct path TA, and may be quite large in its effect on the television screen. The diagram shows another indirect path, TR2, R2A, which may also produce an image due to the reflection at R2.

To give some idea of the effect, it can be said that, with a picture 10 in wide (12 in tube) a displacement of the secondary image of 1/10 in occurs when the difference between the two paths is of the order of 250 yds.

Another effect is that produced when the reflected signal arrives out of phase with the direct one. In this case the "ghost" image may be a negative, with black portions of the picture white, and vice-versa.

The only method of dealing with the reflection problem at the receiving end is to use a type of aerial which is as directional as possible. The dipole with reflector may help, particularly if the reflected signal is arriving at the rear of the aerial. It is also possible to use a dipole with a number of reflector or "director" rods to produce a narrow angle of reception, but this does not usually prove a practical proposition for ordinary domestic installations.

The Signal

Another variety of aerial, familiarly known as the "tilted-wire" type, has an acceptance angle of only 90 degrees, and is in many cases extremely useful in eliminating reflections, as well as other interference. This employs a capacity-loaded cable, arranged to slope at about 40 degrees to the horizontal, and terminates in a short "compressed" (loaded) dipole at each end. When the end not connected to the transmission line points towards the transmitter the maximum signal pick-up is achieved, but as in the case of the dipole with reflector, it is best to make experiments in the direction of the aerial for maximum reduction in interference.

In view of the importance of the aerial in a television receiving installation, particularly in localities where interference is serious, it is likely that this and other special types will be worth investigating where the ordinary dipole with reflector is not entirely satisfactory.

2—The Signal

SEQUENTIAL AND INTERLACED SCANNING;
TRANSMITTED WAVEFORM; BAND-WIDTH
OCCUPIED

BEFORE commencing to describe the circuits of a television receiver, it is important to consider how the picture is built up on the screen of the cathode ray tube. This will make clear the necessity for the fairly complicated type of signal which has to be provided for the transmission of television intelligence, compared with the far more simple sound transmission. A knowledge of the form of the television signal also enables us to understand the need for certain special circuits in the receiver, and the tasks they have to carry out.

It should not be necessary to say that the picture on the screen in a modern television receiver is built up by a succession of almost horizontal lines which are "drawn" by the cathode ray spot. In one form of transmission the spot is caused to move across the screen, tracing out a line, and is then made to return at a much faster pace to a point just below the start of the first line. It then proceeds to trace out a second line, just below and parallel to the first. This continues until a complete picture area has been built up, when the spot moves

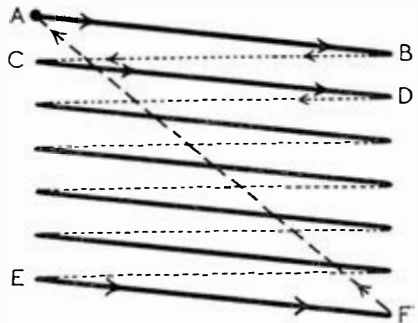

Fig. 5—Diagram illustrating sequential scanning, which is explained in the text. It is not to scale, and only seven lines are shown. The "fly back" from F to A in practice is not a straight line as depicted

back to its starting point and repeats the performance again.

The effect on the viewer, due to persistence of vision and a certain degree of afterglow on the tube screen, is that a complete set of lines is seen, though actually at any given instant there is only the single spot of light drawing out the picture.

The complete set of lines on the tube screen is called a "raster," and as described, of course, it merely produces an illuminated area, with no picture. The picture intelligence is conveyed by causing the television signal to vary the intensity of the spot of light, from zero (black) to maximum (white). Thus each line on the screen in practice consists of a large number of picture elements varying in shade between black and white, and in this way the complete picture is built up.

Each picture area is called a "frame," on the analogy of a cinema film, and as in the cinema, it is necessary to transmit a certain number of frames per second before flicker is eliminated. To a certain extent the amount of flicker noticeable depends on the picture brilliancy, and the B.B.C. television system, by transmitting 50 frames per second, completely eliminates flicker even with brilliant pictures.

The method of building up the picture already described is known as "sequential scanning," and is illustrated diagrammatically in Fig. 5. Only seven lines are shown in the raster for the sake of clarity, and the slopes of the lines are exaggerated

Television Explained

thereby. Let us imagine that the cathode ray spot commences its journey at A. It moves across the screen to the right, and traces out the line AB. At the end of the line, it quickly returns to a point C, which is just below A, ready to trace out the second line. The dotted line BC (which is actually not visible on the tube screen) is known as the "fly-back," and occupies much less time than that taken to trace a line.

From C the spot traces the second line CD, following which there is another fly-back, then the third line, and so on. This continues until the complete raster has been drawn, the last line in our illustration being EF. At F the spot, having finished one frame, flies back to A, where it commences the second frame, and this continues at a frequency depending on the number of frames being transmitted per second. It will be realized that when an actual picture is being received the spot is continually varying in intensity during the periods when it is tracing out the lines.

So much for sequential scanning, which in practice is not at present used by the B.B.C. It has already been stated that the amount of flicker depends on the frequency at which the frames are transmitted, and it is also the fact that as we increase the number of complete scans of the picture per second we also increase in the same proportion the maximum frequency necessary in the transmission, and therefore the band-width occupied in the frequency spectrum.

For instance, it is found that a picture frequency of 25 per second is insufficient for complete elimination of flicker with a bright picture. If the picture frequency is increased to 50 per second flicker is no longer apparent, but the vision signal will require twice the frequency band.

To avoid this, the B.B.C. employ "interlaced scanning," which has the following characteristics. The travelling spot on the cathode ray tube screen traces out parallel lines on the screen as before, but there is a gap between adjacent lines greater than with sequential scanning. The spot, in fact, traces out alternate lines, and when it has covered the picture area it returns to trace out another series of lines in the gaps between those in the preceding frame.

This will be understood by reference to Fig 6, which shows just a few lines (for clarity) of an interlaced raster. Assuming the spot starts at G, it first traces the line GH, and the fly-back HI takes it to I, which is twice as far below G as C was below A in Fig. 5. The spot now traces out the line IJ, and so on until it gets to the bottom line of the raster, starting at K. Instead of completing a full line, however, the spot is arrested half way along, at L, and is caused to fly back to a point M, which is half way (approximately) along a line above GH.

The spot then starts a new frame, completing the line MN, flying back along NO, and tracing the line OP, which, it will be noted, is mid-way between GH and IJ in the previous frame.

It is fairly easy to see that had the spot not been arrested at L, but had been allowed to complete the last line of the first frame, it would have traced the second frame exactly over the first one. As it is, it interlaces as shown in the diagram.

It continues to trace out the second frame as indicated by the lighter lines in Fig. 6, and reaches Q, the beginning of the last line of the second frame. It is allowed to complete the full line QR, and therefore the fly back brings it to point G again, ready to trace out two more interlaced frames.

In the diagram of Fig. 6, the total

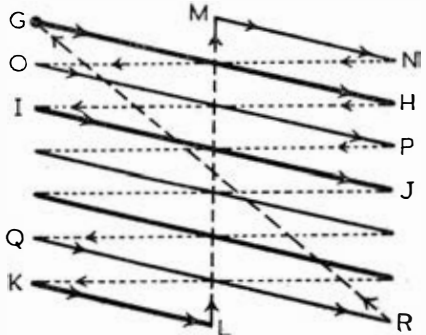

Fig. 6—Diagram showing interlaced scanning, not to scale. The "fly backs" LM and RG are not in practice straight lines, neither does the interlace necessarily start half way across the frame. The diagram has been drawn as shown for convenient explanation in the text

The Signal

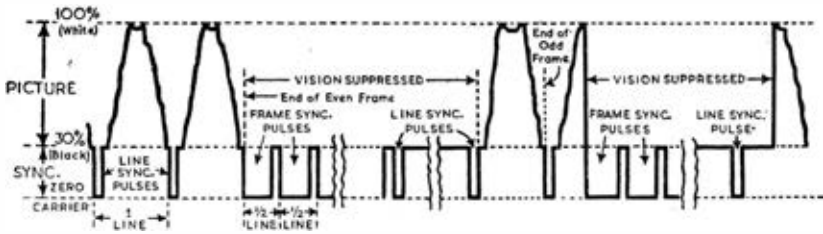

Fig. 7—Simplified diagram of the B.B.C. television waveform, showing the main features, which are fully described in the text

number of lines composing the picture is 7, but these consist of $3\frac{1}{2}$ lines of one frame interlaced with $3\frac{1}{2}$ of the next. Thus we have two frames to each complete picture scan. We have not altered the total number of picture elements scanned in a second compared with Fig. 5, so the maximum frequency required for the transmission is the same as if the 7-line sequentially scanned picture of Fig. 5 were transmitted; we have, however, doubled the number of frames per second, thus reducing the flicker.

It might be thought that to reduce flicker we could increase our picture frequency slightly, thus avoiding the complication of interlacing, and only slightly increasing the frequency band required. However, it is found that the picture frequency must be at the mains frequency or at some multiple or sub-multiple of it, otherwise any residual "hum" in the receiver circuits is likely to cause travelling bands of light and shade across the picture. Hence if it is necessary to go above 25 frames per second, the next frequency permissible is 50. In America, where the standard mains frequency is 60 c/s, the frame frequency is 30 or 60. The present B.B.C. transmission uses 405 lines ($202\frac{1}{2}$ interlaced with $202\frac{1}{2}$) with a frame frequency of 50 (or 25 complete scans per second).

Having seen how the picture is traced out line by line and frame by frame by the spot, which is actuated as to movement by local scanning circuits in the receiver, it is fairly obvious that the television signal must convey not only the means of modulating the light intensity of the spot (the "picture" signals) but also the intelligence necessary to make the spot move in exact synchronism

with the spot which is scanning the scene at the transmitter end.

Not only must the receiver spot move at exactly the same speed as that at the transmitter, but it must always be at the same relative position on the screen. For example, both spots must start at the beginning of the first line of each frame at exactly the same instant, and thereafter they must keep in step.

This result is achieved by suitable synchronizing signals, included in the complete television signal, which at the receiver are separated from the picture signal, and used to control the "time-base" circuits which deflect the spot across the tube screen.

At this juncture, therefore, it is desirable to examine the form of the complete signal which is transmitted, and to see how the picture and synchronizing signals are combined. This will enable a clearer picture of what happens in the receiver to be obtained.

The diagram (Fig. 7) showing the form taken by the television signal has been deliberately simplified as far as possible. Distances measured vertically represent the signal voltage, while horizontal distances represent time. The carrier wave varies from substantially zero to 100 per cent, the latter representing full white in the picture. Black is represented not by zero, but by 30 per cent carrier, so that the complete tone values of the picture lie between 30 per cent and 100 per cent carrier.

Below 30 per cent (often referred to as "blacker than black") we have the synchronizing signals, and it is clear that by the use of an amplitude filter in the receiver it is possible to separate these from the picture signal.

The first section of the diagram, starting from the left, shows two complete lines

Television Explained

of the picture. At the beginning of each line there is a rectangular line synchronizing pulse, extending from 30 per cent down to zero carrier, which occupies in time about one-tenth of the line. Following this, the carrier goes up to "black" level for about one-twentieth of a line before the actual picture signal commences.

The picture signal occupies the carrier between 30 per cent and 100 per cent, the whiter the tone the greater being the carrier voltage. Towards the end of the line the carrier again drops to "black" and remains there for a short period (0.5 per cent of the line period) before the commencement of the next line synchronizing pulse.

Frame synchronizing signals come between each frame, but to secure interlacing, the signal differs at the end of even and odd frames. The next section of the diagram indicates the form of the signal at the end of even frames. Following the last line of the frame there is a series of frame synchronizing pulses, eight in number (though only two are shown). These each occupy $4/10$ of a line, with a return to 30 per cent carrier (black) for $1/10$ of a line between each. Thus the frame pulses are at half-line intervals. Following the eight pulses (four lines), for the rest of the interval between frames (another 10 lines) the vision signal remains suppressed, but the usual line synchronizing pulses are continued.

The next section of the diagram shows the state of affairs at the end of odd frames. Instead of the frame synchronizing pulses commencing immediately, the first pulse starts half a line after the last line of the preceding frame, the carrier dropping to zero, and sending a train of eight pulses at half-line intervals. Following these pulses, the vision again remains suppressed for another 10 lines, during which time only the line synchronizing pulses are transmitted, then the vision signals of the next frame commence, starting with a half-line signal. The whole train of operations then repeats.

To sum up briefly, suppose we have reached the end of line 405 (the end of an even frame). The first four lines of the next frame carry the frame synchronizing pulses; then come 10 black lines, and the 15th line starts the picture, which continues up to line 202, with line synchro-

nizing pulses at the beginning of each line.

After line 202, there is half a line of picture, and then the synchronizing pulses for the next (interlaced) frame, occupying four lines, followed by 10 blank lines. At the middle of line 217 the picture signal recommences, and continues until line 405, when the cycle is repeated.

It will be seen that there are actually 188.5 lines per frame carrying the picture signal, or 377 per picture (two interlaced frames), the other 28 lines being used for frame synchronization.

One important difference between the television signal and an ordinary sound broadcasting signal is that the former must occupy a considerable band-width, and therefore it is necessary for the transmission to take place in the ultra-short waveband. The necessity for high modulation frequencies in television transmission will be realized in the light of the following considerations.

The picture intelligence, as we have seen earlier, is conveyed by scanning the scene to be televised in a large number of horizontal lines 25 times per second. It should be clear that the vertical size of the picture element to be scanned cannot be larger than the "thickness," or height, of one of the lines, and on the assumption of a symmetrical cathode ray spot, and equal definition horizontally and vertically, the horizontal size of each element must be the same. Fig 8 shows part of a single line, much enlarged, with successive square picture elements indicated.

It is possible to calculate the total number of such picture elements that must be transmitted per second knowing the form of the television "raster." Assuming there are 377 lines per picture actually in use (the remaining 28, as we have seen, are used for frame synchronization), the number of elements in a square picture would be 377×377 . However, in the B.B.C. transmission the

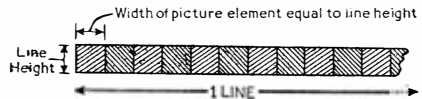

Fig. 8—Diagram of part of a single line (enlarged) to show the conception of picture elements

The Receiver

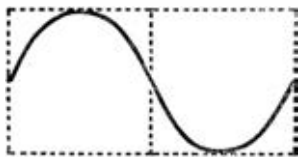

Fig. 9—Showing how the positive and negative half cycles of a complete sine wave cover two picture elements (dotted)

picture is wider than it is high in the ratio of 5 to 4, so that the actual number of elements becomes $\frac{377 \times 377 \times 5}{4}$, or about 178,000.

As there are 25 complete pictures per second the total number of elements to be transmitted per second is $178,000 \times 25$, or 4,450,000. Naturally, this figure determines the highest modulation frequency to be transmitted, but since each complete cycle of a sine wave can deal with two picture elements, the actual signal frequency is one-half the total number of picture elements, or 2.225 Mc/s (see Fig. 9).

In order to transmit the square picture elements, the fundamental frequency must normally be accompanied by a series of harmonics, and the higher the harmonics, the more accurately will the resultant waveform correspond to a square shape. On this basis, the maximum modulation frequency might very well rise to 25 Mc/s or so, and would involve considerable difficulty in transmission and reception.

Actually, owing to the fact that the cathode ray spot on the end of the tube is of appreciable size, and other considerations, it is found that in practice such higher harmonics would be wasted, as the spot would not be able to deal with them. As a result, the highest modulation frequency actually transmitted is only slightly greater than the fundamental frequency as found above. The B.B.C. signal contains modulation frequencies up to about 3 Mc/s, and the total band-width occupied (since double sideband transmission is used) is about 6 Mc/s.

It is clear, in view of the fact that the whole of the M.W. band from 200 to 500 metres only occupies a band-width of 0.9 Mc/s, that, were it possible to

transmit on this band, less than one-sixth of the B.B.C. television transmission would occupy the whole of the band, and in fact the whole transmission would extend from, say, 500 metres down to about 45 metres. This, of course, is quite impossible, and it is only by going down to the ultra short-wave band that television becomes practicable, as far as band-width requirements are concerned.

In any case, the carrier frequency must be several times as great as the maximum modulation frequency, and that is why a value of 45 Mc/s (6.7 metres) is chosen for the vision transmitter of the London station. The vision band thus extends from about 42 Mc/s to 48 Mc/s, and therefore by transmitting the sound at 41.5 Mc/s (7.2 metres), the sound is just clear of the low frequency edge of the vision band.

3—The Receiver

MAIN UNITS REQUIRED; SUPERHET AND TUNED RADIO FREQUENCY CIRCUITS

HAVING dealt with the form of the signal and the considerations which affect its frequency, we can now begin to examine the receiver with a clear picture of what is required of it. Leaving out the sound, for a moment, it will be remembered that the vision signal actually contains two sets of information—the intelligence necessary to form the picture, and the synchronizing pulses for “assembling” the picture correctly.

In the early stages of the receiver both sets of information are dealt with in the same way, but later in the set they have to be separated from each other so that each can perform its particular function.

As in the case of a receiver for ordinary sound broadcasting, the television receiver must first amplify the incoming signal, and then remove the carrier wave, leaving the modulation, which is the part required. It is at this stage that the synchronizing pulses must be separated from the vision modulation, and then the line and frame synchronizing pulses must be separated from each other.

While it is possible to use either the “straight” tuned radio frequency type of receiver circuit or the superheterodyne type for television reception (and each has

Television Explained

its own particular advantages) we will at this stage briefly examine the latter type. Fortunately, it is fairly simple to split the complete circuit up into a number of well-defined sections, and this has been done in Fig. 10, which shows one type of television superheterodyne in block diagram form.

Starting from the dipole aerial on the left, we have first of all an R.F. amplifier, broad enough in its band width to accept both the sound and vision transmissions. Following this is a frequency changer stage, containing a local oscillator running at a suitable frequency to produce the correct vision I.F. (intermediate frequency) signal. As, however, the sound signal is also present in this stage, a sound I.F. signal is also produced, though naturally at a different frequency from that of the vision I.F. signal. It is thus possible, at this stage, to separate vision and sound.

The sound signal therefore splits off at this point, and passes successively through the sound I.F. amplifier, the sound demodulator, and the audio frequency amplifier and output stage, to the loudspeaker. This part of the receiver therefore differs very little from the conventional superheterodyne sound broadcasting receiver.

Returning to the vision signal, after leaving the frequency changer stage this passes to a vision I.F. amplifier, which must, of course, be of the wide band type capable of dealing faithfully with a signal of 6 Mc/s band-width (or 3 Mc/s if single sideband reception is employed). This amplifier will probably contain a number of stages to provide the requisite overall gain.

Following the vision I.F. stages there is a vision demodulator, from the output of which we obtain the vision frequency signal, and the synchronizing signals. This output may or may not need amplification; if it does, then it is passed to a V.F. amplifier of one or more stages. This amplifier must also be capable of amplifying the wide-band signal without serious loss. The output from the amplifier (if used) is split; one part is fed to the modulating grid of the cathode ray tube via a D.C. restoration circuit. This circuit is used to put back the D.C. component of the signal which, as will be seen later, is necessarily removed in earlier stages of the receiver. The other portion of the

signal leaving the V.F. amplifier goes to a synchronizing separator, or filter, which first removes the vision portion of the signal, leaving the synchronizing pulses, and then separates the line and half-line pulses from the frame pulses.

The pulses are fed separately to the scanning generators, or time-bases, of which there are, of course, two. These generators, which are usually followed by amplifiers, are solely concerned with providing the sawtooth currents (in the case of electromagnetic deflection tubes) or the voltages (in the case of electrostatic tubes) necessary to deflect the cathode ray tube beam and produce the "raster" on the screen. The synchronizing signals injected into them are used to control the scanning generators so that every line and every frame of the picture commences at exactly the correct instant.

This completes the receiver proper, but there is naturally a power supply circuit which provides all the operating voltages for the various sections of the receiver, including, of course, the E.H.T. supply for the tube.

The superheterodyne type of circuit has a number of advantages, notably those of high sensitivity with freedom from instability, and comparative ease of separation of the sound and vision signals. However, there are disadvantages, too, such as the possibility of production of superheterodyne "whistles" which in a vision receiver result in dark bands or patterns interfering with the picture; greater complexity; and the problem of frequency stability of the oscillator.

With regard to the latter, however it is on the sound channel that difficulty due to frequency "drift" is most pronounced, owing to the relatively narrow pass band of the sound I.F. amplifier, compared with that of the vision I.F. amplifier.

In modern receivers this is largely remedied by increasing the sound I.F. band-width beyond that necessary for normal high fidelity sound reproduction, so that a slight change of intermediate frequency can be accommodated without sideband cutting. Users of certain pre-war television receivers may have noticed that, until the receiver had been in use for half an hour or so, and everything had settled down to a steady working temperature, it was necessary to readjust the tuning slightly from time to time.

The Receiver

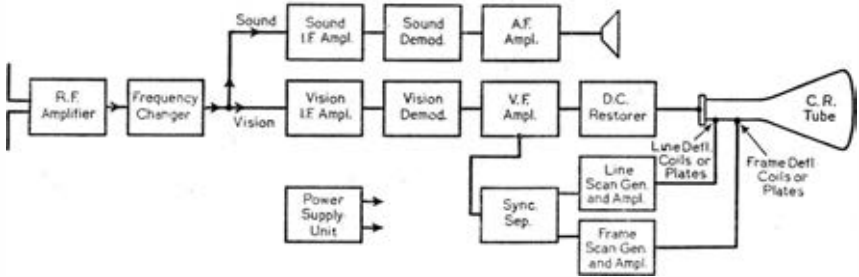

Fig. 10—Block schematic diagram of a complete television receiver of the superheterodyne type

The “straight” R.F. circuit is used by a number of manufacturers, and where extreme sensitivity is not required (that is, within the normal service area of the television transmitter), it has proved entirely satisfactory. It is usually found that three or four R.F. stages are required to give adequate sensitivity coupled with a pass band sufficiently flat to accept the complete vision signal. The necessity for this wide pass band (up to 6 Mc/s), which has been explained, carries with it the problem of discriminating between the sound and the vision signals.

With the vision at 45 Mc/s and the sound at 41.5 Mc/s, and with double sideband reception, the vision extends approximately from 48 Mc/s to 42 Mc/s, and the sound from just above to just below 41.5 Mc/s, so that the lower frequency side of the vision band is slightly under 0.5 Mc/s from the sound channel. With circuits having a pass band of 6 Mc/s, and a necessarily far from abrupt cut-off, the gap between the two channels is small. In practice few, if any, domestic receivers will accept the full 6 Mc/s pass band without a certain amount of attenuation at each edge of the band.

One way of increasing the discrimination between sound and vision is to place a rejection filter tuned to the sound channel in the input to the vision R.F. amplifier, and a vision frequency rejector in the input to the sound R.F. amplifier.

Alternatively, it is possible to use single sideband vision reception, if the R.F. circuits can be accurately tuned, and made so that they are free from drift. In this case, only the vision sideband from 48 to 45 Mc/s is received, and there is thus a gap of slightly less

than 3.5 Mc/s between the sound and vision, which is nearly seven times as great as with double sideband reception. However, single sideband working is more usually employed in superheterodyne receivers.

The effect of sound getting into the vision circuits is that dark irregular bands, usually horizontal, and occasionally patterned, appear on the picture, and vary with the sound modulation being received. Synchronization may also be disturbed.

Fig. 11 shows a block diagram for a “straight” R.F. vision receiver, which should be compared with Fig. 10. It will be noticed that the sound receiver in Fig. 11 is again of the superheterodyne type, and this is quite common, though some manufacturers employ a “straight” circuit for sound as well as vision.

It will also be observed that the diagram in Fig. 11 shows the feeder from the aerial branched, so that one pair of connections goes to the vision receiver and one to the sound receiver. It is possible, however, to couple the aerial to both sets with one feeder connected to two separate coupling coils in series. In this type of circuit there are usually no stages common to both sound and vision, though occasionally it may be found that the first R.F. stage is used for both. In this case, suitable rejectors for sound and vision, respectively, are used preceding the remainder of the vision and sound receivers.

Before considering the various stages of the television receiver in greater detail, a few words on the general design may be of interest. In the superheterodyne type up to the I.F. stages, and in the “straight” type up to the output from

Television Explained

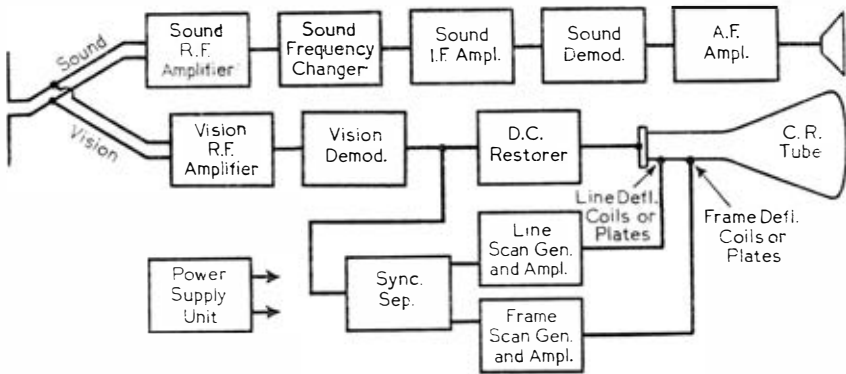

Fig. 11—Block schematic diagram of a television receiver using a “straight” tuned R.F. circuit for vision, and a superhet for sound. In some cases a V.F. amplifier follows the vision demodulator stage, while the D.C. restorer is not always needed

the demodulator, we are dealing with extremely high frequencies. This means, of course, that extreme care has to be taken by the designer in the matter of screening, in the use of short leads, particularly in grid and high R.F. potential circuits, and in decoupling.

The mounting of components on strip assemblies, with the attendant increase in length of connecting wires, is avoided, and “earth” returns to the chassis in each stage are usually all taken to the same point on the chassis to avoid the appreciable impedance which might exist between separate points on the chassis at such high frequencies.

Decoupling capacitors in these circuits are usually of the mica or some other special type. Wherever a change of capacity is liable to affect the stability of tuning to any appreciable extent, temperature-compensated capacitors are desirable.

Variable tuning in the normal sense is not necessary in the present type of television receiver. As a result, ganged tuning capacitors are not needed, and, in fact, practically all the tuned circuits can be of the pre-set type. The exception is, in the superheterodyne, the oscillator tuning capacitor, which is usually of the variable type, or at any rate has a small variable trimmer connected in parallel with it.

4—The Receiver

(Continued)

R.F. AMPLIFIER AND FREQUENCY CHANGER CIRCUITS

IN considering the various stages of a television receiver in more detail, we will assume that a superheterodyne circuit is used for both vision and sound, as this type of circuit is more complicated than that of the tuned R.F. receiver, and will therefore reveal more points in design.

In almost all cases it will be found that an R.F. amplifier stage precedes the frequency changer of the superheterodyne, partly, of course, to amplify the signal picked up by the aerial and improve the signal to noise ratio, but also to minimise the possibility of interfering signals reaching the frequency changer, by increasing the discrimination between wanted and unwanted signals. The latter, which may be harmonics of signals in quite a different waveband, may beat with the oscillator signals, or harmonics of them to produce undesirable I.F. responses which would result in interference patterns on the television screen.

Although the stage gain of a single R.F. amplifier at television frequencies is not likely to be very great using ordinary R.F. pentodes, this amount of pre-frequency changer amplification is useful in that it reduces the amount of gain necessary in the I.F. stages, in which

The Receiver

the majority of the amplification of the signal is attained, and this helps in ensuring a good degree of stability in the I.F. amplifier.

A more important advantage of the R.F. stage of the receiver, particularly in districts of low signal strength, is the improvement in signal to noise ratio which results, compared with a receiver in which the aerial is fed direct to the frequency changer. "Noise" is used here to mean the "grainy" background to the picture on the television screen which is the vision counterpart to background hiss in a sound receiver.

The noise introduced into a receiver due to the valves themselves, and not to external interference, is mainly attributable to the initial stage of the receiver, where the level of the signal is low. If this stage produces a good degree of signal gain, noise in succeeding stages, where the signal level is relatively high, is unimportant. Since the frequency changer valve produces very little gain compared with a good R.F. stage, the importance of feeding the incoming signal into a preliminary R.F. stage is obvious. The explanation given is actually only a very simple statement of the case, but it indicates that, unless a really good signal strength is available, an R.F. stage is very desirable.

The design of a television R.F. stage is complicated by the fact that whereas we obviously require the maximum possible gain, we must also retain a very wide acceptance band for the signal. These two features do not go together, and in practice a compromise must be made whereby we obtain the maximum gain possible with an adequate band-width.

In view of the fact that in the majority of receivers the R.F. stage must accept both the vision and the sound channel, that is, when tuned it should amplify without serious loss all frequencies from 48 to just under 41.5 Mc/s, the band-width should be about 7 Mc/s. In practice it is usually somewhat less than this, since a certain amount of attenuation of the sound channel is unimportant, and the stage can be tuned with the mid-point of its acceptance band slightly closer to the centre of the vision band than to the sound channel.

Another factor in the design of the R.F. stage is that the input impedance

of the R.F. pentode becomes low at television frequencies, and has a big effect on the characteristics of the input circuit. Further, the input impedance will vary considerably with the bias of the valve, and the use of variable cathode bias to control the gain will almost certainly affect the response characteristics of the stage.

In practice, the damping due to the valve, which is applied to the input tuned circuit, is used to good advantage to assist in securing the requisite large band-width; the load caused by coupling the feeder to this circuit also helps in this respect.

The total of the two is often sufficient to obviate any further damping being necessary, though in some cases a parallel fixed resistance is necessary.

Fig. 12 shows a simple R.F. stage with tuned-anode coupling to the following (frequency changer) valve. The aerial feeder wires are connected to terminals of the coupling coil L1. Sometimes they go direct to the tuned grid coil L2, one being connected to its earthy end, and the other to a suitable impedance matching tapping on it. Other, and more complicated coupling arrangements may also be found, and an electrostatic screen is often introduced between L1 and L2.

The tuned coil L2 is shown with a parallel damping resistance R1, which

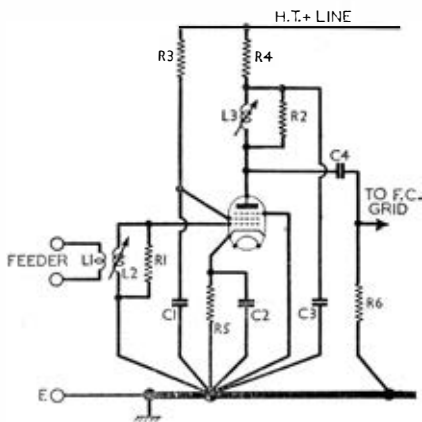

Fig. 12—A simple television R.F. stage illustrating points mentioned in the text. Note that all circuits of the R.F. valve return to a single point on the chassis

Television Explained

may or may not be necessary. No tuning capacitor is shown; in practice the grid/cathode capacitance of the valve, plus stray circuit capacitances, are used for this purpose, the adjustment of tuning being carried out by varying the inductance of L2. This is achieved by sliding in or out of the coil, axially, a brass rod, or slug, or by using an adjustable dust-iron core. This adjustment is usually pre-set.

The tuned anode coil, L3, is also shown shunted by a damping resistance R2, and the amplified signal is coupled, via C4, to the grid of the frequency changer valve, R6 being the grid circuit resistance.

The screen of the R.F. valve is fed from the H.T. line via R3, with the decoupling capacitor C1, and the anode circuit contains the decoupling components R4, C3. The suppressor grid of the valve (which is brought out to a separate pin) is connected to chassis. R5 is the cathode resistor providing fixed bias; it is by-passed by C2.

All by-pass and decoupling capacitors are of the mica type, and it will be noted that all earth returns associated with the valve go to a common point on the chassis to avoid introducing impedance between the various earth returns, which might exist at television signal frequencies. The earth return of R6 need not go to the same point on the chassis as the returns associated with the R.F. valve, since R6 really belongs to the frequency changer circuit.

It will be noted that in Fig. 12 no provision is made for variable gain control, but in Fig. 13 this is included. The feeder in this circuit goes directly to one end and a tapping on the tuned input coil L1, across which is the damping resistor R1. The output from the R.F. valve is coupled by means of R4 and C4 to a tuned circuit L2, R2 in the grid circuit of the frequency changer valve. R3 and C1 are the decoupling components for the anode and screen of the R.F. valve; the suppressor is connected to chassis.

The resistor R5 provides fixed minimum grid bias, and the variable gain control is obtained by means of the fixed resistors R7, R8, and the variable resistor R6, connected as shown in the cathode circuit. Since the suppressor of the valve

is connected to chassis, and not to cathode, the suppressor is biased by the drop in voltage across the resistance network between cathode and chassis, this being varied by means of R6. However, the grid circuit return does not go to chassis, but to the junction of R7, R8, so that the grid bias variation is only that due to the change in voltage across R7. Since R7 is made much smaller than R8 (R7 may be 5,000 Ω and R8 75,000 Ω for the Mazda SP41 valve), the variation in grid bias is only a fraction of the variation in suppressor bias. R6 for the SP41 is 25,000 Ω total.

The result of using this method of gain control is that the variation of the grid input characteristics of the valve with change of amplification is considerably reduced. Other methods of gain control may be employed, but in any case since the special television R.F. pentodes are of the short-grid base, non-variable μ type, the range of control must be limited. In practice, the R.F. gain control is often employed as a pre-set sensitivity control only, the "contrast" control of the receiver operating on the I.F. amplifier.

Although both diagrams show a single tuned circuit in the output of the R.F.

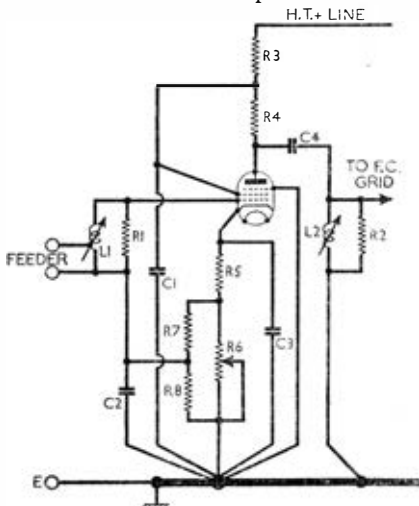

Fig. 13—Another type of R.F. stage, in which gain control by R6 is incorporated, and resistance-capacity coupling to a tuned grid circuit is employed

The Receiver

amplifier (tuned anode in Fig. 12 and resistance-capacitance fed tuned grid in Fig. 13), it is quite common to find a transformer coupling from the R.F. valve anode to the frequency-changer grid circuit. In this case the transformer will have band-pass characteristics necessary to deal with the wide-band signal. Both primary and secondary circuits of the transformer may be damped by shunt resistors, though a resistor across the secondary may not be necessary in view of the damping which is imposed by the grid to cathode impedance of the frequency changer valve.

Following the R.F. stage in the superheterodyne television receiver, we come to the frequency changer. This usually employs a triode-hexode or triode-heptode valve, each of which is quite satisfactory, but occasionally two separate valves, an oscillator and a mixer, are used.

It has already been stated that in the majority of cases the R.F. amplifier stage handles both the vision and sound input, the tuned circuits being broad enough to accept the frequency band involved without appreciable attenuation.

Unless separate frequency-changer stages are to be used for vision and sound, the single stage will have the output from the R.F. stage fed to its mixer grid circuit, and the effect of the local oscillator will be to cause both vision and sound I.F. signals to appear in the mixer anode circuit, but at different intermediate frequencies. It is clear that at this point separation between the vision and sound can be achieved.

Let us see how the two I.F. signals are produced. The input to the mixer contains signals on carrier frequencies of 45 and 41.5 Mc/s. Suppose the local oscillator frequency is 60 Mc/s, then a vision intermediate frequency of 60-45, or 15 Mc/s is produced, while the 41.5 Mc/s sound signal will produce a sound I.F. of 60-41.5, or 18.5 Mc/s. Taking the case where the oscillator frequency is lower than that of the incoming signals, an oscillator frequency of 30 Mc/s would again produce a vision I.F. of 15 Mc/s (45-30), but the sound I.F. would then be 41.5-30, or 11.5 Mc/s. In each case there is 3.5 Mc/s difference between the vision and sound I.F. values thus calculated, which is the same as the spacing between the vision and sound carrier frequencies.

It must not be forgotten, however, that with a wide band input signal the I.F. signal produced will also have a wide band. Thus a 15 Mc/s vision I.F. signal will actually occupy the band from about 12 to 18 Mc/s.

The choice of the value of the intermediate frequency in a television receiver is governed by a number of considerations, which in some cases oppose one another, and as usual the individual designers generally arrive at what they consider to be the best compromise. Having decided on the I.F. values, they must also consider whether the oscillator frequency is to be above or below that of the signals.

Interference problems, due to the feeding back of I.F. harmonics to the input circuits; direct pick-up of extraneous signals at intermediate frequency, which may be due to short-wave stations or their harmonics; and similar causes, all have to be considered when deciding on the I.F. to be employed. The problem is made worse by the wide-band nature of the vision signal.

As an example of the differing solutions to the problem of the best I.F. values, it may be noted that three different pre-war television sets of the superheterodyne type had intermediate frequencies as follows: vision 9.5 Mc/s, sound 6.0 Mc/s; vision 6 Mc/s, sound 2.5 Mc/s; vision 3 Mc/s, sound 455 kc/s.

As an example of a frequency changer stage, let us consider Fig. 14, which shows a circuit in which a triode-hexode valve is used, and separation of the vision and sound I.F. signals takes place in the hexode anode circuit. The input from the preceding R.F. stage is, of course, fed to the mixer (hexode) grid. The usual decoupling is provided for the mixer screen grids (R1, C1) and anode (R2, C2). A small bias for the mixer grid is applied by means of the cathode resistor R3, bypassed by C3.

The triode oscillator section utilizes a Colpitts type of circuit, with the coil L5 and the two capacitors C7, C8, with their junction connected to chassis. C9 and R8 are the usual grid capacitor and resistor, but their values, in conjunction with those of L5, C7 and C8, and the oscillator anode voltage, have to be carefully determined in order to provide a suitable degree of oscillation.

Television Explained

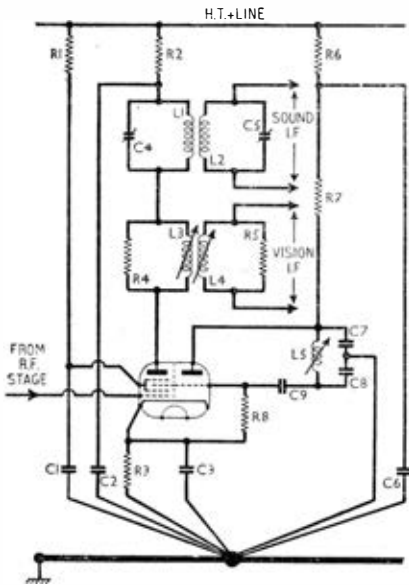

Fig. 14—A typical triode-hexode frequency changer stage, described in the text

L5, in the case shown, is tuned by means of a brass slug or, in some cases, by a movable iron-dust core. This tuning control, which usually only covers a small range either side of the correct point, is the only variable tuning control of the television receiver. All other tuning is pre-set. The oscillator anode voltage is applied via the decoupling and load resistors R6, R7, and the decoupling capacitor C6. Note that all the returns to chassis for this stage usually go to the same point on the chassis.

As explained earlier, both the vision and the sound I.F. signals occur in the anode circuit of the hexode mixer, and if in series in the anode circuit we place two tuned circuits, one tuned to the vision I.F. and the other to the sound I.F., the I.F. signal voltages will appear across their respective tuned circuits, and can be fed to separate I.F. amplifiers.

In Fig. 14, L3, L4 form the vision I.F. transformer unit, with primary and secondary coils damped by R4 and R5 to provide the necessary broad band tuning. L1, L2, tuned by C4, C5, form the sound

I.F. unit. The primaries of these units are in series in the hexode anode circuit; the secondaries are, of course, quite separate.

Certain advantages are claimed for the use of separate mixer and oscillator valves, forming a two-valve frequency changer stage, notably an increased amplification, and in America, in particular, such an arrangement is common. Fig. 15 shows one such stage, in simplified form. The mixer valve is a pentode, with the usual decoupling arrangements to its feed circuits. It has the I.F. coupling units in its anode circuit, though only one is shown, for simplicity.

The oscillator valve is a triode, and in Fig. 15 it is shown operating in a Hartley type of circuit, with a tapped tuned oscillator coil L3. Coupling between the

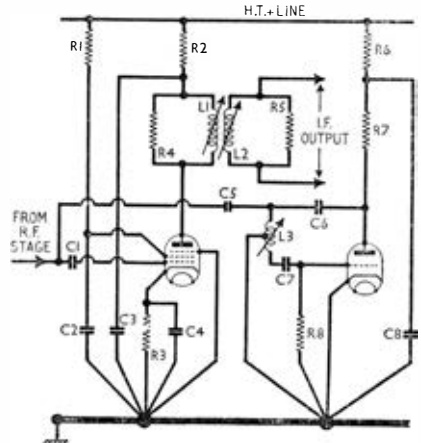

Fig. 15—A 2-valve frequency-changer

two valves is by the small capacitor C5, from the oscillator circuit to the mixer grid circuit, though in place of this inductive coupling by means of link coils is sometimes employed.

Whatever the type of frequency changer, the oscillator circuit must have a reasonable degree of stability with changing temperature, otherwise tuning drift may become noticeable. Provided the I.F. stages of the receiver (particularly those in the sound section) are made somewhat broader than is theoretically necessary, a really high degree of oscillator stability is not essential.

The Receiver

Very complete screening of the frequency changer, and the use of the shortest possible leads, particularly in the oscillator circuit, are important features.

5—The Receiver

(Continued)

I.F. AMPLIFIER STAGES

THE previous chapter took us to the output of the frequency changer stage, in the anode circuit of which separation of the vision I.F. signal from the sound I.F. signal is achieved. In passing, it may be pointed out that complete separation between the two is not always possible without additional filter circuits incorporated in the I.F. amplifiers, as we shall see later. For the present, however, we assume that the two signals are separated and fed to their respective amplifiers, and we will consider the vision I.F. amplifier only.

In general, the design of a television I.F. stage follows the same principles as that of the corresponding stage in a sound receiver, but there are two big differences which naturally influence the problem. In the first place, instead of an I.F. value of, say, 465 kc/s, commonly used in a sound receiver, the vision receiver may have an I.F. up to 12 to 15 Mc/s, as explained in the previous chapter. This at once makes a difference, though with modern valves, coil design and screening technique, the problem is not unduly difficult.

The main difficulty in the design of a vision I.F. amplifier is due to the fact that we need a fairly high overall gain, coupled with a band-width acceptance of 3-6 Mc/s (depending on whether single or double sideband working is employed). It should be fairly obvious that with normal I.F. couplings employing peaked tuned circuits it would be impossible to secure anything approaching a 6 Mc/s band-width acceptance. Since picture detail depends on the retention of the sidebands in the amplifier, some other form of coupling must be used.

Unfortunately, though there are various methods of increasing the band-width of the amplifier, they all result in a reduction in the stage gain, and to compensate for this, more stages must be used. It is quite common for a television receiver

to use three I.F. valves as a minimum, while five valves may be employed in some receivers.

The couplings employed between the valves may be of the tuned anode, tuned grid, or tuned transformer type, and the wide-band properties can be secured in several ways. In practice, a combination of methods is often used in a single receiver.

It will readily be appreciated that one method of broadening the response of a tuned circuit is to introduce resistance in series with the inductance and capacitance of the circuit. More commonly, a resistor is connected across the parallel tuned circuit of such a value as to have the same effect as the requisite series resistance. Such an arrangement damps the tuned circuit, and broadens its response, but at the same time it reduces the efficiency of the circuit, and therefore results in a lower gain for the complete stage.

Another method of securing the necessary pass band is to adopt the principle of "staggered" tuning, in which instead of having all the couplings tuned to the same frequency (the mid frequency of the pass band), some circuits are tuned progressively lower than the mid frequency while others are tuned higher by the same amounts.

By careful adjustment of the various tuning points it is possible to secure a fairly flat-topped response curve of the requisite width, though again with a reduction in overall amplification. It is found, however, that for a given band width the overall amplification obtainable from "staggered" circuits can be made several times as great as if ordinary tuned circuits with resistance damping are employed.

Naturally the correct tuning of slightly staggered circuits is a difficult matter, and any inaccuracy here will result in an asymmetrical or uneven resonance curve which will introduce bad picture quality. Consequently, "staggered" circuits, once adjusted should only be re-adjusted if the necessary equipment and information is available.

In practice, many receivers employ a combination of damped and staggered circuits in the various stages, while it is often found that the final coupling, preceding the vision demodulator, employs damping only, to avoid the possibility

Television Explained

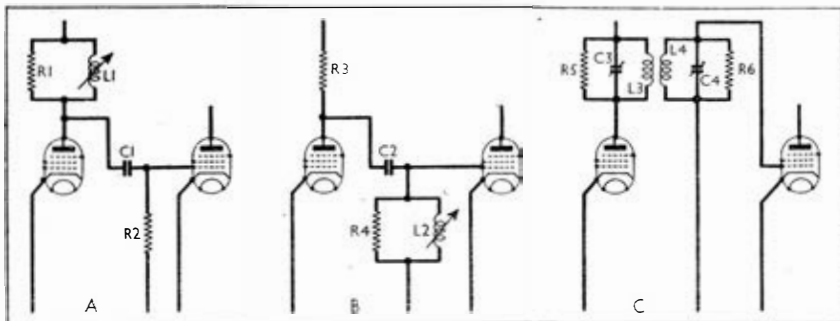

Fig. 16—Three forms of I.F. couplings described in the text. A, tuned anode; B, tuned grid; C, transformer

of introducing phase distortion at this point.

Fig. 16 shows in skeleton form three types of coupling circuit which may be used. Resistance damping is indicated in each case, but staggered tuning may be employed, either additionally or alone, and in the latter case the parallel resistors will not be present.

Fig. 16 at A shows the conventional tuned anode coupling, $L1$ being the coil, tuned by its own and stray circuit capacitances, and adjusted by a variable dust-iron core. $R1$ is the damping resistor, $C1$ the coupling capacitor and $R2$ the grid resistor of the succeeding valve.

At B in Fig. 16, we have the tuned grid form of coupling, with the anode load resistor $R3$, coupling capacitor $C2$, tuned coil $L2$ and damping resistor $R4$.

At C in Fig. 16, two coupled tuned circuits forming a transformer are employed. The coils $L3$, $L4$ are, in this diagram, tuned by $C3$ and $C4$ which are in addition to the circuit capacities, and are adjustable. However, in many cases tuning is achieved by varying the inductance as in A and B. $R5$ and $R6$ are damping resistors, one or both of which may be omitted if staggered tuning is employed.

We have already seen that a gain control is often employed in the R.F. stage of the receiver, and is usually pre-set, and used for adjusting the overall sensitivity of the receiver for any particular location and aerial. An independent gain control is also fitted in the I.F. stages, and this

usually becomes the "contrast" control, which is made readily accessible for adjustment by the viewer.

This control often operates only on the first I.F. valve, which is sometimes of the variable- μ type. Occasionally the control also operates on the second I.F. valve. In its simplest form (Fig. 17A), "contrast" control is by a variable resistor $R2$ in series with a fixed minimum bias resistor $R1$ in the cathode circuit of the first I.F. valve. More complicated systems bias the suppressor and control grid of this valve by different amounts, as was described in the article on R.F. stages. Again, the bias may be obtained from a potential

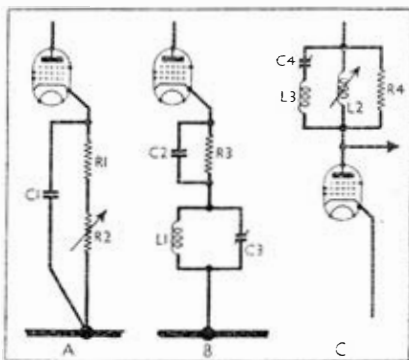

Fig. 17—A, a simple form of contrast control; B, a negative feedback sound I.F. filter; C, another form of filter in parallel with the vision I.F. anode coil

The Receiver

divider across the H.T. circuit, of which the chassis end is made variable.

It has already been stated that the separation between sound and vision I.F. signals in the mixer anode circuit may not be sufficient to prevent a small sound I.F. signal reaching the vision I.F. input, where, owing to the broad tuning circuits, it may pass through the amplifier and cause interference with the vision signal. To prevent this, one or more rejector circuits may be employed.

Fig. 17B shows one preferred form of sound I.F. filter, connected in the cathode circuit of one of the I.F. valves. R3 is a fixed bias resistor shunted by C2, while the parallel tuned circuit L1, C3 is adjusted accurately to the sound intermediate frequency, at which it will have a high impedance, giving strong negative feedback and therefore reduced amplification of any signal of this frequency reaching the grid of the valve. Obviously, the circuit L1, C3 must be fairly sharply tuned, otherwise feedback might occur over part of the vision I.F. band.

Another form of sound I.F. filter is shown at Fig. 17C, where C4, L3 is a series tuned acceptor circuit in parallel with the tuned anode coil L2, damped by R4. Any signals reaching the anode circuit at sound I.F. are by-passed by C4, L3 and are not passed on to the next stage. This type of filter is not very common in commercial receivers.

Reference was made earlier to single sideband working, in which connection the band-width of the I.F. stages can be reduced to one half that needed for double sideband working. The receiver is tuned so that the I.F. signal falls almost entirely on one side of the amplifier response curve, so that one sideband is largely attenuated whereas the other is almost normally amplified.

A reduction in the band-width of the amplifier means that a higher gain per stage can be obtained, and less valves will be needed, but there are disadvantages to this method of working, such as the necessity for very accurate tuning and the possibility of obtaining poor definition and sometimes "plastic" effects in the picture.

The sound I.F. amplifier follows in principle the lines of that in an ordinary radio set, except for the higher frequency and somewhat greater band-width.

6—The Receiver

(Continued)

DEMODULATOR AND VIDEO FREQUENCY AMPLIFIER STAGES; D.C. RESTORATION

IN the sections of the receiver already described we have been concerned primarily with the amplification of the received signal. It is true that, in the superheterodyne circuit considered, we have changed the carrier frequency, but this was only done for convenience, so that adequate amplification could be secured at the lower (I.F.) frequency. In fact, the signal as it leaves the I.F. stages should have exactly the same form as when it entered the receiver, the only differences being that its carrier has been changed in frequency, and its amplitude has become considerably greater.

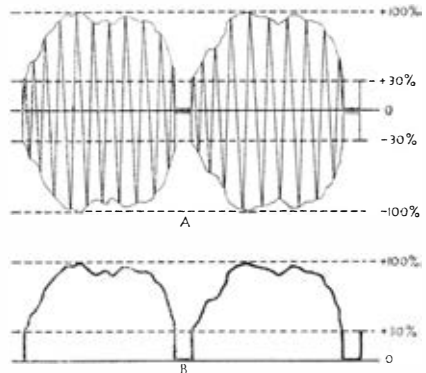

Fig. 18—The form of the signal as it leaves the I.F. amplifier is shown at A; at B is the same signal after passing through the demodulator stage

The diagram at A in Fig. 18 shows the form of the signal at this stage; two complete lines and line synchronising pulses are included, and it will be noticed that the carrier is still modulated by the picture signals at video frequency. The picture signals occupy the carrier from 30 per cent (black) to 100 per cent (white) of its amplitude; the sync pulses are in the "blacker than black" (0-30 per cent) region. The positive and negative phases of the carrier wave are, of course, symmetrical about the zero line.

Just as at this stage in the sound receiver it is necessary to "detect" the signal,

Television Explained

and remove the carrier, leaving the A.F. signal which formerly modulated the carrier, so in the television receiver we now have to "detect" the video signal.

Consequently, the amplified I.F. signal, after leaving the I.F. amplifier, must be fed to a detector or demodulator stage, at the output of which we shall expect to be left with the video signal as at B in Fig. 18. Note that this still contains both the picture signals and the synchronising signals. The removal of the latter for

manufacturer has used an R.F. pentode operating under anode band conditions.

Unlike the majority of sound receivers, the tuned radio frequency type of television set also usually employs diode detection, so that from this point onwards both superheterodyne and tuned radio frequency types operate in a similar manner.

Two single diode television demodulator circuits are shown in Fig. 19. At A is an arrangement giving an output in negative phase, while at B the diode connections are reversed, and the output is in positive phase.

L1 and L2 represent the final tuned circuits of the I.F. amplifier (in the case of a superheterodyne), while R1 and R2 are the respective load resistors and C1 and C2 their by-pass capacitors.

The diode valves used are of a special type with a low internal resistance, and the values of R1, C1 or R2, C2 are much lower than in the same stage in sound receivers. R1 and R2 are often as low as 2,500 ohms, and C1 and C2 are rarely more than a few $\mu\mu\text{F}$; in fact, the stray capacitance of the circuit alone may be adequate, and by-pass capacitors are then omitted.

The correct choice of values for the load resistors and by-pass capacitors is extremely important if a reasonable detector efficiency, coupled with an adequate frequency response, is to be secured.

In addition, however, the demodulator circuit must be properly filtered to prevent any R.F. or I.F. voltage superimposed on the V.F. signal from passing on to the following stage, or getting back to preceding stages. The design of a suitable filter at this point is therefore of considerable importance. The type and complexity of the filter used varies a

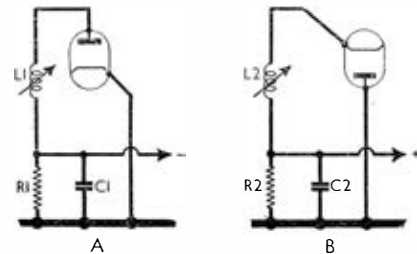

Fig. 19—Two half-wave demodulator circuits, arranged to give an output in the negative sense (A) and the positive sense (B)

use in regulating the time base generators in the receiver is usually a post-detector operation.

The output from the demodulator shown in Fig. 18B is shown as a positive signal, the voltage increasing in a positive direction with increase in signal. In order to secure a positive picture on the tube, this is the correct phase in which to apply the signal to the grid of the tube, as we shall see later. However, it may be necessary to amplify the video frequency signal before applying it to the tube, and if only one stage of video frequency amplification is used, the output from the demodulator will have to be in a negative sense, since 180 degrees phase reversal occurs in the single stage of amplification. It is quite easy to secure a positive or negative output from the demodulator stage, as required.

So far as the actual circuit is concerned, it is possible to employ any of the demodulator circuits used in sound receivers, with suitable modifications made necessary by the 3 Mc/s band width of the video signal. In practice, either a single or double diode detector is employed, though at least one

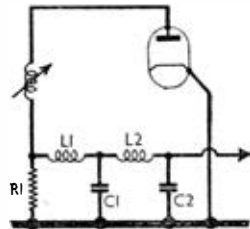

Fig. 20—A simple filter as used in conjunction with a half-wave demodulator valve

The Receiver

good deal, but a simple form of low-pass circuit, in conjunction with the detector diode, is shown in Fig. 20. Here R1 is the load resistor, and L1, L2 and C1, C2 the inductive and capacitive components of the filter.

Sometimes a push-pull demodulator circuit is employed, and a typical circuit is shown in Fig. 21, where two diode valves are used. Filtering problems are less difficult with this type of demodulator, though a simple filter circuit is included in Fig. 21. The input must be fed to the detector valves by means of a transformer with a centre-tapped secondary, of which the correct design is no easy matter.

It is also possible to use two diodes in a voltage-doubler type of detector circuit.

The V.F. signal which emerges from the detector stage is actually of the correct form to be applied to the control (modulator) grid of the cathode-ray tube, provided it is in the positive phase. However, in view of the fact that a medium sensitivity cathode-ray tube requires a peak-to-peak signal of 20 to 25 V before full white is registered on the screen, it is unlikely that the detector output will be adequate for this purpose without at least one stage of amplification.

It must be remembered that apart from the vision content of the signal, which modulates the tube, the synchronizing pulses are also present, so that the actual voltage output required from the detector to ensure a vision output of, say, 25 V, is about 36 V. However, it is possible in the case of a more sensitive tube to eliminate amplification between the detector and the tube, and to feed the output from the diode direct to the control grid of the tube. Apart from other considerations, this is advantageous in that it eliminates the difficulties of retaining in the video amplifier full amplification of all frequencies of the wide band video signal.

More generally, however, tubes of medium sensitivity are used, and in order to obtain the necessary voltage to secure full modulation at least one stage of video amplification is necessary.

The video amplifier in a television receiver is comparable with the audio amplifier in a sound receiver, but with three important differences. The first is that instead of an audio band of, say, 50 to

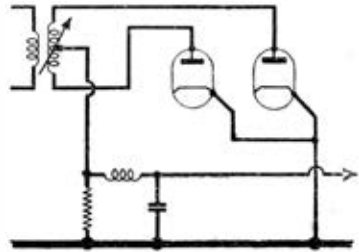

Fig. 21—The basic full-wave demodulator circuit

10,000 c/s, the video amplifier must handle a band of 0 to 3 Mc/s. The second is that a voltage output instead of a power output is required from the video amplifier, and the third (which really follows from the first), is that the video signal contains a D.C. component (0 c/s) which must be retained, or, if removed, must be replaced before the signal is fed to the cathode-ray tube.

The wide frequency band requirement causes the greatest difficulty in the design of the V.F. amplifier. Theoretically, the amplifier should deal equally with all frequencies not only of the usual audio range, but through the normal long-wave and medium-wave ranges right up to a frequency equivalent to 100 metres. It is obvious that this is not an easy problem, particularly since high frequency response will be reduced by stray capacitances due to the valve, the wiring, and the input circuit of the tube.

The valve chosen for the task is usually a television R.F. pentode, though power pentodes or tetrodes may be used owing to their relatively low grid/anode capacitance. They are operated with a resistive anode load, which, to secure adequate high frequency response, must be kept low. This, of course, limits the gain of the stage.

In order to improve the gain without affecting the frequency response, small correction chokes are usually employed. Fig. 22 shows a skeleton V.F. amplifier stage, using a pentode valve, in which R1 is the anode load resistor and L1 a compensating choke in series with it. This choke neutralizes to a large extent the stray circuit capacitance, and incidentally permits a higher value for R1, thereby increasing the gain of the stage.

Television Explained

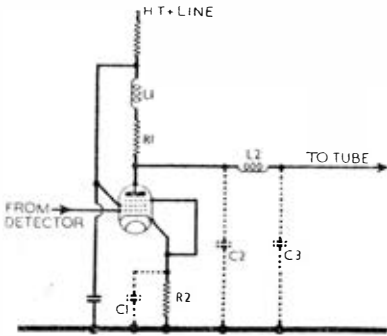

Fig. 22—Basic V.F. amplifier circuit, with two compensating chokes, L_1 and L_2

It is also possible to compensate by means of a choke in series with the output lead from the anode circuit, as shown at L_2 in Fig. 22. This choke, with the valve, tube and circuit stray capacitances C_2 and C_3 , resembles a low-pass filter, and besides improving the performance, has other advantages.

Occasionally chokes are employed in both positions, as in Fig. 22, and this arrangement is best of all, though somewhat critical from the designer's point of view.

R_2 in Fig. 22 is a bias resistance which is normally fitted. The parallel capacitor, however, is often omitted, and the resulting negative feedback helps to improve the overall response of the amplifier, though with reduction of gain.

Turning now to the problem of the retention of the zero frequency (D.C.) component of the signal, it is as well to explain the significance of this feature of the television signal. In the first place, it will be appreciated that every scene televised has a certain range of contrast, from the darkest to the brightest tone. In addition, and this is not so obvious, each scene has an average brightness value.

As an example, take a scene in a living room with normal artificial lighting, which has a certain contrast range. Now suppose the artificial lighting is dimmed. Theoretically the contrast range remains the same, but as the illumination has been reduced, the *mean* brightness is now less.

In the television signal the mean brightness is governed by a bias on the signal, which takes the form of a D.C. component superimposed on the vision modulation, and which fixes the mean brightness datum line of the picture relative to the "black" level. If this bias is removed we still get a similar range of contrast, but the signal contains no information enabling the tube to adjust itself to changes in mean brightness. Consequently, in the example mentioned above, the dimming of the light would not be appreciated, at any rate, after the momentary period during which the signal settles down after the change.

It can be appreciated, therefore, that the D.C. component must be retained, and an obvious way of ensuring this is to employ direct coupling everywhere between the detector and the grid of the tube. This is simple in cases where the detector can feed the tube without a V.F. amplifier stage, and in this case no D.C. restoration is necessary.

Where a V.F. amplifier is essential, one can only retain the D.C. by using a direct-coupled amplifier circuit. Such an amplifier is feasible, but usually not practicable owing to the fact that it involves the use of a special H.T. supply circuit which is completely voltage-stabilized. However, in any case there is always a danger of damaging the tube on switching on or off, or by failure of the V.F. valve, which may place a high positive bias on the tube grid, and so direct coupling for the V.F. amplifier is not normally used in domestic receivers.

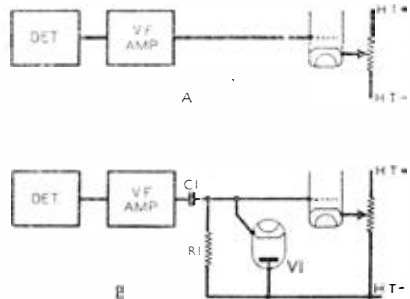

Fig. 23—Direct coupling to the tube grid is shown at A, while capacitive coupling, with D.C. restoration, is indicated at B

The Receiver

The principle of direct coupling is indicated at A in Fig. 23, which shows the grid of the tube fed direct from the V.F. amplifier. The cathode of the tube is connected to the slider of a potentiometer which provides mean bias for the tube, and therefore acts as the "brightness" control.

At B in Fig. 23 is shown the more normal arrangement, in which an ordinary V.F. amplifier is used, with a capacitor C1 coupling the V.F. anode to the tube grid. Obviously, since D.C. cannot pass through C1, the D.C. component of the signal is lost.

It is, however, easily replaced by means of the inverted diode valve V1, with its load resistance R1. This valve, usually a small television diode, is known as the D.C. restoring diode.

With the D.C. component of the signal removed, the A.C. component tends to arrange itself on the grid bias line of the cathode ray tube so that equal "areas" of signal occur above and below the bias line. The main part of the picture signal will, of course, be on the "less negative" side of the line, and the remainder of the picture signal and the synchronizing pulses on the "more negative" side. In order to give the same effect as the D.C. component which has been removed, we must find a means of providing a variable bias voltage which will shift the complete vision and sync signals in a "less negative" direction to a greater or lesser extent, depending on the instantaneous value of the D.C. component.

The D.C. restoring diode, connected as shown in Fig. 23B, achieves this task by acting as a peak voltage rectifier of the signal on the "more negative" side of the bias line. V1 does not conduct during the excursions of the signal on the "less negative" side of the bias line, since its cathode is maintained positive, but the opposite excursion of the signal (that is the largely sync pulse portions on the "more negative" side of the bias line) drive the diode cathode negative. This causes it to conduct, charge the coupling condenser C1, and produce a positive bias across R1, which, providing the time constant of C1 and R1 is correctly chosen, follows the original D.C. component of the signal with reasonable accuracy.

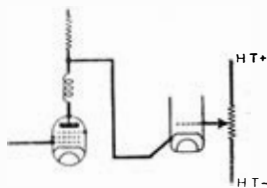

Fig. 24—An anode bend detector directly coupled to the tube cathode

It can be seen, therefore, that in view of the simplicity of D.C. restoration, it is hardly worth while to employ a direct-coupled V.F. amplifier in any ordinary television receiver.

Before completing this section, it is of interest to note that in certain receivers an anode bend detector, used instead of the diode detector, is direct coupled to the cathode ray tube with complete safety. The output from the anode circuit of the valve is in the negative sense, and cannot therefore be applied to the tube grid, which needs a signal in the positive sense.

To solve this difficulty, the signal is fed to the *cathode* of the tube (which must be separate from the heater, of course), and the "brightness" control slider is connected to the grid of the tube. Should the valve fail, its anode, and therefore the cathode of the tube, becomes more positive, which is the same as driving the grid more negative, and reducing the cathode emission. The arrangement is shown diagrammatically in Fig. 24.

7—The Receiver

(Continued)

SEPARATION OF THE SYNCHRONIZING PULSES

I N the previous chapters the complete vision receiver, from the aerial to the modulating grid of the cathode ray tube has been considered, and we must now turn to what may be termed the auxiliary sections of the receiver. These are not concerned specifically with the vision signal as such, but are nevertheless essential to the reception of complete pictures.

Television Explained

It has already been indicated that the tube is "scanned" by suitable scanning generators, and these produce a raster on the tube whether a signal is present or not. In order that these generators may run exactly in step with those at the transmitting end, use is made of synchronizing signals which, as was seen in Chapter 2, form part of the complete television signal.

In order to make use of the synchronizing signals and apply them to the scanning generators (or time bases, as they are less accurately known) it is necessary to separate the synchronizing pulses from the picture signal; in addition, the line pulses and the frame pulses must also be separated from each other.

First of all, to separate both sets of pulses from the picture signal, use is made of the fact that the sync pulses occupy only that portion of the complete signal lying between zero and 30 per cent of the full amplitude (that is, the "blacker-than-black" portion). This

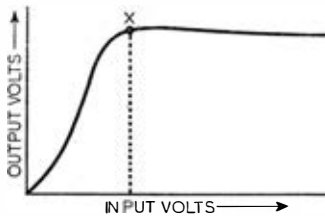

Fig. 25—Characteristic of the filter valve

suggests the use of an amplitude filter of some kind, set so as to pass signals below 30 per cent of the maximum, and block those of 30 per cent and over.

There are numerous methods of accomplishing this, using a diode, triode or R.F. pentode, and one of the most common is that in which use is made of the constant-current properties of a screen grid or pentode valve running with low anode and screen voltages. A typical characteristic curve is shown in Fig. 25. Matters are arranged so that the input to the valve corresponding to "black level" (30 per cent of maximum) brings us to the operating point X on the curve.

Assuming a resistive load in the anode circuit of the valve, any increase in input (that is, picture signal) will bring the operating point somewhere to the right

of X, and practically no change in anode current will take place, and there will be no appreciable variation in the voltage across the load resistor.

On the other hand, a decrease in input, which occurs on each synchronizing pulse, will bring the operating point to the left of X, and there will be a considerable change in anode current and hence in the voltage across the load. These voltage changes represent the sync pulses, which are thus separated from the video signal, and can be passed eventually to the scanning generators. It is also possible to separate the pulses from the vision by working on the lower bend of the valve characteristic, which produces the pulses in opposite phase.

In order to ensure complete separation of the video and sync signals, it is important that the D.C. component of the complete signal should be present to maintain the "black" level at a constant value. Consequently the separation must take place either before the D.C. component is removed or after it has been restored.

In Fig. 26 is shown the basic circuit for sync separation using an amplitude filter of the type already described. It will be noted that this circuit is similar to Fig. 23B, except that in addition to the connection to the tube grid from the cathode of the D.C. restorer valve V1, there is another connection from the cathode to the amplitude filter valve V2, via a series grid resistor. The latter reduces the load of V2 on the signal circuit, and also assists the filtering action. The line and frame sync pulses (mixed) are fed from the anode circuit of V2. Alternatively, by using the suppressor grid of V2 as an extra anode, separate sync feeds can be taken to the line and frame generators (though the pulses so obtained must still be separated from each other). The twin feed is shown to the right of Fig. 26.

Diodes may also be used for sync separation, and it is possible to employ a diode following the detector stage of the receiver for this purpose, the separator diode being so connected and biased that it only passes current on the sync pulses. However, where the demodulator is followed by a V.F. stage, it is unlikely that the V.F. signal available from the demodulator will provide a sufficiently large synchronizing signal without amplification.

The Receiver

Fig. 26—Basic circuit for sync separation using an amplitude filter valve. *Extremes right: the filter valve connected to give two sync outputs*

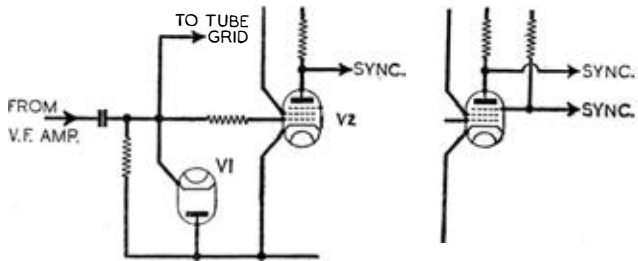

Consequently, the sync separation will often follow the V.F. amplifier stage. As was seen in the last chapter, a D.C. restoration diode is usually necessary between the V.F. stage and the tube; this diode can itself act as a sync separator. In Fig. 27, the diode shown is the D.C. restorer following the V.F. amplifier, but instead of the anode being returned direct to chassis, there is a load resistor R in the anode circuit, which is taken to a tapping on an H.T. potentiometer in such a way as to give a small positive bias on the diode anode. The bias is adjusted to be roughly equal to the amplitude of the sync pulses, and the diode thus conducts during the sync pulses, and develops a voltage across the anode load resistor. It does not, however, conduct when the picture signals arrive and drive its cathode positive beyond the 30 per cent signal amplitude level. The sync pulses are, of course, taken from the diode anode.

It should be noted that the usual type of scanning generator needs a synchronizing pulse which is in the positive sense, and thus the separator circuits must be arranged so that their output is positive. In some circuits it will be found that whereas the feed to the tube grid is taken from the anode, the feed to the sync separator is taken from the cathode circuit.

Having obtained the sync pulses free from the video signal, it is obviously necessary to separate the line pulses from the frame pulses. As we saw, separation of the sync pulses from the video signal was largely a question of using an amplitude filter; for separation of the two types of pulses from each other, some other method of discrimination is necessary.

Since the line pulses occur at relatively high frequency and the frame pulses at

a much lower frequency, it might be thought that some form of frequency filter would be satisfactory. However, ordinary frequency filters do not give adequate discrimination without seriously altering the pulse shape, and allowing the high harmonic components of the pulses, and therefore the sharpness of the slope of the leading edges of the pulses to be lost.

It is desirable that these leading edges are retained without distortion, since they not only control the precise moment at which the generators are triggered, but, if they are tilted or otherwise distorted, interference may be superimposed on them. This may cause displacement of certain lines in a horizontal direction, or, in the case of frame pulses, loss of interlace.

In practice, circuits are used which make use of the duration of the pulses, rather than their frequency, in order to separate them. The duration of a line pulse is about 10 microseconds, and of a frame pulse about 40 microseconds.

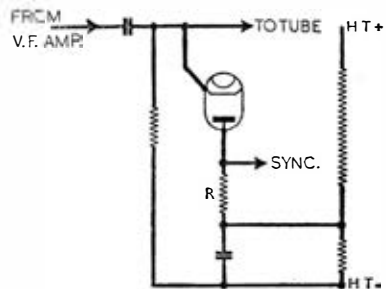

Fig. 27—The D.C. restorer diode used as a sync separator

Television Explained

For separating the line pulses, use is made of a "differentiating" circuit, which is merely a series capacitor and a parallel resistor, of carefully chosen values. Fig. 28A shows, merely for explanatory purposes, two line pulses followed by two frame pulses, which have been inverted so as to be in the positive sense needed for most scanning generators.

At B is the simple differentiator circuit, into the left-hand side of which the mixed pulse train is fed. If the values of $C1$ and $R1$ are so chosen that their time constant has a certain low value (for example, $C1=50 \mu\mu\text{F}$ and $R1=45,000$ ohms) then the circuit responds suddenly to the leading edge of each pulse, but during the period of the horizontal top portion the voltage across $R1$ drops exponentially to zero. The trailing edge of the pulse causes a sudden negative voltage change across $R1$, followed by an exponential return to zero. The wave-

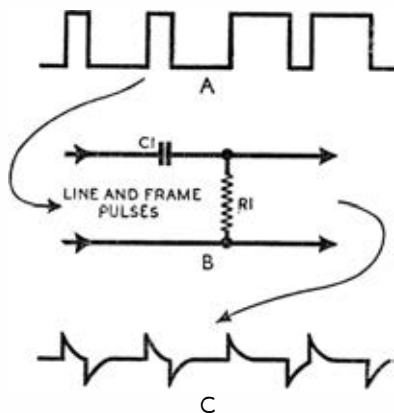

Fig. 28—Separating the line pulses by a differentiator circuit. A, the mixed pulses; B, the circuit; C, the output

form obtained is shown at C in Fig. 28. Actually we are not interested in anything following the initial voltage rise, which triggers the scanning generator.

It will be seen that the frame pulses when passed through the circuit lose their identity and are converted to a set of short duration peaked pulses which help to keep the line scanning generator in synchronism during each frame synchronizing period.

A differentiator circuit may alternatively take the form of an inductance in the anode circuit of a tetrode valve, into the grid circuit of which is fed the mixed pulses in a *negative* sense. The voltage produced across the inductance is the differential of the anode current wave which flows through it, and is of similar form to Fig. 28C, though not identical. The separated line sync signals can be obtained from a coil coupled to the anode inductance, constituting a transformer.

Turning to the frame pulse separation, here use is made of an "integrating" circuit, which consists in its simplest form of a series resistor and parallel capacitor as indicated in Fig. 29E. The time constant of this circuit is also critically adjusted, but to a higher value than in the case of the line separator. Thus $R2$ may have a value of about 20,000 ohms, and $C2$ 1,000 $\mu\mu\text{F}$.

The effect of feeding the mixed pulse train (Fig. 29D) into the integrating circuit (E) is shown diagrammatically at F. The short duration line pulses have little effect on charging $C2$ and so raising its voltage, but the first frame pulse, due to its longer duration, builds up the voltage across $C2$ to an appreciable value. In the short interval before the next frame pulse, $C2$ only discharges slightly, and the next frame pulse builds up its voltage to a higher value, and so on. The result

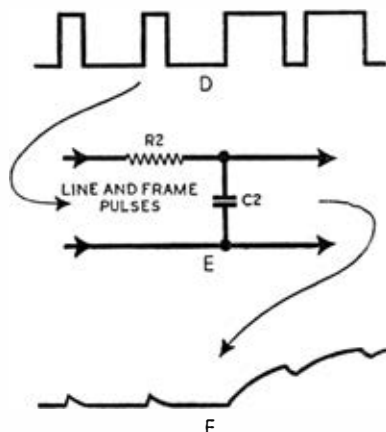

Fig. 29—Separating the frame pulses by an integrator circuit. D, the mixed pulses; E, the circuit; F, the output

The Cathode-ray Tube

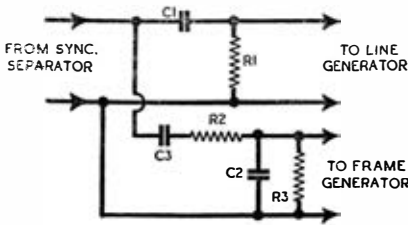

Fig. 30—Combined line and frame pulse separating circuit, in its simplest form

is that, whereas the line pulses after passing through the integrator are too small to affect the frame scanning generator, the frame pulses build up a voltage which at some critical value triggers the generator.

The combined circuit is shown in Fig. 30, C1, R1 and C2, R2 forming the differentiator and integrator respectively. C3 and R3 in the integrator are to remove the effect of any D.C. voltage arriving from the sync separator which would, of course, upset the working of this circuit.

An examination of Fig. 29F shows that the frame pulses have lost their vertical leading edges, and in view of the fact that the first pulse following an "even" frame is only displaced half a line from the first pulse following an "odd" frame, it might be expected that correct interlacing would be difficult. This is indeed the case, and with the normal integrator circuit, extremely accurate adjustment is necessary, and even then a stable interlace is very rare.

To get over this difficulty, many sets employ more elaborate frame pulse separating circuits, not necessarily of the integrator type. One interesting circuit makes use of the intervals between successive frame pulses and converts them to positive pulses of the same duration as line pulses, and with almost vertical leading edges, the first of which is used to trigger the frame generator.

It seems likely that such circuits will be the rule, rather than the exception, in future, because the securing of an accurate and stable interlace between the two frames of a complete picture is of considerable importance. The effect of loss of interlace is to make the line structure of the picture more noticeable, while at the same time considerable detail in the vertical direction is lost.

8—The Cathode-ray Tube

PRINCIPLES OF MAGNETIC TYPE; FOCUSING AND DEFLECTION

IN previous chapters we have dealt with the receiving equipment and have seen how the complete signal reaching the aerial is converted into the correct form for our requirements, and split up into its constituent parts. One of these provides the actual picture information and is used for modulating the grid of the cathode-ray tube; the others are synchronizing signals employed to trigger the scanning generators which provide the "raster" on the tube screen.

The remainder of the complete receiver comprises the tube itself, its voltage and power supplies, and the scanning generators. The latter, of course, operate whether a signal is being received or not; they are merely controlled as to their exact frequency by the sync signals obtained from the receiver, as described in the last chapter.

We must now consider, therefore, those parts of the receiver, mentioned above, which are virtually independent of the received signal, and a good starting point is the tube itself. We shall omit reference to the high-voltage projection tube, and confine ourselves to the types in which the picture is directly viewed on the end of the tube. The principles of operation in the two varieties are, however, very similar.

The television cathode-ray tube is a development of the original C.R.T. which has been used for many years for oscillographic work. The original oscillograph tubes contained a certain amount of gas, and were much smaller than the average television tube, besides having screens which produced green or blue traces, compared with the near-white colour of the modern television type. Later oscillograph tubes were of the "hard" type, since they could respond to much higher frequency inputs than the original "soft" tubes.

Oscillograph tubes are also almost exclusively of the electrostatic deflection type, in which the movement of the spot on the screen of the tube is controlled by voltages applied to sets of parallel deflector plates inside the tube.

Television Explained

Early television receivers also employed electrostatic deflection, and in practice this method is quite satisfactory, but the need for shorter tubes (for a given screen diameter) in order to reduce the depth of the television receiver cabinet has caused tube manufacturers to concentrate more and more on types employing electromagnetic deflection.

This form of deflection greatly simplifies the internal construction of the tube, owing to the elimination of complicated deflector plate systems inside the envelope. The latter systems need very careful construction and alignment when the tube is made, and in short do not lend themselves very well to quantity production at a low cost. It is only fair to indicate, however, that electromagnetic tubes necessitate the use of carefully designed deflector coils outside. The electromagnetic tube also allows easier focusing of the comparatively heavy beam currents needed to secure a bright picture.

A typical "magnetic" (that is, electromagnetic) tube is shown diagrammatically, and not to scale, in Fig. 31. The electrode system comprises, first of all, a heater and cathode assembly which provides the electron stream. Next comes a cylindrical electrode, closed by a disc at the far end in which there is a circular orifice. The electron stream passes through this orifice, and is controlled in intensity by the voltage applied to the electrode. In this way, therefore, the electrode resembles the control grid of an ordinary receiving valve, though its physical construction is quite different. It is commonly referred to as the "grid" of the tube, by analogy, and is normally furnished with a negative standing bias.

Increasing the negative bias reduces the density of the electron stream emerging from the "grid," and eventually cuts it off altogether; reducing the bias increases the stream, and therefore the intensity of the spot on the tube screen. A variable bias control is usually provided, and is termed the "brightness" control.

The video signal from the television receiver, in the form of a varying voltage is also applied to the "grid," and modulates the intensity of the spot on the screen, thereby providing the light and shade of the picture.

The next electrode is the anode, or accelerator, which is used to speed up

the electron stream leaving the "grid," so that it strikes the screen with adequate velocity to cause fluorescence of the screen material. The anode is usually a pierced disc, often with a tubular extension towards the "grid," through which the electron stream passes.

In addition to the anode as described, modern tubes have the inside of their glass envelope coated with a graphitic deposit which is internally connected to the actual anode. This deposit extends from the inside of the neck of the tube, close to the anode, almost up to the screen material, and amongst other things provides a return path for slow-moving electrons which are the secondary products of the impact of the cathode beam striking the screen material.

The anode is provided with a high positive potential, usually ranging from 3,500 to 6,000 V in modern receivers. The higher the voltage, the more dense will be the electron beam, and therefore the brighter the picture for a given setting of the "grid" voltage control. In order to avoid having to connect the extremely high anode potential via the base of the tube, a connector is usually fitted to the conical portion of the envelope of the tube, which is in contact internally with the graphite coating, and hence with the anode of the tube. Some tubes of the magnetic type employ more than one anode. In this case the first anode will have an operating voltage considerably lower than that of the second anode, and its connection will be brought out at the base of the tube.

The end of the tube, which ideally would be flat, but in practice is slightly curved for reasons of strength, is internally coated with a film of material which becomes fluorescent when the electron stream strikes it. The colour produced depends on the screen material, and a very close approach to a black and white image has been secured by the use of suitable mixtures of chemical compounds.

The beam of electrons leaving the anode of the tube tends to spread out from the axis of the tube, with the result that at the screen of the tube we get a diffused fluorescence, covering a large area of the screen. This, of course, is useless for our purpose, and it is necessary to adopt some means of concentrating the electrons into a narrow, dense beam, which will produce a bright spot of very small area on the screen.

The Cathode-ray Tube

Fig. 31—Diagram (not to scale) of the internal arrangement of a typical single anode electromagnetic cathode ray tube. Dimensions of the electrodes have been exaggerated for clarity

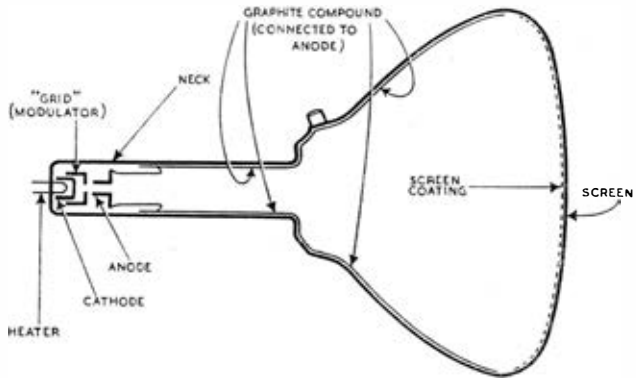

Unless a small spot is obtained, the detail of the picture will be lost.

In view of the analogy with the light passing through a lens, this concentration of the electron beam is termed "focusing," and it is necessary to be able to adjust matters so that exact focus is obtained at the fluorescent surface of the screen.

In the electromagnetic type of tube which we are considering, focusing is usually carried out by causing a uniform magnetic field to be produced with its lines of force running parallel with the axis of the tube. The effect of this, if the direction of the lines of force is correct, is to cause the path of the electrons in the beam which diverge from the axis of the tube to be bent back, or refracted; by suitably adjusting the strength of the magnetic field, the electron beam can be accurately focused on the screen.

In order to produce the requisite field, a circular "ring" magnet, capable of being slipped over the neck of the tube, and of being accurately adjusted in position so that its field is parallel with the tube axis, is employed. The magnet may be of the permanent or of the electromagnetic type. The former is convenient, and needs no current supply from the receiver, but its field is not readily adjustable; the latter permits adjustment of the field to be made very accurately by varying the direct energizing current which flows through it.

In practice, a combination of the two is often used. Either there is a permanent magnet with a subsidiary electromagnetic so arranged that it will affect the field of the permanent magnet sufficiently

to provide the correct range of focusing, or the permanent magnet is made with a self-contained winding to provide the variation in focus required.

In Fig. 32, which shows an electromagnetic tube in diagrammatic form, the "ring" focusing coil is drawn in section. It will be noted that it is positioned a little way past the tube anode, towards the screen, and the effect of the coil can be mechanically adjusted to some extent by sliding it along the neck of the tube.

Since the speed of the electrons in the beam of the tube depends on the anode voltage, the strength of the focusing coil or magnet required also depends on the anode voltage, since it needs a stronger magnetic field to "refract" fast moving electrons than slow ones.

Focusing in electrostatic tubes is usually carried out differently. Here a number of anodes (usually three) are employed for accelerating the electron stream, and one of these (usually the second) is provided with an adjustable positive voltage for focusing. In a sense, this anode acts as would a lens arrangement of adjustable focal length in an optical system.

Having focused the beam into a spot of small dimensions, it is obviously necessary to find a method of deflecting it in such a way that the "raster" of the picture can be produced. At this stage we shall not consider the form of the current or voltage required to do this, but we will see how a suitable deflecting current or voltage can be applied.

In an electromagnetic tube, deflection is produced by electromagnetic means, that is, by a current of correct "form"

Television Explained

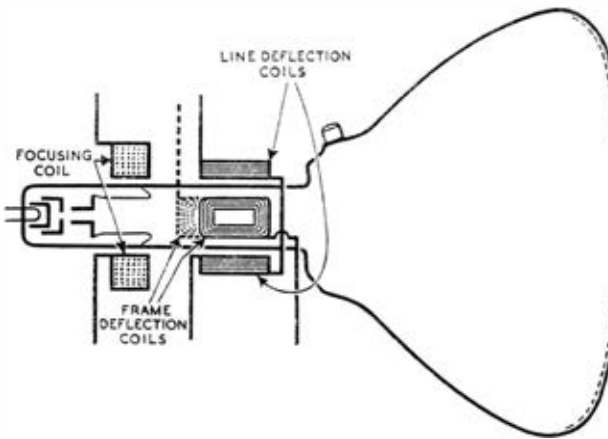

Fig. 32—Diagram of an electromagnetic cathode ray tube showing the disposition of the focusing and deflection coils. The rear frame deflecting coil is displaced slightly to the left so that part of it can be seen. In practice the coils are shaped so that they fit snugly round the neck of the tube, and are provided with iron yokes

flowing through coils suitably disposed. Referring to Fig. 33, this indicates diagrammatically how deflection of the spot in one direction (in this case vertically up or down) can be achieved. It is a section through the neck of the tube, at right angles to the axis (shown by the concentric circles), and through two coils placed one each side of the tube neck, and with their planes parallel to each other.

If a current is passed through the two coils connected in series as shown, a magnetic field, indicated by the fine broken lines, will be produced. As will be seen, these lines, where they pass through the tube, are roughly parallel, and fairly uniform. In practice, means are provided to improve the uniformity of the field.

By applying the well-known laws of a current (that is, the electron stream in the tube) in a magnetic field, it will be obvious that, depending on the direction of the field, the electron stream will be deflected up or down, and a field which alternates in direction will produce the effect of a vertical line, of length depending on the field strength, on the screen of the tube.

This, then, is the elementary principle of electromagnetic deflection. By employing two more coils at right angles to those shown, and producing vertical lines of force, it is possible to deflect the electron stream horizontally.

The disposition of the vertically deflecting ("frame") coils, and the hori-

zontally deflecting ("line") coils, is shown in Fig. 32, where it will be seen that the coils are towards the end of the neck of the tube. In practice, it is not convenient to mount coils as shown, and the coils used in commercial receivers are of rectangular formation, shaped so that they fit snugly round the neck of the tube, and of such a size that the sides of each pair which are parallel to the axis of the tube practically touch each other; the frame coils are generally fitted over, and outside, the line coils, and the gaps between pairs of line and pairs of frame coils are, of course, displaced from each other by 90 degrees, to make the

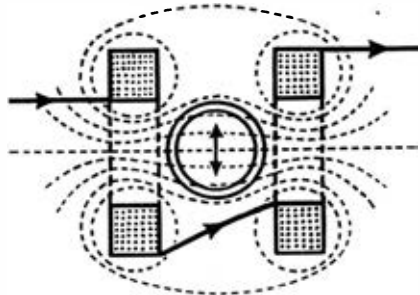

Fig. 33—Diagram of a section through two vertical coils, one on each side of the neck of the tube, showing how the electron beam is deflected vertically by a horizontal magnetic field

Scanning Units

two directions of deflection exactly at right angles to each other.

The arrangement described helps to secure a more uniform field in each direction, but this object is further achieved and the field strength increased, by placing suitable iron yokes round the sets of coils.

Deflection in electrostatic tubes is simplified by the fact that two pairs of parallel deflecting plates, mutually at right angles, are built into the tube, the electron stream passing midway between each pair of plates. By applying suitable *voltages* to the pairs of plates (as distinct from *currents* in the coils of the electromagnet tube) deflection in two directions at right angles is obtained.

9—Scanning Units

PRODUCTION OF SAW-TOOTH WAVEFORM WITH GAS RELAY AND "HARD"-VALVE CIRCUITS

IN Chapter 2 we saw how the television picture is built up from a series of equidistant lines, of which there are 405 in a complete picture. In order to produce this "raster," the fluorescent spot on the screen of the cathode-ray tube has to be swept across the screen from left to right by the line scanning generator at a high speed, and at the end of each line it has to return, at an even higher speed, to the left-hand edge, ready to commence the next line. At the same time the frame scanning generator is moving the spot vertically downwards, but at a slower speed, so that each successive line is slightly below the previous one. Although the lines so produced appear to be horizontal, they actually slope downwards to the right very slightly.

We have already seen that with interlaced scanning as used by the B.B.C. there are 25 complete pictures per second, consisting of 50 frames of $202\frac{1}{2}$ lines each, alternate frames being interlaced. The total number of lines "drawn" per second is thus 10,125, which is therefore the frequency of the line scanning unit. The frame scanning unit has a frequency of 50 per second.

Fig. 34 shows diagrammatically the type of voltage or current waveform needed to

move the spot on the tube in order to produce a raster as described. Both line and frame scanning units must provide this waveform, though at different frequencies. From its appearance, it is usually referred to as a "saw-tooth" waveform.

Assuming we are dealing with the line scanning unit, point O represents the beginning of the first line. As the voltage (or current, in the case of a magnetic tube) rises, the spot moves across the screen until point A is reached. This completes the first line. Ideally, the voltage would now fall instantaneously to zero, ready for the commencement of the second line; in practice, however, this is not feasible, so that instead of the ideal AX, the voltage drops back along the line AB. Thus the "flyback" occupies a finite time interval, represented by XB, and this interval has to be kept short compared with that represented by OX. On arrival at B, the voltage is then caused to rise again, along the line BC, tracing out the second line, and so on.

Owing to the fact that the cathode-ray spot moves much faster during the

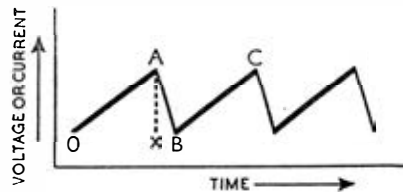

Fig. 34—The ideal saw-tooth waveform

flyback than during the tracing of the actual line, the flyback trace on the screen would in any case be faint compared with the line trace. However, as the flyback takes place at a period when the line signals are at black, or "blacker than black" level, its trace is effectively prevented from appearing on the screen.

It is important that the increase in voltage (or current) produced by the scanning unit should be regular over the whole of the sweep, that is, OA in Fig. 34 must be a straight line. If this is not so, the picture will suffer distortion due to non-linearity.

Television Explained

We must now consider the types of circuits which can be used in scanning units. There are a great number of these, many of which were originated in connection with the production of "time-bases" for cathode-ray oscillographs. Basically, the majority of scanning units depend on the charging and discharging of a fixed capacitor. The main differences lie in the methods of ensuring a regular charging current, and a speedy discharge.

Suppose we connect a resistor in series with a capacitor, and apply a voltage across the combination. Initially, the voltage across the capacitor will be zero, but as the charging current flows through the resistor, the voltage on the capacitor will rise, at a speed determined by the value of the capacitor (the larger the capacitance, the slower the rise in voltage) and by the value of the resistor (the larger the resistance, the slower the rise in voltage).

When the voltage has risen to the value required, we can short-circuit the capacitor, when the voltage across it will fall almost instantaneously to zero. It would, therefore, appear that by adopting some form of automatic switch across the capacitor, operating at the correct speed, we have a means of producing the type of voltage waveform shown in Fig. 34.

There is, however, one difficulty to overcome. When a capacitor is charged in the manner described above, the voltage rise is *not* linear. Actually, the charging rate, and, therefore, the rate of voltage rise, falls off at first gradually, but later with increasing rapidity as the voltage across the capacitor more nearly approaches the applied voltage. The curve actually produced is exponential in shape, and if applied to the tube without correction would produce a picture which was compressed on the right-hand side, and at the bottom.

Fortunately, however, the first part of the capacitor charging curve is in practice almost straight, and if we work on this part of the curve only, the resulting waveform of the scanning unit will not differ appreciably from that of Fig. 34. In order to secure this result, the voltage to which the capacitor is charged each time should not exceed about 5 per cent of the applied voltage.

This means, of course, that unless a very high applied voltage is used, some

form of amplification of the voltage across the capacitor will be needed. This is not a serious disadvantage, and in any case, where magnetic tubes are used, the voltage waveform must be changed to a current waveform with which the deflecting coils are fed.

As an amplifier is necessary, there is no reason why another form of correction should not be used, since it is not necessary that each part of the circuit should be linear, provided that in the final result the spot scans the tube at uniform speed.

In Fig. 35, the upper curve represents the output from the scanning unit oscillator, in which the voltage has been allowed to rise and produce part of an exponential curve. If this is followed by an amplifier having a response to a true saw-tooth curve as shown in the middle, then the resulting effect of the two together is that the distortions tend to cancel out, producing the corrected curve shown at the bottom of Fig. 35.

In this way, the charging of the capacitor can be carried on up to a voltage representing about 15 per cent of the applied voltage, which reduces the amplification required.

Another method of obviating the exponential charging curve of the capacitor in a scanning unit is to charge the capacitor not through a normal resistor, but through a constant current device such as a diode valve operating under saturated conditions, or a pentode or tetrode.

The switching device most commonly used for charging and discharging the

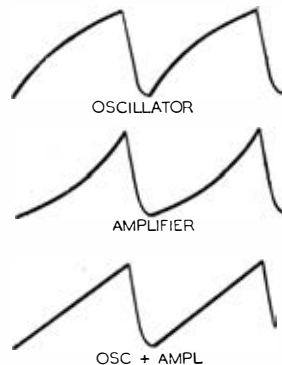

Fig. 35—Showing how two forms of distortion can be made to neutralize each other

Scanning Units

capacitor is a gas-filled triode valve, known as a gas relay. It is also often called a "thyatron," but this name actually belongs to the gas triodes made by one particular firm. The valve is filled with an inert gas, such as neon, helium or argon, the latter two being most suitable for television use.

The action of the gas relay is quite different from that of the conventional vacuum triode valve, though the electrode structure is similar. In use, if the grid of the valve is given a certain negative potential, and the anode voltage is gradually increased from zero, no anode current flows until a certain critical "striking" voltage is reached. At this point ionization of the gas inside the valve occurs and a heavy anode current flows. It continues to flow until conditions change, but is not controllable by the grid.

If now the anode voltage is gradually reduced a point is reached at which ionization ceases, and the valve again becomes non-conducting. This "extinction" voltage is much lower than the "striking" voltage, and it is due to the existence of a difference between the two voltages that the gas triode can act as an automatic switch. Incidentally, adopting the switch idea, the switch is "open" when the valve is non-conducting, and "closed" when ionization is present.

Although the grid has no control on the valve when the latter is in the conducting condition, it can influence the operation of the valve, in the following way. As the negative grid bias is raised a progressively higher anode voltage is needed before the valve will "fire"; in other words, the striking voltage increases with increase in negative grid voltage.

We can now look at a typical gas relay circuit as used to control the charging and discharging of a capacitor in a scanning unit. Fig. 36 shows such a circuit. The shading inside the valve envelope indicates that it is gas-filled. C2 is the capacitor which is charged and discharged. It will be seen that C2 is virtually connected from anode to cathode of the gas relay, though R7, a comparatively low value resistor of a few hundred ohms, is interposed to act as a limiting resistance.

This is necessary because when the valve "strikes" it virtually short-circuits C2, and if there were no limitation of discharge current the valve cathode would

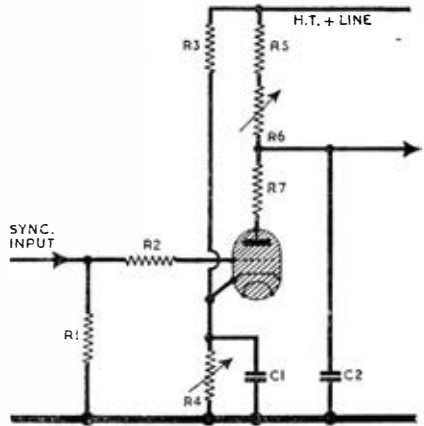

Fig. 36—A typical saw-tooth oscillator circuit employing a gas-filled triode relay valve, and forming part of a complete television scanning unit

be damaged. R7 must not be too large, however, otherwise the discharge will be too slow, and the "flyback" of the trace will occupy too much time.

C2 is charged from the H.T. positive line of the scanning unit through R5 and R6, which are in series with the anode circuit of the valve. The total charging resistance can be carried over a certain range by making R6 variable.

In order to provide variable bias for the grid of the gas relay, the cathode is connected to the tap on the potentiometer R3, R4, across the H.T. supply. R4 is made variable, and is shunted by C1. The bias is applied to the grid in the usual manner via R1 and R2. R1 is a grid resistor which really forms part of the synchronizing input circuit; R2 is provided to limit the grid current of the valve, which might otherwise reach a high value and heat up the grid.

Now let us see how the circuit operates. On switching on the H.T. supply, C2 charges through R5, R6 until the anode voltage of the valve reaches the critical value for the particular grid bias in use. The valve then suddenly ionizes, and C2 becomes practically short-circuited and therefore discharges rapidly. When the anode voltage (that is the voltage across C2) has fallen to the extinction value the

Television Explained

ionization suddenly ceases, the valve becomes non-conducting, and the voltage across C2 starts building up again.

The whole sequence is repeated indefinitely at a frequency depending on the values of C2; R5, R6; and R3, R4. Normally, in a television scanning unit, C2 is fixed in value, and the adjustment of the unit is carried out by varying R4 and R6.

If we consider a free running (i.e., non-synchronized) circuit, an increase in R4 increases the negative bias of the grid, and therefore the striking voltage of the valve increases, which means that the voltage of capacitor C2 can build up to a higher value before discharge occurs. This means that the deflection voltage available is increased, and the spot moves farther across the tube screen. In other words, the amplitude of the raster (picture width or height) is increased.

R4, therefore, can be regarded in a free-running circuit as an amplitude control, though it also affects the frequency of the circuit, since as the voltage across C2 can now rise to a higher value, the time required for this is increased, and the frequency of charge and discharge is reduced, unless R6 is altered to compensate. R6 obviously controls the rate at which C2 charges, and therefore it is primarily the frequency control, though, as mentioned above, it is affected somewhat by R4.

In a television scanning unit we rely on the synchronizing pulses to fire the gas relay at the exact moment and at the exact frequency, and under these circumstances R4 and R6 have less effect on the circuit.

It must be realized that however accurately we adjust R4 and R6, the scanning

generator will not run sufficiently accurately to obtain a picture without synchronizing. The sync pulses, separated as described earlier in this series, are fed to the grid of the gas relay in such a way that each pulse applies a small positive bias (that is, it reduces the standing negative bias provided by R4).

With the controls set to give a free-running frequency slightly lower than the correct one, each sync pulse arrives at the grid just before the anode voltage of the valve reaches the striking value. The pulse suddenly lowers the negative bias, which lowers the striking potential and therefore causes immediate ionization of the valve.

It is clear that the sync pulses not only regulate the frequency of the scanning unit, but they also time the commencement of each line, or frame, very accurately.

The frequency at which the circuit operates, when synchronized, is higher than when it is free running, and the amplitude is less. This follows, of course from the fact that the sync pulses cause the valve to strike earlier than it otherwise would. This can be demonstrated by listening to the note from the line scanning unit which can be heard when a signal is being received, and then unplugging the aerial. The note will fall in pitch.

R4 has little effect on a synchronized generator, while R6 mainly affects the amplitude. However, a large change in value of R4 which alters the natural frequency of the generator seriously will cause synchronization to be lost. R4 therefore becomes the line or frame "hold" control.

The gas triode type of circuit is commonly employed in television scanning generators, but in some cases one or more "hard" valves may be employed in place of the gas triode, and there are a number of different circuits which may be used to obtain results similar to those of the gas-filled valve.

The simplest form of hard valve time base employs a single triode valve in the circuit shown in Fig. 37. This is a "blocking" oscillator, in which inductances in the anode and grid circuits of the valve are tightly coupled so that the circuit oscillates strongly. At each positive peak on the grid, grid current flows round the grid circuit and charges up C1, this having the effect of making the mean grid potential

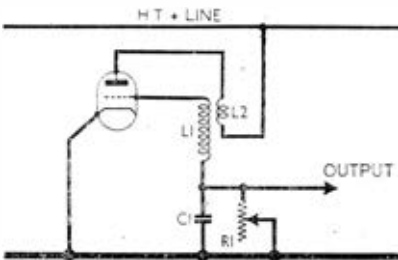

Fig. 37—Simple blocking oscillator circuit employing a hard valve

Scanning Units

more and more negative. After a time this cuts off the anode current to such an extent that oscillation ceases, and the charge on C1 begins to leak away through R1. As this goes on, the negative potential on the grid falls, and a point is reached at which the circuit bursts into oscillation again, and the whole process continues indefinitely.

The sawtooth voltage in this circuit is found between the top of C1 and chassis. The scan occurs when C1 is discharging through R1, and the fly back when the circuit oscillates and C1 charges. The value of R1 obviously controls the speed of discharge, and hence the frequency of the oscillation.

Actually, the circuit as shown is not entirely satisfactory, as the scan so produced is not of good linearity. Certain rearrangements of the components, and additional refinements are usually necessary to linearize the scan. In place of a triode, a tetrode or pentode may be used, and the sync pulses can then be fed to the screen for synchronizing purposes.

Another class of hard valve scanning circuit operates on the multivibrator principle, with variations. This is a form of relaxation oscillator employing two valves in a resistance-capacity circuit, heavily back-coupled. Only one example of this circuit will be described and it is illustrated in a simple form in Fig. 38. The circuit is due to Puckle, and employs a triode (V1) as the discharge valve for the capacitor C1. The anode potential of V1 remains almost constant (R2 being a small resistance) but the cathode of V1 changes in voltage during the charge and discharge of C1. V2 is a pentode, used to effect changes in phase of the grid of V1. V1 is resistance-capacity coupled to V2 by R2, C2, R4, while the anode of V2 is back-coupled direct to the grid of V1. R3 is the anode load resistance of V2, and has a high value.

When C1 is in an uncharged state, since there is no potential across it, the anode and cathode of V1 must be at the same potential. V2 is passing current and its anode has a positive potential which may be less by about 50V than the H.T. line voltage, due to the voltage drop along R3. This means that the grid of V1 is also 50V below H.T. line voltage, and, therefore, 50V below V1 anode and cathode voltage. In other words, the

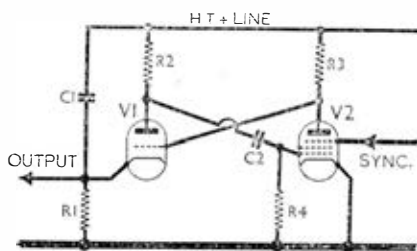

Fig. 38—Simplified Puckle hard-valve circuit which is a variation of the multivibrator principle

grid of V1 is 50V negative to its cathode, and the valve does not conduct.

Now C1 will begin to charge up via the H.T. circuit and R1, and its voltage will rise, causing the cathode of V1 to become more negative, so that the grid of V1 gradually becomes less negative relative to cathode and eventually V1 begins to conduct, causing a small voltage drop across R2. This means that the anode voltage of V1 falls slightly, and this fall in voltage is communicated to the grid of V2 (via C2), making it more negative.

The placing of this negative bias on V2 grid naturally reduces the anode current of this valve, which means that the voltage drop across R3 is reduced, and, therefore, the anode voltage of V2 is increased, and this voltage rise is passed back to the grid of V1, and increases the anode current of V1. This effect builds up quickly, and C1 becomes rapidly discharged.

When it is discharged sufficiently for the voltage drop across R2 to be small, the series of changes takes place in the reverse direction and V1 ceases to conduct, at which C1 commences to charge again, and the whole sequence is repeated indefinitely.

The output of this circuit is taken from the cathode of V1, and from the above description it will be realized that as far as D.C. is concerned, the cathode will be at a high positive potential relative to earth during part of the cycle. Special precautions have to be taken on account of this.

It has been mentioned that in place of a charging resistance (such as R1 in Fig. 38), a constant current device, such as a pentode valve, is sometimes employed to improve

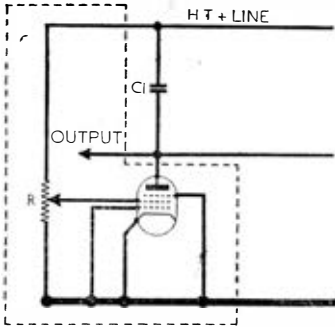

Fig. 39—A pentode used as a constant current charging device, in conjunction with C1. The circuit in the dotted enclosure replaces R1 in Fig. 38

the linearity of the scan. The valve is operated above the “knee” of the anode volts/anode current characteristic, and with a given screen voltage, the anode current will be practically constant at all anode voltages from about 50 upwards.

Fig. 39 shows a charging valve used in conjunction with the capacitor C1 of Fig. 38. It will be appreciated that the valve and circuit within the dotted enclosure takes the place of R1 in Fig. 38. The anode current of the charging valve can be varied by altering the screen voltage by means of the potentiometer R, and this, therefore, acts as a scanning frequency control. Change in amplitude of the scan in the circuit of Fig. 38 is achieved by making R3 variable for this purpose. The synchronization of a scanning generator such as that in Fig. 38 is possible by feeding the sync pulses into the suppressor grid of V2.

It was stressed earlier that the flyback time should ideally be zero, *i.e.*, the scanning spot at the end of a line should return to the beginning of the next line instantaneously. In practice this is not possible, but it is the aim of the designer to keep the flyback time as short as possible. It is interesting to realize that the incoming signal cannot force the cathode ray spot to be back at the commencement of a line just as the line signal starts, and if it is not there when the picture signal commences the left hand edge of the picture will be lost, or folded over.

10—Deflection Amplifiers

ELECTROSTATIC AND ELECTROMAGNETIC TYPES

HAVING generated a sawtooth waveform suitable for deflection purposes in a scanning generator operating on the principles described in the previous chapter, it is necessary to amplify the output of the generator before it is suitable for application to the cathode-ray tube. The form of amplifier necessary depends, of course, on the type of tube to be used.

It has already been pointed out that the electrostatic type of tube requires a sawtooth *voltage* for deflection purposes, this voltage being applied to the parallel deflection plates built into the tube. On the other hand, the magnetic type of tube, now in almost universal use, requires a sawtooth *current*, which is passed through the deflection coils arranged externally to the tube, as described in Chapter 8.

The voltage amplifier employed when electrostatic deflection is in use is almost invariably of the push-pull type, since if the sawtooth voltage is applied to only one deflector plate of each pair the raster produced on the tube suffers from what is known as trapezium distortion, and the picture consequently becomes distorted also.

A simplified paraphase push-pull amplifier for feeding the frame deflecting plates of an electrostatic tube is shown in Fig. 40. V1 and V2 are two triodes, with resistance capacity coupling (R1, C1, R3) between them. The sawtooth voltage after amplification by V1 is taken via C1 and C3 to one horizontal plate of the tube, while the output from V2, which is in opposite phase to that from V1 is taken via C2 to the other horizontal plate of the tube.

The grid potentiometer R3 is provided to reduce the input to V2 to such a value that the output from V2 is exactly equal in voltage (but opposite in phase) to that from V1. R2 is, of course, the anode load of V2. Once R3 is set for a given pair of valves it will normally not need re-adjustment. Except for unavoidable variations in valves, it could be replaced by a fixed potentiometer of a suitable ratio.

It will be noted that one deflector plate is connected via a high value resistor

Deflection Amplifiers

(R4) to a "shift" potentiometer across part of the tube anode supply, which is used to centre the picture on the screen. The other deflector plate is connected via a similar resistor (R5) to the third anode of the tube. Another point to note is that in a receiver in which the negative side of the high voltage supply to the tube is earthed, C1, C2 and C3 must be rated to withstand the third anode voltage of the tube, since the deflector plates are also at this voltage. With a positive earthed system, however, these capacitors need only withstand the H.T. voltage of the scanning amplifier.

The resistance potential divider R3 in Fig. 40 is not suitable for the line deflection amplifier, in which the response must be maintained up to much higher frequencies than are found in the frame deflection amplifier. At these high frequencies, the effect of the input capacitance of V2 in Fig. 40 would come into play, and cause loss in amplification. To avoid this, the potentiometer R3 is replaced by a small variable capacitor in series with a fixed resistor, and the grid of V2 is connected to the junction between the two. The variable capacitor, with the input capacitance of V2, forms a variable capacitive potential divider which can be adjusted so that the outputs from V1 and V2 are equal (but in opposite phase).

The electrostatic deflection amplifiers may have to provide outputs of the order of 1,000 V peak to peak, and the H.T. supply to the valves will not be considerably less than this value.

Centring of the picture on the screen of an electrostatic tube, mentioned briefly earlier, is accomplished by applying a variable D.C. bias to one of each pair of deflection plates, relative to the third anode of the tube.

Turning now to the deflection arrangements in an electromagnetic tube, we find that quite a different arrangement is necessary. Whereas in the electrostatic system we had to provide quite a high voltage sawtooth input to the deflector plates, in the magnetic system we need a low voltage but fairly heavy current of sawtooth waveform with which to energize the deflector coils. In other words, we need an amplifier giving a *power* output.

It is usual to employ a heavy-duty tetrode or pentode for the amplifier, step-

down transformer coupled to the deflection coils, of which there are two in series for line deflection, and a further two (at right angles to the first pair) for frame deflection. The amplifier valve must have an anode dissipation of the order of 20 W, since a mean anode current around 60 mA is required, with an anode voltage of about 300.

Owing to the inductive nature of the coupling of the valve to the deflection coils, and the coils themselves, together with the sudden current reversals at the end of each scan when the fly-back occurs, the design of this part of the circuit is not easy, particularly in the case of the line deflection amplifier. For one thing the back E.M.F. developed at each fly-back may approach 2,000 V in a line amplifier and consequently both the valve and the transformer primary must be adequately insulated. Special valves are available having top cap connections for the anode and otherwise capable of withstanding the high back E.M.F.

It is partly for this reason that a step-down transformer coupling to the coils is used, since otherwise these coils and their wiring would have to withstand the high voltage. The transformer also prevents the D.C. anode current flowing through the deflection coils and providing a permanent spot deflection.

Fig. 41 shows in simplified form a line deflection amplifier for a magnetic tube. The valve is a power tetrode, and negative feedback is provided by not bypassing the cathode resistor R2. L1, L2 form the output transformer feeding the deflector coils. The step-down ratio is usually about 5 to 1 or slightly more, and the transformer must have a low winding

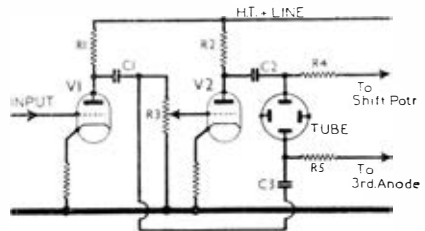

Fig. 40—Simplified circuit of a typical frame deflection amplifier for use with an electrostatic tube

Television Explained

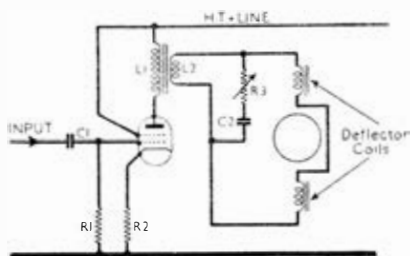

Fig. 41—A power amplifier transformer coupled to the line deflection coils of a magnetic tube. The circuit has been simplified for clarity

capacitance and leakage inductance, otherwise distortion of the scan will ensue.

As a matter of fact, some distortion, which usually takes the form of compression of one end or the other of the scan, is usually unavoidable, and correction for this may be made by connecting a variable damping circuit R3, C2 across the transformer secondary. C2 is sometimes omitted. By varying R3 the linearity of the trace can be improved, and the control in the receiver is usually labelled "line linearity." The damping circuit also helps to limit the inverse voltage induced at the end of each scan.

In the case of the frame amplifier, conditions are rather different. The inverse induced voltage is less and it is possible, though not customary in commercial receivers, to use high-inductance deflecting coils, without a step-down transformer. In this case the output from the valve is resistance-capacity fed direct to the coils. A high-value coupling capacitor, of the order of 200-300 μF is then necessary if distortion is to be avoided.

In commercial practice, however, a transformer is generally used, and this must normally have an extremely high value of primary inductance. The frame-scanning coils will be wound to a higher inductance than those for line scanning. The damping circuit C2, R3 in Fig. 41 is not necessary in a frame-scan amplifier, while it is possible to use a triode valve instead of a tetrode.

By deliberately using valve distortion in one sense to compensate for coupling distortion in the opposite sense, good

linearity can be secured with less stringent requirements for the coupling components. This is an obvious solution in the case of commercial designs.

11—Power Supplies

FOR ELECTROMAGNETIC AND ELECTRO-STATIC TUBES

PRECEDING chapters have dealt with the television receiver stage by stage, and the only section not yet considered is the power supply unit, from which the L.T., H.T. and E.H.T. (extra high-tension) voltages and currents are obtained to operate the receiver.

In view of the fact that the complete television equipment comprises the receiver proper, the scanning units and amplifiers and the cathode-ray tube, it is understandable that the power supply unit is more complicated than in an ordinary receiver, though the main complication lies in the C.R.T. supply unit.

All existing domestic television receivers are for operation from A.C. mains only, and where D.C. supplies only are available it is best to employ a D.C. to A.C. rotary converter to operate the A.C. receiver. However, with the introduction of new circuits for the E.H.T. supply to the tube which do not necessitate a mains transformer for voltage step-up, there is some prospect of television models being produced for operation from D.C. as well as A.C. mains. No battery operated television receiver has yet made its appearance, nor, in view of the relatively heavy power requirements, is this likely.

The H.T. supplies for the receiver unit, and for the scanning units and amplifiers, are usually obtained from a single rectifier valve and smoothing circuit which is quite conventional. The voltage output needed is of the order of 350-400 V, but as the current drawn from this unit may be as much as 200 mA, it is obvious that a rectifier valve of adequate output must be chosen, while the smoothing choke or chokes must be of generous proportions. Incidentally, the smoothing in this unit must be as thorough as possible, since hum voltages in the vision receiver or the scanning units cannot be tolerated.

The cathode-ray tube E.H.T. supply is generally taken from a separate circuit

Power Supplies

using a rectifier valve designed specially for the purpose. The valve is usually of the half-wave type, and a typical circuit is shown in Fig. 42. This is for use with a magnetic tube with only one anode. The anode voltage required is of the order of 4,000 to 7,000 V, but since the current required by the tube is extremely low, smoothing problems are simplified.

It is usually found that the capacitor C1, having a value of $0.1 \mu\text{F}$, and capable of working at the peak A.C. input to the rectifier valve, is adequate. R1, R2 form a potentiometer across the E.H.T. supply, and, as shown in Fig. 42, the cathode of the tube is connected to the junction of R1, R2. R3 is a resistor in series with the positive lead to the anode which acts as a current limiter in case of a short-circuit in the tube or its connections.

The total value of R1 plus R2 is of the order of $10 \text{ M}\Omega$, but R2 forms only a small part of this, sufficient for a voltage drop of about 100 V across it. By connecting the modulator grid of the tube, via R4, to the negative end of the power supply unit, the grid is made negative relative to cathode by the amount of the voltage drop across R2. By making R2 variable we can thus vary the tube bias, and hence the brightness of the picture. R2 is therefore the "Brightness" control. C2 is a by-pass capacitor across R2.

As has already been mentioned in Chapter 8, focusing in a magnetic tube is usually carried out by means of an annular permanent magnet, or electro-magnet, fitted round the neck of the tube just beyond the anode. For convenience in adjustment, a winding through which a variable direct current can be passed is used in conjunction with the permanent magnet, if this is employed.

Fig. 42 shows the focusing coil in section, and a variable resistor, R2, is shown in series with it to indicate the adjustment for focusing. In practice the focus coil is often connected in series with the H.T. supply to the scanning units and amplifiers; a variable resistance in shunt with the coil, or connected across the output of the supply unit, serves to vary the current through the coil by an amount sufficient to provide the range of focusing required.

The method of centring the picture on a magnetic tube is usually the simple one of making the plane of the focus coil or magnet adjustable in its relation to the axis of the tube. A mechanically adjustable mounting for the focusing coil or magnet is provided, and centring of the picture is usually carried out by rotating several milled screws.

The voltage supplies for the electrostatic type of tube are rather more complicated, and are included here for completeness, though modern commercial receivers almost always employ magnetic tubes. Fig. 43 shows the potentiometer network required for an electrostatic tube's supplies, the total D.C. voltage across R1-R6 being of the order of 5,000 V or more.

R1 and C1 provide the variable tube bias, and R1 therefore forms the brightness control, as before. Now the electrostatic tube shown has three anodes, requiring progressively higher positive voltages, and it will be seen that the first anode, A1, is fed from the junction of R2, R3. A2, the second anode, has a voltage which is adjustable by means of R3, and by this means the tube is focused. R3 is therefore the focus control. The third anode, A3, requires the highest voltage, but, as will be seen, it does not receive the full voltage of the E.H.T. unit,

Fig. 42—High voltage supply unit for a magnetic tube, which also provides bias for the modulator grid

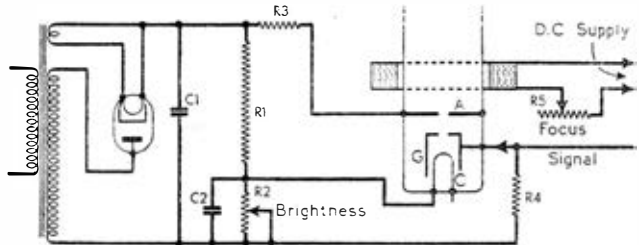

Television Explained

being connected to the junction of the comparatively low value resistors R5 and R6. R4 has a high value, since the difference in voltage between A2 and A3 is considerable.

The resistors R5 and R6 are provided because one of each pair of deflecting

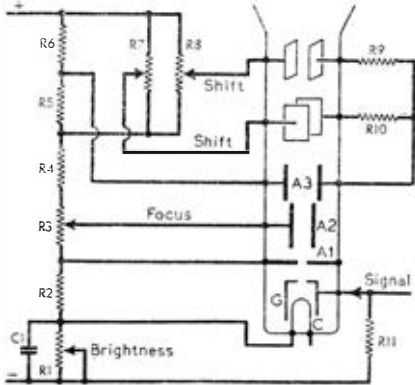

Fig. 43—Showing how the various voltages required for an electrostatic tube are obtained from a potentiometer across the high voltage supply

plates has to be biased relative to the third anode, either positive or negative, to provide the "shift" or picture centring controls. The actual controls are the potentiometers R7 and R8, which are connected in parallel across R5, R6, and therefore provide an adjustable bias voltage either positive or negative relative to third anode. The remaining plates of each pair are usually connected, via high resistors R9, R10, to the third anode.

The problem of the E.H.T. supply to the tube of the television receiver, though on paper a simple question of a mains transformer with a high-voltage secondary, a half-wave rectifier and a reservoir capacitor and safety resistor, is in practice one of the most difficult sections of the receiver for the designer who has to keep cost and reliability in mind.

In the first place, the mains transformer itself is costly because extremely high insulation between the various windings, and between windings and core is neces-

sary. It is not generally realized that for some part of each mains cycle a voltage approximately double that of the E.H.T. supply appears between the rectifier heater winding and the core, and also between the rectifier heater winding and the primary. With a 5,000 V supply therefore, the insulation must stand up to a voltage of some 10,000 V.

Quite apart from the insulation problem, the weight of a suitable transformer is considerable; it uses a good deal of iron and is therefore a costly item.

In recent years, other means of securing the necessary high voltage, low current supply for the anode of the tube have been developed. One of these takes advantage of the normally disadvantageous high peak voltage produced in the line-scanning generator on the flyback. This momentary voltage may rise to 2,000 V, and it is employed as follows.

The primary winding of the line-scanning transformer (the secondary of which feeds the line deflector coils) is extended by an additional winding forming an auto-transformer so that at flyback a voltage of, say, 5,000 V appears across the complete winding. This voltage is fed to the anode of a half-wave rectifier valve, the heater of which is operated from an extra low-voltage secondary on the line-scanning transformer. A reservoir capacitor and a limiting resistance connected in the usual circuit complete the arrangement.

Though this circuit for E.H.T. supply is, of course, only applicable where a magnetic tube is in use, it appears to be attractive. However, the design of the combined line-scanning and E.H.T. transformer is by no means easy, largely owing

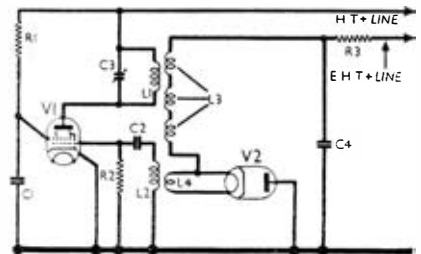
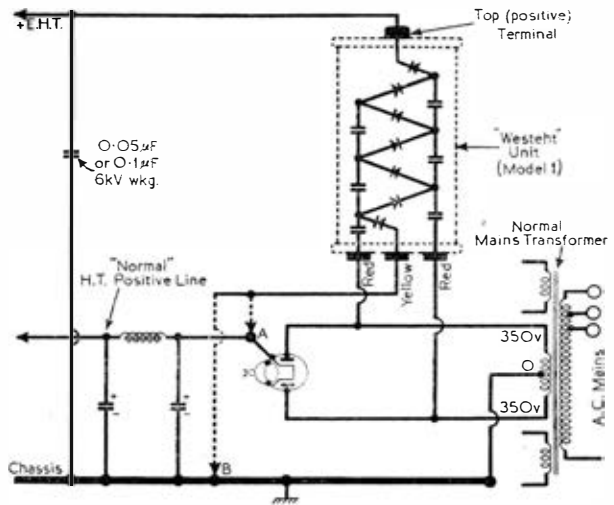

Fig. 44—An R.F. oscillator, followed by a rectifier, used to provide E.H.T. supply

Power Supplies

Fig. 45.—Diagram showing the internal circuit of the "Westeh" E.H.T. unit (enclosed in dotted outline) and the method of connecting it to the normal H.T. circuit in a television receiver. If the yellow terminal is connected to point A, the E.H.T. output is higher by the value of the H.T. circuit voltage than if it is connected to point B



to the effect of the self-capacitance of the E.H.T. winding on the flyback time, which it increases.

Another method of obtaining the E.H.T. supply without employing a large and costly mains transformer is that in which an R.F. oscillator is used. This involves the use of an extra valve as oscillator, but avoids the mains transformer. It also allows the use of a low value high-voltage reservoir capacitor.

One form of circuit is shown in Fig. 44. Here V1 is a power tetrode valve, operating as an oscillator, though a triode can be used for this purpose. The valve must be capable of giving a power output of the order of 5W, or more. Its anode and grid coils (L1 and L2) are coupled in the usual way, so that the circuit oscillates continuously.

The frequency may be anything from 500 c/s (in which case iron-cored coils are used) up to 1 Mc/s (which is employed in some American circuits). An intermediate value of 100 kc/s has been found suitable by at least one British manufacturer. For the higher frequencies air-cored coils are, of course, used.

L1, the anode coil, is sometimes tuned by a pre-set capacitor C3. R1 and C1 are the tetrode screen feed components; R2 and C2 are the grid resistor and capacitor.

The oscillator output is coupled in the special transformer to the secondaries L3 and L4. L4 supplies the heater of a suitable rectifier valve, while L3 is provided with enough turns to give the necessary step-up of voltage to the value required and acts as the E.H.T. secondary. The output from this is rectified by V2, as shown. C4 is the reservoir capacitor and R3 the safety series resistor in the E.H.T. positive lead.

The winding L3, which must be very well insulated from the remaining windings of the transformer, and capable of withstanding twice the peak output voltage, is usually wound in a number of spaced "pi" sections connected in series. The distributed capacity and the inductance of this coil affect the frequency of the oscillator, which, however, is adjustable by C3 to give the required output voltage. If a tetrode is used, adjustment of the screen voltage can also be used to vary the E.H.T. output.

This method of obtaining E.H.T. is already being used in certain commercial receivers. It will be appreciated from Fig. 44 that it can be made up into a neat self-contained unit with few connections to the television receiver circuit.

Another new source of E.H.T. supply, which also avoids the necessity for the conventional high voltage transformer, is

Television Explained

the Westinghouse "Westeht" unit. This utilises a chain of dry contact rectifiers in a voltage multiplying circuit (patents applied for), and takes its input voltage from the whole of the H.T. secondary of the mains transformer which supplies the remainder of the receiver power circuits.

The circuit of this device and the method of connecting it to the normal power circuit of the television receiver, is shown in Fig. 45. With an input of 700 V r.m.s. an output of the order of 5,000 V is obtained, while the extra load placed by the unit on the mains transformer is only about 1 mA, and therefore is negligible. No series smoothing resistor is necessary with this circuit.

12—Receiver Installation and Operation

LOCATION OF THE SET ; INITIAL ADJUSTMENT OF THE CONTROLS

THE previous chapters have dealt with sections of the television receiver circuit in some detail, though it must be emphasized that, owing to the comparative novelty of the television receiver, very little circuit standardization has yet emerged. Consequently, in a book of this size and purpose it has not been possible to deal with all, or even many, of the modifications and variations found in practice.

Many receivers incorporate subsidiary circuits which, though not essential to the working of the receiver, nevertheless improve its performance. Two examples of these are built in interference reducing circuits and the tube de-focusing or over-biasing circuit which comes into action when switching the set off, and prevents a bright cathode ray spot appearing in the centre of the screen (due to the scanning generators ceasing operation before the tube cathode has cooled down).

Many other examples of refinements of this nature could be quoted, but as they are not essential to the understanding of the principles of the receiver they are not dealt with here.

For the benefit of those who are not familiar with the installation and operation of television receivers it is now proposed to touch upon a few points which may be helpful to the non-technical user.

Dealing first with installation, the first point that arises is the location of the receiver. There will probably be little, if any, choice as to the room in which it is to be used, but it is worth giving a certain amount of thought to its position in that room. With a television receiver, more than with an ordinary sound receiver, there are obviously good and bad positions.

Unsuitable positions are, for instance, those with the screen directly facing the main window; or close to the door so that every time anyone enters or leaves he or she has to walk in front of the screen, and possibly allows a stream of light to fall on the screen when the door is opened; or in a corner of the room such that a complete rearrangement of seating has to be made when the set is in use.

There is a good deal to be said for placing the set close to the window, but with its back to it, particularly if there is a suitable bay. In this way the picture can often be clearly seen in daylight without having to draw all the curtains.

Due respect must, of course, be paid to the position of the electric point from which the set is to operate, but it is better to place the set correctly, even if a long mains lead has to be used, than to let the electric point dictate the receiver position.

The distance from the point where the aerial feeder enters the room is immaterial, since any reasonable increase in feeder-length will have no ill effects; on the other hand, as the feeder will usually enter via the window, the positioning of the set near, and with its back to the window, helps in making an unobtrusive feeder run.

Sufficient was said in the first chapter of this book regarding aerial systems to make it unnecessary to deal with that subject again here, and it will be assumed that an efficient aerial system has been installed, and that the receiver end of the feeder has been fitted with a plug which is suitable for the special aerial socket of the receiver in use.

In general, the non-technical member of the public is not expected to know more about the operation of a receiver than to be able to adjust the few variable controls provided, with a moderate degree of intelligence. The more technical user, and the dealer who supplies the set (or his engineer) will want to know how to handle not only the fully variable controls, but also the pre-set ones, which do not

Receiver Installation and Operation

normally need adjustment once the set has been installed at a particular site.

As with circuits, so with controls; there is very little standardization, and the actual adjustments provided vary from make to make. Consequently, it is not possible to give instructions for adjustment and operation which will definitely apply to every make of receiver; only the more usual adjustments can be stated, and it is strongly advised that the instruction manual provided with the receiver should be consulted in cases where it is available.

The first thing to do with a new receiver, which one assumes is supplied with its tube and valves *in situ*, is to make certain that none of the valves are loose in their holders, and that all top cap connectors (where fitted) are firmly in position. The tube mountings should also be examined to verify that the tube has not shifted in transit, and that it is firmly fitted in its holder.

It is important that the voltage adjustment on the mains transformer should be correctly set for the voltage of the supply. It is sometimes advisable to check the mains voltage by means of a meter, as the voltage in some localities may be well off the rated value, and certain receivers are somewhat critical with regard to voltage input.

Needless to say, any adjustments inside the receiver, apart from actual controls, should be made with the set disconnected from the mains. It is important to remember that some points in the set are at a potential of 5,000 or 6,000 volts to earth, and at such potentials actual contact with a live point may not be necessary before a severe shock is received. Also, even when the set is switched off, do not immediately handle any previously live parts, for they do not necessarily lose their high potential immediately. When in doubt, the point to be handled may first be shorted to earth with a long-handled and well-insulated screwdriver.

It is obviously not possible to give detailed instructions for the preliminary adjustment of every receiver, but the following general hints will be applicable to most types. There may, however, be cases where a different procedure will give the best results more quickly. Wherever detailed instructions are supplied by the receiver manufacturer, they should be rigidly followed.

First, remove the aerial plug temporarily if a transmission is coming in; this is not necessary if the station is not transmitting at the time. Now switch on the set, and wait for a minute or two until all circuits are operating correctly. Turn the "brightness" control (tube bias) clockwise until the raster is visible on the screen, then turn the same control anti-clockwise until the raster just, but only just, disappears. This gives a setting for the brightness control which should need little alteration in practice. During actual reception, when the picture is too bright or too dark, it is sometimes difficult for the novice to decide whether the "brightness" or the "contrast" control (signal gain) should be adjusted. Removing the aerial (or cutting the signal input to zero) and adjusting "brightness" as explained above will always give a fairly accurate setting for this control.

Having made this preliminary adjustment of the "brightness" control, the aerial may be plugged in again, if it was previously removed, and an attempt made to adjust the other controls on an actual transmission. For this purpose it is best to wait until one of the B.B.C. test patterns is being transmitted, since these are far more suitable for the preliminary adjustments than any normal moving scene, or even a still picture.

The first thing to do is to turn the "contrast" control (signal gain) clockwise until there is a visible picture of some sort on the screen. It may be broken up, and slipping either horizontally or vertically, but so long as something appears, the receiver is obviously picking up the signal. If nothing (except perhaps, bright interference splashes) is visible, it may be that the receiver is not tuned to the station. Some receivers have no variable tuning control, but there may be a pre-set control which forms one of a group of subsidiary adjustments. If so, this should be adjusted, keeping the "contrast" control (and the R.F. gain, if any) well advanced, until some sort of picture appears. Manufacturers' instructions regarding tuning (if provided) should be followed. The usual recommendation is to tune to maximum sound, which will give the optimum (though not necessarily maximum) vision setting.

We will assume that a picture of some sort is now obtained, and the next thing is to synchronize it by means of the

Television Explained

“line” hold and/or “frame hold” controls. If the picture appears to be stable in a vertical direction (that is, if it is not slipping up or down) it may only be necessary to adjust the line hold control; vertical movement of the whole picture, however, indicates lack of frame synchronization.

When adjusting the two “hold” controls, it will be found that there is a small range of movement of each control over which synchronization holds; the control should be adjusted to the centre of this range in each case. These controls are usually classed as subsidiary ones, and will be found grouped with others at the back of the receiver, or otherwise concealed from view.

Having stabilized the picture on the screen, the next thing to do is to focus it accurately. The focus control is usually one of the group at the front of the cabinet, and its adjustment is fairly obvious. The individual lines of the picture should be sharp and distinct. If it is found that the picture is not equally sharp over its whole area, it is usually advisable to arrange for maximum sharpness to be at the centre of the raster.

Naturally, the lines of the raster must be horizontal, and this will normally be found to be the case unless movement of the tube or deflector coil assembly has occurred since the set left the works. If, however, the lines are not horizontal, resulting in a tilted picture, it will be necessary in the case of a magnetic tube receiver to rotate the deflector coil assembly one way or another until the picture is level. In most cases some sort of clamp will have to be loosened, and subsequently tightened up again after performing this operation. In older receivers, employing electrostatic tubes, it is necessary to rotate the whole tube in order to level the picture.

Another possibility, but one that does not normally occur unless the receiver has been badly handled in transit, or otherwise disturbed, is that the picture may not be centred on the tube face. Receivers using electrostatic tubes have “shift” controls, which move the picture bodily, in a vertical or horizontal direction, so that accurate centring may be carried out. In the case of magnetic tube receivers, centring is usually possible by adjusting the plane of the focusing coil or magnet relative to the axis of the tube. The focusing unit is

arranged on an adjustable mounting for this purpose, and three milled screws, or other mechanical means of adjustment, are provided.

Having levelled and centralized the picture, there is now the possibility that it is too large or too small for the aperture in the tube mask, or that its proportions are not correct. Adjustment for these faults is made by two further controls, usually labelled “picture width” and “picture height” respectively. By adjusting one or both of these, it is possible to get the size and proportions of the picture correct. The size should be such that the “dotted” border of the test pattern is just visible at the edges of the mask; the proportion is correct when the ring at the centre of the test pattern is truly circular. Incorrect proportion will change this circle into an ellipse.

One other fault may appear in the picture, and that is lack of linearity, resulting in either a spreading out or a closing up of the picture in a horizontal direction (in the case of line linearity) or in a vertical direction (in the case of frame linearity).

This form of distortion, if present, is usually found in the horizontal direction, and a subsidiary control, usually marked “line linearity,” is provided for adjustment. This is best carried out using the test pattern border as a guide. The black “dots” should be of equal size and spacing from one side of the picture to the other. On some receivers a “frame linearity” control is provided, and this is adjusted in a similar manner.

It will be found, on carrying out the various adjustments described above that to some extent they are inter-dependent. For instance, adjustment of the picture height and width may disturb the synchronization; adjustment of the line linearity control will probably necessitate a further adjustment in picture width, and so on.

Since the subsidiary controls are often at the rear of the cabinet, and it is necessary to see the picture when making adjustments, a hand mirror is very useful to have available.

If it seems impossible to reduce the picture strength sufficiently, even with the “contrast” control at its minimum position the signal strength is obviously too great, and the R.F. gain control, if provided, should be reduced. If this is not

Receiver Installation and Operation

adequate, or is not provided, the signal input will have to be cut down by means of an attenuator.

A fixed attenuator can be made very simply from three resistors, as indicated in Fig. 46, which shows the well-known T-type attenuator arrangement. The two series resistors, R1, are of equal value, but R2, the shunt resistor, is different, its value being lower than that of R1.

If we assume that the impedance of the feeder and of the aerial input circuit to the receiver is 80 ohms, and if N represents the attenuation factor required, then:

$$R1 = 80 \left(\frac{N-1}{N+1} \right)$$

$$R2 = 80 \left(\frac{2N}{(N+1)(N-1)} \right)$$

Suppose we wish to cut the signal input down 20 times, then $N=20$, so that :

$$R1 = 80 \left(\frac{19}{21} \right) = 72 \text{ ohms approx.}$$

$$R2 = 80 \left(\frac{40}{21 \times 19} \right) = 80 \left(\frac{40}{399} \right) = 8 \text{ ohms app.}$$

There is, of course, no need to employ resistors of extreme accuracy, but they should be non-inductive types.

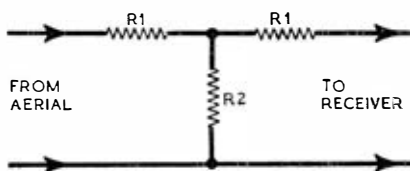

Fig. 46—A simple T-type attenuator for reducing signal input

With the signal input correctly adjusted it should be possible, by the aid of the “contrast” and “brightness” controls, to secure a picture of acceptable quality. Some changes in the settings of these two controls will be necessary if the level of general lighting in the room changes. Light should never be allowed to fall directly on the face of the tube, otherwise the picture quality will be poor.

In the following pages are reproductions of actual photographs * showing the effects of mal-adjustments of the television receiver controls. These should be studied in conjunction with the instructions given on previous pages of this chapter.

*Reproduced by courtesy of Philco Radio and Television Corporation of Gt. Britain, Ltd.

Television Explained

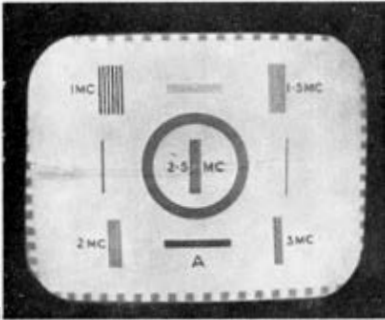

1—Normal test pattern. Controls adjusted correctly

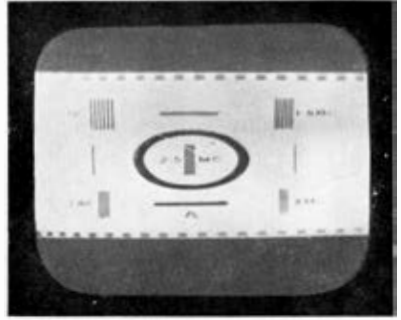

4—Picture height too small and width too great. Adjust "Picture Height" and "Picture Width" controls

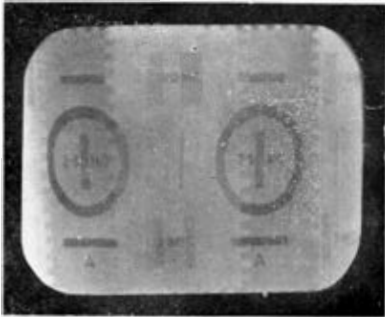

2—Incorrect line frequency. Adjust "Line Hold" control

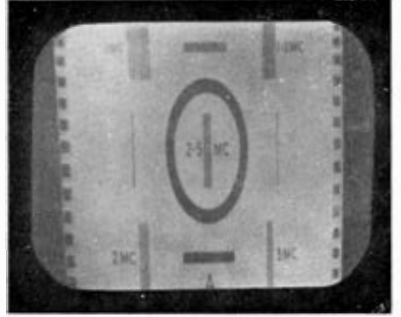

5—Picture height too great and width too small. Adjust "Picture Height" and "Picture Width" controls

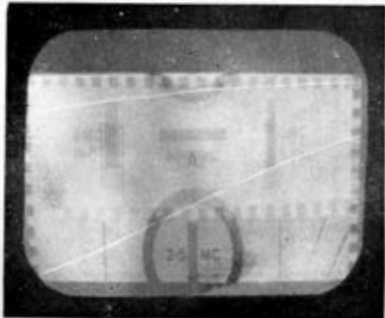

3—Incorrect frame frequency. Adjust "Frame Hold" control

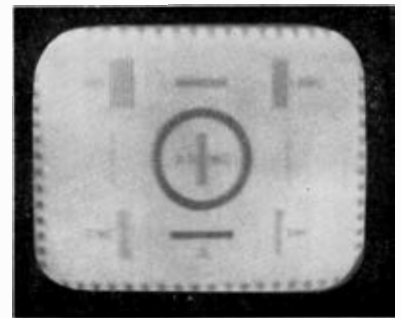

6—Picture out of focus. Adjust "Focus" control

Picture Faults Illustrated

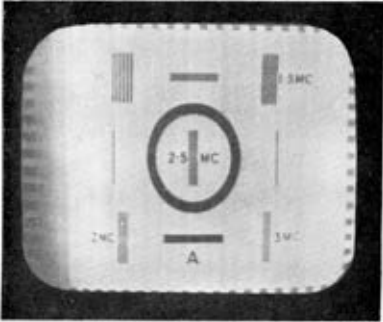

7—Picture distorted horizontally. Adjust “Line Linearity” control

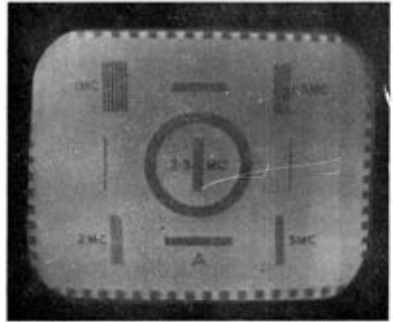

10—Picture too dark. If “Brightness” is set correctly, increase “Contrast” control

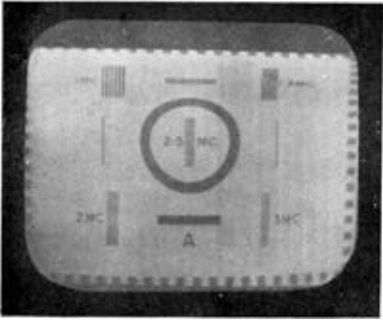

8—Picture distorted vertically. Adjust “Frame Linearity” control (if fitted)

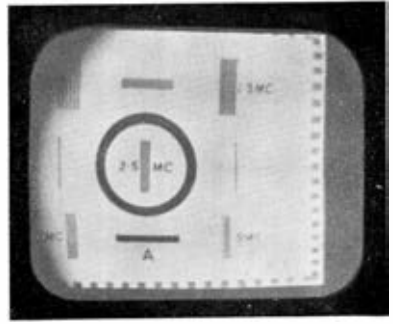

11—Picture displaced. Centre by means of mechanical adjustments on focus coil

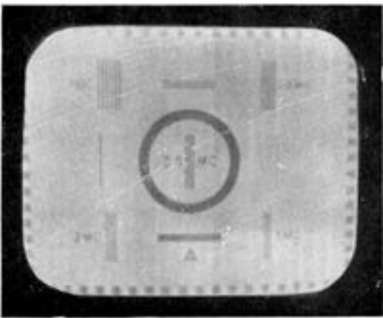

9—Too light background, showing flyback lines. Reduce “Brightness” control



12—Picture tilted. Rotate deflector coil assembly until raster lines are horizontal

Television Explained

Index

Aerials, 5-9

- , compressed dipole, 6, 9
- , half-wave, 5
- , length of, 6, 7
- , siting, 7
- , tilted wire, 9
- Amplifiers, deflection, 40, 41
- , I.F., 14, 21, 22
- , R.F., 16-19
- , V.F., 25, 26
- Attenuator, 49

Band-width, 12, 13, 15, 17

Brightness control, 43, 47

Cathode-ray tubes, 31-35

- Coils, deflection, 34, 41, 42
- Control, amplitude, 38, 40, 48
- , brightness, 43, 47
- , contrast, 18, 22, 47
- , focus, 43, 48
- , frequency, 38-40
- , "hold", 38, 48
- , line linearity, 42, 48
- , R.F., gain, 18, 48

D.C. restoration, 26, 27

- Deflection, 33-35
- Demodulator, 24, 25
- Detector, *see* Demodulator
- Dipoles, compressed, 6, 9
- Drift, frequency, 14

Faults, picture, 50, 51

- Feeders, 5-7, 46
- Filter, sound, 23
- , amplitude, 28
- Flicker, 9-11
- Fly-back, 10, 35, 37, 40, 41
- Focusing, 33, 43, 48
- Frequency, carrier, 13
- , changer, 16, 19, 20
- , intermediate, 19, 21
- , modulation, 13

Generators, scanning, 14, 28, 35-40, 44

- I.F., value of, 19, 20
- Images, ghost, 8

Matching, aerial/feeder, 7, 8

Oscillator, 19, 20

- , blocking, 38, 39
- , for E.H.T., 45

Power supplies, 42-46

- Pulse, synchronizing, 12

Raster, 9, 14, 33, 35

- Receiver, 13-31
- , operation of, 47
- , superheterodyne, 13, 14
- , T.R.F., 13, 15
- Reflections, external, 8
- , internal, 7, 8
- Reflectors, 6, 7
- Relay, gas, *see* Triode, gas

Scanning, 9-11, 35

- , sequential, 9, 10
- , interlaced, 10, 11, 35
- Screen, of tube, 32, 33
- Signal, television, 9-13
- , synchronizing, 11
- Synchronization, 11, 12, 28, 29, 38
- Sync pulses, frame, 12, 28, 30, 31
- , line, 12, 28, 30
- Sync separation, 28-31

Thyratron, 37

- Time-bases, *see* Generators, scanning
- Triode, gas, 37, 38
- Tube, electromagnetic, 32, 33, 43
- , electrostatic, 32, 33, 43, 44

Voltage, E.H.T. (tube anode), 32, 42-46

- Waveform, sawtooth, 14, 35, 40
- , transmitted, 9-13

Watch TELEVISION

In the Pye Research Station at Cambridge, a thorough study is made of the whole field of television from camera to receiver. The experience gained has produced such notable achievements as the Pye Videosonic System, the Pye Outside Broadcast Vehicle and the famous B16T and D16T receivers, which have been acclaimed for their brighter picture and finer definition.

TABLE MODEL B16T
£42.0.0 plus Purchase Tax

CONSOLE MODEL D16T
£52.10.0 plus Purchase Tax



Pye Television Receivers give

- CLEARER VISION
- FINER DEFINITION
- COMPACT CABINETS with LARGE SCANNER
- OUTSTANDING VALUE FOR MONEY

The Pye Mobile Television Unit contains complete equipment for the transmission of outside broadcast features. The unit is housed in a medium sized van equipped with a telescopic aerial, which can be raised in a few minutes and pictures of sport or other events sent out.

PYE LIMITED • RADIO WORKS • CAMBRIDGE

SELECTIVITY

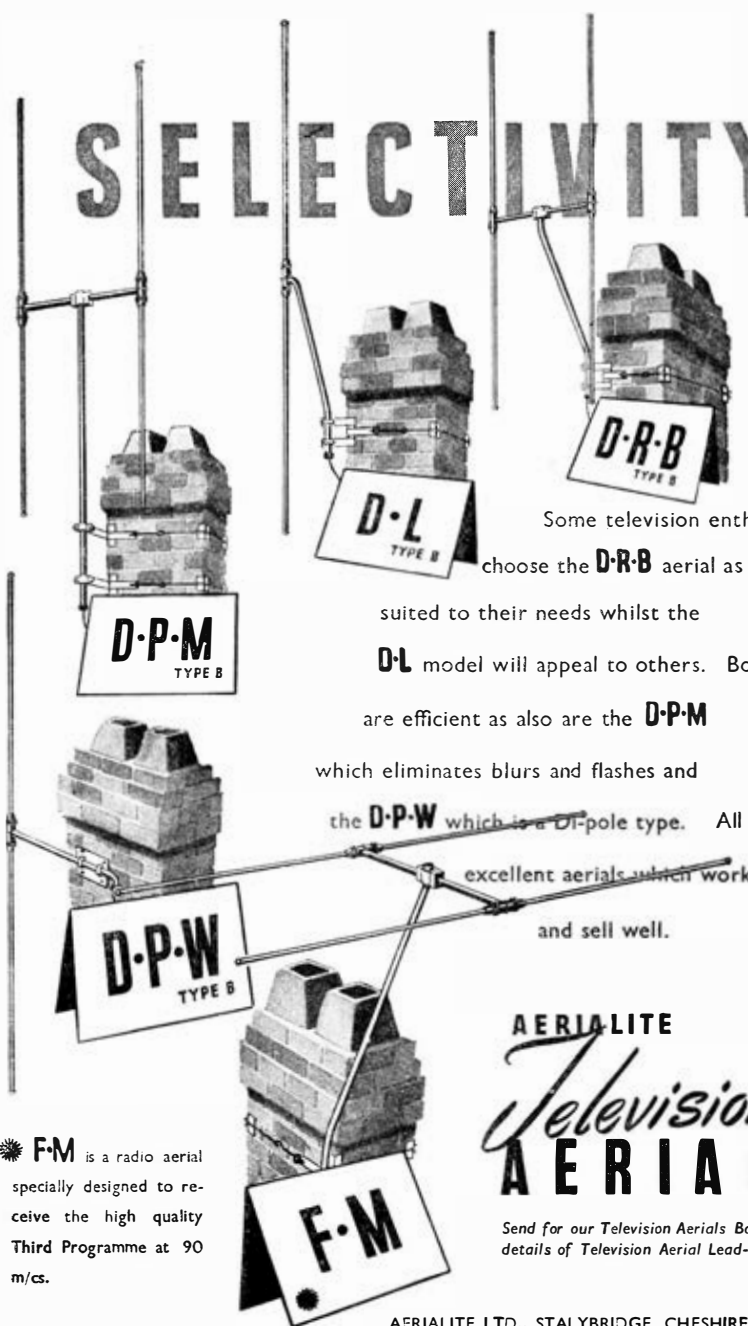

Some television enthusiasts will choose the **D-R-B** aerial as best suited to their needs whilst the **D-L** model will appeal to others. Both are efficient as also are the **D-P-M** which eliminates blurs and flashes and the **D-P-W** which is a Di-pole type. All are excellent aerials which work and sell well.

AERIALITE *Television* **AERIALS**

Send for our Television Aerials Booklet and details of Television Aerial Lead-in Cables.

F·M is a radio aerial specially designed to receive the high quality Third Programme at 90 m/cs.

AERIALITE LTD., STALYBRIDGE, CHESHIRE

MASTERPIECE IN MINIATURE

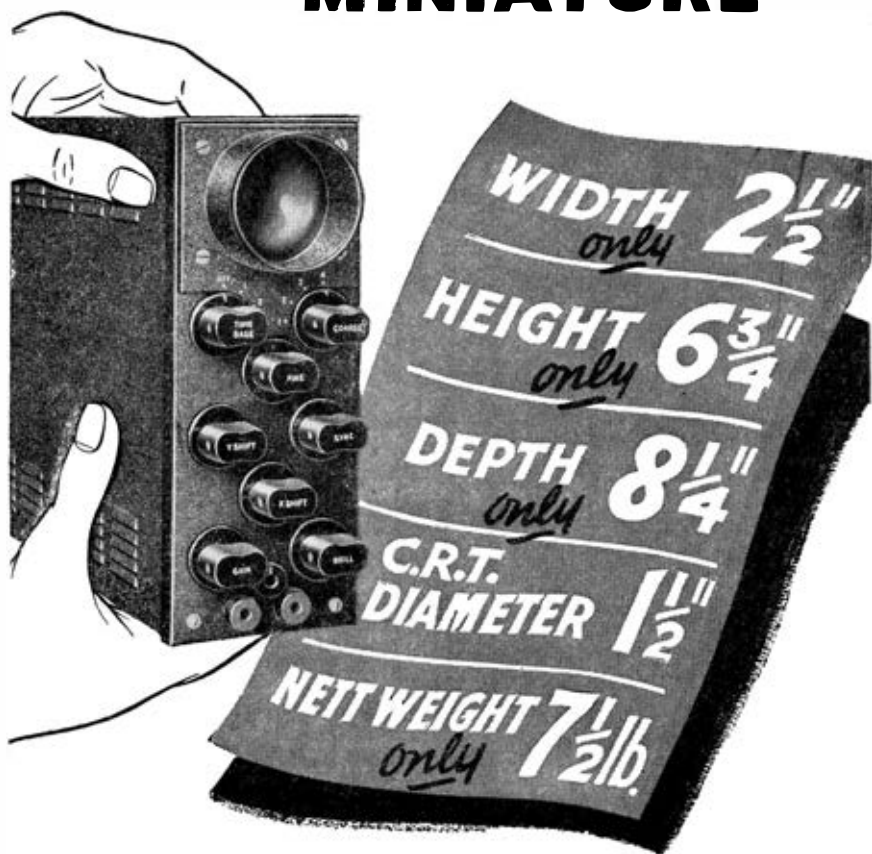

The G.E.C. "Miniscope" is designed for use on 200-250 volts A.C. or 6 volts D.C. Full specification is available on request.

*Miniature
Cathode Ray
Oscilloscope by*

Miniscope G.E.C.

ADVT. OF THE GENERAL ELECTRIC CO. LTD., MAGNET HOUSE, KINGSWAY, LONDON. WC.2.

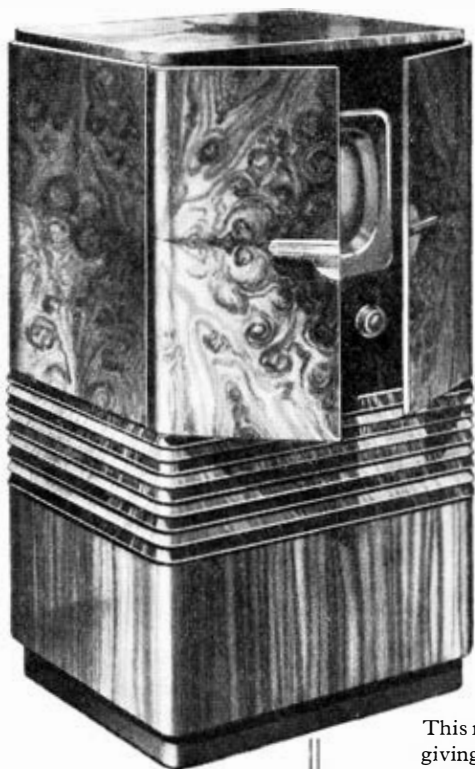

RAYMOND TELEVISION

Console Model F.26

This receiver embodies a 12 in. tube, giving a 10 in. by 8 in. picture. The walnut and sycamore cabinet has quartered doors which enclose the controls and tube. Circuit features include 5-stage R.F. amplifier in the vision chassis; interference limiter; sound chassis with 2 R.F. stages, detector and noise limiter feeding into output valve and operating a 10 in high flux loudspeaker.



RAYMOND ELECTRIC LIMITED, 26 WADSWORTH ROAD, PERIVALE, MIDDLESEX.

LOOK TO PILOT FOR THE BEST IN TELEVISION



Announcing a new Masterpiece
Pilot VS9 TELEVISION

PILOT Television brings you all that's happening NOW, but its a real peep into the FUTURE for performance. 45 sq. ins. of brilliant picture.....synchro-circuits to keep it clear and steady. A superb set in a superb walnut console cabinet with the picture at convenient viewing height. AC mains operated.

£75 plus Purchase Tax

A PRODUCT OF **Pilot Radio** LTD., PARK ROYAL, LONDON, N.W.10

Write for full details

WOLSEY TELEVISION AERIALS

combine all these essentials:—

- ★ TECHNICAL EFFICIENCY
- ★ LIGHT WEIGHT AND RIGID
- ★ SIMPLE AND SECURE FITTING
- ★ ASSURED WEATHERPROOFING

Illustrated is the Model H/M Aerial, constructed with steel tubing and Cadmium plated. Masthead cup fitting for pole mounting. Reflector spaced at $\frac{1}{4}$ th wavelength and suitable for use with all types of television receivers where maximum signal strength is required or for reduction of severe interference in Town areas.

AERIAL ONLY

67/6

LASHINGS AND POLE
extra, 60/6

Also now available for out-of-area districts,
a new Triple Reflector array, **£6 15s.**

FIVE OTHER TYPES OF WOLSEY AERIALS
ARE PRODUCED AND STOCKED

Send for Descriptive Literature

**INSTALLATIONS BY
OUR TECHNICIANS**

To ensure that your aerial is mounted
and fitted to manufacturers' specification,
and entrusted to specialists. We fit our
own or other makes of television aerials
anywhere within 50 miles of our Works.

ASK FOR DETAILS

WOLSEY TELEVISION LTD
75 GRESHAM ROAD
BRIXTON, LONDON, S.W.9

Tel. BR1xton 7566

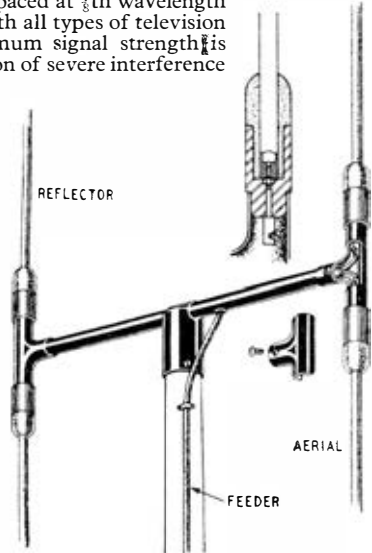
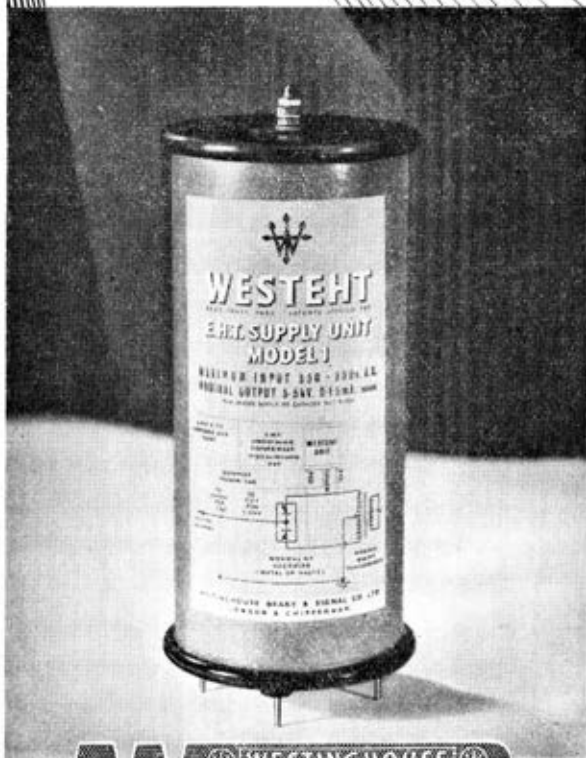

Diagram shows an important feature of the Wolsey type H/M—the p.v.c. waterproof and weather-resisting fittings used at the joints between the aerial rods and junction boxes. Aerial and Reflector elements are of Duralumin and screw into waterproof sockets on the junction boxes. The entire aerial weighs only 4-lb. and is the lightest and easiest-to-fit television aerial at present manufactured.



Introducing A NEW STAR PERFORMER



WESTINGHOUSE
WESTEHT

E.H.T. SUPPLY UNIT

5 kV. D.C. from 350 + 350 v. A.C.

No E.H.T. transformer No E.H.T. rectifier valve, Just plug into the existing standard mains transformer

Write for data sheet No. 52 to Dept. T.E.1—

WESTINGHOUSE BRAKE & SIGNAL CO. LTD., 82 York Way, King's Cross, London, N.I.

FOR NEWS OF LATEST DEVELOPMENTS
IN ALL SECTIONS OF THE RADIO AND
ALLIED INDUSTRIES . . .

**The WIRELESS & ELECTRICAL
TRADER**

**The Trade Journal of the Radio
and Domestic Electrical
Industries**

The Wireless and Electrical Trader provides up-to-date, reliable news of new products, trade activities and technical trends for manufacturers, wholesalers and dealers in the radio, television and light electrical industries.

Especially valuable to dealers is the practical advice on the equipment of premises and workshops, window displays and sales schemes, while each issue contains servicing data on one or more of the current British radio receivers.

Published Fortnightly 1/3

Annual Subscription £1 15s.

Wireless World **The Journal for Manufacturers
Designers and Technicians**

Wireless World is Britain's leading technical magazine in the general field of radio television and electronics. It provides a complete and accurate survey of the newest technique in design and manufacture, and covers every phase of the radio and allied industries, with reviews of equipment, broadcast receivers and components.

Published Monthly 1/6

Annual Subscription £1

**WIRELESS
ENGINEER** **The Journal of Radio Research
and Progress**

Wireless Engineer is read by research engineers, designers and students, and is accepted internationally as a source of information for advanced workers ; only original work is published. Regular features include patent specifications and abstracts and references compiled by the Radio Research Board.

Published Monthly 2/6

Annual Subscription £1 12s.

Subscriptions can only be accepted from overseas at present. Remittances (by International Money Order) should be sent to the respective Subscription Dept. at

DORSET HOUSE, STAMFORD STREET, LONDON S.E.1



I'll be there

with



PHILIPS NEW TELEVISION

You're taken right to the sidelines, to the front row of the stalls, with the *new* Philips television receivers. Every detail of every scene, every movement and expression is so bright and clear — so crisp and vivid — you almost believe that you *are* there, part of the cheering crowd, one of the delighted audience. The new Philips television gives you a picture full of life and action; brilliant and sharp, perfectly steady and of exceptional definition. The high quality of the sound reproduction enhances the realism of the picture. For television, as for radio, choose Philips — the name you can trust.

PHILIPS



*The Dependable Radio
and Television*

PHILIPS ELECTRICAL LTD · CENTURY HOUSE · SHAFTESBURY AVENUE · LONDON · W.C.2.

(R.302)

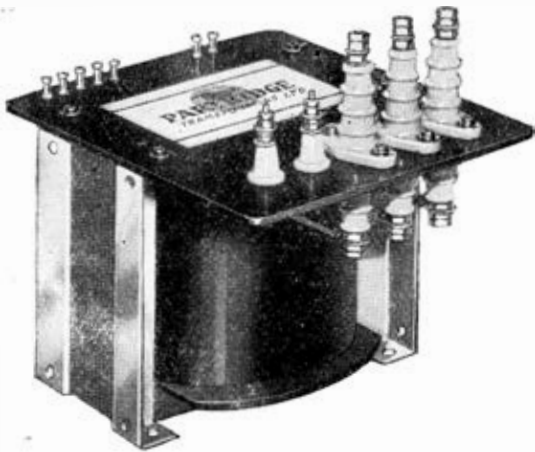

Partridge

have specialised in Television Transformers and Chokes for over 10 years and can manufacture to your own specification

A price list of components available from stock will be sent free on request

PARTRIDGE TRANSFORMERS LTD.

PECKFORD PLACE, BRIXTON, S.W.9

BRIxton 6506

LAB

TESTED

1880

COMPONENTS

In the range of LAB Resistance Products there is a type and value that will accurately match the part to be replaced. You can get LAB Resistance Products from any good Radio dealer

“LAB” RESISTORS

2 watt, 1 watt, $\frac{1}{2}$ watt and $\frac{1}{4}$ watt (insulated only) solid carbon resistors to guaranteed tolerances. R.M.A. Colour Code: minimum humidity factor: minimum voltage coefficient

“LAB” POTENTIOMETERS

Designed and manufactured with an unrivalled technical background. LAB Control production is maintained at an unusually high performance level

“LAB” CAR RADIO SUPPRESSORS

Exactly as developed for use on G.S. Vehicles during the war, special care has been taken to guard against mechanical breakdown. Easy to install; available in kits for 4 and 6 cylinder cars

THE RADIO RESISTOR CO. LTD.

Cumberland Road, STANMORE, Middlesex

Phone: WORDsworth 1138



Television Tubes

FIRST CHOICE OF THE EXPERTS

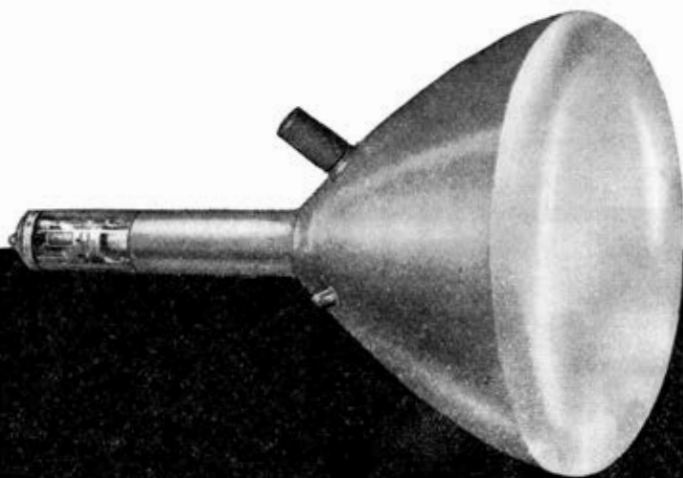

MULLARD ELECTRONIC PRODUCTS LIMITED, CENTURY HOUSE, SHAFESBURY AVENUE, W.C.2
MVM70A



The books listed below are selected from the extensive range published in association with the 31 Technical, Trade and Specialised journals of Associated Iliffe Press.

New titles are frequently added and revised editions regularly issued to ensure that the information is complete, accurate and up-to-date.

Subjects covered include Agriculture, Aeronautics, Architecture, Automobile Engineering, Business Organisation, Electrical Engineering, Engines, Laundering, Motor Cycling, Motoring, Nursing, Photography, Plastics, Radio, Road Transport and Yachting.

RADIO

BASIC MATHEMATICS FOR RADIO STUDENTS.

By F. M. Colebrook, B.Sc., D.I.C., A.C.G.I.

10s. 6d. By post 10s. 6d.

FOUNDATIONS OF WIRELESS (4th Ed., Revised).

By M. G. Scroggie, B.Sc., M.I.E.E.

7s. 6d. By post 7s. 10d.

HANDBOOK OF TECHNICAL INSTRUCTION FOR WIRELESS TELEGRAPHISTS (8th Ed.).

By H. M. Dowsett, M.I.E.E., F.Inst.P., and L. E. Q. Walker, A.R.C.S.

30s. 0d. By post 30s. 8d.

RADIO LABORATORY HANDBOOK (4th Ed.).

By M. G. Scroggie, B.Sc., M.I.E.E.

12s. 6d. By post 12s. 10d.

TELEVISION RECEIVING EQUIPMENT (2nd Ed.).

By W. T. Cocking, M.I.E.E.

12s. 6d. By post 12s. 11d.

TELEVISION RECEIVER CONSTRUCTION.

Reprint of articles from "Wireless World."

2s. 6d. By post 2s. 9d.

WIRELESS DIRECTION FINDING (4th Ed.).

By R. Keen, M.B.E., B.Eng.

45s. 0d. By post 45s. 8d.

WIRELESS SERVICING MANUAL (7th Ed.).

By W. T. Cocking, M.I.E.E.

10s. 6d. By post 10s. 10d.

GUIDE TO BROADCASTING STATIONS.

Compiled by "Wireless World" (3rd Ed.).

1s. 0d. By post 1s. 1d.

THE CATHODE RAY OSCILLOSCOPE (2nd Ed.).

By W. E. Miller, M.A.(Cantab.), M.Brit.I.R.E.

2s. 6d. By post 2s. 8d.

RADIO CIRCUITS: Step-by-Step Survey of Superhet Receivers (2nd Ed.).

By W. E. Miller, M.A.(Cantab.), M.Brit.I.R.E.

3s. 6d. By post 3s. 8d.

RADIO DATA CHARTS (4th Ed.).

By R. T. Beatty, M.A., B.E., D.Sc., Revised by J. McG. Sowerby, B.A., Grad.I.E.E.

7s. 6d. By post 7s. 10d.

RADIO RECEIVER SPECIFICATIONS, 1945-46.

9d. By post 10d.

RADIO WAVES AND THE IONOSPHERE.

By T. W. Bennington

6s. 0d. By post 6s. 3d.

RECEIVER SPECIFICATIONS & PRICES, 1935-40.

1s. 6d., post free.

LEGAL GUIDES

MANUAL OF HIRE-PURCHASE LAW.

By A. C. Crane and A. C. Crane, B.A. (Oxon.).

5s. 0d. By post 5s. 4d.

ROAD TRANSPORT LAW (4th Ed.).

By L. D. Kitchin, A.M.Inst.T.

5s. 0d. By post 5s. 3d.

MOTORIZING & MOTOR CYCLING

KNOW YOUR CAR (3rd Ed.).

2s. 6d. By post 2s. 8d.

LOOK AFTER YOUR CAR: Everyday Maintenance Simply Explained (2nd Ed.).

3s. 6d. By post 3s. 10d.

"THE AUTOCAR" HANDBOOK (20th Ed.).

5s. 0d. By post 5s. 4d.

THE ENDLESS QUEST FOR SPEED: "The Autocar" portfolios of historic motor racing scenes. Series I—12 col. plates depicting events from 1899-1912.

5s. 0d. By post 5s. 3d.

Series II—12 col. plates covering 1913-1927.

5s. 0d. By post 5s. 3d.

TWO-STROKE MOTOR CYCLES (10th Ed.).

3s. 0d. By post 3s. 3d.

MOTOR CYCLIST'S WORKSHOP (5th Ed.).

By "Torrens" of "The Motor Cycle."

3s. 0d. By post 3s. 3d.

PHOTOGRAPHY

PHOTOGRAPHIC SKIES.

By David Charles, F.R.P.S. 5s. 0d. By post 5s. 3d.

BRIGHTER PHOTOGRAPHY FOR BEGINNERS.

By David Charles, F.R.P.S. (3rd Ed.).

4s. 6d. By post 4s. 9d.

PHOTOGRAPHIC ENLARGING (2nd Ed.).

By David Charles, F.R.P.S. 4s. 6d. By post 4s. 9d.

DICTIONARY OF PHOTOGRAPHY (17th Ed.).

15s. By post 15s. 6d.

PHOTOGRAMS OF THE YEAR: 1949

(54th year of issue). Cloth 10s. 6d. Paper 7s. 6d.

By post 11s. 1d. and 8s. 0d.

AVIATION

"FLIGHT" HANDBOOK: A Manual of Aeronautical Theory and Practice (4th Ed.).

Compiled by the Technical Staff of "Flight."

7s. 6d. By post 7s. 10d.

GAS TURBINES AND JET PROPULSION FOR AIRCRAFT (4th Ed.).

By G. Geoffrey Smith, M.B.E.

12s. 6d. By post 13s. 0d.

ROAD TRANSPORT

BUS OPERATION: Principles and Practice for the Transport Student.

By L. D. Kitchin, A.M.Inst.T.

10s. 6d. By post 10s. 11d.

LORRY DRIVERS WAGES and Conditions of Employment.

By G. W. Quick-Smith. 5s. 0d. By post 5s. 3d.

Obtainable from all booksellers or direct from: THE PUBLISHING DEPT.

DORSET HOUSE, STAMFORD STREET, LONDON S.E.1, ENGLAND

AN OUTSTANDING OPPORTUNITY



Get this valuable free book

Keeping abreast of every trend and modern development is a matter of supreme importance to the ambitious Radio Engineer, Retailer, and Wireless enthusiast. To-day, far-seeing men realise that there is an outstanding opportunity for those who can see just a little way ahead of their competitors. How? Where? Surely the answer is . . .

TELEVISION

Make no mistake! Ultimately, Television will be in every home, and Radio Engineers who waited upon events and were content with a sketchy, out-of-date knowledge, will find themselves unable to catch up with the men who had the foresight to commence a thorough and systematic study of Television while there was yet time. The B.I.E.T., for many years predominant in the Wireless Training Field, has prepared, with the aid of some of the leading experts in the country, a thoroughly comprehensive Home Study Course in **PRACTICAL TELEVISION**.

Full details of our unique methods are given in "**ENGINEERING OPPORTUNITIES**"—the valuable 108-page Handbook, which among other intensely interesting matter, gives details of **A.M.I.E.E.**, **A.M.BRIT.I.R.E.**, **CITY & GUILDS**, and other important examinations, outlines special courses in **General Wireless Engineering**, **Sound Film Projection Engineering**, **Radio Servicing**, **Television**, etc., and explains the way to get some letters after your name.

We definitely guarantee
"NO PASS — NO FEE"

Whether you are interested in preparing **NOW** to skim the cream of the new Television market—whether you are interested on your own behalf or wish to encourage and advise your employees, "**ENGINEERING OPPORTUNITIES**" is bound to indicate many opportunities that you might otherwise miss. Write **to-day** for your copy. It will be sent to you **FREE**—and without obligation.

BRITISH INSTITUTE of ENGINEERING TECHNOLOGY
870 Shakespeare House, 17-19 Stratford Place
LONDON, W.1.

Virtually Distortionless

A.D/47 AMPLIFIER



This is a 10-valve amplifier for recording and play-back purposes for which we claim an overall distortion of only 0.01 per cent., as measured on a distortion factor meter at middle frequencies for a 10-watt output.

The internal noise and amplitude distortion are thus negligible and the response is flat plus or minus nothing from 50 to 20,000 c/s and a maximum of .5 db down at 20 c/s.

A triple-screened input transformer for $7\frac{1}{2}$ to 15 ohms is provided and the amplifier is push-pull throughout, terminating in cathode-follower triodes with additional feedback. The input needed for 15 watts output is only 0.7 millivolt on microphone and 7 millivolts on gramophone. The output transformer can be switched from 15 ohms to 2,000 ohms, for recording purposes, the measured damping factor being 40 times in each case.

Built-in switch record compensation networks are provided for each listening level on the front panel, together with overload indicator switch, scratch compensation control and fuse. All inputs and outputs are at the rear of the chassis.

SEND FOR FULL DETAILS OF AMPLIFIER TYPE AD/47

Vortexion
LIMITED

257/261 THE BROADWAY
WIMBLEDON, S.W.19

Phone: LIBerty 2814 and 6242/3
Tel.: "VORTEXION, WIMBLE, LONDON"
