

MAY 1987 \$4.75
NZ\$6.50

**Elektor
Electronics**

The

THE AUSTRALIAN ELECTRONICS



on the way

**SUPER
OSCILLOSCOPE
OFFER!**

**UPGRADE YOUR
TILBROOK 5000 AMP**

**Lab. standard
power supply**

**Rechargeable
batteries**

**RTTY encoder
mate for the
Listening Post**



MULTIMETERS
choosing and using

**VZ-ers! Epson printer patch
FAX interface for C64 and BBC**

audio • video • computing • communications • projects • engineering • technology

Fluke. First Family of DMMs.



When accuracy, performance and value are important, professionals the world over look to Fluke — the first family of DMMs.

Reliable Fluke-quality 3½- or 4½-digit DMMs fit every need — from design engineering to industrial troubleshooting.

There's the low-cost 70 Series — the most DMM you can get for the money. The tough 20 Series — totally sealed and built to survive the dirtiest, grimeiest, roughest jobs. The reliable 8020B Series — made to withstand the rigors of the field service environment. The precise 8060A Series — the most powerful and complete test and measurement system available in a hand-held package. And, of course, the versatile Bench/Portables that carry on the Fluke tradition for precision and durability in lab-quality bench instruments.

Fluke comes in first again with the world's largest selection of quality accessories to help extend the capabilities of your DMM even further.

There's no need to look anywhere else. Uncompromising Fluke design and leading edge technology are the reasons why attempts at imitation will never fool the millions of professionals that accept nothing less than a Fluke.

FROM THE WORLD LEADER
IN DIGITAL MULTIMETERS.



ELMEASCO **Instruments Pty. Ltd.**

Talk to your local Elmeasco distributor about Fluke —

- **A.C.T.** John Pope Electrical (062) 80 6576 • J Blackwood & Sons (062) 80 5235 • George Brown (062) 80 4355
- **N.S.W.** Ames Agency 699 4524 • J Blackwood & Sons • George Brown 519 5855 Newcastle 69 6399 • Bryan Catt Industries 526 2222 • D.G.E. Systems (049) 69 1625 • Petro-Ject 550 1388 • David Reid 267 1385 • W. F. Dixon (049) 61 5628 • Macelec (042) 29 1455 • Ebson 707 2111 • Selectoparts 708 3244 • Geoff Wood 427 1676
- **N. TERRITORY** J Blackwood & Son (089) 84 4255, 52 1788 • Thew & McCann (089) 84 4999
- **QUEENSLAND** Auslec • Petro-Ject (075) 91 4199 • St Lucia Electronics 52 7466 • Cliff Electronics 341 4655 • L. E. Boughen 369 1277 • Fred Hoe & Sons 277 4311 • The Electronic Shop (075) 32 3632 • Thompson Instruments (Cairns) (070) 51 2404
- **S. AUSTRALIA** Protronics 212 3111 • Trio Electrix 212 6235 • Industrial Pyrometers 352 3688 • J Blackwood & Son 46 0391 • Petro-Ject 363 1353
- **TASMANIA** George Harvey (003) 31 6533 (002) 34 2233
- **VICTORIA** Radio Parts 329 7888 • George Brown Electronics Group 878 8111 • G B Telespars 328 4301 • A.W.M. Electrical Wholesalers • Petro-Ject 419 9377 • J Blackwood & Sons 542 4321 • R.K.B. Agency 29 7336 • Sirs Sales (052) 78 1251 • Mektronics Co 690 4593 • Truscott Electronics 723 3094
- **W. AUSTRALIA** Atkins Carlyle 481 1233 • Dobbie Instruments 276 8888 • Protronics 362 1044

Incorporating

**Elektor
Electronics**

AUSTRALIAN ELECTRONICS *Monthly*

POLICE RADAR – SCIENTIFIC MEASUREMENT, OR JUDGEMENT?

The proposal in New South Wales that the radars used by the Police to measure vehicle speed for the purpose of apprehending motorists travelling in excess of the speed limit be declared "scientific instruments" is an issue fraught with inherent, and hidden, dangers. The purpose of having the radars declared scientific instruments means that a reading observed on the machine is regarded as prima facie evidence, making it extremely difficult to challenge in court, regardless of the circumstances. At present, a reading on a radar recording a speed in excess of the limit is only corroborating evidence, supported by the observation of a police officer. Few violations are challenged.

As pointed out in Jonathan Scott's article in our February and March issues last year, there are a number of situations and circumstances in which a Police radar can be 'fooled', even when properly set up and operated within the guidelines. Visual identification by a Police officer is relied upon to select an 'offender'. That officer, of necessity, has to make a subjective judgement in some circumstances as to the identity and likely speed of the offending vehicle. This applies for both the older "down the road" type radars, and the more recently introduced "slant" or "across the road" type radars. One slight slip in attention, or a drop in alertness (it's a boring job!) on the part of the officer, and you may be innocently booked for a violation you did not commit.

A number of people have suggested employing "photographic" radars that take a picture of the scene when an excessive speed is detected, printing on the picture the time, date and speed recorded. It makes the equipment more expensive, but it removes that element of subjective judgement inherent in the current system. Picture-taking Police radars were mooted when the issue first surfaced in the 1970s, and have been proposed at intervals since. But the arguments have fallen on deaf ears. Since the Government collects tens of millions of dollars revenue from speed violation fines, it can hardly be argued the expense of picture-taking radars cannot be afforded. And it should reduce the number of challenges, few though they are. Where human judgement is involved, an instrument or a procedure employing instruments to measure something, cannot be called "scientific".

I fail to understand the reluctance of the authorities and the Government here to implement the clearly obvious course, unless they know or suspect it is likely reduce the revenue, or that the cost will reduce the 'profit'.

LATE ISSUES

As you are all well aware, our issues have been very late these past few months. This was brought about through several problems and difficulties affecting production, but these have now been overcome and we are on the way to putting our issues back on schedule to appear at the beginning of the month. With our new staff members, Andrew Keir and Richard Pakalnis, we all look forward to a vigorous and exciting time ahead!

NEW 'PHONE NUMBER: 487 1207

Our Technical Enquiries number remains the same – 487 1483. But, please, call us – Andy Keir or Roger Harrison – only after 4.30 pm EAST.

Roger Harrison
Editor/Publisher



Roger Harrison VK2ZTB **EDITOR**

ASSISTANT EDITOR

Andrew Keir VK2AAK

NATIONAL ADVERTISING MANAGER

Richard Pakalnis

DRAUGHTING

Kym Baillie

SPECIALIST SERVICES

Jamye Harrison

PRODUCTION COORDINATOR

Val Harrison

PUBLISHER

Roger Harrison

CONTRACT PROJECTS

Technical Systems Australia

ACOUSTICAL CONSULTANTS

Robert Fitzell Acoustics Pty Ltd, AAAC

EDITORIAL ASSOCIATES

Ian Boehm

Neil Duncan VK3AVK

B. App. Sci., Dip. Ed., M. Ed. Studs

Alan Ford VK2DRR/G3UIV FIAADP MBIM

Tom Moffat VK7TM

Jonathan Scott VK2BYN

B. Sc./B.E. (Hons)

EDITORIAL OFFICES Fox Valley Centre,

Cnr Fox Valley Rd & Kiggle St,

WAHROONGA 2076 NSW.

POSTAL ADDRESS

PO Box 289, WAHROONGA 2076 NSW

FAX: (02) 489 1265 **TLX:** 121822 (SY3296)

ENQUIRIES

Advertising: (02) 487 1207

Editorial: (02) 487 1207

Technical: Only after 4.30 pm EAST

(02) 487 1483 – Roger Harrison or

Andy Keir

SUBSCRIPTIONS

\$49.95 Australia; overseas rates on

application.

Published by: Kedhorn Holdings Pty Ltd, Fox

Valley Centre, Cnr Fox Valley Rd – Kiggle St,

Wahroonga 2076 NSW. **Typesetting by:**

Autotype Photosetters Pty Ltd, 397 Riley St,

Surry Hills, NSW. **Printed in 1987 by:** Offset

Alpine, Cnr Derby & Wetherill Sts, Silverwater

NSW. **Distributed by:** Network distributing,

52-54 Park St, Sydney NSW. *Cover Price

\$4.75 (maximum and recommended Australian

retail price only; recommended New Zealand

Price NZ\$6.50). Registered by Australia Post,

Publication No. NBP 7435. ISSN No.

0815-5046.

INTERSTATE ADV. SALES

Victoria: R. T. Wyeth & Associates,

1/128 Dandenong Rd,

Dingley 3172 Vic.

Ph: (03) 551 1212

Queensland: Geoff Horne Agencies,

PO Box 247, Kenmore 4069 Qld.

Ph: (07) 202 6813, Fax: (07) 202 7133

Tlx: (07) AA41398 (Geoff Horne)

West Australia: Stephen Knight,

Hugh Scott & Associates,

122 Aberdeen St, Northbridge 6000 W.A.

Ph: (09) 328 9204

COPYRIGHT © 1987, KEDHORN HOLDINGS P/L

COPYRIGHT: The contents of The Australian Electronics Monthly is fully protected by the Commonwealth Copyright Act (1968). Copyright extends to all written material, drawings, circuit diagrams, printed circuit boards, computer software and photographs. Although any form of reproduction is a breach of copyright, and we especially point out this extends to the construction of projects produced by our laboratory or our associates, we are not concerned about individuals constructing projects for their own private use, nor by bands for example, constructing one or more units for use in performances. Commercial organisations should note that no project or part project, including printed circuit boards produced by our laboratory or our associates and described in this magazine may be offered for sale, or sold, in fully or substantially assembled form, unless a licence has been specifically obtained to do so from the publishers, Kedhorn Holdings Pty Ltd, or from the copyright holders. We will take strenuous legal action against any person or firm found infringing our copyright as aforesaid.

LIABILITY: Whilst all efforts have been made to ensure that all constructional projects and circuits referred to in this issue will operate as indicated efficiently and correctly and that all necessary components to assemble the same will be available, no responsibility whatsoever is accepted in respect of the failure for any reason at all of the project or circuit to operate effectively or at all whether due to any fault in design or otherwise and no responsibility is accepted for the failure to obtain any components in respect of such project or circuit. In addition, no responsibility is accepted in respect of any injury or damage caused by any fault in the design of any such project or circuit aforesaid. The publisher accepts no responsibility for unsolicited manuscripts, illustrations, computer software or photographic material although all care will be exercised. Comments and test results on equipment reviewed refer to the particular item submitted for review and may not necessarily pertain to other units of the same make or model number.

ADVERTISERS INDEX

COVERS

| | |
|---------------------|-----|
| Elmeasco | IFC |
| Subscriptions | IBC |
| Philips | OBC |

INSIDE

| | |
|-------------------------------|-------|
| Ampec | 22 |
| Amtext | 30 |
| Bob McNight Trading | 29 |
| Dick Smith Electronics | 23-26 |
| Eagle Electronics | 63 |
| Email | 13 |
| Emona | 76 |
| Force Electronics | 55 |
| Geoff Wood Electronics | 32 |
| Hi-Com Unitronics | 63 |
| Maestro Distributors | 89 |
| Philips Elcoma | 19 |
| Power Sonic | 28 |
| Printed Circuit Service | 92 |
| Scan Audio | 17 |
| Siomar | 21 |
| Solarex | 27 |
| Statronics | 63 |
| Tandy | 10 |

COVER

Buying a multimeter? See page 11. Our cover shows one of Philips' 18 Series DMMs, a 4.5-digit unit with LCD display and bargraph. Pic by Allan Hedges. Design by Val Harrison.

PROJECTS TO BUILD



AEM6005 Upgrade Your Tilbrook 5000 Amp!

..... 56
Here's how to upgrade your old 5000 stereo amp using a pair of our new 6005 'U-F' topology MOSFET amp modules. It's simple and gives great performance.

AEM3510 Simple RTTY Modulator

..... 64
Here's the simple, low-cost way to get going on RTTY using your computer and public domain software. It makes a great "companion" to the AEM 3500 Listening Post for a full-blown RTTY modem!

AEM2000 Lab. Standard Power Supply, Part 2.

..... 68
This month we detail the circuits and discuss the features of the design.

FABULOUS OFFER!

Philips' PM 3055 50 MHz CRO!
..... 9
Unbelievable offer, for AEM readers — a top-flite CRO from Philips.

CIRCUITS & TECHNICAL ELEKTOR IN AEM

Contents 33

Facsimile Interface

..... 45
Here's a radio facsimile picture decoder that takes audio from a shortwave receiver and sends data to a computer for decoding and printing. It provides local synchronisation, not relying on the computer's software (and hence its clock) to do it. It only requires relatively simple software and listings are given for the BBC and Commodore 64.

Recent Developments in Silicon Sensors

..... 7
Sensors on a chip overcome many limitations of conventional sensors and will find ever increasing applications.

Rechargeable Batteries

..... 20
Secondary, or rechargeable, batteries have been around for many, many years. Recent developments have seen them used in wider fields. Here's a rundown on the various types and their characteristics.

EQUIPMENT REVIEW

The Heathkit Digital Weather Station

..... 31
Do your own forecasts! Well, be able to argue with the weatherman, at least.

Benchbook

..... 94
Useful hints and tips from readers.

PRACTICAL COMPUTING



SPECIAL OFFER

COMX Plotter
..... 84
A plotter that's compatible with AutoCAD, Lotus etc for just \$399!

Towards a VZ-Epson Printer Patch

..... 86
Here's how to get some sensible hard copy from your VZ200/300 and that Epson, or Epson-type, printer.

Dial Up

..... 89
General communications and an answer from Telecom! See how checksum, VRC, LRC, Christenson and other comms protocols operate.

COMMUNICATIONS SCENE

Menu Selectable CW Message Generator Using the Microbee

..... 78
Geoff Wilson VK3AMK shows how to make quite a flexible and useful CW message generator if you've got a Microbee.

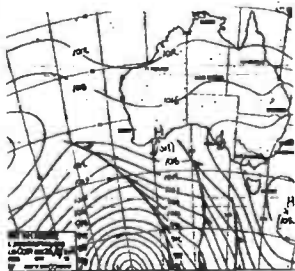

The Listening Post Package

..... 83
Decode those digital modes so prevalent on the HF bands — RTTY, FAX and even Morse — using your receiver, our package and your computer (Apple II, C64 and 'Bee).

FEATURE

So You Want to Buy a Multimeter?

..... 11
Andy Keir takes you step by step through the shoals of perusing and purchasing a modern multimeter.



CONSUMER ELECTRONICS

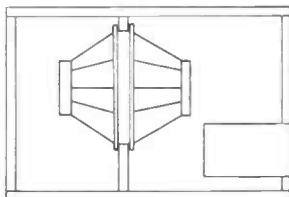

Recent Developments in Bass Speaker Designs

..... 16
Using twin, tuned and coupled box sections loudspeaker makers have managed to do the equivalent of squeezing a quart pot into a pint bottle!

NEWS & GENERAL

News Review 6
SQUIDS raise temps.

Consumer Electronics 15
Palm-sized copier!

Professional Products 18
Anitech to sell Kenwood.

Retail Roundup 54
Remember this one, Sam!

Spectrum 77
New spectrum analyser.

Bytewise 85
High speed solution.

Admarket 76

Letters 96

The Last Laugh 98

Subscriptions IBC

Printed Circuit Boards 97

NEXT MONTH!

BUILD OUR STAND-ALONE V.22 MODEM

Here's a low-cost, 1200 baud full duplex modem. Why throw away your existing modem just to get what you've already got plus 1200/1200 baud in a new modem? build the AEM4622 and get on with some speedy comms at minimum cost.

CLIPPING AND FAULT INDICATOR FOR AUDIO AMPS

This project may be attached to amplifiers of up to 250 watts rating. It employs a LED to warn of the onset of clipping and show dc present on the output. It can be powered from the amp or from a separate supply.

DIGITAL COMMUNICATION MODES

Our feature explores the many digital radio communication modes employed these days. Ever been curious about packet radio, ARQ or RTTY? Don't miss next issue!

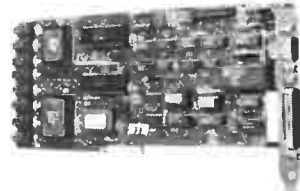

PC PLUG-INS, ADD-ONS AND ENHANCEMENTS

Looking to trick-out your PC or compatible with a few go-fasts and graphics add-ons? Our feature next month goes into the sort of things available on the market right now and what they'll do for your hardware and software.

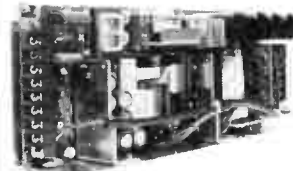

POWER SUPPLY OFFER

..... 93
End-of-line model sellout on a brand-name, quality, multi-output switching power supply.

While these articles are currently being prepared for publication, unforeseen circumstances may affect the final contents of the issue.

Temperatures rise with SQUID advances

Researchers at the IBM Thomas J. Watson Research Centre, New York USA, have made the first thin-film superconducting devices that operate at temperatures high enough to be of practical use.

The new IBM devices, called SQUIDS (Superconducting Quantum Interference Devices), are the most sensitive magnetic detectors known to science. Composed of two thin-film Josephson devices each, the SQUIDS are only one one-hundredth the thickness of a human hair and are superconducting at up to 68 Kelvin (K).

SQUIDS have been used by scientists in studying brain waves, in geological exploration and in fundamental physics research. Previous applications, however, have been limited by the need to cool the SQUIDS to 4 K, the temperature of liquid helium.

The new thin-film SQUIDS made by IBM researchers become completely superconducting in the range where liquid nitrogen can be used as the coolant. Liquid nitrogen boils at 77 K and can be effectively employed at 68 K by reducing its pressure, the IBM scientists say.

Liquid nitrogen is much less expensive and more convenient than the liquid helium used in current superconductivity applications.

In January 1986 J. Georg Bednorz and K. Alex Mueller of the IBM Zurich Research Laboratory discovered superconductivity in a compound of barium, lanthanum, copper and oxygen, which became superconducting above 30 Kelvin (K) or 30 degrees above absolute zero. (Absolute zero is -273 degrees Centigrade, or -459 degrees Fahrenheit).

Superconductivity was discovered in Holland in 1911 by Kamerlingh Onnes, who found that at temperatures close to absolute zero certain metals, alloys, and chemical compounds lose all their electrical resistance — electricity could flow without the wasteful dissipation of power or production of heat.

Progress in finding high-transition-temperature superconducting materials seemed to stall in 1973 after reports that

niobium and germanium compounds exhibited superconducting transition temperatures of 23.2 degrees above absolute zero.

In 1983 IBM's Bednorz and Mueller noticed a class of oxides with low electron concentration relative to metals (which make good superconductors) that nevertheless exhibited superconductivity at about 13 K.

This observation implied that the material had very strong attractive or coupling forces between the pairs of electrons responsible for the superconductivity.

So the IBM scientists began their search for other oxide materials with higher electron concentrations and strong electron-pair coupling.

They made and explored many materials in that class until they became aware of one that embodied a high concentration of electrons. Bednorz and Mueller knew that the material had strong coupling — they knew that class very well by then — so they realised that the material was the one they were seeking. Indeed, it became superconducting at 35 K.

The goal of finding such higher temperature materials has been achieved, but the quest for higher transition temperatures continues.

This announcement of high-temperature SQUIDS continues to build on IBM's seminal work and is a significant step towards producing instruments and complex microcircuits using superconductivity technology, the company says.

Exporting Travellers

A new cellular radio phone, developed by Philips especially for Telecom's MobileNet system, will work with the telephone systems in the US, Canada and New Zealand, and this opens up potential export opportunities for Australia, according to John

Dearn, divisional manager of Philips Communication Systems.

The car-mounted phone, developed here, is being manufactured at the Philips radio centre at Clayton, Victoria. Telecom will sell it as the "Traveller".

Telecom has exclusive Australian marketing rights for the "Traveller" but Philips plan to release a new radio of a similar type, developed and manufactured at the same plant, to be sold directly by Philips both here and overseas.

"As Australia's number one manufacturer, and marketer of mobile radios, Philips have put a multi-million dollar investment into the development and manufacture in Australia of cellular radios", said Mr. Dearn.

"By choosing to go with the AMPS international standard for its MobileNet cellular phone systems, Telecom has opened the way for Australian companies to export into large markets overseas.

"The North American market for Cellular Mobile Telephones has been doubling each year. In



1986 alone, sales were estimated at more than US\$500 million.

"Cellular radio which allows the radio frequencies to be used more effectively, will have a major impact on the way people use the telephone network. Telecom estimates it will have 200,000 cellular mobile telephone users across Australia within 10 years."

Vicom relocates

Vicom has moved to new premises at South Melbourne, which offer expanded areas for its Research and Development, consulting and manufacturing activities.

The new building covers 14 000 square feet and also houses Vicom's National Service & Support Centre.

Vicom commenced business in 1974 and has been forced to move three times because of its rapid growth.

Vicom's new address is 4 Meaden Street, South Melbourne, Vic. (03) 690 9399.

LET'S DO IT OURSELVES!

General Power Controls, a contract electronics manufacturer assembling computers, communications equipment, amplifiers, telephones, home appliance controls and security equipment, opened a new factory in Penrith, NSW recently.

Managing Director, Mr. Christopher Janssen, says he is proud of the way his young company is continuing to grow and reduce the need to import so many manufactured high-tech products from overseas.

Being able to provide such a manufacturing facility has meant that many small local companies are able to gear-up their production rates without tying up their capital in expensive automatic equipment, he says.

Many foreign based companies who have previously imported fully manufactured products, have also started to utilise the GPC production facility. Full static protection is provided throughout the plant which is constantly being up-graded to keep pace with today's technological changes. Details from Chris Janssen, (047) 31 2845.



Recent developments in silicon sensors

J. Middlehurst

Electronic sensors are all the time becoming more sophisticated and finding wider applications. Since 'smart' sensors came along, fields of application have broadened significantly.

SENSORS are devices that convert a property of their surroundings into a measurable signal. Examples of man-made sensors are the thermocouple, which converts temperature into voltage, the microphone which converts pressure fluctuations into varying voltages and the pH electrode which converts the acidity of a substance dissolved in water into a voltage. Over many millions of years living things have evolved a wide range of sensors. For those with a central nervous system, the useful output of the sensor is an electrical charge; for plants it is a chemical, usually a hormone. Animals use their sensors to find food, find a mate, and detect danger, so their sensors are optimized for these tasks. Evolution has managed to reduce the size of a sensor to that of a single living cell (about 1 micron). Man-made sensors have not had much time to evolve so they are not yet optimized and consequently they are usually much larger than living sensors.

The current trend in industry is to use intelligent production lines and intelligent robots. The production lines have sensors at various positions along them monitoring critical properties of the product, and the output of the sensors is used in a number of negative feedback systems to keep these critical properties within the desired limits. Similar sensors and feedback circuits are used in robots so that their movements can be sensitively controlled.

This industrial trend has led to the detailed study of the properties of sensors and of the way in which these properties affect their operation. Particularly important properties are:

1. size (and sometimes shape)
2. sensitivity
3. linearity, and
4. stability.

Size. The maximum size of the sensor is determined by the size of the smallest volume over which the sensor is expected to do its sensing. It is no use trying to determine the properties of waves that affect a rowing boat by using a sensor the size of an ocean liner; it just would not respond to waves of this size. The minimum size is determined by the residual noise of the sensor and its surroundings. To continue the above example, if we used a cork as the sensor, it would generate a lot of output from waves the size of a cork, but these would not have any effect on the rowing boat. So you can see that there is an optimum size for a sensor that depends on the job it has to do.

Sensitivity. This is the ratio of the change in the output (usually voltage) produced by a given change in the property being sensed. For a thermocouple it would be volts/degree. In general the higher the sensitivity the better, but the sensitivity is clearly excessive if the output becomes saturated by a small change in the sensed property. A typical thermocouple has a sensitivity of $40 \mu\text{V/K}$ whereas a modern tempera-

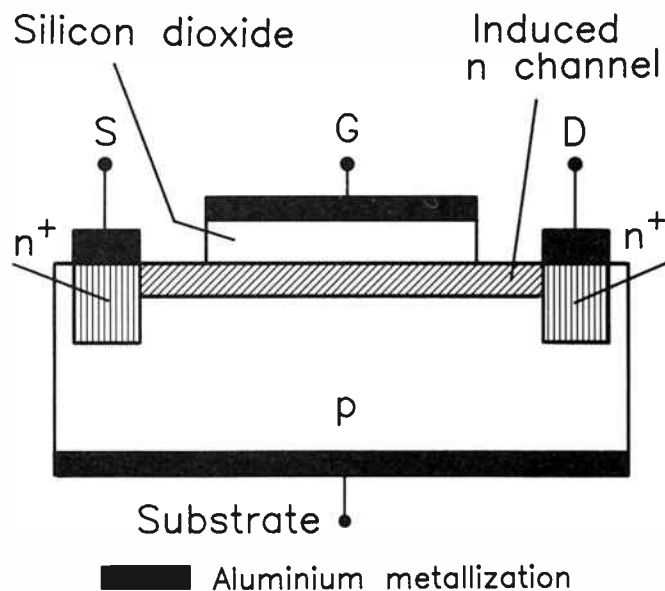

Figure 1. N-channel MOSFET showing the layer of silicon dioxide used to insulate the gate electrode. Any positive potential on this insulating layer induces an n-channel in the surface layers of the p-type silicon between the source and drain. If the gate electrode is exposed, positive ions coming into contact with it influence the source-drain current.

ture sensor has 10 mV/K . However a temperature sensor with a sensitivity of, say, 10 V/K would have very limited use if its output saturated at 10 V .

Linearity. It is convenient and makes for less electronic complications if the change in output is linearly proportional to a change in the property being sensed. If the output is only approximately linear, or if the ratio of output to input is, for example, a square law, linearising amplifiers have to be used within the feedback loops used for control purposes.

Stability. Two characteristic numbers define the properties of a linear sensor. These are the sensitivity and the zero, and both must be stable for a sensor to be useful. A temperature sensor would not be much use if today its sensitivity is 10 mV/K and tomorrow it is 15 mV/K . Likewise it would not help if 0°C was 2.73 V today and 2.51 V tomorrow. All sensors must be calibrated, but it is clearly desirable that, once calibrated, they retain their calibration for as long as possible.

Stability is particularly important where the sensor must work in a hostile environment such as the engine compartment of a motor car. Often it is necessary to sacrifice other properties such as sensitivity to achieve a satisfactory level of stability, and consequently lifetime, for such a sensor. ▶

Conference on sensors

International conferences on sensors started in 1981 and are held every two years. The conference in 1985, held in Philadelphia USA, was entitled "Transducers '85" and was attended by some 600 participants. The proceedings of this conference have recently become available in Australia and are in the University of Wollongong library.

Authors from all over the world presented 115 papers on all aspects of modern sensor development. The subjects ranged from tactile, force and optical sensors for robots to chemical sensors to replace the human nose. Considerable work has been going on in the development of "smart sensors" based on the properties of modified silicon chips.

Silicon sensors

Since transistors were first made, it has been known that a thin layer of water condensed on their surface can have a disastrous effect on their properties. This is particularly the case with FETs. Manufacturers go to considerable trouble to ensure that no water vapour has any access to the interior of the packages of transistors, FETs, or ICs. This effect has now been put to practical use by deliberately designing FETs with some or all of their surface exposed to the atmosphere and using the effect that relative humidity has on their properties. So the FET has become a sensor for relative humidity.

Figure 1 shows the construction of a typical n-channel MOSFET. When a positive gate voltage is applied, an n-channel is induced at the surface between the source and the drain. A sufficiently positive drain voltage will pinch off this channel and the source-drain current becomes independent of the drain voltage. Any change in gate potential changes this current. If, instead of applying a potential to the gate, a substance that generates an electrical field is applied to the gate area, that field can be used to control the drain current. This is why water, a highly polar material, has such a pronounced effect on the characteristics of FETs. Clearly, the thinner the oxide layer of the gate region, the more effect the layer of surface charge has on the current. The idea of putting layers of chemical onto the gate area has proliferated and there are now modified forms of FETs specifically designed to act as sensors for a wide range of gases, vapours, and chemical and biological materials.

The first of these modified MOSFETs was the ISFET or Ion Sensitive FET in which current flow is controlled by the presence of ions at a special gate electrode. This made the ISFET suitable for use as a sensor for the pH of a solution in which it is placed.

The ADFET has an extremely thin gate oxide layer and so is sensitive to the Adsorption of any gases or vapours that have permanent dipole moment. Similarly the SAFET or Surface-Accessible FET is sensitive to polar gases such as alcohol vapour.

More recent developments of the ISFET involve coating the gate area with a substance that will change the ion concentration at the ion sensitive gate. These include the CHEMFETs in which the gate is covered with a microscopically thin chemical membrane which allows only certain ions to pass through it. By modifying the membranes it is possible to make a series of sensors that are specific to particular chemicals. A further development of this idea is the ENFET or Enzyme FET in which an active enzyme is placed in an immobilizing gel on the gate area. Since enzymes act as controllers of very specific biological reactions, the ENFET can be used to measure the presence of minute quantities of particular biological materials. In future it may be possible to use the enzyme as the catalyst in a feedback loop, measuring and controlling its own reaction rate. Experiments are under way in a number of laboratories to develop the BIOFET, in which biologically active substances such as living cells,

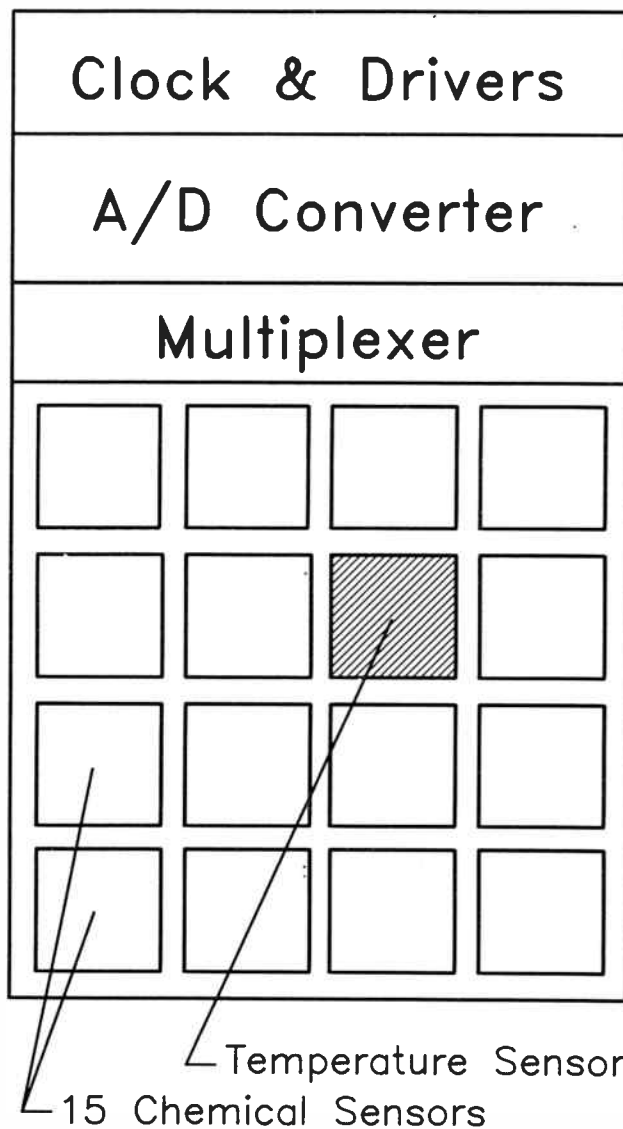

Figure 2. Multi-electrode smart silicon sensor with temperature compensation and complete digital driver system. The output goes direct to a computer for linearization and display of the properties of the system being measured.

bacteria, moulds etc can control the output of FETs, responding to such things as oxygen concentration, nutrient supply, waste product removal rate, and so on. In similar vein, prototype IMFETs or ImmunoFETs have already been developed that are sensitive to specific antibodies and antigens.

In fabrication all these types of modified FETs, great attention has to be paid to the passivation, usually with silicon nitride, of all the surfaces other than the gate. Also, since the metallization of the gate now has to withstand chemical attack by its surroundings, the aluminium that is commonly used in ordinary FETs is replaced by a more inert metal such as gold.

New ideas are not limited to the effects of chemicals on silicon chips. Since the properties of FETs also depend on any stress within the silicon chip, a simple and rugged pressure/vacuum gauge has been constructed by mounting a chip over the end of a tube. Suction on the tube bends the chip and the drain current changes with the degree of suction. The output is a nonlinear function of pressure. In an attempt to make these sensors cheaper and more reproducible, the latest design uses a single chip of amorphous silicon simply

It's the end of the financial year. Here's an
UNREPEATABLE OFFER!

Snap up
 this superlative

50 MHz dual-timebase Philips CRO!

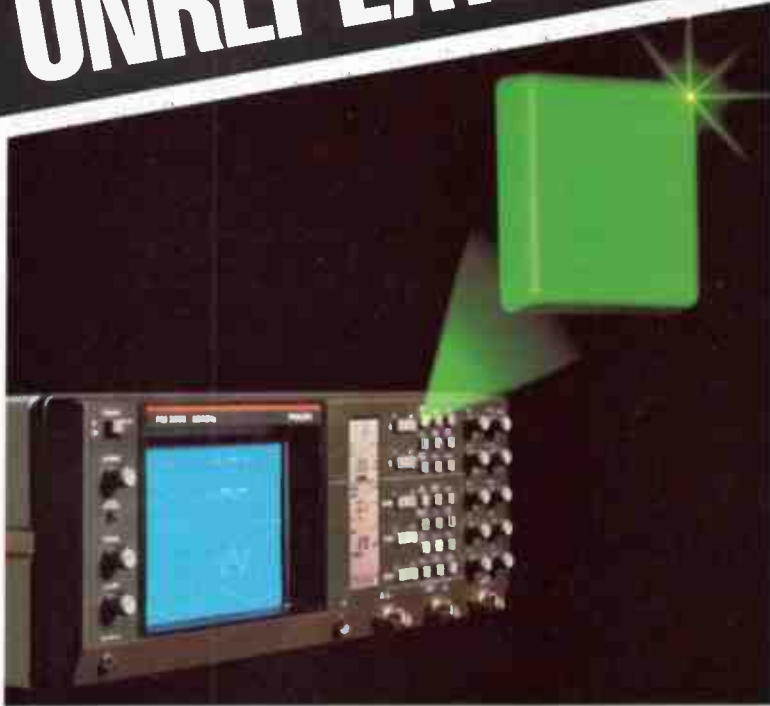

FEATURES INCLUDE:

- Auto-set key sets amplitude, timebase and triggering
- 50 MHz bandwidth
- Sensitivity range 2 mV/div. to 10 V/div.
- Minimum 5 ns timebase sweep
- 100 MHz trigger bandwidth, plus trigger view facility
- Auto, manual and single-shot triggering
- Microprocessor control to 'think' for you
- 16 kV tube accelerator voltage
- Liquid crystal display control setting display
- Multi-function, menu-driven softkeys
- Menu/help functions
- Power supply operates over 90-264 Vac, 45-440 Hz.
- IEEE interface option
- Probe indication: x10, x100
- All-modular construction
- Built-in service program
- Reads like a book – top to bottom, left to right!

Now is the time to buy – take advantage of improved exchange rates and this very special offer on the Philips PM 3055 oscilloscope.

Just \$2795 (Normally around \$3000)
 or **\$3354 tax paid.** (Normally around \$3600)

Delivered to your door
 for just \$20.

SET OF 100 MHz PROBES TO MATCH, worth around \$200 – FOR FREE!

This special offer includes a pair of PM8936/09 probes, free! They feature 100 MHz bandwidth, x10 attenuation, 10M input impedance and 1.5m long leads.

Yes! This is the Philips PM 3055 that has set new standards in its class. Take this limited chance to buy a quality instrument that major electronic labs in government departments, defence establishments and industry are using. The latest production techniques have allowed Philips to produce this market leader instrument at TV set speed. And the faster they can be produced, the lower the price.

This offer is made to readers of Australian Electronics Monthly by Philips Scientific & Industrial, and the magazine is acting as a clearing house for orders.

**Don't delay,
 OFFER MUST CLOSE
 LAST MAIL 20 JULY 1987**

Fill out the coupon now and rush it to:

**Philips CRO Offer
 Australian Electronics Monthly
 PO Box 289, Wahroonga 2076 NSW**

When we reviewed the PM 3055 in the April issue, we were so impressed we just had to have one for the lab!

COUPON

Yes! I want _____ Philips PM 3055 oscilloscope(s) at \$2795 tax free, or \$3354 tax paid, with a free pair of PM8936/09 probes with each unit, plus \$20 for delivery.

TOTAL: \$ _____ sales tax no: _____

I enclose payment by:

Money Order Cheque Visa
 Bankcard Mastercard American Express

Credit card no: _____

Expiry date: _____

Cheque or Money Order no: _____

(Government departments and institutions may proceed on official purchase order, but this coupon must be attached)

Please make cheques or Money Orders payable to "Australian Electronics Monthly"

Name _____

Company _____

Position _____

Address _____

Postcode _____

Signature _____

(Unsigned Credit Card orders cannot be accepted)
 Please allow for normal postal and bank clearance delays.

Andrew Keir



So you're going to buy a multimeter?

Buying a multimeter and buying a car have much in common; consider your needs and consider your bank balance – then walk around the showroom kicking tyres!

I CAN STILL REMEMBER the first multimeter I ever bought. That was around 25 years ago, and it cost me all of five shillings. It was a very basic “instrument” of dubious accuracy but suited a neophyte such as I and represented a major investment in my new found hobby. Multimeters have gone through some pretty dramatic changes since that time, features undreamed of then are now commonplace, but the fact still remains that a multimeter is one of the first purchases a technician, serviceman or hobbyist is likely to make. These days it is not the decision of whether to buy a multimeter which faces the hobbyist, but how to sort through the bewildering array of features and decide on an instrument which suits your needs.

In this article we will take a look at the sort of instruments that are available and examine their features as well as some traps for the unwary buyer. We are not going to discuss the workings of multimeters, except where there is some relevance to new features. If you are interested in how multimeters work then you might like to look back on the June 1986 issue and read the article “Inside the Modern Multimeter”.

Think

Before examining the features offered by modern instruments, you need to think carefully about the uses to which a multimeter will be put in your particular situation. There is little point in buying an expensive, superbly accurate, four and a half digit meter with all the bells and whistles if you are only going to check continuity or make cursory, non-critical measurements. By the same token, it would be unwise to choose an instrument so basic that it would become inadequate as your knowledge and requirements increase,

Philips' Series 18 DMMs are rugged 4½-digit LCD readout meters featuring a variety of sophisticated functions. Measurement selection is by rotary switch, while function selection is by pushbuttons. They are autoranging and feature a linear bargraph along with the digital readout. A useful option is automatic display backlight under dim ambient light conditions.

unless of course it only costs five shillings!

You will need to look at what sort of measurements are likely to be made and what sort of environment the instrument will be used in. Will you ever really want to measure current up to 20 Amps?, check transistors?, measure temperature?. If so, choose a meter with those features, if not you may be better off foregoing the fancy features and putting your money towards better accuracy or extended ranges.

Dollars first

The first thing likely to influence your decision when buying a multimeter is price. There are so many manufacturers producing large quantities of digital multimeters that prices have dropped to unprecedented levels.

For around fifty or sixty dollars you can pick up a basic digital instrument the accuracy of which, in most respects, surpasses that of even top of the line analogue models. Even if you are on a limited budget the choice is not going to be easy. As an example, the Dick Smith catalogue lists no less than eight different models under \$130! Probably, the best approach is to decide on your price bracket and see which instruments in that range offer the features you're interested in.

Accuracy

The next thing to look for in a multimeter is its basic accuracy. The obvious choice when considering digital multimeters is whether you want three and a half or four and a half digits. For general service and hobbyist use, three and a half digits will be quite adequate. If you have a requirement for extreme accuracy or are looking for a laboratory instrument then choose four and a half digits but be prepared to pay a premium for the added accuracy.

Different manufacturers have different ways of expressing the accuracy of their products and this can cause some confusion when comparing one make with another. One way of specifying the accuracy is as a percentage of the full scale reading but some makers specify the accuracy as a percentage of the reading, not the full scale reading which is where confusion can arise. This parameter is usually stated with reference to the dc voltage range as the figure quoted will not look quite so good on other ranges. For a three and a half digit model the basic accuracy will usually be between 0.25% and 0.1%. The lower the figure the better the accuracy and, of course, the higher the price. For a four and a half digit instrument you can expect a figure of between 0.05% and 0.025%. When you consider that even the very best analogue meters will only achieve an accuracy of a few percent, you begin to understand the reasons behind the popularity of digital types.

One other factor which influences the accuracy of a multimeter is its input resistance. The higher the input resistance, the less the meter will load the circuit under test and the more accurate the reading. Even the most basic digital multimeters will generally have an input resistance of around 10 Megohm, and some models boast an input resistance in the Gighom range. Of the analogue meters, the best in respect to input resistance are those using FET input stages.

Readout

Probably the next decision in choosing a meter will be the type of readout you would like. As I have already stated, a good digital meter can be bought for a very reasonable sum, in ►

MICRONTA® DIGITAL MULTIMETERS FROM TANDY

A. Benchtop Digital Multimeter

\$169⁹⁵



B. 21 Range Digital Multimeter

\$99⁹⁵



C. Autorange Digital Multimeter

\$59⁹⁵



D. Fold-up Autorange Digital Multimeter

\$139⁹⁵

A. This accurate benchtop digital multimeter has a convenient all-pushbutton selection and memory. With data hold, bar graph display and much more! Measures to 1000V DC, 750V AC (accurate from 45 Hz to 10 KHz). AC/DC current to 10 Amps. Resistance to 30 megohms. Including separate diode check. 22-195

B. NEW! A 21 range LCD multimeter is ideal for the lab, field, or shop. With conveniently positioned range and function knobs for one-hand control and a fold-out stand for bench or hanging up. DC max 1000V. AC max 750V. Resistance to 30 megohms. Full auto-polarity with negative indication. 22-185

C. Simply select the function this autorange multimeter does the rest. Diode check mode for semiconductor junction testing. Measures to 1000V DC, 500V AC. DC current to 200 mA. Resistance to 2 megohms. Fused and overload protected. An extremely convenient and functional multimeter. 22-188

D. With this fold-up LCD multimeter you simply select the function and it automatically adjusts to the proper range. Features auto shut-off when folded, range hold switch to override autorange and diode check mode. Measures to 1000V DC, 500V AC. AC/DC to 10 Amps and resistance to 2 megohms. 22-193

Tandy
ELECTRONICS

We Service What We Sell

All multimeters come with test probes and manual.

® Trademark of Tandy Corporation, Intertan Australia being a registered user.



Fluke's 20-series multimeters are rugged units featuring autoranging and a bargraph display beneath the digital read-out. The Model 23 features a "touch-hold" facility to capture a reading when the value is varying. Designed for general portable and bench use, a prop-up protective carry case permits easy reading of the display when using the meter on the bench. Elmeasco distribute Fluke in Australia.

fact an accurate, good quality analogue meter is likely to set you back far more than the average digital instrument. In the past, the argument of analogue versus digital has been largely dictated by the nature of the quantity you wished to measure. A static quantity could be measured to a high degree of accuracy with a digital meter, but if the quantity changed during measurement the result was often a meaningless jumble of numbers on the display. For this reason, many preferred an analogue meter for measuring fluctuating parameters.

This problem has been largely overcome in the most recent digital instruments by incorporating a bargraph display together with the numeric display. Any fluctuating measurement will still result in quickly changing numbers but the bargraph display will track the changing measurement allowing a visual interpretation of how it is changing. These bargraph displays are still digital in operation, simply an array of LED or LCD segments arranged to illuminate sequentially. An advantage of the bargraph arrangement is its reaction time. The bargraph will react much faster than the needle of an analogue instrument which, being limited by its own inertia, is unable to track fast changes in quantities under test.

On the subject of displays, you will need to make the choice between LEDs or liquid crystal in a digital multimeter. Most modern portable instruments use liquid crystal displays for a very good reason. LEDs require a lot of current whereas LCDs require very little, and being battery powered a portable instrument with an LCD display will give a decently long battery life.

I remember a few years ago a friend asked me to have a look at a multimeter he was having trouble with. It was described by the maker as a portable instrument and had cost a tidy sum but my friend could rarely get reliable or meaningful readings from it. The clue to its problems came from reading the makers specifications which gave the battery life with standard carbon-zinc cells as five minutes!. The makers suggested alkaline batteries which would run the instrument for seven to ten minutes. The meter used an LED display which was not multiplexed and current consumption was almost half an amp!, a bit more than four penlight cells are happy with. When used with an external supply the instrument gave reliable and accurate readings but was useless within minutes of installing fresh batteries. Hardly what you would describe as portable, even if you could carry it in your pocket. LED displays are fine for bench type multimeters with inbuilt power supplies but it would be wise to stick with liquid crystal for anything portable, unless of course you have shares in Union Carbide!.

Ranges

Getting back to the uses you have in mind for your multimeter, let's take a look at what ranges you might require. If you are going to be working on automobiles or big power supplies then you might choose a meter with a

maximum current range of ten or even twenty amps. Look carefully, as some models only have a maximum range of 200 mA, and check to see if the meter will measure both ac and dc current if you think you will need the facility. Most modern meters will cover voltage up to 1000 Vdc and 750 Vac and it's doubtful that you will want to go much higher. Many manufacturers offer a high voltage probe as an accessory if you do.

The lowest voltage range offered by the meter is often worth looking at, especially if you will be working with small-signal analogue equipment. Most models will cover down to 0.2 V full scale and some of the up-market and four and a half digit models go down to 200 microvolts on both ac and dc.

An important consideration when looking at the ac voltage ranges of multimeters is bandwidth; i.e: the maximum frequency ac voltage that can be measured with accurate results. Some meters maintain accuracy to above 200 kHz whilst others may be unable to cope beyond only 5 kHz. Again, you will have to consider your particular application, but if you are working with audio equipment for instance, it may pay you to choose a model which covers the audio spectrum to at least 20 kHz. You should also ensure that any meter under consideration is ac coupled on the ac ranges otherwise any dc component in the signal being measured will be superimposed on the ac reading giving inaccurate results.

You may see some multimeters advertised as RMS reading types although most are in fact of the averaging type. To properly indicate RMS, a meter should have some sort of heating element and thermocouple arrangement, the output of which is interpolated to give the correct reading on the scale. The averaging type of meter will usually apply the ac input to an A to D converter, the output of which is scaled to give the appropriate RMS reading. There is no problem with this scheme as long as you are aware that it will only give accurate results when measuring sine waves. If you wish to measure complex waveforms then you are probably better off using an oscilloscope instead of a multimeter.

When measuring resistance, even a good analogue meter can only give a reasonable approximation because of limitations imposed by non-linearity and low resolution of the scale. A digital meter will, on the other hand, read resistance accurate to fractions of an Ohm on the lower ranges. The majority of digital instruments will read down to 200 ohms full scale which on a three and a half digit model will give a resolution of one tenth of an Ohm. The highest range usually offered is 20 megohms full scale, although some models can measure up to 300 megohms. Whilst such a high range could

be useful for insulation testing and the like, I doubt that the majority of average users would need to go quite so high.

Features and functions

We have looked at the three universal ranges covered by all multimeters so now let's take a look at some of the additional features and ranges offered by various models on the market. As before, you will need to examine whether some functions are simply gimmicks or whether they will really serve a useful purpose in your application.

One of the first added features you are likely to encounter is autoranging. This can be quite a useful facility and is being offered by an increasing number of manufacturers. A full autoranging meter will automatically select the correct range depending on the input. All you have to do is select whether you want to measure resistance, voltage or current and the meter does the rest.

There are instruments available which provide autoranging for limited types of input only, usually just voltage and resistance and some which offer autoranging only on resistance ranges. There are some benefits with autoranging meters. Apart from the obvious simplicity of use, the range selection switch can be quite simple and therefore cheap to produce and it will be less prone to wearing out with constant use.

An audible indication of continuity is a feature being seen more commonly. It can be quite useful, saving the necessity of looking at the meter face whilst conducting tests. Some caution should be taken when using the facility as most meters will have a minimum resistance (usually 20 ohms) below which the continuity buzzer will work and you can be trapped into thinking you have a short circuit when in fact you may have a low resistance.

The remainder of the additional features you will encounter will probably take the form of extra ranges or measuring capabilities and this is where the description

"multi" meter takes on a new meaning. Once again, don't buy on the strength of little used features unless the extra cost is minimal, and if it is then make sure that having the "bells and whistles" doesn't compromise the accuracy of the features you really need.

Diode testing is a function provided on the majority of modern meters and usually uses one of the lower resistance ranges, thus being cheap to implement. Transistor checking can be quite a useful addition, especially if the meter indicates the hFE of the device under test so that matching of pairs can be accomplished easily. Some multimeters take this feature a few steps further by providing the facility to test FETs and SCRs and one model I saw recently even allowed the testing of zener diodes up to 75 V. If simply checking the occasional transistor to see if it is still intact, you can use the resistance ranges of almost any multimeter.

Dedicated instruments for checking capacitor values have been available for some years but it is only recently that the function has been incorporated in the multimeter. Whilst the range provided is not generally as great as dedicated capacitance meters, it is still useful when you have a junk-box full of unmarked capacitors, or can't figure out a capacitor's marking code.

Several manufacturers are now offering temperature measuring facilities on their products. This feature requires the provision of a special probe, usually a thermistor mounted at the end of a set of test leads. This function can be useful for checking the temperature of solid-state devices under operating conditions as well as general thermometer applications. Most meters will allow readings to be made in both Fahrenheit and Celsius.

The ability to measure frequency is quite a new innovation in multimeters. Most models offering this facility will only cover a limited range of up to a few hundred kilohertz and the accuracy will be limited by the number of digits on the display.

A NEW CONCEPT IN DMM'S!

THE BARGRAPH MULTIMETER

- 105 segment LCD bargraph moves just like an analog meter, but is easier to read.
- More rugged and versatile.
- All the standard features of a normal VOM — Plus some!
- No moving parts
- Sampling at 10 times/second provides response rivaling analog meters.
- **LOW COST**

For further information on the SOAR Bargraph Multimeter, contact your local sales office:

EMAIL LTD
RELAYS & BELLCO CONTROLS



Head Office: • 15-17 Hume Street, Huntingdale, Victoria 3166. Tel.: (03) 544 8244. Telex: AA 30895. Fax: (03) 543 8179.

Relays: • Melbourne (03) 544 8244 • Sydney (02) 439 3311

Bellco: • Melbourne (03) 288 8044 • Sydney (02) 560 7077

Relays & Bellco: • Adelaide (08) 211 7855 • Brisbane (07) 391 6266 • Perth (09) 446 9888

play. It would certainly be a very convenient function to have in some applications however, and beats having to carry around a separate frequency counter if you're a serviceman.

When you are checking the multimeter market you will no doubt come across features which I have not mentioned in this article. Take these on their merit and be guided by their cost and usefulness before committing yourself.

Manufacturers don't stand still for long so more and more features will keep appearing as new models are released. I can't help wondering how long it will be before we see the multimeter which not only measures volts, ohms and current, but allows checking transistors, FETs, SCRs and zener diodes, measures frequency and temperature, checks capacitors and inductors and has an inbuilt audio signal generator. Not long I would suspect.

Environmental considerations

Regardless of which type of meter you choose to buy, you should give careful consideration to where it will be used. If your meter will spend its life on a nice clean workbench it will probably last for years. If you are a serviceman however, the same meter might last only five minutes being jostled around in your toolbox. Some multimeters have very flimsy cases which are easily damaged or range switches which seem to fall apart with the least provocation, and these aspects should be examined when contemplating your purchase.

Another point to consider is the electrical environment you will be working in. If you are a radio amateur for instance, you might find that the meter goes crazy in the presence of strong RF fields. Some meters are better than others in this respect, having adequate shielding incorporated in the design. If the manufacturer includes a common mode rejection ratio (CMRR) figure in the list of specifications it will give you some idea of the meter's vulnerability to extraneous signals entering via the test leads. The figure will generally be expressed in dB with a specification of 100 dB being about average. The higher the figure, the better the meter's ability to reject interference.



Today's equivalent of the "five bob" multimeter. Dick Smith's Q-1026 is a low-cost analogue meter with mirror scale for improved reading accuracy. It features 20 ranges and overload protection.

Here's a digital meter with an analogue display! The new 3600-series meters from Soar feature a linear 105-segment liquid crystal bargraph readout that responds just like its analogue cousin. Sampling rate is ten times per second, so response rivals or betters that of analogue meters. Email distribute the Soar brand meters in Australia. Dick Smith Electronics has just released a similar meter.



Accessories

No discussion about multimeters would be complete without examining what sort of accessories are offered by the manufacturer. High voltage probes, RF probes and protective cases all fall under this category and you should look at these in terms of how much they will expand the usefulness of the instrument and at what cost. One item you should pay particular attention to is the operating manual supplied with the meter. There can be a great variation in the quality of manuals, ranging from single sheets written in poor English, or even worse, poor Japanese, to superb, multi-page booklets covering all aspects of the instruments operation.

Finally, do take a good look at the probes that are supplied and avoid those types which use banana plugs with exposed screw heads to hold the cable. These can be very dangerous when measuring high voltages and I've seen more than one technician shaking hands with the power station when removing test leads from the meter! Choose a type which has properly shrouded plugs even if you think you will never be working with high voltages or on mains powered equipment.

The ultimate decision when choosing a multimeter is yours alone. I trust the information in this article will assist you to reach that decision in an informed way. Who knows?, if you make a good choice you may find yourself 25 years hence, reminiscing about the meter you bought way back in the eighties much as I did with my five bob job. The difference is, yours will probably still work! 📌

A photocopier in the palm of your hand



Sanyo Office Machines has introduced a portable, hand-held copier weighing no more than half a kilo, and only slightly bigger than the average pocket calculator.

Dubbed the HHP-1 it reproduces copy on 68 mm wide thermal paper, allowing a copy width of 64 mm and a length of up to 10 metres (the full length of the roll paper).

It can run on normal ac power or on two "AA" size Nicad rechargeable batteries; a charger and ac adaptor are included with the unit. Up to 10 metres of copy, the full roll paper

length, can be made with one charging.

Sanyo says the compact, highly portable HHP-1 has an almost limitless range of applications in schools and universities, research, government departments, medical, legal and accounting professions and business.

The HHP-1 is available from Sanyo Office Machines offices throughout Australia.

Component video camera system

National Panasonic, recognising the needs of the more discerning video photographer, has released in Australia the new WVPF10 Component Camera System.

The F10 provides the nucleus of a video camera system which can be tailored to meet the

specific needs of the enthusiast and professional alike, while maintaining cost effectiveness the company says. Any shooting situation can be handled, from microscopic study to stargazing, they say.

The $\frac{3}{4}$ " CCD (charged-coupled device) fitted to the F10 exceeds the performance of a conventional pickup at a fraction of the weight and bulk. Its 334 000 pixels ensure superior 380-line resolution and the CCD

lets you record sharp images even under extremely low lighting conditions, as low as 7 lux with the 8x power zoom lens National claim.

The F10's features include one inch electronic viewfinder display, three position gain switch, 2H enhancer; audio and video fade in/out plus negative/positive picture reversal.

Auto tracing white balance continuously adjusts the picture during changes in lighting conditions or can be switched to standard set up as required.

Character generation is provided in the form of opening/closing titles, date and time and can be fully supplemented with the addition of an optional character generator.

The F10 utilises the unique strobe effect shutter which provides blur-free recording of high speed action. Shooting at 1/1000th second exposure at 1/50 second intervals ensures clear, undistorted shots of such action as car racing, golf swing and moving animals.

Optional adaptors for Pentax, Canon, Minolta, Nikon and Olympus camera lenses further extended its capabilities.

The F10 can be purchased in two configurations:

1. WVFP10 (camera head) and WVKT100. This is the basic camera system and includes:



head, 8XAF zoom lens, 1" EVF, shoulder pad/grip, stereo microphone, cheek pad, VTR cable and camera strap.

2. WVPF10 (camera head) and WVKT200 is the basic kit for professional use and include; head, 12x power servo zoom lens, 1" EVF, shoulder pad/grip, stereo microphone, genlock adaptor and VTR cable.

The range of optional accessories available include lens adaptor for Nikon, Pentax, Olympus, Minolta and Canon; a pan/tilt head, remote controller for 8 x AF zoom and pan/tilt, 5" EVF studio remote control, and many more.

National Panasonics' F10 camera system is available through selected video camera dealers.

Sony expands Video 8 camcorder line-up

The sales growth in the video camcorder market is steadily increasing, says Sony, and currently represents approximately six per cent of total VCR sales. However, in dollar value the camcorder represents over 18 per cent of consumer spending on video equipment, they say.

Sony Australia has announced the release of their latest Video 8 camera, the CCD-V100. Equipped with professional style features, Sony says it offers greater creativity and flexibility for home video production.

The introduction expands the Sony Video 8 camcorder range to three models all targeted at different market segments, from



simple operation for the whole family, to the more professional home movie enthusiast.

Features include a titling generator, video wiper function, interval recording auto/manual iris, through-lens auto focus, EVF and variable speed zoom. The CCD-V100 is available through Sony dealers a suggested retail price of \$3999.

Recent developments in bass speaker design

Will Kennedy

Recent advances in the design of bass loudspeakers has resulted in drastic size reductions whilst maintaining or improving performance. Several commercial designs have exploited the techniques and we'll likely see a radical change in speaker system design over the next few years.

GONE ARE THE DAYS of 200 litre bass speaker enclosures. Designers can now "squeeze a quart pot into a pint bottle" following the ingenious application of speaker enclosure and filter theory that has been known for many decades.

Background

Now, a driver mounted in a sealed box behaves as a second-order high-pass filter, with a fairly gentle 12 dB/octave roll-off at the bottom end. At the high frequency end, the driver itself rolls off gently, generally at around 6 dB/octave. Now the size of the enclosure, acting together with the natural mechanical and electrical characteristics of the driver, principally the driver's fundamental resonance and the "Q" or quality factor of the system, will determine whether the bottom end response of the system is under-damped, over-damped or critically damped.

An under-damped response will have a peak just before roll-off, resulting in a "boomy", or "one-note", bass sound. An over-damped response will have a roll-off higher than could otherwise be achieved, while a critically-damped response will have a well controlled "flat" roll-off at a frequency said to be optimum for the system.

It is the box volume that controls the system's Q, assuming other factors (such as the cone stiffness) remain unaltered. Drivers with a relatively stiff suspension (and consequent small cone movement) and a high fundamental resonance require large box volumes, while drivers with a very compliant suspension (large cone movement) and low fundamental resonance require comparatively smaller enclosures.

Ported, or bass-reflex, enclosures are somewhat more complex. The port acts like a tuned circuit, introducing an extra resonance coupled into the whole system. The port dimensions and box size interact with the driver's mechanical and electrical characteristics to form a fourth-order filter. By placing the port resonance at a suitable frequency, the bass response can be extended considerably. The system Q can be controlled by choice of box size and port dimensions to achieve an under-damped, an over-damped or a critically-damped response. Roll-off at the bottom end is much steeper than for a driver mounted in a closed box.

Putting it together

A recently released design employs a bass driver in a sealed enclosure and another bass driver in a ported box placed effectively face-to-face. The arrangement is illustrated in Figure 1. It employs two drivers of the same type, screwed to an internal baffle that separates one half of the box as a sealed enclosure, a port being introduced into the larger chamber. The two drivers are well coupled by the volume between them. What is immediately apparent is that neither driver radiates into free air!

Two realisations of the "bandpass" bass speaker design.

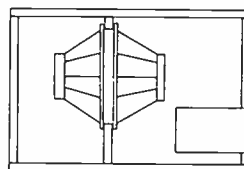

Figure 1.

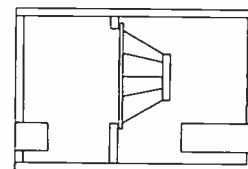

Figure 2.

The port is "tuned" so as to extend the bass end response of the right hand driver here. The sealed enclosure is designed such that it moves the left hand driver's response up the audio spectrum, acoustically "crossing over" in the upper region of the right hand driver's response, thus extending the response of the whole system. By judicious choice of drivers, it is possible to achieve quite small box sizes and a frequency response that extends over 1.5-2 octaves!

The two drivers are driven out of phase, so that one's "pushing" while the other's "pulling". The crossover region response is well controlled and all sound radiation issues from the port, which looks like a high pass filter! The system can actually be driven directly from an amplifier, no electronic crossover components being required!

Scan Audio in Australia recently released a passive subwoofer design based on this principle, using a pair of economical but high quality Vifa P25WO 200 mm (8") drivers. In a box of a little less than 60 litres, the response quoted (DIN standard) extends from 25 Hz to 88 Hz, a little over 1.6 octaves. Overall box dimensions are 600 x 410 x 340 mm!

The advantage of having a separate subwoofer is apparent to any audiophile. Only a single unit is needed as stereo information is lost at the low frequencies owing to the long wavelengths involved. The bass unit may thus be placed almost anywhere in a room. The stereo mid-high speaker system can thus be smaller and less obtrusive.

While a port is conventionally used to extend the bass end response of a system, it may also be used at the other end to lift the driver's response. Bose exploited this in their recently released "Project X" system, which employs a pair of tiny mid-high satellite speakers and a separate bass unit.

What Bose did was to, effectively, take two rear-ported bass reflex enclosures and mount them with the drivers face to face. Then they did away with one driver. The fundamental arrangement is illustrated in Figure 2. The ports are used to separately "tune" each enclosure, which then effectively act as two coupled tuned circuits exhibiting the well-known flat-topped, bandpass response. All radiation is from the ports.

At first thought though, it would seem that the radiation from the two ports in the bandpass region between the two port resonance frequencies would be out of phase because

— to page 63 ▶

CAPTURE AN ORTOFON OM-10 FOR ONLY \$89* AND ESCAPE TO DENMARK WITH *SAS*

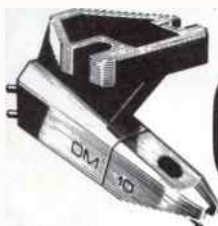

Now is the time to update your Hi-Fi system with one of ORTOFON's superb OM/OMP cartridges. By doing so, you will also have a chance to go to Denmark and visit the ORTOFON manufacturing plant.

WHY THE ORTOFON OM/OMP SERIES CARTRIDGES?

If we were to take away their high output, adjustable mass, diamond quality, superior sound and stylus interchangeability, these cartridges would be no different from all the others.

But with all these features and their sonic excellence, these cartridges have become the most successful range of cartridges ever produced by ORTOFON. In terms of value for money the OM-range is now recognised throughout the world as "the one to buy".

WHAT THE EXPERTS SAY!

GRAMOPHONE: "... the OM-20 showed a more solid bass and midrange and freedom from edginess." "... The OM-30 had a more subtle sound quality with greater clarity and definition, a more positive stereo image."

HIGH FIDELITY: "The OM-40 is the best magnetic cartridge that this Danish manufacturer has ever produced..."

HI-FI CHOICE: "ORTOFON OM-10... BEST BUY!!"

The nomenclature "OM" stands for Optimum Match. By removing the in-built 2.5 gram weight-plate, the OM cartridges can be perfectly matched to any medium or low mass tone arm. The technically identical OMP models are designed for use in P-mount tonearms.

All OM styli are interchangeable. If your budget does not allow the top model initially, start with the OM-10 and update the stylus later.



THE PRIZE LIST

Buy any ORTOFON OM/OMP 10, 20, 30 or 40 cartridge between 1st March and 30th June 1987 and you could win one of the following prizes:

1st PRIZE:

7 days holiday in Denmark. Flying with *SAS* The Businessman's Airline, to Copenhagen and return, including 6 nights first-class hotel accommodation and all transfers. This exciting trip includes a visit to the Ortofon manufacturing plant, plus an opportunity to visit the Danish Royal Theatre, famous Tivoli Gardens and one of the many famous Danish jazz clubs.

SAS

THE BUSINESSMAN'S AIRLINE

Next time you travel to Europe on business, why not give yourself a break and fly SAS, the Scandinavian way - one stop to Copenhagen, the business heart of Europe.

2nd PRIZE:

Ortofon MC30 Super Moving Coil Cartridge. Valued at \$800.

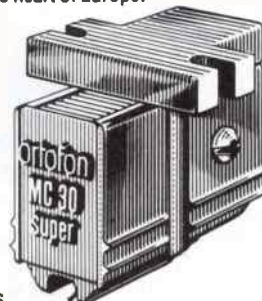

3rd PRIZE:

Ortofon MC20 Super Moving Coil Cartridge. Valued at \$600.

Full details and conditions of entry from your participating ORTOFON specialist.

ortofon

accuracy in sound

For more technical information and reprints of reviews on ORTOFON's full range of products, contact Sole Australian Distributor:
SCAN AUDIO Pty. Ltd., 52 Crown Street, Richmond, Victoria 3121. Phone (03) 429 2199

Anitech to market Kenwood instruments

Anitech, has just reached agreement with Kenwood of Japan to market exclusively Kenwood's highly respected range of electronic instrumentation.

From 1st March, Anitech distributes and supports, through its network of computer-linked offices, a range of equipment including oscilloscopes from 5-150 MHz, a digital memory scope, compact disc encoder, waveform monitors, function generators, frequency counters, regulated dc power supplies, computer test products, and general bench equipment.

"We are extremely pleased to secure this agreement", says Anitech Chief Executive, Ron Thomas, "the Kenwood catalogue ideally complements our existing range of high technology products; and clearly furthers our aim to offer only the best to the Australian marketplace".

Key Anitech personnel will shortly travel to Kenwood's plant in Japan for technical and servicing training.

Further details from: Anitech Head Office, 1-5 Carter Street, Lidcombe, 2141 NSW. (02) 648 1711.

Anti-static board storage

An ingeniously simple system for the anti-static storage and handling of circuit boards and assemblies has been developed by the WEZ organisation, according to the agents, Royce Electronics.

It consists of a stackable container with internal frame (which can be likened to a suspension filing cabinet) and pockets which hang on this frame (like files).

The difference is that the pockets are made from soft, flexible, permanently anti-static material.

These pockets can even accommodate circuit boards with 'exotic' dimensions — in any

direction — including boards without the conventional edge needed for ordinary grooved holders.

Called the "Soft Cell" system, it enables the boards to be stored until required ... and then protects them during handling against both physical and electrostatic damage.

The suspension system is equipped with ten longitudinal pockets for circuit boards up to 550 mm long.

By adding a partition, the format is altered to twenty pockets for boards up to 265 mm long.

The system is available either 150 mm or 280 mm high, and for optimum storage it is compatible with other standard WEZ stackable containers measuring 600 x 400 mm.

Enquiries should be directed to **Royston Electronics, (03) 543 5122.**



CMOS data book

Integrated Device Technology's latest High Performance CMOS Data Book is now available from The George Brown Group. It covers IDT's technology and capabilities, static ram, microslice (TM) digital signal processing, logic, data conversions, subsystems modules and general product information.

Contact your local George Brown Group Office to obtain copies.



Keyboards feature SA synthesis

Ever since the release of the SA piano, Roland has been coming up with new combinations of keyboards and features in order to provide everyone with the type of piano they require. Well it looks as though they haven't stopped developing, because they recently released two new additions to the already strong line up.

The new keyboards are known as the RD-200 and the RD-300 both of which contain not only the now famous SA synthesis but a full compliment of mother keyboard facilities.

The SA sounds are the same as those found in the RD-1000, three pianos, two electric pi-

anos, one clavi, one harpsichord, one vibes. The RD-300 has 88 keys that have the same feel as the HP-3000 whilst the RD-200 has 76 keys which are similar to the keys on the EP-50.

Both keyboards have key split functions, that is, they can split their keyboards at any point. You can turn the upper or lower internal voice off separately whilst functions like Key transpose, Key split, Upper/Lower, MIDI receive channel, internal voice on/off and Chorus/Tremolo can be turned on or off using the optional DP-2/6 pedal.

The outputs on the back of the keyboards is both unbalanced phono jacks or balanced XLR jacks. The weight of the RD-300 is 27.2 kg whilst the RD-200 is 15.5 kg. See your local Roland dealer.

Compressor-mixer like an extra pair of hands

The FP51 Compressor-Mixer from Shure is an updated, modernized, compact replacement for the popular Model SE30 compressor mixer. They claim it is the ONLY four-input, one-output mixer with a built-in gated-memory compressor on the market, and that it is exceptionally well suited for outside and studio broadcast, electronic news gathering, film and video production, many sound reinforcement uses, and other applications.

It provides a wide, flat frequency response at all compression levels while performing with minimal noise, distortion, and RF susceptibility. It's exceptionally rugged construction assures reliable operation even under extremes of temperature and humidity — yet it is small in size, and light in weight for portability, the company says.

The compression circuitry rides gain automatically and eliminates many adjustment problems. It is much more than a simple "extra knob" — it provides true average-responding

compression with an adjustable 40 dB compression range, and maximizes the output level regardless of the program material's peak to average ratio, say Shure.

Once the compression level is set, the FP51 rides gain with smooth, fast system gain adjustment. The output level stays constant — without manual adjustment.

The FP51's gated memory eliminates the "pumping" phenomenon common to audio compressors. The FP51 "remembers" the point where the main signal (such as voice or music) stops and puts a hold on the compression level at that point. When the program material resumes, the hold is released.

The result? No buildup of background sounds, no "pumping." Programs stay smooth, balanced, and natural-sounding, Shure claims. See Audio Engineers in Sydney, Brisbane and Melbourne, Marketec in Perth, for further details, or call (02) 29 6731.

The all-important high-speed CMOS question. Will latch-up cause burn-out?

With Philips high-speed CMOS (HCMOS) logic ICs, the answer's no. Because they're free from latch-up.

What causes latch-up?

Latch-up occurs when SCRs (formed by parasitic bipolar transistors found in all CMOS structures) are triggered by current transients arising from over-voltage at the input, output or supply pins, or by ringing on the signal pins. The resulting

Typical breakdown occurs at $V_{CC} = 22\text{ V}$, $I_{CC} = 5.5\text{ mA}$.



Curve tracer display from latch-up test with excess supply voltage. At no time did latch-up occur in the Philips HCMOS IC, since the supply voltage snaps back to 13V.

short-circuit across the supply rails causes excessive current and inevitably destructive power dissipation.

How is it overcome?

We prevent any current injection into the SCR structures by growing an epitaxial layer on a very low-resistivity substrate. And by using unique design and process parameters to minimize the gain of the parasitic transistors, we achieved complete latch-up immunity. No burn-out.

So you improve system performance, and by eliminating additional components to protect against latch-up you not only cut

component costs but also optimise system speed.

And you gain reliability. With a product that will not fail during system test. Or in the field.

Harsh environments?

Even in noisy, high-temperature environments such as automotive and industrial applications, Philips HCMOS Logic goes on working. And you get exceptional noise immunity because the input switching levels of 74HC/HCU circuits are 30% and 70% of the supply voltage. Moreover, the whole Philips 74HC/HCT/HCU family has a standard temperature range from -40 to $+125^{\circ}\text{C}$.

HCMOS
HIGH SPEED LOGIC

The name is Philips
The product is HCMOS

Want to know more? Then call your local Philips Electronic Components and Materials office. We're on-hand with full technical documentation, including a Designer's Guide to your all-important questions about HCMOS.

| | |
|-----------|---------------|
| Sydney | (02) 439 3322 |
| Melbourne | (03) 542 3333 |
| Adelaide | (08) 243 0155 |
| Perth | (09) 277 4199 |
| Brisbane | (07) 44 0191 |

RCA is an alternate source for Philips HCMOS ICs.



Electronic
components
and materials

PHILIPS

The ins and outs of rechargeable batteries

Roger Harrison

Secondary, or rechargeable, batteries are now made in a very wide variety of types and styles to suit an increasingly diverse range of applications.

RECHARGEABLE BATTERIES, also known as storage batteries or accumulators, have enjoyed a long and honourable history since the Frenchman Gaston Plante invented the lead-acid battery in 1860. It was a serendipitous invention as the previous year Plante made some curious observations while investigating the effects of gas polarisation in electrolytes through which an electric current was passed. Today, lead-acid batteries provide the most widely used source of stored, rechargeable electric energy in the world, the ubiquitous car battery being probably the most familiar example.

Storage batteries all exploit a reversible chemical process employing an electrolyte in which electrodes are immersed or embedded. Chemical energy is converted to electrical energy in the process of discharge, the reverse occurring when electric current is passed through the electrodes during the charging process. There are a variety of possible combinations of electrode material and electrolytes and since the 19th century, research has enabled the further development of systems discovered then, as well as the development of new battery types.

Around the turn of the century, that most famous of all American inventors, Thomas A. Edison, developed the nickel-iron storage battery which he announced in 1900 and put on the market commercially in 1908. The nickel-iron battery enjoyed a commercial life of some 60 years, only being supplanted by the now familiar nickel-cadmium battery,

patented in 1899 by two Swedes, Jungner and Berg. Jungner, independently of Edison, had worked on a nickel-iron accumulator, but further development work led to the use of cadmium in one of the electrodes which gave it some advantages over the nickel-iron system. Jungner founded a company – NIFE Jungner – to make storage batteries, the NIFE reflecting his interest in the nickel-iron system as the chemical notation for nickel is Ni, and for iron, Fe. The company is known these days as SAB NIFE, a division of which manufactures nickel-cadmium batteries in Australia.

Over the years since the development of these batteries, much research has been done with materials for storage batteries aimed at improving energy capacity, reducing weight and increasing service life, among other parameters. By far the most important parameter considered in recent years is energy density or power density – the ratio of power output to size or weight. This work has produced silver-zinc and silver-cadmium batteries with an alkaline electrolyte. More recently, sodium-sulphur cells have made their appearance, which have an alumina electrolyte!, along with aluminium-air batteries which have a salt water electrolyte, one electrode of aluminium and one electrode of air!

Rechargeable batteries are employed in two types of application: mobile and stationary. Mobile applications include the ignition, lighting and starting systems of vehicles powered by internal combustion engines, as well as prime energy sources for electrically-powered vehicles. Stationary applications include such things as energy storage for solar electric power systems, uninterruptible power supplies in burglar alarms and computer systems, emergency lighting, powering portable electronic and communications equipment, etc.

Just to refresh readers on terminology, a cell is a basic electrochemical unit. Cells have low terminal voltages, generally in the range 1.1-2.6 V. A battery is an assemblage of cells connected in series to obtain a higher terminal voltage.

Lead-acid batteries

The basic elements in the lead-acid cell have remained little-changed since Plant's day. It comprises an anode of lead and litharge (lead oxide) and a cathode of red lead immersed in a liquid electrolyte of dilute sulphuric acid, all contained in a case of hard rubber or polypropylene. A filler cap is provided for the replenishment of the electrolyte and a vent hole allows the release of gas (hydrogen) which is generated during charging.

The no-load terminal voltage of a fully-charged cell is between 2.3–2.4 volts. Under load, this drops to around 2.0–2.2 volts, falling to typically 1.85 volts when discharged. Lead-acid cells or batteries are given an amp-hour (Ah) capacity rating determined from a 10-hour discharge rate. The current

TABLE 1. Typical discharge capacity of Pb-acid batteries.

| DISCHARGE CURRENT | DISCHARGE TIME | CAPACITY |
|-------------------|----------------|----------|
| 200 A | 60 secs | 3.3 Ah |
| 120 A | 10 mins | 20 Ah |
| 65 A | 27 mins | 29 Ah |
| 40 A | 1 hr | 40 Ah |
| 8 A | 6.2 hrs | 50 Ah |
| 6 A | 10 hrs | 60 Ah |



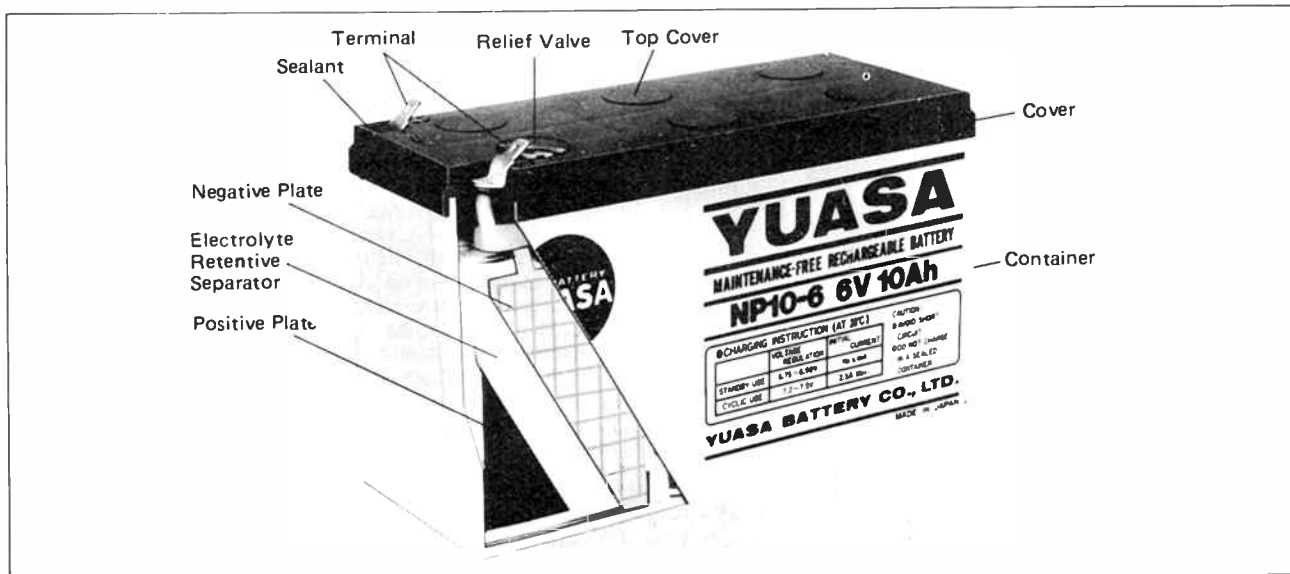

Construction of a typical sealed lead-acid battery.

required to discharge the battery to its end-point voltage of 1.85 V/cell is multiplied by this time. A 60 Ah battery, for example, will deliver six amps for 10 hours before requiring a recharge. However, the Ah capacity varies with the discharge current. That same 60 Ah battery discharged at 10 amps will not last six hours. If discharged at one amp, on the other hand, it will last longer than 60 hours. Typical discharge characteristics are illustrated in Table 1.

A direct indication of the state of charge in a lead-acid battery is the specific gravity (SG) of the electrolyte. This can be measured with a hydrometer which is a cylindrical glass "float", weighted at the bottom and having a calibrated scale along its upper shaft. How high or low it floats depends on the electrolyte's specific gravity. Typically, this lies between 1.210 and 1.275, depending on the manufacturer's specification and intended service. Table 2 shows typical SGs for various common applications.

Lead-acid batteries may be operated over a temperature range of -20 to +38 degrees Celsius, although at the lower extreme Ah capacity and discharge current are much reduced. The electrolyte may freeze, also. Preferably, lead-acid batteries are best operated at temperatures between 10 and 25 degrees Celsius.

The main advantages of lead-acid batteries include low cost, general ruggedness and reliability. Their main disadvantages include size, weight and gassing whilst charging. The water in the dilute sulphuric acid electrolyte evaporates somewhat and also decomposes during charge, giving off hydrogen, which is explosive under certain conditions - something of a hazard! This water loss requires replenishment from time to time, hence the necessity of a filler cap for regular maintenance. This also means they must be operated in an upright position. In addition, lead-acid batteries slowly self-discharge, leading to a limited "shelf life" before requiring charging.

Sealed, maintenance-free lead-acid batteries were developed some years ago to overcome these latter disadvantages. In the main, these employ a paste or gel electrolyte (hence, "gell cells") suspended in porous glass fibre electrode

separators. The positive electrode plates are alloyed with calcium which virtually eliminates gassing, rather than employing lead-antimony alloys as used in conventional lead-acid batteries for providing strength in the electrode plates. The negative electrode plates employ a low-antimony lead alloy to obtain a thin and thus light, but strong electrode.

The suspended, semi-solid electrolyte permits these batteries to be operated in any position. As some gassing still occurs, a ceramic filter vent is provided to safely release the gas. A different approach to the problem employs a plug containing palladium or platinum in small amounts which aids

Ampec

NEW!

Technacell Nickel Cadmium Batteries

The Technacell nickel-cadmium rechargeable batteries are rated at 1.2 volts and are available in single cell capacities from 110 mAh to 4000 mAh standard sizes. These cells are capable of more than 750 charge-discharge cycles. More than eight years of life can be expected when subjected to constant trickle charge at room temperature. High temperature models are also available for ambient temperatures ranging to 65°C.

CALL BILL NIXON - SYDNEY (02) 712 2466
WENDY ANTHONY - MELBOURNE (03) 878 8788

Ampec Technologies Pty Ltd

(Incorporated in NSW)

Mastamedia

TABLE 2. Specific gravity variations of the Pb-acid cell.

| APPLICATION | SG |
|---|-------|
| Low duty cycle use (e.g. emergency lighting) | 1.210 |
| Light duty and intermittent use (alarms) | 1.245 |
| Regular charge/discharge (car batteries) | 1.260 |
| Heavy discharge (truck and tractor batteries) | 1.275 |

the recombination of the oxygen and hydrogen released back into water. Yet another approach, called "recombinant electrolyte", encourages the production of oxygen and then its chemical recombination with the negative electrode. In any case, all sealed cells have a synthetic rubber safety valve for the release of any excessive gas build-up.

Charging liquid electrolyte lead-acid batteries is a fairly simple affair, employing a "constant voltage" source. The unfiltered output of a rectifier may be used ("dirty dc"), or any power supply that will provide the required current at a voltage slightly above the battery's fully-charged terminal voltage. A means of varying the charging current is desirable and low voltage, high current lamps in series with the supply are sometimes employed in simple chargers, while high capacity chargers may employ a variable core-piece transformer to provide current variation.

Initial charging current for a fully discharged battery should be in the vicinity of 20 amps per 100 Ah capacity (that is, 12 A for a 60 Ah battery). Vigorous gassing will occur when the cell voltage climbs to around 2.3 volts, at which point current should be reduced to between a fifth and a third of the initial charging current until charging is complete in around 10-12 hours. Ideally, cell SG should be checked at intervals during charging. Cell voltage may rise to more than 2.5 V, but this will slowly settle to around 2.4 V after charging current is removed.

Higher charging rates may be used, but electrolyte temperature should not be allowed to reach 38 degrees Celsius. Heavy overcharging should be avoided as it causes the plates to buckle and slake lead sulphide which may result in a short circuit. Lead-acid batteries should not be left in a discharged state, either, as the lead sulphide produced during discharge eventually undergoes an irreversible physical change resulting in reduced capacity. In normal operation some overcharging,

DO YOU NEED A RECHARGEABLE BATTERY?

It may seem that rechargeable batteries eliminate all the inconvenience and possible expense associated with primary batteries. However, there are a number of parameters to consider when looking at rechargeables versus primary batteries.

The first thing to consider is recharging — the primary cost and the admittedly small, but real, cost of recharging. Then there's the time required to recharge. With "normal" rechargers this takes up to 16 hours. Whilst fast chargers may be used, they can shorten the life of a rechargeable battery quite considerably. Primary cells of equivalent size to NiCads generally outlast NiCads during discharge. Keeping a "spare" set of rechargeables solves the charge/discharge time problem but doubles the initial cost, not counting the charger.

Rechargeable batteries have a much shorter shelf life than dry batteries and are best kept on trickle or float charge, which adds to their recurrent cost.

With NiCads, to produce an equivalent voltage to dry batteries, extra cells are necessary as NiCads have a lower terminal voltage. This is impractical in systems under 9-10 volts where seven NiCads are required to equal the terminal voltage of six dry batteries. In a nominal 12 V system, ten NiCads are required compared to eight dry batteries.

at about 1.5 times the usual rate, helps remove sulphide and restore the plates to their normal condition.

As copious quantities of hydrogen are released during charging, the process should be carried out in a well ventilated area. Avoid exposure to naked flames, cigarettes or electrical sparks to prevent an explosion.

Sealed lead-acid batteries require quite different charging conditions. Charge voltages are critical and need to be confined within close limits, as specified by the manufacturer, and the charging current should be virtually ripple-free. They are often employed in systems which supply a constant "float" charge to maintain them, only experiencing some discharge occasionally. Manufacturers recommend chargers or charging systems, designed for the purpose and battery type and model, which cutoff once the terminal voltage reaches a preset point.

Conventional lead-acid batteries are made in capacities from about 10 Ah to several hundred Ah for mobile applications, while for stationary applications, they are made in capacities ranging from 40 Ah to some 4000 Ah! They have lifetimes that range from two years to 20 years or more, dependant on construction quality, maintenance and use.

Lead-acid batteries are capable of very high, short-term discharge currents, although they cannot safely be short-circuited as it creates dangerous sparking and rapid internal temperature rise possibly leading to buckling of the plates and internal short-circuiting.

Sealed lead-acid batteries are made in capacities that range from as low as a half Ah up to 30 Ah. While most are housed in rectangular ABS-resin cases, some cylindrical-case models are made which employ foil electrodes and a thin separator all rolled up and sealed in a special plastic case.

Applications of conventional lead-acid batteries range from vehicle starting-lighting-ignition to solar electric storage, telephone and remote data gathering equipment. Sealed no-maintenance types are seen in emergency lighting systems, intruder alarm supply backup systems, portable electrically-operated tools and portable electronic equipment.

Nickel-cadmium batteries

Nickel-cadmium batteries, colloquially referred to as "nycads" (NiCads) employ an alkaline electrolyte of potassium hydroxide with positive and negative plates of perforated steel or steel "pockets", with thin plastic separators. The positive plate is filled with nickel hydroxide, the negative plate with a mixture of finely-divided cadmium and a little iron which helps prevent flaking and loss of porosity. The electro-

SIOMAR BATTERY INDUSTRIES

Suppliers to Defence, Government, Industry, Commerce, OEM etc



SAFT
(09) 443 1000



MANUFACTURE, REFURBISHING, IMPORT & SUPPLY OF NI-CAD, NICKEL IRON, SILVER ZINC, LITHIUM, SEALED LEAD-ACID, THERMAL, PRIMARY ETC., CELLS & BATTERY PACKS.

FOR ALL INDUSTRIES

Button, Coin, Cylindrical, Prismatic, Rectangular Cells, Encapsulated, Free, Flanged, Tagged, P.C. Mounted, Standard Packed or Assembled as Required.

SIOMAR AGENCIES

26 Drake St, Osborne Park, W.A. Fax (09) 443 2566



STOCK CLEARANCE

Keep The Change

Boring, boring, boring . . . Who'd bother reading through lists of components. They're boring, boring, boring!

UNLESS YOU WANT TO SAVE MONEY!

| | Cat No | Was | Now |
|---------------------------------|--------|---------|---------|
| Pack 300 E24 1% resistors | R-7020 | \$19.95 | \$10.55 |
| Pack 300 E48 1% resistors | R-7015 | \$17.55 | \$11.60 |
| 7.5k 5W wire wound pot (metric) | R-6923 | \$6.95 | \$2.20 |
| Mini Electric Motor | J-1041 | | \$1.50 |

| | | | |
|-----------------------------|--------|-----|----|
| 27k 1W resistor | R-1508 | 12¢ | 5¢ |
| 8.2k 5W wire wound resistor | R-1708 | 60¢ | 5¢ |
| 1.8k 1/2W resistor | R-1280 | 7¢ | 5¢ |
| 680 ohm 1W res | R-1470 | 12¢ | 5¢ |

| | | | |
|------------------------------|--------|--------|-----|
| 500k linear pot imp | R-1812 | \$1.20 | 70¢ |
| 100k log pot imp | R-1824 | \$1.20 | 70¢ |
| 20k dual linear pot (imp) | R-1836 | \$1.20 | 70¢ |
| 100k dual linear pot (imp) | R-1840 | \$1.20 | 70¢ |
| 10k dual linear pot (imp) | R-1834 | \$1.20 | 70¢ |
| 10k dual log pot (imp) | R-1849 | \$1.20 | 70¢ |
| 50k dual log pot (imp) | R-1853 | \$1.20 | 70¢ |
| 1M log switch pot (imp) | R-1888 | \$2.40 | 70¢ |
| 100k multiterm trimpot | R-1910 | \$1.25 | 70¢ |
| 50k log pot (imp) | R-1823 | \$1.30 | 70¢ |
| 2M linear pot (imp) | R-1814 | \$1.30 | 70¢ |
| 10k log pot (imp) | R-1820 | \$1.30 | 70¢ |
| 1M linear pot (imp) | R-1813 | \$1.30 | 70¢ |
| 10k log pot (metric) | R-6820 | \$1.30 | 70¢ |
| 10k linear pot (imp) | R-1806 | \$1.20 | 70¢ |
| 20k dual linear pot (metric) | R-6836 | \$2.85 | 70¢ |

| | | | |
|-----------------------------|--------|--------|-----|
| 1k linear pot (imp) | R-1803 | \$1.30 | \$1 |
| 0.1 ohm 5W resistor | R-1600 | 60¢ | 35¢ |
| 100k log pot (metric) | R-6824 | \$1.30 | 35¢ |
| 50 ohm 3W w/w pot (metric) | R-6907 | \$3.95 | 35¢ |
| 200 ohm 3W w/w pot (metric) | R-6911 | \$4.10 | 35¢ |
| 10k 5W w/w pot (metric) | R-6925 | \$6.95 | 35¢ |
| 2.2M 5mm vertical trimpot | R-1954 | 55¢ | 35¢ |
| 3.3 ohm 5W w/w resistor | R-1614 | 60¢ | 35¢ |
| 100k 10mm vertical trimpot | R-1965 | 55¢ | 35¢ |
| 470k 5mm horizontal trimpot | R-1781 | 60¢ | 35¢ |

| | | | |
|-------------------------|--------|---------|---------|
| 1000uF 40V electrolytic | R-4595 | \$19.95 | \$10.55 |
| 4700uF 35V electrolytic | R-4215 | \$4.35 | \$2.10 |
| 33uF 10V electrolytic | R-4330 | 30¢ | 5¢ |
| 22uF 25V electrolytic | R-4319 | 30¢ | 5¢ |
| 12pF 50V ceramic | R-2237 | 17¢ | 5¢ |

| | | | |
|-----------------------------|--------|-----|-----|
| 33uF 10V tantalum capacitor | R-4765 | 95¢ | 70¢ |
|-----------------------------|--------|-----|-----|

| | | | |
|------------------------------|--------|--------|-----|
| 2uF greencap (100V) | R-2140 | \$1.90 | \$1 |
| 47uF 350V electrolytic | R-4120 | \$2.50 | \$1 |
| 2200uF 35V electrolytic | R-4459 | \$1.35 | 35¢ |
| 1000uF 16V electrolytic | R-4175 | \$1.05 | 35¢ |
| 2200uF 16V electro (RT) | R-4459 | \$1.35 | 35¢ |
| 2200uF 16V electrolytic (RB) | R-4196 | \$1.40 | 35¢ |
| 330uF 25V electro | R-4400 | 75¢ | 35¢ |

| | | | |
|------------------------|--------|-----|-----|
| 4.7uF 25V electrolytic | R-4310 | 30¢ | 10¢ |
| 47uF 25V electrolytic | R-4350 | 35¢ | 10¢ |
| .047uF greencap 100V | R-2080 | 30¢ | 10¢ |
| 2.2uF 25V electrolytic | R-4300 | 30¢ | 10¢ |
| .056uF greencap 100V | R-2085 | 30¢ | 10¢ |
| 100uF 25V electrolytic | R-4130 | 45¢ | 10¢ |

| | | | |
|-----------------|--------|---------|--------|
| 74C173 IC | Z-5376 | \$1.50 | \$1.50 |
| 74C922 IC | Z-5380 | \$3.75 | \$2.95 |
| 4029 IC | Z-5629 | \$1.95 | \$1.25 |
| 74HC123 IC | Z-5910 | \$2.75 | \$1.35 |
| MM5865 timer IC | Z-6816 | \$4.00 | \$4.00 |
| 74HC373 IC | Z-5965 | \$1.00 | \$1.00 |
| 74C946 IC | Z-6301 | \$24.50 | \$8.95 |
| 74LS123 IC | Z-5310 | \$1.45 | \$1.00 |

| | | | |
|------------------------|--------|--------|--------|
| TBA120T TV sound IF IC | Z-2510 | \$2.49 | \$2.49 |
| LM335H temp sensor | Z-6050 | \$4.45 | \$2.35 |
| 4116 RAM IC | Z-9310 | \$1.00 | \$1.00 |
| TLC251 op amp IC | Z-6021 | \$5.15 | \$2.35 |
| TBA820M audio IC | Z-2506 | \$4.45 | \$2.55 |
| LM394C IC | Z-6083 | \$7.15 | \$7.15 |
| 74LS244 IC | Z-5294 | \$2.75 | \$1.55 |
| 74C173 IC | Z-5376 | \$1.50 | \$1.50 |
| 74193 IC | Z-5280 | \$2.05 | \$1.50 |
| 74HC244 IC | Z-5950 | \$3.85 | \$1.30 |
| 76604N IC | Z-6835 | \$6.53 | \$2.39 |
| LM3600 IC | Z-6113 | \$2.75 | \$1.50 |
| 4543 IC | J-1070 | \$4.50 | \$4.00 |

| | | | |
|-------------------------|--------|--------|--------|
| 74LS373 IC | Z-5295 | \$2.75 | \$1.00 |
| 74LS241 IC | Z-5293 | \$1.00 | 70¢ |
| 7495 IC | Z-5095 | \$1.00 | 70¢ |
| 7483 IC | Z-5083 | \$1.40 | 70¢ |
| 4526 IC | Z-5744 | 80¢ | 70¢ |
| LM386 IC | Z-6086 | \$2.50 | 70¢ |
| 74LS73 IC | Z-4973 | \$1.45 | 70¢ |
| LM78L12CZ 12V regulator | Z-6110 | 85¢ | 70¢ |
| 74C221 IC | Z-5378 | \$2.10 | 70¢ |
| 4044 IC | Z-5644 | 80¢ | 70¢ |
| 74LS138 IC | Z-5284 | 75¢ | 70¢ |
| 74LS74 IC | Z-4974 | 85¢ | 70¢ |

| | | | |
|-------------------------|--------|--------|--------|
| LM78L15CZ 15V regulator | Z-6111 | 85¢ | 70¢ |
| 74157 IC | Z-5267 | 85¢ | 70¢ |
| 74123 IC | Z-5263 | \$1.25 | 70¢ |
| 74LS32 IC | Z-4932 | 85¢ | 70¢ |
| 7414 IC | Z-5024 | 90¢ | 70¢ |
| 74109 IC | Z-4109 | \$1.55 | 70¢ |
| 4520 IC | Z-5742 | 80¢ | 70¢ |
| 74LS175 IC | Z-5291 | \$1.50 | 70¢ |
| 4024 IC | Z-5624 | \$1.30 | 70¢ |
| 4528 IC | Z-5748 | \$2.75 | \$1.00 |

| | | | |
|------------|--------|--------|--------|
| 74LS373 IC | Z-5295 | \$2.75 | \$1.00 |
| 4051 IC | Z-5651 | \$1.95 | \$1.00 |
| LM308 IC | Z-6045 | \$1.65 | \$1.00 |
| 4020 IC | Z-5620 | \$1.65 | \$1.00 |
| CA3140 IC | Z-5417 | \$1.95 | \$1.00 |
| 74LS10 IC | Z-4910 | 85¢ | 35¢ |
| 74LS08 IC | Z-4908 | 85¢ | 35¢ |
| 74LS14 IC | Z-4914 | 85¢ | 35¢ |
| 74HC367 IC | Z-5960 | 80¢ | 35¢ |
| 7401 IC | Z-5011 | 35¢ | 35¢ |
| 74LS31 IC | Z-4931 | 55¢ | 35¢ |
| 7410 IC | Z-5020 | 90¢ | 35¢ |
| 7408 IC | Z-5018 | 70¢ | 35¢ |
| 74LS06 IC | Z-4900 | 75¢ | 35¢ |
| 7400 IC | Z-5010 | 35¢ | 10¢ |
| 7413 IC | Z-5023 | 50¢ | 10¢ |

| | | | |
|-------------------------------|--------|---------|---------|
| AD162 Germanium transistor | Z-1112 | \$2.95 | \$1.95 |
| AD161 Germanium transistor | Z-1110 | \$3.45 | \$1.95 |
| Pack 100 3mm premium red LEDs | Z-4076 | \$19.95 | \$14.50 |

| | | | |
|--------------------------|--------|---------|---------|
| 2SC710 RF transistor | Z-2512 | \$2.95 | \$1.95 |
| 2N4427 RF transistor | Z-2506 | \$3.99 | \$2.55 |
| 2SC2694 power transistor | Z-2505 | \$44.95 | \$31.60 |
| 3SK121 GaAsFET | Z-1845 | \$8.25 | \$1.80 |
| BF115 RF transistor | Z-1560 | \$2.45 | \$1.40 |

| | | | |
|------------------------|--------|--------|--------|
| MEL12 photo transistor | Z-1952 | \$1.25 | 70¢ |
| BFR91 RF transistor | Z-1691 | \$3.60 | \$1.00 |
| 2N4427 transistor | Z-5740 | 50¢ | 35¢ |
| BF470 trans | Z-1636 | \$1.50 | 35¢ |
| 2N5480 trans | Z-2340 | 95¢ | 35¢ |
| BC549 trans | Z-1329 | 40¢ | 10¢ |
| BC337 trans | Z-2190 | 40¢ | 10¢ |
| BC338 trans | Z-2252 | 35¢ | 10¢ |

| | | | |
|-----------------------------------|--------|---------|---------|
| Speaker connection terminal | H-6770 | 50¢ | 50¢ |
| Vernier Drive, 6:1 | H-3901 | \$8.25 | \$4.10 |
| Instrument Case, 210 x 270 x 73mm | H-2525 | \$37.95 | \$23.40 |

| | | | |
|-----------------------------------|--------|--------|--------|
| Pack 5 Insulated spacers, 20mm | H-1871 | \$2.95 | \$1.95 |
| Pack 5 plated brass spacers, 9mm | H-1832 | \$2.95 | \$2.50 |
| Ultramini toggle switch DPDT, PCB | S-1249 | \$3.25 | \$1.50 |
| Mini toggle switch, DPDT, PCB | S-1177 | \$1.50 | \$1.50 |

Overstocks, discontinued lines, etc etc — with fantasmagorical savings of up to 85% and more . . .

ONLY WHILE STOCKS LAST: HURRY!

| | | | |
|----------------------------------|--------|---------|---------|
| Red/Green (dual col) LED bezel | S-3530 | \$4.35 | \$2.20 |
| Knife Switch | S-1930 | \$1.95 | \$1.30 |
| DPDT | | | |
| Ultramini switch | S-1251 | \$3.60 | \$1.70 |
| DPDT, PCB | | | |
| Ultramini toggle | S-1245 | \$3.95 | \$1.80 |
| DPDT | | | |
| 4 switch bank, interlocked | S-1904 | \$5.45 | \$2.65 |
| Single switch from above | S-1906 | \$2.45 | \$1.95 |
| IDC Connector, 40 way, card edge | P-2762 | \$11.95 | \$4.10 |
| 36 Way | P-2680 | \$12.95 | \$5.65 |
| Amphenol plug | | | |
| 3.5/3.5mm right angle adaptor | P-6620 | \$3.95 | \$2.20 |
| 3.5/6.5mm right angle adaptor | P-6625 | \$4.95 | \$2.32 |
| RCA plug/2xRCA socket adaptor | P-6610 | \$2.95 | \$1.40 |
| P/B illuminated switch (blue) | S-1521 | \$10.95 | \$6.85 |
| P/B illuminated switch (yellow) | S-1523 | \$10.95 | \$6.85 |
| P/B illuminated switch (green) | S-1522 | \$10.95 | \$6.85 |
| 12V 4PDT relay, 185 ohm | S-7020 | \$14.95 | \$11.95 |
| Waterproof 12V DC 10A toggle | S-1195 | \$7.65 | \$4.55 |
| Car lamp relay double pole | S-7304 | \$24.95 | \$16.90 |
| Alternate action p/b, DPDT | S-1197 | \$4.35 | \$2.85 |
| Mini Toggle dpdt on/off/mom | S-1287 | \$4.95 | \$2.67 |
| Mini push button dpdt | S-1220 | \$4.95 | \$2.35 |
| Piano Key Switch, dpdt | S-1393 | \$4.95 | \$2.85 |
| Self tapping screw assortment | H-1680 | \$9.95 | \$6.20 |
| 2x TO3 Heatsink | H-3461 | \$6.55 | \$2.55 |



PTY LTD

WIRE

VARIOUS HOOK-UP WIRES

10 x 0.12 (equiv. 10 x .0048) PVC hook up wire for projects, repair, hanging the washing on ...anything!

- | | |
|---------------------------|----------------------|
| W-2220 RED | W-2227 PURPLE |
| W-2221 BLACK | W-2228 BLUE |
| W-2222 BROWN | W-2229 GREY |
| W-2223 ORANGE | W-2230 CREAM |
| W-2224 YELLOW | W-2231 WHITE |
| W-2225 GREEN | |
| W-2226 BLUE (DARK) | |

\$3.50 PER 100m ROLL
OR 10¢ PER METRE

The Best Test On 2!

The Oskerblock SWR-145 keeps you up to date! Designed to be left 'in-situ' for permanent readings. With a top range on two metres of 250 watts and, for VHF users, it needs very low power for full scale readings!

Cat Q-1341

\$99



VHF Hand-held Power Meter.

Wetz quality, the ultimate versatility and DSE value! Check the output of your hand-held accurately — just connect the TP-05X in place of your antenna and you've got it! Cat Q-1343

\$29

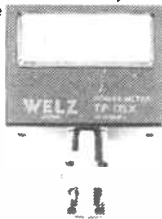

Lightweight Spring

Designed to suit standard loaded ¼ wave mobile whips, to give the type of flexibility required in today's low car parks! Cat D-4500

\$7.95



Quick Disconnect

Enables you to remove your antenna from its mount with an easy press and twist. Saves your antenna being stolen. Cat D-4501

\$10.95

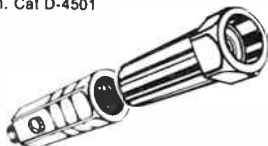

Budget Priced 3.5 Digit

This just goes to prove that you don't have to spend a fortune on quality test equipment! Pocket sized with easy one hand operation the 3.5 digit wide-angle LCD gives accurate readings at a glance. With overload protection, RF shielding, all ohm ranges handle 250V AC or 350V DC indefinitely and much, much more! Cat Q-1515

- 2, 20, 200, 1000V DC
- 2, 20, 200, 750V AC
- Resistance: 2, 20, 200k, 2M
- Robust housing
- Much more!

\$69



4.5 digit with Data Hold Function

What was the result? With most meters the reading is but a moment in time. If you miss it... The DSE Q-1600 solves the problem: hit the "data hold" button and the reading is frozen on the display! Another highly unusual feature is its 20A range — double most meters. Add to that transistor and diode checking, capacitance, plus buzzer and LED continuity, and you have one of the most versatile meters ever produced. Cat Q-1600

- "Data Hold" function
- Up to 20A current reading
- Capacitance & transistors too
- Resistance: 200, 2k, 20k, 200k, 2M, 20M
- Capacitance: 2, 20, 200nF 2, 20uF
- Transistor Check: Hfe
- Continuity: Buzzer & LED
- Top quality rubber insulated leads included

\$225

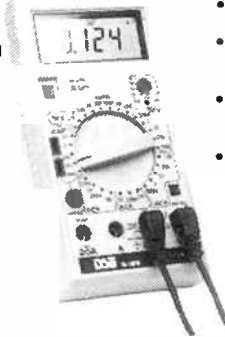

'Pigeon Pair' AF Signal Generator

Square/Sine wave output audio signal generator, essential for work on huge range of circuits. With wide 20Hz-200kHz output and high accuracy, it is the perfect partner for the Q-1312 RF generator. Cat Q-1310

- Frequency range: 20Hz-200kHz
- Output control: High/Low unbal. (-20dB) and fine adjuster
- Sine wave output: 20Hz-20kHz, 5V rms max at 1% or less distortion
- Square wave o/p: 20Hz-20kHz, 10V p-p, 0.5us rise time

\$179

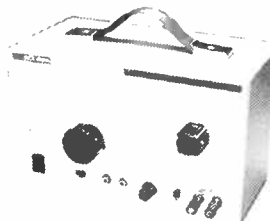

At last! Frequency reading DMM!

It's finally happened: a digital multimeter with frequency reading...as well as all the advanced features of a top DMM (capacitance, transistors & diodes, continuity, etc). Also features direct frequency readout to 200kHz. Ideal for audio and general service work. And it even reads to 20A AC/DC! Cat Q-1505

- Frequency to 200kHz
- Current to 20A
- Transistors, diodes & capacitance too.
- AC: 2, 200mA, 20A
- Transistors: Hfe
- Diodes: Vf
- DC: 200uA, 2, 200mA, 20A
- Top quality rubber insulated probes/leads included.

\$159



Personal LCD with Auto Ranging

An amazing feature-packed 3.5 digit multimeter that's the size of a pocket calculator: only 10mm thick! Perfect for on-the-spot testing. It may be small but it boasts a number of impressive features. There's super-fast auto ranging, automatic polarity indication, 2 times/second sampling and audible continuity. Can even be used as a milli-volt meter (up to 20KHz). Cat Q-1555

- DC Voltage: 2000mV, 20, 200 400V +/- (2.0%rdg +/- 2dgt).
- AC Voltage: 2000mV, 20, 200 400V +/- (3.0%rdg +/- 5dgt).
- Resistance: 200, 2000, 20, 200k ohms +/- (2.0%rdg +/- 2dgt)
- Continuity checks: 200 ohm +/- 10ohm

\$49.95

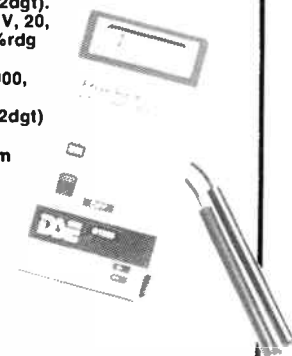

Wideband RF Signal Generator

Low cost RF signal generator that's ideal for the hobbyist/amateur as well as the serviceman. Great for checking tuners in AM, FM, and TV sets plus a huge range of general purpose service, troubleshooting and development work. Cat Q-1312

- Frequency range: 100kHz to 150MHz in six overlapping ranges
- RF output: 100mV rms approx (up to 35MHz)
- Modulation: 1kHz internal, 50Hz-20kHz external
- Audio output: 1kHz at 1V rms (fixed)
- Crystal oscillator: 1-15MHz external crystal, FR243 holder

\$179



GET A FREE SCREWDRIVER WITH EVERY PURCHASE OF \$10 VALUE OR MORE!

Arlec Supertool

What versatility! It sands. It polishes. It engraves. It erases. It mills. It's one of the handiest tools you can have in your arsenal! Includes the Supertool and pluggack, 2 milling cutters, 1 wire brush, 1 grinding wheel, 4 high speed drills, 5 chuck collets (0 to 4mm), eraser sticks and instructions. Cat T-4754

Includes 240V Plug-Pack Adaptor

Complete with ON-OFF switch on the body for convenience

\$59⁹⁵



Supertool Pencil Erasers

Set of 5 Cat T-4762
\$3⁸⁵

Arlec Hobby Vice

Need a third hand? Here's one that won't let go! The mini vice from Arlec attaches to any table, desk, bench, etc. (up to about 40mm thick). 50mm wide jaws hold tight. More than strong enough for cutting, filing, etc.

Cat T-4748

\$12⁹⁵



Wire Stripper

Large adjustable range. Hardened jaws will last a long, long time. Great value at around half the price of other makes. Cat T-3630

\$3⁹⁵

Allen Key Set

Here's an ideal set for the workshop. 7 gunmetal finish Allen keys in a plastic wallet. Sizes 1.4mm, 1.5mm, 2mm, 2.4mm, 2.5mm, 3mm, 4mm. They are ideal for most European and Japanese equipment that have Allen screws. Cat T-5080

\$3⁴⁵

Solder Stand with Magnifier

The helping hand when you need it most: when you have a 'hot stick' in your hand! Heavy die-cast base, solder stand, clips for holding PCB, etc. — plus a unique magnifying lens for those close assembly jobs. Cat T-5710

\$19⁹⁵

Tweezers Pointed

Great for holding small nuts, components and delicate instruments, wires, etc. Also great for removing ticks! Fine points. Cat T-4620

\$1⁹⁵

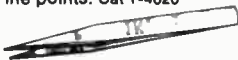

Serrated Jaw

Has flat serrated jaw for positive grip. Cat T-4630

\$1⁴⁵



9 Piece Tool Wallet

Handy go-anywhere wallet contains essential tools for the hobbyist, serviceman, etc:

- 4 flat blade jeweller's screwdrivers from 0.8 to 2.5mm
- 2 Philips blade jeweller's screwdrivers
- Needle pointed surgical tweezers
- Insulated handle cutting nippers
- Mini snap-blade knife

All housed in tough, zip-up vinyl pack. Cat T-4836

\$6⁹⁵



Metal Bender

You can easily make your own with DSE's Sheet Metal Bender. You'll save \$\$\$ making your own heatsinks, RF shields, trays and covers.

Provides a clean, smooth bend up to 90° on metals to 16 gauge. Cat T-5250

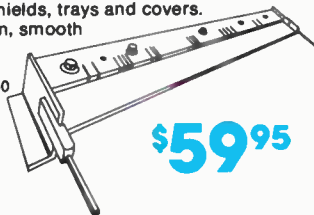

\$59⁹⁵

High Speed Mini Drill Kit

For the hobbyist, technician, toolmaker, etc... this superb mini drill kit is hard to beat. Very high speed — up to 30,000 rpm (depending on voltage used) with a high torque, it's great for drilling, polishing, grinding, deburring, engraving, routing, buffing, carving, sanding, etc. etc. Kit comes complete with four high speed steel twist drills, three collets, grinding bit, spanner and tommy bar, plus DC power cable and plastic case. Cat T-4751

- 12-35V DC operated (external)
- Chuck sizes 0.4-1.5mm, 1.7-2.9mm & 2.8-2.4mm

\$19⁹⁵



Replacement Drills to suit above

1.1mm Cat T-4819
1.0mm Cat T-4820
0.8mm Cat T-4825

\$1⁵⁰ each

IC Extraction Tool

The perfect way to remove IC's without damage. Works with all DIL packs, no bent pins and no static damage! Operates like a pair of tweezers — with hooks! Cat T-4650

\$4¹⁵

BUY BOTH FOR \$10.95

IC Insertion Tool

Don't damage fragile IC's: this IC insertion tool keeps the pins shorted together and in the right place while you get the right position. Handles 14 and 16 pin IC's in standard DIL package. Cat T-4640

\$9⁹⁵

AM/SSB CB under \$200!

Australia's lowest priced full-featured AM/SSB CB? We're sure you won't find better value — anywhere! With maximum legal power, all 40 channels are the extra range and performance that SSB gives, this is the ideal CB for the truckie, the car driver — even the home base with optional power supply. It's fully approved, fully licensable (not like some "bargain" CB's being flogged around!) Cat D-1713

Features:

- Very simple to operate
- Maximum legal power on AM and SSB
- Fully guaranteed (12 months extended guarantee)
- State-of-the-art circuitry with advanced specifications
- Complete with microphone, mounting hardware and instructions

\$199



DOC Approval No: 2440040

Light Duty Antenna Base

Standard 5/8" 26TPI threaded mount in black ABS base. Suits 1/4 wave and smaller CB antennas or small VHF whips. Mounting plate includes solder lugs for coax connection. Cat D-4056

\$3⁵⁰



Antenna Layover

Heavy duty unit allows antenna to be left in three separate positions, vertical, horizontal or angled. Positions are easily obtained at the push of a button. Will not layover if hit. Cat D-4506

\$8⁹⁵



Magna-base Universal Mount

A quality magnetic base — ideal for the company car where holes aren't allowed! Complete with 2m coax and PL-259 plug. Standard thread suits most antennas. Cat D-4514

\$34⁹⁵



Rubber Duck Antenna

Here's a tiny one...just 33cm long! Helically wound, extremely flexible. Standard 5/16" base (not supplied). Cat D-4635

\$10⁹⁵



Splash Out!



Beats a car phone by a nautical mile

The ultimate in marine communications — the MC 480 from Uniden. The 55 Channel VHF Marine Transceiver which allows you to link up to the normal telephone line while you're at sea. Just imagine — you can call home and ask for the chicken to be put on. The heavy duty plastic case is the ideal corrosion inhibitor. Incorporating the full 55 marine channels, PTT mic., 1W/25W selector, channel 16 emergency selector and indicator, bright LED digital channel readout, dim control, squelch and all mounting hardware. Cat D-1400

\$469

Beat Corrosion

Give corrosion a bunch-a-fives; before it's too late! The amazing Cortec 101 corrosion inhibitor protects your valuable equipment. Simply slip the Cortec 101 into your electronic devices and an invisible vapour beats the hell outa those nasty little rust bugs. Lasts up to two years!! Cat D-1300

Was \$5.95 **\$4.95**

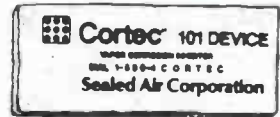

VHF Marine Whip Antenna

You won't beat this one for performance! Quality antenna which comes complete with heavy duty base and mounting hardware for VHF Marine use. Solid flat ground plate makes it easy to fit and keeps it stable when things get a little rough. Cat D-4016

\$79.95



27MHz Helical: no ground plane required

Marine Helical Antenna. Now! A whip antenna for glass, wood and cement boats. This helical antenna doesn't need a ground plane. Helical whip complete with mounting base, cable and simulated ground plane. Great value when you're on the receiving end! Cat D-4070

\$59.95

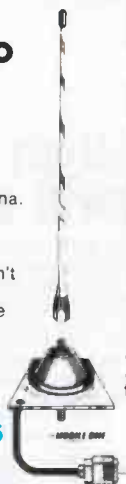

5W 6 Channel Transceiver

Don't leave shore without one!

A top quality high power hand-held from Uniden. Maximum legal power, and all 6 channels fitted with 27MHz marine frequencies. Nothing more to buy! And you can connect a boat antenna and power for maximum performance! DOC Approval No: 242M0172. Also approved for CB use (DOC Approval No. 249A022 with appropriate CB crystals fitted). Cat D-1125

\$199



'Sea Simba' 27MHz Marine

A truly advanced 12 Channel (10 fitted) Marine Transceiver! Advanced circuitry, advanced design, advanced ease of operation. The Sea Simba won't leave you floundering! You get all 27MHz marine channels, PTT mic, large LED channel indicator, ANL switch, PA, LED level indicators, squelch control, mic gain control, RF gain control, etc. and PA jacks, wiring harness and in-line fuse and mounting bracket. Cat D-1718

\$139.95

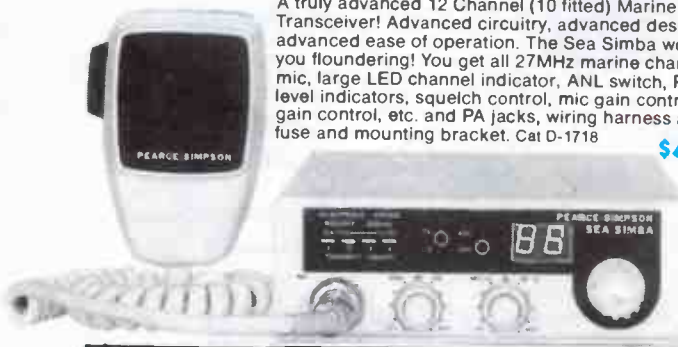

Greater Range with AM/SSB

Trust Uniden to come up with the best! SSB for greater range and more efficient communications. When you're out at sea you don't want to take any chances! All 27MHz channels, S/RF meter, squelch control, digital channel display, RF gain, TX indicator and much more! And it's all packed into a new slimline design — so it looks as good as it performs. Cat D-1715

\$299



DICK SMITH ELECTRONICS

PTY LTD

- NSW • Albury 21 8399 • Bankstown Square 707 4888 • Blacktown 671 7722 • Blakehurst 546 7744 • Bondi Junction 387 1444 • Brookvale (Warringah Mall) 93 0441 • Campbelltown 27 2199 • Chatswood Chase 411 1955 • Chullora 642 8922 • Gore Hill 439 5311 • Gosford 25 0235 • Hornsby 477 6633 • Liverpool 600 9888 • Maitland 33 7866 • Miranda 525 2722 • Newcastle 61 1896 • North Ryde 88 3855 • Parramatta 689 2188 • Penrith 32 3400 • Railway Square 211 3777 • Sydney City 267 9111 • Tamworth 66 1711 • Wollongong 28 3800 • ACT • Fyshwick 80 4944 • VIC • Ballarat 31 5433 • Bendigo 43 0388 • Box Hill 890 0699 • East Brighton 592 2366 • Coburg 383 4455 • Essendon 379 7444 • Frankston 783 9144 • Geelong 43 8522 • Melbourne City 67 9834 • Richmond 428 1614 • Ringwood 879 5338 • Springvale 547 0522 • QLD • Brisbane City 229 9377 • Buranda 391 6233 • Cherside 359 6255 • Redbank 288 5599 • Rockhampton 27 9644 • Southport 32 9863 • Toowoomba 38 4300 • Townsville 72 5722 • Underwood 341 0844 • SA • Adelaide City 232 1200 • Darlington 298 8977 • Enfield 260 6088 • Salisbury 281 1593 • WA • Cannington 451 8666 • Fremantle 335 9733 • North Perth 328 6944 • Perth City 481 3261 • TAS • Hobart 31 0800 • NT • Stuart Park 81 1977

CYLINDRICAL TYPE

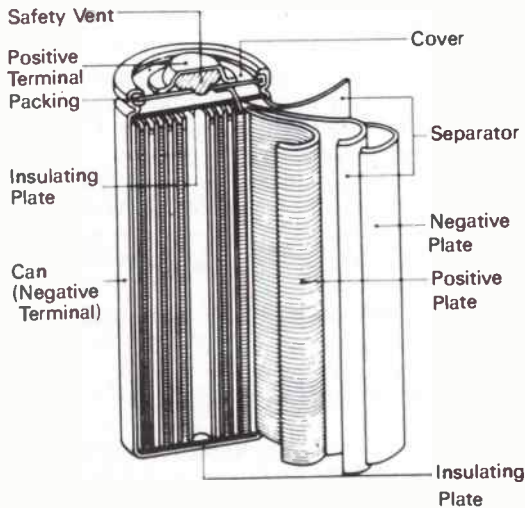

BUTTON TYPE

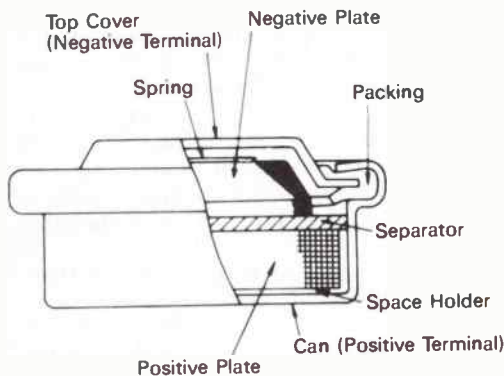

Construction of typical sealed NiCad batteries, showing the button (pressed powder, or mass plate) type and the cylindrical type.

Engineered With Vision



Built With Care

POWER-SONIC, a leading manufacturer of rechargeable batteries, offers a complete line of both sealed lead-acid and nickel-cadmium batteries, engineered to meet the toughest specifications. State-of-the-art design, meticulous quality control and time-proven performance are the reasons why engineers are specifying POWER-SONIC batteries: competitive prices and an outstanding track record for product reliability and on-time delivery have convinced buyers. For more information or a copy of our catalog, contact:

POWER-SONIC AUSTRALIA

61 Buckingham St Surry Hills 2010 PO Box 171 Darlinghurst NSW 2010
(02) 699 2722 699 2521

POWERSONIC

SEALED RECHARGEABLE BATTERIES

lyte's specific gravity is typically 1.15-1.2 (depending on intended service) and it does not undergo a chemical change during discharge as does the lead-acid battery. The positive and negative plates can be quite closely spaced as very little electrolyte is needed, leading to quite compact cells.

The no-load terminal voltage of a NiCad cell is typically 1.3-1.4 volts. Under load, this drops to around 1.2 volts, falling to about 1.1 volts when discharged. The Ah capacity of NiCads is much less affected by the discharge rate than with lead-acid batteries because the electrolyte does not change chemically during discharge. As the electrolyte does not attack the plates, which happens in lead-acid cells, the lifetime of a NiCad cell or battery (treated properly) typically ranges from ten up to 25 years.

As Nicads have a lower energy/volume rating than lead-acid cells, they can be made considerably smaller and are readily manufactured in tiny sizes ideally suited for

use in portable electronic equipment such as calculators and "pocket" computers, hand-held transceivers and camera flash guns, etc. Owing to their construction they can withstand considerable vibration, are free from sulphating or similar problems and can be left discharged without deterioration. The main disadvantages of NiCads are their high initial cost and lower cell terminal voltage which requires more cells to make up a battery of a given voltage. Why the substantial cost disparity compared to lead-acid batteries? Just take a look at the difference between nickel and lead prices in the commodity price lists in your daily newspaper!

There are several different construction methods employed to make NiCads and they each have an important bearing on the price, performance and lifetime of a cell or battery. The perforated plate type is simple to manufacture and relatively low in cost. Pocket-plate types employ perforated thin steel sheets folded so as to make pockets for the active electrode

RELIABLE POWER FROM THE SUN

Solarex, world leaders in photovoltaic technology, manufacture solar power systems to operate reliably in the harshest climatic conditons that Australia has to offer. Whether it is in the Gibson Desert or on the summit of a Snowy Mountain Peak, the heart of a Solarex solar power supply system is a bank of Solarex Solartraction batteries providing a constant supply of electricity on demand. Solarex solar power systems can be found all over the country maintaining Australia's links with the rest of the world. Remote microwave repeaters, radio links, satellite tracking stations, air and sea navigation aids are all powered by Solarex systems.

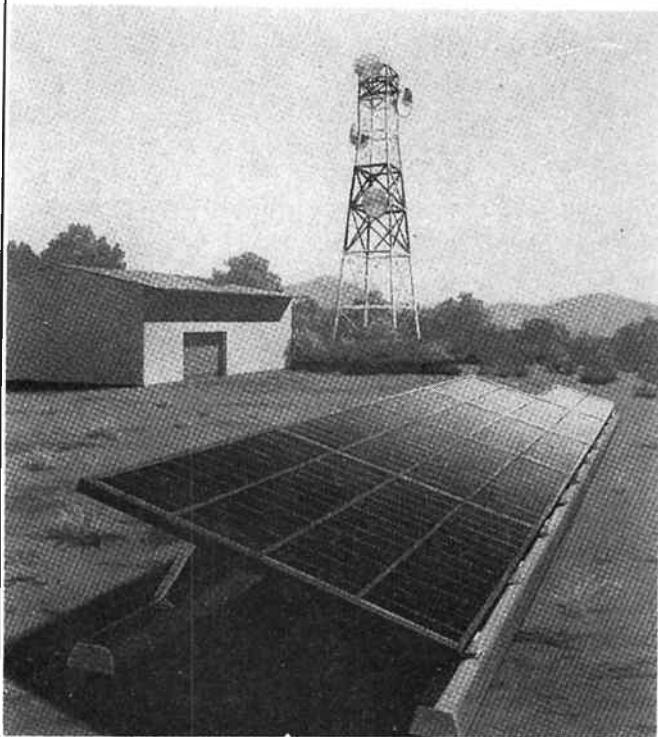

A Solarex solar power system is a reliable, cost effective means of producing DC power with the option of inverting to 240 volts AC 50 cycles if required.

All system components are manufactured in Australia and are thoroughly tested before leaving the factory to ensure a maximum trouble-free life with little or no maintenance. Solarex Pty. Limited is continually developing solar power systems not only for radio and telecommunications but also to provide power for remote homes, villages and for water pumping and irrigation.

SOLAREX PTY. LIMITED

78 Biloela Street Villawood N.S.W.

PO Box 204, Chester Hill, 2162

Tel: (02) 727-4455 Telex: AA121975

Fax: (02) 727-7447

material. These pocketed plates are interleaved, separated by thin plastic strips, the assembly being housed in a polypropylene case. They achieve good ion exchange through the electrolyte which improves performance at high rates of discharge. The large rectangular "industrial" NiCad batteries are of this construction.

Another technique employs a very thin steel foil positive electrodes which has been "sintered" (fired at 1000 degrees C) with a nickel powder, and a cadmium-steel negative electrode produced in a similar manner. Such cells have the advantage of greater active electrode surface area an consequent lower internal resistance.

The tiny "button" cells have electrodes of nickel wire mesh enclosing a compressed "tablet" of plate material with a thin, porous plastic separator between. For obvious reasons this method of manufacture is referred to as either pressed powder or mass plate construction.

Of these, the sintered plate construction is said to provide the best performance, reliability and life span. But it is the most costly to make. Some manufacturers, to reduce costs while providing better performance than other types, use one sintered plate.

Owing to the nature of the materials employed in NiCads, they can be used over a very wide temperature range, typically quoted as extending from -50 to +65 degrees Celsius. At low temperatures the Ah capacity of NiCads does not diminish as much as with lead-acid cells.

Manufacturers recommend charging NiCads with a constant-current charger. Two charge rates are recommended: a "normal" rate - usually 1.5 times the 10-hour discharge rate, and a trickle or float charge rate of 0.01 to 0.05 times the standard charging current. For normal charging, they are charged for 15 hours at the typical discharge rate. Manufacturers usually recommend ripple be kept to a minimum. Typically, during charging, cell terminal voltage rises from around 1.3 volts at the start, reaching a plateau of around 1.4-1.45 V between two hours and seven hours, then rising to a plateau around 1.65-1.7 V between 10-15 hours. Cell temperature rises during charging.

NiCads may be fast-charged, but charge rates and times need to be carefully set and, ideally, cell temperature monitored. Overcharging can play a significant part in cell life reduction, although many types have considerable overcharging tolerance. It is always best to follow the manufacturer's specifications on discharge capacities and charge rates. Readers should be aware that, while NiCad battery capacities are rated in Ah, as are lead-acid batteries, they are actually rated on different scales and a 2 Ah NiCad will likely outperform a 2 Ah lead-acid battery by a wide margin. NiCads are rated on a one-hour or a five-hour discharge rate, while lead-acids are rated on a 10-hour discharge rate. Thus, a 2 Ah NiCad will deliver around 1.8 A for an hour, while a 2 Ah lead-acid battery may only deliver about 1.2 A for the same period. In addition, under the same discharge conditions, the terminal voltage of a NiCad of the same rating as a lead-acid cell will remain more constant than the lead-acid cell.

As with lead-acid cells, NiCads are made for differing applications and duties. A battery intended to undergo long periods of float charge and little work is quite different in



design (and price) to one intended for heavy duty charge-discharge cycling. Some types are not sealed, such as the perforated plate and pocket plate types, while others are completely sealed, but with a safety vent to prevent dangerous pressure buildup when overcharged.

Capacities range from a few mAh to 250 mAh for the tiniest button cells, 100 mAh to as much as 10 Ah for cylindrical types, and from about 1 Ah to 600 Ah for rectangular "industrial" application batteries. Like lead-acid batteries, NiCads self-discharge although they have a longer shelf life than lead-acids. Typical button (mass plate) types lose about 60% of their capacity when stored for a year, while sintered plate types are quoted as losing some 80% of their capacity over the same period.

Lifespans are usually quoted in charge-discharge cycles. Mass plate button cells usually have a life of between 300 and 500 cycles, while pocket plate and sintered electrode types achieve lifespans of some 500-1000 cycles.

NiCads are made in single cell as well as multiple cell, series connected types. The latter have typical terminal voltages ranging from around 7 V up to 24 V. Button cells are often stacked and encapsulated in heatshrink plastic sleeves to make custom batteries to a required voltage. Some battery holders permit stacking button cells.

Silver-zinc/cadmium batteries

These batteries comprise sintered silver cathodes and pressed powder anodes comprised of zinc or cadmium. For clear reasons they are very expensive, but have a very high energy density. On-load terminal voltage lies between 1.1 and 1.5 volts.

While their construction is particularly rugged, rendering them ideal in many military and space applications, their

POWER GONE ... YUASA ON



Australia's No. 1 Standby

When the power goes down, your system is only as good as its standby battery.

Choose the best. Choose Yuasa.

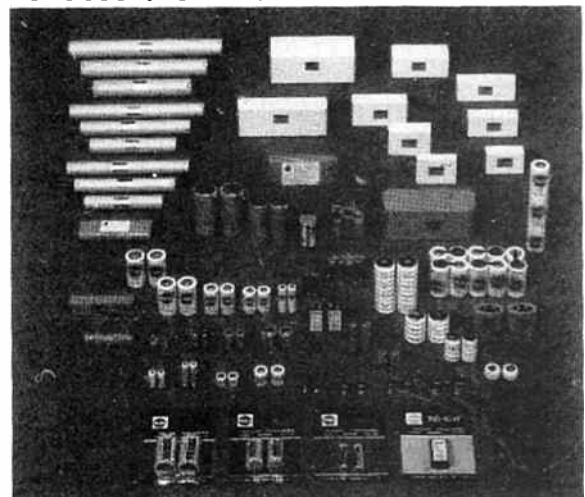

The prime source for every application

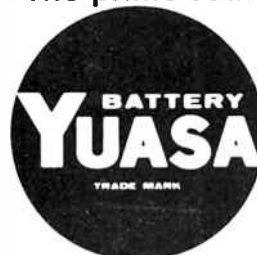

Imported by:-
Bob McKnight Trading P/L
23 O'Connell Tce
Bowen Hills QLD 4006
Tel: (07) 52 7600
Telex: 41846
Fax: (07) 52 5505

The battery with the 60 yrs pedigree.

FAIL-SAFE PROTECTION DESIGN NO **3**
FOR: CMOS MEMORY BACK-UP
STAND BY POWER
PRIMARY POWER SOURCE

AA & AAA BATTERY PACK SERIES

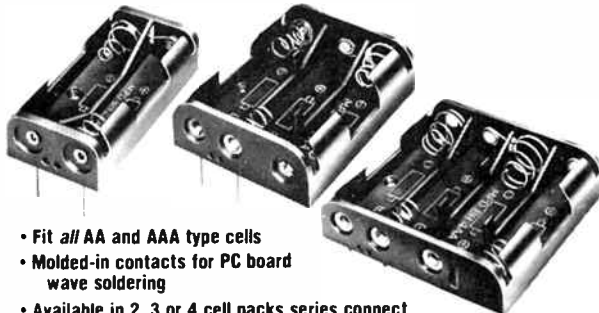

- Fit all AA and AAA type cells
 - Molded-in contacts for PC board wave soldering
 - Available in 2, 3 or 4 cell packs series connect
 - Also 6" UL rated wire and snap fastener male/female terminals
- MPD's AA and AAA battery packs are designed with tapered beam fittings to assure tight fit. Molded of impact resistant nylon flammable rating UL94V-2. Low contact resistance and corrosion free, all parts nickel plated. Accepts NiCd, Carbon-Zinc or Alkaline batteries.

Australian Distributor

 Memory Protection Devices Inc.

 **Quality Trends Australia**
(03) 222 2637
TLX 38943 FAX 03 7626488 QTA

lifespan in terms of charge-discharge cycles tends to be unreliable, varying from a few up to 100 cycles for silver-zinc types. Silver-cadmium types are better in this regard, exhibiting lifespans up to 300-500 cycles.

Aluminium-air batteries

Aluminium may well fuel the vehicles of tomorrow! Or so says Alcan International. Compared volume for volume, aluminium used in an aluminium-air battery releases some four times the energy of petrol burnt in an internal combustion engine! But it has taken the best part of a century to develop and commercially market suitable batteries.

Aluminium-air batteries employ an aluminium anode an alkaline or saline electrolyte (sodium hydroxide or sodium chloride – yep, salt water!) and a metal mesh cathode (to collect the current) with an air-porous but waterproof (hydrophobic) material on one side and a water-porous (hydrophilic) material on the other, open to the electrolyte. Air is pumped over the hydrophobic layer of the cathode. The electrolyte precipitates hydroxides in both cases. For best efficiency, saline systems keep the electrolyte in motion by pumping, stirring it or sloshing it back and forth. This enables the cell to deliver up to four times as much current as static systems.

Alkaline electrolyte systems employ an electrolyte regenerator which removes supersaturated electrolyte from the cell and precipitates-out the hydroxides which are removed, the replenished electrolyte being returned to the cell.

During discharge, aluminium passes into solution (wearing away the anode), hydroxyl ions pass from cathode to anode and water is absorbed into the cathode from the electrolyte.

Aluminium-air batteries have a cell voltage of 2.5-2.7 V and

a specific energy rating of some 300 watt-hours/kilogram (Wh/kg), compared to lead-acid batteries which are rated at only 45 Wh/kg. Even when considering energy density (capacity versus volume), Al-air batteries rate better than lead-acids, the former being rated at 165 Wh/litre while the latter are rated at 100 Wh/litre.

Al-air batteries, unlike other storage batteries, are not replenished by electrical recharging. They are mechanically recharged by replacing the electrolyte at intervals and the aluminium anode at longer intervals. In an article in New Scientist of 17 July 1986, Nigel Fitzpatrick and Geoff Scamans of Alcan International stated that, "An aluminium-air battery is capable of providing enough power to drive a conventional car for 400 kilometres between stops for water to refresh its alkaline electrolyte, and 2000 kilometres before the battery needs more aluminium. Together, the battery and the motor that it drives will be much the same size as an internal combustion engine and its fuel tank."

Apart from traction power, these batteries will likely find application in emergency power generation in remote locations. An ingenious suggestion involves using seawater as an electrolyte in an emergency light in marine applications.

Sodium-sulphur batteries

These batteries also exhibit very high energy densities – being some five to six times that of lead-acid batteries, about the same as the Al-air type. They are ideal for mobile applications because they can deliver some 50 per cent more energy than an equivalent power capacity lead-acid battery, and are only one-third the weight.

Practical sodium-sulphur cells, developed by Chloride in the UK, are cylindrical in shape, with an anode of sodium having a metal current collector embedded in it. A sulphur cathode lines the mild steel case (coated on the inside with

— to page 88 ▶

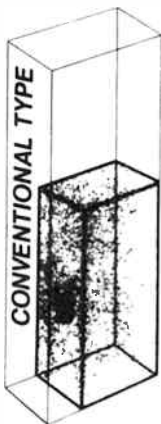

SEALED LEAD-ACID STATIONARY BATTERY

UXL SERIES

10 YEARS LIFE

Conventional vented type stationary batteries require water replenishment due to water decomposition during charge. The "UXL Type" battery introduced herein incorporates further the maintenance-free design which eliminates such troublesome maintenances as electrolyte level check, water topping-up, specific gravity measurement and equalizing charge, making the battery truly maintenance free. This is a sealed type stationary lead-acid battery of long life, high reliability and high performance, which has been developed based on the technologies of the small size sealed batteries.

UXL Saves up to
Half on Space

Ex. UXL220-2

AMTEX

ELECTRONICS

A DIVISION OF METAL MANUFACTURES LIMITED

36 LISBON STREET
FAIRFIELD, NSW 2165
AUSTRALIA

TELEPHONE (02) 728 2121, 727 5444
TELEX AA27922 ATTN AMTEX
FACSIMILE (02) 728 6908, 728 2839.

MELBOURNE.
SUITE 1, 32-34 RUTLAND RD
BOX HILL 3128
TELEPHONE (03) 890 6999
FACSIMILE (03) 898 6427



GENERAL SPECIFICATIONS

| Battery Model | Nominal Voltage (V) | 10HR Nominal Capacity (AH) | Dimensions (mm) | | | Overall Height | Approx. Weight (kgs) |
|---------------|---------------------|----------------------------|-----------------|-------|--------|----------------|----------------------|
| | | | Length | Width | Height | | |
| UXL33-12 | 12 | 30 | 235 | 128 | 190 | 217 | 16 |
| UXL44-12 | 12 | 40 | 299 | 128 | 190 | 217 | 20 |
| UXL55-12 | 12 | 50 | 363 | 128 | 190 | 217 | 24 |
| UXL66-6 | 6 | 60 | 217 | 128 | 190 | 217 | 15.5 |
| UXL88-6 | 6 | 80 | 281.2 | 128 | 190 | 217 | 19.5 |
| UXL110-6 | 6 | 100 | 345.4 | 128 | 190 | 217 | 23.5 |
| UXL220-2 | 2 | 200 | 170 | 106 | 330 | 362 | 16 |
| UXL330-2 | 2 | 300 | 170 | 150 | 330 | 362 | 24 |
| UXL550-2 | 2 | 500 | 241 | 171 | 330 | 362 | 39 |



Heathkit digital weather computer

If you're vitally interested in, or dependant upon weather forecasts, this instrument should give you an edge over the elements, if not the weatherman!

THE HEATHKIT digital weather computer could justifiably be described as the most comprehensive and versatile instrument of its type in the World. The unit can be purchased in both fully built and tested form, or as a kit. Whilst the design is complex and makes extensive use of sophisticated microprocessor technology, the excellent manuals for which Heathkit are renowned make it possible for even relatively inexperienced constructors to succeed in building the kit.

The presentation and standard of finish are typical of Heathkit's attention to detail. The unit, which is housed in a stylish wood-grain cabinet, would not look out of place even in the most tastefully decorated lounge room. The large display area and uncluttered controls make the station functional as well as aesthetically appealing.

The finished article actually consists of two main parts, the indoor unit as described, and the outdoor unit consisting of sensors for wind speed and direction, barometric pressure and temperature. The outdoor unit would normally be mounted in a high, unobstructed position, and connected to the indoor unit by means of a suitable cable.

Some idea of the sophistication of the weather station can be gained by examining the broad range of parameters which it will measure. In the case of wind speed, the instrument will not only measure in knots, miles-per-hour or kilometers-per-hour, but because a memory function is provided, it is possible to display average speed or peak gust. The peak gust memory function will even tell you the date, time and magnitude of the maximum gust by making use of the internal real-time clock. Wind direction is dis-

played by a circular array of 16 LEDs arranged in the form of a compass, thus providing a basic accuracy of plus or minus 11.5 degrees.

In similar fashion, The thermometer function will display both indoor and outdoor readings covering the range from minus 40 degrees to plus 70 degrees Celsius or minus 40 degrees to plus 158 degrees Fahrenheit. In this instance the memory function will remember maximum and minimum readings and give you the date and time of their respective occurrences. Taking temperature measurement one step further, the weather station can combine both wind speed and outside temperature readings to provide an indication of wind chill.

Barometric pressure can be measured over the range of 29 to 31 inches of mercury or 948 to 1083 millibars. As with the other functions, the memory will hold date-stamped readings of maximum and minimum values. When observing weather patterns it is important to know whether the barometric pressure is rising or falling. The weather station will provide this information and also indicate the rate of change per hour.

Calibration

Calibration of the measurement functions is an essential part of setting up this instrument. Time, temperature and wind direction calibration proved quite straightforward. However, barometric pressure provided some frustration. The Heathkit manual suggests you calibrate the barometric pressure using a local weather station or radio station. Now, we don't know about the USA, but that's a bit of a problem in Australia, unless you live near an airport. We would suggest you borrow another barometer. But that also presents a

problem. There are two barometer types – the Toricellian (or mercury column) and the aneroid. Common aneroid barometers do not provide the required accuracy and Toricellian types are now rare. But you can make one using glass tubing, a quantity of mercury and a long rule.

On test

We were fortunate to have the review unit for some months over summer and autumn. Once set up, it performed flawlessly; the calibration held despite the unit being relocated several times. Apart from providing useful data, the weather station generated quite a deal of interest among colleagues in the office as well as visitors. A great point of interest focussed on the difference between the Bureau of Meteorology figures broadcast on TV and radio and the readings obtained on the Heathkit. The only function it lacks is humidity, but that's a parameter that holds fairly constant over relatively large regions and local weather reports can readily provide such data so it's probably not such a drawback.

The Heathkit computer weather station is certainly not inexpensive but then you wouldn't expect such a sophisticated and versatile unit to come cheaply. For the amateur meteorologist, the man on the land, boating organizations or in fact anyone for whom accurate, up-to-date weather information is important, this instrument provides a self-contained solution to all the associated measuring problems.

Review unit kindly supplied by Dick Smith Electronics, PO Box 321, North Ryde 2113 NSW. Catalogue list price \$999. 

WOOD FOR CHIPS ... WOOD FOR CHIPS ... WOOD FOR CHIPS ... WOOD FOR CHIPS ... WOOD FOR CHIPS ... WOOD FOR CHIPS ... WOOD FOR CHIPS ...

WOOD FOR CHIPS ... WOOD FOR CHIPS ... WOOD FOR CHIPS ... WOOD FOR CHIPS ... WOOD FOR CHIPS ... WOOD FOR CHIPS ... WOOD FOR CHIPS ...

Keyboard Specials

A full 20-key numeric keypad for only **\$18.00**. And it has a rigid metal backplate and large typewriter sized keys. Contacts are rated to 30V, 20mA max and have a life in excess of 20 million operations. Measures approximately 125 x 80 x 20mm and has a rows-and-columns configuration. Supplied complete with flexible printed circuit type connecting lead and connector for mounting on your printed circuit. Building your own computer then we also have a full QWERTY keyboard with function keys. Configuration is again in rows-and-columns format and there is NO encoder. Full data supplied. There are 15 function keys in addition to the 67



main keys. One of the cursor keys incorporates a miniature LED. Connection is again by flexible printed circuit leads and connectors are

supplied. Measures 330 x 161 x 20mm approx. A bargain at **\$65.00**. Limited quantities only. Both are quality German manufacture.

Why pay \$10 more for a toroidal transformer for your E.A. 60/60 Amplifier?

Geoff has the Jones Transformers JT353 as specified for the E.A. 60/60 amplifier. It's a balanced C core, diagonally slot wound to improve efficiency and reduce external fields. An alloy mounting bracket is used to reduce fields in steel chassis. Low interwinding capacity reduces the possibility of powerline interference from control tones and switching transients, etc. But best of all it's locally made so it costs less! Geoff's price is **\$69.50**.

Specs JT353
Input: 240V 50 Hz
Outputs: Two 35V windings at 2.5A
Two 15V windings at 0.25A

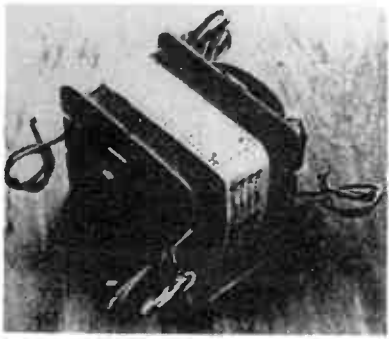

Interlocked Push-Button Switch

Highest quality 5 way DPDT interlocked push-button switch bank with those fancy blinking eye indicators. When you press the white knobs, a green indicator shows so you can see at a glance which circuit you've selected. Switch spacing is 12.5mm. Fitted with solder tags for easy wiring. Limited number only at **\$4.50**.

20MHz SCOPE WITH ALTERNATE TRIGGERING

Compact and easy to operate for hobbyists and professionals

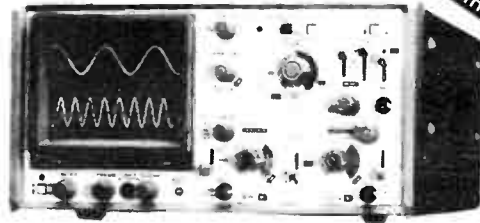

12 MONTH WARRANTY

The GOS-522 is an ideal general purpose scope which we've selected because of its excellent triggering functions. Two channels with big 150mm (6") screen and internal graticule. Fast 20ns/div sweep speed for high precision. Features alternate triggering mode to ensure stable display of both channels - saves a lot of knob twiddling! Trigger circuit is dc coupled too for low frequency signals. Trigger level lock and variable hold-off all add to ease of use. Auto, normal and single shot

sweep modes. Call in for a demo, you will be delighted with the performance and the price -

\$869.95 (incl. tax)
\$745.67 (ex tax)

includes FREE PROBES and a 12month warranty.

IBM PRINTER CABLE

Approx 1.5m long with quality connectors on each end. You couldn't buy the parts and make one yourself for the price. Were \$22.50 but till current stock is exhausted you can have one for just **\$15.00**.

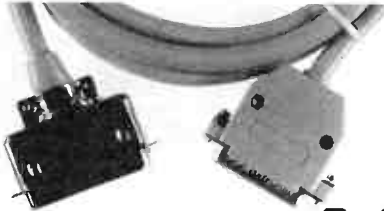

DRAFTING AIDS

We stock a full range - prices on application.



Potted Transformer Special

Here's a handy 240V/24V 250mA (single secondary) transformer for projects and other applications. Quality Australian made and a bargain at only **\$10.00** each.

Heat Shrink now available in metre lengths

There's a thousand and one uses for heatshrink! You can now pick it up in handy metre lengths in red, blue, white, black or clear as follows:

| | | |
|------------------|-------|---------|
| 1.5mm shrinks to | 0.8mm | \$1.20 |
| 2.5mm | 1.5mm | \$1.20 |
| 3.5mm | 2.0mm | \$1.45 |
| 5.0mm | 2.9mm | \$1.45 |
| 7.0mm | 4.2mm | \$1.80 |
| 10mm | 6mm | \$2.05 |
| 13mm | 8.5mm | \$2.65 |
| 16mm | 11mm | \$3.00 |
| 32mm | 16mm | \$6.79 |
| 38mm | 20mm | \$8.50 |
| 51mm | 25mm | \$11.30 |

8.30 to 5 Monday to Friday, 8.30 to 12 Sat.
Mail Orders add \$5.00 to cover postal charges.

All prices INCLUDE sales tax.

Tax exemption certificates accepted if line value exceeds \$10.00.

BANKCARD, MASTERCARD, VISA, CHEQUES



GEOFF WOOD ELECTRONICS P/L (02) 427 1676

INC IN NSW

229 BURNS BAY RD. TWX 71996
(CORNER BEATRICE ST.) P.O. BOX 671
LANE COVE WEST N.S.W. LANE COVE N.S.W. 2066

OR CASH CHEERFULLY ACCEPTED

specialising in electronic components for the professional and hobbyist.



in AEM

CONTENTS

PROJECTS

Motional Feedback
in Loudspeakers 34

Valve Hi-Fi Preamp,
Part 2 40

Facsimile Interface 45

Linkwitz Crossovers 51

ARTICLES

Motional Feedback
in Loudspeakers 34

Electronic Potentiometers 37



The projects and circuits chosen for inclusion in the Elektor section are selected on the basis of interest, local relevance and component availability. Intending constructors should consult our 'PROJECT BUYERS GUIDE' in this issue for a guide to component sources and possible kit suppliers.

Unfortunately the artwork for Elektor project pc boards published last issue and in this issue did not arrive from overseas in time for inclusion. We will publish them in the next available issue following their arrival.

The contents of this section are copyright,

© Uitgeversmaatschappij Elektor B. V. (Beek, the Netherlands) 1986.

Any infringement of this copyright will be prosecuted to the full extent, including unauthorised manufacture of pc boards intended for re-sale.

FEEDBACK IN LOUDSPEAKERS

by R Conell

Electrical feedback is the backbone of many an electronic circuit. Acoustic feedback is not nearly so common, but R Conell suggests some ways of experimenting with it in a low-frequency loudspeaker.

Ever since Thiele and Small published their works on loudspeaker theory, it has been possible to calculate fairly accurately what the ideal enclosure is for a certain type of loudspeaker, or conversely how a loudspeaker will behave in a certain enclosure. According to Small, a closed box will behave as a second-order high-pass filter, while Thiele shows that bass reflex and transmission line boxes act as fourth- or sixth-order filters. From this it is clear that a closed box will give better bass reproduction than an open system.

The performance of a filter is determined by its quality factor Q and its resonance frequency f_c . This is also true of a complete loudspeaker system, including the enclosure, when the total Q is designated Q_{tc} and the resonant frequency f_c . In an ideal bass system, these quantities should have values as follows:

$Q_{tc} = 0.5$ to 0.7 , and

$f_c < 30$ Hz.

Moreover, the volume of the enclosure should preferably not exceed 100 litres; the frequency range should be greater than 300 Hz; and the dis-

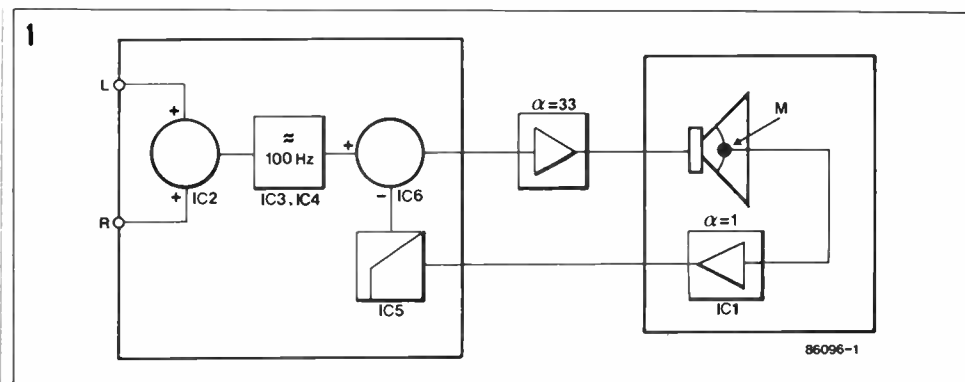

Fig. 1. Block schematic of proposed set-up with modified drive unit.

tortion should not exceed 1%. It is virtually impossible to meet these requirements with a passive speaker system, particularly as regards Q_{tc} and f_c . In an active system, it is far easier to approach the ideal. Frequency response equalization is one way to tackle the problem. Basically, it is better, however, to make use of a controlled system. Unfortunately, such a system is prone to spurious oscillations, which can, however, be obviated by negative feedback.

Basic controlled system

Control is possible by convert-

ing some of the acoustic output of the loudspeaker into an electrical signal and returning this to the input of the power amplifier. To this end, a low-mass acceleration pick-up has to be fitted to the cone of the drive unit.

The block schematic of a possible arrangement is shown in Fig. 1. The left-hand box contains the control electronics, followed by the power amplifier, which has a gain of about 30 dB, and the loudspeaker system.

The control electronics consist of an adder that combines the left- and right-hand signals, a low-pass filter with a cut-off frequency of 100 Hz, and a difference amplifier where the filtered input signal is reduced by the correction signal from the feedback loop.

The power amplifier can be of any type, but its gain should preferably be about 30 dB. A smaller gain would require some adjustment of the control loop, while a higher gain increases the tendency to oscillations in the loudspeaker system.

The loudspeaker system contains the drive unit, fitted with the acceleration pick-up, M, and an impedance converter, IC1.

Impedance converter

The impedance converter—see Fig. 2—consists of a Type TL071 operational amplifier. Its pin-out is shown in Fig. 3. This stage should be fitted as close as possible to the acceleration pick-up, preferable direct onto the chassis of the drive unit as shown in Fig. 7.

Control circuits

Adder IC2 in Fig. 3 combines the two stereo signals into a monaural signal. Potentiometer P1 sets the input level for low-pass filter IC3-IC4. This Bessel filter has a cut-off frequency of 100 Hz and a roll-off of 24 dB/octave.

The control amplifier proper is formed by IC5: the values of R_9 , R_{11} , and C_9 determine the transient response of the overall system. These values will be reverted to under *Setting up*.

The control signal is deducted from the filtered audio signal in subtractor IC6. The output of this stage is fed to buffer IC7 via two low-pass sections, R_{16} - C_{11} and R_{17} - C_{12} . These sections further suppress any tendency to oscillation and are absolutely necessary.

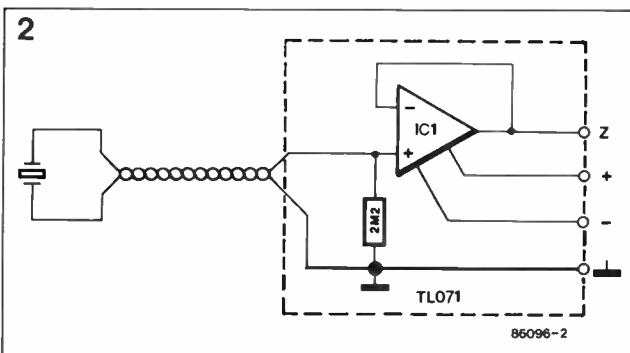
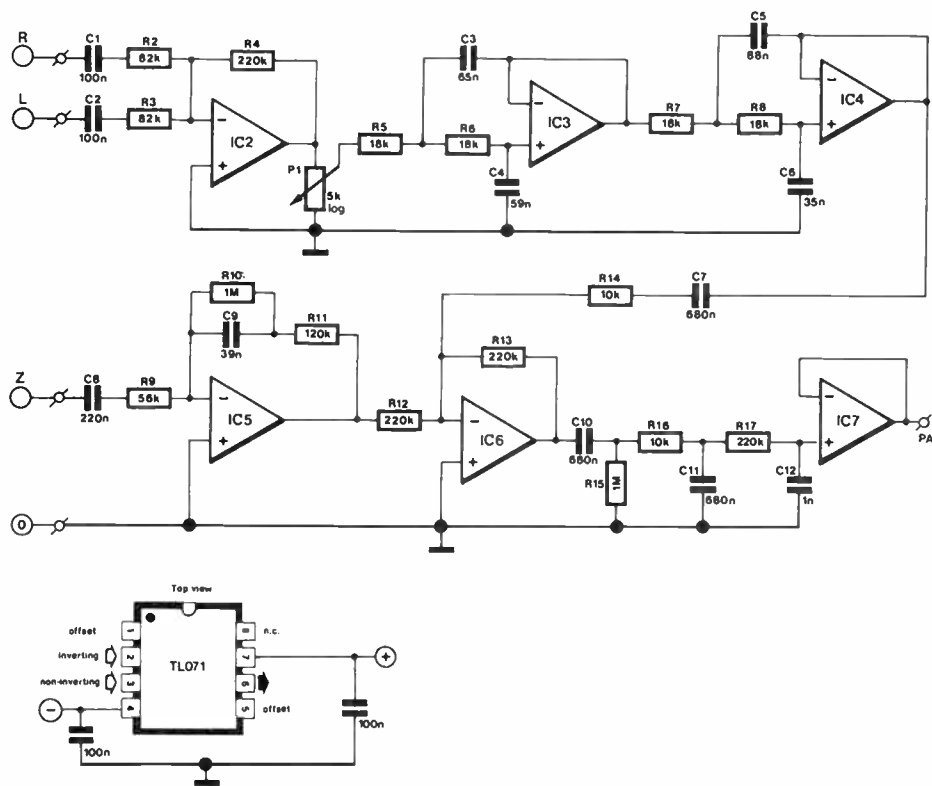

Fig. 2. Circuit diagram of the impedance converter. The pin-out of the TL071 is shown in Fig. 3.



86096-3

Fig. 3. Circuit diagram of the control electronics.

It is possible to omit impedance converter IC₁ and buffer IC₇, but the values of the low-pass sections between IC₆ and IC₇ should then be recalculated with due account of the input impedance of the power amplifier.

Modifying the drive unit

The acceleration pick-up is made from a piezo tweeter from which the chassis has been removed as shown in Fig. 4. The connexion wires have been cut

at the terminals, *not* at the crystal end. The remaining cone is then cut to the same size as the piezo disc.

The resulting acceleration pick-up may be fitted over or under the dust cap of the woofer. The latter method is preferable, but only possible if the dust cap has been fastened with a thermoplastic glue. The cap may then be removed quite easily with a heated knife as shown in Fig. 5. The removal of the cap should, of course, be carried out with the greatest care to avoid damage to the cone of the

drive unit or its speech coil. Once the dust cap has been removed, it should be stiffened with a thin layer of epoxy resin and a piece of glass fibre cloth at its inside—see Fig. 6. The epoxy resin may be used at the same time to fix the pick-up in place. In the mean time, the woofer should be kept upside down to prevent dust entering the air gap. After the epoxy resin has hardened, a thin flexible wire should be soldered to each of the two short connexions of the pick-up. These wires should

also be glued to the dust cap to prevent them vibrating in unison with the cone later. Next, the dust cap can be fastened onto the cone again, preferably with thermoplastic glue to enable removal at a later stage if necessary. Before gluing it in place, however, pierce a small hole in the cone through which the flexible wires are fed. These wires should be glued to the cone in the same way as those to the speech coil. Finally, they should be connected to the impedance converter board as shown in Fig. 2 and

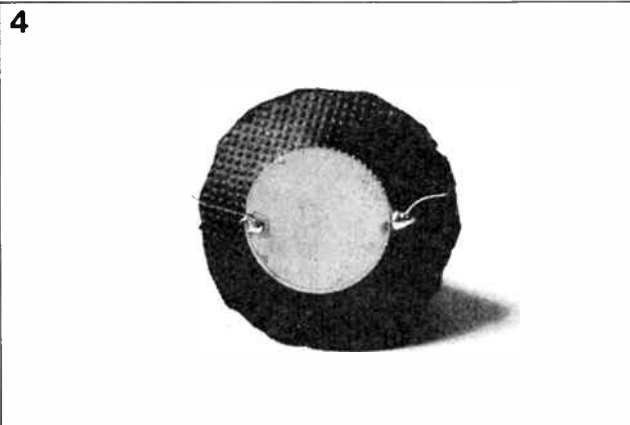

Fig. 4. Piezo tweeter after its chassis has been removed.

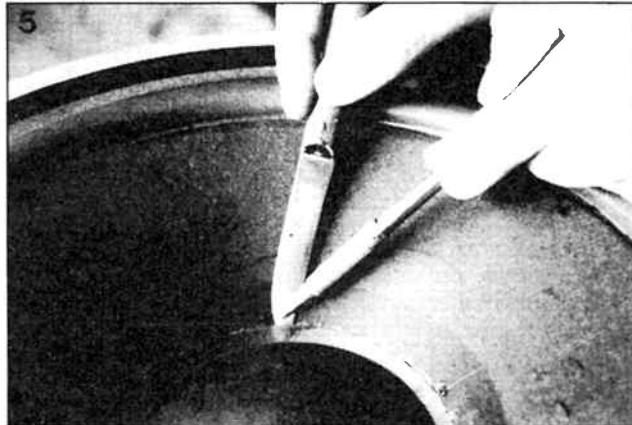

Fig. 5. Removing the dust cap from the cone of the bass drive unit.

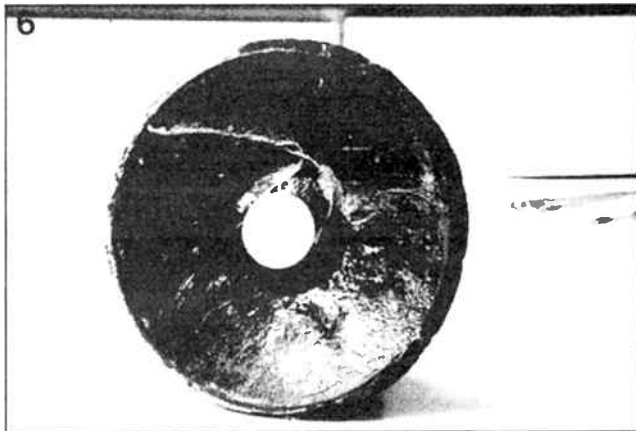

Fig. 6. the dustcap should be stiffened on its inside with a thin layer of epoxy resin, which can be used at the same time to fix the acceleration pick-up.

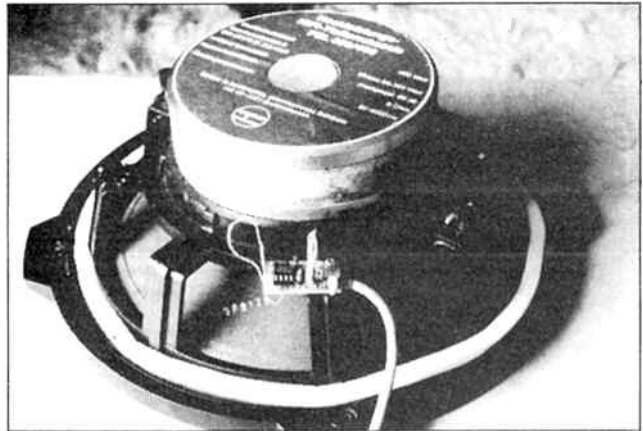

Fig. 7. The modified bass drive unit: note how the impedance changer is fixed to its chassis.

Table 1

Harmonic distortion at 96 dB at 1 m distance

| Frequency (Hz) | 30 | 40 | 70 | 100 |
|------------------|------|------|-------|-------|
| Without feedback | 4.5% | 1.7% | 0.65% | 0.85% |
| With feedback | 1.5% | 0.6% | 0.5% | 0.65% |

Maximum sound pressure at 40 Hz with different enclosure volumes

| Volume (litre) | 50 | 70 | 100 |
|------------------|--------|--------|--------|
| Without feedback | 98 dB | 100 dB | 102 dB |
| With feedback | 101 dB | 103 dB | 105 dB |

System parameters measured in a 70 l enclosure

| | Q_{tc} | f_c | f_3 dB |
|------------------|----------|-------|----------|
| Without feedback | 1.9 | 48 Hz | 29 Hz |
| With feedback | 0.6 | 17 Hz | 20 Hz |

Fig. 7. They should preferably be of about the same length as those to the speech coil. The drive unit is then ready for operational use—see Fig. 7.

Setting up

All the constituent parts of the system should now be interconnected as shown in Fig. 1. Short out R_{11} and C_9 with the aid of a switch to disable the control circuit. When the switch is opened momentarily, one of three things will happen:

- the loudspeaker remains quiet;
- the system oscillates at a low frequency (<100 Hz);
- the system oscillates at a high frequency (>1 kHz).

In the first case, everything is in order and the system can be

taken into use.

In the second case, the connexions from the pick-up to the impedance converter board must be reversed.

In the third case, the oscillations must be damped by changing the values of a few components. First, increase C_{12} to $1n8$ and, if this does not help, C_{11} to $1\mu F$. If that still does not cure the problem, reduce the value of R_{11} and increase that of C_9 . Resistor R_{11} affects the lower cross-over frequency, while C_9 alters the Q_{tc} of the system. The author has built several of these systems and lation problems. Do not forget to remove the switch from across R_{11} and R_9 .

Finally

The frequency characteristics in Fig. 8 show the results of the modification: it is quite evident that the lump between 30 and 100 Hz in the response of the system disappears when the feedback is introduced. The response between 20 and 30 Hz is also much improved.

A number of pertinent measurements are tabulated in Table 1.

The system with feedback was also compared with a number of top quality loudspeaker systems: in all cases, it performed equally well over the bass range, in spite of its cost being only a fraction of that of the competition.

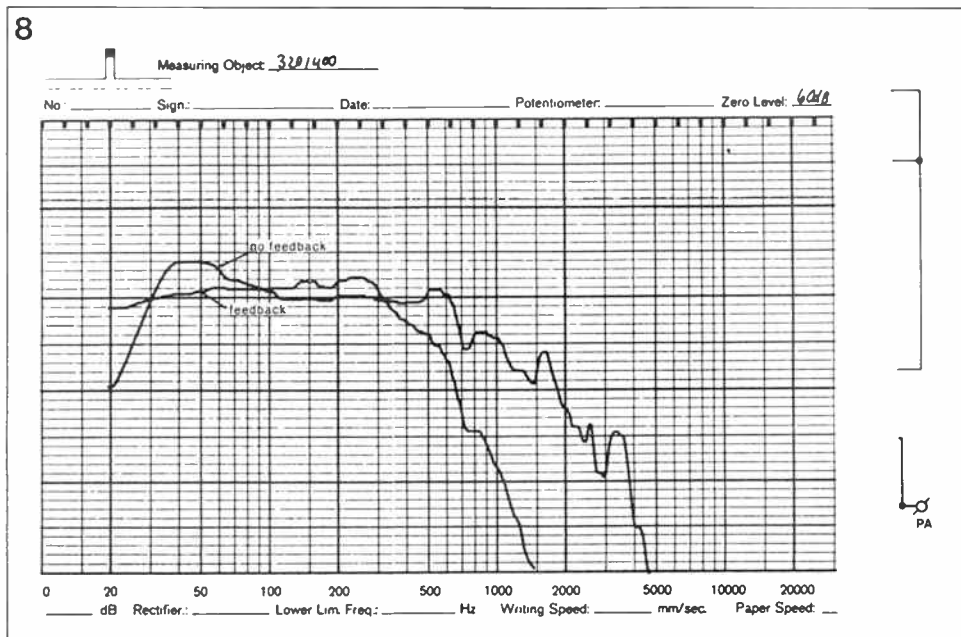

Fig. 8. The frequency response curves of the system with and without feedback.

ELECTRONIC POTENTIOMETERS

by T Scherer

An exploratory look at all-electronic replacements for potentiometers in high quality AF applications.

Potentiometers are, arguably, not the best way of controlling the volume and tone settings in an AF amplifier. We all know that they can cause scratching noises when operated, collect dust, and sometimes develop contact problems giving rise to troublesome discontinuities in the operative range. High quality potentiometers for AF applications are not only difficult to obtain, but also notoriously expensive. In the following sections we will briefly examine a

number of low-cost alternatives to potentiometers used in various circuit sections of AF equipment.

The carbon track potentiometer

This most commonly used voltage divider is generally composed of a carbon film deposit on a ceramic base arranged in a three-quarter circular form (270°). The poor contact definition of the wiper

on this thin carbon film readily gives rise to scratching noises made audible in the loudspeakers. Furthermore, dust and foreign particles can easily enter the potentiometer enclosure, and block certain sections of the carbon track, so that the amplifier falls still at particular volume settings, making the adjustment very difficult.

Stereo potentiometers of the carbon film type are a further source of trouble. With most inexpensive types, the tolerance

on synchronicity of the set resistance is often no less than 20%, even with linear law types. The voltages at the wipers of a logarithmic stereo potentiometer can also differ by some 20%, causing a volume difference between the channels of a maximum of 2 dB, which may be noticeable in listening.

Potentiometers are generally mounted on equipment front panels, and are connected to the electronic circuit with the aid of shielded wires that often

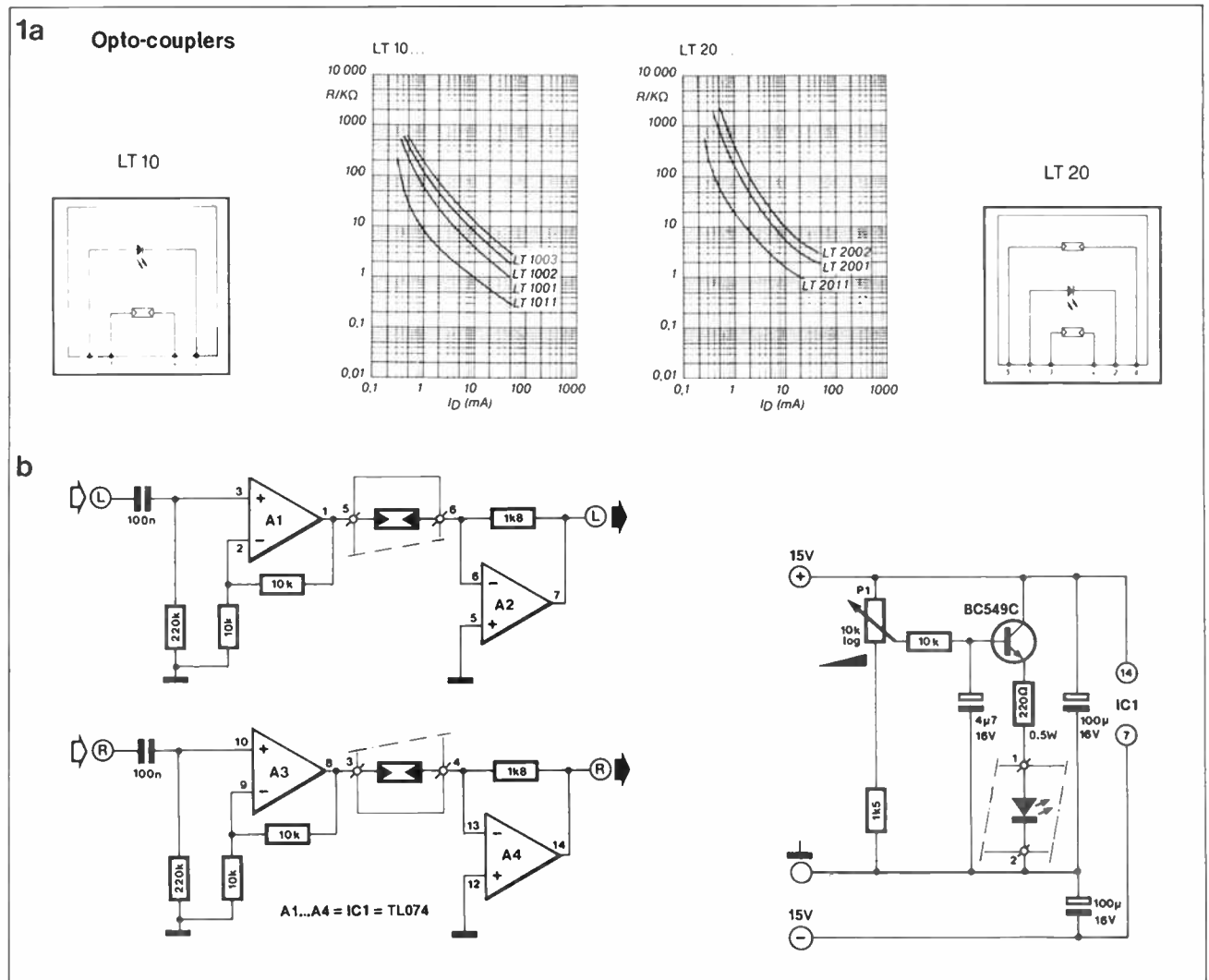

Fig. 1. Experimental stereo volume control circuit based on the use of a LED-LDR optocoupler.

carry very low signal level at relatively high impedance. This makes the amplifier susceptible to noise, hum and strong RF fields, which can still be picked up by the carbon track in the potentiometer (plastic enclosures!), and even in the cable shield.

In conclusion, it is reasonable to say that the standard carbon track potentiometer is unsuitable for a great many critical applications.

Stepping switches

Rotary (wafer) switches with fixed resistors at the contacts are, in principle, a good way to effect volume and tone setting in an amplifier. The tracking is adequate, and scratching noises due to spindle movement are effectively ruled out. However many rotary switches of suspect quality do develop contact problems after prolonged use. A major difficulty in the designing with stepping switches is the finding of types having the number of positions required to ensure a sufficiently smooth adjustment range.

Wire-wound potentiometers

Long ago in the history of electronics, all potentiometers and resistors were made from resistance wire. For a number of specific applications, the wire-wound potentiometer is still in use. Ganged types with motor drive units can be found in some of the most expensive types of amplifier. This application, however, requires sophisticated mechanical engineering on the one hand, and a fairly complex electronic control circuit on the other, making the whole set-up rather cumbersome and expensive at the same time.

An LDR-based potentiometer

The first attempts at making a fully electronic potentiometer were carried out with combinations of LDRs (light dependent resistor) and a small bulb. Although the results were quite satisfactory for AF equipment on the market in the early 1960s, we would nowadays reject the LDR-and-bulb control for incorporation in Hi-Fi equipment in view of the noise production,

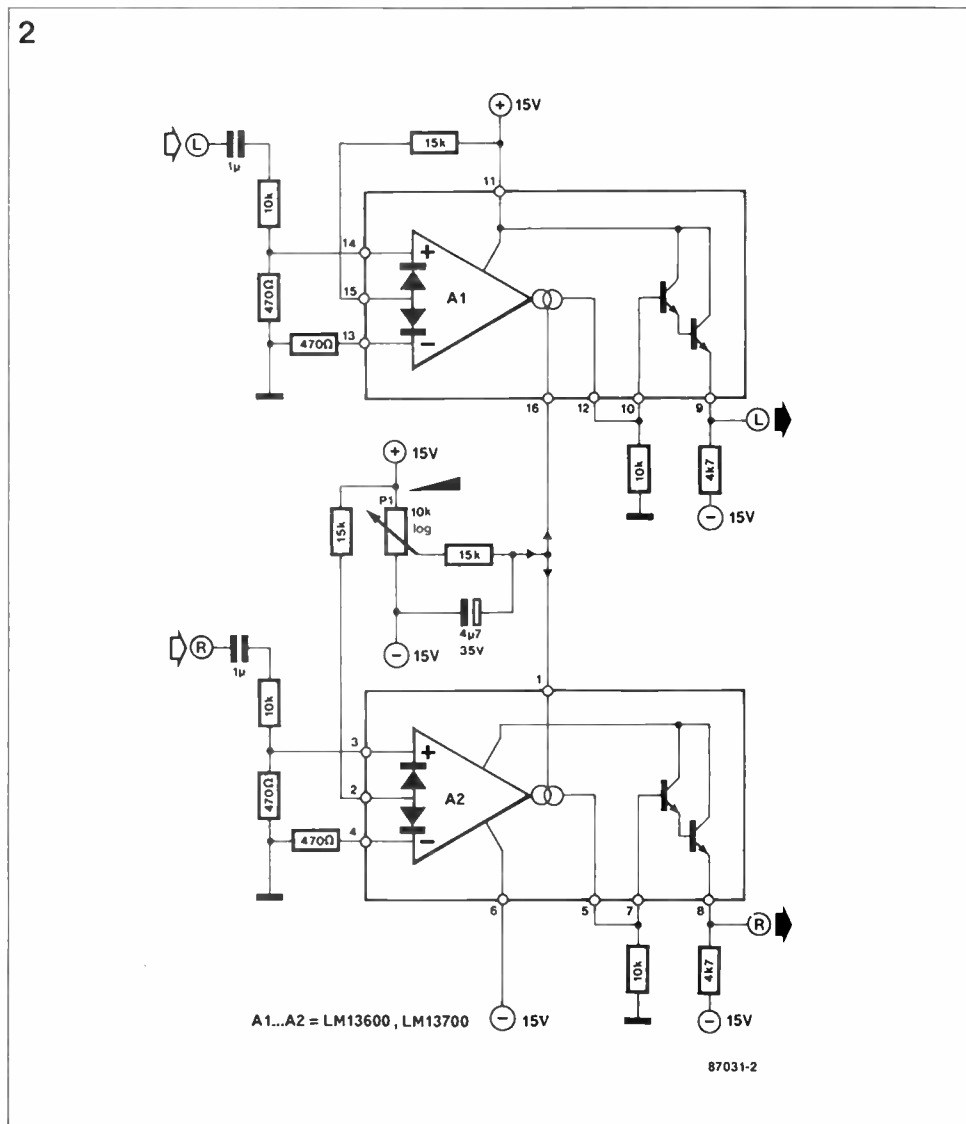

Fig. 2. OTAs in use as a Hi-Fi stereo volume control.

rumble sensitivity, and poor tracking characteristic of the stereo versions.

We all know that each and every electronic component remains subject to continuous enhancement by the joint force of manufacturers and their research laboratories. The German firm Heimann, for instance, took up the long forgotten LDR for further research, and used two of these devices together with a LED to make an optocoupler that has adequate features for Hi-Fi applications. The LDRs in their Types LT10xx and LT20xx optocouplers are of excellent quality, and especially the LT20xx should do very well as a stereo potentiometer with adequate tracking properties—see Fig. 1a for the pinning and R-Ia curves, and Fig. 1b for a suggested application circuit.

An OTA-based potentiometer

A fairly simple potentiometer replacement can be realized with the aid of an OTA (operational transconductance amplifier), which is essentially an amplifier with current-controlled gain. The gain range of about 80 dB, the extensive usable frequency range and linearity of the current-gain correlation, make an OTA such as the Type LM13600 eminently suitable for the applications we are concerned with here.

Those who want to experiment with these devices will find the suggested circuit in Fig. 2 of use for further experiments. The only drawback associated with OTAs is their limited dynamic range, which results in a maximum attainable signal-to-noise ratio of about 80 dB.

Analogue multiplexers

The circuit shown in Fig. 3 is a high-quality, all-electronic volume control featuring 16 dB and 2 dB steps as controlled from a 6-bit digital input. The ICs in this circuit are the well-known Type 4051 eight-channel analogue multiplexer/demultiplexer, which is in essence an electronic version of an 8-way, single pole rotary switch. The contacts are inputs 0-7, the pole is output Z, and the switch position is set with the 3 bits at the A-B-C inputs. Example: applying binary code 010 to the A-B-C inputs of the left-hand multiplexer connects input 2 (pin 15) to output Z. The input signal for opamp A₂ is therefore taken from the -32 dB contact on the resistor ladder. The resistors at the inputs of the second multiplexer driving A₃ are dimen-

3

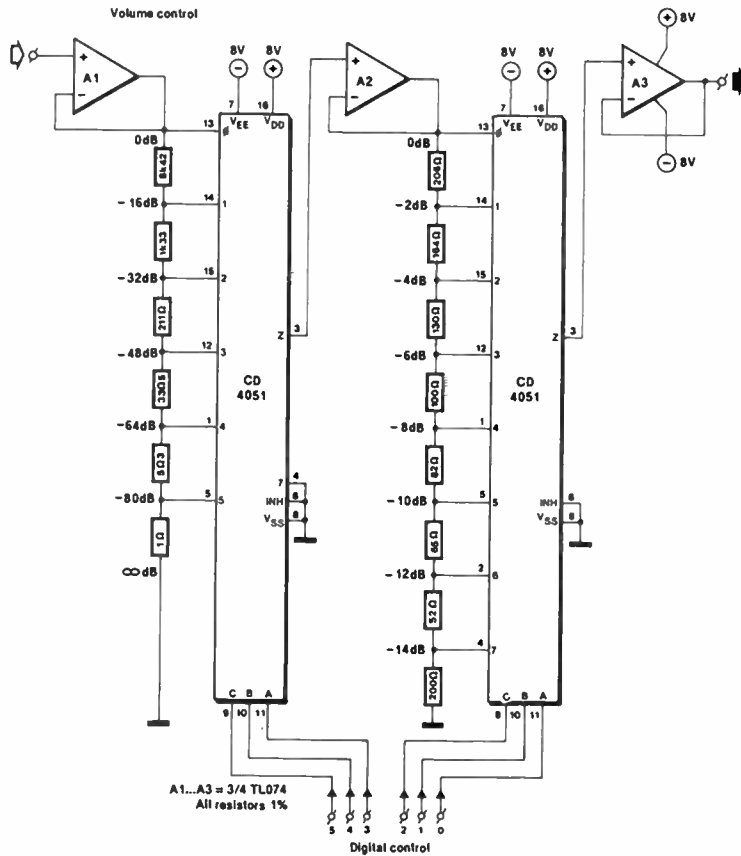

Fig. 3. A 6-bit high quality volume control circuit that uses CMOS analogue multiplexers.

4

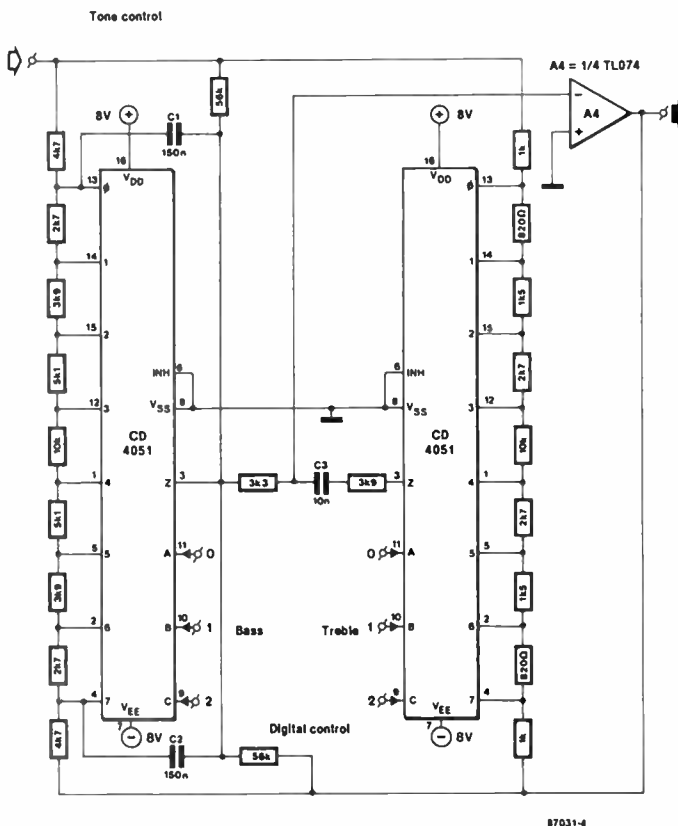

Fig. 4. Using electronic switches instead of a potentiometer in a tone control circuit.

Table 1

| INPUT STATES | | | | "ON" |
|--------------|---|---|---|------------|
| INHIBIT | C | B | A | CHANNEL(S) |
| CD4051B | | | | |
| 0 | 0 | 0 | 0 | 0 |
| 0 | 0 | 0 | 1 | 1 |
| 0 | 0 | 1 | 0 | 2 |
| 0 | 0 | 1 | 1 | 3 |
| 0 | 1 | 0 | 0 | 4 |
| 0 | 1 | 0 | 1 | 5 |
| 0 | 1 | 1 | 0 | 6 |
| 0 | 1 | 1 | 1 | 7 |
| 1 | X | X | X | NONE |

sioned to give 2 dB attenuation steps, so that the overall range of this electronic potentiometer is from 0 to -96 dB as set with 6 bits. A balance control can be made with two of these circuits, operated on the basis of software.

The tone control section shown in Fig. 4 uses the same principle as the above volume adjustment. The resistors as part of the R-C filters in the feedback loop of A₄ are selected with 3-bit codes for bass and treble.

Use high-stability resistors and capacitors when constructing these circuits, and provide ample decoupling of the supply lines. The opamps should be low-noise types such as the TL074 indicated in the circuit diagram. The digital adjustment of the volume and tone control circuits is a matter we leave in your hands. You may want to use an up/down counter, a microprocessor port, or a special switch to arrange for the correct bit combinations at the multiplexer control inputs (consult Table 1).

D

VALVE PREAMPLIFIER — 2

by J P Güls

The design is completed with a multi-voltage supply and a relay control board.

The main task of the boards described in this final instalment of the article is to enable the preamplifier to operate at the top of its potential. To accomplish this, one board holds a relatively extensive power supply, the other a combination of logic circuits for driving the various relays in the preamplifier.

The power supply

The present design is no exception to the rule that high-quality AF circuits, whether preamplifiers or power amplifiers, invariably call for the use of no-compromise supplies that are based on the use of conservatively rated components of the best quality available.

The proposed supply is, therefore, a relatively complex circuit, set up to deliver three voltages to the preamplifier board, and two to the relay control circuitry. The high-voltage (HV) rails for the preamplifier are stabilized with a series regulator to ensure optimum operation of the cascaded triodes, and also to effectively keep low-frequency noise out of these highly sensitive sections.

Not all components in the power supply are accommodated on a printed circuit board. With reference to the wiring diagram shown in Fig. 10, a varistor (SIOV S10 K250) is fitted across the mains lines to suppress noise and voltage peaks. The contacts of the double-pole mains switch have shunt capacitors which afford protection against inductive transients being superimposed onto the mains when the amplifier is switched off. Without these high-voltage capacitors, the loudspeakers in the audio system would be in real danger of being damaged by powerful clicks—or worse, bangs—originating from the preamplifier. The mains transformer, Tr, supplies four

voltages from its five secondary windings. Where a transformer as shown is difficult to obtain or make, two or more may be used to provide for the various alternating voltages.

The circuit diagram of the valve supply appears in Fig. 6. The 6.3 V secondary of Tr only powers the filament of the HT rectifier valve, V₁₀₁, a Type EZ80 or EX81 used in a full-wave rectifier circuit fed from the centre-tapped 360 V windings on Tr. When REC is activated, the cathode voltage of V₁₀₁ is smoothed with the aid of R₁₂₇ and C₁₂₉. Series regulator IC₁₁₁ is a special high-voltage type, protected against excessive dissipation and reverse voltage with zener diodes D₁₁₉–D₁₂₁ and shunt D₁₂₂. The HV rails for the LINE and MD preamplifiers are adequately decoupled with the aid of R-C filters R₁₂₅–C₁₃₀ and R₁₂₉–C₁₃₁, respectively. Series resistor R₁₂₅ also serves to pro-

tect IC₁₁₁ from being damaged by a short-circuit on the +350 V rail.

As an alternative to the regulator circuit, power resistor R₁₂₈ can be fitted to drop the cathode voltage of V₁₀₁ to +350 V. Since it derates the regulation of the supply, this solution should not be adopted, however, if the amplifier is to work optimally. Moreover, the output filter capacitors could then be blown out owing to overvoltage if the valves were removed from their sockets, or if the preamplifier board was not, or not yet, connected to the supply. The TL783 is not very expensive and effectively prevents all this misery from happening.

The filament supply ($\pm U_f$) is arranged to "float" at about +90 V with respect to ground with the aid of voltage divider R₁₃₀–R₁₃₁–C₁₃₂. This ensures that the cathode-to-filament voltage of the upper triodes in the pre-

amplifier stages does not exceed the safe limit. The filament supply based around the Type LM317 regulator is adjustable with P₁₀₁ and features a "soft-start" facility (realized with R₁₃₄–C₁₃₄–T₁₀₁) to enable the valves to heat up gradually at power-on, thus extending the useful life of the emissive elements.

The +12 V & +13 V supply for the relay control circuitry is shown in the lower left-hand corner of Fig. 7. Note that the rectifier diodes have shunt capacitors to suppress noise, and that D₁₁₃ raises the common connection of IC₁₀₉ to about 1 V with respect to ground in order to obtain a sufficiently high relay coil voltage from the 7812 regulator.

Relay control

The relays on the source selector board are controlled by the logic circuit shown in Fig. 7. When the power is first switched on, the LINE OUT relay (REr) is energized after a slight delay, but it is deactivated immediately when the preamplifier is switched off. To ensure noise-free switching operation of the preamplifier, the LINE OUT relay is briefly deactivated if either the TAPE-MONITOR or the SOURCE SELECT switch is operated.

With reference to Fig. 7, the logic configuration at the contacts of S₂ is inverted by gates N₁₀₅–N₁₀₈ and applied to 4-bit comparator IC₁₀₆. The A = B output of this chip is high whenever the two nibbles at the A₀–A₃ and B₀–B₃ inputs are equal. Delay networks R₁₁₇–C₁₁₄, R₁₁₈–C₁₁₅, R₁₁₉–C₁₁₆ and R₁₂₀–C₁₁₇ cause the B nibble to differ very briefly from the A one when S₂ is turned to select another source input for the preamplifier. The negative pulse at the A = B output of IC₁₀₆ triggers monostable multi-vibrators MMV₁₀₁ and MMV₁₀₂, which are configured to pro-

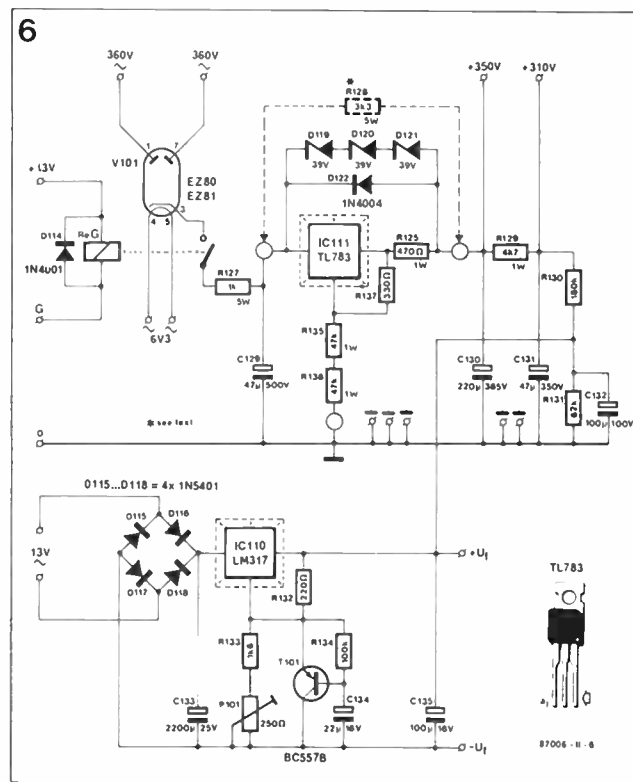

Fig. 6. Circuit diagram of the HV and filament supply.

vide a delay of 0.5 and 1 second, respectively. Monostable MMV₁₀₁ disables the selected relay via the relevant NOR gate N₁₀₁-N₁₀₄, while MMV₁₀₂ disables the LINE OUTPUT relay via N₁₂₃-N₁₁₀-N₁₁₅. When the delay caused by MMV₁₀₁ has lapsed, the newly selected input signal is connected to the preamplifier input via the relevant relay contact. Similarly, the line output connection is restored when the delay caused by MMV₁₀₂ has lapsed. When TAPE/MONITOR switch S₁ is closed, a positive pulse is generated with the aid of N₁₀₉, delay network R₁₂₁-C₁₁₈, and NAND gates N₁₁₈-N₁₂₁. This pulse triggers MMV₁₀₂ so that the LINE OUT relay REr is deactivated. After a delay caused by R₁₂₄-C₁₂₁, TAPE/MONITOR relay REr is energized. The line output relay is re-energized after the delay caused by MMV₁₀₂ has lapsed. During the above operation, the source selection and TAPE OUT connections are not broken.

The LINE OUT relay can not be activated before N₁₂₃ is enabled with the aid of the Q signal from FF₁₀₁, which forms part of the power-on delay and failure detection circuit. Binary counter IC₁₁₂ controls two timing sequences. After a delay of about half a minute, output Q₁₀ switches on the high voltage with the aid of relay G. After another 30 seconds, output Q of FF₁₀₁ enables N₁₂₃ to activate the LINE OUT relay. The binary counter is clocked by its internal oscillator, whose frequency is determined with R₁₀₁-C₁₁₀. Schmitt-trigger gate N₁₂₅ provides a power-up delay for the relay control circuitry, in order to ensure the correct initial logic states of IC₁₁₂, FF₁₀₁ and FF₁₀₂. Gate N₁₂₄ makes it possible to control the LINE OUT relay by an optional failure detection circuit, which should provide a logic low level at the ERR input in response to a direct voltage component or excessive noise at the (pre-

amplifier output. There are two ways of restoring the LINE OUT connection to the power amplifier: either RSTA is made logic high by, for instance, pressing a push button connected to this input, or RSTB is similarly made logic low. The latter operation causes the previously detailed power-up cycle for the high voltage to be restarted before REr is re-energized.

Construction

Before commencing the fitting of parts onto the supply and relay control board, this may have to be cut to suit a particular arrangement in the pre-amplifier enclosure. The track layout and component mounting plan for each section of the board are shown in Fig. 8 (power supply) and Fig. 9 (relay control circuitry).

The high voltage supply

To allow for adequate heat dissipation, all power resistors on

the supply board must be fitted slightly off the circuit board. Filament voltage regulator IC₁₁₀ is fitted onto two heatsinks clamped back to back. The high voltage regulator, IC₁₁₁, needs only one heatsink, which must none the less be adequately sized.

Should electrolytic capacitor C₁₂₉ prove hard to obtain in the stated voltage rating, it is possible to replace it with two series connected 100 μF; 250 V types, each fitted with a 470K; 1W shunt resistor for equal voltage distribution. The circuit board should allow plenty of space to accommodate these additional parts.

The use of the stabilization circuit with IC₁₁₀ requires the voltage across C₁₂₉ to be no more than 450 V, and no less than 400 V. Series resistor R₁₂₇ may have to be adapted to stay within these limits. If it is dimensioned for an output in the region of 400 to 420 V, it becomes possible to use a 450 V rated capacitor in the C₁₂₉

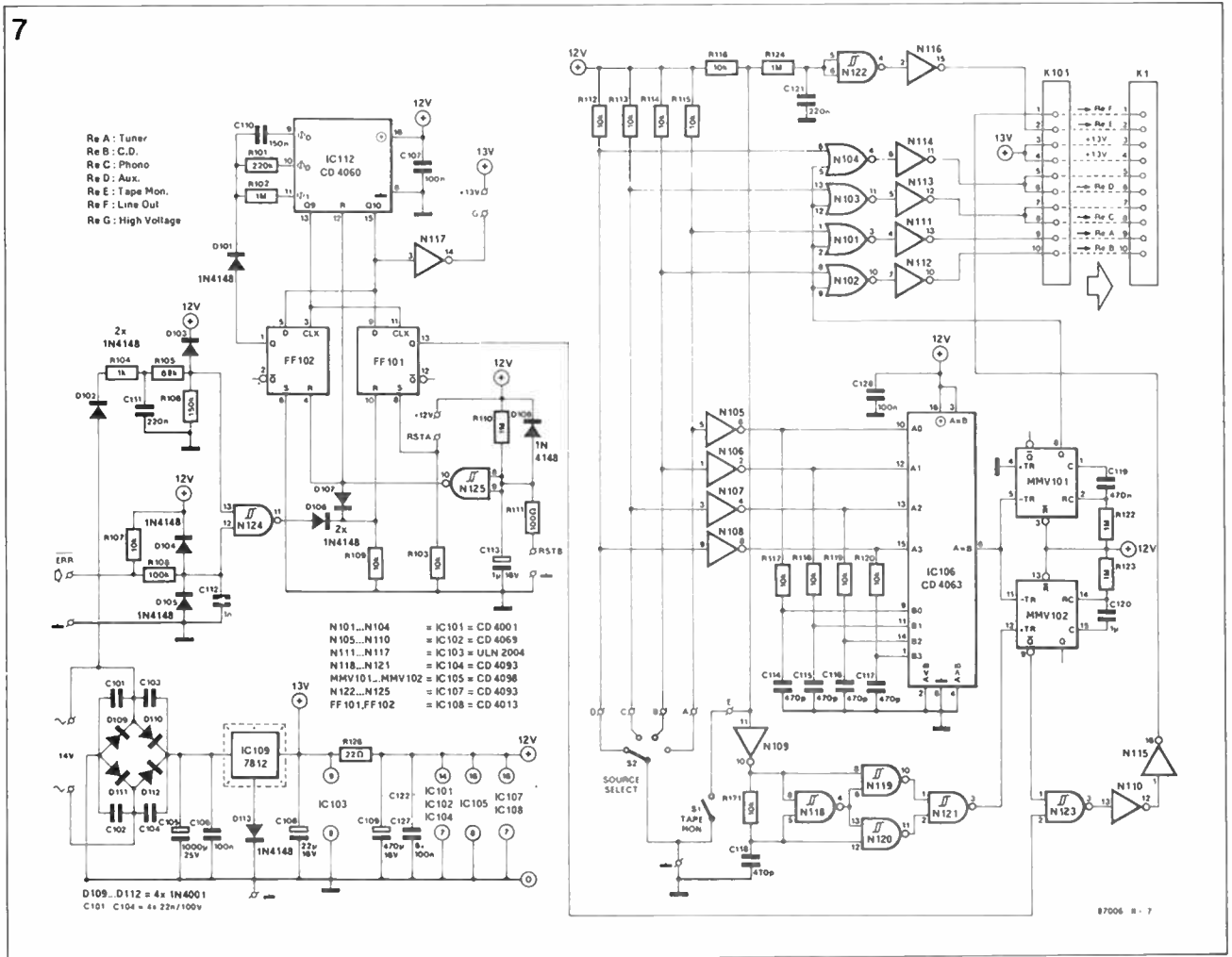

Fig. 7. Circuit diagram of the relay control circuitry.

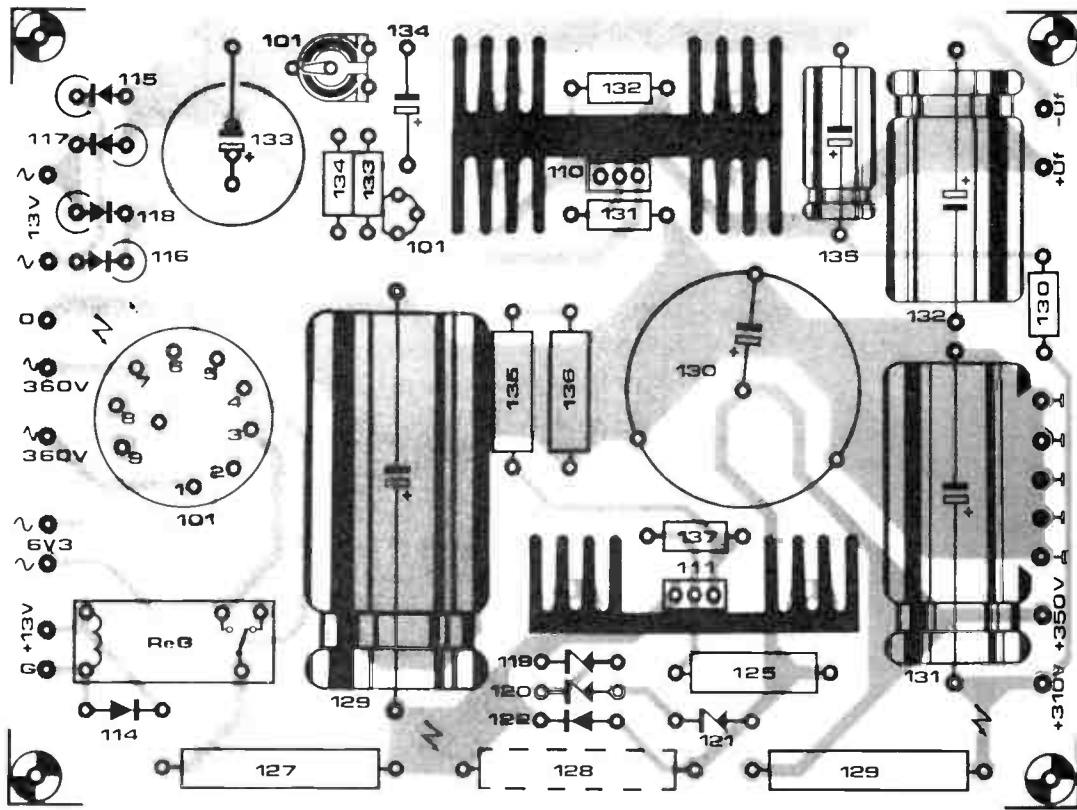

Fig. 8. The printed circuit board for the power supply.

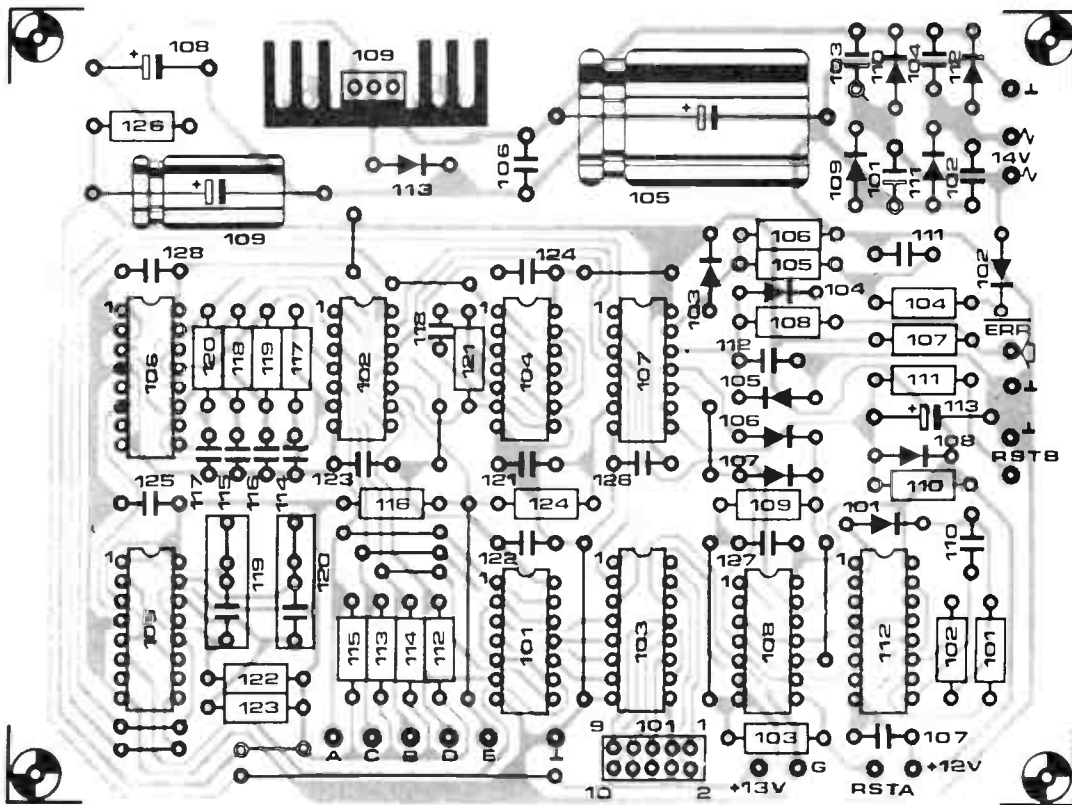

Fig. 9. The printed circuit board for the relay controller.

10

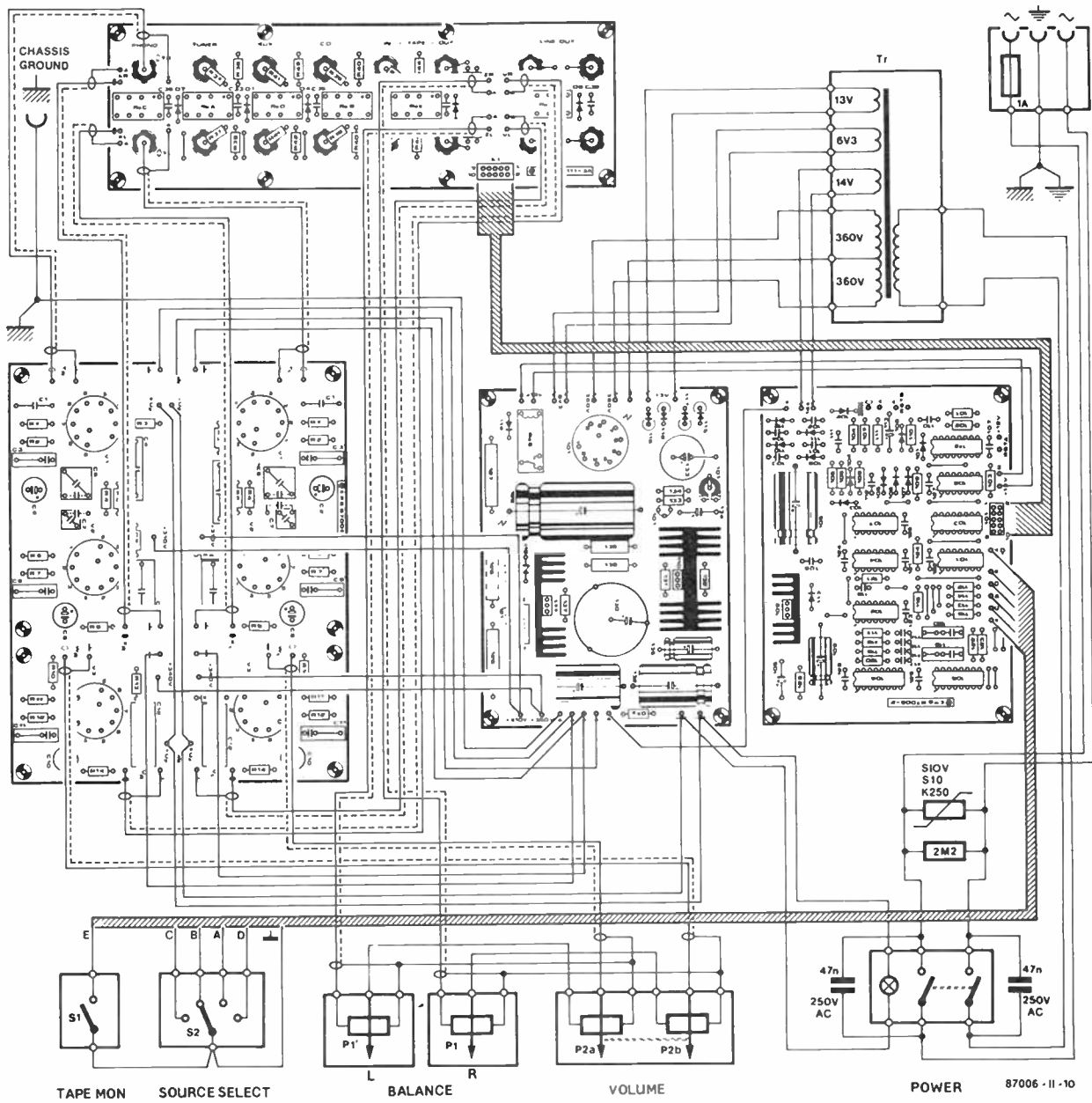

Fig. 10. Wiring diagram for the valve preamplifier.

11

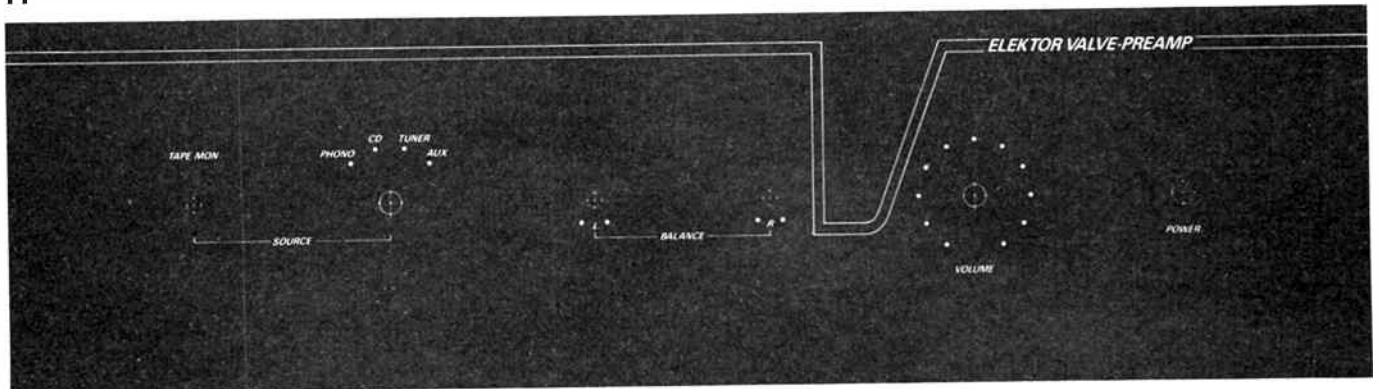

Fig. 11. Suggested front panel layout.

Parts list

Power supply board

Resistors: ($\pm 5\%$)

R₁₂₇ = 1K0; 5 W *
R₁₂₈ = 3k3; 5 W *
R₁₂₉ = 4K7; 1 W *
R₁₃₀ = 180K
R₁₃₁ = 62K
R₁₃₂ = 220R
R₁₃₃ = 1K8
R₁₃₄ = 100K
R_{135; R136} = 47K; 1 W
R₁₃₇ = 330R
R₁₃₈ = 470R; 1 W
P₁₀₁ = 250R preset

Capacitors:

C₁₂₀ = 47 μ ; 500 V axial *
C₁₃₀ = 220 μ ; 385 V can-type radial
C₁₃₁ = 47 μ ; 350 V axial
C₁₃₂ = 100 μ ; 100 V axial
C₁₃₃ = 2200 μ ; 25 V radial
C₁₃₄ = 22 μ ; 16 V axial
C₁₃₅ = 100 μ ; 16 V axial

Semiconductors:

D₁₁₄ = 1N4001
D₁₁₅...D₁₁₈ incl. = 1N5401
D_{119; D120; D121} = zenerdiode 39 V;
0.4 W
D₁₂₂ = 1N4004
T₁₀₁ = BC557B
IC₁₁₀ = LM317
IC₁₁₁ = TL783 or 783

Valve:

EZ80 or EZ81 with 9-pin socket for PCB mounting

Miscellaneous:

Heat-sinks for IC₁₁₀; IC₁₁₁ (see component overlay).
Reg = PCB-mount relay; single contact, e.g. Siemens V23127-E0002-A101 (12 V).
PCB Type 87006-2 (cut as required).

Supply parts not on this board:

2 capacitors, 47n; 250 Vrms.
resistor 2M2; 1 W.
varistor Type S10K250 (Siemens).
Mains transformer: 2 \times 360 V;
60 mA, 6.3 V; 1 A, 13 V; 1.5 A,
14 V; 1 A.

Mains entrance socket with built-in fuseholder.
Double-pole illuminated mains switch.

Parts list

Relay Control board

Resistors: ($\pm 5\%$)

R₁₀₁ = 220K
R_{102; R110; R122}...R₁₂₄ incl. = 1M0
R_{103; R107; R109; R112}...R₁₂₁
incl. = 10K
R₁₀₄ = 1K0
R₁₀₅ = 68K
R₁₀₆ = 150K
R₁₀₈ = 100K
R₁₁₁ = 100R
R₁₂₅ = 22R

Capacitors:

C₁₀₁...C₁₀₄ incl. = 22n; 100 V
C₁₀₅ = 1000 μ ; 25 V axial
C_{106; C107; C122}...C₁₂₆ incl. = 100n
C₁₀₈ = 22 μ ; 16 V axial
C₁₀₉ = 470 μ ; 16 V axial
C₁₁₀ = 150n
C_{111; C121} = 220n
C₁₁₂ = 1n
C₁₁₃ = 1 μ ; 16 V axial electrolytic
C₁₁₄...C₁₁₆ incl. = 470p ceramic
C₁₁₉ = 470n
C₁₂₀ = 1 μ ; polyester/
polycarbonate/MKT

Semiconductors:

D₁₀₁...D₁₀₈ incl.; D₁₁₃ = 1N4148
D₁₀₉...D₁₁₂ incl. = 1N4001
IC₁₀₁ = 4001
IC₁₀₂ = 4069
IC₁₀₃ = ULN2004
IC_{104; IC107} = 4093
IC₁₀₅ = 4098
IC₁₀₆ = 4063
IC₁₀₈ = 4013
IC₁₀₉ = 7812
IC₁₁₂ = 4060

Miscellaneous:

Heat-sink for IC₁₀₆.
Push-to-make switch for RSTA & RSTB (option).
S₁ = miniature SPST.
S₂ = 4-way rotary switch; single pole.

See our
**PROJECT
BUYERS
GUIDE** this
issue for a
guide to
component
sources and
kit suppliers.

position. Whatever type of capacitor is used, however, it should be safely rated above the maximum expectable voltage, including the effects of increased ripple and mains fluctuations.

If a valve-less power supply is required, the EZ80 or EZ81 (V₁₀₁) may be replaced by two silicon diodes Type 1N4007, whose cathodes are joined and connected to socket pin 3, while the anode of one diode goes to pin 1, the other to pin 7. Note that R₁₂₇ may have to be increased to compensate for the ensuing lower voltage drop across the rectifier.

When the power supply board is completed, it can be tested by applying the relevant alternating voltages from the transformer. The high voltage relay REG can be energized with the aid of an external 13 V supply some 30 seconds after applying power to the mains transformer.

As various parts in the power supply are at a dangerously high potential, it is strongly recommended to keep one hand in your pocket while measuring any voltage in the

circuit. Never touch any component while the power is on, and make sure the HV smoothing capacitors are completely discharged before working on the board.

Use a well-insulated 10K; 5 W resistor to discharge the high voltage capacitors before commencing work on the supply board.

The filament supply

The filament supply voltage for the valves on the preamplifier board must not exceed 12.6 V. It may be a good idea to set P₁₀₁ for a supply output voltage of 12.0 V to extend the useful life of the filaments. Remember that the +U_r and -U_r rails are at about +90 V with respect to ground, and, therefore, possibly dangerous to touch.

The relay control circuitry

The circuit board for the relay control section is shown in Fig. 9. With the parts list and its component overlay to hand, its completion is straightforward. Fit regulator IC₁₀₉ with a fairly large heatsink to handle the dissipation. Do not forget any of

- to page 50.

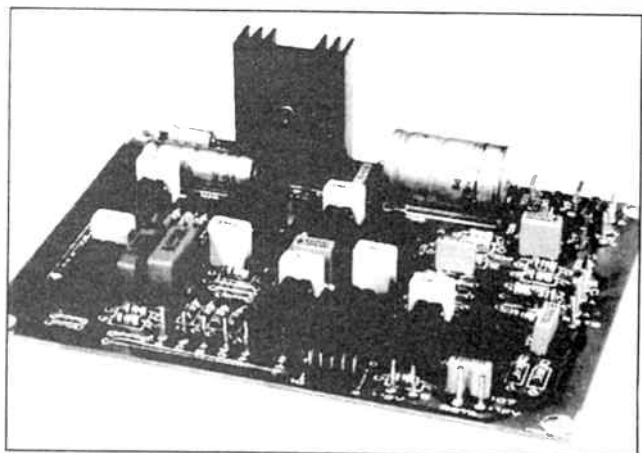
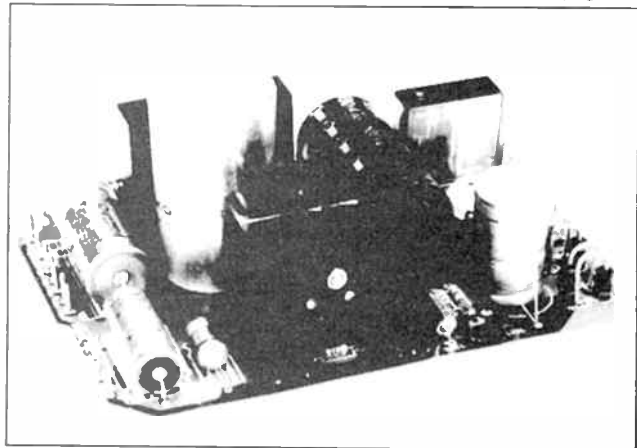

The completed supply and relay control boards.

FACSIMILE INTERFACE

by W A L Passchier

A multi-standard fax converter that is easy to build and set up, for reliable use in conjunction with any good quality SW receiver, a BBC or C64 computer, and an Epson compatible printer.

Facsimile—or fax for short—is a communication technique whereby graphic information is converted into electrical signals for transmission to a receiver which, ideally, reproduces a hard copy printout of the original. Facsimile stations can be received on the short-wave bands, and are intended primarily for the transmission of weather charts (meteorological services), press photographs, and handwritten messages.

A facsimile receiver is traditionally a rather complex electromechanical apparatus which does not lend itself to DIY construction. Numerous radio amateurs, however, are the proud owners of Creed, Muirhead, or Siemens facsimile chassis obtained from surplus outlets at a fraction of the original price. These machines are not generally difficult to modify for amateur use, but remain fairly cumbersome to handle devices when compared with the more recently introduced computer-based versions.

The electromechanical facsimile receiver is generally based on the recording of the received image either on electrolytic or on photosensitive paper, secured on the outer surface of a revolving drum. When electrolytic paper is used, intensity-modulated current is fed to a metal stylus which transfers the image onto the paper. The photosensitive method is essentially identical, but uses a combination of a lamp, an aperture, and a lens to illuminate the spots that make up the received picture. The intensity of the light beam, or the current fed to the stylus, determines the density of the individual pixels, giving the necessary picture definition.

Facsimile signals are mostly transmitted as a frequency shift keying signal (FSK; denotation F4), similar to cassette-based data storage and retrieval available on many home com-

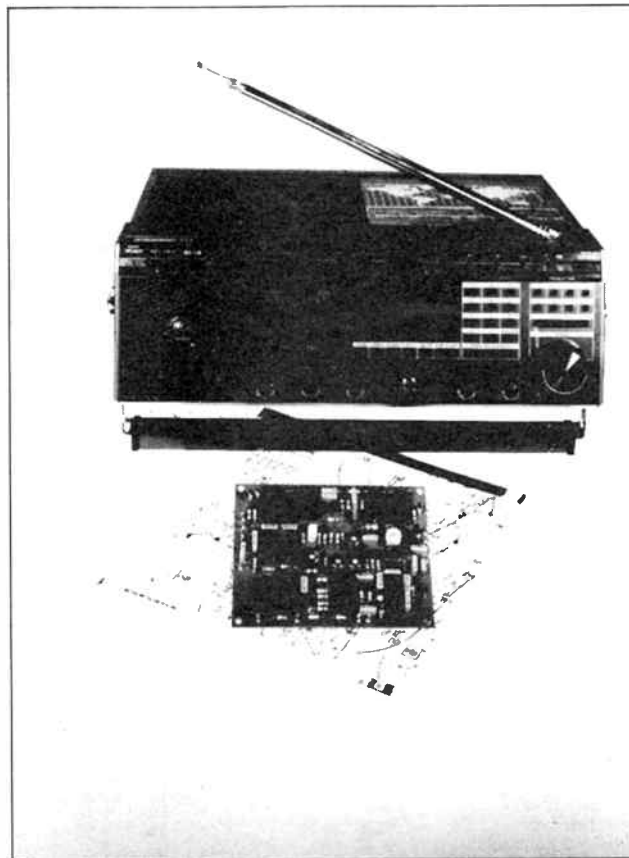

Facsimile interface

Features:

- Crystal-controlled sync circuit for reception of 1, 2 and 4 Hz services.
- Immediate hard copy production on a graphics compatible printer.
- Fast software for BBC and C64 computers.
- Simple interfacing to userport (BBC) or expansion port (C64).
- Sensitive input (250 mV_{pp} min.)
- Cassette recorder interface for separate recording of SYNC pulses and composite facsimile.
- Auto-sync and picture adjustment controls enable reception from any fax track onwards.

puters. The centre frequency is usually 1900 Hz, and white and black correspond to a frequency shift of +400 Hz and -400 Hz, respectively. At the receiver side, a sheet of paper is secured onto a drum with a standard diameter of 152 mm and a minimum length of 550 mm. A worm drive and

clutch assembly are used in conjunction with a precision electric motor to make the drum revolve at 120 revolutions per minute. Prior to the reception of a new picture, the system is synchronized with the aid of a number of black lines with an initial white period, as will be seen below.

After every complete revolution of the drum, this is arranged to move laterally for the recording of the next vertical track. Apart from 120 rev/min stations, there are also services that operate at other multiples of 60, e.g., 60 rev/min and 240 rev/min. By convention, a fax station is, therefore, often referred to as a 1, 2, or 4 Hz service.

The size of the picture elements recorded on paper is usually of the order of 0.1 to 0.2 mm, whence the use of precision-made mechanical parts in fax machines.

The facsimile picture shown in Fig. 1 is purposely printed as it would have been positioned on the scanning drum of a conventional, electromechanical fax machine. The writing of the weather chart proper commences on completion of a number of drum revolutions during which the black lines with initial white portions are written—see the black bar with the white block in the top left-hand corner of the picture. The correct horizontal aspect of the picture as it is written onto the paper is ensured only when the transmitter and the receiver operate at the same, or very nearly the same, clock frequency. If the receiver clock operates at a fixed offset with respect to that used in the transmitter, vertical lines will appear to slant, causing the picture to become confused and distorted.

The interface proposed in this article is based on the use of a computer and a graphics-compatible printer to produce facsimile pictures. Pixel data is read and loaded into a RAM buffer on reception of a "drum advance" pulse (or rather *line feed* in the electronic version), which is derived from the interface clock. Eight fax lines are loaded to form a string of data that can be printed horizontally by a printer set to operate in the *dot image mode*.

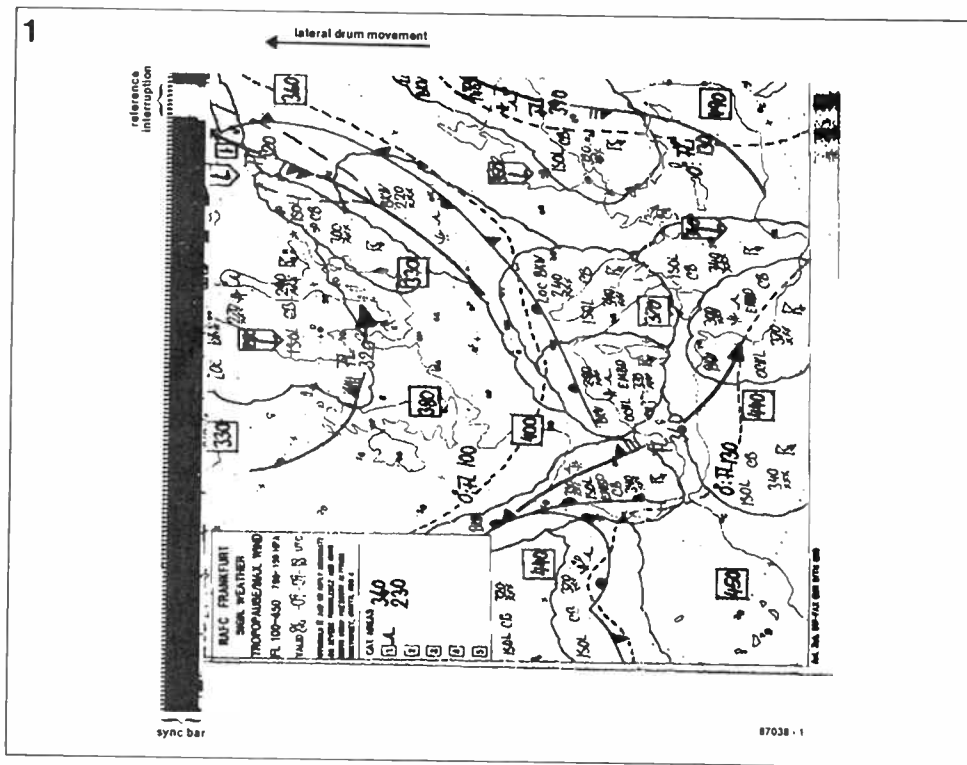

Fig. 1. Example of a weather chart taken from the drum of a facsimile receiver.

The circuit is versatile—it can handle signals from 1, 2 and 4 Hz stations—as well as simple to construct from commonly available parts.

Circuit description

Figure 2 shows the circuit diagram of the interface, which translates the fax signal from an SSB receiver into pulses that can be processed in a computer system.

Timebase.

The central clock signal is obtained with crystal-controlled oscillator/divider IC₁ and the modulo-10 dividers in IC₂. Switch section S_{1a} selects the signal from IC₁ output Q₆ (102,400 Hz), Q₅ (204,800 Hz), or Q₄ (409,600 Hz) for proper synchronization with 1 Hz, 2 Hz, or 4 Hz stations, respectively. The signal at the pole is divided by 100 in IC₂, and made suitable for recording as a sync track on a tape or cassette recorder with

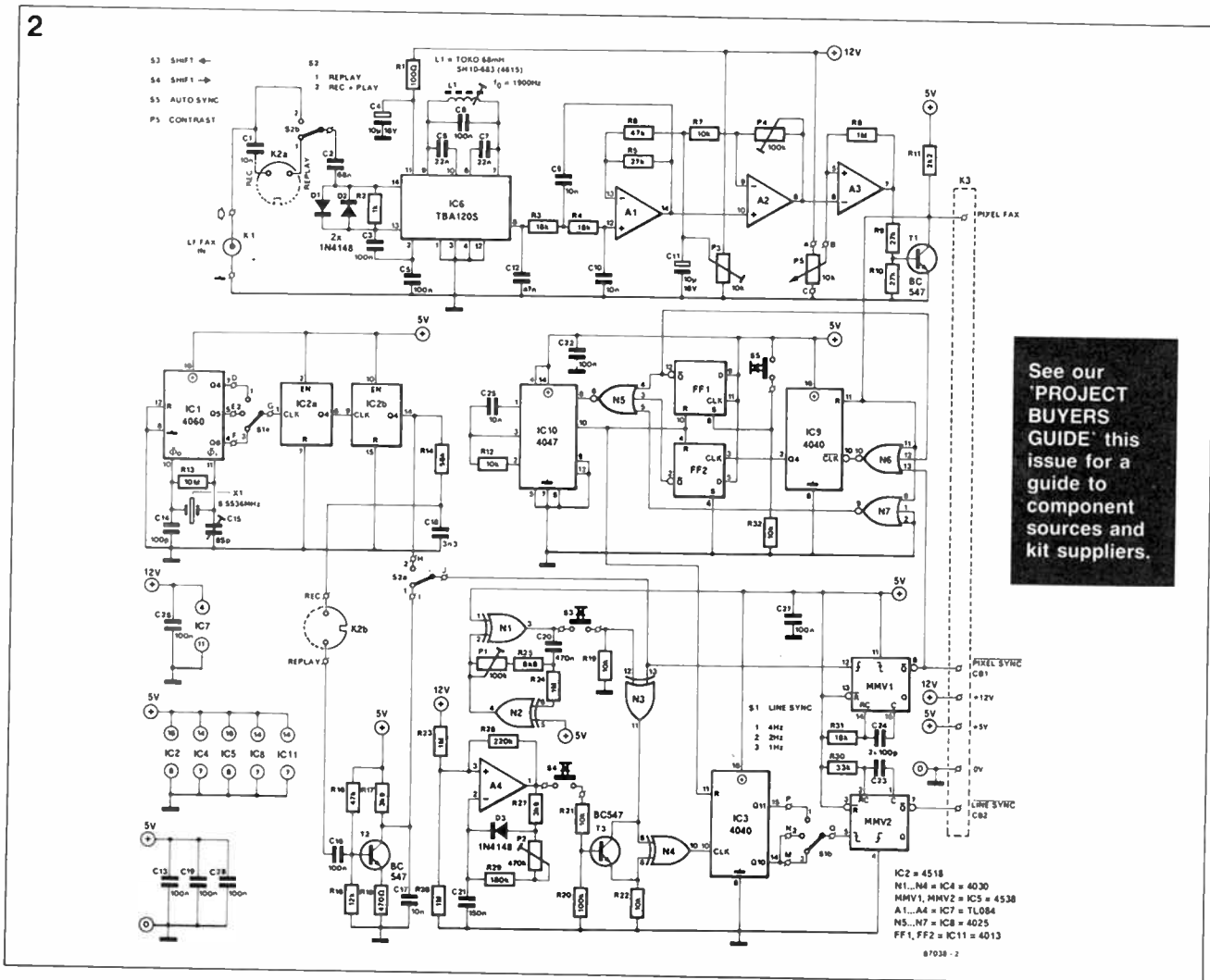

See our 'PROJECT BUYERS GUIDE' this issue for a guide to component sources and kit suppliers.

Fig. 2. Circuit diagram of the facsimile interface.

Parts list

Resistors ($\pm 5\%$):

R₁ = 100R
 R₂ = 1K0
 R₃; R₄; R₃₁ = 18K
 R₅; R₉; R₁₀ = 27K
 R₆; R₁₅ = 47K
 R₇; R₁₂; R₁₉; R₂₁; R₂₂; R₃₂ = 10K
 R₈; R₂₃; R₂₄; R₂₈ = 1M0
 R₁₁ = 2K2
 R₁₃ = 10M
 R₁₄ = 56K
 R₁₆ = 12K
 R₁₇; R₂₇ = 3K9
 R₁₈ = 470R
 R₂₀ = 100K
 R₂₅ = 6K8
 R₂₆ = 220K
 R₂₉ = 180K
 R₃₀ = 33K
 P₁; P₂ = 100K preset
 P₂ = 470K preset
 P₃ = 10K preset
 P₅ = 10K linear potentiometer

Capacitors:

C₁; C₉; C₁₀; C₁₇; C₂₅ = 10n
 C₂ = 68n
 C₃; C₅; C₈; C₁₃; C₁₆; C₁₉; C₂₂; C₂₆; C₂₇;
 C₂₈ = 100n
 C₄; C₁₁ = 10 μ ; 16 V
 C₆; C₇ = 22n
 C₁₂ = 47n
 C₁₄; C₂₃; C₂₄ = 100p ceramic
 C₁₅ = 65p trimmer
 C₁₈ = 3n3
 C₂₀ = 470n
 C₂₁ = 150n

Inductor:

L₁ = SM10-683 (4615) 68 mH variable inductor

Semiconductors:

D₁; D₂; D₃ = 1N4148
 IC₁ = 4060
 IC₂ = 4518
 IC₃; IC₉ = 4040
 IC₄ = 4030
 IC₅ = 4538
 IC₆ = TBA120S
 IC₇ = TL084
 IC₈ = 4025
 IC₁₀ = 4047
 IC₁₁ = 4013
 T₁; T₂; T₃ = BC547

Miscellaneous:

S₁ = 2-pole 3-way rotary switch.
 S₂ = miniature DPDT switch.
 S₃; S₄; S₅ = push-to-make button.
 X₁ = 6.5536 MHz quartz crystal.
 PC board Type 87038 (see Readers Services).
 C64 interface as per Fig. 3 (if required).
 K₁ = 6.3 mm socket for jack plug.
 K₂ = 5-way DIN socket.
 K₃ = 7- or 9-way DIN socket.
 (Note: the stated sockets are suggested types).
 Suitable metal enclosure.

the aid of network R₁₃-C₁₈. Whether the system sync pulses originate from the internal clock, or from the cassette REPLAY interface set up around T₂, they can be "speeded up" or "slowed down" by pressing S₃ or S₄, respectively. When S₅ is closed, N₃ receives an additional clock signal from the oscillator based around N₁-N₂. As N₃ is an XOR gate, its output frequency is then higher than that of the system clock, and hence IC₃ is clocked at a higher

rate, causing the LINE SYNC pulse to come sooner than normal. Therefore, the pressing of S₃ forces the picture to shift to the left; this is useful when tuning in to a picture whose sync bar has already been transmitted. The amount of correction can be set with P₁. When S₅ is closed, T₃ temporarily connects the inputs of XOR gate N₄, so that clock pulses from N₃ can not advance counter IC₃. Hence the LINE SYNC pulse from MMV₂

is delayed, causing the picture to shift to the right. Preset P₂ controls the amount of rightward correction.

Depending on the position of S_{2a}, either the sync pulses from the REPLAY interface, or those from the internal clock section, trigger monostable multivibrator MMV₁, which outputs the PIXEL SYNC pulses that have a period determined with R₃₁-C₂₄. The PIXEL SYNC signal is used to flag the presence of valid pixel data for the com-

3

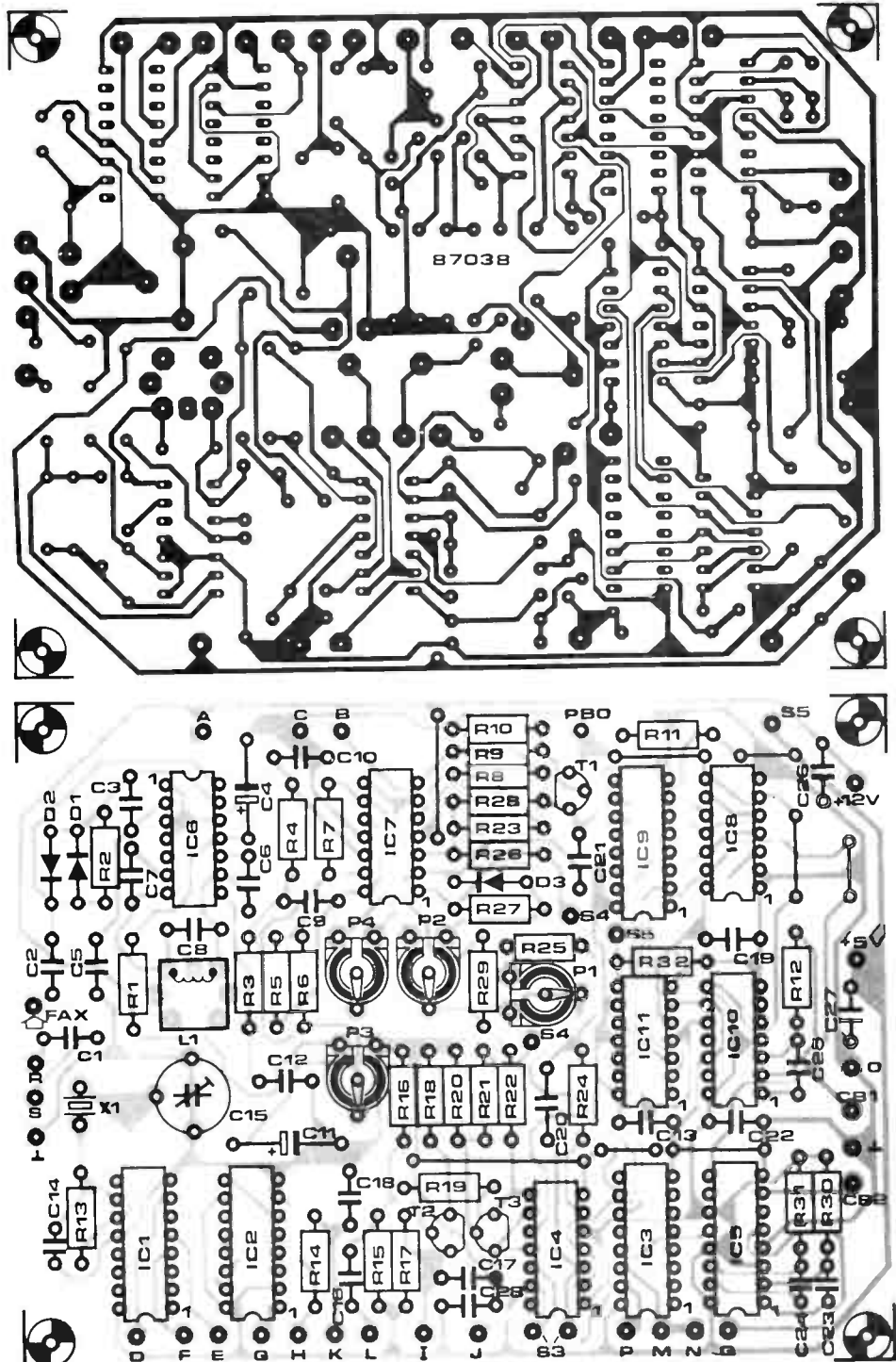

Fig. 3. Track layout and component mounting plan for the FAX interface.

puter to read from the PB0 line. This ensures the correct compilation of pixel data for the printing of one 8-bit wide line on the printer.

Automatic synchronization circuit.

The RESET input of counter IC₂ is driven with a signal obtained from an automatic sync generator composed of IC₁, N₅, FF₁ & FF₂, IC₉, and N₆-N₇. Depression of S₅ forces resetting of IC₂ to generate a LINE SYNC pulse when the transmission of the picture commences; after some practising, you will be able to hear when this happens by carefully listening to the receiver's AF signal. When S₅ is open, the circuit detects the prolonged absence of pixel data during the writing of the black vertical lines to the left of every picture. The white interruption at the beginning of every black track, however, is recognized as the absence of pixel data during 32 clock pulses. For the auto-sync circuit to produce a LF pulse, it must detect 32 successive white pixels, i.e., noise and spurious pulses can not cause erroneous synchronization.

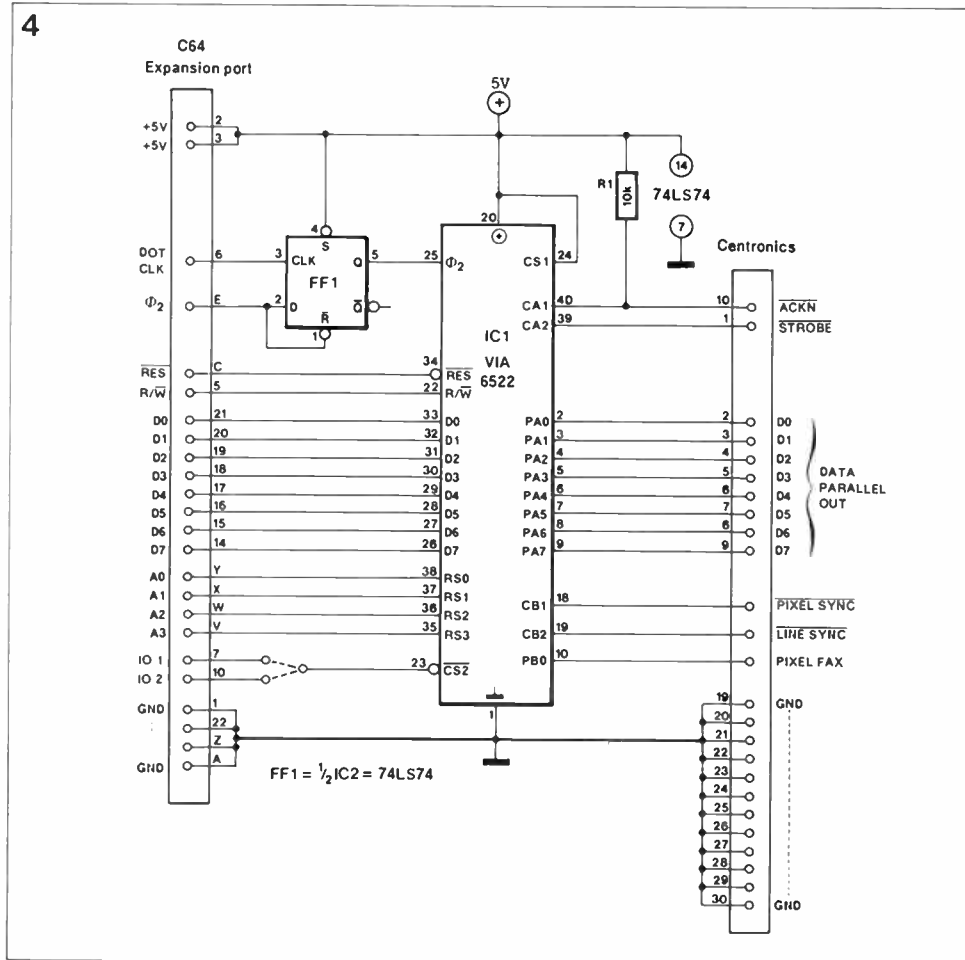

Fig. 4. Construct this interface circuit if you have a Commodore C64 computer.

Tone decoder.

The fax signal from the SSB (single side band) receiver, or the cassette recorder, is applied to quadrature FM demodulator IC₆, the well-known Type TBA120S. This demodulator is tuned to a centre frequency of 1900 Hz with C₅ and variable inductor L₁. The raw fax signal from the demodulator is cleaned and shaped with the aid of a 47 nF capacitor, C₁₂, and active low-pass filter A₁, set up as a second-order Butterworth section. Besides faithfully removing noise and spurious signals from the facsimile information, the active filter has an additional advantage in that it produces a certain amount of overshoot that is useful for raising the contrast level of the needle-shaped pulses. Opamp A₂ is a simple amplifier with presettable gain, and A₃ is the pulse shaper that decides between the black and white signal levels. The pixelfax data for the computer port line is output by level translator T₁. A power supply is not included in this design, but we are confi-

dent that the omission will not present insurmountable problems. A suitable supply can be a very conventional circuit set up to deliver 12 V and 5 V at output currents of the order of several tens of milli-amperes; a Type 7812 and 7805 voltage regulator fed from a common mains transformer will do adequately in this case, while you may also consider taking the +5 V and +12 V from the computer's built-in supply, as suggested in the circuit diagram.

Construction and setting up

The use of ready-made circuit board Type 87038 makes the construction of this fax interface largely a matter of routine; simply fit all the parts as shown in Fig. 3. There are no special precautions for the completion of the interface board, as this holds standard components only. However do not forget to install all eight wire links on the board, as these are easily

overlooked due to the white overlay lines that indicate the position. Fit the interface board in a metal enclosure and use whatever sockets and mating plugs you think suitable for the connections to the receiver and the computer.

For the setting up of the interface you need a good quality SSB receiver tuned to a strong facsimile station. Alternatively, you may find the use of recorded data available from cassette more convenient; drive the interface from the cassette recorder's external loudspeaker or earphone outlet by connecting this to K₁. Later on, you will be able to use K₂ for recording and playing back of the data and sync, recorded separately on the left and right track of the tape.

Set P₃ and P₅ to the centre of their travel, and P₄ for minimum amplification (wiper turned fully towards R₆). Presets P₁ and P₂ are adjusted to personal preference, and can be set to mid-travel initially.

Trimmer capacitor C₁₅ is adjusted until the vertical lines on

the hard copy page run straight; a slanting line indicates that the clock frequency needs further adjustment. For a precise setting of the demodulator centre frequency, apply a 1600 Hz sine wave to the interface, and measure the direct voltage at the output of A₂. Turn the core in L₁ to find the adjustments that give a maximum and a minimum value on the voltmeter, then carefully turn the core back to obtain a reading that lies exactly in between the previously noted extremes. Now adjust P₃ and P₄ to set the extremes to 4 and 8 V, and redo the adjustment of L₁.

At the computer side

Machine language routines have been developed to enable the use of the fax interface with either a BBC or C64 computer. The programs essentially accumulate data in a buffer and redirect this to the printer. The connection to the BBC computer is extremely straightforward by making use of the built-in user port. The Com-

```

LIST
10*KEY07&71=0:MRUN:M
15*KEY17&71=1:MRUN:M
20*KEY100=M
250*8&F IFO=&78THEMGOTO100
30VDU22,7 PRINTTAB(2,5)CHR$129"0"CHR$135,
31PRINT" start program in normal mode"TAB(2,7)CHR$129"1"CHR$135.
32PRINT" start program in inverse mode"TAB(2,13).
33PRINT" halt program with +BREAK:"TAB(25,20)+RETURN:".
34REPEAT-CET UNTILC.13 7&71=0 GOTO100
35
40 (C) ELEKTOR 30 June 1986
45
50 connect pixelsync to CB1
52 connect linesync to CB2
53 connect pixelfax to PB0
60
70 Facsimile decoding routine for 1 & 2 Hz stations
90
100DDRA = &FE63
110DDRB = &FE62
120PA = &FE61
130PB = &FE60
140ACR = &FE6B
150PCR = &FE6C
160INFR = &FE60
170IER = &FE6E
180BUFF = &FF00
190
200MODE7 HIMEM=&7000
205REM OF MODE 3
206REM OF MODE 7 HIMEM = &8000
210DIM MCT 600
220FOR QT=0 TO 2 STEP 2
230M-MCT
240
245OPT OR
250 BEGIN SEI
260 LDA #&70 STA &8F \ clear printerbuffer
270 LDA #&00 STA &8E
280 TAY
290 LDX #&78
300 AA STA (&8F).Y
310 INY
320 BNE AA
330 INC &8F
340 CPX &8F
350 BNE AA
370 STA POINT1:1 \ initialisation
380 STA POINT2:1
381 LDA #&70 STA &73 \ default
382 LDA #&76 STA &74
384 LDA #&7A STA &75
386 LDA #&7B STA &76
390\
400 LDA #&00 STA DDRB \ PB all input
410 LDA #&FF STA DDRA \ PA all output , print
420 LDA #&00 STA PCR \ CB2 IN L independent , CB1 IN L
430 \ CA2 OUT handshake , CA2 IN L
440 LDA #&03 STA ACR \ PB latch en , PA latch en
450 LDA #&FF STA IER \ BIT 7 set with INT
460 LDA #&1B JSR PRINT
470 LDA #&41 JSR PRINT
480 LDA #&08 JSR PRINT \ Linefeed 8/72 inch
495 LDA #&00 STA &72 \ Status printer, bit 7 set as busy
496\
500 LDA #&1B STA &703C STA &743C
510 LDA #&4C STA &703D STA &743D
520 LDA #&C0 STA &703E STA &743E \ double density
530 LDA #&03 STA &703F STA &743F \ 120 dots/in for 960 bytes
535\
540 SWAP ASL &72
550 BCC RESTR
555 JMP ERR
560 RESTR SEC \ ready for printing
570 ROR &72
580\
590 LDA &73 TAX LDA &74
600 STA &73 STA POINT1:2
610 STX &74 STA POINT2:2 \ swapped begin buffers
620\
630 LDA &75 TAX LDA &76
640 STA &75 STA &76 \ swapped end buffers
650\
660 LDX #&40 \ rotate ABS,X
670 LDY #&3C \ print ABS,Y
680 LDA #&0D STA PA \ force CR to set CA1
690 LDA #&08 STA &78 \ ready for 8 lines
695 LDA #&00 STA INFR \ clear CB2 , linesync
700\

```

Table 1. Facsimile decoding program for the BBC computer.

```

1 if peek(4+4096)=7#16+8then40
10 for i=16384 to 16673
20 reada:poke1,a
30 nexti
40 print chr$(147):" fax-decoder elektor c64"
50 print
60 print"this program can not be interrupted with";
70 print"the aid of the cb4 keyboard. ";
80 print
90 print"however switching the printer to offline";
100 print"will halt the program after some time.";
110 print"and return control to basic "
120 print
125 print
130 print"select between printing modes" print
140 print" normal (n)"
150 print" inverse(i)".print
160 print"enter your choice,please"
170 gata:if a$<"i" and a$<"n" then170
180 if a$="i" then poke5*16+8.255
190 if a$="n" then poke5*16+8.250
200 sys4+4096
32000 data120,169,112,133,143,169,0,133,142,168,162,120,145,142,200,208,251,230
32001 data143,228,143,208,245,141,215,64,141,251,64,169,112,133,90,169,116,133
32002 data91,169,116,133,92,169,120,133,93,169,0,141,2,222,169,255,141,3,222
32003 data169,8,141,12,222,169,3,141,11,222,169,255,141,14,222,169,27,32,18,65
32004 data169,65,32,18,65,169,8,32,18,65,169,0,133,89,169,27,141,60,112,141,60
32005 data16,169,76,141,61,112,141,61,116,169,192,141,62,112,141,62,116,169
32006 data3,141,63,112,141,63,116,6,89,144,3,76,29,65,50,102,89,165,90,170,165
32007 data91,133,90,141,216,64,134,91,142,252,64,165,92,170,165,93,133,92,134
32008 data93,162,64,160,60,169,13,141,1,222,169,8,133,87,169,8,141,13,222,173
32009 data13,222,41,8,240,249,169,125,141,13,222,173,13,222,173,94,42,144,248
32010 data165,94,41,16,208,9,165,94,41,2,208,39,76,185,64,173,216,64,197,92,208,211,198,87,240
32011 data62,0,120,232,208,221,238,216,64,173,216,64,197,92,208,211,198,87,240
32012 data143,165,90,141,216,64,162,64,76,173,64,6,89,144,193,102,89,185,0,112
32013 data141,1,222,200,208,182,238,252,64,173,252,64,197,93,208,172,6,89,76
32014 data185,64,141,1,222,173,13,222,41,2,240,249,96,88,108,2,160,25,65,173
32015 data25,65,205,118,0,208,162,14,114,0,76,205,64,141,1,222,173,13,222,41
32016 data2,240,249,96,88,0,88,96,76,130,64,0,0,0,0,0,0,0,0,0,0,0,0,0,0,0,0,0,0
ready.

```

Table 2. Facsimile decoding program for the C64 computer (not suitable for 4 Hz stations).

```

710 WAITNL LDA INFR
720 AND #&08 \ mask CB2 , linesync
730 BEQ WAITNL
740 LDA #&7D STA INFR \ clear flags except CA1
750\
760 FAST LDA INFR STA &80 ROL A
770 BCC FAST
780 LDA &80 AND #&10 \ mask CB1 pixel clock
790 BNE PIXEL
800 LDA &80 AND #&02 \ mask printer ready
820 BNE PBYTE
830 JMP FAST
840\
850 PIXEL LDA PB EOR &71 \ inv/ninv byte
860 LSR A
870 POINT1 ROL BUFF,X
880 INX
890 BNE FAST
900 INC POINT1:2 \ increment high byte pointer
910 LDA POINT1:2 CMP &75 \ end of buffer?
920 BNE FAST
930 DEC &70 BEO SWAP \ if 8 lines read
940 LDA &73 STA POINT1:2 \ else point to begin of buffer
950 LDX #&40 \ and restor X to &40
960 JMP WAITNL.
970\
980 PBYTE ASL &72 \ not if status 0
990 BCC FAST \ restore status
1000 ROR &72
1010 POINT2 LDA BUFF,Y
1020 STA PA \ print byte
1030 INY
1040 BNE FAST
1050 INC POINT2:2
1060 LDA POINT2:2 \ end of buffer?
1070 CMP &76
1080 BNE FAST \ finished printing buffer, status=0
1090 ASL &72
1100 JMP FAST
1100\
1190\
1200 PRINT STA PA
1210 READ LDA INFR AND #&02 \ mask CA1 , printer ready
1220 BEQ READ
1230 RTS
1240\
1250 ERR CLI
1260 BRK
1270 EQUB &FF \ error number
1280 EQUB "Printer overrun error"
1284 EQUB &0D&0A&0A&07
1287 EQUB "Please Press +BREAK"
1288 EQUB &0D&0A&0A&0A
1289 EQUB "Program halted"
1290 EQUB &00 \ close error string
1300\
1300 END CLI RTS
1400\
1410NEXT
1420PRINT""Facsimile decoder for 1 & 2 Hz stations"
1430CALL BEGIN
LIST /35.990
735 USE THIS ROUTINE FOR 4 Hz STATIONS
736 *****
740 RESET LDA #&7D STA INFR \ clear flags except CA1
750\
760 FAST LDA INFR AND #&10 \ mask CB1 pixel clock
770 BCC FAST
780 LDA PB EOR &71 \ inv/ninv byte
800 LSR A
870 POINT1 ROL BUFF,X
880 INX
890 BNE FAST
900 INC POINT1:2 \ increment high byte pointer
910 LDA POINT1:2 CMP &75 \ end of buffer?
920 BNE FAST
930 DEC &70 BEO SWAP \ if 8 lines read
940 LDA &73 STA POINT1:2 \ else point to begin of buffer
950 LDX #&40 \ and restor X to &40
960 PBYTE LDA INFR STA &80 AND #&08 \ mask ML
970 BNE RESET AND #&02 \ mask printer ready
975 BEO PBYTE
980 ASL &72
990 BCC WAITNL \ not if status=0

```

modore C64, however, requires an extension port interface as shown in Fig. 4. This circuit is so simple that it is readily constructed on a piece of prototyping board, connected to the computer by a short length of flat ribbon cable terminated with an expansion port connector.

The software for the BBC micro is an assembler-in-BASIC program listed in Table 1, while that for the C64 appears in Table 2, and makes use of machine language POKEd into the memory and called up with a SYS command. Both programs can only be halted with a general system reset; on the BBC the program is automatically restarted with an OLD command, on the C64 it is erased from the memory, and must be reloaded from tape or disk. Reception of 4 Hz stations is not possible when the C64 computer is used.

| Table 3 | | | | |
|--|----------|--------------------------|--------|-----------------|
| Facsimile stations | | | | |
| Frequency [kHz] | Callsign | Operating hours (GMT) | Mode | Note(s) |
| Bracknell, England (2 Hz) | | | | |
| 2618.5 | GFE 25 | 21.00 | WX | |
| 3289.5 | GFA 21 | 00.00-24.00 | WX | APT 09.00-12.00 |
| 4610.0 | GFA 22 | 18.00 | WX | GFA 21 slave |
| 4782.0 | GFE 21 | 00.00-24.00 | WX | APT 09.00-12.00 |
| Mainflingen, Federal Germany (2 Hz & 4 Hz) | | | | |
| 117.4 | DCF 37 | 00.00-24.00 | WX | |
| 134.2 | DCF 54 | 00.00-24.00 | WX/MET | |
| Paris, France (2 Hz) | | | | |
| 8185.0 | FZE 82 | 00.00-24.00 | WX | special format |
| 4047.5 | FTE 4 | 20.00 | WX | FZE 82 slave |
| 12305.0 | FTM 30 | | WX | |
| Moskow, USSR (1 Hz) | | | | |
| 5355.0 | RND 77 | 18.00 | WX | |
| 7750.0 | RAW 78 | 16.00-23.00 | WX | |
| 15950.0 | RBI 77 | 10.00-21.00 | WX | |
| Frankfurt, Federal Germany (2 Hz) | | | | |
| 139.0 | DCF 39 | 10.00-22.00 | PIX | |
| WX = weather chart transmissions MET = METEOSAT occlusion charts PIX = photofax service APT = automatic picture transmission 1 Hz = 60 rev./min. 2 Hz = 120 rev./min 4 Hz = 240 rev./min | | | | |

Table 3. These are only a few of the dozens of FAX stations operating in the European part of Region 1.

Getting started with fax

When you have completed the interface, aligned it, and have keyed in the software, it is time to see what the while set-up is capable of doing. As already stated, you need a SSB receiver to pick up the signals from amateur and professional fax stations. This receiver should have a reliable BFO (beat frequency oscillator) to enable precise tuning to the often weak signals. After a while, you will be able to unhesitatingly select the typical buzzsaw-like fax signals from the loud hub-bub that generally exists on the overcrowded short-wave bands. Table 3 lists a number of facsimile services that can be received throughout Europe. There are many more stations in operation, but these are generally run at relatively low output power and intended for very specific use only.

The use of the BFO in conjunction with the proposed interface requires some practising to develop a feeling for ob-

taining the best definition of the received pictures, and this also goes for the operating of correction controls S₃ and S₄. The best way to gain experience in fax reception is to make recordings of both weak and clear transmissions, and play these back into the interface, so that a signal is constantly available without the need to re-tune the receiver if a service signs off just when you intend to make the final adjustment. . . Sv

VALVE PREAMPLIFIER — 2

the 16 wire links on the board, and use 10 soldering pins for the connection to the input busboard. A 10-way PCB-mount plug and mating socket is of course the best solution, but these components are probably hard to obtain, as they are mainly used in industrial applications.

Wiring the preamplifier

All the usual rules apply to the wiring of this preamplifier; make the mains and supply connections in relatively strong wire, and protect the ends with insulating sleeving to ensure optimum safety. The signal connections can be made in normal screened wire, or, if this is

preferred, in RG58 coax. If the boards and external components are interconnected as shown in Fig. 10, there is little chance of earth loops arising. Note that there are only two connections to the preamplifier's enclosure.

Inputs ERR, RSTA and RSTB are not connected. As to the mains

section, the noise suppression capacitors, as well as the 2M2 resistor and the varistor, are fitted direct onto the contacts of the double-pole mains switch. As shown in the wiring diagram, the lamp inside the mains switch is powered by the filament supply; this is so arranged to provide a visual indication of the power-up delay. The mains socket at the rear of the preamplifier enclosure is preferably a type with a built-in fuseholder.

The amplifier is housed in a standard 19 inch enclosure with a height of 3 units.

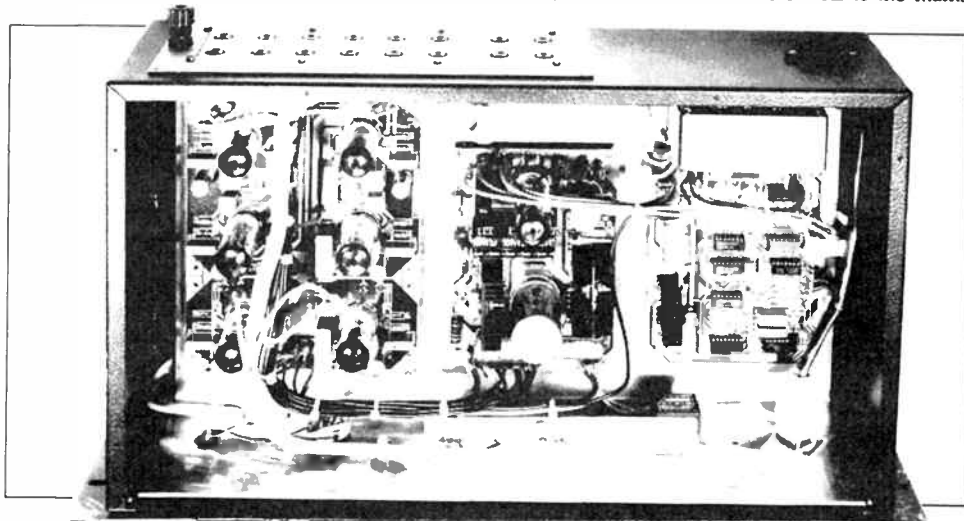

A look inside a prototype of the valve preamplifier.

LINKWITZ FILTERS

A brief look at the theory and practice of passive and active Linkwitz cross-over networks.

An analysis by Siegfried Linkwitz in the January 1976 issue of the *Journal of the Audio Engineering Society* shows that conventional cross-over filters have a negative effect on the radiation pattern of a multi-way loudspeaker system as regards both directivity and amplitude. On the basis of his research, Linkwitz proposed a new type of network that gives a uniform radiation pattern and constant amplitude. This filter, which is essentially a Butterworth-derived type, was first described by Riley and is, therefore, sometimes referred to as a Linkwitz-Riley network.

For simplicity's sake, the following discussion is based on a two-way loudspeaker system.

For optimum results, Linkwitz suggested that the filter must meet three requirements:

- there must be no phase shift between the outputs of the loudspeakers at the relevant cross-over frequency to prevent an upward or downward displacement of the radiation pattern;
- the signal attenuation at each filter output must be 6 dB instead of the usual 3 dB to prevent peaks in the sums of the signals;
- the phase shift between the output signals must be constant at all frequencies to retain the symmetry of the radiation pattern above and below the cross-over frequency; this condition is conveniently met by the use of symmetrical filters in both the low-pass and the high-pass sections.

Linkwitz found that these requirements can be met by cascading two identical second-order Butterworth filters. Higher-order types may, of course, be used, but in practical applications these are less interesting. It should be noted that in any case the filter must be an even-order type, since each order causes a phase shift of 45° at the cross-over frequency.

Fig. 1 shows the amplitude and phase shift behaviour of a Butterworth filter, and Fig. 2 those of a Linkwitz-Riley network. Note the 3 dB peak of the Butterworth filter. This can not be obviated by increasing the separation of the cross-over fre-

quencies of the low- and high-pass sections, because this would violate the first requirement of zero phase shift between the outputs. For clarity's sake, the two characteristics are combined in Fig. 3 to highlight the difference between them.

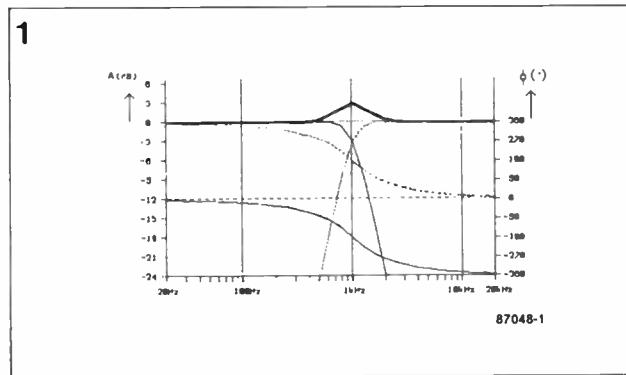

Fig. 1. Butterworth network: amplitude and phase characteristics over the audio frequency range. The fat line represents the sum of the outputs of the filters.

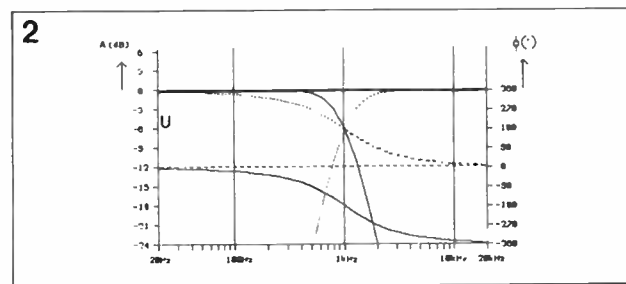

Fig. 2. Linkwitz network: amplitude and phase characteristics over the audio frequency range. The fat line represents the sum of the outputs of the filter sections.

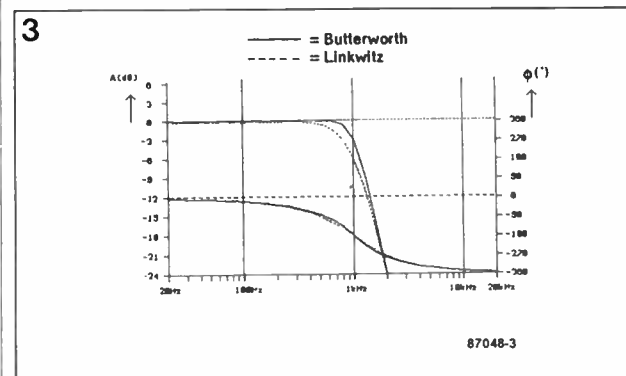

Fig. 3. Butterworth and Linkwitz characteristics combined to highlight their differences. The networks used had a slope of 24 dB per octave.

The Linkwitz curve is rather more rounded in the vicinity of the cross-over frequency, and starts falling off somewhat earlier. The slightly different phase shift of the two filters should also be noted.

The foregoing discussion is true only if the signals are sinusoidal. The pulse (or step) response of the Linkwitz filter causes the same problems as that of a Butterworth filter, assuming that both filters have separate low- and high-pass sections. Even a Linkwitz filter is therefore not perfect.

A practical filter

A Linkwitz filter may be designed as a passive or as an active type. The circuit diagram of an active design is shown in Fig. 4: this may be constructed on the printed-circuit board shown in Fig. 5.

The circuit of Fig. 4 is for a three-way loudspeaker system. The network has cross-over frequencies of 500 Hz and 5,000 Hz and roll-offs of 24 dB per octave. Stage A_1 serves as a buffer for the input signal before this is split three-way. The low-pass section is formed by A_5 and A_6 ; the middle-frequency section by A_7 and A_8 (high) and A_9 and A_{10} (low); and the high-pass section by A_{11} and A_{12} . Each section is provided with a potentiometer for setting the level of the output signal (P_1 , P_2 , and P_3 respectively), and a stage to buffer the output (A_2 , A_3 , and A_4 respectively). The power supply lines are stabilized by voltage regulators IC_7 and IC_8 . The cross-over frequencies may be altered with the aid of Table 1 (any frequency) or Table 2 (the 17 most likely frequencies). The values in Table 2 have deliberately not been rounded off to the nearest

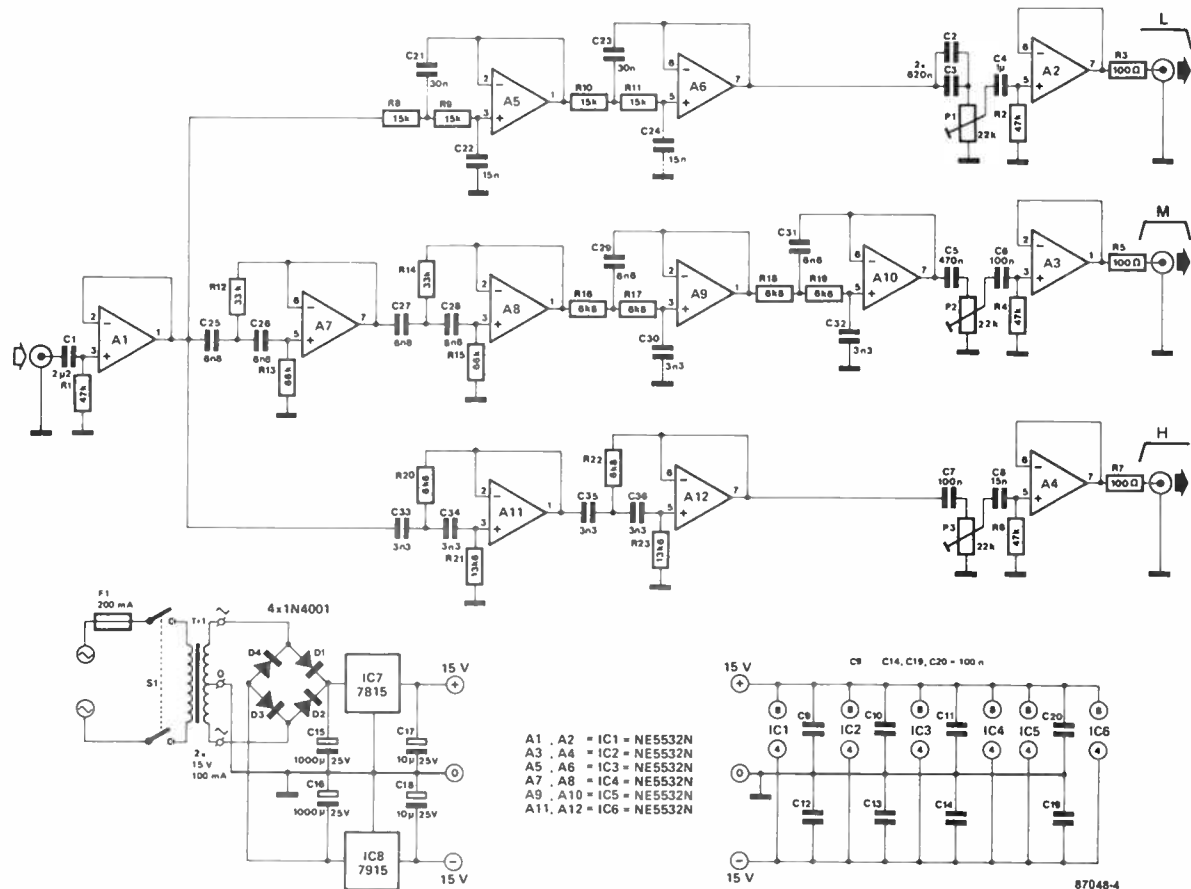

Fig. 4. Circuit diagram of an active Linkwitz filter.

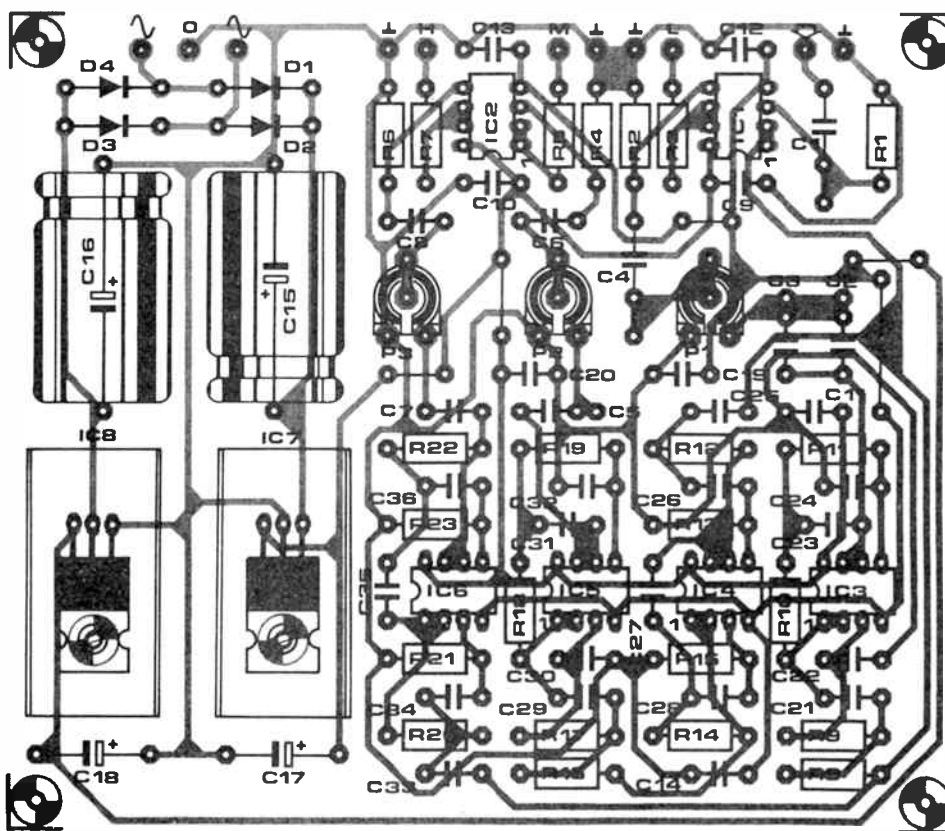

Fig. 5. The printed-circuit board for constructing the Linkwitz filter of Fig. 4.

standard E12 or E24 value. The sections may also be given a slope of 12 dB per octave by using A₆, A₈, A₁₀, and A₁₂ as buffers. Resistors R₁₀, R₁₁, R₁₈, and R₁₉, as well as capacitors C₂₇, C₂₈, C₃₅, and C₃₆, are then replaced by wire links, while R₁₄, R₁₅, R₂₂, R₂₃, C₂₃, C₂₄, C₃₁, and C₃₂ are omitted. The circuit may be adapted for use with a two-way system by the omission of the entire middle-frequency section, except for A₃ which is housed in the same package as A₄. If the slope is changed to 12dB per octave, the connexions to one of the loudspeakers must be reversed, because the phase shift at the cross-over frequency is 180° here. In a three-way system, this should be done at the middle-frequency speaker; in a two-way system at the tweeter. A passive filter may be constructed as shown in Fig. 6. The values of the actual components used should be as close as possible to the calculated ones, otherwise the filter will become a cross between a Linkwitz and a Butterworth

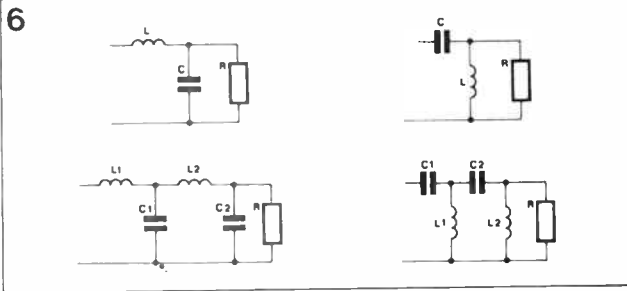

Fig. 6. Passive Linkwitz sections (a) with a 12 dB per octave slope, and (b) with a 24 dB per octave slope.

type. If the filters are given a 12 dB per octave slope, the connections to the middle-frequency loudspeaker (in a three-way system) or those to the tweeter (in a two-way system) should be reversed.

The loudspeaker impedance must be corrected in a manner that ensures that it is constant and ohmic at the cross-over frequency. The corrected impedance of the loudspeaker, R in Fig. 6a and 6b, should be

ascertained as detailed in *Loudspeaker Impedance Correction*

See our 'PROJECT BUYERS GUIDE' this issue for a guide to component sources and kit suppliers.

Table 1

low pass section 12 dB/octave

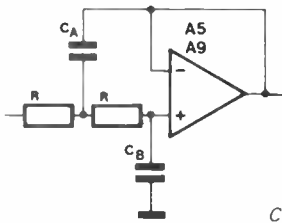

$$C_A = C_B = 1/2\pi fR$$

where $R = 4.7 - 10 \text{ k}\Omega$

low-pass section 24 dB/octave

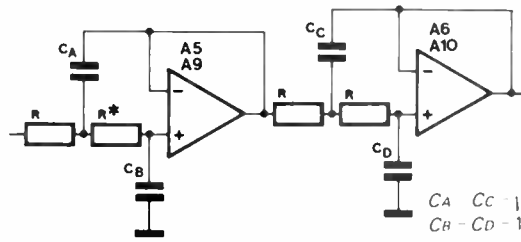

$$C_A = C_C = 1/2\pi fR$$

$$C_B = C_D = 1/2\pi fR$$

where $R = 4.7 - 10 \text{ k}\Omega$

high pass section 12 dB/octave

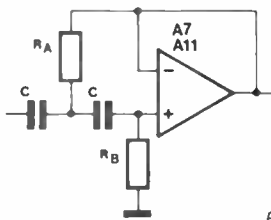

$$R_A = R_B = 1/2\pi fC$$

where $C = 4.7 - 10 \text{ nF}$

high-pass section 24 dB/octave

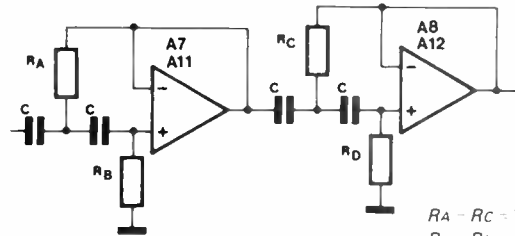

$$R_A = R_C = 1/2\pi fC$$

$$R_B = R_D = 1/2\pi fC$$

where $C = 4.7 - 10 \text{ nF}$

Table 2

| Low-pass 12 dB/oktave | | Low-pass 24 dB/oktave | | | High-pass 12 dB/octave | | High-pass 24 dB/octave | | |
|-----------------------|------------------|-----------------------|------------------|------------------|------------------------|---------------------------|------------------------|---------------------------|---------------------------|
| $R = 5\text{k}\Omega$ | | $R = 5\text{k}\Omega$ | | | $C = 4\text{nF}$ | | $C = 4\text{nF}$ | | |
| f (Hz) | $C_A = C_B$ (nF) | f (Hz) | $C_A = C_C$ (nF) | $C_B = C_D$ (nF) | f (Hz) | $R_A = R_B$ (k Ω) | f (Hz) | $R_A = R_C$ (k Ω) | $R_B = R_D$ (k Ω) |
| 100 | 284 | 100 | 402 | 201 | 100 | 339 | 100 | 239 | 478 |
| 200 | 142 | 200 | 200 | 100 | 200 | 169 | 200 | 120 | 240 |
| 300 | 94.7 | 300 | 134 | 67 | 300 | 113 | 300 | 79.8 | 159.6 |
| 400 | 71.1 | 400 | 100.4 | 50.2 | 400 | 84.7 | 400 | 59.9 | 119.8 |
| 500 | 56.8 | 500 | 80.4 | 40.2 | 500 | 67.7 | 500 | 47.9 | 95.8 |
| 600 | 47.4 | 600 | 67 | 33.5 | 600 | 56.4 | 600 | 39.9 | 79.8 |
| 700 | 40.6 | 700 | 57.4 | 28.7 | 700 | 48.4 | 700 | 34.2 | 68.4 |
| 800 | 35.5 | 800 | 50.2 | 25.1 | 800 | 42.3 | 800 | 29.9 | 59.8 |
| 1,000 | 28.4 | 1,000 | 40.2 | 20.1 | 1,000 | 33.9 | 1,000 | 23.9 | 47.8 |
| 1,500 | 18.9 | 1,500 | 26.8 | 13.4 | 1,500 | 22.6 | 1,500 | 16 | 32 |
| 2,000 | 14.2 | 2,000 | 20 | 10 | 2,000 | 16.9 | 2,000 | 12 | 24 |
| 2,500 | 11.4 | 2,500 | 16.1 | 8.04 | 2,500 | 13.5 | 2,500 | 9.58 | 19.16 |
| 3,000 | 9.47 | 3,000 | 13.4 | 6.7 | 3,000 | 11.3 | 3,000 | 7.96 | 15.96 |
| 3,500 | 8.12 | 3,500 | 11.5 | 5.74 | 3,500 | 9.68 | 3,500 | 6.84 | 13.68 |
| 4,000 | 7.11 | 4,000 | 10.04 | 5.02 | 4,000 | 8.47 | 4,000 | 5.99 | 11.98 |
| 5,000 | 5.68 | 5,000 | 8.04 | 4.02 | 5,000 | 6.77 | 5,000 | 4.79 | 9.58 |
| 10,000 | 2.84 | 10,000 | 4.02 | 2.01 | 10,000 | 3.39 | 10,000 | 2.39 | 4.78 |

You must remember this, Sam!

Adelaide's major retailer, Force Electronics, has an absolute bargain going in memory chips! Always useful in digital and microprocessor projects, you'd better stock up now before they disappear.

The popular and widely used 4164 64K dynamic RAM is priced at under \$2. How could you go past eight of those at under \$16 for a 64K RAM?

And in the statics, Force has 16K 6116s for under \$3 and 64K 6264s at under \$6. Strewth!

Then there's the quarter-meg 256K DRAM, the 41256, as featured in our February Star Project, the PBUFF 256K printer buffer. It's also under \$6!

Force has EPROMs on the bargain list, too. For a 21 V programmed 2764, you'll pay \$5.95. And the CMOS 27C64 is the same price!

Force Electronics has been around for the past seven years, catering to the fastidious and wide-ranging requirements of South Australian enthusiasts and electronics entrepreneurs.

You'll find Force in four locations: in the city at 203 Wright St. (08)212 5505, plus Christies Beach (08)382 3366, Enfield (08)349 6340 and Brighton (08)296 3531.

Solid-state bargains at Dick Smith stores

This month you can snap up some bargains in linear and digital ICs at Dick Smith stores across the nation. Try a 74C922 at just \$2.95, 4116 RAMs at a buck, LM386 one watt audio amp ICs at 70 cents and low power 12 V 78L12CZ regulators also at 70 cents!

MEL12 phototransistors are down to 70 cents from \$1.25, while 3SK121 RF GaAsFETs are down to \$1.80 from \$8.25!

Looking for gates? Try 7400s for just ten cents, 7410s for 35 cents, and 7408s also for 35 cents!

The bargains extend to CMOS, high-speed CMOS and LS devices. Among the linears are audio amps, op-amps, temperature sensors, regulators, TV sound IF chips and complex function generators.

Jaycar opens in Melbourne

Melbourne City's A'Beckett St is now graced by the presence of Jaycar's newest store, located at number 45. Situated at the north end of the city, it's right handy to RMIT and the Museum underground rail station.

This month, you'll find a few bargains worth investigating in all Jaycar stores. First, there are the 1000 V/6 A rectifier diodes—just \$1.50 each!

And for Commodore owners building add-on projects, Jaycar stocks keyed edge connectors for the user port at just \$6.95. Jaycar also stocks a wide range of Centronics and D connectors at keen prices.

Check out your nearest Jaycar store or call their toll-free hotline, (008)022 888.



Jumbo desolder tool

For those wanting a heavy duty, high capacity desolder tool, Scope Laboratories has released their Model SR27 desolderer.

The Scope JUMBO has more than 2½ times the suction capacity of the standard Scope model SR10 (illustrated) and both models offer replaceable Teflon nozzles.

The new JUMBO tool is available through electronic supply houses and is priced around \$25, excl. tax.

Popular Exar ICs

Active Wholesale in Melbourne stock a small range of the popular Exar special function ICs, which includes the XR2206, the XR2211 and XR8038.

Active are located at 289 Latrobe St, City and in 887 Springvale Rd, Springvale. Their order hotline is (03)602 3499. Tell them you saw it in AEM! 🐘

PROJECT BUYERS GUIDE

For owners of David Tilbrook's Series 5000 stereo power amp looking to upgrade using our new 6005 MOSFET amp modules, upgrade kits are available from Eagle Electronics in Adelaide. These do not include the MOSFETs, as you take them from your existing amp. Modules complete with MOSFETs and single mounting brackets are also available from Eagle. Force Electronics in Adelaide has also indicated they'll likely be stocking the 6005 modules.

The AEM3510 RTTY Modulator will be stocked as a kit by Jaycar in Sydney, Brisbane and Melbourne. Note that they also stock the AEM3500 if you're thinking of building up a complete RTTY modem. For constructors assembling their own bits and pieces, the XR2206 is a widely stocked device, and you should have little trouble obtaining it. The board has been laid out to accommodate two common, low-cost miniature 12 Vdc relays—Jaycar's SY-4066, or Dick Smith's S-7112.

As advised last month, the AEM2000 0-55 V/100 W Lab. Standard Power Supply has been designed by Gerald Reiter in collaboration with Force Electronics and is prepared and presented in conjunction with AEM. Force Electronics will be stocking complete kits of the unit. See their advertisement this issue.

The Elektor projects and articles this month contain few components of an unusual nature, and intending constructors should have little difficulty obtaining supplies.

The article on how to add motional feedback to a bass speaker employs bog-standard bits; TL071s and a common piezo tweeter

(which is dismantled to make the acceleration pickup).

The Electronic Potentiometers article employs commonly available components for the main part, and that includes the LM13600 operational transconductance (OTA) amplifiers.

The Valve Preamp, as indicated in this column last month, is for the persistent and adventurous! However, if you include yourself in that hardy band, for your component requirements you might try writing to Audiokits Precision Components, 6 Mill Close, Borrowwash, Derby DE7 3GU England.

The Facsimile Interface employs readily available parts, in the main. All the 4000-series CMOS ICs are widely stocked. The TBA120 is carried by Dick Smith Electronics. The 68 mH Toko coil is certainly a "foreigner". However, you should be able to wind one on a locally available toroid by Amidon, imported by R.J. & U.S. Imports and sold through Geoff Wood Electronics in Sydney, Electronic Components in Fyshwick ACT, Webb Electronics in Albury NSW, Trustcott's Electronic World in Croydon Vic., and Willis Trading in Perth W.A. For data and price list, write to R.J. & U.S. Imports at PO Box 157, Mortdale 2223 NSW. A toroid is not adjustable, so you'll have to be prepared to "pad" C8. The crystal may take a little searching out, or you can order one from a crystal manufacturer.

The Linkwitz Filter crossovers employ NE5532Ns (dual NE5534Ns), obtainable from Geoff Wood Electronics in Sydney and Active Electronics in Melbourne. You might also try Force Electronics in Adelaide. The 7815 and 7915 regulators are obtainable from the same sources.

WHEN YOUR MEMORY'S GONE... REMEMBER US!

10,000 MEMORY CHIPS TO CLEAR
TOP BRANDS AT ROCK BOTTOM PRICES

| | |
|---------------|--------|
| ★ 4164 | \$1.95 |
| ★ 41256 | \$5.95 |
| ★ 6116 | \$2.95 |
| ★ 6264 | \$5.95 |
| ★ 2764 | \$5.95 |
| ★ 27C64 | \$5.95 |

*2IV prog. voltage.



STOP PRESS!

VIDEO SENDERS
JUST PLUG IN TO YOUR
VIDEO AND WATCH
FROM ANY T.V.
IN YOUR HOUSE

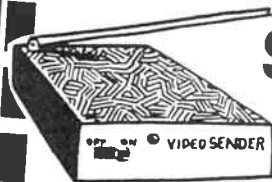

\$59.95

100 ONLY AVAILABLE

OPTIONAL 9V POWER PACK \$9.95

AND DON'T FORGET OUR KITS



RF MILLIVOLT METER KIT

Extremely accurate and valuable tool for the enthusiast.
Specs.: Sensitivity - 20dBm (without attenuator).
Input range 22.3mV max. to +23dBm (with attenuator).
See Jan.-Mar. issue, A.E.M.

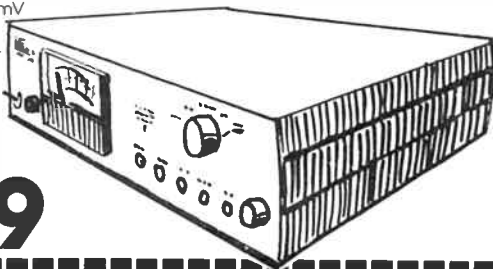

\$269



LABORATORY POWER SUPPLY KIT

A truly professional piece of equipment. Digital readout gives greater accuracy.
Specs. Output Voltage 0-55 Volts. 5 Amp.
Stability against mains variations, less than 1mV.
Stability against load variations, less than 2mV.
Ripple voltage at any load (50Hz) less than 1mV.R.M.S.

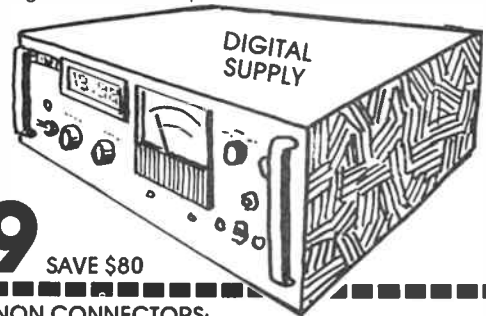

\$399

SAVE \$80

DIODES/SOCKETS:



| | | |
|-------------------------------|-------------|---------|
| ST4 Dial | Were \$1.70 | Now 79c |
| BT139 Triac 16 Amp/500V | \$3.40 | \$1.95 |
| LM 317T 2.300 Impreg. | \$2.95 | \$1.95 |
| WO4 Bridge | 95c | 65c |

7 SEGMENT:



| | | |
|------------------------------|-------------|---------|
| 4N 25 | Were \$1.70 | Now 95c |
| 4N 28 | \$1.70 | 95c |
| MOC 3021 | \$2.95 | \$1.45 |
| HLMP 5301 C/Anode Disp. | \$3.65 | \$2.25 |
| HLMP 5303 C/Cath. Disp. | \$3.65 | \$2.25 |

FANS:



| | | |
|--------------------------------|--------------|-------------|
| 12V 80mm Brushless Motor | Were \$49.95 | Now \$24.95 |
| 240V 80mm Ball Bearing | \$49.95 | \$29.95 |

Connecting Lead Included!

CANNON CONNECTORS:



| | | |
|--------------------|----------|---------|
| DB 15 Male | Were 99c | Now 79c |
| DB 15 F/male | 99c | 79c |
| DB 25 Male | \$1.95 | \$1.75 |
| DB 25 F/male | \$1.95 | \$1.75 |
| DB 37 Male | 99c | 79c |
| DB 37 F/male | 99c | 79c |

T.V. TECH'S SPECIALS:



| | | |
|----------------------------------|-------------|------------|
| BU 406 | Were \$3.25 | Now \$2.25 |
| BU 326 | \$7.95 | \$3.95 |
| BUX 80 | \$8.95 | \$4.95 |
| BU 208 | \$8.95 | \$3.95 |
| BC 547 | 25c | 10c |
| BC 557 | 25c | 10c |
| 1W 4007 1,000V 1 Amp Diode | 16c | 7c |
| 1W 5408 1,000V 3 Amp Diode | 45c | 20c |
| R-250D 400V 6 Amp Diode | \$1.10 | 75c |
| 72 Ω Metal Plug | \$1.70 | 60c |
| 75 Ω Metal Line Socket | \$1.85 | 95c |



ADELAIDE
PH. (08) 212 5505
203 WRIGHT ST

CHRISTIES BEACH
PH. (08) 382 3366
24 BEACH RD

ENFIELD
PH. (08) 349 6340
445 MAIN NTH RD

BRIGHTON
PH. (08) 296 3531
504 BRIGHTON RD.



WE ACCEPT BANKCARD, VISA & MASTERCARD

MAIL OR PHONE ORDERS TO ANY STORE
STANDARD MAIL UP TO 2kg \$4 ON SERVICE UP TO 3kg
ROAD FREIGHT OVER 10kg \$10

S7

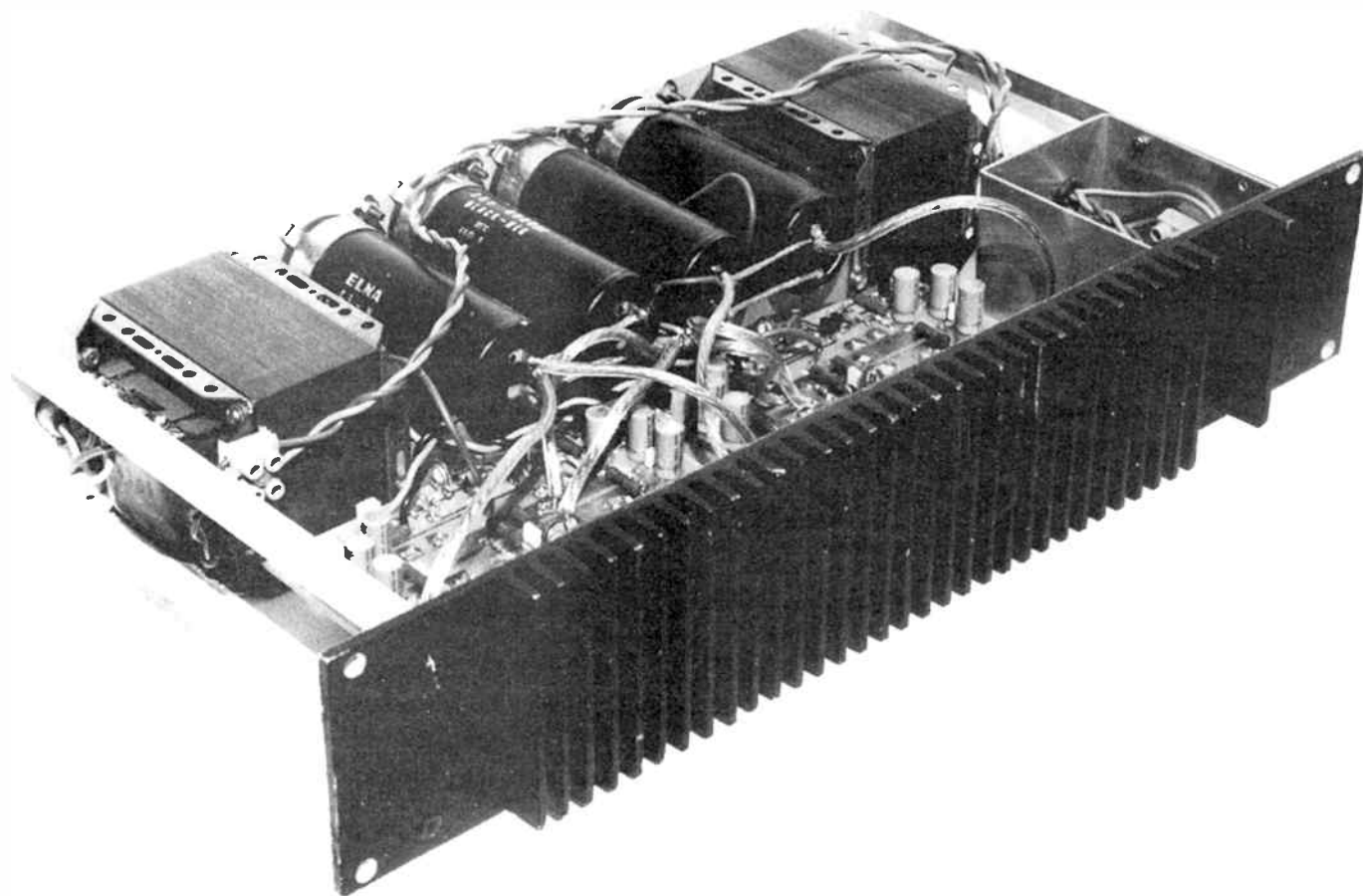

Upgrade your Series 5000 with the AEM6005 100W 'U-F' topology amp module

David Tilbrook
Technical Systems Australia

The 6005 module, described in Part 1, is ideal for upgrading David Tilbrook's now legendary Series 5000 stereo power amp. This article details how it's done and discusses new power supply arrangements.

THE 6005 MODULE has been designed to fit the Series 5000 chassis, providing a relatively simple upgrade and a significant improvement in performance.

Begin the upgrade process by preparing a new heatsink bracket. This is required to accommodate the extra components mounted to it. The complete drilling details of the bracket are published elsewhere in this article. The bracket has been designed to bolt directly to the series 5000 heatsink so as to minimise the need for extra drilling to your front panel. The dimensions shown for the bolt holes used to mount the bracket to the heatsink are for those heatsinks drilled to take bolts through the front, between the fins. Some producers made heatsinks which were drilled and tapped from the rear, which displaces the holes 5-6 mm. Check your heatsink and mark out and drill the new bracket accordingly.

The AEM6005 modules use the same power MOSFETs as were employed in the Series 5000, so these can be removed from your existing 5000 modules if you are doing the upgrade. In this case, care should be taken when removing the MOSFETs from the 5000 pc boards so as not to damage the drain and gate leads. Avoid applying too much heat to these leads so that the risk of damage to the devices is minimised. Use a solder sucker or solder wick to remove all of the solder applied to these leads before attempting to lift the devices from the 5000 pc board.

When mounting the MOSFETs onto the 6005 board, follow the mounting procedure shown in Part 1, Figure 3. The MOSFETs, when mounted in the 6005 modules, need to be secured with insulated bolts and nuts (as shown in Part 1, Figure 3). These insulated bolts are essential so as to avoid shorting

◀ **Front, half-angle view of the upgraded 5000, now the AEM6005, without chassis covers. The "Monster Cable" employed in the power supply wiring is clearly visible.**

the case of the devices to the copper tracks on the underside of the boards.

As described in Part 1, the modules are nearly the same size as the boards used in the 5000 power amplifier and hence can be mounted in place of the previous modules. Before you finally mount the newly prepared bracket and 6005 modules into the chassis it is a wise precaution to power up the modules to check that all is well. The quiescent current and dc offset presets should be adjusted at this stage as this procedure becomes substantially more difficult once the mounting has been completed. This is of particular importance when dealing with the dc offset potentiometer RV1, as it will be difficult to reach.

First power-up

When powering-up your modules for the first time you should connect a 10 ohm, 1W resistor in series with each rail. Do not connect the load at this stage. This simple procedure will prevent most faults within the power amp from causing serious damage. The 10 ohm resistors limit the maximum current that can flow into the modules in the event of a fault condition. Any fault that results in excessive current consumption module will cause the resistors to burn out. If this occurs you must locate the fault before applying power to the modules without the 10 ohm resistors in circuit. Although you can go through quite a number of resistors this way it is definitely preferable to the option of damaging the output devices or pc board!

The 10 ohm resistor in series with the positive rail can also be used to adjust the quiescent current. Connect your multimeter to measure the voltage across this resistor by attaching

Topside view inside the unit, showing the general layout and supply wiring to the boards.

the leads to either side of the resistor and, with power applied, adjusting RV2 until your meter reads 2 Vdc. This should ensure that the correct amount of bias current is flowing through the MOSFET output stage. Run the module in this condition for about 15 minutes and check the heatsink temperature. If the heatsink runs excessively hot (i.e. more than around 40 degrees Celcius), then try decreasing the quiescent current slightly.

The dc offset adjustment may be slightly more complex. It was discovered during the development of the 6005 modules that in some circumstances, depending upon the tolerances of the components, that the correct setting of the dc can be difficult. The preset potentiometer has been configured in such a way that it provides a non-linear amount of adjustment. The preset provides a fine adjustment around its centre position becoming increasing coarse as it is adjusted further from this position.

If component tolerances require this preset to be set near either extreme, the correct setting will be very difficult to make. To correct this imbalance it is necessary to adjust the values of one of the resistors R4 and R5. As specified, they are 220R. However, the value of one of these may have to change slightly to return the preset to a position closer to its centre. This can be done by beginning with a 1k resistor in parallel with R4 or R5 while measuring the voltage between the power amp output and ground. Experiment with different values until the dc on the output is a minimum with the preset set at its centre position. Once you have found the optimum value of resistor that gives the majority of the vernier of the preset around the centre, then you can adjust the preset to give as close to zero dc offset as the preset will allow.

Using this system, you should be able to adjust the offset as low as ± 10 -20 mV. Allow the module time to heat up before ▶

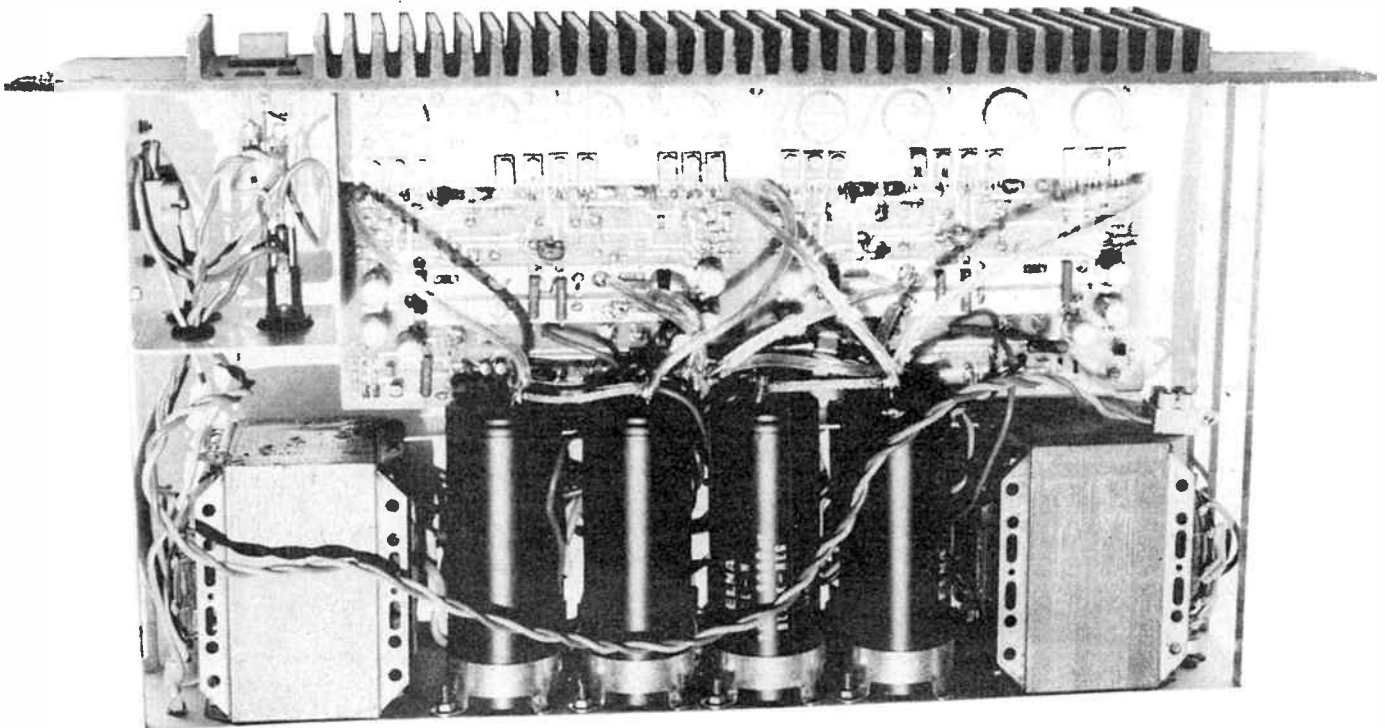

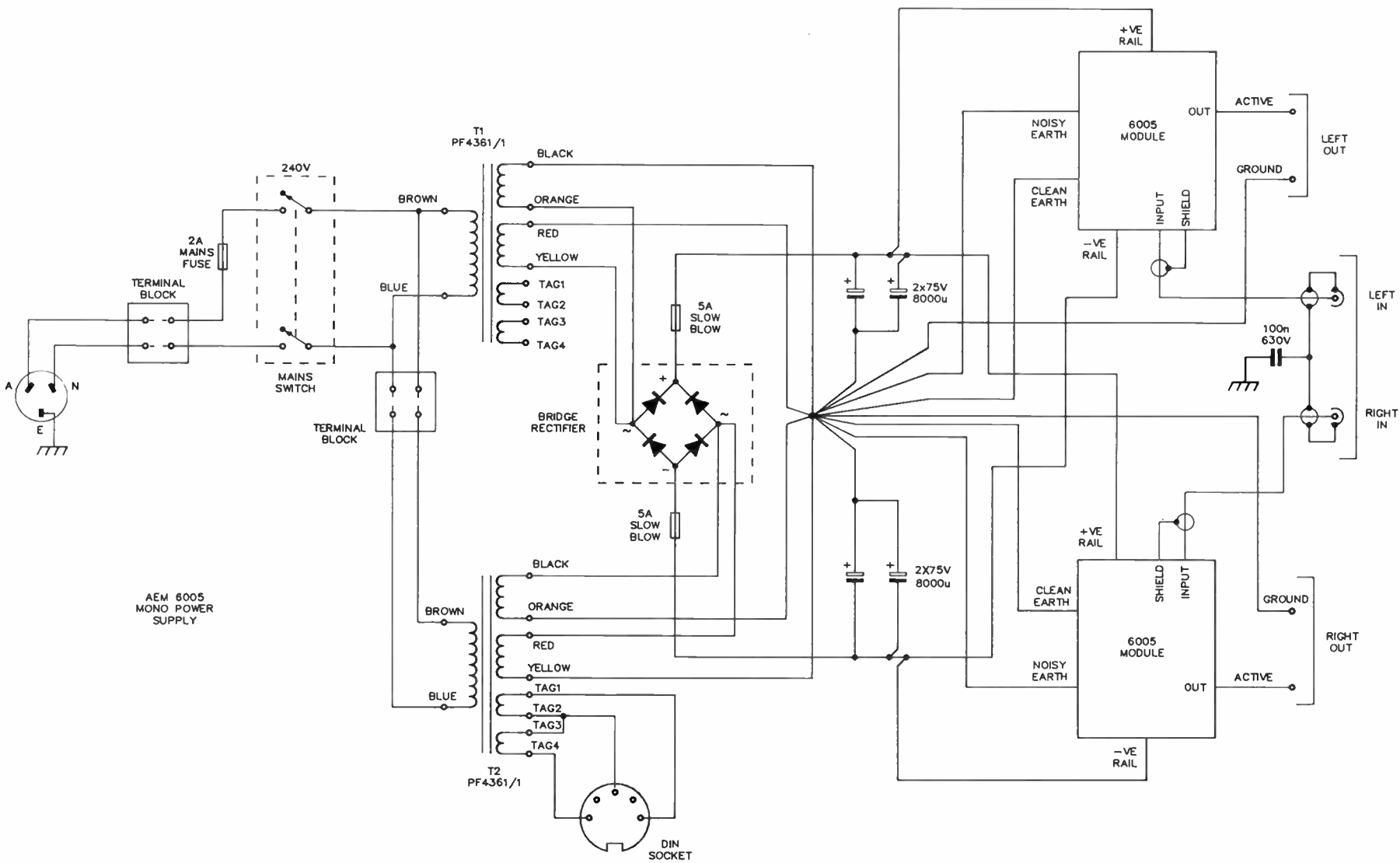

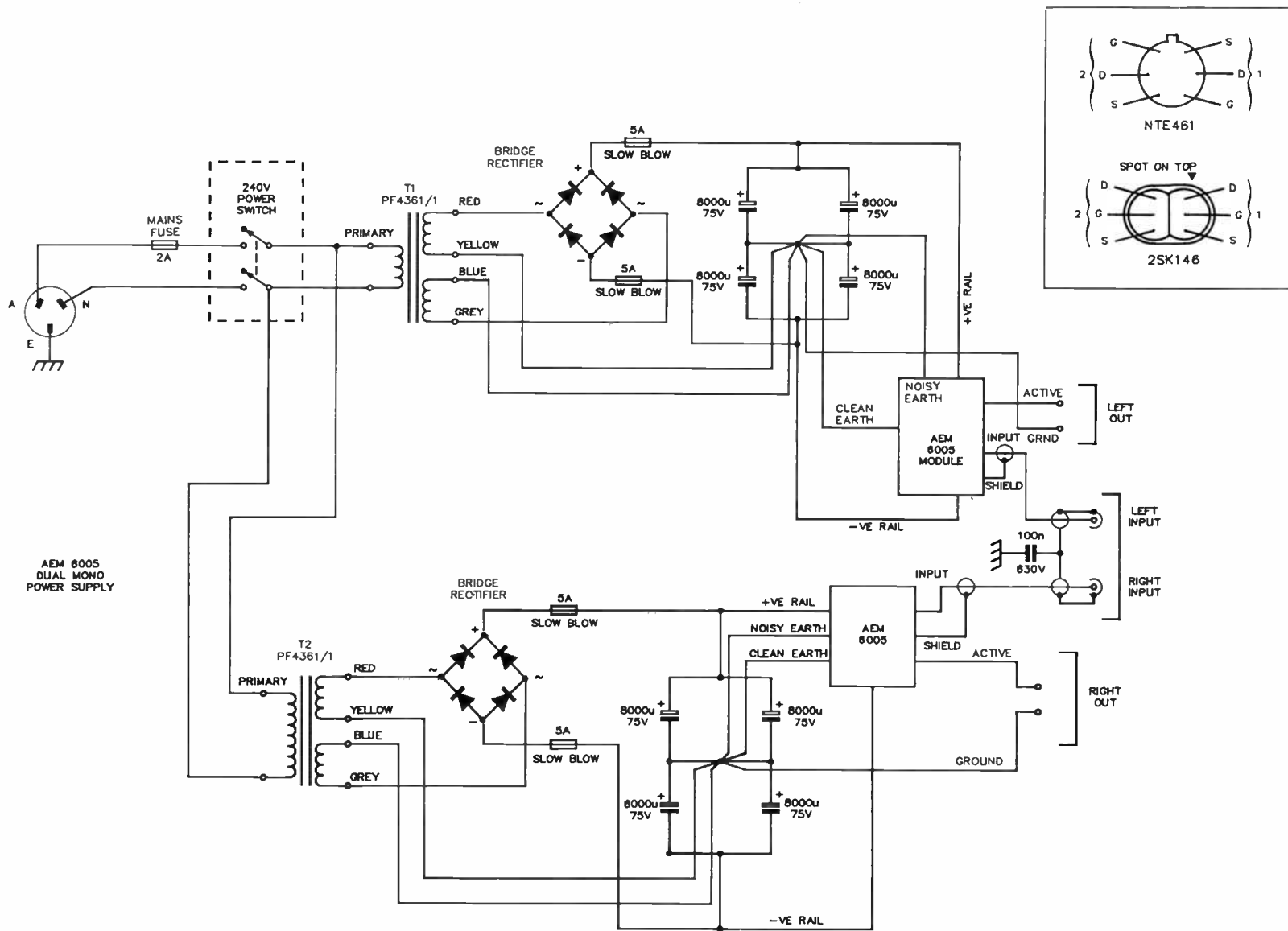

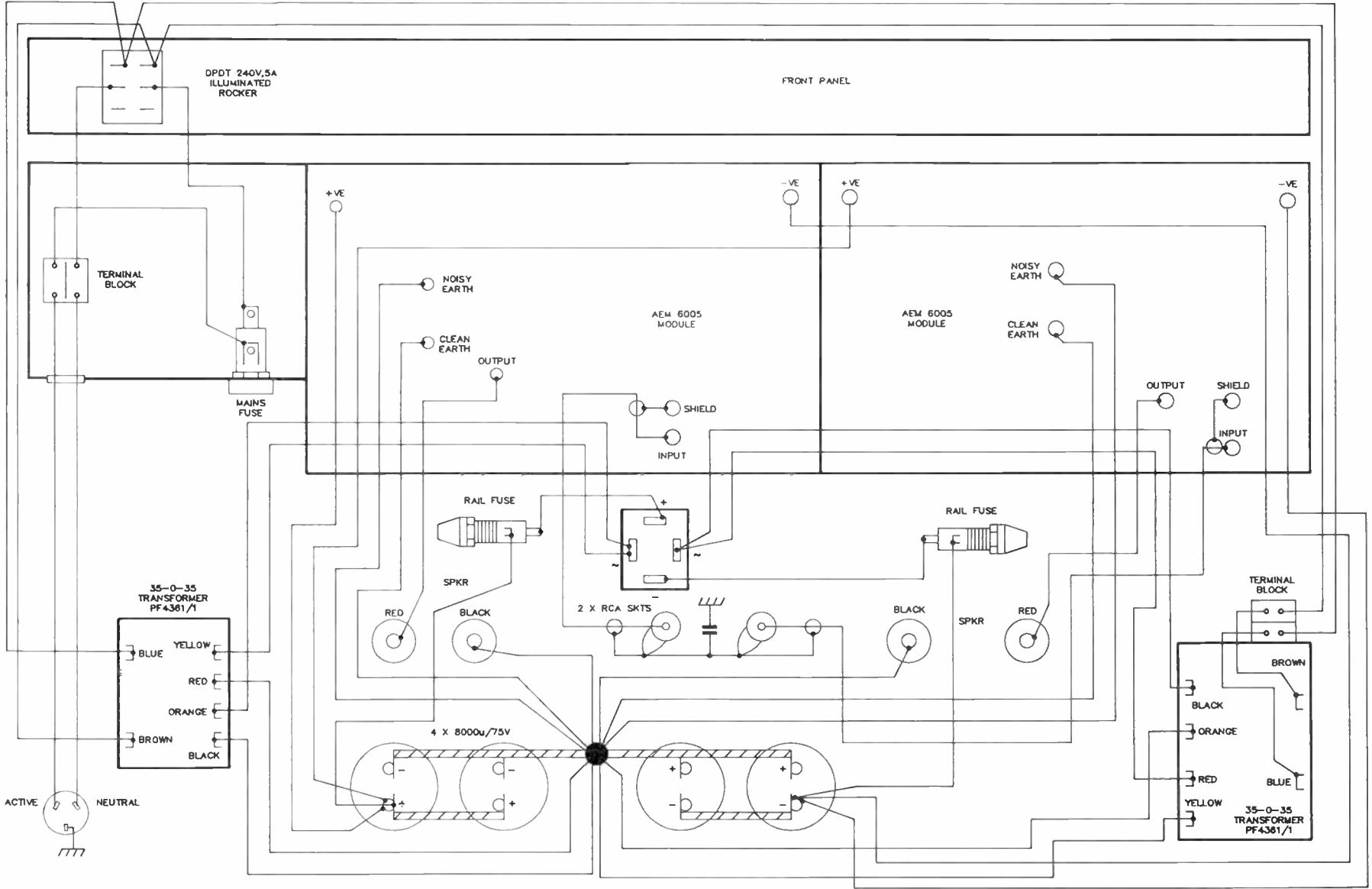

finalising setting of the preset potentiometer as the dc offset tends to drift whilst warming up.

Module mounting and wiring

Once you have completed the mounting of the modules onto the heatsink bracket, you can mount the bracket into the chassis, bolting it on the front panel heatsink. Before doing this, however, be sure to have drilled out the holes on the pc board for the input, output and rail wiring to suit the wire used. The supply rail wires will need to be of substantial size to ensure the best performance and we employed "Monster Cable".

Before actually mounting the modules, it is wise to wire the input into position on the board as this also becomes more difficult after mounting has been completed. Use shielded cable to wire the input as these wires will have to pass fairly close to transformers. Hum is injected into the input wiring simply by its physical proximity to the transformers, so experiment with the location of this wiring if you experience any difficulty with hum. The hum performance of the upgraded unit is extremely good and was achieved with no difficulty.

Once the module has been readied it can be secured to the heatsink, making sure to use a generous amount of thermal paste between the bracket and the front panel heatsink to ensure good thermal contact between them.

The modules should now be securely in position and the rest of the wiring can be completed. One aspect which will need to be looked at, whether you are mounting these modules into your old 5000 or into a completely new chassis, is that of the fusing. The fusing is the last line of defense for your modules in the case of a fault, so it is imperative that the rail fuses not be left out. In the case of the Series 5000 these fuses were incorporated onto the pc board. This has not been done in the AEM6005 module since it can introduce significant resistance in series with the power supply to the MOSFETs which can cause some degradation in overall performance.

The transient performance of a power amp is greatly affected by the capacity of the power supply to deliver current quickly to the output devices. It is for this reason that heavy gauge cables are specified for the rail and output connections. Incorporation of supply fuses into the supply line introduces both resistance and inductance which is not desirable. Instead, fuses are fitted between the output of the bridge rectifier and the main filter capacitors. As seen in the parts list, we recommend the use of 3AG 5A slow blow fuses. The slow blow types are necessary because of the surge current that occurs at the moment of turn on due to the charging of the

Underside view inside the unit. Note the two power supply fuse holders either side of the bridge rectifier which is mounted on an aluminium plate running between the two mains transformers. The mains fuse is seen in the enclosure at top right.

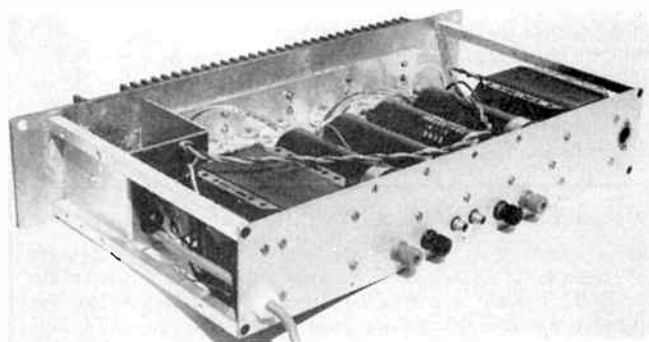
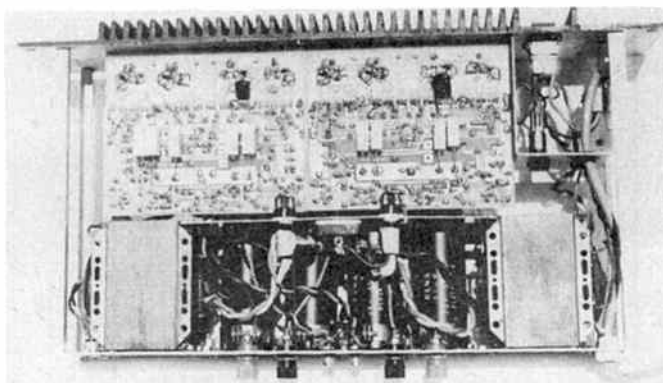

Rear, half-angle view of the unit, showing the connectors mounted on the rear panel. The two input RCA sockets are between the two pairs of speaker terminals, while the DIN socket at upper right provides low voltage ac output for accessories. The mains cord enters via a grommet at bottom left.

main electrolytic capacitors. At the instant of turn on these capacitors represent a short circuit and the resulting huge current surge will blow normal 5 A fuses. The slow blow type will not blow unless the excessive amount of current continues. In the prototype unit these fuses are mounted with 3AG fuse holders which are mounted to the bracket within the 5000 chassis used to secure the bridge rectifier.

Once the fusing is complete you should wire the earth and rail wires. It is essential to ensure that the rails are wired correctly. Check the filter capacitors to see which is the positive, negative and earth and connect these points to their respective positions on the modules according to the component overlay published in Part 1. The earthing arrangement for the 6005 module is just as imperative as it was for the 6000 power amp modules. There are two earth areas on the pc board which need to be connected to the centre point of the filter capacitors. This is to ensure that the clean signal earth is clearly separated from the noisy power supply earth. If this is not done the module will still operate, although with hum and noise figures orders of magnitude worse than those published. The output should be wired directly from the pc board with the black output terminal connected directly to the centre point of the main electrolytic filter capacitors.

If you are upgrading the Series 5000 the same power supply can be used with the exception of the changes to the power supply fusing which has already been discussed. We have ▶

AEM6005 PARTS LIST

- 2 x AEM6005 modules;
- 1 x heatsink bracket;
- 1 x Series 5000 heatsink and chassis;
- 4 x 8000u/75 V electrolytics;
- 2 x PF4361/1 transformers;
- 1 x 100n/630 V metallised film capacitor.
- 1 x 240 Vac DPDT illuminated rocker switch;
- 2 x red binding posts;
- 2 x black binding posts;
- 4 x earth lugs;
- 2 x RCA sockets;
- 1 x PB40 bridge rectifier;
- 2 x 5A 3AG slow blow fuses;
- 3 x 3AG chassis-mount fuse holders;
- 2 x 2-way terminal blocks;
- Two metres of heavy gauge hookup wire of at least 32 x 0.2 mm, or "Monster Cable", for power supply wiring;
- Mains cable, plug and clamp grommet.

Drilling details for the heatsink bracket. Mounting hole positions shown in the upright piece were taken from the original 5000 heatsink which located the mounting bolts between the fins. Later heatsink designs have tapped holes positioned behind the fins which necessitate slightly different hole positions. These should be measured from your unit.

NOTE: SUBSTITUTE DUAL JFET INPUT DEVICES

Some incompatibilities between various input stage devices employed for Q1-Q2 have become apparent since publication of the AEM6000 module (June, July, August September 1986). We specified the NTE461, a New Tone Electronics dual JFET. This device is important to the overall performance of the 6000 and 6005 modules. Some suppliers have substituted alternative devices which some constructors have raised questions about.

The Philips BFQ10 can be used in the circuit instead of the NTE device without any difficulties. The 2SK146 dual JFET will operate in the circuit but has a different pinout and is therefore difficult to mount. We understand that the NTE device is available from Stewart Electronics in Melbourne. The pinout of all these devices, NTE461, Philips BFQ10, and the 2SK146 have been shown elsewhere in this article to clear all such confusion.

also included a diagram for a dual mono power supply for those wishing to employ it. This power supply can be incorporated within the 5000 chassis with the addition of a second bridge rectifier. The 5000 power supply is a single supply which is used for both modules. The dual mono configuration enables the power amp to become two mono power amps in the same box which is said to have superior channel separation compared to the mono supply.

To wire up the dual mono supply, follow the circuit diagram closely to ensure correctness. We have decided not to include drilling details of a new chassis and leave it to the enthusiast who may wish to experiment. Be careful to check the orientation of your electrolytics and bridge rectifiers when following the circuit diagram, along with the wiring of the transformers, as damage will occur if these are incorrect.

Pay particular attention to all of the 240 volt wiring. Ensure that all terminations and solder joints have been securely made. It is essential to be aware that any shorts in the 240 V wiring will cause damage.

Hold breath . . . and switch on

With your wiring completed, before powering-up you should recheck the wiring and run through the amplifier with a continuity meter to ensure all is well.

Power-up the amp. If all is well, then leave the amp to warm up. This is necessary to allow time for the amp to stabilize before any adjustments are made. Set your multimeter on dc volts and connect it to the output of each channel in turn to ensure no dc offset has been disturbed before connecting your loudspeaker. If there is a dc offset, then use an insulated screwdriver to adjust the preset RV1. Finally, before connecting the 6005 to your loudspeakers, you should switch the amp on and off a few times to ensure all is well.

LEVEL

We expect that constructors of an

INTERMEDIATE

level, between beginners and experienced persons, should be able to successfully complete this project.

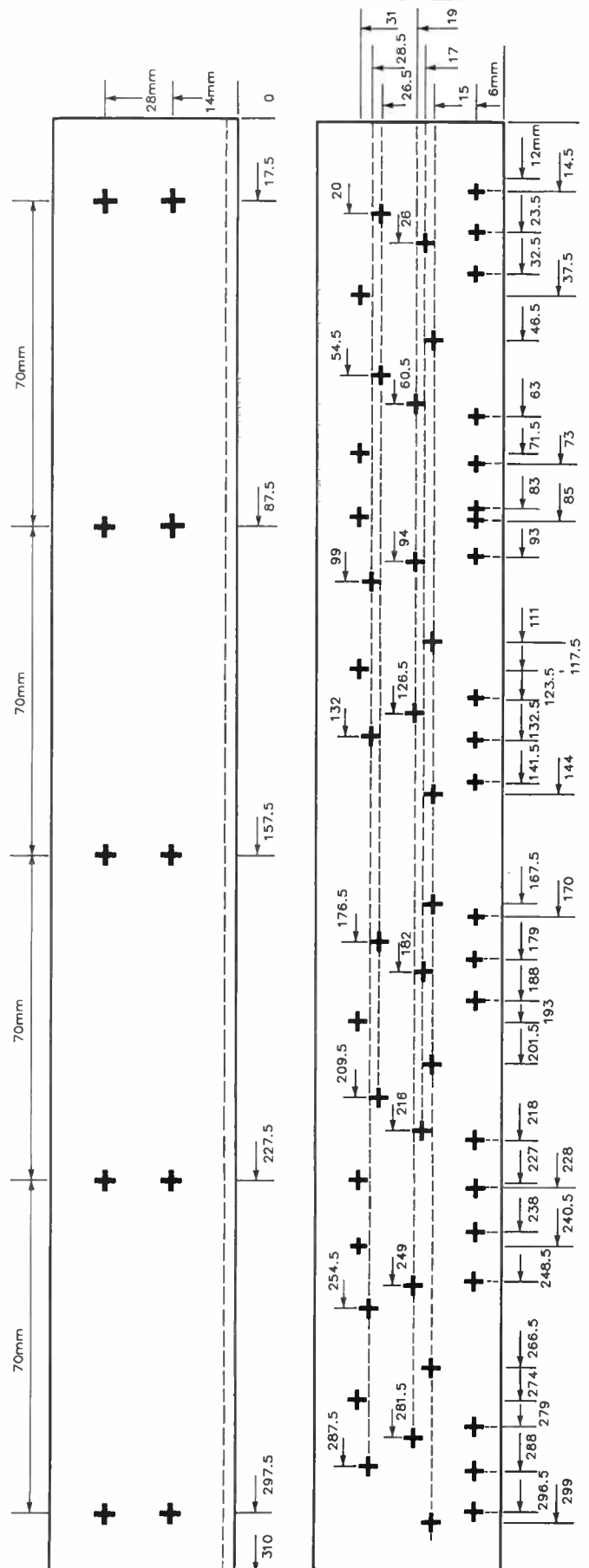

- from page 81.

lead from track 2 under the 1N914 diode and solder to track 4 as shown, crossing track 3 over the insulating gap.

Solder the lead from the 150 R resistor on track 1 to track 2 under the board as shown and place a bridge on top of the board between track 3 and track 5 as shown. Solder the emitter lead from the BD548 to track 4 and fold the end over onto track 5 and solder as shown. All other parts are wired directly in the positions shown.

Connect the free end of the orange wire to the board pin at the junction of the 10n capacitor and the 100R resistor. See Diagram 4. Note that the keyer output is wired for POSITIVE keying lines. If high voltage keying is used replace the BD139 with a suitable high voltage transistor and increase the rating of the 10n capacitor across the RCA socket. If negative keying is used reverse the connections from the keying line across the 1N4007.

Locate the 1k resistor (R26) in the base circuit of the Microbee audio stage (TR3, BC548). This should be visible from the top of the keyboard through the slots in the keyboard frame to the right of the space bar when viewed from the front.

- from page 16

one port and chamber serves the front radiation from the driver while the other port and chamber serves the rear and the driver's front radiation is 180 degrees out of phase with that from the rear. Happily however, the response characteristics of a port comes to our aid here. The port radiation above resonance is 180 degrees out of phase with that below resonance. Thus, the radiation of the lower frequency port above resonance is in phase with that from the higher frequency port which is operating below resonance.

Bose say that a frequency range of typically two octaves can be achieved through choice of driver characteristics together with port and box design that results in optimum port/box Q values to achieve critical coupling which results in the required flat response. Up to three octaves can be achieved, apparently.

NEW COMPACT HIGH EFFICIENCY POWER SUPPLIES!

Just imagine a 12W supply in the space of a matchbox!

Made in
Australia

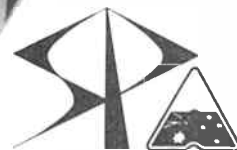

... Yes it's possible with the new
**Statronics Thick Film Hybrid Switching
Power Supplies. Look at the specs —**

- **No external Components**
- **Input Undervoltage Lockout**
- **80 to 85% Efficiency (+0.5W overhead)**
- **3750V rms 1min Input Isolation**
- **Better than 5% Regulation**
- **Better than 100mV Ripple and Noise on 5V supply**
- **60° C ambient operation**
- **Converters over 5W have better than 1mV rms reflected input noise**

Very competitive pricing. Check the table and call NOW!

| Input Range | Sep. Outputs | Total Power (W) | Dimensions (mm) LxWxH |
|---------------------------------------|--------------|-----------------|-----------------------|
| Vrms | V | | |
| <i>Power Supplies</i> | | | |
| 90-280 | 5,12,12 | 5 | 70x25x15 |
| 95-280 | 5,12,12 | 7.5 | 70x25x15 |
| 200-280 | 5,12,12 | 10 | 70x25x15 |
| 90-280 | 5,12,12 | 15 | 95x30x20 |
| 90-280 | 12 | 15 | 95x30x20 |
| 200-280 | 5,12,12 | 20 | 95x30x20 |
| 200-280 | 5,12,12 | 30 | 95x30x25 |
| <i>Converters</i> | | | |
| 21-63 DC | 5.5 | 5 | 25x25x15 |
| 21-63 DC | 5,12,12 | 7.5 | 70x25x15 |
| 21-63 DC | 5,12,12 | 10 | 70x25x15 |
| 21-63 DC | 5,12,12 | 20 | 95x30x20 |
| 21-63 DC | 5,12,12 | 30 | 95x30x25 |
| <i>Conventional "Open Frame" Type</i> | | | |
| 21-63 DC | 5,12,12 | 70 | 150x65x50 |
| 200-280 | 5,12,12 | 70 | 150x65x50 |
| 90-140rms | 5,12,12 | 70 | 150x65x50 |

EAGLE ELECTRONICS

*The End of
an Era!*



**THE FABULOUS NEW 6005 MODULE.
6000 FIDELITY IN A 5000 PACKAGE.**

This new module marks the end of a long and distinguished series of 5000 Amps. This exclusive Eagle Electronics kit enables you to make the conversion with no fuss and at minimum cost.

Kit includes all parts, pcb etc., but no power FETS.

You save by using your existing devices.

They are, of course, available separately if required. As usual the **TOP QUALITY** Eagle Electronics kit contains Roederstein metal film resistors throughout, MKT and MPK capacitors, NTE 461 - the best available, Semis by Philips, Motorola and Hitachi.

\$139⁹⁵

MAIL AND PHONE ORDERS WELCOME.

Eagle Electronics Pty. Ltd.

54 Unley Road, Unley, S.A. 5061

TELEPHONE:

(08) 271 2885

ALLOW \$10 FREIGHT
WITH ORDERS



STATRONICS POWER SUPPLIES

103 Hunter Street

HORNSBY 2077

Tel: (02) 476 5714, 477 5152

May 1987 — Australian Electronics Monthly — 63

dem project 3510

INDIVIDUAL USER PORT CONNECTIONS ARE DETERMINED BY THE INSTRUCTIONS CONTAINED IN THE PARTICULAR PROGRAM.

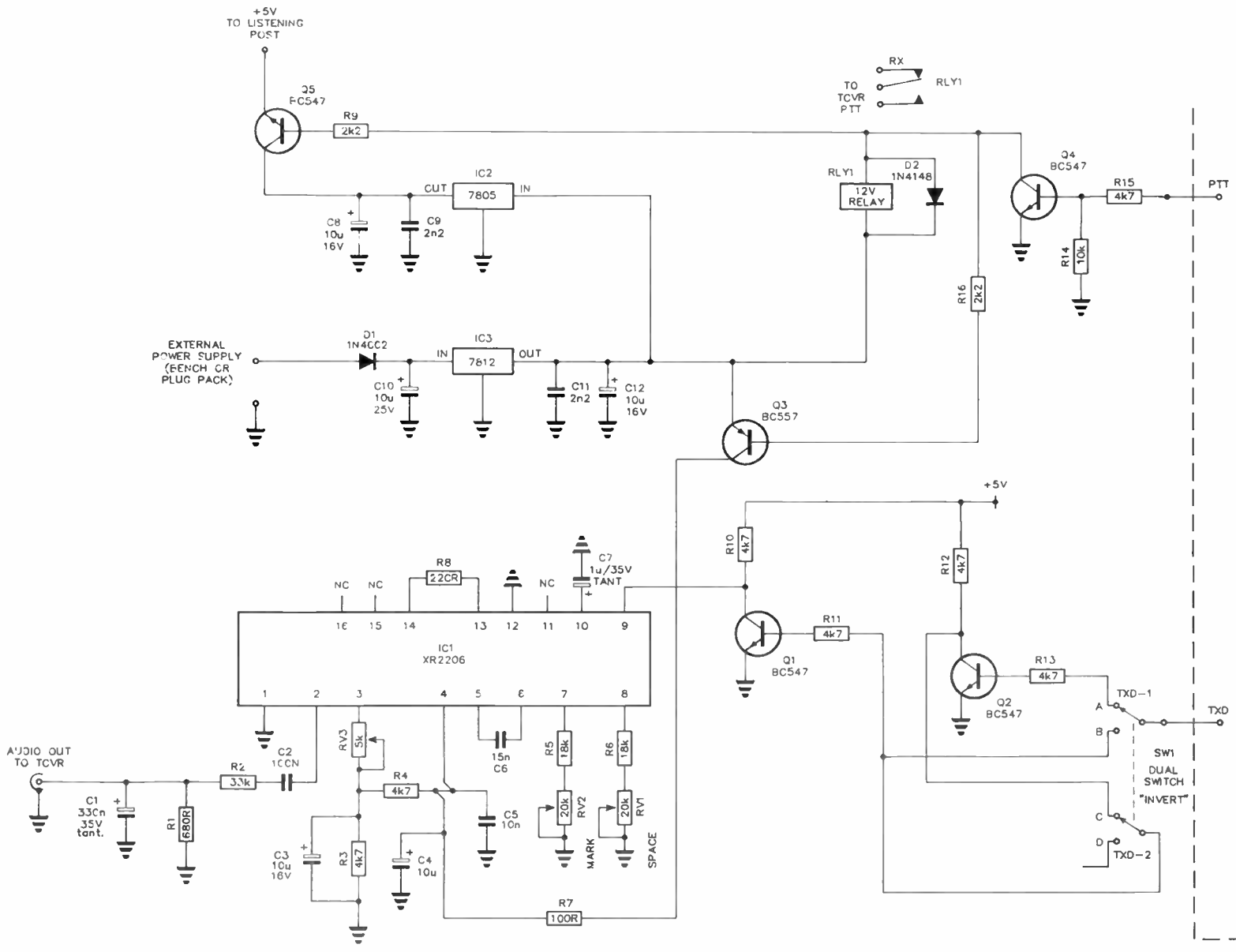

Build this simple radio teletype modulator

Andrew Keir VK2AAK

Based on a circuit submitted by Ron Reynolds VK2AFR, this simple, versatile unit is intended for attachment to a personal computer using software to generate the radio teletype (RTTY) Baudot code characters. It is an ideal companion to the very popular AEM3500 Listening Post decoder unit designed by Tom Moffat VK7TM and published in our first issue, July 1985. Indeed, that's how Ron VK2AFR employs his prototype.

THIS PROJECT describes a simple radio teletype (RTTY) encoder based on the EXAR XR2206 FSK modulator IC. The unit can be used as a stand-alone device or in conjunction with the popular AEM3500 Listening Post demodulator to provide a complete RTTY modem. The project has been designed to be as versatile as possible whilst remaining simple to construct and use.

This unit relies on a host computer to provide the correctly formed and timed Baudot characters and simply converts these TTL level signals to the corresponding "mark" and "space" tones suitable for modulating an amateur transmitter. The output of the modulator is audio frequency shift keying (AFSK), and if fed to a single sideband transmitter, will produce frequency shift keying (FSK). If fed to an FM transmitter, as commonly used on VHF, then the required AFSK signals will be produced. The unit is not computer specific, although the method of connection to any given computer will generally be determined by the software in use. Virtually any machine with a TTL level I/O port can be used successfully. ►

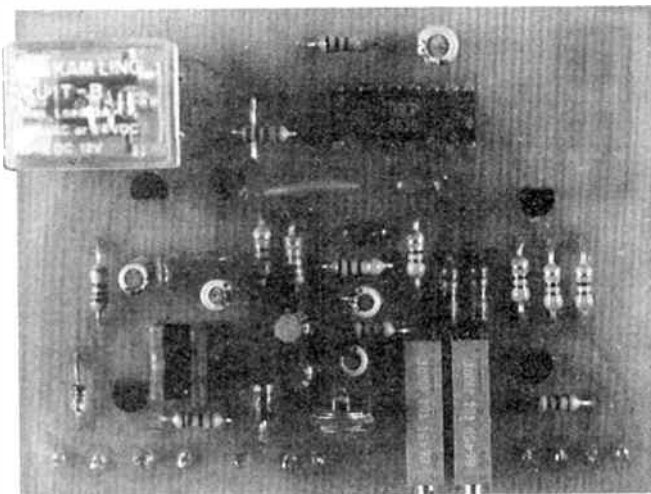

CIRCUIT OPERATION

The circuit is quite straightforward, being based on the XR2206 function generator IC. In the configuration used in this project, the 2206 will produce one of two tones, the frequency of which is determined by the resistors associated with pins 7 and 8 and the capacitor between pins 5 and 6. The signal applied to pin 9 of the IC will determine whether the resistor on pin 7 or the resistor on pin 8 is used as the timing element. If RTTY keying is applied to pin 9, one or other of the resistors is used depending on whether the keying signal is high or low. In this case variable resistors are used on pins 7 and 8 and these are adjusted to produce tones of the desired frequency so the keying input will result in one or other of the two tones being produced.

The remainder of the circuit is concerned with power supply and switching. An unregulated dc supply is applied via a protection diode to IC3, a 7812 three-terminal regulator. The 12 V output from IC3 is fed to a second three-terminal regulator, a 5 V output 7805. This supply is mainly used to power the Listening Post demodulator when used in conjunction with this project.

If you already have a regulated 12 V supply then there is no reason why it cannot be used to power the project. In this case the 7812 becomes unnecessary and a link can be fitted between the input and output terminals (the two outer pins) on the pc board. If you are using an external supply and wish to keep the 7812 then it should supply at least 15 Vdc so that the regulator can function correctly. If you decide to house the unit in a case you may choose to add an internal supply.

A suitable transformer and rectifier which delivers about 15 Vdc will be quite adequate.

The signal path from the computer to the transmitter is quite easy to understand. The keying signal from the computer's I/O port is applied via the "invert" switch, SW1, to either of the two transistors Q1 or Q2, depending on the position of the switch. In one position the signal is fed only to the base of Q1 which results in the signal applied to pin 9 of IC1 being inverted; i.e. if the keying signal is high then Q1 will turn on, pulling pin 9 of IC1 low. If the "invert" switch is in the other position the keying signal is applied to the base of Q2. A high signal will cause it to conduct and its collector will go low. The collector of Q2 is now connected via the second set of contacts on SW1 to the base of Q1 which will turn off, allowing pin 9 of IC1 to go high via the pullup resistor R10. The result in this case is that the signal on pin 9 of IC1 will be of the same sense as the keying signal.

The PTT signal from the computer is applied via resistor R15 to the base of transistor Q4. This transistor controls relay RLY1, the contacts of which are normally open and will close when a high signal is present on the PTT line from the computer. A high PTT signal from the computer will cause Q4 to conduct and its collector will go low. The base of transistor Q5 is connected via a resistor to the collector of Q4 so it will turn off, removing the 5 V supply to the Listening Post demodulator connected to the emitter of Q5. Transistor Q3 performs a similar function but controls the 12 V supply to the modulator. The PTT signal from the computer thus switches power to either the modulator or the demodulator as well as controlling the transmitter.

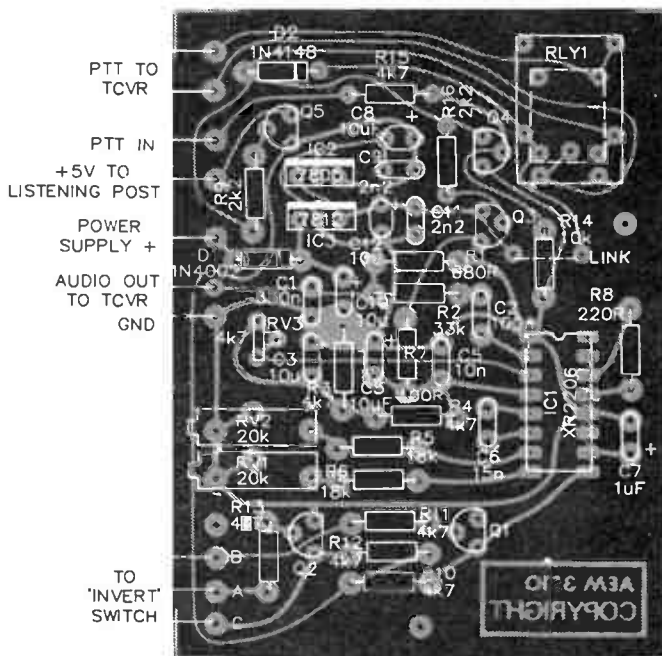

Component overlay.

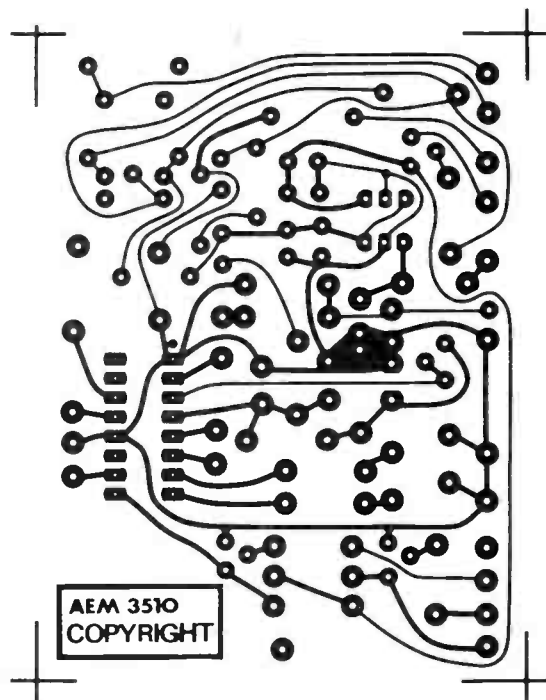

Printed circuit board, full-size artwork.

AEM3510 PARTS LIST

Semiconductors

| | |
|-------|-----------|
| Q1-Q2 | BC547,548 |
| Q3 | BC557,558 |
| Q4-Q5 | BC547,548 |
| IC1 | XR2206 |
| IC2 | 7805 |
| IC3 | 7812 |
| D1 | 1N4002 |
| D2 | 1N4148 |

Resistors all 1/4 W, 5%

| | |
|---------|------|
| R1 | 680R |
| R2 | 33k |
| R3-R4 | 4k7 |
| R5-R6 | 18k |
| R7 | 100R |
| R8 | 220R |
| R9 | 2k2 |
| R10-R13 | 4k7 |
| R14 | 10k |
| R15 | 4k7 |
| R16 | 2k2 |

RV1-RV2 .. 20k ten-turn trimpot
RV3 4k7 mini vert. trimpot

Capacitors

| | |
|-------|-------------------|
| C1 | 330n/35 V tant. |
| C2 | 100n greencap |
| C3-C4 | 10u/16 V electro |
| C5 | 10n greencap |
| C6 | 15n greencap |
| C7 | 1u/35 V tant. |
| C8 | 10u/16 V electro. |
| C9 | 2n2 greencap |
| C10 | 10u/25 V electro. |
| C11 | 2n2 greencap |
| C12 | 10u/16 V electro. |

Miscellaneous

AEM3510 pc board, mini 12 V relay (Jaycar SY4060 or DSE S-7112); DPDT toggle switch; hookup wire.

Estimated cost: \$30-\$35

REAR VIEW OF SW1

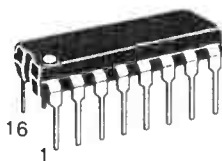
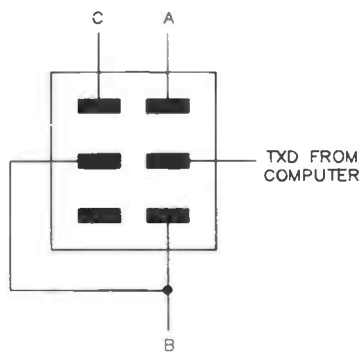

POSITIVE REGULATOR 78xx



DIODE



TRANSISTORS

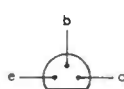

BOTTOM VIEW

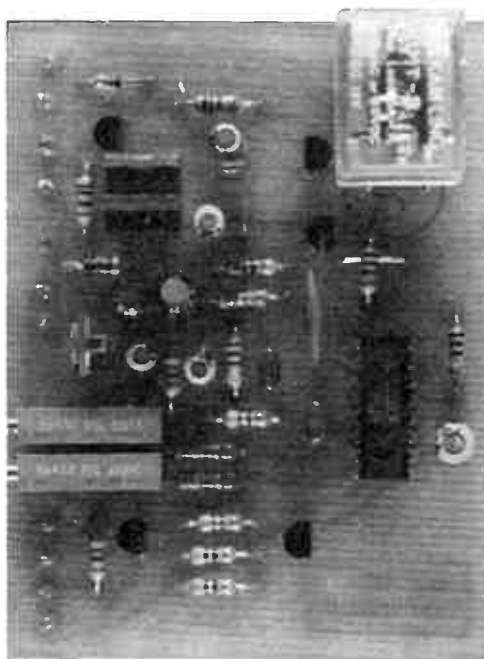

A view of the completed prototype. The pins provide external connection to the Listening Post, computer, switch and power supply. The link under R14 is clearly seen. Note that R16 was mounted under the board when this picture was taken.

Computers and software

There are a number of programs available to suit a wide range of computers. Many are in the public domain and can be obtained by asking amongst amateur operators already active on RTTY. To my knowledge there are several programs to suit Commodore C64 computers as well as the Amstrad and the BBC micro. It would be a good idea to get in touch with ANARTS, the Australian National Amateur Radio Teletype Society, who are the national body representing RTTY enthusiasts. I'm sure they will be able to provide valuable advice and suggest some sources of software. Their postal address is c/o Box 860, Crows Nest, NSW 2065.

We have not provided details of specific connection to particular computers in this article for the simple reason that it will depend on the software in use. As an example, the several programs available for the C64 machine all use different pins to output the transmitted data and PTT signals. The instructions supplied with your software will doubtless indicate which signals will appear on which pins of your computer's I/O port.

Construction

Building the modulator is quite straightforward when using the pc board designed for the project. There is no particular order in which components should be placed, with the exception of the one wire link which is routed under resistor R14 and which should be fitted first. It is usual practice to start with the passive components and leave the semiconductors until last. Check the orientation of the transistors, IC, diodes and electrolytic capacitors and examine the board for shorted tracks or unsoldered joints before applying power. Note that the board has been laid out to accommodate two common low-cost relays.

There are a number of connections to be made to external devices, and these are accomplished by running leads from the pc board to a suitable connector mounted on the case. The connections which need to be made are the press-to-talk (PTT) connection to the transmitter, the audio output from the modulator to the transmitter, the PTT input signal from the computer, the transmit data (TXD) signal from the computer and the power supply connections if using an external supply.

The audio signal to the microphone input of the transmitter is best connected using screened cable. The easiest solution here is to use a two-core screened cable so that the PTT line can be run together with the audio line and both can then be terminated at a suitable microphone plug. Connection to the computer will depend on what type of computer is employed. There are only two signals required by the modulator so there should not be any difficulty experienced.

If you intend using the project in conjunction with the Listening Post then you can probably combine all the signals in the same cable and terminate them in the existing plug. There is one pad left on the pc board which is used to route power to the Listening Post demodulator under control of the PTT line. This will allow switching between transmit and receive under computer control if both projects are combined to produce a complete RTTY modem.

LEVEL

We expect that constructors of an
INTERMEDIATE
level, between beginners and experienced
persons, should be able to successfully
complete this project.

The only remaining wiring to be done is to the "invert" switch. This switch allows inverting the "mark" and "space" tones in case the software in use does not have this facility.

In a following issue we will describe how to combine this modulator with the Listening Post demodulator as well detailing a suitable case in which to fit it all. If you have some other demodulator, this project may be used with it in the same general way.

Alignment

There are only three adjustments which need to be attended to. Two multi-turn trimpots are provided to set the "mark" and "space" tones, while a third trimpot is used to set the level of audio to the microphone input of the transmitter. For aligning the unit, you will need a multimeter and a frequency meter or counter capable of measuring to at least 1 Hz in 3 kHz, or better.

Start by connecting the power supply and check the output pins of the three-terminal regulators, IC2 and IC3. IC2 should show +5 V and IC3 should show +12 V, each with respect to ground.

Connect the PTT input line to +5 V using a jumper lead. The relay should close and you should observe +12 V on pin 4 of the 2206 IC. If everything is OK so far, connect a frequency counter to the junction of R2 and C2. You will probably need to advance the output level trimpot RV3 to get sufficient signal for a stable reading on the counter.

Now use a jumper to connect the transmitted data (TXD) input of the modulator to +5 V and measure the voltage at pin 9 of the IC. If you obtain a reading of +5 V then flip the "invert" switch so that 0 V appears on pin 9. Adjust RV1 for a reading of 2295 Hz on the counter. Flip the "invert" switch to the other position and check for +5 V on pin 9 of the IC, then adjust RV2 for a reading of 2125 Hz. Flip the "invert" switch back and forth a few times and check that the reading on the counter is either 2125 Hz or 2295 Hz accordingly. You may need to repeat the adjustments a few times as there will be some interaction between them.

The adjustment of the output signal level is best left until the project is completed and cased. The pc board has been arranged so that the trimpot RV3 is near the edge. This allows screwdriver adjustment through a suitably located small hole when the unit is fitted into a case. If you prefer, RV3 can be replaced with a panel mounted pot of the same value, although once set it will re-adjustment should be rarely required unless changing to another transmitter.

If you intend using the project with an SSB transmitter, then the output should be set to give the same drive level as normal voice when the transmitter mic gain control is adjusted to its usual level. In this way the transmitter's mic gain control can be used to set the level when using RTTY. If you are using the modulator with an FM transmitter, then the ideal solution is to monitor the output of the transmitter with a deviation meter. Unfortunately, not all of us are lucky enough to have one so an alternative method is to use another receiver to monitor your transmissions. Start with RV3 set to minimum and set the unit to transmit either a mark or space tone. Increase the output by adjusting RV3 and the monitored signal should get louder. Continue adjusting RV3 until the monitored signal no longer increases in level with continued adjustment of RV3 and then back off RV3 so that the monitored signal is only slightly, but noticeably, reduced from maximum. If the output level from the modulator is too high or too low for your particular transmitter, and cannot be brought into range with RV3, it may be necessary to reduce or increase the value of resistor R2 accordingly. ♣

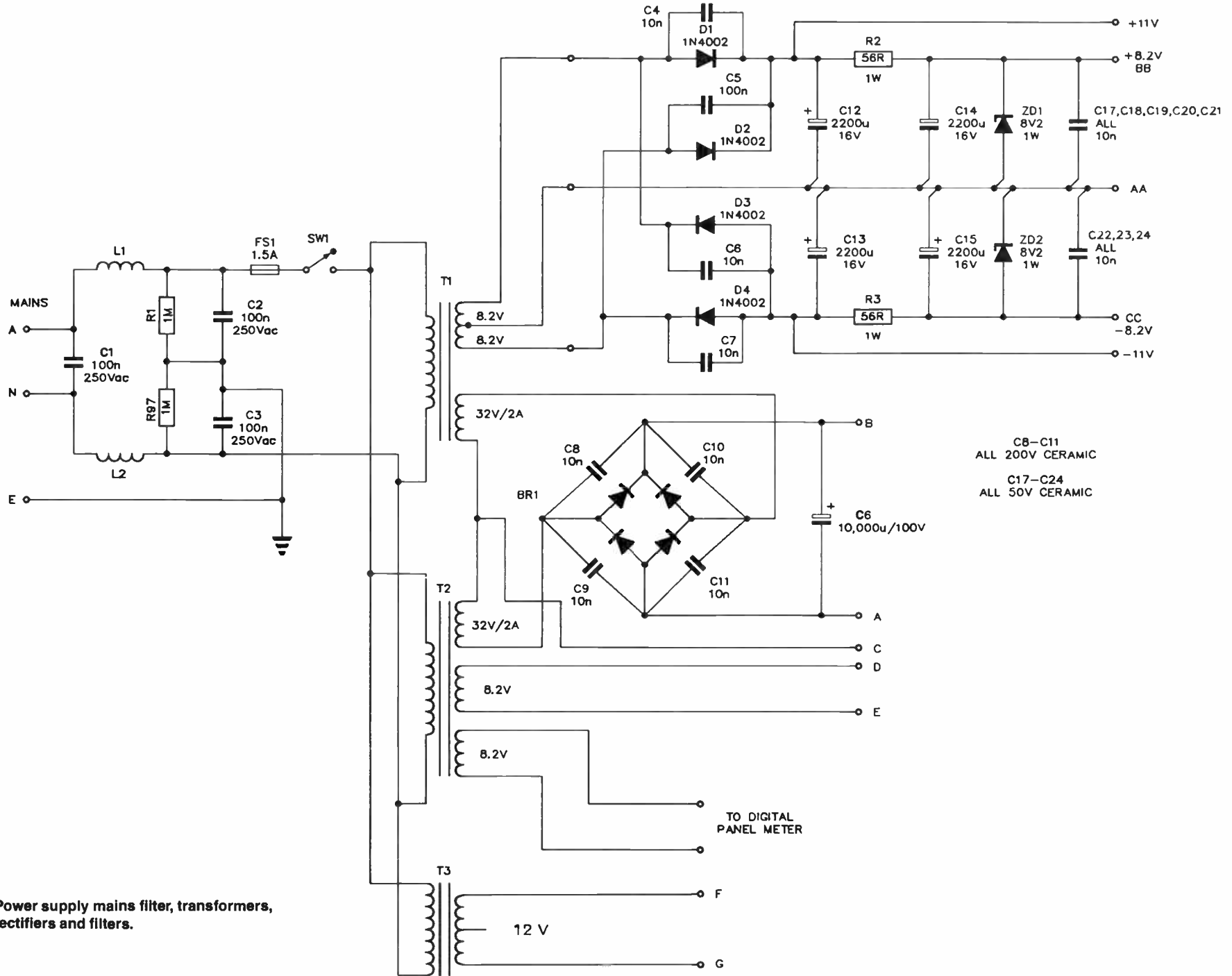

Power supply mains filter, transformers, rectifiers and filters.

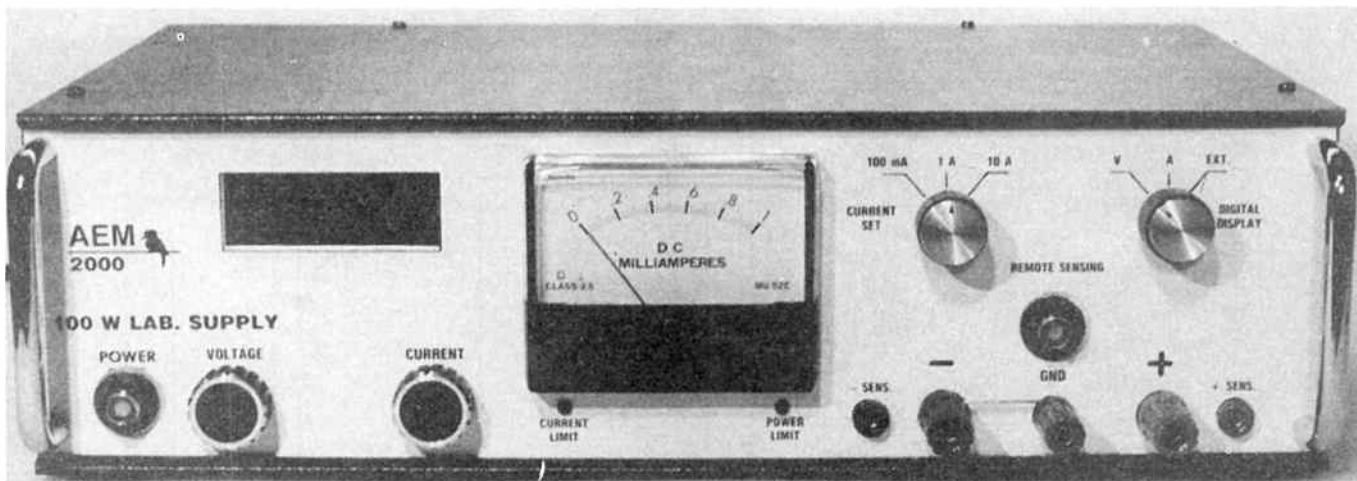

View of a completed prototype. The front panel has since been changed so that it has white lettering on a black background.

A true 'laboratory standard' 0-55V, 10A max. output power supply

Gerald Rafter

This month we describe the power supply circuit in detail, examining each stage in turn as it is fairly important to gain an understanding of the circuit operation should you need to service or fault-find in the unit following construction or at a later date.

THE BEST WAY to gain an understanding of the circuit in detail is to look at it stage by stage, following the arrangement detailed in the block diagram of Figure 1 in Part 1, last article. Space does not permit the inclusion of the digital panel meter circuitry which we will leave until later. So, let us start at the input mains filter and transformer-rectifier stage.

Three step-down transformers are employed, two of the same type – T1 and T2 – each having two 8.2 V low current secondaries and a 32 V/2 A secondary. An additional small transformer, T3, has a nominal 12 V secondary to provide an additional rail for the switched-mode pre-regulator. Transformers T1 and T2 have their 32 V secondaries connected in series to provide a centre-tapped 32-0-32 Vac source for the main rail bridge rectifier, BR1, a BR104. The output of this is filtered by C16, a 10 000 μ /100 V electrolytic, providing 80 V under load. Four 10n ceramic capacitors equalise reverse voltage distribution across the rectifiers also shunting them at high frequencies, reducing the possibility of breakdown from spikes on the line while they aren't conducting.

The two 8.2 V secondaries of T1 are series connected and full-wave rectified to provide a pair of positive and negative rails of about 11 V, each filtered by C12 and C13. Two zeners, ZD1 and ZD2, are used to stabilise these rails to 8.2 V, resistors

R2 and R3 providing their reverse bias current. Capacitors C14 and C15 provide further ripple filtering. Thus, dual ± 8.2 V supply rails are provided for various op-amps employed at various places in the circuit. Capacitors C17 to C24 are various supply rail bypasses located at different points in the circuit, but shown here for clarity.

One 8.2 V secondary of T2 is used to generate an independent negative supply rail in the switched-mode pre-regulator, while the other 8.2 V secondary is used to supply the digital panel meter.

The primaries of the three transformers are all connected in parallel, the active line being switched by the power on/off switch, SW1. A filter reduces noise input from the mains as well as reducing any noise generated in the supply circuitry from being conducted back down the mains. This filter comprises L1 and L2 in conjunction with C1, C2 and C3. Capacitor C1 shunts differential-mode noise, while capacitors C2 and C3 shunt common-mode noise to ground. Inductors L1 and L2 "choke" noise conducted down each line. Resistors R1 and R97 are there to discharge C1, C2 and C3 as they will retain some charge when the unit is switched off at the mains, unless switched off as the mains passes through zero. ►

Complete switched-mode pre-regulator and linear output regulator circuitry.

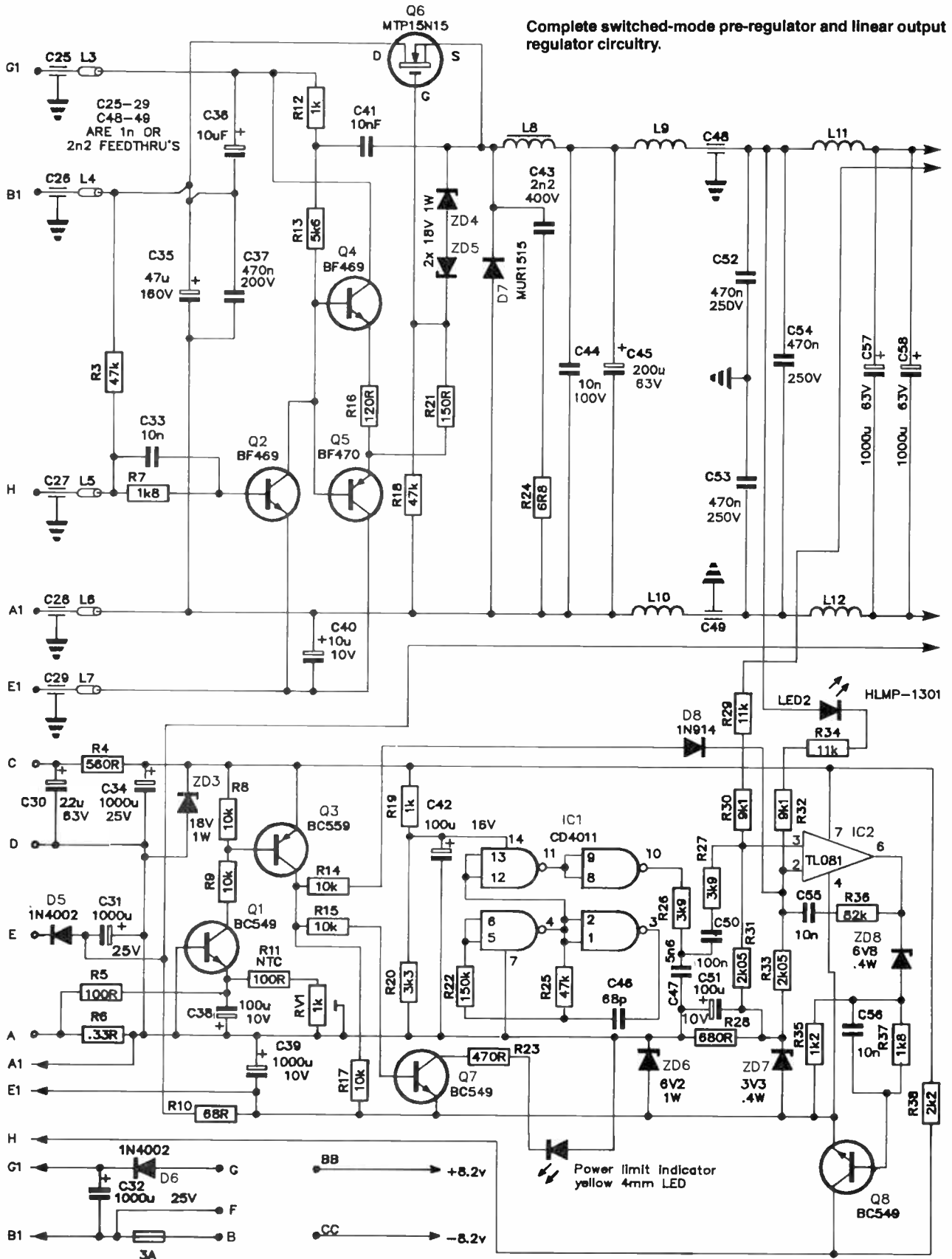

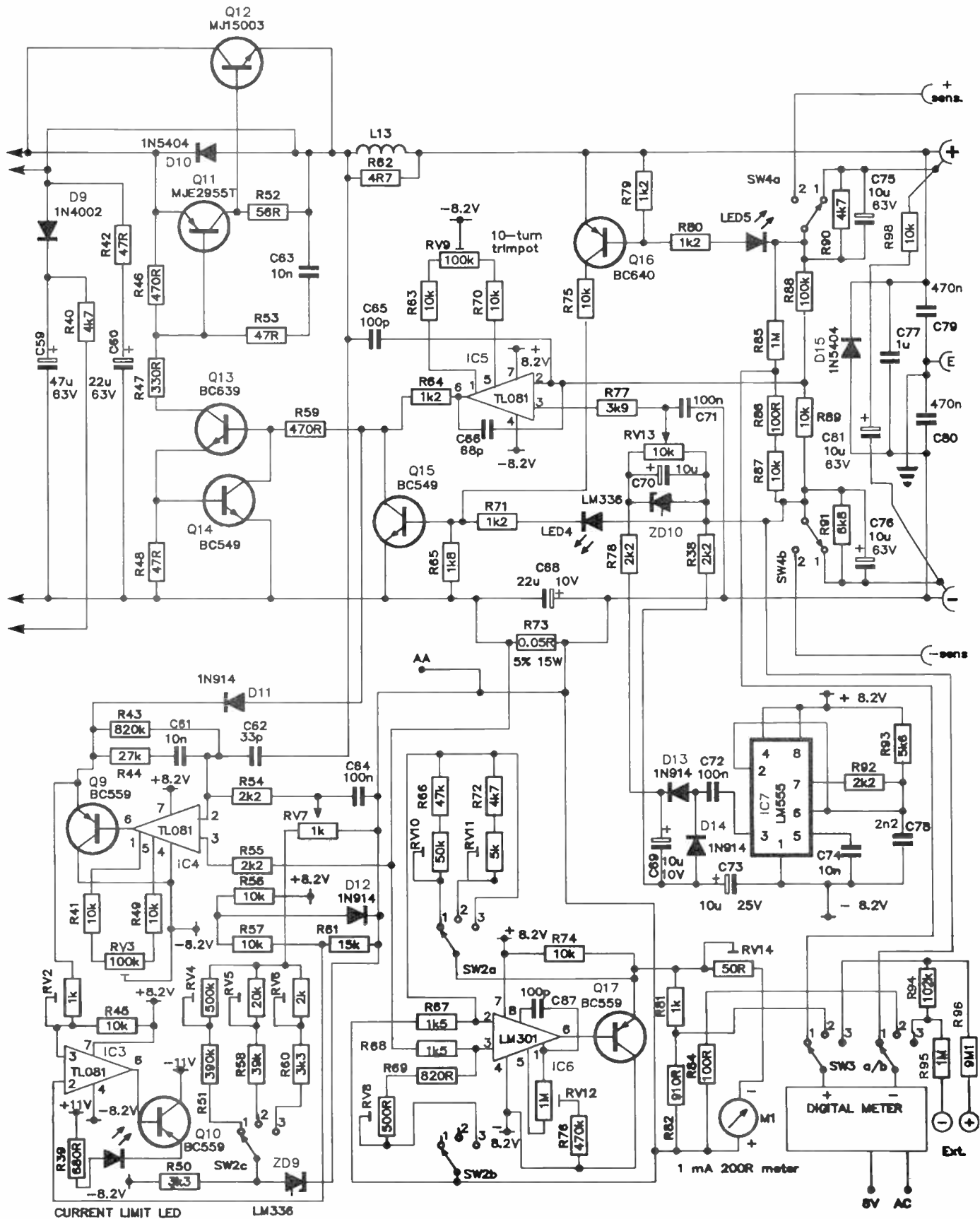

The switched-mode pre-regulator

This portion of the circuit involves the active devices Q2, Q4, Q5 and Q6 and accompanying components. The whole of the switched-mode pre-regulator section is enclosed in a small aluminium box with feedthrough capacitors bypassing dc rails and signals in and out. You can readily identify this section of the circuit as it is "bounded" by capacitors C25 to C29 at the left (input) side and capacitors C48-C49 on the right (output) side.

The main supply rail of +80 V enters via terminal B, 0 V enters via terminal A. It passes to the switched-mode pre-regulator main rail input, B1, via a 3 A fuse, FS1. The 0 V rail passes to the whole regulator circuitry via R6 to terminal A1. This resistor is used to sense the "overpower" condition and we'll get to its role a little further down the track. The pre-regulator drive circuitry requires a somewhat higher positive rail voltage than the main 80 V rail. This was provided by connecting one side of T3's secondary (F) to the 80 V rail at B1 and half-wave rectifying it with D6-C32 to develop +96 V with respect to the main 0 V rail at terminal G1. In addition, a -6.2 V rail for the pre-regulator drive circuitry is provided at E1, derived from a secondary (D, E) of T2, half-wave rectified by D5-C31 and RC filtered by R10-C39.

The switched-mode pre-regulator is a "buck-type" step-down circuit, the switch being Q6, a Motorola power T-MOS device, type MTP15N15 rated at 150 V/15 A. Gate drive is applied via a complementary push-pull drive stage comprising Q2, Q4 and Q5.

A variable duty cycle square wave is applied to the base of Q2, the collector current of which switches Q4, Q5 on and off alternately. The collector of Q4 is supplied with +96 V and the collector of Q5 is supplied with -6.2 V, both with respect to ground. This is to provide the gate of Q6 with a positive and negative swing with respect to the source and to maximise switching speed of the BF469-BF470 drivers. The gate swing is clamped to a maximum 36 V by two 18 V zeners connected back-to-back, ZD4-ZD5. Current limiting is provided by R21, while R18 provides a dc return to the common 0 V line for the gate of Q6.

When Q6 turns on, it allows current to flow into L8, which stores energy in its magnetic field, also charging capacitors C44-C45, the storage capacitors. During the on-cycle of Q6, the end of L8 connected to Q6's source is positive with respect to the end connected to C44-C45; diode D7 is reverse biased. When Q6 turns off, the collapsing field generates a voltage across L8 of reverse polarity to that impressed across it when Q6 was on. This forward biases D7, allowing current to flow from L8, maintaining the charge on C44-C45. Inductor L8 is wound on a Siemens special non-linear characteristic ferrite-core chosen for its greater efficiency over a wider current range than normal ferrite cores. Diode D7 is a 150 V/15 A fast recovery (60 ns) diode, Motorola type MVR1515. The RC network of R24-C43 is a "snubber" for switching transients, protecting D7. Note that Q6 and D7 are mounted together on a 200 x 100 mm heatsink. Two storage capacitors (C44-C45) are employed, C44 to handle the higher frequency charging currents, C45 the lower frequency charging currents.

Capacitors C35 and C37 provide bypassing of the incoming 80 V rail over a broad frequency range. Capacitor C36 bypasses the 96 V rail, the negative end being connected to the +80 V rail so that only a 25 V-rated capacitor is needed. Resistor R12 and capacitor C41 provide a "bootstrap" to improve the drive stage's switching speed.

The seven feedthrough capacitors, C25-C29 and C48-C49, together with the five ferrite beads L3-L7 and chokes L9-L12, all attenuate the RFI generated by the stage's switching transients in order to reduce external interference.

Control of the switched-mode pre-regulator is effected with a pulse-width modulated (PWM) controller comprising IC1, IC2, Q8 and associated components. Before continuing with the description of its operation however, the supply rails for this portion of the circuitry need explaining. A +18 V rail is derived from the centre-tap of the main supply, the two series-connected secondaries of T1 and T2. The voltage here is half the main 80 V supply rail. Resistor R4 limits the current through ZD3, while C30 and C34 provide some bypassing. A -6.2 V rail is derived from a secondary of T2, as explained earlier, half-wave rectified and filtered, regulated to 6.2 V by ZD6, for which R10 provides current limiting.

HI COM

ELEKTOR SOUND MIXER

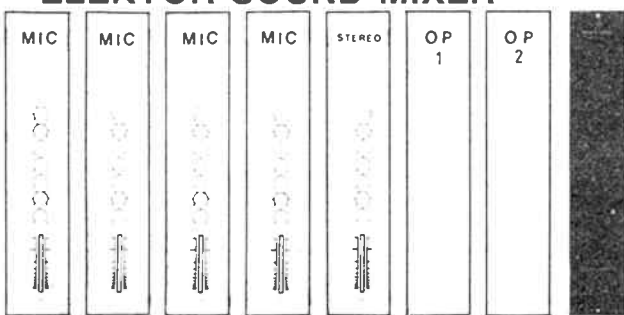

HI COM

THE ULTIMATE MIXER KIT

MODULES

All modules are silk screened, pre-drilled aluminium front panels with knobs, pots, connectors & components.

| | | | |
|-------------|-----------------|----------------|-----------------|
| MIC | \$85.00 | O/P2 HEADPHONE | \$95.00 |
| STEREO MD | \$98.00 | POWER SUPPLY | \$120.00 |
| O/P1 UV LED | \$112.00 | | |

BLACK ALUM. CASES

| | | |
|---------------|-------------|------|
| 8 modules C1 | 350 x 380mm | \$55 |
| 12 modules C2 | 350 x 560mm | \$63 |
| 16 modules C3 | 350 x 740mm | \$70 |

HI COM

Add-on Power Amp modules available SOON!

HI-COM UNITRONICS INT. P/L

7 PRESIDENT LANE, CARINGBAH, N.S.W. 2229
 PHONE: (02) 524 7878
 P.O. BOX 626, CARINGBAH 2229

Visa, Bankcard and Mastercard Welcome

| | |
|------------------------|---------|
| Mail Order | Postage |
| Less than \$50 | \$3.50 |
| \$50-\$99 | \$4.50 |
| \$100-\$250 | \$7.00 |
| Above \$250 | \$10.00 |
| Heavy items adds extra | |

IC1, a 4011 quad two-input buffered NAND gate, has two gates employed as a 100 kHz oscillator, the square wave output being buffered by the other two gates connected as inverters. The output, from pin 10, is integrated into a triangular-shaped wave by the network R26-C47, then applied to the non-inverting input, pin 3, of IC2 which is also 'referenced' to the output of the linear regulator, via R29-R30, which may be varied over the range from 0 to 55 V. The inverting input of IC2, pin 2, is referenced to the linear regulator input (switched-mode pre-regulator output) via R32-R34-LED2. The latter is employed as a low voltage zener with a "knee" of some 1.4-2 V, and here determining the voltage difference between the two inputs of IC2 and thus the input and output of the linear regulator. This maintains a low voltage drop across the ion of Q12, keeping dissipation in Q12 low. Both pins 2 and 3 of IC2 are returned via R31 and R33 to -2.9 V, established by ZD7-R28 from the -6.2 V rail.

Ignoring for the moment the triangle wave from IC1, pin 2 of IC2 will always be held at a slightly higher voltage than pin 3. Thus, the output of IC2, pin 6, will swing towards the negative rail, forward biasing ZD8 and holding the base of Q8 low. Q8 will thus be off and terminal H high (pulled up by R38). During the positive excursions of the triangle wave, pin 3 of IC2 will be driven above the bias on pin 2. Thus, pin 6 of IC2 will swing towards the positive rail for the duration that the triangle wave on pin 3 exceeds the bias on pin 2. This will drive on the base of Q8 which will conduct, its collector pulling terminal H low. The waveform on terminal H is thus the inverted form of that on pin 6 of IC2. Zener ZD8 and R37 limit the base current of Q8. Capacitor C56 speeds-up turn-on and turn-off of Q8. Resistor R36 and capacitor C55 set the gain of IC2 at high frequencies.

When the power supply output is set to a low voltage, pin 3 of IC2 will also be biased at a low voltage. The excursions of the triangle wave superimposed on pin 3 will thus "cut" this bias near the "base" of the wave and the output of IC2, pin 6, will be a square wave of relatively long duration. Thus, the positive-going pulses on terminal H will be of short duration (owing to the inverting action of Q8) and Q6 will be switched on for only short periods. Thus, the average output voltage of the pre-regulator will be low, maintaining a low input-output differential across Q12.

When the power supply output is set to a high voltage, the opposite occurs, the excursions of the triangle wave on pin 3 of IC2 will cut the bias on pin 3 near the peak of the wave, pin 6 will swing positive for relatively shorter periods, turning Q8 on for shorter periods. Thus terminal H will go high for longer periods, turning Q6 on for longer, increasing the average output voltage of the pre-regulator.

To effect power limiting, the PWM controller is "taken over". The power limit circuitry comprises R6, Q1, Q3, Q7, D8 and associated components. The main supply rail 0 V line from the main rectifier, terminal A, is routed to the regulator circuitry via R6, a 0R33/5 W resistor, and terminal A1. Thus, voltage drop across R6 is a measure of total current and total power drawn from the supply. This voltage drop is used to bias on Q1 when the current exceeds around 1.3 A, the point at which the power transformers are delivering about 100 W,

allowing for some output voltage droop with transformer regulation.

When Q1 starts to turn on, its collector current biases on the base of Q3. While Q3 is off, D8 is reverse biased as its anode is returned to the -6.2 V rail via R14-R17. When Q3 turns on, the anode of D8 will be pulled towards the +18 V rail, driving the bias on pin 2 of IC2 more positive which reduces the voltage difference between pins 2 and 3, thus increasing the period for which IC2's output is positive, decreasing the period for which terminal H (drive to the pre-regulator) goes positive. This reduces the turn-on time of Q6, tending to decrease the average output voltage of the pre-regulator and holding the power output down.

In addition, when Q3 turns on, it turns on Q7 via R15, the collector current of Q7 turning on LED7, the "power limit" indicator.

The threshold base current and gain of Q1 will vary with temperature, the gain and threshold base current increasing with increasing temperature. To compensate, R11, a resistor having a negative temperature characteristic (its resistance decreases with increasing temperature), robs emitter current from Q1 as the temperature rises. The power limit threshold, at a nominal operating temperature, is set by the adjustment of RV1.

The linear regulator

This portion of the circuit involves transistors Q11 to Q16, plus IC5, ZD10 and associated components. A more or less conventional series-pass circuit is employed, with Q12 being the series-pass device. As in all linear regulators, the output voltage is compared with a reference voltage. Any difference is then amplified by an "error amplifier" the output being used to drive the series-pass device further on or further off, so as to maintain the output voltage very nearly constant.

Now, facility has been provided for "remote sensing". That is, the voltage AT THE LOAD may be sensed and used to control the linear regulator, thus negating the effects of voltage drop in the leads between the power supply and the load. This facility necessitates a "floating" reference voltage. An LM336 2.5 V Precision Reference Source, ZD10, is used here to provide an accurate positive reference voltage with respect to the negative output terminal or the negative sense terminal. It is supplied by a floating source derived from IC7, a 555 oscillator here used to drive a "charge pump" comprising D13-D14-C69-C72 developing around 10 V across C69. The 555 is connected as an astable oscillator, running at about 100 kHz. It is supplied from the ± 8.2 V rails. A variable reference is available at the wiper of RV13, a 10-turn potentiometer mounted on the front panel, the "voltage" control.

IC5 is the linear regulator's error amplifier in constant voltage mode operation. It is powered from the ± 8.2 V rails. The load voltage at the output terminals (SW4 in position 1), or at the load via the "sense" terminals (SW4 in position 2), is tapped down by R88-R89 and applied to the inverting input of IC5. The reference voltage selected by RV13 is applied to pin 3 of IC5, the non-inverting input. If the voltage at pin 2 of IC5 is less than that on pin 3, this means the supply output voltage is lower than required. The voltage on the inverting input of IC5 will then be below that on the non-inverting input, driving the output of IC5, pin 6, towards the +8.2 V rail. This will increase the base drive current to Q13, increasing its collector current. In turn, this increases base current of Q11, which increases the base current of Q12, which tends to increase the output voltage.

If the voltage at pin 2 of IC5 is above that on pin 3, the output voltage is higher than required. The voltage on IC5's inverting input will then be above that on its non-inverting

LEVEL

We expect that constructors of an

INTERMEDIATE

level, between beginners and experienced persons, should be able to successfully complete this project.

input, pin 6 will then swing towards the -8.2 V rail, decreasing the base drive to Q13, Q11 and Q12, causing a decrease in the output voltage.

Thus, one can see that varying the reference voltage by varying the wiper position of RV13, will vary the output voltage.

Protection for the circuit should the sensor terminals be shorted is provided by Q15-Q16, LED4-LED5 and associated components. The LEDs are used here as low voltage zeners. If the sensor terminals are shorted when SW4 is set to position 2, Q16 will conduct, causing Q15 to conduct, which then shunts the output of IC5, removing drive from Q13, thus turning off Q11 and Q12.

Should the power limit circuitry be activated, Q14 protects Q13 from excessive currents when the power limit circuitry drops the voltage at the collector of Q12 and the error amplifier circuit attempts to compensate.

Capacitors C65 and C66, and C63 together with R53, add to the overall stability of the linear regulator's feedback loop. The RC networks R42-C60, and R98-C81 maintain stability of the regulator when inductive loads are connected, while L13/R62 prevents instability when capacitive loads are connected. Diode D9 along with C59 and R40 maintain the regulator's stability when there is no load at the output. Current through R40 is not returned through R73 so as not to affect the output current meter reading.

Diode D10 protects the regulator should a voltage supply greater than the output be connected to the output terminals, shunting the series-pass regulator and preventing any reverse bias greater than about 0.5 V appearing across it.

Should a voltage source, such as a battery, be accidentally reverse-connected across the output terminals, D15 will be forward biased, shunting the errant input and preventing any reverse voltage of greater than 0.5 V appearing across the terminals, obviating any disastrous effects.

The dc offset of the error amplifier IC5 may be adjusted by RV9, a 10-turn trimpot. Capacitors C70, C71, C75 and C76 are bypasses. The output impedance as seen at the terminals is kept low over a broad frequency range by capacitors C77, C79 and C80. These ensure a "clean" output at high frequencies and a well-bypassed output rail. The values chosen were a compromise between output impedance and transient recovery speed.

Output voltage metering is provided by the digital panel meter, selected by the metering switch, SW3.

Current monitoring and control

Output current is sensed by a 50 milliohm resistor in series with the negative output rail, R73. This is a metal encapsulated 5% resistor rated at 15 watts dissipation. It is mounted on the chassis bottom which acts as a heatsink for it. The voltage drop across this resistor is measured by the current monitoring circuitry used to drive the current meter on the front panel, and also used by the current limit circuitry.

The current monitor and meter drive circuitry comprises IC6, Q17, plus SW2 and M1 with related components. IC6 is powered from the ± 8.2 V rails. The voltage drop across R73 is fed to the two inputs of IC6, an LM301 op-amp. Its output is current amplified by Q17 to drive the meter, M1. The latter is a common 65 mm scale 1 mA panel meter. When the current through R73 increases, the voltage drop across it increases. This increases the difference between the two inputs of IC6, increasing the collector-emitter current of Q17. This draws more current via M1. Resistors R81, R82 and RV14 permit zero calibration of M1. The output dc offset of IC6 is adjustable by means of RV12. Frequency compensation is provided by C67. An LM301 was chosen for use here because of its low drift and low offset voltage.

Three current scale ranges are selected by means of two gangs on SW2 (a and b). These select trimpot networks that set the gain of IC6. Position 1 is 100 mA full-scale, position 2 is 1 A full-scale and position 3 is 10 A full-scale. The scale ranges are ganged with the current limit range selection circuitry so that the correct meter scale range is automatically selected when the current limit range is selected.

The current limit circuit involves IC4, Q9, D11, ZD9, RV7 and SW2. The voltage drop across R73 is sensed by the non-inverting input of IC4 and compared with a variable precision reference from the wiper of RV7, a 10-turn panel mounted potentiometer, the "current" control. Here again, the precision reference employs an LM336 (ZD9). With no output current, pin 3 of IC4 is at 0 V, while pin 2 is at some voltage between 0 and -2.5 V. The output of IC4, pin 6, will swing towards the $+8.2$ V rail, biasing Q9 off. When the output current rises, the voltage applied to pin 3 of IC4 via R55 will go negative (as R55 is connected to the supply side of R73). When this voltage equals the voltage at the wiper of RV7, the output of IC4 will swing towards the -8.2 V rail, turning Q9 on. This then forward biases D11 which pulls the junction of R59 and R64 towards the -8.2 V rail, robbing base current from Q13, thus limiting the regulator output current. Current regulation is effected by IC4 as it now acts as an error amplifier, comparing the voltage drop across R73 with the precision reference set by the wiper of RV7.

Gang c of SW2 selects different trimpots that set up the voltage impressed across RV7 from the LM336 2.5 V Precision Reference Source. Thus, three current limit ranges may be selected. These were set at 100 mA, 1 A and 10 A.

The current limit indicator circuitry employs IC3, Q10 and LED3 plus associated components. The voltage at the emitter of Q9 is applied to the non-inverting input (pin 3) of IC3 and compared with the voltage on the inverting input, pin 2. This is biased at something under 0.5 V, derived from a forward biased silicon diode, D12. This maintains temperature compensation for the current limit indicator circuitry. When Q9 is off, the voltage at the non-inverting input of IC3 will be above that at the inverting input as R45 will pull it towards the $+8.2$ V rail. Hence the output (pin 6) will swing towards the $+8.2$ V rail, turning Q10 off. When Q9 conducts, its emitter will pull the non-inverting input of IC3 towards the -8.2 V rail (via RV2, which adjusts the threshold) and Q10 will conduct as the output of IC3 will swing negative. This will light LED3, indicating the current limit mode.

Resistor R43 sets the dc gain of the current mode error amplifier IC4, while R44-C61-C62 provide high frequency gain roll-off. Capacitor C64 is a bypass.

Next month we get straight down to the nitty gritty of construction! 

"I've got two children, a loving husband, a good job and multiple sclerosis."

I've got multiple sclerosis, but it isn't the end of the world. Like most people with MS, my symptoms are mild. They come and go, but in between I'm fine.

I intend to go on as I am, with a supportive husband, two wonderful children and an understanding boss.

Some MS people are more disabled than I am. They need the activity therapy centres, the nursing homes and

the other services which MS Societies provide.

For their sakes, keep up your donations.

For most of us, though, remember that MS doesn't always mean wheelchairs. Your understanding helps us to keep our jobs, homes and families.

Support MS with your understanding as well as your dollars.

MS

For more information about multiple sclerosis, contact the MS Society in your state.

COMPONENTS, CABLES & CONNECTORS EXHIBITION

June 10-11, 1987

Organised by:
What's New Product Shows

Place:
Ringwood Convention Centre
Mines Rd, Ringwood VIC

Time:
June 10, 10 am to 6 pm
June 11, 10 am to 5 pm

Repeating the success of our first Components, Cables & Connectors show last year in Sydney we now invite our Victorian readers to sample the best of what's new in components, cables and connector products supplied by leading manufacturers from Australia and around the world.

Come and join the many hundreds of electronics specialists who'll be viewing the latest the market has to offer. See all the products from around 30 companies in a congenial but business like atmosphere at the modern Ringwood Convention Centre. If you are in design or manufacturing — don't miss this show.

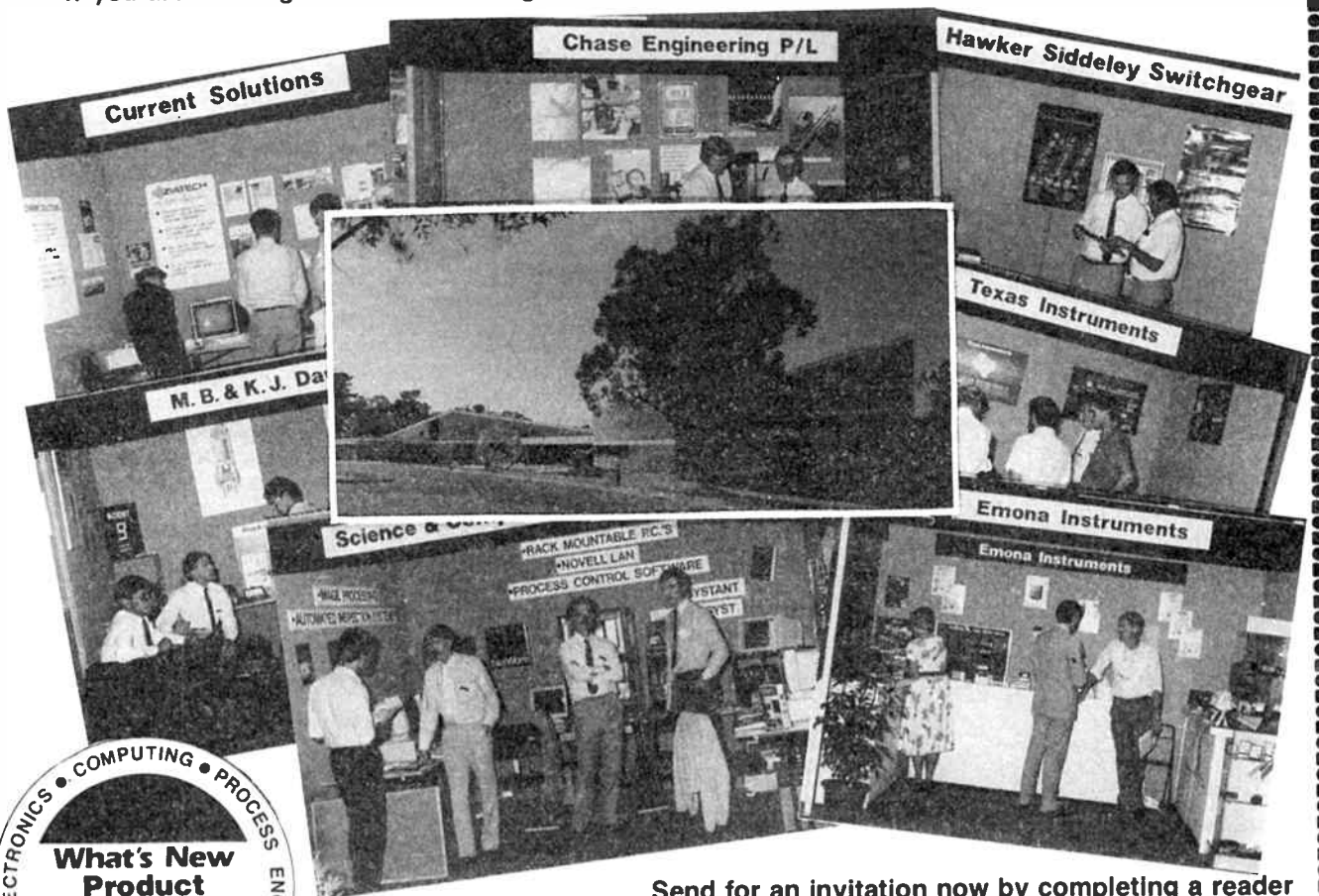

The sign of a professional show

Send for an invitation now by completing a reader feedback card with the number below.

New portable 2.6 GHz spectrum analyser

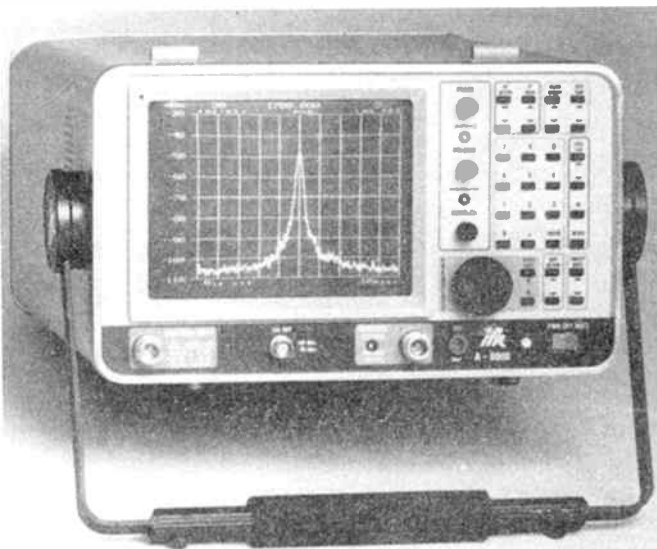

Vicom has released the new IFR A-8000 portable spectrum analyser, the second in a new family of general purpose test instruments. Vicom Managing Director, Mr Russell Kelly, claims that the new low cost analyser is the most advanced on the market.

"The A-8000 is a truly portable instrument and its compact size and rugged construction make the analyser highly suitable for remote field applications where no ac power source is available", he said.

All special functions of the A-8000 are selected from menus which can be displayed concurrently with graticule and trace information for uninterrupted viewing of analyser parameters.

For operational simplicity, the microprocessor system automatically selects and optimises resolution bandwidth, sweep rate and the frequency slewing rate.

The operator can uncouple the automatic optimisations when non-standard settings are required, then with a touch of a button, the analyser will resume the programmed optimised position.

The A-8000 has a coverage of 10 kHz to 2.6 GHz, while the A-7550 released last year operates to 1 GHz. Both instruments have a range of options including an on-board tracking generator, FM/SSB/AM receiver and quasi-peak detector.

The A-8000 comes with a two-year warranty with service backup and support provided by Vicom's Melbourne Customer Service Centre. Further information and a demonstration can be arranged by contacting Vicom at their Sydney, Melbourne, Brisbane and Wellington (NZ) offices.

New service monitor

Associated Calibration Laboratories, recently appointed sole distributors of the range of test equipment manufactured by Ramsey Electronics of the US, has released a new service monitor designed for the communications service technician, the Ramsey COM 3.

It covers the usual frequency range of 1000 kHz to 1 GHz and offers some features not available in other instruments. Price is currently below \$5000.

The direct entry keyboard eliminates the potential mechanical problems of conventional thumbwheel switches and features a programmable memory capable of storing and

recalling up to ten commonly used test set-ups.

Programmable offset keys simplify entry for duplex or repeater radios and incremental step keys allow receivers to be tested throughout its band-pass frequency range.

The audio frequency counter measures from 10 Hz to 1 kHz with 0.1 Hz resolution, and the RF counter gives an instant reading on any transmitted frequency. The encoder generates all standard EIA subaudible tones in the 50-300 Hz range.

As a generator, AM and FM modulation can be applied an internal modulation will provide both CTCSS tones and 1 kHz modulation when in the FM mode.

The unit is the lightest and most compact CSM, weighting less than 6 kg, including the built-in rechargeable battery pack. Optional extras include heavy duty padded cordura travel case and high stability oscillator.

Less is more

In today's world of high technology marine transceivers, small is beautiful, says Icom, so, their new IC-M55, an ultra-compact, go anywhere marine transceiver measures only 140 mm wide by 50.5 mm high and 163 mm deep, smaller than most SATNAV receivers, and it weighs only 1.3 kg. The IC-M55 can be mounted almost anywhere for convenient, easy access.

The IC-M55 covers the 78 international VHF marine channels and can be programmed for almost any authorised VHF marine channels. Ten instant-access memory channels can be used to store your most used

Full details and brochure from Associated Calibration Laboratories Pty Ltd, 27 Rosella Street, Doncaster East, 3109 Victoria. (03) 842 8822

Scalar Minibase

Cellular radio telephone has necessitated the design of a mobile base which reduces signal loss factor, expected in vehicle installations at these frequencies, if a conventional mobile base was used.

To meet these important needs Scalar industries has designed a new miniature UHF 'minibase', type UMB.

The base itself is only 30 mm in diameter and 10 mm in overall height. It requires a drilled hole of only 14 mm. It is suitable for use with the Scalar C54/LB gutter mount, or 2730 mirror/roof bar mount.

These bases accept all M6 (female) ferrules and, as standard, are provided with either 3.5m or 5m lengths of RG58C/U coaxial cable, but other lengths are available as specials, by quotation.

The bases are available now, and information and stocks can be obtained from the manufacturers, **Scalar Industries, 20 Shelley Avenue, Kilsyth 3137 Vic. (03) 725 9677.**

marine frequencies.

A large, bright LCD readout on the IC-M55 makes it easy to read the display even in direct sunlight. A display dimmer switch lets you adjust the brightness of the display to suit your own preferences. The IC-M55 delivers 25 W and, for close quarters operation, one watt output can be used.

The rugged, die-cast aluminium chassis and plastic mylar moisture resistant speaker of the IC-M55 can take a lot of punishment, Icom say. And like all Icom transceivers, the IC-M55 is built to last. See it at your nearest authorised Icom dealer or contact **Icom Australia, 7 Duke Street, Windsor 3181 Vic. (03) 529 7582.**

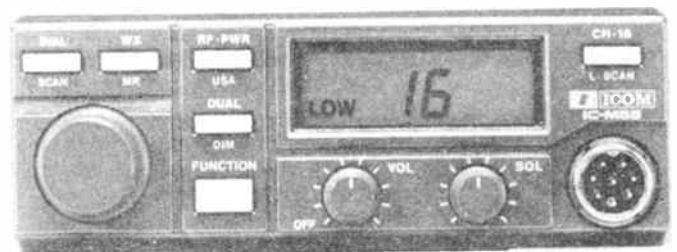

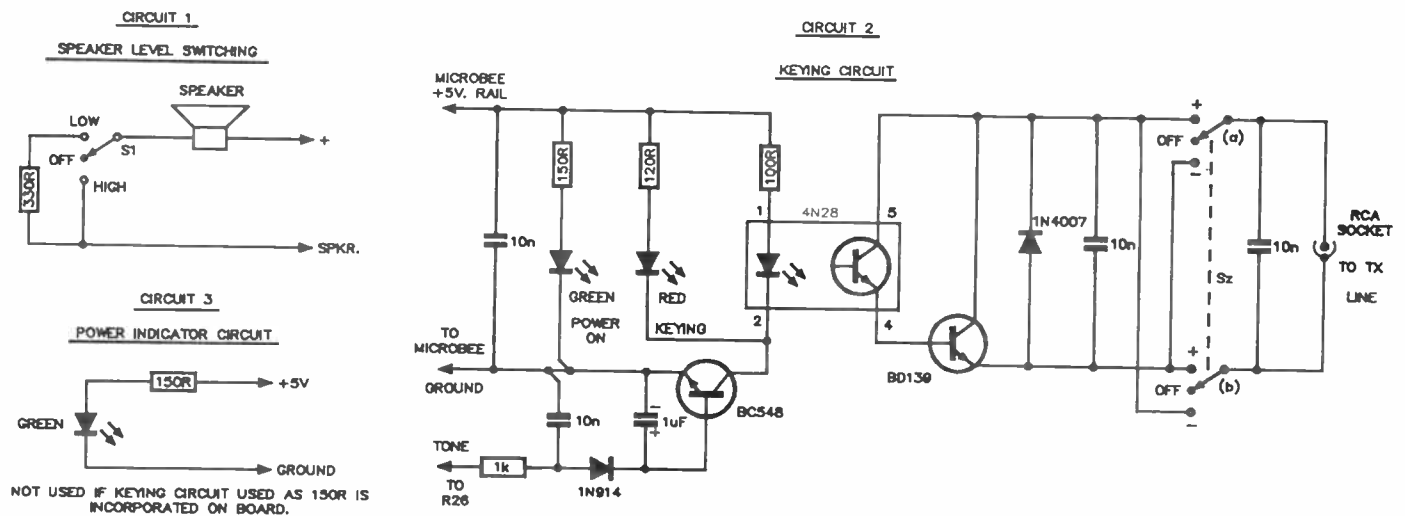

A menu selectable CW message generator using the microbee

Geoff Wilson, VK3AMK

IN THE DECEMBER 1985 ISSUE, I described a variable speed CW memory. The equipment modifications given here show how a standard 32K Microbee was used to generate CW from BASIC software. This does not produce Morse, as such, direct from the keyboard but provides a series of user-selectable messages. The Microbee can then key the transmitter directly or be used to load the CW memory.

The rate at which the CW is sent is fixed and relatively slow, but still quite adequate for beacon or calling purposes. By loading the CW memory from the Microbee at low speed a call can then be sent at variable speeds by adjusting the memory speed control.

At start-up the computer presents a menu of the messages available, the number of times the message is to be repeated and the delay periods to be used for reception.

Operation is based upon the generation of tones by the Microbee from a BASIC program. A small interface using an optic coupler links the input to the computer audio stage and the transmitter keying line. This allows the transmitter to be keyed while maintaining total isolation between the computer and transmitter, thus eliminating any risk of accidental damage to the electronics of either system.

The Microbee was modified but in a way which has no effect upon normal operation. At the same time some other changes were made to improve the Microbee and these can be incorporated regardless of whether the CW modifications are made or not.

A LED was added to indicate when the Microbee has power on. This had always seemed such an obvious omission as there was no way of knowing what its status was with the monitor turned off. The other problem was the fixed audio output level. In noisy situations such as for classroom use it would be satisfactory but for a quiet domestic situation it can frequently be far too loud. This problem was easily solved by adding a three position centre-off switch and a resistor to give LOW, OFF and HIGH selections. This was used in preference to a variable control due to space limitations within the case and the fact that two levels and off are all that is really needed.

To preserve the appearance of the Microbee all controls were placed at the rear and the power indicator was mount-

ed above and to the left of the ESCAPE key where it is clear of the keyboard. When the CW modification was made a complimentary LED to indicate keying was placed above and to the right of the back space key.

An RCA type socket was used for the transmitter keying line and another switch used to break the line and/or reverse the polarity of the keying to suit different types of transmitters.

The keying unit was built on a scrap of Veroboard about 15 x 55 mm and fitted in the space between the main board and the side of the Microbee case.

The software described is a suggested program only. Each operator will have different needs and there should be no difficulty in rewriting the program to suit particular requirements. The CW is based upon the 1/8th second period of the PLAY tones. A dot = 1 unit, a dash = 3 units. A space between characters = 1 unit, a letter space = 3 units and a word space = 6 units. This timing gives quite pleasing results. Each item required in a call, such as "DE", "AR", "K", VK3QRZ" etc, is programmed as a subroutine. To generate a message of a particular type each subroutine is called in the required sequence and the message is formed. Examination of the program will make this self explanatory. By selecting PLAY 0 of various periods the gap between transmissions can be made any time required. e.g: PLAY 0, 80 gives a ten second period, etc.

The simplicity or complexity of the software is totally dependent upon your needs and imagination. By calling a subroutine again and again a particular segment can be repeated over and over. e.g: GOSUB XXX : GOSUB XXX : GOSUB XXX would send "CQ" "CQ" "CQ" if "XXX" was programmed as CQ etc.

The keying unit is quite straight forward and should present no difficulties. It operates from a + 5 V regulated rail taken from within the Microbee. Tone is fed from the output of IC1 (Z80 PIO) to a BC548 in series with a 4N28 opto coupler. As each tone appears as dc at the 1 uF capacitor across the base of the BC548, the LED in the 4N28 is switched. The keying line to the transmitter is then keyed via the output transistor of the 4N28 and the BD139.

N.B.: The modifications described apply to a Microbee Ser-

KEYING UNIT TOP VIEW COMPONENT PLACEMENT

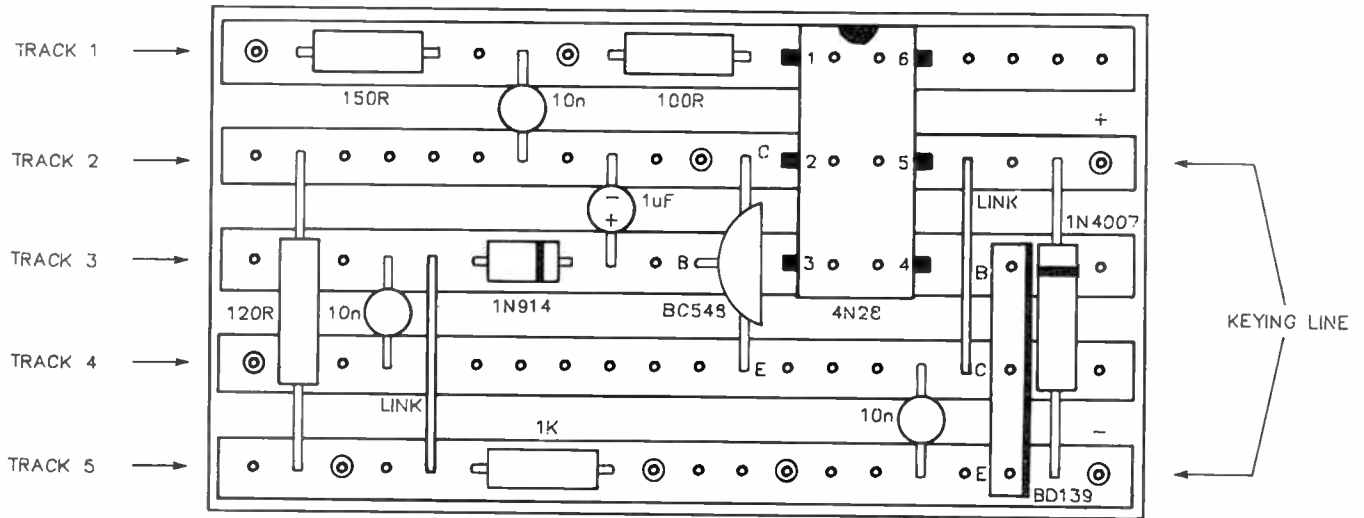

TRACK SIDE VIEW

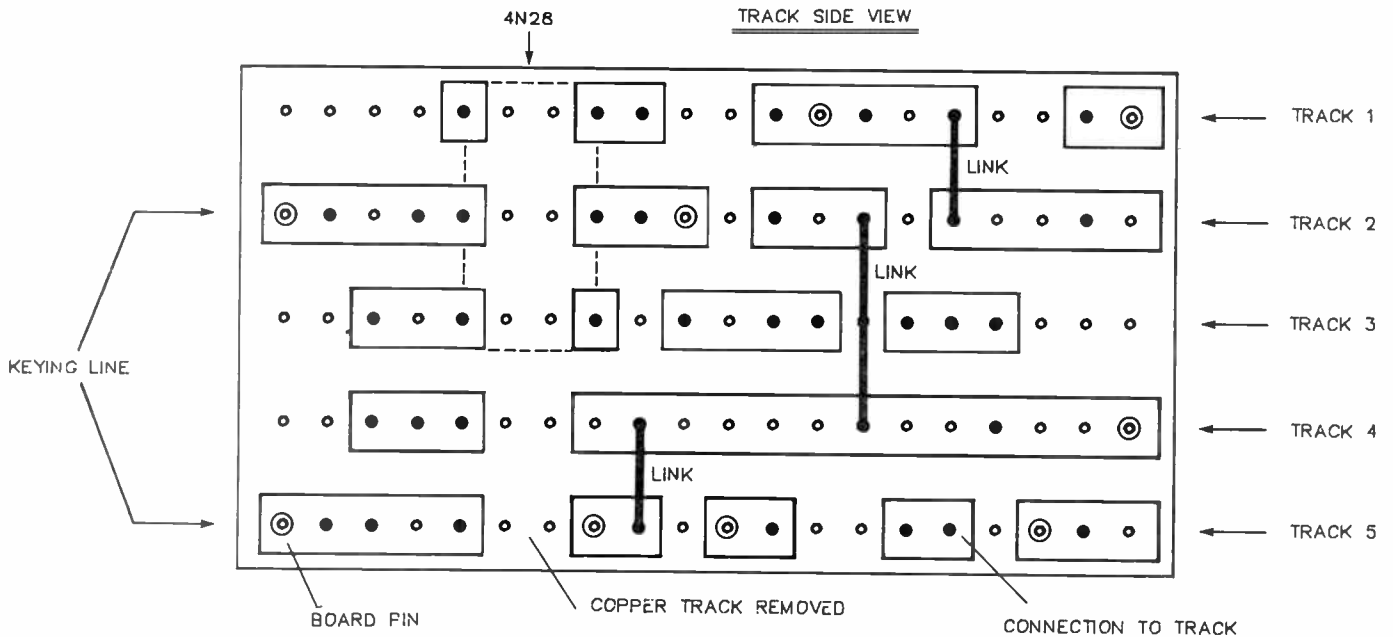

PARTS LIST

- Scrap of Vero board to give five rows, each with 20 holes.
- 9 x pc board pins.
- 1 x 1N914 diode.
- 1 x 1N4007 diode.
- 1 x 3 mm green LED.
- 1 x 3 mm red LED.
- 1 x 4N28 opto coupler.
- 1 x BC548 transistor.
- 1 x BD139 transistor.
- 4 x 10n ceramic capacitors.
- 1 x 1u/63 V electrolytic capacitor.
- 1 x 100R, 1/4 W resistor.
- 1 x 120R, 1/4 W resistor.
- 1 x 150R, 1/4 W resistor.
- 1 x 330R, 1/4 W resistor.
- 1 x 1k, 1/4 W resistor.
- 2 x DPDT centre-off switches.
- 1 x RCA panel socket and matching line plug.
- 1 x plug to suit transmitter key jack.
- 4m shielded audio lead.
- 75 mm IDC or rainbow cable, 7 wires required.
- Heat shrink tubing.

without difficulty. Run a link about 150 mm long between the switch and the RCA socket, place a 10nF capacitor across the socket. **DO NOT GROUND** this socket at the computer as the RCA socket must be totally isolated from the computer circuit. The switch gives three options, the centre position turns the KEYING OFF and the other positions are for **NEGATIVE** or **POSITIVE KEYING** depending upon the type of transmitter in use.

Wrap the keying unit in a small plastic bag to insulate it and seal with tape. Place some very thin foam plastic between the left side of the case and the main and upper boards towards the keyboard from the area of the speaker switch. Insert the keying unit in the space and insulate from all other components. Check and reassemble the case, don't tighten if there is any strain, remember plastic breaks easily! When all is OK, testing may begin.

Reconnect the power lead to the Microbee and check for normal operation. The speaker switch should mute the speaker in the centre position and be high and low in the alternative positions. If the low level is not right vary the 330R resistor as required in the range 100R to 1000R. Use a value to suit likely operating conditions. In a very quiet environ-

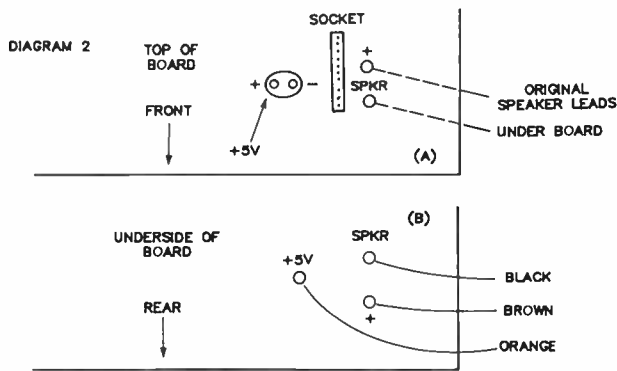

ment a much lower output will seem reasonable but may be almost inaudible in noisier conditions.

Load the program then run it with the speaker on. Distinct CW should now be heard from the speaker. Make a shielded lead to run from the transmitter key jack to the RCA socket and terminate it with an RCA plug making sure that the shell of the socket is at the transmitter ground potential.

If the transmitter locks on in the CW position reverse the connections at the keying unit output by turning the switch in the keying line to the alternative position. The Microbee should then key the transmitter normally.

The modifications

Begin by disconnecting all external leads to the Microbee. Turn the case upside down and remove the two Philips head screws at the rear of the case on each side. The top rear cover can then be lifted off. Remove the back-up battery and store it out of harm's way.

The upper and main circuit boards are joined by multi-pin connectors at each end. Usually these are covered with a Silastic-type sealant. Very gently strip the sealant from the connectors and prise the boards apart. Place the upper board in a safe location before proceeding further.

Remove the remaining four screws from the underside of the case and the lower case section and the black cover around the keyboard can be removed. Unscrew the screws at the left and right centre edge of the keyboard frame and the screws at the serial and I/O port sockets. Use care here as these screws are self tappers into plastic. The lower board and keyboard can now be completely withdrawn. Unsolder the speaker leads at the speaker only.

Drill the rear of the lower case section as shown in Diagram 1, being careful to place the holes accurately. Mount the speaker switch at the edge nearest the I/O port and the RCA socket near the power socket. The switch in the keying line is placed directly above the RCA socket but on the rear panel of the lid, use care in making the measurements as there

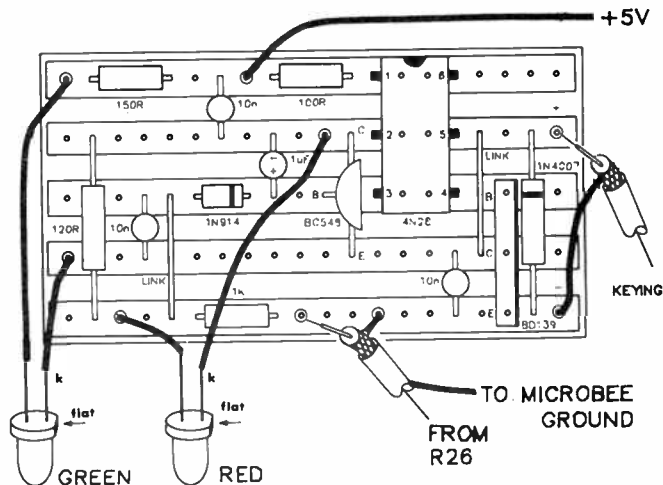

is not a lot of room inside the case if the holes are wrongly placed.

In some models space may not be available for the RCA socket and keying line switch to be placed between the power connector and the rear corner of the case. It should be possible to drill a hole in the back panel of the lid above the speaker switch position and use that for the keying switch. The keying line could then be terminated in a RCA line socket and the cable passed out through the user port hole in the rear panel. If this is done the centre of the hole for the keying switch should be 11 mm below the top of the lid.

Loosen the speaker retaining clamps and turn the speaker so that the terminals are parallel to the rear of the case, then tighten the retaining screws again.

Make a wiring harness approximately 75 mm long using three wires from a strip of IDC or rainbow cable using orange, brown and black. Locate the + 5 V rail near the connection point of the original speaker leads on the underside of the main board. This may be shown on the top of the board as an unused electrolytic capacitor location. Connect the orange lead to the + 5 V rail on the underside of the board. See Circuit (1) and Diagrams (2a) and (2b).

Remove the original speaker leads from the board and again on the underside of the board connect the brown lead to the speaker feed point marked "+" and the black lead to the speaker feed point marked "SPKR".

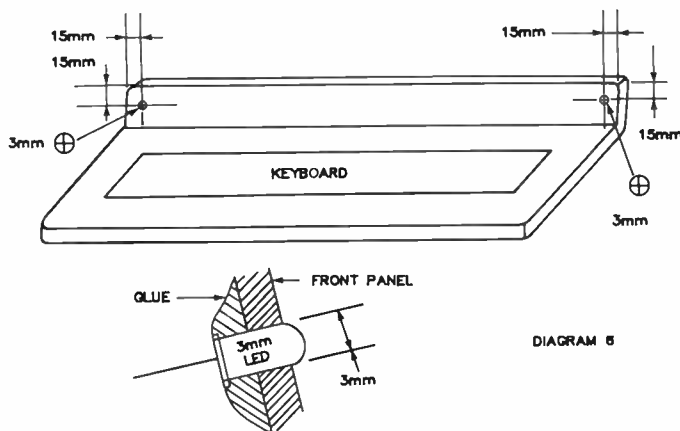
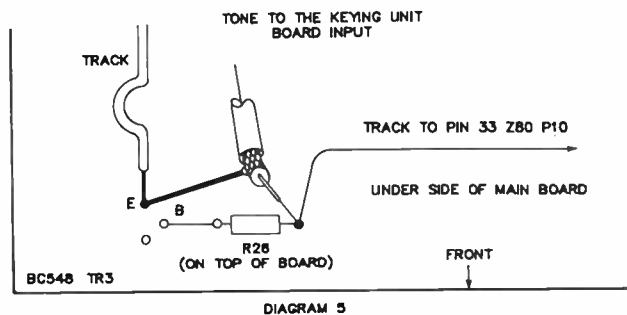

Break the brown lead at the speaker and wire one end to each terminal. The remaining end of the brown lead is connected to the centre terminal (or pole) of the speaker switch. Wire the 330R resistor across the other two switch terminals and wire the black lead to one end of the resistor.

Assemble the keying unit on the piece of Vero board as shown in Circuit 2 and Diagram 3. Solder the opto coupler direct to the board instead of using a socket as six pin devices tend to come adrift more easily than multi-pin ICs. Cut the copper tracks as shown using a spot face cutter. Place a link on top of the board between track 2 and track 4 (between pin 5 of the 4N28 and the collector of the BD139). After soldering the 10nF capacitor between track 1 and track 2 bend the

— to page 63. ▶

AEM PRINTED CIRCUIT SERVICE

Our printed circuit boards are all manufactured on quality fibreglass substrate and feature rolled-tin over copper tracks and silk-screened component overlays.

MAKE A MODEM!



The **AEM4600 Dual-Speed Modem** is quite a popular project. Get yourself on-line with the maximum features for the minimum cost. Features 300/300 and 1200/75 bps modes. Simple RS232 (serial) interfacing. All parts readily available. (Published Dec. '85)

\$17.50
board has some faulty tracks & no components overlay but our package includes full instructions, plus post & handling charges
All boards manufactured on quality fibreglass substrate with rolled-tin over copper tracks

AEM1500 METRONOME

A simple, low-cost project with variable beat from 'presto' to 'largo'. Operates from 9 V battery. (Aug. '85)
\$4.70

2500 AUDIO OSCILLATOR

A simple sine/square signal generator for the bench. It covers to 100 kHz and has output amplitude ranges from 30 mV to 3 V, fully variable. Separate sine and square outputs. (Dec. '85)
\$9.65

2600 PEAK RF POWER METER

This simple, low-cost project features a 10-LED bar display and can be made for power ranges from 5 W peak to 400 W peak. (April '86)
\$10.50

AEM3500 LISTENING POST

Our most popular project, by far! It decodes the audio from a SW receiver and, with software, allows your computer (Apple II/BBC/C64/Microbee) to decode RTTY, FAX and Morse. (July '85)
\$12.20

ELEKTOR BOARDS

85000 RF BOARD

A 'universal' RF board employed in the "RF Circuit Design" series. It has an array of pads, a set of three supply rails and a large groundplane. (Oct. '86)
\$8.00

86002 BATTERY CHARGER

This dc-operated battery charger is designed to charge 9, 12 or 15 volt NiCads from a 12 V car battery. (Oct. '86)
\$15.75

86086 HEADPHONE AMP

Featuring the TEA2025 stereo amp chip, this project has ample output for headphones from 30 to 600 ohms. Uses a 12 V supply. (Oct. '86)
\$15.50

86090 SERIAL DIGITIZER

The project can attach to any computer sporting an RS232 port and features one to eight multiplexed analogue input channels, conversion time less than half ms, variable ref. voltage to 4 V and modular construction. The main board is 86090-1, input boards (up to four) are 86090-2. (Oct. '86)
\$21.10 — 86090-1
\$6.40 — 86090-2 each

3502 SIGNAL-OPERATED CASSETTE CONTROLLER

Just the thing for taping signals picked up on your SW receiver or scanner while you can't attend. Simple to build, powers from 10-15 V. (Mar. '86)
\$9.20

4500 MICROTRAINER

Take the mystery out of micros. A great project for learning the 'guts' of microprocessing, without having to build a microcomputer. (Sept. '85)
\$28.50

4501 8-CHANNEL RELAY INTERFACE FOR COMPUTERS

Get your computer to control something! Hooks up to 8-bit parallel port or data bus ('Bee — Oct. '85, C64 — Sept. '86)
\$13.00

4502 REAL TIME CLOCK

This project plugs into the Microbee's parallel port and gives accurate date/time etc. Battery-backed. (Nov. '85)
\$10.50

4504 LOW-COST SPEECH SYNTHESISER

This simple to build project employs the GI speech chip SPO256-AL2 which allows you to put together 'word parts' to make electronic speech. It employs 8-bit parallel interfacing. ('Bee interface — Feb. '86, with data sheet; C64 interface — July '86)
\$17.30

4505 CODE-TO-SPEECH SYNTH.

Taking ASCII text input from a serial port, Centronics port or IBM slot, this versatile project will 'speak' text files. Double-sided, thru-hole plated board. (June-July '86)
\$55.00



5501 NEG-ION GENERATOR
Clear the air! Our negative ion generator provides around 8 kV output. Simple and low-cost. (Sept. '85)
\$18.35

5502 MICROWAVE OVEN LEAKAGE DETECTOR

Anyone who owns a microwave oven needs one of these! Simple to build and low cost. (Dec. '85)
\$9.15

5503 BED-WET-ECTOR

This is a simple, safe battery-operated alarm that may be used to help overcome bed-wetting problems. (Mar. '86)
\$9.20

5504 ELECTROMYOGRAM

This is a 'muscle activity' monitor, sensitive enough to detect muscle activity that cannot be detected by eye. Can be used for relaxation training, biofeedback, migraine relief etc. (Mar. '86)
\$15.90

5505 MAINS FILTER

This project, dubbed the "Hash Harrier", is a truly effective mains filter that copes with both common mode and differential mode noise, including spikes. It is rated for loads totalling up to 5 A. (April '86)
\$26.00

6000 ULTRA-FIDELITY POWER AMP

A low-distortion amp module that delivers over 200 W into 8 ohms, featuring the high power 2SK176/2SJ56 Hitachi MOSFET output devices. (June-July '86, data sheet in June)
\$31.20

6010 ULTRA-FIDELITY PREAMP

The 'digital era' preamp, featuring low-level cartridge input, CD input, two tuner inputs and one aux. input. There are four boards in the set — 6010LL (cartridge pre-preamp), 6010f, 6010r and 6010ma — the front, rear and main boards. (Oct-Nov-Dec. '85).

6010LL — \$19.10

6010f — \$16.40

6010r — \$16.40

6010ma — \$23.10

Set of four \$74.90

6102 2-WAY CROSSOVER

Crossover board for our popular 2-ways using the Vifa drivers. (Aug. '85)
\$21.75

AEM6500 MOSFET AMP MODULE

A 'universal' amp module using the Hitachi MOSFETs and able to deliver 60 W with one pair or 120 W with two, into 8 ohms. (July '85)
\$9.70

6501 4-INPUT MIXER

A versatile mixer/preamp for a guitar amp or stage amp. Select resistors to select the input impedance of the channels. (Sept. '85)
\$20.40

6503 ACTIVE CROSSOVER

Here's a high performance four channel (use as many as you need) active crossover that's just right for that active speaker project! (Feb. '86)
\$34.40

6504 POWER AMP STATUS MON.

This project prevents dc fault conditions or excessive clipping from exterminating amps and speakers alike. Handles amps up to 300 W and powers from the amp's supply rails. (Aug. '86)
\$19.40

8500 VEHICLE COURTESY LIGHT EXTENDER

Don't get caught in the dark! This project 'holds' your vehicle's courtesy light on for some 30 seconds after you leave or enter it. (Nov. '85)
\$9.90



9500 BEAT-TRIGGERED STROBE

Just the thing for discos and parties! Project can act as a manually variable strobe or, coupled to an audio source, flash in time with the beat. (July '85)
\$11.30

9501 DUAL-RAIL SUPPLY

A utility power supply module that can deliver dual rails from 2.6 V to 26 V at currents up to 560 mA — depending on choice of 5 VA pc-mount power tranny. (Aug. '86)
\$19.30

HOW TO ORDER

Order pc boards by the project number and title • All prices include post and handling • New Zealand purchasers add \$1.00 to these prices • Photostats of the pertinent articles cost \$4.00 each, post paid • With out-of-stock boards there may be a delay in delivery.

All cheques or money orders should be made payable to Australian Electronics Monthly.

Australian Electronics Monthly, PO Box 289 WAHROONGA, 2076 NSW (02) 487 2700.

PLEDGE YOUR PLASTIC!
Bankcard, Mastercard, Visa & American Express accepted.

PAY BY PAPER!
Cheques or money orders OK. Make them payable to "Australian Electronics Monthly".

You can buy the boards at our offices if you wish, at any time during business hours. We're located at the Fox Valley Centre, Cnr Fox Valley Rd and Kiogle St, Wahroonga NSW. The entrance is in Kiogle St.

The AUSTRALIAN ELECTRONICS Monthly



USE YOUR COMPUTER TO RECEIVE

- Radio Facsimile Pictures (FAX)
- Radio Teletype (RTTY)
- Morse Code (CW)

GET THE AEM3500 "LISTENING POST PACKAGE"

for your ● Commodore 64 ● Microbee ● Apple II.

By building the *Australian Electronics Monthly* AEM3500 'Listening Post', a simple add-on decoder project for your computer and receiver, and using our software, you can receive weather map transmissions, amateur RTTY and foreign news services, plus amateur and commercial Morse transmissions.

There's a whole fascinating new world out there among the non-speech transmissions that were just an annoying 'burble' on your receiver previously.

The package comprises:

- Comprehensive' constructional and operational details.
- A quality fibreglass pc board with printed components overlay.*
- Software on either cassette or diskette.

* Components necessary to complete the project are widely stocked by electronics retailers.

All for only

\$33 save over \$6!

Including post & handling

software only - \$23.50

Send to: AEM Software Service
PO Box 289 Wahroonga 2076 NSW

I enclose payment by: Cheque Money Order Credit Card
(circle your choice)

Credit Card No.:

Expiry Date: . . . / . . . / . . .

Signed: _____
(Unsigned orders cannot be accepted)

Cheque or Money Order No. _____
(* Please make cheques or Money Orders payable to 'Australian Electronics Monthly')

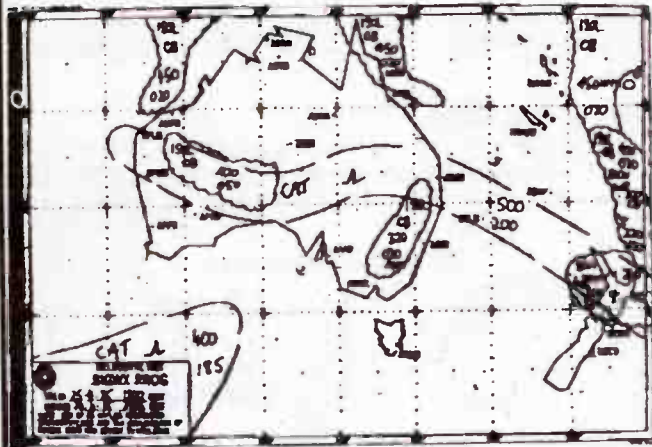

FAX picture

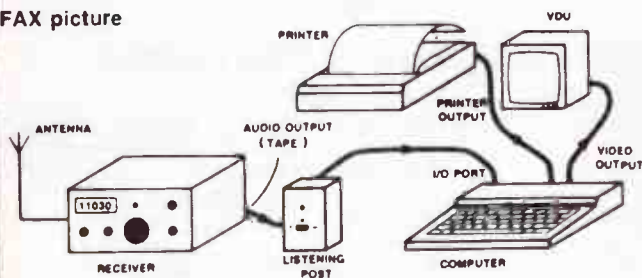

Decode RADIOTELETYPE/RADIO FACSIMILE PICTURES &/or CW using your computer and the AEM3500 Listening Post project.

COMPLETE THE COUPON NOW

(a photostat will do) and send us a blank C10 cassette or formatted disk to suit your computer.

- We will gladly re-record any software that doesn't run.
- Please rush me (tick choices):

- AEM3500 Listening Post software only
 AEM3500 Listening Post Package

to suit the:

| | | |
|--|---------------------------------|-----------------------------|
| Microbee & ... C.10oh 8510-type Epson FX80-type printer | Commodore 64 (most printers) | Apple II (most printers) |
|--|---------------------------------|-----------------------------|

DON'T FORGET TO INCLUDE YOUR NAME & ADDRESS

Special AEM Reader Offer

**A FOUR-COLOUR
PLOTTER FOR JUST
\$399.00!**

COMX PL-80

As an introductory offer for a limited period, the distributor of the COMX PL-80, Mike Boorne Electronics, is offering this remarkable machine to AEM readers at \$100 under the recommended retail price!

That's right, a \$499 plotter for only

\$399.00!

Delivery, \$6.50 anywhere in Australia.

- Credit card phone orders accepted. Call 487 1207.

Emulates Roland DXY800 for AutoCAD, Amdek Amplot II for Lotus and Symphony.



USER FRIENDLY AND ACCURATE

The PL-80 is designed to have both the printing and plotting modes selectable by the user, it can work as a plotter or a normal ASCII character printer with four basic colours: black, red, green and blue. The PL-80 plots up to 92mm per second with a resolution of 0.2mm per step. The friendly control panel can help you perform functions instantly even before looking into operational details of the user manual.

HIGH-LEVEL COMPATIBILITY WITH MOST SOFTWARE PACKAGES

The PL-80 has a standard built-in Centronics Parallel Interface. It is compatible with most micros including IBM PC series, Apple, Commodore, and many others. The PL-80 can easily operate on a handful of popular graphic packages such as AutoCAD, Lotus 1-2-3, Supercalc . . . etc. For the user who wants to write a program by himself, standard graphic and text command sets are provided.

COMPREHENSIVE USER MANUAL

The PL-80 users manual is designed for both hobbyists and professionals. It covers a great variety of graphic functions written in standard BASIC, so that you can tackle almost any graphic tasks required.

FILL OUT THE COUPON NOW

COMX PLOTTER OFFER

**Australian Electronics Monthly
PO Box 289, Wahroonga 2076 NSW**

Please rush me COMX PL-80 plotter(s), priced at \$399.00, plus \$6.50 for delivery.

TOTAL: \$

I enclose payment by:

Money Order Cheque Visa

Bankcard Mastercard American Express

Credit Card No:

Expiry date:

Cheque or Money Order No:

(Please make cheques or Money Orders payable to 'Australian Electronics Monthly')

Name

Address

Postcode

Signature:

(Unsigned Credit Card orders cannot be accepted)
Please allow for normal postal and bank clearance delays.



Sample plot from the PL-80.

LOOK AT THESE FEATURES:

- Plotting area : 192mm x 13000mm
- Paper size : Cut sheet — 215.9mm x 279.4mm (letter size)
210.0mm x 300.0m (A4 size)
Roll paper — 214mm width
50mm core dia. (max.)
- Max. plotting speed : 92mm/sec.
- Step size : 0.2mm
- Pen types : Ballpoint type (water soluble)
OHP type (oil soluble)
- No. of pens : 4 (black, red, green, blue)
- Panel Control : Up, Down, Left, Right, Pen Select, On line
- Indicators : Power, On Line
- Interface : Centronics parallel interface
- Power supply : DC 10V/1.3A adaptor
- Power consumption : 10W typ.
- Dimensions : 320mm(W) x 234mm(D) x 56mm(H)
- Weight : Approx. 1.2Kg (without adaptor & accessories)

AutoCAD is a trademark of Autodesk, Inc.
SuperCalc 3 is a trademark of SORCIM Corp.
Lotus 1-2-3 is a trademark of Lotus Development Corp.

**OFFER CLOSES
LAST MAIL ~~31 MAY 1987~~
EXTENDED TO JUNE 30, 1987**

Roland releases universal color graphics board for IBM PCs

Roland Australia has released a fully multi-resolution video adapter for IBM color graphics users. Called the STB EGA Multi-Res, it will run any IBM compatible monitor including monochrome, RGB color, EGA screen and multi-sync. monitors, Roland claim.

The EGA Multi-Res is a fully enhanced 256K video RAM EGA board with CGA compatibility capable of achieving PGA standard resolution (640 x 480) in the full 16 colors or alternatively 752 x 410 resolution.

"At this time of fast moving technology and 'standards' that are as fixed as a Sahara sand dune, this product provides PC users with truly multi-functional PCs," said Roland's Marketing Manager, Mr Adrian Stephens.

"There are hundreds of possible compatibility combinations of screen, video adapter and appropriate software drivers to be considered with each new software purchase.

"Much new software is first released with drivers for only one type of monitor and card. PC owners purchasing new software often find that a new card or screen needs to be purchased before the software will run," Mr Stephens said.

The EGA Multi-Res can turn a 25 kHz 400-line monitor, such as the Roland CD-240, Taxan Vision IV or Olivetti, into EGA (350-line) screens without losing the 400-line graphics capability for other applications.

Using an EGA monitor it also offers an additional capability for even higher resolution with the 832 x 350 mode.

The EGA Multi-Res comes with drivers for Microsoft Windows, a parallel printer port, 250K of standard display memory, light pen interface, and an optional clock-calendar.

For further technical information from Adrian Stephens, Marketing Manager, Roland DG, 50 Garden Street, South Yarra 3141 Vic. (03) 241 1254.



Plug-in turns IBM PC to Apple

Now you can run Apple educational, business and games software on the IBM PC and most compatibles, even the difficult "copy protected" programs.

Costing only \$795 (ex. tax), the Trackstar 128 board from LOGO plugs into an IBM PC or compatible and turns it into Apple.

Run the Apple (II, II+, IIc, IIe) software of your choice, even "half tracked" programs are no problem, says LOGO, and it has tested 99.99% compatible on over 350 programs, they say.

With Trackstar, an IBM PC acts like an Apple II Plus, IIc, IIe with RAM card, 80 column card, colour graphics card for RGB output. Both 64K and 128K programs are supported.

The TrackStar supports 80 column mode, RGB, composite colour, and monochrome for all Apple text and video modes and includes an Apple games port. Parallel and serial printing is supported via the PC's ports. It even provides file transfer between Apple and MS-DOS.

Contact Peter Klanberck, LOGO Computer Centre, PO Box 389, Drummoyne 2047 NSW (02) 819 6811.

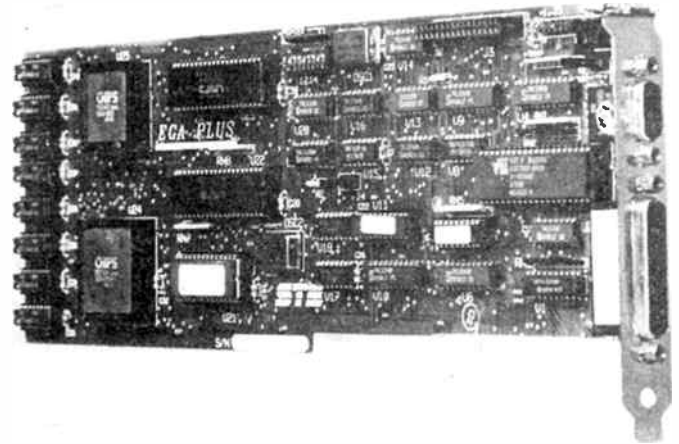

Privatising pollys' party peccadillos

By using a speech scrambling system which can be attached to a telephone handset, political leaders and other users can avoid eavesdropping of their telephone conversations.

DSP, or digital signal processing, semiconductors can be used to encrypt various signals including voice and data, say Texas Instruments, who offer ten types in their TMS320 range.

As well as security applications, the TMS320 family DSP chips can be used to provide high-speed numeric intensive computations to overcome common telephone network problems, TI say.

For example, they can act as an FIR filter is to cancel echo caused by line impedance mismatches, and provide cost effective alternatives for conventional microprocessors and microcontrollers used in multiplexers, line repeaters, protocol converters, and modems.

Several other key applications include voice/speech processing, graphics/image processing, disc controllers, robotics, radar and sonar processing, vibration analysis, DTMF decoding, missile guidance, and instrumentation.

10 MHz and no waiting

For IBM PC owners needing a new motherboard, and for those building a PC from scratch, there is now a very quick solution. Electronic Solutions of Gladesville are selling a 10 MHz no-wait-state motherboard.

It can also run at 4.77 MHz if

required, and is a direct drop-in replacement for the IBM PC board.

Unlike the many speedup cards around, it has complete IBM compatibility, the company claims, utilising an 8088-1 processor. The board comes complete with 640K of memory, using the latest high speed 41256 chips, so it's ready to go.

The cost is just \$475, including tax. And for the timid, Electronic Solutions even offer a 14 day money-back guarantee. Fitting is also available at low cost.

For further information contact: Electronic Solutions, PO Box 426, Gladesville 2111 NSW (02) 427 4422.

CD-ROM drives from Sony

Sony, well-known in consumer electronics and providing, enters the computer peripherals market with a pair of CD-ROM drives — one for internal machine mounting and one for stand-alone use, operated from the 240 Vac mains.

The new drives, dubbed the CDU-5002 and CDU-100, are suitable for use with "... all true IBM PC compatibles," according to Sony.

The CDU-5002 is a specifically designed, inbuilt unit which is the same size as conventional 5¼" floppy disc drive housings. This enables it to fit into a computer's fascia panel.

The release of the CDU-100 is remarkable as it is the first stand-alone CD-ROM to be designed for 240 volt operation, Sony claims.

The CDU-100 is equipped with two 40-pin Sony BUS connectors which are especially useful when organising a daisy chain in which you can use up to four drives.

Towards a VZ-Epson printer patch

Part 1

Larry Taylor

Fed up with your clackerty old printer and long for an upgrade to one of the popular Epson or Epson-type dot matrix printers? Compatibility with the VZ has always been a problem - until now.

FED UP with your clackerty GP-100, and its less than perfect print quality? Do you long to upgrade, but know that whatever you choose, it won't be totally friendly towards your VZ?

Are you the owner of an Epson-type printer, but suffer frustration, as I did, at its lack of compatibility? If so, then take heart, there is hope. The answer is a *printer patch*, that is, a program specifically written to take the place of the existing ROM routines. In this case, the aim is to make the VZ fully compatible with Epson-type printers. Recently, after many hours spent reading and experimenting, I succeeded in producing just such a program.

Having first decided to take the plunge and purchase a VZ computer, I developed a very great need, some short time later, to be able to obtain a printout of my programming efforts. On close examination of available finances, I was left with a choice between the Seikosha GP-100, a slow, noisy machine featuring an unattractive print style, and the BMC BX-80, a noticeably quieter, faster printer, possessing several attractive fonts.

Although a seemingly easy decision, I was immediately faced with a dilemma. The former, whilst initially unattractive, especially so to anyone with sensitive hearing, had two very desirable features: namely, the ability to print the VZ's inverse and graphics characters, in addition to providing, via the COPY command, a dump of the HI-RES screen. These two factors very nearly persuaded me to choose the GP-100, but, after much deliberation, I opted for the superior print quality of the BX-80. In so doing, I resigned myself to having to go without the former's obvious advantages.

No one had at this stage even remotely hinted that I could have the best of both worlds by means of a software patch. Hindered by a lack of information and minimal understanding of computer and printer operations, I persevered with the rather primitive approach of removing all inverse and graphics characters from programs before doing a printout.

A start

Desperate to overcome this huge waste of time, I first began to deal with the problem of printing graphics characters. I realised that my printer was capable of dot graphics and that it should be able, whilst in this mode, to reproduce the shapes I desired. My early efforts, however, ended in frustration as the VZ steadfastly refused to interpret my data correctly. Only when I discovered that I could send the data directly out the ports, thus bypassing the VZ's printer driver routine, did I achieve any success.

Listing 1 gives an example of how this was accomplished. By referring to the table below, you may change the graphics block data in the listing to enable any of the other graphics characters to be printed. Later it will become clearer how the data to print each block was calculated.

GRAPHIC BLOCK DATA

| | HEXIDECIMAL | DECIMAL |
|-----|-------------|-----------|
| 128 | 00 , 00 | 0 , 0 |
| 129 | 0F , 00 | 15 , 0 |
| 130 | 00 , 0F | 0 , 15 |
| 131 | 0F , 0F | 15 , 15 |
| 132 | F0 , 00 | 240 , 0 |
| 133 | FF , 00 | 255 , 0 |
| 134 | F0 , 0F | 240 , 15 |
| 135 | FF , 0F | 255 , 15 |
| 136 | 00 , F0 | 0 , 240 |
| 137 | 0F , F0 | 15 , 240 |
| 138 | 00 , FF | 0 , 255 |
| 139 | 0F , FF | 15 , 255 |
| 140 | F0 , F0 | 240 , 240 |
| 141 | FF , F0 | 255 , 240 |
| 142 | F0 , FF | 240 , 255 |
| 143 | FF , FF | 255 , 255 |

Being an avid user of Steve Olney's Extended Basic, I used my new-found knowledge to write an assembly routine, which linked into the listing routine of his program. It simply checked for graphics and inverse characters. Graphics characters were printed and inverse ones changed to non-inverse. Useful, but not totally satisfactory. On the way I had independently developed my own table of data (above), to print the graphics blocks, only to later discover that there exists in the VZ's ROM a set of data for graphics characters and another for inverse.

The graphics table occupies addresses from 02AFH to 02CEH, whilst the inverse data commences at 3B94H and ends at 3CD3H. The graphics shapes are stored in two-byte form and the inverse characters in five-byte blocks. Their existence makes it a simple enough matter to expand on the program in Listing 1 and print the graphics blocks using the ROM data instead of our own, as in Listing 2. The same may be done with the inverse characters and Listing 3 shows how this is accomplished. Unfortunately, you will notice that the resultant characters, when printed, are in fact upside down. To understand why this occurs, it is necessary to offer a brief explanation of the differences between the code values used to control firing of the pins in the printheads of Epson-type printers, and those of the GP-100 family.

The Epson-type printer

Printers of the Epson-type have eight addressable pins, while the GP-100 has the equivalent of seven pins only. In addition, the value 1, which fires the bottom pin on an Epson printer, actually triggers the top pin on the GP-100. The diagram below illustrates the differences.

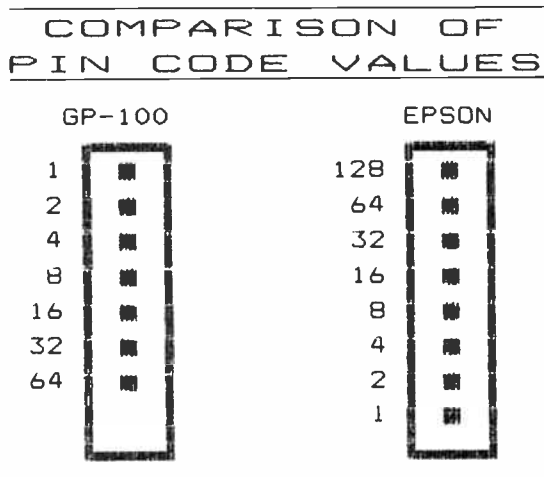

To calculate the code which is required to produce a particular dot pattern we simply have to add up the values of the corresponding pins. The representation of the graphics block, CHR\$(137), can be used to demonstrate how this is done. You may recall that the data values used in Listing 1 to reproduce this particular character were 240 and 15. Notice how these codes correspond to the totals at the base of each column in the diagram. If we examine the first column on the left, we can see that only the top four pins have been fired. By totalling vertically the values assigned to those pins, we arrive at the sum of 240. The same procedure is used to determine the Epson compatible code for each of the remaining columns.

GRAPHICS BLOCK 137

| | | | |
|-----|----------------------|----------------------|--|
| 128 | ████████████████████ | | |
| 64 | ████████████████████ | | |
| 32 | ████████████████████ | | |
| 16 | ████████████████████ | | |
| 8 | | ████████████████████ | |
| 4 | | ████████████████████ | |
| 2 | | ████████████████████ | |
| 1 | | ████████████████████ | |
| | 240 240 240 240 | 15 15 15 15 | |

It can be done

Nevertheless, data which has been prepared primarily for the GP-100, as is the case with the ROM tables, will produce inverted images if sent to an Epson printer. It is necessary, therefore, to convert the data before it can be used. Adding Listing 4 to Listing 3 will produce the desired result. I wouldn't however, advise any of you to hold your breath whilst waiting for the data to be printed. Hence, I have provided Listing 5, an assembler program, which effects the same result, only much more swiftly.

Having now managed to make the characters appear in their more conventional form, a closer examination of them will reveal numerous inaccuracies. Some, such as the 3 and

5, are more noticeable than others, but no less than a dozen of the characters are flawed. After progressing so far, this is a disappointing development but one which will prove, later, to be not insurmountable. In the interim, we need to explore further how we might utilise our somewhat imperfect data.

Fortunately, the designers of the ROM foresaw the possibility that potential users may want to use a different printer. As a result, a vector has been used to point to the location of the printer driver. All output to the printer is directed via a driver routine, which, among other things, checks for control codes and keeps track of line feeds. In the VZ, a block of the communications area of RAM from 7825H to 782CH has been set aside for printer operations, allowing temporary storage of values such as the number of lines printed. Of greatest interest to us is the contents of 7826H-7827H. This is the start of the driver routine, and the cause of our problems, because it is geared to expect that owners of VZeds will be using GP-100 type printers. However, since the previous address lies in RAM, it is possible to insert a pointer to our own driver routine at this location. Once accomplished, all future LPRINT and LLIST commands will be directed, ultimately, to our own printer routine.

We have now proceeded part way to installing a valuable routine for owners of Epson-type printers, but we are still unable to make use of the COPY command. The primary advantage of which is that it allows a dump of the HI-RES screen to be made to the printer. Implementing this very desirable feature will prove to be somewhat more challenging.

LISTING 1 : PRINT A SINGLE GRAPHICS BLOCK

```

100 REM *****
101 REM # PUT PRINTER IN GRAPHICS MODE #
102 REM *****
110 LPRINTCHR$(27);CHR$(75);
120 FOR T=1 TO 2
130 READ D:GOSUB 510
140 NEXT T
200 REM *****
205 REM # READ EACH DATA VALUE IN TURN #
210 REM # AND THEN PRINT IT FOUR TIMES #
215 REM *****
220 FOR N%=1 TO 2
230 READ D
240 GOSUB 510:GOSUB 510
250 GOSUB 510:GOSUB 510
400 NEXT N%
410 LPRINT:END
500 REM *****
501 REM # OUTPUT TO PRINTER VIA THE PORTS #
502 REM *****
510 IF INP(0)>254 THEN GOTO510
520 OUT 13,D:OUT 14,D
530 RETURN
540 REM *****
545 REM # NUMBER OF BYTES TO BE PRINTED #
550 REM # IN LOW BYTE, HIGH BYTE FORM #
555 REM *****
560 DATA 8,0
565 REM *****
570 REM # GRAPHIC BLOCK DATA #
575 REM *****
580 DATA 240,15
  
```

LISTING 2 : PRINT THE ROM GRAPHICS BLOCKS

```

100 REM *****
101 REM # PUT PRINTER IN GRAPHICS MODE #
102 REM *****
110 LPRINTCHR$(27);CHR$(75);
120 FOR T=1 TO 2
130 READ D:GOSUB 510
140 NEXT T
150 REM *****
151 REM # LOCATION GRAPHICS TABLE 02CEH #
152 REM *****
  
```

```

160 M=687
200 REM *****
205 REM # READ DATA FOR GRAPHICS BLOCKS #
210 REM # AND PRINT EACH VALUE 4 TIMES #
215 REM *****
220 FOR N%=1 TO 32
230 D=PEEK(M)-128 :M=M+1
240 GOSUB 510:GOSUB 510
250 GOSUB 510:GOSUB 510
260 REM *****
265 REM # THIS LINE SEPARATES CHARACTERS #
270 REM # FROM EACH OTHER BY A DOT WIDTH #
275 REM *****
280 IF N%/2 = INT(N%/2) THEN D=0 :GOSUB 510
400 NEXT N%
410 LPRINT:END
500 REM *****
501 REM # OUTPUT TO PRINTER VIA PORTS #
502 REM *****
510 IF INP(0)<>254 THEN GOT0510
520 OUT 13,D:OUT 14,D
530 RETURN
540 REM *****
545 REM # NUMBER OF BYTES TO BE PRINTED #
550 REM # IN LOW BYTE, HIGH BYTE FORM #
555 REM *****
560 DATA 144,0

```

LISTING 3 : PRINT THE ROM INVERSE CHARACTERS

```

100 REM *****
101 REM # PUT PRINTER IN GRAPHICS MODE #
102 REM *****
110 LPRINTCHR$(27);CHR$(75);
120 FOR T=1 TO 2
130 READ D:GOSUB 510
140 NEXT T
150 REM *****
151 REM # LOCATION OF INVERSE TABLE 3B94H #
152 REM *****
160 M=15252
200 REM *****
201 REM # NUMBER OF INVERSE CHARACTERS #
202 REM *****
210 FOR N%=1 TO 64
220 D=255:GOSUB 510
230 REM *****
231 REM # NUMBER OF BYTES PER CHARACTER #
232 REM *****
240 FOR R%=1 TO 5
250 D=PEEK(M):M=M+1
339 REM *****
340 REM # PRINT ONE COLUMN #
341 REM *****
350 GOSUB 510
360 NEXT
370 D=255:GOSUB 510
400 NEXT N%
410 LPRINT:END
500 REM *****
501 REM # OUTPUT TO PRINTER VIA THE PORTS #
502 REM *****
510 IF INP(0)<>254 THEN GOT0510
520 OUT 13,D:OUT 14,D
530 RETURN
535 REM *****
540 REM # NUMBER OF BYTES TO BE PRINTED #
550 REM # IN LOW BYTE, HIGH BYTE FORM #
555 REM *****
560 DATA 192,1

```

LISTING 4 : CONVERT THE DATA FOR THE EPSON PRINTER

```

260 REM *****
261 REM # CHANGE CODE FROM GP-100 TO EPSON #
262 REM *****
270 IF D=189 OR D=255 THEN 320
280 V=0:E=0
290 FOR F%=7 TO 0 STEP -1
300 P=2^F%:IF D<P THEN 320
310 E=E+2^V:D=D-P
320 V=V+1
330 NEXT:D=E

```

LISTING 5 : PRINT THE ROM INVERSE CHARACTERS

```

0001 ;*****
0002 ;# PUT PRINTER IN #
0003 ;# GRAPHICS MODE #
0004 ;*****
0005 LD A,27
0006 CALL 3ABAH
0007 LD A,75
0008 CALL 3ABAH
0009 LD A,192
0010 CALL 3ABAH
0011 LD A,1
0012 CALL 3ABAH
0013 ;*****
0014 ;# LOCATION OF THE #
0015 ;# INVERSE TABLE #
0016 ;*****
0017 LD HL,3B94H
0018 ;*****
0019 ;# NUMBER OF INVERSE #
0020 ;# CHARACTERS #
0021 ;*****
0022 LD B,64
0023 NEXT PUSH BC
0024 LD A,255
0025 CALL 3ABAH
0026 ;*****
0027 ;# NUMBER OF BYTES #
0028 ;# PER CHARACTER #
0029 ;*****
0030 LD B,5
0031 PRNT LD A,(HL)
0032 CALL CVRT
0033 CALL 3ABAH
0034 INC HL
0035 DJNZ PRNT
0036 LD A,255
0037 CALL 3ABAH
0038 POP BC
0039 DJNZ NEXT
0040 RET
0041 ;*****
0042 ;# CHANGE CODE FROM #
0043 ;# GP-100 TO EPSON #
0044 ;*****
0045 CVRT PUSH BC
0046 LD B,B
0047 ROTA RR A
0048 RL C
0049 DJNZ ROTA
0050 LD A,C
0051 POP BC
0052 RET

```

— from page 30

chromium to resist corrosion) and a solid "beta alumina" electrolyte separates anode and cathode. The cell is sealed and filled with argon.

During discharge, sodium ions pass through the electrolyte from anode to cathode, forming sodium sulphide at the cathode, the reaction generating the current. Recharging is achieved as with other storage batteries, by passing a current through it in reverse. One problem, though. These cells will only deliver power when operated above 270 degrees Celsius. They have an operating temperature ceiling of 410 degrees C. They must be heated to 'start up' and to maintain them within the operating temperature range, they have to be fully charged and then at least 80% discharged each day. If unused for nine hours, temperature falls below the 270 degrees C.

Sodium-sulphur cells exhibit a terminal voltage of around 2 V and may last some five years or 6000 charge-discharge cycles, which betters the typical lead-acid battery life cycle. In addition, its terminal voltage remains constant until it reaches about 70% of its discharge capacity before tapering off.

Suggested application encompass commercial vehicles such as delivery vans and buses, and military submarines. Satellite applications are also suggested as sodium-sulphur cells are only 20% of the weight of equivalent NiCad batteries of the same Ah output.

General Communications

AS PROMISED, this month I am starting a series of articles on communications protocols. The first topic for consideration is that of error checking codes. Error checking is usually included as part of protocols such as XMODEM, TELINK etc, but may also be an option at the time of data transfer.

The very simplest form of error checking is the use of a checksum. This is simply the addition of each byte in the block being transmitted – blocks are usually 128 bytes long – with the checksum being appended as an extra two byte value. The receiving comms package adds up the bytes as they arrive and then compares the block checksum to that sent by the remote terminal/computer. If the two values disagree, the receiving comms package requests re-transmission of that block, by sending an 'NAK' character to the remote computer. The 'NAK' character (CTRL/U) is called Negative AcKnowledge, meaning "I didn't get that, please re-transmit." If the block checksums both agree, the receiving comms package transmits an 'ACK' character (CTRL/F), indicating that the block was received correctly and that transmission of the next block can commence.

The main disadvantage of the checksum error handling method is that compensating errors can easily occur and there is no way of telling if this has happened. For this reason, checksums have only limited value for data transmission. The Vertical Redundancy Check (VRC) also suffers from the same problem. In the VRC, a parity bit is added to each character and this is then checked by the receiving terminal. The advantage of VRC over checksums is that the chances of a "double-flip" occurring are far less in a group of eight bits, than they are in a block of 128 x 8 bits.

A refinement of the VRC check is the Longitudinal Redundancy Check (LRC), which places a parity bit on a block of characters, rather than on a single character. Block checks such as these provide a more reliable method of error detection than do byte-oriented parity checks. LRC is often combined with VRC to produce a check known as the "two dimensional" parity check. This can improve the normal (unchecked) error rate on a phone line by at least two orders of magnitude.

The Hamming code is another (seldom used) variation of the VRC, which relies on the use of multiple (usually two or three) parity bits in each byte of code. The resulting error rate is two orders of magnitude greater than the two dimensional error check, but the overhead introduced by including multiple parity bits (each byte becomes ten or eleven bits long), is often not justified by the small improvement in error correction.

The most popular error checking routine used in over 90% of comms packages is the Cyclic Redundancy Check (CRC). The CRC operates by dividing the 128 byte block checksum by some pre-determined value and then transmitting the result-

ing figure as the CRC. The divisor used is often based on the polynomial:-

$$X^{16} + X^{15} + X^2 + 1$$

which yields a binary value of 1100000000000101 (Ref. 1). The resulting improvement in error trapping over the two dimensional parity check is 10/5/ to 10/7/ orders of magnitude greater. In practice, this means that the average 1 hour download/upload session on a BBS can be almost totally error free, in spite of noise on the phone lines.

The two most popular methods in use for error checking in comms programs are the checksum method and the CRC. In some comms programs, the user has the option to either specify the type of error checking required, or to allow the comms program to make its own selection. Fido BBS's are one example of this type of error handling. OPUS BBS's (which most services seem to be switching to) automatically select CRC as the error checking procedure. This means that checksum error handling has been almost totally superseded by CRC.

Communications protocols

The reasons that communications protocols are required is fairly simple:-

1. File transfer occurs by means of the phone line and this line is subject to numerous interferences that can modify or destroy the signal – noise, faulty equipment, poor switching in exchanges, line hits (from any one of a number of causes) etc.
2. The two communicating devices may operate at different speeds and use different operating systems that are incompatible with each other.

A communications protocol overcomes all these problems by enabling the use of an error checking procedure, such as was mentioned above and it also allows for transfers of files between two incompatible systems (e.g: file transfer between MS-DOS and CP/M systems – this DOES NOT IMPLY that a .COM file from CP/M will work on MS-DOS – it simply means that files, ASCII for example, can be transferred between the two systems fairly easily).

The very simplest file transfer protocol is the standard ASCII file transfer. This is very similar in operation to creating a log file, with one major exception – log files usually strip out any control characters they receive, whilst ASCII transfers send/receive all control characters except those controlling screen scrolling. No error checking is performed at either end of the transfer, and handshaking (start/stop sending) is limited to ordinary XON/XOFF, provided that this feature is implemented in the comms package. XON/XOFF is usually implemented as CTRL/S (XOFF) and CTRL/Q (XON). Some

MAESTRO DISTRIBUTORS

Calool St, Sth Kincumber 2256 NSW
ph: (043) 69 2913.

present

THE AEM4610
SUPERMODEM



A smart, stand-alone direct-connect serial modem ●
6809 microprocessor controlled ● plugs into any RS232
(serial) port ● fully software controlled (Hayes-
compatible) ● auto-answer, auto-dial, auto-disconnect
● 300/300 and 1200/175 bps CCITT V21 and V23 modes
● IBM and Apple Viatel software available ● automatic
baud rate select ● internal expansion slot ● on-board
speaker ● plug-pack powered ● 3 months warranty.
AEM4611 1200 bps full duplex add-on now available!

AEM4610 SUPERMODEM

\$349.17 ex. tax, \$399.00 inc. tax. Fully built and tested.

AEM4611 V22 board

\$173.58 ex. tax, \$199.00 inc. tax. Fully built and tested. Kit less EFG7515 — \$119.00. Kit complete — \$169.00

BANKCARD WELCOME

dial-up

ASCII transfer packages (like the one provided with Procomm) allow the user to specify some limited transfer features. These are:-

- (a) CR/LF transmit/strip – the ability to either leave or remove Line Feeds and Carriage returns from the transmitted/received text.
- (b) Upload pacing – the ability to pause after the transmission of characters or lines. This feature allows dumb terminals to receive ASCII files without having their limited buffer capacity overflow.
- (c) Character pacing – the ability to pause after the sending of one line of text in an upload. The sending terminal then waits to receive the user specified “pace character” before transmitting the next line. This feature is useful for REALLY dumb terminals.

In the late 70s Ward Christensen in the USA developed the first communications protocol for use with the newly emerged microcomputers and the first microcomputer operating system that supported floppy discs – CP/M. The protocol was designed to allow for file transfer to occur between two computers. Christensen placed his protocol in the public domain, for use by whoever wished to write communications packages. The Christensen Protocol was the first to be used with modem transfers and was renamed the MODEM/XMODEM protocol to reflect its use with modem file transfer. The first MODEM/XMODEM packages were only available with checksum error handling. CRC capability has only recently been added to the MODEM/XMODEM protocol. This involves substituting a “C” character (hex 43) for the normal ‘NAK’ when a CRC error occurs. A diagram of the original protocol is shown in Figure 1 here.

The data to be transferred is divided into blocks of 128 bytes. Four extra bytes are added to the data block – three in front of the data and one after, making a total of 132 bytes for each block transmitted. The three leading bytes are, respectively, the “Start Of Heading” byte (always 01 hex), labelled ‘SOH’ in Figure 1, the Block Number (in hex), labelled ‘BLK#’ and the complement (invert the bits) of the block number. This is labelled ‘COMP’ in Figure 1. A little mathematics on Figure 1 should convince the reader that the sum of the first three bytes will always be zero. This is another way of checking validity of the transfer process. As the blocks arrive at their destination, the comms package using this protocol performs a checksum on the data block and then compares it to

MODEM7 LISTING OF COMMANDS AND OPTIONS

Primary options

- S – send a CP/M file (must specify file/s)
- R – receive a CP/M file (must name file unless B sec opt used)
- T – terminal mode (specify file if memory save wanted)
- E – terminal mode with echo
- M – return to menu
- X – used only when program is called to initially toggle menu off

Secondary options

- B – multi-file mode for sending and receiving files
 - T – return to terminal mode after transfer (memory save off)
 - R – view what is received in file transfer
 - S – view what is being sent in file transfer
 - V – view what is being sent or received in file transfer
 - T – Terminal mode (used with remotely controlled computer)
 - O – originate mode – NOT IMPLEMENTED IN PORTABLE VERSION –
 - A – answer mode NOT IMPLEMENTED IN PORTABLE VERSION
- .xxx– baud rate xxx (xxx = 110-9600 for the serial port)

EXAMPLES (fn = filename, ft = filetype)

Send file, originate mode, 300 baud
SO fn.ft

Receive file on B drive, 600 baud, ans mode, view what is being received, return to terminal mode

RART.600 B:fn.ft

Table 1
Listing of MODEM7 commands with examples

the checksum included by the transmitting computer. If the two agree, the receiving computer transmits an ‘ACK’ (hex 06) and the next block is sent. If the two do not agree, the receiving computer transmits a ‘NAK’ and the block is re-transmitted. See Figure 2.

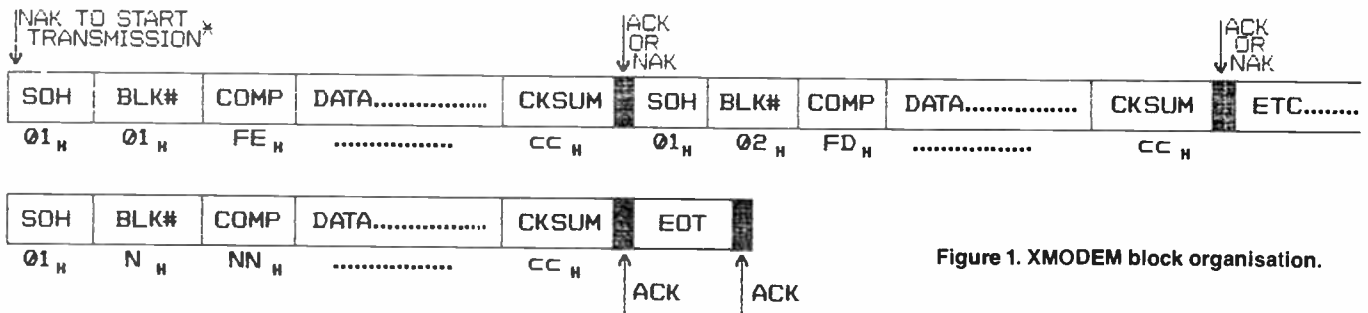

Figure 1. XMODEM block organisation.

* Arrows and associated captions indicate dialog from remote computer/terminal

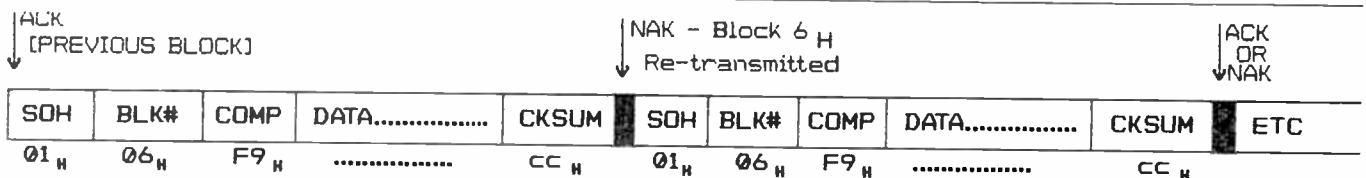

Figure 2. Retransmission of a bad block.

The final task is for the two computers to decide when the transfer is completed. Reference to the last section of Figure 1 will show how this is accomplished. When the last byte of Block N has been sent, the checksum for that block is then sent and a calculation performed by the receiving computer. If the two agree, an 'ACK' is sent and the transmitting computer then sends an 'EOT' (hex 04) "End of Transmission". Both computers then return to the comms package command prompt. At any time during the transfer, 'ACK's or 'NAK's themselves may be lost – this may seem like a real problem, but it's all taken care of. The transmitting computer simply waits a pre-determined period (around ten seconds) and then re-transmits the last block. If the receiving computer already has this block correctly, it simply discards it and returns an 'ACK' and everything continues on its merry way.

In order to start a file transfer in the first instance, the receiving computer should first send a 'NAK' to get things going. Once again, it's possible that this gets lost in Limbo, so the transmitting computer should be programmed to commence transmission anyway, if it hasn't received a 'NAK' within ten seconds.

The main problems with Christensen protocol are:-

- (a) There is no facility for transmission of file details such as creation date and time, and
- (b) the complete file must always be transferred in multiples of 128 bytes. this is not much of a problem for ASCII and .EXE or .COM files, but it can really play havoc with spreadsheet and similar files which require the exact file length for use.
- (c) There is no facility for transferring more than one file at a time.

Other MODEM/XMODEM variants

The two most familiar variations on the above theme are the MODEM7 and YMODEM protocols. The latter comes in two flavours – YMODEM-k, which used 1k byte block lengths (which can cause problems on systems that don't support this length of block) and YMODEM-g, which is very similar to TELINK (see below), in that it allows batch file transfers and retains exact file length and creation date/time data. MODEM7 was fairly primitive in operation – it relied directly on passing commands to CP/M, rather than operating via a comms package. A summary of the MODEM7 protocol is included below, together with two examples.

TELINK

The TELINK file transfer protocol was developed by T. Jennings in 1983, to overcome all of the difficulties mentioned above, whilst still maintaining compatibility with the MODEM/XMODEM protocol. TELINK adds an extra block to each file to be transferred and this block contains all the data necessary to transfer all of the information listed above. TELINK does this by starting each transmission with a block number 0. There is one major difference between this block and all other data blocks (other than the block number) and that is the use of the 'SYN' character (hex 16) instead of the normal 'SOH' character (see Figure 3). The reason for this is fairly simple – if the sending computer is using the TELINK protocol to transmit a file/s and the receiving computer does not support this protocol, then the receiving computer will send a 'NAK' instead of an 'ACK' when it receives this block header. TELINK will try two more times to send block 0 (remember, 'ACK's and 'NAK's can get lost on the line, too) and if it is still unsuccessful, then the transfer continues with block number 1, as would a normal MODEM/XMODEM transfer. It is important that there be not many more than three separate attempts to transmit block 0, as MODEM/XMODEM protocol will abort a transfer after ten unsuccessful attempts. The use of three tries for block 0 still leaves seven attempts for the first data block.

If the receiving computer is operating under the TELINK protocol, it makes a special check on the first block received (block 0) and if the header character is 'SYN' instead of 'SOH', then the receiver pulls out the file creation and size data and sets a flag to indicate that the data has been retrieved. In addition, the exact file size is re-assembled by writing $n \times 128$ byte data blocks and a final block containing any remaining characters. After the last data byte is written to the file, the file creation data is written and then the file is closed and the transfer completed. If the receiving computer has recognised the TELINK format of the first data block, it takes the appropriate action to re-assemble the exact file size.

AEM4610 update

For the benefit of any New Zealanders who may read this column, a V8 ROM is available from Maestro for exclusive use on the New Zealand phone system, which has its pulse dialling system reversed (0 is still ten pulses, but 1 is nine pulses, two ▶

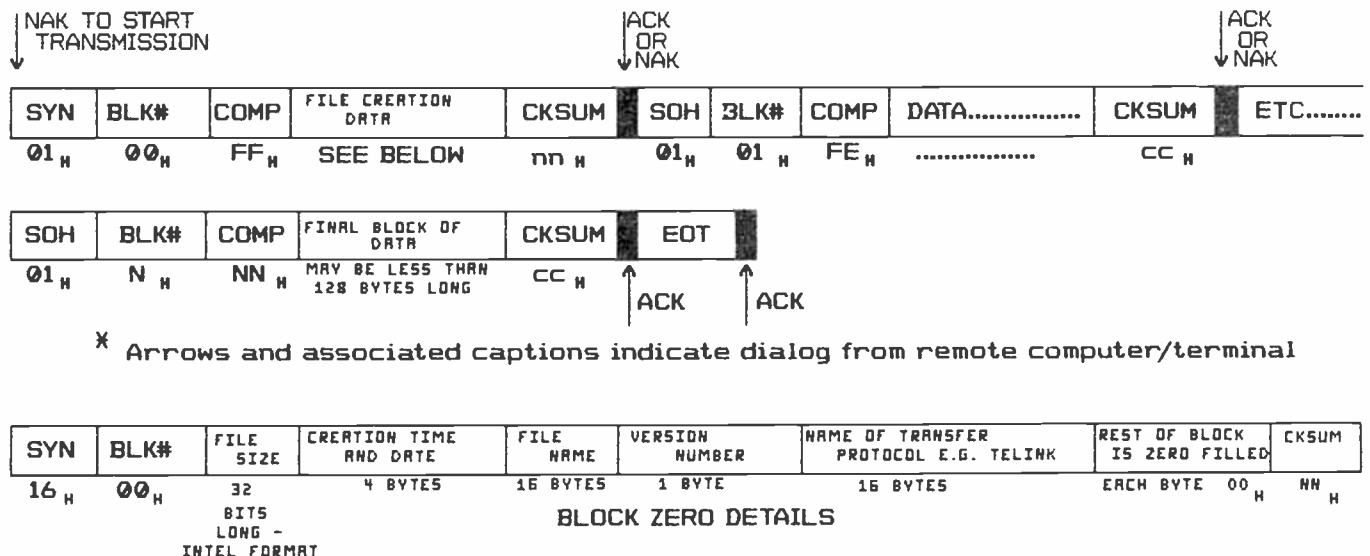

Figure 3. TELINK file transfer protocol.

is eight etc.). This chip is only of use to New Zealanders, who may obtain it by sending A\$39 to Maestro Distributors, Calool St, Sth Kincumber 2256 NSW, Australia.

New chips

Regular readers of this column will know of my interest in the NOVIX NC4000 Forth microcoded processor. Another chip to watch VERY closely is the Inmos T800 single chip transputer. This chip is an enhanced version of the original 32 bit T414 transputer chip and includes floating point processing capacity. The prototype version "is more than 12 times faster than the 80386/80287 pair, 6 times faster than the 68020/68881 pair and 4 times faster than the 32032/32100 pair."(3) It will also be twice as fast as the proposed 68030/68882 pair from Motorola.

Another set of modem chips that we are in the process of examining is the Intel 89024 modem set, comprising the 89026 16-bit digital signal processor and the 89027 analogue front end. This chip set has the Hayes command set in firmware and implements V.22bis (2400 bps full duplex). The chip set sells for US\$35 in 25,000 lots, but should only be about US\$50 in smaller quantities. Sounds very interesting.

Letters – Telecom replies!

We have received a reply from Telecom to our letter in the December, 1986 issue of Dial Up. The letter is reprinted in its entirety below:—

"Your article indicated that Telecom's Regulatory Test Centre was stretched, and this is certainly the case. It might be of interest to your readers to know that Telecom has had in place, since 1982, a policy of encouraging technically competent suppliers of data terminal equipment to undertake their own technical testing and to self-certify their equipment for connection to the network. This policy is working very well and currently 22 organisations are authorised to self-certify. Although this policy is not directly relevant to "kit constructed modems", it has relieved Telecom resources and shortened the delays that would otherwise have occurred.

"Your article referred to delays of up to 6 months in the Telecom approval process. This is not so. Delays are running at about 10 weeks, and we hope to cut that time to 4 weeks with further streamlining. If we need further information from an applicant to progress [sic] an authorisation the process of getting it can slow down the whole matter.

"The fees charged for authorisations by Telecom are very low by world standards and often do not cover costs. The fee for an amendment to an authorisation to cover a modem modification [e.g: a V.22 expansion board – Ed.] is \$300. The fee of \$600 used in your article refers only to an initial authorisation.

"The main point of your article was to suggest a streamlined procedure – the use of an approved line isolation unit, for any modem kit. Telecom welcomes good ideas to reduce cost and delay. Unfortunately, the procedure proposed in your article would not meet the fundamental aims of the authorisation procedure in the first place.

"The use of a plugpack would not reduce Telecom's concerns about mains voltages appearing on the phone lines. Many people incorrectly believe that logic circuits will always go open circuit if 240 volts is applied. This is not necessarily the case. Consequently, Telecom insists that all modems be equipped with a double insulated line interface. This inter-

face may be built into the modem or provided separately. In either case it must comply with relevant insulation standards established by the Standards Association of Australia.

"However, in addition to electrical safety, Telecom's authorisation relates to network interference. Dialling functions need to be assessed to ensure that public exchange equipment is not held up for unacceptably long periods.

"I doubt very much whether the line interface unit suggestion would be of use to a kit modem user. Such a unit would be prohibitively expensive to such users if it was designed to limit power levels and frequencies and perform in a manner acceptable to Telecom.

Yours sincerely,

[signed]

J.R. Holmes
MANAGER, LEGAL & POLICY"

Firstly, I would like to thank Telecom for their reply and to throw the matter over to my readers for their thoughts. I also accept that the approval delay is being reduced considerably. However, the fundamental question is still not answered. The approval cost for individual kit builders is STILL prohibitively expensive, particularly when modem upgrades are involved and I still feel that there are a large number of kit builders out there who will say "what the heck, I'll take the risk of getting caught," despite Telecom's frequent warnings of penalties in appropriate magazines and tabloids.

Do readers have any further ideas or criticisms? Perhaps some of you may feel that I am being overly severe with Telecom. The other disturbing thing about Telecom is the proposal that they are going to introduce timed local call charges for any data transfer calls. This is (apparently) to overcome the problem of business users tying up a normal telephone line all day and using it exclusively for data transfer, instead of renting one of Telecom's more expensive leased data lines. If this occurs, businesses will be affected, but they will probably manage (higher charges to customers is the usual way to cover such costs). However, how will the average hobbyist with his/her modem cope? It really looks as though Telecom is about to declare war on the home computer/modem user.

Final note

Maestro are still keen on hearing of any suggestions for projects that readers may have. The project can be on any aspect of electronics, not just modems. In fact, according to Dan and Chris, they would like a break from designing modems and are keen to tackle anything else. Their Viatel number is 436929130 and my Viatel number is 434147010.

Next month I will continue my discussion of file transfer protocols, looking at such things as Kermit and sliding window protocols. ♣

REFERENCES

1. "Data Communications, Networks and Distributed Processing", Uyles D. Black, Reston Publishing (Prentice-Hall), 1983. (Yes, the name is Uyles – there's no spelling mistake).
2. A large amount of this material has been kindly provided by Bill Bolton of Software Tools of Australia BBS (02-4492618). This BBS was the first in Australia and Bill is a very keen supporter of Communications. He is having problems with hard disk storage at this time and would greatly appreciate any donations to assist.
3. Electronics (McGraw-Hill), November 27, 1986, pp 51-55.

FANTASTIC OFFER!

MULTI-OUTPUT, 150 W SWITCHING SUPPLY!



Here's a great opportunity to get a National brand MF Series high power, multiple output off-line (240 Vac/120 Vac) switching power supply made by Japanese electronics giant, Matsushita Electric.

Features

- Dual input (jumper selectable).
- Open frame construction.
- 150 watt (total output power)
- Up to 5 outputs.
- Designed to conform to UL114, 478, CSAC22.2 NO.143, NO.154, IEC380 (class 1), BS5850 (class 1), VDE0806 (class 1).
- 50 kHz operation.

Measures
350 x 135 x 65 mm

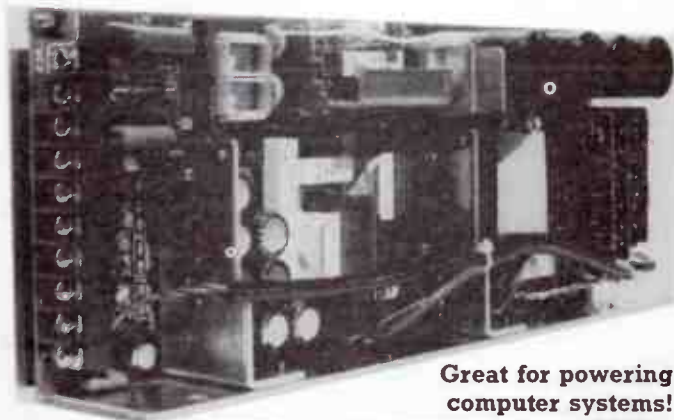

Great for powering computer systems!

| MODEL NO | OUTPUT A | OUTPUT B | OUTPUT C | OUTPUT D | OUTPUT E |
|-----------|-------------|-----------------|-----------------|-----------------|------------|
| ETU-5MF01 | +5V 3 ~ 15A | +24V 0.4 ~ 1.5A | +12V 0.4 ~ 1.5A | -12V 0.4 ~ 1.5A | -5V 0 ~ 1A |

NOTE. If any lower voltage is required on either B, C or D output(s), provision is made for a TO220 78-series regulator to be inserted on the PCB.

End of model sell-out!

The MF Series has been replaced by a new model and the distributors, A.J. Distributors Pty Ltd, have only a strictly limited number left — and they are all to be offered below cost!

Who said it? — you reap the benefit!

All units supplied with a circuit and data sheet.

Electrical Characteristics

| PARAMETER | CONDITIONS | LIMITS |
|--------------------------|--|---|
| Input Voltage | Jumper selectable on the PCB | 85 to 132 VAC 170 to 264 VAC 47 to 440 Hz 240 to 360 VDC |
| Input Line Regulation | Full input voltage range +5V output Other outputs 3 terminal regulator Non reg | 0.2% max 0.6% max 1.0% max |
| Load Regulation | Load change from 20 to 100% of rated output current at rated input voltage +5V output Other outputs 3 terminal regulator Non reg | 0.6% max 1.0% max 5.0%/A (typ) |
| Ripple and Noise | Peak to peak | 1% +75 mV max |
| Over Current Protection | 120% of rated output current (typ) | +5V output |
| Short Circuit Protection | | Other outputs |
| Over Voltage Protection | +5V output | 6.0 ~ 7.0V (typ) |
| Operating Temperature | Convection cooling | 0 to 50°C no derating -25 to 85°C |
| Storage Temperature | | |
| Weight | | 2.0 kg (4.4 lb.) |

A.J. Distributors has made this offer available exclusively to readers of Australian Electronics Monthly, the magazine is acting as a clearing house for orders.

OFFER CLOSES LAST MAIL
31 MAY 1987, or until sold out.

EXTENDED TO JUNE 30, 1987

If you want to inspect a sample, call into our offices any weekday during business hours. We're located at: First Floor, Fox Valley Centre, Cnr Fox Valley Rd and Kiogle St, Wahroonga NSW. The entrance is in Kiogle St.

\$95

less sales tax.

\$111

inc. sales tax.

Delivery, anywhere in Australia — \$6.50

Here's a chance to snap up a 'professional' high power switching power supply at a never-to-be-repeated price!

RUSH THE COUPON NOW, send to:
'Power Supply Offer'
Australian Electronics Monthly
PO Box 289, Wahroonga 2076 NSW

• Credit card phone orders accepted.
Call 487 1207.

COUPON

Please rush me . . . National MF Series power supply unit(s) at \$95.00 each (less tax), or \$111.00 each (inc. tax), plus \$6.50 for delivery.

TOTAL: \$

I enclose payment by:

Money Order Cheque Visa

Bankcard Mastercard American Express

Credit Card No:

Expiry date:

Cheque or Money Order No:

(Please make cheques or Money Orders payable to 'Australian Electronics Monthly')

Name

Address

Postcode

Signature:

(Unsigned Credit Card orders cannot be accepted)
Please allow for normal postal and bank clearance delays.

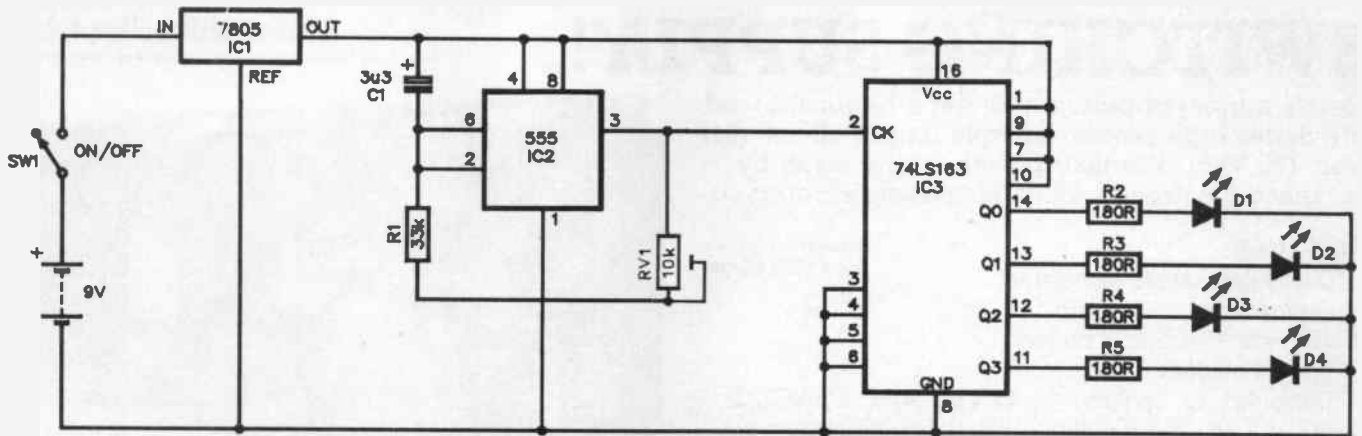

Electronic candle

This circuit was designed basically as a Christmas decoration with a difference — an electronic candle, complete with 'flicker'.

The first part of the circuit, comprising IC2, C1, R1 and RV1, generates a clock pulse. The period of the pulse can be changed by altering the values of either C1 or RV1, but it is easier to use a trimpot for RV1. You should experiment with the value of RV1 to get the speed of the candle 'flicker' to.

The clock pulse is fed to the 'guts' of the circuit — a binary counter. At each upward transition of the clock the counter advances to the next binary state (i.e.: 0000 . . 1111) producing a variable pattern on the outputs. Each output is used to drive a LED through a resistor. I used different coloured

LEDs to make it look interesting.

I found that the circuit works best on 5 V and this is the reason for including IC1 to derive + 5 V from the 9 V battery.

For construction, the bulk of the circuit went in a box with the LEDs mounted in a translucent tube through the top of the box. I used a translucent tube to smear the light from the LEDs a bit and to hide the wires to the LEDs. The LEDs themselves were glued onto an old pen body fixed into a wooden cork on the top of the box that also served to hold the tube in place.

If the LEDs are mounted in the order D1, D2, D3, D4 from the base, the effect looks like that of a candle.

John Dowdell
Northgate, Qld

Doing a printout from HESMON with your C64/VIC-20

Here is a hint for C64 and VIC-20 users with RS232 printers and HESMON. Normally, HESMON does not support RS232 printers, but if the following direct command is entered in BASIC

```
OPEN200,2,2,CHR$(**):CMD200 [RETURN]
```

and HESMON is entered immediately by a "SYS" command, then all commands in HESMON will be directed to the printer.

Printouts of:

D — disassemble
I — interpret
M — memory
etc.

will be listed, but before printing it's best to establish the starting and ending addresses using the normal screen output.

200 = file number (over 127 > LF with CR)

1st 2 = device no.

2nd 2 = dummy

*** = control register — for baud rate, word length and stop bits.

Command register is optional.

CMD 200 = all screen output to RS232 file no. 200.

A. Gibbs
Bringelly, NSW

Example of "I" and "D" printouts.

These were made on an ASR33 teletype. Start address C000 (beginning of BASIC ROM on VIC-20).

```
'C000...CBMBASICOHAG      .C025 C8      INY
'C010M.H&K>K0PEL&I-H    .C026 92      ???
'C020.H'I\HBHQH:I.HJI   .C027 C8      INY
'C030.X.R..25#X.J-J     .C028 D1 C8    CMP($C8),Y
'C040VH(F)FEJ&..C..K   .C02A 3A      ???
'C050AF9\L\X\00.S.S.- .C02B C9 2E    CMP#$2E
'C060T..Y.-...1.K.MX   .C02D C8      INY
'C070.W.T.WXV.V0V.W7W .C02E 4A      LSR
'C080.X.RX.*Z.GC...P   .C02F C9 2C    CMP#$2C
'C090.OF.O.3-ZSN.UPEN  .C031 D8      CLD
'C0A0DFORNEXTDATAINPU .C032 6A      ???
'C0B0T#INPUTDIMREADLE .C033 E1 52    SBC($52,X)
'C0C0TGOTORUNIFRESTOR .C035 E1 61    SBC($61,X)
'C0D0EGOSUBRETURNREMS .C037 E1 B2    SBC($B2,X)
'C0E0TOPONWAITLOADSAV .C039 D3      ???
'C0F0EVERIFYDEFPOKEPR .C03A 23      ???
                        .C03B D8      CLD
                        .C03C 7F      ???
                        .C03D CA      DEX
                        .C03E 9F      ???
                        .C03F CA      DEX
.C000 78      SEI      .C040 56 C8    LSR$C8,X
.C001 E3      ???      .C042 9B      ???
.C002 67      ???      .C043 C6 5D    DEC$5D
.C003 E4 43    CPX$43   .C045 C6 85    DEC$85
.C005 42      ???      .C047 CA      DEX
.C006 4D 42 41 EORS4142 .C048 26 E1    ROL$E1
.C009 53      ???      .C04A BA      TSX
.C00A 49 43    EOR#$43   .C04B E1 C3    SBC($C3,X)
.C00C 30 C8    BMSBFD6   .C04D E1 7A    SBC($7A,X)
.C00E 41 C7    EOR($C7,X) .C04F CB      ???
.C010 1D CD F7 ORA$F7CD,X .C050 41 C6    EOR($C6,X)
.C013 C8      INY      .C052 39 DC CC AND$CCDC,Y
.C014 A4 CB    LDY$CB    .C055 DC      ???
.C016 BE CB 80 LDX$80CB,Y .C056 58      CLI
.C019 D0 05    BNE$C020 .C057 DC      ???
.C01B CC A4 C9 CPY$C9A4 .C058 00      BRK
.C01E 9F      ???      .C059 00      BRK
.C01F C8      INY      .C05A 7D D3 9E ADC$9ED3,X
.C020 70 C8    BVS$BFEA .C05D D3      ???
.C022 27      ???      .C05E ?1 DF    ADC($DF),Y
.C023 C9 1C    CMP#$1C
```

Underlining on a GX-80 printer, and others, another method for C64 owners

On the Easyscript disk are some files that tell you about underlining. These use user-defined characters to underline the text, which works, but on GX-80s, and possibly on other printers, it prints one row at a time, darting backwards and forwards, generally taking a long time. This proved that you can underline on a GX-80, but it wasn't the way I wanted it to, so I experimented.

The lines shown below were not made using user-defined characters, and were all printed from Easyscript.

1) _____
2) _____
3) _____
4) _____
5) _____
6) _____
7) _____
8) _____
9) _____

- from page 8.

as a stress-sensitive resistor. This is also somewhat non-linear but leads to simpler circuitry.

If two identical FETs are constructed on the one chip in such a way that, by using a transistor-size sub-surface heater, one of them can be made hotter than the other, the ratio of the two drain currents becomes sensitive to any air flow across the chip. This makes a very sensitive and small anemometer. By having a number of such pairs of FETs on the one chip, the system can be used to sense wind direction as well as speed.

Smart sensors

Almost all of the sensors discussed so far are non-linear, so their output must be sent to signal processing circuits for linearization. The need to do this is a problem since the size, power consumption, and cost of the additional parts is a disadvantage. There are two ways in which this problem is being attacked.

The first way is to realize that we already have a silicon chip on which the sensor has been produced. By suitable masking of the rest of the chip, integrated circuit amplifiers with laser trimmed resistors can be incorporated for linearizing. While we are at it, we can also incorporate temperature compensation if this is necessary, or by including another sensor, allow for any unwanted sensitivity to, for example, pressure or relative humidity, or whatever.

The second way is to make the sensor have a digital output that can be fed direct to a computer and the non-linearity corrected using software. One of the simplest ways of getting a digital output is to use the sensor to control the mark-space ratio of an astable flip-flop and use this to gate a clock. The resultant pulse trains can easily be converted to binary form. Again, since the chip is already silicon, it is a relatively easy matter to integrate the necessary digital circuits onto the same chip as the sensor. With suitable additional sensors, compensation for temperature and other effects can now be reduced to a few lines of programmes.

Such sensors are called "smart" since they can be tailor made to have more or less any characteristics that are needed for the task in hand. Clearly a temperature sensor for a tomato juice production line needs to have different properties from a temperature sensor to be fitted into the "fingers"

How did I do them? No doubt some of you have already darted away to user manuals, but I'm going to reveal the secret anyway. Use the Commodore key to get the graphics that you need. You can't use Commodore + A, S, U, I, C, V and probably a few others, but you can use quite a few for different effects. The keys I used are:

- 1) = T
- 2) = Y
- 3) = reversed P
- 4) = reversed @
- 5) = P
- 6) = Q W
- 7) = @
- 8) = £
- 9) = +

Stuart Elflett
Toogoolawah, Qld

of a robot that is handling parts that are being laser formed. The technology already exists to fabricate many different types of such sensors.

In the next few years smart sensors based on FETs will become available for the medical profession. These new sensors will be sensitive to a wide range of biochemical reactions within the body and will serve as diagnostic tools for indicating biological dysfunction. As shown in Figure 2., a large number of sensors will be incorporated onto a single chip, together with all the necessary smart circuitry, and the output will be fed direct to a computer. Whether the computer will also make the diagnosis is a matter for the medical profession to decide.

In experimental sensors of this type, problems have arisen because of their imperfect selectivity and the interactions that can occur between the different sensors on the same chip. Rather than delay development until better sensors become available, smart computer algorithms have been written that allow for this, so the final output behaves as if the sensors are quite independent of each other.

The many new types of smart sensor will not only have a major impact on the manufacturing industry, but will also reach into such diverse areas as forensic science, horse racing, robotics, and eventually the motor car. In a few years they will be incorporated into home appliances as the trend towards increasing the smartness of our mechanical domestic servants continues.

Further reading

R. Kobos in "Ion-Selective Electrodes in Analytical Chemistry." Vol 2, Ed by H. Freizer, Plenum Press N.Y. (1980) pp 1-84.

S. Caras & J. Janata "Field effect transistor sensitive to penicillin." Analytical Chemistry Vol 52 (1980) pp 1935-1937.

Y Miyahara, T. Moriizumi, S. Shiokawa, H. Matsouka, I. Karube & S. Suzuki "Micro urea sensor using semiconductor and enzyme immobilizing techniques." J. Chem. Soc. Japan Vol 6 (1983) pp 823-830.

"Transducers '85": International Conference on Solid-State Sensors and Actuators. IEEE N.J. (1985). ↗

letters

Speech synthesiser

Dear Sir,

I have only recently become a reader of the Australian Electronics Monthly and I really enjoy reading the articles. The whole magazine is terrific. Most of the projects come in handy but that doesn't solve my immediate problem.

I own a Sega SC-3000 computer and I have been looking everywhere for a speech synthesiser to suit it. Whilst reading through the December issue I came across an advertisement for the Votalker C-64. As I read about this device I realised that it was exactly what I wanted except that it was only suitable for the Commodore 64. I was wondering if you could publish a project for a speech synthesiser, similar to the Votalker, which would suit the Sega SC-3000 computer.

L. Ross,
Canley Hts., NSW.

The AEM4504 low cost speech synthesiser published in February 1986 was suitable for any computer with an 8-bit I/O port, but you'll have to learn how to program it yourself. The AEM4505 speech synthesiser published in June and July 1986 can be used by connecting to either a "Centronics" type printer port or a standard serial port. Either of these two projects may suit your requirements. Back issues cost \$4.00, post paid.

Turntable troubles

Dear Sir,

I was wondering if you could help me? I am rebuilding a transcription turntable and would like to use a stepper motor for the power unit. However, no companies in Tasmania that I have contacted are able to supply one. It has to be fairly large to drive the bulky solid aluminium platter. The motor previously in use was rated at 30 W and 0.15 HP, if that's any indication.

The original setup used an idler wheel to get power from the motor to the turntable. This generated a lot of rumble, hence I want to obtain the stepping motor for a belt drive setup. I could just go and buy a complete new turntable, however I recently purchased a high quality tone arm, and have become quite attached to the solid, rock-steady rotation of the heavy platter, hence this plea.

Would you please advise me if you know of any company that can supply the above motor? Your help in this matter would be greatly appreciated.

D. Hughes,
Howrah, Tas.

Can any readers assist with suggestions?

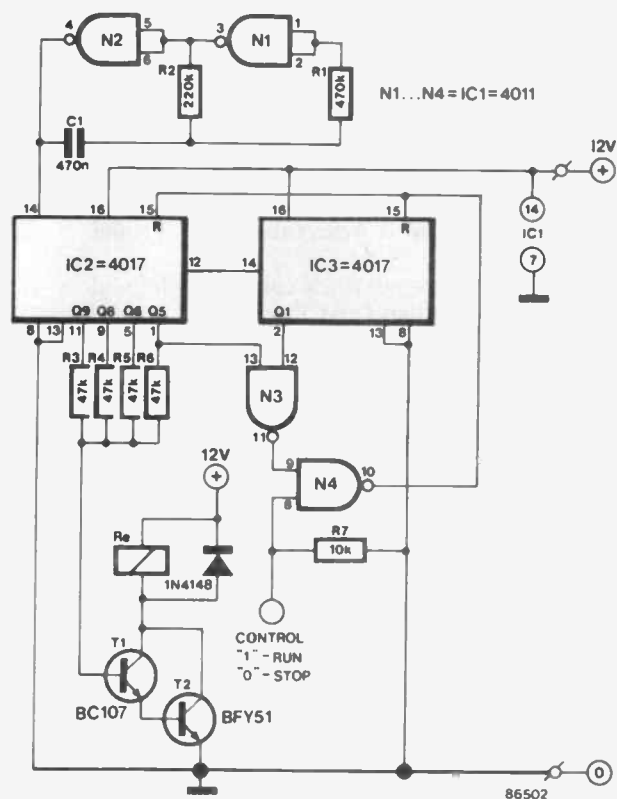

Phone bell simulator

Dear Sir,

I would like to draw your attention to a possible problem with the circuit of the Elektor telephone bell simulator from the January issue of the magazine.

At the instant of transition of the clock oscillator, the voltage on the input to the counter IC2 will have excursions beyond the positive and negative rails due to the voltage stored in timing capacitor C1 being placed in series with the output of N1. Some 4017 counters will resent this and respond by counting on both the rising and falling edge of the clock pulse.

I ran across this problem some years ago when building a virtually identical circuit. I would have thought the protection diodes on the 4017 clock input would be adequate to clamp these excursions but such is not always the case. I finally solved the problem with a series resistor and a zener diode. The problem does not show up with every 4017. In my case the bench prototype worked perfectly but the half-dozen units built for the field were all failures. Murphy strikes again!

On the same subject, resistor R2 may have to be selected on test as the oscillator frequency is dependent on the input voltage threshold of N1 and N2

which can vary widely from chip to chip.

L. McKeon,
Nundah, Qld.

Whilst we have not experienced the problem ourselves, we can appreciate how difficult problems of this nature can be. Thanks for the information. Telephone bell simulator constructors take note!

Andrew Keir

Patch leads

Dear Sir,

Congratulations on producing such an interesting magazine on decent paper and at a decent price. It is good to read a magazine that keeps up with current trends but it's a pity that the hobbyist electronics industry doesn't do the same.

For some years now the "Walkman" type of small stereo cassette players have been on the market. I have spent considerable time and effort looking for a patch lead so that I could record off one such machine onto another. It almost got to the stage where I was going to have to buy a lead and a suitable stereo plug. The miniature plugs are available at most electronics stores but the miniature stereo cable is not. After two years

searching I am still unable to source a suitable cable. Why?

**P. Truscott
Tullah, Tas.**

Any entrepreneurial cable manufacturers out there who can help?

Raising standards

Dear Sir,

Congratulations on an excellent publication. The addition of Elektor to AEM has lifted the standard of your magazine above that of your competitors.

**C. Ivarsen,
Keilor, Vic.**

Baud rate converter

Dear Sir,

In the January 1987 "Dial-up" column you described a baud rate converter based on a universal fully asynchronous receiver/transmitter and a 4020 binary counter. I have some questions concerning the device.

In the diagram there are two pins marked as pin 20. The one labelled SI should be pin 20 and I suspect that the

other one is pin 2 (VGG). Is this correct? Two further pins are not numbered. I expect that RDE is pin 4 and SWE is pin 16.

The output frequencies from pins 6 and 15 of the 4020 I calculate to be 38.4 kHz and 2.4 kHz. Should they be pins 13 and 1 for the correct 19.2 kHz and 1.2 kHz?

When fitting the converter to your magazine's Super Simple Modem, do I just cut the track between pins 28 and 10 of the 7910 and solder the "out" line to pin 10 and the "in" line to pin 28?

**B. Gennette,
Tighes Hill, NSW.**

You are quite correct, there were a few "anomalies" in the diagram. The pin 20 labelled SI is the real pin 20 and the other pin 20 should be pin 2 (VGG) as you point out. The un-numbered pins are as you assumed; RDE is pin 4 and SWE is pin 16. The output frequencies from pins 6 and 15 of the 4020 are correct, not pins 13 and 1 as you thought. Fitting the converter to the Super Simple Modem is accomplished in the way you describe.

Andrew Keir

Thanks

Dear Sir,

Congratulations on your magazine's first birthday and on having such a unique publication. I would like to take this opportunity to express my special thanks to the magazine for the first birthday contests held over the months of July, August and September 1986.

Please send special thanks to Mr Graham Blanchett, Philips Scientific & Industrial, North Ryde, NSW, who was responsible for generously donating the prize of a 50 MHz PM 3055 oscilloscope, and for his arrangement of the presentation. Thanks also to Mr Graham Adams, Sales Manager of Philips Scientific & Industrial, Oakleigh, Vic., for presenting the prize.

My thanks also to all the staff at AEM and the various companies who participated in the production and organisation of the contests and for the selection of the prizes. Without sponsors, there would not be contests such as these.

**B. Celotto,
Nth. Carlton, Vic.**

AEM Printed Circuit Service

NEW BOARDS IN STOCK FOR RECENT PROJECTS

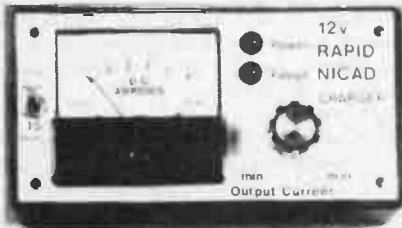

9503 NICAD CHARGER FOR R/C MODELS

Featured in our December '86 issue, this project will fast-charge NiCad battery packs from 12-14 Vdc. Requires only common parts.

\$9.35

6506 WORKHORSE POWER AMP

Delivers 100 W into 4 ohms, 50 W into 8 ohms. Rugged design is simple, cheap to build. Uses only common parts. (Jan. '87).

\$17.64



9502 ELECTRIC FENCE

Project features variable output voltage, simple construction, all parts readily available, (Described Oct./Nov. '86) **\$11.40**



2510 WORKBENCH POWER SUPPLY

Project is a general purpose variable power supply. Delivers 2 A across output range of 3.5-25 volts. Fully protected, 200 mA/2 A current limit. (Described Feb. '87). **\$21.25**



2502 LOGIC/DATA PROBE

Essential fault-finding tool for hardware, hackers and digitologists. Simple, cheap, uses all common parts.

(Described Jan. '87). **\$8.95**

Copies of the relevant articles cost \$4.00 each post-paid

Order pc boards by the project number and title. We do not stock complete kits or components. Send orders to:

Australian Electronics Monthly
PO Box 289, WAHROONGA 2076 NSW
(02) 487 2700.

PLEDGE YOUR PLASTIC!

Bankcard, Mastercard,
Visa & American Express
accepted.

PAY BY PAPER!

Cheques or money orders OK.
Make them payable to
"Australian Electronics Monthly".

The Last Laugh



GREAT MOMENTS IN LATERAL DRINKING

smith



So who's laughing?!

A GOOD DEAL of my time and the time of the academic staff of the Sackville Academy of Lateral Thinking (S.A.L.T. of the Hawkesbury), is taken up laterally thinking at sea. To do this, we use our Research Vessel the 'Hawkesbury Explorer'. She is a handsome ship, about 20 metres long, well equipped with sails, a toilet and a refrigerator.

She came into our possession by chance and a fair amount of Lateral Thinking, although some might see a Greater Force lurking in the background. (Assuming that there is a force greater than lateral thinking.)

This is how it happened. A pupil and I were

out on the river in a small rowing boat that had mysteriously appeared on our beach. We had been doing some Lateral Thinking with a cask of dry white and were rowing our way, somewhat unsteadily, back to the Academy.

We rounded a bend of the river, after several attempts, and there, stuck on a sand-bank, was this handsome vessel. Thinking the crew might be in some trouble we hastened on board. There was not a soul on her but we did find a note, written either in blood or tomato sauce, pinned to the galley table by a bread knife. We read the ominous words 'Back in 10 mins'.

The boat was bumping gently on the sand-bank by now and the 10 minutes were up, so we towed her into a small creek that runs

alongside the Academy. There we hid her under overhanging tree branches in case some dishonest person might steal her.

Over the next few months we worked to get her ready for sea. A few moments Lateral Thinking resulted in an advertisement in the boat magazines about our Creative Boat Maintenance Course, (bring your own tools), and soon we had people paying for the privilege of chipping rust, mending holes and painting our little craft.

She was now ready for sea and the first research voyage planned was with a well-known museum to record the songs of Humpback whales as they migrated north along the coast of NSW.

The Whale-Listener-In-Chief was Bill, of world experience, who had brought with him a hydrophone, (an underwater microphone) for dangling over the side, a preamplifier, a professional quality tape-recorder and a pair of headphones. If whales were in the area, the plan was to stop the ship (which wasn't difficult), lower the hydrophone into the ocean and record what was going on.

So that was how we came to be at sea, in the dark hours of a beautifully calm morning, drifting along, Bill in the wheelhouse with me with headphones glued to his ears.

Bill broke the silence. "I think I'm going mad", he said. I ignored the remark, poured him a scotch and dozed off again. He said it again, "I'm going quite, quite mad."

I woke up. "Overworked, perhaps Bill. Tired, sea-sick perhaps, but not mad."

"I can hear Kookaburras!" he said, between clenched teeth. This sounded serious. "There, there," I said, and led him to the bar.

He thrust the headphones at me with trembling hands. "You try listening," he begged, "see what you hear."

"Placate the poor fellow," I thought and put them on. Sure enough, there they were. Not one, but dozens, all kooking their silly heads off. I took the bottle from Bill.

"You're right," I said.

Here we were, some miles off the coast on a pitch-black night, our hydrophone in about two metres of Tasman Sea, our well-proven gear striving for the faintest sound of a whale, and what do we hear . . . KOOKABURRAS!!!

We sat and pondered, both laterally and vertically. Then I heard a man's voice. This was getting worse. What was he saying? Was it a message from another world?

"This is Radio Australia," said the voice, very clearly, "and here is the news."

What a let-down! What a relief! We were not mad, we were not drunk, we had not been selected to take someone or something to our leader.

Apparently round the ship was some weird circuit there was a diode that was rectifying it and our sensitive equipment was picking it up. And Radio Australia plays Kookaburras laughing as a 'signature'.

"Humpbacks can't compete with kookas," said Bill, "let's go home."

Professor Donald F. Richards
Sackville Academy of
Lateral Thinking
S.A.L.T. of the Hawkesbury

Roger Harrison's

Australian Electronics

Monthly

Incorporating Elektor Electronics

**DON'T MISS
THE JUNE ISSUE!**

*Just look
at these features!*

DIGITAL COMMUNICATIONS

Morse was first, radioteletype followed, and now we have packet radio! Here's a rundown on the various 'digital' communications modes and techniques and a guide to getting on the air.

USING THE MICROBEE IN YOUR SHACK

Geoff Wilson VK3AMK shows how to put your Microbee to good use – printing QSLs!

BUILD A STAND-ALONE V.22 MODEM!

Here's a great little high-speed 1200 bps full duplex modem. Don't throw out your old 300/1200-75 modem to update at great expense, just build our new modem and get going!

And in June's Elektor Section:

- Low-cost portable capacitance meter
- Secondary breakdown in transistors

WHY NOT SUBSCRIBE?

If you work in electronics, communications, computing or servicing, a subscription to Australian Electronics Monthly could be tax deductible.

**SUBSCRIBE FOR JUST \$49.95
for 12 months**

**Australian Electronics Monthly
PO Box 289, WAHROONGA 2076 NSW**

**Roger Harrison's
Australian Electronics Monthly.**

– with more electronics than you'll find
in any other Australian electronics magazines.

Published by Kedhorn Holdings P/L, inc. in NSW, Fox Valley Centre,
Cnr Fox Valley Rd & Kiole St, Wahroonga 2076 NSW

Highlight on multimeters

Our Series 18 digital multimeters are packed with features to meet all types of portable measuring requirements; from general servicing to analog and digital testing to R & D and calibration. Each of the three models in the series can be supplied with illuminated display for low light conditions.

- **PM 2518.** The most cost-conscious RMS meter on the market, it features: 0.1% accuracy; 20 A and 100 M Ω ranges; dB read-out; temp. and relative reference modes.
- **PM 2618** has all the PM 2518 features plus: 200 kHz counter; highly-sensitive analog bargraph; closed-case calibration and 10 MHz logic view with duty cycle info.
- **PM 2718** features all PM 2618 capabilities plus: 0.05% DC accuracy; 100 kHz RMS AC; Min./ Max. measurements; and Data Capture mode with display 'freeze'.



Test the difference

■ **Product credibility** in technology, technique, quality and service is assured because the serie 18 meters are backed by the vast corporate resources of one of the world's largest electronics companies.



Test the difference and you'll also agree that Philips wins on price and performance!

Contact, Philips Scientific and Industrial,
Sydney - tel. (02) 888 8222
Canberra - tel. (062) 95 6140
Melbourne - tel. (03) 542 3600
Brisbane - tel. (07) 844 0191
Adelaide - tel. (08) 348 2888
Perth - tel. (09) 277 4199
Other areas - toll free (008) 22 6661



**Test &
Measurement**

PHILIPS