

"Miniwatt"

DIGEST

VOL. 2. No. 6
MARCH 1963

— TECHNICAL AND COMMERCIAL TOPICS OF
CURRENT INTEREST TO THE ELECTRONICS INDUSTRY

CONTENTS

	Page
NEW CONCEPT FOR A VALVE-EQUIPPED B/C RECEIVER ..	82
POWER TUBES FOR B/C AND TV TRANSMITTING STATIONS ..	84
TRANSISTORISED DC/DC CONVERTER (140 W Unit) ..	86
PHILIPS LOW-VOLTAGE RECTIFIERS ..	88
MINIWATT TRANSISTORISED TACHOMETER ..	90
TECHNICAL BOOKS (X-Ray Diffractometry and X-Ray Spectrography) ..	95

Published by the
Miniwatt
Electronics Division of
Philips Electrical Industries
Pty. Limited,
20 Herbert Street,
Artarmon,
N.S.W., Australia

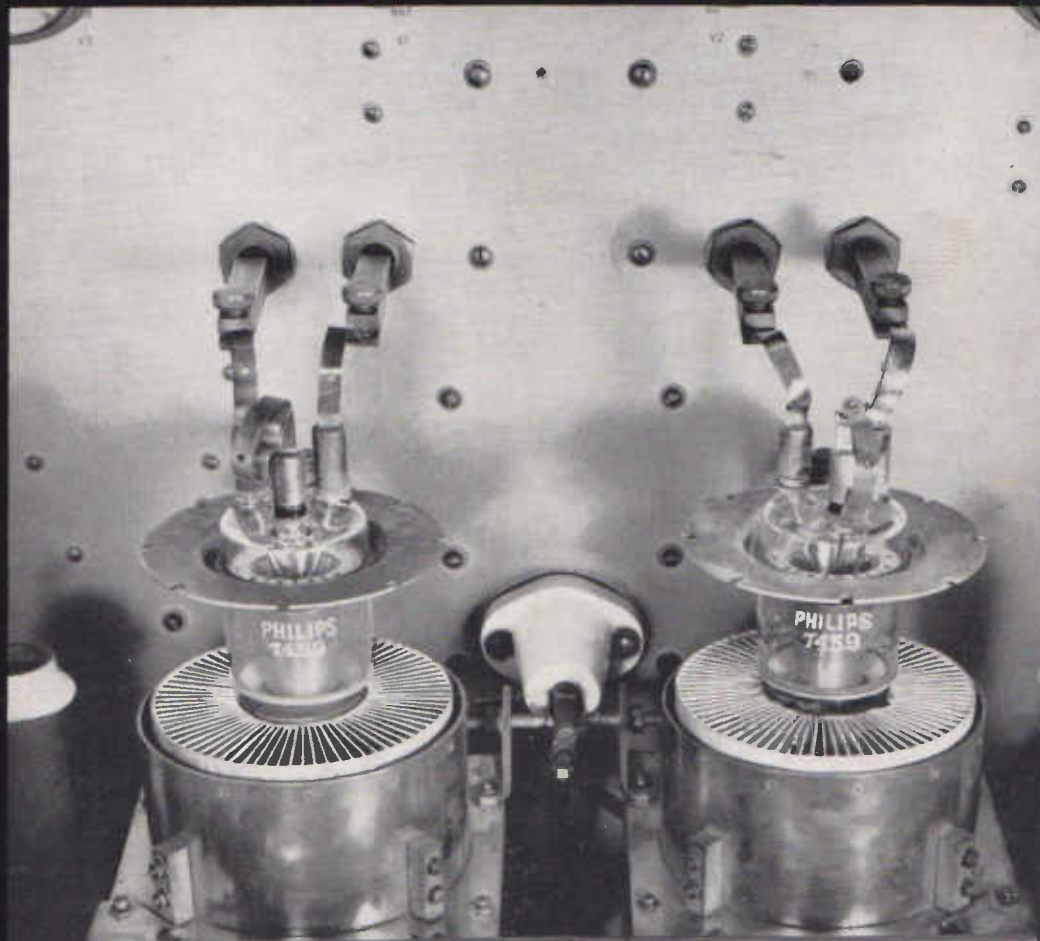

PHILIPS 7459 TRANSMITTING TRIODES
IN BROADCAST TRANSMITTER

(Photograph courtesy Macquarie Broadcasting Service Pty. Ltd.)

New Concept for a Valve Equipped Broadcast Receiver

A concept is presented for a mantel receiver using only three valves plus one silicon rectifier, yet having a performance approaching that of a standard five-valve receiver. Economies in the numbers and sizes of components are possible, resulting in a design which gives good performance at low cost.

The design of broadcast mantel receivers using 9-pin miniature all-glass valves has undergone little change in Australia since the introduction of the Innoval valve range in 1949. A typical mantel receiver uses either four or five valves with more or less standard circuitry and undergoes periodic changes in cabinet styling to match modern trends. A typical valve line-up of a four-valve receiver is:

Converter	6AN7
IF Amplifier + Demodulator + AVC	6N8
AF Power Amplifier	6M5
Rectifier	6V4

A five-valve receiver has, in addition, an AF pre-amplifier using either another 6N8 pentode or a 6BD7 triode with the IF amplifier changed to type 6BH5. The sensitivity of an unreflexed four-valve receiver is about 200 μ V RF input for 50 mW AF output, and of a five-valve receiver between 3 μ V and 10 μ V depending on coil design. The HT voltage is usually between 200 V and 250 V within which voltage range the AF power output is between 2 W and 3 W. This type of performance had become the accepted standard for mantel receivers until the advent of transistor receivers.

With transistor receivers, both for reasons of economy and due to limitations of the transistors themselves, several compromises in performance have been accepted. The sensitivity of a seven-transistor set can equal that of a five-valve receiver, but usually at the cost of reduced bandwidth. Signal-to-noise ratio and cross-modulation are also generally inferior to those of valve receivers, and power output does not exceed 1 W. Yet the price of a seven-transistor receiver is higher than that of a five-valve receiver, which means in fact that the customer is prepared to pay more for inferior performance, apparently considering the small size, light weight and easy mobility of the transistor receiver to be of more importance. It may well be that the reduced performance has passed unnoticed due to the changes in listening habits that have taken place since the advent of television, and that quality-conscious radio listening is now confined more to radiograms. It is believed, however, that there is still a place for mains-operated valve-equipped mantel receivers and this article presents an economic design

concept having a performance approaching that of a standard five-valve receiver, but only using three valves and a silicon rectifier.

Power Supply

The new design starts with the power supply. In the past this has typically been a full-wave rectifier circuit using a 2×225 V, 50 mA transformer and a 6V4 vacuum tube power rectifier. If designers will consider the use of the OA210 silicon rectifier in a half-wave circuit, they will find that worthwhile savings in cost are possible. The main limitation of a rectifying circuit using an OA210 is the peak inverse voltage rating of the diode (400 V absolute maximum), restricting the DC output voltage to a theoretical maximum value of 200 V. In practice, the output voltage should not be higher than 180 V to provide a safety margin against mains voltage fluctuations. As might be expected, a half-wave circuit with 180 V output using a silicon diode must be cheaper than a full-wave circuit using a valve rectifier with 250 V output. The reduction in cost is due to the omission of a valve socket and associated wiring and to a reduction in the size of the power transformer.

The reduced HT voltage will have no effect on the operation of the converter and IF amplifier valves, but it will materially affect the available AF power output. A 6M5 output pentode with 180 V plate and screen supply voltage will have a power output of about 1.5 W at the plate; this valve is therefore not very suitable for the envisaged lower HT. *A better choice is the 6GV8 triode-power pentode, used extensively in TV vertical deflection circuits, which is capable of providing large plate current swings at low supply voltages.* An investigation has been carried out to determine the lowest nominal supply voltage at which the 6GV8 will still deliver an acceptable level of output power. This was found to be 130 V plate supply and 110 V screen supply, thus making it possible to reduce the power transformer size and cost still further.

The final transformer specifications are primary 240 V; secondary HT 122 V, 50 mA DC; secondary LT 6.3 V, 1.6 A. The windings are wound on a $\frac{3}{4}$ " \times $\frac{3}{4}$ " plastic bobbin and the core consists of a $\frac{3}{4}$ " sq. stack of medium resistance interleaved laminations. A power transformer of such a small size will naturally have a high temperature rise—in the present case this is 53° C above ambient for the primary and 35° C for the core, both values being within permissible limits. Together with an OA210 diode and a 40 μ F 150 VW electrolytic capacitor, the transformer will deliver an output of 130 V DC at 50 mA with a ripple voltage of 5.5 V. This is adequate for the plate supply of the 6GV8. A resistive filter, consisting of a 1 K Ω resistor and a 20 μ F 150 VW capacitor, reduces ripple by a factor of 10 and leaves a supply voltage of 110 V for the rest of the receiver.

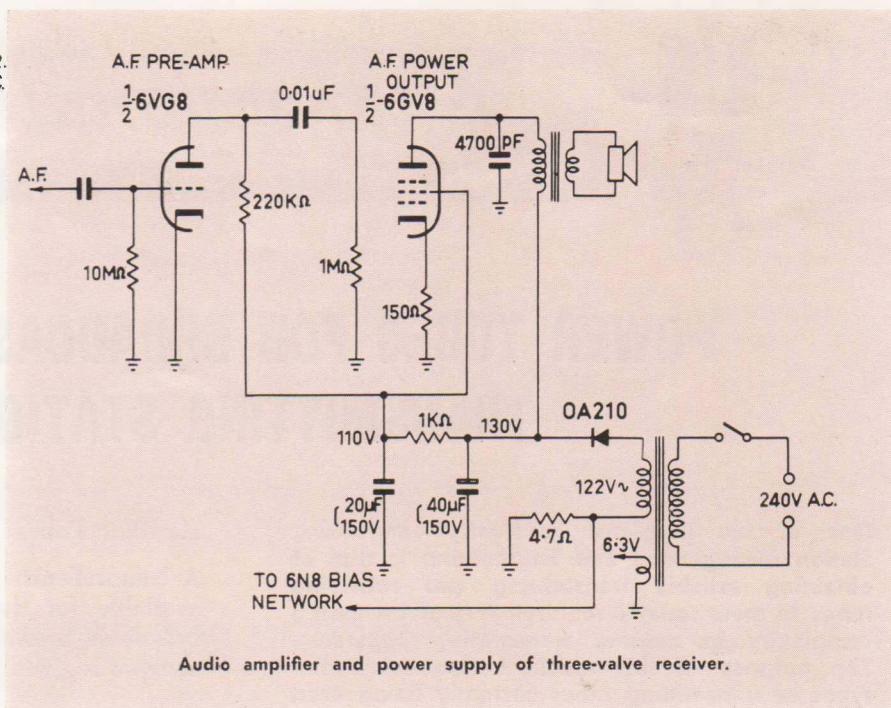
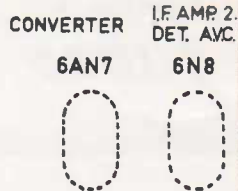

Audio Amplifier

The 6GV8 is suggested as AF amplifier in spite of the fact that this valve is particularly designed for vertical oscillator and output service. Closer investigation shows that such a valve, which in TV has to deliver high peak plate current at low plate voltage, is just the type suitable for AF power output service at low HT voltage. Since there is also a triode section in the 6GV8, this can be used as AF pre-amplifier, thus eliminating another valve from the original five-valve receiver. The optimum operating conditions for the pentode section at 130 V plate supply and 110 V screen supply require a cathode resistor of 150 Ω and a plate load impedance of 2000 Ω. The DC plate current is then 40 mA and the power output at the plate 2.2 W at 11% THD. If feedback is applied by omitting the cathode bypass capacitor, and if a standard $\frac{9}{16}$ " sq. stack output transformer is used, approximately 1.4 W of output power can be expected in the voice coil.

Since both the triode amplification factor and pentode mutual conductance of the 6GV8 are lower than those of, say, a 6BD7-6M5 combination, the AF sensitivity will be lower—in the above case by a factor of two. As mentioned previously, converter and IF stages are not affected by the lower HT, and therefore the overall RF sensitivity of the set using the 6GV8 will be 6dB down.

Converter and IF Amplifier

In most cases it should be possible to omit the oscillator plate voltage dropping resistor and associated bypass capacitor, as the HT voltage is now only

110 V. It is not possible to omit the common screen grid resistor, but since its resistance value has to be reduced it can now be a $\frac{1}{2}$ W dissipation type. If a pentode such as the 6BH5 was used originally as IF amplifier, with the detector diode combined with the AF triode (6BD7) it will be necessary to replace the 6BH5 with a 6N8 in order to retain the demodulator diode.

Conversion of a Standard Five-valve Receiver

A standard five-valve receiver has been converted according to the above principles. The original valve line-up was 6AN7, 6BH5, 6BD7, 6M5 and 6V4. The new complement is 6AN7, 6N8, 6GV8 and OA210. RF sensitivity is 16 μV at 600 Kc/s, 10.5 μV at 1 Mc/s, and 10 μV at 1.5 Mc/s. The following modifications were carried out in the receiver:

Components omitted:

- 2 valve sockets
- 1 6BD7 valve
- 1 1 W resistor
- 1 400 V paper capacitor

Components changed:

From	To
6BH5 valve	6N8 valve
6M5 valve	6GV8 valve
6V4 valve	OA210 diode
1 1 W resistor	1 $\frac{1}{2}$ W resistor
1 24 μF 300 VW electrolytic	1 40 μF 150 VW electrolytic
1 24 μF 300 VW electrolytic	1 20 μF 150 VW electrolytic
1 7000 Ω/3.5 Ω speaker transformer	1 2000 Ω/3.5 Ω speaker transformer
1 $1\frac{1}{8}$ " sq. stack power transformer	1 $1\frac{3}{8}$ " sq. stack power transformer

(This article is based on work carried out in the "Miniwatt" Electronic Applications Laboratory by P. Heins.)

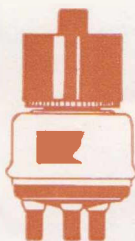

Professional Tubes

POWER TUBES FOR BROADCAST AND TV TRANSMITTING STATIONS

One of the problems constantly confronting Station Management and Engineering is that of obtaining reliable transmitting and rectifying tubes to meet today's requirements of increasing complexity in modern transmitting apparatus. The purpose of this article is to review the types of transmitting tubes currently being used in Australia. Only a brief mention is made of rectifying tubes as these will be treated fully in a future article.

Tubes for Broadcast Transmitters

As the commercial broadcasting stations operate in the power range from about 500 W to 5000 W, the station operator has a wide choice of types in both the triode and tetrode tubes.

Listed in Table 1 are the Philips types recommended for new equipment and replacement purposes in broadcast transmitters. The types listed are for application up to 5000 W—for powers higher than this, details are available upon application to your local Philips branch office.

The tubes listed are representative of popular types used in this country. In the power group 1000 W to 5000 W it will be noticed that a number of duplications occur. This is partly due to the modern trend to use one transmitter for various power ranges, and partly due to the use of two transmitters with a combining unit to give an antenna power of 5000 W.

A noticeable trend today is the swing towards the use of tetrodes at broadcast frequencies. These tubes offer several distinct advantages over triodes, including minimum drive power, minimum neutralising problems and less critical matching problems.

Tubes for Television Transmitters

Listed in Table 2 are types of power tubes currently in use in TV transmitters of various configurations and power outputs. No attempt has been made to list all the types of other tubes used in a transmitter, but the main power types for video and audio service are included.

Rectifier Tubes

A comprehensive range of Philips rectifying tubes is available for the power supplies of both TV and broadcast transmitters, and a handy cross-reference of types is given in Table 3.

The types shown are representative of the rectifier tubes in current use in these applications, but information on other types is available upon request to your nearest Philips office.

Notes on the Care of Tubes

It is strongly recommended that each transmitting and rectifying tube should be examined physically upon receipt at the station and, if possible, tested in the actual socket for which it is intended. It should first be operated without plate voltage and at the rated filament voltage for about 15 minutes; next, plate voltage should be applied at the lowest value possible and increased to half full-voltage for a further 15 minutes; then finally increased to full voltage and the tube operated for an hour or more. The tube can then be placed in storage.

It is in the user's interest to perform the above test on the arrival of each tube, so that any possible claims for damage in transit can be made immediately. The same test procedure should also be carried out on all spare tubes *every three months*, to ensure that tubes are always in good condition if needed in an emergency.

Connections

After mounting the tube, filament and grid leads should be connected so as not to cause unnecessary strain on the glass, or glass-to-metal seal. The glass or ceramic part of the tubes should be cleaned and, if necessary, a cloth moistened with carbon tetrachloride may be used to advantage, provided that the tube is cold. Care should be taken to remove all foreign matter from recesses or re-entrants which are part of the construction of the tube envelope or stem.

TABLE 1—PHILIPS TUBES FOR BROADCAST TRANSMITTERS

(Recommended types for up to 5000 W)

Power Range				
200 W	500 W	1000 W	2000/2500 W	5000/10,000 W
QB3/300 (4.125A)	QB3.5/750 4-250A	TB4/1250 833A	TBL6/6000 TBL7/8000	TBL6/6000 TBL7/8000
TB2.5/400	833A	4279A	7459	7459
TB3/750	TB4/1250	QB5/1750 (6079)	5762A (BR191B)	5762A (BR191B)
810	HF300	QB4/1100GA (4-400A)	QBL5/3500	3CX2500F3
813	212E	3X2500F3	QB5/1750 (6079-QY5-500)	
828	810		4279A	
HF200			3X2500F3	
			4-1000A	

TABLE 2—PHILIPS TUBES FOR TV TRANSMITTERS

(Main power types for Video and Audio Service)

Power Range			
1 W-2000 W	5000 W	10,000 W	10,000 W-20,000 W
QBL4/800 (4X500A)	QBL5/3500 (6076 CR1100)	6166	TBL6/20
QBL5/3500 (6076) (CR1100)	TBL6/6000	6166A	
4-1000A	7459	7007	
	7900	TBL6/20	
	5762A		
	6166		
	6166A		
	7007		

Types used as drivers for above stages—4X150A (QEL/150) 4X250B
4CX250B (Ceramic)
4CX250R (Ceramic)

Cooling

As specified on all Philips data sheets, the maximum glass and seal temperatures should be periodically checked. For this purpose a range of temperature-sensitive paints and crayons ("Tempilaq" and "Tempilstik") is available upon application to your nearest Philips office.

Although in principle there is little difference between the effectiveness of "blowing" and "sucking" the cooling air, preference is generally given to "blowing" because of the higher efficiency of the blower when handling cold air. However, when hot air in the transmitter cabinet is undesirable the suction system may be used.

The preceding notes are intended as a general guide to some practical aspects of the use of Philips tubes. Further information for station personnel is available on application, including full operating data and technical advice on particular problems.

TABLE 3—PHILIPS RECTIFYING TUBES FOR TRANSMITTING STATIONS

(Representative types)
866A (DCG4/1000G)
872A (DCG5/5000)
575A
673
8008 (DCG5/5000GS)
DCG6/18
5563A—(Grid controlled)

Xenon-filled
3B28 (DCX4/1000)
4B32 (DCX4/5000)

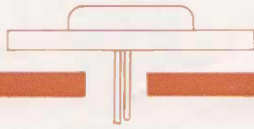

TRANSISTORISED DC/DC CONVERTERS

Part 3—140 Watt Unit

An efficient high-power DC/DC converter has been designed to take advantage of the recently announced⁽¹⁾ current uprating of the Miniwatt ASZ15-18 series of Power transistors. The addition of this unit extends the range of converter circuits published in the Digest to 140 W.

cannot be used above 28 V without exceeding the V_{CE} ratings of the switching transistors. The converter can be positively or negatively earthed with regard to the supply, as the transistors are insulated from their heat sinks by mica washers.

Performance Details (See Fig. 2)

Nominal input voltage	24 V max.
Nominal output voltage	300 V
Power range available	30-140 W
Ripple at full load (VP/P)	0.9 V
Overall efficiency	87%
Frequency of operation	515 cps

Further Information

The Miniwatt Electronic Applications Laboratory will be pleased to supply any further information required, especially if specific designs are needed which are not covered by this or previous articles.

The circuit in Fig. 1 uses the push-pull transformer-coupled principle of operation and is capable of giving the rated power output with unselected transistors in the temperature range 0-55° C.

(This article is based on work carried out in the "Miniwatt" Electronic Applications Laboratory by A. C. Denne and H. R. Jones.)

Construction

The transformer is constructed with an HCR Alloy toroidal core and the winding technique is similar to that used for the high-power DC/DC converters previously described in the Miniwatt Digest, Vol. 2, No. 2.

Reference

1. *Miniwatt Digest*, Vol. 2, No. 1, Oct. 1962, p. 10.

Overload Protection

The DC/DC converter can be protected against overload by adjusting R_1 to limit the base drive conditions of the transistors. Thus, if a heavy overload should occur, the oscillations will cease, thus protecting the transistors and other components until the overload is removed. A value of 15 Ω for R_1 should satisfy most transistor combinations likely to be encountered.

It should also be noted that although this converter will operate reliably with the normal variations of voltage expected in 24 V accumulator operation, it

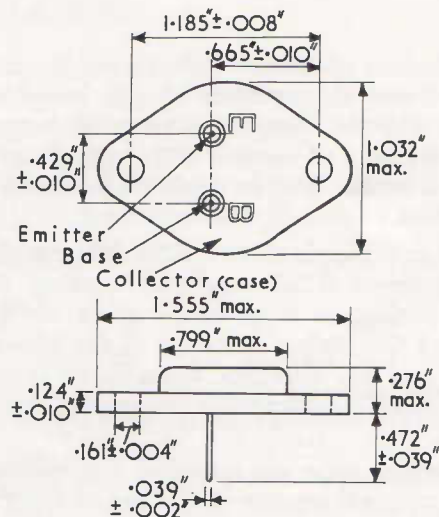

Dimensional outline of ASZ15.

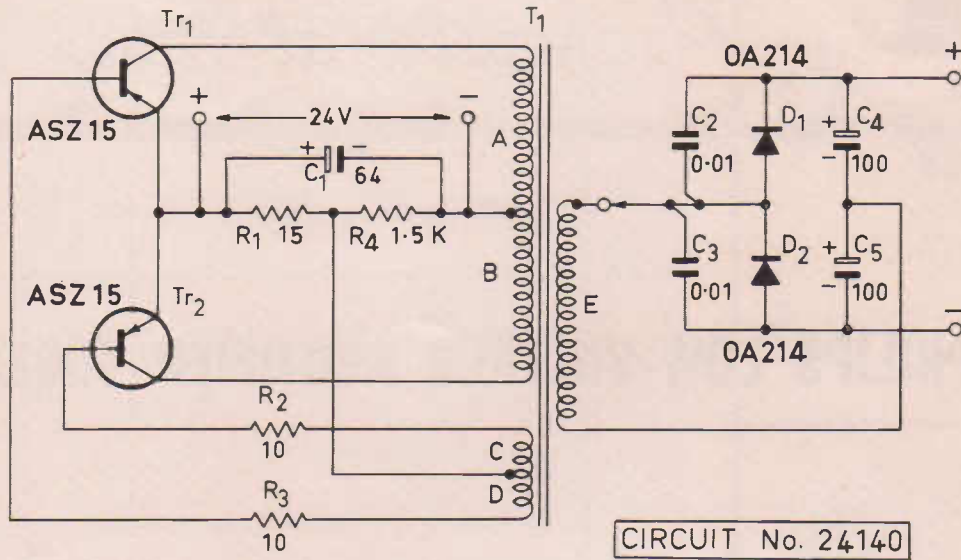

CIRCUIT No. 24140

Components

Components	Philips Type Numbers
Tr ₁ , Tr ₂ * Power Transistors	ASZ15
2 sets of mounting and insulating accessories	56201
D ₁ , D ₂ silicon diodes	OA214
R ₁ 15 Ω 10 W ww	83542A/15E
R ₂ , R ₃ 10 Ω, 5.5 W ww	83540A/10E
R ₄ 1.5 KΩ 1.5 W	B8 305 07B/1K5
C ₁ 64 µF, 40 VW electrolytic	C426AM/G64
C ₂ , C ₃ 0.01 µF 700 V polystyrene	C297AC/B10K
C ₄ , C ₅ 100 µF, 200 VW electrolytic	
T ₁ HCR Alloy Toroid, Telcon Type 7C, tape thickness .002" (dimensions of basic core excluding case, 2½" OD × 1½" ID × ½" depth.)	

TRANSFORMER WINDING DETAILS

Winding	No. of Turns	Enamelled Copper Wire Gauge
A	72	15 B & S
B	72	15 B & S
C	40	24 B & S
D	40	24 B & S
E	490	24 B & S

* Each transistor vertically mounted on heat sink of 12 sq. ins. 16 SWG blackened mild steel. Required tolerance on resistors ± 10%.

Fig. 1. Circuit details of 140 W DC/DC converter.

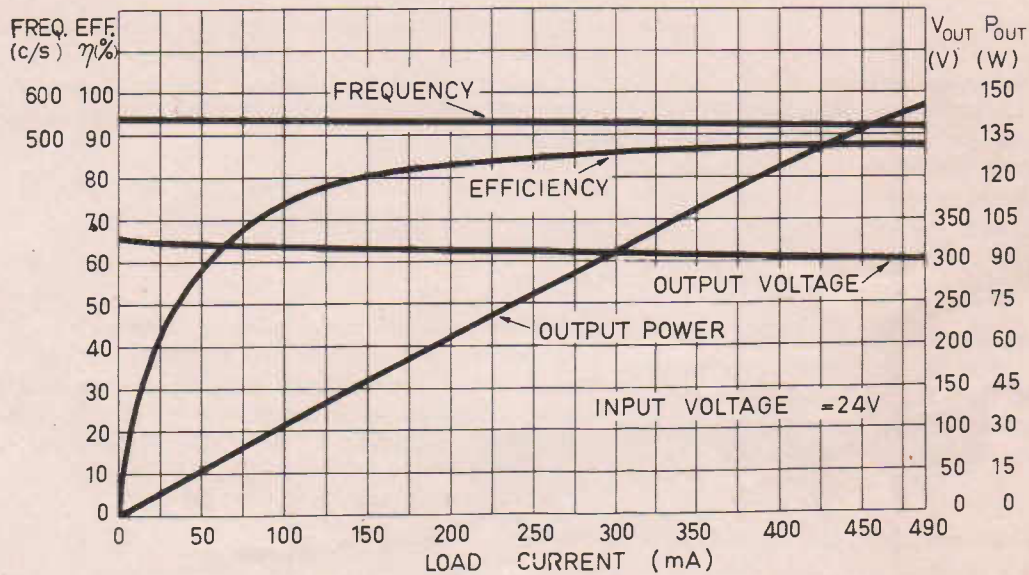
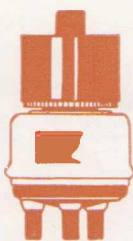

Fig. 2. Typical performance curves for 140 W converter.



Professional Tubes

PHILIPS LOW-VOLTAGE RECTIFIER TUBES

As a result of customer enquiries regarding low-voltage rectifier tubes for replacement purposes, some details of available Philips types are given here. These thermionic gas-filled tubes are mainly used in supplies for battery charging, arc-welding and projector arc lamps.

For new equipment design, it is preferable to use the Philips range of silicon power rectifiers⁽¹⁾, where applicable.

GENERAL OPERATING NOTES

Mounting

All the tubes in this range should be mounted vertically with their base down. The spacing between adjacent tubes should be at least three quarters of the tube diameter, and the distance to other components and to the walls of the cabinet should be at least half the tube diameter. Adequate air circulation is essential.

Filament

Some tube types have flat strips, instead of pins, for filament connections. These strips should be connected carefully, without being bent or stretched. Proper contact is ensured by firmly tightening the fastening screws. To obtain maximum tube life, the use of centre-tapped filament transformers is recommended.

Anode

The anode terminals of many tube types are provided with a clamping screw. First fit the cable lug of the flexible connection cable, then the nickel-plated locking ring, then the resilient washer and finally the milled nut. This nut must be firmly tightened.

Auxiliary Electrode

If the tube has an auxiliary electrode, this should be connected to the auxiliary ignition unit, e.g., the unit 1289 which delivers about 10 mA at 40 VDC.

Initial Operating Precautions

When tubes with a filling of rare gas and mercury vapour are first installed, or after a prolonged period of storage are put into service again, precautions should be taken to ensure that all the mercury has vaporised from the electrodes. This may be achieved if the tubes are run for some minutes at their nominal filament voltage before the anode voltage is applied.

In general, the anode voltage of the rectifiers should never be applied before the specified heating-up time has elapsed.

Temperature

For those tubes filled with a mixture of mercury vapour and inert gas, the temperature limits of the condensed mercury are given in the published data. Normally this value is 20 to 30°C higher than the ambient temperature.

It is of importance that the mercury always condenses just above the base of the tube, in other words that the coldest spot of the tube is at the lowest part of the envelope; otherwise arc-backs and a considerable shortening of life may occur.

For the tubes filled with inert gas, the limits of the ambient temperature are given in the data.

Caution

The tubes will not stand prolonged overloading. A tube may be in a strongly overloaded condition, even though safety fuses in the apparatus have not yet blown. Therefore it is imperative to strictly adhere to the directions given by the manufacturer.

Reference

1. Hancock, D.J., Silicon Power Rectifiers, *Miniwatt Digest*, Vol. 1, No. 10, pp. 150-155.

PHILIPS LOW-VOLTAGE RECTIFIER TUBES

Type	No. of Anodes	Gas Filling	Heater			Typical Characteristics		Limiting Values				
			Filament Voltage (V)	Filament Current (A)	Heating Time (secs.)	Ignition Voltage (V)	Maint. Voltage (V)	Max. Inverse Voltage (V)	Average (A)	Peak (A)	Minimum Anode Resistance (Ω)	Temperature Range ($^{\circ}$ C)
328	2	rare gas	1.9	3.0	15	16	7	90	0.65	4	3	-55/+75
367	2	rare gas	1.9	8	30	16	9	140	3	18	1	-55/+75
1163	1	rare gas	2.25	17	3	16	9	375	6.0	36	0.5	-55/+75
1164	1	rare gas	2.5	25	15	16	9	225	15	90	0.3	-55/+75
1173*	1	merc. + rare gas	1.9	13	60	22	12	685	4	24	0.75	30-80
1174*	1	merc. + rare gas	1.9	12	60	22	12	850	4	20	0.5	30-75
1176*	1	merc. + rare gas	1.9	28	120	22	12	685	6	36	0.5	30-80
1177*	1	merc. + rare gas	1.9	60	120	22	12	850	6	30	0.2	30-75
1838*	2	merc. + rare gas	1.9	21.5	120	28	12	685	25	150	0.1	30-80
1849*	2	merc. + rare gas	1.9	29	120	22	10	850	25	135	0.25	30-75
1859*	2	merc. + rare gas	1.9	60	120	28	12	360	7.5	45	0.2	30-80
								360	12.5	75	0.2	30-80
								360	25	150	0.1	30-80

* requires auxiliary ignition unit 1289

328

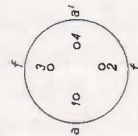

Base A:
Socket: 40465

367



Base: W
Socket: 40221

1163

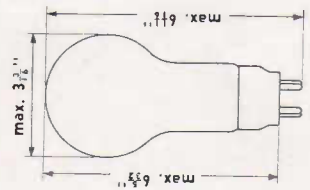

Base: Goliath
Socket: 65909 BG/01

1164

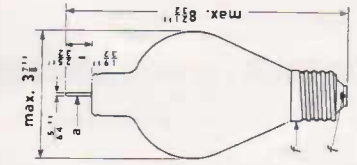

Base: Goliath
Socket: 65909 BG/01

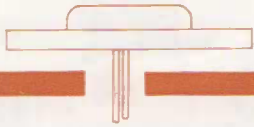

"Miniwatt" Transistorised Tachometer



Fig. 1. Tachometer for mounting on instrument panel.

An accurate road-tested automobile tachometer is described which will operate from the standard supply voltages of either 6 or 12 V (positive or negative earth).

It can be calibrated to suit any four, six or eight cylinder engine, providing indication from 0 to 7000 rpm. By using silicon semiconductors in critical circuit positions, it has been possible to obtain better than $\pm 2\%$ overall accuracy for temperatures up to 70°C .

The tachometer circuit described has been specifically designed for use in either automobiles or boats fitted with four-stroke coil-ignition engines, but it can be adapted to some other types of engines and also to remote speed-monitoring of rotating electrical machinery.

Two circuit configurations are given (Fig. 2)—one for vehicles employing positive earthing and the other for negative earthing. The connections for the usual types of four-stroke engine configurations are listed. In all cases, R_7 serves as the calibration adjustment (refer to page 92).

A comprehensive portable or bench instrument could be constructed using three selector switches, one for positive or negative earthing, another for nominal 6 or 12 V supply, and the third for the number of cylinders (4, 6 or 8).

Circuit Description

The tachometer uses two silicon transistors, type BCZ10, in a monostable multivibrator configuration; the basic multivibrator design has been described by Neeteson⁽¹⁾. The "on" time of Tr_2 is determined by the time constant involving $(R_7 + R_8)$ and C_3 or C_4 . The 0 to 1 mA meter connected in series with this transistor provides a steady indication directly propor-

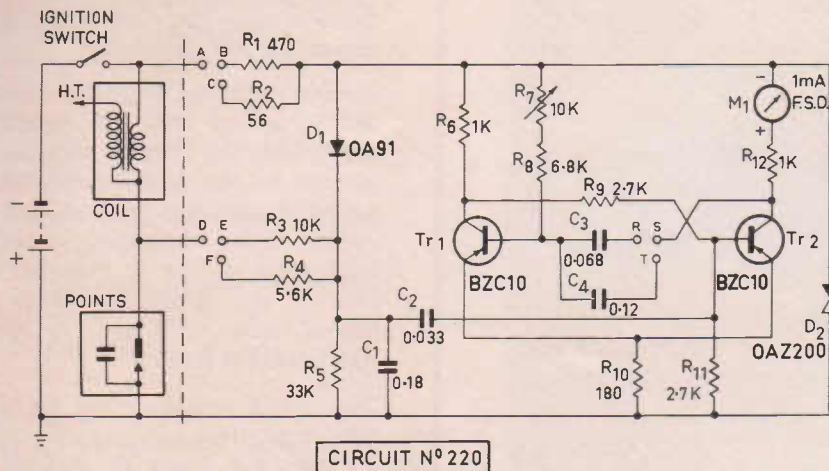

(a) 6 or 12 V Positive Earth.

For—12 V supply
connect (A to B), (D to E)

For—6 V supply
connect (A to C), (D to F)

For 6 or 8 cylinders
connect (R to S)

For 4 cylinders
connect (T to S)

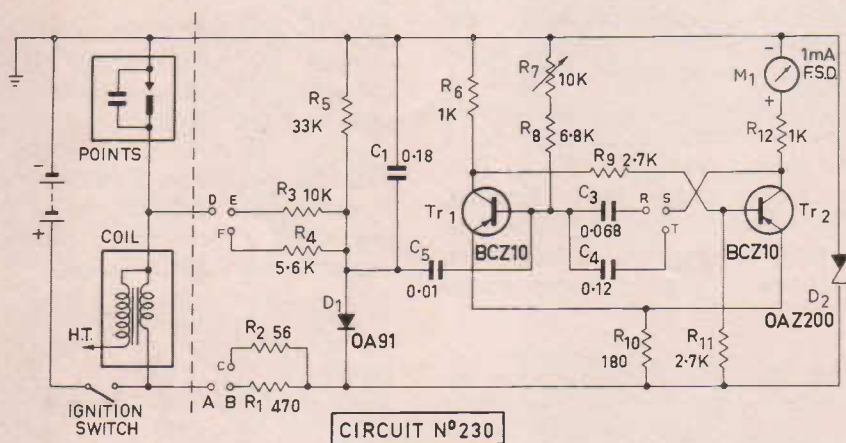

(b) 6 or 12 V Negative Earth.

For +12 V supply
connect (A to B), (D to E)

For +6 V supply
connect (A to C), (D to F)

For 6 or 8 cylinders
connect (R to S)

For 4 cylinders
connect (T to S)

Tr₁, Tr₂ Silicon Transistor, BCZ10
D₁ Germanium Diode, OA91
D₂ Silicon Zener Diode, OAZ200

R₁ 470 Ω, ½ W
R₂ 56 Ω, ½ W
R₃ 10 K Ω, ½ W
R₄ 5.6 K Ω, ½ W
R₅ 33 K Ω, ½ W
R₆, R₁₂ 1 K Ω, ½ W
R₇ 10 K Ω, calibrating potentiometer (E 097 AD/10K)
R₈ 6.8 K Ω, ½ W
R₉, R₁₁ 2.7 K Ω, ½ W
R₁₀ 180 Ω, ½ W

C₁ .18 μF, 400 V polyester (C296 AC/A180K)
C₂* .033 μF, 400 V polyester (C296 AC/A33K)
C₃ .068 μF, 125 V polyester (6, 8 cylinders) (C296 AA/A68K)
C₄ .12 μF, 125 V polyester (4 cylinders), C296 AA/A120K)
C₅ .01 μF, 400 V polyester (C296 AC/A10K)
M₁ 0.1 mA, 100Ω Meter, Ferrier type R/M4-3(0-7000 rpm)

Resistors used were Philips cracked-carbon series B8 305 05B (½W); tolerance required is ± 5%.

The dial lamp should be specified as 6 or 12 V when ordering the meter.

The meter, chrome meter cover and printed board for either positive or negative earth supply are available from Ferrier Electrical Instruments, 45 Albany Street, Crow's Nest.

* After completion of this project it was found, in an isolated case (a particular 4-cylinder positive earth situation) that capacitor C₂ would be better chosen as .018 μF. The choice of a reduced value was effective in reducing upwards meter flicking tendencies, as described in text.

Fig. 2. Circuit details of "Miniwatt" Transistorised Tachometer.

PERFORMANCE SPECIFICATIONS

Range	0-7000 rpm.
Calibrated for	4-stroke coil-ignition engines of 4, 6 or 8 cylinders.
Operating Voltage Range ..	6 V-7 V, or 12 V-14 V.
Current Drain	30 mA (7 V supply), 20 mA (14 V supply).
Temperature Range	Operates within specified accuracy over the temperature range 0°C-70°C.
Accuracy	± 2% full-scale deflection.
Battery earthing	Connections specified in diagram for either positive or negative earthing systems.

tional to the input pulse repetition frequency (derived from breaker points) and thus is proportional to the engine rpm.

The input circuit to the multivibrator (R_3 or R_4 , R_5 and C_1) together with the clamping diode D_1 and reference Zener diode D_2 , serves two purposes. Besides maintaining a pulse height of constant amplitude across C_1 , it also filters out unwanted high frequency components from the voltage derived from the breaker points. The input circuit is followed by a differentiating circuit for correct triggering of the multivibrator. Basically, the voltage derived from the breaker points consists of a square wave of 6 or 12 V amplitude on which are superimposed damped oscillations of approximately 300 V peak amplitude.

The silicon Zener diode type OAZ200 provides a regulated voltage of approximately 5.5 V and, besides aiding in the stabilisation of input pulse amplitude, it also stabilises the amplitude of pulses derived from the multivibrator. The input pulse amplitude is stabilised despite the application of different supply voltages 6 or 12 V, or of supply voltage variations which may occur with varying engine speed, etc.

The input circuit presents a reasonably high impedance to the distributor points (10 K Ω min.) and does not affect their operation.

The use of silicon transistors with inherently low leakage even at elevated temperatures, allows the range of accurate operation to be extended to as high as 70°C. A high leakage current (I_{CBO}) would otherwise cause shunting by R_6 of the timing resistance ($R_7 + R_8$), producing a low meter reading. This effect, although quite serious when using germanium transistors, becomes negligible when silicon transistors are used.

The "on" time of Tr_2 has been adjusted so that the pulse width is always less than the width of the pulse formed with the opening and closing of the points and less than the delay time from the opening of the points to the firing of the spark plug. The advantage of this system is that the tachometer reading is not dependent on the "open duration" or "cam angle" of the points, as it depends only on the leading edge of the pulse which occurs as the points open. However, in order to avoid spurious indications due to variation in timing of this leading edge, the rotor shaft should be checked for abnormal wear, etc., and the breaker points should always be kept in good working condition. Decreases in the previously mentioned delay time of the firing of the spark plugs can also cause spurious indications (upwards meter pulsations).

Thus the tachometer is normally intended for use with a correctly-

tuned engine, although it also has value in revealing distributor faults and in tuning an engine.

As the pulses of collector current in Tr_2 are of constant amplitude and width, the average level as indicated by the meter (with linear scale) is directly proportional to engine rpm. Assuming accurate calibration of the tachometer (as below), this accuracy will be retained within $\pm 2\%$ over an indefinite period of time.

The circuit configurations for positive or negative earthing differ only in that the input is applied to different transistor bases to suit the respective negative or positive polarities of the input pulses.

Meter Calibration Procedures

Several possible calibration procedures are outlined, the choice depending on the equipment available and the degree of accuracy required. In each case, the aim is to set the pointer on the meter scale to correspond to 3000 rpm as this represents a convenient practical engine speed for calibration.

In four-stroke engines, each cylinder is ignited once each two revolutions of the crankshaft. Thus, when the crankshaft speed is 3000 rpm (50 revs/sec.), the ignition rate at each cylinder is 1500 sparks per minute (25 sparks per second). In one revolution of the distributor rotor, all cylinders will have fired in correct sequence and thus, if n is the number of cylinders, the rotor speed is $25n$ revs/sec. Then for four, six and eight cylinders the corresponding rotor speeds are 100, 150 and 200 revs/sec. respectively—and, of course, these are also the interruption rates at the breaker points.

Method A

The timing capacitor (C_3 or C_4) is first selected to suit the number of cylinders in the engine. The calibrating potentiometer R_7 then has to be adjusted to give a reading on the meter of 3000 rpm when square-wave pulses, of approximately unity mark-space and with the following repetition frequen-

cies, are applied to the input of the tachometer. The amplitude of the square-wave input pulse should not be less than $10 V_{p-p}$ for the 12 V supply or less than $6 V_{p-p}$ for the 6 V supply ("mark" should always exceed $1\frac{1}{2}$ msec).

Four-cylinder engines — input of 100 c/s

Six-cylinder engines—input of 150 c/s

Eight-cylinder engines—input of 200 c/s

Before connecting the output of the square-wave generator to the input of the tachometer it is advisable to check the calibration of the square-wave generator against 50 c/s mains.

Before calibrating the tachometer by this method, the smoothing capacitor C_1 should first be disconnected and then replaced after adjusting R_7 . The range of adjustment of R_7 is sufficient to permit calibration with either six or eight cylinders using just the one value of timing capacitor (C_3); a separate capacitor has been provided for four cylinders (C_4).

For best calibration accuracy, the supply voltage should be set at 7 or 14 V (for nominal 6 or 12 V systems respectively), because these values will apply during operation with the engine running.

The maximum deviation of the tachometer will not exceed $\pm 2\%$ full-scale deflection with respect to the original calibration for temperatures ranging from 0 to $70^\circ C$ and for normal fluctuations in battery voltage.

Method B

Although not specifically recommended, a second calibration method consists in comparing the unit with a pre-calibrated mechanical car tachometer which may happen to be on hand. The calibration is once again carried out at 3000 rpm, but C_1 should not be removed.

Calibrating the tachometer against a car's speedometer is not recommended as errors of up to 10% can quite easily occur due to variations in tyre diameter and tyre pressure.

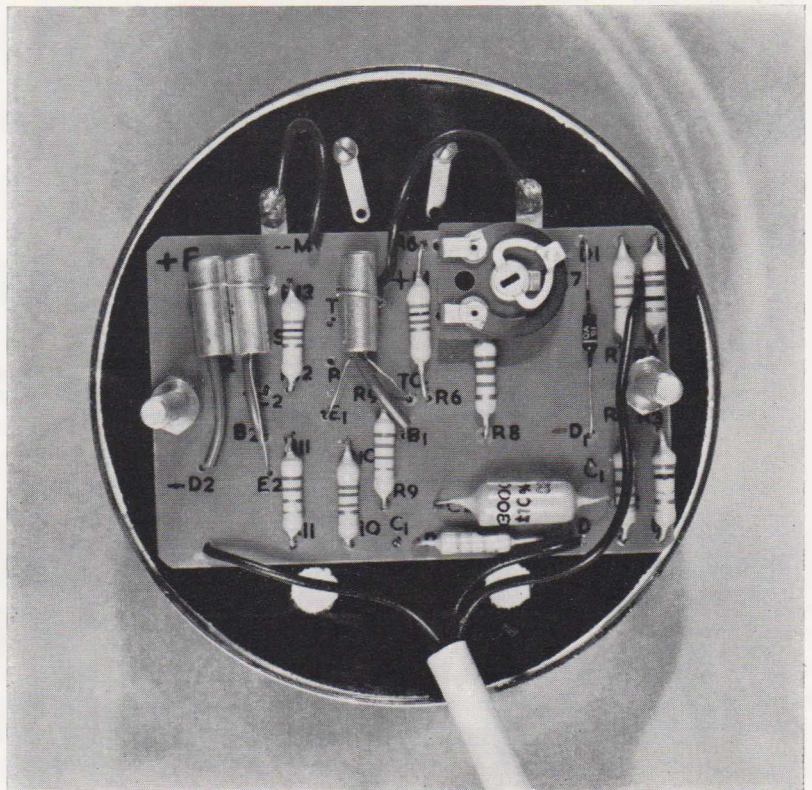

Fig. 3. Back view showing mounting of printed board (chromed cover removed).

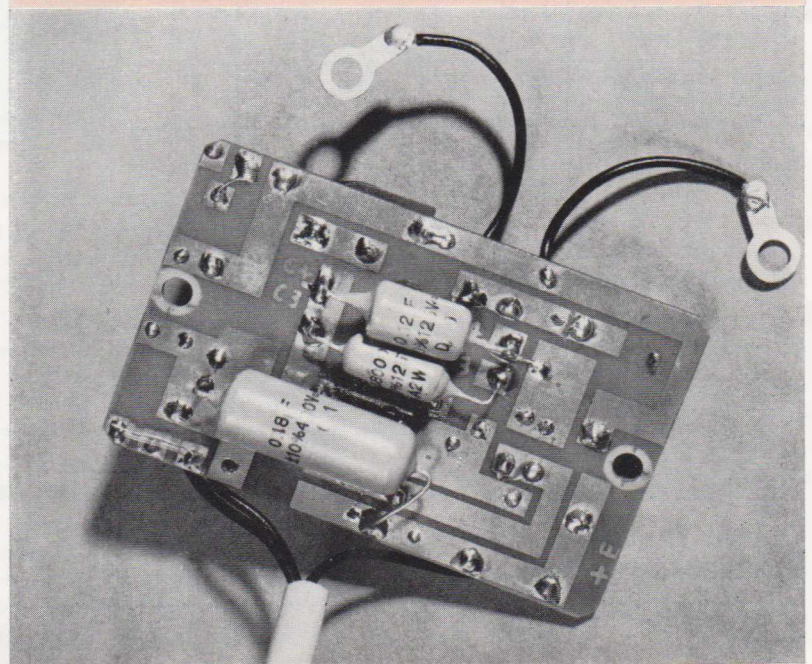

Fig. 4. Printed board showing side facing meter.

Method C

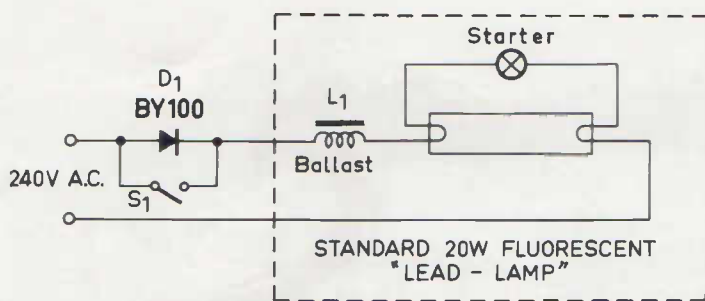

Fig. 5. Circuit of fluorescent lamp and rectifier used for stroboscopic analysis of engine speed. For starting the fluorescent lamp it is necessary to incorporate a shorting switch across the diode. Once the tube is alight the switch can be opened.

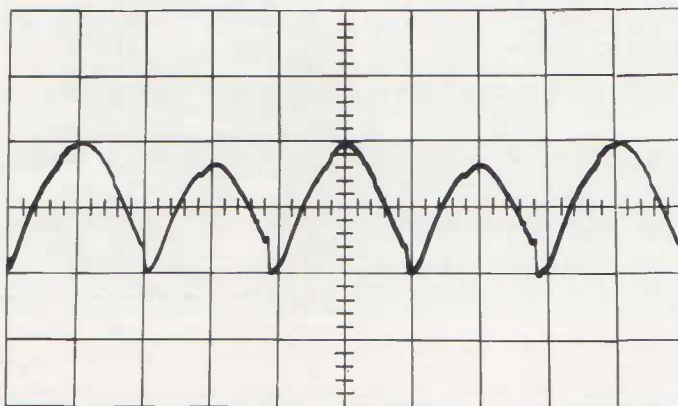

Fig. 6 (a). Typical form of light emission from fluorescent lamp operated from mains supply.

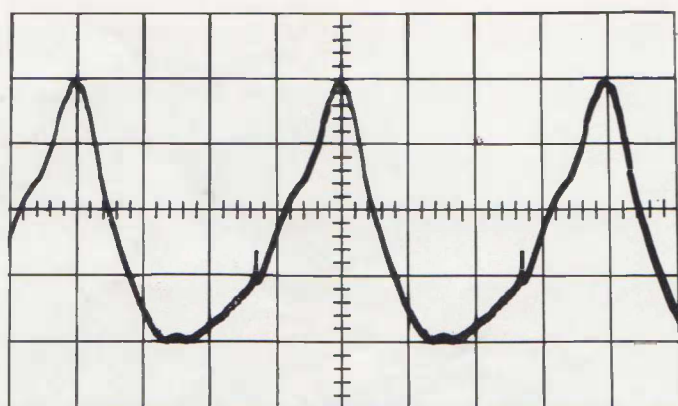

Fig. 6 (b). Typical form of light emission from fluorescent lamp with half-wave rectification of mains supply.

A simple and accurate means of calibrating the tachometer, when it is installed in the car, can be achieved by adapting a standard 20 W fluorescent light unit to act as a strobing device (Fig. 5).

A crankshaft speed of 3000 rpm is equivalent to 50 c/s. The light pulses emitted by a fluorescent lamp operating from mains occur at a 100 c/s repetition rate (Fig. 6a). Even though a frequency of 100 c/s would be satisfactory for strobing, the definition of the pattern would suffer from the poor contrast between "black" and "white" levels. If a high inverse voltage type of silicon diode (BY100) is used in series with the mains supply to obtain half-wave rectification, the waveform of Fig. 6b results. The light emission now occurs at a 50 c/s rate, giving a much improved "black/white" contrast ratio and a far superior strobing device. Furthermore, spot checks can be made at 750, 1500 and 6000 rpm in addition to calibrating at 3000 rpm.

(Method C determined in consultation with A. J. Erdman.)

Strobing Procedure

The strobing can be observed either with a single white mark on the periphery of the crankshaft pulley (or attached balancer), or with a pair of such markings diametrically opposed. If only a single mark is used, it may happen that the spot which has to be periodically illuminated will not be visible from a convenient (above engine) vantage point. However, by judicious adjustment of the throttle opening, the phasing can be corrected to overcome this. If two markings are used, then one of them will always be visible at 3000 rpm. However, at 1500 rpm both spots will be alternately illuminated and if there is an appreciable error in the relative location of the markings (180° apart) then a certain degree of pattern confusion will result.

The advantages of the fluorescent lamp are (a) mains frequency stability of the light pulses, (b)

TABLE 1—COMPONENT VALUE USING CALIBRATION METHOD D

No. of cylinders	4	6	8
Positive Earth	$C_4 = .12\mu\text{F}$ $R_7 + R_8 = 10.8 \text{ K}\Omega$ e.g., 10 K + 820 Ω	$C_3 = .068 \mu\text{F}$ $R_7 + R_8 = 12.7 \text{ K}\Omega$ e.g., 10 K + 2.7 K	$C_3 = .068 \mu\text{F}$ $R_7 + R_8 = 9.4 \text{ K}\Omega$ e.g., 8.2 K + 1.2 K
Negative Earth	$C_4 = .12 \mu\text{F}$ $R_7 + R_8 = 9.7 \text{ K}\Omega$ e.g., 8.2 K + 1.5 K	$C_3 = .068 \mu\text{F}$ $R_7 + R_8 = 10.8 \text{ K}\Omega$ e.g., 10 K + 820 Ω	$C_3 = .068 \mu\text{F}$ $R_7 + R_8 = 7.8 \text{ K}\Omega$ e.g., 6.8 K + 1 K

its availability and (c) the fact that it provides illumination over a large area (thus adding considerably to the safety of the unit because the operator has simply to hold the device well above the engine and rotating fan blades, and observe a stationary white pattern.

Method D

If accurate calibrating facilities are not available, then the calibrating potentiometer can be adjusted until the series resistance of R_7 and R_8 equals the value of resistance set out in Table 1. This assumes the use of accurate capacitors and, in any case, the product of $(R_7 + R_8) \times C$, using the values given, should be maintained.

Construction

The complete circuitry can be wired on to a printed board (Figs. 3 and 4) and mounted on the back of the meter case, provision being made for this with the meter type specified here. Two boards are available from the meter manufacturer—one to suit positive earthing and the other for negative earthing. A separate decorative chromed cover is also available with the meter.

Installation

The installation procedure is quite straightforward. The tachometer, complete with chromed cover, can be mounted on the instrument panel of a car (or boat) in any convenient position where it is visible to the driver. The tachometer requires three connecting leads as shown in Fig. 2, plus a lead for the dial lamp enclosed within the instrument.

The dial lamp could be connected to the instrument light switch on the instrument panel or to the supply lead from the ignition switch. Connecting lead-length is non-critical.

(This article is based on work carried out in the "Minivatt" Electronic Applications Laboratory by H. R. Jones.)

Reference:

1. P. A. Neeteson, Junction Transistors in Pulse Circuits, Philips Technical Library (1959).

Technical Books

Addition to

Philips Technical Library

ADVANCES IN X-RAY DIFFRACTOMETRY AND X-RAY SPECTROGRAPHY

Fifteen Selected Reprints from Philips Laboratories, Irvington-on-Hudson, New York. Edited by William Parrish.

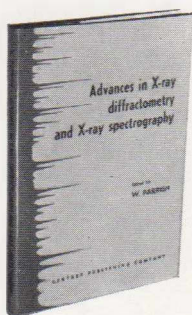

249 Pages,
6" × 9"
Cloth binding.
Price £1/6/2
posted.

This volume contains reprints of fifteen previously published papers written by members of the staff of the X-Ray and Crystallography Section of Philips Laboratories, Irvington-on-Hudson, N.Y. They were selected principally for use in X-Ray Schools and consequently some of the more specialised papers, such as those on centroids, have been omitted. They will provide the reader with a rather broad background in modern X-Ray counter tube methods as well as detailed descriptions of many of the techniques of X-Ray analysis.

The following papers have been collected:

X-RAY DIFFRACTOMETRY

Outline of a Recommended Practice for the X-Ray Counter Diffractometry of Polycrystalline Substances (W. Parrish).

Comparison of X-Ray Wavelengths for Powder Diffractometry (W. Parrish and T. R. Kohler).

Determination of Spectral Contamination of X-Ray Tubes (J. Ladell and W. Parrish).

The "Norelco" X-Ray Diffractometer (W. Parrish, E. A. Hamacher and K. Lowitzsch).

Geometry, Alignment and Angular Calibration of X-Ray Diffractometers (W. Parrish and K. Lowitzsch).

Advances in X-Ray Diffractometry of Clay Minerals (W. Parrish).

Factors in the Detection of Low Concentrations in X-Ray Diffractometry (W. Parrish and J. Taylor).

Experimental Study of Effect of Crystallite Size Statistics on X-Ray Diffractometer Intensities (P. M. de Wolff, J. Taylor and W. Parrish).

Precision Measurement of Lattice Parameters of Polycrystalline Specimens (W. Parrish and A. J. C. Wilson).

X-RAY FLUORESCENCE SPECTROGRAPHY

X-Ray Spectrochemical Analysis (W. Parrish).

Geometry of the Non-Focussing X-Ray Fluorescence Spectrograph (N. Spielberg, W. Parrish and K. Lowitzsch).

Comparison of Power Supplies and X-Ray Tubes for X-Ray Spectrochemical Analysis (N. Spielberg and M. Mack).

Crystallographic Aspects of Extra Reflections in X-Ray Spectrochemical Analysis (N. Spielberg and J. Ladell).

COUNTER TUBES AND STATISTICS

Use of Counter Tubes in X-Ray Analysis (W. Parrish and T. R. Kohler).

X-Ray Intensity Measurements with Counter Tubes.

APPENDIX

Mass Absorption Coefficients.
Emission Lines and Absorption Edges.
Wavelengths.

Emission Lines and Absorption Edges.
Energies.

Reflection Angle Table for Silicon.

Miscellaneous Illustrations.

PHILIPS

- ELECTRONIC VALVES AND TUBES
 - SEMICONDUCTOR DEVICES
- CATHODE-RAY TUBES
 - LIGHT-SENSITIVE DEVICES
- TEMPERATURE-SENSITIVE DEVICES
 - FERRITES
- RADIATION-SENSITIVE DEVICES
 - FINE WIRES
- SPECIALIZED COMPONENTS AND DEVICES
 - SPECIALIZED MATERIALS
- TECHNICAL PUBLICATIONS

For Use in the Fields of—

ENTERTAINMENT — COMMUNICATIONS — INDUSTRY
COMMERCE — MEDICINE — SCIENTIFIC RESEARCH
AND DEFENCE



THE *Minivatt* ELECTRONICS DIVISION

of

Philips Electrical Industries Pty. Limited

20 Herbert Street, Artarmon, N.S.W.

Phone 43 2171

Branches at:—

ADELAIDE	11-13 West Terrace, Adelaide, S.A., phone 51 6051
BRISBANE	56-58 Cordelia Street, South Brisbane, Qld., phone 42 471
CANBERRA	C.B.C. Chambers, Petrie Street, Civic Centre, Canberra, A.C.T., phone J 4498
HOBART	73 Brisbane Street, Hobart, Tas., phone 3 3038
MELBOURNE	252 Sturt Street, South Melbourne, Vic., phone 69 0141
NEWCASTLE	194 Parry Street, Newcastle West, N.S.W., phone MA 5001
PERTH	672 Murray Street, Perth, W.A., phone 21 3131
SYDNEY	67 Mars Road, Lane Cove, N.S.W., phone 42 1261

Production Centre—

HENDON WORKS Tapley's Hill Road, Hendon, S.A., phone 4 5021

The information given in this publication does not imply a licence under any patent. Further information on the products described in this publication may be obtained on application to any of the addresses listed above.