

BUILD OUR SUPER-HET RADIOGRAM **RUN FROM BATTERIES**

# Wireless Magazine

THE BEST SHILLINGSWORTH IN RADIO

JUNE, 1932

1/-

## The *MULTI-MAG THREE*

GIVES EXCEPTIONAL "PUNCH"  
FROM DOZENS OF STATIONS —  
SIMPLE AND CHEAP TO BUILD

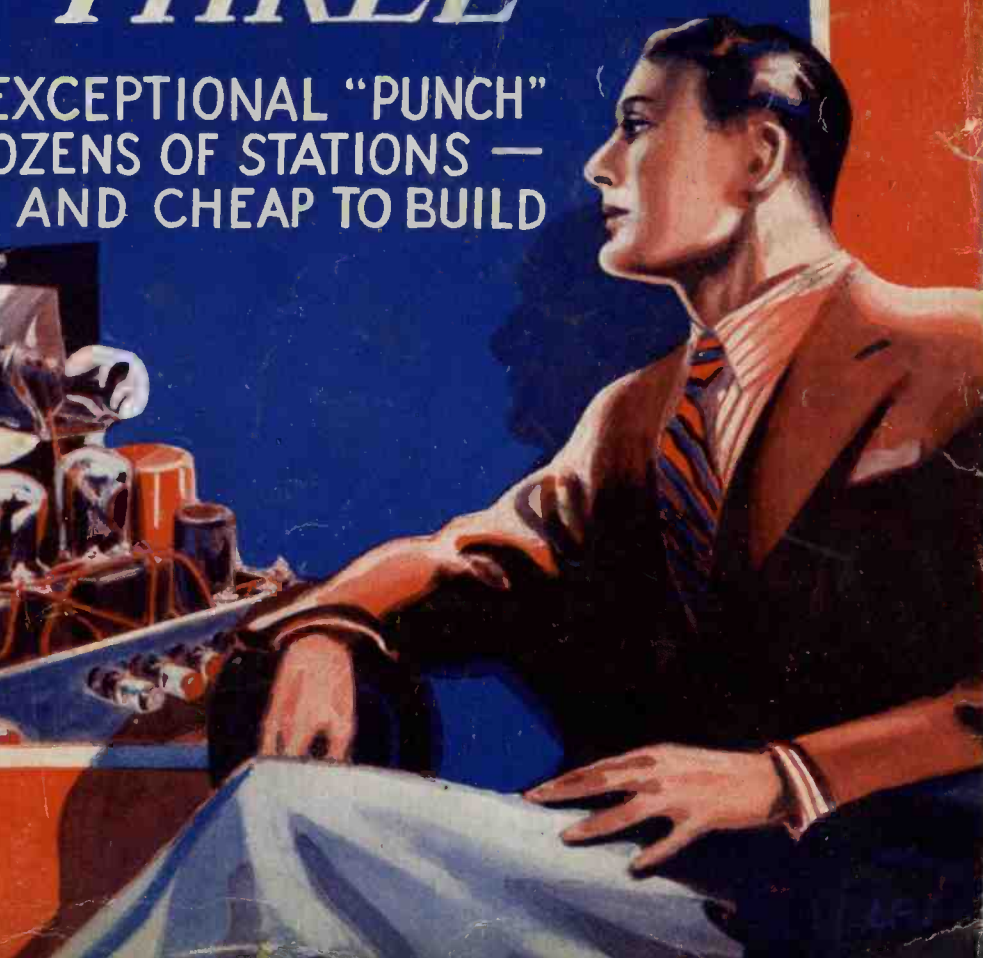
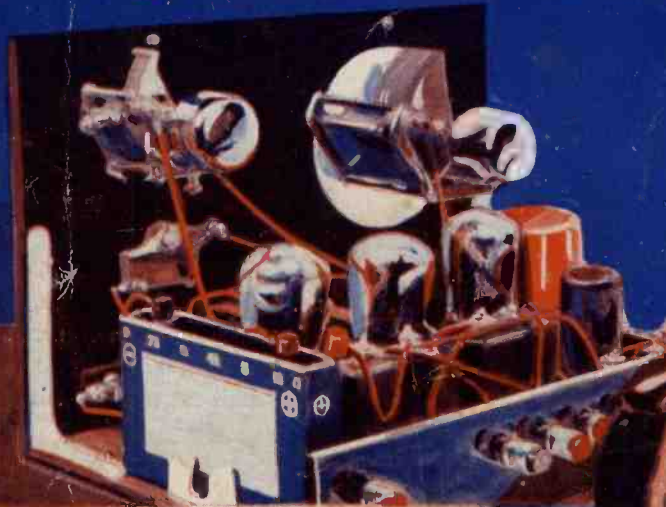



even simple simon could tune this—



—it's the  
**"EASYTUNE 60"**  
**BUT** only  
**LEWCOS** COILS  
Regd.

Make it possible

The co-operation of "LEWCOS" and "Wireless Magazine" experts . . . the use of Special LEWCOS Coils . . . the employment of highly skilled craftsmen and the finest materials in the construction of the coils—these are the factors that combined to produce this masterpiece—the "EASYTUNE 60." Months of experimenting have proved that in order to effectively match an oscillator coil with a Band Pass Aerial Coil, special condensers and coils are necessary. "LEWCOS" have co-operated with the manufacturers of the ganged Condenser. The British Radiophone Co. Ltd., for the "EASYTUNE 60" in order to ensure that both circuits shall match over the complete range of both wave-bands.



1. The Lewcos I.F. Transformer, Reference I.F.T.P. Price 10/6.
2. The Lewcos L.F. Transformer, Reference L.F.T.G. Price 10/-.
3. The Lewcos I.F. Transformer, Reference I.F.T.P. Price 10/6.
4. The Lewcos Band Pass Filter, Reference B.P.F./G. Price 12/-.
5. The Lewcos Twin Oscillator Coil, Reference T.O.S./A. Price 8/6.

F.T.

**LEWCOS RADIO PRODUCTS FOR BETTER RECEPTION**

THE LONDON ELECTRIC WIRE COMPANY AND SMITHS LIMITED CHURCH ROAD. LEYTON. LONDON E10

Editor:

**BERNARD E. JONES**

Technical Editor:

**J. H. REYNER,**  
B.Sc. (Hons.), A.M.I.E.E.

# Wireless Magazine

*The Best Shillingsworth in Radio*

Vol. XV :: JUNE, 1932 :: No. 89

Research Consultant:

**W. JAMES**

Assistant Editor:

**D. SISSON RELPH**

Published by **BERNARD JONES PUBLICATIONS, LTD.**, publishers of "Wireless Magazine" and "Amateur Wireless." Editorial and Advertisement Offices: 58-61 Fetter Lane, London, E.C.4. Telephone: City 3733, 3744. Telegrams: "Beejapee, Fleet, London." Subscription: Great Britain and abroad, 15s. 6d. a year, post free (Canada only, 13s. 6d.). Contributions are invited and will be promptly considered. Next issue published on Wednesday, June 22.

## The Editor's Chat

"DETECTOR and two L.F." This is the answer one gets, so often accompanied by a little apologetic smile, to a request for information about a set. There is a feeling that one cannot very well be proud of a set that will simply pick up the local stations.

But the whole implication is absurd. Look, for example, at the Multi-mag Three in this issue. The arrangements for this article were made many months ago, and I have discussed the set a number of times with the author, Paul D. Tyers, whose name—well known to many radio amateurs—has not often figured in the pages of this magazine, although he contributed frequently to our companion "Amateur Wireless" as far back, I think, as 1922 or 1923.

Mr. Tyers has had great experience in the commercial design of sets and components, and for a long time has been in close touch with amateur needs. In this new "three" he has produced a set of very definite value—possibly of greater value than we can estimate at the moment. His Multi-mag, although only a "three" and just a "detector and two L.F.," gave a member of our staff over forty stations in the course of a two-evenings' test.

The selectivity is something to talk about and is the nearest approach to super-het selectivity that we have heard from a "straight set." The sensitivity, too, is most marked and the cost of construction is low.

The Easytune 60 is carried a stage further this month. This set is a one-knob super of fine performance, and in this issue we explain fully how to convert it into a table radio gramophone, completely self-contained with moving-coil loud-speaker, only the aerial and earth being external.

You will bear in mind that this gramophone, besides being something new for the constructor, is the last

word in battery-operated installations, and I am sure that it will be most warmly welcomed by my readers.

We talk about one other radiogram in this issue—the A-P-A. P. K. Turner described it in the March and May issues, and he now talks about its operation. It is undoubtedly an ideal gramophone for an individual whose ear has developed a very correct sense of quality.

By the way, a reader in Tobago, British West Indies, writing under the nom de plume "60 Degrees West," thinks so highly of P. K. Turner's article "Modern Standards of Quality," which we published six months ago, that he sends us a long and extremely useful letter which we present in the form of an article under the title "Lowering the Cost of Quality."

His keynote is the statement that the man with a slender purse but musical ear has just as much right to be able to get the best out of what he can afford to buy as the rich man. You will read "60 Degrees West"—and think.

Among our general articles this month you will note Kenneth Ullyett's "Wonders of the Transatlantic Telephone." He tells the story of the Rugby station and makes it clear that England is more than holding its own in the commercial short-wave field. If you have a telephone in your house this is an article you will read with more than ordinary interest.

Percy Harris has been busy since last I wrote in travelling round the country with his Town-and-Country Four, which he described in detail in last month's "W.M." He has done some long-range listening on his four-valver, and whether you want a portable as a room-to-room set or for taking out with you into the countryside, you will be helped by what he has to say this month.

B. E. J.

### FOR THE CONSTRUCTOR

THE MULTI-MAG THREE. By Paul D. Tyers	PAGE 502
THE EASYTUNE 60 AS A TABLE RADIOGRAM. By the "W.M." Technical Staff	510
THE SHORT-WAVE DIRECTOR. By J. H. Reyner, B.Sc., A.M.I.E.E.	538
THE ECONOMY A.C. Two. By the "W.M." Technical Staff	549
THE VOLTAGE REGULATOR. By the "W.M." Technical Staff	570

### GRAMO-RADIO SECTION

FEATHERWEIGHTED PICK-UPS	545
CHOOSING YOUR RECORDS. By Whitaker-Wilson and Chopstick	546
THE MODERN RADIO GRAMOPHONE. By the "W.M." Set Selection Bureau	548

### TECHNICAL FEATURES

VALVES TO USE IN YOUR SET	484
IN MY LAB ARMCHAIR. By Percy W. Harris, M.Inst.Rad.E.	517
POSSIBILITIES OF THE HIGH-FREQUENCY PENTODE. By S. Rutherford Wilkins	520
WE TEST BEFORE YOU BUY. By the "W.M." Set Selection Bureau	525

## Contents

H.M.V. TABLE RADIOGRAM (FOR D.C. MAINS)	PAGE 526
FERRANTI SCREEN-GRID 3 (FOR CONSTRUCTORS)	527
REGENTONE ALL-ELECTRIC THREE	528
MAGNUM SHORT-WAVE ADAPTOR	529
GRAHAM-FARISH AMAZING THREE (KIT SET)	530
READERS REPORT ON "W.M." SETS	531
LONG-RANGE LISTENING WITH THE TOWN-AND-COUNTRY FOUR. By Percy W. Harris, M.Inst.Rad.E.	533
LOWERING THE COST OF QUALITY. By "60 Degrees West"	536
SOME CABINET IDEAS	542
EBONITE FOR COIL FORMERS	543
MATCHING THE LOUD-SPEAKER TO THE OUTPUT VALVE	544
TESTS OF NEW APPARATUS	554
ADJUSTING THE TRIMMERS. By W. James	558
THE A-P-A RADIO GRAMOPHONE. By P. K. Turner, M.I.E.E.	562

### GENERAL ARTICLES

GUIDE TO THE WORLD'S BROADCASTERS. By Jay Coote	488
---	-----

WORLD'S BROADCAST STATIONS	PAGE 490
IN TUNE WITH THE TRADE. By Fetter Lane	494
RADIO MEDLEY. By BM/PRESS	499
THE B.B.C. DANCE ORCHESTRA. An Impression by Slade	507
HOW WILL RADIO AFFECT THE FUTURE OF MUSIC? By Corot (in an Interview with Watson Lyle)	508
WONDERS OF THE TRANSATLANTIC TELEPHONE. By Kenneth Ullyett	513
THE LOVE-LORN ANNOUNCER. VERSE	516
SAVOY HILL'S BEST STORIES. By Frank Rogers	522
THE WIRELESS ZOO: THE SNUBBER. VERSE	524
THE DIFFERENCE. VERSE	541
STORIES OF THE OPERAS: TANNHAUSER	543
ON THE CREST OF THE WAVES. By Jay Coote	556
HENRY HALL GAINING POPULARITY. By T. F. Henn	559
RADIO IN REVIEW. By Morton Barr	568
NEWS OF THE SHORT WAVES	574
RADIO CROSS-WORD PUZZLE RESULTS WANTED—SOME GOOD CRITICS. By Whitaker-Wilson	578
BRITISH TELEVISION ON SIX METRES I	582
NEW RADIO CABINET	584
BLUEPRINT AND INFORMATION COUPONS	584
INDEX TO ADVERTISERS	584

**A ONE KNOB SUPER-HET RADIO GRAMOPHONE—SEE PAGE 510**

## SHORT WAVES

ON A.C.  
MAINS  
or  
BATTERY  
SETS

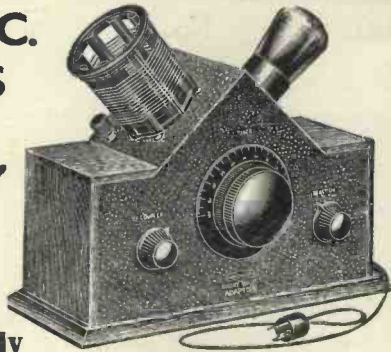

An Entirely  
New Design of amazing efficiency

This Adaptor enables you to enjoy Short Wave reception whether your set is A.C. Mains or Battery Operated. It is supplied complete with one special Short Wave Coil 40/80 metres, Cord and Plug. No extras whatsoever are required. Can be attached to your set in a few seconds. Write now for full particulars and our free trial offer.

Price complete **39/6**  
Extra coil if required 18/40 metres - - - 3/-

## "MULTI-MAG THREE"

We specialize in this receiver and all "Wireless Magazine" Sets, ready wired and tested. Every set is hand made and individually tested by skilled craftsmen, thus ensuring perfect and guaranteed performance. Comprehensive lists, free on application.

## BURNE-JONES

& CO., LTD., "Magnum" House, 296  
Borough High Street, LONDON, S.E.1

Telephones: Hop 6257 and 6258

Scottish Agent: Mr. Ross Wallace, 54 Gordon St., Glasgow, C.1

## SPECIFIED FOR THE 'MULTI-MAG THREE'

MAGNADENSER  
.0005

Price **2/6**

COMPLETE WITH KNOB

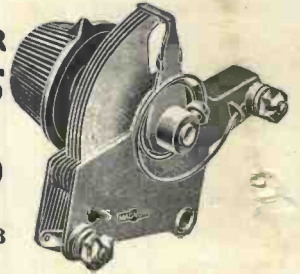

Solid Dielectric Variable Condensers

with a beautifully smooth movement, free of backlash. The vanes are of brass and a pigtail connection is provided to the rotor. Each condenser is tested at 500 volts, A.C. Recommended for Reaction Control and as Series Aerial Condensers. One hole fixing.

Price (.0001, .0002,  
.0003, .0005) - **2/6**  
Price (.00075) - **3/-**

# A FREE COPY OF THE WIRELESS MAGAZINE

*THE interest and pleasure which you derive from the "Wireless Magazine" will be greatly enhanced if you can discuss its monthly articles with a friend who is also familiar with its contents.*

*In order that anyone you know who is interested in wireless but is not yet a reader of "Wireless Magazine" may become acquainted with it, a complimentary copy will be sent to him gratis*

*and post free, if you will kindly complete the attached coupon, or if you do not wish to mutilate your copy, send your request on a postcard.*

**THE "WIRELESS MAGAZINE" IS "THE BEST SHILLINGSWORTH IN RADIO."** Tells you every month all you want to know about recent progress in Radio Design. Look out for the July issue on Wednesday, June 22.

## POST THIS COUPON NOW



Mention of the "Wireless Magazine" will ensure prompt attention

**AND NOW—**

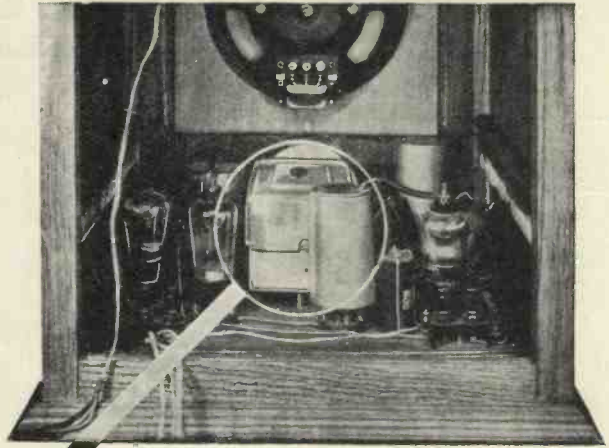

The  
**“EASYTUNE 60”  
 RADIOGRAM**

**T**HAT the latest development in radio and such a wonderful receiver as the “Easytune 60” should be centred round the special Super Heterodyne type British Radiophone Ganged Condensers is a very high credential of their worth.

By virtue of their sound and accurate construction, British Radiophone Ganged Condensers have revolutionised selectivity. All those stations marked with a query on your chart are now established—out of reach no longer—British Radiophone Ganged Condensers bring them in and separate them with clean-cut clarity.

The Lewcos Coils specified for the “Easytune 60” have been specially produced to match the British Radiophone Condensers in this receiver.

For the “EASYTUNE 60” Receiver and the “EASYTUNE 60” Radiogram  
**BRITISH RADIOPHONE 3 gang Super Heterodyne CONDENSER, type 424**      PRICE 27/-  
 Dustproof Metal Cover      - -      3/-  
 Escutcheon and Disc Drive assembly      - - - - -      5/-



The Dubilier Type BB Condenser is a high-efficiency condenser in moulded bakelite case. Working voltage 200 D.C. (peak) test voltage 400 D.C. Capacities from .09 mfd to 4.0 mfd. Prices from 1/9

**BUY THE  
 CONDENSER  
 WITH THE  
 NAME  
 YOU CAN  
 TRUST**

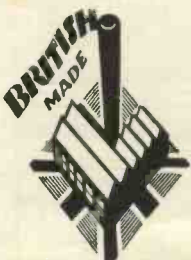

**DUBILIER**  
 CONDENSER CO. (1925) LTD.,  
 Ducon Works, Victoria Road,  
 North Acton, London, W.3

**RADIOPHONE  
 GANGED CONDENSERS**

THE BRITISH RADIOPHONE, Ltd., Aldwych House, Aldwych, W.C.2

*It helps us if you mention "Wireless Magazine"*

# VALVES TO USE IN YOUR SET

Characteristics of All the Most Important British Types

Make	Type	Impedance	Amplification Factor	Filament Current	Mutual Conductance	Anode Current at 120 volts	Grid Bias at 200 volts	Grid Bias at 150 volts
<b>2-volt Three-electrode Valves</b>								
Mazda ..	H210	59,000	47	.1	.8	5	.5	1.0
Lissen ..	H210	50,000	35	.1	.7	1.1	1.1	1.5
Lissen ..	H2	50,000	45	.1	.9	2.0	1.0	1.5
Cossor ..	210RC	50,000	40	.1	.8	5	1.0	1.5
Osram ..	H210	50,000	35	.1	0.7	1.0	—	—
Six-Sixty	210RC	45,400	50	.1	1.1	1.0	1.0	1.5
Mullard..	PM1A	41,600	50	.1	1.2	.75	1.5	1.5
Marconi ..	H2	35,000	35	.1	1.0	1.0	—	—
Osram ..	H2	35,000	35	.1	1.0	1.0	—	—
Six-Sixty	210HF	25,000	19	.1	.75	1.0	—	—
Osram ..	HL210	23,000	20	.1	.87	1.5	—	—
Mullard..	PM1HF	22,500	18	.1	.8	1.0	1.5	3.0
Cossor ..	210HL	22,000	24	.1	1.1	1.75	1.5	3.0
Lissen ..	HL2	21,000	32	.1	1.5	3.0	1.0	1.5
Mazda ..	HL2	21,000	31	.1	1.5	—	—	—
Lissen ..	HL210	20,000	20	.1	1.0	2.2	1.5	4.5
Mazda ..	HL210	18,500	26	.1	1.4	3.0	1.5	3.0
Marconi ..	HL2	18,000	27	.1	1.5	1.0	1.5	3.0
Osram ..	HL2	18,000	27	.1	1.5	1.0	1.5	3.0
Six-Sixty	210HL	17,200	26	.1	1.5	1.0	1.5	3.0
Cossor ..	210HF	15,800	24	.1	1.5	2.25	1.5	3.0
Mullard..	PM1HL	14,000	28	.1	2.0	1.2	1.5	3.0
Cossor ..	210D-st	13,000	15	.1	1.15	2.5	1.5	3.0
Six-Sixty	210LF	12,500	10.6	.1	.85	2.5	4.5	7.5
Mullard..	PM1LF	12,000	11	.1	.9	2.6	4.5	7.5
Osram ..	L210	12,000	11	.1	.92	2.0	3.0	6.0
Six-Sixty	210D	10,600	17	.1	1.6	2.0	3.0	7.5
Cossor ..	210LF	10,000	14	.1	1.4	3.0	3.0	4.5
Lissen ..	L210	10,000	12	.1	1.2	3.0	3.0	7.5
Lissen ..	L2	10,000	20	.1	2.0	3.0	1.5	3.0
Marconi ..	L2 1/2	10,000	15.5	.1	1.55	4.0	1.5	3.0
Mullard..	PM2DX	10,000	17	.1	1.7	2.0	3.0	6.0
Mazda ..	L210	10,000	17	.1	1.7	5.0	2.5	4.5
Mazda ..	L2	10,000	19	.1	1.9	3.0	—	3.0
Osram ..	P215	5,000	7	.15	1.4	6.0	7.5	12.0
Six-Sixty	220P	4,800	7.2	.2	1.5	5.0	7.5	12.0
Mullard..	PM2	4,400	7.5	.2	1.7	5.0	7.5	12.0
Lissen ..	P220	4,000	7	.2	1.75	5.0	7.5	15.0
Cossor ..	220P	4,000	9	.2	2.25	6.0	4.5	9.0
Cossor ..	215P	4,000	9	.15	2.25	5.0	4.5	7.5
Cossor ..	220Pa	4,000	16	.2	4.0	5.5	3.0	4.5
Marconi ..	LP2	3,900	15	.2	3.85	6.0	3.0	4.5
Osram ..	LP2	3,900	15	.2	3.85	6.0	3.0	4.5
Mazda ..	P220	3,700	12.5	.2	3.4	11.0	3.0	6.0
Six-Sixty	220PA	3,700	13	.2	3.5	6.0	3.0	6.0
Mullard..	PM2A	3,600	12.5	.2	3.5	6.5	3.0	6.0
Lissen ..	LP2	3,500	12.0	.2	3.4	8.0	6.0	7.0
Marconi ..	P240	2,500	4	.4	1.6	12.0	15.0	24.0
Osram ..	P240	2,500	4	.4	1.6	11.0	16.0	24.0
Marconi ..	P2	2,150	7.5	.2	3.5	12.0	6.0	10.5
Osram ..	P2	2,150	7.5	.2	3.5	10.0	7.5	10.5
Six-Sixty	220SP	2,060	7	.2	3.4	13.5	7.5	15.0
Mullard..	PM202	2,000	7.0	.2	3.5	14.0	7.5	15.0
Mazda ..	P240	1,900	7	.4	3.7	18.0	6.0	13.5
Mullard..	PM252	1,900	7	.4	3.7	14.0	6.0	12.0
Six-Sixty	240SP	1,900	6.6	.4	3.5	14.0	6.0	13.5
Mazda ..	P2 'A	1,850	6.5	.2	3.5	13.0	9.0	15.0
Marconi ..	P2/b	1,850	6.5	.2	3.5	15.0	—	—
Lissen ..	P22GA	1,700	6.0	.2	3.5	12.0	9.0	15.0
Lissen ..	PX24J	1,500	4.5	.4	3.0	14.0	12.5	22.5
Cossor ..	230XP	1,500	4.5	.3	3.0	15.0	10.5	18.0
Lissen ..	P240A	1,000	5.0	.4	5.0	20.0	15.0	20.0

<b>2-volt Double-grid Valves</b>								
Marconi ..	DG2	3,750	4.5	.2	1.2	—	—	—
Osram ..	DG2	3,750	4.5	.2	1.2	—	—	—
Cossor ..	210DG	3,400	—	.1	.8	—	—	—
Mullard..	PM1DG	—	—	.1	.8	—	—	—
Six-Sixty	210DG	—	—	.1	.8	—	—	—

<b>2-volt Screen-grid Valves</b>								
Lissen ..	SG215	900,000	1,000	.15	1.1	—	—	1.5
Mazda ..	215SG	400,000	450	.15	1.1	—	—	—
Cossor ..	215SG	300,000	330	.15	1.1	1.25	.9	.9
Cossor ..	220SG	200,000	320	.2	1.6	1.5	.9	.9
Osram ..	S22	200,000	350	.2	1.75	3.0	—	—
Marconi ..	S22	200,000	350	.2	1.75	2.5	.9	1.5
Marconi ..	S21	200,000	220	.1	1.1	3.0	.9	1.5
Osram ..	S21	200,000	220	.1	1.1	3.0	—	—
Six-Sixty	215SG	190,000	200	.15	1.05	2.0	—	—
Mullard..	PM12	180,000	200	.15	1.1	—	—	—
Mazda ..	S215A	—	800	.15	1.1	—	—	—

Make	Type	Impedance	Amplification Factor	Filament Current	Mutual Conductance	Anode Current at 120 volts	Grid Bias at 100 volts	Grid Bias at 150 volts
<b>2-volt Variable-mu Screen-grid Valves</b>								
Lissen ..	SG2V	750,000	—	.2	1.6	—	—	—
Cossor ..	220VSG	110,000	—	.2	1.6	—	—	—

<b>2-volt Pentode Valves</b>								
Lissen ..	PT225	71,000	100	.25	1.4	7.0	3.0	6.0
Six-Sixty	230PP	64,000	80	.3	1.25	10.0	6.0	12.0
Marconi ..	PT240	55,000	90	.4	1.65	9.0	6.0	9.0
Lissen ..	PT240	28,000	64	.4	2.3	12.5	7.5	10.5
Lissen ..	PT220A	22,500	45	.2	2.5	15.0	7.5	9.0
Cossor ..	230PT	—	—	.3	2.0	13.0	15.0	15.0
Cossor ..	230HPT	—	—	.3	1.8	6.5	7.5	7.5
Marconi ..	PT2	—	—	.3	2.5	5.0	3.0	4.5
Mazda ..	220Pen.	—	—	.2	2.5	—	—	—
Mazda ..	220A Pen.	—	—	.2	2.5	—	—	—
Mazda ..	Pen.230	—	—	.3	1.3	—	—	—
Mullard..	PM22	—	—	.3	1.3	12.0	6.0	10.0
Osram ..	PT2	—	—	.2	2.5	5.0	3.0	4.5

<b>4-volt Three-electrode Valves</b>								
Marconi ..	H41G	60,000	40	.1	.66	.5	—	1.5
Osram ..	H410	60,000	40	.1	.66	.35	—	1.5
Six-Sixty	4075RC	58,000	37	.075	.66	.3	1.0	1.5
Mullard..	PM3A	55,000	38	.075	.66	.3	1.5	1.5
Cossor ..	410RC	50,000	40	.1	.9	.6	1.5	1.5
Lissen ..	H410	40,000	36	.1	.9	1.6	1.0	1.5
Lissen ..	HLD410	21,000	25	.1	1.2	2.5	1.5	3.0
Marconi ..	HL410	20,800	25	.1	1.2	1.5	1.5	3.0
Osram ..	HL410	20,800	25	.1	1.2	1.25	1.5	3.0
Cossor ..	410HF	20,000	22	.1	1.1	1.0	1.5	3.0
Mullard..	PM3	13,000	14	.075	1.05	2.0	3.0	6.0
Six-Sixty	4075HF	12,500	13.5	.075	1.1	3.0	3.0	6.0
Cossor ..	410LF	10,000	17	.1	1.1	3.0	3.0	4.5
Lissen ..	L410	8,500	15	.1	1.8	3.5	1.5	4.5
Marconi ..	L410	8,500	15	.1	1.77	3.0	2.0	4.5
Osram ..	L410	8,500	15	.1	1.77	3.0	2.0	4.5
Mullard..	PM4DX	7,500	15	.1	2.0	2.0	3.0	4.5
Six-Sixty	410D	7,250	14.5	.1	2.0	4.0	3.0	6.0
Marconi ..	P410	5,000	7.5	.1	1.5	6.0	6.0	10.5
Osram ..	P410	5,000	7.5	.1	1.5	6.0	6.0	10.5
Six-Sixty	410P	4,100	7.8	.1	1.9	7.5	7.5	12.0
Cossor ..	410P	4,000	8	.1	2.0	8.0	4.5	9.0
Mullard..	PM4	4,000	8	.1	2.0	7.5	5.0	8.0
Lissen ..	P410	4,000	8	.1	2.0	7.0	6.0	9.0
Marconi ..	P425	2,300	4.5	.25	1.95	14.0	9.0	16.5
Mullard..	PM254	2,150	6.5	.2	3.0	9.0	9.0	15.0
Six-Sixty	420SP	2,150	6.5	.2	3.0	10.0	8.0	15.0
Marconi ..	P415	2,080	5.0	.15	2.4	14.0	9.0	16.5
Osram ..	P415	2,080	5.0	.15	2.4	14.0	9.0	16.5
Cossor ..	425XP	2,000	7	.25	3.5	13.0	6.0	12.0
Mazda ..	P425	1,950	3.5	.25	1.8	26.0	14.0	26.0
Lissen ..	P425	1,530	4.5	.25	3.0	28.0	12.0	20.0
Cossor ..	415XP	1,500	4.5	.15	3.0	15.0	9.0	18.0
Cossor ..	4XP	1,200	4.8	.6	4.0	18.0	12.0	24.0
Marconi ..	PX4	830	5	1.0	6.0	35.8	12.0	16.0
Osram ..	PX4	830	5	1.0	6.0	35.0	12.0	16.0

<b>4-volt Screen-grid Valves</b>								
Lissen ..	SG410	635,000	700	.1	1.1	—	—	—
Mullard..	PM14	230,000	200	.075	.87	—	—	—
Six-Six								

**P.M.1A**

**P.M.2A**

**P.M.2DX**

Mr. Paul Tyers, designer of the Multi-Mag Three, wanted valves that were reliable and efficient—he chose Mullard. There is a Mullard combination for every receiver. Fit Mullard and notice the improvement; faultless reproduction, pure tone and unlimited power.

**P.M.1A, 7/-**

**P.M.2DX, 7/-**

**P.M.2A, 8/9**

**P.M.2DX**

**OPERATING DATA**

Max. Filament voltage 2.0 volts  
Filament current 0.1 amp.

Max. Anode voltage 150 volts

**CHARACTERISTICS**

(At anode volts 100; grid volts zero)

Anode impedance 10,000 ohms

Amplification factor 17

Mutual conductance 1.7 mA/V

**P.M.1A**

**OPERATING DATA**

Max. Filament voltage 2.0 volts

Filament current 0.1 amp.

Max. Anode voltage 150 volts

**CHARACTERISTICS**

(At anode volts 100; grid volts zero)

Anode impedance 41,600 ohms

Amplification factor 50

Mutual conductance 1.2 mA/volt

**P.M.2A**

**OPERATING DATA**

Max. Filament voltage 2.0 volts

Filament current 0.2 amp.

Max. Anode voltage 150 volts

**CHARACTERISTICS**

(At anode volts 100; grid volts zero)

Anode impedance 3,600 ohms

Amplification factor 12.5

Mutual conductance 3.5 mA/V

MADE IN ENGLAND

**Mullard**  
**THE · MASTER · VALVE**

Advt. The Mullard Wireless Service Co., Ltd., Mullard House, Charing Cross Road, London, W.C.2. ARKS:

When replying to advertisements, please mention "Wireless Magazine"

# VALVES TO USE IN YOUR SET—Continued from page 484

Make	Type	Impedance	Amplification Factor	Filament Current	Mutual Conductance	Anode Current at 130 volts	Grid Bias at 100 volts	Grid Bias at 150 volts
<b>4-volt Pentode Valves—Continued</b>								
Mullard..	PM24A	25,000	50	.275	2.0	15.0	6.0	21.0
Cossor ..	415P	—	—	.15	2.0	13.0	15.0	15.0
Mazda ..	425Pen.	—	—	.25	2.0	14.0	14.0	—
Mullard..	PM24C	—	—	1.0	3.0	—	—	—
Mullard..	PM24	—	—	.15	1.75	16.0	6.0	12.0
Six-Sixty	SS/Pen.SP	—	—	.275	2.0	—	—	—

Make	Type	Impedance	Amplification Factor	Filament Current	Mutual Conductance	Anode Current at 130 volts	Grid Bias at 100 volts	Grid Bias at 150 volts
<b>6-volt Three-electrode Valves</b>								
Mazda ..	H607	90,000	40	.07	.45	1.0	.8	1.5
Mazda ..	H610	66,000	40	.1	.6	1.0	—	—
Marconi ..	H610	60,000	40	.1	.66	.35	1.5	1.5
Osram ..	H610	60,000	40	.1	.66	.35	1.5	1.5
Six-Sixty	6075RC	58,000	42	.075	.7	.5	1.0	1.5
Cossor ..	610RC	50,000	40	.1	.8	.75	—	—
Mullard..	PM5B	49,000	40	.075	.85	.5	1.5	1.5
Lissen ..	H610	40,000	36	.1	.9	1.0	1.0	1.5
Marconi ..	HL610	30,000	30	.1	1.0	1.0	1.5	1.5
Osram ..	HL610	30,000	30	.1	1.0	1.0	1.5	1.5
Osram ..	LS5B	25,000	20	.8	.8	—	—	—
Lissen ..	HL610	21,000	25	.1	1.2	2.5	1.5	3.0
Cossor ..	610HF	20,000	20	.1	1.0	1.75	1.5	3.0
Mazda ..	HL610	20,000	22	.1	1.1	1.8	1.5	3.0
Mullard..	PM15D	20,000	26	.075	1.3	1.0	1.5	3.0
Six-Sixty	607HF	15,200	17	.075	1.1	2.0	2.0	4.0
Mullard..	PM5X	14,700	17.5	.075	1.2	1.6	3.0	4.5
Six-Sixty	610D	9,250	18.5	.1	2.0	2.0	3.0	4.0
Mullard..	PM6D	9,000	18	.1	2.0	2.0	3.0	4.5
Lissen ..	L610	8,000	16	.1	2.0	2.0	3.0	4.5
Cossor ..	610LF	7,500	15	.1	2.0	3.0	1.5	4.5
Marconi ..	L610	7,500	15	.1	2.0	3.0	2.0	4.5
Osram ..	L610	7,500	15	.1	2.0	3.0	2.0	4.5
Osram ..	LS5	6,000	5	.8	.8	—	—	—
Mullard..	PM6	3,500	8	.1	2.25	7.0	6.0	9.0
Cossor ..	610P	3,500	8	.1	2.28	8.0	3.0	7.5
Marconi ..	P610	3,500	8	.1	2.28	8.0	6.0	9.0
Osram ..	P610	3,500	8	.1	2.28	8.0	6.0	9.0
Six-Sixty	610P	3,400	7.8	.1	2.3	8.0	6.0	9.0
Lissen ..	P610	3,200	8	.1	2.5	6.0	6.0	9.0
Marconi ..	LS5A	2,750	2.5	.8	.9	—	—	—
Osram ..	LS5A	2,750	2.5	.8	.9	—	—	—
Cossor ..	625P	2,500	7	.25	2.8	13.0	3.0	12.0
Lissen ..	P625	2,500	7.5	.25	3.0	8.0	7.5	24.0
Marconi ..	P625	2,400	6	.25	2.5	11.0	7.0	24.0
Osram ..	P625	2,400	6	.25	2.5	11.0	7.0	26.0
Cossor ..	610XP	2,000	5	.1	2.5	15.0	7.5	27.0
Mullard..	PM256	1,850	6	.25	3.25	8.0	9.0	27.0
Six-Sixty	625SP	1,780	5.8	.25	3.25	8.0	10.0	15.0
Marconi ..	P625A	1,600	3.7	.25	2.3	20.0	13.5	36.0
Osram ..	P625A	1,600	3.7	.25	2.3	16.0	13.5	24.0
Lissen ..	P625A	1,500	4.5	.25	3.0	12.0	13.5	24.0
Six-Sixty	625SPA	1,500	3.9	.25	2.6	20.0	12.0	22.5
Cossor ..	620T	1,400	3.2	2.0	2.3	—	—	—
Mullard..	PM256A	1,400	3.6	.25	2.6	20.0	12.0	33.0
Marconi ..	LS6A	1,300	3.0	2.0	2.3	—	—	—
Mazda ..	P650	1,300	3.5	.5	2.7	30.0	12.0	25.0
Osram ..	LS6A	1,300	3.0	2.0	2.3	—	—	—
Marconi ..	DA60	835	2.5	4.0	3.0	—	—	—
Osram ..	DA60	835	2.5	4.0	3.0	—	—	—

Make	Type	Impedance	Amplification Factor	Filament Current	Mutual Conductance	Anode Current at 130 volts	Grid Bias at 100 volts	Grid Bias at 150 volts
<b>6-volt Screen-grid Valves</b>								
Six-Sixty	SS6075SG	210,000	190	.075	.9	—	—	—
Cossor ..	610SG	200,000	200	.1	1.0	—	1.5	1.5
Mullard..	PM16	200,000	200	.075	1.0	—	—	—
Osram ..	S610	200,000	210	.1	1.05	4.0	1.5	—
Marconi ..	S610	200,000	210	.1	1.05	4.0	1.5	—

Make	Type	Impedance	Amplification Factor	Filament Current	Mutual Conductance	Anode Current at 130 volts	Grid Bias at 100 volts	Grid Bias at 150 volts
<b>6-volt Pentode Valves</b>								
Marconi ..	PT625	43,000	80	.25	1.85	10.0	6.0	15.0
Osram ..	PT625	43,000	80	.25	1.85	10.0	6.0	13.0
Six-Sixty	SS617PP	28,500	54	.17	1.9	15.0	8.0	14.0
Lissen ..	PT625	24,000	60	.25	2.5	14.0	7.5	10.0
Cossor ..	615PT	—	—	.15	2.0	17.0	6.9	7.5
Mullard..	PM26	—	—	.17	2.0	15.0	9.0	15.0

Make	Type	Impedance	Amplification Factor	Filament Current	Mutual Conductance	Anode Current at 130 volts	Grid Bias at 100 volts	Grid Bias at 150 volts
<b>A.C. Three-electrode Valves</b>								
Mullard..	904V	21,000	75	1.0	3.6	3.0	.75	1.0
Cossor ..	41MRC	19,500	50	1.0	2.6	2.0	—	1.5
Cossor ..	41MH	18,000	72	1.0	4.0	2.0	—	1.5
Six-Sixty	4DX.AC	17,700	85	1.0	4.8	3.0	1.0	1.5
Cossor ..	41MHF	14,500	41	1.0	2.8	2.5	—	2.0
Mazda ..	AC/HL	13,500	35	1.0	3.0	4.5	1.5	3.0

Make	Type	Impedance	Amplification Factor	Filament Current	Mutual Conductance	Anode Current at 120 volts	Grid Bias at 100 volts	Grid Bias at 150 volts
<b>A.C. Three-electrode Valves—Continued</b>								
Six-Sixty	4CP.AC	12,000	36	1.0	3.0	2.0	2.0	3.0
Lissen ..	AC/HL	11,700	35	1.0	3.0	5.0	1.5	3.0
Cossor ..	41MHL	11,500	52	1.0	4.5	4.0	1.2	2.0
Mazda ..	AC2HL	11,500	75	1.0	6.5	3.0	—	1.5
Marconi ..	MH4	11,100	40	1.0	3.6	4.0	1.5	3.0
Osram ..	MH4	11,100	40	1.0	3.6	4.0	1.5	3.0
Mullard..	354V	10,000	35	1.0	3.5	2.0	2.0	3.0
Marconi ..	MHL/4	8,000	20	1.0	2.5	5.0	3.0	6.0
Osram ..	MHL4	8,000	20	1.0	2.5	5.0	3.0	6.0
Cossor ..	41MLF	7,900	15	1.0	1.9	4.5	4.5	6.0
Six-Sixty	4L.AC	7,500	15	1.0	2.0	6.0	3.0	4.5
Mullard..	164V	4,850	16	1.0	3.3	5.0	4.5	6.5
Six-Sixty	SS4PAC	3,000	10	1.0	3.3	10.0	5.9	8.0
Mazda ..	PP3/425	2,900	2.9	1.25	1.0	—	—	100
Osram ..	ML4	2,860	12	1.0	4.2	12.0	5.0	7.0
Mullard..	104V	2,850	10	1.0	3.5	11.0	5.0	8.5
Marconi ..	ML4	2,800	12	1.0	2.5	13.0	4.0	6.0
Mazda ..	AC/P	2,650	10	1.0	3.75	14.0	6.0	12.0
Cossor ..	41MP	2,500	18.7	1.0	7.5	10.0	3.0	6.0
Mullard..	AC064	2,000	6	1.0	3.0	15.0	9.0	14.0
Cossor ..	41MXP	1,500	11.2	1.0	7.5	23.0	6.0	9.0
Mazda ..	PP5/400	1,500	9	2.0	6.0	—	—	32.0
Mazda ..	AC/PI	1,450	5.4	1.0	3.7	—	—	14.0
Six-Sixty	HV4/1	1,450	6.3	1.0	3.0	15.0	9.0	14.0
Mullard..	AC044	1,150	4	.7	3.5	17.0	14.0	23.0

Make	Type	Impedance	Amplification Factor	Filament Current	Mutual Conductance	Anode Current at 120 volts	Grid Bias at 100 volts	Grid Bias at 150 volts
<b>A.C. Double-grid Valve</b>								
Cossor ..	41MDG	40,000	10	1.0	.25	—	—	—

Make	Type	Impedance	Amplification Factor	Filament Current	Mutual Conductance	Anode Current at 120 volts	Grid Bias at 100 volts	Grid Bias at 150 volts
<b>A.C. Screen-grid Valves</b>								
Six-Sixty	4SGAC	1,000,000	1,000	1.0	1.0	1.5	—	—
Mullard..	SV4	909,000	1,000	1.0	1.1	—	—	—
Mazda ..	AC/SG	800,000	1,200	1.0	3.0	5.0	.5	.5
Cossor ..	ACS2	600,000	3,000	1.0	5.0	—	—	—
Mazda ..	MSG/HA	500,000	1,000	1.0	2.0	2.0	1.5	1.5
Marconi ..	MS4	500,000	550	1.0	1.1	2.2	1.5	1.5
Osram ..	MS4	500,000	550	1.0	1.1	2.2	1.5	1.5
Osram ..	VMS4	500,000	550	—	—	—	—	—
Six-Sixty	4XSGAC	485,000	1,600	1.0	3.3	—	—	—
Mullard..	S4VA	430,000	1,500	1.0	3.5	1.7	—	—
Cossor ..	41MSG	400,000	1,000	1.0	2.5	2.0	—	1.5
Marconi ..	MS4B	350,000	1,120	1.0	3.2	3.2	1.0	1.0
Osram ..	MS4V	350,000	1,120	1.0	3.2	3.2	1.0	1.0
Lissen ..	AC/SG	340,000	1,100	1.0	3.25	—	—	—
Lissen ..	AC S6V	300,000	975	1.0	3.25	—	—	—
Six-Sixty	SS4MMAC	300,000	900	—	3.0	—	4.0	—
Osram ..	S4VB	257,000	900	1.0	3.5	4.0	1.5	1.5
Cossor ..	MSG/LA	200,000	200	1.0	3.75	4.5	—	1.5
Cossor ..	MVS6	200,000	—	1.0	2.5	1.5	—	—
Six-Sixty	4YSGAC	—	900	1.0	3.5	—	—	—

Make	Type	Impedance	Amplification Factor	Filament Current	Mutual Conductance	Anode Current at 120 volts	Grid Bias at 100 volts	Grid Bias at 150 volts
<b>A.C. Pentode Valves</b>								
Marconi ..	MPT4	33,000	100	1.0	3.0	—		



**SPECIFIED for the  
"MULTI-MAG THREE"**

The British General H.F. Choke which is recommended for this circuit, has been proved to have a most remarkable performance curve. It is totally enclosed in a non-corrodible moulded case and is mechanically strong and dust and damp proof.



**PRICE 5/6**

British General specialise in the production of high-grade Radio components including Transformers, Band-pass Units and the famous Aerial Tuning Unit which replaces plug-in coils.

*Illustrated catalogue free on request*

**BRITISH GENERAL**

*From all dealers or direct from the manufacturers*  
BRITISH GENERAL MANUFACTURING Co. Ltd.  
BROCKLEY WORKS, LONDON, S.E.4

**SPECIFIED for the  
EASYTUNE 60**

- \* DISTINGUISHED DESIGN
- \* ROBUST CONSTRUCTION
- \* ALL HOLES READY DRILLED
- \* SMITHCRAFT FINISH



The designers of the Easytune 60 naturally wanted really distinguished Cabinet work for their amazing set... so they turned to "Smithcraft" because they, like other prominent designers, know that behind the beautiful finish there is sound, enduring workmanship worthy of such a set.

*In Beautifully Grained Oak*

**£2 15 0**

**Smith's Cabinets LTD**

19/20 HERTFORD ST., LONDON, N.1. Clissold 3725

EVERY SMITHCRAFT CABINET IS HAND-POLISHED

**Specified for the  
"ECONOMY A.C. TWO"**

described in this issue

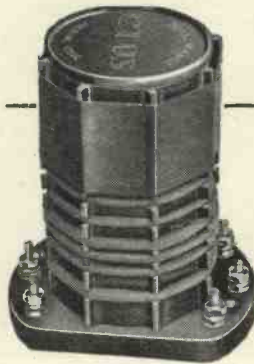

**LOTUS DUAL RANGE COIL**  
Separate windings for long and medium wave-bands ensure highest efficiency. **5/6**  
Screening cans 2/- extra.

Week after week, the leading set designers specify Lotus Components. They know, by test and comparison, that Lotus can be relied upon completely. Follow the experts' lead. Insist on the Lotus Dual Range Coil and other components when you build the "Economy A.C. Two," and post the coupon to-day for your copy of the Lotus Component Catalogue.

and for **"MULTI-MAG" THREE** the

**LOTUS GUARANTEED COMPONENTS**

include L.F. and Power Transformers, L.F. and H.F. Chokes, Variable Condensers, Gang Condensers, Disc and Drum Drives, Coils, Valveholders, Jacks and Switches.



**3 LOTUS ANTIPHONIC VALVE HOLDERS Type V.H.K.** Heavy one-piece phosphor bronze sockets and soldering tags. **6**  
With terminals.

**LOTUS**

**GUARANTEED COMPONENTS**

LOTUS RADIO LTD., MILL LANE, LIVERPOOL

**FREE CATALOGUE COUPON**

To LOTUS RADIO, LTD., Mill Lane, Liverpool.  
Please send me a FREE Copy of the Lotus Component Catalogue.

Name .....

Address .....

WM/5

*Please mention "Wireless Magazine" when corresponding with advertisers*



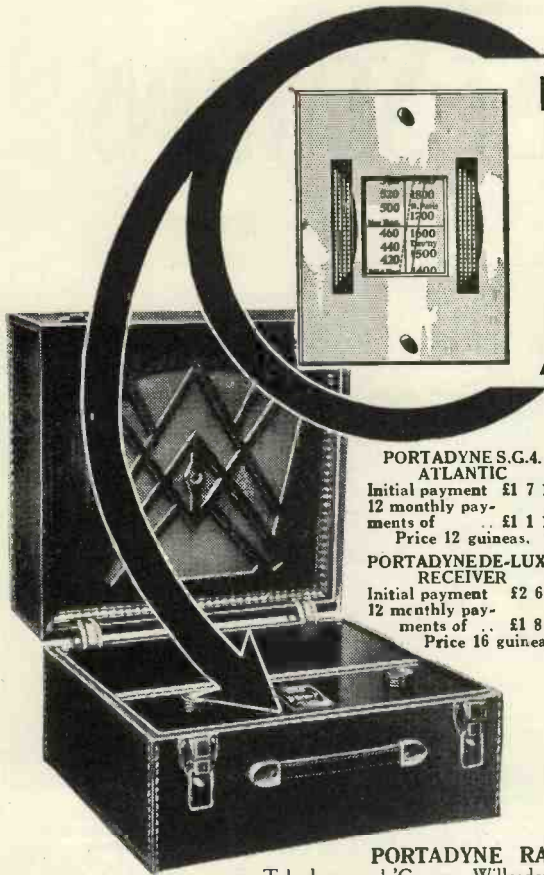

**MOVE TWO LINES TO COINCIDE**  
**AND THERE'S YOUR STATION**  
**IN JUST 3 SECONDS**

**PORTADYNE S.G.4**  
**ATLANTIC**  
 Initial payment £1 7 10  
 12 monthly payments of £1 1 10  
 Price 12 guineas.  
**PORTADYNE DE-LUXE**  
**RECEIVER**  
 Initial payment £2 6 6  
 12 monthly payments of £1 8 4  
 Price 16 guineas.

No longer are all portables very much alike! PORTADYNE stands out alone as the only portable with the INSTANTANEOUS TUNING DEVICE. With this new tuning any chosen station can be brought in in 3 seconds. So simple that a child can operate it. Can't go wrong—won't wear out. Then there are all the other PORTADYNE virtues—the outcome of nearly 10 years' specialisation in Portables—long range, perfect tone, 2-year guarantee. Small wonder that PORTADYNE has been hailed as "the Portable of the year."

Another Portadyne achievement—the S.G.4 Transportable CHALLENGER

Fitted with famous Instantaneous Tuning Device and complete with all valves and batteries. Aerial incorporated in the handsome walnut cabinet £12 17 6 or 12 monthly payments of 24s. 6d.

*Portadyne*

PORTADYNE RADIO LTD., Gorst Road, North Acton, LONDON, N.W.10.  
 Telephone and Grams: Willesden 7541-2-3. And at Belfast, Brighton, Dublin, Glasgow, Leicester, and Manchester.

**YOUR SAFEGUARD...**



This label appears on all C.A.V. battery containers. It is a guarantee that the battery will give you its rated capacity. It is also a stamp of quality: the members of the P.A.M.A. are all long established battery manufacturers.

When next you require an accumulator buy a C.A.V.; you will know that you are getting a good one, with long life and satisfying service.

From all radio dealers or our Agents throughout the country.

FREE: Would you like a useful book on the charging and maintenance of C.A.V. H.T. & L.T. Accumulators? Send a post card for a copy.

DEPT. 1.4.



**H.T. & L.T. ACCUMULATORS**

All enquiries to C. A. VANDERVELL Ltd., Well Street, Birmingham.

When you send your order don't forget to say you "saw it in the W.M."

# WORLD'S BROADCAST STATIONS

Wave-length	Name of Station	Dial Readings	Country	Wave-length	Name of Station	Dial Readings	Country
7.05	Berlin ..		Germany	39.8	Rio Bamba ..		Ecuador
13.95	Boundbrook W3XAL ..		United States	40	Doerberitz DGA ..		Germany
14.27	Buenos Aires LSL ..		Argentina	41	Bangkok HSP2 ..		Siam
14.55	Malabar PMB ..		Java	41.6	Las Palmas EAR58 ..		Canary Isles
14.83	Nauen DGW ..		Germany	41.7	Singapore VSIAB ..		Singapore
15	Prangins (Radio Nations) ..		Switzerland	42.3	Stuttgart D4XAA ..		Germany
15.03	Monte Grande LSG ..		Argentina	42.7	2 RO Rome ..		Italy
15.14	Deal Beach WM1 ..		United States	42.8	Rugles F8BP ..		France
15.198	Aranjuez EAQ ..		Spain	42.9	Lisbon CT1AA ..		Portugal
15.2	Ruysselede (Bruges) ..		Belgium	43	Madrid FAR100 ..		Spain
15.3	Nauen DFA ..		Germany	43.6	Koethen D4AFF ..		Germany
15.33	Saigon FZS ..		Indo-China	43.75	Paris (Vitus) F8LH ..		France
15.3	Sydney VK2ME ..		New South Wales	44.9	Nauen DKG ..		Germany
15.5	Nancy ..		France	45	Constantine FM8KK ..		Tunis
15.51	Deal Beach WNC ..		United States	45.38	Moscow ..		U.S.S.R.
15.93	Bandoeng PLE ..		Java	45.5	Bucarest ..		Rumania
16.0	Maracay YVQ ..		Venezuela	46.18	Elizabethville OQH ..		Belgian Congo
16.3	Kootwijk PCK ..		Holland	46.69	Boundbrook W3XL ..		United States
16.54	Rugby GBW ..		England	46.72	Minsk RW62 ..		U.S.S.R.
16.57	Chicago W9XAA ..		United States	47	Coltano IAC ..		Italy
16.8	Malabar PLF ..		Java	47	Quito HCIDR ..		Ecuador
16.85	Kootwijk PCV ..		Holland	48	Casablanca CN8MC ..		Morocco
16.9	Bangkok HSJ ..		Siam	48.05	Baranquilla HKD ..		Colombia
18.41	Kootwijk PCL ..		Holland	48.35	Bogota HKC ..		Colombia
18.5	Saigon FZR ..		Indo-China	48.59	Halifax ..		Nova Scotia
19	Barcelona ..		Spain	48.8	Winnipeg VE9CL ..		Canada
19.03	Prangins (Radio Nations) ..		Switzerland	48.64	East Pittsburgh W8XK ..		United States
19.03	Kemikamacho (J1AA) ..		Japan	49.02	Richmond Hill W2XE ..		United States
19.56	Schenectady W2XAD ..		United States	49.05	Saigon F31CD ..		Indo-China
19.68	Pontoise FYA ..		France	49.18	Boundbrook W3XAL ..		United States
19.72	East Pittsburgh W8XK ..		United States	49.22	Bowmanville VE9GW ..		Canada
19.84	Rome (Vatican) HVJ ..		Italy	49.34	Chicago W9XAA ..		United States
19.95	Taschkand ..		U.S.S.R.	49.4	Johannesburg ZTJ ..		South Africa
20.49	Deal (N.J.) W2XBJ ..		United States	49.43	Vancouver VE9CS ..		British Columbia
20.5	Chapultepec XDA ..		Mexico	49.5	Nairobi 7LO ..		Kenya Colony
21.5	Bucharest CV1 ..		Roumania	49.5	Philadelphia W3XAU ..		United States
23.5	Coltano IAC ..		Italy	49.83	Chicago W9XF ..		United States
23.8	Rabat ..		Morocco	49.96	Montreal VE9DR ..		Canada
24	Funchal CT3AQ ..		Madeira	49.96	Tegucigalpa HRB ..		Honduras
24.98	Saigon FZR ..		Indo-China	49.4	Vienna UOR2 ..		Austria
25.16	Moscow (Popoff) RW50 ..		U.S.S.R.	49.5	Mason (Ohio) W8XAL ..		United States
25.2	Pontoise FYA ..		France	50	Bogota HKO ..		Colombia
25.25	East Pittsburgh W8XK ..		United States	50	Moscow RV59 ..		U.S.S.R.
25.27	Calcutta VUC ..		India	50	Barcelona EAJ25 ..		Spain
25.465	Saigon (Chi-Hoa) ..		Indo-China	50.1	Caracas YV2BC ..		Venezuela
25.5	Chapultepec XDA ..		Mexico	50.1	Eindhoven ..		Holland
25.53	Chelmsford 5SW ..		Great Britain	50.26	Rome (Vatican) HVJ ..		Italy
25.6	Caracas ..		Venezuela	51.22	Chapultepec XDA ..		Mexico
25.63	Pontoise FYA ..		France	54.4	Moscow RV38 ..		U.S.S.R.
26.22	DHA Nauen ..		Germany	58	Prague Ok1MPT ..		Czechoslovakia
26.7	S.Y. Elettra IBXX ..			58.3	Bandoeng PMY ..		Java
27.3	Wellington ..		New Zealand	60	Prangins (Radio Nations) ..		Switzerland
28.2	Bandoeng PLR ..		Java	60.3	Rugby GBC G6RX ..		Great Britain
28.98	Buenos Aires LSX ..		Argentina	62.5	Deal Beach WOO ..		United States
29	DEQ Nauen ..		Germany	62.5	Long Island W2XV ..		United States
29.04	Ruysselede ..		Belgium	65	Budapest ..		Hungary
29.5	Bangkok HS2PJ ..		Siam	67.65	Doerberitz DFK ..		Germany
30	Belgrade ..		Yugoslavia	70.2	Khabarovsk RV15 ..		U.S.S.R.
30.33	Monte Grande LSN ..		Argentina	82	Paris F8US ..		France
30.426	Madrid EAQ ..		Spain	84	Paris FPC ..		France
30.57	Buenos Aires LSOR ..		Argentina	84	Zurich HBOC ..		Switzerland
30.64	Rugby GBW ..		Great Britain	88.3	Rugby G6RX ..		Great Britain
30.7	EAM Madrid ..		Spain	92.3	Doerberitz ..		Germany
30.77	Ocean Township WNC ..		United States	198.5	Riga ..		Latvia
30.93	Buenos Aires LQA ..		Argentina	208.3	Antwerp ..		Belgium
31.1	Maracay YVQ ..		Venezuela	210	Budapest ..		Hungary
31.28	Hil'ersum P.C.J ..		Holland	210.1	Liège ..		Belgium
31.28	Sydney VK2ME ..		New South Wales	214.2	Warsaw (No. 2) ..		Poland
31.28	Melbourne VK3ME ..		Victoria	215.3	Chatelneau ..		Belgium
31.3	Philadelphia W3XAU ..		United States	215.3	Brussels (Conférence) ..		Belgium
31.35	Springfield W1XAZ ..		United States	217	Königsberg ..		Germany
31.35	Poznan SR1 ..		Poland	218.5	Flensburg ..		Germany
31.38	Zeesen DJA ..		Germany	218.7	Salzburg ..		Austria
31.38	Schenectady W2XAF ..		United States	219.9	Cassel ..		Germany
31.51	Skamlebaek OXY ..		Denmark	219.9	Beziere ..		France
31.55	Melbourne VK3ME ..		Victoria	220	Binche ..		Belgium
31.75	Rio de Janeiro ..		Brazil	222	Fécamp ..		France
31.86	Bandoeng ..		Java	224.4	Cork ..		Irish Free State
32	Dakar ..		French West Africa	227.4	Cologne ..		Germany
32.26	Rabat ..		Morocco	232	Malmö ..		Sweden
33.61	Elizabethville OQH ..		Congo	232.2	Kiel ..		Germany
34.5	KUW Manila ..		Phil. Islands	234.9	Lodz ..		Poland
34.5	Bogota HKF ..		Colombia	235.5	Kristianssand ..		Norway
34.68	Long Island W2XV ..		United States	236.7	Bordeaux-Sud-Ouest ..		France
35	Dakar ..		French W. Africa	239.4	Nürnberg ..		Germany
35	Prangins (Radio Nations) ..		Switzerland	240.5	Stavanger ..		Norway
36.92	Bandoeng PLW ..		Java	242	Belfast ..		Ireland
38.07	Tokio J1AA ..		Japan	244.1	Basle ..		Switzerland
38.3	Taschkend ..		U.S.S.R.	245.9	Linz ..		Austria
39.4	Nuevo Laredo X26A ..		Mexico	246	Berne ..		Switzerland
39.7	Bogota HKF ..		Colombia	247.7	Trieste ..		Italy
				249.6	Prague (No. 2) ..		Czechoslovakia

(continued on page 492)

# LEADS TO BETTER RADIO

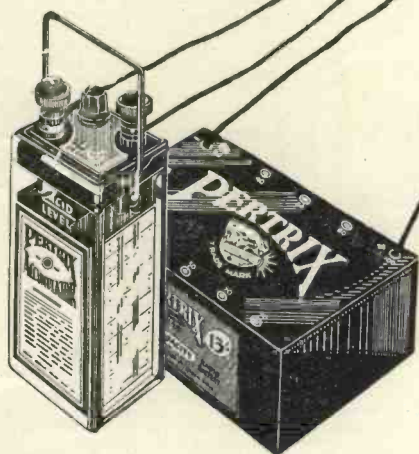
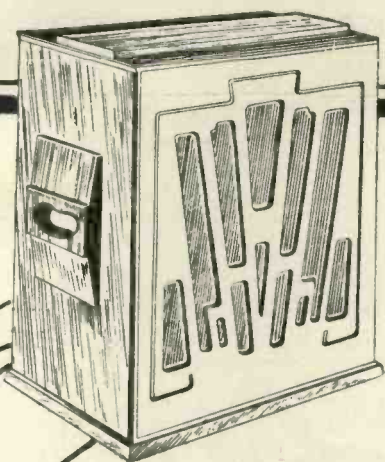

**PERTRIX DRY  
BATTERIES AND  
ACCUMULATORS**  
will definitely improve  
your set

Stations that were "misty" before will become "crystal clear"—And that's not all—Because of its NON-SALAMMONIAC construction, the Pertrix Dry Battery has a definitely longer life. Spread your Radio costs over a longer period—Buy

PERTRIX H.T.  
BATTERIES:  
60 volt, 5/6. 100 volt, 9/-.  
120 volt, 11/-.  
PERTRIX  
STANDARD CAPACITY  
H.T. BATTERIES:  
60 volt, 8/-. 100 volt, 13/-.  
120 volt, 15/6.  
PERTRIX WIRELESS  
ACCUMULATORS  
from 4/6.

# PERTRIX

TRADE MARK

## DRY BATTERIES AND ACCUMULATORS

WORLD'S BROADCAST STATIONS

—Continued from page 490

Wave-length	Name of Station	Dial Readings	Country	Wave-length	Name of Station	Dial Readings	Country
250.3	Juan-les-Pins		France	380.7	Lvov		Poland
251	Barcelona EAJ15		Spain	384.4	Radio Toulouse		France
252.9	Gleiwitz		Germany	389.6	Frankfurt		Germany
255.1	Toulouse PTT		France	394	Archangelet		U.S.S.R.
257	Hörby		Sweden	398.9	Bucharest		Roumania
259.3	Leipzig		Germany	403	Midland Regional		Great Britain
261.6	London National		Great Britain	409.8	Sottens		Switzerland
263.8	Moravska Ostrava		Czechoslovakia	411	Katowice		Poland
265.4	Lille		France	413	Pokrowsk-Volgo		U.S.S.R.
266.5	Valencia		Spain	416	Dublin		Irish Free State
269	Liege (Coinite)		Belgium	419.5	Radio Maroc		North Africa
269.8	Bremen		Germany	427.4	Berlin		Germany
272	Rennes		France	424.3	Madrid EAJ7		Spain
273.6	Turin		Italy	430	Moscow (Stalin)		U.S.S.R.
276.5	Heilsberg		Germany	433.4	Belgrade		Yugoslavia
279.3	Bratislava		Czechoslovakia	441	Stockholm		Sweden
281.2	Copenhagen		Denmark	443.8	Rome		Italy
282.5	Lisbon CT1AA		Portugal	450	Tartu		Estonia
283	Berlin		Germany	453.2	Paris PTT		France
283.6	Magdeburg		Germany	456.6	Danzig		Danzig
285	Stettin		Germany	459	Klagenfurt		Austria
285.2	Brussels SBR		Belgium	466	Porsgrund		Norway
285	Montpellier		France	472.4	San Sebastian		Spain
285.2	Innsbruck		Austria	472.4	Beromuenster		Switzerland
	Aberdeen		Great Britain	480	Lyons PTT		France
	Bournemouth		Great Britain	488.6	Langenberg		Germany
	Dundee		Great Britain	496	North Regional		Great Britain
288.5	Edinburgh		Great Britain	500.8	Prague (Leibnitz)		Czechoslovakia
	Newcastle		Great Britain	509.3	Trondheim		Norway
	Plymouth		Great Britain	517	Florence		Italy
	Swansea		Great Britain	525	Brussels No. 1		Belgium
291	Vuipuri		Finland	526.1	Vienna		Austria
293	Kosice		France	532.9	Riga		Latvia
293.7	Limoges PTT		Czechoslovakia	540	Palermo		Italy
296.1	Hilversum		Holland	541.5	Munich		Germany
298.5	Tallinn		Estonia	550	Tampere		Finland
301.5	North National		Great Britain	556	Sundsvall		Sweden
304.9	Bordeaux PTT		France	559.7	Budapest		Hungary
305.8	Falun		Sweden	563	Hanover		Germany
307	Zagreb		Yugoslavia	569.3	Kaiserslautern		Germany
308.4	Radio Vitus		France	574.7	Augsberg		Germany
309.9	Cardiff		Great Britain	720	Wilno		Poland
312.2	Genoa		Italy	777.5	Freiburg		Germany
312.8	Cracow		Poland	937.5	Ljubljana		Yugoslavia
315	Marseilles		France	1,000	Moscow PTT		U.S.S.R.
	Naples		Italy	1,071.2	Ostersund		Sweden
318.8	Sofia		Bulgaria	1,071.4	Kharkov		U.S.S.R.
	Dresden		Germany	1,083	Leningrad		U.S.S.R.
321.9	Goteborg		Sweden	1,103	Scheveningen-Haven		U.S.S.R.
325	Breslau		Germany	1,153	Oslo		Holland
327.5	Grenoble		France	1,200	Moscow (Popoff)		Norway
328.9	Poste Parisien		France	1,204.8	Kalundborg		U.S.S.R.
331.5	Milan		Italy	1,237	Reykjavik		Denmark
334.4	Poznan		Poland	1,241.6	Istanbul		Iceland
337.8	Brussels No. 2		Belgium	1,250	Vienna (Testing)		Turkey
341.7	Brno		Czechoslovakia	1,348.3	Boden		Austria
345.2	Strasbourg		France	1,380	Luxemburg		Sweden
348.9	Barcelona EAJ1		Spain	1,411.8	Moscow (Trades Union)		Luxemburg
351	Leningrad		U.S.S.R.	1,445.7	Motala		U.S.S.R.
352.1	Graz		Austria	1,481	Novosibirsk		Sweden
355.9	London Regional		Great Britain	1,538	Warsaw		U.S.S.R.
358	Moscow		U.S.S.R.	1,554.4	Paris (Eiffel Tower)		Poland
360.6	Mühlacker		Germany	1,600	Moscow (Komintern)		France
363.4	Algiers		North Africa	1,634.9	Ankara		U.S.S.R.
364	Bergen		Norway	1,725	Daventry National		Turkey
367.6	Frederikstaad		Norway	1,796	Irkutsk		Great Britain
	Helsinki		Finland	1,875	Königswusterhausen		U.S.S.R.
368.1	Seville		Spain	1,935	Radio Paris		Germany
	Bolzano		Italy	2,525	Lahti		France
	Kharkov		U.S.S.R.	2,900	Huizen		Finland
369.4	Radio LL, Paris		France		Kaupas		Holland
372	Hamburg		Germany		Königswusterhausen		Lithuania
376.4	Glasgow		Great Britain		Königswusterhausen		Germany
378	Moscow Regional		U.S.S.R.		Königswusterhausen		Germany

# For A.C. Sets on D.C. Mains use

Latest type M-L Rotary Transformer complete with anti-interference unit and sound-proof cover



D.C. to A.C. Types for operating A.C. Receivers and Radio-Gramophones from D.C. supplies. Electrically and mechanically silent in operation. Can be supplied complete with an anti-interference unit and sound-proof cover (as illustrated).

Input: 12 to 220 volts D.C. Output: Up to 200 watts at 230 volts 50 cycles. Also D.C. to D.C. Types for supplying H.T. Current to large Public Address Amplifiers, etc. Input: 12 to 220 volts D.C. Output: 300 volts to 1,000 volts, etc.

Models for Every Requirement!

## ROTARY TRANSFORMERS

Recommended and used by MARCONIPHONE, McMICHAEL, PHILIPS, PYE, FERRANTI, ETC.  
Get full details, post free, from ROTAX LTD., RADIO DEPT., 7 WILLESDEN, LONDON, N.W.10

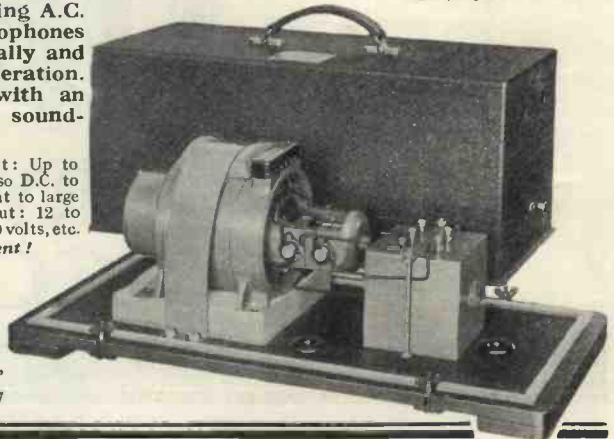

AN UP-TO-DATE COIL WITH UP-TO-DATE

FEATURES

TYPE TD

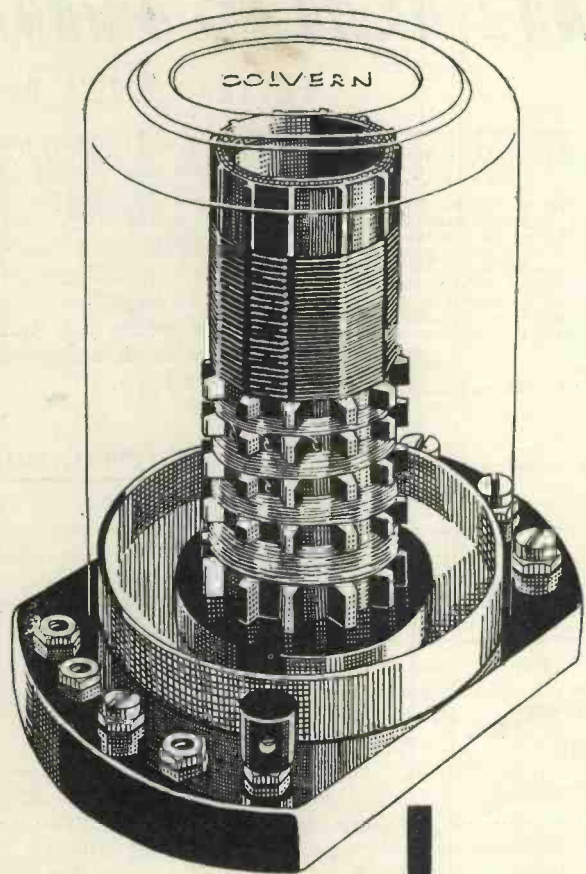

Type TD, an entirely new Colvern Coil, is designed to give super-selectivity on both long and broadcast wave bands. The coil is completely screened giving a very neat appearance and incorporates tapped aerial coupling and reaction, while the four alternative aerial tapplings are arranged as sockets with a wander plug.

The first two tapplings give a high degree of selectivity with weak aerial coupling on the medium wave band—suitable for use in a "swamp" area.

Numbers 3 and 4 give aerial couplings similar to those normally employed, but with greatly increased selectivity.

A most important feature of this coil is that there is no break through on the long wave band from B.B.C. stations.

Price—Type TD—8/6

# COLVERN

LIMITED, MAWNEYS ROAD, ROMFORD, ESSEX

*When you send your order don't forget to say you "saw it in the 'W.M.'"*

# In Tune with the Trade

FETTER LANE'S Review of Catalogues

## SEND TO US FOR THESE CATALOGUES!

Here we review the newest booklets and folders issued by seven manufacturers. If you want copies of any or all of them just cut out this coupon and send it to us. We will see that you get all the literature you desire.

Just indicate the numbers (seen at the end of each paragraph) of the catalogues you want below.

My name and address are:—

Send this coupon in an unsealed envelope, bearing 1/2 d. stamp, to "Catalogue Service," WIRELESS MAGAZINE, 58/61 Fetter Lane, E.C.4. Valid till June 30

## MAINS-OPERATED RAYCRAFT

**N**O doubt you have previously been introduced to the Raycraft method of light control, a handy outfit by which one can fit up burglar alarms, automatically controlled light switches, and so on.

The principle, of course, is that a beam of light, focused on a selenium cell, is interrupted in some fashion and the corresponding electrical action, through a relay, is made to do almost any job you want.

The first Raycraft kit was battery operated, but now I have received details of A.C. and D.C. mains-operated outfits. A line through my catalogue service will secure you a copy of the latest folder. **261**

## BRITISH-MADE TEKADE

### LOUD-SPEAKERS

**W**HY not a new balanced-armature loud-speaker unit? I have just been looking through some literature sent me by the Tekade people and in particular dealing with the new S40 balanced-armature unit.

The makers say that they have a novel method of damping the natural resonances, so that there is a richness of bass, comparable with moving-coil quality, combined with a good high-note response. You can have this unit alone or in several types of attractive walnut cabinet.

Tappings are provided to match up the loud-speaker with any ordinary output stage and there is a very fine control of the armature gap. I certainly think you should investigate the technical merits of this kind of loud-speaker, as the cost is low and there are no maintenance expenses as with an energised type of moving coil. **262**

## CUTTING OUT THE NOISE

**W**HEN you choose a resistance for volume control, variable-mu valve regulation or tone control, you do not want the variation to be accompanied by the crackling noises caused by faulty contacts.

The new Watmel resistances are silent in action and for that reason I think it will be wise to write for a folder which describes the new wire-wound jobs for all radio purposes.

Four useful little circuits are given, showing how to connect up tone and volume controls, and there are full details of the resistance values and current-carrying capacities. There is a useful combined variable resistance and switch, too. **263**

## BURNDEPT DIALS

**I**F you have followed these notes carefully you will know how keen I am on a set with truly useful controls. I take particular interest, therefore, in the particulars of Burndept slow-motion dials sent me by Henry E. Taylor, Ltd.

Burndept apparatus is extremely well made, as you may know, and these control dials are no exception. The gearing reduction is 18 to 1, which is fine enough for all practical purposes. A special detachable scale is available, in a nickelled brass sector, and this carries a card on which station names and wavelength readings may be logged.

A free booklet is obtainable through my catalogue service from Henry E. Taylor, Ltd., describing this and other Burndept products. **264**

## A RAPID VALVE GUIDE

**H**ERE is a thing for every man who has a valve set! It is the Mullard Valve Guide, a most convenient pocket-sized 84-page booklet, which can be obtained free through my catalogue service. It gives a really complete list of all Mullard receiving valves, curves, working details, and so on.

Another section of the book is devoted to circuits and advice on such matters as automatic grid bias, low-frequency amplifier details, and hints and tips on getting better quality by cutting out spurious high-frequency oscillation.

This is a fine little book for the practical man and deserves to be in the possession of every knowledgeable amateur. **265**

## NOVEL TURNTABLE DRIVE

**I**HAD the pleasure of seeing an advance model of Simpson's electric turntable before it was ready for production, and now I hear that the new London factory is in full swing. This turntable drive is of the synchronous type and runs exactly at 78 revolutions a minute.

The A.C. model is now in production and D.C. and accumulator-driven models will soon be available. The current consumption is in the nature of 40 milliamperes. If you want to learn more about the technical details of this new outfit, then drop a line through my free catalogue service. **266**

## NEAT SET CABINETS

**I**KNOW I shall not have to say much in introducing to you the new Camco booklet of set cabinets. This well-illustrated 24-page production is sure to appeal to every set user and I have no hesitation in inviting you to get a copy.

The times come when we are all of us dissatisfied with the appearance of a set and the Camco booklet shows several easy (and economical) solutions. **267**



# Multi-point Filament Suspension Mica Bridge Mounting

—the two vital constructional features that make  
COSSOR Valves—

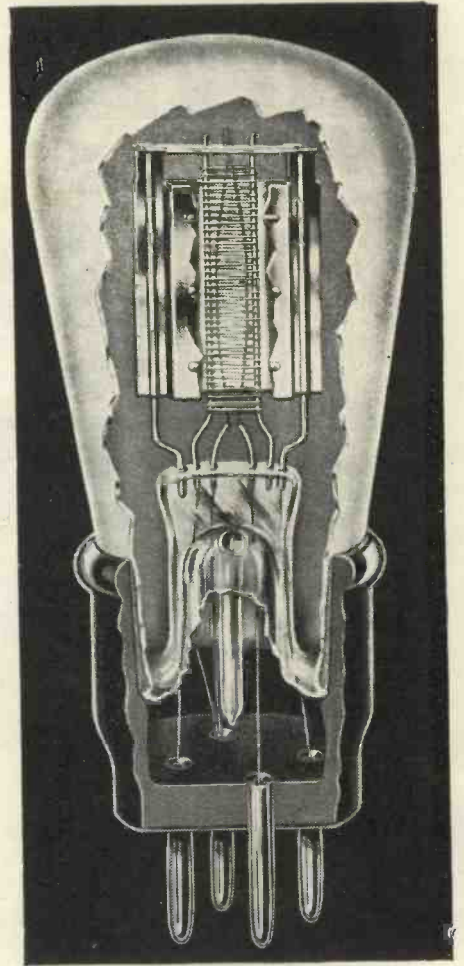

# NON- MICROPHONIC

## COSSOR VALVES FOR "W.M." SETS

- May "A-P-A Radio Unit" \*MVSG, 41 MHL.
- May "Home Garden Four" \*220 VSG, 210 HL, 210 LF, 220 P.
- May "EASYTUNE 60" \*220 SG, 210 LF, 220 SG, 210 HL, 220 P.
- June "Multi-Mag." 210 RC, 210 DET, 220 P.

\* Metallised.

A copy of the 72 page Cossor Wireless Book B11 will be sent you free on application to A. C. Cossor Ltd., Melody Dept., Highbury Grove, London, N.5.

Get one of the new Cossor Station Charts price 2d. Ask your dealer for a copy of this useful novelty or write to us enclosing 2d. stamp.

**M**ICROPHONIC noises are definitely prevented in every Cossor Valve. Firstly by Cossor multi-point suspension—a system of construction which provides as many as four extra filament supports thereby eliminating all tendency to filament vibration.

Secondly by Mica Bridge Mounting, the Cossor

constructional system under which all the elements are rigidly braced together in permanent alignment preventing individual movement, and vibration of the elements. Thus, no part of the valve structure vibrates. And since vibration is the cause of microphonic noises it follows that Cossor Valves are proof against this trouble.

# COSSOR ALL-BRITISH VALVES

A. C. Cossor Ltd., Highbury Grove, London, N.5. Depots at Birmingham, Bristol, Glasgow, Leeds, Liverpool, Manchester, Newcastle, Sheffield and Dublin 63 ♡ 324

Please mention "Wireless Magazine" when corresponding with advertisers

# IMPRESSIVE Performance . . .

AT AN IMPRESSIVE PRICE

BRITISH  
MADE

INCLUDING TRANSFORMER

**45/-**  
AND Baffle Board

Overall Diameter, 9 3/8 in.  
Overall Depth, 4 1/2 in.  
Cone Diameter, 7 in.

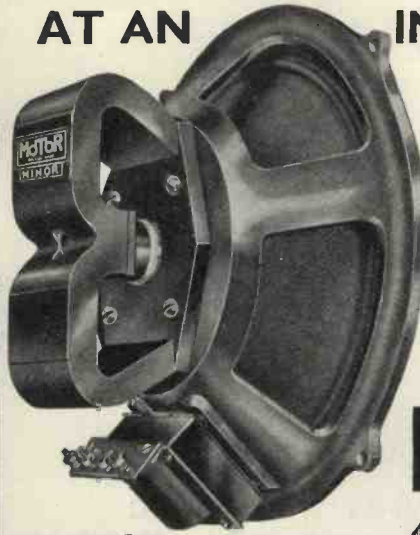

The MoToR "Minor" is not, in spite of its price, a "cheap" moving coil loud-speaker. It has a superior magnet of finest cobalt steel; a large rear suspension providing unusual flexibility; a heavy cast aluminium chassis, non-metallic spider, and every high-grade feature of construction and design for which all MoToR speakers are acknowledged.

Impressive in tone, quality and sensitivity, it gives excellent results on even a two or three-valve battery operated set using ordinary output valves.

**MOTOR  
MINOR**

**PERMANENT MAGNET  
MOVING COIL**

Fully descriptive pamphlet on application.

**The CHESTER**  
This strikingly handsome figured walnut cabinet version of the MoToR Minor Moving Coil measures 16 in. by 15 1/2 in. by 8 in., and has no equal at anywhere near its common sense price of **75/-**

D.C. Resistance: 10 ohms.  
Impedance of Speech-coil: 5 ohms.  
Approx. Coil Gap: 1 mm.  
Transformer Tappings: 25:1, 20:1, 15:1.

TEKADE RADIO & ELECTRIC, LTD., 147 Farringdon Rd., London, E.C.1

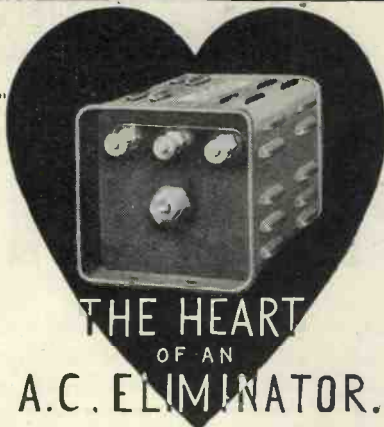
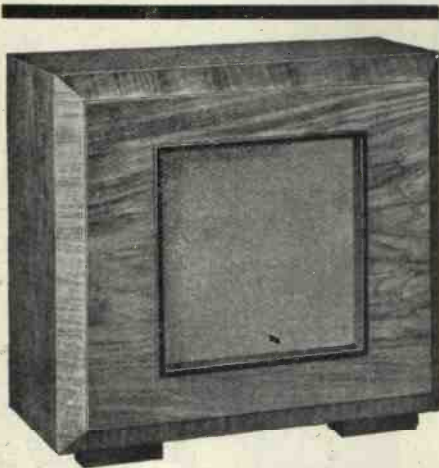

The vital component in an A.C. eliminator is . . . the rectifier. So much depends on its proper functioning. Will its output be maintained? . . . Can it break, burn or wear out? . . . What is its efficiency? . . . questions every purchaser of an A.C. eliminator should ask of the rectifier incorporated therein. Long life, high efficiency and freedom from deterioration or breakdown form a combination only possessed by

THE  
**WESTINGHOUSE**

**METAL RECTIFIER**

See that it is incorporated in the A.C. eliminator YOU buy; or, if you prefer to build your own, send for details of our constructors' range. A 3d. stamp will bring you a copy of "The All Metal Way." Please mark your envelope Dept. "W.M." The WESTINGHOUSE BRAKE & SAXBY SIGNAL CO., LTD., 82, York Rd., King's Cross, London, N.1.

## PEAK CONDENSERS

SPECIFIED FOR "ECONOMY A.C. TWO"

(See page 549)

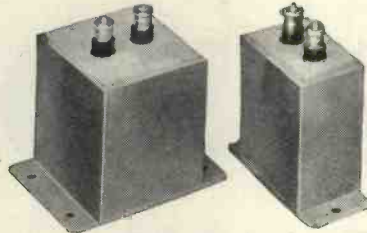

1,500 Volts D.C. Test.  
• 1 mfd. - - 1/10  
• 1 mfd. - - 2/8  
• 2 mfd. - - 3/9  
• 4 mfd. - - 6/9

1,000 Volts A.C. Test.  
1+.1 2/6  
1, 2 and 4 mfd. supplied with Terminals at same prices.



PRICE  
**20/6**

## BRYCE MAINS TRANSFORMERS

RECOMMENDED FOR THE  
"ECONOMY A.C. TWO"

(See page 549).

TYPE :-SUPER 31  
Primary tapped for 200 volts to 240 volts supply at 40 to 60 cycles. Secondary windings centre tapped. Gives 30 milliamperes output at 250 volts, 3 ampere at 4 volts and 1 ampere at 4 volts. Generous size iron core. Aluminium end plates. Screened primary.

**WILBURN & CO.,** 23, BRIDE LANE, LONDON, E.C.4. Cent. 6994.  
**W. ANDREW BRYCE & CO.,** 54 Dawson St. BURY, Lancs. Bury 1251

Speedy replies result from mentioning "Wireless Magazine"

# CLIX

Specified by PERCY HARRIS for the "TOWN & COUNTRY FOUR"

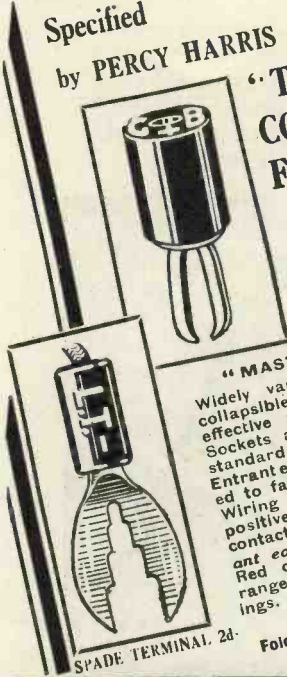

**"MASTER" PLUG**  
Widely variable and non-collapsible prongs. Equally effective with Continental sockets and the smallest standard battery inserts. Entrant end especially curved to facilitate insertion. Wiring device provides positive metal-to-metal contact—a most important feature.  
Red or black.  
Price 11d. Full 12d.

## Cheapest PERFECT Contact

Lectro Linx, Ltd., 254 Vauxhall Bridge Road, S.W.1

# YOUR SET DESERVES

## THE BEST SPEAKER YOU CAN BUY

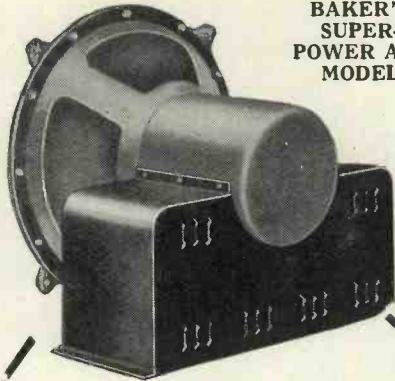

BAKER'S SUPER-POWER A.C. MODEL

A really good Amplifier needs "THE BEST SPEAKER YOU CAN BUY." You cannot do better than choose a BAKER'S SUPER POWER MOVING-COIL SPEAKER for use with the TURNER A-P-A RADIO UNIT AND AMPLIFIER—Discriminating music lovers have become daily more critical in their demand for GENUINE TONE QUALITY. That is why true music-lovers choose a Baker Speaker for unflinching performance every time.

## THE SPEAKER WITH EAR APPEAL

Write at once for our NEW FREE LITERATURE

# BAKER'S 'Selhurst' RADIO

Offices:  
89 SELHURST RD., S. NORWOOD, S.E.25  
Works and Demonstration Rooms:  
42 CHERRY ORCHARD RD., E. CROYDON  
Phone: Croydon 1618

# Now EVERYONE can afford SUPER RADIO!

The NEW Range of TUNEWELL COMPONENTS is Ready!

8 FREE CIRCUITS

The NEW TUNEWELL Components set a standard of quality hitherto approached only by the highest priced products. Unless huge sales result, TUNEWELL prices must advance, but already the demand has made us confident of the success of our effort to bring Super Radio within everybody's reach.

The NEW TUNEWELL Components include Coils, Chokes, Transformers, Resistances, Volume Controls, Mains Components and Eliminators, etc. Whatever the Set, there are TUNEWELL Components to improve performance. Insist on them always.

Should you have any difficulty in obtaining, please write us, giving your nearest dealer's name and address. In any case send the coupon for the new TUNEWELL "Guide to Super Radio," an interesting folder which you will keep for reference. 8 circuits FREE, including Band Pass All Mains 3 and Kit Eliminator.

Tunewell Radio Ltd., 54 Station Rd., New Southgate, London, N.11



# TUNEWELL

Post this Now!

Post in unsealed envelope, halfpenny stamped, To TUNEWELL RADIO, LTD. 54 Station Road, New Southgate, London, N.11 Send new "Guide to Super-Radio" to:

Name .....

Address .....

My nearest dealer is .....

W.M.1

### HINTS TO BETTER RECEPTION. 4.

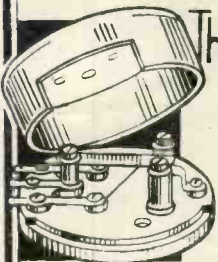

## The SWITCH WITH A "BRAIN"

When switching on an all-mains set by the ordinary method the delay in "warming up" the valves gives rise to alarming peak voltages in the H.T. circuit, and attendant risk of breakdown and damage. The Bulgin Thermal Delay switches the H.T. only when the valve Cathodes have attained working temperature. Endorsed by leading authorities.

Send for 75-page Catalogue and Manual, giving full details.

Type A 4-volt heater

Type B 7.5-volt heater

S 100

S 101

**BULGIN**

The Choice of Critics

76

76

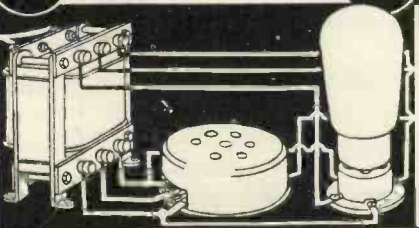

Advert. of A. F. BULGIN & Co., Ltd. Abbey Road, Barking, Essex

# Sir HENRY J. WOOD says

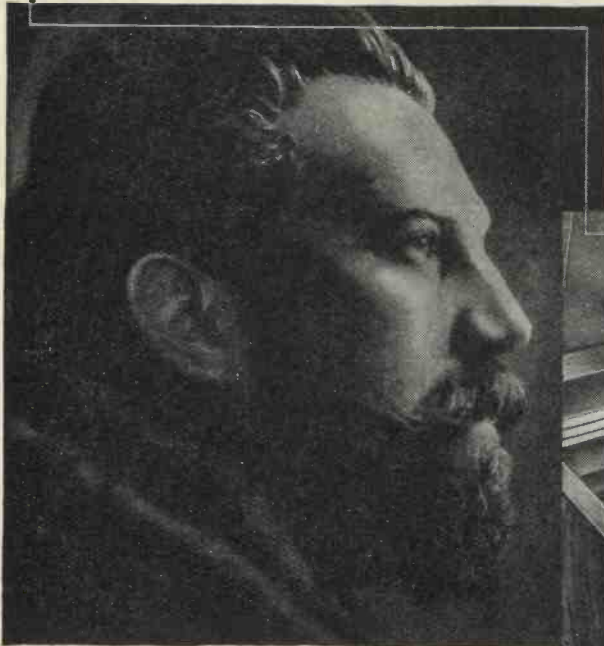

"Your latest Radio-Graphophone is a splendid instrument. Its standard represents the highest achievement in musical performance to-day, and I should like to see one IN EVERY HOME. Indeed, this is not an unreasonable wish, judging by its very modest price."



**"In every home"  
—made possible by the**

# Columbia RADIO-GRAPHOPHONE



The opinion of Sir Henry J. Wood is significant; this instrument indeed "represents the highest achievement in musical performance to-day." This is the greatest tribute yet paid to any radio-gramophone.

Never before has such a wealth of home entertainment been offered at such a low price. This instrument provides the pick of European music—some 40 radio programmes, powerful and distinct, from a set which incorporates two screen grid valves and band-pass tuning. And then—your own programme on the electric gramophone, chosen when you wish, music of superb fidelity, and tonal purity . . . "the highest achievement in musical performance to-day."

For 40 gns. (Model 603) you may obtain the outstanding radio-gramophone of the year possessed of remarkable power and selectivity. For only 7 gns. extra it may be had with the last word in convenience, an automatic record changer (Model 604).

**Model 602**  
**£2. 14s.**  
**monthly**  
deposit £3.9.6 and  
12 payments of £2.14s.  
**32 gns.**  
**cash**

**FREE CATALOGUE OR HOME TRIAL.**

(a)★ I should like to hear Model ..... playing in my home without cost or obligation to myself.

(b)★ I should like a Catalogue of Columbia Radio-Graphophones and/or Columbia Radios.

★ Cross out if not required.

NAME.....

ADDRESS.....

Cut this out and post it in an unsealed envelope bearing ½d. stamp to Columbia, 104C, Clerkenwell Road, London, E.C.1.

Better service results from mentioning "Wireless Magazine" when writing to advertisers

# RADIO MEDLEY

A Radio Fan's Causerie Conducted by  
BM/PRESS

## Money Going Abroad

IN some quarters, I learn, there is talk of pressure being brought to bear once again on Sir John Reith in the matter of broadcasting advertising programmes from the stations controlled by the British Broadcasting Corporation.

The latest argument in favour of sponsored programmes is that of keeping money in the country instead of letting it go abroad. Quite a large sum must now be spent every week by the British firms that sponsor broadcasts from various Continental stations. It is argued that the money thus spent should be kept in the British Isles by making the same broadcasting facilities available over here.

I cannot help feeling that most listeners are more interested in the actual programmes they are going to get than whether money is going abroad or not. Still, there is more in this argument than in some others I have heard in favour of the sponsored broadcast.

## Revolutionary Valves

A development of some importance—in fact, probably of revolutionary importance—is the manufacture of indirectly-heated valves that will work with the full voltage of the mains on the heaters. That is to say, the heater is supplied directly from the house power supply like an electric lamp; there is no need for a step-down transformer in the case of A.C. mains and no breakdown

DANCE TIME IS  
RADIO TIME!



Good use being  
made of a Pye  
portable receiver

resistances are needed for D.C. mains working.

These new types are known as Ostar valves and they are at present made in Vienna by Gustav Ganz and Co. I understand that arrangements are being made to go into production over here. Further details can be obtained from Eugen Forbat, of Greenhill Road, Farnham, Surrey, who is the British agent.

At present four types are listed and following are their characteristics in brief. The maximum anode voltage is 220 volts in each case:

Type A520: Impedance, 8,800 ohms; mutual conductance, 2.5; amplification factor, 22.

Type W310: Impedance, 31,000 ohms; mutual conductance, 1.0; amplification factor, 32.

Type U920: Impedance, 3,700 ohms; mutual conductance, 3.0; amplification factor, 11.

Type L1525: Impedance, 1,850 ohms; mutual conductance, 3.0; amplification factor, 6.5.

## Special Advantages

Each type of valve is available in three heater-voltage ranges; the low current consumption will be appreciated from the following figures:

Heater Voltage, (a) 110-120; (b) 150-160; (c) 220-230.

Money Going Abroad : : Revolutionary Valves : : At Hollinwood : :

Electric Clocks : : Sunday Developments : : A.C. from D.C. Mains : :

Another Radio Handbook : : Capt. West's Lectures

## RADIO MEDLEY—Continued

Heater Current in milliamperes, (a) .05; (b) .030; (c) .030.

If they come up to expectations and the claims that are made for them these valves will revolutionise the construction of mains sets. In an A.C. set there will be no need for a filament transformer; nor will there be need for a high-tension transformer—a high-voltage rectifier is

valve mains super-het that was announced a few weeks ago. I saw some of the first models of this being made; it will certainly be good value for the money. This receiver is still rather "hush hush" so I cannot say more than that it has one-knob tuning.

Ferranti's are now making every part for their own sets. There are some amazing coil-winding machines at Hollinwood, one being capable of winding the bobbins of nine transformers at one time. The paper interleaving between the layers of wire is put in automatically at the right time. Indeed, this machine seemed to be almost human.

### Electric Clocks

I knew nothing about electric clocks until my interest was aroused by J. H. Reyner's article in a recent issue of "Wireless Magazine." I was therefore all the more intrigued to see them actually made at Hollinwood. These clocks are being turned out by the hundred every day—it is the fashion to have one if your A.C. mains are synchronised.

If you are in any doubt about the reliability of electric clocks I may reassure you by saying that P. K. Turner has had one in use for more

than three years. It has never stopped—except when the mains have been accidentally switched off. That, you will admit, is pretty good going.

### Sunday Developments

A friend of mine has some caustic comments to make when he heard of the B.B.C.'s decision to start the Sunday broadcasts at 12.30 p.m. and carry on all the afternoon.

"Most people will be fed up about that, I should think," was his observation, "it will spoil their reception of good programmes from abroad—especially for those whose sets are not particularly selective."

I fear that the B.B.C.'s gesture will not meet with the approval some people expect it to arouse. Unquestionably very great interest is taken in the broadcasts of gramophone records from Continental stations on Sundays and anything that makes the reception of them more difficult for those with simple sets will not meet with universal approbation.

Sunday has always been "foreign-reception day" for thousands of listeners and they will not want to have to forego the pleasure of Continental programmes.

### A.C. from D.C. Mains

Last month I mentioned the value of a rotary converter to those who want to work an A.C. set from D.C. mains. I have now had an opportu-



YOUNG RADIO IN RUSSIA

This special photograph shows the radio experimenting corner in the Central Home of Juvenile Pioneers in Moscow. Great radio activity is taking place all over Russia

in course of manufacture and this will be run direct from the mains.

The construction of D.C. sets will also be greatly simplified for there will be no need to use expensive resistances to break down the voltage to a low value for application to the filament. Moreover, there will be no waste of current.

We shall certainly hear more about this development.

### At Hollinwood

Hollinwood must be associated in the minds of most amateurs with the cipher "AF3," for it is where the famous Ferranti works are located. Recently I had the privilege of going over this vast factory, where five thousand people are employed.

The activities of the radio department just now are concentrated on the production of the new seven-



PRECISION TESTING TO ENSURE ACCURATE GANGING  
Testing and adjusting band-pass and super-het condensers in the Ferranti works at Hollinwood. Great accuracy is needed for efficient one-knob tuning

# A CAUSERIE CONDUCTED BY BM/PRESS

tunity of trying out the M-L model I described last month. It gives an output of 230 volts (50 cycles), but the input wattage is no more than the output wattage.

With its special soundproof cover and Sorbo rubber mounting inside, the converter is mechanically no noisier than an electric fan. There is the faintest purr, which would be almost unnoticeable if the converter were placed in a corner of the room out of the way.

## A.C. Super-het

I first tried it on an experimental four-valve A.C. super-het and the hum was less than the set gave when used off a standard A.C. supply. Indeed, I was astonished at the mechanical and electrical quietness of the whole apparatus.

There is no question that such a converter would be a boon to listeners with D.C. mains who want to use a good A.C. set, such as P. K. Turner's A-P-A Radio Gramophone, for instance.

There is no difficulty about the installation of the M-L converter, or rotary transformer as it is more correctly called. A special switch box is provided and this must be wired up to the transformer; once this has been done there are only two pairs of leads to handle—one pair for the D.C. input and the other pair for the A.C. output.

To operate the machine the D.C. is switched on and then the arm of the special switch is moved over. This starts up the transformer and the arm of the switch is held in position magnetically until the D.C. mains supply is switched off. A child could work the gear after having been shown how to do it once.

I do not know what is the life of one of these rotary converters, but it must be a term of some years. I can certainly recommend the M-L machine as a first-class proposition—even without an earth the hum is no more than experienced with most mains sets, and it is not nearly so



**A SUGGESTION FOR GRAMO-RADIO ENTHUSIASTS**  
Patients at King's College Hospital (London) exercising stiff joints to the tunes from a gramophone. Here is an idea for grammo-radio fans!

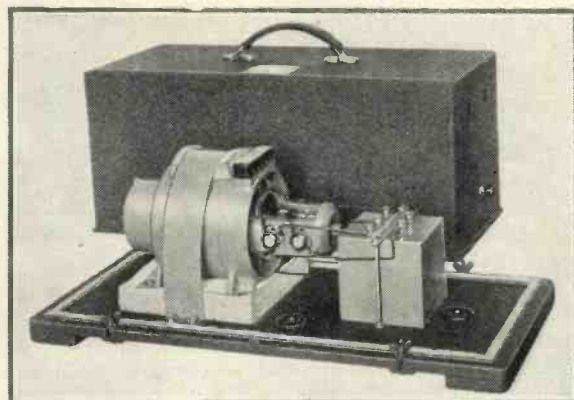

**GIVES A.C. FROM D.C. MAINS**  
This M-L rotary transformer converts current from D.C. mains into A.C. It has an output of 200 watts (230 volts at 50 cycles)

noticeable as from some house supply mains with which I have had to contend with.

## Another Radio Handbook

I was interested to receive from the American Radio Relay League, which will be known to many short-wave enthusiasts for its organising work among amateur transmitters, a copy of "The Radio Amateur's Handbook."

There are thirteen chapters and I think most readers will be more interested than bored if I give the titles of them, so here goes:

(1) Amateur Radio; (2) Getting Started; (3) Fundamentals; (4) How Radio Signals Are Sent and Received; (5) Receivers; (6) Frequency

Meters and Monitors; (7) Transmitters; (8) Radiotelephony; (9) Power Supply; (10) Keying and Interference Elimination; (11) Antennas; (12) The A.R.R.L. Communications Department; and (13) Operating a Station.

Of course, this book deals with American practice, but still I think it will be useful to many. Copies can be obtained for 6s. each, post free, from the Radio Society of Great Britain, 53 Victoria Street, London, S.W.1.

## Capt. West's Lectures

Another most interesting publication is a reprint of the Cantor lectures given before the Royal Society of Arts recently by Capt. A. G. D. West, M.A., B.Sc. The title is "The Recording and Reproducing of Sound," and the lectures deal very thoroughly with electrical gramophone recording and reproduction. This is a book that I can recommend to the more serious grammo-radio fan.

Capt. West will be remembered as a late B.B.C. engineer and at the time he gave the lectures he was with the Gramophone Company.

The price of the book is 3s. and applications for it should be addressed to the Royal Society of Arts, John Street, Adelphi, London, W.C.2

BM/PRESS

London, W.C.1.



# The MULTI-MAG THREE

This is a set that will be talked about. Although it employs only a detector and two low-frequency stages the sensitivity and selectivity are amazingly pronounced. The performance is as good as that of most receivers with a screen-grid valve

## SPECIALLY DESIGNED BY PAUL TYERS

ONE of the earliest types of set was the "detector and two low-frequency" combination; it is still popular because it is simple to handle, and it is economical.

I have recently seen several modern sets of this type, and it immediately occurred to me how tremendously the performance could

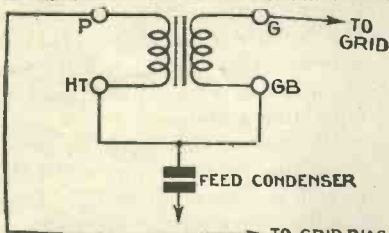

**TRANSFORMER CONNECTIONS**  
Schematic diagram of the auto-transformer arrangement used in the Multi-mag Three

be improved if the set were built on totally different lines. In these pages you see the results of my experiments.

The system which I have used is a highly retroactive low-loss tuned circuit, with very weak aerial coupling, giving a very low detector output. This is followed by a very high-gain auto-coupled amplifier, with a slightly corrected characteristic to compensate for high-note loss introduced by the input arrangement.

### Single Tuning Knob

The set has a single tuning knob, the anode current is well within the capabilities of a standard 120-volt battery, while the quality is as good as can be expected from an output valve of the type used.

The Multi-mag Three is, then, a set for the man of limited means, but at the same time it has a performance approaching that of a far

more elaborate and expensive set.

Before going any further, let me say what it will do. In my own laboratory (which is at Watford), I can regularly obtain at night some nine or ten stations on the long-wave band, all at loud-speaker strength. Zeesen can be received between Radio Paris and Daventry 5XX.

What can be obtained on the medium-wave band depends entirely upon the distance from the local stations, but even some ten miles from Brookman's Park several stations can usually be received between the two London transmissions.

Under average conditions, probably about two dozen stations can be received in all. This, I think it will be agreed, is a performance well above that of the ordinary set.

The principle employed is very simple. In the first place I use a reasonably efficient dual-wave coil and, at the same time, I employ very weak aerial-grid coupling.

Extremely critical reaction is used; so critical, in fact, that there is a certain amount of side-band cutting, particularly on the long waves. The weak aerial coupling and the efficient coil with a high degree of reaction account for the selectivity. The selectivity is also slightly increased by using a special type of anode-bend rectifier.

### High-gain Amplifier

As can be imagined, the detector output is very weak and, accordingly, a high-gain amplifier is employed. For this purpose I use two resistance-fed high-ratio auto-coupled transformers.

Since the transformers are resistance fed, a fairly good response is obtained, while the size of the coupling condensers is adjusted to give a certain amount of bass loss so as to even up the amplification, which is necessary owing to the side-band cutting.

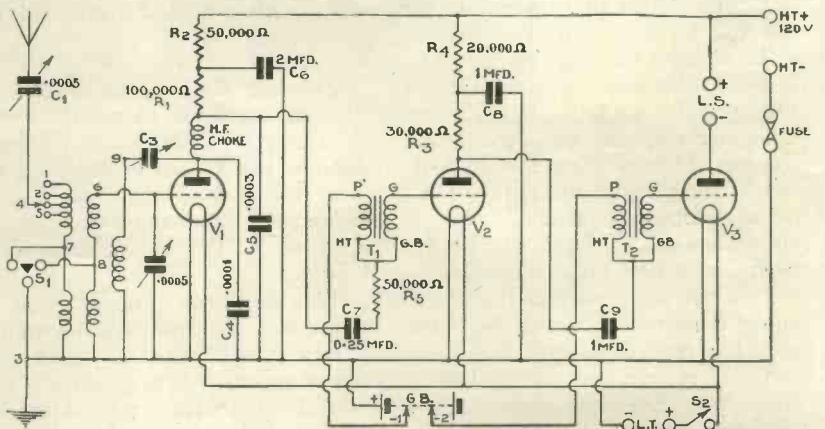

**CIRCUIT THAT GIVES AMAZING SENSITIVITY AND SELECTIVITY**  
Although the Multi-mag Three uses only a detector and two low-frequency stages, the results are comparable with those obtained from a screen-grid receiver



The whole set is very definitely a compromise which is entirely unorthodox, but it is designed to give a comparatively large number of stations with single-dial tuning, simple reaction, and low initial and running costs, consistent with reasonable quality.

The reaction arrangement is different from that of the usual type of set, since practically full reaction is employed all the time, even when listening to the local station. The aerial coupling is so weak that without reaction you will hardly hear your local station, even a few miles away.

### Smooth Reaction

The reaction is so smooth that there should be no possibility of the set falling into violent oscillation. Even if it does, it will hardly cause any interference for two reasons. In the first place, the aerial coupling is extremely weak, while a very high-impedance valve is used, operating at a low voltage and, accordingly, the amount of energy radiated, even when the set is oscillating vigorously, is extremely low.

The special coil which I have designed for this set has four aerial tappings, which means that the set can be used equally well on the coast or close to a high-power transmitter, it simply being necessary to place the wander plug in the socket which

at a low anode voltage without grid bias.

It so happens that this combination gives reasonable efficiency and fairly smooth reaction.

The anode circuit contains, in addition to the high-frequency choke and filter condensers, a 100,000-ohm coupling resistance, which feeds the first auto-coupled transformer. The

full reaction has to be employed.

Apart from increasing the selectivity, the quality is balanced only when very full reaction is used and, accordingly, strong stations must be reduced with the aid of a volume control.

For reasons of simplicity, I have used a .0005-microfarad variable condenser in the aerial lead. This is

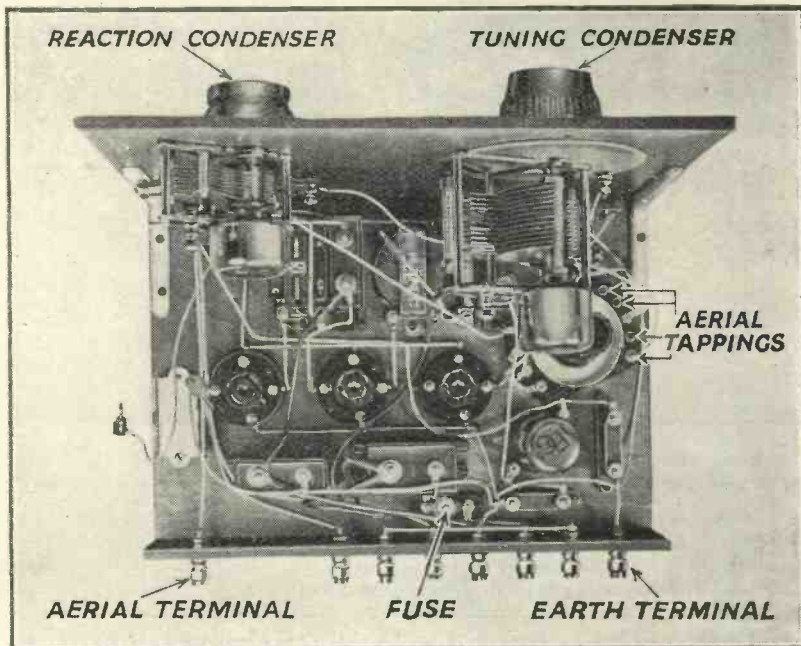

### CONSTRUCTION IS SIMPLE AND STRAIGHTFORWARD

This special plan view shows clearly the disposition of the parts in the Multi-mag Three, a set designed specially for "Wireless Magazine" by Paul D. Tyers

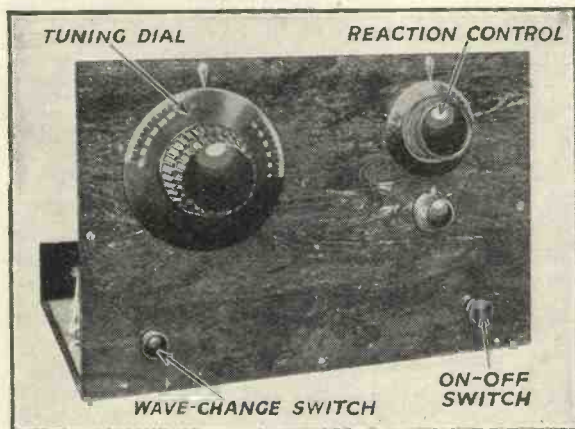

### EASY-TO-OPERATE CONTROL.

The controls of the Multi-mag Three are quite standard and will present no difficulty to the operator

cuts down the spread of the local transmitter to reasonable limits, according to the district in which you live.

Now for the actual circuit itself. The detector valve is a Mullard PM1A, operating as an anode-bend rectifier. The rectifying properties of this valve are obtained by working

a 1-microfarad condenser. A 50,000-ohm series stopping resistance is also used to keep any remaining trace of high-frequency current out of the amplifier.

Although there are four aerial tappings, the volume obtained on the lowest may be too great when listening to the local station, because very

first valve is very fully decoupled through a 50,000-ohm resistance and a 2-microfarad condenser.

The first low-frequency amplifier is a Mullard PM2DX, with a 30,000-ohm resistance in the anode circuit feeding the next auto-coupled transformer. This anode circuit is also decoupled through a 20,000-ohm resistance and

again an unusual size, but with a low tap, in the minimum position, sufficient reduction is obtained, while with the condenser in the maximum position it suits the long-wave winding of the coil quite well.

You will find the tuning is so sharp that very careful handling of the condensers is necessary and very slow-motion controls are used both for the tuning and reaction condensers.

### Constructional Points

Before saying anything more about the handling of the receiver, I will deal with the actual construction of the set itself.

In the past it has not been necessary to take any special precautions in wiring so simple a set as a detector and two low-frequency stages. In the present instance, though, great care is necessary and it is essential to follow the original layout of the set exactly.

If this is not done, several troubles may arise. It should be understood

# THE MULTI-MAG THREE—Continued

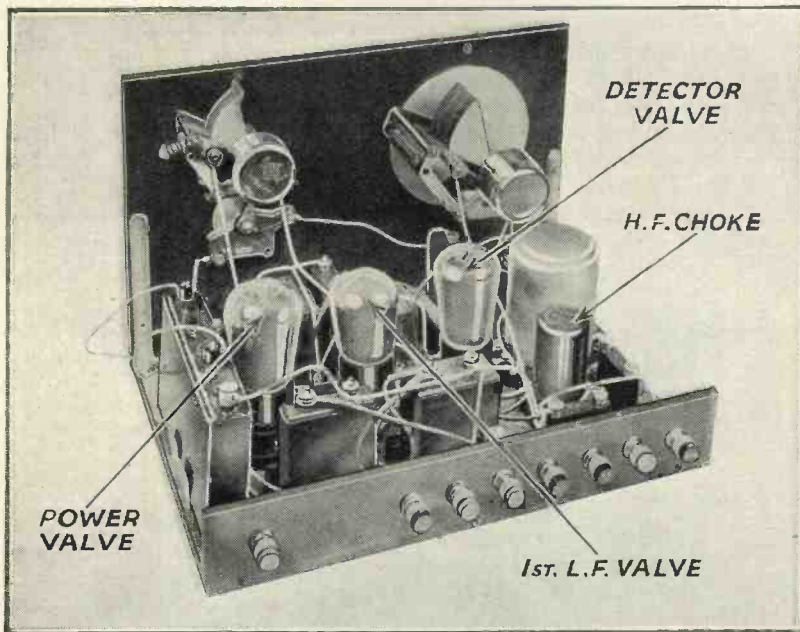

ALL READY TO BRING IN DOZENS OF STATIONS

This photograph shows the set completed and ready for connecting to the batteries. It is particularly compact, yet the parts are not overcrowded

that everything is working "all out." The amplifier, however, is perfectly stable and the set will not "motor-

boat" even when there is quite a high resistance in the common high-tension circuit.

It is essential, however, that the relative positions of the various coupling condensers, resistances, and transformers are not varied, as there may be interaction which will result in poor quality or instability.

As previously mentioned, the set has been designed on compromise principles so as to make it as simple and inexpensive as possible. Actually the tuning condenser should really be screened as well as the tuning coil.

## Great Sensitivity

If you have a good aerial and are within about ten miles of Brookman's Park, you will find that the gain is so great that, with the set tuned to the local station with critical reaction, bringing the aerial lead within about  $\frac{1}{2}$  in. of the tuning condenser will probably overload the loud-speaker.

This means that any wire connected with the grid circuit of the detector valve must not approach the aerial lead. This fact precludes using a symmetrical panel layout, and you will notice that the volume-control condenser which is in the aerial lead is situated in a most unusual place—towards the bottom right-hand corner of the panel.

You will see that the aerial actually comes in at the right-hand side of the terminal strip at the back, and it is then taken straight to the volume-control condenser, a lead running from this to the tapping socket wander plug on the tuning coil.

## Avoiding Stray Pick-up

This certainly seems an extraordinary arrangement, but you will find that if you place the volume-control condenser any nearer to the tuning condenser the capacity effect between the two will cause very considerable pick-up, and it will not be possible to reduce the volume sufficiently on the local station when critical reaction is employed. (Reaction, it will be remembered, is necessary when receiving even the local station, as otherwise the quality will be unbalanced.)

In building the set, the three condensers and the two switches should first be mounted on the front panel, which is then temporarily fitted to the baseboard. The tuning coil, valve holders, and the coupling components can then be assembled on

## COMPONENTS NEEDED for the MULTI-MAG THREE

### CHOKE, HIGH-FREQUENCY

- 1—British General, 5s. 6d. (or Lewcos, Readi-Rad).

### COIL

- 1—Colvern, type TD, 8s. 6d.

### CONDENSERS, FIXED

- 1—T.C.C. .0001-microfarad, upright type 34, 1s. 6d. (or Dubilier, Telsen).
- 1—T.C.C. .0003-microfarad, upright type 34, 1s. 6d. (or Dubilier, Telsen).
- 1—T.C.C. .25-microfarad, type 50, 2s. 3d. (or Dubilier, Telsen).
- 2—T.C.C. 1-microfarad, type 50, 5s. 8d. (or Dubilier, Telsen).
- 1—T.C.C. 2-microfarad, type 50, 3s. 10d. (or Dubilier, Telsen).

### CONDENSERS, VARIABLE

- 1—Ormond .0005-microfarad, type R/207, with slow-motion dial, £1.
- 1—Ormond .00025-microfarad, type R/307, with slow-motion dial, 11s. 6d. (or Formo).
- 1—Magnum .0005-microfarad bakelite dielectric, 2s. 6d. (or Polar).

### EBONITE

- 1—Becol 12 in. by 8 in. panel, 4s. 6d. (or Peto-Scott, Lissen).

### FUSE

- 1—Readi-Rad fuseholder and bulb, 1s. 3d. (or Bulgin, Telsen).

### HOLDER, GRID-LEAK

- 1—Readi-Rad, 6d. (or Bulgin, Telsen).

### HOLDERS, VALVE

- 3—Lotus with terminals, 1s. 6d. (or W.B., Clix).

### PLUGS

- 3—Belling-Lee wander plugs, marked : G.B. +, G.B.—1, G.B.—2, 6d. (or Clix, Eelex).

### RESISTANCES, FIXED

- 1—Bulgin 20,000-ohm spaghetti, 1s. 3d. (or Lewcos, Magnum).
- 1—Bulgin 30,000-ohm spaghetti, 1s. 6d. (or Lewcos, Magnum).
- 1—Bulgin 50,000-ohm spaghetti, 1s. 9d. (or Lewcos, Magnum).

The prices mentioned are those for the parts used in the original set; the prices of alternatives as indicated in the brackets may be either higher or lower

### 1—Dubilier 50,000-ohm metallised, 1s.

- 1—Bulgin 100,000-ohm spaghetti, 2s. 6d. (or Lewcos, Magnum).

### SUNDRIES

- Tinned-copper wire for connecting (Lewcos).
- Lengths of oiled-cotton sleeving.
- 1—Pair of Bulgin panel brackets, type PB4, 1s. 3d.
- 1—Ebonite terminal strip, 11 in. by 2 in.

### TERMINALS

- 8—Belling-Lee, marked : Aerial, Earth, L.S. +, L.S.—, H.T. +, H.T.—, L.T. +, L.T.—, 2s. (or Clix, Eelex).

### SWITCHES

- 1—Readi-Rad on-off switch, 10d. (or W.B., Telsen).
- 1—Readi-Rad three-point wave-change, 1s. 6d. (or W.B., Telsen).

### TRANSFORMERS, LOW-FREQUENCY

- 1—Igranic Midget, ratio 1 : 3, 10s. 6d.
- 1—R.I. Hypermite, ratio 1 : 6, 12s. 6d.

## ACCESSORIES

### BATTERIES

- 1—Pertrix 120-volt high-tension, standard type, 15s. 6d. (or Ever-Ready, Siemens).
- 1—Pertrix 9-volt grid-bias, 1s. 6d. (or Ever-Ready, Siemens).
- 1—Exide 2-volt accumulator, type WZG2, 12s. (or C.A.V., Tudor).

### CABINET

- 1—Pickett in oak, 15s.
- 1—Camco Melodee No. 1 loud speaker cabinet, with baffle board, £1 3s. in oak.

### LOUD-SPEAKER

- 1—Rola permanent-magnet moving-coil, type PM1, £2 9s. 6d.

### VALVES

- 1—Mullard PM1A, 7s. (or Six-Sixty 210RC, Osram H2).
- 1—Mullard PM2DX, 7s. (or Six-Sixty 210D, Osram HL2).
- 1—Mullard PM2A, 8s. 9d. (or Six-Sixty 220PA, Osram LP2).

# AN OUTSTANDING STRAIGHT SET

the baseboard, making quite sure that they all clear the three condensers.

The components can then be screwed in position and wired up very carefully according to the diagram.

After wiring the panel is permanently fitted to the baseboard and the leads are connected to the condensers. Actually, you will find it more convenient to attach the leads to the volume-control condenser and the two switches, making the connections at the other end of these leads when the panel is in position.

### Condenser Leads

Once again a word of warning will be given about the position of the two leads to the volume condenser. The return lead must run well towards the base of the panel, so that it is as far as possible from the tuning condenser.

There is only one other point which requires care, and that is the connection of the transformers. The

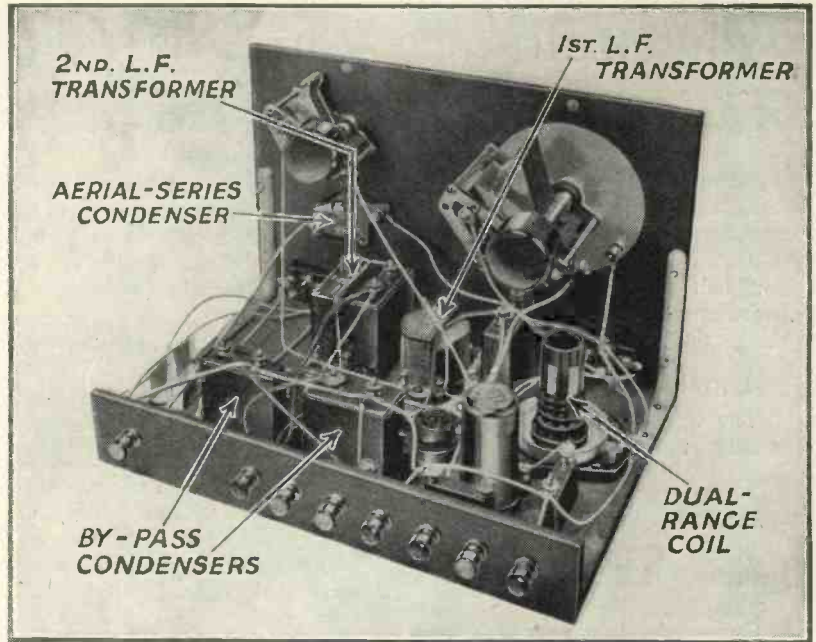

**FIRST USE OF A NEW DUAL-RANGE TUNING COIL**  
The dual-range coil used in the Multi-mag Three is of new type, designed by Paul D. Tyers. The efficiency of the set is largely due to the properties of this coil

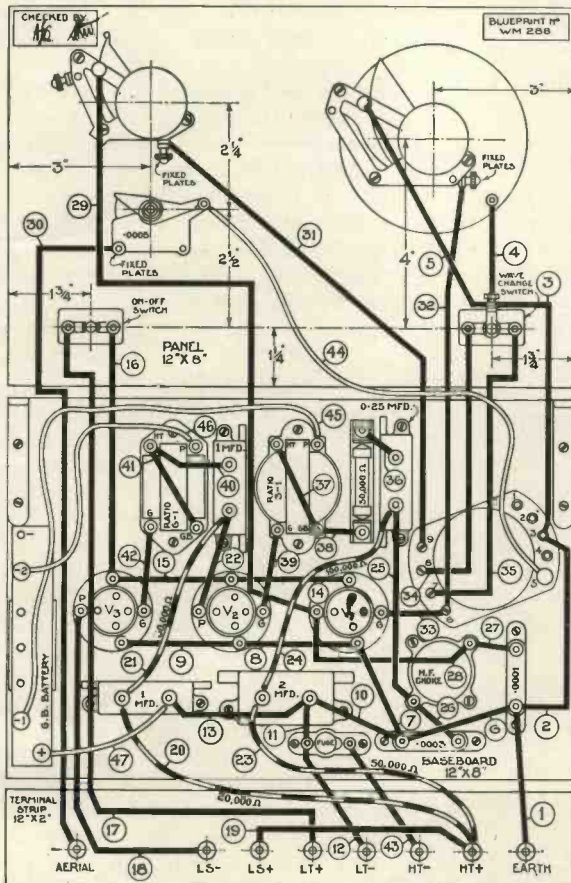

**QUARTER-SCALE LAYOUT AND WIRING DIAGRAM**  
A full-size blueprint (No. WM288) can be obtained for half price, that is, 6d., post free, if the coupon on the last page is used by June 30

first stage employs a 3 : 1 ratio, which is auto-coupled, giving an effective 4 : 1 ratio, while the second stage uses an auto-coupled 6 : 1 ratio.

I have used an Igranic Midget and an R.I. Hypermite transformer which, connected in this manner and in conjunction with the coupling condensers, give a suitable balance.

The transformers are wired in the following manner: The grid terminal of the transformer goes to the grid of the valve as usual, but the anode terminal is taken to the grid-bias tapping. The high-tension terminal and the grid-bias terminal of the transformer are connected together and are taken to the feed condenser, the other side of

which goes to the anode of the preceding valve.

The set will, no doubt, seem a little difficult to handle at the outset. Before switching on, make quite sure that you have the valves in the correct positions, with suitable bias adjusted. The set has been designed around a Mullard PM1A, a Mullard PM2DX, and a Mullard PM2A.

### Grid-bias Voltages

The bias for the first amplifier is 1.5 volts. If you are using a PM2A in the output, this will require 4.5 volts. This valve has a high mutual conductance, and sufficient power will be obtained for a medium-size room with an ordinary type of loud-speaker.

The bias voltages mentioned are those for a 120-volt high-tension supply. The set is sufficiently stable to work from a properly designed mains unit, in which case a larger output valve may be used, with suitable alteration in the bias voltage.

### Alternative Valves

While it is suggested that the recommended valves are certainly employed in the first two stages, it must not be thought that the set will only function with these particular types.

If other types are used the



“It’s Just the Time for Dancing”—“Here’s to the Next Time”



SPECIALLY DRAWN FOR  
WIRELESS MAGAZINE  
by SLADE

An impression of the B.B.C. Dance Orchestra directed by Henry Hall

# HOW WILL RADIO Affect the FUTURE OF MUSIC?

Cortot, the famous French musician, discusses the question in an exclusive interview with WATSON LYLE

THROUGHOUT his brilliant career since 1896 as a concert artist, Alfred Cortot, the great French pianist, has been more in contact with the evolutionary influences in his art than any other musician of pre-eminent international importance.

### Early Activities

Following a notable *première prix* in Paris, as a pupil of Decobers (one of the last pupils of Chopin) and Diémer, with a *début* at the Concerts Colonne, and Lamoureux, his activities in professional life in the French capital quickly became identified with societies, and concerts concerned with performances of works by new composers; and with great music unknown to Paris as, for instance, the first performances he conducted there, when twenty-four, of *Götterdämmerung* and some memorable performances of *Tristan und Isolde*.

When he was kind enough to give me his views on the effect of the newest of all influences—radio—upon the development of music for the benefit of readers of "Wireless Magazine," in the course of a conversation we had recently, I knew that here was an artist who was no haphazard visionary, but whose thoughts for the future of broadcast music sprang from an intimate knowledge of present events, and the rise and fall of new movements coming within a personal experience of nearly four decades.

In a pleasant studio high above the noise of one of London's busiest

thoroughfares, I found him seated at a grand of his favourite Pleyel, not too far from the jolly, big fire blazing in an open grate, and defying the bleak wind outside that was certainly not tempered to the shorn lamb there, or anybody else!

Cortot's genial welcome, as he rose, and quickly came forward to me, completed immediately the thawing process begun by that fire of gracious memory. Establishing me in the easiest of chairs near to this dance of the flames, he seated himself upon the piano stool, which he drew forward in front of it.

Then I put to him the leading question I ask most distinguished musicians because of our insular pride in the B.B.C. I said: "How do you like broadcasting here, as compared with abroad—France, for instance?"

"From the artist's point of view, your system is infinitely superior.

There are no interruptions of advertisements, and your various arrangements for the full use, educationally, of this new influence in music, are excellent."

"You regard radio as an important consideration in the progress of the art?"

### Fervour of a Priest

Instead of immediately replying, he slightly bent towards me, his dark hazel eyes glowing with the fervour of a priest about to enunciate some religious tenet, his pale face, capped by his straight, black hair, momentarily tense, ere his lips parted in a half smile, and he began to speak, expressing his thoughts fluently in ordered sequence.

"There are well-defined stages in the progress of music, and radio is the newest. If we look back historically we know one stage to have been marked by the music of Rameau, and of Lully; another by that of Beethoven, of Wagner, and Brahms; of Debussy, of Ravel, and so on. All along, the existing order of things has had to give way to the new.

"To-day the struggle is between the romantic element, the inner, emotional content of music, and the demands of transmission by wireless. For instance," rising in his alert, quick way, he lifted the stool over to the keyboard, and played those marvellous opening chords of Chopin's B-flat minor Sonata (the Funeral March Sonata) with its concentrated utterance of an anguish too intense for speech, "in broadcasting, the full emotion of such music



A BRILLIANT MODERN MUSICIAN  
Many listeners will be interested in the views expressed by Cortot on the future of radio music. He broadcast from London only a week or two ago

as this does not carry to the listener. It is a noise.

"We must play it—so," he repeated the phrase with altered dynamics which, heard at first hand, sounded anaemic, almost dead by comparison, "to transmit the harmony, the colour, clearly. And so it is with the expression of the emotion in all romantic music; and, too, in the suggestion of drama in those very chords."

Rising, he brought back the stool, and again sat opposite me in front of the fire.

"The listener who does not know that sonata will think, perhaps, something has gone wrong with the set, or the transmission, because of the silence following the chords. It is a pause that the eyes help the ears to take in the full significance of in the concert room.

### Barrier to Expression

"Given its due value in broadcasting, it is inexpressive. By shortening it to the needs of radio, the artist is conscious of a barrier to free expression, as in his control of dynamics—not great, perhaps, but there, all the same. Unless he is able to forget the piano he cannot express himself at his best.

"There are, of course, players who are just very good pianists and who, having little or no art to express, playing their runs habitually like this," again his almost subconscious journey to and from the piano, playing a scale passage with perfectly even, small tone, "sound clearly to the listener, but their playing contains no message; it is of no good to the audience."

### Spiritual Content

"Does not this seem to point to the conclusion that the mechanical demands of radio will suppress, and even kill, the inner, spiritual content of great music?"

"No. I do not think so." In the tones of his voice one could hear that cool, detachment which is Gallic; more, even, that *clarté intellectuelle* which is essentially Parisian.

"The young pianists who are artists will find a way, will have to develop a technique, to express their art by radio. Those who are older can scarcely hope to alter their methods to make the utmost use of this new thing in music."

"This new milestone?"

"Perhaps; all is so unformed yet.

But a way will open up, as in the past.

The young composers will learn to write for radio. Already there is this interest in what they call abstract music. The music of Bloch"—I think it was Bloch M. Cortot mentioned—"and of Hindemith."

"I heard some Hindemith the other week in Queen's Hall and it said absolutely nothing to me!" I objected.

"Ah! But that is where you were wrong. You looked for something in it that it had not to give you, for the emotion, the romantic appeal to which you are accustomed, and which it is the aim of these composers to avoid. So, that you did not find it, shows the composer to have succeeded in his aim."

"At least, when I wrote about it I simply said it conveyed nothing to me. I was just as willing to admit I might be at fault as the composer, by leaving the question quite open."

"There you were right. We may not like the work of an artist, we may not understand it, but we must remember that all true artists express themselves sincerely, and we must therefore give to their work the respect that is its due, whether we like it or not personally."

Into his eyes there came again an unusual brightness, and his lips relaxed in that characteristic half smile, inscrutable, yet wholly pleasant, as he went on to amplify his beautiful view of art, bound up with the future of radio music.

"Think," he continued, "of the

Make certain of getting your copy of the July issue of "Wireless Magazine" — published on Wednesday, June 22 — by ordering in advance

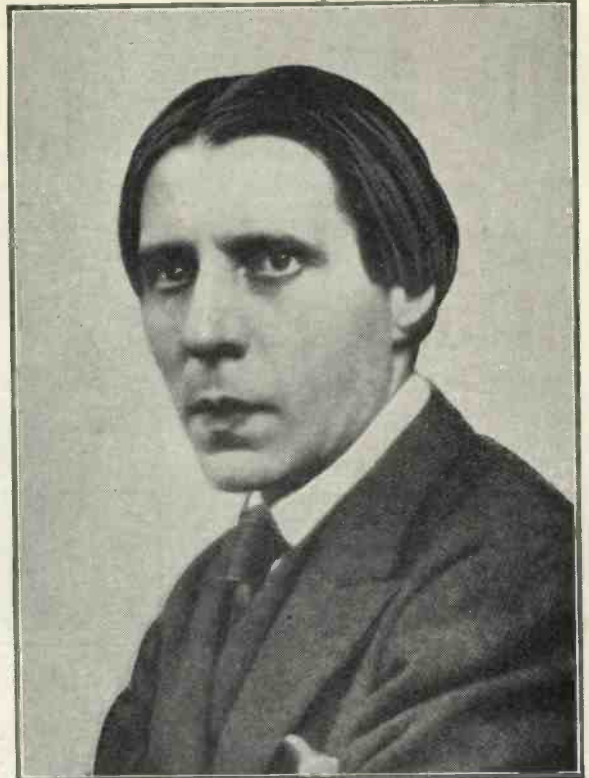

MARVELLOUS TECHNIQUE

Cortot is a musical idealist, but he thinks that broadcasting will do music more good than harm

vast audience to whom radio music goes. Of the thousands and thousands who may discover, by this opportunity of hearing good music (probably only a very small proportion could have heard it otherwise) the delight and the lasting joy it is to them.

### Future Service

"Yesterday, for example, I played at Eastbourne. I had an audience of a thousand people or so. To-morrow I play in the north of England to an audience of two thousand. But in numbers these are as nothing to the audience I can reach when I broadcast. And from listening to good music those to whom it makes its deeper appeal are not content to remain passive, but come to enjoy the greatest happiness of all, the making of their own music. There lies the highest future service of radio music."

Idealistic, you may say. Well—perhaps. But, as I listened to Cortot speaking that afternoon in early spring, beside the fire, itself a symbol of vivid, new life, I understood, in a flash, the force—or, at least part of it—behind the nobility of his interpretations, his brave, his glorious idealism.

# The Easytune As A Table Radiogram

Here we present something new in the way of home-constructor designs—a complete battery-operated table radio gramophone. The radio side of the equipment is the Easytune 60—the one-knob super-het that was fully described in the previous issue



## BY THE "W.M." TECHNICAL STAFF

LAST month we described in detail the construction and operation of the latest development in the super-heterodyne field—a battery-operated set with one-knob tuning called the Easytune 60. The set was presented as a successor to the famous Super 60; it has picked up more than seventy stations during a test extending over two evenings.

The Easytune 60 has aroused very great interest in radio circles everywhere, for amateurs have, in the Easytune 60, the solution to the one-knob super-het problem in a form that they can adapt for their own purposes.

Our description in the May issue of "Wireless Magazine" was complete except for details of the cabinet arrangements. We announced that a new form of radio-gramophone cabinet was being prepared specially for the set; this month readers are able to see the design for themselves.

It is believed that this is the first constructor's battery-operated table radio-gramophone to be published; it has such obvious advantages that we are certain that it will meet with the approval of thousands of readers.

This special cabinet is fully illustrated in these pages. At the top is space for the gramophone motor and turntable; the cabinet is

so arranged that 12-in. records can be played with the lid closed. There is sufficient space under the motor board to accommodate almost any standard motor.

### Spring or Mains Drive

As the Easytune 60 is a battery-operated set we have used a clock-work motor for driving the turntable. Those who have mains, however, and desire to use an electric motor, can do so.

The loud-speaker fret is attractive in design and is of a size suitable for most of the small moving-coil reproducers at present on the market. Although the cabinet is arranged to take a small loud-speaker, there is no need to place the reproducer inside if an ordinary cabinet type of loud-speaker is available.

On a level with the bottom of the loud-speaker fret there is a shelf to accommodate the batteries used for running the set. If a mains unit is to be used for the high-tension supply, this can be placed on the shelf, of course, in place of the high-tension batteries shown.

### Simple Installation

The receiver is placed right at the bottom of the cabinet, with the controls projecting through the front. The cabinet is supplied with the holes for the control spindles already drilled, so there will be no difficulty about installing the set in the case.

The cabinet is so arranged that

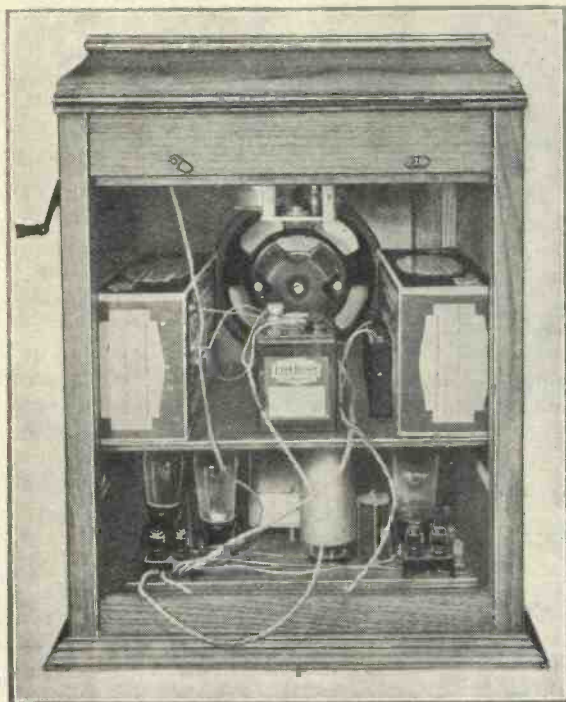

**SELF-CONTAINED LOUD-SPEAKER AND BATTERIES**  
There is space for the batteries on the shelf just above the set. Almost any small type of moving-coil loud-speaker can be accommodated



records can be changed without difficulty when the set is placed on a table of normal height. Some people may prefer to stand the whole outfit on a stool.

The additional parts needed to convert the Easytune 60 into a complete table radiogram are indicated on page 512. It will be seen that the cost is very reasonable.

**Full-size Blueprint Available**

Those readers who did not see the full description of the Easytune 60 in the May "Wireless Magazine" will be glad to know that full-size constructional blueprints are still available for 1s. 6d. each, post free. A limited number of copies of the May issue are also available at 1s. 3d. each, also post free.

Applications for blueprints should be addressed to "Wireless Magazine" Blueprint Dept., 58-61 Fetter Lane, London, E.C.4 (ask for No. WM284), and for back numbers



**WILL PLAY 10-IN. OR 12-IN. RECORDS**

Even when the lid is closed there is clearance for playing 12-in. records. The grammo-radio switch and volume control are seen in the bottom right-hand corner

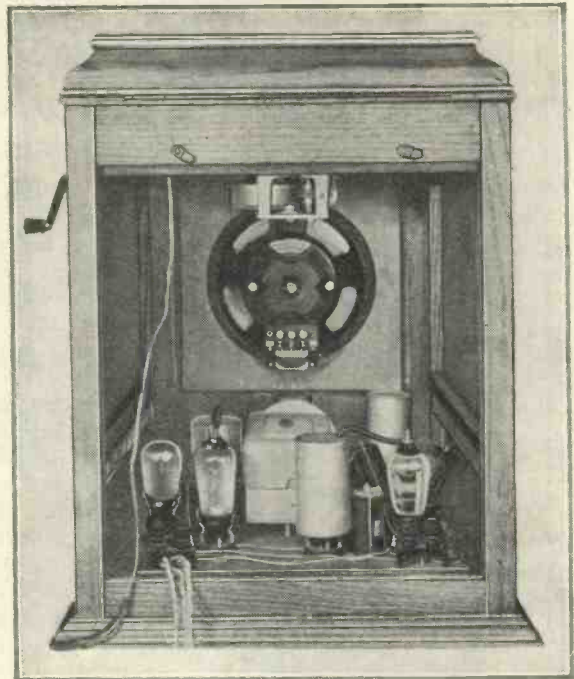

**PLENTY OF SPACE FOR GRAMOPHONE MOTOR**

This photograph shows that there is plenty of space in the special table radio-gramophone cabinet made for the Easytune 60 by Smith's Cabinets, Ltd.

When the grammo-radio equipment has been completed, the method of operation of the set is slightly modified, of course. For radio reception the switch on the motorboard must be put in its "Radio" position; the set is then controlled by the three knobs at the front of the case as explained in the May issue of "Wireless Magazine."

to the Publisher at the same address.

The simple nature of the conversion of the Easytune 60 from a plain radio receiver to a complete radio gramophone will be evident from the diagram alongside, which shows the connections between the grammo-radio switch, the volume control and the set.

Both the grammo-radio switch and the volume control are mounted on the top of the motorboard. (The knobs can just be seen in the bottom right-hand corner of the photograph above.)

It should be emphasised that no drastic alteration to the wiring of the set is necessary; the connections that have to be made are mostly additions.

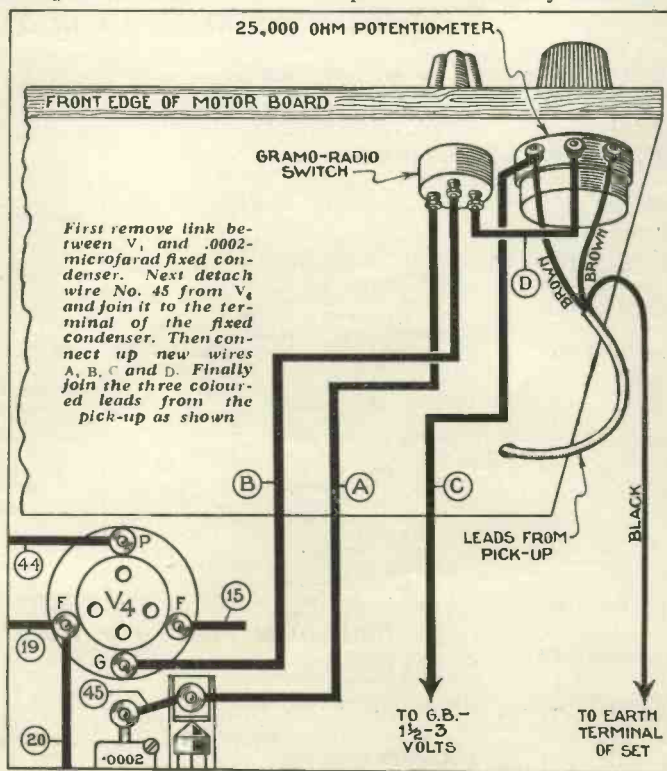

**WIRING OF THE GRAMMO-RADIO EQUIPMENT**

This diagram shows clearly the few alterations and additions that have to be made to the wiring of the Easytune 60 for the addition of grammo-radio equipment

For the electrical reproduction of gramophone records the switch on the motorboard is placed in its "Gram" position. Before a record is played, however, the knob of the volume control (on the front of the cabinet) should be turned as far as possible to the left, that is, in an anti-clockwise direction, so that the intermediate screen-grid valve is put out of circuit.

This will prevent the possibility of any radio programme breaking through and spoiling the reproduction when records are being played.

Volume of record reproduction is controlled by the potentiometer mounted on the motorboard alongside the grammo-radio switch. Should a different pick-up from that

## THE EASYTUNE 60 RADIOGRAM—Continued

**COMPLETE OUTFIT**

This Easytune 60 Table Radiogram is completely self-contained, except for the aerial and earth

recommended be used, the resistance of the volume-control potentiometer should be changed. The particular value recommended for the B.T.H. Minor pick-up is too low for any other type.

There can be no question that anybody building the Easytune 60 Table Radiogram will have the best battery equipment that modern technique can evolve.

Considering that the set uses only five valves the results obtained are really astonishing. The great amplification available is due to the fact that each valve in the set is an amplifying valve.

**Circuit Sequence**

In the Easytune 60 the super-heterodyne circuit has been reduced to its simplest elements. The first screen-grid valve acts as a detector and is followed by a three-electrode oscillator. Then comes the second screen-grid valve, which acts as an intermediate - frequency amplifier. Following are the second detector and the transformer-coupled power valve.

The valves recommended for the Easytune 60 are as follows: First detector, Osram S22 (or Marconi S22); oscillator, Marconi L2/b; intermediate-frequency amplifier, Osram S22 (or Marconi S22); second

detector, Osram H12 (or Marconi HL2); and power valve, Osram P2 (or Marconi P2).

We feel it necessary to emphasise again that the Lewcos band-pass aerial tuner and the dual-range oscillator are of special design to gang up with the British Radiophone super-het condenser, which has specially shaped vanes for oscillator tuning. It is only by the use of this special condenser and the particular coils that have been developed to match up with it that proper one-knob tuning can be obtained.

Those who built the original Super 60 will be able to use the two intermediate coils with pigtail connections. The original oscillator will not be suitable and, of course, the frame aerial must be replaced by the new band-pass tuner.

Constructors of the Easytune 60 are invited, as usual, to send reports to the Editor as soon as they have had the set in use for a reasonable time. Readers are also reminded that half a guinea is paid for every photograph of a home-constructed "Wireless Magazine" set that is

reproduced in these pages.

We have every confidence that the Easytune 60 will come up to the expectations of everybody who builds it. The design is the result of many months' research and there is no question that the method of ganging is fundamentally sound.

**A.C. Mains Version**

Already a number of readers have asked whether we shall be publishing details of an A.C. version of the Easytune 60. The answer is that experiments are now being carried out with this end in view, but it may be a month or two before we are able to give constructional details.

Of course, an A.C. model would be very much more efficient as regards signal strength than the original battery model because of the greater efficiency of mains valves.

Preliminary work that has been done on the mains version leads us to hope that we shall be able to present readers with details of a really outstanding mains super-het—and, remember, it will have only one tuning knob!

**COMPONENTS NEEDED FOR THE EASYTUNE 60****COILS**

1—Set of Lewcos super-het coils comprising band-pass filter, type BPF/G, 12s.; oscillator, type TOS/G, 8s. 6d.; two intermediate band-pass filters, with pigtails, type IFTP, £1 1s.

**CONDENSERS, FIXED**

1—Dubilier .0002-microfarad, type 670, 1s. (or T.C.C., Telsen).  
1—Dubilier .0003-microfarad, type 670, 1s. (or T.C.C., Telsen).  
2—Dubilier .002-microfarad, type 670, 2s. 6d. (or I.C.C., Telsen).  
1—Dubilier .01-microfarad, type 670 (or T.C.C.).  
5—Dubilier 1-microfarad, paper type 13s. 9d. (or T.C.C., Peak).

**CONDENSERS, VARIABLE**

1—British Radiophone .0005-microfarad three-gang super-het type with cover and disc drive, £1 15s.

**GRID-LEAK HOLDERS**

2—Readi-Rad, 1s. (or Bulgin, Telsen).

**HOLDERS, VALVE**

7—W.B. four-pin, miniature type, 4s. 8d. (or Lotus, Clix).

**PLUGS AND TERMINALS**

10—Belling-Lee wander plugs, marked: H.T.+3, H.T.+2, H.T.+1, H.T.+ H.T.—(2), G.B.+(2), G.B.—(2), 1s. 8d., (or Clix, Eelex).  
2—Belling-Lee spade terminals, marked L.T.+ , L.T.—, 4d. (or Clix, Eelex).  
4—Belling-Lee type B terminals, marked

**ADDITIONAL PARTS FOR RADIO GRAMOPHONE****CABINET**

1—Smith table radiogram in oak, £2 15s.

**GRAMOPHONE MOTOR**

1—Gerrard Junior clockwork, model B, £1 13s.

**LOUD-SPEAKER**

1—Celestion permanent-magnet moving-coil, type PPM standard, £2 7s. 8d.

The prices mentioned are those for the parts used in the original set; the prices of alternatives as indicated in the brackets may be either higher or lower

L.S.+ , L.S.—, Aerial, Earth, 2s. (or Clix, Eelex).

**RESISTANCES, FIXED**

1—Bulgin 50,000-ohm spaghetti, 1s. 9d. (or Magnum, Lewcos).  
1—Edison Bell .5-megohm grid leak, 6d. (or Lissen, Telsen).  
1—Edison Bell 2-megohm grid leak, 6d. (or Lissen, Telsen).

**RESISTANCE (VARIABLE) AND SWITCH**

1—Wearite 15-ohm rheostat combined with three-point switch, types Q4 and G23, 3s. 6d.

**SUNDRIES**

Tinned-copper wire for connecting (Lewcos).

Length of oiled-cotton sleeving.

Lengths of rubber-covered flex (Lewcos).

2—Belling-Lee terminal blocks, 1s. 4d. (or Sovereign, Junit).

**TRANSFORMER, LOW-FREQUENCY**

1—Lewcos type LFT6, 10s. (or Ferranti AF8, R.I. Hypermite).

**BATTERIES**

2—Ever-Ready 60-volt, type HP60, £1 10s.  
2—Ever-Ready 9-volt grid-bias, Winner type, 2s.  
1—Ever-Ready 2-volt accumulator, type 2127, 13s. 6d.

**VALVES**

2—Osram S22, £1 13s. (or Marconi S22)  
1—Marconi L2/b, 7s.  
1—Osram HL2, 7s. (or Marconi HL 2)  
1—Osram P2, 12s. (or Marconi P2).

**PICK-UP**

1—B.T.H. Minor with tonearm, £1 7s. 6d.

**RESISTANCE, VARIABLE**

1—Varley 25,000-ohm potentiometer, type CP139, 6s. 6d.

**SUNDRIES**

1—Bulgin duplex needle cup, 2s. 6d.

**SWITCH**

1—Bulgin rotary change-over, type S86, 2s.

# WONDERS OF THE TRANSATLANTIC TELEPHONE



KENNETH ULLYETT describes the Post Office short-wave transmitters and receivers by means of which one can have telephonic communication with practically every country in the world, and by which the B.B.C. receives many American programmes for re-broadcasting in this country

**I**F you want to chat with the Mayor of Chicago, if you want to talk cricket with the Ashes enthusiasts in Australia, or if you want to ask the captain of the *Leviathan* what depressions he is experiencing in mid-Atlantic, you have only to lift up your telephone and ask for "Trunks"!

### In Direct Touch

We are getting accustomed to the transatlantic telephone and although we are not all sufficiently big business men to take advantage of it, we know that the Post Office is in direct wireless touch with New York.

That is only half the story, as I found out, when, at the invitation of the chief of the transatlantic telephone service, I went along to see the really remarkable apparatus used.

At the risk of appearing to want to

publicise the Post Office but, in truth, inspired by the technical marvels I have seen, I want to tell you just what the Post Office wireless telephone will do.

There are four means of communicating with New York—on 5,000 metres (the long-wave Rugby transmission) and on 16, 22, and 30 metres. Through the same wireless link one can speak to many other places, such as Chicago and San Francisco. Other sets of wireless

minute to talk to New York or Australia; less to call up a liner.

As you sit at your telephone, waiting to put through one of these long-distance calls, there is no sign of the wireless transmission which plays such an important part. The operator puts through a report call, your phone bell rings, and within less time than it takes to get through a short-distance trunk call, you can be speaking at ordinary telephone-speech quality the other side of the globe.

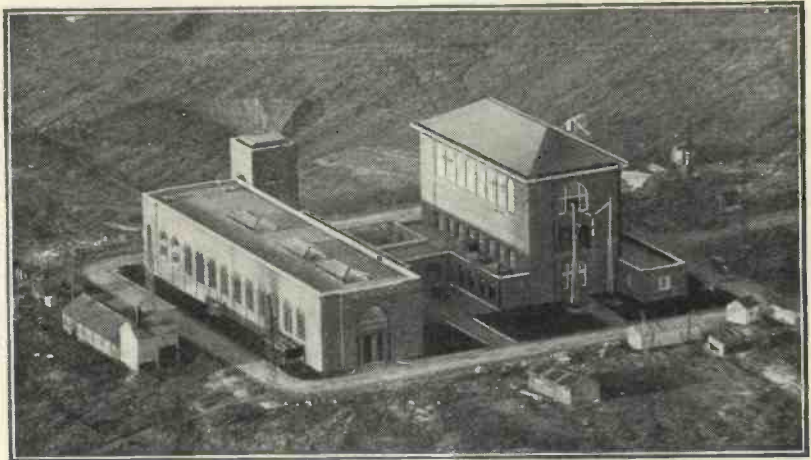

**THE CENTRE OF THE TRANSATLANTIC TELEPHONY TRANSMISSIONS**  
An aerial photograph of the main Rugby transmitter and power buildings. The big generators are in the single-storey building. This is the biggest station in England

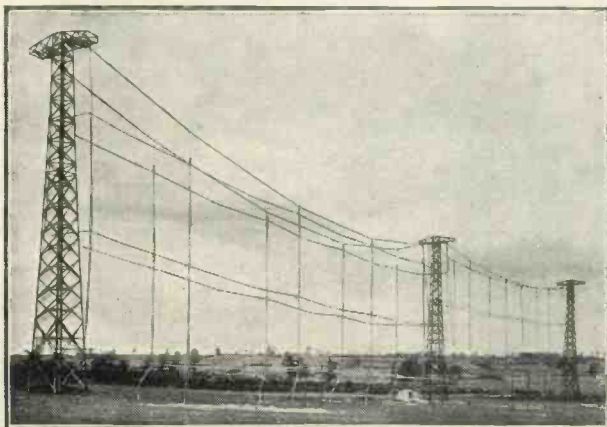

**FACING OUT TO SEA**

A group of semi-beam aerials used for receiving the 16-metre signals. The actual aerials are vertical, the horizontal wires being only supports

transmissions put one in touch with Australia, Canada, the Canary Islands, New Zealand, and a number of the big Atlantic liners, among them the *Empress of Britain*, *Belgenland*, *Majestic*, and *Leviathan*.

The cost is not terribly expensive. It costs £2 a

The principle of the apparatus used is simple, but the technical points involved make it some of the most complicated gear I have ever examined.

### Trunk Exchange

The transatlantic telephone chief took me to a little room on the first floor of the London trunk exchange, under the shadow of St. Paul's Cathedral. There were a number of tall panels with operators, wearing headphones, busy on what appeared to be ordinary telephone work.

"Egypt's on this line, sir," called one of the operators. "Shall I put it through to the frequency tester?"

Two other operators were con-

# THE TRANSATLANTIC TELEPHONE—Cont.

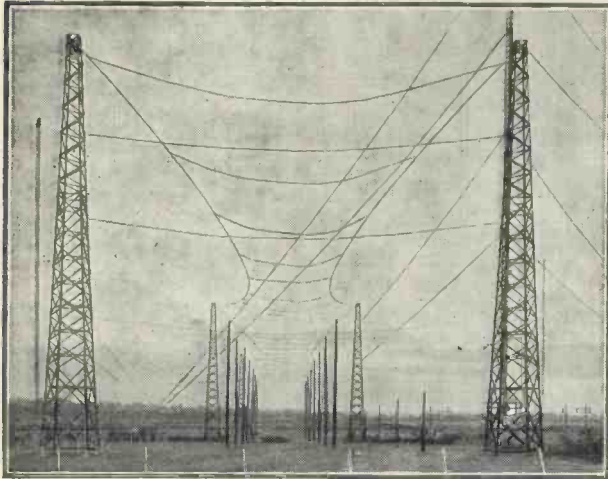

A BEVY OF AERIALS

At Rugby there are aerials for each separate wavelength band. Here are some of the lofty beam-aerial radiators

ducting test conversations with New York. Another man was at work on a calibration panel on which any test conversation can be checked up for speech quality. The whole routine was going on with a *blasé* air, as though the operators were testing a London-Birmingham trunk line!

My guide explained the whole sequence to me.

## Transmissions from Rugby

The Post Office calls, whether at ships at sea or to any of the Continents, are transmitted from Rugby. The wavelength used is varied according to the time of day. The Post Office claims that we are in an impregnable position in short-wave communication compared with the rest of the world. The 5,000-metre wavelength is very reliable. Of the short waves, the 16-metre channel is used during the day, the 22-metre band at twilight, and the 30-metre band during the night. A 44-metre channel is kept in reserve.

Rocky Point is the transmission centre on the American side and Baldock in Hertfordshire is the reception point for all the channels.

Here are big panels carrying the very latest in short-wave super-hets. Semi-beam type directional aerials are used and the parallel feeder wires run direct into the receiver bays.

amplification for the 16-, 22-, 30-, and 40-metre bands. The first detector and oscillator are separate and the screen-grid intermediate stages (there are three screen-grid valves for each receiver in the intermediate-amplifier panels) are tuned to 300 kilocycles.

There is automatic gain or volume control, feeding back in the circuit to the beginning of the intermediate-frequency stages. That is why there is so little fading, such as we amateurs usually experience in short-wave reception.

There are as many as four low-frequency valves to each receiver and the last valve of each section is connected to the specially balanced lines between Baldock and the

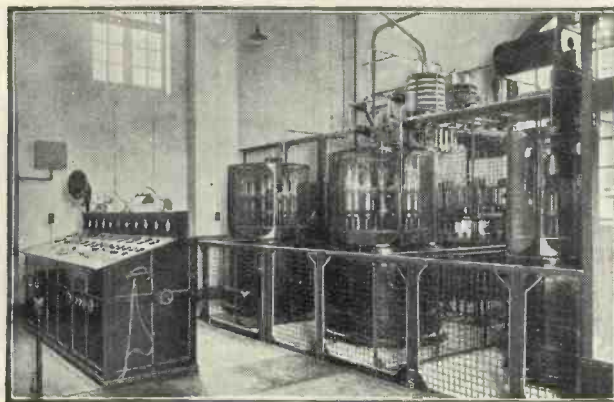

RUGBY IS EQUIPPED FOR THE LONG WAVES

Some of the telephony is carried out on 5,000 metres, and these are the panels of the long-wave Rugby transmitter

Super-het enthusiasts will be interested in these big Post Office receivers. There are separate tuned stages and pre-first detector

London trunk telephone exchange.

Now we come to a most interesting side of the wireless telephony. The conversations are secret and if you have ever listened in to the short-wave Rugby transmissions (a fine test for amateur short-wavers, by the way) you will know that the speech is "muddled" so as to be

absolutely unintelligible. This is done by filter circuits and side-band distortion.

Similar filters at the receiving end turn the speech back to normal again. There is very little frequency cut-off in this process although, as I shall explain later, when broadcasting is done on the short-wave transatlantic



AERIAL FEEDERS

A few of the special feeders connecting the aerials with the transmitters

link, the sideband distorters are switched out.

The muddled speech is received at Baldock and is not converted until it has gone through the main panels of the London trunk exchange.

## Almost Complete Secrecy

Thus there is secrecy over practically the whole of the route. At the touch of a button, the operator in London can hear the speech either in its muddled or "straight" condition.

What happens, in working, is that the operators, when putting through the call, talk with the speech switch in the unmuddled position, so that the receiving engineers at Baldock can judge the quality. Then, when the commercial conversation starts, the "muddlers" are switched into circuit. The Baldock engineers have no need to listen in, though, as they have frequency-testing gear which gives visual indication.

Very clever, but reliable and efficient, valve bridge

# A TRIUMPH FOR BRITISH RADIO

circuits at both ends enable the same wavelength to be used for transmission and reception—"duplex" working, as it is called.

## Remote Control

On the control panels at London are keys which "remote control" the Baldock sets. When a very special conversation is booked, or when a broadcast from America is being taken through the Post Office gear by the B.B.C., the transmission is given on two or three wavelengths simultaneously.

By touching keys on the receiver blades, the London engineers can select the best transmission and switch over to another wavelength

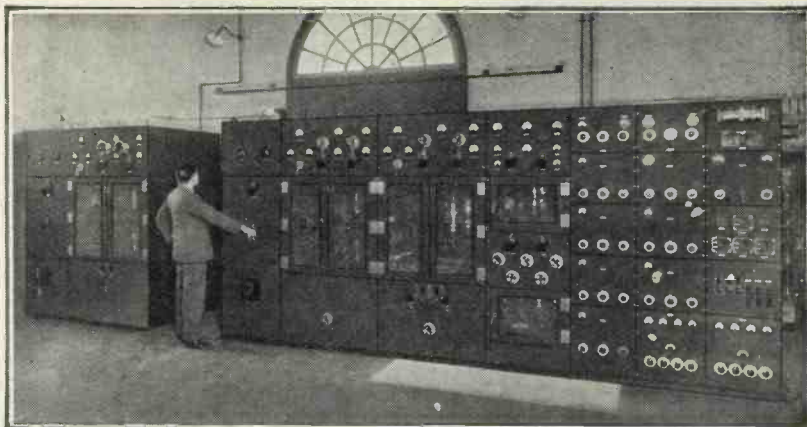

FOR TALKING DIRECT TO AUSTRALIA

There are over fifty tuning controls on these monitoring panels of the short-wave transmitter which is in constant communication with Australia

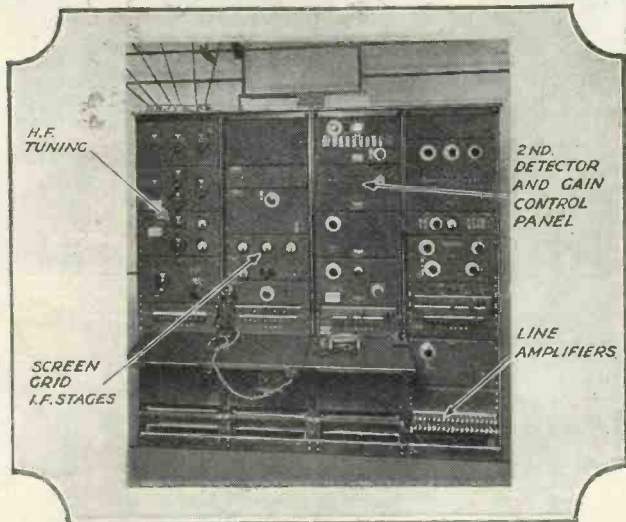

ARRANGEMENT OF THE SUPER-HET RECEIVERS

This photograph shows how the screen-grid super-hets are arranged at the Baldock receiving point

channel without a break immediately "fading" sets in. There are volume indicators and gain controls very similar to those on the B.B.C. programme boards.

The transatlantic telephone link is being used more and more for broadcasting. During the Columbia broadcasting system and B.B.C. programme exchanges, our Post Office apparatus is being used entirely, in conjunction with the American Telephone and Telegraph transmitters on the American side. The speech muddlers are switched out of circuit to broaden the frequency band of reception.

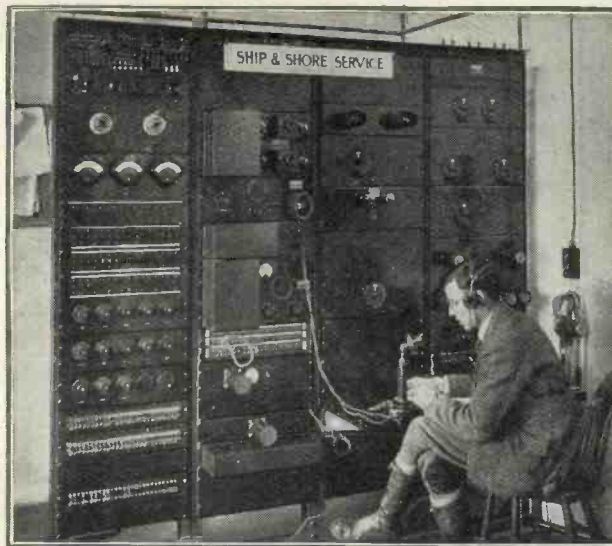

LISTENING TO THE SHIPS

An operator at one of the super-het receivers used on the ship-to-shore telephony service, which is certain to have a great future

The lines for redistribution in America, the transatlantic link is used. The Jack Hylton and Jack Payne broadcasts to a special B.B.C. studio, relayed to America, but not heard in this country, are an example of this American borrowing of programmes of British artists. These broadcasts have nothing to do with the B.B.C.

## P.O. Technical Work

The American liaison official here arranges for the hire of one of the studios and he leaves the technical arrangements to the Post Office. On many occasions the Post Office have had to carry out broadcasts of famous speakers for American transmission. Condenser or Reisz microphones are taken to a convenient site and lines connected to the nearest trunk telephone cable to London.

When broadcasts are made in this country, in the B.B.C. studios and elsewhere,

here are switched on to the new broadcasting bay in the wireless-telephone room and the engineers bring the volume up to the proper level before passing on the programme to the Rugby transmitter. It is certainly a compliment to the British Post Office that our gear is used when the American Columbia and N.B.C. engineers want a relay from this country.

It must be remembered that at present, with the American short-wave transmitters and the B.B.C. short-wave gear at Tatsfield, it would be possible for a programme to be

# THE TRANSATLANTIC TELEPHONE—Cont.

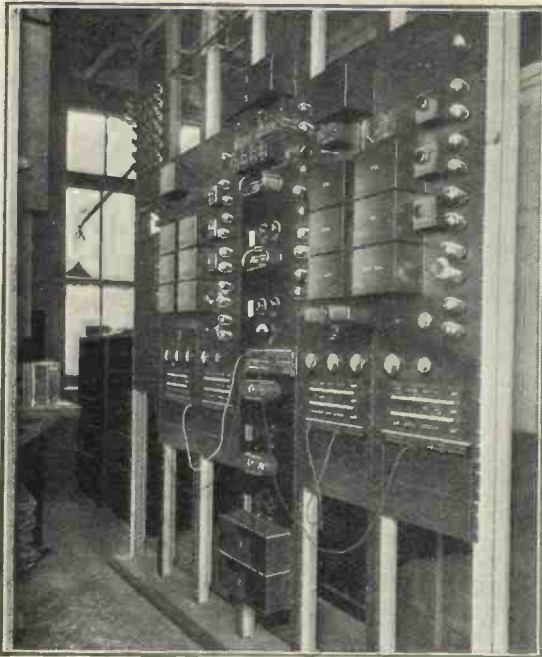

**THE DUPLEX BRIDGE**

At the London Trunk Exchange are the valve bridge circuits which enable the same wavelength to be used for transmission and reception

phone, and the ease with which it can be used, though, are rendering the B.B.C. receivers redundant for this work.

Moreover, the super-hets at Tatsfield are being used frequently for wavelength checking, and so less time is available for their use as American relay points.

### Your Transatlantic Guide

I should remind you that *anybody* on *any* telephone can make use of the transatlantic system. The complete Post Office Guide, which costs only a penny, and which can be had at any branch Post Office, gives you all the details of the wireless service to ships and nearly every country.



**A HISTORIC CALL**

A Post Office official making the first call between London and New York at the beginning of 1927. He is at the London technical control position

taken, in at least one direction, without the help of official Post Office apparatus.

The extreme reliability of the transatlantic tele-

## The Love-lorn Announcer

Before the news I will digress  
And first give out this SOS.  
Will Kitty Jones of 23,  
Orlando Terrace, write to me?  
She's tall and slim, complexion fair  
Has large blue eyes and golden hair.  
Her teeth are perfect and her lips,  
Her face would "launch a thousand ships."  
Her voice is like a blackbird's trill.



She has, to make her sweeter still  
A dimple in one pretty cheek.  
I have not seen her for a week.  
She may be suffering, you see,  
From loss of interest in me,  
But will she, please, communicate  
With me before it is too late—  
In correspondence she is slack—  
Because I have a "heart" attack!

LESLIE M. OYLER.



Value of the Wetted Finger! :: Low-frequency Stability :: Automatic Volume Control ::  
Percentage of Modulation :: Fancy Aerials

**W**HILE it is possible to spend almost any amount of money on laboratory instruments for making and testing sets, one of the most useful of all is the human finger—wetted!

I have been privileged to visit some of the most famous research laboratories in the world—places where the most sensitive and costly instruments are immediately available when required—but do you think the wet finger is ignored in such places? Not a bit of it!

Of course, you have to be careful where you use it, for poking round in this way with a mains high-tension unit may lead to trouble. But you will not do yourself any harm on an ordinary battery-driven receiver with 100 or 120 volts high tension. Where more voltage is used or where the set is mains driven, experience and discretion are required.

The chief test that can be performed with a wet finger is to discover whether the receiver is oscillating. When a valve circuit goes into oscillation there is usually a sudden increase in the plate current and similarly when it stops oscillating the current returns to its previous value.

#### Change of Current

Any sudden change of current through a loud-speaker or telephone headset will produce an easily recognisable click or "plock," so let us see how the wet finger helps us in ascertaining whether or not the set is in the oscillating state.

Before proceeding further, it is interesting to consider why we should

wet the finger before performing tests of this kind. The reason is that in the case of most people in normal health the dry skin offers a very high resistance to the flow of current. The high-frequency currents with which we are dealing in radio do not penetrate beneath the skin and therefore the resistance of the skin itself is an important factor.

#### Low Skin Resistance

By moistening the skin we lower the contact resistance. People vary tremendously in their skin resistance, just as they do in their resistance to new ideas. People whose skin is habitually moist can perform these tests usually without wetting the finger, for their skin resistance is low.

One of the simplest tests to find whether a valve circuit is oscillating is to moisten the finger tip and tap the grid terminal of the valve holder or any part of the grid circuit, such as the terminal of the coil or the particular side of the variable condenser connected to it.

If the set is oscillating you will hear in the loud-speaker a "plock" when you touch the grid terminal and an identical sound when you remove your finger from it. Both of these noises, as we have seen, are due to the change of current brought about by the stopping and the starting again of oscillation.

A similar sound can sometimes be heard when touching the grid circuit of a valve which is not oscillating, particularly when you have considerable magnification following it. If you get a sound or even a pronounced

"plock" when touching the grid circuit, but *no sound* when you remove your finger from it, then the set is *not* oscillating.

Being of an inquiring mind, you will probably wonder why it is that by touching the grid terminals of valves with your finger, with the rest of your body unconnected to any other part of the circuit, any effect can be produced, for no complete circuit seems to be formed.

Actually, however, the surface of your body has a very large capacity to earth and to the rest of the set, and the additional "load" applied to the circuit in this way is generally sufficient to stop oscillation.

Recently I have been doing a good deal of work on the subject of low-frequency stability and obtaining high quality in the low-frequency stages of a set.

#### L.F. Stability Assumed

It is a rather strange fact that engineers and designers for some time have been spending a great deal of energy in obtaining stability in the high-frequency end of a receiver, assuming—far too many of them—that the low-frequency end can look after itself.

Most of us can recognise when the low-frequency end of a set is oscillating, for the oscillations are in the majority of cases at audible frequency, making themselves heard through the loud-speaker, not only to us, but to most of our neighbours!

A set in this condition is, of course, unusable, but what is practically the opposite of low-frequency

## IN MY LAB ARMCHAIR—Continued

oscillation—namely, complete audio-frequency stability—is comparatively rarely obtained.

What often happens is that the audio-frequency end is, so to speak, "halfway" between complete stability and oscillation, enough reaction occurring in the circuit to spoil the quality without actually making the set howl.

### Squawking Noise

Sometimes, when a set is rather unstable, and yet is not oscillating, touching parts of it with the wet finger or even with the dry finger will add to the inherent feedback sufficiently to send the set into oscillation with the appalling squawking noise we know so well.

This is more particularly the case now that valves themselves have improved so greatly in efficiency and when one can get such tremendous gain per stage.

It does not therefore follow that the wet-finger test can always give useful information regarding oscillation at the low-frequency end, but it often does so when you get that puzzling state of affairs due to the low-frequency stages oscillating at a super-audible frequency, say 12,000 or 15,000 times a second, which is above what most of us can hear.

The general manifestation of such a state of affairs is that the quality is thin and very poor, and the strength is far below what it should be. In such cases the wet finger on the loud-speaker terminal will frequently give the double "plock" effect.

One of the best cures for instability of this kind (although it is not infallible) is a sheet of copper or aluminium underneath the detector valve and the low-frequency end of the set, this sheet being connected to the earth terminal of the set. There is no need to alter any wiring or to remove components from the baseboard for the piece of metal can go underneath the baseboard without disturbing anything.

British radio manufacturers have made a lot of progress in the last year or two—I think I can say that the technical progress in the last twelve months has been greater than at any previous period in the history of the industry—but for some reason or other practically nothing has been done with the development of automatic volume control.

American manufacturers are well aware of its advantages and a large number of their receivers are now so fitted.

The handling of such a set for the first time is quite a fascinating business, for as you turn the dial dozens of stations come in, all at approximately the same strength.

The great advantage to the ordinary listener is that when using a sensitive and highly selective receiver you do not suddenly come across a station which roars at you and nearly breaks your ear drums, particularly when you are trying to get distant stations which you know will be weak.

There is a hand control of volume,

used mainly to adjust the strength to what you require, and once you have adjusted this on a station so as to give a pleasant volume, the strength so obtained will remain the maximum for any others, however sensitive the set may be.

The circuits used for automatic volume control are, many of them, rather complex, but practically all are based on the control of the grid bias of an early valve in the set by the strength of the carrier wave in the plate circuit of a later valve.

### Increased Voltage Drop

As you know, the plate current can be made to flow through a resistance and the more current that flows through this resistance the bigger will be the voltage developed across it. Thus we can arrange our circuit so that strong signals will develop a fairly high voltage across the resistance and give a high grid bias to an earlier valve, thus cutting down its amplification.

By a suitable choice of constant the output from the receiver can be kept at a remarkably uniform level, how much or how little of the change of voltage in the resistance is applied being dependent on the setting of a hand control.

There are very many interesting problems, both technical and practical, in connection with automatic volume control on which I did a good deal of work in the United States last year.

It is the custom over there to make receivers extremely sensitive, not



**LISTENING ON A CANADIAN TRAIN TO RELIEVE THE TEDIUM OF TRAVEL**  
*The Canadian National Railways have many radio-equipped trains for the benefit of long-distance travellers. This particular compartment also contains a small library*



## EXCLUSIVE TO "W.M." BY PERCY HARRIS

with a very great efficiency of the stage, but merely by using more valves, one popular receiver using as many as eleven. In a properly designed automatic-volume-control set the receiver is in its maximum state of sensitivity "between stations," that is to say, when the dial is adjusted to a position on which there is no transmission whatever.

#### Insensitive to Locals

As, however, we tune in to a station, so a certain amount of automatic bias is applied to an early valve and when we are tuned in exactly to a powerful local transmission the receiver is in a very insensitive state. Thus strong signals keep their own strength down.

When automatic volume control was first introduced into one manufacturer's receivers, complaints were received from dealers and customers that the set was both noisy and insensitive compared with others. This was not really the case, but the customer got this impression owing to the different way in which the two types of receiver are used.

In a set without automatic volume control the dealer usually manipulates the tuning dial in conjunction with the volume control, turning down the volume very considerably as he approaches a local station; or if he is only tuning in to a few stations to demonstrate quality and general sharpness of tuning, then the set is never turned up to its maximum sensitivity and the noise and mush, static, mains interference, and all those other things which show up in a very sensitive receiver, are kept at a very low level.

#### Apparent Sharpness

Furthermore, as in tuning he approaches a local station with the volume well down, nothing whatever is heard of this station on the "tails" of transmissions, but only when it is dead in tune. This gives an appearance of great sharpness.

In the automatic-volume-control set, as the dial is turned between stations, all the mush and background noises are heard, and as one approaches the "tails" of the local transmission they are heard at the strength at which the manual volume control has been set.

Then, as the dial is turned, and we come more and more into the "middle" of the local transmission,

if I may express it that way, the volume is progressively kept down to the correct level, and so, over several degrees of the dial, the local station is heard at uniform strength, being lost only when we have passed the "tails."

Thus a local transmission may be found to spread over four or five degrees on the automatic-volume-control set, and yet may seem to cover only one degree on the manually controlled receiver, but actually, of course, if the manually controlled receiver were turned up to its maximum sensitivity you would hear the local transmission over at least as many degrees, the volume being about correct on the "tails," but tremendously overpowering in the middle.

A still further problem relates to the percentage of modulation of the transmitter. In America, all the leading stations are practically 100 per cent. modulated and the aim of all stations is to get the highest practical percentage of modulation.

In such cases automatic volume control works well, but in Europe (particularly in many Continental stations) the percentage of modulation varies widely, some being very deeply modulated and others only slightly so.

With automatic volume control, the actual control of the volume is dependent on the strength of the carrier wave and if the setting of the manual control is such that 100 per cent. modulation station sounds right, then a station with only 20 per cent. modulation would be too weak (assuming, of course, that the strength of the carrier wave of both is equal).

However, the whole subject is very interesting and opens up a wide field of experiment for the advanced amateur.

In my notes last month about aerials I mentioned that in most cases I have found it rarely worth while erecting more than one wire for normal broadcast reception and this reminds me that recently a friend

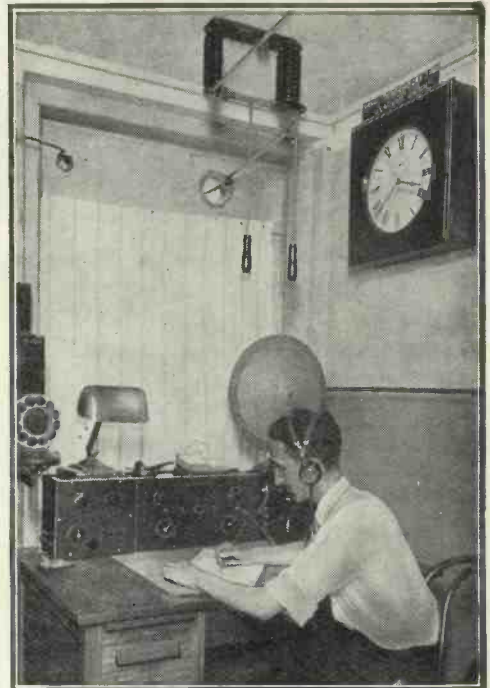

AN EXPERIMENTAL U.S. STATION

A complete transmitting and receiving station. Note the lightning switch from the transmitting aerial to the left of the clock. The glass lead-in insulator can also be seen

wrote to me asking my opinion about the various "fancy" aerials about which all kinds of extraordinary claims are made.

Most of them are quite depressingly ordinary in the results given when measurements are made.

#### No Magic Properties

Actual comparisons, particularly of the indoor type of aerial, are very simple. Many people, particularly with modern sensitive receivers, do not realise what extraordinary good results can be obtained with a simple aerial made of a piece of bell wire taken round the picture rail. They may be led to pay an extravagant price for some "fancy" indoor aerial and on connecting it to the receiver get really wonderful results, which leads them to attribute the success to some magic properties in the new aerial.

If, however, they tune in a station on this type of aerial and then remove it and substitute a piece of bell wire round the room, they will find in most cases just as good results.

There are, however, some very useful devices which may seem  
(Continued on page 535)

# Possibilities of the HIGH FREQUENCY PENTODE

BY S. RUTHERFORD WILKINS

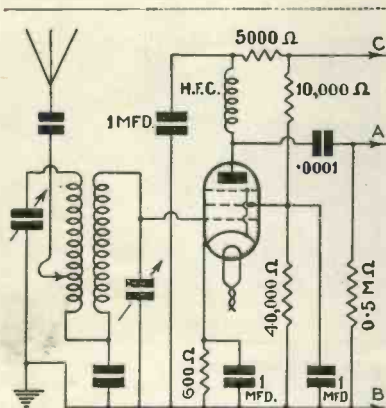

Fig. 1.—Essentials of a circuit for high-frequency amplification. A goes to detector grid; B to high-tension negative; and C to positive

**D**URING the past few years great advances have been made in tuned high-frequency amplifier design, but very little attention has been given to the design of an efficient untuned amplifier.

In the old days of triode valves choke- or resistance-coupled stages were practically useless for high-frequency amplification and often a set employing a single untuned stage gave less amplification than if the stage were omitted.

### Reason Obvious

The reason for this is obvious when one considers the various factors which affect the amplification of a valve under choke-coupling conditions.

The amplification given at any frequency by a valve is shown by Mag. factor of valve  $\times \left( \frac{Z}{A+Z} \right)$  where  $Z$  is the impedance in ohms in the anode circuit of a valve of impedance  $A$ .

Now the impedance of a high-frequency choke is not constant and, whereas it may be 100,000 to 200,000 ohms when dealing with long-wave

signals, it drops to 10,000 to 20,000 ohms when medium-wave signals are being received.

Thus it can be seen that by using a valve of 40,000 ohms impedance as a choke-coupled amplifier, about five-sixths of the amplification of the valve is theoretically obtainable on long waves, but on medium waves only about one-quarter of this amplification can be obtained.

Also, as the interelectrode capacity of this type of triode is of the order of 5 micromicrofarads, the damping introduced on the preceding tuned

signals, it drops to 10,000 to 20,000 ohms when medium-wave signals are being received. However, and it can be seen that on medium waves less than one-twentieth of the amplification factor of the valve is theoretically obtainable, and when this is reduced by incidental circuit losses the stage is rendered useless.

### Constant Stage Gain

It might be argued that if a resistance were used instead of a choke in the anode of the screen-grid valve, the anode-circuit impedance would be constant at all frequencies and therefore the stage gain would be constant over the whole wave band.

In order to get any appreciable magnification from the valve, though, this anode resistance must have a value of 150,000 to 200,000 ohms and therefore to ensure sufficient voltage on the anode of the valve a high-tension supply of about 750 volts would be needed. This would render the set both dangerous and of prohibitive cost.

### CHARACTERISTICS OF THE COSSOR HIGH-FREQUENCY PENTODE

Type .. .. .	MS/PEN-A
Heater Voltage .. .. .	4
Heater Current (Amperes) .. .. .	1
Mutual Conductance .. .. .	4 ma/V with 100 volts on anode, 100 volts on screening grid and 0 volts on grid
Interelectrode Capacity .. .. .	Of the order of .0045 micromicrofarad
Maximum Anode Voltage .. .. .	200
Maximum Auxiliary Grid Voltage .. .. .	150
Anode Current with maximum anode voltage, maximum screen voltage and 2.5 volts grid bias .. .. .	9 milliamperes
Bias Resistance for above conditions .. .. .	200 ohms
(The mutual conductance is maintained under working conditions)	

circuit is equivalent to a parallel resistance of some 20,000 ohms. This resistance has the effect of reducing the efficiency of the coil to a very low level, with consequent reduction of magnification and selectivity.

The introduction of the screen-grid valve with its low interelectrode capacity appeared to give some solution to the problem. The damping introduced on the preceding tuned circuit by the screen-grid valve is negligible, and this source of loss of magnification is therefore eliminated.

The impedance of this type of valve is of the order of 200,000 ohms,

The ordinary pentode has a reasonably low impedance combined with a high magnification factor, and at first sight seems to be an excellent valve for a choke-coupled high-frequency amplifier. Unfortunately, however, the interelectrode capacity of the ordinary pentode is so high that the damping imposed on the preceding tuned circuit is excessive.

It therefore seems that the ideal valve for untuned amplification would be one combining the characteristics of the pentode with those of the screen-grid valve. Accordingly a

valve was designed having three grids, one being earthed as in the ordinary pentode. The anode connection of this valve was brought out to a terminal on the cap, as in a screen-grid valve. The result was extremely encouraging.

**Commercial Job**

A. C. Cossor, Ltd., have lately put on the market a valve employing this principle and having an approximate impedance of 40,000 ohms and a magnification factor of 150 when used under optimum conditions. Furthermore, the interelectrode capacity of this valve is only of the order of .004 micromicrofarad.

These figures are taken with 150 volts on the screening grid of the valve and about 200 volts on the anode. Owing to its low impedance, this valve can comfortably handle a grid swing of 3 or 4 volts without overloading and giving rise to rectification and its attendant evils.

Under suitable conditions this valve presents a very desirable medium around which to build a choke-coupled high-frequency stage.

**Circuit Essentials**

The essentials of the circuit are given in Fig. 1. It will be seen that a band-pass filter is used before the high-frequency pentode in order to provide adequate selectivity. The high-frequency choke should be a good one, and should have an inductance of not less than 200,000 microhenries.

The condenser and grid leak should be given normal values and, assuming that a power-grid detector



**TURNING OUT SETS AT THE RATE OF 240 AN HOUR**  
That is what can be done at the Kolster Brandes works at Sidcup. Our photograph shows visitors to the factory watching a receiver being tested before being despatched

**CHARACTERISTIC CURVE OF THE COSSOR MS/PEN-A**

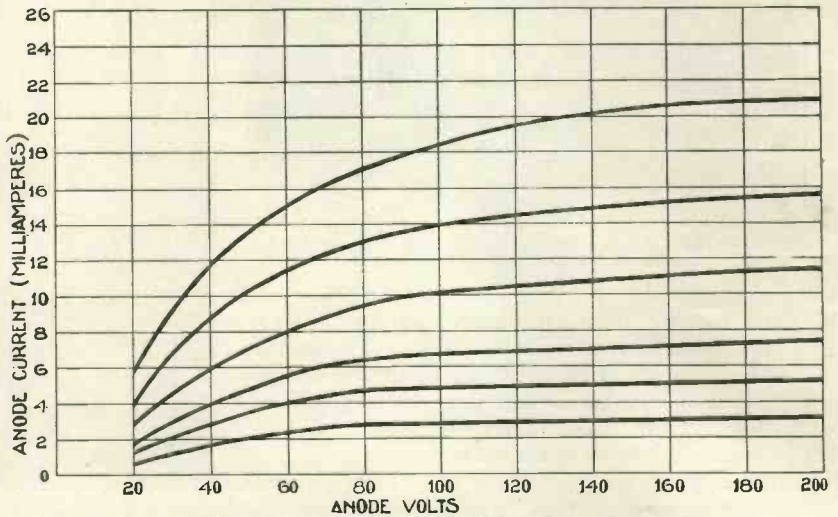

This curve shows the anode volts/anode current characteristics of the new Cossor high-frequency pentode. For high-frequency amplification it is operated at a grid bias of about 4.5 volts

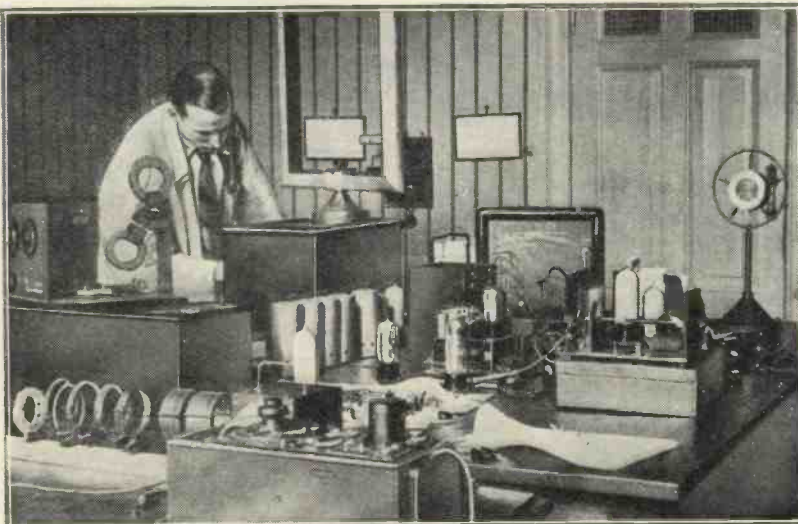

**A GERMAN RESEARCH WORKER'S LABORATORY**

Herr Manfred von Ardenne is reputed to have the largest private laboratory in Berlin; it occupies a spacious three-storeyed house. Here you see one of his assistants at work

is to follow the stage, values of .0001 microfarad and .5 megohm should give the best results.

I have recently built an experimental three-valve A.C. set employing a high-frequency stage of this description which has given very good results, and I hope to publish full details of a similar set in the near future.

**Obvious Advantages**

The advantages of choke-coupled high-frequency amplification in a simple set are obvious. There is a great saving of space owing to the small number and size of the coupling components needed. Ganging is simplified—a great factor in these days of one-knob control—and cross-modulation and other troubles due to restricted grid swing are eliminated.



THE B.B.C. LEAVES SAVOY HILL AND—  
The scene of the B.B.C.'s activities for six years; the old headquarters in Savoy Hill, just off the Strand

NOW that the B.B.C. has practically completed its transfer to the new premises at Broadcasting House we can look back upon the Savoy Hill days and become reminiscent. Let us recall some of the more humorous happenings.

Leonard Henry was once putting on a special Scottish programme for Twelfth Night, and one of his characters was obviously a Scotsman, complete with bagpipes. The particular gag which he was employing was the bursting of the bladder, or whatever the air container is called, by the over-enthusiastic efforts of the piper.

#### Compressed Air

As it was out of the question to burst a real bladder, or to guarantee that if one did the noise would be realistic, he hired a compressed-air cylinder and arranged for an assistant to open the cock at the psychological moment.

Any fears he may have had that the air would not make sufficient noise were instantly dispelled, for there was such a rush of air that all the precious draperies and curtains were blown across the studio, papers were sent flying hither and

thither, even music stands were overturned, and, as for the ladies' dresses—!

To make matters worse, it was impossible to turn off the cock and Leonard Henry was obliged to stand helplessly by watching his schemes go up in pandemonium until the escaping air had spent its force.

Stuart Robertson told me an amusing incident concerning Miss Alice Moxon. One Sunday afternoon she was appearing with Albert Sand-

The B.B.C. has now moved from Savoy Hill to its new quarters in Portland Place. In these notes are recalled some amusing incidents that occurred at the former G.H.Q. of British broadcasting. They concern broadcasters well known to all listeners

# Savoy Hill's Best Stories

By FRANK ROGERS

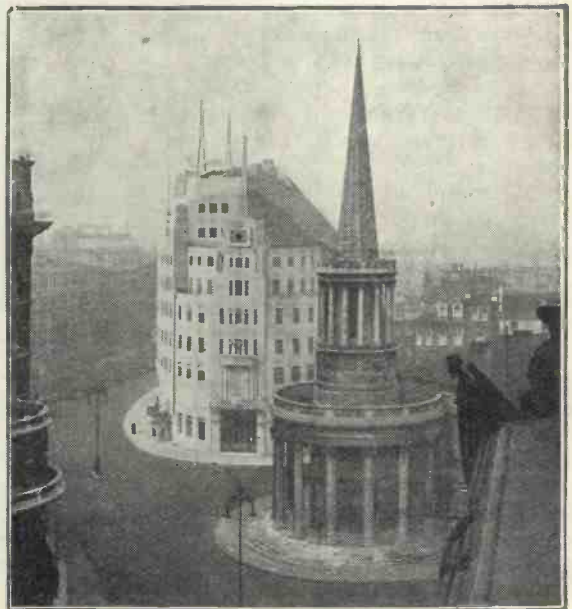

—MOVES TO PORTLAND PLACE  
A fine view of the B.B.C.'s new quarters at Portland Place, Regent Street. The church in the foreground is All Souls

ler and, as is often done, he tried to leave the studio before she started to sing. So quickly did she begin, however, that he could not reach the door in time and he was obliged to sink into the nearest chair.

#### More than Looking

After a moment or two he became aware that she was looking at him over the top of her music. As he exchanged glances with her he realised that she was doing something more than just looking at him. Obviously he had annoyed her. He wished he had managed to leave the studio in time, but it was too late, and the only thing he could do was to apologise the moment the microphone was cut off.

After spending an unenviable ten minutes under the force of her eyes,

he was intensely relieved when the red light told him it was safe to speak. "I am so sorry, Miss Moxon," he began, but she cut him short by interposing, "Oh, I didn't mind your being in here, but you sat on my hat all the time!"

This story has an amusing sequel. Two years later Albert Sandler was staying for a week-end in the country with Stuart Robertson and some friends. Late in the evening they all sat round the fire swapping yarns and Sandler recounted his experience.

**Unexpected Sequel**

"Jolly funny, don't you think?" he asked Robertson. "Yes," he replied, "but it's an old one to me. You see, Miss Moxon happens to be my wife now!"

And now for a story from Tommy Handley. In one of his Radio Revues he had a scene in which a policeman blew his whistle in a room and his brother officers answered from some little distance down the road. He had a man in the studio to take the part of the first policeman and, muttering his thoughts aloud, said: "Yes, now all I want is another man to blow a blast just outside the door."

But his over-eager colleague thought he could do both jobs at once, and urged Tommy to give him the chance to show that it was quite possible for him to blow the first whistle in the studio, and then rush out of the door in time to give

the answering blast in the corridor.

**Great Confidence**

It seemed rather a difficult feat to try to perform, but he was so persistent that he was given the chance. Alas! his efforts ended in complete confusion, for he no sooner took his first flying step for the door than he caught his foot in the leg of the microphone and went crashing to the floor. The whistle was forced partly down his throat and he uttered some of the strangest sounds ever heard in a studio.

As Tommy Handley said when he told me the story: "Thank Goodness, it was only a rehearsal!"

Here is an amusing incident which must be kept anonymous for obvious reasons. A certain show required a cornet solo, and the instrumentalist selected for this task happened to possess two sets of false teeth. When he was in the middle of his solo word came from the listening cabinet in the studio that he was playing far too loudly. Without wasting a second more than he could help the producer dashed across to him and



**LEONARD HENRY WON'T LEAVE THE MIKE!**  
You must read about this popular artist's adventures with a compressed-air cylinder as told by Frank Rogers in these pages

together with a desperate effort, he found his wind again. But his nerves were in such a ragged state that he had no idea what he was doing.

His only concern was to get some sound out of his instrument if he had to blow himself inside out to do it. And blow he did. So much force did he use that his false teeth were loosened from their position and sent hurtling across the studio!

Studio audiences have been responsible for some humorous incidents from time to time, but I doubt if ever the following case has been beaten for the sensation it caused at the time.

An actor was suffering from that common professional complaint, a sore throat, and one of his friends brought in a bottle of cough mixture just before his cue arrived.

**Realistic Imitation**

He had barely time to swallow a draught before he had to speak his lines. "Help! Help! I am dying. Help!" he shrieked. So realistically did he imitate a dying man that one lady in the studio audience actually thought he had taken poison in mistake for medicine, and rushed from her seat to render first aid.



**ALBERT SANDLER**

Every listener knows this fine violinist. He once figured in an amusing incident with Alice Moxon, as explained in these notes



**ALICE MOXON**

This well-known singer often takes parts in broadcasts with Albert Sandler. She is married to Stuart Robertson

waved his hands excitedly to make him play softer.

Unfortunately, this so upset the poor fellow that he became temporarily paralysed and for a moment no sound of any sort came from his cornet. Then, pulling himself

## SAVOY HILL'S BEST STORIES—Cont.



**OLIVE GROVES**

*This popular broadcaster once came to the rescue by whistling a solo—for the first time in her life!*

The resulting scene is difficult to describe with the pen, for it was a mad, feverish attempt to prevent her shouting something which would have gone out into the ether. Someone forced his hand across her mouth, and several more grabbed her as best they could. Everyone who was not actually at the microphone made the most violent signals they could to tell her that his words were part of his character.

### Moments like Centuries

Although scarcely a sound got into the programme it was some moments before they succeeded in quietening her—moments, I might add, that seemed like centuries.

Miss Olive Groves recalls an occasion when she was playing in a sketch which included a baby. Part of the plot was the difficulty of getting the baby to go to sleep. Various methods were tried, but all in vain, and they arrived at the point where, according to plan, they were to accomplish their object by playing "Home, Sweet Home" on a penny tin whistle.

### Missing Whistle

But, when they looked round for the whistle, it was nowhere to be found. For a moment they stood helpless, looking hopelessly at one another, and then with one accord they all turned to Miss Groves and motioned to her to do the whistling. Why they should all have decided to do this none of them ever knew,

nor does Miss Groves know why she fell in with their totally unfair desires.

But whistle she did, although she had never done such a thing in her life before. As she says, it was a good job it was only a studio "baby," for she is sure no real one would ever have gone to sleep to such an awful accompaniment.

In the early days of broadcasting producers used to try to make a studio look like a stage or concert platform, because most of the artistes were drawn from the older forms of entertainment and it was thought best to make them feel they were in their natural element. A little dais was constructed and limes placed so as to produce a spot light in the middle. The rest of the studio was then darkened, and, when the artiste approached the microphone, he walked out into the limes.

This sometimes gave rise to amusing incidents, one of which concerns a midget who was giving a tune on his ukulele. He was making the mistake so many broadcasters do even to this day—standing too far away from the microphone. This fault so spoilt his performance that the producer felt bound to bring him closer.

Accordingly he stretched out his hand to grasp his arm. As it was completely dark except for the spot where the midget stood all that the other people in the studio saw was a ghostly hand steal out of the darkness and grasp him by the bow he was

wearing round his neck and tear it off, pulling away the shirt front as well and undoing most of his waistcoat buttons.

### Visitors at Savoy Hill

I must include a story of a visitor to Savoy Hill, but there are so many that it is difficult to make a choice. One of the best concerns a rather stolid individual who dragged along at the rear of the party and made a point of asking a question just when everyone else was ready to move on to the next studio.

In one room he was noticed to be staring hard and long at the microphone and the cicerone felt obliged to ask him if there was anything he could explain.

"Yes," said the man, "I know this is what makes the noises, but where is the handle?"

"Oh," was the reply, "we always take that off when a party is being shown round the building because so many visitors try to take it home as a souvenir."

### Childish Questions

Another visitor—he must have been the cousin to the first one—absolutely inundated the guide with questions, mostly of an extremely childish nature. When he saw his first microphone he wanted to know what the lead was for.

"Oh, that!" answered the official, "why, that is just to tie the microphone on in case someone tries to take it away."

## THE WIRELESS ZOO

### The Snubber

*The Wireless Snubber is indeed  
Related to the peacock breed;  
He spreads his "tail," i.e., his set.  
"The very finest one can get,"  
He tells you with a pompous air,  
"Unlike that poor thing over there—  
Oh, that is yours? I didn't know.  
I scrapped my straight set years ago!"  
If you have six valves he has eight—  
The peacock is a bird I hate!*

LESLIE M. OYLER



# WE TEST BEFORE YOU BUY

A WORD TO THE WISE

By the "W.M." Set Selection Bureau

FROM letters coming in to the Set Selection Bureau it seems that question No. 4 of the specification panel that appears on this page is frequently misunderstood. You are asked to state whether a self-contained set, *with or without aerial*, or an ordinary set with external accessories, is preferred. What exactly are the alternatives?

### Self-contained Sets

For a start you can have an entirely self-contained set, with the valves, loud-speaker, frame aerial and power supply all contained within the cabinet. Such sets, among mains-driven models, are rare, though many excellent portables of the battery type are still available.

Next there are self-contained sets with external aerials, that is sets having everything in the cabinet *except* the aerial. We call such sets consoles, and these can be either table or pedestal cabinet models.

Then there are still a few sets that are by no means self-contained, in which the cabinet houses only the set. Such sets need external batteries, loud-speaker and aerial to complete the installation.

### Possible Alternatives

Thus we arrive at the conclusion that you must want either a self-contained set *with aerial inside the cabinet*, or a self-contained set *with an external aerial*, or a set with *all external accessories*. Will intending set buyers please make it clear which type is needed when writing to us for advice?

Just one further point to note in

deciding this aerial question; many of the consoles advertised as needing an external aerial work quite well with the mains-aerial attachment. Then only an earth is required to bring in a fair number of foreign stations at good strength. Flat-dwellers should bear the mains aerial in mind.

### FREE ADVICE TO PROSPECTIVE SET BUYERS

To take advantage of this service it is necessary only to mention (1) the maximum price and whether this is for a complete installation or the bare set; (2) where the set will be used; (3) what particular stations are desired; (4) whether a self-contained set with or without aerial, or an ordinary set with external accessories, is preferred; and (5), in the case of mains-driven sets, whether the mains are A.C. or D.C.

A stamped-addressed envelope for reply is the only expense. Address your inquiry to Set Selection Bureau, "Wireless Magazine," 58-61 Fetter Lane, E.C.4. There is no need to send any coupon, but it is essential to give the information detailed above on one side of the paper only. Tell your friends about this useful service.

Although the battery-operated portable can never hope to regain the extraordinary popularity it enjoyed a year or two ago, it still has a great utility, not so much for the picnic or river party but in houses where there is no electricity.

Thanks to the development of the "economy" pentode, the modern battery-operated portable can give enough volume to fill the average

living-room without over-running a standard-capacity high-tension battery.

### Worth Considering

And the extreme sensitivity of the latest screen-grid valves more than offsets the limitation in range that used to be imposed by the portable's frame aerial. In every way the modern portable is well worth considering, especially as this is the only type of battery set the manufacturers have made any attempt to develop.

We have been asked whether there is any technical objection to a console type of set for battery operation. Of course there is not—in fact we are mystified at the entire absence of this type of set from the season's range. So far as we know there is not a single battery console on the market giving really good quality.

### Pentode Advantages

With the modern pentode, giving ample power output for a minimum expenditure of battery current, and the equally modern permanent-magnet moving-coil loud-speaker, why, oh why, is there no such set on the market?

Many readers have asked us to recommend them to makers of this type of set; will some enterprising manufacturer get one ready for next season? The Golden Age of Universal Electricity is not yet here—not by at least half the population. So why concentrate entirely on the mains set?



# H.M.V. Table Radiogram for D.C. Mains



**ACCESSIBLE CONTROLS**

All the controls of the H.M.V. table radiogram are fitted on the motor board with the exception of the volume control. Note the felt-lined lid which prevents pick-up chatter



**FINISHED IN WALNUT**

The complete set is housed in a handsome walnut cabinet. Good reproduction is assured by the permanent-magnet moving-coil loud-speaker fitted behind the ornamented fret

**T**HIS instrument is technically interesting because it makes use of the recently developed indirectly-heated valves for D.C. mains. These valves, as this radio gramophone has clearly shown to us during tests, enable high efficiency to be obtained—comparable to the results given by A.C. valves, and, what is perhaps equally important to the user, these valves take the minimum power from the supply.

We are able to say, after prolonged tests of the instrument down at Dorking, Surrey, that the high standard of performance

**BRIEF SPECIFICATION**

**MAKER:** The Gramophone Company, Ltd.

**PRICE:** 29 guineas.

**VALVE COMBINATION:** Screen-grid (Marconi DSB25), detector (Marconi DH metallised) and pentode (Marconi DPT).

**POWER SUPPLY:** D.C. mains, of voltages from 190 to 250. Note: this type of set cannot be used with 100-volt supplies.

**POWER CONSUMPTION:** Varies with supply voltage from 90 to 110 watts. These figures include the power taken by the gramophone motor. Without this in action the power consumption is only 50-65 watts.

**TYPE:** Table radio gramophone with D.C. mains valves.

**REMARKS:** An outstanding instrument for D.C. mains. The indirectly-heated valves provide high efficiency with economy of working.

obtained on the original model (for A.C. mains) is more than maintained. There is the further point that mains hum is entirely subdued—not the slightest trace of background could be detected even when listening carefully.

Let us briefly run over the main points of the instrument, which

is as compact as a radio gramophone could be. The basis is a three-valve circuit with band-pass tuning, controlled by a gang condenser and a separate aerial trimmer. This chassis drives a permanent-magnet moving-coil loud-speaker which is housed with the set chassis inside

the cabinet. On the top is the gramophone motor and such accessories as the pick-up, needle cup and most of the controls.

When setting up the instrument we noted the provision of heat-dissipating holes in the back of the cabinet. Even after being in operation for an hour or so this radio gramophone does not run very hot—another advantage of the low-consumption valves.

The method of adjusting the mains resistance to suit the supply voltage is quite simple, as is the adjustment of the motor resistance. We soon found that plenty of volume could be obtained from the loud-speaker which, on full-load conditions, gets just one watt undistorted power from the pentode. The loud-speaker is sensitive indeed, and there is enough volume to dance to quite comfortably.

Record reproduction on this instrument lives up to the tradition now so firmly established by H.M.V. There is plenty of rich bass—but no boom. This is rather surprising in view of the general compactness.

The volume-control knob on the right-hand side of the cabinet works a two-gang potentiometer, so that radio and gramophone output are independently controllable. This control makes little difference to the quality.

**Very Selective**

On the radio side the D.C. version of the H.M.V. radio gramophone does extremely well, enabling a dozen or more stations to be tuned in without fuss or bother, simply by turning the calibrated dial to the wavelength of the station you want. Then, with a little more expert treatment of the trimmer knob, you can materially add to this log. We got thirty stations on the medium waves—which is all anyone could want.

Toulouse was clear of London Regional, and Heilsberg was clear of the National.





# Ferranti Screen-Grid 3 <sup>for</sup> Constructors

WE have been supplied with a completely-assembled model of the new Ferranti mains band-pass three-valver, produced to meet the needs of discriminating constructors wanting the latest circuit developments incorporated in an easy-to-make design.

This kit is definitely not in the cheap class, being designed for results rather than to a price. Still, in view of the quality of the components, and the inclusion of every circuit detail

most robust we have seen. It has three .0005-microfarad sections, so accurately matched that, with the coils used for the band-pass and intervalve coupling, that *no external trimmer devices are needed.*

Next we have to note the use of a step-up transformer between the screen-grid and detector valves, matched with the low-impedance Cossor valve. The values of the grid condenser and leak, .00015 microfarad and .5 megohm respectively, give distortionless detection up to the loading limit of the power valve following the detector.

Further points are the high-impedance low-frequency transformer, a Ferranti AF5, and the OPM8 output transformer giving good matching between the power valve and the loud-speaker.

Good results can be obtained with a high-resistance loud-speaker of the moving-iron type, or a low-resistance moving coil having an impedance of about 20 ohms.

Control is perfectly simple. Tuning is done with the single knob of the gang condenser. Volume is controlled by a series-aerial condenser. This has a cut-out contact. Reaction is controlled by a differential reaction condenser.

Tuning goes from 200 to 570 metres on

medium and 1,000 to 2,000 metres on long waves. The band width is claimed to be constant over the whole range, being of the order of 10 kilocycles on medium and 8 kilocycles on long waves.

### Great Output

Instead of the P625 power valve—recommended for the highest possible degree of quality, and giving nearly 1 watt undistorted power—a PT625 pentode can be used for still greater magnification.

On test we were impressed with the *absolute* elimination of mains hum. This is one of the most “silent-background” sets yet tried out. For this test we had to close the lid, which automatically completes the mains connection through a safety-switch device.

The test was made with a good-class moving coil of the correct impedance, and the makers' great care in circuit design is amply repaid by the really fine quality of the reproduction. The P625 power valve gives more than enough volume.

### First-rate Tuning

With regard to the tuning—this is first rate. The band-pass action is well defined, stations having a sharp cut-off on each side of the degree over which they can be heard.

We had no trouble in getting twenty-seven stations on the medium waves, all clear of interference.

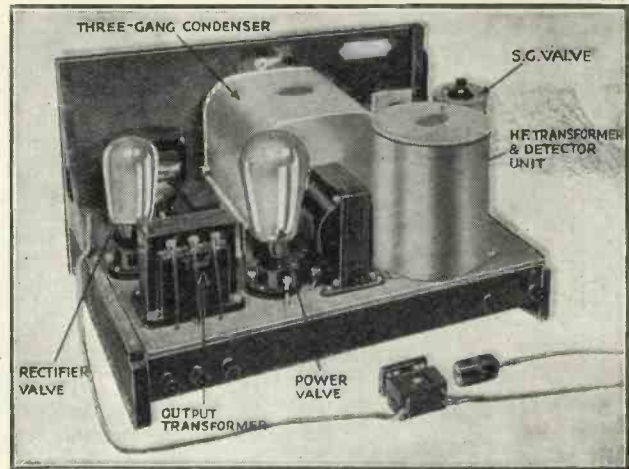

**DESIGNED FOR PERFORMANCE RATHER THAN PRICE**  
The Ferranti set has been designed to give the best quality regardless of cost. A specially screened box—shown on the right of the photograph—holds the intervalve coil and detector valve

#### POINTS ABOUT THIS KIT

**MAKER:** Ferranti, Ltd.

**PRICE:** £12 13s. 6d., including cabinet but not valves. With valves the kit costs £16 2s.

**VALVE COMBINATION:** Screen grid (Cossor MSG/LA), power-grid detector (Mullard 354V) and super-power output (Osram P625) with Osram U10 rectifier valve. Note: Pentode output optional.

**POWER SUPPLY:** A.C. mains, 200 to 250 volts.

**POWER CONSUMPTION:** 30 watts.

**TYPE:** High-quality three-valve kit for A.C. mains operation, with band-pass aerial tuning, and special matched tuning unit.

**REMARKS:** A kit for the connoisseur, giving quality above the average when used with a suitable moving-coil loud-speaker. The design is in advance of average commercial practice.

likely to enhance the perfection of the performance, the complete kit cannot be considered expensive.

As it is intended to interest “knowing” constructors, we think a few of the outstanding circuit points will be appropriate. The most important of these is the matched band-pass tuning circuit.

The tuning condenser is one of the

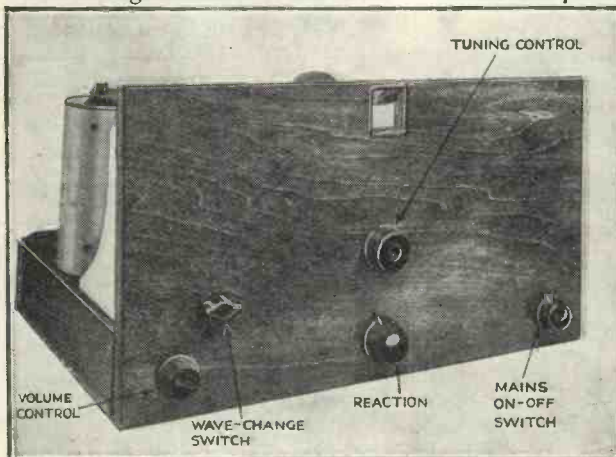

#### A WOODEN PANEL

All the controls of this set are fitted to a wooden panel. The controls have been arranged for efficiency



# Regentone All-electric Three

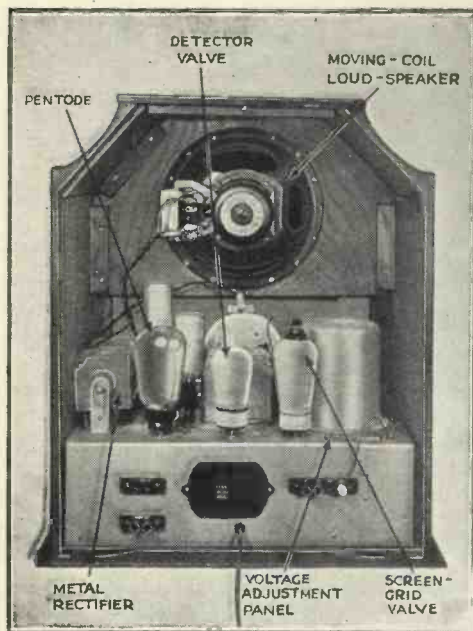

### WELL DESIGNED LAYOUT

An interior view of the Regentone A.C. Three showing the internal layout of the set. The Rola moving-coil loud-speaker fitted is of the energised type

ONE of the best examples of the three-valve console type of set is the new Regentone, which incorporates all the latest developments at a price within the reach of a very large number of listeners.

The layout follows convention in that the loud-speaker, which is of the mains-energised moving-coil type, is housed at the top of the handsome cabinet, with the three-valve chassis fitted below, so that the controls project through the front of the cabinet.

### Easy Access to Back

Access to the back is made easy by the undoing of just one terminal nut and pulling off the back section of the cabinet. Inside is one of the cleanest layouts we have seen.

The valves are easily inserted and the mains voltage tappings are the essence of simplicity. Altogether the installation is unusually simple.

The screen-grid, detector and pentode circuit is notable for the ample decoupling and smoothing. The screen-grid valve in this set provides distortionless control of volume. The detector works on the power-grid system. The pentode is tone-corrected. All three valves are indirectly heated, and all obtain their high tension and grid bias from a Westinghouse metal rectifier.

The loud-speaker is transformer coupled to the pentode.

Although there is no band-passing in the aerial circuit, the two tuned

The combination control knob at the centre is well designed, giving easy switching from medium to long waves, changing over from radio to gramophone pick-up, and switching on and off the mains.

The tuning scale is illuminated when the set is switched on, and is calibrated in both medium and long waves. The stations come in quite close to their marks on the scale.

### Good Selectivity

Selectivity is good for two tuned circuits. With a 60-ft. aerial, and using aerial terminal "A1"—for maximum volume—London Regional was eliminated by the time the scale had reached Toulouse above and Brussels No. 2 below.

London National had a much smaller spread, for we found it possible to get Trieste below and Turin above this local at good strength and clear of interference.

Terminal "A2" improved the selectivity, but only at the expense of volume. We got good separation between Langenberg, North Regional, and Prague.

Long waves were satisfactory. Daventry swamped Zeesen, but Radio Paris was quite clear, and came in at great strength.

We logged twenty stations on the medium waves at really enjoyable strength and quality, and with ease of control.

We commend the control of this set very highly. All the knobs work with admirable smoothness. It is a set likely to give lasting satisfaction.



### HANDSOME APPEARANCE

The set is housed in a neat-looking walnut cabinet. Note the convenient control knobs

circuits provided give very fair selectivity, showing that the aerial and tuned-anode coils have been carefully designed. A two-gang condenser is used for tuning, with a trimmer worked by a knob superimposed on the main condenser knob.

Control is delightful. The volume control on the left is especially good. Reaction on the right is smooth and effective in building up signal strength—on both wavebands.

### BRIEF DETAILS OF THE SET

MAKER: Regentone, Ltd.

PRICE: 16 guineas.

VALVE COMBINATION: Variable-mu screen-grid (Mullard or Mazda), detector (Mullard 354V or Mazda AC/HL) and pentode output (Mullard Pen4V or Mazda AC/Pen). A metal rectifier is used for the mains supply to the set.

POWER SUPPLY: A.C. mains, between 200 and 250 volts. Special models for 100-volt supplies and for 25-cycle periodicities.

POWER CONSUMPTION: 40 watts. TYPE: Self-contained table console, except for aerial and earth. Mains aerial attachment.

REMARKS: A well-designed set likely to be very popular among listeners wanting good-quality reproduction from a wide selection of home and foreign stations.



# Magnum Short-wave Adaptor

HERE is yet another of the short-wave units now so popular among broadcast-set owners wanting to try their luck on short waves. The Magnum is well designed, with a view to making it equally suitable for battery and A.C. mains sets.

## Using Existing Set

The idea is to make use of the existing set's low-frequency amplifying circuit, and to cut out the usual tuning circuit by inserting a plug adaptor in the detector socket. The pins of this adaptor carry the high- and low-tension connections of the unit detector valve, and also the anode connection.

Insertion of the adaptor in the set's detector holder, with the detector valve in the unit, readily converts the set from normal medium- and long-wave tuning into short-wave tuning, since the short-wave tuning circuit is connected to the unit detector valve.

With an A.C.-mains set the procedure is similar, but an additional connection must be made between the earth terminal of the unit and the earth terminal of the set. Another point—with the mains set the valves, if any, preceding the detector must be left in circuit, otherwise the detector and low-frequency valves may be overrun.

Although most suitable for sets comprising a detector and two low-frequency stages, this Magnum unit can actually be used with almost any set, including super-hets and sets with only one stage of low-frequency amplification.

As can be seen from the illustration, the unit is compactly designed, with a neat metal chassis let into the wooden container. The coil on the left is of the interchangeable six-pin type, carrying aerial, grid and reaction windings. The coil supplied with the unit covers a range of 40 to 80 metres, but an additional coil going

### BRIEF DETAILS OF THE UNIT

**MAKER:** Burne Jones and Co., Ltd.

**PRICE:** £1 19s. 6d.

**VALVE COMBINATION:** Detector valve, as used in existing set.

**POWER SUPPLY:** Batteries, as used in the set to which the unit is connected. Or if connected to a mains set the power usually used for the A.C. detector will be used when this valve is placed in the unit valve holder.

**POWER CONSUMPTION:** No additional power required to work the unit, since the detector valve in the unit is removed from the usual socket in the set.

**TYPE:** Short-wave adaptor specially suitable for sets with two stages of low-frequency amplification and little or no high-frequency amplification.

**REMARKS:** This unit should make a wide appeal to those wanting to listen on short waves with existing sets, whether battery or A.C.-mains operated.

Tests show that the reaction works smoothly with the average set, though there may be some threshold howl—instability at the point of oscillation—unless a suitable valve is used. A Mullard PM1HL gave good results with a battery set.

## Eliminating "Blind Spots"

The aerial coupler is simply a small variable condenser in the aerial lead. But it does much to eliminate those "blind spots" in short-wave reception. By the aid of this control it is possible to obtain oscillation right down to the lowest of the wavelengths covered by the small coil.

Very little of interest could be heard on the small coil, only Zeesen being logged among telephony stations. But with the larger coil a host of amateur and other telephony signals were tuned in at fine strength on the loud-speaker.

## Using Headphones

If there is only one stage of low-frequency we recommend the use of headphones, as many stations can be heard at good phone strength that would be missed entirely on the loud-speaker.

The control of the Magnum unit is free from snags, tuning being free from backlash, and reaction being smooth with the average type of detector valve. There was no noticeable hand-capacity effect during the operation.

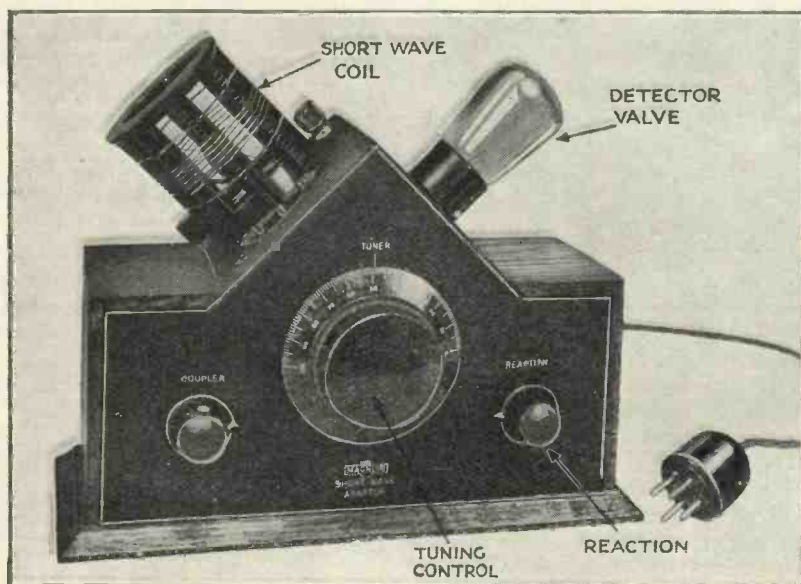

### WHY NOT LISTEN ON THE SHORT WAVES?

The Magnum short-wave converter can be used with either A.C. or battery-operated sets. A wave range of from 40 to 80 metres is covered by the coil supplied. An additional coil to cover from 18 to 40 metres can be obtained for 3s. extra

When using the unit with a battery-operated set all you have to do is to remove the detector valve from the set, put it into the holder on the top of the unit, insert the adaptor plug in the detector holder of the set and connect the aerial and earth to the two unit terminals.

from 18 to 40 metres can be obtained for 3s.

Tuning is done with the slow-motion dial at the centre, working a good-class short-wave tuning condenser. The two knobs on the left and right are for aerial coupling and reaction respectively.



# Graham Farish Amazing Three Kit Set

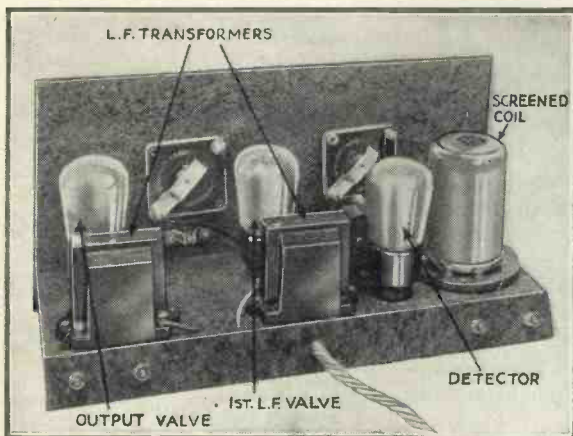

### SIMPLE TO BUILD

The constructor of the Amazing Three should experience no difficulty in building the set. The baseboard and panel are both made of bakelite

**T**HIS kit set was supplied to us ready assembled for test. There are several points of interest in the design. Outstanding is the use of a bakelite chassis for the mounting of the panel and other components. The front of the bakelite panel is engraved to show the functions of the knobs, and this engraving extends to the tuning and reaction scales.

Behind the panel, which carries the tuning and reaction condensers, which are both of the bakelite-dielectric type, and the wave-change and on-off switch, are fitted all the remaining large parts, such as the screened tuning coil and the low-frequency couplings.

Underneath the bakelite base are fitted many small parts, such as fixed condensers and resistances. Most of the wiring is done underneath, so the general appearance of the completed job gives one the impression of extreme simplicity.

### Simple Assembly Chart

We have carefully examined the assembly chart, and we think it is quite easy to follow. In addition to a clear blueprint layout of the parts there is a foolproof wiring chart, giving the point-to-point connections.

The makers claim that no tools other than the screwdriver and

spanner provided with the kit are needed for assembly. This is certainly one of the simplest kits we have examined.

Now for some of the results obtained during tests, which were carried out in south-west London with our standard 60-ft. aerial. The first point we noted was the selectivity of the screened tuning coil. It is always difficult to obtain really good

six stations (apart from the locals) on the medium waves, which is a very satisfactory performance for this type of set.

### Many Foreigners

North Regional at 8.5 degrees was a fair signal during daylight, and after dark many foreigners were heard at worth-while strength.

The reaction needs careful handling, and makes a great deal of difference to the volume. Even for the locals some reaction must be used, owing to the very selective tuning.

The wave-change switch is fitted very conveniently near the screened tuning coil, and when pulled out this switch enables the long waveband to be explored. We got Daventry at good strength at 7.5 degrees, and just above this Radio Paris was logged at medium strength. It was clear of the home station.

The quality of the reproduction is clean-cut, but depends to some extent, as the makers rightly point out, on the valves used. With the super-power Mullard and the Graham Farish Snap-type loud-speaker we obtained pleasing quality of both speech and music.

Although the selective tuning must cut high notes to some extent, it seems that

the low-frequency couplings of this kit more or less balance this effect, for the overall response is crisp.

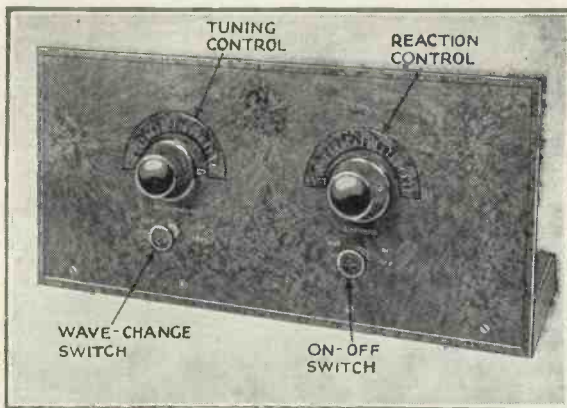

### EASY TO OPERATE

No difficulty should be experienced in operating the set. It is economical to run, the average anode current using the specified valves being only 8.5 milliamperes

selectivity with only one tuned circuit, though such an arrangement offers the great attraction of simple operation and cheapness. The Graham Farish coil has been carefully designed to give the maximum selectivity possible with a single circuit, yet there is plenty of volume available on a good number of foreign stations.

London National was logged at 3.5 degrees on the 10-degree scale, but was cut clean out at 3 and 4.5 degrees. London Regional was tuned in at 6.5 degrees, and was cut out at 5 and 7 degrees. There was thus a clear silent space on the tuning scale between the two powerful locals, which are easily separated.

Including Midland Regional and North Regional, we were able to log

### NUTSHELL SPECIFICATION

MAKER: Graham Farish, Ltd.

PRICE: £1 18s. 6d. without valves.

VALVE COMBINATION: Detector (Mullard PM2DX), first low-frequency stage (Mullard PM1LF or PM2DX) and power output (Mullard PM2 or PM252). These are the recommended valves.

POWER SUPPLY: Externally connected batteries, joined to set by neat battery cable.

POWER CONSUMPTION: Using the economical set of Mullard valves and a 120-volt high-tension battery, the total anode-current consumption was found to be 8.5 milliamperes. This is increased to 14 milliamperes with the alternative valves.

TYPE: Battery-operated kit set.

REMARKS: Selectivity is good, enabling a fair selection of foreign stations to be tuned in clear of the locals.



# Readers Report on "W.M." Sets

## A.C. SUPER 60

(June, 1931)

**Plymouth (Devon).**—I am a very proud possessor of the A.C. Super 60 radiogram. I built this fine set as soon as it was published. Directly I switched on I had success, and have since logged innumerable stations. I reside one mile from the Plymouth station. The most marvellous part is that this station is heard only on one degree of the dial. I wish to thank Mr. James for such an efficient and simple set. The quality is excellent.

## BROOKMAN'S THREE

(November, 1929)

**Marlow (Bucks.).**—I have built four of W. James' sets; two New Brookman's Threes, a Brookman's Four, and a Super Senior. I sent one of the Brookman's Threes to Devonshire and the other to County Down, Ireland. The owner in Ireland says "this is one of the best three-valve sets in the district, and I can get quite a lot of stations. Dublin comes through very strong; very few sets in this part can get it."

## BROOKMAN'S THREE-PLUS-ONE

(April, 1931)

**Sunderland (Durham).**—I made up the Brookman's Three-plus-one and fitted it in a cabinet complete with turntable and pick-up. The set makes a first-class radio gramophone both in appearance and performance. It is one of the best straight fours I have had for selectivity, sensitivity and quality. The reproduction from gramophone records is excellent. I am working the set with a

In these pages we print reports from sixteen readers on ten different "Wireless Magazine" sets. These reports come from all over the country and will enable other readers to check up the results they are getting from the same designs.

It should be noted that full-size blueprints of all of the receivers referred to are still available, but in some cases back numbers describing the actual construction

are now right out of print.

Applications for blueprints should be addressed to "Wireless Magazine" Blueprint Dept., 58-61 Fetter Lane, London, E.C.4, and for back numbers to the Publisher, at the same address.

Readers are reminded that half a guinea is paid for every photograph of a "Wireless Magazine" set built by a home constructor that is used in these pages.

mains unit. I think W. James' Binowave coils are the finest dual-range coils he has ever made.

## FIVE-ADVANTAGE THREE

(October, 1931)

**Southsea (Hampshire).**—Having had this set in use for some months, I can honestly say I have had countless hours of enjoyment. My only complaint is that we work it so hard that we often find both our accumulators run down at the same time, with the result that we have to wait for them to be recharged.

## NEW ECONOMY THREE

(December, 1931)

**Earlsfield (London, S.W.18).**—I

should like to thank you for the New Economy Three. I have made up this set, and it is giving most satisfactory results. So far I have received eighteen medium-wave and seven long-wave stations at full loud-speaker strength. Among the foreign stations I have heard are: Trieste, Fécamp, Heilsberg, Brussels No. 2, Graz, and Mühlacker (when London is not working).

**Holloway (London, N.).**—I have just built your New Economy Three. She is a "beauty." You would do well to remind readers again. I have built over twelve sets.

## REGIONAL BAND-PASS FOUR

(October, 1930)

**York (Yorks.).**—The volume, tone and selectivity are all that can be desired. I can get at least twenty-four stations any time I wish. The gramophone part of the set is great, giving wonderful reproduction of records. All who have heard it are delighted with the performance. It has taken many a long evening to construct, but I have been amply repaid by its performance. I receive such stations as Radio Paris, Huizen and Kalundborg regularly every morning at breakfast.

## REGIONAL D.C. FIVE

(September, 1931)

**Londonderry (Ireland).**—I am getting excellent results. The receiver is as quiet as if it were operated from dry batteries and is absolutely stable.

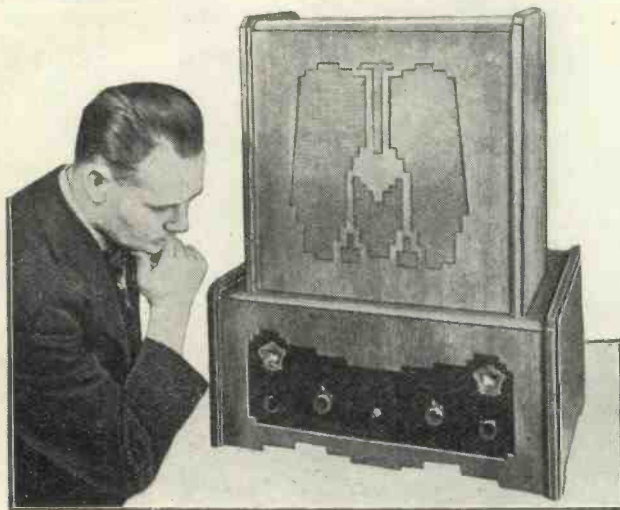

A POPULAR SUPER-HET  
A popular successor to the original Super 60—the 1932 Super 60. Full details of this set were published in the January issue of "Wireless Magazine"

# READERS REPORT ON "W.M." SETS—Cont.

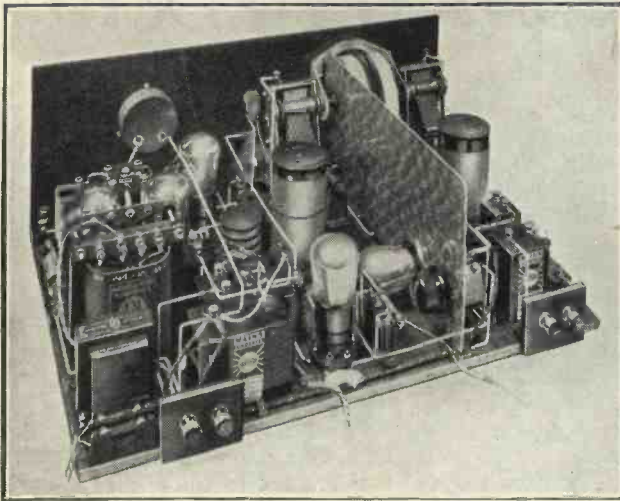

A FIVE-VALVE D.C. MAINS SET  
This is the Regional D.C. Five, which uses the famous Binowave coils developed for "Wireless Magazine" by W. James

## SUPER 60

(March, 1931)

**Chester (Chester).**—The set was constructed about June of last year and has given every satisfaction and great pleasure ever since—although for the first month or two it was used with a scratch lot of six-volt valves.

In the autumn I decided to change over to two-volt valves. The result was wonderful, and practically every station in Europe could be received at good strength.

There is one point that I do not seem to have noticed as being mentioned in connection with this receiver.

I am greatly troubled with electrical interference brought into the house via the D.C. mains. The very marked directional properties of the aerial and the screened coils have enabled me to cut out this trouble better than with any previous set.

In an article entitled "Hotting Up the Super 60" it was recommended that the first detector be replaced with a double-grid valve, certain alterations being made to the connections to the frame. I tried this arrangement, but found that, although the signal strength of various stations was greater, the interference was much worse. Thinking that this was caused by the fact that the whole of the aerial was now used instead of connecting the centre tapping to the grid of the detector, I tried this latter arrangement

with the double-grid valve, but without any noticeable improvement.

I also found that the double-grid valve seemed to work better when a voltage of only twenty volts was used on the plate. It was necessary, however, to use about eighty volts when working on the short waves. I have now gone back to the original first

detector valve, but shall have another try with the double-grid valve later on.

**Halifax (Yorks.)**—Tone is wonderful and, as for tuning, I don't have to search for the stations, the foreigners simply howl at one. If anyone asked me to recommend a set I shall not hesitate now that I have a Super 60 in action.

## 1932 SUPER 60

(January, 1932)

**Hales (Lancs.)**—The 1932 Super 60

is the best of all home-constructed sets. I have received all the long-wave stations and the medium waves; well, they are too numerous to log. To anybody who wants a radio gramophone, anytime or anywhere, I say build the 1932 Super 60. I am always building sets described in "Wireless Magazine," among them the Brookman's Push-pull Three, Brookman's Four and the Celerity Three, and never have I had a disappointment.

**St. Albans (Herts.)**—It is indeed a wonderful set. Although only six and a half miles from Brookman's Park, I can receive Mühlacker and Graz quite clear of London. The volume is all one requires, and the quality of tone excellent. It is a real treat to tune, there being no mush or whistles. The stations roll in one after the other with the greatest of ease.

**Westerham (Kent)**—I have just constructed your 1932 Super 60, and now I wish to congratulate you on a really magnificent set. I have made up a number of different sets during the last six years, but I can easily say that your 1932 Super 60 beats all of them in every respect. One thing that pleases me very much is the way in which it separates the stations.

**West Hartlepool (Durham)**—I think, and all others who have heard it think the same, that this set is the last word in wireless. It certainly does all you claim for it.

## SUPER SENIOR

(October, 1931)

**Devonport (Hants.)**—I am pleased with the performance of the Super Senior. In fact last Sunday I was astounded at the daylight range of the Super Senior on the medium waveband in this reputed notoriously bad district for receiving. The Super Senior is a marked improvement on the Super 60.

**Marlow (Bucks.)**—The Super Senior is a fine set and I am proud to possess one. The range is really wonderful, and the set is simplicity itself to tune. No praise is too great for it.



A READER'S VERSION OF THE 1932 SUPER 60  
The 1932 Super 60 as made by a West Hartlepool reader. His report on its performance appears alongside

# Long-range Listening

on the Town-and-Country Four



Immediate interest was taken by constructors all over the country in the portable design described by PERCY W. HARRIS, M.Inst.Rad.E., in the May issue of "Wireless Magazine." His set was called the Town-and-Country Four and it included an aperiodic screen-grid stage, this giving virtually one-knob tuning. Full-size blueprints of the set are still available from the "Wireless Magazine" Blueprint Dept., of course

**B**OTH the operation and the construction of the Town-and-Country Four are so simple that the reader will soon have his set working in fine style. If it is the first portable he has constructed, he may be surprised at the astounding range obtainable with modern valves on such a small frame aerial.

On the other hand, if he has had a little experience with receivers of various types he will be equally pleased, for the set will stand comparison with many having a larger number of valves and more controls.

While designed primarily for simplicity of handling, and to give good results even in the hands of the unskilled, the peculiar circuit used does lend itself to extremely interesting experiments in the hands of the more advanced amateur, bringing in stations which normally require a good outside aerial to receive.

## Ultra-Sensitive Results

To obtain these ultra-sensitive results the set must be adjusted to get the utmost limit out of the screen-grid valve in the following manner: First of all open the back of the case, and unscrew the compression condenser until the set just does *not* oscillate on the particular part of the dial where you wish to search, even when the



READY FOR INSTANT USE WHEREVER IT MAY BE

*The Town-and-Country Four is completely self-contained with frame aerial, loud-speaker and batteries. It is therefore always ready for instant use anywhere in town or country*

volume-control potentiometer is turned fully in a clockwise direction.

Now set back this volume control to a distance equal to about five minutes on a clock, and then carefully screw down the compression condenser until the set just oscillates. Critical reaction can now be controlled on the potentiometer, and the screen-grid variable- $\mu$  valve will be used at its point of highest magnification.

This, combined with the effect of reaction on the frame, puts the set in a very highly sensitive condition—a condition which is slightly more sensitive than that which gives uniform sensitivity over the whole dial as described last month.

At this point I would like to make it clear to readers that the setting described last month should be followed out carefully for general single-control working. While reaction can be controlled both by the

compression condenser and the potentiometer the correct combination of both of these settings is essential if good results are to be obtained.

## Valve Magnification

It might at first appear that plenty of reaction applied by means of the compression condenser would be advisable, this being held in check by a considerable use of the potentiometer by turning it well back in an anti-clockwise direction, but while oscillation is controlled quite easily by this method the fact remains that when a considerable use of the potentiometer is made the sensitivity of the screen-grid valve is considerably reduced—in fact the whole purpose of this form of control of a variable- $\mu$  valve is to *reduce* its magnification.

The correct general setting is, therefore, that when the set is so arranged that a minimum use is

## LONG-RANGE LISTENING ON—



### COMPLETING ASSEMBLY

Here you see Percy Harris slipping the receiver assembly into the outer shell of the cabinet, thus completing the installation

made of the potentiometer to keep the circuit from oscillating. The method of obtaining a good average sensitivity as described in last month's issue was evolved as the result of a large number of tests.

Another point of importance. While the Town-and-country Four is, as explained previously, very simple to build and operate, the fact remains that in all sensitive sets, and particularly in a portable, departure from the layout evolved by the designer cannot be made without sacrificing results.

### "Altering" the Layout

Do not, therefore, write and ask me how you can "alter" this or that receiver in order to make it into a Town-and-country Four. The layout of the high-frequency end of this circuit, the values, the actual disposition of the windings, and many other points only apply to this particular arrangement.

The alteration of the design from the upright cabinet type shown to that of the flat type, with a lid which opens and has the frame aerial wound inside it, would involve a complete re-designing of the whole outfit. The values of capacity in the high-frequency circuit to produce reaction (or prevent it) are so small

that even the change of the position of a single lead may make a difference.

This is one of the reasons why the positions of the cap of the screen-grid valve, the compression condenser and the radio-frequency choke are arranged as they are.

### Anticipating a Question

I may here anticipate one question which is likely to be put to me in connection with this set. Many readers will like its quality and ease of handling, and in particular its compactness, which avoids any trailing of battery leads or wires to a loud-speaker.

They may be so situated that connection to an outside aerial is a simple matter, and as such an aerial will give a greatly increased range they may desire to use it.

While there are several ways in which this can be done, the simplest is to connect an aerial through a .0001-microfarad maximum compression condenser to the fixed plate of the tuning condenser, the earth being connected to the accumulator negative terminal.

The compression condenser should be set at a very small value, for two reasons. Firstly, the frame aerial is still in use and the outside aerial is used only to add to its sensitivity and, secondly, the set is not primarily designed for use with an outside aerial, as there is only one tuned circuit which, while giving selectivity enough for normal conditions with a frame pick-up, is insufficient for direct use of an outside aerial with its higher damping and greater pick-up.

By setting the compression condenser in the aerial to a small value the selectivity will be sufficiently maintained while still giving high sensitivity.

Another simple way of adapting an outside aerial to any receiver using a frame aerial is simply to wrap two or three turns of wire round the outside of the

cabinet, the coil so formed being connected on one side to the aerial and the other side to the earth.

A compression condenser should also be used in this arrangement, but the value of this capacity can now be made higher, as the aerial is now inductively and not directly coupled to the receiver.

One final tip (and this applies to all portable receivers), be careful just where you place the set in a room before beginning to listen.

A limited number of copies of the May issue of "Wireless Magazine," containing seven pages of constructional matter by Percy W. Harris on the Town-and-country Four, is available from the Publisher (address: 58/61 Fetter Lane, London, E.C.4) at 1s. 3d. each, post free. Early application should be made

Remember that the sole pick-up is by means of the frame aerial and in one part of the room some metal object such as a radiator, steel pipe, some electrical fitting, or even a metal window frame, may be absorbing the energy you want.

I carried out a very interesting experiment in this connection some years ago with a portable receiver in a London office. We were all anxious to receive the Derby Day broadcast, and during the preliminary announcement the reception was particularly weak.

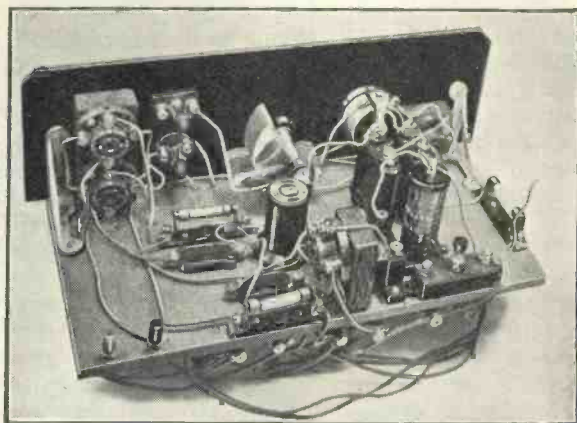

### COMPACT BUT EASILY ASSEMBLED

Although compact, the Town-and-country Four is not overcrowded, and the construction will present no difficulties



# —THE TOWN-AND-COUNTRY FOUR

This was at first thought to be due to a directional effect of the frame, so the receiver was rotated, but the same results were found at whatever angle the frame was placed. The receiver was then taken across the room, and before I had walked a couple of yards, signals had come up ten or twenty times as loud.

## Complete "Exploration"

A complete "exploration" of the room was then made, and it was found that in one or two areas nothing whatever could be heard, although there was no furniture or anything round about to give us a clue to the cause. Apparently something under the floor was acting as an absorbing material, and I have found similar effects in private houses.

Very often reception with a portable set on the ground floor is much inferior to that on the first floor, and sometimes vice versa. Therefore if you have not used a portable set before, and you get disappointing results on first trial, make sure that your position in the room is the best one, and that the receiver itself is turned round to such an angle as to get the best reception on the frame aerial used from the particular station.

## COMPONENTS NEEDED FOR THE TOWN-AND-COUNTRY FOUR

### CHOKES, HIGH-FREQUENCY

- (HFC<sub>1</sub>) 1—R.I. Quad Astatic, type FY2, 3s. 6d. (or Lewcos type MC, Varley).  
(HFC<sub>2</sub>) 1—Readi-Rad standard, 4s. 6d. (or British General, Lewcos type 11).

### CONDENSERS, FIXED

- 1—Dubilier .0003-microfarad, type 670, 1s. (or T.C.C., Telsen).  
1—Dubilier .0003-microfarad, type 620, 1s. 8d. (or T.C.C., Telsen).  
1—Dubilier .01-microfarad, type 670, 2s. (or T.C.C.).  
4—Dubilier 1-microfarad, type BB, 10s. (or T.C.C., Telsen).  
1—Dubilier 2-microfarad, type BB, 3s. 6d. (or T.C.C., Telsen).

### CONDENSERS, VARIABLE

- 1—Formo .0005-microfarad, with slow-motion dial, type 7B, 6s. (or Ormond, Jackson).  
1—Formo .0001-microfarad max., type F, 1s. 6d. (or Igranic, Lewcos).

### EBONITE

- 1—Peto-Scott 14 in. by 4½ in. panel, 2s. 9d. (or Becol, Potter).

### FUSE

- 1—Microfuse 100-milliamper, with holder, 1s.

### HOLDERS, GRID-LEAK

- 3—Readi-Rad, 1s. 6d. (or Bulgin, Telsen).

### HOLDERS, VALVE

- 4—Telsen four-pin, 2s. (or W.B., Lotus).

### PLUGS AND SOCKETS

- 2—Clix wood-screw sockets and plugs for loud-speaker, 8d.  
10—Clix wander plugs, marked G.B.+ (2), G.B.—, G.B.—1, G.B.—2, H.T.+ 2, H.T.—1, H.T.—, H.T.— (2), 1s. 8d. (or Belling-Lee, Eelex).  
2—Clix spade terminals, marked L.T.+ , L.T.—, 4d. (or Belling-Lee, Eelex).

### RESISTANCES, FIXED

- (R<sub>21</sub>) 2—Varley 10,000-ohm spaghetti, 1s. 6d. (or Bulgin, Magnum).  
(R<sub>3</sub>) 1—Varley 30,000-ohm spaghetti, 1s. (or Bulgin, Magnum).

*The prices mentioned are those for the parts used in the original set; the prices of alternatives as indicated in the brackets may be either higher or lower*

- (R<sub>1</sub>) 1—Dubilier 20,000-ohm metallised, 1s.

- 1—Dubilier 100,000-ohm metallised, 1s.  
1—Lissen .25-megohm grid leak, 1s. (or Telsen, Watmel).  
1—Lissen 2-megohm grid leak, 1s. (or Telsen, Watmel).

### RESISTANCE, VARIABLE

- 1—Colvern 50,000-ohm potentiometer, 5s. 6d. (or Wearite, Watmel).

### SUNDRIES

- Tinned-copper wire for connecting (Lewcos).  
Lengths of oiled-cotton sleeving.  
1—Pair of Magnum panel brackets, type No. 2, 1s. 6d.  
100 yards Lewcos 27/40 silk-covered wire, 10s. 6d.

### SWITCHES

- 1—Bulgin two-point, type S22, 1s. 6d. (or Readi-Rad, Telsen).  
1—Bulgin three-point, type S36, 1s. 9d. (or Readi-Rad, Telsen).

### TRANSFORMER, LOW-FREQUENCY

- 1—Ferranti AF10, 6s. 6d. (or R.I. Dux, Lotus)

## ACCESSORIES

### BATTERIES

- 2—Full O'Power 60-volt Cadet, 11s.  
2—Full O'Power 9-volt Cadet, 2s.  
1—C.A.V. jelly-acid 2-volt accumulator, type 2NS17, 13s. 6d.

### CABINET

- 1—Camco Carrier portable, with wooden fittings for set, £1 15s.

### LOUD-SPEAKER

- 1—Ormond portable chassis and unit, type R461/2, 17s.

### VALVES

- 1—Cossor 220VSG, 16s. 6d.  
1—Mullard PM1HF, 7s. (or Cossor 210HL, Six-Sixty 210HF).  
1—Mullard PM1LF, 7s. (or Cossor 210LF, Six-Sixty 210LF).  
1—Mullard PM2, 8s. 9d. (or Cossor 220P, Six-Sixty 220P).

## IN MY LAB. ARMCHAIR

Continued from page 519

strange to the beginner, but which nevertheless prove very useful in certain circumstances. There is, for example, the form of wall aerial consisting of a sheet of gauze or perforated metal in a wooden frame, supported suitably on the wall outside the window, connected to the set by means of a terminal in the centre or on the edge.

### Quite Good Results

Such devices can give quite good results where it is impossible to erect the ordinary or conventional type of aerial and measurements I made some time ago showed that one of these sheets erected at a particular height gave just as strong signals as a plain wire aerial taken 10 or 15 ft. higher.

In some cases, particularly when the user of a set is living in a flat and he cannot possibly erect a wire, even

10 ft. above his window, he may find the frame type practical.

This type is also very useful for erection in a loft, where it can be screwed against the highest rafters available, and the wire taken from it down to the receiver in the house below.

A very good form of indoor aerial of this kind can be erected by purchasing from your local ironmonger a strip of perforated metal, say, a foot wide and four feet long, which can be nailed along the rafters, and a good sound connection taken to it from one end.

As it is often difficult to solder to such metal, the best plan is to pass a metal screw through one of the holes or perforations, putting a washer on each side and screwing down a large terminal. This makes a good sound connection, particularly if you scrape the perforated

metal before putting the washers into place.

I was recently consulted on the subject of hum when using a pick-up with an electric motor in conjunction with an old wireless set.

### Metal-shielded Wire

There are many causes of hum, but in most cases a cure can be effected by using metal-shielded wire for the pick-up leads, earthing the shielding, and also earthing the metal frame of the motor. Hum will always show up prominently when a pick-up is used if the set itself tends to be unstable.

The remedy then is to remove the instability from the set which can be done in most cases by carefully decoupling the detector and the use of a choke-condenser output for the last valve.

# LOWERING THE COST of QUALITY

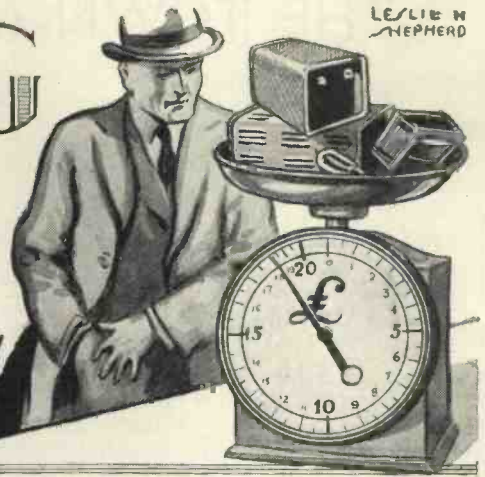

This article has just been written by a keen amateur constructor in Tobago, British West Indies. It will therefore be of more than usual interest to readers. Here is proof that the question of quality is of world-wide interest. The comments made by "60 Degrees West" are very much to the point and should be studied by all who have followed P. K. Turner's articles on quality

**T**HE article on modern standards of quality by P. K. Turner in the December number of "Wireless Magazine" demands much more than mere publication.

It is to be hoped that set designers will pay more attention to the suggested standards of quality in future and that they will do their best to entirely eliminate Class Z, while at the same time reducing Class C to a minimum.

This might be taken to mean that I think our designers are not anxious to achieve this result already—well, I can only say that nothing is further from my mind.

### Dominating Factor

The question of cost, both first cost and running expense, is obviously the dominating factor. The manufacturers design sets which they consider they can sell, and the designers for the technical press publish what they believe their readers can afford to construct.

My excuse for sending this article to "Wireless Magazine" is that I believe more could be done in the way of cheapening first cost of both

B- and C-quality sets and that, if at present there is any valid reason for still producing sets of Z quality, such reason will very soon cease to exist.

Since it is the object of the Press to educate its readers as well as to help them in practical ways, I also believe that it is to such publications as "Wireless Magazine" that one must look for the necessary action and initiative to produce the desired results.

So far as I am aware no Class B set has ever been published by "Wireless Magazine," and if I am wrong in this I am quite sure such publication is exceptional.

I am quite aware that many of the designs published can readily be altered from Class C to Class B by those readers who possess the necessary knowledge so to alter all couplings and decouplings from aerial input to loud-speaker that each stage will work under the best conditions, but what proportion of the

total number of readers of this magazine are capable of doing anything of the sort unaided?

The valves and components necessary for doing all this exist right enough—but they are expensive. They are expensive because they are not yet employed in sufficient quantities to enable their prices to be reduced.

### Demand and Supply

Create the demand and the usual connection between demand and supply will adjust the price.

All this, however, is only generalisation, and I want to try to show more direct ways of reducing first cost and subsequent running expense. The crux of the situation lies in the source of volts and current, whether in amperes or milliamperes.

The two most expensive forms of providing them are storage batteries, whether accumulators or dry cells. It is only a question of time before there will be no necessity to use either, and although that time has not yet come, a great deal can be done for the ever-increasing number of people for whom it has arrived.

### Mains Units

There are already on the market a large number of mains units suitable for Class C sets, both of the all-electric type and those intended to supply high tension only, in conjunction with low-tension accumulators, which they also charge, and dry cells for grid bias.

Can the same be said for B-quality sets, let alone A quality?

This is certainly not the fault of the valve manufacturers, for all the leading makers now list three



**A-QUALITY LOUD-SPEAKER**  
A Parmeko permanent-magnet moving-coil loud-speaker in a Camco Melodee cabinet—an ideal combination

standard rectifiers, A, B, and C, suitable for supplying the needs of C-, B-, or A-quality sets respectively.

I know that unfortunately these rectifiers are not quite so standard as they ought to be since although they are all 4-volt some of the A type require 1 ampere to heat their filaments and others 2 amperes, while in the B and C types some require 2 amperes and others 2.5 amperes, but I imagine this state of affairs will be adjusted so that standard transformers will become possible.

They can be tabulated as follows :

Set	Rectifier	High Tension	Early Valves	Output
C	(A) 2-0-2 volts	250-0-250 volts	2-0-2 volts	2-0-2 volts
	1 ampere	60 milliamperes	3 amperes	1 ampere
B	(B) 2-0-2 volts	350-0-350 volts	2-0-2 volts	2-0-2 volts
	2 amperes	120 milliamperes	3 amperes	1 ampere
A	(C) 2-0-2 volts	500-0-500 volts	2-0-2 volts	2-0-2 volts
	2 amperes	120 milliamperes	3 amperes	2 amperes

This provides for two H.F.-detector-power, H.F.-detector-two L.F., or the latest H.F.-detector straight C sets.

FOR SUPER-HETERODYNE SETS :

Set	Rectifier	High Tension	Early Valves	Output
C	(A) 2-0-2 volts	250-0-250 volts	2-0-2 volts	2-0-2 volts
	1 ampere	60 milliamperes	5 amperes	1 ampere
B	(B) 2-0-2 volts	350-0-350 volts	2-0-2 volts	2-0-2 volts
	2 amperes	120 milliamperes	5 amperes	1 ampere
A	(C) 2-0-2 volts	500-0-500 volts	2-0-2 volts	2-0-2 volts
	2 amperes	120 milliamperes	5 amperes	2 amperes

The above table provides for H.F.-1st detector - oscillator - I.F. - 2nd detector-power or 1st detector-oscillator-two I.F.-2nd detector-power. With the new variable-mu valves now available the second combination is likely to prove the best.

In any case, if the above combinations are specified by set designers for home constructors they will certainly become standard, and at reasonable prices. Also the makers of metal rectifiers are not likely to abandon the field, which will again stimulate competition for the ultimate benefit of the public and the trade.

Effect on Cost

This will have an important result on the cost of sets. At the present time the best are self-contained, which means they are not only costly, but bulky and still more costly to alter to keep pace with up-to-date knowledge.

The power units should be separate and a Class A rectifier, trans-

former, etc., should be available for any C-quality set for several years, and so on for the B- and C-type power units for B- and A-quality sets.

And now as to running costs. Just as there is a very large number of people who do not know that there is the equivalent in receiving sets of a modern Austin Seven, let alone a Rolls-Royce, so there are even more who have no idea what all-mains sets cost to run.

They look at what appear to them as fantastic figures of volts and amperes and, having no standard of

comparison beyond dry cells, just throw their hands in and decide that it is not for them. Here the technical press has an obvious duty.

Let me take an example—a C-quality straight four, with A type valve rectifier, and assume that the maximum high-tension current is used, though this is quite unlikely :

	Watts
Rectifier Filament .. ..	4
High Tension .. ..	15
Filaments of Early Valves ..	12
Filament of Output Valve ..	4
	—
Total .. ..	35
	—

It does not convey much to many people to tell them that this is about the same thing as one electric-light bulb. Let me put it another way.

Suppose 1,000 watts costs  $x$  pence, then the user can run his set for 1,000 hours for 35 multiplied by  $x$  pence—and everyone can easily find out what the actual value of  $x$  is in his particular district.

Another way to cheapen cost of construction is by standardisation of dimensions of components and the use of metal chassis for the various types of sets.

Some people seem to imagine that standardisation leads to stagnation. That is only true when it embraces design and there is not the smallest reason why it should.

And now the last point, and one of the most important, in the search for quality. It cannot be too insistently impressed on the public that



GOOD PARTS FOR GOOD SETS  
For mains smoothing the Ferranti type B1 low-frequency choke needs a lot of bearing

neither the "bes set" nor the "best loud-speaker" in combination will necessarily give the "best results."

It makes little difference whether it is a Z- or A-quality set except that owing to the larger power the A set will make the trouble (if it is present) more evident.

The output valve and the loud-speaker must be matched if speech and music are to be the best that the particular output valve or loud-speaker can give.

This brings me to make a strong plea to makers of loud-speakers to publish sufficient information to the public in their advertisements to enable the best to be got out of their goods, alike in the interest of the public and themselves.

Slender Purses

There is no reason why a man with a slender purse should not possess a very musical ear and he has just as much right to be able to get the best out of what he can afford to buy as the rich man.

Neither can carry out the necessary measurements on a large number of loud-speakers to find which best suits their output stage—but the manufacturers can supply such information.

Would anyone think of buying a car without knowing what power it was rated at?

# The SHORT-WAVE DIRECTOR

Tuning is so sharp on the very short waves that it is not a simple matter to estimate to what wavelength an uncalibrated short-wave receiver is tuned. Any such difficulty will be avoided by the use of the simple wavemeter described in this article by J. H. REYNER, B.Sc., A.M.I.E.E. The wave range is from approximately 6 to 80 metres

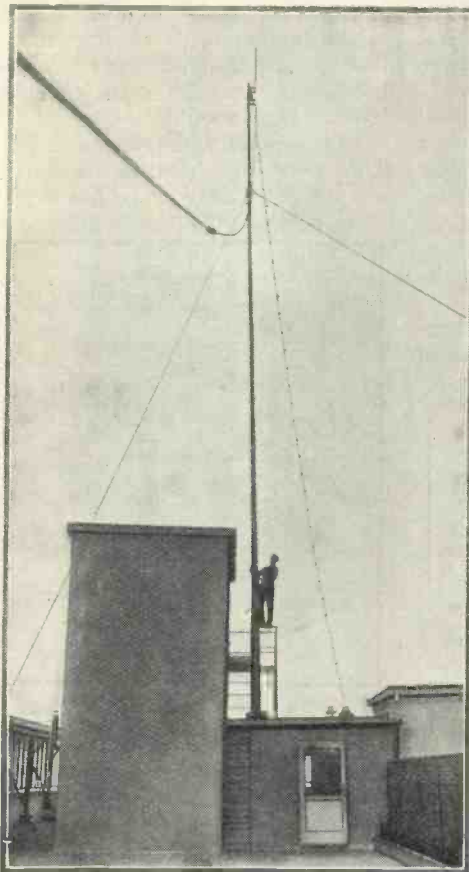

**SHORT WAVES IN GERMANY**  
Aerials for short-wave speech and television being erected on the roof of a ten-storey building in Berlin

**A WAVEMETER** is usually considered a device for the expert. This may be true on broadcast frequencies, but when dealing with short waves it will save many hours of fruitless searching, particularly if one is not used to short-wave reception.

### Tells You the Wavelength

A short-wave meter is merely an instrument which tells you on what wavelength your set is operating. It also gives you some idea as to whether the set is operating correctly. Short-wave reception differs entirely from broadcast reception in that there are many high-speed morse stations working, and telephony reception is the exception rather than the rule.

If one can determine quickly and accurately the wavelength of these morse stations, it is a simple matter to obtain one's bearings.

For example, a station may be found to be operating on approximately 33 metres. One then knows that just below this station W2XAF should be found, if he is working and conditions are sufficiently good.

Then again, the identification of an unknown station is greatly facilitated if one knows the approximate wavelength on which it is operating. Personally, I find myself handicapped to an extraordinary degree if I have to carry out tests on a short-wave receiver without a wavemeter at hand.

The objection, of course, is usually that of cost, but this does not apply in the present instance. The ex-

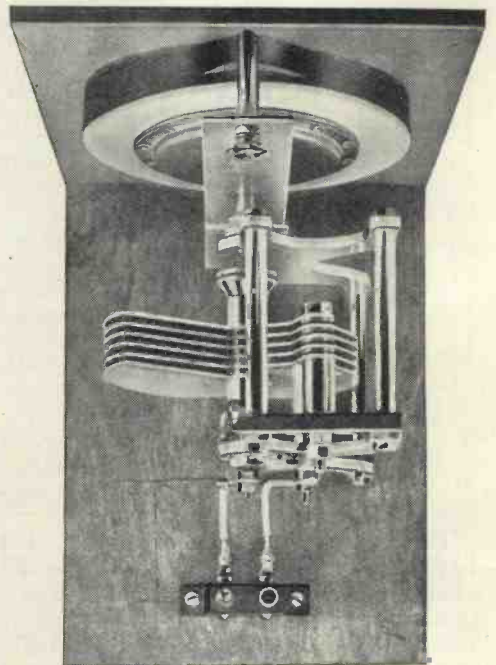

**SIMPLICITY ITSELF**  
Nothing could be simpler than this absorption type of short-wave meter



**AT THE POPE'S SHORT-WAVE STATION**  
Transmissions from the Vatican City station (call: HVJ) are made on 19.84 and 50.26 metres. This photograph shows the control engineer at work

penditure involved is only twenty shillings odd.

The fact of the matter is that a short-wave meter is a comparatively simple device to construct. The skeleton circuit is shown on page 540. It consists merely of a coil tuned with a condenser. As the capacity of the condenser is varied the wavelength to which the circuit tunes also varies; we couple the wavemeter to our receiver in such a way as to indicate when the wavemeter is in tune with the set and *vice versa*.

The exact operation will

be explained later, but it will be clear that the essentials in the construction are few.

The principal difficulty is that of calibration, because we must know the wavelength of the circuit at any particular setting of the dial. This difficulty is not insurmountable, however, because there are on the market coils and condensers which are made sufficiently accurately to enable a calibration to be published.

### Calibration Curves

The instrument described in this article has been calibrated against my own standard, and the calibration is reproduced herewith. Any reader who builds the meter with exactly the same components and uses the same layout will obtain an instrument having substantially the same calibration.

This is perhaps rather a sweeping statement, but it is based on a number of tests which were made before the instrument was constructed. Perhaps the most vulnerable point in the circuit is the coil, for any variation in diameter or spacing of the turns may produce quite an appreciable variation in the inductance which would, of course, throw the calibration out.

I therefore obtained half a dozen sets of short-wave coils selected at random from stock. A wave meter circuit of the type shown on p. 540 was connected up and used to measure the wavelength of an oscillating circuit operating at various different frequencies. The actual setting on the condenser dial was noted at each of the test frequencies chosen.

The first coil was then replaced with another similar coil and the test repeated. This was done for each of the six coils; it was found in the end that the dial readings for the different test wavelengths were all identical within one degree. In

some cases the difference in the readings was even less than this.

This, of course, was very encouraging because it indicated that any reader going into a shop and purchasing a set of these coils would be able to duplicate my results within one degree.

An exactly similar series of tests was carried out with the condenser. A Cyldon condenser was chosen because past experience indicated that production models were surprisingly consistent. This was confirmed on these tests where the same coil tuned with different

is mounted directly on a small ebonite panel, and that the plug-in coil mount is situated exactly  $1\frac{1}{2}$  in. away from the condenser end plate.

Two very short leads are run from the coil-holder terminals to the condenser connections, and if the coil holder is located in the same position as that shown, it will be found that one lead goes straight to the moving plates and the other lead runs parallel with the first and then takes a short right-angle bend on to the fixed plates.

### Duplicating Conditions

No reader will have any difficulty in duplicating these conditions and I feel, therefore, that he will be able to use the calibration curves published with this article with a complete assurance of reliability. The calibration obviously will not

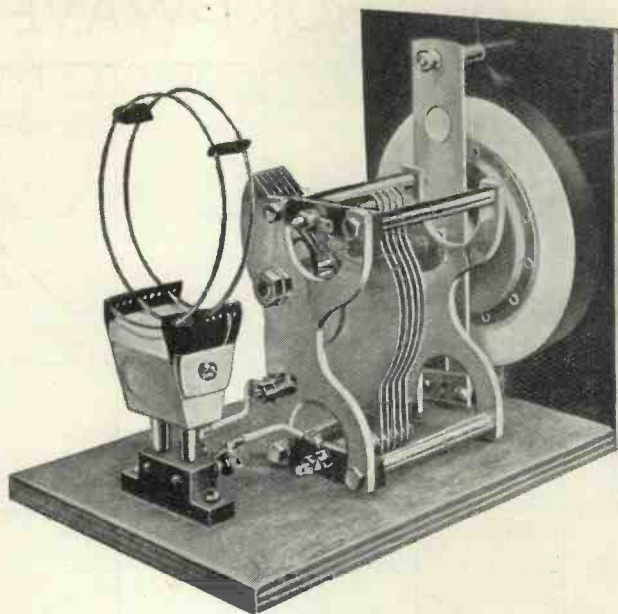

EVERY SHORT WAVE LISTENER SHOULD HAVE THIS METER

The cost of building the Short-wave Director is a matter of a few shillings only. There is no valve, but the variable condenser must be of a high standard

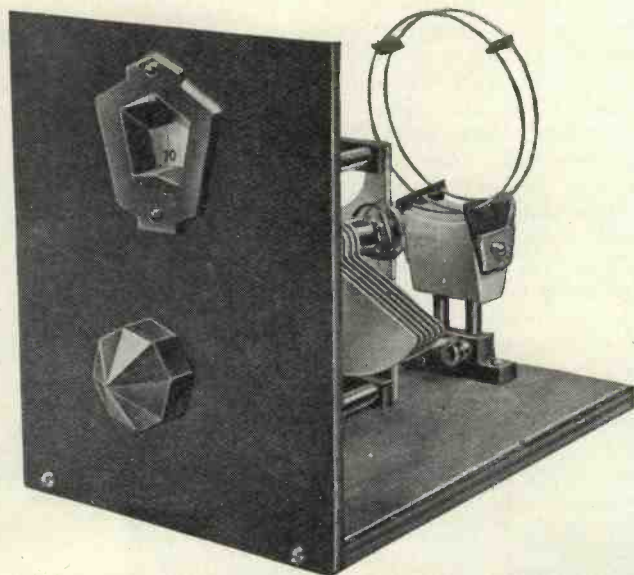

TELLS WHAT WAVELENGTH YOU ARE ON

The Short-wave Director has a range from approximately 6 to 80 metres. Large-scale tuning graphs are reproduced in the following pages

samples of the same type of condenser all gave practically the same reading, the variation in this case being even less than before.

The only remaining point to consider is that of the layout. Reference to the diagram and photographs will show that the condenser

### COMPONENTS NEEDED FOR THE SHORT-WAVE DIRECTOR

#### COILS

- 1—Atlas two-pin plug-in short-wave No. 2, 2s. 6d.
- 1—Atlas two-pin plug-in short-wave No. 9, 2s. 9d.

#### CONDENSER, VARIABLE

- 1—Cyldon .00025-microfarad square law, type A25, with slow-motion dial, type VD, 17s.

#### HOLDER, COIL

- 1—Bulgin two-pin, type P14, 9d.

#### SUNDRIES

- Wire for connecting.
- 1—Ebonite panel, 5 in. by 6 in.
- 1—Baseboard,  $6\frac{1}{2}$  in. by 5 in.

# THE SHORT-WAVE DIRECTOR—Cont.

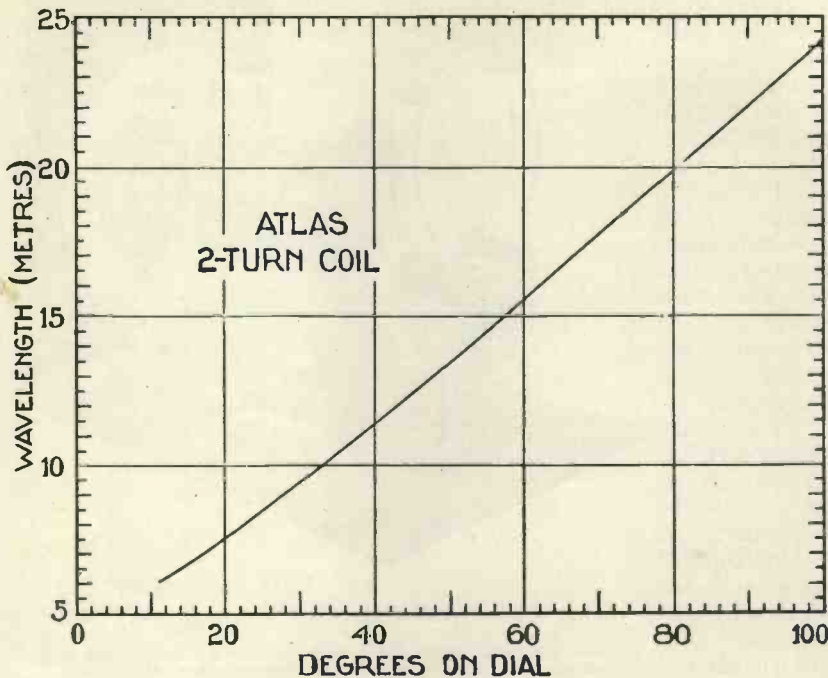

CALIBRATION CURVE FOR 6 TO 24 METRES

This curve is for a Cydon .00025-microfarad condenser and an Atlas two-turn coil. The method of operating the wavemeter is explained in the text

be exactly right, but it should be correct within one degree, which

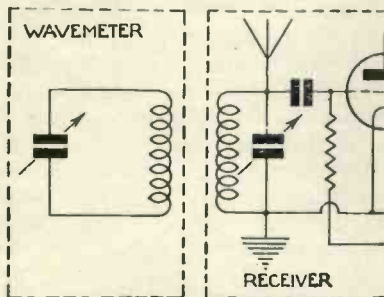

CIRCUIT OF THE WAVEMETER

The unit comprises simply a short-wave coil and a variable condenser

is quite sufficient for all practical purposes.

It only remains to show how this wavemeter can be used. The principle of absorption is employed, this being the most practicable arrangement for short waves.

The wavemeter is brought near to the circuit under test, and the tuning dial is rotated until the wavemeter circuit comes into tune with the test circuit. When this happens currents will be induced into the wavemeter circuit, in the same way as signals are picked up on a receiving aerial when this is

tuned to the required station.

These currents, however, will absorb a certain amount of energy from the circuit and we can detect this in a variety of ways. For example, let us consider an oscillating circuit. If the circuit is just oscillating, then when we bring the wavemeter into tune with the circuit, the extra energy absorbed will be sufficient to stop the circuit from oscillating momentarily.

This will cause a slight click in the telephones or loud-speaker, while more definite results still are obtainable by inserting a milli-

ammeter in the anode circuit of the particular valve. There will then be a flicker on the needle of the milliammeter as we pass through the tuning point, indicating that the circuit has either stopped oscillating or is not oscillating so strongly.

A useful method where no milliammeter is available is to touch the fixed plates of the tuning condenser in the set with one's finger. As long as the set is oscillating this will give a click in the loud-speaker, but when the wavemeter comes into tune and the oscillation stops only a faint sound is heard.

## Carrier or Heterodyne

Alternatively, we may be tuned to the carrier wave of some station, or even to a high-speed morse station, with the receiver just over the edge of oscillation, so that we hear the carrier whistle or the heterodyne note.

As we bring the wavemeter into tune with the circuit this note will disappear, the receiver momentarily reverting to the non-oscillating condition. Very often there is a change in the actual note of the signal as we pass through the tuning point, but this usually indicates that the wavemeter is too close to the circuit.

In actual use the meter may be placed close to the circuit at first in order to find the approximate point where the absorption takes place. It

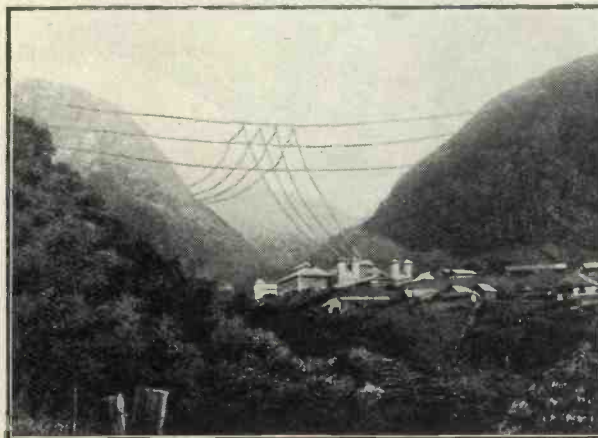

A SHORT-WAVE STATION IN JAVA

The aerials of the Malabar station are arranged in an unusual way. Have you heard its transmissions on 14.65 or 16.8 metres?

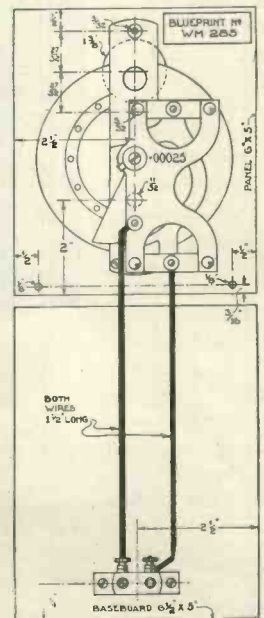

QUARTER SCALE LAYOUT

A full-size blueprint is available for 6d. (No. WM 285)

# TUNES FROM 6 TO 80 METRES

will probably be found that the circuit is prevented from oscillating over several degrees on the scale.

This, of course, is too indefinite for accurate reading, and the wavemeter should, therefore, be moved a little farther away, and the process repeated, until ultimately the absorption only occurs over one degree or so on the dial, when it is possible to locate the point with accuracy.

## Reduction in Strength

In some cases the circuit is not actually oscillating. We may be tuned to a telephony station with the circuit in a non-oscillating condition. In such circumstances the wavemeter may be brought close to the circuit; the tuning point is detected by a reduction in the signal strength due to the absorption. If the wavemeter is fairly close it is probable that the signal will be completely absorbed at the actual tuning point.

As before, the wavemeter should be kept away as far as possible to have the least interaction between the two circuits. Otherwise not only is the reading indefinite, spreading over several degrees, but it is not so accurate, as the wavemeter circuit will have an appreciable influence on the tuning of the set.

After a little practice, however, the use of this simple device will be quickly mastered, and it will be found invaluable in finding one's bearings and generally testing out short-wave receivers of various kinds.

## Wavelength Range

The wave range extends over the whole of the short-wave band likely to be required. The two-turn coil goes down to below 7 metres, so that it will be quite satisfactory for the new 7-metre broadcasting which is to be tried by the B.B.C. experimentally in the immediate future, while at the other end of the scale it is possible to go to 80 metres which is all that is required for ordinary reception, there being little of any interest above 50 metres.

One final point. The tuning on this wavemeter is fairly sharp. Therefore, do not tune too rapidly when searching, as it is possible that you may go right over the absorption point without obtaining any apparent effect.

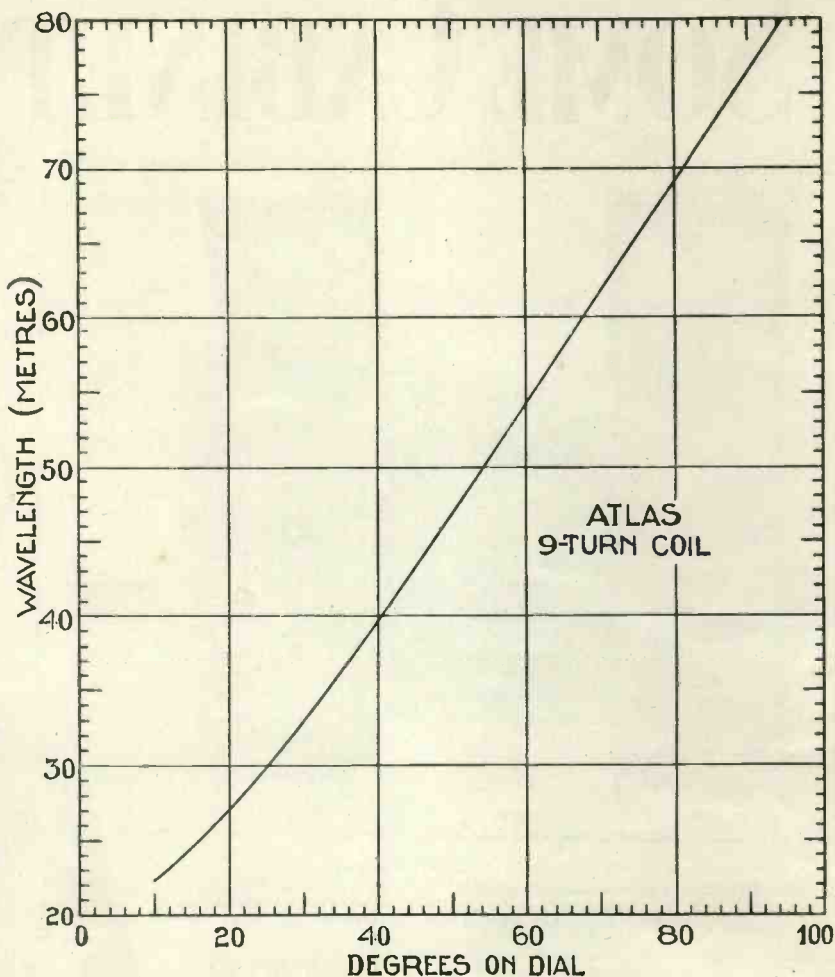

CALIBRATION CURVE FOR 22 TO 80 METRES

This curve is for a Cylcon .00025-microfarad condenser and an Atlas nine-turn coil. These components must be used or the wave range will be altered.

## The Difference

<i>In Grandmama's time, at the close of day, While Grandpapa dabbled with "patience,"</i>	<i>And Big Brother Bill, though "political" still Has become just a shade auto-cra- tic,</i>
<i>Letitia would open the spinet and play And Rosemary give recitations ; And Big Brother Bill, with a spirited quill, Would write letters to prominent Tories,</i>	<i>While Algernon delves on unlimited shelves Making radio sets in the attic !</i>
<i>While Algernon Leigh sat with pad on his knee Manufacturing serial stories.</i>	<i>Autre temps, autre mœurs—other times, other ways— I'm so glad that I'm not very old, sir ; Solitaire and bezique and each similar craze Would have left me too utterly cold, sir !</i>
<i>Those days have all gone : in the year '32 New pastimes have come into fashion ; Letitia has learnt to prepare a good stew And Rosemary's got a grande passion ;</i>	<i>No, give me an evening in this year of grace With a blueprint to con at my leisure, With components and wires all over the place, And there's nothing'd give me more pleasure ! C. P. P.</i>

# SOME CABINET IDEAS

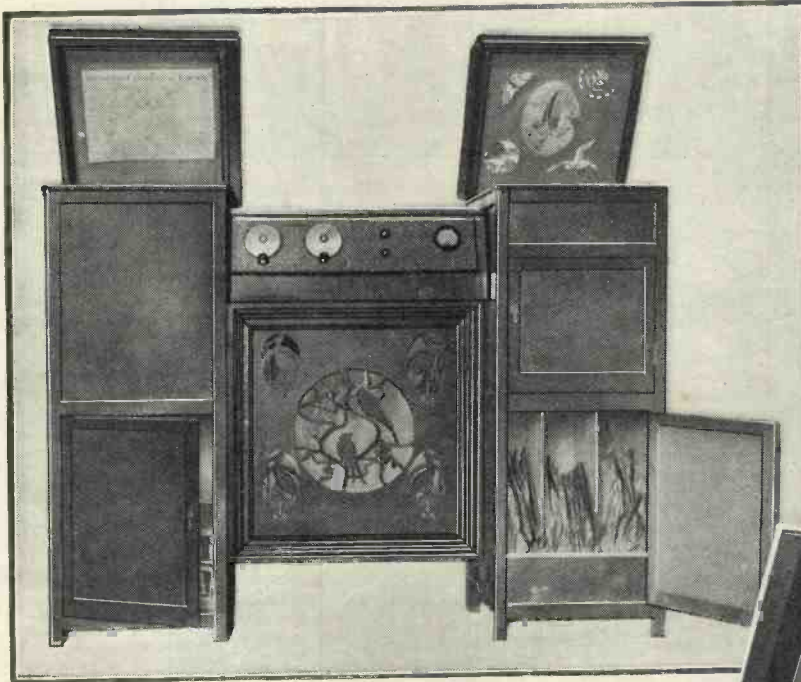

**A NOVEL IDEA IN RADIO CABINETS**

*The left-hand compartment is used for storing the mains units, accumulator, trickle charger, and miscellaneous oddsments. On the right is the radio-gramophone equipment*

Although these notes deal specifically with the problem of housing a set that was described in these pages some years ago, they will nevertheless be of value to all constructors of more modern receivers. Both the cabinets illustrated in these pages are the work of an amateur constructor. Can anyone beat them for originality or better appearance?

**I**N the majority of receivers one of the smallest components is the wave-change switch and yet for many years nothing has more influenced the nature and general appearance of the finished receiver.

The popular demand for increased simplicity in design, as in manipulation, has relegated to the past the old principle of coil changing and it is interesting to note how the necessity of changing the coils influenced cabinet design.

Formerly, no matter how unique or original the cabinet was in design, there was always the need of a hinged top, making the interior of the set immediately accessible.

Later, when radio gramophones became the mode, this characteristic became still more inconvenient since the gramophone motor and pick-up are usually placed immediately over the receiver.

Some years ago there appeared in this magazine particulars of a set which for quality I believe has never since been surpassed. The Lode-stone Five consisted of one stage of H.F., anode-bend detector and one stage of L.F., followed by a pair of LS5A valves in push-pull.

At the time of its publication it seemed that, while the quality of reproduction was all that the most exacting amateur could desire, its range was scarcely equal to that of other receivers.

However, some shadow of the prophet's mantle must have touched the designer, for since then practically every European station has so increased its power that the mountains have indeed come to Mohamet.

## Litz-wound Coils

One of the features of this set was the Litz coils which, of course, had to be changed for long and medium waves.

Two interesting and individual handlings of the difficulty in cabinet design caused by these coils are illustrated in the accompanying photographs.

In one case there is a self-contained radio gramophone of generous proportions—an arrangement which has



**AMBITIOUS DECORATION**

*How many amateurs could decorate their cabinets like this?*

the advantage of supplying ample space for records, which are stored on edge in the presses on the right and which are always convenient to hand. The gramophone motor and pick-up are also in the right of the cabinet, the lid of which is handsomely decorated with appropriate designs.

The corresponding cabinet to the left contains a radio chart and two mains units, trickle charger, and accumulator, and affords a neat repository for the many components that seem to be the inheritance of every enthusiast.

The other cabinet presents quite another arrangement for the same set. It has the advantage where  
*(Continued at foot of next page)*



# Ebonite for Coil Formers

**I**NSULATING material made of impregnated paper has for a long time been the most popular material for coil formers, but there now seems to be a tendency in some quarters to return to ebonite for this purpose.

## Drying Out Insulation

The paper used for the familiar tubular former is impregnated with some insulating compound and very great care must be taken to see that this is dried out properly.

In the past there has been some trouble with fine-wire coils where the insulating material in the paper has not been dried out thoroughly. Electro-chemical action takes place

between the wire and the insulating material with the result that the wire is eaten away and a break occurs in the coil.

The makers of one particular type of dual-range coil wound with fairly fine wire on an impregnated-paper former found this trouble to be so consistent that ebonite formers were substituted, although the cost was thereby put up.

As modern coils seem to be wound with finer and finer gauges of wire it appears probable that ebonite formers will once again become popular. The price of ebonite tube is substantially lower than it was a year or two ago. X. Y. Z.

## SOME CABINET IDEAS—Continued from preceding page

economy of space is required; but on the other hand has the disadvantage of no gramophone motor or pick-up.

These have been mounted on a wheeled tea-carriage, whose shelves again conveniently house the records and which can be produced with little inconvenience when required.

The design and construction of

your own cabinet is not a distinct hobby and scarcely a separate pleasure from the making of your own receiver. The culmination of the pleasure of having made a good set is to arrange it in a cabinet which is the work of your own hands and which shows in its design and finish the impress of your personality.

William Clarke, B.A.



ANOTHER ATTRACTIVE HOME-CONSTRUCTED CABINET

The Lodestone Five housed in a different type of cabinet which is also attractive in appearance. These designs should give inspiration to other constructors

## Stories of the Operas

### TANNHÄUSER (Wagner)

#### CHARACTERS

HERMANN, Landgrave of Thuringia . . . . .	Bass
TANNHÄUSER	Tenor
WOLFRAM	Baritone
WALTER	Tenor
BITEROLF	Bass
HEINRICH	Tenor
REINMAR	Bass

ELIZABETH, niece of the Landgrave  
 VENUS . . . . . Soprano  
 A young shepherd . . . . . Soprano  
 Four noble pages . . . . . Soprano and Alto  
 Time : Early 13th Century. Place : Fies-nach.

#### ACT I

The Venusberg. Venus, the Goddess of Love, takes joy in luring the Knights of the Wartburg into the mountain hall where she holds them captive. Tannhäuser is her latest conquest. He tires of her and desires to return to the world. In a dramatic scene she warns him, in vain, of the dangers and sorrows, and that he will long to return to her. The scene changes to a valley. Pilgrims on their way to Rome pass by, and Tannhäuser joins them that he may be forgiven for the crime of allowing himself to be enticed into the Venusberg. The Landgrave and some of the hunters find him and persuade him to return to the Wartburg.

Wolfram tells him how the beautiful Elizabeth languishes for his return. He has once loved her.

#### ACT II

The Singers' hall at Wartburg. Elizabeth greets Tannhäuser. The Landgrave proclaims he will offer his daughter's hand to the prize-winner at the contest of song soon to be held, feeling sure that Tannhäuser will win. The Pilgrims' March occurs here. Tannhäuser listens to the various love songs and seeks to win by a passionate song of the unholy charms of the Goddess of Love. This horrifies all present. The Landgrave will only forgive Tannhäuser if he goes to Rome with the Pilgrims.

#### ACT III

The Valley. Elizabeth, arrayed in pure white, kneels before the crucifix, Wolfram watching her. The Pilgrims return, singing their chorus. Elizabeth scans the company to see if Tannhäuser is with them. He has not returned. She sadly returns to the castle to die broken-hearted. Wolfram is also in love with her; he now awaits Tannhäuser's return.

Tannhäuser enters, weary and very dejected. He has sought for forgiveness, but the Pope has cast him out. He has come back to re-enter the Venusberg. Wolfram restrains him, but not until the name of Elizabeth is evoked is Tannhäuser saved. A cortege enters and Tannhäuser recognises the form of Elizabeth on the bier; he sinks down on her coffin and dies.

Venus, who has already appeared to try to entice Tannhäuser to return to her, now vanishes.

WHITAKER-WILSON.

# Matching the Loud-speaker

## to the Output Valve of Your Set

*To get the best results it is essential that the loud-speaker should be matched to the power valve. These notes explain how to calculate the ratio of the output transformer*

IT is a well-known rule that the impedance of a valve should match the impedance of the load into which it works. Only in this way can the valve operate efficiently and transfer the maximum amount of power for a given input voltage.

For instance, the impedance of a loud-speaker should be equal to the impedance of the power valve feeding it. In order to comply with this requirement in the case of a low-resistance loud-speaker, it is necessary to insert a step-down transformer, and the question then arises: what is the correct ratio required?

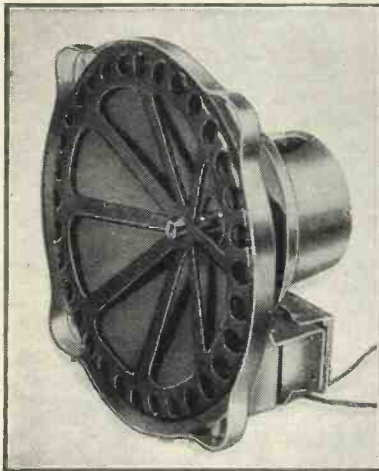

**MAINS-ENERGISED MOVING COIL**  
The Magnavox is one of the best small energised moving-coil loud-speakers. It gives excellent reproduction

In practice the effective impedance is determined by the square of the step-down ratio. For instance, take an LS5A valve rated at 2,750 ohms internal resistance and, say, a 12-ohm moving-coil loud-speaker. One is approximately 230 times more than the other.

To balance matters, a fifteen-to-one step-down transformer is required, because this, in effect, steps-up the loud-speaker impedance  $15 \times 15 = 225$  times, which very

approximately makes it equal to the valve impedance.

The reason will be seen in the accompanying diagram, which shows a valve coupled to the loud-speaker windings through a 15 : 1 step-down transformer, so that if there are 15 volts across the primary windings

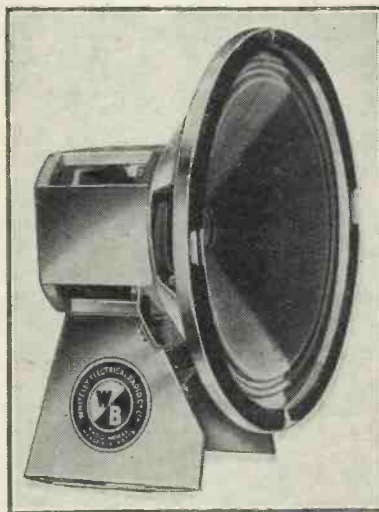

**PERMANENT-MAGNET MOVING-COIL REPRODUCER**

This is the latest W.B. permanent-magnet moving-coil reproducer—type PM4. It is supplied with or without impedance-matching transformer

there will be only 1 volt across the secondary.

Remember that the power expended is the same on both sides of the transformer in a well-designed transformer, and that the primary winding can be taken to be a pure resistance  $R_1$ .

The power on the secondary side is volts  $\times$  amperes. Now

$$\text{Amperes} = \frac{\text{volts}}{R}$$

so that

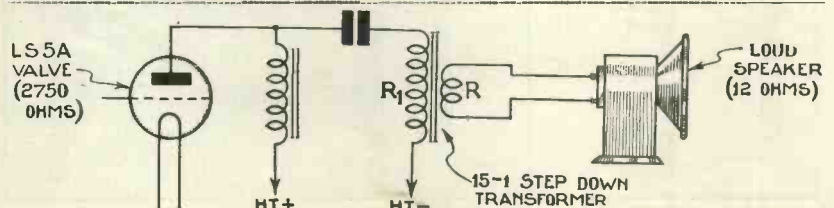

**OUTPUT CIRCUIT SHOWING NEED FOR MATCHING IMPEDANCES**

In this circuit the primary of the output transformer is shown as a pure resistance ( $R_1$ ) while the loud-speaker resistance is represented by  $R$

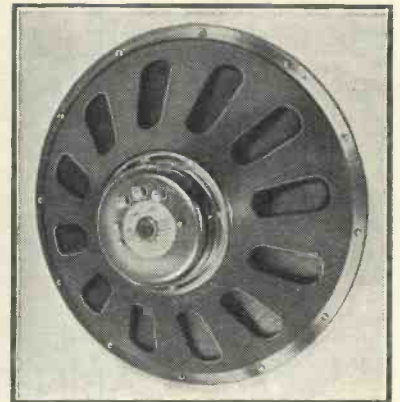

**MOVING-IRON INSTRUMENT**

The Celestion type M12 cone loud-speaker has a moving-iron movement. The chassis is very strongly made

$$\text{Power} = \frac{\text{volts} \times \text{volts}}{R} = \frac{v^2}{R}$$

On the primary side the power expended is similarly.

$$\text{Volts} \times \text{amperes} = \frac{15 \text{ v.} \times 15 \text{ v.}}{R_1} = \frac{225 v^2}{R_1}$$

Equating the primary and secondary powers

$$\frac{v^2}{R} = \frac{225 v^2}{R_1}$$

so that

$$R_1 = 225 R.$$

In other words, the load  $R_1$  into which the valve works is 225 times the impedance  $R$  of the loud-speaker.

The internal resistance (or impedance) of the valve is, as stated above, actually 230 times the resistance of the loud-speaker, but the above approximation comes sufficiently close to the rule of "matched impedances" to give maximum efficiency. B.A.R.

# "Wireless Magazine"

## GRAMO-RADIO SECTION



## Featherweighted Pick-ups

Further Opinions from "W.M." Readers

To the Editor, "Wireless Magazine."  
**S**IR,—As letters dealing with featherweighting are invited, I would like to set out my experience with a very well-known make of pick-up fitted with an adjustment as standard for weighting the head, this having been set to allow the head to rest very lightly indeed upon the record.

### Receiver Used

I am an amateur only, seeking distortionless quality from radio and records, my set being the "W.M." Regional A.C. Four, with push-pull output giving just over 2 watts undistorted power.

1.—*Wear on Records*: I have played a set of records, each one about thirty times, and I cannot observe any wear on any one of them. I therefore assume wear is not likely to present itself upon any particular portions of these records which lend themselves to damage.

2.—*Scratch*: Normally weighted, my pick-up scratches, but featherweighting reduces the amount considerably, but not wholly. This can be eliminated, however, by inserting a medium-tone Columbia needle. Volume then suffers.

### Effect on Quality

3.—*Quality*: To a critical ear, I believe a slight difference is to be detected when the pick-up is running "light," certain notes not being produced with the clarity

they can be through normal loading of the pick-up.

Testing by ear alone, I do not think this difference would be noticeable unless one looked for it deliberately.

4.—*Volume*: To the ear, the all-round output appears unaffected by featherweighting compared with normal weighting of the pick-up.

I may say I use Columbia Talkie and loud-tone needles as a general rule.

5.—*Failure to Track*: No occurrence yet with the degree of featherweighting used.

In conclusion, I believe a very important subject has been opened up by Captain Barnett and I hope it will be explored much further.

Mr. H. E. Gauss undoubtedly has the resources at his command to examine every aspect of the matter and I for one would like to know whether it would not be possible to overcome tracking failure with a featherweighted pick-up by some alteration in the design of instruments in general.

Leeds.

F. R. G.

♦ ♦ ♦  
 To Capt. H. T. Barnett, "Wireless Magazine."

Sir,—I have followed with great interest your articles on featherweighting. I use a Marconi pick-up and find that I get very much better reproduction since I have fitted an additional large piece of metal at the end of the tonearm to take the weight off.

Some of my records are as good as new although I have played them twenty times or more, whilst others are practically worn out that I played before using the new system.

### Output Obtained

I cannot find that needles make any great difference. The pick-up gives the greatest output of any that I know. In your first article you mentioned the Edison Bell Cinema model. I purchased one of these for a friend, but the reproduction, at any weight, has no comparison with the Marconi, although perhaps there is a little more bass, due to an earlier cut-off in the pick-up.

I use a Mazda 220a Pen., output 1 watt, with a Farrand inductor loud-speaker, last valve coupled with a Ferranti AF5 and tapped Atlas pentode choke with 150 volts high tension.

### Playing Six Sides

Incidentally I find that with ordinary weighting with the Marconi pick-up a fibre needle will only play half-way through a record decently, but since I have adopted featherweighting I can play at least six sides before it gets a bit smudgy.

With many thanks for putting me on to a system which has literally saved me money, and hoping you will continue with the good work.

E. R. Herbert.  
 Gloucester.

# Choosing Your Records

## ORGAN MUSIC

★Prelude and Fugue on B-a-c-h (d.s.), G. D. Cunningham, 4s. COL DX340  
By Liszt. The subject of the fugue consists of four notes: B-A-C-H, in this way. In German B flat is B and B natural is H; thus Liszt was able to render Bach's name musically. Cunningham plays this with considerable effect on the Central Hall organ. The bass of the record makes it good for test purposes.

## CLASSICAL ORCHESTRAL MUSIC

★Concerto No. 2 in F Minor, Op. 21, Arthur Rubinstein and the London Symphony Orch., and Waltz in C Sharp Minor, Arthur Rubinstein, 6s.

H.M.V. DB1494-5-6-7

I had better explain this heading. In an album of four complete records Rubinstein plays the Concerto of Chopin in F minor. On one of the sides he plays *solo* the well-known Polish waltz in C sharp minor by the same composer. This concerto is rarely heard in public; more's the pity, as the work has some beautiful moments. I am inclined to point to this album as being worth getting, not only because of the beauty of the music or of his playing, but because it presents Chopin in an unusual light. The hearing of it gave me deep pleasure.

## LIGHT ORCHESTRAL MUSIC

(a) Alublatt, (b) Romance, Frederick Hartley Novelty Quintet, 1s. 6d.

FILMO 436

Good light orchestral music on an equally light disc. Filmos, if you don't know, are bendable records, with their own needles. I think you will like this; the playing on both sides is good and the recording amazingly so.

★(a) Black Eyes, (b) Pan and the Wood Goblins, Commodore Grand Orch., 1s. 6d.

WIN 5472

A very good light orchestral record; (b) delightfully descriptive. The first is an attractive gypsy melody. I enjoyed both very much. The effects, by the way, in (b) are very unusual. Get it; you will not be disappointed.

(a) I'll Whistle Under Your Window, (b) Sleep on, International Novelty Quartet, 2s. 6d.

ZONO 6097

Two very good waltz tunes. I do not think they would be useful in a dance-room, but I regard them as very pleasant light orchestral music. *Sleep On* is particularly attractive.

## LIGHT SONGS AND BALLADS

(a) Absent, (b) Down the Vale,

Here are reviews of the latest releases by WHITAKER-WILSON, the "W.M." Music Critic. Outstanding records are indicated by an asterisk (\*) against the title

Dora Labbette and Hubert Eisdell, 2s. 6d.

COL DB771

The names of the singers in this case should be enough to recommend the record to those who are sufficiently keen on the ballads to hear them. The orchestral accompaniment is



Dora Labbette

well done; indeed, the whole arrangement is musicianly. The singers, of course, are all one would expect them to be.

(a) Absent, (b) Sympathy, Hardy Williamson, ten., with orch., 1s. 6d.

WIN 5481

His voice suits the style of song he sings. If you are keen on either—they are very effective with orchestra, I may add—you cannot do better than get this edition of them.

Ballad Memories (d.s.), Bob and Alf Pearson, 1s. 6d.

BRDCST 3174B

As good as ever! They sing *Because, My Caravan, Little Grey Home, Roses of Picardy*, and other snatches in their own extremely attractive fashion. Someone ought to write them a really good duet with their particular effects in profusion. Very delightful!

★(a) Bit, a Saddle, and a Horse, (b) Give a Man a Horse, Morland Morgan, 1s. 6d.

WIN 5478

I like (b) immensely. I recommend the record unreservedly; his is a fine voice.

(a) Danny Boy, (b) Mother Machree, Peter Flynn, 1s. 6d.

FILMO 459

This is a good-toned disc; Peter Flynn has a touch of the Hibernian about him that makes for a good presentation of these popular songs. Apart from which his voice is attractive and his diction impeccable. I recommend the record.

Harry Welchman—Theatre Memories (d.s.), Harry Welchman and Theatre Chorus, with Orch., 2s. 6d.

COL DB783

Harry Welchman is well able to introduce memories of the

theatre. Here he sings such songs as *Silver Wings; Lover, Come Back to Me; Student Prince*, and others. His baritone voice has a vigorous but also often a very mellow tone; the chorus is a fine support. This is a thoroughly good record.

(a) I'm a Specialist, (b) The Lady of My Dreams Taught Me How to Play the Second Fiddle, Frank Cumit, ten., 2s. 6d.

H.M.V. B4102

If Frank Cumit is a tenor he must be a tenor in the accepted American style; I cannot hear anything in his voice that faintly reminds me of an English tenor. However, he sings *I'm a Specialist*, which is rather feeble, but the other song is not at all bad. Candidly, I am not at all enthusiastic over either side, but (b) is passable.

(a) In a Persian Market, (b) Sanctuary of the Heart, Harold Williams and male quartet, with orch., 4s.

COL DX341

Harold Williams is so well known in wireless programmes that there is no need for me to say anything about his singing. The male quartet adds considerably to the effects he produces; the only blemish I can detect is in some of the orchestral accompaniment. The blemishes are not serious; I can recommend the disc confidently.

(a) O Sole Mio, (b) Somewhere a Voice is Calling, Birrell O'Malley, 2s. 6d.

ZONO 6101

You will know both songs, of course. All I can say here is that his voice is so good that I wish he were singing something worth while. If you like the songs, do not miss them on any account; you will never hear either sung as well again!

★(a) To be Worthy of You, Layton and Johnstone, (b) Trees, Turner Layton, 2s. 6d.

COL DB780

Splendid all through! These two are always worth hearing. I think I never heard them to better advantage. You can buy this on my recommendation.

## MILITARY BAND MUSIC

★(a) Acclamations Waltz (b) Grenadiers' Waltz, Regimental Band of H.M. Grenadier Guards, 4s.

COL DX335

This seems to me exceptional even for the Grenadiers. Which, of course, is saying something. I have rarely heard a military band record I liked better. I noticed a pleasant echo; on looking at the label I saw the cause. The record was made in the Central Hall, Westminster. Thoroughly to be recommended.

## NOVELTY RECORDS

Gracie Fields' Medley (d.s.), Gracie Fields, 4s.

H.M.V. C2378

I imagine this is going to please many people. The items are: *Charmaine, Because I Love You, My Blue Heaven, Ramona, Ee by Gum!* and *Laugh, Clown, Laugh. Ee by Gum!* amused me very much; I have heard it before, but it came back very freshly. Miss Fields has her own announcer and a studio audience. A very entertaining disc.

In the Mystic Land of Egypt (d.s.), Charles Prentice and his Orch., 2s. 6d.

COL DB767

This is rather original; the second side especially is very Eastern in style. Voices "fade in and out" in a wholly attractive fashion. Quite worth having for its novel effects.

(a) Londonderry Air, (b) Melody in F, Eddie Peabody, 2s. 6d.

COL DB769

These works are here played with considerable technique on a banjo, a mando-cello, and a mandoline. To those who play any of these instruments or are interested in them, I can very confidently recommend this disc.

## ADDITIONAL RECORDS REVIEWED BY CHOPSTICK

### PIANO SOLOS

★(a) Bow Bells, (b) Cat and the Fiddle, Bidgood & Jerome, 1s. 6d.

BRDCST 3173A

Good syncopated piano playing is an art that is rarely attained by dance-band pianists. Harry Bidgood, of Bidgood's Good Boys, and Jerome combine to make an outstanding record demonstrating the real art of syncopation. Their rendering is delicate and rhythmic. (b), by the way, is the name of the new musical show at the Palace Theatre, London.

### POPULAR SONGS

(a) All of Me, (b) One More Kiss—Then Good-night, Mellow and Rich, 1s.

BRDCST 832A

Two popular songs sung quite well. The record is well produced.

★(a) By the Fireside, (b) Home, Sam Browne, 2s. 6d.

ZONO 6099

(a) was composed by Ray Noble and sung by the vocalist of Ambrose's Mayfair Hotel band. This singer has excellent diction for these love ballads. Zonophone certainly know the best form of combination for accompaniment work. A pleasant record.

★ **Cat and the Fiddle** (d.s.), Peggy Wood, sop., 2s. 6d.  
**COL DB796**

On one side Peggy Wood sings "Try to Forget" and on the other "She Didn't Say 'Yes'". The orchestra accompanying these two snappy songs is conducted by Carrol Gibbons, the Savoy Orpheans' famous syncopated pianist, who also gives a fine example of syncopated piano playing on both sides of this excellent disc. The "Cat and the Fiddle" music is composed by Kern of *Show Boat* fame.

(a) **Faded Summer Love**, (b) **You Didn't Know the Music**, Al Bowley, 1s. 6d.  
**WIN 5470**

Al Bowley has a style that is decidedly pleasant. It is indeed a treat to find a light singer who does something out of the ordinary. The piano accompaniment on both sides is played with delicate feeling. This is just the record for an interlude in a programme of dance music.

(a) **If I Have to go on Without You**, (b) **Kiss by Kiss**, Billie Lockwood, 2s. 6d.  
**ZONO 6104**

Billie Lockwood is not a "he" but a charming deep-voiced singer after the style of Greta Keller. An excellent recording of two love ballads. I could hear every word without any exertion on my part. An achievement!

## NOVELTY RECORDS

**Congress Dances** (d.s.), Henri Benito's San Marino Accordeon Band, 1s.  
**BRDCST 833**

The music of *Congress Dances* is known too well to need comment. I do not think an accordeon band, however, can do it justice. Schubert's *Marche Militaire*, which is included in the selection, does not lead itself to an accordeon band orchestration.

**Hits of the Moment** (d.s.), International Accordeon Band, 2s. 6d.  
**ZONO 6108**

Accordeon bands are inclined to record rather harshly and this one is no exception. This, nevertheless, is an enjoyable record which I can recommend. The tunes include "By the Fireside," "Three Little Times," and "Flame of Desire."

**He Played His Ukelele As the Ship Went Down** (d.s.), Bobbie Comber, 1s.  
**BRDCST 831**

Leslie Sarony's popular hit is produced in full—seven minutes of Captain Brown's adventures on an excellent disc. I thoroughly enjoyed it.

## HUMOROUS RECORD

(a) **Riddles**, (b) **Stories**, Bobbie Comber, Com., 1s.  
**BRDCST 830B**

What is the difference between a clothes line and an aerial? One draws the... No, I won't give the riddles away. A disc full of pep. Bobbie Comber is too well known to need any comment.

## CINEMA ORGAN MUSIC

(a) **Cuban Love Song**, (b) **Goodnight Vienna**, Wurlitzer Organ, 1s. 6d. **FILMO 454**

The first recording of the Wurlitzer organ at the new Filmophone studios. C. D. Smart plays both these popular numbers in rather an antiquated style and the vocalist is not too good.

(a) **Life is Just a Bowl of Cherries**, (b) **Whistling Waltz**, C. D. Smart, 1s. 6d.  
**FILMO 445**

Smart is the organist of the Plaza Cinema, London, and so we naturally expect good rendering. I was not disappointed. His playing of (b) is out of the ordinary, for he makes full use of many of the numerous effects that are to be found on a Wurlitzer. The recording is good.

★ **Song Hits—Organ Medley**, (d.s.) Reginald Foot, 2s. 6d.  
**COL DB762**

Foot puts his best style into this selection of 1932 song hits. "I Don't Know Why," "Guilty" and "I Wanna Be Loved By You" are among the tunes played. This must surely be the last of Reggie Foot's recordings in the Regal, Marble Arch. He has recently moved to the Regal at Kingston, from which he now broadcasts.

## DANCE MUSIC

(a) **Blue of the Night** (w.), (b) **Songs That are Old Live For Ever** (f.), Henry Hall and his B.B.C. Dance Orch., 2s. 6d.  
**COL CB430**

(a) is a delightful waltz tune played at perfect slow time for dancing. (b) is, I think, rather a "wishy washy" affair. The band records much better than it broadcasts.

★ (a) **By the Sycamore Tree** (f.), (b) **Gettin' Sentimental**, Henry Hall and the New B.B.C. Dance Orch., 2s. 6d.  
**COL CB431**

Henry Hall makes his record debut. This disc shows that Hall's band is a band of soloists and something different from the ordinary run of dance bands. (b) is a very fine tune with some excellent trumpet playing by Frank Wilson. It is an outstanding dance record.

★ (a) **Ev'ning in Caroline** (f.), (b) **Was That the Human Thing To Do?** (f.), Blue Mountaineers, 1s. 6d.  
**BRDCST 3177B**

The Blue Mountaineers band is one of the finest dance orchestras recording to-day. The rhythm background is well defined by heavy strings and piano. (b) contains a unique example of a xylophone and saxophone duet. All dance enthusiasts should buy this disc.

(a) **Fire in My Heart** (slow f.), (b) **Save the Last Dance For Me** (w.), Savoy Hotel Orpheans, 2s. 6d.  
**COL CB426**

Below the usual standard of the Savoy Orpheans. This band seems to be getting a trifle stale. (a) is too fast for a slow fox-trot and (b), although played at good time for waltzing, is spoilt by the vocalist.

(a) **Goopy Geer** (b) **In the Jailhouse Now**, New Devonshire Dance Orch., 1s. 6d.  
**FILMO 430**

One of the best versions of (a) I have yet heard. The recording is of a high standard.

(a) **Goopy Geer** (f.), (b) **Open Up Dem Pearly Gates** (f.), Blue Lyres, 2s. 6d.  
**ZONO 6091**

(a) is one of the popular rages at the moment, but this version is not too well played. The production is rather dull and the piano playing—what there is of it—seems flat. The time is not pronounced enough to make it a good dance record.

★ (a) **It's Just the Time for Dancing** (quickstep), (b) **Here's to the Next Time** (quickstep), Henry Hall's B.B.C. Dance Orchestra, 2s. 6d.  
**COL CB439**

These are the signature tunes of Henry Hall's band. (a) is for beginning his broadcasts and (b) is for fading out. Both are well played. Harry Robbins, late xylophonist of Jack Hylt n's band, gives a wonderful display of his art on (b). The time of both tunes is excellent for quickstepping. I recommend it.

(a) **It Seems All a Dream, But It's True**, (b) **Songs That are Old Live For Ever** (f.), Jock McDermott and his Band, 1s. 6d. **WIN 5473**

The vocal chorus on (a) is well sung and although the rhythm is not too well defined it is a pleasant disc. Jock's band, I believe, is very popular with dancers at the Covent Garden Opera House dances. (b) introduces Jock McDermott and his signature tune, "Bonny Banks of Loch Lomond."

(a) **Javanette**, (one-step), (b) **Senorita** (tango), Cosmopolitan Accordeon Band, 1s. 6d.  
**WIN 5476**

The best accordeon-band recording of the month. (b) is an excellent tango played at the correct tango time. There is no trace of the harshness usually associated with accordeon-band recording. A recommended disc.

(a) **Jealousy**, (b) **Song of the Rose**, Stein's Tango Orchestra, 1s. 6d. **BRDCST 3175**

More real tango music played in the right fashion. This band reminds me of a famous tango orchestra which was all the rage when I was in the Argentine two or three years ago. I think this is one of the finest records that has been issued by Vocalion for some time. The recording is extremely natural.

★ (a) **Kiss by Kiss** (f.), (b) **You Rascal, You** (f.), Blue Mountaineers, 1s. 6d.  
**BRDCST 3176B**

Although it is rather late for (b) this is a case of better late than never. The Blue Mountaineers version of this popular number is the best I have heard. Drums, vocalists and saxes and trumpets make queer noises from start to finish, yet there is a delightful tunefulness about the whole production. It is excellent!

(a) **Maree** (one-step), (b) **Speak to Me of Love** (w.), Henry Hall's B.B.C. Dance Orch., **COL CB440**

(a) is a six-eight number played in a lively style; the orchestration is rather novel.

Val Rosing's voice is improving; his diction is much clearer. The waltz on (b) is delightful. Slow, soft and tuneful, its chief feature is a well-played saxophone solo by Gillis. The B.B.C. Dance Orchestra is coming along.

(a) **My Bluebird's Back Again** (f.), (b) **Blues in My Heart** (f.), Savoy Hotel Orpheans, 2s. 6d.  
**COL CB427**

Howard Jacobs and his boys give a fine rendering of (a) but the honours of the side go to Carrol Gibbons for his perfect syncopated pianisms. A noisy arrangement spoils (b) and makes it rather distasteful.

★ (a) **My Girl Don't Love Me Any More** (f.), (b) **With Love in My Heart** (f.), Ray Noble and his New Mayfair Orch., 2s. 6d. **H.M.V. B6157**

This crowd are getting as "hot" as some of the best



Ray Noble

American dance bands. I felt as much out of breath after hearing (a) as if I had been playing in the band. Congratulations to the banjo or guitar player—whichever he is—his syncopation is "red pepper." A jolly good record.

(a) **She Didn't Say Yes** (f.), (b) **Try to Forget** (f.), Ambrose and his Orch., 2s. 6d.  
**H.M.V. B6153**

All that need be said about this record is that it is typically

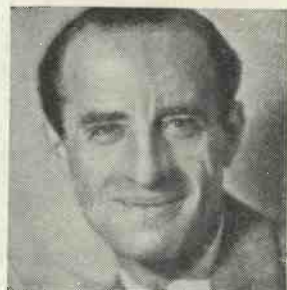

Ambrose

Ambrose. It is, of course, tuneful, but the arrangement is nothing out of the ordinary.

(a) **When the Rest of the Crowd Goes Home** (w.), (b) **Whistling Waltz** (w.), Bidgood's Good Boys, 1s.  
**BRDCST 834B**

Harry Bidgood and his band are among Broadcast's oldest recorders. Both these popular waltzes are played well, although perhaps a little too fast. Harry Bidgood, the pianist, is the outstanding instrumentalist of the band.

# The Modern Radio Gramophone

By the "W.M." Set Selection Bureau

**T**HERE are many enthusiasts who maintain that the radio gramophone is the only musical reproducer of the future—that sets as we know them to-day will give way to the radio gramophone in every home.

There is no doubt that during the present season a great increase in the number of radio-gramophone users has been brought about by the new cheap machines.

For as little as thirty guineas you can buy an instrument capable of bringing in a good number of broadcast programmes, and capable, when such programmes do not appeal or are not being transmitted, of reproducing, with great volume and excellent quality, gramophone records.

We sometimes wonder whether set-buyers realise how little more need be spent to obtain the extra advantage of record reproduction. Perhaps it is not generally realised, even now, that common to a radio set and a modern reproducer of records are a good amplifier and a loud-speaker.

These two constituents are already contained in the set, and the only important extras needed for record reproduction are the motor and pick-up. It is for this reason that the difference in price between say a three-valve radio set and a medium-power radio gramophone is less than ten pounds.

When set buyers ask us to suggest a radio set, mentioning quite a substantial price, and adding that provision for a pick-up would be welcome, we are sometimes led to wonder what sort of accessories are to be used in order to make use of such pick-up facilities.

Is that old and faithful acoustic machine to be given a new lease of life? Or that tinny-sounding portable gramophone to have its turntable utilised with a pick-up, which will presumably have to be bought, and in some way fitted to the motor-board?

We ask ourselves these questions because it does often seem a pity to buy a set for some twenty or thirty pounds and to get record reproduction by makeshift accessories when so many excellent and inexpensive combination instruments are available.

The complaint used to be made that the radio gramophone was deficient in radio efficiency—that what you paid for in such an in-

with one stage of high-frequency amplification, a detector and a pentode power valve.

During radio use all three valves are working, but for record reproduction only the detector and pentode are in action.

The loss of the high-frequency valve for records is more than offset by the fact that the pick-up supplies the detector (which is then working as an amplifier) with just as big a voltage as does the broadcasting station whose signal has passed through the high-frequency stage.

Not all the popularity of the modern radio gramophone can be attributed to the cheap three-valvers. Some very elaborate machines are now on the market at really quite reasonable prices.

For seventy or eighty guineas you can buy the most de-luxe of instruments, with eight or nine valve circuits, automatic record-changing mechanism, and an output enough to fill a concert hall if necessary.

The advantage of automatic record-changing needs no emphasis, but many prospective buyers are still unacquainted with this invention.

By the aid of a fairly simple mechanism it is now possible to play up to eight records without attention. That is to say, if you load the mechanism with eight records it will play eight successive sides without any intervention at the conclusion of each.

In this way it is easy to arrange a pleasant half-hour's entertainment of record reproduction without the tedium of getting up and operating the machine every few minutes.

It is gratifying to know that this labour-saving mechanism can be fitted to a radio gramophone at an extra cost of under ten pounds. It will therefore be appreciated that the radio gramophone offers many advantages in the home; money spent on such a machine is an investment that will give much pleasure.

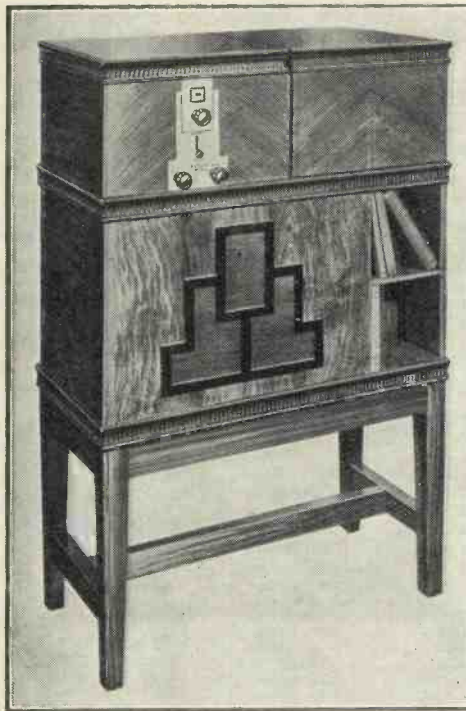

**UNUSUAL RADIO GRAMOPHONE**

*This is a Sixty-Sixty assembly. At the top on the left is the Sixty-Sixty Chassikit receiver, with a box for turntable and pick-up on the right*

strument was chiefly the ability to reproduce by electrical means the records, whereas very little could be heard other than the locals on the radio-reception side.

This complaint, in most of the latest instruments, is no longer justifiable. In fact, one of the greatest advantages of the modern radio gramophone is its balanced power—equally good on radio as on records. Most of the inexpensive machines of which we are thinking incorporate a three-valver

# THE ECONOMY A.C. TWO

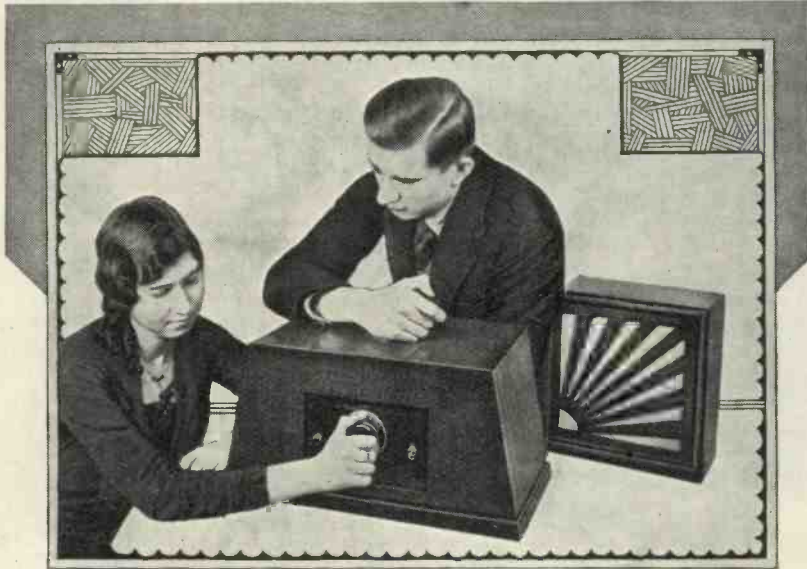

**T**HIS design is an attempt on the part of the "Wireless Magazine" Technical Staff to produce a satisfactory all-mains grammo-radio set (for the reception of the local stations and a few foreigners) that can be built for a £5 note. After reading through these pages even the most sceptical will be convinced that this object has been achieved; in this case low price does not mean inefficiency.

### Good Quality Parts

The planning of a cheap mains receiver is quite a different proposition from the design of a cheap battery set. In a mains set the parts must all be of high standard for, if a breakdown were to occur, there might be serious trouble.

A glance through the list of parts needed for the Economy A.C. Two will reveal that only components made by reputable manufacturers have been incorporated in the design. The smoothing condensers associated with the valve high-tension rectifier are, for instance, of the 1,500-volt D.C. test type.

Beginners may be mystified by our references to this set as a two-valver when three valves are shown in the photographs. It is true that there are three valves in the circuit, but the last of these only rectifies the A.C. electricity supply with which the house is provided into a high-voltage D.C. supply for application to the anode circuits.

As this rectifier valve plays no

part in the detection or amplification of radio signals we see no excuse for including it when discussing the number of valves in the set. Some set manufacturers include the rectifier when speaking of the number of valves in a set, but we object to this practice.

The actual valve combination employed in the Economy A.C. Two is a leaky-grid detector and a transformer-coupled power valve; there is also the rectifier for converting A.C. into D.C., as already explained.

Here the "Wireless Magazine" Technical Staff presents full constructional details for the building of a simple two-valve receiver that takes all its current from A.C. mains.

Although primarily a local-station set, the Economy A.C. Two will nevertheless pick up a number of foreign transmissions at good loud-speaker strength under favourable conditions.

Provision is made for the use of a pick-up so that gramophone records can be reproduced electrically when desired.

rectifier is very much cheaper.

It will be seen from the diagram on page 552 that the circuit is particularly simple and straightforward. In the aerial lead is the usual pre-set condenser for adjusting the degree of selectivity; this has a maximum capacity of .0003 microfarad. The greater the value of this condenser, of course, the less selective the set will be. As the adjusting knob is unscrewed (that is, as the capacity is decreased) so will the selectivity be improved, but at the expense of volume it should be remembered. The aerial-series condenser adjustment is always a matter of compromise.

### Grid Leak and Condenser

Somewhat unusual values of grid leak and detector are employed, namely 1 megohm and .0001 microfarad. Bias is applied to the "detector" valve for gramophone work by the voltage drop that occurs across a 600-ohm resistance in the cathode lead.

This is provided with a 1-microfarad condenser in parallel to by-pass high-frequency currents.

High-frequency currents generated in the anode circuit of the detector valve are blocked by the choke and flow through the reaction coil that forms part of the dual-range aerial tuner. The amount of feedback from

# THE ECONOMY A.C. TWO—Continued

EASY-TO-FOLLOW LAYOUT

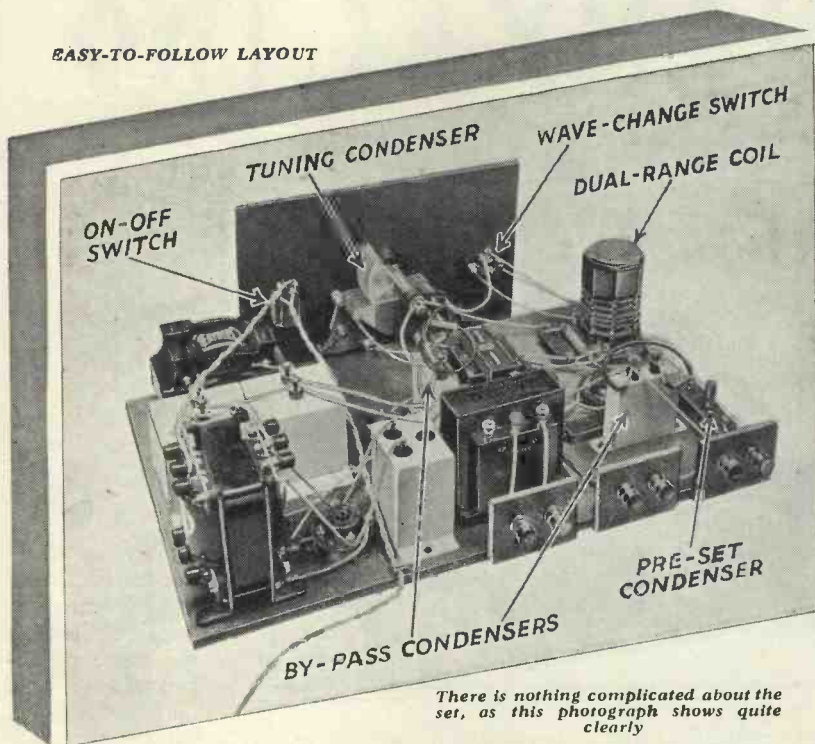

There is nothing complicated about the set, as this photograph shows quite clearly

of preventing any high-frequency ripples from the receiver being fed into the mains part, where they would cause trouble. To some extent these two condensers also help to smooth the output from the rectifier.

In practice it will be seen that both condensers are included in one case, three connecting points being provided.

## Mains Transformers

It should be noted that the mains transformer has three windings on the secondary side. One gives 500 volts (centre-tapped) to be applied between the two anodes of the rectifying valve; the second gives 4 volts (centre-tapped) for running the filament of the rectifying valve; and the third winding gives 4 volts (centre-tapped) at 3 amperes for supplying the heaters of the valves in the actual set.

It will be obvious from this that the particular transformer could be used for a three-valve set (A.C. mains valves take 1 ampere each) and some readers may wonder whether two valves would not be overloaded under these conditions.

Overloading does not occur, though, with a well-designed transformer and the particular model specified can be used in the Economy A.C. Two with every confidence that it will be quite satisfactory in this respect.

A special feature of this set is the

the anode circuit to the grid circuit is controlled by a .0003-microfarad variable condenser. A .001-microfarad by-pass condenser is provided across the anode and cathode of the detector valve.

Also in the anode circuit of the detector is the primary winding of the low-frequency transformer. Although only small this transformer is quite capable of handling the anode current of the detector valve; indeed, the results are surprisingly good, as will be clear from the test report on page 552 of this issue.

## Bias for Power Valve

Grid bias is also applied automatically to the power valve by means of a second cathode resistance; this one has a resistance of 1,000 ohms. It is also by-passed by a 1-microfarad condenser.

It must be understood that the voltages dropped across the grid-bias resistances in this set depend solely on the anode currents passed by the particular valves used. The values of resistances given apply only for the valves indicated in the list of parts. If other types of valves are used these resistances must be changed to give the right bias.

The remainder of the circuit shows the arrangement for obtaining a supply of high tension for applica-

tion to the anode of the detector and power valves. Smoothing after rectification is obtained by the use of a low-frequency choke and a 4-microfarad condenser, which must be of the high-voltage test type specified.

The two .1-microfarad condensers seen in the circuit diagram between the anodes of the rectifier valve and the centre-tap of the transformer high-tension winding have the effect

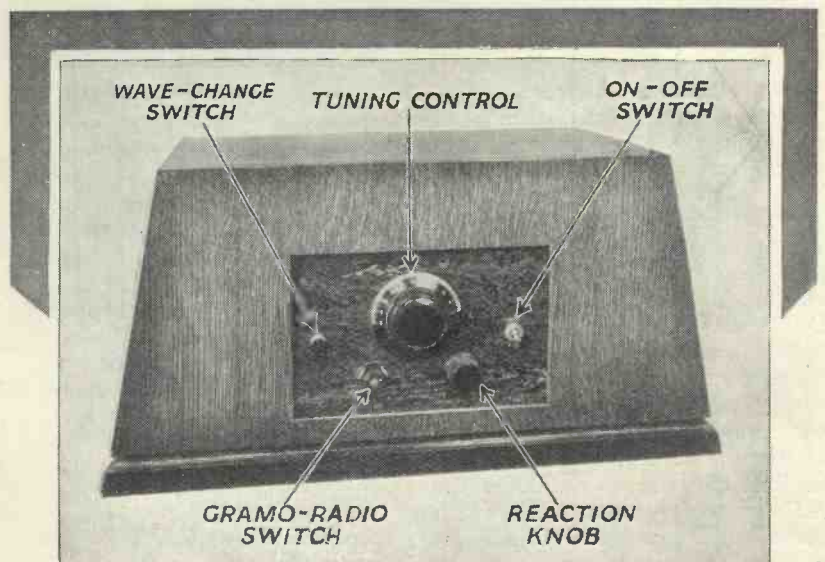

ONLY FIVE CONTROLS ALTOGETHER

This view shows how the controls of the set are arranged. Their operation can be mastered by anybody after a few minutes' practice. Full instructions are given in this article



## DESIGNED BY "W.M." TECHNICAL STAFF

output transformer for matching up the loud-speaker with the last valve. This has two ratios, namely 1:1 and 15:1. The 1:1 ratio is employed when the loud-speaker to be used is of the high-resistance type.

The balanced-armature cone loud-speaker specified in the list of parts is of this type and has been chosen because it is more sensitive than the average moving-coil reproducer and will therefore give better reception of distant stations.

## Using A Moving Coil

Those who desire to use a moving-coil loud-speaker with the set can do so—there is ample power as far as the local stations are concerned. The volume from foreign stations will be reduced somewhat, however, compared with the signals obtained on a balanced-armature type of reproducer.

It is obvious that a set of this type—which, by the way, includes a switch for the reproduction of gramophone records—can be housed in practically any type of cabinet. Those who do not want a complete radio-gramophone equipment will find the type of cabinet illustrated on page 550 very convenient and attractive. A separate loud-speaker is needed, of course, and for the reproduction of records a turntable and pick-up will also be required.

The controls of the set are not in the least complicated. It will be seen that in the centre of the panel

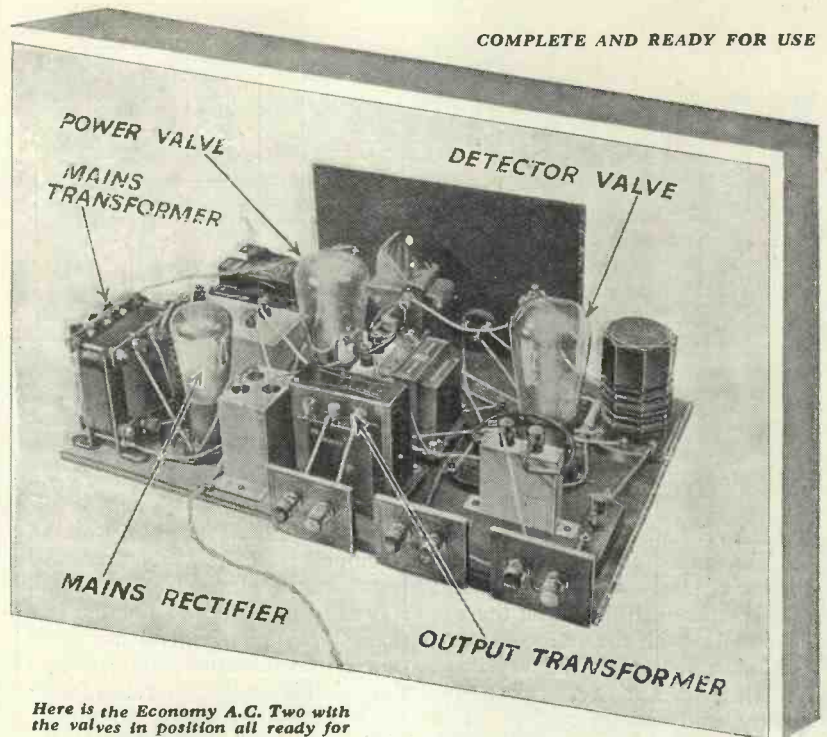

Here is the Economy A.C. Two with the valves in position all ready for switching on

is the main tuning dial, which is of the slow-motion type. Immediately to the left of this is the wave-change switch; this is pulled out for medium-wave reception and pushed in for the long waves. On the right of the main tuning dial is the on-off switch.

There are two other controls just underneath the main tuning dial. That on the left is the gram-radio switch and on the right is the knob

of the variable reaction condenser.

Every detail essential for the construction of the Economy A.C. Two is included in these pages, including a quarter-scale layout and wiring diagram. Those who desire one can obtain a full-size blueprint of the set for half price—that is 6d., post free—if the coupon on the last page is used by June 30.

Ask for blueprint No. WM286 and address your application to "Wireless Magazine" Blueprint Department, 58-61 Fetter Lane, London, E.C.4. A copy will be sent to you by return of post.

## Numbered Leads

As is the case with all "Wireless Magazine" blueprints, that of the Economy A.C. Two is so arranged that each lead is numbered separately in the best order of assembly. Under this system it is impossible to make a mistake in the wiring of a set if the blueprint is carefully followed.

Start with the lead numbered 1 on the blueprint and work through in numerical order until all the connections have been completed. Mistakes will be avoided if the numbers on the blueprint are crossed through with a pencil as the corresponding leads are put in position on the set.

Particular care should be taken to

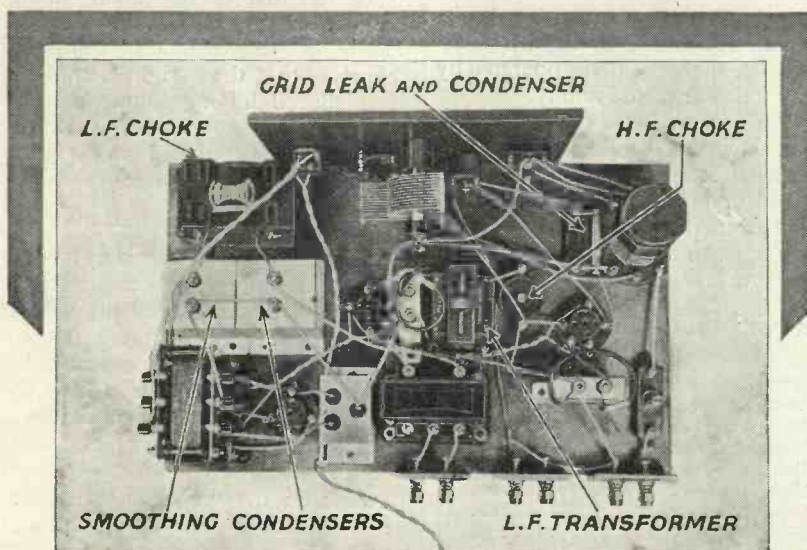

HOW THE PARTS ARE ARRANGED ON PANEL AND BASEBOARD

This special plan view shows the disposition of all the parts in the Economy A.C. Two, the construction of which will present no difficulties even to the beginner

# THE ECONOMY A.C. TWO—Continued

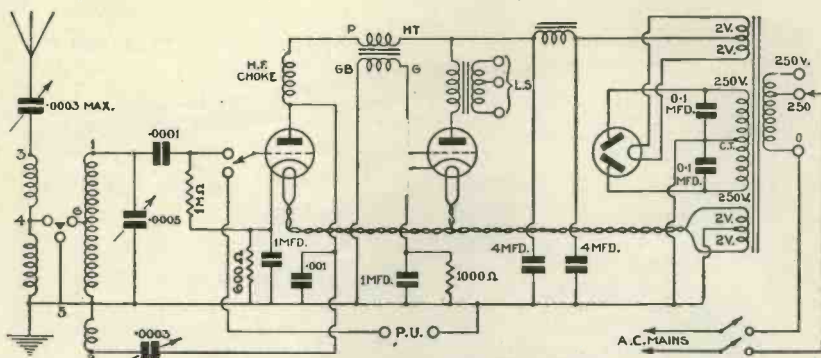

**SIMPLE CIRCUIT WITHOUT ANY SNAGS**

The valve combination is leaky-grid detector followed by a transformer-coupled power valve. A.C. is rectified to D.C. by means of a third valve

see that the leads are properly insulated, particularly in the mains part of the set. Wiring is best done with a fairly stout gauge of copper wire covered with oiled-cotton sleeving cut to the appropriate lengths.

One of the leads to the pick-up terminals (wire No. 9 on the blueprint) should be made with metal-braided cable. This is to prevent hum being picked up by this lead. The metal braiding should be earthed by means of a fine wire twisted round it (No. 10 on the blueprint).

### Pick-up Volume Control

It will be noticed that as the set stands there is no provision for controlling the volume when a pick-up is in use. This is not due to an oversight. So many pick-ups are now supplied with their own volume controls that it is often unnecessary to have one in the set.

Some pick-ups with volume controls that are suitable for use with the Economy A.C. Two are the Limit, the H.M.V. and the Blue Spot.

With a simple set of this type the results depend to some extent on the skill of the operator. There is an art in the best adjustment of the aerial pre-set and reaction condensers—a fine touch will improve a set of this kind out of all knowledge.

When the set is switched on for its first try-out, it is best to start on the medium waves; adjust the wave-change switch accordingly. Next turn the dial of the main tuning condenser to zero, and turn the knob of the reaction condenser slowly to the right until a pronounced hissing sound is heard from the loud-speaker. If the reaction knob is turned too far to the right the set will howl.

### Searching for Stations

Searching is now started by moving the main tuning knob to the right. After it has been moved through an arc of several degrees it will probably be necessary to advance the reaction control slightly to keep the set in its most sensitive condition.

The secret of success when searching for foreigners is to keep the set always on the verge of oscillation. It is difficult to describe this state of affairs in print for the benefit of beginners, but it will soon be recognised in practice.

## Test Report on the Economy A.C. Two

I HAVE had the Economy A.C. Two on test for a whole day and the log of stations given at the end of this report will show that there is little amiss with the set.

Modern sets are nowadays judged on their sensitivity, selectivity, quality, and ease of control. The sensitivity of this set is well up to the average.

I first put the set on test on a Sunday morning. I tried the medium waveband first and the results were better than I expected. At the top of the scale, Langenberg was a fair signal at 78 degrees. I heard two other stations around the middle of the dial, but they were not identified.

The chief feature of the morning test was the reception of the French station Fécamp at 17 degrees at fair signal strength.

On the long waves, Radio Paris was heard at full loud-speaker strength; it broadcast *Good-night Vienna* four times that day!

Several other long-wave stations were also heard.

From 8 to 10 p.m. on Sunday was chosen for the combined test of sensitivity and selectivity under

night conditions. Before London Regional started, Mühlacker was heard at the strength of the local station. When the two London stations started pouring out their huge power into the ether, the capabilities of this little two-valver were tried to the uttermost.

The first adjustment necessary was to unscrew the pre-set condenser to cut down the spread of the locals. This done, it was possible to separate the locals with a wide margin to spare and at the same time bring in a fair number of foreigners.

Rome, Langenberg, and Prague were undoubtedly the best of the bunch. The quality of all stations was pleasant and crisp.

Regarding the ease of control, there is little to be said. There is only one knob to adjust, beside the reaction control, and with little practice the set could be operated by any member of the family.

This is an ideal two-valver for listeners who live in areas around regional stations. The set can be relied upon to provide good reception from the locals, together with half a dozen foreigners at fair signal strength.

K. G. F.

### STATIONS RECEIVED

LONG WAVES			
Huizen .....	91	Langenberg .....	78
Radio Paris .....	83	Beromunster .....	75
Daventry National .....	75	Rome .....	72
Eiffel Tower .....	66	Sottens .....	65
Warsaw .....	64	Midland Regional .....	64
		Toulouse .....	61
		Mühlacker .....	57
		London Regional .....	55
		Hilversum .....	41
MEDIUM WAVES		Heilsberg .....	37
Brussels .....	86	London National .....	32
Prague .....	81	Fécamp .....	17
North Regional .....	80		

# USES A VALVE HIGH-TENSION RECTIFIER

When on the verge of oscillation the set seems to be "alive," whereas when the reaction control is turned back to zero and the set is right off the oscillation point it will seem to be "dead."

The lower the capacity of the aerial series condenser (that is, the more the knob on this condenser is unscrewed) the less will the reaction condenser have to be turned to the right to bring the set to the verge of oscillation.

## Maximum Capacity

When the knob of the reaction condenser is screwed right down, however, and it is at its maximum capacity, then the reaction control will have to be turned further to the right to bring the set to the verge of oscillation.

It should perhaps be emphasised that although the Economy A.C. Two has only two valves, it is very much more powerful than the average two-valve battery set. In the first place, mains valves are considerably more efficient than equivalent battery types and this, of course, results in greater signal strength.

Another point in favour of the mains set is that much higher voltages are available for application to the valve anodes. A voltage of over 200 is available in this set, for instance. At this voltage the power valve, when fully loaded, will give an output in the neighbourhood of 600 milliwatts.

## Local Stations

We have every confidence that this little set will give satisfactory reception in the hands of all who build it. It will be clear from the test report that a large number of foreign stations must not be expected. This is primarily a local-station set and as such it will do all that can be expected of it.

With a set of this type, of course—which has no high-frequency amplification before the detector—the efficiency (or otherwise!) of the aerial and earth system will have a considerable effect on the results obtained. The aerial should be as high and as free from obstruction as possible—especially if foreign stations are desired.

QUARTER-SCALE  
LAYOUT AND  
WIRING DIAGRAM

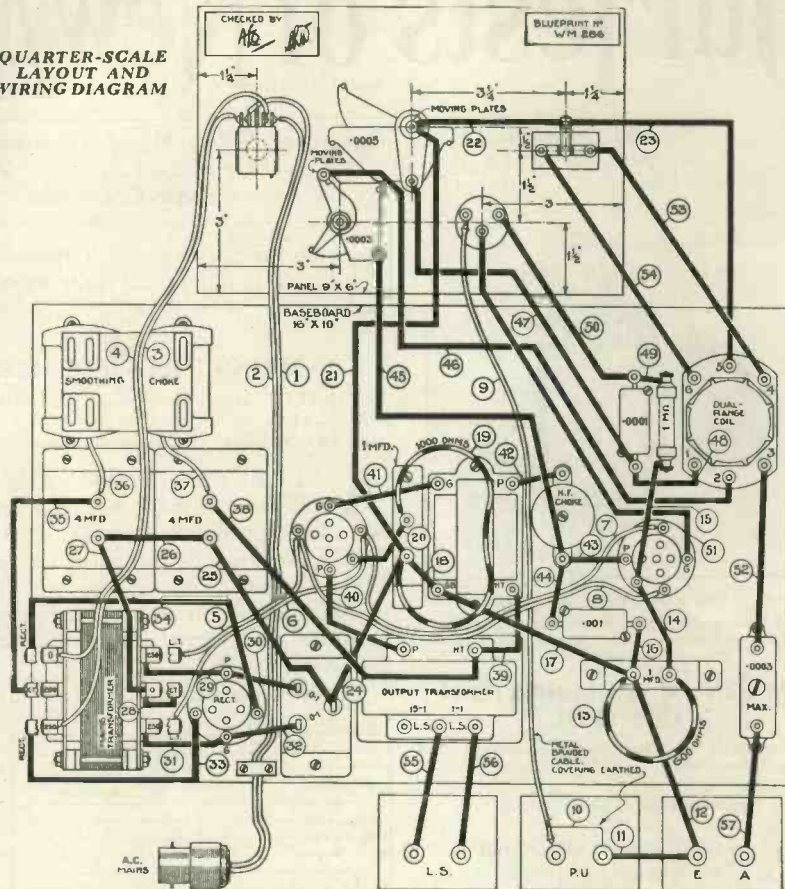

If desired a full-size blueprint can be obtained for half price, that is 6d., post free, if the coupon on the last page of the issue is used by June 30. Ask for No. 286

## COMPONENTS NEEDED FOR THE ECONOMY A.C. TWO

### CHOKE, HIGH-FREQUENCY

- 1—Lewcos, type MC, 2s. 6d. (or Varley, British General)

### CHOKE, LOW-FREQUENCY

- 1—Heayberd, type 752, 12s. 6d. (or Tune-well).

### COIL

- 1—Lotus dual-range, 5s. 6d.

### CONDENSERS, FIXED

- 1—Dubilier, .0001-microfarad, type 670, 1s. (or T.C.C., Telsen).  
1—Dubilier, .001-microfarad, type 670, 1s. 3d.  
1—Peak 1 + .1-microfarad, buffer type, 1,000-volt A.C. test, 2s. 6d.  
2—Peak 1-microfarad, 1,500-volt D.C. test, 5s. 4d.  
2—Peak 4-microfarad, 1,500-volt D.C. test, 13s. 6d.

### CONDENSERS, VARIABLE

- 1—Formo .0005-microfarad, with slow-motion dial, 6s.  
1—Polar Compax .0003-microfarad reaction, 2s. 6d.  
1—Sovereign pre-set .0003-microfarad max., 1s. 6d.

### EBONITE

- 1—Peto-Scott, 9 in. by 6 in. panel, 2s. (or Becol, Lissen).

### HOLDERS, VALVE

- 3—W.B. five-pin, 2s. 6d. (or Lotus, Wearite).

### RESISTANCES, FIXED

- 1—Lewcos 600-ohm spaghetti, 9d. (or Bulgin, Magnum).  
1—Lewcos 1,000-ohm spaghetti, 9d. (or Bulgin, Magnum).  
1—Graham-Farish 1-megohm grid leak, 10d. (or Dubilier, Lissen).

### SUNDRIES

- Tinned-copper wire for connecting.  
Lengths of oiled-cotton sleeving.  
Length of twin flex for mains leads.  
3—Sovereign terminal blocks, 1s. 6d. (or Belling-Lee, Junit).  
Length of shielded wire for pick-up connections.

### SWITCHES

- 1—Bulgin double-pole on-off, type S88, 2s. 9d.  
1—Bulgin rotary change-over, type S86, 2s.  
1—Readi-Rad three-point wave-change, 1s. 6d.

### TERMINALS

- 6—Belling-Lee, marked: Aerial, Earth, Pick-up (2), L.S. (2), 1s. 6d. (or Clix, Ealex).

### TRANSFORMER, LOW-FREQUENCY

- 1—R.I. Dux, 6s. 9d. (or Ferranti AF10).

### TRANSFORMER, MAINS

- 1—R.I., type EY31, £1 1s. (or Bryco).

### TRANSFORMER, OUTPUT

- 1—Ferranti, type OPM8, 12s. 6d.

## ACCESSORIES

### CABINET

- 1—Camco Excelsior in oak, £1 2s. 6d.

### LOUD-SPEAKER

- 1—Ormond popular cabinet cone, £1 9s. 6d.

### VALVES

- 1—Mazda AC/H1, 13s. 6d.  
1—Mazda AC/P, 15s.  
1—Mullard DW2 rectifier, 12s. 6d.

The prices mentioned are those for the parts used in the original set; the prices of alternatives as indicated in the brackets may be either higher or lower

# Our Tests of New Apparatus

Magnum Combination Control : B.S.R. Mains Transformer : Easy Soldering :  
 Wilburn Terminal Block : Bulgin Switches : Watmel Potentiometer :  
 T.C.C. Electrolytic Condenser

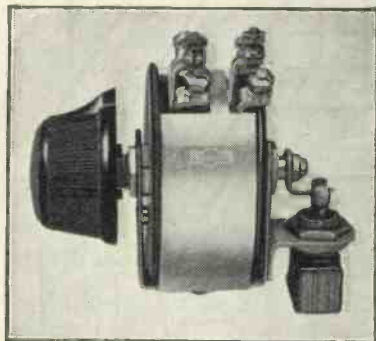

**TWO VOLUME CONTROLS**

This Magnum apparatus incorporates two volume controls and a switch in one component.

## MAGNUM COMBINATION CONTROL

**APPARATUS:** Dual volume control and on-off switch.

**PRICE:** 10s. 6d.

**MAKER:** Burne-Jones and Co., Ltd.

An interesting and perhaps rather special component is the Magnum combined dual volume control and on-off switch. The resistance elements of this component are wire-wound in a form resembling spaghetti resistances.

The elements are embedded in a moulded bakelite base, the contacts thereto being made by means of two metal spring plates which are pressed down on to the elements by means of the moving arms.

The on-off switch is arranged to be operated by means of a small arm fixed to the main spindle of the component. This switch is of the quick-acting type suitable for use in circuits carrying a maximum current of 3 amperes at 250 volts.

### Resistance Values

The resistance elements of our sample had values of 10,000 and 50,000 ohms respectively, these values making the control suitable, for example, as a volume control on the aerial circuit and as a grid-bias potentiometer with a variable- $\mu$  valve.

The overall dimensions are  $2\frac{1}{4}$  in. diameter and approximately  $2\frac{1}{2}$  in. in length. On test we found the con-

trol quite nice to use and it appears to fulfil its requirements quite satisfactorily.

## B.S.R. MAINS TRANSFORMER

**APPARATUS:** Mains transformer, type P2B.

**PRICE:** £1 7s. 6d.

**MAKER:** Birmingham Sound Reproducers.

A VERY neatly made mains transformer is the Birmingham Sound Reproducers model P2B. This transformer is provided with a tapped input winding making it suitable for use on 50-cycle supplies with voltages varying from 200 to 240 volts.

On the secondary side, two wind-

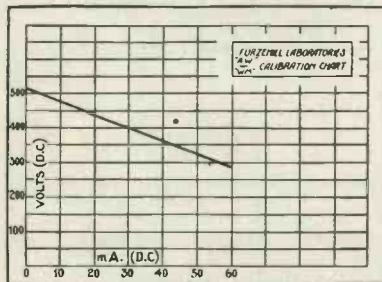

**REGULATION CURVE**

Test curve of the B.S.R. mains transformer type P2B

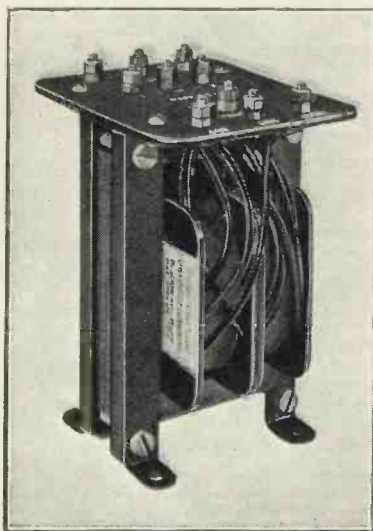

**WELL-MADE INSTRUMENT**

This is the B.S.R. type P2B mains transformer for use with a Westinghouse HT8 metal rectifier

ings are provided, one centre-tapped to supply a maximum of 4 amperes at 4 volts to the heaters of A.C. type valves, and a high-tension winding suitable for use in a normal single-wave rectifying circuit or with a voltage-doubler metal rectifier circuit.

This winding gives 200 volts, with a tap at 170 volts if required.

All connections are brought out to a small terminal board mounted on the top of the transformer. Fair size terminals are employed, each being clearly marked.

### Output Voltage

The transformer was tested on its 200-volt secondary winding with a Westinghouse HT8 metal rectifier and connected up with two 4-microfarad condensers. With a load of 60 milliamperes D.C., the unsmoothed output voltage obtained was 288 volts. The actual variation of voltage with load can be seen from the curve accompanying this report.

With regard to the 4-volt winding, the voltages obtained were very slightly low, the actual value on full load being 3.7 volts at 4 amperes. This is probably deliberate to avoid excess voltage if only two or three valves are used.

## EASY SOLDERING

**APPARATUS:** (a) Connecting wire cored with solder; (b) Resin-cored solder.

**PRICES:** (a) 6d. per 8-ft. coil; (b) 6d. per tin.

**MAKERS:** (a) A. F. Bulgin and Co., Ltd.; (b) W. H. Agar.

INTRODUCED to facilitate the wiring up of amateur-made receivers, Bulgin Soldawyre is worth consideration. This wire consists of six well-tinned copper wires twisted up with a strand of pure solder, the whole being encased in an insulating braiding.

The wire is very simple to use, it being only necessary to push back the insulating braiding and, having brought the end of the wire into the position in which it is to be soldered, to apply a hot copper bit.

The solder runs and makes a firm

joint, after which the insulation should be pushed down over the bare portion of the wire. In this way a very clean joint is possible, and no exposed wire is left.

(b). Agar resin-cored solder is sold in small tins, each containing a hank of about 4 ft. of the solder wire. As indicated by its name, this solder contains a core of resin which acts as a flux when soldering, so that no other composition is required.

This solder is very clean to handle and has the merit of being entirely non-corrosive. It is simple to use, since it is necessary only to clean the two surfaces to be joined and to apply the solder with the bit.

### WILBURN TERMINAL BLOCK

APPARATUS: Five-way terminal block.

PRICE: 2s. 6d.

MAKER: Wilburn and Co.

AN interesting little component having a variety of applications is Wilburn terminal block. This is built up on a small bakelite body and provided with holes for baseboard fixing. This block will accommodate five circuits and a locking screw is provided for each in-and-out wire.

This block can, for example, be used with advantage as a loud-speaker distribution block or as a connecting link between a receiver and its power supply.

The block occupies very little room, the overall dimensions being  $2\frac{1}{4}$  in. by  $\frac{3}{4}$  in. It should prove useful to both experimenter and set constructor.

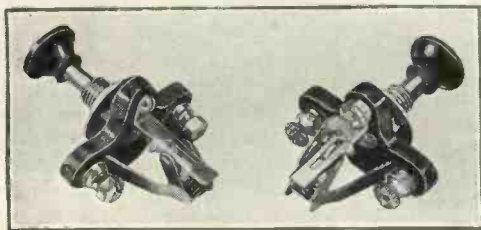

### BULGIN SWITCHES

APPARATUS: (a) Single-pole toggle switch, type S102; (b) two-point on-off switch, type S15; (c) three-point switch, type S13.

PRICE: (a) 1s. 3d., (b) 1s. 9d., (c) 2s.

MAKER: A. F. Bulgin and Co., Ltd.

A SWITCH is an important part in a radio receiver, and we were interested to receive from A. F. Bulgin & Co., Ltd., three samples from their range.

The first of these is a quick make-break type intended to break 3 amperes at 250 volts or 6 amperes at 125 volts. The mechanism is enclosed in a small mottled-green

bakelite moulding, and the whole makes a very neat and small job.

It is arranged for one-hole fixing, a plate indicating the on and off position being included.

The remaining two switches are of the push-pull type and are similar to each other, except that one is arranged with three contacts and the other with two. The action is of the spring-controlled quick-acting type similar to that employed in toggle switches.

As the operating rod is pushed in or pulled out, a small lever is moved over. As it passes the dead-centre point, a spring causes it to complete the remainder of its travel with a rush, thus giving a quick and snappy action.

The central spindle of these switches is not insulated and, as this forms the third contact in the one case, this should be borne in mind when mounting on a metal panel. The body of the switches is of moulded bakelite and single-hole fixing is employed.

### WATMEL POTENTIOMETER

APPARATUS: 50,000-ohm variable resistance.

PRICE: 4s. 6d.

MAKER: Watmel Wireless Co., Ltd.

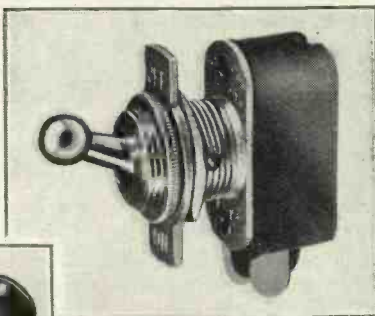

### THREE NEW SWITCHES

Above is the Bulgin type S102 toggle switch; and on the left are the types S15 and S13. All of these will be useful to constructors

A VERY interesting potentiometer which we have tested this month is that placed on the market by the Watmel Wireless Co., Ltd. This potentiometer is not of the wire-wound type, and is intended for use in all circumstances where such is not required; it is, of course, non-inductive.

The construction of the potentiometer is interesting. The body is of brown moulded bakelite and is lid shaped in form, the resistance element being positioned just on the inside of the rim.

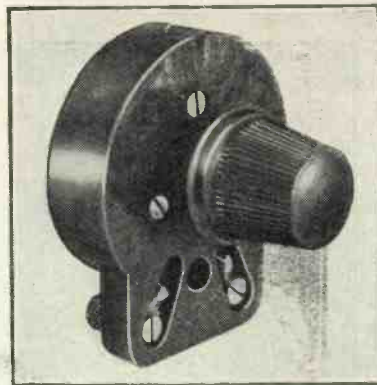

### NON-INDUCTIVE POTENTIOMETER

The Watmel potentiometer is protected by a bakelite moulded case, as this photograph shows

Contact is made with the element by a series of wire loops formed on a piece of black insulating material. These loops are held in very firm contact with the resistance element.

This method of construction ensures that a very good contact is made, and one that will not vary in any circumstance.

Contact with the resistance element is made via the wire loops and a spring arm which moves across them, this latter having two contacts wiping on a metal ring to which is fastened the third terminal. The actual resistance value of the potentiometer is 50,000 ohms, and the element does not appear to be graded. In use we found the component very satisfactory, giving a very smooth and silent control.

### T.C.C. ELECTROLYTIC CONDENSER

APPARATUS: 8-microfarad electrolytic condenser, type 802.

PRICE: 9s.

MAKER: Telegraph Condenser Co., Ltd.

WE learn that the particular type of T.C.C. electrolytic condenser we reported on in the April issue of "Wireless Magazine" has been replaced by a new model in an aluminium can.

On test, the condenser was found to be quite satisfactory. The measured capacity was approximately 9 microfarads, and with a maximum working voltage of 440 volts D.C. the steady leakage current was 3 milliamperes. This latter was considerably higher for a few seconds on switching the condenser into circuit, but rapidly settled down to the steady value.

The condenser withstood the maximum working voltage indefinitely and, in fact, did not break down until 500 volts was reached.



**ALWAYS READY TO ENTERTAIN**  
With a good radio set world-wide entertainment is always on tap. This delightful photograph shows a Pye portable in use

# On the Crest of the Waves

Every listener who is keen on the reception of foreign stations should follow these notes by JAY COOTE. They reveal all the more important developments that are taking place throughout the world.

Government officials, it has been proposed in Brussels to erect a third transmitter of which the programmes would be broadcast in both French and Flemish to please all members of the community. The new station would accommodate various political and

however, had highly praised his transmissions of gramophone records, and it was suggested to the authorities that as a reward for his bold initiative he should be offered a post in the Copenhagen studio!

## FRANCE

Every Sunday night a talk by some eminent French politician, scientist or writer is broadcast from Paris for the benefit of listeners in the United States. These transmissions may be heard on the short waves through Radio Colonial (Pon-toise).

In order to avoid interference with the Nouveau Poste Parisien (Paris), with which a wavelength had to be shared, Grenoble PTT now temporarily transmits on 569 metres. An endeavour, however, will be made to secure a more suitable channel as the station is jammed between Ljubljana and Wilno.

Good reception of the Radio Normandie (Fécamp) programmes having been assured by the increased power of the transmitter, the broadcasts have been daily extended to 1.0 a.m. On Saturdays and Sundays the station is on the air two hours longer.

## GERMANY

On April 1 last, Germany possessed 4,168,440 registered listeners; of these 356,837 licences had been allotted free of charge to unemployed, war invalids, blind persons, etc. Of the total number, nearly 25 per cent. were represented by dwellers in and around the German capital.

## GRAND DUCHY OF LUXEMBOURG

Considerable apprehension has arisen on the Continent in regard

**AUSTRIA**  
THE Austrian stations have reverted to the verbal broadcasting of time signals, the last second of the last minute being indicated by one stroke on a gong. A preliminary warning is given to listeners by the announcer.

Constructional work on the 100-kilowatt high-power broadcasting station to be erected on the Bisamberg Hill (overlooking Vienna) has already begun. A new type of aerial mast composed of both steel and timber is to be tried out on this site.

## ARGENTINE REPUBLIC

Radio Excelsior (LR5) of Buenos Aires is installing a 20-kilowatt broadcasting station in that city; the plant will be constructed in England. It will replace the 3-kilowatt transmitter at present in operation and will rank as the most powerful station in the Argentine capital. The wavelength to be used is 361 metres.

## BELGIUM

In view of the claims put forward by a number of Belgian political organisations and the vigorous protests lodged at the time Radio Schaerbeek was closed down by

religious bodies for which room has not been found in the transmissions made by the existing stations at Velthem-Louvain. The new transmitter would work on 208.3 metres, the third channel allotted to Belgium by the Plan de Prague.

## DENMARK

Contrary to rumours to the effect that a new station was to be installed at Copenhagen, it is now officially stated by the Danish broadcasting authorities that the site of the high-power transmitter will still be at Kalundborg. Plant capable of radiating 90 kilowatts is to be constructed in England, and it is expected that the new station will be launched on the ether towards the beginning of 1933. So far as can be ascertained the 1,153-metre channel will be retained for these broadcasts.

It took the Copenhagen Post Office officials three weeks to trace the whereabouts of a young Danish radio fan who, without licence, transmitted nightly on 281 metres. The mystery station was announced as the "Roskilde high-power transmitter." As, when finally run to earth, the ether pirate had dismantled his plant, he was let off with a caution. Danish listeners,

to the news that the 200-kilowatt Junglinster broadcasting station may transmit on 1,250 metres. The point at issue is that interference is feared with important aviation services, and for this reason alone it is expected that protests will be lodged with the authorities. The Grand Duchy of Luxembourg was allotted an exclusive channel, namely 230 metres, but in view of the fact that the station will be mainly used for publicity purposes, and that the organisers desire that its programmes should be well received throughout Europe, a longer wavelength will almost certainly be chosen.

#### HOLLAND

Steps are being taken to revive the broadcasts formerly put out by the PHOHI short-wave transmitter at Eindhoven and to relay the Huizen and Hilversum studio programmes for the benefit of Dutch listeners in Java, Borneo, and Sumatra.

To avoid interference with North National, Hilversum has exchanged wavelengths with Tallinn and now broadcasts on 296.1 metres. It is also carrying out tests in the early hours of the morning with a 20-kilowatt transmitter.

#### IRISH FREE STATE

It is at Moydrum that the Irish authorities intend to erect their new 120-kilowatt transmitter. Similar to Radio Paris, Radio Normandie and Rome, the station will be largely used for the broadcasting of sponsored concerts.

#### ITALY

It is anticipated that the 20-kilowatt Bari station will be ready for work by May 24, when, following its initial tests, it is to be linked up with Rome and Naples. Stand by, therefore, for experimental transmissions on or about 280 metres.

When simultaneous broadcasts are carried out by Milan-Turin-Genoa-Trieste the call given by the announcer is altered to (phon.): "Eh-yar. Radio Altitalia," the last word denoting that the transmissions emanate from Northern Italy.

Having proved to their entire satisfaction that the 25.4-metre channel was unsatisfactory for the broadcast of the Roma-Napoli programmes through Prato Smeraldo (2RO) the

Italian authorities temporarily adopted 42.7 metres as a wavelength for these transmissions. The 80-metre channel will be reserved for experiments in television.

In view of its limited number of registered listeners, and in order to increase its income, the E.I.A.R. has introduced a bill by which all hotel proprietors and innkeepers, whether they possess radio receivers or not, are compelled to pay an annual tax of 1,500 lire. Small cafés have been let off lightly; they only have to pay a tenth of this amount.

The Holy See provides the authorities of the Roman Catholic Church in foreign countries with special short-wave receivers to ensure good reception of the broadcasts by the Vatican City transmitter on 19.84 and 50.26 metres.

#### NORWAY

Plans for the reconstruction of the old Bergen broadcasting station have been passed by the Radiotjaenst, and the city is to be endowed with a high-power transmitter during the course of the year.

#### POLAND

As an interval signal, Warsaw has adopted a musical-box melody; it consists of the first bars of Chopin's "Polonaise" (for pianoforte) in F major. For some time, every week, the Polish studios have broadcast special concerts of this composer's works, and they have adopted the signal in order to remind the world that he was one of their nationals.

#### PORTUGAL

The power of the proposed Lisbon broadcasting station is to be 20 kilowatts (actual aerial energy) with provision for an increase to 80 kilowatts at a later date. The transmitter will be erected on the outskirts of the capital—possibly at Barcarena—on a site some 260 ft. above sea level. Completion of the station is not expected before 1933.

#### ROUMANIA

At the official opening of the new Bucarest studio, Professor Gusti, president of the broadcasting company, stated that with the assistance of the State a super-power station capable of radiating 150 kilowatts would be built at some distance from the capital.

#### RUSSIA

Receivers have been installed on most trains operating between Leningrad and Moscow. Through loud-speakers, travellers are informed of the names of the stations and news bulletins, talks and musical items are broadcast throughout the journey. The system is shortly to be extended to other lines.

Since March 2, several new Soviet stations have taken the air; they include Leningrad (Kolpino), 250 kilowatts; Nijni-Novgorod; Moscow (Stalin); and Kharkov (RV20). Sverdlovsk (RV58) has closed down for reconstruction.

#### SPAIN

There is a possibility that as a result of measures to be discussed at the International Radio Convention to be held at Madrid this year, some extension of the middle broadcasting band may be obtained. It is pointed out that if European governments were willing to concede a further 100 metres it would allow a frequency separation of 15 kilocycles as against the 9 kilocycles at present in operation. Such a concession would permit a readjustment of channels in consequence of which much interference between transmitters might be avoided.

Owing to the fact that its broadcasts were being swamped by the Moscow (Stalin) station, Madrid (EAJ7) recently decided to reduce its wavelength to 411.5 metres.

#### SWEDEN

Loud-speakers have been installed in the Central prison at Malmo in order that the inmates may listen to the Stockholm programmes during certain hours of the day. The loud-speakers are so placed that the prisoners are able to hear the transmissions from their respective cells. The broadcasts are limited to concerts and educational talks, the apparatus being switched off during the periods when news bulletins are put out by the studios.

An interesting broadcast to be heard on Sundays at 1.20 p.m. B.S.T. through Motala is that of the Changing of the Guard at the Royal Palace at Stockholm. It includes not only a historic ceremony, but also a concert given by

(Continued on page 566)

# Adjusting the Trimmers

W. JAMES Gives Some Tips on Ganging

**I** WONDER how many people have a set with a ganged tuning condenser that does not tune accurately over the whole wave range.

In many instances the parts are satisfactory, but the trimming condensers are not properly adjusted. It is sometimes difficult to set the trimming condensers to the best advantage when testing by listening to the results.

The circuits can be adjusted

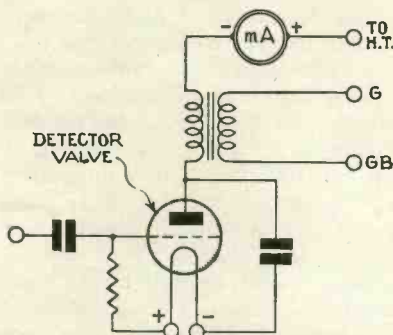

**MILLIAMMETER CONNECTIONS**  
This diagram shows how the milliammeter should be connected in the anode circuit of the detector valve

quite nicely by carefully listening to the results during ganging, but it is so much easier to use a meter when testing, instead of listening to a loud-speaker, that I think a meter should be considered an essential component.

Most battery detector valves pass less than 5 milliamperes under normal conditions. A mains detector valve is usually so arranged that the current does not exceed this value as well. A milliammeter reading to 5 milliamperes is, therefore, required.

It should be connected in the high-tension supply to the detector. Do not connect it between the anode of the valve and the circuit, or the results may be affected by high-frequency currents passing through the connecting leads and the instrument. Always join it on the high-tension side as shown in the diagram.

If the terminals stand out at the back of the meter, be careful not to let them touch any metal part of the set. You might burn out the meter or damage the high-tension

source if a terminal touched an earthed metal chassis, for example.

With the meter connected, turn on the set and note the current passing when no signal is being received.

Now tune in a signal. You will see the needle of the meter move back towards zero (in the case of leaky-grid or power-grid detection) and, as the tuning is altered, so the position of the needle will change.

When the circuit is exactly in tune the reading will be less than when the circuit is out of tune. The point to note here is that, as the signal is increased in strength, the current through the detector falls off. Do not overload the circuit. If the circuit is tuning properly, the needle will move about as shown in the diagrams.

At 106 degrees of the tuning condenser nothing is heard and the detector is passing 3 milliamperes. When the tuning is altered to 103 degrees the signal is very weak, and as the tuning is altered further the signal strengthens, being the maximum at about 100 degrees.

The signal falls off as the condenser is moved back, until at 97 degrees it is weak once more.

The curve shows how the needle of the meter moves as the tuning is altered, and as it has a good slope the circuits are ganged correctly. You could try adjusting the trimmers with the object of increasing the signal strength and reducing the anode current, but probably adjusting the trimmer will reduce the strength of the signal and increase the current.

If the circuits are out of tune, the current will not vary uniformly, but a hump or trough will be noticed. The hump is a sure sign that the circuits are not tuning properly.

With some band-pass circuits the signal may be heard over several degrees, and the current may vary as shown. This is bad, for you would normally tune to one of the points of maximum strength.

You might be able to alter the coupling of the band-pass circuit to avoid this trouble. Try increasing the capacity of the coupling condenser or reducing the magnetic coupling.

## Circuit Out of Tune

When a circuit is out of tune with the others, the needle of the meter will move down and up a little, and then down again, giving the effect of a trough or secondary tuning point. This is illustrated and should be corrected by adjusting the trimmers.

You may find that the tuning is satisfactory at one end of the tuning scale and not correct at the other end. This may show that the circuit values are not right, the inductances or capacities being of wrong values. It is then necessary to match rather carefully.

A trick worth knowing is that a piece of metal, when placed near the end of a coil, will reduce its inductance. If you move the metal nearer the coil, or put it inside the coil, the inductance is still further reduced.

Earth the metal and note the effect. You may discover that the inductance of one of the coils is too high in comparison with the others.

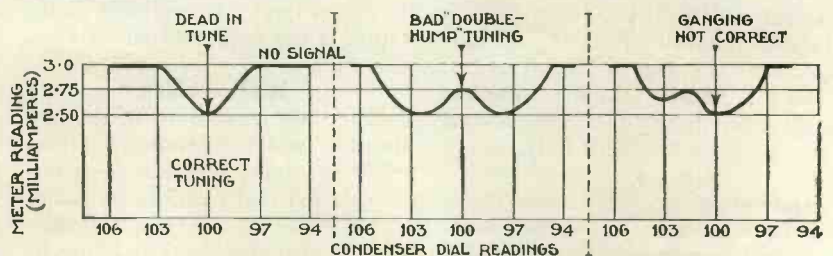

**WHAT HAPPENS WHEN A SET IS NOT GANGED PROPERLY**  
These curves show what happens (1) when the set is properly ganged, (2) when a "double hump" is obtained, and (3) when the ganging is right out



# Henry Hall Gaining Popularity

THE storm that greeted Henry Hall's first few broadcasts now appears to be dying down. Listeners—and critics, I believe—are certainly getting to like the style of the new band.

I, for one, am unconsciously fulfilling the prophesy of those who said that in three months we should dislike the Payne and Hyton style



Edith Athey recently broadcast some fine songs which included examples of Mattel, Hewitt and Friml

and revel in the "sweetness" of Henry Hall.

There is no getting away from the fact that the tunefulness of the new band and its unusual orchestrations have become pleasing. Jack Payne's broadcast from the Leeds studio some little time back was a typical example of the blare of the old days of B.B.C. dance music.

### Note the Difference

Jack Payne will be heard again on June 15. Make a point of listening to this programme and note the difference.

Henry Hall has a large number of admirers in the youngsters. Their support has been won by that little tune, *Perry Werry Winkle* (Pi-Roe-



Mamie Soutter has become as great a radio favourite as her husband, Joe Sargent, of Ross and Sargent fame

Dee), in which he invites the children to send him words to undergo the process of humorous rhyming in the song.

Some of the many hundreds of letters that Henry Hall has received are really amusing. Here are two outstanding ones which I found in a whole bunch of letters at Savoy Hill:



A favourite artist who made her name long before broadcasting began, Ann Penn, the impersonator

Dear Sir Henry Hall,  
Please will you make up a rhyme about Labrador. I shall be very pleased if you can. I remain,  
Your loving friend,

and the other :

Dear Mr. Hall,  
Will you please write a verse to rhyme with jujube with a nice slimy sucking noise.

Love from,

### Classical Works

Henry Hall is very keen on enlarging the repertoire of his band. One of the latest plans afoot is the special orchestration for the B.B.C. Dance Orchestra of standard classical works.

Personally, I am not too keen on hackneying the classics in any form, and especially to the level of everyday dance music, but in these days I suppose it is considered old-fashioned to raise even a mild protest.

There is, however, one point in favour. Henry Hall made a feature of classical music arranged for dancing when he was in charge of the Gleneagles Band, and it pleased the public immensely. His present arrangements of some of Eric Coates's works and Delibes's



A clever pair of ukulele players and vocalists, Max and Harry Nesbitt recently broadcast in a "music-hall" vaudeville programme from London

# HENRY HALL GAINS POPULARITY—Cont.



*A Scottish comedian whose fund of stories is apparently inexhaustible, Sandy Kowan is a frequent broadcaster*

Sylvia waltz are to be commended.

What might be considered the greatest event of the year in the vaudeville programmes takes place on May 30. This is the Variety Artists Benevolent Fund Command Performance which is relayed annually from the London Palladium.

Music-hall artists are, of course, very anxious to be included in the programme, which, prior to performance, is submitted to Their Majesties for approval. Several well-known broadcasters are likely to be included in the programme.

Listeners may remember that the

commentary on last year's relay was given by the Buggins Family; I think it spoilt the show. No doubt commentators are needed to convey the right atmosphere of the house, but the commentators should not act as a counter-attraction.

In spite of the versatile assortment of programme matter broadcast by the B.B.C., there is a popular class of



*Guy Daines is well known to Manchester listeners. He is conductor of the Northern Studio Orchestra*

item of special interest which is left out altogether.

A Gilbert and Sullivan opera is one of the stanchions in the musical life of the country, yet a complete opera has never been broadcast by the B.B.C., and this position



*Betsy de la Porte, who broadcast recently, has a fine contralto voice of exceptional range and quality*

is not at all likely to be reversed.

Savoy Hill states that only published selections are allowed to be broadcast and then only providing they are not vocal. The performing rights have been carefully guarded in this country while, for reasons not forthcoming, the same rigid control does not exist abroad.

The B.B.C. has frequently sought permission to broadcast one of these operas, but their request has always met with a refusal. This is one of the rare cases where British goods are not for the use of the British people. I do not think the action of the copyright holders is to be commended.

Three interesting features are



*Three thousand songs, three musical comedies and 150 revues have been composed by Herman Darewski*



*A popular singer of light songs, Greta Keller, has recently broadcast. Her popularity in this country is due to her fine gramophone records*



*One of the best known of provincial bass singers, Ceredig Jones, has broadcast on many occasions*

# BROADCAST MUSIC ACTIVITIES

announced in the military-band programmes for the next month. Flight-Lieut. R. P. O'Donnell of the Royal Air Force Band is conducting the Wireless Military Band in a special broadcast on May 6. This conductor is a brother of the permanent conductor of the Wireless Military Band, B. Walton O'Donnell.

## A First Broadcast

A first broadcast of any new combination is always an interesting event. Callender's "A" Band is giving its first broadcast on June 2.

There are so many amateur bandmen at Callender's Works that they are able to form a second band, additional to that which has broadcast many times. Listeners will have the opportunity of judging for themselves the talent that exists among these amateur combinations.

A performance by the Kneller Hall Band—often called a band of bandmasters—is to be broadcast in the National programme on May 25. Kneller Hall is the musical college at Twickenham through which every bandmaster in the British Army must pass through before getting his first appointment.

The new military-band studio (No. 8a) at Broadcasting House, which has excellent acoustical properties, will be used for these broadcasts.

The B.B.C. Orchestra has done some good work during the past season and will deserve, if not need, its annual holiday in June and July. Arrangements for the holiday are the same as last year. Half of the orchestra will be away during the beginning of June and the other half



Two well-known radio entertainers, Kenneth and George Western, are popular favourites. They are perhaps better known as "The Perfectly Polite Pair"

listeners will not find the programmes dull through the absence of the orchestra.

## Seaside Music

A large part of the orchestral music of the week will be drawn from the seaside resorts of the North, where light orchestral music is of a high standard. A good deal of the high standard is accounted for by the fact that the famous Hallé Orchestra is disbanded during the summer months and its members scatter

to the seaside resorts of the North. London listeners will also have the opportunity of hearing the Bournemouth Municipal Orchestra, one of the finest symphony orchestras of the south coast.

(Continued on page 576)



Every listener has heard of Murray Ashford (left) and his famous concert party. Here he is with Edgar Sawyer, another well-known entertainer

at the end of June and the first few days in July. There will be no members of the orchestra on duty during the week of June 20 to 27.

Adequate arrangements for suitable musical concerts are being made for this overlapping week and



Ann Bradley has joined the "Bogey Four-some," a new quartet of entertainers organised by Charles Brewer



No introduction is required for Bert Ambrose, who broadcasts from the Mayfair Hotel on Saturday evenings



A famous ventriloquist who manages to put his turn over the ether with realism—Arthur Prince



**THE COMPLETE INSTALLATION**  
This photograph shows the arrangement of the controls on the A-P-A Radio Unit described in the May issue of "Wireless Magazine"

# THE A-P-A RADIO GRAMOPHONE

P. K. TURNER, M.I.E.E., has some further remarks to make on his A-P-A and A-P-A Radio Unit which, in combination, form the A-P-A Radio Gramophone. This is the ideal instrument for the real connoisseur of quality

**L**AST month I described a medium-range radio unit designed to work into the A-P-A, so as to give results of A quality. I propose to add now a few words on the assembly and handling of the complete outfit.

### Points to Note

But first I want to correct one or two errors that crept into the quarter-scale layout. (1) The two volume controls are shown changed over. The one in the centre of the panel should be marked  $R_4$ , and should be 10,000 ohms; the one on the left in the layout should be marked  $R_9$ , and should be the 25,000-ohm one. (2) Owing to a misunderstanding, the numbers on the last few wires do not agree as between the layout and my description. Referring to page 474, the four mains leads are not Nos. 48 to 51, but 50 to 53; and the lead to the anode of the screened valve is not 54, but 48.

Consideration of the whole assembly must begin with the cabinet. The particular cabinet shown in the parts list was chosen as being of reasonable size and moderate price. But it must be remarked that no cabinet at this price can really be perfection for this set, for it will not be as heavily built as it should be.

The cabinet affects the performance of a high-power set in two ways, both usually described as "cabinet resonance." One

is the resonance of the volume of air inside the cabinet. This is usually sufficiently reduced by leaving the back open and putting the whole set across the corner of a room, and not with its back flat against a wall.

The other is actual drumming of the panels of the cabinet. Remember always that a baffle or cabinet should never act as a soundboard; its duty is simply to prevent the sound waves from one side of the cone sneaking round to the other, instead of coming out into the room as they should.

Therefore the front baffle, and the side and bottom panels of the cabinet, should be too heavy and solid to be set into vibration by the low notes. For this reason, timber up to  $\frac{3}{4}$  in. or even 1 in. is none too thick. So, for all who can afford it, I suggest a specially made cabinet

of some really heavy timber.

Alternatively, if with the standard cabinet there should be trouble from drumming on certain low notes, it may be worth while to glue a layer of thick felt on to the sides and bottom of the cabinet.

### Valve Vibration

Another trouble of the same nature which may arise is the effect of vibration from the loud-speaker on the valves and other components of the set, giving "acoustic feedback," which builds up to a loud hum or roar. This should not occur unless you happen to get hold of a specially sensitive valve. If it does, there is only one cure; the whole radio unit must be mounted on four corner-pieces of sponge rubber, so that it is "wobbly" in the cabinet.

In deciding the position of the loud-speaker, get it as near the middle of the front of the whole cabinet as possible, as this helps the baffle effect. The fact that it is not in the centre of the grille does not matter, as it won't show anyway.

The connections offer no difficulties, but it is best to take the 4-volt A.C. leads down one side of the cabinet, and the high-tension and audio-frequency leads down the other—though it is doubtful whether there would be any hum even if they were taken together.

For the same reason, keep the pick-up leads clear of the  
(Continued on page 564)

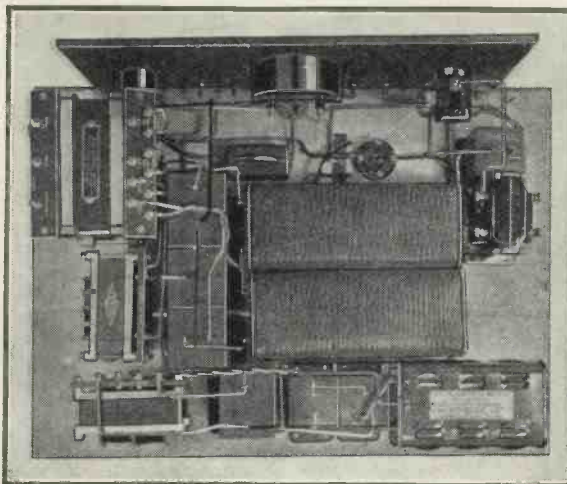

**GREAT POWER BUT PERFECT QUALITY**  
This is the A-P-A. The construction was fully described in the March issue of "Wireless Magazine". Three metal rectifiers are used

# FERRANTI

## CONSTRUCTORS' BAND-PASS RECEIVERS

THE FINEST 3-VALVE SETS, CONSTRUCTORS  
OR OTHERWISE, THAT MONEY CAN BUY

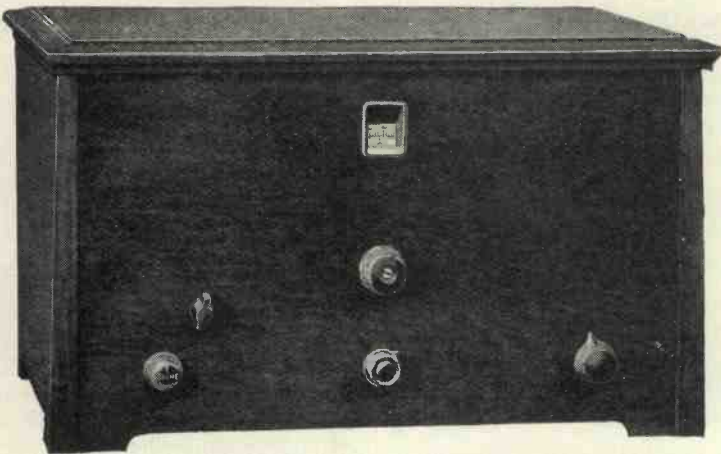

Completed Set in Walnut finish Cabinet.

THESE Receivers have selectivity high enough to receive most of the worth while Radio Transmissions available, maintaining at the same time HIGH QUALITY REPRODUCTION.

This result is largely due to our supplying the coils and tuning condensers adjusted together with great accuracy (plus or minus .000000125 microfarad at minimum and plus or minus .00000075 microfarad at maximum capacity) and having complete control of most of the vital parts on which success depends.

Complete Kits or separate parts may be purchased and may be obtained immediately. A chart for the construction of either the A.C. Mains or Battery Model may be had from your dealer, or will be sent on receipt of your request, with 1½d. stamp.

ALL FERRANTI COMPONENTS ARE  
AVAILABLE FROM STOCK.

**FERRANTI LTD.**  
Charts Division, Hollinwood, Lancs.

PRICES: \_\_\_\_\_

BATTERY KIT, with baseboard and panel (without valves and batteries) ..	£7 12 0
With cabinet, baseboard and panel .. .. .	£8 17 0
A.C. MAINS KIT, with baseboard and panel (without valves) .. .. .	£11 8 6
With cabinet, baseboard and panel .. .. .	£12 13 6
FERRANTI H.F. BAND-PASS STAGE only, comprising triple-gang tuning condenser, band-pass coils, etc. . . . .	£3 13 6

Messrs Ferranti Ltd.,  
Hollinwood.

Dear Sirs.

I have recently assembled your A.C. Mains S.B.P. Receiver and on account of the result of this I feel compelled to write you a line or two of sincere appreciation.

Although I have possessed a radio set for six years or so I have never had the time or inclination to bother about the technical side of wireless. In fact, in this direction I am a veritable tyro. However, this be as it may, I assembled this kit of yours without experiencing the slightest difficulty and I am delighted with the resultant "Set". Your own recommendations about the Receiver are far too conservative. You should "sell the world" about it. It is a delight for one to demonstrate a "Set" like this to one's friends. No mains hum, remarkable selectivity, and quality which must be incomparable. In fact as a good way of describing the instrument is to state that as your A.C.S. Transformer is to other Transformers, so your A.C.S. Receiver is to other Receivers.

I could write quite a lot more on this matter, but to save your time as well as mine I will just thank you for making wireless reception so delightful and state that it will be a pleasure to recommend the Receiver to anyone interested.

Yours faithfully,  
(Signed)

Timperley,  
Cheshire.  
4th April 1932.

The original may be seen on request at our Head Office

## A-P-A RADIO GRAMOPHONE — Continued from page 562

## The A-P-A on Test

I HAVE tried out in my own home P. K. Turner's A-quality power amplifier and radio unit.

The gramophone side was tried first. I have some records which are put aside for special tests. Radio fans will guess that these contain some heavy bass or spots of good treble. These, I decided, would show the capabilities of the gear.

The quality is "A", and nothing but "A". Bass and treble are blended to give an almost exact musical balance which ought to satisfy, without exception, any critical musician.

And the power!

This is simply enormous, yet by turning down the volume control the signal strength can be reduced to almost a whisper without any noticeable deterioration in quality.

The radio side deserves quite as much praise. My home is about twenty miles south of Brookman's Park and I was using an outdoor

aerial 70 feet long during this test.

No criticism can be made of the quality of the transmissions from these two stations! Natural tone was the outstanding feature. My loud-speaker is a Baker Super Power moving-coil model.

The log of stations received numbers about thirty. Of these the two local stations gave the best entertainment. Beromuenster, Rome, Söttens, and Poste Parisien, the new French high-power station, on the medium-wave band, and Radio Paris, Daventry, and Eiffel Tower on the long waves provided first-class entertainment.

In spite of the splendid quality, there is no lack of selectivity. London Regional spread only 10 degrees and London National only 5 degrees on the 180-degree dial. This kind of selectivity is of a very high order.

Undoubtedly the A-P-A Radio Gramophone is ideal for the connoisseur who wants quality above everything else. T. F. H.

## STATIONS RECEIVED ON THE A-P-A

LONG WAVES			
Station	Dial		
Warsaw	93	North National	54
Eiffel Tower	98	Poste Parisien	66
Daventry National	113	Strasbourg	70
Radio Paris	137	London Regional	79
Huizen	163	Mühlacker (when London is not working)	80
MEDIUM WAVES			
Station	Dial		
Trieste	29	Lvov	88
Gleiwitz	32	Toulouse	90
Toulouse (PTT)	33	Midland Regional	97
London National	38	Söttens	99
Turin	43	Stockholm	115
Heilsberg	44	Rome	118
Bratislava	45	Beromuenster	128
Hilversum	52	Langenberg	135
		North Regional	138
		Prague	142
		Brussels	150

turntable motor and its leads. It is best, in fact, to use screened flex for the pick-up, and earth the screening. It is convenient to take out the A-P-A milliammeter, and mount it on the motorboard.

It will be noted that no definite make of loud-speaker or pick-up is given in the list of components. Frankly, I am not prepared to guarantee any marketed make whatever as being of this high quality. In this matter the reader must make his own selection, remembering, in the

case of the loud-speaker, to have the makers' assurance that (1) it will stand the load; (2) its transformer is suitable for the valve, as already explained when describing the A-P-A.

Assuming now that the whole is assembled and ready for use, and that the A-P-A has been proved in good order as described in the March "Wireless Magazine," the first thing to do is to test out the circuit as a gramophone. Turn the radio volume control right down to switch over, and then turn the audio control

up about a quarter to a half.

When the valves warm up, the detector meter should read somewhere about 6 to 7 milliamperes, and the operation of the set on "gram" calls for no particular remarks, except that if the pick-up is an extra lively one, and you find that the volume control always has to be turned too low, this may be got over as follows: cut lead No. 35 about 4 in. from where it goes to the pick-up terminal, and replace that 4 in. by a Dubilier Dumetohm resistor, .25 megohm; and between the switch end of this resistor and the earth wire 39, connect another similar resistor.

## "Scratch"

If by any chance you think that the pick-up gives too much scratch, you can diminish this (at the cost of some loss of high notes) by using 50,000-ohm resistors instead of .25-megohm ones.

When you have the gramophone reproduction to your satisfaction, turn up the radio volume control, screw down the pre-set condenser  $C_2$ , and try for a station. Get on to London National, or some other strong station at the short-wave end of the scale, and trim the three-gang condenser in the usual way.

Remember that a set like this, with radio and audio volume controls and a detector meter, should not be tuned by ear at all, but by the meter. This should read somewhere between 8 and 11 milliamperes with no signals coming in. When you find a station, get it exactly tuned by seeing when the meter shows the greatest depression of current as you move the tuning control.

## Detector Setting

When you have it exactly tuned, adjust the volume control till the meter shows just 1.5 milliamperes less than for no signals. For example, suppose that it stood at 9.5 milliamperes for no station; after getting exact tune as above, adjust the radio volume control till the meter stands at 8 milliamperes. Last of all, adjust the audio volume control till the loudness is what you require.

Summarised, get the right current depression by the radio control, and then use the audio control to get the required loudness.

(Continued on page 566)

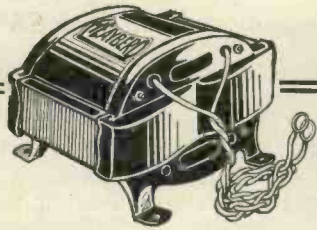

This time it's a  
**CHOKE!**

Once again "Wireless Magazine" have chosen a Heayberd component for use in their latest Receiver—the "Economy A.C. 2"—this time they have selected the 752 Choke. Like all Heayberd products, this Choke is a masterpiece of British craftsmanship, and is thoroughly reliable. High impedance ensures wonderful smoothing.

**HEAYBERD 752 CHOKE**

Inductance 30 henrys	Resistance 350 ohms	Current Cap. 100 m/a
Price		12/6

POST NOW

I enclose 3d. stamps for Lists, with diagrams, dealing fully with the range of Heayberd CHOKES, Transformers, Condensers, Mains Kits and Units.

M \_\_\_\_\_  
Address \_\_\_\_\_

W.M.J.



10 FINSBURY ST., LONDON, E.C.2  
*(One minute from Moorgate Und. Station)*



**PICK-UP**

**CARRIER & VOLUME CONTROL**

Crisp and Clear Reproduction with delightful balance of Treble and Bass

Pick-up, Carrier, with Volume Control	32/6
Pick-up, Carrier, without Volume Control	30/-
Pick-up only	21/-
Specially Designed Carrier only for featherweighting	15/6

Recommended by Noel Bonavia-Hunt, Esq., M.A., in last issue of this Magazine

LIMIT RADIO, Ltd., 15/29 Windsor St., N.1



**PRICE**

**D.C. 35/- P.M. 49/6**

(Complete with Input transformer—single, push-pull, or pentode).  
WRITE FOR FREE LIST

**ROLA SPEAKERS**

for better  
Radio Reception

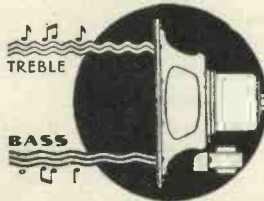

**ROLA**

the World's Finest  
Reproducers

Our Permanent Magnet Model P.M.I. (as illustrated) is specified for use in the MULTI-MAG 3 described in this issue.

British Rola Moving-coil Speakers are used as standard equipment by three out of every four British radio manufacturers—they know a definitely better product is worth a little more.

**THE BRITISH ROLA CO. LTD.**

Brondesbury Works,  
179 High Road, Kilburn, N.W.6  
Telephone: Maida Vale 5017

**ILLUMINATE YOUR SET**

Your "Ether Searcher" or "Wireless World Single Dial Super"—your "Radio for the Million" Set—ANY set using J.B. "R" Type Gangs or Chassimounts. THE NEW J.B. ILLUMINATOR makes it inexpensive and easy. Fixed in a moment. Clips on to condenser frame and throws a bright light from behind the ivory scale. Two screws only, to connect to filament.

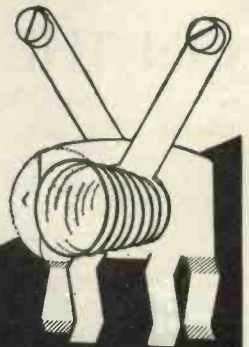

J.B. ILLUMINATOR  
Supplied without lamp,  
complete with instructions  
6d. each.

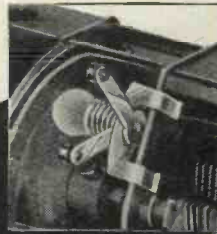
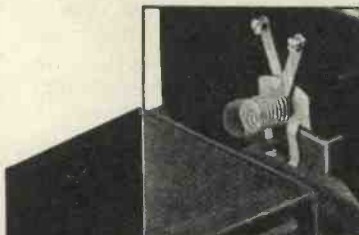

GANG COUPLING DEVICE 9d.



BASEBOARD TRIMMING CONDENSER .00005 and .0001. Each 1/.

**PRECISION INSTRUMENTS**

Advertisements of Jackson Bros. 72 St. Thomas' Street, London. S.E.1

Telephone: Hop 1837

Advertisers like to know you "saw it in the 'Wireless Magazine'"

## A-P-A RADIO GRAMOPHONE—Continued from page 564

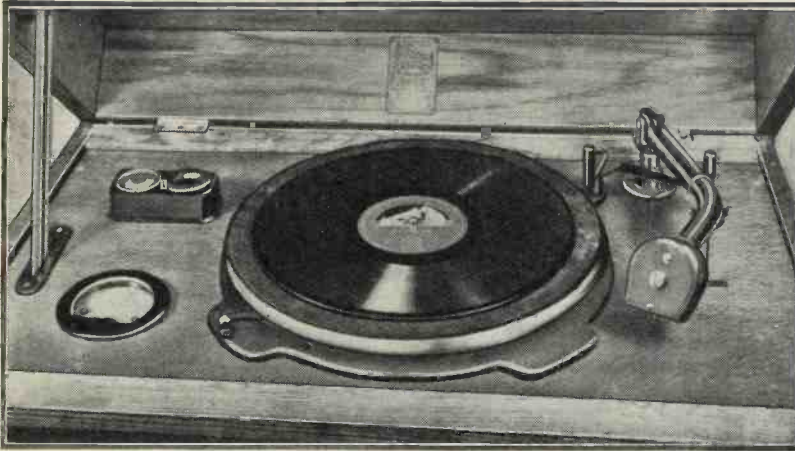

GRAMOPHONE EQUIPMENT FOR THE A-P-A

From left to right can be seen a Bulgin needle cup; the Ferranti milliammeter from the A-P-A; a G.E.C. A.C. induction motor; and a B.T.H. Senior pick-up

If the station is not strong enough to give the right current depression with the radio volume control right up, use some reaction. If you can't get enough without critical reaction, you must conclude that the station is beyond the effective range of the set. By turning up the audio control full, you may be able to get something from it; but not A quality.

When the valves are thoroughly warmed up, mark on the glass of the meter, with paint or, better, with two little triangles of stamp paper, one white and one red (red ink), the two positions for the meter needle. The higher mark, for current with no signals, serves to show that the mains voltage and the valve are normal; the lower one shows when

the radio adjustment is correct. The current on "gram" will probably be 1 or 2 milliamperes lower still, as the valve is then biased; but it is hardly worth while to mark it.

After you have been handling the set for some days, you will be able to decide whether it has the selectivity that suits your particular circumstances. If it is not quite selective enough, unscrew the pre-set condenser a bit, re-adjust the first trimmer, and try again till you get the compromise between power and selectivity that suits you best.

### "Whistle-Killer"

There is just one other thing. If your loud-speaker reproduces the extreme treble as well as mine does, you may be troubled, when receiving one radio station, by the high-pitched 9,000-cycle whistle from the next station. If so, you can cure it by connecting across the audio volume control  $R_0$  the "whistle-killer" circuit described in my article "New Ideas in Tuning" on pages 304 and 305 of the April "Wireless Magazine."

## ON THE CREST OF THE WAVES—Continued from page 557

a military band in the courtyard of the royal residence.

The great increase in power of the Moscow, Leningrad and Warsaw transmitters is inducing Sweden to reorganise its broadcasting system. It has been decided to increase the energy of Motala to 100 kilowatts and the reconstruction of this station is to be put in hand without delay. Owing to interference by the above-mentioned giants, it is often easier to hear the Swedish programmes from Stockholm direct, notwithstanding the proximity of Rome in the wavelength scale.

### SWITZERLAND

As a thrilling stunt the Basle broadcasting station has promised its listeners in the near future a running commentary from a parachute. The pilot of the aeroplane will be equipped with a portable "mike" and transmitter, and will describe his sensations as he jumps from the plane when at a height of about 18,000 ft. Some time would

necessarily elapse before he reached the ground and consequently it is expected that ample opportunity during that period would be given to him to broadcast his impressions. Two years ago a similar experiment was attempted in the United States, but it proved unsuccessful.

### UNITED STATES OF AMERICA

As it was considered that in the course of a day's working some time was lost by both announcers and speakers in reiterating the opening phrase "Ladies and Gentlemen," instructions were given by the National Broadcasting Company to all their studios to cut out this preliminary. Exception only is made when addresses are given by such people as the President or other notable persons.

For their selection of ten new announcers—a post for which there were 2,500 candidates—the N.B.C. of New York adopted the following phrase as a microphone test: "The seething sea ceaseth and thus the

seething sea sufficeth us." A preliminary "canter" reduced the number of applicants to 300, but in the "finals" five speakers only were successful. The French studios utilise a test on similar lines. Try it: "Un chasseur sachant chasser chassa son chien de chasse dans un sachet séché." It does not make sense, but it contains all the difficulties of the English sentence!

It is reported that following an N.B.C. broadcast through twenty-one stations of some unauthorised excerpts from Lehar's operetta *Paganini* it was served with a writ in which damages to the extent of 105,000 dollars were claimed. The result of this exceptional lawsuit is awaited with interest.

WSB, Atlanta (Galveston), which celebrated its tenth anniversary on March 15 last, has been authorised by the United States Federal authorities to increase its power to 50 kilowatts. It broadcasts on 405 metres (740 kilocycles).





THE  
**CAMCO**  
TABLE-GRAM  
CABINET  
**55%**

**ENTIRELY NEW!**

Camco again offer readers of "Wireless Magazine" something entirely new. The illustration shows an attractive Camco Cabinet with sufficient space to house all the necessary parts for a complete Radio Gramophone. It accommodates Set, Motor, Speaker and Pick-up. The front of the Cabinet has only to be drilled for the necessary controls, fret opening 5 1/2 in. Overall height 19 1/2 in., width 17 in., depth 15 1/2 in. The Cabinet is fitted with piano hinge, automatic stay. The lid rests on special material which eliminates Pick-up and Motor disturbances when records are being played. Order the Camco Tablegram Cabinet, build your own Radio Gramophone, and thus be able to play your records at will and have Radio reception at your command.

**CARRINGTON**  
MFG. CO. LTD.,  
Showrooms,  
24, Hatton Garden, E.C.1  
Phone: Holborn 8202  
Works: S. Croydon.

Name \_\_\_\_\_  
Address \_\_\_\_\_

WM.14

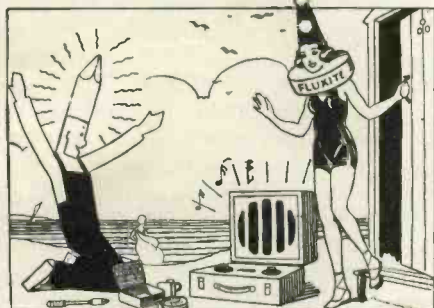

"We're Fluxite and Solder, The reliable pair, Famous for Soldering—Known everywhere!

See that we're with you—When out on that trip; Avoid disappointment—Have that musical 'dip'."

See that Fluxite and Solder are always by you—in the house, garage, workshop—anywhere where simple, speedy, soldering is needed. They cost so little, but will make scores of everyday articles last years longer! For Pots, Pans, Silver, and Brassware; RADIO; odd jobs in the garage—there's always something useful for Fluxite and Solder to do.

**ANOTHER USE FOR FLUXITE**  
Hardening Tools and Case Hardening. Ask for Leaflet on improved method.

**NEW "JUNIOR" SIZE, 4d. per tin**  
**FLUXITE SOLDERING SET**  
Simple to use and lasts for years in constant use. Contains special "small-space" soldering iron with non-heating metal handle; pocket blow-lamp, Fluxite, Solder, etc.; and full instructions. COMPLETE, 7/6 or LAMP only 2/6

**FLUXITE LTD.**  
(D.pt. 332)  
ROTHERHITHE, S.E.16.

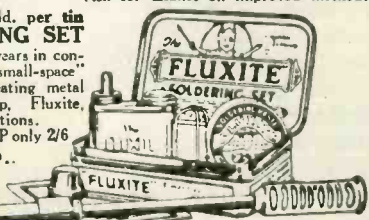

ALL MECHANICS WILL HAVE

**FLUXITE**  
IT SIMPLIFIES ALL SOLDERING

Please mention "Wireless Magazine" when corresponding with advertisers

**PILOT**  
**AUTHOR'S**  
**KITS**

*Exact to Specification*

As suppliers of Constructors' Kits since 1919, Peto-Scott are now the largest and best-known Radio-by-Mail house in the country specialising in supplying constructors' requirements. We shall be glad to quote on anything Radio you may need, including all sets described in "Wireless Magazine"

**IMMEDIATE DELIVERY. CASH—C.O.D.—H.P.**  
Any parts for Wireless Magazine sets supplied separately. If order value over 10/- sent either Carriage Paid or C.O.D., post charges paid.

**ECONOMY A.C. TWO**

*Described in this month's issue*

**KIT "A"** Author's Kit less valves and cabinet.  
CASH or C.O.D.

**£5:12:2**

or 12 monthly payments of 10/4  
Specified valves £2 1 0, Specified Cabinet £1 2 6

**KIT-BITS**

Selected C.O.D. lines for "Economy A.C.2." You pay the postman. We pay post charges on orders value over 10/-

Heyberd Low-frequency Choke, Type 752 .. .. .	12 6	Ferranti Output Transformer, Type 0PMS .. .. .	12 6
Set of 3 Switches, as specified .. .. .	6 3	R.I. Mains Transformer, Type EY31..	1 0

**EASYTUNE**

**60** As described in last month's issue

**PARTS FOR CONVERTING YOUR "EASYTUNE 60" TO A RADIOGRAM**

**CONVERSION KIT** comprising Smith Table Radiogram Cabinet, Garrard Junior Motor (Clockword, model B), Celestion Permanent Magnet Moving-coil Speaker Type P.P.M., B.T.H. Minor Pick-up and Tone-arm, Varley 25,000 ohm Variable resistance, Bulglin rotary change-over switch, Type S.86.

CASH or C.O.D. **£6 7 10**

CASH or C.O.D. **£8 11 6**

Or 12 monthly payments of 11/9

Or 12 monthly payments of 15/9

**MULTI-MAG 3**

*Described in this month's issue.*

**KIT-BITS**

Selected C.O.D. lines You pay the postman. We pay post charges on orders value of 10/-.

**KIT "A"** Author's kit less valves and cabinet.  
or C.O.D. **£5 13 11**  
CASH

Set of specified valves	£1 2 9
Specified cabinet	15 0
Ormond .0005-mfd. Condenser (Type R/207) with slow-motion dial	1 0 0
Ormond .00025-mfd. Condenser (Type R/307) with Slow-motion Dial	11 6

SEND **1/-** ONLY

for PILOT ENVELOPE containing FULL SIZE BLUEPRINT, 5 PHOTOGRAMS, and List of parts with details of newly invented Simplified System of Home Construction for an AMAZING 60 STATION 3-VALVE RECEIVER.

**PETO-SCOTT CO. LTD.** 77, CITY ROAD, LONDON, E.C.1

FOUNDERS OF CONSTRUCTOR KITS IN 1919  
Telephone: Clerkenwell 9406-7-8.

Please send me CASH, C.O.D., or H.P. ....  
**KIT "A" ECONOMY A.C. TWO**    **KIT "A" EASY TUNE 60**  
**KIT "A" MULTI-MAG 3**        **EASY TUNE R.G. KIT**  
 for which I enclose £.....s.....d. CASH/H.P. deposit.  
 NAME .....  
 ADDRESS .....

W.M.6/1932

# RADIO *in* REVIEW

Inside the Bulb : : Recent Valve  
Developments : : Gramophone Motors

By **MORTON BARR**

THE bulb of the modern valve is so highly exhausted that the pressure of the residual gas amounts only to a few microns—a micron being the millionth part of the weight of a metre of mercury. Yet this small content of "free" gas sets a practical limit to the degree of amplification which can be obtained, owing to the accidental collisions which are bound to occur from time to time between the gas molecules and the electron stream.

## Electrons Set Free

Each impact sets free new electrons which combine with the main discharge and cause slight irregularities in the output current, the net effect being to create a certain amount of "tube noise." Although this is hardly noticeable in ordinary wireless reception, it becomes very important when the valves are required to give very high amplification, because then it is apt to mask the required signal.

As a result of recent developments in pumping and "gettering," the vacuum inside the bulb can now be increased to such an extent that tube "noise" is practically eliminated. The new valves are being used, among other things, to measure the electric changes which accompany any muscular movement in the human body.

Every contraction of a muscle, and, in fact, the mere intention to move a muscle, is accompanied by minute changes of electrical potential which can now be accurately located and measured.

## Heart Beats Analysed

Another interesting application of the thermionic valve in medicine is to analyse the beating of the heart, the smallest irregularities being indicated in such detail as to help enormously in the diagnosis of disease.

On the other hand, the presence of a certain amount of free "gas" often serves a very useful purpose, as for example in the gas-filled

rectifier. Here the molecules of free gas are so plentiful, and collisions so numerous, that the whole of the space inside the tube becomes highly ionised.

This, of course, reduces the internal resistance of the valve and allows the passage of a comparatively large rectified current.

Another valve in which the contained "gas" plays an important role is the grid-glow discharge tube or Thyatron, which is now being widely used as a sensitive relay device. Here a very small impulse applied to the grid is sufficient to ionise the narrow gap separating it from the anode, and once this "starting arc" is formed, the whole tube becomes conducting and will pass a large sustained current.

Still another interesting case is the so-called "Bar valve" which made its first appearance in Germany a year or so ago, though so far it does not appear to have been used to any extent over here. One rather unusual point about this valve is that the grid is in the form of a metal cylinder placed outside, instead of inside, the glass bulb, but a more remarkable feature is that the valve is stated to rectify high-frequency signals by the action of free gas molecules inside the bulb.

The gas molecules, being relatively massive, do not apparently react to the high-frequency carrier wave, though they do respond to the low-frequency modulations. Similarly, by suitably adjusting the internal pressure, it is claimed that the valve can be used as a low-frequency amplifier, the gas molecules then preventing the passage of any frequency below 50 cycles, so as to shut out any "hum" from the mains.

One of the very latest developments is announced from the United States, where it is known as the "triple-twin" valve, presumably because it is stated to give three

times the output of the ordinary power valve and twice that of a pentode.

It consists of two distinct sets of electrodes mounted in the same bulb, the inter-stage connections being arranged in push-pull. But instead of the usual push-pull arrangement, where each valve handles its own share of the negative grid swing, the triple-twin utilises the positive as well as the negative part of the input voltage, so that it gives an increased output. Incidentally, it acts as a combined rectifier and low-frequency amplifier.

## More A.C. Mains

The extension of the "grid" system of electric power throughout the country means that the voltage and frequency of A.C. supply mains are rapidly becoming standardised. In due course, this will lead to a welcome simplification in the design, not only of all-electric sets and mains units, but of mains-driven "gadgets" in general.

Amongst other things, it helps to popularise the synchronous type of gramophone motor, which is simpler in construction, more compact, and at least as robust as the so-called universal type, though the latter has the advantage that it can be driven either from D.C. or A.C. mains.

The synchronous motor will not, of course, run on D.C., but when connected up to an A.C. supply of constant frequency it keeps up an absolutely steady speed, and will develop ample power to play the heaviest record at a very small cost in current consumption.

## High- and Low-speed Types

At present there are two available types. One is driven at high speed and is provided with a step-down gearing to the turntable. In the other the rotor is solid with the turntable and is designed to rotate at the standard speed of 78 revolutions a minute. The low-speed model is easier to start, and generally speaking, is to be preferred to the other.



FROM A WHISPER

TO FULL VOLUME



WITHOUT DISTORTION

Regentone built this magnificent all-electric receiver; Regentone, who have specialised in all-electric radio for over seven years. It is the receiver of truthful tone—from a whisper to full volume without distortion. It has a specially designed, engineer built modern circuit, built into a distinctive dual-tone walnut cabinet, and operating entirely from your electric light. It has a built-in moving coil speaker. Super-selective tuning. Only one switch for mains supply, medium and long waves, and gramophone pick-up. Illuminated tuning dial marked in wavelengths. Completely self-contained. Study its advantages for yourself, in your own home, or at your usual dealer's. He will be glad to arrange it. Or

write to us for full details of this and other Regentone products.

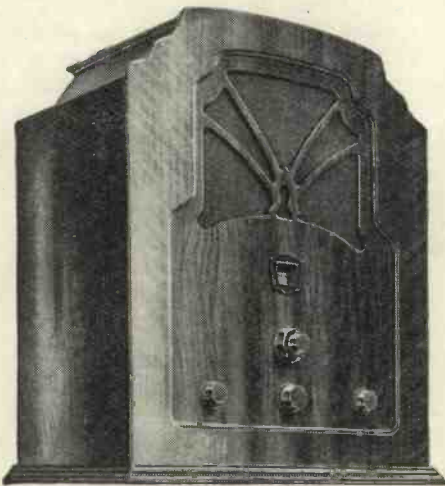

**16 GUINEAS**

Or 39/6 down.

including B.V.A. valves & royalties. For A.C. mains 40/60 cycles, 200/250 volts. Special 25 cycle model 14/- extra.

Write for full particulars and hire purchase terms of this and other Regentone products.

Mains units from 7/6 down.



REGENTONE LIMITED, Regentone House, 21 Bartlett's Buildings, E.C.4

Telephone: Central 8745 5 lines. Irish Free State Distributors: Kelly & Shiel, Ltd., 47 Fleet Street, Dublin.

# YOUR ASSURANCE OF PERFECTION

WHEN you buy a condenser you buy "on trust." Only expensive instruments can tell you if its capacity is as specified—whether it will stand up to stated voltage or whether it is mechanically sound. T.C.C.'s reputation demands that every condenser be up to the extremely high standard set, and to assure this, the most searching tests are made at each stage in their manufacture. That is your guarantee—stage-by-stage test, and the T.C.C. reputation.

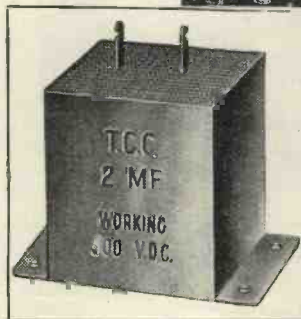
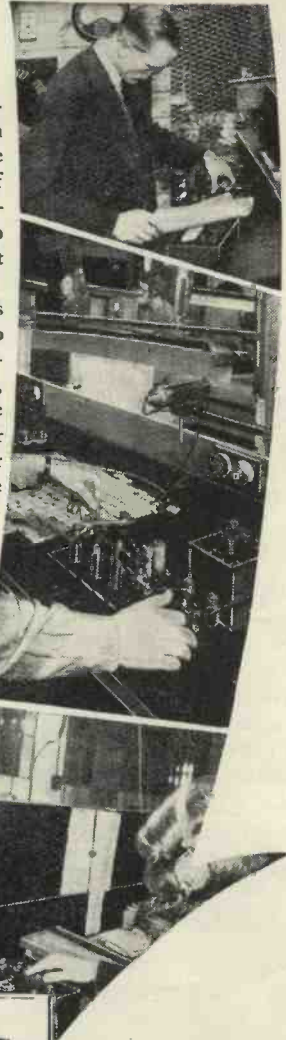

Here is illustrated a 2 mfd. Type T.C.C. 95 Condenser, 1000v. D.C. test, for 500v. D.C. working; below are given prices of condensers in this range.

Capacity	Price each
0.5 mfd.	4s. Od.
1 "	5s. Od.
2 "	7s. Od.
4 "	12s. Od.
6 "	18s. Od.

BE SURE IT IS A "CONDENSER IN THE GREEN CASE"

**T.C.C.**  
ALL-BRITISH  
**CONDENSERS**

The Telegraph Condenser Co. Ltd., Wales Farm Road, N. Acton, W.3.

Better service results from mentioning "Wireless Magazine" when writing to advertisers

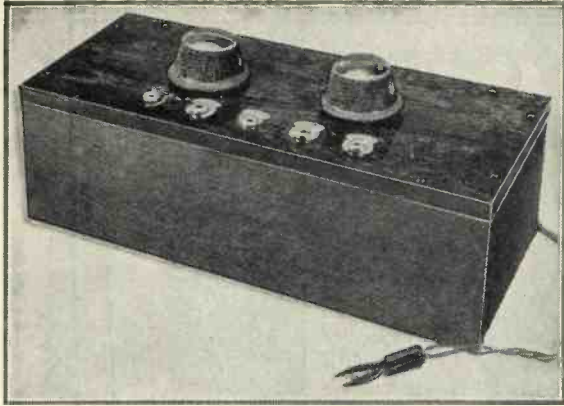

**TO REGULATE YOUR VOLTAGE**

Four separate output points are available on this unit, two being fixed and the other two being variable. Almost any set can be supplied

# The Voltage Regulator

Here the "Wireless Magazine" Technical Staff describes the use of a simple voltage regulator in conjunction with the Simple Mains Unit, the construction of which was explained in the May issue

UNDER the title of "A Simple Mains Unit" the "Wireless Magazine" Technical Staff described last month the construction of an A.C. unit giving a smoothed output of approximately 235 volts at 60 milliamperes.

**Meeting Own Needs**

No provision was made in the unit for regulating the voltage before application to any particular receiver, the intention being that the constructor should make his own arrangements in this respect.

As a guide to what is required we present this month details of a

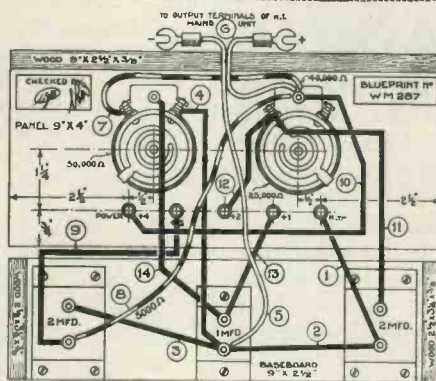

This diagram is reproduced at quarter scale. A full-size blueprint can be obtained for half price, that is 6d., post free.

the Simple Mains Unit. This indicates the maximum voltage that can be obtained for any particular load. For instance, if the total consumption of the set with which the unit is to be used is 50 milliamperes, then the maximum voltage available will be 250; but if the total consumption is only 20 milliamperes the voltage available will rise to 290 volts.

**Large Power Valves**

The voltage available from the point H.T.+4 will always be that indicated by the regulation curve for the particular load under consideration.

It is obvious, therefore, that only large power valves should be supplied from this tap.

We must now consider what happens at the points H.T.+1, H.T.+2, and H.T.+3. These tapplings are intended normally to supply screening-grid voltage, detector-anode voltage and normal anode voltages

(Continued on page 572)

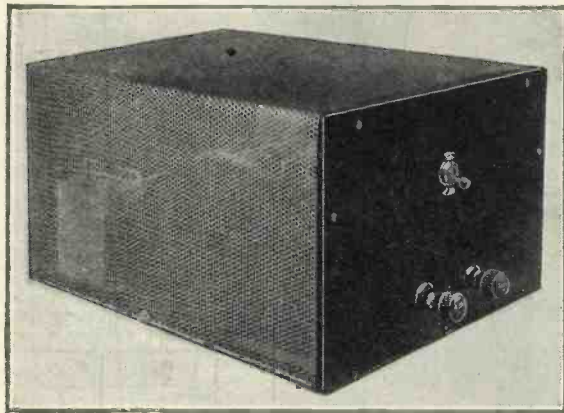

**SIMPLE MAINS UNIT**

This is the A.C. unit that was fully described in the May issue of "Wireless Magazine." Full-size blueprints are available for 1s. each, post free

simple voltage regulator, which can be adapted for use with any type of receiver.

The smoothed high-voltage supply from the mains unit is taken to the voltage regulator, which consists simply of resistances arranged to give four separate output points; the voltages available at these points can be adjusted as desired by changing the values of the resistances.

At the foot of this page appears a regulation curve for

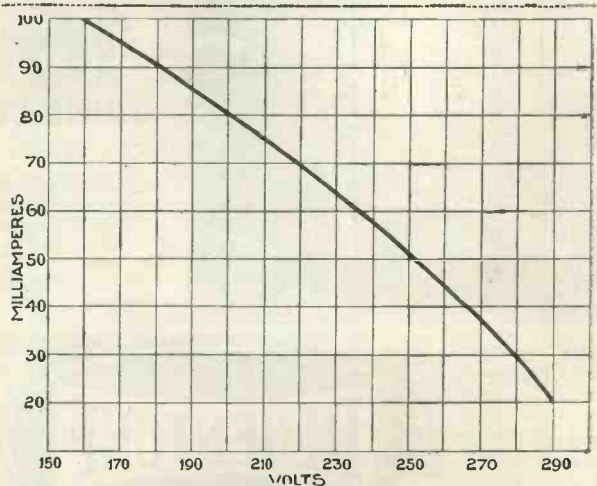

**VOLTAGE-REGULATION CURVE**

It will be seen from this curve that the maximum voltage available for a load of 60 milliamperes is about 235; at 20 milliamperes it rises to 290 volts

EVERYTHING



ELECTRICAL

# Get better results with

# Osram 2 VOLT BATTERY Valves

# with the NEW WEMBLEY FILAMENT

## OSRAM S.21

Impedance 200,000 ohms.  
Slope 1.1  
(also metallised)

The screen grid valve particularly designed for low H.T. current, low leakage capacity, and stability—specially suitable for sets with 2 stages H.F. magnification.

## OSRAM S.22

Impedance 200,000 ohms.  
Slope 1.75  
(also metallised)

The screen grid valve with the highest slope of any 2-volt S.G. type yet made. The ideal valve for S.G. sets with 1 stage H.F. magnification.

## OSRAM H.2

Impedance 35,000 ohms.  
Slope 1.0  
(also metallised)

The High Amplification Detector Valve for Sensitive Reception and increased range.

## OSRAM H.L.2

Impedance 18,000 ohms.  
Slope 1.5  
(also metallised)

The high slope, non-microphonic Detector for efficiency in detection and high quality reproduction.

## OSRAM L.P.2

Impedance 3,900 ohms.  
Slope 3.85

The high efficiency Loudspeaker Power valve, or L.F. amplifier, specially suitable for sensitive reception—adequate power and least possible H.T. consumption.

## OSRAM P.2

Impedance 2,150 ohms.  
Slope 3.5

The 2-volt super power valve capable of wonderful undistorted volume for the minimum of H.T. current consumption.

## OSRAM P.T.2

Slope 2.5

The remarkable new 2-volt Pentode with amazing power output for the lowest possible H.T. consumption.

**THESE  
ARE  
THE  
TYPES**

**MADE IN  
ENGLAND**



### OSRAM VALVES

Recommended by the  
"WIRELESS MAGAZINE"  
for the  
"EASYTUNE 60"

OSRAM S.22 OSRAM H.L.2  
OSRAM P.2

## SUPREMACY IN RADIO - G.E.C. Radio

Advt. of The General Electric Co., Ltd., Magnet House, Kingsway, London, W.C.2

Mention of the "Wireless Magazine" will ensure prompt attention

# THE VOLTAGE REGULATOR—Cont. from page 570

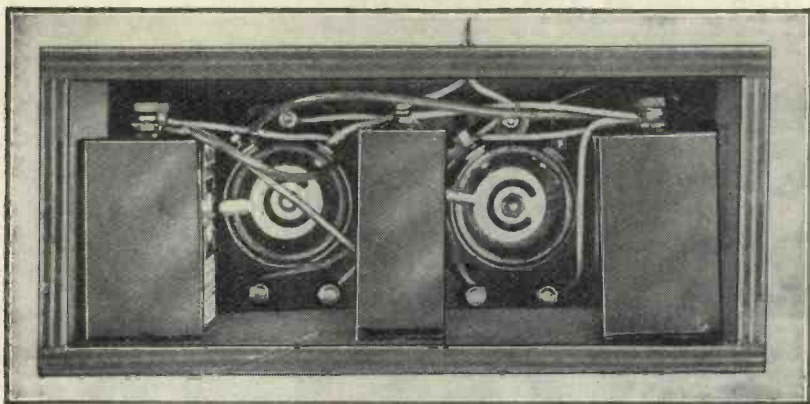

**SIMPLE AND STRAIGHTFORWARD TO CONSTRUCT**

This photograph of the voltage regulator shows how simple is the construction. The cost is only a few shillings

respectively. There is no limit, of course, to the number of valves that can be run from any particular tapping, although this fact must be taken into account in the calculations.

In series with each of three points there is a resistance of some kind or other; these resistances absorb energy so that voltage is lost in proportion to the current that is passed through them. Actually, the voltage drop is given by the expression  $\text{Volt. drop} = \text{Current} \times \text{Resistance}$  (1) where the current is in amperes and the resistance in ohms.

### In Another Form

By simple transition this expression can be changed to

$$\text{Resistance} = \frac{\text{Voltage}}{\text{Current}} \quad (2)$$

Before starting any calculations in practice, however, we must decide what valves are to be supplied from the various tappings and what will be the total anode-current consumption from each point. The valve tables that appear in "Wireless Magazine" every month will prove a great help in this respect for they show at a glance the anode current taken by any particular valve.

Suppose we are going to supply three valves from the point H.T.+3 and that the current needed is 20 milliamperes at 150 volts. We then have to find the resistance that will give this voltage.

Looking up the regulation curve we see that the maximum voltage at 30 milliamperes (which we will assume to be the total load for the whole set) is 280 volts.

The difference between 280 and 150 volts (which is what we need) is 130; this is the voltage that must be dropped across the resistance when a current of 20 milliamperes is flowing. From the expression (2) we see that the value of resistance required is

$$\frac{130 \times 1,000}{20} = 6,500 \text{ ohms.}$$

(We have multiplied the top line by 1,000 to convert milliamperes to amperes). In practice it would be necessary to use a 5,000-ohm resis-

tance, as shown in the circuit and layout diagrams.

It must be understood that under different circumstances the 5,000-ohm resistance might have to be replaced by a different value, calculated as shown by this example.

As far as the output from the point H.T.+2 is concerned there is no need to make any alteration whatever valves are supplied. This resistance is adjustable, and the knob is simply turned until the best results are obtained.

The output from H.T.+1 is obtained from a potentiometer arrangement. It will be seen that two resistances are used in series, one being fixed and the other variable. If the slider is placed right at the top end of the variable resistance the voltage available at H.T.+1 will be exactly five-ninths of the total voltage

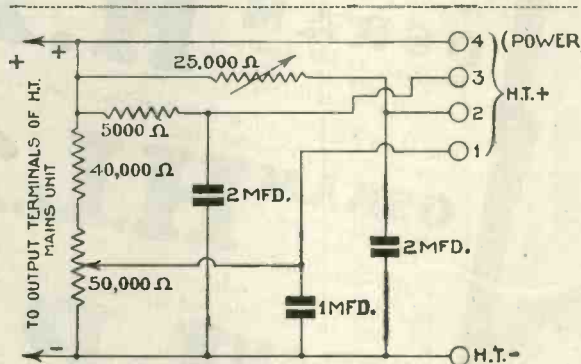

**CIRCUIT FOR FOUR OUTPUTS**

The unit is arranged to give two fixed and two variable outputs. Almost any type of receiver can be supplied

given by the unit for the particular load under consideration.

Still assuming that we are dealing with a receiver that takes a total current of 30 milliamperes, we know that the maximum voltage is 280, so that if the potentiometer slider is in its top position the voltage available at H.T.+1 is

$$\frac{5 \times 280}{9} = 155 \text{ volts.}$$

In addition to this, however, we have to take into consideration the voltage drop across the 40,000-ohm resistance caused by the screening-grid current flowing through it. This is not likely to exceed 1.5 milliamperes, which will account for a drop of 60 volts. The total voltage available for application to the screening grids will therefore be about 95 volts.

### COMPONENTS NEEDED FOR THE VOLTAGE REGULATOR

#### CONDENSERS, FIXED

- 1—Formo 1-microfarad, 2s. 6d.
- 2—Formo 2-microfarad, 6s. 6d.

#### EBONITE

- 1—Panel, 9 in. by 4 in.

#### RESISTANCES, FIXED

- 1—Lewcos 5,000-ohm spaghetti, 9d. (or Bulgin, Varley).
- 1—Lewcos 40,000-ohm spaghetti, 1s. 6d. (or Bulgin, Varley).

#### RESISTANCES, VARIABLE

- 1—Sovereign 25,000-ohm, type WW, 4s. 6d. (or Igranic, Colvern).
- 1—Sovereign 50,000-ohm, type WW, 4s. 6d. (or Igranic, Colvern).

#### SUNDRIES

- 2—Clix spade terminals, marked: H.T.+, H.T.—, 4d. (or Belling-Lee, Ealex).
- 5—Clix sockets with engraved bush heads, marked: H.T.+4, H.T.+3, H.T.+2, H.T.+1, H.T.—, 10d. (or Belling-Lee, Ealex).
- 5—Clix wander plugs, marked: H.T.+4, H.T.+3, H.T.+2, H.T.+1, H.T.—, Clix-lox pattern, 10d. (or Belling-Lee, Ealex).
- Tinned-copper wire for connecting.
- Length of oiled-cotton sleeving.
- Length of rubber-covered flex.
- 1—piece of wood 12½ in. by 5 in. for box.

10'6

The MIDGET L.F. TRANSFORMER

2 Components that turn "amateur" wireless into professional perfection!

Constructors! Profit by the experience of experts!

First—the MIDGET L.F. TRANSFORMER, the famous "miniature masterpiece" in which ultra-efficiency has been packed into convenient size. Reproduction reaches a brilliance never before possible at the price. Ratio 3:1 advised for valves of 10,000-20,000 ohms. Ratio 5:1 for valves from 5,000-10,000 ohms. Second—the IGRANIC SPAGHETTI RESISTANCE—wire wound and protected by insulated sleeving. Made in 13 sizes. Igranic quality—at your price!

The MIDGET Transformer (Ratio 3:1) is specified in the "MULTI-MAG 3" described in this issue

The IGRANIC SPAGHETTI Wire Wound RESISTANCE

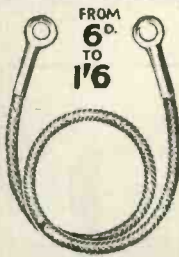

IGRANIC ELECTRIC Co. Ltd., 149 Queen Victoria St., London  
WRITE FOR DESCRIPTIVE LEAFLET No. J.1180.

"If it's IGRANIC—it's BEST for your set!"

DOES YOUR RADIO GIVE TROUBLE?

Whether your set is all-electric or battery-operated, buy a Pifco "All-in-One" Radiometer, the Sherlock Holmes of Radio. Tests every single thing, swiftly and surely. Simple to use, it is the most efficient

instrument ever made. Patented all over the world. Obtainable from good class radio dealers.

De Luxe Model, as illustrated.

£2 2 0

Standard Model, only for Battery Sets.

12/6

Patentees: PIFCO LTD., High Street, Manchester.



The SHERLOCK HOLMES of RADIO



PIFCO ALL IN ONE RADIOMETER

© D2

Our Latest Model —  
*The Lanchester*  
**"B.O.B"**  
PERMANENT MAGNET MOVING COIL SPEAKER

PRICE: **20/-**  
with Transformer 25/6

Although offered at the amazingly low price of 20/- the B.O.B. has a wonderful depth of tone and reproduces speech and music with clarity and brilliance. It will function perfectly with the smallest power valve, yet is capable of handling 1 watt undistorted A.C. without distress.

Write for Particulars and users' opinions

The LANCHESTER range includes models from 3 guineas downwards

Of the 'Special Senior' Moving Coil Speaker at 3 Gns. the "Wireless World" states—

"Magnet system . . . of generous dimensions . . . improved sensitivity . . . Characteristic, which is practically level between 100 and 1,000 cycles, actually rises about 5 decibels from 100 down to 50 cycles. This imparts a full, round tone to the reproduction . . . Speech is of the natural and unforced quality associated with Lanchester Speakers . . . rendering of music is entirely satisfying." *Wireless World*, April 13.

14 DAYS' FREE TRIAL

CATALOGUE No. 241 SENT FREE, AND POST FREE. WRITE FOR IT  
We sell direct to public on 14 DAYS FREE TRIAL against cash with order or G.O.D.

Station: Spring Road, G.W.R.  
**LANCHESTER'S LABORATORIES**  
TYSELEY LIMITED BIRMINGHAM

Better service results from mentioning "Wireless Magazine" when writing to advertisers

# News of the Short Waves

WITH the coming of the summer months we are now beginning to find a really good increase in the strength of a number of the short-wave stations. During the past winter, atmospheric conditions below 100 metres have been anything but kind, the transatlantic stations in particular having been poor, with some exceptions.

## Rome's New Wavelength

The short-wave station at Rome (12RO) has changed its wavelength once again and may now be heard on practically 43 metres. On this wavelength he is perhaps the loudest of all the European short-wave stations and comes in with little fading.

His short-wave transmission is very often received at a better strength than his medium-wave transmission. It is unfortunate, however, that he has chosen a wavelength which comes right in a cluster of amateurs and commercial code stations and his signals are practically always subject to interference of some type.

On Friday nights, he is also joined by CT1AA at Lisbon, Portugal, on 42.9 metres. This station comes in at very good strength nowadays, although the quality is not always what it might be. I particularly like the clear and very frequent announcements from this station, generally given in Portuguese, French, and English.

If you tune his signals in, you will not have the *slightest* difficulty in deciding what station you are listening to!

## Italian Tests

The Italian station Radio Coltano is still to be heard testing at various times. I don't know what the power of this station is, but the volume is generally shattering. The Americans in the 30-metre group have improved lately and the 49-metre stations are also good at times, but provide nothing very brilliant.

Have you ever considered using a crystal detector in a short-wave receiver? The snag which prevents the use of such a detector in a receiver of the "straight" type is, of course, the fact that the crystal cannot be made to oscillate readily, but there is no reason why such a detector should not be used as the second detector in a receiver of the super-het class. This would lower the cost, as well as battery expenses, of such a receiver.

An intermediate-frequency oscillation control could be effected by adjusting one of the intermediate-

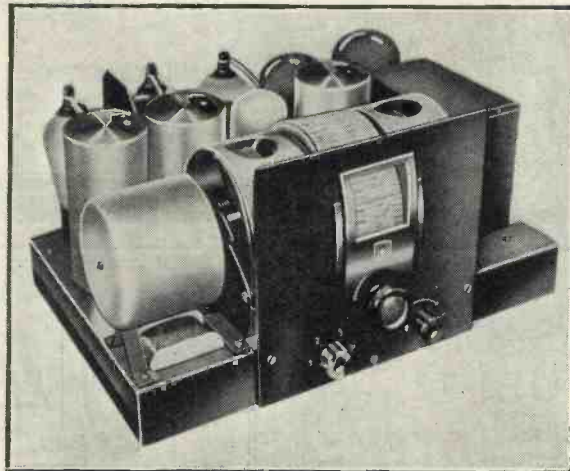

TYPICAL GERMAN SUPER-HET

This Schaub receiver is arranged for reception on wavebands from 16 to 50 metres; 200 to 600 metres; and from 800 to 2,000 metres

frequency amplifier valves to a point of oscillation. Admittedly, a crystal detector is not a very stable affair, but there appears to be room for experiment in a receiver of this type.

The second detector in many present-day supers can easily be replaced by a crystal and this, of course, applies to all-wave receivers of this class, not merely short-wave models.

So far, the police authorities in most European countries have not made very much use of the short waves as a means of communication between police patrols—or, if they have, they are keeping very quiet about the matter. "Over the pond," of course, they couldn't resist the temptation to equip their police cars

with short-wave receivers and there are no less than fifty-one radio police and fire stations, all operating on wavelengths between 121.5 and 187.9 metres.

The power used is generally rather low, being just sufficient to give good reception on a small receiver within a few miles of the city.

## Police-patrol Cars

Each police patrol has a number of cars fitted up with short-wave receivers tuned permanently to the local police transmitter. An aerial is fitted in the roof of the car and a loud-speaker forms part of the equipment, so that all in the car can hear the notices given out from headquarters.

At first sight there appears to be a horrid snag in this system owing to the fact that there is apparently nothing to prevent the doers of the misdeeds, the gangsters, the car bandits, or whatever you prefer to call them, also having a receiver in *their* car and so receiving the hint from police headquarters that a patrol car is on their tracks.

However, the authorities in some states have got over this difficulty by making it unlawful for anybody to equip a car with a short-wave receiver.

It is rather remarkable to notice how we still use the same type of circuit for short-wave reception that was in use when short waves first found any degree of favour. We used our "det. and two L.F." for short-wave reception in 1926 and it is still the favourite arrangement.

## Care in Design

Provided that the low-frequency stages are really stable and due care is taken in the design of the whole receiver, there is very little to beat a receiver of this class. Short-wave high-frequency amplifiers are successful only in certain cases and raise the cost.

Mander Barnett!



As specified for the "Town-and-Country Four" described on page 533

The New  
**SIEMENS**

# FULL O'POWER "Cadet" BATTERIES

BRITISH MADE THROUGHOUT



UP  
to FULL O'POWER  
Quality  
DOWN  
to "Ordinary  
Battery" prices

60 Volts	5/6	120 Volts	11/-
99 "	9/-	9 "	GB. 1/-
108 "	10/-	16½ "	GB. 1/9

THESE PRICES DO NOT APPLY IN THE IRISH FREE STATE

Get one—the improvement in "reception" will astonish you—and they... **LAST**

ADVERTISEMENT OF SIEMENS ELECTRIC LAMPS AND SUPPLIES, LTD., 38-39 UPPER THAMES STREET, LONDON, E.C. 4

## Use these WEARITE Parts in your "EASYTUNE 60"



THE repeated specification of Wearite products is a tribute to their remarkable efficiency. Set designers know that to assure best results only components of unquestionable quality must be used. They, therefore, select parts that are tested and proved, such as this Wearite Combined 3-point Switch and 15-ohms Rheostat.

**COMBINED 15-ohms RHEOSTAT (Q4) and 3-point SWITCH (G.23)**  
(Specified by the designer).

Both are mounted together as one unit. Price 3/6

**INTERMEDIATE BAND FILTER COILS (Type O.T.2, as illustrated)**  
Price, each, 10/6

**GRID-LEAK HOLDER (type A.1.)**  
Price 6d.

**PAXOLIN PANEL, 21 in. by 8 in.**  
Price 10/6

**THE WEARITE EARTH TUBE**  
The perfect earth. No screwdriver or spanner required. Just a match. Price 3/6

### WEARITE COMPONENTS

Write for Special Leaflet. If you have a technical query, let our "Switch Section" solve it for you.

WRIGHT & WEARE LTD., 740, High Rd., Tottenham, N.17.  
Telephone—Tottenham 3847/8/9.

## This OSBORN CABINET

SPECIFIED FOR THE  
"WIRELESS  
MAGAZINE"  
A-P-A  
RADIO  
UNIT

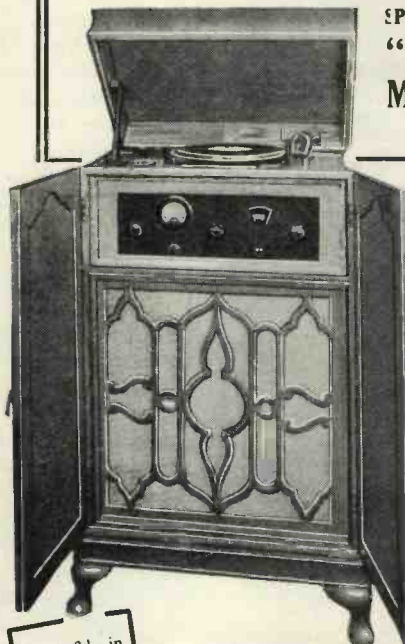

**MODEL No. 218**  
A Queen Anne Radio or Radio Gramophone Cabinet, 3 ft. 10 in. high, 2 ft. 2 in. wide, 1 ft. 6 in. deep. Size of baffle board behind fret, 24 in. by 24 in. Metallic fabric for fret front included. Opening at top and back. Cabinet takes panel 2 ft by 9 in., or smaller Complete with motor board.

**PRICES:**  
Machined ready to Assemble: Oak, £3 10s.; Mahogany, £3 15s.; Walnut, £4 10s. Assembled ready to polish: Oak, £4 10s.; Mahogany, £4 15s.; Walnut, £5 10s. Assembled and polished: Oak, £5 10s.; Mahogany, £6 5s.; Walnut, £7 5s.  
All Models Carriage Paid

**CHAS. A. OSBORN**

DEPT. W.M., The Regent Works,  
Arlington Street, London, N.1.  
Tel.: Clerkenwell 5095. And at 21 ESSEX ROAD,  
ISLINGTON, N.1 (1 min. from the Agricultural Hall).  
Telephone: Clerkenwell 5634.

Send 3d. in stamps for New 1932 beautifully illustrated Catalogue.

Please mention "Wireless Magazine" when corresponding with advertisers

# Radio Cross-word Puzzle Results

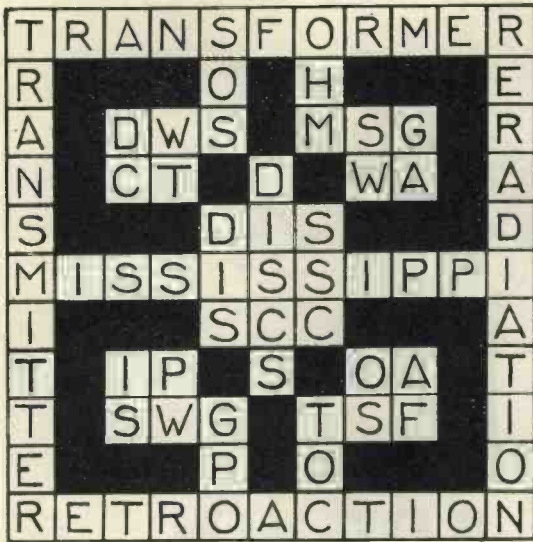

**THE CORRECT SOLUTION**

Here is the correct solution to the cross-word puzzle published in the April issue of "Wireless Magazine"

- (6) Telsen 3 Kit:  
A. E. Roberts,  
51 Neville Road,  
Bromborough,  
Cheshire.
- (7) Telsen 3 Kit:  
M. F. Howard,  
144 Friary Road,  
Handworth Wood,  
Birmingham.
- (8) Telsen 3 Kit:  
Henry J. Scroggie,  
142 Odessa Road,  
London, E.7.
- (9) Telsen 3 Kit:  
W. Clegg,  
234 Coombe Lane,  
London, S.W.20.
- (10) Telsen 3 Kit:  
C. F. Mason,  
10 Chard Road,  
St. Budeaux,  
Plymouth.
- (11) Blue Spot type 100U inductor loud-speaker:  
Lt.-Col. L. Godfray,  
Villa Godfray,  
Biarritz,  
France.
- (12) Set of Colvern coils for the Quadradyne:  
Ldg. Tel. E. W. Manley,  
40 Mess,  
H.M.S. Curlew,  
c/o G.P.O., London.
- (13) Two Jackson variable condensers for the Ideal Home Super:  
D. G. Stonell,  
239 Derinton Road,  
Tooting Bec,  
London, S.W.17.
- (14) Drydex high-tension battery:  
Leslie Seller,  
210 Westbourne Avenue,  
Hull.

CONSIDERABLE interest was taken by "Wireless Magazine" readers in the cross-word puzzle announced in the April issue. Here we are able to give the names of the fourteen prize winners and the correct solution :

- (1) Cossor Empire Melody Maker :  
E. M. Oliver,  
35 Chesham Crescent,  
Anerley,  
London, S.E.20.
- (2) Set of Lewcos coils and low-frequency transformer for the Ideal Home Super :  
A. C. W. Biddell,  
2 Randolph Gardens,  
London, N.W.6.
- (3) Two Guineas worth of T.C.C. fixed condensers:  
John B. Longridge,  
"Rathlin,"  
Mobberley,  
Cheshire.
- (4) Exide low-tension accumulator:  
Kite H. William,  
23 Stirling Street,  
Wallasey,  
Cheshire.
- (5) Telsen 3 Kit:  
B. Arnold,  
25 Maas Road,  
Northfield,  
Birmingham.

## HENRY HALL GAINING POPULARITY—Cont. from page 56 I

A member of the B.B.C. musical staff has been recently touring the Continent, with the result that during June we shall have the opportunity of hearing relays from some of the most famous opera houses in Germany and Austria. No details of the events to be broadcast are yet available.

Listeners who are interested in relays from the Continent should tune in to the French European concert on May 27. This concert, given by a chorus and orchestra of a hundred strong, is not recognised as one of the international exchanges of concerts arranged by the Union Internationale de Radiodiffusion.

An interesting comparison to this concert will be Baron d'Erlanger's *Requiem*, a fine musical masterpiece, which was given its first performance by the B.B.C. Orchestra and National Chorus under Adrian Boult last year. This work, given by the same performers as last year, will be broadcast on May 27.

Listeners will have probably noticed the name of Edward Clark among the conductors of the B.B.C.

Orchestra. It is only recently that Mr. Clark has conducted from the London studios, but listeners in the Newcastle area may remember him as musical director of the Newcastle station as far back as 1926.

Although the concerts conducted by Edward Clark have been of a popular nature, he is an authority on modern music. Present arrangements are for the newcomer to conduct one popular concert every week.

Providing the concerts are kept up to arrangement and not the ideals of Mr. Clark's modernistic tendencies, his broadcasts will be quite welcome.

### Gramophone Records

An interesting point about the orchestra is that they have recently made their first record for H.M.V. Until lately the gramophone contracts of the B.B.C. were placed with Columbia, but now they have expired and only the dance-band contract has been renewed.

The work chosen for the first record of the orchestra (117 members) was Sir Edward Elgar's arrangement of Chopin's *Funeral March*.

T. F. Henn.



**WHO**

were *First* to manufacture wire-wound resistances for radio—

**Varley**

**WHO** were *First* with an L.F. component giving a straight line N.P.L. curve—

**Varley**

**WHO** made the *First* bass-compensated gramophone pick-up—

**Varley**

**WHO** were *First* with H.F. Chokes, constant inductance chokes, and impedance matching output Transformers—

**Varley**

**WHO** were *First* with a band-pass tuner giving a square-topped peak and separation of 9 k.c. on *Both* wavebands—

**Varley**

Advt. of Oliver Pell Control Ltd., 108, Kingsway, W.C.

**EEXLEX**

**3 GOOD LINES!**



**EEXLEX TESTING PRODS**

Amateurs need not risk burning out valves when looking for faults. The Eelex Testing Prods are an insurance policy in themselves. Red and black insulated handles. Price per pair. 3/6

**EEXLEX GRIPS**

For identifying wires use Eelex Standard Name Plates with the Eelex Grips. Name Plates, 1d. ea., 9d. doz. Grips, 1d. ea., 6d. doz.



**THE 2DM SIDE ENTRY PLUG**

This Plug has many uses in the home-constructed set. Supplied in six colours. Type 2DM, side entry. Price 1d. each.



Write for List K.9.

**J. J. EASTICK & SONS**

Eelex House, 118 Bunhill Row, London, E.C.1. and at Swansea & Portsmouth.

Phone: Metropolitan 0314/5/6.

# H.T.

## from your accumulator

**S. G. Brown**

**SUPERSEDER**

The most extravagant way of generating current is with a dry battery, that is why you spend so much on H.T. batteries. The Superseder, S. G. Brown's wonderful invention, prevents all this waste, it supplies your H.T. the commonsense way, **from your accumulator.**

And it not only saves its cost in a year or so, it does what no H.T. battery ever made will do, it supplies H.T. at a constant voltage. Each tapping on the Superseder will give its rated voltage and **will always give it.** The Superseder makes an H.T. battery a thing of the past.

This is what two satisfied users have just written:—

*"It gives me very great pleasure to say how pleased I am with the Superseder . . . I shall not hesitate to recommend it."*

*"Since I have been running a Superseder I have shown it to whole hosts of my friends and they one and all acclaim it as the finest thing ever, with which I entirely agree."*

No. 2 size has three tappings, maximum of 80 volts, and with a 2-volt accumulator has an output of 6 milliamps.

No. 6 size has three tappings, maximum of 150 volts, and with a 4-volt accumulator has an output of 12 milliamps, and with a 6-volt accumulator an output of 19 milliamps.

No. 2 MODEL .. £3 : 15 : 0

No. 6 MODEL .. £5 : 5 : 0

Ask your dealer to show you this wonderful invention. If you have any difficulty please write to us and we will arrange a demonstration.

**S. G. BROWN LIMITED**  
WESTERN AV., N. ACTON, LONDON, W.3

Belmont

It helps us if you mention "Wireless Magazine"

# Wanted-Some Good Critics

A little while ago the B.B.C. tried the experiment of having a critic in the studio to make comments directly after vaudeville items were broadcast. Here WHITAKER-WILSON suggests that the scheme should be extended to more serious programmes—the Proms concerts, for instance. Such on-the-spot criticisms should be very interesting and helpful to listeners.

THERE has been much discussion over the advent of critics for the vaudeville programmes, but it seems that most of the objections have been raised by the criticised. That is only natural, perhaps; it is easily conceivable that most broadcasters would rather be left to do their worst and have nothing said.

If critics are to be invited—as it seems they were in the case of the vaudevilles—to say exactly what they think of the artists and to let them take or leave it, so to speak, I think there may be some justification for objecting.

Criticism is so often supposed to be saying what one thinks; in other words, airing one's opinion to the annoyance of other people.

Personally, I think that sort of criticism does not lead anywhere. Neither am I inclined to ask for critics if that is all they are going to do. I doubt whether there is much merit in a critic giving a list of vaudeville artists each Saturday night and making a few remarks about each one of them.

Up to the time of writing we have not gone very far in the matter. On the other hand, I think we have gone far enough to realise that there is something in criticism from the listener's point of view.

The little experience we have had of the vaudeville critics has, to my way of thinking, proved that they

have felt diffident about standing before the microphone, directly the vaudeville has finished, in order to talk about those who took part in it.

I can see their point of view quite well. It is a little awkward. No critic, if his mind is properly balanced, wishes to hurt people's feelings.

As far as I can see there is not much value in vaudeville criticism if it is to be done on those lines.

I submit that *very little* value can be placed upon a criticism which says, for example, that Doris and Elsie Waters were as funny as usual; that Mr. Jetsam took his low D-flat with his customary ease and grace; that Stainless Stephen spoke his Yorkshire and dictated his punctuation in the manner well known to listeners. That sort of thing gets us nowhere.

So far, it has not occurred to the critics to be helpful to the B.B.C.

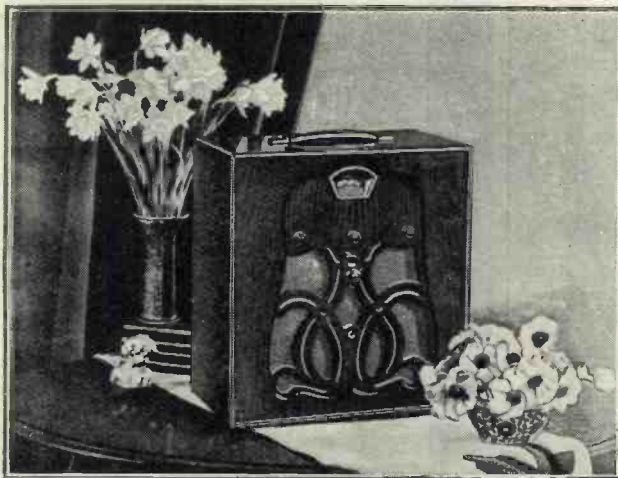

A FINE PORTABLE INSTRUMENT  
This is the Marconiphone Super-tuned Portable, which is now priced at 13 guineas. It is one of the most popular portables at present on the market

Where criticism is to be helpful can only be where it is constructive.

Where most of the vaudevilles themselves have failed, in my opinion, has been where the programmes have not been properly balanced. Any musical programme, serious or light, *must have its climax*. Mere succession of turns has always had a poor effect.

It is very unimaginative to put on

a comedian who makes you ache with laughing and then let you down with some solos on an accordion or a cornet. It is no better to make you wait until the very end before the best (or funniest) artist comes on. Worst of all is the programme which works up to a good climax and then falls headlong with a couple of weak turns.

## Construction

Construction is what is wanted.

Constructive criticism is no less wanted. The man who can handle the weeks' programmes and point out calmly, and quite respectfully, to the vaudeville producer where the weaknesses in the construction lie may prove to be of real use.

Thus far it might seem that I have criticised the critics. What I am really trying to do is to urge that the idea of having them is good, and that men with highly-developed critical faculties are needed for the purpose of delivering really constructive reviews of something that has just taken place.

I imagine that the idea of having critics at all has been largely experimental so far as the B.B.C. is concerned. In spite of what I have said regarding those who have already acted as critics, I am bound to confess that I think the idea has already been an outstanding success.

My reason is this. Criticism or, better, a *review* of something *just heard* is far more valuable than any amount of explanation, either by the announcer or by the printed programme, of

*what is going to be heard.*

I think very few will disagree with me when I say that there is something very attractive in having a review of something one has enjoyed. At the end of the Saturday night vaudeville I imagine many listeners have said to one another: "A very good vaudeville; let's hear what the critic has to say about it."

(Continued on page 580)

# WORLD FAMOUS VALVE HOLDERS

Specified by "Wireless Magazine"



in  
"ECONOMY  
A.C. TWO"

The "W.B." Holder for A.C. valves. Used in the leading test rooms in Great Britain.

4- or 5-pin for A.C. valves. Diam., 2 in., 10d.



in  
"EASYTUNE  
60"

The "W.B." Miniature, for above baseboard mounting. Diam., 1 1/2 in.

4- or 5-pin Miniature. 5-pin, 8d.; 4-pin, 6d.  
Write for interesting FREE Leaflet of Valve Holders, Switches, and the renowned "W.B." Permanent Magnet Moving-coil Speakers.

Whiteley Electrical Radio Co., Ltd., Mansfield, Notts.

Irish Free State Distributors:  
Kelly & Shield, Ltd., 47 Fleet Street, Dublin.



**USED UNIVERSALLY**  
**The World's Standard for Eight Years—Still the Best**

Specified in the "ECONOMY A.C. TWO"  
→ "R" Terminals; in the "MULTI-MAG 3"  
→ "R" Terminals; in the "EASYTUNE 60"  
→ "B" Terminals, 10 Wanderyplugs (2d. each) and 2 Spade Terminals (2d. each)

**BELLING-LEE TERMINALS**

Advert of Belling & Lee, Ltd., Queensway, Ponders End, Middlesex.

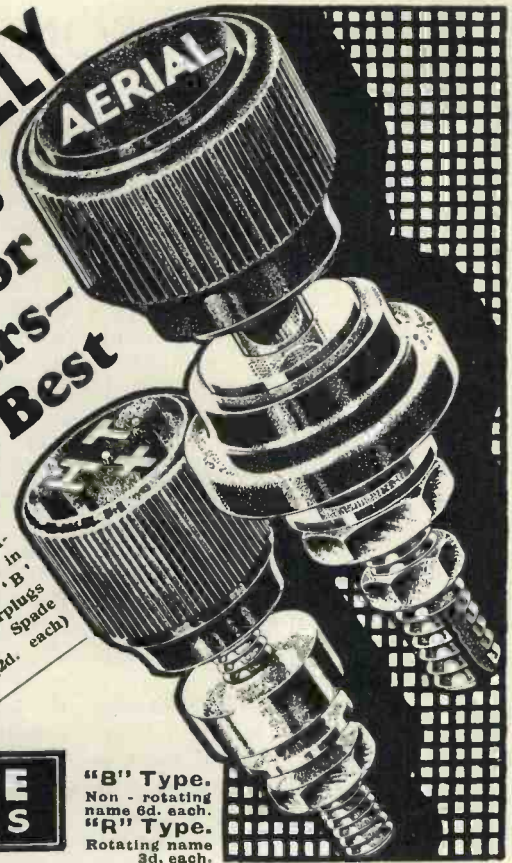

"B" Type. Non-rotating name 6d. each.  
"R" Type. Rotating name 3d. each.

# NEW PARMENKO FACTORY

**"RESULT OF STICKING TO A PRINCIPLE"**

Parmeko have had to build a new Factory as a result of their successful policy of efficiency first and always—regardless of price. Parmeko do not make cheap popular selling lines, only Equipment as efficient as it is possible to make it. The price is then fixed as low as practical considerations will allow.

**IF YOU WANT THE BEST RESULTS YOU MUST BUY "PARMEKO"**

## PARTRIDGE & MEE LTD.,

74, New Oxford Street, LONDON, W.C.1 (Phone: MUSEUM 5070) & Leicester (Phone: Aylestone 487).

**ALL YOUR RADIO FROM READY RADIO**

Eastnor House, Blackheath, S.E.3.

### MICROFU GOLD FILM FUSES

Specified for the "Town and Country Four."  
**NEW FLAT TYPE from 50 m/a upwards.**  
Fuses 6d. Holders 6d. Complete 1/-.  
This is a gold fuse—not wire.



Absolutely Reliable. 100% British.



MICROFUSES, Ltd.  
36, Clerkenwell Road, E.C.1.

Telephone: Clerk. 4049

Wherever you live—save 50% Radio Expense

**YOU MUST JOIN THE RADIALADDIN CLUB**

Write for particulars, Dept., "W.M.," 47 Berners Street, London, W.1.

Better service results from mentioning "Wireless Magazine" when writing to advertisers

## WANTED—SOME GOOD CRITICS—Continued from page 578

Surely that is the same type of thought that causes you and me to read some parliamentary news in our morning paper and then to turn to the leader *to see what the paper itself* has to say about what we have just read.

### Sound in Principle

There is no doubt whatever in my mind that the idea of microphone criticism is thoroughly sound in principle. It is because I am so convinced of this that I am here making an attempt to persuade the B.B.C. to extend the idea to the more serious side of broadcasting.

#### *I want symphony-concert critics*

The day will soon dawn when the last broadcast comes from Savoy Hill. I want the B.B.C. to turn over a new critical leaf, so to speak, from that very hour.

It is quite obvious to every listener that the B.B.C. is out to educate England in good music—I mean as distinct from entertaining it with vaudevilles, dance music, light ballad concerts, and the like. Nothing less is conceivable.

Also I take it that the Promenade Concerts will be relayed nightly this summer, that the usual little paragraphs will appear in the programmes, and that the announcers will render assistance here and there in the matter of explanation of a few of the works to be performed.

My contention is that, however high a value may be placed upon this procedure, it is as nothing in comparison with the value of a good, sensible and clearly worded review of a concert directly it has finished.

### Critics for the Proms

*I want the B.B.C. to consider the idea of asking a critic to be present in Queen's Hall nightly for the Proms and all through the next symphony-concert season. I want that critic to leave the hall immediately the last chord has died away and to walk over to Broadcasting House, there to deliver his review of the concert.*

The value of this is, in my judgment, very great.

You have, let us suppose, listened to a concert of works of various kinds ranging from, say, a Beethoven concerto to some other orchestral work given for the first time. You have thoroughly enjoyed what you have heard and have had enough music

for that evening. You responded to the concerto because you faintly remembered having heard it before, but you remain a little perplexed over the new work which you found to be rather a lot to swallow all at once.

Now, would you or would you *not* appreciate an interesting talk about it all for a few minutes? Would you not be grateful to the critic who was musician enough to play a fragment, here and there, of that symphony you liked—*on the studio piano*? Especially if he had something "snappy" to say about it.

Or a word in season about the singer who sang the operatic aria? A miniature review of the position the song takes in the actual opera, telling you what happens on the stage at that moment. You *would* enjoy it, and you *would* appreciate the fact that you were being taught something in a very pleasant way.

### Education in Criticism

The greatest value of all, though, is that *in time* your own critical faculties would be disturbed; you would begin to differentiate between various composers' styles of writing, and become keener and keener on the interpretation of various works.

You would begin to realise what a difference this conductor or that conductor makes; you would begin to appreciate good, bad, or indifferent tone in instrumental and vocal soloists. There is no end to the possibilities of criticism delivered at the right moment—that is, when the memory of the music is still fresh in the mind.

The B.B.C. has done wisely to welcome the opinions of capable men. Perhaps it is as well that it all began with the lighter forms of entertainment, which are also the most popular forms.

It is now only necessary to proceed with the weekly criticisms to find that the majority of listeners will respond to them. There has, up to now, been negative criticism of the critic, of course; but every novelty invariably brings hundreds of complaints. Everyone at the B.B.C. knows that.

### Popular Critics

My prediction is that the day will come when the critic will be as popular as the folks he criticises.

In any event—whether I am wrong or right in that view—I definitely ask the authorities at Savoy Hill to consider my proposal that they shall mark their entry into Broadcasting House by the engagement of every reliable music critic who can be found to review all Promenade Concerts and all symphony concerts—whether the latter be from Queen's Hall or from the studio.

A few minutes of interesting notes on the Sunday night concerts would make a fitting conclusion to them, and even serve to usher in the Epilogue.

That word has suggested the very thing!

*Let the reviews be Epilogues*—just picturesque, imaginative, absorbing Afterthoughts, delivered with the direct intention of causing the listener to reflect on the beauty of what he has heard.

### After the Event

You remember the Prologue to *Pagliacci*? "Come then! Ring up the Curtain!" The Prologue seeks to win your sympathy *before the event*; I want to feel that there is going to be an Epilogue that, just after the curtain has rung down and the people are leaving Queen's Hall and streaming down Regent Street, will seek to win your sympathy to what you *have just heard*.

The presence of that Epilogue, in my opinion, will do more to cause the great listening public to take a definite interest in good music than anything the B.B.C. has done thus far. *Will the authorities give the Epilogue a trial for this coming season?*

YOU may not be able to obtain a copy of "Wireless Magazine" unless you order it in advance from your newsagent. Ask him now to reserve for you specially a copy of the

**JULY NUMBER,**

which will be on sale everywhere on

**WEDNESDAY,  
JUNE 22**

## Beware of Imitations!

The R. & A. "CHALLENGER" PERMANENT-MAGNET MOVING-COIL REPRODUCER has set a standard in performance, materials and workmanship that cannot be excelled at the price. *Insist on R. & A.*

# The R & A "CHALLENGER"

Write for Descriptive Leaflet and ask your dealer to demonstrate.

REPRODUCERS & AMPLIFIERS LTD.  
Frederick Street,  
WOLVERHAMPTON.

## 35/-

INCLUDING 3-ratio Ferranti TRANSFORMER (to R. & A. specification).

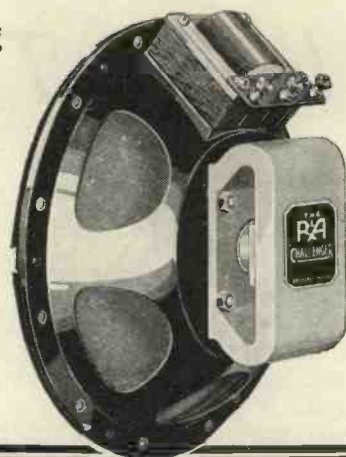

Famous Makers' Offer! **£5** Radio Gram CABINET for **65/-** 7 DAYS' FREE TRIAL

10/- monthly if desired

You save 35/- a few only at makers' prices. Rich Brown Oak "Master Grand" (as made for Radio Press) carriage paid. A fine Bargain. PHOTOGRAPHS and LISTS FREE.

All Models from 35/- to £1.



PIANO TONE

Patent 8123 improved acoustics yields mellow, rich, full volume that your speaker is really capable of. Makers to: (Radio-Press, E.B.C., 3,000 clientele)

SEND FOR LIST

**PICKETTS** Piano Tone Cabinets (M.G.) Alibon Rd., Beleyheath, Kent

## FREE CATALOGUE SERVICE

Turn to page 494 and you will see details of the latest catalogues received in this office. Catalogues giving details of new products right up to the minute in design and production.

If you are interested in any of the articles mentioned on page 494, cut out the coupon and send it in and a catalogue will be sent you direct from the maker concerned. Be up-to-date and get the latest information. Take advantage of this service.

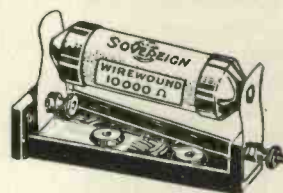

## IN THIS MONTH'S "W.M." SETS

Sovereign Components 4/- and 50,000, 5/-, are specified for two sets in this month's "Wireless Magazine"—in the Simple Mains Unit and Economy A.C.2. In the first set, a Voltage Control Unit is described and 2 Sovereign wirewound resistances (25,000 ohms 4/- and 50,000, 5/-), are specified. The other set uses 3 Sovereign Terminal Blocks (6d. each) and a Sovereign Pre-set Compression Type Condenser, (.003 microfarad, 1/3) in mains radio apparatus too. Sovereign is 100 per cent. reliable.

If your dealer cannot supply you with Sovereign Radio Components—send direct to the manufacturers, also for free Catalogue of full Sovereign Range.



SOVEREIGN PRODUCTS LTD., 52/54 Rosebery Ave., LONDON, E.C.1 S.F.B.

## Photo Cells



are well known for their use in commercial as well as scientific work. For sound films, television, invisible ray, colour comparison and photometry; Counting and timing of passing objects; timing the velocity of a projectile or speed of races; transmission over a beam of light, illumination control, burglar alarm. Measuring photographic plates.

The usual price of these cinema photo cells is £5. 10 or £7. 10 and they

are guaranteed perfect in their sound to light responses. These spares are available because certain famous Talkie producers are adopting a smaller mechanism.

**ELECTRADIX RADIOS,**  
218 Upper Thames St., E.C.4

**15/-**  
as illustrated,  
**25/-**  
mounted.

Make sure of getting your copy early—Place an order now for the

# JULY WIRELESS MAGAZINE

It will be Published on Wednesday, 22nd June.

MAKE SURE OF GETTING YOUR COPY

"OHMITE" RESISTANCE

ALL values from 300 ohms to 5 megohms 1/6 Holder 6d.

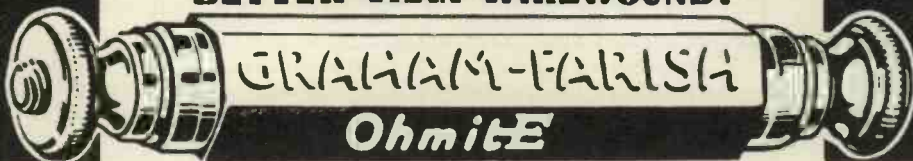

"BETTER THAN WIREWOUND!"

Made by **GRAHAM FARISH** Bromley Kent.

Advertisers like to know whence the business comes—please mention "W.M."

# British Television on Six Metres

## A New Baird Development Demonstrated

Another milestone in the development of British television was the recent demonstration staged by J. L. Baird on six metres. It is hoped that prolonged television transmissions can be put out on the short waves in the near future. Here is another activity that will add to the importance of short waves for British listeners

**J**UST when we were wondering, with some justice, what was happening in television, we received an invitation to witness the latest Baird development—television on the ultra-short waves.

In addition to the usual television signals sent out through the London National and Regional stations, the morning of April 29 was notable for the additional transmission of these signals on a wavelength of 6.1 metres.

### Special Transmitter

A special short-wave transmitter has been erected at the Baird laboratories in Long Acre, London, and signals from this were picked up on the demonstration equipment erected on the roof of the Selfridge building in Oxford Street.

The idea of the demonstration was firstly to show the practical use of the ultra-short waves below 10 metres for television, and at the same time we were given an opportunity to witness another development—the use of a screen instead of a lens for the viewing of the image.

Let us deal first with the short-wave side of the demonstration. As Mr. Baird pointed out, these short waves provide a range of between five and ten miles, free from fading and atmospherics—two factors that often spoil television signals on ordinary channels. The great advantage of 6-metre transmission is that experimental television can now be sent out at all hours of the day and night without interfering with existing services.

For the demonstration in question the ordinary television image was sent out during the first part of the time by both medium and short waves, and latterly through only the short-wave station belonging to the Baird Company.

But, as is well known, the short waves provide scope for much greater frequency bands of transmission, which in turn means greater detail in the image, and therefore greater entertainment value.

The limitation in range would presumably be overcome in due course by the erection of multiple short-wave stations, which are relatively inexpensive.

What we were permitted to see on the roof of Selfridge's was an image of no greater detail than could be seen by the normal broadcasting medium—with the difference that instead of looking through a lens, as in the commercial Televisors now on the market, we were able to see the images projected on a small screen.

This screen diffuses the light source, which we understood from one of the engineers to be a bunched filament. What impressed us mostly was the absence of that tiresome red tinge so characteristic of the earlier demonstrations.

Here were black and white images, and at times the delicacy of the picture was remarkable. Illumination still seems to be the big trouble, for we found a great difference in the brightness of the image when standing right in front of the apparatus compared with a side view.

Those with a dead straight view must have been considerably impressed, as we were, with the occasional clarity of the images; but, as in all previous shows of this kind, there was that proneness to variability in the results that inevitably tempered one's enthusiasm for the fleeting glimpses of wonderfully good likenesses.

### Mirror-drum Scanning

By the way, this demonstration also gave us the first opportunity of seeing how the mirror-drum system of scanning compares with the old slotted-disc system. For some time past the Baird transmissions have been done with a mirror drum, but the extension of this system to the receiving apparatus is another step forward.

The mirror drum modulates the white-light source, and is a great improvement on the neon-light images hitherto built up.

Until Mr. Baird makes complete use of the new short-wave channel,

bywidening the frequency band of the image, we must, of course, suspend final judgment on the results. Up to the present there is every reason to hope that the short waves may indeed be television's salvation.

Meanwhile the erection and successful operation of the 6-metre transmitter at Long Acre means that much more intensive work can be done, for there will be no limitation in the times of transmission.

We are interested to learn from Mr. Baird that he is experimenting with cathode-ray apparatus.

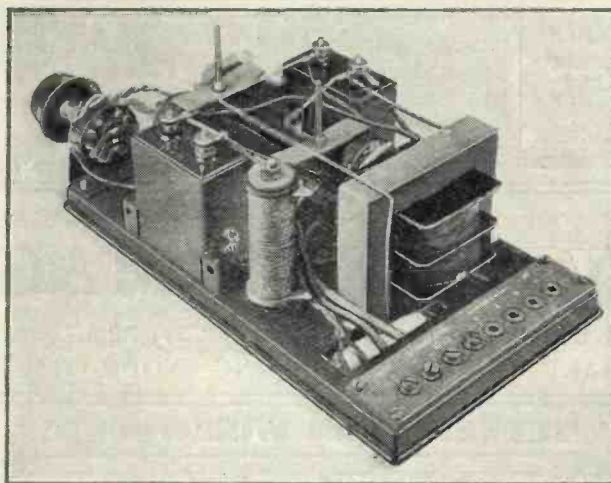

**HIGH-TENSION SUPPLY FROM AN ACCUMULATOR**  
*This photograph shows the inside of a Brown Superseder, a piece of apparatus designed to give high-tension supply from an accumulator. The device should be useful in places where ordinary high-tension batteries are unobtainable or will not stand up to the climate*



YOU CANNOT GO WRONG IF YOU USE A

# FULL-SIZE BLUEPRINT

## CRYSTAL SET

6d. post free

1931 Crystal Set . . . . . AW308

## ONE-VALVE SETS

1s. each, post free

Short-wave One-valver (6d.) . . . . . AW327  
 "B.B.C." One . . . . . AW280  
 Easy-to-Build One . . . . . AW304

## TWO-VALVE SETS

All these 1s. each, post free

Five-point Two (D, Trans) . . . . . WM220  
 Aladdin Two (D, Trans) . . . . . WM231  
 Ever-tuned Regional Two (D, Trans) . . . . . WM241  
 Station-finder Two (D, Trans) . . . . . WM243  
 Music-lover's Two (D, Trans) . . . . . WM260  
 New Economy Two (D, Trans) . . . . . WM265  
 Family Two (D, Trans) . . . . . WM278  
 ★Economy A.C. Two (D, Trans) . . . . . WM286  
 Forty-five Shilling Two (D, Trans) . . . . . AW250  
 Searcher Short-wave 2 (D, Trans) . . . . . AW259  
 Challenge Two (D, Trans) . . . . . AW261  
 Loftin-White 2 (A.C. Set) . . . . . AW263  
 Everybody's All-in 2 (D, Trans) . . . . . AW273  
 Twenty-shilling Two (D, Trans) . . . . . AW274  
 B.B.C. Selective Two (D, Trans) . . . . . AW292  
 The Room-to-Room 2 (D, Trans) . . . . . AW298  
 Big-volume Two (D, Pen) . . . . . AW309  
 Two Star 2 (D, Pen) . . . . . AW315  
 The 25/- Two (D, Trans) . . . . . AW330  
 Ten Station Two (D, Trans) . . . . . AW336

## THREE-VALVE SETS

All these 1s. each, post free:

Gramo-radio D.C. Three (SG, D, Trans) WM196  
 Concert Three (D, 2 Trans) . . . . . WM199  
 De-luxe Three (D, RC, Trans) . . . . . WM209  
 Five-point Three (SG, D, Trans) . . . . . WM212  
 Falcon Three (AC Set) . . . . . WM217  
 New Brookman's Three (SG, D, Trans) WM218  
 Five-point Short-waver (D, 2 Trans) WM223  
 Regional Three (SG, D, Trans) . . . . . WM236  
 Band-pass Inceptor-dyne (SG, D, Pen.) WM244  
 Ether Marshal (SG, D, Trans) . . . . . WM247  
 Five-Advantage Three (D, RC, Trans) WM257  
 Everybody's Radiogram (SG, D, Trans) WM258  
 Meridian Short-waver (D, RC, Trans) WM255  
 Double Band-pass Three (SG, D, Trans) WM259  
 Everybody's Radiogram (with Automatic Grid Bias) . . . . . WM262  
 New Economy Three (SG, D, Trans) . . . . . WM263  
 New Plug-in-Coil Three (D, 2 Trans) . . . . . WM270  
 Transportable Three (SG, D, Trans) . . . . . WM271  
 ★Multi-Mag Three (D, 2 Trans) . . . . . WM288  
 Square-peak Three (SG, D, Trans) . . . . . AW293  
 Universal Short-wave Three (SG, D, Trans) . . . . . AW301  
 Olympian Three (SG, D, Trans) . . . . . AW306  
 Tonality Three (D, RC, Trans) . . . . . AW321  
 35/- Three-valver (D, 2RC) . . . . . AW323  
 Baby Three (D, RC, Trans) . . . . . AW324

A blueprint of any one set described in the current issue of the "Wireless Magazine" can be obtained for half-price up to the date indicated on the coupon (which is always to be found on the last page) if this is sent when application is made. These blueprints are marked with an asterisk (\*) in the above list and are printed in bold type. An extension of time will be made in the case of overseas readers.

1932 Ether Searcher (SG, D, Trans) . . . . . AW325  
 World Wide Short-wave Three (D, RC, Trans) . . . . . AW332  
 New Favourite Three (D, RC, Trans) . . . . . AW334  
 Home Lover's All-electric Three (SG, D, Trans) . . . . . AW335  
 P.W.H. Mascot (D, RC, Trans) . . . . . AW337

## FOUR-VALVE SETS

All these 1s. od. each, post free

Five-point Four (SG, D, RC, Trans) . . . . . WM216  
 Brookman's Three-Plus-One (SG, D, RC, Trans) . . . . . WM233  
 Ether Rover (SG, D, RC, Trans) . . . . . WM266  
 Quadradyne (2SG, D, Trans) . . . . . WM273  
 Double Band-pass Four (SG, D, RC, Trans) . . . . . WM274  
 Economy Radio Gramophone (SG, D, RC, Trans) . . . . . WM276  
 A.C. Quadradyne (2 SG, D, Pen) . . . . . WM279  
 The Orchestra Four (D, RC, Push-pull) AW167  
 All-Europe Four (2HF, D, Trans) . . . . . AW173  
 Stability Four (HF, D, RC, Trans) . . . . . AW182  
 £3 3s. Four (SG, D, RC, Trans) . . . . . AW303  
 £3 3s. Four (Improved Model) . . . . . AW303A  
 Everybody's Radio Gramophone . . . . . AW310  
 Four-star Four (SG, D, RC, Trans) . . . . . AW318  
 The 50/- Four (SG, D, RC, Trans) . . . . . AW331

## FIVE-VALVE SETS

All these 1s. 6d. each, post free

Overseas Five (JSG, D, Trans) . . . . . WM191  
 Regional D.C.5 (SG, D, LF, Push-pull) WM252  
 Ideal Home Super (Super-het) . . . . . WM280  
 Easytune 60 (Super-het) . . . . . WM284  
 James Quality Five (2SG, D, RC, Trans) AW227  
 Britain's Super (Super-het) . . . . . AW311  
 A.C. Britain's Super (Super-het) . . . . . AW322  
 Mains section (1/-) . . . . . AW322a  
 James Short-wave Super-het . . . . . AW328  
 Simple Super (Super-het) . . . . . AW340

## SIX-VALVE SETS

All these 1s. 6d. each, post free

Super 60 (Super-het) . . . . . WM229  
 A.C. Super 60 (Super-het Radiogram) . . . . . WM239  
 A.C. Super 60 (Super-het Table Model) WM245  
 Super 60 (with Weirite Base) . . . . . WM249  
 Super 60 (with Lewcos Base) . . . . . WM251  
 1932 Super 60 (Super-het) . . . . . WM269  
 1932 A.C. Super 60 (Super-het) . . . . . WM272

## SEVEN-VALVE SET

1s. 6d., post free

Super Senior (Super-het) . . . . . WM256

## PORTABLE SETS

Pedar Portable (D, 2 Trans) . . . . . WM197 1/-  
 Super 60 Portable (Super-het) . . . . . WM238 1/6  
 Home and Garden Three (D, RC, Trans) . . . . . WM246 1/-  
 Town and Country Four (SG, D, RC, Trans) . . . . . WM282 1/6  
 Music Leader (SG, D, RC, Trans) with copy "A.W." . . . . . AW203 1/-  
 Merry-maker Portable (D, 2 Trans) . . . . . AW228 1/-  
 Sunshine Three (SG : HF, SG : D, Trans) . . . . . AW235 1/-

## AMPLIFIERS

All these 1s. each, post free

Radio-record Amplifier (DC Mains) . . . . . WM183  
 Selecto Amplifier (HF Unit) . . . . . WM210  
 D.C. Fader . . . . . WM242  
 Quality Amplifier (D.C.) 1s. 6d. . . . . WM264  
 A-P-A (Public Address) . . . . . WM275  
 A-P-A Radio Unit (SG, D) . . . . . WM281  
 Economy Gramophone Amplifier . . . . . WM277  
 A.C. Push-pull Amplifier . . . . . AW291  
 Add-on H.F. Screened-grid Unit . . . . . AW296  
 Universal Push-pull Amplifier . . . . . AW300  
 "A.W." Record Player (LF, Push-pull) AW319

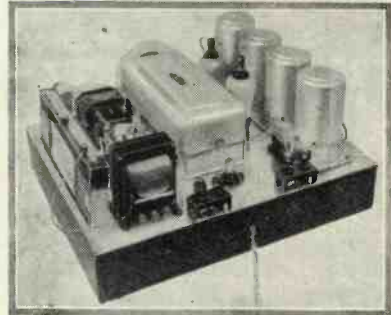

THE LAST WORD IN FOURS

Every modern refinement is incorporated in the Quadradyne, a four valve battery-operated set. An A.C. version is available.

## MISCELLANEOUS

"W.M." Standard A.C. Unit . . . . . WM214 1/-  
 "W.M." Standard D.C. Unit . . . . . WM215 1/-  
 Loud-speaker Tone Control . . . . . WM234 -/6  
 "W.M." Linen-diaphragm Loud-speaker . . . . . WM235 1/-  
 Two-minute Adaptor for Short Waves . . . . . WM240 1/-  
 Super 60 A.C. Unit (for Battery Super 60) . . . . . WM248 1/-  
 Simple Neon Oscillator . . . . . WM251 1/-  
 Plug-in Adaptor . . . . . WM267 1/-  
 Super-het Adaptor . . . . . WM268 1/-  
 A Simple Mains Unit . . . . . WM283 1/-  
 ★Short-wave Director (wavemeter) . . . . . WM285 6d.  
 ✱ Voltage Regulator . . . . . WM287 1/-  
 Simple Battery Eliminator for A.C. Mains . . . . . AW236 1/-  
 Choke Output Unit . . . . . AW240 1/-  
 Simple Tester Unit . . . . . AW246 -/6  
 "A.W." Improved Linen-diaphragm Speaker . . . . . AW248 1/-  
 Handy L.T. and G.B. Unit for A.C. Mains . . . . . AW254 1/-  
 Ohmic Coupled DX Unit . . . . . AW255 1/-  
 Simple Gramophone Amplifier . . . . . AW257 1/-  
 Novel Linen Diaphragm Speaker . . . . . AW260 1/-  
 H.T. Unit for A.C. Mains . . . . . AW262 1/-  
 Gramophone Tone Control . . . . . AW264 1/-  
 H.T. Unit and Trickle Charger for D.C. Mains . . . . . AW272 1/-  
 2-Watt A.C. Amplifier . . . . . AW283 1/-  
 "A.W." Selectivity Unit . . . . . AW290 6d.  
 H.B.C. Official Selectivity Unit . . . . . AW291 6d.  
 A.C. Trickle Charger . . . . . AW305 1/-  
 Amateur's Linen Speaker . . . . . AW307 1/-  
 D.C. H.T. Unit . . . . . AW312 1/-  
 Output Unit for Pentode Sets . . . . . AW316 1/-  
 "A.W." Short-wave Adaptor . . . . . AW317 1/-  
 Short-wave Plug-in Adaptor . . . . . AW326 -/6  
 Super-het Short-wave Adaptor . . . . . AW329 -/6  
 "A.W." Short-wave Adaptor . . . . . AW339 1/-

Each blueprint shows the position of each component and every wire and makes construction a simple matter. Copies of "Wireless Magazine" and of "Amateur Wireless" containing descriptions of most of these sets can be obtained at 1s. 3d. and 4d., respectively, post free. Index letters "A.W." refer to "Amateur Wireless" sets and "W.M." to "Wireless Magazine" sets.

Send, preferably, a postal order (stamps over sixpence in value unacceptable to)

# Wireless Magazine

BLUEPRINT DEPT.,  
 58/61 FETTER LANE,  
 LONDON, E.C.4

## BLUEPRINT COUPON

Valid only until June 30,  
1932 (or until July 31, 1932  
for overseas readers)

### FOR ONE BLUEPRINT ONLY

If you want a full-size blueprint for any ONE of the sets constructionally described in this issue for half price, cut out the above coupon and send it, together with a postal order, to Blueprint Department, WIRELESS MAGAZINE, 58-61 Fetter Lane, London, E.C.4.

This coupon is valid for a blueprint of any ONE only of the following sets at the prices indicated:—

**SHORT - WAVE DIRECTOR** (page 538), WM285, price 3d., post free.

**ECONOMY A.C. TWO** (page 549), WM286, price 6d., post free.

**VOLTAGE REGULATOR** (page 570), WM287, price 6d., post free.

**MULTI - MAG THREE** (page 502), WM288, price 6d., post free.

## INFORMATION COUPON

Valid only until June 30,  
1932 (or until July 31, 1932  
for overseas readers)

If you want to ask any questions, cut out the above coupon and send it, together with a postal order for 1s. and stamped-addressed envelope, to the Information Bureau, WIRELESS MAGAZINE, 58-61 Fetter Lane, London, E.C.4.

Note that not more than two questions may be asked at a time and that queries should be written on one side of the paper only.

Under no circumstances can questions be answered personally or by telephone. All inquiries must be made by letter so that every reader gets exactly the same treatment.

Alterations to blueprints or special designs cannot be undertaken; nor can readers' sets or components be tested.

If you want advice on buying a set, a stamped-addressed envelope only (without coupon or fee) should be sent to the Set Selection Bureau, WIRELESS MAGAZINE, 58-61 Fetter Lane, London, E.C.4.

## New Radiogram Cabinet



THIS illustration shows the new Tablegram cabinet just put on the market by the Carrington Manufacturing Co., Ltd., the makers of Camco products. There is space for a 12-in. turntable, the inside dimensions of the cabinet being 14½ in. deep and 15¼ in. wide. The height is 19½ in.

This form of cabinet should interest many set constructors because of its great utility. The price, in walnut finish, is £2 15s.

## CONSTRUCTION • OVERHAUL • • • • MODERNISING •

Scott Sessions enjoy a hard-won and enviable reputation for first-class workmanship. Only the most experienced mechanics are employed and then only under expert supervision. All types of sets are built, overhauled, or brought up-to-date, and we have in particular made a special study of the various sets described and recommended by "Wireless Magazine." Get in touch with us at once. We will gladly quote for any work, without obligation.

## SCOTT SESSIONS

RADIO ENGINEERS  
MUSWELL HILL, LONDON, N 10

Telephone: Tudor 5326.  
Contractors to H.M. Office of Works, etc.

## INDEX TO ADVERTISERS

	Page
<b>B</b>	
Baker Selhurst Radio .. ..	497
Belling & Lee, Ltd. . . . .	579
British Blue Spot Co. . . . .	Cover iii
British General Mfg. Co. . . . .	487
British Radiophone, Ltd. . . . .	483
British Rola Co. . . . .	565
Brown, S. G. . . . .	577
Bulgin, A. F., & Co., Ltd. . . . .	497
Burne-Jones & Co., Ltd. . . . .	482

<b>C</b>	
Carrington Mfg. Co., Ltd. . . . .	567
Celestion, Ltd. . . . .	Cover iv
Columbia Graphophone Co. . . . .	498
Colvern, Ltd. . . . .	493
Cossor, A. C., Ltd. . . . .	495

<b>D</b>	
Dubilier Condenser Co., Ltd. . . . .	483

<b>E</b>	
Eastick, J. J., & Sons . . . . .	577
Electradix Radios, . . . . .	581

<b>F</b>	
Ferranti, Ltd. . . . .	563
Fluxite, Ltd. . . . .	567

<b>G</b>	
General Electric Co., Ltd. . . . .	571
Graham Farish, Ltd. . . . .	581

<b>H</b>	
Hayberd, F. C., & Co. . . . .	565

<b>I</b>	
Igranic Electric Co. . . . .	573

<b>J</b>	
Jackson Bros. . . . .	565

<b>L</b>	
Lanchester Laboratories, Ltd. . . . .	573
Lectro Lins, Ltd. . . . .	497
Limit Radio, Ltd. . . . .	565
London Electric Wire Co., & Smiths Ltd. . . . .	Cover ii
Lotus Radio, Ltd. . . . .	487

<b>M</b>	
Microfuse, Ltd. . . . .	579
Mullard Wireless Service Co., Ltd. . . . .	485

<b>O</b>	
Osborn Chas. A. . . . .	575

<b>P</b>	
Partridge & Mee, Ltd. . . . .	579
Pertrix, Ltd. . . . .	491
Peto-Scott, Ltd. . . . .	567
Pickett Bros. . . . .	581
Pifco, Ltd. . . . .	573
Portadyne . . . . .	489

<b>R</b>	
Radi Aladdin . . . . .	579
Redy Radio (R.R.), Ltd. . . . .	579
Regentone, Ltd. . . . .	569
Reproducers & Amplifiers, Ltd. . . . .	581
Rotax, Ltd. . . . .	492

<b>S</b>	
Scott Sessions, G., & Co. . . . .	584
Smith Cabinets, Ltd. . . . .	487
Sovereign Products . . . . .	581
Siemens Bros. . . . .	575

<b>T</b>	
Tekade Radio & Electric . . . . .	496
Telegraph Condenser Co., Ltd. . . . .	569
Tunewell . . . . .	497

<b>V</b>	
Vandervell, C. A. . . . .	489
Varley . . . . .	577

<b>W</b>	
Westinghouse Brake and Saxby Signal Co., Ltd. . . . .	496
Whiteley Electrical Radio, Ltd. . . . .	579
Wilburn & Co. . . . .	496
Wright & Weaire, Ltd. . . . .	575

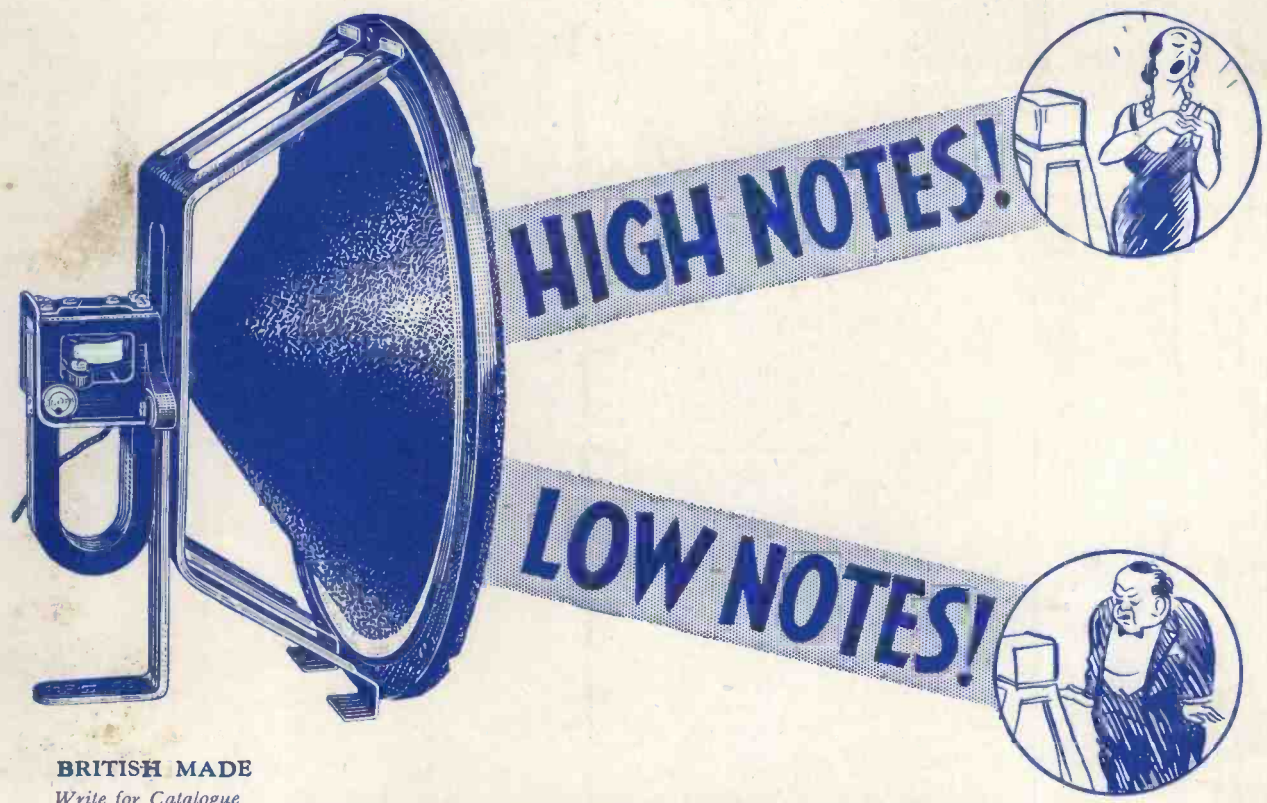

**BRITISH MADE**  
 Write for Catalogue  
 No. WM17U

**... ANY NOTES!**

**B**LUE SPOT 100U, more than any other speaker, has accomplished wonders in the improvement of wireless reproduction. This Inductor Type Speaker can be compared favourably with any first-class Moving Coil Speaker.

Blue Spot 100U gives a depth and colour to the reproduction of speaking and singing voices that has hitherto been completely lacking. It handles the most intricate instrumental music with delightful smoothness, detracting nothing from the freshness and charm of the original. It does full justice to the bass, but is equally fair to the treble—in fact every note in the musical scale is reproduced at its true value.

But to appreciate the difference 100U will make to your enjoyment of wireless programmes, you must hear it and compare it for yourself. Try it out against the most expensive speakers you can find and you will admit, as thousands and thousands of others have admitted, that Blue Spot 100U is better than them all.

Suitable alike for normal power and Pentode valves — no matching transformer required.



**THE BRITISH BLUE SPOT COMPANY LTD.**  
 BLUE SPOT HOUSE, 94/96 ROSOMAN ST., ROSEBERY AV., LONDON, E.C.1  
 Telephone: Clerkenwell 3570. Telegrams: "Bluspot, Isling, London."  
 Distributors for Northern England, Scotland and North Wales: H. C. RAWSON  
 (Sheffield and London), Ltd., 100 London Road, Sheffield: 22, St. Mary's Parsonage,  
 Manchester: 183, George Street, Glasgow.

**100U · 39'6**

# The SPEAKER WHICH HAS MADE HISTORY

**47/6**

Including  
Transformer

PERMANENT  
MAGNET  
MOVING COIL

# P PM

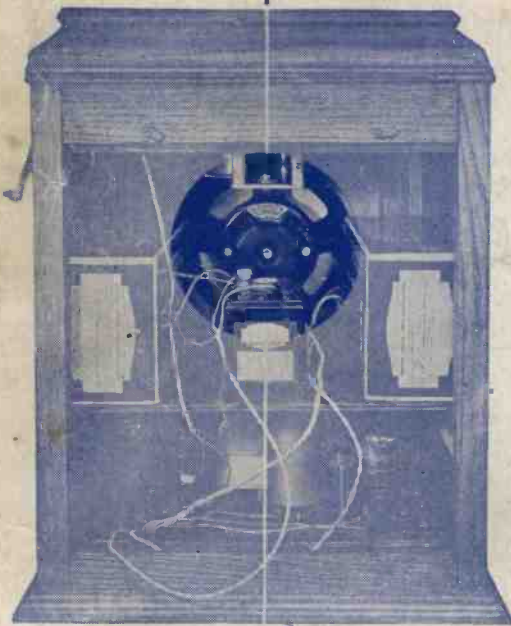

Chosen and recommended  
by "WIRELESS MAGAZINE"  
for the "EASYTUNE 60"

Supplied complete with  
transformer and baffle  
ready for  
mounting  
into cabinet



The Speaker incorporates an IMPREGNATED DIAPHRAGM and a patented twin suspension permitting large cone movements. The new patented cobalt steel magnet produces a very high flux density. Dual impedance output transformer included. (Pentode supplied only if specified.) Easy Payments 10/- down and six monthly payments of 8/-.

# CELESTION

*The Very Soul of Music*