

AUTUMN DOUBLE NUMBER WITH

FREE
STATION
LOG

Wireless Magazine

THE BEST SHILLINGSWORTH IN RADIO

OCTOBER 1931

1/-

The SUPER SENIOR

*W. James
presents a
remarkable sequel
to his World-famous
Super-het, the
"Super 60"*

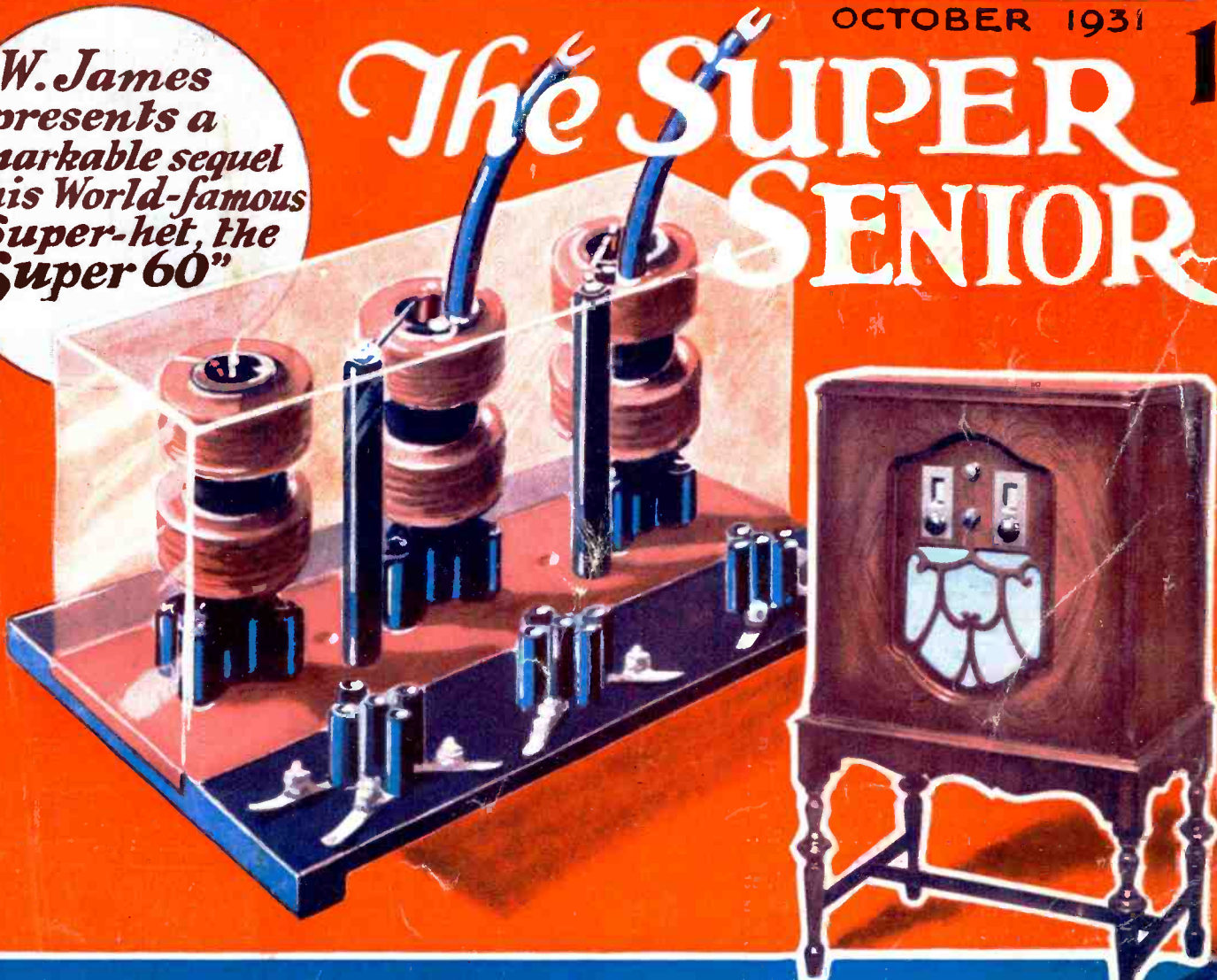

A COMMENTATOR'S SECRETS :: THE TRUTH *about* HIGH-TENSION BATTERIES
RADIO TO FIGHT CRIME :: DOES BAND-PASSING REDUCE STRENGTH?

EVERYBODY'S RADIOGRAM ABC OF THE MAINS TRANSFORMER THE MERIDIAN SHORT-WAVER :: WHAT'S NEW IN RADIO THIS SEASON

AND 30 OTHER FEATURES, PROFUSELY ILLUSTRATED

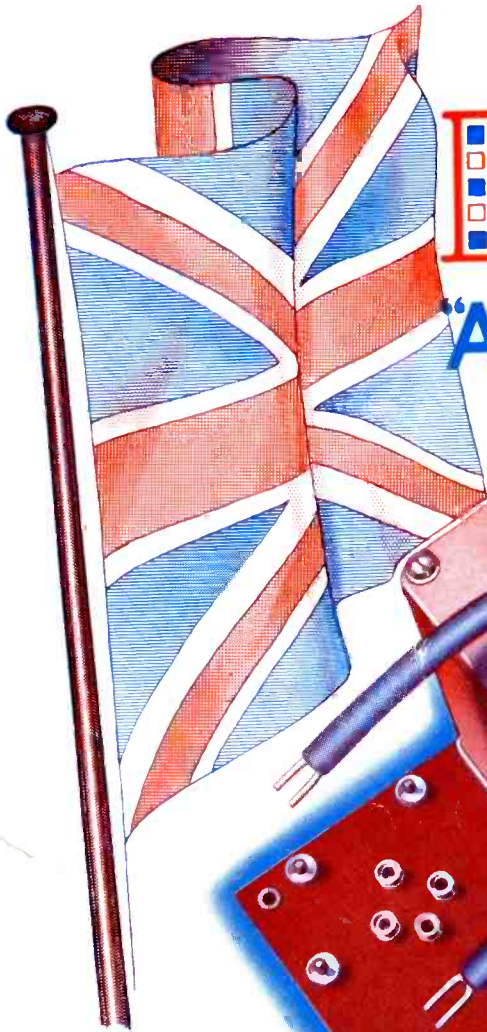

Another

LEWCOS

Regd.

"All-British" Triumph

the

NEW TRIPLE I.F. COIL UNIT

Price
31/6



ANOTHER LEWCOS "ALL-BRITISH TRIUMPH"

Of the recent Lewcos successes the new TRIPLE I.F. COIL UNIT (designed and manufactured at our Leyton Works) is perhaps the most remarkable.

This combined intermediate-frequency coil unit has made possible the extraordinary simplified Super Heterodyne Receiver designed and described by Mr. W. James on page 279 of this Journal.

Particulars of this LEWCOS product are detailed in our leaflet, reference R.72, which we shall be pleased to send you. It may be seen at the LEWCOS Stand, No. 27 (National Hall) at the Radio Exhibition.

THE LEWCOS TRIPLE I.F. COIL UNIT AND OSCILLATOR COIL

ARE SPECIFIED FOR THE "SUPER SENIOR" RECEIVER DESCRIBED IN THIS ISSUE.

SEE ALSO COLOUR PAGE IV OF THIS ISSUE.

WE ARE EXHIBITING AT

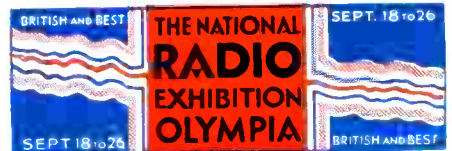

LEWCOS RADIO PRODUCTS—BETTER RECEPTION

THE LONDON ELECTRIC WIRE COMPANY AND SMITHS LIMITED CHURCH ROAD, LEYTON, LONDON E.10

Editor:

BERNARD E. JONES

Technical Editor:

J. H. REYNER,

B.Sc. (Hons.), A.M.I.E.E.

Wireless Magazine

The Best Shillingsworth in Radio

Vol. XIV :: OCTOBER, 1931 :: No. 81

Research Consultant:

W. JAMES

Assistant Editor:

D. SISSON RELPH

THIS is our biggest and most important issue so far. Its appearance coincides with the opening of the biggest and most important radio exhibition. Further, it heralds what will undoubtedly be the biggest and most important season in the history of wireless and broadcasting in this country.

Reversing the order, British broadcasting, in spite of all the criticisms levelled against it, is the most successful system in the world. The Radio Exhibition held annually in London is second to none, and the **WIRELESS MAGAZINE** is now established as the pre-eminent Radio Monthly of Great Britain and probably of the world.

We have made great strides this present year in our particular job of providing a magazine that meets the reader's needs; we have introduced a number of sets—most notably the Super 60—which have caught the taste of an informed and critical public. The Super 60 was a real departure, heartily welcomed by the wireless public, the welcome growing stronger and stronger as the months passed. That set is undoubtedly the most successful of all home-constructor sets introduced by any magazine in the world. We must all be grateful to Mr. James for the brains and hard work he put into his job.

The Super 60 is the success of 1931. Nobody can gainsay that fact. Some have tried to do so, but the more they have tried the more obvious the fact becomes that the Super 60 is an amazing and outstanding success and will remain so.

In this big issue, the first of the new season, we carry the Super 60 into its next stage. Readers will find that the James Super Senior has an even better performance than his earlier model. Alan Hunter tells on page 285 his experiences on submitting this new model for test. I pick out just two phrases:

"The elimination of mush is really extraordinary. I have never tested a set so powerful and, at the same time, so free from squeals, crackles, and other ear-splitting noises."

CONTENTS FOR THE CONSTRUCTOR

THE FIVE-ADVANTAGE THREE: A Band-pass Battery Receiver	Page 245
WHAT IT IS: WHAT IT DOES	247
EVERYBODY'S RADIOGRAM: An A.C. Screen-grid Set	261
A NUTSHELL EXPLANATION	265
THE SUPER SENIOR: W. James' Remarkable Sequel to the Super 60	279
A BRIEF EXPLANATION	281
ON TEST. By Alan Hunter	285
THE MERIDIAN SHORT-WAVER: An Efficient Three-valver	299
WHAT IT IS	301

TECHNICAL FEATURES

VALVES TO USE IN YOUR SET	212
SCREEN-GRID VALVES AS DETECTORS	250
ULTRA-SHORT WAVES HELP THE DOCTOR! By Dr. Alfred Gradenzitz	254
THE TRUTH ABOUT HIGH-TENSION BATTERIES. By J. H. Reyner, B.Sc., A.M.I.E.E.	258
RADIO IN REVIEW. By Morton Barr	287
ABC OF THE MAINS TRANSFORMER. By W. James	293
FUSES	295
YOUR EARS. By J. Cross	306
WE TEST BEFORE YOU BUY	315
COSSOR EMPIRE MELODY MAKER	318
REGENTONE A.C. TWO-VALVER	323
DOES BAND-PASSING REDUCE SIGNAL STRENGTH? By J. H. Reyner, B.Sc., A.M.I.E.E.	326
CUTTING OUT ELECTRICAL INTERFERENCE. By Alan Hunter	346
WHAT DO WE MEAN BY "CAPACITY"? By John Collindale	354
DESIGN DATA SHEETS. By J. H. Reyner, B.Sc., A.M.I.E.E.	364

GENERAL ARTICLES

NOTES AND JOTTINGS	216
BROADCAST IDENTIFICATION SHEETS. By Jay Coote	220
NATIONAL RADIO EXHIBITION: Guide to Stands	224
IN TUNE WITH THE TRADE. By Fetter Lane	232
WHAT'S NEW IN RADIO THIS SEASON	237
A COMMENTATOR'S SECRETS: A Chat with George F. Allison	243
STILL BETTER BROADCASTERS!	251
RECEPTION ON THE COAST	255
RADIO MEDLEY. By BMPRESS	256
RADIO TO FIGHT CRIME. By Gordon S. Mitchell	273
ECONOMY AT SAVOY HILL? By Our Special Commissioner	277
THE SLIP!	278
UNDER MY AERIAL. By Halyard	288
STORIES OF THE OPERAS: Rigoletto	290
WHEN A "MIKE" WAS MISSING! By Kenneth Ulyett	291
A LOW-PRICE ERA	294
THE LEAKY GRID	295
THESE MEN WERE HUMAN. By Whitaker-Wilson	296
ON THE CREST OF THE WAVES. By Jay Coote	304
HEAR THEM NOW! Verse	310
NO COMPETITION ALLOWED! Verse	334
WITH THE B.B.C. AT WATCHET. By Our Special Commissioner	338
A SPECIAL RADIO EXHIBIT	342
RADIO IN A PRISON	358
LISTENING IN SOUTH AFRICA	362
WE NOTICE—	368
BLUEPRINT AND INFORMATION COUPONS	368
INDEX TO ADVERTISERS	368

GRAMO-RADIO SECTION

A REVOLUTION IN PICK-UP PRACTICE. By H. T. Barnett, M.I.E.E.	267
RADIO GRAMOPHONES FOR THE NEW SEASON	269
NINE-INCH RECORDS	269
CHOOSING YOUR RECORDS. By Whitaker-Wilson	270
TURNABLE TORQUE MEASURED. By J. H. Reyner, B.Sc., A.M.I.E.E.	272
MORE "PUNCH" FROM PICK-UPS	272

Published by BERNARD JONES PUBLICATIONS, LTD., publishers of "Wireless Magazine" and "Amateur Wireless." Editorial and Advertisement Offices: 58-61 Fetter Lane, London, E.C.4. Telephones: City 3733, 3734. Telegrams: "Beejapee, Fleet, London." Published about the 23rd day of the month and bears the date of the month following. Subscription: Great Britain and abroad, 15s. 6d. a year, post free (Canada only, 13s. 6d.). Contributions are invited and will be promptly considered. Next issue published on Wednesday, October 21st.

Among the articles of a more popular interest this month I must mention "A Commentator's Secrets," a chat with Mr. George F. Allison; "Radio to Fight Crime," "Economy at Savoy Hill?"; "These Men Were Human," a biographical sketch by Whitaker-Wilson of great composers whose works are frequently broadcast; and "Your Ears," an article which for the first time in my recollection explains the mechanism of the human ear and relates it to amplifier design.

We review this month "What's New in Radio This Season." By the way, already I find I shall be compelled to publish a special supplement next month, and it looks as though the **WIRELESS MAGAZINE**, both in size and in the high quality of fare it will provide, will make another record this season.

Of our more technical articles I must spare a word for J. H. Reyner's "Does Band-passing Reduce Strength?"; "Cutting Out Electrical Interference"; "What Do We Mean by 'Capacity?'," an article appealing direct to the beginner; "The Truth About High-tension Batteries," an article written by Mr. Reyner; "A Revolution in Pick-up Practice," a particularly interesting development due to Capt. Barnett; and "The ABC of the Mains Transformer," a special article by W. James.

The sets this month are varied. We have the Super Senior, to which I have already alluded; a set with a curious name which it well deserves, "The Five-advantage Three," economical, simple to make and operate, and absolutely up to date. The Meridian Short-waver, a world-roamer "three" operating on wavelengths between 15 and 100 metres; and finally, Everybody's Radiogram, a high-quality reproducer—a screen-grid three-valver incorporating a band-pass tuning circuit and designed particularly for working off A.C. mains.

"The Best Shillingsworth in Radio"! Absolutely! Nobody can question it.

B. E. J.

The SUPER SENIOR—W. James' Remarkable Sequel to the SUPER 60—See Page 279.

Registered at the General Post Office for Transmission by Canadian Magazine Post

Edison Bell

TWO OF THE NEW SETS
AT THE EXHIBITION

1932
RADIO

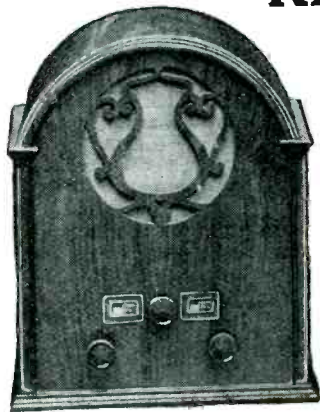

DO NOT MISS
STAND No. 41
Demonstration Room
D-25



	Price Including Royalties
457 All Mains Three-valve S.G. Band-pass Table Model...	19 Guineas
555 All Mains Three-valve S.G. Band-pass Consolette ...	21 Guineas
557 All Mains Three-valve S.G. Band-pass Radio-Gram. ...	29 Guineas
466 All Mains Four-valve S.G. Band-pass Table Model ...	21 Guineas
556 All Mains Four-valve S.G. Band-pass Consolette ...	24 Guineas
467 All Mains Four-valve S.G. Band-pass Radio-Gram. ...	32 Guineas
459 Super-het Five-valve Battery Transportable ...	20 Guineas

Write for
Lists and illustrations.

EDISON BELL, LIMITED,
LONDON - - - S.E. 15.

**A NEW SERVICE TO
OUR CUSTOMERS!**

A cordial invitation is extended to our many friends and customers to visit our new demonstration rooms, where a complete range of all that is latest in Radio will be found—Speakers—Radio-gramophones—Sets—Eliminators—and a complete range of components, conveniently set out for your inspection. Demonstrations given without obligation. Easy payments terms can be arranged. Call in and receive a FREE COPY of our 1932 illustrated catalogue.

WILL DAY LTD. 19 LISLE STREET
LEICESTER SQ.
LONDON, W.C.2
Phone: GERRARD 4476

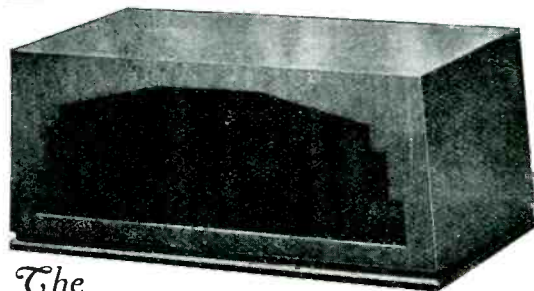

The
Kelston
● Put your set
in
dress clothes

**Stand
160**

Empire
Hall,
Olympia

Here's a cabinet that will delight your eye as your set delights your ear. It has been specially designed for the WIRELESS MAGAZINE "Band-pass" Three.

PRICES:

In OAK 25/- complete with slide base board and back slots as required.

In MAHOGANY 31/-.

Panel for either 16" x 8", Black or Mahogany Ebonite, 4/9.

It is a typical example of the beautiful range of Kabilok Cabinets—you MUST see them all at Stand No. 160 (in the Empire Hall) when you come to OLYMPIA.

Write for beautifully illustrated list.

W. & T. LOCK Ltd., ST. PETER'S WORKS,
BATH
LONDON SHOWROOMS: 11 RED LION SQUARE, W.C.1

Mention of the "Wireless Magazine" will ensure prompt attention

SENSATIONAL NEW DEVELOPMENTS

COMMODORE
MIDGET GANGS

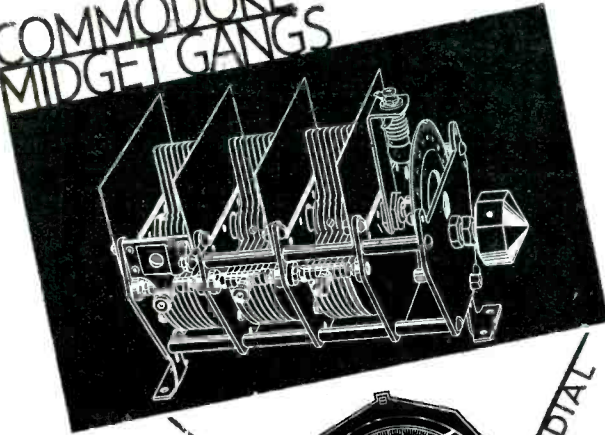

1. CYLDON COMMODORE MIDGET GANGS

CYLDON Midget Gang Condensers for modern sets, particularly those incorporating the VARLEY SQUARE PEAK COIL. Rigid pillar construction, perfect insulation, accurately matched sections separated by massive polished end plates carrying extended interstage screening. Provision for mounting trimmers. A modern condenser embodying all the latest technical refinements. Fitted with wedge friction slow motion drive, if desired.

Single Condenser S.P.1	3 Gang S.P.3 Plain Type	25/6
Plain Type - - - - -	3 Gang S.P.3V	9/6
Single Condenser S.P.1V	Slow Motion	31/6
Slow Motion - - - - -	4 Gang S.P.4 Plain Type	33/6
2 Gang S.P.2 Plain Type	4 Gang S.P.4V	17/6
2 Gang S.P.2V Slow Motion	Slow Motion	23/6
		39/6

Trimmers for above 1/6 each.

2. CYLDON SLOW MOTION DIAL

New wedge friction drive, CYLDON Duplex Illuminated Slow Motion Dial, 8:1 reduction, non-slip, rotation in same direction as condenser, illuminated scale, hair-line sight. Sector vision. CYLDON are proud of the first CYLDON Slow Motion Dial. Price 7/6

AT OLYMPIA
STAND
172 EMPIRE
HALL
(FIRST FLOOR)



SEND FOR
NEW CATALOGUE

S. S. BIRD & SONS LTD. CYLDON WORKS
SARNESFIELD RD. ENFIELD, MIDDLESEX
Enfield 2071/2
Grams:
Capacity, Enfield

cyldon

FIVE YEARS GUARANTEE

DAILY MAIL RADIO

NO WIRELESS
SET COMPLETE
WITHOUT IT!

"At-a-Glance"

A FASCINATING PASTIME!

WITH THE AID OF THIS
CHART YOU CAN LOCATE
ANY OF THE FOREIGN
STATIONS THAT YOU
BRING IN ON YOUR SET.

The wheel is provided with a blank opening so that you can record the dial reading of any of the stations on your own set.

When this has been recorded

ANY MEMBER OF THE
FAMILY CAN IMMEDIATELY
TUNE IN TO THE
STATION REQUIRED.

A CHILD CAN DO IT!

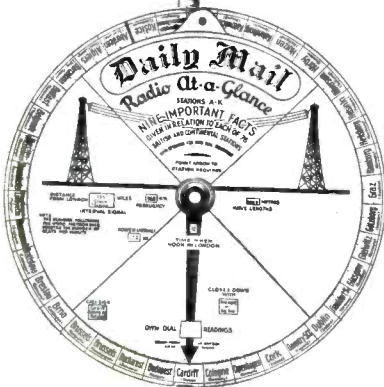

On sale at all
Wireless Dealers,
Bookstalls, and
Stationers.

If any difficulty
write direct to
Frank Pitchford
& Co., Ltd., Well
House, Well St.,
London, E.C.1.

DOUBLE SIDED,
DIAMETER 9 1/2 INCHES.
GIVES
76 BRITISH AND
CONTINENTAL STATIONS
WITH 9 IMPORTANT FACTS
ABOUT EACH ONE.

1/4
EACH



3
YEARS
GUARANTEE

This sensational warrant will be our Olympia revelation. Every Heayberd Mains Unit and Assembled Kit of Parts will be covered for three years against breakdown. An offer unparalleled in the Radio industry. Visit our Olympia stand and see our new season's Models.

MODEL E. 150

Post this to-day

H.T. 150 v. at 25 ma.
L.T. 4 v. 4 amps for A.C.
Valves.
L.T.: 2 v. Trickle Charger.
Three H.T. Tappings—one
variable. Silver embossed H.T.
& L.T. Control Switches. Pilot
& Fuse Lamps. £6:15:0
Ready to switch-on.

I enclose 3d. stamps for full lists
giving many valuable hints on
Mains Units and Transformers
with circuit diagrams.

Name.....
Address.....

Stand
68
Empire
Hall

HEAYBERD

10
Finsbury
Street,
London,
E.C. 2

When replying to advertisements, please mention "Wireless Magazine"

VALVES TO USE IN YOUR SET

Make	Type	Impedance	Amplification Factor	Filament Current	Mutual Conductance	Anode Current at 120 volts	Grid Bias at 100 volts	Grid Bias at 150 volts
2-volt Three-electrode Valves								
Mazda	H210	59,000	47	.1	.8	5	.5	1.0
Lissen	H210	58,000	35	.1	.6	1.1	—	1.5
Cossor	210RC	50,000	40	.1	.8	1.5	—	1.5
Tungram	R208	50,000	35	.1	1.0	1.0	—	1.5
Six-Sixty	210RC	45,400	50	.1	1.1	1.0	—	1.5
Mullard	PM1A	41,600	50	.1	1.2	.75	1.5	—
Marconi	H2	35,000	35	.1	1.0	5	—	1.5
Osram	H2	35,000	35	.1	1.0	1.0	—	1.5
Six-Sixty	210HF	25,000	19	.1	.75	1.5	—	—
Eta	BY2023	23,000	20	.12	.85	1.5	—	3.0
Tungram	H210	25,000	25	.1	1.0	2.0	1.5	3.0
Mullard	PM1HF	22,500	18	.1	.8	1.0	3.0	4.5
Cossor	210HL	22,000	24.0	.1	1.1	.75	3.0	4.5
Lissen	HL210	21,000	18	.1	.85	2.2	1.5	4.5
Mazda	HL210	21,000	26	.1	1.25	3.0	1.5	3.0
Mazda	HL2	21,000	32	.1	1.5	—	—	—
Cossor	210HF	20,000	22	.1	1.1	1.2	1.5	3.0
Mullard	PM1HL	18,500	28	.13	1.5	1.2	1.5	3.0
Marconi	HL2	18,000	27	.1	1.5	1.0	1.5	3.0
Osram	HL2	18,000	27	.1	1.5	1.0	1.5	3.0
Six-Sixty	210HL	17,200	26	.1	1.5	2.0	—	1.5
Tungram	L210	16,000	16	.1	1.0	4.0	6.0	9.0
Eta	BY1814	14,000	18	.12	1.3	3.0	—	2.5
Cossor	210D	13,000	15	.1	1.15	2.5	—	4.5
Six-Sixty	210LF	12,500	10.6	.1	.85	3.0	4.5	7.5
Mullard	PM1LF	12,000	11	.1	.9	3.0	4.5	7.5
Six-Sixty	210D	10,600	17	.1	1.6	4.0	3.0	4.5
Cossor	210LF	10,000	14	.1	1.4	3.0	4.5	3.0
Eta	BY2010	10,000	20	.12	2.0	4.0	1.5	3.0
Lissen	L210	10,000	10	.1	1.0	3.5	3.0	—
Marconi	L2/6	10,000	15.5	.1	1.55	4.0	—	—
Mullard	PM2DX	10,000	17	.1	1.7	2.0	3.0	6.0
Mazda	L210	10,000	15.5	.1	1.55	5.0	2.5	4.5
Mazda	L2	10,000	19	.1	1.9	3.0	—	3.0
Tungram	LG210	10,000	10	.1	1.0	4.0	6.0	9.0
Tungram	PD220	10,000	17	.2	1.7	4.0	4.5	7.5
Six-Sixty	220P	4,800	7.2	.2	1.5	5.0	7.5	12.0
Lissen	P220	4,700	7	.2	1.5	5.0	9.0	15.0
Mullard	PM2	4,400	7.5	.2	1.7	4.0	7.5	12.0
Cossor	220P	4,000	8	.2	2.0	7.5	4.5	9.0
Cossor	215P	4,000	9	.15	2.25	7.5	3.0	7.5
Cossor	220Pa	4,000	16	.2	4.0	10.0	3.0	4.5
Eta	BW1304	4,000	13	.2	3.2	6.0	1.5	6.0
Marconi	LP2	3,900	15	.2	3.85	10.0	—	—
Osram	LP2	3,900	15	.2	3.85	10.0	—	—
Mazda	P220	3,700	12.5	.2	3.4	11.0	3.0	6.0
Six-Sixty	220PA	3,700	13	.2	3.5	10.0	3.0	6.0
Mullard	PM2A	3,600	12.5	.2	3.5	6.5	4.5	6.0
Tungram	P215	3,300	5	.2	1.5	12.0	9.0	12.0
Eta	BW303	2,700	3	.32	1.1	11.0	15.0	25.0
Marconi	P240	2,500	4	.4	1.6	12.0	15.0	24.0
Osram	P240	2,500	4	.4	1.6	11.0	16.0	24.0
Tungram	SP230	2,500	5	.3	2.0	15.0	15.0	23.0
Marconi	P2	2,150	7.5	.2	3.5	15.0	—	—
Osram	P2	2,150	7.5	.2	3.5	15.0	—	—
Six-Sixty	220SP	2,060	7	.2	3.4	—	—	—
Lissen	PX240	2,000	4	.4	2.0	14.0	12.5	22.5
Eta	BW602	1,900	6.5	.32	3.4	12.0	4.5	12.0
Mazda	P240	1,900	7	.4	3.7	18.0	6.0	13.5
Mullard	PM252	1,900	7	.4	3.7	14.0	10.5	12.0
Six-Sixty	240SP	1,900	6.6	.4	3.5	16.0	4.5	13.5
Marconi	P2.6	1,850	6.5	.2	3.5	15.0	—	—
Cossor	230XP	1,500	4	.3	2.3	18.0	13.5	22.5
2-volt Double-grid Valves								
Cossor	210DG	27,000	5.1	.1	.19	—	—	—
Tungram	D6210	5,000	5.0	.1	1.0	—	—	—
Marconi	DC2	3,750	4.5	.2	1.2	—	—	—
Osram	DC2	3,750	4.5	.2	1.2	—	—	—
Six-Sixty	210DG	—	—	.1	.8	—	—	—
Mullard	PM1DG	—	—	—	—	—	—	—
2-volt Screen-grid Valves								
Tungram	S210	430,000	300	.12	.8	—	—	—
Mazda	215SG	400,000	450	.15	1.1	—	1.5	1.5
Cossor	215SG	300,000	330	.15	1.1	—	—	—
Eta	BY6	300,000	300	.15	1.0	2.5	—	—
Six-Sixty	215SG	220,000	190	.15	.87	2.0	—	—
Mullard	PM12	212,000	200	.15	.94	—	—	—
Cossor	220SG	200,000	320	.2	1.6	—	—	1.5
Lissen	SG215	200,000	180	.15	.9	—	—	1.5
Marconi	S22	200,000	350	.2	1.75	—	—	—
Marconi	S21	200,000	220	.1	1.1	—	—	—
Osram	S21	200,000	200	.1	1.1	3.0	—	—
2-volt Pentode Valves								
Lissen	PT225	64,000	90	.25	1.4	7.0	3.0	6.0
Six-Sixty	230PP	64,000	80	.3	1.25	10.0	6.0	12.0
Mullard	PM22	62,500	82	.3	1.3	10.0	6.0	12.0
Marconi	PT240	55,000	90	.4	1.65	9.0	6.0	9.0
Osram	PT240	55,000	90	.4	1.65	9.0	6.0	9.0
Lissen	PT240	22,500	45	.4	2.0	12.5	7.5	10.5
Cossor	230PT	—	—	.3	2.0	11.5	9.0	15.0
Mazda	220Pen.	—	—	.2	2.5	—	—	—
Cossor	230HPT	—	—	.3	1.8	9.5	7.5	12.0

Make	Type	Impedance	Amplification Factor	Filament Current	Mutual Conductance	Anode Current at 120 volts	Grid Bias at 100 volts	Grid Bias at 150 volts
4-volt Three-electrode Valves								
Marconi	H410	60,000	40	.1	.66	5	—	1.5
Osram	H410	60,000	40	.1	.66	.35	—	1.5
Lissen	H410	60,000	40	.1	.66	1.6	—	1.5
Six-Sixty	4075RC	58,000	37	.075	.64	1.35	1.0	1.5
Mullard	PM3A	55,000	38	.075	.66	.3	1.5	1.5
Cossor	410RC	50,000	40	.1	.8	.6	—	—
Marconi	LH410	30,000	25	.1	.83	1.0	2.0	3.0
Osram	LH410	30,000	25	.1	.83	1.25	1.5	3.0
Tungram	H407	25,000	35	.07	1.4	2.5	1.5	2.0
Lissen	HLD410	21,000	25	.1	1.2	2.5	1.5	3.0
Cossor	410HF	20,000	22	.1	1.1	1.5	1.5	3.0
Tungram	R406	18,000	25	.06	1.4	3.5	2.0	3.5
Mullard	PM3	13,000	14	.075	1.05	2.0	3.0	6.0
Six-Sixty	4075HF	12,500	13.5	.075	1.1	3.0	3.0	4.5
Cossor	410LF	10,000	17	.1	1.75	3.0	2.0	4.5
Lissen	L410	8,500	15	.1	1.8	3.5	1.5	4.5
Marconi	L410	8,500	15	.1	1.77	3.0	2.0	4.5
Osram	L410	8,500	15	.1	1.77	3.5	3.0	4.5
Mullard	PM4DX	7,500	15	.1	2.0	2.0	3.0	6.0
Six-Sixty	410D	7,250	14.5	.1	2.0	4.0	3.0	6.0
Tungram	LD410	7,000	16.5	.1	2.3	4.5	4.5	7.5
Marconi	P410	5,000	7.5	.1	1.5	6.0	6.0	10.5
Osram	P410	5,000	7.5	.1	1.5	6.0	6.0	10.5
Six-Sixty	410P	4,100	7.8	.1	1.9	7.5	7.5	12.0
Cossor	410P	4,000	8	.1	2.0	7.5	4.5	9.0
Mullard	PM4	4,000	8	.1	2.0	5.25	7.5	10.5
Tungram	L414	3,300	10	.15	3.0	6.0	6.5	9.0
Marconi	P425	2,300	4.5	.25	1.95	14.0	9.0	16.5
Osram	P425	2,300	4.5	.25	1.95	14.0	9.0	16.5
Lissen	P425	2,250	4.5	.25	2.8	28.0	12.5	19.5
Six-Sixty	420SP	2,150	6.5	.2	3.0	10.0	13.5	22.5
Marconi	P415	2,080	5.0	.15	2.4	—	—	—
Cossor	425XP	2,000	7	.25	3.5	—	6.0	13.5
Mullard	PM254	2,000	4.2	.18	2.1	10.0	13.5	22.5
Mazda	P425	1,950	3.5	.25	1.8	26.0	14.0	26.0
Tungram	P414	1,700	5	.15	3.0	12.0	9.0	18.0
Cossor	4XP	1,200	3	.6	4.0	20.0	12.0	—
Marconi	PX4	830	5	1.0	6.0	35.0	12.0	16.0
Osram	PX4	830	5	1.0	6.0	35.0	12.0	16.0
4-volt Screen-grid Valves								
Tungram	S407	400,000	350	.07	.9	—	—	—
Mullard	PM14	230,000	200	.075	.87	—	—	—
Six-Sixty	4075SG	220,000	190	.075	.87	3.0	—	—
Cossor	410SG	200,000	200	.1	1.0	—	—	1.5
Marconi	S410	200,000	180	.1	.9	3.5	1.5	1.5
Osram	S410	200,000	180	.1	.9	3.5	—	—
Lissen	SG410	200,000	180	.1	.9	—	—	—
4-volt Pentode Valves								
Marconi	PT425	50,000	100	.25	2.0	8.0	4.7	7.5
Osram								

AN ENTIRELY NEW RANGE

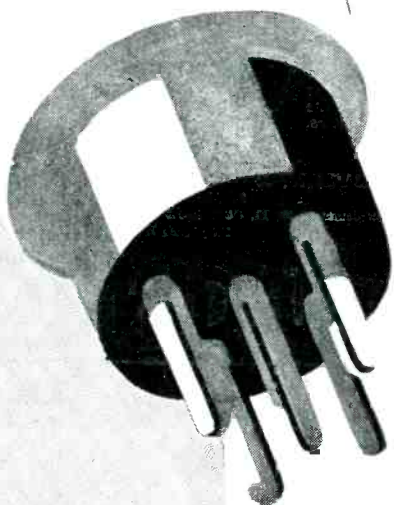

MULTI-GRID VALVES

An entirely new range of Tungram Multi-grid Valves—the first of the new Tungram series. Of unique construction, they supersede entirely the pentodes at present on the market; they are so arranged internally that the electron stream is *twice* controlled by the grid.

These new valves can be used in any existing pentode receiver without any circuit alteration whatsoever; in ordinary receivers only one extra connection is necessary. Three types of Multi-grid Valves have been introduced: PP230 (2 volt), PP415, and PP430 (4 volt). PP230 will very materially increase the output of the small receiver, although the anode current consumption will in most cases be below that of the ordinary power valve. PP415 and PP430 will be found extremely efficient for the output stage of A.C. Receivers. All Tungram Multi-grid Valves can be supplied with a 5-pin base, or 6-pin base with side terminal.

For characteristic curves and other technical information write to Dept. ST1.
Prices: Multi-grid Valves Type PP230, 16/-; PP415, 16/-; PP430, 19/-. Other types from 5/6 to 19/-. Tungram Barium Valves are manufactured under one or more of the following Patent Nos.: 289,762, 289,763, 311,705, and 313,151.

TUNGSRAM ELECTRIC LAMP WORKS (GT. BRITAIN), LTD.

Radio Department, Commerce House, 72 Oxford Street, London, W.1.

Makers of the famous Tungram Electric Lamps.

Branches in Birmingham, Bristol, Cardiff, Glasgow, Leeds, Manchester, Newcastle, Nottingham, Southampton, Lamp, Valve and Glass Factories: Austria, Czecho-Slovakia, Hungary, Italy and Poland. I.F.S. Organisation, Tungram Lamps & Radio, Ltd., 11 Burgh Quay, Dublin. Tungram photo-electric cells: Nava "E" (for scientific measurement), £2 17s. 6d.; Nava "R" Red sensitive cell (for colour matching devices), £3 3s.; Nava "EH" (for talkie work), £3 13s. 6d.

3125

TUNGSRAM

Advertisers like to know whence the business comes—please mention "W.M."

EASY TERMS

We supply all good quality Radio Receivers, Components and Accessories on deferred terms. We carry adequate stocks and can give prompt delivery.

NEW GOSSOR 1932 EMPIRE KIT No. 234.—A remarkable advance on last season's model.

Cash Price, £6/15/0

or 10/- with order and 10 monthly payments of 13/6.

NEW HEAYBERD A.C. ELIMINATOR KIT C.150.—Complete Kit of Parts for building an H.T. Eliminator, including steel case. Output 25 m.a., 150 volts, 3 H.T. Tappings, one variable

Cash Price, £3/16/-

or 7/6 with order and 11 monthly payments of 7/-.

12 EXIDE W.H. HIGH-TENSION ACCUMULATORS (120 volts, 5,000 m/a.). Higher voltages if desired.

Cash Price, £3/15/-

or 7/6 with order and 11 monthly payments of 7/-.

Carriage charged on all orders from Scotland.

B.T.H. PICK-UP AND TONE ARM.—One of the best pick-ups available.

Cash Price, 45/-

Or 5/- with order and 9 monthly payments of 5/-.

NEW BLUE SPOT 66R UNIT.—The finest balanced armature movement on the market. Complete with large Cone and Chassis.

Cash Price, £2/10/-

or 5/- with order and 10 monthly payments of 5/-.

NEW CELESTION MOVING COIL L.S. UNIT (PERM. MAGNET), with Transformer.

Cash Price, £4/5/-

or 13/6 with order and 10 monthly payments of 8/-.

Send list of requirements and quotation will be sent by return.

LONDON RADIO SUPPLY CO.

11 OAT LANE

NOBLE STREET, LONDON, E.C.2

Telephone: National 1977

WIRELESS IS THE WORLD'S
FINEST HOBBY!

MAKE IT A PROFITABLE ONE

Save Money!
Make Money!
No Outlay!

JOIN THE ELECTROCET CLUB

EVERY
WIRELESS
AMATEUR
EXPERIMENTER,
CONSTRUCTOR,

Should write his name and address in the margin, and post this advertisement in a 1d. unsealed envelope to:—

THE ELECTROCET CLUB

POPLAR ROAD, SOLIHULL, BIRMINGHAM

(Promoted and controlled by the Electroset Radio Co.) W.M.

There are Many Fine
Things for You to See
on STAND 71
at OLYMPIA.

LOOK-NEW & OUTSTANDING

Examine the New BULGIN Products

At the Radio Exhibition be sure and see the latest additions to the world's largest range of QUALITY Radio Components. They include: Fixed Potentiometer, Double-pole Toggle Switch, Change-over Toggle Switch, Thermostatic Switch, Wirewound Volume Controls, Volume Controls with Switch, Vibration-proof Terminals, Long-contact Valve-holders, Twin Enclosed Fuseholder, Combined Plug and Fuseholder, High-Test Tubular Condensers, Heavy-Duty Grid Leaks, Moving-coil Voltmeters, Moving-coil Milliammeters, D.C. Mains Resistance, D.C. Mains G.B. Potentiometer, Gramophone Needle-cups, Drum Dialite, Tapped Anode Resistors, New Range Spot-welded Spaghetis, Super-type Spaghetis, Quickwyre, Bakelite Differential Condensers.

STAND No 102

EMPIRE HALL, GROUND FLOOR

British Made
to the highest
electrical standards at the
new extensive
Bulgin works.



Send 2d. Postage for the new edition of the famous Bulgin Illustrated Catalogue and Manual.

A. F. BULGIN & CO., LTD., Abbey Road, Barking, Essex

Telephone: GRANGEWOOD 3266/3267.

Showrooms: 9, 10, 11, CURSITOR STREET, CHANCERY LANE, LONDON, E.C.4.

Telephone: HOLBORN 1072, 2072.

FROM BULGIN—OF COURSE

CIRCUITS

Our 1932 Radio Catalogue contains original and interesting diagrams for two-, three- and four-valve circuits. Every serious constructor should send for his copy which will be mailed free by return of post.

The Benjamin Electric Ltd.,
Tariff Road, Tottenham,
N. 17. Tottenham 1500.

BENJAMIN

Read "A.W."—3d. Weekly

Advertisers take more interest when you mention "Wireless Magazine"

LET RADIO EXPERTS BUILD YOUR SET

Sets described by WIRELESS MAGAZINE and other receivers are scientifically constructed to specification without delay. Accuracy in



every detail is a great point of our service and another great point to remember is that our prices are very moderate considering the high standard of craftsmanship. We will also modernise, repair or overhaul your present receiver. Scott Sessions and Company, the Leading Radio Doctors of Great Britain, will diagnose your most intricate radio trouble and offer you the simplest and most inexpensive solution.

Write for list giving price for building the following sets described in this issue:—

"The Super Senior"
"Meridian Short-waver"
"Everybody's Radiogram"
"The Five-advantage Three"

G. SCOTT SESSIONS & CO., Muswell Hill, London, N.10. (Phone: Tudor 5328)

Look Out for Another
Fine Issue of
WIRELESS MAGAZINE
on October 21.

**Listen-
you
Radio
fans**



**The
new and
improved
Lamplugh
INDUCTOR
DYNAMIC
Speaker..**

**CHASSIS
£3.10**

The Original British Inductor Dynamic Speaker.
Unquestionably the most modern and natural reproducer.
Ordinary Cone Loud Speakers are definitely obsolete.
Moving coil Speakers (mains energised) even if cheap to buy are expensive to run and suffer from mains hum.
Moving coil Speakers (F.M. type) with small magnets are low in efficiency and bear no comparison, to give efficiency approaching that of the In-

You'll agree with every word we say when you've heard it at your Dealers.

- and after all isn't that the real test!

ductor, they require very large magnets making the price nearly double that of the Silver Ghost Inductor Dynamic.

'Modernise your Radio with the latest Reproducer'

Size: Cone frame 12 in. diameter.
Depth: Depth back to front 7 in.
Weight: 4 lbs.

CABINET MODEL of this SPEAKER from £4.15..

Licensed under Farrand Patents and Patent Applications.

Write for all details direct, or on our Stand at the Show No. 168 Empire Hall
S. A. LAMPLUGH LTD.
Little Park Street, Coventry.



**CAPT. P. P.
ECKERSLEY
late of the B. B. C.**

is contributing a weekly review of the latest developments in every phase of wireless exclusively to *The Daily Mail* every Wednesday. World-famous as one of the pioneers of broadcasting, both in connection with the Marconi Company and the B.B.C., his expert knowledge and unique experience are at your service.

*See
The Daily Mail
every Wednesday!*

**World's Amateur
Champion uses
only**

**FRANKLIN
CONDENSERS**



MR. L. O'Heffernan, winner of the International Relay Competition, and therefore recognised World's Amateur Radio Champion, uses in his set FRANKLIN Condensers exclusively. He has recognised that there is no more reliable Condenser than Franklin; and surely if Mr. O'Heffernan has found that Franklin Condensers stand up to the heavy demands of his set, you cannot do better than use FRANKLIN Condensers yourself.

BEWARE OF IMITATIONS! The good name of Franklin has caused several imitations to appear. See the name Franklin on the carton when you buy.

None Genuine without the NAME!

FRANKLIN ELECTRIC CO., LTD.

150 CHARING CROSS ROAD, LONDON, W.C.

Northern Distributors: W. E. Beardsall & Co., Ltd., Victoria Bridge, Manchester. Irish Free State Distributors: L. R. Wood, Cork.

There is news in the "Wireless Magazine" advertisements

VALVES TO USE IN YOUR SET—Continued from p. 212

Make	Type	Impedance	Amplification Factor	Filament Current	Minimal Conductance	Anode Current at 120 volts	Grid Bias at 100 volts	Grid Bias at 150 volts
6-volt Three-electrode Valves—Continued								
Cossor ..	610P	3,500	8	.1	2.28	8.0	3.0	7.5
Marconi ..	P610	3,500	8	.1	2.28	6.0	6.0	9.0
Osram ..	P610	3,500	8	.1	2.28	7.0	6.0	9.0
Tungsrām ..	P615	3,300	10	.15	3.0	10.0	4.5	7.5
Six-Sixty ..	610P	3,400	7.8	.1	2.3	8.0	6.0	9.0
Marconi ..	LS5A	2,750	2.5	.8	.9	—	—	—
Osram ..	LS5A	2,750	2.5	.8	.9	—	—	—
Cossor ..	625P	2,500	7	.25	2.8	13.0	3.0	9.0
Lissen ..	P625	2,500	7.5	.25	3.0	8.0	7.5	12.0
Mazda ..	P625B	2,500	7	.25	2.8	11.0	6.0	12.0
Marconi ..	P625	2,400	6	.25	2.5	11.0	6.0	24.0
Osram ..	P625	2,400	6	.25	2.5	11.0	6.0	12.0
Tungsrām ..	SP614	2,300	6	.15	2.6	17.0	6.0	18.0
Cossor ..	610XP	2,000	5	.1	2.5	22.0	7.5	15.0
Six-Sixty ..	625SP	1,780	5.8	.25	3.25	—	—	15.0
Mullard ..	PM256	1,850	6	.25	3.25	—	9.0	36.0
Marconi ..	P625A	1,600	3.7	.25	2.3	20.0	13.5	24.0
Mazda ..	P625A	1,600	4	.25	2.5	27.0	10.0	20.0
Osram ..	P625A	1,600	3.7	.25	2.3	16.0	13.5	24.0
Lissen ..	P625A	1,500	4.5	.25	3.0	12.0	13.5	24.0
Six-Sixty ..	625SPA	1,500	3.9	.25	2.6	25.0	12.0	22.5
Mullard ..	PM256A	1,400	3.6	.25	2.6	—	—	—
Marconi ..	LS6A	1,300	3.0	2.0	2.3	—	—	—
Mazda ..	P650	1,300	3.5	5	2.7	30.0	12.0	25.0
Osram ..	LS6A	1,300	3.0	2.0	2.3	—	—	—
Marconi ..	DA60	835	2.5	4.0	3.0	—	—	—
Osram ..	DA60	835	2.5	4.0	3.0	—	—	—
6-volt Screen-grid Valves								
Six-Sixty ..	SS6075SG	210,000	190	.075	.9	—	—	—
Cossor ..	610SG	200,000	200	.1	1.0	—	—	1.5
Mullard ..	PM16	200,000	200	.075	1.0	—	—	—
Osram ..	S610	200,000	210	.1	1.05	4.0	1.5	—
6-volt Pentode Valves								
Marconi ..	PT625	42,000	80	.25	1.85	10.0	6.0	15.0
Osram ..	PT625	42,000	80	.25	1.85	—	—	—
Six-Sixty ..	SS617PP	28,500	54	.17	1.9	35.0	8.0	14.0
Mullard ..	PM26	25,000	50	.17	2.0	—	9.0	15.0
Lissen ..	PT624	24,000	60	.25	2.5	14.0	7.5	15.0
Cossor ..	615PT	—	—	.15	1.5	17.0	6.9	7.5
A.C. Three-electrode Mains Valves								
Eta ..	DW4230	23,000	40	1.0	1.75	2.5	—	1.5
Tungsrām ..	G150	20,000	10	.5	.5	—	—	1.5
Cossor ..	41MRC	19,500	50	1.0	2.6	2.0	.5	—
Tungsrām ..	R150	18,000	25	.5	1.4	1.5	—	—
Six-Sixty ..	4DX.AC	17,700	8.5	1.0	4.8	—	—	—
Mullard ..	904V	17,000	85	1.0	5.0	3.0	.75	1.0
Six-Sixty ..	4DX.AC	17,700	85	1.0	4.8	—	—	—
Tungsrām ..	AR4100	16,000	33	1.0	2.0	2.5	1.5	2.0
Cossor ..	41MHF	14,500	41	1.0	2.8	2.5	1.5	3.0
Mazda ..	AC.HL	13,500	35	1.0	3.0	4.5	1.5	3.0
Six-Sixty ..	4GP.AC	12,000	36	1.0	4.5	3.0	.9	1.5
Cossor ..	41MHL	11,500	32	1.0	6.5	3.0	—	1.5
Mazda ..	AC2HL	11,000	40	1.0	3.6	4.0	1.5	3.0
Marconi ..	MH4	11,000	40	1.0	3.6	4.0	1.5	3.0
Osram ..	MH4	11,000	40	1.0	3.6	4.0	1.5	3.0
Mullard ..	354V	10,000	35	1.0	3.5	2.0	2.0	3.0
Marconi ..	MHL4	8,000	20	1.0	2.5	5.0	3.0	6.0
Osram ..	MHL4	8,000	20	1.0	2.5	5.0	3.0	6.0

Make	Type	Impedance	Amplification Factor	Filament Current	Minimal Conductance	Anode Current at 120 volts	Grid Bias at 100 volts	Grid Bias at 150 volts
A.C. Three-electrode Mains Valves—Continued								
Tungsrām ..	AG4100	8,000	16	1.0	2.0	5.0	—	—
Cossor ..	M41LF	7,900	15	1.0	1.9	4.5	4.5	6.0
Eta ..	DW1508	7,500	15	1.0	2.0	5.0	3.0	6.0
Six-Sixty ..	SS4Det.AC	7,000	16	1.0	2.3	7.5	3.5	8.0
Mullard ..	I64V	4,850	16	1.0	3.3	5.0	4.5	6.0
Cossor ..	M41P	5,000	10	1.0	2.0	6.5	4.5	7.5
Six-Sixty ..	4L.AC	5,000	16	1.0	3.2	—	—	—
Eta ..	DW704	4,500	7	1.0	3.3	10.0	6.0	13.5
Mullard ..	DW1003	3,300	10	1.0	3.3	12.5	7.5	13.5
Marconi ..	ML4	2,800	12	1.0	2.5	—	—	—
Six-Sixty ..	SS4PAC	3,000	10	1.0	3.2	10.0	5.9	8.0
Osram ..	ML4	2,860	12	1.0	4.2	12.0	5.0	8.0
Mullard ..	I04V	2,850	10	1.0	3.5	11.0	5.0	8.5
Mazda ..	AC/P	2,650	10	1.0	3.75	14.0	6.0	12.0
Cossor ..	41MP	2,500	18.7	1.0	7.5	15.0	3.0	5.0
Eta ..	DW702	2,250	7	.23	3.2	18.0	10.0	17.0
Tungsrām ..	P4100	2,200	7	1.0	3.2	—	—	—
Eta ..	DX502	2,100	5	.15	2.4	12.0	4.5	15.0
Six-Sixty ..	HV4/1	2,100	6.3	1.0	3.0	—	—	14.0
Cossor ..	41XP	2,000	4	1.0	2.0	15.0	12.0	19.5
Mullard ..	AC044	2,000	6	1.0	3.0	15.0	9.0	14.0
Tungsrām ..	P430	2,000	5	.3	2.5	20.0	—	—
Eta ..	DW302	1,800	3.5	1.05	1.95	33.0	—	20.0
Cossor ..	41MXP	1,500	11.2	1.0	7.5	23.0	6.0	9.0
Mazda ..	AC/PI	1,450	5.4	1.0	3.7	—	—	—
Mullard ..	AC044	1,150	4.0	.7	3.5	17.0	16.5	28.0
A.C. Screen-grid Mains Valves								
Six-Sixty ..	4SGAC	1,000,000	1,000	1.0	1.0	1.5	—	—
Mullard ..	SV4	909,000	1,000	1.0	1.1	—	—	—
Eta ..	DW6	800,000	1,000	1.0	—	1.0	—	—
Mazda ..	AC/SG	800,000	1,200	1.0	3.0	5.0	.5	.5
Mullard ..	ACS2	600,000	3,000	1.0	5.0	—	—	—
Tungsrām ..	ASH100	600,000	900	1.0	1.5	—	—	—
Cossor ..	MSG.HA	500,000	1,000	1.0	2.0	2.0	—	—
Marconi ..	MS4	500,000	550	1.0	1.1	2.2	1.5	1.5
Osram ..	MS4	500,000	550	1.0	1.1	2.2	—	—
Mullard ..	SAVA	430,000	1,500	1.0	3.5	1.7	—	—
Cossor ..	41MSG	400,000	1,000	1.0	2.5	2.0	—	1.5
Marconi ..	MS4B	350,000	1,120	1.0	3.2	—	—	—
Osram ..	MS4B	350,000	1,120	1.0	3.2	3.2	1.0	1.0
Mullard ..	SAVB	257,000	900	1.0	3.5	4.0	1.5	1.5
Cossor ..	MSG-LA	200,000	200	1.0	3.75	4.5	—	1.5
Eta ..	DW2	200,000	240	1.0	2.5	—	—	—
D.C. Three-electrode Mains Valves								
Mazda ..	DC.HL	13,000	35	.5	2.7	—	—	—
Marconi ..	DH	10,800	40	.25	3.7	—	—	—
Osram ..	DH	10,800	40	.25	3.7	—	—	—
Mullard ..	DC3HL	10,000	37	.1	3.7	—	—	—
Marconi ..	DL	2,660	12	.25	4.3	—	—	—
Osram ..	DL	2,660	12	.25	4.3	—	—	—
Mazda ..	DCP	2,220	10	.5	4.5	—	—	—
Mullard ..	DCP2	2,220	10	.1	4.5	—	—	—
D.C. Screen-grid Mains Valves								
Marconi ..	DS	450,000	500	.25	1.1	—	—	—
Osram ..	DS	450,000	500	.25	1.1	—	—	—
Mullard ..	DCS6	—	1,000	.5	2.75	—	—	—
D.C. Pentode Mains Valves								
Marconi ..	DPT	30,000	90	.25	3.0	—	—	—
Osram ..	DPT	30,000	90	.25	3.0	—	—	—
Mazda ..	DCPen.	—	—	.5	3.5	—	—	—
Mullard ..	DC2Pen.	—	—	.1	3.5	—	—	—

NOTES AND JOTTINGS

A NEW edition of the Radio At-a-Glance station finder has just been published. It gives nine important facts about each of seventy-six British and Continental stations, arranged in alphabetical order. There is a blank space for recording dial readings for each particular station. The price is 1s. and the publishers are Frank Pitchford & Co., Ltd., of Well House, Well Street, E.C.1.

We understand that the Lincoln cabinet used for the Super Senior and made by the Carrington Manufacturing Co., Ltd., is a registered design (No. 764,139).

The price of the Watmel type DX3 high-frequency choke has now been reduced to 4s.

It should be noted that the price of the Formodensar type G is 1s. 6d., and not 2s. 3d., as appeared from the advertisement on page 106 of the September issue.

We have received an interesting book, *The Ways of the Navy*, by Rear Admiral D. Arnold-Forster, who, in the past, has written wireless stories for WIRELESS MAGAZINE. It describes fully all the customs and ceremonial associated with

the British Navy and in addition gives a general survey of modern seafaring conditions. This book is published by Ward, Lock, & Co., Ltd., at 7s. 6d.

In the advertisement of the British Clarion Co., Ltd., that appeared on page 201 of the September issue of WIRELESS MAGAZINE, of an eight-valve super-het, the price was omitted. It is 25 guineas (model 90) and royalties are extra.

The Edison Swan Electric Co., Ltd., have a new range of B.T.H. "R.K." moving-coil loud-speakers from £1 11s. 6d. upwards.

The NEWEST in RADIO

Have you examined yet the new Chassikit principle of construction? Write NOW for the big beautifully illustrated folder. Intensely interesting—telling you how simply and without possibility of error you can build the complete all-metal chassis of the most modern 3-Valve S.G. Pentode Receiver. With these:—Pre-Selector band-pass tuning (*the most successful solution of selectivity problems*) . . . Multistat COMBINED Switch and radio and gramophone volume control (*also entirely new*) . . . Triple ganged tuning with ONE KNOB . . . latest metallised S.G. and Det. valves, and PENTODE output valve.

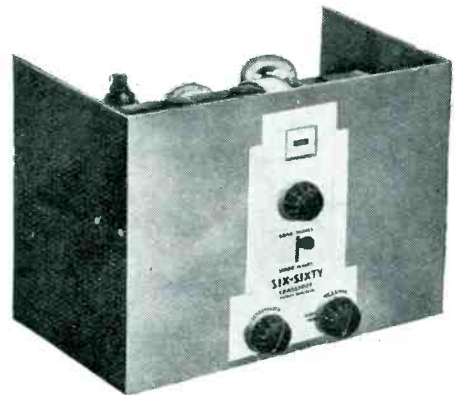

Examine also the wonderful scope it gives you to express your own individuality in housing it, your batteries or eliminator and loudspeaker. A simple table radio receiver may expand gradually, on small occasional outlay, up to a magnificent ALL-ELECTRIC Radio-Gramophone. There's the thrill of building without the risk! *All uncertainties* eliminated. The Six-Sixty Chassikit is "Radio-built"—really better than a completely factory-built four-valver. By all means SEND FOR THE FREE FOLDER TO-DAY

The SIX-SIXTY Chassikit comprises three factory-built units—condenser assembly, coil assembly and the valve unit accommodating the remaining essentials. Screening is COMPLETE. Result an all-metal Chassis of the most advanced type. Each unit factory-tested. A variety of beautiful cabinets from 10/6 to 12 gns. Or incorporate it in cabinet of your own design. There is great adaptability.

Made by the makers of the renowned SIX-SIXTY (B.V.A.) Valves

OLYMPIA STAND NO. 20

SIX-SIXTY CHASSIKIT

£6-17-6

Complete Chassikit, 3 Gang band-pass tuning-S.G.-Det.-PENTODE. Ornamental Oak Cabinet. 10/6 extra.

Get the FREE folder—YOU WILL BE GLAD—COUPON

To Six-Sixty Radio Co., Ltd.,
Six-Sixty House, 17/18 Rathbone Pl.,
Please send me FREE and POST FREE the
Chassikit illustrated and descriptive Folder.

NAME _____
ADDRESS _____

W.M.

Speedy replies result from mentioning "Wireless Magazine"

TEST then Rest



The SHERLOCK HOLMES of RADIO

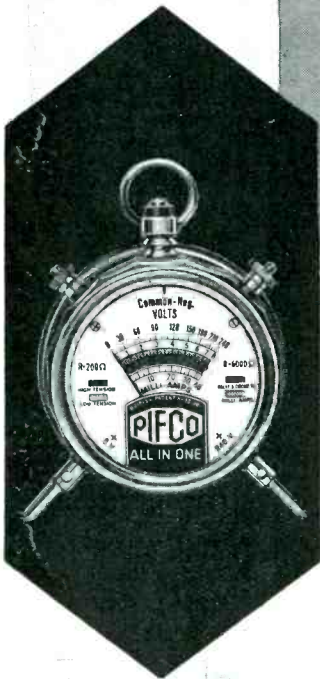
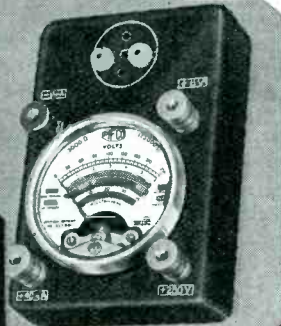

Assured

With the "All-In-one" Radiometer you can instantly check the performance and efficiency of any Valve, Circuit, Battery or Component. This little instrument tests everything—in a few minutes—with absolute certainty. If the "All-In-One" Radiometer says such a thing about any part of a set—then it is so!

Think of the time, trouble and money you could save if you had an "All-In-One" Radiometer of your own. Then look at the amazingly low price—12/6. You'd save that over and over again in a year, by entirely cutting out costly guesswork and also being independent of the need for expensive expert assistance. Ask your Radio Dealer to demonstrate the "All-In-One" Radiometer. See how efficient it is—how speedy—how economical.

Patentees: Pifco Ltd., High St., Manchester.

**TESTS VALVES
FILAMENT . .
ANODE & GRID
COMPONENTS
AND CIRCUITS
H.T. AND L.T.
MILLIAMPS
Everything!**

PIFCO ALL IN ONE RADIOMETER

STANDARD MODEL 12'6

DE-LUXE MODEL 22'0

Standard Model shown above on left. For Battery Operated Sets only. Price 12/6.

De-Luxe Model shown above on right. For Battery Operated Sets, Electric Receivers and Mains Units. Price £2 : 2 : 0



It holds your attention; it makes you realise the beauty of music. Every day "Wufa" enthusiasts write giving evidence of the singular qualities of this loudspeaker.

Read these Extracts: "A great speaker at a small price."
"The purest speaker I have ever heard."
"The Wufa Speaker is great, considering I use only a 2-valve set."

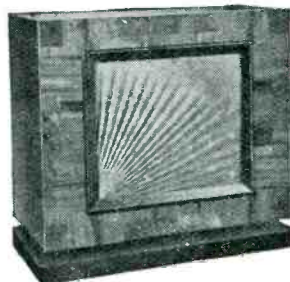

CABINET SPEAKER (No. 75)
Embodies the Wufa 60 Pole unit, which has alternative resistances to match your set. This cabinet speaker of attractive modern design is fully qualified to take its place in any home. Excellent volume and reproduction. Polished Walnut cabinet. Gold Tinsel fret. **Price 75/-**

Your Dealer will willingly demonstrate.

M. Lichtenberg, 4 Gt. Queen St., Kingsway, W.C.2

Four Sovereign New Type Spaghetti Resistances are specified by Mr. W. James for his new amazing Super Set! Unquestionably a further great tribute to their high level efficiency. But the price level is low which is true of the complete Sovereign Range. Ask your dealer for Sovereign—it's the surest way to better Radio. New Catalogue on request.

SPAGHETTI RESISTANCES
Sovereign made from finest Nickel-chrome Resistance wire with improved fixing. Every one guaranteed.
600 and 1,000 ohms, 4d. 2, 3, 4 and 5,000 ohms, 7d. 10,000 ohms, 9d. 15 and 20,000 ohms, 10d. 25, 30 and 40,000 ohms, 1/-. 50 and 60,000 ohms, 1/1. 80 and 100,000 ohms, 1/3.
NOW FROM 4d.

MR. JAMES CHOOSES WELL—SOVEREIGN PARTS FOR HIS NEW SUPER-SENIOR

Pre-set Condensers now 1/3 and 1/6 instead of 1/8 and 2/3. Dual range Coils now from 8/6.

If your dealer cannot supply, send direct, also for details of full new range to:—

SOVEREIGN PRODUCTS Ltd.
52-54 ROSEBERY AVENUE,
LONDON, E.C.1

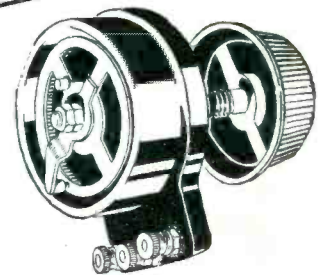

SOVEREIGN
S.F.B. OF BRITISH MANUFACTURE
STAND 64
AT OLYMPIA

The Sovereign Volume Control is still one of the most popular components to-day. It is so much better. **4/6**
All values

GRASSMANN UNIVERSAL RED A.C. MOVING COIL £5 5 0

TAPPINGS FOR 110 v., 125 v., 150 v., 220 v. A.C.

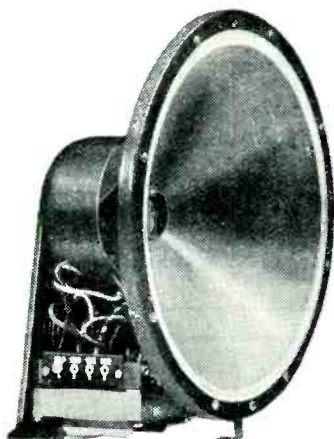

Never before in the history of Radio has such a sensational Speaker been offered to the public. The Grassmann Universal A.C. is revolutionary in itself. A Moving Coil that is suitable for all A.C. voltages and incorporates four separate tappings for 110v., 125v., 150v., 220v., A.C.

It gives a clearness and depth of tone previously thought unattainable and at last sound is reproduced retaining all the beauty of the actual broadcast.

This Speaker is offered at the revolutionary price of £5/5/-

For D.C. users the Grassmann Moving Coil 220v.-240v. is obtainable. A genuine mains-operated Moving Coil with a 10-inch cone, acoustically and mechanically perfect. Price £3/7/6

Should your dealer not have this new Red A.C., he can obtain samples to demonstrate to you, without you or your dealer being under any obligation to purchase.

Only a Quality Product could be offered on these terms. Full descriptive Grassmann leaflet now available. Send post card.

ROTOR ELECTRIC LTD.

2/3 Upper Rathbone Place . LONDON, W.1

Specified for the
**FIVE-ADVANTAGE THREE
IGRANIC
"J" Type Transformer**

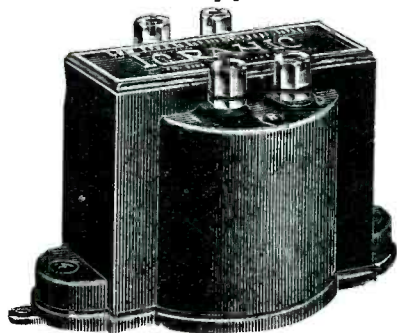

A compact instrument, with a straight line performance and a purity and constancy of amplification far above any transformer in its priced class.

**Price
Reduced to
15/6**



See our Exhibit
at the
Radio Exhibition
STAND No. 28

If you cannot obtain Igranic Components locally, write Dept. J.1143. We will supply C.O.D.

Used and specified by the designer of the EVERYBODY'S RADIOGRAM



"CLARKE'S ATLAS"

PENTODE CHOKE

A new addition to the famous range of "ATLAS" Radio Components, this Pentode Output Choke provides more tappings for matching different speaker impedances with maximum efficiency and accuracy than any other.

The windings are ample, even for the output of 2 Pentode Valves in parallel, and the inductance with 60mA. D.C. is 30/35 H. The six tappings provide no less than 9 alternative ratios varying from 1-1 to 5-1.

If your dealer cannot supply, write direct to the makers for full descriptive leaflet.

Type C.P. (Plain)	17/6	Type C.P.S. (Shrouded)	21/-
-------------------	------	------------------------	------

"CLARKE'S ATLAS"

HIGH EFFICIENCY COMPONENTS

H. CLARKE & CO. (M/cr) Ltd., OLD TRAFFORD, MANCHESTER
LONDON OFFICE: Bush House, W.C.2.
GLASGOW OFFICE: 24 Oswald Street.

Speedy replies result from mentioning "Wireless Magazine"

Broadcast Identification Sheets

For the benefit of readers we are publishing each month a series of panels specially compiled for the WIRELESS MAGAZINE by Jay Coote.

In these, readers will find a ready means of identifying foreign stations. To prevent any confusion in a.m. and p.m., the times are given on the Continental twenty-four-hour system. Example: 8 a.m.=8.00; 8 p.m.=20.00.

In the event of alterations in wavelength, power or call, a special panel bearing the alteration will be published at the earliest opportunity.

These identification sheets should be cut out and filed either alphabetically or in order of wavelength as they appear.

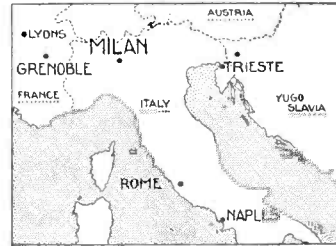

750 miles from London.

247.7m.
(1,211 kc.)

Power: 15 kw.

TRIESTE
(Italy)

Standard Time: Central European (coincides with B.S.T.).

Announcer: Woman.

Call (phon.): *Eh-yah, Rah-dee-owe Tree-ess-tay.* When working with Milan group of transmitters: *Radio Milano, Korino, Genova e Trieste.*

Opening Signal: Gramophone record (orchestra, choir, organ, bells).

Language: Italian only.

Main Programme: B.S.T. 12.50, gramophone records; 18.00, concert; 20.00, news; 20.45, main evening entertainment; 23.00 (or later), news; dance music.

Works S.B. with Milan, Turin, and Genoa.

Closes down, as other Italian stations, with Italian National Anthem (*Marcia Reale*) and Fascist hymn (*Giovinezza*) and words: *Buona notte a tutti.*

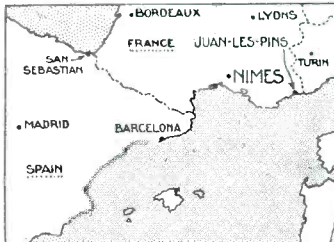

640 miles from London.

249m.
(1,205 kc.)

Power: 0.5 kw.

JUAN-LES-PINS
(France)

Standard Time: Greenwich Mean Time (France adopts B.S.T.).

Announcer: Man.

Call: *Allo! Allo! Ici le poste de Nice-Cannes et Juan-les-Pins; Emissions de la Société Radio Côte d'Azur, abbreviated between items to Ici radio Côte d'Azur, Juan-les-Pins.*

Main Programme: B.S.T. 12.30, news, play, or concert; 20.30, news, weather, play, concert, or relay from *Palais de la Méditerranée* (Nice); dance music (Sats).

Closes down at about 22.30 nightly with usual French formula, followed by *La Marseillaise.*



815 miles from London.

263.4m.
(1,139 kc.)

Power: 11 kw.

MORAVSKA-OSTRAVA
(Czechoslovakia)

Standard Time: Central European (coincides with B.S.T.).

Announcers: Man and woman.

Call: *Hallo! Moravska Ostrava* (or, if relaying Prague and other Czech stations, their names are included).

Language: Mainly Czech; on some days special transmissions are given for the German-speaking population, in which case bi-lingual announcements are made.

Main Programme: Most entertainments are relayed from Prague, Brno, and Bratislava.

Own Transmissions: B.S.T. 12.30, luncheon concert (daily); 18.15, brass band (Fri., Sat.); 22.15, light music or dance (Sat.). Closes down with the words *Halo radio Journal Moravska-Ostrava konci anesni vysilani a preje vsem posluchacum doma i za hranicemi, dobrou noc* (Hallo! Moravska Ostrava closes to-day's programme and wishes all hearers in this country and beyond the frontiers, good night).



1,555 miles from London.

1,304m.
(230.6 kc.)

Power: 165 kw.

MOSCOW
(U.S.S.R.)

Standard Time: Eastern European (B.S.T. plus one hour).

Announcers: Man and woman.

Call (phon.): *Sloo-schah-eet-ye Moskva Cent-rarl.* (In French: *Ici la grande station des Unions professionnelles de Moscou*; in English: This is the high-power station of the Central Trades' Unions of Moscow on 1,304 metres.)

Opens its transmissions by playing the *Internationale* (gramophone record, vocal and orchestral, or grand organ from studio).

Languages Used: Russian, German, French, English, Polish, Dutch, Spanish, and Italian.

Main Programme: B.S.T. 04.00, physical exercises, news, gramophone records; 06.30, concert; 12.00, concert; 21.00, international transmissions of concerts and talks, German and French (Mon.), Dutch (Tues.), German (Wed.), English (Thur.), French (Fri.), German and Esperanto (Sat.), German or English (Sun.). Broadcasts are simultaneously relayed to two short-wave stations working on 50.1 and 46.6 metres.

NEW BROADCAST IDENTIFICATION SERVICE

In conjunction with Jay Coote, WIRELESS MAGAZINE has organised a new service that will be of great value to all listeners in calculating a new receiver or compiling a log.

This Broadcast Identification Service, as it is called, is available for identifying stations from information supplied by readers. Only stations giving a regular broadcast service can be dealt with.

The fee is 6d. for identifying any one station, but if three identifications are required at any one time the fee is only 1s. A stamped addressed envelope must be supplied and the following details given:—

- 1.—What type of set are you using?
- 2.—Date and time when transmission was heard.
A.m. or p.m.?
- 3.—Approximate wavelength.
- 4.—Call or interval signal, if heard.
- 5.—Details, if any, of programme received.
- 6.—WRITE LEGIBLY on one side of paper only.

Address your enquiry to Broadcast Identification Service, WIRELESS MAGAZINE, 58/61 Fetter Lane, E.C.4.

INEXPENSIVE KB RADIO!

Look for
this sign



K.B. Eliminators Reduced in Price

The drastic reductions in the prices of K.B. H.T. Eliminators make it more economical than ever to obtain the H.T. supply from either A.C. or D.C. electric mains. With a K.B. H.T. Supply Unit constant, unfailing H.T. power is ensured while the performance of the receiver is enhanced, and remains consistently good. Supplied in various models to suit any kind of battery receiver.

- K.B.262 D.C. Eliminator, 120 volts at 10 milliamperes £1 9 6
- K.B.263 D.C. Eliminator, 150 volts at 30 milliamperes £2 5 0
- K.B.261 A.C. Eliminator, 120 volts at 10 milliamperes £2 15 0
- K.B.259 A.C. Eliminator, 120 volts at 20 milliamperes £3 7 6
- K.B.260 A.C. Eliminator, 150 volts at 25 milliamperes £3 17 6

All models available on generous Hire Purchase Terms.

K.B. 261 (A.C.) and K.B. 262 (D.C.) Eliminators, as illustrated, have been specially designed for the famous K.B. Battery "Pup."

Ask your dealer for details or send form below.

To Kolster-Brandes, Ltd.,
Cray Works, Sidcup, Kent.

Please send me full details of the K.B. H.T. Supply Units, together with the name of the nearest K.B. dealer.

Name

Address

..... W.M.2

See and hear the K.B. "Pup" Receiver which is the Radio wonder of the year. Complete with speaker, valves, batteries, and royalties, £5 3s. 9d., or 10s. down.

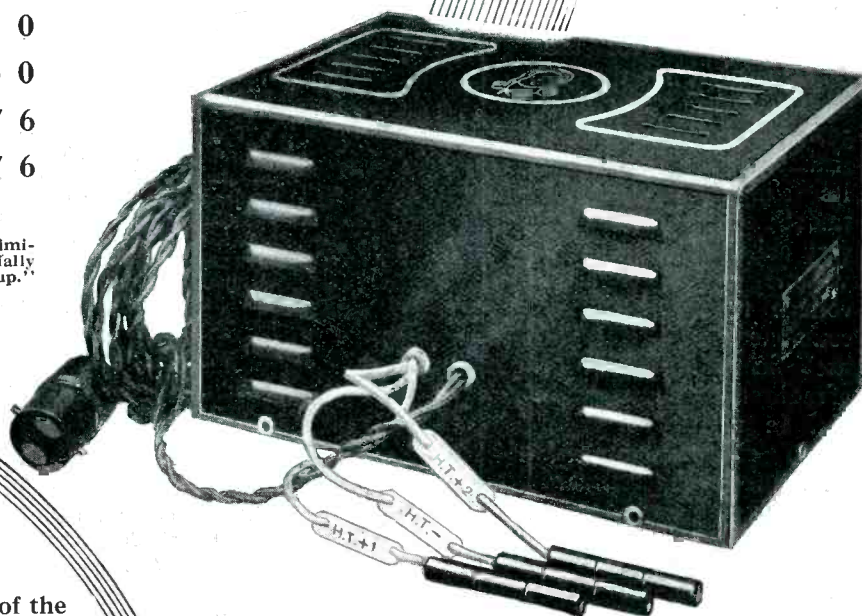

SIMPLE, SAFE, RELIABLE, SAVES BATTERY COSTS

THERE IS NO ALTERNATIVE

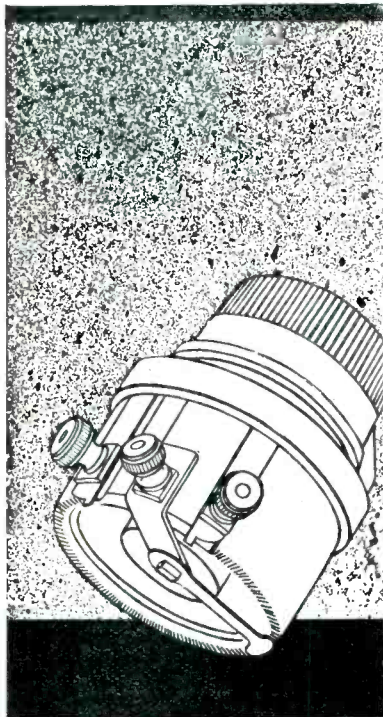

IT MUST BE COLVERN!

No other component has been specified for the Super Senior, but the designer insists that the 50,000-ohm Variable resistance be the Colverstat. Its simple fixing and smooth operation make it very suitable for use as a volume control or as a voltage regulator. This component has established itself firmly in the world of radio and has been specified in numerous other home constructed sets. In the following standard resistances :

2,500, 5,000, 10,000, 15,000, 20,000, 25,000 and 50,000 ohms.

PRICE - - - 5/6

COLVERN RADIO

Send for the Colvern Booklet

Colvern Ltd., Mawney's Road, Romford

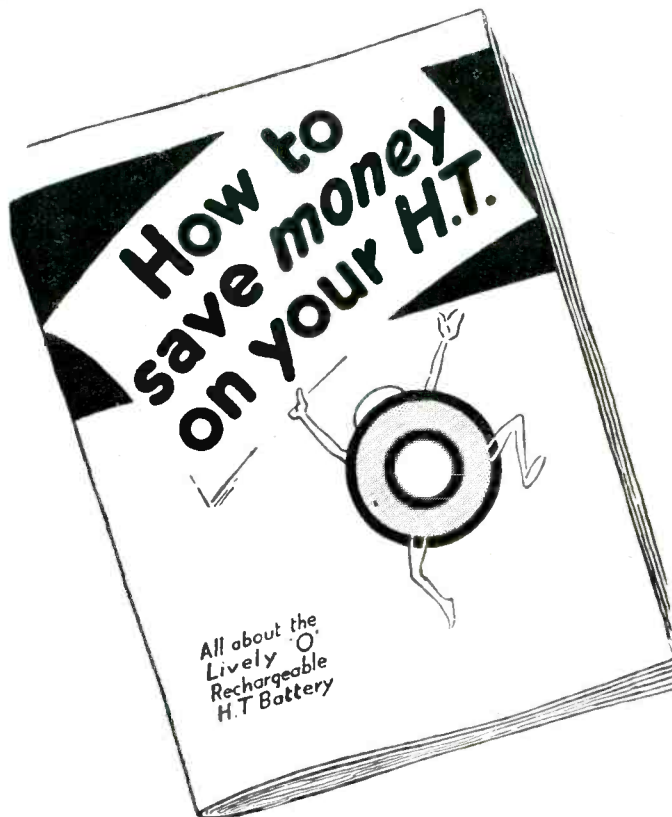

Send for this Book—it's free!

IT tells how you can end, once and for all, the expense of renewing Dry H.T. Batteries. It tells you how you can get the very last ounce out of your present Battery while gradually replacing it with a Lively "O" Rechargeable H.T. It tells you all about the Lively "O" Rechargeable H.T.—how it works—why it will improve your reception—how it will save you money—how it lasts for years—how it can be recharged at small cost. It is one of the most informative books on H.T. Batteries ever published. Send for your copy now . . . use the coupon.

TWO TYPES:

Standard 10 volt Unit (2,750 milliamps)

5/6

Extra large capacity (5,500 milliamps) per 10 volt Unit

6/9



The Lively 'O'



LIVELY 'O'
Rechargeable
H.T. BATTERIES

To OLDHAM & SON, LTD., Denton, Manchester.

Please send me, free of charge, a copy of your book, "How to Save Money on Your H.T."

NAME

ADDRESS

W.M. Oct.

Better service results from mentioning "Wireless Magazine" when writing to advertisers

for
**INCREDIBLE!
 AMAZING!**
 selectivity

NEVER BEFORE
 ACHIEVED
*without loss of
 Sidebands*

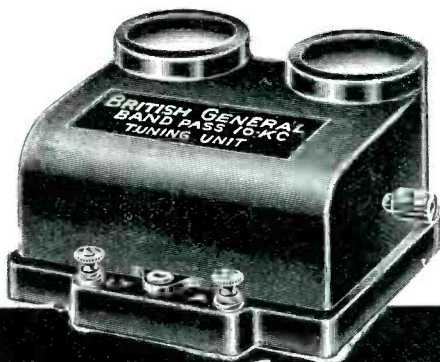

BRITISH GENERAL
BAND PASS 10 KC.
TUNING UNIT

PRICE

14/6

STAND 30
 RADIO
 EXHIBITION

Here is a new development in Tuning Units which is unique in its scope. It overcomes the difficulty which many listeners are experiencing in achieving separation of near stations without destroying the effective range of the Set. This new Band Pass Unit gives the separation of 10 Kilocycles as laid down by the International Radio Convention and yet covers the entire waveband between 230 to 550 and from 800 to 2,000 metres on one dial.

14/6 from all dealers of repute or direct from the manufacturers.

BRITISH GENERAL MANUFACTURING CO. LTD., Brockley Works, London, S.E.4

**GET THE
 BEST
 OUT OF
 RADIO**

The B.B.C. transmissions are worthy of the best possible reproduction. You cannot obtain the best possible reproduction unless your receiver comprises a good circuit, incorporates the best possible components, and operates a good speaker. Recognising this, FERRANTI from the outset produced the best possible components, and a receiver built on FERRANTI lines will give profound and lasting satisfaction.

Charts showing the construction of Receivers, Amplifiers, and Eliminators, free on request accompanied by 1½d. stamp to cover postage.

AUDIO-FREQUENCY TRANS., OUTPUT TRANS., and PUSH-PULL TRANS. CHOKES, CONDENSERS, and RESISTANCES. MEASURING INSTRUMENTS, A.C. & D.C. BATTERY ELIMINATORS FROM £3 10 6 TO £11 11 0. SPEAKERS: PERMANENT MAGNET MOVING COIL, £5 15 0 TO £11 10 0. A.C. MAINS ENERGISED £9 10 0, D.C. MAINS ENERGISED £4 5 0 TO £7 17 6. REXINE CABINET £1 extra.

Also Available in Chassis form.

Fully descriptive pamphlets available on request.

The third Edition of "The True Road to Radio" is now available, price 5/-, obtainable from any dealer.

FERRANTI
 FOR TRUE REPRODUCTION

FERRANTI, Ltd, Head Office & Works, Hollinwood, Lancs.
 London: Bush House, Aldwych, W.C.2.

When replying to advertisements, please mention "Wireless Magazine"

NATIONAL RADIO EXHIBITION

A Guide to the Stands at Olympia

The seventh National Radio Exhibition will be held at Olympia (London) from Friday, September 18 to Saturday, September 26. Hours of opening are from 11 a.m. to 10 p.m. daily; the price of admission is 1s. 6d. There are nearly two hundred exhibitors and many demonstration rooms.

LIST OF EXHIBITORS

Firm	Stand
Adies & Co., Ltd.	169
Amateur Wireless	71
Arding & Hobbs, Ltd.	171
Atalanta	191
Auto Electric Devices, Ltd.	159
Automatic Coil Winder and Electrical Equip. Co., Ltd.	207, 208
Audiovisor, Ltd.	226
B. & S. Electrical Co., Ltd.	181
Baird Television, Ltd.	157
Bakers Selhurst Radio	216
Beaver Electrical Supply Co.	165
Belling & Lee, Ltd.	13
Benjamin Electric, Ltd.	99
Betta Electric Motors, Ltd.	218
Bird, Sydney S., & Sons, Ltd.	172
Birkbys, Ltd.	206
British Blue Spot Co., Ltd.	65
British Broadcasting Corporation	211
British Ebonite Co., Ltd.	153
British General Mfg. Co., Ltd.	30
British Hard Rubber Co., Ltd.	182
British Radiophone, Ltd.	155
British Rola Co., Ltd.	250
Brown Bros., Ltd.	105
Brown, S. G., Ltd.	2
Brownie Wireless Co. of G. B., Ltd.	37
Bulgin, A. F., & Co., Ltd.	102
Bullphone, Ltd.	12
British Wireless for the Blind Fund	254
Brooks, Ltd., Kenneth	225
Burton, C. F. & H.	31
Cadisch, R. & Sons	184
Calders, Ltd.	183
Carrington Mfg. Co., Ltd.	51
Catesbys, Ltd.	245
Celestion, Ltd.	40
Chloride Electrical Storage Co., Ltd.	8
Churchmans, Ltd.	200
Clarke, H. & Co., (M/c), Ltd.	33
Climax Radio Electric, Ltd.	42
Colassion, Ltd.	209
Cole, Ltd., E. K.	26
Columbia Graphophone Co., Ltd.	7
Colvern, Ltd.	38
Concordia Electric Wire Co., Ltd.	248
Cossor, Ltd., A. C.	146
Craufurd Wireless	242
Crypto Electrical Co., Ltd.	235
Danipad Rubber Co., Ltd.	70

Firm	Stand	Firm	Stand
Darwins, Ltd.	101	Garrard Engineering & Mfg. Co., Ltd.	178
Dayzite, Ltd.	251	General Electric Co., Ltd.	24
De La Rue & Co., Ltd., Thos.	164	Goodmans	239
Department of Overseas Trade	253	Graham, R. F., & Co.	189
Dew & Co., Ltd., A. J.	104	Graham Amplion, Ltd.	75
Dibben & Sons, Ltd., Wm.	1	Graham Farish, Ltd.	32
Downing & Sons, Ltd., John S.	54	Gramophone Co., Ltd.	See page 342
Dubilier Condenser Co. (1925), Ltd.	92	Greatrex & Co., R. G.	197
Dulcetto-Polyphon, Ltd.	230	Gripso Co.	81
Dyson & Co. (Works), Ltd., J.	78	Grosvenor Electric Batteries, Ltd.	72
Donotone (Regd.) Loud-speaker	161	Gutta Percha Co.	196
East London Rubber Co., Ltd.	176	Hacker & Sons, H.	95
Eastick & Sons, J. J.	252	Halcyon Wireless Co., Ltd.	96
Ecco Radio, Ltd.	214	Harlie Brothers (Edmonton), Ltd.	84
Econasign Co., Ltd.	241	Heayberd & Co., F. C.	68
Edison Bell, Ltd.	41	Henderson Wireless & Electrical Service	170
Edison Swan Electric Co., Ltd.	21	Hillman Brothers, Ltd.	166
Electric Gramophones, Ltd.	89	Hobday Bros., Ltd.	175
Electrical Devices, Ltd.	185		

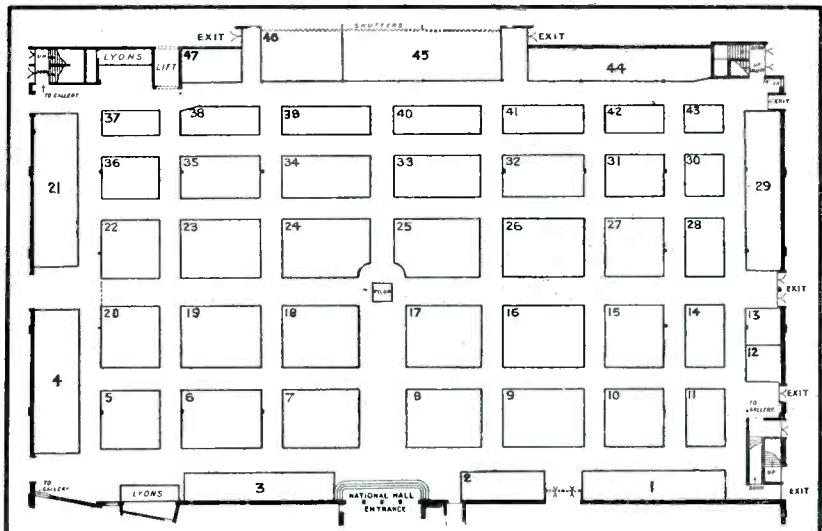

NATIONAL HALL—GROUND FLOOR (Stands 1 to 47)

Electrical & Radio Products, Ltd.	3	Hunt, Ltd., A. H.	232
Electric-Dynamic Construction Co., Ltd.	228	Hunton, Ltd.	233
Ensign, Ltd.	85	Hustler, Simpson & Webb, Ltd.	86
Epoch Radio Mfg. Co., Ltd.	106	Igranic Electric Co., Ltd.	28
Ericsson Telephones	219	Itonia Gramophones, Ltd.	167
Ever Ready Co. (G. B.), Ltd.	76	Jackson Brothers, Ltd.	62
Falk Stadelmann & Co., Ltd.	87	Jewel Pen Co., Ltd.	156
Faudels, Ltd.	192	Johnson Talking Machine Co., Ltd.	180
Fay Home Recorders, Ltd.	220	Junit Mfg., Co., Ltd.	97
Ferranti, Ltd.	45	Kalisky (Aldgate), Ltd., S.	151
Flinders (Wholesale), Ltd.	204	Kolster-Brandes, Ltd.	25
Formo Co.	61	Lamplugh, Ltd., S. A.	168
Francke, F.	224	Lectro-Linx, Ltd.	202
Fuller Accumulator Co. (1926), Ltd.	36	L.E.S. Distributors, Ltd.	88
Fullotone Gramophones (1929), Ltd.	201	Lissen, Ltd.	17
Gamage, Ltd., A. W.	195	Lithanode Co., Ltd.	249
Garratt Stores	240		

(Continued on page 228)

NEW

PERMANENT MAGNET MOVING COIL SPEAKER

P.M.3

CHASSIS
45/-

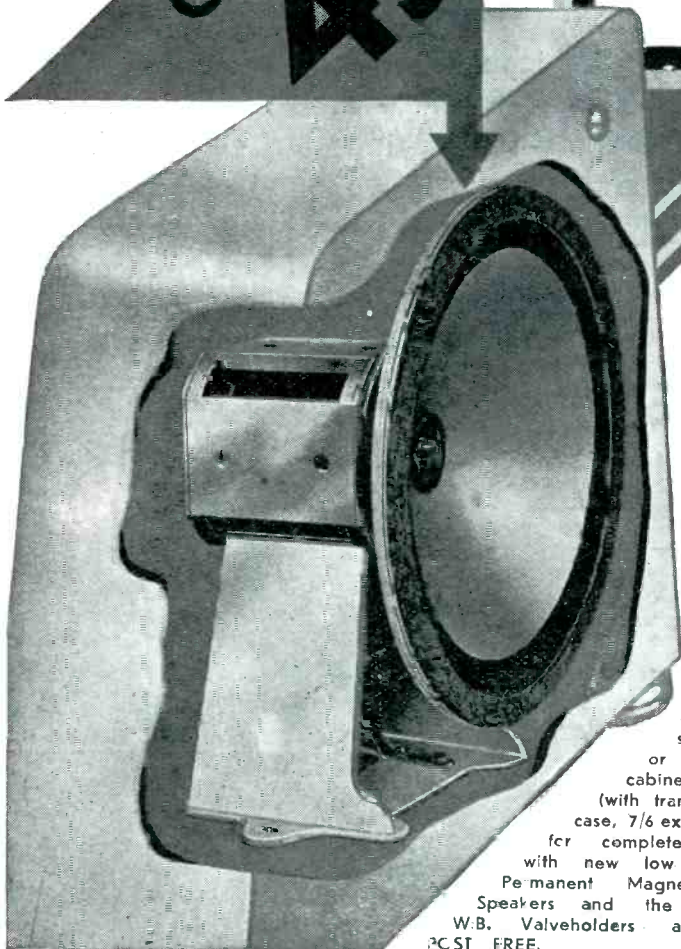
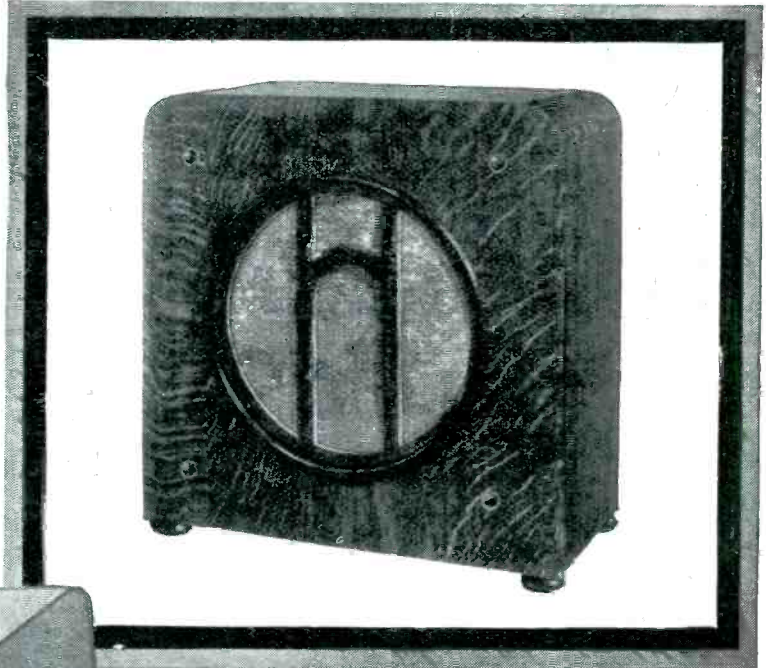

The most astonishing value ever offered. Made by "W.B." — the pioneers in Permanent Magnet Speakers. Very sensitive — large volume. Gives true moving-coil reproduction from any 2 or 3 valve set. A class instrument despite the low price. No mains or batteries needed.

OLYMPIA
Stand No. 46

Completely assembled chassis 45/-, or in attractive oak cabinet, as above, 75/- (with transformer, in either case, 7/6 extra). Write to-day for complete illustrated list with new low prices of W.B. Permanent Magnet Moving Coil Speakers and the equally famous W.B. Valveholders and Switches — POST FREE.



Whiteley Electrical Radio Co., Ltd., Radio Works, Nottingham Road, Mansfield, Notts.

Better service results from mentioning "Wireless Magazine" when writing to advertisers

WHERE DO YOU BUY YOUR GRAMOPHONE RECORDS?

DO you go to your local store and hear a selection played or do you order by post from the lists distributed by the makers? Maybe you choose whichever title interests you. Perhaps you pick out your selection from records broadcast.

Whichever method you use, the WIRELESS MAGAZINE Record Review will assist you in your choice. The best records are submitted to our Music Critic before their release to the public. He then hears each one, frankly criticising, favourably or otherwise, according to its merits.

This WIRELESS MAGAZINE
SERVICE SAVES YOU
TIME—TROUBLE—
MONEY AND POSSIBLE
DISAPPOINTMENT



Speedy replies result from mentioning "Wireless Magazine"

Increased
range
—improved
selectivity

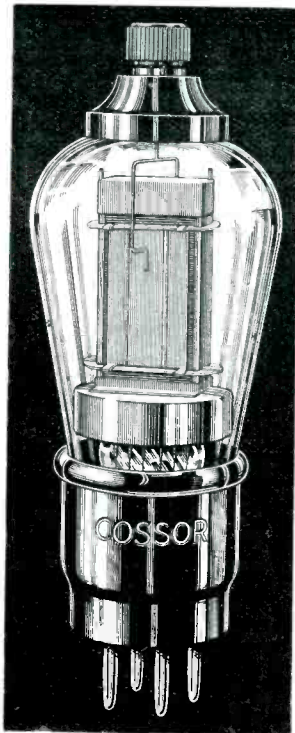

both follow the fitting of
this—Britain's most popular
Screened Grid Valve

YOU can materially improve the performance of your S.G. Receiver—widen its range and increase its selectivity—by fitting a Cossor Screened Grid Valve.

Because of their abnormally low inter-electrode capacity which is of the order of .001 micro-microfarads, lower than that of any other S.G. Valve on the market—and because of important constructional improvements—Cossor Screened Grid Valves permit a substantial increase in effective amplification.

As a result, therefore, the use of a Cossor S.G. Valve in any Screened Grid Receiver will result in a considerable increase in efficiency.

**COSSOR
215 S.G.**

Cossor 215 S.G.
2 volts, .15 amp.
Impedance 300,000.
Amplification Factor 330. Mutual conductance 1.1 n.a./v.
Normal Working Anode Volts 120.
Positive Voltage on Screen, 60-80.
Price - - **20/-**

**COSSOR
220 S.G.**

Cossor 220 S.G.
2 volts, .2 amp.
Impedance 200,000.
Amplification Factor 320. Mutual Conductance 1.6 m.a./v.
Normal Working Anode Volts 120.
Positive Voltage on Screen, 60-80.
Price - - **20/-**

Cossor Screen-grid Valves are obtainable from any Wireless Retailer in types to suit every S.G. Receiver. Full technical details will be sent post free. Ask for Folder L 36.

Definitely specified
for the
**"Super
Senior"**
by the designer
Mr. W. James.

Cossor
SCREENED GRID
VALVES

A. C. Cossor Ltd., Highbury
Grove, London, N.5.

♥ 9041

**200 page book on
engineering careers**

All who are interested in Engineering should send for a copy of this Book to-day.

Modern Home Study Courses in all branches of
**CIVIL, MECHANICAL, MOTOR,
ELECTRICAL, WIRELESS
AERONAUTICAL, "TALKIE" ENG.
ETC.**

Special Courses to cover
B.Sc., A.M.I.C.E., A.M.I. Mech. E.,
A.M.I.E.E., A.M.I.A.E., A.M.I. Struct. E.,
C & G, etc., Exams., and for entry
into the Public Services.

OVER 90% SUCCESSES.

We alone Guarantee—
"No Pass - No Fee."



**THE B.I.E.T. IS THE
LEADING INSTITUTE
OF ITS KIND
IN THE WORLD**

Write at once, stating subject of most interest.
**BRITISH INSTITUTE OF ENGINEERING TECHNOLOGY,
283 SHAKESPEARE HOUSE, OXFORD STREET, LONDON.**

**ELECTRADIX
HEADPHONE BARGAINS!**

War Office Economy Sale of Huge Parcel
of New Headphones and Single Earpieces

A wonderful opportunity of buying Headphones at a price below
the wildest cut price ever imagined

LIGHT HEADPHONES H.W. Sullivan's Wireless Light Headphones, new,
120 ohms 3s. 6d. Ditto store soiled unboxed 120 ohms. 2s. 9d. New
High Res. Long Range Model 8000 ohms. 4s. 3d. S. G. Brown's Head-
phones with Headbands 120 ohms. 7s. 6d. Ditto, 1500 ohms. 12s. 6d.

FIELD HEADPHONES Double Field Headphones D.III with all-leather
Headbands and cords L.R. 2s. 6d. Ditto pairs without Headbands
2s. 6d. Single phone with cord, each 11d.

We guarantee these Headphones for 12 months
Send a stamped envelope for New Sale List

**ELECTRADIX RADIOS, 218 Upper Thames Street,
LONDON, E.C.4**

Preserve your
copies of the
"WIRELESS MAGAZINE"

THE ideal way of keeping your copies of the "Wireless Magazine" is to have them bound into volumes, each with its appropriate index, in the handsome grey-tinted stiff covers which are obtainable, at 2/6 each (inclusive of the index for each volume of six copies), plus postage, 3d. from the publishers.

**BERNARD JONES PUBLICATIONS LIMITED,
58-61 Fetter Lane, London, E.C.4**

NATIONAL RADIO EXHIBITION—

Continued from page 224

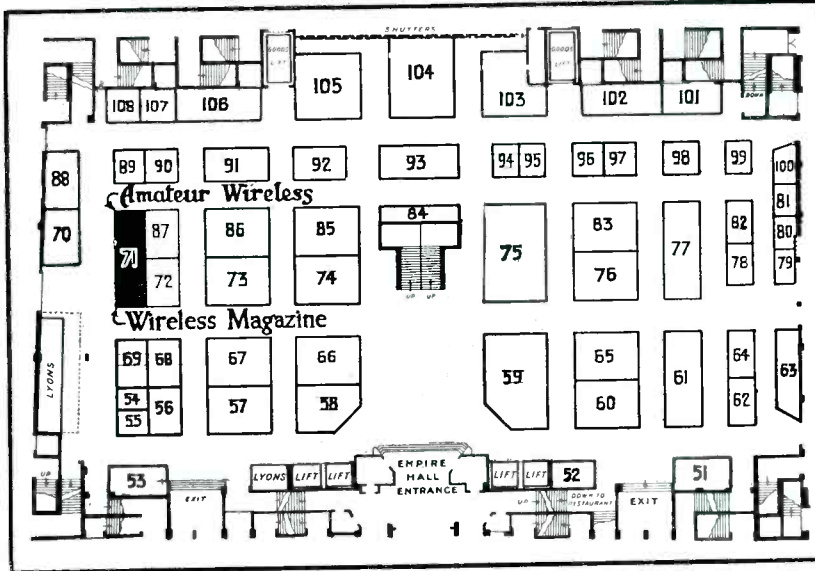

EMPIRE HALL—GROUND FLOOR (Stands 51 to 108)

Firm	Stand
Lock, Ltd., W. & T.	160
London Electric Wire Co., and Smiths, Ltd.	27
Lotus Radio, Ltd.	23
Magnavox (G. B.), Ltd.	108
Mains Power Radio Co.	229
Mains Radio Gramophones, Ltd. Manufacturers' Accessories, Co. (1928), Ltd.	53
Marconiphone Co., Ltd.	186
McMichael, Ltd., L.	4
Montague Radio Inventions and Development Co., Ltd.	5
Mullard Radio Valve Co., Ltd.	47
Murphy Radio, Ltd.	18, 80, 199, 221
National Accumulator Co., Ltd.	59
New London Electron Works, Ltd.	15
Oldham & Son, Ltd.	35
Oliver Pell Control, Ltd.	66
Ormond Engineering Co., Ltd.	58
Osborn, Charles, A.	34
Osram Valves	205
Overseas Trading Corporation	77
Park Royal Engineering Co., Ltd.	173
Paroussi, E.	194
Partridge & Mee, Ltd.	158
Partridge, Wilson & Co.	177
Pegasus, Ltd.	43
Pertrix, Ltd.	238
Peto Scott Co., Ltd.	39
Pioneer Mfg. Co., Ltd.	179
P. R. Products	188
Priestly & Ford	187
Primus Mfg. Co., Ltd.	69
Pritchard & Simpson, Ltd.	193
Pye Radio, Ltd.	243
R. C. Radio Electric, Ltd.	9
Radio Gramophone Development Co., Ltd.	237
Radio Instruments, Ltd.	11
	29

Firm	Stand
Radio Society of Great Britain	246
Radio Service (Ldn.), Ltd.	162
Ready Radio (R. R.), Ltd.	6, 93
Rees Mace Mfg. Co., Ltd.	215
Redfern's Rubber Works, Ltd.	163
Regentone, Ltd.	22
Rolls Caydon, Ltd.	56
Rooke Brothers, Ltd.	79
Sel-Ezi Wireless Supply Co., Ltd.	190
Selfridge & Co., Ltd.	234
Siemens Electric Lamps & Supplies, Ltd.	74
Six-Sixty Radio Co., Ltd.	20
Shapland & Petter, Ltd.	217
Smurthwaite, F. W.	107
Sovereign Products, Ltd.	64
Speakeasie Home Recorders	236

Firm	Stand
Standard Battery Co.	94
Stratton & Co., Ltd.	98
Sun Electrical Co., Ltd.	203
Swain Ltd., Charles	244
Swift Levick & Sons, Ltd.	52
Synchrophone, Ltd.	223
Selectors (1931), Ltd.	83
Tannoy Products.	63
Taylor, Ltd., Henry E.	212
Telegraph Condenser Co., Ltd.	14
Telsen Electric Co., Ltd.	19, 213
Tonex Co.	231
Thompson, Diamond & Butcher	210
Turner & Co.	82
Ultra Electric, Ltd.	10
Umello, Ltd.	73
Vandervell & Co., Ltd., C. A.	91
Voltron Electric, Ltd.	227
Watmel Wireless Co., Ltd.	100
Westinghouse Brake & Saxby Signal Co., Ltd.	44
Whiteley Electrical Radio Co., Ltd.	46
Whiteley, Ltd., William	198
Whittingham Smith & Co.	103
Wilkins & Wright, Ltd.	90
Wingrove & Rogers, Ltd.	60
Wireless Magazine	71
Wireless Retailers' Association of Great Britain	174
Wright & Weaire, Ltd.	152
Yagerphone, Ltd.	222

Make Certain of Seeing all the New
WIRELESS MAGAZINE
Designs on STAND 71

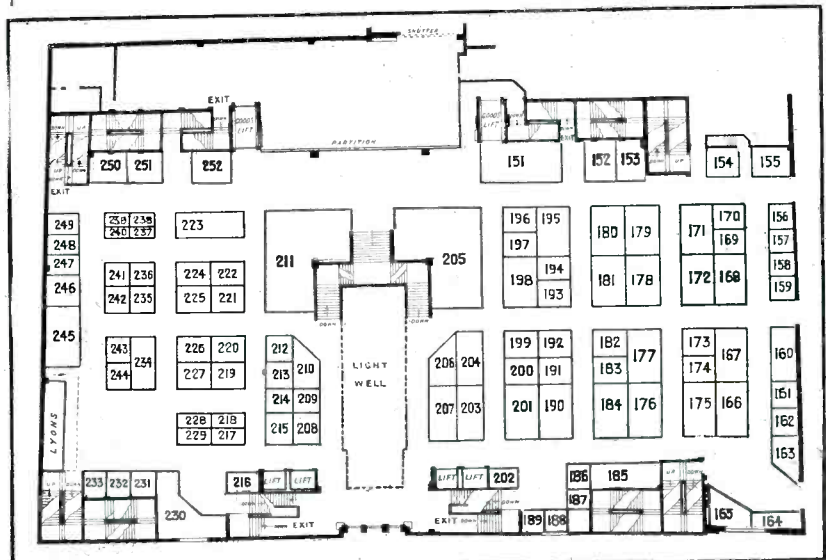

EMPIRE HALL—FIRST FLOOR (Stands 151 to 254)

WIRELESS BATTERY SURPRISES EXPERT

“Almost unbelievable results”

AN EXTRAORDINARY CONTRAST

The writer of the following letter resolved to make a scientific test. He bought two H.T. batteries of different makes. Here, in his own words, is the remarkable result.

“Dear Sirs :

You may be interested in an experiment I am at present making, the details of which I will supply you with from time to time. In March last, I built Mr. James' magnificent set, the 'Super 60,' and I had a doubt as to what batteries to use. I finally decided on a 60-volt EVER READY and a 60-volt '——' my intention being to test them and then carry on with the best make. Day by day I have religiously carried out the tests, each day changing the batteries so that one took the full load every other day : (this in my opinion being the only method of testing accurately). The enclosed graph will show you the almost unbelievable results obtained so far. I am wondering if you have accidentally stored a mains unit in this battery ! The graph of the other battery I dare not send as it may get me into trouble with the makers. Sufficient to state that the EVER READY is worth well over double the price.”

Leonard Foley, Manchester.

(This letter may be inspected at the office of the Company).

This unsolicited testimonial confirms what the EVER READY Company has been telling the wireless public for years—that for elimination of distortion, for unwavering power and for long life, an EVER READY battery is better than any other battery on the market. This is no accident, but the result of the exclusive process by which every EVER READY battery is made. There is an EVER READY battery to power every kind and size of set, portables included. Write for free list to the address below.

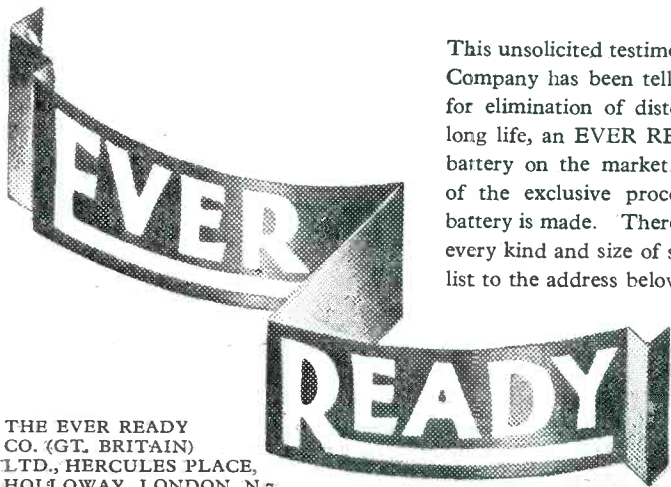

THE EVER READY
CO. (GT. BRITAIN)
LTD., HERCULES PLACE,
HOLLOWAY, LONDON, N.7.

**THE BATTERY
THAT LASTS A
LONG TIME**

Advertisers like to know whence the business comes—please mention “W.M.”

KEEP IN LINE WITH THE LATEST DEVELOPMENTS IN RADIO — READ BRITAIN'S LEADING RADIO WEEKLY

The new Radio Season this Autumn will bring to light many startling developments. "Amateur Wireless," by reason of its unique news service, will give its readers exclusive information of every new production. There will be some really outstanding sets to build—receivers that will prove even more popular than the famous W. James' Century Super and the 1931 Ether Searcher. Make sure you get a copy of "Amateur Wireless" Exhibition Number—September 19. It contains 116 pages packed full of details of all new season's productions, together with a complete guide to every stand at Olympia.

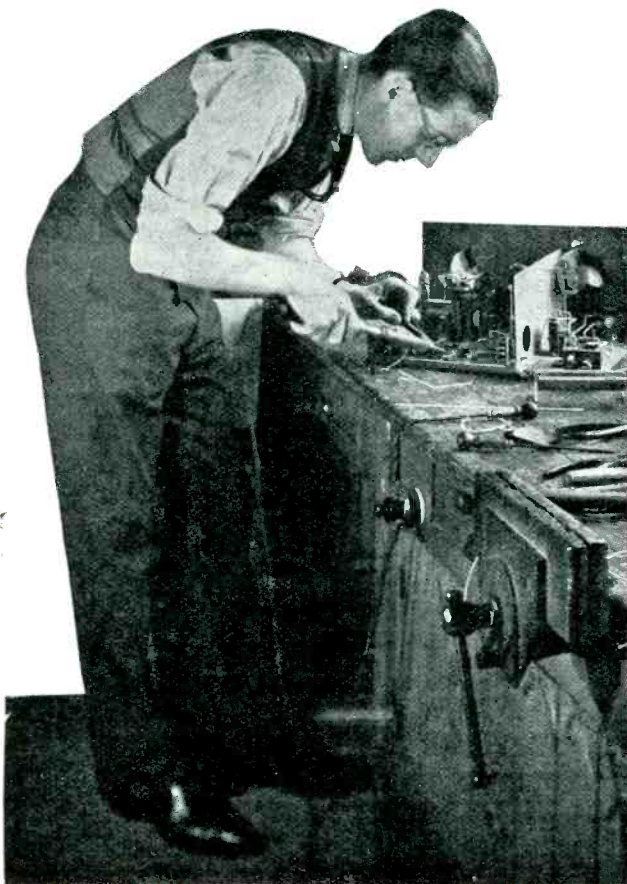

GET YOUR
COPY WEEKLY
ON SALE EVERY
THURSDAY
PRICE - - 3d.

AMATEUR WIRELESS

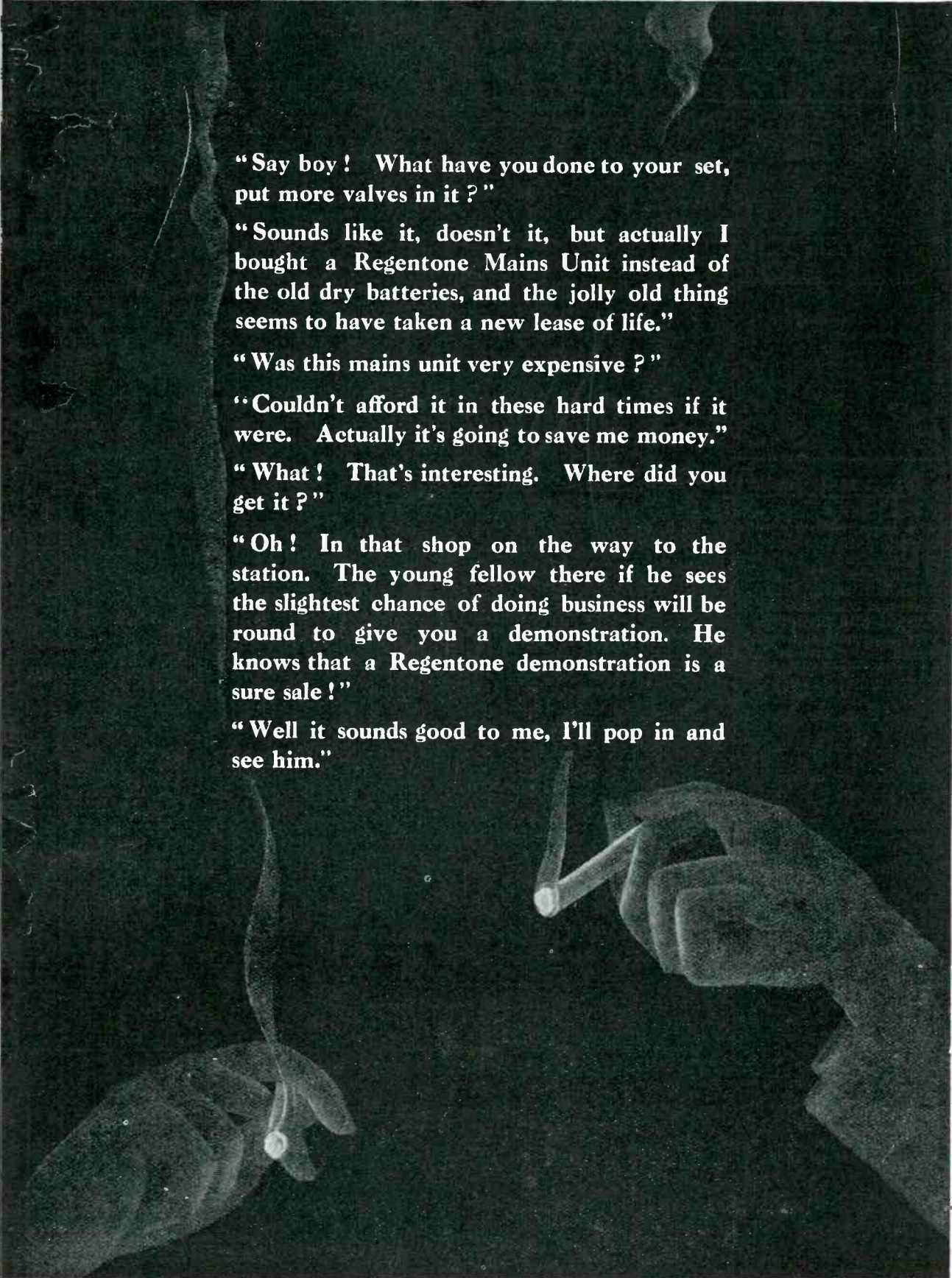

“Say boy! What have you done to your set, put more valves in it?”

“Sounds like it, doesn’t it, but actually I bought a Regentone Mains Unit instead of the old dry batteries, and the jolly old thing seems to have taken a new lease of life.”

“Was this mains unit very expensive?”

“Couldn’t afford it in these hard times if it were. Actually it’s going to save me money.”

“What! That’s interesting. Where did you get it?”

“Oh! In that shop on the way to the station. The young fellow there if he sees the slightest chance of doing business will be round to give you a demonstration. He knows that a Regentone demonstration is a sure sale!”

“Well it sounds good to me, I’ll pop in and see him.”

IN TUNE WITH THE TRADE

FETTER LANE'S Review of Catalogues and Pamphlets

SEND TO US FOR THESE CATALOGUES!

Here we review the newest booklets and folders issued by Seven well-known firms. If you want copies of any or all of them just cut out this coupon and send it to us. We will see that you get all the literature you desire.

Just indicate the numbers (seen at the end of each paragraph) of the catalogues you want below.

My name and address are:—

Send this coupon in an unsealed envelope, bearing 1/4 d. stamp, to "Catalogue Service," WIRELESS MAGAZINE, 58/61 Fetter Lane, E.C.4. Valid till Oct. 31/30

FOR MAINS-SET USERS

MAINS-DRIVEN sets are popularly supposed to represent the zenith of perfection, the peak of achievement, or however else you like to put it, when in optimistic mood about some radio outfit which is perfectly *pukka*. But I have never yet come across anybody who is satisfied with his set for more than a year at a time, and even in the mains-driven jobs there are little alterations which one wants to carry out.

When this mood takes you, then write through my free catalogue service to Partridge & Mee, Ltd. for their new catalogue of mains components and complete rectifiers. If you want to improve the output of your mains-driven apparatus then search round the Parmeko parts and find some new transformer or choke which will pep the performance.

Parmeko make a permanent-magnet moving-coil loud-speaker, too. **209**

A GOLTONE TOME

THE Goltone tome (alliteration has me in its grip to-day) is a handy forty-eight-page book in which, without question, you will find most of the gadgets ever needed in the construction and operation of a set. From simple parts for home constructors—coils, valve holders, and whatnot—through to loud-speakers and mains units, there is a whole range of accessories of outstanding interest.

Not only is the complete gamut of Goltone parts described, but there are, too, a number of parts by other manufacturers and it is very handy to have these catalogued in the one booklet. You can get a copy of this free through my catalogue service. **210**

ABOVE CRITICISM

WHEN a firm adopts "Above Criticism" as a slogan for one of its components, one is tempted to reply in the American mode, "Sez you!" But when

Celestion use this slogan one must pause before being Americanishly sarcastic. They say that the W5 pick-up is above criticism. I am beginning to think they are right.

In this pick-up they have scrapped the old-fashioned method of clamping the needle and the new quick-needle release allows the needle to be changed in two seconds. The tone arm is corrected to give true tracking and the arm moves on a ball-bearing support. These are just the sort of features one expects to find in a good pick-up, and as the price of the complete job is well under £3, then I think Celestion are going a long way towards justifying their ambitious slogan.

When getting the little folder giving details of this, ask also for the new literature on the Celestion RPM permanent-magnet loud-speakers. **211**

THE IMPORTANCE OF EBONITE

ISOMETIMES think that we set builders are apt to overlook the importance of ebonite. There are a large number of sets made up nowadays with wooden panels and with other general lack of insulation at points where, two or three years ago, we would have been frightened to use anything but ebonite.

A set designed for a wooden panel is, of course, safe with one. A set not designed for a wooden panel and with parts of greatly varying direct-current and high-frequency potential on the panel demands the very best insulation.

Here comes a booklet from the British Ebonite Co., Ltd., to support my contention. It contains a wealth of helpful details about panels, coil formers, and other ebonite parts. Becolettes, consisting of handy pieces of sheet, rcd, and tube, made up in special cartons, should be very useful when building up a set. **212**

A NEW RADIO GRAMOPHONE

THE Radio-Gram Development Co., Ltd., specialises in the development of radio gramophones. Obvious, but true! They have certainly done some developing for 1932 and the new models are, in my opinion, just what a good radio gramophone should be. Now, take the popular model R.G.D, gramophone.

which sells at 48 guineas. This has two screen-grid valves and, of course, three tuned circuits. It has special power-output arrangements and volume controls for radio and gramophone reproduction operated by the same knob. Very cute.

Extraneous noises from the turntable drive is completely eliminated by a sound track, and there is a special tone control working both on radio and gramophone reproduction. The controls in the front of the set are he-manish in size and do not call for any delicate finger-twiddling. To save me rhapsodising at length on the R.G.D., get a free copy of a folder just issued and read about it for yourself. **213**

EKCO IN 1932

EKCO is now more than an echo of what it was. Pardon the pun! Ekco is one of those amazing firms which have grown up rapidly in the remarkable progress of radio and, starting in a humble way, now rank among the leaders of the industry.

Their position among the brass hats is unquestionable this year and their new two-, three-, and four-valve sets, not to mention the RG5 and RG6 radio gramophones, are among the best sets for 1932.

Take my tip and write for a most attractively got-up booklet, which will keep you interested. I like, too, the way in which Ekco have gone in for chassis construction in their mains units; this not only makes for lower cost, because of the easier assembly, but also minimises the job of trouble tracking in the rare event of a fault cropping up. **214**

MORE LOUD-SPEAKERS

LET me introduce Rola loud-speakers, marketed over here by the Rothermel Corporation, Ltd. There is a good book just issued, giving details of the F, K, and PM1 series. The F is a large moving-coil, the K is a slightly different type, also energised, and the PM1 is, of course, a permanent-magnet job, as its indicating initials imply. I prophesy a big demand for the PM1's. The D.C. resistance of the moving coil is only 2 ohms and the impedance about 2 1/2 ohms. Each loud-speaker is fitted with a transformer and there are special models for push-pull and pentode working. **215**

WE WANT TO SEE YOU AT OLYMPIA

On the "Wireless Magazine" stand at Olympia will be many things that the listener should see. All our new sets will be on view and members of the staff will be on duty at all times of the day to answer visitors' enquiries.

A hearty welcome awaits every visitor to Stand 71, on the ground floor of the Empire Hall. Let us explain to you how simple it is to build your own set and demonstrate what good value for money is obtainable this season.

COME TO STAND 71—GROUND FLOOR

WE ARE EXHIBITING AT

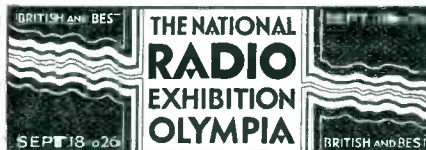

See it on
Stand 44

THE NEW

WESTINGHOUSE

METAL RECTIFIER

STYLE H.T.8.

which gives an output of
250 volts 60 milliamps (after smoothing)

*A complete range of all our other units will
also be on view.*

*Call at the Stand for a copy
of the 1932 "All Metal
Way," which gives full
details and circuits, etc.*

The Westinghouse Brake
& Saxby Signal Co., Ltd.,
82 York Road,
King's Cross, London, N.1

When you send your order don't forget to say you "saw it in the 'W.M.'"

Amateur Wireless HANDBOOKS

each 2/6 net

*Of all Newsagents and Booksellers, or 2/9 post free from
Cassell and Company Limited, La Belle Sauvage, E.C.4.*

Wireless Controlled Mechanism **The Practical Wireless** **For Amateurs.** **By Raymond Phillips** **Data Book**

This book is an illustrated practical guide to the making and using of short-range wireless control apparatus, and it has been written so simply that it can be understood by any enthusiast possessing an elementary knowledge of wireless.

The intelligent novice, and particularly the home constructor and the keen wireless amateur who is always rigging up different circuits and experimenting for progress will find this Data Book extremely helpful.

The Book of the Neutrodyne

By J. H. Reyner, B.Sc. (Hons.) A.M.I.E.E.

CONTENTS: Why Neutralising is Necessary ; Systems of Neutralising ; Difficulties Encountered in Neutralised Circuits ; How to obtain Good Selectivity without Loss of Quality ; Designs of High-frequency Transformers ; Lay-out in Neutralised Receivers ; Some suitable circuits.

Price **1/6** net, or post free for 1/9

A Useful Series for Wireless Amateurs

Cassell  **Books**

La Belle Sauvage,

London E.C.4.

The new RADIO WONDER

SPECIFICATION	CLARKE'S ATLAS
I Variable Tapping	0/100 V.
I " "	0/120 V.
I Fixed " "	150 V.
Output at 150 V.	25 m.A.
L.T. Trickle Charger	2, 4 & 6 V.
Charging Rate	0.5 A.
4 Grid Bias Tappings	1½, 3, 9, 16 V.
Guarantee	12 months
Price	£6-10-0
Yours for	10/- down

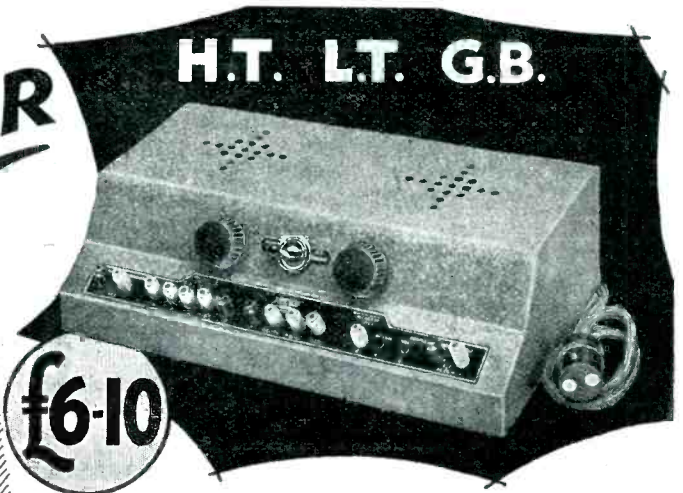

£6-10

ALL-MAINS UNIT A.C. 290
COMPARE THESE
UNIQUE FEATURES
FOR YOURSELF

You can't beat "Atlas"

4 OTHER NEW "ATLAS" UNITS



MODELS No.
A.2. and A.K.22

"ATLAS" Model A.2.—H.T. Unit for 1-, 2-, and 3-valve sets. Three Tappings, 60/80 volts, 90/100 volts, and 120/150 volts respectively. Output 12m/A.
Price 52/6 cash or 10/- deposit and 6 monthly payments of 8/- each.
"ATLAS" Model A.K.22.—All-mains Unit, has similar tappings but incorporates a L.T. Trickle Charger for 2-volt Accumulators at .3 amperes.
Price 77/6 cash or 10/- deposit and 9 monthly payments of 8/6 each.



MODELS No.
A.C. 244 and
A.K. 260

"ATLAS" Model A.C.244.—H.T. Unit, 3 Tappings 60/80 volts (maximum and minimum), 50/90 volts (maximum, medium and minimum), 120/150 volts respectively. Output 20m/A at 120 volts.
Price 59/6 cash or 10/- deposit and 8 monthly payments of 7/- each.
"ATLAS" Model A.K.260, All-mains Unit, has similar tappings but incorporates a L.T. Trickle Charger for 2-, 4- and 6-volt Accumulators at .3 amperes.
Price 90/- cash or 10/- deposit and 9 monthly payments of 10/- each.

"CLARKE'S ATLAS" MAINS UNITS

H. CLARKE & CO. (MANCHESTER) LTD.
OLD TRAFFORD . MANCHESTER

London Office - - BUSH HOUSE, W.C.2

Please mention "Wireless Magazine" when corresponding with advertisers.

What's inside a FULLER 'SUPER' battery!

A DRY BATTERY is still a mystery to most wireless enthusiasts. Yet it plays a most important part in reception. That is why Fuller's have devoted all their energies and resources to improving dry batteries. They have recently installed entirely new automatic manufacturing and testing machinery. They have standardised every component part, every process of manufacture. Here you see the cell cases, with the 'dolly' being prepared for sealing up—each perfect—identical in size, weight and latent energy. This uniformity and regularity of manufacture gives a dry battery which is infinitely superior to the hand-made type. Fit a Fuller 'Super' and your wireless will take a new lease of life.

FULLER
'SUPER' BATTERY

60 VOLTS EMISSION UP TO 20 MILLIAMPS - - PRICE 7/5
108 VOLTS EMISSION UP TO 20 MILLIAMPS - - PRICE 13/9

*Contractors to British and Overseas Government Departments,
Railways, etc.*

Full list of sizes and names of local depots on application
to Fuller Accumulator Co. Ltd., Chadwell Heath, Essex.
Telephone: Seven Kings 1200. Telegrams: "Fuller, Chadwell Heath."



Mention of the "Wireless Magazine" will ensure prompt attention



The new Blue Spot inductor loud-speaker

A Review of Autumn Developments

LOWER prices and improvements in details of design are the most striking features of the exhibits at Olympia this year. Radio technique has not been revolutionised by the advent of any new component or method.

Attention to Detail

Every improvement—and the improvements that have been made are considerable—is due to close attention to detail on the part of designers in every branch of the radio field. The result is that prices have been reduced to a considerable extent while efficiency has been maintained at a reasonably high level.

There is no lack of new and improved products to interest the constructor. Nearly every firm of component manufacturers has embarked on a new production programme for the season 1931-1932 and it will be some time before the average listener is familiar with all the new parts that are available for building sets, so great is their number.

In these notes it will be possible

to make only brief references to the more outstanding productions offered to the listener. Whilst many manufacturers have already announced their autumn programme, there are still some who are keeping their new products very secret, and details of these can only be obtained by a personal visit to the Radio Exhibition.

Let us begin at the beginning and see what is being done regarding aeri-als. A few months ago there seemed to be a move towards the adoption of frame aeri-als, but now there is a tendency towards the use of small "open" aeri-als, rigged up either indoors or out in the garden.

Many makers of mains sets are arranging their new models so that the electric-light wiring can be utilised as an aerial, which of course is of great convenience when it is desired to move the receiver about from room to room.

Next in importance comes the question of tuned circuits, and here a very real advance has been made. Faced with the need of obtaining still

greater selectivity, most manufacturers have been forced to develop the band-pass type of tuner to a really practical proposition.



A Belling-Lee product-terminal type H

It is not easy to design a band-pass coil that is equally efficient on both medium and long wave-bands, and the problem has been still further complicated until recently by the lack of satisfactory ganged condensers at a reasonable price.

Manufacturers of complete sets are, on the whole, much further advanced in band-pass technique than are the firms catering for the needs of the home-constructor. But it is good to know that at least six manufacturers have in hand the production of band-pass tuners suitable for use in home-assembled sets.

Interesting advances have also been made in the manufacture of ganged tuning condensers. More firms are now able to supply com-

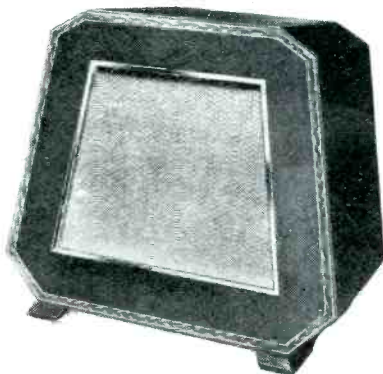

The new Gecophone moving-coil reproducer is attractive in appearance

WHAT'S NEW IN RADIO—Continued

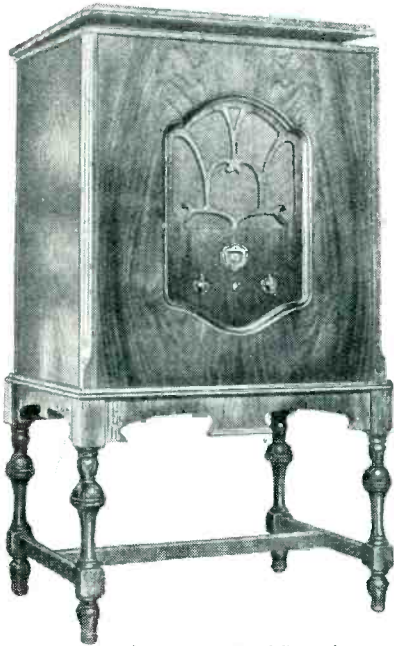

Made by Tannoy—the Westminster cabinet radio gramophone

appearance as many commercial productions.

It is an easy step from variable condensers to those of the fixed type. Here, the chief development is towards a reduction in price. Lower manufacturing costs have been achieved by cutting down the size of the moulded cases and adopting mass-production methods.

An interesting feature is the introduction of high-voltage electrolytic condensers. These have the virtue of giving a large capacity with very

power amplification—has improved characteristics. No important reductions in price have been made but, on the other hand, we are now getting very much better value for our money, which comes to much the same thing.

Special D.C. Mains Valves

Valves that deserve special mention are the new D.C. series with indirectly-heated filaments. These will be welcomed by listeners who are under the disadvantage of living in areas served with direct-current lighting supplies. The new D.C.

valves are arranged to be run in series so that no more current is actually taken from the mains whether two or five are used.

Although only suitable for special purposes interesting valves are the double-grid and multi-“mu” types; the former will find their chief use in super-het circuits, but it is likely that they will also be found of value as detectors of super efficiency in ordinary circuits.

The multi-“mu” valve has attracted considerable attention in the United States, where it was first developed. It is a screen-grid valve so arranged that the magnification factor can be adjusted within wide limits to suit different circuit conditions.

Complete Valve Guide

In these notes it is impossible to go into further details, but a list of all

VISIT STAND 71



Dubilier's condenser for the Varley band-pass coil

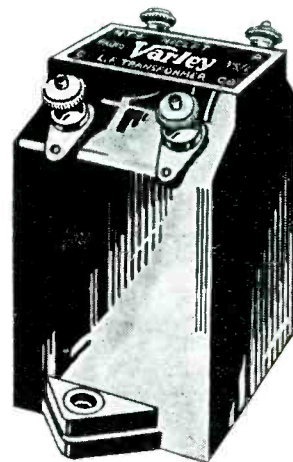

A new low-frequency transformer—the Varley Niclet

pletely shielded models, but in some cases little thought seems to have been given to the accessibility (or otherwise) of the trimming knobs.

The prices of ganged condensers still seem to be on the high side when the cost of an ordinary single condenser is considered. No doubt the increased demand for ganged models that is certain to arise from the increasing popularity of band-pass tuners will result in price reductions before many months have passed.

Disc Drives Popular

Not only have condensers been much improved electrically, but there are also considerable improvements in mechanical arrangements. Of particular interest is the tendency towards disc drives, with a small inspection window let into the panel.

Neat Sets

In this way large dials spread over the main part of the front of the set are avoided and there is at last a possibility that constructors will be able, this autumn, to make sets that are as neat and attractive in

small volume. They are of particular value in the construction of mains sets and units of all kinds, and there is no doubt that they will be welcomed by all constructors.

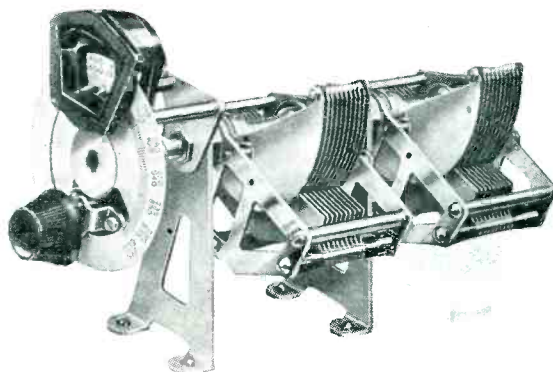

The Jackson type M20 two-gang condenser developed for the Varley band-pass coil

Enormous improvements have been made in valve construction and every type—whether for high-frequency amplification, detection, or

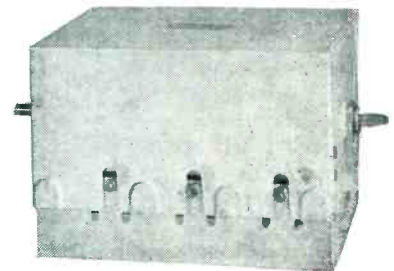

A completely shielded three-gang condenser made by Utility. The construction is very robust

A GUIDE TO THE LATEST APPARATUS

the latest types will be found under the feature entitled "Valves to Use in Your Set," on pages 212 and 216.

On the whole, there are few changes in low-frequency transformer practice, although many firms seem to have given up the manufacture of the

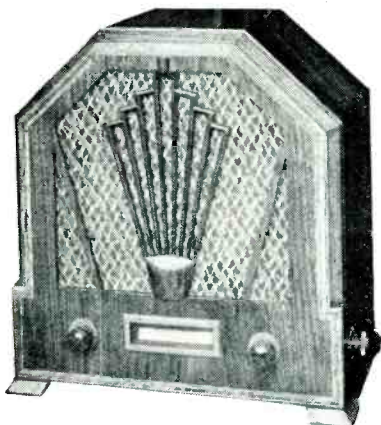

A self-contained Gecophone screen-grid three-valve set

heavier types. There is a tendency towards reducing the size of the components by using cores of "radio" metal.

Many of these transformers must be used in a resistance- or parallel-feed circuit in order to get anything like good quality of reproduction.

Output Circuits

Output transformers and chokes are enjoying an increase in popularity as many more listeners realise the need for a special output device in order to get good quality. Until recently output transformers were few in number and costly to buy. Now, many more firms are making these components and the prices have been reduced to a surprising extent.

There is now no reason why every home-constructed set should not be provided with a proper output arrangement.

Flexible Resistances

The old cartridge type of wire-wound resistance seems to have become nearly extinct, so quickly have those of the flexible or "spaghetti" type become popular. In place of bulky parts costing several shillings we now have resistances that

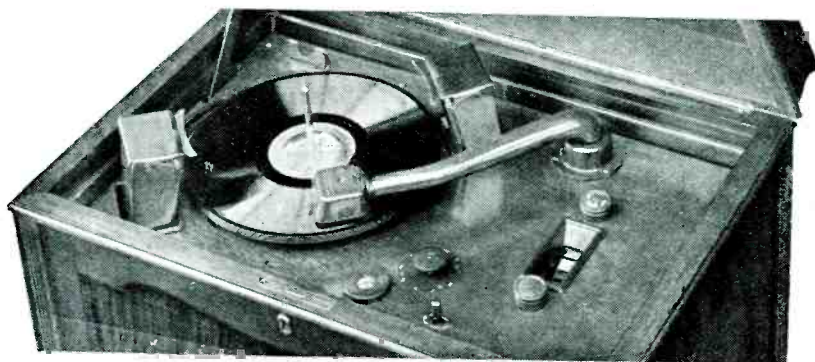

Note the neat control arrangement on the H.M.V. model 522 radio gramophone with automatic record changer

can be used as connecting wires and which cost only a few pence.

A refinement that has come to be regarded as essential for every up-to-date set is a volume control. For this reason there has been a greatly increased demand for potentiometers, the wholly wire-wound type being most in demand.

There has been a certain amount of difficulty in the past with the wire-tapped composition type and it is gratifying to see that a number of manufacturers are now producing wire-wound models at low prices. One firm has provided a special form of carbon track that will carry heavy currents.

Now that a high-frequency choke is needed for nearly every receiver, of whatever type, it is not surprising that prices have been reduced considerably; but apart from this there



This H.M.V. automatic record-playing desk (model 117) will convert almost any set into an efficient radio gramophone

are no changes to be recorded in this respect.

Lack of Co-operation

There is still an absurd lack of co-operation between manufacturers making parts that have control knobs which must of necessity be mounted on the front panel of a set. This point has been repeatedly referred to in these pages and it is high time that the Radio Manufacturers Association looked into the matter.

Component manufacturers know

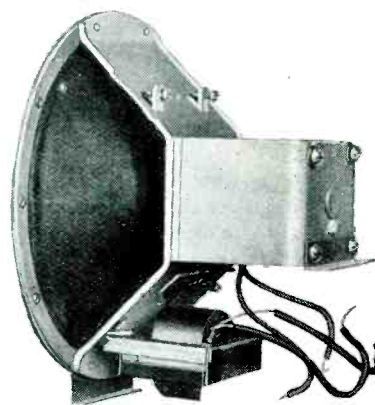

A new Blue Spot model—the type 72 moving-coil reproducer

perfectly well it is inevitable that parts made by different firms have to be used when one is building a set, and they should make some effort to standardise control knobs, in the interests of appearance.

There is no reason nowadays why home-built receivers should have to look "botchy" when compared with commercial models.

In the high-tension battery field

WHAT'S NEW IN RADIO—Continued



A new Atlas mains unit for high tension and trickle charging

there is a welcome tendency to reduce prices. The maintenance cost of a battery set during 1932 will be lower than ever before. Not only are dry batteries cheaper, but they are much more consistent in performance.

Far Ahead

There was some justification three or four years ago for the opinion that foreign battery manufacturers were more advanced in production technique than British makers, but this no longer holds. Our makers can hold their own with any foreign productions and in most cases are far ahead as regards consistency of performance.

Constructors interested in mains gear will find that they can now get high outputs at a very much lower price than was the case a year ago. There are improved and cheaper metal rectifiers to supply the power needs of every type of receiver. Smoothing chokes and condensers are also cheaper and reduced in size.

Complete Mains Units

An interesting possibility is the production (by manufacturers) of complete mains units that can be built into a home-assembled receiver. So far, only one firm seems to have explored the possibilities in this direction and those readers who are familiar with the design of the A.C. Super 60 will realise what a boon the extension of this

policy would be to all who want to build their own mains sets.

In the case of mains units intended for use with battery sets, there is a tendency to do away with variable tappings.

VISIT the "W.M." STAND—No. 71.

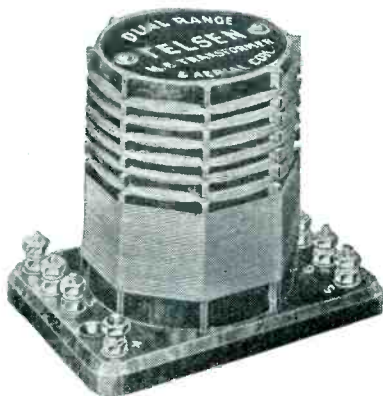

For tuned-grid or tuned-anode circuits—the Telsen dual-range coil

In the case of tappings for supplying screen-grid valves, for example, it is found much cheaper to take two or three fixed tappings off a potentiometer than to provide a continuously variable control. This, of course, means that prices of mains units can be reduced considerably on this score alone.

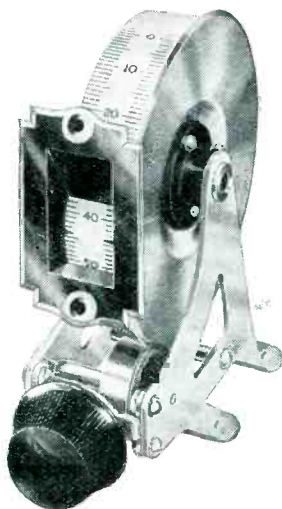

The new J.B. baseboard drum dial



The new Varley Popular type of wire-wound resistance

The finishing touch to any home-built set is the

cabinet and in this connection many improvements can be recorded.

There is still a preference for cabinets of the open-fronted type to take an ebonite panel, but the panel opening is now shaped in an attractive design instead of being purely rectangular.

This seems to be a small improvement, but it makes a surprising difference to the appearance of a finished receiver.

Consoles

Home constructors now also have available a number of attractive console or pedestal-type cabinets. These will appeal particularly to those who do not want to spoil a well-furnished home with a cheap-looking wireless cabinet. Some of the new productions are really fine examples of the cabinet maker's art and will satisfy the most fastidious tastes.

No Straggling Wires

Cabinets so arranged as to incorporate the loud-speaker and batteries or main units are also growing in popularity and many fine examples of this type are available. One great advantage of this type of cabinet is that there are no straggling connecting wires to constitute an eyesore in the home.

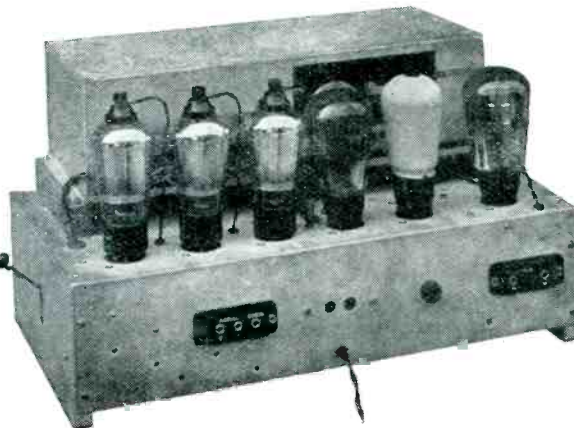

This is the chassis of the new Kolster Brandes super-het receiver

A BRIEF SURVEY OF AUTUMN PROGRESS

Cabinet Loud-speakers

Very great improvements have also been made in the appearance of cabinet-type loud-speakers. It is surprising, however, that more manufacturers do not take steps to produce designs that will harmonise with

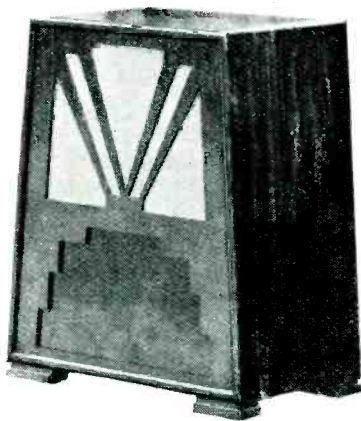

Something unusual in cabinets—the Kabilok Moderne model

some of the more popular sets on the market.

Even if a set and loud-speaker are obtained from the same manufacturer, it is not always possible to get them exactly matched in colour and grain of wood.

Perhaps the most outstanding loud-speaker development is the production of low-priced permanent-magnet moving-coil models. But on the whole, the performance of these small loud-speakers is disappointing.

It seems at present that the best policy is to use only a large permanent-magnet model or a small energised moving-coil, leaving the smaller permanent magnets alone until they are developed to a higher degree of efficiency.

Good Quality

The quality obtained with these small permanent magnets is good on the whole, but the sensitivity is in most cases on the low side and a large output valve is needed to get good volume.

Interest in the inductor type of loud-speaker is maintained and at least two firms

are making this type for the first time this autumn. They are likely to be more satisfactory in use than the smaller sizes of permanent-magnet moving-coil reproducer.

Units and Chassis

Those who need loud-speaker units and chassis to build into their own cabinets are well catered for. The price of units—and British made at that—has fallen considerably and a number of small drives suitable for moderate-sized receivers are available for less than 10s.

There are also a number of new chassis of the metal type. Many firms still make their chassis too large and it is something of a problem to find models that will fit the new constructor's cabinets, which in most cases seem to have been designed for moving-coil reproducers which have

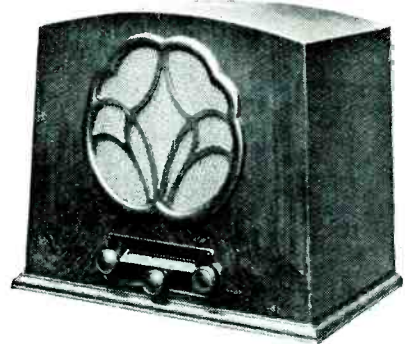

H.M.V.'s first radio set is a three-valver (type 435)

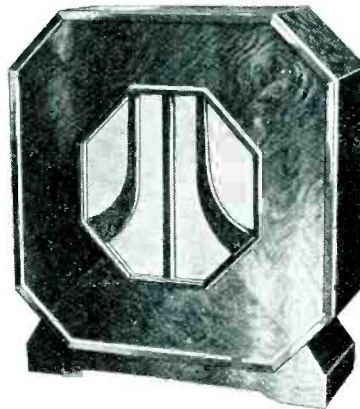

A Celestion permanent-magnet moving-coil reproducer (model RPM12B)

only a 7-in. or 8-in. cone diaphragm.

The outstanding development in complete commercial receivers is the production of screen-grid superhets. Interest in this direction, we may fairly claim, was due almost entirely to the production by WIRELESS MAGAZINE of

the Super 60 last March.

The chief difference between this and the commercial super-hets that are now being produced is that the latter are all for mains operation, while the former was specially designed for economical running with dry batteries.

An Omission

Except for a special short-wave model, we believe that there is no commercial super-het designed for battery operation. This is an omission which, in our opinion, should be rectified without delay.

Set manufacturers seem to ignore entirely listeners who have no electric-light supply available. On the other hand, there seems to be a glut of mains receivers and one cannot help wondering whether there is not considerable over-production in this field.



The new Kolster Brandes radio gramophone is a fine job in an attractive walnut cabinet



Metallised mains screen-grid valve—the Cossor MSG/HA

WHAT'S NEW IN RADIO-Continued

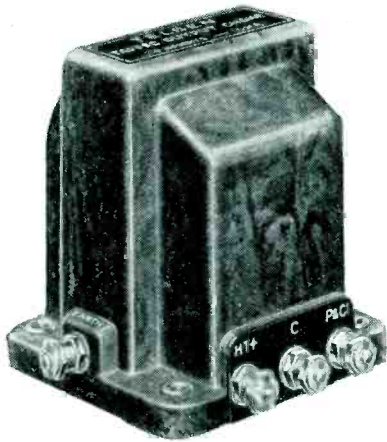

Telsen's tapped output choke has an inductance of 20 henries

Leaving super-hets, one cannot fail to notice the great increase in the number of radio gramophones being produced. Most of these comprise a

three- or four-valve screen-grid receiver with an electrically driven motor and pick-up for playing gramophone records. A new departure is the production of table-model radio gramophones, which have been long overdue. Models of this type will undoubtedly attract the interest of large numbers of listeners. Undoubtedly there will be further developments in this field. There is also an increase in the number of self-contained receivers being made, but these are not of the transportable type. They include a loud-speaker, but need an external aerial and earth system. In many cases, as already noted, arrangements are made for using the electric-light wiring as an aerial; this means that the set can be moved from room to room with very little difficulty.

Controls have been considerably simplified. Many sets are now provided with a combined wave-change and on-off switch, while in several cases a dual form of volume control works for both radio and gramophone-record reproduction.

Direct wavelength calibrations instead of degree divisions are a feature of many tuning dials. There is thus no need for a special wavelength chart when one desires to tune in a

particular station. Every member of the family will be able to operate sets of this type without any difficulty.

On the whole, amazing reductions have been made in the prices of com-

ponent manufacturers who may be relied upon to develop its possibilities still further.

A welcome surprise awaits those who use some of the new pick-ups that are at present being developed. The maximum output up to the present has been in the neighbourhood of 1 volt or so, but several firms are now engaged in the production of improved types that will give an output of 2 volts or more on an average record.

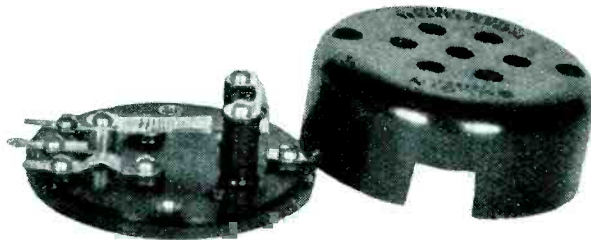

This is a thermostatic switch made by Bulgin for A.C. mains sets

plete receivers and there are now models of high efficiency and attractive appearance to suit every purse.

VISIT OUR STAND No. 71

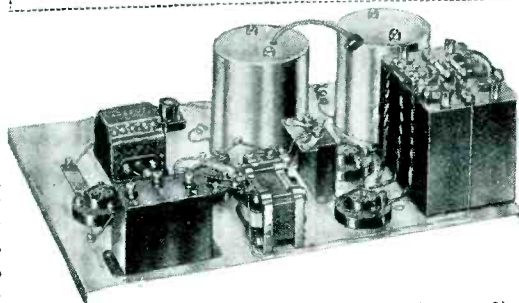

Here is the Cossor Mains Melody Maker (type 238) partly constructed

Nor have makers of kit sets been idle during the summer. Some really fine receivers are now available—and at competitive prices. The three-valve receiver incorporating a screen-grid high-frequency stage,

detector, and pentode output valve retains its popularity and several efficient designs are now available.

There is at least one four-valve kit with two screen-grid valves for those who want something more powerful than the ordinary run of receivers.

Home recording, like television, seems to have come to a standstill temporarily, but one system that has enjoyed considerable popularity during the past year has now been taken over by a well-known firm of com-

Less Record Wear

Not only will greater amplification result, but record wear with the new models will be distinctly less than it has been in the past.

All these improvements will result in simpler and more satisfactory receivers. No matter whether the listener builds or buys his receiver complete, he is assured of much less trouble with his outfit in the future than has been the case in the past.

With falling prices and improved performance there is no longer any need for obsolete sets to be kept in commission. Almost every week the broadcasting channels become more congested and only an up-to-date receiver will give the satisfactory results that everybody desires.

Only one question remains to be answered: Is the British Broadcasting Corporation taking steps to see that its service in the future will show equivalent progress to that made by manufacturers in the technical field?



Useful for any set—the Belling-Lee wander fuse

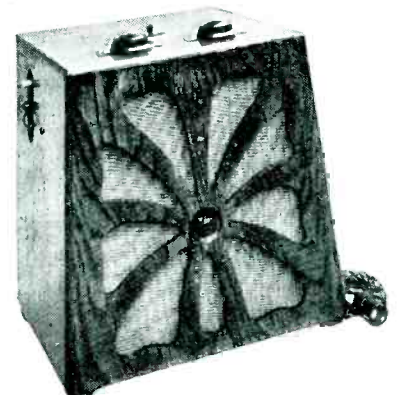

The new A.C. Pup (two-valver), made by Kolster Brandes

A COMMENTATOR'S SECRETS

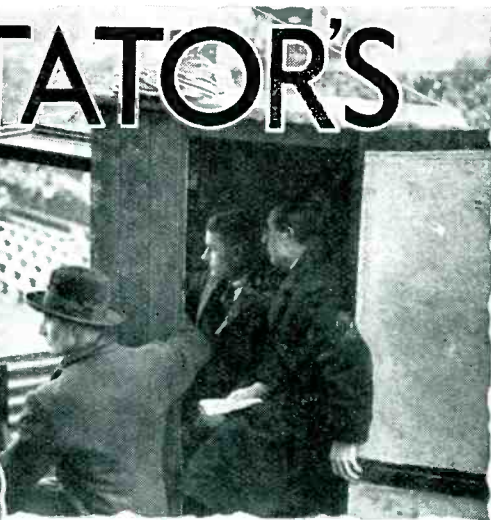

GEORGE F. ALLISON, of running-commentary fame, chats with HAROLD A. ALBERT and reveals some of his secrets.

IT is always interesting to picture a broadcaster, and then to meet the person in the flesh—to have one's idea confirmed or denied. More often it is the latter.

One expects George F. Allison, for instance, to be a blond giant. Instead, he is a very spruce business man, with horn-rimmed glasses, alert, not at all what one would imagine.

As he said to me: "By profession, I'm a sort of general mixture. A business man and a journalist and goodness knows what else. One of my interests is photography. I suppose that is what gave me my eye for detail. And there are other interests—."

There are. Dozens of them! Which may explain why George Allison is successful. He enjoys most things. He lives.

Diversity of Experience

"I suppose that is why the B.B.C. asked me to make my first running commentary," he said, "because I have had such diversity of experience. I'm one of the directors of the Arsenal Football Club, and I've been interested in soccer ever since I can remember. I've played myself, and attended hundred of matches. I ought to be able to comment on the game if anyone should.

"Oh, yes, it's fairly easy. In any case, I should be getting used to commenting now after four years of it. I've done the Derby and the Grand

National, as well as football matches. Of course, it is football that interests me most. I know hundreds of players by sight. Those I do not know I generally manage to see before the match, either while they're practising or else in the dressing-rooms. Then I memorise their faces, and that's that. I flatter myself that my total of mistakes is less than point one.

Something Instinctive

"Besides, commenting is not like keeping a thing in your head and writing it down afterwards. You just repeat what you see happening . . . talk as the words come into your head. Something instinctive inside you does the rest."

I was rather disappointed by this. Was his work really so easy? But one has to be with Mr. Allison some little time to understand him. And then he begins to cough up his difficulties.

"Of course, the great thing is not to get excited. It's fatal to have any emotional interest in the match. When the team that a partisan favours scores a goal or gets pretty near to scoring one, he generally gets so excited he can do nothing more than repeat like a parrot: 'Great game! Good! Oh, good! Oh, good!' That is fatal. The public are not interested in a set of superlatives. Listeners want to know what is happening, and they also want to share in the game as it goes on.

"My great secret is to appear excited without really being so. In other words, I have to act. Were I to describe the incidents of the field in an expressionless voice as calm as my feelings, the commentary would be like a funeral dirge. And listeners would simply switch off. That is all there is to it. Mind you, it is difficult to keep calm sometimes.

"There are other difficulties, too. I never use field-glasses to see the players, but simply rely on my natural eyesight. It has never failed me yet. The only drawback is that weather conditions may be unsuitable for observing. Fog or mist may wreak havoc with the view. The only thing to do under these circumstances is to talk about what one does see—ghostly figures flitting here and there, and so on. The listener still gets at least as good an impression as the unfortunates who have paid gate money to see the game.

Drawback of Noise

"The clamour of the excited crowd is occasionally a drawback as well. It is sometimes so great that it penetrates through the glass of the broadcasting booth to such an extent that I can hardly hear myself speak. The drawback here is that I never know how the transmission is going over.

"I have shouted into the microphone when there was absolutely no need for volume. Once or twice I have stopped altogether, being under

A COMMENTATOR'S SECRETS—Continued

the impression that listeners would never be able to hear me . . . only to be informed after the broadcast by the engineers that my voice would have been heard perfectly well.

"Do I visualise my listeners? As a general rule, yes. It depends on the occasion. I always feel that I am helping those who cannot help themselves, and who through one reason or another, through sickness or disability, cannot see the match. Sometimes I imagine one person, sometimes a little group of friends. Occasionally it will be a crowd millions strong.

Keeping in Touch

"The letters that listeners send enable me to feel that I keep in touch. You would be surprised! My listening public seems to be limited to no particular type or class. I have had letters from old ladies of eighty who declare that they took no interest in football . . . until they heard me. It is all very pleasant, comforting in a way. I appreciate the fact that people take the trouble to write to me, and for this reason I always answer them.

"Funny experiences? Yes, I have had a few. Try broadcasting in a place like a stuffy telephone booth on

a hot day! That's funny. No wonder I keep slim.

"Again, people pop their heads into the booth before we begin the broadcast. 'Could you send a message over the wireless to Aunt Edith?' they ask.

"Then there was that occasion when a high-kicking back 'ballooned' the ball over the crowd. I saw it come sailing towards me, and felt certain that it must crash through the window glass. I passed the glad news on to listeners. 'In a second you will hear the smash. It's coming, coming. I'll dodge down.' I did, but the ball luckily missed us and went to the side.

"Another time, my maid sent some trunks that were urgently wanted by goods service instead of by passenger train. I despaired, for I thought that it would be hours before they reached their destination. In the end, I telephoned a certain famous firm of carriers to implore their aid.

"The voice at the other end asked who was speaking. 'George Allison,' said I. 'George Allison? What! Not the bloke that radiates?' 'The same,' I answered,

'I radiate commentaries and goodwill to everyone.' 'Blimey!' said the unknown, and he seemed to like my broadcasting so much that the matter of the trunks was swiftly straightened out. And as far as I know, even to this day I have not received the bill.

"Oh, and by the way! Some people wrote to me the other day about their parrot. It is always a well-behaved bird, but it invariably swears whenever it hears me."

Football Decision

There was one last question to be asked. I inquired what Mr. Allison thought of the decision of the Football League and the Football Association to bar broadcasting for ordinary matches during this coming season on the grounds that it interferes with the gate money.

"I don't agree with the decision at all," he answered, "but at the same time I have to regard it as a mighty compliment. To think that they should bar broadcasting—and all because of me!"



This spectator at a football match took a portable along to hear what the commentator had to say. Certainly a brain-wave, wasn't it?

NO MORE FOOTBALL BROADCASTS?

As far as can be ascertained at present, there will be no broadcast commentaries on football matches this season, except in the case of the Football Association Cup Final, which is held at Wembley. Many listeners will miss these broadcasts and it is to be hoped that some way will be found out of the present deadlock.

Designed by the
"W.M." Technical
Staff.

See it at the
Radio Exhibition—
Stand 71.



WITH the opening of a new radio season, many listeners will want to build themselves something better in the way of receivers than those they are using at present, and large numbers of people will also desire to build their own sets for the first time.

Meets All Needs

For these reasons some weeks ago the WIRELESS MAGAZINE Technical Staff began work on designing a receiver that would meet the needs of the largest number of readers.

The cost had to be moderate, the construction and operation as simple as possible, and the utility more than ordinary.

Various circuits were tried and a large number of new components tested in order to make sure that everything was of the best.

The result is one of which we are proud. As the receiver has five special points that will appeal to every listener, we have called it the Five-advantage Three.

Five Advantages

Advantage 1 is that the set has only one tuning knob—a very real advantage in those cases where the receiver is needed for general use by the family, for it can be operated by anybody after a few minutes' experience.

Advantage 2 is that a band-pass tuning circuit is employed. This means that the selectivity is of a high order and stations transmitting

- 1.—Only one knob to tune when operating.
- 2.—Band-pass tuning for good selectivity.
- 3.—Radio reception or gramophone - record reproduction.
- 4.—Dual volume control for radio and records.
- 5.—Efficient and powerful circuit with many refinements.

on adjacent wavelengths can be separated readily; and also that the very best quality is obtained, with no cutting off of the top or treble notes in the reproduction.

Advantage 3 is that the set can be used for picking up broadcast programmes or for reproducing gramophone records electrically. For the latter purpose it is only necessary to connect an electro-magnetic pick-up to two terminals provided for the purpose.

Advantage 4 is that a special "fader" volume control is fitted. This one knob in itself produces three effects, for it controls volume for both broadcast and record reproduction and changes the set over from radio to gramophone as desired.

Advantage 5 is that the foregoing features are all obtained with the use of what experience has proved to be

the best type of circuit for ordinary use, where a fair number of stations is required at good strength—and for a reasonable first cost and low maintenance expense. The set incorporates a stage of leaky-grid detection and two low-frequency amplifiers, one resistance coupled and the second transformer coupled.

A Real Advance

One or other of these special features will appeal to every listener and, taken together, they mean that the Five-advantage Three is a real advance in three-valve receiver design. As such the receiver will have a wide appeal.

Very many constructors who have previously built their own sets will be glad to see that the Five-advantage Three makes use of the ever-popular two-contact type of plug-in coil. Thousands of listeners already have sets of such coils and will be pleased for the opportunity to use them in an up-to-the-minute circuit.

Refinements

It will be seen from the circuit diagram reproduced on page 250 that many refinements have been incorporated in the set, and it will be just as well to run through the main points of the theoretical design before discussing the construction and operation.

Directly in the aerial lead there is a series condenser of the semi-variable type; this has a minimum

An Ideal Three-valve Battery Receiver

THE FIVE-ADVANTAGE THREE—Cont.

capacity of .00025 microfarad and a maximum of .0003 microfarad. This is adjusted according to the length of the particular aerial to be used with the set; this point will be discussed in detail when we come to the ganging of the band-pass circuit.

Band-pass Coupling

In order to produce the band-pass action, two coils are used. These are coupled both inductively and capaci-

or X-tapped coil can be used in this position, but the latter is preferable as it enables a better adjustment to be made.

The second coil in the band-pass circuit can be a plain one, for here no advantage is gained by tapping down on the winding.

As the set incorporates a detector and two low-frequency stages, the tuning circuit is connected directly across the grid and filament of the

tion coil itself is coupled inductively with the second band-pass coil, the amount of feedback or oscillation being controlled by a .00035-microfarad variable condenser.

Detector By-pass

The efficiency of the detector valve is increased by the use of a high-frequency by-pass condenser connected between anode and filament. This condenser has a capacity of .0001 microfarad.

The detector is coupled with the second valve by the resistance-capacity method. For this purpose there is a fixed resistance of 50,000 ohms in series with the high-frequency choke. One end of this resistance is taken to a tapping on the high-tension battery.

A fixed condenser of .01-microfarad capacity is used to couple the detector-anode circuit with the grid circuit of the first low-frequency valve. In place of the usual grid leak there is a special potentiometer. This has a total resistance of 1 megohm, but, as it is centre-tapped, the effective value acting as a grid leak is only .5 megohm.

Controlling Volume

It will be seen that the grid of the second valve is connected to the potentiometer slider. When this is in a position between the top end of the resistance and the centre tap, the volume of radio signals is controlled from a mere whisper to full strength.

When the slider is moved round, so that it is between the centre tap and the bottom end of the resistance (in the circuit diagram, of course), the detector valve is effectively cut out and the input from a pick-up for playing records is controlled within the same limits.

Transformer Coupling

In this way a single component is used as a grid leak and as a volume control for both radio and gramophone-record reproduction. A further advantage of the system is that the pick-up can be kept permanently connected to the receiver.

The coupling to the second valve and the power output stage is provided by means of a low-frequency transformer in the ordinary way. But in order to prevent any possibility of motor-boating or low-

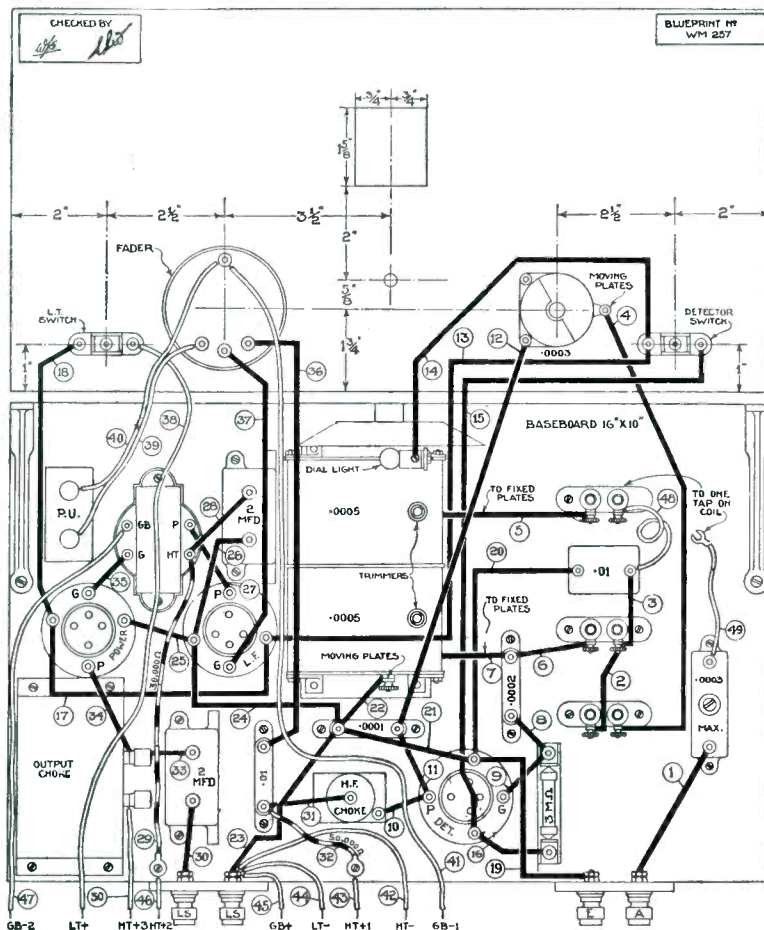

QUARTER-SCALE LAYOUT AND WIRING DIAGRAM

A full-size blueprint can be obtained at half price, that is 6d. post free, if the coupon on last page of this issue is used by October 31. Ask for No. W.M. 257.

tatively, a .01-microfarad fixed condenser being used for this purpose. The inductive coupling can be varied at will by changing the relative positions of the two coils. In fact, the best coupling must be found by trial.

Use of Tapped Coil

To effect the best compromise between signal strength and selectivity, a tapped coil is used for the first circuit. Either a centre-tapped

detector valve, which is arranged on the leaky-grid principle in order to obtain maximum sensitivity. Normal values of grid leak and condenser are used, namely 3 megohms and .002 microfarad.

In the anode circuit of the detector valve is placed a high-frequency choke. This stops the passage of high-frequency currents into the low-frequency circuits, and also gives a good control of reaction. The reac-

THE FIVE-ADVANTAGE THREE

What It Is : What It Does

THIS set is best described as a receiver for general use by the family. There is only one tuning knob and

the change from radio to gramophone-record reproduction is made by moving a single knob. Besides being

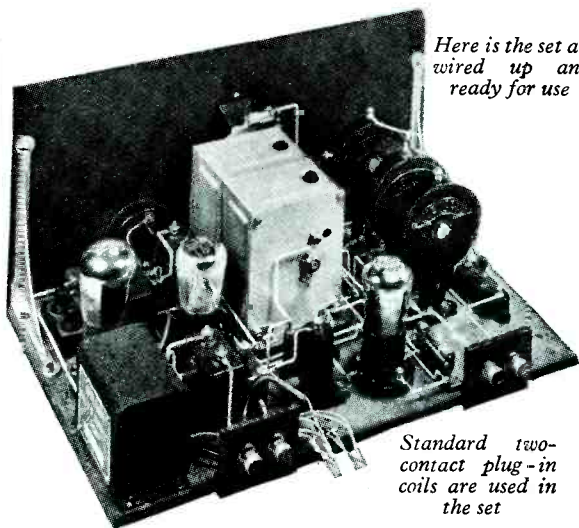

Here is the set all wired up and ready for use

Standard two-contact plug-in coils are used in the set

A band-pass circuit is used for selectivity

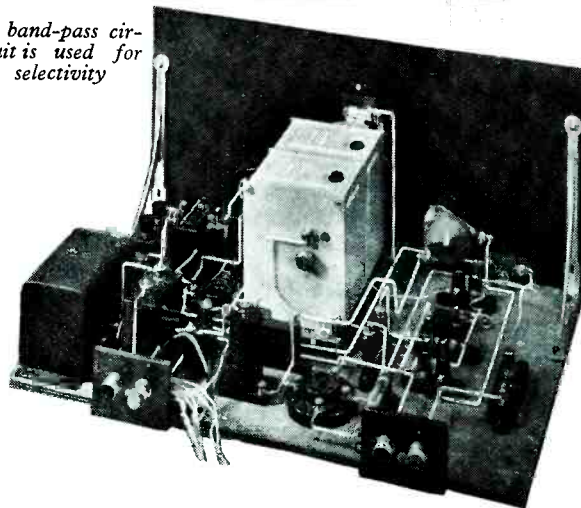

particularly selective, the set is also powerful and can be relied on to give a good selection of foreign programmes wherever it is used.

The basis of the set, which has been specially designed by the WIRELESS MAGAZINE Technical Staff, is a simple three-valve circuit, incorporating a leaky-grid detector and two low-frequency stages.

Experience has proved that this type of circuit can be relied on to give excellent results with the minimum running costs.

The coupling between the

detector and the first low-frequency valve is accomplished by means of a resistance-capacity coupling, while a transformer is used to couple the first low-frequency valve with the power valve.

While all three valves are used for radio, of course, only the last two valves are used for gramophone reproduction.

Five Features

As its name implies, this receiver has five special features. These are: (1) only one tuning knob, (2) band-pass tuning for selectivity, (3) radio or gramophone reproduction, (4) dual volume control for radio and gramophone, and (5) a very efficient circuit.

There is no question that the Five-advantage Three will have a wide appeal, for it meets the radio needs of nearly all listeners.

Another feature of the design is that the ever-popular type of two-contact plug-in coil is used. Many listeners already have a set of such components on their shelves and will be glad of the opportunity to use them in a really up-to-date design.

Use of Pick-up

There is no pick-up switch on the set, a special potentiometer making the change from radio to gramophone and also controlling the volume of both forms of reproduction.

Not only is the set reasonable in first cost, but the maintenance expense is also low. The consumption of the three valves should not be more than 10 milliamperes or so and a high-tension battery of the double-capacity type will give satisfactory working.

COMPONENTS NEEDED FOR THE FIVE-ADVANTAGE THREE

CHOKE, HIGH-FREQUENCY

- 1—Readi-Rad, Hilo type, 4s. 6d. (or Watmel, Telsen).

CHOKE, LOW-FREQUENCY

- 1—Bulgin 20-henry, 12s. 6d. (or R.L., Lotus).

COILS

- 1—Lewcos No. 25 plug-in, 3s. 6d.
1—Lewcos No. 60 plug-in, 3s. 6d.
1—Lewcos No. 60 X-tapped plug-in, 4s. 9d.
1—Lewcos No. 100 plug-in, 4s. 6d.
1—Lewcos No. 200 plug-in, 4s. 6d.
1—Lewcos No. 200 X-tapped plug-in, 6s. 6d.

CONDENSERS, FIXED

- 1—T.C.C. .0001-microfarad, type 34, 1s. 6d. (or Telsen, Dubilier).
1—T.C.C. .0002-microfarad, type 34, 1s. 6d. (or Telsen, Dubilier).
2—T.C.C. .01-microfarad, type 40, 3s. 6d. (or Telsen, Dubilier).
1—T.C.C. .01-microfarad, type S flat, 2s. 6d. (or Dubilier).
2—T.C.C. 2-microfarad, type 50, 7s. 8d. (or Telsen, Dubilier).

CONDENSERS, VARIABLE

- 1—Lotus .0005-microfarad two-gang, with disc drive, £1 5s.
1—Lotus .00035-microfarad reaction, 2s. 6d.
1—Sovereign preset .0003-microfarad maximum, type V, 1s. 3d. (or Lewcos, Formo).

EBONITE

- 1—Becol 16 in. by 8 in. panel, 6s. 11d. (or Red Triangle, Readi-Rad).

HOLDERS, COIL

- 3—Lotus two-pin, 2s.

HOLDER, GRID-LEAK

- 1—Readi-Rad, 6d. (or Bulgin, Lissen).

HOLDERS, VALVE

- 3—W.B. four-pin, rigid type, 3s. 9d. (or Benjamin, Telsen).

PLUGS AND TERMINALS

- 4—Ealex terminals marked: Aerial, Earth, L.S. (2), 1s. 6d. (or Belling Lee, Clix).
2—Ealex spade terminals, marked: L.T.—, L.T.—, 4d. (or Belling Lee, Clix).
7—Ealex wander plugs, marked: G.B.—,

The prices mentioned are those for the parts used in the original set; the prices of alternatives as indicated in the brackets may be either higher or lower

- G.B.—1, G.B.—2, H.T.—3, H.T.—2, H.T.—1
H.T.—1s. 2d. (or Belling Lee, Clix).

RESISTANCES, FIXED

- 1—Readi-Rad 30,000-ohm spaghetti, 1s. 6d. (or Lissen, Tunewell).
1—Readi-Rad 50,000-ohm spaghetti, 1s. 9d. (or Lissen, Tunewell).
1—Readi-Rad 3-megohm grid leak, 10d. (or Telsen, Watmel).

RESISTANCE, VARIABLE

- 1—Magnum Dissolver, 10s.

SUNDRIES

- Glazite insulated wire for connecting.
1—Pair Camco panel brackets, 1s.
2—Sovereign terminal blocks, 1s. (or Belling Lee, Junit).
1—Belling terminal block with terminals for pick up, 1s. 2d. (or Junit).
2—Wooden blocks, 3¼ in. by ½ in. by ½ in.

SWITCHES

- 2—Telsen on-off, 2s. (or Lissen, W.B.).

TRANSFORMER, LOW-FREQUENCY

- 1—Igranic ratio 1 to 3, type G, 15s. 6d. (or Lotus, Lissen).

ACCESSORIES

BATTERIES

- 1—Ever-Ready 120-volt, type PP120, £1 4s. (or Lissen, Fuller).
1—Ever-Ready 9-volt grid-bias, 1s. (or Lissen, Fuller).
1—C.A.V. 2-volt accumulator, type 2AG7, 11s. (or Oldham, Exide).

CABINET

- 1—Kabilok Kelston model, £1 5s.

LOUD-SPEAKER

- 1—Amplicon cabinet model, type AB4, in oak, £2 10s. (or Wufa, Hegra).

VALVES

- 1—Six-Sixty 210HF (or Mullard PM1HL, Osram HL2).
1—Six-Sixty 210D (or Mullard PM2DX, Osram HL2).
1—Six-Sixty 220PA (or Mullard PM2A, Osram LP2).

THE FIVE-ADVANTAGE THREE—Cont.

frequency oscillation, a decoupling device is provided at this point. This takes the form of a 30,000-ohm resistance and a 2-microfarad bypass condenser. Bias is applied to the grid of the power valve through the secondary of the transformer.

Choke-output Circuit

A further refinement is the use of a choke-output circuit to prevent the anode current of the last valve from passing through the windings of the loud-speaker; and so prevents any possibility of burning-out or demagnetising.

leads, numbered in numerical order for the easiest and best assembly.

A copy of this blueprint can be obtained by every WIRELESS MAGAZINE reader for half-price (that is, 6d., post free) if the coupon on the last page of this issue is used by October 31. Address your inquiry to Blueprint Department, WIRELESS MAGAZINE, 58-61 Fetter Lane, London, E.C.4, and ask for No. WM257.

There are only two points about the construction that need special mention. In the first place, the two-gang condenser is mounted on blocks of wood $\frac{1}{2}$ in. high. Secondly, the

should be assembled in the numerical order indicated on the blueprint or the quarter-scale layout reproduced on page 246.

Methods of Wiring

For connecting the set any one of the three normal forms of wiring can be employed, namely (1) stiff insulated wire, such as Glazite, (2) copper wire covered with Systoflex sleeving cut to the required lengths, or (3) rubber-covered flex.

We must emphasise one fact about the coils to be used for this set. The two band-pass coils should, if possible, be matched, but this is a job that few constructors can tackle. For this reason we have specified only one make of plug-in coils, for experience proves that these are so similar in their electrical characteristics that they can be used with every satisfaction.

Panel Controls

Before going into details of operation, it will be as well to explain the use of the five panel controls. On the extreme left is a push-pull on-off switch, controlling the detector valve only. This should always be kept in the "on" position, except when the set is being used in conjunction with a pick-up for reproducing gramophone records, when the detector valve should be switched off.

Next to this switch is the knob of the reaction condenser, which is, of course, used in the ordinary way; it is turned to the right when it is desired to increase signal strength.

In the centre of the panel is the knob controlling the two-gang tuning condenser. This is adjusted in the ordinary way to tune the set to the wavelengths of the desired stations.

The third large knob on the panel is that of the "fader" potentiometer. When this is turned to its extreme left position, radio reproduction at full strength is obtained. Turning the knob from the left to the half-way position reduces the strength of radio signals gradually to zero.

Pick-up in Circuit

As soon as the knob is turned past the half-way mark position, radio reproduction is cut out and the pick-up is brought into circuit gradually, full volume being obtained when the knob is turned as far as possible to the right.

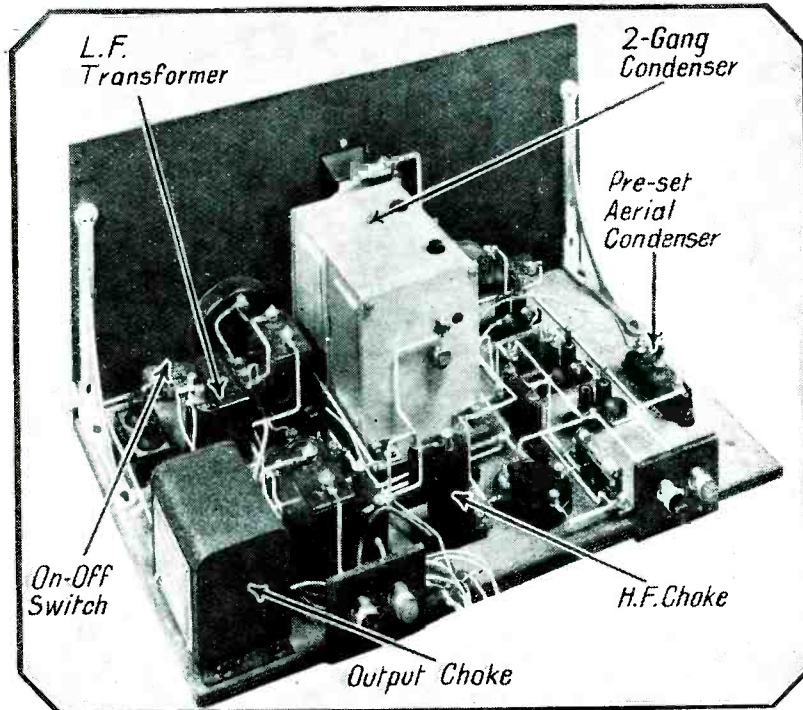

A FINE SET FOR RADIO AND GRAMOPHONE REPRODUCTION

This set is ideal for general family use; it will give musical programmes at any time of day—or night!

It will be realised from this description that no features essential for good performance have been omitted.

The circuit itself is simple, but it is one that can be relied upon to give the best results from the particular combination of valves employed.

Full-size Blueprint

Every essential detail for the construction of the set is included in these pages, but those who desire it can obtain a full-size blueprint showing the sizes of all the panel holes to be drilled; the exact positions of all the components; and the connecting

holder for the first band-pass coil (that is, the one nearest the panel) is held with only one screw, which acts as a pivot so that the coil can be swung round to vary the coupling, as already explained.

The gang condenser, which, it will be noted, is of the completely shielded type, has one of the new disc drives, and a small electric bulb is placed behind the panel so that the condenser scale can be read easily even if the set is placed in a dark corner.

As soon as all the parts have been firmly fixed in position on both panel and baseboard, wiring-up can be started. All the connecting leads

IDEAL FOR BEGINNERS AND OLD HANDS

It should be noted that as soon as the potentiometer knob has been turned to the gramophone side the left-hand on-off switch should be pushed in, so that the detector valve is cut right out of circuit. Then radio signals cannot break through and so spoil record reproduction, as might happen if the set were tuned to the local station when the change-over is made.

At the extreme right of the panel is the usual on-off switch. This controls all three valves and is pulled out to switch the set on.

Suitable Valves

Valves for the Five-advantage Three are not difficult to choose. For the detector position a medium-impedance type should be employed; something in the neighbourhood of 20,000 ohms will give the best results.

A similar type of valve can be used in the second stage, although here a somewhat lower impedance would not be amiss.

For the power stage a low-impedance valve is desirable for, within limits, the lower the impedance the better will be the quality of reproduction.

Certainly this power valve should

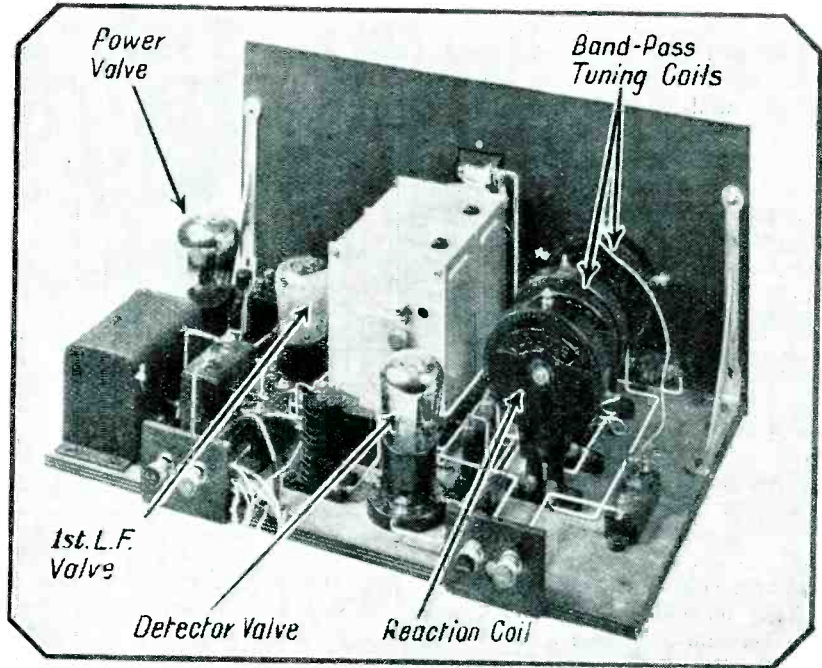

ALL WIRED UP AND READY FOR USE

This photograph shows the set completed in every detail and ready for use

have an impedance lower than 5,000 ohms, but the final choice must depend on the source of high tension available.

It is recommended, if dry batteries are to be utilised, that one of the

double-capacity type should be obtained. Such batteries have an economical discharge rate of the order of 12 milliamperes and the power valve should be chosen so that the total consumption of all three valves does not exceed this figure.

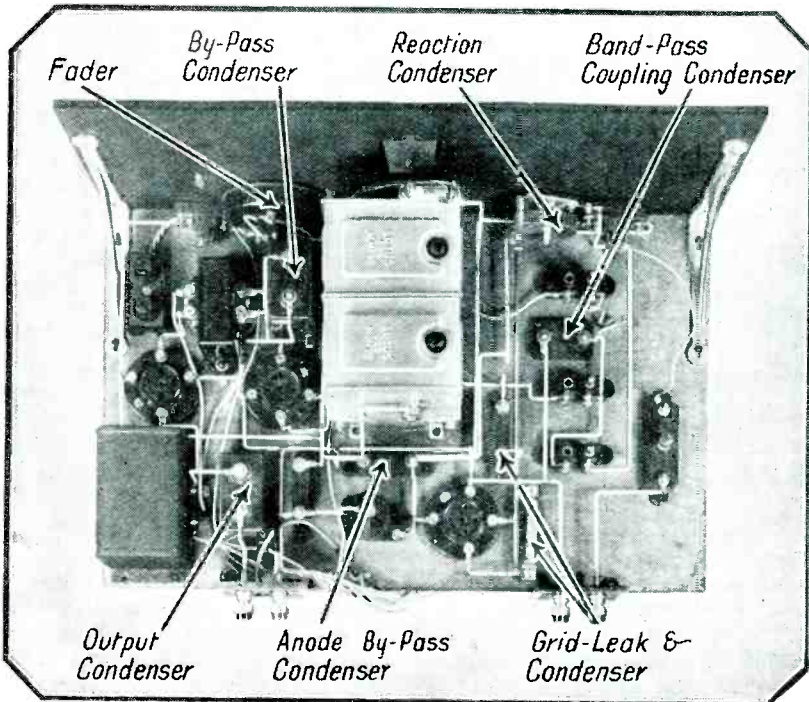

EVERY PART ACCESSIBLE AND EASY TO ASSEMBLE

A plan view which shows clearly the disposition of all the parts in the set. There is no overcrowding

Current Consumptions

The current consumptions of a large number of valves will be found in the feature, "Valves to Use in Your Set," that appears in the front part of this issue.

Now for the method of operating the Five-advantage Three. It is best to start on the medium wavelengths, and therefore two No. 60 coils and one No. 25 should be picked out. Looking from the front of the set, the No. 60 tapped coil should be placed in the first holder, the No. 60 plain coil in the second, and the No. 25 reaction coil in the third holder.

Trimming Condensers

To begin with, the pre-set condenser should be adjusted approximately to its half-way position and the small knobs of both trimming condensers on the top of the two-gang condenser should be unscrewed to the fullest extent.

(Continued at foot of next page)

SCREEN-GRID VALVES AS DETECTORS

SCREEN-GRID valves are normally used as high-frequency amplifiers, but it is possible to use this type as well for rectification.

An example of its use for this purpose is to be seen in the A.C. Super 60, in which the first detector is a screen-grid valve. The diagram shows how the valve can be connected for detection in an ordinary set. The anode-bend method is used, the control grid being biased negatively.

Minimising H.F. Currents

A resistance coupling is used and there is a resistance-capacity filter in the circuit. This is for the purpose of minimising the flow of high-frequency currents into the low-frequency circuit. A resistance may well be used as the resistance of the rest of the circuit is so high.

The anode resistance is of about 250,000 ohms, so there is not much loss in the 25,000-ohm filter resistance. To couple the detector to the

next valve a condenser and grid leak are used, as usual. These are shown in the diagram.

Poor results will be obtained unless

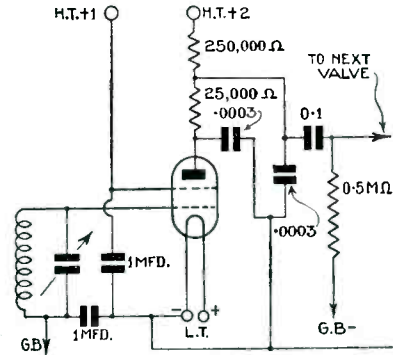

Typical circuit values for using a screen-grid valve as a detector

the voltage of the high tension is considerable, and care must be taken in setting the stage. It is possible to adjust both the grid bias and the voltage of the screen.

In practice it is convenient to fix the bias at -1.5 or -3 volts, according to the valve, and then to vary the voltage applied to the screen in order to obtain the maximum sensitivity.

If you experiment with the arrangement you will find the quality good enough and the sensitivity may be more than that from a normal stage. It depends upon the voltages applied to the circuit, the valve used and how it is adjusted.

Automatic Grid Bias

The arrangement is to be found in some manufactured A.C. sets, with automatic grid bias. The results are quite satisfactory, good magnification being obtained and the quality is satisfactory.

There is probably not much to be gained by using the arrangement in battery sets, but in A.C. sets the scheme is worth trying.

W. JAMES.

THE FIVE-ADVANTAGE THREE—Continued from previous page

When the set has been switched on, tune-in a station that is not too powerful by adjusting the centre knob on the panel. It will probably

position of the first coil until these two tuning points merge into one and the proper band-pass action is obtained.

First, try screwing down slowly the knob of the trimming condenser nearest the panel; also loosen the coupling between the band-pass coils by swinging the first coil round towards the panel.

If these adjustments do not result in the removal of the double-hump or double-tuning effect, then the capacity of the pre-set aerial condenser should be decreased by unscrewing the knob. When this is done the trimmer and the position of the first coil should again be adjusted.

Second Trimmer

In the ordinary way, there will be no need to touch the trimmer on the two-gang condenser that is remote from the panel. This can normally be kept unscrewed; that is, at its minimum capacity.

If these instructions are carefully followed, no difficulty should be experienced in getting the set to work properly. Once the band-pass circuits have been ganged properly, they should need no further attention, and tuning can be carried out by adjusting the single knob of the two-gang condenser provided for that purpose on the panel.

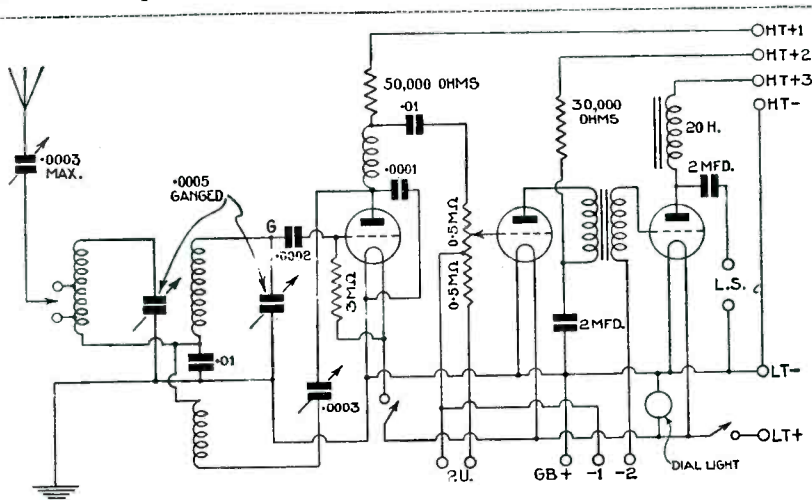

EFFICIENT THREE-VALVE CIRCUIT

The valve combination is a leaky-grid detector followed by two low-frequency stages, the first resistance coupled and the second transformer coupled

be found that the station is received at two points adjacent on the dial. The problem is then so to adjust the pre-set condenser, the trimming condenser nearest the panel, and the

This effect can only be obtained after a certain amount of trial, and the constructor must be prepared to spend some little time adjusting these parts.

The Month's Radio Music

The Serge
Krisch Septet



Still Better Broadcasters!

BROADCASTS of classical music are rapidly rising to an extraordinarily high standard, as advance details of the forthcoming winter season of B.B.C. Symphony Concerts at Queen's Hall prove.

It is, indeed, a pity that the lighter side is not showing the same improvement; in fact, programmes of that kind are decidedly falling off in quality for want of fresh talent and initiative from the compilers.

Symphony Concerts

As most listeners are aware, the B.B.C. Symphony Concerts start about ten days after the conclusion of the Promenade Concerts, that is, on October 14 next.

Arthur Catterall will again lead the B.B.C. Symphony Orchestra, which has now been enlarged to 117 players. Last year, it will be remembered, this orchestra made its debut with 114 players.

The extra three are accounted for by the addition of oboe, bassoon, flute and trombone players, and the withdrawal of a second tuba player.

If we take the renderings at the present Promenade concerts

—they have been really excellent—as a guide, the performances of the coming season of symphony concerts should be of a standard never before heard in this country.

Listeners who have an opportunity of getting to Queen's Hall to hear these concerts should do so. They will never regret it.

Some of the most famous conductors in the world will take charge. Those who will conduct one concert each include Richard Strauss, Felix Weingartner, Bruno Walter, Ernest Ansermet and Sir Landon Ronald.

In addition, Adrian Boult and Sir Henry Wood will be conducting twelve and five performances respectively.

These concerts will begin at 8.15 p.m., instead of 8 p.m., as in previous years.

The most eagerly anticipated event is the concert on October 21 when Richard Strauss, the famous composer and con-

ductor, will appear. Amongst the items to be played at this performance are *Three Hymns of Hölderlin* and *Ein Heldenleben*, both composed by Richard Strauss.

The latter work, very rarely played, is a vivacious tone-poem for orchestra, which even the most non-musically minded will thoroughly enjoy. The soloist at this concert will be Arthur Catterall.

Adrian Boult will conduct the opening concert on October 14, in which the soloists

will be Florence Austral, the famous prima donna; and Wilhelm Backaus, one of the most brilliant of German pianists.

Independent Piece

Backaus will play Schumann's *Pianoforte Concerto in A*. The first movement of this concert, written in 1841, was originally intended to be played as an independent piece called *Fantasia*. Schumann wrote the two remaining movements four years later, in 1845.

This concert will be primarily of a popular nature and will include Bach's *Brandenburg Concerto No. 3*,



A fine character actor,
Gordon Bailey is well
known to listeners



A singer heard in the
Children's Hour and studio
concerts, April Pendarvis

STILL BETTER BROADCASTS!—Continued



A singer who has broadcast nearly 150 times—Esther Coleman

Symphony No. 4 by Beethoven and the closing scene from *The Dusk of the Gods* by Wagner. The concert on October 28 will again be conducted by Dr. Boult. Elgar's *Symphony No. 1* will be the main work of this concert, in which the soloists are Herbert Janssen and Harold Bauer, the famous pianist.

Violinist for Nine Years

Bauer made his *début* in London in 1883 as a violinist and played as such for nine years in various parts of the country. Paderewski took an interest in his playing of the piano and became his only tutor. He is now world-famous for his renderings of Beethoven's piano works.

The "Proms" are nearly over. They have been a revelation of what a really first-class symphony orchestra can accomplish. Performances have, as a whole, been nothing short of wonderful.

The remaining concerts do not bristle with any outstanding performances except on Saturday, September 26, when Marcel Dupré, the organist of Notre Dame Cathedral (Paris) will play Handel's organ concerto, No. 10 in G, and Thursday, October 1, when Sir Edward Elgar will personally conduct his *Second Symphony in E flat*.



One of the best known tenors in the Midlands, Horace Priestley

Of course, the last night of the "Proms" is always the night which everybody enjoys. Liszt's *Hungarian Rhapsody No. 2* and Sir Henry Wood's arrangement of a *Fantasia on British Sea-songs* again are the mainstay of the popular programme. This is on Saturday, October 3; make a note of the date.

When the late Siegfried Wagner, son of the great Richard, came to England four years ago to conduct for the B.B.C., the suggestion was made for operatic performances at the famous Festspielhaus at Bayreuth to be relayed.

Although Herr Wagner has since died, the idea was pursued and on August 18 last a microphone was installed for the first time at the opera house in the home of Wagner's music. The relay which we recently heard, conducted by Dr. Wilhelm Furtwängler, was performed only as Bayreuth could perform it.

Enthusiastic Reception

It was a decided success for modern radio engineering as well as a great enjoyment for listeners. Probably the thought that it came from Bayreuth accounted for its enthusiastic reception.

It is interesting to know that this performance was relayed throughout Europe and Morocco, and even American stations picked up and



Zoltan Szekely, a Hungarian violinist heard recently in the familiar Mendelssohn Concerto

relayed the short-wave transmissions from Europe.

Recent changes in programme timing of the National and Regional



Thalben Ball will play the organ at the "Prom" on Sept. 30



A soprano heard frequently in the National programme, Evelyn Scotney



A popular baritone heard in Irish concerts, Robert Watson



Margaret Wilkinson, a soprano with a particularly fine voice

THE B.B.C. SETS A HIGHER STANDARD

programmes on August 31 have been made primarily to ensure that regional programmes shall be free from all talks and to permit a more varied programme.

The effect of this change will be that listeners to the Daventry National programme—and there are many thousands who cannot get any other station—will lose much musical entertainment and in its place will now hear all broadcast talks.

Listeners' Needs

An idea of this kind works admirably in regional areas, but surely the needs of every listener, and not groups, should be considered. An extension of musical entertainment, however, has been announced to begin on Saturday, October 3, when



A child prodigy violinist who has broadcast on many occasions, Nina Joel

extra music of a light type will be provided between 2.0 and 3.30 p.m.

This idea is certainly an improvement, but why not an hour's broad-

cast of light gramophone records at breakfast time? That would be a still greater improvement!

The quality, not quantity, of the lighter side of broadcast entertainment calls for comment. Much of the late evening dance music has fallen to such a low standard that most listeners will have switched off long before midnight.



Ernest Sefton, a character actor and entertainer, broadcasts regularly in revues

May we suggest that dance-band leaders should listen to broadcasts given by Continental dance orchestras, especially from Berlin. The hyper-modern trend of cat-calls has reached a limit and the title "dance music" should drop the "music" and adopt something different.

Cannot or will not the B.B.C. supply an alternative programme, say, from 10.30 till 11.30 p.m.?

Our vaudeville artistes, too, are giving equally poor turns. The old-time favourites still pump out items we heard twelve months ago and



A clever entertainer at the piano, Ida Sargent writes her own material

newcomers rarely show any sign of genius. The B.B.C. Theatre Orchestra with its delightful light musical programmes has certainly relieved some of the monotony.

We hope that the programme department at Savoy Hill has not entirely forgotten evening organ recitals in their keenness for better symphony concerts.

In Original Part

One artiste of whom we never seem to tire is Paul Robeson. He will take his original part, that of the Emperor Jones, in Eugene O'Neill's play of that name, when it is broadcast at the end of October. This should be worth hearing.

Of course, you have heard that stories for broadcasting told by Edgar Wallace are to be given on Saturdays in October. This is sure to be a popular non-musical feature.

T. F. HENN.



An English composer who conducted a programme of his own works, Haydn Wood



Sophie Wyes, an operatic soprano, has been heard in orchestral concerts

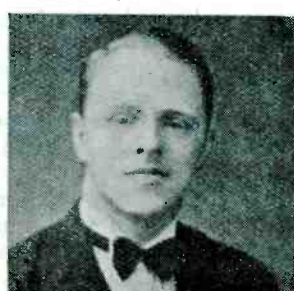

A provincial pianist heard from Northern Regional, Donald Edge



One of the earliest of broadcast entertainers, Foden Williams



*Ultra-short Waves
Help the
Doctor!*

A NEW FORM OF ELECTRICAL TREATMENT FOR DOCTORS TO USE

How the patient sits to undergo treatment by the new apparatus described in this article

A NEW apparatus, first demonstrated at the Radiologists Congress held in Paris, enables very short waves to be utilised for therapeutic purposes, thus endowing medicine with a new tool of surpassing efficiency.

Curative Properties

The possibility of using the curative virtues of such waves was first suggested by Professor Esau, of Jena, and investigated by Dr. E. Schliephake at the University Clinic of that town, who, during the last few years, has ascertained all the beneficial as well as noxious effects of ultra-short waves.

Noxious effects have been experienced by many a scientific worker spending part of his time in

the neighbourhood of powerful short-wave transmitters—head-ache, congestions, lassitude and somnolence being the more striking symptoms.

Dr. Schliephake paid particular attention to the electric field between condenser plates; insects were found to perish there within a fraction of a second, and mice after a few seconds, while larger animals would keep alive for longer periods.

That a heat effect is mainly at work in this connection was shown by tests of organic matter, when grass and leaves were found to be carbonised and bread could be baked thoroughly.

In oil and other insulating materials (for example, in quartz and most kinds of glass) on the other hand, there is hardly an appreciable heating effect, and the same applies to metals.

At the same time, there is a particularly intense conversion of energy in electrolytes, the degree of heating varying in accordance with their concentration. In the case of common salt a maximum heat effect is noted with a .5 per cent. solution, which is equivalent to the concentration of the blood.

Heating Blood

However, this applies only to one given wavelength, namely 3 metres, whereas in connection with both longer and shorter waves the maximum is shifted to other concentrations. Distilled water is found to be heated very little, whereas the heating effect in blood is particularly marked. Being a medical man, Dr. Schliephake, of course, took special interest in the behaviour of organic matter placed in the electric field. He first investigated the heating effect in various dead tissues, bones and the liver being found to come first, fat and the brain second, and the skin and muscles third.

This behaviour is all

the more interesting inasmuch as the order in the case of diathermics, which otherwise has so many points of likeness with the new therapy, is just opposite.

Both the diathermic and ultra-short wave treatments are mainly based upon a heat effect which, however, in the case of the latter, goes to far greater depths, and, moreover, can be controlled as to its direction, being adjusted at will to any given organ of the human body.

Below 10 Metres

Diathermics uses waves of about 600 metres, and the new short-wave therapy those below 10 metres.

Another important fact is that the effect of these ultra-short waves decreases as the electrodes come into actual contact with the patient's

A Special Article by Dr. Alfred Gradenwitz

body. This is why they should be kept at a short distance from the body, effects being varied by varying the thickness of the intermediate air layer.

The ultra-short wave apparatus, developed at the laboratories of the Siemens & Halske people, comprises a valve transmitter and operating circuit. The condenser leads are silvered brass tubes, which, by means of ball joints, are readily adjusted in any direction.

Aluminium Electrodes

The electrodes are aluminium plates coated with a protective layer of some insulating material. As soon as the proper radiation is obtained glow tubes are lighted.

It is, of course, impossible at the

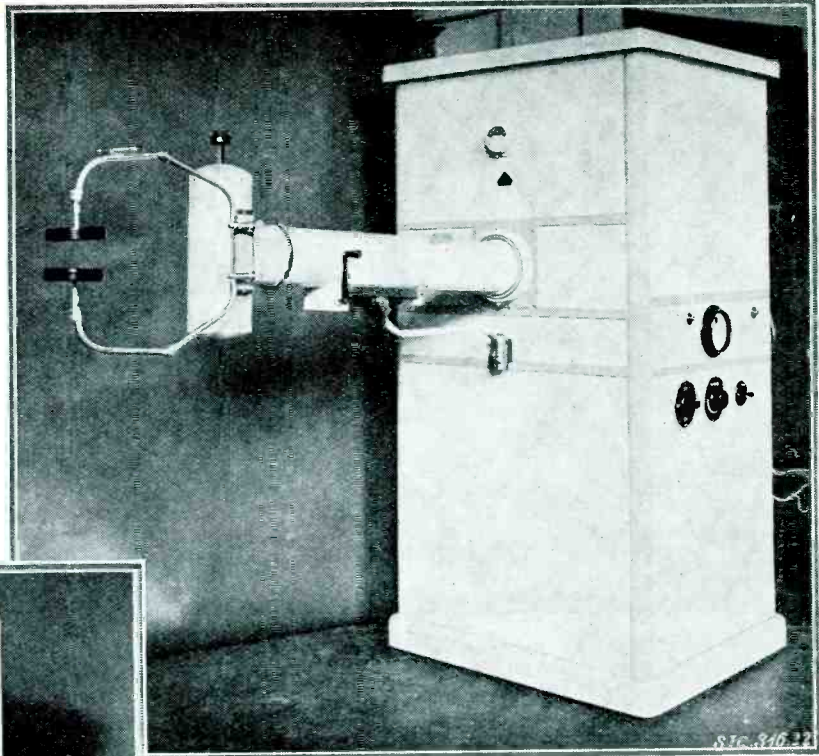

PROFESSIONAL-LOOKING GEAR

Another view of the new ultra-short wave apparatus for medical treatment

present time to state even approximately the possible applications of the new therapeutics. However, according to Dr. Schliephake's tests, it may be affirmed that there is a striking checkling effect upon the growth of bacteria (for example, tuberculous bacteria) cultures, providing that the proper wavelength be chosen.

Immediate Healing Effect

An immediate healing effect (for example, upon suppurating processes) has likewise been noted, furuncles have been found to disappear after one or two applications, and chronic diseases of the joints, which could not otherwise be controlled, have been distinctly improved.

Ultra-short waves, passing readily through the skull, will enable the head to be treated electrically.

Apart from the heat effect, there seems to be some biological effect, about which, however, nothing definite can as yet be stated.

RECEPTION ON THE COAST

SOME of us whose holidays are unfortunately over have very pleasant recollections of wireless reception by the seaside. Perhaps the first and worst feature of coast reception is interference from morse signals.

Living inland, you scarcely ever experience morse interference, and when you get to a coastal town, this old type of trouble comes as a surprise.

You know the generally accepted belief that wireless waves travel better over the sea than over the land. Have you ever tested this belief at the seaside? On the south coast you can make use of French stations for your test. On the east coast you can use the Scandinavian stations, and on the west coast the Irish stations. E. H. C.

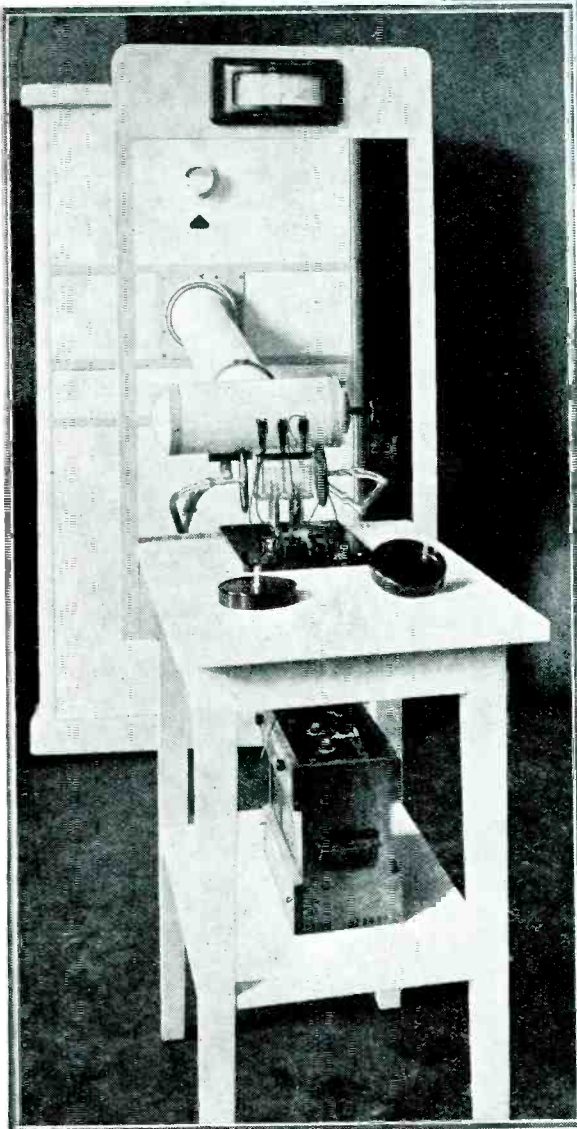

THE APPARATUS IN USE

This photograph shows the apparatus being used for experimental purposes



A RADIO FAN'S CAUSERIE :: CONDUCTED BY BM/PRESS

Wavelength Calibrations

I SUPPOSE the outstanding feature of this season's commercial sets is the inclusion of wavelength-calibrated dials in many models. This is a real advance and one that both expert and novice appreciate.

How are we constructors going to keep pace with the set manufacturers in this direction? We are entirely in the hands of the component makers.

Before now, I have suggested in these notes that coil and condenser manufacturers should combine to produce complete tuning units. If we once got our tuning circuits boxed up in a case as a single component, then I see no difficulty in having a wavelength-calibrated tuning dial.

Once again I recommend the idea to our more progressive manufacturers.

Death of the Baffle?

Are baffle boards for loud-speakers becoming extinct? It seems like it, for there is a general movement towards the use of cabinets for housing loud-speakers of all types.

One of the chief disadvantages of a moving-coil reproducer was, to many people, the fact that it was supposed to be used with a baffle "about 4 ft. square."

That looks all right on paper and sounds all right in theory, but what happens when you want to use one in the dining-room? I know more than one radio fan whose wife has refused to allow any such contraption

in the house—very rightly, too, in my opinion.

The problem is overcome nowadays by decent-sized cabinets that give a baffle effect equivalent to that obtained from a large flat board. Technical and household requirements are thus satisfied.

Radio Gramophones

Looking through a copy of WIRELESS MAGAZINE for February last I have just noted a reference I made to an "interesting rumour." It was that a certain gramophone company would not make any more mechanical gramophones after its existing stocks were exhausted, but would produce only electric models.

Well, I can say now that the rumour referred to The Gramophone Company, but it has not reached fruition yet. If you look at the new H.M.V. programme you will find that three models of mechanical gramophones are still being made—a pedestal machine, with space for filing records, and two portables.

Perhaps next year—but no more prophecies at present!

A Moving-coil Advantage

It has just occurred to me that sometimes a moving-coil loud-speaker can be much simpler to use than a reproducer of the type that has an adjustable-reed drive.

I am referring to the difficulty of fitting some balanced-armature loud-

speakers in console and radio-gramophone cabinets. It does happen often that the adjusting knob comes through the opening in the cabinet just where there is a thin piece of fretted wood, which is troublesome.

Moreover, there is always the difficulty that the silk cloth at the back of the fretted opening will "ladder" if a hole is made in it for the loud-speaker adjustment. That is to be avoided at all costs.

On the whole, you will be well advised to look out for this point when you build a new set for, if you are wise, it will be of the all-enclosed type.

A "Gramophone" Kit

One of the surprises of the new season was the announcement that the British Zonophone Co., was entering the kit field with a three-valver, complete in a "mantel" type cabinet with a loud-speaker.

British Zonophone is a subsidiary of the Gramophone Company, I believe, and up till now has been exclusively engaged in the production and sale of gramophone records.

Some people were suspicious when a well-known motor-cycle firm made radio sets a number of years ago, but the gramophone companies tackle their radio productions in such a businesslike way that some of the purely wireless manufacturers will have to look to their laurels. The gramophone people, remember, are out to sell entertainment.

Elaborate Equipment

One of the most elaborately organised and best equipped factories I have visited is the H.M.V. works at Hayes. There are some most ingenious roller-conveyor systems, so arranged that the parts to be dealt with come to the man concerned at just the right intervals quite automatically.

For instance, in the cabinet shop there is a conveyor on which all the pieces of wood for a cabinet are passed along from section to section, each worker supplying a different piece shaped and planed all ready for assembly.

The complete kit of pieces is assembled by two men, who make use of a most ingenious framework for pressing the cabinet to exactly the right shape. There is no possibility of bad jointing. A complete kit arrives on the conveyor at four-minute intervals.

Permanent Magnets

After having heard a number of samples of the small type of permanent-magnet moving-coil loud-speaker—what a mouthful that is; can't somebody invent a good contraction?—I feel that our manufacturers are making a mistake.

On the whole, results are disappointing. The chief snag is a falling-off in sensitivity, as compared with reed-driven cones. Nor am I particularly impressed with the quality of reproduction of these small P.M.'s.

Here is an instance, I think, of too much efficiency being sacrificed to bring price down to a low level in order to interest a new type of buyer.

My advice to anybody buying a moving-coil loud-speaker is to get one of the *large* permanent-magnet models or a *small* energised one.

Lunch at Sidcup

At Sidcup a few days ago, I sat down to lunch in company with 600 radio dealers. The occasion was a special trade lunch given by Kolster Brandes to introduce their new season's models.

After lunch I saw a most impressive moulding plant and in the cabinet shop there were hundreds of K.B. Pup cases ready to meet the autumn demand.

One K.B. dealer has his own aeroplane and often flies over to Sidcup to get urgent supplies of sets.

About 1,200 people are employed

by Kolster Brandes. At the peak of the autumn rush this figure will rise to 2,000. Thanks to mass-production methods comparatively unskilled workers can be found jobs in many of our large wireless factories.

Easier Mains Working

All-mains enthusiasts will welcome the appearance of high-voltage electrolytic condensers. You can get a 4-microfarad job that occupies about half the baseboard space needed by a Mansbridge-type condenser of the same capacity.

This means that both mains sets and units can be made much more compact than has hitherto been possible. One point to remember, though, is that these condensers have a positive and negative pole and must be joined up the right way round.

I am glad also to see a tendency for mains transformers to assume smaller proportions. The Regentone S60 mains unit is a good example of how compact the "all-electric" end of a set can be made.

Without Comment

From an evening newspaper I quote the following, which appeared under the heading "Your Problem Solved":

"You will gain very little in using low-loss reaction coils. A small bunched winding of fine wire, in a low capacity to a good inductance coil, usually gives best results."

Mains Aerials

Quite a number of set manufacturers are so arranging their receivers that the electric-light wiring of a house can be used in place of the usual aerial.

There is nothing new in the idea, of course. Some eight or nine years ago the Dubilier people produced a gadget for this very purpose. In those days of low-powered transmitters and insensitive receivers, the results were not too encouraging, I remember.

Perhaps mains aerials are more satisfactory with up-to-date receivers. A point that puzzles is the effect of the earthed metal sheathing used in modern house installations.

I shall be glad to hear from any readers who have had experience of this method of reception on a modern receiver.

Success of the Super-het

It seems that the WIRELESS MAGAZINE technical people knew what they were doing when they introduced the new type of super-het with screen-grid valves.

At least two of the most prominent makers this season have a super-het as the *piece de resistance* in their programmes.

As you know, Mr. W. James is preparing a new model for the Exhibition. I have seen the original; it looks the real goods. It has the best-finished radio cabinet I have yet seen. Here we have a constructor's set that looks as good as any commercial receiver.

I am sure it will be even more popular than the original Super 60.

Identification Signals

Now that radio sets are improving so rapidly and even two-valvers can pick up a number of high-power Continental transmitters, cannot something be done about identification signals?

At present it is not at all easy to tell what foreign stations are being received, for one has to be pretty quick to recognise a call even if one has a phonetic guide to what the announcer says.

From time to time various schemes capable of international application have been suggested, but not one has been good enough, apparently, to convince the powers that be that it is worthy of universal use.

Probably some distinctive interval signal—such as a cuckoo, chimes or a hooter—is the best thing for such a sound is easily recognisable.

At the Show

Every good listener will make an effort to visit the Radio Exhibition. From what I have seen and heard I have no doubt that everybody who goes to Olympia will come away wiser and with more enthusiasm than ever.

What a fine thing it would be if every reader of WIRELESS MAGAZINE made a point of taking at least one non-listening friend along with him. Thousands of converts would be made.

Remember also that the more listeners there are the quicker will the broadcasting service be developed. It is in our own interests to introduce as many new people as possible to our hobby. Don't you agree?

BM/PRESS

The Truth About High-tension Batteries

By J. H. REYNER, B.Sc., A.M.I.E.E.

THERE seem to be more fallacious arguments advanced and fewer real facts concerning high-tension batteries than any other radio component. So much so that many people believe there is nothing to choose between different makes of battery.

They say that the claims made by

With the idea of clearing up this position I started a series of tests some months ago. I was not sure whether we should obtain much real information from the experiments because the publication of comparative figures is always a somewhat difficult procedure.

Unless you show that all the components tested are of exactly the same performance (in which case the tests are more or less waste of time) one obviously cannot please everybody.

However, the experiments were started and they have, I think, yielded fruitful results.

The first question to be settled was the type of test to be placed on the battery. The British Standard Specification on the subject suggests three tests.

The first is a discharge through a constant resistance continuously. The second is an intermittent discharge through a constant resistance, the battery being left on for a certain period and then switched off and allowed to recuperate for another period. Thirdly, the battery may be discharged at a constant current.

Of the three,

the second is obviously the most nearly representative of the practical conditions obtaining in a wireless receiver. Its drawback is that it takes a long time to complete any one test, and sometimes in an endeavour to obtain a more rapid indication of the performance, recourse is had to the first test, namely the continuous discharge through a constant resistance.

The constant-current test, although useful in that it tells the scientist some things he wishes to know more quickly, is not really representative of practical conditions.

Quicker Discharge?

The first question to be decided, therefore, was whether an intermittent test was necessary or whether the much quicker continuous discharge would be permissible.

Some experiments which I had done a long time ago indicated that there was not much to choose between the two, and I found that as far as the voltage of the battery was concerned, this was quite correct.

The fall of the voltage as the battery was discharged was similar, whether the battery was discharged continuously or intermittently.

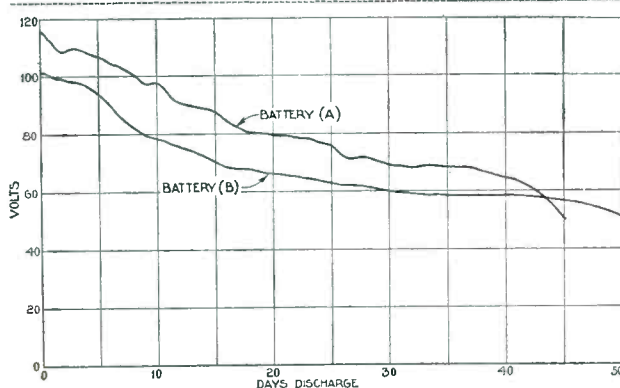

Fig. 1.—Voltage curves of two batteries, A and B. Which is the better battery?

one manufacturer for superiority do not mean anything in actual practical use, and that test reports are equally futile, so that it is quite a satisfactory procedure to walk into a shop and order simply "a high-tension battery" without specifying a make.

Such an assertion gains colour from the unsatisfactory methods in use for testing batteries. The customary procedure is to discharge the battery through a resistance and to determine the voltage after varying periods of discharge.

Different Opinions

There are several ways in which this may be done, and opinions differ widely, firstly as to how the test should be carried out and, secondly, as to what interpretation should be placed on the results, and whether the curves so obtained are of any value whatever.

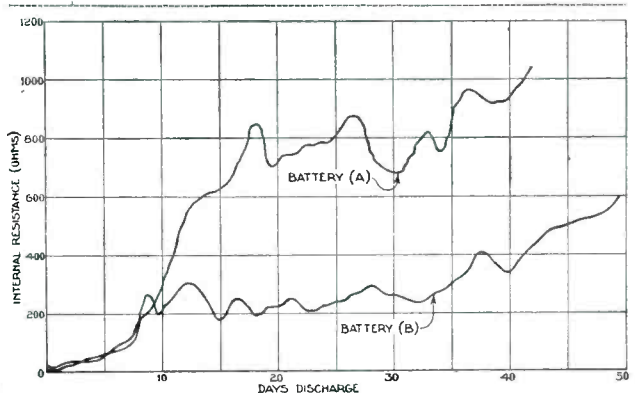

Fig. 2.—Internal resistances of the two batteries referred to in Fig. 1

The voltage of the battery, however, is not the only quality we require to know, as will be evident shortly. As the tests proceeded further it became clear that these other factors had different effects when the battery was discharged continuously, and that the only really satisfactory procedure was to discharge in an intermittent manner, leaving the battery on for a certain number of hours, and then switching it off to rest.

Results Unaffected

Within reason, the duration of the periods of discharge and recuperation did not seriously affect the results, and in the test finally adopted the batteries were discharged for a period of eight hours and then allowed to

the latter part of the discharge but most people seeing the two curves would without hesitation choose battery A as being the better battery. Indeed, I should have done so myself.

Now let us refer to Fig. 2.

This shows the internal resistance of the two batteries. Both batteries start at a fairly low value and immediately rise to about 200 ohms. At this point, however, battery B "stays put," and continues with a fairly low

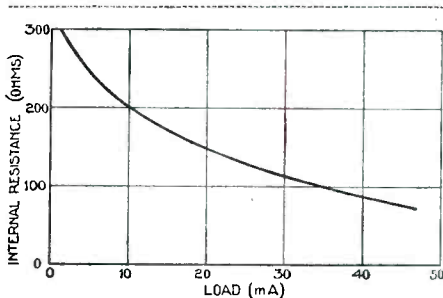

Fig. 3.—Internal resistance of a partly used battery at different loads

resistance, of course, is the resistance of the chemical paste of the interior of the cells, and also the resistance of the zinc containers in which the paste is housed.

The internal

resistance until the end of its life, where it is beginning to rise somewhat rapidly.

Battery A, on the other hand, soars quite early in life and after seventeen days discharge is over 800 ohms, and remains around

resistance, of course, is the resistance of the chemical paste of the interior of the cells, and also the resistance of the zinc containers in which the paste is housed.

A low internal resistance indicates that this paste is still in good active condition, whereas when the battery has become used up the internal resistance becomes very high. Thus it will be clear that the ideal state of affairs is for the internal resistance to be low as long as the voltage remains good.

When the voltage falls off, as it must do towards the end of the useful life, then the internal resistance should also rise, and not before.

Little Published

As a matter of fact, very little has been published about the internal resistance of batteries. When undertaking an investigation of any kind, one naturally endeavours to collect such information as is available on the subject as a starting point.

All the information on this subject,

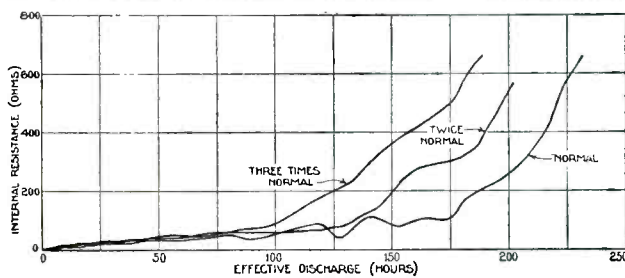

Fig. 4.—Internal resistance of single-capacity battery at different loads

recuperate for sixteen. This gives a little more severe use than is experienced in ordinary practice, but the difference in the results obtained is only quite small.

Having decided upon a satisfactory method of testing, the next step is to decide what we wish to know about the battery. Hitherto the almost universal practice has been to discharge the battery until the voltage had dropped to one-half its initial value, when the discharge was considered finished and the battery rated accordingly.

Now this really tells us nothing. The judging of a battery from the voltage-discharge curve can give utterly misleading results.

Voltage Curves

Fig. 1 shows the voltage curve of two batteries. Both these batteries were nominally 100 volts, and it will be seen that battery A starts off at 115 volts, and delivers a high voltage for a large number of days. Battery B starts more nearly at its rated value and gradually falls away in voltage in the normal manner.

There is certainly a tendency for the voltage to remain constant during

this figure all the rest of the time, subsequently climbing over the 1,000-ohm mark. Thus for three parts of its useful life its resistance is four times as great as that of the other battery.

Now, if one returns to the Fig. 1 curve again, it will be seen that while the first battery is rapidly falling in voltage at the end of its life, battery B is maintaining its voltage quite well. The reason for this is that the internal resistance is still low and that there is still life in the battery.

Taken in conjunction with the almost constant voltage from twenty days of life onwards it is clearly a better proposition, despite the lower voltage over the greater part of the run.

These curves were actually taken from two well-known makes of battery. They indicate the incom-

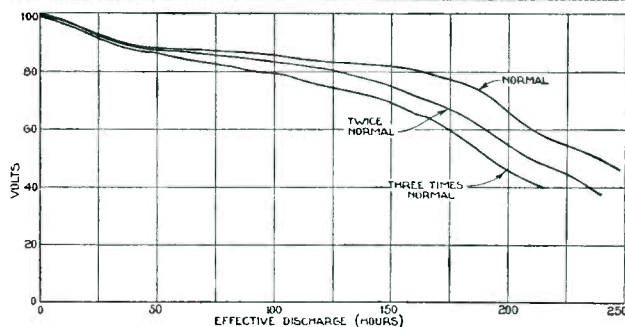

Fig. 5.—Voltages of different sections plotted to same scale as Fig. 4

however, seems to have been written from the point of view of heavy-duty cells designed to give large currents and, indeed, the customary method of measuring the internal resistance is to short-circuit the battery through a resistance of 1 ohm per cell, which results in a current of over 1 ampere! Such a method is clearly unsuitable

HIGH-TENSION BATTERIES—Continued

for radio practice, and a good deal of work was necessary before a suitable method could be evolved.

Fig. 3 indicates the internal resistance of a partly used battery at different load currents. The normal discharge current of this particular battery was about 15 milliamperes, so

known make of single-capacity battery, different sections of which were discharged at the normal current of 7 milliamperes, and twice and three times the current respectively.

Under normal conditions the resistance remained under 100 ohms until 175 hours elapsed, after which it began to rise more rapidly, accompanied by a falling-off in the voltage. When the battery was discharged at twice the normal current the rise in resistance takes place at 135 hours, and at 21 milliamperes as early as 100 hours.

The battery, therefore, has only remained good for a little over half the time when discharged at three times the normal rate. This bears out the argument which has been put forward in these pages that it does not pay to overrun a small-capacity battery.

In plotting these curves the discharge times have all been reduced to the same scale. Clearly if we discharge a battery at three times its normal rate we should only expect it to last one-third as long. Therefore the actual discharge time has been multiplied by three in the case of the 21-milliamper discharge in order to bring the curve to the same scale as the normal discharge.

What these results show is that the battery discharge at three times its normal current does *not* last one-third of the time, but only a little more than one-sixth. The same correction has been applied to the 14-milliamper curve, the actual discharge times being multiplied by two in order to make the results comparable.

This, again, is an instance where the internal resistance shows the defects in a battery where the voltage curve does not indicate the state of affairs to the same extent.

Fig. 5 shows the voltages for the various sections again plotted to the same scale so that they may be strictly comparable. As one would expect, the voltage with the excessive load is below that with the normal load, but one would not say that the discrepancy was really serious.

For example, under normal discharge conditions the battery reaches half voltage after 240 hours, whereas under the double rate it reaches this point after 210 hours, and after 190 with three times the normal discharge.

The internal-resistance curve, however, shows that while under normal

conditions the battery has been holding up quite well, the same is not true with the abnormal discharge rates. At 175 hours discharge, for example, the resistance at the normal rate is still only 100 ohms, whereas it is 300 and 500 ohms respectively with the other curves, although at this point the voltage is above 60 in each case.

Variation of Resistance

It is clear, therefore, that the information principally required about a battery is the variation of its internal resistance during the discharge and not the variation of the voltage.

We have seen that the voltage curve can be entirely misleading, showing a battery which is really inferior as a better proposition, whereas if the internal resistance of a battery is low it may be relied upon to give good service.

In all future tests on batteries, therefore, the internal resistance will be specified.

Voltage Curve

There is something to be learned from the voltage curve, because the theoretical ideal for a battery is that the voltage should be high over practically the whole of the normal working life, and should then fall rapidly when the end of the life has been reached.

Other things being equal, a battery which had such a performance would be a better battery. Fig. 6 illustrates such a discharge curve, this time purely fictitious, and this may be considered as the ideal of performance for a dry battery. No actual battery was as good as this, although several came quite near it.

Effect of Resistance

In order to make this information of real value it is desirable to know what the effect of internal resistance is, and what order of resistance may be tolerated. It is well known that internal resistance causes battery feed-back, which is a form of oscillation either at high or low frequencies, due to the fact that oscillating currents have to pass through the resistance of the battery and set up reaction effects in so doing.

Tests which have been made on simple receivers indicate that battery resistance is appreciable at 500 ohms, and that at 1,000 ohms the battery is definitely poor.

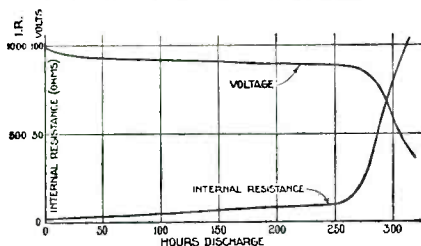

Fig. 6.—Ideal, but fictitious, discharge curve for high-tension battery

that a variation of plus or minus 50 per cent. in the resistance is easily obtainable if the current is not specified.

In all the subsequent experiments, therefore, the internal resistance of the battery was measured at the actual load current. Each battery was placed on discharge at its rated value and thereafter the conditions were not altered.

Lower Discharge Current

Consequently, as the voltage on the battery fell the discharge current also became less, as it does in an ordinary practical case. The internal resistance was measured on each occasion with the actual current flowing at the time.

This decrease in internal resistance as the current is increased only applies when a measurement is being taken. As far as the discharge current is concerned the tests showed that overloading the battery is always accompanied by an increase in the internal resistance.

Increased Resistance

As long as the current was around the normal value the resistance tended to remain low, but as soon as the battery was called on to supply much more than its rated current a rapid increase in internal resistance resulted. This increase did not show up immediately, but became increasingly evident towards the end of the useful life.

This is exemplified by the results shown in Fig. 4, taken on a well-

Everybody's Radiogram

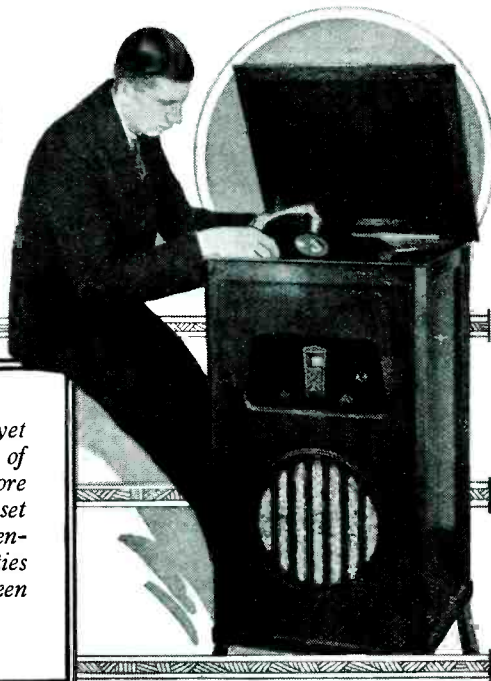

Here is one of the best three-valve A.C. sets yet presented to the constructor. Thanks to the use of a special boxed-up mains unit construction is no more dangerous than the use of an ordinary battery set supplied with high tension from the mains. A screen-grid valve ensures adequate distance-getting properties and the band-pass avoids all interference between stations working on adjacent wavelengths.

ONE of the most popular developments in the radio field during the past three years has been the improvement in radio gramophones. Everybody who can afford it desires to have one—and because it is particularly cheap we have called the model described and illustrated in the following pages “Everybody’s Radiogram.”

Good Radio Set

The basis of every good radio gramophone must be a good radio set. In this instance, the WIRELESS MAGAZINE Technical Staff have excelled themselves and the “skeleton” of the outfit is really good.

Everybody’s Radiogram is an “electric” machine; that is, it is provided with power from the electric-light mains, but only those of the A.C. (alternating-current) type are suitable. This particular set cannot be used in districts supplied with D.C. (or direct current).

All in One Cabinet

In one cabinet, which while being attractive in appearance is low in cost, are provided a mains three-valve screen-grid receiver with band-pass tuning; loud-speaker; electric gramophone motor; and electromagnetic pick-up.

With Everybody’s Radiogram the listener can have a twenty-four hour service of music—and when desired

he can choose his own programme of records and not have to put up with what the B.B.C. thinks is best!

Because there is some confusion on the subject amongst non-technical listeners, may we just emphasise the economy of running a set from the mains? So little current is actually consumed that even if the receiver is in operation for five or six hours a day the addition to the electric-light bill at the end of a quarter will be almost negligible.

A set of this kind takes no more current than an ordinary 60-watt lamp!

As shown in these pages, the outfit includes an electric motor to drive the turntable, but, of course, if this is too expensive an ordinary spring motor can easily be substituted. But so reasonable is the cost of the electric drive that we do not anticipate that many constructors will want to make the change.

Screen-grid Circuit

The circuit utilised for this set is the ever-popular “screen-grid, detector, and power” combination. It is much more efficient than an equivalent

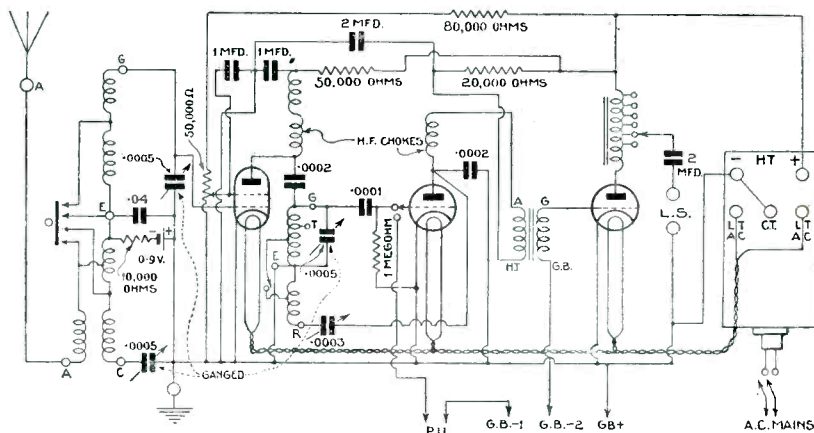

POPULAR AND UP-TO-DATE CIRCUIT

There is a band-pass tuner and the valve combination is the ever-popular “screen-grid, detector and power” sequence. Decoupling devices are incorporated to prevent any possibility of motor-boating or low-frequency oscillation

EVERYBODY'S RADIOGRAM—Continued

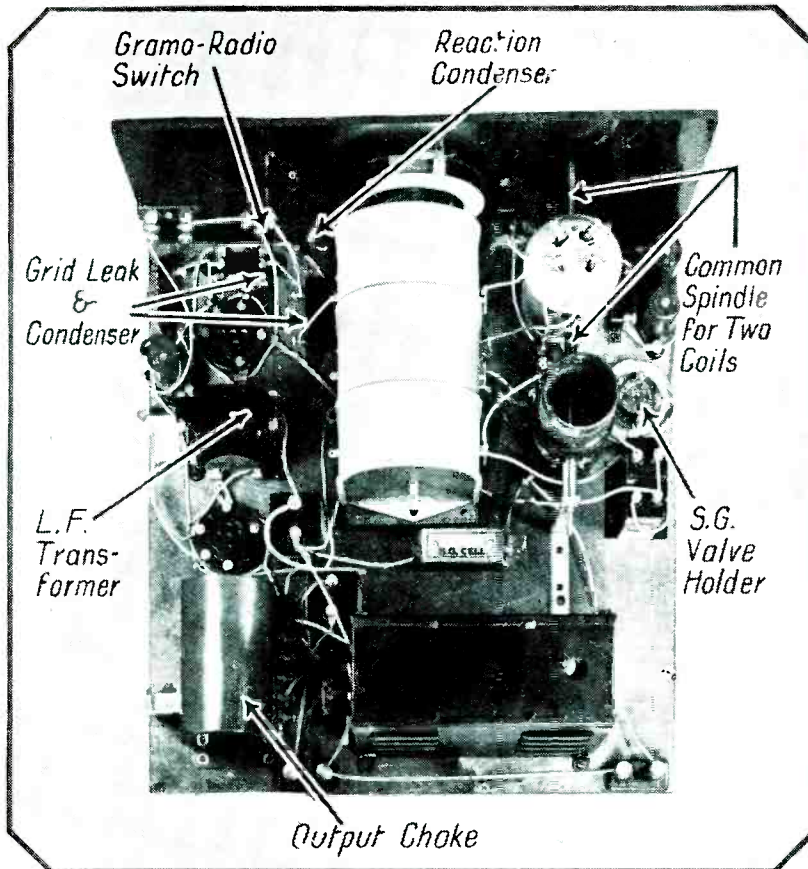

EXTREMELY SIMPLE FOR A MAINS RECEIVER

Construction is greatly facilitated by the use of a completely boxed-up mains unit

battery circuit for the reason that mains valves have very much better characteristics than corresponding battery types. A mains circuit of this description is as good as, or even better than, the average four-valve battery combination.

Use has been made of one of the most efficient commercial band-pass units yet produced. The result is that not only is the selectivity of a very high order, but the signal strength is well maintained.

Combination Coupling

There is no need to go into any details regarding the theoretical arrangement of the band-pass circuit used in this set. It makes use of a combined inductive and capacitive coupling, a .04-microfarad fixed condenser being used for the latter purpose.

Each part of the band-pass circuit has, of course, to be tuned by a .0005-microfarad condenser, and for this purpose a ganged model is used.

The band-pass tuning circuit is fol-

lowed by the screen-grid high-frequency valve, which is provided with a bias cell of .9 volt to give the best results. In the anode circuit there is a high-frequency choke to couple the first valve to the tuned-grid circuit associated with the detector stage.

Leaky-grid Detector

A coupling condenser of .0002 microfarad is used, and the grid coil is tuned by a third .0005-microfarad condenser. The detector valve works on the leaky-grid principle, a 1-megohm leak and a .0001-microfarad condenser being employed.

A second high-frequency choke is used in the detector-anode circuit, and the reaction coil is coupled with the grid coil. Control of reaction is obtained by a .0003-microfarad variable condenser, while the efficiency of the detector action is kept at a high value by means of a fixed .0002-microfarad high-frequency by-pass condenser, placed between anode and filament.

Low-frequency Transformer

Between the detector and the power valve an ordinary low-frequency transformer is employed.

In order to match up the loud-speaker with the power valve, a tapped low-frequency choke is used in a standard choke-output circuit,

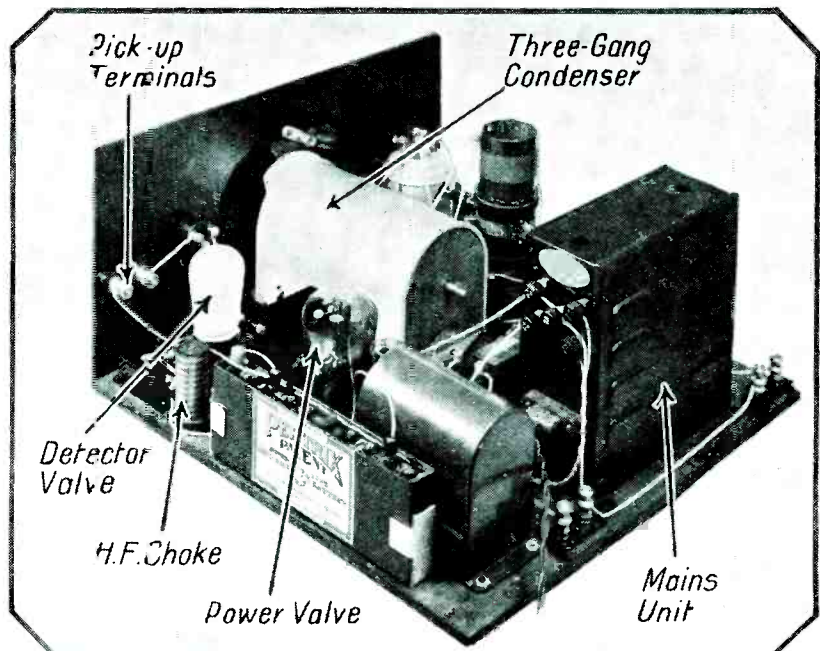

READY TO PUT IN THE CABINET

Here is the set wired up and with the valves in position. Note the many metal-shielded components, to prevent any possibility of interaction

A FINE A.C. SCREEN-GRID THREE

which includes a 2-microfarad by-pass condenser.

In a set of this type, where high voltages are available from the mains, special arrangements must be made to apply the best values to the valves.

Reducing the Voltage

It will be seen that a 50,000-ohm resistance is used in the anode circuit of the screen-grid valve to reduce the voltage to the required value. In order to prevent the possibility of motor-boating, a 1-microfarad by-pass condenser is associated with this resistance.

A potentiometer is, of course, needed to supply the proper voltage to the screen grid of the high-frequency valve. This takes the form of a 50,000-ohm variable resistance placed in series with an 80,000-ohm fixed resistance. Variation of the slider position across the variable resistance gives any desired voltage between zero and about 80 volts. The 80,000-ohm resistance is provided with a 1-microfarad by-pass condenser.

Detector Resistance

As the detector valve takes more anode current than the screen-grid valve, a lower value of anode resistance will produce the desired voltage drop. For the particular valve used

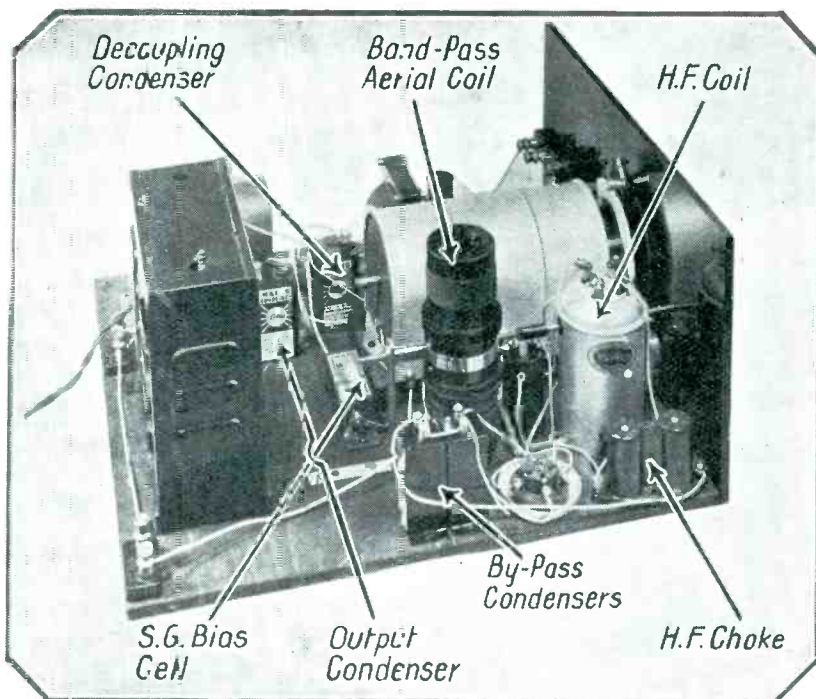

JUST THE SET FOR MODERN CONDITIONS

With its band-pass tuner and screen-grid valve the set combines great selectivity with distance-getting properties

a value of 20,000 ohms is sufficient. This is used in conjunction with a 2-microfarad by-pass condenser to prevent any possibility of motor-boating in the detector stage.

Both high-tension and low-tension supplies are obtained from a single mains unit, which is completely boxed

up in a metal case. We wish to emphasise this feature, for it means that Everybody's Radiogram is no more dangerous than an ordinary battery receiver provided with a mains unit for giving high tension.

Simple Construction

As the mains unit is complete in itself, the constructor is saved the trouble of assembling the various condensers, chokes, and metal rectifier that are required. Moreover, the cost of the complete unit, although it is already assembled, is lower than the cost of the individual parts would be if the constructor had to buy them separately.

When the set is used for the reproduction of gramophone records, an electro-magnetic pick-up is inserted in the grid circuit of the detector valve. At the same time, bias is applied to this valve so that it functions as a low-frequency amplifier instead of as a detector.

Low-tension Supply

The heaters of the three valves are supplied with raw A.C. at 4 volts; this supply is, of course, obtained from the mains unit. As the valves are of the indirectly-heated type, they each have a special cathode



HOW THE RECORDS ARE PLAYED

Here is the electrically-driven turntable and pick-up for the reproducing of gramophone records

EVERYBODY'S RADIOGRAM—Continued

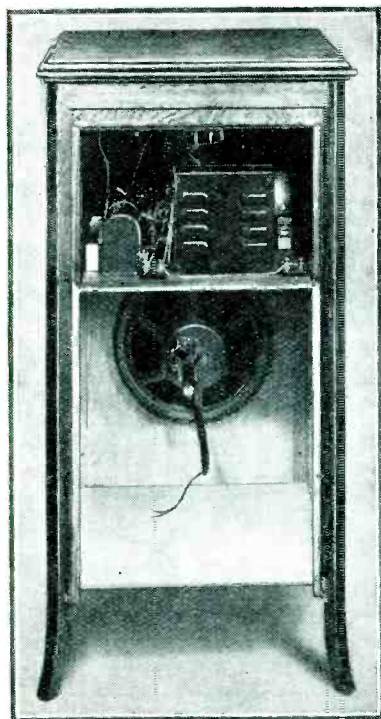

ALL READY FOR USE

The set and loud-speaker mounted in the cabinet ready for use

connection, which corresponds to the negative sides of the filaments of battery valves.

So much for theoretical considerations. Let us now turn our attention to more practical points.

All Essential Details

Every essential detail for the construction of the set is included in these pages. If desired, however, a full-size constructional blueprint can be obtained for half-price (that is, 6d., post free) if the coupon on the last page is used by October 31. Address your inquiry to Blueprint

Department, WIRELESS MAGAZINE, 58-61 Fetter Lane, London, E.C.4, and ask for No. WM258.

A feature of this set is the use of screened components to prevent interaction between the various parts. For instance, the tuned-grid coil is completely screened and the high-frequency valve is also shielded.

Three-gang Condenser

From the theoretical description it will have been noted that three .0005-microfarad condensers are required for the tuning circuits; in practice it has been found possible to use a three-gang condenser, so that only one tuning knob has to be operated. It will be seen that this condenser is of the completely shielded type.

The low-frequency transformer, output choke, and mains unit are also metal cased.

The construction of the set is quite straightforward and no difficulties will be experienced in the assembly.

It should be noted that the switch spindles of the band-pass and tuned-grid coils are ganged on a single rod, and care should be taken to mount the coils in line.

The only other special point to be noted is that the gang condenser is mounted on $\frac{1}{8}$ -in. blocks in order to keep the escutcheon plate well up on the panel.

When all the parts have been firmly fixed in position, wiring-up can be carried out. All the connections should be put in position in the numerical order indicated on the blueprint or the quarter-scale layout.

The particular gang condenser used in the original set is provided with a dial light behind the panel. The bulb is wired directly across the

low-tension terminals of the mains unit if required.

The panel controls are arranged in an accessible way. In the centre is the knob for the main tuning condenser. Immediately to the left of this is the potentiometer controlling the voltage applied to the screen grid of the high-frequency valve, which, of course, acts as a pre-detector volume control. The small switch on the left of the panel is for changing the wavelength range; it is pulled out for long-wave reception and pushed in for medium-wave stations.

To the right of the main tuning dial is the knob of the reaction condenser, and a small switch for changing over from radio to gramophone. It should also be noted that a block for the pick-up terminals is screwed on to the back of the panel.

Avoiding Complications

To avoid complications, and also to allow of the constructor using alternative valves without a lot of trouble, grid bias is taken from a battery in the ordinary way. Those who want to incorporate automatic bias will be able to do so on their own. Most constructors, however, will not mind buying a new grid battery once a year.

Suitable valves for use in Everybody's Radiogram are indicated in the list of parts on page 265. If other types are used instead of those recommended it may be necessary to change the value of the voltage-dropping anode resistances and in this case the new values will have to be calculated.

Before going into details of operation, we may say a few words about the rest of the outfit. For instance,

(Continued on page 266)



WHERE THE PICK-UP IS PLACED

Top view of the motor-board showing position of pick-up alongside the turntable

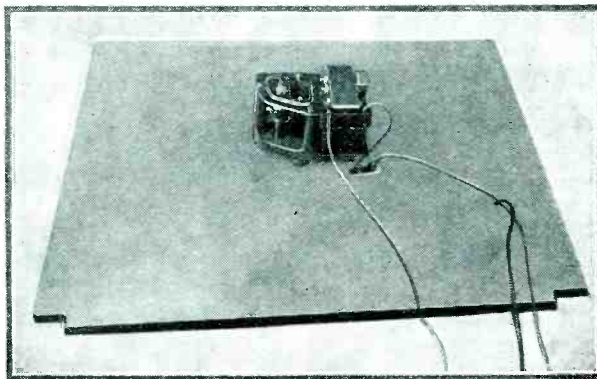

SMALL BUT EFFICIENT MOTOR

This motor is very easy to fit in position. Although small it is powerful

A Nutshell Explanation of

EVERYBODY'S
RADIOGRAM

RADIO gramophones are increasing in popularity every day for very obvious reasons. It is a great convenience to have combined in one cabinet a radio set and

on radio will be disappointing and the volume from record reproduction will be very little better than that obtained from an ordinary mechanical type of gramophone.

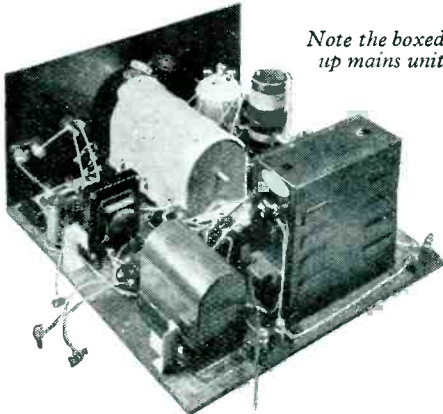

Note the boxed-up mains unit

also an electrically-reproducing gramophone.

In order to get a satisfactory service from the outfit it is essential that the radio set should be of high quality otherwise the performance

which has the further advantage of incorporating a band-pass tuning circuit to get a high degree of selectivity.

The arrangement finally adopted has excellent distance-getting properties for

radio reception; the efficiency of the circuit is of a high order and, thanks to the selective properties of the band-pass tuner, a large number of foreign stations can be obtained at good strength almost anywhere in the British Isles.

One point that beginners should carefully note about Everybody's Radiogram is that it can be run only from A.C. (alternating-current) mains. This is because the set uses indirectly-heated mains valves, which can only be satisfac-

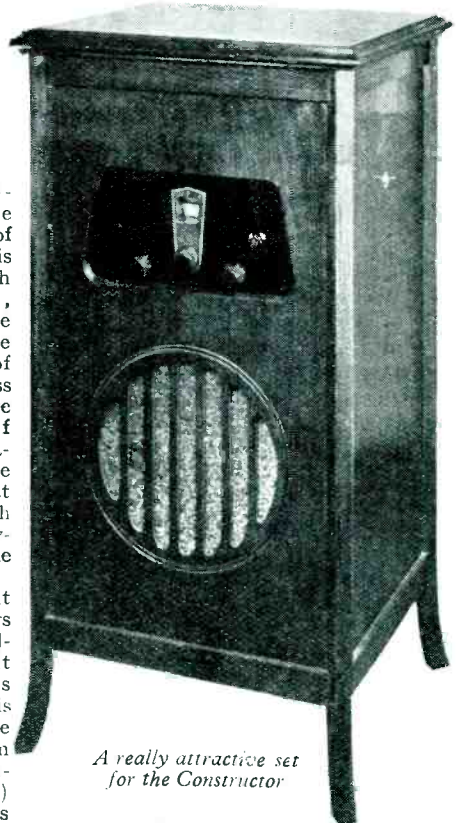

A really attractive set for the Constructor

torily run from an electric-light supply. Those who are not certain about what type of electric supply they have should make certain that it is not D.C. (direct current), for the set will not work on a mains of that kind.

COMPONENTS NEEDED FOR EVERYBODY'S RADIOGRAM

CHOKE, LOW-FREQUENCY

1—Atlas, type CFS, £1 1s.

CHOKES, HIGH-FREQUENCY

1—Wearite, standard type, 6s. 6d. (or Telsen, Lewcos).

1—Telsen binocular, 5s. (or Varley, R.I.).

COILS

1—Varley Square Peak, 15s.

1—Varley H.F. Intervalve, 8s. 6d.

CONDENSERS, FIXED

1—Lissen .0001-microfarad, 1s. (or Telsen, Magnum).

2—Lissen .0002-microfarad, 2s. (or Telsen, Magnum).

1—Dubilier .04-microfarad non-inductive, 2s.

2—Formo 1-microfarad, 5s. (or T.C.C., Dubilier).

2—Formo 2-microfarad, 6s. 6d. (or T.C.C., Dubilier).

CONDENSERS, VARIABLE

1—Polar .0005-microfarad three-gang Tub, with disc drive, £1 15s.

1—Telsen .0003-microfarad reaction, 2s.

EBONITE

1—Red Triangle 16 in. by 8 in. panel, 8s. (or Becol, Lissen).

HOLDER, GRID-LEAK

1—Lissen, type LN160, 6d. (or Bulgin, Telsen).

HOLDERS, VALVE

1—Telsen 5-pin, 8d. (for S.G. valve).

2—Benjamin 5-pin, 3s. 6d. (or Lotus, W.B.).

MAINS UNIT

1—Regentone, type S60, £4 10s.

PLUGS

3—Belling-Lee wander plugs, marked: G.B.+ G.B.—1. G.B.—2. 6d. (or Clix, Ealex).

RESISTANCES, FIXED

1—Telsen 10,000-ohm spaghetti, 1s. (or Lewcos, Bulgin).

1—Telsen 20,000-ohm spaghetti, 1s. (or Lewcos, Bulgin).

1—Telsen 50,000-ohm spaghetti, 1s. 6d. (or Lewcos, Bulgin).

1—Telsen 80,000-ohm spaghetti, 1s. 6d. (or Lewcos, Bulgin).

1—Telsen 1-megohm grid leak, 9d. (or Telsen, Watmel).

RESISTANCES, VARIABLE

1—Wearite 50,000-ohm wire-wound potentiometer, 4s. (or Colvern).

1—Graham-Farish volume control, 3s. 6d.

SUNDRIES

Tinned copper wire for connecting.

Length of insulated sleeving (Lewcos).

Length of rubber covered flex.

3—Lissen terminal blocks, 3s.

1—pair Bulgin grid-bias battery clips, 6d.

1—Readi-Rad valve screen, 2s. 9d.

1—Bulgin needle cup, 2s. 6d.

SWITCHES

1—Bulgin gramo-radio, type S86, 2s.

1—Bulgin on-off, mains type S88, 2s. 9d.

1—Bulgin on-off, mains type S89, 3s. 3d.

TRANSFORMER, LOW-FREQUENCY

1—Ferranti AF3, £1 5s. (or Lewcos LFT3, Telsen).

Accessories

BATTERIES

1—Oldham 16½-volt grid-bias, 2s. (or Pertrix, Ever-Ready).

1—Siemens .9-volt grid cell, 1s.

CABINET

1—Borst radio-gramophone model A in oak, £3 18s. 6d.

GRAMOPHONE MOTOR

1—Pailiard Junior A.C. induction, £2 5s. (or Wates).

LOUD-SPEAKER

1—Blue Spot 66R unit with special chassis, £2 2s. 6d. (or Celestion, W.B.).

PICK-UP

1—Graham Farish, £1 12s. 6d. (or B.T.H., Edison Bell).

VALVES

1—Mazda ACS2, £1 2s. 6d.

1—Mazda AC2HL, 15s.

1—Mazda AC/P, 17s. 6d.

The prices mentioned are those for the parts used in the original set; the prices of alternatives as indicated in the brackets may be either higher or lower

Good Results

It might be thought that a three-valve set is not sufficiently powerful to give really good results, but that is not the case when A.C. valves are used. Valves of this type give very much greater magnification than corresponding battery valves, and a mains three-valve set is as good as, if not better than, a four-valve battery receiver.

Gramo-radio Switch

The change from radioreception to record reproduction is made by the turn of a single switch, which puts an electromagnetic pick-up in circuit. In the original model of Everybody's Radiogram an electric motor is used for driving the turntable, but if desired this can, of course, be substituted by an ordinary clockwork-spring motor.

It will be seen from the photograph in the top right-hand corner of this page that the complete outfit is handsome in appearance.

EVERYBODY'S RADIOGRAM—Continued

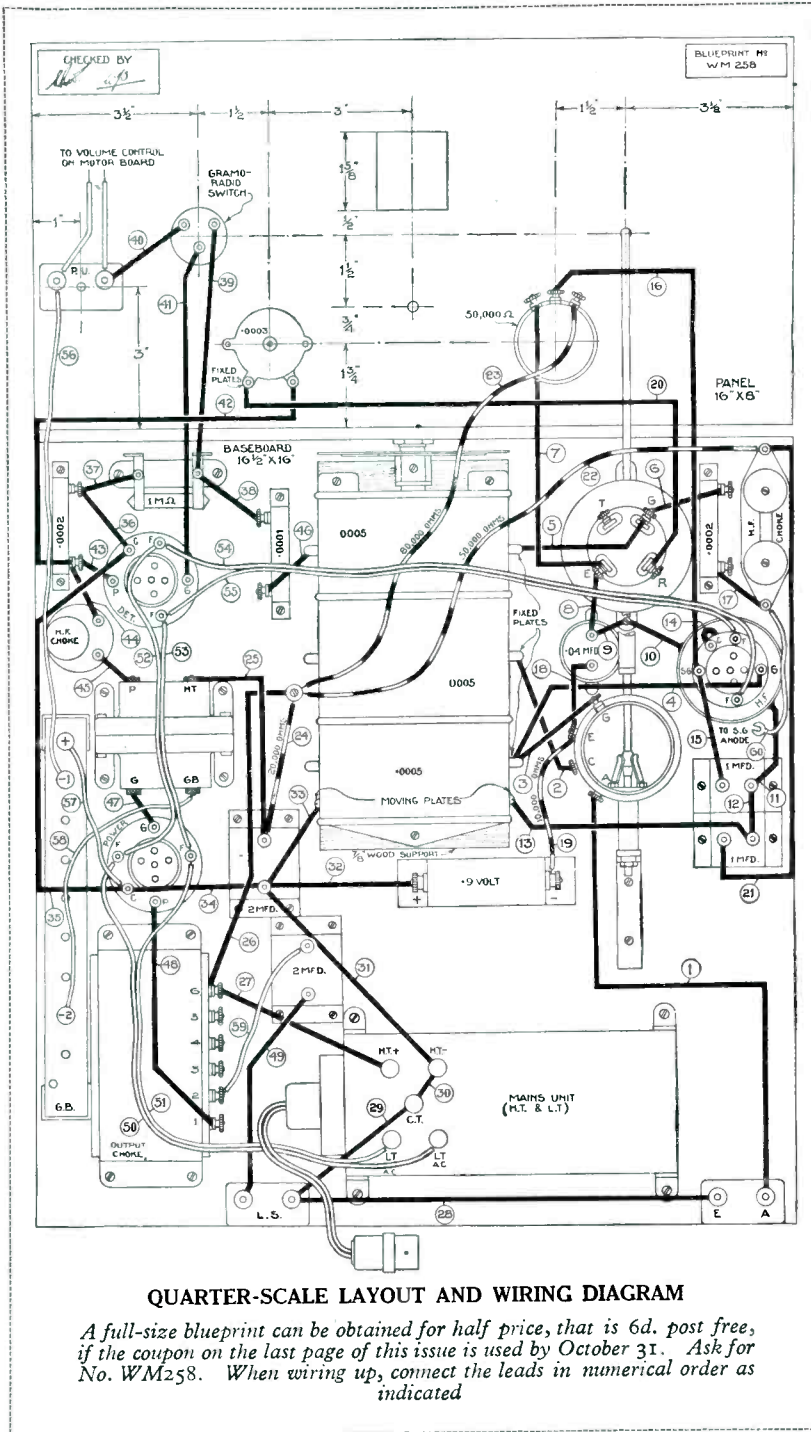

across the two outside terminals, while the two pick-up terminals on the set itself are connected to one side of the potentiometer and to the slider respectively.

In our original design we mounted the mains on-off switch on the right-hand side of the cabinet.

Simple Operation

The operation of the set is not at all difficult, as will be clear from the following explanation: After switching the set on, the gramophone switch should be turned to radio. Next, adjust the wave-change switch for medium-wave reception, and turn the potentiometer knob to the halfway position. See that the reaction knob is turned to the left, and then tune the main condenser until a station is heard at fair strength.

Now unscrew the trimmer associated with the condenser remote from the panel, so that it is at its minimum capacity. Next adjust the first trimmer (that is, the one nearest the panel) until the maximum strength is obtained. The same operation should then be repeated with the middle trimmer.

Readjusting Main Condenser

As each trimmer is adjusted, the main tuning knob should also be moved slightly so that the position of maximum signal strength is obtained.

The trimming condensers should be so adjusted with respect to the main tuning dial that they are neither at their maximum nor their minimum capacity, or it may not be possible to tune a station to the greatest strength.

During ordinary reception, the knob of the screen-grid potentiometer should be adjusted as a volume control, but care should be taken not to turn it too far to the right.

Gramo-radio Switch

For gramophone reproduction it is only necessary to turn the gramophone switch to the right, and adjust volume by means of the control on the motor-board. A separate mains switch for the motor should be mounted alongside the turntable.

It will probably be found advisable to use metal-sheathed cable for the pick-up connections as there is then much less possibility of howling and other noises occurring.

This set will be on view at Selfridges during the currency of this issue.

the constructor has some choice regarding the cabinet. It can be obtained as a complete kit of parts ready for assembling at home. This is a simple operation and only a few nails and a hammer are required. Alternatively, a completely assembled and polished cabinet can be obtained. Price will, in some cases, be the

deciding factor in this respect.

There will be no difficulty about mounting the motor and pick-up on the top board of the cabinet for full instructions are supplied by the makers of these parts.

A volume control for the pick-up is mounted alongside the turntable. The pick-up is connected directly



"Wireless Magazine" GRAMO-RADIO SECTION

YOU CAN DANCE AT ANY TIME IF YOU HAVE A RADIO GRAMOPHONE

This photograph shows one of the new H.M.V. radio gramophones in use. It has an automatic record changer

A REVOLUTION IN PICK-UP PRACTICE

Capt. H. T. BARNETT on "Featherweighting"

IN the account of these experiments in the two last issues, we have seen that in the case of the Edison-Bell Cinema pick-up and arm, which comprises variable counterweight springing capable of raising the whole weight of the pick-up and needle from the record, it is only necessary to allow the pick-up to drop until the needle just touches the record in order to obtain full volume reproduction of the music.

No Record Scratching

This was the case although the contact was so light that the pick-up could be knocked about over the surface of the record without the least fear of the needle producing scratches, the actual weight on the needle being so small that it could neither be weighed nor estimated.

Any addition to the weight borne by the needle, any relaxing of the

tension spring, was at once accompanied by an increase in surface noise and a decrease in the detail of definition. Under the featherweight loading, needles wore hardly at all and records did not wear but became burnished, an ordinary Columbia soft-tone once-play needle lasting for an hour and finishing almost in new condition.

This particular kind of needle gave the smallest surface noise in proportion to its tone volume and also the best defined and smoothest reproduction in this Cinema pick-up, whose needle angle is approximately 50 degrees.

The arm is remarkably frictionless, both in its rotary and in its up-and-down movement, so that the needle easily follows either a swinging or a warped record.

All those interested in record reproduction and keen on eliminating surface noise and wear of

records and needles with accompanying improvement in definition should read in full the account of the experiments as they were made.

To continue from where we left off last month: Messrs. Schott have been so good as to send me from Jena some glass rod of gramophone needle diameter. Unfortunately, it is not the tough kind of glass I hoped it would be; in fact, it is extremely hard and brittle and needles drawn from it are too liable to break off at the point in use to be a practicable proposition.

Stronger Spring

The Limit Engineering Company have kindly made for me one of their well-known pick-up arms with a much stronger counterbalance spring than that first supplied.

It is strong enough when screwed down to its full extent entirely to balance the weight of the arm and

A REVOLUTION IN PICK-UP PRACTICE-Cont.

also the heaviest pick-up made.

By means of this useful fitting I have now been able to extend the featherweighting tests to discover whether other pick-ups can be worked satisfactorily on such lightly weighted needles, and whether 50 degrees remains the best needle angle under the new conditions, as it always proved to be with heavy or with medium weighting.

Needle Angle

So far as needle angle goes, I can at once summarise work done with half a dozen pick-ups, all very different from one another, by saying that *50 degrees is always the best needle angle*; 55 degrees is passable but 60 degrees, even with Columbia records, always shows notably rougher reproduction.

For the information of new readers I may mention that 50 degrees is the angle made by the *hour* hand of the clock when the time is 7.20. Sixty degrees corresponds to 7 o'clock. Care must be taken not to get a flatter angle than 50 degrees and not to get a steeper angle than 55 degrees.

The Edison-Bell pick-up, as I have said before, is set at 50 degrees. The B.T.H. (on arm) is roughly at 55 degrees, and the Marconi at 60 degrees.

I may also summarise results as regards needles: With all pick-ups the needle showing the cleanest reproduction and the smallest surface noise in proportion to tone volume was the soft-toned Columbia. Each needle may be used from half an hour to an hour without the least fear of damaging the records.

The Tungstyle needle may be used "feather-weighted" without the usual or indeed any disastrous results—the worst that can happen is that the point may bend and the reproduction become smudgy in consequence; in my opinion it is always a rough sounding reproducer.

A loud-tone needle, not too bad for surface noise with any pick-up, is the new Broadcast; it has an excellent point.

When starting work with my new Limit Featherweight pick-up arm I found a certain amount of friction in the up-and-down motion.

In order to compensate this in the

case of warped or out of centre records, it is necessary to use a little weight, but this weighting, such as it is, must be very small indeed, because it is not sufficient to prevent one from knocking the reproducer across the record without causing the needle to scratch it.

Nor can the weight be estimated, because the lightest touch of one's finger on the underside of the arm will raise the needle from the groove.

The first pick-up I tried on the arm was the Parlophone; it has rather more volume than the Edison-Bell Cinema, shows less surface noise than any other pick-up I have, is not too good for speech, but is quite the sweetest-toned thing for pianoforte solos and for all jazz records.

It is the pick-up for the man with no variable scratch filter on his set. Its performance is quite obviously improved as weight on the needle decreases to something less than half an ounce.

The next pick-up tried was the Limit. It is a heavy one, has a volume equal to the Parlophone, and a response from the very high periods to the lowest, so that it is suitable for all-round work.

The weight increases the friction in the drop joint of the arm, but even so it worked perfectly on swinging or warped records with less than one ounce needle weighting.

The Marconi pick-up and arm is the heaviest thing I know on records. Messrs. Seals, who do the Corporation work at Portsmouth, were good enough to lend me one. They cut off 5 in. of $\frac{1}{8}$ -in. rod and screwed, a short distance at one end, forty threads to the inch.

Sliding Counterweights

I took out the screw at the back end of the arm and screwed this rod in the place of it; then on the rod I put a couple of Perophone Chromogram sliding counterweights.

There was a good deal of friction on the up-and-down motion and the bulk of this I relieved. The pick-up worked well even when feather-weighted, but the 60-degree needle angle and the rather unsatisfactory tracking (the pick-up axis angle is not "set off" sufficiently) caused a rougher reproduction than I am accustomed to.

Volume is excellent and so is response in the high treble. For the convenience of those who wish to counterweight these arms, the Perophone people are willing to supply a pair of weights and the screwed rod for 4s., plus postage.

My old B.T.H. pick-up (I have used it for nearly two years) on the Limit Featherweight arm, when it came to be very lightly weighted, showed too much surface noise. I suppose there was a little slackness somewhere.

To overcome this I had to raise the weighting to nearly an ounce. The reproduction then became ideal for all *musical* records, big volume, natural tone quality, and ample bass.

Of course, there is not the bite on vocal consonants one gets with the Cinema or the Limit, but the very highest violin harmonics come out perfectly.

Specially Treated

A new B.T.H. pick-up and arm were then treated for me by Seals specially for counterweighting. The spring was removed, the tremendous friction in the U-point relieved by filing away metal on the interior flats, the arm bent up a little to improve the needle angle somewhat on the 55-degree setting, and a rod for Perophone counterweights screwed into the back end of the arm.

The set-off angle of the pick-up gives beautiful tracking. Tried on all kinds of records, three-quarters of an ounce weighting was ample.

Volume was magnificent with most natural tone quality on all musical records, giving bright deep bass and brilliant fiddle harmonics.

Now, I have reason to believe there is no type of pick-up whose moving parts will not respond truly to a needle, no matter how lightly it may be weighted, so long as it can *drop* into the record groove.

I urge all engineers responsible for pick-up arm design to eliminate friction on the moving parts of the arms, to set off the pick-up axis at the correct angle for good alignment from the outside of a 12-in. record to the inside of an 8-in., to make the needle angle 50 degrees, and to provide counterweighting or counter-springing such that we may, if we wish, have no more than one ounce weight on the needle.

RADIO GRAMOPHONES FOR THE NEW SEASON

IN common with all types of broadcast receiving apparatus, the new season's radio gramophones represent very much better value for money than in previous years.

Average Price

We have not yet been able to work out the average price for a radio gramophone, but the undoubted advantages of this combination type of instrument can

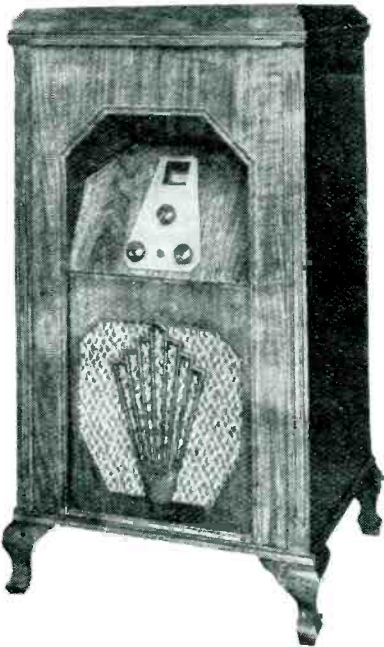

The new Gecophone all-electric radio gramophone for A.C. mains

certainly be enjoyed now for as little as 30 guineas. Only two years ago the average price of the radio gramophone was probably 75 guineas.

It is not merely in price reduction that the new season's radio gramophones are notable. Many improvements, small perhaps in themselves, have combined to make the latest instruments easier to operate than those introduced a year or so ago. Mechanical improvements have gone hand-in-hand with circuit development.

Universal Motors

We find in the modern radio gramophone a very smoothly running record turntable. Where the machine is to be run from the A.C. mains an induction-type gramophone

motor is frequently employed. It must also be said that the universal motors for A.C. and D.C. mains supplies have been greatly improved.

The disposition of the pick-up near the turntable has, in most of the latest machines, been tackled from the point of view of good needle tracking.

Record wear has also been reduced to a minimum and this is due not only to the use of counterweights on the pick-up arm but also to the improved design of the pick-up armature. The latest pick-ups are much more sensitive. The undistorted amplification has been increased by the use of much larger power valves.

From the circuit point of view, this season's radio gramophones are greatly improved. The radio side usually consists of two stages of high-frequency amplification and the tuning circuits are very selective. For most instruments, a short external aerial is needed to pick up broadcast programmes, but for flat dwellers the mains aerial connection enables the local stations to be reproduced at good volume.

Quality of reproduction, in all the new radio gramophones so far examined, is very pleasing. This is



H.M.V.'s cheapest radio gramophone (model 501) which sells at 29 guineas

partly due to the use of larger power valves, which can take the full output without distortion; but we must not overlook the fact that most of the latest radio gramophones

include first-class moving-coil loud-speakers, specially designed to match the output valve.

Another welcome improvement is to be found in the improved control of tone.

This means that the widely differing degrees of recording can be handled without needle scratch or "blasting."

Altogether the appearances of the new models are particularly attractive.

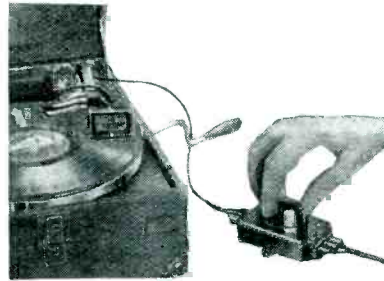

Here is the new H.M.V. pick-up and volume control

NINE-INCH RECORDS

OF all the pleasant surprises that came to gramophone lovers in September I think the one that will bring the greatest good to the greater number is the new issue of 9-in. Broadcast records by the Vocalion Company, of Hayes.

Enormously costly preparation must have been made for this issue, because the recording and the surface both have a quality rarely reached and never yet surpassed by any manufacturer.

The choice of items and the performances are all so good that any average gramophone owner might order the whole group entirely without respect to titles.

Groove Cut

The groove cut has the most correct shape in the trade. I would point out that only needles having very perfect points should be used for reproducing these excellent records.

H. T. B.

CHOOSING YOUR RECORDS

Here are reviews of the latest releases by WHITAKER-WILSON, the "W.M." Music Critic. Read them carefully before buying your next batch of records. Outstanding records are indicated by an asterisk (*) against the title.

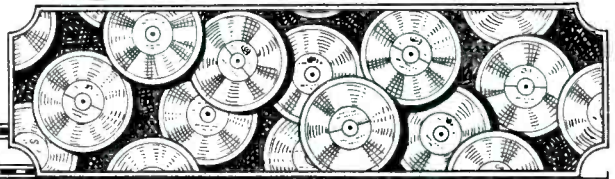

Sacred Music

(a) Abide with Me, (b) Jerusalem the Golden, Full Choir of St. Mary-le-Bow, with organ, 1s.

BRDCST 732

Too slow and stodgy. I hate hymns at this rate. There may be a use for hymn records, but this type of rendition is enough to kill it.

Harvest Festival Service, St. Mary-le-Bow, Cheapside, (d.s.), 1s. 6d. **BRDCST 3076**

Too stogy! I don't think much of the Bow choir!

Classical Orchestral Music

★Nursery Suite (Elgar), London Symphony Orch. (d.s.), 6s. **H.M.V. D1998-9**

A very charming suite; you will probably know it. Elgar is always worth hearing, and here he is in a simple mood.

Chamber Music



RACHMANINOFF

★Duo for Piano and Violin in A major (Schubert, Op. 162), Rachmaninoff and Kreisler, 6s. **H.M.V. 1465-7**
Three discs of the very best playing. It is worth the expense every time!

Light Orchestral Music

★Hungarian Dance (Brahms), Viennese Light Orch. (d.s.), 2s. **BRDCST 5246**



KREISLER
(see Chamber Music)

Very good. Ask for it; I imagine you will consider 2s. cheap for it.
Martha, Berlin Symphony Orch. (d.s.), 2s.

BRDCST 5244

The overture to *Martha*, that is to say. Very well played. It makes admirable light orchestral music.

★Old Favourites, Gershom Parkington Quintet (d.s.), 2s. **BRDCST 5245**

Lovers of the G.P.Q. should ask for this; it is good.

Light Opera & Songs

★(a) Abraham (Frank and Phil Crow), vocal duet, (b) I'm a-gettin' Ready to Go (Phil Crow Trio), 2s. 6d. **H.M.V. B3886**

The first is really entertaining. It is a negro spiritual, but quite worth hearing, which many are not. Ask to hear this; the Trio is excellent.

(a) Beautiful Love, (b) By the River Sainte Marie, Lewis James, ten., with orch., 1s. 6d. **ZONO 5934**

His voice is a little strident, but I think he will appeal to many. The songs are quite attractive and light.

★(a) I found You, (b) Lazy Day, Patrick Waddington, bar., with two pianos, 2s. 6d. **H.M.V. B3913**

He is a delightfully light baritone, with a pleasant tenor quality in his upper notes. The songs, too, are attractive. I suggest that you ask to hear this. The accompaniment is very pleasing.

★(a) Just Two Hearts and a Waltz Refrain, (b) You are



PATRICK WADDINGTON
(see second column)

My Heart's Delight, Sidney Hamilton, ten., with orch., 1s. **BRDCST 736**

I do not care for the style of song particularly, but the voice is excellent and I recommend the disc on that account.

★(a) Lazy Day, (b) Roll on, Mississippi, Roll On, Bob and Alf Pearson, with piano, 1s. 6d. **BRDCST 3072**

Quite original. I enjoyed it immensely. Ask for it!

(a) Let's Get Friendly, (b) Why Shouldn't I? Jack and Jill, 1s. 6d. **ZONO 5932**

I like these two; they give an intimate little performance which, though vocally not wonderful, is quite entertaining.

★(a) Life, (b) Poor Kid, Billy Desmond, with Hawaiian acc., 1s. **BRDCST 730**

A nice voice and the Hawaiian accompaniment makes the record really attractive.

(a) Little Sweetheart of the Mountains, Johnny and Frank Marvin, with orch., (b) Would You take Me Back Again? Johnny Mar-

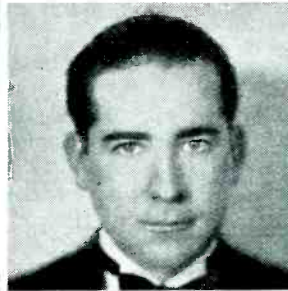

JOHNNY MARVIN

vin, with orch., 2s. 6d. **H.M.V. B3904**

Very attractive; the singing is not without blemish; Marvin should take good lessons. I hope he will not mind my saying that. His voice is good.

(a) Lost Chord, (b) Good-bye, Eroica Singers, with organ, 2s. **BRDCST 5247**

Quite good, if you want them. This is 1931, though!

★(a) Love Song of Old Valencia, (b) I'm Painting Pictures, Maurice Elwin, bar., 1s. 6d. **ZONO 5928**

Very pleasant. The recording is excellent and Maurice Elwin is up to form.

(a) Party's Getting Rough, (b) I'll Always be True, Gracie Fields, com., with orch., 2s. 6d. **H.M.V. B3908**

Very much like her other records; Miss Fields should strike out a new (and higher) line.

★(a) Sing a Song of England, (b) Musical Confession, Mr. Flotsam and Mr. Jetsam, with piano, 2s. 6d. **COL DB559**

Splendid! This is a very characteristic performance. Admirers of these excellent broadcasters will enjoy this record immensely.

★(a) When You Were the Blossom of Buttercup Lane, (b) In the Mountains of the Pine, Solemn and Gay, 1s. 6d. **ZONO 5930**

Very evenly balanced. These two sing delightfully; this is one of the best I have heard of theirs.

★Vocal Gems from "Florodora," soloists, chorus and orch. (d.s.), 1s. 6d. **BRDCST 3073**

An excellent light opera record—one of the best I have heard. I sincerely recommend it.

Military Bands

★Dorothy (Selection), H.M. Coldstream Guards, 4s. **H.M.V. C2228**

Very well done. I have been asked to point out good military band records; here is one of the best.

★Highland Sing-Song, Band of H.M. Welsh Guards (d.s.), 1s. 6d. **BRDCST 3074**

Well worth hearing. These military band records are really excellent.

**Humorous
Records**

Music Hall Show in Grandpa's Day, Bobbie Comber and Company, with chorus and orch. (d.s.), 1s. 6d.

BRDCST 3071

Not worth hearing. Merely rubbish. "The next song will be a dance" is the height of its humour. Really, Broadcast! What are you thinking of?

(a) **My Brother Makes the Noises for the Talkies**, (b) **Skin-a-ma-Link, the Sergeant**, Jack Payne and his B.B.C. Dance Orch., 2s. 6d.

COL CB317

The first of these is quite amusing; the second, though containing a good tune, is rather poor in the dialogue. Both are a trifle vulgar in effect.

(a) **Sandy, the Doctor**, Sandy Powell, com. (d.s.), 1s.

BRDCST 728

An improvement on the last I heard of his. The dialogue of



SANDY POWELL

these Powell records wants going over; there are spaces where the lines are poor. On the whole, however, this is amusing. As usual, vulgarity spoils it. The last line might have been omitted. For Heaven's sake, keep it clean!

★**Theatre Queue Entertainers**, Sandy Powell's Mouth-organ Band (d.s.), 1s.

BRDCST 731

Quite a success. It is original. I think it will amuse you.

(a) **When I Met Sally at the Seaside**, Bobby Comber, (b) **Skin-a-ma-link, the Sergeant**, Bobby Comber, com., with orch., 1s.

BRDCST 729



FLOTSAM AND JETSAM
(see Light Opera and Songs)

ABBREVIATIONS USED IN THESE PAGES

bar.	baritone	IMP	IMPERIAL
BRDCST	BROADCAST	orch.	orchestra
BRUNS	BRUNSWICK	PHONY	PHONCORD
COL	COLUMBIA	PIC	PICCADILLY
com.	comedian	RAD	RADIO
con.	contralto	scp.	soprano
DEC	DECCA	ten.	tenor
d.s.	double-sided	w.	waltz
f.	fox-trot	WIN	WINNER
H.M.V.	HIS MASTER'S VOICE	ZONO	ZONOPHONE

Moderate only. His interpretations are rather silly.

Dance Music

(a) **Bullfighter (March)**, (b) **Piano Pastimes**, Three Brothers Nehring, H.M.V. B3917

Three xylophones! Quite entertaining. The sort of record to hear once and then forget. That is what I am doing, anyway!

(a) **Fall In and Follow the Band**, (b) **Sally (w.)**, Riverside Dance Band, 1s.

BRDCST 734

This is a good band and the disc is worth hearing because the refrain is well sung.

★(a) **For You (w.)**, (b) **I Found You (f.)**, Manhattan Melodymakers, with organ, 1s. 6d.

BRDCST 3079

Quite up to their high standard. The singing has improved all round lately. I am glad of this; it certainly needed to improve.

(a) **If You're Really and Truly in Love (f.)**, (b) **Lights of Paris**, Riverside Dance Band, 1s.

BRDCST 733

The tunes are well known. I recommend the record because of the singing and the rhythmic qualities of the general production.

★(a) **I'm Thru' with Love (slow f.)**, (b) **I'm an Un-employer, Sweetheart**, Ambrose and His Orch., 2s. 6d.

H.M.V. B6049

The second is very attractive. I consider this one of the best dance records I have heard this year—and that is saying something!

★**On With the Show, 1931**, Harry Bidgood's Holiday-makers (d.s.), 1s.

BRDCST 726

Quite good. This is a very good band and the "Show" is quite entertaining.

(a) **Put Your Loving Arms Around Me (w.)**, (b) **When the Moonlight Comes Over the Mountains**, Lew Sylva's Band, with organ, 1s.

BRDCST 735

Not too good. The organ ruins everything.

(a) **Tie a Little String Around Your Finger (f.)**, **Pardon Me, Pretty Lady (f.)**, Jack Harris and His Grosvenor House Band, 1s. 6d.

BRDCST 3078

Harris generally gives you something good; this is excellent. A valuable dance record.

Viennese Nights, Ned Fox &



JACK HYLTON

★(a) **Were You Sincere? (f.)**, (b) **It Looks Like Love (f.)**, The Rhythmic Eight.

ZONO 5939

The latter is the quicker of the two. Both are admirably done. The Rhythmic Eight are always well worth hearing.

(a) **Yet (f.)**, Jack Hylton and His Orch., (b) **Little Sweetheart of the Prairie (w.)**, Jack Hylton and His Orch., 2s. 6d.

H.M.V. B6043

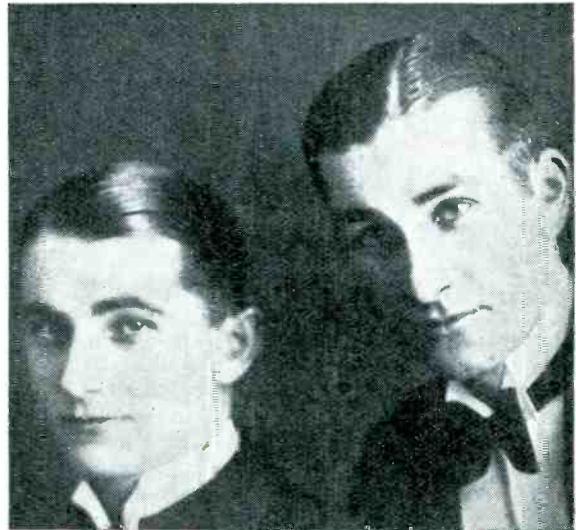

BOB AND ALF PEARSON
(see Light Opera and Songs)

Film Fans, with vocal refrains (d.s.), 1s.

BRDCST 727

A very good light record with a splendid voice.

★(a) **Wedding of the Garden Insects (f.)**, Debroy Somers' Band, **Way to Paradise (f.)**, April Jazz Orch., 2s. 6d.

COL CF315

An outstanding dance record; one of the best I have heard for some time. (a) is a splendid tune.

I prefer the fox-trot; the waltz is a bit sticky! But the playing is up to Jack's standard.

★(a) **You're Just a Lover (f.)**, (b) **My Cigarette Lady (f.)**, Rudy Vallee and His Connecticut Yankees, orch., 2s. 6d.

H.M.V. B6033

Of these two, the second is much the slower. Both are very attractive from the melodic point of view. I thoroughly enjoyed them.



DEBROY SOMERS



RUDY VALLEE

TURNTABLE TORQUE MEASURED

By J. H. REYNER, B.Sc., A.M.I.E.E.

DURING some early experiments on home recording it became obvious that certain forms of tracking device could not be driven by small portable machines. An investigation was, therefore, undertaken to see what variation there was in the torque developed by various classes of machines, and to find to what extent this limitation was likely to apply in practice.

Simple Apparatus

For this purpose a simple apparatus was arranged as shown in the diagram. It consisted of a rubber disc with a hole in the centre. Screwed into the side of this was a long brass rod. The rubber pad was placed on the centre of the turntable, the centre hole being of such a size as to be forced lightly over the pin.

Thus, if the turntable was set in

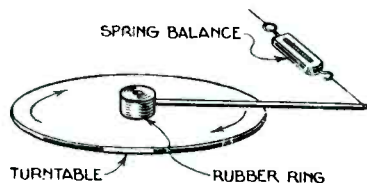

Use of spring balance to measure turntable torque

motion, the arm tended to be carried round with the table.

Attached to the outer end of the arm, however, was a spring balance so that the arrangement was not free to rotate. According to the driving torque of the motor, however, the pull developed at the end of the arm varied and this gave a reading on the spring balance from which the required calculation could readily be made.

Few Ounces Pull

Incidentally, the pull developed was only a few ounces at the end of the rod so that the torque is not very great. This, of course, is in accordance with customary gramophone practice where the clockwork motor is designed to give just sufficient torque to drive the disc round against the friction of the needle, and to sustain this torque for a relatively long time.

In point of fact, as the results

showed, double-spring motors and even more powerful ones did not develop appreciably larger torque, but used the extra energy of the spring to maintain the turntable in motion for a greater length of time.

The results of a number of machines tried at random in a gramophone-dealer's shop gave almost the same results in every case. It was only where one used electric motors that there was any appreciable increase in the torque provided, and here there certainly was a distinct improvement. The results

obtained are tabulated herewith:

MAKE	TORQUE Foot-pounds
Columbia	
Portable	.05
Decca Portable	.05
Dulcitone	
Portable	.04
H.M.V. Portable	.05
H.M.V.	
Pedestal Model	.06
Electric Motor	1.2

MORE "PUNCH" FROM PICK-UPS

ALTHOUGH details of the new season's gramophone pick-ups are not generally available, we have good reason to expect that more than one pick-up will have an output of at least two volts. This marks a great increase in sensitivity, for up to the present time most pick-ups have had an output of less than one volt.

It is interesting to consider what effect the new pick-ups of greatly increased sensitivity will have on amplifier design. Generally, better quality of reproduction should be the result, for reasons that may not be obvious to the average amateur.

With the normal pick-up, giving less than one volt output, at least two valves are needed in an amplifier. And the input valve

must have a fairly high amplification factor if the output valve is to be fully loaded by the voltage from the pick-up.

Suitable Transformers

With a high-magnification input valve is inevitably associated a high impedance. An average impedance for a high-magnification valve such as the H210 is 30,000 ohms. To get good quality from this valve, the impedance following it, namely the primary winding of the low-frequency transformer, must also be high. As this is only possible with expensive transformers, some loss of quality is usually endured for the sake of the extra volume obtained from the high-magnification valve.

Now, with a two- or three-volt pick-up output, it is obvious that less amplification will be needed to load the power valve. In fact an L-type of valve with an impedance of about 10,000 ohms should give quite sufficient amplification. This lower impedance preceding the transformer would tend to improve quality.

The lower impedance valve would, of course, pass more anode current. One would have to be careful that this increased anode current did not saturate the core of the transformer. H.

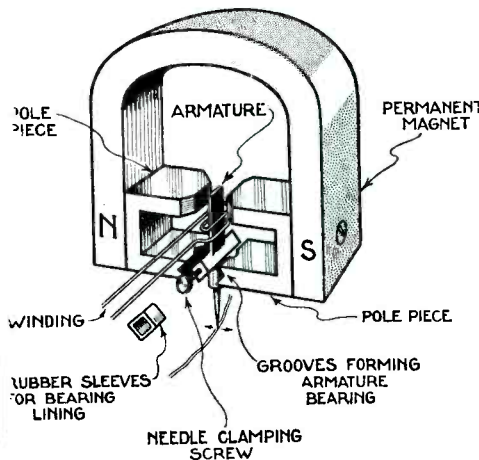

Construction of a typical pick-up or "electrical soundbox"



**THINK OF
ONE—
YOU THINK OF
THE OTHER . . .
JUST LIKE
GOOD RADIO
AND
PERTRIX**



**YOU'LL HEAR THEM
BETTER WITH PERTRIX**

"Hullo, people! You know my old woman, don't you? Here, old woman! Meet the people." • Now you can settle down to a good ten minutes or so of real fun. When Claude Hulbert and Enid Trevor are 'on the air' troubles are forgotten. Smiles become the order of the day • Suppose though, that these two had never met. What a wealth of entertainment the world would have lost . . . how many happy hours of enjoyment you, too, would have missed • But do you hear your favourites at their best? Do you get the volume—the clear reproduction—the excellence of tone that only the most modern Dry Batteries and Accumulators can give? If you don't—get PERTRIX today. From tomorrow, good radio will be inevitable. And PERTRIX last longer, too • Your dealer has PERTRIX—ask him.

*Made by BRITANNIA BATTERIES, Limited
at Redditch who also make:*

Batteries for Central Stations • Batteries for Country House Lighting • Emergency and Stand-by Lighting Batteries for Theatres, Cinemas, Hospitals, etc. • Batteries for the Starting and Lighting, and Lighting and Ignition of Motor Cars, Motor Cycles, Buses and Coaches • Batteries for Electric Vehicles, Trucks, Locomotives, Ships and Yachts • The only Nickel-Iron Alkaline Battery on sale in Britain that is entirely made in this country.

PERTRIX
SUPER LIFE
DRY BATTERIES
&
ACCUMULATORS

THE PERFECT PAIR FOR PERFECT RADIO

Advert. of PERTRIX LIMITED, 233, Shaftesbury Avenue, London, W.C. 2
Telephone: Temple Bar 7971 (5 lines) Works: Redditch P.P. 2

TO INTRODUCE

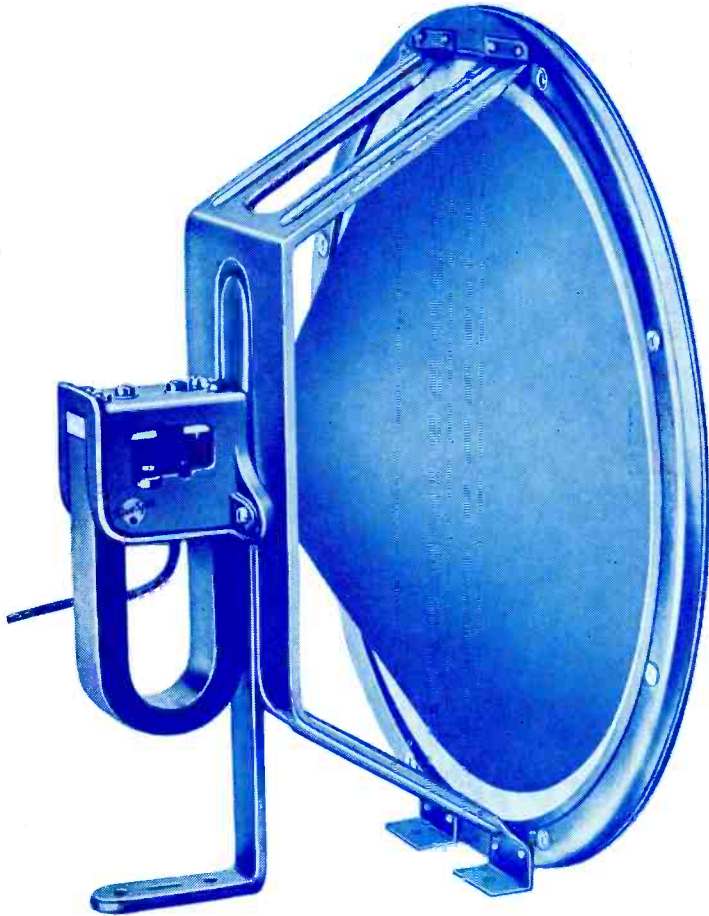

39'6

The Wonderful New Inductor Type LOUD SPEAKER UNIT

This new BLUE SPOT Unit will be enthusiastically received by amateur and professional alike. It is comparable in performance to the best type of dynamic speaker. It has, however, many advantages over it. Connections to the receiver are exceedingly simple, and no field current is required.

A broad frequency band enables 100U to reproduce voices and music with perfect fidelity, and in the bass notes particularly, it gives a clarity that is absolutely unique.

100U is suitable for use with any receiver whether mains driven or battery operated. It will handle very large inputs without blur, discordancy or rattle. The exceptional sensitivity ensures very good volume with even small inputs. Make a point of seeing and hearing this new unit.

THE BRITISH BLUE SPOT COMPANY LTD.

BLUE SPOT HOUSE, 94-96 ROSOMAN ST., ROSEBERY AV., LONDON, E.C.

Telephone: Clerkenwell 3570. Telegrams: "Bluospot, Isling, London."
Distributors for Northern England, Scotland and North Wales: H.C. RAWSON, (Sheffield and London) Ltd., 100, London Road, Sheffield
22, St. Mary's Parsonage, Manchester: 183, George Street, Glasgow

COMPLETE RANGE OF BLUE SPOT PRODUCTS FOR 1931-1932

66R The most efficient balanced armature unit on the market. Price 35/-

PERMANENT MAGNET SPEAKER with chassis and transformer. A remarkably fine instrument. Price 75/-

MOVING COIL SPEAKER (D.C.) MCDEL 72 Neat and compact. Extraordinary efficient. Price 47/6

MAINS DISTURBANCE ELIMINATOR Effectively eliminates mains hum. Price 10/6

REJECTOR WAVE-TRAP Cuts out unwanted stations with ease. Price 15/-

66K UNIT Price 25/-

66P UNIT Price 27/6

CHASSIS Specially designed for BLUE SPOT Units. Major Chassis 15/- Special Chassis 7/6

PICK-UP Complete with volume control 63/-

SPEAKERS IN CABINETS

BLUE SPOT 70R (with 66R unit) Price 75/-

BLUE SPOT 44R (with 66R unit) Price 52/6

BLUE SPOT 45R (with 66R unit) Price 52/6

BLUE SPOT 100D (with 100U unit) Price 63/-

BLUE SPOT 30PM (permanent magnet) Price 110/-



TRADE MARK

Regd. Nos.: 515639 and 516180.

NOW A

NEW
MINOR



**PICK-UP
and Tone Arm**

PRICE

27/6



"Minor" B.T.H. Pick-up and Tone Arm. Price complete **27/6**

A B.T.H. Pick-up and tone arm is the choice of leading radiogram experts—the choice of the enlightened home constructor—the pick-up that's chosen when a man "must have the best."

Now comes the B.T.H. "Minor" Pick-up and tone arm at a price which places first class reproduction within the reach of a wide public—the public which knew and appreciated the best but which couldn't afford to possess it.

The new "Minor" is an amazing success. Its brilliant performance on test records is a revelation. Bass, treble and middle register — all reproduced with amazing brilliance. The "Minor" is a product of the same technical experience and engineering skill that have made the "Senior" model the standard of excellence against which other makes are judged.

See one for yourself and ask for a demonstration at your local dealers.

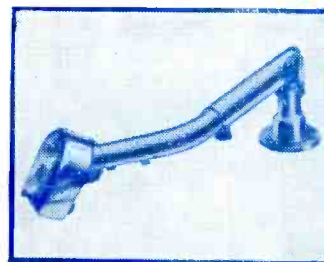

"Senior" B.T.H. Pick-up and Tone Arm. Price **45/-**

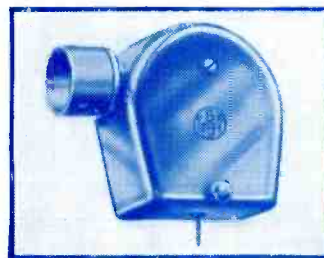

"Senior" B.T.H. Pick-up only with adaptors. Price **27/6**



THE EDISON SWAN ELECTRIC CO. LTD.
Incorporating the Wiring Supplies, Lighting Engineering and Radio Business of the British Thomson-Houston Co. Ltd.
Radio Division:
155 Charing Cross Road, London, W.C.2
Showrooms in all the Principal Towns

EDISWAN
RADIO PRODUCTS

LEWCOS (Regd.) Components

*The Criterion of
Craftsmanship*

Perfect symmetry and elegance of design, and maximum efficiency on every technical point have made LEWCOS components the standard by which all others are judged. This pre-eminence has been achieved by skilled workmen using only the very finest of materials, and by a staff of experts who constantly experiment to ensure that LEWCOS components live up to their manufacturers' reputation for being in the forefront of radio design.

Use LEWCOS components in your new Super-Het. Receiver and you will taste of the joys of perfect reception.

The Lewcos Components Illustrated above are the:—

- Dual-Range Frame Aerial
- L.F. Transformer (Ref. L.F.T. 3)
- Super-Het. Coil Kit
- Lewcos Spaghetti Resistances
- Eight-way Base

Fully descriptive leaflet, Ref. R.71, will be sent on request

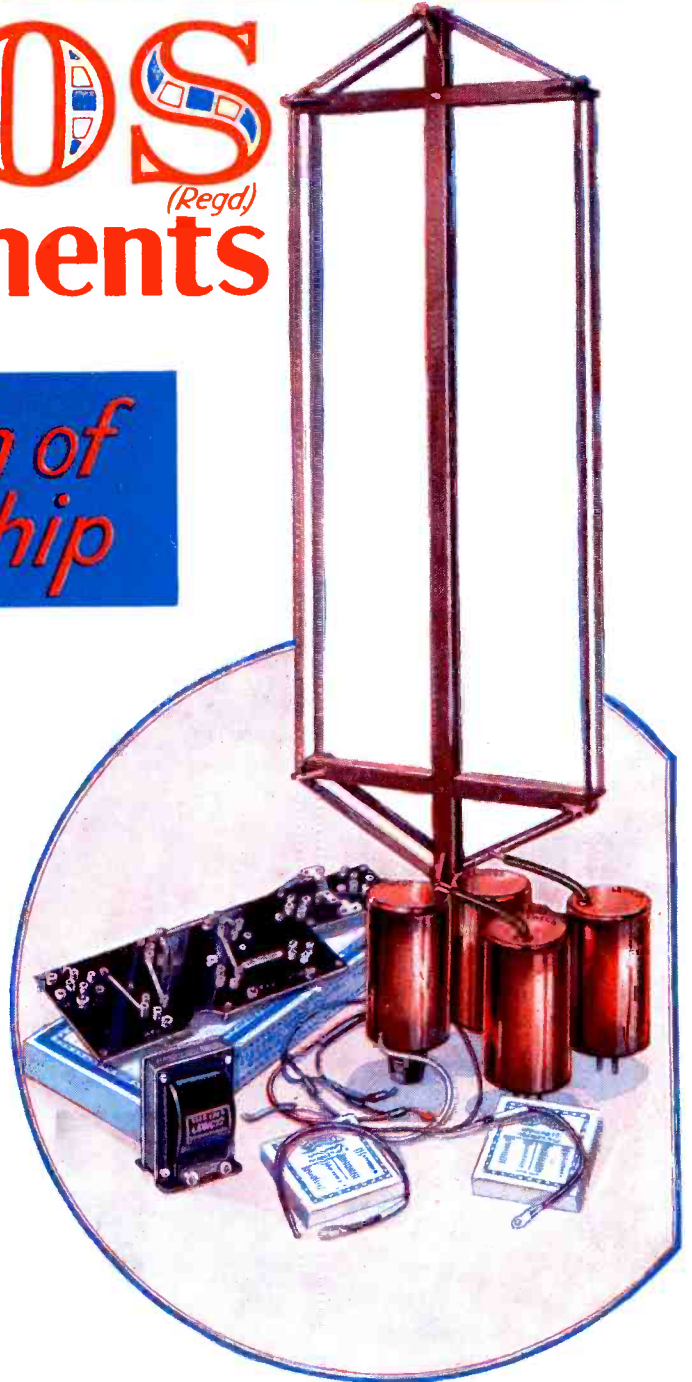

WE ARE EXHIBITING AT

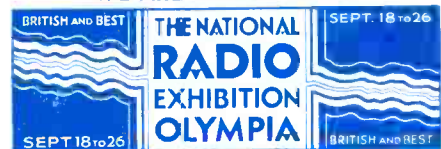

VISIT OUR STAND No. 27
(NATIONAL HALL)



LEWCOS RADIO PRODUCTS—BETTER RECEPTION

THE LONDON ELECTRIC WIRE COMPANY AND SMITHS LIMITED CHURCH ROAD, LEYTON, LONDON E10

A radio-equipped
police car

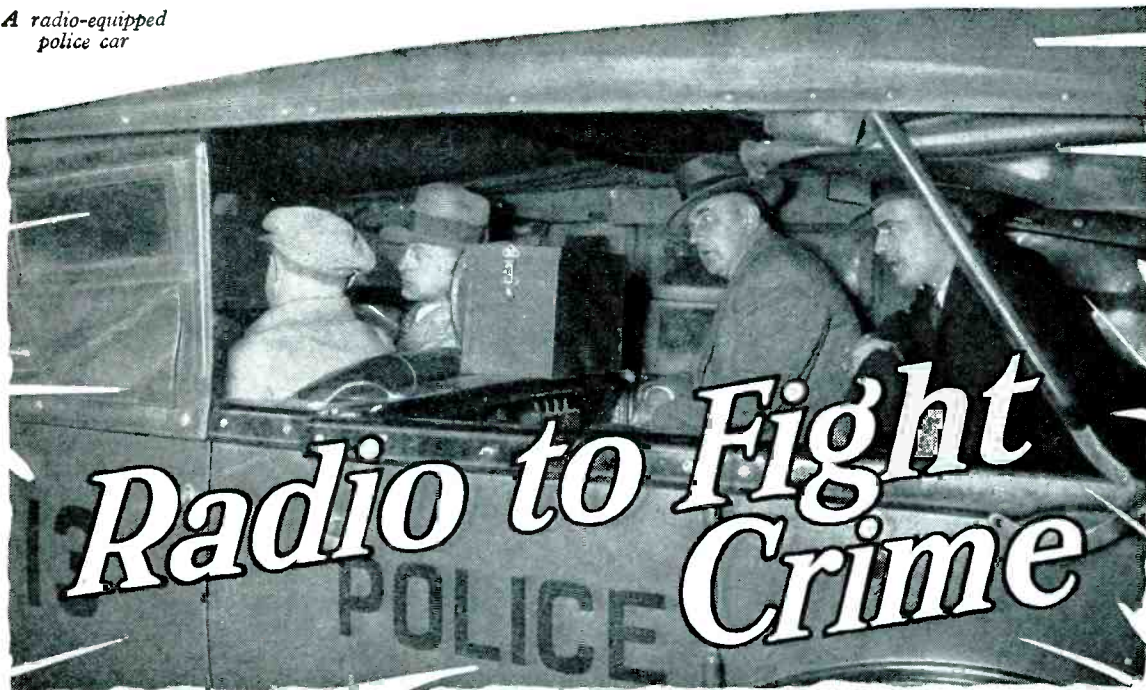

We hear a lot about the use of radio by the police. Here is an authoritative article by GORDON S. MITCHELL explaining how wireless is helping the police in America. It is exclusive to "Wireless Magazine."

THE use of radio in the never-ending warfare between police and criminal has increased until at the present time a great many American cities have equipped their police departments with radio transmitters and receivers which enable the operators of police cars to be in constant and immediate communication at all times with headquarters.

Thwarting the Criminal

While there are many cities throughout the United States which are making use of this new weapon in their attempts to thwart the criminal in his nefarious activity, a description of the system as used by the Los Angeles Police Department is given here as being representative.

Some twelve months ago the advantage of the use of radio as a police weapon was realised and steps were taken by Los Angeles police officials to allow for the equipment of police cars with radio sets.

The city is organised into several police districts, each district having its own station house under the direction of a captain of police, who is responsible for all police work in his own district.

With the introduction of the radio, problems of organisation presented themselves. Obviously, it would be impossible to maintain the same

organisation for the radio division, in that a broadcasting station for each precinct would be unnecessary for a variety of reasons.

Consequently it was decided to construct one transmitting station and maintain telephonic communication between each precinct house and the broadcast station—using the broadcast station in turn to maintain contact with each receiver-equipped car throughout the city.

A transmitting station was constructed in Elysian Park, which is a naturally wooded and hilly park located a few miles north of the business section of the city. Direct telephone lines were run from this station to the police headquarters in various parts of the city.

The receiving sets were specially built by radio engineers with the problems of police reception in mind. They are sufficiently sensitive to pick up the broadcasts at loud-speaker volume.

Under the Dashboard

The receiver is located under the dashboard in the driver's compartment of the car, with the loud-speaker immediately to the right of the receiver, also under the dashboard. (This method of mounting differs from that illustrated in the accompanying photographs, which illus-

trate the method of mounting the receiver as used by the police of Chicago.)

The radio technicians were considerably handicapped at first in their efforts to obtain satisfactory results with the receivers on account of the aerial location. Various places about the car were tried, best results finally being obtained with a sheet of copper netting placed up and inside the top of the tonneau of the car.

Crew of Three Men

Each radio car carries a crew of three men, and is assigned a certain district in which to work. A clear understanding of the system may probably best be gained by tracing a call as it progresses through the police department from citizen to officer who responds to the call.

Let it be supposed, for instance, that a citizen residing in Hollywood, which is a suburb of Los Angeles city proper, has found, on coming home after an evening spent at the theatre, that his house has been entered and ransacked by a person unknown to him.

However, from appearances, the citizen gathers that the intruder has only recently left the building and has reason to believe that he may still be in the neighbourhood. He hastens to the telephone and calls police

RADIO TO FIGHT CRIME—Continued



HANDING A REPORT TO THE RADIO ANNOUNCER

The squad operator can keep in touch with 100 cars cruising about in the various districts of Chicago

headquarters either by number or by a request for "Police."

The citizen is connected with his precinct headquarters, but in addition a private line is opened at the same time which permits the radio announcer on duty at the transmitting station to listen to the citizen as he recites details of the burglary of his house to the officer on duty at the station house.

Consequently there is no delay in transferring calls from police headquarters to the radio broadcasting station. If the case is urgent and requires the immediate presence of officers at the citizen's home, the announcer without further ado speaks into the transmitter of the broadcast set.

Definite District

As mentioned above, each car is assigned a definite district in which to work and, in addition, operates under a number.

The radio announcer, then, from the citizen's recital of the facts of the case, obtains the address and either from memory or a quick perusal of a district map determines which car has jurisdiction over the particular dis-

trict in which the citizen lives. He then places his call over the radio transmitter somewhat in the following manner:

"This is Radio KGPL—KGPL, the Los Angeles Police Department KGPL calling Radio Car No. 4—

calling car No. 4. A burglary has just been committed at 5837 Camerford Avenue in Hollywood. Burglary at 5837 Camerford Avenue. KGPL calling Radio Car No. 4. KGPL—"

All important details of the call, such as the identifying letters of the station, the number of the car being called, and the address are repeated several times in order that no essentials will be missed.

Constant Tuning

The receivers in each car are tuned to the police broadcast station at all times, and whenever the broadcast announcer speaks into the transmitter his voice is heard by the operators of all radio-equipped cars.

Notwithstanding the very great size of the city of Los Angeles, it is possible for a radio car to proceed to any point within its district of operation within three minutes of the time of placing of the call by the citizen.

This means that the entire city is covered by police protection within a three-minute period, which has proved to be a great deterrent to crime.

Preventative

The radio, in addition to its very great increase in efficiency in apprehending criminals, acts as a powerful crime preventative, with its constant threat of speedy capture to any lawbreaker. The fact that a criminally inclined person knows positively that



AUTOMATIC PRINTER TELEGRAPHS FOR THE POLICE

Two printer telegraphs at the Chicago police headquarters connect the central office to each of the forty-one districts of the city

EXCLUSIVE TO "WIRELESS MAGAZINE"

if he is discovered there will be officers on the scene within a three-minute period makes him hesitate before acting!

Figures show that since the inauguration of the radio system by the Los Angeles Police Department there has been a marked decrease in crime in the city, although there has been a greatly increased number of arrests in comparison to the number of crimes committed. This increased police efficiency is directly attributable to the use of the radio system.

Maximum Use

The radio system is in use throughout the twenty-four hours of the day, each car being manned by three separate shifts of officers, who are on duty for eight-hour periods. Thus a maximum amount of use is gained from the system.

An interesting point regarding the

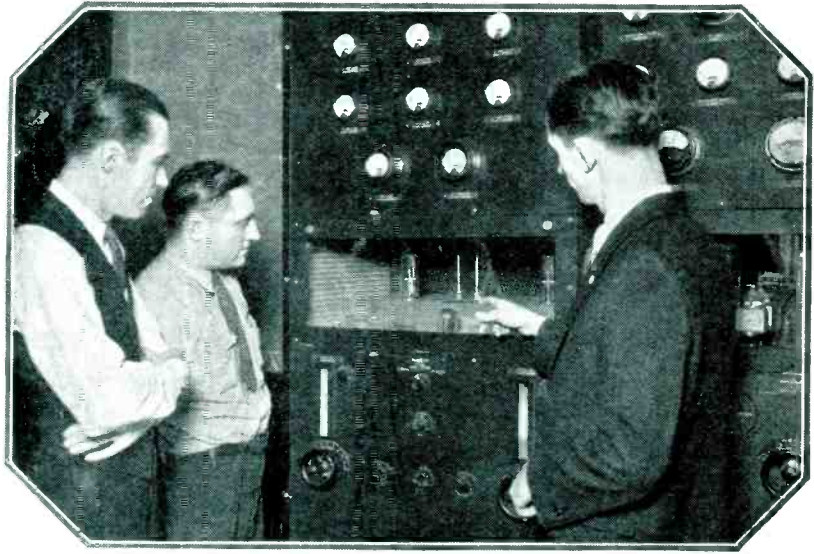

THE CHICAGO POLICE TRANSMITTERS

Chicago police officials inspecting one of the 500-watt Western Electric transmitters



A GOOD ANNOUNCER IS NEEDED

The police announcer's voice must be crisp and clear, so that it cannot be misunderstood by the squad-car operators

use of radio by the police is that although the broadcasts are pre-eminently for the ears of the officers manning the cars, listening to the police broadcasting station has taken on the aspects of entertainment to vast numbers of the public, who tune in on the station and derive considerable enjoyment from the crime reports.

This would be harmless were it not for the fact that the average American, imbued with a great spirit of

curiosity, has taken to, in greater and greater numbers, rushing to the scene of any untoward event, oftentimes arriving simultaneously with the police car, and in many cases hampering the work of the officers in dealing with the situation.

This is made possible by the fact that the police broadcasting station operates on a wavelength of approximately 175 metres, which is just below the broadcast band and is a

wavelength which can be tuned by a great many broadcast receivers.

In fact, such widespread interest has been aroused in the use of the radio by the police department that many radio technicians and service men are advertising their ability to alter the ordinary broadcast receiver in such a way that it will be possible to tune this wavelength if the set is not already capable of so doing.

Special Action Needed

So serious has become the situation in the last month that high police officials state that some action, legislative or otherwise, is necessary if the police radio system's usefulness is not to be seriously curtailed.

While this article has dealt in the main with the use of radio by the Los Angeles Police Department, this is not the only city by any means which has equipped its police department with a radio system. Many of the smaller cities and towns throughout the United States have done so.

Startling Results

In Detroit, Michigan, even more startling results have been noted since the inauguration of a radio system by the police department. During the first few months in which the system was used 32,000 messages were transmitted, of which number 10,000 were direct orders to head for the scene of some actual or reported crime.

As a result of these orders, 1,600

RADIO TO FIGHT CRIME—Continued

arrests have been made at an average time of only ninety seconds per arrest from the time of the placing of the call by the citizen until the arrival of the officers. Crimes investigated, and arrests made for these crimes, have ranged from petty thievery to manslaughter and murder.

Two Transmitters

The Chicago Police Department radio division is equipped with Western Electric transmitters. The system as used in that city is unique in that there are now two transmitting stations, with a third under process of construction. The announcer, by pressing a button, is able to

one car in Los Angeles, the cars operating in two adjacent territories, if not busy, are supposed to go immediately to the scene of the crime.

This makes it certain that one of the three interested crews will be available for each call, except in those rare instances when all three cars are busy on previous calls. In that case, of course, as the business on which they are engaged is terminated, each car will proceed to the scene of the disturbance, the first one to arrive taking charge of the situation.

However, differing from the method used in Los Angeles, the City of Chicago is laid out in districts in such

receivers. The city is divided into three sections, each section having a radio maintenance car which is in operation twenty-four hours a day.

The receiver-equipped cars report by telephone to the broadcast station in the event of trouble with their receiver. The broadcast station then directs the nearest maintenance car, by radio, to proceed to the squad car and attempt repairs to the receiver.

Spare Parts

Each service car carries spare and replacement parts and is manned by a crew which is capable of repairing minor faults in the set. Major repairs are made in the radio shop. The receivers are R.C.A. Victor sets slightly modified for police work, and cost including installation, about £40. The cost of receiver maintenance, including depreciation of equipment, is approximately £7 per month per receiver, or the total maintenance cost for the one hundred cars of the department is £740 per month.

Cost of Transmitters

The transmitters are modified Western Electric "106-B" 1,000-watt sets, operating with a normal output of 500 watts each on a frequency of 1,712 kilocycles. The transmitters cost approximately £5,400 each (installed). The cost of operation of each transmitter, including depreciation, labour of repair and operation, and all materials, is approximately £320 per month.

While this cost seems rather high, it should be borne in mind that the transmitters are in operation twenty-four hours per day, which partially accounts for the rather high operational expense.

More and More Difficult

With the increasing use of radio by the police of various cities, crime is becoming more and more difficult. The underworld is face to face with the realisation that the police have a powerful and unseen weapon—a weapon which has proved more effective in the few short months of its use than any innovation which has heretofore been introduced.

With the perfection of the minor details of operation and procedure, which are proving troublesome, it is certain that a still greater efficiency will result. Radio is proving to be a powerful aid in the fight of the people against the criminal.



WHERE POLICE CALLS ARE SORTED OUT

All phone calls are handled by these police officers, who report to the radio announcer when necessary

broadcast his message through either one of the transmitters, depending upon the location of the reported crime or disturbance.

One Hundred Cars

One hundred Chicago police cars are equipped with radio receivers, giving complete coverage to all portions of the city.

The operational procedure as used in Chicago differs somewhat from that used in Los Angeles in several minor particulars. While the announcer in making a report of a crime calls only

a manner that two cars are responsible for each district. When the announcer places a call through the radio transmitter, he calls the number of both of these cars, ordering each to proceed to the scene independently.

Thus it is fairly certain that one of the two will be available and will be able to handle the situation.

The cost of the installation and operation of an extensive police radio system is of interest. Quite an extensive radio organisation is maintained by the Police Department in Chicago for servicing defective radio

*By Our Special
Commissioner*

*The bedtime story—
on a Marconiphone
portable*

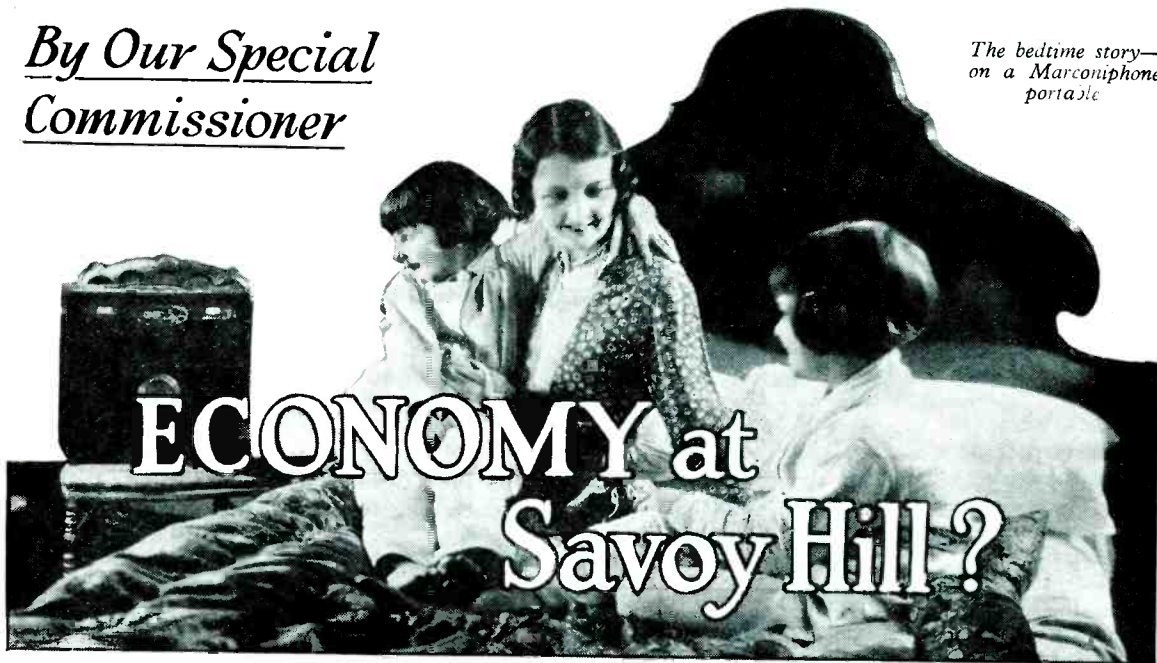

ECONOMY at Savoy Hill?

ECONOMY RUMOURS :: BROADCASTING HOUSE :: WELSH PROGRAMMES

CONSTERNATION is felt at Savoy Hill over the recommendations affecting a levy on broadcasting, made by the Committee on National Expenditure.

In view of its heavy commitments on the regional scheme and on Broadcasting House, the B.B.C. has been looking forward to a progressive income as the fruits of its labours, in order that programme expenditure shall not be diminished because of other extraordinary demands on its finances; to put the matter in another way, the B.B.C. has all along envisaged the possibility of a considerably increased outlay on programme material, keeping pace with the increasingly elaborate machinery of programme distribution.

Suffering for Success

No one can regard it as other than a set-back for the Corporation to be told that it must suffer for its success; that instead of the £1,380,000 to which it would be normally entitled as its share of the licence revenue, based upon the estimated growth of licences during the present year, its income from that source should be reduced to £900,000.

The gain to the Exchequer, if the Committee's recommendations are carried out, will be about a million pounds a year in all.

Officially the Corporation cannot

be expected to put up much of a protest against the proposed raid on its funds. As a public service it must be as deeply concerned as any over the country's economic condition; and would be as ready as any ordinary Government Department to bear its share of sacrifices which were unavoidable.

But when the Committee says that at the time the main agreement was under discussion it was generally contemplated that a revenue of about £800,000 per annum would meet requirements, and suggests that something approximate to that figure should meet the needs of broadcasting in 1931, Savoy Hill surely cannot help demanding whether public expenditure will likewise be put back five years and all schemes involving additional financial outlay during that time be abrogated.

In 1930 the Exchequer took £596,166 as its share of the licence revenue; a greater amount, that is, than the B.B.C. was able to spend on programmes; add to this a sum of £50,000 due as income tax on the amount received by the Corporation and then add the £475,000 which would accrue to the Exchequer if the recommendations of the Economy Committee were adopted, and it will be seen that broadcasting is likely to become a milch-cow rather than a channel through which economies

are called for in the national interest.

If the reader is about to become a radio listener, and contemplates the payment of his ten-shilling licence fee, let him realise that out of this amount only 1s. 10d. will actually go to the B.B.C. towards the provision of a year's programmes, one shilling will go to the Post Office for collecting the ten shillings and the balance of 7s. 2d. to the Exchequer.

The potential listener can, then, at any rate, congratulate himself on making a useful contribution out of a modest outlay towards the expenses of the State; but in his thoughtful moments he will not be impressed by this example of the workings of State ownership.

Ill-informed Criticism

Savoy Hill is not particularly pleased with the ill-informed criticisms which are beginning to make their appearance in some quarters over the new building in Portland Place. One such comment is that Broadcasting House will not be big enough to accommodate everyone and that when the time comes for the Great Remove, a proportion of the staff will have to remain behind at Savoy Hill.

No ground exists for such an assertion. In designing Broadcasting House the architect, Mr. Val Meyer,

ECONOMY AT SAVOY HILL?—Continued

was naturally guided by the knowledge of the B.B.C.'s own civil engineer, Mr. Tudsbery, as regards the requirements on the technical side; hence the central tower, containing the studios, was planned first and the rooms to accommodate the staff were next planned around the tower.

No Under-estimate

But as the building was designed for a known purpose, it was not really difficult for Messrs. Val Meyer and Tudsbery to make the requisite provision for all persons who will have to be accommodated in the offices. The exact number of such people was known and there could be no excuse for an under-estimate.

The fact that the site adjoining Broadcasting House is to be bought for £50,000 is not relevant. This is merely a safeguard against probable future requirements. It is, indeed, quite on the cards that the younger generation will live to see the home of broadcasting extending even further along Portland Place than the adjoining site.

The nature of the building design indicates as much. Broadcasting House as it now appears will, however, meet all immediate staff needs, without the necessity—which is another of the criticisms which have been ventilated—of herding anyone in underground rooms to work by artificial light all day.

The only people who will use the accommodation below the street level as a regular thing are the staff in charge of the ventilating, electric-lighting and power plants.

One or two studios also are below the street level; but such of the staff and artistes whose duties require their presence in these studios will hardly realise that they are working below ground; for all studios are normally artificially lighted at all hours and provided with specially arranged ventilation.

Ahead of Schedule

The work on the building is now slightly ahead of schedule; but a good deal remains to be done in the way of wiring and decoration. The panelling of some of the more important rooms is also coming in for criticism on the part of officials who will have to occupy the rooms; it is felt that the wood—most of it from

the colonies—gives a heavy appearance.

This is noticeable both in the chairman's (Mr. Whitley's) room and in that of the director-general, Sir John Reith. Some alterations may therefore be made.

It now seems likely that the whole of the Savoy Hill staff will find themselves installed in Broadcasting House before Christmas; but no arrangements have yet been made for anything in the nature of a formal opening.

Not the least of the B.B.C.'s problems calling for prompt solution

THE SLIP!

HIS face whitened and he gasped as the enormity of his offence swept over his mind.

It would not have been so serious, he thought miserably, if it did not affect many innocent people.

He could not deny that he was responsible—there were many witnesses to prove that he was the culprit, and it was impossible to throw the blame on anyone else.

He had never done such a thing before. He thought back over the past years. He had had every chance to make good; a public-school education, Oxford, and now he had done this. What would his people think?

Finally, the announcer, who had inadvertently dropped an "h," shrugged his shoulders and decided he would be more careful in future.

N. E. M.

is that of the position of broadcasting in Wales. At the beginning of this year Savoy Hill issued a defence of its attitude towards Wales, admitting the reality of Welsh national aspirations and expressing "keen disappointment" at being prevented by circumstances from helping Welsh music, drama, and culture "to the degree both desired by the B.B.C. and deserved by Wales."

The back-handed compliment was intensified by a comparison of the licence figures in different areas, tending to show that in the natural order of things consideration for London and the Home Counties, for

the North of England and for Scotland, must take precedence of consideration for Wales.

With this policy, so far as it affects the building of regional transmitters, Welsh listeners probably are not themselves disposed to quarrel; although many of them cannot understand exactly why it is impossible to provide North Wales with a station of the calibre of Newcastle, for the distribution, simultaneously with the West Regional transmitter which is to be erected at Watchet, of a Welsh programme.

Very English Attitude

Where, however, Welsh nationalists do join issue with Savoy Hill is in the latter's very English attitude towards a definitely existing body of Welsh cultural opinion which has little in common with England.

The West Regional transmitter is not likely to be of much greater use to North Wales than the Cardiff station has been in the past. Reception of the North Regional transmissions is opposed by those from the Dublin station.

The peasantry of North Wales use little or no English; their language is used in religion, in the school and at public meetings—not because of any hostility to English, but because, by reason of their environment and training, the opportunity of extending their knowledge of the English language is limited.

Sir John Reith has promised greater facilities for Welsh programmes when the National 5XX transmitter is reconstructed. This means that there would be a likelihood of a greater proportion of the long-wave's programme time being devoted to Welsh transmissions—which can only be done at the expense of some millions of listeners in other areas.

Better Counsels

That idea has not yet got beyond the exploitation stage—better counsels are already prevailing; for Welsh opinion would not be altogether satisfied with such a sop.

The only means of satisfying Welsh nationalist opinion and at the same time of adding to licence revenue in the principality is to give Wales a wavelength of its own—and that fact will be faced and if possible solved by the B.B.C.

The Super Senior

W. JAMES Presents A Remarkable Sequel to His World-famous Super-het, the Super 60 :: Our Star Receiver for the Radio Exhibition That Will Make More Radio History



GREATER daylight range, better selectivity, a bigger factor of safety, and the elimination of the frame aerial and the use instead of an outdoor or indoor aerial are, briefly, the chief advantages of the Super Senior in comparison with the well-known Super 60.

Moderate Consumption

There are seven valves, one more than in the Super 60, and one of them is a four-electrode valve. The high-tension current consumption remains within the capacity of dry batteries, however, as it is about 14 milliamperes, depending to an extent upon the position of the volume control.

There is a stage of high-frequency amplification before the first detector of the super-heterodyne part of the set. This is so arranged that the locally-generated oscillations are not radiated and, therefore, an open aerial may be used with perfect safety.

This constitutes a great advantage over some super-heterodyne sets for, as you may have expected, the great success of the Super 60 in March of this year caused a stir in wireless circles and led to other types of super-heterodyne receivers being issued.

But the chief advantage of the tuned high-frequency stage lies in the reduction of certain forms of interference. With the Super 60, for example, it is noticed in certain districts that when the receiver is switched to the long wavelengths the powerful local medium-wavelength station is heard at several tuning points.

This does not happen when the high-frequency stage is connected, and those who have experienced this form of interference will be glad to know of a safe method of eliminating it.

Then, again, the magnification provided by the high-frequency stage

is useful. This stage is perfectly stable and, being tuned with a two-gang condenser, does not affect the ease of operation.

When you come to consider the relative merits of the frame and open-type aerials a number of points crop up. In the first place, the ratio of the signal to noise with a frame may be much less than when an open aerial is used. Some amateurs have found that reception with a frame aerial is not good because of the mush and noise brought in with the signal. Better results are usually obtained when an outdoor aerial is used.

Sharp Tuning

It is generally argued that the selectivity is better when a frame aerial is used instead of an outdoor aerial. This may be true enough under certain circumstances, but when you have a set with the sharp-tuning properties of the Super Senior the effect is of no importance.

The Most Attractive Constructor's Set Yet!

THE SUPER SENIOR—Continued

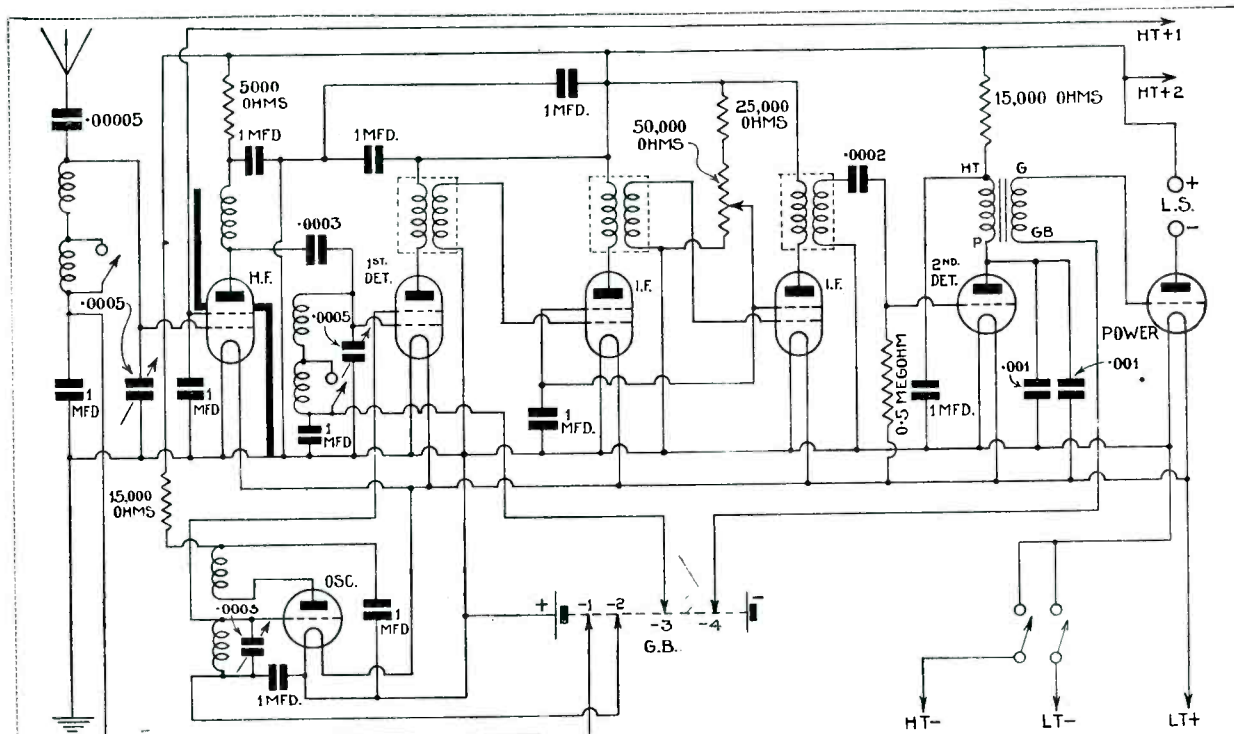

There is a preliminary stage of high-frequency amplification, followed by the four-electrode first-detector and oscillator valves. Then come two stages of intermediate-frequency amplification, the second detector, and a transformer-coupled power stage

This set is definitely so selective that Mühlacker can be received whilst London is working, and without interference. The selectivity, so far as the actual separation of stations is concerned, is slightly better than that of the Super 60, and that was reckoned to be sharp enough for all practical purposes.

Much Better Set

We gain, however, by avoiding other interferences. Various squeaks and whistles are avoided, and so we have a much better set.

The open aerial is often a better collector than a frame aerial. It depends upon the local conditions, of course, but there are some places where the signal strength is relatively poor when a frame is used and good when a short open aerial is fitted. The set can be used with an outdoor aerial; use a length of wire in the form of an indoor aerial if there is no outdoor one available. An earth should be used, as with ordinary sets.

The combined effect of using an open aerial and a stage of high-frequency amplification before the first detector is to increase the daylight range, to provide a more certain reception in localities where the signals are usually of poor strength,

and to eliminate many forms of interference.

I cannot claim that more volume is obtained, as the size of the power valve decides this, but there will be even more stations heard clearly at full strength.

A claim was made that the Super 60 was good for about sixty stations under average conditions, and the number of letters received from readers indicating the reception of many more than this number proved that our claim was modest enough.

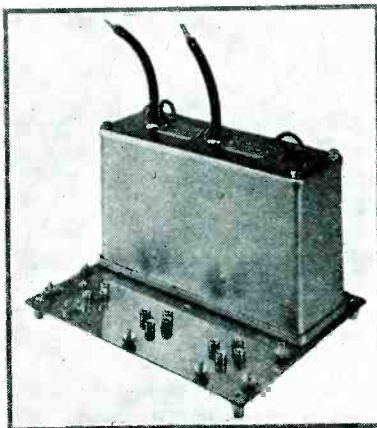

THE HEART OF THE SET

This is the Lewcos triple coil unit, containing three band-pass filter units

For this set we can claim even more stations, greater ease of reception, and less interference.

The circuit diagram shows how the high-frequency stage is arranged. The aerial is connected to the grid end of the aerial coil through a fixed condenser having a capacity of .00005 microfarad, or 50 micro-microfarads. Included in the circuit is a 1-microfarad condenser to by-pass the grid bias.

Screen-grid Bias

The first valve, an ordinary screen-grid, is biased 1.5 volts negatively in order to improve the results and to minimise the anode current.

A screen-grid coil is used and its switch is ganged with the tuned-grid circuit joined to the output of the valve. This also has a 1-microfarad condenser joined to it and a wander plug, in order that bias may be applied through the coil to the valve to which it is connected.

A choke-fed circuit is used in order to simplify the ganging and for stability. Both tuning coils are screened and are of the two-range type, having a push-pull switch fitted. The rod connected to the switches is arranged to project through the side
(Continued on page 282)

"THE BEST AND MOST HANDSOME SET I HAVE YET DESIGNED," Says W. James



THAT is what the designer says of his latest constructor achievement—the Super Senior, a remarkable sequel to the world-famous Super 60.

Here we have a set that has not only an enormous

programme value, but which can definitely be claimed to be the most attractive home-creator's design yet produced.

Every essential part is included in the cabinet illustrated here. There is no frame aerial—only a few feet of wire are needed, either indoors or out in the garden.

A Hard Job

So great has been the popularity of the Super 60 receiver that W. James was tackling no ordinary job when he started on the design of a special Exhibition set for WIRELESS MAGAZINE. It was obvious that the only way to improve on the performance of the Super 60 was to add still another valve.

That is what has been done. In essence the Super Senior is a Super 60 with a preliminary stage of screen-grid high-frequency amplification. But this addition

of two tuned circuits does not mean that the operation of the set has been complicated.

As on the Super 60, there are only two main tuning dials, between them being arranged the volume control (top) and oscillator wave-change switch (bottom). The latter has three positions—to the left for ultra-short waves, (not needed with this set), in the centre for medium waves and to the right for long waves.

The aerial and anode coils of the high-frequency input stage are con-

trolled by a two-gang condenser, and the ganged wave-change switch is mounted on



PARTS YOU WILL NEED FOR THE SUPER SENIOR

CHOKE, HIGH-FREQUENCY

- ✓ 1—Wearite, standard type, 6s. 6d. (or Lewcos, British General).

COILS

- 1—Lewcos triple I.F. unit, type No. 49, £1 11s. 6d.
- 1—Lewcos oscillator, 18s. 6d. (or Wearite, Igranic).
- 2—Varley H.F. Intervalve, type BP6, 17s.

CONDENSERS, FIXED

- 1—T.C.C. .0005-microfarad, type 34, 1s. 6d.
- ✓ 1—Dubilier .0002-microfarad, type 620, 1s. 8d. (or T.C.C., Telsen).
- ✓ 1—Dubilier .0003-microfarad, type 620, 1s. 8d. (or T.C.C., Telsen).
- 2—Dubilier .001-microfarad type 620, 4s. (or T.C.C., Telsen).
- 10—Dubilier 1-microfarad, type BB, £1 5s. (or T.C.C., Telsen).

CONDENSERS, VARIABLE

- 1—Jackson two-stage .0005-microfarad Chassis-mount, with drum drive, type D2RA, £1 6s. 6d.
- 1—Jackson single-stage .0005-microfarad Chassis-mount, with drum drive, type D1, 19s.

HOLDER, GRID-LEAK

- 1—Readi-Rad, 6d. (or Telsen, Lissen).

HOLDERS, VALVE

- 1—Junit S.G., 1s. 9d. (or W.B.).
- ✓ Telsen four-pin, 1s. 6d. (or W.B., Lotus).

PLUGS AND TERMINALS

- 2—Belling-Lee terminals, marked: Aerial, Earth, 6d. (or Clix, Eelex).
- ✓ Belling-Lee spade terminals, marked: L.T.+ , L.T.—, 4d. (or Clix, Eelex).
- 8—Belling-Lee wander plugs, marked: H.T.+2, H.T.+1, H.T.—, G.B.+ , G.B.—1, G.B.—2, G.B.—3, G.B.—4, 1s. 4d. (or Clix, Eelex).

RESISTANCES, FIXED

- 1—Sovereign 5,000-ohm, flexible type, 7d. (or Lewcos, Bulgis).
- 2—Sovereign 15,000-ohm, flexible type, 1s. 8d. (or Lewcos, Bulgis).
- 1—Sovereign 25,000-ohm, flexible type, 1s. (or Lewcos, Bulgis).

The prices mentioned are those for the parts used in the original set; the prices of alternatives as indicated in the brackets may be either higher or lower

- ✓ Dubilier .5-megohm grid leak, 1s. 9d. (or Telsen, Watmel).

RESISTANCE, VARIABLE

- 1—Colverstat 50,000-ohm wire-wound potentiometer, 5s. 6d.

SUNDRIES

- Tinned-copper wire for connecting.
- 1 ft. of shielded cable (Lewcos).
- Length of rubber-covered wire.
- ✓ Sovereign terminal block, 6d. (or Junit, Belling-Lee).
- 1—Readi-Rad screen and bracket to specification, 2s. 3d. (or Peto-Scott, Wearite).

SWITCH

- 1—Bulgin double-throw toggle, 2s. 9d.

TRANSFORMER, LOW-FREQUENCY

- ✓ Varley Nicore I, 17s. 6d. (or Ferranti AF3, R.I. Hypermu).

Accessories

BATTERIES

- 1—Drydex 120-volt, Orange series, £1 4s. (or Pertrix, Ever Ready).
- 1—Drydex 9-volt grid-bias, 1s. 6d. (or Pertrix, Ever Ready).
- 1—Exide 2-volt accumulator, type ICXG7, 17s. 6d. (or C.A.V., Lissen).

CABINET

- 1—Camco Lincoln pedestal in walnut, £5 17s. 6d.
- 1—Baseboard, 20 in. by 12 in. by ½ in.

LOUD-SPEAKER

- 1—Ormond special chassis model, £1 5s.

VALVES

- 3—Cossor 215SG, £3 (or Mullard PM12, Osram S22).
- 1—Mullard PM1DG, £1.
- ✓ 1—Mullard PM1HF, 8s. 6d. (or Cossor 210HL, Osram HL2).
- ✓ 1—Mullard PM1LF, 8s. 6d. (or Cossor 210LF, Osram HL2).
- ✓ Mullard PM2A, 10s. 6d.

the left-hand side of the cabinet, as is the on-off switch.

In essentials the remainder of the set is similar to the Super 60. There are two screen-grid intermediate amplifiers, with band-pass coupling coils. Instead of three separate screened coils being used, a single unit with three coils and three valve holders is utilised.

Another innovation is the use of a double-grid valve as the first detector.

Seven Valves

The Super Senior will bear comparison with all-comers in the super-het field. It has seven valves, but its anode-current consumption is only of the order of 15 milliamperes. Without the cabinet the cost of construction is about £18—and with the cabinet you have the most handsome constructor's set yet produced!

There is practically no limit to the number of stations that can be received. Although a frame aerial is not used, there is no need for a large outside aerial with the Super Senior.

THE SUPER SENIOR—Continued

of the case and so the wavelength range is easily altered.

A four-electrode valve is used as the first detector. This valve has two grids. One is connected to the tuned circuit in the ordinary way and the other is joined to the grid of the

Mullard four-electrode valve is used. It has a terminal on the base, and it is to this terminal that the grid of the oscillator is connected.

It is possible to use the four-electrode valve as a combined oscillator and detector, but this is hardly

worth while, owing to the disadvantages. The scheme is an old one, however, having been used, particularly by the French, for many years.

Six Tuned Circuits

Following the mixer valve is the beat-frequency amplifier, having three band filters comprising six tuned circuits adjusted by the manufacturers. Instead of being arranged as in the Super 60, in the form of three separate units, the makers have arranged them in a single box, which is fitted on a base having three valve holders as well.

This unit is wired by the makers and is a great convenience, besides being less costly than the separate parts. There are two screen-grid valves in the beat-frequency amplifier. These have their screens connected to a potentiometer in order that the volume may be varied.

Proper Decoupling

Following them is the detector, having a grid leak and condenser. This is coupled to the power valve through a transformer. Care has been taken to decouple the circuits properly. In the detector circuit are two by-pass condensers and the usual anode decoupling resistance and condenser are included. The set is easily built.

A two-gang and a single tuning condenser are used for tuning the

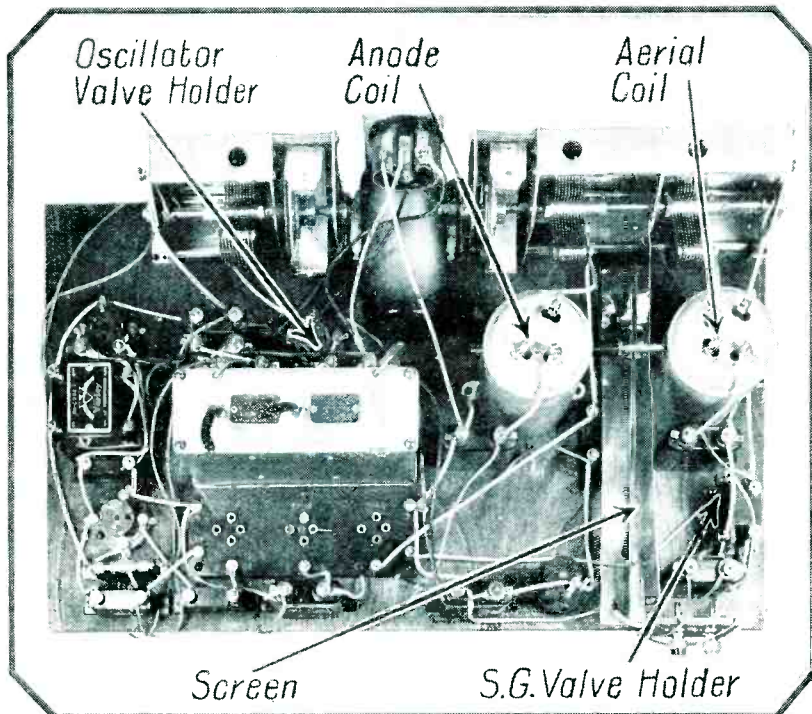

A BIG SET—BUT EASILY ASSEMBLED

As can be seen from this plan view, the layout of the parts is not complicated and the construction is within the capabilities of any listener

oscillator. The oscillator is arranged as in the Super 60, excepting that the white wire is not used and should be cut off and insulated.

We apply the oscillations to the first detector or mixer valve, as it is often called, by connecting the grid end of the oscillator circuit to the second grid of the mixer.

We therefore have applied to this valve the signal being received and the oscillations, and in the anode circuit appears the new signal having the frequency of the beat-frequency amplifier.

Minimum of Distortion

The connections are such that tuning the oscillator has practically no effect upon the tuning of the grid circuit of the mixer valve. We get effective rectification with the minimum of distortion and the oscillations do not reach the aerial circuit.

Thus it will be seen that the four-electrode valve is well worth while.

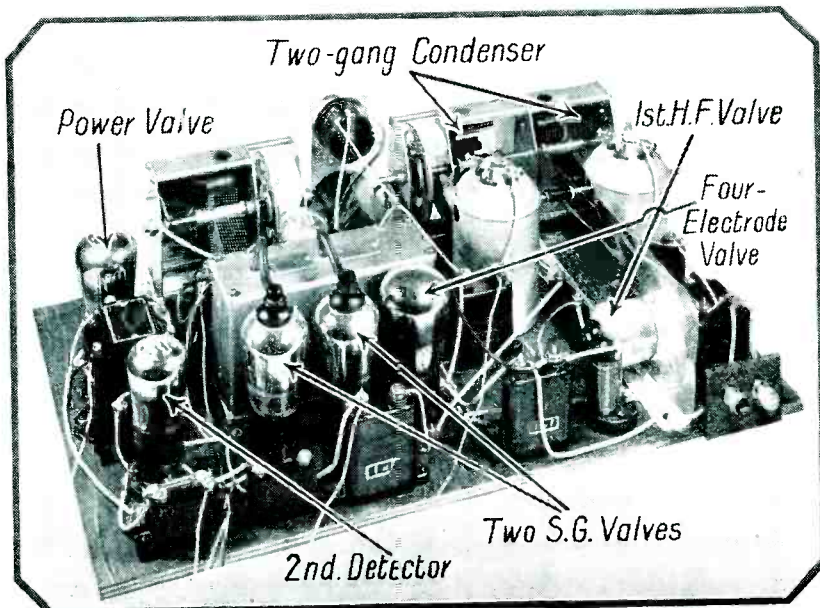

HOW THE SEVEN VALVES ARE ARRANGED

The anode-current consumption is approximately 14 milliamperes and the set can be run from double-capacity batteries quite economically

OUR STAR EXHIBITION SET

high-frequency circuits and the oscillator. These are mounted on short brackets to the baseboard, with their drum drives. Between them is a bracket of aluminium, to which is fitted the oscillator unit at the bottom and at the top the volume control. To the left of the set is the aerial coil and the condensers. Then there is a screen and the apparatus joined to the anode circuit of the screen-grid valve.

Valves in Coil Unit

The oscillator valve is arranged near the oscillator unit. There are three valves in the coil unit, the first being the four-electrode valve and the other two are screen-grid types. To the right of the unit is the detector with its condensers and transformer, and then comes the power valve. The set is so arranged that it may be completed and tested before it is fitted in the cabinet.

It is better to commence the constructional work by fitting the tuning condensers and the bracket carrying the oscillator unit and the

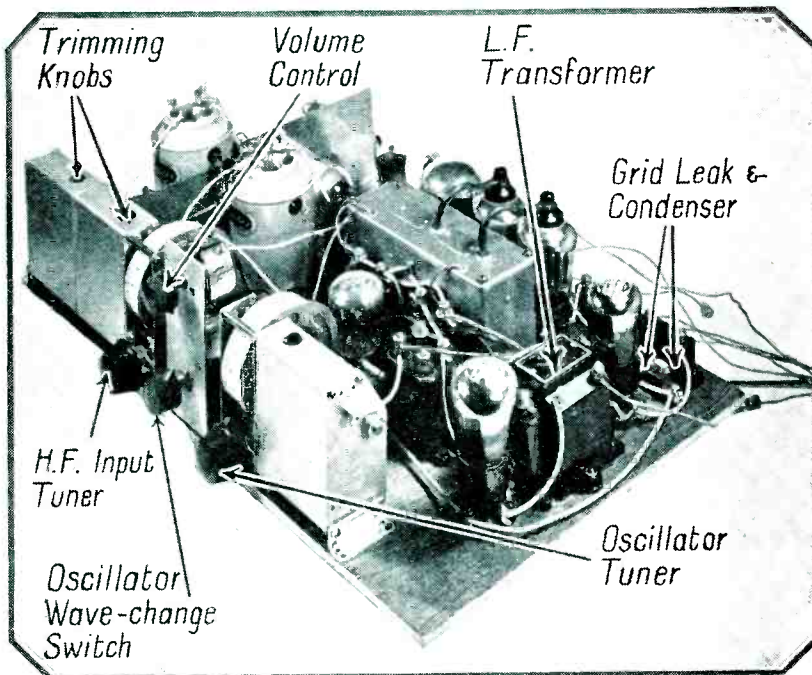

THERE ARE ONLY SIX CONTROLS

The controls are (1) H.F. input tuning, (2) oscillator tuning, (3) volume control, (4) oscillator wave-change switch, (5) H.F. wave-change switch, and (6) on-off switch. (Nos. 5 and 6 are on the left-hand side of the cabinet)

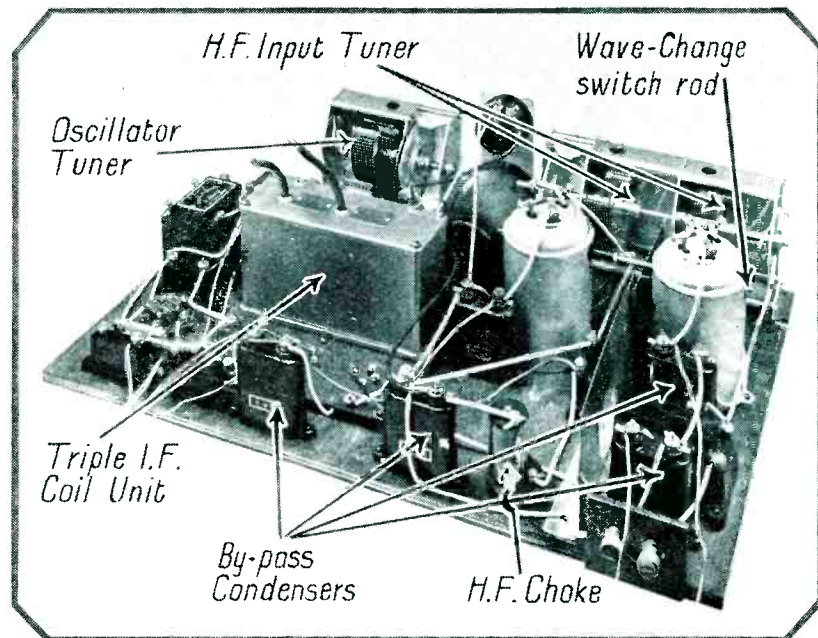

ATTRACTIVE OUTSIDE—AND INSIDE AS WELL

The most attractive constructor's set yet designed—that is our claim for the Super Senior, W. James' star Exhibition receiver

volume control. These parts are fitted at the front edge of the baseboard.

Then the two screened coils should be placed in position and be properly fitted with the connecting rod for the

two switches. A little trouble must be taken here to ensure that the switches work nicely and so the two coil units must be placed in line.

A screen is fitted between the two coils and the first screen-grid valve,

which fits in a vertical-type holder, projecting through a hole in the screen. There are various condensers about this valve and a high-frequency choke.

Triple Coil Unit

The beat-frequency coil unit is easily fitted in position, but before it is fastened to the baseboard two 1-microfarad condensers should be mounted in the places provided on the base of the unit.

There is ample room for the detector and power-valve circuits and for the oscillator, but the parts should be neatly arranged in the positions indicated.

The wiring of the receiver is easy enough, there being no really difficult connections. Tinned-copper wire and Systoflex can be used and no soldering is needed. Be careful when wiring the aerial and tuned-grid circuits that the right terminals on the two coil units are connected, leaving two terminals on each disconnected.

Unused Oscillator Wire

The white wire of the oscillator unit is not used and should be cut off and insulated.

There is a shielded wire passing from the grid of the oscillator to the side terminal (second grid) of the four-electrode valve. This wire has its

THE SUPER SENIOR—Continued

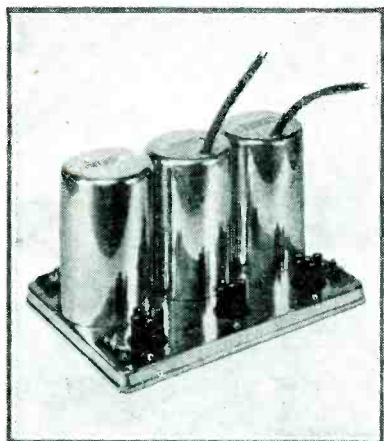

ANOTHER COIL UNIT

Next month we shall show how to use another triple-coil unit—that made by Wearite—which was received too late to be incorporated in this design

ends cleaned in the usual way, care being taken that the wire covering is well removed from the copper wire. It had better be bound with cotton at the ends for safety.

The wire covering is taken to the low-tension terminal of the intermediate-frequency amplifier unit, connection with the covering being made by wrapping a few turns of bare wire about the covering and taking the end of wire to the terminal.

Short Oscillator Leads

All the wires from the oscillator must be made as short as possible. There is no object in having the wires of unnecessary length and they may reduce the efficiency.

At the back of the intermediate-frequency coil unit are two flexible wires. These should be cut to length and be taken to the 1-microfarad condensers mounted upon the base of the unit.

Earthing the Screens

There is an earthing terminal, which is joined to low-tension negative. Both the screen and the two small coil units are earthed by a wire which can be fastened beneath screens used for fixing the components. There is one hole in the screen, through which the insulated wire from the low-tension positive circuit passes.

It is important to wire the grid-bias circuits correctly. The coil in the aerial circuit goes to G.B.—1; the grid circuit of the oscillator is taken to plug G.B.—2; the second coil,

connecting to the four-electrode valve, is joined to G.B.—3, and the last valve is biased through the low-frequency transformer and G.B.—4.

The on-off switch is fitted to the side of the cabinet and is included in the negative high- and low-tension circuits in order that both circuits may be broken, but if adjustments have to be made it is advisable to remove both high-tension positive plugs.

It is easy to wire the switch to the batteries and the circuit when the set is in its place in the cabinet. The loud-speaker is also easily connected when the set is in position.

There is one point regarding the supports for the tuning condensers that should be made clear and that is they should not be in contact with the central support for the oscillator and volume control. There should be a space between the two inner supports of the tuning condensers and the central bracket. If this is not seen

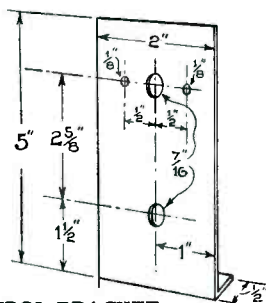

CONTROL BRACKET

This is needed for mounting the volume-control potentiometer and the oscillator unit

to part of the grid battery may be short-circuited.

The photos show the positions of the valves. In the first high-frequency position fit a screen-grid valve. Next

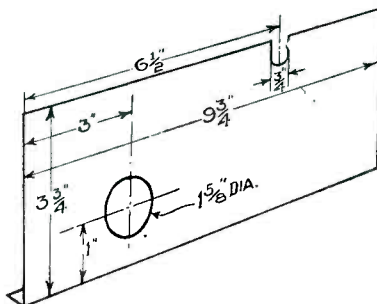

CAPACITY SCREEN

Here are the dimensions of the simple metal screen used in the set

comes the four-electrode valve, in the first holder of the three-coil unit, which is followed by two screen-grid valves. The end valve is the second detector, a valve having a medium impedance, such as one of the HL series.

For the oscillator use a valve of about 10,000 ohms impedance and in the power stage an ordinary power valve.

Use of Mains Unit

If you are going to employ a mains unit the power valve may be of a large size if the unit is large enough, but when dry batteries are used the last valve had better be of the small size in order that the current shall be reasonable.

A high-tension voltage of 120 is recommended, but may be higher if the power is available.

Usually the bias for the power valve is about -9 volts, but it should, of course, be chosen to suit the valve and the high tension. Wander plug G.B.—1, for the first screen-grid stage, should be taken to -1.5 volts and G.B.—2 to -3 volts. The wander plug marked G.B.—3, which is connected to the four-electrode valve, may be taken to -4.5 volts to commence with, but you will find that this may be varied quite an amount.

Bias for Best Results

When the set is working, and a distant station is tuned in, this plug should be tried in the different sockets of the grid battery, being finally connected to the one with which the best results are obtained. About 60 volts is applied to the screen of the first valve, at H.T.+1, but this may be varied to suit the valve.

When first trying the set place the coil switch in its medium-wave position and also the oscillator. Then with the volume control tuned to the position where the set is sensitive, adjust the two tuning dials, the single condenser tuning the oscillator, of course, and being turned very slowly.

Ganging the Circuits

Having heard a station you must gang the input circuits. Unscrew both tuning condenser knobs (also the oscillator condenser, although this has nothing to do with the ganging). Then adjust the volume control until the signal is weak.

(Continued on page 286)

THE SUPER SENIOR ON TEST

An independent critic, ALAN HUNTER, tests the Super Senior and gives his impressions for the benefit of "Wireless Magazine" readers

WHEN the Assistant Editor handed me W. James' latest set, the Super Senior, I was glad enough to accept the invitation to be the first unbiased critic to put it through its paces.

The memory of a certain evening with the original Super 60 still fresh, I fell to wondering how much better this new set would be and in what particular respects it would outclass the original.

Poor Conditions

Here I must explain that the test about to be related was one during the week ending August 22, a time when the conditions for long-distance reception could certainly not be considered first class.

Few will dispute the contention that the phrase "programme value" took on a new significance when the original Super 60 was introduced. By this was meant that the new set would not merely get the foreigners in extraordinary numbers, but would get them at such strength and quality as to render them true alternatives to the home stations.

It seems to me that the new set is a real advance on the old. Many people object to frame aeriels and have asked for the Super 60 in a form that can be used with an ordinary aerial wire. The original set induced strong oscillations into the aerial circuit, though, and while this is of no account when a non-radiating frame is used, it means very serious interference when an open aerial is used.

Extra H.F. Stage

The only way of preventing the oscillations from reaching the aerial is to insert a stage of well-screened high-frequency amplification in between the first detector and the aerial.

Thus the first reason for adding still another valve to the existing six is sound enough, namely, for those who want to use the set on ordinary aeriels. But my tests have shown that this extra valve confers other and

less obvious advantages.

The elimination of **mush** is really extraordinary. I have never tested a set so powerful and, at the same time, so free from squeals, crackles, and other ear-splitting noises.

From this point of view, the Super Senior is, in my opinion, a great advance.

For these reception tests I made use of my standard indoor aerial, consisting of 60 ft. of wire. As an alternative, I fixed up a 3 ft. vertical length of wire.

Now for my impressions. The first, as already hinted at, was the wonderfully silent background. Truth to tell, I thought something must be wrong, until I rotated the dials and proved that everything was very much right.

Brussels No. 1, at 72 degrees on the right dial, and Langenberg at 65 degrees were both full-strength signals—and it was only 6 p.m. Changing over to the 3-ft. aerial, I could still hear Langenberg on the loud-speaker. The left dial was then at 68 degrees, showing that, between the extremes of aerial lengths, there is very little change in the condenser setting.

For all practical purposes the two tuning dials are set to similar readings for any given station.

Tests soon showed that the two-dial tuning is very easy to handle. I found the best plan was to search with the right dial, keeping the left dial somewhere near the setting of the right dial. Having found a station, I then adjusted the left dial, which is not so critical in its setting.

The volume control, at the top centre of the panel, worked like a charm. I found that, with the valves mentioned, the point of oscillation on the volume control was about a third of the way from its minimum setting.

It is important to get right the positions of the wave-change switches. The oscillator switch knob under the

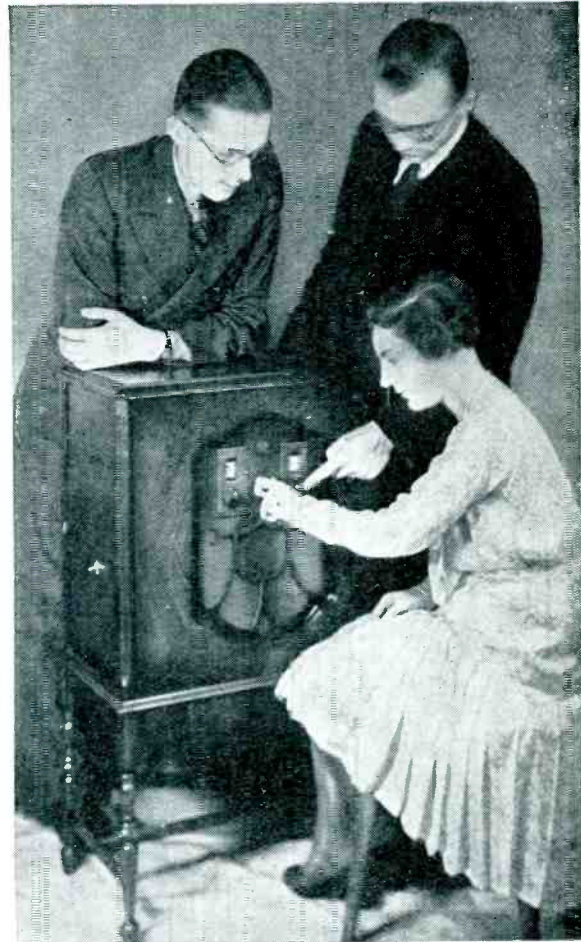

JUST THE SET FOR YOU THIS WINTER!

Build the Super Senior and have the best possible set to enjoy during the winter evenings

volume control is set to its centre position for medium waves, while the wave-change switch on the left of the set is pulled out. For long waves the oscillator switch is moved to the right, that is, in a clockwise direction. The left-hand switch is then pushed in.

Quality of reproduction depends a lot on the power valve and the power supply. I obtained very pleasing music using a Marconiphone permanent-magnet moving-coil loud-speaker with the accessories already mentioned.

Now for a few figures, to indicate sensitivity and selectivity. I waited until dark for these, so as to approximate the conditions under which the reader will undoubtedly test the set.

London Regional came in at 43 on the oscillator dial, with Mühlacker quite clear of the local at 44. Not far below was Graz, 41. The old thrill of getting the stations adjacent to London! Next,

Söttens at 55, quite clear of Midland Regional, just below at 54. Then Lengenber at 70, without a trace of North Regional at 71.5.

Could this good selectivity hold on the long waves? That was a question I answered by switching over forthwith. There was Zeesen at 70, clear of the signals from Daventry at 68 and Radio Paris at 74.

Great Strength

Back to the medium waves, where London National at 34 was dismissed in a degree for Hörby at 32, and then Moravska-Ostrava at 35. So on through the whole gamut of the stations, which simply rolled in. So great was the strength level that I changed over to the short bit of vertical wire.

It was quite enough. None of the worth-while stations was sacrificed by the change. In fact, I consider it a sheer waste of time and effort to put up a "proper" aerial for this set!

THE SUPER SENIOR—Continued

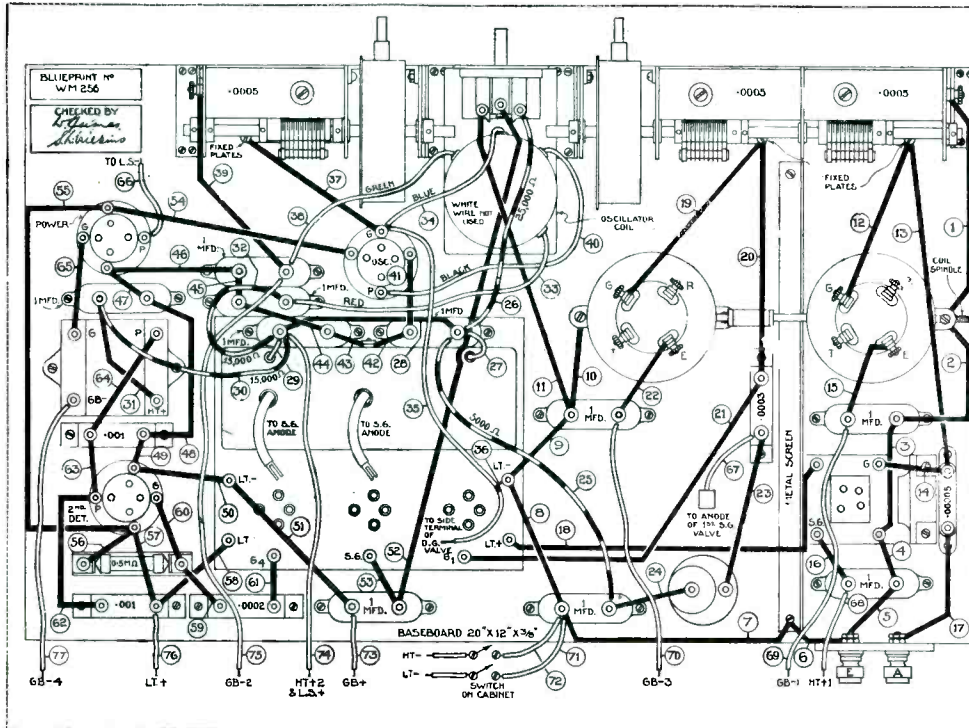

LAYOUT AND WIRING GUIDE

This can be obtained as a full-size blueprint for half price (that is, 9d., post free) if the coupon on the last page is used by October 31. Ask for No. WM256.

Wire up the connections in numerical order as indicated.

With each blueprint will be supplied a full-size drilling guide for the front of the cabinet. Note that a baseboard of the size indicated in the list of components is needed. The shelf supplied with the cabinet must not be used as a baseboard, or the escutcheon plates for the condensers will not fit on the front wooden panel properly. The holes in the front of the cabinet must be drilled to clear the control spindles, the knobs being fitted when the set has been pushed into position

If now the gang condenser is operated, and the left-hand trimmer is screwed down a little, the signal may be brought up to the maximum strength. It is rarely necessary to adjust the right-hand trimming condenser of the two-gang unit and the best results will be obtained when testing with a distant station. Do not attempt to gang on the local station.

Use of Pre-set Condenser

If a large outdoor aerial is used, the input may be reduced with advantage, using a pre-set condenser for the purpose, as a moderate aerial only is required for the set. Test the accuracy of the ganging at several points.

There should be no double tuning when operating this circuit and the

station should come in and go out clearly without a suspicion of being heard at the maximum strength in two positions quite close together.

It should not be necessary to adjust the trimmers on the long wavelengths after the circuit has been set on the medium waves. The bias of the oscillator and of the four-electrode valve should be adjusted after the ganging has been seen to. Actually, the ganging can be set in a minute or so, but it is always as well carefully to test the tuning at several tuning points.

If you have a millimeter it can be connected to the anode circuit of the second detector and the movement of the needle watched during the tuning. On strong stations the volume control must be set very near

the minimum position. As with the Super 60, the tuning of the oscillator is very sharp and this condenser should therefore be moved very slowly.

No Tricks in Tuning

It is easiest to work both tuning controls together, moving them slowly. Stations will then be found to come in and to go out in less than a degree of the oscillator. The quality is good, there are no tricks in the tuning and dozens of stations can be received.

The daylight range is much better than that of the Super 60 and there is freedom from much of the noise and heterodyne interferences sometimes experienced with that set. The Super Senior is, in fact, an all-round improvement over the Super 60.

SEE THIS FINE SET AT THE RADIO EXHIBITION

The Super Senior—and many other WIRELESS MAGAZINE receivers of interest to all constructors—will be on show at our stand at the Radio Exhibition at Olympia, from Friday, September 18 to Saturday, September 26.

Every reader is assured of a warm welcome at Stand 71, on the ground floor of the Empire Hall.

Not only will many WIRELESS MAGAZINE sets be on view, but members of the technical staff will be in constant attendance to help and advise inquirers.

One exhibit of particular interest will be the famous Super 60, the set that has been more talked of since last March than any other home-constructor design ever produced.

This year's show is the largest to be held in this country and every listener who wants to keep abreast of the times should make an effort to attend. A visit to Olympia will be time and money well spent.

Make straight for Stand 71, ground floor, EMPIRE HALL!

RADIO IN REVIEW

By MORTON BARR

THE aim of every circuit-designer is to combine perfect selectivity with perfect quality. At first sight this may seem to be a fairly obvious proposition, yet the ideal solution has still to be found.

There are, of course, a multitude of circuits which offer fair selectivity combined with fair quality, or high selectivity with tolerable quality, or some degree of selectivity with very excellent quality, but in every case the result is a compromise.

Root of the Difficulty

The root of the difficulty is that from the very beginning we have depended upon the use of tuned circuits to separate one programme from another. That is to say, we adjust the inductance and capacity of the input circuit and the high-frequency interval couplings so that they are "resonant" to the desired signals, which simply means that they respond more energetically to one particular frequency than to any other.

So far so good, but it is unfortunately not so good from the point of view of quality.

In order to get true reproduction in the loud-speaker of all the notes that go into the microphone it is necessary that the receiving circuit should respond not to a single frequency, but to a fairly wide band of frequencies on each side of the carrier wave.

But, on the other hand, the more sharply the receiving circuits are tuned, the less able they are to deal with these side-band frequencies in their proper proportions. The consequence is that certain of the transmitted frequencies never reach the loud-speaker, and so the quality of reproduction falls off.

Band-pass Couplings

Some modern designers get over this difficulty by the use of pre-selector or band-pass couplings in the high-frequency circuits.

A band-pass circuit consists of two or more tuned circuits closely coupled together in such a way that the combination responds energetically to a definite "band" of frequencies as

distinct from a single frequency. This, of course, ensures the desired result so far as quality is concerned.

At the same time it serves to exclude any station operating, say, within 10 kilocycles of that being received, but any attempt to increase selectivity beyond this point leads inevitably to a corresponding falling-off in quality.

The super-heterodyne circuit offers what is probably the best compromise possible, particularly for reception between, say, 250 and 500 metres. Under present regulations all broadcast transmissions must be separated by a gap of at least 9, or say 10, kilocycles.

That is to say, if one station is operating on 1,000 kilocycles, which corresponds to 300 metres, its nearest neighbour in the frequency band is transmitting either on 990 kilocycles or on 1,010 kilocycles. In either case the difference between the desired and "interfering" station is then only 1 per cent., which represents a very small movement indeed on the tuning dial.

The super-het overcomes this difficulty by changing the incoming signal frequency to a very much lower value by means of a local oscillator or heterodyne.

In practice a 300-metre wave (1,000 kilocycles) might be converted to an "intermediate frequency" of 100 kilocycles (or a wavelength of 3,000 metres). The neighbouring station is simultaneously converted to 110 kilocycles (or 2,800 metres).

This is a very different state of affairs, because now the difference between the two is 10 per cent. instead of 1 per cent., which corresponds to 36 instead of 3.6 degrees on the tuning dial.

A further advantage of the super-het is that tuning of the intermediate-frequency circuits can be made relatively flat so that they will embrace the side-band frequencies necessary for high-quality reception, whilst still excluding interference from the adjacent station.

In short, the modern super hetero-

dyne receiver may be said to come as near to perfection as any circuit yet designed. It has certain limitations which have still to be overcome.

These are (a) the difficulty of ganging all the circuits so as to be able to use one control knob instead of two, and (b) the liability to second-channel interference, or "whistling," due to the fact that each station can be tuned in on two different settings of the oscillator control.

The first difficulty is of little practical importance, whilst the second can always be reduced by using at least two tuned circuits prior to the first detector.

"Free" Voltage

The provision of "free" grid bias is now a standard feature of most mains-driven sets. The word "free" is, however, somewhat of a misnomer because in actual fact the high-tension supply voltage is raised above the value that would otherwise be necessary and is then "dropped" across the biasing resistance.

This means additional current consumption, though, of course, the extra wattage is negligible when taken from the mains.

Another "free" supply that is coming into vogue is that of field current for moving-coil loud-speakers. Here again the term is rather misleading. In practice the loud-speaker field requires anything up to 100 volts, and the normal high-tension output must be boosted up accordingly before it can be "dropped" across the series field windings.

Smoothing

In some arrangements the field windings also serve as a smoothing choke. This is a distinct advantage because it means either that one of the ordinary chokes in the filter circuit can be dispensed with, or that a higher standard of smoothing is secured without extra cost.

When the field windings are inserted in the negative lead, the voltage drop across them can be used in place of a separate resistance to give really "free" grid bias.

A far-distant broadcasting station. The masts of the transmitter at Java

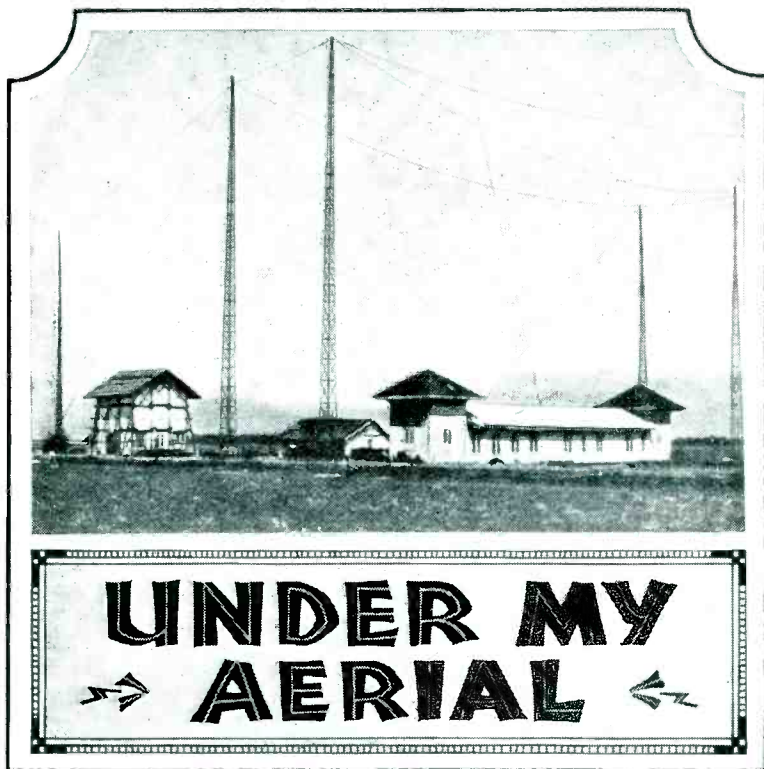

Wanted Badly

IF there is one thing above all others that I should like to see at the Radio Exhibition this year it is an accumulator which would whistle, gurgle, or go off like an alarm clock when it was in desperate need of charging.



At the Radio Exhibition

The reason for this extravagant wish is that I have just had one come to grief through its having been pushed into a dark corner of one of my wireless cupboards, and left there all the summer. I don't know whether I pushed that accumulator into that dark corner or not. Anyhow it has been there for months.

This particular accumulator came out of a discarded, or rather a re-modelled, portable set. It was a tall and distinguished-looking accumulator and I am very sorry it has come to grief. When I discovered it this morning and brought it out

into the light of day, I could see it was pretty well all up with it.

The plates were covered with that nasty-looking white substance and, what was worst of all, the acid had evaporated so much that a good half, or rather a bad half, of the plates was high and dry above the acid level.

I shall do what I can to prevent the accumulator from becoming a total loss, but it will be hard and patient work. So if you see or hear of an accumulator which will give an audible warning of neglect, let me know about it, will you?

George and Olympia

"There are two things I should like to ask you about Olympia, George," I said to my technical adviser last night at the end of a long discussion on the possibilities of the new wireless season. "When and why are we going?"



Great lover of wireless literature

"When are we going—when——" said George thoughtfully. "We ought to be there on the opening day, that's certain. Everybody of importance goes on the first day. I suppose you can manage to be free that day. It's a Friday."

"Yes, George."

"I thought so. Makes rather a nice break in the week, Friday followed by a Saturday, doesn't it?"

"What other day ought we to go, George?"

"The last day is another good day and it's a Saturday. I know you can have two Fridays off in succession, but I can't."

"Very good, George. We'll go the first day and the last day, and if we can fit in another afternoon in between, we'll do so. Now *why* do we go to the Exhibition, George?"

"Speaking for myself, I go because it is cheaper than writing."

"Whatever do you mean by that, George?"

"Well! You see, I happen to be a great lover of wireless literature in the form of the book, the catalogue, the pamphlet, the leaflet, the blueprint, and the circuit diagram. If I were to make my usual autumnal collection of wireless literature by writing to all the wireless firms, it would cost me far more, in money and in time, than a visit to the Exhibition. See?"

The Silver Lining

Don't you think it is somewhat remarkable that, throughout the whole world, wireless should be the silver lining to the black cloud of trade depression?

It speaks well for the popularity of wireless that this should be so, and it is a sure proof that wireless has become, not only one of the steadiest industries of the present age, but also an essential part of our modern civilisation.

I have heard something of the success of the wireless trade in Canada from two Canadian friends who have been in the Old Country on holiday this summer, and I have just been reading of the success of the wireless trade in Australia and New Zealand, where I also have wireless friends.

Our great Dominions are not exceptional in this matter of a well-established and successful wireless trade. It is the same in the United States and on the Continent of Europe.

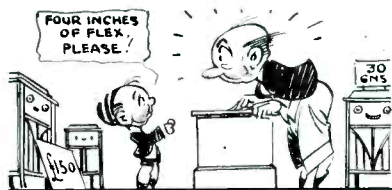

Successful wireless trade

Do you see any signs of the prosperity of the wireless trade in your district? Is your local wireless shop one of the busiest in the locality? It ought to be, especially at this time of the year.

Seaweed

What a long story could be written about the efforts of the B.B.C. engineers to produce the perfect studio! In the early days of broadcasting the studios were draped with heavy curtains. These curtains were most effective in killing all echo, but there was a lack of brilliance about the curtained studio which caused our broadcast transmissions to be unfavourably compared with Continental transmissions.

Light curtains, felt, wallpaper,



B.B.C. seaweed

plain walls, have all been tried in our broadcasting studios, but the material having the right degree of sound-absorbing properties has yet to be found.

The B.B.C. engineers, however, have apparently found in dried seaweed an almost ideal insulator of sound. You will have noticed that large quantities of seaweed are being used in the new Broadcasting House in London to insulate the studios from each other and to keep out unwanted noises from the studios.

This seaweed sound-insulator rather puzzles me though. How does it come about that seaweed is such a good insulator of sound? Is it because of its long immersion in salt water? Seaweed is such a common and familiar thing to us, especially just now after the holiday season, that it seems incredible that it should have any mysterious scientific properties of its own.

George wonders whether modern-day seaweed is as good a weather

indicator as the seaweed of his boyhood days and, if so, whether the B.B.C. seaweed walls will be streaming with moisture on the Friday before a wet week-end.

Power Control

What is wanted just now more than anything else in broadcasting is a definite understanding amongst the nations as to the maximum permissible power of a station. At the present time there is no upper limit to the power which can be used.

Hence, the best efforts of European wireless engineers are being directed towards the increase of power in their transmitters rather than to the improvement of their transmissions.

This struggle for power supremacy is being carried on with a certain amount of dignity, but when all is said and done, it is somewhat ridiculous that the broadcasting nations should expend so much money and energy in trying to outshout each other in the ether.

Last Monday morning I met an old wireless acquaintance of mine who could talk of nothing else but his splendid reception of Moscow the previous Sunday night. He was particularly struck with the excellent English spoken from the Moscow station. The present power-rating of this Russian giant is 75 kilowatts.

I wonder what my old acquaintance will say when he receives the new Russian station, which is to have a power of 200 kilowatts.

Recent "power" developments include Radio-Paris, which has increased its power from 17 kilowatts to 85 kilowatts, and a new station, Cesky Brod in Czechoslovakia, with a power of 120 kilowatts. Our solitary reply is the projected increase

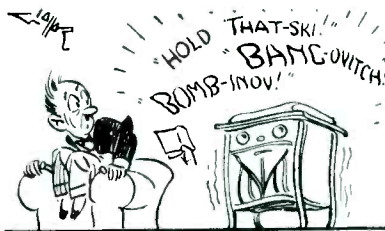

Splendid reception of Moscow

of the power of Daventry 5XX to 100 kilowatts.

Do you think this craze for power, more power, and yet more power is a good thing for broadcasting? I am very doubtful about it and I cannot see where it will all end. Can you?

Metal Masts

Do you know anything about metal aerial masts? I know a fair amount about wooden poles, how to fix them in trees, and all that sort of thing, but I have had no experience of metal aerial masts. Wait a minute, though.

I remember that I once helped a neighbour of mine to erect a metal aerial mast, but that was in the locality in which I lived before I came to my present house.

Let me tell you why I am interested in metal aerial masts at the moment. During a recent night thunderstorm



A metal aerial mast

the wind rose to gale force and blew down my aerial at the far end of the garden. The pole at that end is fixed in a tree, and in order to put a new rope through the pulley, there is nothing for it but to take the pole out of the tree and lower it to the ground.

George's suggestion of hiring a trained monkey is, of course, ridiculous, although I did see last week—but that has nothing to do with wireless.

As I know from experience, taking that pole out of the tree is a big task, and one which requires three good men and strong, especially when it comes to putting the pole back in position in the tree.

Would it be a much easier task to replace a broken aerial rope if I had a light metal mast at the far end of my garden? If I had such a mast, would the metal have a bad effect on my reception from distant stations in line with the mast and aerial? I shall have to give serious consideration to these problems before I decide what to do.

Short Work

For the last three nights I have had a great time with a short-wave coil in a three-valve set, a foretaste, perhaps, of even greater times I shall have with short-wave reception this coming season.

I started this new work by making a coil on a cardboard basket former. Without unwinding the coil, I cannot

Stories of the Operas

RIGOLETTO

(Verdi)

ACT I

A SALON in the Duke of Mantua's palace; a fête in progress. The Duke (tenor) and Borsa (his servant, also tenor) discuss Gilda (Rigoletto's daughter, soprano) and her beauty. The Duke openly flirts with Countess Ceprano.

Here comes the hunchback jester, Rigoletto, whose satires have caused annoyance amongst the courtiers. The Count is now the object of his ridicule and plots with the other courtiers for revenge upon the jester. The aged Count Monterone denounces the Duke, who has dishonoured his daughter. His arrest is ordered and Rigoletto mocks him.

Monterone replies by a "father's curse" that terrifies Rigoletto, who ceases his gibing. Monterone is led off. (A change of scene to the street.)

Sparafucile, a hired assassin (bass), offers to help Rigoletto if he needs him. Rigoletto still broods on the curse and cautions Gilda, his daughter, to beware of the Duke.

The courtiers steal in, after the Duke has gone, to abduct Gilda, but the jester appears. They tell him they have come to abduct the Countess. Rigoletto holds a ladder against what he thinks in the darkness the Cepranos' house and the abductors carry off Gilda. Rigoletto realises the curse is having effect.

ACT II

The ducal palace. The courtiers have brought Gilda. Rigoletto follows to find her. Gilda appears and tells her father of her abduction. Monterone is led through the apartment on his way to execution for denouncing the Duke. Rigoletto vows vengeance.

ACT III

Sparafucile's house. Gilda has been really fascinated by the Duke, but Rigoletto tells her of his real character. He here sings the famous "La Donna è Mobile." Having impressed her, he tells her to don male attire and go to Verona.

A great storm springs up. Gilda cannot forget her lover the Duke, and chances to overhear Sparafucile being persuaded by his sister Maddalena to spare the Duke's life. Sparafucile says he will give him one chance: if any other man comes to the house before midnight he will kill him instead.

Rigoletto pays Sparafucile to kill the Duke, and Gilda (in male attire) determines to sacrifice her life for his. There is half-stifled cry and Rigoletto rejoices; the Duke has been killed. Sparafucile brings out a sack with a body in it.

Rigoletto gloats over it. Suddenly he hears the Duke singing. He tears open the sack and beholds his daughter. She is dying and sings "Too much I loved him—now I die for him." Thus the curse comes true.

WHITAKER-WILSON.

UNDER MY AERIAL—Cont.

tell you exactly how much wire there is on it, for I made it more or less haphazard. Hence I started off with only the vaguest idea of the wavelength range covered by the coil and that made the work all the more exciting.

Purely by chance this hit-or-miss coil turned out to be the best short-wave coil I have ever wound. I can easily keep the set "alive" over the whole range of the tuning condenser when using this coil. My voyage of adventure into the unknown with this coil has been one of my happiest.

After using the coil three nights in succession, I have but one clue as to wavelength range. On the third night I picked up a transmission at seventy degrees on the tuning condenser, and I just caught the words "about forty-five," so possibly 45 metres comes in the range of the coil.



Comparable with a nightingale

Speech, music, slow morse, rapid morse, harsh morse, and morse comparable with a nightingale singing on one note, have all come in on this coil. If you want a really adventurous time with your set, make a short-wave coil at random as I did, and see what you get with it. You'll get something and plenty, all right.

In France

When the proposed new wireless taxes are adopted in France, it should be interesting to watch the consequent developments. Two taxes are proposed—one, a tax on receiving sets, and the second, a separate tax on valves.

This is not the first time we have heard of a tax on receiving sets, and it is unlikely that there will be much opposition to it in France. A tax on valves is evidently a new idea, however, and, as is usually the case with a new tax, there is a considerable amount of opposition. Indeed, if this proposal for a tax on valves is proceeded with in France, there is bound to be a general outcry against it from everybody in wireless.

Supposing, though, a tax on valves



Two taxes are proposed

were imposed in France, what do you think the ultimate effect would be? Would such a tax lead to a much smaller consumption of valves, or would it lead to the development of a valve with a much longer life than present valves?

The most interesting speculation, though, is this: Would a tax on valves lead to a return to the humble crystal detector? I have often wondered what could be done these days of high-power broadcasting stations with a simple crystal receiver. Perhaps we shall find out by reason of the proposed tax on valves in France.

A Wireless Crop

"Have you ever had a wireless haircut?" asked George as he overtook me in the main road home to my house.

"No, George," I replied as we ganged-tuned our homeward steps.

"Then don't," advised George.

"Why?" I asked, puzzled by the severity of his manner.

"Look at me," said George as he took off his hat.

"I can see you have had a pretty good crop, George. It looks O.K., suits you, in fact."

"Yes, it may look all right, but it feels most irregular. It was irregularly done and all through that wretched loud-speaker."

"How was that George?"

"There was a loud-speaker going in the hairdresser's place, trio music



That wretched loud-speaker

from 5XX. I sat it as long as I could and then I simply had to get up and adjust that rattling cone. Five times I had to get up to that cone during my haircut, most disturbing for both of us. Absolutely spoilt my haircut!"

*Secrets of
Outside
Broadcasts*



GREAT CARE IS NEEDED IN BROADCASTING AFTER-DINNER SPEECHES

Mr. Lloyd George speaking at a special dinner given in his honour. It is on such occasions as this that the outside-broadcast engineers have to be particularly careful

"IT is a pity that somewhere about 1924 the WIRELESS MAGAZINE did not publish an article on the strange experiences of the outside-broadcast men," said a B.B.C. O.B. official last week after we had discussed the Schneider Trophy broadcast.

At the Last Minute

"Those were the days when, literally, everything that could go wrong *did* go wrong, and often matters were put right only at the very last minute. Now we have reached a sort of standard in O.B.'s, and as a general rule everything runs smoothly. We have standard amplifiers, standard microphone arrangements and even standard settings for the volume controls and 'faders' for various events.

"And yet there are times when things go wrong—nearly! I remember the occasion of a big banquet at the Guildhall, when nearly every important personage in the City was present, from the Prince of Wales downwards. Several were due to speak, and a microphone was fixed up in front of the chairs at the head table.

"This was vitally necessary because there is so much *blurr . . . blurr . . . blurr . . .* in the back-

ground at these 'do's' in the Guildhall, where the echo is bad, that one microphone for the whole lot would have been useless.

"All the mikes were fitted up, the amplifiers tested out, the control men given their 'cues' for each speaker, and everything seemed to be going swimmingly; so swimmingly, in fact, that I left the B.B.C. gear and took my place at the festive board.

"Then I had a shock! The Master of Ceremonies had shifted the people along at the head table so that one very Important Personage hadn't a microphone! It was too late to do anything, and the microphones were fixtures. It was too much of a State occasion to risk an explanation and have engineers running all about the banquetting room at the head-table end.

"For ten minutes I sat in a cold sweat, dreading the report from the chief in the morning, and the inevitable explanations (futile) for the *blurr blurr* that would be broad-

KENNETH ULLYETT interviews an "outside-broadcast" official and tells of some of the amusing—but often serious—incidents which sometimes happen behind the scenes

cast instead of a speech by this Important Personage.

"But an O.B. engineer, who certainly deserves the V.C. for a spot of bright thinking, saved the situation.

"All round the Guildhall banquetting hall are loud-speakers connected up to a public-address system which cuts down the echo. Right at the far end of the hall out of the way was a solitary loud-speaker which was working with really high-class quality.

"Out rushed this bright-thinking engineer with a mike and a length of flex, and stood it down right in front of the trumpet of the speaker. He hurriedly connected it up to a fader and to the main amplifier.

From the Loud-speaker

"So, when the mike-less personage was due to speak, the engineer faded in the additional microphone in front of the speaker, and cut it out of circuit when he had finished!

"As a matter of fact, queer things often happen at broadcast dinners, but many events are unrepeatable! Once we were due to give speeches at a dinner, prefaced by a few minutes of 'background' noise from the dining-room. It happened that two very well-known people in the City, who really should know better, were resorting to violent anti-B.B.C. talk

WHEN A "MIKE" WAS MISSING!—Cont.

as dinner-time conversation—and they were right under the microphone.

"Now, the B.B.C. doesn't mind being criticised over its own microphones, but these two people were saying things which they certainly wouldn't have liked broadcast, which is the result of being over-merry at a public dinner.

Good "Atmosphere"

"An engineer switched on, and said to himself, 'that sounds good "atmosphere" to put over before the official speeches,' and he was just about to touch the button which would switch on the main line through to Savoy Hill when, pushing the phones tighter to his ears, he caught a snatch of the conversation! He had the presence of mind to fade out the microphone quickly, and thereby saved nasty comments in the daily Press the following morning!

"As a matter of fact, most of these *faux pas* are the result of bad organisation, and at Savoy Hill we have a social 'black-list' of organisers—headed by a well-known Society woman—who can always be trusted to make every possible mistake!

"As you see, often these trivial arrangements in seating at a dinner are fatal to us, because they are not discovered till zero hour, and till the microphones are due to be switched on.

"And now, for a change, let's talk about troubles at outdoor events. Rex Palmer had a stroke of luck once. Back in the early days—1924 I think it was—he went out nightingale hunting.

"Birdy" Broadcasts

"It was probably the first 'birdy' broadcast. In those days we captured the nightingale's song by means of a travelling microphone on a long length of cable, and one brave soul carried this through the undergrowth until the control engineer signalled that the song was loud enough.

"Rex Palmer did this one night, and after a short spell of bush-

crawling discovered that he had lost a gold pencil which had particular sentimental value, and which was simply inscribed 'Rex Palmer.' He never expected to find it again, but in 1930, six years afterwards, a workman digging foundations on the old land found the trophy, and, such is fame, sent it straight back to Savoy Hill!

"O.B. engineers are not always so lucky, though. I will tell you just one little incident which amused me very much, though it may not mean much to those outside the B.B.C. Once upon a time we had a strong argument with a certain sporting



BROADCASTING THE NIGHTINGALE

Outside-broadcast engineers hiding a microphone in a hen-coop

body controlling an event at which we wanted to have an O.B. running commentary.

"The argument got to a head, and the mere mention of the name 'B.B.C.' was anathema to any of the officials of this sporting body.

"Well, I went down to the event, and after a while was met by the Press official who begged me to have a ticket for free refreshment at the Press buffet. I demurred. He insisted; I made excuses. He insisted again, and was politeness itself. He described the amenities of the Press buffet, and fondly entreated me to have a ticket!

"Perhaps I shouldn't take one,' I explained, 'for I am—of the B.B.C.'

This Press official drew himself up to his full height and became the personification of frigidity. 'I beg your pardon,' he said, and strode off into the crowd!

A Free Lunch

"The ending of this story is that, if I remember aright, I *did* have a free lunch at the expense of another official!

"Strange things happen at theatres and cinemas, sometimes. There was the famous opening night at a West End cinema where we had considered making a broadcast, but fortunately had no gear installed. In the panic of

the opening night the operators became so flurried that they started the 'talkie' and switched on the amplifier before the horns were fitted up behind the screen.

"The audience was astonished to hear the echoes of voices from the flies of the cinema, instead of the full-throated roar of high-pressure Americanisms!

"One night at the Park Lane, when Sandler was broadcasting, listeners were surprised to hear a famous singer stop short in her song and, after a pause, start again. The Press was full of it, and there was a danger of it doing damage to her reputation. The truth is that some careless and probably over-imbibed idiot got up in the middle of the performance and nearly knocked the micro-

phone over. The singer was so frightened to see the whole contraption rocking for no apparent reason that she stopped short—and had to start again.

Drowning His Sorrows

"Then there was the occasion at a sporting event when things went so completely wrong owing to bad organisation, and not owing to the B.B.C., that in despair I went down into the cabin of one of the commentators' boats (it was *not* the boat race) and tried to drown my sorrows in a full bottle of champagne, praying that the broadcast would be a success.

"And it was!"

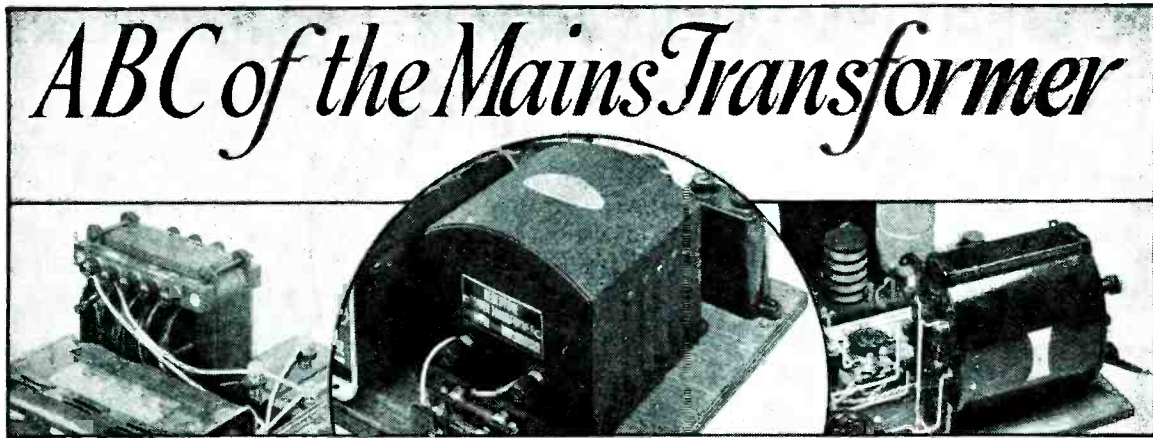

W. JAMES Explains Some Fundamental Points

THE makers of indirectly-heated valves for alternating-current circuits are very careful to tell us that the heaters must be supplied with current at exactly 4 volts.

No Resistance

They say that when a number of the valves are used the supply must be one providing the necessary current of one ampere for each valve at 4 volts; that it is not advisable to use a heater circuit resistance for regulating the voltage.

As the manufacturers insist upon the voltage across each heater being 4, it is up to us to see that the valves are provided with current at this voltage.

In practice, as is usually found to be

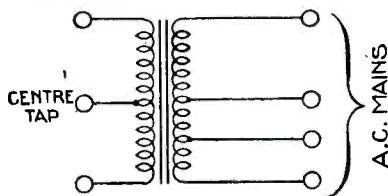

Fig. 1.—Tapped primary and plain secondary winding

the case, there are one or two snags in the way of fixing the voltage. Our supply mains vary in many instances by several per cent.

Thus, if the voltage of the supply is 5 per cent. higher than the rated voltage the chances are that the voltage of the supply to the heaters is also 5 per cent. high. Instead of being 4 volts, it is more likely to be 4.2 volts.

So you see that here is the first snag. We cannot all have A.C. voltmeters to measure the pressure of the supply and so we assume the voltage of the mains to be the rated value.

A transformer is used to couple the A.C. mains with the heaters of the valves. No other scheme is practicable. The transformer accomplishes the work with but little wastage. If we have three valves, for example, taking an ampere each at 4 volts, or a total of 12 watts, the power taken from the supply is not greatly in excess of this. Actually, about 14 watts might be taken, giving an efficiency of about 85 per cent. This is reasonable enough for a small transformer.

If this is designed to provide, say, 3 amperes at 4 volts when the input voltage is correct, then the heaters of the three valves will be receiving exactly the right amount of power. Should the mains vary in voltage, a corresponding variation in the voltage across the heaters will occur and this normally cannot be avoided by the user.

Transformers are usually provided with a primary winding having tappings. One may be for 200 volts, another for 220 volts, and so on, with the full winding for the greatest voltage.

It is not usual to tap the heater winding for the purpose of providing different voltages, but a centre tap is often made. This is generally connected to the negative side of the high-tension circuit.

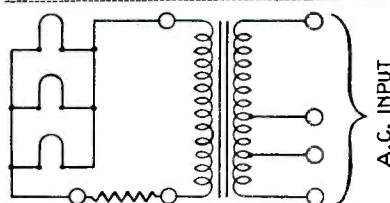

Fig. 2.—Perfect transformer with series resistance

Our transformer, therefore, has two windings, one of them, the primary, which is connected to the supply of electricity, has tappings for the different voltages, and the other winding, the secondary, is

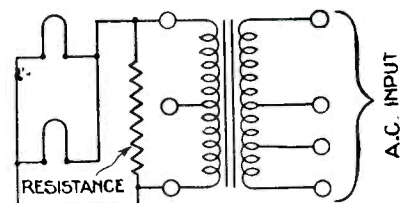

Fig. 3.—Resistance to increase load and regulate voltage

designed to provide the 4 volts needed by the heaters of the valves and may have a centre tap. This is shown in Fig. 1.

Now we have assumed the transformer to be one designed to provide 4 volts at 3 amperes, this being the current taken by three valves. What will happen if we use this transformer to supply two valves? The answer, briefly, is that the voltage across the heaters will be just a little over the 4 volts and, naturally, the current will be a shade over 2 amperes. The voltage is no longer exactly 4, but is a little greater. Now why is this?

Not Perfect

Because our transformer is not a perfect appliance for changing the voltages between primary and secondary. The windings have resistance. When current flows through them they are heated, showing that electrical energy is being turned into heat.

The loss is proportional to the square of the current multiplied by the resistance. As the resistance

ABC OF THE MAINS TRANSFORMER—Cont.

remains fairly constant the loss is proportional to the square of the current.

We could represent our transformer for the purpose of explanation as a perfect one, having no losses, in series with a resistance as Fig. 2. The resistance represents that of the primary and secondary and not merely that of one of them.

a transformer designed for supplying three valves it is as well to consider whether the windings will stand the extra current.

Of course, the voltage will fall a little to 3.9 volts if the effective resistance is .1 ohm. But as the current is about 4 amperes instead of 3 amperes, the heating has increased.

A good transformer would certainly

The output from a transformer is affected by factors besides the resistance. The voltage across the output will therefore vary a little more than by the amount due to the resistance of the windings.

Varying Voltage

There is also a further point to be remembered, and that is that the voltage across the heaters will vary a little with changes in the load taken from any other windings.

Thus, if the transformer is used to supply heating current for valves, and there are further windings for high tension, the voltage across the heaters will decrease a little when the high-tension circuit is switched on.

If, therefore, you are measuring the voltage across the heaters the other circuits must be connected in the normal way or a false reading may be obtained.

I have measured a number of mains transformers and find that the voltage across the heaters of the valves is about .1 volt lower or greater as a valve is added or withdrawn.

In the case of a transformer rated at 4 volts 3 amperes, the voltage was 3.95 for four valves and 4.05 for two valves. Another transformer, having a winding for high tension as well, gave readings of 3.9, 4, and 4.1 volts for four, three and two valves respectively.

Good Regulation

So you see that the ordinary well-made transformer has a sufficiently good regulation for one more or one less valve to be used with safety. If a further valve is added the transformer may heat a little and this point must be watched.

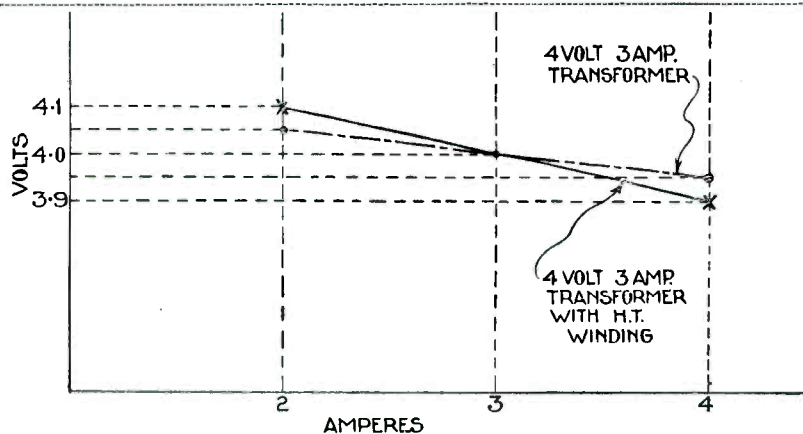

Fig. 4.—Regulation curves of typical mains transformers

Let us suppose it is .1 ohm. Then the voltage across the output will fall by .1 volt when a valve is connected and .2 volt for two valves.

If, therefore, the transformer is designed to give exactly 4 volts at 3 amperes, it will in this instance give 4.1 volts when only two valves are connected.

The transformer will not be damaged in any way because it is designed to deal with 12 watts, that is 4 volts at 3 amperes. There will be less heating when the two valves are connected because the current taken is reduced. But the heaters of the valves will have slightly more than the 4 volts recommended.

Lives of Valves

In the case of a good transformer the increase in voltage is not likely materially to affect the lives of the valves. But if the transformer is a poor one the increase in voltage may be greater. It would then not be desirable to use it for supplying two valves unless a load resistance of 4 ohms is connected across the transformer as well as the heaters.

This resistance, which will pass 1 ampere at 4 volts, will bring up the total current to 3 amperes and so the voltage will be 4 volts, Fig. 3.

Before connecting four valves to

carry the current without heating to the point where the life of the transformer would be materially reduced. With a transformer only just able to deliver the 3 amperes it is probable that a load of 4 amperes would result in the windings overheating.

As a matter of fact, the best transformers are usually made to be suitable for a little above or below the normal output. Thus, if the transformer is rated at 4 volts 3 amperes, it will probably be quite satisfactory for two, three or four valves, but the makers should always be consulted on this matter (see Fig. 4).

A LOW-PRICE ERA

IN the past, we have had a straight-line era, a low-loss era, and a short-wave era. The next wireless era will be a low-price era.

If you look through the advertisements and catalogues of our manufacturers and compare present prices with prices eight or nine years ago say, you cannot help but be struck with the great reductions that have taken place.

For example, in the pre-broadcasting days, when low-frequency transformers were cheerfully bought for thirty shillings, who would have thought that, several years later,

such transformers could be bought for five or six shillings?

Again, in the old days when even the smallest loud-speakers cost pounds, who would have thought that nowadays one could get a choice of loud-speaker units at twenty-five shillings?

There have been some wonderful reductions in wireless prices since broadcasting started, but I do not think we have seen the lowest prices yet. In fact, I feel quite confident that the new wireless season will prove to be the start of a real low-price era.

E. H. C.

THE LEAKY GRID

SPECIAL SUPPLEMENT

THIS month I am having a Special Supplement of my own. As a matter of fact (between you and me), this is the only part of the magazine worth reading. I think you will find that it gives you all the main features of the magazine at a glance. There is no need to wade through all the other stuff.

TECHNICAL FEATURES

I Test Before You Buy

Free Advice to Prospective Buyers

Coupons are required—either Black Cat or Ardath Cork. I don't mind which, so long as you send me fifty with each inquiry. I have pleasure in introducing to you the marvellous

THE NEEDLES LIGHTHOUSE PERMANENT WAVE SIX (Shingle Set).

It is quite light to carry, weighing only 126 lb. *Maker*: Woolworth. *Price*, £20 (second-hand. 15s. 6d.). *Power Supply*: 2½-volt jelly (acid) and 4-volt blanchmange (sweetened) accumulators. Grid bias only necessary if used on a bowling green. *Power Consumption*: I inserted a milliammeter between the carburetter and the niblick and obtained no reading at all. *Valve Combination*: There are nineteen valves in this set; eight of them out of tune, and fairly frequent, six are leaky-grid detectives, and the rest are very high frequency and generally choked. *Sensitivity*: Excellent. I have made exhaustive tests and utterly failed to separate the Limehouse Regional from Radio Cork; both programmes came through at equal strength. *Appearance*: Very artistic. Bound in half-calf. The output condenser, held upside down, makes an excellent cocktail shaker. Sandwiches can be kept in the H.F. choke.

FOR THE CONSTRUCTOR

A very important section. I am really the only person on the staff who knows anything about construction, though the others never admit it. Jealousy, probably. I now give my Broadcast Identification Sheet. Next month, if the weather turns chilly, I will supply a blanket:—

Konigsbustertausen.—*Standard Time*: Central London and Bakerloo plus four. *Call*: "Wot cheer Radio Whipsnade." *Interval signal*: Clinking

of glasses. *Announcer*: Big Boy. *Main Daily Programme*: Music for the Million, generally consisting of saxophone solos, cinema organs, and talks in the morse code. Then continuous until 1933. *Good night*: Bungo Troops, and Nigh Nigh, alternately fifteen times.

Super 60 Operating Hints

Have you heard of this wonderful set? There has not been much said about it so far; I cannot imagine why more publicity has not been given to it. I hope you will all build it. I tried hard to purloin the original for my house, but some underling betrayed me. All the same, I know all about it.

The great thing is to build a nice little aquarium in the garden and keep a Pentoad. *You must have a Penload.* These attractive little animals can be bought at the Whip-snade Zoo for a few shillings. They are easily trained, and feed on spaghetti without the least resistance. Our Technical Editor is mad

on them. He says they are becoming a craze; I think he is right. I have noticed several ladies in the Park carrying them under their arms.

The Technical Editor says they are simply splendid for telling the weather. When it is going to be fine they curl themselves up; when it is going to be showery they hold up their forepaws. When they do that, he says he knows it will Reyner little.

GENERAL ARTICLES

Radio Medley

I have received a charming letter from Dr. Silas P. Hucks, of New York, U.S.A. He is a great enthusiast. He bought the first copy of WIRELESS MAGAZINE in 1880. He builds two sets every day, recently including the Sez You Short-waver, the Big Boy Short-wave Four, and the Oh Yeah Two.

I have to deal with those readers who are still clamouring for gang control. I am a keen gangster myself, and shortly expect to be voted King of the Radio Underworld. I shall be pleased to bump off any reader who applies, but it must be understood that coupons are to be used.

GRAMO-RADIO SECTION

Welter-weight on the Needle

I have been experimenting recently with a heavy pick-up. I find that it wears the records badly unless care is taken to counter-weight it. The pick-up weighs over 11 lb.—just too heavy for parcel post. By suspending the tone-arm from a piece of rope attached to the top of the stairs, I find it is possible to use the needle 300 times without the slightest sign of wear.

I found the noisiest record in my stock—and that is saying something, I can assure you—and played it through eighty-seven times in succession.

My mother-in-law says she possesses the first record ever made. It is of a work by Chuskowsky, or some name like that. Anyhow, she knows it is dated "1812."

W.-W.

FUSES

THE fuse is an important component in mains apparatus and should never be omitted. The small first cost of a fuse holder with two fuses (one for each mains lead) is an insurance against short-circuiting or overloading in the various components which compose the mains unit and set.

If a short-circuit occurs, the fuse, if correctly proportioned to the amount of current normally required in the unit or set, will blow before any damage is done and the replacement of the fuse—

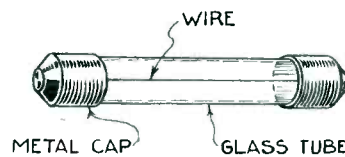

Typical fuse construction

after remedying the cause of the short-circuit—will be the only cost incurred.

Fuses should be fitted which will blow at 50 per cent. above the normal current used, so that if the unit or set uses ½ ampere or 250 milliamperes, an abnormal increase of the current to ¾ ampere or 375 milliamperes will cause the fuse to blow instantaneously before damage is done.

The ordinary household fuse is of little or no use in protecting mains sets or units as these fuses will not blow until a comparatively large current is passed.

WHITAKER-WILSON on the Great Composers

These Men Were Human

JOHN SEBASTIAN BACH and
GEORGE FREDERICK HANDEL

THEY were born in the same year, 1685, within a few weeks of each other. They never met, though they sent cordial messages through friends. Both were German born, though Handel became a naturalised Englishman eventually; Bach never left Germany.

Both Totally Blind

Finally, they were totally blind at the end of their lives: it even goes further; *they were both operated on by the same surgeon*—an Englishman—who succeeded in blinding them in turn. Something of a record, one would think.

The outstanding characteristic of all the great composers was *determination*, and J. S. Bach was no exception to the general rule.

He came of a long line of musicians; perhaps there never has been such a family as that of the Bachs. For a century or more the very name was held to be synonymous with the term music. In 1740 the family numbered—literally—some hundreds; the last of them died a few years ago—in Australia, of all places.

There are records of the Bachs congregating together for a little music, with Sebastian himself present, when as many as a hundred of them have been known to attend. All were Bachs and all were musicians. There is, of course, no parallel case.

I do not think Bach can be regarded as a great prodigy. I do not imagine that you will think so when I have told you the story of the life of Mozart. You can view Bach as being musical because he was a Bach; he certainly could not have been a Bach without being musical.

For the rest—well, hear

the story, which is that of the development of an overwhelmingly great personality.

His parents died before he was ten and he lived with his elder brother, John Christoph Bach. Christoph promised his father he would train Sebastian, but when it came to doing so, he found it hard not to be jealous. What had taken *him* an hour to understand seemed to be taking Sebastian only twenty minutes.

When Sebastian begged to be allowed to study some organ pieces which Christoph had in a volume, he was told to mind his own business. The book was kept in a kind of cupboard which had a wire lattice door to it, but Sebastian could not bear to see the book there and not have it to study. He therefore managed to extract it and set about copying its contents.

This had to be done after the

family had retired and, what was more, Sebastian had to avoid using a candle. So he waited for the moonlight nights and wrote by its rays instead. It took him six months; we can imagine his disappointment when the nights were cloudy.

The story ends sadly; Christoph caught him with the finished script, which he promptly confiscated.

Christoph died when Sebastian was fifteen and the boy was thrown on his own resources. He began life in Luneberg, where he joined the choir of St. Michael's Church. Whenever there was a chance, he made journeys to Hamburg, about thirty-three miles distant, in order to hear the veteran Dutch organist, Reinken, play at St. Catherine's. Reinken was then seventy-seven, but he continued to play until he was ninety-seven; he lived to be very nearly a hundred years old.

Journey on Foot

Bach always accomplished the journey on foot, having no money to go any other way. He generally allowed three days for the expedition in order to be fit and fresh to hear the music. On one of these jaunts he found that Reinken was giving two recitals on two successive days, and was greatly troubled because he had no money to pay for a night's lodging.

The only thing to do, after the first recital, was to trudge home again, and this he began to do very unwillingly.

The road was a lonely one at the best of times, and by the time he reached an inn by the roadside he was feeling very tired, having walked fourteen miles. He sank down wearily on to a bench outside the inn and was not

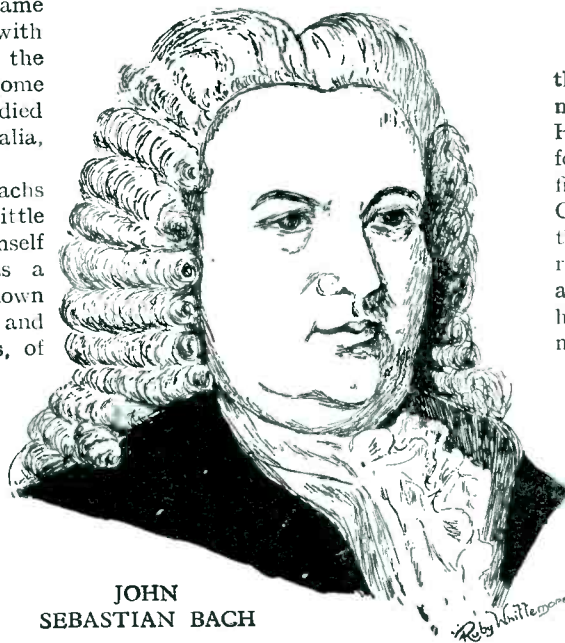

JOHN
SEBASTIAN BACH

comforted exactly when the aroma of an excellent meal assailed his nostrils.

He tried to think of the music he had heard and to forget that he was hungry. Suddenly a window above his head was thrown open and two herring-heads fell at his feet. As they did so somewhat heavily, Bach picked them up and examined them. Each contained a Danish ducat.

Bach promptly entered the inn, ordered a substantial, though very modest meal, and *tramped straight back to Hamburg!* Thus he heard Reinken's second recital.

When he was organist at Arnstadt he heard of the great playing of Buxtehude, of St. Mary's, Lubeck. This was nearer three hundred miles than thirty, but he set out at four o'clock one October morning. Probably he had a few lifts on the way, at least, I hope so.

A Month's Holiday

He had obtained permission to be away for a month. The attractions in Lubeck were too much, however, especially as Buxtehude did everything he could to help him. Unfortunately, about the third week in January, he received a sharp note from Arnstadt ordering him to appear at once before the Consistory. Bach thought it wise to comply, said farewell to his friend, and tramped home.

He arrived, looking the picture of health after his exercise, and faced his patrons. They wanted to know where he had been. He told them that he had been to Lubeck to learn something about his art. Then he "went through it," as we say.

The Consistory complained that his accompaniments were too elaborate and that he played too long after service, and when he was told of it he went to the other extreme.

There was no denying all this, so Bach said very little. He was a trifle surprised, though, when the Consistory expressed its horror because a "strange maiden" had been allowed to sing in the church.

Cautioned

Whether Bach explained that she was his cousin and that he intended to marry her later on, or whether it made much difference if he did, I have never been able to find out. At all events, he got off with a caution.

Naturally he soon became famous as a player. Never had an organ been played as he played it. He went to Dresden in the autumn of 1717 and

found the noted French organist, Marchand, giving recitals there to crowded congregations.

Marchand had managed to offend the Dresden organists in some way and they made it their business to persuade Bach to enter a sort of contest, both he and Marchand being given an opportunity of hearing each other in secret.

That finished it; Marchand was not to be found when the day came for the contest.

The last twenty years of Bach's life were spent at Leipzig, where he was organist of St. Thomas's Church. I dare say some of you will remember a splendid broadcast of the Passion music from that church on Good Friday, 1930. Bach liked Leipzig but complained that it was "too damned healthy." By this he meant that there were not enough funerals and he lost fees!

Frederick the Great appointed Carl Philip Emanuel Bach to be his organist and asked him to persuade his famous father to pay a visit to Potsdam. Bach went with Friedmann, another of his sons.

When they arrived at the palace the King was about to play a flute concerto with his private orchestra, but when Bach entered he gave up the concert and devoted himself to his guest. Bach's improvisations on the piano took the company by storm and he was naturally made much of.

All the same, his fame did not reach England for nearly a hundred years after his death in 1750; it was Mendelssohn who discovered his music and popularised it in this country.

Now let us turn to Handel. You know the story of his playing on the dumb spinet, of course? I need not tell that again. His father was a barber-surgeon who thought music was one of the evils of the world.

George Frederick was forbidden to hear *any* music, save that of the church. However, it so happened

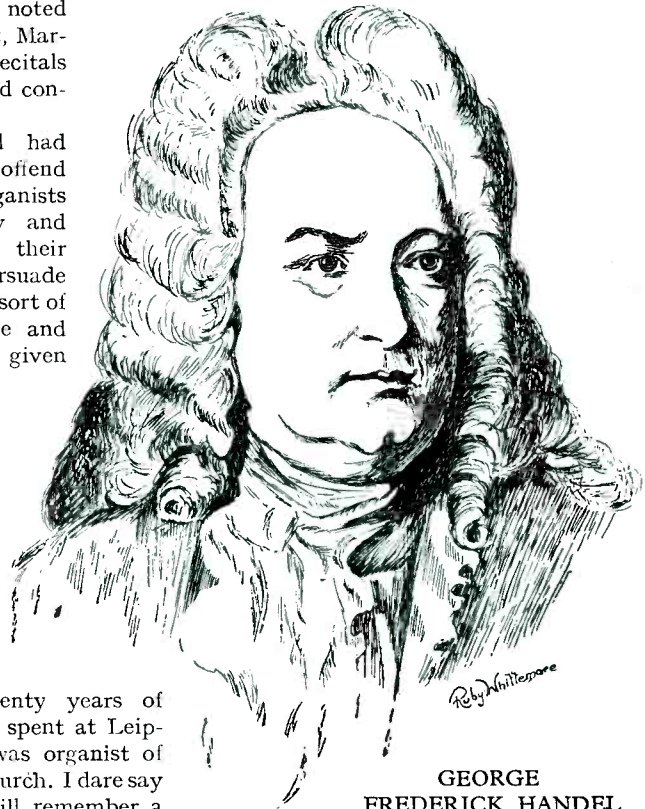

GEORGE
FREDERICK HANDEL

that the worthy doctor went to visit a son (by a former marriage) in the service of the Duke of Saxe-Weissenfels. George Frederick asked to be allowed to go also, but was told that he could not be taken. He was said "good-bye" to and told to be a good boy.

His interpretation of the injunction took the form of running behind his father's conveyance, yelling at the top of his voice. In the end he had to be taken. At the Duke's palace he was caught playing on the organ.

His father did not even know that he could play, and was furious when the young gentleman was summoned to play before the Duke. His Grace soon saw how the land lay and talked to Dr. Handel like a Dutch uncle.

A Close Shave

The worthy barber then had his small son trained, and that is how he was allowed to become a musician. To borrow the barber's own expression, it had been a close shave.

Now we must skip a few years. Handel has grown into a huge burly creature who would stand nonsense from no one. In Hamburg he met Mattheson, a famous opera composer, and they became fast friends. One night, however, the friendship nearly broke.

THESE MEN WERE HUMAN—Continued

Mattheson had written an opera and asked Handel to conduct the first act so that he himself could play in it. When the second act came on Mattheson went into the orchestra and asked Handel to let him take the baton. "I'm damned if I do," said Handel, rudely. Mattheson could do nothing but wait.

A Real Fight

After the opera was over they met outside and Mattheson flew at Handel immediately. Swords were drawn and the two composers were soon fighting in real earnest. Suddenly Mattheson lunged at Handel and caught his rapier on a metal button. The point broke, fortunately; otherwise we should certainly never have had any Handel festivals.

The following night Mattheson sent Handel a note asking him to dinner. Handel accepted and the two became firmer friends than ever.

In 1709 George, Prince of Hanover, offered Handel a post as court composer. Some English nobles happened to visit the Prince shortly afterwards and Handel rather took to them. He was invited over to England before they left and asked permission to go. Like Bach, he outstayed his leave.

As a matter of fact, he found London mad about Italian opera. He soon began to write operas for the Haymarket, and became very popular at the court of Queen Anne. He, also like Bach, received a peremptory note to return. He soon became tired of the stodgy German courtiers and once more escaped to England.

Then Queen Anne died and Prince George came to the English throne as George I. This was a trifle disturbing, but Handel presented himself at court, all smiles, as usual. The King, however, refused to have anything to do with him. "All right; I can wait," said Handel. And "wait" he did.

Handel Ignored

Then an Italian violinist came to play before the King, and Handel accompanied him. George petted the violinist, but ignored the accompanist. "I can *still* wait," said Handel.

Shortly after this the King went up the Thames in the state barge. Handel heard of his intention beforehand. He therefore sat up half the

night writing some music which he hurriedly rehearsed with a number of musicians the following morning, packed musicians and band parts into a flat-bottomed barge, and sent them to meet the King.

George was entranced with the music and ordered his barge to stop. "Of course, it is Handel's," he said to those around him. He sent for Handel the following day.

That is the story of the writing of the Water-Music. I am not sure that it is really authoritative, but there may be some truth in it.

Handel's social position was now a great one. He was asked everywhere.

Everything might have gone smoothly but for the advent of Buononcini, an old enemy. He had a considerable following, his satellites declaring that he was indeed a rival to Handel. Factions rose and there was a good deal of enmity.

The following, ascribed to Dean Swift (but also to John Byron), caused some amusement at the time.

Some say that Signor Buononcini
Compared to Handel is a ninny;
Whilst others vow that to him
Handel
Is hardly fit to hold a candle.
Strange such difference should be
'Twi'xt Tweedle dum and Tweedle
dee.

Handel's Opinion

As for Handel himself, all he said was: "Vat de tefil I care vich likes vich!"

While he was successful Handel had things all his own way; he made singers behave themselves. But bad times came; his operas began to fail. It was his own fault; he would not see that London had tired of Italian opera. That was long before he began to write oratorio, of course.

Carestini returned an aria of Handel's with a polite note to say that he did not care for it sufficiently to sing it. Handel exploded with rage. "Don't I know better as yourself vat you sing?" he roared. "You sing vat I give you or I not pay you ein stiver." The song was sung.

Madame Cuzzoni fared worse still. She refused to sing *Falsa Imagine*. Handel strode on the stage, seized her by the arm, shook her until she could hardly see, and dragged her to the balcony. "I always said you vas ze fery tefil," he spluttered. "Now I

vill show you I am Pe-eltsepup, ze Brince of Tefils." He held the lady over the street, and she chose there and then! She also sang with success.

Sometimes there would be trouble at the band rehearsals. After the usual storm over the playing of some passages, the first flautist protested that it was not he who had made the mistake. "I did not say it *vas* you, plockhead," snapped the worthy *maestro*. Then under his breath: "It vas zat plasted oboe!"

Troublesome Occasions

On occasions there was trouble at the performances. Handel, I must tell you, could never endure to hear a fiddle tuned; consequently all that sort of thing had to be done before he arrived.

It so happened that he had had an altercation with an attendant for letting in people after the opera had begun, and the attendant determined to be revenged for whatever Handel had called him. He wound down every string in the band. The first chord was enough. Handel rushed out of the orchestra, kicking a hole in a double-bass as he went. He picked up a kettle-drum and hurled it at the leader's head. It missed, fortunately. The Prince of Wales was present, but it took him all he could do to persuade the composer to calm himself.

Yet Handel was the most lovable of men. He could hold a dinner party enthralled while he discoursed on some excellent topic. He had a temper like a fiend and his language at times would have curled your hair; but he usually kept his friends.

Operas to Oratorios

When London would not have his operas, he turned them into oratorios; the *Messiah* contains much that was originally conceived for secular purposes. When it was performed in Dublin, in 1742, the effect was electric. Handel was treated like a god. It has lived ever since.

When his blindness came Handel quietened down and became a gentle old man. Both he and Bach were deeply religious; both were "up against it," often enough. But their determination brought them through, and their work has lived till now; indeed it will never be forgotten so long as music is treated as an art and taken seriously.



The MERIDIAN SHORT-WAVER

HERE is a simple receiver that will enable the listener to roam the world. It is specially designed for reception on the short waves, that is, on wavelengths between 15 and 100 metres. A set for these wavelengths needs a special layout and every care has been taken by the WIRELESS MAGAZINE Technical Staff to ensure the utmost efficiency.

New Programmes

By listening on the short waves it is possible to pick up many stations at good loud-speaker strength that are never heard on an ordinary broadcast receiver.

A short-wave receiver such as the Meridian Short-waver opens up an entirely new field. For instance, there is no difficulty in picking up a number of American broadcasting stations at good loud-speaker strength on short wavelengths.

Among the hundreds of stations that work on these wavelengths, there are a dozen or so that can be consistently received at good strength almost anywhere in the British Isles.

Following are the wavelengths of some of the more important short-wave broadcasters:—

Metres	Station
19.56	W2XAD, Schenectady, U.S.A.
23.8	Radio Maroc, Rabat, Morocco.
25.25	W8XK, East Pittsburg, U.S.A.
25.4	3RO, Rome, Italy.
25.53	G5SW, Chelmsford, England.
28.98	LSX, Buenos Aires, Argentine.
30	Belgrade, Yugoslavia.
31.28	PCJ, Eindhoven, Holland.
31.38	Zeesen, Germany.
31.48	W2XAF, Schenectady, U.S.A.
31.75	Rio de Janeiro, Brazil.
41	HSP2, Bangkok, Java.
43	EAR100, Madrid, Spain.
48.86	W8XK, East Pittsburg, U.S.A.
50	Moscow, Russia.

Four of these stations, namely, Madrid, Rabat, Rome, and Zeesen, are short-wave relays for programmes sent out from better-known transmitters working on the ordinary medium waveband. It is often possible to pick up one of these programmes on the short waves when the

medium-wave transmission is suffering from interference and cannot be received properly.

Although a special design of set is needed for short-wave reception, the circuits are usually similar to those employed for ordinary broadcast receivers. The difference lies mainly in the type of components used.

Short Leads Essential

It is generally realised by constructors that all connecting leads in a set should be kept as short as possible. In a short-wave receiver this point is of still greater importance and the results obtained depend largely on the care that is taken in wiring up the parts.

After a considerable amount of experimental work, the WIRELESS MAGAZINE Technical Staff was able to produce a set which is not only particularly efficient in use, but which is also attractive in appearance.

The front-panel layout, for instance, could hardly be simpler, as a glance at the heading photograph will show. The main tuning dials, with their black knobs and aluminium scales, look particularly attractive when mounted on

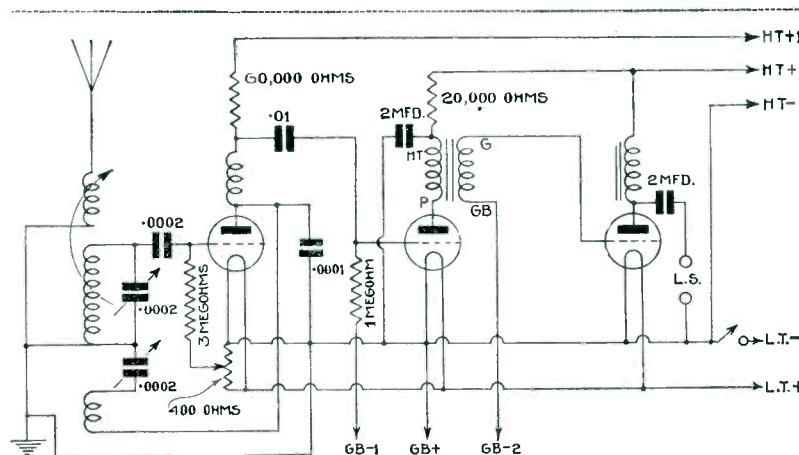

A "STRAIGHT" CIRCUIT IS ALWAYS BEST

The valve combination consists of a leaky-grid detector followed by two low-frequency stages, one resistance-coupled and the second transformer-coupled

THE MERIDIAN SHORT-WAVER—Continued

a mahoganite panel. The only other panel control is an ordinary pull-on push-off switch.

In order to avoid hand-capacity effects, a sheet of aluminium or copper foil is stuck to the back of the panel. As the metal is earthed, it forms an effective capacity screen and there is no instability in operation. Moreover, special low-loss tuning condensers are used and these

suit varying aerial conditions.

There are three duplex grid-reaction coils which plug in to a fixed mount. This coil mount is of a special low-loss type and is designed for maximum efficiency in a short-wave receiver.

In the original layout great care has been taken to keep the detector-grid connections as short as possible. It should also be noted that the valve

tuning and reaction condensers, which are of the same type, have a capacity of .0002 microfarad.

Leaky-grid Detector

In order to get the maximum sensitivity to cope with the comparatively weak impulses obtained from short-wave stations, a detector of the leaky-grid type is used; the condenser has a capacity of .0002 microfarad and the grid leak is of 3 megohms.

Normally, one end of the grid leak is taken to the positive side of the low-tension battery, but in this case it is connected to the slider of a 400-ohm potentiometer, so that the bias on the grid of the valve can be varied within close limits and a fine control obtained.

Resistance-capacity Coupling

The coupling between the detector and the first low-frequency stage is of the resistance-capacity type. For the greatest magnification the anode resistance should be approximately three times as great as the valve impedance and, as the ordinary detector valve has an impedance of about 20,000 ohms, it is recommended that the anode resistance should be of 60,000 ohms. The coupling condenser is of .01 microfarad and the grid circuit of the low-frequency valve is provided with a 1-megohm grid leak.

A special short-wave choke is placed in series with the anode resistance in order to give a good reaction effect. The amount of feedback or oscillation is controlled by a .0002-microfarad condenser. The .0001-microfarad fixed condenser connected between the anode of the detector valve and earth is to improve the detector efficiency.

No Motor-boating Possible

A standard low-frequency transformer coupling is used between the first low-frequency amplifier and the power valve. In order to prevent interaction in the low-frequency circuit a decoupling device is included in series with the primary of the transformer. This consists of a 20,000-ohm resistance in conjunction with a 2-microfarad by-pass condenser; this device does away with any possibility of instability or motor-boating in the low-frequency stages.

Although it is possible to receive
(Continued on page 302)

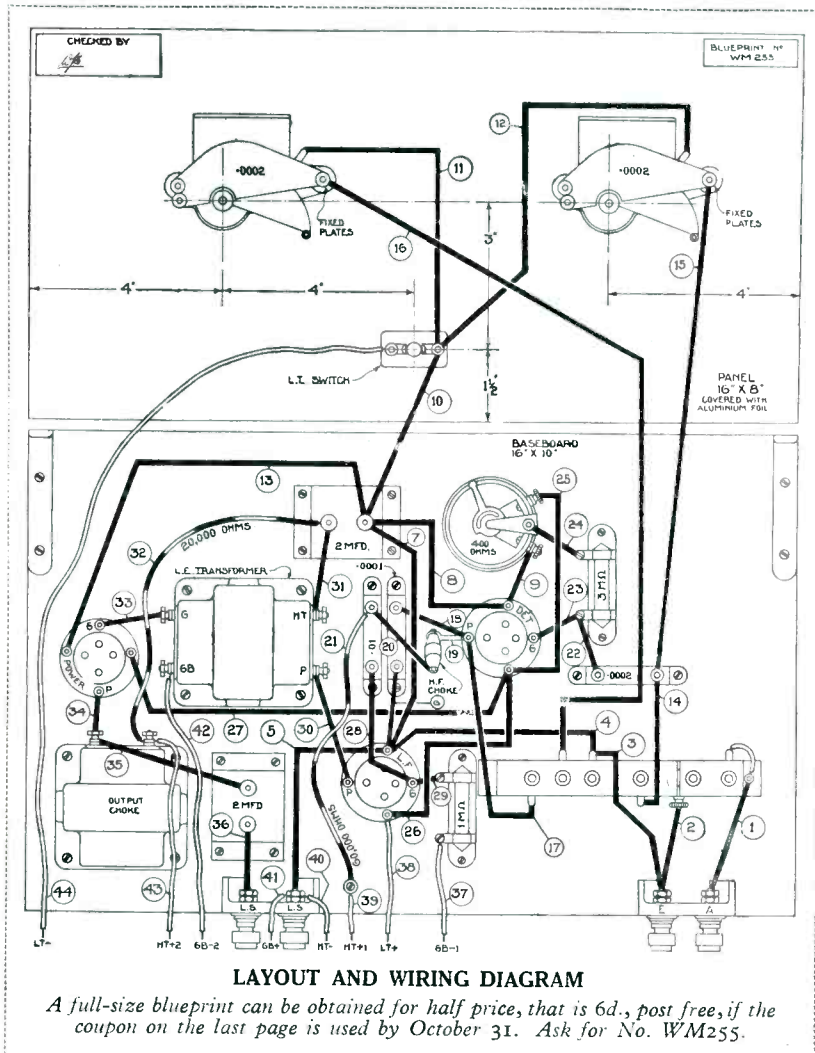

LAYOUT AND WIRING DIAGRAM

A full-size blueprint can be obtained for half price, that is 6d., post free, if the coupon on the last page is used by October 31. Ask for No. WM255.

also are provided with their own metal screens.

For tuning, a specially-designed short-wave coil unit is utilised. This has three windings in all: an aperiodic aerial coil, a tuned grid winding and a separate reaction winding. To cover the wave range of 15 to 100 metres, two aperiodic aerial coils are provided. This coil is inserted in a hinged mount, so that the coupling with the grid coil can be changed to

holders are of a special low-loss type and that the high-frequency choke is one made specially for short-wave reception.

Ordinary parts can, of course, be used in the low-frequency side of the receiver without any loss of efficiency.

The electrical arrangement of the set will be clear from the circuit diagram that appears on page 299. It will be seen that both the grid-

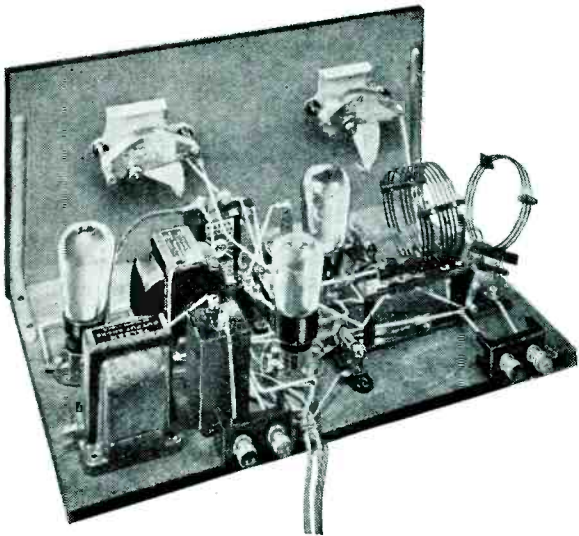

FOR reception on the very short wavelengths, that is between about 15 and 100 metres, special types of sets are necessary. Standard circuits can be successfully employed, but special precautions must be taken in the layout of the parts.

Special Parts

It is also often desirable to use special low-loss components, for the efficiency of ordinary apparatus falls off rapidly at the high frequencies that correspond to short wavelengths.

Very special care had therefore to be taken by the WIRELESS MAGAZINE Technical Staff in the production of this short-wave receiver. We believe that it is one of the best "straight" three-valve short-wavers it is possible to produce with modern components and we have every confidence that it will give satisfaction to hundreds of constructors.

Simple to Operate

The set is extremely simple to operate, for there are only two tuning controls. That on the left of the panel adjusts the wavelength, while the right-hand condenser is a reaction control to vary the sensitivity of the set. Apart from these two dials, there is only the usual on-off switch on the panel.

Valve Combination

Because years of experience have proved that perfectly straight circuits are always the most satisfactory, there are no tricks about the Meridian Short-waver. A sensitive leaky-grid detector is followed by two stages of low-frequency amplification, the first being resistance-capacity coupled and the

second transformer coupled. A standard choke-output circuit is provided for the best results.

Among the refinements incorporated in this set are a full-size reaction condenser with a large slow-motion dial

WHAT IS THE MERIDIAN SHORT-WAVER?

ciency from every part of the circuit, but at the same time it has been possible to produce an attractive looking job. The simple appearance of the panel layout is a point that will appeal to many listeners.

Every component used in the set is a standard product and there will be no difficulty in obtaining parts from any radio dealer. Those who have previously built their own receivers will, no doubt, have one or two spare parts that can be worked into the design.

The total cost of the construction, including valves, but none of the other accessories, specified in the list of components is approximately £6 10s. For this price the con-

Almost any night it will be possible to receive stations as far distant as Morocco, Buenos Aires, Java, and Russia. At least a dozen stations can normally be obtained at good loud-speaker strength.

No Limit

If headphones are used, there is no limit to the number of transmissions that can be picked up. There are literally hundreds of short-wave stations all over the world, although not all of them transmit telephony. Those who can read morse signals will have more transmissions at their disposal than they can possibly cope with. On a short-wave set the ether is never idle.

COMPONENTS NEEDED FOR THE MERIDIAN SHORT-WAVER

CHOKE, HIGH-FREQUENCY

1—Wearite short-wave, type HF3, 4s. 6d.

CHOKE, LOW-FREQUENCY

1—Telsen 20-henry, 8s. (or Varley, Igranic).

COILS

1—Eddystone short-wave inductance unit, £1 2s. 6d.

CONDENSERS, FIXED

1—Magnum 0001-microfarad, 1s. 6d. (or Trix, Readi-Rad).

1—Magnum 0002-microfarad, 1s. 6d. (or Trix, Readi-Rad).

1—Magnum .01 microfarad, 2s. 6d. (or Trix, Readi-Rad).

2—Formo 2-microfarad, 6s. 6d. (or Telsen, Ferranti).

CONDENSERS, VARIABLE

2—Utility .0002-microfarad, type W187, with slow-motion dials, £1 6s. (or Stratton, Cyldon).

EBONITE

1—Lissen 16 in. by 8 in. panel, 7s. 8d. (or Red Triangle, Cameo).

HOLDERS, GRID-LEAK

2—Bulgin, type G6, 1s. 6d. (or Telsen, Readi-Rad).

HOLDERS, VALVE

3—Clix terminal type, 2s. 6d. (or Wearite, Magnum).

PLUGS AND TERMINALS

6—Clix wander plugs, marked: H.T.+2, H.T.+1, H.T.—, G.B.+1, G.B.—1, G.B.—2, 1s. (or Belling-Lee, Eelex).

2—Clix spade terminals, marked: L.T.+1, L.T.—, 4d. (or Belling-Lee, Eelex).

4—Belling Lee marked: Aerial, Earth, L.S.(2), 1s. (or Clix, Eelex).

RESISTANCES, FIXED

1—Magnum 20,000-ohm, flexible type, 1s. 6d. (or Bulgin, Leweos).

1—Magnum 60,000-ohm, flexible type, 2s. (or Bulgin, Leweos).

The prices mentioned are those for the parts used in the original set; the prices of alternatives as indicated in the brackets may be either higher or lower

1—Telsen 1-megohm grid leak, 9d. (or Dubilier, Watmel).

1—Telsen 3-megohm grid leak, 9d. (or Dubilier, Watmel).

RESISTANCE, VARIABLE

1—Lissen 400-ohm potentiometer, type LN140, 1s. 6d. (or Wearite).

SUNDRIES

Glazite insulated wire for connecting.

Length of rubber covered flex.

2—Belling-Lee terminal blocks, 1s. 4d. (or Sovereign, Junit).

1—Sheet of aluminium foil, 16 in. by 8 in. (Peto-Scott, Parex, or Readi-Rad).

1—Pair of Bulgin panel brackets, type PB4, 1s. 3d. (or Lissen).

SWITCH

1—Readi-Rad on-off, 10d. (or Lissen, W.B.).

TRANSFORMER, LOW-FREQUENCY

1—Telsen Radiogrand, ratio 1 to 7, 8s. 6d. (or Ferranti AF6, Igranic).

Accessories

BATTERIES

1—Pertrix 120-volt, standard type, 15s. 6d. (or Siemens, Oldham).

1—Pertrix 9-volt grid bias, 1s. 6d. (or Siemens, Oldham).

1—Fuller 2-volt accumulator, type LDG, 9s. 6d. (or Young, Tudor).

CABINET

1—Osborn, table model, 15s. (or Pickett, Lock).

HEADPHONES

1—Pair Ericsson 4,000-ohm, 12s. 6d. (or Brown).

LOUD-SPEAKER

1—R. & A. cone model, 16s. 6d. (or Ormond, Brown).

VALVES

2—Osram HL2, 17s. (or Six-Sixty, 210HL, Marconi HL2/C).

1—Osram LP2, 10s. 6d. (or Six-Sixty 220PA, Marconi LP2/C).

to give fine control of sensitivity; a short-wave coil unit with adjustable aerial coupling; and a grid potentiometer to enable the best possible results to be obtained from the detector valve.

The set has been specially designed with the object of obtaining the maximum effi-

ciency from every part of the circuit, but at the same time it has been possible to produce an attractive looking job.

Reception of American stations on the loud-speaker is a commonplace with such a receiver as this and under favourable conditions there should be no difficulty in picking up Americans.

There is nothing difficult about the construction of the Meridian Short-waver, and with the aid of one of the full-size blueprints for which WIRELESS MAGAZINE is so well known, even the beginner will be able to assemble the set without any troubles whatever.

THE MERIDIAN SHORT-WAVER—Continued

quite a number of short-wave stations on the loud-speaker, there are dozens more that can only be received with headphones. As the headphone windings would undoubtedly be damaged if placed directly in the anode circuit of the power valve, a choke-output circuit is incorporated.

Protecting the Windings

This prevents the steady anode current from the battery from passing through the reproducer windings, and is a great advantage whether a pair of headphones or a loud-speaker

is used, but readers of WIRELESS MAGAZINE can obtain a copy for half price, that is 6d., post free, by using the coupon that appears on the last page. This is valid only until October 31, and should be sent, together with a postal order, to the Blueprint Department, WIRELESS MAGAZINE, 58-61 Fetter Lane, London, E.C.4.

There is nothing special to be said about the construction of the set except to remind readers that all the wires should be kept as short and direct as possible. The original set was wired with Glazite; if desired,

tery specified in the list of components (which appears on page 301).

The anode-current consumption of most of the valves produced by the well-known firms appear in the tables, entitled "Valves to Use in Your Set," that appear elsewhere in this issue.

Best Detector Voltage

When the set is first put into operation, it is worth taking some trouble to determine the best voltage for the detector valve, which is supplied through the tapping marked H.T.+r. With the detector valve specified, it was found during our tests that the best results were obtained with about 100 volts. But this value is not constant and may be quite different for a valve of another type.

After the high-tension voltage has been adjusted the slider of the potentiometer (mounted on the base-board near the panel) should be moved round slowly until the best results are obtained. What happens is that a rough adjustment is obtained by altering the high-tension tapping and a final regulation made by moving the potentiometer slider.

Wavelength Ranges

The wavelength ranges of the coils will have to be found by trial, for they vary slightly under different conditions. As already mentioned, there are two aperiodic aerial coils and three duplex grid-reaction coils.

The smaller aperiodic coil (A) has three turns and the larger coil (B) has six turns. Of the three duplex coils, the smallest (c) has three grid turns and two reaction turns; the middle-sized (d) six grid turns and three reaction; and the largest size (E) fifteen grid turns and five reaction turns.

Coil Combinations

The following combinations of coils (the letter references are ours, and not those used by the makers) will cover approximately the wavelength ranges indicated:—

	Metres		Coils
(1)	15 to 40	...	A and C.
(2)	25 to 70	...	A or B, and D.
(3)	50 to 100	...	B and E.

In some cases it will be found that the set works best when the aperiodic coil is not connected to earth, that is, when wire No. 2 is disconnected

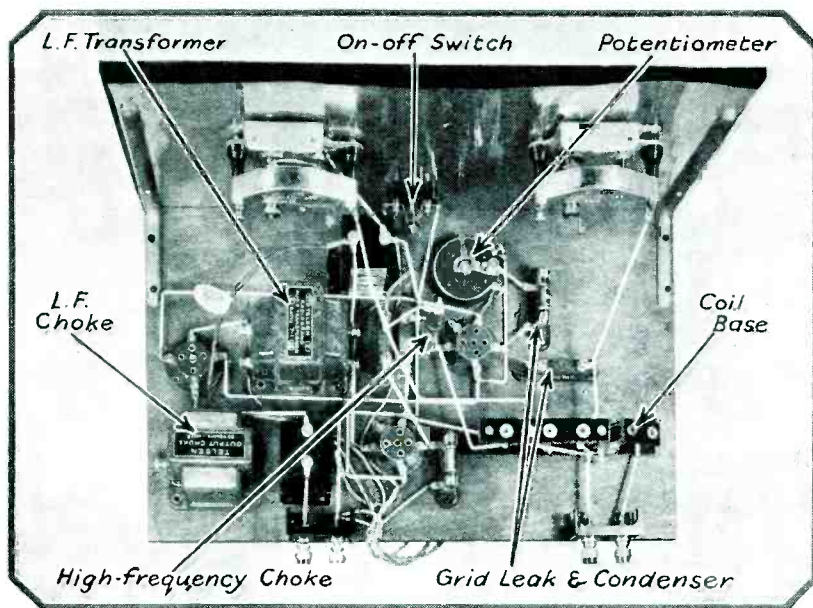

EVERY PART IS ACCESSIBLE

As this plan view shows, there is no overcrowding and the set is easily assembled and wired

is used. The choke-output device consists of a 20-henry low-frequency choke and a 2-microfarad coupling condenser.

The general layout of the receiver will be clear from the photographs that are reproduced in these pages. In addition to these, there is a quarter-scale layout and wiring diagram; this appears on page 300.

Full-size Blueprint for 6d.

If desired, a full-size blueprint can be obtained. This shows the exact positions of the holes that have to be drilled in the panel, and the positions of all the parts on both panel and baseboard. No beginner will have any difficulty in following such a full-size diagram.

Normally the price of a full-size blueprint for a three-valve receiver

however, bare wire can be used with Systoflex sleeving or ordinary rubber-covered flex can be utilised.

It will be found that the set is not at all critical as regards valves and any ordinary types can be successfully used.

As already mentioned, the detector should have an impedance of the order of 20,000 ohms. The first low-frequency valve should be of lower impedance, say between 10,000 and 12,000 ohms, while the power valve should have an impedance of the order of 4,000 ohms or lower.

For economical running, it should be seen that the three valves do not consume more than 12 milliamperes anode current, as this is the maximum economical rate of discharge for the particular high-tension bat-

THREE VALVES TO WORK A LOUD-SPEAKER

altogether. This will only be necessary when a particularly large aerial is used.

When the set is being operated, there is normally no need to change the coupling of the aperiodic coil with the grid coil. During the preliminary tests, the best coupling for smooth reaction and good sensitivity should be found, and once the coil has been adjusted at this angle in its mount it can be left undisturbed.

Reaction and Dead Spots

Stronger reaction is obtained when the coupling is loosened, that is, when the aperiodic coil is moved away from the grid coil. If a dead spot occurs in the tuning range anywhere, then the coupling should be varied to overcome it.

Very great care should be taken with the adjustment of the reaction condenser. On short waves the control of reaction is almost as critical as the grid-coil tuning and for this reason a full-size condenser with a large slow-motion dial has been used.

On Verge of Oscillation

For the best results the set must always be kept on the verge of oscillation. With a proper adjustment of the detector-anode voltage, the position of the potentiometer slider and the degree of aerial coupling, a fine control of reaction

Get a full-size blueprint for 6d., post free.

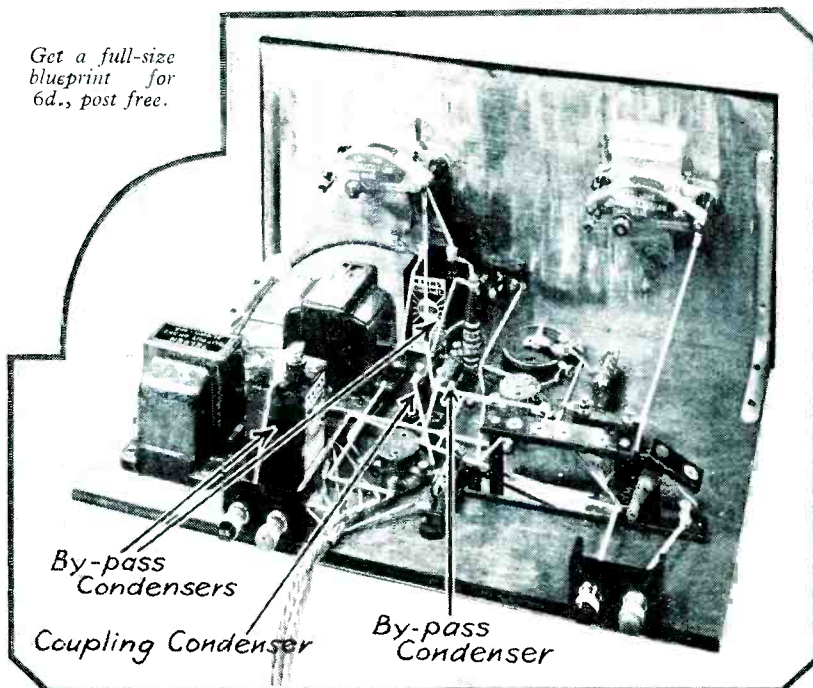

BRINGS THE WORLD TO YOUR FIRESIDE

With the Meridian Short-waver you can listen to the whole world; the operation is very simple, as this article explains

will be obtained without any popping or overlapping.

It is not too much to say that the secret of any straight short-wave set depends on its reaction circuit and in this respect the Meridian Short-waver cannot be beaten.

Right from the beginning of this

article we have referred to this set only as a short-wave receiver; it can, however, be utilised for ordinary broadcast reception on the medium and long wavebands by obtaining additional coils from the makers.

All-wave Receiver

This feature will undoubtedly appeal to a large number of constructors for, at a slight additional cost, they will be able to assemble an efficient all-wave set.

This issue of WIRELESS MAGAZINE is published at the beginning of a new season when interest in short-wave reception is once more coming to the fore. We have no doubt that any constructor who builds the Meridian Short-waver will get a great deal of enjoyment out of it during the winter months. Of course, we shall be glad to have as many reports on its capabilities in various districts as possible.

At the Radio Show

The original model of the Meridian Short-waver will be on show at the WIRELESS MAGAZINE Stand at Olympia, of course, and every reader is invited to inspect it before starting on the construction. The dates are Friday, September 18, to Saturday, September 26.

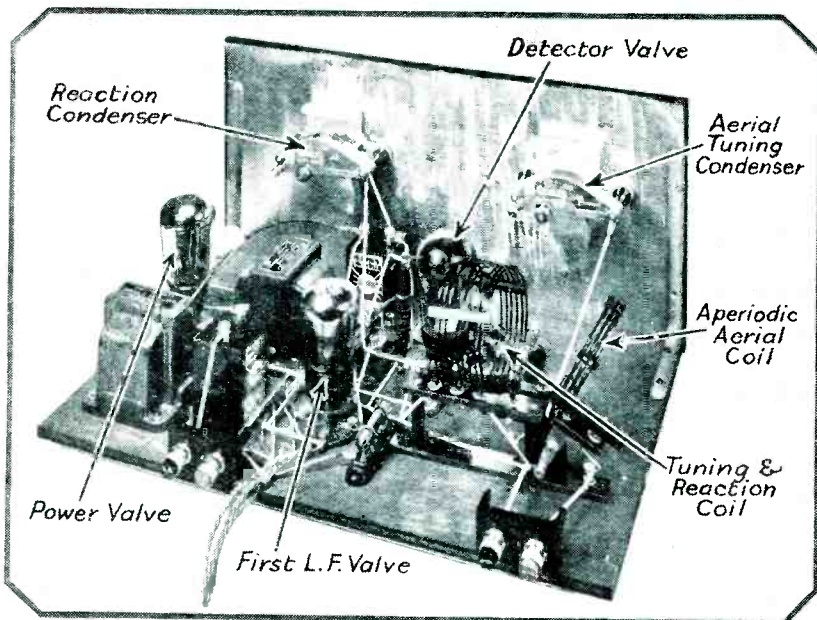

ORDINARY VALVES ARE USED HERE

Quite standard three-electrode valves that can be supplied from batteries are used in this receiver

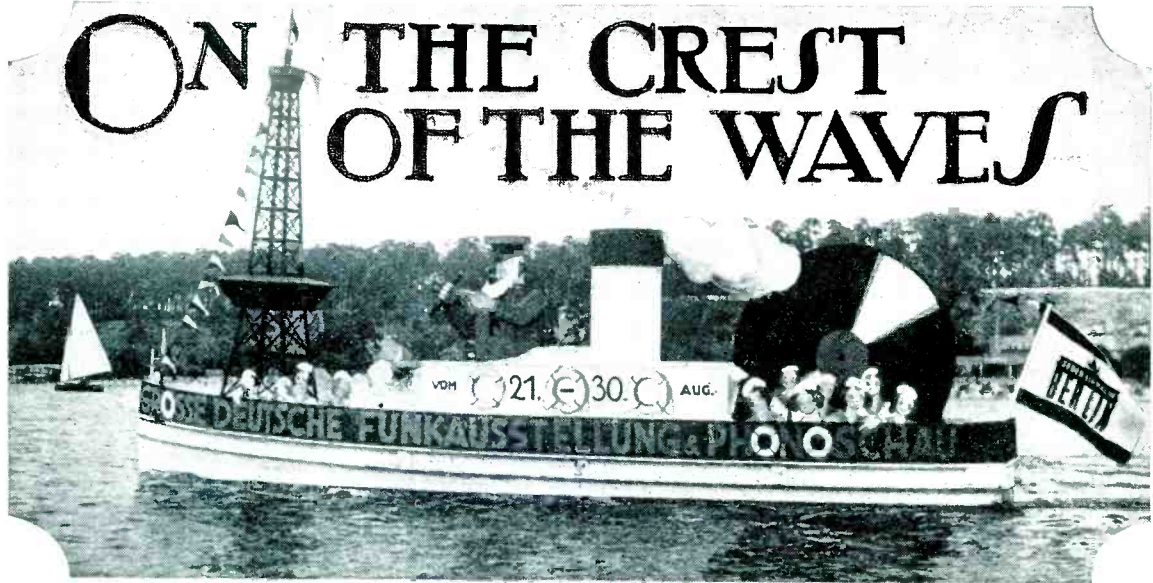

HOW THEY DO IT IN GERMANY

This "radio" boat was seen on the river in Berlin recently. It is advertising the German Radio Exhibition

THE famous Mosque of Aghia Sofia, for many years the orthodox church of St. Sophia at Istanbul (Turkey), will shortly be converted into a broadcasting station for the purpose of Mohammedan propaganda.

Both the Königswusterhausen and Nauen stations are used for broadcast telephony on long wavelengths, but these transmissions only include news bulletins, stock exchange quotations and political *communiqués* for the benefit of the German press. The channels reserved for these special services are 1,250, 2,525, and 2,900 metres. The stations are on the ether day and night.

"Nachrichtenvermittlungsmöglichkeiten" is the one-word title used by a German wireless journal as a heading to an article dealing with the possibilities of installing loudspeakers in city streets for the purpose of broadcasting news bulletins in cases of emergency.

Following the example offered by its neighbours, Budapest is to erect a high-power transmitter at Laki-hégy and three smaller relays at Miskolcz, Magyar-Ovar, and Pecz. It has not yet been definitely decided whether the existing station in the capital is to be retained for an alternative programme or whether it shall be transferred to a provincial town.

From 8 p.m. B.S.T. on

Mondays, Wednesdays, and Saturdays the Vienna concerts are simultaneously broadcast on 517 and 1,249 metres, the latter wavelength being used in the nature of a test. The Ravag is anxious to possess a long-wave transmitter and wishes to ascertain whether that channel is a favourable one.

As the telephone and telegraph systems are still undeveloped in the land of the Soviets, but few of the provincial newspapers can rely on this means of communication for their supply of news. The Press in Russia is entirely under Government control and pending increased facilities, three of the high-power broadcasting stations are brought into action during the night. From midnight onwards long news bulletins and official communiques are slowly transmitted in order to allow shorthand writers to take down the information. By this means the provincial "dailies" are able to publish all the news simultaneously with those of Leningrad and Moscow. No alteration is allowed to be made in the wording of the bulletins.

Early-morning broadcasts are regularly made by the German studios; in some instances they consist of relays of orchestral concerts given at fashionable spas and watering-places. Hamburg, as a rule, takes its 7 a.m. musical entertainment from one of the North German

Lloyd or Hamburg-America liners in port at the time.

Although the Belgian police authorities have threatened dire punishment to all unlawful users of wireless receivers, from the sales of sets made to date it is computed that the little country is blessed with at least 70,000 radio pirates. The number of registered licence holders does not exceed 80,000.

Norway is now in direct wireless telephonic communication with the United States through its transmitting and receiving stations at Jeloy, near Stavanger. A 15-metre wavelength is used during the day and a 30-metre channel at night.

During the autumn and winter months a series of international concerts will be broadcast by Germany, Austria, Hungary, Czechoslovakia, Poland, and Belgium. These transmissions will be relayed by telephone cable to a number of European cities. The first of these entertainments will emanate from Berlin on September 30; Budapest will follow on October 15; Vienna on November 7; Prague on November 26; and Brussels on December 17. The completion of the new special Continental cable system will permit, later, France, Switzerland, Italy, Holland, Roumania, and the Scandinavian states to take part in these broadcasts.

Instead of a "bald" news bulletin Radio Paris, with the opening of its new station, proposes to entrust all such topical information to a well-known French journalist. Political, criminal and even commercial news is to be dealt with daily in the nature of a humorous talk, as it is considered that in this manner listeners would find greater pleasure than in the mere recital of long lists of stock exchange and other market quotations as now practised.

A high-power television transmitter, to be erected by a well-known German firm, is to be installed at Rome; it will work in connection with the existing broadcasting station. Every effort is to be made to bring it into operation before the Christmas festivities.

In order to encourage the use of receivers the Zagreb station has offered to present a crystal set to every applicant for a listening licence in that city. The measure has been adopted in view of statements made to the effect that trade depression will not allow a large number of inhabitants to purchase instruments necessary for the reception even of local programmes.

Amateurs interested in the logging of ultra-short waves may like to know that the Berlin Central Post Office and the Telefunken Company both possess special experi-

mental stations with which tests are carried out daily between 5 and 8 p.m. B.S.T. Their respective wavelengths are 6.75 and 7.05 metres.

When you listen to the broadcasts of the Moscow Trades Unions transmitter you will notice that they appear to be given in a large hall and in many instances with a numerous audience. It is not a special theatre, but a studio of vast proportions which has been built in one of the old palaces of the late Czar, now renamed Palace of Industry.

Nowadays many European transmitters work without intervals from the time they open up in the morning until the announcer signs off late at night. Leipzig gives its engineers fifteen minutes during the afternoon to effect any adjustments which may be required by the transmitting plant.

Until recently the majority of the European broadcasting stations were equipped with steel masts to support the aerials. In Germany, experiments having demonstrated that better results could be obtained by the use of non-metallic structures, for the new high-power transmitters only wooden-latticed masts will be used in future.

In Italy, house porters of flats and apartment houses must act as radio sleuths for detecting unlicensed possessors of wireless apparatus. Printed questionnaires supplied by the police authorities must be filled up by them with full details regarding the radio instruments in the particular houses under their care and lodged with the local post offices. Heavy penalties are inflicted in the case of convicted pirates.

When closing down at the end of the day the Austrian stations seldom play the national anthem of that country. After the fall of the Hapsburg monarchy in 1918, the hymn was replaced by a revolutionary song, but the studios have now decided to use the original Haydn melody, as adopted by Germany, on special occasions.

Prato Smeraldo is the name by which the Rome short-wave transmitter on 25.4 metres is known. It relays the Rome-Naples programmes nightly.

For the purpose of experi-

ments the afternoon concerts radiated by Radio Strasbourg are relayed to the Government short-wave station at Nancy (France) and re-transmitted on 15 metres.

In a competition organised by the Frankfurt-on-Main studio it was recently clearly demonstrated that but few listeners were able to detect the difference between the transmission of a gramophone record and the same composition played immediately afterwards by a "live" orchestra. Out of 16,274 replies sent in by competitors only 52 supplied the correct answer.

In Bavaria, if telephone subscribers are only interested in the Munich pro-

grammes, they may receive them through a special loud-speaker installation hired out to them by the post office authorities without going to the expense of purchasing wireless receivers. The rental is roughly four shillings monthly.



A PLEASANT AFTERNOON
*A scene on the Wannsee, the popular lakes near Berlin.
Note the unusual aerial on the yacht*

grams, they may receive them through a special loud-speaker installation hired out to them by the post office authorities without going to the expense of purchasing wireless receivers. The rental is roughly four shillings monthly.

With a view to effecting economies in the operation of their services the Czechoslovakian stations rely on the Prague studio for all symphony concerts and news bulletins. In exchange,

records and all announcements are made in the English language.

During the past few months Radio Toulouse has extended its daily programmes until midnight. At 11.15 p.m. a late news bulletin destined to French residents in North Africa is transmitted. On Sundays at 10.15 p.m. a gramophone concert is broadcast for the benefit of British listeners; it is sponsored by a well-known manufacturer of

In Germany and Austria the listener's tax may be paid in monthly instalments if desired and the money is collected by the postman on his rounds. It is suggested in France that the same method should be adopted when a radio bill is passed.

When the German dirigible Graf Zeppelin takes a trip it remains in constant

touch with the coastal radio station at Norddeich from which it obtains weather reports affecting the area covered by the tour. The wavelengths used are 18, 26.4, 36, and 52.9 metres, the call sign of the airship being DENNE.

The bugle call blown from the top of the St. Mary's Tower at Cracow (Poland) is a tradition dating back to the Middle Ages, when the city was once besieged by an enemy. The sentry was killed before he could sound the alarm and to-day the unfinished call is given hourly as a time-signal.

At the bottom of your long-wave coil, namely on 900 metres, you may pick up aerodrome and aeroplane telephony transmissions; if situated in the southern area of the British Isles it will be found possible to follow aircraft plying between Amsterdam, Brussels, Paris, and London and *vice-versa*. Calls to the travelling 'planes made by Croydon can be heard at regular intervals.

It was rumoured that the Italian stations proposed to replace the women by men announcers, but such does not now appear to be their intention for you will find that items from the new Trieste transmitter are given out in a female voice. This seems to prove that the Italians are unwilling to part with these lady officials.

Although in their language the French were unable to coin a new word to denote a loud-speaker, but used a literal translation, "haut-parleur," in criticisms of wireless talks they do not say that a speaker has a good vocal organ. The term employed is "une voix radiogénique." In the same way a film face is "photogénique." These new words are also frequently heard in connection with reviews of sound films released in France.

Leipzig is not satisfied with its interval signal and the engineers of the broadcasting station are puzzling their heads to find one agreeable to listeners. The monotonous tick-tock of the metronome has now been replaced for some time by a vibraphone on which various melodies have been already tried.

JAY COOTE.

The Most Important

Factor of All in Listening

YOUR EARS

Some Interesting Points Explained by J. CROSS

IF I were to ask what you considered to be the most important factor in your enjoyment of broadcasting, I wonder what you would answer. A good set—a suitable programme—a perfect transmission—a good dinner and a comfy arm-chair; items such as these spring to mind very quickly, but is any one really *the* fundamental and all-important requirement?

When Money is Useless

No. These are all desirable—even necessary—but there is something without which the finest of all that money can buy is useless—I mean the sense of hearing.

The whole of broadcasting is based on this one faculty, which by its individual peculiarities determines the interpretation we shall each of us place on every sound delivered from the loud-speaker, and a proper understanding of which is essential to the student of acoustics and sound reproduction.

To strive to design the perfect amplifier or the perfect loud-speaker without some idea of how one's ear is going to react to the results is in a way similar to the building of a house on unsurveyed ground.

For instance, suppose we reproduce a low note A and a high note B with the same energy delivered to the air; will they sound equally loud? If we wish to double the loudness, must we double the energy? If we double the energy in A or B independently, will the increase of strength

appear similar? Is straight-line amplification always desirable?

Now, these questions simply cannot be answered without reference to the characteristics of hearing, and, given this reference, the answers are far from what one might expect from purely mathematical considerations. So let us see what it is all about.

A simple diagram of the ear is given in Fig. 1. Here we have first the external ear or "pinna," A; the outer auditory channel or "meatus," B; and the eardrum or "membrana tympani," C, forming the outer ear.

Then in the middle ear we have the tympanic cavity, D, which contains a delicate and complicated system of bones for transmitting the movements of the eardrum to the oval window, E; this system consists of the "hammer," F, attached to the

eardrum itself and coupled at its upper end to the "anvil," G, which in turn presses on the "stirrup," H; finally, the flat foot of the stirrup closes the oval window into the inner ear.

The Round Window

A second opening into the latter is situated at the lower end of the middle ear cavity, and is covered by a thin membrane known as the round window, K. The middle ear is connected to the air through the small eustachian tube, L, which emerges into the upper throat behind the nasal cavity.

The inner ear is filled with a fluid and consists of three main parts: the "vestibule," M, a space immediately behind the oval window; the cochlea, N; and the semi-circular canals, O, which play no part in hearing, but are connected with the sense of balance.

Of these, the cochlea is the important member; it consists of a central bone carrying a spiral of about two and a quarter turns in which is wound a three-fold tube, divided lengthwise by the basilar membrane and Reissner's membrane (Fig. 2).

The section of the tube known as the "scala vestibuli" is connected to the oval window, the "scala tympani" ends in the round window, and centrally there is the "canal."

Movements of the eardrum are transmitted through the system of bones and the oval window to the fluid in the "scala vestibuli," thence

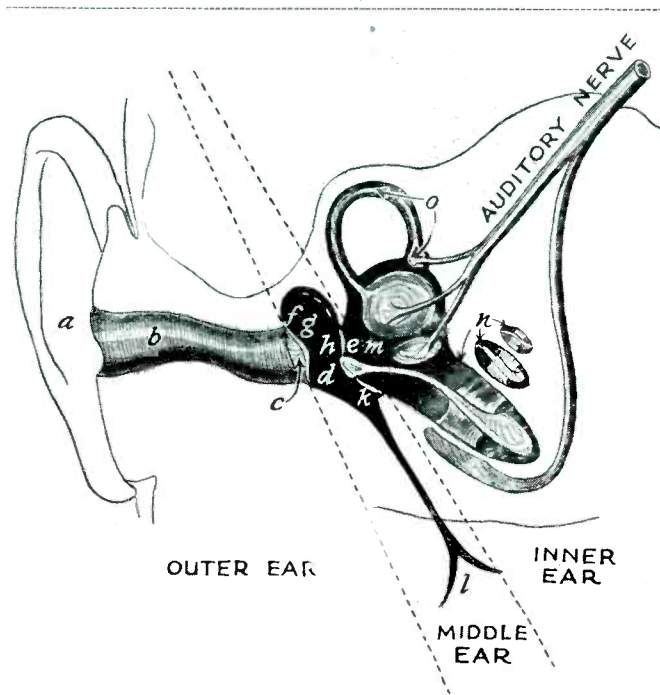

Fig. 1.—Pictorial section through ear, indicating principal parts

through Reissner's membrane, which is very thin and flexible, to the fluid in the canal, and from there to the fluid in the scala tympani, the expansion and contraction being taken up by the membrane in the round window (κ in Fig. 1).

Increased Pressure

It is interesting to note that the pressure at the oval window is between thirty and sixty times the air pressure on the eardrum, this "transformer effect" being accomplished by the system of bones; the impedance ratio of air to water is roughly 3,400 to 1, which for theoretically correct matching would demand a transformer ratio of $\sqrt{3,400}$ to 1 or nearly 58 to 1. Apparently Dame Nature does not ignore mathematical principles!

We have reached the point where pressure is being transmitted from the canal to the scala tympani, and here we meet one of the most interesting

Remember that this sketch is part of Fig. 2, which is a cross-section of the tube curled round the spiral bone of the cochlea. The basilar membrane thus extends the full length of the two and a quarter turns, and at the extreme tip has a small hole named the "helicotrema" actually joining the canal directly to the scala tympani, so that the fluid can flow from one to the other under certain conditions (Fig. 4).

When a pressure variation occurs in the canal the resultant motion stimulates the hair cells, thus setting up nerve impulses which travel to the

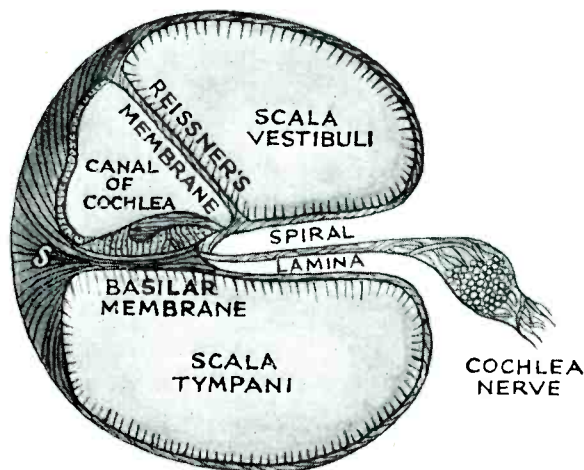

Fig. 2.—Cross-section of cochlea. S is the spiral ligament. The spiral lamina is the bone indicated in Fig. 1 (N)

As the pitch rises and the rate of pressure vibration increases, this "by-pass" action diminishes and the energy is diverted entirely to movement of the membrane, hence the sensitivity of the ear increases, as we shall see when studying the average audibility curve.

Drop in Sensitivity

At the other end of the scale the mass of the bones (F, G and H in Fig. 1) imposes a limit to the rapidity of motion which can be transmitted, so that there is a gradual drop in sensitivity up to the point of complete inaudibility.

These bones have another effect, because their movement is not proportioned to the applied pressure; they introduce harmonics of every tone heard, thus producing extremely complicated pressure waves on the membrane and so modifying our power of distinguishing pure tones.

Tuned Resonators

Within the audible limits it has been shown that low notes influence the upper end of the basilar membrane, middle notes influence the central region, and high notes affect the nerves nearest the oval window. In fact, we have here apparently a series of tuned resonators which give us our sense of pitch.

Each note we hear affects particularly one section of the membrane, and also adjacent sections to a lesser extent—one may visualise this by imagining the curve for a fairly flatly tuned circuit. It is this slight "spread over" which gives us our ability to follow continuous variations in pitch.

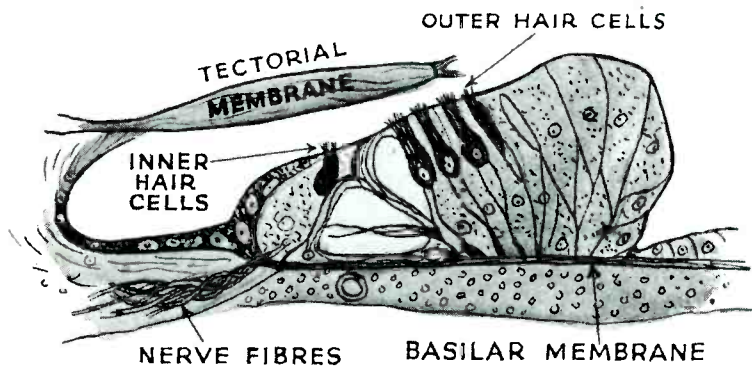

Fig. 3.—Greatly enlarged section of Corti's organ

structures imaginable—the basilar membrane.

This is the flexible connecting link between the two tubes, as well as being the link between the ear's mechanism and the auditory nerves, and it is shown in greater detail in Fig. 3.

Corti's Organ

Here is a section of the membrane with what is known as Corti's organ, in which the auditory nerves terminate in the shape of short hairs emerging into the canal. These hairs are loosely covered by a soft membrane known as the tectorial membrane.

There are five lines of hair cells with about 3,500 in the inner line and 5,000 in each outer row, a total of 23,500, and each terminates in about a dozen smaller points.

brain and give the sensation of hearing.

The next point is whether all the nerves are stimulated by every sound, or whether there is some selective action, and experiment has verified theory in showing the second alternative to be correct.

If the cochlea is unrolled and laid out flat it is found to taper slightly, as in Fig. 4. The cross-section varies along the entire length, which totals only 3.1 cm.; the greatest area is less than 4 sq. mm. and the basilar membrane itself is only .25 mm. wide!

When a sound of very low pitch, say under 25 cycles per second, vibrates the fluid in the canal, its chief effect is to cause a flow of fluid to and fro through the helicotrema, the action on the basilar membrane being small; thus we get the lower limit of audibility determined.

YOUR EARS—Continued

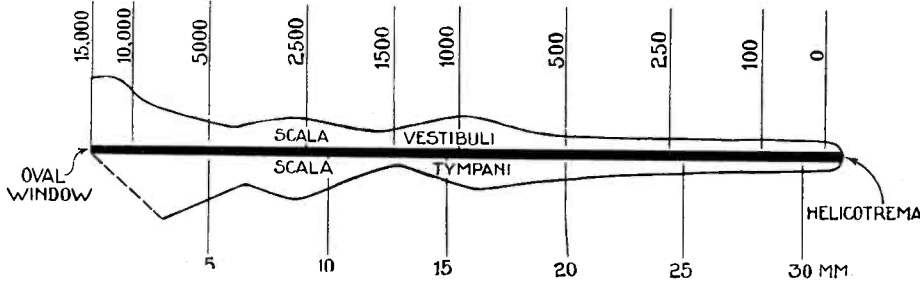

Fig. 4.—How the cross-sectional area of the cochlea passage varies. The basilar membrane is the thick central line (actually only $\frac{1}{4}$ m.m. thick)
The positions at which certain frequencies are sensed are shown

We cannot enter here into the reasons which lead to this theory of resonators, but it may be said that very good experimental proof has been obtained of its accuracy.

Highly Damped

“Resonators” is hardly the correct term because, although these rods or fibres respond to a definite note, like a piano string, they stop vibrating immediately the pressure stops or changes in frequency—in other words, they are very highly damped, as a string would be if pressed firmly against a long felt-covered block.

This is important, because it means that the ear has no appreciable persistence; it will follow extremely rapid changes of tone and strength, whereas the eye, as is well known, has a persistence which may be as high as $\frac{1}{15}$ second or so—the fact which makes moving pictures and television possible.

To complete the story we should, I think, spend a moment on the transmission of the sensation of sound to the brain. The auditory nerve is very similar to a trunk telephone cable, having some 3,000 fibres, each carefully insulated from the others—but there the resemblance ends, for the actual transmission of impulses is very different.

Proportionate Increase

If we apply a small voltage to a cable a certain small current flows, and as the voltage is raised, so the current increases proportionately.

In the case of the nerve fibre, the application of a very small impulse has no effect, but as the strength of the impulse is increased a point is reached at which the nerve appears to “trigger off” and transmits a full-powered signal, if we may call it so, to the brain.

From that point onwards, whatever the strength to which the impulse is raised, no increase of signal can be detected. In other words, the nerve is like an automatic revolver, which can only fire one size of bullet however great the

increases—in other words, loudness depends primarily on the number of discharges arriving at the brain.

Then, how do we distinguish one note from another? This is a more difficult question, but we know that each note affects one part of the basilar membrane more than the rest, so we deduce that the important factor is the position of the particular nerves receiving the maximum impulse.

Thus each tone will produce its own “impulse pattern” at the brain, depending on the positions of the nerves affected and their relative rates of discharge, and so we recognise one sound from another.

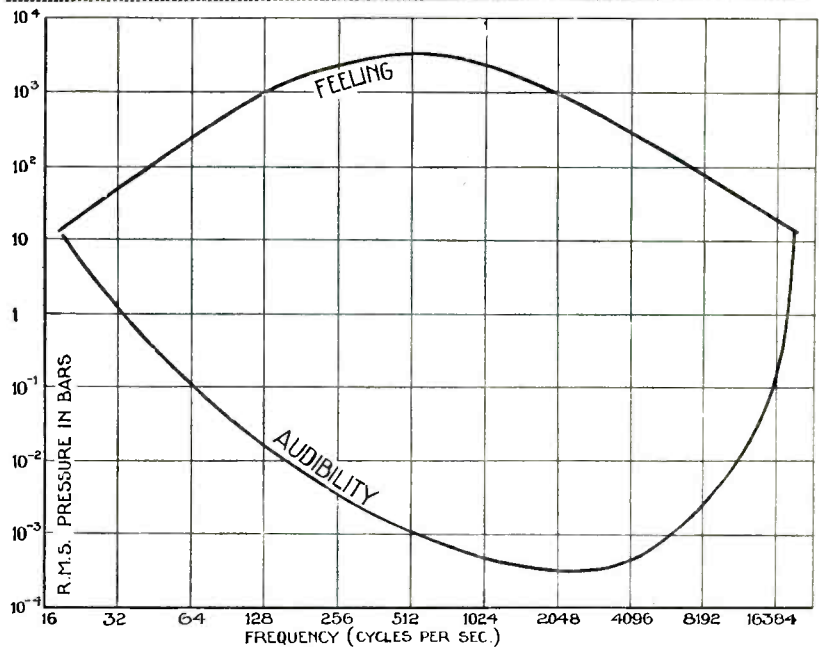

Fig. 5.—Curve showing limits of audibility

As 1 bar is 1-millionth of atmospheric pressure, the ear can sense as little as $\frac{1}{1,000,000,000}$ th. change in the normal air pressure when the change takes place at a medium audio-frequency! Furthermore, it will continue to sense changes up to about $\frac{3}{1,000}$ of an atmosphere, above which the effect merges into pain. The range of audible pressure is therefore roughly 3,000,000 to 1!

pressure applied to the trigger.

The question then arises—how do we sense loudness? It has been shown quite conclusively that there are two factors; firstly, as the strength of the impressed tone increases, the rate of discharge increases; and secondly, that the number of nerves discharging also

You can now appreciate the fact that we must expect some rather curious features in the ear’s general behaviour—and we shall not be disappointed!

Firstly, as is well known, there are limits to the range of audible frequencies, and this range varies very considerably with individuals. Fur-

WHAT THEY HEAR—AND HOW

thermore, these limits are not sudden, but are the result of a gradual falling off in sensitivity due to peculiarities in the ear's structure, as we have just seen.

As a matter of fact, the audibility curve for any one person is most irregular, showing as many "ups" and "downs" as an accurately taken loud-speaker characteristic, but when the average of a large number of such curves is taken and a fair line drawn

that 8-16, 16-32, 32-64, etc., each occupy an equal distance, as also do 0.1-1, 1-10, 10-100, etc. This system is adopted because the ear follows such a law very closely.

Over the greater part of the scale the minimum perceptible change in frequency is proportional to the frequency itself, instead of being a constant; for instance, at 500 cycles a change of 1.5 cycles can be distinguished, whereas at 4,000 cycles the smallest noticeable change is 12 cycles (note that 1.5/500 equals 12/4,000).

Similarly, the minimum pressure variation we can perceive depends largely upon the level at which we start; the actual law followed is rather complex, but if we reduce it to its simplest form we may say:—

(a).—At medium to high levels of volume the smallest percentage change in intensity which can be perceived is about 5 to 10 per cent., this figure being constant over a wide range of intensities and holding good over the audible range of frequencies.

(b).—At low levels of volume a marked divergence from law (a) takes place, as follows:—

1.—The percentage change necessary to produce an audible effect rises rapidly—that is, the

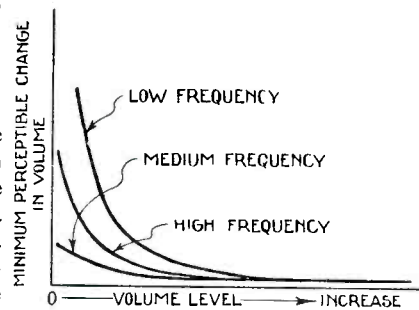

Fig. 6.—Showing how the ear's sensitivity to change in volume varies with the actual volume level

ear is less sensitive to changes of intensity.

2.—The percentage varies widely with frequency, being greatest at low frequencies, falling to a minimum at about 2,500 cycles, and then rising again—that is, the ear is less sensitive to changes at the ends of the audible scale than in the middle.

Clearly Illustrated

These effects are clearly illustrated by Figs. 6 and 7, which need no further explanation.

Our use of the logarithmic scale is therefore justified by (a) as long as we bear the exceptions of (b) in mind.

(Note.—When equal changes produce equal effects the law is arithmetic and we use scales with equal

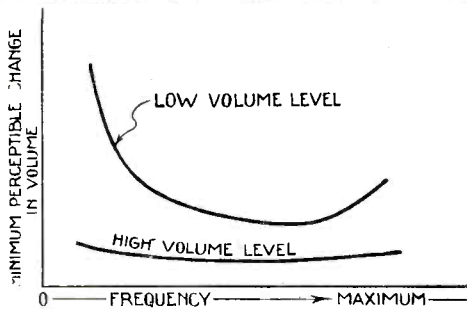

Fig. 7.—Showing how the ear's sensitivity to change in volume varies with frequency

through the points, the result is Fig. 5, which requires a little explanation.

You will notice that two curves are shown, the lower one marked "audibility," and the upper one "feeling." The lower curve shows the minimum pressure variation (expressed as a fraction or multiple of a "bar"—a unit equal nearly to one millionth of the standard atmospheric pressure) which the average ear can perceive over a range of frequencies, and the upper curve indicates the pressure at which the effect produced merges from hearing into feeling.

The intersections are then a reasonable guide to the upper and lower limits of audibility, which we see to be round about 20,000 and 20 cycles per second respectively.

Effect of Harmonics

Many of us can hear much higher frequencies, but it is difficult to define the lower limit at all accurately (not that the upper limit is by any means precise!), particularly owing to the introduction of harmonics by the three ear bones and the fact that the lowest notes seem to be heard and felt simultaneously.

You will note that the chart has logarithmic scales for both pitch and pressure change: that is, you can see

figure being constant over a wide range of intensities and holding good over the audible range of frequencies.

(b).—At low levels of volume a marked divergence from law (a) takes place, as follows:—

1.—The percentage change necessary to produce an audible effect rises rapidly—that is, the

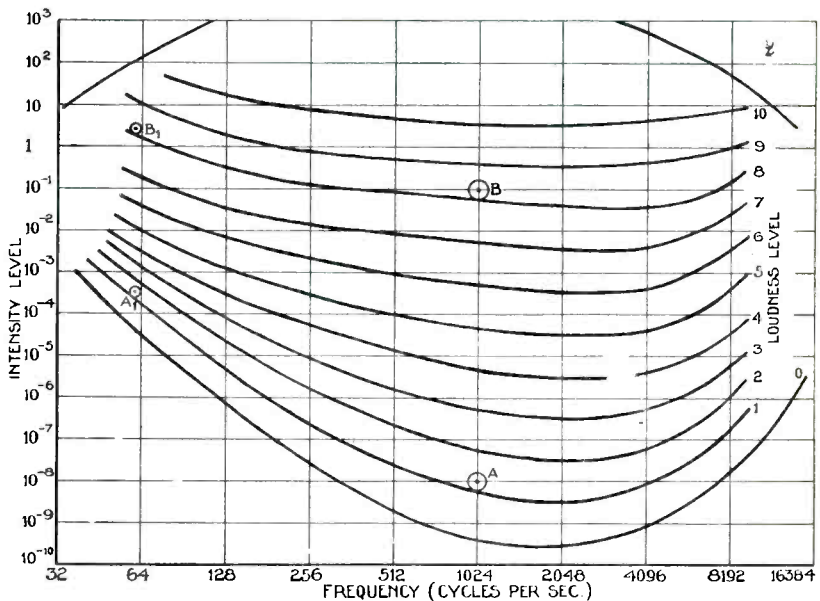

Fig. 8.—Chart showing relation between loudness, intensity level, and frequency

YOUR EARS—Continued

divisions; when equal *percentage or fractional* changes produce equal effects the law is logarithmic and we use scales which diminish as the actual value increases.)

Important Chart

From this point we can proceed to the construction of a very important chart, showing how apparent loudness, actual intensity, and frequency are related. This is shown in Fig. 8 and from it we can deduce one or two surprising things.

Firstly, take a note having a frequency of, say, some 1,000 cycles per second, and play it at an in-

tensity of, say, 10^{-8} microwatt/cm²; the effective loudness (at point A) will be approximately 1.2.

To produce the same effect at 60 cycles (A1) we shall have to set up a vibration energy of nearly $\frac{1}{2} \times 10^{-3}$ microwatt/cm²—or nearly 50,000 times as much!

On the other hand, if we raise the energy in the first note to, say, 10^{-1} (that is 1/10) microwatt/cm², it will have a loudness level of 8.4 (B), and to produce a corresponding 60-cycle note (B1) we must set up a vibration energy of some 3 microwatts—or thirty times as much.

Now, it is obvious that if these two

notes at a loudness level of 1.2 each are put through a "straight-line" amplifier which raises the first (1,000 cycle) to 8.4, the second will be well above the threshold of feeling; in fact, it will be an intolerable vibration.

Reduced Amplification

Then, if we reduce the amplification until the 60-cycle note is at a loudness of 8.4, the other will appear at a level of only 5.2.

And, if you look once again at the diagram, you will see that the same thing happens, though to a much less extent, at the top of the audible range.

So it seems that we are not entirely correct in our search for the "straight-line" amplifier after all, but that what we really want is something which will enable us to tilt both ends of the audio-frequency band up or down according to the general level of the reproduction and the balance of the input.

Effect on Output

Secondly, it is clear that this difference in the amount of energy to be produced at the ends of the scale must affect the required output of the amplifier very considerably.

True, at fairly high levels of loudness the disparity in energy requirements is far less than in the first example quoted, but nevertheless the ratio is still of the order of 50 to 1, even assuming that the loud-speaker itself has a "straight-line" relation between output and input.

Hundredfold Margin

In practice the great majority fall off in efficiency at both ends of the scale, so that the position is rendered still worse.

Thus it is obvious in order to reach a given maximum average loudness level without having to curtail or distort the lower notes we should provide for something like a hundredfold margin over the energy required for the notes in the centre of the scale.

Here, then, are the answers to the questions we asked in our first few paragraphs, and you must agree that they are extremely interesting, as they explain a good deal for us and help very considerably towards a correct appreciation of the factors involved in obtaining really first-class reproduction.

HEAR THEM NOW!

*Now I know the Autumn's here
For Budapest
And all the rest
Are coming through both loud and clear,
A thing they haven't done since June
Or was it May?
I cannot say—
Not, anyway, for many a moon.*

*The long-drawn days of summer pass
When atmosphere
Lies rent the air
And, if I tuned to Rome or Graz,
A constant roar and crackle blurred 'em!
So that it was
A bore because
It was not often that I heard 'em!*

*But now the ether-searcher's glad
For round the dial
They come in style—
Those towns which formerly he had
And every day as dusk is falling
He ventures free
O'er land and sea
To hear the "Continental" calling!*

C. P. P.

Telsen's first claim to fame

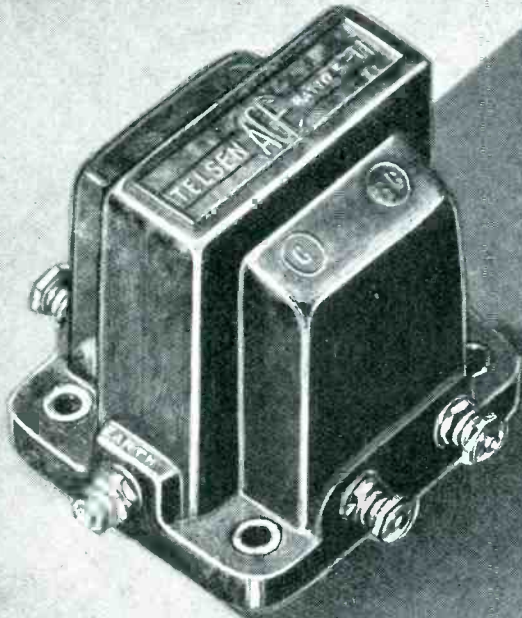

TELSEN L.F. AND OUTPUT TRANSFORMERS.

Telsen transformers have achieved fame in the radio world on account of the high standard of their quality and performance. Designed and built on the soundest of engineering principles, these robust, full-size transformers will give not only efficient but enduring service.



TELSEN L.F. TRANSFORMERS

Telsen "Ace" Transformer, Ratios 3-1, 5-1	Price 5/6
Telsen "Radiogrand" Transformer, Ratios 3-1, 5-1	Price 8/6
Telsen "Radiogrand" 5-1 Super Ratio Transformer	Price 12/6
Telsen Intervalve Transformer, Ratio 1 75-1	Price 12/6

TELSEN OUTPUT TRANSFORMERS

Telsen Multi-Ratio Output Transformer, giving three Ratios of 9-1, 15-1, 22.5-1	...	Price 12/6
Telsen Output Transformer, Ratio 1-1	...	Price 12/6
Telsen Pentode Output Transformer	...	Price 12/6

TELSEN L.F. CHOKES

Telsen L.F. Intervalve Coupling Choke, 40, 100 and 125 henrys	...	Price 5/-
Telsen Output Choke (Plain), 20 henrys	...	Price 8/-
Telsen Output Choke (Tapped), 20 henrys	...	Price 8/6
Telsen Heavy Duty Power Grid L.F. Choke, 40 henrys	...	Price 8/-

TELSEN

THE LARGEST RADIO COMPONENT MANUFACTURERS IN THE WORLD

BUILD BETTER WITH

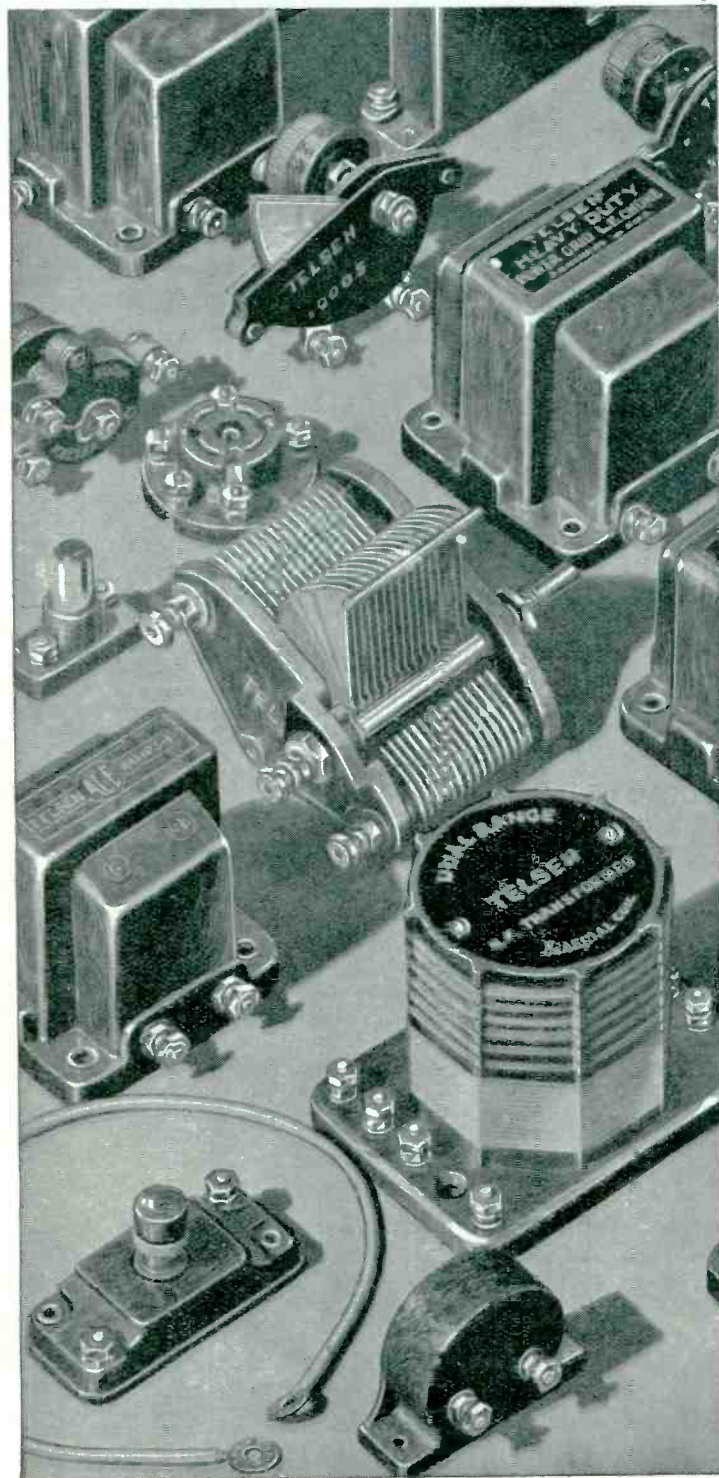

The foundations of Telsens's amazing success were established long before Olympia. The crowds at Stand 19 are only the crowning achievement of years of patient research and careful planning, and the justification of the new Telsens Components and new Telsens prices announced in June of this year.

Experts and amateurs, mass constructors of radio sets, and enthusiasts whose keenness is confined to one home set—all have paid generous tribute to the construction, the finish, and the performance of the whole Telsens range of radio components.

They build better than they know who build on Telsens.

Valve Holders ...	from	6d.
Push-Pull Switches	from	1/-
H.F. Chokes ...	from	2/-
Transformers ...	from	5/6
Output Chokes ...	from	8/-
Power Grid Chokes ...	8/-	
L.F. Coupling Chokes ...	5/-	
Slow-Motion Dial ...	2/6	
Mica Condenser ...	6d.	
Pre-Set Condenser ...	1/6	
Variable Condenser ...	4/6	

TELSEN

THE LARGEST RADIO COMPONENT
MANUFACTURERS IN THE WORLD

It helps us if you mention "Wireless Magazine"

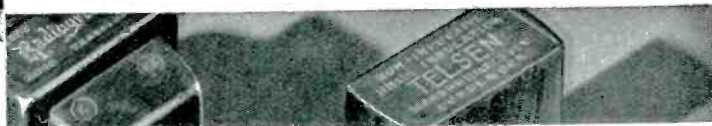

TELSEN COMPONENTS

You can see for yourself at the Telsen Stand at Olympia that everything claimed for the new Telsen Components is, if anything, understated. Pick up these components, admire the solid construction—from smallest to largest, each one a work of real craftsmanship. Consider the handsome Bakelite casings and the grained finishings and marvel that such proud quality can be priced so modestly. Ask any questions you like and read the specifications for yourself—and finally put Telsen to the test of actual performance—you will be proud of the achievement of an all-British firm.

They build better than they know who build on Telsen.

Tuning Condenser	...	2/-
Reaction Condensers from	2/-	
Differential Condenser	...	2/-
Paper Condensers	from	1/6
Spaghetti Resistances from	6d.	
Loud-Speaker Unit	...	5/6
Aerial Coils	...	from 5/6
Fuse Holder	...	6d.
Grid Leak	...	9d.
Grid-Leak Holder	...	6d.

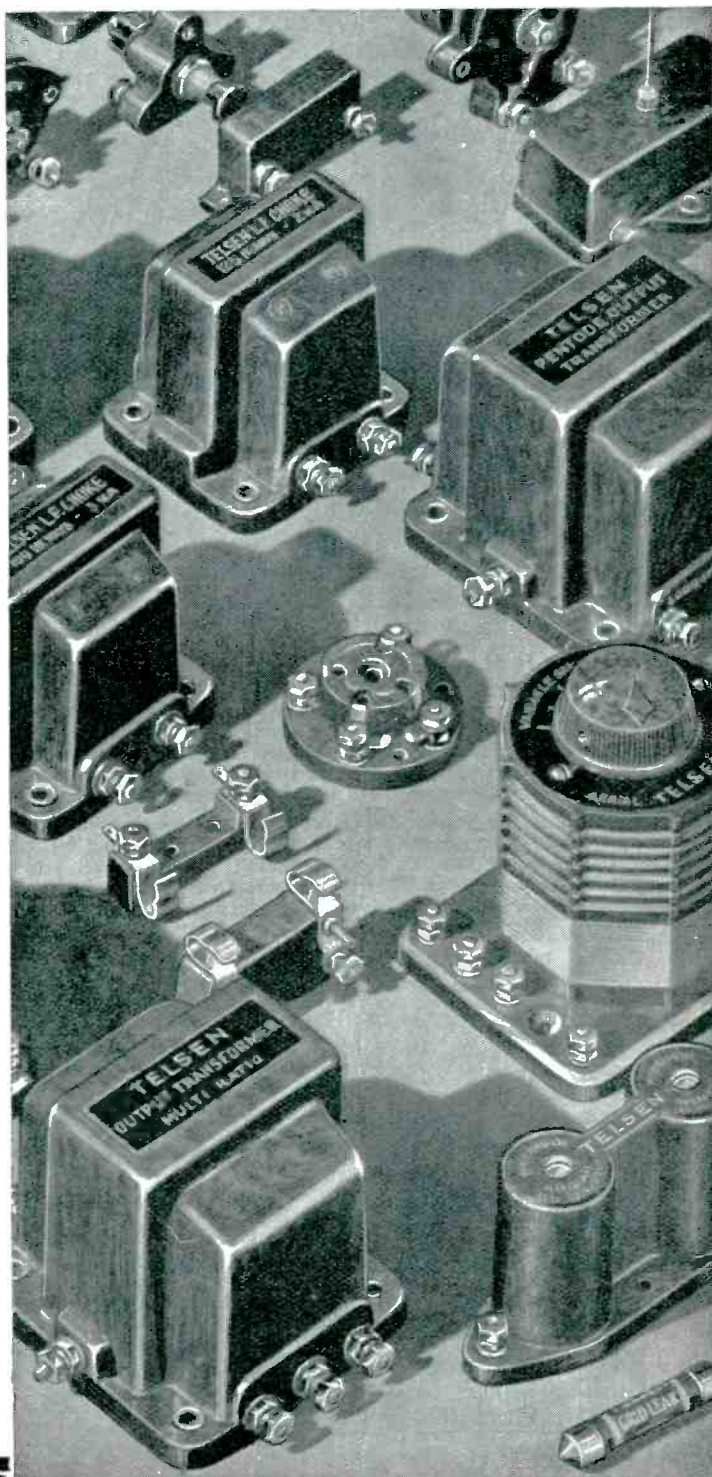

TELSEN

ALL-BRITISH
RADIO COMPONENTS

Better service results from mentioning "Wireless Magazine" when writing to advertisers

One of Telsen's latest achievements

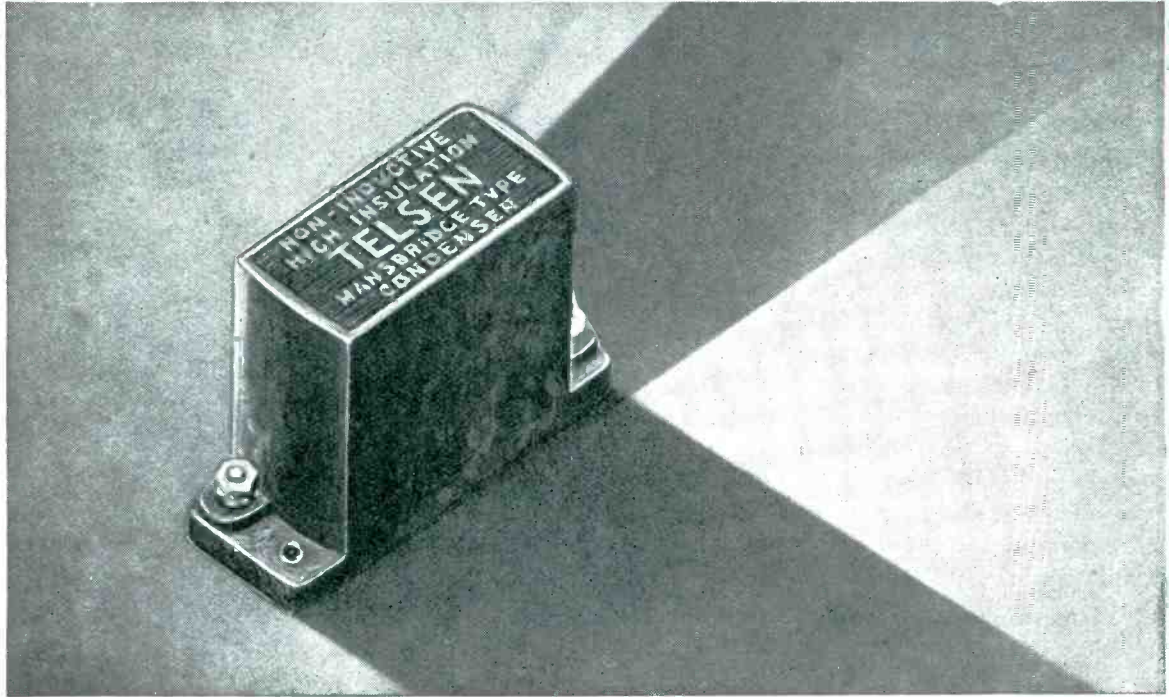

TELSEN MANSBRIDGE TYPE CONDENSERS

From **16**

Telsen have installed the most advanced plant in the world for the manufacture of Mansbridge Type Condensers. Only genuine Mansbridge foil paper and the finest linen tissue are employed in the exclusive method of manufacture. Every Telsen Mansbridge Type Condenser is hermetically sealed from the atmosphere and Post Office standards of insulation are adopted throughout.

The preliminary research, the most modern plant in the world, the finest raw materials, the latest methods of manufacture, and the final test all combine to give Telsen Mansbridge Type Condensers a high insulation over years of service, with freedom from breakdown. The type of construction employed makes them genuinely non-inductive. The following values are guaranteed within 5 per cent. :

Cap. mfd.	500 Volt Test. Price.	1,000 Volt Test. Price.
.01	1/6	2/6
.04	1/9	2/9
.1	1/9	2/9
.25	2/-	3/-
.5	2/3	3/3
1.0	2/3	3/6
2.0	3/-	5/-

TELSEN

**ALL-BRITISH
RADIO COMPONENTS**

WE TEST BEFORE YOU BUY

We Test Before You Buy

Conducted by the "W.M." Set Selection Bureau

AS this is written some time before the Radio Exhibition, complete details of the new season's sets have not been fully disclosed. But we have examined many of the new models, from which a general idea of the trend in design and circuit arrangement has been obtained.

super-het type of set, first introduced to home constructors by W. James with his Super 60. Several of the big firms announce multi-valvers with super-het circuits. Of course, these are in the de-luxe class.

During the ensuing months we shall give full details of our tests of the new season's

gramophone, using a nine-valve super-heterodyne circuit. This is the "ace" set of the H.M.V. range. In spite of the many de-luxe features of this instrument, such as the automatic record-changer and the super-het circuit, the price is only 70 guineas.

The undistorted power output is exceptionally high, being no less than $4\frac{1}{2}$ watts. A local-distance switch is provided, so that local stations do not swamp the low-frequency side.

An unusual type of set is the H.M.V. model 501 three-valve table radio gramophone. Included in the table cabinet is a three-valve all-mains set, a moving-coil loud-speaker, gramophone pick-up and electric motor. The price is £30, a figure that should appeal to many set-buyers wanting radio and gramophone reproduction without the expense usually associated with radio gramophones.

Another H.M.V. set that is bound to appeal is model 435, a straight three-valver for mains operation, providing nearly 2 watts undistorted output to the self-contained moving-coil loud-speaker. The price is 22 guineas.

Among the Columbia sets are many that will appeal to our readers. Probably the lowest priced cabinet two-valver is the new Columbia model 351, price £5. This includes everything except the aerial and earth. Inside the cabinet is the two-valver, a cone loud-speaker, and the necessary batteries and valves.

We are interested in the new Columbia radio gramophones. There is model 602, price 32 guineas, embodying all the latest improvements. This is certainly very good value for money.

Electric Gramo.

Model 500 is an electrically-driven gramophone with a two-valve amplifier and volume control. The price is 20 guineas. This is an instrument that should appeal to those already possessing good radio sets but wanting a separate electric gramophone.

We shall deal with all the leading kit sets in our forthcoming set reports. Among these will be the Zonophone three-valve kit, produced by the British Zonophone Company known already to our readers for their excellent gramophone records.

We recently attended an impressive demonstration of this kit, which is a product of the H.M.V. Research Department. The price is 6 guineas, complete with self-contained cone loud-speaker and three Marconi valves.

Value for Money

Another firm with a very big range of complete new models is the General Electric Co., Ltd. Value for money is the key-note of all the new Gecophone sets. For example, the Gecophone A.C. four-valver is only 20 guineas, or as a console 29 guineas, including an inductor-dynamic loud-speaker.

(See also pages 318 and 323 of this issue.)

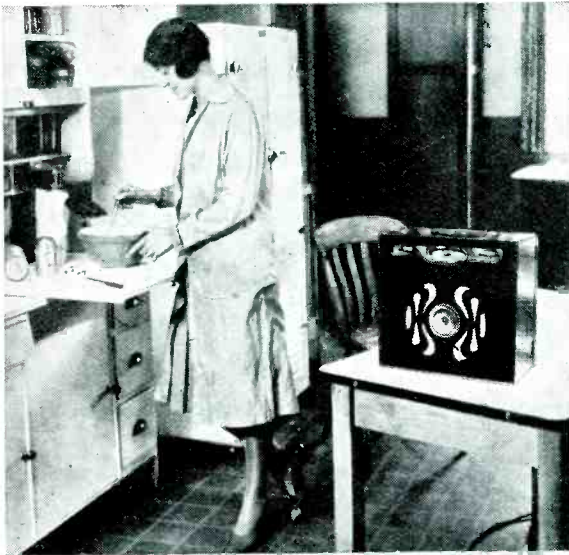

RADIO IS A BOON TO THE HOUSEWIFE

A good illustration of the value of a portable receiver—it can be so easily moved about. This is the well-known Marconiphone model

As we have already forecast, one of the most outstanding aspects of 1931 radio is a general lowering of price levels. You get a good deal more for your money when buying the latest sets than was the case last year. These price reductions can be noted throughout the range, from elaborate super-heterodyne sets in ornate cabinets to the simplest two-valvers.

Table Cabinets

For the man in the street, one of the most useful developments is undoubtedly the three-valve table-cabinet type of set. Such a set, with a self-contained loud-speaker of the cone type, is probably the most popular. Prices for three-valve table-cabinet sets are extraordinarily low, one model recently examined being only 14 guineas.

We feel we can claim some credit for the present popularity of the screen-grid

sets. This month we are passing through the transition period from the old to the new models and for this reason the number of reports is limited.

The Cossor kit set and the Regentone two-valve A.C. set reviewed are typical of the developments to be embodied in their respective types. The prices of these two sets are also indicative of the new and lower price level.

Here we can give details of only a few of the many new sets to be described during the coming months. We would emphasise the point that only a small proportion of the many interesting sets that will be on view at Olympia can be mentioned in this short article.

From the Gramophone Co., Ltd., comes a large range of entirely new models. Outstanding is the model 531, which is the H.M.V. automatic record-changing radio

FREE ADVICE TO PROSPECTIVE SET BUYERS

To take advantage of this service it is necessary only to mention (1) the maximum price and whether this is for a complete installation or the bare set; (2) where the set will be used; (3) what particular stations are desired; (4) whether a self-contained set (with or without aerial), or an ordinary set with external accessories is preferred; and (5), in the case of mains-driven sets, whether the mains are A.C. or D.C.

A stamped-addressed envelope for reply is the only expense. Address your inquiry to Set Selection Bureau, WIRELESS MAGAZINE, 58-61 Fetter Lane, E.C.4. There is no need to send any coupon, but it is essential to give the information detailed above on one side of the paper only. Tell your friends about this service.

GRAHAM FARISH

— LTD. —
BROMLEY :: KENT

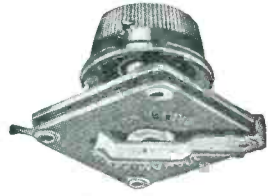

GRAHAM FARISH "LITLOS" VARIABLE CONDENSER
A solid dielectric tuning condenser, with log midline capacity variation. With knob. Made in capacities .0001 mfd., .0003 mfd., and .0005 mfd.
Price **2/-**



GRAHAM FARISH "SNAP" SPEAKER UNIT
A marvellous production at the price. Powerful cobalt magnet gives sensitivity and the unit handles large outputs. Bakelite cased and complete with reed.
Price **5/6**
Delivery 3 weeks



GRAHAM FARISH FIXED CONDENSERS
Complete range of capacities, upright or flat mounting. Registered design No. 723271 and tested on 750 volts D.C.
Capacities:
.00005 mfd. to .002 mfd. ... **6d.**
.003 mfd. to .006 mfd. ... **1/-**
.007 mfd. to .01 mfd. ... **1/6**



GRAHAM FARISH VOLUME CONTROL
Potentiometer type for pick-up or any grid circuit control. Finely graduated, with smooth action. Max. value, 500,000 ohms approx.
Price **3/6**

GRAHAM FARISH "LITLOS" DIFFERENTIAL CONDENSER
Similar to the tuning condenser but with two sets of fixed vanes, each side being accurately matched. Complete with knob. Capacities, .0001, .00015, and .0003 mfd.
Price **2/-**



GRAHAM FARISH FLEXIBLE RESISTANCE LINKS
Nickel chrome wire wound, accurate and well within their ratings. All sizes from: 1,000 ohms to 20,000 ohms
25,000 ohms to 100,000 ohms, 1/6



GRAHAM FARISH KONE KAP GRID LEAKS
A good carbon type Grid Leak. Fits all condensers and holders. Made in 1, 2, 3, 4, and 5 megohms.
Price **9d.**

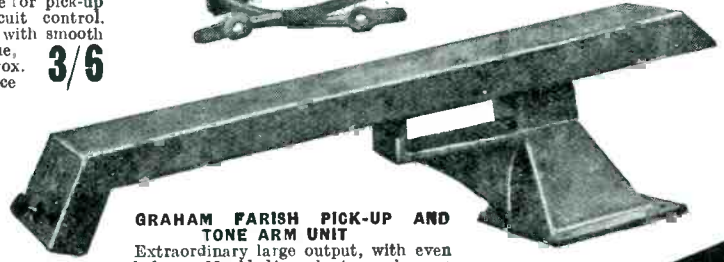

GRAHAM FARISH PICK-UP AND TONE ARM UNIT
Extraordinary large output, with even balance. Moulded in walnut or mahogany in modern design. Ball-bearing pivots.
Price **32/6**
Delivery 3 weeks.



GRAHAM FARISH STANDARD GRID LEAKS
Counterpart of above, but fitted with terminal ends for sure contact.
Price **10d.**



GRAHAM FARISH HOLDERS
Suitable for all resistances. Upright or horizontal mounting.
Price **6d.**



G.F. PRE-SET CONDENSER
Popular capacities covering all requirements.
F. .00005 to .0001 mfd.
J. .000025 to .0003 mfd.
G. .0002 to .001 mfd.
H. .001 to .002 mfd.
Price **1/6**

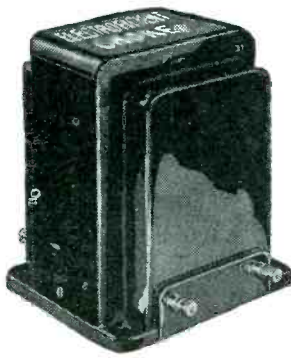

GRAHAM FARISH AUDION L.F. CHOKES
A range of chokes covering all L.F. requirements and including smoothing chokes.
25 henry 15 milliamperes
Price **10/6**
25 henry 20 milliamperes **15/-**
30 henry 50 milliamperes **20/-**



GRAHAM FARISH AUDION R.C. UNIT
Another popular line reduced in price. Incorporates Ohmite (100,000 ohms) and Megite (2 meg.) resistances on base with sealed MICA condenser of correct capacity.
Price **4/6**



GRAHAM FARISH MULTI-WAVE H.F. CHOKE
Specially designed Choke for all radio frequencies between 50 and 3,000 metres. Impedance at 480 metres, 147,000 ohms. Complete with holder.
Price **4/6**

See what Graham

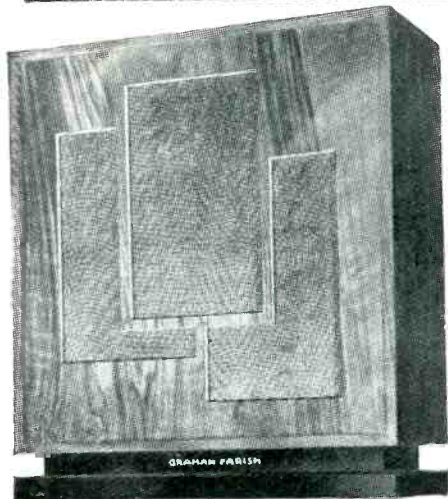

THE GRAHAM FARISH "AMAZING" SPEAKER
Permanent cobalt magnet system of great power. The piston movement cone gives remarkable sensitivity at all frequencies and ensures a fidelity of tone value unsurpassed by any. The cabinet work is second to none and can be supplied in oak, mahogany, or walnut at the same price. Price **42/-**

GRAHAM FARISH H.F. CHOKE
Of new design, this choke covers medium and long broadcast wavelengths. D.C. resistance, 400 ohms. Price **2/-**
Delivery—3 weeks.



GRAHAM FARISH PUSH-PULL SWITCH
Exceptional value. Positive contact with snap action. Will give satisfaction for years. Self-cleaning contacts. Price **8d.**
Delivery—7 days.

Farish does to prices!

GRAHAM FARISH ANTIMICROPHONIC HOLDER
Beautifully sprung with spring contacts, sure grip, easy withdrawal. Price **9d.**

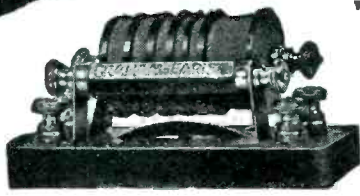

GRAHAM FARISH AERIAL CAPACITY UNIT
A continuously variable condenser for series aerial connection, conveniently arranged for mounting. Price **3/6**

GRAHAM FARISH COUPLING UNIT
A complete H.F. coupling unit incorporating the "Multwave" H.F. choke and "Megite" grid leak, mounted on base, with sealed condenser. Price **5/6**



GRAHAM FARISH A.C. CHASSIS SPEAKER
Incorporating powerful and sensitive motor, with special waterproof fabric cone of new design. Aluminium housing finished in frosted black. Price **21/-**

GRAHAM FARISH "SNAP" L.F. TRANSFORMER AND CHOKE
A remarkable transformer of small size—gives true stage gain at high and low frequencies, especially when used in conjunction with the "Snap" L.F. Choke in parallel feed following detector valve. Price **5/6**
Transformer—3:1, 5:1 5/6
"Snap" L.F. Choke 5/-

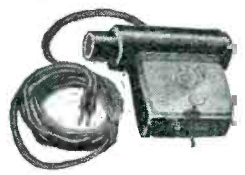
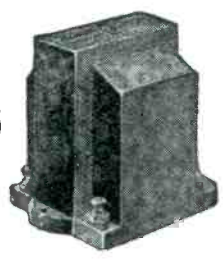
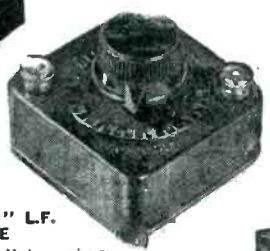

GRAHAM FARISH PICK-UP
Of similar internal design to the Pick-up and Tone Arm Unit, but without arm for easy connection to existing tone arm. Price **22/6**



GRAHAM FARISH OHMITES AND MEGITES
A popular resistance for all general purposes. "Better than Wire Wound." All values from 100 ohms to 5 megohms. Price **1/6**



GRAHAM FARISH HEAVY DUTY OHMITE
Where the required current is too high for the ohmite resistance use the heavy duty type. All values from 100 ohms to 5 megohms. Price **2/3**

STAND 32 AT OLYMPIA :
will have a complete range of our Radio Components. We shall be there to answer your questions. You will have an opportunity of seeing the quality of Graham Farish components. Our eleven years' experience of component manufacture has enabled us to give you tip-top quality at rock-bottom prices. This is our invitation—we shall be pleased to see you at Olympia.

Advertisers like to know whence the business comes—please mention "W.M."

COSSOR EMPIRE MELODY MAKER (KIT SET)

Maker.—A. C. Cossor, Ltd.
Price.—£6 15s. This price is inclusive for the kit of parts and valves.

Power Supply.—This kit works from batteries. For the high-tension battery, the makers recommend a 120-volt supply. A 2-volt accumulator is needed for the

control is achieved by means of a 25-ohm variable resistance in the negative filament lead of the screen-grid valve.

The coil-switching arrangement for the aerial and high-frequency coupling coils is conventional, for when medium waves are

the grid leak and condenser of the detector valve. The grid condenser has a capacity of .0001 microfarad and the grid leak is 2 megohms. These values prevent frequency distortion and certainly suit the Cossor 210HL detector valve.

Assembly.—We were supplied with a completed Cossor Empire Melody Maker, but from an examination of the large and easy-to-read instruction chart we have no doubt about the simplicity of assembly. Copious notes are provided for the constructor as well as stage-by-stage instructions for the assembly of the components.

Controls.—Although there appears to be rather a large number of

controls on the new Cossor Empire Melody Maker, quite a short examination shows that nothing superfluous has been included. The two main controls are the two slow-motion dials of the two variable condensers, one in the aerial circuit and the other in

not very difficult, once the discrepancy between the dials has been found by tuning in the local station.

Between the two tuning condenser dials is the filament on-off switch. To the left of this we find the knob of the filament resistance controlling volume, and to the right the knob of the reaction condenser. That completes the front panel controls.

On the left-hand side of the cabinet is fitted the aerial series condenser for volume control or selectivity control. Near this control are the aerial and earth terminals. At the right-hand end of the cabinet are the loud-speaker terminals. The battery leads come out of the back of the cabinet, except those for grid bias, which go to the bias battery inside.

Selectivity.—We were agreeably surprised at the selectivity of this set. London National had a spread of only 8 degrees and London Regional only 10 degrees. This was with our standard aerial, using the pre-set condenser half-way towards its minimum.

Sensitivity.—The following readings show how stations come in round the two tuning dials. London National 25 and 30; London Regional 50 and 56; Midland Regional 56 and 65; North Regional 70 and 75. Between these readings for home stations we logged a very creditable number of foreigners. The set has extraordinary distance-getting properties. We were really impressed with the strength of the foreigners.

Quality.—Due to the inclusion of a Cossor P2 power valve, we were able to work our standard moving-coil loud-speaker with this set. The reproduction can be first-class.

Summary.—This is an excellent kit set for the constructor. The assembly is easy, and novices can tackle it with every confidence. The new Cossor Empire Melody Maker is excellent value for money.

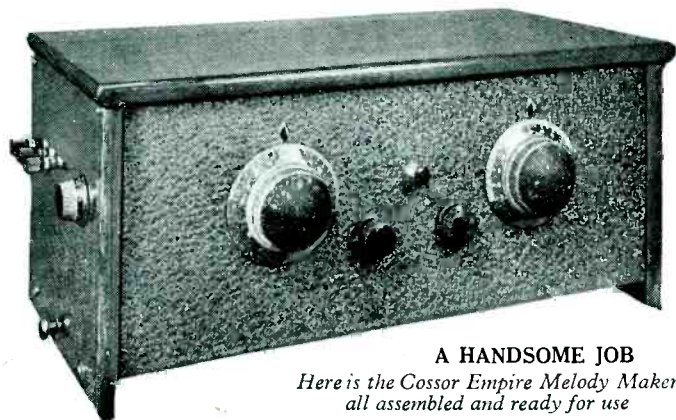

A HANDSOME JOB
 Here is the Cossor Empire Melody Maker all assembled and ready for use

filament supply; also a 9-volt grid-bias battery.

Power Consumption.—We measured the anode-current consumption of this set during tests and it was found to be 12 milliamperes. This means that the most economical running will be obtained with a double- or treble-capacity high-tension battery. The most convenient capacity for the 2-volt accumulator is 30 ampere-hours.

In view of the high standard of performance of this set, both in sensitivity and volume output, the running costs must be considered quite moderate.

Valve Combination.—The three valves in this kit are arranged in the popular sequence of screen-grid high-frequency-amplifying valve, detector valve and transformer-coupled output power valve. An examination of the circuit diagram given with the large instruction sheet shows that modern improvements have been incorporated throughout.

For example, the aerial is aperiodically coupled to the aerial-tuning circuit and can be connected to a tapping point on the aerial coil through a .0003-microfarad pre-set type of condenser for added selectivity. Volume

being tuned in, the long-wave windings are short-circuited.

Reaction is applied to the tapped tuned-anode coil by means of a winding in the anode circuit of the detector valve.

There is no high-frequency choke between the anode of the detector valve and the primary winding of the low-frequency transformer. To make up for this omission, that is, to ensure that high-frequency current does not get into the low-frequency valve circuit, a .0001-microfarad condenser is connected across the anode-filament circuit of the detector.

Still another refinement is the insertion of a .5-megohm grid leak between the grid of the power valve and the grid end of the secondary winding of the transformer. This grid leak serves to prevent any high-frequency current passing into the output circuit.

We note that modern values have been chosen for

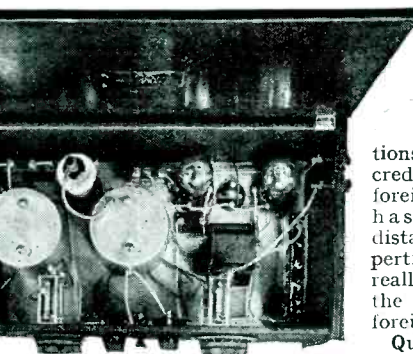

EFFICIENT DESIGN
 This set is very well laid out and gives excellent results

the tuned-anode circuit. As subsequent tests indicated, these two dials do not register similar readings for any given station, but as they keep fairly well in step over the whole available wavelength ranges, tuning is

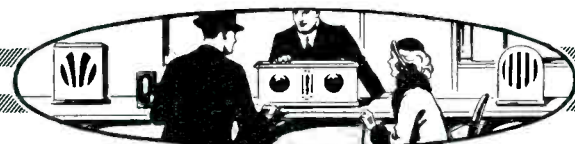

NEW PRINCIPLE NEW PERFORMANCE

The first of the "Square Peak" Sets—the astounding new Varley Mains Receivers and Radio-grams. Stations that before were only names to you come crowding in at full strength . . . no trace of "mush" or background . . . heard with unequalled clarity and perfection . . . on the built-in Moving-Coil Speaker.

Tens of thousands of constructors have built Varley "Square Peak" Coils into their sets . . . with *ten-fold increase in selectivity*, and marked *gain in quality*. Now the same principle that underlies the Coils has been applied to this new range of Varley Sets and Radio-gramophones—the wonderful "Square Peak" principle.

"SQUARE PEAK" 4-VALVE MAINS RECEIVER.—Complete with built-in Moving Coil Speaker as illustrated—*one-dial tuning*. Calibrated in metres and logged to 20 station points. Equipped for gramophone pick-up and fitted with special volume control.

A.C. or D.C. Models 29 guineas
4-Valve Console Model, A.C. or D.C. . . . 34 guineas

Valves and royalties included.

Hire Purchase facilities are available.



SQUARE PEAK

(REGD TRADE MARK)

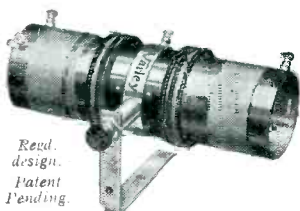

Revd.
design.
Patent
Pending.

VARLEY "SQUARE PEAK" COIL

An aerial band-pass coil, giving a constant square-topped peak and separation of substantially 9 kilocycles over the whole of *both* wave-bands. Complete with wave-change switch and mounting bracket. **15/-**

List No. BP.5.

matched coils ensure perfect ganging

H.F. INTERVALVE COIL (Dual range) for use with above. Completely screened. Its inductance *inside the screen* is exactly matched to that of the "Square Peak" Coil to ensure perfect ganging. Complete with extension rods for coupling the switch to that of the "Square Peak" Coil. **8/6**

List No. BP.6.



Varley

STAND NO. 58 OLYMPIA

**You'll be
lost in wonder
at Radiolympia**

Make a beeline for Radiolympia where all that is new in Radio is displayed for one week only. You will be amazed at the simplicity of the latest methods. Here's something new for every purpose—something to suit every pocket.

COME TO RADIOLYMPIA

NATIONAL **RADIO** EXHIBITION

WHERE BRITISH IS BEST

OLYMPIA
SEPT
18-26

11 a.m. to 10 p.m. DANCING
ORGANISED BY THE RADIO MANUFACTURERS' ASSOCIATION,

**KABI COMPONENTS
FOR QUALITY!**



**PURE WIRE WOUND
POTENTIOMETERS**

IN BAKELITE CASE

PRICES WITH KNOB :-

3 watt type :-	5 watt type :-
10-5,000 ohms., 3/-	10-5,000 ohms., 4/-
7,500-25,000 ,, 5/-	7,500-50,000 ,, 6/-

Manufacturers models on application.

Guaranteed accurate within 5%.

**QUICK MAKE AND BREAK
MAINS SWITCH
FOR SINGLE HOLE FIXING**

240 volts 2 amps. 1/6
Change over type 1/8

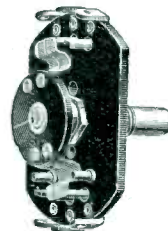
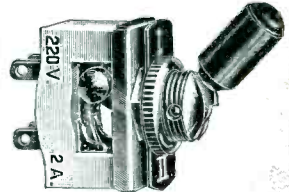

**NEW COMPACT
WAVE - CHANGE SWITCH**

1 - 6 brushes (3-18 contacts)
2/6 to 4/-

STUD SWITCHES (3-19 contacts)
2/3 to 3/-

Further particulars—

A. BRODERSEN,
11, NORTHAMPTON SQ., GOSWELL RD.
Telephone: Clerkenwell 7286. E.C.1

The R & A
"100"
PERMANENT MAGNET
MOVING COIL
REPRODUCER

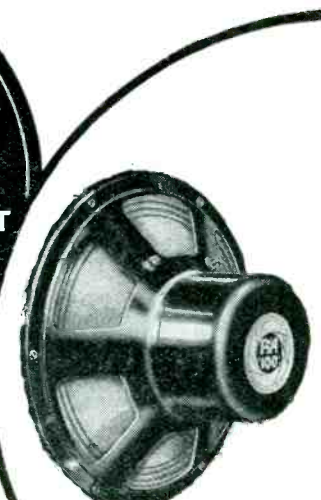

Although offered at the amazingly low price of 45/-, the R. & A. "100" was designed for performance, and afterwards priced. Perfect reproduction is paramount, and will satisfy the most critical listener.

Sensitivity is of a high order and equal to the most expensive energised types. Ideal for small receivers and also for those with inputs in excess of domestic needs.

The R. & A. "100" is exhibited at the Radio Exhibition, Olympia, on the stands of the leading distributors. Your dealer will demonstrate, but in case of difficulty write us for name of nearest dealer who can supply.

Overall dimensions 10" dia. x 4 1/2" deep.
Descriptive Leaflet Free on request.

REPRODUCERS & AMPLIFIERS LTD.
FREDERICK ST., WOLVERHAMPTON

Speech coil resistance
8.5 ohms. Requires a
suitable output
transformer

45/-

It helps us if you mention "Wireless Magazine"

Columbia

for 1932

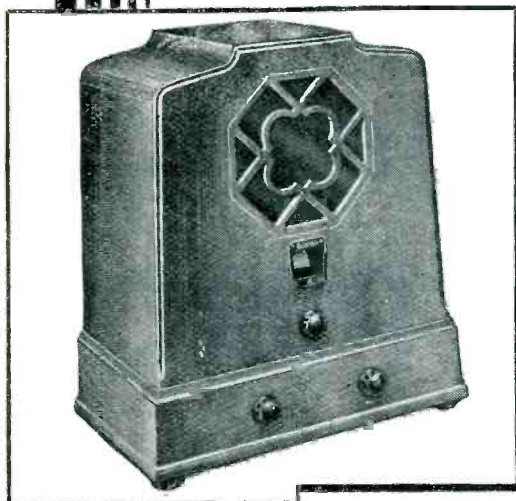

Columbia has advanced ahead of the times . . . the new season's models include radio and radio-graphophones of super efficiency in performance and at amazingly low prices.

The best in technical skill and workmanship has gone to their making. Every purse and every requirement are met by radio sets from £5, and radio-graphophones as low as 32 Guineas.

In design and price Columbia has advanced ahead of the times . . .

NEW 4-VALVE RECEIVER WITH MOVING COIL SPEAKER

Model 352

A long distance high power set of ultra modern design and appearance. One knob tunes three ganged condensers; no reaction. Volume control also acts as the "off" switch. Coil excited speaker. Provision for connection to a gramophone pick-up, and to an additional speaker. Mains aerial attachment. In Walnut Cabinet. For A.C. Mains.

23 Gns.



THE NATIONAL
RADIO EXHIBITION
OLYMPIA

Sept. 18th—26th

STAND 7

Demonstration Room

D.2.



A NEW RADIO-GRAPHOPHONE ADVANCED in DESIGN AND PERFORMANCE

Model 602

A highly efficient Radio-Graphophone, embodying the latest 3 valve circuit with two screened-grid valves. Double band pass tuning for great selectivity. Single tuning control, illuminated and marked in wave-lengths. Mains aerial equipment. Coil excited speaker. Standard Columbia Graphophone equipment with electric motor. Dark oak cabinet. For A.C. mains.

32 Gns.

Also 4-valve Radio-Graphophone 40 Gns.
and Electro-Graphophone 20 Gns.

COLUMBIA —The first and last word in home entertainment for a quarter of a century.

THE COLUMBIA GRAPHOPHONE CO. LTD., 98 108 CLERKENWELL ROAD, LONDON, E.C.1.

It helps us if you mention "Wireless Magazine"

Exide

LEAD

THE BATTERY WORLD WITH **25% REDUCTION IN PRICES**

OF L.T. BATTERIES FOR PORTABLE SETS

• In some instances the reduction is slightly over 25 per cent. and in some slightly under.

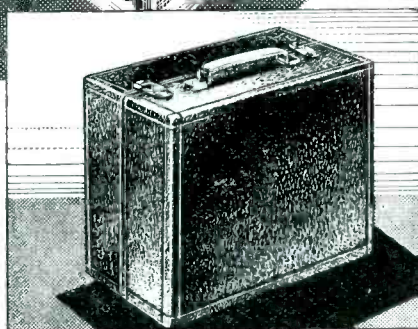
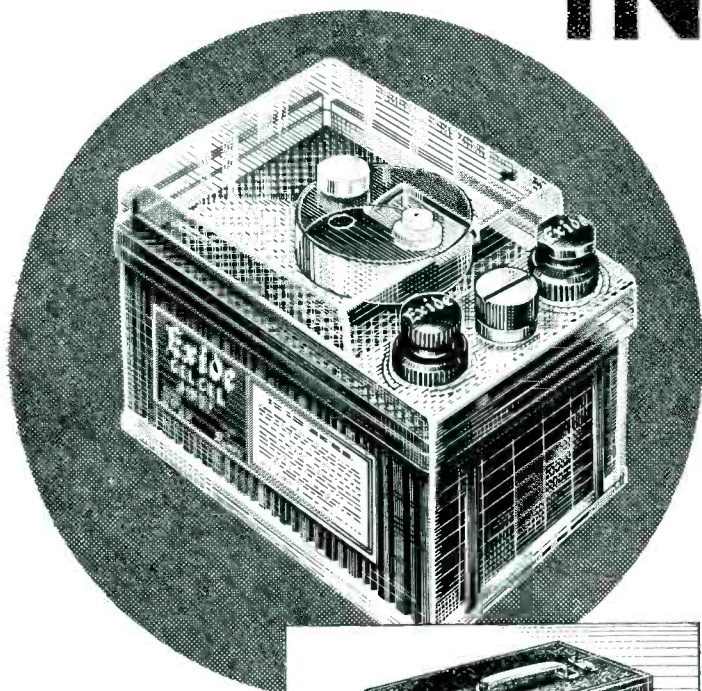

The most important official price-movement in the wireless industry of recent years. These reductions apply not only to the Exide free-acid "unspillables" but also to Exide "Gel-Cel"—the first satisfactory jelly-acid battery ever produced. Exide "unspillables" live up to their name. They are *utterly* unspillable. They are fitted almost universally by the leading manufacturers of portable sets. They are chosen by the general public for their known strength and efficiency and for the great name they bear. When you replace the battery in your "portable," get an Exide.

● **Exide "C" TYPE BATTERIES** for Low Tension also reduced in price.

Exide Batteries, Clifton Junction, near Manchester. Branches at London, Manchester, Birmingham, Bristol, Glasgow, Dublin and Belfast

N.23.

Mention of the "Wireless Magazine" will ensure prompt attention

REGENTONE A.C. TWO-VALVER

Maker.—Regentone, Ltd.

Price.—£6 15s. This, in our opinion, is extremely reasonable for such a well-produced set.

Power Supply.—A.C. mains. At present the Regentone all-electric two-valver is available only for A.C. mains operation. As voltages and frequencies differ so widely in this country the makers have provided a neat and accessible tapping arrangement so that all voltages between 200 and 250 volts can be used if the set is suitably adapted before reception is undertaken.

The standard model is suitable for periodicities between 40 and 100 cycles. There is also a special model for 100-volt mains and for 25-cycle frequencies.

No corresponding model is available for D.C. mains or for battery operation.

Removal of the metal back of the set reveals the neat and accessible chassis. On the right hand side is the voltage tapping panel, with a wander plug inserted in one of three sockets.

These sockets enable the set to be worked efficiently from any supply between 200 and 250 volts.

Power Consumption.—15 watts. This is really quite negligible, being less than the consumption of a small electric light.

Valve Combination.—As there are only two valves in this set, the circuit combination is naturally limited to a detector and one low-frequency-amplifying valve. The detector is a Mullard 904V, which has a 4-volt indirectly-heated filament. The low-frequency valve, which is, of course, also the output power valve, is a Mullard AC104.

These two valves are coupled together by means of a transformer. Ample output volume can be obtained from the local station, sufficient to work a moving-coil loud-speaker. As the detector valve is provided with reaction the set is quite sensitive and should be suitable for loud-speaker reproduction up to 50 miles from a regional broadcasting centre.

Controls.—As the circuit is so simple, the controls are naturally few in number. This fact does not in any way

detract from the makers' simple disposition of the control knobs. There are three controls altogether, and these are mounted on the front of the bakelite container.

An unusually well-moulded tuning knob occupies the centre position on the control side of the set. It is regrettable that the makers have moulded their name on this knob as well as on the lower part of the case. The name itself is, of course, very attractive, but the principle of stamping it on the set is one we have strenuously opposed for the last two years.

All praise is due for the moulding of the controls, especially for the two subsidiary knobs on the left and right of the tuning knob. That on the left is for reaction and tests show that one can approach the point of oscillation very smoothly. This means that the last ounce of sensitivity can readily be obtained from the detector valve. From this it follows that with careful control the set will bring in several foreign stations when

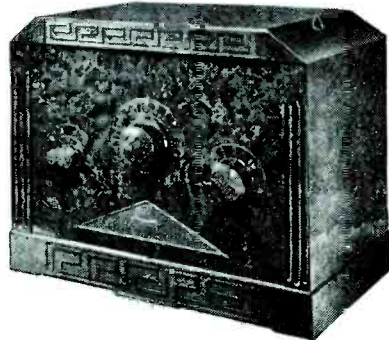

MOULDED CASE

A brown moulded bakelite case houses the Regentone two-valver

conditions are favourable.

The knob on the right, which is the same shape as that on the left, and therefore equally handy to grip, is a wave-change switch control. This is moved to the left for medium waves and to the right for long waves.

As this is primarily a local-station set and therefore likely to have only a few logging points, the tuning

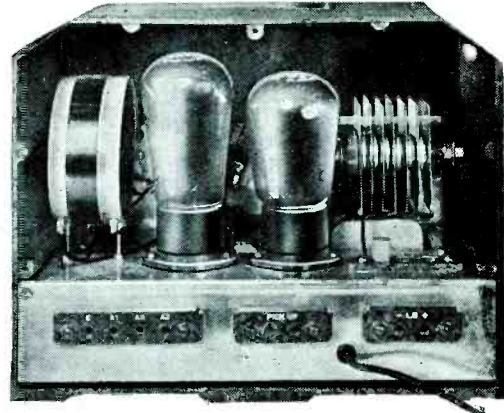

COMPACT AND EFFICIENT ASSEMBLY

Although extremely compact, the Regentone two-valver is nevertheless an efficient little receiver

dial, which is engraved on the bakelite case, is divided into only 10 degrees. This is a simplification not merely justifiable but commendable in a local-station set.

Selectivity.—In estimating the selective properties of this set we have to remember that the main need is for the separation of the two local stations. If the set will do this it fulfils its main function. Tests on our standard aerial in South-west London showed that both Brookman's Park stations could be heard perfectly clear of each other.

We should mention that three aerial terminals are provided, so that different degrees of selectivity can be obtained with any given aerial. More accurately we should say that these three aerial terminals enable the set to provide the best compromise between selectivity and volume with various lengths of aerial wire.

Our tests showed that terminal A2 gives a very satisfactory volume output with complete separation of the two programmes. The tuning coils are well designed and cope more than ade-

quately with regional broadcasting conditions.

Sensitivity.—As already mentioned, the two London stations were received on this set. National came in at 2 degrees and Regional at 4.5 degrees. We were gratified to find Midland Regional at 5.5 degrees. This was a fair loud-speaker signal with full reaction. Curiously enough, North Regional at 7 degrees was almost as strong.

Foreign stations were not difficult to find. We counted six on the medium waves. These included Beromünster, Söttens, and the new high-power Cesky Brod station.

On the long waves Davenport was a good loud-speaker signal at 7 degrees, with Radio Paris and Eiffel Tower fair at 8 and 6 degrees respectively.

Gramophone Reproduction.—This little set worked well as a gramophone amplifier, but a potentiometer volume control was needed between the pick-up and the pick-up sockets on the set (as explained in the instruction book).

Summary.—This is one of the best two-valvers for A.C. mains we have yet tested. In view of the very moderate price the results are remarkable. Especially suitable for the reception of regional broadcasting, this little set will separate the alternative programmes with ease.



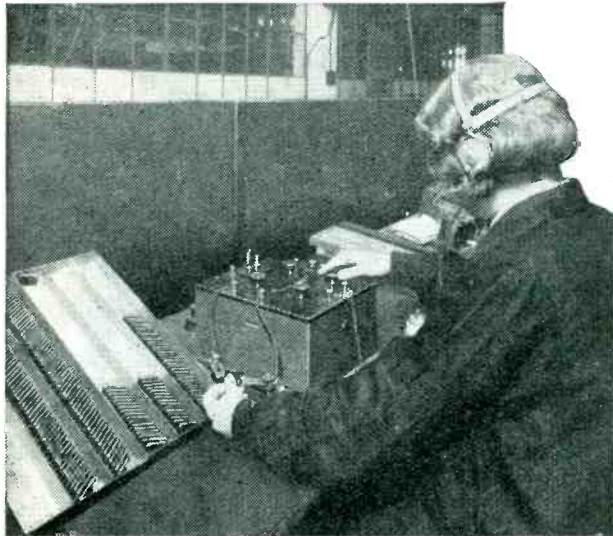

TO ASSURE ACCURACY AND RELIABILITY!

NOTHING is left to chance by T.C.C. every possible test is employed to be sure that only perfect condensers find their way to the stock room. Tests for true capacity. Tests for insulation, for mechanical strength, indeed tests covering every likely condition under which a condenser may be used. Because of this systematic series of tests, because of the use of only the best materials, and because of the unique experience of a quarter of a century's specialisation in condenser manufacture, T.C.C. can and do, guarantee every condenser to be up to specification. That is your safeguard—Whatever your condenser need insist on the condenser with a reputation — T.C.C.

T.C.C. CONDENSERS

TELEGRAPH CONDENSER CO., LTD., N. ACTON, W.3.

8806



Get a Thrill!

BREAK AWAY FROM THE TIES OF ORDINARY BROADCAST, AND RECEIVE WORLD-WIDE TRANSMISSIONS DIRECT WITH

THIS MODERN SHORT-WAVE ASSEMBLY

The 'Scientific Two'

WE ARE EXHIBITING AT

No Soldering. No Technical knowledge required.
Free from hand capacity. Perfectly smooth reaction. Absolute simplicity in erection and control.

Price for complete assembly, with coils for 15-55 metres

£3-16-0

(Individual parts obtainable)

Blueprint and full details, 1/- post free.

Designed by the Short-wave Specialists

STRATTON & CO., LTD.

Bromsgrove Street, BIRMINGHAM



STAND NO. 98

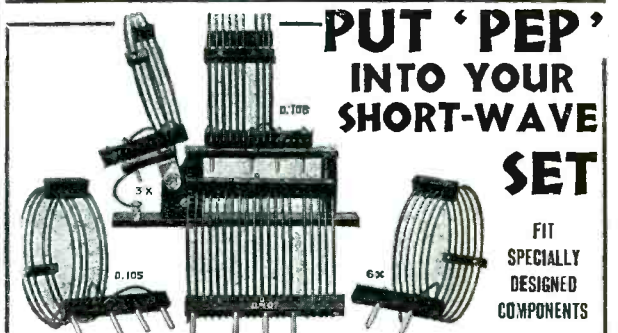

PUT 'PEP' INTO YOUR SHORT-WAVE SET

FIT SPECIALLY DESIGNED COMPONENTS

SHORT-WAVE INDUCTANCE UNIT

This unit forms the complete inductance portion for a short-wave receiver, providing variable aperiodic aerial coil, grid coil and reaction winding. Complete with stand and 5 coils, it covers efficiently the whole short waveband from 15-95 metres. Price 22/6 complete with full circuit details. Extra coils for B.B.C. waveband can be obtained.

Remember!—
STAND NO. 98

SHORT-WAVE CONDENSER

Thought out in every detail for efficient short-wave reception. Double spaced vanes soldered at four points. Low series resistance and minimum H.F. losses. Perfectly noiseless in use. Min. cap. 5 micro-microfarads. Max. cap. .00016 mfd. Price 10/6.

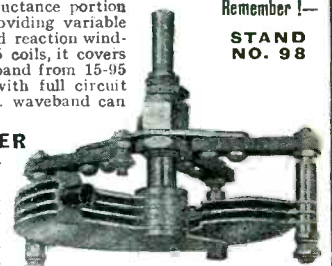

STRATTON & CO., LTD.
Bromsgrove Street,
BIRMINGHAM.

London Service Depot—
C. WEBB, Ltd.,
164 Charing Cross Road, W.C.2.
Telephone: Temple Bar 2944

EDDYSTONE

SHORT-WAVE APPARATUS



Advertisers like to know you "saw it in the 'Wireless Magazine'"

THE PARMEKO DIAMOND MEANS

that the transformer, choke, or eliminator bearing the diamond is made to the most exacting standard—"the best—regardless," a standard which has ensured their use in every field of wireless research. Ask for PARMEKO if you want the best. Lists from

PARTRIDGE & MEE LTD

26 Dover St. LEICESTER and 74 New Oxford St. LONDON

Central 22276.

Museum 5070.

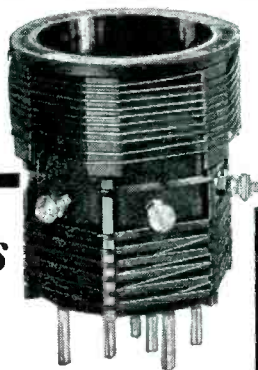
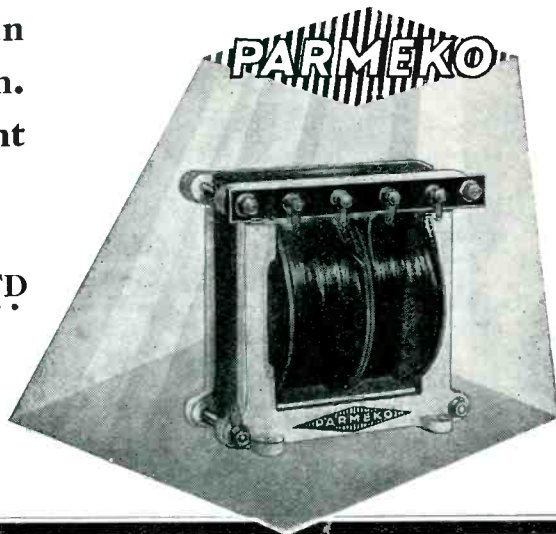

The Experts say:

"UNEQUALLED for SELECTIVITY"

"... I do definitely state that there are no coils on the market to-day which will give a greater degree of selectivity..." The Tunewell Ultra Selective Dual Range Coil gives greatly improved range and sharper tuning to any straight or S.G. circuits.

TUNEWELL ULTRA SELECTIVE DUAL RANGE COILS—AERIAL, or ANODE, 7.9. (6-pin base, 2/-). With "Blunter" tuning tapping 1/- extra. PANEL MOUNTING 10/6. (3-pt. switch 1/3) SHORT WAVES, 3/11.

Write for lists, or see the complete range of TUNEWELL COILS, RESISTANCES, MAINS COMPONENTS, SPEAKERS, CHOKES, etc., at

STAND NO. 82

NATIONAL RADIO EXHIBITION, OLYMPIA

TURNER & CO., 54, Station Road, New Southgate, London, N.11

The Lanchester

PERMANENT MAGNET MOVING-COIL SPEAKERS

You cannot afford to be without our New 1932 CATALOGUE, beautifully illustrated, and containing full particulars and prices of our season's products available from 14th September onward.

It contains in addition a mine of useful information, and is FREE and POST FREE.

Lanchester Speakers are sold direct to the public only, on 14 days' FREE TRIAL against cash with order or C.O.D.

We do not exhibit.
**NEW MODELS
HIGHER SENSITIVITY
PRICES DEFY
COMPETITION**

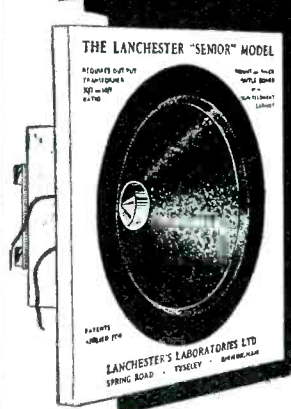
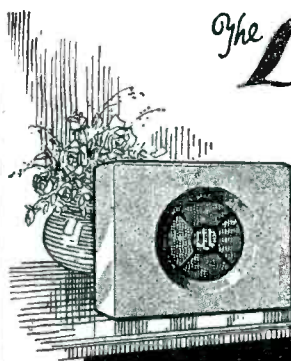

LANCHESTER'S LABORATORIES LIMITED BIRMINGHAM

Speedy replies result from mentioning "Wireless Magazine"

Does Band-passing Reduce Signal Strength?

By J. H. REYNER
B.Sc., A.M.I.E.E.

Our Technical Editor answers a question that is asked by many amateurs and raises an interesting possibility regarding the use of band-pass tuners in high-frequency amplifying currents

THIS season is going to see the introduction of band-pass tuning on a large scale. At least six manufacturers are marketing band-pass coils in one form or another, and the

development being held up unnecessarily.

The present article, however, deals with a matter which has occupied the minds of many readers, namely, the

In ordinary use one is not struck by any marked difference in signal strength, and of course, the selectivity is literally amazing to those who have not previously tried the band-pass circuit.

Common sense shows that there must be some loss of signal strength when going from one circuit to the next. We all know that the resistance in the circuit prevents the current from rising to the high value which it would otherwise attain, and the greater the resistance the more is this damping effect on the oscillation.

Handing Out Energy

We have introduced a voltage into the first circuit, and currents accordingly build up to the maximum value which they are permitted to do by the resistance. Instead of using this voltage, however, we hand out the energy to the next circuit, where a similar building-up process takes place, limited once again by the resistance of the circuit.

Thus the voltage is limited by the
(Continued on page 330)

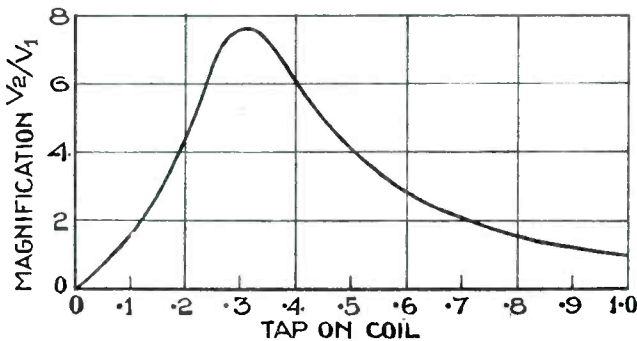

Fig. 1.—Effect of aerial tap on voltage developed across tuning circuit

condenser manufacturers are beginning to produce apparatus to suit this new form of tuning.

At the time of writing no one has met my suggestion of a dual condenser, with dial, at a price of around 10s., and this is the one thing which we are waiting for in order to make band-pass really popular.

Extended Chassis

After all, there are on the market single condensers at a price of 4s. Surely it is not beyond the wit of condenser manufacturers to make a dual condenser—not a two-gang condenser—with the same parts but an extended chassis at a price two and a half times as great.

From a strictly logical point of view the price ought to be less than twice as great, but we can let that pass. I hope I may be forgiven for labouring this point, but the advantages of band-pass tuning are so great that it is irksome to find its

others say that it is possible by a proper design to obtain more signal strength with a band-pass circuit than with a single coil.

Which of these two conflicting statements is correct?

It is not easy to give a definite answer, because the results depend on the conditions, but we can say, right at the outset, that the signal strength on a properly designed band-pass arrangement is only distinguishable from that on an equivalent single coil after careful comparison.

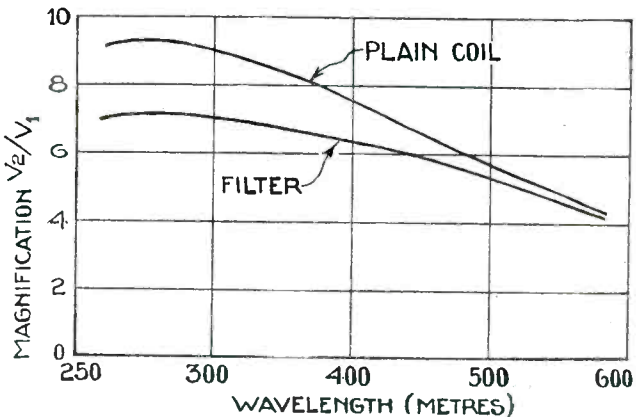
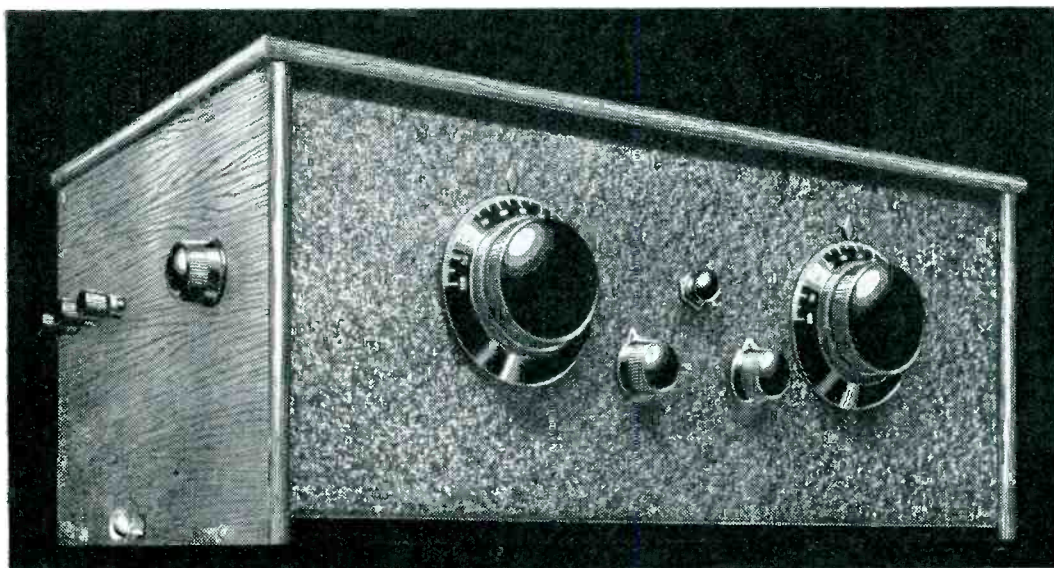

Fig. 2.—Voltage step-up to be obtained from circuit of Fig. 3. (See page 330)



NEW!

—more powerful—more selective—
even better all-round performance

Here is an entirely new standard of Radio value—a powerful 3-valve, Screened Grid Receiver for the amazingly low price of £6.15.0—the Cossor Empire Melody Maker Model 234.

This remarkable Receiver incorporates all the most up-to-date developments in Set design. It uses the very latest types of the famous Cossor Valves. As a result it possesses outstanding performance.

Its selectivity is remarkable—its range is enormous. Even when used close to a Regional transmitter it will

cut out its powerful transmission like magic and bring in the programme you want to hear—all the main European stations are within its reach. Its performance is equal in every way to that of the most costly 3-valve S.G. Receiver.

Yet in spite of its efficiency it is so simple that you can easily assemble it yourself—no Wireless knowledge is necessary. Merely bolt the components on to the drilled, all-metal base plate, connect a few wires and it is ready for use. Get full details of this outstanding Set—Use the Coupon.

Cossor EMPIRE Melody Maker Model 234

HIRE PURCHASE TERMS

You can obtain the Cossor Empire Melody Maker for only 15/- down and nine monthly payments of 15/-.



COMPLETELY SCREENED COILS

The coils used in the Cossor Empire Melody Maker are completely screened in metal "pots," entirely eliminating direct pick-up, thus further improving selectivity.



EXTERNAL WAVE-CHANGE SWITCH

Wave Change Switching is effected by operating the switch at the end of the cabinet—"in" for long—"out" for short.



COSSOR METALLISED SCREENED GRID VALVE

Even better performance is ensured by the use of a Cossor Metallised Screened Grid Valve with its record low inter-electrode capacity and its ability to eliminate stray coupling effect between anode and nearby components.



SERIES AERIAL CONDENSER

The variable Series Aerial Condenser permits adjustment of selectivity to give the fine tuning necessary to cut out powerful local stations.

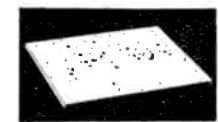

ALL-METAL BASEPLATE

Construction is simpler than ever, due to the Metal Base Plate, which is supplied with every hole drilled, thus automatically positioning every component.

To Messrs. A. C. Cossor, Ltd., Highbury Grove, London, N.5.
Please send me free of charge one of your Constructional Charts which tells me how to build the Cossor Empire Melody Maker.
Name.....
Address.....

W.M.10.31.

Advertisers like to know you "saw it in the 'Wireless Magazine'"

EVERYTHING **The G.E.C.** ELECTRICAL
your guarantee

GECOPHONE

New and improved models - revelations in performance and price

The new range of GECOPHONE Radio Receivers and Loud Speakers presents many striking developments in design—features which raise the pleasures of radio entertainment to a much higher standard of excellence than previously attained. For many months G.E.C. radio experts have applied themselves ceaselessly to the task of improving quality of reproduction, ease of operation and intrinsic beauty of cabinet construction. The result has been a triumph of technical skill and experience. A GECOPHONE Receiver or Loud Speaker impresses not only by its wonderful audible efficiency, but also by the high-grade workmanship which is obvious in every part of its make-up.

WHY YOU SHOULD CHOOSE A "GECOPHONE"

The name GECOPHONE is a guarantee of high-class wireless engineering achievement. In the extensive GECOPHONE range there are models to suit all needs and all tastes. Each model embodies the inherent G.E.C. Radio characteristics—reliability, sturdy and expert workmanship, high-class appearance and simplicity of operation. Any receiver in the range will get you a full choice of Home and Continental stations with amazing power and purity. *Fill in and post coupon below for full particulars.*

HIRE PURCHASE—terms are stated in each example of GECOPHONE Radio Receivers and Loud Speakers given in this advertisement. Equally attractive terms for other models are also stated in Folder B.C. 5958 which gives full particulars of the complete GECOPHONE range. A copy will be sent you **POST FREE** for coupon at bottom right-hand corner. All sets and loud speakers are illustrated in actual colours and fully explained. **WRITE FOR A COPY TO-DAY.**

**GECOPHONE
INDUCTOR
DYNAMIC
LOUDSPEAKER**
(Farrand Inductor Pat.)
PRICE, Chassis only
£3. 10. 0

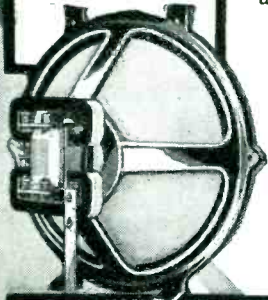

**GECOPHONE INDUCTOR
DYNAMIC LOUD SPEAKER**
Unrivalled performance on all types
of receivers. Attractive walnut cabinet.
PRICE . £5 . 10 . 0
HIRE PURCHASE: Deposit £1 and
12 monthly payments of 8 -

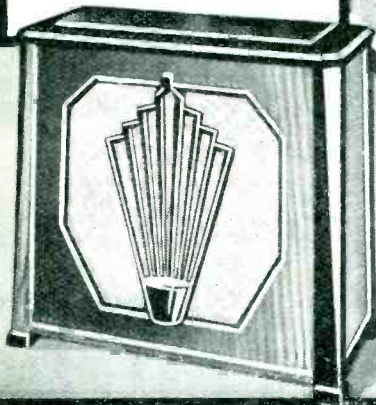

**GECOPHONE
ALL-ELECTRIC
TABLE "FOUR"**
(For A.C. Mains)

A really powerful Receiver giving the finest performances under modern broadcasting conditions. Cabinet medium walnut with front panel to match.

PRICE, including OSRAM VALVES and Royalty

20 Gns.

HIRE PURCHASE:
Deposit £2 10s. od. and
12 monthly payments
of £1 13s. od.
D. C. MODEL £25 0 0

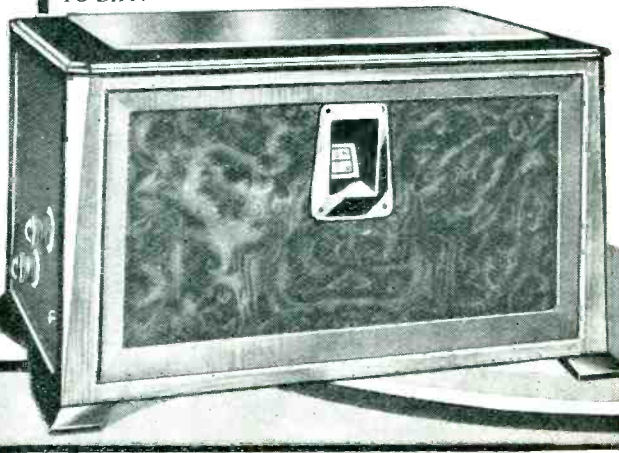

SUPREMACY IN RADIO

Advt. of The General Electric Co. Ltd. Head Office and Public Showrooms: Magnet House, Kingsway, London, W.C.2

EVERYTHING **G.E.C.** ELECTRICAL
your guarantee

RADIO RECEIVERS AND LOUD SPEAKERS

MADE IN ENGLAND
Sold by all Wireless Dealers

**GECOPHONE
CONSOLE ALL-
ELECTRIC RECEIVER**
 (For A.C. Mains)

A self-contained floor cabinet type Receiver with built-in Inductor Dynamic Loud Speaker. Inlaid Walnut Cabinet.

PRICE including OSRAM VALVES and royalty **29 GNS.**

HIRE PURCHASE: Deposit £3 10s. 0d. and 12 monthly payments of £2 8s. 6d.

NATIONAL RADIO EXHIBITION

If you are visiting the NATIONAL RADIO EXHIBITION do not fail to see the GECOPHONE Radio Receivers and Loud Speakers on the 2 G.E.C. Stands and the Special Demonstration Room in the Gallery, National Hall.

**GECOPHONE
ALL-ELECTRIC
RADIO-GRAMOPHONE**

(For A.C. Mains)

A model which sets a new standard of radio-gramophone entertainment. An enormous advance for this type instrument. Inlaid walnut cabinet.

PRICE including OSRAM VALVES and Royalty **40 GNS.**
HIRE PURCHASE: Deposit £4 10s. 0d. and 12 monthly payments of £3 7s. 6d.

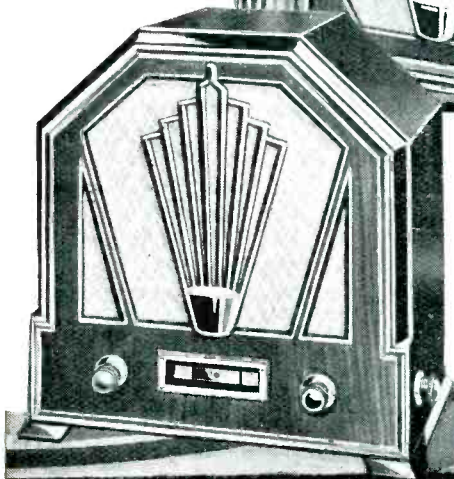
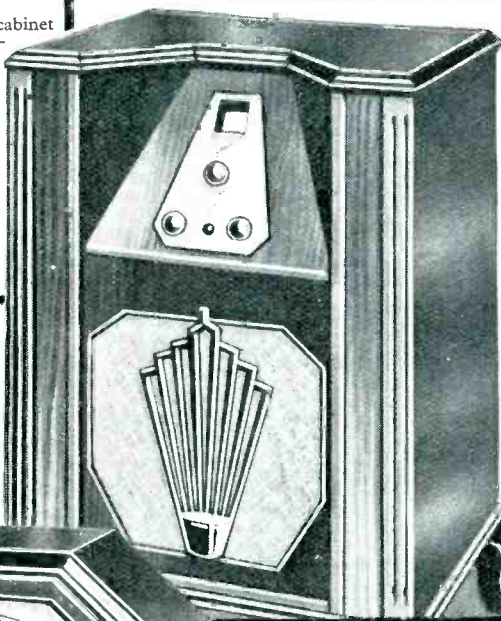
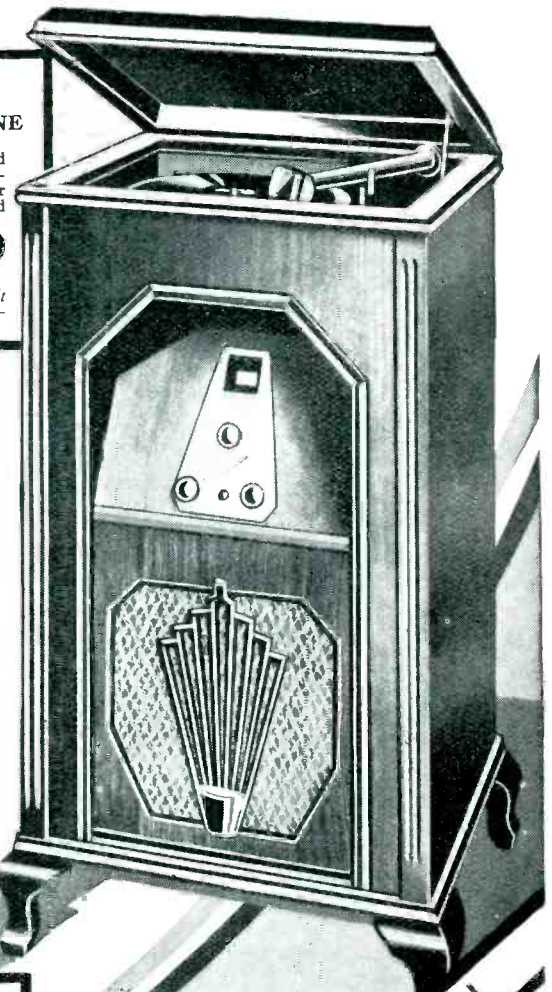

**GECOPHONE ALL-ELECTRIC
"COMPACT" RECEIVER**
 (For A.C. Mains)

WITH BUILT-IN INDUCTOR DYNAMIC LOUD SPEAKER.

A new self-contained Receiver giving pure and powerful output from a wide range of stations. Handsome polished walnut cabinet.

PRICE including OSRAM VALVES and Royalty **18 GNS.**

HIRE PURCHASE: Deposit £2 and 12 monthly payments of £1 10s. 0d.

POST THIS COUPON

Please send me Folder No. B.C. 5958 giving particulars of GECOPHONE Radio Receivers and Loud Speakers.

Name.....
 Address.....

The General Electric Co. Ltd.
 Magnet House, Kingsway,
 London, W.C.2

W.M.

Cut out and paste on postcard, or enclose in unsealed envelope. Halfpenny postage in either case.

G.E.C. RADIO

Branches & Public Showrooms throughout Great Britain.

BAND-PASSING—Continued from page 326

resistance in *both* circuits and the maximum possible voltage must clearly, therefore, be less than that on a single circuit.

The obvious solution to this problem is to increase the aerial coupling. We are obtaining a distinctly better selectivity from the system. Can we not afford to sacrifice a little of this

Fig. 1 illustrate; the manner in which the voltage from the valve varies in accordance with the aerial tap. This curve is plotted for a simple single circuit having an inductance of 180 microhenries and a resistance at 400 metres of 6 ohms.

Much the same state of affairs obtains with a band-pass filter.

The voltage in the first circuit is stepped up by the auto-transformer action in the aerial coil. Although we are not utilising the voltage directly in this instance, it is clear that if the voltage is high the current is also high, and we therefore hand on a correspondingly larger amount

is used, the coupling being chosen to give the maximum transfer of energy from one circuit to the other. (This condition obtains when the reactance of the coupling is equal to the high-frequency resistance of the coil.)

It will be seen that this voltage step up varies from between five and seven over the wave range and is fairly uniform, which means that the set is lively over the whole scale and not only at the bottom end.

Optimum Coupling

The optimum aerial coupling of just over one-third was used in obtaining these figures, and in the same diagram I have also plotted the voltage step up for one of the coils alone used as a plain aerial circuit. The aerial tap requires to be a little farther down on the plain coil in order to obtain the best signal strength, and the curve shown in Fig. 2 is for the optimum tap.

It will be seen that the voltage step up is rather higher and reaches the neighbourhood of ten at 250 metres. Therefore under these conditions the band-pass coil is only giving about 70 per cent. of the signal strength of the aerial coil at the lower end of the scale, although the discrepancy is not nearly so large at the upper end.

Uneven Characteristics

There can be little question, however, as to which is the better circuit to handle, for the simple aerial coil is uneven in its characteristics, the voltage at 500 metres being little more than half what it is at 250.

Just as a matter of interest, I have worked out a further set of figures for the band-pass filter using twice the aerial coupling that was employed for the single coil.

The step-up here hovers around five the whole time, so that we have a very even characteristic, but the actual voltage developed is even less than with the optimum coupling, thus proving completely that the increase in aerial tap cannot be continued indefinitely in the hope of regaining lost signal strength. (Fig. 4.)

(Continued on page 334)

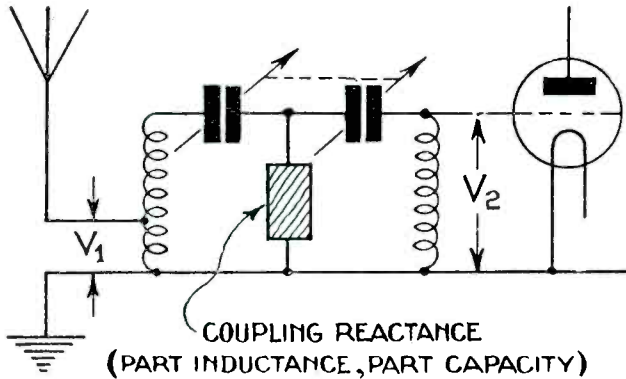

Fig. 3.—Typical band-pass circuit with mixed couplings

selectivity and increase the aerial coupling to bring the signal strength up to the same value as would be obtained with a normal circuit?

This process can be carried out to a certain extent, but only up to a point, and even under best conditions the signal strength is still a little below that of a single coil.

It is not generally appreciated that the aerial circuit as we use it to-day is a step-up transformer. We induce in the aerial circuit a certain voltage from the wireless wave passing over the aerial, and we apply five or ten times this voltage to the first valve in the receiver due to this step-up action in the transformer.

Compromise

If the aerial tap is too low down, then we do not hand on enough energy to build up sufficient voltage in the secondary. On the other hand, if we take our tap too far up we lose the step-up effect. A quarter tap, for example, gives twice the step-up ratio that would be obtained with a centre tap, and this more than offsets the extra amount of energy received from the aerial.

of energy to the next circuit.

As in the case of a simple aerial coil, there is an optimum value for the aerial coupling, and if we exceed this we begin to lose in step-up ratio. Sometimes it pays to do this in order to obtain a flatter characteristic, but for maximum signals the optimum

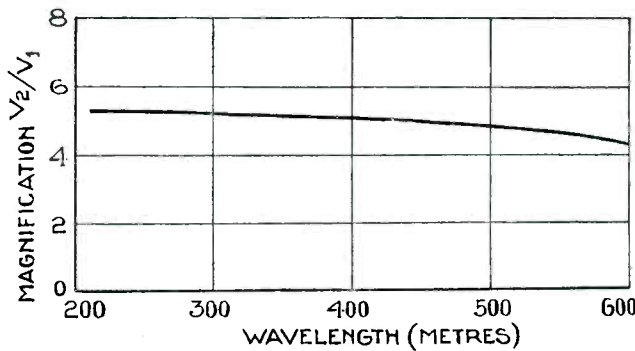
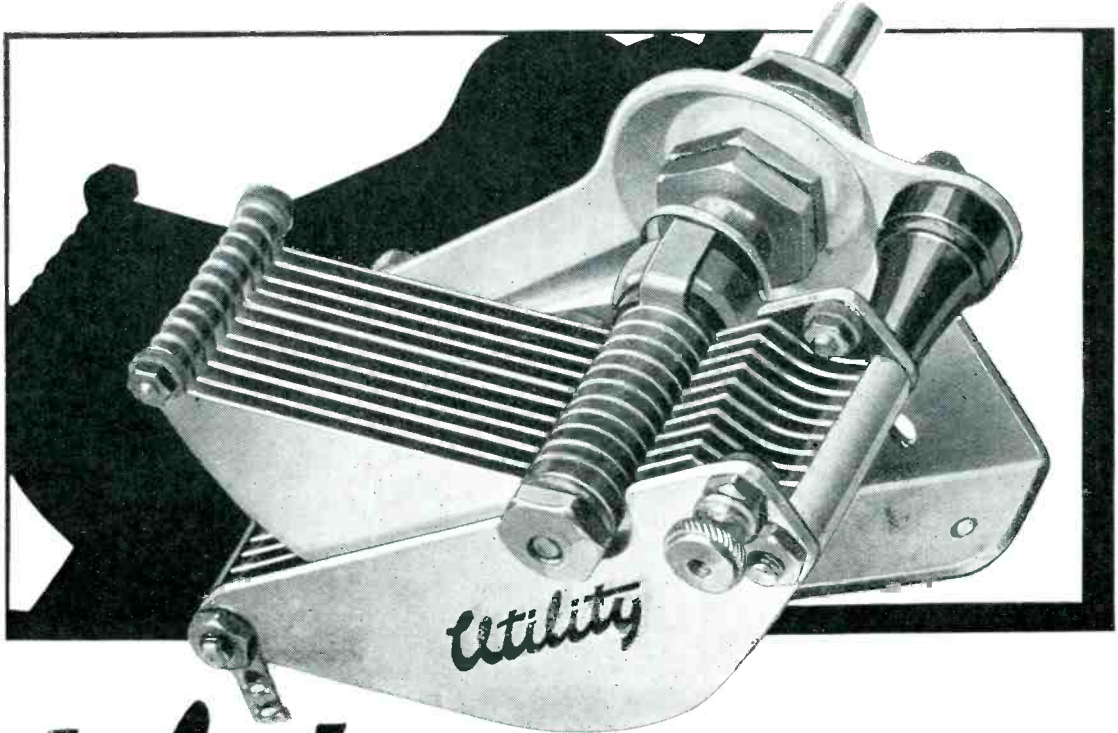

Fig. 4.—Amplification curve of typical band-pass circuit

value must not be exceeded.

In order to show what order of difference may be expected I have plotted in Fig. 2 the actual voltage step up which would be obtained from aerial to grid of a band-pass circuit of the type shown in Fig. 3.

I have assumed in this particular instance that a mixed coupled filter



Utility

FOR THE

'MERIDIAN'

SHORTWAVER

For the "Meridian" 3-valve Short-wave Set the designers specify two Utility W 187 Condensers, the pre-eminent condensers for short-wave work.

Short-wave work provides the most searching tests for variable condensers. At all times the tuning is so highly critical that only the very best condensers will give satisfactory results. That is why Utility were chosen for the "Meridian." To the expert they are the logical and only choice.

Build this fine set and enjoy the pleasures of short-wave work. But remember that the secret of satisfactory results is the Utility variables. Insist on the designer's specification.

2 No. W 187 with vernier 13/- each.

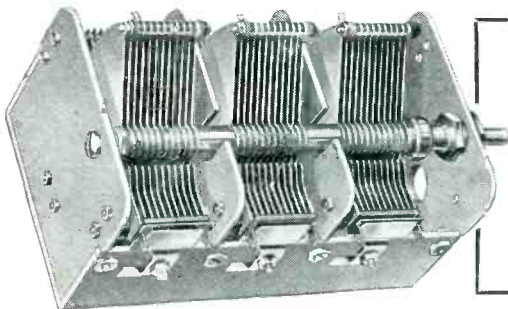

● GANGED CONDENSERS ●

We have just introduced a new range of screened and semi-screened ganged condensers which are of the most advanced type. Designed to work to "the last ounce" these condensers are imperative if you wish to get the very best results from any of the new circuits which require ganged condensers. If in doubt write to us for advice and in any case write for our new catalogue.

WILKINS & WRIGHT, LIMITED
 "UTILITY" WORKS, HOLYHEAD ROAD, BIRMINGHAM.

AGENTS—London: E. R. Morton, Ltd., 22 Bartlett's Buildings, Holborn Circus, E.C.1. Scottish: E. B. Hammond, 113 Vincent Street, Glasgow. Lancashire and Cheshire: J. R. Lister, 93 Old Road, Blackley, Manchester. Westmorland, Cumberland, Durham, Northumberland, Yorkshire and Derbyshire: H. C. Rawson, Ltd., 100 London Road, Sheffield.

WE ARE EXHIBITING AT



STAND NO. 90

TANNOY RADIO

for the connoisseur

MIDGET SUPER-HET RECEIVER

Comprising of a high-grade chassis which embodies pre-detector H.F. amplification on multi band-pass tuning, with corrected L.F. amplifier. Housed in an attractive walnut figured veneer domed cabinet, with single dial tuning. Incorporating Radio and Gramo switching with independent volume control and moving-coil speaker.

PRICE (complete)
MAINS operated - - 28 gns.
BATTERY " - - 25 gns.



SUPER-HET RADIO GRAMOPHONE (JUNIOR MODEL).

This Radio receiver and Gramophone combined has a high-grade chassis which embodies a pre-detector H.F. multi band-pass tuning super-het receiver and corrected L.F. amplifier. Independent volume control, with necessary Radio and Gramo switching are provided. Automatic brake on Gramo Motor which works on any make or size of record without independent setting.

Housed in a beautifully figured polished walnut cabinet of Tudor design.

This instrument is not mass produced but is individually built for a discerning buyer.

All models incorporate specially matched moving-coil speakers.

PRICE, MAINS operated 45 gns.
BATTERY " 43 gns.

SUPER-HET RADIO GRAMOPHONE (SENIOR MODEL).

Similar in appearance to the Junior Model but incorporating a considerably larger Radio and Gramophone output.

PRICE, MAINS operated 55 gns.



TANNOY PRODUCTS

1-7 DALTON ST., WEST NORWOOD, S.E.27

NEW HEGRA SPEAKERS

THE PERMANENT MAGNET MOVING COIL SPEAKER

A new and exceptionally sensitive speaker requiring no energising current. The magnet system possesses a very high degree of lasting magnetisation thanks to the patent Hegra method of magnetising steel.

The Air gap is perfectly symmetrical and the coil is located so that chatter is impossible, yet there is no field leakage.

This speaker gives a high degree of purity and sensitiveness through the whole range.

Type P M 55/-

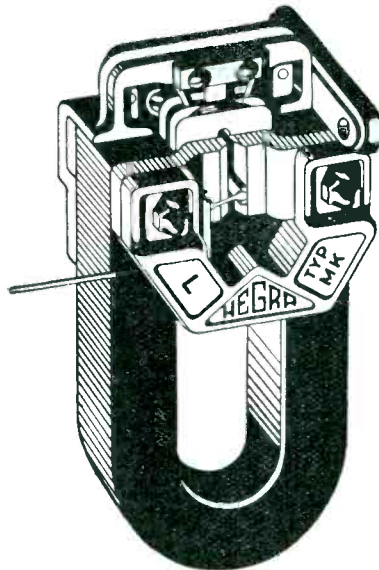
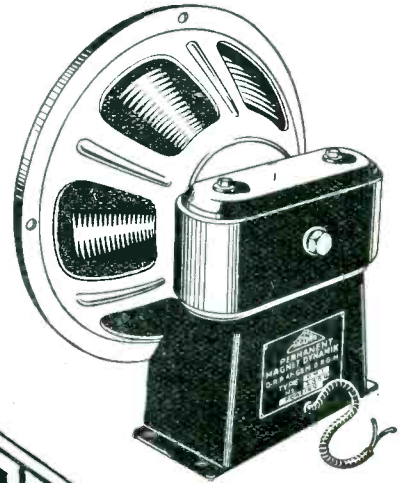

The Hegra Standard Power Unit is a new 4-pole balanced armature speaker with quite astonishing sensitivity and volume. It is a triumph of design for efficiency, neatness and performance. It takes very big loads without the least trace of distortion or chatter. There are 4 tappings giving various impedance values for matching with various output valves.

Type M K complete with cone clips 21/-



Geo. Becker Ltd., 39 Grafton Street, Tottenham Court Road, W.1

M.C.34

When you send your order don't forget to say you "saw it in the 'W.M.'"

AMAZING VALUE with the high quality of 'POLAR'

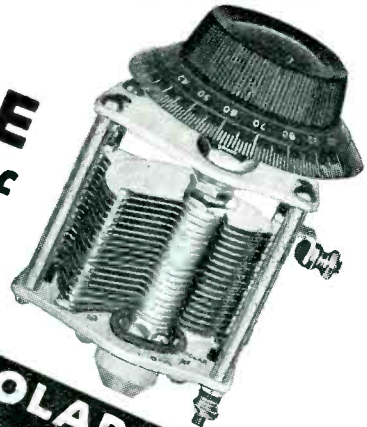
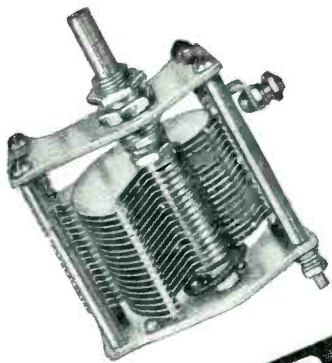

These two New Condensers, popularly priced and maintaining the high efficiency of Polar design and construction, offer you the greatest condenser value obtainable.

Both are made with aluminium vanes and end plates. Bonded rotors and ball-bearings. Rigid construction with four brass pillars. Capacities for both models:—

·0003 ·00035 ·0005

Obtainable from all dealers.
Catalogue free on request.



POLAR

CONDENSERS

Wingrove & Rogers, Ltd., 188/9 Strand, London, W.C.2.

Polar Works, Old Swan, Liverpool.

"We're Fluxite and Solder, The reliable pair, Famous for Soldering—Known everywhere! Cut out 'bad connections,' Leave 'soldering' to us; We'll give you perfection—Without any fuss!"

See that Fluxite and Solder are always by you—in the house, garage, workshop—anywhere where simple, speedy soldering is needed. They cost so little, but will make scores of everyday articles last years longer! For Pots, Pans, Silver, and Brassware; RADIO; odd jobs in the garage—there's always something useful for Fluxite and Solder to do.

All Hardware and Ironmongery Stores sell Fluxite in tins, 8d., 1/4 and 2/8.

NEW "JUNIOR" SIZE, 4d. per tin.

FLUXITE SOLDERING SET
Simple to use and lasts for years in constant use. Contains special "small-space" soldering iron with non-heating metal handle; pocket blow-lamp, Fluxite, Solder, etc.; and full instructions.

COMPLETE, 7/6, or LAMP only, 2/6.

FLUXITE, LTD.

(Dept. 332)

ROTHE & HITHÉ
S.E.16

ANOTHER USE FOR FLUXITE
Hardening Tools and Case Hardening.
Ask for Leaflet on improved method.

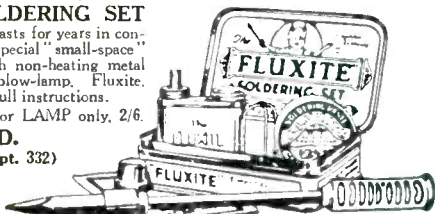

ALL MECHANICS WILL HAVE

FLUXITE

IT SIMPLIFIES ALL SOLDERING

A Wonderful Circuit, Plus PERFECTION IN MANUFACTURE The EAGLE

W.M. SUPER 60

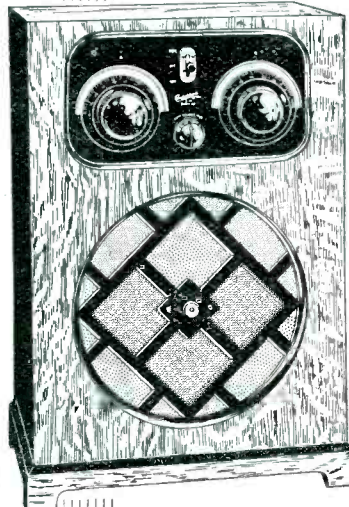

A set of real quality which has revolutionised radio reception—an entirely self-contained set which gives razor sharp tuning. Range only limited by atmospheric conditions.

SOME EAGLE IMPROVEMENTS

- ★ Entirely self-contained. Wave bands covering 250 to 550 and 1,000 to 1,900 metres.
- ★ World-famous "Chakophone - Colossi" Speaker incorporated in cabinet.
- ★ One switch operating wave band and filament switching.
- ★ Burndept slow-motion tuning dials are fitted having Etholog scales, which are actually calibrated in wavelengths and a number of station settings are given. This greatly facilitates tuning and station identification.

★ We can confidently recommend this Receiver for the novice or expert. It is available in either oak or walnut cabinets. Price complete with all accessories, ready to operate, 20 guineas. Send for full particulars from the manufacturers:—

THE EAGLE ENGINEERING Co., Ltd., Eagle Works, WARWICK

Supplied only through your 'radio dealer'

Trade Enquiries Invited

Advertisers like to know you "saw it in the 'Wireless Magazine'"

BAND-PASSING—Continued from page 330

We may summarise the position as regards the aerial filter by saying that under the most unfavourable conditions the band-pass filter gives about 70 per cent. of the signal strength of a plain coil, but that as an average over the whole scale the proportion is higher than this. It also has a noticeably flatter characteristic, tending to make the set more uniformly lively and thus facilitating tuning.

A drop of 20 or 30 per cent. on the voltage is quite difficult to detect by ear, and in nine cases out of ten the user would notice no difference whatever.

Before leaving the subject it is interesting to consider the possibilities of using band-pass with high-frequency circuits. The conditions here are somewhat different because there is no aerial circuit to interfere with the characteristics. I do not propose to go into this aspect of the subject in great detail but, generally speaking, the same arguments apply, namely, that, other things being equal, the band-pass filter may be made to give a performance of the same order as a straight coil.

It is questionable whether one can assume the conditions to be the same in the two cases however. It seems

from certain preliminary experiments which I made recently that a band-pass filter obtains more amplification from the valve than a straight coil, which means that the signal strength applied to the detector may actually be more with a band-pass circuit than with a plain high-frequency transformer!

Two Sources of Damping

In an ordinary high-frequency transformer the tuned circuit is damped not only by its own resistance, but by two external sources. The first of these is the anode circuit of the high-frequency valve itself, and the second is the grid circuit of the detector valve, which introduces a considerable load if the customary power-grid detector is being employed.

These two effects together add to that of the coil and make the tuning circuit so inefficient that there is no danger of reaching the maximum permissible amplification from the valve.

With a band-pass filter, on the other hand, these two sources of loss are separated. The detector damping is applied across the second circuit and only affects the first circuit by quite a small amount.

The release of this damping from the first circuit sharpens the tuning and increases the magnification to such an extent that there is a definite and marked increase in the amplification obtainable from the valve. If a simple circuit is being used without very much screening and with wiring of an average character, then if the high-frequency transformer is removed and replaced with a band-pass filter it is almost certain that the set will become unstable.

Cleaning Up the Layout

This is due to the greater amplification being obtained from the valve, which is now sufficient to produce feedback and self-oscillation. Stray couplings must be minimised and the layout must be cleaned up considerably before the set can be made stable.

Thus the possibility of using band-pass in high-frequency stages is one which seems worthy of attention. Apart from the sharper tuning and greater selectivity, there is a prospect of obtaining more from one's circuit than with a simple coil.

NO COMPETITION ALLOWED!

"No person shall take or cause to be taken into any part of the estate any wireless receiving set."—(A bye-law at Whipsnade Zoological Park)



*The wolves may wail at Whipsnade,
The yaks may puff and blow;
The peacock in his leafy glade
May screech till all your nerves are
frayed,
But if your portable you played—
Out—you—go!*



*The ducks may quack from morn
till dark,
The geese may scream and crow;
The bears may grunt, the muntjacs
bark,
The rooks and jackdaws scream out
"Krark!"
But may you "switch on" in the
Park?
Oh—dear—no!*



*So when to the Zoo I hie awa'
My set, alas! mayn't go;
Although its voice is sweeter far
Than many of Whipsnade's
animals are
I'll have to leave it in the car—
WHAT—a—blow!*

C. P. P.

Convert your "SUPER 60" "ETHER MARSHAL" or "BROOKMAN'S 3 PLUS ONE"

TO AN AUTOMATIC RECORD - CHANGING RADIO-GRAMOPHONE OR AN ARMCHAIR- CONTROLLED RADIO - GRAMOPHONE



In a handsome walnut cabinet of compact design is fitted the new "His Master's Voice" automatic record changing mechanism, pick-up and volume control. By connecting it to your radio receiver up to eight 10 or 12 inch records (unmixed) may be played at one loading or a single record repeated up to eight times. A unit you have been waiting years for. A.C. or D.C. Model 117.

Price 18 guineas

The new "His Master's Voice" pick-up, volume control, electric turntable motor and automatic start and stop housed in an oak cabinet of pleasing design. By connecting it to a loudspeaker radio-receiver records may be played from one's armchair. Interchangeable resistances may be clipped in to the volume control to match the pick-up to any radio receiver. A.C. or D.C. Model 116.

Price 10 guineas



NEW "HIS MASTER'S VOICE"

RADIO ACCESSORIES FOR THE RADIO EXPERIMENTER

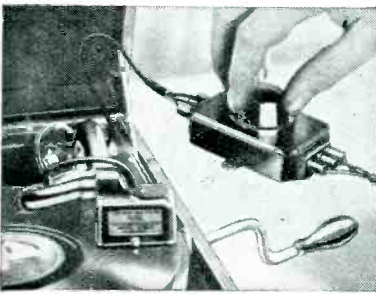

This pick-up is similar to the one fitted to all our new instruments. It can be attached easily to any type of tone-arm and is supplied complete with a logarithmic volume control and connecting leads. The weight of the pick-up is 5½ ozs.; it has an input of over 1 volt R.M.S., and a D.C. Resistance of 6,000 ohms.

Price Complete 2 gns.

A permanent magnet moving-coil loudspeaker in an arched walnut cabinet of attractive design. It is extremely sensitive and will handle up to 3 watts without difficulty. A universal input transformer incorporated in the instrument enables it to be matched to receivers with triode, pentode or push pull output.

Price 5 guineas



★ See all the new "His Master's Voice" Models at the "His Master's Voice Modern Hall of Music," opposite Olympia, September 18th-26th. Admission free. Special measuring apparatus designed in the "His Master's Voice" Research Laboratory will be shown publicly for the first time.

"His Master's Voice"



The Gramophone Co. Ltd., London, W.1.

When you send your order don't forget to say you "saw it in the 'W.M.'"

**OLYMPIA'S PRIZEWINNER
WITH 1930 MODEL
GREATLY IMPROVED
ALL 1931 MODELS
UNAPPROACHABLE!!
THE 1932 MODELS**



Write for illustrated leaflets of these famous models

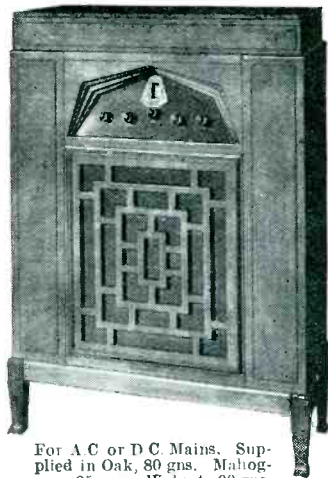

For A.C. or D.C. Mains. Supplied in Oak, 80 gns. Mahogany, 85 gns. Walnut, 90 gns.

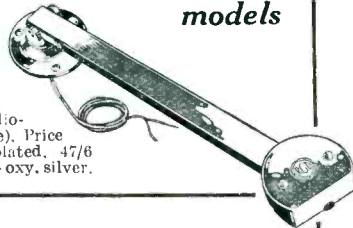

The R.G.D. PICKUP (as fitted to the R.G.D. Radio-Gramophone). Price 45/- nickel plated. 47/6 bronze. 50/- oxy. silver.



For A.C. or D.C. Mains. Supplied in Walnut, 48 gns.

R.G.D.

Radio Gramophone Development Co., Ltd.,
17-20 Fredrick Street, Birmingham.

**THE GREATEST
OF ALL
RADIO-GRAMOPHONES**

When better are made R.G.D. will make them.

**Your Set is no better
than its Speaker!**

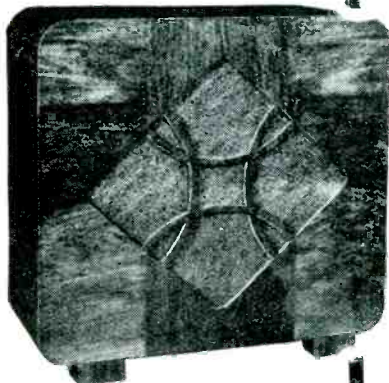

MOTOR LOUSPEAKER
"REX"
60/-

YOUR set gets the programmes you want to hear, but your speaker determines *what* you hear. It takes a MoTor Loudspeaker to give you best results from your set.

The better performance of a MoTor Loudspeaker is a reality which speaks for itself. Hear the new MoTor Speakers, Chassis and Units at your dealer's and judge for yourself.

MoTor Cabinet Speakers range from 47/6 to 120/-. MoTor Chassis from 43/6 to 56/-. MoTor Units from 23/6 to 35/-. Ask your dealer for the illustrated MoTor Booklet.

MoTOR
UNITS ● CHASSIS ● SPEAKERS

TEKADE RADIO & ELECTRIC, LTD.
147 FARRINGDON ROAD, LONDON, E.C.1

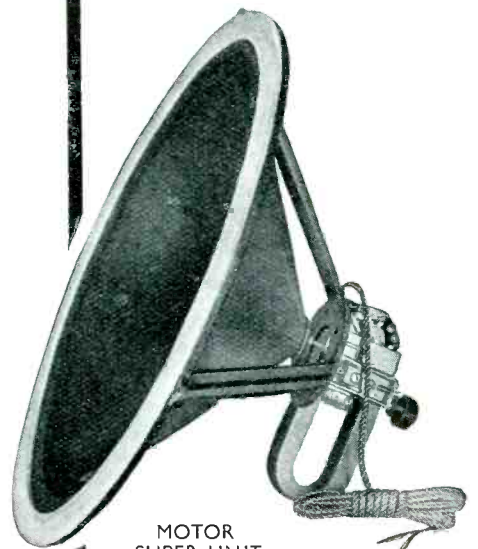

MOTOR
SUPER UNIT
Type S8
23/6

MOTOR CHASSIS
Model C88 (as illustrated)
Fitted with Type S8 Unit
43/6

Northern Wholesale Distributors: L. KREMNER, Ltd., 2 Bradshaw Street, Manchester. HARDMAN & Co., Ltd., The Baum, Yorkshire Street, Rochdale; 61 Bridge Street, Manchester; 12 Back Lord Street, Blackpool; 25 Trinity Street, Leeds. Agent for Scotland: R. G. J. NISBET, 132 Renfrew Street, Glasgow, C.2. West of England: BRUNWEC, LTD., 28 Cumberland Street, St. Paul's, Bristol.

Mention of the "Wireless Magazine" will ensure prompt attention

Wireless Magazine

SPECIFY
DUBILIER
CONDENSERS
FOR THE
JAMES
SUPER
SENIOR

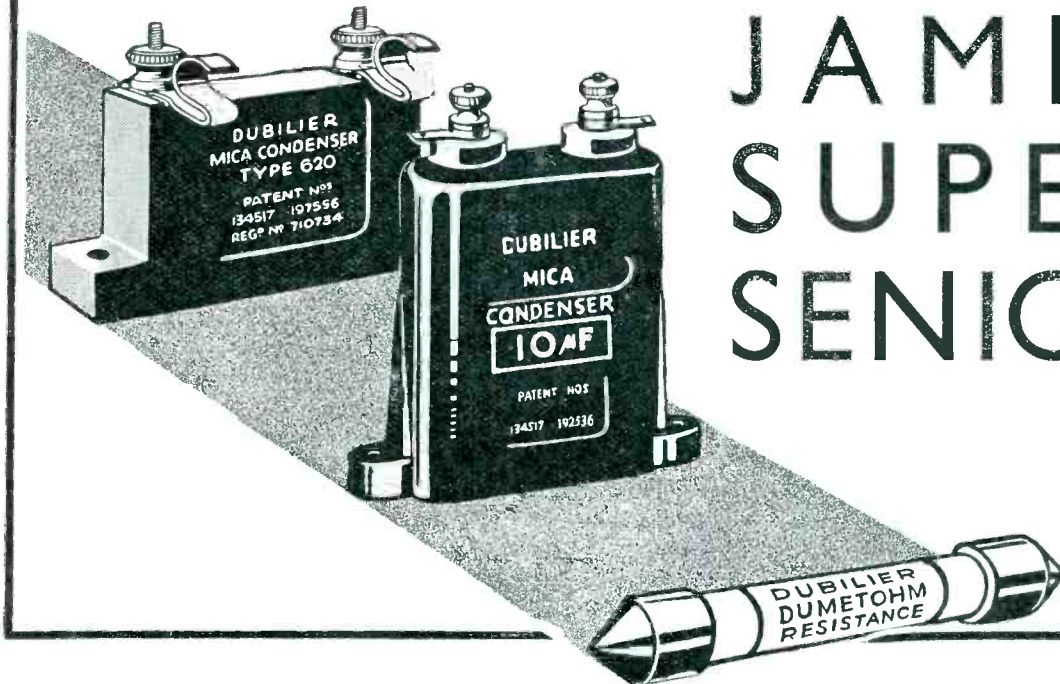

- 10—1 mf. BB Condensers
- 2—.001 mf. Type 620
- 1—.0002 mf. Type 620
- 1—.0003 mf. Type 620
- 1—1 megohm Dumetohm

All the leading set designers incorporate Dubilier Condensers in their new circuits. They know that Dubilier Condensers and Resistances are unapproached for efficiency and long service. That is why Mr. James used them in designing his new Exhibition Receiver (the Super Senior). Build this amazing receiver and be assured of perfect results by using the specified Dubilier Condensers and Resistances.

YOU CANNOT BUY BETTER

We are exhibiting at the National Radio Exhibition, Olympia, September 18th to September 26th.

STAND No. 92

DUBILIER

CONDENSER Co. (1925) Ltd.

Ducon Works, Victoria Road, N. Acton, London, W.3

Advertisers like to know you "saw it in the 'Wireless Magazine'"

News of the West Regional Transmitter

With the B.B.C. at Watchet

Here our Special Correspondent, who has been closely following B.B.C. developments in the West of England, explains what was done when choosing the site for the new West Regional transmitter

WHY all the delay in choosing the site for the West Regional transmitter?

I was at Watchet while investigating what was being done at Watchet and Washford, and I think there are many reasons which explain the apparent delay in selecting the site.

Usual Difficulties

There were, of course, the usual difficulties which came up at Savoy Hill under the heading of "policy." Landowners raised certain natural objections, the programme authorities made representations, and the engineers had the final word in selecting the site.

The engineers' work is now practically finished until the plant is installed at the new station. Several months ago tiring days were spent in broadcasting from the proposed Watchet site and in receiving at specified points in the district in order to get an accurate idea of the sort of reception which would be had by West Country listeners.

Portable Transmitter

A portable transmitter was taken down to the site and put out a $1\frac{1}{2}$ -kilowatt test signal. At specified points field-strength measurers were worked. The B.B.C. standard field-strength measurer is an interesting piece of apparatus. It is housed in two completely screened aluminium boxes, and is a sort of double receiver connected up to special windings on a big frame aerial carried above the top box.

There are special ultra-slow motion dials controlling the frame and high-frequency stages. A volume control on the high-frequency side cuts down the strength to the necessary amount for the testing apparatus and a two-

way switch enables the operator to use either phones or a milliammeter in the output circuit for checking up the volume. A rough indication is obtained with phones and then the field-strength measurer is switched over to the meter, and a chart of readings made.

There are several field-strength measurers, the one I have just described seeing in use being specially made for the B.B.C. by a leading electrical firm. The B.B.C. also has measurers made in its own work-

made in laboratory fashion. The testing engineers work the field-strength measurers and obtain contours worked out in millivolts per metre for the West Regional district.

Practical Unit

"Millivolts per metre" is a technical expression implying the strength received in fractions of a volt for each metre height of aerial. Field strength on the B.B.C. testers is always measured in millivolts per metre, this being the only sort of unit that one can employ for practical purposes.

Well, after a prolonged period of testing with a portable transmitter and the field-strength sets, a chart was obtained and compared with the stock data at Savoy Hill. First the service area for the new West Regional station had to be defined, and this was done by comparison with the "A," "B," and "C" areas specified way back in May, 1928.

An "A" service area is one in which the field strength is greater than 10 millivolts per metre, a "B" area in which the field strength is greater than 5 millivolts per metre, and a "C" service area in which it is greater than 2.5 millivolts per metre.

Various Areas

What these mean in practical reception, as would be obtained by listeners in the West Regional district, is

that in an "A" area a man gets good reception no matter what ordinary amount of interference is close at hand. A "B" service area man can be guaranteed good crystal reception with an outdoor aerial, but in this area there will probably be 5 per cent. of cases of poor reception.

(Continued on page 342)

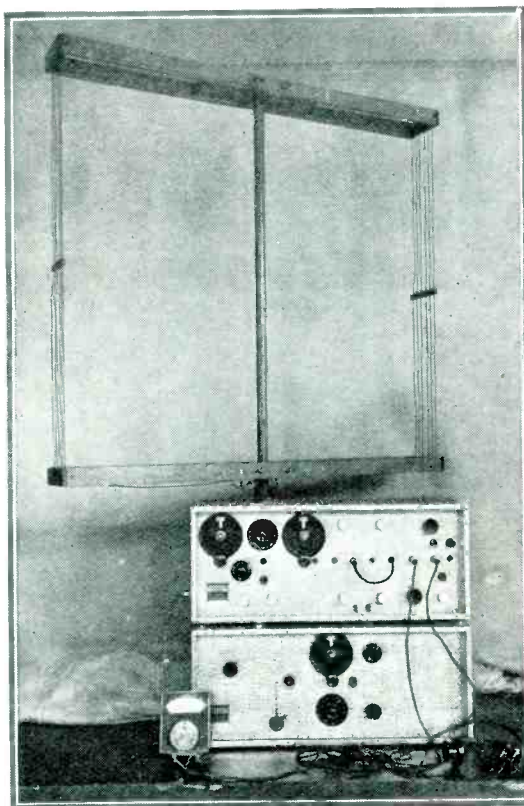

FOR MEASURING SIGNAL STRENGTH

This is the apparatus used by B.B.C. engineers for measuring signal strength

shops and one or two other field-strength testing kits, one of Continental manufacture.

At certain times during the day and evening the portable transmitter is switched on and a whining carrier wave emitted. Speech is never broadcast for these tests as it is quite unnecessary, the measurements being

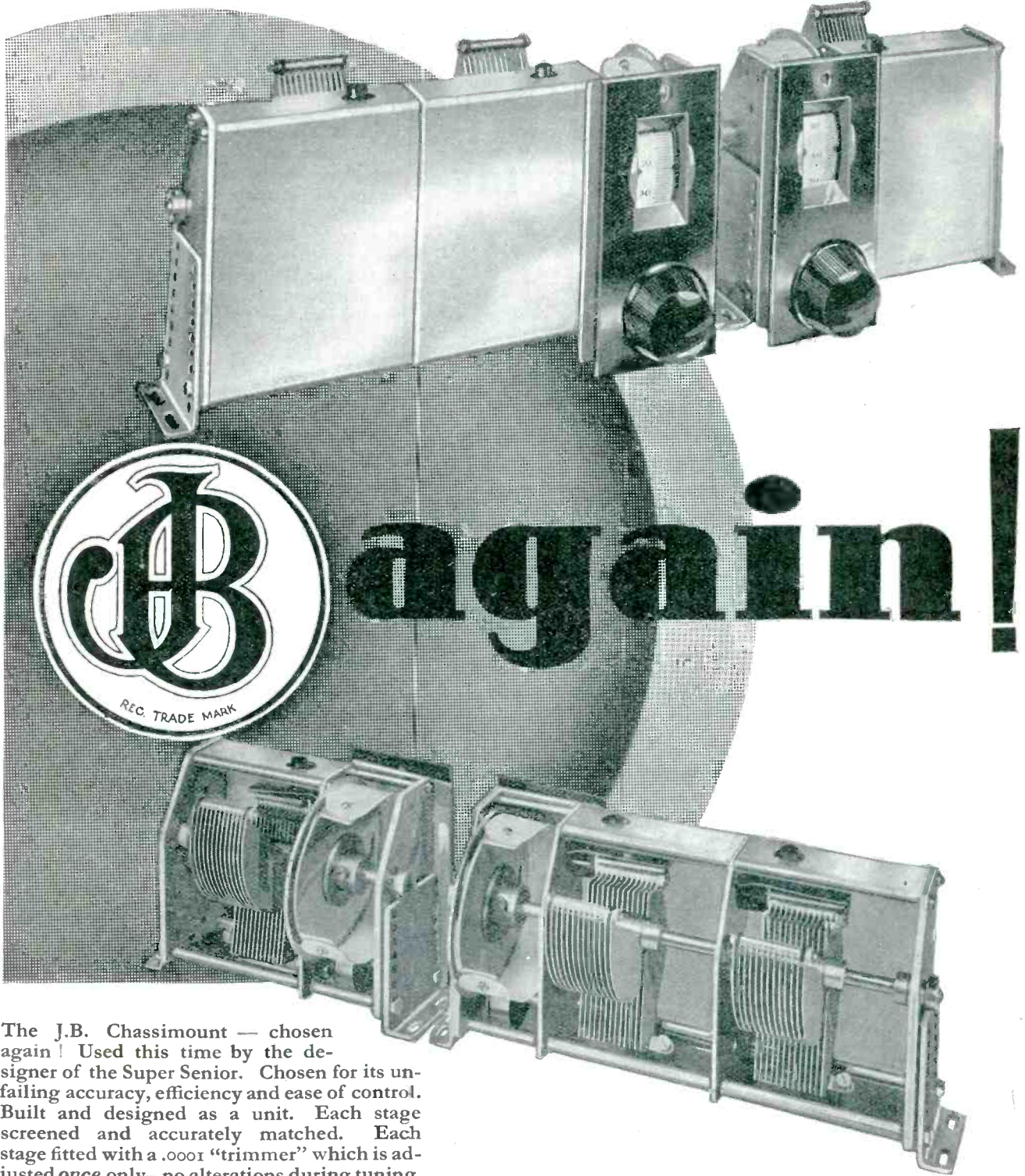

The J.B. Chassimount — chosen again! Used this time by the designer of the Super Senior. Chosen for its un-failing accuracy, efficiency and ease of control. Built and designed as a unit. Each stage screened and accurately matched. Each stage fitted with a .0001 "trimmer" which is adjusted *once* only—no alterations during tuning.

For the Super Senior

J.B. Chassimount. Type D1A. 19/-
Type D2RA. 26/6

Made in various types to give one-dial control for from 2 to 6 tuned circuits.

**USED & SPECIFIED
IN THE SUPER SENIOR**

STAND N° 62 NATIONAL RADIO EXHIBITION

Advertisement of Jackson Bros., 72 St. Thomas' Street, London, S.E.1

Telephone: Hop 1837

Speedy replies result from mentioning "Wireless Magazine"

A COMPLETE RANGE OF FUSES for EVERY REQUIREMENT . . .

TECHNICAL REASONS

A fuse in a mains lead is a totally different proposition from a fuse in a H.T. or G.B. lead. In the mains lead it is unsound to use a lower rating than 1 amp, because the mere switching on and off of current creates a surge which might easily blow a fuse of lower rating. Further, in a mains lead fuses should always be more than 1 in. long, to make arcing impossible. In H.T. and G.B. leads and rectifier circuits, on the other hand, it is unnecessary for fuses to go beyond ½ amp, even with multi-valve sets. Nor need they be longer than ½ in., even with a powerful H.T. supply. H.T. fuses should be kept as short as possible, for the fine high-resistance wire is liable to act as a coupling between the circuits and to set up "motor-boating" if too long.

That is why Belling-Lee now make their fuses in two lengths: H.T. ratings, 60 m/a., 150 m/a., and ½ amp, ½ in. long; mains ratings, 1, 2, and 3 amp, 1½ in. long.

Spare fuses of all ratings are sold at 6d. each.

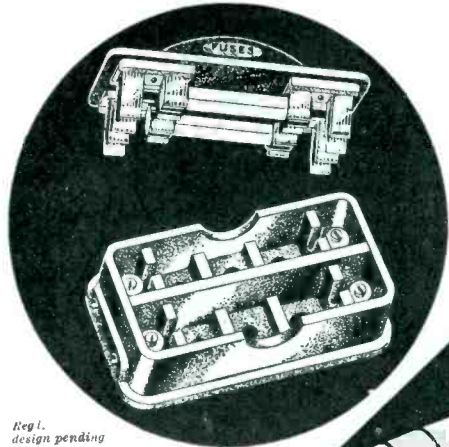

Reg. I. design pending

TWIN BASEBOARD FUSEHOLDER, with two 1-amp. fuses for mains leads (illustrated above) ... 3/6
WANDERFUSE, combined wander plug and fuse, with 60 m/a. fuse. 1/6
FLEXIBLE LEAD FUSEHOLDER, short type, with ½-amp fuse ... 1/- (Longer type with mains fuse, 1/-).
BASEBOARD HOLDER, with ½-amp. fuse. The best method of mounting a fuse inside a set or mains unit ... 1/3

STAND No. 13, NATIONAL RADIO EXHIBITION

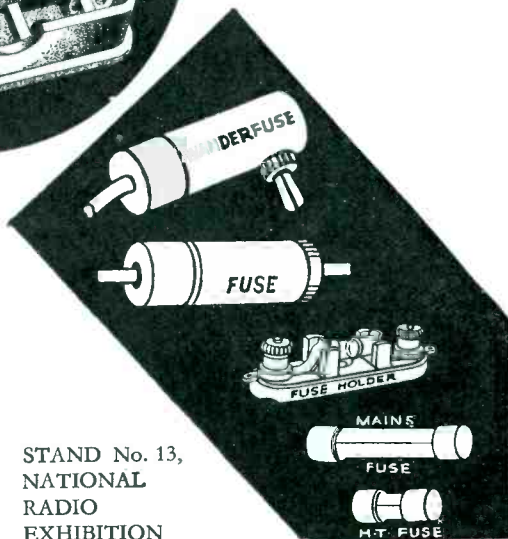

BELLING-LEE
FOR EVERY RADIO CONNECTION



COMPLETELY SCREENED

TRIPLE-GANG CONDENSERS

INSIST ON FORMO FOR EFFICIENCY IN RADIO

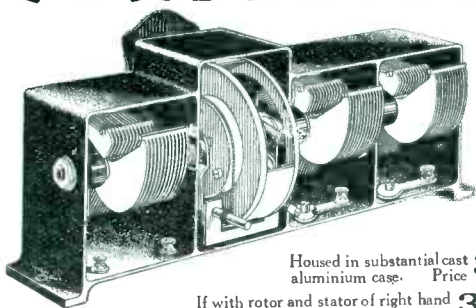

Housed in substantial cast aluminium case. Price **30/-**
 If with rotor and stator of right hand condenser insulated ... **31/6**

The vast experience of the Formo Company in the design and construction of precision condensers, has culminated in the introduction of an entirely new Triple-gang condenser for circuits employing Band-pass.

Two controlling knobs are provided. The right hand for the rotor vanes of all three condensers and the left hand for the stators of the two left-hand condensers.

A unique feature is the hidden pointer which clearly shows the position of the stators by a shadow thrown upon the illuminated drum dial.

Full particulars of this precision instrument, and the varieties of ways in which it can be made up, will gladly be sent on request.

Obtainable from all Formo Stockists

ARTHUR PREEN & CO., LTD.

Golden Square, Piccadilly Circus, LONDON, W.1. (See also pages 363 & 365) Crown Works, SOUTHAMPTON

OSBORN READY-TO-ASSEMBLE RADIO CABINETS



THERE'S A CABINET FOR EVERY SET ON THE MARKET

MODEL No. 218 SPECIFIED FOR THE "WIRELESS MAGAZINE" A.C. SUPER 60

A Queen Anne Radio or Radio Gramophone Cabinet, 3 ft. 10 in. high, 2 ft 2 in. wide, 1 ft. 6 in. deep. Size of baffle board behind fret, 24 in. x 24 in. Metallic fabric for fret front included. Opening at top and back. Cabinet takes panel 2 ft. x 9 in., or smaller.

PRICES:

Machined ready to Assemble: Oak £3.10.0, Mahogany £3.15.0. Assembled ready to polish: Oak £4.10.0, Mahogany £4.15.0. Assembled and polished: Oak £5.10.0, Mahogany £6.5.0.

All Models Carriage Paid

Send 3d. in stamps for 56-page illustrated catalogue.

CHAS. A. OSBORN (DEPT. W.M.)

The Regent Works, Arlington St. London, N.1. Tel.: Clerkenwell 1005. And at 21, ESSEX ROAD, ISLINGTON, N.1 (1 min. from the Agricultural Hall) Telephone: Clerkenwell 0684.

STAND No. 205
FIRST FLOOR
EMPIRE HALL
NATIONAL RADIO
EXHIBITION
OLYMPIA -
SEPTEMBER 18-26.

OSBORN MODEL No. 178 SPECIFIED for the "WIRELESS MAGAZINE" Meridian Short-wave described in this issue.

It helps us if you mention "Wireless Magazine"

A MOVING COIL UNIT BY AMPLION

FOR 676

THE famous Amplion M.C.6 Unit is acknowledged as representing the best value and the greatest efficiency amongst small permanent magnet moving coil speakers. Its reproduction and sensitivity are really remarkable, and it will handle without distortion adequate volume for all normal requirements. It requires no external excitation and the universal transformer which is fitted, enables the speaker to be correctly matched to either Power, Super Power or Pentode output from standard British 2, 3, or 4 valve receivers.

Make a point of visiting the Amplion Stand No. 75 in the EMPIRE HALL, Olympia, during the Radio Exhibition, where all AMPLION Moving Coil Speakers will be working.

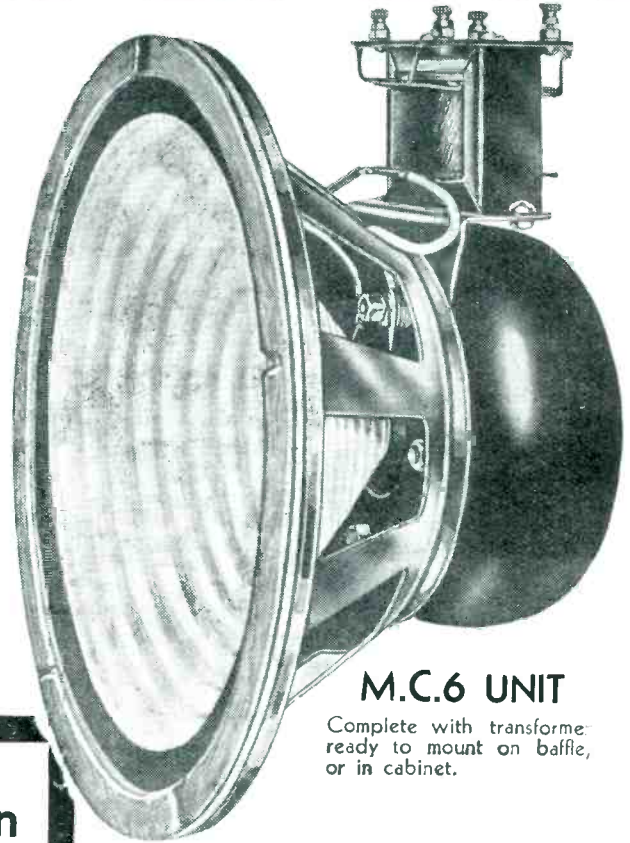

M.C.6 UNIT

Complete with transformer ready to mount on baffle, or in cabinet.



Also in
Handsome
Cabinets

(complete with transformer)

The M.C.6 Unit is also available in handsome cabinets of very modern and striking design. The oak model is illustrated here.

M.C.6 Oak £5-10-0

M.C.6 Walnut £5-19-6

Available on Deferred terms

Graham Amplion Ltd., 26, Savile Row, W.1

M.C.9 MODELS

The M.C.9 Unit is also a permanent magnet type, but is much larger and more powerful than the M.C.6. A suitable matching transformer for this model can be supplied at 15/- extra.

M.C.9 UNIT ONLY £6 - 0 - 0

M.C.9 OAK - - £9 - 9 - 0

M.C.9 WALNUT £10-10-0

All M.C.9 models are available on deferred terms. Both the Cabinet Models are fitted with matching transformers.

D.C. ENERGISED MODEL

A most efficient unit for D.C. Voltages 160/110, 200/240, very suitable for A.C. sets. Unit only.

29'6

Unit with matching transformer

42'-

Write for folder W.L.61, which gives full details.

A SPECIAL RADIO EXHIBIT

Yelling for a Loud speaker!

EVERY visitor to the Radio Exhibition at Olympia should make a point of seeing also the special His Master's Voice Modern Hall of

Round the hall are arranged eleven alcoves, each one containing a particular batch of H.M.V. products. The automatic record-changing radio

connected to a common output, and a continuous programme of H.M.V. records will be given from an automatic record-changing instrument.

There will also be a large demonstration-room in which the H.M.V. model 531 (the super-het), model 553 (the automatic record-changing push-pull gramophone amplifier), model 501 (the three-valve table radio gramophone), and model 435 (the first H.M.V. straight radio receiver) can be heard operating on radio besides records.

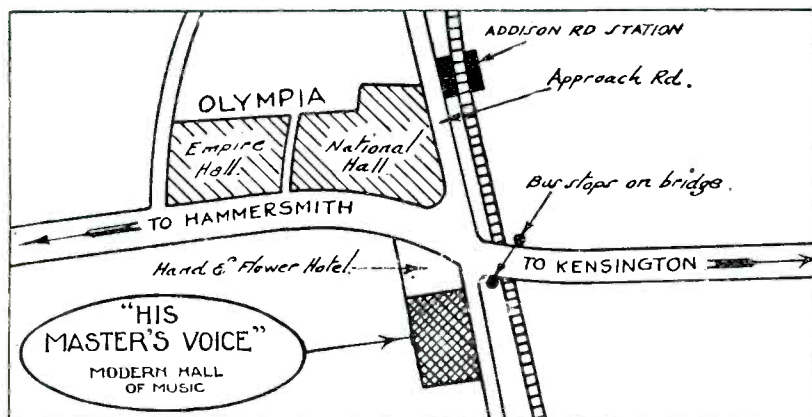

HOW TO GET TO THE H.M.V. MODERN HALL OF MUSIC

This street plan shows how close the special H.M.V. exhibit is to Olympia

Music, just opposite. The exact location will be clear from the street plan reproduced on this page.

The Gramophone Co., Ltd., have found it necessary to build a special hall because they were unable to obtain a large enough space in Olympia to show adequately their large range of new instruments.

Soundproof Room

In the centre of the H.M.V. hall is a special soundproof room, in which will be demonstrated a measuring instrument that automatically converts electrical units into units of "loudness" (T.U. or transmission units). It is believed that this equipment is the only thing of its kind in the world; it has been developed specially by H.M.V. engineers.

A novel competition is being run in connection with this apparatus, which will register the slightest change in volume of the human voice. Everyone visiting the hall is invited to shout a word of not more than one syllable in front of the microphone.

A Fine Prize

A prize of the new H.M.V. type S7 permanent-magnet moving-coil loud-speaker is offered to the competitor who registers the greatest reading on the T.U. meter.

Here is a case of yelling for what you want—and getting it if you yell loud enough!

gramophone and the nine-valve super-het are certain to attract a good deal of attention.

The loud-speakers in the various instruments in the main hall will be

Showing the "Insides"

The exhibits shown in each alcove will not be "dead." Chassis, condenser assemblies, motors, and pickups will be shown alongside the complete instruments. Many readers will be interested to know that circuit diagrams of all the instruments will be placed round the walls.

A complete stand guide to Olympia, with the names of exhibitors arranged alphabetically, appears on pages 224 and 228 of this issue.

AT WATCHET—Continued from page 338

A "C" service area listener could be assured of an 80 per cent. service.

Now just where these service areas will fall was shown after the field-strength tests and Mr. Noel Ashbridge and the chiefs of the various departments had to consider these field-strength contours.

Unfortunately, one cannot plant down a field-strength tester twenty miles from a portable transmitter and be sure that the received strength as shown by the meter will at all times be correct. The strength varies according to the time of day and the attenuation of the direct and ground rays.

You would be surprised if you could wade through the long lists of technical calculations and find the precise way in which the B.B.C. engineers can calculate the method of travel of ground waves and how this is likely to affect South Wales and Cornwall reception.

When there is a long stretch of flat ground and this is a good conductor, the wave travels almost vertically, but when the wave reaches a non-conducting area—and there are many such in Cornwall and North Devon,

as the contours prove—the wave front leans forward and this may affect the strength of reception in certain districts.

Reception in South Wales

The Bristol Channel will certainly make for good reception in South Wales, but it is probable that there will still be difficulty in reception anywhere in the district extending from Bude in the North to Fowey in the South and then on to Land's End.

This is difficult country from the radio point of view and when the West Regional station is working the wavelength chosen will have a big effect on deciding whether Cornish listeners will get the sort of service they have been asking for ever since the start of broadcasting.

Waveband Position

Unfortunately, the wavelength of the new West Regional station is closely bound up with the field-strength contours plotted out months ago by the field-strength testers and the whole success of this new station may depend on choosing a suitable place for it in the waveband.



Tested & passed

G.P. Kendall
CHIEF ENGINEER
READY RADIO

THE SUPER SENIOR

	£	s.	d.
1 Polished plywood panel, 12 in. by 6 in. by 1/4 in., drilled to specification	2	6	
1 Readi-Rad super-het. H.F. choke	5	6	
1 Lewcos triple I.F. unit, type 49	1	11	6
1 Lewcos oscillator coil	18	6	
2 Varley H.F. intervalve coils, type HP6	17	0	
1 T.C.C. .0005-mfd. fixed condenser, type 34	1	6	
1 T.C.C. .0002-mfd. fixed condenser, type 34	1	6	
1 T.C.C. .001-mfd. fixed condenser, type 34	1	6	
10 T.C.C. 1-mfd. fixed condensers	1	8	4
1 J.B. 2-stage chassimount .0005-mfd. condenser with drum drive, type D2RA	1	6	6
1 J.B. single-stage chassimount .0005-mfd. condenser, with drum drive, type D1	1	19	0
1 Readi-Rad 5-megohm grid leak and holder	1	4	
1 Junit S.G. valve holder	1	9	
3 Four-pin valve holders	1	8	
1 Lewcos 5,000-ohm spaghetti resistance	1	0	
2 Lewcos 15,000-ohm spaghetti resistances	3	0	
1 Lewcos 25,000-ohm spaghetti resistance	1	6	
1 Colvern 50,000-ohm wire-wound potentiometer	5	6	
1 Baign double-pole toggle switch	2	8	
1 R.I. Hypermu L.F. transformer	17	8	
1 Readi-Rad screen and bracket to specification	2	3	
1 Sovereign terminal block	6		
2 Belling-Lee "R"-type terminals, marked: Aerial and Earth	6		
8 Belling-Lee wander plugs	1	4	
2 L.T. spade terminals	1	8	
1 Packet Readi-Rad "Jiffilix" for wiring	2	6	
7 Valves as specified: 3 Cossor 215SG, 1 Mullard PM1DG, 1 PM1HF, 1 PM1LF, and 1 PM2A	5	7	6
Flex, fixing screws, and 1 ft. shielded cable	10		

TOTAL (including Valves) £15 8 6

Kit "A" (less valves, less cabinet)	10	1	0
Or 12 equal monthly instalments of	18	6	
Kit "B" (with valves, less cabinet)	15	8	6
Or 12 equal monthly instalments of	1	8	3

COMPLETELY ASSEMBLED RECEIVER in polished walnut pedestal cabinet, with 7 valves aerial tested and royalties paid £24 16 0

Or 12 equal monthly instalments of £2 3 9

RECOMMENDED ACCESSORIES

1 Polished walnut pedestal cabinet to specification	5	17	0
2 Fuller 60-volt triple capacity H.T. batteries	1	3	0
1 Fuller 9-volt G.B. battery	1	0	0
1 Fuller type SWXH L.T. accumulator	10	3	
1 Ormont portable unit and chassis	1	5	0

FIVE ADVANTAGE THREE

	£	s.	d.
1 Polished ebonite panel 16 in. by 8 in. by 3/16 in., drilled to specification	5	6	
1 Readi-Rad H.F. Choke	4	6	
1 R.I. L.F. choke, type G.P.	12	6	
1 Lewcos plug-in coils, Nos. 25, 6C, 100 and 200	16	0	
1 T.C.C. .0002-mfd. fixed condenser, type 34	11	3	
1 T.C.C. .0001-mfd. fixed condenser, type 34	1	6	
1 T.C.C. .01-mfd. fixed condenser, type 40	3	6	
1 T.C.C. .01-mfd. fixed condenser, type 34	2	6	
1 T.C.C. .001-mfd. fixed condenser, type 34	7	8	
1 Lotus .0005-mfd. 2-gang condenser, with disc drive	5	0	
1 Readi-Rad .00035-mfd. reactor condenser	3	6	
1 Sovereign pre-set condenser, .0003-mfd.	1	3	
1 Readi-Rad 2-pin coil holders	2	6	
1 Readi-Rad 3-megohm grid leak and holder	1	4	
3 Four-pin valve holders	1	6	
1 Lewcos 30,000-ohm spaghetti resistance	1	6	
1 Lewcos 50,000-ohm spaghetti resistance	1	6	
1 A.E.D. fader centre-tapped type resistance, 1 megohm	10	6	
2 Sovereign terminal blocks	1	0	
1 Belling-Lee terminal block with terminals for pick-up	1	2	
1 Pair panel brackets	10		
2 Readi-Rad on-off switches	1	8	
1 R.I. low-frequency transformer, type G.P.	10	6	
4 Belling-Lee "R"-type terminals	1	0	
2 L.S. spade terminals	1	3	
7 Belling-Lee wander plugs	1	2	
1 Packet Readi-Rad "Jiffilix" for wiring	2	6	
3 Mullard valves - PM1HL, PM2DX, PM2A	1	7	6
1 Polished oak cabinet with 10 in. baseboard	1	5	0
Flex, 2 wooden blocks, 3 1/2 in. by 1/2 in. by 1/2 in., fixing screws, etc.	11		

TOTAL (including Valves and Cabinet) £9 8 6

Kit "A" (less valves and cabinet)	6	16	0
Or 12 equal monthly instalments of	12	6	
Kit "B" (with valves, less cabinet)	8	3	6
Or 12 equal monthly instalments of	15	0	
Kit "C" (with valves and cabinet)	9	8	6
Or 12 equal monthly instalments of	17	6	

COMPLETELY ASSEMBLED RECEIVER in polished oak cabinet, with 3 Mullard valves, aerial tested and royalties paid £11 0 0

Or 12 equal monthly instalments of £1 0 3

RECOMMENDED ACCESSORIES

2 Fuller 60-volt triple capacity E.T. batteries	1	3	0
1 Fuller 9-volt G.B. battery	1	0	0
1 Fuller type SWXH L.T. accumulator	10	3	
1 Cleston D.10 oak cabinet loud speaker	3	0	0

Mr. G. P. Kendall, B.Sc., has now joined the staff of Ready Radio as Chief Engineer. He was, for 8 years, Assistant Editor and Chief of Research in "Popular Wireless" and "Modern Wireless." Meet him at STAND No. 6, National Radio Exhibition, Olympia.

OVERSEAS—

Everything Radio can be supplied against cash. In case of doubt regarding the value of your order, a deposit of one-third of the approximate value will be accepted and the balance collected by our agent upon the delivery of the goods. All goods are very carefully packed for export and insured. All charges forward.

TO INLAND CUSTOMERS—

Your goods are despatched post free or carriage paid.

ANY COMPONENT CAN BE SUPPLIED SEPARATELY

THE MERIDIAN SHORT-WAVER

COMPLETELY ASSEMBLED in metal cabinet, with Mullard valves, aerial tested, guaranteed, and including royalties £7 12 6

In the interests of our Overseas customers we have made a special feature of this receiver. The set is extremely simple to operate and has been specially designed for reception on the very short wavelengths, namely between 15 and 100 metres. The receiver has been constructed in a specially designed handsome art-metal cabinet which will withstand extreme climatic conditions.

To Ready Radio Ltd., 159 Borough High Street, London Bridge, S.E.1.

Tel. Nos.—Head Office: Lee Green 5678; Showrooms: Hop. 3000. Grams: Readirad, Sedist.

CASH ORDER. Please despatch to me at once the goods specified for which I enclose payment in full of £.....

C.O.D. ORDER. Please despatch to me at once goods specified for which I will pay the sum of £.....

EASY PAYMENT ORDER. Please despatch my Easy Payment order for the goods specified for which I enclose first deposit of £.....

Ready Radio Ltd

159 BOROUGH HIGH STREET
 LONDON BRIDGE · S·E·1

PHONE: HOP 3000 GRAMS: READIRAD, SEDIST

HEAD OFFICE AND WORKS
 EASTNOR HOUSE · BLACKHEATH
 PHONE: LEE GREEN 5678

See also page 351

THE NEW STANDARD OF VALUE **LOTUS** ALL-MAINS LUXURY SET for £14.14.0

for A.C. & D.C. Mains

- MAGNAVOX MOVING COIL SPEAKER - -**
- MAZDA VALVES - -**
- IRRESISTIBLE H.P. TERMS**

Never before have such outstanding features, such a luxurious cabinet, such magnificent reception been available at such a low price.

The new Lotus Table Console is made for both A.C. and D.C. Mains. It is conceived and designed by J. Sieger, the famous radio engineer, who is now a member of the Lotus Research Laboratories.

One-knob Tuning, and All-mains operation make for the acme of simplicity. The Magnavox Moving-coil Speaker, Mazda Valves, S.C., Detector and Power, make for unequalled reproduction. Guaranteed full strength, perfect reproduction of 12 European Stations.

The Lotus Table Console is entirely self-contained in a beautifully polished walnut cabinet of matchless proportions and finish.

TRULY THE RADIO OF THE FUTURE—NOW!

The Hire-purchase Terms are irresistible—27/9 deposit secures this marvellous set, the balance being paid in 11 monthly instalments of 27/9 each. Ask your dealer for a demonstration.

Cash Price £14 14s., A.C. or D.C

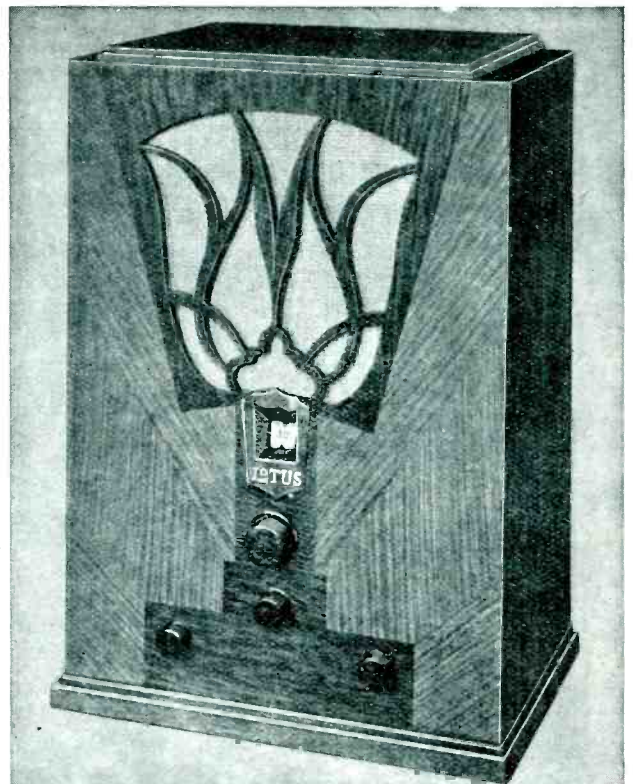

RADIO OF THE FUTURE — NOW!

TABLE

CONSOLE

LOTUS

THE WORLD'S KEENEST TUNING KEENEST PRICED POWER SET



**ALL
BRITISH
MADE**



LOTUS

A complete range of new Components at keenly competitive prices by J. Sieger, the famous radio designer.

In addition to the new Lotus Components illustrated below, there are many new lines, including Gang Condensers, Transformers, Chokes, Switches, Slow-motion Drives, etc. You will be interested in the complete range, write to-day for full descriptive list.

Famous from the earliest days of broadcasting, Lotus Components have always enjoyed the esteem of the radio constructor. This year many new lines have been born from the Lotus Research Laboratories. Designed by the genius of J. Sieger, and manufactured with the unequalled resources of the Lotus Works and experience, they are miracles of efficiency and value.

In no case has quality been sacrificed for price. Nevertheless, through highly intensified production, they are within the reach of every pocket. All the leading set designers specify Lotus. They know that for reliability and efficiency they are absolutely dependable. Follow the expert's lead—insist on Lotus Components.

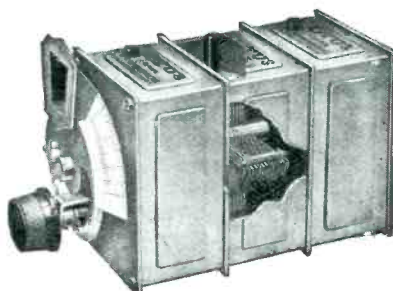

GANGED CONDENSERS.—Each unit is totally screened and precision matched, and sturdy construction ensures lasting accuracy. With Disc Drive, 5/- extra, or with Drum Drive, 7/6 extra. 3 Gang, 30/- 4 Gang, 40/- (as illustrated)

2-GANG
20/-

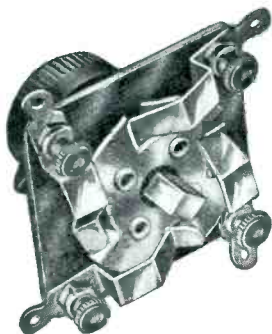

UNIVERSAL SWITCH.—A provisionally patented rotary switch with self-cleaning contacts. Easily ganged. For many types of switching arrangements.

1/6

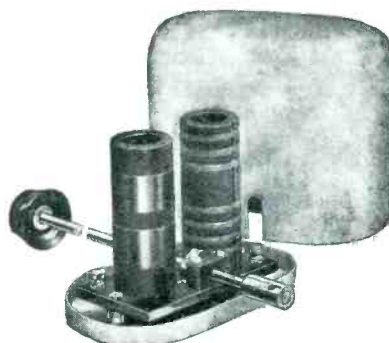

BINOCULAR DUAL-WAVE COIL.—Long and short wave windings on separate formers, silent wave-change switch. These coils are all matched and can be ganged. Completely and compactly screened. Designed by J. Sieger for hair-line selectivity.

10/6

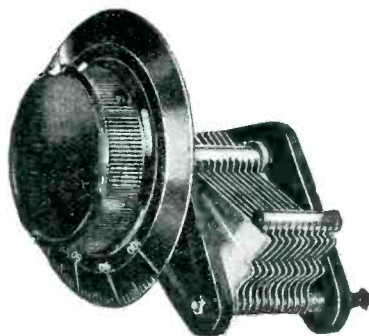

RIGID DRIVE LOG CONDENSER.—An inexpensive but reliable component for the home constructor. With knob-dial, .0003 and .0005 capacity.

3/6

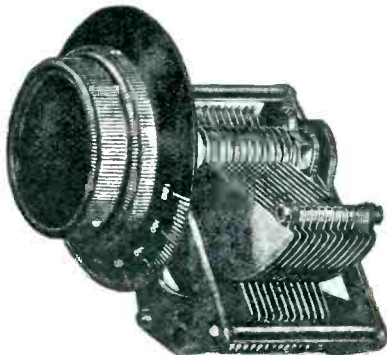

SLOW-MOTION CONDENSER.—Stout construction with integral ball-bearing slow-motion device. Complete with knob-dial. Capacity, .0003 and .0005.

6/6

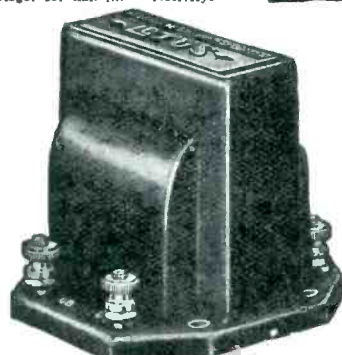

AUDIO TRANSFORMER No. 1. An inexpensive instrument for the home constructor. It is remarkably efficient and has a good straight-line amplification curve. Ratios 3-1 and 5-1.

5/6

LOTUS RADIO LTD., MILL LANE, LIVERPOOL

Cutting Out Electrical Interference

This article by ALAN HUNTER explains how various forms of electrical gear cause interference in radio reception and some of the schemes that have been evolved to overcome the trouble. This sort of interference is much more difficult to remedy than that caused by stations working on adjacent wavelengths

ALTHOUGH a set can now be obtained capable of tuning in programmes with first-class quality of reproduction, reception is all too often marred, especially in large towns, by background noises over which the listener has no control.

Reception Impossible

In certain quarters, broadcast reception is sometimes quite impossible owing to interference from domestic and industrial electric apparatus, such as electric motors and vacuum cleaners and fans.

Everyone, except the owner of the offending apparatus, has good reason to seek redress—the listener, the broadcaster, and the manufacturer of broadcast receivers. The time is coming when listeners will have to establish their right to interference-free broadcast reception.

Protecting Listeners

How can listeners be protected against interference from electric machinery? The answer is that in some countries it is already a legal offence to cause broadcast reception interference. In Germany, for example, telephone installations must by law be arranged so that no interference to an existing receiver can be caused.

In Germany, also, there is an organisation to combat radio interference. The country is divided for this purpose into 1,240 interference zones. From all quarters thousands of interference tracers have been enrolled. A Ger-

man listener now troubled by radio interference simply gets into touch with the interference squad attached to the broadcasting company in his zone.

More than half of the many thousands of interference cases investigated by this German organisation have resulted in the complete suppression of the interference.

One of the most encouraging facts about electrical interference is that the cost of altering apparatus so that it does not interfere with broadcast reception is usually very moderate. Incidentally, it is a fact that sparking is the major cause of interference and as sparking means rapid wear of the apparatus it is really in the owner's interest to stop it.

For use by manufacturers of interfering apparatus, such as electrical

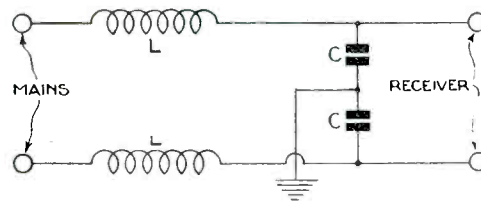

Fig. 1.—Simple filter for insertion in mains leads to set

motors, vacuum cleaners, etc., as well as by tramway companies and by all who are taking action in the solution of the interference problem, a very informative booklet has been published by Philips Lamps, Ltd., entitled "The Elimination of Radio Interference."

From this booklet much general and detailed information about radio interference problems and their solution can be readily extracted.

The compilers of the booklet divide causes of reception into five distinct groups.

One: Interference due to regenerative receivers (reaction).

Two: Interference due to heterodyning of two

transmitting stations.

Three: Interference due to A.C. mains, indicated by a more or less musical note.

Four: Interference due to motors, high-frequency electro-medical apparatus, electric bells, buzzers, and in general, all make and break contacts causing sparking.

Five: Atmospherics.

Crackling and Hissing

The interference due to the causes enumerated in the fourth and fifth groups are mostly of a high-frequency nature and are manifested by irregular crackling and hissing noises.

It is suggested that there are four ways of suppressing interference, apart from atmospherics, in radio reception.

One: Increasing the power of the transmitters. This is the only way atmospherics can be relatively reduced. The degree of interference is determined by the ratio of interference to signal. Increasing the power of transmission has the effect of decreasing interference, as the ratio of signal to interference is increased.

Two: Suppression at the receiving set itself.

Three: Suppression at the source of interference.

Four: Screening of the lines transmitting the disturbances.

Dealing with the four main interference groups, it is suggested that group one interference, caused by reaction, can be suppressed by suitably designing the set. Either a screened-grid high-frequency valve should come between the aerial and

(Continued on page 350)



Fig. 2.—How to stop high-frequency radiation from electric-light wires

A BIG SUCCESS—A BIG DEMAND

**NOW A BIG REDUCTION IN
PRICES OF Drydex**

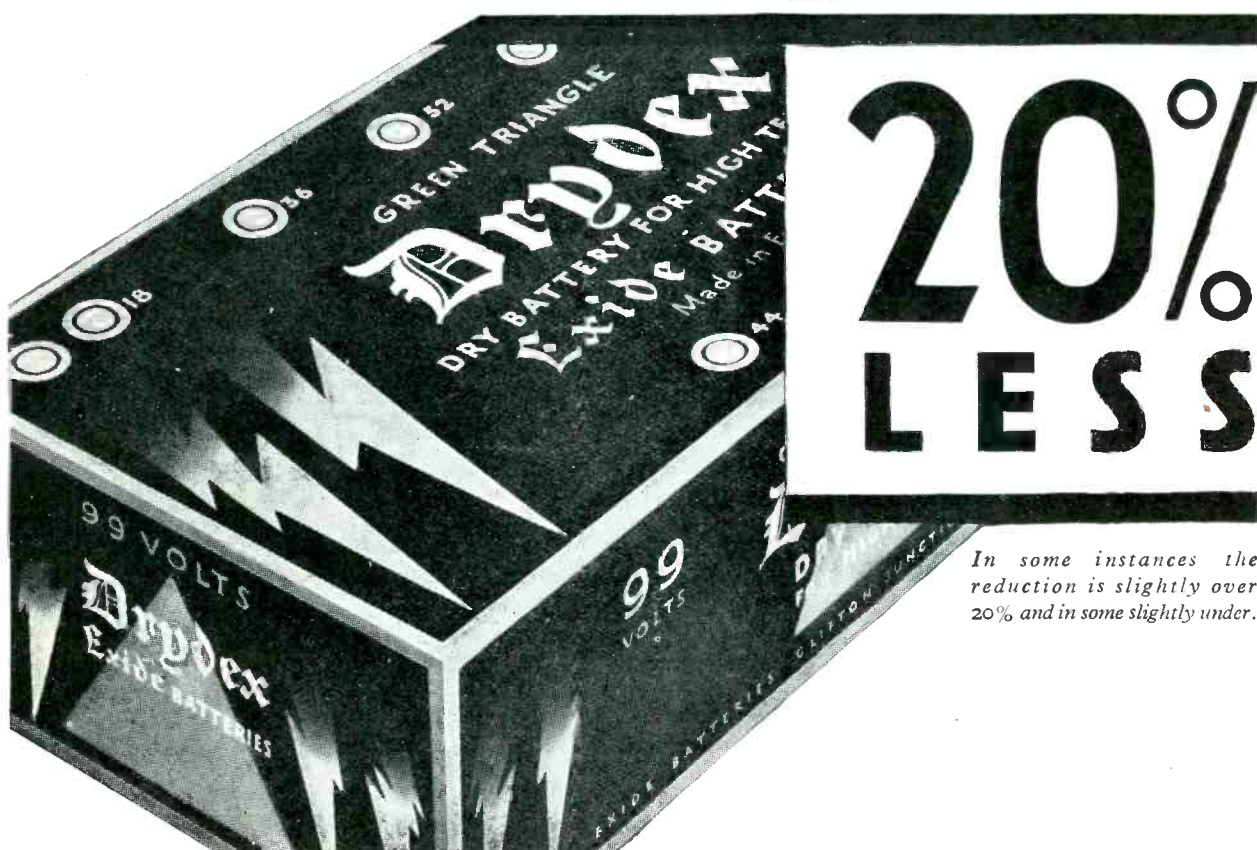

SOME OF THE NEW PRICES.

Makers of world-famous Exide offer greatest Dry Battery value!

RED TRIANGLE	GREEN TRIANGLE	ORANGE TRIANGLE	BLUE TRIANGLE
60 volts 5/6 • 66 volts 6/-	60 volts 8/6 • 66 volts 9/6	Triple Capacity • 60 volts 12/-	For portable sets • 63 volts 7/6
99 volts 9/- • 120 volts 11/-	99 volts 14/- • 120 volts 16/9	105 volts 21/- • 120 volts 24/-	99 volts 11/6 • 108 volts 13/-

For Grid Bias: Red Triangle. 9 volts—1/-. 16.5 volts—1/9. Green Triangle. 9 volts—1/6. 16.5 volts—2/6.

Prices of Torch, Bell and Flash Lamp Batteries also reduced.

These prices do not apply to the Irish Free State.

Obtainable everywhere from all good dealers

Exide Batteries, Clifton Junction, near Manchester. Branches at London, Manchester, Birmingham, Bristol, Glasgow, Dublin and Belfast.

Dx.31

Please mention "Wireless Magazine" when corresponding with advertisers

Build the MERIDIAN SHORT-WAVER

as described in this issue.

£ s. d.		£ s. d.		£ s. d.							
1	Wearite short-wave choke, type HF3...	4	6	2	Clix spade terminals as specified ...	4	1	Pair Bulgin panel brackets, type PB4	1	3	
1	Telsen 20-henry L.F. choke ...	8	0	4	Belling-Lee terminals as specified ...	1	0	1	Sheet aluminum foil, 16 in. by 8 in., Glazite, rubber covered flex, etc.	2	10
1	Eddystone short-wave inductance unit	2	6	1	Magnum spaghetti resistance, 10,000 ohms ...	1	0				
1	Magnum .0001-mfd. fixed condenser ...	1	6	1	Magnum spaghetti resistance, 60,000 ohms ...	1	0				
1	Magnum .0002-mfd. fixed condenser ...	1	6	1	Telsen 1-meg. grid leak ...	9	6				
1	Magnum .01-mfd. fixed condenser ...	2	6	1	Telsen 3-meg. grid leak ...	9	6				
1	Formo 2-mfd. fixed condenser ...	6	6	1	Lissen 400-ohm potentiometer, type LN140 ...	1	6				
2	Utility .0002-mfd. var. condensers, type W187, with vernier dials ...	1	6	0	1	Telsen radiogrand 7-1 L.F. transformer	8	8			
1	Ebonite panel, 16 in. by 8 in. ...	7	6	1	W.B. on-off switch ...	1	3				
2	Bulgin grid-leak holders, type G6	1	6	2	Belling-Lee terminal blocks ...	1	4				
3	Clix valveholders (terminal type)	2	6								
6	Clix wander plugs as specified ...	1	0								

ACCESSORIES £ s. d.
 2 Osram HL2 valves ... 17 0
 1 Osram LP2 valve ... 10 6
 1 Pertrix 120-volt standard H.T. battery ... 15 6
 1 Pertrix 9-volt grid-bias battery ... 1 8
 1 Fuller 2-volt accumulator, type LDG ... 9 8
£2 14 0
 Any parts supplied separately as required.

THE MERIDIAN SHORT-WAVER, as above, ready wired and tested, including coils, valves and batteries, royalty paid, **£10**

MAGNUM SPAGHETTI RESISTANCES

As specified for the "Meridian Short-waver."

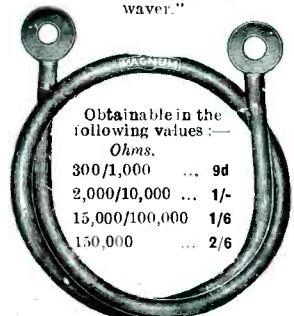

Obtainable in the following values—
Ohms.
 300/1,000 ... 9d
 2,000/10,000 ... 1/-
 15,000/100,000 ... 1/6
 150,000 ... 2/6

MAGNUM SHORT-WAVE CONVERTOR

Readily converts any battery-operated receiver into a highly efficient short-wave receiver. Complete with two coils, 20/40 and 40/80 metres.

Sent on 10 days' free trial against cash. **£3:15**

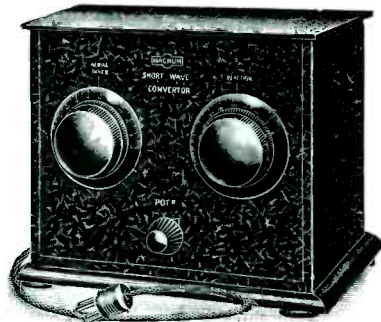

WE specialise in all sets described in "Wireless Magazine." Full particulars with a comprehensive range of lists dealing with Magnum Mains and Battery Operated Receivers and high-grade components, including a list of leading short-wave stations—free on request.

BURNE-JONES & CO., LTD. "MAGNUM" HOUSE, 296 BOROUGH HIGH ST., LONDON, S.E. 1
 Telephone: Hop 6257 and 6258. Scottish Agent: Mr. Ross Wallace, 54 Gordon Street, Glasgow, C.1.

CLIX

Specified for the "MERIDIAN" SHORT-WAVER



Specified

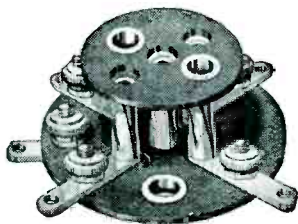

Specified

VALVEHOLDER (Type B.)

The perfect valveholder for short-wave work. Built for efficiency—not for appearance. 4-pin type with terminals. 3 required. 10d.



Specified

"VICEGRIP" WANDERPLUG

Fits securely into any battery socket. Positive metal to metal wiring. 1 1/2 6 required. 1 1/2 d.



Panel Terminal

Insulated knob with easily read markings. Adds to the efficiency and appearance of any set. 3d.

"Fit-All" SPADE TERMINAL

Fits all screw terminals. Lead-coated or Nickel-plated. 2 required. 2d.

STAND

202
 Radio Exhibition, OLYMPIA

Illustrated Folder Free.

Cheapest PERFECT Contact

LECTRO LINX LTD., 254 Vauxhall Bridge Rd., S.W. 1

Write for these TWO new Booklets— BEFORE you buy your Moving Coil Speaker! 40 pages of valuable information on Realistic Reproduction. FREE of course!

NATIONAL RADIO EXHIBITION
 STAND NO. 216 IN EMPIRE HALL. DEMONSTRATION ROOM, NO. 23, IN NATIONAL HALL.

The Pioneer Manufacturers of Moving Coil Loud Speakers

BAKER'S 'Selhurst' RADIO

OFFICES:
 89 SELHURST ROAD, S. NORWOOD, S.E. 25
 * WORKS & DEMONSTRATION ROOM:
 42 CHERRY ORCHARD ROAD, E. CROYDON
 (15 minutes from VICTORIA or LONDON BRIDGE.
 *Phone: CROYDON 1618.)

The Pioneer Manufacturers of Moving Loud Speakers

Advertisers take more interest when you mention "Wireless Magazine"

DO NOT BE DECEIVED!

"Wearite" Super-het Coils, originally specified by "Wireless Magazine" for the "Super 60" and kindred sets, are now manufactured in London under letter patents No. 349403 and can be supplied only by Wright & Weaire Ltd. When you purchase Super-het Coils remember the name "Wearite" and insist upon the originals.

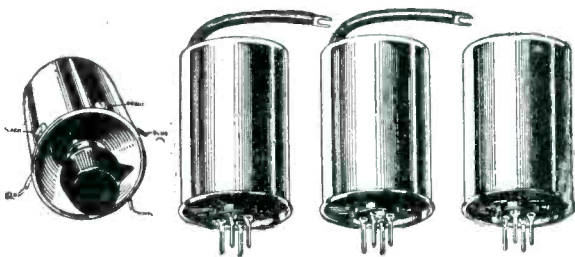

These SUPER-HET coils consist of TRIPLE RANGE Oscillator Coil, designed for panel mounting and three Band Filter units fitted with standard SPLIT PINS TO PLUG INTO VALVE SOCKETS OR SPECIAL CHASSIS.

Price of complete set of 4 coils,
50/-

Write for **FREE** illustrated
Lists and Leaflets

WEARITE

COMPONENTS

WRIGHT & WEAIRE LTD.

74o High Road, Tottenham, N.17

Telephone: Tottenham 3847/8/9

VISIT OUR STAND No. 152 FOR NEW MODELS

WEARITE COMPONENTS ARE SCIENTIFICALLY CONSTRUCTED WITH THE FINEST MATERIALS AND WORKMANSHIP AND ARE THE BEST VALUE OBTAINABLE

WEARITE H.F. CHOKE

A first-class component especially recommended for the "Super Senior." It covers efficiently the remarkable range from 10 to 2,000 metres without any marked resonances. Self-capacity very low.

Type H.F.O. **6/6**

For the "Meridian Short-waver" use our Short-wave Choke type H.F.3. Price **4/6**



WEARITE SUPER FRAME AERIAL

A dual frame aerial entirely new in design. The windings are of Litzendraht wire, carefully wound at even tension, centre tapped. The Frame Aerial rotates through 180 degrees on a polished mahogany or oak base.

Price **42/-**



We have designed a special completely wired chassis for the "Super Senior," enabling you to use your present Band-filter by just plugging in.

Price **4/6**

Please mention "Wireless Magazine" when corresponding with advertisers

CUTTING OUT INTERFERENCE—Cont. from page 346

the source of oscillation or the set should be designed so that it cannot oscillate.

The group two interference, caused by two stations transmitting too closely together, and so producing a

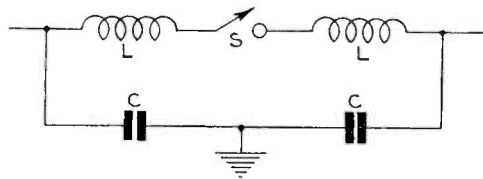

Fig. 3.—Stopping interference caused by making and breaking switch contacts

characteristic whistling note, is of course, eliminated only by increasing the frequency separation of the two stations.

Sometimes a frame aerial will cut out the interfering signal, although such a device cannot suppress a heterodyne note on the wanted signal.

High-frequency Filter

Another way is to use a filter, so that the very high frequencies in the audible range are cut off. The heterodyne note is often of such high frequency that a filter can be used to suppress it without greatly affecting the quality of reproduction.

The group three interference, and also the group four interference, caused by A.C. mains, motors, bells, and other sparking contacts on make-and-break circuits, can often be cut down, or cut out entirely, by one or several of the following schemes:—

If the interference gets to the set through the mains it can be cut out by inserting a filter between the mains as shown at Fig. 1. The coils *L* may have 50 to 200 turns and the condensers a capacity of 1 microfarad.

Stopping Radiation

Sometimes high-frequency radiation occurs in the various mains wires, especially if there are several yards of aerial lead in. This source of interference can be stopped by connecting two condensers, with the central tapping earthed, to the plug point nearest the set (see Fig. 2). It is most important that an entirely separate lead be used to earth these condensers.

Wherever a make-and-break contact is used in the circuit, interference waves are sent out when the flow of current is interrupted and restored by the opening and closing of the circuit.

Interference of this type can usually be cut out by means of choke coils or resistances and condensers.

Fig. 3 shows a simple arrangement of two coils and two condensers. Condensers of .1 microfarad are specified and the coils can be 40-turn plug-in coils of the honeycomb type. In this circuit, *s* represents the two terminals of the make-and-break contact.

Interference from electric bells is not a very common trouble, but Fig. 4 shows how the normal bell circuit at *A* can be slightly modified by making it symmetrical. This is quite a simple circuit alteration, as indicated at Fig. 4B. If this does not do the trick a .01-microfarad condenser, as shown by the dotted lines, can be shunted across the make-and-break contacts.

Electric heating apparatus, fitted

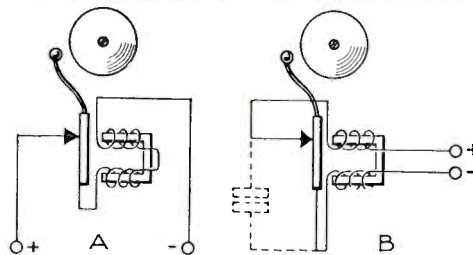

Fig. 4.—Modification of bell circuit to prevent interference

with a temperature regulator, sometimes causes interference. A peculiar sound like the croaking of a frog is caused by the action of the temperature regulator. This interference can be remedied by bridging the make-and-break contact with a .05-microfarad condenser, shown at Fig. 5.

Undoubtedly, electric dynamos and motors are a frequent cause of crackling and humming noises in broadcast reception. An adjustment of the brushes and a conversion of series wound motors to a symmetrical circuit are well-tried remedies. If these fail, the use of large fixed condensers is often worth while.

There are many other causes of interference dealt with in the booklet mentioned. Towards the end, reference is made to tramway interference. This is of three classes.

One: Crackling sounds when switch-

ing over; these disturbances are not serious, as they are of brief duration.

Two: Hissing and buzzing of the commutators of the motors; these disturbances are sometimes troublesome, but sometimes faint and scarcely audible.

Three: A loud buzzing and crackling occurring at night, due to faults in the collector, of the bow or trolley type. This is especially noticeable in dry weather.

Signal Lights

Four: Electrical devices along the line, such as signal lights and level crossing signals, often add to the disturbance.

As there are so many causes of tramway interference it follows that no single remedy is available. Many experiments have been made to eliminate interference from the current collector, as this is a continually moving electrical contact.

The Fischer bow collector has given good results with several tramway systems on the Continent. This bow is so constructed that it prevents interruptions of current and consequently avoids sparking.

Unfortunately, the collector is not the most serious source of tramway interference. Recent experiments by the Post Office indicate that considerable

relief can be obtained by modification of the tram motors; by connecting the series coil in the high tension side so that it acts as a choke between the motor and overhead wire thus preventing radiation of interference.

As indicated in the Philips booklet, the problems of suppressing "man-made atmospherics" are not inca-

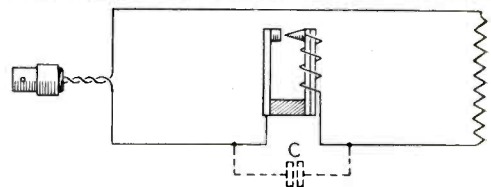
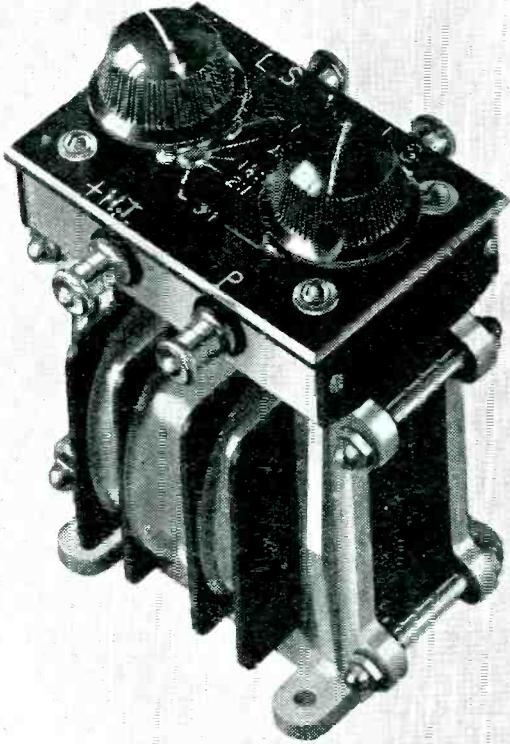

Fig. 5.—How to remedy interference caused by automatic temperature regulators

pable of being solved. What is needed is properly organised collaboration between the various users of electrical apparatus and broadcast listeners.

QUALITY DEPENDS

on your OUTPUT STAGE



INSTAMAT

Your output stage must be right. You can have the best set and the best speaker that money can buy, but, unless they are accurately matched, quality must suffer.

Any radio expert will tell you that an output circuit is essential in a receiver capable of giving good quality and volume. It not only isolates the loud-speaker from the set, thereby protecting the windings and guarding the user against shock, but also prevents the voltage to the output valve being reduced. But the output transformer must be correctly designed. It must have very low D.C. resistance and yet be able to carry a heavy current without core saturation and—it must be of the correct ratio.

The most positive means of obtaining the correct ratio is to try a number of different ones, switching rapidly from one to another until the actual reproduction from the loud-speaker proves definitely that you are obtaining the perfect ratio.

That is just what the INSTAMAT enables you to do. It is an output transformer of the most perfect design, fitted with an ingenious switching arrangement with which you can vary the ratio whilst you are actually listening. No need to switch off the set or disconnect wires—just turn the switch knobs and hear the tone change. It is the only output transformer capable of giving you perfect quality by the turn of a switch.

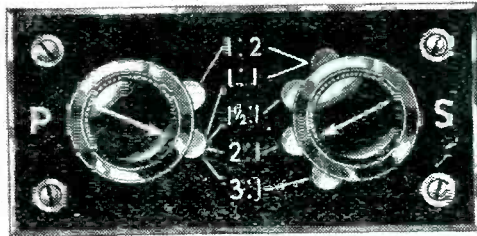

**INSTANT MATCHING SWITCHING
ON THE INSTAMAT**

INSTAMAT OUTPUT TRANSFORMER (5 YEARS' GUARANTEE)

Connect between last valve and loud-speaker. For all types except moving-coil speakers. Gives instant matching by the choice of five different ratios, all clearly marked. Extremely low D.C. Resistance, very heavy current carrying capacity and particularly generous core. Price **27/6**

MAJOR FOR LOW RESISTANCE MOVING-COIL SPEAKERS. Six ratios—10 to 1 up to 25 to 1. Heavy gauge windings and particularly large core. Current carrying capacity up to 150 milliamperes, without core saturation. Primary D.C. Resistance only 40 ohms: secondary 2 ohms. Weight 4 lb. Price **37/6**

If unable to obtain from your local dealer, we will send you an Instamat or Instamat Major direct upon receipt of cash with order. If you are not entirely satisfied with the Instamat and return it to us undamaged within 7 days we will refund your money in full. 5 years guarantee.

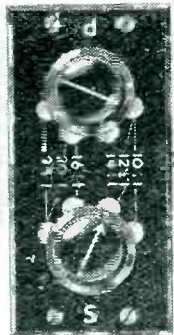
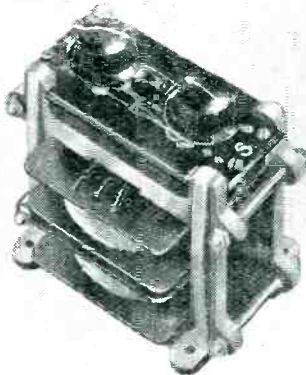

INSTAMAT MAJOR

Ready Radio Ltd

Ready Radio Ltd., 159 Borough High Street, London Bridge, S.E.1
Telephone: Hop 3000. Grams: Readirad. Sedist

HEAD OFFICE & WORKS: EASTNOR HOUSE, BLACKHEATH, S.E.3

All Portable Sets need a spare -

Perfect
for all
Portables

C.A.V. Jelly Acid Cells are now offered at greatly reduced prices with still further improvements in design and additional types suitable for the latest popular sets. Buy a C.A.V. replacement cell for use whilst yours is being recharged and enjoy continuous reception. There is a C.A.V. type suitable for every Popular Portable.

Examples of batteries for Popular Portables.

Pye Q and Marconiphone 55 - Type 2VN9/3 **12/6**
 Pye Twintriple B4D - - - Type 2VN11/1 **14/-**
 McMichael - - - - - Type 2VN11/2 **14/-**

C.A.V. BATTERIES Ltd.,
 WELL STREET, BIRMINGHAM.



**JELLY
ACID**



NON - SPILLABLE

**MAKE SURE OF COMPLETE
SATISFACTION BY FITTING
YOUR RADIOGRAMPHONE
WITH THE
PAILLARD INDUCTION MOTOR**

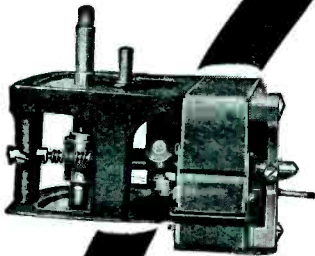

4 1/2" x 3 1/4" x 2 1/2"

The new Paillard Junior 2-pole asynchronous Induction Motor is made on an entirely new principle (patent applications pending). It gives a perfectly smooth drive without any kind of interference, and has an ample margin of power to play the heaviest recordings. Current consumption about 13 watts. No. 1501 for 100-130 v. No. 1503 for 200-250 v.

Price, complete with 12" Turntable, and combined brake and switch:
Automatic Brake 2/6 extra.

**NEW 45!
PAILLARD JUNIOR
ELECTRIC INDUCTION MOTOR**

HIRE PURCHASE TERMS Junior motors with automatic brake 5s. 3d. deposit and 11 monthly payments of 4s. 3d.
APOLLOGRAMOPHONE CO LTD. (Dept. W.M.)
 4-5 Bunhill Row, London, E.C.1
Fully illustrated price lists on application.

THE



**INDUCTOR
LOUD SPEAKER**

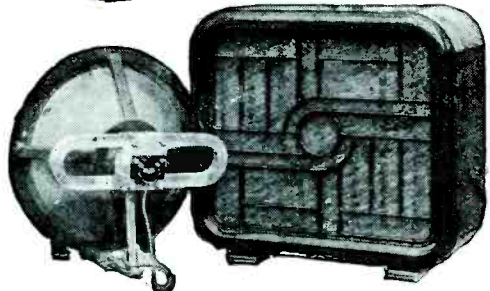

**CHASSIS
£3 10 0**

**IN BAKELITE CABINET
£5 5 0**

The great demand for the N & K Speaker proves that there is something more in it than its low price. Hear it for yourself and you will be convinced of the quality of reproduction.

IT WILL BE YOUR ULTIMATE CHOICE.

COMING SHORTLY!

N & K ALL MAINS RECEIVING SETS ON THE LOFTIN-WHITE PRINCIPLE, EMBODYING THE N & K INDUCTOR.

Drop us a P.C. and be on our Mailing List.

A. BRODERSEN, 11 Northampton Square,
 Goswell Rd., LONDON, E.C.1
 Phone: Clerkenwell 7286.

Agent for the Irish Free State:
L. R. WOOD, 41 MERCHANT STREET, CORK

DUX

THE WORLD'S BIGGEST VALUE TRANSFORMER

TAKES COMMAND

R.I. OUTCLASS COMPETITION

R place "DUX" in the field of universal competition to uphold British Radio Prestige and to protect the interests of the British Radio public who demand *low priced commodities with the efficiency to which they are entitled.*

LOW PRICE WITH EFFICIENCY

The transformer is the heart of the modern receiving set — its reliability must be certain despite low price, and "DUX," the most modern of all transformers, is *guaranteed to be absolutely dependable by its makers, who have been the pioneers in radio for over 30 years.*

"DUX" A PROVED SUCCESS

"DUX" is already acclaimed by the Wireless Press as the "Leader"—its qualifications of low price high efficiency are unchallenged.

BUY "DUX" FOR ECONOMY & SATISFACTION

The published technical data supplied with every "DUX" transformer is your guarantee of satisfaction. Remember this information is as essential with a low priced transformer as with the higher priced article.

"DUX" L.F. TRANSFORMER

Primary Inductance 30 Henries

Full diagrams supplied with each transformer

"DUX" Transformer, List No DY.29

Ratio 1 : 3½ (standard) or 1 : 4½ (auto-connection).

Weight, 11½ ozs. Dimensions: 2 x 3¼ x 2½ ins. high.

6/9

Get a copy of the new edition of the R.I. Catalogue. It is the finest component reference obtainable.

SFE "DUX"
at STAND No. 29
National Hall
(Ground Floor)
1931 Radio Exhibition
OLYMPIA

Radio Instruments Ltd. . . . Croydon, England

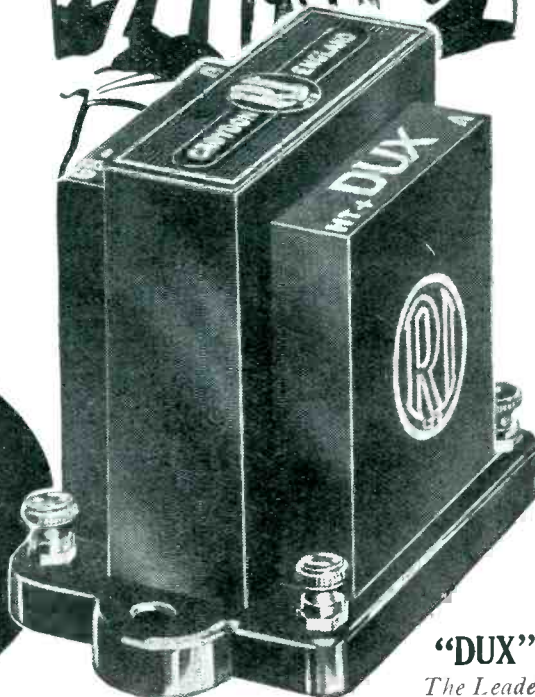

"DUX"
The Leader

What Do We Mean by "CAPACITY"?

John Collindale Answers the Question

YOU have probably wondered at some time or another why certain technical terms are applied to two separate qualities or quantities which, apparently, have little more than their name in common.

Take, for example, the term "capacity." It is used to denote the

CAPACITY—



This condenser has a "capacity" of 10 microfarads. It is one of the new T.C.C. wet electrolytic type.

properties of a condenser, and it is also used for expressing the quantity of electricity which can be drawn from a fully-charged accumulator. "Two totally different things," you say, "which ought to have two distinct names."

Not a Bad Choice

But wait a bit. Although the use of one word to express the two ideas seems at first rather confusing, closer examination will reveal that the choice of the word "capacity" as

applied both to a condenser and to an accumulator is not, perhaps, such a bad choice after all.

First let us take the case of the accumulator, the action of which is perhaps the more familiar to listeners.

You know, of course, that the accumulator consists of two sets of lead plates immersed in sulphuric acid, and that during the charging process a chemical action takes place, lead peroxide being formed on the positive plate and pure lead being deposited on the negative plate.

When the charged accumulator is connected to a circuit—the filament circuit of your valves, for instance—a current flows from the battery, while at the same time the reverse chemical action takes place, the lead peroxide and the lead being changed to lead sulphate.

It is important to realize that in the charging process the charging current produces a chemical action, and that in the discharging process the chemical action produces a current.

Now in all electro-chemical actions, the extent of the reaction depends upon two factors, (1) the current strength, and (2) the time during which the current is flowing.

Consequently the quantity of "active material" produced during charging is proportional to the strength of the charging current in amperes and to the time taken in charging in hours.

Similarly the quantity of electricity which can be drawn from a fully charged accumulator is approximately the same as that expended in charging it, and can be expressed in exactly the same way—as a certain number of "ampere-hours."

It seems, therefore, quite reasonable to speak of the number of ampere-hours obtainable from an accumulator as the "capacity" of the accumulator.

Now let us consider the action of a condenser in order to understand why

the term "capacity" can fairly be used to describe its properties.

Condenser action will be made clearer by the following simple analogy. Suppose we take one of those toy rubber balloons and blow into it. What happens? "Why, it becomes inflated," you say. Quite right, but exactly what does inflated mean?

Why the Bag Stretches

It means, does it not, that the pressure exercised by your lungs overcomes the atmospheric pressure outside the balloon, overcomes, too, the elastic pressure of the rubber bag, so that the bag stretches to accommodate an extra quantity of air?

The amount of air which can thus
(Continued on page 358)

—AND CAPACITY



An Exide accumulator having a "capacity" of 30 ampere-hours. Note the special identification label.

PILOT AUTHOR'S VITAL DECISION dictates 1932 POLICY

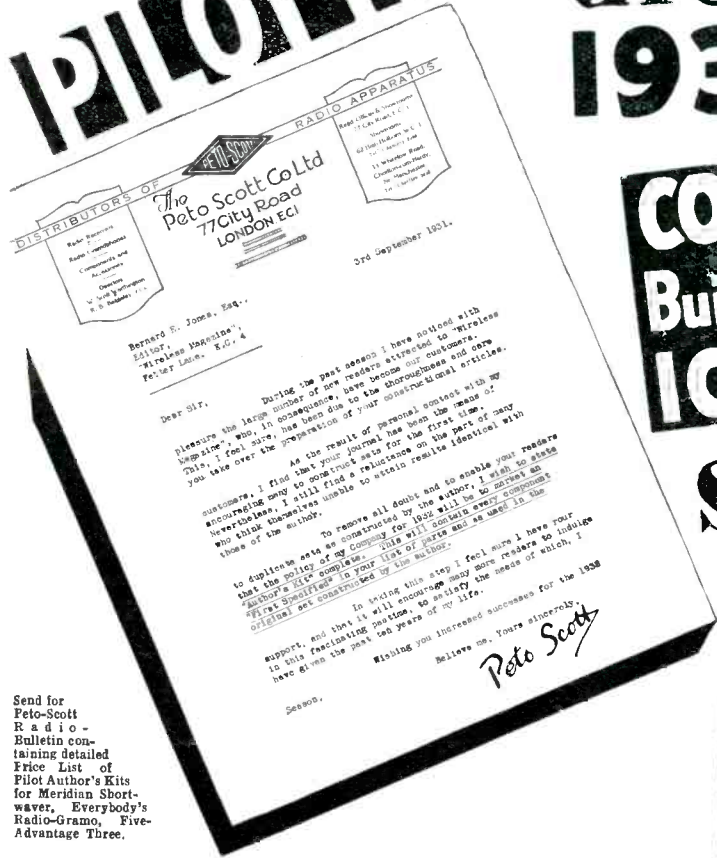

CONSTRUCTORS! Build "Authors" Sets with 100% SUCCESS

START NOW WITH MR. JAMES' SUPER SENIOR



Send for Peto-Scott Radio Bulletin containing detailed Price List of Pilot Author's Kits for Meridian Short-waver, Everybody's Radio-Gramo, Five-Advantage Three.

PILOT AUTHOR'S KIT FOR GREAT NEW SUPER

CHECK list of parts with the Author's specifications, photographs and wiring diagrams.

	£	s.	d.
1 Weaire standard H.F. choke	6	6	
1 Lewcos triple I.F. coil unit, type No. 49	1 11	6	
1 Lewcos Oscillator coil	18	6	
2 Varley H.F. intervalve coils, type BF6	17	0	
1 T.C.C. .0006-mfd. fixed condenser, type 34	1	6	
1 Dubilier .0002-mfd. fixed condenser, type 620	1	8	
1 Dubilier .0003-mfd. fixed condenser, type 620	8		
2 Dubilier .001-mfd. fixed condenser, type 620	4	0	
10 Dubilier 1-mfd. fixed condensers, type B3	1 5	0	
1 Jackson 2-stage .0005-mfd. chassis mount, with drum drive, type D2RA	1 6	6	
1 Jackson singlestage .0005-mfd. chassis mount with drum drive, type D1	19	0	
1 Ready Radio grid-leak holder	6		
2 Belling-Lee terminals, marked: A, E	6		
2 Belling-Lee spade terminals, marked: 1T, 1T	4		
8 Belling-Lee wander plugs, marked: 1T	1	4	
1 Sovereign 5,000-ohm flexible resistance	7		
2 Sovereign 15,000-ohm flexible resistances	1 8		
1 Sovereign 25,000-ohm flexible resistance	1	0	
1 Dubilier 5-meg. grid leak	1	8	
1 Colverstat 50,000-ohm wire-wound potentiometer	5	6	
Tinned copper wire for connecting	9		
1 ft. shielded cable	6		
Length rubber covered wire, screws, etc.	2	8	
1 Sovereign terminal block	6		
1 Ready Radio screen and bracket to specification	2	3	
1 Bulgin double-throw toggle switch	2	9	
1 Varley Nicore 11F transformer	17	6	
1 Baseboard, 20 in. by 12 in. by 3/8 in.	2	0	

Kit "A" C.O.D. or CASH PRICE **£9:14:9**

Any Parts supplied separately, orders over 10/- sent C.O.D. Post charges paid

P.S.
Of course! customers wishing to depart from the Author's Kit may depend on the co-operation and advice of our technical staff in the choice of approved substitutes. Again, we shall be pleased to supply separately any part for the sets described whether specified or substitutes.

KIT "A" Less Accessories £9:14:9
Or 12 monthly payments of 17/-

AUTHOR'S ACCESSORIES

	£	s.	d.		£	s.	d.
1 Camco Lincoln pedestal cabinet in walnut	5	17	6	1 Drydex 120-volt Orange Triangle H.T. Battery	1	4	0
3 Cosor 215 S.G. valves	3	0	0	1 Drydex 9-volt grid-bias battery	1	6	
1 Mullard PM 1DG valve	0	0	0	1 Exide 2-volt L.T. accumulator, type 1CX7	17	6	
1 Mullard PM 1HF valve	8	6					
1 Mullard PM 1LF valve	8	6					
1 Mullard PM 2A valve	10	6					

Accessories £13 8 0

FINISHED INSTRUMENT Assembled as lists here, less Batteries and Speaker. Aerial tested, **£25:0:0**
Royalties paid

Or 12 Monthly Payments of **£2:5:10**
N.B. Finished Instrument fitted with any speaker to choice at cost of speaker only.

C.O.D. CASH or H.P.



PETO-SCOTT CO. LTD. Head Office: 77 CITY ROAD, LONDON, E.C.1. Clerkenwell 9406. 62 HIGH HOLBORN, LONDON, W.C.1. Chancery 8266. MANCHESTER: 33 WHITELOW ROAD, CHORLTON-CUM-HARDY. Phone: Chorlton-Cum-Hardy 2028. NEWCASTLE, STAFFS: 7 ALBANY ROAD. Phone: 67190

TO BE CONTINUED

● ● ● YOU BEGIN WHERE WE LEFT OFF

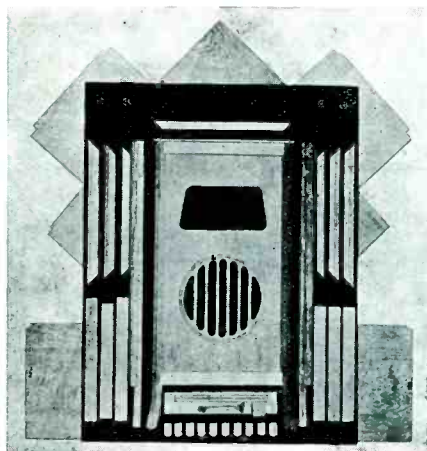

THE SET OF PARTS

PRICES :

KIT C, in Oak . . . £2 7 6

KIT C, in Birch . . . £2 0 0

MODEL A, in Oak, Complete Cabinet, polished . . . £3 18 6

MODEL B, in Oak unpolished . . . £3 7 6

NO EXTRA COST FOR PACKING AND CARRIAGE

AT LAST you can obtain a complete SET OF PARTS

of a very distinctive

RADIO-GRAM CABINET

We have done all the tedious work—work that can only be done by modern machines.

Your job is to assemble them. To do this the only tools required are a screwdriver, hammer and gimlet. You have no cutting to do and your result must be as if we had continued.

5 POINTS WORTH NOTING

- (i) Latest Design.
- (ii) No bulky doors in front.
- (iii) Reasonable size.
- (iv) The VIBRANTI Baffle is incorporated in front panel.
- (v) Accuracy of parts throughout.

CHARLES BORST & SONS
306-308 EUSTON ROAD
LONDON, N.W. 1

THE COMPLETE CABINET

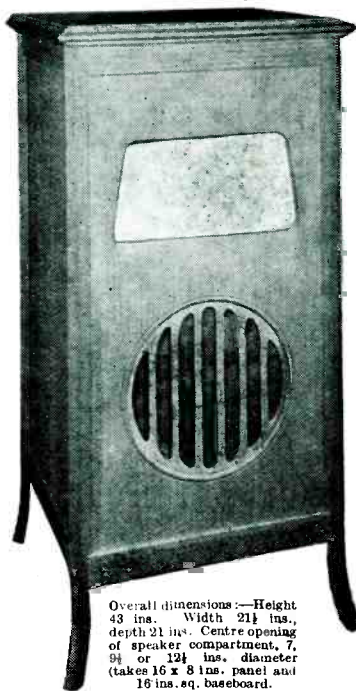

Overall dimensions:—Height 43 ins. Width 21½ ins. depth 21 ins. Centre opening of speaker compartment, 7, 9½ or 12½ ins. diameter (takes 16 x 8 ins. panel and 16 ins. sq. baseboard).

Size of panel opening, 13½" (widest part) x 6½". Distance between baseboard and Motor board, 11".

IMPORTANT.—When ordering please state size of centre opening of Speaker Compartment.

Let Your Friend Enjoy the "Wireless Magazine" Too!

The interest and pleasure which you derive from the "Wireless Magazine" will be greatly enhanced if you can discuss its monthly articles with a friend who is also familiar with its contents.

In order that anyone you know who is interested in wireless but is not yet a reader of "Wireless Magazine" may become acquainted with it, a complimentary copy

will be sent to him gratis and post free, if you will kindly complete the attached coupon, or if you do not wish to mutilate your copy, send your request on a p.c. The "Wireless Magazine" leads the way in Radio.

FILL IN THIS COUPON NOW ➡

"The Best Shillingsworth in Radio" Tells You Every Month All You Want to Know About Recent Progress in Radio Design—Look Out for the Next Issue on October 21!

To the Publisher "Wireless Magazine," 58/61 Fetter Lane, E.C.4

Please send a specimen copy of the "Wireless Magazine," free and post free, to my friend:

My own name and address are

Put this coupon in an unsealed envelope bearing 1d. stamp

A Mullard A.C. Mains Combination

The latest types of Mullard indirectly-heated A.C. mains valves in your new-season's receiver will ensure perfect reproduction. S4VA for the H.F. stage; 354V the improved super-detector; and 054V the new indirectly-heated output valve.

This combination will give you great sensitivity, perfect quality, and ample power for operating a large moving iron or moving coil speaker. For H.T. supply direct from A.C. mains use the D.W.2 as rectifier.

S4VA. Price 22/6

Max. Heater Voltage	- - - -	4.0 volts
Heater Current	- - - -	1.0 amp.
Max. Anode Voltage	- - - -	200 volts
Screen Voltage	- - - -	75-100 volts
Anode Impedance	- - - -	430,000 ohms
* Amplification Factor	- - - -	1,500
* Mutual Conductance	- - - -	3.5 mA/volt
* At Anode Volts 100:	Screen Volts 75.	Grid Volts Zero.

354V. Price 15/-

Max. Heater Voltage	- - - -	4.0 volts
Heater Current	- - - -	1.0 amp.
Max. Anode Voltage	- - - -	200 volts
* Anode Impedance	- - - -	10,000 ohms
* Amplification Factor	- - - -	35
* Mutual Conductance	- - - -	3.5 mA/volt
* At Anode Volts 100:	Grid Volts Zero.	

054V. Price 20/-

Max. Heater Voltage	- - - -	4.0 volts
Heater Current	- - - -	1.0 amp.
Max. Anode Voltage	- - - -	200 volts
* Anode Impedance	- - - -	1,250 ohms.
* Amplification Factor	- - - -	5
* Mutual Conductance	- - - -	4.0 mA/volt
* At Anode Volts 100.	Grid Volts Zero.	

D.W.2. Price 15/-

Filament Voltage	- - - -	4.0 volts
Filament Current	- - - -	1.0 amp.
Max. Anode Voltage	- - - -	250 - 250
		volts R.M.S.
Max Rectified Output	- - - -	60mA D.C.

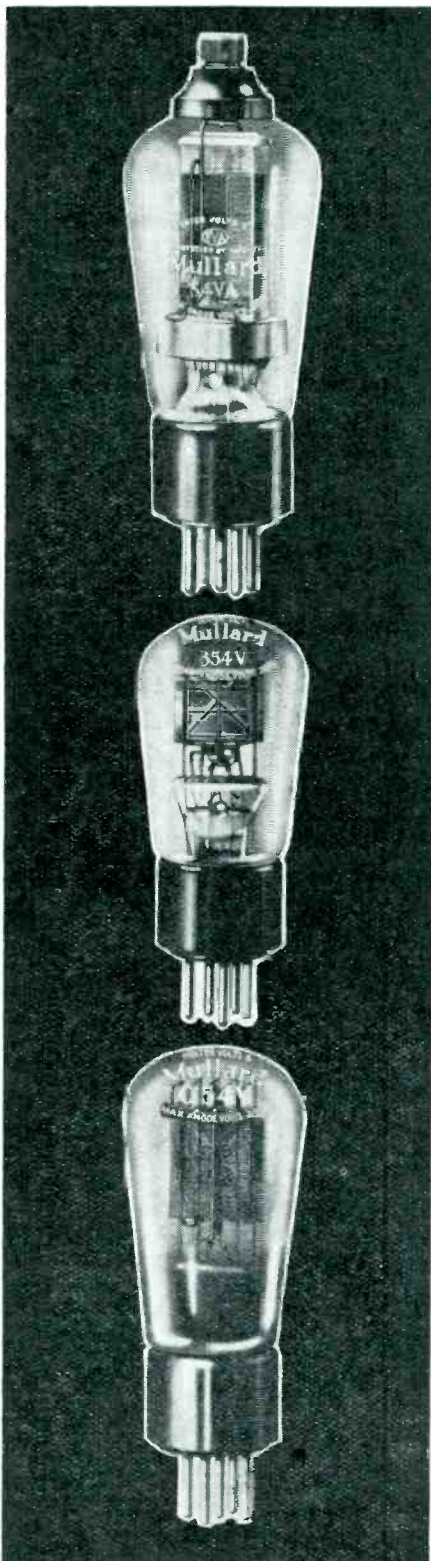

WE ARE EXHIBITING AT

THE NATIONAL RADIO EXHIBITION OLYMPIA

SEPT. 18 to 26

BRITISH AND BEST

Mullard

THE MASTER VALVE

Advt. The Mullard Wireless Service Co., Ltd., Mullard House, Charing Cross Road, London, W.C.2

Arks

MEANING OF "CAPACITY" — Continued from page 354

be forced into the balloon depends upon three things, (1) the difference between the pressure applied by the lungs and the atmospheric pressure; (2) the original size of the balloon when deflated, and (3) the elasticity of the rubber.

"Capacity" of Balloon

The size and elasticity of a given balloon being fixed once and for all, the "capacity" of a balloon may be fairly defined as the quantity of air, in cubic inches, which can be forced into it at a given pressure—say, at a pressure of one atmosphere.

This analogy describes perfectly the action of a condenser, which, as every listener knows, consists of two sets of plates separated by a non-conductor or "dielectric," which may be air, or mica, or waxed paper.

When a difference of electric pressure is applied between the plates the dielectric is placed in a condition of electric stress in the same way that the rubber of the balloon is placed under mechanical stress when air-pressure is applied. If the electric pressure is removed the dielectric will remain in a state of stress until a circuit is established between the two plates, when a momentary current will flow through the circuit and the stress will be relieved.

Stressed Dielectric

The quantity of electricity thus stored in the stressed dielectric and released when the condenser is discharged depends upon three things, (1) the size of the plates and the distance between them (corresponding to the size of the rubber balloon); (2) the "specific inductive capacity" of the dielectric (corresponding to the elasticity of the rubber of the balloon), and (3) the difference of electric pressure applied to the plates.

Quantity of Electricity

The dimensions of the plates and the nature of the dielectric are, of course, fixed for any one condenser, so it is perfectly logical to define the electrical "capacity" of a condenser as the quantity of electricity which can be forced into it by a pressure of one volt.

Now the unit of electrical quantity is the "coulomb" and represents the quantity conveyed in one second by a current of one ampere—in other

words one ampere-second. The unit of capacity, therefore, will be the capacity of a condenser which will take a charge of one coulomb when a pressure of one volt is applied to it, and this unit is called the "farad."

Because a capacity of one farad is inconveniently large as a unit, the practical unit of capacity is taken as the microfarad, or one-millionth part of a farad, and the charge given to a one-microfarad condenser by a pressure of one volt is one-millionth of a coulomb, corresponding to one-millionth of an ampere-second.

Thus we see that the capacity of an accumulator is measured in ampere-hours (one ampere-hour, of course, is 3,600 ampere-seconds) and the capacity of a fixed or variable condenser

in millionths of an ampere-second.

The two "capacities" are of the same kind and differ only in quantity, so that there is nothing inconsistent in using the same term for both.

Practical Differences

It should be remembered, however, that in the case of the accumulator the action is a reversible chemical change, while in the condenser the change is purely physical. But the two effects are identical, the practical differences being that an accumulator deals with comparatively large quantities of electricity and is charged and discharged slowly, while a condenser deals with very minute quantities of electricity and is charged and discharged at a very rapid rate.

RADIO IN A PRISON

What Is Being Done "Down Under"

THE following paragraph appeared in the Melbourne *Sun News Pictorial* a few weeks ago:—

PRISONERS SEND GAOLERS TO SEE FOOTBALL.

Geelong, Sunday.—Yesterday about 170 prisoners at the Geelong Gaol offered to go to their cells an hour earlier than usual to allow as many as possible of the warders to attend the Geelong-Richmond football match. The Governor was reluctant to accept the offer but, as the prisoners were insistent, they were put into their cells before the starting time of the football match.

Behind this short paragraph lies a romance.

For some time past the Geelong Gaol has been fitted with a wireless receiving installation and loudspeakers were placed in the work-rooms. Recently, however, the equipment was enlarged and extended to headphones in each individual cell.

The above-mentioned football match was between the local Geelong team and the Richmond team from Melbourne and naturally excited great local interest.

The prisoners, by returning to their cells early, were able to listen in to the match right from the start, and the warders were able to visit the Geelong Oval and see the play from the beginning.

The local team won with a con-

siderable margin, with the result that the locals were highly delighted, and interesting incidents of the game were a great source of conversation between prisoner and warden for the following few days.

Remarkable Event

Next day, Sunday, a more remarkable event was to take place. Prisoners at the gaol entertained listeners-in when the station 3GL broadcast a programme from the gaol, which included community singing by the prisoners.

The Gaol Quartet party sang a special number—"The Singer and the Song"—and the Gaol Mouth Organ Band contributed some quite classical items. Artistes from station 3GL also assisted.

The reception in the home loud-speaker was particularly good, but in the community singing there seemed to be an absence of female voices and the applause had a very solid but nevertheless hearty tone about it.

Very Free Trial

At the end of the programme everybody sang "The More We Are Together," and closed with "God Save the King." The most sentimental of pentologists must admit that this system is being given a very free trial. May the results supply full justification. E. W. L.

FOR MULTI-VALVE RECEIVERS

Unfluctuating power from FULLER H.T. wet accumulators



A receiver with more than three valves simply must have an absolutely dependable supply of Power which "comes through" evenly, steadily, without any variation or mains hum. Fit Fuller H.T. Wet Accumulators and banish all troubles. They will improve the selectivity of the receiver and purify its tone. They run for months without re-charging and then the renewal cost is very small. The micro-porous pasted plates (exclusive to Fuller) have a texture not merely finer and smoother than that of ordinary plates, but much more durable in wear. Then there are patent grease-cup terminals, effectively preventing corrosion and bad contacts. Fuller H.T. Wet Accumulators are contained in moulded glass boxes and are supplied dry charged.

- Type MHG 10 v. 3,000 M.H. - - - - 5/-
- Type DMHG 10 v. 6,500 M.H. - - - - 6/9
- Type QMHG 10 v. 10,000 M.H. - - - - 11/6

Obtainable through Fuller Service Agents or any reputable dealer.

FULLER

SUPER BATTERIES

Contractors to British and Overseas Government Departments, Railways, etc.

LONDON AND PROVINCIAL DEPOTS:

- LONDON: Hanover House, 73-78, High Holborn, W.C. 'Phone: Chancery 7453
- BIRMINGHAM: 29, Guildhall Buildings, Navigation Street. 'Phone: Midland 3103.
- MANCHESTER: 19, Chapel Walks, Cross St. 'Phone: City 0857.
- GLASGOW: 101, West Nile St. 'Phone: Douglas 4367.
- BRISTOL: 28, Cumberland St. 'Phone: Bristol 7958.
- LEEDS: 9, Mill Hill. 'Phone: Leeds 22865.
- SHEFFIELD: 48, Sandford Grove Rd. 'Phone: Sheffield 20738
- HULL: 69, Ryde Street. 'Phone: 502Yz.
- NEWCASTLE: 59, Side. 'Phone: Central 24068.
- SWANSEA: 10-11, St. Helen's Rd. 'Phone: Swansea 3208.
- BELFAST: 23a, University Rd. 'Phone: Belfast 5565.
- DUBLIN: 17, Pearse St. 'Phone: Dublin 44977.



"NON-SPILL" L.T. ACCUMULATORS JELLY ACID TYPE

For Portable Receivers. Micro-porous pasted plates. Indestructible separators; large non-spill vents. Standard on many well-known Portable Sets. Can be used in any position. JAP 11 22 a.h. 12/-, JUA9 18 a.h. 11/6. Ask for new list.



L.T. ACCUMULATORS

Dry-charged. New patented "Life Preserver" tells state of charge at a glance. Micro-porous paste; patent double grease-cup terminals; patent non-slip metal carrying handle free. LDGH 20, 60 a.h. 5/6. Also MSGH 2 v. 22 a.h. 4/6. Ask for new list.

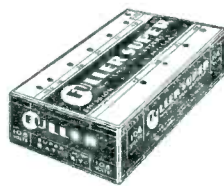

FULLER SUPER H.T. BATTERY

Machine made and tested throughout, each battery is guaranteed perfect and gives up to 20 milliamperes emission. 60 v. 7 1/2, 120 v. 15/3. Complete range of standard, super power and grid bias batteries available.

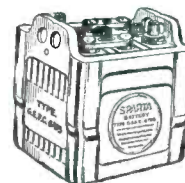

MOTOR CAR BATTERIES

Patent double grease-cup terminals eliminate risk of acid creep. Strong, durable ebonite container. Micro-porous paste. There is a type for every car. Ask for lists.

Full list of H.T. Dry Batteries and L.T. and H.T. Accumulators on request. 'Phone: Seven Kings 1200. 'Grams: "Fuller, Chadwell Heath."

FULLER ACCUMULATOR CO. (1926) LTD., Chadwell Heath, Essex.

You will get prompt replies by mentioning "Wireless Magazine"

McMICHAEL'S EVOLVE *the* PERFECT RADIO-GRAMOPHONE



Price 48 gns.
(Inclusive of Royalties)

Or by means of our "Deferred Payments on Hire Purchase Terms" system £7 13s. down and 10 monthly payments of £4 16s.

In the McMichael Radio-Gramophone reproduced sound finds its truest medium of expression. Every semitone of the chromatic scale—the characteristics of every instrument—every shade of expression in the human voice—all these things are reproduced with amazing lifelike reality. Call on your nearest McMichael dealer as soon as you can make it convenient, to-day if you can! He will be pleased to demonstrate this marvel of modern entertainment without obligation of any sort.

The McMICHAEL All-Electric A.C. RADIO-GRAMOPHONE

BRIEF SPECIFICATION

1. Built into this instrument you will find the famous McMichael All Mains Three—a receiver of exceptional power and tonal quality.
2. The electric motor used for rotating the records is perfectly noiseless, the tone and volume being easily controlled.
3. The Moving Coil Loudspeaker sets new high standards—truly, perfection in reproduction.
4. The cabinet is beautifully fashioned in figured walnut—a piece of furniture which adds dignity and charm to any room. You must see this set for yourself!

L. M^c MICHAEL LTD

Manufacturers of Wireless and Scientific Apparatus
WEXHAM ROAD, SLOUGH, BUCKS.
Telephone: Slough 441-442. Telegrams: Radiether, Slough
London Showrooms: 179 STRAND, W.C.2. (Tel.: Holborn 2466)

We are
EXHIBITING
at
OLYMPIA
Stand No 5
National Hall

ALL BRITISH—Built at our works at Slough and embodying the experience of eleven years successful Radio manufacture.

A STROBOSCOPIC SPEED-TESTER FREE



FOR ALL INTERESTED IN PERFECT GRAMOPHONE REPRODUCTION



Correct, steady Turntable speed—a pick-up that faithfully interprets all the beauty of tone which modern electrical recording has placed upon your record—correct Volume Control; these are the three first steps towards Perfect Reproduction. These conditions can easily be satisfied—

Let your Motor be our famous
"DIEHL" "ARISTOCRAT" (Induction Type

It sells for 84/-. Complete with Automatic Stop, etc. It is guaranteed for two years and backed by the World-famous Singer Organisation. It is positively "hum-less" and non-interfering.

Our "AUDAK" ELECTROCHROMATIC PICK-UP, Price 84/-. complete with specially designed Volume Control and Leads, and designed by Maximilian Weill, the acknowledged foremost authority on reproduction devices, is the best Pick-up made. Why not use it?

Booklet describing both instruments, free and post free. Request at the same time one of our Stroboscopic Speed-Testers (illustrated), printed on stout white card: Full instructions sent with each.



CLAUDE LYONS, LTD.

Head Offices: 76 OLDHALL ST., LIVERPOOL
London: 40 Buckingham Gate, WESTMINSTER, S.W.1

Advertisers like to know you "saw it in the 'Wireless Magazine'"



IT'S ACCURACY THAT TELLS!

If your condensers and their control is not accurate, you lose half the joy of radio. Buy "Astra" and accuracy.

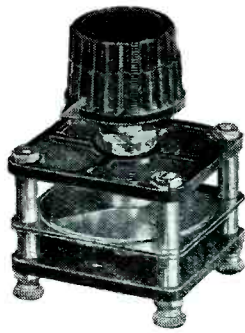

Pro. Pat.

NEW "ASTRA" DIFFERENTIAL

Fast and Slow Motion.
A condenser that gives you precision control. High insulation. Metal to metal contact. Patented ball-bearing movement. One hole fixing.

.00015, 3/6 .0003, 4/-

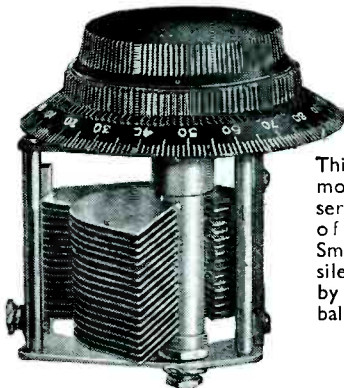

Pro. Pat.

NEW "ASTRA" SUPER SLOW MOTION

This new fast and slow motion all-brass condenser is highly accurate and of rigid construction. Smooth movement and silent action are obtained by the Patented "Astra" ball-bearing control.

.0005, 6/-
.0003, 6/-

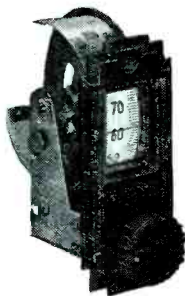

Pro. Pat.

NEW "ASTRA" DRUM DRIVE

The famous geared movement as used in "Astra" Dials, gives to the "Astra" Drum and Disc drives, that accuracy of control essential to secure the best from your set. No backlash. Clear scale 0-100 illuminated by pilot lamp. Artistic escutcheon. One hole fixing.

DRUM Drive - - 6/9
DISC Drive - - 4/6

"ASTRA" CONDENSERS and DIALS for ACCURACY

Obtainable from All Dealers.

Advert. of Enkabe Radio Co., Ltd., 47 Farringdon Rd., London, E.C.1

SPECIFIED

for the **"MERIDIAN" SHORT-WAVER**

and no wonder!



THE marvellous sensitivity of Ericsson Super Sensitive Telephones has made them standard for short-wave work. Every short-wave set of any class these days seems to have a pair hooked up.

This sensitivity is not the only feature for which they are renowned—their tonal qualities are most pleasing in their "roundness" of reproduction.

120, 2,000 and 4,000 ohms.
12/6

Sturdily made for hard work and so really comfortable that they do not cause any "phone fatigue" during long spells at the dials.

All good dealers stock them, or you can apply direct to
ERICSSON TELEPHONES, LTD.
67/73 Kingsway, London W.C.2



BRITISH SUPERSENSITIVE TELEPHONES

Please mention "Wireless Magazine" when corresponding with advertisers

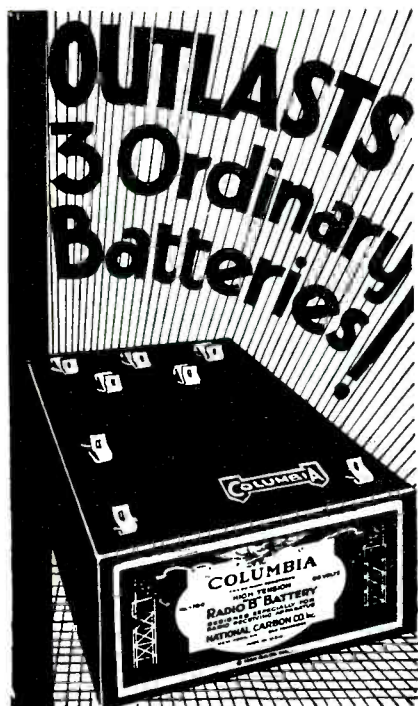

The Columbia Triple-capacity Battery (4780) is still the world's most economical battery. Its larger cells give you longer service than three ordinary batteries. They give you reception clear and undistorted, built on smoothly flowing power, free from all crackling noises.

Ask your dealer for Columbia 4780 (Triple Capacity), 60 volts. Now reduced to 17/6.

If your dealer has not Columbia in stock, send to us, giving his name.

Other famous Columbia Batteries.

4486.—"Layebilt," for large sets using power valves. Truly a battery and a half. 45 volts. 24/-.

4755.—For portables. 99 volts. 18/-.

No. 6.—Dry Cell, Red Label. Highly recuperative. 2/6.

MILLIONS IN USE ALL OVER THE WORLD

Columbia RADIO BATTERIES

J. R. MORRIS, Imperial House, 15 Kingsway, London, W.C.2

Scotland: J. T. Cartwright, 3 Calogian Street, Glasgow.

LISTENING IN SOUTH AFRICA

TO those of you who live in Old Blighty and have never left her shores, a distance of a thousand miles seems a tremendous long way. Look at a map of Europe; a circle with a diameter of a thousand miles, whose centre is, say, London, will embrace Algiers, Budapest, Warsaw, and Oslo.

To log these stations in London would be considered good for the average set, and yet, in South Africa, where there are only three main stations and where, therefore, there is little scope for the radio fan, distances five and six times this have to be traversed in order to be in touch with European broadcasting.

Because of our geographical position, too, we are at a disadvantage theoretically, since almost the whole of the distance is over land. The intervening space between us and America, on the other hand, is almost entirely water, which probably accounts for good reception from that country in spite of the extra distance.

Three Main Stations

There are three main stations in South Africa—Johannesburg, Durban, and Capetown. The first named is to have a relay station in Pretoria and another in Bloemfontein, while a short-wave transmitter operating on a wavelength of 49 metres has recently come into operation. The main stations work between 375 and 450 metres.

Bearing in mind the above, it will be seen that there is little scope for "local" work, so the short waves have to be relied upon for variety.

The writer lives in Johannesburg, so that the remaining two transmitters in Durban and Capetown are approximately 420 and 950 miles distant respectively. They can, of course, be picked up easily, but reception conditions are nothing like as good as in the Old Country; atmospherics are almost invariably present, and when a stage or two of high-frequency amplification precede the detector they become unbearable on most nights of the year.

Rome, working on 441 metres, would come in exceptionally well if it were not for the curse of the X's. Langenburg and Radio Toulouse can also be heard when conditions are favourable, although for some reason or other the British high-power stations are seldom more than

an un-resolvable carrier wave.

It seems that Continental stations modulate to a greater degree than the home stations. The same applies to the Empire station at Chelmsford. The carrier waves are most encouraging, but disappointment awaits their solver.

Rome on the Short Waves

On the short waves, again, Rome, operating on 25.4 metres, is the most reliable, and can be received well on almost any night. The same applies to the new experimental station in Paris, working on a slightly higher wavelength. Time out here is two hours ahead of G.M.T., so "waiting up for the Yanks" is even more of a vigil than in England.

Reception from America is usually at its best just before daybreak. The midnight chimes in New York can be heard at 7 Ack Emma, England, America, Germany, France, Italy, Holland, Australia, India, and the Philippine Islands can all be heard on the short waves when conditions are favourable.

A few nights ago Marconi's yacht *Elettra* was heard carrying out telephonic tests with New York. The yacht was in Genoa Bay at the time.

The licensing scheme in South Africa is interesting, and is based on the distance of the receiver from the broadcasting station. A fee of £1 15s. a year is charged for a radius up to a hundred miles, £1 5s. up to 250 miles and 15s. for all distances in excess of that.

In Johannesburg, apart from the usual wireless time signals, a scheme is in operation whereby at eight o'clock each evening the residents receive a time signal through the medium of their electric lights. On the stroke of the hour the lights are momentarily dimmed.

Hearing Big Ben

During B.S.T., that is, when London time is only an hour behind South Africa, it is interesting to tune in Chelmsford and hear Big Ben strike seven and compare it with the dimming of the lights.

Wonderful as it may seem, the first stroke of the hour at Westminster exactly synchronises with the dimming of the lights in Johannesburg. "Well done, Big Ben," would say some of our Colonists!

J. W. B.

A WORTHY CABINET FOR A FINE SET— The "Lincoln"

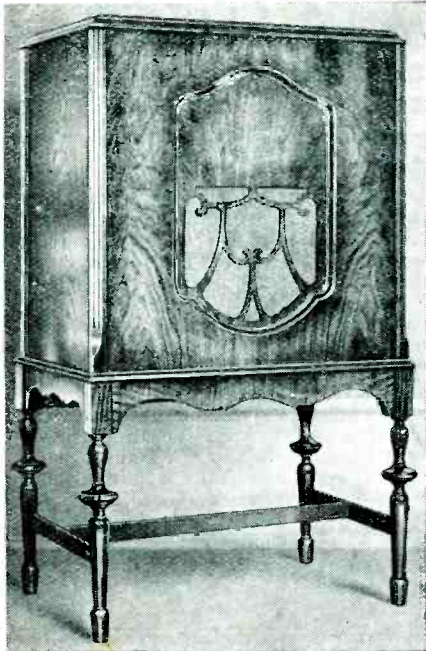

The "Lincoln"
£5 : 17 : 6

A  CABINET

A striking tribute is again paid to CAMCO by Mr. W. James, who describes the "Super Senior" Receiver as "The Most Handsome Set I have ever designed." In the "Lincoln" Cabinet you have dignity, grace and an acoustically designed Pedestal Cabinet for Set and Speaker. In beautiful shaded Walnut.

Send coupon for NEW 24-page Catalogue of Radio Cabinets to:

GARRINGTON MFG. CO., LTD.

24 Hatton Garden, London, E.C.1

'Phone: Holborn 8202.

Works: S. Croydon

COUPON

Name.....

Address.....

W.M 6

Engineers' Guide

containing the widest choice of engineering courses in the world

Qualify for a well-paid post in Engineering by studying at home with The T.I.G.B. Become an A.M.I.C.E., A.M.I.Mech.E., A.M.I.E.E., A.F.R.Ae.S., etc. Training until Successful is Guaranteed for the one fee. WRITE NOW for "The Engineers' Guide to Success," stating the branch, post or qualification that interests you, to

THE TECHNOLOGICAL INSTITUTE OF GT. BRIT.,
105 Temple Bar House,
London, E.C.4

Founded 1917. 17,000 Successes.



To Success

A CABINET "DE-LUXE"
for your **RADIO-GRAM SET!**
A Remarkable **MAKERS' OFFER!**
£12 12s. reduced to £8 8s.
£7 7s. reduced to £4 18s.
£3 3s. reduced to £2 15s.
(Cash or deferred)

The Superior QUALITY (delights! A fine charm of style that people desire. Advantages also of PIANO-TONE Baffle and sound chamber (no distortion, no drumming). Quite new—as supplied to leading experts, B.B.C. and Radio Press. You may have ON APPROVAL and return at OUR expense if you wish to part with it! This bargain offer is open for ONE MONTH. Photographs and full details FREE!

PICKETTS, Radio Furniture Works (M.G.),
Albion Road, Bexleyheath, Kent.

—SOLVE ALL H.T. TROUBLES—

Per doz.	No. 1.	No. 2.
	s. d.	s. d.
Jars (waxed)	1 3 1 8	
Sacs	1 2 1 9	
Zincs	10 1 11	
Rubber Bands (24)	4 4	
Terminals	8 10	

Trade Supplied

LONG LIFE : SILENT : ECONOMICAL
Sample doz. (18 volts), complete with bands and electrolyte. No. 1, 4/1; No. 2, 5/-; post 9d., terminals extra. No. 3 with terminals, 7/6 (10,000 milliamps). Sample unit, 6d. Orders 10/- carr. paid. New illustrated catalogue post free.

FREE. Bargain List of Receivers, Amplifiers & Components.

B. TAYLOR, 57 Studley Road, Stockwell, London.

When you want to replace Valves in your set consult our Valve Tables on pages 212 and 216

SLOW MOTION CONDENSER

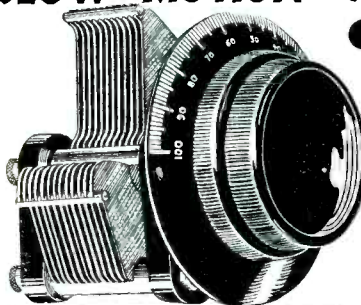

The Formo Company with their great experience in construction of variable Condensers introduce this new model Fast and Slow Motion Condenser, confident that this is the highest quality instrument available. The slow motion drive is silky and permits the tuning of close stations to a degree of accuracy that vastly improves the reception of your set. Other features are the Internal Pigtail and its small size and light weight. PRICE 6/-

Formo Products are obtainable from all Radio Dealers.

INSIST ON FORMO FOR

Complete Catalogue from:—

ARTHUR PREEN & CO., LTD.

THE FORMO-DENSOR

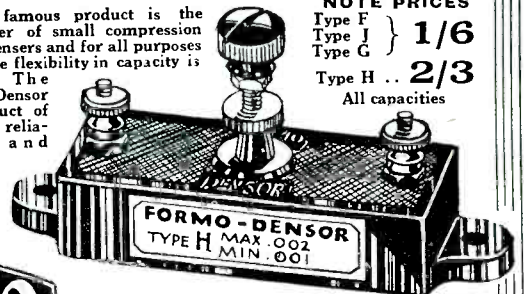

NOTE PRICES

Type F } 1/6

Type J } 1/6

Type G } 1/6

Type H .. 2/3

All capacities

FORMO-DENSOR
TYPE H MAX 002
MIN. 001

See also pages 340 and 365



EFFICIENCY IN RADIO

GOLDEN SQUARE, PICCADILLY CIRCUS,
LONDON, W.1 Crown Works, Southampton

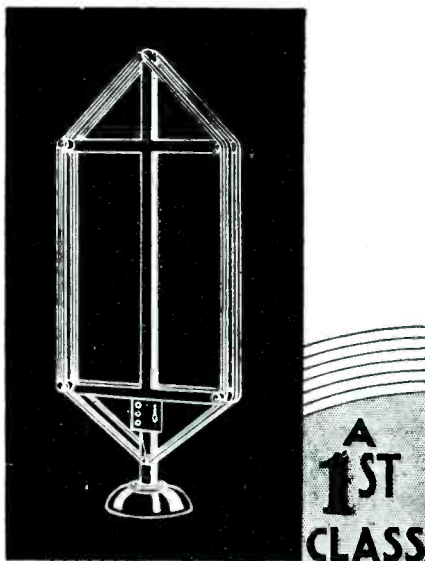

A 1ST CLASS FRAME AERIAL FOR ONLY 20/-

A wonderful frame aerial at an amazingly low price. This aerial was especially designed for use with Super-het receivers, but can also be employed in any circuit with or without centre tap.

The Ealex Frame Aerial has a definite minimum silent point.

AND THE EALEX SHORT WAVE CONVERTOR

which enables existing sets to be used for the reception of ultra-short-wave bands—thus giving you more and better programmes. Price 60/-.

J. J. EASTICK & SONS
118 Bunhill Row, London, E.C.1

Phone: Metropolitan 0314/5/6

OLYMPIA—STAND 252

EALEX FRAME AERIAL

DESIGN DATA SHEETS *By J. H. Reyner, B.Sc., A.M.I.E.E.*

"W.M." Design Data

No. 21

RECTIFIERS, CURRENT FOR

CONFUSION often arises regarding the current to be supplied by a transformer feeding a rectifier for high-tension supply. The A.C. required is not the same as the D.C. output but is appreciably greater, the difference depending on the type of rectifier used and the smoothing circuits employed.

If the D.C. output, for example, is 50 milliamperes, the alternating current to be supplied by the transformer may be over 100 milliamperes, and if this is not taken into account when designing the transformer the system will not work satisfactorily.

The voltage on the secondary will fall below the proper value owing to the excessive current and, in addition, the transformer winding will probably overheat.

The reason for this discrepancy is that the current is taken by the rectifier in the form of sudden pulses, whereas the D.C. load is a steady stream of current. In order to draw sufficient energy during each pulse a very large momentary current has to flow, and the effective value of this current is appreciably greater than the steady D.C.

As mentioned above, the type of

rectifier has a great influence on the wave-form of the current, a single-wave circuit being much more "peaky" than a double-wave arrangement, and therefore requires relatively more A.C. input. The effect is aggravated if too large a reservoir condenser is used and a value of 4 microfarads should not be exceeded, while in many cases a 2-microfarad condenser is adequate.

The table given below shows the ratio between the alternating current supplied by the transformer, and the full load D.C. taken from the output of the system. These figures are based on the use of a 4-microfarad reservoir condenser:

Type of Rectifier	Ratio A.C./D.C.
Valve Rectifier—double wave	1.6
Metal rectifier—double wave	1.8
Valve rectifier—single wave	2.0
Metal rectifier—single wave or voltage-doubling circuit	2.5

"W.M." Design Data

No. 22

MUTUAL INDUCTANCE

AN approximate estimate of the mutual inductance between two coils is often desired, particularly when designing band-pass filters. In such circumstances an accurate formula is not required and, in any case, such formulae are very cumbersome. For ordinary design purposes, however, simple formulae are available.

Two cases arise in ordinary practice.

The first of these is when the coils are co-axial as shown in Fig. 1. Here if A is the cross sectional area of the coil in square centimetres, N the number of turns, and d the distance between the centres of the windings, the mutual inductance is given by

$$M = \frac{AN^2}{500d^3} \text{ microhenries.}$$

Thus the coupling varies inversely as the cube of the distance so that if the

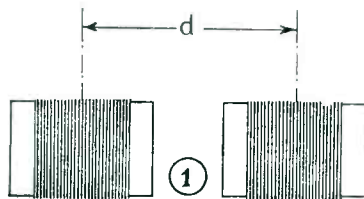

Fig. 1.—Coils mounted co-axially

coils are moved twice as far apart, the mutual inductance is reduced to one-eighth.

It is assumed that both coils are of identical construction.

The second case arises when the coils are side by side as shown in Fig. 2. In

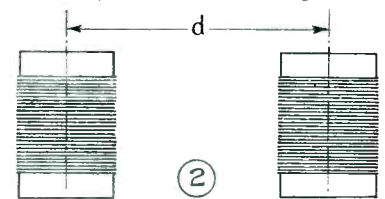

Fig. 2.—Coils mounted side by side

this case the mutual inductance between the two coils is half what it is when the coils are co-axial.

It is often desirable to mount the coils co-axially, and yet to obtain a small mutual inductance. To avoid having to place the coils a large distance apart, a single short-circuited turn of stout copper wire or strip may be placed midway between the two coils. This also has the effect of reducing the mutual inductance to one half the normal value.

COME TO OUR STAND 106

AT OLYMPIA (Ground Floor)

AND INSPECT (AND HEAR) the FINEST RANGE OF

MOVING COIL SPEAKERS

The World has ever seen.

Prices from 27/6 to £75

The FAMOUS

EPOCH SPEAKERS

If you cannot get near enough because of the crowds around our Stand, write for the new big Booklet MS5.

EPOCH RADIO MANUFACTURING CO., LTD., Exmouth House, Exmouth Street, (at junction of Farringdon Rd. and Rosebery Ave.), London, E.C.1.

Telephone: CLERKENWELL 6666 (4 lines)

BECOL QUALITY EBONITE SPECIFIED FOR FIVE-ADVANTAGE THREE

16" x 8" - 5s. 11d.

DESCRIBED IN THIS ISSUE

USE THE FAMOUS BECOL FORMER
26 TYPES

SEE OUR STAND No. 153 OLYMPIA

SOLE MAKERS:

The BRITISH EBONITE Co., Ltd.

HANWELL, LONDON, W.7

IT'S THE **LIMIT** YOU ARE WANTING



THE PICK-UP
With the Adjustable Reed

Combined Pick-up and Arm

H. T. BARNETT, Esq., writes:
"The variable damping feature is so valuable that the LIMIT should certainly be added to the Radiogram."

Pick-up only with leads and Ferrules 2/1-.

LIMIT RADIO LTD., 15-21 Windsor Street, Essex Road, N.1

32/6

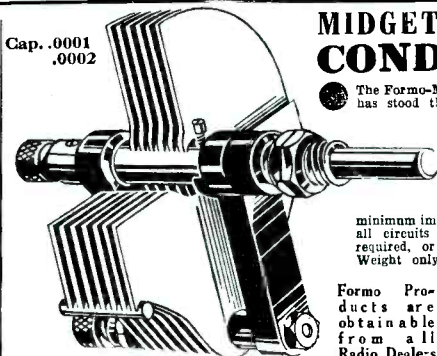

Cap. .0001
.0002

MIDGET REACTION CONDENSER

The Formo-Midget Reaction Condenser has stood the test for years, and is designed to reduce all losses to an absolute minimum. The concealed internal piston avoids use of bearing surfaces for current conduction, ensuring silent operation and minimum impedance, and is suitable for all circuits where reaction control is required, or where space is limited. Weight only 2 1/2 oz. Price 2/9 Knob 6d. extra.

Formo Products are obtainable from all Radio Dealers

See also pages 340 and 363



DIFFERENTIAL CONDENSER

For reaction, the Formo differential condenser achieves the smoothest possible control. The vanes are insulated from each other and in such a way as to avoid abrasive defects and "shorting." Use always Formo differential condensers and get highest possible results. PRICE 3/- complete with moulded knob. Capacity .00015

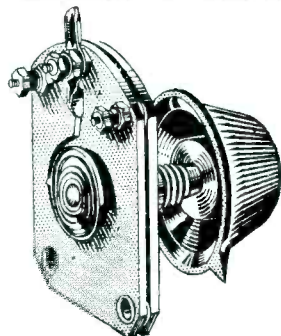

INSIST ON FORMO FOR

Complete Catalogue from:—
ARTHUR PREEN & CO., LTD.

EFFICIENCY IN RADIO

GOLDEN SQUARE, PICCADILLY CIRCUS,
LONDON, W.1. Crown Works, Southampton

It helps us if you mention "Wireless Magazine"

Watmel's latest!

THE WATMEL SQUARE-LAW TAPERED WIRE-WOUND RESISTANCE

OUR latest product—the Watmel 50,000 ohms wire-wound potentiometer specially wound on a tapered former giving a perfect square-law reading. This is the first resistance of its kind and has been very favourably commented upon.



NOTE THE POINTS—

- 1—Contact finger. Phosphor-Bronze.
- 2—Large contact plate.
- 3—Wire Wound Former.
N.B.—The resistance is WIRE, NOT compound with wire contacts. It is specially wound on a tapered former.
- 4—Engraved Bakelite front plate.
- 5—Polished pointer-knob.
- 6—Stops at end of wiring.
- 7—Insulating bush to insulate spindle from panel.
- 8—Back self-cleaning contacts.
- 9—Bakelite case—protects winding.
- 10—One-hole fixing—Brass bearing bush resulting in perfect bearing.

ANY RESISTANCE UP TO 50,000 OHMS ... 5/6

This is our latest product. Every part is made from the finest materials. Try Watmel components in your new sets this season. Ask your dealer for full particulars, or write to us direct.

TRADE ENQUIRIES INVITED

Watmel

GETS THE BEST OUT OF ANY SET
WATMEL WIRELESS CO. LTD.,
 Imperial Works, High Street, Edgware,
 Telephone: Edgware 0323 (M.C.40)

DESIGN DATA SHEETS—Cont.

"W.M." Design Data

No. 23

OUTPUT VALVES, DIRECTLY-HEATED

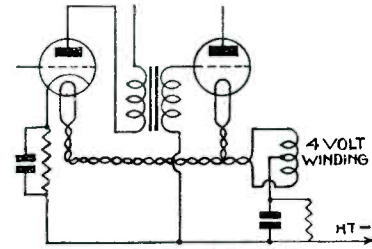

Method of using directly-heated output valve in A.C. circuit

IN an A.C. receiver employing indirectly-heated valves for the high-frequency and the detector stages, the output stage may use a valve of the directly or indirectly-heated type. In the latter case the filament and cathode connections are similar to those in the preceding stages, but if a directly-heated valve is used a slight modification is necessary.

In some cases an entirely separate heater winding is provided, but this is not essential, and the circuit herewith shows the arrangement of connections where the output valve draws its filament current from the same winding as the indirectly-heated valves.

The H.T.— point is not connected to the centre of the heater winding as is

usually the case, the connection being taken through a bias resistance shunted by a condenser of 1 microfarad or more as required. In general, more than 1 microfarad is not required in the output stage.

This connection ensures that the filament of the output valve shall be positive with respect to the H.T.— point by an amount equal to the voltage drop on the biasing resistance, and the low-potential end of the transformer is connected to H.T.— in the usual way, so obtaining the necessary negative bias.

In calculating the bias required, a value 3 volts greater than the specified value for the particular working conditions must be used. This is to allow for the alternating voltage on the filament. The voltage between the grid and the negative side of the filament is equal to the grid-bias voltage minus the instantaneous value of the alternating voltage.

The peak value of the alternating voltage is $2\sqrt{2}$, which is 2.8 volts, so that to allow for this and to ensure that the grid shall never be positive with respect to any part of the filament, the grid bias should be 3 volts greater than the normal working value.

"W.M." Design Data

No. 24

POWER TRANSFORMERS

THE winding on a power transformer must be designed to allow the iron circuit to operate at a certain magnetic flux density. If the number of turns in the primary winding is small, then the current drawn from the mains to magnetise the iron will be relatively large, and the iron circuit will be magnetised to a high degree.

If there are too many primary turns then the wire used will have to be fine in order to accommodate the necessary number of turns in the space, and the resistance of the winding will increase, giving a transformer having a poor regulation (that is, large variation of voltage with load) and over-heating. Satisfactory design lies in effecting a compromise between these two extremes.

If the flux density is too high the wave-form is distorted; and instead of being a pure sine wave it becomes irregular and difficult to smooth. Moreover, the transformer emits a large stray field, which induces mains

hum in the neighbouring components, and this form of disturbance cannot be smoothed out. An otherwise good set may thus be spoiled by an inadequately designed transformer.

For small transformers a flux density of 60,000 lines per square inch is satisfactory, and the table below gives the turns per volt in terms of the cross-sectional area of iron core passing through the centre of the transformer coils.

The approximate number of turns, therefore, is obtained by multiplying the voltage which the winding is to take or deliver by the turns per volt appropriate to the particular area of core:

Core Area (Square Inches)	Turns per Volt
0.2	38
0.4	19
0.6	12.5
0.8	9.5
1.0	7.5

YOU CANNOT GO WRONG IF YOU USE A

FULL-SIZE BLUEPRINT

CRYSTAL SETS

6d., post free

Regional Crystal Set	WM176
"B.B.C." Crystal Set	AW281

ONE-VALVE SETS

All these 1s. each, post free

Hartley One	WM198
One Control One	AW205
Regional Ultra-selective One	AW278
"B.B.C." One	AW280
Easy-to-Build One	AW304

TWO-VALVE SETS

All these 1s. each, post free

Brookman's Two (D, Trans)	WM168
Merlin Two (AC Set) (D, Trans)	WM213
Five-Point Two (D, Trans)	WM220
Brookman's A.C. Two (D, Trans)	WM225
Aladdin Two (D, Trans)	WM231
Ever-tuned Regional Two (D, Trans)	WM241
Station-finder Two (D, Trans)	WM243
Talisman Two (D, Trans)	AW194
Hyper-Selective Two (D Pentode)	AW198
British Broadcast Two (D, Trans)	AW215
Easy-tune Two (D, Trans)	AW226
Wavelets Two (D, Trans)	AW229
No Battery Mains (A.C.) Two (D, Trans)	AW230
No Battery Gramo-radio 2 (D, Trans)	AW238
1930 Talisman 2 (D, Trans)	AW239
Easy Tune Short-wave 2 (D, Trans)	AW242
Searcher Two (D, Trans)	AW245
Arrow Two (D, Trans)	AW249
Forty-Five Shilling Two (D, Trans)	AW250
Searcher Short-wave 2 (D, Trans)	AW259
Challenge Two (D, Trans)	AW261
Loftin-White 2 (A.C. Set)	AW263
Everybody's All-in 2 (D, Trans)	AW273
Twenty-Shilling Two (D, Trans)	AW274
B.B.C. Selective Two (D, Trans)	AW292

THREE-VALVE SETS

All these 1s. each, post free

Brookman's Three (SG, D, Trans)	WM161
Celerity Three (SG, D, Trans)	WM173
Music Marshal (D, 2 Trans)	WM190
Gramo-Radio D.C. Three (SG, D, Trans)	WM199
Concert Three (D, 2 Trans)	WM199
De-Luxe Three (D, RC, Trans)	WM209
Five-Point Three (SG, D, Trans)	WM212
Falcon Three (AC Set)	WM217
New Brookman's Three (SG, D, Trans)	WM218
Five-Point Short-waver (D, 2 Trans)	WM223
Battle-board Three (D, RC, Trans)	WM226
Plug-in Coil Three (D, 2 Trans)	WM232
Regional Three (SG, D, Trans)	WM236
Gramo-Radio AC3 (SG, D, Trans)	WM237

A blueprint of any one set described in the current issue of the "Wireless Magazine" can be obtained for half-price up to the date indicated on the coupon (which is to be found on page 368) if this is sent when application is made. These blueprints are marked with an asterisk () in the above list and are printed in bold type. An extension of time will be made in the case of overseas readers.*

Band-pass Inceptordyne (SG, D, Pen.)	WM244
Ether Marshal (SG, D, Trans)	WM247
★Five-Advantage Three (D, RC, Trans)	WM257
★Everybody's Radiogram (SG, D, Trans)	WM258
★Meridian Short-waver (D, RC, Trans)	WM255
Knife-edge Three (D, RC, Trans)	AW201
Everybody's Three (SG, D, Trans)	AW209
1930 Ether Searcher (SG, D, Trans)	AW211
New All-Britain Three (HF, D, Trans)	AW214
Best-by-Ballot Three (SG, D, Trans)	AW217
Price 4d. free with copy of "A.W."	AW220
Brookman's By-pass Three (D, 2 Trans)	AW220
Everybody's All-electric Three (SG, D, Trans)	AW221
1930 Clarion Three (SG, D, Trans)	AW223
Auto-Coupler Three (D, 2 LF)	AW225
Beginner's Regional Three (D, RC, Trans)	AW233
Car Three (D, RC, Trans)	AW244
"A.W." Exhibition 3 (SG, D, Trans)	AW247
"A.W." Challenge Kit 3 (SG, D, Trans)	AW250
Push-pull Two for D.C. Mains (D, Push-pull)	AW270
1931 Ether Searcher (SG, D, Trans)	AW271
1931 Ether Searcher (A.C. Mains)	AW276
Mains Section	AW277
Ultra-Selective Straight Three	AW282
1931 Ether Searcher (D.C. model)	AW284
Mains Section	AW285
Square Peak Three (SG, D, Trans)	AW293
1931 Britain's Favourite Three (D, RC, Trans)	AW299
Universal Short-wave Three (SG, D, Trans)	AW301
Olympian Three (SG, D, Trans)	AW306

FOUR-VALVE SETS

All these 1s. 6d. each, post free

Lodestone Four (HF, D, RC, Trans)	WM193
Searcher's Four (SG, D, RC, Trans)	WM194
Regional Band-pass Four (SG, D, RC, Trans)	WM211
Five-Point Four (SG, D, RC, Trans)	WM216
Supertone Four (SG, D, Push-pull)	WM227
Brookman's Three-Plus-One (SG, D, RC, Trans)	WM233
Broadcast Picture Four (HF, D, 2RC)	AW163
The Orchestra Four (D, RC, Push-pull)	AW167
All Europe Four (2HF, D, Trans)	AW173
Stability Four (HF, D, RC, Trans)	AW182

FIVE-VALVE SETS

All these 1s. 6d. each, post free

Overseas Five (3SG, D, Trans)	WM191
Regional D.C. 5 (SG, D, LF, Push-pull)	WM252
James Quality Five (2SG, D, RC, Trans)	AW227

SIX-VALVE SETS

All these 1s. 6d. each, post free

Hyperdyne	WM221
The Super 60 (Super-het)	WM229
A.C. Super 60 (Super-het) Radiogram	WM239
A.C. Super 60 (Super-het) Table Model	WM249
Super 60 (with Wearite Base)	WM245
Super 60 (with Lewcos Base)	WM251
Century Super (Super-het)	AW287
A.C. Century Super (Super-het)	AW295
Mains Unit (1/-)	AW295a

SEVEN-VALVE SET

1s. 6d. post free.

★Super Senior (Super-het)	WM255
-----------------------------------	-------

PORTABLE SETS

Pedlar Portable (D, 2 Trans)	WM197
--------------------------------------	-------

Super 60 Portable (Super-het)	WM238	1/6
Home and Garden Three (D, RC, Trans)	WM246	1/-
Music Leader (SG, D, RC, Trans)	AW203	1/-
with copy "A.W."	AW228	1/-
Merry-maker Portable (D, 2 Trans)	AW235	1/-
Sunshine Three (SG HF, SG, D, Trans)	AW241	1/-
Continental Portable (SG, D, Trans)	AW279	1/6
Companion Portable (21HF, D, 2 Trans)	AW297	1/6
Portable Century Super (Super-het)	AW297	1/6

AMPLIFIERS

All these 1s. each, post free

Radio-Record Amplifier (DC Mains)	WM183
Selecto Amplifier (HF Unit)	WM210
The D.C. Fader	WM242
"A.W." Gramophone Amplifier	AW205
Simple Gramophone Amplifier	AW257
High Quality Amplifier for A.C. Mains	AW275
2-Watt Amplifier for A.C. Mains	AW283
A.C. Push-pull Amplifier	AW291
Add-on H.F. Screened-grid Unit	AW296

MISCELLANEOUS

"W.M." Standard A.C. Unit	WM214	1/-
"W.M." Standard D.C. Unit	WM215	1/-
Falcon A.C. Unit	WM219	1/-
Hyperdyne S.W. Adaptor	WM228	1/-
Big H.T. Unit for A.C. Mains	WM230	1/-
Loud-speaker Tone Control	WM234	-/6
"WM" Linen Diaphragm Loud-speaker	WM235	1/-
Two-minute Adaptor for Short Waves	WM240	1/-
Super 60 A.C. Unit (for Battery Super 60)	WM248	1/-
Simple heon Oscillator	WM251	1/-
James H.T. and L.T. Charging Unit	AW232	1/-
Simple Battery Eliminator for A.C. Mains	AW236	1/-
Choke Output Unit	AW240	1/-
Simple Tester Unit	AW246	-/6
"A.W." Improved Linen Diaphragm Speaker	AW248	1/-
Handy L.T. and G.B. Unit for A.C. Mains	AW254	1/-
Ohmic Coupled DX Unit	AW255	1/-
A Simple Gramophone Amplifier	AW257	1/-
Novel Linen Diaphragm Speaker	AW260	1/-
H.T. Unit for A.C. Mains	AW262	1/-
Gramophone Tone Control	AW264	1/-
Short-wave Super-het Adaptor	AW268	1/-
H.T. Unit and Trickle Charger for D.C. Mains	AW272	1/-
High Quality Amplifier for A.C. Mains	AW275	1/-
2-Watt A.C. Amplifier	AW283	1/-
Booster Speaker	AW286	-/6
"A.W." Tone Changer	AW285	-/6
"A.W." Selectivity Unit	AW290	-/6
B.B.C. Official Selectivity Unit	AW304	-/6
A.C. Trickle Charger	AW305	1/-

Each blueprint shows the position of each component and every wire and makes construction a simple matter. Copies of "Wireless Magazine" and of "Amateur Wireless" containing descriptions of all these sets can be obtained at 1s. 3d. and 4d. respectively, post free. Index letters "A.W." refer to "Amateur Wireless" sets and "W.M." to "Wireless Magazine" sets.

Send, preferably, a postal order (stamps over sixpence in value unacceptable to

Wireless Magazine

BLUEPRINT DEPT.
58/61 FETTER LANE,
LONDON, E.C.4

BLUEPRINT COUPON

Valid only until October 31, 1931 (or until November 30 for overseas readers)

FOR ONE BLUEPRINT ONLY

If you want a full-size blueprint for any ONE of the sets constructionally described in this issue for half price, cut out the above coupon and send it, together with a postal order, to Blueprint Department, WIRELESS MAGAZINE, 58-61 Fetter Lane, London, E.C.4.

This coupon is valid for a blueprint of any ONE only of the following sets at the prices indicated:—

THE SUPER SENIOR (page 279), No. WM256, 9d., post free.

FIVE-ADVANTAGE THREE (page 245), No. WM257, 6d., post free.

EVERYBODY'S RADIOGRAM (page 261), No. WM258, 6d., post free.

MERIDIAN SHORT-WAVER (page 299), No. WM255, 6d., post free.

INFORMATION COUPON

Valid only until October 31, 1931 (or until November 30 for overseas readers)

If you want to ask any questions cut out the above coupon and send it, together with a postal order for 1s. and stamped-addressed envelope, to the Information Bureau, WIRELESS MAGAZINE, 58-61 Fetter Lane, London, E.C.4.

Note that not more than two questions may be asked at a time and that queries should be written on one side of the paper only.

Under no circumstances can questions be answered personally or by telephone. All inquiries must be made by letter so that every reader gets exactly the same treatment.

Alterations to blueprints or special designs cannot be undertaken; nor can readers' sets or components be tested.

If you want advice on buying a set a stamped-addressed envelope only (without coupon or fee) should be sent to Set Selection Bureau, WIRELESS MAGAZINE, 58-61 Fetter Lane, London, E.C.4.

WE NOTICE—

THAT W.B. are producing a new type of permanent-magnet moving-coil reproducer. The price of the chassis is £2 5s., while an oak cabinet model is available at £3 15s.

THAT Six Sixty are producing a "screen-grid, detector, and pentode" chassis kit at £6 17s. 6d. It has band-pass tuning and a combined radio and gramophone volume control.

THAT Lotus have a three-valve screen-grid table console set complete with moving-coil loud-speaker at 14 guineas.

THAT a new Wufa "60-pole" loud-speaker has been produced in cabinet form at £3 15s.

THAT Kabi components are supplied by A. Brodersen at 61 Spencer Street, E.C.1.

THAT Astra have a new disc drive at 4s. 6d. and a drum drive at 6s. 9d. There is also a differential reaction condenser, with fast- and slow-motion control, for 4s. (.0003 microfarad).

THAT Tungram are producing a range of double-grid valves at 16s. and 19s.

THAT a three years' guarantee is now given by Heayberd's with all their mains equipment.

THAT Graham-Farish have a new Snap loud-speaker unit at 5s. 6d.

THAT the R.G.D. people have a radio gramophone at 48 guineas for A.C. or D.C. supplies.

THAT Ormond have produced a permanent-magnet moving-coil cabinet reproducer at £4 19s. 6d.

THAT Ready Radio have two tapped output transformers known as the Instamat Standard (£1 7s. 6d.) and Major (£1 17s. 6d.) respectively.

THAT Hegra have a permanent-magnet chassis at £2 15s. and a new unit with cone clips for 1 guinea.

THAT B.T.H. have produced a new pick-up, called the Minor, at £1 7s. 6d. complete with arm.

THAT there is a new Blue Spot inductor loud-speaker chassis at £1 19s. 6d. (type 100U).

THAT Exide announce a 25 per cent. reduction in the prices of unspillable accumulators for portable sets.

THAT the New London Electron people have a "screen" aerial at 15s. for use indoors.

INDEX TO ADVERTISERS

	Page
Apollo Gramophone Co., Ltd.	352
Baker-Selhurst Radio	348
Bellini & Lee, Ltd.	340
Benjamin Electric, Ltd.	214
Bird, S.S., & Sons, Ltd.	211
Borst, Chas., & Sons	356
British Blue Spot Co.	351
British Ebonite Co., Ltd.	365
British General Manufacturing Co., Ltd.	223
British Institute of Engineering Technique	227
Brodersen, A.	320, 352
Bulgin, A. F., & Co., Ltd.	214
Burne-Jones & Co., Ltd.	348
Carrington Mfg. Co., Ltd.	363
Chloride Electrical Storage Co.	347, 323
Clarke, H., & Co. (M/cr), Ltd.	219, 235
Columbia Graphophone Co., Ltd.	321
Colvern, Ltd.	322
Coscor, A. C., Ltd.	327, 327
Daily Mail	215
Day, Will, Ltd.	210
Dubilier Condenser Co., Ltd.	337
Eagle Eng. Co., Ltd.	333
Edison Bell, Ltd.	210
Edison Swan Electric Co., Ltd.	Cover 4, iii
Eastick, J. J. & Sons	364
Electradix	227
Electroret Radio Co.	214
Emkabe Radio Co., Ltd.	361
Epoch Radio Mfg. Co., Ltd.	365
Eriesson Telephones, Ltd.	361
Ever Ready Co. (G.B.), Ltd.	229
Ferranti, Ltd.	223
Fluafite, Ltd.	333
Formo Co.	340, 363, 365
Franklin Electric Co., Ltd.	215
Fuller Accumulator Co., Ltd.	230, 359
General Electric Co., Ltd.	328, 329
Graham Amplion, Ltd.	341
Graham Farish, Ltd.	316, 317
Gramophone Co., Ltd.	335
Heayberd, F. C., & Co.	211
Hegra	332
Igranic Electric Co., Ltd.	219
Jackson Bros.	339
Kelster Brandes, Ltd.	221
Lamping, S. A., Ltd.	215
Leachester's Laboratories, Ltd.	325
Leetro Lins, Ltd.	348
Limit Radio, Ltd.	365
Lichtenberg, M.	218
Lock, W. & T., Ltd.	210
London Electric Wire Co., and Smiths, Ltd.	2, iv
London Radio Supply Co.	214
Lotus Radio, Ltd.	344, 345
Lyons, Claude, Ltd.	360
McMichael, L., Ltd.	360
Morris, J. B.	362
Mullard Wireless Service Co., Ltd.	357
Oldham & Son, Ltd.	222
Ormond Engineering Co.	Cover 3
Osborn, Chas. A.	340
Partridge & Mee, Ltd.	325
Pertrix, Ltd.	1
Peto Scott, Ltd.	355
Pickett Bros.	383
Pitoo, Ltd.	218
Pitchford, F., & Co., Ltd.	211
Radio Gramophone Development Co., Ltd.	336
Radio Instruments, Ltd.	353
Radio Mfg. Association	320
Ready Radio (R.R.), Ltd.	343, 351
Regentone, Ltd.	231
Reproducers & Amplifiers, Ltd.	320
Rotor Electric, Ltd.	219
Scott Sessions, G., & Co.	214
Six-Sixty Radio Co., Ltd.	217
Sovereign Products, Ltd.	218
Stratton & Co., Ltd.	324
Tannoy Products	332
Taylor, B.	363
Texado Radio & Electric Ltd.	336
Telegraph Condenser Co., Ltd.	324
Telsen Electric Co., Ltd.	311, 312, 313, 314
T.I.G.B.	363
Tungram Electric Lamp Works, Ltd.	213
Turner & Co.	325
Vandervell, C. A., & Co., Ltd.	352
Varley	319
Watmel Wireless Co., Ltd.	366
Westinghouse Brake and Saxby Signal Co., Ltd.	233
Whitely Electrical Radio Co., Ltd.	225
Wilkins & Wright, Ltd.	331
Wingrove & Rogers, Ltd.	343
Wright & Weaire, Ltd.	349

ORMOND

proudly present -

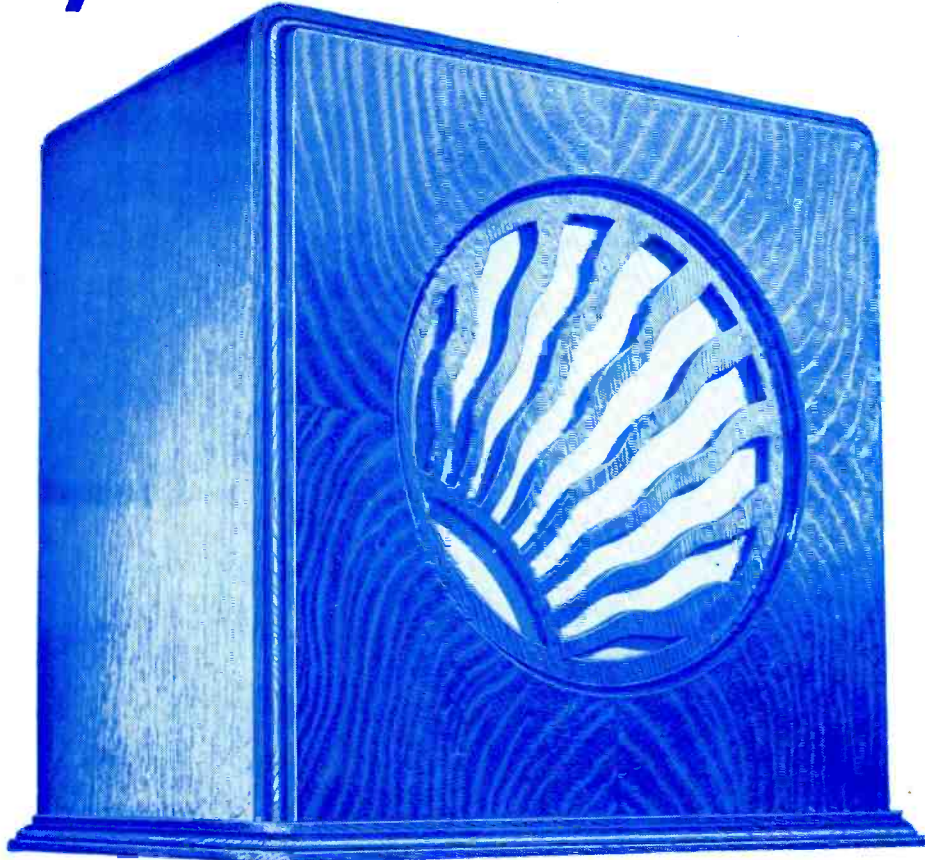

**MOVING-COIL
CABINET
LOUD-SPEAKER**

PUNCH, POWER and PURITY

The ORMOND ENGINEERING CO., LTD.
ORMOND HOUSE, ROSEBERY AVENUE, LONDON, E.C.1
Telephone: Clerkenwell 5334-5-6 and 9344-5-6. Telegrams: "Ormondengi, Isling"

- their latest Achievement!

In a new field of endeavour Ormond again takes the lead with a product of superb quality. Here's a speaker for the man who demands the best in all things. A balanced frequency response renders reproduction "as near to nature" as reproduced sound can ever be.

The Cabinet is handsomely constructed in figured Oak, and provided with terminals for connecting wires. A speech transformer is incorporated in the cabinet, and three sockets are fitted at the back, together with two leads complete with plugs, which allow for a choice of alternative ratios for matching with the valve used in the output stage of the receiver.

Cat. No. R/466. Height 16½ in. Width 16½ in. Depth 10½ in.

£4.19.6

WE ARE EXHIBITING AT

BRITISH AND BEST	THE NATIONAL RADIO EXHIBITION OLYMPIA	SEPT. 18 to 26
SEPT 18 to 26		BRITISH AND BEST



If you change to
MAZDA
 you'll find your
 set even better

If you can't get that station you want—
 change to Mazda. If you need a little more
 selectivity—change to Mazda. "Amazing"
 was the original verdict—and amazing
 still they are. There is exactly the valve
 for your purpose in the Mazda range. Ask
 your dealer for Mazda valves and see that
 you get them.

A 4-VALVE COMBINATION.

S.G.215	H.210	H.L.210	P.220 or P.220
20/-	8/6	8/6	10/6 13/6

MAZDA
 THE
 BRITISH
 VALVES

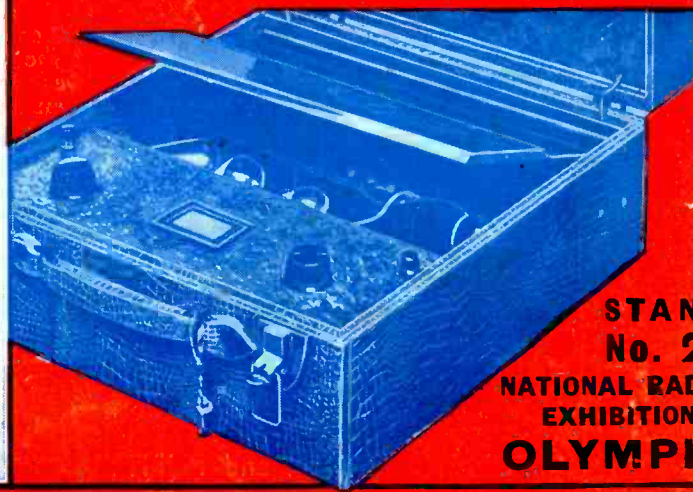

STAN
 No. 2
 NATIONAL RAD
 EXHIBITION
 OLYMPI

EDISWAN RADIO PRODUCTS

The Edison Swan Electric Co. Ltd.



155 Charing Cross Road, London, W.C.