

WEEK-ENDING WITH THE CONTINENTAL STATIONS (SEE P.239)

Wireless Magazine

VOL.9. No 51 APRIL, 1929

*Clipper Two
for £5!*

INCLUDING VALVES & COILS



FOUR SETS :: D.C. MAINS UNIT :: "MOTOR-BOATING"

THE MOST HIGHLY RECOMMENDED BATTERY ON THE MARKET — and why.....

... Performance—

has proved this claim of being the most efficient battery on the market, British made in every detail by the world famous electrical firm with over 50 years' battery manufacturing experience.

Whether you require the 60-volt "Popular" Type at 8/- or the 50-volt "Super Radio" Type at 25/-, you are offered the best battery value obtainable to-day.

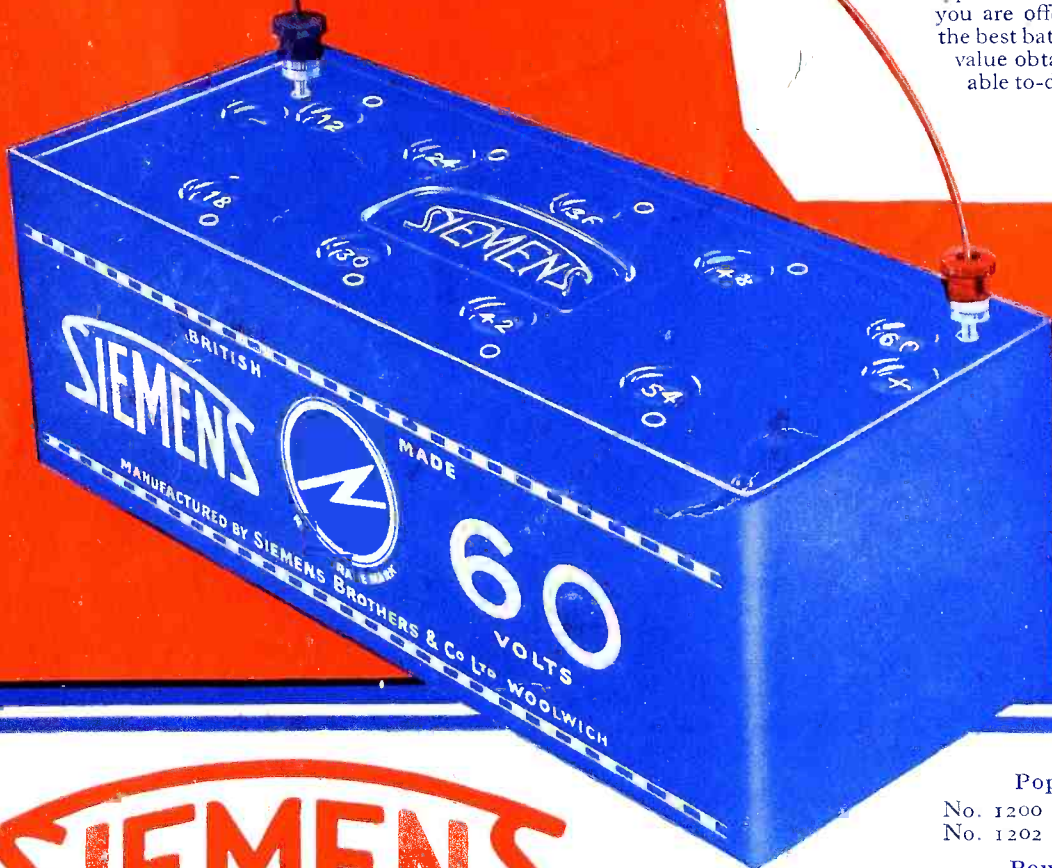

SIEMENS

RADIO BATTERIES

SIEMENS BROTHERS & CO. LTD., WOOLWICH, S.E.18

Popular Type		
No. 1200	60 volts	8/-
No. 1202	100 volts	13/-
Power Type		
No. 1204	"Power 60" volts	13/6
No. 1206	"Power 100" volts	22/6
Super Radio Type		
No. 1035	50 volts	25/-

Editor:
BERNARD E. JONES

Technical Editor:
J. H. REYNER,
B.Sc. (Hons.), A.M.I.E.E.

Wireless Magazine

The Best Shillingsworth in Radio

Vol. IX :: APRIL, 1929 :: No. 51

Research Consultant:
W. JAMES

Assistant Editor:
D. SISSON RELPH

This Month—Next Month

IN this little chat month by month, I seek to introduce my special features to the always-appreciative and sometimes critical reader. But as my mind, at the moment of writing is concerned more with the future than the present, I must, on this occasion, make my bow with an announcement of things to come.

Next month the WIRELESS MAGAZINE promises to be one of the most popular issues that has ever been produced by me. Its special feature will be an illustrated review of the portable sets now on the market.

At last the portable set has come into its own. 1927 saw a large number of really successful portables almost for the first time, and this year a steady improvement.

That is why I have thought it desirable, in my May issue, to place before my readers a special 16-page supplement occupied with illustrations and particulars (including prices) of the portables now obtainable. This supplement will show you how to choose, buy, and operate the various portables on the market.

In addition, I shall present constructional details of an absolutely new portable on which J. H. Reyner has been working for some time. So far in advance has he been able to get his designs completed that he has found it possible to put drawings and specifications of his set in two, or three different hands and thus to have the set independently built so as to make assurance doubly sure that every detail of it will be reliable.

Now, to my real job—to say a word about the chief features of my present issue.

Our cover this month shows you a very smart little set—the Clipper Two—which with valves and coils can be made for £5 and will prove to be an ideal set for the beginner. The Dominions Four is a general-utility set, which will have special advantages for the overseas reader, who, although we refer to him in the singular, is a rapidly increasing constituent of our circulation; the Dominions Four easily becomes a short-wave super-het.

All my readers living in houses supplied with A.C. current will look at the Dynamic Three—an all-electric set using an A.C. screened-grid valve.

You will turn over the pages for yourselves and find other constructional features, but I must mention W. James' Safe H.T. Unit for D.C. Mains, which is a companion to his A.C. Unit described in February.

W. James is the author also of an article on motor-boating, and how to remedy it, a curious trouble which has arisen co-incident with the increased efficiency of valves and other components.

The people—often young people—who are having a new house built, will find in "Wiring Your New House for Radio" many special worth-while hints.

The title of J. Godchaux Abraham's article is not "If You're Sick of the B.B.C." but the idea behind it is; he shows—and nobody can do so better—what you could get from the continental stations were the B.B.C. eliminated for just one week-end!

My readers will agree with me that this is one of our "peak" issues, but even so, the curve will go higher next month.

Do Not Overlook the Half-price Blue-print Coupon on Page iii of the Cover.

CONTENTS

	PAGE	PAGE	
Valves to Use in Your Set	208	Continental Appreciation..	251
Start Radio with the Clipper Two for £5!	211	What You Want to Know About Wired Wireless ..	252
A Broadcast Revolution.	217	Short-wave Relays from Colombo	254
Under My Aerial. . . .	218	Wiring Your New House for Radio!	255
If Your Set Starts Motor-boating. By W. James ..	221	Seeing When Distortion Occurs	257
More About the Lodestone Loud-speaker. By W. James	224	Hints for Success on the Short Waves. . . .	258
GRAMO-RADIO SECTION		A Wireless Fictionary. . .	259
Can You Cut Out Needle Scratch?	225	The Letters of Priscilla Playne-Smythe	260
Where to Place A Volume Control	225	Radio Quarrels in the United States	261
Is Gramo-Radio at A Standstill?	225	The Dynamic Three. A Set for A.C. Mains. . .	262
If I Were Bass Deaf. By H. T. Barnett. . . .	226	It's Better with A Baffle! ..	266
A Good Pick-up. By W. James	227	When Air-liners Talk by Radio!	267
Designing Scratch Filters. By J. H. Reyner, B.Sc., A.M.I.E.E. . . .	228	Half Hours with the Professor.—Amp Solves the Tuning Problem ..	270
The University of the Ether. By B.B.C. Officials ..	231	Japan's Pirate Listeners ..	274
Our Cartoonists "Review" Some Broadcasters ..	231	Broadcast Music of the Month. By Studius ..	276
"Show Me the Way to Go Home." Verse ..	232	In Tune with the Trade! (28)	280
A Safe H.T. Unit for D.C. Mains. By W. James ..	233	Leaves from A Listener's Log. By Jay Coote ..	282
Is the Aerial Doomed? ..	236	Loud-speakers from A New Angle. By Kenneth Ulllyett	286
Studio Audiences. By Tommy Hardley ..	237	The Drum-Major. A Four-valver for Quality..	290
A Visit to Savoy Hill. . .	238	A Cone Loud-speaker ..	297
My Radio Week-end. By J. Godchaux Abrahams..	239	Readers' Questions Answered	297
Wavelengths of the European Stations	242	Using the Melody Maker on the Short Waves ..	298
Wireless Fallacies. . . .	243	New System of Focused Radio	298
What Readers Think of Our Sets	244	Reference Sheets. Compiled by J. H. Reyner, B.Sc., A.M.I.E.E. . .	300
The Dominions Four. Can Be Converted into A Short-wave Super-het	246	A Free Broadcast Map ..	304
		Index to Advertisers ..	304

Published by BERNARD JONES PUBLICATIONS, LTD., publishers of "Wireless Magazine" and "Amateur Wireless." Editorial and Advertisement Offices: 58/61 Fetter Lane, London, E.C.4. Telephone: City 3733, 3734. Telegrams: "Beejapee, Fleet, London." Published about the 25th day of the month and bears the date of the month following. Subscription: Great Britain and Abroad, 15s. 6d. a year, post free (Canada only, 15s. 6d.). Contributions are invited and will be promptly considered.

Tell Your Friends About the Extra Portable Supplement Next Month!

Registered at the General Post Office for Transmission by Canadian Magazine Post

**AMAZING
NEWS!**

**OF THE
WORLD
FAMOUS**

**NEARLY 50%
REDUCTION
IN PRICE**

Brown

**H.Q. LOUD
SPEAKER**

THINK of it! The price of a world-famous BROWN Loud Speaker cut almost in half! Now anyone can have a loud speaker of the very highest quality. For, remember that this H.Q. Loud Speaker incorporates the base and movement of the famous ORIGINAL BROWN H.1. Loud Speaker—the instrument on which BROWN success is founded. Remember, too, that a horn speaker gives greater volume on distant stations than a cone instrument.

Why this big reduction has been made

Only by concentration in manufacturing on this Speaker has it been possible to make such an amazing price reduction. Design is the same. Materials are the same. Workmanship is the same. Only the price is changed. We are out to bring true radio reproduction within everyone's reach. Hear the 3 guineas H.Q. Loud Speaker at your Dealer's and you'll agree that we've succeeded. There's bound to be an enormous demand. Don't risk disappointment! Look in at your Dealer's to-night!

**Never before
have you
had such an
opportunity!**

**SAME Speaker
SAME Results
NEW PRICE!**

PREVIOUSLY

SOLD AT

£6

NOW

3 GNS.!

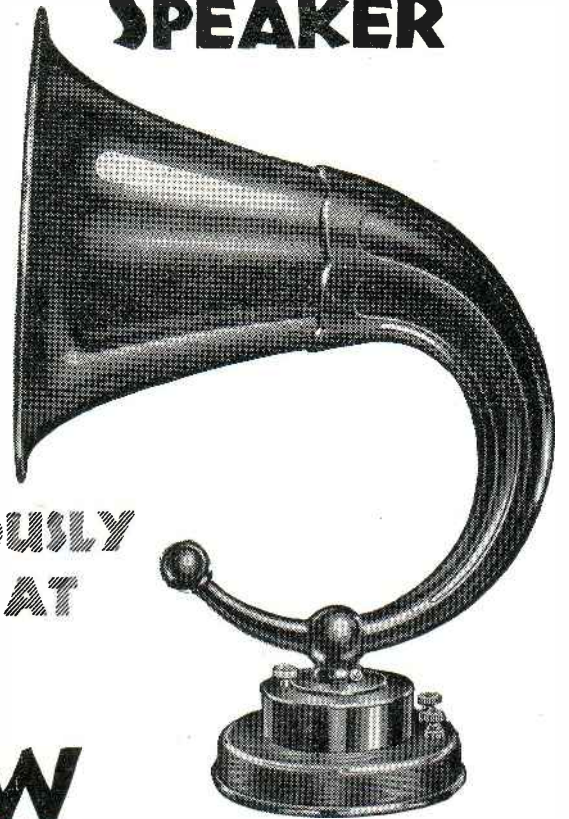

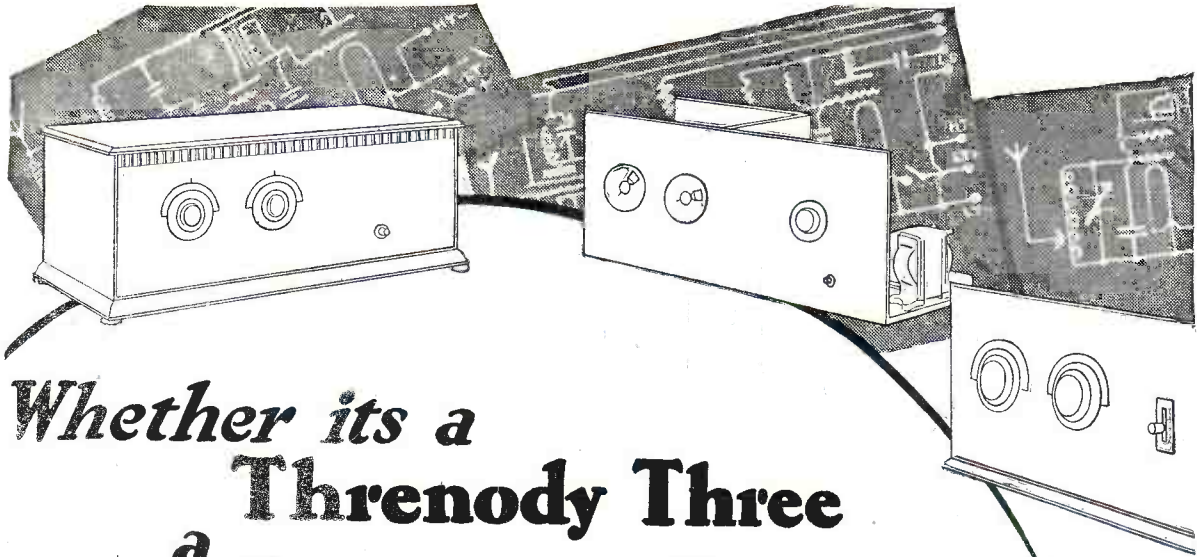

Whether its a
Threnody Three
 a
Fortissimo Four
 or
Multi-Melodian
 its the Valves that matter

The Range of Mazda Nickel Filament Valves TWO VOLTS

Type	H.T. Volts	Ampl. Fact.	Imp. ohms.
G.P. 210	120	13	14,000
H.F. 210	150	20	28,000
R.C. 210	150	40	86,000
L.F. 215	120	7	7,000
P. 227	120	4	2,900

FOUR VOLTS

Type	H.T. Volts	Ampl. Fact.	Imp. ohms.
G.P. 407	120	14	14,000
H.F. 407	150	18	21,000
R.C. 407	150	40	100,000
L.F. 407	120	8	5,700
P. 415	120	5.5	2,900

SIX VOLTS

Type	H.T. Volts	Ampl. Fact.	Imp. ohms.
G.P. 607	120	14	12,500
H.F. 607	150	20	20,000
R.C. 607	150	40	90,000
L.F. 607	120	9	5,300
P. 615	120	6	2,600
P.X. 650	200	3.5	1,750

The prefix letters indicate the purpose of a valve, and the figures which follow, the filament volts and amps. For example: L.F. 215 represents a 2-volt low frequency amplifying valve taking 0.15 ampere.



WHEN your set is ready for test, see that you select valves which will enable it to give the very best results. There are several reasons why your valves should be Mazda Nickel Filament Valves—Mazda Valves are the only valves which have nickel filaments, and it is this exclusive feature which gives them that wonderful degree of efficiency and their extraordinary long life.

The construction and disposition of the electrodes obviate leaks and losses. These features together with other constructional improvements assure better results in any circuit.

Your "Threnody Three" "Fortissimo Four" or any other set, will, if equipped with Mazda Valves, give the best results of which it is capable. We can't say more.

MAZDA
 THE NICKEL FILAMENT
VALVES

The British Thomson-Houston Co. Ltd., Crown House, Aldwych, London W.C.2

Valves to Use in Your Set

TWO-VOLT VALVES: Three-electrode Types

Make.	Type.	Impedance.	Amp. Factor.	Fil. Volt.	Fil. Cur.
Ediswan	RC2	150,000	30	2	.1
Mazda ...	RC210	86,000	40	2	.1
Cosmos ...	SP16B	70,000	35	1.8	.09
Six-Sixty	210RC	68,000	35	2	.1
Ediswan	RC210	67,000	40	2	.1
Cossor ...	210RC	60,000	40	2	.1
Mullard...	PM1A	51,000	36	2	.1
Marconi...	DEH210	50,000	35	2	.1
Osram ...	DEH210		35	2	.1
Mazda ...	HF210	28,000	20	2	.1
Six-Sixty	210HF	27,000	13	2	.1
Ediswan	HF210	25,000	20	2	.1
Marconi...	HL210	23,000	20	2	.1
Osram ...	HL210		20	2	.1
Mullard...	PM1HF	22,500	18	2	.1
Cossor ...	210HF	20,000	15	2	.1
Six-Sixty	210LF	18,000	8.5	2	.1
Cosmos ...	SP16G	17,000	16	1.8	.09
Mazda ...	GP210	14,000	13	2	.1
Ediswan	LF210	13,000	13	2	.1
Cossor ...	210LF	12,000	10	2	.1
Marconi...	DEL210		11	2	.1
Mullard...	PM1LF	11	2	.1	
Osram ...	DEL210	11	2	.1	
Mullard...	PM2DX	10,700	13.5	2	.25
Cosmos ...	SP16R	10,000	9	1.8	.09
Six-Sixty	215P	7,300	6.4	2	.15
Mazda ...	LF215	7,000	7	2	.15
Ediswan	PV215	6,600	8	2	.15
Cossor ...	220P	5,000	5	2	.2
Marconi...	DEP215		7	2	.15
Osram ...	DEP215	7	2	.15	
Cosmos ...	SP18RR	4,500	6.5	2	.2
Mullard...	PM2	4,400	7.5	2	.2
Cossor ...	220P	8	2	.3	
Six-Sixty	230SP	4,000	3.9	2	.3
Mazda ...	P227	2,900	4	2	.27
Ediswan	PV225	2,700	3	2	.25
Mullard...	PM252	2,600	5.4	2	.3
Marconi...	DEP240	2,500	1	2	.4
Osram ...	DEP240		1	2	.4
Cossor ...	230XP	2,000	1	2	.3

FOUR-VOLT VALVES—Continued

Make.	Type.	Impedance	Amp. Factor	Fil. Volt.	Fil. Cur.
Mullard...	PM4DX	7,500	15	4	.1
Mazda ...	LF407	5,700	8	4	.075
Ediswan	PV410	5,500	5.5	4	.1
Marconi...	DEP410	5,000	7.5	4	.1
Osram ...	DEP410		7.5	4	.1
Ediswan	LF410a	4,500	9	4	.1
Mullard...	PM4	4,450	8	4	.1
Cossor ...	410P	4,000	8	4	.1
Six-Sixty	425SP	3,600	3.2	4	.25
Mullard...	PM254	3,500	3.15	4	.25
Mazda ...	P415	2,900	5.5	4	.15
Marconi...	P425	2,250	4.5	4	.25
Osram ...	P425		4.5	4	.25
Cossor ...	415XP	2,000	4	4	1.5
Ediswan	PV425		3	4	.25

SIX-VOLT VALVES: Three-electrode Types

Make.	Type.	Impedance.	Amp. Factor	Fil. Volt.	Fil. Cur.
Mazda ...	RC607	90,000	40	6	.075
Six-Sixty	6075RC	74,000	37	6	.075
Cossor ...	610RC	60,000	50	6	.1
Marconi...	DEH610		40	6	.1
Osram ...	DEH610	40	6	.1	
Mullard...	PM5B	53,000	40	6	.075
Ediswan	RC610	50,000	40	6	.1
Marconi...	HL610	30,000	30	6	.1
Osram ...	HL610		30	6	.1
Marconi...	LS5B	25,000	20	5.25	.8
Osram ...	LS5B		20	5.25	.8
Ediswan	HF610	21,000	25	6	.1
Cosmos ...	DE50	20,000	9	6	.09
Cossor ...	610HF		20	6	.1
Mazda ...	HF607	20,000	20	6	.1
Six-Sixty	6075HF	14,700	20	6	.075
Mullard...	PM5X		17.5	6	.075
Mazda ...	GP607	12,500	14	6	.075
Ediswan	LF610	10,000	15	6	.1
Mullard...	PM6D	9,000	18	6	.1
Cossor ...	610LF	7,500	15	6	.1
Marconi...	DEL610		15	6	.1
Osram ...	DEL610	15	6	.1	
Marconi...	LS5	6,000	5	5.25	.8
Osram ...	LS5		5	5.25	.8
Six-Sixty	610P	7.2	6	.1	
Mazda ...	LF607	5,300	9	6	.075
Mullard	PM6	5,200	7.1	6	.1
Ediswan	PV610	4,200	5	6	.1
Six-Sixty	625SP	3,600	3.2	6	.25
Cossor ...	610P	3,500	8	6	.1
Marconi...	DEP610		8	6	.1
Mullard...	PM256	3.15	6	.25	
Osram ...	DEP610	8	6	.1	
Ediswan	PV625	3,000	3	6	.25
Marconi...	LS5A	2,750	2.5	5.25	.8
Osram ...	LS5A		2.5	5.25	.8
Mazda ...	P615	2,600	6	6	.15
Marconi...	P625	2,400	6	6	.25
Osram ...	P625		6	6	.25
Cossor ...	610X1	2,000	5	6	.1
Mullard...	DFA9		5	6	.6
Mazda ...	PX650	1,750	3.5	6	.5
Ediswan	PV625A	1,600	4	6	.25
Marconi...	P625A		3.7	6	.25
Osram ...	P625A	3.7	6	.25	

FOUR-VOLT VALVES: Three-electrode Types

Make.	Type.	Impedance.	Amp. Factor.	Fil. Volt.	Fil. Cur.
Mazda ...	RC407	100,000	40	4	.075
Six-Sixty	4075RC	64,000	34	4	.075
Ediswan	RC410	61,000	40	4	.1
Cossor ...	410RC	60,000	40	4	.1
Marconi...	DEH410		40	4	.1
Osram ...	DEL410	10	4	.1	
Mullard...	PM3A	55,000	38	4	.075
Ediswan	HF410	22,000	25	4	.1
Mazda ...	HF407	21,000	18	4	.075
Cossor ...	410HF	20,000	20	4	.1
Six-Sixty	4075HF	16,500	13	4	.075
Mazda ...	GP407	14,000	14	4	.075
Mullard...	PM3	13,000	14	4	.075
Ediswan	LF410	10,500	13	4	.1
Cossor ...	410LF	8,500	15	4	.1
Marconi...	DEL410		15	4	.1
Osram ...	DEL410	15	4	.1	
Six-Sixty	410P	8,000	7.3	4	.1

FOUR-ELECTRODE VALVES: Screened-grid						MAINS VALVES: Three- and Four-electrode					
Make.	Type.	Impedance.	Amp. Factor.	Fil. Volt.	Fil. Cur.	Make.	Type.	Impedance.	Amp. Factor.	Fil. Volt.	Fil. Cur.
Mullard...	PM12	230,000	200	2	.15	Marconi...	S Point 8	200,000	160	.8	.8
Six-Sixty	215SG	220,000	190	2	.15	Osram ...	S Point 8		160	.8	.8
Cossor ...	220SG	200,000	200	2	.2	Marconi...	H Point 8	55,000	40	.8	.8
Marconi...	S215		170	2	.15	Osram ...	H Point 8		40	.8	.8
Osram ...	S215	140,000	170	2	.15	Marconi...	HLPoint 8	17,000	17	.8	.8
Ediswan	SG215		140	2	.15	Osram ...	HLPoint 8		17	.8	.8
Mullard...	PM14	230,000	200	4	.075	Marconi...	P Point 8	6,000	6	.8	.8
Six-Sixty	4075SG	220,000	190	4	.075	Osram ...	P Point 8		6	.8	.8
Cossor ...	410SG	200,000	200	4	.1	Marconi...	KH1	30,000	40	3.5	2.0
Ediswan	SG410	115,000	140	4	.1	Osram ...			KH1	40	3.5
Marconi...	S625	175,000	110	6	.25	Marconi...	KL1	3,750	7.5	3.5	2.0
Osram ...	S625		110	6	.25	Osram ...	KL1		7.5	3.5	2.0
Ediswan	SG610	100,000	140	6	.1	Cossor ...	MRC	50,000	50	4	1.0
FIVE-ELECTRODE VALVES: Pentodes						Ediswan	M141RC	50,000	45	4	1.0
Make.	Type	Impedance.	Amp. Factor.	Fil. Volt.	Fil. Cur.	Cossor ...	M11P	20,000	20	4	1.0
Ediswan	5E225	65,000	80	2	.25	Cosmos ...	AC/G	17,500	35	4	1.0
Six-Sixty	230PP	64,000	80	2	.3	Ediswan	MI41	9,000	16	4	1.0
Mullard...	PM22	62,500	82	2	.3	Cossor ...	MLF	8,000	8	4	1.0
Marconi...	PT235	55,000	90	2	.35	Cossor ...	MP	6,500	5.5	4	1.0
Osram ...	PT235		90	2	.35	Cosmos ...	AC/R	3,000	10	4	1.0
Cossor ...	230QT	20,000	40	2	3	Cossor ...	MXP		3.5	4	1.0
Mullard...	PM24	28,600	62	4	.15	<i>A glance through the constructional articles in this issue will give the novice some hints regarding the best valves for the various types of circuits</i>					
Six Sixty	415PP	27,000	60	4	.15						
Cossor ...	415QT	20,000	40	4	.15						
Mullard...	PM26	25,000	50	6	.17						

THERE IS A REASON

Why The Lewcos H.F. Choke Stands Alone for Efficiency—
and the reason is not far to seek.

The finest quality materials and the high-class workmanship used in the manufacture of the LEWCOS H.F. CHOKE make it supreme.

The terminals are arranged one at the top and the other at the base of the coil to eliminate the risk of additional self-capacity in the wiring of the receiver.

Equip your set with a LEWCOS H.F. CHOKE and be confident of perfect reception.

The LEWCOS H.F. CHOKE is obtainable at all Radio Dealers.

A Chart showing its performance and full particulars will be sent on application.

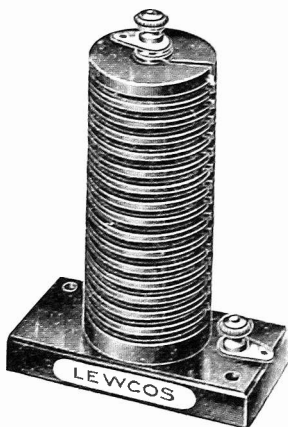

H.F. CHOKE
Price - 9/-

LEWCOS
(REGD.)
HIGH-FREQUENCY CHOKE

**SPECIFIED FOR "THE
DOMINIONS FOUR"**



THE LONDON ELECTRIC WIRE COMPANY AND SMITHS LIMITED, CHURCH ROAD, LEYTON, LONDON, E.10.

Trade Counter and Cable Sales: 7, Playhouse Yard, Golden Lane, E.C.1.

FULL STRENGTH TUNING

easy and definite separation of stations

The new Lissen Variable Condenser enables you to enjoy a new standard of tuning—a new sense of smooth control—a new ease in separating stations close together—*simply because there is no condenser loss, and incoming signals are therefore retained at full strength.*

See the unshakeable rigidity of its construction, see the long bearing, and the extended spindle for ganging purposes. Notice that there is no end pressure, no tendency to distortion of the vanes. The fixed vanes terminal is in a new and convenient position well away from the end plates. There are feet for baseboard mounting or standard one-hole-fixing for panel mounting.

Compare it with any condenser at any price whatever—remember it can be used in any circuit and is practically everlasting—remember it is a low-loss condenser such as you have never before been able to buy at these prices.

LISSEN LOW-LOSS VARIABLE CONDENSER

.0001 mfd. capacity	5/9
.0002 " "	6/-
.0003 " "	6/-
.00035 " "	6/3
.0005 " "	6/6

LISSEN LIMITED, 500-520, FRIARS LANE, RICHMOND, SURREY
 (Managing Director: THOS. N. COLE)

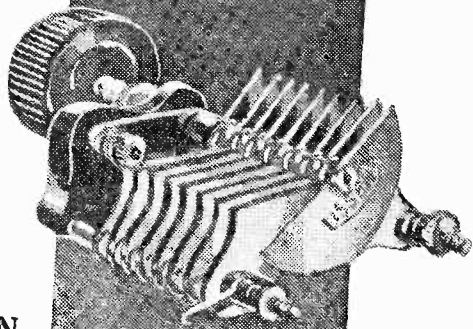
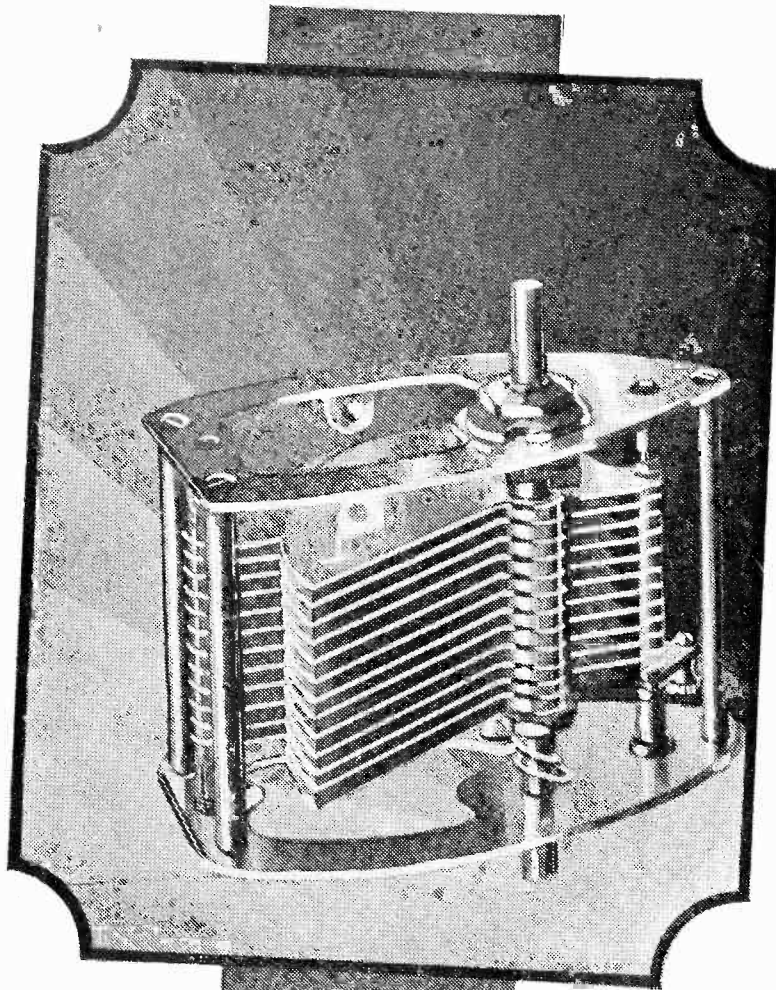

LISSEN REACTION CONDENSER

Embodies many of the exclusive features of the big Lissen Condenser, including no end pressure on any end plate to distort frames or vanes.

"A" Type **4/-**
 "B" Type, with insulated bushes for mounting on panel. Price 4/6

Start Radio With
The
Clipper
Two
FOR £5!



A Remarkably Efficient Set That Can Be Used for Reception on the Short, Medium and Long Waves :: A Complete Installation With Loud-speaker and Batteries for Less Than £10!

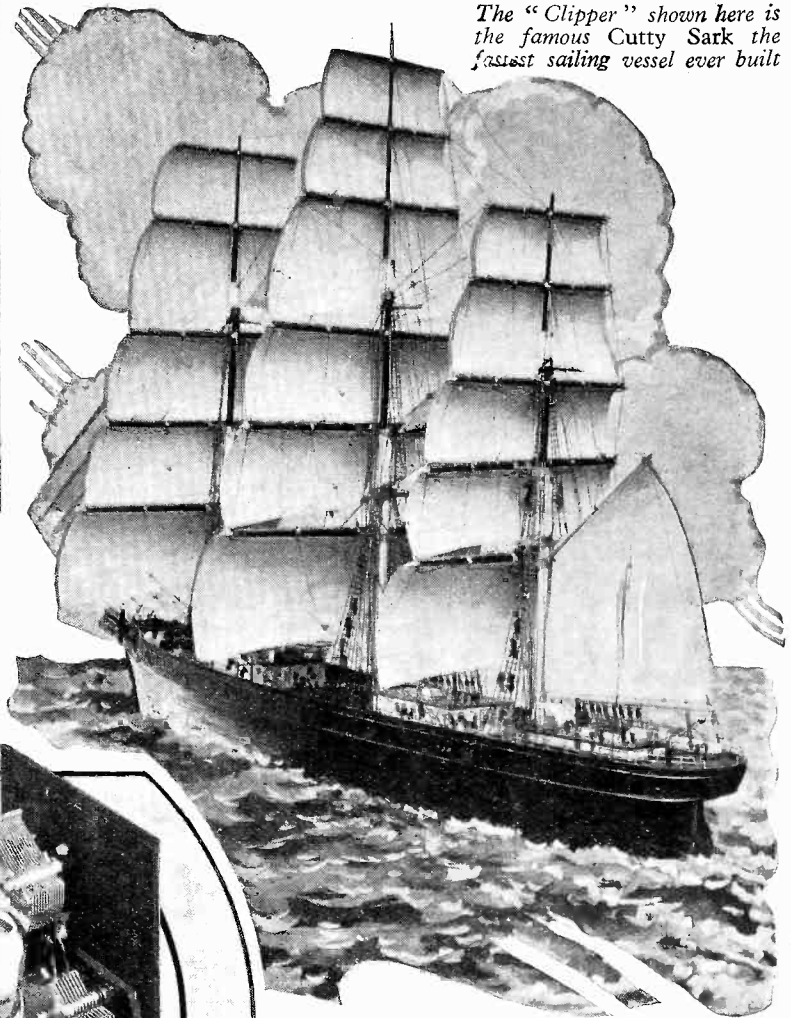
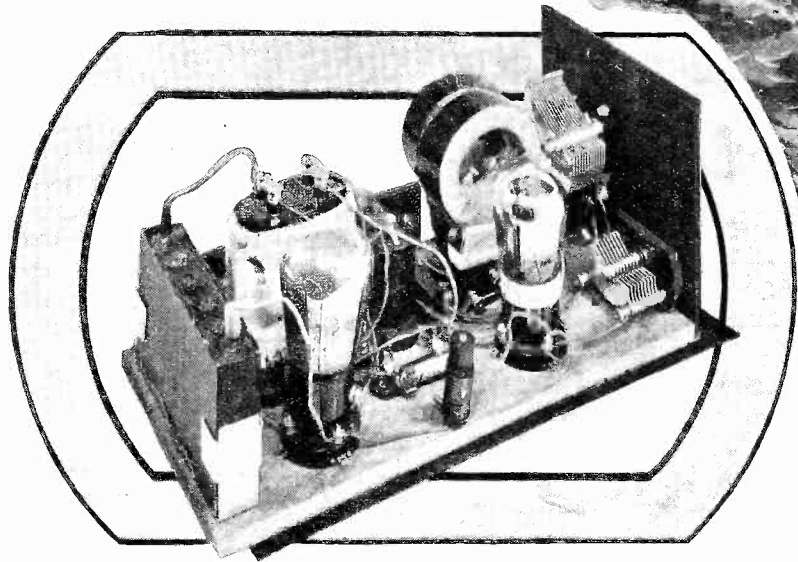

The "Clipper" shown here is the famous Cutty Sark the fastest sailing vessel ever built

An Ideal Receiver for Beginners :: Full-size Blueprint Available for Half Price :: All Connecting Leads Numbered :: No Soldering :: Designed and Tested by the "Wireless Magazine" Technical Staff

LET no readers suppose that we are misleading them when we state that the Clipper Two can be built for £5. That price includes valves and coils for reception on the medium and high waves, but does *not* include short-wave coils, high-tension battery, accumulator, loud-speaker, headphones—or licence fee!

Complete for £10

A glance at the lists on page 213 will show that the Clipper costs actually £4 14s. 4d., provided the components manufactured by the firms mentioned first in the brackets are used. A complete broadcast receiver, with loud-speaker and batteries, can thus be assembled for less than £10!

The Clipper Two is not a headphone set. No exaggerated claims are made for what is a perfectly straightforward circuit, which long experience has proved to be extremely satisfactory, but under normal conditions it will be possible to receive a number of stations at good loud-speaker strength.

Indeed, the efficiency of the set can be gauged by the fact that at two miles distance from 2LO this station can be tuned out and 5GB received on the loud-speaker, *with an indoor aerial and a poor gas-pipe earth*. With headphones, of course, several Continental stations are audible.

Even the novice will realise that these results can be very much improved upon where a normal outdoor aerial and earth are employed.

In May of last year, the WIRELESS MAGAZINE published details of a two-valver—called the Crusader—which was designed on similar lines to the Clipper. Regular readers will recall that almost every month we have published letters from readers recording the amazing results they obtained.

The set described here will give just as good a performance, but it is considerably simpler.

Installing the Set

Realising that a set of this type will appeal particularly to the newcomer to radio, both on account of its cheapness and its simplicity, we have shown exactly what parts are needed to build the Clipper and complete the installation.

Start

Radio with the Clipper Two! (Cont.)

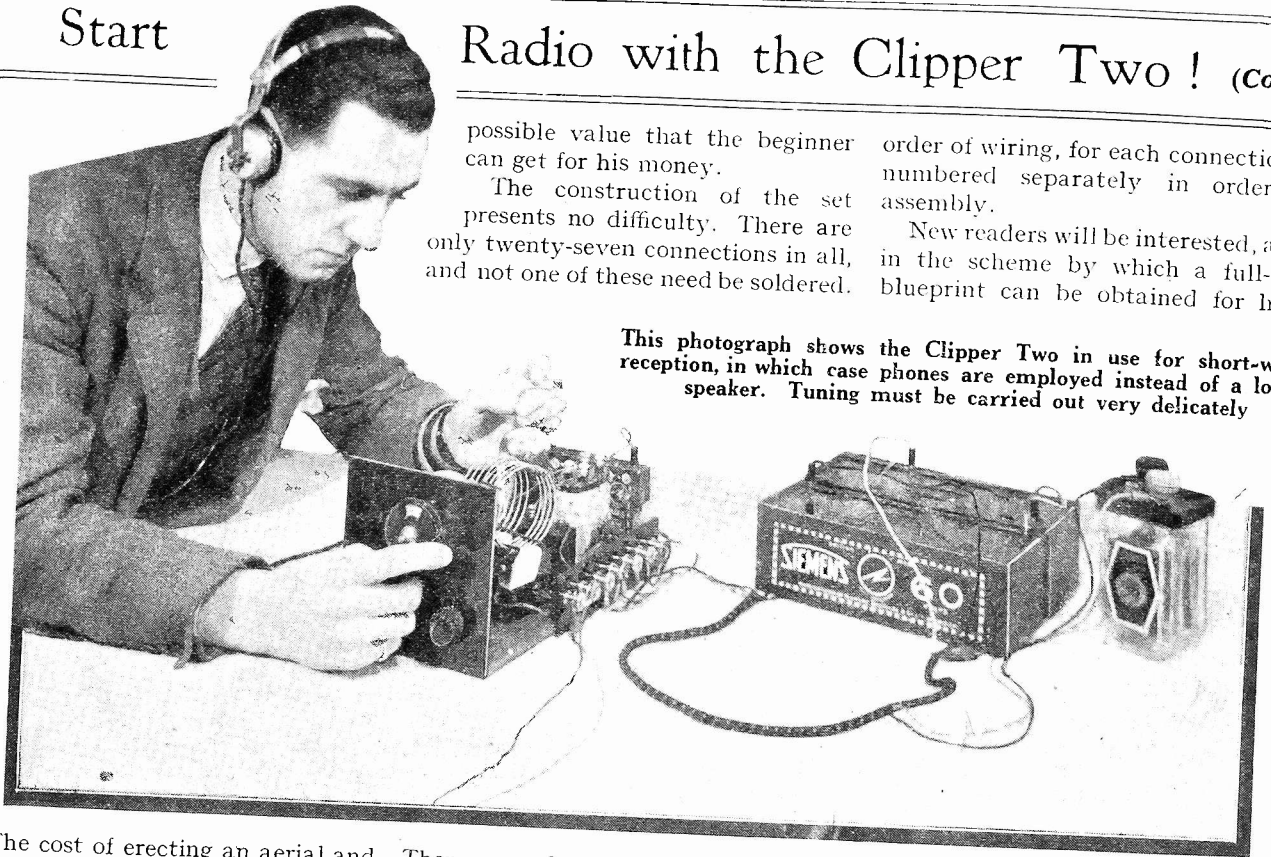

This photograph shows the Clipper Two in use for short-wave reception, in which case phones are employed instead of a loud-speaker. Tuning must be carried out very delicately

possible value that the beginner can get for his money. The construction of the set presents no difficulty. There are only twenty-seven connections in all, and not one of these need be soldered.

order of wiring, for each connection is numbered separately in order of assembly. New readers will be interested, also, in the scheme by which a full-size blueprint can be obtained for half-

(The cost of erecting an aerial and earth is not included in our schedule as this varies so much with individual circumstances.)

In our choice of components for the Clipper Two we have picked those that represent the best value for money and it would be possible for the constructor to reduce the cost by a few shillings by using parts other than those specified. This course is not recommended, however, as the performance of the set would probably be materially affected.

Accessories

As regards accessories, we have estimated for the use of a really first-class horn loud-speaker. This is the famous Brown HQ model, recently sold at £6. At its reduced price it undoubtedly represents excellent value for money. Although large, the movement is particularly sensitive, and it does give excellent results in conjunction with the Clipper.

It will be apparent, then, that the Clipper Two and the accessories recommended represent the best

There are only six holes in the panel and these can easily be drilled with the aid of the full-size blueprint that is available.

We particularly wish to emphasise

price up till April 30. On page iii of the cover will be found a blueprint coupon; if this is sent to the Blueprint Dept., WIRELESS MAGAZINE, 58/61 Fetter Lane, E.C.4, by the end of the month (April), a blueprint will be supplied at half-price (that is, 6d., post free). Ask for No. WM135.

Overseas Readers

After April 30, the full price of 1s. will be charged, except in the case of overseas readers, who are allowed an extension of time.

This blueprint (a reproduction of which appears on page 214), together with the photographs, ensures that no constructor can go wrong, even if he is not acquainted with the appearance of the different parts.

Circuit Used

Readers with some technical knowledge will be interested in the circuit, which is reproduced on this page. As shown, there is an aperiodic coil in the aerial circuit, but this is only needed for reception on the very short waves, that is from 15 to 120 metres.

For ordinary broadcast reception,

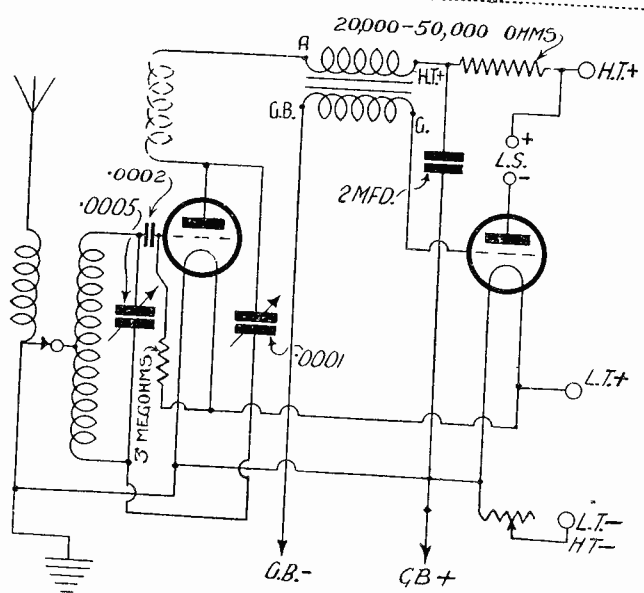

Here is the circuit of the Clipper Two—detector and one low-frequency stage with Hartley reaction

the value of a full-size blueprint in constructing a set. It shows (a) the positions and size of all the holes to be drilled and will act as a template, (b) it shows how all the components are placed, and (c) it indicates the best

A Remarkable Broadcast Set For Only £5

on the medium and long waves, this coil can be dispensed with, in which case the aerial is joined direct to the grid end of the grid coil.

Centre-tapped Coil

This grid coil is centre-tapped, and in conjunction with two variable condensers, forms the well-known Hartley circuit. The whole coil is tuned by a .0005-microfarad condenser. That half of the coil from the centre-tap downwards (in the circuit diagram) acts as a reaction winding, the degree of oscillation being controlled by a .0001-microfarad condenser.

Not only does the use of a Hartley circuit make the construction simpler and the cost lower, but it also gives very selective tuning. Moreover, it is a great advantage to have only one coil to change in going from one waveband to another.

Increased Sensitivity

For the sake of sensitivity, a leaky-grid rectifier is employed, the grid condenser having a value of .0002-microfarad and the leak a resistance of 3 megohms.

In the anode circuit of the detector

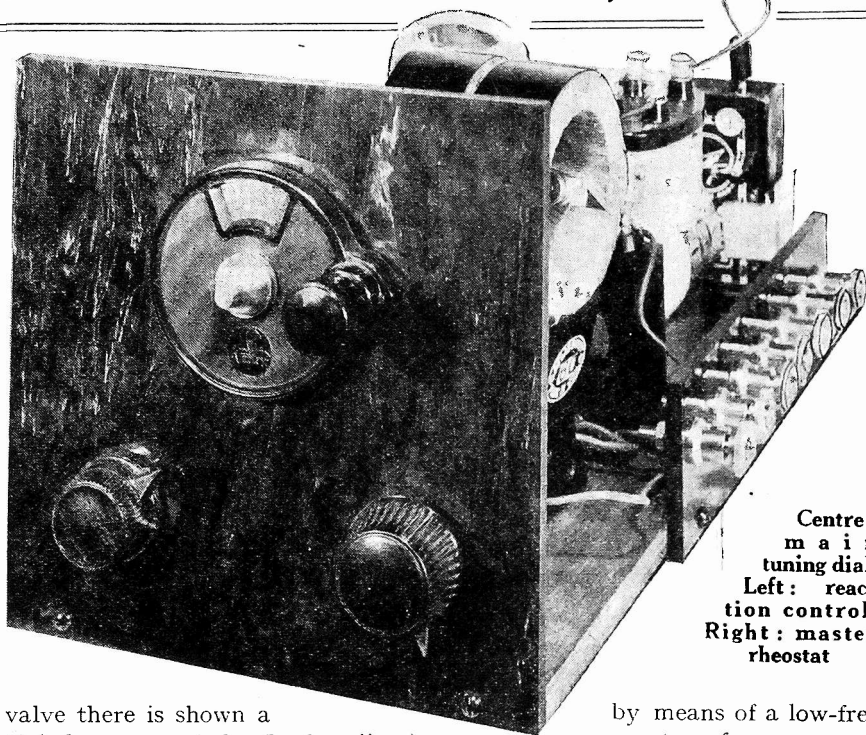

Centre :
main
tuning dial.
Left : reac-
tion control.
Right : master
rheostat

valve there is shown a high-frequency choke (broken lines). This also is only needed for short-wave reception, when it may consist of about 100 turns of No. 30-gauge d.s.c. wire, wound round a pencil. For ordinary broadcast reception this can be omitted.

The detector valve is coupled to the low-frequency amplifying valve

by means of a low-frequency transformer.

In series with the primary of this transformer is a resistance, the value of which may vary from 20,000 to 50,000 ohms. This serves two useful purposes.

Reducing Detector Voltage

In the first place, it cuts down the voltage applied to the anode of the detector valve (which normally needs less than the low-frequency amplifier) and enables a common high-tension terminal to be used for both valves.

The second use of this resistance, in conjunction with a 2-microfarad fixed condenser, is to prevent "motor boating." This is a nasty popping sound which sometimes occurs when the high-tension battery is nearly exhausted and develops a high internal resistance. Its inclusion in the set means that the high-tension battery can be kept in service much longer than would otherwise be the case.

Grid Bias for Purity

Two other points to note are that the low-frequency valve is supplied with grid bias (to give purity of reproduction and incidentally to cut down the amount of high-tension current consumed) and that a master rheostat is used for switching on and off both valves.

This explanation of the electrical working of the set will seem rather

COMPONENTS REQUIRED FOR THE CLIPPER TWO

For Broadcast Reception

	s.	d.
1—Ebonite panel, 6 in. square (Parfait, Raymond, or Will Day) ..	1	7
1—.0005-microfarad variable condenser (Formo, Utility, or Peerless) ..	5	0
1—Vernier dial (R.I. & Varley) ..	3	9
1—.0001-microfarad reaction condenser (Peto-Scott, Bulgin, or Lissen) ..	4	6
1—15-ohm rheostat (Igranic, Lissen, or Peerless) ..	1	6
1—Single coil holder (Lissen, Peto-Scott, or Lotus) ..	1	0
2—Anti-microphonic valve holders (Lotus, W.B., or Formo) ..	2	6
1—3-megohm grid leak with holder (Lissen, Dubillier, or Ediswan) ..	1	6
1—.0002-microfarad fixed condenser (Lissen, Trix, or T.C.C.) ..	1	0
1—2-microfarad fixed condenser (Lissen, T.C.C., or Ferranti) ..	3	6
1—20,000-ohm resistance with holder (Graham-Farish, Ediswan, or Cosmos) ..	2	9
1—Low-frequency transformer (R.I. and Varley, British General, or B.T.H.) ..	15	0
1—Terminal strip, 7 in. by 2 in. (Raymond, Will Day, or Ready Radio) ..	0	9
7—Terminals, marked: Aerial, Earth, L.T.+, L.T.-, H.T.+, L.S.+, L.S.- (Ealex or Belling-Lee) ..	2	8
1—Pair grid-battery clips (Bulgin) ..	0	6
1—9-volt grid-bias battery (Siemen's Popular, Every-Ready, or Gecophone) ..	1	6

TOTAL £10 2s. 6d., for complete two-valve installation, with valves, coils, headphones, batteries, and loud-speaker, for reception on short, medium, and long waves.

2—Wander plugs, 1 red and 1 black (Lectro-Linx) ..	0	4
1—Spring clip (Raymond or Ready Radio) ..	0	3
1—No. 60 centre-tapped coil (Atlas, Lissen, or Lewcos) ..	4	3
1—No. 200 centre-tapped coil (Atlas, Lissen, or Lewcos) ..	6	6
4 yards rubber-covered flex (Lewcos) ..	0	6
1—Detector valve (Cossor 210HF) ..	10	6
1—Power valve (Cossor 220P) ..	12	6
1—Baseboard, 12 in. by 6 in. ..	0	6
Total, with valves and coils ..	£4 14	4

Accessories

2—60-volt high-tension batteries (Siemen's Popular, Ever-Ready Popular, or Columbia) ..	16	0
1—2-volt accumulator (Oldham OVD, Gecophone, or C.A.V.) ..	5	6
1—Horn loud-speaker (Brown HQ) ..	63	0
1—Pair headphones (Ericsson) ..	12	6
Total ..	£4 17	0

Extra for Short-wave Work

1—Single-coil holder (Lissen, Peto-Scott, or Lotus) ..	1	0
1—Set short-wave plug-in coils (Atlas) ..	10	0
Total ..	£0 11	0

Another view of the Clipper Two

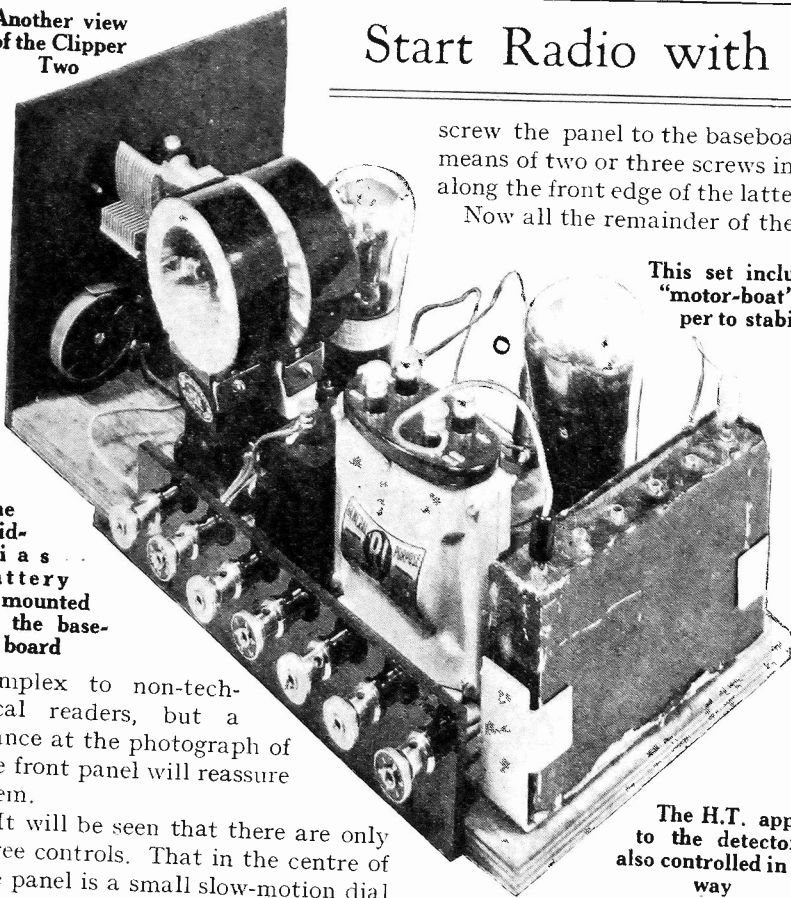

The grid-bias battery is mounted on the base-board

complex to non-technical readers, but a glance at the photograph of the front panel will reassure them.

It will be seen that there are only three controls. That in the centre of the panel is a small slow-motion dial for controlling the main tuning condenser and enables the set to be tuned to any desired wavelength.

Volume and Range Control

On the left is the knob of the reaction condenser, which can be looked upon as a volume and range control. The knob on the right is the filament rheostat; it switches the whole set on and off. This requires no other adjustment than to be turned right on or right off.

Before beginning any part of the construction, it is advisable to have all the parts ready. There will then be no hitch whatsoever in the assembly of the set.

The first operation to be undertaken is the drilling of the front panel; this will present no difficulty at all if a full-size blueprint is used as a template. Simply lay the top part of the blueprint over the panel and mark through with a sharp point the positions of the holes to be drilled.

Mounting the Components

When the holes have been drilled, mount on the panel the .0005-microfarad variable condenser, with its slow-motion dial, the .0001-microfarad reaction condenser, and the 15-ohm filament rheostat. Then

Start Radio with the Clipper! (Continued)

screw the panel to the baseboard, by means of two or three screws inserted along the front edge of the latter.

Now all the remainder of the parts

can be laid out on the baseboard as indicated in the blueprint and the photographs.

Don't forget that the positions shown are only suitable for the makes of components mentioned first in the brackets in the list on page 213; if any of the alternatives are used it may be necessary to alter the layout very slightly.

This set includes a "motor-boat" stopper to stabilise it

For Broadcast Reception

If the set is to be used only for ordinary broadcast reception, the holder for the aperiodic aerial coil should be omitted (the aperiodic coil is required only for short-wave reception), in which case the lead numbered 1 on the blueprint should be connected to the lead numbered 11.

How to adapt the set for short-wave work will be discussed later.

There are seven terminals, a 9-volt grid-bias battery being mounted along the back edge of the baseboard by means of special clips. There is only one H.T.+ terminal, and L.T.— and H.T.— are "commoned" to one terminal.

The H.T. applied to the detector is also controlled in this way

YOU CAN GET A FULL-SIZE BLUE-PRINT FOR 6d., POST FREE

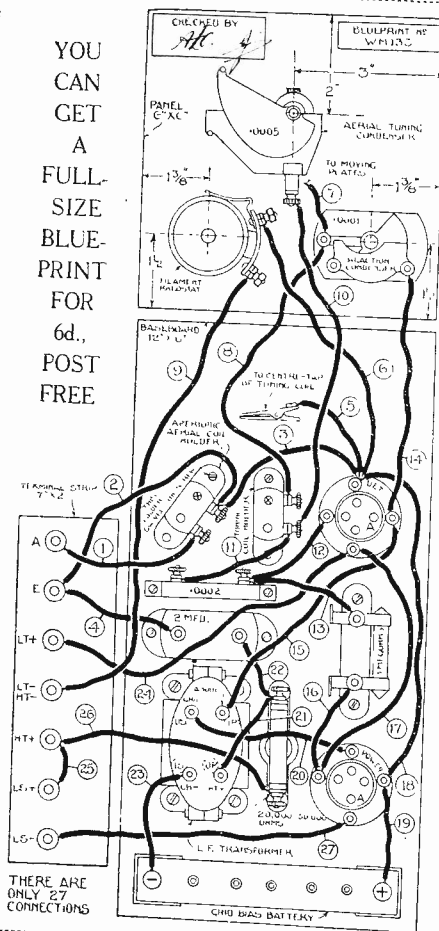

Suitable Valves and Coils

Before the set can be tested, the proper valves and coils must be inserted in their respective holders.

As noted in the list of components, we have found the Cossor 210HF (as detector) and Cossor 220P (as low-frequency amplifier) specially suitable in the Clipper Two. In association with the rest of the components they give great range and pleasing quality of reproduction.

In the list of components we mention a 20,000-ohm resistance; this is the combined stabilising device and voltage control. Actually any value between 20,000 ohms and 50,000 can be used.

Current from the H.T. Battery

The lower this resistance, the higher the voltage applied to the detector valve and consequently the greater the current taken from the battery.

For broadcast reception, it is not of great importance what value is

This layout and wiring diagram can be obtained for half-price (that is, 6d., post free) if the coupon on page iii of the cover is used by April 30. Ask for No. W.M.135

For the Reception of Short, Medium and Long Waves

used, although normally there is little to choose between 20,000 and 30,000 ohms. When the set is to be used extensively for very short-wave reception, then it is worth while for the operator to try higher values of resistance.

The reason for this is that reaction is likely to prove too fierce on the very

For reception on the lower band of wavelengths, that is, from approximately 250 to 550 metres, a No. 60 centre-tapped coil should be used. A No. 200 coil will give a wavelength range of about 900 to 2,000 metres.

Aerial Differences

It must be clearly understood that these figures vary within quite wide limits. On any aerial, however, it should be possible to receive 2LO and 5GB with a No. 60 coil and 5XX with a No. 200 coil.

Having inserted the valves and coils in the set, the batteries must be connected up. First of all see that the knob of the filament rheostat (on the right of the panel) is turned as far as possible to the left, that is "off."

To H.T.+ connect the positive (marked +) end of the one of the 60-volt high-tension units. Connect the negative

On the right is a plan view of the Clipper Two which shows clearly the positions of all the parts

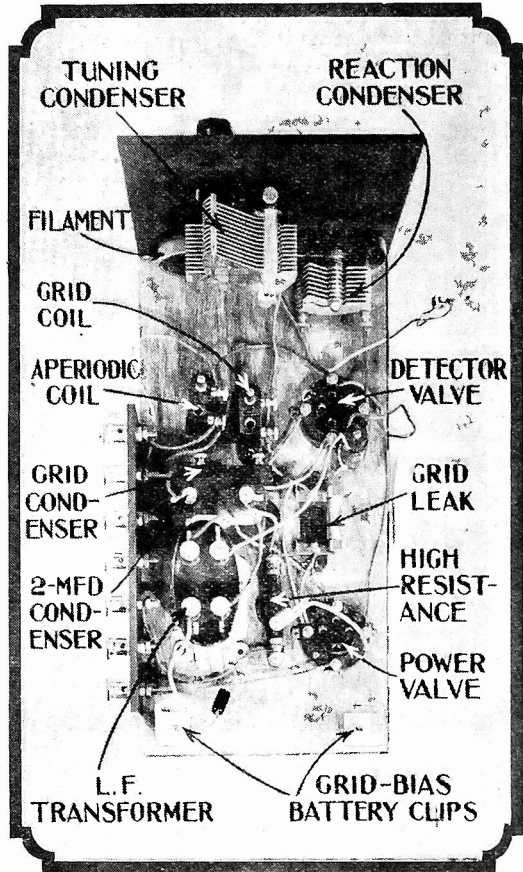

Details of the cover for the Clipper Two

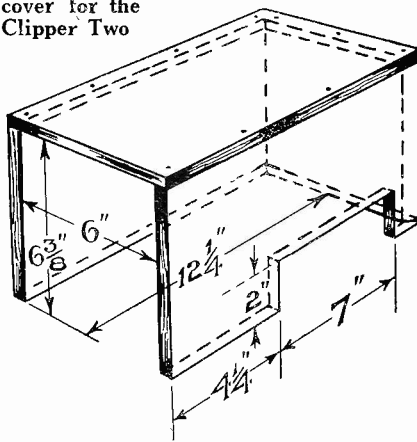

short waves when a low resistance is used, and a comparatively high anode voltage applied to the detector valve.

Positions of Valves

The detector valve, that is the Cossor 210HF, is placed in the holder nearest the panel, while the low-frequency amplifier or power valve, the Cossor 220P, is inserted in the holder nearest the grid-bias battery.

This view shows a simple H.F. Choke for short-wave work

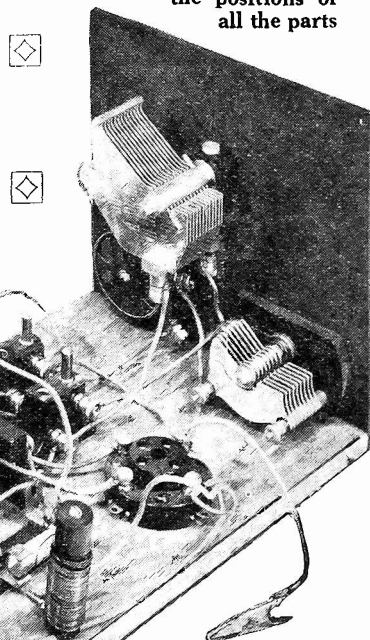

end (marked -) of this unit to the positive end of the second unit and the negative end of the latter to the terminal marked L.T. -.

Next, connect the positive side of the accumulator (red terminal) to L.T. + and the negative side (black

terminal) to L.T. -, with the high-tension negative lead.

Loud-speaker Connections

The connections to the aerial and earth terminals are obvious, but it is important to connect the positive side of the loud-speaker (it is marked) to the L.S. + terminal; the same remark applies to the phones when used, in this case the positive lead being distinguished by a red mark.

Make sure also that the positive grid-bias lead is connected to the positive socket of the small battery mounted on the baseboard and that the negative grid-bias lead is plugged into the 9-volt socket.

Switching the Set On

These connections having been properly made (they should be carefully checked if the Clipper Two is the constructor's first set—particularly to see that the H.T. and L.T. connections have not been mixed up!), the set can be switched on by turning the knob of the filament rheostat as far as possible to the right.

Now turn the left-hand knob until a very slight rustling or hissing

The clips for the grid-bias battery

Start Radio

with the

Clipper! (Continued)

Full-size blueprint available for 6d, post free, until April 30th

TELL YOUR FRIENDS ABOUT THE CLIPPER TWO!

Here you see the Clipper Two in use for broadcast reception. The loud-speaker is a Brown HQ, with Siemens high-tension batteries and an Oldham accumulator



sound is heard from the loud-speaker. Do not turn it too far or a howl will start. Should this occur, turn the control back.

Maximum Sensitivity

A point will be found where the rustling sound just becomes inaudible—this indicates that the set is in its state of maximum sensitivity.

At this point turn the knob of the slow-motion dial until a station is picked up. As the main tuning dial is operated so it will be necessary to make slight readjustments of the reaction condenser to keep the set at its most sensitive condition.

It should be remembered that all the time the rustling sound is heard the set is in a state of oscillation and is liable to cause interference with neighbours.

As soon as a station is tuned in, make a note of the dial reading. Then on subsequent occasions it will only

be necessary to adjust the knob to this position and switch on to get the station.

Do not forget that to switch the set off it is only necessary to turn the right-hand knob as far as possible to the left. There is no need to disconnect any of the batteries from the terminals.

Now for some remarks on purely short-wave reception, that is, of American and Continental stations working on wavelengths between 15 and 120 metres.

In the first place it will be necessary to wind a special high-frequency choke; as already mentioned this can consist of about 100 turns of No. 30-gauge d.s.c. wire wound round a pencil. The lead numbered 13 should be broken and this choke inserted.

Moreover, entirely different coils are needed—a set of four short-wave coils. These have 2, 4, 6, and 9 turns respectively, and together they cover

a wavelength band of about 15 to 120 metres.

For the best results an aperiodic aerial coil should be used and for this purpose another coil holder should be fixed next to the existing one on the baseboard; if it is fixed by only one screw, instead of two, it can be swivelled and the degree of coupling between the aperiodic coil and the grid coil varied to give the best results.

Size of Aperiodic Coil

The coil in the "aperiodic" holder should be a size smaller than the grid coil with most aeriels.

With that we can complete our description of the Clipper, proud in the knowledge that the WIRELESS MAGAZINE is once again able to give its readers a two-valver, which, like the Crusader of last May, is a winner—and within reach of everybody's pocket!

NOBODY INTERESTED IN PORTABLES SHOULD MISS THE NEXT ISSUE

It will contain a complete review of portable receivers, giving all the details the prospective buyer needs to know before making his choice. This feature will appeal to everybody interested in the development of receiver

design and no pains will be spared to make it complete. There will also be included in this issue particulars of a special portable super-set for home-construction, developed by J. H. Reyner, B.Sc. (Hons.), A.M.I.E.E.

DON'T MISS THE MAY "WIRELESS MAGAZINE"—PUBLISHED ON APRIL 24

A Broadcast Revolution!

Political broadcasting will undoubtedly raise protests from many unlooked-for quarters:—DAILY PAPER.

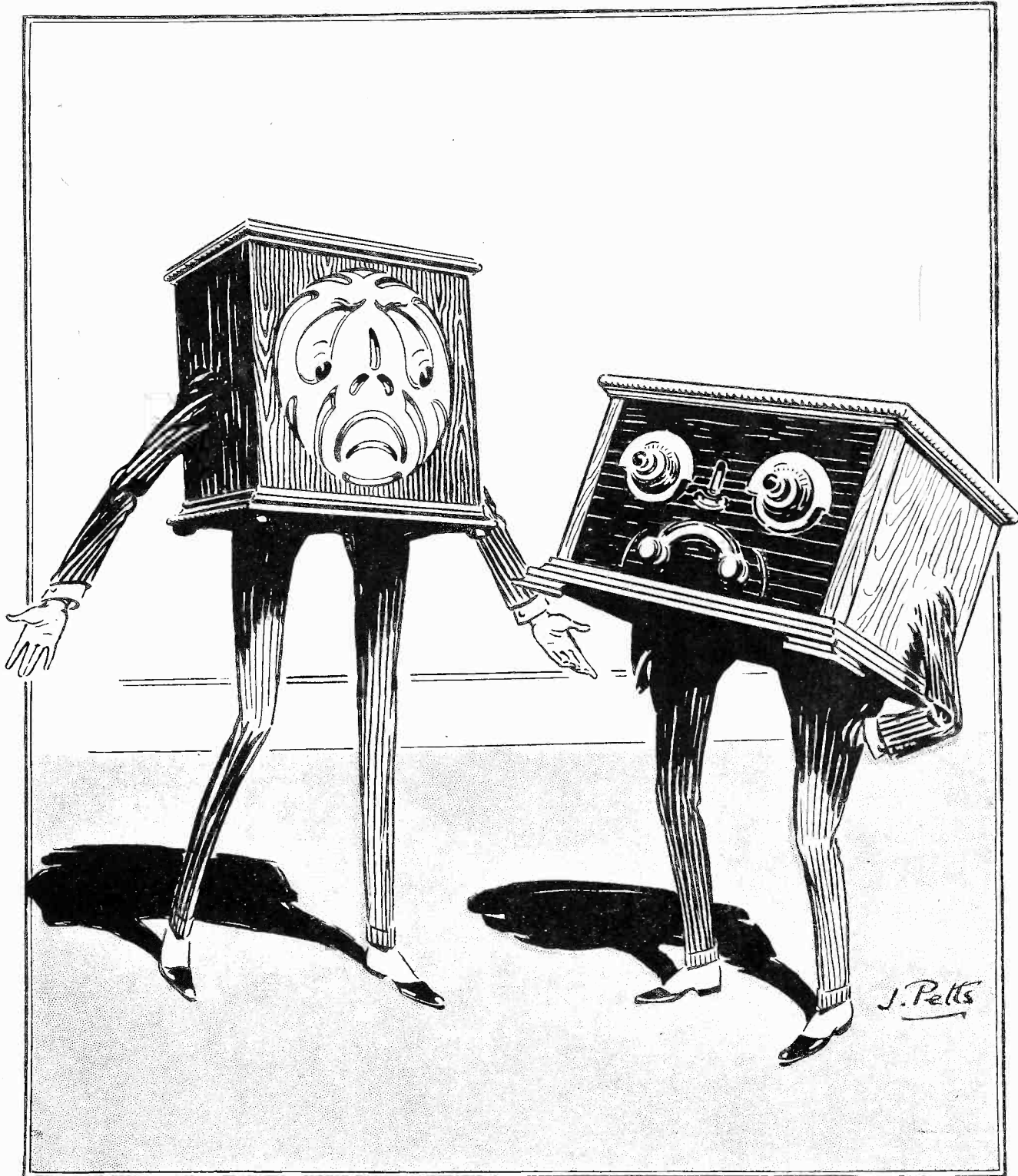

Loud-speaker:—"As a conscientious speaker I feel I must protest against this proposed political diet!"

Wireless Set:—"Yes! I'm with you there, old chap, I'm afraid it will aggravate *MY* valvular trouble!"

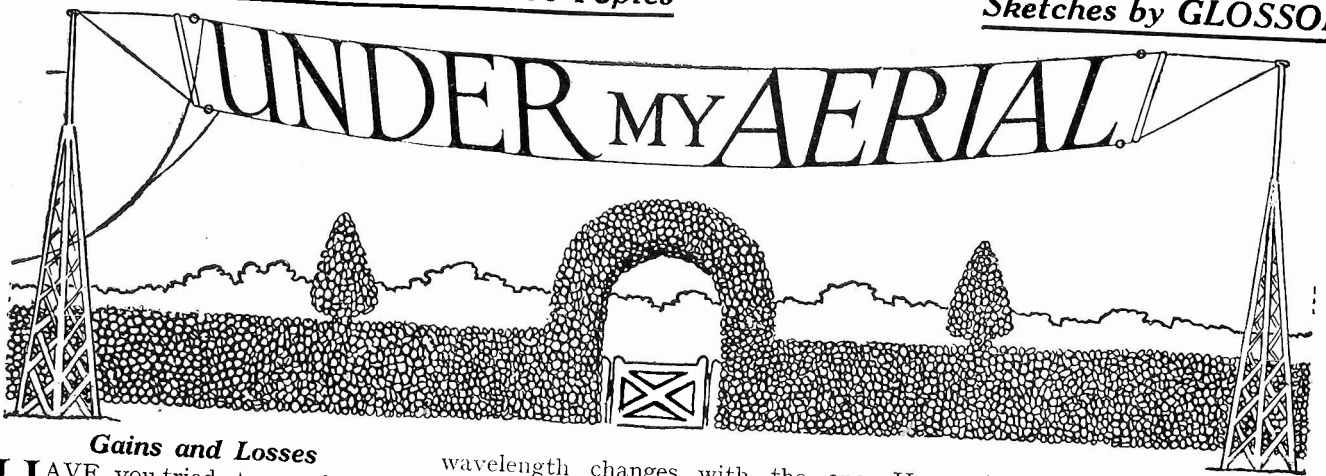

Gains and Losses

HAVE you tried to work out a profit-and-loss account as between your reception on the old wavelengths, or Plan de Geneve, as it is called, and your reception on the present wavelengths, or Plan de

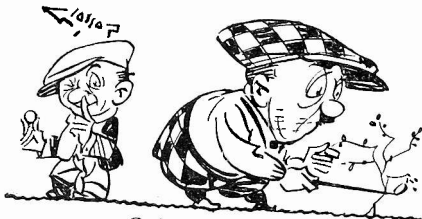

Gains and Losses

Bruxelles? What stations have you gained by the changes and what stations have you lost? Which stations come in better than before and which come in worse?

Your profit-and-loss account depends to a great extent, of course, on your situation with respect to our own broadcasting stations, especially Daventry. How would it be if a number of us, situated in different parts of the country, were to exchange profit-and-loss accounts? Don't you think such an exchange would be interesting to us all?

Taking the gains first, it strikes me as somewhat of a coincidence that the Plan de Bruxelles should have brought most of us vastly improved reception of Brussels. Other distinct gains or improvements to many of us are Goteburg, Nurnberg, and several of the French stations.

What about the losses? If you are within the 100-mile circle round Daventry, I might risk a guess that your reception of a couple of good Continental stations is now restricted to the few periods of time when 5GB is off the air. Barcelona may also be a distinct loss to you, if you live within easy reach of 2LO.

Our own British stations seem to have been better placed by the

wavelength changes with the one exception, perhaps, of Newcastle, which, in the south of England, is now a difficult signal to pick up because of the nearness of its wavelength to that of Nurnberg.

Name, Please?

An unusual amount of interest is being taken in the planning and building of the new B.B.C. headquarters in London. As one would expect, many of the chief features of the new building have come in for a good deal of criticism. I have been surprised, though, to see objections raised to the name "Broadcasting House" for the new building.

Why shouldn't the new building be called Broadcasting House? asks one critic. Why should it? asks another critic in reply. What do you think of the name Broadcasting House?

One good point in favour of the name is that it brings London more into line with the provincial stations. London has had its Savoy Hill, while Manchester, Birmingham, Glasgow, etc., have had their Broadcasting Stations.



Name, Please?

If the name Broadcasting Station is good enough for the provincial stations, surely it is good enough for London. Personally I would like to see the new London headquarters called the London Broadcasting Station.

Perhaps you read the suggestion made some time back that the new building should be called Fleming

House in recognition of Professor Fleming's invention of the valve. You may also have read a suggestion that Sir Oliver Lodge's name might be considered to have a very good claim to perpetuity in the name of the new building.

I discussed this knotty point as between Fleming and Lodge with George, my technical adviser, who is a very Solomon in all wireless matters. He said the difficulty could be got over very easily by calling the new building Fleming Lodge.

If a name must be perpetuated, I should suggest calling the new building Reith House. Scientists may have made broadcasting technically possible, but Sir John Reith is the man who has made our broadcasting system what it is to-day, the admiration of the whole world, and I venture to predict that history will endorse that view.

2ZY in Piccadilly

I wonder how many of our Manchester readers have paid a visit to the new broadcasting headquarters of station 2ZY in Piccadilly. By this time, listeners to the Manchester station should be receiving, or should be about to receive, their Manchester transmissions from the new studios.

Manchester listeners have not had much to be proud of in the old studio headquarters of 2ZY. If you happened to visit the old 2ZY as I did, on a dull, wet afternoon, you could scarcely imagine a more dreary place.

The new headquarters in Piccadilly, however, will be something which Manchester listeners will view with civic, as well as with wireless, pride, for the new Manchester Broadcasting House will put Manchester an indisputable first amongst the provincial broadcasting stations.

In the old 2ZY building, the main studio is, or was, of only ordinary room height. The main studio in the new Picaddilly headquarters is a double-decker with a gallery which may be used to seat an audience on



About to Receive

special occasions. The control room of the new 2ZY, by the way, has the most up-to-date ideas incorporated in it.

George says that the most interesting feature of the new Manchester headquarters is the bank on the ground floor, underneath the studios and offices. He thinks this bank will prove a useful counter attraction.

Another Death-ray

"What do you think of the new 1929 death-ray, George?" I asked my scientific adviser during the course of a recent technical conversation.

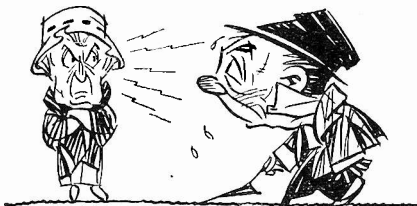

Another Death-ray

"Which one?" asked George.
 "There's only one as far as I know."
 "Well, the year is young as yet."
 "I mean the Jena death-ray, George."

"Jena—er—let me see now, Jena is the German town where the famous Zeiss lenses are made, isn't it?"

"I didn't know that, George, but about this death-ray, one of the professors of the University of Jena claims to be able to radiate ultra-short waves which will kill small animals instantly."

"What kind of small animals?"

"I am afraid the reports do not tell us, George."

"Pity. I was wondering about those shares an old aunt of mine has in Keatings. What else will the new ray do?"

"It will exterminate bacillus cultures."

"Serve them right too."

"Do you believe there is really such a thing as a death-ray, George?"

"I've never seen one, but I've heard of a good many in my time. On the one hand there may be a death-ray, on the other hand there may not. I preserve an open mind. Electricity has always been a specially attractive mystery to the non-scientific mind. The death-ray is the modern expression of the centuries-old idea that there is something very mysterious about electricity."

The Next Loud-speaker

What will be the next big development in loud-speakers? The moving coil loud-speaker has come and stayed with us. The exponential horn loud-speaker has slowly gained favour amongst us. The linen-diaphragm loud-speaker, thanks to the WIRELESS MAGAZINE and *Amateur Wireless*, has attained a high degree of popularity amongst wireless home-constructors the last few months. What will follow?

In America it is being predicted that the next big sensation in loud-speakers will be the electrostatic type, which has been developed so successfully in Germany during the last two years.

Our loud-speakers are mostly of the electromagnetic type, you know. That is to say they contain an electromagnet made up of a bar of magnetised iron round which is wrapped a coil of wire. An electrostatic loud-speaker then, is one which contains an electrostat.

Wait a minute, wait a minute now. There isn't such a thing as an electrostat. No, it's like this: An electrostatic loud-speaker is one which works on an entirely different principle from that on which the electromagnetic loud-speaker works.

Briefly, the principle of the thing is this: There are two large perforated plates in the loud-speaker and between these two plates is placed a metallic diaphragm. This diaphragm is insulated from the plates by rings of insulating material. One of the two plates, the outer one, is connected to earth. Leads from the secondary of the output transformer of the



Big Development in Loud-speakers

wireless set are taken to the two plates of the loud-speaker. The diaphragm is given a high positive potential, and that's all I can tell you.

Perhaps the most interesting feature of the electrostatic loud-speaker is that the principle involved is not a new one. Discovered many years ago, use was made of the principle in ordinary land-telephony. The much more efficient electromagnetic telephone was invented, however, and the electrostatic type was discarded.

Frame-aerial Values

In view of the increasing popularity of the portable set with its small, enclosed frame aerial, the results recently obtained by a distinguished German experimenter with frame

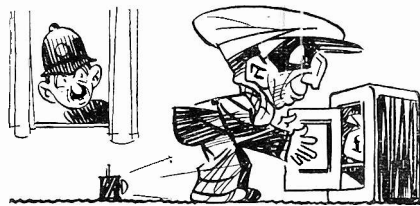

In View

aerials of different sizes are of more than usual interest.

Working by comparison with an outdoor aerial, this German experimenter found that a frame aerial, made in the form of a square of 3 ft. side, picks up about $\frac{1}{12}$ the signal strength the outside aerial picks up.

Other results obtained by this experimenter are that a square frame aerial of 18 in. side has a pick-up value of $\frac{1}{28}$ that of the outside aerial, and an ordinary fifty-turn plug-in coil gives no more than $\frac{1}{660}$ of the signal strength of the outside aerial.

These figures are surely of great value to the designers of our portable sets. Suppose that the designer of a portable set is restricted to a frame aerial equivalent in size to a square frame of 18 in. side. It is immediately evident from the figures quoted above that, if the portable set is to give results comparable to those given by a set working on an outside aerial, twenty-eight times as much high-frequency amplification must be provided.

Such amplification could be provided by incorporating a screened-grid valve having an amplification factor of thirty say, or it could be provided by employing two high-frequency amplifying valves having an amplification factor of six, since the effect of the two valves would be

Under My Aerial (Continued)

a multiple one, namely, six times six, or thirty-six.

I wonder if the designers of present-day portable sets go into things with such numerical accuracy or whether they just trust to luck, more or less.

Big Figures

Did you happen to notice the 1929 wireless trade figures for the United States? They were quite big enough to make one gasp with astonishment, weren't they?

The total amount spent on wireless sets and component parts "over there" last year was equivalent in value to £130,000,000. This huge figure represented an increase of £45,000,000 on the corresponding figure for the previous year. Somebody must have made something out of wireless in 1928 in America.

At the beginning of the year 1928 the number of wireless listeners was estimated as 26,000,000. At the end of the year the estimated number was 35,000,000. Hence there was an increase of 9,000,000 in the number of listeners in the United States during 1928.

These new 1928 listeners could have easily accounted for the big increase in the wireless trade of the year. £45,000,000 amongst 9,000,000 listeners work out at £5 each, quite a possible figure.

I haven't the least idea what caused the great boom in wireless in the United States last year, but I should think that there is a distinct possibility that the increasing interest in short-wave reception over there

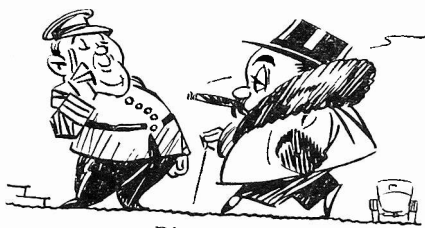

Big Figures

might cause an even bigger boom in the wireless trade of 1929.

At the Cinema

George and I went to the cinema last Friday night, and our frank and outspoken criticism of one of the pictures drew a rude remark from a bad-tempered man sitting behind us. Very wrong of us to talk in the cinema, I know, but how could you expect



At the Cinema

two old wireless enthusiasts like George and myself to keep quiet when a wireless receiving set appeared on the screen half a dozen times or more?

In the story of the film there was a swimming race, and a poor fellow

NEXT MONTH!

A special additional 16-page supplement

on special paper, dealing with Portables, will be included in the May

Wireless Magazine on sale everywhere April 24.

Of particular interest to every radio enthusiast will be an Illustrated Buyers' Guide to Portable Sets!

who ought to have been in the race was fast in bed with mumps, of all things. By his bedside he had a wireless receiver and we saw him periodically listening-in to the race.

The first time the set came on the screen neither of us spoke, but George grunted. The second time the set flashed before us George said:

"What's the frame aerial for?"

"To pick up signals, of course," I replied.

"Not a bit of it," said George, "it's to make the thing look like a wireless set. That aerial is a dummy one."

"How do you make that out, George?" I asked.

"Well, it's a portable set and the frame aerial is of less size than the set. Modern practice is to put the frame aerial inside the set. Nobody would put a *small* frame aerial on top of a portable set of that size. Besides there's too much wire on that frame aerial for the broadcast wavelengths."

"He might be listening to Davenport, George."

"Not in America, my boy. What a set it is to be sure! Look at the size of it, and yet the poor fellow has to lift himself up, mumps included, lean out of bed and put his ear to the loud-speaker before he can hear anything."

It was just then that the rude request to be quiet came from the bad-tempered individual behind us. No, George did not reply. We were in the wrong and George knew it as well as I did.

Easy Money

Whenever I look through an American wireless periodical, I am always attracted by the advertisements which tell you how easy it is to make money out of wireless. We don't find such advertisements in our own wireless periodicals, more's the pity. Why shouldn't some of us have the chance of earning good money by learning how to turn our spare time to profitable wireless employment?

Quoting from these advertisements it is a fact that, all over the United States, owners of wireless sets are crying out for wireless experts to improve the tone of their sets, to increase the volume of sound from their loud-speakers, to change their multi-dial sets to sets with single-dial controls, and to alter their sets so that they can be operated from the electric-lighting mains.

It is also a fact, again quoting from these advertisements, that owners of gramophones everywhere in America

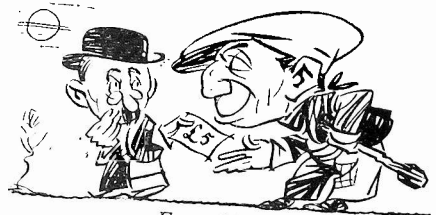

Easy Money

are yearning for men to come along and electrify their gramophones and add wireless to them—I beg your pardon, radioty them.

Why are there no such golden opportunities here in our country? If I lived on the other side of the Atlantic I should certainly fall for one of those wireless correspondence schools and reap the proffered harvest.

HALYARD.

If Your Set Starts

MOTOR-BOATING

This Article by W. JAMES will Enable You To Stop It!

IT is well known in telephone engineering that there must be practically no resistance in the battery or machine circuit which supplies the subscribers' telephones. Therefore, the power supply between points A and B (Fig. 1) is so designed that it has the least possible resistance, and the subscribers' lines are joined to the copper bus-bars.

Why Cross Talk Occurs

Were the resistance appreciable, there would be interference between lines in the form of cross talk, when one subscriber who was using his telephone would hear another subscriber connected to a different circuit. This is because the varying currents coming from the power supply and produced by speech before a microphone would set up varying voltages across the points of distribution and, therefore, be applied to the other lines.

In wireless receivers, the same principle applies. When two or more circuits are connected to a single power supply, having resistance, there will be mutual interference. The interference may be such that the amplification is reduced, or, on the other hand, the amplification may be increased, and, when the inter-valve couplings are favourable, the effect known as "motor-boating" will be produced.

What Motor-boating Is

Motor-boating is a popular term employed in connection with the popping sounds emitted by a loud speaker connected to a receiver which is oscillating at a low frequency, but it must be remembered that very serious distortion may be produced by a power supply having resistance, even though these actual sounds are

not heard. It is, therefore, very necessary for precautions to be taken in order to prevent, or at least to minimise, the ill effects of a common resistance present in a power supply.

This may, of course, be a dry battery or a mains unit; high-tension batteries of accumulators generally have so low an internal resistance that they need not be considered, although it must be remembered that all connections must be clean and well made or the battery will have a resistance which is by no means negligible.

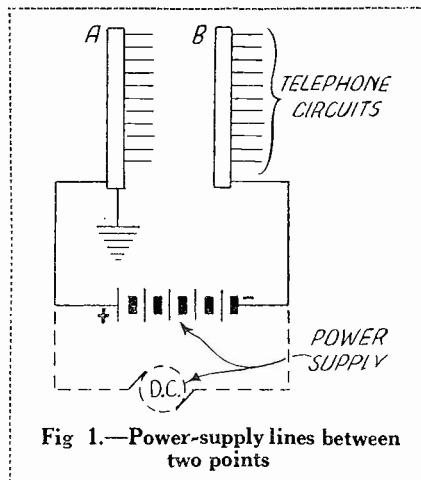

Fig. 1.—Power-supply lines between two points

Let us take, as an example, a four-valve receiver connected as in Fig. 2. Here we have a tuned-anode shielded-valve high-frequency stage, followed by a leaky-grid detector and two low-frequency stages, and a high-tension battery whose resistance is represented for convenience by a resistance R .

The set is tuned to a station and signals are being received, with the result that the current flowing through the loud-speaker is varying by a considerable amount. The current flowing through the other

circuits is, of course, also varying, but we will first deal with the last stage comprising valve v_4 and the loud-speaker.

This varying current, passing, as it does through the resistance, represented by R , of the power supply, sets up voltages across it, from which it follows that, instead of a perfectly steady and unvarying supply being fed to the first three anode circuits the voltage of the battery has superimposed upon it the voltage fluctuations due to the power valve.

When Distortion Arises

In the case of valve v_3 , this will tend to produce distortion by reducing the amplification, as the voltage fluctuations produced by the resistance of the battery tend to act in opposition to the voltages applied to the grid of the power valve v_4 by the signal.

The distortion may not be noticeable, or it may be quite serious, depending upon a number of factors. One of them is the magnitude of the resistance R of the power supply, whilst another is the characteristics of the last stage, including the valve used and the loud-speaker.

It will also be clear that the values of the anode resistance R_2 , coupling condenser C_3 and grid leak R_5 , are also important factors, from which it follows that the distortion may be more noticeable with one receiver and loud-speaker than another.

Effect on Detector Valve

Let us now see what effect the varying currents flowing through the loud-speaker have on the detector valve v_2 . The varying voltages set up across the resistance R will be communicated to the grid of v_3 through the anode resistance R_1 , coupling

If Your Set Starts Motor-boating (Continued)

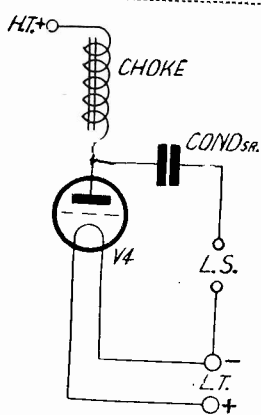

Fig. 3.—Choke output circuit

the motor-boating will be decided by the electrical values of the parts used in the circuit and of the loud-speaker itself.

Grid Circuit of Detector

When we come to consider the grid circuit of the detector, which is, of course, joined to the high tension through the tuned-anode circuit L_C , we see that here again distortion will be produced when the common resistance R is sufficiently great and, further, there is the possibility of the H.F. valve giving trouble should the screening-grid voltage fluctuate.

Having now indicated in a general way how a power supply, having resistance, may influence the various valves and produce distortion, let us consider what steps may be taken in order to obtain those results which we should expect when the receiver is connected to a supply having a negligibly small resistance.

An Obvious Remedy

The obvious thing to do is to prevent the fluctuating currents produced by a signal from passing through the high-tension supply, for then there will be no voltages built up across the supply by the signal.

Now the power valve produces the largest fluctuating current, and therefore the power-valve circuit should be dealt with first. Thus, a choking coil may be included in the anode circuit, as in Fig. 3, and the loud-speaker be jointed to the anode through a condenser of 2 or more microfarads capacity.

Fluctuating currents of any magnitude will then not pass through the

condenser C_2 and grid leak R_4 , and in this instance the coupling will be such that the tendency is to strengthen the signals.

Bad distortion and motor-boating may, therefore, be produced, and the frequency of

power supply to this valve when the choking coil has sufficient inductance, because its impedance will be great compared with that offered by the alternative path provided by the fixed condenser and loud-speaker.

This circuit is as simple as it is effective, and has the further advantages that direct current does not flow through the loud-speaker, which is also not in direct connection with the high tension.

The inductance of the choking coil must be so high when the normal anode current to the valve is passing that practically no varying current passes through it. Were the inductance too little, the lower notes would be weakened, relative to those of the middle and higher frequencies, and it is, of course, important that the choking coil has little self-capacity, or the higher notes may be weakened.

The addition of a choke-condenser

ing Fig. 2, that the back coupling to the anode of the detector valve was such that bad distortion and low-frequency oscillation might be set up. Here a simple resistance-capacity filter will help us.

It comprises a resistance A connected in series with the supply to the anode, and a fixed condenser C connected between the filament of the valve and the junction of the filter resistance, and the anode-circuit resistance B , as shown in Fig. 4a.

Minimising Back Coupling

In order to minimise the back coupling, the filter resistance and condenser must have certain minimum values, but, unfortunately, it is not possible to employ too high a resistance, as this may seriously interfere with the proper functioning of the detector valve.

When the high-tension supply is of

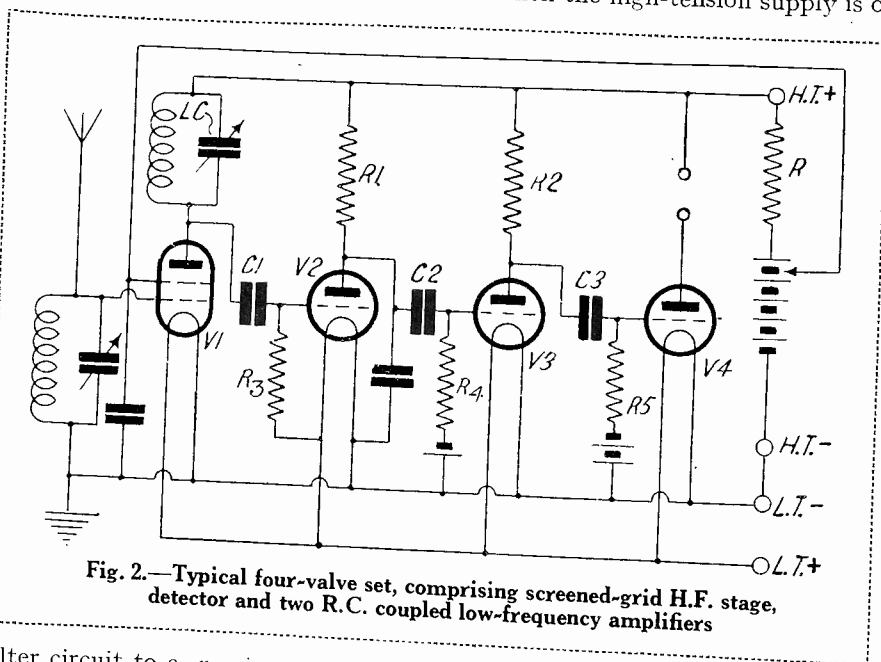

Fig. 2.—Typical four-valve set, comprising screened-grid H.F. stage, detector and two R.C. coupled low-frequency amplifiers

filter circuit to a receiver will often prevent motor-boating, because the relatively heavy current fluctuations produced by the last valve are diverted from the anode to the filament. But, when effective inter-valve couplings are employed, the addition of this filter may only minimise the motor-boating and will almost certainly not prevent distortion, provided, of course, the resistance of the supply is above a certain value, and it is, therefore, necessary to deal with the other circuits in the receiver.

I mentioned above, when describ-

adequate voltage, the filter resistance may be given a value of as much as 100,000 ohms or more, but sometimes it is not possible to employ more than a 40,000-ohm resistance depending, of course, upon the voltage of the supply, the type of valve used at V_2 and the resistance of B .

The resistance should, however, always be made as high as convenient, for then the best filtering action will be obtained. The effect of the resistance-condenser filter may be explained with the help of Fig. 4b, which shows the complete anode

A Practical Article by W. James

circuit of the detector valve, connected to an alternating voltage, representing the voltages developed across the common resistance of the high-tension supply.

Effect of A.C. Voltage

The A.C. voltage sends a current through the resistance *A* and by-pass condenser *C*, connected across the anode resistance *B* and the valve. A certain amount of current will naturally pass through resistance *B* and the valve, depending upon the actual voltage across condenser *C*.

This will obviously be small when the resistance of *A* is large and when the condenser *C* has a large capacity, because the impedance of a condenser is reduced as its capacity is increased.

If the resistance of *A* were halved, for example, more current would flow through resistance *B*, and the valve, and, as a result, a greater back-coupling voltage would be applied to the grid of the next valve. The filter, therefore, reduces the amount of the back coupling, and it also tends to prevent current from *V2* entering the supply.

Use of Larger Condenser

A condenser *C* of 2 microfarads is often employed, but from this explanation it should be evident that one of 4 microfarads, or of even greater capacity may have to be used in order to obtain the desired results. The type of valve and value of anode resistance are also important factors, and when the value of the filter resistance *A* is fixed by other considerations, one should remember that it may be necessary to employ more than the 2 microfarads so often recommended.

Filter for Low-frequency Stage

A similar filter should be connected to the first low-frequency amplifying valve when the finest results are required, but as more current will probably be flowing through this circuit than the detector, a filter resistance of lower value may have to be used. A condenser of 2 microfarads and sometimes 4 microfarads, in association with this medium resistance, will usually result in practically the complete elimination of back-coupling effects.

We have now to consider the

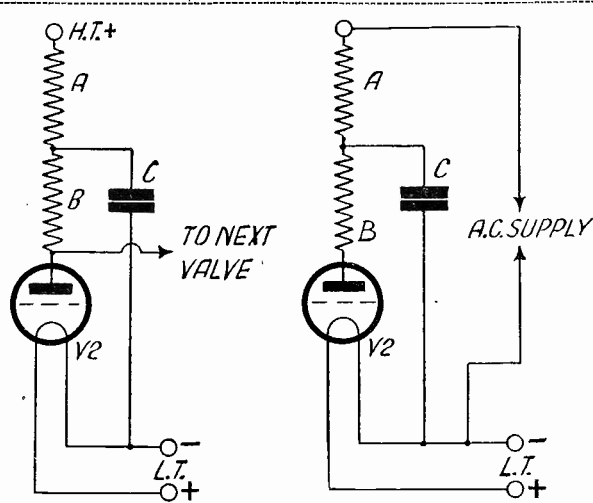

Fig. 4a.—Simple resistance-capacity filter

Fig. 4b.—Complete anode circuit of valve

high-frequency stage, which is tuned-anode coupled to the detector. Low-frequency variations applied to the anode of this valve, therefore, pass to the grid of the detector, although it must be remembered that the grid condenser, being of small capacity, helps cut down the variations.

When a high-frequency transformer is employed, the low frequency would not reach the grid of the detector, because the transformer would not pass it, but tuned-anode circuits and their variations will pass the low frequency, which must, therefore, be eliminated.

A simple resistance-capacity filter will do this, and one should be employed when the power supply is suspected of having more than a negligible resistance. The shielding grid of the valve is better treated in the same manner.

The addition of resistance-capacity filter circuits to the high-tension supplies of the amplifying and detector valves of a receiver may upset

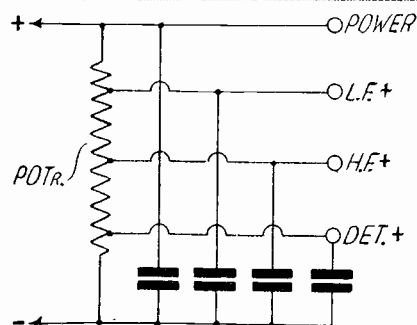

Fig. 5.—Mains unit with potentiometer

the normal working conditions, unless it is understood there is a fall in voltage across the filter resistances.

Thus, 1 volt is lost for each 1,000 ohms when the current is 1 milli-ampere. A resistance of 50,000 ohms will, therefore, drop the voltage applied to the anode circuit by 50, when the current flowing is 1 milli-ampere, and it is necessary to consider each stage separately in order to determine

the maximum value of the resistance that may be connected to the particular value of H.T. available.

A Practical Example

As an example we will assume the high-tension voltage is 150, and that the anode current of the shielded valve of Fig. 2 should be 2 milli-amperes for a voltage of 120. The difference between the voltage required and that available is 30, and the current is 2 milliamperes; therefore, the resistance should have a value of 30,000 divided by 2, or 15,000 ohms.

Those who employ a dry-battery high tension are recommended to include the filtering circuits described. A dry battery increases in resistance as it discharges; when it is new its resistance may be so low that even when the receiver deals properly with the whole range of musical frequencies there is no sign of motor-boating.

But, after a time, the resistance of the dry battery may have increased to such a value that bad distortion is produced, and when the circuit conditions are suitable a low-frequency oscillation may be set up.

Increase in Resistance

Most mains units have filtering resistances included in them, but there are types fitted with a potentiometer, as in Fig. 5, from which voltages of various values may be obtained

(Continued on page 232)

MORE ABOUT THE LODESTONE LOUD-SPEAKER!

The Special Low-current Moving-coil Instrument Designed for the "W.M."
by W. JAMES

Described and Illustrated in the February (page 7) and March (page 134) Issues of "W.M."

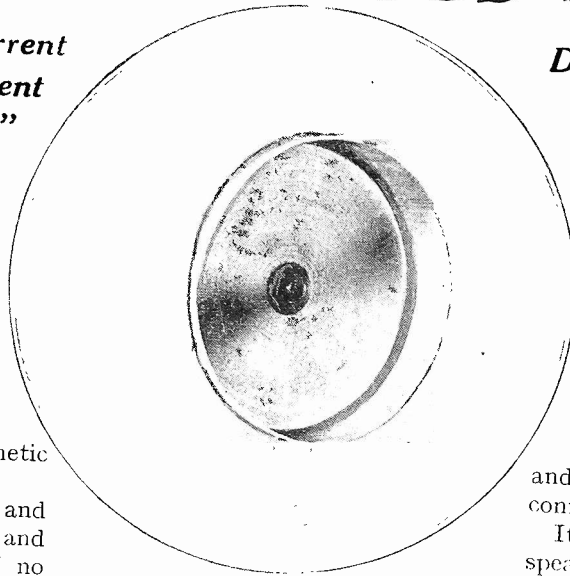

This view shows the centre pole and aluminium coil former of the Lodestone Loud-speaker

IN earlier articles I have discussed the more important factors that have to be considered when designing a moving-coil loud-speaker. Thus, there must first of all be an adequate magnetic field, which can only be obtained by properly proportioning the magnetic circuit.

This comprises the metal shell and centre pole with the air gap, and when efficiency is a matter of no small importance, the necessary field strength must be obtained with a current of about half an ampere from a six-volt source.

Use of Steel Centre Pole

Good magnetic materials must, therefore, be employed, and in the Lodestone loud-speaker I have used a steel centre pole and front plate, with a cast iron barrel and back plate.

With an air gap of $\frac{1}{16}$ in. the magnetic field in the air gap amounts to from 8,000 to 10,000 lines per square centimetre. This is adequate, and the fact that this strength is obtained with so small a magnetising current is due to careful proportions and choice of materials. A weaker field would result in reduced sensitivity, and one of the reasons why the Lodestone is as sensitive as the average cone-type loud-speaker is because the magnetic field is so intense.

Improved Centring Device

The second point to which attention must be given is in the arrangement of the cone and coil with its centring device. It is obviously desirable that the cone be free to

move backwards and forwards with comparative freedom over a distance which will not be exceeded during reception. Should the movement be restrained and vary according to the amplitude of the motion, the sound output will be less than it might be and will not be according to the currents flowing in the moving coil.

Sideways movement should be restricted, if possible, in order that the assembly may move backwards and forwards under the influence of the forces set up by the currents in the coil without twisting, which might allow the coil to rub against the poles.

It is, therefore, necessary that the surround be not fastened too tightly, but, at the same time, there should not be too much slack. One is able to judge whether the assembly is sufficiently flexible by gently moving it backwards and forwards with the fingers.

Care must be taken when assembling that all nuts and bolts and connections are tight and the air gap must be quite clear. A few iron

filings in the air gap may spoil the results by setting up a buzzing sound of quite remarkable intensity.

For the same reason the fine wires coming from the speech coil must be carefully secured; they should be stuck to the cone and sufficient left for the flexible connections to the terminals.

It is usual to mount a moving-coil speaker in a cabinet or to employ a flat baffle. Care must be taken here to ensure that the speaker fits tightly against the front of the baffle, and for this purpose it is advisable to stick felt around the inner surface in order that a good joint may be made without fear of rattling.

Thick Baffle Desirable

Do not use as a baffle a piece of thin wood or material such as three-ply. It should be made from wood of about $\frac{3}{4}$ in. thickness, although for experimenting a cheaper material such as cardboard may be used.

The strength of the low tones depends a good deal upon the size of the baffle, which should therefore be as large as possible, even up to 3 or 4 ft. square. Satisfactory results may be obtained by employing a large cabinet which is also used to house the amplifier.

Worth a Good Baffle

But care must be taken that the valves do not vibrate, or they may tend to cause a howl to be emitted from the speaker. The quality of the reproduction provided by the Lodestone is so good when it is connected to a reasonably well-designed receiver that it is worth a good baffle.

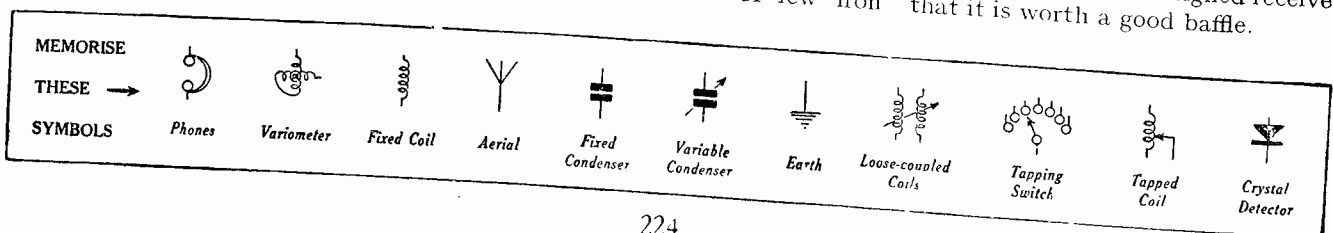

Wireless Magazine Gramo-Radio Section

A SPECIAL SUPPLEMENT FOR THOSE INTERESTED IN
THE ELECTRICAL REPRODUCTION OF GRAMOPHONE
RECORDS—THE FIRST OF ITS KIND TO BE PUBLISHED

Can You Cut Out Needle Scratch?

WHEN I was first introduced to grammo-radio I was told that one of its chief advantages was the elimination of needle scratch. This, I have found, is true with proper equipment, but is only a half-truth in the case of the average amateur receiver used in conjunction with an electrical sound-box.

Reducing Surface Noise

What I mean is that some makes of pick-up tend to reduce surface noise, and this is a good point. But a real "purity" amplifier will amplify the remaining scratch sounds in just the same proportion as it amplifies speech and music.

This is because the scratch itself is the result of unevenness of the bottoms of the sound grooves, and the production is a hiss having a frequency of about 5,000 cycles per second.

This is similar to the sibilant, and often I have found that an amplifier, the owner of which claimed that it gave no surface noise, was apt to lisp and miss its "esses." Sometimes, even, immunity from scratch was obtained by cutting off the whole of the top notes.

Cutting It Out

Let me hasten to add, before I raise the wrath of other grammo-radio enthusiasts, that it is, of course, possible to cut out needle scratch with electrical reproduction, and there is, in fact, far more chance of being successful than with mechanical reproduction.

But in order to do so without spoiling quality the following other factors must obtain: The pick-up must be fairly heavily damped, for a lightly-damped reed may accentuate surface noise; this may necessitate an extra stage of amplification,

for heavily-damped pick-ups are generally the least sensitive.

The amplifier itself should be capable of covering a frequency band up to the "s" and "hiss" strata, and the latter should not be cut down by the ruthless method of adding a by-pass condenser to

'lose" all the really high notes.

The proper way of minimising scratch is by means of a scratch filter, which need not be very complicated, and one such will be found in the grammo-radio amplifiers of all true *critiques*.

F. TUR.

(See also page 228)

Where to Place A Volume Control

PERSONALLY, I make good use of the volume control on any grammo-radio outfit, and this is, I am sure, a feature which must appeal to all musically-minded gramophone listeners. It is all very well and correct to have dance-band records going "all out," but vocal items, organ solos in indifferent recordings, some solo piano items, and so on are frequently better if played *a demi jeu*.

The best place for a volume control is at the pick-up end of the set, and not at the power-valve end. My own favourite method of connection is to use a high-resistance

volume control as the grid leak of the first R.C. coupled L.F. stage, one side of the large grid blocking condenser being taken to the volume control tapping on this.

No Tonal Change

In this way volume can be varied without effecting a tonal change. This is important, because if the volume control is incorrectly wired it may be found that the tone becomes "tinny" as the volume diminishes, or vice versa the amplifier may blast and overload as the control knob is tuned to the "full on" position.

B. MARSHALL.

Is Gramo-Radio At A Stand-still?

BY a "gramo standstill" I mean this: Is it worth while for grammo-radio "fans" to use the very best possible equipment, from the point of view of purity and wide frequency-range amplification? Are not even the best electric recordings at present far behind the almost perfect radio amplifiers available?

I am not trying to raise a scare, but I was led to think about it recently when one well versed in the technical side of record production told me that most records show a distinct falling-off under middle C (256 cycles) and above about 4,000 cycles. Also, said this expert, the full range in commercial practice is from about 100 up to about 5,000 cycles.

Thus I asked myself the query

indicated in the first paragraph, for many of the receivers described in this journal will cover a wider band than this, when used with a good pick-up.

My own opinion is that record manufacturers, who are at present doing good work in electrical recording, will soon realise that so many wireless men use electrical reproduction that there is a big market for special records for the purpose.

Use Of Good Amplifiers

And in any case it is better to use, as we do at present, really good-quality amplifiers with the best electrical recordings rather than to cut down the scope or quality of valve amplification.

M. R. BULL.

A Discussion from an Original Point of View

IF I WERE BASS DEAF

By H. T. BARNETT, M.I.E.E.

IT may now be a suitable time for me to explain the standpoint I have gradually been led to take up in reference to the deep bass notes of the scale, their generation, auditory effect, recorded proportion and proportional reproduction.

In the first place, I must explain that I am talking chiefly about what people can *hear*, about those bass notes constituting a part of *music* and not bass tone (if it can be called tone) dynamic effects that need a physical laboratory for their measurement or estimation.

Difficulty in Hearing

A deep bass note constituted by the fundamental tone alone I can hear only with considerable difficulty, and then quite likely purely by mental inference from the group of harmonics or upper partials it must necessarily create in the cavities and structures of my head.

If I sling up, out of doors, a couple of heavy coils of wire close to one another and energise them with our 60-cycle alternating current, so that they are vibrating freely under its influence, and communicating quite a lot of energy to the air, I can hardly hear the note, although from a musical point of view it is not by any means a very low one.

Quality of the Note

Now if I bring those coils into a room I can hear a note directly the current is switched on, and the quality of the tone of the note varies with the harmonic-generating capabilities of the room; should I then bring a sheet of wood or some other article into contact with one of the coils, there are changes in the character of the tone produced and determined by the capacity of the article for generating certain of the harmonics peculiar to the 60-cycle fundamental.

If I go to our power station, where the whole air is throbbing at the rate of sixty vibrations a second, I am less conscious of the musical

note corresponding with that period than if it were played on a bass saxophone with an expenditure of a millionth part of the energy that must be thrown into the air by the great coils, conductors, and masses of magnetised metal vibrated by the hundred thousand horse-power of our electricity department.

The 16-ft. to 32-ft. pipes of an organ will produce very different

The point of view expressed in this article will be new to many radio and gramophone enthusiasts. Moreover, we believe that it will raise a good deal of controversy.

We shall welcome correspondence on this interesting subject—both from the wireless and gramophone standpoints.

effects upon the listener, according to the nature of the building in which the organ is housed.

If a 16-ft. organ pipe of great tonal purity (generating only the fundamental) could be made and if it were sounded *out of doors*, I do not believe I should hear it as anything but a muffled tone, certainly it would only produce a small percentage of the audible effect that could be got by using far less energy to vibrate the equivalent string on a piano.

The other day I played all my best organ records on my Micro-Perophone 22 to a couple of organists.

They agreed that the best recording of deep bass tone was in "Easter Hymns" (H.M.V., 3s.), and then they asked me what organ had been used and I replied "Kingsway Hall." My answer led to laughter and when I inquired the reason they said there were no very long pipes on this organ, but that the deep bass tone had been got by the builders "synthetically."

After that, of course, we had a little talk about fundamentals and harmonics, concluding with the pious wish that all organs, and particularly those used for recording, might comprise a synthetic bottom octave.

Stringed Instruments

Now let us leave the production of pure fundamentals (by electrically-energised coils) and of nearly pure deep tones (by the long organ pipes) and consider the production of deep bass tone by stringed instruments.

The bottom notes on the piano and on the double bass produce the same pitch impressions on our auditory nerves as do the very long organ pipes, but how little of the fundamental tone can their notes comprise!

Play the Brunswick Polydor pianoforte record "Fugue in A Minor" (6s. 6d.) and the H.M.V. Philadelphia Orchestra's "Tocatta and Fugue" (6s. 6d.) on H.M.V. 202 machine, or on the M.-P. 22. How absolutely true to life is the tone quality and how perfect the scale balance.

The fact that such tone can be proportionately recorded with one hundred groove turns to the inch proves conclusively that our ears do not need the fundamental in the deep bass in order to furnish us with the mental impression of it.

Different Kinds of Pianos

How greatly may the groups of harmonics suggesting deep bass notes differ in their make up when obtained from different kinds of pianos! After playing the piano record just mentioned, in which the tone appears to be that of a big Blüthner, play the first disc of Percy Grainger's *Brahms Sonata* (Columbia, 6s. 6d.): can you not instantly identify the deep bass as that of the Chickering piano, or one of similar construction?

If you listen very carefully I think

you could almost plot the harmonic groups of the lower strings.

Now do not say that I am bass deaf and that other people's hearing is different from mine; if that were the case, no one could work in an alternating-current generating station, and certainly no one could live within a mile of one.

I Am Not Bass Deaf

If I were bass deaf the bass on a good record played on a good gramophone would not suggest a perfect scale balance.

Do not say the double bass produces a great volume of fundamental tone which other people can hear and which I cannot. I have not played the orchestral record just mentioned to a single musician who has not been perfectly satisfied both with the tone characteristic and volume value of the double basses.

It is the capacity of a big or little fiddle for generating agreeable and convincing harmonic groups that constitutes its value—were that not the case, were we merely desirous of having a greater area than that of the string vibrating at the fundamental rate, then a large flat plate of thin glass under one foot of the bridge would be of more value than the work of Stradivarius.

How different 'cellos (for example) can be in their tone, listen to the instruments of Casals and of Squire, either in the concert-hall or from their records; Blüthner and Chickering pianos have no greater difference of tone quality.

Simplified Recording

In conclusion, may I say that in the future I believe the work of recording would be simplified were some physicist to make a set of graphs showing the audible group of harmonics: (1) from a 16-ft. organ pipe in the open air and in various cathedrals, (2) from big fiddles of various makes and shapes, and (3) from the deep bass notes of pianos of various manufacturers.

And will some hard-working inventor please give us a new electrical bass instrument (for the orchestra) of great and regulable power, in which we may vary the harmonics (suggesting the fundamental) at will so as to produce any tone characteristic desired.

A Good Pick-up

By W. JAMES

A FEW months ago I tested a number of gramophone pick-ups and published curves showing the variations in the output voltage with frequency. For the purpose of the tests I put together a single-stage resistance-coupled amplifier and so adjusted the values of the components employed that it gave uniform magnification over the frequency range of from 50 to 10,000 cycles.

A special record was used and the pick-up was connected to the input of the amplifying valve which

duction was noticeably more brilliant and there was a marked absence of chattering or noise.

Certain makes of pick-up are rather more noisy than others, with the result it is necessary to close the lid of the set in order to avoid interference with the reproduction. The R. I. & Varley, being quiet in operation, therefore offers a definite advantage. The illustration shows the output obtained over the frequency range, and if the curve be compared with the one given in my earlier article the reason for the

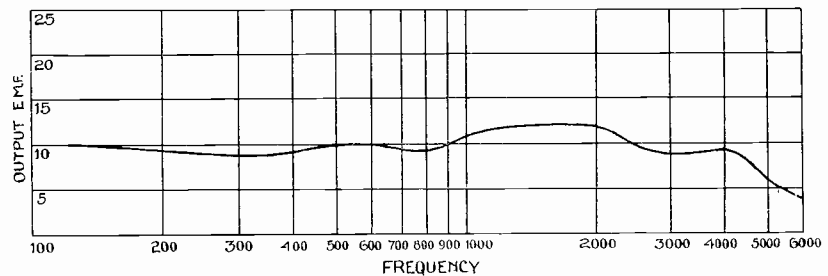

Frequency-output curve of the R.I. and Varley pick-up, which shows a marked improvement in the upper registers

had the calibrated valve voltmeter joined across its output circuit. The magnifier was employed in order that large readings on the valve voltmeter could be obtained, as the usual form of instrument has a non-uniform scale and accuracy was essential.

Four pick-ups were tested, and the results were published on page 47 of the February number. One of them was an early pattern supplied by R. I. & Varley, Ltd., and I have lately had the opportunity of testing a more recent standard product. It would appear that those now being issued are rather better than the first samples of which I had a specimen, as, when trying one in my radio-gramophone set the repro-

more brilliant reproduction will be understood, as the more recent model gives more output at the higher frequencies.

The shape of the curve from 100 to 1,000 cycles is about the same for the two pick-ups; the marked improvement in the performance is due to the increased output over the range from 1,000 to 5,000 cycles.

I understand this pick-up is particularly good from the point of view of minimum record wear, but it is, of course, essential to employ a good carrier, which must be properly set. As the instrument gives the maximum output of not more than a few tenths of a volt only a small negative grid bias is needed for the first amplifying valve.

Whatever you want to know about Gramo-Radio, consult the "Wireless Magazine" Technical Staff. For many months they have kept abreast of this latest development and can reply to any query that may be raised in connection with it.

So that the Staff is not absolutely overwhelmed with queries (and to avoid the trouble of answering any of a frivolous nature, which results from a free

service) a nominal fee of 1s. is charged for each question asked.

Write your query or queries (not more than two can be answered for each reader) on one side of a sheet of paper and send it, together with a stamped addressed envelope, a postal order for 1s. and the coupon from page iii of the cover, to Gramo-Radio Queries, "Wireless Magazine," 58-61 Fetter Lane, E.C.4.

Designing Scratch Filters

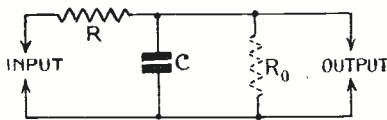

Fig. 1.—Simple resistance-capacity filter

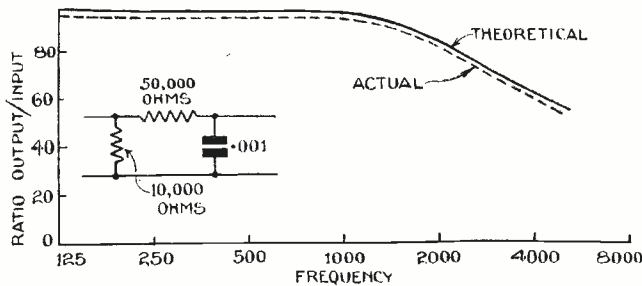

Fig. 2 (below).—Type of cut-off obtained

WE discussed last month the practicability of the use of scratch filters for electrical gramophone reproduction. It is proposed in this article to give practical data regarding the characteristics of various forms of filter. This will enable a filter to be designed for any specific purpose with the minimum of difficulty.

We will consider first the simple type of resistance-capacity filter having a relatively high resistance in series with a condenser, the output being connected across the condenser itself, as illustrated in Fig. 1.

For low frequencies, the reactance of the condenser is large, compared with the resistance. In consequence, most of the voltage is developed across the condenser, and the output voltage is practically identical with the input voltage. As the frequency is increased so the reactance of the condenser decreases (a condenser affords a more ready path to high-frequency currents than to low-frequency ones).

Falling Off of Voltage

Consequently, a point is reached where the reactance of the condenser becomes comparable with the resistance, in series therewith

and at this point, the output voltage begins to fall off.

The actual output voltage can easily be calculated, if it is remembered that the voltages on the resistance and the voltage on the condenser are 90 degrees out of phase. This means that the cut-off is not as rapid as one would expect at first sight.

For example, it is a fairly easy matter to determine the point at which the voltage on the resistance and the voltage on the condenser are equal.

The voltage across the two, however, is not twice the voltage across each, because of the phase difference, but is 1.4 times that across each

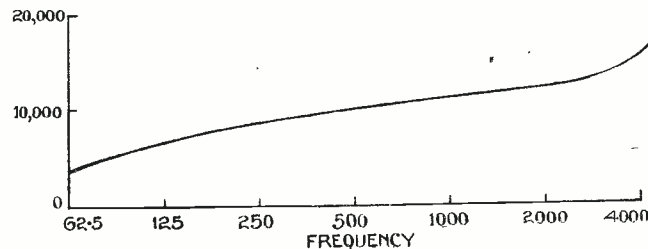

Fig. 3.—How pick-up impedance varies with frequency

component individually. Consequently, at this point, the output voltage is 70 per cent. of the input and not 50 per cent., as would appear from first considerations.

The curve shown in Fig. 2 illustrates the type of cut-off obtained with a simple filter of this type. In taking this curve the resistance was made 50,000 ohms and the condenser was .001 microfarad. The full curve is the theoretical curve obtained by actual calculation while the dotted curve,

By J. H. REYNER, B.Sc., A.M.I.E.E.

just underneath, illustrates the results obtained from an actual practical test of such a filter.

It will be observed that the cut-off point occurs at the same frequency, the two curves running absolutely together over the whole of their length.

The fact that the actual curve is slightly below the theoretical curve arises from the small shunting effect which the scratch filter has on the pick-up. This can easily be allowed for, but the discrepancy is so small as to be negligible.

Results Unaffected

It will be seen that the order of the results is not affected by making use of this approximation. At the same time, this brings up an interesting point.

The relation between the impedance of the pick-up and the impedance of the filter is obviously one of some importance. The subject is one which cannot be discussed in a brief survey such as the present, but it will suffice to note that, in order to duplicate practical conditions throughout the measurement, a representative pick-up (an Igranac Phonovox) was taken, and the impedance measured at various frequencies.

This was found to rise from about 2,000 ohms at 50 cycles to 10,000 ohms at 500 cycles. Thereafter the increase in the impedance was only relatively slow, owing to self-capacity effects which come into play to an increasing extent.

A general form of variation is as illustrated in Fig. 3, and a mean value of 10,000 ohms was chosen as representing an average value of pick-up impedance. This value was used throughout the tests.

The actual cut-off point in a simple resistance-capacity filter,

such as this, is rather difficult to determine, owing to the gradual falling-off. It is necessary to choose a point at which the output has fallen to some pre-determined percentage of the input in order to specify the performance of the filter.

Choosing a Special Value

This critical frequency, taken in conjunction with the general shape of the curve, enables some forecast to be made on the performance of the particular filter. In the case of a simple resistance-capacity filter, we can choose a point where the impedances of the condenser and the resistance become equal so that, as already pointed out, the output is 70 per cent. of the input.

This occurs at a frequency given by:—

$$f = \frac{1}{2\pi CR}$$

where C=capacity in microfarads, R=resistance in megohms.

It may be noted that in the particular case just considered this occurs at 3,190 cycles, while the voltage is reduced to about half its actual value at 4,000 cycles, so that the constants just given are suitable for ordinary purposes, tending to reduce frequencies of 4,000 and upwards to an increasing extent.

Volume Control

In many cases it is desired to connect a resistance across the output of the filter. This may be of the nature of a volume control and may, therefore, be a resistance of the order of .1 to .25 megohm.

It should be emphasised in passing

that if such resistance is used as a volume control, it should be employed as a potentiometer, so that the actual resistance connected across the

output of the filter remains fixed and is not varied. Unless this is done, the constants of the filter will be changed every time the volume is altered, and particularly with small volumes it is found that the upper notes are very seriously reduced.

The performance of a filter of this type can also be calculated from ordinary alternating-current theory. The calculations involved are somewhat more laborious than in the simple case, but a number of calculations which have been made, followed up by practical tests, indicate the following conclusions.

The presence of a resistance across the output of a filter reduces the output over the whole of the frequency band. This means that in the non-attenuating portion of the frequency band (that is, the portion where the filter should not affect matters), the output from the filter, instead of being practically the same as the input, is reduced in value. The same sort of cut-off effect occurs, but the actual voltage at any point is lower than without any output resistance.

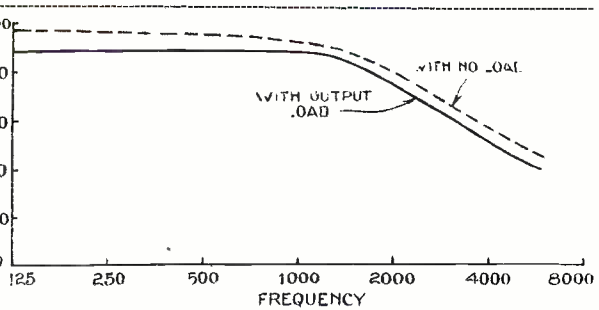

Fig. 4.—Curves obtained with and without an output resistance

the relative voltages will be in the ratio —

$$\frac{V_1}{V_2} = \frac{R}{R + R_o}$$

where V₁=voltage with output resistance in position.

V₂=do., without do.

R=series resistance.

R_o=output resistance.

Experimental Confirmation

These results are confirmed experimentally, as is illustrated in Fig. 4. The top curve indicates the cut-off obtained without any output resistance, and the bottom curve shows the effect of adding a .25-megohm leak across the output. A reduction in voltage is of the order given by the formula just quoted, there being one small point, however, which is of interest.

This is that the cut-off effect is slightly sharper with a resistance across the output in this manner, as is the case with the simple filter, due to certain phase changes which take place as the frequency rises. Neither arrangement, however, can be considered as giving anything like a sharp cut-off.

Inductance-capacity Filters

We now come to the consideration of inductance-capacity filters, such as that shown in Fig. 5. Here an inductance, or choke, takes the place of the resistance, and the action is such as to give a somewhat sharper cut-off. At low frequencies, the choke has a negligible impedance, while the condenser has a very high impedance, so that the full voltage is developed across the output.

At high frequencies, the position is reversed, the inductance having a very high impedance, and the condenser a very small impedance, so that little of the original voltage

This is what one would expect, for the presence of the resistance across the output means that a current will flow through the filter at all frequencies, and we have, in effect, a simple resistance potential divider with a capacity coupling across one portion.

There must always, therefore, be a reduction in the voltage, and

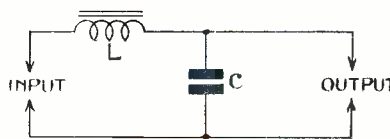
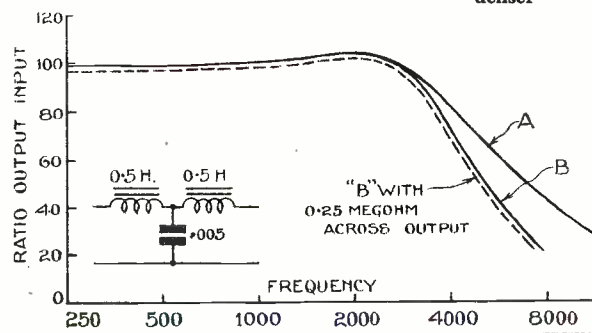

Fig. 5.—Inductance-capacity filter Fig. 6 (below).—Cut-off obtained with choke of .5 henry and .095-microfarad condenser



Designing Scratch Filters (Continued)

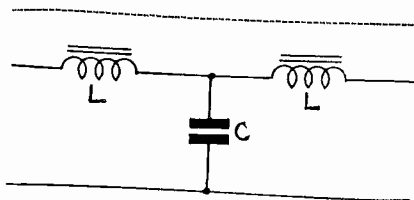

Fig. 7.—Complete section of filter

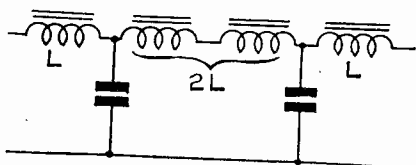

Fig. 8.—Two-section filter made up of two sections of Fig. 7

reaches the output. The relative sharpness of the change-over depends entirely upon the resonant properties of the circuit, and the same considerations that make a good tuning circuit apply here. Thus we require a choke of low resistance relative to the inductance and a condenser of good quality.

Rise of Voltage

There is another point, however, to be considered here, and that is that at the resonant point when the voltage of the condenser and the voltage on the choke are equal, it is possible for both these voltages to exceed the input voltage. Indeed, if the choke had no resistance, the voltages developed across each component would rise to an infinitely high value at the resonant point.

In practice, the rise is only comparatively small, because of the somewhat large resistance usually found under practical conditions, but nevertheless, there is a definite rise, due to resonance just before the cut-off effect takes place.

Where Cut-off Point Occurs

The actual cut-off occurs just beyond the resonant point, which thus gives an indication of the performance of the filter. The resonant point is given by the expression:—

$$f = \frac{1}{2\pi\sqrt{LC}}$$

where L=Inductance in henries.

C=Capacity in farads.

It is possible, however, to obtain

a closer evaluation to the actual cut-off point, by treating the circuit as a filter and this gives the cut-off frequency as:—

$$f = \frac{1}{\pi\sqrt{2LC}}$$

We may rewrite this, putting L in henries and C in microfarads as follows:—

$$f = \frac{225}{LC} \text{ cycles/sec.}$$

It will be seen that the cut-off frequency given by this expression is approximately 1.4 times the resonant frequency, and the value obtained from this formula actually falls into line with practice to quite a close extent.

The curve A in Fig. 6 illustrates the cut-off obtained with a choke of 0.5 henry inductance, with a capacity of .005 microfarad. It will be seen that this filter hardly attenuates at all until 3,000 cycles is reached, when it starts to cut off. There is an indication of a slight rise in the voltage just before the cut-off takes

inductance has quite a marked effect on the cut-off, the curve B being taken with such an arrangement, the inductance and capacity values being as before. The cut-off point will be seen to occur at the same frequency but the cut-off itself is much sharper, and this could be considered as quite a satisfactory scratch-filter, the output being well maintained up to the cut-off point.

Effect of Resistance

The effect of resistance across the output of a filter of this type is much less marked than in the case of a resistance-capacity filter. The dotted curve just under curve B in Fig. 6 shows the effect of a .25-megohm leak across the output, and it will be seen that it does not affect the characteristic of the filter in any way, but merely reduces the actual voltage at the output, over the whole of the frequency scale. This reduction, however, is quite small and can easily be tolerated.

Still sharper cut-off is obtainable

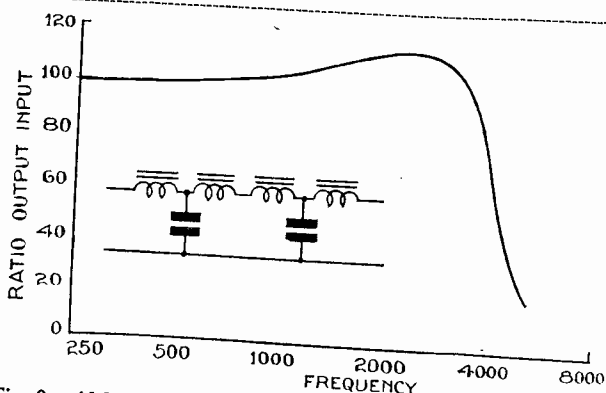

Fig. 9.—Although the resonance hump is slightly accentuated, the cut-off is exceptionally sharp

by using two or more sections. Fig. 8 illustrates a two-section filter, made up by placing two sections as shown in Fig. 7 in series. It will be seen that the resonance hump (Fig. 9) is slightly accentuated, but that the cut-off is exceptionally sharp.

place, but this rise is not very high, showing that the resistance of the choke is correct for the purpose in hand.

A simple filter such as this, however, is only, strictly speaking, a half-section. The whole question is one involving somewhat abstruse theory, but it may be observed that the filter should be symmetrical as far as possible. The complete section of the filter is as shown in Fig. 7, having an inductance on each side of the capacity.

The addition of this extra

The cut-off is given by the same formula as before. Incidentally, this formula is different from that given in Reference Sheet No. 109. This is because we have taken the end and middle sections as L and 2L respectively, whereas in the reference sheet they were taken as L/2 and L.

The values chosen in making these experiments are such as to match the surge impedance of the filter, with the input resistance of 10,000 ohms already referred to. This is one of the essentials of satisfactory filter design.

The University of the Ether

IT is believed that prior to the advent of broadcasting no precedent existed for the transference by a Government department of one of its officials to the service of a public company. From the subsequent history of the sporadic attacks made upon the broadcasting of educational matter pure and simple, it was clear that insufficient importance had been attached to the action of the Board of Education in seconding one of the ablest of its assistants, in the person of Mr. J. C. Stobart, to British broadcasting.

Cautious Developments

He was a man who had had not only a brilliant academic career, but an intimate association with the educational system of Great Britain. To him was given the task of proceeding cautiously to develop what every educational authority recognised as the inevitable aim and consequence of the wireless medium in one of the most important phases of its activities. Changes in plenty have taken place in the personnel of broadcasting.

Fresh faces have made their appearance at Savoy Hill and other brains have essayed the task of unravelling

Specially Written for the "W.M." by B.B.C. Officials

the problems associated with the broadcasting of the spoken word; but Mr. Stobart remains, as he was at the beginning of the chapter, the B.B.C.'s director of education, and he is the man to whom posterity will accord whatever praise or blame is, in the passage of years, meted out to the pioneers who laid the foundations of our broadcasting system.

While he has spent the last six years in devising methods of instruction by entertainment, so far as it has been possible to do so under the restrictions imposed by the fact that control could only be exercised at one end, he is beginning to feel a considerable sense of satisfaction over the experiment which is to be undertaken during April by the Extension Committee and Joint Committee for Tutorial Classes of the University of Hull.

The average schoolmaster is enabled not only to systematise and control his executive duties, but also

to supervise and gauge the effects of his work on the minds of his pupils. Mr. Stobart, as the wireless headmaster, has merely cast the bread upon the waters and left to chance (blended with hope) the possibility of its return at some remote future. Especially has this been so in the case of adult education. Here the listener himself plays as great a part in the realisation of the educational value of broadcasting as those responsible at the transmitting end.

Adult Education Groups

In many parts of the country adult education groups exist, which meet for the purpose of listening collectively to the broadcast lecture and discussing afterwards the points dealt with by the lecturer. These isolated groups organise their own arrangements, make their own rules and altogether assume the duty of co-operators whose zeal is measured by their own willingness to absorb knowledge through the loud-speaker.

But the need of systematic guidance has become definitely patent to those associated with many of these discussion groups, and the Hull experiment is intended both to

(Continued on next page)

OUR CARTOONISTS "REVIEW" SOME BROADCASTERS

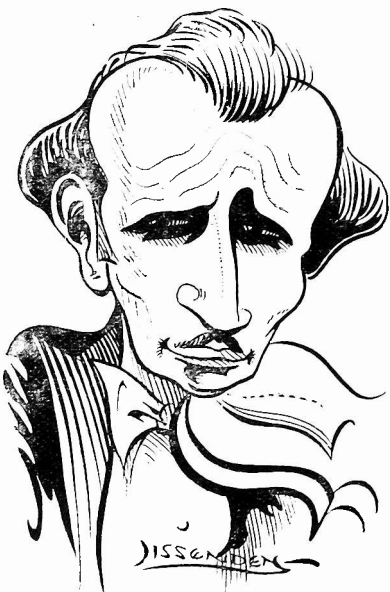

M. Georges Haek, conductor of the Frascati Restaurant Band



Helen Alston, who takes part in 2LO's Children's Hour



Arthur Whelan, the well-known Australian entertainer

The University of the Ether (Continued)

explain the aims and methods of broadcast adult education and to provide instruction and practice in methods of leading wireless discussion groups.

Thus the opinion emphasised by the B.B.C. ever since the beginning of its educational activities, that the loud-speaker was not intended to replace the teacher, to whom it could only be a useful adjunct, finds fresh proof.

Training for Group Leaders

From April 19 to 21, at a week-end school in Hull, training will be afforded wireless discussion group leaders selected in co-operation with all the more important educational bodies in Yorkshire and comprising the Workers' Educational Association, women's institutes, educational settlements, etc.

It was the Kent Educational Authority which acted as the pioneer in providing for the systematic use of the loud-speaker in the schools within its area; and now Yorkshire has not only taken a pioneer step in furthering the cause of adult education, but Hull is the first University to regard the possibilities of broadcast education for adults so seriously as to contemplate organising the work at the listening end.

Why the Scope is Limited

The limited sphere in which broadcasting can be useful is mainly due to the fact that the range of London and Daventry extends far beyond the limits of any one authority. Co-operation and unity on the part of such educational organisations as are assisting in the Hull experiment point the way to a solution of much of the B.B.C.'s difficulty; and if the listening end can be left to those bodies which are fitted to represent the educational interests of listeners, a bridge will be formed to span that gap between broadcasting and adult education which seemed to be so formidable, even as recently as the end of the year 1925, that scarcely any official at Savoy Hill could foresee the most desirable way of spanning it, although many suggestions were advanced that were not likely to lead to the desired end.

One such suggestion was that programme time should be allocated to

district committees and this amount of time re-allocated among the constituent local committees based on the Universities. Committees organising wireless lectures without any supervision or control by those who had already gained experience would undoubtedly have made the same mistakes as were inevitable at the beginning.

To perfect and build upon the beginnings already made with the group discussion system is to put the clock forward instead of back.

In the Hadow Report on broadcast adult education, it was pointed out that discussion groups would depend upon the personality or keenness of one or two persons. The group leader would play the most important part in supplying contact between his fellow listeners and the lecturer by formulating the questions

of the group, keeping in touch with headquarters and with the lecturer, and stimulating and directing the discussions.

The task was one of some magnitude. Discussions do not automatically result, even where a group has been got together to listen. Everything depends on the presence of some person capable of taking charge of the discussion and prepared in advance to take the lead.

Material Assistance

This has been recognised by Hull University and if other bodies follow the example which is to be set by Hull in the middle of April, by helping to provide group-leaders qualified to take charge of the discussions, they will assist in the most material way the advancement of educational broadcasting.

"SHOW ME
THE WAY
TO GO HOME."
(Revised version.)

Said Mr. Volt to Mr. Amp,
"I'll tell you something fine,
We'll take Old Man Resistance
And make him toe the line.
Just by ourselves we're somewhere wrong,
And don't know where to roam,
But if we joggle him along,
I'm sure that we'll get OHM." H. L. P.

Motor-boating (Continued from page 223)

from tappings. With such an arrangement, there is certain to be a back coupling and it is essential to fit filters as described. The taps may then be ignored, and the correct voltages be obtained by using suitable resistances.

We have described in particular a four-valve set having two resistance-coupled low-frequency stages, but it should be understood that when a transformer is employed, instead of one, or both, of the resistance couplings, the resistance-capacity filters must still be employed.

Screened-grid Valve

It is not necessary to connect a filter to a high-frequency stage when a high-frequency transformer is used, but shielded high-frequency valves having a tuned-anode coupling must be properly dealt with. Similarly, it is advisable to join a filter to the priming grid of a pentode valve, in order to avoid distortion.

To conclude: When the finest quality of reproduction that the set

will give is desired, connect a filter to the detector and first low-frequency stage, and also to the high-frequency stage when this is tuned-anode coupled. Further: Employ a well-made choke-condenser output circuit.

Choke-output Circuit

When the circuits and loud-speaker are such as not to warrant the addition of filters to each stage, connect a choke-condenser output circuit, and if this is not sufficient, add a resistance-condenser filter to the detector.

Mention must be made of the push-pull output circuit. As the current is supplied to the pair of output valves through a centre-tapped choking coil, or primary winding of a transformer, a negligibly small fluctuating current will pass through the power supply. The system is, therefore, one which tends to minimise back coupling, and is to be strongly recommended. Finally, it should be understood that L.F. chokes may be employed in place of the resistances in the filters described.

A Safe H.T. Unit for D.C. Mains

IN THIS ARTICLE IS DESCRIBED THE CONSTRUCTION OF A COMPANION UNIT FOR D.C. MAINS TO THE A.C. INSTRUMENT DESCRIBED IN THE FEBRUARY ISSUE OF THE "WIRELESS MAGAZINE." BOTH UNITS HAVE BEEN SPECIALLY DESIGNED BY W. JAMES, AND ARE PARTICULARLY SUITED FOR USE WITH HIS TOUCHSTONE AND BINOWAVE RECEIVERS.

THOSE who have a direct-current supply of electricity in the house for lighting sometimes consider they are not so fortunate as those having an alternating-current supply.

Whilst it must be admitted that it is much easier and cheaper to obtain a supply of current for filament circuits, or for battery charging, from an alternating-current source, the user who has access to direct current of 200 volts or more is generally the more fortunate in the ease with which current for high tension may be secured.

Difficulty of Increasing Voltage

Those having direct current of less than 200 volts are handicapped, as they cannot easily increase the voltage in order to supply high-tension circuits with the maximum voltage which the valves will take.

When a higher voltage is available, however, it is usually easier, and certainly cheaper, to build the equipment required. In fact, a high-tension mains unit for employment with a direct-current supply may be considered as equivalent to the smoothing and voltage-lowering equipment of an alternating-current unit.

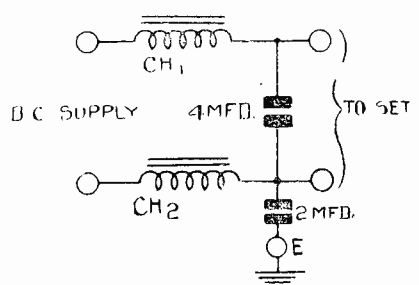
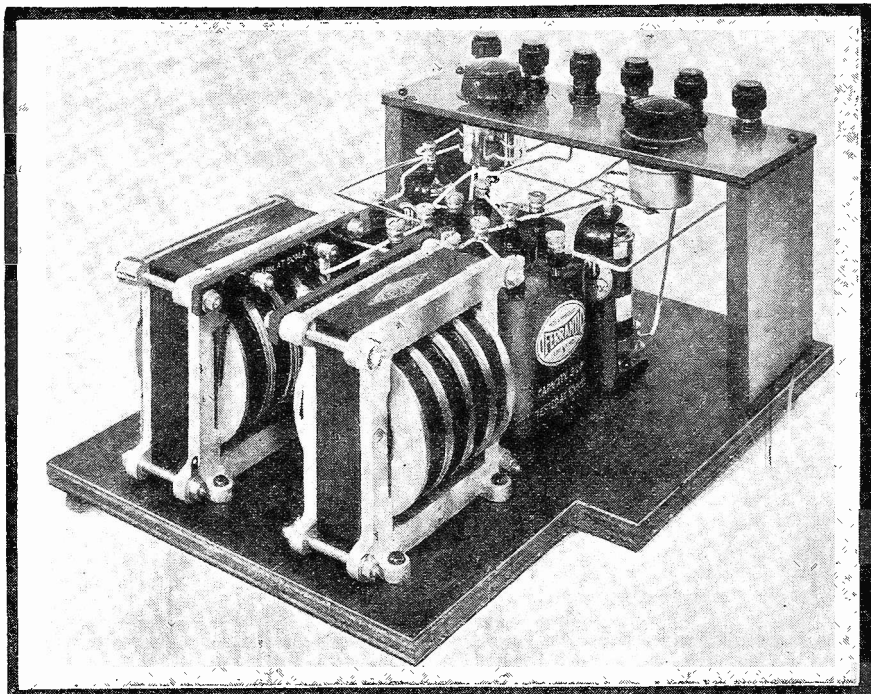

Fig. 2.—Arrangement of a filter circuit. The condenser in the earth lead plays an important part



This view of the High-tension Unit for D.C. Mains clearly shows the two smoothing chokes. Four different voltage tappings are available

The cost of a rectifier and its transformer are, therefore, saved, although against this economy must be placed an additional condenser and frequently a further choking coil. This additional condenser is connected in the earth lead of the receiver and is conveniently fitted in the mains unit proper, whilst the extra choking coil, when required, is joined in the negative main, in order to help the remainder of the filter eliminate noise and hum.

In certain districts the direct current is so steady and unfluctuating in voltage that very little apparatus is needed in order to ensure that the current passed to the circuits of the receiver is perfectly steady and uniform. Variations in the voltage applied to the circuits of the receiver would affect the quality of the reproduction.

Slow changes such as might be produced by an alteration in the number of lamps connected to the mains do not matter in the least; it is the variations which occur at a frequency within the audible range which cause the hum and noise that necessitate the employment of a good filter.

This filter is, therefore, connected between the mains and the circuits of the receiver, in order to suppress the variations. The current flowing through a resistance connected

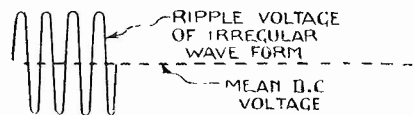

Fig. 1.—Alternating current superimposed on direct current

across the mains may be considered to comprise, in effect, a steady unidirectional current with an alternating current superimposed somewhat as indicated in Fig. 1, where the voltage indicated by a direct current instrument might be 200 for example, with an alternating current having a peak value of 5 or 10 volts.

Ripple in the Supply

If this were applied to a receiver direct, the variations in the voltage would cause a similar current to pass through the loud-speaker and a noise or hum would be heard depending upon the ripple in the supply. The function of a filter is to prevent the

A Safe High-tension Unit for D.C. Mains (Continued)

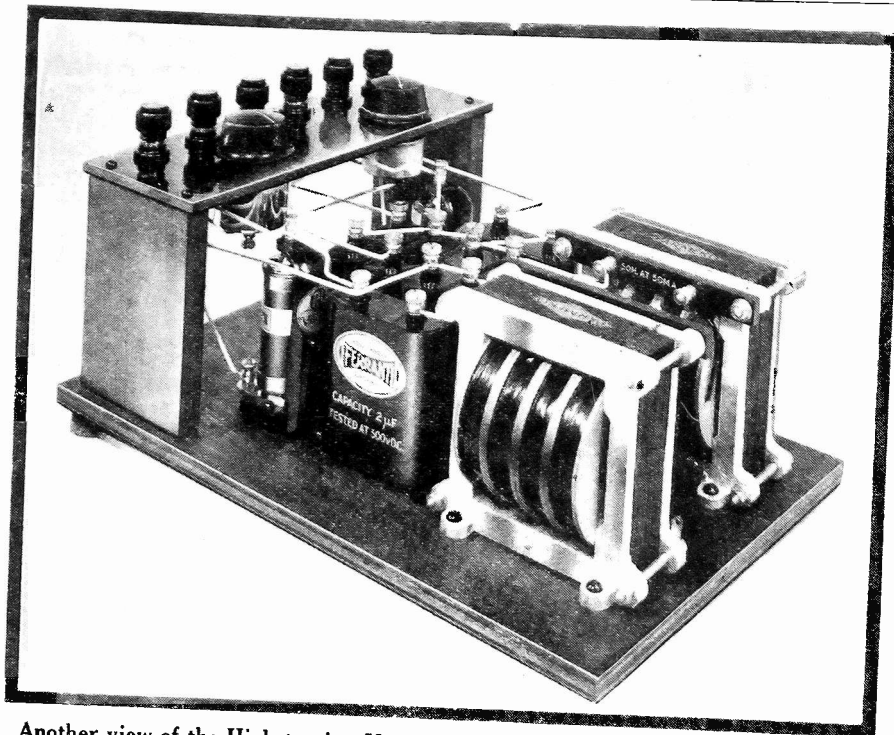

Another view of the High-tension Unit for D.C. Mains, which gives a choice of four voltage tapplings. All the condensers used are of 2 microfarads capacity each

For the Worst Supplies!

The choking coils have been given values which, in association with the 4-microfarad filter condenser, and the 2-microfarad earthing condenser, should prevent hum and noise on even the worst circuits. Less filtering would suffice in many instances, as there are many supply mains comparatively free from ripple. But, on the other hand, a few supplies are so "rough" that is, have such a large percentage of ripple, that a really good filter is essential if quiet operation is to be assured.

The filter condenser used is of the type tested at 500 volts D.C.; actually two 2-microfarad units are connected in parallel. They are joined across the receiver side; no condensers are connected on the mains side of the chokes.

A New Earth Connection

A further condenser of this type is joined in the earth circuit. The earth wire must be taken from the receiver and connected to the new earth terminal provided on the mains unit. If this small point be overlooked, the mains will be earthed, and a fuse will probably blow.

It is customary with the three-wire system of distribution to connect certain houses to one pair of

ripple reaching the receiver. It comprises the choking coils and fixed condenser indicated in Fig. 2. A further condenser is shown in the earth lead, and this also plays an important part.

It is, of course, necessary that choking coils having a certain minimum amount of inductance under working conditions be employed. The inductance of an iron-cored choking coil varies considerably with the value of steady current passing through it, and it is, therefore, essential that the choking coils used possess the desired inductance when carrying the maximum anode current required by the receiver.

carry much heavier currents with safety from the heating point of view, but the inductance will be less, and should anyone expect to pass a much heavier current, such as 100 milliamperes, it would be better for them to mention this when ordering.

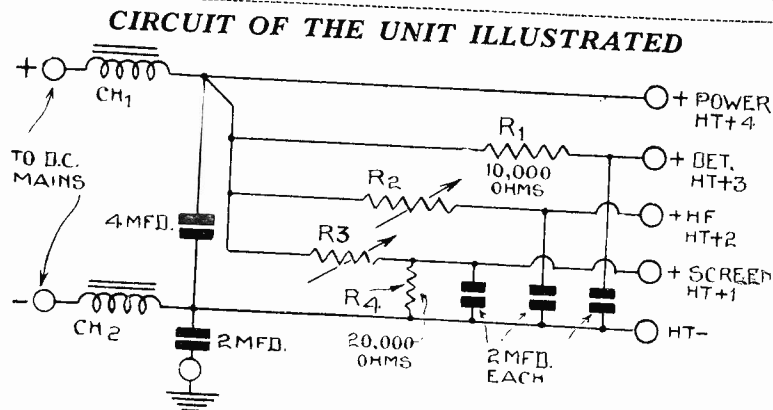

Fig. 3.—Suitable connections for use with three- or four-valve sets. This is the wiring of the unit illustrated by the photographs

wires, and other houses to a second pair, with the result that in one house the negative main may be more nearly at earth potential with the positive main from 200 to 250 volts, according to the supply, above earth.

In a second house, however, the positive main may be the one more nearly at earth potential, and then it will be the negative main which is 200

to 250 volts negative, with respect to the earthed main.

A user must now take the precaution of connecting a small fixed condenser, such as .001 microfarad, in the aerial lead to the receiver, and to be careful when handling the filament accumulators, or touching wires or other exposed parts.

Chokes Actually Used

Those used in the unit illustrated here were made by Partridge & Mee, Ltd., and have an inductance of 50 henries each when the steady current flowing through them is 50 milliamperes. They will, of course,

A number of factors enter into the design of a choking coil and one of them is the length of the air gap. This depends, amongst other things, upon the amount of the direct current which will pass through the choke, and the makers are able to adjust it to a suitable value provided the working conditions are explained

Specially Designed by W. James

The resistance of the choking coils employed is about 700 ohms each, and the voltage drop through the pair of them will, therefore, be 1.4 volts per milliampere. With a 20-milliampere load the drop amounts to 28, with the result that the actual voltage available across the terminals of the filter condenser is the mains voltage less 28. By winding the choking coils with thicker wire, the resistance and, therefore, the voltage drop would have been reduced, but the inductance would also be less.

Four Voltage Tappings

The various valves in a receiver have to be supplied with high-tension voltages according to their type, and how they are employed. In a typical four-valve receiver, having a stage of balanced radio frequency, four different high-tension supplies may be required. Thus, the power valve will have the full voltage applied to it; the first low-frequency valve will have a lower voltage, such as 120, whilst the detector may have to be supplied with from 60 to 120 volts. A further voltage, usually of 100 or more, is required for the high-frequency valve.

A three-valve

receiver with a screened-grid high-frequency stage also requires four supplies as a rule, one of which is for the shield of the valve. Receivers also differ in the arrangement of the detector, one being so adjusted that anode-bend detection is obtained, whilst the other is fitted with a grid condenser and leak for grid current rectification.

These points have to be remembered when building a mains unit, and two diagrams are given. That of Fig. 3 will suit, for example, a four-valve set with an anode-bend detector and a balanced high-frequency stage, whilst the same eliminator is suitable for a three-valve set having a shielded valve and a leaky-grid detector.

The diagram of Fig. 4 is of a mains unit suitable for a three-valve set having an anode-bend detector and a shielded grid stage of high frequency

COMPONENTS REQUIRED FOR THE D.C. MAINS UNIT

- 1—Metal safety box (Ferranti).
 - 2—50-henry chokes (Parmeko).
 - 6—2-microfarad fixed condensers, 500 v. test (Ferranti, T.C.C., or Dubilier).
 - 1—10,000-ohm resistance with holder (R.I. & Varley, Dubilier, or Ferranti).
 - 1—20,000-ohm resistance with holder (R.I. & Varley, Dubilier, or Ferranti).
 - 2—High variable resistances (Regentone or Clarostat).
 - 1—Insulated terminals, marked: Earth, H.T.—, H.T.+1, H.T.+2, H.T.+3, H.T.+4 (Belling-Lee).
 - 1—Ebonite strip, 8½ in. by 3 in. (Ready Radio).
 - 1—Baseboard to fit box.
- Insulated wire for connecting (Glazite).

ALTERNATIVE CONNECTIONS FOR 3-VALVE SET

Fig. 4.—Connections suitable for use with three-valve set

conditions, and it is, therefore, not always advisable to rely upon a simple resistance connected in series. Instead, it is better to employ two resistances, and to connect the detector valve to the junction point. Thus in Fig. 3 two resistances R3 and R4 are employed to provide a suitable voltage for a detector valve, operating as an anode rectifier.

It is also advisable to provide a similar arrangement for a shielded valve, as the amount of the current taken by the shield of valves of this type appears to vary considerably.

Potentiometer Arrangement

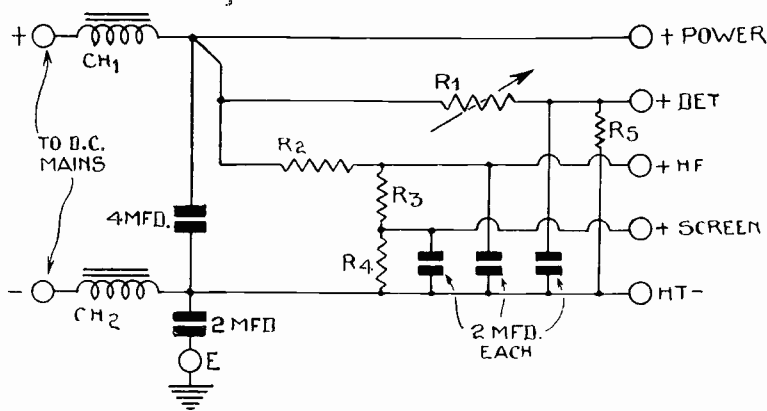
It will be noticed in Figs. 3 and 4 that screen voltages and anode-bend detector voltages are taken from a potentiometer arrangement.

Variable resistances have been included where experience indicates they are desirable. These are marked R2 and R3 in Fig. 3, and R1 in Fig. 4. In the arrangement of Fig. 3, the two adjustable resistances are so connected that the user is able to regulate the voltage to those circuits which often need to be fairly accurately set.

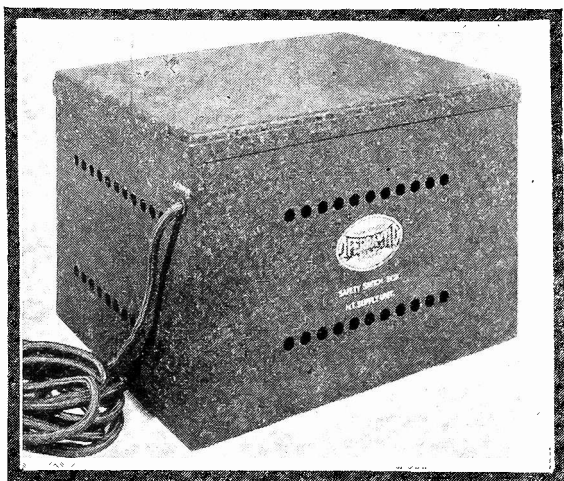

This is the completed High-tension Unit for D.C. Mains complete in its metal box

and other circuits.

There are one or two points which perhaps call for an explanation. The method of reducing voltages by a resistance is well known, and when the amount of the high-tension current passed by a certain valve at a given high tension is known, the value of the resistance is easily worked out. But the current taken by an anode-bend rectifier varies considerably with the working

A Safe High-tension Unit for D.C. Mains (Continued)

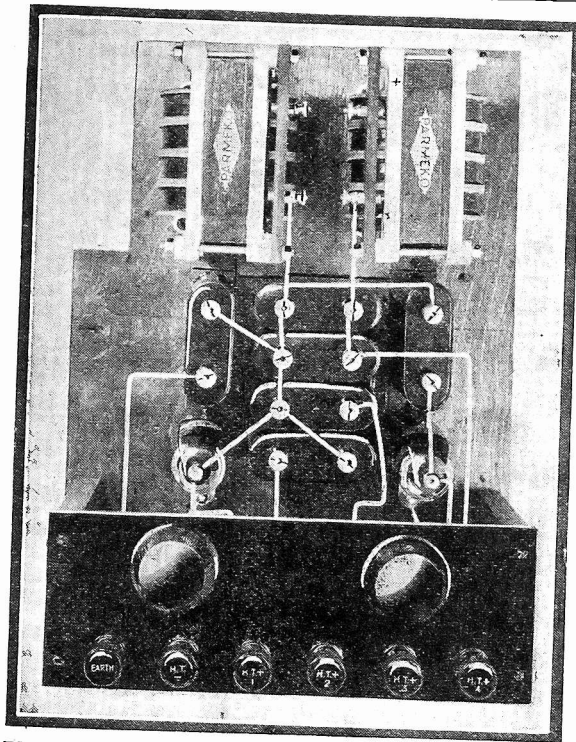

Plan view of the High-tension Unit for D.C. Mains, showing layout of the parts. The mains are connected to the choke terminals shown without leads

The mains unit illustrated is wired according to the arrangement of Fig. 3. A Ferranti metal safety box is employed, and it is equipped with a safety switch and fuses and also a connecting cord.

How the Unit Is Assembled

The parts are fitted on a wooden baseboard of the size indicated in the drawing, and the terminals and adjustable resistances are fastened to a raised ebonite strip. It does not take very long to fit these parts to the baseboard, and the wiring is also a very simple matter. Remember that a pair of flexible wires have to be taken one from each choking coil to the pair of terminals on the safety box, and do not forget to employ well-covered connecting wire.

Voltage Test of Condensers

If condensers of the same type as those used in the unit illustrated are not employed, be very careful that they are able to withstand the full mains voltage, which means that they should have a test voltage rating of at least twice the voltage of the mains.

Good average values for the fixed resistances are 20,000 ohms for R_1 (Fig. 3), and 50,000 for R_4 . In the

arrangement of Fig. 4, R_2 may be of 20,000 ohms, R_3 of 30,000 ohms, and R_4 of 40,000 ohms.

The actual voltages applied to the valves will depend upon the total amount of the current flowing as well as the individual currents to the valves and will, of course, vary a little as between one receiver and another. But modern valves used for amplifying or power work are not very critical and with the adjustable resistances provided the best results should be obtained.

Terminal H. T. + 1 should be connected to the anode-bend

detector, or the shield grid of an H. F. valve, whilst terminal H. T. + 2 is suitable for the H. F. valve or a leaky grid detector. Terminal H. T. + 3 may be connected to an L. F. or H. F. valve, and terminal H. T. + 4 is, of course, for the power stage.

Do not forget to take the earth connection from the receiver to the mains unit and unscrew the resistances by an anti-clockwise movement of the knob when less voltage is desired. Also, be sure and connect a .001-microfarad fixed condenser in the aerial wire to the set, and fit it inside the cabinet.

SPECIAL NOTE

Since this unit was constructed we learn that Ferranti, Ltd., are now making their safety boxes of slightly larger dimensions. As a number of dealers may still have the smaller size in stock, we show baseboard dimensions to suit it. When he buys the box the constructor should get a baseboard to fit. There is no need to alter the arrangement of the components on the larger baseboard and the layout diagram can be followed exactly.

IS THE AERIAL DOOMED?

PROBABLY for many years some kind of an aerial will be necessary, though it be a small indoor one. For the time being the outdoor aerial is necessary in case of the average set. Until the day comes when the outdoor aerial shall be abolished there should be a movement among radio enthusiasts to keep as much ugliness as possible out of the aerials.

To see a forest of aerials of all shapes and kinds—some on long wooden poles, others on steel masts, some attached to chimneys, others to trees—is ugly to sensitive eyes.

From an æsthetic point of view, the aerial is condemned. It is left to the ordinary listener to minimise the soreness the aerial creates until that day when our sets will find the indoor aerial that is adequate for all listening purposes.

E. B. R.

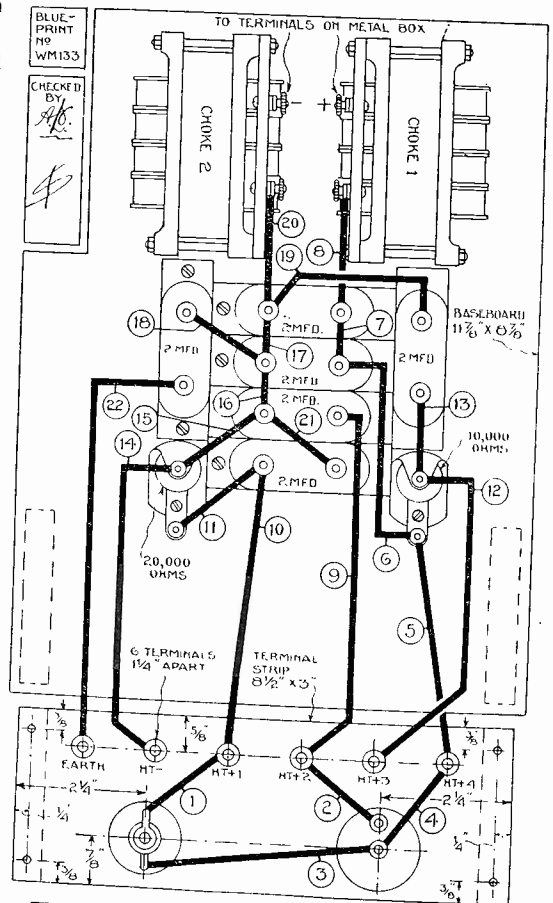

This layout and wiring diagram can be obtained for half-price (that is, 6d., post free) if the coupon on page iii of the cover is used by April 30. Ask for No. W.M1.33. Wire up connections in numerical order



Tommy Handley
is on the immedi-
ate right

Tommy Handley
believes in -

Studio Audiences

THIS is a subject upon which opinions are divided. Indeed, there is probably no branch of wireless entertainment which has given rise to so many conflicting views. Listeners range from those who are furiously "con" to those who are joyfully "pro."

It is in this second group that I find myself. And why? Because, as an entertainer, I find applause almost a *sine qua non*, without which I experience the greatest difficulty imaginable in "getting going." This is probably the main reason why the B.B.C. have gradually brought studio audiences to permanency.

There are some who cannot appreciate the artist's point of view. They can't understand what difference it makes to him whether there is somebody there in the studio with him or not. In the first place it prevents a man from feeling lonely—a tremendous handicap to struggle against.

Ready to Hang You

I know of few worse sensations than the impression that, while everyone is hanging on each word, and ready to hang you for a mistake, yet no one feels *for* you, trembles when you tremble, and bucks up when you do.

An audience can supply this need for two main reasons. In the first

place, they are not looking for entertainment for which they have paid; the evening is in the nature of an adventure for them and naturally their sympathies are with the artist.

Identical Anguish

When he goes to the microphone they imagine for one moment what they would feel like if it were themselves. If he looks like making a mess of things they go through almost the identical anguish that he does. And when it becomes clear that he is "on form" then they are jubilant with him.

The second reason is subsidiary to this; since the studio is only small, the audience is limited and paucity of numbers makes for a more friendly atmosphere still, something like a fireside gathering.

There is another further point to be considered, too. If you have tried your hand at entertaining, or even "spinning a Christmas yarn," you must know that you are affected by your listeners. One gathering will simply eat whatever you say, and another will force you to speak with all the dramatic emphasis you can summon.

In either case you are quickly forced into the atmosphere they have already prepared, regardless of the manner in which you previously thought you might "spill the beans."

Now in broadcasting my lines, atmosphere is absent. I write a gag, some patter, or a song, and form some idea of how it ought to go. But when I start my performance in the studio I keep my eye on the audience, and not once in twenty times do I find my own idea the right one. Either I have to alter my speed, emphasise this instead of that, or make a slight alteration somewhere or another. The studio crowd helps me to gauge the pulse of my bigger audience.

It also helps me to time my laughs. You can never tell just when a laugh is coming, or how long the audience wants for this purpose. Yet there is nothing more annoying to a listener, or so I imagine, than to be constrained to laugh and so cut himself off for a word or two.

Waiting for the Audience

This sort of thing is always happening in the theatre or music-hall, but then someone else is the cause of the trouble, not oneself. This can be avoided in broadcasting, by waiting for the studio audience to stop their noise before proceeding.

I have one more "pro" argument before coming to the "cons." Listeners are found to exist mostly in twos and threes, and as such to miss the companionship of an audience. When a good laugh is scored they want to clap, but what is the use?

Tommy Handley Believes in Studio Audiences (Continued)

They would like to hear the others laughing too, as they would in a theatre.

A studio audience supplies this need, and makes the isolated listener feel less lonely. In other words, it helps along the aural illusion, so that one can almost imagine oneself present at a real concert.

A Double

Now for the "cons." In one of the many plays in which I have taken a part, a lady had to step in front of her husband and so take a detective's bullet and die instead of him. This part was taken by a rather elderly lady, whom we did not wish to have to fall down on the floor as the part required. We therefore had a double, a man.

All of us concerned were so inured to this sort of thing that we thought nothing of it, but on the night there was almost a calamity. The dying wife forced her last words, "This-is-my-getaway," and her male double promptly fell down to convey the sound of her collapse.

Shrieking with Laughter

This seemed so funny to the audience, who, of course, had never witnessed anything like it before, that they almost shrieked their

laughter. We made frantic efforts to stop them, and even cut out the mike for a second or so, but I believe some of the noise got over.

This story points to one of the biggest drawbacks of studio audiences. If they are strangers to the microphone then there is always the chance that they will laugh or applaud in the wrong place, because so much of our performance is illusion, the listener hearing something very different from what actually takes place.

If one has a permanent staff of "laugh prompters" then they would soon get stale and artificial. I expect, too, that the news of the existence of a professional audience would soon get round and listeners would become somewhat disgusted at the idea.

Since a studio is small, the clapping and laughing must of necessity seem "thin" and the atmosphere thus created is a trifle false. It is too small to be a proper concert-hall performance, and too big to be the listener's own room. It does at times seem a little puerile too, something like the greeting a "first turn" receives at a music-hall.

An advantage can very easily be changed into a disadvantage if an artist is not careful. He relies on his audience to set him his *tempo*, but he must never forget that the first

rule of broadcasting is "be conversational." That is try to talk and sing as though you were sitting round the fireside in the third chair.

Playing to the Gallery

If an audience enjoys the entertainment, and if he knows only too well that he is a "roaring success" as far as they are concerned, there is the possibility, not to say probability, that he will forget all about the listener sitting at the loud-speaker and play to the gallery. They may, too, set him on a wrong track for some inexplicable reason.

I have known a crowd absolutely fail to appreciate what is going on, yet knowing full well myself that I am putting over the right stuff. There was only one thing to do and that was to forget them, but it would have been easy to have been swayed by their criticism and so ruined the listeners' programme.

Ideal Audience

The ideal studio audience is the "house" at the Proms., where a good performance is being given, both into the auditorium and into the microphone. Everybody knows that the clapping is real and comes from hundreds of people. The acoustics are perfect into the bargain.

A VISIT TO SAVOY HILL—WITH OUR CARTOONIST

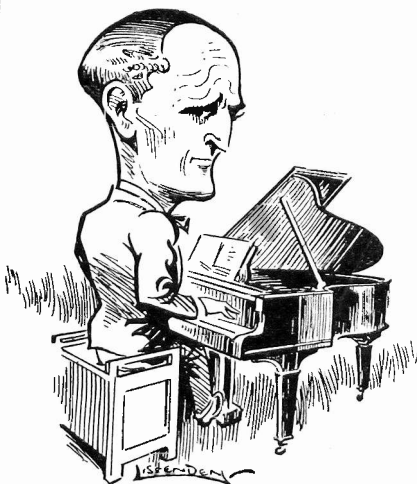

Here is Harry Pepper, who takes part with Miriam Ferris (right) in the Children's Hour



Percy Pitt, the popular musical director of the British Broadcasting Corporation

My Radio Week-end!

by
**J. GODCHAUX
ABRAHAM**

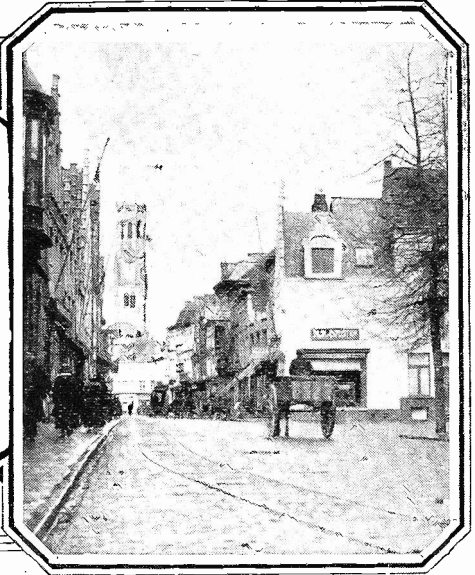

The photograph, taken by the author, shows a street in Bruges

IN the seventh year of broadcasting, when so great a number of registered listeners in the United Kingdom have acquired the habit of simply pulling out a knob or throwing over a switch in order to secure the local radio programme, I have sometimes wondered what I should do if situated in some spot which prevented me from hearing the English programmes. I endeavoured to collect for my enjoyment, a daily entertainment from the ether.

Turning to Other Countries

Suppose, for instance, Great Britain instead of being the pioneer in Europe had been backward in the establishment of a broadcasting service, and that to-day the British listener was compelled to turn to other countries for the reception of concerts, theatrical performances or other wireless fare, what kind of entertainment could he capture?

Putting myself in his place, I decided that a week-end experiment would be quite an interesting sensation and for this purpose, taking as an excuse that the weather was too inclement to allow of my leaving the house, I arranged to spend all my time in the wireless den.

Finding Foreign Broadcasts

On Saturday and Sunday, therefore, presumably cut off from direct communication with Great Britain, it was up to me to find a sufficiency of interesting broadcasts to while away a number of leisure hours.

Friday evening, I might mention, I devoted to putting my house in order; newly-charged accumulators were obtained, high-tension batteries were

tested and more than a fatherly interest was taken in the two receiving sets which were to be brought into operation.

The next morning, Saturday, saw me out of the bed at a very early hour—earlier perhaps than I had visualised in the first instance—and I decided that a short run round was necessary to pick up the first of the daily news items. It was dark, cold and generally uncomfortable in my little room.

What should we do for radio entertainment if the development of British broadcasting was backward and we had to rely on foreign stations?

In this article a well-known authority on broadcasting affairs explains how for one week-end he confined himself entirely to Continental transmissions. His conclusions will interest every listener

5.15 a.m. in March is an unsympathetic hour and it was with some doubt that I switched on the valves and twirled the condensers. Luck was with me, however, for I picked up a carrier wave, followed by a call: "Hier Frankfurt-am-Main und Cassel." For two minutes I held the transmission, then realising that the studio was intent on giving me a course of physical jerks, I sought for better entertainment elsewhere.

All luck dogged my footsteps, because in quick succession I picked up Koenigsberg and one of the Munich

relays both indulging in the same kind of gymnastics. At 5.48 a.m. I tuned in to Hamburg putting over the ether a gramophone record—a military band—a preliminary warning to stand-by for a time signal, to which I set my watch, bearing in mind that the German had seen daylight an hour earlier than I had.

Uninteresting Morse

As no other telephony stations appeared to be on the air at this early hour, a search was made in other directions. For some twenty minutes I rotated the dials without capturing anything more interesting than morse transmissions which, in view of my ignorance of the symbols, did not hold my interest.

Towards 6.25 a.m., I found myself on the long waves and again picked up a broadcast from Copenhagen via Kalundborg proving that the Dane also indulged in early morning health exercises. Fifteen minutes later Radio Paris appeared on my horizon, but was quickly abandoned when it was realised that, by the same means, the studio was equally anxious to keep listeners fit.

A Breakfast Interval

Clearly there existed an interval in the European broadcasts during which the studios rested and refreshed their staff—a hint which I gratefully accepted. At a few minutes before 8 a.m. I was back at the receiver and at that hour the ether was "alive."

Both Radio Paris and Ecole Superieure were putting out the first news bulletin and dodging from one to the other I managed to pick up

My Radio Week-end (Continued)

considerable information not included in the previous evening's paper. The transmission was distinctly newsy and helped me to while away over half an hour of what would otherwise have been a blank period.

Generally speaking, by 9 a.m. several German transmitters had opened up with their daily broadcasts of agriculture reports, and had reeled off stock exchange and other quotations *ad nauseam*. At 9.15 a.m., however, I found a gramophone concert and identified its origin: Cologne received through Langenberg.

Hilversum's Concert

Most of the other German stations, although faintly heard, were received at too weak a strength to prove of any value, but in the majority of cases they were indulging in weather reports. Hilversum, as an alternative, at 9.40 a.m. gave me a time signal, and a short concert; Kalundborg following with a meteorological forecast which rammed home the fact that we were in for a dirty day!

From 10.30 a.m., however, interest was quickened by the capture of aerodrome telephony transmissions, both of questions and replies, sent out by cross-Channel aircraft. In one instance I was able to follow a plane from its start in England, over the "ditch," to a point when it was well on its mainland route to Amsterdam. For nearly two hours from this source something of interest was to be secured, and I only left this wave when Hilversum announced its mid-day concert, to which until 12.30 p.m. I listened with considerable pleasure.

Alternative Programmes

From that moment, I possessed alternative programmes on the long waves; Radio Paris reviewed in the course of thirty minutes an international collection of gramophone dance records; Eiffel Tower at that time relaying from the Ecole Supérieure the Jazz Hour, incorporating the latest successes heard at London restaurants and cabarets. As a running accompaniment to a leisurely lunch, the transmission was all that could be desired and the loud-speaker

filled the dining-room with lively melodies.

Apparently, this was to be a busy day, for at 2 p.m., when Radio Paris sought a well-earned rest, Eiffel Tower put out a series of official announcements, and after an interval

HAVE YOU HEARD THE CHIMES?

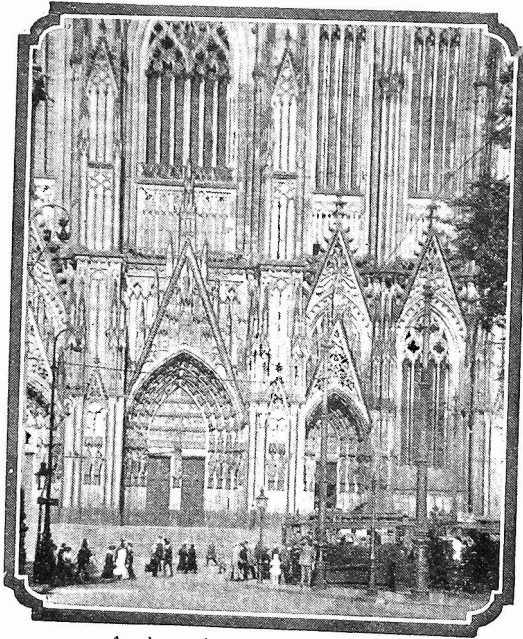

A view of Cologne Cathedral

of a few minutes linked up with the PTT provincial transmitters for a relay of an excellent vocal and orchestral entertainment from the Théâtre des Champs Elysées in the French capital.

Meanwhile, Copenhagen was also offering me a programme of light music, a trio of very brilliant musicians, a piano, a violin and a 'cello. Zeesen was tuned in once or twice at this period of the day, but as educational talks were monopolising the energies of this high-power station, no time was lost in getting away from it.

Hilversum proved a staunch friend by taking me over to the Tuschinsky Theatre at Amsterdam for an interesting musical hour which included some organ solos of a popular character.

Realising that the Germans could not be talking during the whole afternoon, a return visit was paid to Zeesen; it proved a happy strike; at 3.30 p.m. a relay was carried out of a concert given by the Hamburg studio, a pot-pourri of Italian songs and operas. Some trouble was caused

by incursions made by 5XX, but with a little patience the German was cleared of interference.

At 3.45 p.m. again Radio Paris turned up with a smile and offered me a further dose of dance music; at 4 p.m., Motala came through—feebly at first, but at good strength some thirty minutes later—with popular band items from the Stockholm studio.

As daylight failed, so the ether livened up considerably; snatches of music or talks were pulled in with every movement of the condenser and the only difficulty experienced was that of making a judicious choice of available transmissions.

From 6.30 p.m. I was hard put to it to log the various concerts and performances brought to my ears.

Relay from Oslo

At 7.40 p.m. Hilversum with a concert was again tuned in; from 8 p.m., my attention was drawn to Motala putting over a good revue, and to Oslo broadcasting a variety performance, relayed from the Black Cat Theatre.

Going over to the German stations I caught strains of *The Merry Wives of Windsor* as broadcast from the State Opera House at Breslau, and held this transmission through Gleiwitz, then a twist of the wrist brought me a Donizetti performance at 8 p.m. from the Scala Theatre through the Milan transmitter.

By this time I realised that for my evening entertainments, at least, I was not in any way dependent on a British station; Europe offered me all the variety I needed.

Infinite Variety

In sequence I listened to a symphony orchestra from Berlin, given to me by Zeesen, to a restaurant concert at Kattowitz at 9.45 p.m., and from 10 p.m. until midnight my loud-speaker delivered gypsy music from Buda-Pest, dance tunes from the Industri Restaurant at Copenhagen and an excellent transmission over the ether by Radio-Belgique from the Palace Hotel in Brussels.

As I closed down at 12.30 a.m., to retire for a well-earned rest, Posen

A Special Article by J. Godchaux Abrahams

was still merrily entertaining its near and distant listeners with a special night transmission. The good results obtained on the previous day fully warranted an early stand-by on the Sunday morning and in the light of past experience a quick search was made for the main German stations before 8 a.m.

German Transmissions

At 7.55 a.m. a carillon was heard from Berlin—later confirmed as that of the Garrison Church at Potsdam—immediately followed by a sacred concert from the capital studio. Frankfurt provided a similar transmission; Hamburg appeared to follow its usual early morning schedule with the exception that at 8.40 a.m. it took a sacred service from the University Church at Kiel, and Cologne, from 8 until 9 a.m., indulged in a semi-secular musical entertainment.

Most of the transmissions picked up were of a sacred nature, and church services were heard from Copenhagen, Stockholm, Huizen, Munich (via Nurnberg), and Breslau.

It was hardly to be expected that Sunday would offer the same number of entertaining broadcasts as an ordinary week-day, but at 10.30 a.m., from Berlin, an excellent concert given at the Great Playhouse was received through the high-power station. Langenberg at mid-day started its programme with light orchestral items, as a prelude to a choral recital and its press broadcast.

Symphony

From the number of transmissions available it seemed evident that my afternoon was to be a busy one, as Motala and Hilversum were on the air as the clock struck 2 p.m., both taking symphony concerts from their principal concert halls, Kalundborg simultaneously providing an interesting programme from the Copenhagen studio.

On and off during the afternoon I

tuned in to entertainments from Radio Paris and Eiffel Tower and thus bridged a gap until dusk, a period during which it is difficult to hear some of the weaker stations. At 5.30 p.m., however, no difficulty was experienced in holding for some twenty minutes an operatic relay from the Teatro del Liceo, Barcelona, offered by EAJI, and at 6.30 p.m. strains of Gilbert and Sullivan's *Mikado* from the New Theatre, Leipzig filled the wireless den.

From that moment, the choice of entertainments was so great that I hardly knew which way to turn. Atmospheric conditions were peculiarly favourable and, for my experiment, I had been favoured with a peculiarly kind and generous ether.

Stations which a week earlier had emitted but anaemic signals, were healthy and vigorous, putting out such powerful broadcasts that the volume control on the receiver had to be brought into action.

In turn, between 7 and 10 p.m. G.M.T. I listened to performances of *The Merry Widow* as given at the Metropole Theatre, Berlin, to a studio version of *The Barber of Bagdad* from

warded by a particularly clear reception of dance music and variety turns received through Radio Maroc (Rabat) from a local cabaret.

A Clear Field

At odd dates, I had already picked up the North African transmitter, but as ill-luck would have it in each instance its programme had been jammed by either Kattowitz or Grenoble, or for the matter of that, at its worst moments, possibly by both. On this Sunday night, however, Radio Maroc for some reason unknown was given a clear field and so loud were the signals that I had no difficulty in jotting down disjointed French phrases, expressions of approval, peals of laughter, and applause from the audience.

I could repeat *ad nauseam* a list of the stations to which I returned time after time in the course of the evening, and in most instances I found programmes of interest.

In my opinion, the experiment had been entirely successful and had conclusively proved that I was far from being dependent on local broadcasts for my daily wireless entertainments;

further, providing the listener possessed but a modest smattering of French and German, it was open to him to hear many news bulletins, transmissions which are peculiarly fascinating.

Extra Items

Bear in mind that if I have been able to demonstrate that the possessor of a multi-valve set is capable of making up for himself an almost continuous programme of transmissions from continental sources, as the conditions are to-day,

these are *additional* to the regular entertainments offered to him by some home broadcasters.

The broadcast licence holder who is equipped with a selective receiving set can turn to it at all hours of the day; at no time will he find perfectly blank periods devoid of all interest. The radio fan of 1929 is a lucky man!

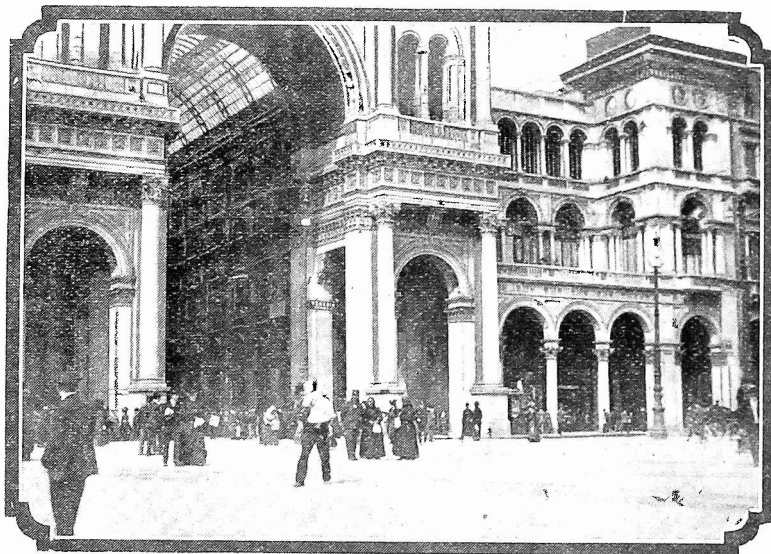

The Galleria Vittorio Emmanuele, Milan

Cologne, to an outside relay of Humperdinck's fairy opera *Hansel and Gretel*, played at Milan, and to *Mignon*, sung in French by a touring company at Hilversum.

On that evening, in the intervals, the ether was thoroughly searched for transmissions less frequently heard, and patience was duly re-

WAVELENGTHS OF THE EUROPEAN STATIONS

IN ORDER OF WAVELENGTH

UNDER THE PLAN DE BRUXELLES



A view in the Grande Place, Brussels

Wavelength	Station and Call Sign	Kilocycles	Wavelength	Station and Call Sign	Kilocycles
211.3	Beziers	1,420	374.1	Stuttgart	802
219	Klagenfurt	1,370	378	Manchester (2ZY)	793
222.2	Cork (5CK)	1,350	387.1	Dresden	776
238	Bordeaux (Sud-Ouest)	1,260	391.6	Bremen	766
240	Nurnberg	1,250	396	Hamburg	757
243.9	Newcastle (5NO)	1,230	396.3	Plymouth (5PY)	753
250	Kiel	1,200	400	Bucharest	750
252.1	Cassel	1,190	401	San Sebastian (EAJ8)	750
258	Juan-les-Pins	1,160	404	Glasgow (5SC)	748
254	Leeds (2LS)	1,180	406	Radio Espana	744
260.1	Toulouse (PTT)	1,153	408	Berne	739
263.2	Hoerby	1,140	411	Reval (Tallin)	735
265.5	Cologne	1,132	414	Dublin (2RN)	732
265	Muenster	1,130	414	Radio Maroc (Rabat)	724
269	Trollhattan	1,116	416.1	Kattowitz	721
269	Kosice	1,116	416.6	Grenoble (PTT)	720
272.7	Lille (PTT)	1,100	421.3	Frankfurt	712
273	Kaiserslautern	1,100	423	Madrid (EAJ7)	708
273	Limoges (PTT)	1,100	432.3	Brunn (Brno)	694
273	Sheffield (6LF)	1,100	438	Stockholm	655
275	Turin	1,090	443.8	Rome (Roma)	676
277.8	Ghent	1,080	449.8	Paris (Ecole Sup., PTT)	668
280	Bratislava	1,080	452	Aachen	661
280.4	Rennes	1,070	455.9	Porsgrund	654
282	Koenigsberg	1,069	456	Bolzano	658
282	Innsbruck	1,060	460	Aalesund	653
283	Berlin (E)	1,061	462.2	Lyons (PTT)	649
283	Stettin	1,061	475.4	Langenberg	631
285	Magdeburg	1,050	475.4	Berlin	622
285	Barcelona (EAJ13)	1,050	482	Daventry (5GB)	613
288.5	Bournemouth (6BM)	1,040	489.4	Zurich	604
288.5	Edinburgh (2EH)	1,040	496.7	Oslo	600
288.5	Hull (6KH)	1,040	500	Tromso	595
291.3	Bradford (2LS)	1,030	504.2	Milan	586
291.3	Radio Lyons	1,030	511.9	Brussels	577
294.1	Dundee (2DE)	1,020	519.2	Vienna	570
294.1	Liverpool (6LV)	1,020	525	Toulouse	568
294.1	Stoke-on-Trent (5ST)	1,020	528.2	Riga	559
294.1	Swansea (5SX)	1,020	536.7	Munich	550
297	Notodden	1,010	545.5	Sundsvall	541
301	Bordeaux (PTT)	997	554.5	Budapest	530
303	Belfast (2BE)	988	566	Augsburg	520
303	Strasbourg	988	577	Hanover	517
305	Agen	982	580	Hamar	441
308	Zagreb (Agram)	973	680	Freiburg	395
309	Oviedo (EAJ19)	970	760	Ljubljana	390
310	Vitus (Paris)	968	770	Lausanne	363.5
311	Alderdeen (2BD)	964	825	Geneva	323
314	Wilno	955	925	Ostersund	300
314	Cracow	955	1,000	Moscow	297
315	Marseilles (PTT)	953	1,010	Homel	280
315.7	Falun	950	1,071	Leningrad	277.6
321.2	Breslau	937	1,080	Basle	262
323	Cardiff (5WA)	928	1,153.8	Hilversum	250
326.4	Gleitwitz	919	1,200	Motala	223
329.7	Brussels	910	1,370	Warsaw	214
333	Naples	901	1,401	Moscow	207
333.3	Reykjavik	900	1,443	Paris—Eiffel Tower	202
336	Posen	890	1,488.15	Lahti	199
336.3	Paris—Petit Parisien	892	1,522	Daventry (5XX)	192
339.8	Copenhagen	883	1,562	Norddeich	182
343.2	Prague (Praha)	871	1,648.3	Zeeseu	178
346.8	Goteborg	865	1,680	Kharkov	170
350.5	Barcelona (EAJ1)	856	1,761	Radio Paris	165
354	Algiers (PTT)	846.7	1,818	Angora	163
354.2	Graz	847	1,841	Huizen	161
358	London (2LO)	838	1,852	Scheveningenhaven	150
361.9	Leipzig	829	2,000	Kovno	142
365.9	Bergen	820	2,041	Bergen	142
370	Paris (Radio LL)	811			
371	Seville (EAJ5)	809			
374	Helsingfors (Helsinki)	800			

W. Hadfield Craven Discloses Some—



WIRELESS FALLACIES

EVERY subject has its popular fallacies and wireless is no exception to the rule, as can readily be imagined when it is remembered how many hundreds of thousands of laymen are to-day interested in it. It is both amusing and enlightening to explode some of them.

Who has not known the owner of a modest receiver who has replaced his modest loud-speaker by one of magnificent proportions "so that all may hear better"?—in other words, so that he can get louder signals. Here is a fallacy, if ever there were one, and one of the most profoundly rooted in budding enthusiasts.

A large loud-speaker, of course, can no more increase the volume output of a small set than can a small loud-speaker cope with the intensity of the signals from a large set. The loud-speaker must be chosen to match the set: a big loud-speaker for powerful signals and a small loud-speaker for weak signals.

Talking of a large set reminds me that some people refer to their sets as "powerful" when they mean that they are capable of picking up distant stations. One frequently hears

"ful" is actually entirely fallacious.

And here we drop across another fallacy, for, failing "powerful," the long-range set is often described as "selective." What should be understood is not that the set is "powerful" or "selective," but that it is *sensitive*—sensitive to the comparatively weak signals of distant stations.

Selectivity has to do with the ease

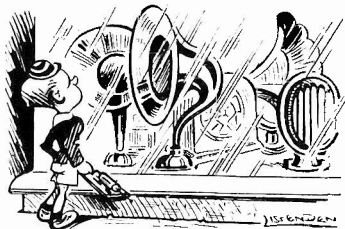

The loud-speaker must be chosen to match the set

with which one can eliminate interference; where the tuning of a set is said to be "sharp" it is also selective; where it is "flat" it is not selective.

Another wireless fallacy lies in the belief that the Post Office is denying us something by restricting the length of the amateur aerial to 100 feet. It is true that if very long-wave signals are to be received—say, of the order of 10,000 to 20,000 metres—a long aerial is useful in that it dispenses with excessively large loading coils, and in the days before broadcasting amateurs regularly amused themselves in these regions.

It is true, also, that a long, low aerial, such as the type due to the American, Beverage, is in favour in many quarters for ultra-short wave reception; but, whatever these uses may have had to do with popular belief, the fact remains that for the ordinary broadcasting waveband no length could be better suited to our purpose than that officially allotted.

That prominent wireless feature, the accumulator, is another very frequent source of misconception. For example, when an accumulator

is said to be charged, what is meant is not that electrical current has been taken from the mains and compressed into and stored in it, but that the passage of the current through the battery has changed the chemical composition of the plates, so that, in turn, an electric current will be generated by them when they are allowed to interact by placing the battery on discharge—that is, when the accumulator is connected up to and is operating the set.

The term "storage battery," by which an accumulator is alternatively known, is probably as much to blame for this very popular fallacy as is the word "accumulator" itself.

If both "storage battery" and "accumulator" are understood to mean not a battery for the storing of electricity or a battery for the accumulating of electricity, but a battery for the accumulating and/or storing of chemical energy capable of giving rise to an electric current, the true function of this much misunderstood piece of apparatus would be perfectly clear.

Incidentally, the expression "battery," which I have used many times

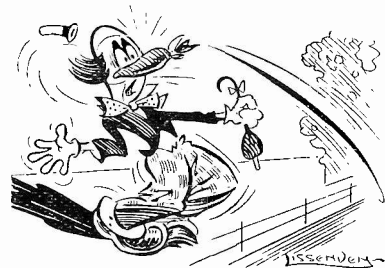

Much misunderstood

above, is not one to be applied indiscriminately—it has a definite meaning. An electric "cell" is the initial combination of plates capable of producing a current—usually of the order of 1.5 volts; a "battery" is a multiplicity of such cells. Thus when a grid bias of about 1.5 volts is in use in a set, it is a "cell" that is being utilised and not a "battery."

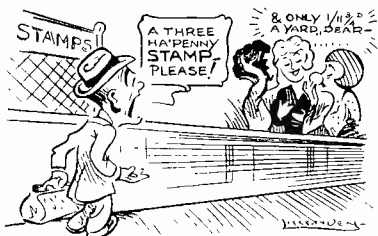

The Post Office is denying us something

such remarks as: "Is yours a powerful set?" "Yes, I get Bratislava and Stamboul regularly."

It is rather hazy to say that any set is "powerful," unless it is intended to convey that it will create a great din—which means simply that you are using a lot of valves and heaping on the H.T. juice. To say that a long-range set is "power-

What Readers Think of Our Sets

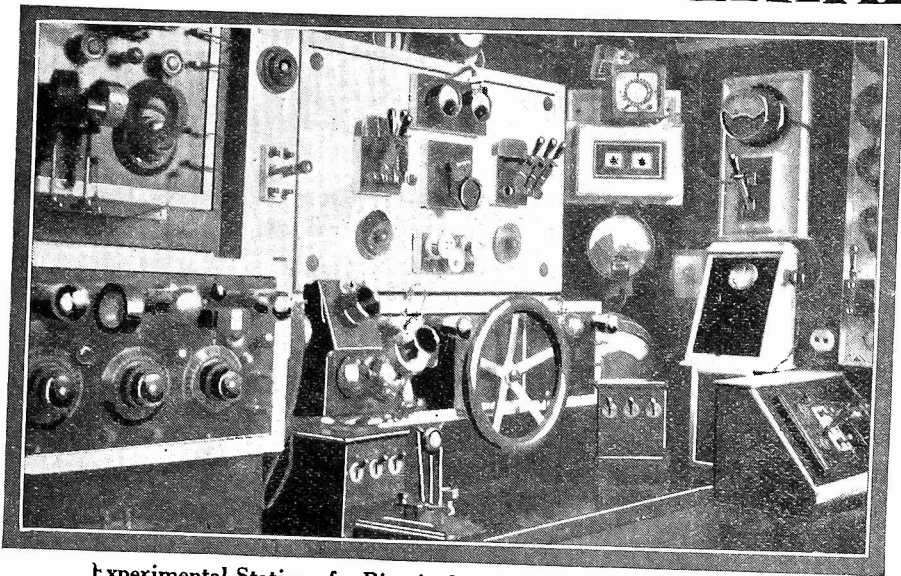

Experimental Station of a Birmingham "Wireless Magazine" reader

INCEPTOR 3

THERE has never been any doubt about the utility of the Inceptor 3 (WIRELESS MAGAZINE, October, 1928). A Birmingham reader has even received American stations with it. This is what he says:

As a reader of the WIRELESS MAGAZINE I feel I should like to make a report on the Inceptor 3.

On December 26, at 2.40 a.m., I was receiving three American stations on my long-distance receiver, using two H.F. detector, and two L.F.

I then connected the Inceptor 3 in place of my long-distance receiver and to my amazement I received the same stations, namely KFAB, WGY and KWKH, on headphones. The H.T. voltage was 100 and I was not using a pentode valve.

By placing one more stage of L.F. in circuit it was working a large G.E.C. cone speaker perfectly.

I have made two more tests since and I have met with every success.

I am enclosing a photograph of my experimental station, which I think may interest some of your readers.

STILL another reader, this time at Leicester, finds that from the Inceptor 3 he obtained a tone and clarity never before experienced with any set:

I have built and tried out your Inceptor 3, and should like to give you my views on this set. I am pleased with the clarity, power, and especially the tone.

I find it very selective on the anode side, but slightly flat on the aerial. Foreign stations come in at very excellent strength and with a tone and clarity that I have not before obtained.

The only fault is the flex lead to the anode coil. I consider this a great mistake, as one has to hold it in one hand and change coils with the other, for the obvious reason that if it is dropped, one

would immediately short the H.T., and if the rheostat was not fully off one stands a very great chance of losing the three valves. Have you a suggestion to make re this?

Another point is the size of baseboard. I built mine on 17 in., it is rather crowded, 19 in. to 20 in. would have given more room in which to work. However, it is a good circuit and capable of a lot.

ANOTHER reader at Eccleshall has also received KDKA:

I am writing to express my great appreciation of your wonderful set, the Inceptor 3, in the October issue of the WIRELESS MAGAZINE. I have tried many circuits employing screened-grid valves, but up to now I have not found one to compare with the Inceptor 3, in either range or volume.

Up to date I have had no less than twenty-five stations at good loud-speaker strength. Of these twenty have been identified. The other night, at approximately 12 p.m., I had KDKA at very fair loud-speaker strength.

THE CRUSADER

REALLY astounding are the results obtained with the Crusader Two (WIRELESS MAGAZINE, May, 1928), by a Dovercourt reader, from whom we have received the following enthusiastic letter:

Possibly my experience with the above set might interest you and WIRELESS MAGAZINE readers. It was my first attempt at short-wave reception and for a whole week I had little or no luck, except morse and unintelligible German and French chatter. After many hours of searching I found 5SW (on a slow-motion dial of 100 degrees), which came in and was gone in a space of less than 2 degrees.

After that I soon mastered the difficulty. Trying short-wave reception for

Something more than just praise for the WIRELESS MAGAZINE are the letters from readers reproduced in these pages—they are a definite help to the amateur who wants to build a new set, for they do give an unbiased view of what each set will accomplish in different localities.

Remember that back copies describing any of these sets can be obtained for 1s. 3d. each, post free, and that full-size blueprints are available as indicated on another page of this issue.

Readers are invited to send us photographs of WIRELESS MAGAZINE receivers they have built; for each one printed we shall pay a fee of half a guinea.

the first time in my opinion is not easy (that is for people like myself who have no expert or medium helper at their back). After some practice it becomes easy and most interesting.

During June and July I found distant stations like 3LO, 2XAF, and 2XAD came in much stronger and with greater certainty than later months—October, November, and December. 3LO I heard every Sunday, often as plain as 2LO, with, of course, the usual fading.

Lately I've heard very little of him. Searching for him a few weeks ago, I heard 6AG Perth at good strength.

Coils used: Atlas Nos. 2, 4, and 6. Components and wiring as recommended in WIRELESS MAGAZINE of May, 1928. Have occasionally changed the .0001-microfarad reaction condenser for a .00025-microfarad; this seems to give more control. Have received the following on short waves: Madrid (EAM), Copenhagen (7MK), Nairobi (7LO), SXK, APK, and PCLL. Have received frequently at good loud-speaker strength 2XAF, 5SW, and PCJJ. Also many amateurs, Blackpool 5DC, 5QZ, 6WT, etc.

I noticed one correspondent remarked on the absence of hand- and body-capacity effects. This hand-capacity is rather too much in evidence with my set. Touching the headphone lead often upsets everything. This is only so with very distant stations like 3LO and U.S.A.

On the higher wavelengths I have received fifty stations at good loud-speaker strength from Stettin 236 metres to Huizen 1,852 metres. Every station logged several times over.

The Crusader is a really wonderful little two-valver. Loud-speaker reception on such a wide range with a cheap two-valve set surely cannot be beaten.

Am now building the Tetrode Two, but shall be greatly surprised if this will equal the Crusader.

P.S.—Am always very interested and pleased to read letters from WIRELESS MAGAZINE readers on the sets built by them, and all the space in your excellent magazine you can spare am sure will be much appreciated by readers.

In comparison with others the WIRELESS MAGAZINE is certainly "the best shillingsworth in radio," for reasons too numerous to mention.

ANOTHER reader at Hylton (nr. Sunderland) has also been successful with the Crusader—in this case with an indoor aerial:

Having built the Crusader with such good results I decided to add one more L.F. stage. The stations I receive are as follows: Newcastle (local), Aberdeen, Daventry 5GB, Berlin, Gleiwitz, Frankfurt, Langenberg, Budapest, Motala, Ostersund, Königswusterhausen, Daventry 5XX, and Kharkov—all on the loud-speaker.

Bournemouth, Cardiff, London, Toulouse, Stuttgart, Hamburg, Munich, Milan, Oslo, Barcelona, Berne, and a few others I get on the 'phones.

Short-wave stations on the loud-speaker: Kootwijk, Eindhoven, Nauen, Doberitz, at good strength; occasionally WGY, but receive this on phones every day either morning (8.30 till 10 a.m. BST), or 12 midnight till 5 a.m. Also various telephony stations not yet identified—two of which are Spanish and one Maltese (at good strength, but indistinct).

The above are the results with a very good inside aerial.

I thank you very much indeed for publishing such a good circuit, for after building sets for eight years have not had one to compare with the Crusader "Three."

I sincerely hope all readers derive the same satisfaction as I have done, then you will be assured of the success of your WIRELESS MAGAZINE.

P.S.—If you care to readjust this letter for publication you may, as I can guarantee these results.

A GLASGOW reader also reports good results; his letter is reproduced below:

I am writing once again to let you know the results, which are splendid, from the Crusader, which I first hooked up inside a soap-box, but have now given it a new home in the form of writing desk. Last night I logged quite a good number of stations on the broadcast waveband, with little interference from the local transmitter.

Langenberg came in at good strength, also Stuttgart, Frankfurt, Prague, Dublin, Belfast, 5GB, Toulouse (France), and later in the evening Madrid.

On the short waves I received KDKA and 2XAF, with a little fading. Altogether I have logged, and have had each verified, 2XAF, 2XAD, KDKA, 2NM. I am waiting on verification of the following: 3LO, WBZ, 3XL. I have had many others but have been unable to make out call signs.

I should like to state here that last February I hooked up in three hours Britain's Favourite Two (also cheap components) and in March of this year received WGY and had my reception verified by way of a gold stamp from this station.

To anyone wishing a good all round two-valver for broadcast reception I would ask them to try Britain's Favourite Two, and for those who wish reception on the three wavebands to make the Crusader.

I am more than satisfied with both sets, and I thank you for what I consider excellent two-valvers.

ECONOMY SCREENED-GRID FOUR

FIFTY stations is the record of a Basingstoke reader with the Economy Screened-grid Four (WIRELESS MAGAZINE, December, 1928). He finds it "perfectly stable and easy to operate."

Having constructed the Economy Screened-grid Four described in the December number I must congratulate you upon producing such an excellent and, what is important to most of us, inexpensive receiver. The volume and tone are all that can be desired and the set is perfectly stable and easy to operate.

I am using an Ediswan SG610 in the H.F. stage and a Mullard PM6 in the last stage, and I find a 50,000-ohm resistance is most suitable for use with the Ediswan valve.

I first tested the set on a Sunday morning, using only three valves and immediately I switched on Radio-Paris "came through" at excellent strength. This was quickly followed by Königshausen and Hilversum and the strength of these stations told me I could expect an excellent log of transmissions.

I have used the set for a week now and below I give a list of stations so far identified. Those marked * were received at tremendous volume:

Brussels	*Königshausen
*Budapest	Koenigsberg
*Bournemouth	Klagenfurt
Barcelona	*Kaiserslautern
Breslau	*London
Bordeaux PTT	Leningrad
Berlin	Lyons
*Cologne	*Langenberg
*Cardiff	Leipzig
*Daventry 5XX	Munich
*Daventry 5GB	Milan
Dresden	*Motala
Dublin	*Münster
*Eiffel Tower	Nurnberg
*Frankfurt	Newcastle
Frederikstaad	*Kalundburg
Gleiwitz	Oslo
Glasgow	Prague
*Goeteborg	Rome
*Hamburg	*Radio-Paris
*Hörby (testing)	*Stuttgart
*Hilversum	Schenectady
Huizen	(U.S.A.)
Hanover	*Toulouse
Kiel	Vienna
Kattowitz	*Warsaw

If you wish to print this letter you may as I would like others to know that an excellent set is within their reach.

Wishing the WIRELESS MAGAZINE every success.

ALL-WAVE SCREENED-GRID THREE

EVEN a reader who knows "very little regarding the technical details of wireless" had no difficulty in constructing the All-wave Screened-grid Three (WIRELESS MAGAZINE, November, 1928). The following letter shows what it will do at Staines:

I have recently completed building the All-wave Screened-grid Three from your November issue and I feel I should like to write my results and appreciation of the design.

I preface my notes by saying that I know very little regarding the technical details of wireless. I found very little difficulty in assembling the set and in

choosing my valves. I find that the Cossor SG 220, Ediswan RC 210 (impedance 6,000 ohms) for a detector, and Mullard PM 22 give excellent results.

I tried detector valves of 20,000-ohms impedance as suggested in the magazine, but I found that these gave poor results. I am using 2 volts L.T. and about 120-5 volts H.T. and the results are wonderful.

On using my original aerial of about 50 ft. in length the volume was tremendous and tone distorted. I then cut the aerial down to about 25 ft. and with this length I can pull in station after station at full volume and purity of tone.

In broad daylight I can pick out all the high-wave stations—Hilversum, Warsaw, Copenhagen, Stockholm, Eiffel Tower, 5XX, Berlin, and Radio Paris with ease; on the medium band there are quite a number that can be obtained. Towards the dusk all the stations come in with ease, of course there is variation according to jamming, morse, etc.

I find that by using grid bias of 10 to 12 volts my reception is just as good as 9 volts or less and this higher grid bias reduces my H.T. consumption to approx. 15 milliamperes, whereas with 9 it is about 22.

I originally had a cone speaker, but I found this would not accept the volume. I then tried a Geophone speaker with excellent results, but not as I liked; I now have their super-cone loud-speaker and I must say that the results as to power, tone and purity are wonderful. I felt I should like to write my appreciation of this set as one of your constant readers, who is very satisfied with the results.

My set, which I have replaced the All-wave Screened-grid Three with, was also one out of your magazine about 18 months ago—the Gloria Four—and this was an exceptionally good set, but of course in a different category.

THE TOUCHSTONE

A TRADER at Bournemouth suggests that the Touchstone would be better if the resistance-capacity and transformer coupling were in the reverse order, but we do not agree with him. Here is his letter:

The writer has recently built up a Touchstone receiver for a customer with the following additions and modifications which greatly improved matters:—

Separate tuning condensers; an Igran-ic P70 jack inserted in detector circuit for gramophone pick-up; an output jack also controlling all filaments; valves controlled by fixed resistors; volume controlled by a variable resistance in the last valve circuit (grid).

The H.T. condenser is out of circuit when the set is off, thus preventing drain by absorption charge. Another Clarostat control is inserted to reduce H.T. of the H.F. and first L.F. valves, thus obviating a separate H.T. tapping, and so discharging the battery evenly.

The opinion is expressed that greater volume would be obtained by reversing the positions of the transformer and R.C. stage, for the latter usually has a far greater efficiency where there is a strong signal, and distortion caused by the M value of the valve could be compensated by the use of a suitable resistance across the secondary.

The DOMINIONS FOUR

A SCREENED-GRID FOUR THAT CAN BE CONVERTED INTO A FIVE-VALVE SHORT-WAVE SUPER-HET

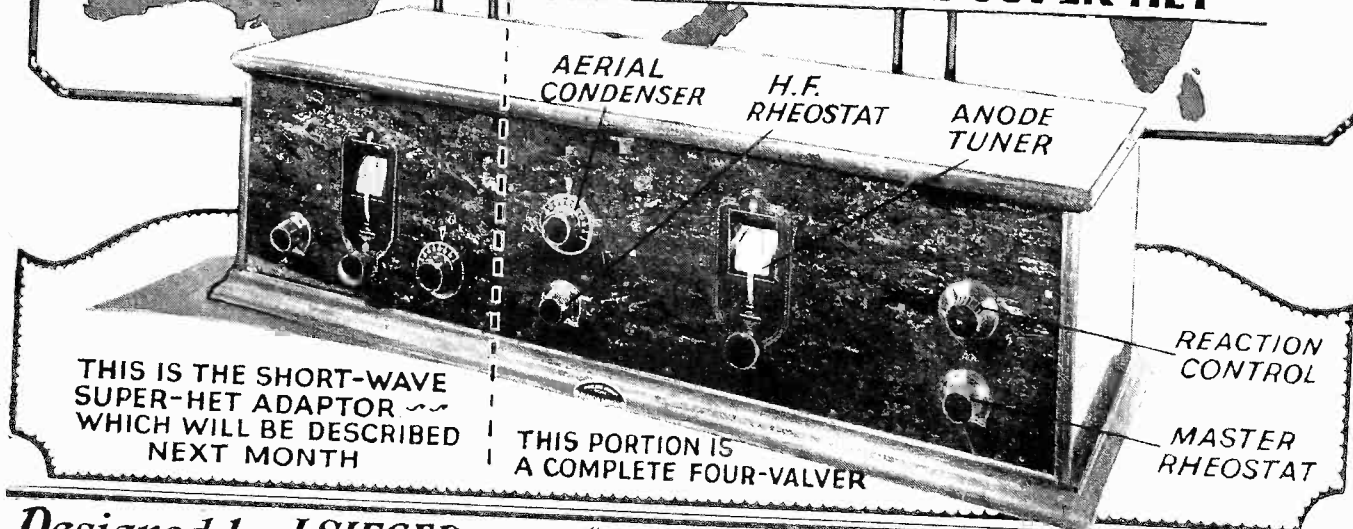

THIS IS THE SHORT-WAVE SUPER-HET ADAPTOR WHICH WILL BE DESCRIBED NEXT MONTH

THIS PORTION IS A COMPLETE FOUR-VALVER

Designed by J. SIEGER, of the "Wireless Magazine" Technical Staff

CRITICS sometimes tell us that too many different kinds of receivers are described in the WIRELESS MAGAZINE (on an average there are five a month), and that as a result the prospective constructor is confused and unable to reach a decision as to which he should build.

All Classes of Readers

The answer is fairly obvious. Readers of the WIRELESS MAGAZINE embrace all classes—there are many who are just beginning to take an interest in radio and have to take designs "on trust," so to speak, and there are thousands who know enough about the technicalities of the subject to have definite ideas on what type of circuit they need.

Every day we get letters asking for some particular combination of circuit which has not been embodied in any of the sets yet described in these pages. Such requests are filed and acted on as occasion arises.

We believe that our readers would rather have the choice of building any one of five sets every month than only of two or three and this belief is strengthened by the steady increase in the sale of blueprints and components for WIRELESS MAGAZINE receivers which is recorded.

Although about seven four-valve sets have been described in the WIRELESS MAGAZINE during the last

six months, no excuse is needed for this description of the Dominions Four, which embodies a type of circuit hitherto not used in any existing set.

Let us explain the name first. The utility of the Dominions Four is by no means limited to use in the Dominions, but it will have a special appeal to overseas readers who are constantly asking for a set of this type. There is no doubt that this design will meet the needs of thousands of amateurs scattered all over the world, as well as the needs of a large public in the British Isles.

What, then, exactly is this Dominions Four? How does it differ from other four-valvers, and what will it do?

The circuit combination employed is two stages of high-frequency amplification with screened-grid valves, an anode-bend detector, and one stage of transformer-coupled low-frequency amplification. This combination ensures the greatest possible range and adequate volume if one of the high-magnification power

valves now obtainable, is used in the last stage.

Two-dial tuning is a feature of the set, which has been designed and built by J. Sieger, of the WIRELESS MAGAZINE Technical staff after many months of special experiment. Reception on both upper and lower broadcast bands is possible, without coil-changing, by the use of special dual-range coils.

Short-wave Super-het

But the most important feature of the Dominions Four—the feature that we believe will appeal particularly to overseas readers exiled in the world's lonely places—is that by adding a one-valve adaptor it can be converted, in a minute, into a short-wave super-het.

When so used, the Dominions "Five" is capable of achieving really extraordinary results, and is probably the most powerful short-wave receiver that has yet been produced in this country by any technical journal.

It will be appreciated, then, that the Dominions Four (or "Five," as the case may be) represents the most up-to-date design for a powerful all-wave receiver, and as such, it will readily find favour amongst WIRELESS MAGAZINE readers.

No attempt at economy has been made, either in the choice of circuit,

Don't miss next month's description of a one-valve adaptor that will convert the Dominions Four into a five-valve short-wave super-het!

or components used, but the cost is quite justified by the results obtained, and no constructor need fear that he will not be getting full value for his money.

A number of refinements are included in the circuit, which is reproduced below. For instance, in the grid and anode circuits of both screened-grid high-frequency valves, H.F. by-pass units, or "stoppers," are included. These terms appear to be contradictory, but actually they mean the same thing.

The units, which are specially recommended by Capt. H. J. Round for use in all screened-grid circuits, "stop" high-frequency currents from passing into parts of the circuits where they are not wanted, and "bypass" then to earth. They are sometimes called "decoupling" devices.

No Self-Oscillation

Each unit consists of a 500-ohm resistance and a .1-microfarad fixed condenser. The set would probably work without them (they are often omitted when price is a primary consideration), but their use ensures absolute stability and freedom from self-oscillation.

Three tuning coils are used, and in each case the grid circuit is tuned. In the case of the couplings to the second screened-grid valve and the detector, experience shows that

tuned-grid (instead of tuned-anode) circuits give sharper control and, therefore, much more selectivity, as grid bias can be easily applied—a great point in a powerful receiver.

Maximum selectivity is obtained by centre-tapping all three coils. What may be termed "aerial"

contact No. 3; or (3) to the grid end of the coil, that is to contact No. 1. The first connection gives the greatest selectivity and should be employed for all normal aerials.

Where the receiver is to be used very close to a broadcasting station it will, of course, be necessary to employ a frame aerial. The flex connection should be connected to contact No. 1 on the coil base and the coil removed. The frame aerial can then be connected across the aerial and earth terminals.

Gang Control

Each of the three grid-tuning coils is tuned by a .0005-microfarad variable condenser, those associated with the second high-frequency and detector valves being ganged in the ordinary way. High-frequency chokes are included in the anode circuits of both screened-grid valves, and it is essential that these should be of the very highest quality, or the results will be materially affected.

Three further points regarding the screened-grid valves should be noted. In the first place, each has its operating grid biased 1½ volts negative, to give the maximum efficiency. This would result in self-oscillation if "stoppers" were not included in the grid and anode circuits.

In the second place, the voltage fed

A FOUR-VALVER TO BE PROUD OF!

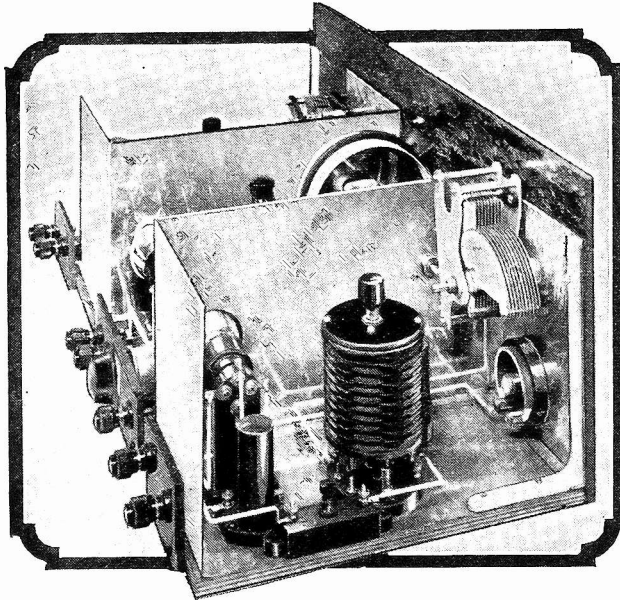

This photograph shows the Dominions Four from the aerial end. Note the special type of dual-range coil, with the change-over switch mounted at the top

selectivity can be controlled by three different ways of connecting the aerial to the receiver: (1) It can be connected through a semi-variable condenser of .000025 to .0003-microfarad capacity, which can be adjusted to give the best results with any particular aerial; (2) direct to the centre-tapping of the aerial coil, that is to

This is the circuit used in the Dominions Four. Special centre-tapped coils are used which cover both wavelength ranges by means of a simple switch mounted at the top. The combination of valves is two screened-grid high-frequency amplifiers, detector, and one transformer-coupled low-frequency stage

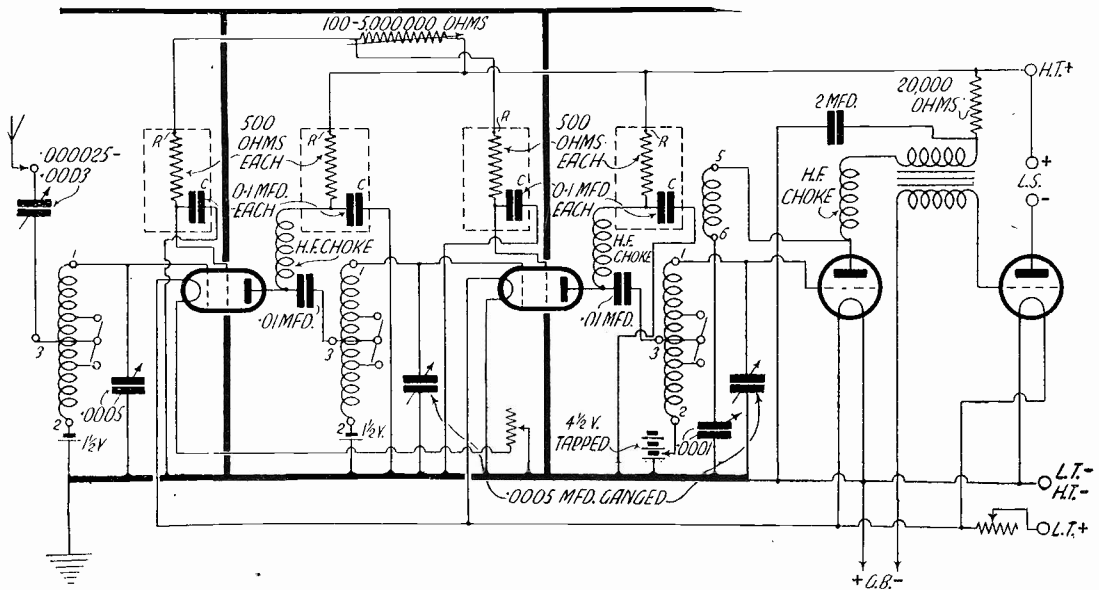

The Dominions Four (Continued)

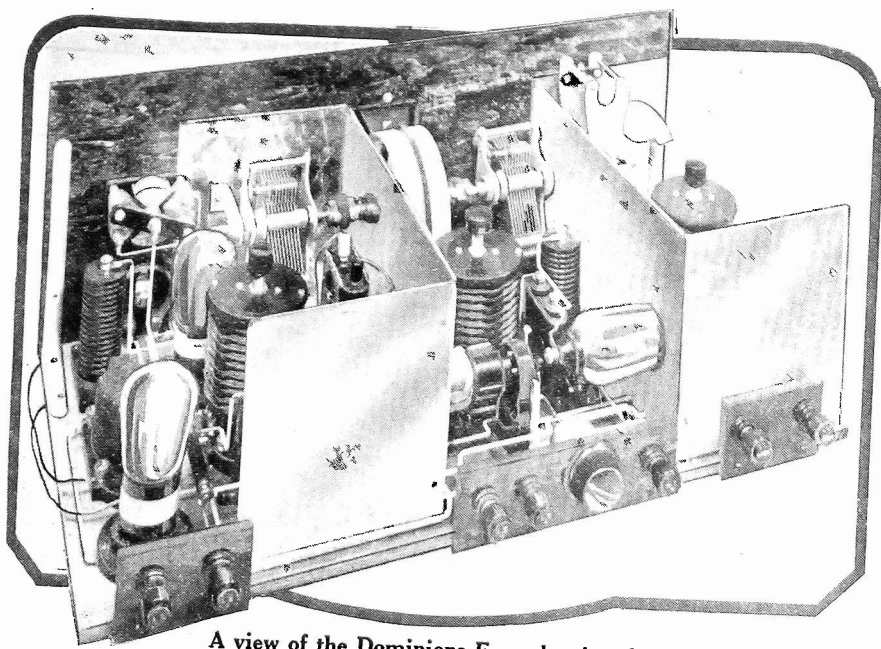

A view of the Dominions Four showing the general layout
Note the positions of the screened-grid valves

to the two screening grids can be controlled within fine limits by means of a variable resistance in the screening grid circuits. This makes it possible to feed all the high tension from one point for all four valves.

Screened-grid Rheostat

Thirdly, a rheostat is provided to control the filaments of both valves. This enables selectivity to be increased to a considerable extent, by reducing the filament current, and there should be no difficulty in

cutting out unwanted stations.

The grid coil associated with the detector valve is provided with a reaction winding connected in the detector anode circuit, and the amount of oscillation or feed-back is controlled by a .0001-microfarad variable condenser.

High-frequency currents are kept out of the low-frequency circuit by means of a choke, in series with the primary winding of the intervalve transformer. This detector valve is also provided with a "decoupling"

unit or "motor-boat" stopper, which takes the form of a 20,000-ohm resistance and 2-microfarad condenser, and ensures stability in the low-frequency circuit.

Instead of an on-off switch, a master rheostat is provided for controlling all four valves.

Use of Moving-coil Loud-speaker

No output choke or transformer is included in the set, as it is assumed that in most cases it will be used with a moving-coil loud-speaker, which will incorporate its own transformer. If this is not the case, an output choke or transformer should be added externally.

So much for details of the circuit, now for some particulars of the actual components used.

It has already been mentioned that the three tuning coils cover both the upper and lower bands of broadcast wavelengths. They are mounted in standard six-pin bases. The change from long waves to medium waves is made by short-circuiting the middle section of the coil, an arrangement that retains the centre-tapping feature for each range.

Switch Positions

The switch takes the form of three contacts, one of which short-circuits the other two when the knob is pulled out. Each switch is mounted at the top of its coils; the knob is pushed in for long-wave reception,

COMPONENTS REQUIRED FOR THE DOMINIONS FOUR

- | | | |
|---|---|--|
| 1—Ebonite panel, 20 in. by 8 in. (Becol, Parfait, or Radion). | 1—Semi-variable condenser, .000025 to .0003-microfarad (Formo type J or Igranic). | 3—Grid-battery clips (Bulgin, 2 type GB6 and 1 type GB2). |
| 1—.0005-microfarad variable condenser (Igranic Lokvane, Cyldon, or Ormond). | 4—High-frequency by-pass units (Marconiphone). | 3—Terminal strips, 3 in. by 2 in., 6 in. by 2 in., and 3 in. by 2 in. (Becol, Parfait, or Radion). |
| 1—Twin-gang .0005-microfarad variable condenser (Igranic Lokvane, Cyldon, or Ormond). | 3—High-frequency chokes (Lewcos, Wearite, or Peto-Scott). | 7—Terminals, marked: Aerial, Earth, H.T.+, L.T.+, L.T.—, L.S.+, L.S.— (Belling-Lee or Ealex). |
| 1—2-in. dial for aerial condenser (Cyldon, Trolite, or Igranic). | 2—.01-microfarad fixed condensers (Dubilier, T.C.C., or Graham-Farish). | 1—Copper screen with baseboard foil (Parex, Ready Radio, or Raymond). |
| 1—Vernier drum control (Igranic). | 1—100 to 5,000,000-ohm variable resistance (Clarostat Standard). | 1—Pair panel brackets (Bulgin, Raymond, or Magnum). |
| 1—7-ohm panel rheostat (Finston, Lissen, or Peerless). | 1—2-microfarad fixed condenser (Dubilier, T.C.C., or Ferranti). | Stiff wire for connecting (Glazite). |
| 1—15-ohm panel rheostat (Finston, Lissen, or Peerless). | 1—20,000-ohm resistance (Graham-Farish, Cosmos, or Ediswan). | Rubber-covered flex, about 3 ft. |
| 1—.0001-microfarad reaction condenser (Ormond, Cyldon, or Lissen). | 1—Low-frequency transformer (Philips, Mullard, or Brown). | 3—Spade tags. |
| 3—Six-pin coil bases (Tunewell, Formo, or Cason). | 2—1½-volt dry batteries (Ever Ready type UW3 or Siemens type GT). | 2—Wander plugs, red and black (Lectro Linx). |
| 2—Screened-grid valve holders (Parex). | 1—4½-volt tapped battery (Siemens type G1 or Ever Ready type UW3). | 1—Dual-range aerial coil (Tunewell). |
| 2—Anti-microphonic valve holders (Lotus, W.B., or Benjamin). | | 2—Dual-range anode coils (Tunewell). |
| | | 1—Cabinet with 10-in. baseboard (Pickett). |

Two Screened-grid Valves, Detector and Power Stage

and pulled out for short-wave reception.

A glance at the photograph of the front panel on page 246 will show that there are five controls in all. They are arranged thus: Top, left, aerial-tuning condenser; bottom, left, rheostat for screened-grid valves; centre, thumb dial for gang condenser tuning second H.F. and detector grid circuits; top, right, reaction control; bottom, right, master rheostat for switching set on and off.

Screening Arrangements

The other photographs show how the receiver is screened. In the first compartment is the aerial coil and the bottom half of the first screened-grid valve. In the second compartment is the second grid coil and the bottom half of the second screened-grid valve. Both the detector and power valve with their associated components are included in the third compartment.

The thumb dial used for the two ganged condensers is provided with an optional vernier device controlled by a small knob which can be brought into operation as desired. Critical tuning is carried out with this control, while the aerial condenser is used more as a volume control.

Special Valve Holders

Special holders are used for the two screened-grid valves, enabling the most efficient screening to be carried out.

It will be observed that the number of terminals has been kept at a minimum. The biasing batteries for the two screened-grid valves and the anode-bend detector are mounted directly on the baseboard, while the battery for applying grid-bias to the power valve can be fixed on the side of the cabinet by means of clips.

Only Seven Terminals

By commoning L.T. — and H.T. —, and supplying all the high-tension voltage from one terminal, only seven terminals are needed.

In spite of the apparent complexity of the Dominions Four, no real

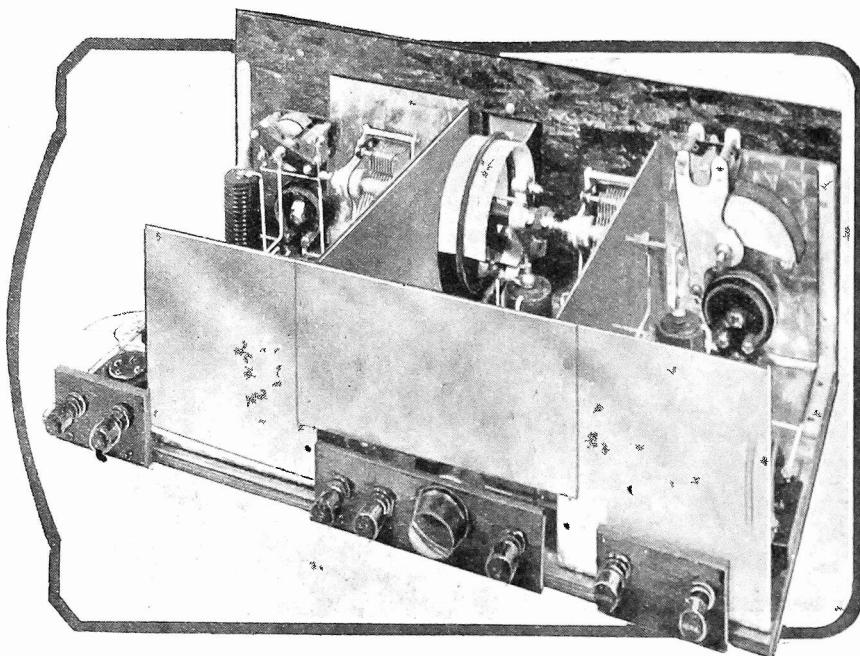

Another view of the Dominions Four. Note the efficient screening provided. The knob at the back controls the voltage applied to the screening grids of the high-frequency valves

difficulty will be experienced in the construction if use is made of a full-size blueprint. This acts as a panel template, layout guide, and wiring diagram; copies can be obtained for half price, that is, 9d. post free, if the

is a great help in construction, it is not essential, for all the necessary details are given in these pages.

The constructor can start work by preparing the screen, which can be of copper or aluminium. The dimensions and positions of holes for wiring are indicated alongside. If desired,

the screen can be obtained all ready cut to size and drilled from one of the firms mentioned in the list of components.

Panel Drilling

As soon as the screen has been obtained or prepared, the panel can be drilled. This can easily be accomplished by laying the blueprint over the ebonite and marking through the centres of the drilling holes with a sharp point.

Now cover the baseboard with copper foil, as indicated, and mount the panel and screen in position. Proceed with the fixing of the various components, as indicated on the blueprint or the reduced reproduction of this on page 251.

When all the components have been firmly fixed in position, wiring up can be started. For this operation, the blueprint will save a good deal of

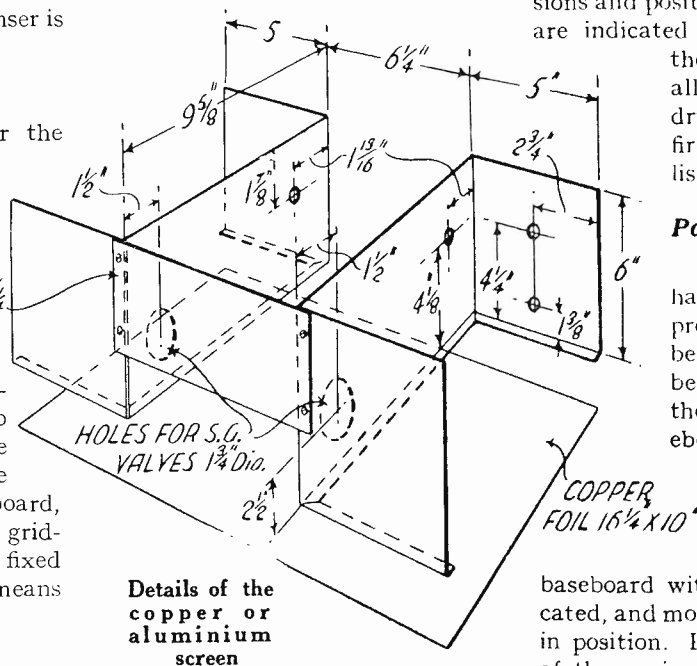

Details of the copper or aluminium screen

coupon on page iii of the cover is used by April 30.

Address your inquiry to Blueprint Dept., WIRELESS MAGAZINE, 58/61 Fetter Lane, E.C.4, asking simply for No. W.M.134. Although a blueprint

The Dominions Four (Continued)

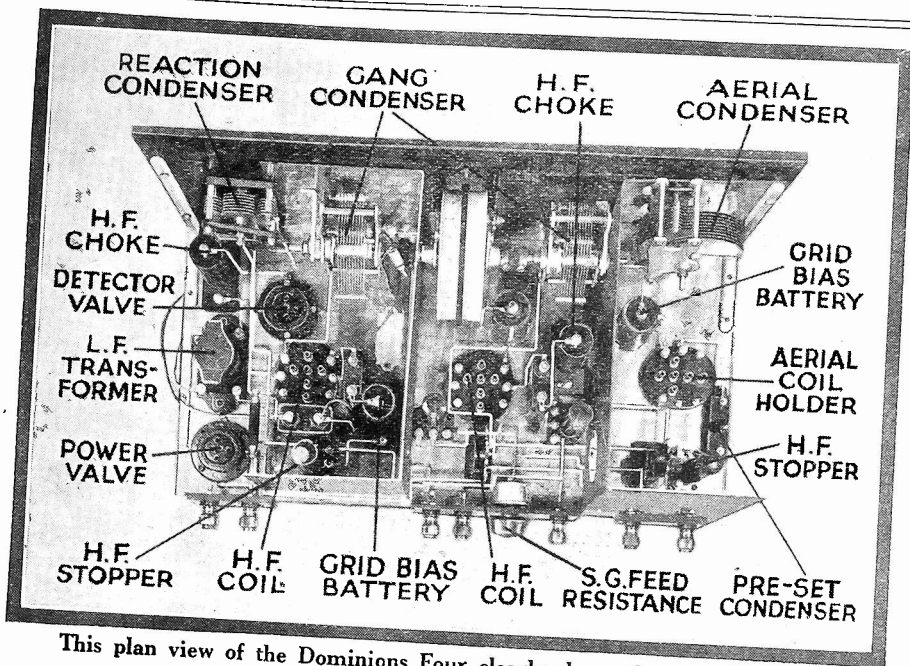

This plan view of the Dominions Four clearly shows the arrangement of all the parts

time, even if the constructor is capable of following a theoretical circuit without difficulty.

How to Connect Up

Connect all the wires in numerical order, and as each connection is made, cross through that number on the wiring diagram. If this procedure is followed, no mistake can be made and the set is certain to work as soon as it is switched on.

The Dominions Four

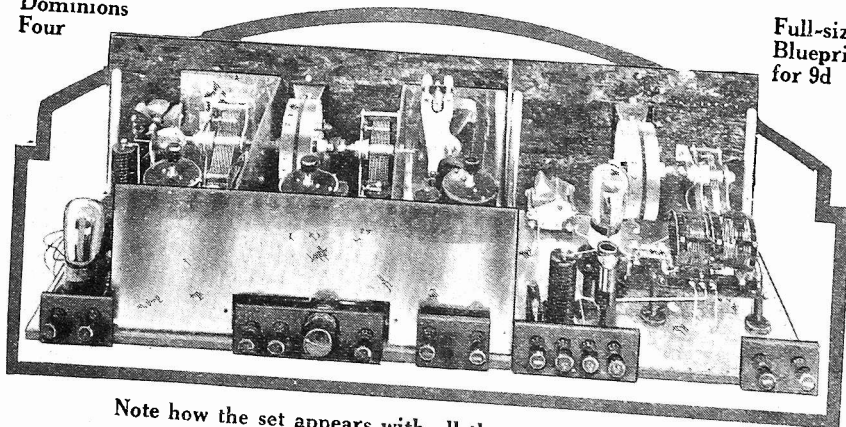

Note how the set appears with all the screening in position

Start with wire No. 1, and carry on in order to No. 59, which completes the receiver.

Before the set can be used, suitable valves must be chosen, and for this purpose the list on pages 208 and 209 should be consulted. Two-, four-, or six-volt valves can be used, but of the six-volt screened-grid valves, only the Ediswan SG610 will fit the particular holders used. (The Marconi and Osram S625 have both the anode and screening grid connections brought out at one end.)

Suitable Two-volters

If two-volt valves are used, there is a choice of six makes, any of which

will be quite satisfactory. With the particular transformer used, the detector valve can have a moderately high impedance. We suggest a valve with an impedance between about 15,000 and 25,000 ohms, such as the Mullard PM1HF or PM5X, the Marconi or Osram HL210, and the Cossor 210HF or 610HF.

For the power stage a valve with

valves and coils in their respective positions, not forgetting to place a coil with a reaction winding in the third socket.

Connect up the necessary accumulator and apply 120 to 150 volts to H.T.+. Apply about 1½ (for two-volt valve) to 3 volts (for six-volt valve) bias to the anode-bend detector.

Operating the Receiver

Now turn on the master rheostat (bottom, right), and the rheostat for the screened-grid valves (bottom, left). Turn the knob of the reaction condenser (top, right) so that the vanes are right out of mesh—reaction will only be needed for distant stations.

To search for stations, turn the centre thumb control slowly and critically, at the same time swinging the knob of the aerial condenser right around the dial and back, relatively quickly. When a station is picked up, adjust the aerial condenser critically for the greatest volume. The screening-grid feed resistance, mounted on the terminal strip at the back, should be adjusted for the best results, and so that there is no trace of self-oscillation.

To gang the receiver properly, tune in a weak station, loosen the clamping nut for one half of the gang condenser and adjust it separately until the best results are obtained. The locking nut should then be clamped in position again.

Aerial Condenser

By adjusting the semi-variable series condenser in the aerial lead, it will be possible to adjust the main aerial condenser so that it "gangs" more or less with the twin-gang condenser.

These adjustments may be spread over some days while the operator is getting the hang of the set. For instance, various adjustments of the screening-grid voltage should be made until the best results are obtained

Can Be Converted Into a Short-wave Super-het

from distant stations. The bias applied to the detector valve should also be varied.

Easier Searching

Normally, reaction will not be necessary, but if the control is adjusted so that the receiver is just oscillating, searching from distant stations will be very much easier as it will be possible to hear the carrier waves, which would otherwise be inaudible.

When interference on a particular station is very bad, just reduce the filament voltage of the screened-grid valves a trifle. This has the effect of increasing the impedance and sharpening the tuning.

There is one special point that should not be overlooked. Never touch the valves or coils without first disconnecting the lead to the H.T. terminal. An accidental flick of one of the flexible anode leads against the screening will short-circuit the high-tension supply, perhaps with disastrous results.

Results at Once

A few days spent in trying out the set will teach the operator more about the set than even two or three pages of description. Sufficient has

been said, however, to enable the constructor to tune in some stations right from the start.

When once all the voltages have been critically adjusted, and the aerial system arranged for the maximum selectivity there is practically nothing that is beyond the range of the Dominions Four—it is a set that will get all that is going.

We expect to get fine reports of its performance from Australian readers particularly—in that Continent they know what range really is. English listeners, however, will be no less pleased with the results.

Next month we shall describe how, by adding a simple one-valve adaptor, the Dominions Four can be converted into a Dominions "Five"—resulting in a short-wave super-het.

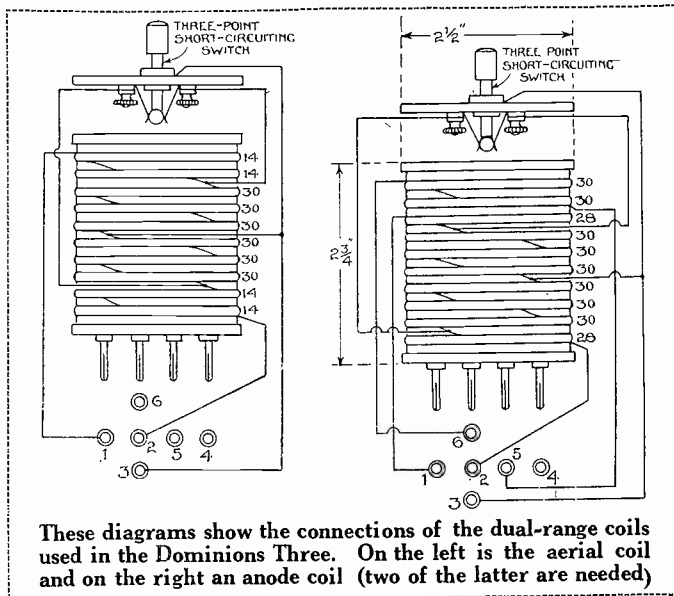

These diagrams show the connections of the dual-range coils used in the Dominions Three. On the left is the aerial coil and on the right an anode coil (two of the latter are needed)

Continental Appreciation

I HAVE just been reading in a French radio contemporary a little paragraph under the heading, which is, I think, self explanatory: "Le developpment de la radio-diffusion anglaise." It is all about the regional scheme, and concludes with the contented sentiment: "And we, in France, will most certainly benefit by it." Well, *cordialement*, we hope they'll enjoy it.

Reliance on British Stations

As a matter of fact there is, in my experience, a large number of amateurs in France, particularly in the provincial areas, who place great reliance in British stations. The sole trouble from their point of view is that strength of reception is not too great, because the B.B.C. does not utilise such a deep degree of modulation as do many of the foreigners.

Purity First

This is in the interests of purity, for the B.B.C. is not primarily out to please D.X. listeners.

But, in between our periodic grumbles about everything that emanates from Savoy Hill, it is pleasing to think that our broadcast service spreads over and is appreciated by the Continent.

K. U.

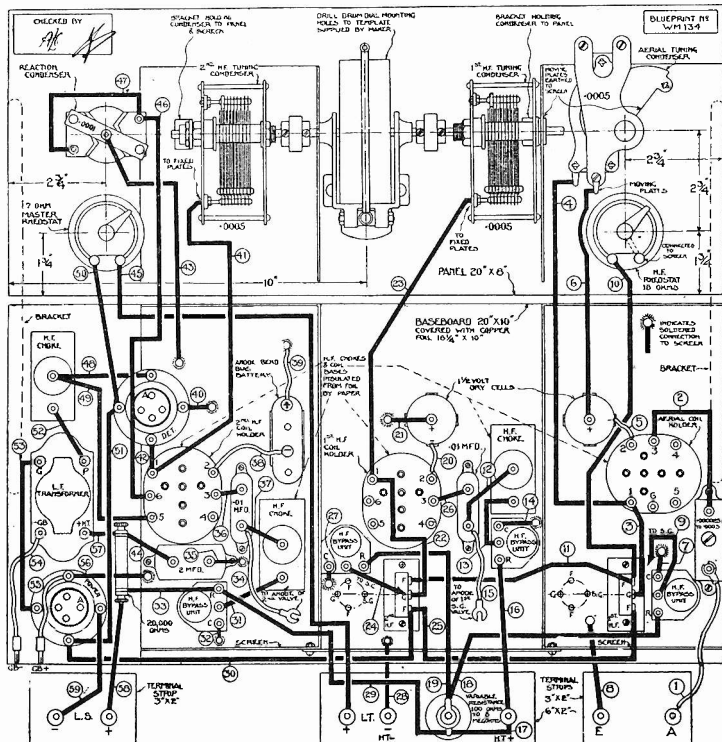

This layout and wiring diagram can be obtained as a full-size blueprint if the coupon on page iii of the cover is used by April 30. An extension of time will be made in the case of overseas readers. In wiring up, follow the numerical sequence indicated.

When sending for a blueprint, ask for No. W.M. 134

What You Want To Know About Wired Wireless

At first sight, the heading of this article suggests a contradiction in terms. It seems obvious that if a message is transmitted over a wire it is not transmitted by wireless, or, alternatively, if the message is transmitted by means of wireless it is not sent over a wire. It is for this reason, among others, that technical men chose to refer to this new develop-

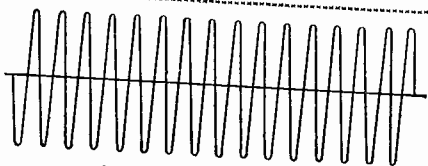

Fig. 1.—Carrier wave

ment in the art of electrical communication as the "carrier current" system.

But at the same time, the system does actually involve the transmission of radio messages over physical circuits, and it will be seen that the term "wired wireless" sums up very aptly a description of the main principles behind the new development.

Fixed Wavelength

The operation of a broadcasting station is probably well known to readers. At all events, everybody knows that each broadcasting station transmits on a fixed wavelength which is special to that station. Another way of expressing this fact is that each station transmits a steady carrier wave of constant frequency. The frequency of a wireless wave, multiplied by its wavelength, is always equal to a constant, the rate of progress of the wave.

Carrier Frequency

To say that a station transmits on a wavelength of 361.4 metres is the same as saying that it transmits a carrier wave with a frequency of 830,000 cycles (or complete waves) per second. Similarly, 491.8 metres wavelength is equivalent to 610,000 cycles per second (or 610 kilocycles) and so on. This carrier wave spreads out from the broadcasting aerial in all directions and is normally constant in amplitude.

It may be considered as a steady pulsation travelling through the ether

at a constant speed and can be assumed as similar in form to Fig. 1.

But although the idea of the transmission of a steady carrier wave presents little difficulty, it is perhaps not quite clear how the actual broadcasting of speech and music takes place.

Sound from the vocal chords or from some musical instrument impinges on a microphone and causes sympathetic fluctuations in the current flowing through a circuit. These fluctuations correspond in frequency to the sounds impinging on the microphone and they are referred to as audio-frequency currents.

By means of a suitable valve device these audio-frequency currents are used to modulate the high-frequency carrier current wave and impress upon it the form of the audio-frequency current. If, therefore, the wave form of the original sound is assumed to be similar to Fig. 2, the carrier wave broadcast from the aerial, instead of being a steady pulsation (as Fig. 1) will assume a shape similar to Fig. 3.

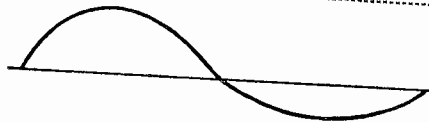

Fig. 2.—Sound wave

This modulated carrier wave will set up corresponding vibrations in a receiving set which is in tune, or which has been adjusted to respond to the natural frequency of the carrier wave. These sympathetic or induced vibrations will have the same wave form as the modulated carrier wave, and it is obviously only necessary to reverse the process carried out at the studio (that is, to demodulate the carrier) to separate the audio-frequency and radio-frequency components of the carrier wave.

Similar to Broadcasting

In the process of telephone speech transmission the processes involved are, up to a point, the same as those in broadcasting. Speech or music, through the intermediary of a microphone, are converted into audio-frequency currents. But instead of

There are many people who hold the opinion that "wired wireless" has a great future; it has been tried in Germany with some success. This article by A. W. WILLSMORE explains exactly what the system is and how various transmissions can be sorted out

these speech currents being used to modulate a radio carrier wave and being transmitted through the ether as a high-frequency vibration, they are transmitted as audio-frequency currents along a pair of copper wires strung up on poles or contained in a cable.

That is to say, before two locations can be in touch with each other by telephone it is necessary to have a physical metallic connection between them.

Additional Circuits

Let us imagine two distant towns connected together by a single pair of wires strung up on a pole route. As more facilities are needed to cope with increased traffic it is necessary to string additional wires on the pole route, and obviously there is ultimately a time reached when there is no more room for additional circuits.

When this juncture is reached the officials responsible for the line are faced with the problem of providing increased traffic facilities at an economical cost.

Granted that in certain cases where the electrical characteristics of the line are suitable, it is possible to employ "phantom" working in which induced speech current is transmitted over a phantom circuit made up of two separate pairs of wires. But in all

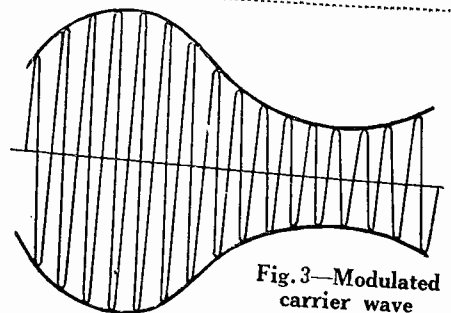

Fig. 3.—Modulated carrier wave

cases there ultimately comes a time when it is necessary either to construct a more extensive pole route or to lay a cable.

Either of these alternatives is very costly, especially in view of the fact that traffic will only increase at the usual rate and that in consequence it will be several years before the increased facilities are used to a sufficient extent to make them an economical proposition.

Use of Radio Principles

Obviously some scheme whereby the construction of a new line could be delayed until the traffic would be sufficiently increased to pay its capital charges would be very welcome. To meet this need telephone engineers have called radio principles to their aid.

It is well known that provided a fairly selective receiving set is in use several stations can be transmitting on different frequencies at the same time without interference one with the other. It is patent that because of the heavy cost the provision of broadcasting stations would be out of the question for dealing with the conditions outlined above.

Out of All Proportion

This heavy cost is due to the fact that the energy transmitted by a broadcasting station is out of all proportion to the energy received, since the carrier wave spreads out in all directions. By an arrangement of the aerial, however, it is possible to confine the bulk of the energy transmitted to a comparatively narrow path with a consequent reduction in the aerial output necessary to cover a given distance. This possibility is put to practical use in the beam system of radio communication.

Logical Conclusion

In the carrier system this development is carried to its logical conclusion and the carrier wave is transmitted along a metallic circuit. By employing different carrier frequencies it is possible to have as many as four separate two-way conversations taking place at the same time over one pair of wires.

One conversation is carried by means of normal audio-frequency currents, the other three are transmitted in the form of modulated carrier currents. The modulated carrier waves, however, are not transmitted as such. If reference is

made to the modulated carrier wave shown in Fig. 3 it will be noticed that both the upper and lower side bands of the carrier frequency have impressed upon them the voice-frequency modulation.

For this reason it is not essential to transmit both side bands, as either would on demodulation give the original audio-frequency currents.

Normal speech frequencies cover a range of from 200 cycles per second to 2,000 cycles per second and it is therefore necessary to have a side band wide enough to accommodate this range of frequencies if good speech transmission is to be obtained. If, therefore, a carrier frequency of 14,000 cycles per second is being used the side bands will cover a range of from 11,300 to 13,800 cycles per second for the lower band and 14,200 to 16,700 c.p.s. for the upper band.

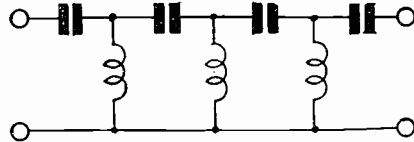

Fig. 5.—High-pass filter

Since the limit to frequencies that can be transmitted over an ordinary telephone line is about 30,000 c.p.s. it will be apparent that the transmission of a single side band instead of the complete modulated wave enables more speech channels to be provided within a given range of frequencies.

The carrier system manufactured by Standard Telephones and Cables, Ltd., of London, enables three carrier

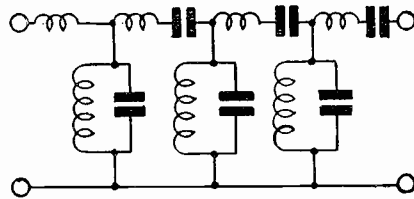

Fig 6.—Filter for limited band of frequencies

channels to be provided in addition to the ordinary facilities. To prevent interference between transmitting and receiving circuits six separate carrier frequencies are employed in this case.

The following table indicates the carrier and side-band frequencies which are used in the system :

Carrier Frequency	Side-band Frequency
Low Group	
Cycles per sec.	Cycles per sec.
7,700	5,000 to 7,500
10,700	8,000 to 10,500
14,000	11,300 to 13,800
High Group	
16,100	16,300 — 18,800
19,750	19,950 — 22,450
23,400	23,600 — 26,100

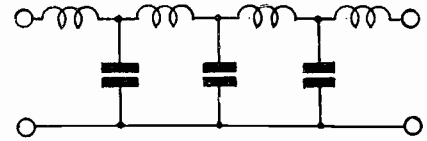

Fig. 4.—Low-pass filter

It will be noticed that the gap between the upper frequency of one side band and the lower frequency on the following side band is only 1,150 cycles per second. This corresponds to less than 1 metre difference in wavelength, and the question naturally arises as to how it is possible to transmit these six frequency bands over the same circuit at the same time without causing interference.

Ingenious Filter Devices

The solution has been found in the use of a very ingenious group of filter devices consisting of capacity and inductance arrangements similar in principle to radio wavetraps. An arrangement similar to Fig. 4 can be adjusted so that it will freely pass frequencies below a certain value, but impede the passage of all frequencies above that value. By means of Fig. 5, frequencies above a certain value can be passed while lower frequencies are cut out.

Lastly, by employing a circuit such as that of Fig. 6 frequencies within a certain band are allowed to pass freely, but frequencies above and below the limits of that band are eliminated.

Separating the Side Bands

By the use of such devices as these the various side bands can be easily separated and individually demodulated. Since, however, only the side band is transmitted in each case, it is necessary to again apply the normal carrier frequency to the side band before demodulation can

(Continued at foot of next page)

Short-wave Relays from Colombo

RELAYING is going to be a regular feature in Colombo broadcasting programmes. For some time now the authorities have been experimenting to find out exactly what foreign stations would be most suitable for successful relaying from Colombo.

They have now found that one of the best stations to be received here clearly is Chelmsford. Chelmsford programmes will, therefore, be relayed very often from Colombo, and it is, in fact, the intention of the authorities to give Colombo subscribers a regular fortnightly relay from that station.

Unfavourable Atmospherics

Another station which is received well in Colombo is Bombay. But Bombay is not received as clearly as Chelmsford owing to unfavourable atmospherics. Several programmes from Bombay have already been given to Colombo subscribers.

Still another station capable of being well relayed from Colombo is a station in Holland. It is possible that other foreign stations will also come within the range of the Colombo

FROM OUR OWN CORRESPONDENT

station, and the experiments now carried on will show how many of these can be utilised by Colombo in the attempt to give its listeners a first-class service.

The use of wireless by the police, in conformity with the practice existing in England and the Continent, is proposed in Ceylon and the Government has appointed a committee to report on the feasibility of the scheme.

It is pointed out that wireless would be of great service to the police in broadcasting police notices and warnings to the public, while an extension to other Government departments is mooted on the grounds that a department such as the Public Works Department would be able by this means to broadcast the approach of floods in time to warn railway authorities and the motoring public.

Considerable effort has been made within the last few months to attract more listeners-in to local broadcasting, as it was felt that the return derived by the licence fee of Rs. 10 per head for a year would make broadcasting here a paying proposition if there were a sufficiently large number of subscribers and thus justify increased recurrent expenditure.

Thirty Licensees A Month

In spite of a fairly steady increase, the average addition, since March last, of only thirty licensees per month, is viewed with disappointment. It is estimated that, considering the amount of business done in the sale of receiving instruments by local dealers, the legitimate number of licensees on the list should be far in excess of what it is at present.

The number of licensees to the end of August were 1,163, and judging from the rates of increase during the last six months, it would not be before the middle of 1930 when the number of licensed listeners-in would reach the 2,000 mark.

What You Want to Know About Wired Wireless

(Continued from previous page)

proceed. This is done by means of a local oscillator connected to the demodulator.

The carrier-current telephones system was first demonstrated in the United States late in 1918 over an open wire line of 250 miles between Baltimore and Pittsburgh. Since that date the development of the system has been phenomenal and thousands of miles of carrier circuit are now in operation.

Australian Developments

Outside the United States, the country which has made the most use of the new development has been Australia. One three-channel system has been in use on a line between Melbourne and Sydney since September, 1925, and two three-channel systems have been working on lines between Sydney and West Maitland since May 1926. More recently carrier systems have been applied to the Sydney-Brisbane route and, in fact, there are over 10,000

miles of carrier telephone system in operation or in course of installation.

Nearer home, the carrier telephone system has been applied to give further facilities on the London-Paris-Madrid route and very extensive use of the system has been made in Spain, Germany, and elsewhere on the Continent.

The British Post Office has not yet utilised the new development to any great extent, but interesting experiments have been made and it is highly probable that before long several systems will be in operation. The system will probably be adopted not so much because of its use in enabling constructional work to be delayed as because of the facilities it gives for relieving congestion in enabling heavy seasonal traffic to be dealt with in an economical manner.

For instance, seaside resorts have a much heavier traffic in the summer months than in the winter, and if actual lines were put up to deal with

the summer traffic a large part of the equipment would be lying idle throughout the winter months.

A type of equipment has been developed, however, which can be transported from place to place and used to meet such traffic needs, serving to relieve holiday traffic in the summer months and being put in service during the winter months at race courses or elsewhere where urgent traffic needs occasion its use.

National Speech Grid

A further development of the carrier system enables speech to be transmitted over high-power overhead electrical distribution lines and the proponents of the system look forward to the day when speech communication will be possible over the national grid now in course of erection. The facilities of carrier equipment for this purpose and for the transmission of telegraphy are, however, another story.

THE opportunity for a radio "fan" to wire out a house for wireless while it was being built does not occur to most of us more than once a lifetime, but it is a chance not to be missed.

The main scheme was, of course, to have a point in every room and to provide accommodation for either headphone or loud-speaker at each position, with some arrangement for switching the set on and off and changing the programme.

Set in the Wireless Room

It was thought better to have the set out of the way, and arrangements were therefore made to work it in the wireless room.

In the first place, experience showed that it was most important to know where such things as beds and chairs were going to be placed before deciding on the point at which the wires should emerge from the wall.

The wireless room was on the first floor, and arrangements were made to bring an electric-power point out about 6 ft. from the floor in order to be handy for the gear on the bench. The electric supply is A.C. at 240 volts 50 cycles, which while being extremely handy for charging purposes was likely to give trouble from the radio point of view.

Five Lead-covered Wires

Lead cable was for this reason decided on and, in actual fact, five wires were laid. Three only were necessary, but it was thought desirable to have an extra pair in case of accidents during building; these duly occurred and it is the experience won from these that the writer wishes to pass on!

The chief anxiety was to lay the wire before the plastering and flooring were done, in order that they should be concealed as far as possible.

The time to do this is when the roof is on and the plumbers and joiners have done as much work as possible before the plastering is started. But there are a good many points to be watched.

Over-enthusiastic Workers!

Reviewing the number of mistakes that he made, the writer considers himself extremely lucky that he did not have more than one circuit put "down" by an over-enthusiastic carpenter.

It would, perhaps, be more convenient to consider a three-wire system and follow its progress through



Fig. 2.—The control block extended on to the chimney breast

HOW IT WAS ACTUALLY DONE AT LOW COST

the home in the light of past experience.

The wiring was started in the dining-room on the ground floor. Single lead-covered lighting cable was used and each lead run separately.

It is a great mistake to attempt to secure one end and pay out from the coil, as you go along, as in various places it will be found to be impossible to pass the coil through apertures in sleeper walls which can otherwise be made use of, as illustrated in Fig. 1.

The tedious method of leaving the coil behind, and taking the end with you as you go will be found to pay in the long run.

The dining-room position was chosen to be about 3 ft. 6 in. from the floor level, that is to say about 3 ft. 7 in. above the floor joists so that it appeared about 4 in. above the level of the sideboard and can, if necessary, be concealed by a decanter or ornament.

In the drawing-room a position was selected about 3 ft. from floor level on either side of the fireplace about 1 ft. from the chimney breast. It was found afterwards that it would have been far better to have the wires brought out on the breast itself, instead of upon the walls, as in the case under discussion this arrangement proved far more convenient and was less conspicuous.

Example of Bad Position

Photograph No. 2 shows this bad position and the control block extended on to the chimney breast. The illustration was made before the plaster was cut to hide the extension wire. This is an extremely messy job, and, unless very skilfully patched up, can leave an ugly scar on the wall.

It is of the utmost importance to decide exactly which are the most convenient positions for points in order to avoid having to cut up the

Wiring Your New House for Radio! (Continued)

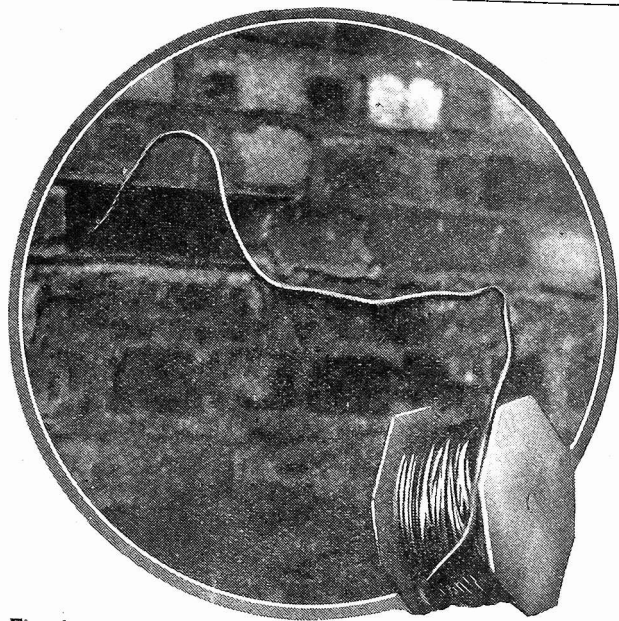

Fig. 1.—It is impossible to pass a coil of wire through apertures in sleeper walls. It pays to take the end with you and leave the coil behind

wall and "make good" again. In general, it is unwise to have a point so low that it is likely to be damaged by a broom or a vacuum cleaner.

When working on the ground floor, under no circumstances allow a lead to pass across an open space between floor joists. It is almost certain to be damaged. It pays to go round, rather than take tempting short cuts.

Essential Looping

Fig. 3 shows the right and the wrong way to do this. It will be noticed that the lead which is passed correctly across the room along a floor joist has a loop in it before it starts to climb the wall.

There are three reasons for this:—

1.—At the stage of building which is most convenient to do the work under discussion, the floor joists are not by any means always rigid where they butt into the walls. Apart from lateral movement, it is frequently possible to rock them. They only become rigid when the carpenters have nailed the floor boards down.

"Pulling" of Joists

2.—The putting of the floor boards down will frequently "pull" a joist which seemed perfectly rigid before.

3.—In a new house there is always a tendency to "settle" slightly. If no loop of wire is left to allow for possible movement of this kind, a

breakage is almost certain to occur.

The writer had to re-lay a section of a burglar-alarm circuit before he was warned by his architect of the danger of too tight a run from the joist to the wall.

A fresh snag is encountered on the wall itself. It has to be remembered that the skirting board is nailed into the wall after the floors have been laid; and, therefore, that it is important to cut the brick away so that the wiring lies flush with its surface. This can be done quite easily with a cold

If the direct nailing method is used, the only hope is to run perfectly straight up to where the wires are to emerge; and to warn, and, if necessary, financially encourage the carpenters on the job to keep nails away from any area directly under a plug point; because it should be remembered that the wires are concealed by the plaster at this stage of the work.

Frequent Visits Advisable

It is worth while to pay a good many visits while the carpenters and gas fitters are at work, as these gentlemen have a habit of suddenly moving, or being moved from the job, and being replaced by someone else, who is sublimely ignorant of any precautions which have to be taken; and who usually has to be "encouraged" all over again!

The wiring was continued to the kitchen and the "point" placed within a few inches of where the dresser was to be, in order to have it handy for the loud-speaker built into the dresser; and also to dodge the white tiling and heat behind the stove.

Study the Plans First

These last three points help to emphasise the importance of studying the house drawings and furniture arrangements when deciding where to place points.

From the kitchen the leads were taken straight up the walls to a position just on the left of where the bed was to be. It should be remembered that it is easier to manipulate with the right hand on the left-hand side of a bed.

From the bedroom the wire was taken across the floor joists to the wireless room, a separate lead being run from this to the other three bedrooms.

Working On Ceiling Joists

Working along the ceiling joists is not so easy as ground-floor work, as, to begin with, it is difficult to work in comfort perched on a 2-in. joist. It will pay to provide a small plank to sit on. This can be laid across the joists. It should be long enough to leave room for tools and nails. Balancing a bag of staples on a 2-in. joist usually means a series of

These hints on wiring a house for radio in every room will be found of help by every "Wireless Magazine" reader who is moving into a new residence this Spring, and will also be of value to builders and professional electricians who are often called upon to carry out this kind of work. The author has just wired his own house

chisel, still more easily if there is enough wire to make use of the joints between the bricks as the mortar can then be chipped away with a knife.

There are three ways by which the skirting boards are nailed to the wall:—

1.—By laying at intervals a breeze block brick, into which a nail can be driven direct.

2.—By inserting wooden plugs.

3.—By simply driving large nails into a bonded joint (that between two courses of bricks) and hoping for the best.

When the first and second methods are used it is easy to dodge any possible nails by simply avoiding any breeze blocks or plugs like the plague.

The Chance of A Lifetime—Not to Be Missed!

exasperating climbs up and down to collect things that fall off.

It is as important upstairs, as down, to avoid running across joists, but it is not always possible to pass underneath ceiling joists as it has to be remembered that the plasterers' laths will be nailed on the under side.

It may, in fact, be necessary to run over the tops of the ceiling joists, but this should be done as near to the wall as possible, leaving loops between each joist and cutting the joist so that the floor boards will lie flat.

Allowing for Plaster

It is well to allow for at least 2 inches of plaster when bringing the wire out at each point.

The leads were not cut, but simply looped, the loops being then doubled back and lashed together by insulating tape into a solid lump round which the plasterers can work. As the wire is run, it is advisable to put a drop of coloured paint on each loop to obviate a good deal of unnecessary testing when the time comes to wire up.

Don't make the loops too large, otherwise they are apt to get dragged

down and appear about 2 ft. lower than they ought. They should be inspected frequently, as the job goes on, to avoid this happening.

The best way to fix the wire to wood work is a loop of lead strip and a nail.

If staples are used they should be large enough to avoid cutting the lead in the neck of the staple. Apart from breaking the lead casing, there is a serious risk of putting an earth on a wire which it is extremely important to avoid.

Where brickwork is encountered, the wires must be very firmly held and lashed together at the point where the loops emerge and it is a good plan to put on a wire lashing soldered to each lead casing to ensure a continuous earth when the time comes to cut the loops. If this

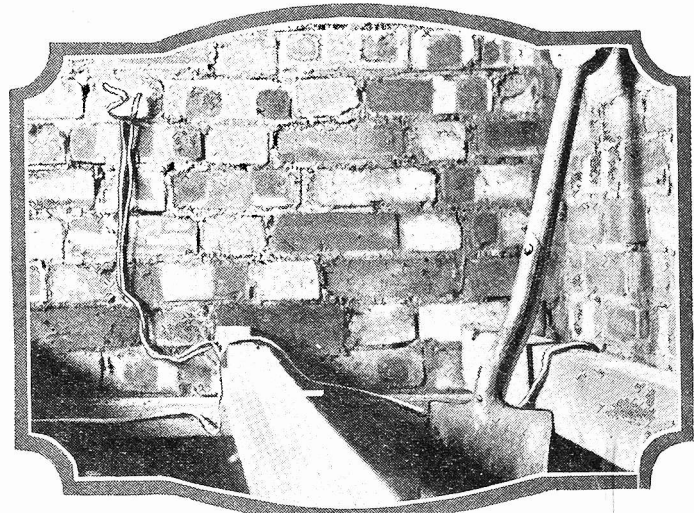

Fig. 3.—Right and wrong ways of leading wires over flooring joists. A loop must be left before the wire climbs the wall

is not done now, it will have to be done later when the plaster is on and it is apt to be messy.

Large staples of hard metal can be used to hold the wires on to the surface of the brickwork and any nails or staples used should be galvanised to obviate the risk of rust working through the plaster.

The nails or staples can be driven into bonded joints, Fig. 4 showing a completed point ready for the plasterers.

INTER-ALIA.

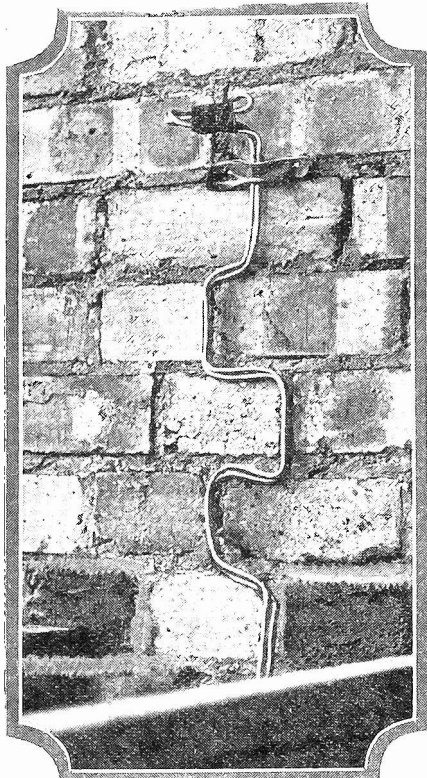

Fig. 4.—Completed joint ready for the plasterers. If the loop is too long the wire may appear much lower than it should when the plastering is finished

Seeing When Distortion Occurs

IF all amateurs could see the simple way in which a check is kept on distortion with the B.B.C. amplifiers, the sale of milliammeters would go up by leaps and bounds! For a milliammeter, which, after all, need not be very expensive, indicates something more useful than the amount of current passing in anode circuits.

It is, of course, very useful to know the anode current, for without this knowledge a valve cannot be adjusted to the most economical working point: but the milliammeter actually shows distortion by movement of the needle. With the meter in circuit, and the set working under normal conditions, the needle should indicate the exact amount of anode current passing. When distortion occurs,

however, the needle will flicker, the degree of deflection approximating to the deviation from the straight-line working characteristics of the valve.

The reason for the flickering of the needle is not generally known, however, but it is quite simple to understand. The working characteristic of an L.F. amplifying valve is a straight line, for the grid bias value should be adjusted so that the curved portions of the characteristic do not come into the working range. The mean value of the oscillating anode current is thus zero.

If the battery values are wrong, or if the valve is overloaded, the working characteristic is not a straight line and the varying current is shown by movement of the milliammeter needle.

K. U.

Hints for Success on the Short Waves

By E. H. ROBINSON
(5YM)

THE new rule of the Postmaster-General that every British amateur transmitter must be in possession of a dependable wavemeter is a thoroughly good one; but it seems to have been a cause of trouble to quite a number of stations.

Licences Withheld

I hear that there are a good many licences still withheld until the applicant can satisfy the authorities that he is so equipped that he can hold his transmissions to the narrow wavelength bands now authorised. Whilst one has every sympathy with those who have done good work in the past, with the very minimum of apparatus, there is no doubt that considerable interference has been caused by wavelength wanderings.

Those whose interest in the short waves is confined to the professional telephony stations must often wish that other authorities were as strict as our own and that some of the professional morse stations could be made to stick to their own bit of the ether.

Importance of Wavemeters

A good wavemeter is really an essential for short-wave working. All that a listening station needs is the possibility of borrowing one every few weeks, since a good short-wave receiver is so built that it can be calibrated. If one is bought, an absorption meter will be found cheap and reliable within fairly close limits.

The amateur transmitter is in a different case. Without a constant check on his meter he cannot be sure that his operating frequency really is what he supposes it to be. The best possible check is a good crystal oscillator and if this has a fundamental somewhere in the close neighbourhood of 160 metres, strong harmonics can be picked up on 80,

40, 20, 10, and 5 metres, giving a positive check on the very frequencies that are required.

With a good crystal in the grid circuit of a valve and a milliammeter in the plate circuit there is no difficulty, save the initial expense, in setting up a crystal oscillator, and such a piece of apparatus will generate continuous waves with only a very minute "creep" over very long periods.

Since the Igranic Company set us all agog, over a year ago, with a really efficient neutralised H.F. amplifier for short-wave work, a great many enthusiasts have been experimenting with amplification before the detector. The screened-grid valve has made the work fairly simple; but neutralisation still seems to be necessary if we are to get any useful signal magnification much below about 30 metres.

The conventional circuits as used for screened-grid amplification on broadcast frequencies are quite all right, but some form of reaction is necessary. This can be applied most usefully to the coil in the grid circuit of the detector valve and it does not seem to matter much whether this coil is the tuned-anode coil or the tuned-grid coil of a shunt-feed arrangement.

Any sort of short-wave receiver is the better for proper screening with either copper or aluminium. In the usual sort of detector-L.F. receiver it is quite a good plan to screen the detector from the L.F. side, and to provide either a metal panel or an ebonite panel backed with copper

foil. The screen should, of course, be earthed.

When we get down to 10 and 5 metres very complete screening is a great help. It is quite useful to screen the whole cabinet, if the receiver is boxed up, or, at any rate, put a sheet of copper foil under the baseboard.

Filters Advisable

Means of keeping the H.F. circulating currents out of the L.F. stage should also be incorporated. For short-wave receivers the most useful method is to put a resistance of about .25 megohm in the grid lead of the L.F. valve. Choke-capacity output is a further refinement and assists in reducing body-capacity effects—which are liable to be troublesome on the very high frequencies.

There are now to be obtained commercially made chokes that are guaranteed to work well on all wavelengths between 20 and 2,000 metres and so our old troubles about choke winding are, more or less, at an end.

It should be noted, however, that all shop-made chokes are not equally suitable for short-wave receivers. In some positions a choke will act in a very strange manner if the operator is not well aware of what is going on in his set.

Reliable Chokes

Generally speaking a choke made by a good firm and said to be suitable for short waves will be quite all right when used in the anode circuit of the detector in order to allow of capacity-controlled reaction; but some of them seem to have peaks that cause blind spots when used as part of a high-frequency amplifying circuit. In such a case it is as well to wind a smaller choke, when the blind spot in the tuning will disappear.

NOBODY INTERESTED IN PORTABLES SHOULD MISS THE NEXT ISSUE

It will contain a complete review of portable receivers, giving all the details the prospective buyer needs to know before making his choice. This feature will appeal to everybody interested in the development of receiver

design and no pains will be spared to make it complete. There will also be included in this issue particulars of a special portable super-set for home-construction, developed by J. H. Reyner, B.Sc. (Hons.), A.M.I.E.E.

DON'T MISS THE MAY "WIRELESS MAGAZINE"—PUBLISHED ON APRIL 24

A WIRELESS FICTIONARY

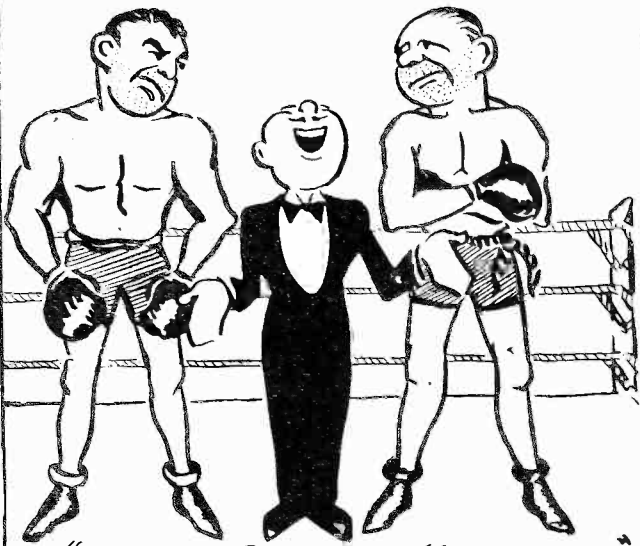

"FURTHER OUTLOOK-UNSETTLED."



"UNUSUAL CAPACITY."



"A HOWLING SET."

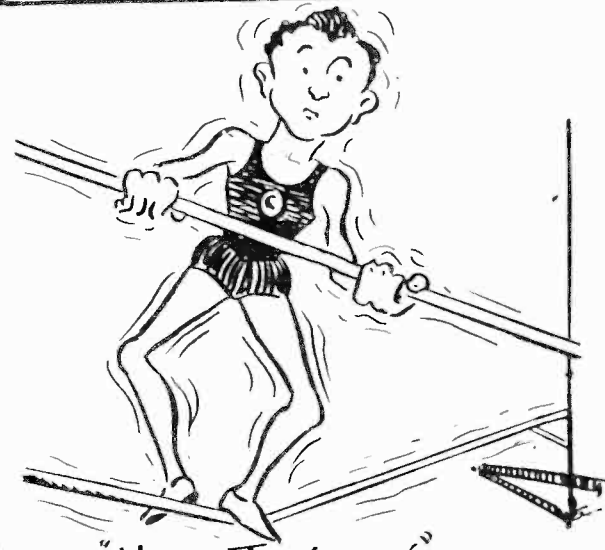

"HIGH TENSION"



"EXCEPTIONAL RESULTS."



"WEAK TRANSFORMER."

Roberts

THE LETTERS OF Priscilla Playne-Smythe

Stewcombe Manor,
Little Bodley, Nr. Hurdham.

19/2/1929.

DEAR MR. EDITOR,

Believe me, I should *not* have written to you again *so* soon, but for the fact that I have been, and still am, in *great* trouble. My wireless set—you know the one my nephew Tom *so* skilfully constructed for me—suddenly stopped *three* days ago, and since then, notwithstanding a close examination of *all* its intricate parts—I never realised that Tom was *so* clever a lad until now—I cannot find what is wrong with it.

Do you think it *could* be the programmes we have been having lately, which have upset it? Is it at all possible that the ultra-modern music so frequently included in the entertainments could break anything truly vital; it is very discordant and *quite* different to the entrancing ballads of my youthful days.

And then again, I learn that many of the stations have been remeasured and now possess new wavelengths. Could I purchase a set of these anywhere and what would they cost?

Also, if I am not intruding on your valuable time too much, must I get a fresh supply of what the radio papers refer to as frequencies, and if so, would they *suit* my set as well as the old ones? I cannot believe those originally embodied in the box can be worn out for to all appearances the wires seem *quite* all right, and the bobbins still perfectly clean.

I wrote to my nephew Tom at once, but his answer seemed to me to be curiously irrelevant; he replied very vulgarly, I thought, that whilst at school he could do nothing, if I insisted on "keeping all that punk"—whatever that may be—and that instead of listening to the "tripe" broadcast I would do better to get him two days hols. from the Head, if—and this is what I cannot understand—I had actually "been bitten by the radio bug."

This I consider a disgusting expression, and most certainly *untruthful* as we have never found one of these *horrid* things in the house.

I really do *not* know to whom to turn for assistance because in Little Bodley we have no experts of any

description, and the man who sees to our clocks and bells is laid up with influenza; at least, *so* my housemaid tells me, although personally I believe that his daily visits to the Goat and Compasses are too frequent to be explained away as interviews with prospective customers.

At my wits' end yesterday, I sent a message to the chauffeur at the Lodge and he *very* kindly called on me during the evening, just at that moment when I particularly miss the cheerful and enlightening talks which at that hour so brighten the day's programmes.

I very much fear that his knowledge

SIR OSWALD STOLL—

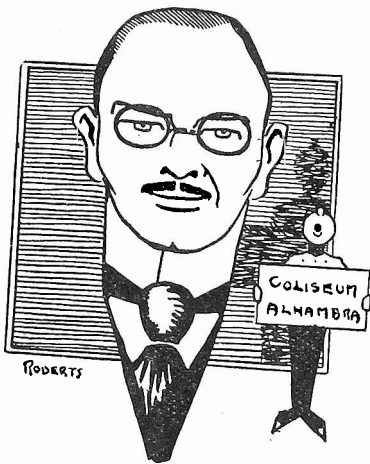

—who lifted the ban on broadcasting from the Music Halls under his control

of wireless has been somewhat *confused* by his study of motor cars, for after spending half an hour in my drawing-room where the set is installed, he only succeeded in soiling an antimacassar with ash and burning the top of a table with a lighted cigarette; it was no doubt my fault for giving him permission to smoke whilst at his work.

As I take *so* keen an interest in scientific matters, I could not restrain myself from asking questions whilst he endeavoured to diagnose the trouble, but I can assure you that his running commentary as he played with the receiver was *pure* Greek to me, and totally incomprehensible, although as you know, I religiously read through your adorable magazine from the title to the back page.

His references to a choked jet, a dirty plug and a missing cylinder did not enlighten me as to the cause of the fault, and I was quite unable to tell him whether we suffered from "lack of juice," or not. In the end, saying he would call back another day, he forgot to drink the glass of dandelion wine I had offered him as refreshment, and left Tom's set in the *same* condition as he found it.

Now I feel sure, dear Mr. Editor, that the details I have given will enable you to advise me in the matter, and I *anxiously* await a few lines from you, telling me *what* I can do.

You will readily realise how much I miss the delightful programmes which are given to us. Did you hear a very fascinating talk on "How to bring up a family of eight on £1 6s. 4d. per week," which was given last Saturday night? It was *most* interesting, and I made notes of the daily menus, as I am certain they would suit some of our villagers *so well*; potatoes and beans are very plentiful in this district.

Most of these talks, as you will no doubt agree with me, contain a wealth of useful information on everyday matters, and truly constitute what Mr. Goodacre, our dear Vicar, so aptly terms "a beneficent shower of uplift."

Do please forgive this long letter, but remember that I am a regular subscriber and a great admirer of your publication,

Yours faithfully,
(Miss) PRISCILLA PLAYNE-SMYTHE.

P.S.—Shortly after writing this letter, I had a visit from Mr. Candlemas, our organist. Curiously enough, although he does not profess *any* knowledge of wireless, he found a loose wire hanging near the loud-speaker. On placing this against what I always took to be a disengaged knob, we heard "London and Daventry calling," and the set is now working well.

On investigation I find that Mrs. Muggins, the woman who comes in daily to do the rough work, took the loud-speaker down to dust it, and I presume that she was the cause of all the trouble. Silly, was it not?

Radio Quarrels in the United States

Demands for 382 Commercial Short-wave Channels and only 165 Channels available!

GRAND-FATHER VALVES

Two film stars take an interest in giant transmitting valves. On the left is Jean Arthur with a 10-kilowatt water-cooled valve and on the right Fay Wray is inspecting a 10-kilowatt rectifying valve



that these companies want to do. In such respect the radio commissioners realised that they must be circumspect in their judgments—not to infringe on the surveillance and authority of the Interstate Commerce Commission.

Also there is the maintenance of competition, the avoidance of monopoly, which the Federal Trade Commissioners like to oversee. Already the Postal Telegraph and Western Union are sending telegrams and photograms over Bell Telephone wires. The International Telephone and Telegraph Co. has not abandoned its hope of buying control of the Radio Corporation of America.

Competition to Persist?

Yet the appearance of competition seems certain to persist. Transoceanic wireless has forced the reduction of cable rates until the two services now charge practically the same price. What land wireless rates will do to land wire rates no one before the Federal Radio Commission could estimate.

All these demands, ideas, and implications the radio commission could not digest immediately. It adjourned for bureaucratic, secret, yet nonetheless conscientious, deliberation.

F. P.

THE great U.S. communication systems are (1) American Telephone and Telegraph Co. (telephones); (2) International Telephone and Telegraph Co. (telegraph, cable, wireless, foreign telephone); (3) Western Union Telegraph Co. (telegraph, cable); (4) Radio Corporation of America (wireless telegraph, radio telephone). The four corporations are separate units and compete against each other for the U.S. communication business.

A Badgered Commission

Their lust for business recently befuddled the much badgered Federal Radio Commission. Two of the companies—the I. T. & T. (through its subsidiary Mackay Radio and Telegraph Co.) and R. C. A. demanded the right to install wireless telegraph stations and sell service between cities in continental U.S.

Heretofore, with a minor exception, they have kept their business to sending messages overseas—to stations abroad, to ships on the great oceans or great lakes, to coastal shipping points.

That one exception is on the Pacific coast. Between Los Angeles, San Francisco and Portland, Ore., the Mackay Companies (now part of the I. T. & T.) operate a land wireless system. It is the only continental

commercial radio service in the world.

The I. T. & T. wants to make such land wireless service cover the continent. It demanded of the Federal Radio Commission sixty short-wave wireless channels.

The Radio Corporation of America declared that it needed thirty-two point to point stations at once, wanted the right to sixty-seven, would like one hundred and forty-eight all told.

The members of the Federal Radio Commission listened to these demands. They listened also to two other similar demands—from Inter-city Radio Telegraph Co. of Cleveland, for fifty stations, from Universal Wireless Communication Co. of Buffalo, a new concern, for one hundred and twenty-five stations.

In A Quandary

These demands put the Federal Commission in a quandary. Wireless experts figure that two hundred and eight short-wave wireless channels can be used for communication within the U.S. Of that number forty-three are now being used by foreign countries and so are forbidden to U.S. commercialisers. Not enough channels are available to satisfy even the present four petitioners.

Then there is the interstate business

IF YOU KNOW OF ANY FRIENDS WHO WANT TO START RADIO IN THE CHEAPEST WAY TELL THEM ABOUT THE CLIPPER TWO, WHICH IS DESCRIBED IN THIS ISSUE. IT IS AN EFFICIENT TWO-VALVER THAT WILL RECEIVE ON ANY WAVELENGTH BAND—INCLUDING THE VERY SHORT WAVES

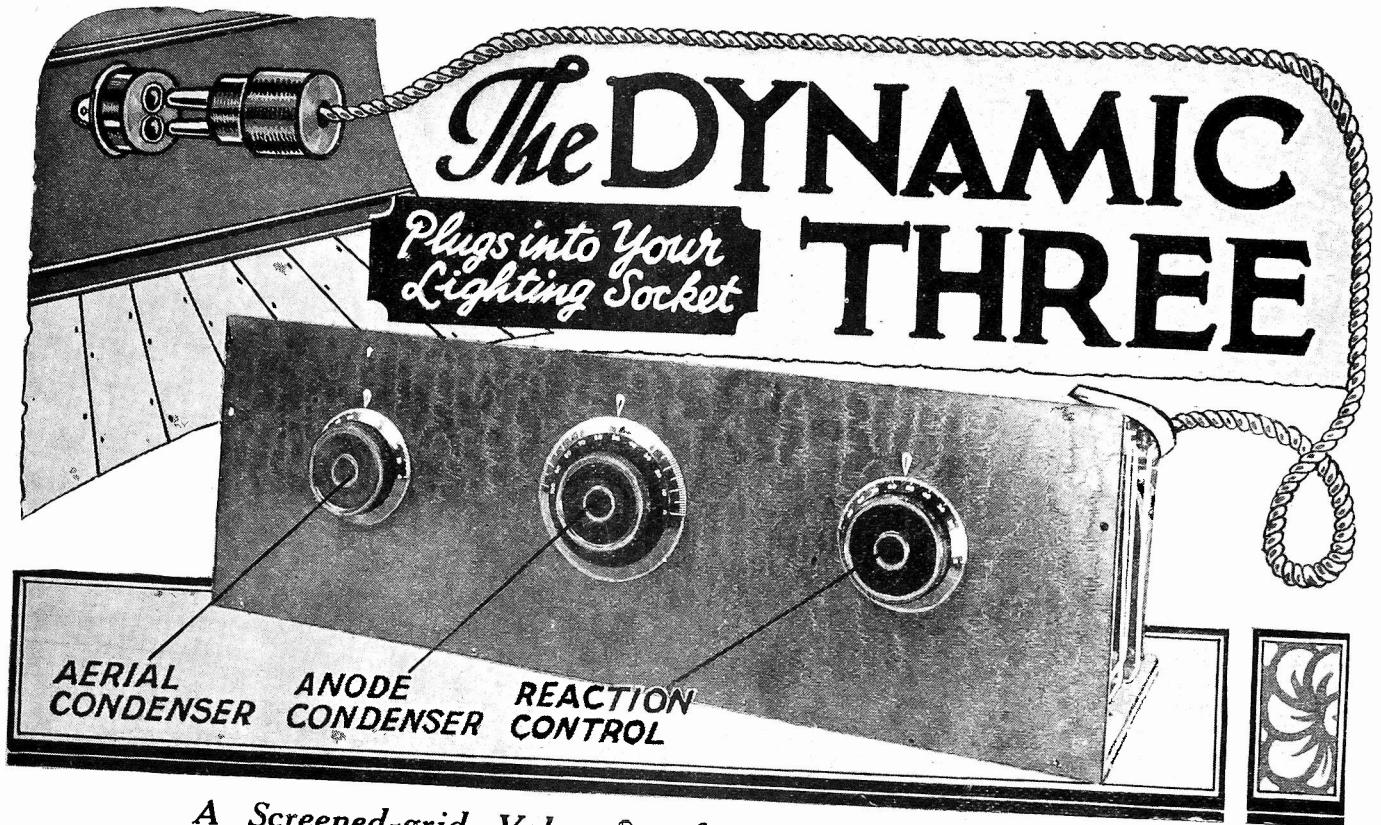

A Screened-grid Valve Set for Direct Operation from A.C. Mains :: Designed by the "W.M." Technical Staff

AMONGST those living in houses supplied with an alternating-current (A.C.) lighting supply sets operated entirely from the mains are steadily gaining favour because of their great convenience and utility.

No Danger in Their Use

Provided reasonable precautions are taken (such as putting off the main switch before changing coils) there is no danger in the use of mains-operated receivers and their construction can be undertaken by the amateur without any qualms.

With the exceedingly efficient mains valves that are now available in this country there is no reason why "power-socket" sets should not soon become as popular in Great Britain as they have been for a considerable time in the United States.

In this article we shall describe the construction of a three-valve set that takes its high-tension and low-tension current direct from A.C. mains. The only battery required is a 16½-volt dry one for grid bias.

It is sometimes suggested that if

one is going to make a mains-operated receiver it should be a large one with four or more valves. Actually, however, mains valves are so efficient that three of them will give results comparable with a battery-operated five-valver. This will be evident when it is mentioned that the three

used in this particular receiver. Experimental work on this set was carried out for some weeks by J. H. Reyner, B.Sc., A.M.I.E.E., in the Furzehill laboratories, who reported excellent results. The finished design has also been tested exhaustively by other members of the WIRELESS

MAGAZINE Technical Staff, who also record great range and volume.

This is not the place to digress at length on the superior merits of the mains valves compared with ordinary "battery" valves, but the reader can take it for granted that they are relatively considerably more efficient.

Non-inductive Heaters

In the valves employed in this receiver, the "filaments" are not heated directly from the mains. A non-inductive heater wire enclosed in a porcelain insulator is supplied with a current of 1 ampere at 4 volts and causes a specially prepared coating on the outside of the porcelain to emit a stream of electrons. This method of construction definitely eliminates any trace of A.C. hum. Such valves are known as the

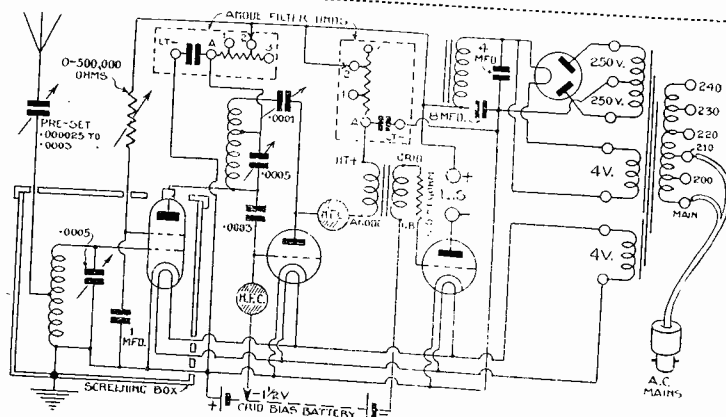

This is the circuit of the Dynamic Three, which makes use of one new A.C. screened-grid valve

valves used in the Dynamic Three have rated amplification factors of 1,200, 35 and 10 respectively!

The circuit combination employed is a screened-grid high-frequency amplifier, a detector, and a stage of transformer-coupled low-frequency amplification. Only Cosmos Short-path A.C. mains valves can be

"indirectly heated cathode" type, sometimes abbreviated to I.H.C.

As far as circuit connections are concerned the equipotential emitting surface is treated as the ordinary filament, as a glance at the circuit diagram on page 262 will reveal.

Great Amplification

Although the screened-grid valve has a rated amplification of 1,200 this figure is not obtained in practice, of course, owing to various losses that occur. However, even if the losses are high it will be appreciated that the actual amplification obtained is still very much greater than is possible with normal valves.

Ignoring for a moment the purely "mains" portion of the set, let us trace out the ordinary receiving circuit.

The aerial is led through a semi-variable series condenser to the centre tap of a two-pin plug-in coil, which is tuned by a .0005-microfarad variable condenser. This coil is connected across the control grid and "filament" of the screened-grid valve in the ordinary way.

Voltage Regulation

In series with the screening grid is a variable resistance (0 to 500,000 ohms) to control the voltage applied. A 1-microfarad condenser is connected between the screening grid and the "filament" to by-pass high-frequency currents.

In the anode circuit of the screened-grid valve there is a double-tapped two-pin coil, also tuned by a .0005-microfarad. This coil is not tapped for selectivity, but so that part of the winding can be used for reaction, in

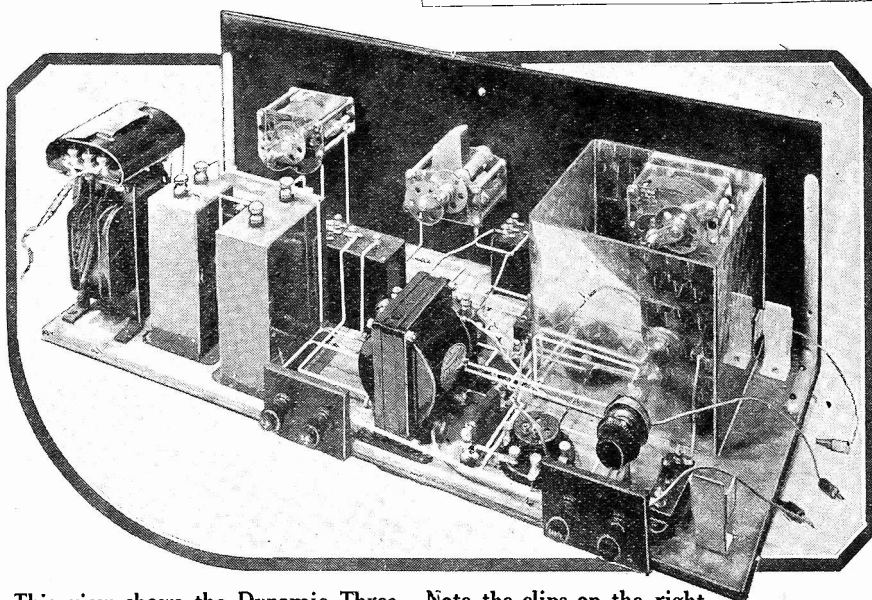

This view shows the Dynamic Three. Note the clips on the right for the grid-bias battery

conjunction with a .0001-microfarad variable condenser.

An anode filter or "stopper" is provided in the anode circuit. This consists of a tapped resistance (having values of 10,000, 15,000, and 20,000 ohms) and a 2-microfarad condenser. In this way stability of operation is ensured.

Voltage variations set up across the anode coil are passed through a .0003-microfarad coupling condenser to the grid of the detector valve, which is led to a grid battery through a high-frequency choke.

Another high-frequency choke is provided in the anode circuit of the detector valve so that reaction can be obtained. The detector anode circuit is also provided with a similar filter unit to that used in the first anode circuit, but with higher values of resistances.

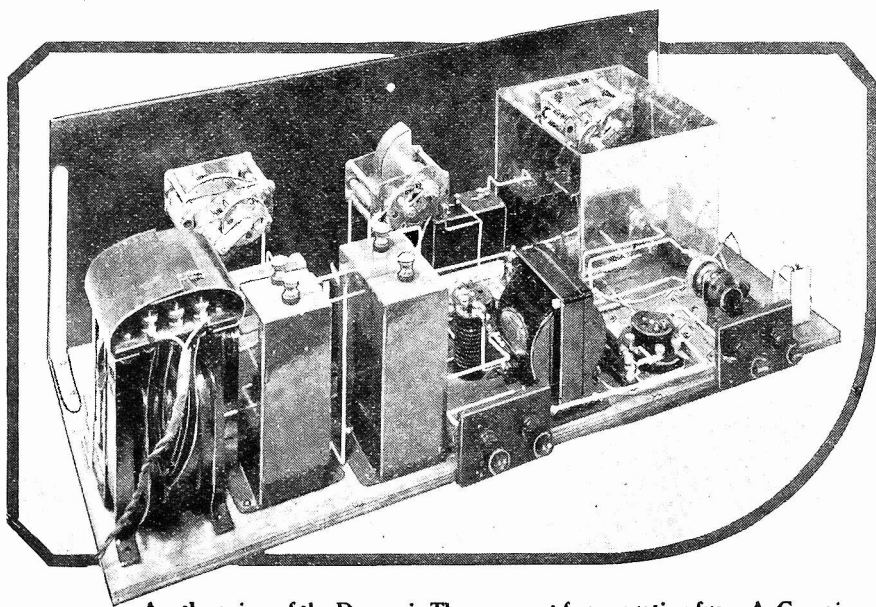

Another view of the Dynamic Three—a set for operation from A. C. mains

A further precaution against instability through high-frequency currents passing into the low-frequency circuits is the use of a .25-megohm resistance in series with the grid of the power valve.

So much for the receiving side of the set. Let us now consider the mains portion. Here a transformer with one primary (tapped for use on 200-, 210-, 220-, 230-, or 240-volt mains of 40 to 100 cycles) and three secondaries is employed.

Users of Secondaries

The first secondary gives 4 amperes at 4 volts and can be used to heat four mains valves of the type utilised in this receiver. The second winding gives 2 amperes at 4 volts for heating the filament of a full-wave rectifying valve for converting the alternating current into direct current for feeding the valve anodes and screening grid.

A third winding, which is centre-tapped, enables 250 volts to be applied across the two anodes of the full-wave rectifier. Smoothing is carried out by two condensers of 4-microfarads and 8-microfarads respectively and a low-frequency choke.

Simplicity of Operation

It will be seen that there is nothing especially complicated about the set which is, in fact, extremely simple to operate. A glance at the photograph of the front of the receiver, reproduced on page 262, will show that there are only three controls. These are for aerial tuning, anode tuning, and reaction. The set is always ready for use simply by plugging the connector into a lighting socket or wall plug.

The Dynamic Three (Continued)

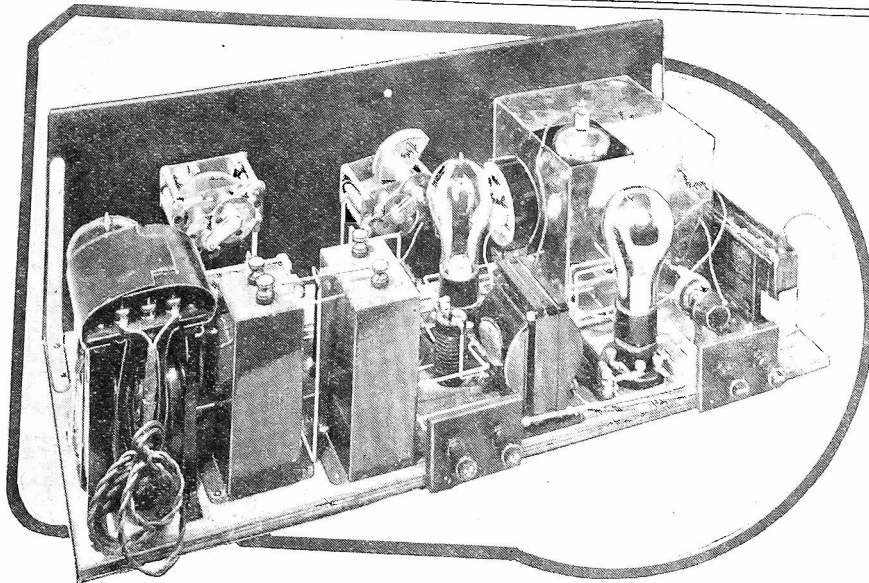

Note the efficient screening for the high-frequency valve in the Dynamic Three

The full-size blueprint which is available for half price, that is 6d. post free, if the coupon on page iii of the cover is used by April 30, shows the positions of all the parts and the correct order in which to wire them; it will be found of great help by the constructor and is a safeguard against making faulty connections.

Copies of the blueprint can be obtained on application to Blueprint Dept., WIRELESS MAGAZINE, 58/61 Fetter Lane, E.C.4. Ask simply for No. W.M.136.

Screening Box

It will be observed that the high-frequency valve is completely screened in a copper box. This can be obtained all ready cut out and drilled from one of the firms mentioned in the list of components.

There is no difficulty about the assembly of the set. Reference to the photographs and layout diagram or blueprint will show clearly how all the components are placed. There is no likelihood of the constructor going wrong in this respect.

How to Wire Up Correctly

When the time comes to wire up the full-size blueprint will be found of very great assistance. If it is followed closely it will be impossible to make a wrong connection. A brief inspection will reveal that each wire is numbered; these numbers indicate the best order of assembly.

For instance, first connect up wire

No. 1 (remember that insulated wire is essential in a mains-operated receiver) and then cross that number through on the blueprint. Proceed with connection No. 2 and cross through that number as soon as the wire has been fixed. In this way it is impossible to go wrong and the wiring will be built up in the most convenient way from the bottom

Before the set is tested, the proper valves and coils must be inserted in their respective holders. While this is being done keep the plug-connector well away from the mains socket

Additional Rectifying Valve

Although the set is only a three-valver, four valves are needed, the extra one being the full-wave rectifier for supplying the high tension.

The valves used must be Cosmos Shortpath's, as special holders are incorporated in the set for these and the whole receiver has been designed expressly for their use.

Mains valves are not interchangeable to anything like the same extent as ordinary types.

Characteristics of Valves

Actually the valves to be used are as follows:—

High-frequency Amplifier.

Cosmos AC/S. Amplification factor, 1,200; impedance, 800,000 ohms.

Detector.

Cosmos AC/G. Amplification factor, 35; impedance (at 120 volts), 17,500 ohms.

COMPONENTS REQUIRED FOR THE DYNAMIC THREE

- 1—Ebonite panel, 24 in. by 8 in. (Parfait, Trolite, or Raymond).
- 2—.0005-microfarad variable condensers with slow-motion control (Gecophone, Jackson, or Ormond).
- 1—.0001-microfarad variable condenser with slow-motion control (Gecophone, Jackson, or Ormond).
- 2—Single coil holders (Lotus, Lissen, or Peto-Scott).
- 3—Mains valve holders (Cosmos).
- 1—Standard valve holder (Cosmos).
- 1—.0003-microfarad fixed condenser (T.C.C., Mullard, or Dubilier).
- 1—1-microfarad fixed condenser (T.C.C., Mullard, or Dubilier).
- 1—Semi-variable condenser, .000025 to .0003-microfarad (Formo type J or Igranic).
- 1—0 to 500,000-ohm variable resistance (Clarostat Volume Control).
- 2—High-frequency chokes (Peto-Scott, Wearite, or Omnora).
- 1—.25-megohm resistance (Graham-Farish, Cosmos, or Lissen).
- 1—Low-frequency transformer (Ferranti AF5, Brown, or Igranic G).
- 2—Anode-filter units (Wearite, 1 H.F. and 1 L.F.).
- 1—4-microfarad fixed condenser (T.C.C. or Dubilier, 400 volts working).
- 1—8-microfarad fixed condenser (T.C.C. or Dubilier, 400 volts working).
- 1—Smoothing choke to carry 30 milliamperes (Parmeko, Ferranti, or Igranic).
- 1—Mains transformer (Cosmos)
- 2—Terminal strips, 3 in. by 2 in. (Parfait, Trolite, or Raymond).
- 4—Terminals, marked: Aerial, Earth, L.S. +, L.S. — (Belling-Lee or Eelex).
- 1—Pair grid-battery clips (Bulgin).
- 1—16½-volt grid battery (Siemens, Ever Ready, or Hellesen).
- Insulated wire for connecting (Glazite).
- 2 yd. rubber-covered flex.
- Length of twin lighting flex with lamp-socket connector or wall plug.
- 3—Wander plugs, 1 red and 2 black (Lectro Linx).
- 2—Spade tags.
- 1—Cabinet with 10-in. baseboard (Caxton).
- 1—Screening box, 5¾ in. by 5¾ in. by 5¾ in. (Parex, Raymond, or Ready Radio).

A Powerful Set for Operation from A.C. Mains

Power Valve.

Cosmos AC/R. Amplification factor, 10; impedance (at 120 volts), 3,000 ohms.

Rectifying Valve.

Cosmos SP42/U. Maximum D.C. output, 60 milliamperes.

As regards coils, two centre-tapped and double-tapped two-pin plug-in coils will be required. For the medium waves two No. 60 coils will be suitable, while for the long waves two No. 200's should be obtained.

Checking Connections

Before switching the set on to the mains for the first time make sure that all the valves and coils are in their proper positions and the leads connected up.

The grid-bias tappings for the anode-bend detector and power valve should also be adjusted. Apply $1\frac{1}{2}$ to 3 volts negative to the detector and $4\frac{1}{2}$ to $10\frac{1}{2}$ volts negative to the power valve.

It may be noted here that the comparatively small bias required by the last valve does not mean it is a poor power type; its characteristics are such that it requires only about half the input to give the same output as an equivalent "battery" valve.

Switching On the Set

When everything has been connected up, then, put the plug-connector into the mains socket; this operation switches the whole set on and nothing should be touched inside the cabinet, the lid of which should be

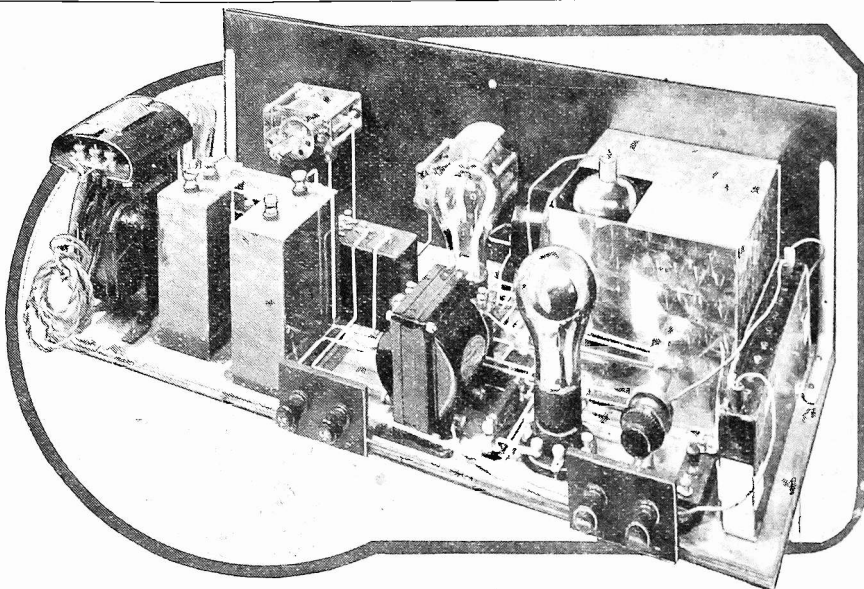

Another view of the Dynamic Three with valves and coils in position ready for use

kept closed when the receiver is "live."

Now carefully tune the centre dial (anode condenser), whilst at the same time swinging the left-hand dial

(aerial condenser) backwards and forwards through a relatively wide arc.

During this operation the vanes of the reaction can be kept out of mesh; reaction will be needed only for the reception of really distant stations.

Reducing S.G. Voltage

If there is any tendency for the set to oscillate, reduce the voltage applied to the screening grid of the high-frequency amplifier by means of the variable resistance fixed on the baseboard.

When carrying out these and similar adjustments it is the wisest policy to break the main switch. In fact, the operator should make it a strict rule never to open the lid of the cabinet without first switching off.

Should there be no tendency to self-oscillation—unwanted whistling and squealing—the voltage applied to the screening grid can be increased up to the point just before instability occurs.

Quality of Reproduction

The grid-bias applied to the detector and power valve should also be varied until the very best quality of reproduction, is obtained—remember that the Dynamic Three will give at least as good reproduction as any normal battery-operated set.

Variation of the tappings to the two anode-filter units may also be made when the operator has some

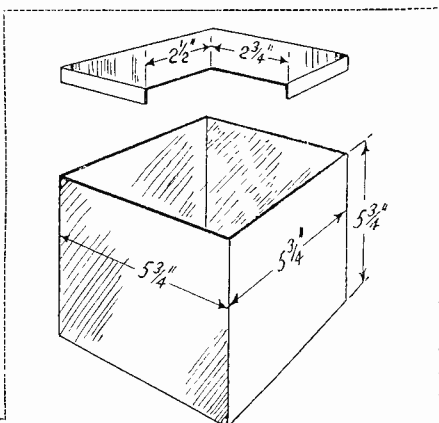

Details of the screening-box

THIS SET NEEDS ONLY ONE SMALL GRID-BATTERY — H.T. & L.T. ARE OBTAINED DIRECT FROM A.C. MAINS

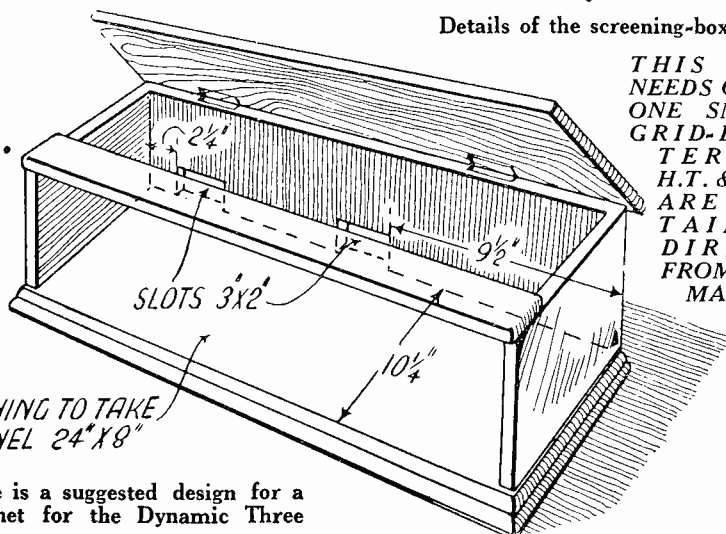

Here is a suggested design for a cabinet for the Dynamic Three

The Dynamic Three (Continued)

It's Better with a Baffle!

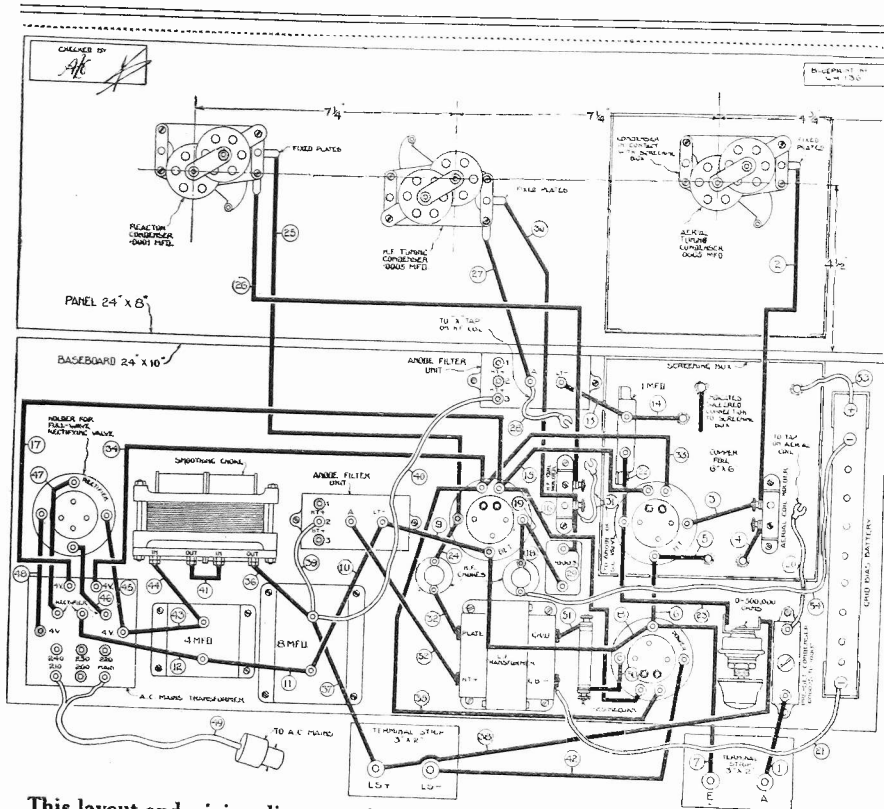

This layout and wiring diagram of the Dynamic Three can be obtained as a full-size blueprint for half-price, that is 6d. post free, if the coupon on page iii of the cover is used by April 30. Ask for No. WM 136. Wire up in numerical order.

experience of the receiver. At the beginning they can be connected as shown.

Mains Connection

One final note about the mains side of the receiver. In the blueprint and wiring diagram the mains transformer is shown connected for a 210-volt supply as that is the voltage on which the set was tested.

Ascertain the exact voltage of your supply and connect up the transfor-

mer accordingly. Connecting a 240-volt supply to the 200-volt tap means a 20 per cent. overload that may damage the valves.

And don't do what one WIRELESS MAGAZINE reader did some months ago—build a set for A.C. mains operation and then discover that it won't work because your supply is D.C.!

[A UNIT FOR SUPPLYING HIGH TENSION TO A SET FROM D.C. MAINS IS DESCRIBED ELSEWHERE IN THIS ISSUE]

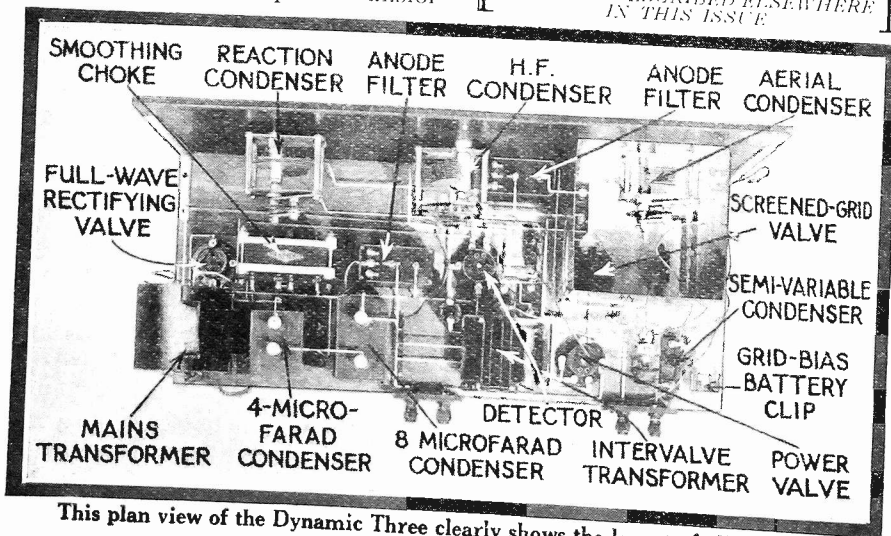

This plan view of the Dynamic Three clearly shows the layout of all the parts

LOUD-SPEAKER experts and enthusiasts woke up to the fact that a baffle brings out the low notes when they first had extensive experience of moving-coil instruments. If you read various technical descriptions you'll find that it is considered something of a crime to operate a coil-driven unit "bare," and now it is understood by most people that baffles are not the prerogative of coil drives.

Why Improvements Occur

Quite a number of ordinary cone loud-speakers, in fact, are improved if provided with a baffle. Why? Well, just consider how a cone speaker delivers sound energy.

The vibrations of the large diaphragm alternately push and pull the air on both sides, but before sound energy is transmitted the air must not be shifted as a whole surrounding unit, but must definitely be compressed and expanded. The pitch of the sound is determined by the frequency of these compressions and expansions.

At comparatively high sound frequencies, say those resulting from above middle C on the piano, the cone diaphragm has no difficulty in producing this air-moving work on both sides of the vibrating cone; but with the lower frequencies there is time for the slower-moving air compressions to expand around the edge of the cone, and in thus leaking round to the other side the air is simply transferred instead of vibrated, and there is thus a loss of the low frequencies.

Preventing Wastage

The obvious purpose of a baffle is to prevent this wastage of energy, and this it does simply by preventing the easy path of the vibrating air column from one side of the diaphragm spreading to the other side.

The argument has been put up that as the coil-drive instrument is the only one which really does give the low notes, it is the only type worth bothering about so far as baffles are concerned. This is quite wrong, for many cone-speakers give sufficiently good low-note reproduction to make it worth while fitting a baffle to prevent loss.

MAC.

When Air-Liners Talk by Radio!

You Can Understand What is Happening in the Air If You Decode Aircraft Ether Messages as Explained in This Article by W. OLIVER

THERE are two important branches of civil-aviation radio work. One is the communication between air-liners and ground stations that is maintained on 900 metres, and the other is the inter-aerodrome correspondence in wireless-telegraphy on 1,400 metres.

Telephonic Messages

The messages on 900 metres are chiefly in radio telephony, and if you have a valve set that will tune to that wavelength you are probably quite familiar with them. But it is unlikely that you have even discovered the transmissions that take place on the higher wavelength, as they are all in continuous-wave Morse, which becomes audible only when it is heterodyned, and the stations are all sharply tuned to wavelengths within a metre or two of 1,400.

It is therefore very easy to overlook their existence altogether, even when you are "searching" for broadcasting in the vicinity of that wavelength.

Most of the 1,400-metres transmissions consist of "route service" messages, relating to the arrivals and departures of commercial aircraft at the various aerodromes situated on the network of air routes which now extend over the Continent like a gigantic spiders-web, linking up all the principal cities of Europe.

Messages of Interest

If you have the requisite knowledge of the Morse code to enable you to "read" these messages, you will find them very interesting—but especially so if you happen to live near one of the air routes to the Continent and can see the actual air-liners passing overhead after hearing

full particulars about them on the wireless!

You can easily identify the various planes when you see them, as the wireless call-signs are formed from the registration marks which are painted in enormous letters on the wings and body of each machine. A glance at the diagrams accompanying this article will show you just where to look for the lettering when you see an air-liner in flight. (The letters on the wings are generally much bigger than those on the body of the machine, therefore it is best to look at the former if the machine is in a position in which they are visible).

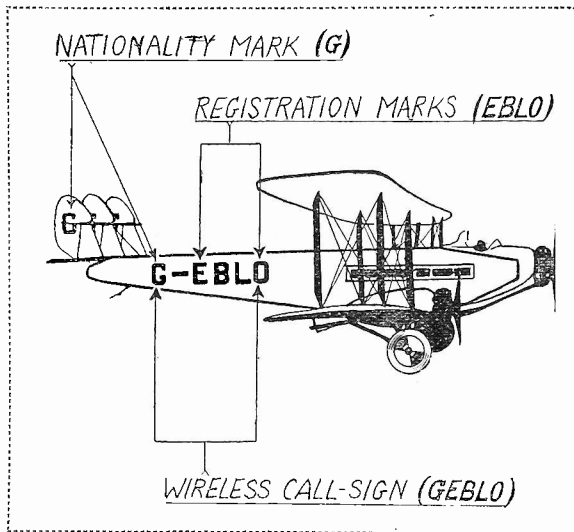

An ordinary pair of field-glasses will enable you to read the letters quite easily, unless the machine is flying at a very great height.

The registration-marks consist of four letters, which are preceded by a fifth letter indicating the nationality of the air line which owns the machine. On the plane itself the nationality mark is separated from the remainder of the letters by a hyphen, but in the wireless call-sign this is omitted. For example:

WIRELESS CALL-SIGN (GEBLO)

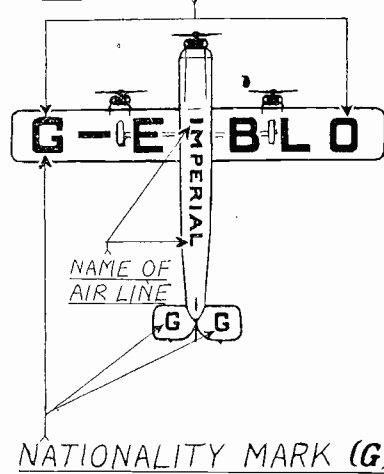

"G-EBLO" becomes "GEBLO" in wireless telegraphy.

The following is a list of nationality marks used by some of the nearer European countries whose aircraft you are likely to hear mentioned most frequently in these messages:

Nationality Marks

- Great Britain G
- France F
- Holland H, followed by N
- Belgium O, followed by B
- Switzerland C, followed by H
- Sweden S, followed by A
- Germany D, followed by numerals.

You will notice that the registration-marks used by the German aircraft are an exception to the rule of four-letter combinations, as they consist of a number, preceded by the letter D (for Deutschland).

Now, suppose you tune in to 1,400 metres, adjust the reaction control carefully so that the set is just over the oscillation point (in order to heterodyne the incoming signals, thereby making them audible in your phones), and move the condenser knob to and fro a little in order to cover the wavelengths a few metres above and below 1,400, what will you hear? Probably something of this description:

Sample Message

"FNB de GFK nr 5 w 20 1235—GEBLF Smith d 1230 17 pp 1355 lbs bag and fret . . . FAECU Deso-andso d 1234 10 pp 376 lbs bag . . ."

Although that imaginary example will serve to give you some idea of

When Air-Liners Talk by Radio! (Continued)

the kind of thing you may expect to hear, I think you will agree that it needs some explanation to make it intelligible! Well, the meaning of the messages would be as follows:

"To FNB, Le Bourget Aerodrome, from GFK, Croydon Radio. Message number 5, number of words in message 20, time 12.35 G.M.T. The Imperial Air liner G-EBLF, piloted by Mr. Smith, departed for your aerodrome (Le Bourget, Paris) from here (Air Port of London) at 12.30 with 17 passengers and 1,355 lbs. of baggage and freight. The French Air Union plane, F-AECU, piloted by M. Desoandso, followed at 12.34 with 10 passengers and 376 lbs. of baggage. End of message," (indicated by finishing signal, "AR" in morse).

Composition of Message

So you see the "departure" messages generally consist of the following: firstly, the call-sign of the station to which the message is addressed, the letters "de" or "v" and the call-sign of the station that is transmitting the message; then "nr," short for "number," followed by the number of the message—in the above example, "5" indicating that this was the fifth message sent from London to Paris that day; "w," short for "words," followed by numerals giving the number of words contained in the message; and four figures indicating (on the 24-hour dial method) the time at which the message was handed in.

This preamble is followed by the "break sign," (— . . —) and then comes the message proper, commencing with the call-sign of the air liner; the name of the pilot is given next, then "d," short for "departed," with four figures giving the time of departure; the number of passengers on board (abbreviated to "p" for passenger and "pp" for "passengers"); the weight of the load in pounds ("lbs") followed by an indication of the nature of the load, that is, "bag," short for "baggage," "fret," short for "freight," or "po" short for "post" or mail. Finally, there comes the finishing signal, "AR," and the invitation to transmit reply, "K."

You will find that, in the case of messages from the Continental stations, the nature of the load is

generally indicated before, instead of after, the weight, and the latter is expressed in kilogrammes (abbreviated to "k"), thus:

"GFK v FNB Nr 2 w 12 1237—GEBMM Brown d 1230 12 pp bag 259 k fret 152 k AR K."

When the air-liner mentioned in a message is bound for an aerodrome other than that to which the message

WITH THE CLIPPER TWO, DESCRIBED IN THIS ISSUE, YOU WILL BE ABLE TO PICK UP ALL THE AIRCRAFT MESSAGES DISCUSSED IN THIS ARTICLE.

is addressed (or when part of the passengers and load are to be landed at a destination *en route*), this fact is indicated in the message, as you will see from the following example:

"FNI v FNG Nr 2 w 6 1236 GMT —GEBZJ Robinson d pour Berck 1235 AR K," meaning, "à FNI, Abbeville, de FNG, St. Ingelvert, No. 2, etc., G-EBZJ, pilote Robinson, parti à 12 h. 35 pour Berck" ("G-EBZJ left here at 12.35 p.m., bound for Berck.") Various abbreviations, such as "Ps" meaning Paris and "Am" meaning Amsterdam, are often used in indicating the destination of aircraft.

So much for the departures. The messages notifying the safe arrival of the air-liners at the aerodromes for which they were bound are shorter and simpler, generally something after this fashion:—

"ONN v GFK Nr II w 3 1147—OBAHG a 1147 . . . ONN v GFK Nr 12 w 3 1200—HNAEH a 1200 AR . . . — . AEK v GFK Nr 5 w 3 1217 — D356 a 1217 AR K."

What It All Means

The meaning of this is as follows: "To ONN, of Ostend from GFK, Croydon; No II, etc., the Belgian Sabena machine, O-BAHG, arrived at its destination at 11.47 a.m. The Dutch K.L.M. Air Liner, H-NAEH, arrived at 12 noon; end of messages to you. To AEK, Cologne, from GFK, Croydon, No. 5, etc. The German Luft Hansa plane, D356, arrived at 12.17 p.m."

All these route service messages are acknowledged by the stations to which they are addressed. The last of the examples given above, for instance, would be acknowledged by Cologne thus:

"GFK v AEK R Nr 5 R Nr 5 AR," meaning: "I have received your message, No. 5," the abbreviation "R" being short for "received."

If you hear a message giving the time of departure of a machine from a certain aerodrome, and also the subsequent message giving the time of arrival of the plane at its destination, you can not only see at a glance just how long the flight has taken, but, given this information, you can measure the distance between the two places on a map, and calculate approximately the average speed of the machine.

Aerodrome Call Signs

When the names of the aerodromes between which the machine is flying are not specified in the "departure" message, that indicates that it has departed from the aerodrome that is transmitting the message, and is bound for the aerodrome to which the message is addressed. As the call-signs of the two aerodromes in question are given at the beginning of the message, you can easily ascertain the names of the aerodromes by looking them up in a list.

It is very interesting to take down the departure message in morse on 1,400 metres, giving full particulars of an outward-bound air-liner, and then to tune in at once to 900 metres, and listen to the messages in telephony (or, in the case of German machines, in C.W. morse) from the pilot, reporting his position as he passes over various landmarks *en route*.

These reports are checked back (repeated word for word) by the operator at the ground station to which they are sent.

By listening to these messages, and finding on a map the places mentioned, you can follow the progress of the aeroplane throughout its flight, and then finally you can, if you like, tune back to 1,400 metres again, and pick up the arrival message in morse, stating the time at which the machine reached its destination.

Use this wonderful NEW **Cossor Transformer**



It has a marvellous performance on all notes from the highest to the lowest



Improve the tone of your Receiver—use the wonderful Cossor Transformer and hear the sonorous double-bass—hear the piping clarinet—hear all the notes from top to bottom of the musical scale reproduced with amazing fidelity. The superb reproduction of the famous Cossor Melody Maker is largely due to its Cossor Transformer. The Cossor Transformer will give your Set a better tone than it has ever had before. See one at your Dealer's.

Price 21/-

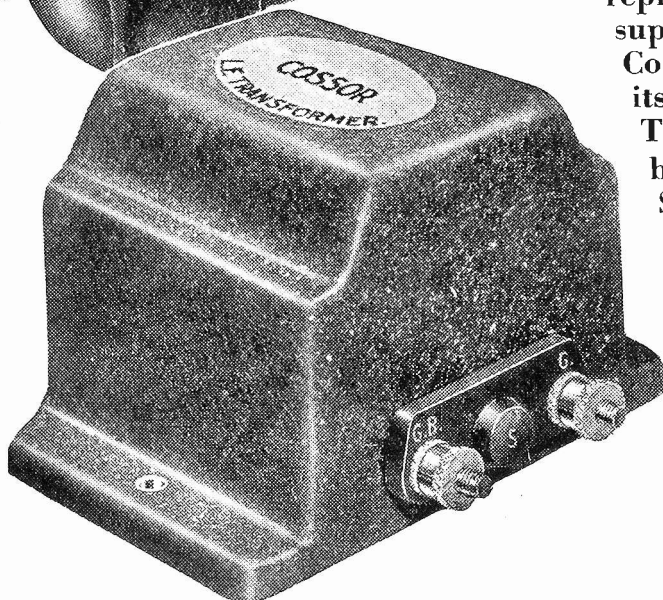

FREE! Double your Radio enjoyment—get the Cossor Broadcasting Map. It gives positions, wave-lengths and dial readings of 200 European stations. And it tells you how to identify them too! Write for it at once, enclose 2d. stamp to cover postage.

Send at once

Half Hours with the Professor



Amp Solves the Tuning Problem

THE door of the laboratory opened almost noiselessly and young Amp crept in, followed by a stranger who stood, cap in hand, looking round with awe. Megohm looked up from his work and, seeing Amp there, started in surprise.

"Why, whatever is the matter, Amp?" he exclaimed. "Are you just recovering from 'flu, or what?"

"I don't quite get you," stammered the boy.

"Well, I never heard you come in, and usually everyone for miles round is aware of your entry."

In Search of Enlightenment

Amp grinned, feeling at once more at home. Truth to tell he had been a little nervous, because he had brought with him a friend who was anxious to obtain enlightenment on certain wireless matters.

"Er—this is Mr. Plarz, who is making some alterations to our electric wiring for us."

Megohm nodded. "I see. So you thought you would like to bring him over here to see what a delightful muddle professors can get in when they really start?"

Amp and the newcomer both laughed. "No, not exactly," replied the boy. "'S'matter of fact, Mr. Plarz is frightfully interested in wireless and we got talking about it, but we got rather tied up over one or two points."

"I see," Megohm said, encouragingly. "Well—"

All Open Circuits

"Well," continued the lad, "you see, we were talking about tuning and I drew out a simple wireless circuit to try and explain what I meant and Mr. Plarz said he never could understand wireless diagrams, anyhow, because they were all open circuits."

"That's right," chipped in Mr. Plarz, speaking for the first time, "they're all open circuits to me. Don't go anywhere."

Megohm smiled. "You mean the circuits appear incomplete. Quite

right, so they do. But I have no doubt, however, that young Amp here successfully got you out of your difficulty?"

The boy looked rather crestfallen. "Well, er—no. I—I had not looked at the matter in that light before and I did not quite see the way out of the difficulty. And then," he rambled on hurriedly, "there was another nasty one that he put to me. If you have an aerial—"

"Wait a minute," broke in the Professor, "let us get to the bottom of one difficulty first; we can then come on to your other problem later on. Now," he added, turning to the wireman, who was standing there, drinking it all in, "I take it you are familiar with the ordinary ideas of

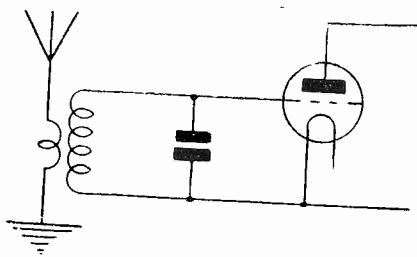

Fig. 1.—Amp's explanatory circuit

alternating-current circuits. I mean you understand that if two coils are placed together, one of which carries an alternating current, a similar alternating current will be set up in the next coil."

"Yes, I understand that all right," was the reply.

"And, of course," continued Megohm, "you are familiar with the ordinary ideas of circuits, but you are rather puzzled by the apparent lack of completion. I can quite understand that. Now," he added, turning to the boy, "let's have a look at this circuit which you drew."

Amp delved in his pocket and produced a once resplendent notebook, which he opened and proudly displayed to the Professor. "There," he remarked, "quite a simple, straightforward circuit, you know." The

Professor perused the circuit, which is reproduced in Fig. 1, and then said, "Yes. Well, now, let us start in the middle."

"The middle?" echoed Amp.

Assuming an Oscillating Current

"Why, yes. Have you never done that before? It is often quite a useful proceeding. Here I suggest that we assume an oscillating current in the aerial circuit without worrying for the moment how it has got there. This will induce currents in the secondary coil coupled to it just like an ordinary power transformer. That, I take it, is quite straightforward, Mr. Plarz?"

"I guess I can see that all right, Professor, but then it looks to me as if the transformer was an open circuit."

"What have you got to say to that, Amp?" queried Megohm.

Amp looked up in surprise, but seeing that the Professor was in earnest he scratched his head. "Well," he said, "of course, there's the condenser across the circuit. I mean the coil and the condenser form the circuit by themselves."

"Well," broke in Mr. Plarz, "I can't see that quite. A condenser, as I see it, will store voltage, but I don't see how you can have a circuit through it."

Megohm looked at Amp, but seeing that no explanation was forthcoming he proceeded to elucidate the point himself.

Charging a Condenser

"A condenser certainly offers no circuit to direct currents," he said. "Suppose we apply a voltage to the condenser, however. The condenser will charge up, but, as you probably know, it will not reach its full charge at once, but will take a certain amount of time to do it. Actually, it will charge up something like this."

(Continued on page 272)

STOP BUYING POWER

YOU CAN'T USE!

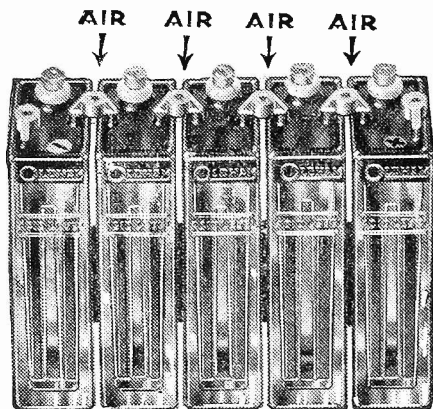

OLDHAM Air-spaced H.T. Accumulators have full rated capacity.

They give you all that you pay for. Air-spaced cell construction ends electrical leakage and waste.

OLDHAM H.T. ACCUMULATOR

Extra large Capacity
[5,500 milliamps]
Per 10-volt Unit

6/9

Complete with two plugs and length of connecting cable.

Standard 10-volt Unit
Capacity 2,750 milliamps

5/6

Wooden trays extra if required. Ask your wireless dealer to show them to you.

If you own a leaky, old-type monobloc H.T. Accumulator you are paying for current you can't use. When you get it back from the charging station it is fully charged. But it may not hold that charge for long. Electrical leakage starts immediately. All along its unbroken top, current creeps from cell to cell—current for which you have already paid. And this waste may go on all the time—even when the Accumulator is idle. Electrical leakage is definitely prevented in Oldham H.T. Accumulators. Look at the illustration. See the air gaps between each cell. Air is one of the finest insulators known. These air gaps form an impassable barrier to electrical leakage. Waste cannot take place. Oldham Air-spaced H.T. Accumulators hold their current—because that current cannot leak away. They store up all the power put into them when they are charged. And because they do this they do not need frequent recharging. Send at once for the latest booklet which fully describes Oldham Air-spaced H.T. Accumulators—it will be sent you post free.

Stop wasting power—use . . .

OLDHAM

H.T. ACCUMULATORS

Charge your H.T. Accumulator at home!

If you have electric light you can charge your H.T. Accumulator at home with the Oldham H.T. Charger. It is simple, efficient, has no moving parts—nothing to wear out—nothing to go wrong. See it at your dealer's.

OLDHAM H.T. CHARGER
A.C. Type 55/- D.C. Type 40/-

Oldham & Sons, Ltd., Denton, Manchester.
Telephone: Denton 301 (4 lines).

London Office: 40, Wicklow Street, King's Cross, W.C.1.
Telephone: Terminus 4446 (3 lines).

Glasgow: 200, St. Vincent Street
Telephone: Central 4015.



Half Hours with the Professor (Continued)

Here Megohm drew the curve shown in Fig. 2. "Is that clear?"

Both his listeners nodded.

"Now," he resumed, "suppose we apply an alternating voltage to the condenser—that is to say, a voltage which is continually varying from a maximum in one direction to a maximum in the other direction—and we start with no charge in the condenser and consider the voltage suddenly switched on to its maximum value.

Discharging the Condenser

"The condenser will immediately begin to charge up and the whole of the time that the voltage is falling from its maximum to zero the condenser will continue to charge. Beyond the zero point, however, the voltage will be reversed and we shall tend to discharge the condenser."

"Thus the whole of the time that the voltage is negative the condenser will discharge and will charge up in the opposite direction. During the next voltage cycle, a similar state of affairs will take place, so that we have the condenser charging, discharging, and recharging in the opposite direction continually in a similar manner to a fluctuation in the voltage applied to it."

Amp Sees Light

"But," broke in Amp, "surely a succession of charges and discharges like that will constitute a current?"

"Exactly," said Megohm, "that is the point I am driving at. As long as we are applying an alternating voltage across the condenser we shall have an alternating current flowing through it."

A look of enlightenment gradually spread over the wireman's face. "Ah," he said at length, "I begin to see now; but then," he objected, as he turned it over in his mind, "if I were to connect a tiddley condenser like we use in wireless across my mains it wouldn't make any difference at all."

Importance of Frequency

Megohm looked at Amp. "Well, my boy," he said, "what do you say to that?"

"Oh," exclaimed Amp, cheerfully, "that's because of the frequency."

"And there you are, Mr. Plarz,"

said Megohm, gravely. "Now you know all about it."

"I'm blown if I do," was the reply. "My frequency's 50 cycles, but what's that got to do with it?"

"Oh, but it's got everything to do with it," cried Amp, warming to his subject. "The current flowing through a condenser depends upon the frequency at which you charge and discharge it. I mean, the more rapidly you charge and discharge a condenser, the greater the current,

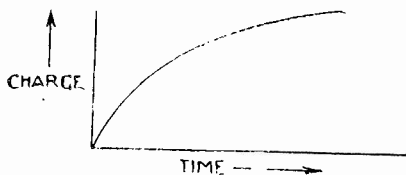

Fig. 2.—Illustrating build-up on a condenser

that's obvious, isn't it?" he added, ingenuously, appealing to the Professor.

Megohm, however, said nothing, seeing which Amp continued. "In wireless we use frequencies of a million a second or more."

"A million a second!" echoed his astonished friend. "How on earth do you get that?"

"Oh," continued Amp, "by resonance."

"Resonance," echoed the other.

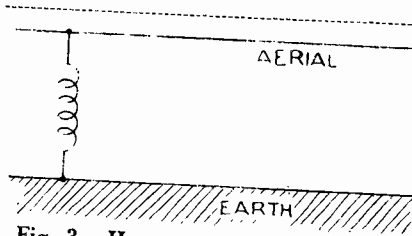

Fig. 3.—How an aerial acts as plate of a condenser

"All I know about resonance is that you mustn't leave a synchronous motor connected to a line when the power is cut off."

It was Amp's turn to look astonished.

"I think you had better explain that, Mr. Plarz," broke in Megohm gently. "Our young friend here has just discovered something he does not know."

"You bet, it's all Greek to me," said Amp cheerfully, ignoring the Professor's thrust.

"Well," said the other, scratching his head, "explaining is not much in my line, but if you have a synchronous motor running it generates a frequency proportional to the speed. If you shut it down and let the motor run down to rest, the frequency falls gradually to nothing.

Possible Damage

"All that I know is that if you leave it running and connected to a long cable, you find that at some frequency on the way down you probably get resonance between the inductance and capacity of the cable which does a devil of a lot of damage."

Amp listened in amazement. Here was something outside his ken altogether. Megohm, however, seized on the point at once. "Yes," he said, "that is a well-known phenomenon to power engineers, the reason for the damage being the high voltages which are produced."

"Why?" asked Amp.

An Oscillating Circuit

"You ought to know why," replied the Professor severely. "The system constitutes an oscillating circuit containing inductance and capacity in series. The capacity is charged up and then discharges through the inductance; the inductance, however, will not let the current die away at once, but keeps it flowing so that the condenser charges in the opposite direction. A similar discharge then takes place and the condenser continues to charge and discharge on its own account."

"An ordinary oscillating circuit, in fact," interjected Amp.

"Exactly," said Megohm, "the current oscillating at the natural frequency of the system as determined by the values of inductance and capacity."

What Resonance Really Is

"By itself, this effect would soon die away, but if the frequency at which these discharges take place happens to correspond with the frequency of the supply current, then, instead of dying away, the effect builds up and we obtain very large voltages in the system. That is what is known as resonance."

"You mean when the natural frequency of the system coincides with

(Continued on page 274)

THIS CURVE TELLS THE TRUTH ABOUT THE TRANSFORMER THAT TELLS THE TRUTH

THIS National Physical Laboratory Curve tells the truth about the Brown L.F. Transformer. It proves beyond all words, that the Brown evenly amplifies every note throughout the whole harmonic scale. Treble and bass—the delicate strains of the violin and the deep notes of the bassoon—the Brown gives you them all distinct and clear, yet each in its proper place and at its correct strength. In short the Brown Transformer tells the truth about the broadcast. The secret is in its special alloy core and its unique method of winding. Ratio 3.5 to 1. Ask your dealer for further particulars.

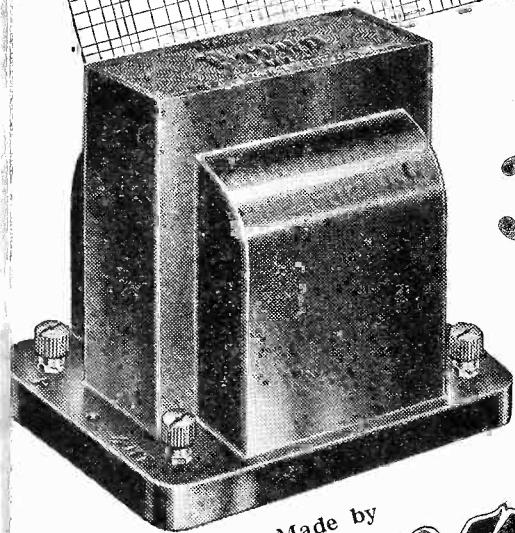
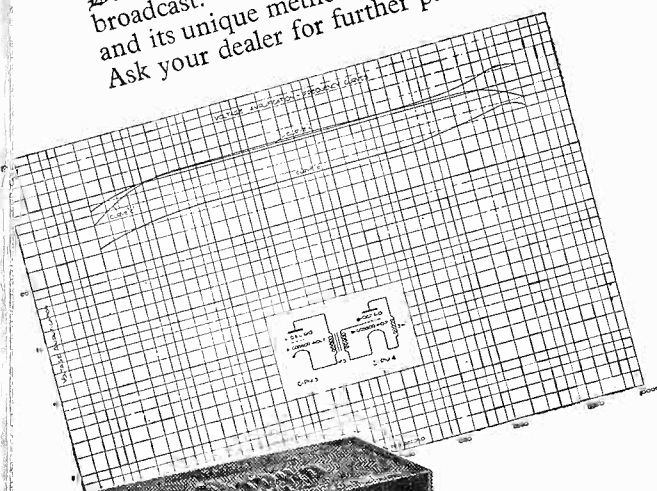

PRICE 30/-

Made by

Brown
of Loud Speaker Fame

G. BROWN, LTD., Western Avenue, North Acton, London, W.3.

7268

BEST WAY TO ALL STATIONS

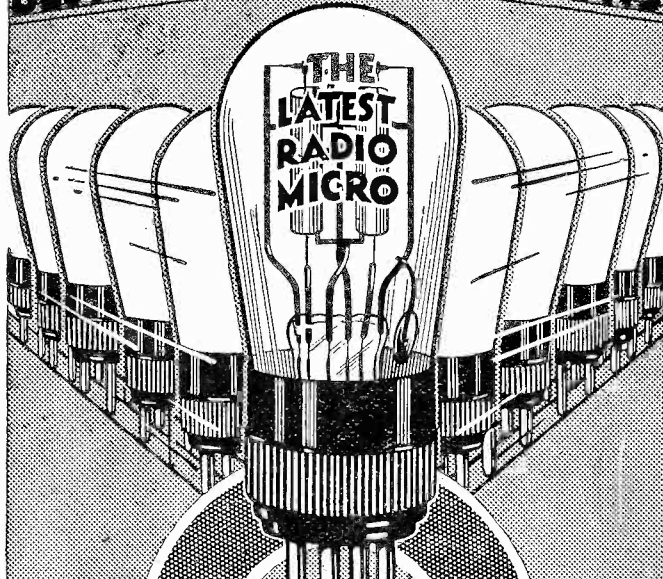

DARIO

VALVES

—AND THE CHEAPEST WAY, TOO,

guaranteeing utmost satisfaction. Just look at the prices below—made possible by reason of the biggest valve output in the world. Radio without Dario can never be radio at its best.

SUPERLATIVE FINISH—LOWEST CONSUMPTION

TWO VOLTS		FOUR VOLTS	
General Purpose, .05 amp.	5/6	General Purpose, .05 amp.	5/6
R.C.C., .06 amp.	5/6	R.C.C., .07 amp.	5/6
Super-Power, .18 amp.	7/6	Super-Power, .1 amp.	7/6
Super H.F. & R.C.C. .18 amp.	7/6	Super H.F. & R.C.C. .1 amp.	7/6
Pentodion, .15 amp.	21/-	Pentodion, .15 amp.	21/-

From your dealer or direct:

IMPEX ELECTRICAL, LTD.

Dept. B.

5/6

538, High Road,

Leytonstone,

E.11.

7/6

Half Hours with the Professor (Continued)

the supply system," said Mr. Plarz. "That is quite in my line; I mean, I can understand that."

"Well," said Megohm, "the circuit you have here is exactly the same arrangement, but the supply frequency here is that of the energy received on the aerial, which is one million per second, and the inductance and capacity values are very much smaller than you ever deal with in your work in order to resonate at this extremely high frequency."

"Then you actually want resonance, do you?"

Building Up Voltage

"Certainly. The energy received is so very small that we must make use of resonance to build up the voltage to a measurable amount. We deliberately encourage resonance in a wireless circuit by making the resistance of the circuit as low as possible so that the voltage built up on the circuit at resonance is many hundreds of times greater than the supply voltage originally received.

"This voltage we apply to our amplifying or detecting arrangement. Here you see we apply the voltage developed across the condenser to the grid and filament of a valve, which is only a sensitive relay receiving energy at one end and paying out a greatly increased quantity of energy at the other end."

"Well," said the wireman, "I must admit that the whole thing seems rather simpler if you look at it in that light. It never occurred to me that it was the same sort of thing as ordinary electrical practice."

"That is quite a common fallacy. As a matter of fact, the two forms of engineering are essentially the same, the only difference being in the frequency. Effects which are utterly negligible at power frequencies become of great importance in radio frequencies and vice versa. And now," he continued, turning to Amp, "I imagine you will be able to put your friend right on any further problems which arise."

"Yes, I expect so, Professor," was the reply, "but, oh," he broke off, "there is one point, though, I was going to tell you about before."

"What is that?"

"Well, the aerial we use for receiving makes up two plates of a con-

denser, doesn't it, the earth being one and the aerial being the other?"

Megohm nodded.

"Well, Mr. Plarz says that you put up your condenser and then you proceed to short-circuit it by connecting it to earth. I mean, here are the two plates of the condenser (drawing the diagram shown in Fig. 3) and here we connect it to earth—oh—of course, how stupid of me."

Megohm watched the boy with a twinkle. "What's the matter now?" he queried.

"Well, 't isn't short-circuited at all, it's simply connected through the inductance, isn't it?"

Megohm again nodded. "What you have there is an exactly similar circuit to the original oscillatory circuit which we discussed. In this case, however, the voltage instead of being induced by a transformer action from one coil to another actually appears in the form of a charge on the condenser.

"The condenser, being of an elevated nature, collects energy from the wireless waves and is therefore being continually charged and discharged by the wireless waves themselves. This is the voltage which is produced in the circuit, and if we tune the arrangement to resonance we shall obtain, as we have seen, a relatively large voltage."

"What sort of voltages do we get, then, in practice?"

Signal Strength from 2LO

"The signal strength from 2LO at a distance of about six miles on an average 100-ft. aerial is of the order of 50 millivolts. This may be amplified a hundred times by resonance, so that the actual voltage applied to the grid of the first valve is of the order of half a volt."

Neither of the visitors spoke for some time, thinking over all that had been said. Finally Amp said, "Well, Professor, thanks most awfully for this talk. I thought I knew quite a lot about wireless until this gentleman here started asking me questions."

"I expect," answered Megohm, "that his questions will teach you more about wireless than anything I have been able to tell you yet. So run away and get him to question you some more."

Japan's Pirate Listeners

THE radio broadcasting stations in Japan, especially JOAK, in Tokio, and JOBK, in Osaka, are surprised at the imposing number of unlicensed listeners-in.

The Tokio and Osaka broadcasting stations roughly estimate the number of these "freebooters of the air" to be about 150,000 and 60,000 respectively. It is considered that these "fee dodgers" throughout the country will amount to more than 500,000. The control of these persons is the problem that is taxing the brains of each station's officials.

The JOBK station has for some time been making every effort to discover the unlicensed listeners-in, and persuade them to be officially enrolled. As the result of this, a radical increase of filing applications has been seen recently and about 400 applications daily pour in 700 offices in charge of receiving them in Osaka.

Thus the total number of the listeners-in of the JOBK up to September amounted to more than 118,000. JOBK is now expecting that the number will amount to 150,000 by the end of this autumn.

It is alleged, in some quarters, that the way the broadcasting stations try to discover the unlicensed listeners-in is too strict, or rather intruding. These people declare that the inspectors attached to the stations intrude into many a home without notice to investigate if it has a radio set without a licence.

The reason of this, it is said, is that each station gives some "encouragement money" to the inspectors when they discover an unlicensed listener-in, and naturally they become over zealous.

In this connection, Director Hiroe, of JOBK, has the following to say: "We are astounded at the large number of unlicensed listeners-in. At present, our way of controlling them is quite reasonable, I think. If, however, an inspector resorts to some unreasonable act, we will not be slow to take the proper measure.

"The 'encouragement money' in question, though it is criticised in some quarters, cannot be helped. We pay it simply because it promotes business efficiency."

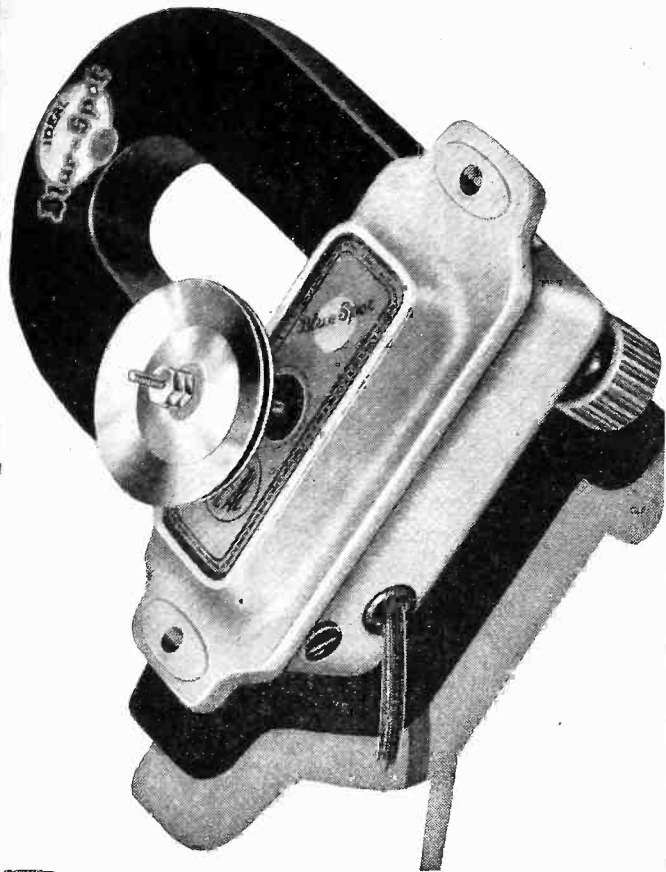

BLUE SPOT 66K UNIT 25/-

Here is the wonderful loud-speaker unit that gives such amazing results. It is a completely discharged 4-pole magnet with adjustable reed and is capable of handling any output without any trace of distortion. Why not make-up a speaker of your own using the famous Blue Spot 66K Unit. Full instructions are given with each unit. Obtainable at all leading wireless retailers. Price 25/-

F. A. HUGHES & CO., LIMITED
204-6, GREAT PORTLAND STREET, LONDON, W.1

Distributors for Northern England, Scotland and North Wales:
H. C. RAWSON (SHEFFIELD & LONDON) LTD., 100, LONDON ROAD, SHEFFIELD; 185, PRINCESS STREET, MANCHESTER.

Ideal Blue Spot Cone Speakers are sold under full protection of the patents owned by Standard Telephones and Cables and the Hopkins and Lektophone Corporations.

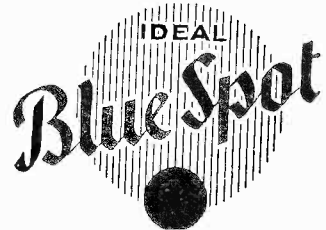

Make certain of your set's success

*Build it with
Lotus Components*

Every Lotus Component you use is to be depended upon as a sound, well constructed unit, for it has been made from the best available materials and by careful British workmen, and has been examined and tested thoroughly before it comes to you. Your usual dealer sells Lotus Components.

Lotus Buoyancy Valve Holders, Anti-Microphonic, 1/3; Lotus Variable Condensers from 5/-; Lotus Vernier Dial, 4/9; Lotus Drum Dials; Remote Controls, Jacks, Switches, Plugs, etc.

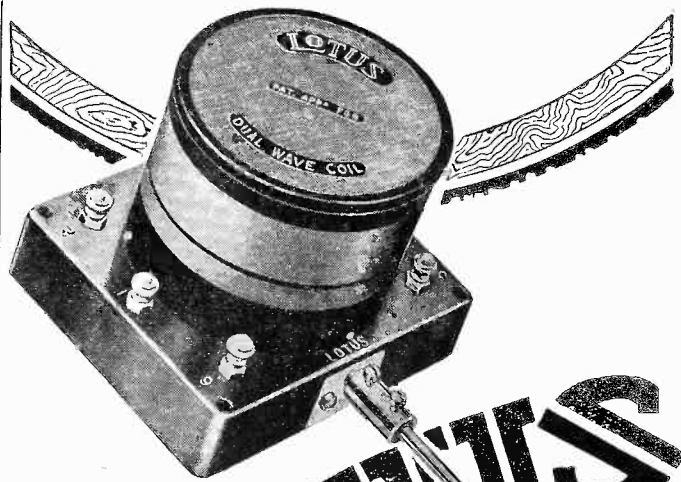

LOTUS COMPONENTS

*Lotus Dual Wave Coils,
15/-, 16/6, 21/-.*

Garnett Whiteley & Co., Ltd., Broadgreen Rd., Liverpool

Caution.

BROADCAST MUSIC OF THE MONTH

Reviewed by **STUDIUS**



Leonard Gowings



Jeanne Chevreau, harpist of the B.N.O.C. (above)

At first sight, the high-brows would be said to have had all their own way this month, from February 1 when the National Symphony Concert at Queens Hall was mainly devoted to Berlioz' work *The Damnation of Faust*, conducted by Sir Hamilton Harty with his Hallé Orchestra.

Cast Above Reproach

The names of the cast, however, were above reproach, for they included Lilian Stiles Allen, Tudor Davies, Harold Williams, and Herbert Simmonds. As compared with the music of Gounod's *Faust* there is nothing to be said, but the music of Berlioz is at times impressive, and given adequate orchestral and choral interpretation, makes interesting hearing.

The concerts on February 15 and February 23 announced as conductors Albert Wolff, Director of the Opera Comique and the Lamoureux Concert of Paris, and Sir Henry Wood. A great feature of the first-named programme was the inclusion of Delius' pianoforte Concerto in G, with Katherine Goodson as solo pianist, and the famous Prelude to Act 2 of *The Wreckers* (Ethel Smyth).

No Cause for Complaint

An equally famous pianist announced for 5GB on February 23 was Johanne Stockmarr in the Pianoforte Concerto No. 2 of Brahms. With the Hallé Concert also relayed to 5GB on February 14, performing *The Flying Dutchman*, and the performance of an abundance of Chamber music, lovers of the classics have had no cause for complaint.



Juliette McLean, soprano

Very welcome to the great body of listeners have been the bands and orchestras giving us a little lighter fare.

The arrangement of the dance orchestras has given us substitutes for the famous Savoy Hotel orchestra—many other equally well-known bodies of players.

Naturally, the orchestra under Emilio Colombo at the Hotel Victoria comes first to mind, with those of Moschetto, Albert Sandler, Rene Tapponnier, Ciro's Club, Piccadilly Players, Abe Lyman, Jay Whidden, Jack Hylton, and Marius B. Winter, the last, one of the first dance bands

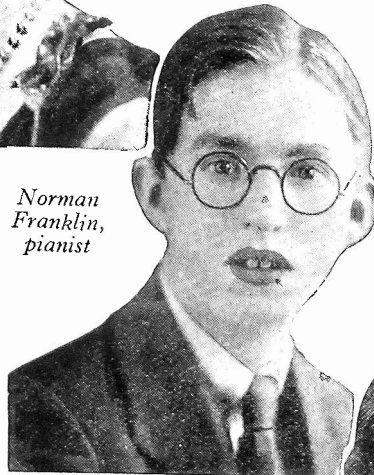

Norman Franklin, pianist



Muriel Childe, mezzo-soprano

to broadcast from Marconi House. Then Paul Raffman, a new-comer to wireless concerts, but the leader of a very picked body of players.

One would like to draw attention also to the excellent performances of Callender's Band, a group of amateurs admirably conducted by Tom Morgan, who has had a long professional experience, and who adjudicated for the Brass Band Contest, Nov. 20.

World-famous Artists as Soloists

This month has seen the appearance of world-famous artists, as soloists. The B.B.C. is certainly doing one piece of good work, and that is to convince the general public that the violin is a melody making instrument and not one for merely fiddling at dances.

In the hands of such masters as Albert Sammons, Emilio Colombo, Louis Godowski, and a few others, the pure singing quality of tone raises it to be King of Instruments.

Albert Sammons, besides being a noted soloist, was the founder-leader of the London String Quartet, one of the earliest and most noted of all chamber music players. Godowski from a "child prodigy" has attained rank as soloist, on the
(Continued on page 278)

We make it

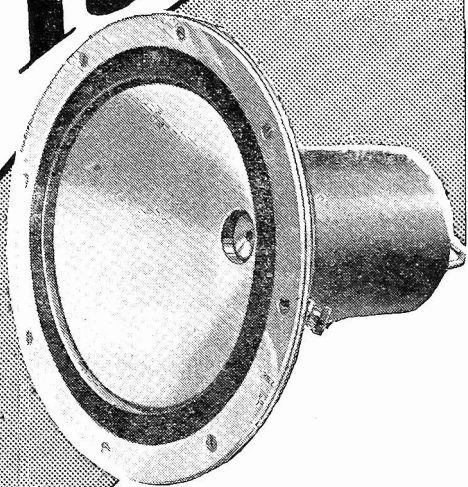

exactly to
Mr. W. James'
specification

Whiteley Boneham & Co., Ltd., are the sole makers of Mr. James' remarkable new Moving-coil Loud-speaker, specially designed for "Wireless Magazine." The aluminium moving coil incorporated in "The Lodestone" is a novel feature in Loud-speaker design that needs wonderfully careful manufacture. Another notable feature is the very low current consumption of 0.5 Amp. The Lodestone is sold as a kit of parts for £4:4:0, and can be assembled with perfect ease by anyone.

Demonstrations given daily at 21, Bartlett's Buildings, Holborn Circus, E.C.1. Literature from here or Nottingham Road, Mansfield, Notts.

WHITELEY BONEHAM & Co. Ltd.,
 Nottingham Road, Mansfield, Notts.

Miles ahead of any other Transformer at the price



Because it can be relied on to give really good results under all conditions this R. I. and Varley General Purpose Transformer is one of the most popular in this country to-day. It is far and away the best transformer at its price. It costs only 15/-, yet it ensures practically uniform amplification at all audible frequencies.

R. I. and Varley
 General Purpose
 Transformer

15/-

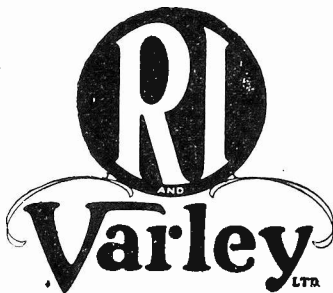

THE MARK OF BETTER RADIO

Kingsway House, 103 Kingsway, London, W.C.2.
 Telephone; Holborn 5303.

Broadcast Music of the Month (Continued)



Paul Raffman, conductor of his own orchestra



Doris Sylvia Price, of the Cardiff station

classical platform, making a welcome re-appearance at Wigmore Hall late last month, as well as broadcasting again on the 11th. His tone is full and warm, possessing a singing quality that makes his playing of especial value over the ether.

Some excellent work also has been heard from Frank Cantrell, the leader and deputy conductor of the Birmingham orchestra; Wynn Reeves, Kneale Kelley, Maud Gold, one of the few violinists whose playing records well, as witnessed by her Brunswick records; Harold Fairhurst, Pierre Fol and David Wise.

Pianoforte Exponents

The piano, often termed the "national instrument of Britain," has had its fair share of exponents. The big names which literally jump to notice are Solomon, Pouishnoff, Arthur Rubinstein, the last one of the first of the classical pianists to introduce the works of the American composer MacDowell, Irene Scharrer, Johanne Stockmarr and Katherine Goodson, while others include Una Truman, Norman Franklin, a clever young Bournemouth soloist, and Angus Morrison, also an early broadcaster.

Pianist and Composer, Too

For lighter work at the piano mention must be made of Toni Farrell, who is also the composer of many well-known songs.

The 'cello has had clever exponents in the hands of Carl Fuchs of Manches-

ter. Seth Lancaster, a clever provincial soloist, while of more unusual instruments, the harpsichord was played recently by Mdme. Wanda Landowska, and the harp by Jeanne Chevreau, the harpist of the B.N.O.C. and a noted Parisienne player.

In the vocal art, of course, the number of singers becomes legion.

For choice one must distinguish the operatic singers, for their delivery and diction make them ideal broadcasters.

This month, listeners have been fortunate, for they have had opportunities not only of hearing the two great English operatic companies, the B.N.O.C. and the Carl Rosa Company, while on

as Dora Labbette and Ben Davies.

Many other artists have been heard to advantage, including Dorothy King, a capital soprano; Colleen Clifford, the well-known actress and singer; Mildred Forster, Alice Fettes, a soprano and member of the Radio Players and Station Choir at Aberdeen, Muriel Childes, a mezzo-soprano, Doris Price, Juliette McLean, also a member of the Aberdeen Radio Players, Jenny Wynne, and John Rorke, a fine baritone. For concerted music, the Harmonic Singers have featured well.

Variety Features

This is probably the most popular item of each programme, and apart from the preponderance of synco-pated work, the programmes have been fairly diverse. A popular feature is the relay from the two big variety halls, the Alhambra and Palladium, with the addition of the Coliseum.

On the personal side, at the studio the Roosters are always sure of a welcome, and their appearance this month came from Kingsway Hall on March 9, when they had the support of Alice Lilley, Allan Brown, Grace Ivell and Vivian Worth, with Barrington Hooper as vocalist.

Artists of the month have included Norah Blaney and Ronald Frankau, Mario di Pietro, Wish Wynne, Dora Maughan and Walter Fehl, with Herman Darewski for a special programme.

With a few judicious "cuts" made in the list of heavy plays and operas, even despite a plethora of talks, there is much improvement shown.

TELL YOUR FRIENDS ABOUT THE CLIPPER TWO—FULLY DESCRIBED ON PAGE 211

tour at Bradford and Glasgow, but also the singers themselves in the studio and concert hall.

Helen Ogilvie played the part of Marguerite in the first relay of the Carl Rosa Company some months ago, and is heard again in various rôles during the tour. George Baker is another well-known operatic and concert hall vocalist.

Very popular broadcasters are Leonard Gowings, one of our finest of tenors, Arthur Fear, Rosa Alba, who made her first appearance in England at a Promenade Concert at Queens Hall. The special concert at Newcastle City Hall on March 9 engaged the services of such artists



Colleen Clifford, comedienne



Dorothy King, soprano

BUILD IT YOURSELF
 THE GRAMOPHONE THAT GIVES THE
 PARTICULAR TONE YOU DESIRE

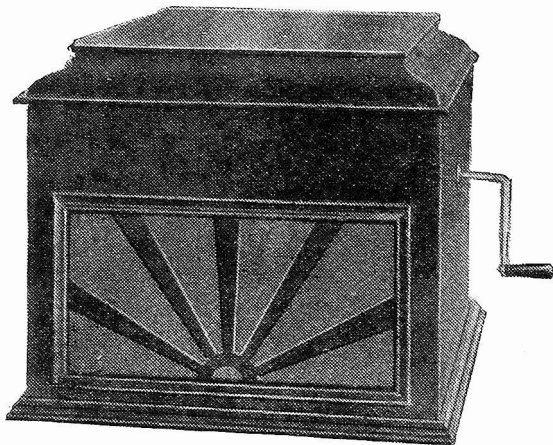

Complete kit with blueprint and full instructions, price

£6 6 0

Write for Leaflet No. 1:

**THE ALESTRIAN
 GRAMOPHONE COMPANY**
 Stour Road, Old Ford, London, E.3

Telephone: East 6266

SUPER VALUE TRANSFORMER

Thousands of satisfied listeners who use Weilo, will tell you that now it is no longer necessary to pay high prices to secure that perfect design and quality essential to good transformer performance. Specify Weilo and obtain one of the finest all round jobs on the market. Weilo is built by Transformer Specialists and guaranteed two years and gives a remarkable purity of maximum amplification. Tested and approved by the greatest expert of all—the listening public! Send for yours now and really transform your reception. Hundreds of testimonials.

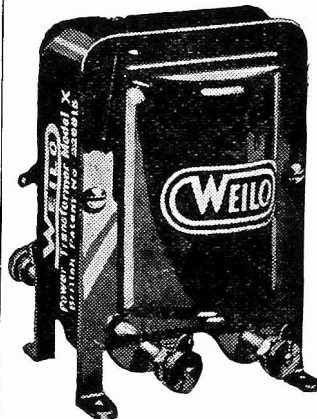

'WEILO'
 + POWER
 TRANSFORMERS

Model 10 Model 3

11/6 8/6

Supplied in Ratios 1-1, 3-1, 4-1, 5-1, 25-1

Supplied in Ratios 3-1, 4-1, 5-1

Send for vitally interesting and useful Radio catalogue of complete range of W. S. F. and Weilo Components free. Stocked by Harrods and most good dealers. Obtainable by post direct.

S. W. LEWIS & Co., Ltd.
 Dept. W.M.
 39 Victoria St., London, S.W. 1

PORTABLE CABINETS 30/-

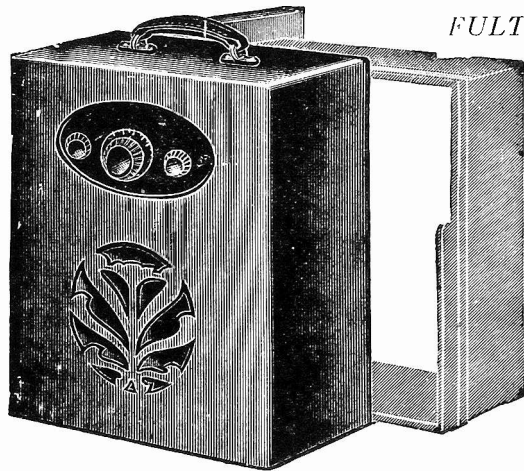

FULTOGRAPH

The
 Wireless
 Picture
 Receiver
 demonstrated every
 day, 2-
 2.30 p.m.,
 in our
 window.
 Details on
 request.

Beautifully covered in leatherette. Choice of six colours, antique, dark claret, black, blue, brown, green. Complete with inside chassis for aerial and set, carriage extra. Outside size, 17 in. high, 9 in. wide, 14½ in. length.

SUITABLE FOR MULLARD MASTER FIVE

Linen diaphragm loud-speaker parts. Including woodwork, linen, dope, fixing screws, screwed rod, brackets, 66k Blue Spot unit, reed adaptor and nut **£2-12-9**

ALL COMPONENTS ABOVE £5 SUPPLIED ON GRADUAL PAYMENT SYSTEM £1 DEPOSIT 9/- PER MONTH FOR TEN MONTHS

Write for full particulars.

WILL DAY, Ltd.,

(THE BEST IN THE WEST)

19, Lisle Street, Leicester Square, London, W.C.2

Telephones (2 lines): Regent 0921 and 0922. Telegrams: Titles, Westrand, London

DUBILIER MIDGET CONDENSER

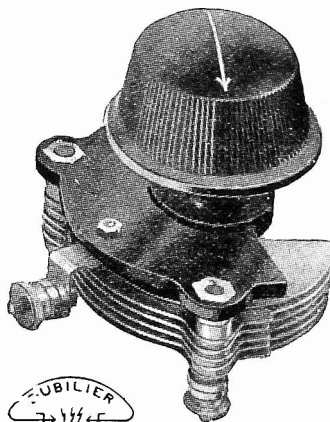

A small variable condenser for panel mounting. Especially appropriate for use as a reaction condenser, it can also serve when a neutralising condenser for panel mounting is required.

If unobtainable from your dealer write direct to us giving his name and address

**DUBILIER
 CONDENSERS**

**DUBILIER FOR
 DURABILITY**

Advt. of Dubilier Condenser Co. (1925), Ltd., Ducon Works, Victoria Road, N. Acton, London, W.3



IN TUNE WITH THE TRADE!

FETTER LANE'S Review of Catalogues and Pamphlets

Pentones Please!

HAVING now learned to call Mullard five-electrode valves "Pentones" and not "pentodes," I turned kindly to a new folder which deals with the latest addition to the Mullard range, the PM26.

This is the six-volt Pentone, which, according to the figures given, shows a marked dislike for "juice" in any shape or form. *Par example*, it needs only 150 volts H.T., and eats up only .17 ampere at 6 volts. A reasonable fellow in its demands, and its creators are the Mullard Wireless Service Co., Ltd., of Nightingale Lane, S.W. 12.

16

Unconventional H.T.

COLUMBIA is certainly an unusual H.T., and it seems to me that there is a great deal in the argument put forward by the makers of the Layerbilt battery, namely, that for many purposes it is better to arrange the battery elements in flat horizontal layers, rather than the usual cylindrical cells.

The Layerbilt range of Columbias is made up in this way, while other batteries in the Columbia *gamut* have "internals" of the usual form. But Columbias do not limit themselves to H.T.'s, which is a fact of which I was not aware until I received a folder dealing with all of the A, B, and C batteries from J. Morris, of 15-19 Kingsway, W.C.2.

A is the U.S. equivalent of L.T., B is H.T. and C is grid bias, but it will all be very explicitly explained to you if you read this folder.

17

Purity and Power, Please!

THE last stage being proverbially worse than the first, the G.E.C., to whom we are thankful for Osram valves, have issued a most helpful booklet dealing with valves for power amplification with cone and coil-drive loud-speakers.

A vast organisation, such as the G.E.C., should have heaps of helpful hints at its finger tips, and, expecting this, I was not a bit disappointed when I carefully perused this new Osram booklet.

There are circuits of loud-speaker output and valve push-pull arrangements, battery-value recommendations, valve curves which tell the whole story in a nut shell, and a wealth of good advice on loud-speaker reproduction.

Finally, realising that batteries are rather an expensive proposition in the case of some large H.T.-consumption sets, the booklet gives full details of Osram rectifying valves, suitable for getting H.T. from A.C. mains.

The folk at Magnet House are to be congratulated on their effort to help the constructive amateur, for a goodly proportion of the 2,600,000-odd listeners would appreciate and benefit by further advice, such as is contained in this booklet.

18

"We Speak . . ."

*O*N *parle francais, mann sprecht deutsch*, and American understood! Excuse the trilingual verbosity, but I am moved to it by a folder in a fearsome assortment of Continental tongues, from H. Clarke and Co. (Manchester), Ltd., of Atlas Works, Eastnor Street, Old Trafford.

The folder, need it be said, deals with Atlas battery eliminators, A.C. or D.C., and if you want to read about them in your mother tongue, without

the fun of translating from French, and so on, an all-English leaflet (No. 28) can be had for the asking.

The chief claim of Atlas battery eliminators is *keine bewegliche teile und keine flüssigkeiten vorhanden sind* (I beg your pardon ; "no moving parts, no liquids"), and the range of models, both for *courant continu* and *courant alternatif*, is comprehensive.

Lotus Look at This!

19

PARDON the poor pun in the heading! I have been glancing through an illustrated folder from the Lotus people, dealing with the Lotus remote-control, and it is worth looking at.

Without going into technicalities, I am moved to recommend remote control, because I am very convinced by the simplicity of the way in which the Lotus control is carried out.

This folder gives a wiring diagram showing how any typical set can be remote-controlled from any number of rooms, and it is certainly no more difficult to arrange the control wiring than it is to arrange an ordinary extension from room to room.

And, as the cost is very moderate, I cannot see any reason why radio should be confined to one room.

20

Eelex Terminals

IN the list of components for nearly every WIRELESS MAGAZINE receiver you will find Eelex terminals featuring either as standard or as alternatives. Judging by a pamphlet which I have just had from the Bunhill Row folk, I fail to see any use to which one or other gadget from the Eelex range could not be adapted.

The treble-duty terminals with coloured tops, wander plugs, sockets, multiple connectors and all the host of "bits and pieces" beloved by enthusiasts are all "starred."

Get it, because ignorance is not always bliss, and I myself did not know the wide range of colours and indications available for the terminals. You can get Eelex gadgets from any wireless shop, but the pamphlet I have mentioned was sent to me direct from J. J. Eastick & Sons themselves, of 118 Bunhill Row, E.C.1.

21

A NEW SERVICE FOR READERS

As a keen wireless enthusiast you naturally want to keep abreast of all the latest developments and this new feature will enable you to do so with the minimum of trouble.

Here we review the newest booklets and folders issued by six well-known firms. If you want copies of any or all of them just cut out this coupon and send it to us. We will see that you get all the literature you desire.

Just indicate the numbers (seen at the end of each paragraph) of the catalogues you want below:—

My name and address are:—

Send this coupon in an unsealed envelope, bearing 1d. stamp, to "Catalogue Service," WIRELESS MAGAZINE, 58/61 Fetter Lane, E.C.4, April

**Little
before
mend**

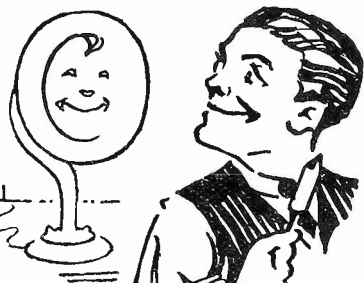

**saves
much
after
spend**



FLUXITE

simplifies all soldering

FLUXITE is sold in tins, price 8d., 1/4 and 2/8.

Another use for Fluxite: Hardening Tools and Case Hardening.

Ask for leaflet on improved methods.

FLUXITE LTD.,
(Dept. 10)
Rotherhithe, S.E.16

**SOLDERING
SET Complete**
7/6
or LAMP
only
2/6

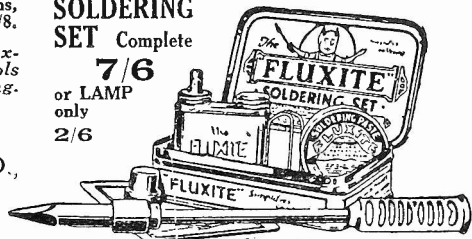

EFFICIENT



**EBONITE PANELS
SPECIFIED FOR
DOMINIONS FOUR**

(Described in this issue)

and for all other popular circuits

**GUARANTEED. READY FOR USE.
LOOK FOR TRADE-MARK.**

Write for BECOL handbook on Wireless Circuits giving general data and illustrations of windings. Price 4d. Post Free.

SOLE MAKERS:
THE BRITISH EBONITE CO. LTD.
HANWELL, LONDON, W.7

**KEEP
"IN TUNE WITH
THE TRADE"**

by reading every month **FETTER LANE'S** review of catalogues and pamphlets, in connection with which we offer our readers a special service

**TURN TO PAGE
280 BEFORE
YOU FORGET!**

PRICE
1/6
BULBS 6d.
EXTRA

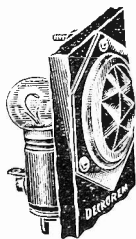

**RUBY REFLECTOR
FITTING**

Gives a warning signal when the Set is switched "on." Use with an L.C. Bulb—this only consumes .06 amps.



PRICE
2/-
EACH

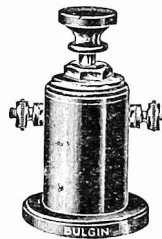

BASEBOARD SWITCHES

A useful Switch for baseboard mounting. Can be used for various purposes and is an ideal experimenter's component. Terminal connections.

MINIATURE MILLIAMMETERS

Handsome and accurate these British-made Meters are worth incorporating in your Receiver. They should be wired in series with the anode of the last valve. They indicate distortion, overloading and correct grid biasing.

10/6
PRICE

A.F. BULGIN & CO.,
9/10/11, CURSITOR STREET,
CHANCERY LANE, LONDON, E.C.4

TELEPHONE Nos.:

HOLBORN 1072 & 2072

Leaves from A Listener's Log

SINCE I last contributed to these pages I have added further stations to my log, one of which I have confirmed as being the new Italian transmitter at Turin. At the time of writing, I have only been able to pick up the broadcasts clearly when Kaiserslautern has been off the air, as the latter station comes in at my home at such great strength that it swamps the newcomer.

Reminiscent of Milan and Rome

When the Bavarian is silent, Radio Torino is well heard and possesses all the characteristics of both Milan and Rome. So far, from this studio, I have only picked up a male voice—the staff may not yet be complete—but the announcer puts a call over at frequent intervals: "Allo! Stazione Experimentale di Torino," with, now and again, a French translation.

This 7-kilowatt transmitter, I am informed, is the one which had been erected in 1927 at Como for the period of the Volta Centenary Exhibition, and of which the musical broadcasts had been well received in the British Isles. Its new site is on the top of the Torre dell'Eremo, a hill two thousand feet high, which dominates the Italian city.

The studios are at Turin, and by landlines are connected to most of the theatres, including the well-known Teatro Regio, in which operatic performances are given nightly.

When You Can Hear It

Possibly, by the time these notes are in print, the station will have been formally opened and added to the Italian broadcasting system, but in any case in the meantime you should be able to pick it up between 4.45 and 6 p.m., or between 8.25 and 11 p.m. G.M.T. on a wavelength of 275.2 metres; if not found immediately, search around that wavelength, for some of the French transmitters have jumped into unauthorised positions and may be a cause of interference.

Although it is definitely stated that Genoa has been regularly testing on 387 metres, I have failed to find any trace of it. On one or two occasions when pottering around, I thought I

heard a few words in Italian on this wavelength, but I could not swear to it.

On the other hand, both Leningrad and Moscow have been entered in my log as stations capable of being picked up in London on any moderately favourable night. I should add that these additions to my list are due to the fact that I am using a receiver with two stages of screened-grid H.F. amplification, and their capture has only been possible, in view of their respective wavelength proximity to Hilversum and the Eiffel Tower, by the adoption of a small and highly directional frame aerial.

Leningrad, for your guidance, puts

In these notes JAY COOTE discusses developments in Italy, Russia, Luxembourg, Belgium, France and Iceland! He discusses his logging of new stations and explains what transmissions you can expect to pick up on your own receiver

out excellent musical concerts, and apparently possesses a studio of well-balanced acoustic properties. On many nights, also, I have listened to this station when it has relayed operatic performances from an outside theatre, and have been struck with the quality of both voices and orchestra.

Moscow has given me less satisfaction inasmuch as although I have tuned in at various times, I seem to have struck interminable talks, of which, I need hardly say, I do not understand a word!

But I have heard the Kremlin Bells, and although I did not recognise the strains of the International, I put it down to the fact that much of the interference was due to street noises from the famous square which the Spassky Tower dominates. The relay of the carillon appears to be a regular feature; if you wish to hear it, tune in just before 9.55 p.m. G.M.T.

References are frequently made to Moscow Komintern and it may be interesting to know that this word

is an abbreviation of Kommunist International, and is a term applied to a number of official Soviet stations and not limited to the Moscow high-power transmitter. In the same way, Narkompotschel, as the designation of the long-wave Kharkov station, merely indicates that it is a P.T.T. transmitter, and does not refer to the district.

Radio Luxembourg

Whether or not at some favourable moment you will capture Radio Luxembourg is a matter for conjecture. It is but a small station privately owned by a group of dealers in wireless apparatus in the capital of the Grand Duchy, and can only afford to broadcast three entertainments weekly.

Although by the Plan de Bruxelles a wavelength of 220.6 metres was allotted to it, Radio Luxembourg decided that 1,200 metres suited it better, and without thanking the authorities for their kind consideration, it has broadcast on the higher wavelength ever since.

It might be worth your while to try for it on Sundays between midday and 4 p.m., and on Tuesdays and Thursdays between 9 and 11 p.m. G.M.T. The call: "Ici Radio Luxembourg" is given out both in French and German, a dialect of the latter language being largely used in that little country.

Activities in Belgium

Two more little broadcasters have sprung up in Belgium, with a view to filling a gap until the new high-power dual-wave transmitter is erected in the neighbourhood of Louvain. Radio Arlon, situated in the capital of the Belgian Province of Luxembourg, is but a ¼ kilowatt, and transmits at irregular times on a wavelength of 312 metres, a particularly congested position.

The second newcomer is in reality a revivalist, namely, Radio Wallonie, situated at Liège; it has arbitrarily thrust itself on 280 metres. Short musical transmissions are given at 4 p.m. and 7 p.m. on Sundays, at

(Continued on page 284)

FINE CABINETS!

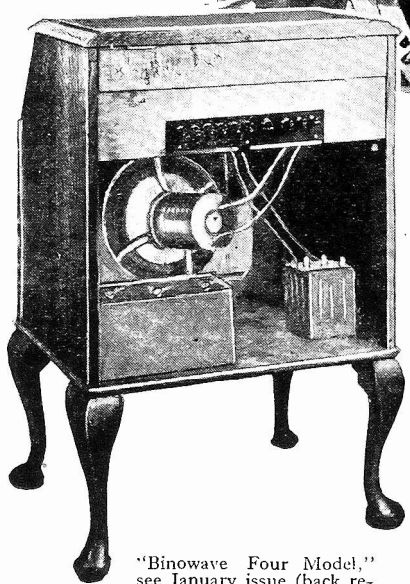

"Binowave Four Model," see January issue (back removed). For the "LODESTONE"—also any Moving-coil or Cone Speakers, Baffle Board and removable back fitted. Takes *heaviest* batteries.

"RADIOLA" FULFILS YOUR EVERY NEED!

- If you want your Wireless trouble-free.
- If you want to rebuild or add improvements.
- If you want to combine the Gramophone or Speaker.
- If you want to keep batteries and equipment dust-free.
- If you want to have a fine drawing-room Receiver.

OVER 3,000 DELIGHTED USERS!

The "RADIOLA" is sent ON APPROVAL from the actual makers, who take all risks and GUARANTEE satisfaction or money refunded.

"RADIOLA" DE LUXE MODEL "A." Highest-grade Oak or Mahogany, hand french-polished. De Luxe, from £5 5 to £11 11. Popular, from £3 15. (Prices according to size and finish)

Write for further particulars and photos, and let us help you!

PICKETT'S
Wireless **Cabinets**
W.M.
WORKS BEXLEY HEATH NEAR LONDON
PHONE: BEXLEY HEATH 194

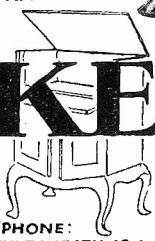

Beautiful Homes!

Add to the efficiency of your Radio the fine beauty of the RADIOLA, and you have a combination hard to beat. Up to date! Stylish! Modern! The admiration of all! A fine Cabinet that will not fail you; an instrument for music and entertainment at a touch! More often used than the piano or the gramophone. Used by Radio Press, Percy Harris, W. James, etc.

YOUR SET!

Just slide it in—a few seconds—nothing to touch. Holes for all leads. Pickett's will adjust cabinet to your own set—free.



"The 'CLIPPER TWO' and Ericsson Phones make a wonderful combination"

"I've tried lots of short-wave sets and headphones, but a finer partnership than the "CLIPPER TWO" and Ericsson Supersensitives I never had.

"Between them they pull in an astounding number of stations."

Ericsson Supersensitive Telephones are found in every true short-wave worker's den, on the radio society's bench, in the B.B.C. studios. Need we say more? Their *tone* on ordinary broadcasting is wonderfully pure—the response to all tonal frequencies is amazing.

They consist of two aluminium-cased double-pole watch-pattern receivers with a double "Duralumin" headband, with 6 feet 2-way best quality flexible cord. All terminals enclosed (to prevent short circuits). Adopted in 1909 as *standard* by the Admiralty and the R.A.F. in 1917.

Three resistances (120, 2,000, 4,000) One Price 12/6

At all good dealers or direct:

ERICSSON TELEPHONES, Ltd., 67/73, Kingsway, London, W.C.



SUPERSENSITIVE TELEPHONES

Leaves from a Listener's Log (Continued)

7:30 p.m. on Tuesdays, Wednesdays, Thursdays, and Fridays; Mondays and Saturdays being days of rest.

For our lunch-time music—why should not we do the thing in style?—through the kindness of the B.B.C. we are taken over to various London restaurants almost daily. It would not be fair to mention names, but on certain days I do not avail myself of the invitation; on others I do, for, as you may have noticed for yourselves, there are such things as *poor* orchestras, and if these are playing to a noisy background of diners and the clatter of plates and dishes the combination is not a pleasing one.

musicians and second-rate artists.

Gramophone records, I notice, are used much more on the Continent to fill a gap in a programme than is the custom in this country, and it strikes me that by so doing the foreign stations greatly increase the interest of their radio entertainments.

Personally, if there are a few minutes to spare, I prefer to hear something played by one of the big symphony orchestras than to listen to the tinkle of a piano followed by the bashful announcement to the effect that "I have just played you Watrotski's variations on the *Maiden's Prayer*," or words to that effect. In some instances I have noticed that

From the mass of correspondence received by the station it was clearly demonstrated that the listeners actually noticed a *difference* between the artist's personal transmission and that of the record, although, as a matter of fact, the consensus of opinion proved that the difference in quality was but a *small* one.

Unable to Discriminate

In the final test made, the announcer did not give out which of the two broadcasts was being made; curiously enough, correspondence referring to *this* particular item showed that in most instances the listeners were unable to discriminate.

Generally speaking, the studio arrived at the conclusion that direct transmission through the microphone was of better quality and of richer tone, in a studio possessing good acoustic properties, if accompanied by a selected orchestra, but, on the other hand, the registered voice, always recorded in favourable circumstances, showed to advantage in comparison with an identical broadcast by the same singer in a small and perhaps unfavourable studio in which the accompaniment was effected by a strictly limited number of musicians.

Although one hears but little of Iceland, I am assured that the Reykjavik station broadcasts merrily every night: It is doubtful whether listeners situated in any part of the British Isles other than Northern Scotland and Ireland would be successful in picking up these transmissions. Moreover, the station works on almost the same wavelength as Naples, a fact which, in view of the strength of the latter, might prevent its reception.

Icelandic Standard Time

On the other hand, a correspondent informs me that on a recent night when the Italian appeared to be working on just under 330 metres he distinctly picked up the call: "Allo! Reykjavik" (pronounced "Ray-key-ahveek"). At the moment the station was closing down. This was followed by nine strokes on a gong, and as his watch pointed to 10.30 p.m. he took it that Icelandic Standard Time was $1\frac{1}{2}$ hr. behind us.

JAY COOTE.

THE FIRST SCHOOL FOR RADIO ARTISTS



Franz Adam, the artistic director of the Munich station, has opened a school for broadcast singers, reciters and dramatists

Now, on these occasions I invariably turn to the Continent for the midday transmissions, sometimes to Radio Paris or Eiffel Tower, but much more frequently to Hilversum, from which, by experience I find I can always get an enjoyable hour. The studio does not make it a regular rule to broadcast a concert trio, but very judiciously alternates these programmes with a transmission of picked gramophone records, which, to my mind, are always welcome.

I think you will agree with me that good quality canned music as executed by well-known orchestras or dance bands or the now almost perfect reproduction of the human voice are both more satisfactory than the feebler attempts of mediocre

after a statement that "I will now play you—" both voice and music have faded into oblivion to make way for a talk or local announcements, "if any." Now, this is where the gramophone record scores.

Radio Toulouse recently carried out an interesting experiment and one which could very well be copied in this country. On a certain evening when the studio was in possession of a full orchestra of some fifty-four musicians, as well as a noted operatic soprano from Paris, the announcer was struck with the bright idea of broadcasting gramophone records registered by this particular singer some few weeks before the concert.



What you want!

Even as
is
So
ELIM
descri

This 28 PAGE
WONDER BOOKLET
all about D.C.&A.C.
"ELIMINATORS"
and getting the
BEST OUT OF RADIO
WITH THE
CLAROSTAT
FREE AT YOUR DEALER
OR POST FREE FROM
T.C.C.
CLAUDE LYONS LTD.
76, OLDHALL ST., LIVERPOOL.

Get it now - It's free.

Advertisement of **CLAUDE LYONS, LTD., 76 OLDHALL STREET, LIVERPOOL.**

CLAROSTAT

Beautifully
Made.
Micrometer
Adjustment.



10/6

STANDARD CLAROSTAT

The Standard ClarOstat is a *variable* resistance of UNIVERSAL RANGE, practically zero to approximately 5 megohms. It will carry quite large currents in milliamperes, and is therefore extremely useful in battery eliminators for varying voltages. If your present eliminator

has fixed tapings, this component can be added externally, *without altering the wiring*, to give one or more variable tapings.

The ClarOstat has also *innumerable* other uses in radio receivers, such as throttle control of reaction, adjustment of screen-grid voltage, as a volume control (although there is a special model for this purpose at a cheaper price), *variable anode-feed resistance* (thus obviating the necessity of buying many resistors to find the one, *and one only*, which will be suitable), etc., etc.

There are all kinds of other special types of ClarOstats, too, such as the DUPLEX (two-in-one), variable GRID LEAK (essential in short-wavers), and the TABLE-TYPE (a distant control for volume and/or "tone"). All described in our thoroughly interesting FREE LITERATURE.

VOLUME CONTROL TYPE 8/6

SPECIFIED IN THIS ISSUE!

"DYNAMIC 3"

"DOMINIONS 4"

1 Volume Control @ 8/6

1 Standard @ 10/6

SHOW THIS AD. TO YOUR DEALER AND HE WILL GET THEM FOR YOU PROMPTLY. LARGE STOCKS. NO WAITING.

FINSTON "Q" COILS

are a very efficient type of coil with a dual wavelength covering 250/2,000 metres. Made to J. H. Reyner's specification and officially approved. With Finston coils you are guaranteed the best possible results.

BINOWAVE COILS

Made to specification and specially designed for circuits employing Screened Grid Valves. A change-over switch is embodied which gives you immediately either Short- or Long-wave reception. The coils are mounted on a base and have terminals at side for connections.

Price complete 25/- per set.

COILS FOR THE ALL BRITAIN THREE Q.A. 15/- Q.S.P. 21/-

SEND FOR ILLUSTRATED LEAFLET (B/A)

STONE MFG. Co., 108, GREAT SAFFRON HILL, LONDON, E.C.1 Tel.: Hol. 4844

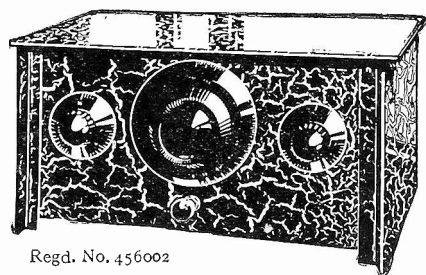

Regd. No. 456002

Anyone can build this set in 60 minutes. Circuit allows use of standard valves (1 H.F. and 1 Power). Blueprint and easily followed Diagram of Connections included with every set. Cabinet and full Kit supplied in carton.

TO HOME CONSTRUCTORS! BUILD THE PEERLESS "RESONIC 2"

No drilling.
No soldering.
All wires cut and bent.
Just assemble.

COST £3.15.0 ONLY

Obtainable from all Dealers, or
THE BEDFORD ELECTRICAL & RADIO CO., LTD.
22 CAMPBELL ROAD, BEDFORD

WIRELESS CABINETS in SOUND QUALITY of WOOD

Highly Polished First-class Cabinet Work

MAKERS OF ALL DESIGNS FOR OLD AND NEW WIRELESS SETS AS PERIODICALLY ANNOUNCED IN THIS JOURNAL

Special line of closed cabinets totally enclosing Batteries and Accessories

Thousands of satisfied users. Send for Illustrated Price List

Money returned if quality and workmanship not equal to our guarantee

CAXTON WOOD TURNERY CO., MARKET HARBOROUGH

By **KENNETH
ULLYETT**

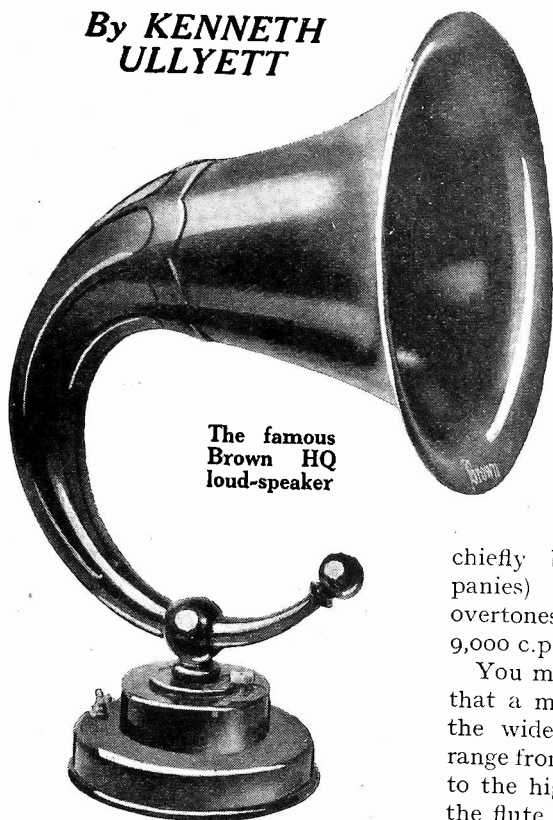

The famous
Brown HQ
loud-speaker

Loud-speakers from A New Angle

EVERYONE knows that imagination plays a most important part in hearing, and even sight is not disconnected with the transmission of the human voice. For example, it is possible to *understand* speech even if reproduced by a set or loud-speaker which cuts off all the overtones, and a deaf mute can read speech very often by lip movement.

Loud-speaker's Difficult Task

Most people appreciate that loud-speakers have a very difficult task to reproduce the human voice with any degree of naturalness, and the human voice is generally considered to be the most fitting test of a loud-speaker.

With the aid simply of a vibrating cone or diaphragm it has to reproduce something appreciably like the very complicated transmissions of the vocal cords, the tongue, the lips, the roof of the mouth and the teeth!

Speech and Mouth Formations

What is so often forgotten is that the frequency response range of a loud-speaker has very little to do with the naturalness it will give on speech, for speech depends not on a modest frequency range but a whole gamut of mouth formations.

As a matter of fact, the pitch of a man's voice is something like 128 cycles per second (afterwards abbrevi-

ated to c.p.s.), and that of a woman's about 256 c.p.s. There are overtones, of course, just as there are in any musical sound, and experiments (conducted

chiefly by the gramophone companies) have shown that these overtones frequently extend up to 9,000 c.p.s.

You must take as a basis the fact that a modern church organ covers the widest range, in practice, the range from the bottom pedal bourdon to the highest top F or C of one of the flute stops (usually on the swell manual) being about 16 c.p.s. to 4,000 c.p.s. Diapasons, and the piano and harp tone, are characterised by a prominent first harmonic, which it is important to "get in" in order to make the reproduced sound realistic. This makes the effective range from 16 c.p.s. to about 8,000 c.p.s.

Now compare the voice frequencies. An average shows that (without definite limits) the bass extends from 32 c.p.s. to 130 c.p.s., alto or tenor from 130 c.p.s. to 1,000 c.p.s., and soprano from 1,000 c.p.s. to 4,100 c.p.s. Various overtones widen the range up to about 9,000 c.p.s.

I have checked over these figures very carefully with a manufacturer of records for "talkie" purposes, and they tally in showing what are regarded by the technical recorders as being the limits for each type of voice.

Before showing just how all this affects the loud-speaker I must mention a fact or two about the "receiving" side—the ear.

The ear, in ordinary speech, picks up most speech waves as pure vibrations caused by the vocal cords. These are known as voiced sounds. The *unvoiced* sounds are those symbolised in the English language by the letters f, k, p, t, s, and the compounds ch and sh, and th (soft), as in "thin" and not as in "the." These are all produced without the aid of the vocal cords.

When you think how easy it is to understand very softly whispered speech, in which the vocal cords do not act at all, you will see that the formations of the cavities of nose and mouth, and *not* the vocal cords, give character to the reproduced speech. This makes the loud-speaker's job hard.

A woman's voice is harder to reproduce properly than a man's, for a woman's voice does not contain so many tones as a man's voice, and therefore demands a less "contrasty" response of the ear's membrane.

"Masking" Effect

What is so frequently forgotten, and what I want to take as a standpoint for viewing "loud-speakers from a new angle," is the so-called "masking" effect, which is in live conversation one of the ear's faults, and in radio work one of its blessings.

The masking effect is the result of the fact that owing to the shape of the audibility curve (which I will mention later) the low notes tend to deafen the hearer to the high notes. This becomes more marked as the strength of both is increased, and means that when strength is really great the lower tones will be accentuated if the reproducer has given *equal* amplification to all tones.

Over-accentuated Bass

This means that, according to the "masking" theory, a perfect microphone, transmitter, receiver, and loud-speaker, giving a very loud final output, will sound unnatural owing to the over-accentuated bass—the over-accentuation being done by the listener's hearing mechanism in the middle and inner ears.

As you know, this is what frequently happens in practice. Anode-bend detection, generous R.C. amplification and a moving-coil loud-speaker, the whole working "all out," give an unnatural, boomy effect on

(Continued on page 288)

If it's the Flat Type you want—

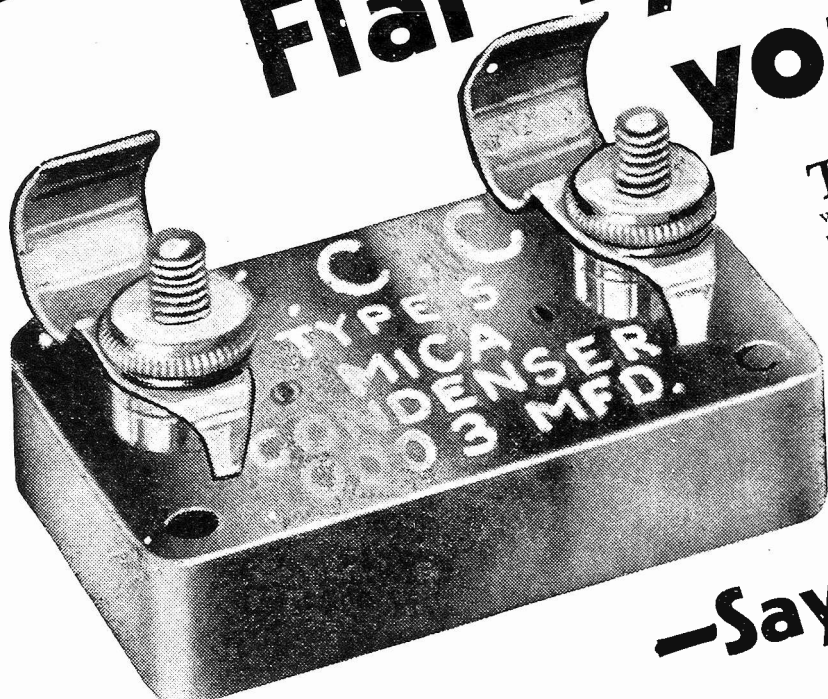

THERE'S no condenser requirement that is not served by T.C.C. To the wide T.C.C. range—mica condensers and paper condensers, smoothing condensers and electrolytic condensers, and the rest—has been added the T.C.C. Flat Type Condenser (or which a much-enlarged illustration appears on 1 ft). But remember: whatever the type, the letters T.C.C. on a condenser are the undisputed hall-mark of accuracy and dependability. T.C.C. Flat Type Mica Condenser is made in capacities from .0001 mfd., 1/10 to .01 mfd., 3/6.

—Say 'T.C.C.' Just the same!

Advt. Telegraph Condenser Co., Ltd., Wales Farm Rd., N. Acton, London, W.3

7301

Yet another proof of **TUNEWELL DUAL COIL**

Supremacy

Selected for the

DOMINIONS FOUR

in this issue

- Price Per Coil - - 10/6 each
- Price Per Base - - 2/- each
- Price Per H.F. Choke 5/9 each

Make sure of success and fit TUNEWELL parts where possible.

Also **DUAL COILS** for GLOBE DX 2, BROADCAST PICTURE 4, COSSOR S.G. 3, LISSEN S.G. 3, & THE CLARION THREE, 10/6 each. MULLARD MASTER THREE DUAL COILS, BANTAM THREE COILS, & ORCHESTRAL FOUR COILS, 7/9 each. TWO-PIN COILS OF ALL TYPES FROM 1/6 each.

TURNER & CO.,
54 Station Road, New Southgate, N.11



WIRELESS ACCESSORIES

are specially designed to minimise the possibility of a wrong or accidental connection; and each individual part is of a standardised size.



EELEX T14E

An Eye Connector specially suitable for connections to accumulators to safeguard a short circuit, etc. Red or black sleeve. Each 2d.

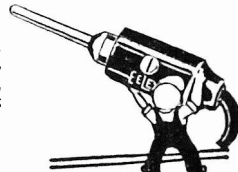

EELEX T14P

This Pin is specially suitable for making connection to terminals, etc. Red or black sleeve. Each 2d.

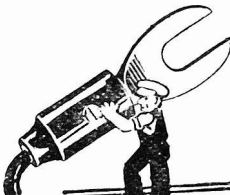

EELEX T14S

Spade End for immediate multiple connections. Nickel-plate. Red or black sleeves. Each 2d.

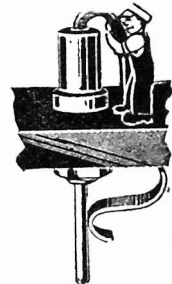

EELEX Spring Connector showing method of using a phone tag in conjunction with a socket. Spring only costs 1d.

Write for the new EELEX Booklet X67 which gives full details.

J. J. EASTICK & SONS
EELEX WORKS, BUNHILL ROW, CHISWELL ST., LONDON, E.C.1. Phone, Clerkenwell 9282-3-4.

Loud-speakers from a New Angle (Continued)

speech. Moreover the bass seems so accentuated as to give an unpleasant sensation in the throat when an organist is treading well to the left of the pedal board!

Boomy and Indistinct

Moving-coil loud-speakers are not the only apparent offenders in this respect, for well-designed cone instruments, if used with a large baffle and a reed movement capable of dealing with a large input, often give what we term the "moving-coil tone," and are boomy and indistinct on speech.

There is, too, a loss of the higher notes owing to the masking effect of the lower notes, and it is possible largely owing to this loss of brilliance by the overtones that some instruments are incorrectly accused of lacking "attack." True, there are many cases where faulty design results in an actual loss of "attack," but I believe that an audible illusion due to the predominance of bass is sometimes responsible for bad "attack."

Cure by Volume Control

It is interesting to see just where "masking" starts and finishes, for obviously a cure can be obtained by volume control, and not by wholesale scrapping of cone and moving-coil instruments!

A typical audibility curve is shown here and this is plotted between the co-ordinates of frequency and "received loudness." The curve drops almost in a straight line from the usual bottom point of about 16 c.p.s. (both lower and upper limits vary, of course, in different people) to the middle C frequency, has a shallow bend between 256 c.p.s. and about 4,000 c.p.s., and then rises rapidly to the upper audibility limits.

When Volume Is Super-normal

It will be seen that masking is most likely to occur when the volume is super-normal, and the frequency below about 1,000 c.p.s.; and in practice, fortunately, masking cuts off at about middle C.

You will perhaps want to know what is meant by the co-ordinate of "received loudness." It is possible, obviously, to measure the pressures of sounds, and these figures can be

used as a measure of "received loudness." This is not always convenient, however, and when an arbitrary "loudness" scale is required units known as "sensation units" are often employed. A sensation unit, as a matter of fact, is twenty times the pressure of the sound in dynes, but you won't want to bother about that!

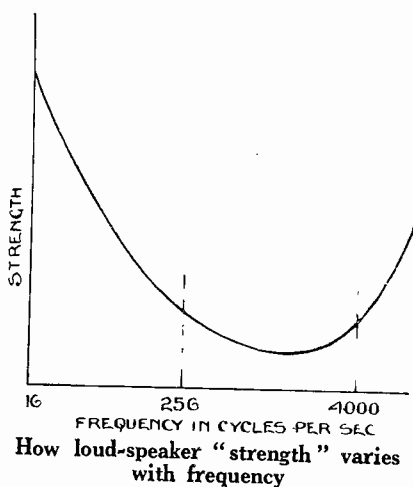

What is interesting, however, is that at intensities above about 20 sensation units sounds can be felt, and may hurt because of their great strength. Masking is most pronounced when this "threshold of feeling" commences.

The curious point about masking is that it is at one and the same time a boon and a bugbear! It means that with simple reed movements and large cone diaphragms it is necessary only to increase signal strength in order to give an effect of plenty of bass, even though a little brilliance is lost thereby. This accounts for the very natural results obtained with some large-diaphragm loud-speakers—frequently a naturalness excelling, on speech, that evinced by coil-driven jobs.

On the other hand it means that the most cannot be made of coil-drives, or, indeed, of any reproducer with a straight-line characteristic; for directly the volume of sound exceeds a certain limit the bass notes, being actually at the same strength as the treble notes, give the effect to listeners of over-pronounced bass, owing to masking.

The more you prove for yourself

that the ears of most people do give a masking effect when the volume heard is great, and the more you experiment with more-or-less perfect coil-drive job, the more you realise what stress must be placed on volume control.

Bass Unnaturally Loud

Formerly the argument used to be "I don't like moving-coil speakers, because they have to be worked at 'open throttle' to give plenty of bass, and that amount of volume is too loud for a small room." Now it is becoming obvious that if any good loud-speaker is made to give too great volume the bass will be unnaturally loud in proportion to the rest of the frequency range.

With this realisation in mind you will see how great is the need for instruments which, like the Lodestone of W. James, when working at a pleasing volume for an average room, give just the right proportion of bass to treble.

Importance of Volume Control

The pointer to note is that, when a good amplifier and loud-speaker are being used, the volume control knob is most important. Not only does it regulate volume, but by varying the strength of sounds heard by the listeners, it proportions for their defective aural apparatus the amount of treble and bass!

BUYING OR BUILDING A PORTABLE—

is a job not to be undertaken lightly if subsequent disappointment is to be avoided.

Various types of sets meet different needs, and expert advice is always of value.

Everything you want to know about portable developments will be found in the next issue of WIRELESS MAGAZINE, which will contain a complete buyers' guide and constructional details of a new set designed by J. H. Reyner, B.Sc., A.M.I.E.E.

Look out for the May WIRELESS MAGAZINE on April 24!

Make the Melody

LOUDER and CLEARER



Change now to **Cossor Valves**. They give you full-toned melody—every note crisp and clear. Cossor Valves made possible the wonderful Cossor Melody Maker. Cossor Valves improve *any* Receiver. Use them in yours. Every Radio Dealer sells them.

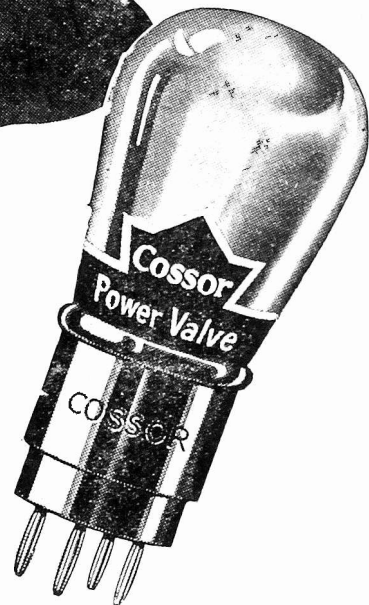

with

COSSOR VALVES

Have you got your copy of the **COSSOR Broadcasting Map**?

It shows positions and gives wave-lengths and dial readings of 200 European stations. It will double your radio enjoyment. Write for it now, enclose 2d. stamp to cover cost of postage.

Send at once.

A. C. Cossor, Ltd., Highbury Grove, London, N.5.

 7287

FOR
QUALITY
USE

The DRUM MAJOR

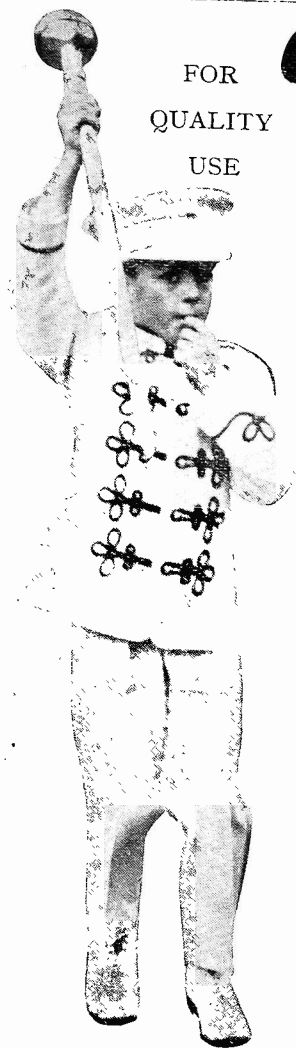

A QUALITY FOUR-VALVER CONSTRUCTED WITH THE BEST MODERN HIGH-CLASS COMPONENTS

INCORPORATES SPECIAL STABILISING DEVICES AND OUTPUT FILTER TO PREVENT "MOTOR-BOATING"

SPECIALLY DESIGNED, BUILT AND TESTED BY THE "WIRELESS MAGAZINE" TECHNICAL STAFF

THE military drum major represents perfection in a particular branch of musical art; the WIRELESS MAGAZINE Drum Major represents perfection in the reception of broadcast programmes.

Without being particularly elaborate, the Drum Major is definitely a "quality" receiver. Advantage has been taken of some of the most efficient components to be put on the market in recent months, and the result is a set above the average as

valve, a leaky-grid detector, one stage of resistance-capacity coupled low-frequency amplification, and one transformer-coupled stage.

A particular feature of the set is that the first three stages are provided with "motor-boat" stoppers and a choke output is used for the last stage. (See the special article by W. James on page 221.) This means that the set can be used in conjunction even with the most inefficient mains supply units.

Only Two Plug-in Coils are Required

Those who frequently desire to change from one wave-band to the other will note with interest that only two coils are required. A high-frequency choke is used in the anode circuit of the first valve and the grid circuit of the detector is tuned.

Reaction is obtained on the Hartley system by using a centre-tapped coil in this position.

far as quality of reproduction is concerned.

Actually the circuit is an extension of the system utilised in the Standard-coil Three and Standard-coil Four, published in recent issues of the WIRELESS MAGAZINE.

Use of Plug-in Coils

In these receivers a single double-tapped plug-in coil is employed for aerial tuning and neutralisation, the smaller tapped-off portion of the coil being made to balance the high-frequency valve capacity in the ordinary way in conjunction with a neutralising condenser.

For reception on the lower broadcast it is possible to use a centre-tapped coil. Instead of using a No. 60 double-tapped coil for the 250 to 500-metre band, a No. 75 centre-tapped coil could be used satisfactorily. On the long waves a No. 250 double-tapped coil should be used, as a No. 250 centre-tapped coil will not give the required wavelength range, on some aeriels.

The combination used in the Drum Major is a stage of neutralised high-frequency amplification, using an ordinary three-electrode

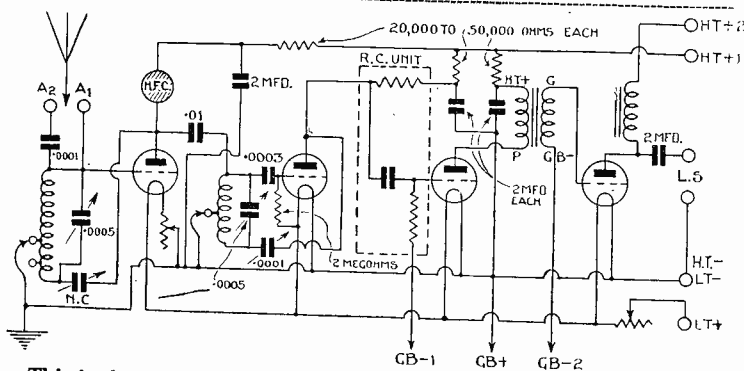

This is the circuit of the Drum Major, a four-valver with one stage of H.F., detector, and two L.F. stages

No high-frequency choke is used in the anode circuit of the detector valve, as the resistance-coupling unit used incorporates a special device to stop high-frequency currents from passing into the low-frequency circuits.

In the case of each

(Continued on page 292)

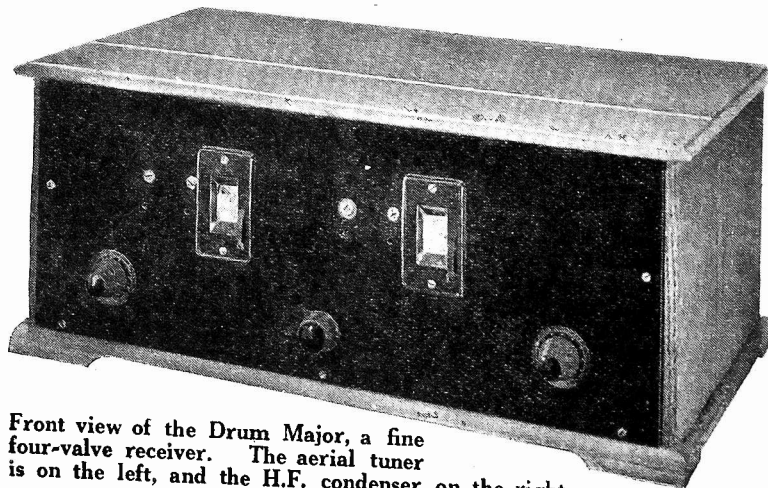

Front view of the Drum Major, a fine four-valve receiver. The aerial tuner is on the left, and the H.F. condenser on the right



SPECIFIED FOR THE DOMINIONS FOUR

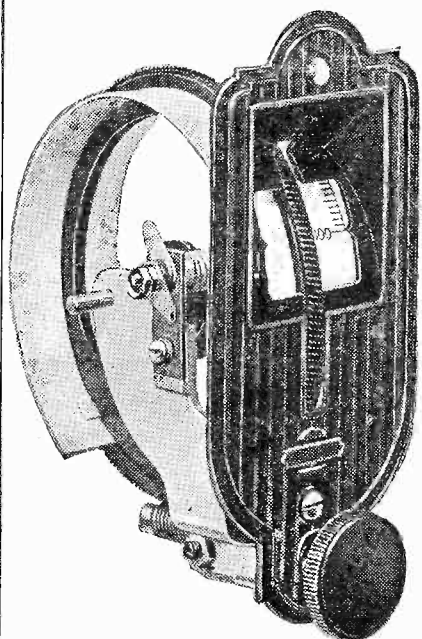

This wonderful receiver demands a control which is utterly reliable and deserves a handsome appearance. These features are ensured by specifying Igranvic Vernier Drum Control. Very silky and positive in action, it has the usual thumb control for coarse tuning and a knob for fine vernier adjustment. A bulb at back of scale may be lit from L.T. battery.

**17/6 IGRANIC
DRUM CONTROL**

IGRANIC LOKVANE CONDENSERS

Now famous for absolute constancy and low loss characteristics. The vanes are rigidly spaced and braced by a locking bar while double self-aligning bearings secure smooth turning with no chance of slip.

As illustrated
.0005 mfd. **10/6**

Twin Gang, [.0005
mfd. each section] **50/6**

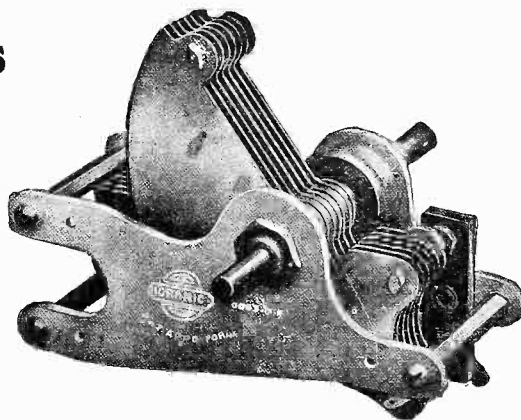

IGRANIC ELECTRIC CO. LTD.
149 QUEEN VICTORIA ST., E.C.4
Works: **BEDFORD**

Apply to your dealer. If he cannot supply you, please write to Dept. J.821.

The Drum Major (Continued from page 290)

The Drum Major complete and ready for reception

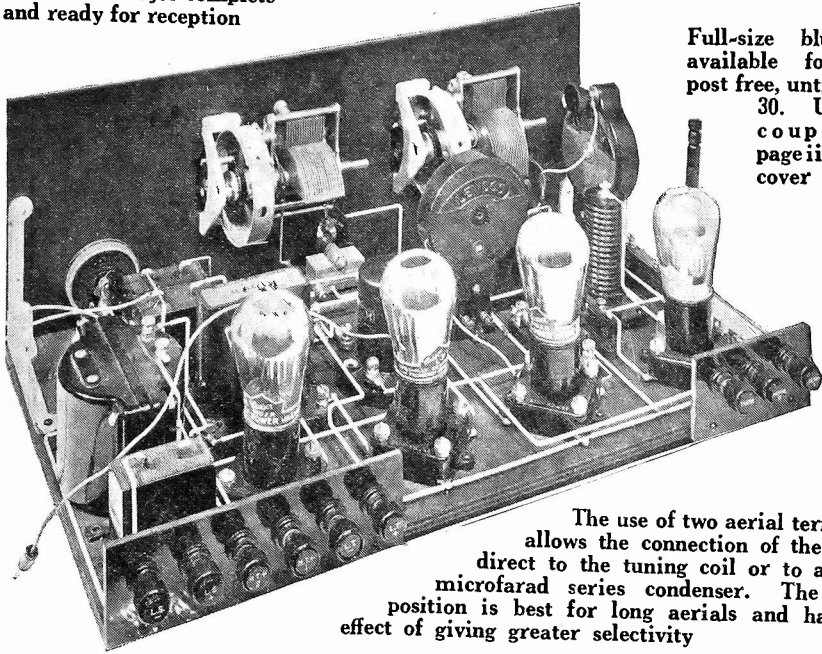

Full-size blueprint available for 9d., post free, until April 30. Use the coupon on page iii of the cover

The use of two aerial terminals allows the connection of the aerial direct to the tuning coil or to a '0001-microfarad series condenser. The latter position is best for long aeriels and has the effect of giving greater selectivity

of the first three valves the stabilising device or "motor-boat" stopper takes the form of a high resistance and a 2-microfarad condenser.

For the high-frequency stage a resistance of about 30,000 to 50,000 ohms is suitable, while for the detector a value of 20,000 ohms should be sufficient to stop all traces of instability.

Use of Good Valves

The value of the third resistance, in series with the primary of the intervalve transformer, depends to some extent upon the actual valve used, for the increased efficiency of modern valves (especially in conjunction with such a good transformer as the Brown) tends to set up "motor-boating" where an old valve would not.

Readers should note that the presence of "motor-boating" in a set, unless special precautions have definitely been taken to overcome it, is a sign of efficiency rather than of inefficiency.

High-tension Supply

A common terminal is used for supplying high tension to the first three valves, so it will be seen that the value of the stopping resistance to some extent controls the voltage applied to an individual valve.

In the anode circuit of the power valve a choke-output filter is incor-

porated; this not only gives increased stability, but prevents the heavy direct current in the power-valve anode circuit from doing harm to the loud-speaker windings.

All four valves are controlled by a master rheostat, which is used as an on-off switch, but in addition a separate rheostat is supplied for the high-frequency valve; this acts primarily as a volume control and also enables the valve to be switched off for ease in neutralising.

A glance at the photograph of the front of the Drum Major, which

IT IS HARD TO BEAT THE DRUM MAJOR FOR QUALITY!

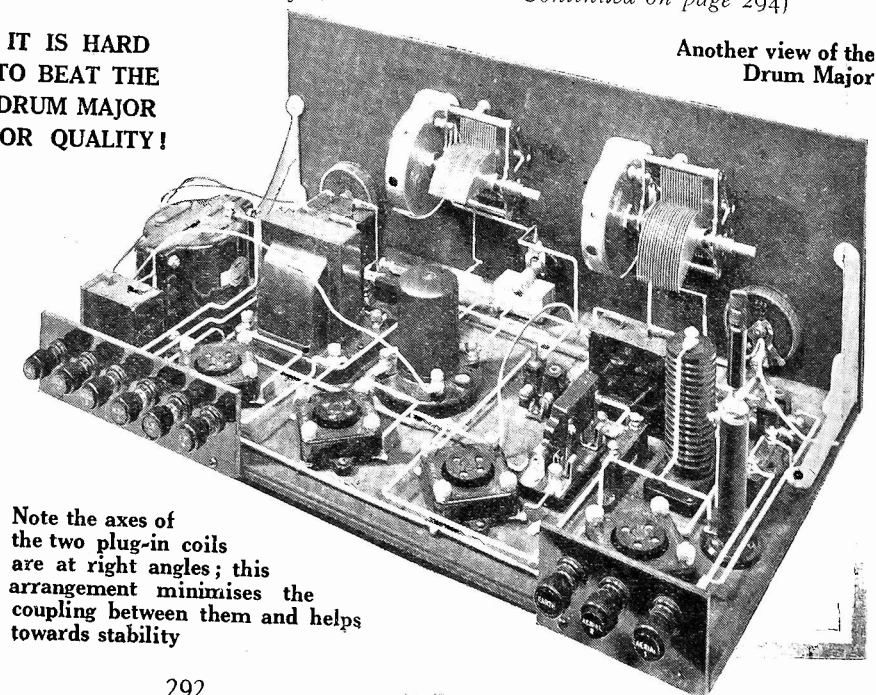

Another view of the Drum Major

Note the axes of the two plug-in coils are at right angles; this arrangement minimises the coupling between them and helps towards stability

appears on page 290, will show how neat is the completed receiver. Apart from the two rheostats already mentioned, there are only three tuning controls.

The thumb control on the left is for the aerial-tuning condenser, while that on the right tunes the detector-valve grid circuit. The small knob in the centre is the reaction control.

Mounting the Variable Condenser

Looking at the back of the set, it will be seen that the variable condensers are mounted to the right of their respective drum dials. The manufacturers intended them to be the other way round, but in order to keep the wiring of the tuned circuits reasonably short, we found it necessary to reverse the positions.

This necessitates the use of small nuts for making the connections, as the terminals supplied would foul the dials with the condensers on the right-hand side.

Efficient Components

It would be a difficult matter to pick out more efficient components than have been utilised in the Drum-Major, and those who believe that the best is always the cheapest in the long run will find it a most satisfactory four-valver to use.

As regards the actual construction, little need be said. As is the case with

Continued on page 294)

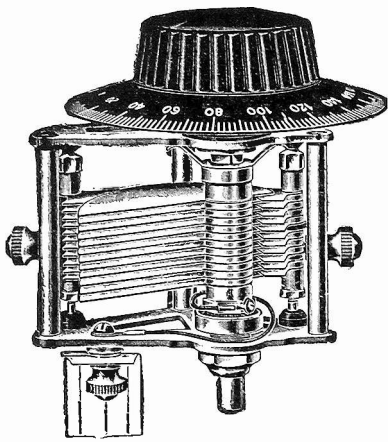

The 'DRUM MAJOR' results depend on 'ORMOND' super Quality!

"Wireless Magazine." To ensure the best possible results always fit Ormond Components and enjoy the utmost precision at the lowest price.

THE ORMOND LOGARITHMIC CONDENSER. Designed to meet the demand for a smaller type of Condenser and to give the greater efficiency where space is limited. Adaptable for "one-hole fixing" baseboard mounting, or "along panel mounting" for drum control.

Capacities :—	.00013	..	7/6	.00025	..	7/6
	.00035	..	7/9	.0005	..	8/-

THE ORMOND SLOW MOTION DRUM DIAL. This dial is of very attractive appearance, designed for simplicity and ease of attachment. No slip and no back lash. The control knob moves in the same direction as the dial. **PRICE 5/-**

Leaflets and Booklets on request



The ORMOND ENGINEERING CO., LTD.
199-205 Pentonville Rd., King's Cross, London, N.1

Phone : Clerkenwell 9344-6. Grams : "Ormondengi, Kinross."
Factories : Whiskin Street, and Hardwick Street, Clerkenwell, E.C.1.
Continental Agents : Pettigrew & Merriman, Ltd., "Phonos House," 2 and 4 Bucknall Street, New Oxford Street, London, W.C.1.

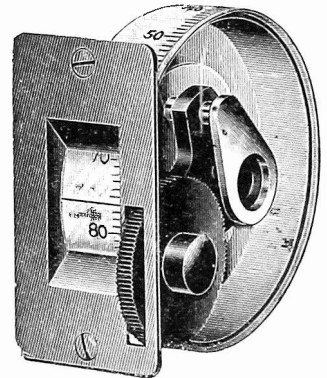

Build your own H.T. Unit

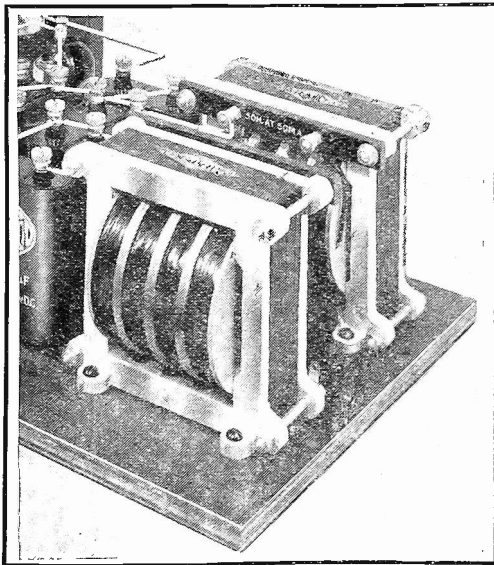

"Parmeko" 50 Henry Smoothing Chokes.

Price 30/- each.

Build your own H.T. Unit and put end to all the troubles usually experienced with dry batteries. The "Safe H.T. Unit for D.C. Mains," described by Mr. W. James on page 233 of this issue will give you an ample supply of silent, trouble-free H.T. continuously and without variation. But you must use the "Parmeko" Chokes specified by the designer. "Parmeko" Chokes were chosen because of their high inductance, ample current carrying capacity and robust reliable construction.

Write for full particulars of the above and other "Parmeko" Products. We are specialists in Mains Radio Components, and if there is not a standard component to meet your requirements we shall be pleased to quote you for any type of Transformer, Choke, or Rectifying Apparatus.

PARTRIDGE & MEE, LTD.,
12 Belvoir Street, LEICESTER

The Drum Major (Continued from page 292)

The Drum Major is a "quality" Set

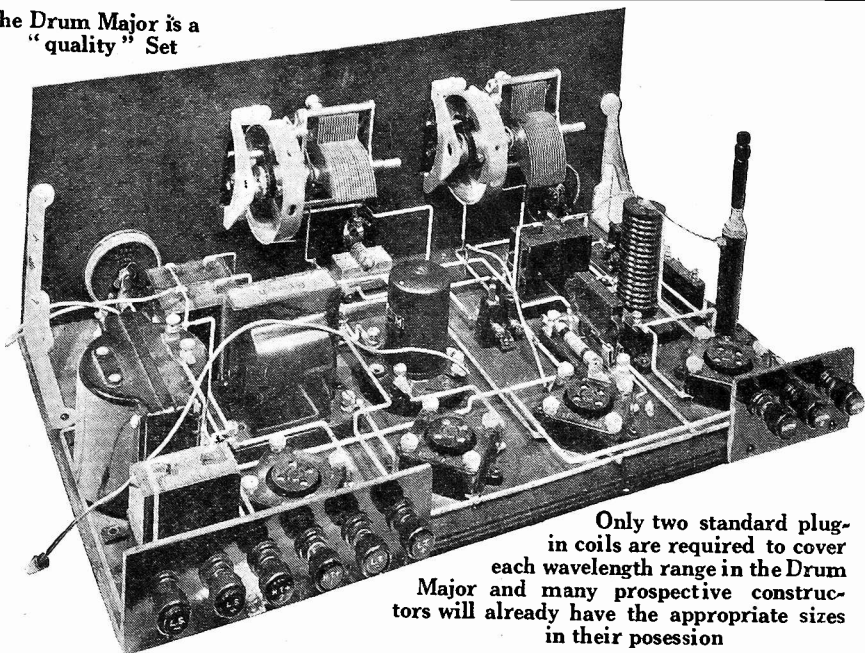

Only two standard plug-in coils are required to cover each wavelength range in the Drum Major and many prospective constructors will already have the appropriate sizes in their possession

all WIRELESS MAGAZINE receivers, a full-size blueprint is available; this can be obtained for half price, that is 9d., post free, if the coupon on page iii of the cover is used by April 30.

Ask for No. W.M. 137, and address your inquiry to Blueprint Department, WIRELESS MAGAZINE, 58/61, Fetter Lane, E.C.4.

What the Blueprint Shows

This full-size blueprint (a reduced reproduction will be found alongside) shows clearly the arrangement of all the parts. Each connection is numbered in order of assembly, and all drilling points and sizes are clearly indicated.

Little need be said about the actual construction of the receiver, which will be found quite straightforward if the blueprint and photographs are referred to constantly.

As soon as all the parts are firmly fixed in position, wiring up can be started, and at this stage the full-size blueprint will be found of particular benefit. On this, and on the reduced reproduction of it on this page, every wire is numbered separately and in order of assembly.

If the wiring is carried out as recommended, the leads will automatically take their most convenient positions for the baseboard upwards.

Coils Tapped at Socket End Must be Used

For each wavelength band two plug-in coils will be needed, of course. The set is wired for a Lewcos coil in the aerial holder, as these coils are tapped from the socket end. If other makes of double-tapped coil are used, make sure that they are also tapped from the coil end or neutralisation will not be obtained until the aerial-coil holder is reversed.

A No. 60 double-tapped or No. 75 double-tapped coil can be used in the aerial position for

the lower wavelength band, with a No. 60 centre-tapped coil in the detector grid circuit.

For the long waves use a No. 200 or 250 double-tapped coil in the aerial position and a No. 200 centre-tapped coil in the second holder.

The valves for use in the Drum Major must be chosen with care, not because the set is critical as regards valves, but because the best results will not be obtained unless the valves match up properly with the components used.

High-frequency Amplifier

The high-frequency amplifier should have an impedance between about 20,000 and 50,000 ohms; the value is not at all critical. For the detector stage a valve with an impedance between 50,000 and 100,000 ohms should be employed; a value between these figures will give the best result with the 200,000-ohm anode resistance included in the Mullard resistance-coupling unit.

For the first low-frequency stage a valve with a low

(Continued on page 296).

LAYOUT AND WIRING OF THE DRUM MAJOR

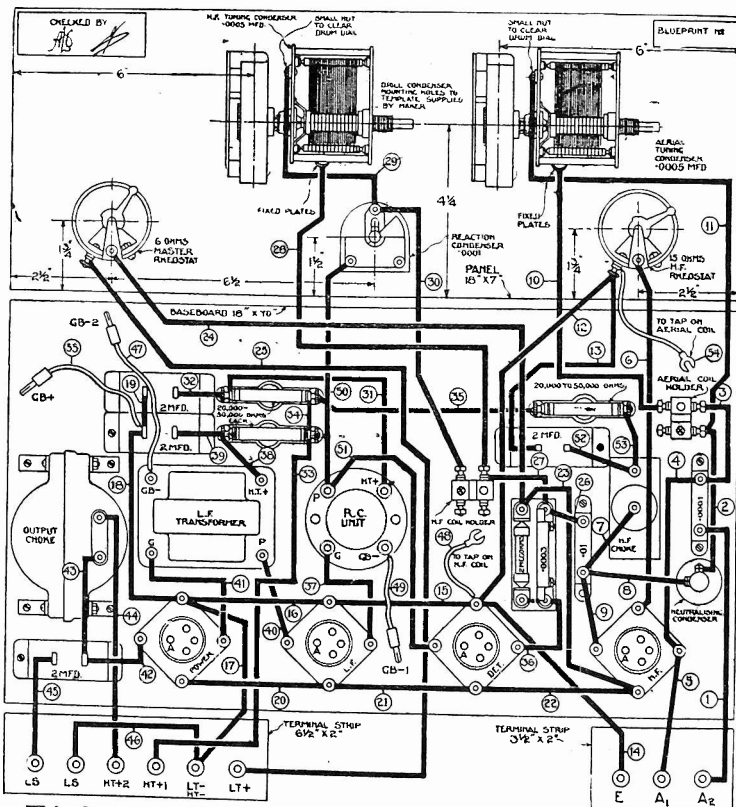

This layout and wiring diagram can be obtained for half-price that is, 9d., post free) if the coupon on page iii of the cover is used by April 30. Ask for No. WM137

WEARITE COMPONENTS

**WRIGHT &
WEAIRE, LTD.**
740, High Road
TOTTENHAM
N.17

W. James Special 3 Coils per pair 25/-
" Binowave Coils " 25/-

Q COILS

Aerial, 15/- each. S.P. H.F., 21/- each.
S.G. H.F., 21/- each. Reinartz, 21/- each.
Mullard Master 3 Star, 15/- each.

Q Coils for Simple Screen 3 per pair 36/-
Screen for " " each 3/6

Coils for Lodestone 3 .. per pair 30/-
Screen for Lodestone 3 .. each 3/6

ANODE FILTERS (see this issue)

H.F., 8/6 each. L.F., 9/6 each.

Standard H.F. Choke each 6/6
500-w. or 600-w. Resistances .. 1/6

Paxolin Tubes, 3 by 3½ 1/2½
" " 2 by 4 1/-

All Coils and Screens as published in "Wireless Magazine" and "Amateur Wireless."

WRITE FOR LISTS.

TELEPHONES TOTTENHAM 3847-3848.

PRICE REDUCED !



PERMANENT CHARGER.

With L.T. Coupler	Without L.T. Coupler
½ amp. 47/6	½ amp. 42/6
1 amp. 70/-	1 amp. 65/-



The Regent Radio Supply Co., 21 Bartlett's Bldgs, E.C.4



The valve with
the wonderful
Mullard P.M.
Filament

Hear the radio programmes with Mullard P.M. Valves in your receiver. Let them put life and colour into the performance, bringing it to you clean, clear and well defined.

Get a set of Mullard P.M. Valves to-day—all radio dealers sell them.

Mullard

THE MASTER VALVE

Advt.—The Mullard Wireless Service Co., Ltd., Denmark House, Denmark Street, W.C.2

THERE MUST BE A REASON-

WHY 'CELESTION' IS THE MOST POPULAR LOUD-SPEAKER AMONG THE MANY THOUSANDS OF LISTENERS.

IT IS RECOGNISED

as the one Loud-speaker which shows you just how good Broadcast Transmission really is.

CELESTION

THE VERY SOUL OF MUSIC

Models from £5. 10. 0. Made under Licence. Insist on your dealer demonstrating, or call at our showrooms, one minute from Victoria Station, where you can also hear the finest sets. Write for illustrated booklet to

CELESTION, LTD. (Dept. K)
KINGSTON-on-THAMES

SHOWROOMS:

106 VICTORIA STREET,
LONDON S.W.1.

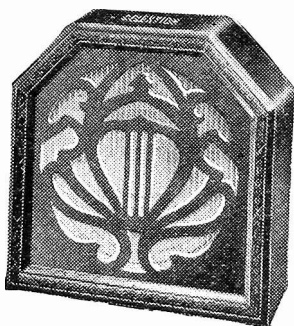

Model C12

WHEN A BETTER LOUD-SPEAKER IS MADE CELESTION WILL MAKE IT

The Drum Major (Continued from page 294)

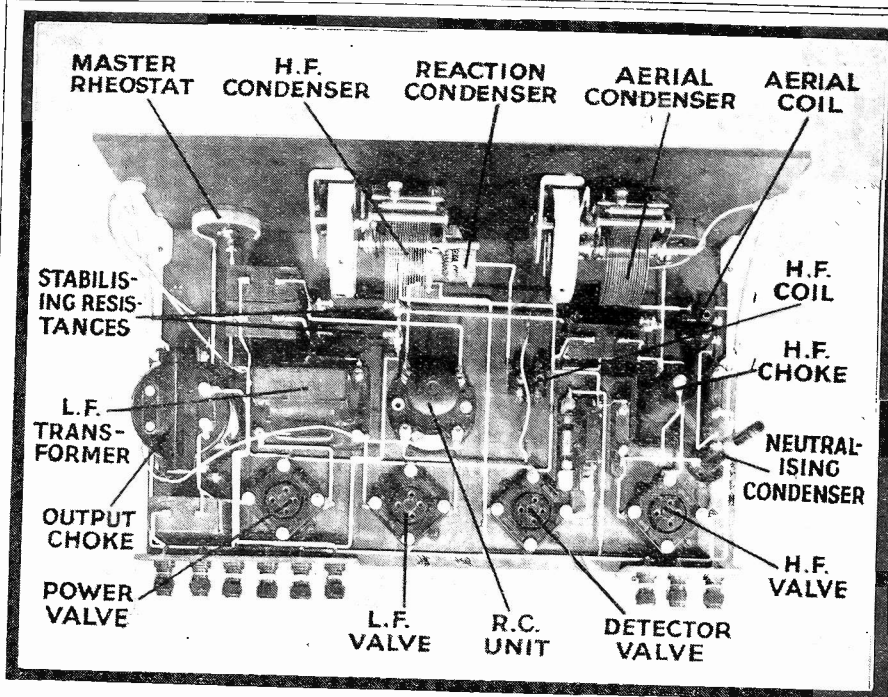

This plan view clearly shows the layout of all the parts in the Drum Major. There is no crowding

impedance is desirable, say, between 8,000 and 12,000 ohms. The power valve should have a very low impedance, certainly not more than 3,500 ohms. A good value for most cone loud-speakers is 2,500 ohms.

To be more specific, we give here details of suitable valves of three representative makes:

SIX-VOLT VALVES

Cossor: 610HF, 610RC, 610LF, 610XP.

Osram: HL610, DEH610, DEL 610, P625.

Mullard: PM5X, PM5B, PM6D, PM256.

(Continued on page 299)

COMPONENTS REQUIRED FOR THE DRUM MAJOR

- 1—Ebonite panel, 18 in. by 7 in. (Becol, Radion, or Trolite).
- 2—.0005-microfarad variable condensers (Ormond Midget, Burndept, or Jackson).
- 2—Thumb dials (Ormond or Utility)
- 1—15-ohm panel rheostat (Lissen, Peerless, or Igranic).
- 1—6-ohm panel rheostat (Lissen, Peerless, or Igranic).
- 1—.0001-microfarad reaction condenser (Bulgin, Peto-Scott, or Cyldon).
- 2—Single coil holders (Magnum, Lissen, or Lotus).
- 1—.0001-microfarad fixed condenser (Trix, Dubilier, or T.C.C.).
- 1—.01-microfarad fixed condenser (Trix, Dubilier, or T.C.C.).
- 1—Neutralising condenser (Gambrell or Jackson).
- 1—High-frequency choke (Lewcos, Wearite, or Bulgin).
- 2—20,000-ohm resistances with holders (Graham-Farish, Ediswan, or Igranic).
- 1—30,000-ohm resistance with holder (same makers).
- 1—Combined .0003-microfarad fixed condenser and 2-megohm grid leak (Mullard).
- 4—Anti-microphonic valve holders (Benjamin, Formo, or Lotus).
- 4—2-microfarad fixed condensers (Mullard, T.C.C., or Lissen).
- 1—Resistance-capacity coupling unit (Mullard).
- 1—Low-frequency transformer (Brown).
- 1—Output choke (Marconiphone Ideal, Igranic, or Parmeko).
- 2—Terminal strips, 3½ in. by 2 in. and 6½ in. by 2 in. (Becol, Radion, or Trolite).
- 9—Terminals, marked:—Aerial 1, Aerial 2, Earth, L.T.+ , L.T.—, H.T.+1, H.T.+2, L.S.+ , L.S.— (Belling-Lee, or Ealex).
- 2—Spade tags (Lectro Linx).
- 3—Wander plugs, 2 black and 1 red (Lectro-Linx).
- Length of rubber-covered flex (Lewcos).
- Stiff wire for connecting (Glazite).
- 4—Two-pin plug-in coils (Lewcos).
- 1—Cabinet with 10 in. baseboard (Carrington).

A Cone Loud-speaker

Tested by J. H. REYNER, B.Sc., A.M.I.E.E.

A CONE of suitable material and a balanced armature unit are two important items in the design of a good cone loud-speaker. Judging from the popularity which this combination has enjoyed recently, the reproduction obtained from such an assembly is pleasing to the general public.

There are, however, other matters which have an important influence on the final results, such as the mounting and housing of the cone in some suitable cabinet, which should be sufficiently large to make an effective baffle and have sufficient internal space to prevent box resonance.

We have received for test an Eloden loud-speaker (submitted by Lessingham's, of 13 Victoria Street, S.W.1). This is manufactured in Germany under various British patents. The cone is firmly fixed to a wooden baffle, 15½ in. wide and 11½ in. high, which also forms a case 3½ in. deep. The cone is protected by an attractive brocaded silk covering, which adds to the general appearance of the speaker. A balanced armature and cone unit is securely mounted internally and clamped to the

centre of the 8½ in. cone. This unit has an adjusting screw and is fitted with a short length of flex.

When placed on test, the sensitivity appeared to be up to standard for cone loud-speakers, whilst the reproduction

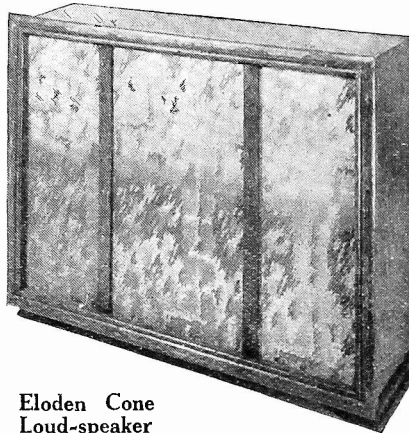

Eloden Cone Loud-speaker

was quite pleasing, the speech being clear and free from undesirable drumming.

Readers' Questions Answered

Moving-coil Loud-speakers

Q.—When using a moving-coil loud-speaker is it essential that an output transformer or an output-filter circuit be interposed between the receiver and the moving-coil winding?—H. D. (Birmingham).

A.—It is not absolutely essential in all cases to use an output transformer or filter circuit between the receiver and the loud-speaker, but, in view of the fact that the A.C. resistance of the moving-coil windings in no way approximates to the A.C. resistance of the output valve, it is very advisable to use an output circuit of some sort between the set and the speaker.

As far as high-resistance moving coils are concerned, an output-filter circuit is usually satisfactory, but where a low-resistance moving coil is used an output transformer is generally required.

H.T. and L.T. from House Lighting Cells

Q.—I wish to obtain my H.T. and L.T. from the house lighting system, which consists of a 150-volt battery of cells, which are charged periodically by means of a private generator. Do I require an eliminator system for this purpose or not? If such is needed, can you advise what components are necessary?—K. O'D. (Maidstone).

A.—There is really no need for an eliminator system as your house-lighting batteries supply a smooth direct current. You will only need to run separate leads from the house batteries to the respective H.T. and L.T. terminals on your set and then make sure that you have a large-capacity reservoir condenser between each positive H.T. terminal on the

set and negative H.T. A similar reservoir condenser should also be connected across the L.T. terminal; on the set.

As the long leads from the house system batteries to the set will create a certain voltage drop, it will be necessary to allow at least a 2-volt drop for the L.T. supply circuit. In other words, if you are using 2-volt valves in the set, then tap off two cells, equalling 4 volts, from the house battery for your L.T. supply. If 4-volt valves are used, then tap off 6 volts from the house batteries for L.T., whilst if 6-volt valves are used, tap off 8 volts or, if necessary, 10 volts, from the house batteries for L.T. supply.

In all cases it would be a good plan to arrange for a voltmeter to be connected permanently across the L.T. terminals of the set to ensure adequate L.T. voltage supply at the terminals of the receiver.

Check for Filter Circuit

Q.—What is the best value for the choke used in a filter circuit attached to the output of an amplifier?—R. V. (Glasgow).

A.—No definite value can be stated to be best. It all depends upon the D.C. resistance of the choke being low, so that the voltage drop across it will be small, whilst the A.C. resistance or impedance should approximate that of the valve in whose plate circuit it is connected.

Generally speaking, a 20-henry or 30-henry choke are found to combine the above desirable features, and chokes of the above values by reliable makers are suggested. Should you have a preference for any particular manufacturer's choke, then a letter to the service department of that firm would elicit the information you require.

K. RAYMOND

27 & 28a LISLE STREET, LONDON, W.C. 2
Come to Leicester Square Tube.
This address is at the back of Daly's Theatre. Phones: GERRARD 4637 & 2621

WE ARE OPEN

ALL DAY EVERY DAY. Hours 9 a.m. to 8 p.m.
ALL DAY SATURDAY. Sat. 9 a.m. to 9 p.m.
ALL DAY THURSDAY. Sunday morning 11-1.

C.O.D. Goods despatched Cash on Delivery (pay postman) at slightly increased charge.

LEADING HOUSE for KITS of PARTS

See weekly Advt. all wireless papers.

140p. CATALOGUE Illustrated all Latest Components, and Price Lists FREE FOR CARD.

Any list of components over 25/- quoted for at a special price, where possible.

Q COILS

Q.A. 15/- Q.A.M. 21/-
Q.A.R. 21/- Q.S.P. 21/-
Q.S.G. 21/-
Lewcos or Finston.

S.G. VALVES

Mullard .. 22/6
Six-Sixty .. 22/6
Cossor .. 22/6
CLEARTRON 12/6

We stock Igranic, Climax, Ever-Ready, Hellesen, Siemens, Formo, Ferranti, Wearite, Ormond, J.B., Benjamin, Lotus, Mullard, Dubilier, Lissen, Lewcos, Utility, Magnum, Peto-Scott, Peerless, Burndept, Pye, Marconi, McMichael, Cosmos, Carborundum, R.I.-Varley, Gambrell, Browns, Sterling, Amplions—in fact, everything it is possible to stock in Radio Components.

DARIO RADIO-MICRO.

2-v. and 4-v. G.P., 5/6;
Power, 7/6; H.F. Super,
7/6. Post 6d. (3 free).

TRIOTRON VALVES

H.F., Det., R.C., 5/2
each. Power, 6/9. 2-v. or
7/6. 4-v. Post 4d. (10/- free).

LATEST SQUIRE 97

RIGID ALUMINIUM CRADLE, FLOATING CONE, CLAMPING BOARD ASSEMBLED AND 15/6 SPARE CONE KIT FOR

Our model 97 is supplied assembled complete with duplex woven floating cone, clamping board AND a KIT of Parts for making Kraft cone. Diameter of cone 9½ ins.

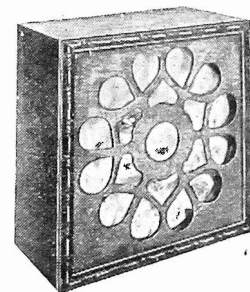

HANDSOME OAK POLISHED SPEAKER CABINETS. 13x13x6

12/11 Post 1/3

Cannot guarantee exact pattern of front panel, but all good designs.

Blue Spot 25/- 66K (101)

4 POLE BAL. ARM OR THE LOT WITH BUCKRAM CONE 12 in.

Carriage 35/- Paid

ALSO TO TAKE ASSEMBLED SQUIRE CRADLE. 17/6, post free.

GLIPPER TWO

SET OF PARTS ("W.M." April, 1929)
0005 Formo, 5/- S.M. mfd. Dubilier or Lissen,
Dial, 3/- Coil Holder, 3/6, 20,000 ohm. Edi-
1/- .0001 Reaction, 4/- swan, 2/6, holder, 6d.
15 ohm. Igranic, 2/- 2 L.F., R.I. & Varley, 15/-
Spring Valve Holders, (ANY OTHER, add
2/6, 3 meg. and Holder, balance). 60 C.T. Lissen.
1/6, .0002 fixed. 1/- 2 6/4. 250 C.T. Lissen, 9/9.

ALSO

Strip 7 x 2, 7 Engraved Terminals, Battery Clips, 9-v. G.B., Plugs, Spring Clip, Flex, Panel 6 in. square, Baseboard 12 x 6.

The Lot 63/- C.O.D. 1/- Extra VALVES—Power 12/6, H.F. 10/6 Short-wave Coils, Set (4) 7/6, 10/-

COUPON. "W.M." SPECIAL

For every 30/- you spend you can buy for 3d. extra ANY ONE of following Lots:
S.M. Dial, 100 ft. 7/22 Copper Aerial, 12 yds. Lead-in, Fuse and Holder, 12 Nickel Terminals, 60X Coil, H.F. Choke, Permanent Detector, Battery Switch, 9003 and 2-meg. Leak, 9-volt Grid Bias, Panel Brackets, 6-pin Coil Base, 100 ft. Insulated Aerial, Loud Speaker Silk Cord, 30 ft. Covered Connecting Wire, 12 yds. Twin Flex, 100 ft. Indoor Aerial, 100 ft. Silk Frame Aerial Wire.

See Advt. in all Wireless Journals
COUPONS AVAILABLE at K. RAYMOND'S ONLY



THE SECRET OF TROUBLE-FREE RECEPTION . . .

Trouble-free reception is what every listener desires, but finds difficult to obtain. The source of most trouble is H.T. supply. Dry batteries are associated with crackling and are an unknown quantity as to length of life, and, on the average, cost anything from 50s. to £3 per annum for renewals. Accumulators require re-charging—often when you least expect.

The solution to these troubles is a Clarke's "Atlas" Battery Eliminator. The first cost is the last, and even on the largest set the cost of current consumed is not more than 2d. per week.

The model illustrated is D.C.50, a super model for use with receivers requiring large output current, and has two variable tappings of 0/180 volts each and two fixed tappings, one of which is 120 volts and the other 200 volts.

Maximum output varies from 20 m/A. to 60 m/A, according to voltage used. Price £7 15s.

All "Atlas" Elim'ators are backed by the "Atlas" guarantee, and the full range covers every need and purse for either Alternating or Direct Current.

Ask your dealer or send direct for beautifully illustrated Brochure No. 32, which gives full details of all

CLARKE'S "ATLAS" BATTERY ELIMINATORS

CLARKE'S "ATLAS" COILS

are specified for "The Clipper Two" Set described in this issue. Send for descriptive Leaflet and Price List.

**H. CLARKE & CO.
(M/CR) LIMITED
ATLAS WORKS
OLD TRAFFORD
MANCHESTER**

Using the Melody Maker on the Short Waves

THOSE readers who run a Cossor Melody Maker will be glad to know that the short waves are now accessible to them, since a set of

night to see what we could do in the way of the American short-wave stations.

We found at first that the handling of the set on these wavelengths was rather tricky owing to the necessity for keeping the two condensers in step; after a little while, however, we were able to pick out the various stations without much difficulty.

Soon after 11 p.m., we picked up the carrier wave of 2XAF and soon obtained music and speech at good loud-speaker strength.

We found that a little care had to be exercised in operating the reaction control owing to the fact that there is a noticeable hand-capacity effect on the short wavelengths. Another station, 2XAD, on 19 metres, was also tuned in, but with less volume.

These coils can be recommended.

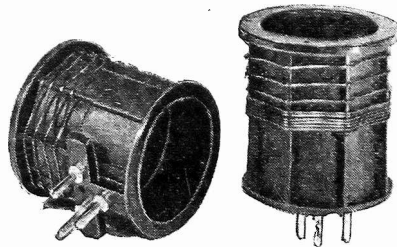

Cason Short-wave Coils for the Cossor Melody Maker

suitable short-wave coils has now been marketed by Cason Mouldings, of Chiswick Road, Lower Edmonton, N.9. The coils are plugged in in place of the ordinary coils.

To test the coils we stayed up one

New System of Focused Radio

DR. FREDERICK AUGUST KOLSTER, who has contributed as much to radio as any man now alive, has invented yet another radio device, a machine for shooting a radio beam at whatever point on earth he pleases.

Its shape, size, and attachments all concentrate the short waves from the transmitting valve in a straight, narrow beam, much like the beam from a search-light.

Tangential to Earth's Surface?

By lay supposition, such a straight-going beam would be tangential to the earth's curvature and so never reach distant earth points where radio stations may be. By scientific theory, two possibilities exist. The Kolster beam may be skillfully aimed at the Heaviside Layer and be reflected down to its receiving station, just as a billiard player bounces a ball from cushion to pocket. The other possibility is that gravity will drag the beam to the proper curve of the earth.

How It Differs from Marconi's

Dr. Kolster's beam differs from Marconi's. In the Marconi system the number of wires at each side of the sending aerial keep the waves from spraying sideways, but not from up and down. It is not properly a beam at all.

It is a very narrow sheet of short waves that go round the earth like a ruff. They suffer the same troubles, in less degree, that the diffuse long waves do. F. P.

Previous Inventions

His previous inventions have been the invaluable radio compass, the radio fog-signal system, the mobile radio beacon to protect ships in fog, the decimeter which measures wavelengths and dampens radio oscillations.

He created the Bureau of Standard's radio section in America and is its chief. He is chief research engineer of the Federal Telegraph Company and its allied companies.

News of Dr. Kolster's latest invention developed recently as work went on to set up an experimental station near his home in Palo Alto, California.

Arrangement of Transmitter

The transmitter consists of a parabolic reflector, at whose butt end is an enormous vacuum valve. The valve looks like the heating element of the common portable electric heaters. The heater's reflector is so vast (20 feet across the rim) that it resembles a funnel.



THE WIRELESS WAVE-WIZARD

BANISH STATION INTERFERENCE—LISTEN IN CLEARLY TO THE STATION YOU WANT TO HEAR WITHOUT DISTRACTION FROM OTHER STATIONS.

GET STATIONS YOU HAVE NEVER HEARD BEFORE—HOME AND FOREIGN.

HEAR CLEARLY EVERY WORD, EVERY NOTE YOU LISTEN-IN TO—AND WITH GOOD VOLUME.

ELIMINATE MORSE INTERFERENCE. MAKE YOUR RADIO A REAL ENTERTAINMENT.

ONLY ONE WIRELESS COMPONENT WILL GUARANTEE TO DO THESE THINGS FOR YOU WITH YOUR PRESENT RADIO SET AND THAT IS THE

HARLIE WAVE SELECTOR 12/6 ONLY

10,000 SOLD 10,000 SATISFIED

It definitely converts an old type set into the most modern and makes the most modern more selective, clearer and louder. It equals the performance of many screen-grid valve sets. All you have to do is just plug your aerial into the socket provided on the Harlie Wave-Selector. Instructions supplied. No alterations to your set are necessary. The selector is neat and small, being only 4 3/4 inches high and 3 3/4 inches in diameter. It is finished throughout in black crystalline.

OUR £100 GUARANTEE ASSURES YOU SATISFACTION OR MONEY RETURNED

If found unsatisfactory and returned to us within 7 days of purchase, we guarantee to return your money in full, or forfeit the sum of £100. This is providing it is purchased direct from us, but a similar arrangement can be made with your dealer.

If unobtainable, either model will be sent on receipt of 12/6, or per C.O.D., on receipt of P.C.

TWO MODELS SUPPLIED
(a) Normal Waveband—200 to 700 metres.
(b) High Waveband—700 to 2,000 metres.

Write to-day to:

HARLIE BROS. (Dept. X.) BALHAM RD., LOWER EDMONTON, LONDON, N.9

Telephone. Tottenham 3446

The Drum Major (Continued from page 296)

TWO-VOLT VALVES

Cossor: 210HF, 210RC, 220P, 230XP.

Osram: HL210, DEH210, DEP215, DEP240.

Mullard: PM1HF, PM1A, PM2, PM252.

Before the set can be used the appropriate valves and coils must be inserted in their respective holders and the batteries connected.

On the terminal strip there are points for two high-tension positives and low-tension positive, high-tension and low-tension negative being common to one terminal.

High-tension Supply

To H.T. +1 apply about 100 volts (for the first three valves), and to H.T. +2 apply 120 to 150 volts (or the maximum for the particular power valve used). No terminals are provided for the grid-bias battery, as it is intended that this should be mounted inside the cabinet by means of clips.

Operating the Drum Major

There is no difficulty at all about the operation of the Drum Major. For many stations the reaction control need hardly be adjusted, while the thumb control used with the new Ormond condenser gives fine control.

Switch on the set by turning the knob of the master rheostat to the right as far as it will go. Now turn the thumb control of the right-hand condenser until the local station is picked up. Normally this will be received without any adjustment of the aerial condenser, which can be brought into tune afterwards to give the maximum signal strength.

Neutralising the Set

At an early stage it is desirable to neutralise the high-frequency valve. To do this tune in a station strongly and turn off the left-hand rheostat (on the left of the panel), but do not remove the valve from its holder.

Next adjust the neutralising condenser on the baseboard until the station previously tuned-in becomes inaudible. At this point the valve capacity is neutralised or balanced and the set can be used in the ordinary way. Neutralisation must be carried out on each waveband.

OMNORA LTD.

THE SET BUILDERS SUPPLY STORES

Build the DOMINIONS FOUR

as described in this issue.

	£	s.	d.
1 Cabinet with 10 in. baseboard	1	5	0
1 Mahogany or Black panel, 20 in. by 8 in. ready drilled	9	0	0
1 Lokvane .0005 variable condenser	10	6	0
1 Lokvane twin gang .0005 variable condenser	2	10	0
1 2-in. dial for aerial condenser	1	0	0
1 Igranac Vernier drum control	17	6	0
1 Lissen 7-ohm panel rheostat	2	6	0
1 Lissen 15-ohm panel rheostat	2	6	0
1 .0001 reaction condenser	2	6	0
3 Magnum 6-pin coil bases	6	0	0
2 Screened-grid valve holders	7	0	0
2 Lotus anti-microphonic valve holders	3	6	0
1 Formodenser, type J	2	0	0
4 Marconiphone H.F. by-pass units	1	9	0
3 Wearite H.F. chokes	19	6	0
2 Fixed condensers, .01-mfd.	5	0	0
2 Rheostat variable resistance, as described	10	6	0
1 Dubilier fixed condenser, 2-mfd.	3	6	0
1 Ediswan 20,000 ohm resistance	2	6	0
1 Phillips L.F. transformer	1	5	0
1 14-volt battery U.W.3	1	0	0
1 44-volt battery U.W.3	1	3	0
3 Grid battery clips as specified	9	0	0
3 Terminal strips as specified	2	0	0
7 Belling-Lee terminals as specified	3	6	0
1 Special screen with baseboard foil	15	0	0
1 Pair Magnum panel brackets	1	6	0
Glazite connecting wire	8	0	0
3 ft. R.C. flex	6	0	0
3 Spade tags and 2 wander plugs	10	0	0
1 Tunewell aerial coil	10	6	0
2 Tunewell anode coils	1	1	0
	£14	14	0

1 Set of valves for above £3 8 0
Any of the above parts supplied separately as required.
The "DOMINIONS FOUR," ready wired and tested, including valves and cabinet £20 0 0
We can supply as constructional Kits or ready wired and tested all Wireless Press receivers.

OMNORA LTD. Home Construction Specialists

258 NEW CROSS ROAD, LONDON, S.E.14

Phone: New Cross 1273.

BERCLIF COILS

FOR THE

TOUCHSTONE & LODESTONE THREE

Per Pair 30/-

INTERCHANGEABLE Long and Medium Wave

SET OF FOUR COILS & BASES £3-16-6

Made by the original EVERYMAN Specialists

SIMMONDS BROS., SHIRELAND ROAD, SMETHWICK

Illustrated List Free. Trade Supplied

Prevent that Acid Creeping!

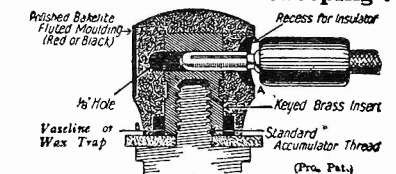

CLIX KNOBS on your accumulator means an end to corroded terminals, bad contact, noisy reception and all the troubles and damage caused by the creeping of acid. THE VASELINE TRAP in the Clix Knob makes corrosion impossible and ensures clean contact. Connection is made by inserting Clix-Lox or Clix Parallel Plugs into the socket provided.

Red or Black 5d. each.

Extension stems for countersunk type, 1d. each.

LECTRO LINX, LTD., 254, Vauxhall Bridge Road, London, S.W.1.

BUY "AMATEUR WIRELESS" 3d. Weekly

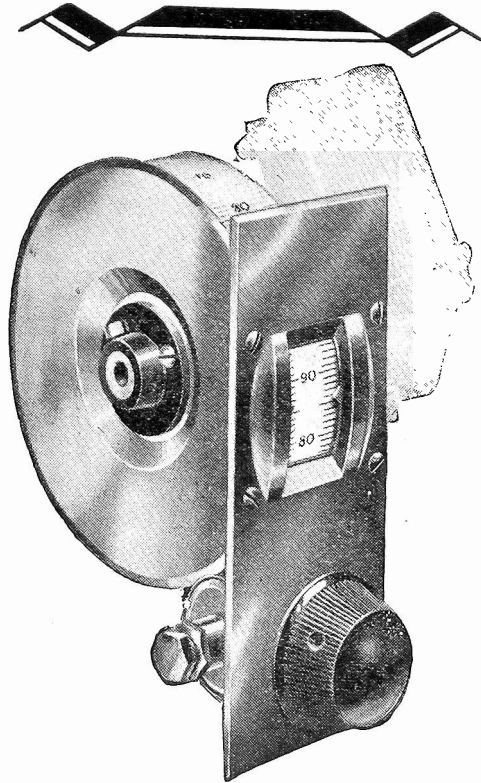

A Real DRUM DIAL

It has been left to J.B. to improve on models of recent years and to produce a perfect Drum Dial—the only *real* Drum Dial. The design is most ingenious, the control knob being placed just under the scale, which is thus flush with the panel plate and easily readable. Positive Friction Drive eliminates backlash. This new product reaches that high standard of finish and precision found in all J.B. instruments. The Condenser may be mounted on left or right of Dial. The drive will handle a heavy gang condenser with ease. Panel Plate in either bronze or oxydised silver.

PRICE **10/6** COMPLETE



left-hand Condenser and bracket. Price, complete, .0005, £1-10-6; .0003, £1-8-6.

PRECISION INSTRUMENTS

Adv. of JACKSON BROS., 72, St. Thomas' Street, London, S.E.1. Telephone: Hop 1837.

"Wireless Magazine" REFERENCE SHEETS

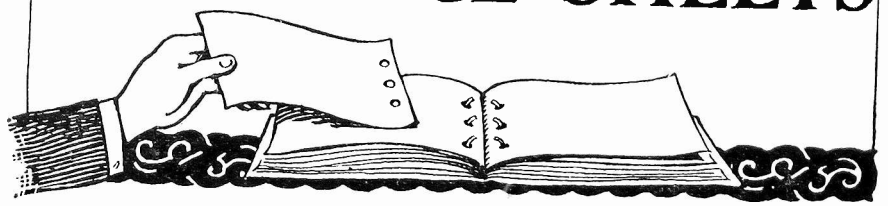

Compiled by **J. H. REYNER, B.Sc., A.M.I.E.E.**

Month by month these sheets can be cut out and filed—either in a loose-leaf folder or on cards—for reference. The sequence of filing is

a matter for personal choice. In a short time the amateur will be able to compile for himself a valuable reference book.

WIRELESS MAGAZINE Reference Sheet

No. 116

Grid Current in Detector Valve

THE resistance of the grid-filament path of a detector valve has an important bearing on the quality of reproduction where a cumulative-grid detector is employed, as also upon the sharpness of tuning of the preceding circuit. These points were discussed in Sheets Nos. 113 and 114, the latter sheet containing information regarding the approximate order of resistance obtainable with modern valves in the two-volt series.

The table given herewith indicates the average order of grid-filament resistance to be expected with 4-volt and 6-volt valves. As in the previous instance, both H.F. and R.C. valves have been tested, a number of samples being tried of different makes, the results given below being an average value.

The resistance increases as the positive potential on the grid is increased and consequently a number of results have been taken corresponding to the connection of a 2-megohm grid leak to $\frac{1}{2}$, $\frac{2}{3}$, and the full way across the LT.

The formula quoted in Sheet No. 113 shows that if the frequency characteristic is to be maintained uniform up to 5,000 cycles per second, the grid resistance must not be greater than 600,000 ohms. This condition is complied

with in every test shown below and it would therefore appear that a quarter tap is the best on 4- and 6-volt valves.

Type of Valve	Potential of grid, connected through 2-megohm leak	Resistance of grid-filament path (ohms)
H.F. (4-volt) ..	1.0	300,000
	2.0	210,000
	3.0	140,000
R.C. (4-volt) ..	4.0	100,000
	1.0	170,000
	2.0	95,000
H.F. (6-volt) ..	3.0	65,000
	4.0	55,000
	1.5	250,000
R.C. (6-volt) ..	3.0	135,000
	4.5	90,000
	6.0	75,000
	1.5	200,000
	3.0	130,000
	4.5	100,000
	6.0	85,000

WIRELESS MAGAZINE Reference Sheet

No. 117

Multi-layer Coils, Inductance of

AN approximate formula of the calculation of the inductance of all types of coil was given in Reference Sheet No. 115. Single-layer coils are best calculated by the use of Nagaoka's formula, which involves a simple calculation depending upon the dimensions of the coil together with the application of a correcting factor, also depending upon the dimensions of the coil, to allow for the departure from the ideal infinitely long solenoid. Details of this formula were given in Sheet No. 49.

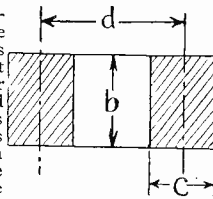

tical results assisted by theory. It only applies to multi-layer coils and is not accurate if extended to single layer coils by putting $c = 0$. The formula is as follows:—

$$L = \frac{9.87 n^2 d^2}{0.2317a + 0.44b + 0.39c}$$

Where L = inductance (microhenries).

d = mean diameter of coil.

b = length of coil.

c = winding depth.

It will be observed that here the diameter is the mean diameter of the coil which is obtained from the expression

$$d \text{ (mean)} = \frac{D_1 + D_2}{2}$$

where D_1 and D_2 are the outside and inside diameters.

The other dimensions are as shown on the figure attached.

READY RADIO

SUPPLY COMPANY

159 BOROUGH HIGH STREET
LONDON BRIDGE, LONDON, S.E.1

3 Minutes from London Bridge Southern Rly and Tube Stations.

Telephone: HOP 5555 (Private Exchange).

Telegrams: READY HOP 5555, LONDON.

IMMEDIATE DESPATCH OF ALL CORRECT PARTS FOR DOMINIONS FOUR

	£	s.	d.		£	s.	d.
1 Ebonite panel, 20 by 8 in. ...	10	0		1 Philips L.F. transformer ...	1	5	0
1 Igranite Lokvane .0005 var. condenser ...	10	6		1 Siemen's 1½ volt battery (Type GT) ...			6
1 Igranite Lokvane twin gang .0005 var. condenser ...	2	10	0	1 Siemen's 4½ volt tapped battery (G.1) ...	1	3	
1 Cydon 2 in. dial ...	2	0		3 Bulgin battery clips (2 G.B.6, 1 G.B.2) ...			9
1 Igranite vernier drum control ...	17	6		3 Terminal strips ...	1	6	
1 Lissen 7-ohm P/M rheostat ...	2	6		7 Belling-Lee terminals (insulated) ...	3	6	
1 Lissen 15-ohm P/M rheostat ...	2	6		1 Ready Radio copper screen ...	17	6	
1 Ormond .0001 reaction condenser ...	4	0		1 Pair Panel brackets 30 ft. Glazite ...	2	6	
3 Tunewell six-pin bases ...	6	0		1 Tunewell dual range aerial coil ...	10	6	
2 Parex screened grid valve holders ...	3	6		2 Tunewell dual range anode coils ...	1	1	0
2 Lotus valve holders ...	3	0		1 Ready Radio polished oak or mahogany cabinet ...	1	15	0
1 Formo "J" semi-var. condenser ...	2	0		2 Screened grid valves ...	2	5	0
4 Marconiphone H.F. by-pass units ...	1	2	0	2 Valves (1 det., 1 power) ...	1	3	0
3 Lewcos H.F. chokes ...	1	7	0	3 spade tags, 2 wander plugs, 3 ft. rubber flex. screws, etc. ...	1	6	
2 Dubilier .01 fixed condensers ...	4	0					
1 Clarostat 100 to 5,000,000 variable resistance ...	8	6					
1 Dubilier 2-mid. condenser ...	3	6					
1 Graham Farish 20,000 ohms resistance ...	2	3					
				Total including Valves	£18.11.9		

THE CLIPPER TWO

Complete set of parts (exact to specification) as described and PRICED on page 211.

A reliable Two Valve receiver which covers short, medium and long wave-bands. EFFICIENT but INEXPENSIVE.

DYNAMIC THREE

All parts Supplied for this remarkable ALL MAINS RECEIVER. Price list free on request.

READY RADIO SCREENS

SPECIFIED IN ALL CIRCUITS.

Made exact to specification of best untarnishable copper.

FREE BLUEPRINT with all orders over £2.
ALL COMMISSIONS RECEIVE IMMEDIATE PERSONAL ATTENTION.

Send for our 144-page Illustrated General Catalogue, price One Shilling. Sent free with all orders if requested.

INLAND: All orders post free. OVERSEAS: Consignments carefully packed and insured, charges forward.

The Panel to match Modern Components and High Efficiency Circuits

Made in Six finishes

Matt, Semi-Polished Mahogany, Semi-Polished Black, Cube Surface, Highly Polished Mahogany, Highly Polished Black.

Stocked by most wireless dealers. If any difficulty in obtaining locally, write for name of nearest stockist to:

H. B. POTTER & CO., LTD.
Station Buildings, ROCHDALE



Now on Sale.

Letts's 1929.

"AMATEUR WIRELESS" NOTEBOOK DIARY

88-page Reference Section. Full of Useful Information.

Prices: 1/6 and 2/6

Order from:

"AMATEUR WIRELESS" OFFICE
58 Fetter Lane, London, E.C.

FAMOUS



CONDENSERS

AS SPECIFIED in this month's "Wireless Magazine"

"CLIPPER TWO"

"1928" LOG (mid-line)
.0005 .00035 .00025 5/- each

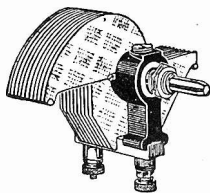

"DE LUXE" Model with
NOISELESS INTERNAL "PIGTAIL"
.0005 .00035 .00025 .00015 6/- each

"DOMINIONS FOUR" and "DYNAMIC THREE"

Type "J" Specified, 2/-

Also obtainable
Type F .0001—.000075 2/-
" G .001—.0002 2/-
" H .002—.001 3/-

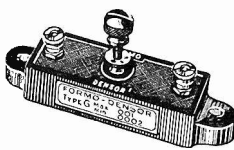

ANTI-MICROPHONIC VALVE HOLDER 1/3

First grade Bakelite throughout, including baseplate.

Practically dustproof and indestructible.

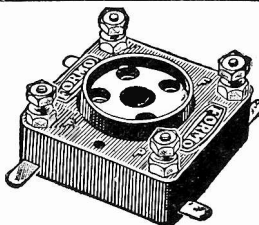

THE FORMO CO., Crown Works, Cricklewood Lane, London, N.W.2

The Easy Way TO PERFECT RADIO

In addition to their own extensive range, PETO SCOTT offer YOU Every Known Radio Receiver or Component—all on

EASY TERMS!

The following list is merely representative, and we ask you to fill in the coupon below or send us a list of your requirements.

COSSOR MELODY MAKER. Send only 10/-, balance in 11 monthly instalments of 14/7.
MULLARD MASTER THREE STAR. Send only 10/-, balance in 11 monthly payments of 15/3.

LEADING MAKES OF H.T. ELIMINATORS from 4/7 down. Balance in 11 monthly payments of 4/7.

ULTRA DOUBLE ACTION AIR COLUMN LOUD SPEAKER. Send only 8/3, balance in 11 monthly payments of 8/3.

BRANDESET THREE. Send only 13/4, balance in 11 monthly payments of 13/4.

NEW MARCONIPHONE 3 VALVE SET, with valves, batteries and speaker. Send only 20/-, balance in 12 monthly payments of 17/4. Also available for mains operation.

ADAPTA-GRAM-OPHONE to your Radio Receiver. Marvellous new instrument. Inexpensive and simple to fit. Send coupon for full details.

Build your own set the Easy Way NOW! Our Catalogue contains all leading makes of Receivers, Accessories, Kits of Components for the Home Constructor.

Mail Coupon in unsealed envelope under *Ed. stamp.*

PETO SCOTT CO., LTD.

Please send me your big Illustrated Lists.

NAME

ADDRESS

..... W.M.1/4

Free Demonstrations & Advice by Qualified Engineers at our Shops—

77 CITY ROAD, LONDON, E.C.1.
62, HIGH HOLBORN, LONDON, W.C.1.
4, MANCHESTER STREET, LIVERPOOL.
33, WHITELOW ROAD, CHORLTON-CUM-HARDY, MANCHESTER.

PAROX

SCREENS COILS

are again used in

THE DOMINIONS 4

Set of screens and foil as specified ... 17/6

"PAROX" valve holders, matt. 3/6 polished 4/6

DYNAMIC THREE

Screening Box with foil as specified ... 12/6

SCREENS FOR ALL CIRCUITS

"SIGNAL BOOSTER" SCREENS 7/6

"LODESTONE 3" SCREEN 4/6

From your Dealer or direct from

E. PAROUSSI 10 Featherstone Buildings London, W.C.1 Phone Ca. 7010

Simple Valve Tester

THE importance of repeated checks of the efficiency of valves in use cannot be over-estimated. The experimenter who uses his valves in all types of circuit is liable to be seriously handicapped if his valves are working unsatisfactorily, and a periodic test of all the valves in one's stock will indicate an appreciable proportion of poor samples.

If a circuit is not found to be operating satisfactorily it is very convenient to be able to check each valve rapidly to make sure that it is efficient as otherwise considerable time may be wasted before the source of trouble is discovered. A simple valve tester for this purpose is illustrated herewith. An oscillating arrangement is the simplest because most modern valves, of whatever characteristics, will usually maintain a good oscillation in a suitably designed circuit, and this oscillation is indicated by an increase in the anode current flowing. If a simple test of milliamp consumption is adopted, it is necessary to have a somewhat complicated arrangement owing to the very small emission of an R.C. valve and the relatively great emission of a super-power valve.

The circuit shown can easily be connected up and will constitute a simple tester which is always in readiness.

The correct voltage should be applied to the filament terminals of the arrangement and the suspected valve plugged into position. If the valve is operating satisfactorily a large milliamp indication is obtained, while if the valve is weak or is not functioning properly little or no current will be indicated. The valve, therefore, is tested under actual working conditions for if it will oscillate satisfactorily, it will usually rectify and amplify with equal satisfaction.

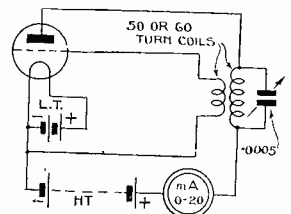

Circuit of Tester

Shunt Resistance, Effect on Tuned Circuits

IT is often desired to estimate the effect of a shunt resistance across a tuned circuit. This introduces damping which may usually be more conveniently estimated if it is expressed in terms of a series-resistance. This is quite easily accomplished, the equivalent series-resistance being obtained from the expression:—

$$R_e = \frac{L}{CP}$$

where L=inductance in microhenries.

C=capacity in microfarads.

P=shunt resistance in ohms.

R_e=equivalent additional resistance in ohms. This must be added to the normal circuit resistance R.

If the resistance is only connected across a portion of the circuit, the damping effect introduced is proportional to the square of the tapping; thus with a centre tapping the effect is equivalent to the connection of a resistance four times as great as the whole circuit and the additional damping introduced into the circuit is one quarter of its previous value.

From this point of view it is often convenient to connect the detector across a portion of the circuit only. This particularly applies to crystal

circuits where the resistance of a crystal is very low and considerable damping is otherwise introduced. The reason for this is that the minimisation of the damping allows the voltages in the circuit to build up to a higher value and this may more than compensate for the loss due to the tapping down the circuit.

The optimum tapping (where there is no step-up effect) may be obtained from the expression:—

Optimum tapping is 1/n of the way up the coil where

$$n = \sqrt{\frac{L}{CRP}}$$

L, C, and P have the same values as above, while R=H.F. resistance of circuit in ohms.

It may be found that this expression gives a tapping greater than unity, which indicates that no advantage will be obtained in the particular circumstances by tapping down the coil.

The expression may be written $n = \sqrt{R_e/R}$ so that it does not pay to tap down the coil unless R_e is greater than R; that is, unless the extra damping introduced by the shunt resistance is greater than the original circuit resistance.

Capacity Bridge

A SIMPLE capacity bridge for the measurements of capacity may be made up as shown in the diagram herewith. This has two arms consisting of two capacities in series. The top arm is known as the ratio arm and the two capacities here must be known in value. The bottom arm contains the standard condenser, which is variable and is calibrated in series with the condenser of which the capacity is known.

An alternating voltage of audible frequency obtained from a buzzer or other suitable source is connected across the ends of the bridge while a pair of telephones is connected between the junction point in the top and bottom arms. The variable condenser is then adjusted until a silent point is obtained when the division of voltage in the top and bottom arms is exactly the same so that no voltage is applied across the telephones.

When this condition of affairs obtains, the ratio of the two condensers in the top arm must be the same as that of the two condensers in the bottom arm. Thus, the capacity of the unknown condenser is obtained from the expression:—

$$C_3 = \frac{C_2}{C_1} \times C_4$$

All the factors of the right-hand side of the expression are known so that the capacity can be evaluated.

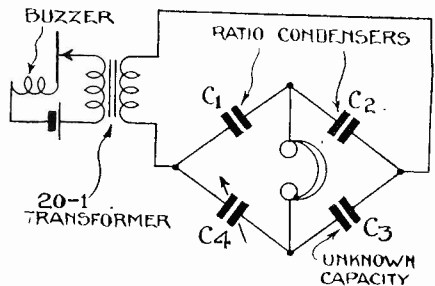

Circuit of Capacity Bridge

Equal to Three Ordinary Batteries

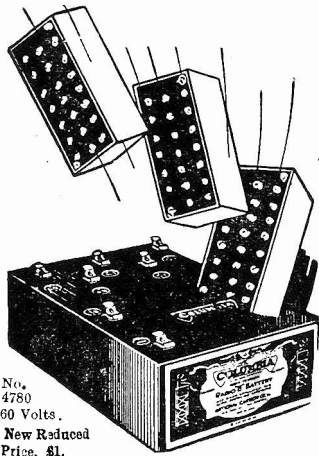

No. 4780
60 Volts.
New Reduced Price, 81.

Columbia RADIO BATTERIES

The Columbia No. 4780 Triple Capacity H.T. Battery possesses the emission, the lasting power, and the quality of three ordinary batteries. For the man with the good Receiver, this Columbia battery is indispensable. It's as essential as the good valves he uses.

J. R. MORRIS,

Imperial House, 15, Kingsway, LONDON, W.C.2.
SCOTLAND—J. T. Cartwright, 3, Cadogan Street, Glasgow.

NORTHERN RADIO CO.

WE CAN SUPPLY:—

THE FIDELITY FOUR	£13 0 0
LODESTONE THREE	£6 17 6
SIGNAL BOOSTER	£3 10 0
NORTHERN S.G. 4	£7 0 0
KILOGRAM FOUR	£12 10 0
BINOWAVE FOUR	£12 0 0

Further details on application. All sets are wired up, aerial tested, and guaranteed. Royalties paid.

We undertake to wire up free of charge any set published in the radio press if parts bought from us.

THE CLIPPER TWO.

Set, wired up, complete with Valves and Coils	£5 0 0
H.T. Battery (free), Accumulator, Ideal Blue Spot Cone (37/6), and Headphones (12/6)	2 10 0
TOTAL	£7 10 0

Coils for short waves, 11/-.

FREE.

During March and April a 100-volt H.T. Battery will be supplied free to each customer buying a wired-up set.

SUMMER'S COMING. A PORTABLE !

Let us send you details of the best Portable on the market to-day—bar none.

THE 5-VALVE NATIONAL RADIO PORTABLE
Price £15 cash, or pay as you listen.
Delivered on receipt of 20/- deposit and 30/- per month.

SCREENS.

Supplied in copper or aluminium, for any circuit. Quotations given for any pattern.

THE TITAN THREE. P.W. 2/2/29.

Using S.G. Valve. Extraordinary results; outstanding simplicity; inexpensive; bang up to date. compact, and powerful. Price £4 15 0.

THAT OLD SET OF YOURS.

If built two or three years ago, it's now as out of date as the crinoline. Let us quote you for modernising and making it a "Twenty Stations on Loud-speaker" Receiver.

THE DOMINIONS FOUR.

As described in this issue. Completely wired, with three Dual Coils. Price £12 10 0.
Ask for alternative set of parts.

THE SIGNAL BOOSTER.

If your receiver is not sufficiently selective, or if your range is not wide enough for you to receive distant stations with ease, get the "Signal Booster," which will add punch to ANY set. Increases Range, Volume, and Selectivity. Price £3 10 0.

THE CLARION THREE. A.W. 9/3/29.

A real distance getter. Dual range coils, with waveband changing switches on panel. Extremely selective; local station can be received free from any interference. Really amazing results. Easily twenty stations on speaker. Let us send you full details. ...

NORTHERN RADIO CO.

Temple Row, WREXHAM.

NOW WITH Your 1928-9 COSSOR MELODY MAKER YOU CAN GET THE 3 "A's"

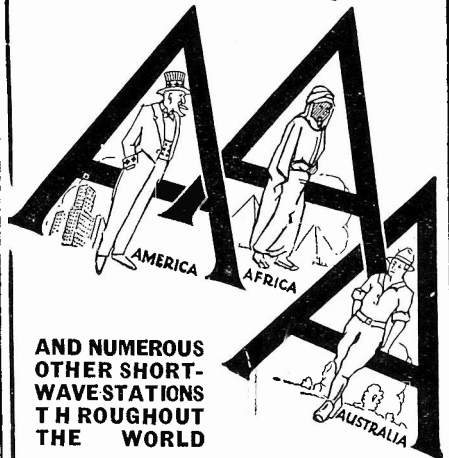

AND NUMEROUS OTHER SHORT-WAVE STATIONS THROUGHOUT THE WORLD

DEFINITELY, and for 12/6 only, you can now get America, Africa and Australia on your

1928-29

COSSOR MELODY MAKER

by just interchanging your present Cossor Coils with the amazing **NEW CASON 1928-29 ULTRA SHORT-WAVE COILS 12/6 SET**
Full instructions for tuning in short-wave Stations sent with Coils.

See test report on page 298 of this issue where these coils are recommended

If unobtainable from your Dealer, these special coils will be sent on receipt of 12/6 or per C.O.D., on receipt of post card.

Write for free folder.

CASON MOULDINGS,
Dept. B, CHISWICK ROAD
LOWER EDMONTON, N. 9
Telephone: Tottenham 3446



CASON ULTRA SHORT-WAVE COILS 12/6 PAIR

"Where did that one come from"

Type "B"

Even when their heads are engraved, terminals are apt to be very muddling—if the tops come off.

The tops of Belling-Lee terminals cannot possibly come off—one of the many advantages to be gained by using these excellent little products.

Made in Three types. Type "B" 6d.
Type "M" 4½d. Type "R" 3d.

Selling & Lee, Ltd., Queenway Works, Ponders End, Middlesex

BELLING-LEE TERMINALS

A Free Broadcast Map!

COSSOR'S OFFER

ALL foreign-station listeners will want a copy of the new broadcast map which Cossor, Ltd. have just issued. This shows all the chief broadcasting stations within normal receiver range, and also gives a full list of the foreigners in order of wavelength.

The map is certain proof that there is a wide field for conquest by the D.X. enthusiast. The map can be obtained free, by mentioning the WIRELESS MAGAZINE, from A. C. Cossor, Ltd., Highbury Grove, N.5, but 2d. should be sent to cover postage.

A CORRECTION

AN unfortunate printer's error occurred in the formula which forms part of Reference Sheet No. 113 (see page 199 of the March issue). The expression "0.71" should read ".071". This can easily be corrected on the sheet itself with a pen; we do not think there is any need to republish the sheet.

LOUD-SPEAKER CABINET

CONSTRUCTORS of W. James' already famous Lodestone moving-coil loud-speaker (on which further notes appear on page 224), will need some kind of baffle or cabinet to use with it. Those who prefer the latter, which undoubtedly has a better appearance than a bare baffle board, will be interested in a model supplied by Hobbies, Ltd., of Dereham, Norfolk.

This consists of a supply of wood and details of assembly for the home-construction of the cabinet by the amateur, and will appeal to a large number of WIRELESS MAGAZINE readers.

WIRELESS PICTURES

IN view of the great success attending the transmission of wireless pictures, the Fultograph Company, in co-operation with the B.B.C., announce more convenient times of transmission, as recommended in the last issue of the WIRELESS MAGAZINE.

It will be possible to receive Fultograph pictures at the following times: **From 5XX** on Tuesdays and Thursdays, 2 to 2.25 p.m.

From 2LO and 5XX on Monday and Friday evenings, 12 (midnight) to 12.15 a.m.

From 5GB on Wednesday and Saturday evenings, 11.15 p.m. to 11.45 p.m.

Many amateurs will benefit by being able to receive the pictures in the evening, and we anticipate that still greater interest will be taken in this new form of entertainment.

NEW MULLARD VALVES

IN our last issue we promised I further notes this month on a number of new Mullard valves. At the time of going to press, sample valves had not been received, however.

EVISON & PAYNE

83 Borough High St., London Bridge, S.E.1.
'Phone: Hob 1221

Can supply at once correct parts for any of the sets described in this issue. Before purchasing your parts see our price lists free, on application.

Hear the "Lodestone Three"

Demonstrations during broadcast hours up to 7 p.m. or by appointment.

Inland: All orders post free. Abroad: Carriage paid over £5
Cash, C.O.D., or Easy Terms
Blueprints free with each order for complete kits.
Panels drilled free.

WIRELESS, TELEVISION & ELECTRICAL EQUIPMENT

INDEX TO ADVERTISERS

	Page
Alestrian Gramophone Co., Ltd.	279
Bedford Electrical & Radio Co., Ltd.	285
Belling & Lee, Ltd.	303
British Ebonite Co., Ltd., The	281
British Thompson Houston Co., Ltd.	207
Brown, S. G., Ltd.	206, 273
Bulgin, A. F., & Co.	281
Cason Mouldings	303
Caxton Wood Turnery Co.	285
Celestion, Ltd.	296
Clarke, H., & Co. (M/c), Ltd.	298
Cossor, A. C., Ltd.	269, 289
Day, Will, Ltd.	279
Dubilier Condenser Co., Ltd.	279
Eastick, J. J., & Sons	287
Ericsson Telephones, Ltd.	283
Evison & Payne	304
Fluxite, Ltd.	281
Formo Co.	301
Garnett Whiteley & Co., Ltd.	275
Harlie Bros.	299
Hobbies, Ltd.	304
Hughes, F. A., & Co., Ltd.	275
Igranic Electric Co., Ltd.	291
Impex Electrical, Ltd.	273
Jackson Bros.	300
Lectro Linx, Ltd.	299
Letts, A. W. (1929) Diary	301
Lewis, S. W., & Co., Ltd.	279
Lissen, Ltd.	210
London Electric Wire Co. and Smiths, Ltd.	209
Lyons, Claude, Ltd.	285
Marconiphone Co., Ltd., The	Cover iv
Morris, J. R.	303
Mullard Wireless Service Co., Ltd.	295
Northern Radio Co.	303
Oldham & Sons, Ltd.	271
Omnora, Ltd.	299
Ormond Engineering Co., Ltd., The	293
Paroussi, E.	302
Partridge & Mee, Ltd.	293
Peto Scott Co., Ltd.	302
Pickett Bros.	283
Potter, H. B., & Co., Ltd.	301
Raymond, K.	297
Ready Radio Supply Co.	301
Regent Radio Supply Co.	295
R. I. & Varley, Ltd.	277
Siemens Bros. Co., Ltd.	Cover ii
Simmonds Bros.	299
Stone Manufacturing Co.	285
Telegraph Condenser Co., Ltd.	287
Turner & Co.	287
Whiteley Boneham & Co., Ltd.	277
Wright & Weaire, Ltd.	295

A "LODESTONE" HOLDER & CABINET

14 3/4 ins. WIDE
14 3/4 ins. HIGH
12 3/4 ins. DEEP

When you have made up the "Lodestone," house it in this handsome cabinet. Any handyman can make it. Sound quality mahogany boards are supplied planed and cut true ready to fit together for the Cabinet and the loud-speaker support as shown. A piece is also included to cut the fretted front to a simple design movement. You cannot go wrong because all necessary construction details are given on an illustrated leaflet in the parcel. A special bargain for "Lodestone" builders.

Obtainable from any of Hobbies branches in London, Glasgow, Manchester, Birmingham, Sheffield, etc. Or send a P.O. or Cheque for 13/6 to Dept. 26, Hobbies, Ltd., Dereham, Norfolk, for one to be sent post free.

12/6

Postage 1/3

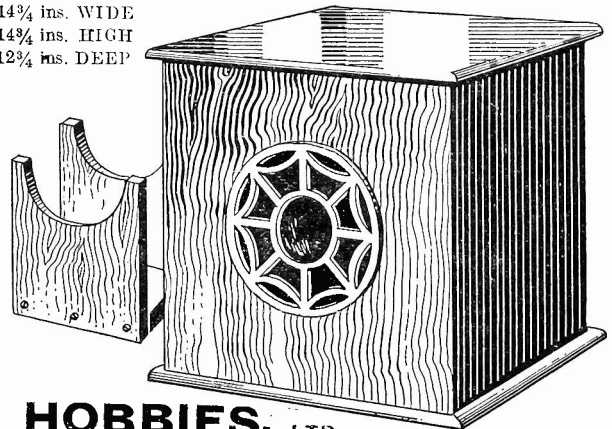

HOBBIES, LTD.

FULL-SIZE BLUEPRINTS FOR EVERY REQUIREMENT

Each blueprint shows the position of each component and every wire and makes construction a simple matter. Copies of "Wireless Magazine" and of "Amateur Wireless" containing descriptions of all these sets can be obtained at 1s. 3d. and 4d. respectively, post free. Index letters "A.W." refer to "Amateur Wireless" sets and "W.M." to "Wireless Magazine" sets.

CRYSTAL SETS

All these 6d. each, post free.

Two-programme Set	WM125
Centre-tap Set	WM150
Super Set	AW 64
"Best-yeet" Set	AW114
1929 Crystal Receiver	AW165

ONE-VALVE SETS

All these 1s. each, post free.

Long-range Hartley	WM154
Reflexed One for the Loud-speaker	WM166
Special One	WM116
Reinartz One	WM127
All-wave Reinartz	AW 2
Hartley DX	AW 27
Economy One	AW 71
Loud-speaker Special	AW 78
Ultra-sensitive Hartley One	AW103
Fan's Short-wave One	AW119
Super Reinartz One	AW127
Beginner's One-valver	AW140

TWO-VALVE SETS

All these 1s. each, post free.

British Broadcast 2 (D, Trans)	WM44
Two-programme 2 (D, Trans)	WM156
Q-coil 2 (D, Trans)	WM162
Crusader (D, Trans)	WM169
Flat-dweller's 2 (HF, D)	WM176
Two-Dauntry Two (D, Trans)	WM197
Tetrode Short-wave Two (SG, D)	WM109
Key-to-the-Ether Two (D, Pentode)	WM107
Meteor Two (D, Trans)	WM114
★Clipper Two (D, Trans)	WM135
Wide-world Short-wave (D, Trans)	AW 11
Empire Short-wave	AW 28
Next Step 2 (D, Trans)	AW 34
Centre-tap 2 (D, Trans)	AW 42
Rover 2 (HF, D)	AW 53
General-purpose 2 (D, Trans)	AW 55
Yule (D, Trans)	AW 59
30/- 2 (D, Trans)	AW 61
Economical 2 (D, RC)	AW 66
Two-wave (D, Trans)	AW 83
Ultra-selective Hartley (D, Trans)	AW 90
Oceanic Short-wave (D, Trans)	AW 91
Trapped Reinartz (D, Trans)	AW 92
"Q" 2 (D, Trans)	AW 99
Long Distance Two (HF, D)	AW 110
Three-waveband Two (D, Trans)	AW 112
DX Headphone Two (HF, D)	AW 134
Ace of Twos (D, Pentode)	AW 143
Home Two (D, Trans)	AW 146
Chapman-Reinartz Two (D, Trans)—4d. with copy of "A.W."	AW 148
Globe DX Two (SG, D)	AW 157
East to West Short-wave Two (D, Trans)	AW 159
Beginner's Two (D, Trans)	AW 171
Auto Two (D, Trans)	AW 174

THREE-VALVE SETS

All these 1s. each, post free.

Five-guinea 3 (HF, D, Trans)	WM29
Mains Three-valver (D, 2LF)	WM34
Tuned-anode from the Mains (HF, D, LF)	WM43
Metropolitan (D, 2LF)	WM48
Everyday (D, 2 Trans)	WM52
Music Charmer (D, RC, Trans)	WM60
Britannia (D, RC, Trans)	WM67
Pole-to-Pole Short-waver (D, RC, Trans)	WM89
Glee-singer Three (D, 2 RC)	WM92
Aladdin Three (HF, D, LF)	WM95
Inceptor Three (SG, D, Pentode) Price 1s. 3d. with copy of "W.M."	WM105
All-wave Screened-grid Three (HF, D, Pentode)	WM110
Gramophone Three (D, 2RC)	WM115
Standard Coil Three (HF, D, Trans)	WM117
Festival Three (D, 2 LF-Dual Imp)	WM118
Wide-world Short-waver (SG, D, Trans)	WM120
New Year Three (SG, D, Pentode)	WM123

A blueprint of any one set described in the current issue of the "Wireless Magazine" can be obtained for half-price up to the date indicated on the coupon (which is always to be found on page iii of the cover) if this is sent when application is made. These blueprints are marked with an asterisk (★) in the above list and are printed in bold type. An extension of time will be made in the case of overseas readers

The Q3 (D, RC, Trans)	WM124
Lodestone Three (HF, D, Trans)	WM129
Simple Screen Three (HF, D, Trans)	WM131
★Dynamic Three (SG, D, Trans)	WM136
Split-primary (HF, D, Trans)	AW 24
Modern Tuned-anode (HF, D, Trans)	AW 35
Tetrode 3 (HF, D, Trans)	AW 36
Special (D, 2LF)	AW 44
Economy 3 (D, 2RC)	AW 48
Short-wave (D, RC, Trans)	AW 50
Ether-searcher (D, RC, Trans)	AW 52
Standard (D, 2 Trans)	AW 56
Hartley DX (D, RC, Trans)	AW 63
Broadcast 3 (D, RC, Trans)	AW 70
Selectus 3 (HF, D, Trans)	AW 81
Q-coil 3 (D, RC, Trans)	AW 84
Clarion 3 (D, 2 Trans)	AW 88
Miniature Hartley Three	AW 101
Summer-time DX Three (HF, D, Trans)	AW 106
Three-valve Mains Receiver (HF, D, Trans)	AW 109
British Station Three (HF, D, Trans)	AW 122
Optional Two-three (D, 2LF)	AW 124
"Simpler Wireless" Mains Three (D, 2LF)	AW 126
Simplicity Screen-grid Three (HF, D, Trans)	AW 132
"Proms" Three (D, 2 RC)	AW 137
Adaptable Three (D, 2 Trans)	AW 139
New-style Baffle Three (D, RC, Push-pull—Price 1/6)	AW 141
All-wave Mains Three (HF, D, Trans, Rectifier—Price 1/6)	AW 144
All-purpose Short-wave Three (D, RC, Trans)	AW 147
Screen-grid Q-Coil Three (HF, D, Trans)	AW 150
New-style Mains Three (HF, D, Trans—Price 1/6)	AW 151
All-Round Three (D, RC, Trans)	AW 155
James Special Three (HF, D, Trans)	AW 156
All Britain Three (HF, D, Trans)	AW 158
Bantam Three (D, RC, Trans)	AW 160
Hartley Dual-range Three (D, RC, Trans)	AW 166
Listener's Three (HF, D, Trans) Price 4d. free with copy of "A.W."	AW 160
Binowave Three (D, RC, Trans)	AW 172
Clarion Three (SG, D, Trans)	AW 175

FOUR-VALVE SETS

All these 1s. 6d. each, post free.

Revelation (HF, D, RC, Trans)	WM124
Simplicity (HF, D, 2 Trans)	WM49
Astral (HF, D, 2 RC)	WM53
Trapped 3-4 (D, 2RC Paralleled)	WM61
Gramo-Radio 4 (D, RC, 2 Trans Push-pull)	WM77
Q-coil 4 (HF, D, Trans, RC)	WM71
Screened grid 4 (HF, D, 2RC)	WM77
Five-pounder Four (HF, D, RC, Trans)	WM91
Frame-aerial Four (HF, D, 2RC)	WM85
Touchstone (HF, D, RC, Trans)	WM109
Reyners—Furzehill Four (SG, D, 2 Trans)	WM112
Economy Screen-grid Four (SG, D, RC, Trans)	WM113
Binowave Four (SG, D, RC, Trans)	WM119
Standard-coil Four (HF, D, 2RC)	WM122
★Dominions Four (2SG, D, Trans)	WM134
★The Drum Major (HF, D, RC, Trans)	WM137
All-purpose 4 (HF, D, RC, Trans)	AW 43
Special 4 (HF, D, 2LF)	AW 70
"Q" 4 (HF, D, RC)	AW 98
Explorer Four (HF, D, RC, Trans)	AW 120
Summertime Searcher (2HF, D, Trans)	AW 128
Overseas Shortwaver (HF, D, 2 Trans)	AW 133
Ranger Four (SG, D, RC, Trans)	AW 145
Facility Four (HF, D, 2 RC—Q-coil)	AW 154
Broadcast Picture Four (HF, D, 2RC)	AW 163
The Orchestra Four (D, RC, Push-pull)	AW 167
All Europe Four (2HF, D, Trans)	AW 173

FIVE-VALVE SETS

All these 1s. 6d. each, post free.

Exhibition 5 (2HF, D, RC, Trans)	WM33
Phoenix (2HF, D, 2LF)	WM42
1928 Five (2HF, D, 2 Trans)	WM46
All-the-world 5 (2HF, D, 2RC)	WM63
Cataract 5 (HF, D, RC, Push-pull)	WM79
Empire Five (2SG, D, RC, Trans)	WM96
Fidelity Five (HF, D, 2RC-parallel)	WM130
Individual 5 (2HF, D, 2 Trans)	AW 25
School 5 (HF, D, 2RC)	AW 85
"Q" Gang-control Five (2HF, D, 2Trans)	AW161

SIX-VALVE SETS

1s. 6d. each, post free.

Nomad (2HF, D, RC, Push-Pull, Trans)	WM11
--------------------------------------	------

Connoisseur's Six (2HF, D, RC, Push-pull)	WM88
Eagle Six (3HF, D, RC, Trans)	WM106
Short-wave Super-6 (Super-het, Trans)	AW 67
Adaptor for above (see miscellaneous list)	AW67a

SEVEN-VALVE SETS

1s. 6d., post free.

Simpladyne (Super-het)	WM22
------------------------	------

PORTABLE SETS

	Price Post Free
Springtime 2 (D, Trans)	WM12 1/-
Countryside 4 (HF, D, 2 Trans)	WM17 1/6
Chummy 4 (HF, D, RC, Trans)	WM80 1/6
Chummy 4 (with modification for LS and HT)	WM80a 1/6
Pilgrim Portable (D, Trans)	WM04 1/6
Holiday 3 (D, 2 Trans)	AW32 1/-
Table Grand 4 (HF, D, 2RC)	AW93 1/6
Attaché Portable 2 (HF, D)	AW96 1/-
Daventry Portable (D, Trans)	AW105 1/-
Daventry Loud-speaker Portable (2HF, D, RC, Trans)	AW107 1/6
Town and Country (HF, D, RC, Trans)	AW111 1/6
House and Garden (SG, HF, D, RC, Trans)	AW116 1/6
"Best-yeet" Portable (SG, D, 2 Trans)	AW136 1/6
House Portable (SG, D, RC, Trans)	AW168 1/6

AMPLIFIERS

All these 1s. each, post free

True-tone Amplifier (3 valves)	WM47
Gramo-radio Amplifier (2 v.)	WM72
Super-power Unit (2 v.)	WM103
Signal Booster (HF Unit)	WM128
Auditrol Amplifier	WM132
One-valve DX Unit	AW 37
Utility (RC, Trans)	AW 68
Screened-grid HF Unit	AW 75
One-valve LF Unit	AW 79
Super-power Push-pull	AW 86
Hook on Short-waver	AW104
Purity Amplifier	AW108
Add-on Distance-getter	AW117
Screened-grid HF Amplifier	AW138
"A.W." Gramophone Amplifier (3RC)	AW162

MISCELLANEOUS

	Price Post Free
A.C. Mains Eliminator	WM41 1/-
Cone Loud-speaker	WM55 1/-
A.C. Adaptor for "Simpler Wireless" Sets	WM57 1/-
Moving-coil Loud-speaker	WM58 1/-
D.C. Mains Eliminator	WM59 1/-
Wavetrap	WM64 1/-
Portable Cone Loud-speaker	WM73 1/-
"Junior" Moving-coil Loud-speaker	WM81 1/-
Universal Short-wave Adaptor	WM82 1/-
Linen-diaphragm Loud-speaker	WM90 1/-
Valveless A.C. Power Unit for L.T.	WM100 -/6
Valveless A.C. Power Unit for H.T.	WM101 -/6
Simple Cone	WM111 1/-
Buzzer Wavemeter	WM121 -/6
James H.T. Unit for A.C. Mains	WM125 1/-
Lodestone Loud-speaker	WM126 1/-
★James H.T. Unit for D.C. Mains	WM133 1/-
Heterodyne Wavemeter	AW 7
Rectifying Unit for "Simpler Wireless" Sets	AW 62
Adaptor for Short-wave Super 6	AW 67a -/6
H.T. from A.C. Mains	AW 73 1/-
"AW" Moving-coil Loud-speaker	AW 97 1/-
H.T. Eliminator for A.C. (200 v. output)	AW 102 1/-
L.T. and H.T. Mains Unit (DC)	AW 123 1/-
Knife-edge Wavetrap	AW 131 -/6
All-metal Eliminator for H.T.	AW 135 1/-
Duplex-diaphragm Loud-speaker	AW 142 1/-
Power-plus Loud-speaker	AW 149 1/-
Linen-diaphragm Loud-speaker with Baffle	AW 152 1/-
Pedestal Cone Loud-speaker	AW 164 1/-
Listener's Speaker, price 4d. with copy of "A.W."	AW 170 -/4

Send, preferably, a postal order (stamps over sixpence in value unacceptable) to

Wireless Magazine

Blueprint Dept., 58/61 Fetter Lane E.C.4

Half-price BLUEPRINT Coupon Valid until April 30, 1929 FOR ANY ONE SET CONSTRUCTIONALLY DESCRIBED IN THIS ISSUE.

Fee of 1s. INFORMATION Coupon Valid until April 30, 1929 NOT MORE THAN TWO QUESTIONS TO BE ASKED AT A TIME

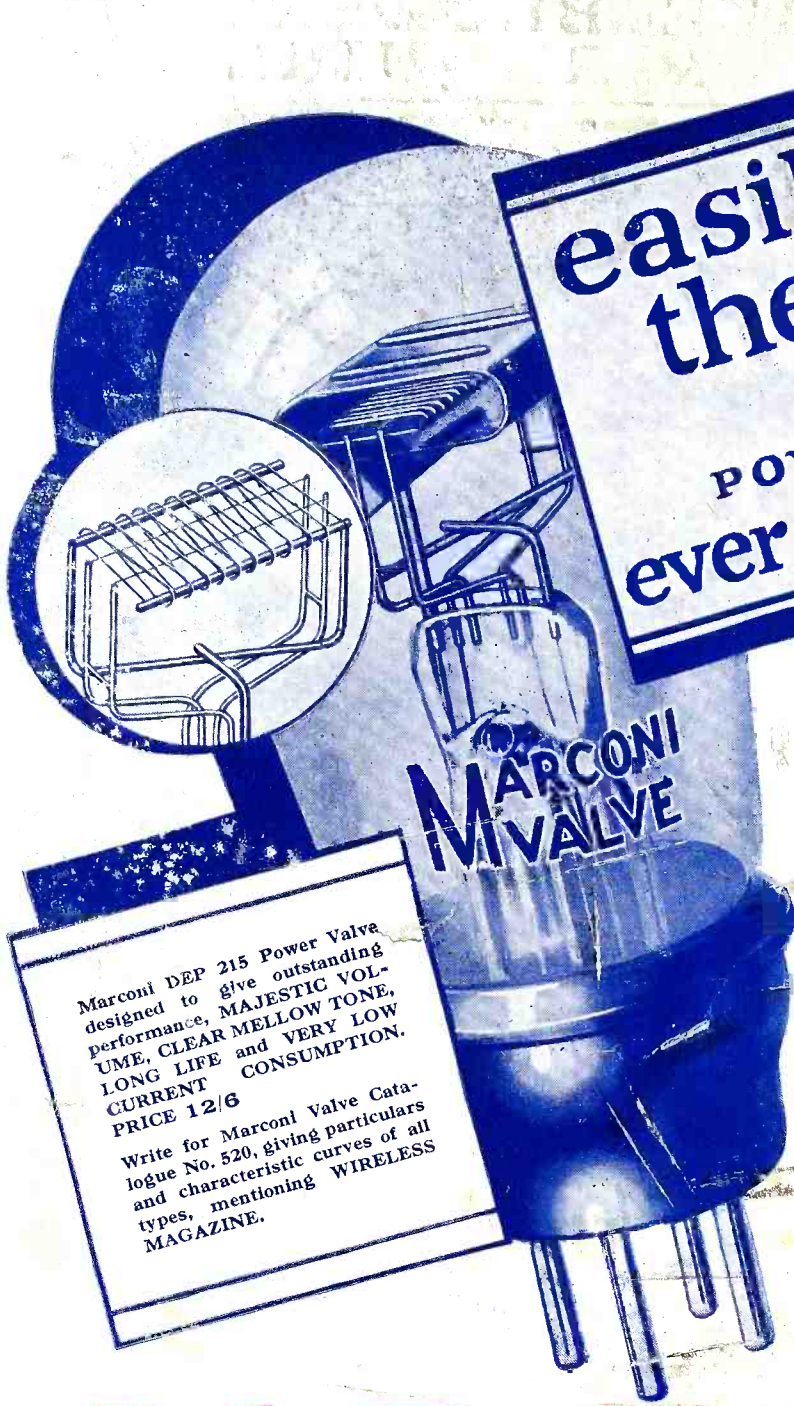

**easily
the best
2 VOLT
POWER VALVE
ever designed**

Marconi DEP 215 Power Valve designed to give outstanding performance, MAJESTIC VOLUME, CLEAR MELOW TONE, LONG LIFE and VERY LOW CURRENT CONSUMPTION.
PRICE 12/6
Write for Marconi Valve Catalogue No. 520, giving particulars and characteristic curves of all types, mentioning WIRELESS MAGAZINE.

TESTED *once*
TESTED *twice*
TESTED *3 times*

Not only are all components of Marconi Valves tested at every stage of manufacture, but before they can get into the purple box bearing the name Marconi the completed valves have to pass the following triple test.

- (1) The "qualifying" or Factory test.
- (2) The "passing out" or Stock test.
- (3) The "third degree" or headquarters test.

Marconi Valves are consistently good because they are triple tested.

MARCONI

DEP 215

TRIPLE TESTED

The Marconiphone Co., Ltd., 210-212 Tottenham Court Road, London, W.1

MV 23-151