

BUILDING A CONE LOUD-SPEAKER

Wireless Magazine

EDITOR: BERNARD E. JONES

TECHNICAL EDITOR: J.H. REYNER, B.Sc. (Hons) A.M.I.E.E.

VOL. 7, No. 37.

FEBRUARY, 1928

1/6

*The Astral
Four*



SELF-CONTAINED
BATTERIES

NO COIL CHANGING

Full-size Blueprint at half-price

YOUR CHOICE OF THE WORLD'S PROGRAMMES (SEE PAGE 6)

A BLUEPRINT WILL HELP YOU!

Full-size Blueprints, each one being a photographic contact print, from the draughtsman's original design, and produced on stout paper, are now available of the following sets.

ONE-VALVE SETS

	Price, post free	No.	s.	d.
One valver for Frame Aerial ..	W.M.	4	1	0
One-valve All-wave Reinartz ..	A.W.	2	1	0
All-in-all One-valver ..	A.W.	13	1	0
Hartley DX One-valver ..	A.W.	27	1	0
Alpha One† ..	W.M.	26	2	3
Reinartz Plug-in One-Valver ..	A.W.	46	1	0
Constant Coupled One ..	A.W.	65	1	0
★Long Range Hartley One ..	W.M.	54	7	0

TWO-VALVE SETS

All Broadcast Two ..	W.M.	5	2	3
Two-valver embodying K.L.I. Valves ..	A.W.	5	1	0
One-control Two ..	A.W.	6	1	0
Wide World Short-wave Two ..	A.W.	11	1	0
All-wave Two-valver ..	A.W.	15	1	0
Loftin-White Two† ..	W.M.	20	2	3
Reinartz Two ..	A.W.	21	1	0
One-dial Two ..	W.M.	23	1	0
Empire Short-wave Two ..	A.W.	28	1	0
Screened-trap Two ..	A.W.	31	1	0
"Next-step" Receiver ..	A.W.	34	1	0
Girdle Two† ..	W.M.	30	1	3
Centre-tap Two ..	A.W.	42	1	0
Mains-fed Two ..	W.M.	37	1	0
Three-option Two ..	A.W.	51	1	0
British Broadcast Two ..	W.M.	44	1	0
The Rover Two ..	A.W.	53	1	0
All-wave Two ..	A.W.	57	1	0
General Purpose Two ..	A.W.	59	1	0
The "Yule" Two ..	A.W.	59	1	0
30/- Two-Valver ..	A.W.	61	1	0
Economical Two ..	A.W.	66	1	0
★Two Programme Two ..	W.M.	56	1	0

THREE-VALVE SETS

Continental Three ..	W.M.	7	1	0
Victory Three ..	A.W.	9	1	0
Hi-nu R.C. Three† ..	W.M.	9	2	3
M.C.3 Star ..	A.W.	16	1	0
Wave-catcher Three ..	W.M.	19	1	0
Excelsior Three ..	A.W.	20	1	0
Split-primary Three ..	A.W.	24	1	0
Lighthouse Three ..	A.W.	29	1	0
Purity Three-valver ..	A.W.	33	1	0
A Modern Tuned Anode Three Tetrode-three for Shielded Valves ..	A.W.	35	1	0
Alternative-programme Three ..	A.W.	36	1	0
A "Mains" Three-valver ..	A.W.	38	1	0
Screened-grid Three ..	W.M.	34	1	0
"Simpler Wireless" All-from-the-Mains Receiver ..	W.M.	21	1	0
	A.W.	41	1	0

	Price, post free	No.	s.	d.
"Simpler Wireless" Special Three-valver ..	A.W.	44	1	0
"Home Station" Three ..	A.W.	45	1	0
Five-guinea Three ..	W.M.	29	1	0
"Dominions" Short-wave Three ..	W.M.	39	1	0
The "Economy" Three ..	A.W.	48	1	0
Short-wave Three ..	A.W.	50	1	0
The Ether Searcher Three ..	A.W.	52	1	0
Tuned-Anode Three—from the Mains (D.C.) ..	W.M.	43	1	0
Three Continent Three ..	A.W.	54	1	0
The Standard Three ..	A.W.	56	1	0
Screened-grid Short-wave Hartley DX Three ..	W.M.	51	1	0
Straight Line Three ..	A.W.	63	1	0
	A.W.	60	1	0
★Metropolitan Three ..	W.M.	48	1	0
★Everyday Three ..	W.M.	52	1	0

THREE-FOUR-VALVE SETS

Tuned-anode Three-four ..	A.W.	49	1	6
Concord Three-four ..	W.M.	45	1	6

FOUR-VALVE SETS

M.C. Four ..	A.W.	8	1	6
Household Four ..	A.W.	17	1	6
Revelation Four ..	W.M.	24	1	6
Auto-selector Four ..	W.M.	35	1	6
"A.W." Gramo Radio ..	A.W.	40	1	6
All-purpose Four ..	A.W.	43	1	6
All-wave Roberts Four, and copy of "A.W." ..	A.W.	47	0	7
The Simplicity Four ..	W.M.	49	1	6
C.T. Four ..	A.W.	58	1	6
★Astral Four ..	W.M.	53	1	6

FIVE-VALVE SETS

1927 Five ..	W.M.	6	1	6
Two-volter's Five ..	W.M.	11	1	6
Individual Five ..	A.W.	25	1	6
Exhibition Five ..	W.M.	33	1	6
Phoenix Five ..	W.M.	42	1	6
1928 Five ..	W.M.	46	1	6

SIX-VALVE SETS

Nomad Six ..	W.M.	31	1	6
Short-wave Super-Six ..	A.W.	67	1	6

SEVEN-VALVE SETS

Simpladyne Seven (Super-het) ..	W.M.	22	1	6
---------------------------------	------	----	---	---

AMPLIFIERS

	Price, post free	No.	s.	d.
Range Extender (H.F. amplifying unit) ..	W.M.	38	1	0
Two-valve D.C. Mains Amplifier ..	W.M.	16	1	0
Gramophone Amplifier ..	W.M.	32	1	0
True-tone Amplifier ..	W.M.	47	1	0

PORTABLE SETS

Springtime Portable (two-valver) ..	W.M.	12	1	0
Countryside Four ..	W.M.	17	1	6
Motorists' Portable (four-valver) ..	A.W.	14	1	6
M.C. Three Portable ..	A.W.	22	1	0
Handy Three ..	W.M.	27	1	0
Holiday Portable (three-valver) ..	A.W.	32	1	0
Club Portable (three-valver) ..	A.W.	30	1	0

CRYSTAL SETS

Crystal Set for the R.C. Enthusiast ..	W.M.	13	0	6
Hi-lo Crystal Set ..	W.M.	18	0	6
Two-programme Crystal Set ..	W.M.	25	0	6
Alternative-programme Crystal Set ..	A.W.	39	0	6
Half-hour Crystal Set ..	W.M.	28	0	6
Centre-Tap Crystal Set ..	W.M.	50	0	6
Super Crystal Receiver ..	A.W.	64	0	6

MISCELLANEOUS

Heterodyne Wavemeter ..	A.W.	7	1	0
Made-to-measure Wave Trap ..	A.W.	19	0	6
New Current Supply Idea ..	A.W.	26	1	0
DX One Valve Unit ..	A.W.	37	1	0
Battery Eliminator for A.C. Mains ..	W.M.	41	1	0
Volume control Unit ..	W.M.	40	0	6
Loud-speaker Tone Control and Filter Unit† ..	W.M.	1	2	3
"Simpler Wireless" Rectifying Unit ..	A.W.	62	1	0
★A.C. Mains Adaptor (for any "Simpler Wireless" Set) ..	W.M.	57	1	0
★Cone Loud-speaker ..	W.M.	55	1	0

†With a copy of "Wireless Magazine," complete.

SPECIAL NOTE: Only those Blueprints marked ★ are supplied at half-price with Coupon from page iii of wrapper. This offer is valid until February 29th.

Send a postal order to-day to:

WIRELESS MAGAZINE

Blueprint Service, 58/61, Fetter Lane, London, E.C.4

Buy Igranic and you buy the best

The range of Igranic Radio Devices is the most comprehensive range of high-grade radio components in the world. These few examples are typical of the excellence of design, materials and workmanship which they represent. For full particulars of the many other Igranic Radio Devices, send for the complete illustrated catalogue, List No. J404. In it you will find a better component for every position in your set.

Indigraph Vernier Dial



Lokvane Variable Condenser



Wirewound Shielded Resistor

IGRANIC INDIGRAPH VERNIER DIAL
 Makes tuning a pleasure. Smooth operation, very attractive appearance. It may be illuminated from behind, as the scale is translucent. No live metal parts exposed.
 Price 7/6

IGRANIC LOKVANE VARIABLE CONDENSER
 The best moderately-priced condenser. Square law. The method of locking the vanes ensures absolute accuracy.
 .00015 mfd. Price 8/6
 .0003 " 9/6
 .0005 " 10/6

IGRANIC WIRE-WOUND SHIELDED RESISTOR
 A highly efficient and resistance with the special feature that it is shielded to prevent capacitive coupling.
 80,000 ohms Price 4/6
 150,000 " 5/6
 250,000 " 7/6

Igranic components are always stocked by reputable dealers. All reports received by us of difficulty in obtaining them receive immediate attention.

Branches:
 Birmingham,
 Bristol,
 Ca diff,
 Glasgow,
 Leeds,
 Manchester
 Newcastle.



149 Queen Victoria St., London, E.C.4
 Works: Bedford.



No coil changing
No removable screens
Perfectly balanced Coils
Panel control in multi coil units
Wavelength range 250-550 and 1000-2000 metres in one unit

(In view of the widespread demand for these units, it is advisable to place your order as early as possible)

Pat. 276867



COMPLETE UNIT
 Ref. No. DSP/2 for
 the ASTRAL FOUR
 (as illustrated)
£3 7s. 6d.

As specified in the ASTRAL FOUR

LEWCOS Dual Screened Coils are designed to facilitate the change from the 250-550 m. Broadcast Band to longer waves used by Hilversum, Radio Paris and Daventry. The change is effected by a switch incorporated in the coils and operated by a single panel control.

The sets are perfectly balanced before leaving the factory and complete wiring instructions are provided with each unit.
Obtainable through all Wireless dealers.

LEWCOS

(Regd. Trade-Mark)

Dual Screened Coils

THE LONDON ELECTRIC WIRE CO. & SMITHS, LIMITED
 Playhouse Yard, Golden Lane, London, E.C.1

FREE

Full-size **Blueprint**

“Britain’s Favourite Three”

with

Amateur Wireless

On Sale on January 26th

Readers of “AMATEUR WIRELESS” were recently invited to place in order of popularity six out of twelve sets. The one which was accorded most votes—“*Britain’s Favourite Three*”—will be fully described in this issue of “AMATEUR WIRELESS.”

Make sure of your copy of “AMATEUR WIRELESS” by getting it early on Thursday, January 26th. Usual price, 3d.

THE PEERLESS FIXED RESISTOR

as specified for the "Everyday Three" Receiver on page 52 of this issue. A neat, one-hole-fixing unit, base of solid insulation, wire evenly wound, fitted terminals and soldering tags.

In various sizes to suit all types of valves

1/3 each.



Send for list of "Peerless" components
BEDFORD ELECTRICAL & RADIO CO., LTD.
22 Campbell Road, Bedford

"Amateur Wireless" HANDBOOKS

each 2/6 net.

The Shielded Four - electrode Valve Loud-speaker Crystal Sets.

Wireless - controlled Mechanism for Amateurs.

The Wireless Man's Workshop.

The Practical "Super-set" Book.

Perfect Broadcast Reception.

The Short-wave Handbook.

The Practical Wireless Data Book.

each 1/6 net.

Wireless Telephony Explained.

Crystal Receiving Sets and How to Make Them.

Wireless Component Parts and How to Make Them.

Wireless Telegraphy and Telephony and How to Make the Apparatus.



Of all Newsagents and Booksellers, or by post, 3d. extra, from Cassell & Co., Ltd., La Belle Sauvage, London, E.C.4



JUST A REMINDER

CLIX RAINBOW TERMINALS 5d. each.

In nine distinctive colours complete with colour Identity Rings.

For use in conjunction with

CLIX Spade Terminals	2d. each.
CLIX Pin Terminals	2d. each.
CLIX Parallel Plugs	2d. each.
CLIX Parallel Sockets	1d. each.

LECTRO LINX LTD.,
245 Vauxhall Bridge Road,
Westminster, S.W.1.

Telegrams: "Trollinx," Churton.

Telephone: Victoria 5120.

BATTERIES! ABOLISHED!

By using the "Simpler
Wireless" Model—

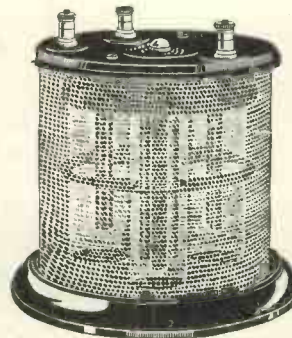

designed by J. F. JOHNSON, and specified for use in the Special A.C. Mains Adaptor for the "Simpler Wireless," as described in the current issue, complete with full directions.

PRICE 30/-

Packing and carriage, 1/6 extra.
Please mark your order "Simpler Wireless" Model.

**OTHER MODELS
OR BATTERY CHARGING**

The F.G.1, for charging H.T. Accumulators from alternating current mains. Charge rate, 50 to 200 milliamps. PRICE 30/-

Packing and carriage, 1/6 extra.

The F.G.3 Model is designed to pass a greater charge than the F.G.2 Model, which is 1 ampere, and is used for a few hours once a week, will not only keep the L.T. accumulator up to concert pitch, but will double its life. PRICE 50/-

Packing and carriage, 1/6 extra.

Full particulars on request

Simple
Safe &
Silent

Faradex

RECTIFIERS

No Fumes
Sediment
or Heat

ROOKE BROS. LTD., 55, CARDINGTON ST., N.W.1

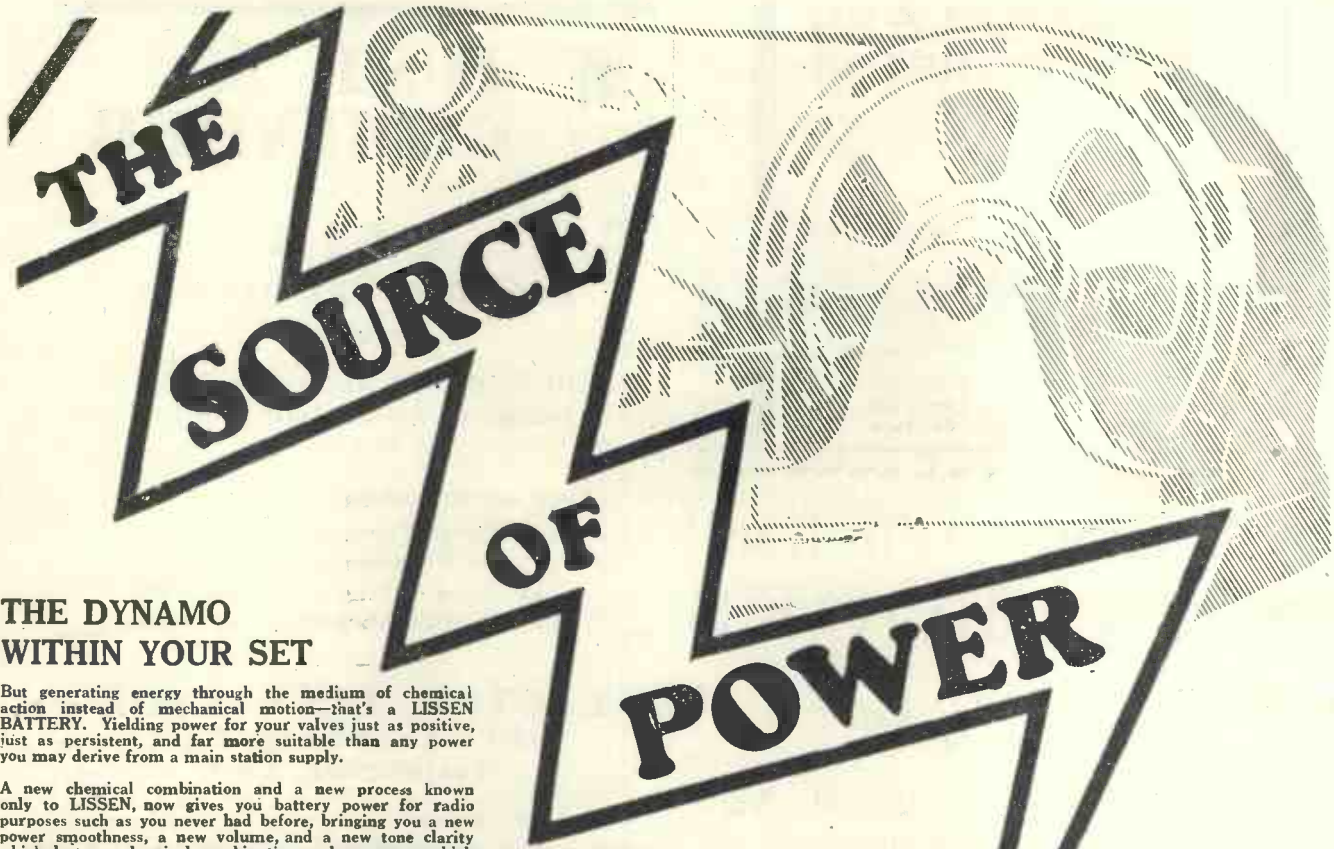

THE DYNAMO WITHIN YOUR SET

But generating energy through the medium of chemical action instead of mechanical motion—that's a LISSEN BATTERY. Yielding power for your valves just as positive, just as persistent, and far more suitable than any power you may derive from a main station supply.

A new chemical combination and a new process known only to LISSEN, now gives you battery power for radio purposes such as you never had before, bringing you a new power smoothness, a new volume, and a new tone clarity which lasts—a chemical combination and a process which generate pure D.C. current, absolutely noiseless in its flow, strong and long sustained so that the most prolonged programme will never affect it. There is no ripple to smooth out, because there is no ripple in the current to begin with. There is no moving mechanism to cause a humming sound and a fluctuation in supply.

LISSEN Battery power is safe in the home, it is economical in first cost, it requires no upkeep, it is long lasting, it costs you shillings instead of pounds—in fact, a LISSEN BATTERY IN USE WILL PROVE TO YOU, AS IT HAS PROVED TO TENS OF THOUSANDS OF OTHER USERS, THAT IT IS THE ONLY SATISFACTORY POWER PLANT FOR YOUR RADIO RECEIVER.

You can obtain a LISSEN Battery on your way home at the nearest one of 10,000 radio dealers

60 volts (reads 66) 7/11
 100 volts (reads 108) - 12/11
 9 volts (grid bias) - - 1/6



LISSEN LIMITED
 16-20 FRIARS LANE
 RICHMOND, SURREY
Managing Director: Thos. N. Cole

LISSEN NEW PROCESS BATTERY

Wireless Magazine

Vol. VII. No. 37. February, 1928

CONTENTS

	PAGE		PAGE
Your Choice of the World's Programmes. A Special Article by R. W. Hallows ..	6	Our Half-price Blueprints ..	44
The Astral Four. No Coils to Change: A Self-contained Receiver for Long-distance Work ..	10	Those Amazing Short Waves!	45
Working Ranges of Broadcast Receivers. By Capt. H. J. Round, M.C., M.I.E.E. ..	15	Austrian Broadcasting As It Is To-day. By Dr. Alfred Gradenwitz ..	46
The Wireless Encyclopaedia ..	17	The Ideal Radio Concert Party. By Murray Ashford ..	50
A Screening Hint ..	17	Radio Curiosities ..	51
Under My Aerial. Halyard's Chat on the Month's Topics ..	18	The Everyday Three. A Simple Set that Will Please Everybody ..	52
Making a Cone Loud-speaker. A Simple and Efficient Unit any Amateur can Construct ..	21	Among the German Stations ..	56
The Metropolitan Three. A Special "Simpler Wireless" Receiver for Use Direct from D.C. or A.C. Mains ..	22	Telephony on the High Seas ..	57
Make a Fair Test ..	26	Sandy Broadcasts. By Richard Carol ..	58
A.C. Mains Adaptor for "Simpler Wireless" Sets ..	27	A Long-range Hartley One. Specially Intended for Head-phone Reception ..	59
Experiments in Empire Broadcasting. By D. Sisson Relph ..	30	Gramophone Pick-ups ..	62
Batteries and the Listeners' Budget ..	32	"Excommunicated" Broadcasters. By B.B.C. Officials ..	63
The 1928 Five. Details of Long-wave Coils ..	33	The Exhibition Five ..	64
Archibald Puts Things Right. A Wireless Story ..	34	Making a Nuisance Interesting!	65
What Readers Think of Our Sets ..	36	Best Loud-speaker Positions ..	66
The Two-programme Two. 5XX or 5GB without Changing Coils. By J. H. Reyner, B.Sc., A.M.I.E.E. ..	37	The New "Q" Coil. By J. H. Reyner, B.Sc., A.M.I.E.E. ..	67
Short-wave Tests in a Coal Mine ..	41	Using Two Valves to Detect ..	70
Radio Tracks the Criminal! ..	41	Broadcast Music of the Month ..	72
Half Hours with the Professor. II.—Another Chat About Tuning ..	42	How Low Can We Go? ..	76
The Innocent Oscillator ..	44	Continental Notes ..	78
		The World's Broadcasting ..	80
		Oscillating to Produce Music!	86
		A Hint on Radio Income and Expenditure ..	88
		Questions Simply Answered ..	90
		The Five-guinea Three ..	91
		Test Reports ..	91
		A Handsome Cabinet ..	92
		Good Lard! ..	92
		Germany's High-power Station ..	93
		Reference Sheets ..	94
		Catalogues and Pamphlets ..	96
		The Phoenix Five ..	96
		Index to Advertisers ..	96

The Editor Tunes In—

In this issue I am again able to offer to home constructors details of five special WIRELESS MAGAZINE receivers, one of which will be found to meet almost any need. In particular I should like to call the attention of my readers to the Astral Four, which, with its self-contained batteries, makes a particularly neat household receiver, and to the Everyday Three, an exceedingly simple receiver incorporating moving-coil reaction and switching for the use of either two or three valves.

The details of an experimental cone loud-speaker will undoubtedly appeal to large numbers of WIRELESS MAGAZINE readers who have not yet had any experience with this type of reproducer. They will find it simple to make, although there is great scope for individual modifications of the design.

J. F. Johnston's "Simpler Wireless" system has aroused great interest in all parts of the country supplied with D.C. mains. In this issue I am able to include constructional details of the best "Simpler Wireless" three-valve set that has yet been designed. As it stands this can be operated straight from D.C. mains; readers who live in districts where only an A.C. supply is available will find the details of a special A.C. mains adaptor of particular benefit and utility to them. I have no doubt that the publication of these two units will mark a new era in home-constructed mains receivers.

In a special article entitled "The New 'Q' Coil" our Technical Editor, J. H. Reyner, B.Sc. (Hons.), A.M.I.E.E., gives full particulars of a new and very much improved type of coil he has produced in the Furzehill Laboratories.

WIRELESS MAGAZINE readers will watch this latest development with very keen interest, for there is at the present time undoubtedly a great demand for a more efficient and simpler type of tuner, particularly for use in high-frequency circuits. I shall be able to publish further particulars of this new development in future issues of the WIRELESS MAGAZINE.

Those who are less technically inclined will find in these pages a representative collection of articles of general interest to all radio fans, and in particular I should like to call attention to the article entitled "Your Choice of the World's Programmes."

Even now there are large numbers of people who do not realise the tremendous scope that a simple wireless receiver affords in the way of entertainment. If any of your friends are hesitating about going in for wireless on the score of lack of sufficient variety of programmes I suggest that you let them read what R. W. Hallows has to say on the subject.

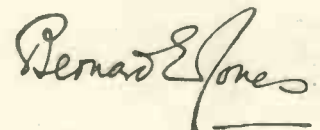

Published by BERNARD JONES PUBLICATIONS, LTD., publishers of "Wireless Magazine" and "Amateur Wireless." Editor: Bernard E. Jones. Technical Editor: J. H. Reyner, B.Sc. (Hons.), A.M.I.E.E. Editorial and Advertisement Offices: 58-61, Fetter Lane, London, E.C.4. Telephone: City 3733, 3734. Telegrams: "Beejapee, Fleet, London." Published about the 25th day of the month and bears the date of the month following. Subscription: Great Britain and Abroad, 15s. 6d. a year, post free (Canada only, 13s. 6d.). Contributions are invited and will be promptly considered.

Registered at the General Post Office for transmission by Canadian Magazine Post

Even after five years of broadcasting there are still in the country pessimists who belittle its entertainment value and the Editor has pleasure in publishing this article by a keen listener who is an optimist. In his article our contributor shows how easy it is to ensure a continuous variety of programmes from all corners of the earth. Read it and take heart if you are at all despondent regarding what broadcasting can offer you!

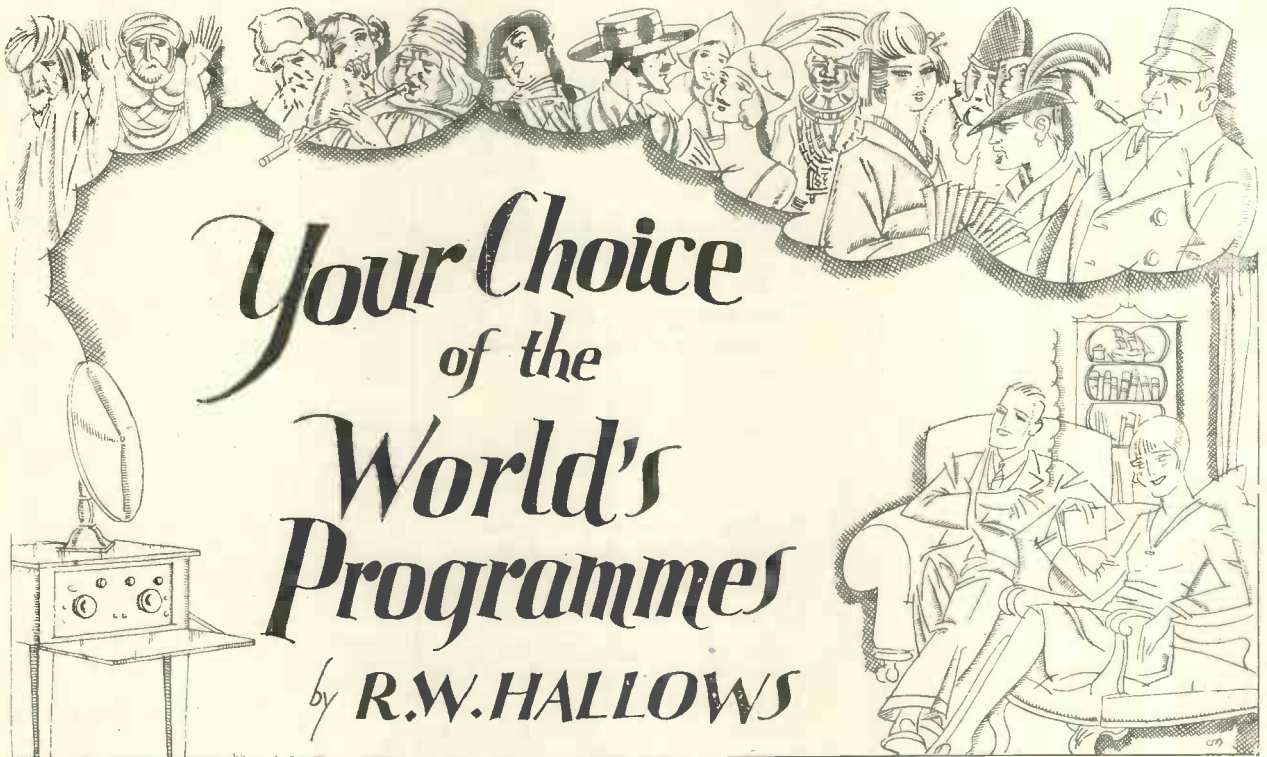

Your Choice of the World's Programmes

by R.W. HALLOWS

LAST night with the help of my main wireless set I listened to programmes from stations upon both sides of the Atlantic; this afternoon with the short-wave receiver yet more distant countries have been heard. In twenty-four hours my wireless sets have brought in music from each of the world's five Continents—Europe, Asia, Africa, Australasia, and America.

Thrill of Distant Stations

There are those who claim that the thrill of bringing in transmissions from distant places is one that soon wears off. I often wonder if the makers of such statements have ever handled a really good set designed for reception upon the medium and upper wavelengths or a first-rate short-waver.

The greatest thrill in wireless that ever came my way was certainly that experienced when the first radio signal was received upon weird home-made apparatus constructed a good many years before the War. A great many turns of wire had been placed upon the queer-looking coil and one had not the slightest idea of the wave

lengths to which it would tune. Such crude adjustments as were then possible were being made when suddenly in came a strange rhythmic pinging sound.

Nothing much could be made of the message, but the call-sign was unmistakable. It was FL, the Eiffel Tower. Possibly the broadcast listener nowadays can hardly understand how anyone can bless a spark signal or be thrilled by it; I



The wanderlust is upon us and we desire to travel

can assure you that I both blessed and was thrilled!

Since then I have done a great deal of long-distance work upon wavelengths ranging between 10 and 23,000 metres, but the joy of picking up new stations in distant countries has never become stale.

Most of us rely upon the local station or upon Daventry Senior or Daventry Junior for the bulk of our reception. That is only natural, for we know that they can give us the very best in point of purity and clearness that wireless has to give.

A Sheer Joy

But there are times when it is a sheer joy to use the wireless set as a magic vehicle for travelling to the distant places of the earth. It may be that none of the local programmes fits the mood of the moment or it may be simply that the *wanderlust* is upon us and that we desire to travel. Being unable to visit foreign countries in person we can bring them, so to speak, into our homes with the wireless set.

Those who in the past have journeyed upon the Continent of Europe

may pick up broadcasting from towns in the countries that they know, may hear again the speaking of foreign languages and may thus recapture old memories.

Those who have never left this island, but yet long to do so, can with the wireless set obtain an insight into the atmosphere of life abroad. You may hear typical *cabaret* entertainment from one of the French stations or grand opera from Germany.

Life in Spain

You wonder perhaps what life in sunny Spain is like, or if you have been in that country you desire to have the memory sharpened. You will find that there is very little doing from the Spanish stations until late in the evening as a rule. The

“The German programmes are far better than ours.” Are they? Don’t form an opinion until you have heard them for yourself and made a direct comparison. “The American programmes go with a real swing.” Is that actually so? Perhaps it is, perhaps it isn’t; in any case, why not listen to them at first hand and find out?

“We have the best broadcasting service in the world”: “Any other country would be ashamed of our programmes.” Clearly one of these statements must be wrong. Which is it? Only the man or

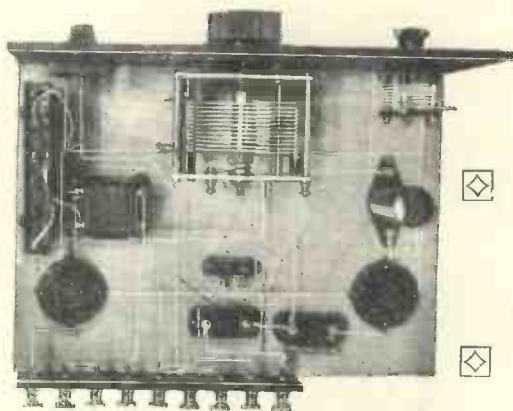

A Simple two-valver—the British Broadcast Two—which was described in the December, 1927, issue

Those are points that have been made to me again and again, both by the man-in-the-street and by experts connected with broadcasting in this country. It is usually argued under point number one that the long-distance enthusiast does not care *what* he hears so long as he hears *something*—no matter how distorted—that he knows comes from a distant spot.

I admit at once that there are those who cheerfully write letters to the lay Press to say that in thirty-five seconds they tuned-in seventeen stations. It is perfectly clear that such people can derive no aesthetic pleasure from what their telephones or loud-speaker bring in.

Still a Station

There are those again to whom a station, no matter if it sounds like a duet between a dying pig and a shooting match, is still a station and is to be logged as such.

There are yet others who, hurling the set into oscillation, travel round in search of carrier waves and then go through the process known in certain circles as “resolving” them. In less scientific language this means finding the silent point between

Reyner's Phoenix Five

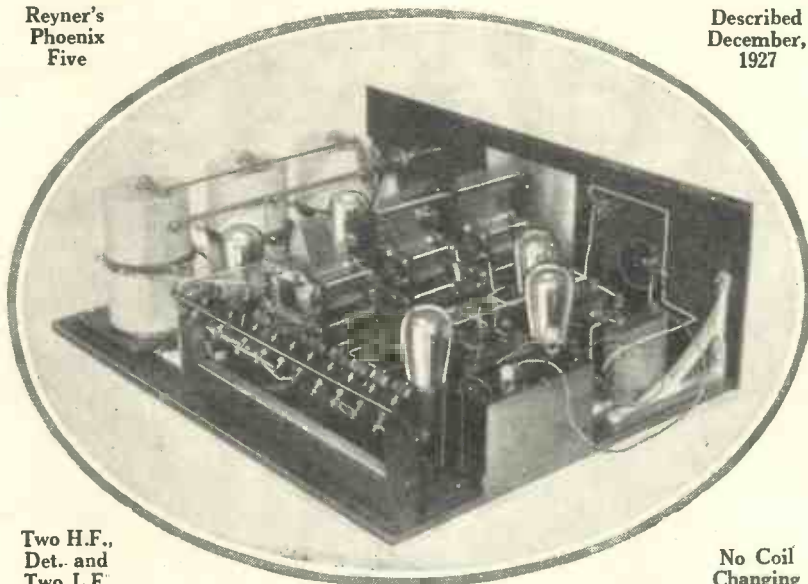

Two H.F., Det. and Two L.F.

Described December, 1927

No Coil Changing

plain and simple reason is that in Spain the evening does not start until late, or end until the small hours.

There may be music at an earlier time, but it has not the “go” of that which you will hear after the home stations have closed down. Though you may not understand one syllable of the language you cannot help grasping something of the spirit of Spanish life, if your set will bring in stations such as those of Barcelona, Madrid, and San Sebastian.

Keeping in Touch

One keeps in touch, too, with the great world of broadcasting, for it is a great world nowadays. Too often we are content to accept the truth of a statement if we hear it several times repeated or see it frequently in print.

woman who tours the world occasionally by wireless can supply the answer.

Yes, the reader may say, what you have said is all very well, and I quite agree with it up to a point. There are, however, two fairly strong objections to the line you are taking; in the first place we are told by the most eminent authorities that the quality of distant stations must always be of the poorest; in the second you cannot possibly listen to foreign countries without building a large receiving set, expensive to make and expensive to run.

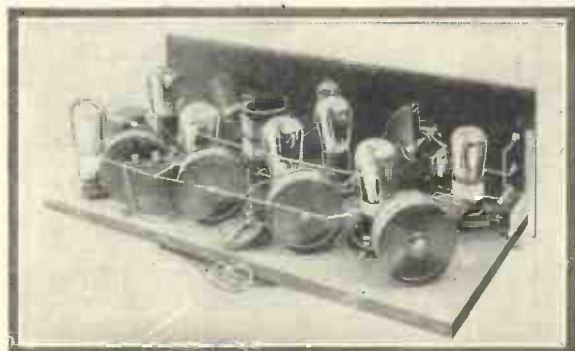

The simpladyne Seven is a super-het it was described in August, 1927

Your Choice of the World's Programmes! (Continued)



A typical cabaret entertainment

squeals. Anything heard in this way must be muzzy to a degree; yet to them it is another scalp to add to the tally.

Knob-twiddling Fiend

Then there is a fiend who asks you in for the evening and spends his whole time in twiddling knobs. You have two bars of a foxtrot in Frankfort, three words of a topical talk from Vienna, a snatch of a news bulletin from Stockholm, a syllable or two from Berne and a few chords from Prague.

Whether it is sparked, jammed, heterodyned or mushed, a station is still a station to him and in no circumstances can he allow himself or you to listen to it for more than about five seconds.

If something really good appears to be going at one station and you beg him to hold it he says: "Oh, we will come back to that presently." Usually you don't, but if by chance you do it is generally at a much later time when a glorious musical transmission has given place to a talk on vitamins or bunions or something of that kind.

The true long-distance enthusiast does care very much what he hears. He may, in fact he must, during the process of calibration, flit from station to station as a bee flits from blossom

to blossom; but once he knows his way about the broadcast band he is able to pick up twenty or thirty stations which it is worth while to tune-in and on these he relies mainly for his own entertainment or for demonstration purposes when friends come round.

He knows, too, that if these twenty or thirty form his "star" list he must not expect that each and every one will be coming through perfectly whenever he tries for them. On a given night one may be interfered with by spark signals, another by jamming, a third by a heterodyne. Still, he may feel perfectly sure that he will find a goodly number that can be received at fine strength and with such quality as makes them only worth listening to. These he will try for before attempting any of the others.

Can the quality of distant transmissions ever be such that they are genuinely worth listening to? All that I can say is this: On many occasions when musical friends have come in for the evening I have worked

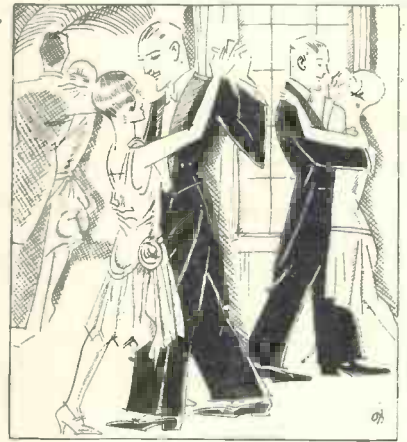

In a few moments everyone was fox-trotting again

"Your reception of London is really wonderful."

Perhaps the greatest long-distance triumph that one can claim was that which came at the end of a small dance some weeks ago. On searching round with the telephones I found that WGY was coming through extraordinarily well. Greatly daring, therefore, I threw in an extra stage of note-magnification and put him

on to the loud-speaker. As luck would have it his dance band was at work at the time. *In a few moments everyone was fox-trotting again.* "How extraordinarily lucky," said one of the party, "to find London sending out dance music at this hour of the morning; I didn't know that he ever did such a thing." He doesn't!

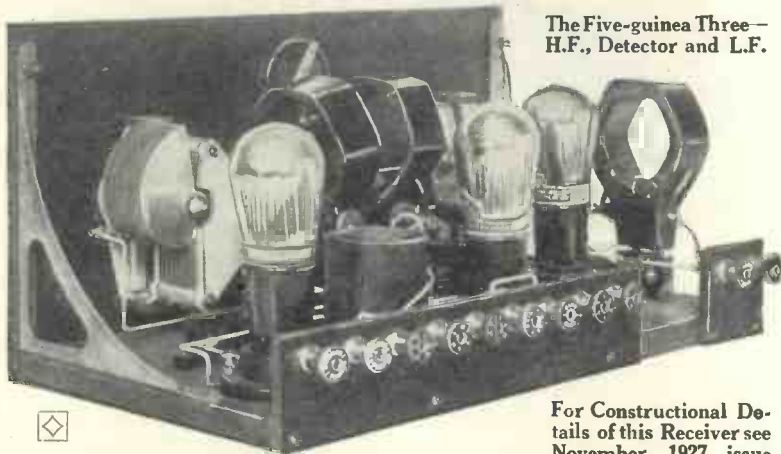

The Five-guinea Three—H.F., Detector and L.F.

For Constructional Details of this Receiver see November, 1927, issue

a little stunt upon them by putting on to the coil-driven loud-speaker a station such as Radio-Paris, Hilversum, Motala, Kalundborg, Vienna, Langenberg, Frankfort, Berne, Hamburg, Prague, Barcelona, Milan, Dortmund, Toulouse PTT, Malmö, Kiel, Münster, or even one of the Swedish relays, without making any comment.

Sometimes the experiment has proved a failure owing either to atmospheric or to mush; but more often than not they have said to me

Now we come to the second point; that of the receiving set itself. For world-wide travelling upon the medium and higher waves you do not need a large receiving set. Results can be obtained in two different ways. Either you may use two or more high-frequency stages, relying not at all upon reaction, or you may employ a single very efficient high-frequency stage and make use of reaction as a combined volume and quality control.

Myself, I never use more than four valves. The first of these may be

And the Best Receivers to Use to Get Them

either a screened-grid valve, giving an enormous degree of amplification with what may be called automatic stability, or a three-electrode H.F. amplifier with a first-rate modern coupling device. Whether the rectifier is of the leaky-grid or the anode-bend type must depend very much upon the amount of amplification available.

Reaction for Real Success

Reaction for real success in long distance work must be of silken smoothness—an ideal which it is not at all difficult to achieve if the designs published in the WIRELESS MAGAZINE are carefully followed. On the low-frequency side two stages are required, there being preferably an arrangement whereby it is possible to use one or both as may be required.

You cannot hope for success with an unstable receiver or one whose reaction is "floppy." It is hopeless again to attempt real long-distance work on the medium and upper bands without one good stage of high-frequency amplification. It may be—in fact it *is*—possible to receive Budapest without high-frequency amplification; but such reception is a mere travesty of what it ought to be and usually causes neighbours to register all kinds of black marks in the Recording Angel's book owing to what they have to say about "that oscillating fellow next door."

The Exhibition
Five

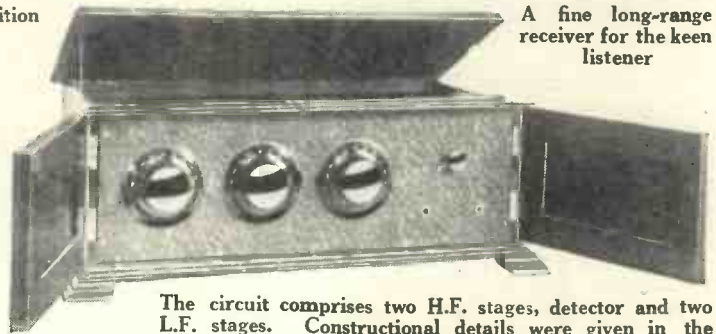

A fine long-range
receiver for the keen
listener

The circuit comprises two H.F. stages, detector and two L.F. stages. Constructional details were given in the October, 1927, number

High-frequency amplification is important not only because it magnifies the tiny impulses that reach the aerial from distant stations, but also because each H.F. stage acts as a filter and makes the set more selective, thereby reducing the wipe-out of the local or semi-local station,

And the cost? A careful examination of the constructional details that appear from time to time within these covers will show that such a receiver can be constructed for a remarkably small outlay.

Admittedly a crystal or a one-valver can be purchased at less expense. But considering the limitations of these small sets the bigger fellows are surely well worth while.

No Wiring Complication

"But," says Doubting Thomas, "just look at the wiring complications of these multi-valvers." My dear D.T. (those initials are unfortunate, are they not?) there are certainly a few more wires in a multi-valve set, but there is no greater difficulty about connecting them up than in taking those of the single-valve set to their proper places. With the diagrams given, or better still the blueprints, one can scarcely go wrong.

Very little more labour is involved in building a three- or four-valver than in making a single-valve set. Both are good in their way, but with the big set the world is one's oyster, whilst with a single valve limitations of strength and range are clear cut.

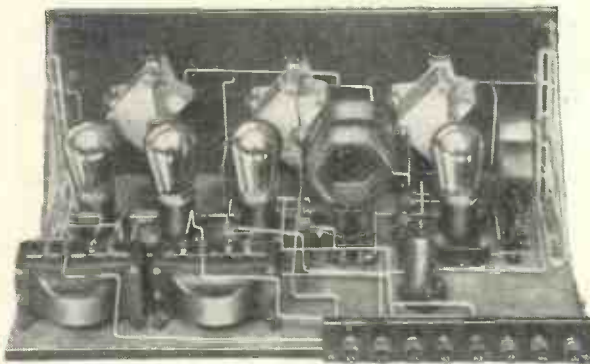

The Simplicity Four was described in the January, 1928, issue. It makes use of two-pin plug-in coils

We realise, then, that the minimum set for loud-speaker distant reception is one of four valves, one H.F., a rectifier and two L.F. If the telephones will do all that is needed, the second L.F. stage may be cut out and a three-valve set will suffice.



In this article is described the construction of a powerful four-valver that has been designed, built and tested by the "Wireless Magazine" Technical Staff. Besides being almost entirely self-contained (with the exception of a loud-speaker) it has the further advantage that reception can be carried out on both lower and upper broadcasting bands without the need of changing coils



A Special "W.M." Technical Staff Set

No Coil Changing and is Self-contained

NOT the least of the advantages that modern component progress has given us is that we can build efficient multi-valve receivers that will operate on both the lower and upper bands of broadcast wavelengths without the need for changing coils. Such a four-valver is described in this article; it has been designed, built and tested by the WIRELESS MAGAZINE Technical Staff.

Volume and Clarity

The receiver has been entitled The Astral Four, and keen "etherites" will not have to puzzle their heads long to find the *motif* that led to the adoption of this name. "Astral" suggests something vast and all-embracing: we believe that The Astral Four will be found capable of bringing in a large number of broadcast programmes from all parts of the world with volume and clarity.

Whilst it is true that there is a very large number of stations working on the lower broadcast band that can be received at good loud-speaker strength with four valves, yet a number of really good alternative programmes are missed if reception

cannot also be carried out on the upper broadcasting band.

Normally this change-over is made by actually changing a set of tuning coils in the receiver—a somewhat troublesome operation in cases where two or three tuned circuits are involved. In this receiver the WIRELESS MAGAZINE Technical Staff has

THE CIRCUIT COMPRISES ONE STAGE OF NEUTRALISED HIGH-FREQUENCY AMPLIFICATION, UTILISING A SCREENED SPLIT-PRIMARY TRANSFORMER, A DETECTOR WITH REACTION, AND TWO STAGES OF RESISTANCE-CAPACITY COUPLED LOW-FREQUENCY AMPLIFICATION.

overcome the difficulty by using one of the "double-decker" tuning units which have been recently placed on the market.

The actual coils are of the familiar six-pin type and each metal shielding box contains two coils, one for the band of wavelengths between 250 and

550 metres, and the other for wavelengths between 1,000 and 2,000 metres.

Change-over of wavelength range is accomplished merely by turning a small knob, which actuates a switch inside the shielding case itself, which changes over the coil connections. In the case of The Astral Four, this knob is immediately accessible by opening the lid a few inches.

The combination of valves used is (1) a high-frequency amplifier, (2) a detector, (3) a stage of low-frequency amplification and (4) another stage of low-frequency amplification.

Self-contained Batteries

Constructors should note that besides covering both wavelength bands The Astral Four is also completely self-contained except for the loud-speaker. At either end of the cabinet is a compartment for accommodating the necessary batteries. That on the right will house the high-tension and grid-bias batteries, while that on the left will give ample room for quite a large low-tension accumulator.

Other details of The Astral Four

will be clear from the circuit diagram, reproduced on this page. It will be seen that the aerial tuner comprises an auto-coupled arrangement, the primary being provided with three tapings and the secondary, which in untapped, being tuned by means of a .0005-microfarad variable condenser.

Split-primary H.F.

For the high-frequency circuit in connection with the first valve a split-primary arrangement has been employed in order to effect neutralisation in an efficient and satisfactory way. The centre tap on the primary winding, it will be observed, goes to high-tension positive, while that end of the primary remote from the anode of the first valve is connected back to the grid through the medium of a neutralising condenser.

A double winding is shown in the circuit diagram for the "secondary," but this is not a split-secondary circuit. The top portion of the winding is the true secondary, while the lower portion is actually a reaction winding.

Controlling Reaction

A more detailed examination will show that the top portion, which is tuned by a .0005-microfarad variable condenser, is connected between the grid of the second (detector) valve and its filament, while the bottom portion is connected between the anode of the same valve and its filament. Control of oscillation or feedback is obtained by the use of a small variable reaction condenser.

Both of the low-frequency amplifying valves are coupled on the resist-



View of front panel of The Astral Four. There are two large tuning dials, for the aerial and high-frequency circuits respectively, a small reaction control, and a loud-speaker jack

ance-capacity principle in order to ensure the greatest possible purity of reproduction. Actually the complete coupling units are in each case contained in the base of a combined valve-holder and R.C. coupling unit.

Other points to specially note about the circuit are the loud-speaker jack, by means of which the filaments are automatically switched on when the plug is inserted, and the two filament rheostats. One of these controls the high-frequency and

detector valves, and the other the two low-frequency amplifiers. Both are of the baseboard-mounted type and are of a new and efficient plunger design recently put on the market.

High-frequency Choke

An important unit of the receiver is the high-frequency choke included in the anode circuit of the detector valve. This component must choke effectively on both broadcast bands if good results are to be obtained and

The Astral Four has only two tuning controls and reception can be carried out on both wavelength bands by manipulating a simple switch

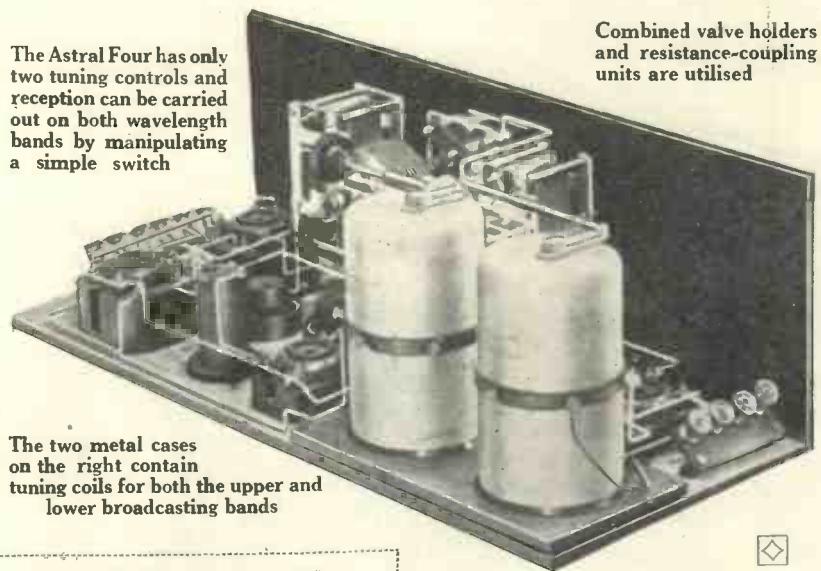

Combined valve holders and resistance-coupling units are utilised

The two metal cases on the right contain tuning coils for both the upper and lower broadcasting bands

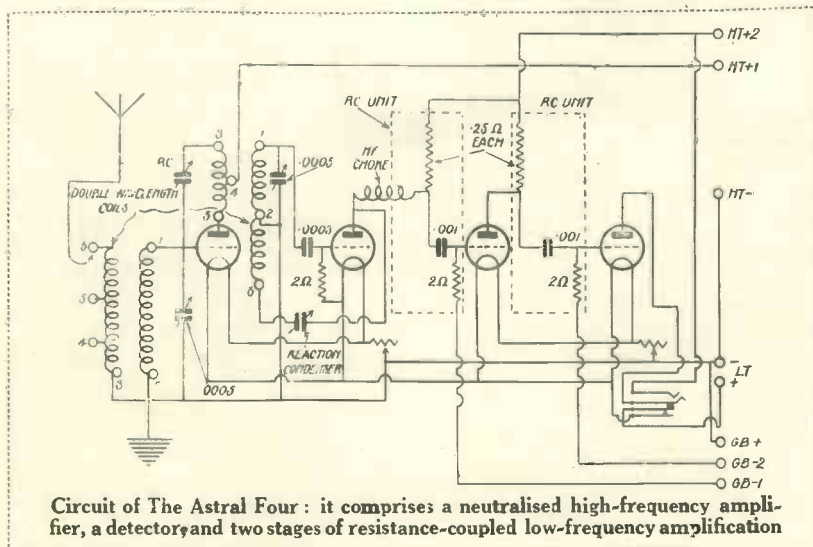

care should be taken in its choice.

Essential Components

Following is a complete list of the components required for building The Astral Four:

- Ebonite panel, 21 in. by 7 in. (Becol, Red Triangle or Will Day).
- Two .0005-microfarad variable condensers (Cyldon Log Mid-Line, Jackson or Raymond).
- Reaction condenser (Ormond, Cyldon or Igranic).
- 4-point loud-speaker jack (Lotus No. 4).
- Loud-speaker plug (Lotus).
- 2 dial indicators (Bulgin or Belling-Lee).
- Double screened-coil unit, aerial and one high-frequency stage (Lewcos DSP2).

The Astral Four (Continued)

The Astral Four ready for use with a P.M. loud-speaker

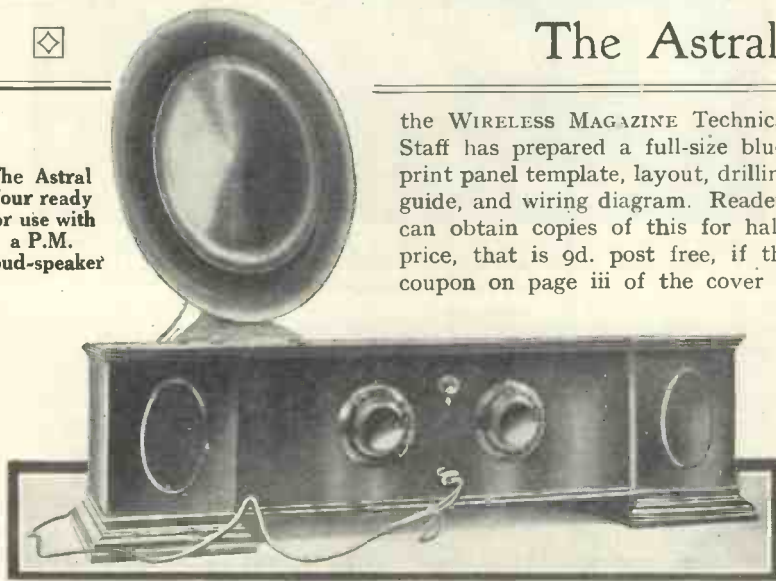

the WIRELESS MAGAZINE Technical Staff has prepared a full-size blueprint panel template, layout, drilling guide, and wiring diagram. Readers can obtain copies of this for half-price, that is 9d. post free, if the coupon on page iii of the cover is

photograph reproduced at the top of the facing page.

Disposition of Components

On the extreme left of the baseboard is seen that special dual screened-tuner unit, immediately in front of it being placed the holder for the high-frequency valve and the neutralising condenser.

To the right of these are the grid condenser and grid leak, the detector-valve holder, the high-frequency choke and the two baseboard rheostats (almost in line). At the right of the baseboard, one behind the other, are the two combined valve-holders and resistance-capacity coupling units for the two low-frequency amplifying valves.

Terminal Strips

A word may be said here regarding the two terminal strips. These are screwed to the baseboard in a special way, the screws being passed through short lengths of ebonite tubing of which one end has been cut at an angle of approximately forty-five degrees. This will be clear from a glance at the bottom photograph reproduced on page 11.

As soon as all the parts have been securely fixed into position, wiring-up can be started. At this stage the blueprint or the smaller reproduction on page 14 will be found particularly useful. A glance at either will show that each terminal point is marked with a small letter of the alphabet; these letters indicate the points which should be connected and in what order.

For instance, first connect together all those points marked *a* with one wire or as few wires as possible; next connect up all those points marked *b*; and so on throughout the alphabet until everything is connected.

Suitable Valves

Before going into the details of completing all the connections prior to a rough test of the receiver, it will be as well at this stage to discuss suitable valves. It is immaterial whether 2-, 4-, or 6-volt valves are

Neutralising condenser (Peto-Scott, Wearite or Igranic).

Two anti-microphonic valve-holders (B.T.H., Lotus or Benjamin).

Two combined anti-microphonic valve-holders and resistance-capacity coupling units (B.T.H. type A).

.0003-microfarad fixed condenser (T.C.C. type SP).

2-megohm grid leak (Dubilier, Mullard or Lissen).

Two 6-ohm baseboard-mounting rheostats (Gecophone, Lissen or Igranic).

High-frequency choke (Bulgin, Igranic or Wearite).

Two terminal strips, 4 in. by 2 in. and 3 in. by 2 in. (Becol, Red Triangle or Will Day).

4 in. length of 1/2-in. dia. ebonite tube (Economic Electric).

Cabinet with battery compartments and baseboard 8 1/2 in. deep (Carlington).

Ten terminals marked: Aerial, Earth, L.T.+ , L.T.- , H.T.+1, H.T.+2, H.T.- , G.B.-2, G.B.-1, G.B.+ (Ealex).

It should be noted that in cases where more than one make of component is indicated that mentioned first was used in the original receiver.

Alternative Parts

In the choice of alternative components other than those recommended in the list of parts reproduced above great care should be taken to see that they will fit the available spaces and that they are of high quality. Before any part of the construction is started it is especially recommended that all of the components should be got together.

For convenience in construction,

used before February 29. In the case of overseas readers an appropriate extension of time will be made.

When everything is ready for beginning the construction, lay the blueprint flat on the panel and mark through the centres of all the holes to be drilled. There are ten, excluding two or three for screwing the panel to the baseboard and two for fixing dial indicators, which are not indicated. Those constructors who do not use a full-size blueprint will

Rear view of the Astral Four

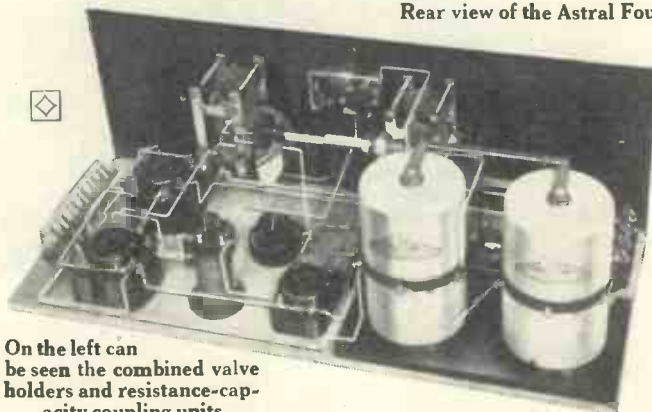

On the left can be seen the combined valve holders and resistance-capacity coupling units

find the panel layout indicated on page 14.

First, mount the reaction condenser and the loud-speaker jack, afterwards placing the two large variable tuning condensers in position. When the dials have been fixed, two dial indicators can be screwed into position.

When this has been done, carefully screw the panel to the edge of the baseboard and mount the baseboard components in position. The arrangement will be clear from the

A Fine Set for Long-range Loud-speaker Work

used, but it is important that the correct types should be used in the respective stages.

As a split-primary high-frequency transformer is included in the anode circuit of the first valve this should have a moderately high impedance, something in the neighbourhood of 20,000 to 30,000 ohms, say—as a matter of fact increasing the impedance of this first valve does, to some extent, increase the selectivity of the receiver.

R.C. Detector Valve

The detector valve, which has a resistance-capacity coupling in its anode circuit, should have a higher impedance than the high-frequency amplifier—any valve of the resistance-capacity type can be used here.

The valves mentioned in the table

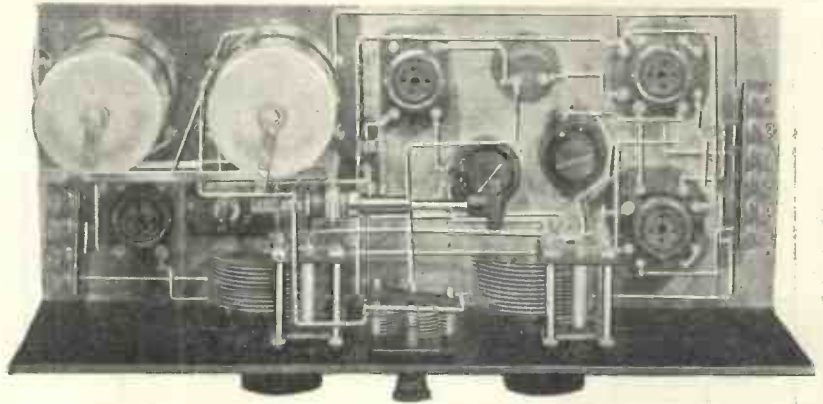

Plan view of the Astral Four, showing disposition of the components

preferably something below 5,000 ohms for the best results. A high anode voltage is very desirable for this last valve and in this connection it may be noted that many valves on the

show that terminals for the accumulator are provided on the left of the baseboard (looking from the front of the set). The accumulator should therefore be placed in the left-hand battery compartment. Terminals for the high-tension and grid-bias batteries are provided on the right of the baseboard and both these batteries should, in consequence, be placed in the right-hand battery compartment of the cabinet. Holes are provided in the wooden partitions through which the necessary leads can be passed without difficulty.

Testing the Receiver

In order to carry out a test of the receiver insert the panel and baseboard in the central compartment of the cabinet, and the batteries in the outside compartments, and the proper valves in their respective holders. Connect up as indicated on the blueprint and layout. To H.T. +1 apply a potential of about 80 volts and to H.T. +2 about 120

VALVES TO USE IN THE ASTRAL FOUR

Make	H.F. Amplifier and 1st L.F. Amplifier			Detector			2nd L.F. Amplifier		
	2-v.	4-v.	6-v.	2-v.	4-v.	6-v.	2-v.	4-v.	6-v.
Cosmor	210H	410H	610H	210R.C.	410R.C.	610R.C.	210P	410P	610P
Marconi	DEH 210	DEH 410	DEH 610	DEH 210	DEH 410	DEH 610	DEP 240	DEP 410	DEP 610
Mullard	PM1 H.F.	PM3	PM5X	PM1A	PM3A	PM5B	PM2	PM 254	PM 256
Osram	DEH 210	DEH 410	DEH 610	DEH 210	DEH 410	DEH 610	DEP 240	DEP 410	DEP 610

reproduced in these pages are for use with coupling elements on the following values: Anode resistance, .25 megohm; grid condenser, .001-microfarad; grid leak, 2 megohms.

The first low-frequency amplifier is also coupled to the last stage by means of a resistance-capacity coupling unit and the valve used in this position *could* be one of the resistance-capacity type (the same as the detector valve) but for the sake of purity in reproduction it is especially recommended that a lower impedance valve should be used in this position. This valve can well be of the same impedance as the high-frequency amplifier.

Valve for the Last Stage

Considerable volume will have to be handled by the last valve and this should be of the power or super-power type with a low-impedance—

market of which the maximum anode voltage is rated at 120 volts can be used quite satisfactorily with a considerably higher voltage.

A glance at the blueprint or layout diagram reproduced on page 14 will

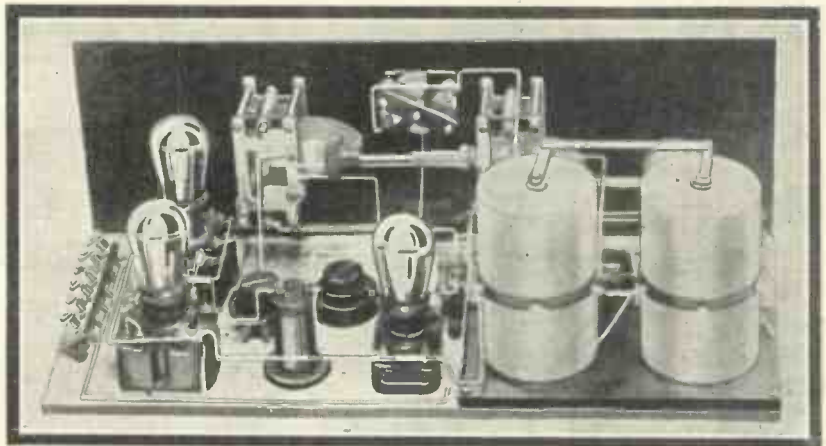

Rear view of the Astral Four, with valves in position ready for receiving

The Astral Four (Continued)

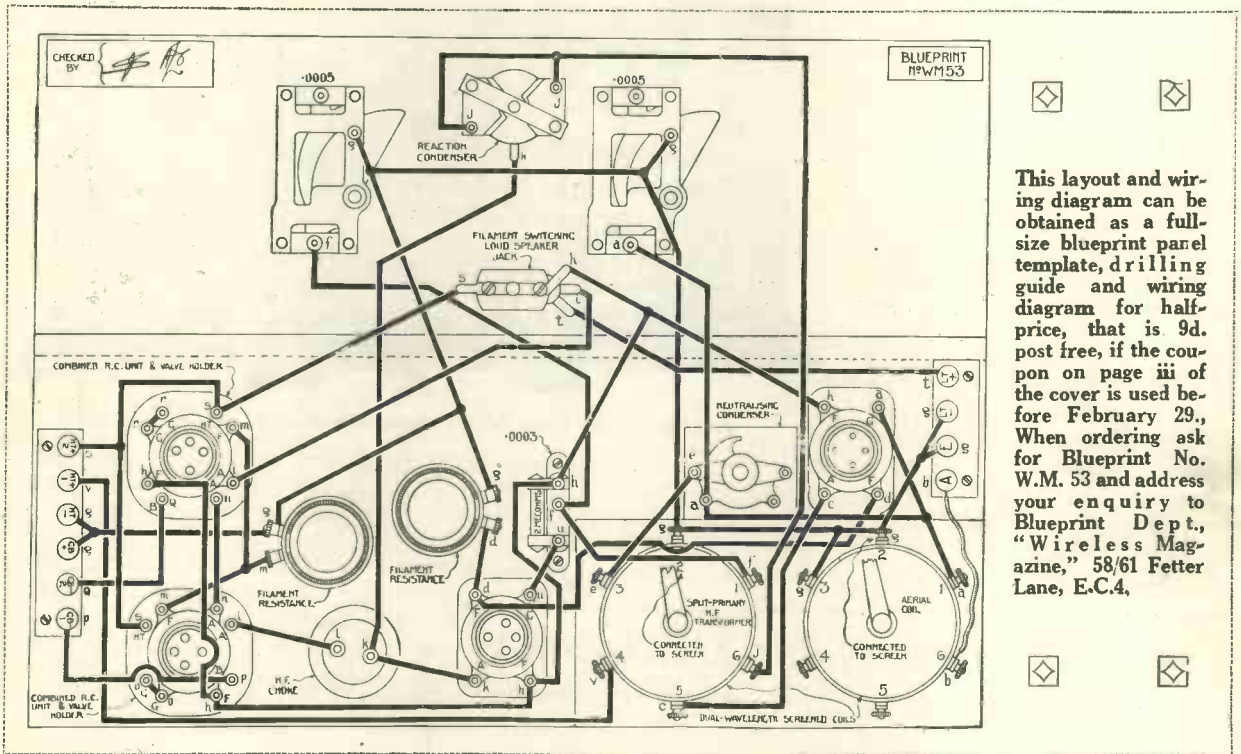

This layout and wiring diagram can be obtained as a full-size blueprint panel template, drilling guide and wiring diagram for half-price, that is 9d. post free, if the coupon on page iii of the cover is used before February 29. When ordering ask for Blueprint No. W.M. 53 and address your enquiry to Blueprint Dept., "Wireless Magazine," 58/61 Fetter Lane, E.C.4.

volts (or more if possible). A negative bias of $4\frac{1}{2}$ to 6 volts should be applied to G.B. - 1 and of 9 to 12 volts to G.B. - 2.

Before shutting down the lid of the cabinet attach the aerial and earth leads to their respective terminals and turn the knob on the dual screened coil to the short-wave position. Attach the loud-speaker leads to the plug and insert the latter into the jack on the panel. This will automatically connect up the valve filaments and switch on the set.

Place the neutralising condenser about half-way in and adjust the reaction condenser until the slight rustling or hissing sound is heard that indicates that the receiver is on the verge of oscillation, first putting the two main tuning condensers to the same dial readings. In order to tune in a station, rotate the two main tuning dials in unison until a transmission is picked up.

Readjusting for Quality

As soon as signals are heard, readjust the reaction condenser (keeping the vanes as much out of mesh as possible) and remove one of the filament leads of the first (high-

frequency) valve-holder. Now adjust the neutralising condenser until signals become almost or quite inaudible,

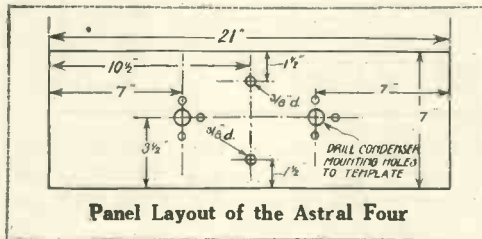

not removing the unlit valve from its holder whilst this is being done.

When signals have completely disappeared the high-frequency valve is properly neutralised and no feed-back is taking place through its plate-to-grid capacity. The broken filament connection can now be restored.

In order to receive on the upper broadcasting band of wavelengths it is only necessary to turn the knob of the tuning unit (just lifting up the lid of the cabinet a few inches to get at

it), when the long-wave coils are automatically put in circuit. When receiving on the long waves it will be necessary to alter the setting of the reaction condenser and it may also be desirable in some cases to re-neutralise the high-frequency valve.

The degree of selectivity and the results obtained generally will depend a great deal on which tap (of Nos. 4, 5 and 6) the aerial lead is taken to on the left-hand screened-coil (looking from the front of the receiver).

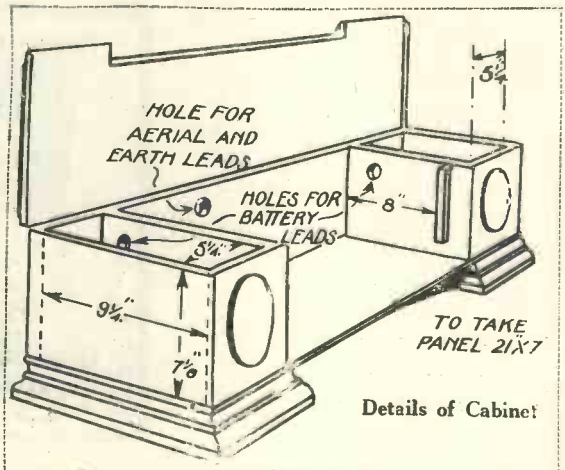

Details of Cabinet

A Special Article by Capt. H. J. ROUND, M.C., M.I.E.E.

WORKING RANGES of BROADCAST RECEIVERS

CAPT. ECKERSLEY has recently been writing of the regional scheme using millivolts per metre of field strength for defining the goodness of reception. This method of expressing the strength of signals will undoubtedly get quite

Distance in miles from transmitter	Millivolts per metre of aerial height
5	30
10	10
20	4
40	1
80	2

Fig. 1.—Approximate field strengths at various distances from the London transmitter.

popular before long and we shall want to know our own particular millivolts for all the important stations we receive.

Millivolts are used, of course, instead of volts just to avoid decimals, as it is a very big field strength which ever reaches a volt. The meaning of this field strength is that in one metre height of conductor so many millivolts will be induced—somewhat in the same way that two volts, or two thousand millivolts, will be induced into a conductor by connecting an accumulator to its ends.

Battery Analogy

The analogy with the battery is probably not quite true but superficially, just as the battery will produce a current in the conductor proportional to the voltage applied divided by the resistance of the conductor, so the millivolts will produce a current in the conductor of a value given by the millivolts divided by the impedance of the conductor or the resistance of the aerial when we are in tune.

The Americans have made many measurements of the field strengths of their broadcasting stations and published maps of these strengths and I believe the B.B.C. in England are making measurements in a similar way. I hope the results will be published sometime, because it will enable us to sit down and determine exactly what circuits are suitable at certain distances.

It must not, however, be forgotten that these field strengths are daylight readings and at night-time a receiver which is good for, say, 2LO at 80 miles in the daytime on the loud-speaker is probably quite good enough to get a large number of "continentals" at night.

Design of the receivers should, however, be done on the daylight strength as their night signals are of an erratic nature and are only of value when the power of the station is considerable.

I want to take up here one or two cases to show how these field strengths can be used to estimate the capabilities of a receiver and I am going to start with circuits which are of the simplest types but nevertheless they are probably the most difficult to calculate actually. They are basic circuits round which any receiver is built.

Fig. 1 shows approximately the field strength of 2LO at various distances up to 80 miles, and an easy figure to remember is that the strength at 10 miles is 10 millivolts per metre. These approximate figures have been taken from a recent paper by R. H. Barfield.

I propose to limit myself very severely by only considering the field strength necessary on any receiver to produce full loud-speaker strength, and many who have considered the problem accurately will be able to see where I have slurred over difficult points it is only possible to discuss at much greater length.

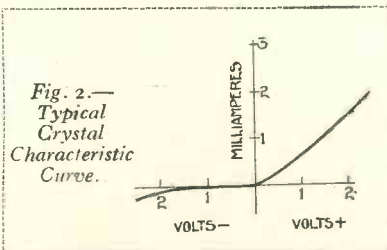

Fig. 2.—Typical Crystal Characteristic Curve.

Such points as the change of the efficiency of the rectification with strength I am avoiding, but with some justification in these particular cases.

At any site chosen for a receiver we shall be able to obtain the millivolts per metre of field strength, and we can if we know the aerial height and its resistance determine the aerial current. To determine the aerial resistance a delicate measurement is necessary, but

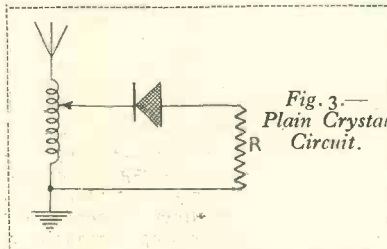

Fig. 3.—Plain Crystal Circuit.

designers know within limits what this is likely to be if the aerial is a good one.

Suppose, for instance, we take an aerial six metres high and we are told that the field strength is ten millivolts per metre and the resistance of the aerial

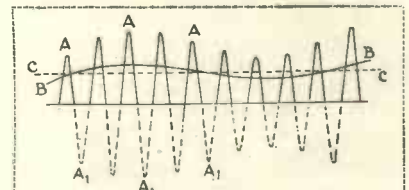

Fig. 4.—How a signal current is changed by the rectifier.

AA1 represents the high frequency
AA " " rectified half-waves
BB " " average modulated D.C.
CC " " D.C. Component
and the difference between BB and CC the modulation component.

plus tuning coil, measured or estimated, is twenty ohms, the total voltage that will act on the aerial is the height in metres multiplied by the field strength, which will be 60 millivolts.

This voltage divided by twenty gives us the aerial current in amperes if we convert the millivolts to volts before doing the calculation, which is a very wise thing to do, otherwise later on we are apt to forget that we are using millivolts, or, of course, the result will be in milliamperes if we keep to millivolts. In this particular case the current is

$$\frac{60}{1,000 \times 20} \text{ amps. or } .003 \text{ amps, or } 3 \text{ milliamperes.}$$

Tuning-coil Voltage

When we have obtained the current in the aerial the next step is to find out what voltage this gives across the tuning coil, because in nearly all cases of reception it is the voltage across the tuning coil or across part of it which is applied to the crystal or valve.

Suppose that the inductance of the tuning coil is L and the frequency N then the impedance of the tuning coil will be $2\pi NL$ and the voltage required to force a current through the impedance is $2\pi NLI$.

Let us take an example. In the previous case we have a voltage of 60 millivolts and an aerial resistance of 20 ohms, so that the current was .003 amperes. If our inductance is 100 microhenries and the frequency is a million, which is about 300 metres in wavelength, then the voltage across the inductance is

$$2\pi \times 10^6 \times 100 \times 10^{-6} \times .003 = 1.8 \text{ volts}$$

Working Ranges of Broadcast Receivers (Continued)

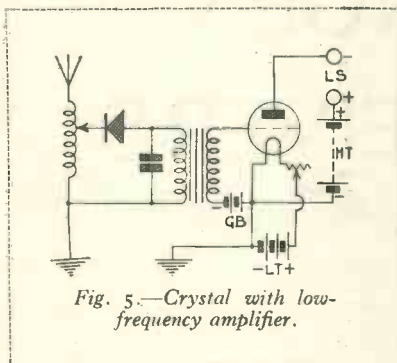

Fig. 5.—Crystal with low-frequency amplifier.

By means of this aerial tuning arrangement we have converted 60 millivolts into 1.8 volts, a kind of step-up transformer arrangement which is very frequently used in radio circuits.

The voltage across the whole tuning coil is 1.8 and the voltage across half of it would be about half of this value, and across a quarter of it about a quarter of this value.

If we took a very low-resistance crystal and put it right across the tuning coil, the voltage would attempt to put a heavy current through the crystal, and in doing so would drop its value largely, rather like a high-tension battery, especially an old one, drops its voltage when a load is taken from it.

Using all the Voltage

With a valve, particularly if used as a plate-bend rectifier or amplifier, the whole of this tuning coil voltage can be used as the valve absorbs very little energy, and in comparing crystals and valves this difference has to be carefully noted.

If we took the low-resistance crystal and started tapping it down the aerial inductance we should find a place where maximum current passed through the crystal, and the best tap position would be when the energy absorbed by the crystal was equal to the energy being wasted in the aerial.

Calculating the Best Tap-off

If we know the aerial resistance and the crystal resistance it is not difficult to calculate approximately the best tap, off position for the crystal and a little later I will give an actual practical example.

Tuning is affected by the position of this crystal tap-off. Tap-off positions above the maximum current position give less current and worse tuning, so that they are obviously not useful positions. Tap-off positions below the maximum current position give less current but better tuning, and in certain cases they may be advantageous.

A crystal has a characteristic, just as a valve has, but it is a far simpler one. There is nothing else to plot but the curve between voltage applied to the crystal and current flowing through the crystal, and in Fig. 2 I have shown the

characteristic of a modern semi-permanent detector which shows that a comparatively heavy current will flow with the voltage in one direction but practically no current will flow in the opposite direction up to voltages of at least two volts.

The behaviour of the crystal when applied to the aerial is rather complex. The high-frequency energy coming from a broadcasting station, varying in amplitude with the voice or music, applies a voltage across the crystal in series with some type of circuit. A theoretically perfect rectifier has an infinite resistance to one direction of the voltage, and a low resistance to the opposite direction.

So that if the outside circuit R connected to the crystal (see Fig. 3) is of a large impedance compared with the crystal resistance with one direction of voltage, then the voltage drop will chiefly be across the outside circuit. Now if when the voltage is reversed the crystal becomes a much higher resistance than the outside circuit, the resulting

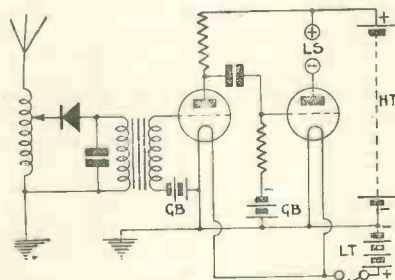

Fig. 7.—Combination good for loud-speaker signals at 15 miles.

voltage drop is nearly all across the crystal and none across the outside circuit. So that across the outside circuit we can assume in effect a series of half waves of voltage, these half waves being all on one side of the zero line.

We must now carefully separate out the different effects which occur, due to this application of voltage. Due to these half waves being all on one side of the zero line a D.C. current will flow through the circuit, and the D.C. voltage component will be approximately one-half the peak amplitude of the high-frequency component. Also the high-frequency component which is still in these half waves will pass any current it is permitted to through the circuit. As a usual thing a condenser of some size is applied to effectively short circuit this high-frequency.

A third type of current is, however, of great importance. The original high-frequency voltage is a modulated one so that the D.C. voltage produced by the rectifier is actually varying in amplitude and in consequence there is a low-frequency alternating current component. Thus from the original high-frequency in the aerial is obtained three types of

voltage—a high-frequency voltage, a direct-current voltage, and finally a low-frequency voltage.

If the other side of the rectifier was simply connected to earth, all these components would be used to heat the detector, but, of course, on the other side of the rectifier we have got useful apparatus designed with the main object of picking out the low-frequency alternating component with the maximum efficiency.

Interfering Currents

We are not very interested in the direct-current component or in the high-frequency component, except where either of them interferes with getting the best results from the low-frequency component. Nearly always a bypass condenser is inserted so as to short-circuit the high-frequency component, and the direct-current component is nearly always short-circuited by the comparatively low resistance of the telephone or transformer windings.

A little energy may be obtained from it which is, however, not useful, but which heats the telephone windings or the transformer windings, but the A.C. component must be treated very carefully so as to get the maximum from it.

Rectifier and Transformer

At the moment I am not interested in direct telephone working, so that we will consider the working to a transformer, intended for operating a valve. To avoid at first the complexity of the transformer let us reduce it to what is called its equivalent circuit, that is a choke L of the same value as the primary of the transformer shunted by a condenser C, the natural frequency of this combination being the same as that which the secondary of the transformer would have. We will neglect losses in the transformer and consider this arrangement in series with the crystal.

In this case, of course, we do not need a bypass condenser as the tuning condenser we have added will act as such.

The troublesome part of the process to follow mentally is that after rectification the original high-frequency voltage is split up into three different voltages,

(Continued on page 82)

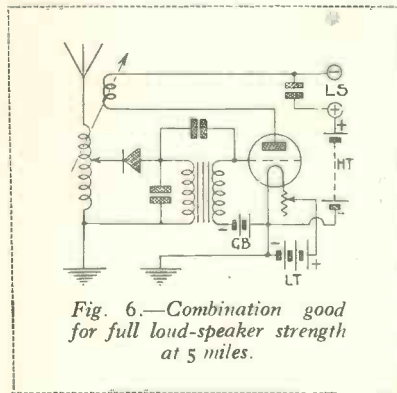

Fig. 6.—Combination good for full loud-speaker strength at 5 miles.

Some Suggestions by IRVINE FOSTER for

The Wireless Encyclopaedia

THE B.B.C. Handbook is a very comprehensive guide to broadcasting, but it is inevitable that in the first number there should be certain omissions. The scientific and official aspects are adequately dealt with; the point of view of the average listener has, however, been somewhat neglected and it is suggested that future editions should contain homely, commonplace information on the elements of wireless, more or less on the following lines:—

Acid Drops should on no account be taken to listening-in parties.

Aerials (Indoor). The unsightly appearance of outdoor aerials and the difficulty of erecting a large pole in small gardens has led to the increased use of indoor aerials, which, if the set is powerful enough, are remarkably efficient. (See also **Licences**.)

Breakdown. Even modern sets break down occasionally, and when this happens the fault should be looked for systematically in a definite order.

1. See that the aerial and earth connections are good.
2. Look at the valves or crystal.
3. Examine the accumulator and H.T. battery.
4. Test the panel for surface leakage.
5. Inspect every internal connection in the set, re-soldering where necessary.

If all these tests fail to locate the fault, it will probably be found that the loud-speaker or headphone is not connected to the set. (See also **Epithets, Opprobrious**.)

Etiquette. It is a mark of exceedingly low upbringing to argue with the announcer. The only answer made to anything on the wireless should be a cheery "Good night, Horace," in reply to "Good night, everybody." (See also **Acid Drops**.)

Mr. Henry Whopple earned the thanks of all gardeners who are also listeners by his successful pleading at the Hoppington Police Court last June, when summoned for not having a licence. He claimed that what was apparently a wireless aerial was, in fact, a framework for training his runner beans; and his story so impressed the Bench that he was discharged.

Programme (Alternative). The declared aim of the B.B.C. to give every crystal set user an alternative programme is deprecated by sociologists as leading to inter-family strife. On the other hand, it can be urged that the father who is able to insist on tuning in to a talk on "The Origins of the Ostrogoths" while his family is clamouring for the Savoy acquires a new authority and added dignity. Such cases are, however, the exception. The term Alternative Programme is also used, with other perhaps less refined expressions, to refer to the musical efforts of the child learning to play the piano next door when one is trying to hear a good concert on a crystal set. (See also **Infanticide** and **Epithets, Opprobrious**.)

Talks. Statistics compiled by the Ministry of Health show that there has been a remarkable fall in the number of insured persons suffering from insomnia since 1922. It is thought, perhaps, that the soporific effect of addresses on such subjects as "Next Week's Work in the Garden" or "Facts about the Fiduciary Issue" have helped to bring about this result. (See also **Programme, Alternative**.)

Uncle Inigo, as he is popularly known, is the famous announcer from 2LO. His beautiful accent and enunciation have so endeared him to female listeners that he has but to catch his breath while quoting the closing rate for Spanish pesetas and ten thousand female eyes glisten. Born at Winchester on September 16, 1866, Uncle Inigo was educated at Miss Primme's Select Academy for Genteel Boys, where he acquired the accent which has made his fortune. Is married, has six children; is a numismatist and a member of the A.O.F.B. Hobbies: Reciting and eating raw onions to preserve his voice. All applications for interviews must be addressed to his wife.

Soldering. Many people are deterred from constructing their own sets because they do not know how to use a soldering b.t. This is a great mistake, as there is no real need to solder connections. The whole science of wireless reception is in a state of transition and home-made sets should always be regarded as of an experimental nature. Wires, therefore, should merely be wound round the various terminals without making the connections permanent. This ensures that leisure moments are profitably spent in adjusting the set instead of aimlessly listening to the programme, and also simplifies the work of demolition when, as often happens, the only sound that can be heard is the alternating current of the electric light.

A new type of coil that will be of considerable interest to every reader of the WIRELESS MAGAZINE is described by our Technical Editor, J. H. Reyner, B.Sc. (Hons.), A.M.I.E., on page 67 of this issue. Do not omit to read his article.

A Screening Hint

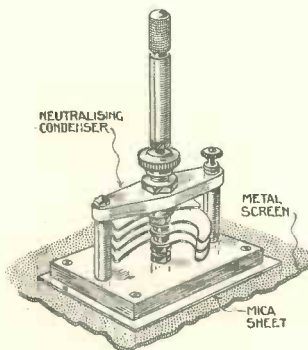

GREAT care should be taken with sets with copper screening over the baseboard to see that all the screws on the bases of instruments mounted thereon are properly countersunk, or a short-circuit may take place. An additional safeguard is to mount such components on small pieces of mica sheet, as shown in the diagram reproduced above. This precaution in construction may save a considerable amount of trouble later.

K.B.G.



5GB

Now that we have had five months experience of the high-power, medium-wavelength station 5GB, at Daventry, we ought to be able to express a pretty definite opinion as to the value of that station.

What do you think of 5GB? Do



5GB

you look upon 5GB merely as a station which fulfils the alternative programme promises of the B.B.C.? Or do you, on the contrary, look upon 5GB as a most useful addition to those stations which can be used as a basis for experimental work in reception?

I recently heard it stated in my district that the great thing resulting from the establishment of 5GB has been an increase in the selectivity of the wireless receiver. The statement was made to me by a wireless dealer, and I rather think that that particular dealer has made considerable profit over his efforts to increase the selectivity of the valve receiver in our district.

Although I am quite ready to believe that 5GB has proved of great use to the valve user, I have an idea that 5GB has proved to be of even greater use to the crystal user in certain districts.

A week ago I paid a visit to a small town seventy-five miles or so from Daventry, and I was really astounded at the results a friend of mine there was getting with a very simple crystal set. 5GB and 5XX both came in with enjoyable strength on the telephones. Of the two Daventrys, I thought 5GB decidedly the better.

There must be a large number of

crystal users who, like my friend, have been able to enjoy the programmes of a second station since the establishment of 5GB.

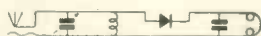

The Coat of Arms

How do you like the coat of arms adopted by the B.B.C.? The design does not seem to me to be extraordinarily suitable, but that may be because I do not understand the why and the wherefore of such things.

In the design the only things that are apparently connected with broadcasting, and that only slightly, are the "terrestrial globe proper" and the "thunderbolt" which the "lion passant" is "grasping" in its "dexter forepaw."

Of these two things, while the globe is a suitable reminder of the worldwide power and appeal of broadcasting, the thunderbolt is, perhaps, an unpleasant reminder of atmospherics.

There may, however, be some hidden significance in the "amulet," the "seven estoiles," and the supporting eagles.

I think we are all agreed that the motto "Nation shall speak peace unto nation," is an excellent one, and one that could scarcely be im-



The Coat of Arms

proved upon. It is particularly pleasing that the motto should be given in our own language.

George thinks that the B.B.C. coat of arms is a one-sided affair. He suggests a reverse side dealing with the listeners' point of view. Trans-

lated into the picturesque language of heraldry, George's idea of our coat of arms is:

Azure, or azure were, an Aerial proper encircled by a Tuning-coil Or, and Six Valves and a Crystal in orle, and, for the crest, a Lion passant Or, grasping a Ten-shilling Note proper in its dexter forepaw. Supporters on either side, a loud-speaker rampant in a Magnetic Field.

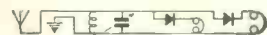

Frost

Have you ever noticed any falling off in the strength or quality of your wireless reception when the ground round about your house is in the grip of a hard frost?

It would be very interesting to know if the freezing of the ground



Frost

makes our earth connections in the slightest degree less efficient. I do not think I have ever come across any theory at all on this rather seasonal topic, have you?

We are all of us aware that, if the soil round a wireless "earth" is kept damp, better reception is obtained. What is the effect, then, when that same soil becomes frozen hard in winter?

I discussed this little problem with my meteorological friend the other day. His idea is that frost has little effect on a wireless "earth" where that "earth" is placed in the ground at a depth of three feet for more. Frost seldom penetrates to a depth of three feet, he informed me.

So you see that, if you have buried

your "earth" at a depth of three feet or more, frost is unlikely to get at it. If you are using a water-pipe earth, your earth should be out of harm's way from frost, otherwise there would be some pretty trouble from burst pipes on the occasion of a severe frost, I'm thinking.

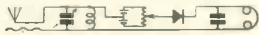

Good Reading

Do you ever get a chance of looking through a catalogue of wireless component parts? If you do, I hope you find that catalogue as good reading as I do.

One of the latest wireless catalogues to come into my hands has provided me with something to read and something to think about for a good many hours. I could spend ten pounds on wireless component parts selected from that catalogue, and then not have all I fancy from its pages.



Good Reading

Amongst the many new things in this latest wireless catalogue of mine, I have been particularly interested in vacuum grid leaks, anti-capacity switches, ebonite formers for winding choke coils, decrement variable condensers, short-wave coils, improved earthing devices—but why go on? Your interests may not be my interests.

To my mind, one of the greatest fascinations about wireless is that there is always something new in it. There is always some new or improved component part waiting to take the place of some older part in your set.

If you have any doubt about this, look through a wireless catalogue, or go through the advertisement pages of the WIRELESS MAGAZINE or *Amateur Wireless*. You'll find the reading good reading.

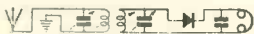

Less Morse

If you happen to be one of the very large number of listeners who have suffered unduly from morse interference, you will have received with great delight the official Post Office statement regarding the Post Office coastal wireless stations.

In this official statement it was given that the general policy of the Post Office in the future will be to

abolish spark communication at its coastal stations. Valve transmission has already been established at the Seaforth and Humber stations in place of the old spark transmissions



If you happen to be one

there, much to the advantage of broadcast listeners in those districts.

Morse has always been one of the most troublesome sources of interference the broadcast listener has had to contend with. I know nothing more irritating in broadcast reception than that quietly persistent scratch, scratch, scratch, which becomes evident during the silent intervals between the different items of the programme you are enjoying so much.

Apart from the noisiness of morse itself, oscillation is often caused quite unknowingly by a listener who forces his set in the attempt to obliterate the morse which is spoiling his reception.

Just now, I happen to be getting my worst spark interference round about 5GB's wavelength and it is a great nuisance at times.

What a good thing it would be if 1928 saw the complete obliteration of spark transmission throughout the whole world of wireless!



High Aerials

To travel is an education, in wireless, as in everything else. It does not matter where your journeys take you in these islands, you are bound to see something different in wireless, and to see something different is to learn something.

I have just returned from a short visit to a seaside district on our western coasts. If you were to ask me at this moment what impressed me most about that seaside district,



To travel is an education

I should say the large number of high aerials to be seen there.

Most of these high aerials were single wire aerials. In the majority of cases, extra height had been obtained by the fixing of a light mast to the top of the aerial mast proper.

Seeing so much "top-grafting" on the aerial masts made me wonder if someone in the district had suddenly discovered the advantage of a higher aerial and had passed the news of his discovery to all and sundry wireless folk in the vicinity.

Even where a cage aerial was the type of aerial employed, extra height had been obtained. One cage aerial I took particular note of was erected at such a great height above a chimney stack that the down-lead, in itself, must have constituted a very fine aerial.



Flying Lessons

"Of all the novel uses to which broadcasting has been put, this takes the biscuit," I remarked to George earlier in the evening as we sat before a bright-emitter fire in my reception room.

"Even the thin arrowroot," said George who happened to be suffering from the effects of seasonal over-feeding.

"Listen, George. From station KOA, Denver, Colorado, U.S.A., lessons in flying are being broadcast. What do you think of that, now? Novel idea, isn't it?"

"Such lessons are certainly on a higher plane than usual."

"Higher plane, George?"

"Yes, the aeroplane."



Flying Lessons

"Students of flying who take these lessons are told to sit on the floor with a broomstick between their knees, said broomstick to represent the joystick of an aeroplane, George."

"Are they told to sit at the top of the stairs when the lesson happens to include nose-diving?"

"Can't say, George, but the students are told to sit with an electric fan blowing into their faces."

"What's that for?"

"To give the illusion of rushing air, I suppose."

"Oh, I see. I thought it might be to give the illusion of a stiff neck."

"Don't you wish they would broadcast lessons in flying from our broadcasting stations, George?"

"Scarcely. The idea does not appeal to me very strongly. Home lessons on flying, flying in the face of—er—trouble. No thank you. It's

Under My Aerial (Continued)

a novel idea, very novel, a little too novel for me though. Let's stick to our own good old talks."

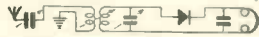

Shorted

Earlier on in the evening, I did one of the very silliest things I have ever



Shorted

done in wireless. Two friends had called to see me and they expressed a desire to hear my favourite three-valve set. I accordingly connected up, turned on the valves and set the condenser dials for the reception of 5GB. Not a sound came from the loud-speaker.

I went over the connecting wires quickly. I examined the batteries carefully and I even went outside to see if the aerial was still there. Everything was O.K.

My attempt to get 5XX was no more successful. The atmosphere became a trifle strained. I began to mop my brow with my handkerchief, I—but I dare say you know all about it. Very likely you have had the same kind of experience when friends have called specially to hear your wireless set.

When I did discover the fault, I could have kicked myself, it was such a silly thing I had done. I doubt if you would guess, though, what the trouble actually was.

Recently, I adapted my three-valver for short-wave reception. A special type of Reinartz circuit is employed in this three-valver, and there are two coils in the receiver. There is a three-way switch to change from one coil to the other.

In order to work on the very short waves, I brought out three leads from the centre points of this switch and connected those three leads to three terminals mounted on a small piece of ebonite.

When I want to receive on the very short waves, I put the switch to its middle position, thus placing out of circuit the two coils fixed in the set, and I connect my short-wave coil to the three terminals on the piece of

ebonite. I am rather proud of this little adaptation.

This was the silly thing I did. I forgot to disconnect my short-wave coil from the terminals on the small piece of ebonite. Hence there were always the short-wave coil and one or other of the fixed coils in circuit. No wonder I could get neither 5GB nor 5XX.

My mathematical friend might be able to work out the wavelength I was working on with the short-wave coil and another in circuit. I know I can't.

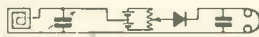

Electricity and Wireless

Have you ever realised how useful a supply of electricity in the house can be to the wireless enthusiast? I never did so until one night last week when I called on an old friend of mine whom I had not seen for eight years.

My old friend had an extremely good wireless set installed in his sitting room and his first act as I entered that room was to switch off the set. He soon found out, however, that I was as keen on wireless as he was himself, and we had a great time together.

His three-valve set was of a well-known type, detector valve followed by two low-frequency amplifying valves. I did not trouble much with the set. What interested me most was the way my old friend was using his electricity supply in connection with his wireless reception.

He had a high-tension battery eliminator. In other words, he had a piece of apparatus by means of which he obtained a direct current high-tension supply from the alternating current of the mains. He also had a battery charger by means of which



I never did so

he was able to charge his accumulator (he had only one accumulator) from the mains.

Just think of it as I did. No carrying of accumulators to and from the local charging station. No bothering trouble with non-ever-lasting high-tension batteries.

What a grand thing it is to have electricity in the house. I wish I were so fortunate.

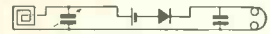

Wrinkles

When it comes to picking up ideas from other wireless enthusiasts, who is the sharpest amongst your wireless friends? Who is the one in your little wireless circle who can size up a receiving set at a glance and who never lets anything good escape him when he is looking over the gadgets of a fellow enthusiast?

I'll tell you who is the sharpest in this way in my own immediate circle of wireless friends. His name is, well!—obviously, I refer to George.

To look at George, you would never think he was so sharp, especially if he happened to be assuming his high-power vacuum look. Still, as George himself once said, if you take a man at his face value, you are very liable to make a large error in capacity.

Now George went away on a visit to some wireless friends early in the



Wrinkles

New Year. When I first saw him on his return, naturally I asked him if he had picked up any useful wireless wrinkles on his holiday.

"I picked up a home-made loud-speaker one night. There were plenty of useful wrinkles about that."

"What were they, George?"

"The crinkly pleats in the paper diaphragm."

"George, you old—"

"There was one rather good tip I can pass on to you from that home-made loud-speaker, though."

"What was that, George?"

"The paper diaphragm was stretched by and held in a circular embroidery frame. You know the kind of thing I mean. The ladies use such a frame to stretch and hold the canvas, or whatever it is, when they are doing multi-coloured embroidery patterns."

Rather a good idea, isn't it? What about trying it? Loud-speaking units are not expensive things to buy and excellent results can be obtained from them.

HALYARD

Cone loud-speakers are deservedly popular, particularly for their true rendering of bass notes in reproducing broadcast music. Every reader of the "Wireless Magazine" who builds the experimental instrument described below will get many hours of pleasurable listening from it. No overloading will occur with any normal receiver and the quality is all that could be desired.

MAKING A CONE LOUD-SPEAKER

A
SIMPLE UNIT
THAT ANY
AMATEUR CAN
MAKE

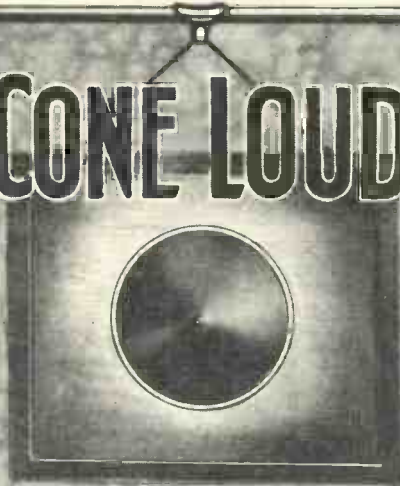

DESIGNED
AND BUILT
BY THE "W.M."
TECHNICAL
STAFF

AN attractive cone loud-speaker in the form of a picture frame can easily be put together by the experimenter who has a few tools in his possession; a simple experimental design which has been found to give excellent results is here described by the WIRELESS MAGAZINE Technical Staff.

Experiments

Anyone making up a cone loud-speaker on these lines will be able to carry out some interesting experiments, such, for instance, as trying different kinds of paper for the cone itself and making comparisons with horn-type loud-speakers, for both volume and quality.

The parts required are easy to obtain and not in the least expensive. The finish of the completed instrument is a matter of personal taste, and constructors with artistic talent will have plenty of scope to make the most of their abilities.

If the WIRELESS MAGAZINE design is followed exactly, the following component parts will be required:—

Loud-speaker unit, with extension arm and 2 conical washers (Bullphone).

Stiff paper for 12 in. cone (Sixty).

Oiled silk (or other suitable material) of same size for mounting cone.

3-ply wood, measuring approximately 18 in. by 24 in.

21 in. of brass strip, ½ in. wide by ¼ in. thick.

Small nuts, bolts, and screws.

For the convenience of those who desire to cut out their own cones (almost any stiff damp-proof paper

Having cut out the cone or bought it already cut to size, stick the edges together with some strong adhesive (Croid or Seccotine is suitable), and put it on one side to dry. Next cut a 12-in. hole in the 3-ply wood and mount the latter in the frame.

The loud-speaker unit can now be fixed to three brass strips of the dimensions shown on the blueprint or the small reproduction reproduced on page 29.

Preparing the Cone

Place the cone, point upwards, on a perfectly flat surface, and with the tips of the fingers carefully flatten it for about half an inch all round the periphery. After this, cut a hole about 9½ in. in diameter in the oiled silk.

Now place the oiled silk on a flat surface, moisten the flattened edge of the cone with Croid or Seccotine, and place it on the oiled silk. When thoroughly dry cut off the square corners of the oiled silk, but leave enough to stick round the hole cut in the wooden baffle.

When the cone has been fixed to the baffle (make sure that it is in the centre of the hole), mount the loud-speaker unit with its three brass arms

(Continued on page 29)

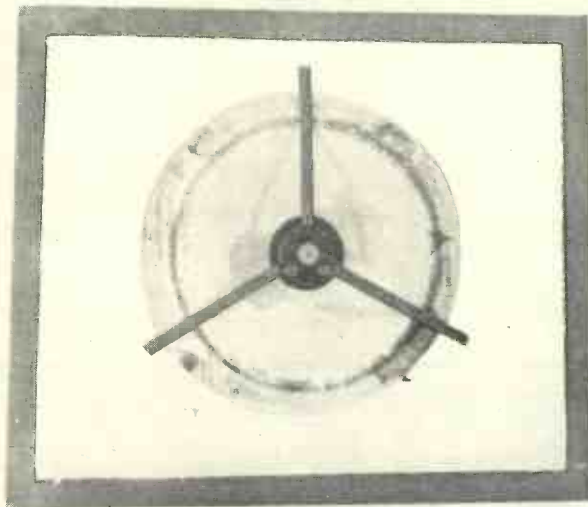

Rear View of the Completed Cone Loud-speaker

is suitable) a full-size blueprint template has been prepared. This can be obtained for half-price (that is, 6d., post free) if the coupon on page iii of the cover is used before February 29. Ask for Blueprint No. WM 55, and address your enquiry to Blueprint Dept., WIRELESS MAGAZINE, 58-61 Fetter Lane, London, E.C.4.

In the first part of this article is described a special three-valve receiver which can be worked direct from D.C. (direct-current) mains, while in the second part are given details of a simple adaptor by means of which the same receiver (or any other "Simpler Wireless" sets already described in the "W.M.") can be operated direct from A.C. (alternating-current) mains. Both set and adaptor were built by the "W.M." Technical Staff from designs evolved by J. F. Johnston, the inventor of the system

The Metropolitan Three

FOR
D.C. MAINS

FOR
A.C. MAINS

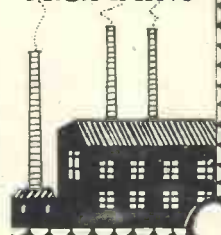
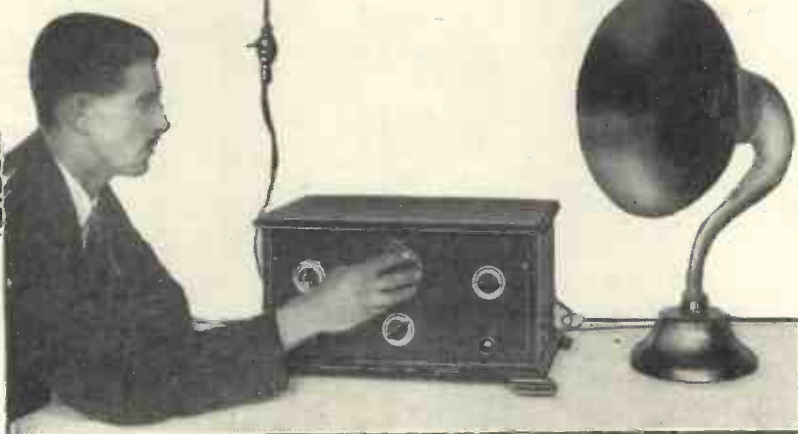
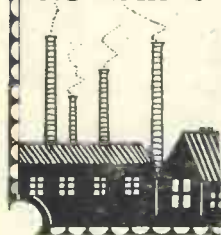

THE idea behind the design of the present set has been to produce a receiver capable of working directly from D.C. mains having a voltage between 200 and 250 (thus eliminating batteries, and even "battery eliminators," altogether) which has a good range for loud-speaker work, which gives faultless reproduction, and which is, above all, absolutely safe to operate.

Attention to Safety

The greatest attention has been concentrated on the safety problem, and, as many of the components have been chosen from this point of view, readers are particularly urged not to use any components in building this set other than those mentioned in the list of components given in this article.

When the set is in its cabinet and the mains are connected up, nothing that can then be touched will be "live" if the original design has been followed exactly. Should one forget to turn off the current before withdrawing the set from its cabinet, there will still be no danger, as the special "safety plug" will ensure that the mains are automatically disconnected

from the set as the latter is withdrawn.

As the circuit diagram shows, the set incorporates the Johnston system, and comprises a detector and two L.F. stages. A fixed condenser (capable of withstanding a high voltage) is placed in series with the aerial lead, and this prevents the aerial becoming "live" should the positive main happen to be earthed. Another fixed condenser in the earth lead ensures against a short-circuit of the mains.

Reaction is obtained in this receiver by coupling a coil in the plate

circuit of the detector valve to the aerial-tuning coil, these two coils being mounted in a two-way coil holder.

A special feature of this receiver is the loud-speaker filter circuit, which completely isolates the loud-speaker itself from the mains. At the same time, it is not recommended that headphones be used with this set, which has an ample range for loud-speaker work. A .1-ampere lamp is used as a fuse to protect the valve filaments, and this lamp also serves as a useful indicator as to whether the set is "on" or "off."

Components Required

The following are the components used in the original Metropolitan Three, together with approved alternatives:

Ebonite panel, 16 in. by 8 in. (Raymond, Becol, or Red Triangle).

Baseboard, 16 in. by 10 in. (Raymond).

Cabinet to take above (Raymond).

2 terminal strips, 3 in. by 2 in. each (Raymond, Becol, or Red Triangle).

3 (or 4) 400-ohm potentiometers (Igranic).

2 400-ohm resistance strips (Igranic).

50-ohm potentiometer (Igranic).

.0005-microfarad variable condenser (Gecophone).

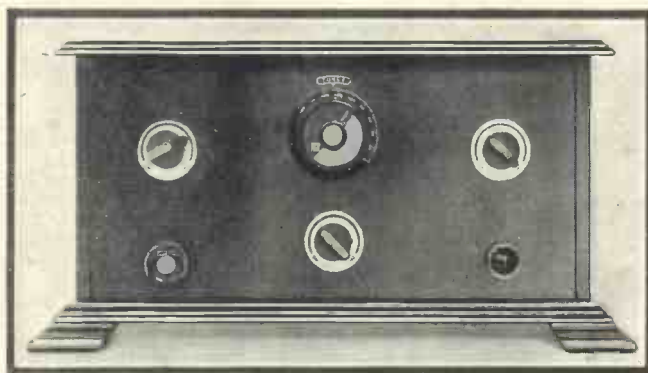

Front view of the Metropolitan Three for use with either D.C. or A.C. mains

.0003-microfarad fixed condenser (Dubilier, type 577).

3 2-microfarad fixed condensers, tested 500 volts A.C. (Hydra, Dubilier, or T.C.C.).

4-microfarad fixed condenser, tested 500 volts A.C. (Hydra, Dubilier, or T.C.C.).

Two-way coil-holder (Lotus).

3 valve-holders (Lotus, Precision, or Benjamin).

2 L.F. choke coils (Lissen, Formo, or Success).

2-megohm grid leak and holder (Dubilier, Lissen, or Mullard).

Loud-speaker jack (Lotus).

Panel signal lamp (Bulgin).

.1-ampere bulb (Bulgin).

Safety plug (Bulgin).

2 panel brackets (Collett).

2 terminals marked "Aerial" and "Earth" respectively (Belling-Lee).

Dial indicator marked "Tuner" (Belling-Lee).

Connecting-up wire (Glazite).

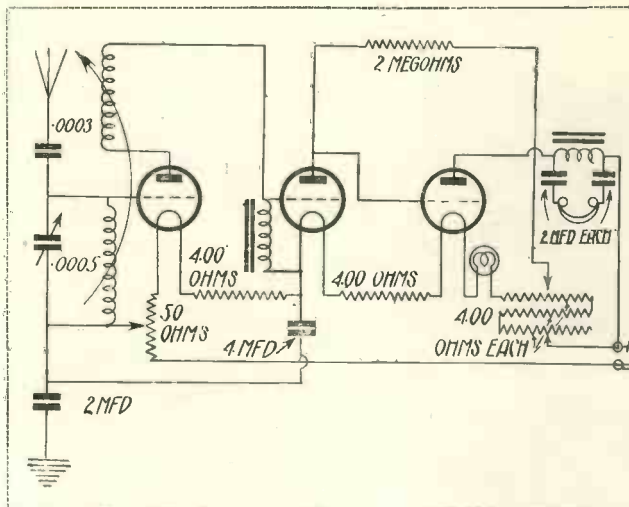

Circuit of the Metropolitan Three, suitable for operating direct from D.C. mains. Later in these pages is described a simple adaptor unit by means of which the set can be run direct from A.C. mains

A few remarks about the above list may not be out of place here. One of the reasons for choosing the Gecophone tuning condenser is that the dial is *not* secured to the spindle by means of a grub-screw. In the event of the positive main being earthed the spindle of the condenser will, of course, be at the potential of the mains above earth, so that the presence of an exposed grub-screw, in contact with the spindle, would have nullified the efforts that have been made to make this receiver absolutely "shock-proof."

Resistances

The three 400-ohm potentiometers, two 400-ohm resistance strips, and the 50-ohm potentiometer will have sufficient resistance for mains voltages of from 200 to 210. For voltages between 210 and 240 another potentiometer will be required.

When purchasing the fixed condensers, care should be taken to obtain the *types*, as well as the makes, specified in order to ensure that they will stand up to the voltages which will be applied across them. The two-way coil-holder used in the original set is of a type that can be mounted so that no metal part is exposed on the panel—even should a lead break loose in the set and come into contact with the metal spindle, it will be impossible to get a shock while the set is in its cabinet.

Before building the set it should first be ascertained what is the voltage of the mains so that the correct number of potentiometers may be obtained.

Before mounting the potentiometers on the panel, the centre hole

of each of the metal dials should be enlarged slightly so as to leave no chance of the metal spindles coming into contact with the dials. It will be noticed that one potentiometer is mounted on the baseboard and that this is wired up only as a fixed resistance—the slider being left unconnected. The slider of this potentiometer may, if desired, be removed altogether.

Should the mains voltage be above 210 another potentiometer should be mounted on the baseboard and wired, as a fixed resistance, in series with the other baseboard-mounted potentiometer, that is to say, in series with the lead marked *gg* on the wiring plan and blueprint.

The coil-holder should be so mounted that the knob is close up

against the panel, thus leaving none of the metal spindle exposed.

Before mounting the valve-holders (it should be noticed that the centre one of these is turned round the opposite way to the other two), they should be connected together by means of the resistance strips, as, if the spacing of the valve-holders is not accurate, it will be impossible later to fix the resistance strips in position.

Wiring Up with Care

The wiring up should be carried out with special care, it being constantly borne in mind that this is a mains receiver. Even though the connecting-up wire be insulated, no two leads should be allowed to touch unless they are connected together.

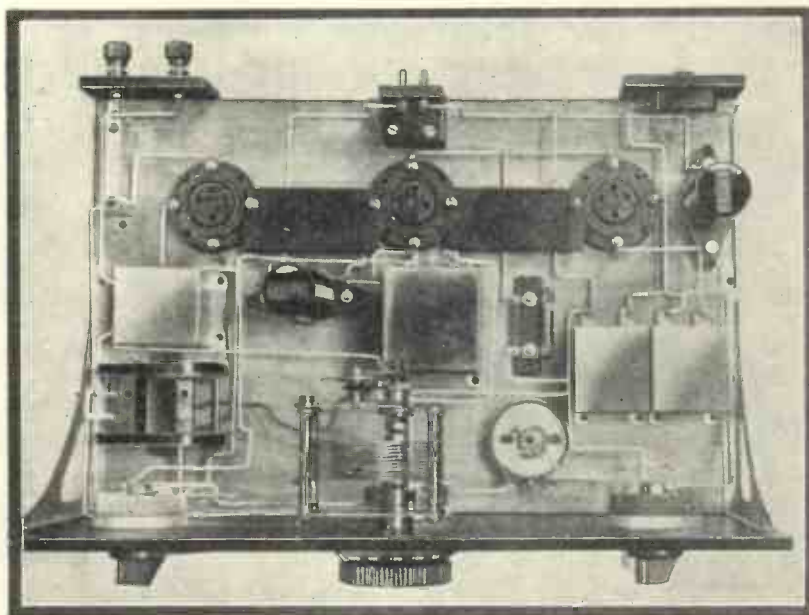

Plan view of the Metropolitan Three showing disposition of the components

The Metropolitan Three (Continued)

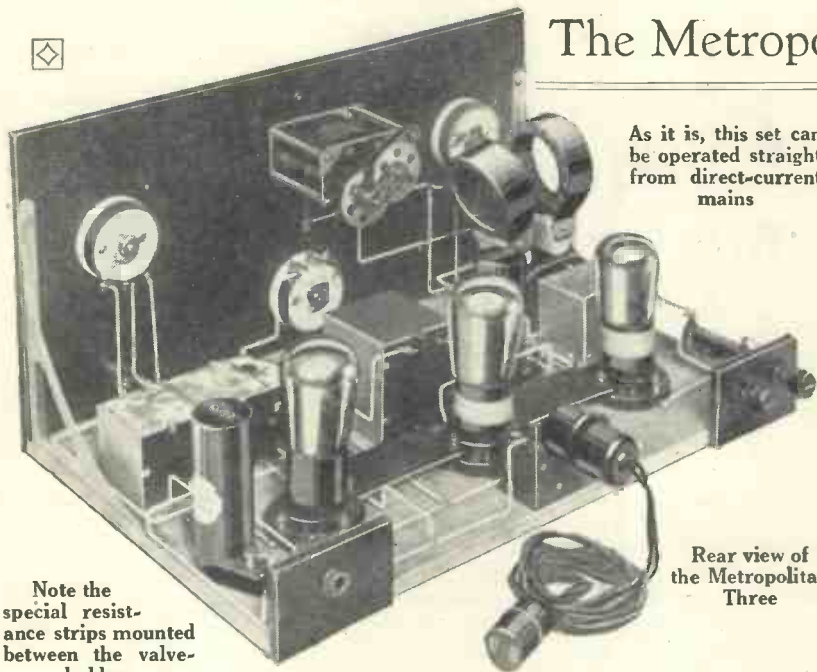

Note the special resistance strips mounted between the valve-holders

As it is, this set can be operated straight from direct-current mains

Rear view of the Metropolitan Three

broadcasting band a No. 35 or No. 50 coil in the aerial socket and a No. 50 or No. 75 coil in the reaction socket will be correct. For 5XX these sizes should be increased to Nos. 150 or 200 and Nos. 200 or 250 respectively. If the two coils used are not of the same make and type, it may be necessary to reverse the connections to the moving socket of the coil-holder before reaction is obtainable.

Operating the Set

After the set has been placed in its cabinet, the aerial and earth may be connected and the loud-speaker plug placed in the jack. The filament-current control (the potentiometer mounted in the centre of the panel immediately below the tuning condenser) should be set at its maximum resistance and the mains plug can then be connected up. If there is a click in the loud-speaker on connecting up the mains, all is well. If not, the mains plug should be reversed.

Checking with Milliammeter

If a milliammeter reading up to 100 milliamperes is available, it may be temporarily inserted in series with one of the leads to the mains so that the filament-current control can be adjusted until just 100 milliamperes pass through the filament circuit. If such a meter is not available, the filament-current control should be adjusted to its maximum resistance consistent with good results

It might be mentioned that as the actual resistances of potentiometers

The wiring should be kept away from the metal panel brackets in order to ensure that, should a lead break way, the screws attaching the panel to the brackets shall not be "live."

Soldered Joints

All the joints should be well and truly soldered, not only to prevent leads coming adrift, but also because a poor joint in this set is much more likely to cause crackling noises than it would be in an ordinary set. The two flexible leads to the moving socket of the coil-holder should be kept as short as possible consistent with the free movement of the socket.

A drawing of the cabinet, with dimensions marked, is given for the benefit of those who wish to make their own. The back of the cabinet must be cut away as shown to accommodate the small pieces of ebonite carrying the aerial and earth terminals and the loud-speaker jack. The hole for the "safety plug" should be $1\frac{1}{8}$ in. diameter, so that the plug goes through it easily far enough to make contact, but is prevented from passing through it altogether by the flange.

Full-size Blueprint

When all the components have been fixed into position, wiring up can be started, and this will be greatly facilitated by frequent reference to the full-size blueprint or smaller wiring diagram reproduced in these pages.

A glance at either will reveal the

fact that each terminal point is marked with a small letter of the alphabet. All those points marked with like letters should be connected together, in alphabetical sequence. Thus, all those points marked *a* should first be connected with one wire or as few wires as possible; then all those points marked *b*; and so on, until wiring is completed.

After the set is completed and before it is placed in the cabinet to be tested, the wiring should be very carefully checked. When convinced that everything is in order, the valves and coils may be inserted and the set placed in the cabinet.

As usual with these special mains sets, all the valves used should be of the .1-ampere type. The first valve should have a fairly high (but not a *very* high) impedance. The type of valve usually described as an H.F. valve will be suitable. A valve with a really high impedance and amplification factor should be used in the first L.F. stage—a valve, in fact, of the R.C. type. The correct valve to use in the last stage is a good L.F. or power valve having a fairly low impedance.

For the ordinary

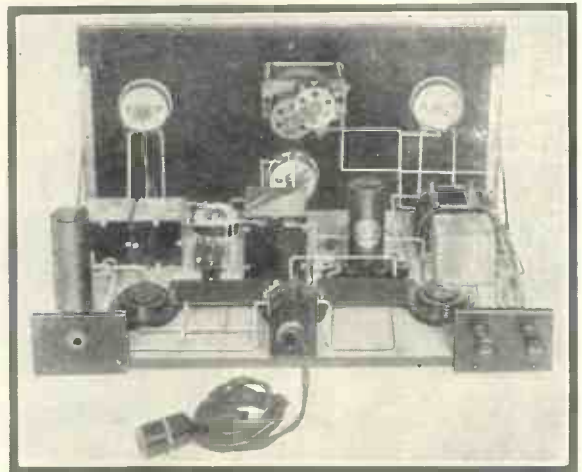

Rear view of the Metropolitan Three, showing mains plug in position

For D.C. or A.C. Mains

vary slightly in practice, it may sometimes be impossible, when using 240-volt mains, to cut down the current sufficiently by means of the filament-current control. In such a case still another extra 400-ohm potentiometer should be connected in series with the one already added.

Other Controls

The filament-current control, when once set, will remain constant. Of the other two potentiometers mounted on the panel, the left-hand one controls the grid bias of the anode-bend rectifier and the right-hand one controls the grid bias applied to the last valve. Regarding this last-mentioned potentiometer, should best results be obtained with it fully positive, a lower value anode resistance in the plate circuit of the second valve would probably be an improvement; if this potentiometer has to be hard over to the negative side, a higher value anode resistance should be tried.

When Signals are Best

With the anode-bend potentiometer near one end of its scale, a more or less loud "hum" will probably be heard, while near the other end of the scale of this potentiometer the set will appear "dead." Somewhere between these two settings a point should be found where the hum is absent or negligible and where signals are best.

In the case of supplies where the commutator ripple is exceptionally

This set can be adapted for A.C. mains by adding the unit described on page 27

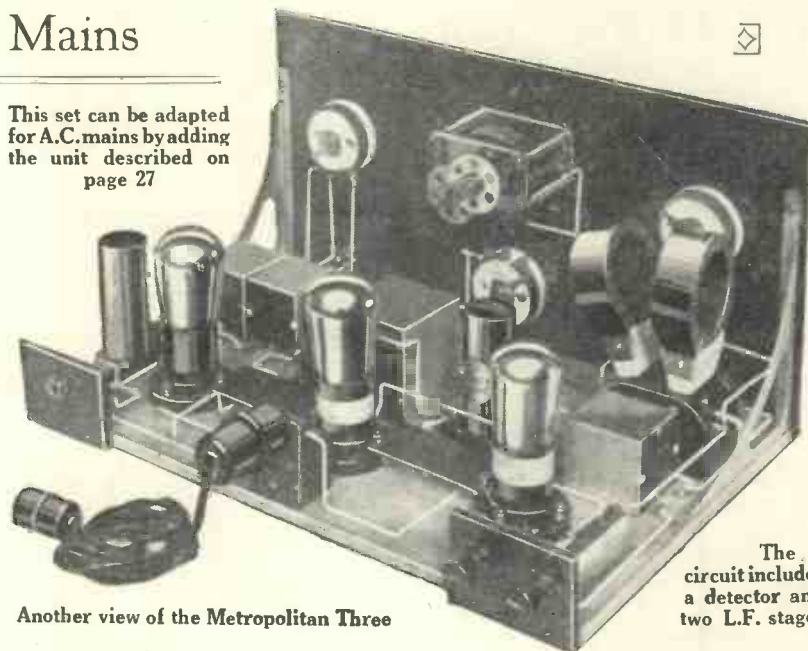

Another view of the Metropolitan Three

The circuit includes a detector and two L.F. stages

pronounced, it may be advisable to do a little preliminary rough smoothing by connecting a 2-microfarad condenser across the mains plug of the set and a choke coil, designed to pass 100 milliamperes, in series with one of the leads to the mains, though it will very rarely be necessary to resort to this.

If nothing seems to cure the hum, this is very probably due, not to commutator ripple across the mains socket, but to direct induction from the house wiring acting on the aerial, earth wire, or loud-speaker leads. The remedy then is to alter the disposition of these with respect to the house wiring.

In many cases it may be found that the set works as well without the earth as with it (as one of the mains is generally earthed), and there will then be no object in using the earth terminal of the set. In some cases better results will be obtained without the ordinary earth connection. The set should be tried with and without the ordinary earth.

It should be mentioned that if ever it is necessary to take the set out of its cabinet for any reason it would be

advisable, after the mains plug has been withdrawn, but *before* the earth (if one is used) has been disconnected, to short-circuit the mains pins *on the set* for a moment, using a wood-handled screw-driver or similar instrument. This precaution is advised because, under some circumstances, the earth condenser may be charged up and, if the filament of the first valve has burnt out, the 4-microfarad condenser as well.

Results Obtained

On test this receiver proved to be about the best three-valver built on the Johnston system which we have described up to date. At a point ten miles south of London 2LO, 5GB, Langenberg, and two other German stations were all received at slightly less volume. In fact, the set proved to be the efficient, no-trouble, general-utility receiver which it professes to be.

For A.C. Mains

So far, reference has only been made to working the Metropolitan Three from D.C. mains, but with the addition of the special adaptor unit described on page 27 this receiver, without any alteration at all, can also be used direct off A.C. (alternating current) mains.

Instead of taking a lead direct from the mains to the safety plug on the

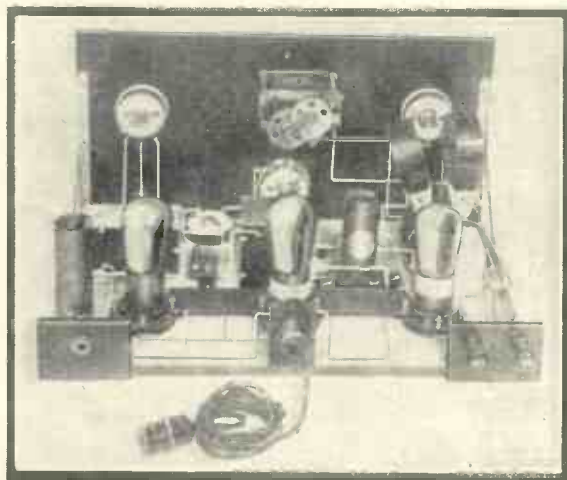

Another view of the Metropolitan Three with valves and coils in position

A.C. MAINS ADAPTOR

for the Metropolitan Three or any other "Simpler Wireless" Receiver

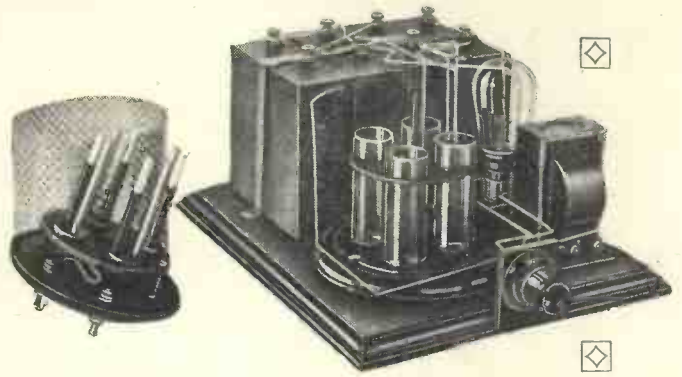

THOSE who wish to work the Metropolitan Three (or any other of the "Simpler Wireless" sets which have been described either in the WIRELESS MAGAZINE or in *Amateur Wireless*) from an A.C. electric-light supply can do so very easily by building a "Simpler Wireless" rectifying unit and connecting it between the mains and the set.

A Simple Matter

In place of the H.T., L.T., and grid-bias supplies needed by an ordinary set the only current supply required by a "Simpler Wireless" receiver is one of 100 milliamperes at 200-250 volts. It is, therefore, a very simple matter to work such a set from A.C. mains as all that is required is a rectifying and smoothing unit which, while deriving its input from the A.C. mains, is capable of delivering a smoothed D.C. output of 100 milliamperes at 200-250 volts when a resistance of 2,000-2,500 ohms (the resistance of the filament circuit of a "Simpler Wireless" receiver) is connected across its output terminals.

Rectifying valves could, of course,

be used for this purpose, but suitable ones would be rather expensive. Moreover they would involve the use of transformers (more expensive items) and the voltages that would have to be used would be so high as to render the apparatus dangerous in amateur hands.

The unit to be described, on the other hand, is reasonably cheap to build and costs next to nothing for maintenance. It is very easy to construct, perfectly safe in operation (as no very high voltages are used

and has been thoroughly tested and found eminently satisfactory.

Chief Feature of the Unit

The chief feature of the unit is a very much improved form of electrolytic rectifier in which all the usual disadvantages of such rectifiers have been entirely overcome. It is very compact, gives off no obnoxious fumes, does not overheat, and, above all, requires no attention whatever, beyond the occasional addition of distilled water to make up for that lost by evaporation.

Four small cells are used, each of which consists of two electrodes, one of aluminium and the other of a special alloy, immersed in a special electrolyte. In the "Simpler Wireless" rectifying unit the cells are so connected up that the output voltage is greater than the input voltage although no transformers whatever are used.

This allows a good 250 volts to be available for application to the set, even allowing for the loss in the rectifier and for the voltage-drop across the smoothing chokes. As a matter of fact, even if the input voltage were only 150 this would still be so.

Lamp Resistance

Therefore a lamp is inserted in series with one of the leads to the rectifier to act as a resistance, and by using a suitable lamp the unit can be worked directly from any single-phase 200-250 volt A.C. supply.

From the circuit diagram it will be

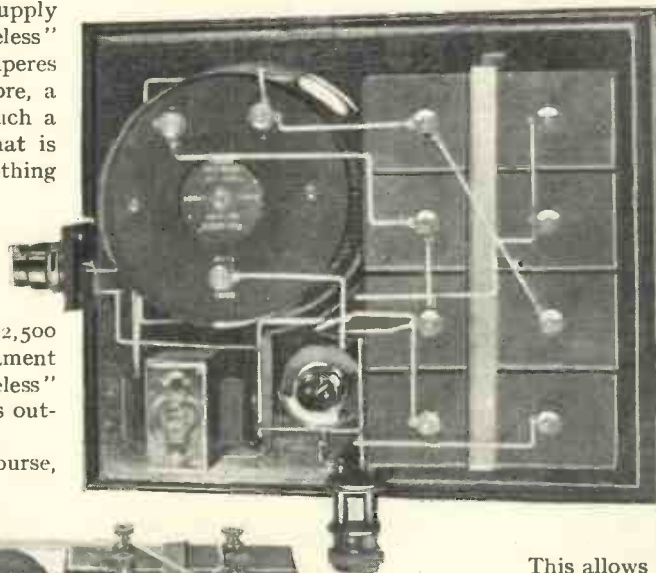

Two views of the A.C. Mains Adaptor for use with the Metropolitan Three or any other "Simpler Wireless" receiver

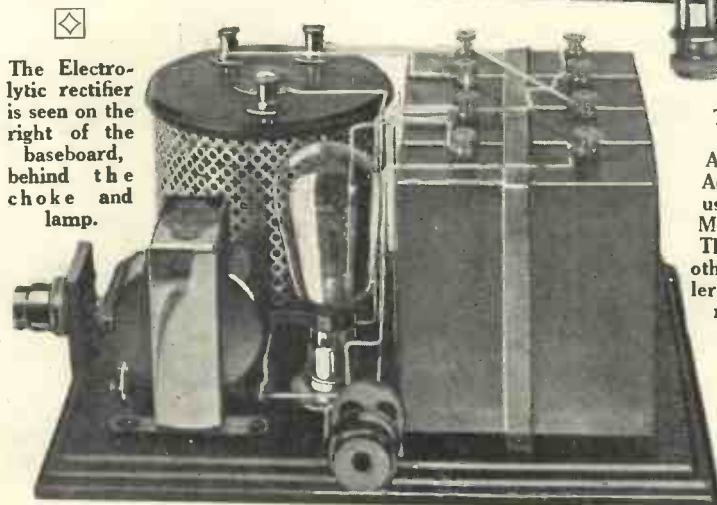

The Electrolytic rectifier is seen on the right of the baseboard, behind the choke and lamp.

A.C. Mains Adaptor for the Metropolitan Three (Continued)

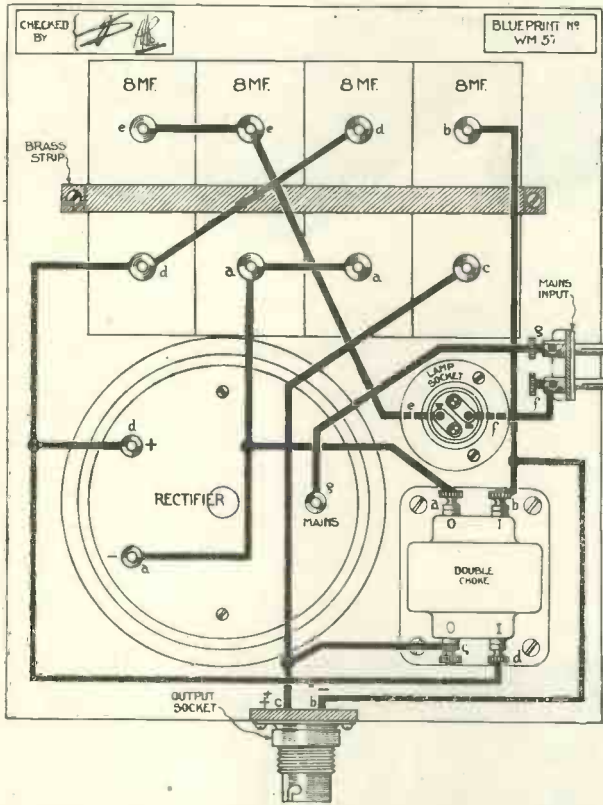

This layout and wiring diagram of the A.C. Mains Adaptor for the Metropolitan Three or any other "Simpler Wireless" receiver can be obtained for half-price, that is 6d. post free, if the coupon on page iii of the cover is used before February 29

seen that the cells are connected up in two pairs, each pair charging up a fixed condenser. These two condensers are in series as far as the output circuit is concerned, and feed the set through the two windings of a double choke. A fixed condenser is connected across the supply leads to the set, both before and after the choke windings to aid in the smoothing.

Simple Construction

The actual construction of the unit is very simple. All the components are mounted on a baseboard and are protected by a perforated metal cover. The cover ensures that no one shall receive a shock through accidentally touching a "live" part of the apparatus.

The following components will be required:—

Baseboard and perforated cover (City and General Radio).

Above is shown the circuit of the A.C. Mains Adaptor and on the right is a photograph of the completed unit

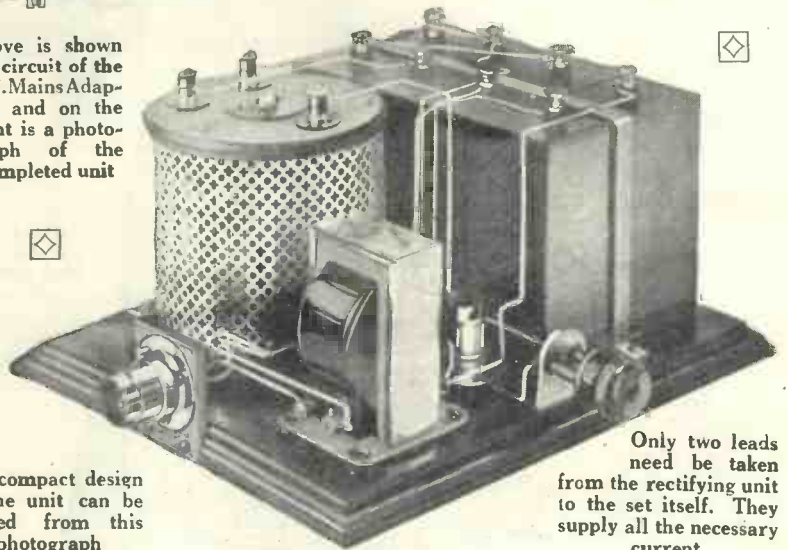
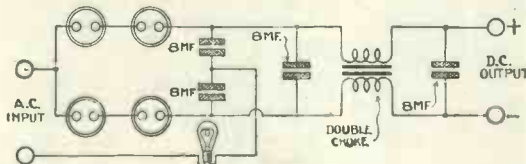

Only two leads need be taken from the rectifying unit to the set itself. They supply all the necessary current

One "Simpler Wireless" model rectifier (Faradex)

4 fixed condensers, 8-mfd. each, tested to 600 volts D.C. (T.C.C., Dubilier or Hydra).

Double choke (Igranic).

2 battery-type lamp holders (Economic Electric)

Safety-plug (Belgian)

Piece of ebonite, 2 in. by 2 in. (Becol).

Connecting-up wire (Glazite).

Strip of brass, 1/2 in. wide, 1/16 in. thick and 18 in. long.

The Faradex rectifier is to be obtained from Rooke Bros., Ltd., of 55, Cardington Street, Euston, N.W.1, and costs 30/- (or 31/6, post free). When ordering

this, readers should be very careful to state that it is the "Simpler Wireless" model they want, as other types of this rectifier are sold for accumulator-charging purposes.

Disposition of Components

The positions that the components should occupy are clearly shown by the wiring diagram and the blueprint. The fixed condensers are, as shown by the photographs, clamped down by means of the brass strip, which must be suitably bent for the purpose. A hole must also be drilled in each end of the strip through which the fixing screws can pass.

One of the lamp holders is mounted on the baseboard, but is spaced a little way above it by placing a 1/4 in. length of tube (which may be of ebonite or any other suitable material) around each of the fixing screws, between the flange of the lamp holder and the baseboard. The other lamp holder is mounted on the small piece of ebonite which is then screwed to the baseboard.

Filling the Rectifier Cells

The cells of the rectifier itself should be filled with the electrolyte (as far as the fibre disc) before commencing to wire up. The rectifier is dismantled by removing the plated nut when the wooden top, with the electrodes attached, will come away. The base of the rectifier should be screwed firmly to the baseboard in the correct position, the electrolyte

Use A "Simpler Wireless" Set from the Mains

should be poured into the cells, and the top replaced. The unit is then ready for wiring up.

Whichever "Simpler Wireless" set it is desired to use (the one just described being the best three-valver that has yet been designed) it should be constructed as though for 240-volt D.C. mains. That is to say the extra 400-ohm potentiometer should be incorporated.

Connecting up the Unit

Connection is made between set and unit by inserting an adaptor attached to a length of twin flex (leading, of course, from the set) in the lamp-socket mounted on the small piece of ebonite fastened to the baseboard of the unit. Similarly connection is made between the unit and the mains by taking another length of twin flex from the socket portion of the safety plug to an adaptor which is inserted in one of the house lamp-sockets.

It does not matter in the least which way round the adaptor is inserted in the house-lamp socket, but there is a right way and a wrong way (which must be found by

experiment) of inserting the adaptor in the lamp-socket of the unit.

It is highly important that the correct type of lamp should be used as a resistance in the unit. This lamp should, in all cases, be rated at 110 volts, but its wattage will depend upon the voltage of the house-lighting supply. If this is between 200 and 220 a lamp rated at 110 volts 40 watts should be used in the rectifier, while if the mains voltage is from 230 to 250 the lamp should be rated at 110 volts 60 watts. A metal-filament, carbon-filament, gas-filled, or other lamp may be used provided it complies with the above conditions.

When working from A.C. mains in conjunction with this unit it will often be found better not to use an earth connection. Therefore, when building a "Simpler Wireless" set for A.C. work the earth terminal and the fixed condenser in series with it may be omitted.

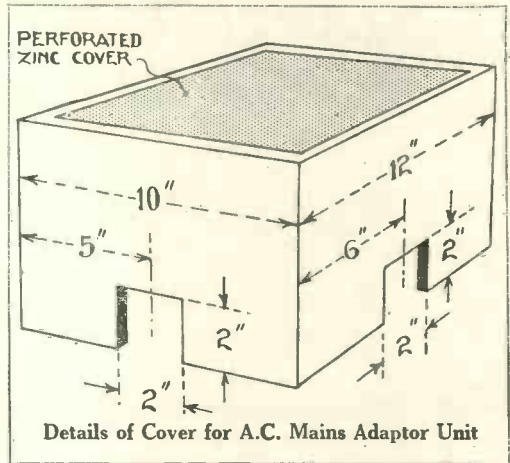

Just one word of warning is necessary in connection with the unit. When it is in operation the fixed condensers, of course, are charged up.

When it is desired to handle the unit at any time, therefore, the mains and set should first be disconnected, the cover removed, and the fixed condensers short-circuited with the metal portion of a wood-handled screw-driver or similar instrument.

Making A Cone Loud-speaker (Contd. from page 21)

(as shown in the photograph) and attach the extension arm on the unit to the apex of the cone by means of the conical washers.

When completed, a pleasing appearance can be given to the whole unit by spraying it with gold paint and Indian ink with a special blow-pipe sold for the purpose by dealers in art materials. During this process the frame itself is best protected with strips of paper.

It will be found that many different kinds of paper can be used for making the cone itself and experiments can also be made by mounting the cone on other substances than oiled silk—paper or thin rubber sheet can be tried, for instance.

On the right is a reduced reproduction of the full-size blueprint template. This can be obtained for half-price (that is, 6d., post free) if the coupon on page iii of the cover is used before February 29. Ask for Blueprint No. WM 55.

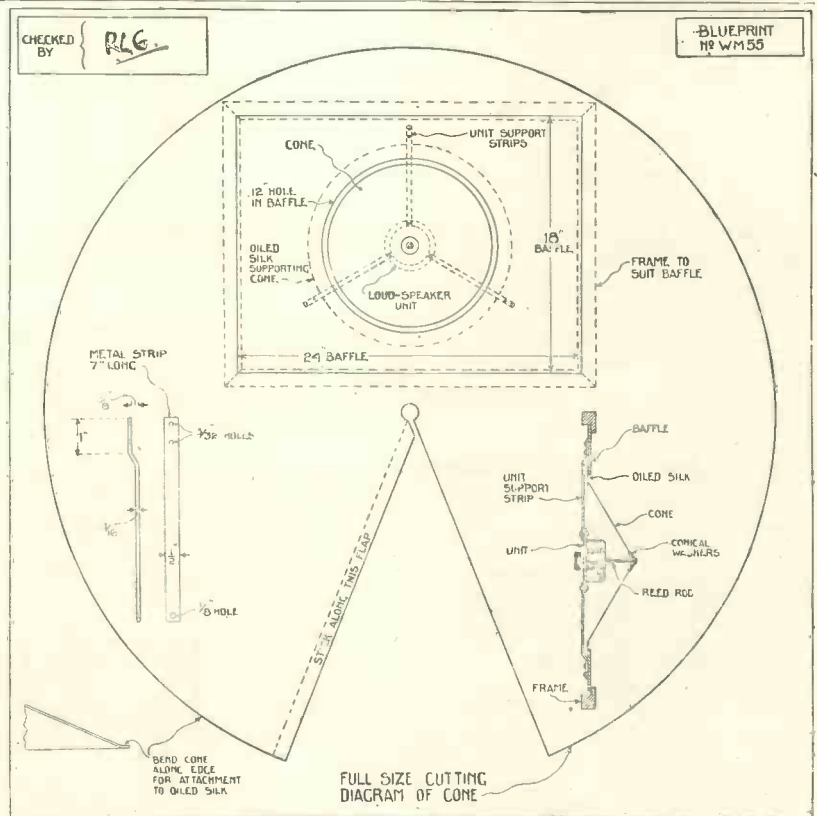

Experiments in Empire Broadcasting

Behind the Scenes at 5SW.: By D. SISSON RELPH

AFTER announcing itself to the world with a special Armistice Day programme on the evening of November 11 last the B.B.C. short-wave experimental station located at the Marconi works at Chelmsford was silent for some weeks, a fact that provoked a good deal of comment in amateur wireless circles generally.

No Minimum Guarantee of Service

But the reason is not far to seek. Ever since short-wave broadcasting was first suggested it will be remembered that Capt. P. P. Eckersley, Chief Engineer of the B.B.C., has insisted that no minimum guarantee of service could be given.

From the broadcasting programme point of view, reception of the Armistice night broadcast at many places abroad was not a success, although the transmission was all that could be desired.

The results varied considerably in different parts of the world and a rough analysis of reports of the strength of signals received at various observation posts through the Empire indicates that one of the difficulties of the observers was that the wavelength was not equally suitable for all places.

For the first experiments a wavelength of 24 metres was utilised, but the desirability of trying out other wavelengths is now under consideration.

A Visit to the B.B.C. Short-wave Station

Quite recently I had the opportunity, on behalf of the WIRELESS MAGAZINE, of visiting the B.B.C. short-wave station 5SW, which is run under a system of close co-operation between the B.B.C. and Marconi engineers. Actually the experimental apparatus for this short-wave broadcasting is installed in the same part of the Marconi works as the original 5XX and 5GB transmitters were tried out.

Making Use of Beam Apparatus

A considerable amount of time in installing the station was saved by using part of the standard Marconi short-wave beam apparatus. An outstanding feature of the 5SW installation is the special type of aerial employed for getting maximum radiation; the diagram of it reproduced on

this page will give the reader some idea of the practical difficulties that are encountered in short-wave work.

Already in existence at the Marconi works at Chelmsford were two 450-foot masts and the 5SW aerial is a vertical wire suspended from a "stay" wire slung between these masts. But the aerial itself is of a very particular form as used for beam services, to obtain the greatest possible efficiency in short-wave working.

Aerial Built Up in "Half-wave" Sections

The aerial is built up in "half-wave" sections—that is, at the top there is a straight length of wire equivalent in length to approximately half the wavelength used for transmitting; then a length of wire again equal to approximately half the wavelength of the transmission is actually coiled up in the air, somewhat in the manner indicated in the sketch on this page.

Below this first coil there is another half-wave straight section, followed by another coiled up half-wave section and so on, making five straight half-wave sections and four coiled half-wave sections in all

Larger Bottom Section

As a matter of fact, for special reasons in connection with the feeder system from the transmitter itself to the bottom of the aerial, the lower section is a little over half a wave in length; it really consists of a half-wave section plus a quarter-wave section in one vertical piece.

How the Wavelength is Changed!

Those amateurs who have wondered why the B.B.C. have taken so long in trying further experimental transmissions from 5SW will realise some of the obstacles that prevent rapid change of conditions at the transmitter itself. Every time the wavelength is changed it is necessary to take down the aerial and rebuild it on this special half-wave sectional scheme. It will be readily appreciated that such a procedure is not a matter of a few hours only, but of days.

Section of approximately half the length of the wave in use.

"Half-wave" length of wire coiled up.

Last section consists of a half-wave length section and a quarter-wave section.

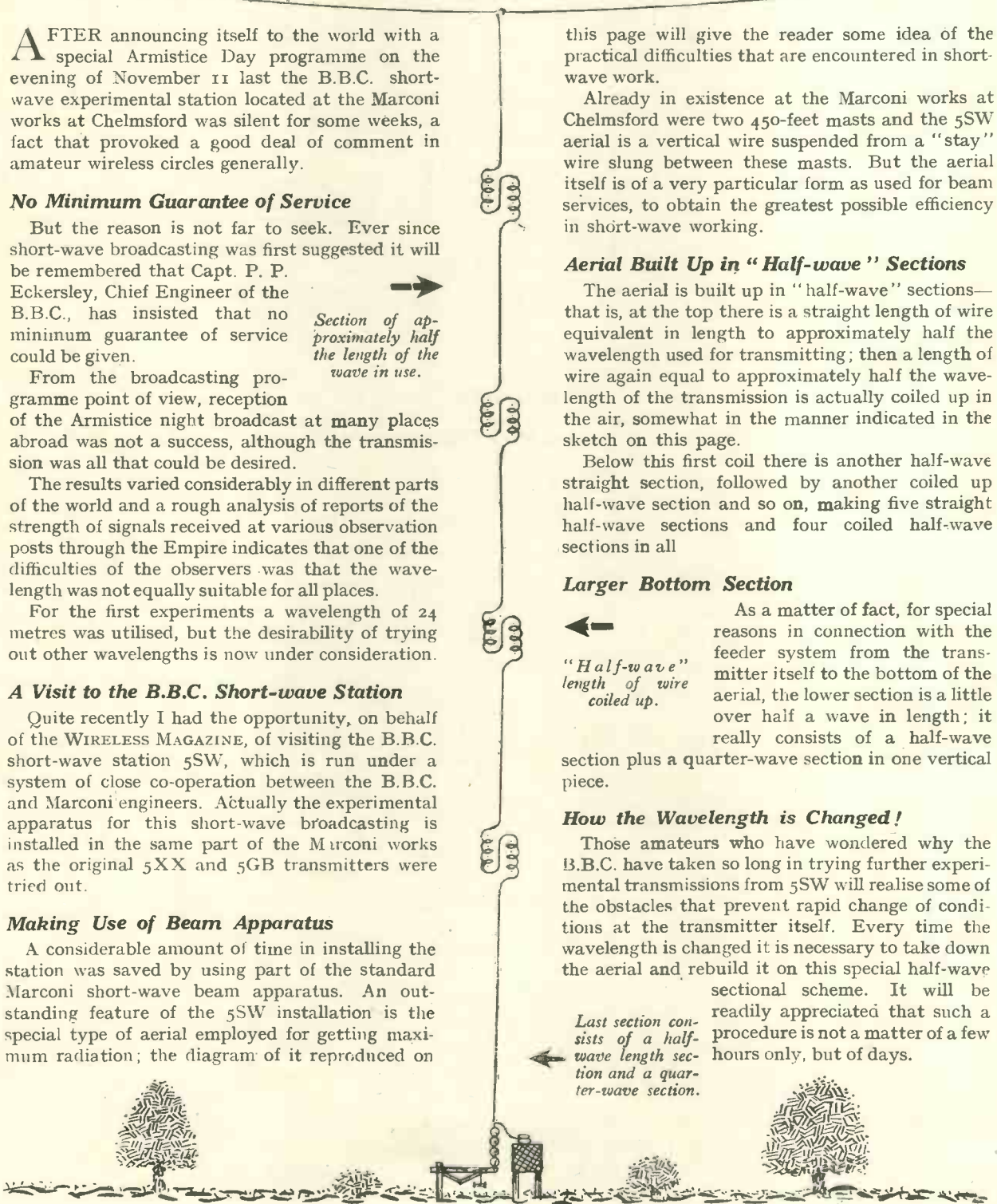



The transmitter consists of a 60-watt oscillator valve followed by a 200-watt amplifier. After this the current is amplified by a push-pull arrangement of two valves in parallel, each handling $1\frac{1}{2}$ to 2 kilowatts. Following these and still in parallel on the push-pull system are two specially-neutralised oil-cooled valves, each of which is capable of handling 10 kilowatts of power, and is supplied with an anode potential of 8,000 volts and 300 volts grid

One of the large CAM1 valves is shown on the left, while on the right is a view of the modulator panels at the Chelmsford experimental short-wave broadcasting station.

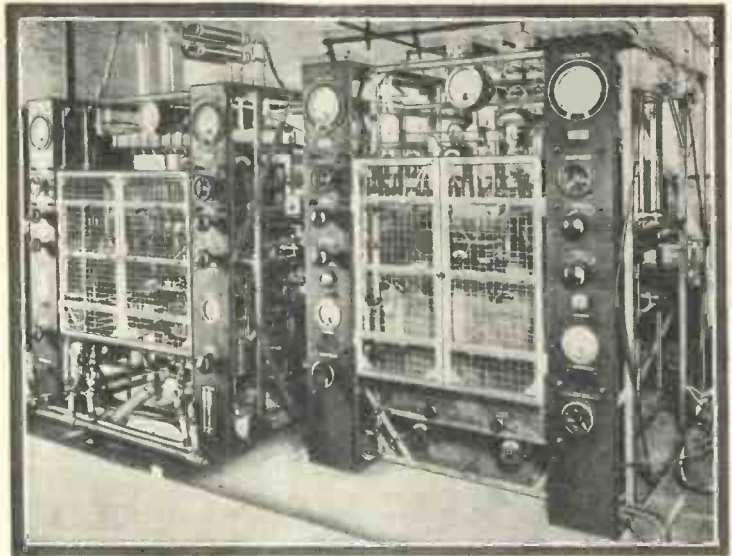

bias. The output of these two amplifiers is combined and fed to the aerial.

Huge Double-ended Valve

Reproduced in these pages is a photograph of one of the main amplifier valves, known as the CAT2. It will be seen that this valve is double ended, the anode forming part of the container through which cooling oil is passed.

The heat generated in the valves is quite considerable and special precautions have to be taken to keep them cool. For short-wave work oil cooling is preferable to water cooling because the dielectric losses with oil are very much less than those which occur when water is used.



Signal currents from the studio microphone are amplified by a series of line amplifiers and low-power modulating valves. The final modulation stage consists of four large valves in parallel. Each of these is capable of handling 4 or 5 kilowatts of energy and the modulators give an output of the same order as the final amplifiers in the main transmitter. Current from the four modulating valves in parallel is fed to the main transmitter through a huge speech transformer which stands nearly 2 feet high and about 3 feet long.

Last Word in Low-loss Tuners

The tuner is the last word in low-loss arrangements and consists of a number of separate turns of wire, each about 1 foot in diameter, arranged in a series-parallel system to reduce the resistance as much as possible. Coupled to the tuners, one of

Another view of the short-wave "beam"-type apparatus used at Chelmsford is seen on the left, as is also a CAT2 oil-cooled transmitting valve. On the right is an MT10 transmitting valve.

which is provided in the anode circuit of each main amplifiers, are two small coils connected to a junction box at one end of a feeder wire.

The Intriguing "Feeder"

This feeder was to me the most intriguing part of the installation; and it is one over which very great care has to be taken when a short-wave station is erected. An idea of its formation will be gathered from a glance at the diagrams reproduced in these pages. The feed wire consists of a copper rod of approximately 1 inch in diameter led through a copper shielding pipe of nearly 4 inch diameter. The small rod is insulated from the pipe by special

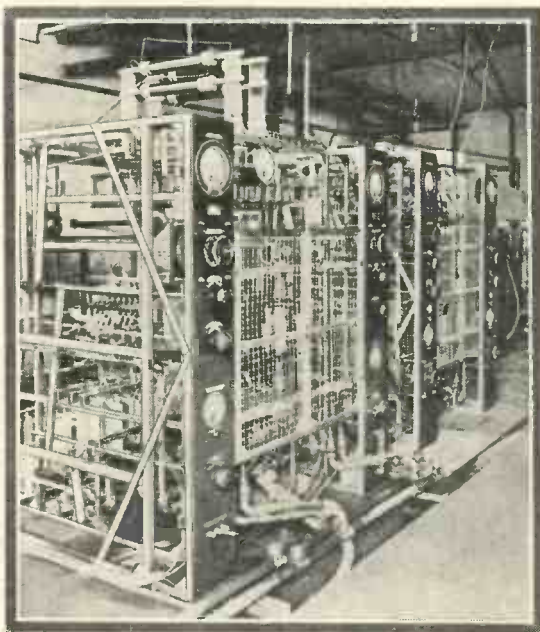

Experiments in Short-wave Broadcasting (Continued)

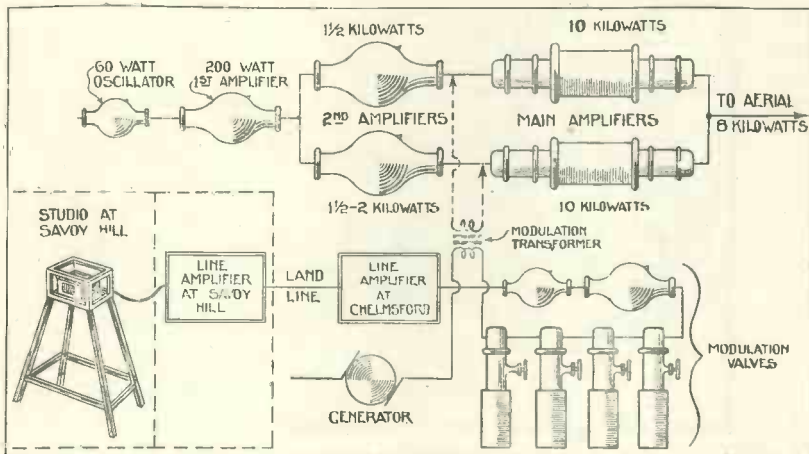

Diagrammatic sketch showing the arrangement of the apparatus at the Chelmsford experimental short-wave broadcasting station

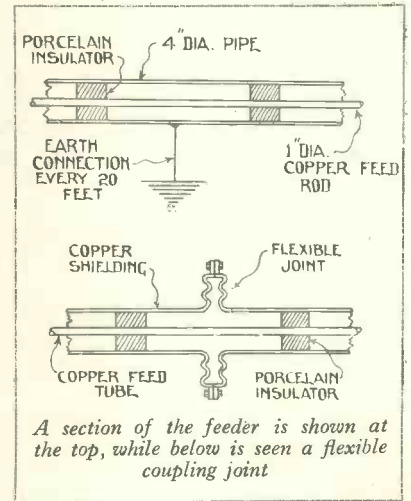

A section of the feeder is shown at the top, while below is seen a flexible coupling joint

porcelain insulators, of which there are four to every 10 feet length of piping. It is most important, of course, that the outside pipe should shield the inner feed rod efficiently and for this reason it is earthed at 20 foot intervals throughout its length from the transmitter to a second junction box directly at the foot of the aerial.

During hot weather, the copper piping is liable to expand and distort badly. In order to obviate any risk of this happening at Chelmsford, flexible joints of corrugated copper are disposed along the feed pipe at intervals. When expansion takes place these joints undergo a concertina action and the pipe itself is not buckled.

No Feeder Radiation

It is important that no radiation should take place from the main feed rod inside this copper pipe and the absence of "standing waves" in the feed system is ensured by keeping the current the same at each end of the feeder system. This is checked by means of ammeters placed in the junction boxes at each end of the feeder.

So that the aerial has a certain amount of mechanical freedom in gales the bottom of the aerial is attached to a pivoted metal arm. The counter-balancing weight consists of a large and very rusty nut and bolt fixed to the aerial by a short piece of wire. However, it serves its purpose well and the engineers tell me that aerial sway at

5SW does not produce any change in wavelength at all.

These impressions of a visitor to the first British short-wave broadcasting station will have served their purpose if they make clear to WIRELESS MAGAZINE readers some of the precautions that have to be taken and

some of the difficulties that have to be overcome before even a service with "minimum guarantee" can be started, but it is not perhaps too much to hope that this enterprise of the B.B.C. will benefit British listeners scattered over all parts of the globe.

Batteries and the Listener's Budget

IF the ordinary listener were asked for criticisms on the present standard valve set for broadcast reception he would probably concentrate on the batteries. The filament accumulator is troublesome because it requires periodical recharging and, in addition, exhibits a perverse tendency to run down just when it is most wanted.

As regards high tension, the dry-cell battery is a recurring charge on the wireless budget, and after the first few weeks of service usually develops artificial "atmospherics" of its own.

The remedy seems to lie in the use of eliminator units which are adapted to derive all the current and voltage necessary to run a multi-valve set direct from the electric lighting mains. At the present time the ideal combination is probably to be found in the indirectly-heated cathode type of valve in which special "false" filaments are fed directly from the mains; with a special eliminator unit

for supplying the plate voltage from the same source.

Eliminator units designed to produce both filament and plate supply from the mains are, of course, available, but the indirectly-heated valve has the advantage that it is peculiarly free from noise, whilst owing to the fact that no current flows through the actual cathode, the latter is maintained at the same potential throughout its length and thus operates at maximum efficiency.

High-tension Eliminators

With regard to high-tension eliminators, it is generally found that the alternating-current type gives more satisfactory results, all round, than the D.C. type, though, of course, the latter is cheaper to install. In the former type the A.C. transformer completely separates the eliminator unit from the outside mains, and thus protects the receiving set from variations in load and corresponding fluctuations in voltage. M. A. I.

In our previous issue we gave particulars of the 1928 Five receiver (see page 506), which comprises two stages of high-frequency, a detector, and two stages of low-frequency amplification. Now we are giving particulars of the necessary long-wave coils, only those for the lower broadcast band having been so far described.

1928 FIVE



The 1928 Five, published in our previous issue

IN the previous issue of the WIRELESS MAGAZINE we gave details of the revised 1927 Five, under the title 1928 Five. In these notes we are giving particulars of the necessary

to No. 1 contact; and the end of the winding to No. 3 contact.

The second coil consists of 240 turns of wire, the winding beginning in this case at the top of the former.

of the coil and the winding carried on for another thirty turns, starting from the top and ending at the bottom of the coil. In all there are 130 turns in the lower section of the coil.

The top of the coil goes to No. 3 contact; the 110th tap to No. 4; and the end of the winding to Nos. 1 and 2, which are connected together as indicated.

The six-contact high-frequency coil consists of two separate windings, one of 220 turns and another reaction winding of thirty turns placed on top.

The winding of this coil can be started from the bottom, a tapping being taken at the 110th turn (centre point). When this winding has been completed, an extra and separate winding should be put on; this consists of thirty turns separated from the main winding by means of strips of card.

The top end of the main winding goes to No. 3 contact; the 110th tap to No. 4 contact and the bottom to Nos. 1 and 2 contacts. The top end of the reaction winding goes to No. 6 contact and the bottom to No. 5 contact.

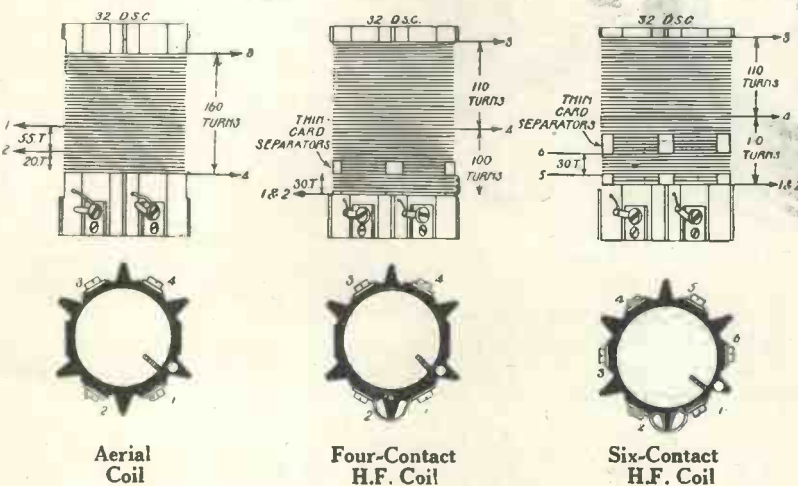

long-wave coils. Readers will remember that two of the coils have four contacts and the third coil has six contacts.

As a matter of fact no tuned-anode circuit is quite as efficient on the long waves as it is on the low waves, and this is to some extent the case with the special high-frequency circuit used in the 1928 Five. When receiving on the long waves do not use more than 30 or 40 volts on the H.F. valves.

For winding all three coils obtain 5 oz. of No. 32-gauge double silk-covered wire (Lewcos). The first (aerial) coil consists of a plain winding of 160 turns, tapped at the twentieth turn and again at the seventy-fifth turn. The bottom of the winding goes to No. 4 contact on the special Becol former; the twentieth tap to No. 2 contact; the seventy-fifth tap

The first tap is taken at the 110th turn, then another 100 turns are wound on, which fills the former.

At this stage small strips of thin card are placed over the bottom part

TEST REPORT OF 1928 FIVE ON LONG WAVES

Station	Aerial Condenser	1st H.F. Condenser	2nd H.F. Condenser	Wavelength
Leningrad	30	55	58	1,000
Hilversum	50	60	60	1,060
Warsaw	60	65	65	1,111.1
Königswusterhausen ...	70	75	75	1,250
Daventry 5XX	78	80	82	1,600

Archibald Puts Things Right

by HUGH POST

UNCLE ARCHIBALD'S set was originally employed, I imagine, to amuse the family on dull evenings in the Ark. Anyhow, it looks like that kind of set, and sounds like it. But Uncle doesn't think so, and when Aunt Geraldine deigns to listen in she is too busy criticising the shortcomings of the B.B.C. to worry about the quality of the reproduction.

When the set developed curious crackling noises a few weeks ago, you and I would have taken them as part of the normal performance of Uncle's peculiar loud-speaker. But Uncle knew better.

"Did you notice that?" he asked Aunt.

"I did," she replied. "I wonder what foolishness the broadcasting people will give us next. A firework display is all right in the proper place and at the proper time, but not on Sunday evening on the wireless."

"I'm rather afraid it's the set," Uncle apologised.

"And do you mean to say," demanded Aunt "that you are calmly sitting there and letting the set behave like that without putting it right!"

Now you must not think that Aunt Geraldine is a confirmed fault-finder. It is true that she frequently finds it necessary to call Uncle's attention to little points, such as leaving pipes full of tobacco ash on the mantelpiece, and reading the newspaper over breakfast, and not listening when she mentions such matters, but this is doubtless because she sets a higher standard for him than for the ordinary male. Naturally she expects the man she chose for husband to be pretty considerably above the average.

So when Uncle used to confess that he didn't know something or other, or didn't think he could do something else, he always had to do a lot of explaining first, and then answer the problem, or make a shot at the job, as well. Consequently he gave up not knowing, and not knowing how to, quite a long time ago.

"Of course, it is quite a simple matter to remedy," he said, "but I have been thinking of having the set

modernised in any case. There have been so many improvements lately that the set is probably a bit out of date. I'll take it round to the dealer's."

"Archibald," said Aunt quite decidedly, "will you kindly explain



Uncle withdrew the soldering bit from the fire

why you litter the house with WIRELESS MAGAZINE'S and suchlike papers if you can't stop a few crackling noises without professional assistance?"

Uncle Archie had heard that argument before, and knew the only acceptable answer.

"All right. I'll do it," he replied. "It only wants a touch of solder somewhere. I'll get some to-morrow."

He bought a neat little soldering bit, complete with solder and tin of flux, all threaded on a pretty card, and next evening he pushed the head of the bit between the bars of the dining-room fire while he spread a newspaper on the table and lifted the set off its usual stand. The batteries tried to come with the set at first, but fortunately the H.T. leads pulled loose, and the L.T. flex broke where the acid had got at it, and apart from a temporary shorting of the accumulator, no harm was done.

The set was a bit dusty, and Uncle's screwdriver was not in its proper place, but in half an hour or so the wiring was exposed and Uncle, ready

for anything, opened the tin of flux and withdrew the soldering bit from the fire. To be exact, he withdrew part of it. The neat little one-ounce head stayed behind in the fire.

It would not do to admit an accident right at the beginning of things; as Aunt Geraldine was in another room, he put on his hat and stepped across the road to Pettigrew's.

Pettigrew responded nobly to the request for the loan of a soldering bit. He not only produced one, but he offered to come and use it, and within five minutes he was poring over the tangle of wire and systoflex that was somewhere responsible for the crackling noises.

"Why not rewire it?" he suggested.

Uncle liked the idea, but he was afraid it would be rather a task. He confessed that he had mislaid the original plan, and also that he was contemplating something more modern in the near future—a set to run off the mains, and bring in foreign stations without interference, and so on.

"Take my advice and don't think of that," Pettigrew urged. "I can see the idea of this set. It's not at all bad, and with a little bit of alteration it would be lots better. There's the cause of your crackling noises, by the way."

He pointed to a broken contact.

They adjourned to the kitchen, and with Pettigrew's big soldering bit on a small gas ring they proceeded to unsolder and reconnect. After an hour the wire entanglements seemed to Uncle Archie to be a trifle denser than before, but Pettigrew was quite happy and very busy.

"Haven't you any more systoflex?" he asked. "Well, we must be careful that these wires don't touch. We'll bend that one so, and bring this one round the transformer. That's got it, I think."

"Is it finished?" asked Uncle, who had been standing by and saying very little during the process.

"It is," said Pettigrew. "and if it isn't fifty per cent. better than ever before, I'll—I'll rewire it again for you."

He took out his watch and glanced at it.

"I'd no idea it was so late!" he exclaimed. "We've got some people coming in for bridge. But you'll be all right now. Just connect up, and I'll be able to hear Vladivostok across the street."

He departed, and Uncle gently slid the baseboard back into its cabinet, took the set to its usual place, and connected up the leads. He set the rheostats, threw over the switch—and saw two tiny flashes in the first two valves. There was not a sound.

Now the valves had always given a faint glow when they were burning. They were not exactly new ones; they ought to have been discarded as obsolete a couple of years before.

At last Uncle noticed the absence of glow in two of the three.

"That ass Pettigrew has made a mess of things," he commented.

"So you had to call in Pettigrew," said Aunt unkindly. "You have cured the crackling between you, anyhow."

"I didn't call him in," Uncle asserted. "He offered to come and make the set work wonders. This is what he has done. I'm going to put things right now."

Uncle's hands shook a little as he took the set back to the kitchen, and removed the two useless valves and the one survivor from their holders. He really was annoyed with Pettigrew. Even when he found a spare bit of wire

the wiring had been like, he soldered up again.

It was not exactly an exhibition set when he had finished. There was a good deal more solder on some joints than was strictly necessary, and on others there was more flux than solder. But it looked as though it might work. He traced the filament connections conscientiously to make sure that the high-tension couldn't get at them.

As a matter of fact, if Uncle had only realised it, the set was as nearly like Pettigrew's wiring as made no difference.

Uncle hurried home from business the next evening with two new valves, and even before he took off his hat and coat, he stuck them in their places and switched on.

Nothing happened.

He turned the tuning dials and there came the old familiar rustling noise that the condensers always gave, and a howl or two of splendid power. Uncle grew excited. At last, a burst of music came, and went in an instant.

"By Jove!" he exclaimed.

He back-pedalled with one condenser, eased the other up with the edge of the dial, and speech poured forth with truly delightful volume—in German.

Uncle stroked his neck, and slowly advanced the tuning. French now and—a degree further on—faint, but distinct music. He snatched at his evening paper. It was the news hour. It could not be a B.B.C. station.

He shouted for Aunt Geraldine. She came, and he repeated the performance.

"That shows what a bit of careful wiring can do," he commented.

"Your dinner is getting cold," Aunt replied. "You can play with the set afterwards."

Uncle bolted his dinner and hurried back to the set. In half an hour he logged twenty stations, without changing his coils. He had never known anything like it. It was astounding.

Then suddenly the set went dead. Uncle just happened to catch his knee on a corner of the cabinet—nothing more—and the set was as silent as the grave. He peered at the valves. The new ones were silvered all over. They told him nothing. But the third valve, the stalwart of four winters, was black and cold. He tugged it out of its holder and flung it into the fireplace.

"No more chances for me," he muttered and went to his desk.

Ten minutes later the room was littered with stationery, old papers, receipts, circulars, price lists and catalogues. But Uncle had found what he wanted; the original wiring diagram of the set.

The shops were still open. He dashed out and bought another valve,



"Your dinner is getting cold," Aunt replied.
"You can play with the set afterwards"

two shillings worth of solder, and six lengths of systoflex.

By ten o'clock he had finished his task. The wiring of the set looked more wonderful than ever, but there was systoflex everywhere, and the set was "as you were."

He connected it up. 2LO boomed in familiar style. 2LO was good loud-speaker strength all round the dials. The tone, thanks to a general-purpose valve in the last position, was just what it had always been. Uncle and Aunt listened contentedly.

"You've made a good job of it at last," said Aunt Geraldine, with sparing praise.

"It was simple enough," said Uncle pleased at the flattery, "except for Pettigrew's muddling."



Just connect up and I'll be able to hear Vladivostok across the street

that had been dropped in among the "works," he still felt that Pettigrew was to blame.

Fortunately the man had forgotten to take his soldering bit. Uncle set to work and unsoldered everything that had been touched that evening. Then, relying on his memory of what

EVERY "W.M." READER CAN OBTAIN A FULL-SIZE BLUEPRINT OF ANY SET DESCRIBED IN THIS ISSUE (ONLY) FOR HALF-PRICE BY USING THE COUPON ON PAGE iii OF THE COVER.

What Readers Think of Our Sets



P. T. T.'s
Girdle Two

Girdle Two

Published September, 1927

To the Editor, "Wireless Magazine."

SIR,—I have read many times the opinions of your readers regarding the different sets which you advocate in your journal. So far I have seen no reports on the Girdle Two, so here's one for you.

I commenced the construction of my Girdle Two the day I sailed from Bombay and completed it about six hours after leaving that port. The only deviations on my set are the following: Solid ebonite panel and plug-in coils.

Since my arrival at Calcutta I have added a further L.F. stage, but to go back to my test: I plugged in a No. 75 coil (aerial), No. 100 (grid), and No. 75 (reaction) to see what would happen on ordinary broadcast wavelengths. Bombay, on 375 metres, came thundering in, and when Bombay closed down for half an hour, Calcutta was easily tuned in.

Night after night right around Ceylon up to Calcutta, Bombay was audible about six feet from the loud-speaker, but Calcutta was not quite so strong.

For about five days the average distance we were away from Bombay (direct over land) was approximately 1,050 miles. So much for the broadcast wavelengths.

One Tuesday night I decided to try for PCJJ, and at exactly 17.00 G.M.T. I tuned in and his carrier simply screamed at me. He was immediately tuned in and some exceedingly good items were heard (5,400 miles).

The Sydney station on 26 metres came in quite well and amongst key-pushing

amateurs who were "legion" three Americans and two Italians came through on the loud-speaker.

There seems to be no state at which the set refuses to oscillate, and I am very glad I built it. With best wishes for the WIRELESS MAGAZINE.—P. T. T. (Calcutta).

P.S.—I forgot to state that from 1 a.m. Indian Standard Time, Langenberg comes in very strong, whilst many carriers are also heard which most probably can be resolved with careful tuning.—P. T. T.

British Broadcast Two

Published December, 1927

SIR,—I have been a wireless enthusiast since the very beginning of broadcasting and have constructed several

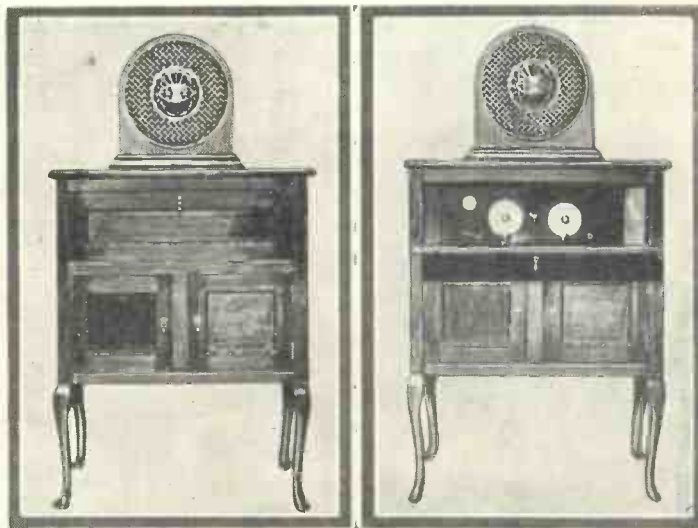

A. E. Revelation Four. This set was described in our July, 1927, issue.

sets, although I am not by any means an expert.

Being rather dissatisfied with my old straight two-valve set, I made a — but found that it was not suitable here; why, I do not know, but I could only get London and Daventry.

Well, I thought that I would go back to a straight two-valver, so I constructed your British Broadcast Two, and I have not had such excellent results since I started. The tuning is absolutely fine; I can get practically any station I want

Full-size Blueprints of All These Sets Are Available

as each station cuts out in about two or three degrees.

Also I find that the "power" I have usually had in the loud-speaker is absent — by this, I mean the rushing noise one often gets. The stations come bang in or not at all, and that is what I like about the set—no noise while tuning, ample reaction and ample volume.

I am not a distant-station fiend, but I do like to get what I want and get it good, and this set does that. One other point, there is no distortion whatever. Thanking you for your help by publishing this circuit.—A. N. (Croydon).

Revelation Four

Published July, 1927

SIR,—I am enclosing two photographs of my personal efforts in the construction of your Revelation Four.

I must say that it certainly lives up to its name and its performance has surprised many friends.

On the first try-out I registered over 30 foreign stations and the strength of Berlin, Hamburg, Stuttgart, and other continental stations was surprising.

The only fly in the ointment seems to be the heavy drain on the H.T. battery, but I think that perhaps this is due to a faulty neutralising condenser which I am going to alter.

Please accept my thanks for the many useful articles and hints which have appeared in both the WIRELESS MAGAZINE and *Amateur Wireless* and have helped me to success in both past and present sets.—A. E. (London, S.E.).

Five-Guinea Three

Published Nov., 1927

SIR,—I am writing to let you know how pleased I am with the above circuit.

I have just finished making the set, and must say the results obtained very much exceed my best expectations.

Using a low aerial, I have tuned in easily the following stations at full loud-speaker strength: 5GB, Dublin, Manchester, Liverpool, Aberdeen, Langenberg, Frankfurt, Hamburg, Munich, Toulouse, and several more.—H. (Formby).

Particularly suitable for general use by the family, the Two-programme Two enables both the upper and lower broadcasting bands to be covered without the need of changing coils, which, by the way, are of the ordinary two-pin plug-in type. In this way the local station and both Daventry's can be received without difficulty.

THE TWO-PROGRAMME TWO

5XX or 5GB Without Changing Coils

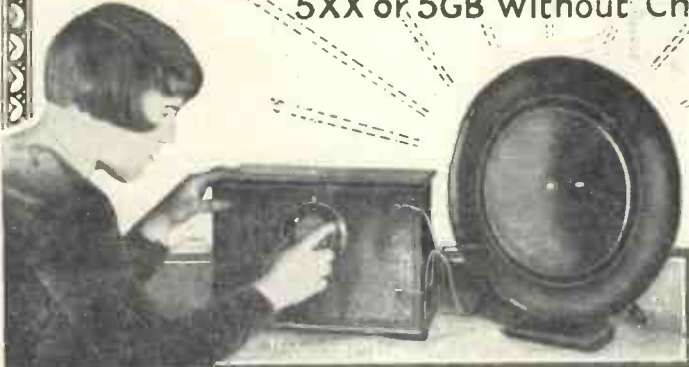

DESIGNED, BUILT &
TESTED BY

J. H. REYNER

B.Sc. (HONS.) A.M.I.E.E.

THE efficiency of the modern valve receiver is considerably greater than it was a few years ago. I obtained interesting proof of this fact only a short time back, when I installed a simple two-valve receiver, consisting of a detector and one L.F. stage, in a country district some sixty or seventy miles from London.

Equally Good Results

Previously a three-valve receiver, using one stage of high-frequency amplification, a detector, and one note-magnifier had been employed to give telephone signals only. Yet the two-valve receiver which I had brought with me gave excellent loud-speaker strength from London.

The particular two-valve receiver to which I refer was straightforward in every particular except that a high-ratio transformer was used following a medium-impedance de-

detector valve. In these days of high quality, the design of low-frequency transformers has progressed considerably, and we are now able, by using suitable combinations of valve and transformer winding, to obtain substantially uniform response over a very wide range of frequencies.

With the usual form of detector valve, having an impedance in the neighbourhood of 20,000 to 30,000 ohms, it is customary to utilise a transformer having a primary inductance of the order of 50 to 70 henries. With such a trans-

former, we can obtain a step-up ratio of the order of 3 or 3½ to 1, and with such conditions the amplification can be made remarkably uniform down to frequencies as low as 100 cycles per

second. Such an achievement would have been impossible two or three years ago. In order to obtain such inductances, large quantities of wire have to be used in the coils and a heavy iron circuit has to be employed. We have found out the various difficulties in the practical manufacture of low-frequency transformers, and as a result, we are able to obtain these excellent results

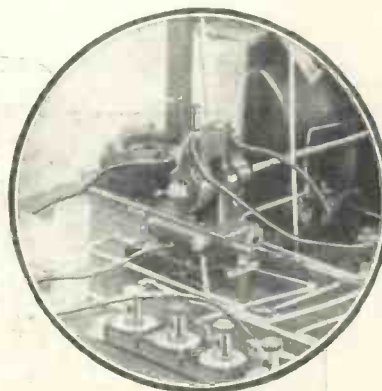

Special three-way coil holder, which incorporates a change-over switch.

by modern manufacturing methods. Yet a very popular transformer three years ago, giving a step-up ratio of $3\frac{1}{2} : 1$, had a primary inductance of the order of only 7 henries, which, by our present standards, we should consider hopeless.

Larger Ratios

Using this same increased experience, we are able to make transformers for later stages of receivers having a greater ratio with a somewhat smaller primary inductance. Such transformers are designed to be used with valves having lower impedances, and the increased step-up

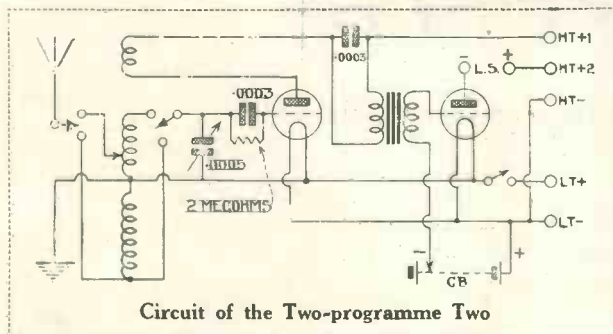

Circuit of the Two-programme Two

The Two-programme Two (Continued)

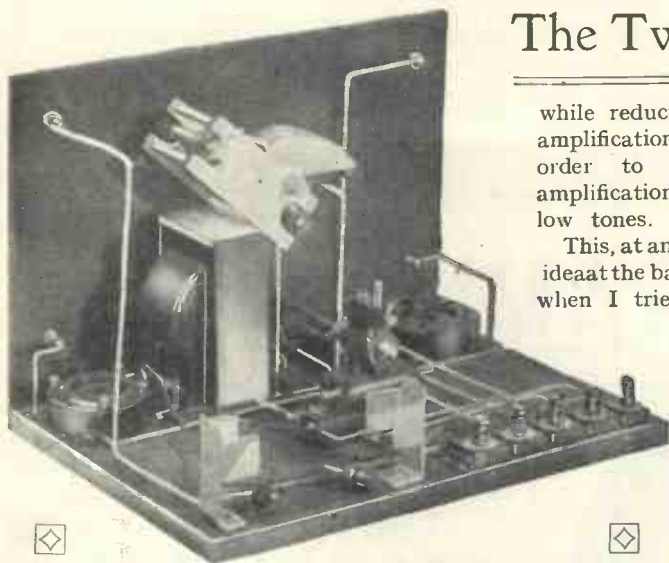

Rear view of the Two-programme Two. Note the grid-bias battery, clips, and special terminals.

while reducing the mean amplification by a half in order to preserve the amplification of the very low tones.

This, at any rate, was the idea at the back of my mind when I tried out the ar-

special two-way coil stand has been employed. This is an ingenious device (which has recently been placed on the market) in which one reaction coil is used and two tuning coils, only one of which is in circuit at any particular time.

Midway Position

When the reaction coil is placed in the midway position, the receiver is switched off completely and the aerial is connected direct to earth. As the coil is moved to one side or the other, so the particular tuning coil is brought into operation, and thus long waves or short waves can be tuned-in on the same arrangement without any coil changing or any switching other than that which is automatically provided by the coil stand itself.

Aerial Connections Changed

Not only does the movement of the coil change over the connections from one tuning coil to the other, but the aerial connections are also changed over. In the first place, the aerial is connected to a tapping on the short-wave coil, so that the full wavelength range is obtainable from the coil, together with the benefit of slightly increased selectivity. On the long waves, however, the aerial is placed in parallel with the coil, so that by suitable choice of a coil Daventry and Radio-Paris can quite easily be received.

ratio largely offsets the actual drop in amplification in the valve itself. The point is, however, that by modern manufacturing methods we are able to make the primary inductance of such high-ratio transformers better than that of the standard types of a few years ago. For example, the Igranic 7.2 : 1 transformer which has been used in this receiver has a primary inductance of 17.5 henries, with a steady anode current of 2 milliamperes.

Double Volume

It is clear, therefore, that if we were to use such a transformer following a medium-impedance valve, we should obtain not only better quality, but about twice the amplification as compared with the standard types of transformer of a few years ago.

It is clear that we shall lose a little of the low notes in comparison with an instrument having an inductance of, say, 50 or 60 henries, with a step-up of the order of 3 to 1, but with the average type of horn loud-speaker we are not able to reproduce frequencies much below 150 cycles per second, and therefore it is not greatly worth

arrangement of following an ordinary detector valve with a high-quality second-stage transformer, and the results proved immediately to be very satisfactory. A considerable increase in volume was obtained, while the quality was quite pleasant and did not appear to be lacking in any particular when tested on an ordinary horn-type loud-speaker.

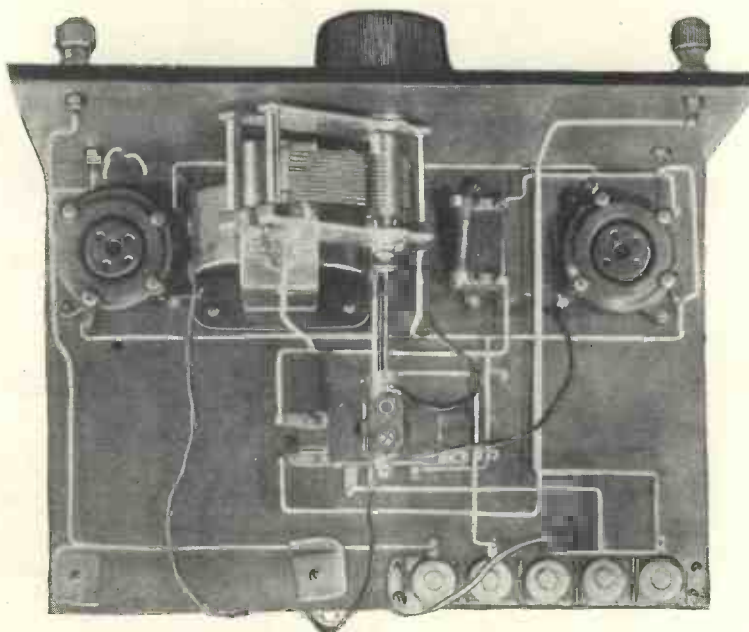

Plan view of the Two-programme Two, showing the disposition of the components on both panel and baseboard.

The detector circuit used in front of the low-frequency transformer was standard in all normal respects except that in order to make the receiver as universal as possible a

Reaction

A combination of coils can easily be found, therefore, whereby the same reaction coil serves to give smooth and satisfactory oscillation on both wavelength ranges without any difficulty. This is the case with the present receiver, and suitable coils are specified later in the article.

These, then, are the principal features of this two-valve receiver:

Coil Changing Eliminated

It will receive programmes on the ordinary 200-to-600-metre band and will change over to the long-wave band without any further operation than that of simply swinging the reaction coil to the other side of the central position. It will give good quality with surprising volume, even at considerable distances from the particular station being received.

High Amplification

Tests taken on the actual amplification of the receiver indicate that the step-up due to the detector valve and transformer is in the neighbourhood of 120, so that we have practically a two-valve set with a three-valve performance, which largely offsets the increased cost of the low-frequency transformer employed.

The circuit of the receiver is shown in these pages, and from it the vari-

Ebonite panel, 12 in. by 8 in. (Redferns, Becol, or Will Day).

.0005-microfarad variable condenser (Jackson Bros. or Ormond).

Another view of the Two-programme Two, in which the special coil holder can be clearly seen

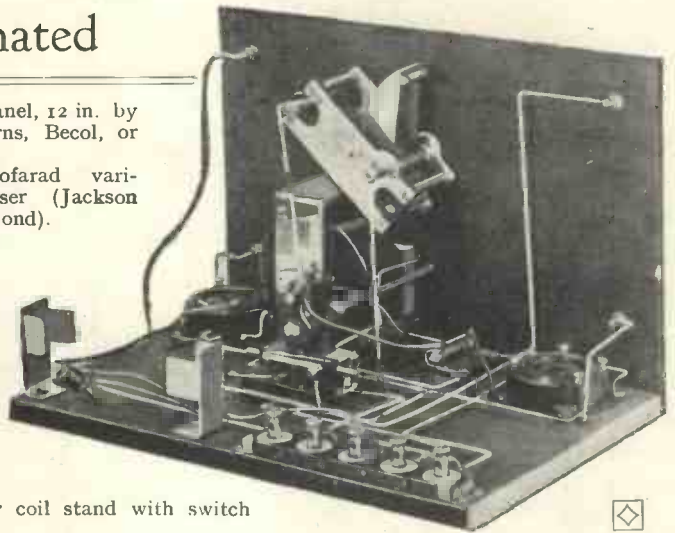

Three-way coil stand with switch (Wearite).

2 valve holders (Bretwood, Lotus, or W.B.).

Low-frequency transformer, ratio 7 to 1 (Igranic Super Audioformer).

.0003-microfarad grid condenser (Dubilier, Lissen, or T.C.C.).

2-megohm grid leak (Dubilier, Lissen, or Mullard).

.0003-microfarad fixed condenser (Dubilier, Lissen, or T.C.C.).

Pair of grid-bias battery clips (Deckorem).

4 terminals, marked Aerial, Earth, L.S. +, L.S. - (Belling-Lee).

5 baseboard mounting terminals, marked L.T. +, L.T. -, H.T. +1, H.T. +2, H.T. - (Aermonic).

2 wander plugs and 1 spade tag (Lectro Linx).

1 yd. flex.

Dial indicator (Bulgin).

It should be noted that in each case the component mentioned first is that used in the original receiver.

In order to preserve a compact arrangement of the parts, a slightly unusual layout has had to be adopted. The coil stand carrying, as it does, two coils in a horizontal position, occupies rather a large space on the baseboard, and it was found best to mount this towards the rear of the baseboard with the two valves in the front near the panel.

Transformer Position

The obvious place for the transformer was then between the two valves, and it was found that by mounting the condenser in a slightly oblique position, this could be placed immediately on top of the trans-

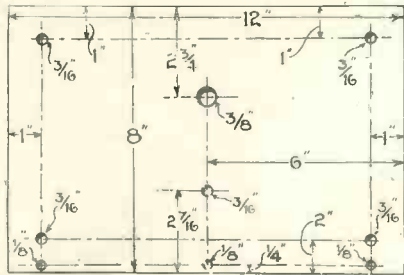

Details of Panel and Cabinet

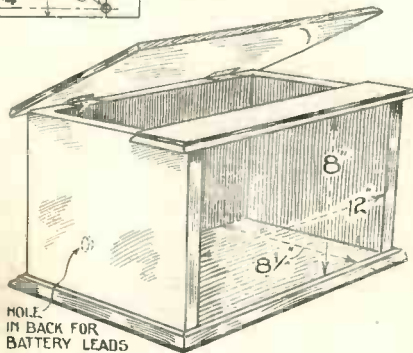

ous combinations on the coil stand can be traced out. With the reaction coil in the central position, the battery is switched off and the aerial is earthed. In the short-wave position the aerial is connected to one tap

and the tuning condenser connected to the appropriate coil, while on the long waves, as has already been pointed out, the aerial is connected across the whole coil, the tuning condenser being again changed over. Beyond this no comment is required on the circuit.

Components Required

The components required for building the Two-programme Two are as follows:

The Two-programme Two with valves and coils in position ready for use

Cabinet and baseboard, 8 in. deep (Artacraft).

Glazite for wiring.

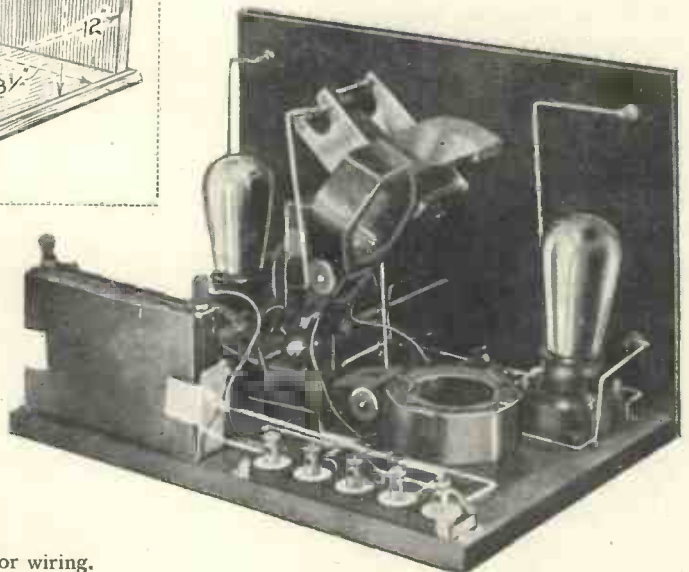

The Two-programme Two (Continued)

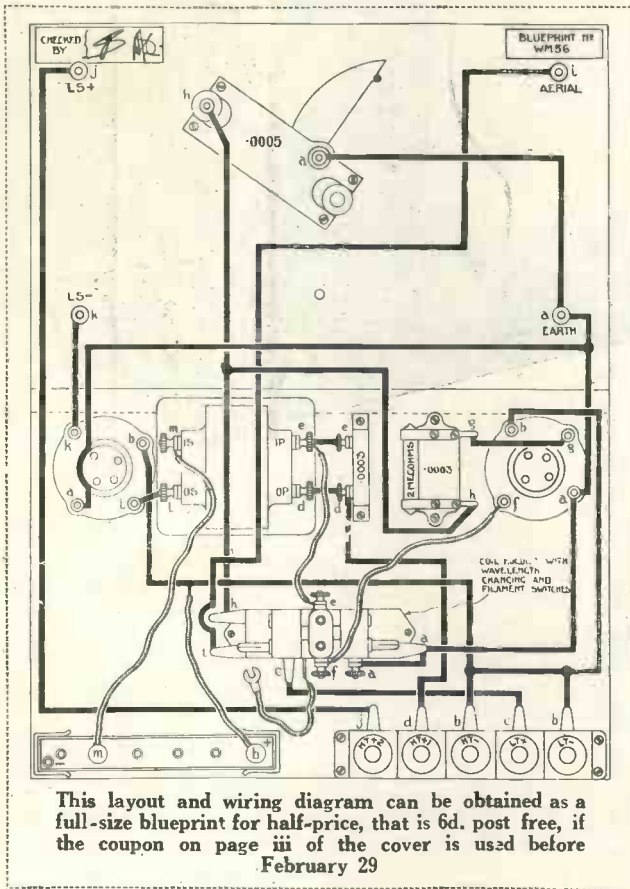

former, which gave us a symmetrical panel layout, having the tuning dial in the centre and the reaction dial (which is also the range switch and on-off switch) immediately below.

Thus, as far as the operating controls are concerned, these are reduced to the minimum, there being only these two dials and the four terminals on the panel, making it an ideal set for the novice.

Construction

Little need be said about the construction of the receiver. Drill the panel with the six holes necessary: two in the centre for the condenser and the reaction knob, and two on each side for the terminals. Then mount the components on the baseboard in the positions shown in the accompanying wiring plan. For those who prefer it, a full-size blueprint may be obtained at half price, that is, 6d., post free, until the end of February, by using the coupon on page iii of the cover. Address your inquiry to Blueprint Department,

need not be screwed down to the baseboard at all.

On the other side of the spindle we have the grid condenser and leak, while at the back of the baseboard, on the left, is the five-way terminal strip. The rear right-hand portion of the baseboard is occupied by the grid-bias battery, which is mounted inside the set for completeness. If any reader prefers to do so, however, he

WIRELESS MAGAZINE, 58-61 Fetter Lane, E.C.4, and ask for No. W.M. 56.

The coil stand is mounted in the centre of the baseboard, the valve holders towards the front, and the low-frequency transformer between the valve holders, but slightly to the right-hand side in order to clear the operating spindle of the coil stand. The .0003-microfarad condenser is simply fixed across the primary of the transformer, with two leads of thick wire, and

may utilise a seven-way terminal strip having two grid-bias terminals on, and wire up to this in the normal way.

Having placed the components in their approximate position, mount the variable condenser on the panel in the position shown in the photographs and diagram. Mount the panel temporarily in position and make sure that the condenser does not foul the transformer.

Wiring Up

The condenser may then be screwed up tight and the remainder of the components finally secured in place. The wiring of the receiver will occupy no appreciable time, and this may be carried out with little trouble, from the wiring diagram given. It will be observed that each terminal point is marked with a small letter of the alphabet; these letters indicate which points should be connected together and in what order.

For instance, first connect together all those points marked *a* with one wire or as few wires as possible; then all those marked *b*; and so on through the alphabet. If the alphabetical sequence is followed, the wiring will automatically be built up most efficiently from the bottom upwards.

Operating the Receiver

The operation of the receiver is the next care, and this will again prove a matter of simplicity.

Place a No. 50 plug-in coil in the centre socket of the coil stand. A No. 150 coil should be placed in the left-hand socket looking from the front of the set and a No. 75 double-tapped coil should be placed

VALVES TO USE IN THE TWO-PROGRAMME TWO

Make.	Detector.			L.F. Amplifiers			Make.	Detector			L.F. Amplifiers		
	2v.	4v.	6v.	2v.	4v.	6v.		2v.	4v.	6v.	2v.	4v.	6v.
B.T.H.	B210 L	—	B4	B215 P	—	B4	Mullard	PM1 L.F.	PM3 X	PM5 252	PM 254	PM 256	
Cossor.	Red Band	Red Band	Red Band	Green Band	Green Band	Green Band	Osram	DEL 210	DEL 410	DEL 610	DEP 240	DEP 410	DEP 610
Ediswan	GP2	PV8	ES5 L.F.	PV2	PV4	PV5	Short- path	SP 18R	—	SP 55 R	SP 18 RR	—	SP 55 RR
Marconi	DEL 210	DEL 410	DEL 610	DEP 240	DEP 410	DEP 610	Six-Sixty	SS 210 L.F.	SS 410 P	SS 610 P	SS 215 P	SS 425 SP	SS 625 SP

A Simple Receiver for Family Use

in the right-hand coil socket.

Then rotating the moving spindle to the left will connect the circuit up for long waves and will bring the reaction coil in position relative to the long wave coil. On the other side, the receiver will be connected for short waves, and the reaction coil will again be in the correct position. As has been pointed out, placing the coil in the central position cuts off the set.

Valves

A medium - impedance valve should be used for the detector stage and a suitable power or super-power valve in the low - frequency stage. The receiver is not critical as regards valves and various types may be used with equal success.

The principal point is that the first valve should not have too high an impedance or the quality may be a trifle thin. I found the Cossor H.F. an excellent valve for the first stage and a Cossor Stentor for the last stage. This applies in 2-, 4-, and 6-volt ranges. Similar pairs such as the B.T.H. 210L and 215P have also been tried in the 2-volt range with satisfactory results. Provided the valves have somewhat similar characteristics to these, therefore, they may be used quite satisfactorily (see also the table reproduced in these pages).

Special Coil Stand

A word may perhaps be given concerning the coil stand. This is sent out from the makers adjusted to give the automatic change-over necessary. It operates by means of two plungers which bear on two leaf springs, one on each side of the coil stand. The moving-coil block is shaped to act as a cam and pushes these plungers down or leaves them alone as the case may be.

With the coil in the left-hand position (long-wave), the two leaf springs are both pushed down and make contact with appropriate stops. On the

right-hand side the leaf springs are allowed to come up against other contacts, which change over the connections correspondingly.

In the centre position, the springs are pressed right down and this cuts off the battery and earths the aerial.

It may be found that the proper operation does not begin for about 20 or 30 degrees on each side of the centre position, and some peculiar effects may be obtained in this region. The high-tension voltage on the detector valve, therefore, should be so adjusted that the reaction coil has to be fairly close to the tuning coil before any oscillation sets in. By this means any possible difficulty with the coil stand can be avoided for the connections will have been correctly changed over when the reaction coil is in position.

SHORT-WAVE TESTS IN A COAL MINE



A receiver that has picked up PCJJ without either aerial or earth is being used for special tests in a coal mine, 600 feet below ground, at Jamuria, India. Wavelengths of from 0 to 8, 30 and 330 metres are employed. Part of the apparatus shown is a semi-portable 30-metre transmitter that is entirely self-contained and has only one control; normally it works under the call sign AIZAM and is located at 2, Short St., Calcutta, India. Its owner, Mr. P. I. Keith Murray, a reader who carried out the tests referred to, will be glad to hear from listeners should they pick him up

Radio Tracks the Criminal!

COUR of being the first notable criminal to be tracked down by wireless, but great progress has been made in radio as a policing factor since that sensational arrest in the early nineteen-hundreds.

The motor vans used by Scotland Yard's "Flying Squads" are nearly all equipped with receivers enabling the drivers to keep in constant touch with "H.Q." "H.Q.," incidentally, has been experimenting with receivers since 1922 or thereabouts. These New Scotland Yard radio experiments, of course, are of quite an official nature, but unofficial tests are frequently being made by police in

other parts of the country. It is not giving away a State secret to announce that the police in the West Riding of Yorkshire have, within recent months, been making tests, and we understand that a small transmitting plant with an amateur licence has been used.

Photos of "Wanted" People

Radio transmission of photographs is now sufficiently accurate to be of use in broadcasting photographs and even fingerprints of "wanted" people. A fingerprint diagram has already been sent by picture radio across the Atlantic to New Scotland Yard.

P. C.

Half Hours with the Professor



12.—ANOTHER CHAT ABOUT TUNING

"I SAY, Professor," exclaimed young Amp, "I tried some of those experiments you did last time and I got them to work fine."

"Did you, now," murmured Megohm, absently waving his slide-rule in time with the music coming from a loud-speaker in the background. "Did you, now," he repeated, suddenly coming down to earth and looking at Amp quizzically. "You seem quite surprised about it."

Really Quite Easy

"Well, it seemed so fascinating that I thought there must be some trick about it, but I found that it was really quite easy. S'matter fac'," he prattled on merrily, "I showed it to Bill Higgins—you know him—ever since he built the Phoenix Five he's been frightfully stuck up. Well, he watched it all with interest and then at the end he wanted to know what all that had got to do with wireless."

Megohm nodded and a pause ensued.

"Well, what had it, anyhow?" queried the Amp in a puzzled way. "I couldn't tell him, but all the same when you were talking to me last time, it seemed to have some bearing on the matter."

The Professor laughed. "Perhaps I did not make myself clear," he said. "I thought that I explained that the two pendulums acted as a transmitter and a receiver and—"

"Oh, yes, I got that all right," interrupted the boy, "but what I don't quite get is where the pendulums come in in ordinary wireless sets."

"Ah, now I see your difficulty. That is a problem which can soon be overcome. I showed you last time," he went on, "that the whole basis of tuning in wireless is the use of oscillatory systems. We set one system going and make the other system tend to oscillate at the same rate; in other words, we tune it, and

it will then pick up from the first system and build up to quite a good oscillation." Amp, remembering the experiments last time, muttered an agreement.

"Now a pendulum," resumed Megohm, "is one of the simplest forms of oscillating system. It merely consists of a weight of some sort tied on the end of a cotton. If we pull the weight to one side, we raise it a little above its former level, so that when we let it go, it is pulled downwards by gravity and therefore swings to and fro."

"You explained that last time," said the boy.

"Good," replied the other. "Now the point is that a pendulum is quite stable until we start it going, as it were. Simply attaching the weight to the end of the cord does not do anything in itself. When we draw the weight to one side, however, we lift the weight slightly and thus we actually store some energy in the system. When we release the weight, this energy dissipates itself again by causing the pendulum to swing. That is clear, I take it."

Amp nodded his agreement.

Equivalent State

"In a wireless circuit we have an equivalent of this state of affairs in the condenser."

"I know, Professor," interrupted the lad. "You told me all about condensers once before."

"Did I really?" responded the Professor. "In that case, you know what I was going to show you, then," he said, with a twinkle in his eye.

"No," cried Amp, "I didn't mean that I knew all about it. . . ." He broke off falteringly, but the Professor had already moved towards the apparatus cupboard from which he took out a large 4-microfarad condenser.

"Now," he went on, "I have here a large condenser which I am going to charge to a high voltage." This he

did by connecting it across the output terminals of a battery eliminator. "This condenser is now charged to 200 volts. If I take it off, it will remain charged." Megohm here suited his action to the words.

"Assuming that the condenser is of good quality and that there are no leakages across it, it will maintain that charge for some considerable time—this particular condenser will actually retain its charge for some hours—and theoretically a condenser will retain it indefinitely until we discharge it."

A Brilliant Spark

With these words, the Professor took up a piece of wire and held it across the terminals. As he made the connection there was a brilliant spark which made young Amp jump at its intensity.

"That," said the Professor with a wave of his hand, "that indicates the presence of the charge on the condenser which has now discharged through the short-circuit path which we provided. This is just the same as pulling aside the bob-weight of a pendulum and releasing it. When we let go the pendulum discharges its store of energy just as the condenser does."

"I'd rather have the condenser experiment," interposed the Amp, with a grin.

"Yes," agreed the other. "it's certainly more spectacular. So far, however, we have only considered half the story. When the pendulum reaches the bottom of its swing it does not stop because the weight has already gained a certain momentum, as we call it. This causes it to continue to swing almost to an equal distance on the other side of the central position. Every inch it goes this side, however, it is lifting the weight, and so the momentum is gradually used up and the pendulum comes to rest."

"This is not a stable position,

however, because the pendulum is now above its zero position and the weight will tend to fall so that the pendulum swings back again and so the process is repeated."

"Yes, I've got that all right, I think, Professor."

Similar State of Affairs

"Good. Well, in the electrical case, we have an exactly similar state of affairs. Suppose instead of discharging the condenser with a simple piece of wire, we place a coil across the terminals. A coil possesses inductance, as a result of which a magnetic field would be produced by the sudden rush of current through the coil. Now this magnetic field has to come from somewhere and consequently it cannot suddenly disappear. Thus when all the energy in the condenser has discharged, the current cannot suddenly cease, but it continues to flow, getting smaller and smaller, with the result that the condenser charges up in the opposite direction."

"Then," broke in the boy, "I suppose the condenser will go on charging and discharging just as the pendulum swings to and fro?"

"Exactly; that is just what does happen. The actual charges get less and less, of course, because a certain amount of energy is wasted each time due to the resistance of the wire and the radiation of energy in the form of wireless waves and suchlike."

Amp thought this over for a bit, turning the various points over in his mind. "But," he said at last, "we don't use a condenser as large as you showed me just now for ordinary wireless work."

"No, but that is only a matter of degree. As a matter of fact the actual frequency of the oscillations which the currents make, that is, the number of charges and discharges per second, depends entirely upon the values of the condenser and the inductance. You have to remember that the coil not only tends to keep the current flowing after the condenser has fully discharged but it also objects to the starting of the current and will tend to prevent any current from flowing.

Thus, if we use a large inductance, the currents cannot rise to their full value as quickly as if we use a small one. Looking at it from this point of view you will see that the larger the inductance the slower will be the actual rate of charge and discharge of the condenser or, as we call it, the frequency of the oscillations."

"Yes," exclaimed the boy, "that seems quite straightforward."

Slower Vibration Rate

"Similarly the size of the condenser has some effect, the larger the condenser the slower being the vibration rate. We specify the frequency in terms of the number of complete cycles which occur in one second. The condenser is first charged in a certain direction and, after a certain interval of time, during which it has discharged, and charged in the opposite direction, it becomes charged once more in the same direction as at first. This is called a complete cycle and we speak of a frequency of so many cycles per second in consequence."

"That is interesting," observed young Amp. "I had often heard of cycles, but I did not know at all what they were."

"Well, now you do. It is really quite simple, as you see. The point is that according to the actual value of the inductance and capacity so we can obtain oscillations varying from 100 or 200 per second, right up to several millions per second, and by taking special precautions can even go lower or higher than these limits."

Several Million a Second

"Several million a second, did you say?" said the lad with his eyes wide open.

"Yes, that is quite right. Your own broadcasting station works with currents oscillating 830,000 times per second. Think of it, eight hundred and thirty thousand! You can work out the number of oscillations which are used up in one evening if you like just to amuse yourself."

Amp grinned. Then "The higher the frequency, the smaller coils and condensers you want, is that it, Professor?"

"Yes, that is right. For the somewhat high frequencies wanted in broadcast work we need only have a coil of some 50 or 100 turns and a condenser of .0005-microfarad and, to enable us to vary the frequency to which the circuit will respond, we make the capacity of the condenser variable."

"Then all we do when we tune-in is to make the capacity and the inductance fit the frequency we want, is that it, Professor?" asked Amp.

"That is just what does happen and

Try the Professor's Experiment for Yourself

JUST TOUCH THE LEADS FROM A HIGH-VOLTAGE BATTERY OR ELIMINATOR ACROSS THE TAGS OF A LARGE-CAPACITY FIXED CONDENSER —

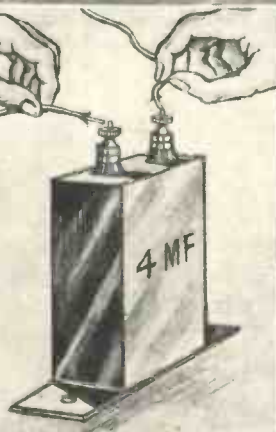

— THE FACT THAT ENERGY HAS BEEN STORED CAN BE PROVED BY "DISCHARGING" THE CONDENSER. HOLD A PIECE OF WIRE ON TO ONE TAG AND BRING THE OTHER END OF THE WIRE NEAR THE OTHER TAG. A SPARK WILL JUMP ACROSS THE GAP.

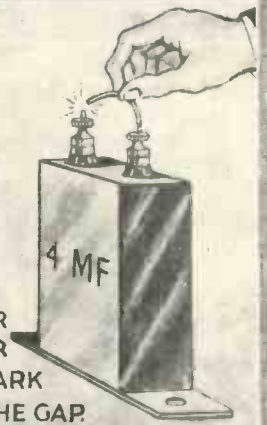

Half Hours with the Professor (Cont.)

with any given coil, we can cover a certain range of frequencies or wavelengths."

"What do you mean by a wavelength, then?" queried the boy.

Wavelength Relationship

"The wavelength is only a property connected with the actual wireless waves which are radiated. It bears a fixed and constant relationship to the frequency and the higher the frequency the shorter is the actual wavelength of the wireless wave produced. If you remember this, you will be able to interpret everything I have said in terms of wavelength and vice-versa."

"I don't quite see that part of it, as a matter of fact," admitted Amp. "But you must be getting a bit tired of talking."

"Well, it is quite a long business to explain briefly and perhaps we had better leave that. You should try and think in frequencies because it is currents oscillating at a certain frequency or rate of vibration which we are primarily concerned with. Any other points you want to know now?"

All Pretty Clear

"No, I don't think so, Professor. It seems all pretty clear," answered Amp.

"You had better take this down and keep it by you. It is a formula to show you what the frequency will be with any inductance and capacity." Here the Professor wrote down the following formula:—

$$\text{Frequency} = \frac{159,000}{\sqrt{LC}} \text{ cycles per second,}$$

where *L* is inductance in microhenries
C is capacity in microfarads

"Here you are," he went on. "Shove it in your pocket and come and listen to this, it is much more interesting than all this talk." And thus they moved off together to the Professor's latest set.

The Innocent Oscillator

ONCE upon a Time, in the Land of *Saa-voy*, during the Reign of the Caliph Bi-Bee-Ci, a Youthful

SIR GERALD DU MAURIER



—has an ideal "broadcast" voice

Cobbler who, to beguile weary Hours, had built himself a Magic Device of Wires and small Lamps which burned Nightly without the aid of Oil, was accosted on his way to the Mosque by a Neighbour, an aged Man of Unprepossessing Appearance.

Holding the Youth firmly by the Hem of his Garment, the Old Man spake thus: "O, Disturber of my Slumbers! O, Vile Destructor of the Night! Wouldst Thou bring Shame on this Ancient City of *Saa-voy* by Thy Diabolical Magic and thus spoil Thy Neighbours' sweet Repose at the end of their Daily Labours? Of a Surety, shall I take my Grievances to the local Kadi and request Him to prevent a Continuance of Thy Evil Practices."

But the Youth, with the Arrogance and Obstinacy which is of Youth, scornfully laughed at these Threats, the which raised the Ire of the Ill-natured Neighbour. "Thou Ill-begotten Fool! Wilt Thou not respect the Grey Hairs of Thy Elders? Shall the Night Hours be made Hideous by Thy ghoulish Moanings, Screechings, and Howls?"

Now, by this Time a Crowd of Worshipers encompassed them, for They had been attracted to the Spot by the Harshness of his Angry Tones.

To them the Old Man cried: "In this Youth, O Dwellers in *Saa-voy*, I find the Miscreant, who for many Days hath marred my Enjoyment of the Verses sung by the Enchanting Zuleika of the Bazaar, and who hath polluted the Air with Weird and Revolting Sounds at the Hour when I had but One Desire, to listen to the Wise Words of the Storyteller."

The Youth, making a Gesture of Contempt, said to his Unpleasant Neighbour: "From Thy own Lips, I learn that Thou dost possess in Thy Dwelling a Magic Crystal by which all these Voices are brought to Thine Ears. Has the Kadi also vouchsafed unto Thee a *ly-cence*?"

Whereupon the Irate Neighbour pulled at his long Beard and his bleary Eyes sought the Faces of the Worshipers around him. And they did not heed his Appeal, for, "As we well know," they said, "he hath no *ly-cence*." Nor did the Elderly Man accept the Proffer made by the Cobbler to accompany him to the local Kadi, but departed in Haste.

But the Youth, however, did listen to Words of Wisdom and promised, by the Beard of Mohammed, that he would mend his Ways.

Moral: Be not too ready to give ear to the threats of an angry man, but remember the words of the Mighty Sheik to the bastinadoed Slave: "Cut out the Howl!"

JAY COOTE.

Our Half-price Blueprints

AS some slight confusion seems to exist regarding the special half-price blueprint coupon given with each issue of the WIRELESS MAGAZINE we wish to point out this can only be used for obtaining blueprints of sets described in the current number.

Thus the coupon on page iii of the cover of this issue, is only available for any one set described in this issue. Not more than one blueprint can be supplied at half-price for each coupon. Overseas readers will be allowed an appropriate extension of time.

5YM, the Well-known Experimenter, Discusses—

THOSE AMAZING SHORT WAVES!

THERE is still a "kick" left in listening, a thrill that comes even to those who have been working with wireless since those far-off days when spark transmission was the rule and telephony was not thought of.

Chime in Melbourne

As I write these words I have just heard a chime in Melbourne, Australia, strike the hour of five o'clock on a Monday morning—and I was listening at seven o'clock on Sunday night! I heard it at quite good strength, on a loud-speaker, too, after hearing a remarkably good programme. And, ten minutes later, I was listening to a programme from the United States. Great are the wonders of short-wave reception.

The point about this reception is that I was using a stage of high-frequency amplification, which, until quite recently, has been thought to be an impossibility on anything much below 200 metres. I have mentioned this wonder before; but now I am having much practical demonstration of the fact that it really is a great boon in short-wave work.

With an ordinary and very efficient two-valve receiver, I found it quite impossible to "resolve" the Melbourne carrier wave; but the stage of H.F. amplification made the job an easy one. The set was built with the special Igranic short-wave transformers and neutralising system, and used ordinary valves. I hope, on some future occasion, to have more to say about H.F. amplification for short-wave work.

Empire Broadcasting

The Marconi people and the B.B.C., between them, seem to be getting a good measure of success with the Empire short-wave broadcasting scheme. Of course, there is a lot to be learned, and the difficulties of pleasing everybody and of transmitting at hours when the different parts of the Empire are ready to listen are very great; but the work is progressing, and one day—soon, most probably—we shall have an Empire

broadcasting service that is really worthy of the Empire.

In the course of my work I am in communication with ardent wireless experimenters all over the world, and the enthusiasm for short-wave reception is really remarkable. From all over the place I hear of the feverish building of short-wave receivers in order that some out-of-the-way corner of the Empire may be put in touch, not only with London, but with the whole world.

One friend, whom I have never seen, but with whom I have had much correspondence, says that a man in the extreme north of British South Africa, for whom he built a short-wave set, was so overcome when he heard the chimes of Big Ben, for the first time for forty years, that the tears rolled down his cheeks and he could not listen to the subsequent announcements.

Wedded as we are to broadcast listening at home, there are yet few of us who can understand what it means to a really lonely family far away from all social life.

Short-wave Super-hets

From time to time I have been rather rude on the subject of short-wave super-het receivers, but I am beginning to change my mind, though I am not yet quite sure that the multiplication of valves and the corresponding increase of upkeep costs really does make the super-het a worth-while proposition, as against the ordinary two-valve set. I certainly do not think that it has any advantages at all over the short-wave receiver with a stage of H.F. in front of it.

However, I have built recently a super-het that is available for listening to telephony on all waves from about 3,000 metres down to 20 metres, and it is a comfort to be able to sit by the fire, these cold winter nights, and listen in to the world without being tied to my aerial, which leads into a room that is never really warm.

The great charm of the super-het is the ease with which it will bring in distant signals, once you have got

the hang of using it. The tuning is easier than with an H.F. stage. For the receptionist, pure and simple, such an instrument is probably an excellent investment, but I still hold that for quick working, which is what the transmitting amateur requires, the old two-valver is very hard to beat. It is certainly the cheapest of all valve receivers, both to build and to work with.

Washington Conference

At the time of writing, complete news of the result of the Washington Conference, so far as amateur transmitters are concerned, has not come to hand, but it seems likely that the Americans will have some of their much vaunted privileges severely curtailed. As regards ourselves, I am not sure what is going to happen, but it seems very likely that we shall go on much as we have been going.

The G.P.O. has given us a lot, but they have not been over-generous, and so we are not likely to have taken away from us that which we have. There may have to be some slight adjustment of working wavelengths, but I really do believe that that is about all.

In the United States there has been an enormous development of amateur transmitting, and certain wavelength bands are crowded right out over there. The consequence is that some of the less law-abiding of the United States citizens have wandered from their given wavelengths very considerably, to cause great trouble to commercial stations working near-by in the radio spectrum.

Important Commercial Work

Now, though it is an undoubted fact that it was the amateurs who discovered how remarkably useful short waves are in spanning the world, it is also a fact that very considerable and important commercial and official work is now carried on between 12 and 80 metres, and it cannot be interfered with by those who, after all, are merely doing the thing for fun.

5YM.

An Exclusive Article by Dr. Alfred Gradenwitz



A fine photograph of the Klagenfurt transmitting station

THE Austrian broadcasting service is controlled by the Oesterreichische Radioverkehrs A.G. ("Ravag"), of Vienna, which is paying particular attention to the cultural and educative aims of wireless. It is, for instance, mainly due to the earnest endeavours of the "Ravag" that the Warsaw Conference, in October last, was able to lay the basis of a Central European exchange of programmes.

Mutual transmission tests between the transmitters of Southern Germany, Prague, Warsaw, and Vienna have led to such favourable results that a regular exchange of programmes between these stations is likely to be started in the near future.

Vienna's Success

The general appreciation of the Vienna programme was strikingly shown by the unanimous appointment of "Radio Wien" to the presidency of the Commission de

Rapprochement, whose task is the promotion of mutual understanding between nations. One of the means by which this goal is to be attained is the organisation of periodical "European National Nights," which has everywhere met with enthusiastic applause, so that English, French,

on general subjects of ethical or economic interest by leading personalities of European renown—sovereigns, statesmen, scientists, artists, and *littérateurs*—which are to be exchanged between European broadcasting companies.

The number of wireless listeners in Austria is rapidly increasing, the total having exceeded the 300,000 mark. A monthly fee of two schilling (1s. 2d.) is paid by each subscriber to the broadcasting service.

The scientific programme of "Radio-Wien" comprises a number of foreign language courses,

lectures on a multitude of scientific subjects, and many tests of unusual interest; for example, wireless conversations between the station and the pilot of an airplane, an experiment on the breaking up of atoms, etc.

Improving the Stations

Attempts have been made during the year 1927 to improve the

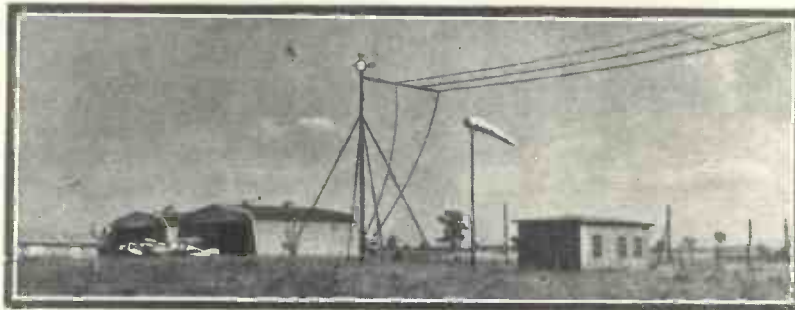

A meteorological station at Aspern, Austria, which works in connection with Austrian aviation

Spanish, German, and Austrian nights could be arranged for by the various European broadcasting companies.

The same end is served by international relays, that is, the re-transmission of foreign broadcasting with or without wires.

It is also contemplated to provide gramophone records of short lectures

technical equipment of the various stations, so as to increase the range of Austrian broadcasting and to widen the field accessible in making up programmes.

Relay Transmitters

The various centres of the country are accessible through relay transmitters. The opening of sub-stations at Klagenfurt, Innsbruck, and Linz has disposed of such difficulties as formerly existed for large sections of the population. Inasmuch as the individual energy of these intermediary transmitters has been limited at $\frac{1}{2}$ kilowatt (their waves being "joint waves" shared by other stations), there is, however, even now no possibility of crystal reception in large sections of the country.

The Vienna transmitting plant comprises a building located at 4b, Johannesgasse, in a central situation admirably suited for administration offices and studios. The following is a list of some of the technical features.

A small talks studio, a small room lined with Turkish carpets, which mainly serves as studio for the announcer of economic information, news of the day, etc. The plant for transmitting the time signal is likewise situated here.

In this, as well as in the remaining

studios, there have been provided small windows at the level of the eyes, thus enabling the speaker to communicate with the operators of the station. Between this talking cabin and the large studio destined for the transmission of concerts and theatre performances, there are situated the input amplifier rooms.

This large studio, as well as a somewhat smaller room set apart for chamber music, cabaret, and other performances, is provided with central heating. The heavy large wall curtains are arranged to slide, and the rooms can readily be sub-divided by partitions, thus enabling any suitable acoustic conditions to be produced for any given performance.

Microphones of the most diverse types are available in these studios, though the Reisz microphone, the usual type in German broadcasting stations, has recently been given

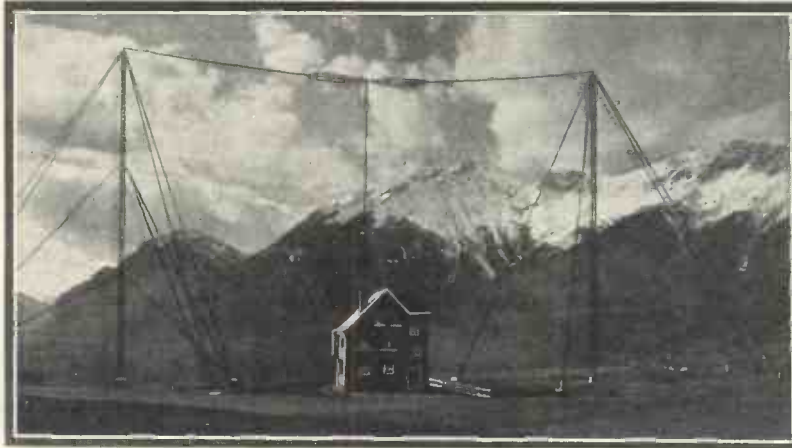

The Innsbruck transmitting station



The Ravag building in Vienna, the headquarters of the Austrian Broadcasting Company

tems and amplifiers have been installed, so that any performances therefrom can be transmitted to radio listeners in Austria and abroad.

Pupin cables are generally used in this connection, and several transmitting systems are resorted to, namely, both low- and high frequency transmission, as well as a combined system. Ordinary telephone lines have, however, in some cases to be resorted to, thus adding to the diffi-

culties of transmission.

A special switch box located near the input amplifiers facilitates operation over telephone lines, the oscillators and low-frequency amplifying valves being operated by means of accumulators fitted into the cellar. The charging machines, which, after converting the alternating currents from the mains into continuous current supply it to the accumulators, are likewise situated there.

Constant Wavelength

The high-frequency wave is maintained constant by means of several tuning circuits, the wavelength being 577 metres. This refers to the Stubenring transmitter, located in the late War Department building, which has a tertiary circuit tuning, thus largely disposing of upper harmonics.

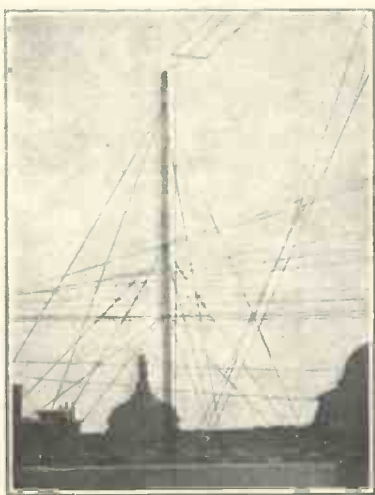

Masts of the Stubenring station on the old War Department building

preference. In fact, Dr. Reisz has been working in conjunction with another well-known Austrian scientist, Dr. von Lieben, who has taken such a prominent part in the development of vacuum tubes and to whom a memorial tablet at the entrance of the building has been dedicated.

The input amplifiers, which are intended to reinforce the sound as it comes from the microphone, are arranged in a long and narrow room, which also accommodates the controlling apparatus, giving perfect amplification, so that the low-frequency vibrations can be connected to the cables leading to the Stubenring and Rosenhuegel transmitters, as well as by the relay transmitters.

Special cables have been provided to ensure a connection with the Opera, the Comedy, and the Concert Hall, where special microphone sys-

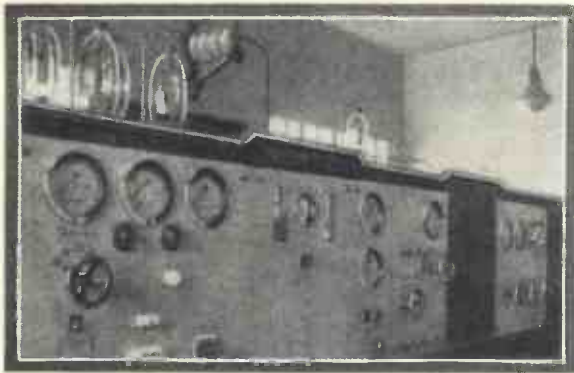

Part of the Rosenhügel transmitter

When broadcasting was started in the spring of 1924, the 1-kilowatt telegraph transmitter then used by the Postal and Telegraph Department, in connection with the aero safety service and for communication with foreign countries, was at first resorted to for the sake of preliminary tests.

Better Aerial

When the possibilities of further development and the defects of the plant had been realised, the Telefunken people were entrusted with the construction of a special 1-kilowatt broadcast transmitter and the antenna system was at the same time improved. The masts on the roof of the building were lengthened from 25 to 42 metres, and the sheet metal roof, in conjunction with suitable earth conductors, was utilised as a counterpoise. The mean telephone output was 300 watts.

Increased Power

As, however, general interest in the service increased rapidly, another extension of the plant soon proved indispensable, and the number of transmitting valves was doubled, the output thus being raised to 1.5 kilowatts. The transmitter is worked on what is known as the Schaeffer principle, the grid current being controlled by a relatively small modulating valve. Behind the latter is

meter is accommodated on a small table to the right of the transmitter. There are further provided six

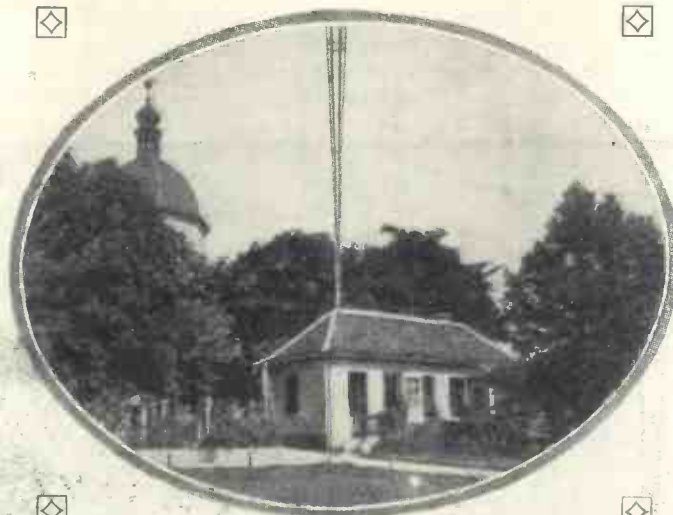

The picturesque Graz transmitting station

measuring instruments for controlling the heating, the anode current, and, primarily, the antenna current. The

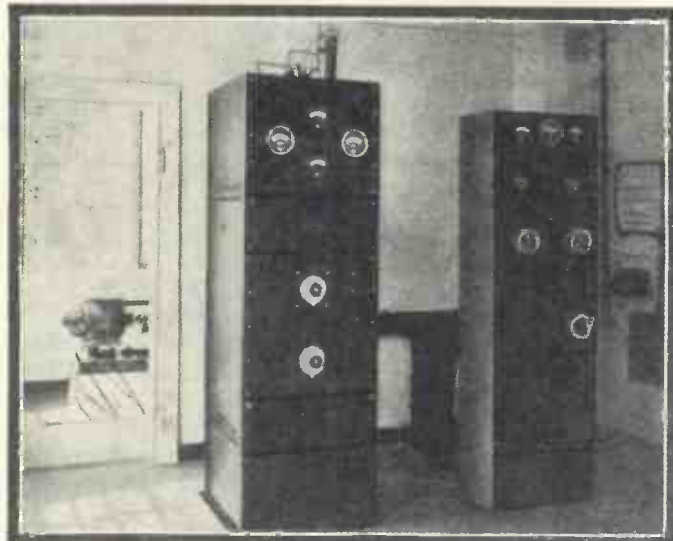

Inside the Graz 1/2-kilowatt (relay) station

Austrian Broadcasting (Continued)

located a large copper tube coil, and on the front wall there are provided handles for controlling the coupling, the condenser, the regulating resistance, and the sliding resistance for the heating of the valves. The wave-

meter at the same time serves for checking the constancy of wavelength. The old studio is still in use for transmitting the morning concerts and the nightly dancing music; this is also the room where Silving is in the habit of giving his concerts.

High-power Station

However, the original transmitter, known as the Stubenring transmitter, at present plays a secondary part, the broadcasting service being mainly taken charge of by a high-power transmitter situated on the Rosen-

hügel (Rose Hill), about five miles from central Vienna, with an average telephone output of 7 kilowatts and a peak output of 20 kilowatts. This station is characterised from afar by three huge antenna masts, each 85 metres (about 280 ft.) in height.

The large rectifier valves supplying the high-tension anode current, and the water-cooled high-frequency and modulating valves are seen in the photographs. As the transmitter is switched on, the doors are bolted automatically, thus preventing any interference

with actual operation. The switches and measuring instruments are mounted on marble plates. The excellent modulation and satisfactory rendering are well known to amateurs all over the world. Fading phenomena, which in the beginning were rather troublesome, have eventually been reduced considerably.

Water Cooling

A distinguishing feature from all broadcast transmitters previously designed by the constructors, the Telefunken Company, is the use of only two water-cooled transmitting valves, each of which has an output of 10 kilowatts. This

An Exclusive Article

reduction in the number of valves obviously simplifies the layout and operation of the transmitter, while reducing operating expenses and facilitating modulation.

Wavelength Range

The energy for operating the transmitter is derived direct from a 50-cycle, three-phase current system of 220 volts, this current being rectified by six large rectifier valves, and, after transformation to 12,000 volts, is supplied to the anodes of the transmitting valves. The filament-heating current is derived from batteries. The range of wavelengths is from 450 to 900 metres.

The rapid development of European broadcasting soon resulted in the necessity of increasing the energy of the Rosenhuegel transmitter. Orders for doubling the output were, therefore, given in July last, and the building had, by the autumn of 1927, been adapted for accommodating the new plant, the installation of which is expected to be completed by May, 1928. The relatively long duration of this reconstruction is due to the fact

that the whole work had to be carried through without interfering with the existing broadcasting service.

The new transmitter will comprise all the latest developments in the field of broadcast transmitter design, actual experience in connection with the Rhineland (Langenberg) transmitter being fully accounted for.

Extended Range

This increase in the energy of the transmitting station will result in a considerable extension of the crystal range, while even those listeners living at considerable distance will be able to do with less powerful receivers or, in the case

of existing apparatus, will get better results. Moreover, the Vienna broadcasting service will make itself heard to far greater distances beyond the frontiers of the country.

Construction of the Innsbruck relay station, which comprises a $\frac{1}{2}$ -kilowatt Western Electric transmitter, was started in 1926, a one-storey station building, which also

southern terrace of the Inn Valley. Experimental transmissions with an unpretentious local programme were started shortly before Christmas, 1926.

Remote Control

The contemplated remote control by high-frequency currents could not be carried out over the whole of the distance between Vienna and Innsbruck, so that programmes could not be transmitted from Vienna before a heterodyne plant at Linz and corresponding receiving post at the Woergl repeater station had been provided. The Innsbruck station was opened in June last.

The high-frequency connection between Linz and Woergl is used for re-transmissions both from Vienna to Innsbruck and vice versa. In fact, the plant is resorted to by the Austrian Postal Department in connection with the Vienna-Innsbruck-Switzerland telephone service during the hours of greatest rush.

Improved "Earth"

The Graz relay station has lately been considerably improved by an extension of the earth system, a more economic service being ensured by the installation of a new relay receiver in the transmitting station. The Klagenfurt relay station was opened in 1927.

(Continued on page 51)

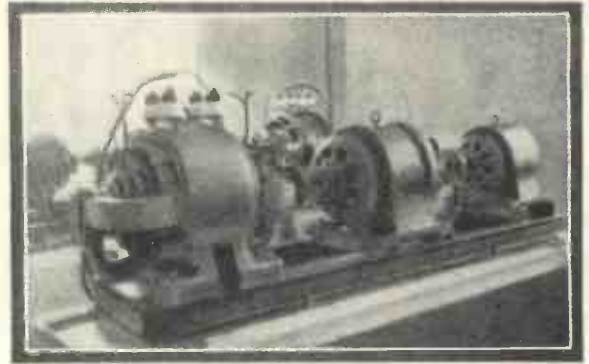

Generators at the Innsbruck Station

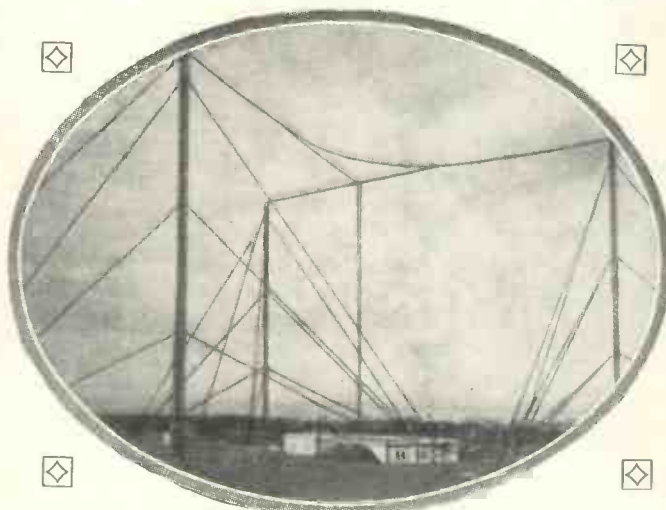

General view of the Rosenhuegel transmitter, near Vienna

contains the offices, being erected by the Tyrolese Government to the east of the village of Aldrans, on the

Linz and Woergl is used for re-transmissions both from Vienna to Innsbruck and vice versa.

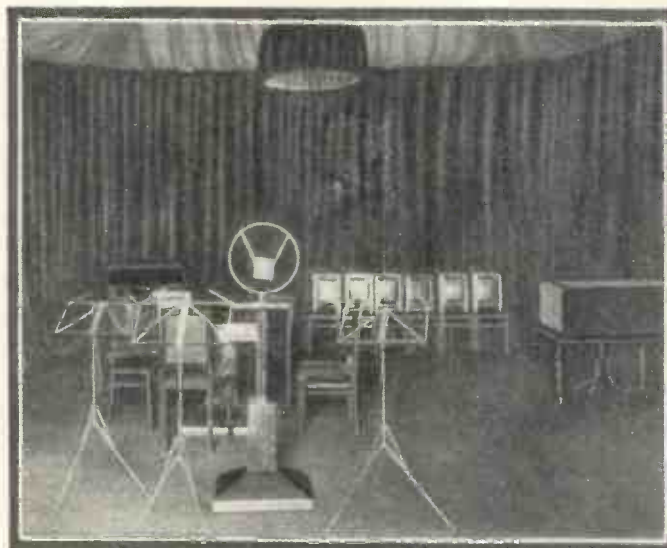

The studio at the Graz relay station

Mr. Murray Ashford
the well-known
entertainer



WELL KNOWN to many thousands of holiday makers, both in person and by microphone, Murray Ashford in this article explains some of the difficulties that a concert party has in "getting across" the ether and gives his views on the ideal requirements for broadcasting.

"LOOK at this, my dear," says Mr. Listener to his wife, "to-night they're broadcasting the concert party we heard down at Seagate last summer. We really mustn't miss that!" And with a sigh of contentment they settle down to recapture something of the care-free happiness of that August evening within ear-shot of the murmur of the waves.

If they do not succeed quite as they thought they would; if what they hear entertains them but just fails to re-create the holiday atmosphere, they may feel a little disappointed. But in this there is no legitimate cause for surprise, because the broadcasting of concert parties is for many reasons one of the hardest of all the varied branches of the wireless programme.

A Question of Mood

It is difficult for the audience. In their case mood is probably the root cause. The mood of a holiday audience is entirely different from the mood of an audience which has recently come from the trials and tribulations of the office or shop only to learn that the final demand for the income tax is to hand or that

The Ideal Radio Concert Party

By MURRAY ASHFORD

little Willie simply must have a new pair of school boots!

A holiday audience in the Pier Casino at Seagate is definitely on pleasure bent; it is easy to please, uncritical, and what is really more important still, it is an entity which can be swayed and provoked to merriment in an intimate way by those who are entertaining it. In five minutes the concert party comedian has the whole audience in his hands, as it were, by some reference to the weather.

The hall is rather cold—right! The comedian senses the feelings of his audience, makes a jocular reference to the necessity for bringing fur coats; an atmosphere is created immediately; the audience forgets all about the cold, sits back and murmurs to itself "This is going to be good."

Different Environments

Now it is not the slightest use a radio concert party comedian making a facetious remark concerning the atmospheric conditions of the room in which his listeners are seated, for the very simple reason that their environments are all different!

For this, and other reasons, it is extraordinarily difficult to establish contact. If there are strangers in the broadcasting studio, the listener hears applause; if there are none the conclusion of each item is followed by a freezing silence and the listener thinks to himself "I wonder what the studio is like?"

This is why I am sure that the summer relays from seaside resorts must be far more realistic from the point of view of the listener. Hearing the applause of the happy audience of holiday makers makes it infinitely easier for him to visualise the scene and its happy associations.

If radio concert parties are difficult for the audience they are doubly so for the performer. As I have already pointed out, he cannot create the

personal atmosphere which is usually peculiar to the concert party, and he is always denied the use of facial expression and gesture upon which so much of the success of his work normally depends.

Lack of Personal Contact

He misses the personal support of his audience, and more than this he misses its continual laughter and applause. Oh—the heartbreaking stillness and silence of the studio, unless, as it sometimes the case, a few people are present to constitute a sort of consolation for the large, helpful, warm hearted audience to which he is accustomed!

He misses this laughter and applause more than do the performers in a radio play or opera because in a play or opera the applause as a rule comes only at the end of the scene or act, whereas with a concert party it is continuous throughout the show.

In fact he misses his audience so much that his work becomes a nerve shattering experience; he is terrified of forgetting his part, and I have actually known members of my own party, when broadcasting, to hold the script of their part in their hands—such was their dread of the words slipping completely out of their minds.

Of course, I am an optimist, I believe that all these difficulties are gradually being overcome. Radio concert party performers are sharing a discovery which is being made by every radio artiste in his own sphere—the discovery that broadcasting demands a technique of its own.

Different Appeal

Many things that you can do on a stage cannot be conveyed over the ether. Your appeal must be a verbal appeal; it must not leave too much to the imagination of the listener, and it must remember the technical limitations of the microphone.

I have in mind a particular concert item which will be familiar to many listeners. It concerns a man who is constantly pestered by a friend who wants to borrow money. In desperation he decides to put the former off by the old method of shouting at him at the top of his voice.

Very Effective Item!

Now in the Pier Pavilion at Seagate this makes a very effective item, you can shout to your heart's content; three or four of you at once, if necessary! In the studio your shout would simply become a blare, unintelligible to the listener, if you were at a normal distance from the microphone, and if you moved too far away, you would not be heard at all.

This is the sort of thing which must be borne in mind by those who arrange programmes for the radio concert party of the future. The first thing they must remember is that not more than two people should be performing at the same time for the show to be effective. The second important point is the necessity for the ruthless rejection of material which, however good for stage purposes, is unsuitable or broadcasting.

A Trifle Difficult

It may seem a trifle difficult for a concert party to follow this advice and still retain the characteristics which made it popular. But it is the only way if this form of radio entertainment is to retain and develop the large need of popularity which it has already gained with the public.

It is not impossible. It means simply an adaptation to the needs and peculiarities of radio, and there will be many ready so to adapt themselves.

Austrian Broadcasting

(Continued from page 49)

A further step in the development of the broadcasting service is being made by the erection of a 1/2-kilowatt Marconi transmitter on the Frein Mountain, near Linz. Particular care was necessary in the choice of the proper location of this, as well as of

other repeater transmitters, because of the relatively small amount of energy allowed for each of them.

Moreover, the beginning of building operations was, in this case, delayed by the electrification of the Federal Railway Station of the city of Linz. This plant, which it is thought will open up to crystal detector reception another section inhabited by 120,000 people, will be taken into operation in the spring of 1928.

Photo-telegraphy

Both the Thorne Baker-Fulton and Tschoerner processes of phototelegraphy were submitted to compre-

hensive tests, which, however, have not yet been concluded. Anyhow, the mere fact that tests on a commercial scale could be made in this field strikingly shows that broadcasting is preparing to supplement its present resources with the transmission of pictures and samples of handwriting.

Eliminating Interference

Another series of tests was made with a view to devising suitable means of eliminating such disturbances as are due to the use of electro-medical apparatus. The possibility of guarding against such trouble by the use of special connections has been definitely shown.

Radio Curiosities

NOT many stations have yet followed the fashion and adopted mascots. Moreover, there is only one at present which has a mascot that can be heard. It is the "cuckoo" at L'Ecole Superieure (PTT) which fills in items with its musical chirrup, and sometimes is allowed to relieve the monotony of a

does the same thing, only more politely

The call-sign of the Eiffel Tower station, FL, is well known to old hands at radio. It is perhaps not generally known, however, that the call is derived from the name of the station, F—L being the phonetic pronunciation of the French word Eiffel.

Mrs. Aki Midorikawa, of Tokio, is the first lady announcer to officiate in Japan.



The wavelength of Warsaw, Poland, has recently been shifted a tenth of a metre. It is, therefore, not so much of a "curiosity" as it was a few weeks ago, when the official figure was 1,111.1 metres.

The latest in programmes emanates (need it be said?) from America. These novel "programs" are issued weekly by KDKA, and contain a complete list of items for the week. Each day's programme is on a perforated slip which can be torn off when the items have been broadcast.

talk by creating a sort of "noises off."

Some broadcasters are far more considerate of their listeners than are others. The announcer at Königsberg, Prussia, for instance, nightly warns listeners to earth their aerials before closing down for the night.

Until quite recently Berne's lady announcer regularly wished listeners "Good night," at the end of the evening's programme, and Hilversum has an announcer who

A draft has been prepared of a new Bill for the Australian Government which provides for wireless licences at 3s. 6d. per annum. This is a radio curiosity which may cause many people to think of emigrating!

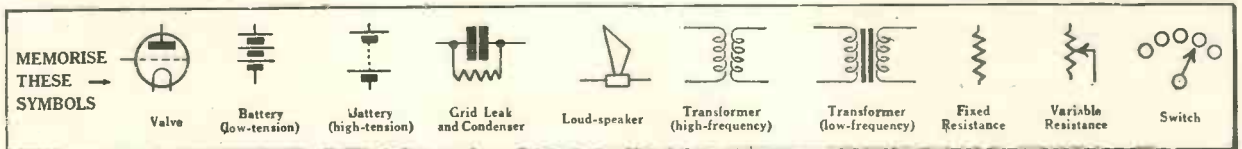

An ideal set for loud-speaker reception of several stations almost anywhere in the British Isles is described in this article. The components used are simple and easily obtainable, while simple switches are incorporated so that either two or three valves can be used at will. There is nothing to go wrong and the receiver can be relied upon to give consistently satisfactory results

THE EVERYDAY THREE

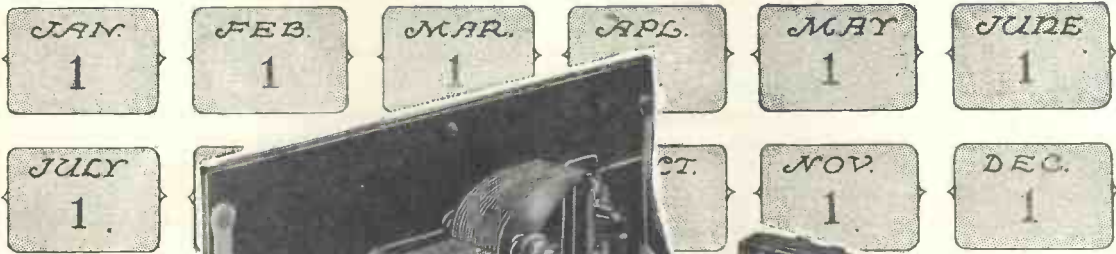

**Specially
Designed,
Built and
Tested by the
"W.M."
Technical Staff**

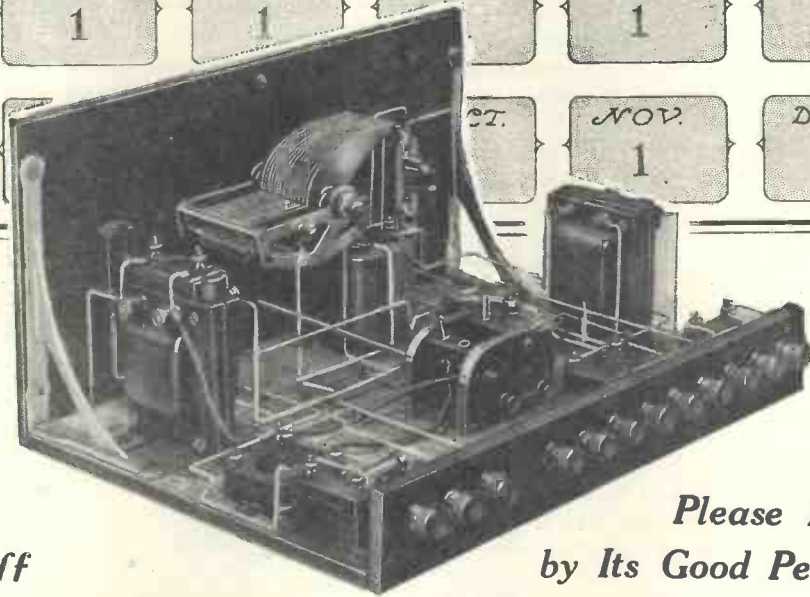

**A
Simple
Set
that will
Please Everybody
by Its Good Performance**

TO be quite frank, it may as well be stated at the outset that in this article the WIRELESS MAGAZINE Technical Staff intends to describe a plain set for the plain man. It introduces no particularly novel features, but it is good and will be found of particular utility by those who need a simple set for everyday use.

Quite Straight-forward

In other words, the Everyday Three is as straightforward as it is possible to make a loud-speaker receiver with any degree of efficiency at all, and there is nothing about it to get out of order. It is essentially a receiver that will give unfailing good service once it has been installed.

That a set of this particular type is needed by many hundreds of amateurs has been known for some months to the WIRELESS MAGAZINE Technical Staff, for many inquiries for full-size blueprints of such a circuit have reached our office.

Essentially a receiver that will give

excellent loud-speaker reception from the local station and will also pick up a number of other stations at reasonably good strength, the Everyday Three is not tremendously selective, and when used *within three or four miles* of a main B.B.C. station some difficulty may be expected in cutting out the local transmission to receive

DETECTOR & TWO L.F. STAGES
(TRANSFORMER COUPLED)
EITHER TWO OR THREE VALVES
CAN BE USED
ORDINARY TWO-PIN PLUG-IN
COILS ARE SUITABLE

signals within 30 or 40 metres either side of the tuning point unless reaction is forced.

Readers who require three-valvers with a greater degree of selectivity are referred to the Continental Three (April, 1927), Wave-catcher Three (July, 1927), Screened-grid Three (September, 1927), Five-guinea Three

(November, 1927), or the Tuned-anode Three for the Mains (December, 1927).

Actually the circuit of the Everyday Three comprises a detector and two stages of low-frequency amplification. So that the detector is as sensitive as possible and the loudest results are obtained, reaction is provided, and this is arranged on the moving-coil principle, as so many amateurs already have the necessary sets of coils in their possession.

Provided it is not so abused as to give offence to neighbours, control of reaction does impart a certain degree of selectivity to the receiver, but at the expense of some loss in quality of reproduction.

Transformer Couplings

Transformer couplings are used for both low-frequency stages, so that the maximum volume is obtained without the use of special valves such as resistance-capacity couplings would necessitate. Provided that power

valves are used in the last two stages; moreover, the purity of reproduction is really astonishingly good.

In order to make the set of the greatest possible utility, the WIRELESS MAGAZINE Technical Staff has provided two switches—one to switch off the whole set and the other to cut out the last valve when sufficient volume can be obtained from two.

“Value for Money”

“Value for money” is the keynote of this receiver, for, while the designers have not deliberately studied economy, they have made use of components that are of a comparatively high standard of quality when their price is taken into consideration.

By the judicious use of alternative parts for those specified it is possible to build the Everyday Three down to almost any price; such a course is not recommended, however, as the use of very cheap and probably foreign parts almost always results in unsatisfactory results.

One Tuning Dial

A glance at the photograph of the front of the receiver will reveal that there are four knobs in all. The large dial in the centre is the control for the aerial-tuning condenser, and is the only one, in the ordinary way, that need be manipulated during reception. Immediately below it is the knob attached to the spindle of the moving (reaction) coil, and this should be used with very great care to control volume, and to some extent, range and selectivity.

It cannot be too forcibly impressed upon constructors of this receiver that *very serious interference to other listeners may result from the wrong manipulation of this control.*

On the left of the panel is a small knob which actuates a jack switch; when the knob is pulled out two valves are in use, while when it is pushed in all three valves are put in circuit. The filament of the disused valve is automatically switched off.

The other small knob on the right is an on-off switch, which controls all three valves. When the knob is “in” the set is “off,” and when it is “out” the set is “on.”

Behind the panel the layout is

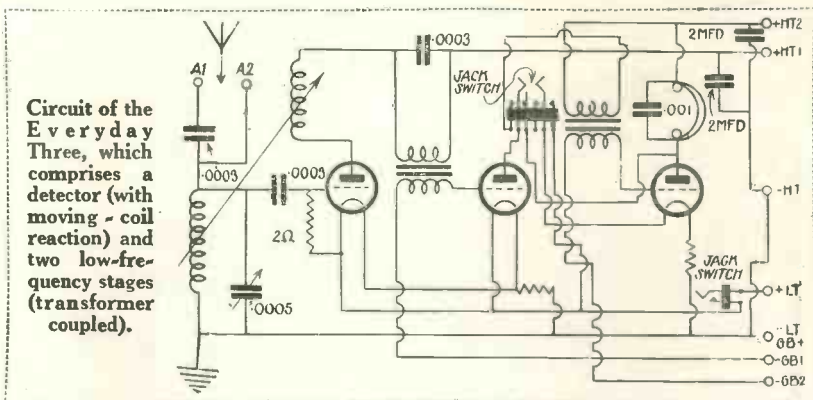

Circuit of the Everyday Three, which comprises a detector (with moving-coil reaction) and two low-frequency stages (transformer coupled).

equally simple and straightforward, as a glance at the photographic plan view of the receiver will show. Looking at this view (see page 54) and the wiring diagram (see page 56), with the panel at the top, the holder for the detector valve is on the extreme left, while the first low-frequency transformer appears immediately on

noted that the moving coil is the reaction coil.

Below the coil holder appears a fixed resistor, while on the right are two more valve holders and the 2-microfarad fixed condensers. The top holder is that for the first low-frequency amplifier, while the lower is for the second low-frequency valve. On the extreme right of the baseboard will be seen another fixed resistor and the second low-frequency transformer.

UTILISES MOVING-COIL REACTION ONE-DIAL TUNING IS NOT CRITICAL AS REGARDS VALVES

top of it. Below will be seen a .0003-microfarad series aerial condenser, the grid condenser, and grid leak.

In the centre of the panel is the .0005-microfarad variable condenser, while below this appears the two-way coil holder, which has an extra long control arm, so that the coils do not foul the condenser. It should be

Omitting the Resistors

While in many cases the resistors act as some kind of protection to the valve filaments against overrunning, they can be omitted entirely if the constructor so desires, especially if .1-ampere filament valves are used.

For the proper value the valve manufacturers should be consulted, although in the ordinary way the value will be 2 or 4 ohms. The resistor on the extreme right of the baseboard controls the detector and

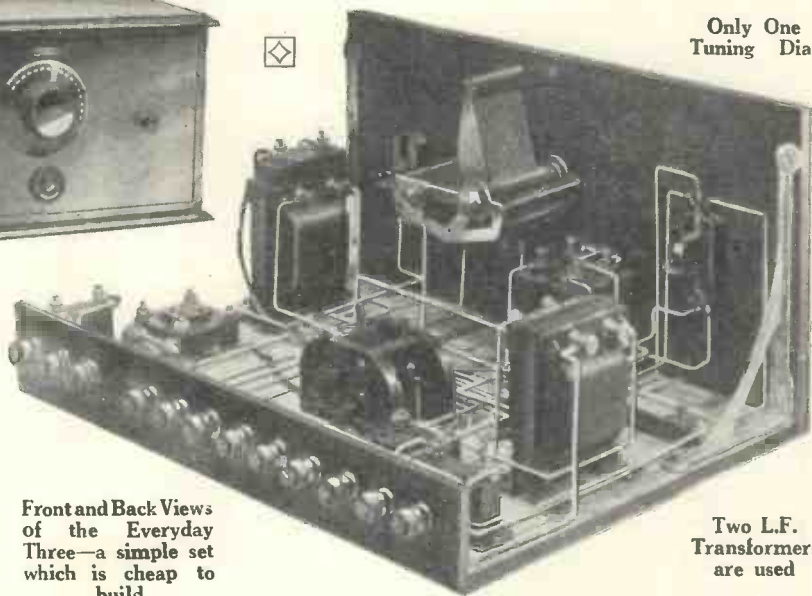

Only One Tuning Dial

Front and Back Views of the Everyday Three—a simple set which is cheap to build

Two L.F. Transformers are used

The Everyday Three (Continued)

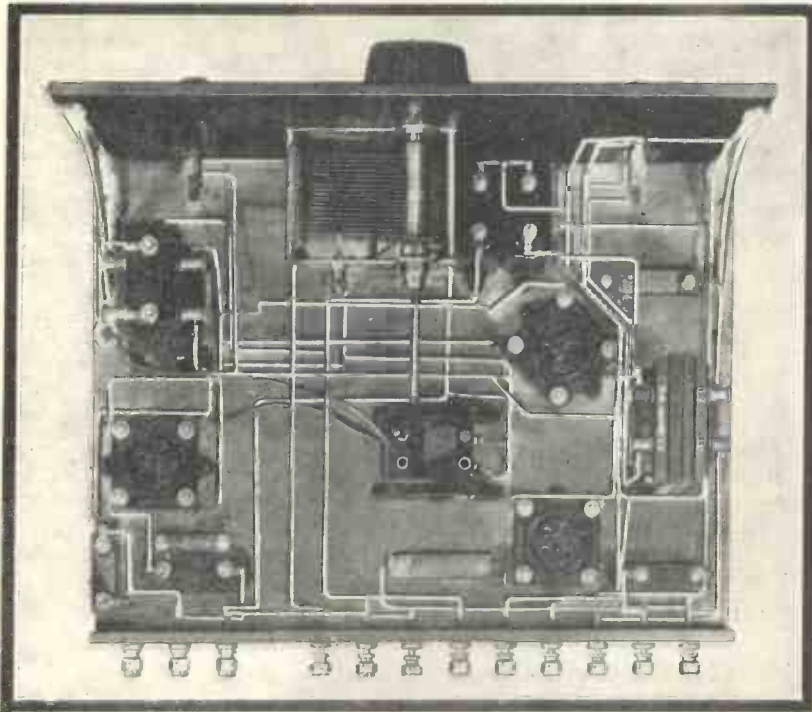

Plan view of the Everyday Three which clearly shows the disposition of the components

first low-frequency valve, while the other controls the last amplifier.

Components Required

It will readily be appreciated that many amateurs have already in their possession a number of parts that can be used to advantage in the construction of the Everyday Three, as a glance at the following list of components will show:

- Ebonite panel, 14 in. by 7 in. (Becol, Trolite, or Will Day).
- .0005-microfarad variable condenser (Ormond, Cyldon, or Raymond).
- Two-way coil holder (Lotus or Lissen).

- 3 valve holders (Benjamin, W.B., or Lotus).
- 2 low-frequency transformers (Ormond, B.T.H., or R.I. & Varley).
- .0003-microfarad grid condenser, with insulating grid-leak clip (Dubilier).
- 2-megohm grid leak (Dubilier, Mullard, or Lissen).
- 2 fixed resistors (Peerless, Tempryte, or Ormond).
- .0003-microfarad fixed condenser (Dubilier, Lissen, or T.C.C.).
- .001-microfarad fixed condenser (Dubilier, Lissen, or T.C.C.).
- 2 2-microfarad fixed condensers (Dubilier, Lissen, or T.C.C.).
- 2 jack switches (Lotus, Nos. 9 and 6).
- Panel brackets (Carrington).

- Terminal strip, 14 in. by 2 in. (Becol, Trolite, or Will Day).
- 12 terminals, marked: Aerial 1, Aerial 2, Earth, H.T.+1, H.T.+2, H.T.-, L.T.+ , L.T.-, G.B.-1, G.B.-2, L.S.+ , L.S.- (Belling-Lee).
- .0005-microfarad fixed condenser (Dubilier, Lissen, or T.C.C.).
- Dial indicator (Belling-Lee).
- Cabinet and baseboard, 10 in. deep (Ready Radio Supply Co.).
- Glazite for wiring and 18 in. flex.
- Two-pin plug-in coils (Igranic, Lissen, or Atlas).

It should be noted that in each case the particular components used in the original set and allowed for in the layout are mentioned first.

Full-size Blueprint

Before beginning the actual construction of the receiver, readers are recommended to collect together all the necessary components and obtain a full-size blueprint drilling guide, layout, and wiring diagram from this office. Such a blueprint can be obtained for half price, that is, only 6d., post free, if the coupon on page iii of the cover is used before February 29.

Whatever alternative components are used, little difficulty should be experienced in laying them out on either panel or baseboard. Two notes regarding the blueprint (or the wiring diagram, reproduced on page 56) should be noted: (1) Above the first low-frequency transformer, and held in position by the wiring, is a .0003-microfarad fixed condenser. (2) The shaded portion of the grid condenser represents a special *insulating* clip; in other words, the end of the grid leak marked *c* must not make contact with the side of the grid condenser marked *d*.

Simple Wiring Up

When all the components have been fixed in position, wiring up can be started, and here the blueprint will be found particularly useful. It will be seen that each terminal point is marked with a small letter of the alphabet; these letters indicate which points should be connected up and in what order.

Thus, first connect all those points marked *a* with one wire, or as few wires as possible; then all those points marked *b*; and so on. Although "right-angle" wiring such as carried out by the WIRELESS MAGAZINE Technical Staff is very neat and efficient, it is not absolutely essential; satisfactory results can be

VALVES TO USE IN THE EVERYDAY THREE

Make	DETECTOR			L.F. AMPLIFIERS		
	2-volt	4-volt	6-volt	2-volt	4-volt	6-volt
B.T.H. ...	B210L	—	—	B215P	—	B4
COSSOR ...	Red Band	Red Band	Red Band	Green Band	Green Band	Green Band
EDISWAN ...	GP2	GP4	PV8	PV2	PV4	PV5
MARCONI ...	DEL210	DEL410	DEL610	DEP215	DEP410	DEP610
MULLARD ...	PM3 1.F.	PM3	PM5X	PM2	PM254	PM256
OSRAM ...	DEL210	DEL410	DEL610	DEP215	DEP410	DEP610
SHORTPATH...	SP18R	—	DE50	SP18RR	—	SP55RR

Gives Full Loud-speaker Strength

obtained with direct point-to-point connections made with flexible wire.

Before going any further, it will be advisable to discuss suitable valves and coils to use in the Everyday Three. The detector valve should be of fairly low impedance, something in the neighbourhood of 15,000 to 20,000 ohms.

The first low-frequency valve can have an impedance of 10,000 to 15,000 ohms, but preferably both this and the last valve should be of the power type, with impedances of 8,000 or less. Either 2-, 4-, or 6-volt valves

To H.T.+1 apply about 60 to 80 volts, and to H.T.+2 120 volts, or even more, if available.

To pick up signals switch on the set and move the reaction coil towards the aerial coil till a slight rustling or hissing sound is heard in the loud-speaker; this indicates that the receiver is on the point of oscillation, but on no account move the reaction control so far that a howl results.

Next turn the variable condenser dial until a transmission is picked up, all the time adjusting the reaction control (if necessary) to keep the receiver on the edge of oscillation. If reaction is "ploppy" or unstable, vary the high-tension voltage applied to H.T.+1, and also change the reaction coil if necessary.

When a reasonably-powerful station has been picked up, readjust the grid bias voltages applied to the last two valves. Also try putting the aerial lead to the terminal "Aerial 1," and re-tune. Connecting the aerial to

"Aerial 1" will, in some cases enable an unwanted station to be tuned out without difficulty.

As a matter of fact, the selectivity of the receiver can be increased considerably by using a tapped coil in the aerial circuit instead of an ordinary untapped coil. In this case place the tapped coil in the aerial-coil holder and attach the aerial lead direct to the tapping point on the coil itself and not to either of the two aerial terminals on the set.

Using the Valves

Once the receiver is properly adjusted, it may happen that the local station is received at too great a volume to be comfortable; in this case the left-hand switch should be manipulated to cut out one valve, an operation that in no way upsets the adjustments of the rest of the receiver.

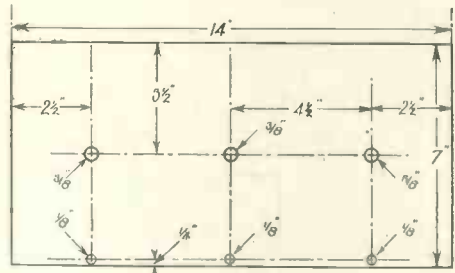

Panel Layout of the Everyday Three

Details of Cabinet

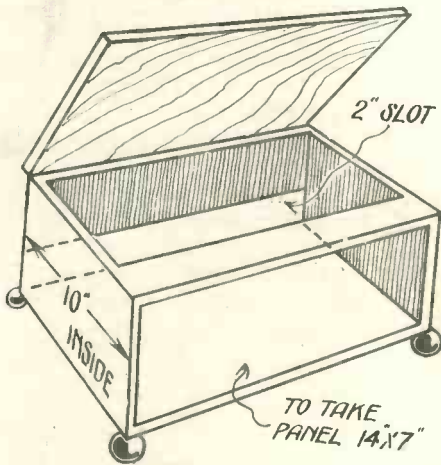

can be used, and a list will be found on page 54.

For a large number of stations on the lower broadcast band a No. 60 aerial coil, with a No. 50 reaction, will be found quite satisfactory, while most of the important long-wave broadcasting stations will be received with coils Nos. 150 and 100 in the same positions.

To carry out a rough test of the receiver, place suitable valves and coils in position and see that the on-off switch is "off" (that is, "in") and that the other switch is "in" for all three valves.

Next connect up all the terminals, putting the aerial lead to the terminal "Aerial 2." Connect both low-tension negative and grid bias positive to the terminal marked "L.T. -, G.B. +" on the blueprint and wiring diagram, applying a bias of $4\frac{1}{2}$ to 9 volts to G.B.-1 and 9 to 18 volts to G.B.-2.

Either two or three valves can be used at will

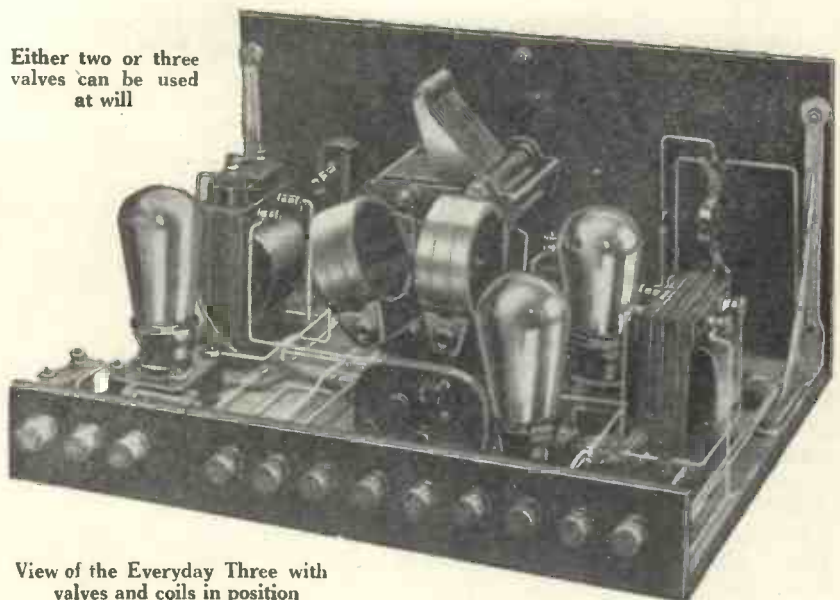

View of the Everyday Three with valves and coils in position

The Everyday Three (Continued)

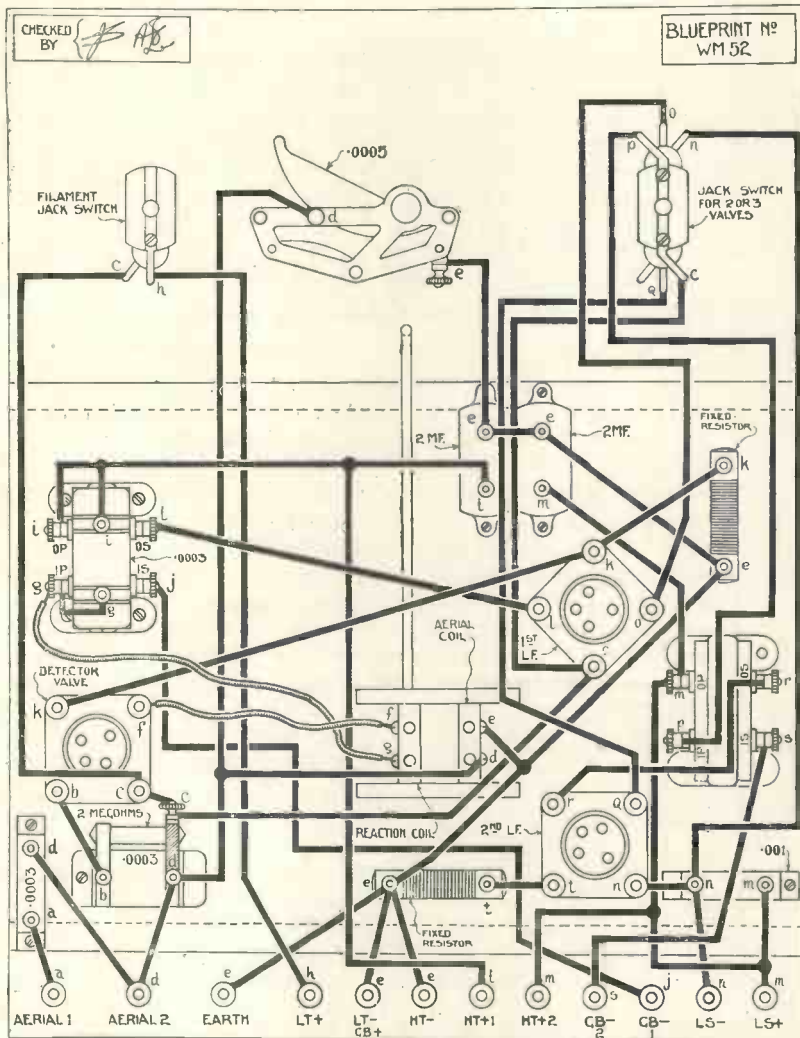

This layout and wiring diagram can be obtained as a full-size blueprint for half price, that is 6d. post free, if the coupon on page iii of the cover is used before February 29

Even an inexperienced operator will find little difficulty in operating the Everyday Three, and a few hours' practice will soon make him feel quite at home with the few controls that there are.

Results to Expect

During a very short test carried out in one evening the stations mentioned in the table on this page were received at full loud-speaker strength. Actually many more transmissions were picked up, but they were not actually identified and have not been included in the list.

We believe that the "Everyday Three" will meet the needs of a large number of listeners and that those

who build it will be entirely satisfied with its performance.

TEST REPORT

No. 60 Aerial Coil. No. 50 Reaction Coil.

Station.	Dial Reading	Wave-length.
London ...	10	361.4
Hamburg*	30	394.7
Langenberg*	120	470
Daventry (5GB)*	130	491.8
Brussels ...	145	508.5

No. 150 Aerial Coil. No. 75 Reaction Coil.

Hilversum*	70	1,060
Daventry (5XX)*	120	1,600
Radio-Paris*	148	1,750

* Received without any trace of London at one mile from 2LO.

By the way, in the case of overseas readers who wish to obtain a full-size blueprint under our special half-price scheme, a proper extension of time will be allowed. In all other cases applications must be received by February 29.

Among the German Stations

Bremen

The frequency of the English talks. The fondness of the orchestra conductor for the music of English composers.

The emphasis given to internationalism in the talks.

The poverty of the humour. A speaker who kept referring to the *Capital of Wales*. (A solution of this vexed Welsh question might still come from Germany if the speaker gave the name of the capital.)

The intimate knowledge of things English shown in the general conduct of the station.

Berlin

The tremendous change in the whole programme since a year ago. The good news service.

Edifying remarks of the announcer before, and sometimes after, every item.

An expert music announcer for a musical programme.

A magnificent talk on modern English literature, concluding by saying that the B.B.C. has done untold good to our literary possessions.

Many slight hitches between items.

Hamburg

The Fatherland spirit that predominates the programmes.

The style of programme much after that of 2LO.

Compared with other German stations, a great silence about England and English affairs.

One of the best announcers on the ether. He is witty and humorous all the evening.

General Remark

The German stations use much more English than the B.B.C. stations use German. E. B. R.

Telephony on the High Seas

A New German Telephone Service with Transatlantic Liners

SPECIAL tests conducted by engineers of the German Reichpost between ordinary land-line telephones and a Transatlantic liner have met with such great success that it is hoped to start operating a regular service during the next few months.

Clear Speech

Clear speech could be obtained from the "Columbus," the ship on which the installation is located, and German officials in the Berlin office of the Debeg Company soon after the "Columbus" left New York.

These tests are a result of experiments conducted with German submarines during the war, and it is now possible to obtain good results right across the Atlantic. The land station used is Norddeich.

Seven Ships

It is hoped to open the new service with the seven largest ships owned by the Hapag and Norddeutscher Lloyd lines. To begin with calls will be made from any ordinary house phone in twenty German cities; later the service will be extended.

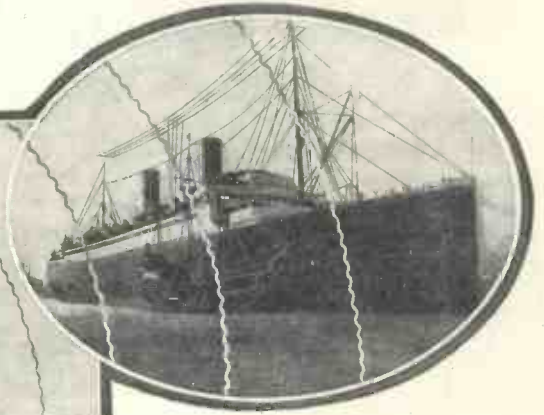
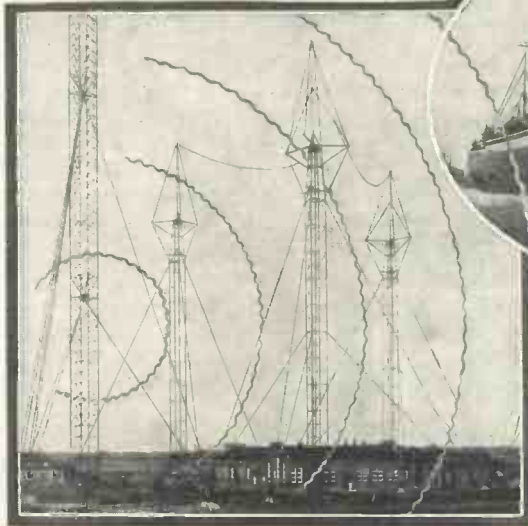

(Left and above).—The German station at Norddeich and the "Columbus," a giant German liner.



On A Ferry

Experiments on these lines have been carried out for some years, beginning on the ferry running between Denmark and the German coast. Results were so good, that in 1923 the whole outfit was installed on the "Albert Ballin," plying between Hamburg and New York.

(Above).—Microphone installed on board the "Columbus." (Right).—Corner of the wireless room on the "Columbus." (Left).—Another view of the "Columbus," employed on the Transatlantic service.

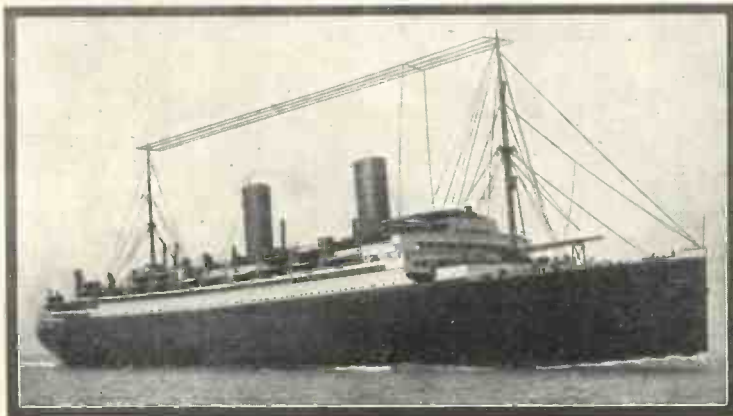



Sandy Broadcasts



OH, folks, I'm that excited. Ye ken, I'm going to broadcast. Ay, I am that. Eject ma accents to the uttermost ends o' the earth on the etherial waves. Jist think o' that. Is it no' wonderful? Jist picture them, the furry wee Eskimos in their wee huts wi' polar bears and reindeers sittin' at the door; and the Chinks all decked out in their long flowing mandarins drinkin' in ma words.

Ay, and the wee Japs'll be sittin' doon on their hind legs squintin' doon the loud-speaker to have a bit keek at me; and mebbe a lassie or twa wi' jist a bit o' grass draped round her, reclinin' languid on a coral atoll under the spreadin' palm trees, will be stoppin' eatin' her Jamaica banana to list to ma words. Och, it's fine to think o' the pleasure wireless has brought into the uttermost ends o' the earth.

But mebbe the night I'm broadcastin' ye'll be oot at a body's hoose which is no' eddicated up to wireless; or ye've been tryin' to improve yer set to hear me at ma best and ye've burnt oot yer valves and the shop's shut. Sae I'll jist give ye ma wee talk the now; for I ken fine ye wouldna like to be missing it.

Ye see, I'm in grand form, me havin' been practising every night for the last three weeks wi' appropriate gestures, dramatic and sich like, ye ken, afore a fine mirror which I may remark I sell in ma shop at the remarkably low price o' three-and-six. As a matter o' fack, I generally throw in a fine nail to hang it on the wall wi'.

However, picture me afore the microphone, arrayed like Solomon in all his glory, jist as calm and full o' sang froid as if I'd been dain' it all ma life like Maister Macaroni.

Folks, here and everywhere (here I spread ma arms oot to encompass the earth, as ye might say), I'm here the night to talk to ye about a subject that's appropriate for young and auld, rich and poor, o' baith sexes, married or single, a subject which has brought mair discussion, mair sorrow and mair pleasure into the world, than

ony ither wi' the exception mebbe o' Adam's awful apple. I'm referring to the immortal game o' gowf.

Now, folks, there's some o' ye agrees wi' that man which said that gowf was the pursuit o' a pale pill by purple people. But I've discovered that he was a bittie soft in the heid; sae if you're for believing him ye're either daft, tae, or an awful ignorant body. And I hope ye're no'. For it's terrible being daft or ignorant.

For ye see, in the first place, there's nae question o' pursuit. Ye dinna chase yer ball, run after it as if it was tryin' for to escape ye. Unless, of course, wee Bobbie Gourlay's about. He's an awful man for finding yer ball afore ye've lost it, if ye jist take yer eye off it for a meenit. But if Bobbie Gourlay's absent, ye jist dander after it slow and dignified, cogitatin' on yer next shot and observin' yer opponent for fear he misses countin' a shot or gives his ball a bit kick if it's in a whinb bush or a hole.

In the second place, the pill's no pale at all. At least, no' if ye get one o' ma repaints price sixpence. They're real good, I'm telling ye, and they dinna get pale at all, jist black when the paint slips off the candle grease I've ingeniously employed to hide the cracks. Besides it's no' a pill ye play wi'. Ye've seen a pill, have ye no'? And ye've seen a gowf ball, eh? Weel, would ye like to be swallowin' a gowf ball if ye're stomach was upset? Jist tell me that.

Now about the purple people. I think that's about the daftest bit o' it. I play a fine game o' gowf, I dae, handicap six. I'm on the committee, ye ken, and all us on the committee fixes oor ain handicaps. But I'm no' purple. And Jamie McKay plays no' a bad game; but he's no' purple. In fack, I dinna ken onybody which plays gowf which is purple.

I mind the time I was practising a swing, a fine swing it was, tae, and Jamie MacKay maist unfortunately prevented ma follow-through. He'd a purple bit for mebbe a week, but ye wouldna be callin' him a purple

body jist because o' that, would ye now?

There's anither body said gowf was a disease. Ay, he actually said that, the feckless gumph. Jist silly havers, folks. Gowfers dinna get spots on their anatomy, dae they, or indigestion or see things that isna there? Or get temperatures and sich like? No' them. Then how the deil can gowf be a disease?

Ay, gowf's a fine game, folks. I mind weel the day Tammas McPhee, he's the butcher, ye ken, and he's no' a bad butcher is Tammas, and he tellt me that he didna ken how he could abide matrimony if it wasna for gowf. Hannah's an awful wumman, ye ken. She's got a terrible tongue. Aye clack, clack, clackin'. She's got a sort o' perpetual hiccup tae, sae ye can imagine what Tammas's life's like. Ay, poor Tammas.

He tellt me he's never got used to it and he'll be holdin' his breath for five meenits, jist in a sort o' anxious anticipation. And then it'll no' come at all. Tammas thinks she daes it intentional and I shouldna be a bit surprised. She's jist that sort o' wumman.

Sae ye see what a wonderful game gowf is, folks, and I'm sure ye ken all about it now. And I must say I'm real pleased to have been able to tell ye all about it's psychology, as ye might say; for unless ye're an expert ye'd miss all they fine points I've enlightened ye about.

"What's that, Maggie, a letter for me?" What's this? Ma conscience, folks, I'm no' goin' to broadcast at all. The local station says they canna fit me in, as they dinna think ma talk would be o' general interest. Would ye believe it? And would ye tell me if slugs is o' general interest and being bitten in twa parts by a shark and sich like.

Ay, I'm real sorry about the furry wee Eskimos and the lassies wi' a bit o' grass. Ye ken, I dinna think this wireless brings pleasure to sich folks as them, no' the way they're dain' it at present, onyway.

RICHARD CAROL.

In the following article will be found full constructional details of a modern and very efficient one-valver, which can be relied upon to give satisfactory headphone reception from a large number of broadcasting stations, both British and Continental. This set is not intended for loud-speaker reception

A Long-range Hartley One

*Specially
Intended
for
Headphone
Reception*

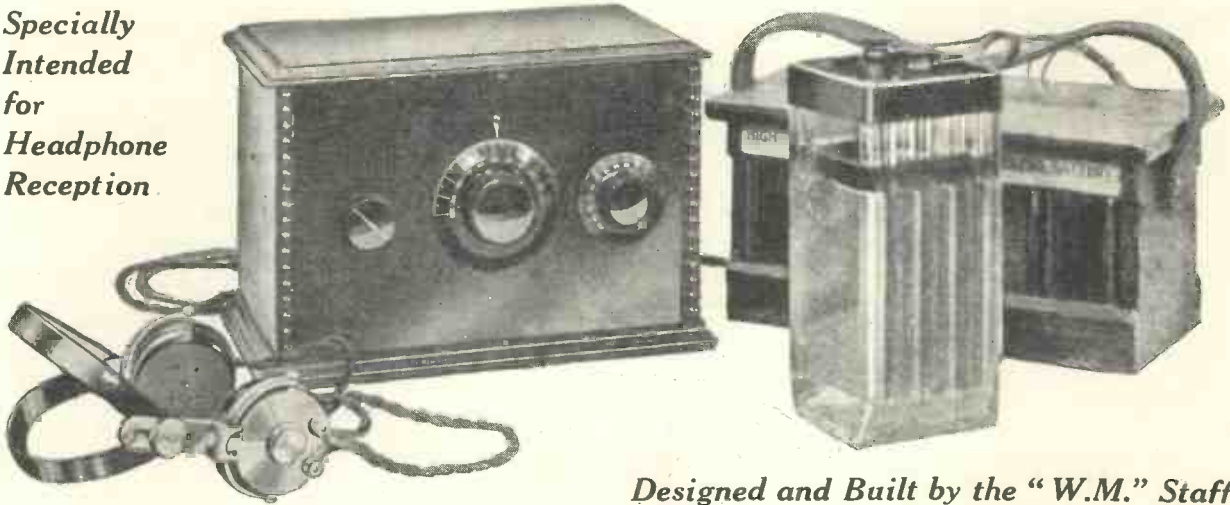

Designed and Built by the "W.M." Staff

SO many listeners nowadays insist on nothing less than full loud-speaker reception at all times that the humble headphone enthusiast is liable to be neglected.

For Phone Work

In order that the WIRELESS MAGAZINE Technical Staff may not be reproached in this respect a description will be given in this article of a one-valver that will give really good phone reception from a large number of both British and continental stations.

A large number of those who now

are only interested in loud-speaker work have memories of one-valve sets that were tricky to adjust and that gave the choice of only a few spark transmissions when once they had been properly adjusted.

But the single-valver of 1928 is a vastly different proposition from its five-year-old brother and even multi-valve enthusiasts will find it interesting to make up this set—nothing will be more convincing to them of the great progress that has been made in the quality of components, and of broadcast transmissions, during a few years.

To keep the set as simple as possible and also electrically efficient, use has been made of a Hartley circuit—employing a centre-tapped coil. A glance at the circuit diagram will show that this gives an auto-coupled aerial tuner, the top half of the coil acting as an aperiodic aerial tuner self-coupled to a secondary circuit, which comprises the whole coil tuned by a .0005-microfarad variable condenser.

As only half of the coil is actually in the aerial circuit proper, it will readily be appreciated that to cover any given wavelength band a coil of twice the size of one that would be

used in an ordinary single aerial circuit will be necessary. That is, where a No. 50 coil would ordinarily be used a No. 100 centre-tapped coil will be required for this receiver.

Efficient Reaction

Reaction is obtained through the bottom half of the coil, which is actually in the anode circuit of the valve and which is also coupled to the aperiodic aerial coil (top half of the centre-tapped coil in the circuit diagram). The degree of oscillation (or feed-back) from the anode circuit to the grid circuit is controlled by a

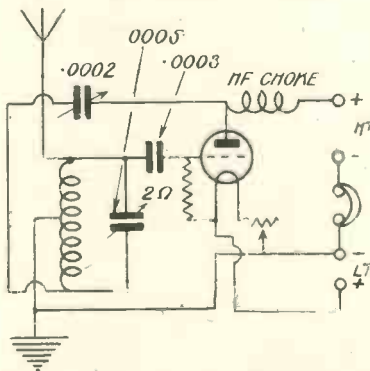

Circuit of the Long-range Hartley One, which has an excellent headphone range

VALVES TO USE

Make.	2-7.	4-7.	6-v
B.T.H.	B210L	—	—
Cossor	210 L.F.	410 H.F.	610 H.F.
Ediswan	DR2	GP4	ES5 L.F.
Marconi	DEL 210	DEL 410	DEL 610
Mullard	PM1	PM3	PM5X
Osram	DEL 210	DEL 410	DEL 610
Shortpath	SP16 G	—	DE50
Six Sixty	210 L.F.	410 P	610 P

A Long-range Hartley One (Continued)



Rear View of the Receiver

.0002-microfarad reaction condenser.

For the sake of sensitivity leaky-grid rectification is employed, the grid condenser having a value of .0003 microfarad and the leak a resistance of 2 megohms. It should be noted that the leak is not directly in parallel with the grid condenser, although it appears so in the photographs and wiring diagram.

Special Clip

One of the clips on the condenser that supports the leak is actually an insulator—in other words, the end of the grid condenser marked *c* is not connected to the end of the grid leak marked *e*, a special ebonite clip with an extra terminal being employed.

The high-frequency choke is an important part of this circuit; it prevents oscillations being fed back to the grid of the valve, except through the reaction winding. To a great extent the results obtained from the receiver will depend upon the efficiency of this component and only one of good quality should be used.

Filament Rheostat

A slight extra amount of sensitivity is often obtained by a fine adjustment of the filament temperature of a detector valve, and for this reason a filament rheostat has been mounted

on the panel where it is readily accessible.

The filament rheostat used in our original receiver is of a new type. In the end of the contact arm is a spring plunger which makes a rubbing contact with the resistance winding. The result is a pleasing and very smooth movement. These new rheostats are made by the General Electric Co., Ltd.

The headphones, by the way, are kept at a low potential by being placed in the negative high-tension lead.

Following is a complete list of components required for constructing

.0002-microfarad reaction condenser (Cylton, Bebe, Peto-Scott or Igranic.)

Anti-microphonic valve holder (Lotus, Benjamin or W. and B.)

High-frequency choke (Wearite, Lissen or Igranic.)

.0003-microfarad grid condenser with special insulating clip (Dubilier).

2-megohm grid leak (Dubilier, Lissen or Mullard).

Single coil holder (Lissen, Lotus or Peto-Scott).

Centre-tapped coils (Atlas, Lissen or Lewcos).

Terminal strip, 8 in. by 2 in. (Beco, Will Day, or Raymond).

8 terminals, marked: Aerial, Earth, L.T.+, L.T.—, H.T.+, H.T.—, Phones+, Phones— (Eastick).

Cabinet and baseboard, 5 in. deep (Ready Radio).

Glazite for wiring.

Short length of flex with spade tag.

Dial indicator (Bulgin or Belling-Lee).

It should be noted that in each case the particular component used in the original set and allowed for in the layout is mentioned first.

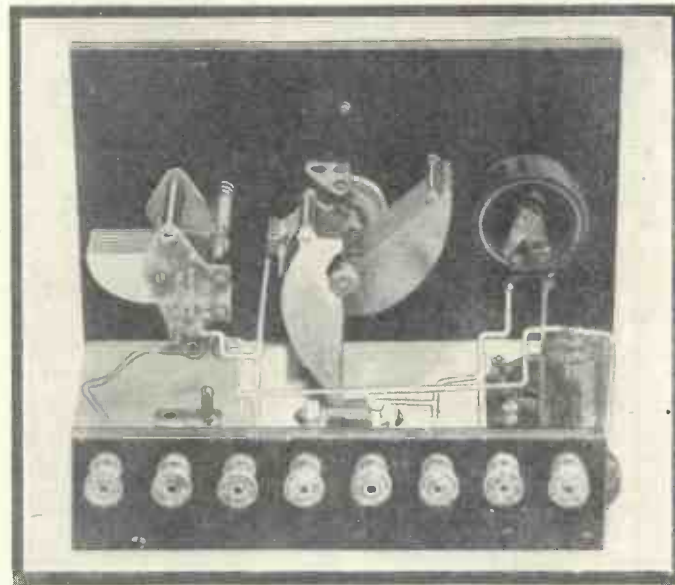

Back View of the Long-range Hartley One

the Long-range Hartley One. Before other components than those recommended are used the constructor should assure himself that they will fit in the spaces provided:

Ebonite panel, 9 in. by 6 in. (Beco, Will Day or Raymond).

.0005-microfarad variable condenser (Utility, Igranic or Formo).

15-ohm panel-mounting rheostat (Gecophone, Benjamin or Lissen).

Blueprint

Before beginning to build the receiver constructors are recommended to get together all the components and a full-size blueprint. This can be obtained from the WIRELESS MAGAZINE for half price, that is 3d. post free, if the coupon on page iii of the cover is used before February 29. Ask for blueprint No. 54 and address your inquiry to Blueprint Dept., WIRELESS MAGAZINE, 58-61 Fetter Lane, E.C.4.

Panel Drilling

When everything has been got together lay the blueprint out on the panel squarely and prick through all the drilling centres with a sharp-pointed instrument. Drill all the necessary holes and mount the panel components (the two variable condensers and the filament rheostat) in position.

Next, screw the panel and terminal

A Half-price Blueprint of Any Set Described in this Issue—

For Headphone Reception

strip (with terminals already mounted) to the panel and lay out the rest of the components. It is desirable to keep the coil as far away from the variable condensers as possible.

When everything has been securely fixed in position a start can be made with wiring up, an operation that is very simple and which should not take more than half an hour or so.

Marked Points

Reference to the wiring diagram reproduced in these pages, or to the blueprint, will reveal the fact that each terminal point is marked with a small letter of the alphabet. These letters indicate which points should be connected together and in what order.

For instance, the two points marked *a* should first be connected; then those marked *b*; and so on, through the alphabet.

Before the set can be used, however, a suitable coil and valve must be chosen, and a few words may be said about these here. It has already been explained that, as only half of the coil is actually in the aerial circuit, a coil of twice the usual size must be used. For the lower broadcast band a No. 100 will be found suitable with most aerials, while for the upper broadcasting band a No. 250 or 300 coil will be necessary.

Suitable Valves

The valve should be one having a medium value of impedance, say between 15,000 and 30,000 ohms (a table is included in these pages to save readers the trouble of referring to the maker's specifications). Either 2-, 4- or 6-volt valves can be used and the choice will depend largely upon what accumulator or charging service is available.

To test the set put the rheostat in the "off" position, and insert valves and coils in the proper holders. Connect up the aerial, earth and phones. Apply the necessary voltage to the low-tension terminals and a potential of 60 to 80 volts to the high-tension terminals.

Now switch on the rheostat until the set sounds "live" and manipulate the reaction condenser (the right-hand knob on the front of the panel) until a slight rustling or hissing sound is heard that indicates the receiver on the point of oscillation.

Next, turn the knob of the main tuning condenser (centre) until a transmission is picked up. As soon as

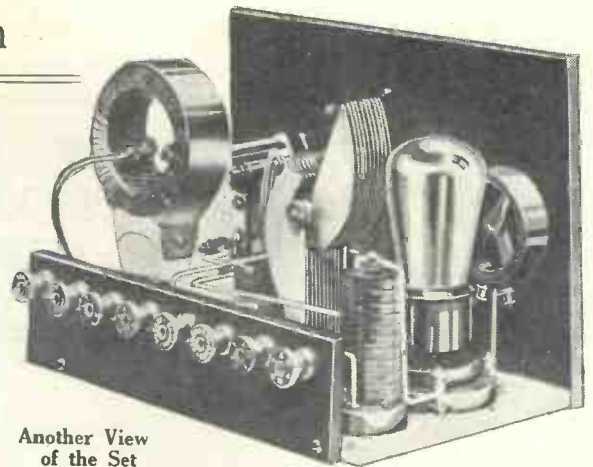

Another View of the Set

Of course, with such a receiver as this particular one, care should be taken to obtain a really efficient aerial and earth system; attention to this point will give greatly improved results.

Unobstructed Aerial

Keep the aerial high and as far away from metallic roofs, walls, etc., as possible and make sure that the earth connection really does make good contact with "earth." A buried plate "earth" is usually better than a water-pipe "earth."

The WIRELESS MAGAZINE will be especially interested to hear what results readers get with this set. With a little coaxing it should give remarkably good headphone results. One word more: *Do not oscillate!*

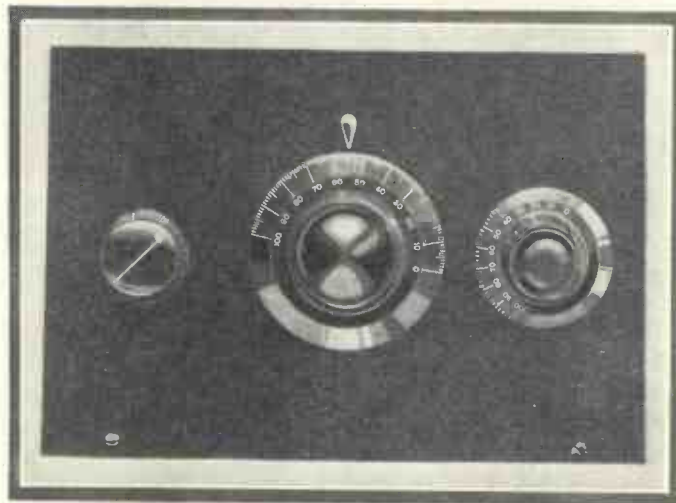

Front panel of the Long-range Hartley One. In the centre is the aerial-tuning control, while on the left and right respectively are the filament rheostat and reaction condenser. Centre-tapped plug-in coils are used

a signal is heard re-adjust the reaction condenser and the setting of the filament rheostat.

If the set oscillates too easily reduce the voltage applied to the anode of the valve, while if it does not oscillate all over the tuning scale, no matter what the setting of the reaction condenser is, the high-tension voltage should be increased.

FOR PHOTOGRAPHIC
PLAN AND WIRING
DIAGRAM
SEE NEXT PAGE

IF you are interested in any particular type of receiver of which a representative design has not been published in these pages during the last six months will you let us know? We are at all times glad to hear from readers as to what types of receivers particularly appeal to them.

—Just Cut the Special Coupon Off Page iii of the Cover

A Long-range Hartley One (Continued)

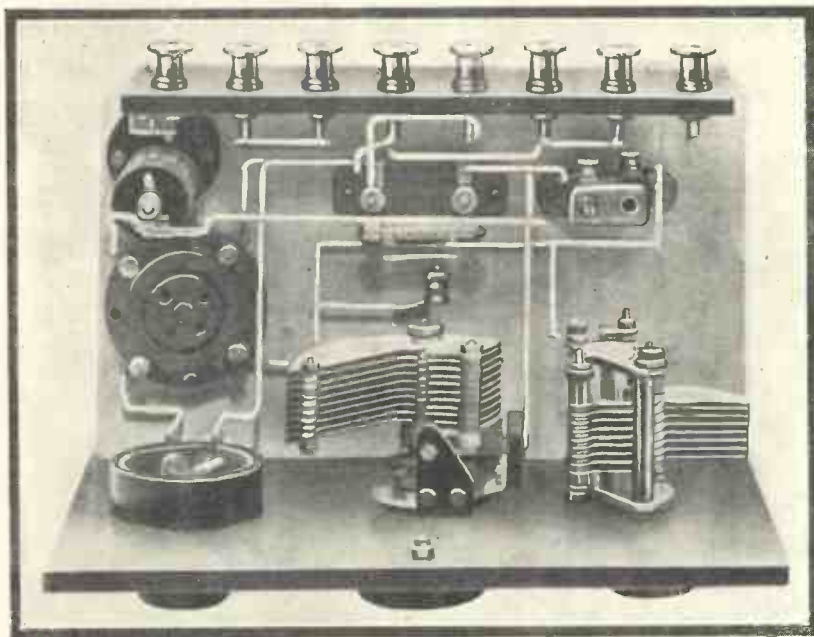

On the left are reproduced a photographic plan view and a wiring diagram of the Long-range Hartley One. This layout and wiring diagram can be obtained as a full-size blueprint (No. W.M. 54) for half price, that is 6d., post free, if the coupon on page iii of the cover is used before February 29.

Gramophone Pick-ups

IN the case of very many of the gramophone electrical pick-ups at present on the market it is possible to add these in the grid circuit of the detector valve of a set. This is, of course, an economy, and saves the expense of one amplifying valve. It is only necessary to adjust the detector grid bias in order to make the valve act as an amplifier and not as a detector.

In Place of Aerial Coil

With most straight circuits the pick-up is put in place of the aerial coil, the bias voltage is correctly adjusted, and everything is in working order.

The simplicity of the arrangement has induced some people to incorporate the pick-up permanently, additional "aerial" and "earth" terminals (across the tuning coil) being provided for the gramophone pick-up.

Loss of Energy

There is a danger that in this way the pick-up leads may cause a loss of signal energy, and to prevent possible diminution of strength a small H.F. choke should be connected in one lead to the gramophone device. The working of the pick-up will not be affected in any way. K. B. C.

Short wave work in Great Britain is progressing slowly, but surely, amongst amateurs. The past year has brought out nothing very astonishing, unless it has been the amazing ease with which it has, sometimes, been possible to communicate over really immense distances with quite low power, and the amazing difficulty of making any contact at all on other occasions. We are learning slowly, but surely, however. M.

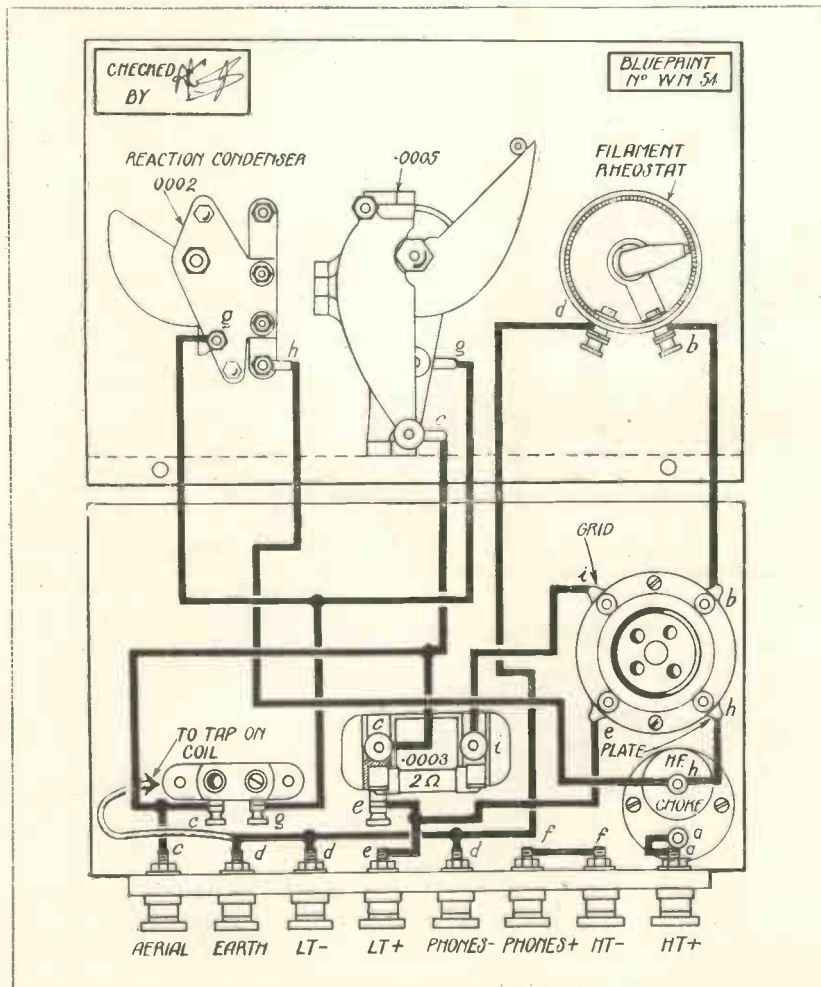

Specially Written for the "W.M." by Officials at Savoy Hill.

"Excommunicated" Broadcasters

FOR perhaps the ninety-ninth time, a storm has threatened the long-suffering listener in connection with the relations existing between the B.B.C. and variety managers. In the majority of cases, the listener has been bored by reading in his favourite newspaper that So-and-so's place in the broadcasting programme will be filled by a substitute, the Big Stick Syndicate (here insert proper name of member-group of the Entertainment Proprietors' Association) having informed So-and-so that he will be "excommunicated" if he should dare to broadcast.

Two Most Recent Cases

The two most recent cases of the kind are those of Wish Wynne and Mona Grey, artists famed respectively for the character studies and impersonations which they have given on the variety stage from time to time. Both had been booked to appear before the microphone one evening, when, like a bolt from the blue, came an ultimatum from the Stoll Theatres—be it noted, only three or four hours prior to the broadcast—"No more contracts from us if you do this thing."

The threat had been sufficient on other occasions to scare away some artists from the portals of the B.B.C.; but somehow this time it lost its potency. Maybe Miss Wynne and Miss Grey did not realise the enormity of such an offence as to give of their

talent to several million listeners on the wireless.

Maybe they thought that, as they had no music-hall engagement at the moment, they were not injuring other interests by broadcasting, or, perhaps, with the characteristic courage which has become a trait of twentieth-century womanhood, they decided that the time was ripe to strike yet another blow for emancipation.

What boots it to inquire too closely into their reasons? The fact remains that rather than let the B.B.C. down they fulfilled their contract to broadcast. The attitude of Savoy Hill is clearly demonstrated in the offer made to both artists of further broadcasting engagements, and it would be regarded all round as a friendly gesture on the part of the variety managers if no more were heard about a "ban."

B.B.C.'s Position

The B.B.C.'s position in connection with these contretemps is none too happy. Sometimes a variety artist has gone to Savoy Hill almost in tears and has said: "I beg you to release me from my broadcasting engagement. It is true that at present I have no engagement with any theatrical combine. One has been promised me for the future; but in the meantime I wished to keep my name before the public, as well as earn more bread and butter. I have signed a contract with the B.B.C., I know; but Mr. So-and-so or Sir Horace says that if I broadcast I shan't get any more contracts with him. He is an old friend, and I have been appearing for him for years, etc. . . ."

What should the B.B.C. do? Should it hold the high contracting party to his contract and possibly prejudice his stage career, or should it show magnanimity which will very likely be misunderstood and resign its claim to his services?

It has frequently adopted the latter course, after taking all the circumstances into consideration, and has thereby aroused the feeling in certain quarters that its action is a confession of weakness, or an admis-

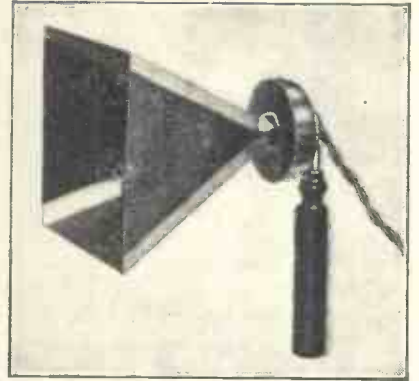

One of the first microphones ever used for broadcasting. Dame Nellie Mella sang into it when she went to Marconi House in 1920

sion of unwarranted poaching on the allegedly strict preserves of the music-hall managers.

"The 'ban' on broadcasting has not been lifted," says a statement issued from theatrical headquarters. Then it is rather one-sided to bill artists appearing on the halls in such terms as the following: "Of broadcasting fame," "You have heard him on the wireless," "Of the B.B.C.," etc. If the B.B.C. desired to indulge in retaliatory measures, it might put a decisive end to these attempts to steal its thunder. But the feeling that is aroused is only one of good-natured tolerance.

Attempts are invariably made to deflect public opinion by raising the bogey of the B.B.C.'s monopoly. Let us call this Argument 1. It is an argument that invites the deadly parallel; for the variety profession itself is largely controlled by a few big groups, often acting in concert and sometimes exhibiting no qualms in encroaching on other interests, such as the cinema.

Inflated Prices

One of these variety groups inaugurated inflated prices some years ago, and in recent times all the groups have combined in an endeavour to recover these prices and control fees. It may be contended that if fees are controlled, how comes it about that certain eminent names are known to be in receipt of professional incomes that sound fabulously large? Th-

WHAT STATION WAS THAT?

The Editor of the "Wireless Magazine" has made arrangements to assist readers who are in difficulty over the identification of broadcasting stations they receive.

Each query should give as many particulars as possible and should be accompanied by the coupon on page iii of the cover and a fee of one shilling (postal order or stamps).

Address each query to "Station Identification," "Wireless Magazine," 58-61 Fetter Lane, London, E.C.4.

“Excommunicated” Broadcasters (Continued)

answer is that by agreement among the groups, or even in a sort of rivalry that has a superficial friendliness as between group and group, the payment of extravagant fees is felt to be justified as much on publicity grounds as from the standpoint of talent.

Injured Parties?

Argument 2 is that broadcasting injures both management and artist by spelling the entertainment death of the artist. And yet the hint has been thrown out that the managerial ban could be automatically lifted by the payment of a high indemnity to the groups, singly or collectively. Should the inference be that, although an artist becomes figuratively moribund, the payment of a lump sum to the manager will bring about a kind of post mortem revival?

Such a suggestion is absurd on more grounds than one. For example, what right would the B.B.C. have to subsidise any interest without adequate return, and how could the return from the music-hall interests be considered adequate, when, as has been proved, some 85 per cent. or 90 per cent. of their turns are unsuitable for broadcasting?

Further, as the artists would naturally be paid individually, what right would the B.B.C. have to dispose of listeners' money by making a double

payment—subsidy and fee—for a single service?

Argument 3 concerns the setting up of broadcasting stations by the variety managers themselves. Incidentally, it is curious, in the light of the chaotic conditions produced in the United States of America five years ago, when anybody who wished to go on the ether did so without let or hindrance, how many interests in our own country have hankered after the possession of a broadcasting station of their own.

However, consider this opposition to broadcasting on the ground that performances by artists in the B.B.C.'s studios keep people away from the music-halls; whereas if the managers themselves were permitted to set up stations in order to broadcast the turns, the public would be attracted to the actual performance in greater numbers. If broadcasting is fatal to an artist's reputation and drawing power, what earthly difference can it make whether he is heard by the world through a microphone in a music-hall or in a broadcasting studio?

Breath Taken Away!

One suggestion apropos the cases of Miss Grey and Miss Wynne that fairly took away the breath of the Savoy Hill officials was that the B.B.C. should “change its policy”

and come to a “fair agreement” with the variety managers. Assuredly not the slightest change in policy is involved. The B.B.C.'s attitude from the beginning has been to act in harmony with all other interests that impinge in whatever degree on its work.

The arrangements made with the Church, the Press, the theatre, with music interests and with educational authorities are the witness; add to this the pacific intentions shown in the voluntary release from broadcasting contracts of artists who have expressed their fear of penalty from their managers if the contracts were carried out, and the policy of the B.B.C. becomes crystal clear.

Significant Fact

A significant fact that the public must not overlook is that variety artists themselves have not been given a legitimate opportunity of expressing their views. The danger of their being regarded as mere chattels, to be disposed of in whatever way the organisation with the longest purse desires, must be realised and met. The present position is really unfortunate for them; for they have either to remain inarticulate, or “play to the gallery” of managerial opinion. It is not by any means a healthy state of affairs.

The Exhibition Five

Two Readers Express Their Opinions

FIRST published in the October, 1927, issue of the WIRELESS MAGAZINE, the Exhibition Five was an instant success and many are the congratulatory letters that have reached this office on its design and performance.

Only standard parts, such as can be obtained without difficulty at almost any dealers, were used in its construction. The circuit comprises two high-frequency stages, a detector, and two low-frequency stages. Switching is provided so that either three or five valves can be used at will.

Full-size blueprints of this receiver

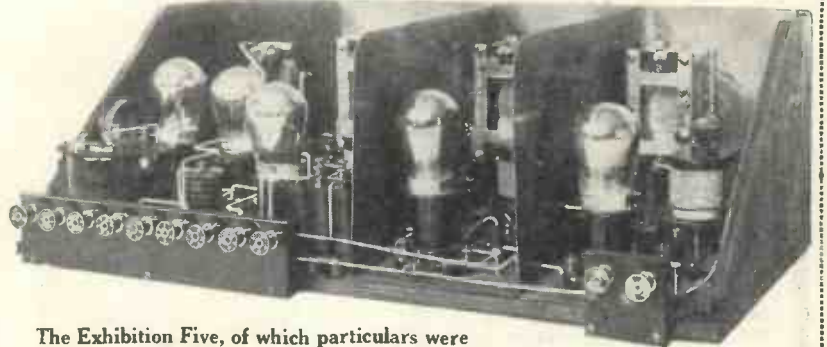

The Exhibition Five, of which particulars were published in October, 1927

(ask for blueprint No. W.M.33) are still available, of course, at 1s. 6d., post free, for readers who want to build the set.

These two expressions of opinion from readers will convince prospective builders of the efficiency of the Exhibition Five.

One reader at Palmer's Green, N.13, writes: "The result was amazing. As soon as I plugged in the loud-speaker, London came in with a fearful roar, far too loud for any size room, and foreign stations I get by galore; all at loud-

speaker strength—in fact, too loud. Re selectivity: I am only five miles (as the crow flies) from 2LO and have no trouble of tuning it right out. You can guess how pleased I am."

Another reader at New Cross, S.E.14, says: "I find that the Exhibition Five is just as wonderful on the higher wavelengths as on the broadcast band. I have logged over seventy stations direct on the loud-speaker, many at almost unbearable strength."

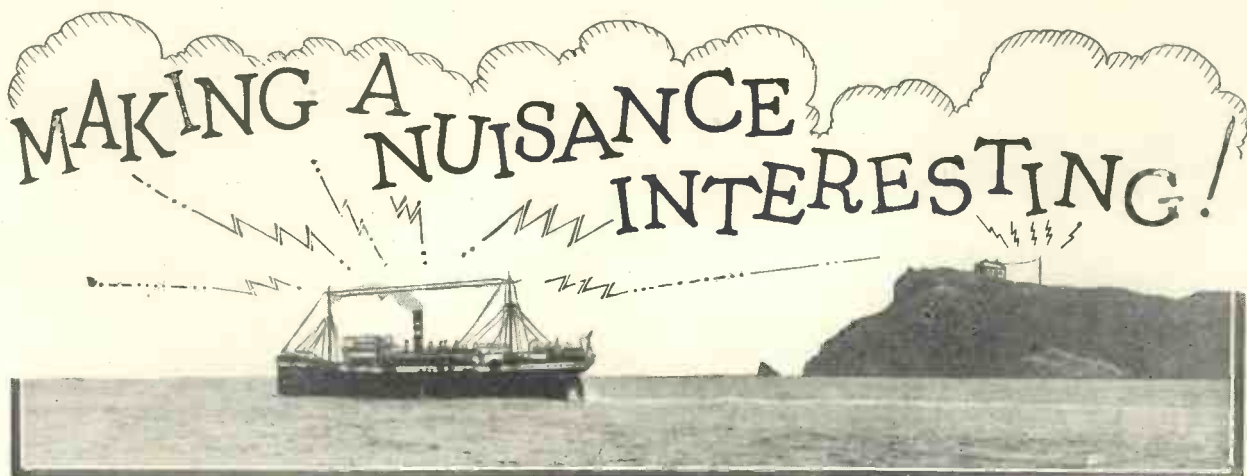

5 GB calling! The orchestra will now play a—dah-dit-dah-dit-dah! dah-dah-dit dah-dit dit-dit-dah-dit!" and so on, ad nauseam.

Yes, those morse messages can be very irritating if they happen to interfere with a broadcast programme that you particularly want to hear. But at other times, given a working knowledge of the morse code, such messages can be a source of considerable interest, instead of annoyance.

Change from Broadcasting

When you want a change from music and speech, speech and music, or at odd times when the broadcasting stations are silent, just tune up to the wavelengths used by the various telegraphy transmitters, and you will hear half the world in morse—if your set is reasonably sensitive.

The only special equipment you will need for your "tour" of the transmitters consists of a pencil and a handy-sized pad of ruled paper, on which to take down the messages, also a directory of wireless call-signs.

Your receiver should, of course, be provided with a set of coils of the usual sizes covering wavelengths up to about 2,600 metres.

In order to form some idea of what you can hear from the various telegraphy stations, imagine that we have donned headphones and are tuning-in on an efficient two- or three-valve set.

Are you ready? Yes? Then off we go.

A Pandemonium

As we tune up above the waveband occupied by the B.B.C.'s "family," we first of all glide into a veritable pandemonium of spark transmissions.

These, of course, emanate from the ships and coastal stations which are theoretically supposed to work on a

Why not make morse interesting by learning enough of the code to be able to get some idea of what is taking place between the stations that sometimes interrupt your broadcast reception? This article reveals a new field for the listener to explore.

wavelength of 600 metres, but which, in actual practice, can be heard over quite a wide band of wavelengths owing to the "spreading" tendency which is characteristic of most spark transmitters.

The call-sign that we hear most frequently on this wavelength is GNF. This belongs to the telegraphy station at North Foreland, Kent, which works with most of the ships in the vicinity of the Thames, and therefore handles a very large number of messages.

A little above GNF's wavelength (if a spark station can be said to have a definite wavelength!) we can hear GNI, the station at Niton, in the Isle of Wight. Then GKZ of Grimsby begins to transmit a radiotelegram addressed to a passenger on a ship.

Morse Procedure

This message is soon "drowned" by a ship calling GCC of Cullercoats, near Newcastle. On receiving Cullercoats' reply, the ship's wireless operator sends the letters "TR," and then proceeds to report the name of his vessel, whither it is bound, whence it has come, and its distance and direction from the Cullercoats station. These particulars, in addition to telling us all about the ship, enable us to find her present position on a map.

A particularly loud spark transmission, which we recognise as originating from FFB of Boulogne, suddenly makes itself (very much)

heard. Of all the continental stations I think FFB deserves first place, because it seems to be the noisiest. And noisiness, mark you, is undoubtedly a virtue from the point of view of those who want to hear FFB, for it is only by being exceedingly noisy that a coastal station can succeed in making itself heard above the babel of "spark" on 600 metres!

There are, of course, a great many other coastal stations to be heard on this wavelength, as, for instance, GNV of Newhaven, GLV of Liverpool, FFH of Havre, FFI of Dieppe, FUC of Cherbourg, OST of Ostend, and PCH of Scheveningen, Holland.

"Jamming"

Suddenly, however, the wireless operator of a ship (evidently in the London docks judging by the strength of the signals) begins to transmit a long series of "v's" in order to test his apparatus. As the ship is comparatively near to us, it is "jamming" all other stations on the shipping wavelength as far as we are concerned, so we will tune up to 900 metres and see what the civil aviation stations are doing.

Most of the messages from aerodrome stations on 900 metres are in telephony, but C.W. morse is sometimes used, especially when conditions of reception are bad or when a message of special importance has to be transmitted to a fairly distant station.

Thrilling Messages

In the case of any special excitement or emergency, these messages are often very interesting, or even mildly thrilling. For instance, on that memorable occasion when the airship R33 broke loose from her moorings at Pulham and drifted over to the Dutch coast, I heard the

Making a Nuisance Interesting! (Continued)

messages, special weather forecasts, and instructions which were transmitted to the R33 from GEP of Pulham in C.W. morse.

Croydon is, of course, by far the loudest station as far as London listeners are concerned, but Pulham, Lympne (FEG), St. Inglevert (FNG), Le Bourget (ENB), Cologne (GEK),

is now in use. Information regarding these call-signs is not available to the general public.

Resuming our "tour," let us tune up past Daventry and Radio-Paris until we reach a wavelength of about 2,000 metres.

Between 2,000 and 2,400 metres we shall probably pick up a number of interesting messages, as this is the waveband used by the various liners, and the land stations with which they communicate, for C.W. morse work.

Yes—here is a C.W. transmission coming in at ear-splitting strength. This must originate from GKU, the powerful radio station at Devizes, which handles most of the messages to and from the liners.

GKU has just given the "change-over" signal now, so if the liner with which it is working is not too far distant, we shall be able to hear the reply quite easily. Listen! There it is:

"GKU GKU GKU de GBZW GBZW GBZW—R., O.K." ("GKU being called by GBZW. Received O.K.") A glance at our call-sign directory shows us that we are listening to the well-known liner the *Berengaria*.

From time to time you can hear all the principal liners working on this waveband, including such familiar ones as the *Aquitania*, the *Empress of Scolland*, the *Homeric*, the *Majestic*, and the *Leviathan*.

Most of the messages take the form of radio-telegrams to and from

passengers on board. Many fall into the "Arriving 11 p.m. sea choppy all well—Reggie" category, but others, of course, are of a more serious and important nature.

From 3,000 metres upwards, there are many high-power morse transmissions, but these are rather beyond the wavelength range of the coils used in ordinary broadcast receiving sets and, also, most of them transmit at far too high a speed for their messages to be taken down by hand in the ordinary way.

Widened Field

You should, of course, bear in mind that our imaginary "tour" of the morse transmitters is to be regarded merely as an indication of what can be done almost any day with quite a simple receiving set employing only two or three valves. In the case of a really powerful multi-valve set the range and the number of stations receivable would be greatly increased.

In conclusion, perhaps it would be as well just to remind you that, in compliance with the numerous rules and regulations which adorn the reverse side of your receiving licence, you "shall not divulge or allow to be divulged to any person (other than a duly authorised officer of His Majesty's Government or a competent legal tribunal) or make any use whatsoever of any message received by means of the station other than time signals, musical performances, and messages sent for general reception."

W. OLIVER

Every Beginner

at some time or another is likely to come across a difficult problem that he is unable to solve. In such cases he can, for a very small fee, consult the "Wireless Magazine" Technical Staff, who have years of practical experience behind them.

All queries (ask not more than two at a time) should be written on one side of the paper only and sent, together with a stamped addressed envelope, a fee of 1s., and the coupon from page iii of the cover, to Information Bureau, "Wireless Magazine," 58/61 Fetter Lane, London, E.C.4.

and Rotterdam can all be heard quite easily with a fairly sensitive set. Some of these stations use alternative wavelengths in the neighbourhood of 1,400 metres for C.W. morse work.

The waveband between about 1,200 and 1,600 metres is thickly sprinkled, so to speak, with C.W. morse transmissions from Royal Air Force stations.

Among others, you can hear the transmitters that work in connection with such well-known aerodromes as those at Cranwell, Felixstowe, Andover, Calshot, Gosport, Shotwick, Farnborough, Uxbridge, Lee-on-Solent, Henlow, and Howden.

Three-letter Calls

The ordinary three-letter call-signs such as GFC, GFF, GFI, etc., etc., which you will probably find in your call-sign directory, are still used by the Royal Air Force stations for public services.

In the case of messages relating to various official matters, not intended for general reception, you will find that another system of call-signs, consisting of two letters and a figure,

Best Loud-speaker Positions

THE position in which a loud-speaker gives the most satisfactory sound effect depends almost entirely, of course, upon the type of sound projector embodied in the instrument.

Ordinary cone loud-speakers give a good general distribution of sound waves, and are, therefore, not sensitive, as a rule, to the position in a room in which they are worked.

Horn-type loud-speakers (and, to a certain extent, moving-coil speakers) have rather more pronounced "directional" properties and are

largely affected by the position of objects in a room.

When a horn-type loud-speaker is operated in a room containing many sound-reflecting objects it is advisable to mount the speaker at a fair height from the floor. This prevents air-wave formations from being checked too much by tables, chairs, and so forth—a condition which is very likely to obtain when the loud-speaker is situated at the usual "table" height from the ground.

In some cases it may be convenient to suspend the speaker by a length of cord from a picture-rail. B. F.

J. H. Revner, B.Sc., A.M.I.E.E., Explains the Advantages of

THE NEW "Q" COIL

First Details of A New Component Which Should Prove of Universal Application

ABOUT two years ago the attention of radio engineers became directed to the interaction between various circuits in a receiver. The evils to which the ordinary wireless receiver is prone were becoming appreciated and were removed, with the result that there was a gradual increase in efficiency of wireless apparatus generally.

For instance, the discovery that the internal capacity between anode and grid of the valve was responsible for the uncontrollable oscillation obtained in high-frequency amplifiers led to the development of neutralised circuits whereby stable high-frequency amplification could be obtained.

Stability

The stabilising adjustments, however, did not hold good at all points, and in the early circuits it was very often necessary to re-neutralise towards the bottom of the scale if the adjustment had previously been made at the top and vice versa. This was found to be due largely to interaction between the circuits themselves.

Magnetic and capacity coupling existed between the coils in use and the extent of this coupling might, in some cases, be greater than the internal coupling in the valve which was being neutralised. Consequently there was little uniformity about the results, and in some instances a circuit would work, while in others it would not.

Placing of Components

Under such conditions, the design of wireless apparatus was very largely a matter of careful placing of the components. Layout is always a matter of considerable importance in the design of a wireless receiver, but if, in addition to this, we have to consider the possibilities of stray couplings between the various parts of the circuit, then the problem is made considerably more difficult.

Coupling of this nature arises from two principal sources. There is, firstly, the direct magnetic coupling due to the fact that the magnetic field of one coil extends for some

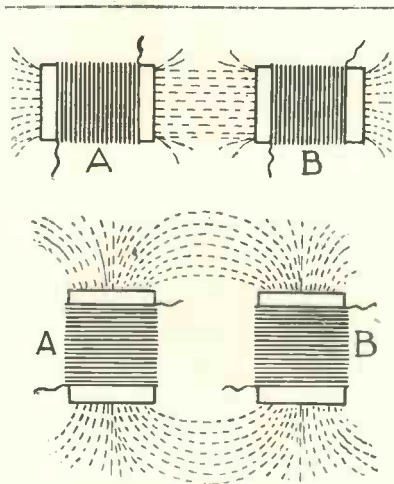

Fig. 1.—Two examples of magnetic coupling, as obtained with ordinary coils: (i) coils end on and (ii) coils side by side

distance away from the coil and will interlink with that of any other coils in the vicinity, so inducing voltage in these other circuits.

Two examples of magnetic coupling are shown in Fig. 1. The first case shows the two coils end on, in which case the magnetic coupling is at maximum. The magnetic field extends along the axis of the coil and diverges outwards on each side, as

indicated by the dotted lines, from which it will be seen that quite a large proportion of the magnetic field from the first coil interlinks with that from the second coil and will therefore induce voltage in it.

Due to this spreading effect, quite appreciable magnetic coupling will result, even if the coils are placed side by side as in Fig. 1. Here, although the axes of the two coils are parallel, the side fringes of the magnetic field, as it were, affect the second coil, with the result that quite a considerable magnetic coupling will be obtained in such a position.

Capacity Coupling

The second difficulty that we encounter is that of capacity coupling between the coils. This effect is illustrated in Fig. 2. One end of the coil A is at earth potential, and the other end, therefore, is at a relatively high potential to earth. There is always a capacity effect existing between any two bodies and, in consequence of this, small leakage currents flow from the high potential end of the coil across to any adjacent body.

This effect is represented by dotted lines between the coils A and B in Fig. 2, this transfer of energy taking place progressively down the coil and not from one particular point only.

If the body to which the capacity currents leaks away is earthed, or is at a low potential, no difficulty arises beyond a slight loss of energy. If the second body, however, is a coil such as B in Fig. 2, then the capacity currents will actually cause voltages to be set up in the circuit B, where we probably do not wish to have any such coupling.

Obviating a Difficulty

This difficulty may be obviated by interposing between the two coils an earthed metal screen. The voltages on the first coil A simply send capacity currents to earth, but they cannot effect the coil B. In a similar manner, although the coil B has a capacity effect to the screen, this cannot affect the coil A.

This is the basis of the capacity

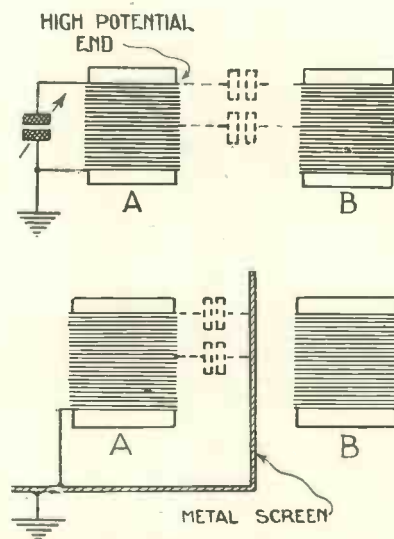

Fig. 2.—Capacity coupling between two coils and how it can be overcome.

The New "Q" Coil (Continued)

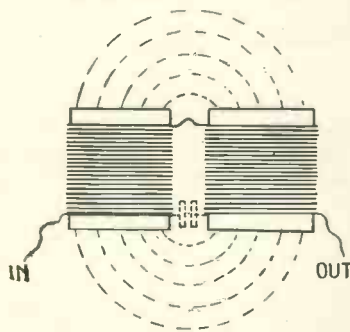

Fig. 4.—Field of binocular-type coil

screening which is very common to-day. It has the disadvantage that the presence of the screen introduces a slight loss in the circuit, the actual damping depending upon whether the screen is near to or far away from the coil. It also somewhat complicates the construction of wireless receivers.

Capacity screening does not overcome the magnetic effect, and in order to overcome both these sources of loss, complete screening is necessary. The coil should be enclosed in a complete metal box and, in order to avoid loss, this must be made large in comparison with the coil to be screened.

As a compromise I designed the well-known screened coils some two years ago, and the popularity of these coils is some testimony to their past usefulness. There was definite loss introduced into the circuit, however, the effective resistance being increased about 30 per cent, in some cases, it being felt that some sacrifice of efficiency was desirable in order to obtain reasonable compactness.

Origin of the Six-pin Base

The loss, however, was present, and this is naturally undesirable, while apart from the question of efficiency, the coils were relatively expensive, and in order to bring the leads through the base of the screen, some more or less compact formation of contacts had to be adopted which, of necessity, introduced extra losses into the circuit. The now familiar six-pin base originated with the screened coils and served its purpose for the time admirably.

If the matter is examined it is found that capacity coupling is some-

what less important than magnetic coupling. It should not be thought that capacity coupling is by any means negligible. Actually, it exercises a very considerable effect, but of the two effects the capacity coupling is the less important at the normal distances which we usually separate our circuits.

Various investigators, therefore, have turned their attention to the production of coils having negligible magnetic fields external to the coil. One of the earliest of such devices was the toroidal coil. This consists in essence of an ordinary single-layer solenoid bent round to form a complete circle. Thus the magnetic field is closed on itself, as it were, and the external field is quite small.

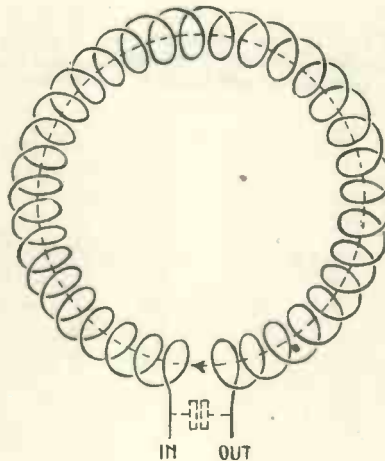

Fig. 3.—Form of toroid coil

Actually it will be clear from Fig. 3 that in going from I to O , the current has formed a complete loop and therefore the toroid is equivalent to a single-turn coil as far as its external magnetic field is concerned.

The toroid has the advantage that the beginning and end of the coil are fairly close together, which tends to minimise the capacity coupling between such a coil and its neighbour. The principal disadvantage of this method of winding is in the efficiency, for repeated tests have shown that it is not an efficient type of winding, the high-frequency resistance of such a coil being markedly greater than that of an efficient solenoidal coil.

A toroid also suffers from the disadvantage that it is difficult to wind

mechanically and involves the use of special machinery if it is to be produced commercially. A simpler form of coil which has gained popularity in this country is the binocular coil. This consists of two solenoids placed side by side so that the whole coil resembles a pair of binoculars. Hence the name.

Closed Magnetic Circuit

This form of coil is illustrated in Fig. 4, and it will be seen that the coils are so wound that the magnetic field passes up one coil and down the neighbouring coil, thereby again giving a more or less completely closed magnetic circuit.

This type of coil has the advantage that it can be made rather more efficient than a plain toroid, while again the capacity coupling is comparatively small. In both these cases, however, it is desirable to use some capacity shielding in order to obtain the best results.

Another type of coil is that illustrated in Fig. 5, where we have two coils, wound on the same former, slightly separated from each other, the two sections being wound in the opposite directions. Consequently, the magnetic field produced by the two halves of the coil oppose one another, and at any small distance away from the coil the resultant effect is zero.

It may be remarked in passing that the coil itself must have some magnetic field, as otherwise it could have no inductance, and the object of the designer is not the production of a coil which has no field at all, for this would have no inductance.

He endeavours, therefore, to obtain a coil in which the field is so located that, as far as any external

(Continued on page 70)

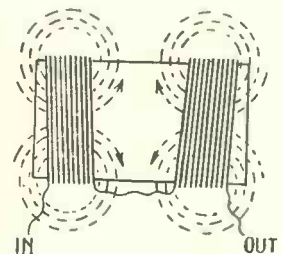

Fig. 5.—Simple astatic coil

VOLUME TONE

LONG LIFE

For volume, tone and long life B.T.H. Nickel Filament Valves are without equal. This is not an empty statement, but based on tests carried out under actual broadcast conditions and endorsed by thousands of users. Their volume and tone you can judge yourself by putting them in your set. Their long life you can only appreciate in use. You will be getting good results from B.T.H. Nickel Filament Valves when other valves have declined into inaudibility. If you use two volts use B.T.H. Nickel Filament Valves.

B 210 H	B 210 L	B 215 P
<i>R.C. and H.F.</i>	<i>General Purpose.</i>	<i>Power Amplifying</i>
Fil. Volts 2	Fil. Volts 2	Fil. Volts 2
Fil. Amps. 0.10	Fil. Amps. 0.10	Fil. Amps. 0.15
Max H.T. Volts 150	Max H.T. Volts 120	Max H.T. Volts 120
10s. 6d.	10s. 6d.	12s. 6d.

The above prices are applicable in Gr. Britain and N. Ireland only.

The New



VALVES

NICKEL FILAMENT

2893.

Made at Rugby in the Mazda Lamp Works.

The British Thomson-Houston Co. Ltd.

The New "Q" Coil (Continued)

influences are concerned, the coil behaves as if it were fieldless. Coils of this nature are often called "fieldless" for this reason, although the word is really a misnomer, and the term "astatic" is a better word to employ.

The type of coil just discussed is not as astatic as the other two and is

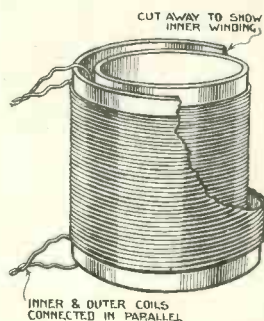

Fig. 6.—Arrangement of the New "Q" Coil

about on a par with them as regards the actual efficiency. This question of efficiency is an important one, and the average astatic coil has an efficiency distinctly lower than that of a simple solenoid, which is one of the most efficient types of coil to-day.

From this starting point, as it were, a number of experiments have been carried out at the Furzehill Laboratories extending over several months. Tests have been made on the relative efficiency of various forms of windings. Not only were existing types tried, but all manner of experimental coils were made up if it was thought that they might possibly have astatic properties.

Gauging Efficiency

Rough tests were devised in order to check quickly the relative astatic properties of any type of windings and, at the same time, to obtain some gauge of its efficiency, as a result of which the types of windings which gave most promise were able to be singled out for further experiment.

At this stage of the proceedings, more accurate testing apparatus was prepared and very careful measure-

ments were taken on the astatic properties of the various coils, while accurate measurements of high-frequency resistance were made from time to time in order that the important question of efficiency should not be lost sight of.

As a result of this research, a new form of coil has been produced which, while being sufficiently astatic for all practical purposes, has an efficiency comparable with that of the ordinary solenoid and, moreover, has a further somewhat valuable property.

As normally constituted, the coil tunes over the normal broadcasting wavelength of 180 to 550 metres, but by a simple change of connections in the actual coil itself, the tuning range is altered to cover the long waves, extending from 700 to 2,000 metres.

The coil, therefore, seems to be one of considerable promise, since it dispenses with the old difficulty of changing coils and since it is the same coil which tunes to the two wavelengths, no difficulty arises from interaction between the long- and short-wave portions.

The method of winding adopted has been protected, and a number of firms will be able to supply these

coils to WIRELESS MAGAZINE readers. For those readers who prefer to wind their own coils and conduct experiments for themselves, details will be given in future issues enabling them to do this. The construction, however, is a little critical if the best results are to be obtained.

Full Details Later

Full details of the coil and its construction will be given next month, but a rough diagram of the new coil is shown in Fig. 6. It will be seen to consist of two concentric solenoids wound in a particular manner and connected in parallel. This coil has shown not only a low magnetic field, but also a surprisingly low capacitive coupling. In fact, it behaves to a very large extent as if it were an equipotential arrangement, and it is from this property that the name "Q" coil has been derived.

The simple use of any two coils is, of course, not sufficient, and the relative sizes of the two coils have to be carefully proportioned. Further information on the new coil and its development will be given in a later article.

Look out for more details of this development in next month's issue.

Using Two Valves to Detect

IT is, perhaps, not generally realised that in most receivers the detector valve has two duties to perform, and that in certain circumstances better results would be obtained were each function undertaken by a separate valve. The large majority of sets have provision for reaction, and the detector has thus to operate as a reactor and as a rectifier of H.F. energy.

To obtain the very best results, therefore, it is a good plan to consider the use of a separate reactor valve, arranged as in a superheterodyne receiver. One noticeable advantage is that very smooth reac-

tion results from the use of a separate reactor, the reason being that this valve may be operated on the straight part of its characteristic curve. Detector valves are usually operated on the bottom bend (as in an anode-bend rectifier), and this is the cause of much uneven reaction control.

'Ware Distortion

Distortion is just as likely to be caused with a separate oscillator if reaction is pressed over a reasonable limit; however, even though anode-bend rectification is used for the detector.

M. L. B.

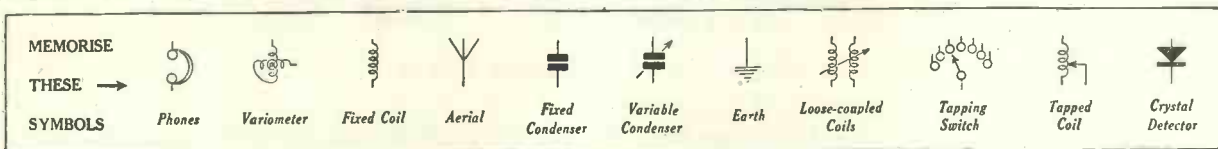

Supreme examples of Scientific Engineering.



Forth Bridge



carries on the tradition

Throughout history there are many landmarks of British Engineering Skill. In the development of wireless, "Cyldon" will be handed down as the pioneers of Better Condenser Manufacture. Since the earliest days of broadcasting "Cyldon" have led the way, not only in quality of manufacture, but in actual scientific design.

"Cyldon" Condensers have been imitated, but never equalled, and to-day are used by all leading authorities. That in itself is good reason why you should fit them on your set.

"CYLDON" CONDENSERS are specified by the Designers of
THE "ASTRAL FOUR" THE "LONG-RANGE" HARTLEY I.
 "Cyldon" Log Mid-line Condenser "Cyldon" 'Bébe' Condenser

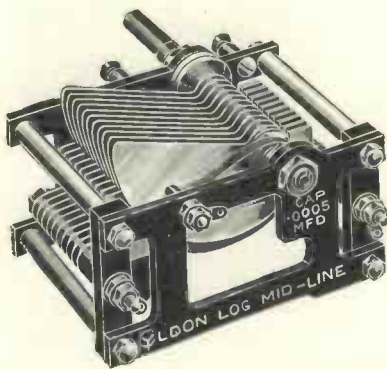

Is a true Logarithmic Condenser, designed and put on the market by us nearly 12 months ago. To-day it is almost universal, and owing to its numerous advantages over other types must be the condenser of the future: it is fully explained in our free booklet, see below. Two .0005 Models are required for the "Astral Four"

PRICES:

- List No. D1 .001 19/-
 - " D5 .0003 15/6
 - " D3 .0003 14/6
 - " D25 .00025 14/-
 - " D2 .0002 13/6
- With large 4-inch knob-dial 2/- extra.

Recent developments in Radio science have necessitated the use of a small capacity variable air-spaced condenser. For Reihartz circuits, reaction, and balancing stray capacities, etc., this new "Cyldon" product is ideal.

The vanes are shaped true square law, which is the proved best law for this particular type of condenser.

The dielectric is outside the electrostatic field. A small graduated Bakelite knob-dial, 2 inches in diameter, is supplied with each condenser.

One .0002 Model is required for the "Hartley I." Long Range Receiver

PRICES:

- List No. BB1 .0001 7/8
- " BB15 .00015 8/-
- " BB2 .0002 8/6
- " BB25 .00025 9/6
- " BB3 .0003 11/-

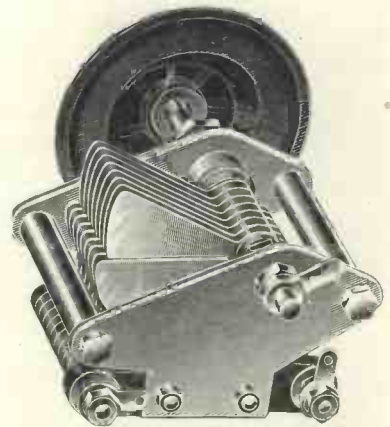

A WARNING

There is hardly anything in the world that some man cannot make a little worse and sell a little cheaper, and the people who consider price only are this man's lawful prey. Be wise—buy on quality and insist on seeing the "Cyldon" trademark on every condenser.

USE ONLY TEMPRYTES
 You will get better reception and your valves will last longer if you use "Temprytes." Write for the "Tempryte" Chart to-day. Temprytes, 1/6 each. Mounts, 1/-, Shorting Plugs 6d. Comprehensive Valve Chart FREE on application.

Write To-day for the FREE "Cyldon" booklet
 "Concerning Variable Condensers." Post Free

SYDNEY S. BIRD & SONS, LTD.
 Cyldon Works, Sarnesfield Road, Enfield Town, Middlesex

Phone: Enfield, 2071/2

"Grams: Capacity Enfield"

Contractors to the B.B.C., H.M. R.A.F., H.M.O.W. and all the leading manufacturers of quality receivers. Sole Australian Agents: E. V. Hulson, 56-57 Charlotte Street, Brisbane, Queensland. Sole Indian Agents: Bombay Radio Co., 73-75 Queens Road, Marine Lines, Bombay 2.

BROADCAST — MUSIC — OF THE MONTH



W. H. Squire, 'cellist



Leila Megane, singer



Joan Maxwell, soprano

Reviewed by *STUDIUS*

JANUARY is pre-eminently a month of good resolutions, and one cannot help wondering if the powers that mis-direct the broadcast programmes made any good resolves, such as to "cut" the talks by unknown bores, make lighter concerts without the negroid element, and, lastly, to try and forget "Who is Sylvia" and overcome the desire to "drink only with mine eyes!"

Just a few such alterations would make a vast difference. It is useless to review past events or tell us what were considered the most popular items.

Concentrate on going "better!"



Robert Chignell, singer



John Rorke, singer

A Good Musical Opening

Nicolai's comic opera, *The Merry Wives of Windsor*, made a good musical opening to the month from 5GB, and was repeated subsequently from 2LO and 5XX. One of the best known of broadcasters, Doris Vane, was announced as Mistress Page.

The old traditional ceremonies of "Auld E'el Nicht" still hold good in many parts of Northern Scotland, and Aberdeen gave an appropriate programme on January 12, when a representation of a characteristic "nicht" was transmitted.

Two works of widely contrasted character were heard also in Monteverdi's opera, *The Return of Ulysses*, and Mendelssohn's rarely heard oratorio, *Athalie*. The principals for the latter included the two excellent singers, Marjorie Parry and Rizpah Goodacre.



Dorothy Smithard, contralto



Nan Davidson, pianist

The Ceremony of the Keys

The Ceremony of the Keys, relayed from the Tower of London, was probably of interest to many people, especially, perhaps, to foreign visitors who did not hear the last transmission, December, 1926. It is one of the most difficult transmissions, as several microphones have to be employed, owing to the fact that the rounds of the guard cover a considerable area.

(Continued on page 74)



Leonard Dennis, singer



Alex McCredie, talker



Leslie Sarony, ukulele player



Sandy Rowan, entertainer



Muriel Levy, "Auntie" at 6LV

Tungstone High Tension 96 Volt De Luxe

Special Ebonite and Rubber Insulation. No Current Leakages. 3 Amp. Hour Actual Capacity.
Patented 12-16 Volt Low Tension Removable Charging shown on the Front of Illustration removed.

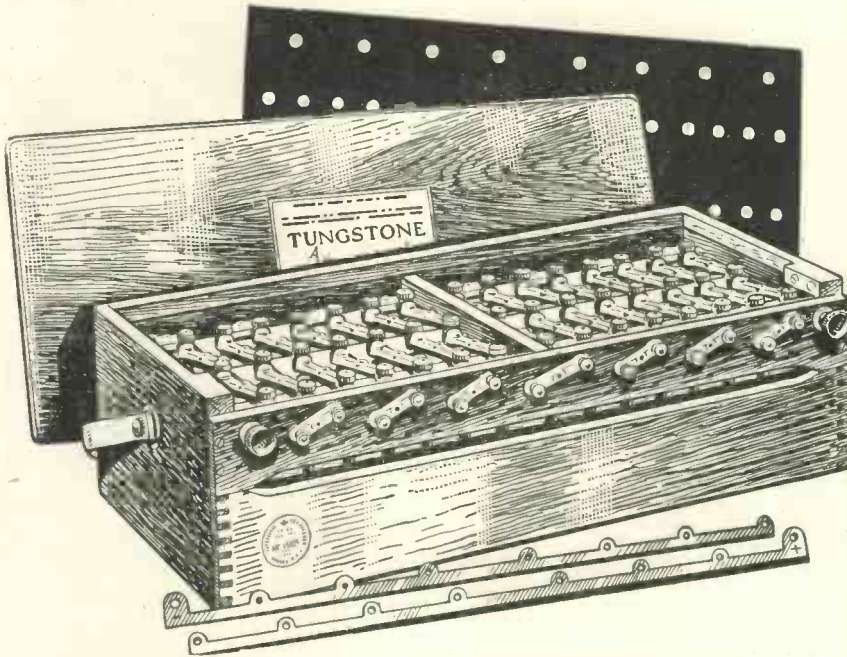

Showing Low Tension Charging Equipment removed.

Thick ebonite panel is fixed between each 48 volt section. All terminal bridge pieces are firmly mounted on an ebonite panel which forms the front of the cabinet. Rubber bands round each 2 volt unit secures independent separation and perfect insulation. Additional insulation is provided as all units stand on Rubber mat, and cabinet is fitted with rubber feet. The Cabinet is solid teak highly polished, with the new enamel, giving a glass hard surface that cannot be soiled or scratched. Twelve volt Sections can be taken out separately.

Price :

60 Volt - £5 15s. 0d.

96 Volt - £10 10s. 0d.

Sold U.K. on Extended Monthly Payments.

Apply for Details.

TUNGSTONE DE LUXE HIGH TENSION Fitted with Patented Equipment for Charging on 12-16 Volt Low Tension Plant.

First Charge completed in the Short Period of 12 Continuous Hours. Re-Charges in Seven Hours.

The practical advantage of Tungstone's exclusive feature of BALANCED PLATES, in combination with Low Tension Charging Equipment, guarantees that the First Charge and all Re-charges are fully completed, consistently and reliably, which the present-day long period charging cannot guarantee and never secures, the basic fault necessitating heavy costs for repeated re-charges at short intervals.

HIGH TENSION PLATES. EXCLUSIVE FEATURES Never Before Achieved by any other Maker.

All Tungstone High Tension Plates are SCIENTIFICALLY BALANCED in correct weight proportions of the Grid and Pure Lead Paste, so that the Ampere Hour Capacity is evenly used up by an automatic proportional discharge of current from Positive and Negative Plates securing steady voltage. No abrupt changes in the potential. The drop slow and imperceptible. No Wood Separators prevent Voltage fluctuations due to polarization and internal resistance which is negligible. No frothing or foaming. No Sulphation. No Parasitical Noises in Phones or Loud Speaker. No sudden Plate failure at a critical moment demanding Voltage adjustments. The respective Plates are Certain to get their required proportionate charge of current. If correctly First Charged is a guarantee against uneven strain and irregular drain on Plates on Charge and Discharge, and there is no chance of a separate Cell discharging and reversing long before the others. The loss of charge on standing is low and the local action small.

The open Circuit Voltage will give due warning of the approach of the Battery to a discharged state. As H.T. Cells are small it is difficult to test the Specific Gravity. Balanced Plates allow greater dependability to be placed on voltage readings. Cells are not permanently ruined by being left standing for months.

For Post Free Copy of Free Booklet on MODERN BATTERY FAILURES containing Special Illustrated Articles, send name on Postcard to:—

TUNGSTONE ACCUMULATOR CO., LTD., The Independent Battery of the British Empire,
3, St. Bride's House, Salisbury Square, Fleet Street, London, E.C.4.

Broadcast Music of the Month (Continued from page 72)



Effie Kalisz, pianist

Despite a tendency to a super-abundance of German songs, or the most banal of folk rhymes, the singers, on the whole, have proved of an excellent standard. It is always good to hear the various members of the B.N.O.C., for they have gained by long experience the art of carrying their voices over stage and ether, and articulate clearly enough to enable their words to be understood—which is an art in which too few singers are experienced.

Good Singers

Miss Doris Lemon, with Mr. William Michael, were heard early in the month, and two other

popular singers, Miss Gladys Haysack and Margaret Wilkinson. The latter, who comes from the Cardiff station, sang some really popular music.

Special mention, too, should be



Percy Bush, conductor

The orchestral element is always well represented, not only by the big symphony orchestras, but also by the smaller bodies, which I think come over much better than the large orchestras. The National Concerts at the People's Palace and the Queen's Hall have been highly successful.

Smaller Bands

Amongst the smaller bands mention must be made of Percy Bush and his Aeolian Band, heard from Newcastle, where he is a popular figure in musical circles, Paul Moulder's Rivoli Theatre *(Continued on page 76)*



Edith Penville, flautist



Nicol Pentland, talker



Glyn Eastman, singer



Gerda Nette, pianist

made of such singers as Leila Megane, one of the best-known classical singers; Miss Dorothy Smithard, a fine contralto; Miss Joan Maxwell; Mr. Leonard Dennis, heard from Daventry; and Mr. Glyn Eastman, from the Cardiff station.

Also a Composer

Mr. Robert Chignell is not only a singer, but has composed songs and operatic compositions and has long been one of the most popular of broadcasters.



Margaret Wilkinson, soprano



Melsa, famous violinist



SPECIAL OFFER

EBONITE PARTS For 1928 FIVE

DESCRIBED IN THE JANUARY ISSUE

- 4 - 4 Contact Formers
- 2 - 4 Contact Bases
- 2 - 6 Contact Formers
- 1 - 6 Contact Base

Special Low Price to Assist
Constructors of this Set

40/- THE SET

(DELIVERED FREE INLAND)

(The usual price of this set is 49/6 plus postage)



THE BECOL PANEL AND TERMINAL STRIPS SPECIFIED WILL BE SUPPLIED AT FOLLOWING SPECIAL PRICES IF ORDERED WITH FORMERS

	USUAL PRICE	SPECIAL PRICE
	s. d.	s. d.
R2 Quality Mat Panel 26 in. x 8 in. x 1/4 in.	11 5	10 4
R Polished Quality Panel, 26 in. x 8 in. x 1/4 in.	12 4	11 2
Mahogany Grained Polished Panel, 26 in. x 8 in. x 1/4 in.	17 4	15 7
Mat Terminal Strip, 5 in. x 2 in. x 1/4 in.	11	9
Mat Terminal Strip, 7 in. x 2 in. x 1/4 in.	1 0	10

PACKING AND POSTAGE ON PANEL AND 2 STRIPS 1/- EXTRA

SEND YOUR ORDER NOW—ORDERS DEALT WITH IN STRICT ROTATION

THE BRITISH EBONITE COMPANY, LIMITED
HANWELL LONDON W.7

New Lines for the New Year

THE NEW MOVING COIL LOUD-SPEAKER. All parts to make up this marvellous sound reproducer in stock. All parts of the very highest quality now in stock for COSSOR'S MELODY MAKER THREE and MULLARD'S MASTER THREE.

Why not electrify your gramophone? All makes of pick-ups now in stock. Igranic 35/-, Burne Jones 35/-, Brown £4, etc., etc.

What about a new Receiving Set either as a present for a friend or for your own use at home? Two, three, four or five valve MARCONI SETS SUPPLIED ON THE HIRE PURCHASE SYSTEM. Write in for leaflet giving all particulars and secure one of these most efficient sets.

An ideal present. Only a few left. AMPLIFLEX LOOP AERIALS. The most efficient loop yet devised. To clear, 30/-

Our new Catalogue is now ready. Send to-day for your copy—66 pages profusely illustrated with all the latest wireless components. Price 6d. to defray postage and packing. CALLERS FREE.

Secure at once the new list of parts for the moving coil loud-speaker and special reference work on same by C. P. ALLINSON, A.M.I.R.E. the well-known technical expert.

WILL DAY, LTD.

(The best in the West)

19 Lisle Street, Leicester Square, London, W.C.2.
Telephone: Regent 4577. Telegrams: Titles, Westrand, London



New Model 9/6
Pocket Volt-
meter. High
resistance.
4000 ohms.
heavy nickel
plated
case

ISN'T IT GREAT!

Sifam control brings the true realisation of what perfectly balanced reception really means. "Isn't it great!" you'll say, as the undistorted beauty and naturalness of reception is borne upon you.

The popular-priced Sifam Meters have proved a great boon to thousands of enthusiasts who have learnt the value of testing their sets every night with these precision meters, and so avoiding expensive repairs to over-discharged batteries, and burnt-out valves.

Plate and filament current is controlled in exact proportions, and distortion is banished for ever!

All instruments unconditionally guaranteed; finished in heavy nickel plate and easily adaptable to panel mounting. Ask your dealer to show complete range.

SIFAM ELECTRICAL INSTRUMENT CO., LTD.,
(Dept. M), 10a Page Street,
WESTMINSTER - S.W.1



Broadcast Music of the Month

(Continued from page 74)

Orchestra, and Fred Kitchen's Orchestra from the Astoria, London.

Solo Instrumentalists

The solo instrumentalists have included many celebrities. Amongst them was Arnold Trowell, the violoncellist. Born in New Zealand of a musical family, he played Klengel's great Concerto in A minor at the age of ten: Jean Gerardy, who was touring New Zealand, heard him and advised him to go to Europe to study. The young artist went to Frankfurt, and later to Brussels, where, at the public *Concours*, he carried off the first prize. Since his debut, he has become one of the foremost 'cellists of the day.

Another famous 'cellist heard just recently is W. H. Squire. After being principal 'cello at the Royal Opera, Covent Garden, he concentrated on solo work and became professor and examiner at the R. A. M. He has played before royalty on many occasions and at every great concert hall throughout the country. For his public performances he uses a very famous old 'cello by Bergonzi.

Amongst the Violinists

Amongst the violinists the palm must go to Melsa, one of the finest of all the great Russian violinists who have been heard in London. His debut here was made in 1913, and he quickly established himself amongst the great soloists at the London and provincial orchestral concerts. His own favourite work is Brahms's Concerto, which he plays as only a virtuoso can.

Arthur Catterall, another Hallé orchestra violinist and a Queen's Hall leader, and Signor Colomb were amongst the stars of the month.

Piano Well Represented

The piano has also been well represented, though one has heard it too much perhaps. Amongst those whose recitals may be said to be of real value are Miss Gerda Nette, Nan Davidson, who is heard most frequently from Aberdeen, Effie Kalisz, the Queen's Hall artist, and Rae Robertson.

Notwithstanding the drawbacks of only hearing and not seeing, plays still continue to be highly popular,

and by their encouragement the art of writing clever one-act plays should be revived.

For many years, owing to its neglect in the theatre, the one-act play has become the Cinderella of the drama, though one might say that it had been given the "boot" rather than the slipper! Broadcasting has brought new life to the art. A clever little example was announced from Manchester on January 11. Entitled *A Quiet Hour*, it is written by the well-known story and serial writer, Maud Isidore Douglas. Few writers have had a fuller career, and her stories are as widely read in America as they are on this side. This little play should speedily find its way on to the legitimate stage.

Three Revues

As André Charlot has joined the entertainment staff of the B. B. C., he must have joined the great majority in believing that broadcasting will not harm the theatre. He has produced three revues this month, and it is open to question as to whether he has not solved the riddle of really bright wireless entertainment.

Syncopated sounds still prevail.

As a change, the ukulele has gained as much prominence as the saxophone. One of the finest of its exponents is Leslie Sarony, the revue star. Peter and "Joan," his ukulele, were heard on January 7. Art Fowler, who broadcast twice during the month, is known as the ukulele champion. Not far behind either is Joe Fermini, of the Kit Cat Orchestra, who has been one of the chief attractions at the Alhambra with his steel guitar.

A Change in Instruments

A change in instruments was heard in the concertina, played by George Foster, and the appearance of Santa and Barbara in duets with guitars and castanets at Newcastle.

Stars in the variety world are still Tommy Handley, Mabel Constanduros, John Henry, Sandy Rowan, who made a last appearance prior to a foreign tour, Jen Latona, and Tom Clare, favourites all.

There are still too many talkers on the broadcast horizon, and most of them might well be placed on Gilbert's List—they never would be missed! On the other hand, there are a few who would be missed quite badly. Alex McCredie and Nicol Pentland, up in the North, are well liked, and Sir William Bragg, Sir Oliver Lodge, and Captain P. P. Eckersley are heard all too seldom.

How Low Can We Go?

IT has now been definitely established that with ordinary receiving and transmitting valves it is impossible to work on wavelengths of less than about two metres. This rather contradicts several of the rumours which were current when amateurs first became interested in super-short-wave working, and many almost impossible claims of successful working on one and even half a metre were made.

Valves Set A Limit

Valves set a definite limit to the minimum wavelengths workable, for below a certain range (usually about ten metres) the capacity of the electrodes becomes too great to be balanced out. The size of the electrodes may be reduced a little to

lower the capacity effect they present, but the mass cannot be cut down too far or the valve will not function.

Need for Accuracy

A wavelength of 5 metres means a frequency of 60 millions of cycles per second, and the need for accurate tuning adjustment will be obvious. As an instance of the extreme care necessary in adjusting ultra-short-wave sets, it may be mentioned that in 5-metre experiments conducted recently at WGY, Schenectady, the actual transmitter was placed in the centre of a Hertz-type aerial (a vertical wire, one half of which is aerial and the other earth) and tuned by ropes from a distance of approximately 100 yards. K. B.



Fresh as the Dawn *every morning!*

A PERMANENT SOURCE OF H.T. SUPPLY THAT RE-CHARGES ITSELF WHILE YOU SLEEP.

NO matter how much you use it—night after night, week in and week out—the Standard self-generating Leclanche battery will provide your set with abundant H.T. supply.

Enthusiasts everywhere are loud in its praise, and they have good cause to be.

It brings constant, permanent, unfailing H.T. current at a price within the reach of all. The secret IT RE-CHARGES ITSELF OVER-NIGHT!

Get this Free Book

Stocked by Halford's Cycle Stores. State number and type of valve when ordering.

For 2 Valve Sets, A.4, 90 volts, 25/1.
For 3-5 Valve Sets, D.6, 108 volts, 37/3.
For Super Sets, F.6, 126 volts, 69/6.

Goods value 10/- or over carriage paid. Deferred Terms easily arranged.



Take the first step by sending for FREE Booklet describing every detail for installing and maintaining this super-efficient and money-saving battery.

Write NOW to
Dept. E,
WET H.T.
BATTERY CO.
12, Brownlow
Street, London,
W.C.1

STANDARD

SELF-GENERATING

PERMANENT
HT.
SUPPLY

The Vital Power in Radio!

M.B. 32

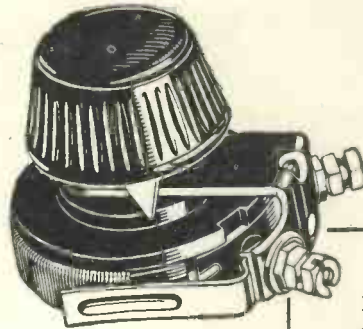

Actual Size

PRICE

2/-

The Latest and Best Rheostat

A really high-grade rheostat possessing every known refinement necessary for perfect filament control at the exceptionally low price of two shillings.

The Igranic C.H. Filament Rheostat is the greatest value in rheostats ever offered. It is not cheap and nasty, but the very best filament rheostat yet designed, backed by Igranic's unrivalled experience in the manufacture of rheostats.

The Igranic C.H. Filament Rheostat

embodies every feature which experience has shown desirable for perfect filament control. The body is of Bakelite, providing perfect insulation. The contact finger is of a well-tried type which provides a smooth-running contact free from chattering and noises. Terminals are conveniently placed and easily accessible from the top of the set.

A particularly attractive feature is its compactness. It is only 1 3/8 in. in diameter and projects only 3/8 in. behind the panel. One-hole fixing, for panels 1/8 in. to 3/8 in. thick, makes it easy to mount. Supplied in three resistance values, viz., 6, 15 and 30 ohms. Price 2/-.

Your dealer has them or can get them for you immediately.

Write to Dept. J 397

Igranic components are always stocked by reputable dealers. All reports received by us of difficulty in obtaining them receive immediate attention.



149, QUEEN VICTORIA STREET,
LONDON, E.C.4
Works: Bedford.

BRANCHES:

Birmingham, Bristol, Cardiff, Glasgow, Leeds, Manchester, Newcastle.



Specially Prepared by JAY COOTE

DURING the past twelve months but little broadcasting developments appear to have taken place in Spain, although on many occasions we have been told that the Union Radio group of Madrid would undoubtedly obtain a sole concession from the authorities and thus be empowered to rule the roost.

Control of Six Stations

EAJ7, as the G.H.Q. of this association during 1927, has managed to secure control of broadcasting stations at San Sebastian, Cadiz, Seville, Bilbao, and Barcelona, and to a certain degree has been able to introduce an S.B. system for the broadcast of its principal entertainments.

Generally speaking, however, individual programmes from these stations have not greatly benefited, and to Spain, as a rule, on some evenings per week, I merely turn for the relay of operas via Barcelona, performed at the Gran Teatro del Liceo in that city, or for excellent dance transmissions effected at the Madrid Alcazar.

When other broadcasters have signed off for the night and tucked up their announcers in their little cots, you will still pick up the "Ayah-hota-siete" call at frequent intervals. Both EAJ7 and San Sebastian come on the air at 10 p.m. with transmissions, and it is at this time of the night that on three days weekly Madrid gives you a glimpse of the life and gaiety inherent to its brilliantly decorated Alcazar.

Favourite Ousted

For some eighteen months the Ice Palace, in the Spanish capital, was the popular dance-hall; it has now been ousted by the Alcazar, in which nightly from 11 p.m. until the early morning hours the Palermo and Robinson bands perform in rapid relays.

But a Spanish dance-hall is in no way similar to a *palais de danse* you may have visited in England or

Wales. You will hear the playing by the orchestras of many up-to-date charlestons and blues; you may even recognise some of the melodies, as you are sure to catch the words of a chorus sung in English, but the entertainment does not consist of dancing alone.

Between items an announcement will be made in Spanish, followed by much applause, and to your surprise your ears will capture the tinkling of guitars accompanying some popular Spanish song rendered by a female chorus. Or, again, a solo will be given, in which, after each verse, the entire audience and orchestra will sing the chorus. There will be more applause—perhaps an encore—and dancing to modern syncopated music will be resumed.

Mixed Entertainment

The Alcazar "nights" are a mixture of dancing, professional ballet, variety, and music-hall entertainments. There would appear to be no time limit to the studio hours, for if it is a really jolly night the broadcaster remains on the air far beyond its scheduled closing-down hour.

Now that the new German super-power station of Königswusterhausen-Zeesen is in full operation, but few listeners can have failed to hear its transmissions. For the time being, at least, it will continue to operate on 1,250 metres, and its power is already such that it blots out any chance of receiving a transmission on a neighbouring wavelength. I am informed that the engineers play with some 120 kilowatts as input energy, of which for some weeks they will continue to modulate 45 kilowatts, giving a final output of about 18 kilowatts. Later, however, it is expected that the power will be increased.

Although the new transmitter is actually erected on the banks of Lake Zeesen, it will still retain the name of Königswusterhausen; but,

as the most powerful of the German transmitters, it has adopted the distinctive title of Deutschlandsender. The original Königswusterhausen, so familiar to you, has been relegated to the more prosaic commercial services.

New Short-wave Service

Zeesen, too, very shortly will boast of a new 10-kilowatt short-wave equipment for the broadcasting of the Berlin programmes, which the authorities are anxious our U.S.A. cousins should enjoy.

Even with the installation of the 45-kilowatt giant, the German Posts and Telegraphs do not consider their system complete, and before next spring a relay station of small power will be erected at Flensburg, in Schleswig-Holstein. Until now the German inhabitants of this province, on the borders of Denmark, have had to turn to Copenhagen for their wireless entertainments, but in future, through their local transmitter, they are to be connected to Berlin or Hamburg—most probably the latter.

Later, also, in the spring, a further relay of Munich is to be opened at Hochspeyer, near Kaiserslautern, the second station to be erected in territory still occupied by the allies.

A Home for the Old Plant

What will eventually be done with the Dortmund plant, which has now been superseded by Cologne, I am not quite sure, but I have no doubt that a new site will be found for it. If I were given to guessing, I would suggest Silesia, where both Breslau and Gleiwitz—especially the latter—are both over-powered by the new Polish Cattowitz station. *Nous verrions.*

Time after time, when tuning-in to German stations, at night, you must have listened to concert transmissions from some famous café or restaurant. Langenberg, on several evenings, weekly, takes its listeners for outside broadcasts to Cologne,

Dusseldorf, Essen, Münster, and Dortmund, and there is no doubt that on occasion you must have expressed surprise at the excellent quality of the orchestras heard.

Different from Our Cafes

When doing so you should bear in mind that the German café-restaurant is in but few details similar to what we term a café (usually pronounced *kafe*) in this country.

In the latter we realise an exaggerated teashop in which light refreshments, usually of the temperance order, are dispensed. In London and two or three other of our main cities we do find establishments conducted on a larger scale, but in many ways, although they may possess an orchestra, they cannot be compared to the café-restaurants so numerous in continental cities.

Home Life in Germany

Generally speaking, of the European nations, Germany is the one which, in its home life, mostly coincides with British ideas; but, notwithstanding this fact, it is a recognised rule that at least three to four times weekly Herr Muller and his wife, sometimes flanked by multiple little Mullers, should spend an hour or two at one of the gaily lighted and somewhat over-ornamental *Bierkeller*, or *brasseries* as they are termed in France.

Some of these establishments I have visited, in Berlin, Frankfurt, Hamburg, and other important provincial cities, are of majestic proportions and, apart from a spacious ground floor, usually possess an extensive gallery at both ends of which orchestras perform. It is not an uncommon sight to find in these houses concerts provided by some thirty musicians, under the leadership of a bandmaster of repute. Notwithstanding the fact that the average German in the course of an hour or so can dispose of several quarts of Munich or other lager, he is noteworthy for his sobriety.

A Happy Gathering

Should you visit one of these cafés on a popular night, you would wonder at the number of marble-topped tables closely packed together, and the interminable rows of stone beer-mugs in front of which the German paterfamilias sits, placidly smoking his cigar, the while his wife, also

(Continued on next page)

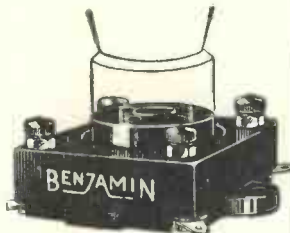
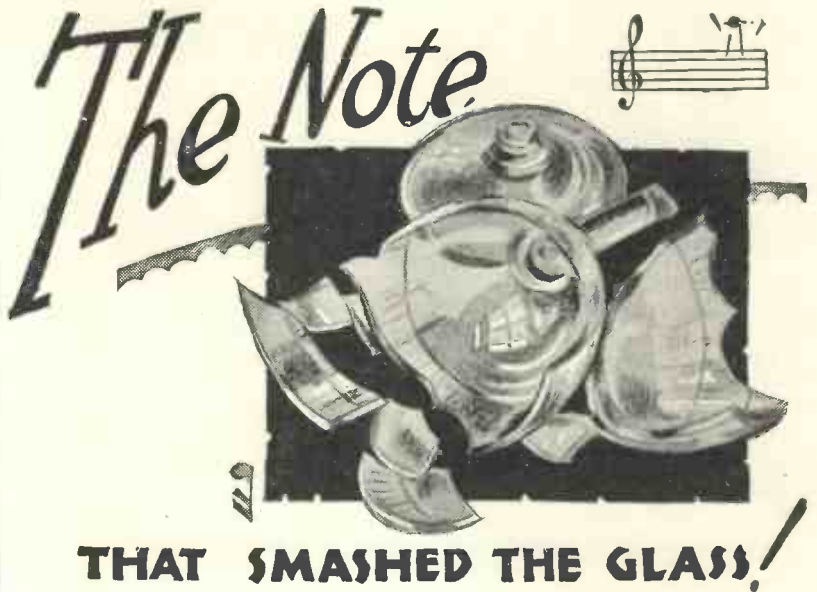

BENJAMIN Clearer-Tone Anti-Microphonic VALVE HOLDER

Make sure that the anti-microphonic valve holders you buy are Benjamin, because in these alone you get these 5 essential features:—

- (1) Valve sockets and springs are made in one piece with no joints or rivets to work loose and cause faulty connections.
- (2) Valves are free to float in every direction.
- (3) Valves can be inserted and removed easily and safely.
- (4) Valve legs cannot possibly foul the base-board.
- (5) Both terminals and soldering tags are provided.

Price 2/- each

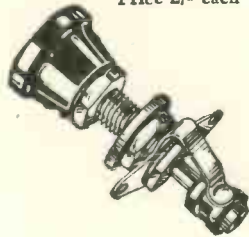

BENJAMIN BATTERY SWITCH

A sturdy positive action switch for high or low tension. It's OFF when it's IN, thus preventing the accidental turning on of current. Single contact. One-hole fixing.

Price 1/- each

There is a story told of a famous singer that he could sing a certain note into a wineglass and smash it into fragments by the vibration.

This is an extreme instance of the damage vibration can do. Nearer and dearer to you is the damage vibration does to the delicate filaments of your valves.

Every time a lorry rumbles past your house a wave of vibration travels to your radio set. Every time you walk across the floor another wave is sent.

The only way you can thoroughly stop vibration reaching the filaments is to fit Benjamin Anti-microphonic Valve Holders.

The smallest shock and vibration is quenched by the wonderful one-piece springs. Microphonic noises are entirely eliminated. The life of the valve is trebled at least.

BENJAMIN

ANTI-MICROPHONIC VALVE HOLDER

PRICE 2/- EACH.

THE BENJAMIN ELECTRIC LTD.

Brantwood Works, Tariff Road,
Tottenham, N.17.

Continental Notes *(Continued)*

provided with her *litre*, feeds her offspring with cakes or other delicacies extracted from time to time from a capacious handbag.

“*Stammtisch*”

Some tables, in the middle of which you will find a small metal menu-holder bearing the word *Stammtisch*, are reserved to men only. The *Stammtisch* is an institution which you will only find in Teuton countries, although its equivalent also exists amongst the Slavonic nations. The German but seldom belongs to a social club; his favourite café acts as a substitute, and here, at least three times or more weekly, he will meet his “cronies.” If he is a regular customer the table is reserved for him and his friends.

In smaller towns the *Stammtisch* in the principal café is the centre of social interest; it is at this table that the local doctor, the lawyer, the chemist, and other notables meet to

discuss political matters. To be invited to one of these sessions is considered a great honour, greatly envied by one's neighbours.

The average concert given in these establishments, although termed “popular” from the German point of view, is usually made up of musical compositions which in these isles would be considered to err on the high-brow side. Some restaurants, in addition to their musicians, sometimes even possess a large manual organ.

The Teuton, on the whole, greatly appreciates good music, of which he has a good all-round knowledge; when listening to broadcasts from these establishments you must have noticed how a sound performance of a classical work is greeted with rounds and rounds of applause.

From the point of view of comparison, I find that the quality of the concert broadcast from these café-restaurants is quite on a par with

those made from studios; if anything, they show more variety.

If your programme informs you that a German transmitter is going over to some outside hotel, do not jump to the conclusion that you will only hear charlestons of the “Ain't She Sweet?” variety; you will be agreeably surprised at the entertainment offered to Herr Muller or Herr Schmidt and his little family.

Poland's Activities

Poland has added a further transmitter to her broadcasting system; it is the station of Wilno or Vilna, a city which remains a bone of contention between the Polish and Lithuanian republics. Wilno, for most of its programmes, is dependent on the Warsaw studio; its wavelength is 434.8 metres; its power a nominal 1½ kilowatts. I doubt very much whether its transmissions will be heard on this side of the Channel.



Wave-length in Metres	Station	Call Sign	Wave-length in Metres	Station	Call Sign	Wave-length in Metres	Station	Call Sign	Wave-length in Metres	Station	Call Sign
24	Chelmsford	5SW	294.1	Hull	6KH	370.4	Bergen	—	491.8	Davenport Experimental	5GB
30	Beigen	—	—	Innsbruck	—	375	Helsingfors	—	500	Aberdeen	2BD
37	Vitus	—	—	Stoke-on-Trent	5ST	—	Madrid	EAJ	504	Porsgrund	—
40	Radio Lyon	—	—	Swansea	5SX	379.7	Stuttgart	—	508.5	Brussels	—
56.7	Nauen	—	297	Liverpool	6LV	384.6	Manchester	2ZY	517.2	Vienna	—
61	Paris	—	—	Radio Agen	—	394	Toulouse	—	535.7	Munich	—
158	Beziars	—	—	Hanover	—	394.7	Hamburg	—	549	Milan	—
200	Biarritz	—	300	Koscice	—	400	Aachen	—	555.6	Budapest	—
223.0	Leningrad	—	302	Radio Vitus	—	—	Bilbao	—	566	Harmir	—
236.2	Stettin	—	303	Nuremberg	—	—	Cork	6CK	566	Augsburg	—
238	Bordeaux	—	306.1	Belfast	2BE	—	Cadiz	EAJ3	—	Cracow	—
241.9	Munster	—	309	Marseilles	—	—	Madrid	Radio 5	—	Freiburg	—
250	Gleitwitz	—	—	Oviedo	—	—	Mont de Marsan	Esp11	573.6	Vienna	—
252.1	Bradford	2LS	312.5	Newcastle	5NO	—	Plymouth	5PY	588	Zurich	—
—	Montpellier	—	317	Milan	—	—	Salamanca	EAJ22	675	Moscow	Popoff
—	Kiel	—	—	Almeria	—	405	Glasgow	55C	680	Lausanne	—
254.2	Toulouse	—	319.1	Dublin	2RN	405.4	Reval	—	760	Geneva	—
260	Bratislava	—	322.6	Breslau	—	408	Beine	—	1,000	Leningrad	—
263.2	Strassburg	8GF	326.1	Bournemouth	6BM	411	Gleitwitz	—	1,100	Basle	—
268	Sheffield	6FL	329.7	Konigsberg	—	422	Cattowitz	—	1,060	Hilversum	HDO
272.7	Bremen	—	333.3	Naples	—	—	Notodden	—	1,111	Warsaw	—
—	Cassel	—	335	San Sebastian	EAJ8	423	Frankfort	—	1,153	Kalundborg	—
—	Danzig	—	—	Cartagena	—	428.6	Freidriksstad	—	1,180	Stamboul	—
—	Klagenfurt	—	—	Reykjavik	—	434.8	Seville	—	1,250	Königswusterhausen	LP
273	Limoges	—	337	Copenhagen	Radio-raadet	—	Viina	—	1,320	Motala	—
275.2	Dresden	—	—	Paris	Petit Parisien	441.2	Brunn	—	1,450	Moscow	RDW
—	Nottingham	5NG	340.9	Barcelona	FAJ1	448	Rjuken	—	1,600	Bucharest	—
277.8	Leeds	2LS	—	Posen	—	450	Rome	—	1,604	Davenport	5XX
278	Grenoble	—	344.8	Prague	—	458	Paris	—	1,760	Kharkov	—
279	Bordeaux	—	—	Cardiff	5WA	461.5	Oslo	—	1,750	Paris	CFR
283	Dortmund	—	348.0	Graz	—	462	Barcelona	—	1,800	Norddeich	—
—	Cologne	—	353	London	2LO	470	Langenberg	—	1,804	Angora	—
287.0	Lille	—	357.1	Leipzig	—	476	Lyons	—	1,850	Huizen	—
288.5	Edinburgh	2EH	361.4	Paris	RadioLI	481.0	Berlin	—	1,950	Scheveningen	—
291	Radio Lyon	—	365.8	—	—	—	—	—	2,650	Paris	FI
294.1	Rennes	—	370	—	—	—	—	—	—	—	—
—	Dundee	2DE	—	—	—	—	—	—	—	—	—

PERSONAL SHOPPERS

WE ARE OPEN TWO SHOPS if one is closed the other is open.

ALL DAY SATURDAY ALL DAY THURSDAY ALL DAY EVERY DAY Hours 9 a.m. to 8 p.m. Sat. 9 a.m. to 9 p.m. Sunday morning 11-1

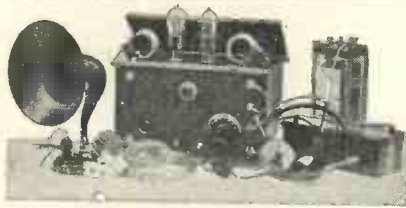

THREE-VALVE LOUD-SPEAKER SET
NOTE THE WONDERFUL VALUE. TRY ONE OF THESE!
(The set shown is two-valve.)

Gets Local Daventry and many Continental stations. THIS MAGNIFICENT 3 VALVE SET (D & L.F.) includes Handsome Polished American-Type Cabinet (all parts enclosed), 3 Dull Emitter Valves, Tuning Coils, H.T. & L.T. Batteries, Aerial Equipment, Leads, Loud Speaker of Phones. Tax paid £6/6/0 Net

JUST THINK OF A 3-Valve Set £6/6/0 It sounds unbelievable. doesn't it?

TWO-VALVE SET exact to above specification
£5 5 0 CARRIAGE AND PACKING 5/-

MARCONI, EDISWAN, OSRAM, B.T.H., COSMOS VALVES at USUAL PRICES.

UNITS and PICK-UPS, all makes. AMPLION, CLIMAX, BENJAMIN, WEARITE, COLVERN, DETEX, DUBILIER, PENTON, EDISWAN, ORMOND, FERRANTI, HARLIE, IGRANIC, LOTUS, LISSEN, FORMO, MARCONI, MULLARD, OLDFHAM, WATMEL, POLAR, EXIDE, W. & B., DUBILIER, McMICHAEL, UTILITY, HELLESEN, B.T.H., SIEMENS, BURNEPT, EVER - READY, LEWCOS, BELLING-LEE, and all proprietary lines stocked.

THE NEW NO. 3 ORMOND S.L.F. CONDENSER

00025, 5/6; 00035, 5/9; 0005, 8/-. With 4 in. Dial. With Friction 55-1 4 in. Dial, 6/- each extra. ORMOND, Square Law Low-Loss. 0005, 9/6; 0003, 8/6 (1/6 each less no vernier); Friction Geared, 0005, 15/-; 0003, 14/6; 00025, 13/6. Straight Line, Frequency Friction Geared, 0005, 20/-; 00035, 19/6. S.L.F. 0005, 12/-; 00035, 11/-.

FILAMENT RHOESTATS, Dual, 2/6; 6 ohms or 30 ohms, 2/-. Potentiometer, 400 ohms, 2/6. 0001, Reaction, 4/-; Air Dielectric, 2/-; Neutralising 4/-; Neutrodyne, 2/-; Twin Gang, 0005, 32/-; Triple, 40/-; H.F. Choke, 7/6. Geared Dial, 5/-.



LOW LOSS SQUARE LAW CONDENSER
0003 4/11
0005 4/11
By Post 5/11
With VERNIER 1/- extra.



LOG-MID-LINE CONDENSERS
Try our NEW VARIABLE CONDENSERS, made on the Log-Mid-Line principle. 0005 or 0003, with a 4-in. Triolite Dial, the best you can buy, for the moderate price of 5/11 each post free

LISSEN

Valve-Holders, 1/-; Fixed Con., 1/-, 1/6; Leaks, 1/-; Switches, 1/6, 2/6; Latest 2-way Cam Vernier, 4/6; Rhoestats, 2/6; B.B., 1/6; Lissenola, 13/6; L.F. Transformers, 8/6; 100 v. H.T., 12/11; 60 v. H.T., 7/11; Coils, 60 X, 6/4; 250 X, 9/9.

J.B. CONDENSERS

T.T. Friction Ver. 0005, 16/6 00035, 15/9 00015, 16/- S.L.F. 0005, 11/6 00035, 10/6 00025, 10/- 00015, 10/- Sq. Law 0001 9/6 0005 8/- 0003 7/- Neutralising 3/6



CABINETS

Large stocks of really useful cabinets kept or made to order. Solid oak, glass finish, American type, hinged lid, baseboard.

10 x 8 x 8	8/11
12 x 8 x 9	11/6
14 x 7 x 9	13/11
16 x 8 x 9	16/11
18 x 8 x 9	19/11
20 x 8 x 9	22/6
21 x 7 x 9	25/-
24 x 7 x 9	27/6

Carr. & Packing 2/6 extra. MAHOGANY POLISHED 5/- EACH EXTRA.

IT IS IMPOSSIBLE TO ADVERTISE ALL THE WIRELESS PARTS NOW ON SALE BUT IF YOU WANT THEM TRY RAYMOND'S FIRST! BE SURE YOU VISIT THE Bargain Window.

New 100-page Catalogue. Profusely illustrated Price 1/- Post FREE, allowed off first 10/- order

SET OF THE SEASON COSSOR MELODY MAKER COMPONENTS FOR SAME £4 10 0 Kit.

2 Ormond 0005; 2 Do. S.M. Dials; 6 T.C.C. Condensers, 001, 002, two 0003, 0001, 2 mfd.; 2 Grid Lk. Clips, B.B.; 1 Var. B.B. Rhoestat; 3 Dubilier Leaks, 25, 3, 4 meg.; 3 Lotus V.H.; 1 Ferranti A.F.3; 2 Panel Switches; 1 Cossor Melody Wound Coil; Terminals, Name Tabs, Glazite, 9-v. Grid Bias (all as specified).

NOTE Drilled High-grade 21 x 7 Polished Panel, with Radion Strip, FREE with above kit.

NOTE Handsome American Cabinets, hinged lid, Baseboard. List: Oak, 23/-, for 13/11; Mahogany, polished, list 32/-, for 22/6. If purchased with above kit, ALL CARRIAGE AND PACKING EXTRA.

'MULLARD MASTER THREE'

NO SOLDER—ONLY 20 WIRES TO CONNECT. COMPLETE SET OF COMPONENTS

- The components specified:
- | | |
|--|---|
| 2 Terminal strip, 2 1/2 in. x 2 in. x 1 1/2 in. | 1 Broadcast wave Master Three coil (Colvern). |
| 1 Coil base | |
| 1 S.L.F. variable condenser, -0005 mfd. (J.B.) | 1 On and off switch (Bulgin). |
| 1 S.L.F. variable condenser, -00035 mfd. (J.B.) | 1 R.C.C. unit, type A (R.I.-Varley). |
| 1 H.F. choke (Climax). | 1 L.F. transformer, G.P. (R.I.-Varley). |
| 3 Anti-vibratory valve holders with terminals (Pye). | 1 Combined grid leak, 2 menohms, and condenser, -0003 mfd. (Mullard). |
| 1 Pair panel brackets | 8 Wander plug—4 red, 4 black |
| 4 Terminals—A, E, L.S.—, L.S.+ (Belling-Lee). | Suitable length of red and black flex |
| 1 Set of A B C connecting links (Junit). | 1 Ebonite bush, 3/16 in. diam., 3 in. hole, 3/16 in. thick. |
| 2 Spade terminals—1 red, 1 black | |

And 3 Mullard P.M. Valves. ABOVE KIT £6 17 6

FREE. High-grade Aluminium Panel (drilled), G.B. Battery and 108 volt H.T. given free with above. All carriage and packing extra, or Panel free and Cabinet 18 x 7 x 10 deep. (American type hinged lid) for 15/- with above kit only (list price 25/-.)

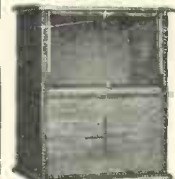

OAK CABINETS

American type, opens at back, compartment underneath for batteries, etc. 12 by 8 by 9 in. deep 18/11 16 by 8 by 9 in. 25/11 Case and Carriage 2/6 Solid Oak, glass finish, beautifully made.

DARIO VALVES

(Genuine Radio Micro) Best in the World. BIVOLT 2-v. .05, 7/6; Loud Speaker Valve, 10/9; E.C. 1-8, 7/6; 3-5 7/6; Loud Speaker Valve, 10/9; 3-5 R.C. .07, 7/6. Post 6d. each.

BARGAIN COLUMN

MAGNIFICENT VALUE Sold to Callers only when buying other goods. See matter at side.

LOUD SPEAKER UNITS

IF YOU SPEND 20/- further in ORDINARY full list priced goods, you can at the same time (only) buy one of these WONDERFUL UNITS, handsome appearance, make lovely presents. JUST THINK, ONLY 5/-

BRAND NEW. LIST PRICE 9/11
OUR PRICE 5/-

DOUBLE READING VOLTMETERS

For H.T. & L.T. A VOLTMETER is always useful and acceptable. If you want one for 3/11, you need only make up a little order value of a further 20/-, at ordinary list prices and it is yours!

BRAND NEW. LIST PRICE 7/11
OUR PRICE 3/11

EBONITE PANELS

Panels are always in demand. These can be had at prices mentioned if you spend 6/6, 7/6, 8/6 or 10/6 more respectively.

BRAND NEW
10 x 8 1/-
12 x 8 1/6
14 x 8 2/-
16 x 8 2/9

ACCUMULATORS, 2 v. 40 amps.

OF COURSE, you say there is a catch in it—but where? Well, there is NO CATCH. It's simply we want all your business, and in return we help you. In the case of your wanting this high-class Accumulator for 4/11, just give an order for a further 20/- of ordinary goods and it is yours.

BRAND NEW. LIST PRICE 8/11
OUR PRICE 4/11

LOUD SPEAKERS

THESE LOUD-SPEAKERS are really wonderful VALUE. And you can purchase at same time with other goods value from 20/- up to 50/-. Many well-known non-proprietary makes are shown in window.

BRAND NEW. With other goods only. LIST PRICES: 16/11, 20/-, 21/-, 25/-, 30/-, 40/-, 50/-.

OUR PRICE 8/11, 10/6, 12/11, 15/-, 21/-, 30/-

HIGH TENSION BATTERIES

JUST AS MANY HIGH-TENSION BATTERIES are being sold (but they must be good). These are a first-class make. Buy a 60-volt for 3/6 with your 20/- order, and a 100-volt for 5/11 with 25/- order. LOOK WHAT YOU SAVE!

60 volt. BRAND NEW. LIST PRICE 6/11	OUR PRICE 3/6	100 volt. BRAND NEW. LIST PRICE 11/6	OUR PRICE 5/11
-------------------------------------	---------------	--------------------------------------	----------------

SLOW MOTION DIALS for fine tuning

THESE ARE WONDERFUL DIALS, and you must have one to make your set more selective. Make up your order for a further 10/6 worth ordinary goods and it is yours for 2/3.

BRAND NEW. LIST PRICE 4/6
OUR PRICE 2/3

VARIABLE CONDENSERS (LOG MID-LINE BALL BEARINGS.)

THIS IS A FIRST-CLASS CONDENSER for true tuning (and with the addition of a vernier dial you have as good an article as can be bought elsewhere for the price). It only needs you to purchase 12/6 worth of ordinary goods to secure one for 2/3.

0003, 0005
BRAND NEW.
LIST PRICE 4/11
OUR PRICE 2/3

AMERICAN CABINETS

(Mahogany Polished) Hinged Lid, Baseboard. NO WIRELESS SET is complete without a cabinet, is it? So just to help you on the way, you can buy a 12 in. by 8 in. for 5/- with 25/- worth of ordinary goods, and 14 in. by 8 in. for 7/11 with 35/- worth.

12 x 8 BRAND NEW. LIST PRICE 10/9	OUR PRICE 5/-	14 x 8 BRAND NEW. LIST PRICE 15/11	OUR PRICE 7/11
-----------------------------------	---------------	------------------------------------	----------------

INDOOR AERIALS

With Lead-in and Insulators A SPLENDID LITTLE AERIAL, copper, special design. You can buy one for 1/- with a further 5/- worth of goods at usual prices.

BRAND NEW. LIST PRICE 2/-
OUR PRICE 1/-

SIX-PINE F. Transformer, long or short wave. Split Primary or Split Secondary

THESE are a first-class make and need only to be seen to be appreciated. A purchase of a further 15/- worth of goods entitles you to buy one at 3/6.

BRAND NEW. LIST PRICE 7/6
OUR PRICE 3/6

ABOVE GOODS SOLD TO CALLERS ONLY.—NO POST.—Please read matter at side of each item carefully to avoid mistakes.

DON'T FORGET TO READ THE BARGAIN COLUMN.

K. RAYMOND
27 & 28a, LISLE St., LONDON, W.C.2.
Phone: Gerrard 4637.

COME TO LEICESTER SQ. TUBE (Important) Ask for back of Daly's Theatre This address is opposite.

Working Ranges of Broadcast Receivers (Continued from page 16)

each of which produces different currents because each has a different circuit to flow through, or rather the circuit has different impedances for the three types of current.

The D.C. voltage produces a current through the crystal and choke L, the high-frequency a current through the crystal and condenser C, and the combination of these two currents decide an average position in the crystal characteristic round which the L.F. alternating-current voltage operates, and this position must be taken to determine the crystal conductance, which conductance, being the slope of the characteristic, will obviously alter with amplitude.

High-impedance Circuit

The low-frequency voltage in the transformer or equivalent transformer case is not allowed to produce a large current, but we attempt to get as much of it across the transformer primary or the equivalent choke L, and we do this by making the circuit LC of high impedance compared with the crystal resistance, so that practically all the applied voltage is across L.

The natural frequency of the combination LC will be about 1,000 cycles, and at 1,000 cycles, if there are no losses in L and C, then the LC combination is of infinite impedance.

As we go away from the 1,000 cycle point the decrease of impedance will depend upon the ratio of L to C, the lower L is the more rapidly the impedance will drop. As in audio reception it is necessary to keep the reception fairly uniform over wide ranges of frequency, there is a certain value of L below which we must not go, and this value depends upon the crystal resistance. The lower the crystal resistance the lower the value of L can be.

In transformers one factor that is fixed is the inductance of the secondary because in practice a limit is reached of L, due to self-capacity of the windings and the capacity of the valve, and in a transformer we can increase the number of secondary turns only by accepting a lower natural frequency, so that lowering the primary inductance is the usual way of obtaining higher step-up ratio. The best winding is that with no more falling-off of magnification at the limits of the audio frequency scale than we can stand for.

Working a Loud-speaker

An ordinary crystal, such as that I have shown the characteristic of, will give a very fair frequency curve with a choke value of about 1 henry shunted by appropriate condensers. Now by the simple operation of putting a secondary round the choke and converting it into a transformer and removing the condenser all but just sufficient to act as a high-frequency bypass, we shall get a step-up ratio in practice of between 10 and 15. The stepped-up voltage we can apply to the valve for the purpose of working a loud-speaker.

As a concrete example of this crystal arrangement, illustrated in Fig. 5, I

will now give some approximately accurate figures, and from these we shall be able to estimate at what distances the circuit will work the loud-speaker at full volume.

Taking firstly a good aerial 6 metres high at ten miles from 2LO, the total millivolts will be 60. The aerial of 20 ohms will have its resistance doubled when the crystal is applied, and the current will be .0015 ampere.

The H.F. voltage across a tuning

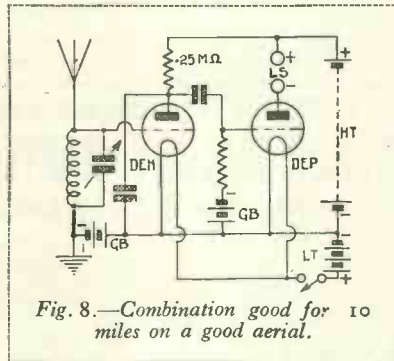

Fig. 8.—Combination good for 10 miles on a good aerial.

inductance of 100 mhys at 360 metres will be .75. The best tap-off for a crystal with a slope of 1,000 ohms will be one-third up the tuning-coil so that the real voltage applied to the crystal will be .25 volt.

I find from these figures that across the secondary of a transformer 15/1 ratio there will be an alternating voltage of 1.5 volts, taking normal maximum modulation at the transmitter.

This 1.5 volts is a peak voltage and as a normal power valve at 120 volts requires about 8 volts grid bias, we shall need a strength at least five times that which we have to load the power valve up to full strength. By using reaction from the power valve, illustrated

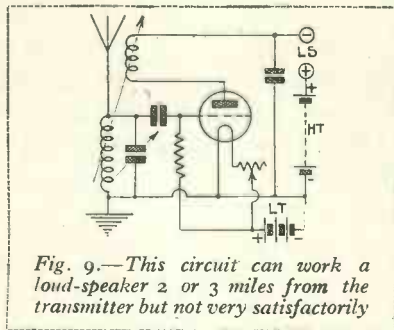

Fig. 9.—This circuit can work a loud-speaker 2 or 3 miles from the transmitter but not very satisfactorily

in Fig. 6, it might be possible to safely double the 1.4 to 2.8, but to get a further doubling will need a bigger aerial or a nearer broadcasting station.

As the field strength at five miles is likely to be 30 millivolts per metre, with a good aerial and a little reaction, it should be possible to get full loud-speaker signals at a distance of five miles, but (1) a really good aerial must be erected; (2) the aerial resistance must be low and this includes a good earth; (3)

the crystal must be a good one capable of rectifying well up to two volts; (4) a high ratio of transformer must be used.

Having taken up fairly minutely this crystal case, let us take up more briefly some further arrangements.

If the 1.5 volts which we obtained from the crystal at ten miles are applied to a DEH valve with a resistance in the plate circuit of 25,000 ohms we can obtain about 25 volts across the resistance, much more than sufficient to work the power valve with R.C. coupling fully out and if everything went well, the combination should be good for 20 miles (Fig. 7) but as crystal rectification falls off with strength of signals we can probably give the combination a range of 15 miles, if a little reaction is used.

Plate-bend Rectifier

If a DEH valve is used as a plate-bend rectifier, and no crystal is used the problem is a little different. We can now put the grid right on to the top of the aerial coil without adding any resistance to the aerial as the crystal does, and we shall get about 1.5 volts applied to the grid. I work this out as giving about 10 volts on to the power valve, enough to give full strength and ample without reaction at ten miles.

A grid-leak rectifier is a very indefinite article as the volume obtainable depends so much upon the quality we want, but anyhow it is very unsuitable for running a loud-speaker direct, but if we consider it carefully we can see that to some extent it is equivalent to a crystal and low-frequency magnification with resistance coupling and without the advantage of a step-up transformer it is not so good as the crystal transformer and power valve arrangement, therefore with a power valve attached it is not so good as a crystal and two valves, if resistance-capacity-coupling is used between the rectifier and the power valve, but as in this grid leak rectifier case we can use a ratio transformer, the whole combination will probably just about equal the crystal and two valves, with possibly the advantage of a slightly easier reaction circuit but with a more doubtful quality.

Everything points to the best balanced combination of all being the anode-bend rectifier and two low-frequency stages (Fig. 10) resistance-capacity-coupled and, as we avoid transformers in this arrangement, the cost should not be more than the two-valve grid-leak-transformer set although three valves are used. I should give this combination a range of 15 to 20 miles.

Comparison of Ranges

The final comparison of ranges will be:

- (1) Crystal and power valve—5 miles.
- (2) Crystal, one L.F. and power-valve R.C. coupled to power valve—15 to 20 miles.
- (3) Grid-leak rectifier—two to three miles.
- (4) Grid-leak rectifier and power-valve (transformer-coupled)—15 to 20 miles.

(Continued on page 84)

MAKE YOUR OWN CONE SPEAKER

with THE NEW WONDER BULLPHONE CONE UNIT

as recommended by the "WIRELESS MAGAZINE" Technical Staff



AMAZING VALUE

ASTONISHING RESULTS are guaranteed with this Unit equal to the most expensive Loud Speakers yet made.

SATISFACTION GUARANTEED OR MONEY REFUNDED

Obtainable from your Local Dealer or direct from:-



COMPLETE INSTRUCTIONS ON PAGE 21 OF THIS ISSUE

EXACTLY AS FITTED TO OUR CAB.NET CONE SPEAKERS

Price only **15/-**

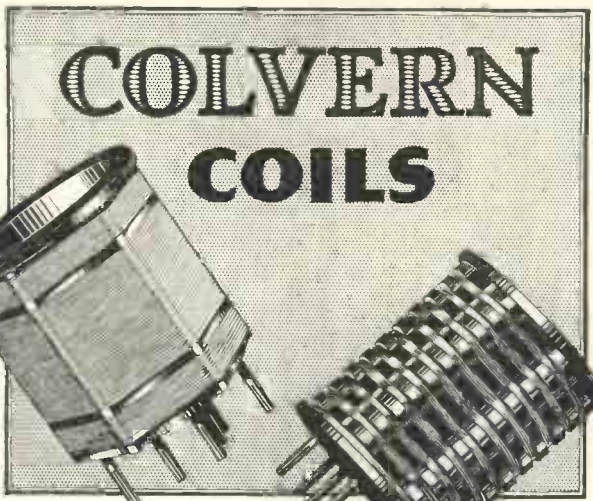

COLVERN COILS

BUILD STRICTLY TO THE AUTHOR'S SPECIFICATION



Colvern Accurate Space - wound Coils are specified by the Editor of *Radio for the Million*, for the Mullard Master Three, the Mullard Toreador P.M. and the Mullard Mikado P.M. Receivers because of their efficiency.

If you intend to build one of these receivers you should be very insistent with your dealer that it is your wish to adhere strictly to the published specifications.

Apart from the fact that by so doing you will be able to duplicate the published results, within a degree or two either way you will be able to locate stations with the assistance of the published dial readings.

Remember to use Colvern Accurate Space-wound Coils—these give the best results on both wave bands.

BROADCAST WAVE - - - 7/6
LONG WAVE - - - - - 8/6

COLVERN ACCURATE SPACE WOUND COILS

Colvern Ltd., Mawney's Road, Romford.

Working Ranges of Broadcast Receivers (Continued)

(5) Anode-bend rectifier and power valve—10 miles.

(6) Anode-bend rectifier, one L.F. and power valve all R.C. coupled—15 to 20 miles.

It must be definitely remembered that this classification is merely for strength and not for distance reception on telephones. It represents the distance at which, under favourable conditions, a power valve can be loaded up when it has 120 volts on its plate, but in most cases the aerial will be hardly so favourable as I have demanded.

With a knowledge of field strength, it is now easy to estimate on the effect of high-frequency amplification, assuming as a basis a field strength required to work any of these combinations of detector and low-frequency, the sum being a simple multiplication one, used in connection with a field strength chart.

Take the case of the anode-bend rectifier and power valve, good for ten millivolts per metre with a good aerial. A high-frequency magnification of 30 will take us to 65 miles range, greater ranges can only be estimated if the field strength is known.

Again, if smaller aeriels are used the additional high-frequency magnification required can be estimated fairly well.

Heterodyne and Super-het Rectification

In all simple rectification problems, such as broadcast reception, the questions involved in the rectifier are considerably more complicated by the fact that the efficiency of reception falls off as signals get weaker and also the apparent resistance of the detector varies considerably as signals alter in strength.

We have seen how by taking the D.C. component which flows through the transformer primary we can estimate from the position this current sets us on the crystal or valve characteristic what the resistance of the crystal is for that particular signal and we either have to take up some very local problem such as consideration of signals always of the same applied strength to the detector, or preferably, of course, the best thing to do would be to work out all the cases and plot them as curves.

There happens to be one case of reception where the doubt as to our rectifier resistance and efficiency is partially removed and that is the case of heterodyne reception. In this particular case we can supply sufficient field strength from the local oscillator so that we are set, whatever the strength of signals, at the same position on the crystal characteristic.

When this heterodyne is used to produce beat notes with the received signal,

an interesting problem is introduced—what is the strength of the low-frequency A.C. produced by the combination of rectifier and separate oscillator? The problem is probably more interesting when the valve is used as a rectifier and is particularly interesting when the beat tone is of an inaudible frequency as we use it in the supersonic-heterodyne.

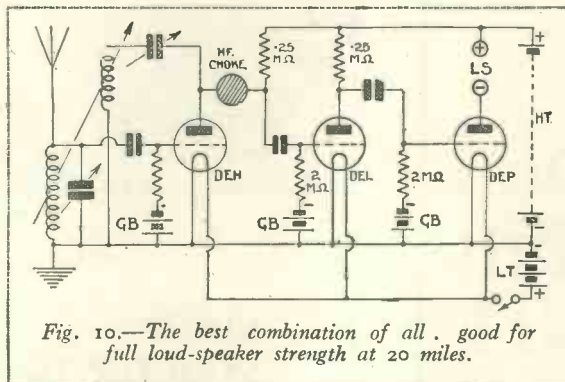

Fig. 10.—The best combination of all . good for full loud-speaker strength at 20 miles.

Normal telephonic reception is, of course, a type of heterodyne reception in that speech and music is produced by the beating of the carrier wave with the side waves, but as we recede from a transmitter both carrier and side waves decrease, and the decreasing efficiency of the detector, together with its variation of resistance, enters very strongly. Signals fall off more rapidly than the field strength of the signal indicate that they should.

When, as in heterodyne reception, we supply the carrier wave, this can be kept always at the same strength, so that the case is thus more amenable to calculation than in the simple telephony case, as it is well known in heterodyne reception the efficiency remains approximately

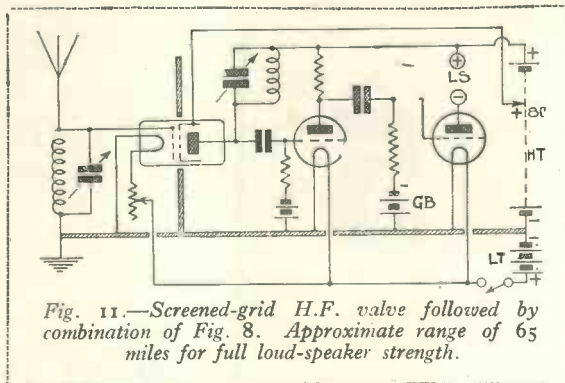

Fig. 11.—Screened-grid H.F. valve followed by combination of Fig. 8. Approximate range of 65 miles for full loud-speaker strength.

constant down to the weakest signals.

I have pointed out that if in series with the rectifier we place an LC circuit and the impedance of this circuit is high at all frequencies being used compared with the rectifier resistance taken with voltage applied in one direction then we can say that the low-frequency A.C. component of the mixed voltages

obtained after rectification will be all exhibited across the L.C. combination.

As we have seen before, if the applied peak voltage of the high frequency is V then the average D.C. component

after rectification is about $\frac{V}{2}$. Let us

suppose that two sets of high frequencies are arriving at the aerial at once, one a strong one and the other a weak one, and let us suppose these are slightly different in frequency, then at certain times their voltage will add and at other times their voltages will subtract so that the peak voltage at times will increase to $V + V_1$, at other times will be $V - V_1$.

A.C. Component

To get the A.C. component after rectification we have to divide these voltages by two, and it is easy to see that if V_1 is the voltage of the weak signal applied to the rectifier then if a crystal is used as a rectifier, the beat tone peak voltage across the transformer

will be $\frac{V_1}{2}$.

Suppose we were using an anode-bend detector as our heterodyned rectifier. In this case the magnification of high-frequency would be a certain figure determined by the value of external resistance constants, but the beat tone produced would be only half this figure in voltage. In other words we only get half the magnification of the valve, but at the same time it points out that we do get a magnification and if the valve is suitably chosen, this is quite a good one.

Super-het Amplification

The case is very interesting when we come to think of the super-het. The first valve is a heterodyned rectifier, and we can from the previous work approximately determine its magnification. This part of the super heterodyne has always been slightly in doubt as to how much it is really amplifying.

Owing to considerable pressure on our space we are obliged to hold over until next month the reports of tests of new apparatus made by our Technical Editor, J. H. Reyner, B.Sc. (Hons.), A.M.I.E.E. at the Furzehill Laboratories. Attention is drawn to a special article by J. H. Reyner on page 67.

At the time of going to press, rumours are current regarding important alterations that may take place at the B.B.C. headquarters. It is understood that Mrs. Snowden is to raise the question of "controversial" broadcasts. Listeners have felt for a long time that if the ban on controversial matters were lifted more interesting programmes would result.

PERFECT TERMINALS



Make your set distinctive by fitting Belling-Lee Terminals. Recommended and used by all the leading Radio experts, and by manufacturers of the best battery eliminators, the Belling-Lee patented terminal has long since proved itself to be the best designed terminal for Radio. Following are a few of its unique advantages :-

- Insulated Non-Rotating engraved top.
- Highly finished screw-action insulated head.
- Non-threaded stem and cross-hole.
- Specially made to grip spade or pin terminal, or flex.
- Shielded metal clamping faces.
- Highly finished insulated collar.
- Metal parts nickelled.
- Transverse slot with clamping nut eliminating soldering.

PRICES

Type "B"—Standard large insulated, and guaranteed model. Polished black bakelite, 9d. each.

Type "M"—As Type "B," but smaller and with only the engraved top insulated. Rest nickel-plated brass. 6d. each.

Made with 30 different engravings. Send for attractive Illustrated Brochure.

BELLING-LEE TERMINALS

Belling & Lee, Ltd., Queensway Works, Ponders End, Middlesex



FLUXITE



UNITES

IT SIMPLIFIES SOLDERING

FLUXITE SOLDERING SET - Complete 7/6
or LAMP only, 2/6

All Hardware and Ironmongery Stores sell FLUXITE in tins, price 8d., 1/4 and 2/8. Another use for Fluxite—Hardening Tools and Case Hardening. Ask for leaflets on improved methods.

FLUXITE LTD.

(Dept. 332), Rotherhithe, S.E.16.

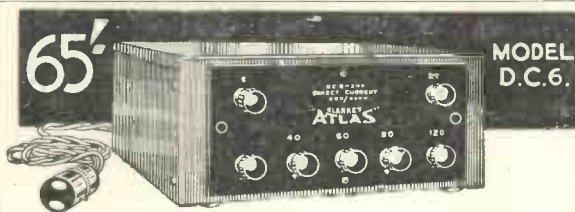
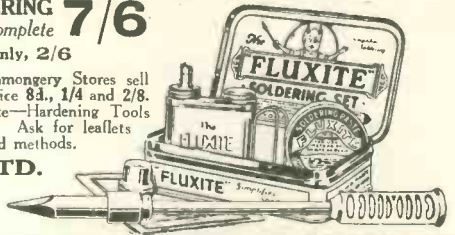

H.T. for NOTHING!

You simply can't estimate how little it costs to keep a smooth, silent, constant supply of H.T. current from the nearest lamp socket to your set by means of a

CLARKE'S "ATLAS" H.T. BATTERY ELIMINATOR

There are models for Direct and Alternating Current, to suit every purse and every purpose. Insist on the "ATLAS" A.C. Model and ensure full wave rectification. Every Eliminator guaranteed.

Prices

Direct Current Models From £3:5:0 to £6:10:0
Alternating Current Models From £5:10:0 to £9:0:0
Royalties and valves extra on A.C. Models only.

Write for Folder 24 for particulars & prices

Manufacturers:

H. CLARKE & CO. [M/CR] LTD.
Atlas Works, Old Trafford, Manchester

WEARITE COMPONENTS

H. F. CHOKE
Range 30-2000 Metres

6/6 EACH.

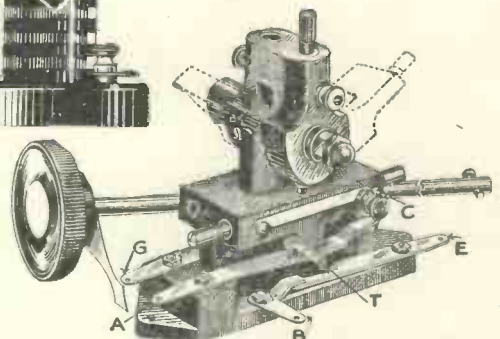
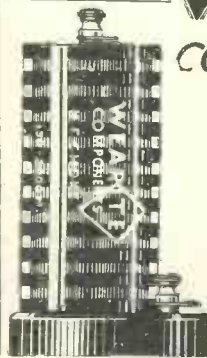

DUPLEX AUTOMATIC COIL HOLDER 10/6

(PATENT PENDING) EACH.

SEND FOR PRICE LISTS.

WRIGHT & WEAIRE, Ltd.
740 High Road, TOTTENHAM, N.17.

'Phone: Tottenham 3132

A Special Article on the Latest Radio Development

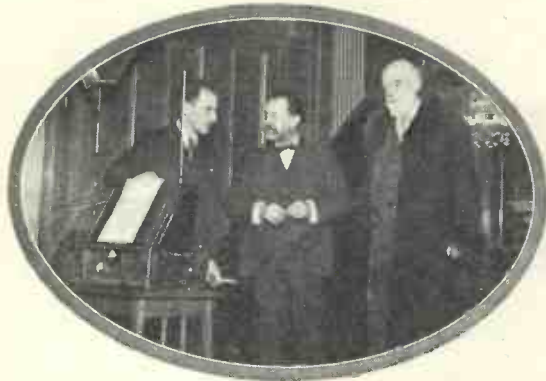

Professor Theremin (left) demonstrating his apparatus to Sir Henry Wood (centre) and Sir Oliver Lodge (right).

OSCILLATING TO PRODUCE MUSIC!

A New Musical Instrument Evolved by A Russian Research Worker

VERY great interest has been aroused in all quarters, and particularly in radio circles, by the announcements that have appeared in the daily Press regarding the "radio music" demonstrated publicly by Professor Theremin at the Albert Hall recently.

Representatives of the WIRELESS MAGAZINE were present at this demonstration, and also at a private demonstration that had been given previously at the Savoy Hotel.

Harnessing the Howl

Professor Theremin's development has been called "harnessing the wireless howl" in the lay Press, and this expression sums up in simple language the fundamental principle of the apparatus. Many WIRELESS MAGAZINE readers must, unfortunately, be only too familiar with the fact that by coupling a coil in the

rod, he can control with absolute accuracy the note emitted from a loud-speaking device associated with the apparatus.

An idea of how this is accomplished can be gained from a glance at the photograph reproduced at the bottom of this page. Here Professor Theremin is seen standing in front of his instrument. The vertical metal rod already referred to can be seen mounted on the right-hand side of the cabinet, and, by moving his right hand to and from the rod, he can produce pure musical notes of any desired pitch.

Controlling the Volume

But this is not all. This ingenious Russian investigator can also control the *volume* of the music produced by moving his left hand over a single turn of wire mounted on the left-hand side of the receiver. This turn

can be clearly seen in the photograph reproduced at the top of this page (on the left).

Playing a Duet

A photograph taken during a demonstration Professor Theremin gave in Berlin recently is reproduced on page 88. In it will be seen two tables, on each of which is placed one of the radio "music boxes." Professor Theremin is seen operating the left-hand instrument, while an assistant is controlling that on the right. One music box was connected to the special loud-speaker mounted on a stand in the background, while the other was connected to a loud-speaker of the ordinary horn type.

When each operator manipulates his instrument a very fine duet results—of such fine quality, in fact, that trained music critics have expressed keen enthusiasm.

(Continued on page 88)

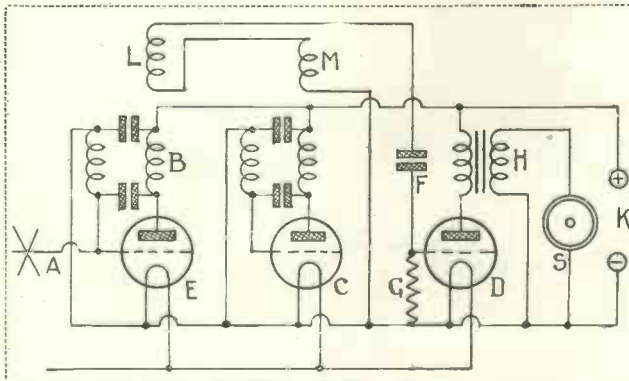

anode circuit of a valve, sufficiently close to a coil in the grid circuit, it is possible to produce a musical note—of sorts.

What Professor Theremin has done is to so arrange his circuit that by a simple movement of his hand in the proximity of a very short vertical

Above is reproduced the fundamental circuit of Professor Theremin's apparatus, and on the right he is seen playing one of the instruments.



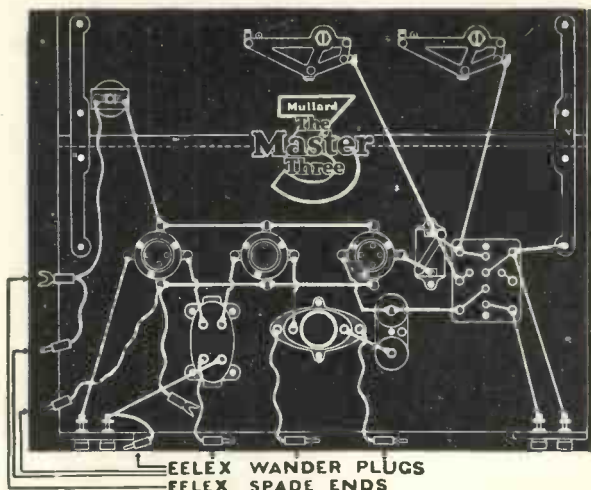

WIRELESS ACCESSORIES

are chosen and recommended for the Mullard "Master Three" and the Cossor "Melody Maker," and "1928 Solodyne," also Eexlex Treble Duty Terminals. They are also used and specific for all the best sets to-day. This alone is sufficient testimony that Eexlex Accessories are the best obtainable. Write for catalogue V33 which gives details of all the EEXLEX accessories. Complete set of EEXLEX Terminals, Plugs and Spades required for "Master Three," 2 10 (Plugs & Spades only, 1/4) "Melody Maker," 3/4, "1928 Solodyne," 6 3 (Fuse-holder 4d. extra.)

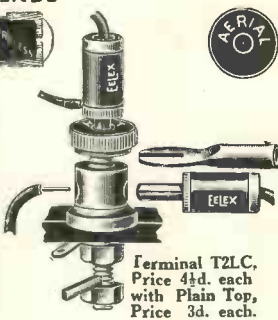

Terminal T2LC, Price 4d. each with Plain Top, Price 3d. each.

Coloured spades, plugs, pins and eyes 8d. each; coloured flex 1 1/2s. yard. **J. J. EASTICK & SONS**
Eexlex Works, Bunhill Row, Chiswell Street, London, E.C.1

Build your own H.T. Eliminator

3d. brings book that shows you how to do it

SEND 3d. in stamps and we will send you in return, "How to build your own H.T. Eliminator," a book written by Mr. Percy W. Harris, M.I.R.E., which will show you how to build an H.T. Eliminator quickly and economically, and one which, because it uses T.C.C. High-voltage Condensers, is perfectly safe and entirely reliable. Write, to-night, to Telegraph Condenser Co., Ltd., Wales
Farm Road, N. Acton, London, W.3



T.C.C. Condensers

CA 1216



Full Catalogue sent post free on request

THE COMPONENTS used in the

"PHOENIX FIVE"

(See "Wireless Magazine," December)

FORMO "TRUE SCALE" IMPEDANCES
THE LATEST METHOD OF L.F. AMPLIFICATION



ANODE IMPEDANCE

12/6



GRID IMPEDANCE

12/6

For CLARITY with VOLUME

The method employed gives a correct proportional amplification of Frequencies, so that the light and shade of music are reproduced in their proper value, and with a fidelity unobtainable by any other method.

THE FORMO Co., Crown Works, Cricklewood Lane, N.W.2
Phone: Hamstead 1787.



W.B. CONE SPEAKERS

The W.B. Cabinet Cone gives utmost volume with perfect fidelity of tone; driving unit, cone and cabinet are all designed with this one end in view.

All Bakelite Cabinet Model ... £4 4s.
Oak or Mahogany, ... £3

Write for Lists
When building a set, remember W.B. Anti-phonics Valve Holders

WHITELEY BONEHAM & Co., Ltd.

Nottingham Rd., Mansfield, Notts

CUT THIS OUT FOR CABINETS

and post to us for new FREE list illustrating Cabinets as shown in "Wireless Magazine," etc., etc.

NAME _____
ADDRESS _____



(Write in block letters please.)
CARRINGTON Mfg. Co., Ltd.,
Camco Works, Sanderstead Road,
South Croydon.
Telephone: Croydon 0623 (2 lines).

Another part of Professor Theremin's apparatus.

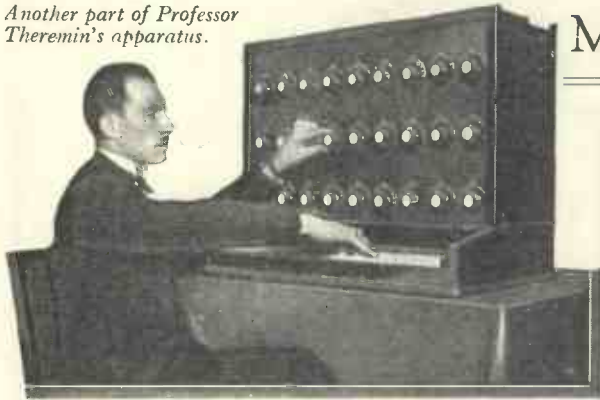

The fundamental circuit employed for producing this music by controlling radio oscillations is shown on page 86. The symbol marked A represents the vertical copper rod. Two high-frequency valves, B and C, are shown with their plate circuits tuned. A detector valve D is provided with a grid leak F and a grid leak D. Also in the grid circuit of this valve are included two coils, L and M.

Coupled Coils

The coil L is coupled to the tuned anode circuit B associated with the first valve E, whilst the coil M is coupled similarly to the tuned-anode circuit associated with the valve C. H represents a low-frequency transformer connected with a sound-producing device S, the necessary anode potential being applied across the terminals X.

It will be understood that varying the capacity associated with the rod A, such as by moving the hand to and from it, will affect the tuning of the high-frequency circuit B and so alter the pitch of the oscillation audible from the loud-speaker.

Although it is true that Professor Theremin has been able to so control oscillations as to produce real music,

Musical Oscillations (Cont. from page 86)

enthusiastic amateurs are recommended not to try to produce similar results with a tightly-coupled reaction coil in an ordinary broadcast receiver.

It requires a magic touch to produce music,

and further developments are best left in the hands of Professor Theremin, who has proved himself to be a most competent research worker in this field.

Have you any friends who are not readers of the WIRELESS MAGAZINE? If so, send us their names and addresses—we will send them each a free specimen copy.

WHAT STATION WAS THAT?

The Editor of the "Wireless Magazine" has made arrangements to assist readers who are in difficulty over the identification of broadcasting stations they receive.

Each query should give as many particulars as possible (such as time, date, wavelength, language, and distinctive call or signal) and should be accompanied by the coupon on page iii of the cover and a fee of one shilling (postal order or stamps).

Address each query to "Station Identification," "Wireless Magazine," 58-61 Fetter Lane, London, E.C.4.

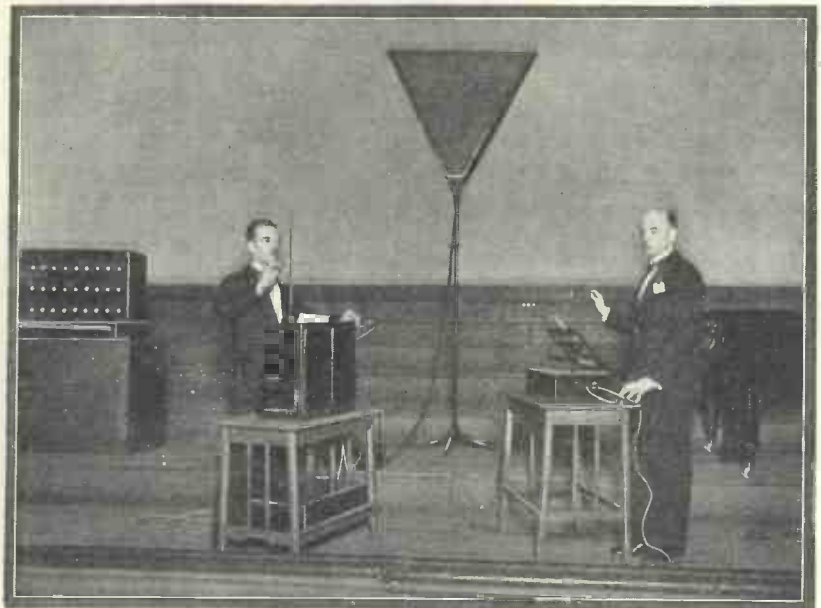

Two operators playing a duet on two of Professor Theremin's instruments.

A Hint on Radio Income and Expenditure

AT the beginning of the New Year we always balance up last year's accounts. I was agreeably surprised upon balancing up my 1927 wireless accounts, surprised at the cost and surprised that this expenditure had been met. Three high-tension batteries at 12s., twenty-six chargings of my accumulator at 6d. a time, one G.B. battery at 1s., and the annual licence—total of obtaining "income" £3. This was met by a certain method I have adopted.

It is not Father alone who uses the wireless set, in fact he probably listens less than the other members of the family, and yet he is expected to pay for the set's upkeep. So last year I adopted this plan.

Whenever there was a good programme and the whole family listened with enjoyment, at the end of that programme I "passed the hat round" and insisted that every member of the family put in twopence or more.

In other words I bought a small wooden box like those used for hospital collecting, and at the end of the year the amount collected paid for the upkeep of the set.

Several of my friends also tried this scheme and have expressed their satisfaction at the result—in fact one has enough balance in hand to open a "New Loud-speaker Fund" as he calls it.

R. W. T.

WIRELESS CABINETS in SOUND QUALITY of WOOD

Highly Polished First-class Cabinet Work

MAKERS OF ALL DESIGNS FOR OLD AND NEW WIRELESS SETS AS PERIODICALLY ANNOUNCED IN THIS JOURNAL

Special line of closed cabinets totally enclosing Batteries and Accessories

Thousands of satisfied users. Send for Illustrated Price List

Money returned if quality and workmanship not equal to our guarantee

CAXTON WOOD TURNERY CO., MARKET HARBOROUGH

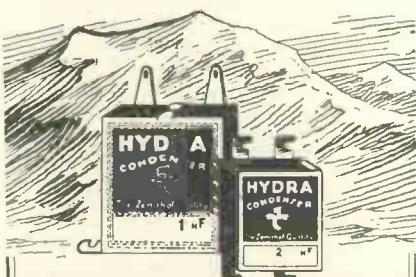

FIXED FOR LIFE!

Hydra Condensers are unmoved by atmospheric conditions. They are guaranteed accurate to within 5 to 10 per cent. of their rated capacities that remain constant through all variations of temperature.

You can buy Hydra Condensers with the assurance that their capacities are fixed for life!

PRICES

Tested on 500 volts D.C.
1 mfd., 2/6; 2 mfd., 3/6; 4 mfd., 5/3. Tested on 750 volts D.C., equal to 500 volts A.C.
1 mfd., 3/-; 2 mfd., 4/-; 4 mfd., 6/9. Inquire for prices of condensers tested at 1,000, 2,000, 4,000 and 6,000 volts D.C.

HYDRA

From all good dealers, or direct

LOUIS HOLZMAN

34, KINGSWAY, LONDON, W.C.2

Telephone: Holborn 6200

DIGBY'S CABINETS

Write for New 16-page Catalogue

Please note new address:

F. DIGBY, 9 The Oval, Hackney Road, LONDON, E.2



WET H.T. BATTERIES

Solve all H.T. Troubles

SELF-CHARGING, SILENT, ECONOMICAL.

Jars (waxed) Zincs Saes

2 1/2 x 1 1/4 sq. (new type) 1/2 doz.

1/3 doz. 1 1/2 doz.

Sample doz. (18 volts) complete with leads and electrolyte 4/3, post 9d

sample unit 6d. 16-page booklet free

Bargain list free.

AMPLIFIERS: 1 VALVE 19/- 2 VALVE 30/- 2 VALVE ALL-STATION SET 24

B. TAYLOR, 57 Studley Rd., Stockwell, London

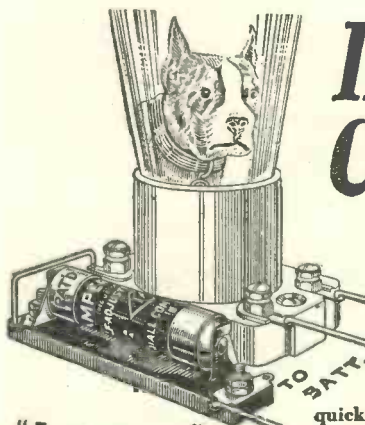

"AMPERITE"

Watch Dog
of Your
Valves

AMPERITE

The "SELF-ADJUSTING" Rheostat

If Valves Could Talk!

They would tell you—that only at the precise and definitely prescribed filament current, or temperature, can their tonal qualities, clarity and sensitiveness be brought out to the full. That L. T. battery current constantly varies according to the age of the battery and state of charge—and operation with too little or too great current is certain death to efficient valve performance—and too quickly, of the valve itself. That only AMPERITE can automatically supply and control this exact current despite battery variation—as long as sufficient current is to be had. That you should never confuse AMPERITE with fixed filament resistors which do not do the Amperite's job. AMPERITE is sold by dealers everywhere.

Price 5/-, complete with mounting.

Write for FREE "Amperite Book" of the season's best circuits and latest construction data.

Distributors for Great Britain

ROTHERMEL RADIO CORP. OF GT. BRITAIN LTD.
24 Maddox St. London W-1

You can get a full-size Blue-print of any set described in this issue for half-price by using the Coupon on page iii of the cover.

SCREENS COPPER BOXES

ANY SIZE TO ORDER

CITY & GENERAL RADIO CO. LTD.,
79 CANNON STREET, LONDON, E.C.4

TELEPHONE: CITY 9280.

EASY PAYMENTS

We specialise in the supply of All Wireless Goods (Components, Sets and Accessories of any make) on the Easy Payment system—10% down—balance spread over 10 months.

EFFICIENT SERVICE

Send list of requirements to—

LONDON RADIO SUPPLY CO.,
11 OAT LANE, LONDON, E.C.2 Telephone: City 1977

Frequency and Wavelength
Loud-speakers Connection
Water and Ice
Reception Spoilt by Fading



"Simpler Wireless"
Battery Eliminator
Phoenix Five
Potentiometer Control of Grid Bias

Frequency and Wavelength

Q.—How can one determine the frequency of any signal when only the wavelength of that signal is known?—B. O'C. (Dublin).

A.—This is quite a simple matter, provided that one remembers the following formula: Frequency = velocity divided by wavelength in metres. The velocity of wireless or Hertzian waves is 300,000,000 metres per second, so that should the wavelength of the signal to be determined be 300 metres, then the frequency is 1,000,000 cycles per second.—L. A. C.

"Simpler Wireless"

Q.—I have read with interest the notes relating to the A.C. side of "Simpler Wireless," but you do not appear to have studied the interests of those whose supply is round about 100 volts A.C. What will be necessary in order to obtain satisfactory results from the above-mentioned mains?—S. V. (London).

A.—Exactly the same form of rectifier will be required, but between the mains and the eliminator-rectifier unit should be fitted a transformer having an output of between 150 and 200 volts and a current of approximately .1 ampere.—C. A.

Loud-speaker Connections

Q.—Is there a right way and a wrong way to connect the loud-speaker to the set?—F. L. (Bournemouth).

A.—There certainly is if the anode current of the last valve flows through the loud-speaker windings, as it will do unless a transformer or filter circuit is used before the loud-speaker. With the current flowing through the windings in one direction (the correct one) the permanent magnet of the loud-speaker will be strengthened, while if the current flows the other way this magnet will be weakened and, in time, perhaps completely de-magnetised.

If your loud-speaker terminals are marked, that marked positive should go

to the loud-speaker terminal on the set, which is internally connected to H.T. positive.

If the loud-speaker is not marked, connect it up to the set either way round and, while strong signals are being received, adjust the magnets until they just touch the diaphragm. Then reverse the loud-speaker connections, and if this results in the diaphragm being freed the first method of connecting up was correct.—R. D.

Battery Eliminator

Q.—In making up the battery eliminator described in the December number of the "Wireless Magazine," would it be possible to use a 4-volt accumulator, for 4-volt valves, in place of the 6-volt accumulator in the L.T. eliminator of the unit?—R. D. (Ruislip).

A.—It will be quite satisfactory to utilise a 4-volt accumulator in place of the 6-volt accumulator specified, provided that only 4-volt valves are employed in the receiver for which the eliminator is intended. No alteration to the remainder of the eliminator will be necessary to effect this change.—L. C.

Water and Ice

Q.—Why is it that water is a conductor of electricity and yet ice is said to be an insulator?—A. H. (London).

A.—Water is only a conductor of electricity when it is impure. Pure distilled water has a greater resistance to electric currents than almost any other insulator, and, in fact, has a specific inductive capacity value of approximately eighty. From some comparative tests conducted at the National Physical Laboratory it was found that pure distilled water gave a resistance of 320,000 ohms for a centimetre cube, whilst ordinary tap water of the same volume gave a resistance of 5,400 ohms only.—L. C.

Phoenix Five

Q.—As there are two different values stated for the reaction condenser in the

list of parts and wiring plan of the Phoenix Five, will you please say which is the correct one or which gives the better result?—P. B. (Cardiff).

A.—The capacity of the reaction condenser used in the original set was .0001 microfarad, but if a condenser of .0002-microfarad capacity is used it will be quite satisfactory, as the reaction can be controlled with the larger condenser merely by arranging the H.T. voltage to the H.F. and detector valves to suit. If you have not already purchased the reaction condenser, than it would be advisable for you to get one of .0001-microfarad capacity.—L. C.

Potentiometer Control of Grid Bias

Q.—Is there any way in which I could control the grid bias applied to an L.F. valve very critically? I should like to use a potentiometer if at all possible.—C. P. L. (Bolton).

A.—This can be done, but you should not connect the potentiometer winding across the grid-bias battery, as this would result in the battery becoming exhausted very quickly. The potentiometer should be connected across the L.T. battery and the positive end of the grid-bias battery, which would, in the usual way, go straight to L.T. negative, should be taken to the potentiometer slider instead.

The grid-bias voltage can then be varied roughly by altering the tapping point on the grid-bias battery in the usual way and finely by moving the potentiometer slider.—G. N.

Reception Spoilt by Fading

Q.—Recently my reception of foreign stations has been badly spoilt by the signals themselves disappearing altogether at intervals. I have checked for faults in my receiver, and have also tested all batteries, but everything seems to be in good working order. Can this trouble be due to some nearby neighbour?—K. M. (St. Albans).

A.—It is doubtful whether you will be able to overcome the difficulty you experience. This is due to natural fading of signals, for which no really satisfactory explanation can be offered. Fading is experienced at all times from distant stations, and this is usually more pronounced on the short waves than on the long waves. There is no remedy at present, and when signals disappear you must needs wait for them to return. Do not alter your tuning adjustments during these fading periods, as this will only mean further difficulty in tuning in the signals again when they do return to normal strength.—C. L.

When You Are In Difficulty—

It does not matter whether your knotty problem is a theoretical or a practical one—in either case the Technical Staff of the "Wireless Magazine" is ever ready to help you out of the difficulty. Just write your query out on one side of a sheet of paper (this small point saves us time and enables us to send an answer quicker) and send it with the coupon on page iii of the cover, a stamped addressed envelope and a fee of 1s. (postal order or stamps) to:—Information Bureau, "Wireless Magazine," 58-61, Fetter Lane, London, E.C.4.

OMNORA LTD

THE SET-BUILDERS SUPPLY STORES

Build THE ASTRAL FOUR as described in this issue.

	£	s.	d.
1 Special Type Cabinet, with baseboard (Mahogany)	3	3	0
1 Panel, 21 in. by 7 in., by 1 in., ready drilled	0	12	0
2 Cydon Variable Condensers, .0005	1	11	0
2 Condenser Dials	0	4	0
1 Ormond Reaction Condenser	0	4	0
1 Neutralising Condenser	0	5	0
1 Lotus No. 4 Plug and Jack	0	4	6
1 T.C.C. Condenser, .0003, S/P type	0	2	4
2 B.T.H. Valve-holders	0	5	0
2 B.T.H. Coupling Units, with valve-holders	1	1	0
2 G.E.C. Variable Rheostats, baseboard type	0	5	6
1 Bulgin H.F. Choke	0	5	6
10 Eastick Terminals	0	3	9
1 Dubilier Grid Leak, 2 megohm	0	2	4
1 Set Lewcos Dual Screened Coils	3	7	6
1 Terminal Strip, 4 1/2 in. by 1 in., ready drilled	0	0	6
1 Terminal Strip, 3 in. by 1 in., ready drilled	0	0	4
Glazite and Sundries	0	2	7
	£12	0	0

Cabinet can be supplied in Oak, price £2 18s.
Any of the above parts supplied separately as required.

Mullard The Master Three

NO SOLDERING REQUIRED

and so simple, that it can be assembled and ready for use in one hour.

Only twenty wires are used, and the only tools required are a screwdriver and pair of pliers.

Components as specified :

	£	s.	d.
1 Lewcos Coil Base	0	2	9
1 J.B. S.L.F. Variable Condenser, .0005 mfd.	0	11	6
1 J.B. S.L.F. Variable Condenser, .00035 mfd.	0	10	6
1 Climax H.F. Choke	0	8	6
3 Pye Anti-Vibratory Valve-holders, with terminals	0	6	0
1 R.I. Varley R.C.C. Unit (type A)	1	0	0
1 R.I. Varley L.F. Transformer (G.P.)	0	15	0
1 Mullard Combined Grid Leak and Condenser	0	5	0
1 Bulgin On and Off Switch with terminals	0	1	6
4 Belling-Lee Terminals, A., E., L.S., L.S.	0	2	0
1 Colvern Broadcast Wave Master 3 Coil	0	7	6
1 Colvern Long Wave Master 3 Coil	0	8	6
1 Collinson Aluminium Panel, 18 in. by 7 in.	0	7	6
1 Agar Baseboard, 18 in. by 10 in. by 1/2 in.	0	2	0
1 Pair Magnum Angle Brackets	0	2	6
2 Terminal Strips, 2 1/2 in. by 2 in. by 1/2 in., ready drilled	0	1	0
1 Set Connecting Links and suitable length Red and Black Flex	0	1	0
2 Spade Terminals (1 Red and 1 Black)	0	0	3
8 Wander Plugs (4 Red and 4 Black)	0	1	0
	£5	14	0

If preferred, the set can be supplied ready wired and tested for an extra charge of 11/- Plus Marconi Royalty, £1 17s. 6d.

A suitable Cabinet can be supplied in Oak or Mahogany, price 30/-.

Carriage and packing is free (Great Britain) on cash orders value £2 and over.

Lists dealing with "The Master Three," "Cosor Melody Maker," and recent sets and apparatus, described in "Wireless Magazine" and other Radio publications will be sent on receipt of 1/6d. stamp.

As specialists in kits of parts for the Home Constructor, you are assured of satisfaction and service after purchase by dealing with us.

Omnora Ltd., Home Construction Specialists,
258 New Cross Road, London S.E.14.
Phone: New Cross 1273.

Five-guinea Three November, 1927

EXCELLENT results have been obtained with this receiver (described in our November, 1927, issue), as this letter from a Warrington reader shows:

"Regarding the Five-guinea Three, it may interest you to know that I made this set up with all the spare parts I could rake together and have been astounded at the results I obtained from this set. The only thing I bought was the Lissen transformer.

"The volume and tone quality are everything that you claim for it, and I am proud of this little set.

"Regarding the coils, the only type I had were Igranic coils untapped, so had to risk tapping these myself. I first found the approximate centre as near as I could place it and drew out the wire, being careful not to snap it, scraped the insulation off, and carefully soldered the wide end of a soldering tag to it.

"Then I got two thin strips of ebonite, fixed a small terminal on to one piece and bolted the two together on top of the coil.

"When bolting one end, pass the bolt through the eye of the soldering tag that is soldered to the coil wire.

"Then I soldered another small wire from the end of the soldering tag and on to another tag previously placed at the base of the terminal on the top piece of ebonite.

"With a little care, this little job can be done very neatly, and for the extra trouble involved I was amply repaid by the much increased selectivity obtained. I did both anode and aerial coils in this way.

"Have had a French and German station (unplaced) and can get 5GB, Manchester, Liverpool, Dublin, at very good loud-speaker strength."

Test Reports: A Correction

WE regret that owing to a printer's error, the capacity of the Dubilier K.C. condenser was stated to be 500 microfarads. This should read, of course, 500 micro-microfarads.

Some doubt may have been raised in the minds of readers concerning the reliability of the slow-motion mechanism which was described as being due to a drag between a steel ball and a metal disc.

Actually the steel ball causes one of the metal surfaces to rock with a rotary motion and it is this which gives rise to the slow motion. There is no danger of slipping with this principle, which is well-known in engineering circles and has been applied to a variety of mechanisms.

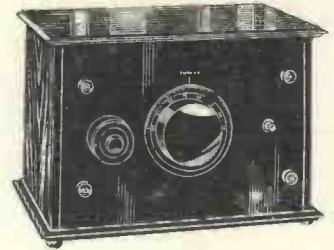

Build this £6

Polar-Two Receiving Set

for £4 : 12 : 2

Success is assured. You know beforehand that, on completion, just the turning of one knob tunes in one station after another—that you are building the circuit of a proved success.

Mr. J. H. Reyner
B.Sc. (Hons.), A.M.I.E.E.

has prepared the Polar-Two Envelope which contains all details, including full-size blue-print and drilling template, price list of components required, photographs, constructional and operating data, coil chart and general notes written and planned in a simple manner so that no technical knowledge is needed.

Price of Envelope 1/-

Polished Mahogany Cabinet and all necessary parts ... £4 : 12 : 2

Polar-Two Receiving Set may be purchased for £6. (Royalties extra.)

Ask your Dealer to show you the Polar-Two and Polar-Three Envelopes now. There is a big demand for them.

Wingrove & Rogers, Ltd
ARUNDEL CHAMBERS, 185, STRAND, LONDON, W.C.2
POLAR WORKS, OLD SWAN, LIVERPOOL
Manchester, Glasgow, Cardiff, Newcastle-on-Tyne

Telephone: CITY 0332
(3 lines)

DECKOREM
BRITISH MADE

Several of our original and efficient components are incorporated in sets described in this issue.

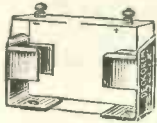

GRID BIAS CLIPS
These Baseboard mounting clips grip your battery firmly yet not fiercely. Made of Aluminium. Used in more "Star" sets than any other on the market.
Price 6d. per pair.

SAFETY PLUG FOR MAINS RECEIVERS

This is a special plug and fitting which entirely prevents operators receiving "shocks" when connecting up sets worked direct from the mains.
Price 4/6

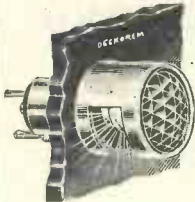

SIGNAL LAMP ILLUMINATOR

A well-finished component which shows by red light that set is in operation, while a white light is thrown on panel for dial reading. This illuminator is an artistic and essential addition to every set.
Price 3/-.

SPECIAL BULBS as specified by Mr. Johnson for all "Simpler Wireless" circuits. Consumption 1 amp.
Price 6d.

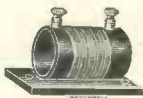

SHORT-WAVE CHOKE
A special high frequency Choke for working on 8 to 80 Metres. Guaranteed to function efficiently. A well constructed Choke designed in consultation with Mr. J. H. Reynier, B.Sc., A.M.I.E.E.
Price 3/-.

CHOKES FOR HIGH FREQUENCY STAGES

The "Deckorem" H.F. Choke on Laboratory test showed inductance as 72,000 m.h.; with Self Capacity of only 8 mfd. Use one of these chokes and get over your difficulties for choking effect on wide range of wave-lengths.
Price 5/6

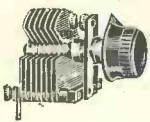

ELECTROSTATIC REACTION CONDENSER
This miniature condenser has a maximum capacity of .0001 mfd. and a very low minimum capacity. Fitted with heavy gauge vanes and smooth in action. One hole fixing. Designed for all circuits using electrostatic reaction.
Price 5/-.

DIAL INDICATORS WHICH MAKE FOR ACCURACY

The use of "Deckorem" Dial Indicators ensures correct readings, and are easy to fix to the panel.
Price 2d. each.



PUSH-PULL SWITCH
Here is a Midget switch that is strongly built and gives un-failing service. Clean contact. One-hole fixing. Adjustable for panels of 1 to 1 1/2 inch.
Price 10 d. each.

FIVE FREE CATALOGUES SENT ON REQUEST
Obtainable from all dealers or

A. F. BULGIN CO.

9-10-11, CURSITOR STREET, CHANCERY LANE, E.C.4.

ARTCRAFT
RADIO **BRITAIN'S** **CABINETS**
BEST VALUE
New Catalogue Free
THE ARTCRAFT COMPANY
156, CHERRY ORCHARD ROAD, CROYDON

When replying to Advertisements mention "Wireless Magazine" to ensure prompt attention

A Handsome Cabinet

A CABINET of a receiver can be just a plain box or, on the other hand, it can be an attractive piece of furniture. More and more people nowadays demand the latter type of cabinet for their sets and a pleasing Queen Anne design is shown here.



Pickett's Queen Anne Cabinet

This particular cabinet is manufactured by Pickett Bros. of Bexley Heath in various sizes and finishes. That illustrated is suitable for the Phoenix Five.

Good Lard!

THE man who makes my tailored suits, except when lack of funds compels me to buy a reach-me-down, told me a delightful story against himself the other day. This tailor man of mine is something of a wireless



Good Lard!

enthusiast and we often have a chat about the great hobby.

Recently he had become very troubled because the panel of his wireless set had warped badly. He was advised to take the component parts off the panel, soak the panel
(Continued on next page)

"WIRELESS MAGAZINE" SERVICE

Full-size Blueprints

By using the coupon on page iii of the cover, every reader of the WIRELESS MAGAZINE can obtain a full-size blueprint of any one receiver described in this issue only up to the end of February for HALF PRICE. After that date the normal prices will be charged, namely, (1) crystal sets, 6d.; (2) sets up to three valves, 1s.; (3) sets with more than three valves, 1s. 6d. These prices include postage in each case, whether the blueprint is bought under the half-price scheme or not.

Information Bureau

TECHNICAL QUERIES

A charge of 1s. is made for answering technical queries; not more than two should be asked at once. The coupon on page iii of the cover and a stamped addressed envelope should be sent with the query.

BUYING RECEIVERS

This service also covers advice regarding suitable proprietary receivers to suit the particular conditions and needs of readers. The rules above outlined apply in this case also.

Station Identification

Arrangements have been made with the leading authority on foreign broadcasting matters in this country to answer questions relating to the identification of particular transmissions. As many details of the reception as possible should be given. Each query should be accompanied by a fee of 1s., a stamped addressed envelope, and the coupon on page iii of the cover.

ADDRESS:

58/61

Fetter Lane,
London, E.C.4

Germany's High-power Station

Some idea of the complexity of the controls at the world's most powerful broadcasting station, just opened by the German authorities at Zeesen, near Berlin, can be gained from the photograph reproduced on the right.

At present this station works on a wavelength of 1,250 metres, and WIRELESS MAGAZINE readers who have receivers capable of tuning to the upper broadcasting band of wavelengths should have no difficulty in hearing it.

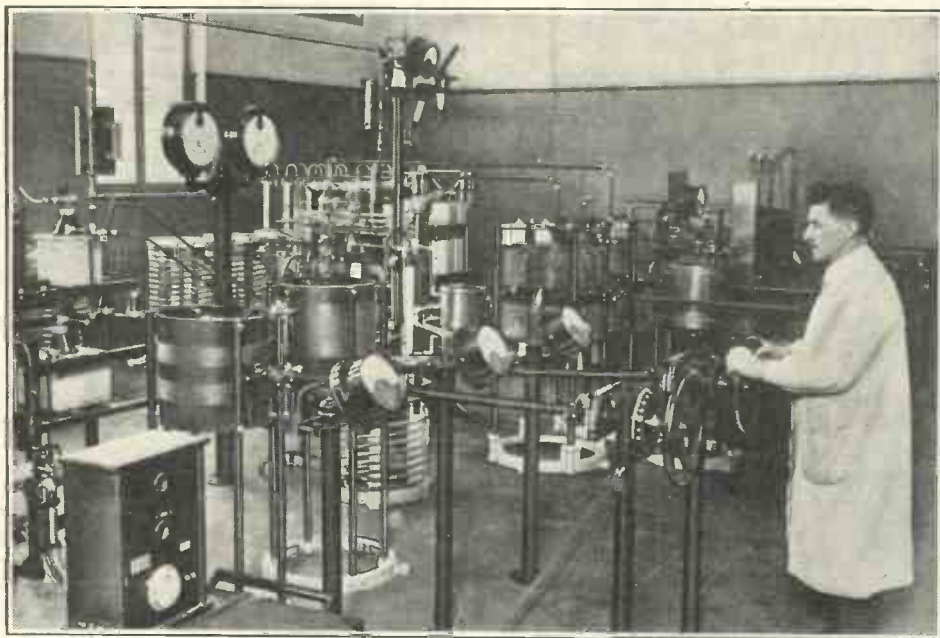

(Continued from preceding page) in hot water, and press the panel straight again while hot.

To Press the Panel

The advice seemed good to him. To carry out the pressing of the panel, he took a heavy press with a screw-down top home with him from his place of business.

At home, he soaked his panel well and truly in water good and hot, put the hot panel between two boards, placed the boards and panel under the press and screwed the top of the press down. Not satisfied with his own strength, he brought in a local 'bus driver who had a reputation for great strength. This 'bus driver gave the screw-top an extra partial turn.

They left the panel in the press over night. Next morning, my tailor took the panel from under the press and what do you think he found?

A Beautiful Inscription!

On the panel was a beautifully-printed inscription "KILVERT'S LARD" from one of the boards between which the panel had been placed.—R.

The "Utility" LOGARITHMIC CONDENSER

gives perfect smoothness of action, the moving vanes rotating on a ball-bearing spindle of novel design which is absolutely rigid. Electric continuity is ensured by the provision of a pigtail connection from the moving vanes direct to the terminal. The solid dielectric is reduced to the minimum and takes the form of two light thimbles, the walls of which are only about 1/32 of an inch thick. The Vernier pattern is fitted with the well-known "UTILITY" Micro-Dial with its ratio of 70 to 1, which makes tuning perfectly simple.

Write for attractive Free List of all "Utility" productions including Neutrodyne Condensers, Micro-dials, Switches, etc.

WILKINS & WRIGHT LIMITED
"Utility" Works, Kenyon Street, Birmingham

Utility
GUARANTEED
COMPONENTS

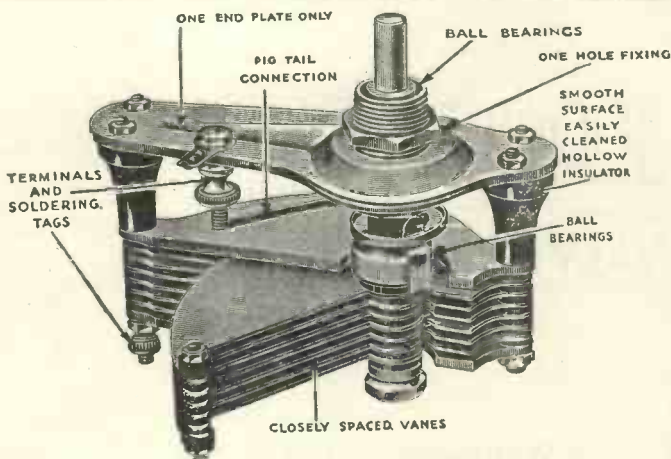

BRASS				ALUMINIUM			
Capacity	Ref. No.	Price including 4" dial	With Vernier	Capacity	Ref. No.	Price including 4" dial	With Vernier
.0005	W182	11/6	17/-	.0005	W185	9/6	15/-
.0003	W183	10/6	16/-	.0003	W186	8/8	14/-
.0002	W184	10/-	15/6	.0002	W187	7/6	13/-

PROTECT YOUR VALVES!

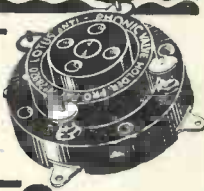

If your reception is unsatisfactory, see that your valve-holders are guaranteed to absorb and eliminate microphonic noises.

Only valves efficiently protected by good valve-holders give perfect results.

When the valve pins enter the valve sockets of the Lotus Valve Holder there is an immediate and lasting connection. The leg sockets expand and automatically lock, and the floating platform in which they are fixed is suspended by four phosphor-bronze springs. These springs have great mechanical strength, but are sufficiently resilient to absorb any external shock liable to damage the valve.

NOTE THE NEW PRICES:

- Valve Holder without Terminals . . . 1/6
- Valve Holder with Terminals . . . 1/9
- All Anti-microphonic Type.

Lotus Valve Holders are used and recommended in the Mullard circuits in "Radio for the Million," and are ideal for use in the Master Three and the Cossor Melody Maker.

Use them in YOUR next set.

From all Radio Dealers



Made by the makers of the famous Lotus Remote Control, Lotus Vernier Coil Holder and Lotus Jacks, Switches and Plugs.

Garnett, Whiteley & Co., Ltd.

Lotus Works, Broadgreen Rd., Liverpool

"Wireless Magazine" REFERENCE SHEETS



Compiled by **J. H. REYNER, B.Sc., A.M.I.E.E.**

Month by month these sheets can be cut out and filed—either in a loose-leaf folder or on cards—for reference. The sequence of filing is

a matter for personal choice. In a short time the amateur will be able to compile for himself a valuable reference book.

WIRELESS MAGAZINE Reference Sheet

No. 46

Turns of Wire per inch

TURNS PER INCH WITH COVERED WIRE				
S. W. G.	Enamelled	S. Silk	D. Silk	D. Cotton
22	33	33	32	27
24	42	42	39	31
26	50	50	47	35
28	61	60	56	40
30	72	71	64	44
32	83	81	75	50
34	98	93	85	58
36	122	110	101	64
38	140	133	120	71
40	175	159	141	78

IN designing coils, more particularly of the single-layer type, it is useful to know the number of turns per inch which can be obtained with any particular gauge of wire. The figures given herewith will be of service in this connection, since they give the approximate turns per inch with varying types of covering.

The exact number of turns may not coincide exactly with that in the table, especially with the smaller gauges of wire where there may be two or three more or less turns to the inch.

Minor differences in the manufacture of various samples of wire are sufficient to cause slight discrepancies, while in addition the actual method of winding has some small bearing on the matter and a tight winding with new wire will often result in a greater number of turns per inch being obtained than if older or slightly kinked wire is employed.

The figures, however, serve as a useful guide in designing the coil.

WIRELESS MAGAZINE Reference Sheet

No. 47

Voltmeters

IF a voltage is applied across a resistance a certain current will flow depending upon the value of the applied voltage and the resistance, the quantities being connected by the relationship

$$I = \frac{E}{R}$$

where I is the current in amperes, E is the applied voltage in volts, and R is the resistance in ohms.

We can measure currents accurately by making use of the magnetic effect of the current. This is caused to influence a light mechanism carrying a pointer and the movement of the pointer can be made proportional to the current flowing through the instrument (see Sheet No. 48).

We often require to measure the voltage between two particular points in a circuit, and to do this an instrument known as a voltmeter is employed. This actually does not read the voltage itself but measures the current flowing through a suitable circuit.

Consider the arrangement shown in the figure. Here we have a battery across which is connected a resistance in series with a milliammeter. This latter instrument, being a sensitive electromagnetic instrument of the type just described, is arranged to read the current passing through it in milliamperes.

Knowing the resistance R and the current

flowing in the circuit, it is easy to find the voltage from the expression given above. Moreover, if we keep the resistance constant, then the current flowing in the circuit will be directly proportional to the voltage.

Consequently, we can calibrate the milliammeter, not in terms of current, but in terms of the voltage across the whole circuit and the instrument then becomes a voltmeter. The series resistance is usually included in the instrument itself, and the scale is arranged to read directly in volts at whatever particular range is desired.

An instrument of this type must take some current from the source of voltage. The more sensitive the milliammeter, the less current is required to make it operate and, therefore, the higher can the series resistance be made so that the drain on the source of supply is reduced.

Pocket testing voltmeters are usually of a very simple character and relatively inefficient in design.

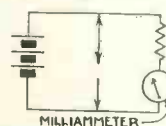

Circuit for calibrating a milliammeter as a voltmeter

Ammeters, D.C.

MEASUREMENTS of the current in a circuit is one of the fundamental factors in electrical work. This is a matter of the difficulty of which depends upon the nature of the current. With direct current, such as is supplied by a battery, the matter is fairly easy and ammeters for D.C. measurements are simple to construct.

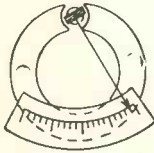

Arrangement of moving-coil instrument.

These instruments make use of the magnetic effect produced by the passage of current through a circuit. There are two principal methods of making use of this phenomenon. The simplest is known as the moving-iron method, in which a current to be measured is passed round a coil. Inside the coil is a piece of iron pivoted between two light bearings in such a manner that any alteration of the magnetic field will cause the iron to take up a slightly different position. In doing this, it will rotate on its pivot and this movement can be observed by

means of a pointer attached to the pivot itself. The end of the pointer travels over a scale which is calibrated to read the current flowing.

Such instruments are not very sensitive and are therefore only suitable for relatively large currents. A more sensitive type is known as the moving-coil type in which a small coil of wire is pivoted in a strong magnetic field, usually obtained by means of a permanent magnet. The passage of current through the coil causes it to rotate in the magnetic field, the actual extent of the movement being directly proportional to the current. The movement of the coil is again communicated to a pointer and the indication can thus be read off as required.

Moving-coil instruments are more sensitive owing to the presence of the permanent strong magnetic field and they can be made to give a full-scale deflection on a current of 10 microamperes only. This current is 1,000 times as small as the high-tension battery current taken by a small three-valve receiver.

The third type of instrument is known as the hot-wire type but this is principally employed for measuring alternating currents. (See Sheet No. 52).

Inductance Coils, Design of

THE number of types of inductance coils which have been tried from time to time is very large, but, broadly speaking, the most used types can be divided into three classes:

- (a) Single-layer solenoid inductances.
- (b) Single-layer pancake inductances.
- (c) Multi-layer coils.

Where the greatest efficiency is required, the first class has been found to be the best. The second type has certain advantages, and an efficient coil can be made using two pancake-type coils connected together.

The design of single-layer solenoids is a matter of compromise between various factors. The inductance of a coil depends upon the inter-linking of the magnetic field produced by the current with the turns of wire in the coil itself. Thus the number of turns in the coil enters into the inductance twice over, for the value of the magnetic field produced depends upon the number of turns.

Owing to the fact that the coil is of finite length, it is clear that some of the magnetic field at one end of the coil cannot effectively interlink with the turns of the coil at the other end, and some correction is necessary to allow for this effect.

In fact, with the ordinary single-layer solenoid, the inductance, instead of being proportional to the square of the number of turns, is more nearly proportional to the number of turns alone. This effect has considerable bearing upon the actual size of wire used in the coil. (See Sheet No. 51.)

The inductance of any single-layer coil is best determined from Nagaoka's formula, which is as follows:

$$\text{Inductance (microhenries)} = \frac{d^2 n^2}{100b} k$$

where d = diameter of coil
 b = length of winding
 n = number of turns

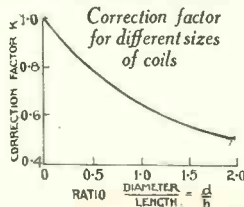

The term k is a correction factor to allow for the length of the coil as just described; values of k for ordinary coils are given in the figure.

Index to Sheet Nos. 2 to 50

Page	Page	Page	Page
Accumulators, Charging of, L.T. 38	Four-electrode Valves 35	Power Output 12	Proportional Distortion 14
Accumulators, Charging of, H.T. 2	Frame Aerial 5	Regulation, in Battery Eliminators 10	Resistance Coupling 8
Aerials, Coupling Arrangements 19	Gain Factor 36	Resistance Coupling, Size of Coupling Condensers 34	Saturation 32
Aerials, Frame 5	Gas-discharge Tube 37	Screened-grid Valves 35	Selectivity 21
Aerials, Resistance of 6	Grid Rectification 1	Self-capacity 20	Smoothing, L.T. 27
Ammeters, D.C. 48	Grid Rectification, Effect on Quality 44	Smoothing, H.T. 9	Transformers, Power 42
Battery Feedback, Elimination of 43	High-frequency Choice 22	Transformers, Power (Turns per Inch (of Wire) Valve Damping 15	Valves, Mutual Conductance in 41
Capacity Coupling (in H.F. Transformers) 4	High-frequency Transformers, Capacity Coupling in 4	Valves, Rectifying, L.T. Valve Tester 3	Volume Factor 11
Charging H.T. Accumulators (from D.C. Mains) 2	Inductances, Design of 49	Wave-traps 7	Wire Table (Turns per Inch) 46
Charging L.T. Accumulators (from A.C. Mains) 38	Inductances, in Series and Parallel 25		
Coupling Condensers (in R.C. Amplifiers) 34	Interference, Elimination of 33		
Damping, Valve 15	Kilocycles 23		
Decrement 16	Leakage Inductance 45		
Distortion, Checking 40	Low-tension Smoothing 27		
Distortion, Proportional 14	Low-tension Charging 38		
Dual-impedance Circuits 13	Mutual Conductance 41		
Field Strength (Magnetic) 29	Neon Lamps 24		
Field Strength (of Wireless Waves) 30	No-load Current (in Power Transformers) 31		
	Output Circuits 39		
	Permeability 28		
	Phasal Stabilisation 26		
	Phase Difference 18		
	Power Factor 17		
	Power Transformers 42		

Set Builders!

Use "Red Triangle" Panel for your "Wireless Magazine" Set and we will drill it FREE!

CHEAP ebonite can spoil a good Set. Don't use it. Use a good panel. Use a guaranteed panel. Use "Red Triangle" panels. Every "Red Triangle" is cut dead square and highly polished one side—matt the other. Any size available. Sent by return—24 hours' cut panel service.

Black: 1/4 in. thick, 3/4 d. sq. inch.
 Beautifully Mahogany Grained: 3/16 in. thick, 1 d. sq. inch.
 Post Free

RED TRIANGLE EBONITE

—Specified in all leading Sets, including the COSSOR MELODY MAKER Keystone "Midget" Reaction Condenser

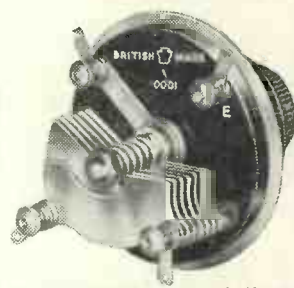

Ideal for the many positions where a small capacity condenser is required. An aluminium shield prevents hand-capacity effects, and a special taper bearing gives a beautifully smooth movement. Accurately designed and rigidly constructed, this Keystone condenser is backed by the usual Keystone guarantee of efficiency. Capacity, .0001 mfd. Price 5/6

Keystone Neutralising and Balancing Condensers



Used in all the popular circuits this season. These condensers have been designed by experts, and they are suitable for neutralising the electrode capacities of all types of valves. Very low minimum capacity. The wide spacing of the vanes renders accidental "shorting" impossible. Very well made from best quality material and beautifully finished.

Board mounting 5/-
 Panel mounting 6/3

Balancing Condenser similar to the illustration, but having two sets of fixed vanes instead of one. 7/6 Equally well finished

Send a post card for full list of details and, if required, fully illustrated Catalogue of quality components.

PETO-SCOTT Co., Ltd.

77 City Road, and 62 High Holborn, London

ALSO 4 MANCHESTER STREET, LIVERPOOL

READY RADIO SUPPLY CO.

41 Newcomen Street, London Bridge, S.E.1

PRICE LIST OF COMPONENTS
FOR

"The ASTRAL FOUR"

as described in this issue

	£	s.	d.
2 Cydon .0005 variable condensers	1	11	0
2 Condenser Dials	4	0	0
1 Ormond reaction condenser	4	0	0
1 Peto Scott neutralising condenser	5	0	0
1 Lotus jack (No. 4)	5	2	6
1 Lotus plug	2	0	0
1 T.C.C. fixed condenser .0003 (Type, S.P.)	2	4	0
2 B.T.H. valve holders	6	0	0
2 B.T.H. coupling units with valve holders	1	1	0
2 O.E.C. variable rheostats, basebd. mtg.	5	6	0
1 Bulgin H.F. choke	5	6	0
10 Enstick terminals as specified	3	9	0
1 Dubilier 2-meg. grid leak	2	6	0
1 Set of Lewcos dual screened coils (as specified)	3	7	6
1 Ebonite panel, 21 in. by 7 in.	9	2	0
2 Terminal strips, 4 1/2 in. by 1 in. and 3 in. by 1 in.	4	0	0
1 Ready Radio Art Cabinet in polished oak, teak or mahogany, with baseboard	2	5	0
4 Coils (10 ft.) of Glazite	3	4	0
2 Dial indicators	3	4	0
Total	£11	0	9

This list details the particular components used in the original set and allowed for in the lay-out. Any of the above parts can be supplied separately.

Write for price lists of the components for: THE EVBRYDAY THREE, METROPOLITAN THREE, TWO PROGRAMME TWO, LONG-RANGE HARTLEY ONE, A. C. MAINS ADAPTOR, COSSOR MELODY MAKER, EDISWAN R.C. THREESOME and all "WIRELESS MAGAZINE" CIRCUITS.

INLAND: All goods sent POST FREE.

OVERSEAS: All orders over £5 CARRIAGE PAID. EVERYTHING WIRELESS.

PICKETT'S CABINETS

THE RADIOLA BUREAU

(As reviewed in this issue of "Wireless Magazine")

PROTECTS your Set from DUST or INTERFERENCE ensuring BETTER REPRODUCTION.

Designed by Experts—not only lends distinction to your HOME, but will add to long life and efficiency of your Set. The well-appointed top compartment takes your Panel or completed Set. Strong lower cupboard takes HEAVIEST batteries. The leads connect up neatly out of sight. A Radiola de luxe!



3 ft. high Solid Oak or Mahogany, Queen Anne period, beautifully finished, in sizes and price for every pocket.

From £5 5 0 to £15

SENT ON APPROVAL DIRECT from FACTORY.

No need to rebuild—in sizes for every Set and Heaviest Batteries.

LISTS FREE from actual makers.

PICKETT'S WIRELESS CABINET (M.G.) WORKS, BEXLEYHEATH, KENT.

When replying to Advertisements mention "Wireless Magazine" to ensure prompt attention

Catalogues and Pamphlets

Readers who desire to obtain copies of the publications referred to below can do so free of charge by mentioning the "Wireless Magazine."

RADI-ARC Electrical Co. Ltd., of Bennett Street, Chiswick, W.4, are issuing a leaflet giving particulars of their Liberty Supersonic Unit, which has been re-designed.

Particulars of the Thermataix are given in a folder issued by Attaix Ltd., of 106 High Street, Southampton. The Thermataix is a thermo-junction instrument which will supply the filament current for wireless receivers and which works from either the gas or electric mains.

The McGraw-Hill Publishing Co. Ltd., of 6 and 8 Bouverie Street, E.C.4, have sent us their section catalogue No. 11, dealing with books on wireless.

Magnum receivers and radio units are detailed in a profusely illustrated little catalogue for the 1928 season which Burne-Jones & Co., Ltd., of Magnara House, 288 Borough High Street, S.E.1, have sent in.

The Edison Swan Electric Co., Ltd., of 123-125 Queen Victoria Street, E.C.4, have sent in two leaflets containing particulars of their new components, the local-station eliminator and low-tension battery charger.

Some very attractive leaflets come in from M.P.A. Wireless, of 62 Conduit Street, W.1, giving particulars of their transportable receivers and reproducers.

The Phoenix Five

SPECIAL NOTE

SPECIAL attention is drawn to a draughtsman's error in the blueprint of the Phoenix Five which have been supplied up to the time of going to press and also to the layout reproduced on page 382 of the December issue, in which the receiver was originally described.

On the holders for the detector and the first low-frequency valve the lugs for attachment to the baseboard are shown on the wrong side, and if the holders are placed in position as indicated by the lugs, the filaments of the valves will be wired in the anode circuits.

Before screwing down these two holders constructors should assure themselves that the sockets are in the correct positions.

Index to Advertisers

	Page
Amperite	89
Artcraft Co.	92
Bedford Elect. Co.	3
Belling & Lee, Ltd.	85
Bernard Jones Publication Ltd.	Cover ii, 2
Benjamin Electric, Ltd.	79
Bird (Sydney S.) & Sons	71
Bretwood, Ltd.	96
British Ebonite Co.	75
British Thomson-Houston, Co., Ltd.	69
Bulgin & Co.	92
Bullphone, Ltd.	83
Carrington Mfg. Co., Ltd.	87
Caxton Wood Turnery Co.	89
City & General Radio Co.	89
Clarke, H., & Co., Ltd.	85
Colvern, Ltd.	83
Day, Will, Ltd.	75
Digby, F.	89
Dubilier Condenser Co., Ltd.	Cover iv
Eastick, J. J., & Sons	87
Fluxite, Ltd.	85
Forno Company	87
Garnett, Whiteley & Co., Ltd.	94
Holzman, Louis	89
Igranic Electric Co., Ltd.	1, 77
Lectro Linx, Ltd.	3
Lissen, Ltd.	4
London Electric Wire Co., and Smith's, Ltd.	1
London Radio Supply Co.	89
Mullard Wireless Service Co. Ltd.	Cover iii
Omnora, Ltd.	91
Peto-Scott Co., Ltd.	95
Picketts Cabinets	96
Raymond, K.	81
Ready Radio Supply Co.	96
Rooke Bros.	3
Sifam Electrical Instrument Co.	75
Taylor, B.	89
Telegraph Condenser Co., Ltd.	87
Tungstone Accumulator Co., Ltd.	73
Wet H.T. Battery Co.	77
Whiteley, Boneham & Co., Ltd.	87
Wilkins & Wright, Ltd.	93
Wingrove & Rogers, Ltd.	91
Wright & Weaire	85

As used in the "TWO PROGRAMME TWO" described in this Issue

The importance of the right choice in valve holders is a vital matter. It is essential that for this set you should have those specified, because they are truly Anti-microphonic, have no capacity effects or leakage, always give perfect contact and have both Terminal and soldering tags for connections.

"BRETWOOD" VALVE HOLDER
Anti-microphonic Baseboard Mounting
Price 2/-

Illustrated Leaflets of the full range of



World Famous Components, including the popular De Luxe Variable GRID LEAK or Anode-resistance will be sent FREE to all readers of the Wireless Magazine

BRETWOOD LTD.
12-14 Andsell Street, Kensington, London, W.8

Station after Station

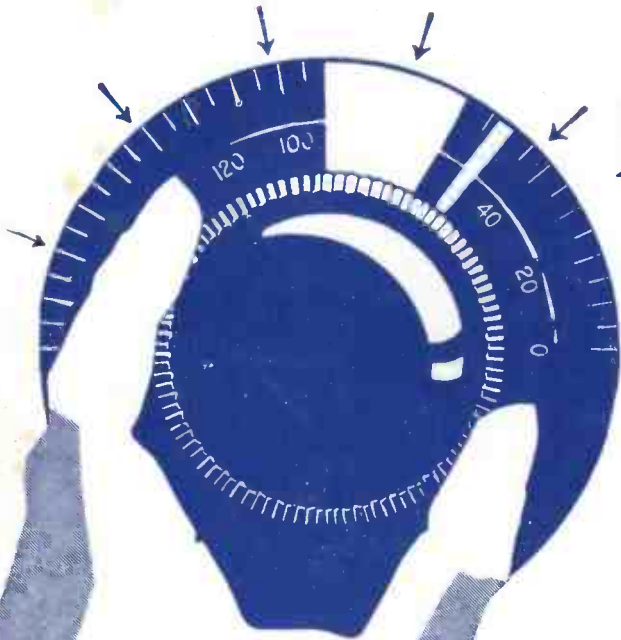

As easy
as setting
the hands of a clock

In one hour using only a small screw-driver you can build the Mullard Master Three—the finest three valve receiver yet designed.

No soldering The packet of A.B.C. Connecting Links contains a complete set of 20 wires cut to the correct length and eyeletted ready to fix under terminals.

Simple certain tuning One dial to bring in station after station, another to increase volume. Used in London, cuts out London.

FREE Complete simplified Plan of Assembly and full instructions for the Mullard Master Three.

Build this wonderful 1928 receiver now!

Mullard

The Master Three

The Editor, "Radio for the Million," 63, Lincoln's Inn Fields, London, W.C.2
Please send me FREE complete instructions and Simplified Plan of Assembly for the MULLARD MASTER THREE with No. 5 "RADIO FOR THE MILLION"

NAME (Block Letters)
Address

W.M.1

Mullard

MASTER · RADIO

iii

Half price **BLUEPRINT** Coupon Valid until February 29, 1928
FOR ANY ONE SET CONSTRUCTIONALLY DESCRIBED IN THIS ISSUE.

Fee of **INFORMATION** Coupon Valid until February 29, 1928
NOT MORE THAN TWO QUESTIONS TO BE ASKED AT A TIME

MAKE A JOB OF IT

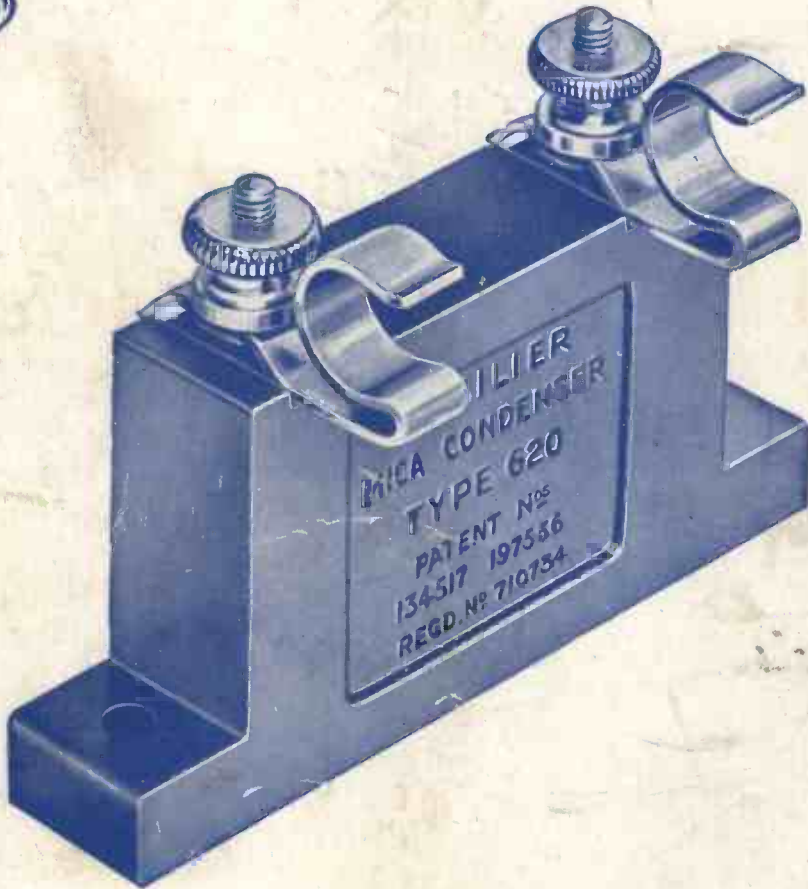

Sheer superiority in materials and design have put and kept the Dubilier Condenser at the top of the tree ever since the first wireless set was constructed. Fit Dubilier Condensers and make a job of it.

DUMETOHM CLIPS.

Both 610 and 620 condensers between the capacities of 0.00005 and 0.0005 mfd. are supplied with a pair of detachable Dumetohm grid leak clips (as shown) as well as with an insulated terminal clip for series mounting.

TYPES 610 & 620

Capacities.		Prices
0.00005 to 0.0009	mfd.	2/6
0.001 to 0.006	"	3/-
0.007 to 0.009	"	3/6
0.01 mfd.	"	4/-
0.015 "	"	4/6

DUBILIER

Advt. of the Dubilier Condenser Co., (1925) Ltd.

Ducon Works, Victoria Rd., North Acton, W.3

T.C.98