

£25 IN CASH FOR CONSTRUCTORS SEE PAGE 391

Wireless Magazine

VOL. 5, No. 29.
June — 1927.

EDITED BY BERNARD E. JONES
TECHNICAL EDITOR: J.H. REYNER, *B.Sc.(Hons) A.M.I.E.E.*

**BUILD
REYNER'S
COUNTRYSIDE
FOUR**

1/-



FREE BLUEPRINT of a Special Reinartz R.C. Three

Lotus Relay

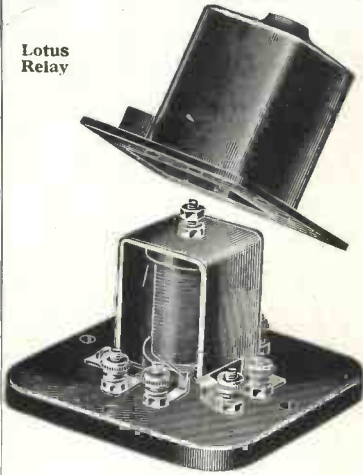

Lotus Wall Jack

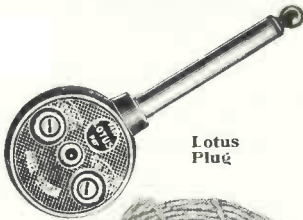

Lotus Plug



4 Strand Wire

COMPLETE OUTFIT FOR WIRING UP TWO ROOMS

1 "Lotus" Radio Relay,
2 "Lotus" Relay Filament Control Wall Jacks, 2 "Lotus" Jack Plugs, 21 Yards of Special 4-Strand Wire. Price **30/-**

EACH ADDITIONAL ROOM:—
1 "Lotus" Relay Filament Control Wall Jack, 15 Yards of Special 4-Strand Wire. Price **7/6**

THE LOTUS REMOTE CONTROL
gives simultaneous reception in every room!

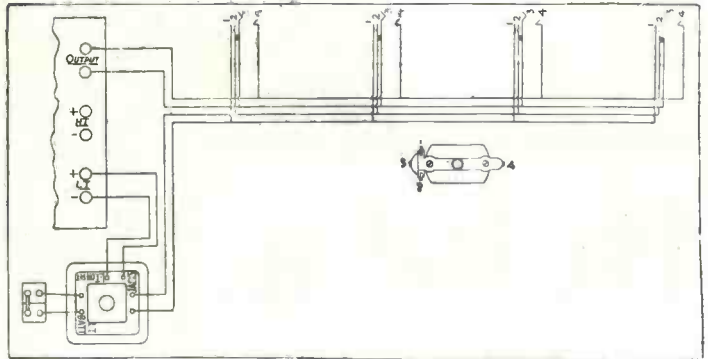

It is impossible for one listener to interfere with another.

The last plug to be withdrawn cuts off the Filament Circuit—there is no uncertainty. The Receiving Set is controlled from any point where a wall jack is fixed, distance does not matter. SUITS ANY WIRELESS SET.

SEND FOR FREE BLUEPRINTS AND INSTRUCTION FORMS.

THE LOTUS REMOTE CONTROL

GARNETT, WHITELEY & CO., LTD., Broadgreen Road, Liverpool.

Makers of the famous "LOTUS" Coil Holder and "LOTUS" Buoyancy Valve Holder.

FILL IN THIS COUPON for Free Blueprints and instructions explaining how two rooms can be wired in half-an-hour.

To ADVT. DEPT., GARNETT, WHITELEY & CO., LTD., LOTUS WORKS, BROADGREEN ROAD, LIVERPOOL.
Name
Address
W.M.2 J.C. & S.

When you send your order don't forget to say you "saw it in the 'W.M.'"

COUPON 2770E

The British Thomson-Houston Co., Ltd.,
Publication Department, Rugby.

Dear Sirs.
Please send me a free copy of your "RESISTOR"
Book of Resistance-Coupled Receivers.

Name

Address

PLEASE WRITE IN BLOCK LETTERS



Build a "Resistor" Set for £2-2-0 (or less)

Here is an opportunity to build a highly efficient 2-valve receiver for the ridiculously small sum of two guineas or even less. This receiver will give excellent loud speaker reception from Daventry and the local station, and, under normal conditions, all main B.B.C. stations and many continental ones can be received on headphones.

The extreme simplicity of this receiver and the small number of components required will be noted from the diagram. The Resistance-Capacity method of amplification is employed giving perfect purity in reproduction. In the past this system involved a considerable loss of volume. The B.T.H. B.8 valve, however with its extraordinary high amplification factor of 50 (unsurpassed by that of any other valve) gives as great a sound magnification per stage as the best L.F. transformer. By its use you may now have all the volume of transformer coupling with the purity of resistance coupling.

Fill in the coupon and post to-day. You will receive in return a free copy of the "Resistor" Book giving all necessary details for the construction of 2, 3, 4, or 5 valve receivers and a 2-stage L.F. amplifier.

Price given for the B.8 valve is applicable in Great Britain and Northern Ireland only.

Characteristics of the B.8 Valve.

Fil. Volts	Fil. Amps.	Anode Volts	Amplification Factor	Impedance
1.8 to 2.8	0.1 at 1.8v.	90 to 120	50	180,000 ohms.

It will be noted that the filament is rated at 1.8 to 2.8 v. The B.8 will function perfectly through out this range. It can be used directly from a 2-volt accumulator or from a 4 or 6 volt accumulator with suitable resistance.

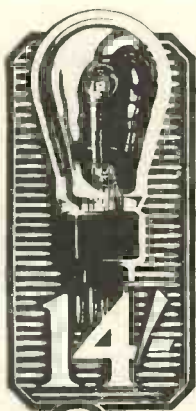
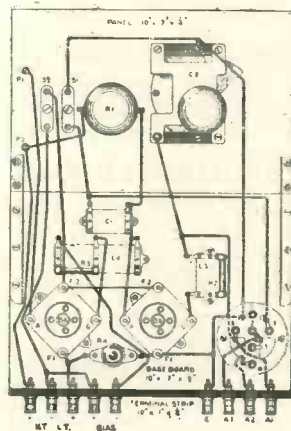

FOR RESISTANCE CAPACITY COUPLING

B 8 VALVE

AMPLIFICATION FACTOR 50

2770

Advertisers like to know whence the business comes—please mention the "W.M."

Amateur Wireless HANDBOOKS

each $2/6$ net

Loud-speaker Crystal Sets How to Make and Manage Them

Provides working instructions for building a number of highly efficient crystal sets; making an attachment for simple connection to existing wireless set; and designs for crystal sets embodying the crystal loud-speaker system.

Wireless—controlled Mechanism For Amateurs

This book is an illustrated practical guide to the making and using of short-range wireless control apparatus, and it has been written so simply that it can be understood by any enthusiast possessing an elementary knowledge of wireless.

The Wireless Man's Workshop By R. W. Hallows, M.A.

Written by a practical home constructor, this book—containing much useful wireless information—enlightens readers on the selection and right methods of using the tools and materials used in constructing wireless sets.

The Practical "Super-het" Book

Explains what the Super-het is, what it does, how it works, and how to build up a number of super-het sets made of tested, British-made components.

Perfect Broadcast Reception By Ernest H. Robinson (5YM)

Explains how most sets fall short of the ideal and how to obtain perfect reception. Is virtually a popular exposition of the main problems of transmission and reception. Very valuable alike to listeners and experimenters.

The Short-wave Handbook By Ernest H. Robinson (5YM)

Describes in very simple language the wireless apparatus used in short-wave work, shows how to make it and how to use it, and explains the technical principles with which the beginner will need to become acquainted.

The Practical Wireless Data Book

The intelligent novice, and particularly the home constructor and the keen wireless amateur who is always rigging up different circuits and experimenting for progress, will find this Data Book extremely helpful.

*Of all Newsagents and Booksellers,
2/6 net each, or 2/9 post free from
Cassell and Company Limited,
La Belle Sauvage, London, E.C.4.*

each $1/6$ net

Wireless Telephony Explained

CONTENTS: The Electron; Induction and Electro-magnetism; Waves and How they Travel; Inductance and Capacity; Rectification; Amplification; Reaction and Beat Reception; Aerials and Earths. Transmission Systems; Receiving Sets; Useful Formulae and Data. Index.

Crystal Receiving Sets And How to Make Them

CONTENTS: A Simple and Efficient Receiving Set; A Single-slider Set; Set with Semi-circular Tuner; Crystal Set with Tapped Single Coil; A Loose-coupled Set; Set with Plug-in Basket Coils; Combined Crystal and Valve Receiver; Some Miniature Receiving Sets; Crystal Circuits; How Crystals Work; Making a Buzzer; Receiving C.W. Signals on a Crystal Set; Converting Low-resistance Phones; The Morse Code; Index.

Wireless Component Parts And How to Make Them

CONTENTS: Components and Their Varied Purposes; Crystal Detectors; Coils, Making and Mounting; Condensers; Variometers and Vario-couplers; Resistances or Rheostats; Transformers; Making a Test Buzzer; Index.

Wireless Telegraphy and Telephony And How to Make the Apparatus

CONTENTS: General Principles of Wireless Telegraphy; Some Informative Experiments; Tuning and Resonance Explained; Transmission and Reception; Various Detectors Explained and Described; Thermionic Valves as Detectors, Amplifiers and Generators; Making a Single-circuit Receiving Set; Making a Complete Short-wave Receiving Set; Making a Valve Panel for a Receiving Set; Making a Five-valve Amplifier; Wireless Telephony; Arrangement and Erection of Aerials; Index.

*Of all Newsagents and Booksellers,
1/6 net each, or by post 3d. extra
from Cassell and Company Limited,
La Belle Sauvage, E.C.4.*

Practical Guide to Wireless (1s. net, postage 2d.)

CONTENTS: An Outline of Present Broadcasting The Aerial; Tuners and Tuning; The Crystal Set; The Valve and Valve Sets; Telephones and Loud-speakers; Current for Valve Filaments; Index.

A Useful Series for Wireless Amateurs

Cassell Books

La Belle Sauvage, London E.C.4.

When you send your order don't forget to say you "saw it in the 'W.M.'"

Your interests catered for

"Amateur Wireless" deals with every phase of wireless in an informative, interesting and helpful way; it is lavishly illustrated with photo reproductions and many explanatory drawings and diagrams. A great feature is Expert Replies to Readers' Questions.

Other regular features, many fully illustrated—On Your Wavelength! (Chatty paragraphs by "Thermion"), Practical Odds and Ends, Components You Can Rely Upon, Around the Showrooms, Progress and Invention, Latest News in Brief, Times and Wavelengths of Home and Foreign Stations, Chief Events of the Week, Club Doings and Correspondence.

Brightly written and brimful of information, "Amateur Wireless" informs, instructs, directs, advises and enthuses its readers.

Amateur Wireless

is on sale at all news-
agents every Thursday **3d.**

NO SULPHATION

*All the
World's Makers
of
Portable Storage
Batteries
(only exception
"Tungstone")
make the Plate Grids
with
Antimony
a dead metal that
cannot generate or
Store Electricity
Antimony
an excessive weight
of
Dead Metal
insecurely holds
the Paste
in the Plate Grid
and only Conducts
the Electricity*

LATEST EXCLUSIVE FEATURES.

Each Plate Fitted with Acid Resisting Rubber Belt to act as a Road Shock Absorber Minimizing Intensified Plate Vibrations.
Tungstone can be Constantly Overcharged.
Continuous High Charging Recommended.
Plates cannot be Excessively Overheated.
Metal Containers Dissipate Internal Heat.
No Celluloid and Compound Containers that hold Internal Heat Lowering amp. hour Capacity and Shortening Plate Life.
No External Acid Sweating or Creeping.
Plates Cannot Internally Short-Circuit.
Negative Plates cannot Tree. LOW Acid Heat.
Guaranteed Negligible Internal Resistance.
No Decaying Wood Separators creating Impure Acid.
Inefficacious Silting or Paste Dropping out of Plate.

Sulphation cannot Permanently

BECOME DEEP-SEATED. IT CANNOT DEFINITELY DAMAGE or EVENTUALLY DESTROY A TUNGSTONE BATTERY.

Tungstone Plate on the surface only may temporarily, in parts, become Sulphated under the exceptional conditions of Plate exposure to the air; or if left Discharged for a long period. If promptly refilled with acid solution and immediately fully re-charged, this temporary face sulphation will disappear.

There is a permanent natural affinity existing between the Tungstone Plate Grid and paste, because both are made of Pure Lead, therefore immediately our First Partial Charge comes into operation at the Works, it at once forms a perfectly reliable and permanent cohesive assimilation of the Plate Grid with Paste giving exceptional electrical capacity, and it also possesses natural elements that securely holds the Paste in the Plate during its active life.

The greatest practical value of Tungstone's perfect cohesion of Plate Grid and Paste is, that on the inside hidden surfaces of the Lattice Grid Lead Bars where the Paste is always in direct contact at innumerable points, there is

Permanently Formed a Pure Lead Interlocking Connection which acts as an effective Barrier. This absolutely prevents the Original germs of Sulphation from forming and growing.

ANTIMONY, AN INERT METAL (Electrically), ENCOURAGES AND STIMULATES SULPHATION. Immediately after Pasting Sulphation germs start to form and grow at these hidden contact points. Sulphation, the deadly Plate destroying disease, at once becomes permanent with continuous increasing growth that cannot be stopped or eradicated. It is naturally and physically impossible for Competitors' Plate Grids made of Antimony to grow into unison with their Paste made with an Expander. This is the cause of permanent Sulphation which also Disintegrates the Paste forcing it to drop out of the Plate of all other Batteries except Tungstone.

"NO SULPHATION" FOLDER from Dealers, or sent post free on receipt of Post Card. S.1.

Wireless Magazine

for June, :: Vol. V
1927 :: No. 29

Contents of This Issue

	PAGE		PAGE		PAGE	
Popularising the Portable! By the Editor	391	Commercial Telephony ..	421	A New Method in Reception	446	
Towards Home Television	392	Oscillating Crystals ..	421	Novelties and New Appa- ratus	448	
The Listener's Catechism ..	394	Parlez-vous Maggie? ..	422	Low-frequency Reaction ..	449	
<div style="border: 1px dashed black; padding: 5px; margin: 10px 0;"> <p>The Countryside Four</p> <p>J. H. Reyner's Special Portable Receiver for Loud-speaker Work .. 395</p> </div>			Grid Condensers	422		
		Radio and the Mentally Afflicted	423	<div style="border: 1px dashed black; padding: 5px; margin: 10px 0;"> <p>A Two-valve D.C. Mains Amplifier</p> <p>Can be added to an Existing Crystal or Valve Set 409</p> </div>		
Under My Aerial. Halyard's Chat on the Month's Topics	401	Below the Broadcasting Belt	424			
What You Want to Know About Portable Sets for 1927	404	Things Heard from 2LO ..	429	Half Hours with the Pro- fessor. 4.—A Chat About Frame Aerials	450	
Aurora Borealis	407	Voices of the Night. By J. Godchaux Abrahams ..	430	"Giving 'Em Beans!" A Wireless Story by Alan Duke	453	
Turn Your Rheostats into Fixed Resistors	408	Why Is It?	431	Through My Loud-speaker	454	
Finding the Best Coil Tap- ping	408	Jottings on the Month's Progress	432	What the B.B.C. is Doing..	455	
High-power Broadcasting Tests	413	What Readers Think of Our Sets: The 1927 Five ..	433	Little-known Facts About Distortion	456	
Simpler Wireless!	413	<div style="border: 1px dashed black; padding: 5px; margin: 10px 0;"> <p>The Fonotrol Crystal Set</p> <p>Incorporating a Novel Long- and Short-wave Switching Device .. 418</p> </div>			What the Reader Thinks ..	460
Continental Notes	414	Radio Ruralities	434	The World's Broadcasting	462	
<div style="border: 1px dashed black; padding: 5px; margin: 10px 0;"> <p>A Reinartz R.C. Three for the Family</p> <p>Free Full-size Blueprint with this Issue .. 425</p> </div>			Broadcast Music of the Month	438	Questions Simply Answered	464
Capt. Round's Causerie: Cone Loud-speakers ..	415	Heard Over the Ether ..	440	Gadgets, Hints and Tips ..	466	
Summer the Best Wireless Time	417	About the Loftin-White Cir- cuit. By J. H. Reyner, B.Sc., A.M.I.E.E. ..	441	<div style="border: 1px dashed black; padding: 5px; margin: 10px 0;"> <p>How to Make a Wet H.T. Battery</p> <p>That possesses a Number of Advantages over Other Types.. .. 435</p> </div>		
		Dry-cell H.T. Batteries ..	443	"Wireless Magazine" Refer- ence Sheets. By J. H. Reyner, B.Sc., A.M.I.E.E. ..	468	
		Making the Lead-in Con- nection	443	The Buyer's Guide	472	
		Lost Signals. By Capt. Jack Frost	444			
		Inserting Screws	445			
		Music Wherever We Go! ..	445			

Published by BERNARD JONES PUBLICATIONS, LTD., publishers of "Wireless Magazine" and "Amateur Wireless." Editor: Bernard E. Jones. Technical Editor: J. H. Reyner, B.Sc. (Hons.), A.M.I.E.E. Editorial and Advertisement Offices: 58-61, Fetter Lane, London, E.C.4. Telephones: City 3733, 3734. Telegrams: "Beejapee, Fleet, London." Published about the 25th day of the month and bears the date of the month following. Subscription: Great Britain and Abroad, 15s. 6d. a year, post free (Canada only, 13s. 6d.). Contributions are invited and will be promptly considered.

Do not miss this!

"1927 Five" Set
as described in the October "Wireless Magazine".

Set of 3



Low Loss Coil FORMERS

and Discs for High or Low Wave Lengths. Ready to receive fittings and windings.

Per Set **12/6**

Packing and Postage 9d. ex.

For the **"AMERICA SEVEN" Set**
as described in 1927 January issue "Wireless Magazine".



Six Point Low Loss FORMERS, each 4" long, 3" dia.

3 Formers with discs and 3 Tubes as detailed, ready for winding.

Price **12/6**

Packing and Postage extra, 9d.

1 Tube, 2½" diam., 2½" long.
1 Tube, 2½" diam., 3" long.
1 Tube, 1" diam., 2½" long.



All made in the famous BECOL. Ebonite. Look for the trade mark. Delivery from stock. Apply to your dealer. If unobtainable come to us.

Write for List "M."

THE BRITISH EBONITE CO. LTD.,
Nightingale Rd., Hanwell, London, W.7.

Registered Trade Mark.

Why

LEWCOS Frame Aerial Wire is recommended for the 4 VALVE PORTABLE

Enthusiastic users have proved that LEWCOS Wire guarantees an efficient Frame Aerial—the first essential in a portable receiver. Mr. G. Brammer, of Copenhagen, says: "It works excellently. . . I simply can't get a better frame." For every type of Frame Aerial, use this guaranteed wire. Made by the manufacturers of Glazite. In cartons in the following colours: Bright Red, Bright Blue, Bright Green, Maroon, Old Gold and Golden Brown. 3/6 per 100 ft. coil, from all Radio dealers. Full particulars from:

THE LONDON ELECTRIC WIRE COMPANY & SMITHS LTD.,
Playhouse Yard, Golden Lane, E.C.1.

LEWCOS
Frame Aerial Wire

Write to advertisers for particulars of their goods and mention the "W.M."



IGRANIC ensures good results

Success or failure in set construction depends a lot on efficiency of components and accessories; and that is why the experienced Radio Constructor exercises the utmost care in choosing his components. If you specify "Igranic" components you will get the best results obtainable.

Igranic-Pacent "PRE SET" Resistors

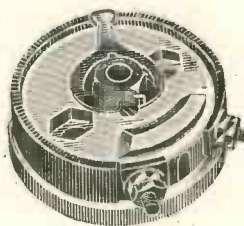

have all the uses of fixed resistors and yet are almost as easily variable as rheostats. Their use prevents overrunning the valves and reduces the number of controls on a panel. Made with resistances of 6, 10, 20, 30 and 50 ohms. The position of the contact finger is easily variable over the whole range.

Price 1/8 each

Igranic "Indigraph" Vernier Knob & Dial

The Igranic Indigraph Vernier Knob and Dial is a handsome slow motion dial which greatly facilitates fine adjustment. Two scales of 0 to 100 each are provided reading in opposite directions making the Indigraph suitable for different types of condensers. Space is provided opposite the scale for recording station settings. The metal dial acts as a shield against hand capacity effects.



Price 7/6 each

Igranic Centre Tapped "Xllos" (Extra Low Loss) Coils



Igranic Centre Tapped "XLLOS" Coils possess special windings of very high efficiency, enclosed in a sealed Bakelite shell which excludes dust and moisture and prevents the coils being damaged, thus preserving absolute constancy in operation.

Igranic Centre Tapped Coils actually contain two separate inductances which may be used singly or may be joined in series to form a single coil to which a centre tapping can be taken.

Made in five sizes for wavelengths from approximately 110 to 3,350 metres.

Prices: from 7/- each.

Mounting Base 4/6

WRITE FOR THE NEW IGRANIC CATALOGUE. List No. J.245.

IGRANIC ELECTRIC CO. LTD

149, QUEEN VICTORIA STREET, LONDON
WORKS: ELSTOW ROAD, BEDFORD

Popularising the Portable!

The Editor Offers £25 in Cash Prizes

"**MORE SUMMER WIRELESS**" must be our slogan. It is quite ridiculous to suppose that wireless is for winter only and that there is necessarily a summer rest of six months. Wireless is now a part of our everyday lives, and is becoming increasingly so. It has advantages which no scientific development of any age has possessed and these advantages are not alone for the dark months.

"I want a set for my yacht," said a man to me the other day. "I like to keep in touch with the news and of course wireless is the only way." To yachtsmen and motorists wireless is easy and simple, and the mystery is why more of them do not carry a set.

Many more portables should be built and used. There is any amount of fun to be got out of them and much development is possible. The designer and constructor of portables is never finished; he has in front of him a problem which he can tackle and re-tackle—the production of an effective loud-speaker set in small compass and of low weight.

In this issue Mr. Reyner puts forward a design which is not particularly remarkable for what it includes but rather because of what has been left out. Mr. Reyner, experimenting in the Wye Valley, put the set through a series of tests lasting over many days, until he was satisfied with results. In its present form it is easily controlled, the tone quality is good, the weight is but 28 lb., and the cost of construction is estimated at about ten guineas.

A simple switch movement gives you any local British station or Daventry at will, and the cost of a special loud-speaker has been avoided by arranging that the set shall work your existing instrument.

I should like some hundreds of readers of the WIRELESS MAGAZINE to build this set for themselves and let me know how they get on with it. Our Information Bureau, in conjunction with Mr. Reyner, will be only too glad to assist anyone who comes across any point of difficulty in connection with it.

Further to making it I want them to use it and to send me some evidence of their so doing. I should like them to send me photographs of their happy little outings in the country, their picnics, their boating parties, their motoring excursions, in which the Reyner portable is in use. Let me put forward my suggestion in detail.

To assist this magazine in popularising the portable, let my readers build the Reyner set, test it out and use it on every possible occasion this summer. Let them send me photographs of it in use, the sort of photographs they would like to see reproduced in the WIRELESS MAGAZINE—happy, intimate pictures, full of the atmosphere of the country and telling at a glance of the enjoyment of the listeners.

Let readers send me these photographs from time to time as they take them, or if they like they can send them to me towards the end of the summer, certainly not later than Saturday, September 3. I shall print a number of these photographs in the WIRELESS MAGAZINE, and the best eight of them will win prizes, the winners' names and addresses to be announced in the October issue, published September 23.

I am offering a first prize of £15 cash, a second of £3, a third of £2 and five other prizes of £1 each, all in cash.

Purely for the protection of competitors in general, I am reserving the right to have any prize-winning set examined locally.

Not only will you be getting some fun yourselves with a chance of a good prize but you will be encouraging other people to take an interest in summer-time wireless, and that will be to the good of everybody.

By the way, don't be afraid to send in your photographs because you use a small camera. Any bright, clear prints will suit, but it might be wise in the case of pictures under quarter-plate in size to send me the negatives as well as the prints, so that if necessary I can enlarge them.

I should like all constructors to keep as closely as possible to the Reyner design as set forth in this issue. Every constructor likes, I know, to introduce little modifications of his own, but the photographs as submitted should show essentially the set which Mr. Reyner has described in this issue, and as indicated in the blueprint of the set which can be sent to any reader for 1s. 6d. post free. The blueprint is in itself a very valuable aid to constructors, as it shows the layout, wiring, and all components full-size.

Bernard Jones



Early example of photograph transmitted by wireless by the Alexanderson system.



More recent example of photograph transmitted by wireless by the same system; the reproduction is much better.

Of Interest to Every Listener

TOWARDS HOME TELEVISION

In our April issue we gave some particulars of the television research carried out by the British inventor, J. L. Baird; in this article a special correspondent reviews the work of Dr. Alexanderson in America

MANY internationally known scientists and experimenters have declared that television is an impossibility, but Dr. Alexanderson, consulting engineer to the General Electric Company of America, has devoted a great deal of time to telephotography and television, with the result that the expectation of commercial television is not unreasonable, and may be accomplished soon with means that are at present in the possession of experimenters.

Practical Success Imminent

How long it will take to attain practical television it is impossible to say at present, but everything points to a successful issue.

Radio transmission of a single photograph has already been accomplished in two minutes in the research laboratories of the G.E.C., and it has proved that television will require the transmission, reception, and reproduction of a single picture in one-sixteenth of a second. One of the main difficulties in the way of a speed of sixteen pictures per second is the development of a suitable projector which will enable a person to see on a screen the movement of objects several miles distant.

In the course of an address given to the members of the St. Louis Section of the American Institute of Electrical Engineers, held recently in the States, Dr. Alexanderson explained the television projector which is now in operation in his laboratory, and by means of which he is hopeful of getting the 300,000 brush strokes per second that are essential for producing motion pictures.

Necessary Operating Speeds

Dr. Alexanderson stated that it is easy enough to design a television system with something like 40,000 picture units per second, but the images so secured are crude, and would, therefore, have no practical value. Work in radio photography has shown that an operating speed of 300,000 picture units per second will be required to give pleasing results.

Speeding up of the process in this way is, unfortunately, one of those cases where the difficulties increase by the square of speed. The method adopted by Dr. Alexanderson in speeding up the process of mechanical moving parts is the introduction of seven distinct light

**PHOTOGRAPHS OF DR.
ALEXANDERSON'S EXPERIMENTAL
TELEVISION APPARATUS**

How soon will it be suitable for use in the home? In a comparatively short time, we may hope, if present rates of progress are maintained.

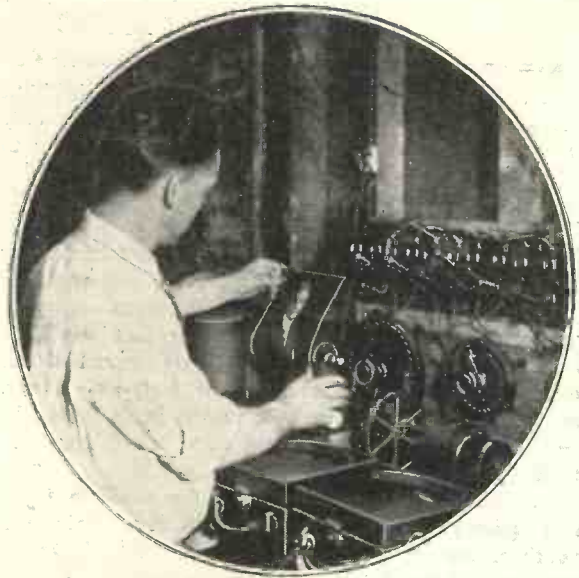

Inserting an original photograph in the transmitter.

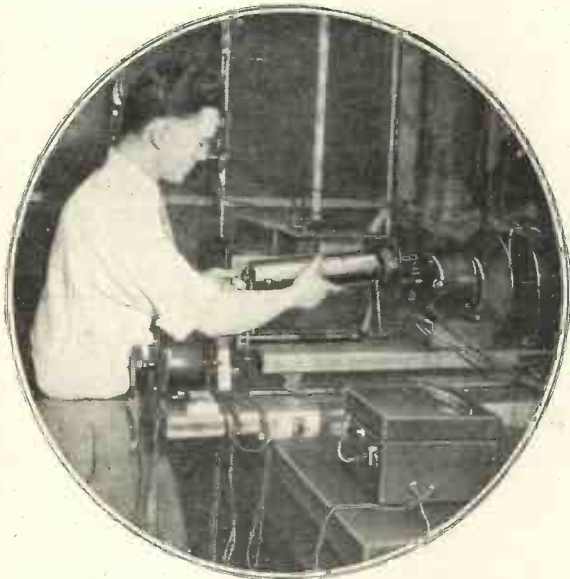

Part of the telephotographic receiving instrument.

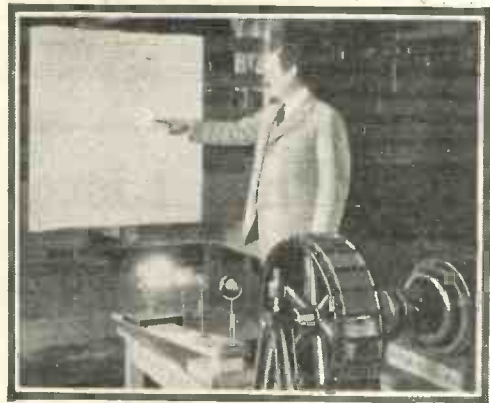

The projector that produces seven points of light.



A photograph showing the general arrangement of Dr. Alexanderson's apparatus for transmitting pictures by wireless.

Towards Home Television (Continued)

sources, the lights converging in a cluster of brilliant spots which scan the picture, each light painting only one crude picture, but all seven interlacing optically to produce a single good picture.

Seven Light Sources

The model of the television projector constructed by the doctor comprises seven light sources converged by an optical system to a revolving drum carrying twenty-four mirrors. These mirrors reflect the light cluster to a screen. Using seven lights instead of one the useful illumination is increased forty-nine times. Further, in utilising seven light beams in multiple, the speed at which each light beam must travel has been reduced in the proportion of 7 to 1.

In addition to these advantages for multiple light-beam operation, each beam needs to move only one-seventh as fast, and therefore needs to give only 43,000 instead of 300,000 independent impressions per second. A modulation speed of 43,000 per second is high in present radio practice, but is yet within reason, being only ten times as fast as is used in broadcasting.

In Dr. Alexanderson's plan a complete television system requires an independent control of the seven light spots. For this purpose seven photo-electric cells are located at the transmitting machine, and control a

multiplex radio system with seven channels. A multiplex system known as the Hammond is used with seven intermediate carrier waves which are scrambled and sent out by a single transmitter and then unscrambled at the receiving station, so that each controls one of the seven light beams.

In discussing radio photography Dr. Alexanderson showed some of the results he had obtained in the radio transmission of pictures—both by modulated and interrupted signals. Under the former system any broadcasting station can transmit photographs at such distances as music of good quality can be transmitted by that station. For long-distance transmission the short-wave telegraphic system can be used.

Reception Independent of Signal Strength

Reception of pictures by telegraphy is independent of signal strength. Thus, if the signal is strong enough to be recorded at all, it gives the same kind of records at the maximum as at the minimum signal intensity, thus making the recording independent of fading.

If, furthermore, the signals are stronger than the prevailing static, it is quite possible to eliminate the effects of static by introducing a threshold value of signal strength in the receiver, and nothing is received unless the signal exceeds this value. F. G. B.

The Listener's Catechism

By Irvine Foster

THERE is much to be said in favour of the suggestion that every listener should be allowed, as he pays his fee at the Post Office, to indicate by his answers to questions on the licence counterfoil the kind of programme he wishes to hear broadcast. The only practical difficulty lies in drafting the questions in such a form that they give offence to nobody.

Breach of the Peace

To ask a retired Indian Army officer whether he would favour the Children's Hour being put back to 7 p.m. and renamed the "Bairns' Bed-time" would merely be to provoke gratuitously a breach of the peace, while an unfortunate enquiry such as "Which do you prefer, cornet solos or musical items?" might easily lead to serious trouble.

But the problem is not insoluble. The massive brains of the Post Office administrators have already been set in motion and a rough draft of the questionnaire has been drawn up. It

is a lengthy document, somewhat on the lines of the income-tax assessment form, with two tables, three appendices and a blank addendum sheet, but the more important questions are as follow:—

(1) Which type of programme do you like best: (1) Highbrow, (2) hybrid, (3) lowbrow, or (4) merely vulgar? If none, write NONE in column.

(2) Which type of programme does your wife like best?

(3) Which type of programme do you usually listen to? N.B.—Replies to this question will be treated as strictly confidential.

(4) What, frankly, is your opinion of Professor Dullas Dichwater's weekly talks on "Functional Disorders of Parallelepiped and other Succulent Bivalves"? N.B.—As this is a privileged occasion, the Criminal Libel and Blasphemy Laws may be ignored in giving your reply.

(5) Compare the relative merits of the Annual General Meeting of the National Union of Undertakers'

Mutes and the shipping forecast from Daventry as a soporific.

(6) What sort of programme do you generally listen to between 7 and 9 p.m.? N.B.—Facetious or misleading replies to this question, such as "My neighbour's oscillating exercises" are offences under Section 29 (c) of the Wireless Telegraphy Act, 1905.

(7) Place in order of preference the following musical items:—Jazz, music-hall songs, Beethoven's concertos, chamber music, sentimental ballads.

(8) Now drop all pretence and say which you really prefer.

(9) Do you consider the weather forecasts depressing?

A Special Question

(10) (For ladies only.) Which announcer is your favourite; the one with the lovely mellow voice who pronounces "pesetas" so divinely or the one with the "refained" accent who takes the difficult place-names in his stride?

To constructors of this receiver the Editor offers £25 in cash as prizes—full details are given on page 391. But apart from your chance of winning a prize you must build the Countryside Four to get the most enjoyment during the fine days of summer. This set weighs only about 28 lb. and costs less than 10 guineas to build.

Adjusting the set.



The Countryside Four

Specially Designed, Built and Tested by J. H. REYNER, B.Sc., A.M.I.E.E.,
Technical Editor

IN the summer weather, if it is at all seasonable, people want the open air. In fact, usually the sunshine is so precious that every available moment which can be taken out of doors is so spent. In such circumstances the ordinary wireless receiver is not brought into commission to any considerable extent.

Out-of-door Activities

The general tendency is to disregard wireless reception in the summer time, not because wireless loses its interest, but because out-of-door activities are more intriguing at this time of the year. There are, however, many occasions when the

normal routine of the wireless programme to which one has become accustomed in the winter is missed in the summer months.

It may be very pleasant to disappear for the afternoon, or perhaps for a week-end, and find some distant spot where one can laze in the sunshine and enjoy a rest. At such periods the presence of wireless can add appreciably to the pleasure of the holiday, be it brief or lengthy. It gives one a feeling of pleasure and a certain degree of comfort to be in touch with the broadcast world at will wherever you may happen to be.

To obtain these advantages it is necessary to possess a portable re-

ceiver. Many people regard portables as unsatisfactory. There can be little doubt that some of the portable receivers which were made in the early days of wireless were not particularly encouraging. They required excessive reaction in order to produce satisfactory signal strength, and, in consequence, what was there was bad!

Really Good Portable

It occurred to me, therefore, that the production of a really good, and yet simple, portable loud-speaker receiver which could be made up comparatively cheaply, and which would "deliver the goods" any-

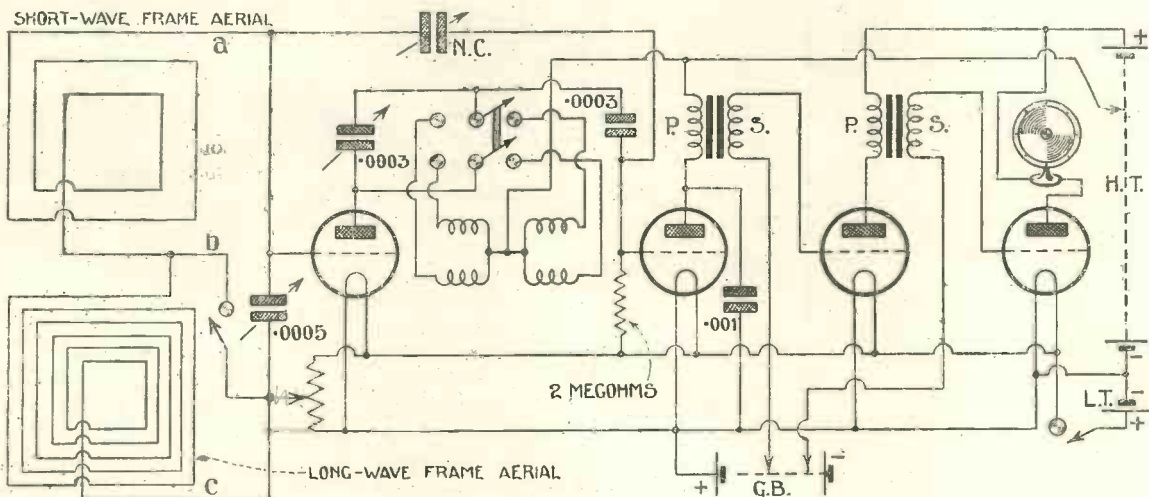

Diagram of the Circuit specially Developed by J. H. Reynér, B.Sc., for the Countryside Four.

The Countryside Four (Continued)



Used in conjunction with a Celestion loud-speaker, the Countryside Four gave excellent results in the Wye Valley.

where, would supply a long-felt want. The problem was one requiring a certain amount of experiment in order to determine how best to achieve the necessary results in an effective manner, and I addressed myself to this task some considerable time ago so that I could give WIRELESS MAGAZINE readers the benefit of this research work in time for summer.

I had, of course, to decide what was required from the point of view

HERE IS A LIST OF THE COMPONENTS

They cost less than 10 guineas.

- Ebonite panel, 14in. by 7in. (Becol).
- .0003-microfarad variable condenser (Peerless).
- .0005-microfarad variable condenser (Peerless).
- 2 L.F. transformers, ratios 2 to 1 and 4 to 1 (B.T.H. or Ericsson).
- 4 antimicrophonic valveholders (Whiteley, Boneham).
- Baby Binocular long- and short-wave coils (Wearite).
- Potentiometer (Lissen or Igranic-Pacent).
- 2 single-pole push-pull switches (Bulgin).
- Frame-aerial hinge (Igranic).
- Two-pole change-over switch (Wearite).
- 2 terminals loud-speaker- \dagger loud-speaker— (Igranic or Belling-Lee).
- .0003-microfarad fixed condenser with 2-megohm grid leak (Watmel).
- .001-microfarad fixed condenser (Igranic).
- 8-way battery cord (Lewcos).
- 2-volt 20-ampere-hour non-spillable accumulator (Exide type DO4 or Oldham).
- .99-volt Hellesen H.T. battery, type Porup (A. H. Hunt).
- Neutralising condenser (McMichael).
- 2 panel brackets (Bulgin).
- Cabinet (Caxton).

of readers. It is quite feasible to build portable receivers having six, seven, or eight valves which can be mounted in a reasonably compact space, and which will supply programmes from various distant stations as well as those comparatively near by.

Fascinating

There can be no doubt that a receiver such as this is a fascinating proposition, but at the same time it is apt to be expensive. Moreover, the weight of the receiver is bound to be fairly heavy, not only as regards the receiver itself, but because of the necessary battery power which has to be supplied with it.

All things being considered, I felt that a receiver of this type was not quite what was required. If the reception of distant stations, therefore, is not considered necessary, then the problem becomes somewhat simpler, and all that is required is the provision of an efficient arrangement for the loud-speaker reception of the local station and Daventry, with, perhaps, one or two other stations under suitable conditions. This is a much cheaper proposition, although not necessarily a simpler one.

I have spent a considerable time on finding the arrangement which I considered the most suitable for the purpose in view, and, in fact, for some six weeks I tried different types of circuit and different arrangements of valves in order to obtain what I considered to be adequate results.

Novel Features

The upshot of all this work has been the Countryside Four, a receiver which will be found to contain one or two novel features, and which can be built by readers with full confidence that it is the best simple four-valve portable which can be devised.

The circuit of the receiver is shown in Fig. 1. It will be seen that there is one high-frequency valve, a detector, and two transformer-coupled

DO THESE FEATURES APPEAL TO YOU?

- 1.—Reliable signals with the minimum of trouble.
- 2.—Batteries and frame aerial self-contained.
- 3.—Excellent tonal quality
- 4.—Weighs only 28 lb.
- 5.—Costs only about 10 gns. to build.
- 6.—May win you a cash prize of £15 (see p. 391 for full particulars).

low-frequency valves. Considerable experiment was made in order to find whether it was desirable to include more than two stages of low-frequency amplification, because the object I had in view was the production of adequate loud-speaker strength from Daventry and the various local stations practically anywhere in the country, provided, of course, that reasonable conditions prevailed.

I found that I could obtain the degree of signal strength required quite adequately with two transformer-coupled stages, and that the use of further L.F. stages was not practicable in a compact space.

Numerous different forms of high-



J. H. Reyner's Experimental Model of the Countryside Four; the frame aerial has since been modified.

frequency circuit were devised from time to time in order to find which gave the greatest signal strength combined with smooth control, and after considerable experiments a modified form of tuned-anode circuit was adopted. This, as is well known, is an efficient form of high-frequency amplification, particularly if one of

Build This Set and Win £15 in Cash! (See p. 391)

the new high- μ valves now on the market is used. A difficulty with the tuned-anode system on a frame aerial, however, rises from what may be called "neutralising overlap."

It is a well-known fact that in an ordinary neutralised circuit as the capacity of the neutralising condenser is increased so the circuit becomes more and more stable until the capacity of the valve is adequately balanced. At this point the circuit should be stable, but in practice it is often not found to be the case.

Oscillation

This arises from the fact that a simple neutralised circuit is also a Hartley oscillator circuit, the neutralising condenser in that case serving as a reaction-control condenser, which exercises a throttle effect on the anode feed to the oscillator circuit. As the value of this condenser is increased so the circuit tends to oscillate more and more readily, and at a certain critical value actually will burst into oscillation.

Now the difficulty in some neutralised circuits is that the Hartley oscillator action comes into operation before the neutralising action has finished. If this happens before the valve can be correctly neutralised, the circuit will burst into oscillation as a Hartley oscillator, so that it is not possible to obtain any position at which the circuit is stable.

This is a very unsatisfactory state of affairs, and is particularly likely to happen when a frame aerial is used owing to the low resistance of the frame winding. Because of this the reaction demand as a Hartley oscillator is quite small, and can easily occur before the circuit has been correctly neutralised.

Good Amplification

At the same time the amplification obtained from this system when adequately stabilised is very good indeed. It was, therefore, considered desirable to concentrate on this form of circuit, and to find a method of securing adequate stabilisation, and this has actually been done in the case in point.

Another point which was borne in mind when experimenting with this circuit was the necessity for switching the circuit from the short waves

to the long waves, and I found that by using a system of the nature just outlined the switching could be considerably simplified.

After some time it was found that the best results could be obtained by

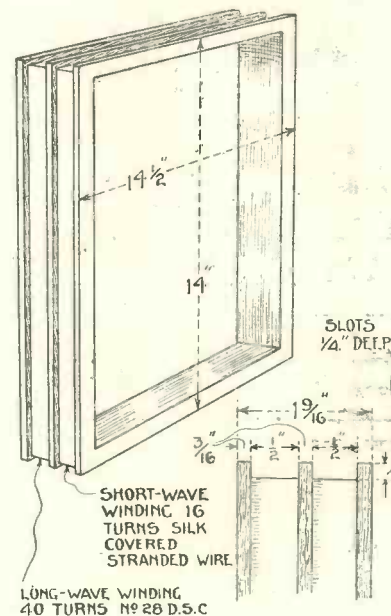

Details of Frame Aerial.

utilising an inverse feed process, in which the grid circuit of the detector valve is not connected directly to the anode of the preceding valve, but is

fed from the opposite end of the tuned-anode circuit.

The high-tension connection goes to the centre point of the winding as before, while the neutralisation becomes a form of grid-to-grid arrangement. This was found to minimise the neutralising overlap which was experienced by other methods, and also it gives an improved signal strength on comparatively weak signals.

Reaction Control

It was necessary to incorporate some form of reaction control, and at first sight it appears that the neutralising condenser could be used for this purpose. This, however, proved unsatisfactory, because it was liable to be severe in its action. It is usually found that the use of the neutralising condenser for reaction gives rise to "ploppy" action, and in this particular case the difficulty was aggravated because the neutralising condenser itself had some small effect on the tuning of the circuit.

Sharp Tuning

As the tuning is naturally somewhat sharp, particularly if the receiver is being operated at some distance from the nearest station, then any alteration of the tuning by the reaction control is undesirable.

It was finally decided to incorporate a potentiometer on the high-frequency valve and to produce a small

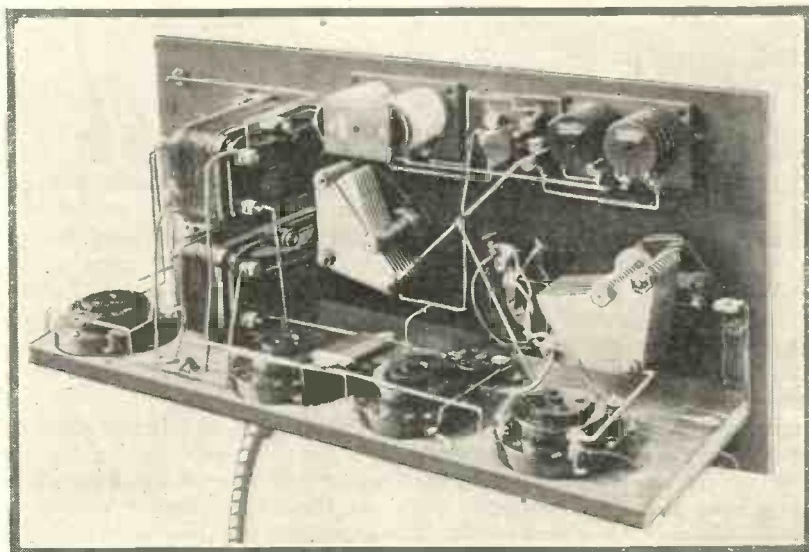

Layout of Components of the Countryside Four.

The Countryside Four (Continued)

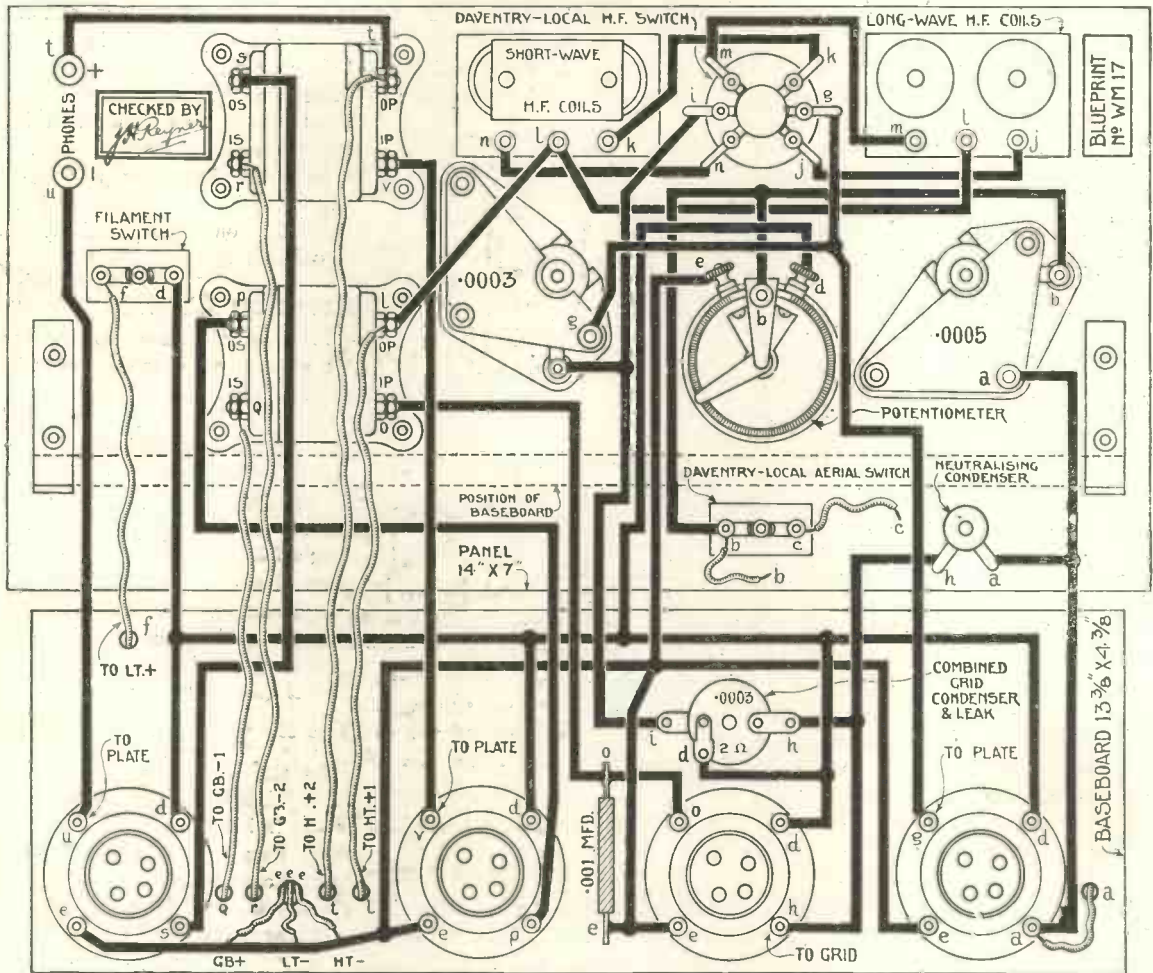

This layout and wiring diagram can be obtained as a full-size blueprint for 1s. 6d. post free. Ask for Blueprint No. WM17, and address your letter to Blueprint Dept., "Wireless Magazine", 58-61, Fetter Lane, E.C.4.

reaction effect by slightly over-neutralising the valve. By placing a small amount of positive bias on the grid it is possible to control the oscillation, and this, moreover, can be done in a very smooth and easy manner.

Switching

Reception is obtained on either the short waves or the long waves at will by a simple process of switching. The frame aerial carries two windings, one designed for the shorter waves and the other for the Daventry waveband. The practice of using the short-wave frame for Daventry and loading it up with a plug-in coil of some sort is not efficient, and much better results are obtainable if a special frame for the longer waves is

incorporated. It is necessary to short-circuit this longer-wave frame when reception is being carried out upon the short waves, this being accomplished by a simple push-pull switch.

Three leads have been brought from the frame aerial to the receiver proper, and a small push-pull switch at the bottom of the panel serves to change the frame winding over from the short waves to the long waves, and *vice versa*.

For the H.F. circuit two additional coils have been used, one for the short waves and one for the long waves, and these are changed over by a second switch. In order to avoid any possibility of coupling between the circuits, it was not considered desirable to operate both the frame and

H.F. circuit on the same switch, and two separate switches have been arranged. This occasions very little difficulty, and certainly results in an arrangement which is likely to give less trouble.

Interaction

Apart from any difficulty arising from coupling through the switches, however, it is necessary to avoid interaction between the H.F. circuits and the frame circuit. This, of course, could be achieved by some form of screening, but it would have to be practically complete owing to the variable position of the frame relative to the remainder of the circuit, and this would result in a somewhat bulky arrangement.

The only other solution to the diffi-

You Cannot Build A Better Set for the Money

gulty is the use of some form of fieldless coil, and after some experiment it was ultimately decided to utilise Baby Binocular coils. These coils occupy a very small space, and are thus ideal for a portable receiver, while at the same time tests indicate that they are surprisingly efficient for their size and give excellent results in practice.

High and Low Wavelengths

The use of these coils not only enables both the high-wave and the low-wave windings to be placed comparatively close to each other, and in quite a small space at that, but it also obviates any coupling between the frame aerial

POINTS THAT WILL INTEREST YOU

- 1.—Long or short waves can be received without changing coils.
- 2.—Filament consumption in less than $\frac{1}{2}$ ampere.
- 3.—High-tension consumption is 6 milliamperes.
- 4.—Will work your existing loud-speaker.

and the inverse tuned-anode circuit. It is thus possible to rotate the frame at will without any variation of the reaction.

In order to make perfectly certain that there shall be no undesirable interaction of any sort, arrangements have been made for the frame aerial to swing in such a position that it never comes nearer than 6 in. to the coils in question, thereby making doubly sure that no trouble will ensue. The L.F. stages of the receiver are straightforward, and require no particular comment.

Frame Aerial

A particular feature which will no doubt appeal to readers is that of the combined hinge and rotating system adopted on the frame aerial. With

Photograph of J. H. Reyner's Experimental Set.

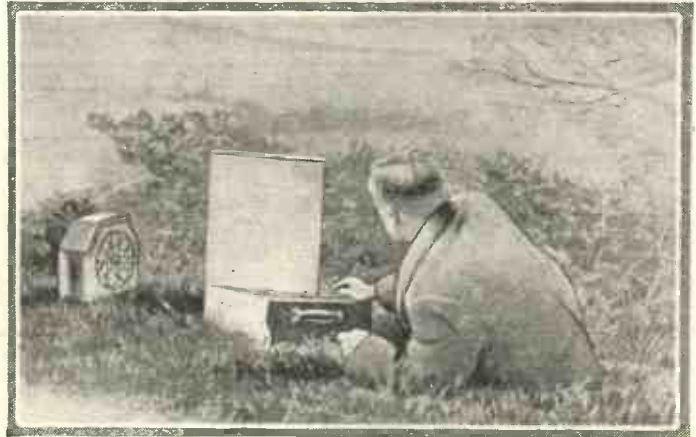

J. H. Reyner testing his experimental Countryside Four in the Wye Valley.



an average portable receiver quite a considerable amount of difficulty arises in connection with the frame aerial. Either it is necessary to have a separate frame aerial, which has to be made portable in some manner so that it can pack up with the rest of the receiver, or it is necessary to mount the frame aerial either in the lid or in the framework of the receiver in some manner, in which case—and assuming that difficulties due to interaction have been overcome—there is always

the difficulty of rotating the frame to get the best position in a suitable manner.

If the frame is in the receiver itself, then it is necessary to turn the whole set round, which is undesirable. If the frame is wound in the lid, then the motion of the frame is limited in the case where the frame is hinged vertically, and where it is hinged horizontally it is still necessary to rotate the whole of the set.

Now in this particular case, as we have seen, the interaction difficulties have been made practically non-

(Left.)—Photograph of the Countryside Four showing Eight-way Battery Cord.

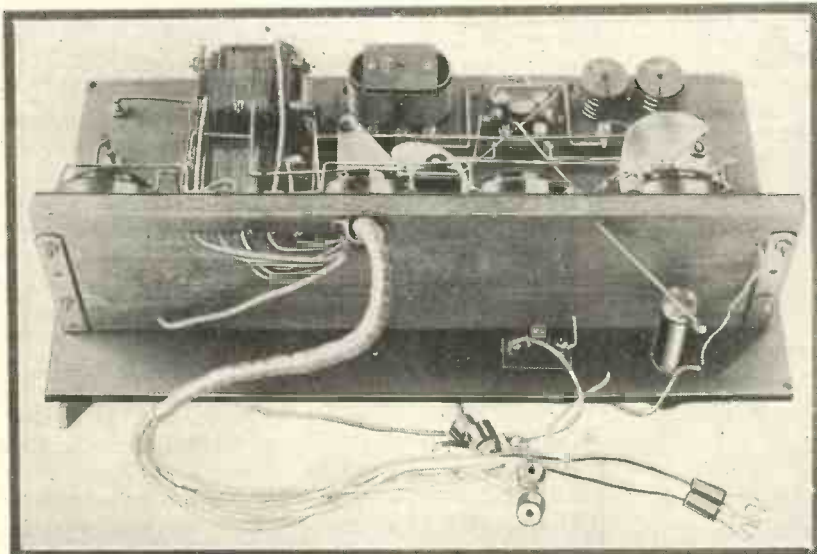

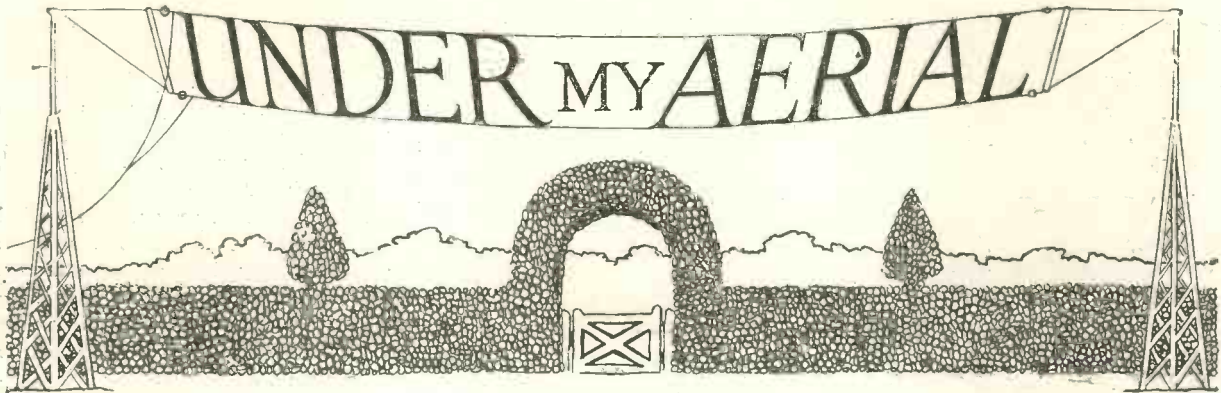

Temperature this Time

THE latest addition to the list of natural phenomena suspected of being responsible for variations in the received strength of wireless signals is air temperature.

An American scientist has come to the conclusion that, whenever a fall of temperature takes place over the area between transmitting station and receiving station there is an increase of signal strength and, conversely, that whenever there is a rise of temperature along the path of the wireless waves, there is a decrease of signal strength.

I wonder if you could bring forward any evidence in support of this theory? Do you think that any changes brought about in signal strength by changes in air temperature would be great enough to be noticeable in our telephones or loud-speakers? I rather think it would be necessary to have delicate recording apparatus to detect such changes.

Right from the very beginning of wireless attempts have been made to prove that fluctuations in the strength of wireless signals were con-



Temperature.

nected with various weather and other natural phenomena: Sunspots, the moon, the aurora, barometric changes, rain, and the electrical condition of the atmosphere have all been blamed at one time or another for those fluctuations in signal strength.

My own impression on this rather interesting subject is that when we know more about the electrical con-

dition of the atmosphere and the electrical changes which are always taking place in the air above us we shall be a good deal nearer to a proper understanding of those fluctuations in signal strength which are due to natural causes

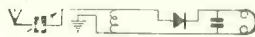

Old Man Static

When will some ingenious wireless inventor provide us with a means for



Just a word!

the complete elimination of that troublesome wireless bugbear the Americans call "static"? Already I have had trouble with this interfering old man of the atmosphere, and we are not in the middle of summer yet.

I rather like the short and expressive word static used on the other side of the Atlantic to denote what we call "atmospherics" on this side. If you say the word static quickly, it sounds rather like one of the noises it produces in phones or loud-speaker. Say "atmospherics" quickly, however, and it sounds like . . . well! just a word and that's all.

The worst of static is that the disturbing crackles, crashes, and bangs it produces always seem to be at their worst on the wavelength of that distant station you particularly want to listen to.

It is now generally accepted that a low aerial does not pick up as much static as a high aerial, and that an underground aerial is the best proposition when immunity from static

is the chief consideration, so you will know what to do this summer if you get more than your fair share of static.



High-tension

Have you noticed a decided tendency towards an all-round drop in the price of high-tension batteries?

Some manufacturers of dry batteries have already made considerable reductions in their prices and other manufacturers will doubtless follow suit in due course.

Probably manufacturers of dry-cell high-tension batteries are feeling the competition of the high-tension accumulator and the wet Leclanché battery.

A year or two ago manufacturers of the dry high-tension battery had things entirely their own way. Scarcely anybody ever thought of using anything but the dry battery for wireless work. Now, in addition to the high-tension accumulator and the Leclanché wet-cell battery, we have the high-tension eliminator



Have you noticed?

which gives high-tension supply from the electric-lighting mains.

All the same, in spite of this very strong competition, I do not think that the high-tension battery is likely to become obsolete. It has its own special uses, as in the portable set, and as a grid-bias battery. Then again, it will always appeal where cleanliness is of primary importance in the "reception" room.

Under My Aerial (Continued)

By the way, I wonder what is the price of the huge grid-bias batteries used at a broadcasting station? They are dry-cell batteries giving up to six hundred volts, and they last for eight months.

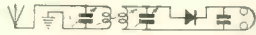

The Other Tele's

"Let's see, how many senses are there, George?" I asked my never-

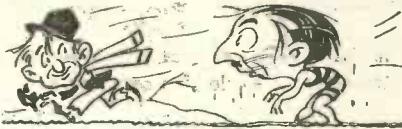

Leaves me cold.

at-a-loss-for-an-answer scientific friend one evening last week.

"Three," replied George, "common-sense, nonsense, and horse-sense."

"No, no, George. I am referring to the human senses. There are five, I believe, the sense of hearing, the sense of sight, the sense of smell, and—er—surely you know the other two, George?"

"Of course I do—the sense of taste and the sense of touch. But what has all this to do with wireless, Mr. Halyard?"

"Everything, George. Wireless telephony depends on our sense of hearing. Wireless television, now an accomplished fact, depends on our sense of sight. What next, George? Surely it will be tele-something or other depending on either our sense of smell, taste or touch. Which will it be?"

"It's all the same to me, old man. The idea of a telesnieller or a tele-taster or a combined telesmaister leaves me cold. Can't see any use in such a thing. The police might use direction-finding telemellers instead of bloodhounds, but the shipwrecked mariner starving in the middle of the Sahara Desert with only the ship's telemeller would get little satisfaction out of the smell of a London restaurant broadcast from 2LO."

"What about a teletoucher then, George?"

"Awful idea, awful. I've two nephews who touch me pretty well now by direct contact. I dread to think what they would accomplish with a teletoucher."

A Suggestion

I have just been studying a fascinating map of the British Isles, a kind of crazy-work map made up of yellow, brown, red, and black patches—in other words, a map showing the varying density of population over these islands.

Small black squares on this map of mine represent towns which have a population of over a hundred thousand. Red patches represent areas with over five hundred people per square mile. Different shades of brown and yellow represent areas with less and less people per square mile, until you come down to the palest yellow which indicates areas with less than thirty people to the square mile.

I expect you are wondering why I am telling you all this. Well! it's like this. With the aid of this population map, I have been trying to find likely positions for those new high-power transmitting stations



A suggestion.

about which so much has been said lately.

The new stations, you know, are to be placed where they will serve the greatest possible number of listeners and yet be well away from the thickly-populated areas in which the present main and relay stations are situated.

I do not know how many of these new high-power stations are to be established, but my population map leaves me with no doubt as to the ideal position for the first of those stations.

That ideal position is in Derbyshire, a few miles to the east of the point at which the three counties Cheshire, Derbyshire, and Staffordshire meet. Look at your own map and you will see how well a high-power station so placed would serve the thickly-populated areas of Lancashire, Yorkshire, and the Potteries. You will also see how well removed this station would be from the large towns in the area it would serve.

A calculation I have made shows that over a third of the population of England and Wales lies within a circle of radius fifty miles drawn with our suggested station in West Derbyshire as centre. Pretty good, that, isn't it?

As it is not an easy matter to find other excellent positions for these proposed new high-power stations, we had better remain content with our one suggestion of a station in West Derbyshire, and leave the problem of the positions of the remainder of the stations to the B.B.C.

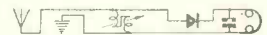

Veterans of Croydon

Seven years is a pretty good age for a wireless installation, either transmitting or receiving, isn't it? Yet that is the age of the old transmitter now in use at the Croydon Aerodrome.

This old Croydon transmitter, however, is not likely to survive to its eighth birthday, for arrangements have been made to replace it with a modern and more powerful type of transmitter this summer.

There is another piece of wireless apparatus at Croydon Aerodrome which, I should imagine, is quite a veteran in its way. At least it looks like a veteran. I refer to the direction-finding ten-valve receiver used for the detection of distant thunderstorms.

The big frame aerial used in connection with this thunderstorm-

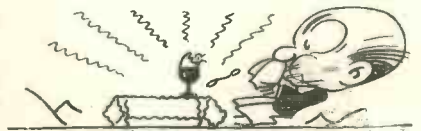

A pretty good age.

locating valve receiver was housed in a small, square room on the first floor of the building. So beautifully balanced was this frame aerial that a mere touch of the finger would cause it to move round. In fact, it was as delicately poised as any rocking stone to be found in Cornwall or Derbyshire, or elsewhere.

When used for observational work, this frame aerial was rotated by a wheel mounted on a vertical shaft,

Halyard's Chat on the Month's Topics

the wheel being in a room on the ground floor immediately below the frame aerial.

If this Croydon thunderstorm-locating wireless receiver is not yet seven years old it very soon will be, and I daresay it will see a good many seven years' service before it is placed on the retired list.



Noises Off

It was the fourth wireless play George and I had listened to that week, and after its conclusion we switched off and began to discuss the wireless drama in general.

"Seems to me, George," I said, "that the most important person in the production of a wireless play is the fellow who makes the stage noises."

"You mean the performer who goes a-noising round the studio, so to speak," said George.

"Yes. I mean the man who rattles the thunder sheet and makes the noise of pattering feet and all that kind of thing."

"Stage noises in a wireless play are very risky things to mess about with," said George in his most thoughtful manner.

"How do you make that out, George?" I asked.

"Well, so much depends on the listener's imagination and on his association of ideas. For example, suppose the producer of a wireless play, wishing to convey the idea of a farmyard in the country, broad-



Drana.

casts the noise of a farmyard rooster in full cry. In nine cases out of ten the listener would get the right idea. The tenth case, however, might be a suburban gentleman who is awakened at six ack emma every morning that ever was by the crowing of his neighbour's he-hen. He might conceivably throw his slipper at the loud-speaker."

"You're prevaricating again, George."

"Not a bit of it. Let me give you another example. The noise of a typewriter is broadcast. Everybody would get the right idea, business office, except the old soldier just nodding off to sleep with the headphones on. The old soldier's interpretation, machine gun, might cause him to dive under the table and take the set with him. See?"



Thunder Will Come

Have you had any serious amount of thunder yet in your district this year?

If your experience of wireless reception extends over twelve months, you will not be one of those people who think that it is unusual for us to have thunderstorms before the hot weather of July and August sets in.

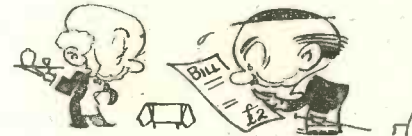

Serious amount.

On the contrary, you will know that thunder is more often than not very troublesome to wireless enthusiasts in May and June. I think I am right in saying that, during May and June of the last three years, thunderstorms were a source of great annoyance to the wireless listener.

Last summer one of the worst thunderstorms experienced in the British Isles was that which broke over Norwich on June 17, about the middle of the day. You can gather some idea of the intensity of this particular storm from the facts that the centre of the town of Norwich was flooded in a couple of minutes, and some of the hailstones which fell during the storm measured half an inch across.

It is not so long now to June 17, and a thunderstorm of similar intensity might break over your district some time in the near future, so, once again, let me beg of you to see that your earthing switch is in order and is as safe a protection against lightning as can be devised.

Better Earths

Don't you think that we might adopt, with great advantage to our powers of reception, earthing systems planned and laid out on something of the same lines as the earthing systems at the most recently erected of the world's high-power broadcasting stations?

Whenever I read a description of the earthing system of a modern



Powers of reception.

high-power broadcasting station, I am struck with two things, first, the great amount of land area covered by the earthing system, and secondly, the symmetry of that system.

Take Langenburg, the German super-power broadcasting station in the Ruhr, for example. The earthing system at this much-discussed station is stated to consist of eight miles of copper wire laid out in symmetrical form all round the station, the wire being buried at a depth of a yard.

Over what ground area does your earthing system extend, and what degree of symmetry does it possess? If your earth consists of one or more metal objects buried in the ground, the area covered by your earthing system is not likely to be more than a square yard, say, and there is little symmetry about it. If you use a water-pipe earth, you know little of the actual ground area covered and less about the symmetry of the system.

I would like to put forward the suggestion to you that you try a more extensive and a more symmetrical earthing system than your present one. You might make your new earthing system in the form of six, twelve, or even twenty equally-spaced "spokes," all radiating out from a point just under the window of your "reception" room. Bare copper wire or lead piping would do well for such a system, and the longer the "spokes" the better.

Why not put in such an earthing system while the digging is good?

HALYARD.



Complete with batteries, frame aerial on a hinged door, and loud-speaker, this Cecophone seven-valve super-het has a tuning range of 250 to 600 and of 800 to 2,800 metres. It measures 21 in. long, 9½ in. deep and 15 in. high.

It is manufactured by the General Electric Co. Ltd., of Magnet House, Kingsway, W.C.2.



Particularly neat in appearance is this Henderson portable five-valver, which, as can be seen from the photograph, has only two tuning controls.

The loud-speaker is particularly well placed.

The manufacturers are W. J. Henderson & Co., Ltd., of 351, Fulham Rd., S.W.10

Both models of the Oxford portable, with either four or five valves, are of identical size and weigh about 28 lb. each. Batteries, frame aerial and an Amplion loud-speaker are contained in the cabinet.

The Oxford Wireless Telephony Co., Ltd., of 22 and 29, Queen Street, Oxford, are the makers.



Made with two, three, four, five or seven valves each Alphant receiver is calibrated; extra terminals are provided for attachment to an ordinary aerial-earth system in place of the enclosed frame, a point that will be appreciated by many users. All of the sets make use of dry cells for filament heating.

The address of Alphant Wireless, Ltd., is 99, Mortimer Street, Regent Street, W.1.

What You want to Know-

THIS season sees the portable set much more of a practicable proposition than ever before. Every summer since broadcasting began there has, of course, been a demand for wireless sets which could be carried about from place to place and so enable the broadcast programmes to be enjoyed without the necessity of staying indoors.

Former Short-comings

But if the truth must be told many of the portables available in previous years had certain shortcomings which considerably detracted from their popularity. It was difficult to design a receiver which combined, to a satisfactory extent, the desirable features of lightness, reasonable dimensions, and the ability to give good loud-speaker reproduction when used on a frame or improvised aerial at some distance from a broadcasting station.

Recent developments have, however, done much towards solving the problem. The principle of neutralisation has made it possible to employ sufficient H.F. amplification to secure a good range, even when using a frame aerial, without any trouble due to instability. The improvement in resistance-capacity couplings has enabled the weight and size of the set to be cut down by the omission of bulky and heavy L.F. transformers with little or no reduction in the amplification obtained per stage.

Low Consumption

The fact that very low consumption valves are now available which give every bit as good results as were previously only obtainable by using comparatively heavy filament currents has enabled the size of the L.T. battery to be reduced considerably, while the

About Portable Sets for 1927

use of high-impedance valves has reduced the strain of the H.T. battery.

Loud-speakers

The coming of the hornless loud-speaker has done a great deal to make the loud-speaker portable set really practicable. Previously it was necessary either to mount a horn-type loud-speaker in the set, thus wasting a great deal of room, or to carry the loud-speaker separately, which was a great inconvenience.

Of course, even the modern portable receivers vary greatly in size and weight, depending upon the capabilities of the sets and the method by which it is intended to transport them. When the set is to be carried about by car, for instance, a five-valve straight circuit or an eight-valve super-het. becomes a possibility, as lightness and size are relatively unimportant compared with the range and volume obtained.

If the set has to be carried about entirely by hand something much more compact is desirable, and one should be satisfied with two or three stations only on the loud-speaker, especially if a frame aerial is used. This a good four-valve set with one H.F. stage, detector, and two resistance-coupled stages will give in many parts of the country.

Question of Aerial

Although it is very convenient to use a collapsible frame aerial, it should, however, be borne in mind that much better results will be obtained by using an improvised open aerial and either a counterpoise or an earth connection. Such an aerial may be used without affecting the portability of the outfit in the slightest degree, as it is just as easy to carry about a coil

This Liberty eight-valve super-het has only two controls and is calibrated before being sold. It measures 20in. square and is 7in. deep. A cone loud-speaker and compass are included.

Liberty portable receivers—three- and four-valve models are made also—are manufactured by the Radi-Arc Electrical Co., Ltd., of Bennett Street, Chiswick, W.4.



The Rolls portables are made in two-, three- and five-valve models. The last is provided with a switch so that two valves can be cut out if desired; it measures 14in. by 11½in. by 17½in. and weighs 23lb. with a self-contained loud-speaker.

Hoare & Jagels, of 28-29, Gt. Sutton Street, Clerkenwell, E.C.1, are the makers.



This elaborate portable outfit is the Igranic Neutro-sonic Seven—a five-valve super-het preceded by an H.F. stage and followed by an L.F. amplifier—with a combined battery case and frame aerial, and also with a portable loud-speaker. On test we have found it to give really excellent results.



It is manufactured by the Igranic Electric Co., Ltd. of 149, Queen Victoria Street, E.C.4.

Built into an attaché case, this Levis portable four-valver is neat in appearance; it measures 18in. by 12in. by 6in. Separate control is provided for each of the valve filaments.

The manufacturers are Butterfields, Ltd., of Stechford, Birmingham.

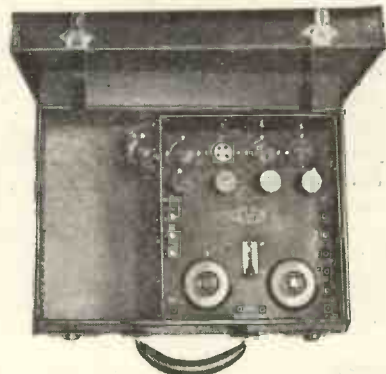

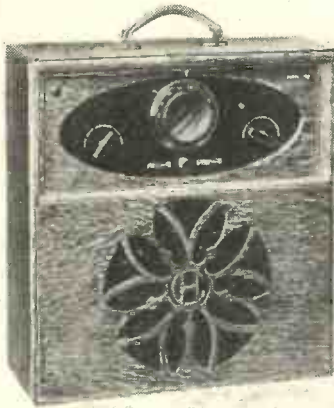

This portable receiver is made by Hart Collins, Ltd., of 38a, Bessborough St., S.W.1. As can be seen from the photograph, it is especially neat in appearance.

There is only one tuning control and provision is made for reception on both the higher and lower bands of broadcast wavelengths.

Weighing approximately 19lb. and measuring 16½ in. by 12 in. by 7½ in., this Edison Toovee set makes use of a 50ft. length of rubber-covered cable attached to any convenient object as aerial.

The manufacturers are the Edison Swan Electric Co., Ltd., of 123-125, Queen Victoria Street, E.C.4



Each Cantophone portable set—five models are made—has the dials marked with the call-signs of the local stations and Daventry at the correct settings. A loud-speaker is built into each receiver except the two-valver (illustrated here).

The Cantophone Wireless Company, of 310, Regent Street, W.1, are the manufacturers of these portable sets.

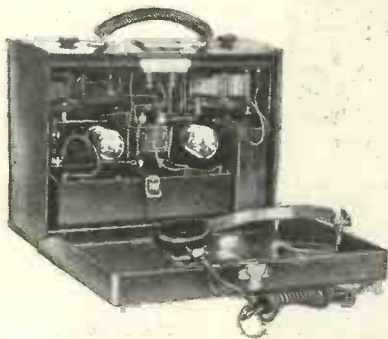

Following the conventional lines of gramophone construction in general appearance, the Eureka Orthodyne Five has only two tuning controls. It comprises two stages of high-frequency amplification, a detector and two stages of low-frequency amplification. All the batteries are enclosed in the case and the aerial is included in the lid, with a loud-speaker.

The set is made by Portable Utilities Co., Ltd., of 8, Fisher Street, W.C.1.



What You Want to Know—

(Continued from —

of insulated wire as it is a frame aerial.

Although the chief considerations when designing a portable receiver are lightness, compactness, and good performance, there are several other points which should not be forgotten. It should be remembered, for instance, that a portable set will, in all probability, get knocked about a good deal. It should therefore be of much more robust construction than the permanent receiver at home.

Panel Material

The panel need not be of ebonite, a substance which fractures fairly easily. Either wood or metal can be used instead, provided that ebonite bushes are employed, where necessary, when mounting components on the panel. In modern sets, however, the panel-mounted components are few in number, often consisting solely of the variable condensers.

The valves will, of course, be of the dull-emitter type and will be mounted on sprung valve holders. It should be remembered, however, that these valve holders allow the upper portions of the valves to vibrate through a considerable arc, and the valve bulbs must not be allowed to bang against the inside of the cabinet, the back of the panel, or against other components.

The bulbs may be protected by placing a rubber band around their widest part or by fixing pads of spongy rubber on the inside of the cabinet or on the back of the panel.

If this is done there need be little fear of the valves coming to any harm.

Finish of Cabinet

In the case of sets intended for permanent installation in the home, it is usual to house the panel and base-board in a handsome polished cabinet of oak, mahogany, or some similar wood. It is a waste of time to do this in the case of the majority of portable sets, as the finely polished surface will soon become scratched. Far better to use teak for the cabinet or case and to cover this with some waterproof material. Such a case may not present a very attractive appearance, but

—About Portable Sets for 1927

—preceding page)

it will be very serviceable and will stand a lot of wear.

When out with the set one should remember that, in all probability, the receiver is working under conditions very far from ideal, and one should not be disappointed if the results obtained are not quite equal to those given by the same number of valves at home, where an excellent aerial system is available. It should also be remembered that a loud-speaker used in the open air requires a greater input in order to give the same apparent volume as when the speaker is used inside a room.

Favourable Districts.

Although a good portable set will function well almost anywhere in these islands when the main object of an outing is the open-air reception of broadcasting, preference should be given to those districts favourably situated for wireless reception.

It will often be found that when reception is poor, much better results can be obtained by walking, say, half a mile farther on if this means climbing a hill or getting clear of trees.

M. P. T.

Aurora Borealis

OWING to the inclination of the earth's magnetic axis to its geographical axis, the centre of the auroral disturbances in the northern hemisphere is displaced about 10 degrees from the North Pole in the direction of Canada. As the ionisation which accompanies "Northern lights" activity should theoretically tend to absorb wireless waves, it follows that messages sent from Europe to America ought to be more subject to absorption or "fading" losses than those travelling in the opposite or easterly direction.

Observation

This hypothesis has recently been borne out by actual observation. It constitutes an interesting corroboration of the generally accepted theory of atmospheric ionisation and its effect upon ether-wave propagation.

B. A. R.

Making use of one of the well-known Celestion loud-speakers, this receiver is particularly neat and gives excellent signals. A four- and a five-valve model is made; the first measures 17in. by 13in. by 8in., and the second 20in. by 13in. by 8in.

The manufacturers are the Celestion Radio Co., of 29-37, High Street, Hampton Wick, Kingston-on-Thames.



Not a portable receiver, but a neat carrying case for the famous Celestion loud-speaker. It will be found particularly useful for portable work during the summer.

The Celestion Radio Co., of 29-37, High Street, Hampton Wick, Kingston-on-Thames, are the makers.

MORE SETS WILL BE REVIEWED NEXT MONTH

This B.T.H. three-valve portable super-het weighs 23 lb. complete, with enclosed frame aerial and all the necessary batteries; it measures 13in. by 16in. by 16in., and is supplied in either a leather cloth or polished mahogany case.



For use with this super-het a special two-valve amplifier and loud-speaker is made. This weighs 27 lb. and measures 15in. by 14in. by 8in.; this also is supplied in two finishes by the British Thomson-Houston Co., Ltd., of Crown House, Aldwych, W.C.

Turn Your Rheostats into Fixed Resistors

EVERY year brings its share of progress in radio, and although the long-desired super circuit giving eight-valve results with only three tubes has failed to put in an appearance during the past year, 1926 gave

The three Lissenstats are mounted upright on a stiff brass strip which is screwed to the wooden baseboard. A spacing of about 2 in. from centre to centre will result in a very compact resistor block (as is shown).

kept smaller than the diameter of the rheostats to make the terminals readily accessible. Labels pasted on the strip can again indicate which valve the resistor controls.

C. A. OLDROYD.

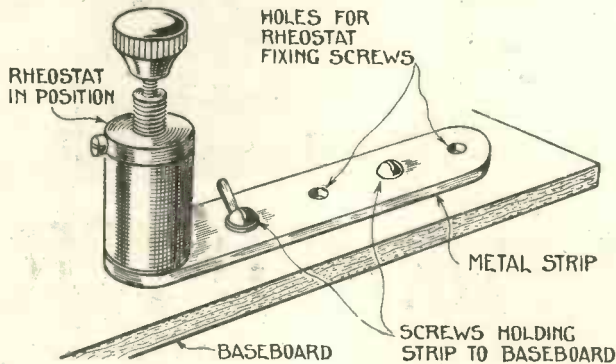

Fig. 1.—Method of Mounting Lissenstat or Similar Pattern Rheostat.

us something of real importance—the gradual elimination of the filament rheostat.

In skilled hands a rheostat helps to get the last ounce out of a set; but an unskilled user may easily overrun the filaments, especially with dull-emitters.

Old Into New

Amateurs who have accumulated a variety of rheostats contemplate with some disgust the necessity of having to buy new fixed resistors for the new set. No doubt the standard commercial fixed resistor is inexpensive, but why not turn the old Lissenstat or other rheostat into a fixed resistor?

It is obviously impossible to give details of this conversion for all kinds of rheostats, but for the two main types the necessary modifications have been sketched out. Fig. 1 shows the method of mounting Lissenstat or similar pattern models of the carbon-pile compression type.

Three Rheostats

Three Lissenstats are assumed to be used as fixed resistors in a four-valve set, one for the H.F. stage and two for the L.F. stages, since many amateurs prefer to retain the adjustable panel-mounted rheostat for the detector.

with two small screws, while under one of the nuts a soldering lug for the battery connection is placed.

Needless to say, the surface of the brass strip and of the end discs in the Lissenstats should be carefully cleaned to avoid undue resistance and a corresponding drop in voltage.

With this arrangement all three Lissenstats are automatically joined up for the battery connection; the leads to the valves are soldered to the lugs fitted near the top of the barrel.

Small labels can be glued to the strip between the Lissenstats to show which valve is controlled by each resistor.

The wire-wound barrel type of rheostat can be adapted as a fixed resistor in a similar fashion (Fig. 2). The rheostats are here mounted on a narrow strip of ebonite; four distance pieces cut from ebonite tubing lift the assembly some distance from the baseboard. The width of the ebonite strip has intentionally been

The Lissenstats are mounted by means of the original screw fitted in the metal disc at the lower end of the barrel. To clear the screw-heads under the strip recesses are made in the baseboard. The brass strip with the three Lissenstats in position is clamped to the board

Finding the Best Coil Tapping

THERE are numerous occasions when the exact point at which a coil is tapped has a great bearing on the working of the set. If the set is not being built to some published design the best tapping point can obviously be found only by experiment.

Temporary Connection

It would be very laborious to re-wind the coil again and again, each time with the tapping taken from a different place, in order to find out which gave best results. However, the wire which is to go to the tapping may be connected, temporarily, to a needle.

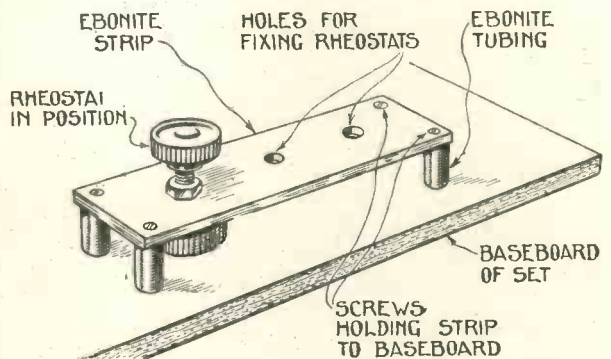
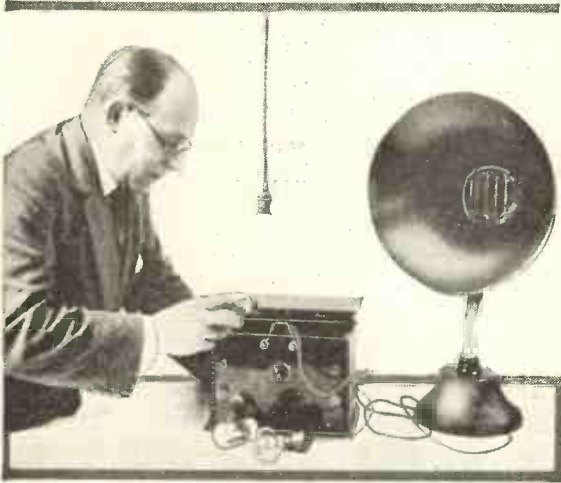

Fig. 2.—Method of Mounting Wire-wound Barrel Type of Rheostat.

The point of the needle can be forced through the insulating covering of the coil at various points and so the effect of various tapping points can be observed and the permanent tapping made to that point on the coil which proves to be best.

P. S. B.

Specially designed, built and tested by the "Wireless Magazine" Technical Staff, this two-valve amplifier that takes its high-tension, low-tension and grid-bias supplies from direct-current mains will appeal to many listeners who want loud-speaker results without the trouble of installing and maintaining batteries. Such sets as this are quite safe to use if the instructions are followed exactly.



A TWO-VALVE D.C. MAINS AMPLIFIER

FROM time to time in these pages the Technical Staff of the WIRELESS MAGAZINE has described the construction of complete sets and amplifiers that can be operated direct from the house-lighting mains.

for general purposes. Indeed, when on test in the WIRELESS MAGAZINE Constructional Department, although directly coupled to a crystal set without any transformer, the volume was more than is required in a house.

resistance and, for the second valve, the main's voltage less the drop across the smoothing choke and the loud-speaker windings. In the case of 200-volt mains it will be appreciated that fairly high anode

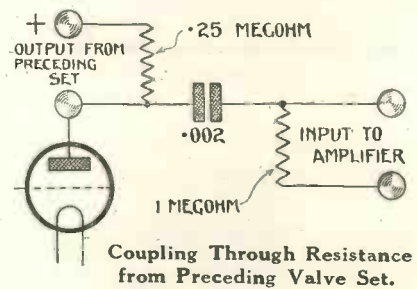
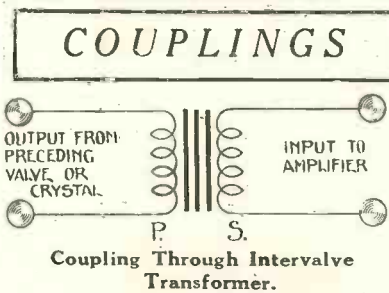
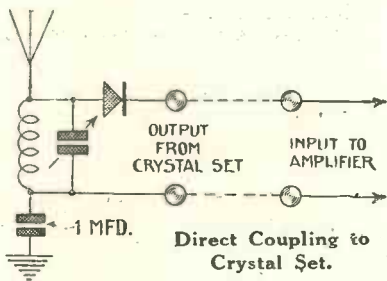

These articles have been received with considerable interest in wireless circles generally, and we are now giving particulars of a useful two-valve power amplifier that takes its high-tension, low-tension and grid-bias supplies from direct-current mains.

No Batteries

Such an amplifier is of particular value for use in conjunction with an existing receiver which will give only headphone reception, whether it be crystal or valve, for, without the addition of any batteries, in either case, excellent loud-speaker results are assured if there are D.C. lighting mains in the house.

Used in this way the amplifier gives adequate loud-speaker volume

The voltage of the mains in this case was 200.

Partly for the sake of purity of reproduction and partly for the sake of simplicity in construction use has been made of the resistance-capacity method of coupling the amplifying valves. The voltages applied to the anodes of the valves, as can be seen from a glance at the circuit diagram, are, for the first valve, the main's voltage less the drop across the smoothing choke and the .25-megohm anode

potentials are available, and advantage can be taken of this state of affairs to employ a valve of the super-power type in the last stage.

The valve filaments are fed direct from the mains by means of a lamp

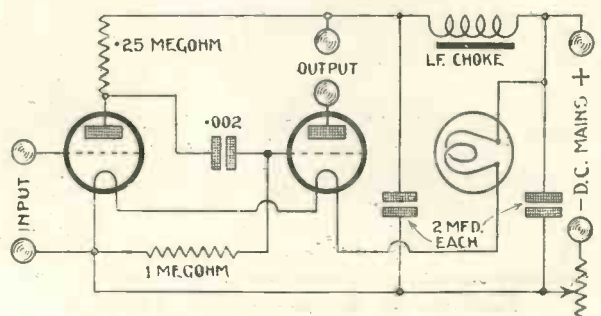

Circuit Diagram of Two-valve D.C. Mains Amplifier.

A Two-valve D.C. Mains Amplifier (Continued)

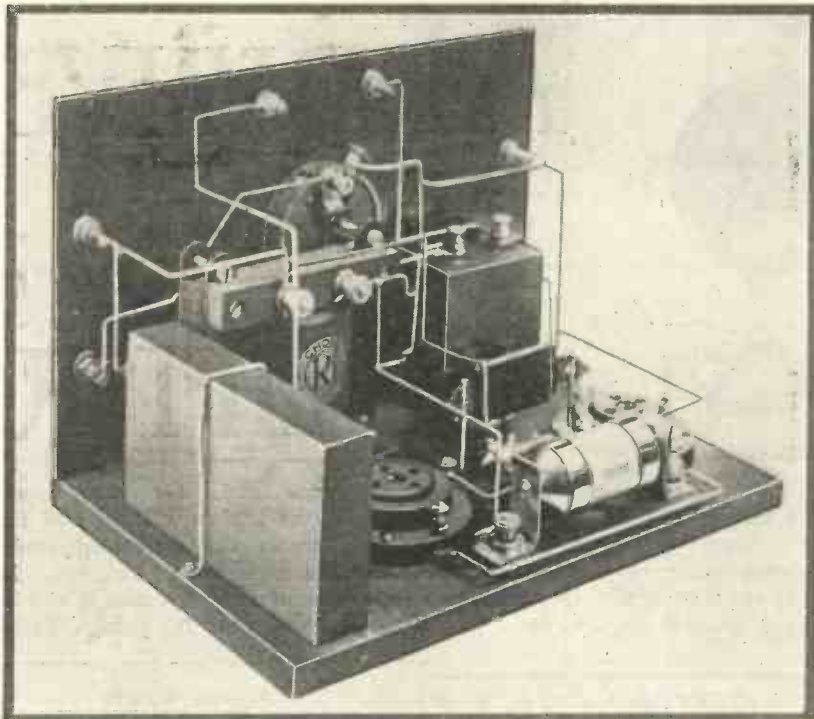

Rear View of Amplifier. Note method of fixing 1,000-volt condenser in position (on left).

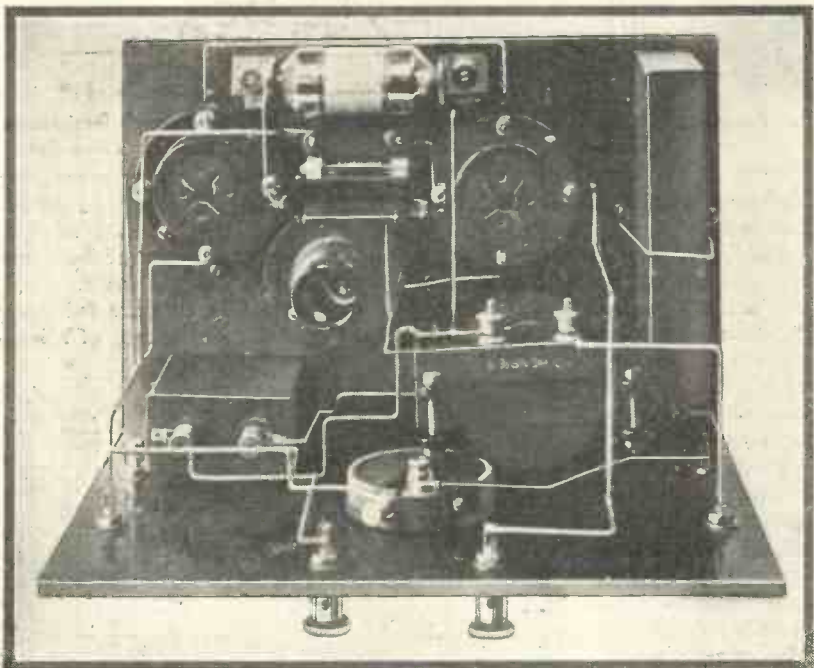

Plan View of Amplifier showing Layout and Components on Panel and Baseboard.

resistance. Any voltage valves can be used as long as they have the same filament consumption; that is, a 6-volt .1-ampere valve can quite satisfactorily be used in conjunction with a 2- or 4-volt .1-ampere valve, but a valve taking .25 ampere would be unsuitable.

As regards the lamp, this must be of such a size that the wattage divided into the mains voltage will be equivalent to the current required by the valve filaments. In other words, if .1-ampere valves are used, the lamp must pass .1-ampere when the particular mains voltage in question is applied across it.

In practice, of course, it is advisable to decide on the types of valves that will be used first and then work out details of the particular lamp required afterwards. Suppose, for instance, that .25-ampere valves are to be used; we have to find the wattage of a lamp that will pass just that current at the mains voltage. This will be equivalent to the mains voltage multiplied by the current—and in the case of 200-volt mains the necessary lamp will have a wattage of $.25 \times 200$, or 50.

Simple Formula

Reduced to a formula the wattage of the lamp required can be calculated as follows:—

Wattage of lamp = mains voltage \times filament current required by valves.

It is recognised, of course, that the "commercial" wattage of a lamp is not determined with any degree of mathematical precision, and to compensate for any slight deviation a variable filament resistance is included in the negative lead.

In some cases when the set has been completed it will be found that the 2-microfarad condenser shown in the circuit diagram between the mains and the choke will give better results if placed in parallel with the second condenser, after the choke, that is, in the position usually associated with the high-tension battery reservoir condenser.

Couplings

Although when used in conjunction with a crystal set no coupling device is necessary—the crystal-set phone terminals being connected directly to the amplifier input terminals—some form of coupling will be required if the preceding receiver makes use of valves. (It is not recommended, by the way, that this amplifier should be used with a valve set already em-

playing any low-frequency amplification.)

A suitable form of coupling to a valve set is provided by an ordinary inter-valve low-frequency transformer, or, alternatively, a resistance-capacity coupling can be used if the detector valve is of the high-impedance type. The methods of connecting up both forms of coupling are shown in the diagrams.

In either case it is essential to place a 1-microfarad fixed condenser in the earth lead of the preceding set in order to prevent any possibility of directly earthing the mains.

Components Required

For the construction of this amplifier the following components will be needed:—

Ebonite panel, 9 in. by 6 in. (Becol).
2 antimicrophonic valve holders (Precision).

.25-megohm anode resistance (Varley or Dubilier, Mullard).

1-megohm grid leak with holder (Dubilier).

.002-microfarad fixed condenser (Igranic or Cosmos).

2 2-microfarad fixed condensers, one only tested to 1,000 volts (Dubilier).

L.F. choke (R.I. or Formo).

Baseboard-mounting lamp socket (Economic Electric).

3 $\frac{1}{4}$ -in. pieces of ebonite tube (Economic Electric).

30-ohm filament rheostat (Lissen or Igranic).

6 terminals:—2 input, loud-speaker +, and loud-speaker -, red, black (Eastick).

Cabinet and baseboard (Arcraft).

N.B.—It should be noted that the components allowed for in the dimensioned layout and used in the original set are in each case mentioned first.

Although all the essential details are reproduced in these pages some constructors will prefer to make use of the full-size blueprint layout, drilling guide, and wiring diagram that is available. (Send to Blueprint Dept., WIRELESS MAGAZINE, 58-61, Fetter Lane, E.C.4, for Blueprint No. W.M.16, price 1s., post free.)

When the necessary holes have been drilled in the panel the terminals and filament rheostat can be fixed in position. Next, the baseboard components should be mounted and the panel screwed on.

It should be noted that the 2-microfarad fixed condenser tested to 1,000 volts is that shown at the extreme left of the baseboard in the wiring diagram. It is held in position by means of a stout piece of wire looped at each end and screwed to the baseboard.

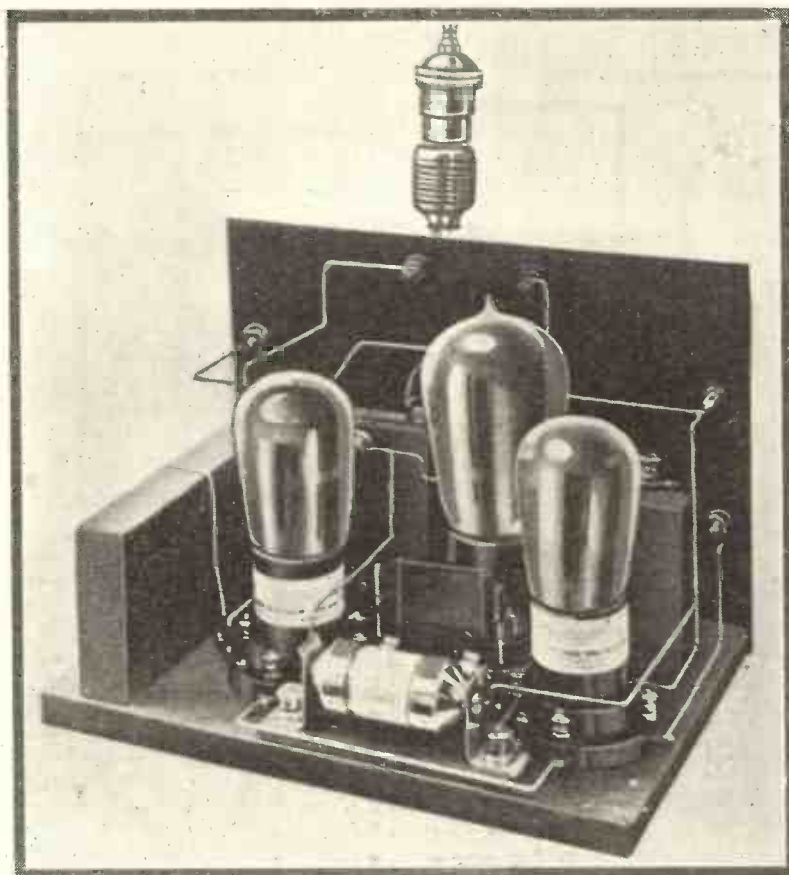

D.C. Mains Amplifier with Valves and Lamp in Position Ready for Use.

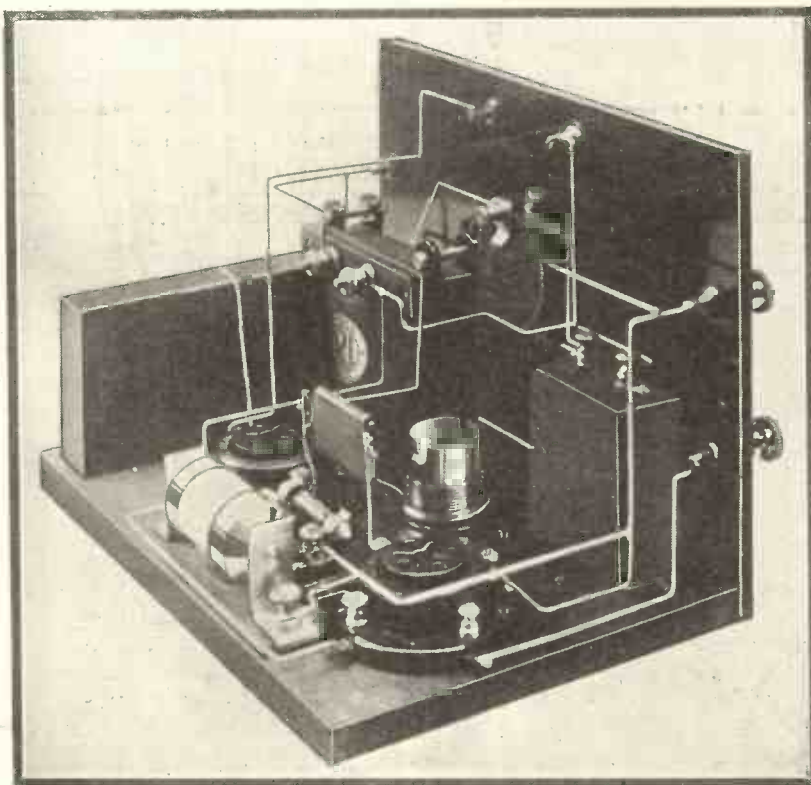

Another Photograph of the Amplifier, which illustrates how simple is the wiring.

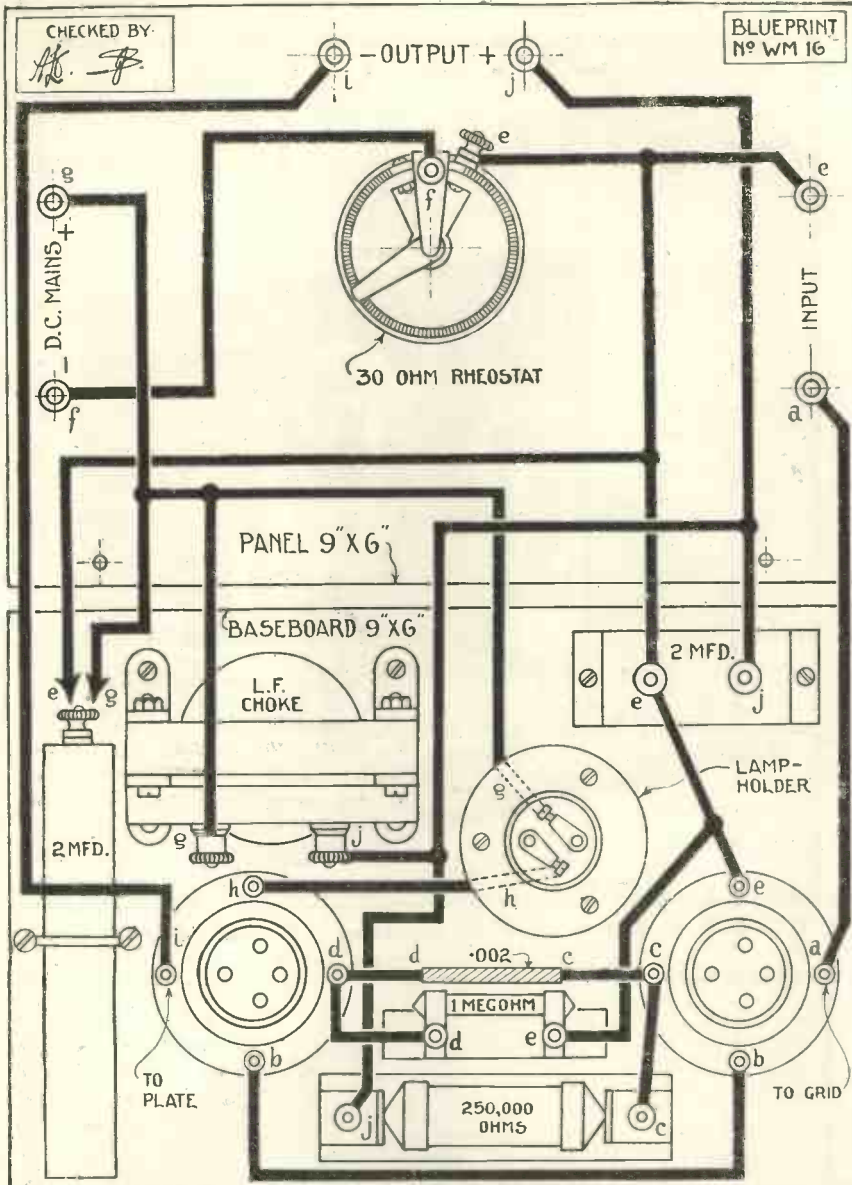

A Two-valve D.C. Mains Amplifier (Continued)

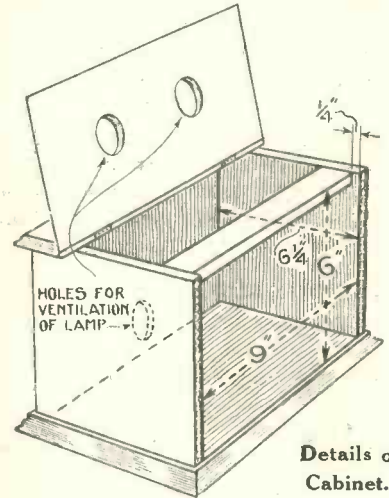

Details of Cabinet.

Wiring Up

The set is now ready for wiring up. This is a part of the construction that will present little or no difficulty if full use is made of the wiring diagram, either the blueprint or the smaller diagram reproduced on this page. A glance will show that each terminal point is marked with a small letter of the alphabet—these letters indicate the order in which wiring should be carried out.

To begin with, all those points marked *a* should first be joined together with one wire or as few wires as possible; next, all those points marked *b*; and so on through the alphabet, until wiring is completed. In order to prevent any possibility of short-circuits it is recommended that insulated wire such as Glazite should be used.

Flexible Leads

The leads to the mains should be of flexible wire, terminating in a type of plug that will fit a convenient socket.

In order to allow room for wiring, the baseboard-mounted lamp socket is raised by means of three $\frac{3}{8}$ in. lengths of ebonite tube that act as distance pieces.

To test the set connect it through the appropriate coupling to the out-
(Continued in third column of next page)

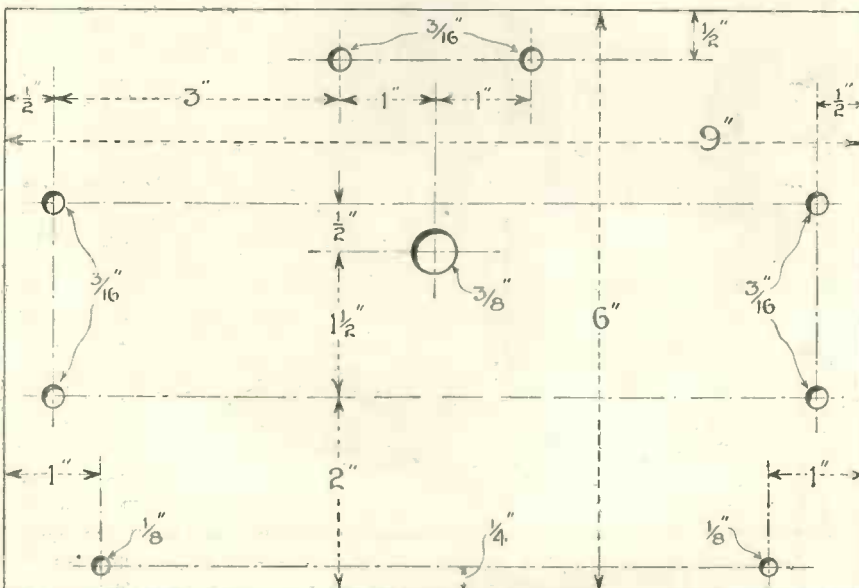

(Left, above)—Half-scale Layout and Wiring Diagram. (Left, below)—Half-scale Drilling Guide.

HIGH-POWER BROADCASTING TESTS

EXPERIMENTS have recently been concluded between Daventry and other stations on the continent of Europe affecting the use of long wavelengths for broadcasting. The experiments were carried out by Captain P. P. Eckersley, Chief Engineer of the B.B.C., who was appointed to the task by the Union Internationale de Radiophonie. Captain Eckersley had the advantage of the co-operation of M. Brillard, of Belgium, President of the Technical Committee of the Union of Broadcasting Organisations.

First Test

The first test was carried out between Daventry on a wavelength of 1,690 metres and Königswusterhausen on 1,600 metres, the separation being ten kilocycles. Both stations began by using a power of 5 kilowatts, and the British station rose by steps of 5 kilowatts until its power reached 20 kilowatts, the German station meanwhile remaining on 5 kilowatts. There was no interference on Daventry; but Königswusterhausen's transmission was interfered with as Daventry's power increased.

The second test was between Daventry (1,580 metres) and Moscow (1,500 metres), this separation of 10 kilocycles being maintained while the Russian station was working on 5 kilowatts and the British station varied its power between 5 and 25 kilowatts. Daventry's transmission became more audible on Moscow's wavelength as the power of the British station increased.

Radio-Paris

For the test between Daventry and Radio-Paris the plan was that both stations should work on a power of 6 kilowatts, the French station to maintain a wavelength of 1,750 metres, while Daventry varied between 1,750 metres and 1,567 metres, thus giving various separations up to twenty kilocycles.

With a five-kilocycle separation (1,700 and 1,750 metres wavelength respectively) the heterodyne note on Radio-Paris

was stronger than that on Daventry; the same thing occurred when a nine-kilocycle separation (wavelengths 1,662 and 1,750 metres respectively) was used; but as the wavelength separation increased the interference diminished.

During a subsequent test between Daventry and Radio-Paris, when the kilocycle separation was constant and equal and the power varied, the heterodyne note on Radio-Paris became more audible as Daventry increased its power from 6 to 12 and then to 18 kilowatts.

A curious phenomenon occurred during the test between Daventry and Karlsborg. It appeared that as Daventry shifted its wavelength further away from Karlsborg the strength of the Swedish station diminished. Both stations started the test on 1,600 metres and Daventry moved gradually to 1,790 metres, a twenty-kilocycle separation.

The impression among wireless experts gained from these tests is that long-wave high-power stations cannot be worked at a closer separation than ten kilocycles, and stations

which are comparatively close together should be separated by 15 kilocycles or more. It may be found desirable, for example, to separate Daventry and Radio-Paris by 20 kilocycles.

Reports are now awaited from the Continental stations which took part in the tests, and these will be fully discussed by the Union Internationale at Geneva. B. B. C.

A Two-Valve D.C. Mains Amplifier

(Continued)

put terminals of an existing receiver (preventing the earthing of the mains by placing a 1-microfarad condenser in the earth lead of the preceding receiver), connect up also a loud-speaker, place valves and the appropriate lamp in their proper positions, and insert the mains plug into the socket (it is assumed that the filament-rheostat control is in the "off" position).

Now turn the rheostat. If no sounds are heard reverse the position of the mains plug in the socket to apply a positive potential to the plates of the two valves.

In order to get the very best results it may be desirable, with some valves, to try different values of anode resistance and grid leak, but in most cases this will not be necessary.

Switching Off

The amplifier, when no longer required, should be switched off by operating the lighting switch or removing the mains plug from the socket, and *not* by putting the rheostat in the "off" position. The latter method may result in the operator receiving a bad shock while unthinkingly touching a wire or component in the set.

It should be emphasised, however, that there is nothing in the least dangerous about the set if it is constructed and operated as described in this article.

Simpler Wireless!



"Now, my dear, do you understand how the set works?"
 "Yes, Henry, but how often does the man call to read the wave-meter?"



ALMOST weekly we register new arrivals in the ether, a fact which, considering the restricted limits of the broadcasting band, must cause no little anxiety to the Geneva Bureau. The new star in the firmament on this occasion is Radio Lisboa, a small broadcasting station installed in the Portuguese capital. Transmissions are daily effected on a wavelength of about 303 metres, perilously near to that of Belfast.

Official News

For some time back rumours had reached us that the Portuguese Government had contemplated the opening of "broadcaster" mainly for the purpose of disseminating official news bulletins, but by arrangement with a small association of local wireless enthusiasts regular musical programmes are being transmitted. The station, as a rule, does not work much before 10 p.m., and its transmissions are limited to approximately two hours; later they will be extended.

The Portuguese, as a whole, do not rise early, nor do they retire at a reasonable hour; as in Spain, dinner seldom takes place before 9 p.m., and consequently the main items of the programme are usually given towards the end of the evening.

Although possessing a power of but roughly 500 watts, in view of its geographical position, the Lisbon transmitter should enjoy certain advantages, and there is no reason why listeners in the British Isles should not capture these programmes when fairly favourable conditions prevail.

Two New Stations

To its small net of relays, the Ecole Supérieure des Postes et Télégraphes of Paris has now added two new stations, one of which, Lille, has been anxiously awaited by the Northern districts of France. As a matter of fact, the transmitter is but a small one, and apart from a few local items will devote itself entirely to taking the Paris PTT programme.

For the present its wavelength is 287 metres, and in view of the comparatively short distance which separates the British Isles from that city, we are able to add these broadcasts to our evening entertainments, should we desire to do so.

The second relay to be brought into operation is that of Grenoble. Two years ago, on the occasion of an exhibition in that city, a portable transmitter had been installed for the broadcast of official speeches, after which it was "withdrawn from circulation." The present 500-watt plant relays the Paris entertainments nightly on 350 metres—one of the most congested portions of the broadcasting band.

It is to be hoped that by the time these notes are in print another position in the ether may have been found for it.

* * * * *

Spanish Activities

The number of broadcasting stations in Spain does not decrease, although in view of the growing influence exercised by the Union Radio interests, arrangements are being made by which most of the Madrid transmitters will share the same studio.

As a result of a recent understanding between this group, Radio Madrilena, Castilla and Iberica, acting upon a suggestion put forward by the Posts and Telegraphs Authorities, it has been possible to establish a rota time-table, according to which the transmitters, either singly or as "duets," operate at different times on alternate days of the week, thus providing the Madrid listener with a more or less continuous programme.

As a matter of fact it is no secret that these stations are practically under one control, and with Cadiz (EAJ3), Barcelona (EAJ1), Bilbao (EAJ9), Seville (EAJ17), and Salamanca (EAJ23), make considerable use of exchanged programmes or relays of broadcasts from Madrid or Barcelona. Notwithstanding the adoption of this scheme, the indi-

vidual stations still transmit on their respective wavelengths, and although in some instances the entertainments may be heard from more than one source, to identify the original sender it is necessary to pick up the call.

Wavelengths

The question of wavelengths is one which has not been satisfactorily settled, and it is apparent that although these stations have been allotted definite positions in the broadcasting band, they have not troubled to adopt them. Whether the Government authority has been withheld is not clear, but it seems more than a coincidence that most of these transmitters should have individually taken wavelengths to suit themselves regardless of the fact that by so doing they are causing interference to friendly neighbours.

There is no doubt that much of the heterodyning of broadcast transmissions in Europe is due to Latin stations, and it is a pity that they cannot be made to understand the advantages of a conference.

* * * * *

A La Français

For some time past the Paris Press has pointed out the tendency adopted by French radio fans to use words of English or American origin in connection with wireless matters, instead of those which already exist in their own language. The following is an example of a report received by a Paris technical journal, and although you may not be thoroughly acquainted with the language, I feel convinced that you will have no difficulty in deciphering the paragraph:

"Hier, j'ai entendu le *speaker* du poste de *broadcasting* de Berne, qui a 1.5 H.P., en employant trois *sels standards* montées en *tickler*. Malgré l'excellence de mon *square law*, *low loss*, et la puissance de mon *push-pull*, ma réception a été troublée par le *fading* et par le *buzzer* d'un voisin."

JAY COOTE.

Captain Round's Causerie

Large Cone Loud-speakers

THE Rice-Kellog cone loud-speaker and the large cones, although both employing paper diaphragms without horns, work on entirely different principles.

In the Rice-Kellog type the diaphragm is intended to move as a whole, which it does for all practical



Fig. 1.—Side View of Violin.



Fig. 2.—A suggested cone violin, to show how the double cone is a modified form of the violin body.

purposes, but the larger cones employ a subtler and perhaps more interesting method, which I think has great possibilities when it is fully developed. The main principle is that of the sounding board, known in musical instruments for thousands of years.

History

It would be interesting to speculate how far back in the world's history the horn and the cone in their primitive forms date, particularly in the art of musical instruments; all our modern orchestras are formed of instruments which employ one or other of these methods of sound production.

Even the human voice is composed of sounds from the throat and sounds from the chest—the horn and the large diaphragm, a popular combination with lots of quality-seeking amateurs.

The horn seems to have been developed into a greater variety of musical instruments than the large diaphragm, for we have the horn in one form as an organ and in its very latest form the saxophone, and an infinite variety in between, whereas the violin and piano are practically the only soundboard instruments, and have remained almost stationary for a long time.

In the search for new tone colour the musician should now be helped by the loud-speaker expert. These old-fashioned large-diaphragm instruments are out of date. The recent development in the loud-speaker art, the double cone, a scientifically constructed instrument based on the violin, should give suggestions to violin constructors as to how to greatly improve their instruments.

New Instrument

Fig. 1 shows a side view of a violin and Fig. 2 is an attempt on my part to invent a new instrument and also show how the cone body and violin body are very similar, and incidentally how the driving force is applied in a similar way.

The principle of the cone is a scientifically designed board or sound radiator, and the question of how the device radiates its sound is of extreme interest.

The problem of large diaphragms is closely analogous to the problem of radiation from a wireless aerial without, however, the added difficulty that in most aerial work we have only to send out one frequency whereas in loud-speaker or soundboard work we have to send out all frequencies as far as possible equally well.

Try to imagine how bad our wireless aerials would be if they had to be damped down with resistance to work equally well on the long Transatlantic wavelengths or on the broadcast band without any alteration.

Grudging Wasteful Resistance

At the moment we grudge every wasteful ohm in aerials, whereas if we desired one to work equally well over a large band of wavelengths we should have to insert at least 1,000 ohms. Radio signalling would hardly be possible except on the very shortest waves.

Let us try to get some idea of how radiation behaves in both the aerial and the air-wave cases.

An aerial is stuck up vertically from the ground and by means of our transmitter we send waves of elec-

tricity up the aerial. These waves of electricity produce a field of force in the ether spreading outwards and upwards. The field of force goes out from the aerial and part of it goes on outwards to infinity. There is no reason for a field once generated to stop moving outwards into space. The amount of power that goes outward indefinitely, however, represents quite a small proportion of the energy that is stored at any moment by the aerial.

If we could have an aerial of normal size with a gadget at the top which absorbed all the energy which reached there then when we applied energy at the bottom the amount that would be absorbed by the gadget would be less than the amount that left the bottom, because part of it would be absorbed by the resistance of the aerial and part would go out as radiation, but with an aerial of normal size this difference would be quite small.

The point I wish to make, however, is this: Suppose we doubled the length of the aerial, then more energy would be radiated and absorbed by the aerial resistance and less would have to be absorbed by the gadget. So if we make the aerial (under these circumstances) long enough the gadget will be almost unnecessary. In the end, if there were no resistance losses in the aerial, all the energy

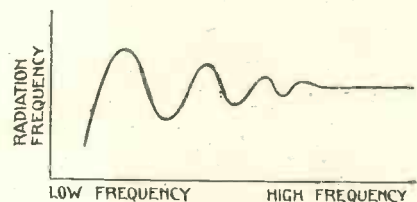

Fig. 3.—How aerial radiation varies with frequency.

could be radiated and none absorbed by the gadget.

Such a very long aerial, if made suitable for a very long wave (low frequency), will obviously be suitable for a short wave. It is something to be thankful for that radio does not need aerials of this type because an

Captain Round's Causerie (Continued)

efficient aerial for all wavelengths in use would be about 100 miles high!

Suppose our gadget at the top is attached to an aerial which is not long enough to radiate all the energy before it comes to the gadget, and suppose the gadget is not good enough to absorb the rest, then some energy starts flowing back again down the aerial—it is reflected, in fact, and this reflection will give still further radiation which, however, may be in opposition to the first radiation.

If by the time the energy has arrived at the bottom of the aerial it is not all absorbed it will be reflected again, and due to these two reflections our object will be thwarted, for this reflected energy going down and up the aerial again may interfere or add to the first effects as the energy is flowing up the aerial and we shall get different effects at different frequencies.

In fact, if the aerial is short enough and the gadget steadily weakened in absorbing power we get to the normal state of affairs in an aerial where the energy runs up and down many times until it is all radiated—but only one or two frequencies will be radiated because all the other frequencies will be interfering with one another in their up-and-down motion.

It is obvious that if we are not after the absolute ideal we can permit the energy to run up and down once or twice before it is all absorbed.

Best Method

The nicest way to carry out this absorption effect instead of using the gadget at the top of the aerial is by gentle absorption all the way, but this will have to be reduced steadily as the aerial size is increased.

In this way we can arrive at the most efficient "aperiodic" aerial by choosing our greatest possible height and making the aerial wire of a certain definite resistance per unit length, any lower resistance making the radiation un-uniform.

Just one further point about this aerial—the radiated energy is, with a short aerial, greater and greater with rise of frequency, so that obviously we must make our aerial and its resistance of dimensions to suit the lowest frequencies and then the highest frequencies will take care of

themselves. At some low frequency, however, any practical aerial we build will give a number of reflections. In Fig. 3 I give an idea of how the radiations will vary with different frequencies.

The Cone Acts Like an Aerial

What has all this to do with cone loud-speakers? A very great deal, because the large cone works very similarly to this extended aerial system. (See Fig. 4.)

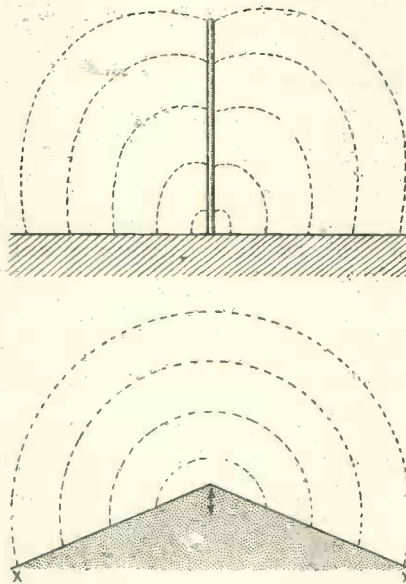

Fig. 4.—Energy in an aerial produces a field of force in the ether. Reflections can take place at the top. A cone similarly produces a sound field of force and reflections can take place at the edge.

The mechanical energy supplied at the centre of the cone sends waves outwards on the cone. These cone waves, like the aerial currents, produce an air force field, some of which goes on radiating indefinitely outwards and just the same factors come in. The internal friction of the paper and the size of the cone enter into the question of deciding what the shape of the frequency and radiated energy curve is, and it is obvious that if we have in mind a certain shape of radiation curve, as we increase the size of the cone we can decrease its friction and get louder signals (more radiation) for the same energy input.

Somewhere or other in the frequency scale at the low-frequency end the radiation will be un-uniform, but

by making this point low enough down we can make its effect negligible.

Why the Cone?

In an aerial the waves travel up and down at a speed very nearly the same as that of radiation—any slower speed than the radiation would result in less radiation.

If we chose instead of a cone a flat sheet of paper and applied a force to its centre the speed of travel outwards of the paper wave would be very slow, much slower than the radiated air wave. We can speed the paper wave up by using stiffer paper, or finally wood or metal, but to get the right speed we shall get a heavy diaphragm if we make it flat.

By taking our original paper and making it in the form of a cone we get the stiffness enormously increased without an increase in weight.

With the same weight increased stiffness means greater speed of wave, and in this way we can get our paper speed up to the radiation speed and imitate the electrical aerial.

The Lumière paper fan does the same thing in a slightly different way.

But why do we need to keep down the weight? Why won't the flat metal or board work just as well?

The answer is that a heavy thing cannot be moved as fast as a light one, so that the strength of the sound field will be less with a heavy diaphragm than with a light one—and to get as much energy radiation we shall have to use a larger diaphragm and less internal friction in the material.

Practical considerations of size enter here.

Force Producer

Let us look at the aerial or the cone from the point of view of the force producer.

It is obvious that the long aerial over most of its frequency range will appear to the energy producer as a constant resistance, and only on those frequencies where there is reflection will peculiar effects be produced.

A resistance is something which eats up energy as fast as it is delivered. A long aerial or cone which takes energy away from a source acts

(Continued on page 465.)



A Special Article by R. W. HALLOWS

MANY people put away their long-distance sets when summer comes round because there is a general idea that during the warmer and lighter portion of the year D.X. work is of very little use. So far as I am concerned I look upon summer as the best time for this kind of reception. My reasons for so doing are several.

Space in the Ether

In the first place one has peace. The owner of the single-valver next door, who during the winter can just manage to get Rome or Vienna, finds as spring comes along that even his doughtiest work with the reaction coil brings them in no more. He ceases to trouble the ether, and for four or five blissful months his howls do not assail my ears when I am searching.

So long as your set has one or two stages of really efficient high-frequency amplification you can undertake summer long-distance work with every hope of success. You will not obtain the same signal strength as in winter time, and some of the very weak and distant transmissions may disappear altogether.

I find, though, that speaking generally the number of stations that I log during the summer is not greatly less than during the autumn and winter months.

Reduced "Repertoire"

It is quite true that one's loud-speaker repertoire is somewhat reduced owing to the decline in signal strength, but this can be set right, if you think it worth while to do so, by the addition of a note-magnifying valve. Personally I am quite content to be able to bring in seven or eight stations on the loud-speaker when I want to, and to hear the others on the telephones.

The great enemy of reception in summer time is to be found in atmospherics. When we in this country grouse about atmospherics we do not

realise how lucky we really are. Except in thundery weather they are seldom strong enough here to render reception impossible, but in many other countries atmospherics so violent that phones can be used only with extreme discomfort are the rule rather than the exception for quite a large portion of the year.

Turning back the pages of my log I find that there were only four nights during the whole of last summer on which reception was entirely out of the question, and that there were comparatively few when it was really seriously interfered with.

Perhaps the most fascinating aspect of summer long-distance work is that one has the feeling always that one is working in the face of difficulties. Bringing in Continental stations on especially favourable nights in winter is so easy that it is almost on a par with shooting sitting rabbits. But matters are very different in summer. Whenever, in fact, you pick up some small fellow from a great distance you may award yourself a pat on the back and conscientiously feel that you have deserved it.

Winter Laziness

During the winter one is apt to become rather lazy, for unless it is a complete "dud" the set functions so well that there is no particular incentive to think out improvements or to spend much time in keeping things right up to the mark.

In summer one is kept continually busy. The received energy is then so very small that one has nothing to play with, so to speak. You are spurred on to put your aerial and earth system into perfect order, to wind efficient inductances, to try experiment after experiment with a view to reducing losses and to utilising the greatest possible amount of the received energy.

The summer is the ideal time for testing out receiving sets. Almost

any set will give a fairly good account of itself in the darkness of a winter evening, but it takes something pretty efficient to bring in, say, a dozen Continental stations between seven o'clock and nine o'clock on a June evening when broad daylight prevails.

Learning to Tune

It is, too, the best of all times for learning to acquire the real art of tuning a wireless receiving set. If you give a beginner a first-rate receiving set and ask him to operate it you will find that he passes over station after station, missing them altogether simply because he does not hear them.

The expert's ear is much more delicate. It hears and recognises tiny sounds which denote that signals are "there," signals that if one exercises a little skill can be brought up to full strength. But it is not the ear only that requires practice.

The expert succeeds in producing station after station where the beginner can find nothing, largely because the expert is able to make the fine adjustments necessary. Summer D.X. work immensely improves your fine-tuning abilities.

In summer time there are comparatively few dead easy stations. The great majority require careful listening and fine tuning to bring them up to good strength. If, therefore, you go in for D.X. in summer you will find it surprisingly easy in winter when stations are coming in more strongly.

Worth While

If you are a howl-fiend I sincerely hope that you will not believe a word of what I have written; if on the other hand you can search without squealing, then I hope just as sincerely that you will take my tip and go in for D.X. work this summer. You will find it worth while!

THE FONOTROL CRYSTAL SET

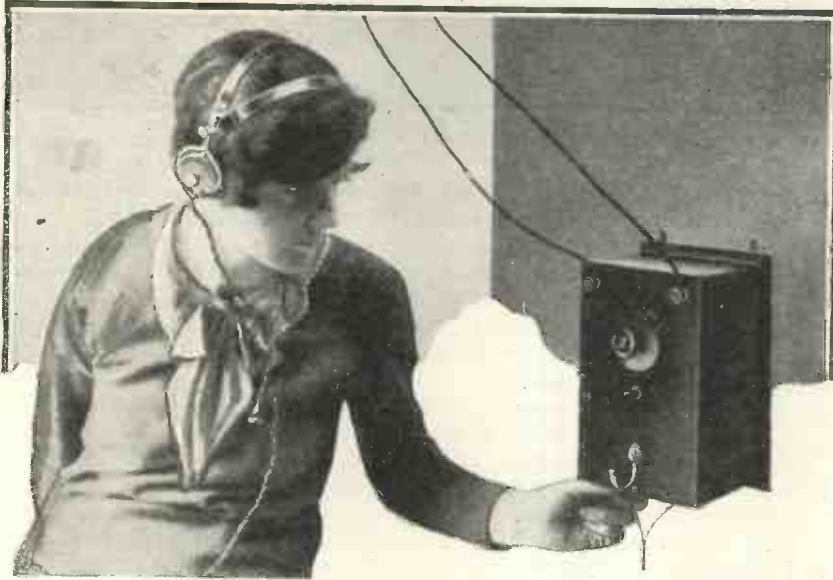

Specially Designed, Built and Tested by the "Wireless Magazine" Technical Staff

Incorporates Two Novel Features

Easy - to - adjust Crystal Detector

Will Receive on the Upper or Lower Broadcasting Band

SO great is the range of the Daventry high-power broadcasting station that there are many thousands of persons within crystal range. This set is intended for such people—and so that they shall not always be restricted to 5XX's programme provision is made also for the reception of the local station.

Special Features

That briefly was the object of the WIRELESS MAGAZINE Technical Staff in designing the Fonotrol Crystal Set. Novelty is introduced into the design,

moreover, by two special features, one of which is quite original.

The first is that the set can be fixed to a wall (in some corner, if needs be) so that it is out of the way; there is no difficulty about adjusting the crystal even if the receiver is in a dark place as a detector of the semi-permanent type is used.

The second feature is an original switching arrangement—by simply pulling one or other of the phone cords as the set is hanging from the wall the tuning arrangement can be made suitable for either the upper or

lower broadcasting bands of wavelengths—in other words, either for Daventry or for the local station. That is, of course, how the set gets its name.

Constructors who follow the detailed drawings carefully will encounter no difficulty in building the set.

Components Required

A list of components required is given below:—

Ebonite panel, 9-in. by 6-in. (Becol or Will Day).

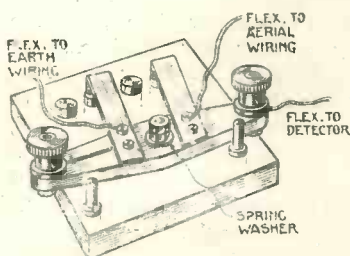

Completed "Fonotrol" Switch.

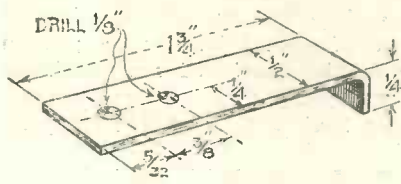

Details of Contact Arm.

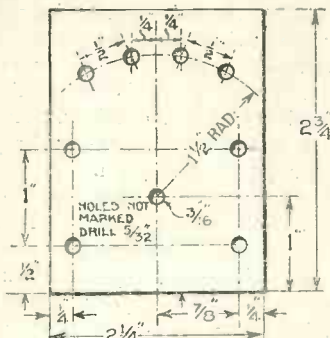

Layout of Switch Base.

DETAILS OF THE "FONOTROL" SWITCH.

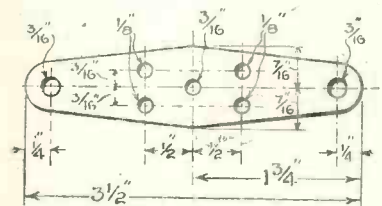

Details of Switch Arm.

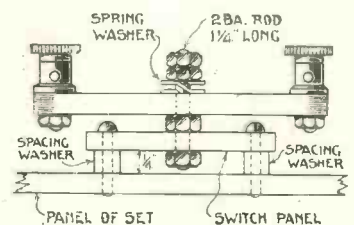

Elevation of Switch.

- .0005-microfarad variable condenser (Formo or Igranic-Pacnet).
- 2 single-coil holders (Burne-Jones or Trix, Lotus).
- Semi-permanent crystal detector (Jewel Pen or Trix, R.I.).
- 4 terminals:—Aerial, earth, 2 phone (Eastick).
- 4 ½-in. brass wood-screws (Economic Electric).
- No. 40 and No. 200 plug-in coils (Lewcos or Igranic).
- 2 ebonite strips, 2½ in. by 2½ in., and 3½ in. by ½ in. (Becol or Will Day).
- 6 ¼-in. 4B.A. brass screws (Economic Electric).
- 2 ¼-in. tubular distance pieces (Economic Electric).
- Brass strip, ½ in. by 5 in. by ⅜ in. (Economic Electric).
- 4 ½-in. 6B.A. bolts with nuts (Economic Electric).
- 4 tapping studs (Economic Electric).
- 1½ in. 2B.A. screwed rod (Economic Electric).
- 2 switch-arm stops (Economic Electric).
- Cabinet, 5 in. deep (Picketts).
- 2 wall-hanging plates or screw eyes.
- Hook for headphones.
- 4 2B.A. nuts (Economic Electric).
- 2B.A. spring washer (Economic Electric).

NOTE:—The particular components shown in the photographs and allowed for in the dimensioned layout are in each case mentioned first.

Making the Switch

When all the parts have been obtained the constructor can start work

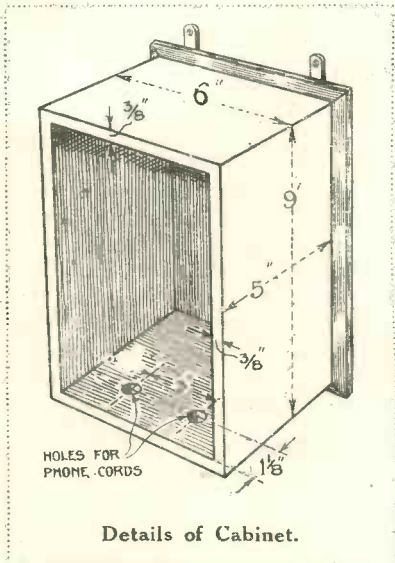

on the special "fonotrol" switch. All the details of this are clearly shown in the diagrams, and the photographs show the finished job. Looking at the back of the switch it will be observed that only the left-hand brass strip is connected to a terminal.

The rest of the layout is clear from the combined layout and wiring dia-

gram reproduced. If desired, constructors can obtain this as a full-size blueprint (No. WM14) for 6d., post free, from Blueprint Dept., WIRELESS MAGAZINE, La Belle Sauvage, E.C.4.

As soon as the switch has been completed the panel should be drilled and the components fixed into position. This is a simple matter if the layout is followed carefully.

Wiring Up

Wiring up, also, will present no difficulty if the diagram is studied. It will be observed that each terminal

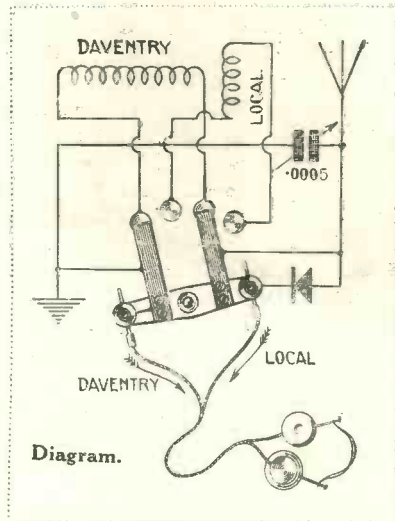
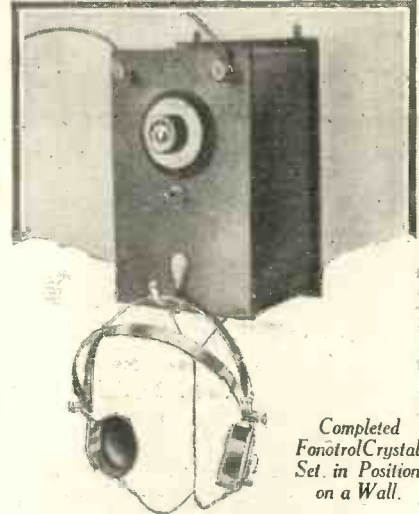

Diagram.

point is marked with a small letter of the alphabet; these indicate that all the points marked with like letters should be joined together. In other words, first connect up all those points marked *a* with one wire or as few wires as possible; then all those points marked *b*; and so on.



Next drill two holes in the "bottom" of the cabinet (see diagram), lead through the headphone cords and attach them to the terminals on the switch arm. Place two coils in the coil holders behind the panel, a No. 40 or 50 in one holder, and a No. 200 in the other. It is immaterial which coil is placed in which holder, but note should be made as to the positions so that the switch for changing from one coil to another can be manipulated as desired. The set can then be hung on a wall.

Testing the Set

Attach the aerial and earth to their respective terminals and don the headphones. Pull out the trigger of the crystal detector and allow the plunger to spring lightly back into position. Now turn the variable condenser until signals are heard. If no broadcasting becomes audible it may be because (i) the detector is not

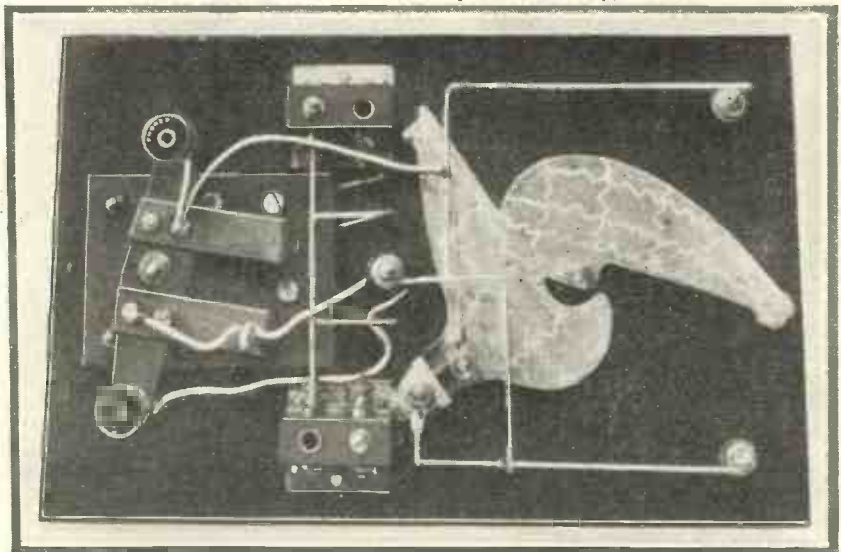

Below Panel View of the Fonotrol Crystal Set.

The Fonotrol Crystal Set (Continued)

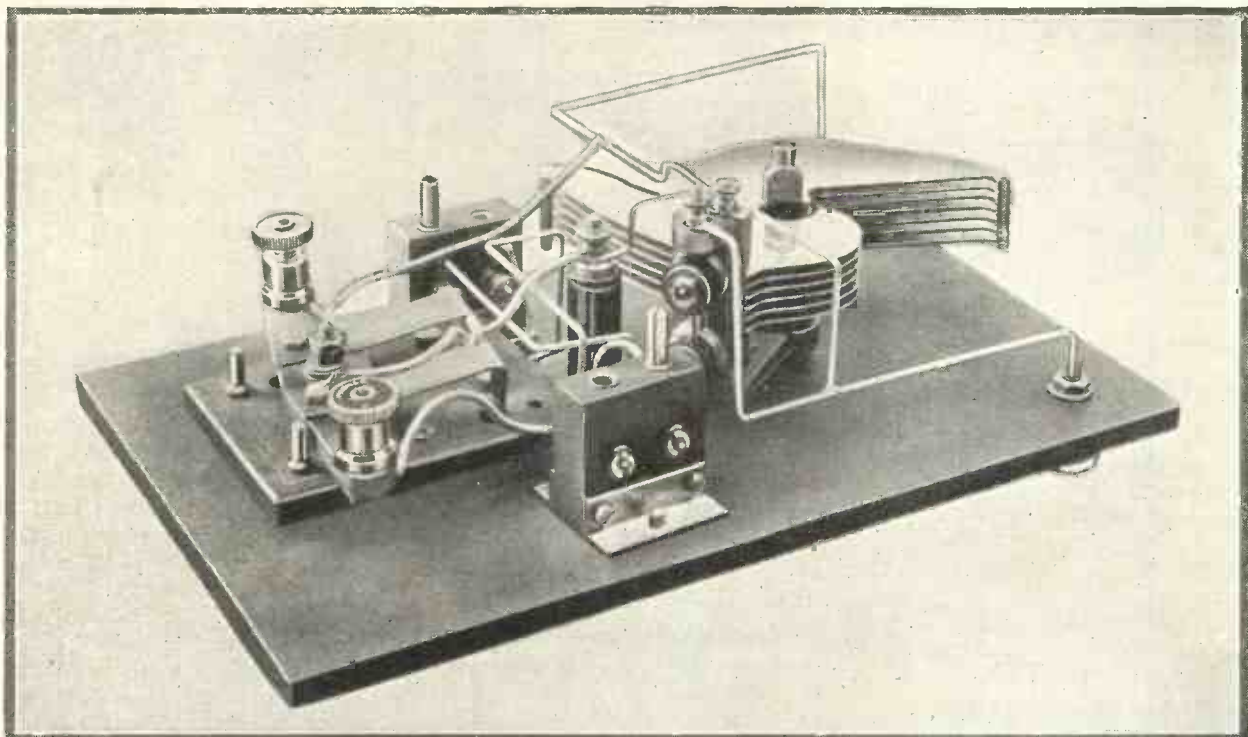

This photograph clearly shows the construction of the Fonotrol Crystal Set. The headphone cords are attached to the two terminals seen at the left of the picture.

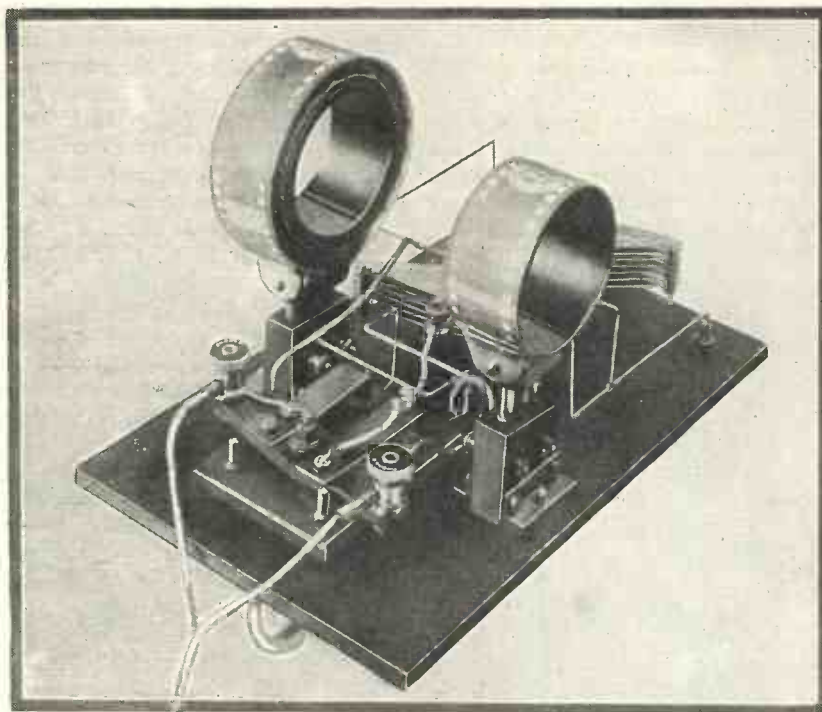

Another photograph of the under side of the panel of the Fonotrol Crystal Set showing the tuning coils in position.

See opposite page for Panel Layout and Wiring Diagram.

adjusted properly; (ii) the wrong coils are in use (the sizes recommended are for an average aerial), or (iii) the set is out of range. (It is assumed, of course, that the listener has glanced at a programme to see that a transmission is taking place.)

It is difficult to estimate the range of a crystal receiver at any time, and no guarantee can be given at what distances from a broadcasting station this set will operate satisfactorily—so much depends upon local conditions. In most cases, however, the set will work within 20 miles of a local main station, and 80 miles or so from the Daventry high-power station, with an average full-size outdoor aerial.

Test Report

On test the receiver has given very good signals at a distance of 12 miles from the London station, and reasonably loud reception at a distance of 60 miles from Daventry.

It will be found in practice that the crystal detector can be left without re-adjusting for long periods; this is a great advantage as parts of the programme are not missed through continual manipulation of the plunger.

A further advantage of having the set on a wall by the way, is that the aerial lead-in and earth wires can be kept short.

A Special "Wireless Magazine" Receiver

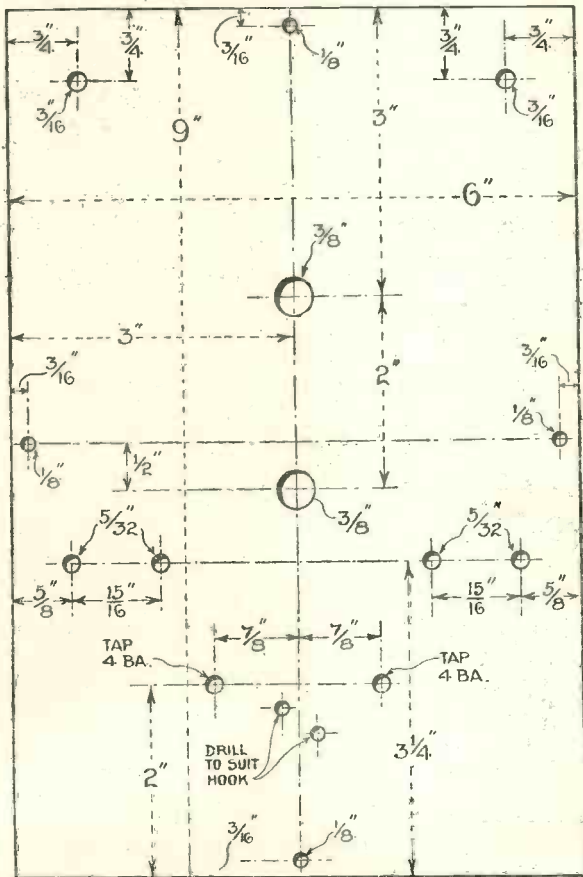

Panel-drilling Layout of the Fonotrol Crystal Set.

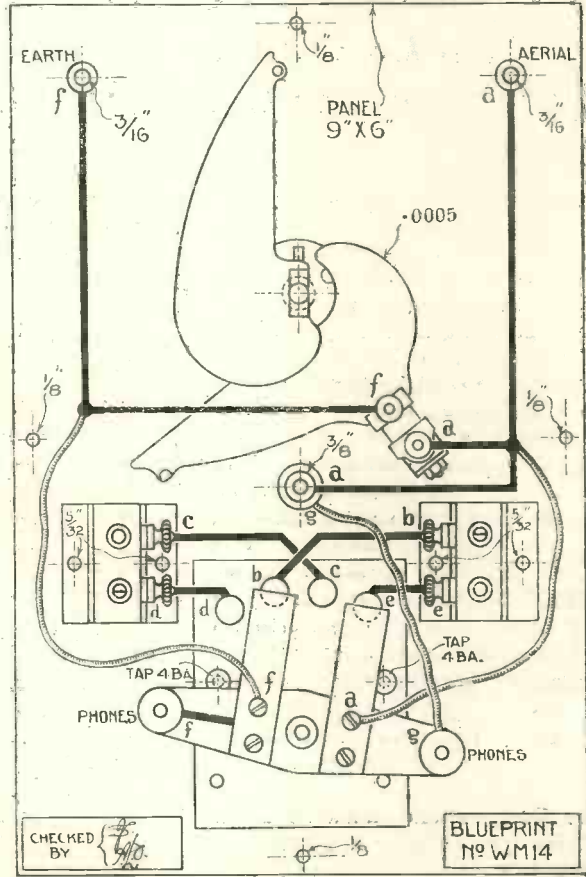

Layout and Wiring Diagram of the Fonotrol Crystal Set.

Commercial Telephony

YET more and more commercial telephony is to be heard on the short waves. By commercial telephony I mean broadcasting and broadcasting tests as distinct from the work of amateurs. The latest station to join the merry band is the Dutch station, PCJJ, on 30 metres.

Amateurs with sets that will work on 15 metres should make a point of listening for 2XG, which is usually transmitting telephony throughout the afternoon. The crystal-controlled morse signals from 2XS, another American commercial station, which works with South America, may be heard close to this wavelength and

will serve as a useful guide point. Both these stations are supposed to be on 15 metres, but as they are obviously many kilocycles apart they cannot both be correct. Both are crystal controlled, however, and both are quite near enough to 15 metres to form a good calibration point for any ordinary wavemeter.

Famous Station

The famous 2XAF, the Schenectady experimental station, which relays WGY's programmes on 32.77 metres, is now to be heard on Thursdays as well as on Saturdays and Tuesdays. The times I gave in "Below the Belt" a month or two ago are still correct, and the Thursday times may be added. In B.S.T., the starting times are midnight Tuesdays and Thursdays, and half after midnight on Sunday morning. 5YM.

Oscillating Crystals

THE early promise of the oscillating crystal detector as a substitute for the thermionic valve does not appear as yet to have materialised to any great extent. At the same time it is interesting to note that experimenters are still busy with the subject.

For instance, Dr. F. Seidl, of Vienna, has recently discovered that by suitably adjusting the biasing potential the so-called "Lossev" crystal oscillator can be made to vibrate at audio as well as radio frequency, giving rise to clear, sustained notes of variable pitch. The action appears to be very similar to that of the well-known "singing arc." R.

Parlez-vous Maggie?

By RICHARD CAROL

THE last time ma literary inspiration had me in thräl, I telt ye about the catastrophe which eventuated frae ma effort to convert Maggie's sister Miss Deborah (signifyin' "the bee") McCurdy frae a crystal set to a valve. I succeeded, if ye mind, but Miss McCurdy gaed awa wi' ma twa valves, an' for twa nichts we was without news an' musical entertainment.

Then providentially Angus came in. Ye mind Angus, him wi' mair siller nor sense, wha had provided ma original valves without kennin' it. Weel, him. An' he telt me his set was all wrong again an' all he could get was a buzz or twa an' a series o' splutters. Sae I gaed roond, an' telt him his valves had burnt out. I put in twa new valves an' cleaned his terminals, which was causin' all the trouble. And his burnt-out valves are bringin' in the music, etc., to Maggie an' me vera nicely, thank ye.

I had been cogitatin' on the programme one evenin' when suddenly a deep thought enveloped ma mentality.

"Do ye realise, Maggie, that Dutchmen can speak in three or even four languages?"

"Is that so, Sandy?" she says. "They must be awful dillicult to please. I'm quite content wi' one."

"Ay," I says, "but what if ye found yersel in a foreign country? What would ye do then?"

"I'd jist point to what I was wantin'," says Maggie.

"Ay," I says triumphantly, "an' if ye was in yer bedroom in a state of dishybille an' there was no soap how would ye point to it?"

"I'd pretend to wash ma face."

"They'd think ye was daft," I says sardonically. "Na, Maggie, we've jist got to learn languages, an' as they're giein' French lessons on the wireless we might as weel have them for naething. But we'll have to do a fair bit by oorsels as they're quite advanced an' we must catch up on them."

"Was ye thinkin' of takin' me to France?" says Maggie eagerly.

"Na," I says quick, "ye ken fine we couldna leave the shop. But it's as weel to be prepared."

I got oot a wee book on French Simplified an' applied mase! wi' assiduity for twa-three nights. Then I felt I kennt enough to start educatin' Maggie.

"Maggie," I says, "I'm going to gie ye yer first lesson. Ye'd better put yer knittin' on the dresser. Ye canna knit an' learn French simul-

going to speak to him. Ye say 'Parlez-vous Français.' Say it now."

"Parly voo frongshy. Parly voo frongshy," says Maggie.

"Yer accent is no' very good," I says, "but we canna expect perfection in a meenit. He replies 'Oui.'"

"Wee?" says Maggie. "What's that?"

"That means 'yes.'"

"It's awful funny, Sandy. An' what if he doesna say 'Wee.'"

"Weel, it means he canna speak French. But dinna mind him. The body you've addressed says 'Oui'; so now ye've got to ask him politely about his health in the following manner: 'Comment vous portez-vous?' That means 'How do you do?'"

"They canna have very much to do, thae Froggies," says Maggie, "if they turn a simple wee thing like 'How d'ye do' into 'Commong voo voo voo.'"

"Comment vous portez-vous?" I repeats without impatience at her manifest ignorance.

"Commong voo porty voo? Ha, ha, Sandy. Commong voo porty voo? Wee, wee, wee."

"Yer levity," I says asperiously, "is ill-timed. He replies 'Bien, merci,' which signifies 'Very well, thanks.'"

"They're awful thieves, thae Froggies," says Maggie, "that's twa words they've taken frae us. 'Wee' and 'mercy.'"

"The words are quite different," says I.

"But what if he's no' very weel, Sandy?"

"He'll say 'Bien, merci' jist the same," says I.

"They're no' a very truthful race."

"It's no' a question of truth," I responds, "it's jist politeness."

"Oh," says Maggie, "Be-yang-mercy. Wee, wee."

"The 'oui, oui' is oot of place," I says. "Perhaps ye would kindly eliminate it in future."

"Ay," says Maggie, slowly. "I'll try, but it sounds awful chick."

"What's chick?" I says.

"Och, Sandy," responds Maggie proudly, "that's French. It's what

Things To Know About

Grid Condensers

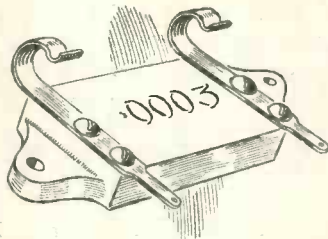

IN most circuits now in use rectification is carried out by a valve which has a fixed condenser, usually having a value of about .0003 microfarad, connected in its grid circuit. This condenser is called the grid condenser and one type of grid condenser is shown in the drawing.

As the electrons which reach the grid cannot escape through the grid condenser a path is provided for them by shunting the condenser with a grid leak of high resistance. This generally has a value of about two megohms and is often made in the form of a tube (which contains the resistance element) provided with metal caps at each end.

On the condenser illustrated here clips are provided to hold a grid leak, the metal clips making contact with the metal ends of the grid leak.

aneously. They dinna harmonise, ye ken."

Maggie did it without argyment, which surprised me.

"Now," I says.

"Now," says she.

"First," I says in the intellectual manner o' a fine lecturer, "I'm going to teach ye how to prepare a body for the fact that it's French ye're

they put on thae wee bits o' things in crêpe de shiney ye see in the shops in Glasgow, an' it means they're just awful nice."

"Nae doot, nae doot," I says, seein' her mind was gettin' into expensive channels, "but ye'd better concentrate on 'Parlez-vous Français' for the moment."

The next few days we continued our preparation for the next wireless lesson: We had oor being, as ye might say, in an elevated atmosphere. Twice in one day she called me from the shop into the kitchen, an' when I hastened at her call she said "Parly voo frongshy Moosoo," an' when I said "Be daumed to ye!" she said I should follow the French an' observe politeness towards the gentle sex, meanin' her. Ay, it's aye the

way wi' wumman. They've nae idea o' the propriety o' things, the circumspection, as it were.

Personally I utilised ma every endeavour to incarcerate knowledge into her mind, as, for example, viz., when she asked me if I'd have some stew I'd reply "Oui, beaucoup." As a matter o' fact I got jist the same amount as if I'd said "Ay," but I hoped it would improve her.

Unfortunately I was absent durin' the next wireless lesson, bein' engaged on a maist important committee meetin' at The Highland Laddie. When I returned in a benignant frame o' mind Maggie looked at me an' said:

"Tong tay tatil oty ta too?"

I regarded her wi' amazement exudin' frae ma eyes, an' for the

moment I thought she must have been at The Highland Laddie hersel.

"What does it mean, Sandy?" she continues. "It's French."

I shook ma head.

"It means," says Maggie triumphantly, "Has yer tea cured yer cough?"

"Oh," I says, "that reminds me I have a bit of a cough masel. I'll jist mak' a glass o' toddy."

"Na," says Maggie, "I'm sure a cup o' tea would be better. Moosole Blow said so when he gied us that sentence."

Ye ken, I've got ma doots about the advisability o' puttin' silly foreign ideas into a wumman's heid. They canna use education wi' discretion an' circumspection. "Cherchez la femme," as ye might say.

Radio and the Mentally Afflicted

THE boon which broadcasting affords to the sick and the afflicted is recognised as one of its greatest virtues, but little attention has been drawn to the part that it plays in relieving the lives of those who suffer from mental trouble. In many asylums throughout the country, however, wireless has been introduced to enhance the amenity of existence.

Interesting details have been secured from a Scottish mental hospital, where, it is stated, two items of the broadcast programmes which are specially popular are the Sunday evening religious services and the talks on serious topics. Amongst the men inmates the broadcasting of sporting events has also been highly appreciated.

Many diseased minds are under the necessity of attributing their difficulties to the use by their enemies of the latest scientific appliances, and wireless, as well as the cinematograph, is looked upon with suspicion by some patients. Several who suffer from hallucinations of hearing explain that wireless is used to taunt, to threaten, or to flatter, as

the case may be. Imaginary wireless in the hands of unscrupulous persons is held to be the cause of

woman patient. For long she had had the idea that her most intimate thoughts were being read by some external agency, the nature of which was to her very vague. One day her uncertainty on this score was dissipated when some of her neighbours began to talk of "listening-in sets." Being a little hard of hearing, she concluded that it must be these "listening insects" that heard and then exposed her inmost wishes. Other stories could be told of the surprising ways in which wireless is held responsible for a variety of circumstances and conditions.

S. A. F.

THE sleuth-van of the G.P.O. has been very active lately in its search for oscillators. In one district in the suburbs of one of the London boroughs it bore down on the "howlers" and found that in every case the use of reaction was being abused. The offenders were informed that next time it would be an action.

"THE B.B.C. thinks in centuries," writes C.O. This is part of the trouble—it is expected to think in 1927.

A BLIND BOY BROADCASTER



Ronald Matthews, through the medium of the Canadian National Railway broadcasting station, CNRV, at Vancouver, has become one of the best-beloved figures on the Pacific coast of Canada.

all their particular personal troubles.

In one case wireless has given a new direction to the delusions of a

A Reinartz R.C. Three for the Family (Continued)

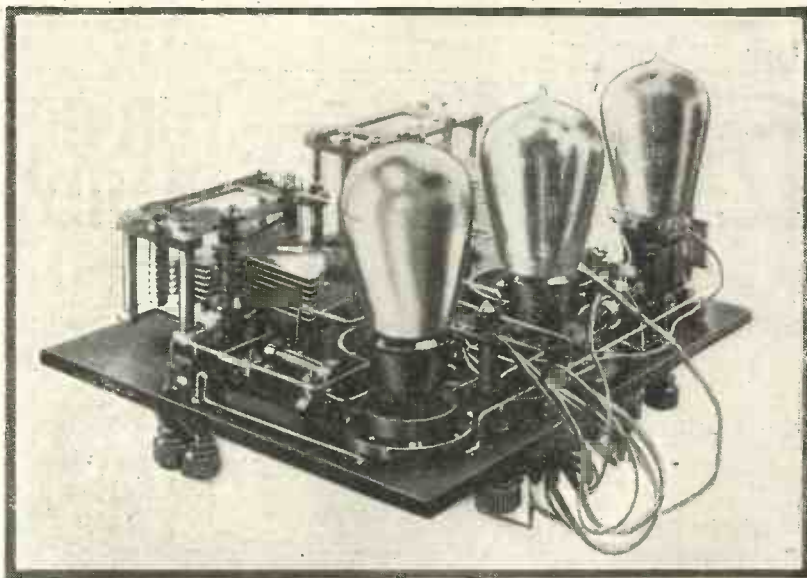

Reinartz R.C. Three with Valves in Position.

usual baseboard. This system also helps to add to the efficiency: wiring is kept shorter, for instance, without any fear of causing interaction.

Components Required

For building the set the following components will be required. The actual parts used in the original set made by the WIRELESS MAGAZINE Technical Staff cost about £6 10s., but this figure can be reduced in some cases by using different makes of components:—

Ebonite panel, 10 in. by 8 in. (Becol or Trolite).

Holder for centre-tapped coil (Igranic Xllos).

.0005-microfarad variable condenser (Cydon Log Mid-line or Peerless).

.0003-microfarad variable condenser (Cydon Log Mid-line or Peerless).

2 3-in. clockwise condenser dials (Trolite or Becol).

2 antimicrophonic valve holders (Lotus or Precision).

Antimicrophonic valve holder with 2-megohm grid leak combined (Lotus).

2 30-ohm rheostats (Igranic; Pacont or Peerless).

Nos. 1 and 4 Xllos centre-tapped coils, for lower and upper broadcasting bands (Igranic).

2 .25-megohm grid-leak type anode resistances (Dubilier or Mullard).

2 1-megohm grid leaks (Dubilier or Mullard).

.0003-microfarad fixed condenser (Cosmos or Igranic).

.0001-microfarad fixed condenser (Cosmos or Igranic).

2 .002-microfarad fixed condensers (Dubilier or Lissen).

Double-pole double-throw push-pull switch (Lissen or Lotus).

4 terminals:—Aerial, earth, loud-speaker+, loud-speaker- (Belling-Lee).

8-way battery cord (Lewcos or Burne-Jones).

Cabinet (Artraft).

N.B.—The particular components shown in the photographs of the original

set and allowed for in the dimensioned layout are in each case mentioned first.

By making proper use of the free full-size blueprint layout, drilling guide, and wiring diagram given with this issue no difficulty will be encountered in construction. First of all lay the blueprint over the panel and mark through with a sharp-pointed instrument the centres of all the holes to be drilled.

Drilling and Tapping

Most holes are drilled right through the panel, but a few, notably those for fixing the R.C. grid coupling condensers and the antimicrophonic valve holders, are tapped only about two-thirds of the way through the ebonite. By taking care over this operation the appearance of the top of the panel in the completed receiver will be kept neat. When the drilling has been completed and all the holes have been cleaned out the components should be screwed into position.

Before wiring up, the condensers should be arranged so that the moving vanes are right out, and valves

REDUCED REPRODUCTION OF FREE BLUEPRINT

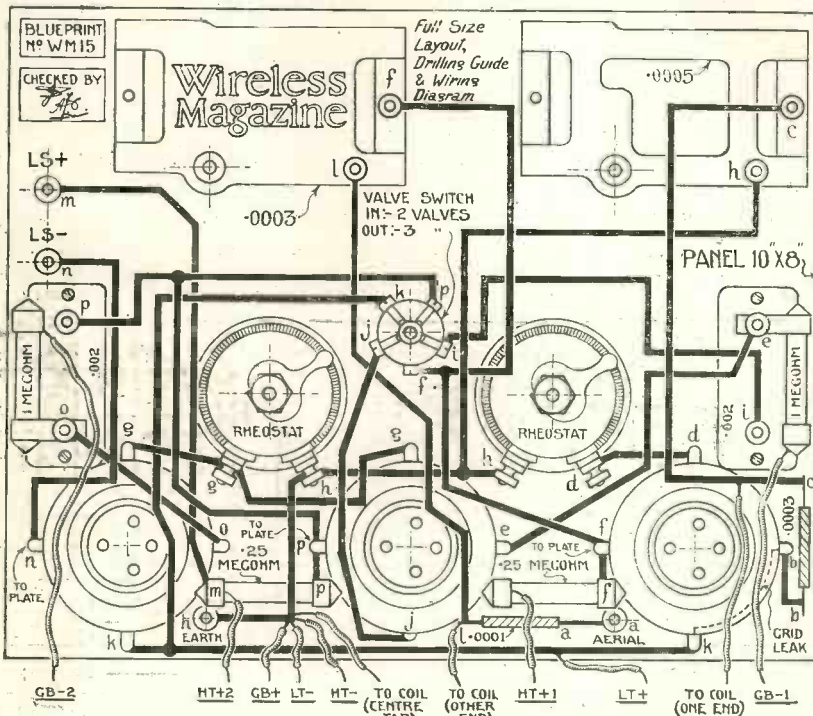

If, by some misfortune, you lose your free blueprint, this reproduction will help you.

Free Full-size Blueprint with This Issue

should be placed in the holders. If these precautions are not taken it may be found that the wiring falls foul of some component, which either cannot be adjusted or cannot be placed in its proper position.

Coil Leads

It will be noticed that the leads to the low-loss coil holder are taken through three holes in the panel. The three terminals on the front of the coil holder, it should be further noted, are joined together by means of a flexible lead. The other two coil-holder connections are made to the end terminals.

By carefully following the blueprint given free with this issue there should be no difficulty about wiring up. It will be observed that all the terminal points are marked with small letters; this indicates that all those points marked with like letters should be joined together. In other words, first connect up all those points marked *a* with one wire or as few wires as possible; then all those points marked *b*; and so on until wiring is completed.

Condensers and Leaks

The .0001- and .0003-microfarad fixed condensers are not fixed to the panel, being held in position merely by the wiring. The same applies to the two .25-megohm grid-leak type anode resistances, which are held by means of small metal clips.

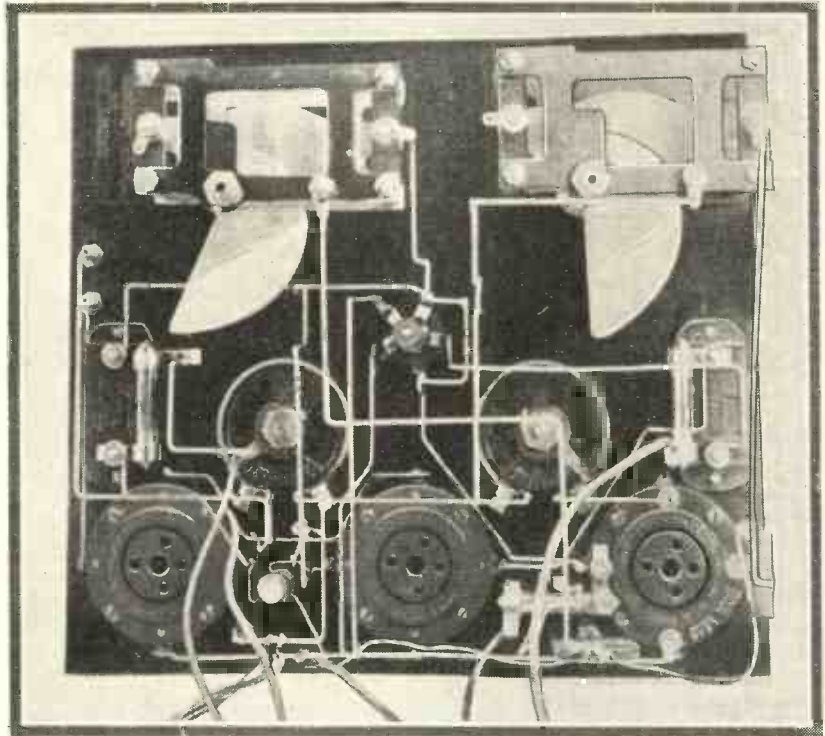

Plan View of the Reinartz R.C. Three.

For the sake of convenience use has been made of an eight-way battery cord. The connections to this are clearly indicated on the blueprint and can be followed also from the photographs.

As soon as wiring has been completed the set is ready for test. Before putting it in the cabinet, however, the valves should be placed in

the holders. In doing this it should be noticed that the split legs are sufficiently wide open to ensure a firm grip in the holders, otherwise the valves may fall out on to the floor of the cabinet. Even if this did occur it is extremely unlikely that the valves would be damaged in any way, but very cautious constructors may care to place a layer of cotton wool, or other absorbent material, in the bottom of the case.

Connecting Up the Batteries

Lead the battery cord through the hole previously made in one side of the case and connect up the appropriate batteries. The voltages will, of course, depend entirely upon the types of valves used, and in this respect the manufacturer's recommendations should be closely followed. It should be noted that the H.T. + 1 lead

DETAILS OF THE CABINET OF THE REINARTZ R.C. THREE FOR THE FAMILY

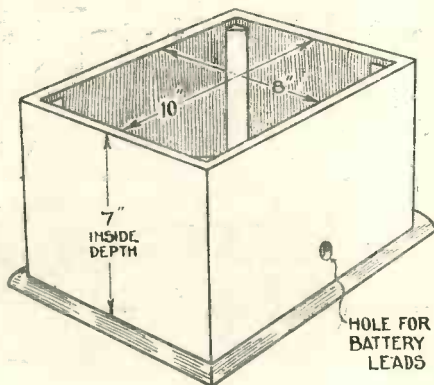

A Reinartz R.C. Three for the Family (Continued)

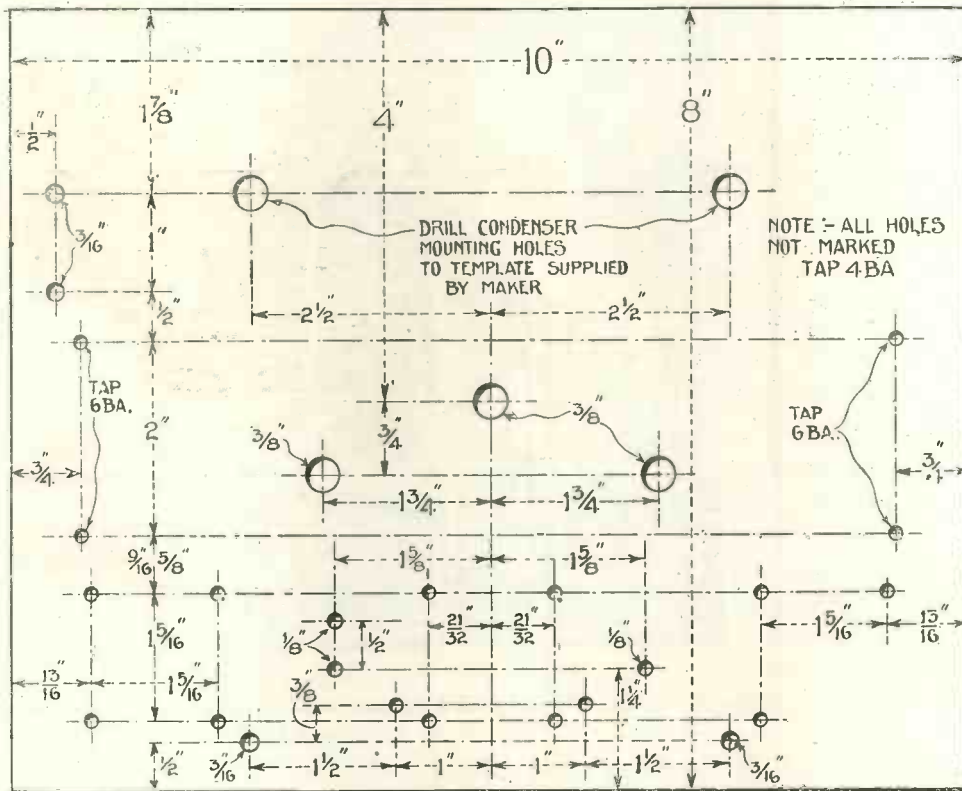

**HALF-SCALE
PANEL
LAYOUT OF THE
REINARTZ R.C.
THREE FOR THE
FAMILY**

This is supplementary to the full-size blueprint given with this issue and will not be needed at all by many constructors. If different components from those used in the original set are employed, this layout must be adapted accordingly. As far as possible constructors should follow the original arrangement—by so doing they will save themselves trouble and ensure that the set will give the expected results.

will go to a lower-voltage tapping than the H.T. +2 lead, and the G.B. - 1 lead will also go to a lower-voltage tapping than the G.B. - 2 lead. A table of suitable valves for various voltage batteries is included on this page. Other valves can be used, of course, but they must be of the same types.

Terminal Connections

When the batteries have been connected up the aerial, earth, and loud-

speaker leads can be screwed to their respective terminals on the top of the panel.

Pull up the knob of the push-pull switch to put all three valves in circuit (pushing down the knob cuts out one valve) and turn the rheostats on. Plug a No. 1 or 2 Xilos coil in the holder for the local station (or a No. 4 coil for Daventry). Now turn the reaction condenser until a sound is heard which indicates that the set is oscillating.

If this sound is not heard at any setting of the reaction condenser it is most probable that insufficient current is being supplied to the valve filaments (it is assumed that the voltages recommended by the manufacturers are applied to the anodes and grids) and the rheostats should be adjusted accordingly.

Improving Quality

Next turn the aerial-tuning condenser until signals are heard. The

VALVES TO USE IN THIS SET

Make.	Detector.			1st L.F.			2nd L.F.		
	2-v.	4-v.	6-v.	2-v.	4-v.	6-v.	2-v.	4-v.	6-v.
B.T.H.	B8	—	—	B8	—	—	B23	—	—
Cossor	Blue	Blue	Blue	Blue	Blue	Blue	Stentor	Stentor	Stentor
Ediswan	RC2	—	RC610	RC2	—	RC610	PV2	—	PV5
Marconi or Osram	—	DEH410	DEH612	—	DEH410	DEH612	—	DEL410	DEL612
Mullard	PM1A	PM3A	PM5B	PM1A	PM3A	PM5B	PM2	PM4	PM6
Shortpath ...	SP18B	—	SP50B	SP18B	—	SP50B	SP18R	—	SP55R

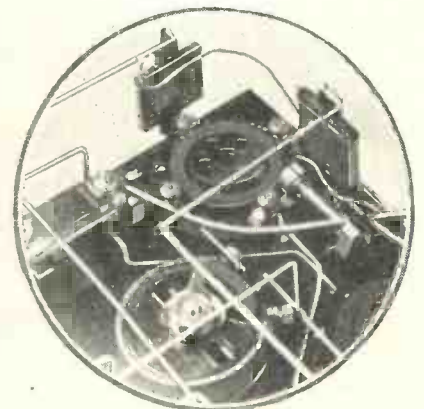

Wiring of Fixed Condensers.

A Special "Wireless Magazine" Receiver

TEST REPORT.

Station.	Coil.	Aerial Condenser Setting.
London	No. 1	85°
Langenburg ..	No. 2	50°
Daventry	No. 4	95°
Radio-Paris ..	No. 5	10°

These represent four stations that can be relied upon for loud-speaker reception anywhere in the south of England.

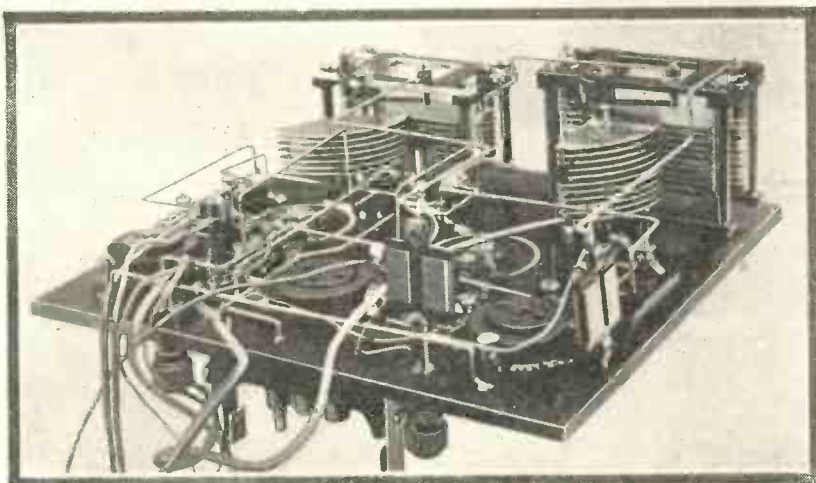

Under View of Panel of the Reinartz R.C. Three.

quality should be improved as much as possible by manipulating the reaction condenser (this should have the smallest possible dial reading) and filament rheostats. Finally, the high-tension and grid-bias voltages can be altered to find out if any improvement results.

Avoiding Overloading

When the middle valve is switched off (by pushing the switch knob down) it is desirable to readjust the right-

hand rheostat, bringing more resistance into circuit, otherwise the filament of the last valve may be slightly overloaded.

A few hours' manipulation of the set will soon give the operator the "feel" of the two tuning controls. It will be found, provided the proper voltages are applied to the valves used, that the reaction condenser gives a fine control of oscillation.

This set will, we know, give many pleasant hours of broadcast reception

to every listener who makes it up. May we remind constructors, moreover, that we are always glad to hear of the results they obtain with WIRELESS MAGAZINE sets? We prefer letters of praise, naturally—we should hardly be human if we did not—but we are not afraid of letters of criticism; they enable us, in the few cases when we get them, to put the disappointed listener on the right track. We want you to get the best out of wireless.

Things Heard from 2LO

On a Saturday

A VOICE which kept on saying, as if in a fever: "Section 1, Section 2, Section 4, Section 8." Is this a new timekeeper 2LO has employed?

A description of a Rugby football match in geometrical formulæ.

A rude Celtic voice shouting: "Play up, Wales."

The refrain of a well-known Welsh hymn, which reminded one of a revival.

Fifty thousand people taking their Saturday afternoon lung exercise.

A very excited announcer when England scored a goal from a mark.

On Another Saturday

A band.

"Programmes 'ere. Official programmes, 'ere."

Community singing.

Unofficial English.

A Northern dialect.

Many Voices: "Chuek 'in off."

The usual what's-his-name shouting: "Play the game, ref."

A thunder peal of "Ooh."

At half-time the announcer saying:

"I'm going to have a drink now."

Lemonade, one expects!

A Voice: "Choc'lat's."

On a Wednesday Afternoon

The prominence given to dropped "h's" by a lady speaker.

The prominence of the "r" by another.

A bit of information for men: "Men are not interested in their homes." What about meal-times?

The funny things women can talk about.

A viola, the strings of which were not tuned properly.

A B.B.C. announcer who pronounced profligacy wrongly.

A speaker who credited Hans Andersen with a tale which he never wrote.

On a Friday Evening

Pauses which amounted to 17½ minutes in two hours.

Three different voices that were decidedly not broadcasting voices.

Was it the announcer's time-table that fell from his hands?

Eleven corrections and apologies in 50 minutes. Is this a record?

A talk on something like metaphysics.

A whisper: "Stand just there."

A soprano considerably out of tune.

E. B. R.

WM
15

FREE BLUEPRINT SUPPLEMENT

A REINARTZ

BLUEPRINT
No WM15

CHECKED BY

F. A. S.

Wireless Magazine

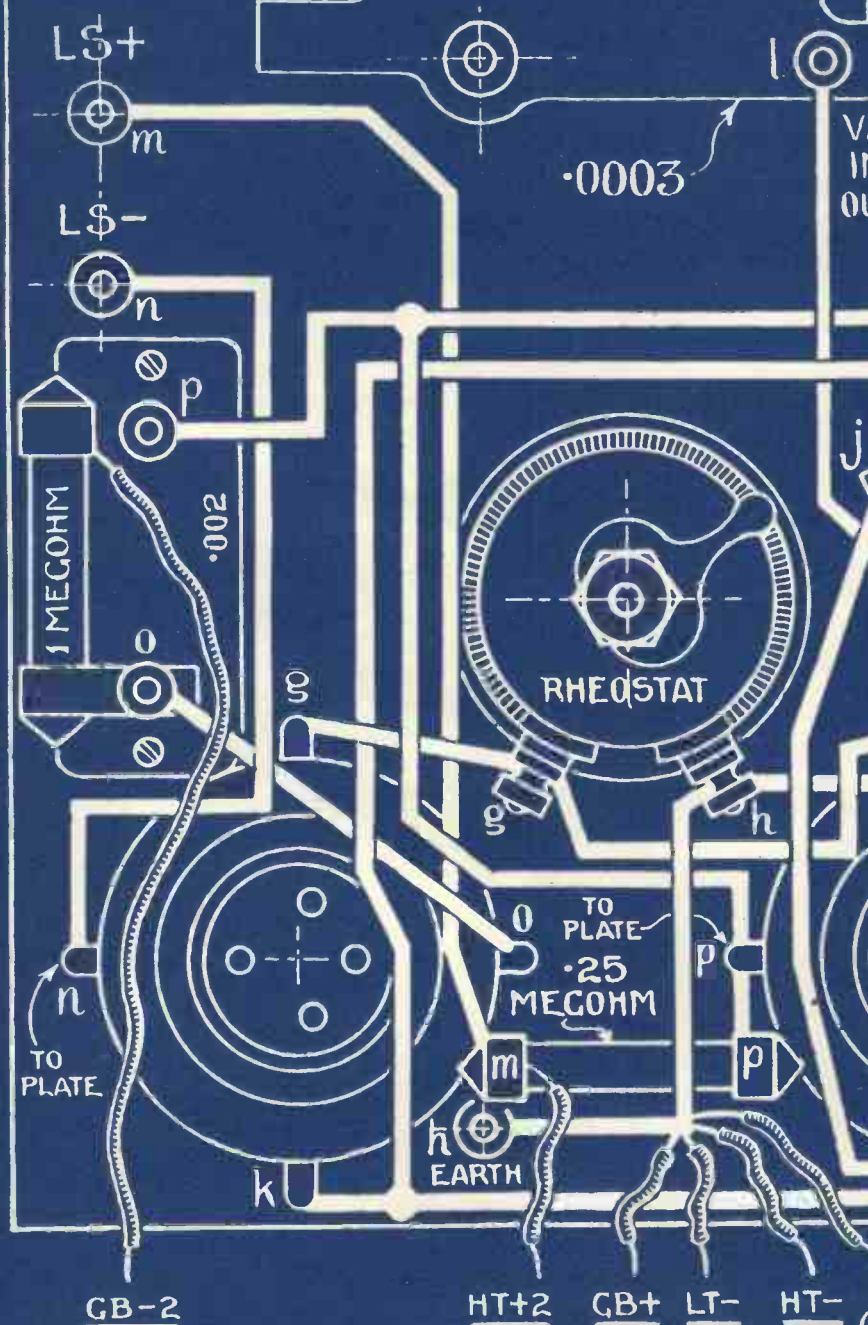

When wiring up connect all points marked with like letters together

MENT TO THE "WIRELESS MAGAZINE" JUNE 1927

R.C. THREE FOR THE FAMILY

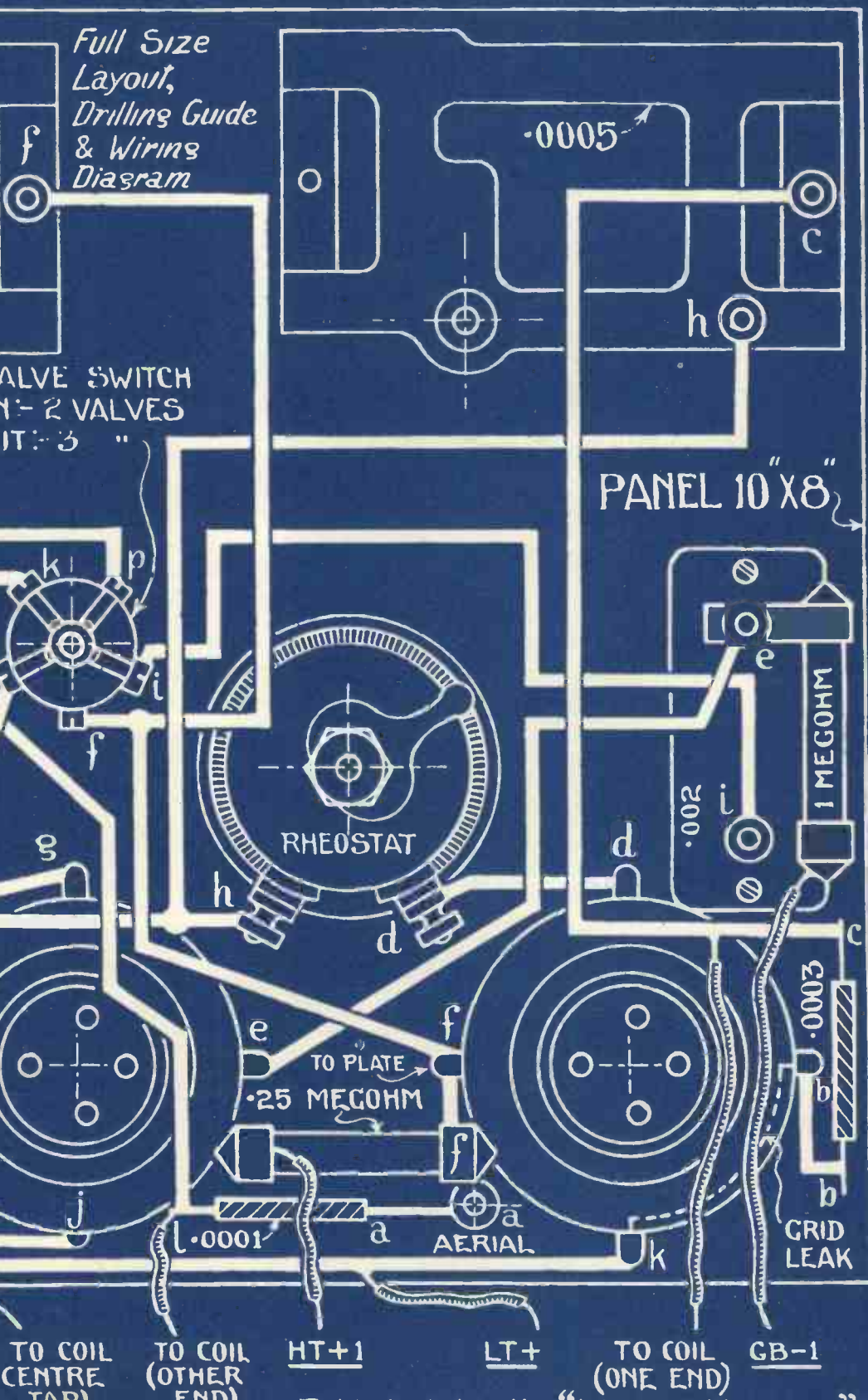

Published by the "Wireless Magazine"
La Belle Sauvage, London, E.C.4.

VOICES OF THE NIGHT

Five-minute Biographies of the World's Announcers

Collected by J. GODCHAUX ABRAHAMS



M. André Gaudelette, of Radio-Paris.

PARIS (FRANCE)

DAILY, for close on three years, you may have listened to the midday, afternoon or evening concerts broadcast by Radio-Paris. Throughout these transmissions you will have heard the breezy accents of Radiolo, the studio announcer; his voice, style and delivery are unmistakable. And yet, in October last, the original Radiolo (Marcel Laporte) returned to the stage, and was replaced by André Gaudelette, the official "speaker." Personally, had I not known this fact, I could not have detected any difference in the voices.

Quite by Chance

It was quite by chance that Monsieur Gaudelette was called to the studio. He was professor at the Paris University, having taken his full degrees in literature and science. Since the advent of broadcasting he has been an enthusiastic radio fan, and in 1924, when listening one evening to Radio Paris, he heard an SOS broadcast for an assistant announcer.

Settling Wagers

"As a wireless amateur the call appealed to me," says Monsieur Gaudelette, "and within a few minutes I had reached the offices of the Compagnie Française. My voice test was soon carried out; the verdict was a satisfactory one. I had in my favour a similarity of expression, timbre and turn of phrase to the original Radiolo, and for over a year listeners did not know that the duties of the studio speaker had been taken over by two different

men. Even to-day I am compelled to settle wagers on that point."

In his opinion, an announcer should possess so many qualities that they can seldom be found in one individual. In the words of Monsieur Ponce: "N'importe qui ne peut faire un speaker. On nait speaker, on ne le devient pas." (Everybody cannot be a speaker; a speaker is born, not made.)

"Personally," adds M. Gaudelette, "I do my best; my experience as a lecturer has been of considerable assistance. I cannot remember suffering from microphone fright,



Sr. Bucheli, of Radio Catalana, Barcelona.

although I have seen artists paralysed by this complaint in a bare and empty studio. When delivering a lecture in a hall I feel somewhat shy; in the studio I do not attempt to visualise the thousands of listeners who make up my unseen audience, and for this reason you will detect no trace of nervousness in my voice."

Monsieur André Gaudelette has already received many appreciative letters from the British Isles: his "Bonsoir Mesdames, Bonsoir Mesdemoiselles, Bonsoir Messieurs" is a liberal education in itself.

BARCELONA (SPAIN)

SEÑOR A. BUCHELI, *el Locutor* (speaker) of Radio Catalana, is twenty-seven years of age; his father was Swiss, his mother Spanish, and he was born at Barcelona. Most of his studies were made in Switzerland, and on that account the German, Italian and French languages were easily acquired. To his knowledge of Spanish, Portuguese and Catalan he has since added English.

Dialect Plays

There are but few announcers in Europe who can tackle a programme destined to so many different nationalities without outside assistance; Señor Bucheli on many occasions has spoken to distant listeners in their respective tongues. Catalan, in the North-east provinces of Spain, is used to a very great extent by the people, and even newspapers are published in this language. For the benefit of the local population the Barcelona station frequently gives dialect plays; even a fluent Spanish linguist would not understand them.

Bucheli has not only taken upon himself the duties of studio announcer, but also acts as secretary to the broadcasting company. Radio Catalana is an independent concern which, as do most of the Spanish transmitters, relies on broadcast advertisements as a source of income. The announcer is also organiser of programmes, and it is he who puts over the publicity items.

Trying Advertisements

"These advertisements," said Bucheli, "between you and I, are rather trying to listeners who are expected to listen to them nightly, and it is one of my jobs to wrap them up (the advertisements, not the listeners) in a palatable form. Some humorous touch, or turn of phrase, has to be

improvised in each instance, a matter which preoccupies my mind during the whole three hours of our evening entertainment."

For some fourteen months he has nightly faced the microphone, and on an average has broadcast some four thousand words every day. Weekdays, Sundays and holidays find him in the studio: Señor Bucheli is not afraid of hard work.

Too Varied Work

"My duties as *el Locutor* are not to be compared with those of a similar post in other countries. If only I were limited to the announcement of items with a few notes written in advance, the task would be an easy one. Unfortunately, in my case this is impossible: my work is so varied. As the organisation of the concerts is under my supervision I am compelled to speak from the room in which the entertainments are given. This gives me the opportunity of talking to the visitors and artists; of praising their performance or recommending to them some of the wares which in the course of the programme I shall later advertise!"

It must be difficult to combine advertisement and art—tactfully, at least. The possession of the qualities required by a Spanish announcer should fit him for the diplomatic service.

Señor Bucheli is a great favourite in Barcelona; although very young,

he appears to acquit himself well of his onerous duties. The profession of studio announcer is a difficult one in Spain.

BERNE (SWITZERLAND)

BERNE boasts of a lady announcer; since it started broadcasting no mere male has "bossed" its studio. If at any time you have tuned-in to that station you cannot have failed to hear



Fraulein Greti Weidmer and Mr. Frederick Bieri, of Radio Berne

the call, "Hier Radio Berne," "Ici Radio Berne," in melodious feminine tones which later gave you the details of the last and next item in the programme in both German and French. That was Fraulein Greti Wiedmer. Her Italian is equally good; as for her English, she spent some time in England and Ireland. As a matter of fact, now and again in her

announcements in our language you will find just a trace of Irish brogue!

When at the end of the evening transmission she gives Berné's grand good-night, she passes in review most of the neighbouring countries, and Great Britain is not forgotten. Her "Good-night, everybody, good-night" is in true B.B.C. style!

Fred Bieri is not an announcer—at least, not a regular one, although on the first Monday in each month, when Radio Berne indulges in a special late transmission for the benefit of listeners in distant countries, invariably you find him in the studio to assist in putting over the ether announcements destined to British listeners.

But Frederick Bieri has acquired fame as Berné's Teddy Bear, and is responsible for the half-hour English chats from that station which you may have heard from time to time. He felt quite bucked when I assured him that his growls and grunts had been heard in England!

English Life

It is to him the Swiss listeners turn for descriptions of English life, short talks on our customs, explanations of such things as Bank Holidays, Christmas puddings and mince pies. Although resident in Switzerland, he is keenly interested in all that takes place in these isles. Frequently, as a fitting end to his talks, he closes with "Good night, London."

Why Is It?

A Nutshell Novel

HENRY JOSLIN awoke with a start. It was dark, and he wondered how long he had been asleep. Perhaps half an hour, perhaps more. Anyway, he felt infernally stiff and cramped. There was a pain, too, as though a heavy weight were pressing on the top of his head.

And then he remembered. He had fallen asleep while he had been waiting. Instinctively he dropped his hand to his side and began to feel about. No, it was not there.

"Funny," he murmured, "I could have sworn I left it there." He twisted round uncomfortably and tried

the other side. The object of his search was not there either.

"It's positively miraculous," he muttered angrily. "There's been no one in this room, and yet it's gone. It beats me."

Slowly he struggled into a sitting position on the sofa, and looked into the eerie darkness around him. There was a tug. He could not move any further. Stretching out his hand he felt a tautened cord in the darkness.

He tried to move forward so as to reach a glimmering white spot in the gloom. Surely that must be what he wanted. Very softly he pulled against

the cord and it gave a little, and then a little more until his hand was right over the white object. He leant down to grasp it.

Simultaneously something crashed to the ground.

Tearing himself free, he leapt for the light switch.

There lying on the floor were the remnants of weeks of patient toil.

Henry Joslin smiled cynically. "Remarkable, isn't it," he sneered, "that the programme is always a little further away than a fellow can reach when he's wearing phones?"

J. A. D.

JOTTINGS *on the* MONTH'S PROGRESS

Short-wave Development

MR. ECKERSLEY'S recent lecture before the Institute of Electrical Engineers disclosed some interesting facts in connection with modern short-wave working. A noticeable development in actual practice is the use of aerials specially designed to radiate energy at a high angle to the horizontal, with the object of utilising the conducting properties of the Heaviside layer.

Polarised Waves

The use of polarised radiation is another innovation of unusual interest. In the Marconi beam transmission the waves are vertically polarised. That is to say, the electric field is orientated more or less perpendicular to the earth's surface, whilst the magnetic field is mainly horizontal. Pickard and Alexander-son, on the other hand, found that horizontally-polarised waves radiated from a flat loop-aerial suspended at a considerable height above the ground were remarkably free from "fading."

Circling the Globe

The lecturer quoted instances of short-wave transmission in which the signals after travelling right round the world were picked up by a receiver located close to the transmitter, and gave rise to an "echo" effect which lagged a fraction of a second behind the main signal.

Lost in Space

For wavelengths of over ten metres it appears that the effective range increases proportionally to the square of the frequency. Curiously enough, energy radiated at a wavelength of ten metres, especially when projected at a high angle, seems to penetrate the Heaviside layer and disappear into outer space. This is an interesting discovery for those who

may still cherish the desire to communicate by wireless with the denizens of Mars or the other planets.

* * * * *

Beam Progress

Following the successful inauguration of the beam service to Australia, Senatore Marconi points out that his system provides for the first time a direct line of communication with the Commonwealth. Not only is it the longest direct telegraph link in the world, but it has been proved capable of dealing with over 150,000 words a day in each direction, or more than three times the existing total signal traffic between the two countries.

Duplex Working

Recent tests have also established the practicability of superposing telephony or speech messages upon the existing beam telegraph service to Canada. A double channel of communication is thus opened up without the expense of providing separate stations and personnel for dealing with telephone messages. The same advantage will apply equally to the Australian service, direct speech with that country having, in fact, already taken place.

Picture Transmission

As a further development Senatore Marconi referred to the possibilities of picture and facsimile transmission over long distances by the beam system. Owing to the shorter wavelength used in beam transmission the time taken for photographic transmission is materially reduced. Senatore Marconi expects, in fact, to be able to transmit a whole sheet of newspaper print and to reproduce it legibly over the beam channel inside a period of five minutes.

A Neon-tube Indicator

An interesting application of the "flashing" properties of the neon tube is due to Colonel Edgcumbe and Mr. F. E. Ockenden. It utilises the known fact that a neon tube, when exhausted to the point of minimum impedance, "flashes" over at a definite voltage which is independent of the frequency of supply.

The tube is shunted by a variable condenser and placed in series with a high-grade electrostatic voltmeter, the "flash" point being detected either visually or by means of headphones. In tests carried out for the purpose of determining the maximum value of electric strain applied to certain insulating materials, the error of the neon tube indicator was proved to be less than 1 per cent. when measuring the peak voltage of a current of three amperes at a frequency as high as five million cycles per second.

A Novel Valve

Another use of the neon tube, this time as a substitute for the thermionic valve for amplification and rectification, has lately been patented by an English inventor, T. A. Master-son. The chief advantage lies in the fact that no low-tension supply is necessary for the operation of the device.

An electron discharge stream is first created across the two electrodes of a tube filled with a mixture of neon and helium gas by the application of a pressure of 150 volts supplied from any suitable source. The stream of liberated electrons is then forced to pass through a narrow passage, outside which is coiled a grid or control winding.

The field from the control winding varies the conductivity of the neon gas mixture, and thus regulates the value of the current reaching the anode of the valve. B. A. R.

What Readers Think of Our Sets

*Señor Galan, of
Madrid, with the
1927 Five he
constructed.*



THE 1927 FIVE

LETTERS telling of the success of the 1927 Five still reach us from all parts of the world in gratifying numbers—there must be thousands of sets giving satisfactory service to their constructors. When details of the set were originally published in October of last year we claimed that it was a year ahead of any other receiver—and that claim still holds good.

For many months the original details have been out of print, but amateurs who desire to build the receiver will find the essential details reproduced on p. 262 of the April issue and a copy of Blueprint No. WM6 (price 1s. 6d., post free, from Blueprint Dept., WIRELESS MAGAZINE, La Belle Sauvage, E.C.4) all that they require.

Below we reproduce a letter received from a member of the Spanish wireless trade which gives some indication of the world-wide popularity enjoyed by the 1927 Five.

It is hardly necessary for us to say, is it, that we are at all times glad to hear from readers who have made up WIRELESS MAGAZINE sets?

Unsurpassed

To the Editor, "Wireless Magazine."

SIR,—I want to write you a few lines to express my opinion about your set 1927 Five apparatus. I can assure you that now in Spain there is not another apparatus whose qualities of earshot, purity of tone, selectivity, etc., may surpass those of yours.

As you can examine it by the enclosed snaps, I have introduced in my apparatus none important modification. I have only put a fibre interrupter of the current in order to avoid of removing the hind plug, what is always a wearisome operation.

I must confess you that I should see with great pleasure the reproduction of the enclosed snaps in your magazine, which is, for me, the most interesting of all I read.

Only a thing grieves me: it is, the

impossibility of keeping the apparatus which I have constructed for account and by order of a client, and, indeed, I cannot withhold it. As I am a modest constructor, and my means do not allow me of constructing an apparatus for my particular use, I should desire to keep the snaps, which are the unic remembrancers that I can keep of this beautiful receptor.

I should add that all the stations have

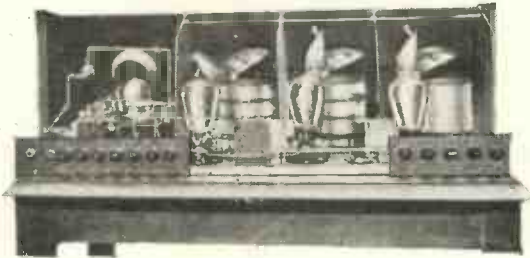

Another photograph showing the neat appearance of the 1927 Five built by Señor Galan of Madrid.

been heard with only four valves, because with five valves it is impossible of withstanding the great strength of sound.

I conclude my letter by sending you my sincere congratulations for the success of your apparatus, and by giving you my thanks for your kindness by publishing my snaps.—José MA. DOMINGUEZ GALAN (Madrid, Spain).

Within 1½ miles of 2LO

SIR,—I thought that you might be interested to hear from a user of the 1927 Five in a locality 1½ miles from 2LO's aerial, and under very inefficient aerial and earth conditions. I wish to say at once that I do not consider any set would give perfect reception with the handicaps I have to work under, but the 1927 Five is the first of the different sets I have tried in my home to give any degree of selectivity on the local station and at the same time to bring in distant stations during 2LO's transmissions. I can work clear of London at about 33 metres either side of its wavelength, that is, about 394 and 326 metres.

The set differs from your published design only as follows:—(1) .0003-microfarad condensers in the H.F. circuits instead of .00035-microfarad; (2) 2-volt

Cosmos valves; (3) one transformer-coupled L.F. and one resistance-capacity L.F.; (4) 90 volts H.T. instead of 120 volts.

The aerial is about 18ft. long, about 8 ft. above a lead roof, with 20-25 ft. lead-in, and a choice of earthing on a gas pipe or a water pipe on which a two-valve set downstairs is already earthed (neither of them really any use); and in addition there is Amberley Road power station about 300 yards away in a direct line.

In spite of the above difficulties, I can tune to these stations at almost any time:—

Good Loud-speaker Strength.—Vienna, Brussels, Aberdeen, Bournemouth, Langenberg, Frankfurt, Hamburg, Milan.

Moderate Loud-speaker Strength.—Zurich, Ecole Supérieure, Rome, Berne, Glasgow, Toulouse, Birmingham, Belfast, Dortmund,

and one or two more not yet finitely identified by name.

I think I have reason to be well pleased, and I would certainly have no hesitation in recommending anybody who is situated close to a local station which they have never yet succeeded in losing to follow my example and try the 1927 Five, upon which I can very sincerely congratulate you.—E. A. MEYER (London, W.9).

Any Station in Europe

SIR,—I feel I ought to write to you and express my very best wishes on the best set I have ever had or heard, and that is your 1927 Five. It is indeed a marvel.

Although I live within half-mile of the local station I can get any station in Europe—in fact I have had America on two nights. It is the ease with which these stations roll in within one degree of the dial. Thirty stations any night is a usual thing.

For the local station I turn both H.F. valves out and connect the aerial to the grid terminal of detector valve holder, using two valves, which are ample for the local station.

Again thanking you for your most excellent set and wishing you the very best of success in your future experiments.—W. CLARK (Hull).

LET US HEAR WHAT YOUR
"WIRELESS MAGAZINE" SET
WILL DO

Described in this article is a special type of high-tension battery that will appeal to many amateurs. It is not difficult to make, possesses a number of advantages over other types of batteries, and will give good service if properly constructed. All the parts can be easily renewed when necessary—and at low cost.

How to Make ■ A Wet ■ H.T. Battery

By the "Wireless Magazine"
 Technical Staff

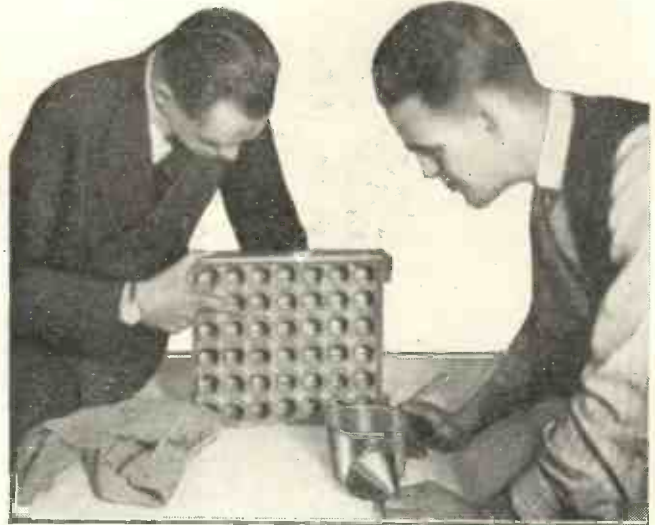

BY far the most expensive item in the maintenance bill of a modern multi-valve receiver is the high-tension supply, especially if this is obtained from dry cells, as is so often the case. There are, of course, alternative sources of supply—H.T. accumulators and mains battery eliminators, for example—that may not cost so much in actual upkeep, but these are in many instances prohibitive in first cost.

Leclanché Batteries

Recently, however, a fourth source of supply has become available to the home constructor, and that is the wet Leclanché-type H.T. battery. This is low in maintenance charges, and (comparatively) also in first cost. Moreover, if carefully constructed it will give satisfactory service with little attention.

There is, of course, nothing new in the principle of this form of H.T.

supply. As long ago as two years members of the Technical Staff of the WIRELESS MAGAZINE were experimenting with this type of battery. The reason why the construction of such a battery has not been described

zinc plates and make up one's own carbon elements.

Now, however, a number of firms specialise in making the necessary parts at a very reasonable price, and in this article the WIRELESS MAGAZINE Technical Staff is able to describe the construction of a satisfactory form of wet H.T. battery that will appeal to many amateurs. It has a voltage of approximately 120, and costs about £3 to build (this figure depends to a certain extent on the make of the actual components used).

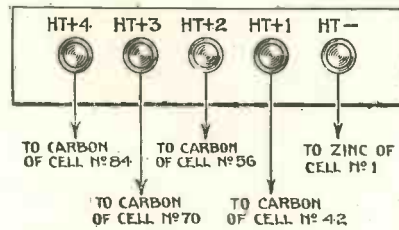

Terminal Connections.

in these pages before is because until comparatively recently there was considerable difficulty in obtaining suitable containing jars, and it was a laborious process to cut one's own

Action of Cell

It is hardly necessary to explain, of course, that a wet Leclanché cell consists of a glass containing jar, a zinc (negative) element, and a "sac" consisting of a depolarising agent packed round a carbon rod (positive). The electrolyte used is a solution of sal-ammoniac in water. This

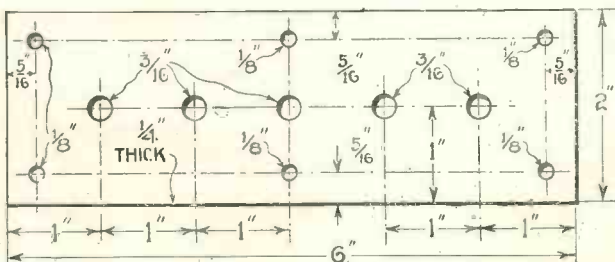

(Left).—Details of Terminal Strip.

(Right).—Filling Cells with Electrolyte to within 3/8 in. of the top.

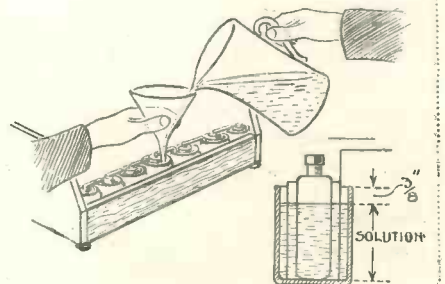

How to Make a Wet H.T. Battery (Continued)

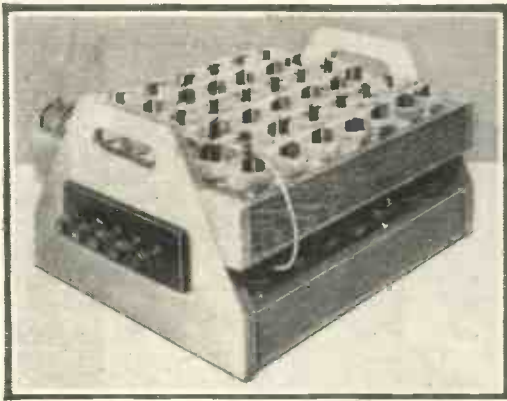

Completed Wet H.T. Battery.

is quite "safe," and will hardly harm the most delicate materials if accidentally spilled.

As is the case with any type of H.T. battery, the total plate current required by the set is an important factor, and one that cannot be given too much consideration. Most firms nowadays make the carbon elements for wet H.T. batteries in two sizes, the smaller size being suitable for loads up to 7 milliamperes, and the larger sizes for loads up to 15 milliamperes.

For Heavy Duty

In the case of the battery made up by the WIRELESS MAGAZINE Technical Staff—which was required for heavy duty with multi-valve receivers—the larger sacs were used, but it should be understood by the constructor that if his set *does not take more than 7 milliamperes total current in the plate circuits the smaller size of sacs is quite suitable.* The use of the smaller sacs results in a saving of about 10s.

From the photographs it will be observed that the battery is built up in two tiers for the sake of compactness, the top tier being easily removed from the wedge-shaped side pieces when it is desired to gain access to the lower tray. This is a special WIRELESS MAGAZINE design, and is believed to be an improvement on any existing type of container. As manufactured, the trays are finished off with special varnish that will prevent "creeping."

Tappings

Another feature of the battery is that it is tapped at approximately 60,

80, 100, and 120 volts. As a matter of fact, the zinc elements are drilled to accommodate a wander plug at any point in the battery; the system of fixed tappings means, however, that the electrolyte is less likely to be disturbed, and therefore that the battery will give better service and longer life.

For the construction of a 120-volt battery for supplying plate currents up to 15 milliamperes

the following components are required:—

- 84 glass jars with waxed tops (Wet H.T. Battery Co.).
- 84 zinc elements (Wet H.T. Battery Co.).
- 80 No. 2 sacs (Wet H.T. Battery Co.).
- 4 No. 2 sacs with terminals (Wet H.T. Battery Co.).
- 2 small brass terminals (Economic Electric).
- Two-tier container (Carrington).

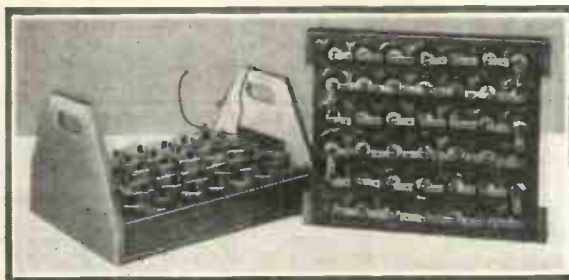

View of Wet H.T. Battery, Showing Sequence of Wiring.

- Ebonite strip, 6 in. by 2 in. (Becol).
- 5 terminals:— H.T.—, H.T.+1, H.T.+2, H.T.+3, H.T.+4 (Belling-Lee).
- 1½ lb. paraffin wax (Economic Electric).
- 1 yd. 2-mm. rubber-covered flex (Economic Electric).
- 7 spade tags (Collett).
- 7 boxes of rubber bands for No. 2 sacs (Wet H.T. Battery Co.).
- 4 bottles and packets of electrolyte (Wet H.T. Battery Co.).
- 6 ½-in. No. 4 brass wood-screws (Economic Electric).

As mentioned before, if the battery is required only to supply plate currents not exceeding 7 milliamperes No. 1 sacs can be substituted, with a consequent saving in cost.

Having obtained all the necessary materials, the first step is to place

the glass jars in position in the trays. It will be seen that the jars are equally divided, 42 being placed in each tray.

It is important to place the jars in the trays so that the spaces between them are equal. When this has been done melt ¾ lb. of paraffin wax in an old saucepan (take care that it does not ignite in the process) and pour it into one of the trays. The wax will set quickly, when it will be found that the jars are held firmly in position. Pour the second ¾ lb. of paraffin wax into the second tray in a similar way.

Preventing "Creeping"

The object of pouring the wax into the trays in this way is not, of course, merely to hold the jars in position, although that is an advantage. The primary object is to prevent "creeping" of the electrolyte between the jars.

Alternatively, it is suggested that wooden separating strips might be used—similar in style to the familiar type of egg box with divisions.

Next take all the zincs and "tin" them with a soldering bit on the underside of the connecting strips round the holes. It is also necessary to clean and tin the brass caps on the sacs. For this purpose a non-corrosive paste, such as Fluxite, is

recommended for easy working.

When this has been accomplished the zincs can be slipped into the jars. In some cases it will be found that to get them into the mouth it is necessary to press the free edges together. When in the jars the zincs will open out again and grip the sides of the glass. It is desirable that this should occur in the case of every cell.

Rubber Bands

After this two rubber bands should be placed round each sac, at the top and bottom respectively. The sacs can then be placed in the jars. The positions of the sacs with terminals for taking tappings can be seen from the diagram of the terminal strip.

An Exclusive "Wireless Magazine" Design

When all the zincs and sacs are in position they can be connected up. This is accomplished by placing the zinc connecting strip of one cell over the carbon cap of the sac in the next cell, putting a little Fluxite between them, and touching them with a hot soldering bit. If they were well tinned, as mentioned previously, a good electrical and mechanical joint will result.

In the case of the sacs with terminals the appropriate zincs can be screwed in position.

Terminal Leads

Next, leads should be taken from the appropriate terminals on the ebonite strip (see diagram) ready for attaching to the cells. When the tapping leads have been soldered to the terminals, the slot in the side wood support can be filled with paraffin wax, again to prevent creeping and corrosion. (It will be obvious that the tapping points can be altered, if desired, by placing the sacs with terminals at different points from those shown in the diagram.)

Make up the electrolyte solution according to the manufacturer's instructions (if desired a solution of 6 oz. sal-ammoniac and 4 oz. zinc chloride to a pint of water can be

used), and pour it into the glass jars, taking particular care not to spill any over the trays. A small glass funnel should be used.

Do not fill the jars right up at first, as the sacs expand when they are thoroughly wet. When the sacs have swollen the solution should come to within $\frac{3}{8}$ in. of the tops of the jars.

To prevent evaporation it is desirable to pour a small quantity of thin oil, such as cycle or machine oil, over the electrolyte in each jar. It is also essential for satisfactory working to smear a little vaseline over each zinc connecting strip and brass cap—in fact, over all exposed metal parts. These precautions *must* be taken to prevent creeping.

A slightly more efficient method of protecting the metal parts is to take each pair of zincs and sacs out of the cells, invert them, and dip the top parts into molten paraffin wax.

In use it is desirable to move the battery about as little as possible and to keep it in a cool place. From time to time the battery should be tested with a high-reading high-resistance

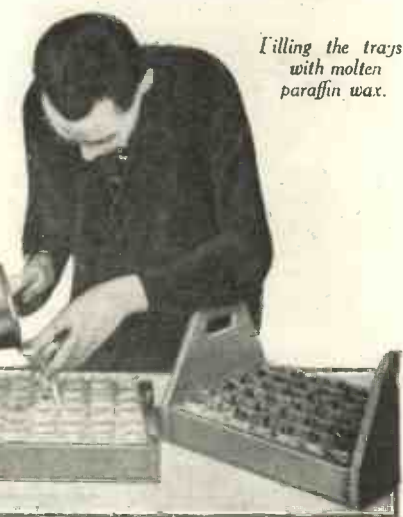

voltmeter. Fresh electrolyte should be placed in the jars when the voltage of each cell has fallen to about 1.

Batteries of this type, when run within their capacity, will give a steady discharge for a considerable number of hours.

Not Irksome to Make

To the "let's-listen-quick" type of constructor it may seem that the making of such a battery is a laborious job, but actually there is nothing very irksome about it if things are done systematically. But it is certain that the constructor who takes the most trouble over the work will be rewarded with the most satisfactory and efficient battery.

To those who *are* prepared to take a little more trouble than usual over constructional work, we can promise a satisfactory battery that is inexpensive in upkeep and adequate in output.

A RADIO poet has expressed himself as follows:—

I've heard the moans of the saxophones,
But sweeter than pipes of Pan
Was to hear my neighbour's radio
going —
Going away in a van.

The best definition of oscillation is *vandalism*.

THE U.S.A. station WIZ is always active. Whenever one listens on its wavelength melody, music, and mirth are one's lot. Before every item one can hear "ABC calling." This is evidently whizzing the alphabet.

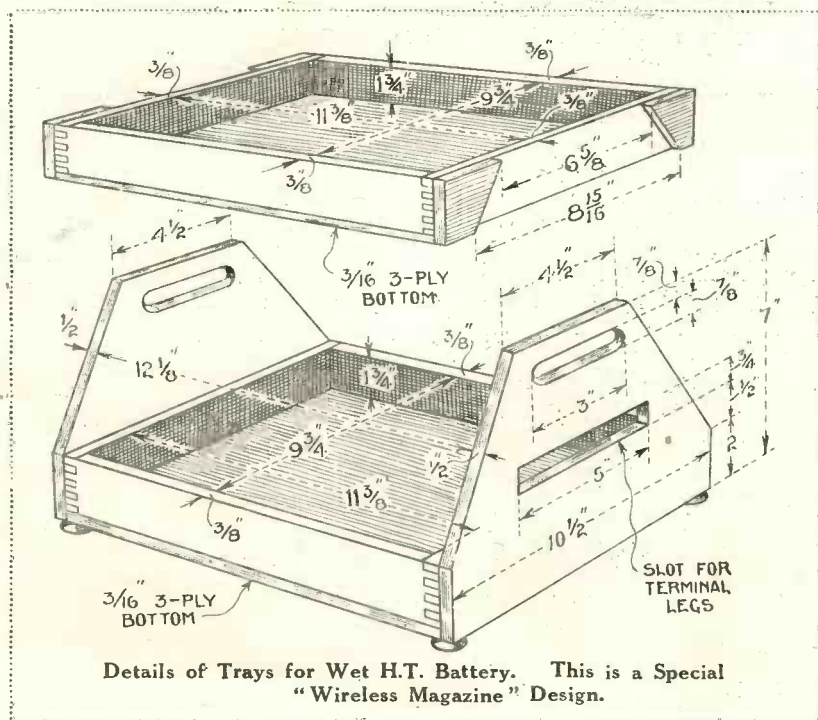

Details of Trays for Wet H.T. Battery. This is a Special "Wireless Magazine" Design.



Mr. Herbert Fryer.

Broadcast Music

Reviewed for the "Wireless"

"STUNTS"
SINGERS
SPEAKERS
CELLISTS

DURING the past weeks there have been many performances which might well be termed "stunts" put over by the B.B.C., such as many and almost superfluous "running commentaries" on various football and cricket matches, the Royal Military Tournament at Olympia, and the Welsh miner's programme from Cardiff, when part of the transmission was announced to take place from the actual pit.

The programmes have been framed so as to include many of the early broadcasters as well as newcomers to the microphone.

Some Great Names

Such names as those of Sir Dan Godfrey (whose concerts at the Winter Gardens, Bournemouth, have become of national importance), Nelson Keys (the well-known actor), Stanislaus Niedzielski (the pianist and pupil of Paderewski), Norman Allin, Leonard Gowings and Miriam Licette need no further comment—one and all are giants in their art, both on the concert and operatic platforms as well as over the ether.

Amongst the singers mention must be made of Mary Jarred, for she is one of the best-known singers in the provinces; although she only began studying the art in 1918 she has gained the highest diplomas and, apart from her concert work, has broadcast from the principal stations, singing on Good Friday with Frank Mullings.



Miss Helen Maclean.

Miss Florence Cleeton is a soprano who possesses that rare musical gift—a natural voice, and she has been singing since the age of five years, when she made her first public appearance. Since the era of broadcasting she has become one of the leading artists at the Birmingham station and has given well over fifty recitals for the B.B.C.

Mme. Edith Gunter

Another singer who has contributed largely to the programmes is Edith Gunter, principally from Cardiff station, where she has broadcast some three hundred songs already. A pupil of Alberto Randegger (jnr.), she

Miss Ethel Williams.



has acquired a facile range and a repertoire that not only includes over fifty oratorios and operas, but the type of song that made her one of the most popular artists in Miss Lena Ashwell's Concert Parties at the Front during the Great War.

Mme. Gunter's favourite work, however, is that of oratorio singing, and she

is heard this month in *A Tale of Old Japan* (Coleridge Taylor) and *Ode to St. Cecilia* (Sir H. Parry), besides in other performances. In London she has been heard at Queen's Hall and Albert Hall, and she has also been heard at the Welsh National Eisteddfod concerts.

From the Manchester Station

Miss Margery Farnham, who is heard most frequently from the Manchester station, may be almost reckoned as the youngest operatic *prima donna* for, after singing the soprano solos in Handel's *Messiah* when only sixteen, the following year she toured the provinces in Joseph O'Mara's opera company, playing the principal



Miss Mary Jarred.



Mr. Walter Glynn.



Miss Rita Sharpe.



Mr. Sidney Crook

of the Month

Magazine" by **STUDIUS**

rôles in *Faust*, *Maritana*, *The Lily of Killarney*, and others. She is one of the most popular of broadcasters also.

A Principal Contralto

Miss Ethel Williams, a well-known Birmingham singer, began her career as a pianist, "winning her spurs" at Trinity College, but later, turning singer, she became principal contralto in the big oratorios in the Midlands, and then afterwards became a member of the Repertory Company of the Birmingham station. Here, too, she is a popular member of the Children's Hour, known as Cousin Ethel. Miss Williams gives many recitals as a pianist, while she is also principal contralto at one of the big Handsworth churches.

At 2LO, amongst the singers, have been announced many famous names, including Dora Labbette and Muriel Brunskill (of the B.N.O.C.), who joined issues with Spencer Thomas and Rex Palmer in the production of Mendelssohn's oratorio *Elijah*, while others are Esther Coleman, Doris Vane, Frederick Ranalow and Joan Elves.

In a plethora of talkers there have been a few to whom it was a real pleasure to listen. Amongst these mention may be made of Mr. George Dodds, L.R.A.M. As regards broadcasting interest, he is a member of the Musical Advisory Committee, Newcastle, and his illustrated talks on orchestral instruments, as well as on various sections of vocal art, have proved of immense value.

Jarrow Philharmonic Society

He is widely known as a conductor, notably of the Jarrow Philharmonic Society, and as a writer.



Mr. George Dodds.



Miss Florence Cleeton.

CONCERTS
PIANISTS
SKETCHES
VARIETY

Up in the north, from the Glasgow station, the sketches and talks of Miss Helen Mitchell are warmly appreciated. She is one of the few writers who believe that their native Doric should be preserved and has worked hard to this end. Many of her sketches will probably be heard in the future. At Glasgow, where she has run her series of "Granny Ferguson," or the "Knockendoch" Series, she is assisted by Mr. Augustus Beddie.

A Northern Elocutionist

Another northern elocutionist is Miss Helen Alexa Maclean, a daughter of the Rt. Rev. Dr. Maclean, Chaplain-in-Ordinary to the King, and a famous literary man also. Miss Maclean has inherited some of her father's gifts; she has broadcast from the Glasgow studio sketches of life in the Hebrides.

Amongst the instrumentalists we have had, of course, many well-known names, including Mr. Percy Kahn (the composer-pianist), Arthur Caterall (the late leader of the Hallé Orchestra), Rita Sharpe (the charming young cellist and one of the earliest of 2LO's cellists).

There is also a very young member who will make a name for herself, for Miss Ethel Jowsey is but sixteen, yet already a violinist of repute up in the Midlands. A winner of the Achille Rivarde scholarship, she became his pupil and later



Miss Helen Mitchell.



Miss Ethel Jowsey.



Sir Dan Godfrey.



Mme. Edith Gunter.



Mr. Osmond Sans.

Broadcast Music of the Month (Continued)



Mr. Philip Bertram.



Miss Margery Farnham.



Miss Joan Elwes.



Saint-Saëns.

returned to Newcastle, where she has broadcast many times. Clearly she has a future before her.

Concerted Music

Amongst the concerted-music performers, the Victor Olof Sextet is well liked. Led by Mr. Olof himself it includes a pianist who made his *début* on the classical concert platform at Wigmore Hall, namely, Mr. Sidney Crook. He has developed his ability so that he can turn from the classics to popular music with equal skill.

The Kneller Hall Military Band, which has been heard on so many occasions, was the subject also of an

interesting talk by its late commander, Colonel Somerville.

Many special programmes have been devoted to composers, one of the best being a Saint-Saëns programme. Camille Saint-Saëns was a French organist as well as composer, and "Softly Awakes my Heart" from his opera *Samson and Delilah* was known over here as a song, for concert singers, long before the actual opera achieved such success.

Variety and dramatic excerpts seem to be on the increase, though it is a pity to inflict so much syncopated sounds upon us, and variety turns which in many cases would not be tolerated by the average music-hall

audience because of their sheer inanity.

Amongst the "plums" possibly may be reckoned a performance of *The Arcadians* for lovers of the old-time musical comedy, *The Policeman's Serenade*, a little grand opera from *Riverside Nights*, and *The Importance of Being Earnest*, Oscar Wilde's comedy, produced for broadcasting purposes by Howard Rose.

Unknown and Unwanted

For the rest there are still too many unknowns and unwanteds, and inaudible discussions on things that don't matter either to the talker or the unhappy listener. STUDIOS.

Heard Over the Ether

From 2LO (News Bulletin)

AN announcer's three unsuccessful attempts to say "absolute discretionary powers."

The word amateur pronounced *amatir*.

"— will follow in half a minute," and it took three and three-quarter minutes.

Amatir pianoforte selections after Daventry shipping forecast.

From Radio Agen

Very frequent references to wine lists and prices.

Numerous advertisements.

The poorest music in Europe's radio programmes.

The dominance of the church in the programme.

Sly references to the State.

The orchestra playing *Men of Harlech* like a funeral march.

From Kristinehamn (SMTY)

A mouth-organ soloist.

A tin whistler.

A bone-clapper entertainer.

A discordant violin duet.

A most original love dialogue—the man who acted the woman's part could not disguise his voice.

From Paris (Radio Nituo)

Highbrow concerts:

Highbrow talks.

More highbrow talks.

Highbrow dances.

Highbrow music.

Highbrow news.

From Orebro

A talk on woollens.

Market quotations of Orebro woollens.

An official announcement asking listeners to buy home-made woollens.

A doctor's talk which tried to show the advantages of wearing woollens rather than silk and other materials.

An orchestral symphony the title of which sounded like "Woollensia." It was not a fox-trot.

E. B. R.

About the Loftin-White Circuit

By J. H. REYNER, B.Sc., A.M.I.E.E., Technical Editor

In his article last month J. H. Reyner referred to the constant-coupling principle, which has been described both theoretically and practically in "Amateur Wireless" for some considerable time past. This article has been specially written to give WIRELESS MAGAZINE readers a résumé of the principles underlying this development and the practical information which our Technical Editor has discovered in his researches on the subject.

ONE of the most outstanding developments of recent times has been that of the constant-coupled non-reactive circuit, which was first brought to perfection by E. H. Loftin and S. Y. White, two American radio engineers.

The neutralised circuit has held sway for some considerable time, and some exceedingly efficient and selective circuits have been constructed, utilising the methods suggested by Rice, Hazeltine, and others. There were, however, one or two disadvantages which were associated with the neutralised circuit.

Apart from difficulties arising from the necessity for modifying the adjustments if the valves were replaced by those of another type, or even in some cases if the coils were changed for those of another wavelength band, difficulties arose, particularly with the Rice method of neutralisation, owing to parasitic oscillation and similar difficulties.

Finally, all the usual types of circuits suffered to a greater or less extent from the difficulty that they were not uniformly sensitive over the whole of the tuning range.

Variable Coupling

Efforts have been made to remedy the lack of uniform sensitivity in various quarters. In America there was the Karas Equamatic system, which employed a variable coupling

between the primary and the secondary of the transformers, the primary winding being mounted on an extension of the condenser itself. This system was not neutralised, and was stabilised by a form of loss method.

The Hammarlund-Roberts Hi-Q receiver embodied the principle of the variably-coupled transformer, but utilised neutralisation on the split-primary principle, as we call it in this country, for obtaining stability. This, combined with complete shielding of the individual stages, has resulted in a receiver of high performance.

In this country use has been made of the variably-coupled principle in the Cyldon Paradyne unit, which differs from the other two, however, in that it uses a phasal form of stabilisation, the anode circuit being so

this gives more satisfactory results in many ways than neutralisation.

Loftin himself lays great stress on this aspect of the question, and considers that what he terms the *non-reactive plate circuit feature* is, if anything, rather more important than the constant-coupled effect.

Energy Transfer

In any high-frequency transformer circuit currents flow in the primary winding, and voltages are produced in the secondary winding due to the mutual coupling between the windings. In the case of the ordinary magnetic coupling the voltage induced by a given current depends directly upon the frequency. Thus as we increase the wavelength by increasing the tuning capacity we decrease the frequency and we decrease the voltage induced into the secondary for a given primary current.

In other words the receiver is less lively on the top end of the capacity scale than it is at the bottom.

This is a simple explanation of why any variation takes place. There are certain secondary effects due to the interdependence of the valve and the circuit which follows it. The actual amplification obtained from any valve depends upon the relative impedance of the

anode circuit, and in a high-frequency transformer, due to the variable condenser which is employed for tuning purposes, the impedance of the whole circuit is continually varying.

This, in turn, gives rise to a varying amplification from the preceding valve, which is a secondary effect also tending to lack of uniformity in amplification over the whole of the tuning range.

Electrical Variation

Now, what may be termed the mechanically-variable system overcomes this lack of uniformity by rotating the primary winding upon an axis, so that the magnetic coupling between the primary and secondary coils is definitely increased as the tuning

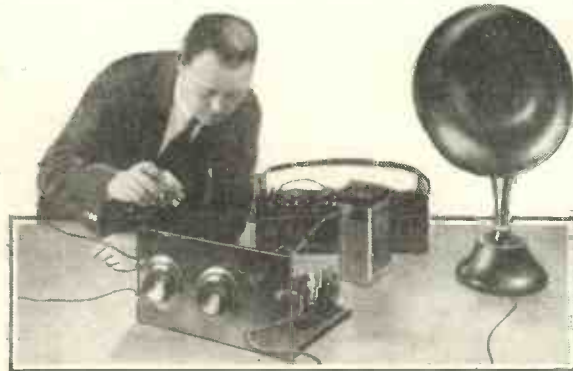

J. H. Reyner's latest constant-coupled development—the M.C. Three Star. This was described in "Amateur Wireless," dated May 7.

arranged that the valves have no tendency to oscillate, whilst still remaining perfectly efficient.

This method of phasal stabilisation is one of the principal features of the Loftin-White circuit, although it is applied in a somewhat different manner. The constant-coupled circuits which have been embodied in the popular M.C. receivers obtain a uniform sensitivity by having an electrically variable coupling instead of a mechanical adjustment, and at the same time it utilises a phasal stabilisation.

The constant-coupling principle could be applied quite satisfactorily to neutralised circuits, but the constant sensitivity of the circuit enables phasal stabilisation to be used, and

About the Loftin-White Circuit (Continued)

capacity is increased, and by a suitable mechanical adjustment, combined with correct design of the electrical portion of the equipment, a constant sensitivity can be obtained over the whole of the scale.

No Mechanical Variation

In this particular case we wish to achieve the same result without a mechanical variation, and the only variable factor in the whole of the circuit is the condenser. It is necessary, therefore, to utilise this variation in some manner in order to produce the necessary constant-coupled effect.

Nearly a year ago I tried out a number of circuits designed to make some use of the variation of the tuning condenser in order to produce constant activity. It will be clear that in order to do this some form of capacity coupling must be adopted in place of the usual magnetic coupling, and a circuit employing what may be termed a capacity transformer is given in Fig. 1.

Here it will be seen that, in place of the usual primary winding, the anode circuit of the previous valve is tapped across a fixed condenser. This condenser is a part of the tuned circuit, and the actual tuning is accomplished by a variable condenser in series with the fixed condenser, the whole being connected across the tuning coil, which in this case is the secondary winding.

Currents in the anode circuit will flow through this fixed condenser and will develop a voltage across it which, in turn, will set up voltages in the secondary circuit, thus handing on energy similarly to an ordinary transformer.

Capacity Transformers

The energy transfer in this capacity transformer will depend upon the ratios of the capacities in circuit. Moreover, when dealing with this type of circuit it must be remembered that the voltage developed across a given capacity is *inversely* proportional to the value of the capacity itself. Thus, as we increase the capacity the voltage developed across it decreases.

In the limit, when we increase the capacity so much that it becomes infinite, or, in other words, a short-

circuit, then the voltage developed across it will also become infinitely small, or, in other words, zero.

Suppose, therefore, that in the particular circuit shown the two condensers are equal in capacity when the tuning condenser is at its maximum position. We shall then have the equivalent of a centre tapping, and this would give a fairly tight

of which remains the same as before. In other words, we have divided the voltage in an unequal ratio, the voltage across the fixed condenser being now definitely less than half, so that we have, in effect, weakened the coupling between the primary and secondary.

This is just what we require, since it results in a smaller transfer of energy which counteracts the tendency to increase in liveliness on the higher frequencies.

Suitable Values

It is possible to arrange a capacity transformer in this manner which will give a fairly constant transfer of energy over the whole of the frequency scale covered by the variable condenser, but, in order to achieve this result, it is necessary to utilise a somewhat small value of fixed condenser, which seriously restricts the tuning range. If, on the other hand, the value of the fixed condenser is made five or six times as large as that of the variable condenser, then the tuning range is hardly affected at all, but we no longer obtain a constant transfer of energy.

The net result in such a case would be that the circuit tended to oscillate more readily on the longer wavelengths, that is, towards the top of the tuning scale, which is the exact opposite of the normal state of affairs in a magnetically coupled arrangement.

Solution of the Difficulty

The solution of the difficulty, therefore, which is the basis of the Loftin-White arrangement, incorporates both forms of coupling. A small magnetic coupling is introduced of such a size and such a direction that it will exactly counteract the effect of the capacity coupling, with the result that a uniform coupling is obtained over the whole scale (Fig. 2).

At the lower end of the scale the magnetic coupling predominates, while as the tuning capacity is increased the magnetic effect falls off and the capacity effect increases, the two being so designed that they maintain the amplification at a uniform level.

This is the first feature of the arrangement, and it follows that with

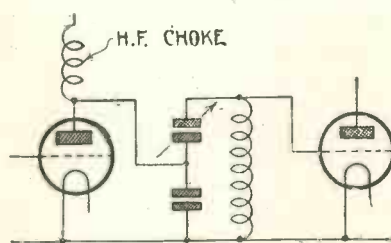

Fig. 1.—"Capacity Transformer Coupling."

coupling. Suppose now that we reduce the capacity of the condenser. This would increase the frequency of the circuit, and, with a normal arrangement, the energy transfer would increase more or less proportionally, so that the circuit would become much more lively.

If, therefore, we had arranged to stabilise the circuit by some suitable means in the maximum position, then it is quite possible that it would develop self-oscillation at the lower end of the scale.

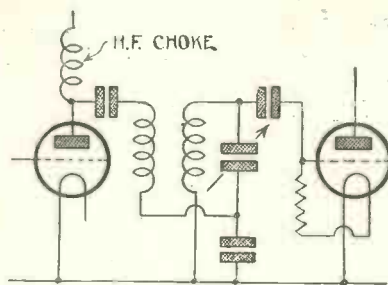

Fig. 2.—Loftin-White Circuit.

With the capacity-transformer arrangement shown, however, we have made the tuning condenser smaller, and therefore the voltage developed across it will be greater than that across the fixed condenser, the value

suitable design the usual reaction controls can be dispensed with. In my interpretation of this principle I have not cut out this reaction control altogether, but have provided a small tickler condenser by which the receiver may be brought to the most sensitive condition.

Sensitive Over Whole Scale

It is then found that, by utilising this system of coupling, the receiver remains sensitive over the whole scale, and tuning is a simple matter of rotating the condenser dials, no further adjustments being required. For a commercial receiver which can be balanced up and where the layout is under exact control, it is possible to dispense with reaction altogether, and this, of course, is what is being done in the complete receivers made in America which incorporate this principle.

It is because of this constancy of coupling that one is able to obtain the second feature of the system, namely, the possibility of stabilising the circuit without neutralising. As I mentioned previously, Loftin himself considers this is a very important aspect of the question, although it is really a corollary of the constant-coupling principle itself.

As is well known oscillation occurs in ordinary high-frequency circuits due to the feed-back of energy through the inter-electrode capacity of the valve. The direction and to some extent the intensity of this feed-back, however, depend almost entirely upon the nature of the anode circuit. With the ordinary transformers in use, that is, an anode circuit which is inductive in character, the feed-back is positive, and therefore will tend to cause oscillation.

If the anode circuit is resistive the feed-back is neutral, and has neither one effect nor the other, being out of phase the whole time; if the anode circuit is made capacitive, the feed-back is negative, and tends to damp out oscillation rather than to produce it.

Loftin-White "Phaser"

The complete Loftin-White circuit inserts a phasing condenser in the feed from the anode of the valve to the mixed-coupled transformer, the value of this condenser being so arranged that the anode circuit is non-inductive or just capacitive. In such circumstances the circuit is perfectly stable, and there is no ten-

dency to feed-back through the valve, irrespective of the valve in use.

This principle can be applied quite easily to any ordinary circuit, but normally the particular balance necessary to obtain a non-inductive anode circuit applies only for one particular frequency. Owing to the constant-coupled effect, however, in the Loftin-White arrangement, the balance, once found, applies over the whole of the tuning scale, and therefore the circuit remains not only effi-

Things To Know About Dry-cell H.T. Batteries

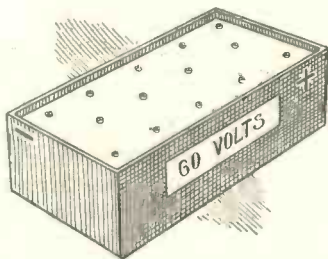

WHEN electrons leave the filament of a valve they will not proceed to the plate, as is desired, unless this latter is at a considerable positive potential with respect to the filament. Consequently it becomes necessary to connect a high-voltage or "high-tension" battery between the filament and the plate to establish this difference of potential.

The voltage of this battery usually varies between 60 and 120 volts (the latter voltage being required by most power valves) but the current that is taken from this battery is very minute. It is therefore possible to construct a suitable battery by connecting a number of small cells in series with each other.

The illustration shows a common form of H.T. battery which contains a number of small dry cells, similar to those used in flash-lamp batteries, all connected in series. Any desired voltage, up to the voltage of the battery, can be obtained by inserting wander-plugs in the sockets shown.

cient but stable throughout the whole of the tuning range.

This is a point of the utmost importance, because it means that the circuit can be designed to give stable and efficient amplification irrespective of the valves in use, and therefore if one valve is changed for another type the circuit does not necessarily

become unstable. There may be a difference in the performance due to the relative suitability of the various classes of valves, and there is also the question of minor interaction between the various circuits, so that in some cases replacement of one valve by another will actually cause oscillation, but this is not due to the circuit itself but to stray coupling effect.

H.F. Problems Solved

This circuit, therefore, seems to offer a solution to the problem of the high-frequency circuits, for we are able to obtain stable and efficient amplification without the necessity of neutralising with the attendant disadvantages which are introduced by this method, and, in addition, we have the advantage of a uniform sensitivity and selectivity, neither of which is obtainable by the ordinary methods except by going to a fair amount of trouble.

Those readers who are interested in more precise details, including practical descriptions of receivers incorporating this principle, should refer to "Amateur Wireless."

Making the Lead-in Connection

WHEN only a short span is available it is often of advantage to use a multi-wire aerial, spacing the various wires well apart. These wires should only be joined together at the point where they meet at the lead-in tube.

Simple Connector

Some difficulty may be encountered in connecting all the wires satisfactorily to the lead-in terminal unless some form of connection is provided. A simple but efficient connector can be made from a short length of copper tube. The inside of the tube should be cleaned, as should also the ends of the wires. The ends of the wires should be forced into one end of the tube and soldered in position.

The other end of the tube can then be hammered out flat and a hole drilled in it through which the brass rod of the lead-in insulator can be passed. The terminal nut, when screwed down on the flattened tube, will ensure a good connection.

M. P. S.

Captain Jack Frost, M.I.R.E., Explains Some Facts About—

LOST SIGNALS



IN this life one loses many things, from trains to collar studs. But have you ever lost signal strength owing to something unknown taking power from the wireless wave before it gets to your aerial? Are you a sufferer from screening? You may be and hardly realise it. Yet you may wonder as to why it is that your neighbour, with a no more efficient receiving set than your own, and with an aerial which is certainly no better than yours, gets louder signals and a greater number of distant stations than you do. It may be that screening is at the root of your trouble.

Conducting Materials

There is electrical energy within the ether wave which comes to you from the local broadcast station and Daventry. Some substances offer an easier path to electric currents than others do, and, because of this, are called good conductors. Copper, iron, water, or anything saturated with water, and the sap of trees, are all good conductors of electricity.

Those substances which offer more resistance to an electric current, and which allow electricity to pass through them only with difficulty, are called bad conductors or insulators. Porcelain, dry wood, and brick, ebonite, paper, and cloth are all bad conductors. Hence the name given to those insulators upon your aerial.

Never Interrupted

There is one peculiar thing about that wireless wave which comes to you with its burden of music and speech, and that is that nothing really and truly ever interrupts its progress. Everything which we call a solid, liquid, or a gas, is composed

of atoms which are, in turn, made up of other things, the smallest known "particles" of electricity, electrons and protons.

These little fellows are so very small that they form within the atom a miniature solar system all complete with sun and planets revolving around that sun. In the case of the atom, the "sun" is the central nucleus, whilst the "planets" are the electrons and protons circling around the nucleus.

Great spaces divide our earth from its brother planets and from the sun of our solar system, spaces which we regard as enormous, comparatively speaking. Similarly, the spaces within the atom which divide the electrons and protons from each other, and both from their central nucleus, are immense when compared to the size of those units. But there is space, that is what I want to get at.

"Spaces" Everywhere

Now, if all solids, liquids and gases are made up of those little solar systems, which contain more space than "units," it follows that the buildings in which we work and dwell, the table upon which we place our eatables, so solid to our eyes, have, in reality, spaces through which we could see were our eyes, sufficiently microscopic.

The scientist tells us that all of this so-called "space" between the planets and the sun, and between the electrons and protons of each and every atom, is filled, not with nothingness, but with ether. A little thought will show that, as everything which we call material is enclosed and compassed about by space through which our old world rolls along, the ether which fills the heavenly spaces has continuity with

that which fills the "space" within the atoms of which everything is composed.

Trifling Obstructions

A wave set up within that wonderful ether, just as a wave is set up upon the surface of the Atlantic Ocean, would not suffer interruption in its passage from place to place by such a trifling thing as a house or building. Because "space," because ether, has this wonderful continuity, an inside aerial, even when all doors and windows are closed, is able to pick up the energy from the wave and to convey to us the sounds made in front of the broadcasting microphone.

The wireless wave, being a wave within the ether, is not dismayed by the barred window and door, nor even by the "solid" brick wall. But suppose that when the building was erected a steel frame was used, and that the electrically charged wireless wave, to affect the inside aerial, had to pass through the space within the atoms of the steel as well as of the brick and wood work? Dry wood and dry brick are bad conductors of electricity, and, because of that the ether wave, in passing through them, loses none of its electric charge.

Charge Left Behind

But when it is required to affect an inside aerial placed within a steel-framed building, or behind a belt of high trees with sap, a good conductor of electricity, flowing in them, some of the electric charge will be left behind upon the steel or iron of the building, leaving less for the aerial sheltering behind. In other words, screening has taken place.

If your aerial happens to be the one within that steel-framed building or

with that belt of trees between it and the wireless station from which you desire reception it will not give as good results as it might otherwise do. It cannot give to your receiving-set the energy which it does not receive, and your reception strength suffers. I know of two people who live within twenty yards of each other. The first has a good aerial, but it is unavoidably "screened" by trees which are higher than itself. The second has a good aerial, too, but is not in the unfortunate position with the trees which the first man is. The difference of power and of range of reception would hardly be represented by the effect of the addition of a power valve to the receiver belonging to number one! Yet he can do nothing except cut down the trees.

Iron and steel, the sap of trees, water or anything which is saturated with it, will all "screen." One aerial may screen another if it is higher than, or above, the other. It is often a case of give and take with folk who live in adjoining houses.

Aerials must needs be close to one another, but they need not be parallel, nor need one be so much higher than the other that screening results.

Ware screening, then, if any amount of wariness upon your part can alter matters. If you are under the shadow of a great steel-framed building and that happens to be between your aerial and 2LO, then you can hardly demolish the "screen," can you?

AN advertiser in one of the wireless papers states that his set is guaranteed to give satisfaction even when there are tramcars in the vicinity. One has heard of sleuth-vans equipped with a receiver.

THE Rev. Bernard Walke, Vicar of St. Hilary, near Marazion, Cornwall, wrote thanking the B.B.C. for the fine response to the appeal on behalf of the St. Hilary Cornish Home for Children. He stated that about £1,000 had been received. What a wonderful receiver to have!

Inserting Screws

WHEN several components are mounted close together difficulty is often experienced in holding the small wood-screws, which are to secure the components to the base-board, until they "bite" into the wood.

One way of doing this is to pass a screw through the end of a strip of thin cardboard, the other end of this strip being held in the left hand while the screwdriver is manipulated with the right. When the screw is nearly home the cardboard can easily be torn away.

Another way is to secure the screw to the end of the screwdriver with a little Chatterton's compound which will hold the screw in place until it is started. There will, however, be no difficulty in detaching the screwdriver after the screw has been driven home.

B. S. V.

Music Wherever We Go!

Public-speech Outfit and
Community Singing



Although the football season has ended it is likely that the fine weather will result in an increase rather than in a decrease of interest in community singing. These photographs show how Graham Amplion public-speech outfits—consisting of microphone, valve amplifier and practically any number of loud-speakers—is used for leading the singing of large assemblies of people.

of the H.T. battery were increased by 36 volts.

Typical Circuit

The circuit given in Fig. 2 will illustrate the arrangement clearly. Here the filament of each valve is heated by a separate L.T. battery. Those people who use a 4-volt accumulator with the cells in parallel for 2-volt valves have only to use the two cells of the battery separately if they wish to try the arrangement.

It may be regarded as an inconvenience to have to use a separate source of L.T. supply for each of the valves and a rather high-voltage H.T. battery, though this is a small price to pay for almost perfect reception. However, even one L.T. accumulator and a normal H.T. battery are considered by many people to be a nuisance, and consequently the derivation of the L.T. and H.T. supply from the electric-lighting mains is becoming more general.

Either A.C. or D.C. mains can be used for this purpose. If the supply is A.C. it has first to be rectified, when, of course, it becomes D.C. So that if we consider the case of a D.C. supply, the same method, with the addition of a suitable rectifier, can be applied to A.C.

When a D.C. supply of 200 volts or so is available, the use of direct coupling between one valve and the next becomes a very simple matter—much more simple, in fact, than when ordinary couplings are used.

Study the diagram of any three-valve set designed to work entirely from the mains, and then look at

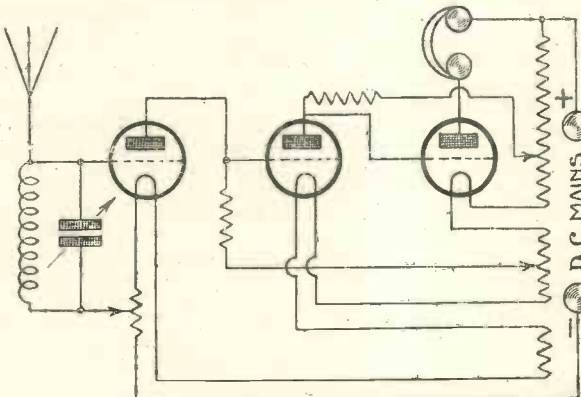

Fig. 3.—Three-valve Mains Circuit Based on New Method.

Fig. 3. Which is the simpler diagram? Here the filaments of the valves are connected in series with a number of resistances, the values of which are so calculated that exactly the correct current for the filaments is allowed to flow through them. It is necessary, of course, that all three valves should have the same filament current requirements.

The resistances, besides limiting the current which flows through the filaments, also serve as a potential divider; and if the plate circuits of the valves are connected to suitable

tapping points, the potentials of all the electrodes of each of the valves will be such that all three valves are worked at fullest efficiency.

The results obtained with a set built to this circuit were really remarkable. The volume was great—too much on the local station unless a frame aerial was used—while the purity of reproduction was really excellent.

A very important point was that, although no smoothing device of any kind was used, not the slightest suspicion of commutator-ripple could be heard

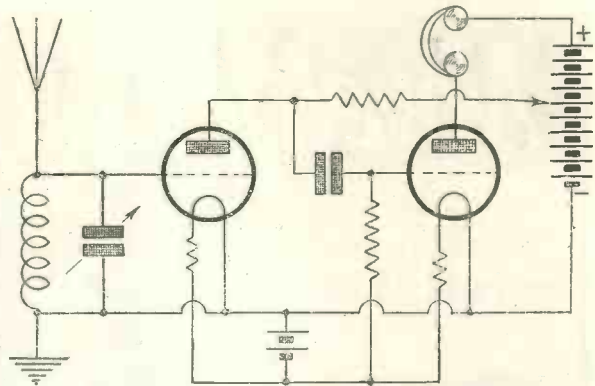

Fig. 1.—Ordinary R.C. Coupled Circuit.

when once the set was properly adjusted.

It might be thought that large-capacity fixed condensers connected between the filaments and the variousappings on the resistances would be an improvement, but such condensers were found to be quite unnecessary in practice—in fact, not a single fixed condenser was used in the set.

No earth connection was required as the negative main was earthed, and the resistance of this ready-made "earth" must have been extraordinarily low, so good were the results.

The fact that no smoothing device was required may be explained as follows: When it is attempted to obtain the H.T. current for a valve set from the mains in the usual way, any variation in the voltage of the mains alters the potential of the plates of the valves with respect to the filaments and grids, and as this is done at audible frequency the familiar commutator-ripple is heard.

Nearly Cancelled Out

As a glance at Fig. 3 will show, when the voltage of the mains varies it affects the potentials of the plates, grids, and filaments of the valves. These variations do not quite cancel out, but they do so to a very considerable extent, sufficient to reduce the "ripple" to inaudibility.

The new address of the "Wireless Magazine" is:—
58-61, Fetter Lane, E.C.4.

Novelties and New Apparatus

TESTED BY THE
TECHNICAL EDITOR
J. H. REYNER
B.Sc. (HONS.), A.M.I.E.E.



A CORNER OF THE
ELSTREE LABORATORY

Cosmos Valve

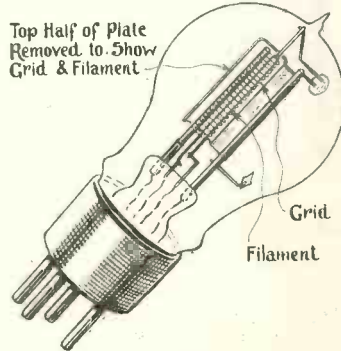

COSMOS valves are well known on account of their short-path construction; the grid is placed very close to the filament, and thus has a better control over the electron flow from the filament to the plate. Moreover, in consequence, the amplification factor for a given impedance is unusually high. The cost of construction is only made possible by very careful design and fitting of the various electrodes and valves.

The SP18R has for some time been a very popular two-volt power valve capable of giving excellent results as the last valve in a receiver. The makers have now evolved a new type, the SP18RR, which has an astonishingly high amplification factor of 6.5 with an impedance of only 4,500 ohms. It is capable of handling an appreciably greater power than the SP18R, although the amplification is almost as high.

The filament current and voltage are 0.3 ampere and 1.6 volt; thus it is economical in use. In the last stage of a high-power multi-valve receiver the reproduction obtained was excellent for

a two-volt valve, and marks a further advance in combining efficiency and economy.

Cosmos valves are marketed by Metro-Vick Supplies, Ltd., of 145, Charing Cross Road, W.C.2.

Deckorem Holder

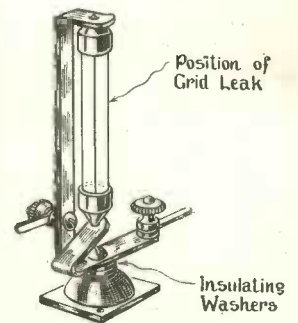

THIS Deckorem grid-leak holder is similar in design to the fixed-resistor holder of the same pattern. The grid leak is held in a vertical position between a fixed metal arm and a thin metal spring; a small, but neat, aluminium base is provided, which can be screwed down to the baseboard.

The possibility of such a device for holding grid leaks has only been made possible by the approximate standardisation of the leak as regards length. Owing, however, to the metal spring employed, some latitude is allowed in the sizes of grid leak.

Mounted in a vertical position, the component takes up very little room, and can be removed from its holder more readily than from the usual horizontal type of holder. Two terminals and soldering tags are provided.

These holders are marketed by A. F. Bulgin & Co., 9-11, Cursitor Street, E.C.4.

Siemens Battery

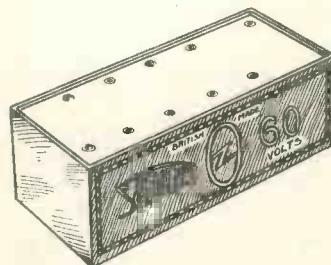

THIS Siemens product is a 60-volt battery made up specially for wireless purposes. Owing to the process adopted in its manufacture, the makers are able to offer it at a comparatively low price. The battery is compact in size and measures 10 in. by 3 3/4 in. by 3 in. Tappings are taken at 15 volts, and after that at every 6 volts. This enables any required voltage to be obtained.

Siemens batteries are well known as eminently reliable units, and this new type is by no means an exception. Throughout our tests it has proved satisfactory and shown itself capable of standing up well to its work. We think this battery will meet a demand among our readers.

The manufacturer's address is Siemens Bros. & Co., Ltd., Woolwich.

For further particulars write to the makers

Ormond R.C. Unit



THE Ormond L.F. resistance-capacity coupling unit comprises the essential resistances and condensers required for resistance-capacity coupling in low-frequency amplifiers. The various components are housed in a neat ebonite case, and the necessary leads are taken to four terminals mounted on the top of the case. At the base of the unit there is an aluminium plate which can be screwed on to the baseboard.

On test, the values of anode resistance and grid leak were found to be about 5 and 10 megohms respectively, the coupling condenser being .0006 microfarad. These values are correctly proportioned for use with very high-impedance valves.

We found on a megger test that the resistance material was somewhat variable in character, particularly in the case of the anode resistance, but this did not appear to upset the operation of the unit, which gave good signal strength with clear reproduction.

The manufacturers are the Ormond Engineering Co., Ltd., of 199-205, Pentonville Road, N.1.

Bretwood Grid Leak

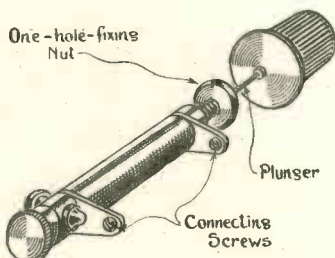

THIS particular type of leak will be well known to most readers. Improvements have been made, however, from time to time; the latest pattern is similar in its essential constituents to the original type. The resistance element consists of a glutinous substance into which a threaded brass spindle dips. By rotating the knob at the other end of the spindle it can be dipped further into or pulled away from the bulk of this element.

A high resistance is obtained when the spindle is well withdrawn, owing to the fact that the resistance element is drawn out in a fine string. On test we found that the minimum resistance was in the neighbourhood of 200,000 ohms. This could be varied gradually up to a value of about 2 megohms, and then more rapidly up to a value exceeding 20 megohms. It is possible to obtain any desired value of grid leak.

Of the two types submitted for test, one was adapted for baseboard mounting and the other for panel mounting. A neat and compact ebonite knob is fitted and the article is well finished.

They are manufactured by Bretwood, Ltd., of 12-18, London Mews, Maple Street, W.1.

Centroid Coil

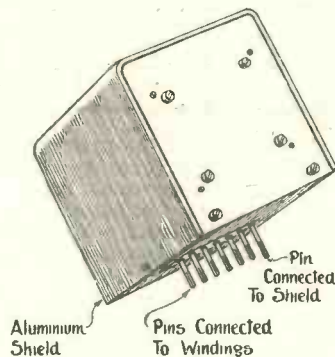

UNLIKE the majority of screened coils, this Centroid component has an inductance wound in rectangular form surrounded by a rectangular screen having dimensions $3\frac{1}{2}$ in. by $4\frac{1}{2}$ in. by $4\frac{1}{2}$ in. The winding of this coil is of Litz wire. The primary and reaction windings are placed inside the tuned secondary winding, connections being taken to six pins arranged in line at the base of the screen.

A six-socket base is supplied, into which the complete screened coil fits. The sockets are numbered from 1 to 6, and there is an extra socket at the end, which is out of line with the others, so that no mistake can be made due to inserting the coil the wrong way round. This extra socket, which makes contact with the aluminium screen itself, should be connected to earth.

Full wiring directions are given by the makers, and a diagram of connections included.

On test, in the aerial circuit of the valve receiver, quite satisfactory results were obtained. The tuning range with a .0005-microfarad condenser in parallel extended from 240 to 620 metres; a standard aerial was employed.

A .0001-microfarad variable condenser was inserted between the reaction and secondary winding, and satisfactory control of reaction was obtained throughout the tuning range. The insulation resistance between the sockets proved to be infinity.

The Camden Engineering Co., Ltd., of Bayham Place, N.W.1, are the makers.

LOW-FREQUENCY REACTION

IT is well known that in a low-frequency circuit a certain amount of low-frequency reaction takes place between the various components and as the result of the capacity between the plate and grid of the low-frequency valves. If this reaction is carried to excess oscillation takes place at audible frequency, and is commonly known as low-frequency howling. Even if this oscillation is not so excessive as to cause any howl it may have some effect on the reproduction.

Resistance

Reaction in any circuit tends to cut down the resistance of that circuit.

Thus it happens that low-frequency reaction cuts down the resistance of the low-frequency circuit, and causes oscillations to persist; in consequence, we get that ringing effect in the loud-speaker which is so often evident and need not be caused through oscillation of the rectifying-valve electrodes.

The practice of shrouding low-frequency transformers and choke coils in iron has done much to eliminate audio-frequency reaction, and has therefore lessened our difficulties in this respect.

W. Q. K.

WHEN YOU ARE IN TROUBLE—

do not forget that the Technical Staff of the "Wireless Magazine" is always at your service to help you out of your difficulty and put you on the right path.

If you want advice on buying a set, address your query to the Buyers' Advice Bureau, not forgetting to mention how much, roughly, you wish to spend, where you are situated, what stations you wish to receive, and whether you intend to use phones or a loud-speaker for listening-in.

In all other cases, address your letters to The Editor, and not to the Buyers' Advice Bureau. Our address is the "Wireless Magazine," 58-61, Fetter Lane, E.C.4.

When sending a query, write on one side of the paper only, and do not forget to enclose the coupon on page iii of the cover, a stamped addressed envelope for a reply and a fee of 1s.

Half Hours with the Professor



4.—A Chat About Frame Aerials

YOUNG AMP, whistling cheerfully, strolled merrily along with his hands in his pockets. It was a fine Saturday afternoon, and he had nothing in particular to do. He contented himself with throwing stones at various birds within sight—not a very enlightening proceeding certainly, but one in keeping with his mood.

He strayed aimlessly across the road, but before he had taken two steps, he was brought up short by an ominous grinding noise behind him. He turned round, startled, to find Professor Megohm glaring at him from the driving seat of his little two-seater.

"Hello, Professor," cried the Amp, his face lighting up with pleasure, "how lucky that you happened to come along."

"How lucky that I happened to stop, you mean," growled the Professor. "Why on earth don't you look where you are going?"

Questions

"Why on earth don't you sound your horn?" retorted the Amp, quite unabashed. "Anyhow, you did stop, so what does it matter, and where on earth are you off to with all that junk?"

The Professor's good humour was fast returning. Indeed, seeing Young Amp usually caused more pleasure than the reverse to those with whom he came in contact. Replying to the Amp's query, therefore, the Professor said: "Oh, that is a portable receiver which I am going to take out into the country with me for an afternoon's enjoyment."

Time to Spare

"I say, Professor," exclaimed the Amp, his eyes shining with expectancy, "do let me come with you. I haven't anything to do this afternoon."

"I shall be delighted," was the

reply, "only be careful how you get in."

The injunction was necessary, because the floor of the car was littered with odd batteries and gadgets of various sorts. The Professor, remembering the track of destruction usually left by the Amp in his progress through the lab., eyed him

At this time of the year many listeners are turning their attention to portable receivers, and this chat between the kindly Professor Megohm and Young Amp will clear up numerous points regarding the operation of frame aerials. The least technical reader will be able to understand the Professor's lucid explanation.

nervously as he made his way into the car, and heaved a thankful sigh of relief when the young irrepressible was safely seated.

Fortunately the various sights and incidents which occurred on the journey kept the Amp comparatively quiet, and the Professor was able to proceed without the usual string of chatter. Once or twice the Amp asked questions as to their destination and similar points, but on the whole he remained quiet. Finally, after some time, they came to a wild, open common on to which the Professor turned the car, and found a convenient spot for parking.

As he stopped the Amp was galvanised into activity after his period of comparative quiet. "Shall I get some of the things out, Professor?" he exclaimed. "I can give you a hand with some of the apparatus!"

Without waiting for a reply, he flung open the door, picked up an accumulator and several valves which were on the floor of the car, and precipitated himself on to the common. It was, perhaps, unfortunate that he paid more attention to the parcels in his hands than to his feet, for had it

not been for a timely grab made by the Professor he would have landed head first.

This little contretemps served to curb his impetuosity somewhat, and the remainder of the apparatus was removed from the car without any difficulty. In a very short space of time the set had been connected up and pleasant sounds of dance music were issuing from the loud-speaker.

The Amp watched with interest, but made no comment until he saw the Professor turn the frame round. Signals immediately disappeared, and as the Professor continued to rotate the frame so the signal strength came back again.

"Why does that happen?" said the Amp.

"That is simply due to the directive effect of the frame," was the reply. "When I turn the frame at right-angles to the transmitting station, the signals disappear."

Home Aerial

"But is that always the case?" asked the Amp. "I mean, should I make sure that my own aerial at home is pointing in the right direction?"

"The phenomenon is only obtained to any extent in the case of a frame aerial," said the Professor. "With your normal aerial at home you would not obtain any appreciable directive effect, but with a small frame or loop aerial such as we are using here the directive effect is very marked."

Different?

"Then does this aerial that you are using work in a different way from mine at home?"

"It does and it doesn't," responded Megohm with a smile. "I see, however, that you are not very clear about the point, and perhaps I had better explain just how a frame aerial does work."

"I wish you would, Professor,"

said the Amp eagerly. "I don't really understand much about it."

"Very well," resumed the Professor, diving into his pocket for his inevitable pipe. "I think the simplest way of looking at the matter is to consider a single turn of wire." Then the Professor produced an old envelope from his pocket and drew a simple loop as shown.

At the Transmitter End

"Now let us consider for a moment how the ordinary wireless wave upsets an aerial. The current in the transmitting aerial produces a series of vertical electric fields, first in one direction and then in the other, which follow each other at regular intervals and travel outwards in all directions with a speed of 186,000 miles per second.

"At the receiving end we erect some form of collecting system, and these electric fields, travelling rapidly by, induce a small voltage in the aerial system. Thus we get pulsating currents, first in one direction and then in the other, induced by the electric fields in their passage by. We tune the aerial system so that it responds to the particular frequency of the currents in use, and we thus build up an oscillating current flowing first in one direction and then the other, which is fed continually by the voltages received from the electric waves passing the aerial."

"What happens," interrupted the Amp, "if you do not tune the aerial system?"

"In that case," replied the other, "the voltages induced in the aerial are usually too small to cause any appreciable effect unless the transmitting station happens to be very close indeed, or of very high power. It is only when we tune the aerial system to the incoming signals that we can obtain sufficiently large currents to produce any appreciable effect. Indeed, it is by this method of tuning that we are able to select the particular stations we require."

"That is what they call selectivity, isn't it, Professor?" cried the Amp, eager to fit this information in with his existing ideas.

"That is so," replied Megohm, noting how quickly the lad was assimilating the idea. "Selectivity is really a measure of the capability

of any tuning system to respond to one frequency and to offer little response to any other frequency."

The Amp nodded thoughtfully to himself while the Professor puffed contentedly at his pipe. After a moment's pause, Megohm resumed his discussion.

"Now let us figure the effect of these travelling electric fields or wireless waves upon a loop such as I drew a moment ago. Suppose the waves are travelling in the direction of the arrow. They will then produce an effect on the left-hand half of the loop and a fraction of a second later a similar effect is produced in the right-hand half."

"What happens to the top and bottom?" broke in the Amp.

"They are not affected by the wave because they are at right-angles to the electric field, and in this position no voltage is induced in them. We thus have only to consider the two vertical sides."

After pausing to make sure that this point had been understood, the Professor continued.

Induced Voltages

"Therefore we have voltages induced in the two sides of the loop, both acting in the same direction, but one occurring a fraction of a second later than the other." Here he put two arrows on the two sides of the loop.

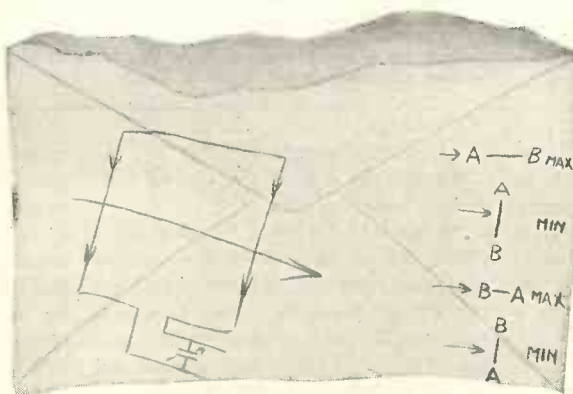

What the Professor drew on the back of the envelope.

"But," remarked the Amp, "you said the voltages were acting in the same direction, whereas you have shown them in the opposite direction."

"I don't think so," said the Professor, "although I can see your difficulty. If you consider each side of

the loop independently as a small aerial, then the two voltages are both in the same direction. If you consider these two sides joined up, however, you have these voltages acting in opposite directions."

"But if that is so," said the boy with a puzzled frown, "don't they wash each other out?"

Time Lag

"Not quite," was the reply, "although they tend to do so. You will remember, however, that the voltages in the two sides of the loop were not produced at the same moment, but there was a slight time lag between them. The voltage in the first side, therefore, will have a small opportunity to produce a current before its effect is cancelled out by the second voltage."

"I see," exclaimed the Amp. "Then it is really entirely due to the slight time lag that there is any effect on the loop whatsoever."

"Exactly," said the Professor. "Due to this time lag the two voltages do not cancel out. Actually the voltages introduced in each side are not momentary, as we have assumed, but are continually varying, but the fact that there is a time lag between them leaves a small difference when they are placed in opposition so that they do not quite cancel out and there is a very small pulsating voltage left in the circuit."

"Then I suppose we have to tune the system in order to make use of this voltage," said the Amp, "just as you do with an ordinary aerial?"

"Yes, that is so. In this case, however, we arrange to tune the complete circuit formed by the loop itself, and this is done by connecting a condenser of suitable size across the terminals of the loop. It is the voltage developed across the terminals of this condenser that we take to the rectifying or amplifying valve as required."

Young Amp thought about it for a moment and then said: "But where does this directional effect come in? Is that something to do with the time lag?"

"Yes, it is entirely due to the time-lag effect that we obtain any directional properties," answered the other. "If we turn the loop in such

Giving 'em Beans!

A Wireless Story by ALAN DUKE

“AND 'ow's William?” ses Bob Mandy, as William Wilk comes into The Crow's Nest and peers around anxious like, as if 'e expects to see 'is missus a-sitting in a corner waiting for 'im. Just like that, d'ye see, for William ain't got no missus which is some'ow ex-



In The Crow's Nest.

trordinary when you thinks as 'ow William's not quite right in the head. Why, 'e's so bad 'e thinks Bob's real eddicated and believes everything 'e tells 'im.

“Middling, Mr. Mandy,” ses William. 'E sits down and takes 'is pint. 'E lifts it up, 'e puts it down and 'e turns to Bob. Then 'e lifts it up agin, takes a gulp at it, and turns back to Bob all of a sudden.

“Mr. Mandy,” 'e ses, “do you 'appen to know anything about this 'ere wireless?”

“Well,” ses Bob, drawing hisself up and striking a learned attitood, “I'll not say as I don't.”

William's eyes brightens, 'e takes another gulp and ses to Bob.

“Mr. Mandy,” ses 'e, “'ave you 'eard that wireless 'as a wonderful effect on crops?”

“So you've 'eard that too?” ses Bob, just as if 'e knows all about it. 'E's a sly one is Bob.

William nods in a pleased way.

“I was thinking of taking up agriculture on modern lines—in a small way, d'ye see.”

Bob puffs 'is pipe and nods thoughtful.

“Quite,” ses 'e.

“I was thinking of trying beans.” ses William eager like. “There's that spare bit o' ground behind the house and I could raise 'uge beans for the show and win a prize, d'ye see, with this 'ere wireless.”

“Quite,” nods Bob.

“But I'm not quite sure 'ow to work it. That's why I come to you for a bit o' advice, Mr. Mandy.”

“Quite,” nods Bob understanding. “What is it you're not exactly sure about?”

“Well,” ses William, “it's like this. Do you think beans needs a loud-speaker or just earphones?”

Bob puffs slow, takes a pull at 'is beer, wipes 'is mouth, and turns to William.

“And that's a very good point,” ses 'e. “Loud-speaker or earphones? A very good point.”

William looks tremendous pleased and watches eager while Bob closes one eye, then the other, and strokes 'is chin.

“And wot's your opinion?” ses Bob, taking 'is pipe from 'is mouth.



William a-bringing 'is earphones out and 'olding 'em up over them beans.

“Well, Mr. Mandy,” ses William, “I thought it out this way, d'ye see. The loud-speaker might be a bit strenuous like when the beans is young, so I thinks earphones when the beans is young, so's they'll get used to it, and the loud-speaker when they're bigger.”



“They're six feet 'igh.”

Bob raises 'is mug, takes a pull, and lays it down with a bang.

“And a very good idea, too, William. Phones when they're young, loud-speaker when they're older. William, I don't see as 'ow I could advise you better nor that, I don't really.”

“Do you really think so?” ses William.

“Certain of it,” ses Bob.

“I knew you would be able to 'elp,” ses William grateful. “I'll plant them beans to-morrow.”

“I'll come and give you a 'elp,” ses Bob.

When William's gone, Bob turns to the others.

“Wot is this new-fangled idea?” But nobody knows nothing. Bob puffs thoughtful at 'is pipe.

“Poor William,” ses Bob, “I must give 'im a 'elp.”

* * * * *

Well, just about a week after, 'in comes William agin and sits down.

Giving 'em Beans! (Continued)

"Mr. Mandy," ses 'e, "I'm not quite sure about it."

"About wot?" ses Bob.

"Well," ses William, "about wot I lets them beans 'ear. I can't see as 'ow fairy tales can 'elp beans, Mr. Mandy."

"Quite," ses Bob, "a very good point."

"Nor talks on cannibals."

"Nor talks on cannibals," ses Bob.

"Nor topical noos."

"Nor topical noos," ses Bob.

"It's worrying," ses William, "thinking out wot's best for beans."

"A very good point," ses Bob.

"Wot do you think'd be best, Mr. Mandy?"

Bob puffs slow and closes 'is eyes one after the other.

"Well, now you come to ask me, William, it is a very difficult question. But I do seem to remember 'earing as 'ow music 'ad a extrornary effect on plants. 'Ow would it do to give them beans the musical selections?"

"That's just wot I thought," ses William, 'is face ashining with joy.

"And Mr. Mandy," 'e adds 'esitating, "I 'ad a idea as 'ow it would 'elp them beans no end if the wireless people'd play 'The flowers that blooms in the spring, tralala!'"

Bob slaps 'is leg.

"You do think things out, to be sure, William. Why not write up and ask 'em to play it for you?"

"D'ye think they'd do it?" ses William.

"Certain of it," ses Bob, "they're terrible keen on agriculture."

Well, we was all mighty interested in the experiment, specially Bob, and we watches William a-bringing 'is earphones out and 'olding 'em up over them beans and putting 'em down near the ground, a-giving each bean a bit o' a toon. Some gets a fox-trot and some gets a bit o' Bach, and whether it were that the classical stuff were a bit slow, some o' the beans comes up just ornary, while others comes up twice the size. So Bob suggests pulling up the little uns, which William does.

* * * * *

Under the infloence o' guitar and saxophone and 'arpiscord them beans

shoots up amazing. William could 'ardly contain hisself.

"They're four feet 'igh," ses 'e, "and going like blazes."

"Quite," ses Bob, careless-like.

* * * * *

"They're five feet 'igh," ses William. "I wonder when they'll stop."

"I wonder," ses Bob.

* * * * *

"They're six feet 'igh," ses William. "'Ave you ever sced beans like 'em, Mr. Mandy?"

"I 'aven't," ses Bob, truthful.

* * * * *

As Bob said: "It's amazing wot a fine crop o' sunflowers can come out 'o one o' last year's 'eads." It was a eye-opener to all of us, specially William, who's wrote up to the papers about the effects o' wireless on beans, 'ow equal dozes o' classical and jazz turns 'em into sunflowers.

Next year, 'e's told 'em, 'e intends trying beans agin, concentrating on fox-trots and one-steps and is expecting scarlet runners or 'p'raps 'ollocks.

Through My Loud-speaker

From a B.B.C. Studio (Sunday)

Not good singing
Not the atmosphere of worship.
Restlessness.
Laughter.

A tenor who out-tenored himself.
The reader of a lesson who pronounced six words incorrectly.

From a Church

A real parson.
A parson without the parson's voice.
A parson's cough.
Many more diminutive parson's coughs.

Amen pronounced Ā-men.
Amen pronounced Ā-men.
Amen pronounced Amen.
Amen pronounced A-mén.
A collection plate which emptied its contents on the floor.

A hymn which was broadcast on eight consecutive Sunday evenings.

From a Cafe

Only one item cheered out of eleven.

A chorus of coughs.
Was it a toothpick in operation?
The conductor of the orchestra saying: "Come on there."

The general weakness of the orchestra.

From another B.B.C. Studio

Gramophone records — three of them cracked.

From a Cinema (Lunch Time)

Roars of laughter.
Roars of groans.
A voice: "My neck is aching already."

Many voices: "Caught."
An attendant whispering rather too loudly: "Will you move up to the next seat, please?"

Hardly any music worth mentioning. Perhaps it was the orchestra's lunch hour too.

From another Church

The organist trying to get rid of something that had stuck in his throat.

The same organist touching the wrong foot pedal.

To the same organist: Was there a cramp in his left-hand fingers?

Aberystwyth as it should not be sung.

A motor horn at frequent intervals.
What was supposed to be a sermon.

The significance given to the collection.
E. B. R.

Specially Written by the Officials at Savoy Hill

WHAT THE B.B.C. IS DOING



LIKE a smouldering fire which bursts into intermittent flame and dies down again, so the passages-at-arms proceed between the B.B.C. and the music-hall interests. At the moment of writing it is reported that Mr. Charles Gulliver and Sir Oswald Stoll have fixed the subsidy prices to be paid by the Corporation before the big groups controlling the variety profession will allow their artists to broadcast.

"Subsidies"

These "subsidies" vary between £10,000 and £60,000; and as some 90 per cent. of music-hall turns are unsuitable for the microphone, the B.B.C., it will be seen, is expected to pay pretty dearly for the remaining 10 per cent.

However, these suggestions of "subsidies" have not been made to the B.B.C. direct; they have been published in the daily Press, and therefore cannot form a basis of negotiation; for surely the B.B.C. and the music-hall groups are capable of negotiating among themselves without extraneous assistance.

Points to Bear in Mind

Meanwhile, the points which it would be well for listeners to bear in mind, in considering the attitude of broadcasting towards the variety interests, are these:—Broadcasting can only be supplementary to the variety stage, as it is impossible for the B.B.C. to compete with long-term music-hall contracts; broadcasting cannot be made a dumping ground for unwanted turns for which the variety groups cannot find halls on their tours; variety artists are themselves in general favourable to broadcasting, which, as many have discovered for themselves, have subse-

quently helped them when they have been on tour; the technique required of artists for the microphone is something entirely different from that required for the music-hall stage, and by no means all the leading artists of the music-hall are successful over the microphone; despite the opposition of the music-hall interests, the B.B.C. has secured nearly all the material likely to be of value for broadcasting; and, finally, the B.B.C. criterion in any negotiations which may take place now or hereafter will be programme value.

With these points as a formula the B.B.C. is prepared at any time to enter upon some working arrangement with the music-halls in the interests of the public, which both sides aim to serve.

* * * * *

Great attention is being concentrated by the B.B.C. and educational authorities on the possibilities of wireless in schools, and the summer term sees a marked development in school

transmissions. It is now generally admitted that in schools where wireless lessons have been tried and proved successful a considerable improvement has taken place in composition and clearness of expression in replying to questions put by the teacher—due, no doubt, to the stimulating effect of the expert's explanations and the enlarged vocabulary brought to the pupils' notice.

School Transmissions

The broadcasting programmes now contain subjects of great interest to schools throughout the country. The transmissions include the following:—

Mondays: Everyday Things of the Past, by C. H. B. Quennell.

Tuesdays: Elementary Music, by Sir Walford Davies; Elementary French, by E. M. Stéphan, of University College, London; The Shadows of the Stars, by H. H. Turner, D.Sc., Professor of Astronomy in the University of Oxford.

Wednesdays: Plays of Shakespeare, by A. de Selincourt, of the Dragon School, Oxford.

Thursdays: How Things Grow, by E. Kay Robinson.

Fridays: How English Laws are Made by King and Parliament, by Sir Ernest Gray, ex-M.P.; Let's Go Round the World, by Clifford W. Collinson; and on alternate Fridays School Concerts by the People's Concert Society, and Talks on English Folk Music and Dance, by Douglas M. Kennedy and Maud Karpeles, illustrated by country dancing by arrangement with the English Folk Dance Society.

Valuable Ancillary

It is not claimed that these broadcasts can take the place of personal contact, nor replace the lessons taught by the visible teacher. Supervision and oral explanation always will be necessary, but broadcast lessons are proving a valuable ancillary. B.B.C.

THE HELPING HAND

of the "Wireless Magazine" is ever ready to come to your aid when you are in difficulty over any wireless trouble, whether practical or theoretical.

Just write your query out on a piece of paper (write on one side only, please!) and send it, together with a stamped addressed envelope, the coupon on page iii of the cover, and a fee of 1s., to the Editor, "Wireless Magazine," 58-61, Fetter Lane, E.C.4.

Little-known Facts About Distortion

MUCH has been written in the technical Press on the presence of distortion in reproduction of telephony. Most of the articles on the subject have dealt with frequency distortion, and in consequence one is apt

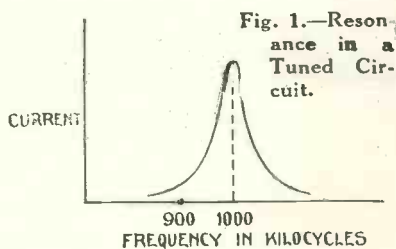

to imagine that perfection is attained with an amplifier responding equally to all audible frequencies. There are, however, other types of distortion which may cause effects equally or even more displeasing than frequency distortion.

Difficulties

It is true that at present we are unable to cope with some of the less-known forms of distortion, and in order, perhaps, not to increase the troubles and the worries of the wireless enthusiast, these forms are seldom set down on paper.

The performance of high-frequency amplifiers and, indeed, any part of the receiver associated with high-frequency currents does not, as a rule give much trouble in the way of distortion, and the possibility of spoiling faithful reproduction in an H.F. amplifier is not very great.

L.F. and H.F. Relations

Before going into this question any further it would be instructive to point out the position and relation which the audible-frequency oscillations have with respect to the high-frequency oscillations.

At the transmitting end the audible frequencies are taken direct from the microphone and imposed upon high-frequency oscillations generated in the form of a carrier wave. The former modulate, or alter, the wave form of the latter, but do not upset in any way its fundamental frequency.

Each audible frequency produces two radio frequencies, one larger and

the other smaller than the carrier wave, and differing from this by an amount equal to the audible frequency. Thus the wave-form of the high-frequency oscillations reaching a receiving aerial includes a number of side-band frequencies.

The purpose of rectification at the receiving end is to convert the side-bands into their corresponding audible frequencies. If, however, any of the side-band frequencies are cut off or diminished in strength, it follows that there will be some distortion due to the absence or diminution of the corresponding audible frequencies.

Resonance

Fig. 1 illustrates the phenomenon of resonance in a tuned circuit. The circuit has a maximum response at a frequency of 1,000 kilocycles; the amplification falls off more or less rapidly on either side of this frequency, depending on the resistance of the tuning inductance.

If the resistance is very low the peak value of the curve will be higher but will fall off more rapidly on either side. If, on the other hand, the resistance is comparatively high, the curve will become flattened out and the peak value will be smaller. It therefore follows that a low-resistance circuit is more selective and more efficient than a high-resistance one; this fact, however, does not concern us in this article.

As mentioned previously, the high-frequency oscillation consists of a number of frequencies differing slightly from the fundamental, and in amplifying these at radio frequencies it is necessary to preserve the side-band frequencies.

If, however, the resonance curve has a high peak value and falls away very rapidly on either side it may occur that the fundamental and some

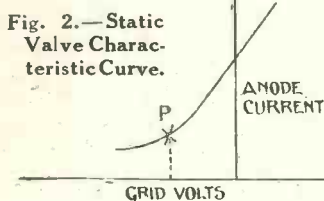

of the side-band frequencies will be amplified to a greater extent than the more distant side-bands. This will mean that, after rectification, the reproduction will be lacking somewhat in the higher tones.

Sharper Tuning

In practice the resonance curve of a tuned circuit is not sharp enough to have any material effect on the amplification of side-band frequencies, but by the use of reaction and similar devices for decreasing the resistance of a circuit, the tuning can be made very sharp, and will therefore tend to accentuate the lower frequencies. This is most noticeable when attempting to tune-in a distant station: the reaction is adjusted to the maximum value possible without self-oscillation, and speech or music becomes noticeably lower in tone.

There are other forms of distortion

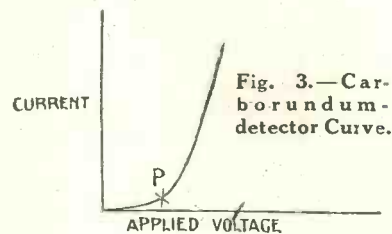

which may occur due to reaction. If, for example, reaction is employed in a tuning circuit, its high-frequency resistance is diminished, and in consequence H.F. oscillations will tend to continue even after the cessation of the incoming signal. This has the effect of introducing additional frequencies, and can be noticed in practice when reaction is carried to a point just short of oscillation.

Distortion in Rectifiers

Distortion, which is very difficult to overcome, occurs due to the non-linearity of rectifiers. Fig. 2 shows the static characteristic curve of a thermionic valve. We will suppose that rectification is obtained by working on the lower bend of this curve: we give the valve a negative grid bias corresponding to point P, at a position in which the change of slope of the curve is a maximum.

In rectification we rely upon the fact that an increase of grid potential in a positive direction will have more effect on the resulting anode current than an equal increase in a negative direction. We notice, how-



Fig. 4.—(A) Perfect Rectification. (B) Rectified Oscillation in Grid Leak and Condenser.

ever, that the anode bend is approximately a parabola, so that for a weak signal the rectified current will be relatively weaker than for a strong signal, which means that differing volumes will not be rectified in their correct proportion.

Fig. 3 shows the characteristic curve for a carborundum detector. The bend of this curve also approximates to a parabola, in consequence of which similar effects will occur. If the incoming oscillations are strong enough to carry the working signal past the curved portion on each side of P, it follows that approximately linear rectification will take place, thus anode-bend rectification and crystal rectification are more efficient for strong rather than weak signals.

There have been certain cases in which both valves and crystals have had characteristics which include a very sharp bend, and in consequence rectification efficiency is much improved; the crystal lenzite is an example of such a type.

Grid-leak Rectification

The most common form of rectification, and perhaps the most criticised, is that known as grid-leak rectification. Here we do actually operate on a straight portion of the valve characteristic. Unfortunately, due to the alternate blocking and leaking of the grid condenser, the resulting oscillation curve is not a true sine-wave, and is not entirely similar to the input curve at the transmitter. There is a certain time lag which is illustrated in the full-line curve of Fig. 4. The dotted curve shows the true shape.

Distortion caused by grid-leak rectification is not very noticeable, although it is considered to be somewhat worse than anode-bend rectification. On account of the increased signal strength obtained by grid-leak rectification it is rather doubtful

whether it is worth while to employ anode-bend rectification.

It is not intended to discuss in detail frequency distortion occurring in low-frequency amplifiers, as this subject has been treated exhaustively already by numerous writers. Let us consider the efficiency of a transformer or other form of low-frequency coupling as a means of transferring energy from one circuit to another.

The low-frequency transformer is capable of transferring small amounts of energy from the primary to the secondary in a very efficient manner, but as the extent of this energy is increased the efficiency falls off somewhat, in consequence of which we obtain a curve such as that shown in Fig. 5.

Shape of Curve

It will be noted that the curve is linear for low energies, but tends to flatten out as the input energy increases. It follows that such a transformer may cause appreciable distortion in a low-frequency amplifier where high-voltage swings are applied to the grid of the low-frequency valve.

Imagine that an orchestra is playing at the broadcasting station, the soft notes will be amplified in their proper ratio, but as soon as the full orchestra begins to play, and the music swells, the energy transferred through the transformer will not increase at a corresponding rate.

This may explain why so many broadcast receivers fail in their attempt to produce efficiently a loud volume without obtaining a muffled effect.

Distortion may occur in like

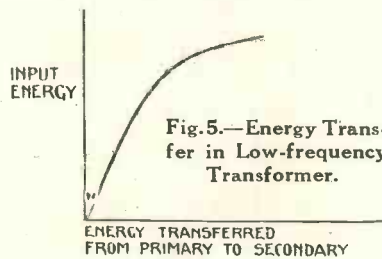

Fig. 5.—Energy Transfer in Low-frequency Transformer.

manner to any individual tone. Each tone consists of a number of harmonics besides the fundamental frequency, and the resonant effect of these harmonics gives the characteristic which individualises a particular tone. Thus it may happen that some of the harmonics, being considerably

stronger than others, are not amplified in correct proportion to the others, in consequence of which the tone creates a different impression on our aural senses.

Other Couplings

Other forms of coupling may be employed for transferring energy from one circuit to another, notably choke coupling and the resistance coupling. The essential details of such a circuit are illustrated in Fig. 6. Now, provided the condenser C has sufficient capacity, it will transfer large or small quantities of energy from the plate of V_1 to the grid of V_2 .

Whereas this circuit has the dis-

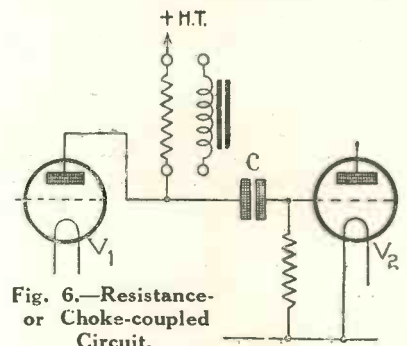

Fig. 6.—Resistance or Choke-coupled Circuit.

tinct advantage as far as energy transference is concerned, there is one outstanding disadvantage which limits its overall performance. This disadvantage lies in the fact that the grid of the second valve V_2 is almost isolated. A resistance is placed between the grid and the filament in order to maintain the former at a fairly constant potential, but unless this resistance has a very low value it is not capable of adjusting the grid potential with sufficient rapidity when a strong signal is applied.

If we use a low-resistance grid leak at this point it may perform in a more efficient manner its particular work, but it will tend to diminish the strength of weak signals to a very great extent.

Practical Compromise

In practice some compromise has to be effected, and a grid leak having a reasonably small value must be fitted. If the curve is plotted between the input energy of the valve V_2 and the output energy, it will be somewhat similar in form to that shown in Fig. 5, illustrating the fact that strong signals tend to block the grid.

W. Q. KAY.

The Countryside Four (Continued from page 400)

Two-volt Valves to Use in this Set

Make.	H.F.	Detector.	1st L.F.	2nd L.F.
B.T.H.	B21	B21	B22	B23
Cossor	Red Band	Blue Band	Black Band	Stentor Two
Ediswan	RC2	DR2	GP2	PV2
Marconi	DE2 H.F.	DE2 H.F.	DE2 L.F.	DEP215
Mullard	PM1 H.F.	PM1A	PM1 L.F.	PM2
Osram	DE2 H.F.	DE2 H.F.	DE2 L.F.	DEP215
Shortpath	SP18B	SP18G	SP18R	SP18RR

sibility, since the dial readings could be seen at a glance without any awkwardness, while at the same time the apparatus can be used on any reasonably level position, and, due to the use of the special frame-rotating device, there is no difficulty whatever concerning the aerial system.

Battery Positions

From the photographs it will be seen that the batteries are at the bottom of the case when the instrument is shut for carrying, while the use of an unspillable accumulator renders the tilting of the receiver on one side for use quite a satisfactory proposition.

As far as the portability of the arrangement is concerned, I myself went for a brief motor tour in the West of England with the express intention of finding out whether the receiver really was portable and whether any difficulties arose in transport. I found that the arrangement provided was adequate for the purpose.

Constructional Work

The first portion of the constructional work is the making up of the cabinet. Full details of this are given in the accompanying diagram, or, alternatively, the cabinet can be purchased ready made. It will be seen that there are three compartments in the main body of the receiver. One of these carries the two-volt accumulator of the unspillable type. The second of these carries the high-tension and grid-bias batteries, while the third carries the receiver itself.

If desired grid bias may be obtained on the negative end of the H.T.

battery. GB2 then goes to the negative terminal, GB1, to +3 volts and HT- and GB+ to +7 volts.

The whole of the back of the cabinet is hinged, and is let down for the insertion of the necessary batteries, connecting up the various plugs, etc., and the insertion of the valves in the receiver proper.

The frame for the aerial is fitted with two grooves, as can be seen from the diagram, each of which carries a winding, one for the short waves and one for the long waves. Details of these windings are as follows, and the method of placing them on the former can readily be seen from the diagram:—

Short-wave winding: 16 turns of Lewcos frame aerial wire.

Long-wave winding: 40 turns of No. 28-gauge d.s.c. wire.

The end of the short-wave winding is connected to the beginning of the long-wave winding, which is put on in the same direction. The three connections, namely, the beginning of the short-wave winding, the junction between the two windings, and the end of the long-wave winding, are connected to the three terminals on the metal pivoting hinge, and the corresponding connections can then be taken off inside the receiver without any difficulty.

Limited Space

The layout of the receiver proper was one which required very considerable thought owing to the very limited space available. It is therefore essential that the layout should be followed in every detail, as owing to the confined space difficulties may easily arise if this is not done.

The two high-frequency circuits are on the left-hand side of the panel. The .0005-microfarad condenser serves to tune the frame aerial, while the .0003-microfarad condenser serves to tune the tuned-anode circuit. A capacity of .0003 microfarad was used in this case in order to obtain a high impedance for the tuned-anode circuit and so obtain the greatest possible step-up.

L.F. Transformers

It is necessary to mount the two L.F. transformers one above the other, and the two L.F. valves one on each side of the two transformers. In order to avoid any possibility of L.F. howling the wiring to these transformers should be taken exactly as shown. Care has been taken to keep the leads as short as possible, although with the layout chosen this was a little difficult.

The actual connections to the batteries are taken with an eight-way lead, which was cut off short and fixed in position under the baseboard with a small cleat.

Apart from these general instructions, no difficulty will be found in fixing up the receiver. Two condensers are one-hole fixed, while the Baby Binocular coils are each fixed by means of a single screw. Two switches are of the single-hole-fixing type, as also are the on-off switch

£25 CASH PRIZES FOR BUILDERS OF THIS SET!

For photographs of the Countryside Four in use the Editor of the "Wireless Magazine" is offering cash prizes to the value of £25. Are you going to win one? Turn to page 391 now for further details.

J. H. Reyner's Special Portable

and the remaining controls. A little care will be required in fixing the two L.F. transformers.

Rough Tests

Having completed the constructional work the receiver should be tested out roughly on the bench. Three flexible leads may be taken to the frame aerial, and the receiver may be tried out to ensure that all the details are correct. It may then be inserted in the correct position, and the wiring from the frame aerial to the receiver completed. The necessary batteries may then be inserted in the correct compartment, and the connections may be made with the battery cord.

The valves used should be as follows:—For the H.F. valve an H.F. or resistance-capacity valve may be used. There is little to choose between these two types. The detector valve may be of the high-impedance type, and in practice I have found the resistance-capacity valve quite suitable here, although an ordinary H.F. valve is satisfactory. An L.F. valve is utilised for the first low-frequency stage, while a power valve

is employed in the last stage. A list of suitable valves is given.

The H.F. and detector valves require from 40 to 60 volts H.T., and a suitable point should be chosen until the potentiometer of the H.F. valve gives a smooth reaction control without any tendency to plop. The L.F. stages require the maximum voltage possible up to the rated limit of the valve. In the particular case in point a 99-volt battery was used. Grid bias was 3 and 9 volts respectively, these figures, of course, depending on the actual valves.

Operating the Set

The actual operation is as follows:—Place the potentiometer control at about the middle of the scale. Turn the neutralising condenser all out. Place the two tuning dials about the correct setting for the local station or Daventry as required, making sure the switches are correctly set. The switch positions are:—

Daventry: Top switch in. Bottom switch to right.

Local: Top switch out. Bottom switch to left.

The station should then be heard. Turn the potentiometer to the negative side and the strength will increase. Re-tune if necessary, and continue to increase until the required strength is attained.

If the set does not oscillate with full negative potential, increase the neutralising capacity slightly until it does, and then control the oscillation with the potentiometer.

Large Capacity H.T.

It will be observed that provision has been made for a large-capacity H.T. battery to be employed. Although this increases the weight of the equipment to a small extent, yet it was considered desirable to take this step, as it would be justified by the freedom from trouble. The actual high-tension current consumption of the receiver is only 6 milliamperes when correctly adjusted.

This is just about the limit of capacity for the ordinary small battery, but it is more economical to use the next larger size, which has been done in this case. All told, the increase in weight occasioned by this step is not excessive.

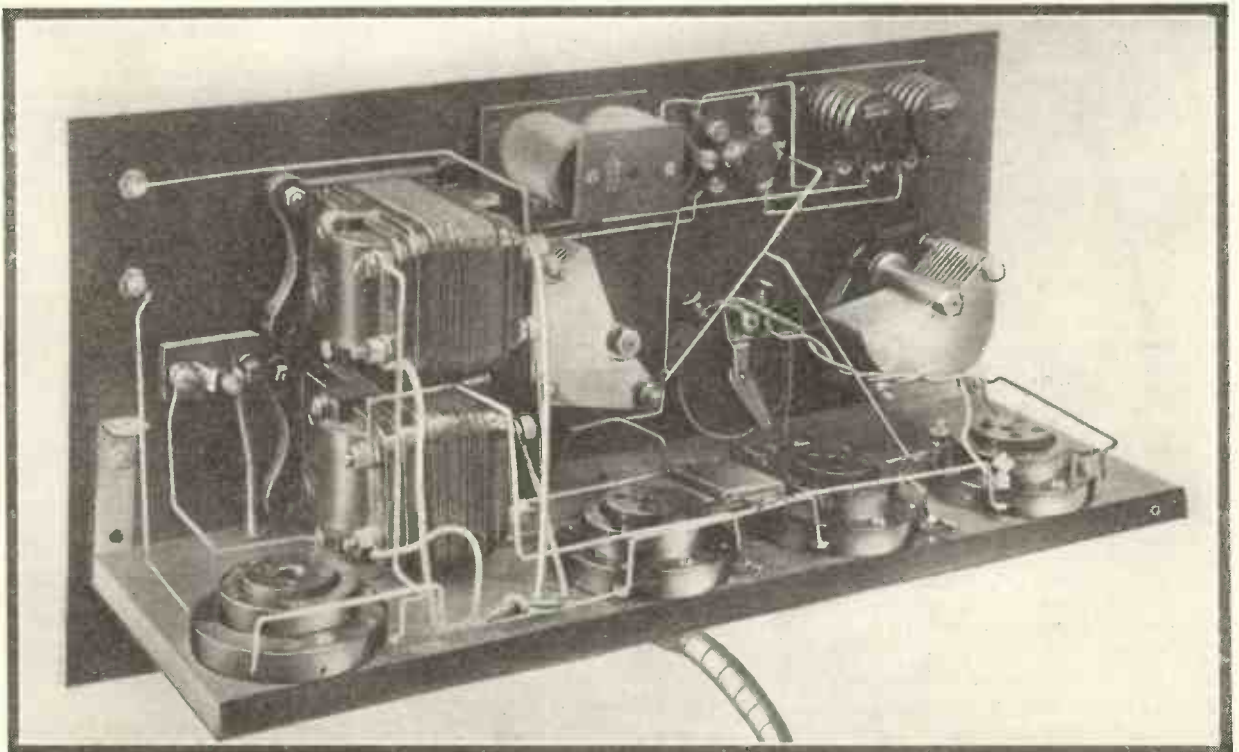

This photograph clearly shows the layout of the components in the Countryside Four.



What the Reader Thinks

Our Readers Contribute Items of Interest to Every Listener

Broadcast Programmes "On Tap"

To the Editor, "Wireless Magazine."

SIR,—In your May issue, under the above heading, "Raydio" describes the working of what has come to be known as a wireless "exchange," at Collins Road, Southsea, by Mr. J. Tubb, which, the writer tells us, is claimed by this Southsea resident as being the first of its kind in the British Isles.

It may fairly be remarked that such a claim may be justified as regards several switching details of this particular "exchange," but the installation of the first wireless "exchange" in the British Isles is to the credit of Mr. Wallace Maton, a wireless enthusiast residing in this little village of Hythe, on the borders of the New Forest, and standing on the opposite side of Southampton Water to that town.

This village wireless supply station was put into operation in January, 1925, by Mr. Maton, since when it has been continuously working to the satisfaction of numerous subscribers. Mr. Tubb tells me that his station commenced working in June, 1926.

In August, 1926, a letter of mine describing the Hythe "exchange" was published by a London daily, which resulted in a large amount of publicity being given to Mr. Maton's system in both the London and provincial Press, which publicity caused the Postmaster-General at that time to order an enquiry into the legality of the working of such an "exchange," and a month later Mr. Maton was notified by the P.M.G. that he would be allowed to continue working his station on the condition that all his subscribers had wireless licences.

After reading "Raydio's" article I had an interview with Mr. Tubb, in which he agreed that he did not claim to be the originator of the wireless "exchange" system in this country, only claiming that his system was the first of its kind as regards being entirely automatic.

I trust that, in justice to Mr. Wallace Maton, you will give publicity to this communication, which, I may say, Mr. Tubb agrees to be a fair statement of the circumstances.—Bertram H. Tubbs (Hythe).

Broadcast Reception near the Pyrenees

SIR,—A number of your readers might be interested to hear of my results, in this rather unknown district, with broadcast reception. For the past month or two I have been operating a four-valve tuned-anode set.

The set is situated 40 ft. up in an hotel. The aerial is a twin—100 ft. long, 70 ft. high at the lead-in end, 35 ft. high at the free end. The two wires converge at the lead-in end, and are spaced 30 ft. at the free end. Our earth is the central heating pipe, 8 yd. from the set. Thus our system is seriously handicapped for a start. (I may mention that reversing the earth and aerial leads makes not the slightest difference.)

The amount of local interference is prolific. Our reception is constantly marred by violent crashes, cracks, etc.,

Write to the "Wireless Magazine" about it!

due to the faulty A.C. lines; electrical storms occur in bad weather, causing discharges across the aerial condenser (in series). I have found that it is possible to draw $\frac{1}{2}$ in. sparks from the aerial sometimes. No thunder is associated with these squalls, which last about five to fifteen minutes. Occasionally we get brush discharges.

On the broadcast band spark interference from Bordeaux is terrific. On the long waves EGE, a Spanish station which sends spark on 800 metres, mars our reception of 5XX on 1,600 (its first harmonic up). The terror of the long waves is the high-power station LY at Bordeaux, which has a spacing wave. This antiquated apparatus has its multiples on all wavelengths from 200 metres upwards, and renders listening on long waves impossible when it is working. It usually works all Sunday and is silent during the week.

Despite all these the reception here is uncommonly good. All B.B.C. main stations come in at full loud-speaker strength after dusk. (I do not wish to be suspected of overestimating loud-speaker strength. Three years' experi-

ence on B.C. and ultra-short waves tells!) We are able to guarantee thirty-five identified stations on a loud-speaker any night between 280 and 500 metres, with a huge number of "unknowns."

The "locals" are Toulouse, Barcelona, and San Sebastian, which, curiously enough, are not as strong as Stuttgart, Langenberg, Frankfurt, or 2LO. Vienna, Lyons, Königsberg, Rome, Copenhagen, Brunn, Prague, Brussels, and an unidentified Swede, are very strong considering (1) that they come over land; (2) their distance.

On the long waves Daventry is always here O.K. Sometimes it fades very badly at sunset to R2 on a loud-speaker. The new high-power Swedish station, working between 1,300 and 1,600 metres, is as strong as 5XX. Königswusterhausen, Hilversum, Moscow, etc., are all good strength. FL and SFR understood.

I have been making weather observations, and I find that we obtain the best results in strong sunshine and cloudless sky. In overcast weather all we can hear is Toulouse and the "locals"—during the afternoon. We are using a cone loud-speaker made of a tough, canvas-like material. In view of the simple apparatus and the bad aerial system I consider that the results are superb as regards strength and distance.

I hope soon to be on the ultra-short waves, when I shall be only too pleased to give a report on conditions here on the 20-50 metre band.—A. E. Livesey, G.2BZT (Basses Pyrénées).

From Sunny South Africa

SIR,—As a reader of many wireless papers, I must say that the WIRELESS MAGAZINE is a remarkable piece of work and very well got up.

Could you kindly give my name and address to some keen radio enthusiast living in London?

I would prefer an amateur who is keen on transmitting, and who is not more than 25 years of age. My age is 18 years.

I would like this amateur to correspond with me, and would be very pleased if you could help me in this way.—Edgar Courtney ("Ailsa," 20, Muir Street, East London, Cape Colony, South Africa).

Please note our new address:—

58-61, Fetter Lane, London, E.C.4.



Cossor

—the
Melody Maker

EVERY valve buyer wants purity of reproduction and long service. One is useless without the other. When you buy a Cossor you get both. The Kalenised filament is incredibly strong. It has been proved capable of withstanding the crashing impact of 600 ft. drop from an aeroplane. That is why every Cossor gives long service.

Tonal quality with adequate volume is dependent upon emission. The Kalenised filament gives off such an intense and long-lasting emission—that Cossor users are now priding themselves that at last they can hear every chord re-created in all its natural beauty—truthfully and without distortion upon a background of dead silence.

Cossor Red Band Valves for H.F. or Detector use. Cossor Blue Band Valves for Resistance Capacity Coupling. Cossor Black Band Valves for Detector or 1st L.F. Stage. Cossor Stentor Valves (Green Band for power amplification.

Cossor Valves are now available for use with 2-volt, 4-volt and 6-volt Accumulators. Every Dealer stocks them. Twelve types from 14/- each.

COSSOR

THE WORLD'S BROADCASTING



Wave-length in Metres.	Station.	Call Sign.	Wave-length in Metres.	Station.	Call Sign.	Wave-length in Metres.	Station.	Call Sign.
178	Beziers	—	308	Paris	Radio	434.8	Fredriksstad	—
196	Karlscrona	SMSM			Vitus	438	Bilbao	EA J9
200	Biarritz	—	310	Zagreb	—	441.2	Brunn	—
201.3	Joenkoeping	SMZD			PTT	443	Rjukan	—
202.7	Kristinehamn	SMTY	312.5	Algiers	5NO	450	Rome	1RO
204.1	Gefle	—	315.8	Newcastle	—	454.5	Stockholm	SASA
217.4	Luxemburg	—	319.1	Breslau	—	461.5	Oslo	—
218	Orebro	—	322.6	Dublin	2RN	462	Barcelona	EA J13
220	Karlstadt	SMXG	325	Milan	—	464	Paris	L'Ecole Sup.
	Juan-les-Pins	—	326.1	Malaga	EA J23			
	St. Etienne	—	329.7	Birmingham	5IT			
238	Bordeaux	—	329.7	Konigsberg	—	468.8	Langenberg	—
241.9	Münster	—	333.3	Naples	—	478	Lyon-la-Dona	—
250	Casablanca	—			—	483.9	Berlin	—
	Eskilstuna	—	335	Reykjavik	EA J15	491.8	Bournemouth	6BM
	Gleiwitz	—	337	Cartagena	Radio-	496	Zurich	—
	Bradford	2LS			raadet	497.5	Upsala	—
252.1	Montpellier	—	340.9	Paris	Petit	500	Aberdeen	2BD
	Saeffle	SMTS			Parisien		Linkoeeping	—
253	Toulouse	—	343.9	Seville	EA J17		Tromso	—
254.2	Kalmar	SMSN	344.8	Barcelona	EA J1	504	Porsgrund	—
	Kiel	—		Cadiz	EA J3	508.5	Brussels	—
260.9	Malmo	SASC	346	Seville	EA J5	517.2	Vienna	Radio Wien
268	Strassburg	8GF	348.9	San Sebastian	EA J8			—
270.3	Posen	—	350	Prague	—	526.3	Riga	—
272.7	Sheffield	6FL	353	Grenoble	—	535.7	Munich	—
	Klagenfurt	—	358	Cardiff	5WA	545.9	Sundsvall	SASD
	Cassel	—	361.4	Graz	—	555.6	Budapest	Ssepel
	Danzig	—	365.8	London	2LO	566	Berlin	—
	Nottingham	5NG		Leipzig	—		Hamar	—
277.8	Leeds	2LS	370	Paris	RadioLL	577	Freiburg	—
278.2	Norrkoeping	SMVV	370.4	Bergen	—	720	Ostersund	—
283	Dortmund	—	375	Helsingfors	—	760	Geneva	HB1
287	Lille	—		Madrid	EA J7	850	Lausanne	HB2
288.5	Edinburgh	2EH	379.7	Stuttgart	—	1,000	Leningrad	—
291	Radio Lyon	—	384.6	Manchester	2ZY	1,060	Hilversum	HDO
294	Stoke-on-Trent	6ST	390	Radio Toulouse	—	1,100	Basle	—
	Swansea	5SX	391	Madrid	Radio	1,111	Warsaw	—
294.1	Dresden	—			Espana	1,153.8	Soro	—
	Dundee	2DE	394.7	Hamburg	—	1,200	Boden	SASE
	Hull	6KH	400	Cork	6CK		Constantinople	—
	Innsbruck	—		Falun	SMZK		Königswustel-	—
297	Liverpool	6LV		Plymouth	5PY		hausen	LP
	Hanover	—	402	Bremen	—		Moscow	—
	Radio Agen	—	404	Salamanca	EA J22		Motala	—
300	Bratislava	—	405.4	Reval	—	1,450	Moscow	RDW
	Marseilles	—	411	Glasgow	5SC	1,600	Daventry	5XX
303	Lisbon	PLAA	416.7	Berne	—	1,757	Paris	CFR
	Nuremburg	—	419.5	Gothenburg	SASB	1,800	Norddeich	KAV
306	Madrid	EA J12	420	Bordeaux	—	1,850	Carthage	—
306.1	Belfast	2BE	422	Bilbao	EA J11	1,950	Scheveningen	—
			428.6	Cracow	—	2,000	Kovno	—
				Frankfort-on-Main	—	2,650	Paris	FL



The outcome of research

CYLDON LOG MID-LINE

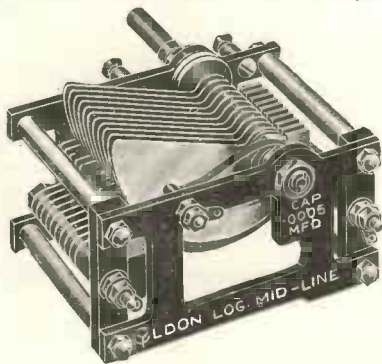

PRICES :

*001	21/-
*0005	17/6
*0003	16/6
*00025	16/-
*0002	15/6

With 4 in. Knob Dial. If dial is not required, deduct 2s.

SYDNEY S. BIRD & SONS, Cyldon Works, Sarnesfield Road, Enfield Town, Middlesex.

After months of exhaustive research CYLDON have produced an entirely new and incomparably better designed variable condenser than any hitherto seen—a condenser *built on the logarithmic principle.*

It is known as the "CYLDON Log Mid-Line" Condenser and by its skilful design avoids in the only possible manner the defects inherent in both Square Law and Straight Line Frequency types. Only by designing a condenser on the "Log" principle is it possible to spread stations really satisfactorily over the whole dial, without any falling out of step at the beginning and the end. By using individual "log" condensers in multi-tuned circuits remember that all dial readings are the same. Thus tuning is an extremely simple matter.

In time all condensers sold will be designed on the "log" principle, but so far CYLDON Log Mid-Line Condensers—just placed on the market—are the first log principle condensers to be made in this country.

The CYLDON Log Mid-Line Variable Condenser is *not a copy* of any other instrument, British or foreign.

It was placed on the market after many months painstaking research in our own laboratories.

It is entirely British in design and workmanship.

It has absolutely NO equal and when you purchase a CYLDON you have the

WORLD'S FINEST CONDENSER.

They can be obtained from stock, by return, and do not believe any statements to the contrary.

If any difficulty

'Phone: ENFIELD 0672; Wire: ENFIELD 0672; or use the C.O.D. system.

CYLDON Temprytes, the best means of valve control, are guaranteed to function perfectly with any type of valve. Comprehensive valve chart, showing correct Tempryte for every valve, free on application.

CYLDON TEMPRYTES, 2/6 each. HOLDER MOUNTINGS, 1/6 each.

OMNORA LTD

THE SET BUILDERS SUPPLY STORES

**BUILD A REALLY GOOD SET
—AND ENSURE SUCCESS.**

"Reinartz R.C. Three"
as described in this issue.

	s.	d.
1 Cabinet 10"×8"	7	6
1 Ebonite Panel 10×8×½	5	0
1 Cylidon Log Mid-line Condenser '0005	17	6
1 " " " " "0003	16	6
2 Igranic Pacent 30 ohm rheostats	5	0
3 Lotus Valve Holders	6	9
1 Lissen Push Pull Switch	2	6
2 Dubitier Grid Leaks 1 meg.	5	0
1 " " " " 25 meg.	2	6
1 " " " " 5 meg.	2	6
1 Lewcos 8-way Lead	9	6
4 Belling-Lee terminals as described	3	0
1 Igranic Xloss Coil	3	9

£4 7 0

Any of the above parts supplied separately, as required.

Lists dealing with "Wireless Magazine" Constructional Sets are now ready and will be sent post free on application.

Note.—Where a complete set of components is purchased together, the Marconi Royalty of 12.6 per valve-holder is payable.

Omnora Ltd., Home Construction Specialists,
258, New Cross Road, London, S.E.14.
Phone: New Cross 1273.



Laminated Cores

Q.—What is the object of building up the cores of intervalve L.F. transformers from a number of thin laminations? What is the objection to using a solid iron core?—T. R. D. (Berwick).

A.—The iron core constitutes a mass of conducting material lying in the varying magnetic field set up by the varying currents flowing through the transformer windings. The core will, therefore, have induced currents set up in it which will represent so much energy withdrawn from the circuits in which the windings are included.

It is with the object of reducing the amplitude of these induced currents, and so restricting the wastage of energy, that the core is built up of laminations. As each lamination is insulated from those next to it, by being enamelled or by some other method, the induced currents can circulate freely throughout the core.—D. B.

Potentiometer

Q.—What kind of an instrument is a potentiometer, and for what purpose is it used?—S. L. (Bournemouth).

A.—A potentiometer consists of a resistance provided with a moving contact which enables connection to be made at different points of the resistance winding. If the ends of the potentiometer winding are connected across a battery there will be a voltage-drop across the winding equal to the voltage of the battery.

If the position of the moving contact is altered any desired difference of potential, up to the voltage of the battery, may be obtained between the moving contact and one end of the potentiometer winding. A potentiometer is therefore useful for providing a critical adjustment of the voltage applied to a carbondium crystal, the grid of a valve, etc.—D. B.

Earth Connection on Boat

Q.—I want to fit a receiving set in a small wooden sailing boat, and am puzzled as to how I should make the earth

connection. Can you advise me?—D. M. (New Brighton).

A.—The best plan would be to fasten a copper plate measuring about three feet long by two feet wide to the outside of the boat, well below the water-line, and take the earth lead to this plate. The plate should not, of course, be painted.—D. B.

Use of Power Valve

Q.—I am at present using a two-valve set, detector with reaction and one L.F. stage, with ordinary receiving valves in both positions. Should I obtain a greater volume of sound from the loud-speaker by using a power valve in the last stage?—C. L. (Oldham).

A.—Unless at present you have reason to think that the last valve is being overloaded we should not advise you to make the change.

A power valve is certainly capable of dealing with more power than an ordinary valve, but the ability to do this is only obtained at the expense of a high amplification factor.

If you will study the figures of the various valve manufacturers you will find that the amplification factor of a power valve is always low. In your case we think that you will do better to continue using a valve with a moderately high amplification factor in the last stage.—D. B.

Series and Parallel

Q.—At present I am using my aerial tuning condenser in parallel with the tuning coil. If I put the condenser in series I understand that I will have to change my present coil. Will I have to use a larger or a smaller coil?—T. P. (Hammersmith).

A.—By putting the aerial condenser in series, instead of in parallel, with the coil you will decrease both the maximum and minimum wavelengths to which you can tune with the present coil. Therefore, in order to cover the same wave-band as at present you will have to use a larger tuning coil when the condenser is in series with it.—B.

Eliminates Soldering



Transverse slot with clamping nut, eliminating soldering.

The Top does not rotate.
The Head does not come off.
The Smooth Stem ensures that strands of wire will not bind up with thread.
The finish is perfect throughout.

The Belling-Lee Patented Terminal, made with 30 different engravings, is used by the manufacturers of all the best battery eliminators.

Standard Model (Bakelite insulated), Type B 9d. each.
Popular Model (non-insulated), Type M 6d. each.

Illustrated catalogue free on request. Obtainable from all dealers, but in case of difficulty send your order to us, enclosing your dealer's name and address.

**BELLING-LEE
TERMINALS**

Belling & Lee, Ltd., Queensway Works, Ponders End, Middlesex.

When You Are In Difficulty—

It does not matter whether your knotty problem is a theoretical or a practical one—in either case the Technical Staff of the "Wireless Magazine" is ever ready to help you out of the difficulty. Just write your query out on one side of a sheet of paper (this small point saves us time and enables us to send an answer quicker) and send it with the coupon on page iii of the cover, a stamped addressed envelope and a fee of 1s. (postal order or stamps) to:—Information Bureau, "Wireless Magazine," 58-61, Fetter Lane, London, E.C.4.

Captain Round's Causerie (Continued from page 416)

towards that source just like a resistance. But at those frequencies when reflection takes place the source of energy will "think" it has a storer of energy to deal with, that is, a capacity or an inductance. What happens in this area will be rather complex, and we shall only consider the frequencies where the aerial "looked at" by the energy source acts as a resistance, or where the cone acts as a pure absorber.

Constant E.M.F.

Our source of energy has merely got to provide a constant E.M.F., in the electrical case, or a constant force, in the mechanical case, to give a constant radiation over the frequency range.

I shall not go into the difficulties involved here, but will merely mention one case where the force will be the same at all frequencies and that is with the moving-coil type of movement, but even in this case the con-

sideration is a little complex because the moving coil has weight.

The problems involved in the production of constant force have been theoretically solved both with moving-coil and moving-cone instruments, and in a later article I may take this question up, because much of the modern work on loud-speakers and gramophones depends upon it.

I have tried to indicate that the extended cone can be a highly efficient radiator of sound, possibly just as efficient as the horn—and that over a very large proportion of the frequency scale its output can be made uniform if the various factors of stiffness, weight, damping, and size are taken into consideration, and, of course, if we supply the force at the centre in a correct way.

Great developments are going to take place here, but the field is obviously for those who patiently make accurate measurements.

CAXTON WIRELESS CABINETS THOUSANDS OF SATISFIED CUSTOMERS.

All Polished with new enamel that gives a glass hard surface that cannot be soiled or scratched. Ebonite or Radion Panels Supplied and Perfectly Fitted at low extra cost. SENT FREE—Catalogue of Standard Wireless Cabinets in various sizes and woods.

Elstree "Solodyne"

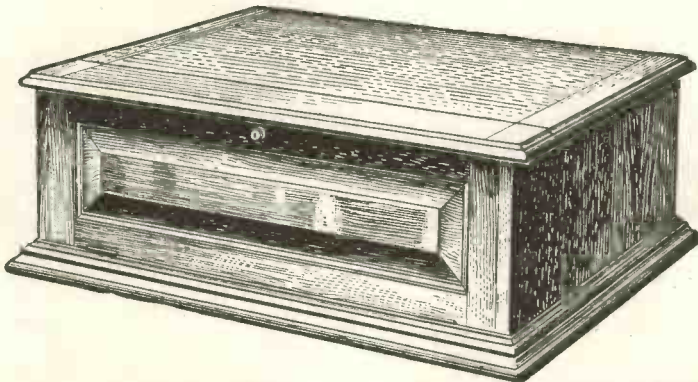

Specially designed for this famous Radio Press Circuit. All details and dimensions conform to their specification, enabling constructors to follow the layout without difficulty.

PRICES:

Light Fumed Oak **66/-** Dark or Jacobean Oak **70/-** Real Mahogany **73/-**
Prices include either "fall front" with handsome solid raised panel, as illustrated, or beaded doors, allowing ample space for tuning controls, etc. Glass panelled doors can also be supplied at 3/- extra.

CASH WITH ORDER. CARRIAGE PAID U.K. PROMPT DELIVERY.

Packing Case 5/- extra repaid if Case returned within 14 days Carriage paid to Works.

CAXTON WOOD TURNERY CO., MARKET HARBOROUGH.

Write to advertisers for particulars of their goods and mention the "W.M."

STANDARD SAC-LECLANCHE WET H.T. BATTERIES.

**EVEN FLOW
EFFICIENCY
ECONOMY**

SEPARATE PARTS.



Sac.



Zinc.



Jar. 1 1/2" square 2 1/2" high.



Complete Cell.

1 1/2 VOLTS PER CELL.



Illustration of 90 volt 60 cell battery. Size 11" x 17 1/2"
Mahogany tray 8/6 extra.
Double Tier Tray as described on p. 437 of this issue
12/6.

PRICES OF COMPLETE SETS.

Complete sets of parts for making up batteries of various voltages, including Jars (waxed), Sacs, Zincs, Rubber Insulating Bands, and Electrolyte.

Voltage.	No. of Cells.	Size of Sacs.	Price for the complete set.
60	40	No. 1	14 3
60	40	2	18 7
72	48	1	18 8
72	48	2	£1 2 0
90	60	1	1 1 0
90	60	2	1 7 8
108	72	1	1 5 0
108	72	2	1 13 0
126	84	1	1 9 0
126	84	2	1 18 3
136	91	1	1 11 0
136	91	2	2 1 0

Prices of other voltages on application.

If Terminal Sacs are required add 9d. per dozen cells extra.

SPECIAL OFFER.

For a limited period we are offering a sample set of 12 Cells, comprising 12 waxed jars, 12 No. 1 sacs, 12 new pattern zincs with socket holes for inserting winder plug in each cell. Sample lot of Electrolyte for 20 cells, rubber insulating bands, and full instructions for assembling and upkeep. This battery will give 18 volts. Price complete, 4s. By post 9d. extra.

No Charging—Economical—Permanent—Silent

Send 1d. stamp for illustrated list giving full particulars, maintenance hints and useful information. We shall be pleased to advise the best battery to suit your set on receipt of full details.

WET H.T. BATTERY CO.,
12, Brownlow St., HIGH HOLBORN, W.C.2.

By First Avenue Hotel.

GADGETS, HINTS & TIPS

Use for Burnt-out Transformers

MOST constructors possess one or more transformers in which the primary winding has broken

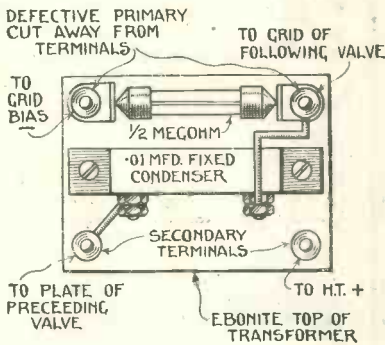

Method of Making Connections.

while the secondary winding is intact.

An excellent choke-coupling unit using such a transformer can be con-

structed in the manner shown in the illustration.

A fixed condenser of .01 microfarad capacity, and a 1/2-megohm grid leak will be required for the unit, the grid

secured to strips of ebonite, as shown, are used for plugging in.

Two-, four-, or six-pin coils, as required, may be successfully made in this manner. F. S.

When you write to the "Wireless Magazine" will you note that our address is now:—
58-61, Fetter Lane, London, E.C.4.

leak being clipped between two strips of brass clamped in the primary terminals.

The condenser may be fastened to the top or side of the transformer by means of screws.

Connections to the unit should be made as shown in the illustration.

C. E.

Making an R.C. Coupling Unit

THE sketch shows a simple method of constructing a resistance-capacity coupling unit suitable for use with present-day high-impedance high-amplification factor valves.

The values shown for the condenser and resistances need not be rigidly adhered to, but should preferably be made to suit the valve manufacturer's instructions if given.

The values shown, however, will give good results with most present-day R.C. valves.

If the unit is required for use with ordinary moderate impedance valves a wire-wound resistance of 100,000 to 150,000 ohms should be substituted for the 1-megohm resistance; the condenser should be changed to .01 microfarad, while for the grid leak of

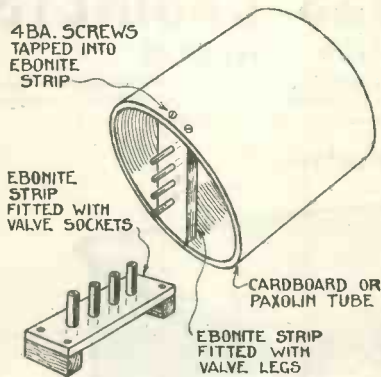

Method of Mounting Coil.

Home-made Plug-in Coils

MANY modern sets incorporate plug-in coils of the multi-pin type. While there are several excellent makes of this type of coil on the market, their cost may prevent the constructor from incorporating them in a set.

A simple method of making coils of the multi-pin type which has the advantage of low cost is shown in the illustration.

Shellacked cardboard may be employed for the winding former, while ordinary valve legs and sockets

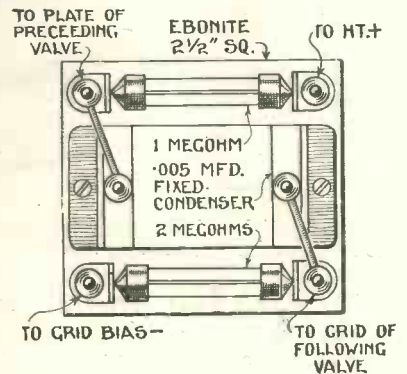

Connections of R.C. Unit.

2 megohms a leak of 1/2 to 1/4 megohm should be used. T. L. M.

CELESTION FIRST-ON-MERIT

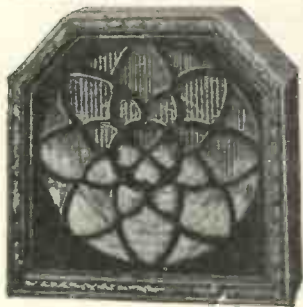

A 3 Model—Radiophone.

The Loudspeaker of Distinction.

Its efficiency and tonal qualities are beyond question. It was officially used at Olympia 1927.

AS USED BY MR. REYNER with his "Countryside Four" which is described in this issue.

Write for full particulars or ask for a demonstration at

CELESTION CO.,
33, VILLIERS STREET,
STRAND, W.C.2.

Now is the time to experiment in short-wave practice.

We have in stock the following :-
Bremer-Tully short-wave Tuning Unit and set of coils
from 12½ to 200 metres. Price 41/6.

Igranic short-wave coils from 10 to 100 metres.
10/- per Set.

Brandes Special Low Loss Condensers specially constructed
for short wave reception.
'0003 18/- each. '0005 18/6 each.

For up-river work and outdoor reception the new McMichael
set of parts for constructing your own portable Receiver
including Cabinet with Loud Speaker, Aerial, Batteries,
Valves, etc., etc.
Price £21 : 15 : 0 complete.

Do not fail to secure one of our Daycomar Loop Aerials
with Compass in base. Positively the best Frame Aerial
yet devised. Usual price £3 : 10 : 0. A limited number
only to clear at 30/- each.

OUR INTERNATIONAL RADIO CATALOGUE
(3rd Edition) will be sent to all enthusiasts send-
ing 6d. to cover cost of postage and packing.

WILL DAY LTD. (Dept. W.M.),
19, Lisle Street, Leicester Square, LONDON, W.C.2.
Telephone: Regent 4577. Telegrams: "Titles, Westrand, London."

ARTCRAFT RADIO CABINETS

Made in Oak and Mahogany. Properly Hand French Polished.

BRITAIN'S BEST VALUE.

"Artcraft Popular Type" Cabinets

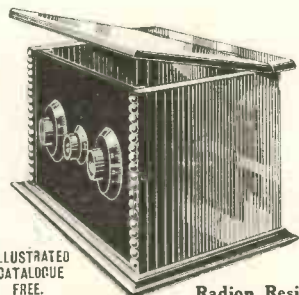

ILLUSTRATED
CATALOGUE
FREE.

Panel Size	Depth	Price in Oak	Price in Mahog.
9 x 6	6	6/0	10/0
10 x 8	6	8/0	12/0
12 x 10	8	12/0	16/0
14 x 10	8	14/0	19/0
16 x 8	8	14/0	19/0
18 x 12	9	21/0	29/0

Baseboards Free. Hinged Lids 1 6 extra.

CARRIAGE PAID England & Wales.
Enclose 1/- for part packing.

Cabinets for all "Wireless Magazine" Sets.

Radion, Resiston and Ebonart Panels Supplied.
THE ARTCRAFT COMPANY, 156, Cherry Orchard Rd., CROYDON.

Farrs Ad.

"PEERLESS" for the

FOUR-VALVE PORTABLE set—as specified in this issue.



The "Peerless" Resicon Con-
denser is a precision instru-
ment, compact and efficient.
Gives uniform tuning over
whole scale, operating finely
even without vernier. No
side strain. No backlash.
Prices 15/- to 18/-
(Dial and Vernier 2/6 extra.)
From all dealers or direct from

THE BEDFORD ELECTRICAL & RADIO Co. Ltd.,
22, Campbell Rd., Bedford.

Ask also to see the famous
"Peerless" Rheostats.

You will need these parts to build your



"Resistor 3"

and they are all made and
guaranteed by Dubilier.

- 1, 0.00025 mfd. Fixed Con-
denser, Type 610 with clips.
- 2, 0.001 mfd. Condensers,
Type 610 with series clips.*
- 4, 2MΩ Dumetohm Leaks.
- 1, Dumetohm Holder.
- 1, Duvarileak, 0 to 5MΩ.
- 1, Condenser, 0.00025 mfd.,
Type 610.

* For those who already possess
Type 610 condensers of this
capacity, these series clips can
be obtained for 6d. each.

The entire set listed above
costs only 30/- and your usual
Dealer will supply. In case
of difficulty apply to us direct.



Advt. of the Dubilier Condenser Co. (1925), Ltd.,
Ducon Works, Victoria Road, North Acton, W.3.

M.C. 274

Advertisers like to know whence the business comes—please mention the "W.M."

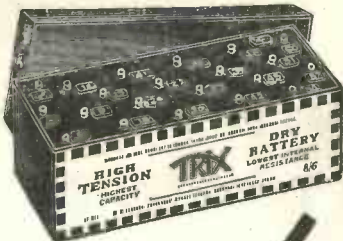

SIXTY VOLTS
Tapped every 3



NOW
ONLY
6/11

From all Dealers
or if any difficulty
POST FREE
from
ERIC J. IEVER
33 Clerkenwell Green,
London, E.C.1.
Phone: Clerk. 3014/5.

This is our original TRIX 8/6 sixty-volt battery which we are now able to reduce in price owing to greatly increased production. Satisfaction guaranteed.

WET H.T. POROUS POTS

Genuine miniature porous Pots for Wet H.T. to fit 2 1/2 x 1 1/2 Jar, registering 1.4 volts, 3 - per doz. Non-conductive Glass Jars 1/- doz., Waxed 1/3 per doz. Sacs 1/6 doz., Zincs 1/- doz. Send 1/4d. stamp for Price List and Instructions. Carriage and Packing extra.
Trade inquiries: **THE ETY GLASS BATTERY CO.** DEPT. C, 45, St. Mary's Road, E.10.
"PRIMARY BATTERIES." An excellent work on Wet Batteries published by Messrs. Cassell & Co., 1/6. Post free 1/8.

REMARKABLE OFFER

ENGLISH DULL EMITTER VALVES
5/- each. 2 volt '06 H.F., 2 volt '06 L.F., 2 volt Power '34. All one price 5/-, all guaranteed.
"Uncle Tom," **PAYNE & HORNSBY Ltd.** Rokér Avenue, Sunderland, Garden St., North Shields; 10, Queen Victoria Street, LEEDS; Gallowgate, NEWCASTLE-ON-TYNE.
All postal orders to Newcastle (Dept. 5). 3d. extra per valve for postage must be included.

Don't use Ebonite!

The brilliant red of Padouk wood lends beauty to your set, and has excellent insulating properties. It is only half the price of ebonite, and being an open wood is easily cut and sanded. A descriptive leaflet with technical opinions and tests, as well as cost of suitable boards, FREE on application.
HOBBIES Ltd. (Dept. 23), **DEREHAM, NORFOLK**, or from any Hobbies Branch in London, Glasgow, etc.

Read
"Amateur Wireless"
Every Week.

When you send your order don't forget to say you "saw it in the 'W.M.'"

"Wireless Magazine" REFERENCE SHEETS

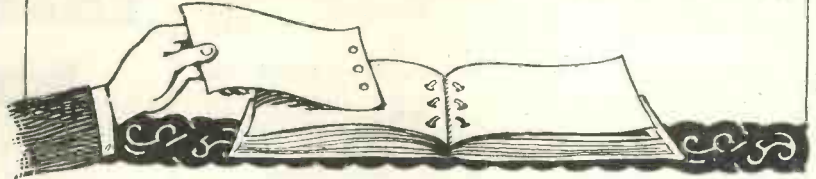

Compiled by **J. H. REYNER, B.Sc., A.M.I.E.E.**

Month by month these sheets can be cut out and filed—either in a loose-leaf folder or on cards—for reference. The sequence of filing is

a matter for personal choice. In a short time the amateur will be able to compile for himself a valuable reference book.

WIRELESS MAGAZINE Reference Sheet

No 6

Aerial Resistance

THE resistance of an aerial circuit is made up of a number of factors. First, there is the conductor resistance which comprises the resistance of the wire of the aerial itself, including the tuning coil in the aerial circuit, together with the earth resistance.

Thirdly, there is the radiation resistance of the aerial, which is a measure of the property possessed by the aerial for converting high-frequency currents to electric waves which are radiated into space, or conversely, for receiving waves from a distant transmitting station and converting them to electric currents.

These various effects vary with the wavelength. The conductor resistance falls off as the wavelength increases, being inversely proportional to the square root of the wavelength. The dielectric loss increases with the wavelength, being directly proportional thereto. The radiation resistance falls off rapidly as the wavelength increases and is inversely proportional to the square of the wavelength.

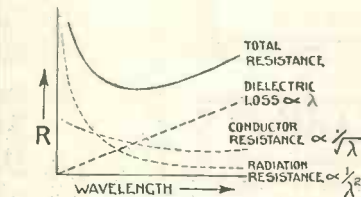

Aerial Resistance Curves.

Secondly, there is the dielectric resistance of the aerial, which is due to the losses introduced by dielectric in the field of the aerial. This includes buildings, trees, grass and similar objects immediately underneath or in the proximity of the aerial which are in the electric field and so introduce dielectric loss.

The total resistance is made up of the combination of these three effects, as shown in the figure, and it will be seen that there is a minimum value for the resistance, so that it is most efficient at one particular wavelength.

This minimum resistance occurs at about two or three times the natural wavelength of the aerial, which latter quantity is about four times the actual length of the aerial. A 100-ft. aerial is therefore most efficient in the region of 350 metres, which is about the middle of the European broadcast band.

WIRELESS MAGAZINE Reference Sheet

No. 7

Wavetraps

TUNING in a wireless receiver may be obtained by a series of cascade-coupled tuned circuits which exercise a progressive filtering effect so that the current is a maximum for one particular frequency to which the circuits are tuned and falls away more or less rapidly for frequencies on either side of the resonant point.

affecting stations operating on wavelengths comparatively close.

A circuit which enables these two desirable features to be obtained is that shown in the accompanying diagram. This is known as the series reactor trap. The aerial lead to the receiver is

This form of tuning is satisfactory when dealing with a number of stations all more or less distant, but difficulties are introduced if it is desired to eliminate one station operating very close to the receiving station.

In such cases the use of a wavetraps may be resorted to. This consists of a tuned circuit, which is tuned to the interfering station, and is placed in such a position that it will cause the whole circuit to exercise a very high impedance at that particular frequency while exhibiting quite a low impedance, if necessary, at frequencies only slightly removed.

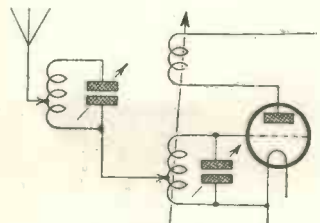

Wavetraps Circuit.

For best results it is essential that the tuning of the wavetraps itself shall be independent of the main tuning circuits of the receiver so that the wavetraps can be left set to the particular interfering station and tuning carried out on the remainder of the receiver in a normal manner.

Another desirable feature is that the wavetraps shall eliminate the local station completely without

fed through the trap, being tapped across a small portion of the trap tuning inductance. The extent of the trapping action is varied by a decreasing or increasing of the amount of inductance in the aerial circuit.

Blueprints

Contact prints from the draughtsman's original design, being full-size working blueprints, showing the method of wiring and disposition of components, are now available of the following "Wireless Magazine" and "Amateur Wireless" Sets.

	No.	Price post free.
		s. d.
ONE VALVE SETS.		
One Valver for Frame Aerial	W.M.4	1 0
One Valve All-wave Reinartz	A.W.2	1 0
All-in-All One Valver	A.W.13	1 0
TWO VALVE SETS.		
All-broadcast Two*	W.M.5	1 3
Safeguard Two	A.W.3	1 0
Two-valver embodying K.L.1 Valves	A.W.5	1 0
One-Control Two	A.W.6	1 0
Wide World Short-wave Two	A.W.11	1 0
All-wave Two Valver	A.W.15	1 0
THREE VALVE SETS.		
One-knob Three	W.M.3	1 0
Continental Three	W.M.7	1 0
Shielded Searcher	W.M.8	1 0
Victory Three	A.W.9	1 0
Regulator Three	A.W.12	1 0
M.C. Three, with copy of "Amateur Wireless" giving full instructions	A.W.1	7
A.W. Ballot Three, with copy of "Amateur Wireless" giving full instructions	A.W.4	7
The Hi-Mu R.C. Three*	W.M.9	1 3
M.C.3 Star	A.W.16	1 0
FOUR VALVE SETS.		
Paradyne Four	W.M.2	1 6
M.C. Four	A.W.8	1 6
The Distance Getter	A.W.10	1 6
Household Four	A.W.17	1 6
DX Four	A.W.18	1 6
FIVE VALVE SETS.		
1927 Five	W.M.6	1 6
Two-volter's Five	W.M.11	1 6
AMPLIFIERS.		
All-broadcast Amplifier	W.M.10	1 0
Two Valve D.C. Mains Amplifier	W.M.16	1 0
PORTABLE SETS.		
Springtime Portable Two-valver	W.M.12	1 0
The Countryside Four	W.M.17	1 6
Motorists Portable (4-valver)	A.W.14	1 6
CRYSTAL SETS.		
Crystal Set for the R.C. Enthusiast	W.M.13	6
Fonotrol Crystal Set	W.M.14	6
MISCELLANEOUS.		
Loud Speaker Tone Control and Filter Unit*	W.M.1	1 3
Heterodyne Wavemeter	A.W.7	1 0

* With copy of "Wireless Magazine," complete.

Send a postal order to-day to

Wireless Magazine

Blueprint Service,

58/61, Fetter Lane,

London, E.C.4.



DO YOU KNOW?

That you can have this wonderful TWO-VALVE General Radio set installed in your house for £1 down?

NOTHING ELSE TO BUY.—The set is complete with LOUD SPEAKER, HEADPHONES, Dull Emitter Valves, Accumulator, Battery, complete aerial equipment, all cords and plugs, etc., and the Royalty is paid.

Every set and every part is guaranteed. The price of the complete set is £1 down and 20/- a month for twelve months only, or £12 cash.

FREE INSTALLATION.—On receipt of the first payment of 20/- one of our own Installation Engineers will come to your house anywhere in the country and will erect, instal, demonstrate and leave the set playing for you—free of charge. It is only necessary to provide an aerial pole if trees, etc., are not available.

By having the set installed by our own Engineers we ensure that you cannot buy a General Radio set that does not give you perfect satisfaction. No other wireless firm gives you this service and this safeguard.

Send a P.C. to-day for our new illustrated catalogue No. 452 and full particulars of this unique offer.

General Radio

GENERAL RADIO CO. LTD.
RADIO HOUSE, 235 Regent St., W. 1



Your HOME Radiola! taking your Set and Batteries Complete.
In many Artistic Models Beautifully Finished.
SENT ON APPROVAL.
Latest Proc.
Picketts Cabinet (M.G.) Works, Bexleyheath.

From **£5 5 0**
Cash or Easy Payments.

THE READY SUPPLY CO.
41, NEWCOMEN STREET,
LONDON BRIDGE, S.E. 1.
LOW PRICES. PROMPT DELIVERY.

Write to-day for price lists of components for circuits described in this issue.

- (1) Country-side 4-valve Portable.
- (2) Reinartz R.C.3 for the Family.
- (3) Fonotrol Crystal Set.
- (4) 2-Valve L.F. Amplifier from D.C. Mains.

We specialise in radio components for all "Wireless Magazine" Circuits.

L.F. Resistance Coupling

THE resistance-coupled circuit is an attempt to obtain uniform amplification at audio frequencies irrespective of the actual frequency within very wide limits. For satisfactory quality it is necessary that differences between the ranges of 50 and 5,000 shall be uniformly amplified. A 10 per cent. variation is permissible over the whole of the amplifier, since experiments indicate that the ear cannot distinguish variations of intensity of less than 10 per cent.

The voltage across the resistance in the anode circuit is more or less independent of the frequency. At the very high frequencies there is a tendency for the voltage to fall off owing to a certain shunting effect due to capacity in the resistance. It is essential therefore in the first place to avoid excessive capacity across the resistance if the high tones are to be preserved.

It is in transferring the voltage from this resistance to the next valve that possibilities of uneven amplification arise. The impedance of the coupling condenser employed must be low even at the lowest frequencies which have to be handled. The presence of these coupling condensers is necessary in order to prevent the high-tension voltage from the anode circuit of the preceding valve from being applied direct to the grid of the preceding valve.

Such a voltage would polarise the succeeding valve completely, and it is necessary therefore to isolate the direct potential by means of a coupling condenser which still permits varying voltages to be transferred from one valve to the next.

With the grid isolated in this manner it is necessary to provide a leak to the filament and the value of the leak depends on the choice of the coupling condenser.

In designing a resistance stage it is necessary first to choose an anode resistance of three or four times the impedance of the valve and then to choose a grid leak having a value about four times that of the anode resistance.

The coupling condenser is then determined by the value of the grid leak and the following figures will give some idea of the minimum condenser desirable:—

Grid Leak (Megohms).	Coupling Condenser (Microfarads).
0.5	0.02
1.0	0.01
2.0	0.005
3.0	0.0035
5.0	0.002

Smoothing in Eliminator Circuits

IN circuits designed to provide high-tension voltages from the electric-light mains, it is necessary to smooth out the ripple so that no disturbance is introduced into the receiver to which the eliminator is connected.

In the case of D.C. mains this ripple arises from

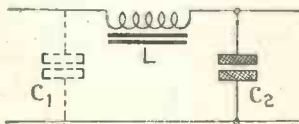

Simple Filter Circuit.

small variations in the voltage produced by the generator itself at the power station. In the case of an alternating current some rectifying system is incorporated to convert the current into unidirectional pulses, after which this fluctuating current must be smoothed to a more or less steady value.

A suitable smoothing circuit is of the type shown in the figure. In the case of an alternating-current system the first condenser C₁ is a reservoir condenser which stores up the pulses from the recti-

fying system and delivers the current again in a more or less steady flow. This condenser must be of adequate capacity for the load to be supplied.

The output from this condenser is passed through a choke coil L which tends to damp out any fluctuations whilst still leaving the D.C. current unaffected. The condenser C₂ serves to augment this filtering action and must again be of adequate capacity.

The necessary smoothing action is obtained by suitably choosing the values of L and C₂, the larger the values of these components, the greater being the smoothing effect. It is found preferable in practice to increase the condenser rather than the choke because the increase in the inductance of the choke is usually accompanied by extra resistance which spoils the regulation (see sheet No. 10). In practice values of 30 to 50 henries for L and at least four microfarads for C₂ are satisfactory.

In the case of D.C. eliminators the input condenser C₁ is quite unnecessary and has practically no effect on any ripple which may be present. There is already so much capacity in the mains themselves that the addition of this extra capacity is of little importance. This point is often not appreciated.

Regulation in Battery Eliminators

THE regulation of a machine is the percentage change in the voltage between the no-load and full-load conditions. It has particular application in the case of battery eliminators, where careful design is required if the voltage is to be maintained under reasonably heavy loads. A good eliminator should be able to give a current of 20 to 30 milliamperes without drop in voltage of more than 20 per cent., although many H.T. units do not give a performance as good as this.

The principal source of voltage drop is the choke used in the smoothing circuit. The steady current has to flow through this choke and in consequence there is a certain voltage drop. The voltage on the output of the unit therefore is less than the full voltage by the amount of this drop, which increases with the load so that there will be a steady fall off in the voltage. It is essential therefore to keep the choke of low resistance in order to maintain a satisfactory regulation.

In the case of A.C. mains units the filter proper is preceded by a reservoir condenser which stores up the impulses received from the rectifying system and supplies current to the output at a steady rate. The size of this reservoir condenser also has a considerable effect on the regulation.

As current is withdrawn from the condenser the

voltage tends to fall and is restored again on a pulse of current arriving from the rectifier. The actual voltage is a balance between these two and consequently depends to a large extent upon the current taken from the output. Thus, as the output increases the voltage tends to drop, but this

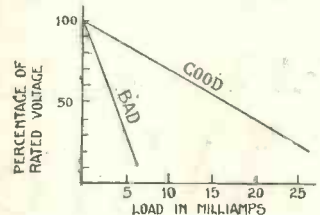

effect may be minimised by using a large value of reservoir condenser, and in practice a value of at least four microfarads is desirable.

The choke should then have an inductance of 20 to 30 henries, with as low a D.C. resistance as practicable. If careful attention is paid to these two factors a good eliminator will result.

Write to advertisers for particulars of their goods and mention the "W.M."



SAFETY SWITCH
 Comprising: Switch, Lightning Arrester, Lead-in Tube and Weatherproof Cover. The Eelox safety switch, the latest development in Safety First devices, enables the operator from inside to earth the aerial outside the house. By pushing the knob the set is at once connected to the aerial. A pull instantly disconnects the set from the aerial system, automatically earthing the aerial. The spark gap provides ample means of by-passing any electrical discharge which may occur while set is in operation.

If unable to obtain locally write for list "W.M. 7" giving local dealers' names and addresses.

6 in. Tube PRICE **5/6**
 12 in. tube 6/6. 18 in. tube 7/6.
 Phone: Clerkenwell 9282/9283.
J. J. EALICK & SONS
EELIX HOUSE,
 118, BUNHILL ROW, LONDON, E.C.1.

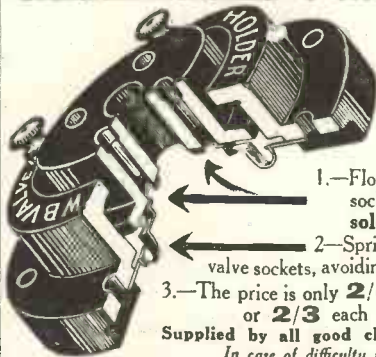

W.B. ANTIPHONIC LOW-LOSS VALVE HOLDER
 Cut open for your inspection
 Notice that—

- 1.—Floating springs and valve sockets are riveted and soldered.
- 2.—Springs are at right angles to valve sockets, avoiding side strain and snapping.
- 3.—The price is only 2/- each, without terminals or 2/3 each with terminals.

Supplied by all good class dealers from stock.
 In case of difficulty write to the makers:
WHITELEY, BONEHAM & Co., Ltd.
 Duke Street, Mansfield, Notts.

WEAK JOINTS



NEED FLUXITE!

Fluxite Soldering Set complete **7/6**

All Hardware and Ironmongery Stores sell FLUXITE in Tins, price 8d., 1/4 and 2/8. Another use for Fluxite—Hardening Tools and Case Hardening. Ask for leaflet on improved methods.

FLUXITE LTD.
 (Dept. 332).
 Rotherhithe, S.E.16.





TRUE TUNING "INDIVIDUAL-GANG" CONTROL CONDENSER

again to the fore!

FIRST we gave our customers a highly efficient and low-priced Variable Condenser and L.F. Transformer. Now we lead in the design of a Gang Control Condenser with individual adjustment which has all the advantages of the ordinary Gang and Single Condensers without ANY of their disadvantages.

CROWN WORKS, Dept. 6,
 Cricklewood Lane, N.W. 2.
 Phone: 1787 Hampstead.

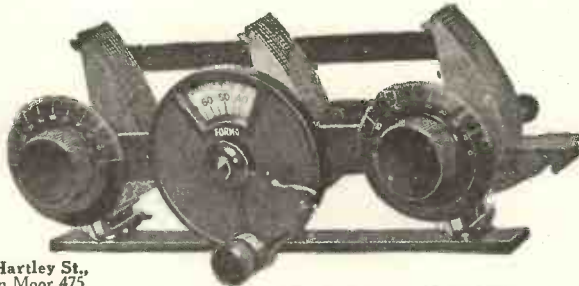
Manchester: Mr. J. B. Levee, 23, Hartley St.,
 Levenshulme. Phone: Heaton Moor 475.



TWIN-GANG - - £2 : 12 : 6

TRIPLE-GANG - £3 : 3 : 0

TUNE with the centre dial until you hear your station.

ADJUST with the side dials for maximum signal strength.

**IT'S SIMPLE!
 IT'S EFFICIENT!!
 IT'S GOOD!!!
 IT'S FORMO!!!!**

WEARITE COMPONENTS

WRIGHT & WEAIRE, LTD.,
 70, HIGH ROAD,
 TOTTENHAM, N.17.
 Phone: Tottenham 3132.

THE COUNTRYSIDE FOUR.

Mr. J. H. REYNER'S PORTABLE.

- Special Midget Binocular Coils - - 15/- pair.
- B.B.C. Wavelength - - - - - 6/6 each.
- 5XX Wavelength - - - - - 8/6 each.
- Rotary Change-over Switch No. G 11 - 2/6 each.

CUT THIS OUT FOR CABINETS

and post to us for FREE list illustrating Cabinets as shown in "Wireless Magazine", etc., etc., and for our additional Bulletin No. 2.

NAME

ADDRESS



(Write in block letters please)
CARRINGTON Mfg. Co., Ltd.,
 Camco Works, Sanderstead Road,
 South Croydon.
 Trade enquiries especially invited.



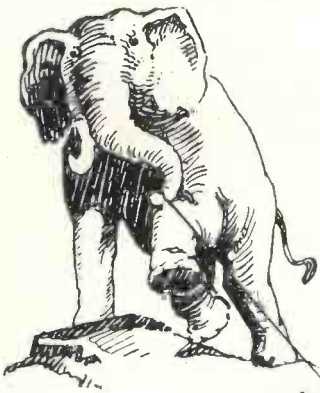

THE WONDERFUL P. M. FILAMENT



A master filament . . .

huge in proportions and gigantic in emission surface . . . tough and always ductile so that it may be tied in knots . . . proved by National Physical Laboratory Test to be constant and lasting . . . gives majestic volume free from microphonic noise . . . too economical even to glow . . . a wonderful filament . . . British made . . . to be found only in Mullard P.M. Valves

Mullard THE MASTER VALVE

ADVT. THE MULLARD WIRELESS SERVICE CO. LTD.,
MULLARD HOUSE, DENMARK ST.,
LONDON, W.C. 2.

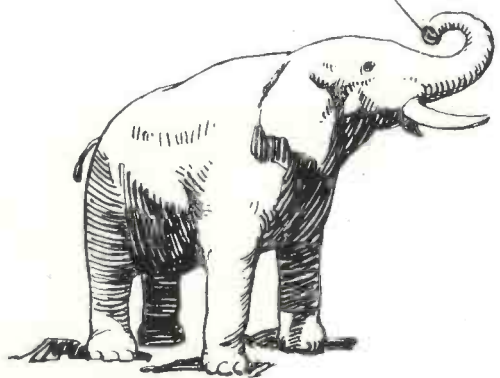

Write to advertisers for particulars of their goods and mention the "W.M."

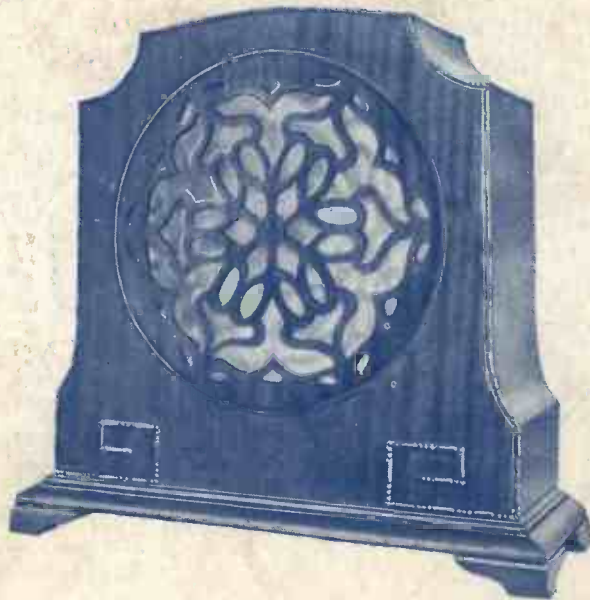

Radio Realism

No longer is there need to suffer from the well-known "phonograph effect" so commonly associated with wireless loud speaker reproduction, even of the best obtainable quality. The new **AMPLION** Cone Speaker — designed and constructed by the manufacturers of the world's Standard Wireless Loud Speaker—gives the correct pitch and equal balance to all notes, bringing out the subtle shades of tone which characterise the different musical instruments and human voices. It affords for the first time what may be truly termed "**RADIO REALISM.**" Your dealer will gladly demonstrate.

CONE
AMPLION
SPEAKER

The model illustrated above is the Amplion "Chippendale" Mahogany Cabinet at £7:0:0. Other models from £3:15:0.

Send for Illustrated Booklet WL5
**GRAHAM AMPLION
LIMITED**
25, Savile Row, London,
W.1