

FREE BLUEPRINT OF ? TONE CONTROLLER

Wireless Magazine

Vol. 5. No. 26
MARCH, 1927.

Edited by Bernard E. Jones
Technical Editor: J.H. Reyner,
B.Sc.(Hons) A.M.I.E.E.

1/2 MONTHLY

Build
Reyner's
Paradyne
Four



**SPECIAL
BLUEPRINT
SERVICE**
SEE
PAGE 102



THE BIG BRITISH WIRELESS MONTHLY

Do you use a 6 volt accumulator?

B.T.H. HAVE NOW EVOLVED THE IDEAL VALVE COMBINATION

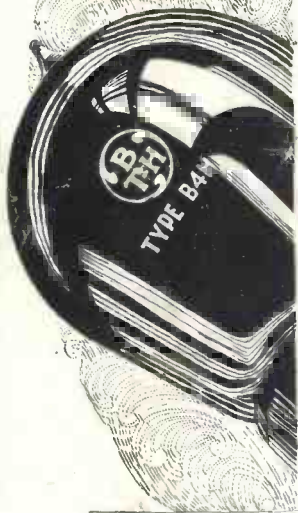

The famous B.4. Valve—the finest power amplifying valve ever made—has now its counterpart in the new B.4.H. In these two valves we have provided the ideal combination for 6 volt accumulators.

The B.4.H. is intended for H.F., detector and early L.F. stages, and the B.4. for the final L.F. Stage. Those who have had experience of the B.4. valve will find the B.4.H. no less remarkable in its own sphere, while from the combination they will obtain a quality of reproduction hitherto undreamed of.

If you have a B.4., buy a B.4.H. If you haven't, buy both.

B4H

Filament Volts 6
Filament Amps. 0.25
H.T. Volts.....60 to 120
Impedance 28,000 ohms

Price - 14/-

B4

Filament Volts 6
Filament Amps. 0.25
H.T. Volts.....40 to 120
Impedance.....6,000 ohms

Price - 18/6



VALVES

Thoroughbreds!

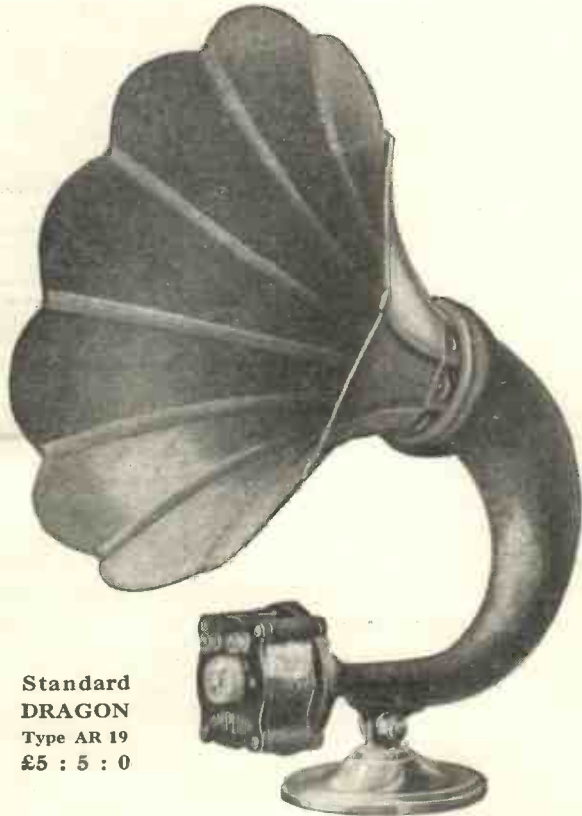

Standard
DRAGON
Type AR 19
£5 : 5 : 0

There are 21 varieties of the world famous

AMPLION LOUD SPEAKER

At prices varying from 38/- to £13-13-0

There are horn types in the Dragon design (as illustrated) or in the graceful swan-neck shapes. There is the Radiolux Cabinet type and there is the new Amplion "Cabinette."

Every member of this famous family is a thoroughbred, having a pedigree dating back no less than 40 years.

There is no Substitute for a genuine Amplion

Announcement of Graham Amplion Limited, 25 Savile Row, London W.1.

Mention of the "Wireless Magazine" will ensure prompt attention.

Amateur Wireless HANDBOOKS

each 2/6 net

Loud-speaker Crystal Sets How to Make and Manage Them

Provides working instructions for building a number of highly efficient crystal sets; making an attachment for simple connection to existing wireless set; and designs for crystal sets embodying the crystal loud-speaker system.

Wireless—controlled Mechanism For Amateurs

This book is an illustrated practical guide to the making and using of short-range wireless control apparatus, and it has been written so simply that it can be understood by any enthusiast possessing an elementary knowledge of wireless.

The Wireless Man's Workshop By R. W. Hallows, M.A.

Written by a practical home constructor, this book—containing much useful wireless information—enlightens readers on the selection and right methods of using the tools and materials used in constructing wireless sets.

The Practical "Super-het" Book

Explains what the Super-het is, what it does, how it works, and how to build up a number of super-het sets made of tested, British-made components.

Perfect Broadcast Reception By Ernest H. Robinson (5YM)

Explains how most sets fall short of the ideal and how to obtain perfect reception. Is virtually a popular exposition of the main problems of transmission and reception. Very valuable alike to listeners and experimenters.

The Short-wave Handbook By Ernest H. Robinson (5YM)

Describes in very simple language the wireless apparatus used in short-wave work, shows how to make it and how to use it, and explains the technical principles with which the beginner will need to become acquainted.

The Practical Wireless Data Book

The intelligent novice, and particularly the home constructor and the keen wireless amateur who is always rigging up different circuits and experimenting for progress, will find this Data Book extremely helpful.

*Of all Newsagents and Booksellers,
2/6 net each, or 2/9 post free from
Cassell and Company Limited,
La Belle Sauvage, London, E.C.4.*

each 1/6 net

Wireless Telephony Explained

CONTENTS: The Electron; Induction and Electro-magnetism; Waves and How they Travel; Inductance and Capacity; Rectification; Amplification; Reaction and Beat Reception; Aerials and Earths; Transmission Systems; Receiving Sets; Useful Formulae and Data; Index.

Crystal Receiving Sets And How to Make Them

CONTENTS: A Simple and Efficient Receiving Set; A Single-slider Set; Set with Semi-circular Tuner; Crystal Set with Tapped Single Coil; A Loose-coupled Set; Set with Plug-in Basket Coils; Combined Crystal and Valve Receiver; Some Miniature Receiving Sets; Crystal Circuits; How Crystals Work; Making a Buzzer; Receiving C.W. Signals on a Crystal Set; Converting Low-resistance Phones; The Morse Code; Index.

Wireless Component Parts And How to Make Them

CONTENTS: Components and Their Varied Purposes; Crystal Detectors; Coils, Making and Mounting; Condensers; Variometers and Vario-couplers; Resistances or Rheostats; Transformers; Making a Test Buzzer; Index.

Wireless Telegraphy and Telephony And How to Make the Apparatus

CONTENTS: General Principles of Wireless Telegraphy; Some Informative Experiments; Tuning and Resonance Explained; Transmission and Reception; Various Detectors Explained and Described; Thermionic Valves as Detectors, Amplifiers and Generators; Making a Single-circuit Receiving Set; Making a Complete Short-wave Receiving Set; Making a Valve Panel for a Receiving Set; Making a Five-valve Amplifier Wireless Telegraphy; Arrangement and Erection of Aerials; Index.

*Of all Newsagents and Booksellers,
1/6 net each, or by post 3d. extra
from Cassell and Company Limited,
La Belle Sauvage, E.C.4.*

Practical Guide to Wireless (1s. net, postage 2d.)

CONTENTS: An Outline of Present Broadcasting; The Aerial; Tuners and Tuning; The Crystal Set; The Valve and Valve Sets; Telephones and Loud-speakers; Current for Valve Filaments; Index.

A Useful Series for Wireless Amateurs

Cassell Books

La Belle Sauvage, London E.C.4.

When you send your order don't forget to say you "saw it in the 'W.M.'"

EELEX

YOUR Requirements fully met by the TREBLE DUTY Terminal and Standardised PLUGS and Sockets System INVESTIGATE for yourself by writing for List W.M.4

EELEX TREBLE DUTY Terminal 4 1/2d. ea. Nickel Finish.

J. J. EASTICK & SONS
EELEX HOUSE
118, Bunhill Row, E.C.
 118, Bunhill Row, E.C. Clerkenwell 9282/3.

"1927 Five" Set as described in the October "Wireless Magazine."

Set of 3 BECOL Low Loss Coil Formers and Discs for High or Low Wave Lengths. Ready to receive fittings and windings. Packing and postage 9d. ex. per Set. **12/6**

For the "AMERICA SEVEN" Set as described in 1927 January issue "Wireless Magazine."

Set of 3 BECOL SIX POINT

Low Loss FORMERS, 1 Tube, 2 1/2" diam., 2 3/4" long. each 4" long, 3" diam. 1 Tube, 1" diam., 2 1/2" long. **3 Formers with discs and 3 Tubes as detailed above, ready for winding. Price 12/6**

Ebonite Rod 3/8" diam., 2 1/4" long.
Ebonite Terminal Strips—
 One piece, 12" x 2" x 1/4" thick.
 One piece, 3" x 2" x 1/4" thick.
 One piece, 2" x 2" x 1/4" thick.
 Rod and Strips as detailed above. Price **3/-**

All made in the famous BECOL Ebonite. Look for the trade mark. Delivery from stock. Apply to your dealer. If unobtainable come to us.

Packing and Postage 9d. extra.

Write for List "M." THE BRITISH EBONITE CO. LTD. Nightingale Road, Hanwell, London, W.7. Trade Mark.

BECOL
 Registered

RAZOR-SHARP WAVEMETER.

As described by Mr. J. H. Reyner in R.P. Envelope. No. 14.

Complete set of parts, including coils covering 180-2,000 metres .. **£4 4 0**

The instrument, ready wired and tested .. **£5 0 0**

Coils for the above can be supplied as follows:—

No. 1 Coil 180-600 metres ..	10/-
No. 2 Coil 600-2,000 metres ..	10/-
3-Pin Coil mount with brackets ..	4/-

MAGNUM RESISTORS.

Supplied in ranges to suit all types of Valves.

Note.—When ordering, state make and type of Valve used and voltage of Accumulator.

Magnum Resistors eliminate unsightly knobs, ensure correct filament temperature, and prevent overrunning.

Price:

Resistor on Base	2/6	No. 1059.
Resistor only	1/9	Size:
Shorting Plug	1/-	Overall size of base 2 1/4 in. x 1 1/2 in.
		Overall height 1 3/8 in.

Special Battery strip complete with cords 7/6, as used in the Paradyne Receiver described in this issue by Mr. J. H. Reyner.

BURNE JONES & CO., LTD.,
 Manufacturing Radio Engineers,
 Magnum House,
288, BOROUGH HIGH ST., LONDON, S.E.1
 Telephone: Hop 6257. Telegrams: "Burjomag, Sedist, London."
 Cables: "Burjomag, London."

Get the best out of your set by reading

AMATEUR WIRELESS

Week by week it contains useful constructional articles, written by experts, and helpful contributions on new developments and novelties, all profusely illustrated.

See this week's issue. **3d. Every Thursday.**

CUT THIS OUT FOR CABINETS

and post to us for FREE list illustrating Cabinets as shown in "Wireless Magazine," etc., etc., and for our additional Bulletin No. 1.

NAME

ADDRESS

CAMCO CASEWORK

(Write in block letters please)
CARRINGTON Mfg. Co., Ltd.,
 18-20, Normans Buildings, Mitchell Street, Central Street, London, E.C.1.
 Trade enquiries especially invited.

Better service results from mentioning the "Wireless Magazine" when writing to advertisers.

THINK THIS OUT—

your judgment will improve your set and save you money.

WHEN you see Radio parts mentioned in any circuit or receiver built up for publication in any radio journal that the best parts have always necessarily been used for that circuit, because naturally advertisers expect a share in that kind of mention and USUALLY GET IT. Always remind yourself of that when building. Remember, too, that you are free to choose your own parts, and should do so if you can benefit. **HOW TO GAIN, AND GAIN CONSIDERABLY**—let LISSEN parts predominate in your receiver. You gain in clarity of signals and in wealth of volume, you gain in money saved. Before you buy any radio part ask yourself, "Can I get it in the LISSEN range?" If you can, then insist upon seeing the LISSEN part side by side with anything else mentioned, and you will buy LISSEN, for your own judgment will then convince you that LISSEN is pre-eminent in the making of fine parts for radio.

FOR AN AMPLIFIER
 1 LISSEN Transformer 8/6,
 1 LISSEN Wire Rheostat 2/6,
 1 LISSEN Fixed Condenser, 1/-,
 1 LISSEN Valve Holder 1/-; you can see it is not dear, and IT IS CERTAIN IN PERFORMANCE.

ON FIXED CONDENSERS.



You gain in this way if you use a LISSEN—you get a condenser accurate to 5% of its marked capacity, and a condenser which will never leak, never vary. You get, too, a condenser which LESS THAN A YEAR AGO WAS BEING SOLD AT TWICE ITS PRESENT PRICE—AND NOW YOU ACTUALLY GET A BETTER CONDENSER, TOO, THE FINEST FIXED CONDENSER THAT IS MADE TO-DAY.

LISSEN Fixed Mica Condensers:—.0001 to .001, 1/- each (much reduced). .002 to .006, 1/6 each (much reduced). (Every grid condenser has a pair of clips included free.) Note the new improved case which enables the LISSEN condenser to be fitted upright or used flat. Note the convenient grid leak fixing.

Add 10 per cent. to the life of your H.T. Battery.



Put a LISSEN 2 mfd. condenser across it (1 mfd. will do, but the larger size is better). Your H.T. battery will then GROW OLD WITHOUT YOUR KNOWING IT. Your dealer will tell you how easily to fit.

LISSEN (Mansbridge type) Condensers:—
 2 mfd., 4/8. 1 mfd., 3/10.
 Other capacities are:—

.01	2/4
.05	2/4
.25	3/-
.025	2/4
.1	2/6
.5	3/4

YOU PAY NO MORE FOR A LISSEN, YET GET A BETTER CONDENSER.

To a fine quality condenser has been added a specially moulded case, which, itself a solid insulator, gives you much needed protection when you use big capacity condensers for eliminator circuits. The LISSEN condenser cannot short circuit on to its case—that is an important advantage which is exclusive to this LISSEN condenser.

SILENT GRID LEAKS.

Never a sound do they make in use, for they never alter. This has been proved by the drastic step of testing them by exposure to rain and sun on our factory roof—once made, THEY ARE FIXED IN THEIR RESISTANCE VALUE. All resistances one price—Previously 1/8. NOW 1/-.



BUILD WITH ALL LISSEN PARTS—and your receiver will yield clearer and louder signals than ever you can get with parts of assorted make, because every LISSEN part will pull strongly with the other.

LISSEN PARTS—WELL THOUGHT OUT, THEN WELL MADE.

LISSEN LIMITED, 500-520, FRIARS LANE, RICHMOND, SURREY.

Managing Director: THOMAS N. COLE.

L171.

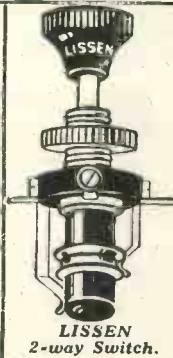

LISSEN 2-way Switch.

NEAT SWITCHES, EFFICIENT SWITCHES.

LISSEN switches, one for every switching use in radio. Every one LISSEN ONE-HOLE FIXING, OF COURSE. Previously. NOW

LISSEN 2-way	2/9	1/6
Series-Parallel	3/9	2/6
Double Pole		
Double Throw	4/-	2/6
Key Switch	2/6	1/6

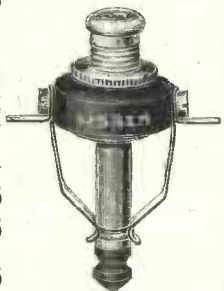

LISSEN Key Switch.

Quality RHEOSTATS—previously 4/- NOW 2/6.

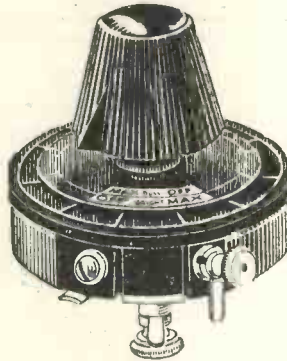

Made as LISSEN only can make—LISSEN quality, and note the irresistible appeal of the price. Previously. NOW

LISSEN 7 ohms, patented	4/-	2/6
LISSEN 35 ohms, patented	4/-	2/6
LISSEN Dual, patented	6/-	4/6
LISSEN Potentiometer, patented, 400 ohms	4/6	2/6
LISSEN ONE-HOLE FIXING, OF COURSE. Baseboard mounting type rheostats, 7 and 35 ohms, and potentiometer, 400 ohms, reduced from 2/6 to 1/6.		

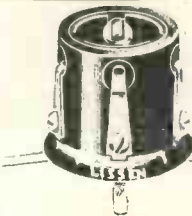

SCOOPED OUT TO YIELD CLEARER AND BETTER SIGNALS—

Low capacity, low loss, therefore stronger, clearer signals. You cannot get a good valve holder less than LISSEN sell this one for. Patented. Shown ready for baseboard mounting, can also be used for panel mounting by bending springs straight. Previously 1/8. NOW 1/-.

IMPORTANT TO THE TRADE.—Retailers who have not already been notified of our new direct-to-dealer policy of distribution should, in their own interests, communicate with us without delay. All orders must now be sent direct to us at Richmond, and not to usual factors.

Wireless Magazine

for March, :: Vol. V
1927 :: No. 26

CONTENTS

	PAGE		PAGE		PAGE
The Editor Announces the Special Blueprint Service	102	What Boys Think of Wireless. By a Schoolmaster	134	Round the Broadcasting Stations	159
Radio Verse	106	The Crystal Gazer. A drawing by Slade	135	The P's and Q's of I.F.T.'s	160
At 60 Miles an Hour!	106				

A LOUD-SPEAKER TONE CONTROL & FILTER UNIT .. p. 103

Under My Aerial. Halyard's Chat on the Month's Topics	107	Extraordinary Multiple Valves!	140	Wireless Through the Looking Glass	161
Capt. Round's Causerie	110	Voices of the Night! By J. Godchaux Abrahams	141	Novelties and New Apparatus	162
				Broadcast Music	164

THE PARADYNE FOUR. By J. H. Reyner, B.Sc., A.M.I.E.E... p. 115

Heard from Gefle	113	One-station Listeners	142	"This is the Truth—"	166
Two Circuits You Should Try	113	How to Use a Wavemeter	143	More About Push-pull H.E. Circuits	167
Sandy on the Scent. By Richard Carol	114	In the Night-watches	144	With the Foreign Broadcasters	169
		Radiophoning to a Train!	145		

AN H.T.-FROM-D.C.-MAINS UNIT. Easy to construct .. p. 129

Do We Want Broadcast Novels? A special article by Cecil Palmer	122	How the Valve Wastes Power. By Com. H. W. Shove	147	The Calling Voices. By Philip Austin	170
Round the Foreign Stations	123	Jottings on the Month's Progress	149	When Ships Talk	171
A Cabinet Three-valver	123			All's Well with the Accumulator!	172
				The Loud-speaker Convert	174

THE ONE-KNOB THREE. Entirely self-contained .. p. 136

Have You Built the 1927 Five Yet?	124	Between You and Me. By Fishglue	150	Gadgets, Hints and Tips	176
Radio on the Road	125	Photograph Your Broadcast Reception!	152	What the Reader Thinks	178
Half Hours with the Professor. 1. A Chat about the Grid Leak	126	Below the Broadcasting Belt	153	The World's Broadcasting	180
		Why Have An Ugly Aerial?	154	Continental Notes. By Jay Coote	182

A ONE-VALVER FOR A FRAME AERIAL .. p. 156

The New B.B.C. Double-decker Studio	128	The Greater Hard-faced Borrower	155	Questions Simply Answered	184
The Vindication of Simpkins	132	Was Mars Signalling? By Dr. E. E. Fournier d'Albe	159	What the B.B.C. is Doing	186
Wireless in the Wards!	133			Catalogues and Pamphlets	190
				The Buyer's Guide	192

Announcements.—The WIRELESS MAGAZINE, edited by Bernard E. Jones, is published about the 25th day of the month and bears the date of the month following. Research Editor: J. H. Reyner, B.Sc. (Hons.), A.M.I.E.E. One Shilling Net. Subscription rates are 15s. 6d. a year, post free; Canada, 13s. 6d. a year post free.

Contributions, accompanied by stamped and addressed envelopes, are invited. All editorial communications should be addressed to The Editor, WIRELESS MAGAZINE, La Belle Sauvage, E.C.A. Subscriptions should be addressed to The Publisher.

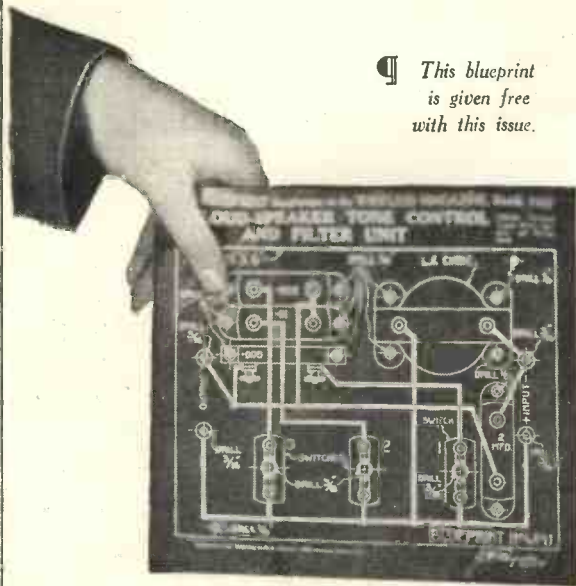

This blueprint is given free with this issue.

The Editor Announces the Special Blueprint Service

MY grateful thanks to all readers who have written wishing the WIRELESS MAGAZINE success under its new and individual ownership.

I have many plans in hand for the steady improvement of this magazine month by month and for increasing the facilities which I can place at the disposal of readers.

May I say a word about our new blueprint service? I have been asked hundreds of times for blueprints of the sets described in the pages of this magazine, and in general have been obliged to state my inability to supply.

It has recently been borne in upon me, though, that readers would appreciate a system by which they could at small charge get a full-size blueprint layout showing the disposition and wiring of any set described in the WIRELESS MAGAZINE, and so I have now made arrangements towards that end and am happy in announcing that, starting with the sets described in this present issue, I shall be able to send, almost by return of post, I hope, a blueprint of any set described in a constructional article.

For instance, in the present issue we have Mr. Reyner's Paradyne Four, the One-knob Three by the WIRELESS MAGAZINE Constructional Staff, and a One-valver for a Frame Aerial, another product of the office workshop. In each

case a full-size blueprint layout and wiring diagram is available to anyone who cares to send the necessary postal order.

At the moment my draughtsmen are too hard pressed to allow of the scheme being made retrospective to any considerable extent, but there is one important exception, that being the 1927 Five, of which we originally presented a Structograph wiring diagram free with the WIRELESS MAGAZINE. That Structograph is out of print and we continue to receive a great number of requests for the full-size layout diagram; consequently it has been thought desirable in this special instance to prepare a blueprint and this is now available.

It will be an easy matter to remember the prices of the blueprints supplied under this service. The price varies according to the size of the set; thus, for one-, two-, and three-valve sets, the price is 1/-; and for four- and five-valve sets, and over, the price is 1/6. Prices of blueprints of crystal sets will be announced later. All prices are post free.

Until further notice please address requests for blueprints to Blueprint Service, WIRELESS MAGAZINE, La Belle Sauvage, Ludgate Hill, E.C.4.

The Editor '27.

A free full-size blueprint of this unit, designed by J. H. Reyner, B.Sc., A.M.I.E.E., is given with this issue. The unit cannot fail to improve the results obtained from any loud-speaker set and is especially useful in cases where extended leads are used.

The unit in use, in conjunction with a B.T.H C2 loud-speaker.

A Loud-speaker Tone Control and Filter Unit



Variation in tone is obtained by operating the three push-pull switches. If desired, the adjustment can be altered for different kinds of music.

NOW that power and super-power valves are in general use in a large number of receiving sets, it is asking too much of delicate instruments, such as high-resistance loud-speakers, to withstand the continuous heavy plate current which these valves are capable of giving.

Strain on Winding

In the majority of cases the loud-speaker is placed directly in the plate circuit of the last valve, so that the delicate winding of the instrument, which it is absolutely necessary to employ, must withstand a continuous current which may be as high as 15 milliamperes.

One does not often hear of cases where a high-resistance loud-speaker has broken down due actually to this current, although this is liable to occur. However, there are other evils which may arise, due to its presence in the windings.

It is well known that when a current flows through a coil of wire, which is wound round an iron core,

this core becomes magnetised. That is to say, it will have a North and a South pole at opposite ends. The telephones and loud-speakers which we use are provided with windings wound round pole-pieces which are permanently magnetised, and the speech and music currents cause variations in the magnetism which produce a movement of the diaphragm. This principle is adopted because it gives greater sensitivity.

In the ordinary loud-speaker circuit we have a permanent steady anode current flowing, and this will also produce a magnetising effect. If this current is passed in the wrong direction it may, even if comparatively small, cause the magnets to become demagnetised after prolonged use in a valve circuit.

It is for this reason that manufacturers mark one lead of their telephones and loud-speakers with a positive sign, so that they can be connected up in such a manner that the current will flow in the right direction.

In the case where long leads are employed, however, it is difficult to find the correct polarity unless special wire is employed. In consequence, the wireless amateur is liable to connect his loud-speaker without taking into consideration the fact that he may be passing the plate current through the windings in the wrong direction.

My Own Experience

I recently had an experience of such a mishap which resulted in the complete demagnetisation of the loud-speaker after it had been in use for six months. The anode current which passed through the windings had a value of only 5 or 6 milliamperes.

There is, however, another aspect of the question—that of tonal "colour." It is often found that placing fixed condensers in series or parallel with the loud-speaker improves the quality. With the normal circuit parallel capacity can be added; a series condenser cannot be used as

A Loud-speaker Tone Control and Filter Unit (Cont.)

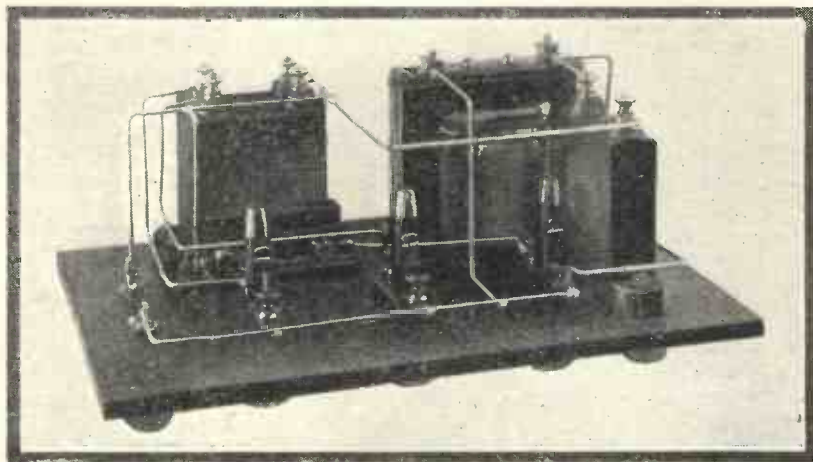

View of the Unit showing the Push-pull Switches.

it would, of course, disconnect the H.T. supply, and therefore the tone correction possible is limited.

It is thus in the interests both of economy and purity of reproduction

last valve, the secondary of which is connected to the loud-speaker.

It is a well-known fact that if a steady current is applied to the primary of a transformer no current will flow in the secondary. If, however, in addition to this steady current a fluctuating current is applied, such as that obtained in the reception of wireless telephony, this fluctuating current will be reproduced in similar form in the secondary winding, and can thus be applied to the loud-speaker. There is, however, the danger of distortion with this method.

Another, but simpler, method is that in which an iron-core choke, having an inductance of about 20 henries, is used in conjunction with a large-capacity condenser. This arrangement is illustrated in the diagram, Fig. 1.

One end of the loud-speaker is connected to the fixed condenser, having a capacity of about 2 microfarads, and the other end is connected to one end of the choke and the plate of the last valve. The voltage fluctuation in the plate of this valve sets up a P.D. across the choke, which is applied to the phones, via the condenser.

This condenser presents an infinite resistance to the steady plate current, but, provided it has a capacity of

sufficient value, will readily pass fluctuating voltages of the usual audible frequencies.

A Combined Effect

In the unit described in this article this method of filtering the steady plate current from the fluctuating current is employed, but a tone-control device has been included, which forms a valuable addition to the complete unit.

The circuit which is adopted is shown in Fig. 2. It will be noticed that a number of fixed condensers are placed in parallel with the loud-speaker. The purpose of such condensers is to accentuate the lower tones by lessening the effect of the higher frequencies. This method of control gives a very pleasing tone to many loud-speakers.

It is well known that low-frequency transformers and loud-speakers tend to bring out the high frequencies to a

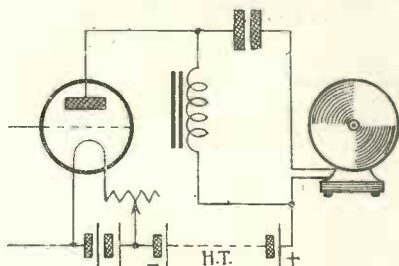

Fig. 1.—Simple Filter Circuit.

that we should "isolate" the loud-speaker from the last valve. One method of doing this is to employ a transformer in the plate circuit of the

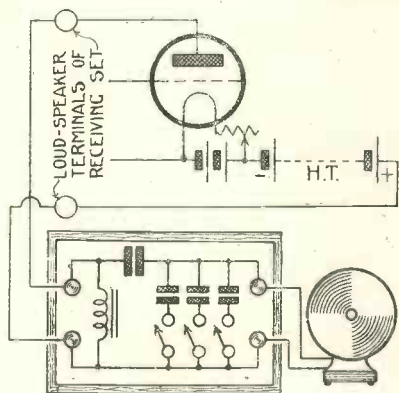

Fig. 2.—Circuit of the Unit described in this article.



Photograph of the Completed Unit.

greater extent than the low frequencies, so that these condensers provide a correction.

On test it has been found possible to vary the tone to suit different types of loud-speaker, and also various kinds of music and speech. For example, it was found that no condenser was required as a rule for the reception of speech, but choral and orchestral items were greatly improved with the addition of a certain capacity across the loud-speaker.

Values of Components

Experiments were first made with the object of finding the effect of inserting condensers of different capa-

With Free Full-size Blueprint

city between the loud-speaker and the plate of the valve. A small capacity would tend to cut off the lower frequencies and accentuate the higher frequencies. However, when this was done the tone become remarkably thin, and it was decided in consequence that no advantage would be obtained by this method of control.

The construction of this unit presents little difficulty. A Formo choke has been employed, as this has sufficient inductance to suit all types of valve. The series condenser has a capacity of 2 microfarads. The parallel condensers have capacities of .005, .01, and .025 microfarad respectively.

Four pull-and-push switches are employed for connecting the condensers in parallel with the loud-speaker. These switches are made by the London and Provincial Radio Co., Ltd., and are particularly smooth in action. By suitably operating the switches, seven different capacities are obtained. These are as follow:—

Switch Positions.	Capacity.
S ₁ alone	.005
S ₂ alone	.01
S ₁ and S ₂	.015
S ₃ alone	.025
S ₁ and S ₃	.03
S ₂ and S ₃	.035
S ₁ , S ₂ and S ₃	.04

The actual components required will be as follows:—

- Ebonite panel, 8 in. by 6 in. by $\frac{1}{4}$ in. (Becol or Siemens).
- Case to suit, 4 in. deep (Caxton or Carrington).
- Low-frequency choke (Formo or G.E.C., Marconiphone).

- 2-microfarad fixed condenser (Lissen or Dubilier, T.C.C.).
 - .025-microfarad fixed condenser (as above).
 - .01-microfarad fixed condenser (as above).
 - .005-microfarad fixed condenser (as above).
 - 3 push-pull switches (London and Provincial or Benjamin).
 - 4 terminals (Eastick or Belling and Lee).
- NOTE:—The particular components shown in the photographs and allowed for in the dimensioned layout are in each case mentioned first.*

Constructional

Work

The constructional details require very little explanation. It is first of all necessary to mark out the panel for the four terminals and the three push-pull switches. The various other components, comprising the L.F. choke and four fixed condensers, should then be placed in position and the centres for the fixing holes marked out.

If the components specified are used, the actual positions of these holes may be obtained from the free blueprint which is given away with this issue.

After the various holes have been drilled the panel should be turned over and the various fixing holes should be countersunk. The three holes for the push-pull switches should be enlarged to $\frac{3}{8}$ in. diameter. The various components can then be mounted in their appropriate positions.

The choke and condensers are held in place by countersunk screws and nuts. This method has the merit of simplicity, although the heads of the screws will show on the front panel. The appearance of this panel, however, can be improved by using nickel-plated screws, or alternatively by touching the heads with a spot of black lacquer.

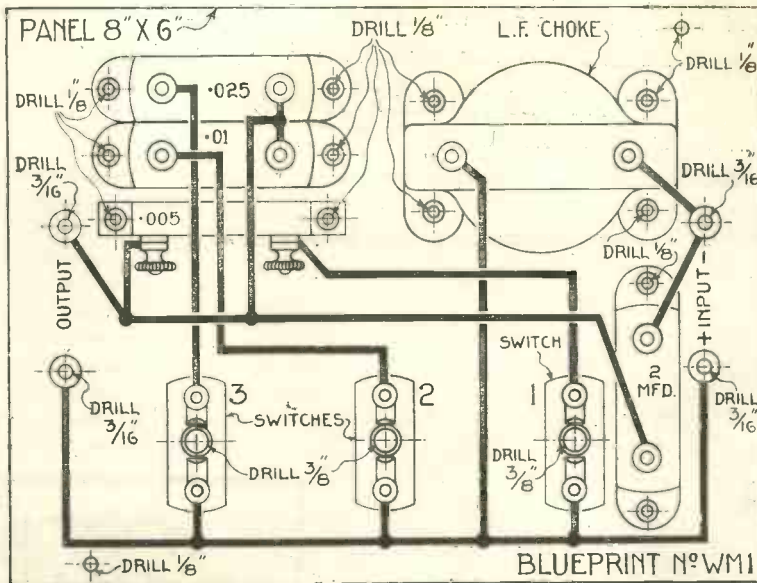

Reduced Reproduction of the Free Blueprint of the Tone Control Unit given with this issue.

In practice, of course, the required capacity is obtained by pushing in or pulling out the switches like organ-stops until the most pleasing effect is produced.

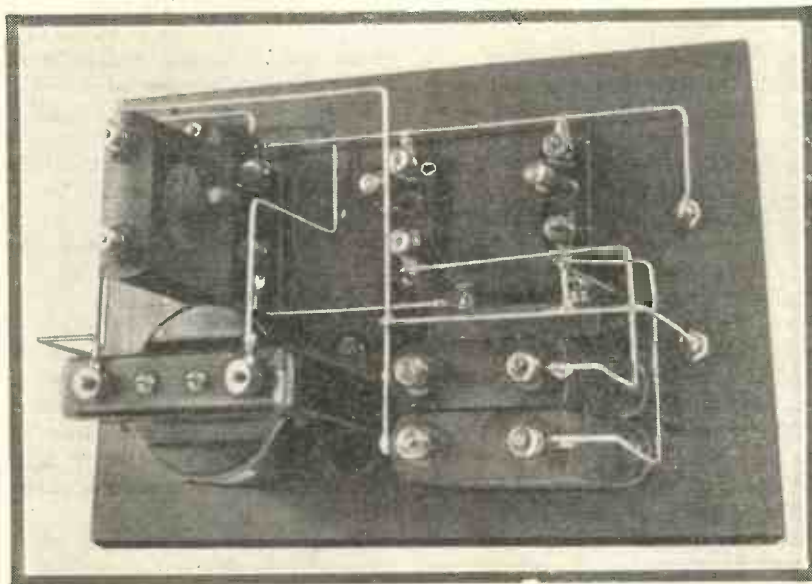

Plan View of the Tone Control Unit.

The wiring of the unit can easily be seen from the photographs and blueprint provided, and little difficulty is likely to ensue during this stage of the proceedings. When the wiring is completed the instrument can be mounted in its case; it is then ready for use in conjunction with any loud-speaker receiver.

As previously mentioned, the input terminals should be connected to the loud-speaker terminals of the receiver, the actual loud-speaker being connected to the output terminals of the unit. It is then possible, by choosing a suitable combination of the push-pull switches, to vary the tone at will to suit either music or speech, or even to make up to some extent for defects in any particular type of loud-speaker.

Finally, there is the considerable advantage that no damage is likely to occur to the loud-speaker through any inadvertent error of connections, so that the unit is one which can be made up with profit by any loud-speaker owner.

Heard from Bilbao (Radio Vijcaya) (EAJ11)

A prayer.

Elementary scientific talks.

A reference to a book of Mr. Bernard Shaw entitled *Aristocratic Swine*. (I can find no book of Mr. Shaw bearing a title anything like the above.)

The extreme poverty of the music and musical programme.

Praise of religion and denunciation of science.

A priest's voice.

Another priest's voice.

A number of priests.

Nothing.

Radio Verse

WE are told that there is a boom in poetry, and that the movement is extending so gradually that it will go on for many years. I made inquiries that I might know at first hand whether there was a boom and a revival in the reading and study of poetry. Three booksellers, with whom I claim an acquaintance-

source of evidence as to the reading of the average reader, I made my way there. There were only two volumes of the poets on the shelves. "All the others are out," said the librarian. "The demand for poetry, anything that goes under the name poetry, is tremendous. I can't supply the demand at present,

although for years these shelves were hardly looked at. A reader now comes into the library and goes for these shelves immediately."

I compared the papers which now publish poetry whenever they can get it with copies of those papers two and three years ago. I find that seven daily and weekly papers which would not publish poetry a year ago are now printing anything of value which comes along. They are catering for a de-

AT 60 MILES AN HOUR!



Tuning-in an Ethodyne Seven on the Cornish Riviera Express (see p. 145).

mand, on being asked, were very definite in their answers that there is a boom, and the greatest boom experienced since the Great War in any branch of learning.

The poets have come into their own at last. One bookseller has sold more copies of the works of the classical poets since the beginning of this year than he has done in any other five years of his forty years' life as a bookseller. In September he sold more volumes of poetry than in any other month of this year.

The other booksellers did not give me any figures, but they were also definite and optimistic. "We are selling more of the poets now than ever before," said one. "You would be amazed at the demand for the poets," said the other.

The town library being a good

mand, and a demand that is by no means adequately supplied.

Why this boom in poetry? There is only one answer. The boom and movement is caused by wireless talks on poets and their poetry. At the outset very little poetry was broadcast from the B.B.C. stations, but look at any programme now.

A Week's Poetry

As I write I have before me the B.B.C. programmes for the week. Thirty-one talks on poets and poetry are advertised for the week from all the stations, and eight other talks which deal with either poets or poetry indirectly.

This is one of the ways in which wireless is turning our nation into a college. We are becoming a nation of poetry lovers. E. B. R.



Changing Over

WHAT did you think of all those changes which took place in our busy world of wireless a few weeks ago?

We were prepared for the change over from the British Broadcasting Company to the British Broadcasting Corporation, but we were taken somewhat unawares by the changes which were made in connection with some of our wireless periodicals, weren't we?

Readers of the *WIRELESS MAGAZINE* and *Amateur Wireless* (and I count myself in amongst such readers, you know) have great cause for satisfaction in that there has been neither change of Editor nor break in editorial policy of those two periodicals.

George has rather a neat way of putting things at times. When I was talking to him about the change in proprietorship of "W.M." and "A.W." he said:

"There's not much to worry about over that, my boy. It's like changing the organ-blower without changing the organist. The music will be as good as ever was."

Speaking of these two favourite periodicals reminds me that the *WIRELESS MAGAZINE* has passed its second birthday and that *Amateur Wireless* is well on the way towards its fifth birthday. It makes some of us feel quite old to see these wireless infants growing up into such sturdy, not-to-be-denied youngsters.



Still Waiting

Reference to the age of *Amateur Wireless* prompted me to search amongst my files of wireless litera-

ture for the earliest numbers of that periodical, and I spent a very interesting hour looking through those early numbers.

An article in the sixth number of "A.W." on fortunes awaiting the wireless inventor especially took my attention, and I was surprised to find, on reading that article, that practically all the fortunes awaiting the 1924 wireless inventor are still unclaimed and are there for the 1927 inventor to grasp.

Amongst the fortunes known to be there for the asking, in 1924 and still unclaimed as yet are those which will reward the inventor of a substitute for the valve, the inventor of a new and revolutionary wireless circuit, the inventor of a method of eliminating atmospheric completely,



Wanted—a substitute for a valve.

and the inventor of a good, cheap, and thoroughly efficient loudspeaking device.

It is perhaps the last of these which will interest and surprise you the most. As in 1924, our loud-speakers are most inefficient, since they simply eat up energy without giving a corresponding increase in the volume of sound.

Great improvements have certainly been made in our loud-speakers since 1924, but the loud-speaker of 1927 is the same gluttonous energy-eater as the loud-speaker of 1924.

Speaking of wireless fortunes, it would be most interesting to know which men have really made fortunes out of wireless and how they made them. I do not seem to have seen

a reference to a wireless millionaire anywhere, have you?

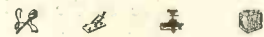

The Cold Valve

"What is the great dream of the wireless scientist the world over, George?" I asked during the course of an interesting conversation with my ever-welcome wireless friend.

"Depends on what he has had for supper," replied George. "Personally, I always have my best wireless dreams after—"

"Be serious for once, George. The great dream of the wireless scientist is to design a cold valve—that is to say, a valve which will work without a filament battery."

"I know a greater dream than that, old man."

"What is it, George?"

"To make such a valve."

"You ought to know, George, that the world's greatest physicists and chemists are working on the problem of the cold valve. They know that the cold valve is theoretically possible."

"Like hot ice-cream. It is aggravating not to be able to make a thing known to be theoretically makeable. No wonder they dream about it so much. Do you know, old man, I once dreamt a beautiful solution to the cold-valve problem?"

"Did you, George?"

"I did, and, of course, it was a ridiculously simple idea. I wonder I never tried it."

"What was the solution you dreamt, George?"

"It was to wrap the valve up in a roll of —"

"Yes, George."

"—moistened thermogene—a tish-shoo."

Under My Aerial (Continued)

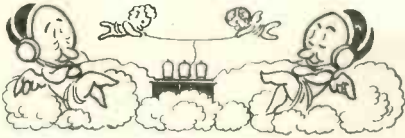

A wireless paradise.

A Wireless Paradise

Have you ever been to a place called Bude, on the north coast of Cornwall? If you haven't, you really ought to go there as soon as possible and take your wireless set with you.

Bude, a small holiday resort and seaport, is attractive to the ordinary visitor because of its position amongst beautiful scenery at the mouth of the river of the same name.

It should be attractive to you, though, because it is the wireless paradise of the world. At Bude every one of the British broadcasting stations can easily be picked up, American broadcasting stations can be tuned-in at any time of day or night, and European stations can be heard with surprising volume even in the hot summer months.

Wireless visitors to Bude say that signals come in there better than in any other place they have ever lived in or have visited.

Strange to say, at Bodmin, twenty-five miles to the south of Bude, there exists a dead spot as dead as a door-nail. So dead is this dead spot at Bodmin that the nearest broadcasting station can scarcely be heard on a five-valve set.

Have you ever heard of this wireless paradise at Bude or this wireless cemetery at Bodmin? I hadn't until I read about them in an American periodical. Somebody must have been talking for the news to leak out in this way.

What do readers in Bude or in Bodmin say about it all, I wonder?



A New Idea

Will the new B.B.C., with its greater freedom and its promise of increased revenue, make an attempt

this spring-time to bring the sounds of nature's awakening to the city dweller and the hospital patient?

It would be a wonderful thing for the new B.B.C. to do something of this kind, and I am sure that the country listener would tune-in as keenly as the townsman and the invalid.

There is an almost unlimited choice of spring-time sounds which might conceivably be broadcast to wireless listeners. The spring-time songs of the birds come first to mind—the thrush and the blackbird, two birds whose songs are almost as beautiful as that of the nightingale. One might make special mention of the missel-thrush (the storm-cock of the north), a songster which makes a special point of singing in the rain.

A harder problem for the transmitter and the receiver would be an attempt to broadcast the call of the great tit—two short, high-pitched notes—or the sweet little song of the chaffinch.

Perhaps the gay song of the rippling brook would bring joy to many ears. Certainly the baa-a-a of the newly born lamb would please the younger listeners.

One of my nature-loving schoolboy friends suggests to me that the call of the curlew, the bark of the fox, and the crowing of the cock pheasant might be chosen for broadcasting from amongst the lesser-known sounds of spring-time.

There seems to me to be a great



Greater freedom

deal in the idea, and I should really welcome such an innovation, wouldn't you?

A New Profession

Will the broadcasting of eye-witness accounts of important sport-

ing and other events during the present year lead to the establishment of a distinctly new profession, namely, that of the broadcast reporter?

To speak into a microphone a running commentary on an event as it is actually occurring, and to keep up with the event in more ways than one, seems to me to be a formidable task for whoever is called upon to do it.

A newspaper reporter who makes notes of what he sees on the spot and afterwards writes up a descriptive account from his notes has the chance of correcting his work. The broadcast reporter will have no such chance. Once a word is spoken into



A running commentary.

the microphone it is gone beyond the reach of correction, hence the difficulty.

Broadcasting has, of course, one new profession to its credit, that of the broadcast announcer. I suppose it is highly probable that broadcast reporting will be done at first by announcers.

American broadcasting stations rely a great deal on outside events to fill up their programmes, and it is common practice for them to send out their announcers to act as broadcast news reporters or as broadcast sports reporters.

When our British broadcasting stations do the same sort of thing, it is to be hoped that they will be duly discreet in their choice of announcer.

For example, it would be most indiscreet for a director of programmes to send an announcer with a too intimate knowledge of racing to report the Derby, for such an announcer might conceivably wind up a brilliant description of the race with the words of the butler in Ian Hay's play, *The Sport of Kings*: "Dammit, that's another bob gone."

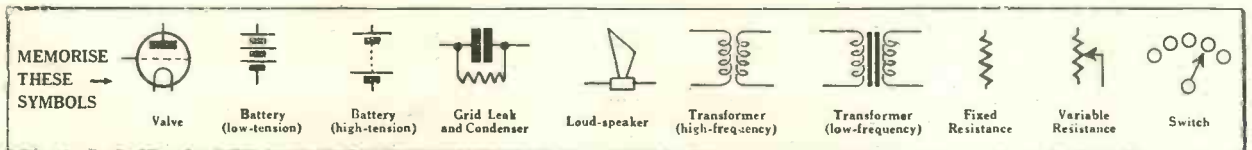

Halyard's Chat on the Month's Topics

Spring is Coming

One afternoon last week I met my meteorological friend in a country lane a couple of miles away from my home. We had both been tempted out by the sunshine and the special kind of vitality there was in the air.

"Feels like spring, almost, doesn't it?" I said.

"It certainly does," replied my meteorological friend, "but spring hasn't really started yet, you know."

"When does spring really start?" I asked.

"Meteorologically speaking, spring begins on the first day of March. Astronomically speaking, spring begins on the twenty-first of March."



"Feels like Spring."

"Indeed; and when does spring begin, wirelessly speaking?"

"Taking all the various factors into consideration, I should say about the middle of March. By that time evaporation and percolation have begun to get the better of rainfall, and the earth loses its winter dampness. That, I suppose, will make your earth connection less efficient. Then, of course, the chances of thunderstorms begin to increase. On the other hand, the chances of strong winds and gales get less from that date, and your aerial wire doesn't swing about so much."

"I don't think any of those things make a great deal of difference to wireless reception. The lengthening day makes more difference, in my opinion."

"Possibly so, possibly so. Then why not put the beginning of your wireless spring to April 10, the day on which summer time comes in?"

"A jolly good idea. That gives us another month and a half of the best season of the year for wireless reception."

Don't you agree that it is a jolly good idea?



Too Much S.B.

If you were to ask me to give you my very candid opinion on our present broadcast programmes, I should say that we have far too much simultaneous broadcasting.

It is not that I have any qualms about the desirability of giving the provincial stations the excellent and varied programmes of 2LO. My objection lies in the fact that so much simultaneous broadcasting gives the wireless experimenter so few opportunities of testing his receiving sets on our own broadcasting stations.

With present-day straight-line wavelength or straight-line-frequency variable condensers it is necessary only to identify four or five broadcasting stations in order to calibrate a receiving set completely.

There are not, however, many occasions on which it is possible to pick up and identify four or five of our broadcasting stations with certainty.

One very trying feature of simultaneous broadcasting to the experimenter is that he is so easily misled as to the identification of a broadcasting station.

A friend of mine once pinned his faith on the identification of two of our broadcasting stations in order to calibrate his set. One identification was unfortunately wrong, and so his straight-line calibration chart was hung out of it at one end. He was



Simultaneous Broadcast.

some time before he discovered his mistake.

During the last week simultaneous broadcasting has caused me to spend the greater part of three evenings over some testing work which I could easily have done in an evening when there was no simultaneous broadcasting.



One has to live and learn.

Tags

I have just been examining a four-valve set belonging to a wireless friend of mine. There were several striking features about the set, but what interested me most was the clever way in which my friend had used soldering tags in the wiring up of his set.

Do you ever make use of soldering tags when wiring up your receiving sets? I am afraid that I have made little use of such tags. Perhaps I should have done so had I ever experienced any difficulty in making good soldered connections quickly.

Soldering tags are distinctly useful things, and there are several places on a wireless set where they can be used with great advantage. For example, they are especially useful when connections have to be made to the small terminals which are to be found on certain types of low-frequency transformer.

If you ever feel afraid of applying a hot soldering bit to the terminals of a low-frequency transformer you should use soldering tags. It does not matter how much heat you apply when soldering a tag to the end of a piece of connecting wire.

Some constructors use soldering tags when making connections to terminals on the under side of a panel. This is a good plan for it avoids heating the terminal unduly. You know that when you heat up a terminal with your soldering bit the terminal becomes loose in its appointed hole.

One has to live and learn in wireless as in everything else. My friend's four-valve set has shown me that soldering tags are distinctly useful things and that they can be employed with advantage by the home constructor.

HALYARD.

MEMORISE THESE SYMBOLS												
	Crystal Detector	Aerial	Earth	Headphones	Fixed Condenser	Variable Condenser	Fixed Coil	Coil with Slider	Coupled Coils	Variometer	Wires Joined	Cross Wires not joined

2 1/2" wide.



Great possibilities are opened up by the new wireless-picture service across the Atlantic. Many readers of the WIRELESS MAGAZINE will have already seen evidence of the success of Capt. Ranger's system in their daily newspapers. On the left is reproduced a photograph of a cheque that was sent by radio across the Atlantic; it was honoured by the bankers concerned without question.

CAPTAIN ROUND'S CAUSERIE

Topical Technicalities by Capt. H. J. Round, M.C., M.I.E.E.

THE year 1926 ended with a display of radio fireworks. First we had the completion of the short-wave beam system between England and Canada, and one can say, from a few months' working of this service, that it completely proves the confidence that Senatore Marconi has expressed in it since he first conceived the scheme on a large scale. The working is so good that we have for the coming year a promise of a really extraordinary system of linking up of the Empire, and of other countries with the Empire.

Success with Telephony

The system as worked out last year is entirely for telegraphic purposes, but recent tests, the results of which have already been published, indicate equal success in telephony, though whether political and business considerations will warrant the opening up of beam telephony services in 1927 is a matter that has not yet been decided.

The linking up of the Empire with our central broadcasting in England is something for 1927, and I think the results, when this is tried on a grand scale, will be surprising.

I have already seen it suggested that the Duke of York's speech at Canberra should be sent to England by the beam and radiated here, but as the time is likely to be in the middle of the night it may not be very convenient for broadcasting; and the opposite possibility—that of

the King speaking to the Parliament at Canberra—which has also been suggested has a similar disadvantage.

Picture Transmission

During 1926 an American—Capt. Ranger—developed a practical system of picture transmission and put it into operation on the long-wave service between England and New York. This picture transmission, although by no means what one might desire, seems to be all that it is possible to do with long waves, and it has been at least extremely useful and also very suggestive for future work. Capt. Ranger's work stands out as one of the minor but important developments of 1926.

The end of 1926 has seen the final

development of that wonderful mathematical conception called side-band telephony and the opening up of a service between New York and England. This engineering feat on the old long waves must have its first credit given to the mathematician—an American, Mr. Carson—who conceived the idea of analysing the operations of transmitting wireless telephony signals.

Waste of Power

The analysis indicated that there was a great deal of waste of power in the ordinary way in which we broadcast speech. But bit by bit from this analysis a system has been built up which concentrates all the available power into just that part of the modulation which is essential

for transmitting speech, so that the station at Rugby, which is stated to transmit with a power of 300 kw. to New York, is really the equivalent of a broadcasting station of five to ten times that power.

A rough analogy of this side-band telephony can be imagined in this way: Suppose our speech consisted of only one vowel and consonants—and I have no doubt



Reproductions of a photograph before and after transmission by wireless by a German system.

whatever that such a language could be made up—we could speak by emitting the vowel the whole of the time and consequently wasting power on that vowel, but as our listeners would know what vowel was coming there would be no real necessity to speak the vowel. We could simply emit the consonants and save energy.

Inserting the Vowel

In a way this side-band telephony consists in emitting these consonants and leaving the vowel to be inserted at the other end. Of course, the vowel is equivalent to the carrier wave in ordinary broadcasting and the side bands are the equivalents of the consonants. As the wave is known at the other end it can be inserted at that end and not transmitted at all, thus saving a great deal of power which can be used to strengthen up the side bands.

Whether such a system using long waves will be useful in more than one or two cases and whether in the face of the much more economical short-wave beam it will be worth while to repeat the Rugby experiment is very doubtful. Certainly long waves such as Rugby uses do not exist in sufficient numbers to give more than one or two services.

It is just possible, however, that the economical methods used in this side-band telephony may in the future be superimposed on the beam system, so as to make that still more efficient.

Minor Problems Solved

Notwithstanding that half-criticism on my part, this side-band telephony remains as a wonderful scientific feat developed in its initial stage purely by mathematical effort. If 1926 could show only these three great feats of engineering it would be sufficient, but I think it will be found that there have been solved a number of minor problems, and of

these mention might be made of developments in filaments of valves, enabling greater economy to be obtained in ordinary reception and ensuring longer lives of the valves.

Developments in crystal control of transmission, although started earlier than 1926, have been chiefly completed and brought into practice during that year. There has been a remarkable improvement in transmissions on short waves.

The year 1927 promises to be one in which we shall make as much use as is possible in the time of some of the developments of 1926.

I have mentioned previously the possible linking up of the Empire by telephony on beams for ordinary commercial conversation and for broadcasting, and there is no doubt

tions that takes place from the time the telegram is written down to the time it is delivered, it will be seen that if these operations could be reduced in number the expense of telegrams would be reduced, and consequently there would be a great benefit to commerce generally.

Handling of Messages

One of the great expenses in telegraphy is the fact that at the present time a message has to be handled in the clumsy, old-fashioned way of turning it into morse (a human operation of some type always has to be used), and then at the receiving end, except under ideal conditions, the same human operation is required for converting the morse back into writing, although at the receiving end, when conditions are ideal, this human operation can sometimes be avoided.

One of the developments of 1926 was the practical transmission of pictures by the old long-wave system across the Atlantic. Specimens of these transmitted pictures are reproduced here. The coarseness of grain is, of course, very marked, but Capt. Ranger, who worked out the system, kept in mind the fact that the long-wave systems, such as used on the Carnarvon-New York service, were not capable of more than a very limited number of dots per

second, say, at the most, 150.

The reason for this limitation lies chiefly in the fact that the aerial current with long waves takes quite a considerable time to grow to a maximum, and this pulls down the speed of transmission to the figure I have stated.

Limited Number of Dots

Consequently, to send a reasonable-sized picture through in a reasonable period of time, Capt. Ranger had only a certain number of dots with which to do it, and he had to make the best use of them. It



Wireless picture being received from New York by Capt. Ranger's system.

whatever that some attempt will be made to carry out the broadcasting part of this scheme during 1927, but engineers are looking a little further ahead than these well-known problems of telephony.

Telegraphy has always been an expensive art, but it remains and will still remain for a long time the chief commercial link. It is essentially the telegram which one sends when one wants accuracy. Telephony, of course, has its uses, but telegraphy approaches to some extent the written word. However, when one considers the multiplicity of opera-

Captain Round's Causerie (Continued)

would not be practicable with the system as it is at present to send through very closely grained pictures, but, as is well known, both in the United States and Germany, and I may say in England also, the transmission of pictures of a far finer quality than those at present used commercially has taken place; but more ideal systems of transmission than these long waves have been used in these cases.

So fine is the quality of some of these pictures that it is quite possible to send a telegram through as a picture in an extremely short space of time, probably not quite so quickly as it could be sent by morse, but there would be a reduction in the number of operations. There would be no necessity for laborious hand punching of the telegram; the original could be merely placed in a piece of apparatus, and within a minute appear as a duplicate at the other end with the tremendous advantage that one really has the original duplicated and not merely the words letter by letter.

Short-wave Developments

Enormous strides with the short waves have taken place, and the tremendous speeds already proved possible on the beam certainly indicate that, if not in 1927, then at some date not very far distant attempts will be made to transmit telegrams in this way.

It is a curious fact that the thing that will probably hold up such duplication of telegrams practically is the fact that the land-line is not so reliable or so fast as we are apt to think, and very special lines will be necessary.

We could afford to put down special land-lines for long-distance work, whereas for short-distance work it might not pay, but all telegraph engineers are recognising that there is a revolution coming before long, and some are rather hoping that it will start in this present year.

Television

If what I say about television is not quite liked by those who are

intensely interested in the subject, I hope they will keep a copy of my remarks with which to face me if I turn out to be wrong. But with a clear recognition of the extraordinary difficulties of transmitting a still picture, say one of 6 in. square, in the time of a minute, it is difficult to see how we are going to do that same operation 600 times as fast, a speed which would be necessary if

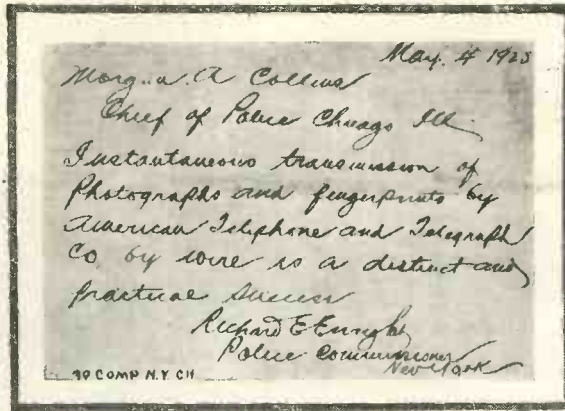

A written message sent by wireless by an American system.

we required to transmit a moving picture. The problem is certainly not insoluble, but I do not think that at the present we have the weapons ready and developed for more than the crudest efforts.

We shall require for television considerably more sensitive instruments than our present photo-electric cells, and we shall need to develop more reliable and practical methods of synchronising our transmitting and receiving ends, but, of course, if we can be content with something a little bit coarser than Capt. Ranger's Transatlantic telegraph pictures, there is just a possibility of doing it in the laboratory at the present time; but such a coarseness would not be very acceptable.

Television, as I consider it, will be of little commercial value unless it can be used in connection with broadcasting, and there, for quite a long time to come, I cannot see its advent, until someone springs on us a new and cheap device for making pictures visible at the receiving end as simple and reliable as the present valve.

So far I have touched little upon broadcasting. This has now developed into a stable art. The methods

used during 1926 have not seriously changed, but detail improvements have taken place all round. Unfortunately, at the transmitting end the chief development seems to have taken place in Germany, but this, no doubt, is due to political and not to scientific influences.

On the receiving side we have gone steadily ahead, improving and cheapening bit by bit. Valves are better, more reliable; component parts are better and cheaper. We have learnt how to put these all together to get long distance, high quality, and selectivity, and the very nearly perfect loud-speaker has arrived, although at the present time its price is rather prohibitive.

Cheaper Loud-speakers

Let us hope that in the coming year we shall see loud-speakers just as good in every way as the expensive one produced at a reasonable cost. It must be admitted, however, that in one direction we are certainly making a muddle of things. The question of power for our receivers is nowhere near a satisfactory solution. This is partly due to the fact that our electrical systems in England are very mixed, but I rather fancy that America, although better off in this way, is still up against difficulties in producing power for the receivers in an economical way.

Cost of Dry Batteries

Dry-battery working for high tension still remains the stand-by, and in this direction the price for power is really terrible. When one realises that for high tension we pay something like £7 10s. per unit instead of the 6d. we pay for lighting power, our failure becomes very annoying.

To popularise broadcasting, particularly in the direction of multi-valve sets, this problem will have to have a standardised cheap solution, but none of us can throw any serious light on the subject yet.

I do not mean to decry the many sets for delivering power from the mains which are at present on the market, but they undoubtedly are expensive, and must be, to be reliable.

The unfortunate thing is that we have to make so many kinds of these sets, have so many adjustments to meet the different main conditions not only of voltage and frequency, but to eliminate the noises which are particularly common on D.C. mains. Perhaps by December, 1927, some new facts may have been evolved, but I am not very hopeful.

Advances in Broadcasting

Broadcast transmission in England will undoubtedly in the New Year make great strides. No expense whatever should be spared to improve the situation, not only because of the national importance of having far better stations than exist at present, but because the international importance to Great Britain of being ahead of all European competitors is very great indeed. If half a million pounds is needed to put our broadcasting so far ahead of our rivals in Europe that they will be unable for a long time to go one better, it would be money well spent.

My own opinion is that we should go to the absolute technical limit and that everybody should help towards this end. When one can build stations quite easily of 50 or 100 kilowatts, why do we think in tens and fiftens?

Heard from Gefle

A TALK on English proverbs pointing out their poverty and criticising them.

An estimation of the mining industry of Great Britain, and an assurance that the English world coal markets are lost for ever. (Gefle is an important mining town.)

Selections by a celebrated trio; although listening for thirty minutes only a violin and a piano could be heard.

A fine, rich and melodious soprano voice.

Sir Oliver Lodge described as "a young scientist with a tremendous future." (It might have been a reference to his interest in spiritualism.)

Coal price lists. If the coal is of good quality the Swedes are fortunate.

Seven of the latest English songs the same evening.

E. B. R.

Two Circuits You Should Try

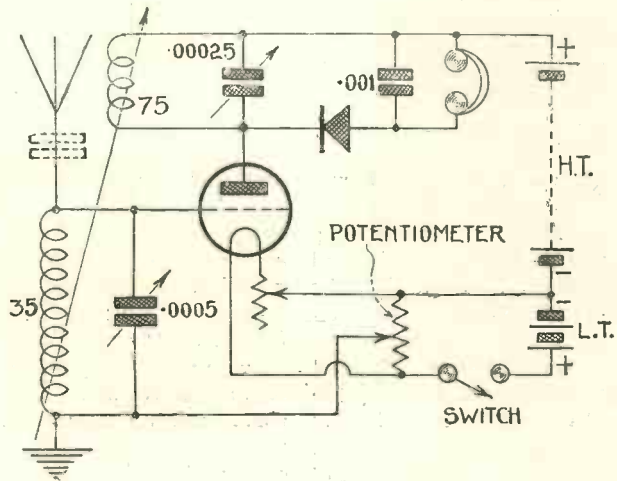

In this one-valve and crystal circuit the valve acts as a high-frequency amplifier, while the crystal detects. For best results the valve should be one sold especially for H.F. purposes, while the potentiometer should have a resistance of at least 300 ohms.

Owing to the valve acting as an H.F. amplifier, this circuit gives good headphone signals up to 40 miles from a main station with an outdoor aerial, but is not recommended for loud-speaker work.

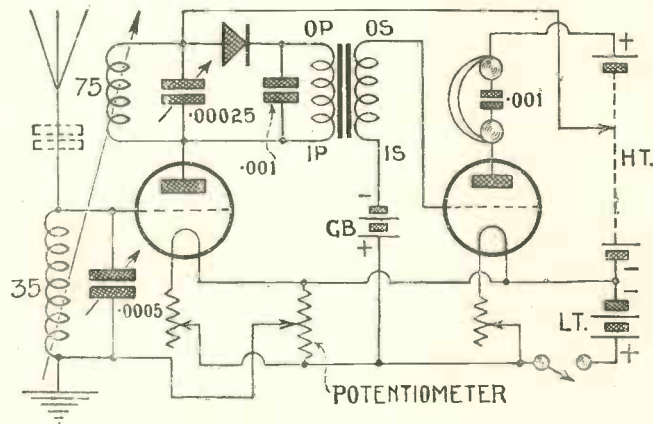

This is a two-valve and crystal circuit in which the first valve amplifies at high frequency, while the second valve amplifies at low frequency the output from the crystal detector. The first valve should therefore be of the type suitable for H.F. amplification, while the second should be of the L.F. amplifying type

A fixed condenser of .0002-microfarad capacity (shown dotted) in the aerial lead may be tried when first testing the circuit.

Using a good outdoor aerial several B.B.C. main stations may be heard on the phones when using this circuit, while a loud-speaker may be satisfactorily worked up to 10 miles from a main station.

Sandy on the Scent

by
Richard
Carol

SINCE ma party, which didna eventuate vera satisfactorily, as I tellt ye, there's been nae speecial episode, incident or ither romantic adventure worthy o' ma pen. For I'll jist no' hae it gaun doon to posterity that I wasted ma time an' intelligence in the chronickin' o' treeivialities.

The ither nicht, hooever, I was listenin' in to the seeven o'clock news bully-tin when ma ears prickd up like a dug's an' ma eyes near jumped oot their sockets. In the maist matter o' fac' tones, the announcer-chiel said:

"I've got an SOS for ye. A noted criminal has escaped an' is believed to be in hidin' roon about the village o' Clumtochty. Height sax feet, broon hair, broon eyes, last seen in a suit o' cheviot tweeds. £50 reward is offered for the capture o' this criminal, wha is kennt as Ted Hawkins alias Slick Jim."

I rushed oot into the street an' caught sicht o' Tammas McKay. Briefly, I explained the poseetion an' we decided on the spot to organise an armed force an' utilise the remainin' twa or three hoors o' licht to run the criminal to earth.

Seizin' the lang hook wi' which I push up an' doon the shutters o' ma shop, I turned aff the wireless and strode oot for the man-hunt. By seeven-fifteen we were five ootside the Hieland Laddie, me wi' ma hook, an' Tammas wi' a spade, Andrew wi' a sword wi' a wee bit tourie on the end o' it, Alister wi' his meat-chopper, an' Rabbie wearin' a tin-hat an' a gas-mask.

I took the lead; me kennin' a' about it.

"Jist think," I said for the speecial benefit o' Tammas an' Alister, "that if it hadna been for wireless ye wouldna be noo expeekin' to participate in the £50 reward. Incedentally, as we're a' freends, I'll fix ye up ony time ye like vera reasonably. But o' that, mair anon. For the present we are huntin' a noted criminal wha's name is Ted Hawkins alias Slick Jim; height sax-feet, broon hair, broon eyes, wearin' a suit o' cheviot tweed, wha is believed to be in this veecinity. Fellow-citizens — let us hunt."

Alister brandished his meat-chopper in a mainer that boded ill for the criminal, an' amidst the cheers o' the assembled populace we marched up the hill.

Arrived at the furst fairm we cam to, we inquired whether they had, perchance, encoonterd, the criminal. Unfortunately, they hadna, an' though at furst I was tempted to accept their kindly offer o' a collie to act as a bluidhoon, I decided in the negative.

After several futile inquisitions at fairms, about eight-thurty we cam to a hoose whaur they tellt us they had seen a man resemblin' the description about häuf an' hoor syne. In fac', the mair they thoct, the mair like a criminal he did seem. Finally, after judeecious cross-questionings, we elicited the information that the noted criminal had ta'en the road to Glen Toddy.

We quickened oor steps; for I feart the fall o' nicht micht prevent the cairryin' o' oor enterprise to a succesfu' conclusion.

At 9.11 approx. the criminal was discerned enterin' a sunken lane abuttin', on the eastern side, on a field inhabited by coos (varieties unknown), an' on the western side a field o' tatties. The criminal was walkin' vera slowly. Nae doot the load o' crime on his back lay heavy. I decided to deploy ma forces an' ambush him.

Bein' the *deus ex machina* in the affair, as ye micht say, I detailed masel' for the maist dangerous part, namely, to slip aheid o' the criminal along the coo-field an' boldly step oot afore him.

I would tak Rabbie wi' his tin-hat and gas-mask wi' me to deal with the ruffian frae in front if he should try to escape ower ma deid body. Andrew wi' his sword was to cut aff his retreat. While Alister wi' his chopper an' Tammas wi' his spade gairded the flanks.

It a' eventuated as I had foreseen. Wi' ma hooked pole in the on-gaird poseetion, I steppit oot afore the amazed criminal.

"Halt, Ted Hawkins alias Slick Jim," I cries, gi'ein' him a prod in the wame, "yer number's up"

"Ye're daft," he says.

"We'll soon see," I replies. "Hola, ma merry men," I cries, gi'ein' him anither prod, an' they a' cam roon cautiously.

"It's a' richt," I cries easily. "Form a gaird roon him an' we'll tak him back."

He was a bittie obstreporous, but we persuaded him quietly wi' the meat-chopper.

"Sandy," says Rabbie in a whisper, "yon's no sax feet."

"Och," I replies, "mebbe he's weighted doon a wee wi' the burden d' his crimes."

"His hair's no' broon, it's black," says Alister a meenit later, also in a whisper.

"He'll hae dyed it to disguise himsel'," I replies.

As we marched along I took the opportunity o' broachin' the question o' the division o' the £50. Tammas was for equal shares. But me bein' the oreeginator an' brains o' the expeetion, I felt it was an insult. Finally, hooever, we agreed that I should hae twa shares.

It was gettin' dark an' we were noo no' vera far frae Auchterauchty. At a wee disused hut I halted the armed gaird an' suggested to Tammas that me an' him should slip doon to ma hoose an' jist draw up an agreement to put it a' on a proper basis. They agreed, though wi' some reluctance.

Whiles Tammas was criticisin' ma phraseology, I steppit ben the hoose an' Maggie gied me a maist interestin' bit o' news. In consequence o' which I returned to Tammas and tellt him the strain o' leadin' the man-hunt was already takin' its toll an' that I felt I could safely entrust to him the task o' deleeverin' the criminal into the hauns o' justice.

Tammas was awfu' pleased—for the moment. I believe subsequently he was rale annoyed, as was Alister an' Rabbie an' Andrew an' the polisman.

Ye see, the interestin' bit o' news I had got frae ma guid-wife was that the polisman had steppit ower to tell me I didna need to hunt ony mair for the criminal as he had gi'ed himsel up at Clumtochty.

Incorporating a special system of constant coupling this four-valver (which comprises one high-frequency amplifier, detector, and two low-frequency amplifiers) is especially suitable for long-range loud-speaker work. As explained on page 102, a full-size blueprint of this set can be supplied for a small sum. A test report is given on page 121.

The Paradyme Four

Designed, Built and Tested by
J. H. REYNER, B.Sc.
 (Hons.), A.M.I.E.E.

READERS who have made up and handled for themselves the usual type of receiver incorporating one or two stages of high-frequency amplification, together with an appropriate amount of note magnification, will have noticed that such receivers in general are more sensitive on the shorter waves.

This results in the stations operating on wavelengths of 250 to 350 metres being received remarkably well in most cases, while there seems to be a falling off in the strength of stations working above this wavelength.

Reaction Control

If a reaction control is fitted it will be found, as a rule, that, in order to maintain the receiver in a state of sensitivity, it is necessary to increase

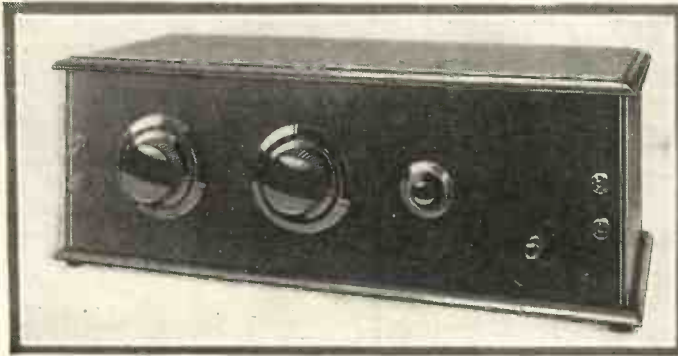

Note the Neat Appearance of the Paradyme Four.

the reaction adjustment as the tuning capacity is increased. This means, of course, that there is another adjustment on the receiver to operate, while if a station towards the upper end of the wavelength range has been tuned-in, then it is found that on the lower end of the scale the receiver will oscillate and the reaction adjustment must be reduced.

In some cases receivers are ob-

tained which are fairly sensitive over the whole of the scale, so that these remarks do not apply with the same force, but such results are usually due to a fortuitous combination of local conditions in the layout of the receiver, and very often cannot be duplicated or are completely upset by the replacement of one of the valves by another, even if of a similar type to the original.

Effect of Frequency

Let us examine the reason for the non-uniformity of response obtained in the average receiver. It is customary to transfer the energy from one valve to the next by means of a transformer arrangement as in Fig. 1. A tuned-anode arrangement is really a particular case of a transformer, and we can consider it as such.

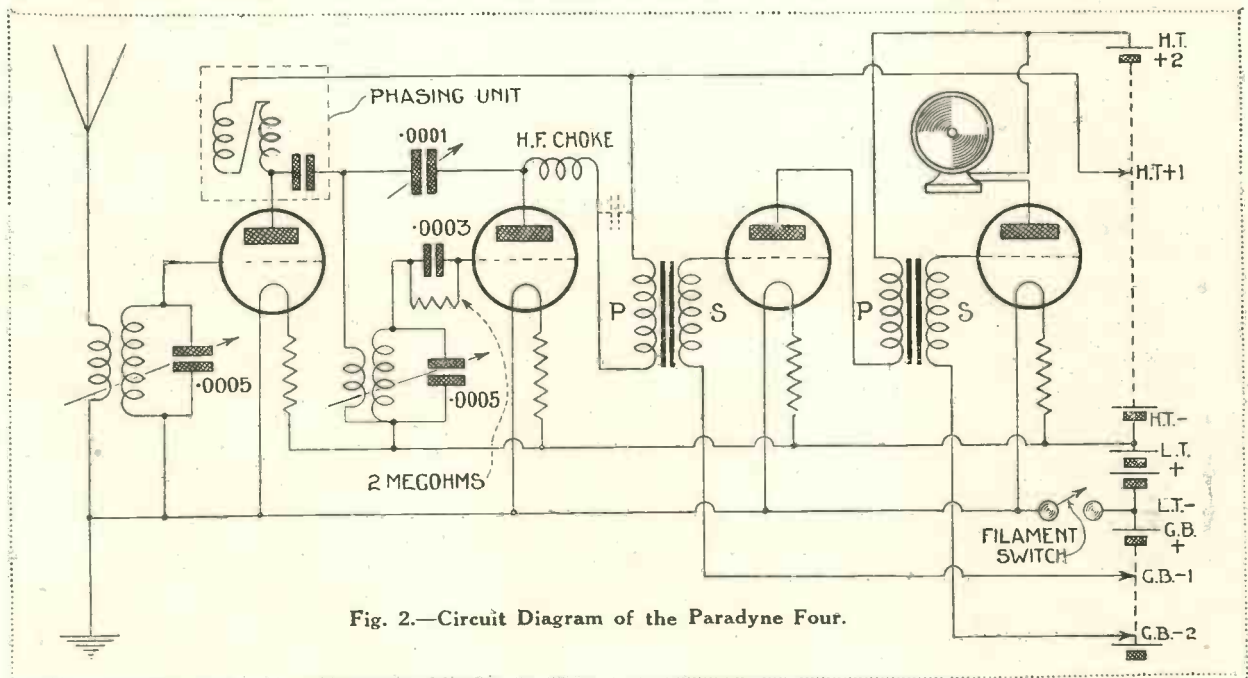
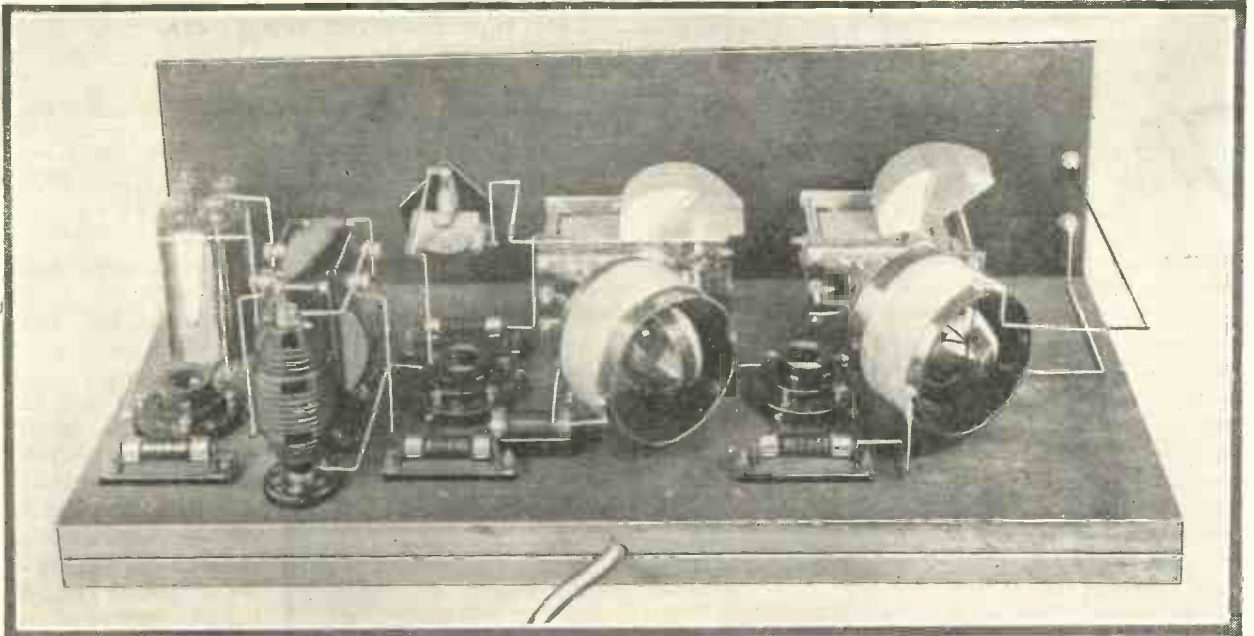

Fig. 2.—Circuit Diagram of the Paradyme Four.

The Paradyne Four (Continued)



This photograph of the Paradyne Four shows how the sub-baseboard system of wiring enhances the appearance of a set.

We have two effects which exercise some control over the total amplification obtained from the stage. In the first place, we have the amplification obtained from the first valve in the stage. This depends upon the impedance of the external anode circuit relative to the impedance of the valve itself. It will be clear that this external impedance varies continually with the frequency.

The reaction of the primary winding of the transformer, which is the external anode circuit of the valve V_1 , is partly made up of pure inductance and partly reflects the characteristics of the secondary winding which, as will be seen, is tuned. The general effect, without going into details, is that, as we increase the tuning capacity and so decrease the frequency, so the effective impedance of the primary winding falls off gradually.

Effect on Sensitivity

Thus from this consideration alone the receiver would be less sensitive at the top of the tuning range than it would be at the bottom. We have also the effect of the actual coupling

between the primary and secondary of the transformer. We apply signals to the grid of the first valve, and we obtain amplified signal currents in the anode circuit. This energy is now transferred to the secondary circuit and thus to the grid of the second valve by means of the magnetic coupling between the primary and secondary of the transformer.

At the Top of the Tuning Scale

Now the actual voltage introduced into the secondary depends upon:—

- (1) The strength of the current flowing in the primary;
- (2) The mutual inductance between the primary and secondary; and
- (3) The frequency of the current.

Now (1), as we have just seen, depends upon the amplification obtainable from the previous valve. The mutual inductance (2) between the two windings is usually kept fixed, while the frequency of the current (3) is continually decreasing as we increase the tuning capacity. Thus we have a second reason for the insensitivity of the receiver at the top of the scale, due to the fact that the actual energy

transfer across the high-frequency transformer falls off as we reach the top of the tuning scale.

A Solution

The obvious remedy lies in making the mutual inductance between the primary and secondary of the transformers variable instead of fixed. This can be done in two ways. We can either arrange that the characteristics of the transformer vary electrically with the frequency, or we can adopt a definite mechanical variation of the coupling. The first method is one with which I have been experimenting for some time and which has ultimately been brought to a high pitch of perfection by Loftin and White in America. This aspect of the question is being discussed in my articles on "Constant Coupling" which have been appearing in *Amateur Wireless* week by week.

The fact that satisfactory results can be obtained by such a method, however, does not preclude us from examining the possibilities of the other system, and the receiver described in this article actually makes

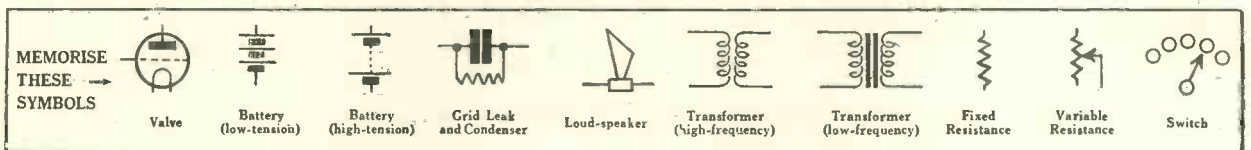

A. J. H. Reyner Receiver

use of the mechanical variation of coupling.

Special H.F. Transformer

Experiments have been carried out recently with the object of producing a satisfactory H.F. transformer having a variably-coupled primary which could be mechanically connected to the spindle of the variable condenser used for tuning the secondary. The experiments, however, were not confined to the production of a variable coupler only, but aimed at a further simplification of the high-frequency amplifier, an attempt being made to omit the usual stabilising arrangements without the sacrifice of efficiency.

Now for any particular frequency

it is possible, by making the anode circuit of the high-frequency amplifying valve possess certain definite characteristics, to maintain the valve completely stable, so that it will amplify efficiently without any tendency to self-oscillation. The difficulty is that this applies only for one particular frequency. It is possible to design the circuit in such a manner that at the highest frequencies to be received, that is, at the bottom end of the tuning scale, the circuit is both efficient and yet stable.

With a simple arrangement such as this, however, as we increase the tuning capacity and so reduce the frequency, the arrangement becomes more and more inefficient.

If, however, we have a variable

coupling on the transformer, so that as we reduce the frequency we increase the coupling between the primary and the secondary, then we shall tend to increase the efficiency of the arrangement progressively and we can make this counteract the effects caused by the decrease in frequency. With proper design, therefore, it should be possible to achieve both the desired objects at once.

What the Paradyne Four Will Do

In other words, we can:—

- (a) Increase the coupling between the primary and secondary progressively as we increase the tuning capacity, which will result in constant sensitivity over the whole scale.
- (b) Design the arrangement to be

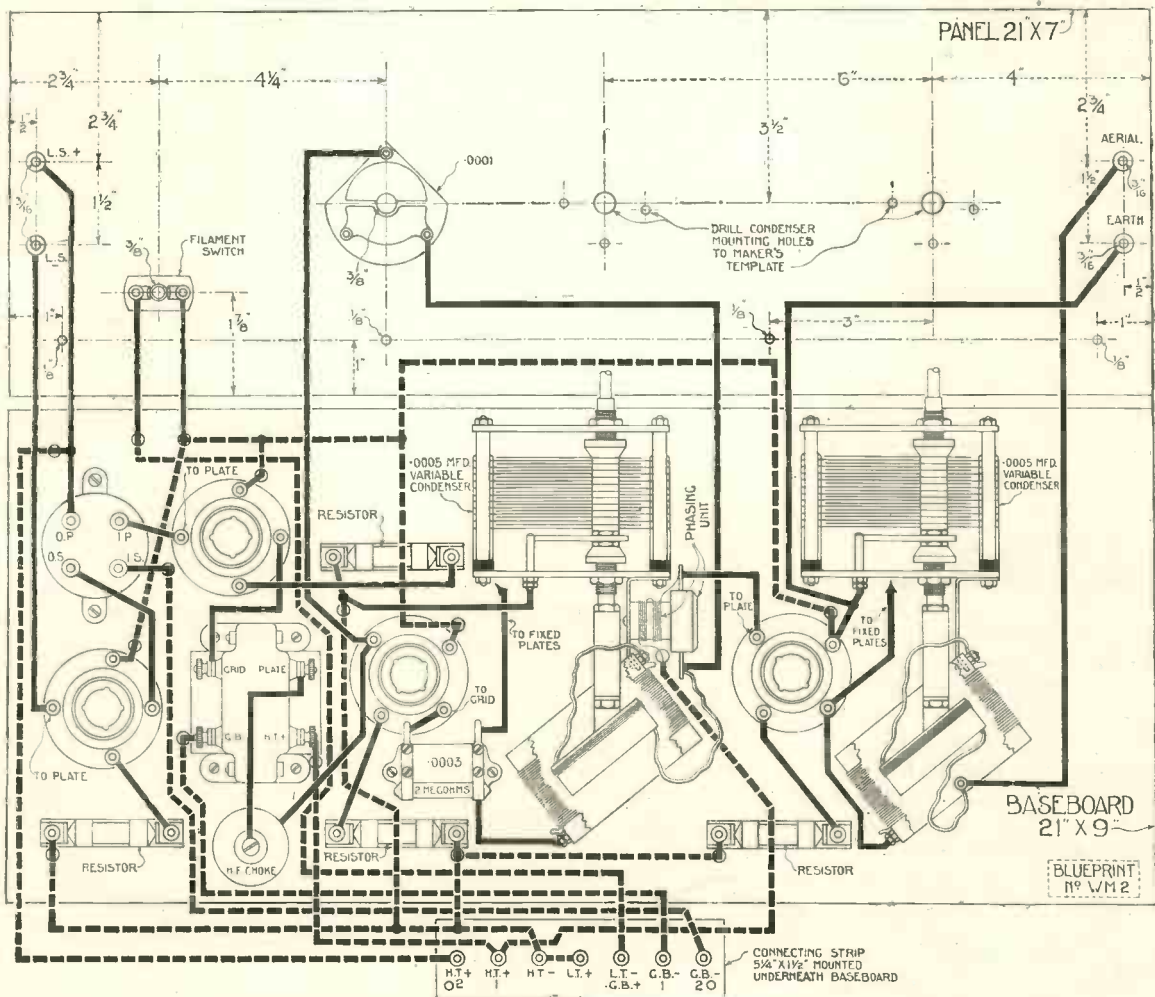

Layout and wiring Diagram of the Paradyne Four. A full-size blueprint (No. W.M.2) can be obtained.

The Paradyne Four (Continued)



J. H. REYNER,
B.Sc., A.M.I.E.E.,
designer of the
Paradyne Four.

stable at the bottom of the tuning scale, when it will remain stable over the whole of the band.

No little experimental work has been required in order to achieve this result. I hope in further articles to give some account of the difficulties which had to be overcome in achieving the final successful model, but it will suffice for the present to remark that it has been done and that S. S. Bird and Sons are now manufacturing special H.F. transformers which fulfil the requirements just laid down.

Circuit

The final arrangement adopted in the receiver in question is shown in Fig. 2. The aerial circuit will be seen to be of the more or less conventional type, the aerial itself being coupled to the first grid circuit. The only difference here is that this coupling is variable in a similar manner to that in the H.F. transformer. This gives an increased coupling on the longer waves, while still retaining adequate selectivity on the shorter waves.

Special Phasing Unit

The high-frequency valve is fed, as will be seen, with high-tension current through a special phasing coil, while the high-frequency cur-

rents pass, through a fixed condenser, through the primary winding of the transformer. As will be seen, the coupling between this primary and the secondary is variable in order to obtain a constant transfer of energy. The second valve acts as a detector, and the remaining two valves are straight-forward low-frequency amplifiers.

The adjustment of the transformers to such a point that they are continuously on the verge of oscillation is not a practicable proposition commercially, and in consequence a reaction adjustment has been provided. This adjustment is set in conjunction with the coupling on the H.F. transformer to give a constant

feed-back over the whole range, after which it is not necessary to alter its setting.

Reaction is provided by feeding a small amount of high-frequency current from the anode circuit of the detector valve, through a small control condenser on to the primary winding of the H.F. transformer.

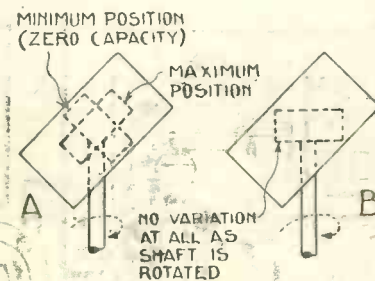

Fig. 3.—Positions of Primaries: (A) Maximum variation; (B) Minimum variation.

It will be as well at this stage to describe the high-frequency transformer and aerial coupling. These units consist of the variable condenser having an extension on to the spindle which carries a variable coupling. The necessary winding in each case is carried on a bracket also mounted on the condenser.

The condensers employed are not of the usual type, but are a specially

designed "mid-line" type. This condenser obeys a law between that of the S.L.W. and S.L.F. condensers, and is responsible to a large extent for the constancy of the coupling. The primaries of the transformer are arranged on a pivot so that the degree of coupling variation can be altered at will. In one position the coupling varies from zero at the bottom of the scale to a maximum at the top, while in the other extreme position the coupling remains fixed at an average value over the whole of the scale.

The positions of the primaries for these two extreme arrangements are outlined in Fig. 3. In practice the primary is kept in some position intermediate between these two, which, with the reaction setting, gives a constant sensitivity.

The aerial coupler consists of the moving primary with a fixed secondary. The high-frequency transformer is similar generally, except that it contains a phasing unit.

Components Required

The following components will be required to make up this receiver:—

Ebonite panel, 21 in. by 7 in. by $\frac{1}{4}$ in. (Becol or Trelleborgs, Siemens).
Cabinet with baseboard, 9 in. deep (Caxton).

Paradyne aerial coupling unit (S. S. Bird).

Paradyne H.F. transformer unit (S. S. Bird).

4 valve holders (Wearite).

H.F. transformer, 1st stage (Ferranti A.F.3).

L.F. transformer, 2nd stage (Eureka Concert Grand).

H.F. choke (McMichael or Varley).
.0001-microfarad reaction condenser (Peto-Scott or Ormond).

On/off switch (London and Provincial or Lotus).

Battery strip with 8-way cord (Lewcos).

Layout

A few remarks concerning the layout will be of interest, as there are one or two unusual features. In the first place, a combination of sub-baseboard and surface wiring has been adopted. The baseboard is not fixed at the bottom of the front panel, but at a height of $\frac{3}{4}$ -in. up, a special batten being fixed at the rear under edge of the baseboard as a support.

Fixed underneath the baseboard is the battery strip. This is a new development of Burne-Jones & Co., Ltd., which consists of an

A Set with Constant Reaction Coupling

ebonite strip carrying eight soldering tags fitted in place. The battery leads are already connected to these soldering tags, and it is simply necessary in wiring the receiver to take the connecting wires to the tags themselves and solder them up. In this way all terminal connections are avoided as far as batteries are concerned.

The battery connections, therefore, are taken underneath the panel to the various points, the remainder of the wiring being carried out above the panel. A second point of interest is that a space has been left towards the L.F. end of the receiver, immediately above the on/off switch. This has been done deliberately because several readers may prefer to incorporate some form of switching arrangement for cutting out one of the L.F. valves.

In a future article one or two alternative methods of switching the L.F. valve will be described. The usual methods of jack switching are not altogether satisfactory, and other methods will be discussed. Space has been left so that readers may incorporate whichever of the schemes they desire at a later date.

Constructional Work

Apart from these features, there is little unusual in the constructional work of the receiver. The first operation is the drilling of the panel to

take the two H.F. units (which, as will be seen, are mounted by three-hole fixing in an exactly similar manner to an ordinary condenser), the reaction condenser, the on/off switch, and the four terminals. Fixing holes for the baseboard should also be drilled, remembering that the baseboard is to be $\frac{3}{4}$ in. off the bottom of the panel.

The H.F. units can then be

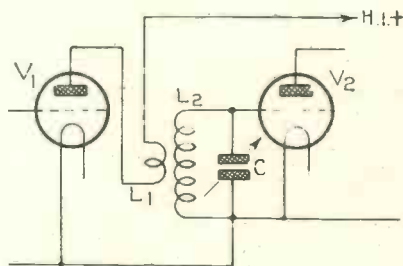

Fig. 1.—Ordinary H.F. Transformer Coupling.

mounted on the panel, the aerial coupler going on the left-hand end, with the H.F. coupler attached to it. All the panel components can be mounted in position, and the panel can then be placed on one side while the baseboard components are considered.

As will be seen, the baseboard components are principally L.F. items. There are the four valve holders, the two L.F. transformers, and the H.F. choke, while on the underside of the

baseboard there is the battery strip. The H.F. and detector valves must, of course, be placed in such a position that they do not foul the aerial and H.F. couplers, which are mounted on the panel, but the positions of the other components are not critical.

A little space should be left behind the panel, however, immediately above the on/off switch, in order to allow for any switching arrangement which may subsequently be introduced. This has been done in the particular receiver shown.

Wiring Up

The instrument is now ready for wiring up. The baseboard components can be wired up completely before the panel is placed in position. It is only necessary to bring the two leads through to be connected subsequently to the on/off switch. The combination of sub-baseboard and surface wiring may be a little confusing at first, but everything has been plainly marked, and little difficulty should arise from this point.

When the baseboard wiring has been completed, the panel can be mounted in position and the remainder of the wiring put in. There is, indeed, very little wiring to be done on the coupler units, owing to their self-contained nature, and if the wiring diagram and photographs

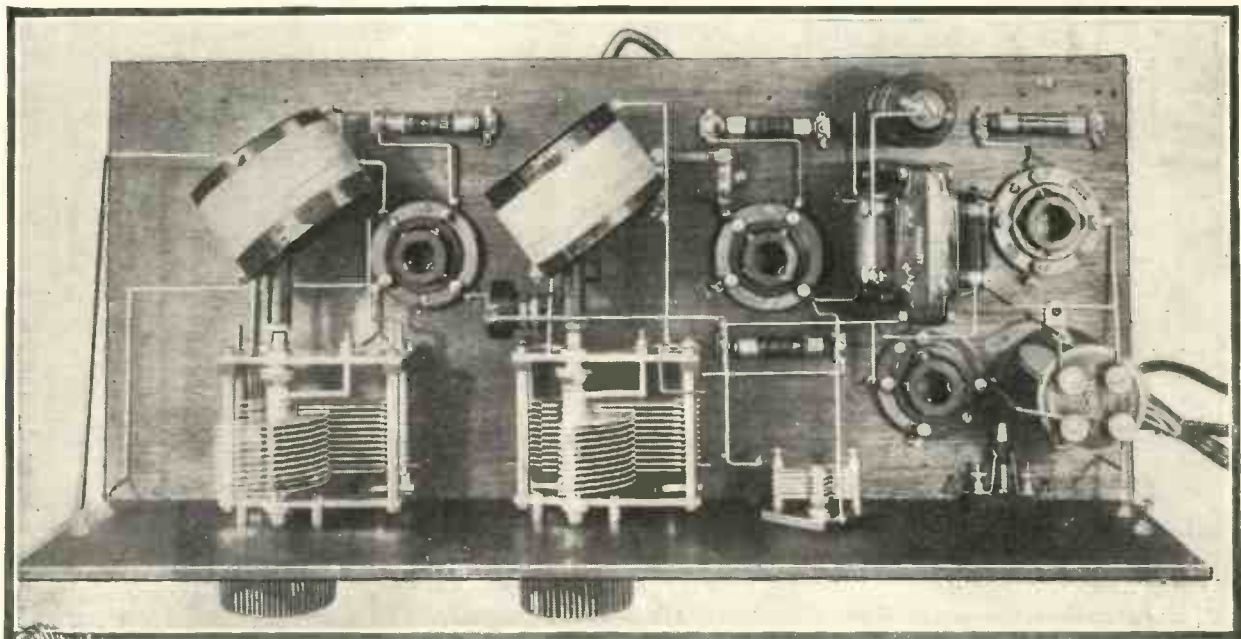

Baseboard View of the Paradyne Four showing simplicity of layout.

The Paradyne Four (Continued)

given are followed, the construction of the receiver will be found to be a simple matter.

The testing out of the receiver is, indeed, the most interesting part. Having completed the usual test for accuracy of wiring, etc., the receiver should be switched on and tested in the following manner:—

Place appropriate valves in the several holders, as detailed in the paragraph below. Set the reaction condenser at zero. Place the aerial coupler so that the maximum variation of coupling is obtained, and place the H.F. coupler so that a medium variation is obtained somewhere in between the maximum variation and the zero variation position. Tune-in the local station (which will be found comparatively easy) and bring in a little reaction with the reaction condenser.

Now, rotating both dials simultaneously, try to obtain some other station. A very good test is to go to the top of the range and tune-in the 600-metre shipping stations. Adjust the reaction condenser until the receiver is just on the point of oscillating on this wavelength.

Next rotate the dials together a little at a time, and it will be found that a number of stations will be heard as progress is made down the tuning dial. It may be that the receiver bursts into oscillation at some point a little way down, this oscillation being

checked by reduction in the reaction condenser.

If this is found to be the case, that is, *if the receiver oscillates more readily at the bottom of the scale*, the H.F. transformer coupler should be altered so that a *greater variation*

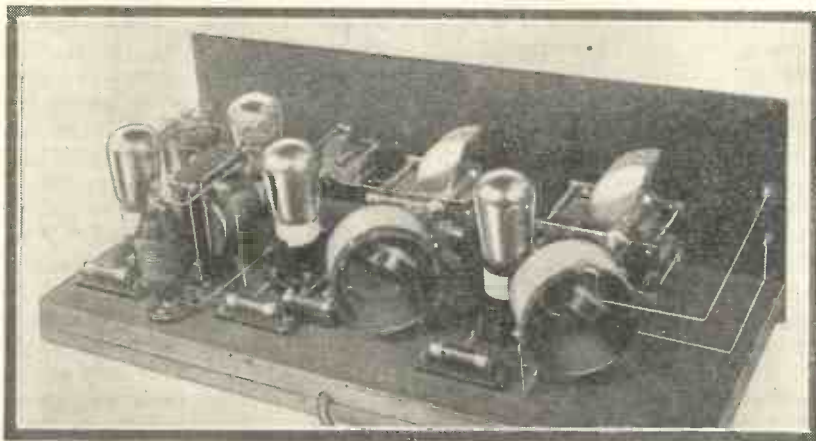

Photograph showing valves in position in the Paradyne Four.

of coupling is obtained. This, of course, will result in the fact that at the particular point the coupling is also a little bit greater and the reaction condenser will have to be eased off a little bit farther.

If, on the other hand, it is found that the receiver falls off in sensi-

By a process of trial and error, a setting on the coupler will readily be found for which the reaction remains constant over the whole of the scale right down to something like 20 degrees on the dial. Below this point it may be found that the receiver bursts into oscillation, and the reaction condenser has to be moved right out before this can be checked.

It may even be found in the very lowest ranges that the receiver oscillates uncontrollably. This is a point on which investigations are being carried out at the moment, but it should be observed that this oscillation occurs well outside the normal tuning range, and it is therefore not a serious difficulty.

It may be remembered that in the early days of neutralising difficulties of this sort were experienced, and as they have been overcome no doubt

this minor trouble will in due course be conquered.

I shall have more to say about the adjustment and the operation of the receiver next month, and for the present this must suffice.

The valves to use should be as follows:—

For the H.F. valve, a general high-impedance type of H.F. valve should be employed. This

valve is not critical, however, and in the particular circuit in use it does not affect the tendency to oscillate to any appreciable extent.

For the detector valve, a high-impedance high-amplification valve should be employed. Since a Ferranti transformer follows the detector valve (this

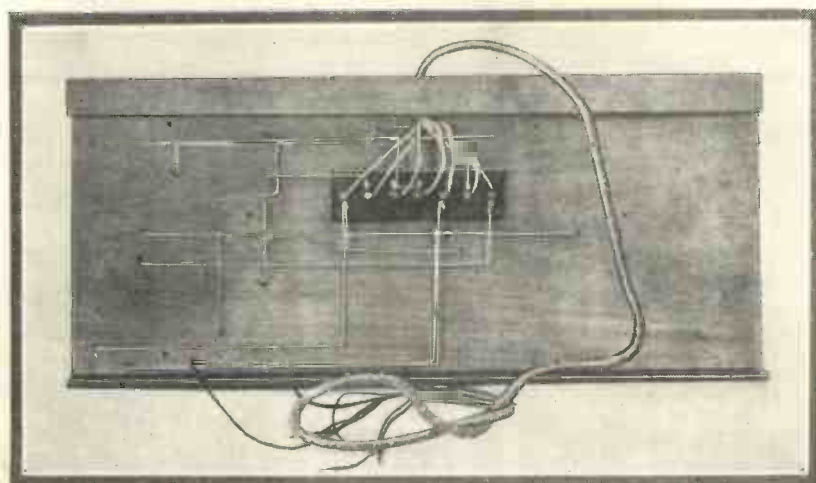

View of the sub-baseboard wiring and terminal strip.

tivity as progress is made down the dial, in other words, *if the receiver is more sensitive at the top of the scale*, then the coupler should be adjusted to give a little less variation, accompanied in this case by a little greater reaction setting.

A Long-range Loud-speaker Set

being a transformer which has an exceptionally high primary impedance), these high-impedance valves may be used without fear of poor quality resulting.

For the last two stages, suitable power valves may be used, and, particularly if good quality is desired, a super-power valve having a very low impedance should be used in the last stage. One of the features of the receiver, however, is that it is not over-critical as regards valves, provided that the correct types are used in the various positions.

H.T. Voltages

The high-tension voltages may be 60 to 90 volts on the H.F. and detector (H.T.1), and up to 120 volts on the L.F. stages (H.T.2). The grid bias on the L.F. stages, of course, depends upon the actual high-tension voltage used and the types of valves employed, and the makers' directions should be followed in such cases.

A test report on this receiver is appended herewith. The stations were all received at full loud-speaker strength during the course of a run from top to bottom of the dial. A number of other stations were heard, but as they could not be considered full loud-speaker strength, they are not included in the list. Telephones were not used, all tuning being done on the loud-speaker.

Tuning

The tuning operations require a little experiment before the "feel" of the receiver is obtained. Owing to the fact that the coupling between primary and secondary of the trans-

former is somewhat weak, the receiver does not behave in quite the same manner as a neutralised receiver. Until the tuning dials are in tune the weaker stations can easily be missed, although a number of distant transmissions will be heard without any difficulty.

This, however, is only a minor difficulty, and will not occasion any trouble, but the point is raised because at first the receiver may seem to be behaving in a somewhat peculiar manner.

tween the high-frequency and detector stages; such troubles could be overcome by screening, and future receivers embodying this principle will be described; but in the present instance it was considered desirable to keep the arrangements simple, so that the benefit of the new system could be appreciated by everybody.

Identical Readings

It is interesting to note that with the particular condensers employed in these Paradyne units it is possible to rotate the dials on the spindles until they both give identical readings on any particular station. They will then be found to keep in step over the majority of the scale, which considerably facilitates tuning-in.

Below about 50 degrees the tuning may be found to become a little difficult at first. This is partly due to the fact that the aerial load is almost completely removed, due to the rotation of the aerial coupling coil.

Since, however, 50 degrees corresponds to a wavelength of 250 metres, this is quite a minor detail, and for the normal range of reception above this point the receiver will give excellent and fascinating results.

Normal Range

As was mentioned earlier in the article, a tendency to instability may be observed below the 50-degree mark, but the same remarks apply here, this portion being outside what may be considered the normal range of the receiver.

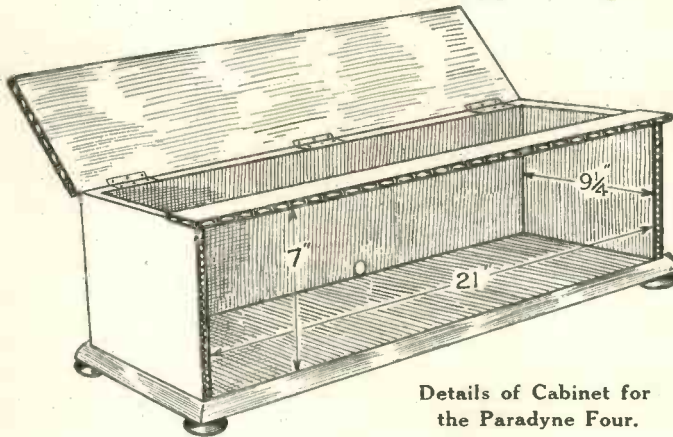

Details of Cabinet for the Paradyne Four.

The selectivity of the present arrangement is only moderate, but any shortcomings in this direction are compensated for by the ease with which the various transmission may be tuned-in.

The present receiver was tested comparatively close to 2LO, which accounts for the fact that no other stations are received for about 10 degrees on each side of his wavelength. London was also heard in the background over some portion of the scale, this being largely due to direct pick-up and interaction be-

STATIONS RECEIVED ON THE PARADYNE FOUR AT LOUD-SPEAKER STRENGTH

Dial Readings.	Station.	Wave-length.	Dial Readings.	Station.	Wave-length.	Dial Readings.	Station.	Wave-length.
163	Vienna	577	131	L'Ecole Superieur	458	86	Nuremburg	330
161	Berlin	566	129	Stockholm	454.5	82	Birmingham	326.1
152	Munich	536	127	Rijukan	443	80	Dublin	319.1
147	Rosenhugel (Vienna)	517	124	Porsgrund	434	78	Newcastle	312.5
145	Brussels	508	122	Frankfurt	428.6	76.5	Zagreb	310
143	Aberdeen	500	118	Bordeaux	419	75	Belfast	306
140	Bournemouth	491.8	116	Berne	411	74	Königsburg	303
138	Berlin (Witzleben)	483.9	115	Glasgow	405.4	65	Dortmund	283
137	Riga	481.9	114	Bremen	400	61	Radio Castilla	275
135	Lyons	476.2	110	Hamburg	394.7	55	Malmo	260.9
134	Langenburg	468.8	103	Madrid	375	18	Joenkoeping	201.3
132	Bergen	461.5	90	"Le Petit Parisien"	340.9			

Cecil Palmer, the well-known publisher, answers the question

Do We Want Broadcast Novels?



The Pros and Cons Considered

THE recent experiment of the B.B.C. in broadcasting a novel is interesting as an experiment. But it is very unlikely that the novel will ever take a permanent place in radio entertainment, for it is by its very nature unsuited for broadcasting if only for the reason that it was never intended to be read aloud.

Novels Read Aloud

In the early days of novels, particularly those which appeared in instalments, it is, of course, historically true that in certain villages the inhabitants would gather and listen eagerly to one of their number who read aloud each part as it was published. No one would suggest, however, that this was on account of a definite preference for hearing the novel read aloud; it was, on the other hand, simply due to the fact that a large percentage of the population could not read!

In any case this does not affect the primary feature of the novel; unlike poetry, it was definitely meant for private, personal consumption.

Poetry is in a different category altogether. It is a form of Art whose value is frequently enhanced by the services of a sympathetic interpreter. In common with music and the drama it really requires three persons—creator, interpreter, and listener.

Two Participants Only

The other form of Art, in which the novel finds its true place, demands only two participants—its creator and someone else who combines the rôles of interpreter and listener. When a novel is broadcast the announcer is brought into action as an intermedi-

ary, and at once strikes a false note, for the novel simply does not require his services.

A novel is the fulfilment of phantasy. The effect produced on each individual reader is different in accordance with whatever he himself reads into it. He is entirely his own interpreter; directly a third person intervenes between himself and the author the phantasy is destroyed. From being a private and personal

Readers will frequently write to me and ask when I intend publishing another novel by Mr. X. Perhaps I reply that I shall have nothing from the pen of Mr. X. in the near future; possibly the reader would like to see something by Mr. Y.? As a rule the answer is a definite "No!" Mr. X., and only Mr. X., will do.

Definite Tastes

If novels were extensively broadcast there would be no appeal for the listener with very definite tastes. He would have to listen to whatever was offered—or switch off.

Certain types of novel which find a ready public would be quite impossible to broadcast. What of the long, psychological, introspective novel with its difficult passages requiring reading and re-reading in order fully to understand them? Would the announcer repeat such passages so that their full significance could sink in?

The truth is that such novels would be deadly dull for many listeners and too rapidly read for their devotees to follow. It would be impossible for the listener to recall anything he had not quite grasped.

Maintaining Interest

And if it is difficult to suggest a semblance of reality in a broadcast play, where separate persons playing separate rôles lend individuality to the various characters, how much more difficult it would be to maintain interest in a novel where one voice attempted to suggest the conversation of all the characters!

In reading a novel the reader imagines the conversation in accordance with the dictates of his own fancy,

THE HELPING HAND

of the WIRELESS MAGAZINE is ever ready to come to your aid when you are in difficulty over any wireless trouble, whether practical or theoretical.

Just write your query out on a piece of paper (write on one side only, please!) and send it, together with the coupon on page iii of the cover, a fee of 1s. (postal order or stamps), and a stamped addressed envelope to: The Editor,

**WIRELESS MAGAZINE,
La Belle Sauvage, E.C.4.**

adventure in the realm of the imagination, the novel becomes merely a number of words issuing from a loud-speaker.

Quite apart from the fundamental unsuitability of the novel for broadcasting purposes, there are many purely practical difficulties. How are you going to choose a novel which will be sure to please even half of your listeners?

From my experience as a publisher I know that the novel-reading public of this country is sharply divided into sections, each of which prefers the works of one type of novelist—and probably reads very little else.

and the endeavours of the announcer to do so by proxy would lead to irritation if it did not achieve actual flatness. Here, too, is another danger.

Consistent High Level

Could a novel, on account of its length, consistently keep at a high enough level to be interesting evening after evening? It must be realised in this connection that far more concentration would be demanded in listening to a novel than in reading it in the usual way. The listener would have to carry the memory of what had happened from instalment to instalment unless a synopsis were read at the beginning of each.

It seems, therefore, that from the radio listener's point of view the broadcast novel would not probably have a very great appeal. It is also quite certain that the average novelist would not give it a very warm welcome, chiefly because it tends to destroy the most cherished feature of his Art—the element of permanence.

At present the novelist has one very important advantage over the actor. When the actor dies he is but a name to succeeding generations—but the child who can read to-day can appreciate Dickens as well as if he were still with us. A novel is a book; solid evidence of the industry of its author, and not many

authors would care about broadcasting their novels, for the reason that comparatively few novels bear re-reading. Not many people who heard the novel broadcast would be induced to buy the book.

Special Novels

I doubt, too, if any author of repute could be persuaded to write a serial novel specially for radio purposes. Here again he would be guided by his passion for permanence, for it is improbable that a publisher would risk bringing out in permanent form a novel which had previously been broadcast. I still feel that the future of the novel is with the reader—not with the listener.

Round the Foreign Stations

From Naples

A FASCISTI announcement that £50,000 was to be spent on the roads of Naples and neighbourhood. (The streets of Naples are a by-word.)

An announcement that Pompeii had revealed more mysteries.

An English talk on the beauties of Capri.

Wine price lists.

Two hours of a trio. (two voices and a guitar) singing love ballads.

The wonderful improvement in this station.

From Dortmund

Coal prices.

Account of a huge coal combine.

Description of a coal mine explosion.

Next evening a solo in English entitled, "Don't go down the Mine, Daddy."

From Moscow (Trades Union Council)

Speeches.

More speeches.

Still more speeches.

An attack on a celebrated British Cabinet minister.

A comparative table of workers' wages in European countries, according to which the British workman was the poorest paid of all.

A criticism of British labour leaders.

From Aalesund

Talk on "Herrings."

Fish prices.

Fishermen songs.

Description of herring fishing.

Queerest orchestra in Europe—extremely "fishy."

Shortage of hands.

From Karlserona (SMSM)

Einstein's theory explained in ten minutes.

A talk on "How to Grow Hair."

An evening of Welsh music—two of the airs were Irish, seven items were certainly not Welsh, and the average Welshman would not recognise the other selections as Welsh. E.B.R.

A CABINET THREE - VALVER — Neat and Out of the Way

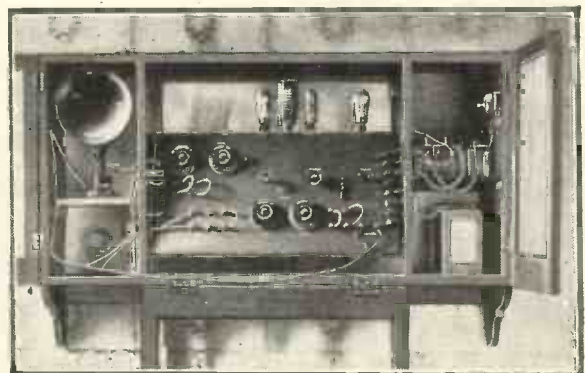
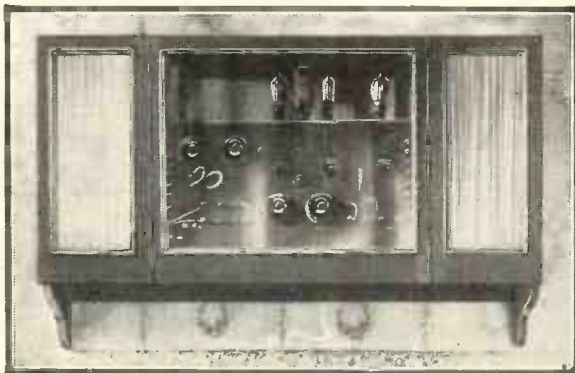

These photographs show a neat three-valve cabinet set made by a reader of the WIRELESS MAGAZINE. The side doors each

have a panel of silk and are kept closed while reception is being carried out. The batteries are in the right-hand compartment.

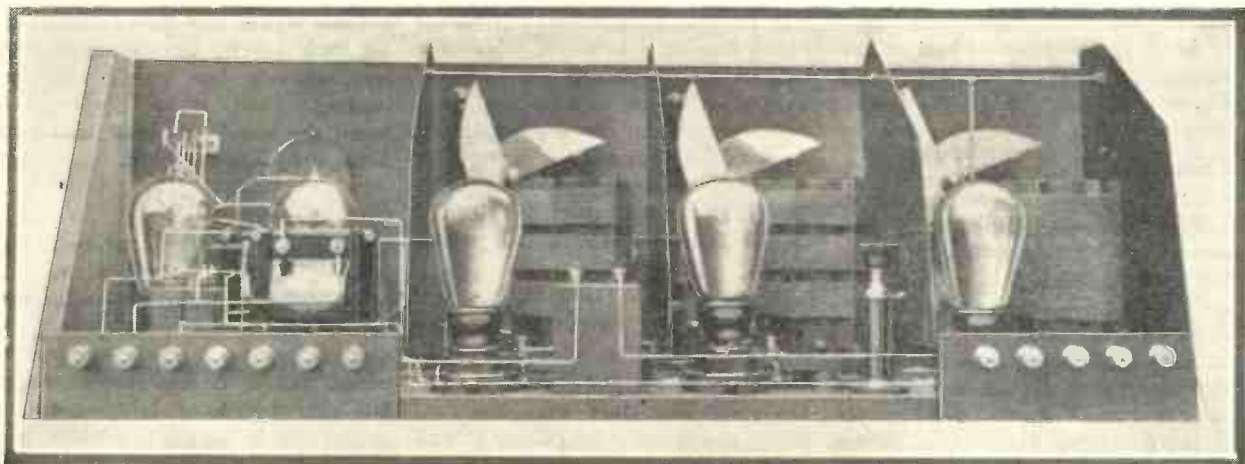

The neat layout of the 1927 Five is well illustrated by this photograph of the set which was made by Mr. C. L. Drake, of West Wimbledon.

Have You Built the 1927 Five Yet?

Full-size Blueprints Now Available (see p. 102)

"Last Word in Efficiency"

SIR,—In your issue of October last you give particulars of the 1927 Five, and state you would be interested to hear

Fourthly, I have put in suitable rheostats for the two H.F. and detector valves, using fixed resistors for the L.F. section only. By being able to control the current greatly assists the finding of

through with it. I used what parts I had which were at all suitable, going to no expense where I had parts of same capacity by other makers.

I made the coil formers for the low wavelengths first, and was amazed at the number of stations I could receive at full loud-speaker strength, and also the quality of reception.

Naturally, I wished to get Daventry, so I made the higher-wave coil formers to the particulars published in the WIRELESS MAGAZINE. Here I was sadly disappointed, the tuning being very broad and strength not what I expected or what I had been accustomed to.

As I have had some previous experience with five-valve neutrodyne circuits I began to try to solve the problem.

I give below the result which, if you care to pass on to your readers, you can with pleasure.

The original aerial coil, I believe, is connected:—*Earth* *Grid*. In place

of this I used the ordinary coils connected:—*Aerial* *Grid*. I used a

Earth
No. 100 coil in the aerial circuit and a No. 150 coil in the grid circuit.

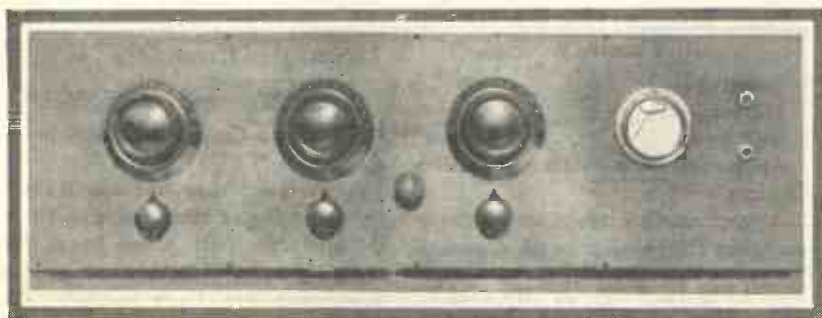

Modified Panel Layout of Mr. Drake's 1927 Five.

from any readers who have constructed the set.

I have built the set in my spare time, and I consider it the last word in efficiency. If carefully studied, and the design followed, no better set can be built or bought for any money, and it fully justifies all you claim for it. Distant stations can be located with ease when one gets the proper hang of it.

Here are a few photographs which I have taken myself (reproduced on these pages).

You will notice I have gone away from the original design in four instances only. The panel is at right angles instead of sloping. This was done purposely for fitting into my own designed cabinet.

Secondly, I have used No. 22-gauge copper shields instead of aluminium.

Thirdly, the jacks are on the panel instead of on the terminal strip at the back. This is for convenience, obviously.

distant signals.—CECIL L. DRAKE (West Wimbledon).

Coil Hints

SIR,—I commenced to make the 1927 Five set directly after the publication of the particulars. As I had a good five-valve set in use I was in no hurry to get

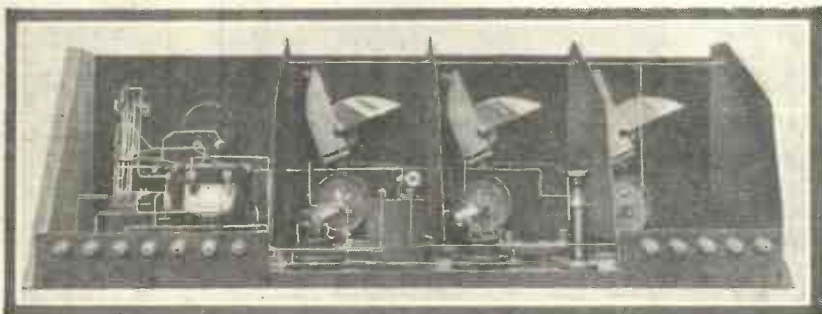

Photograph of Mr. Drake's 1927 Five showing filament rheostats.

The result was quite 50 per cent. stronger; the tuning fine enough to cut out Daventry and get Radio-Paris at good loud-speaker strength. Using a No. 75 coil and a No. 100 I got Moscow, Berlin, and two other stations at extra good loud-speaker strength.

The original coils for high waves were so broad in tuning as to be of no use for distant stations when Daventry was broadcasting, whereas the coupling I describe will cut out Daventry entirely and get the other high-wave stations without any interference.

I used DEV valves for the first three, DE5B for fourth, and DE5A for last. I had used these previously in a five-valve set on 6 volts, and was surprised to find they would work comfortably in the 1927 Five on 4 volts, not just when newly charged, but right along to usual time; the accumulators had run previously on six. I can say the 1927 Five will take some beating.—JAMES WM. TAYLOR (Huddersfield).

SOME QUESTIONS ANSWERED

(See also p. 184.)

Reservoir Condensers for H.T. Eliminator

Q.—I am following the design of a three-valve receiver in which three 2-microfarad condensers are used across the separate H.T.appings. As I intend using a home-made H.T. eliminator to obtain my H.T. direct from D.C. mains, will it be necessary to retain these large condensers in circuit when building the set?—E. J. (Teddington).

A.—If you have not incorporated large-capacity fixed condensers across the tapping points of your H.T. eliminator, then you are advised to fit the large capacity fixed condensers in your receiver when constructing the latter. These condensers are advantageous in that they

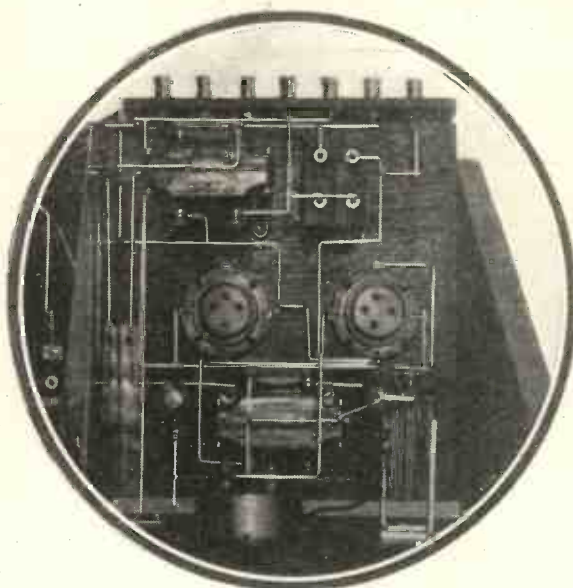

This photograph of Mr. Drake's 1927 Five shows the alteration in the jack positions.

will act as a filter or smoothing device still further to smooth out the ripples due to the current supplied by the H.T. unit.—L. A. C.

The Best Possible Aerial

Q.—Provided that one is not restricted to a certain space for the purpose of erecting an aerial, and the only restrictions imposed are those laid down by the P.M.G., what type of aerial do you con-

sider would give best results as far as reception is concerned?—N. C. (Surrey).

A.—The ideal aerial, bearing in mind the P.M.G. regulations, would be a vertical aerial projecting 100 ft. into the air above the lead-in tube of your station. Even if it is impossible for you to obtain a full 100 ft. vertical aerial, one of the maximum height would still be better as regards efficiency and selectivity than an ordinary overhead aerial of the single- or double-wire type. Bear in mind that a single-wire aerial will always give maximum selectivity provided that the distance between it and any earth object is considerable.—D. R.

Valves for Resistance-coupled Amplifiers

Q.—I have built your four-valve set, As Good a Set as Money Can Buy, and have been delighted with the results, and I now wish to build the Gloria Four described in No. 25. Can I use my existing valves for the latter receiver?—N. M. (Essex).

A.—You may use your existing H.F. amplifying valve for the H.F. amplifier in the Gloria Four, and also the power-amplifying valve of your existing valve set may be used for the last valve in the latter receiver. The detector and first L.F. amplifying valves of this latter receiver, however, must be of the high-impedance type such as the SP55B (Blue Spot) or other similar types.—C. L.

Look Out for Another Special
Reyner Set Next Month

Radio on the Road

A Dash-board Receiver

A NEAT dash-board wireless set has been built into a 14 h.p. Park Lane Standard Saloon by the Standard Motor Co., Ltd., of Coventry.

From this photograph the neat way in which the set forms part of the dash can be seen. Note the dash lights, which light up the various controls, and the double multi-plug which makes or breaks the fourteen connections to the various current-supply points, loud-speaker, aerial, amplifier and remote controls.

Plug holes will also be noticed in which a jack can be inserted for headphone use when needed.

The ample leg room allowed in Standard cars is not in any way diminished by the installation.

The remote control on the steering wheel can also be seen. Underneath the steering wheel are two dummy plugs, on one of which the double multi-plug can be secured whilst the set is out of use, thus preventing any tampering or chance of short circuiting.

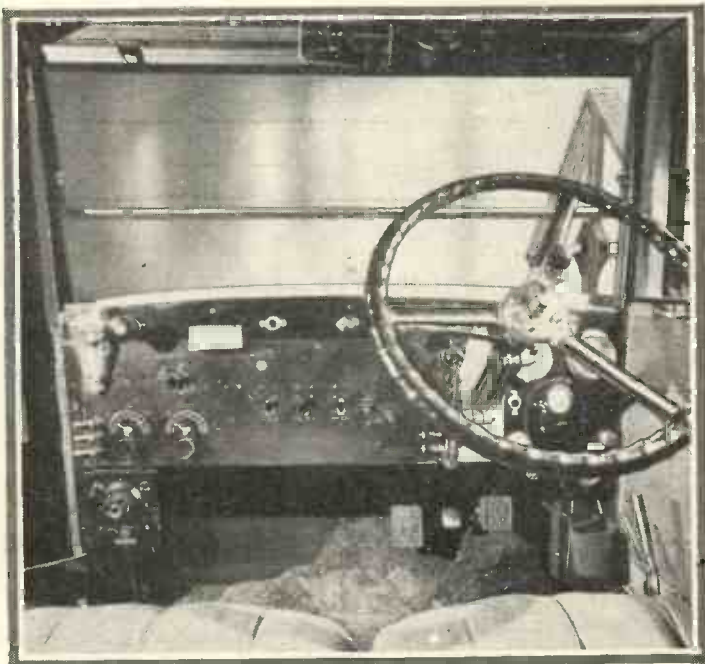

Half Hours with the Professor



I. A CHAT ABOUT THE GRID LEAK

"MAY I come in?" but Young Amp was not waiting for permission. He was in, and Prof. Megohm was glancing round his laboratory in an apprehensive manner. Young Amp had a way of prying into things and could not always keep his fingers to himself. But he had a persuasive way about him and Prof. Megohm could never pluck up his courage to conduct him to the door and slam it.

A New Idea

"Hullo, my boy. Yes, yes, come in. I didn't expect you. I'm just trying a new idea."

"Let me help," was the impetuous reply. "I have got plenty of time to waste—and perhaps I shall be able to learn something."

"Very good," said Old Megohm. "Let me see, I want a grid-bias battery, is there one in that cupboard?"

It was a few minutes before the article in question was discovered. Megohm was not exactly a tidy man!

"Let me connect it up for you," said Young Amp in his most engaging manner.

"Not that way, my boy." Young Amp noticed that the old Prof. took particular care to disconnect the H.T. battery before making any alteration whatever to the receiver. "The easiest and most satisfactory way to blow your pocket-money is to make alterations with the H.T. battery in circuit—a slight mistake or a slip of the hand and bang goes another of your valves. Always make a point of disconnecting the H.T." Amp was quite unruffled.

A Fuse?

"Not bad," he said, "but surely you could safeguard yourself by dropping in some sort of fuse in the high-tension lead?"

"Yes," agreed the Professor, "as a matter of fact, most of my permanent high-tension batteries contain a small flashlamp bulb, or other

H.T. fuse, definitely included in the lead from the negative terminal. Then in case of danger this fuse will burn out before the current grows to sufficient strength to damage the valves. In this case, as you will see, I am using an ordinary battery, in which I have not had time to incor-

In this, the first of a series of articles intended especially for the beginner in radio, Professor Megohm discusses H.T. safeguards in general and the grid leak in particular.

Another article will be published next month.

porate the fuse, but even with a fused circuit I often disconnect the battery, because it is a very good habit to get into."

Young Amp would help. There was no denying him a hand in any little job that was going forward. The Prof. nearly had a fit as a 30s. valve which the Amp had laid carelessly on the bench started rolling to

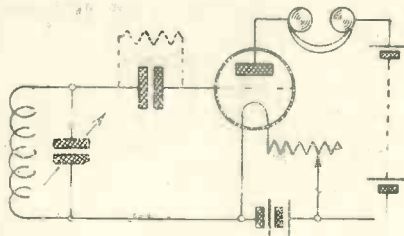

Fig. 1.—Prof. Megohm's diagram to explain the rectifying action of the valve.

its possible smash, but it was caught in time.

The receiver was set in working order again and the Prof. proceeded to tune-in signals.

"Ah!" he said, as he brought up the reaction control, "that's more like it," and Amp noticed that as he turned the reaction knob, so the

signal strength gradually increased without any tendency to flop.

The Amp's eyes glistened. "By Jove! What did you do? You will have to come and look at my set, I can see. I have played round with it for night and nights. I have altered the H.T. values and the filament rheostat, but it still remains a dud. To get any distant station at all is frightfully difficult."

Harsh Reaction

"That so?" was the reply, "you often obtain conditions of affairs in which the reaction is harsh, but it is really quite an easy matter to put right. I am producing reaction here in the usual manner by coupling a coil back from the anode circuit of the detector valve, and when this is done the detector valve itself must be operated on a satisfactory portion of the characteristic if smooth reaction is to be obtained. All I did there was to change the position of the grid leak on the detector valve."

"That's funny, but nearly every circuit I've seen lately has had the grid leak connected to the positive side of the filament, so, of course, I thought it always had to be."

The Prof. smiled. "That," he said, "is both untrue and true at the same time. Sit down and I'll put it more clearly for you."

The Prof. settled himself comfortably, while Young Amp, to his consternation, perched himself upon the table, almost upsetting the whole apparatus.

Amplifies As Well

"What we have to remember," he said, "is that the detector valve, operating on the cumulative-grid method, not only rectifies, but it also serves to some extent as an amplifying valve. If we wish to get smooth reaction control, we have to pay attention particularly to the latter aspect of the valve as well as the former. I will just run over the

essential principle of the rectifying action first of all." (Here the Professor drew the diagram shown in Fig. 1.)

"If we insert a fixed condenser in the grid circuit of the valve, we isolate the grid entirely. If we leave it free and isolated in this manner, we are likely to obtain trouble when signals are being received, and to avoid this we connect a high resistance, usually of the order of several megohms, between the grid and the filament, which stabilises the steady voltage on the grid. We will refer to this, however, again in a moment or two; for the present we can neglect it.

Potential Variations

"Now let us suppose that we apply a signal across the grid and filament of the valve. This will cause alternate increases and decreases in the potential of the grid relative to the filament. If the grid is made positive, then a small amount of grid current will flow. This current, however, cannot return to the filament, and will, therefore, simply serve to charge the grid condenser slightly.

"When the grid is made negative no grid current flows, and the grid potential therefore does not vary during this portion of the signal. The next positive grid current, however, causes a little more charge to build up on the grid condenser, and so we get an accumulated building-up of the charge on the grid condenser. At the end of the signal, therefore, we have the grid condenser charged up negatively so that the grid is decidedly more negative with regard to the filament than it was originally."

Here the Amp jumped up in excitement, thinking he had caught the Professor making a mistake, scattering apparatus and tools.

A Negative Charge

"How can that be, Professor? You said just now that it was only when the grid was positive that any current would flow into the grid condenser. How is it, then, that the grid condenser will charge up negatively?"

The Professor stopped to pick up the apparatus, then continued: "Don't be in too much of a hurry, my boy. You must remember this. The filament of the valve emits negative particles of electricity or electrons. These are attracted to the

grid when it is made positive, and repelled from it when it is made negative. Every time we make the grid positive, therefore, we attract a small charge of negative electrons, and these will charge up the condenser negatively.

"At the end of the signal, therefore, the grid condenser has acquired a large number of these negative

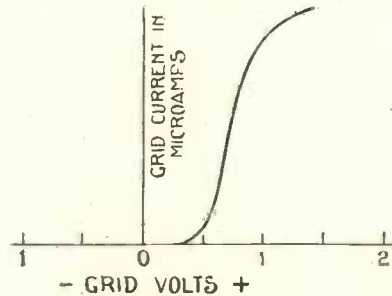

Fig. 2.—Grid-current curve roughly sketched by the Professor.

electrons, so that it will be negatively charged. Is that quite clear now?"

Amp thought it over for a moment then, a little disappointed at not having caught the Professor in a mistake, agreed that he was right. "Although, you know, Professor, it is a little misleading at first sight, isn't it?"

"Now," the Professor continued, "we must consider the effect of this grid potential on the anode current. You know that if you make the voltage on the grid more negative, the anode current in the valve will decrease and vice versa. The effect, therefore, of this negative charge on

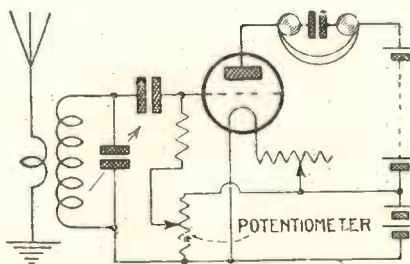

Fig. 3.—The circuit young Amp intended to try.

the grid condenser would be to cause a decrease in the anode current flowing.

"Now the currents sent out by the transmitting stations consist of a series of pulses modulated in accordance with the speech or music, so that for each of these pulses we obtain a decrease in the anode current

of the valve, the extent of the variations depending upon the strength of the current pulse, so that we obtain variations in the anode current corresponding to the original speech or music. Is that quite clear?"

"Yes," Amp said, "I understand that part, but I always thought the grid leak had some effect on the action."

Value of Grid Leak

"You're right there," agreed the Professor, "and this is really the interesting part of the whole discussion. Suppose we connected the grid direct to the positive of the filament. The grid voltage would then be six volts positive relative to the negative end of the filament, which is always considered zero potential. Suppose, however, that instead of connecting it direct we connect it through a resistance. Then the grid will still be positive and a grid current will flow, but this current in flowing through the resistance will cause a certain voltage drop so that the actual voltage on the grid itself will not be as much as six volts, but will be something less depending upon the actual voltage drop on the resistance.

"Thus by varying the value of the resistance we can alter the actual voltage on the grid within fairly wide limits. The voltage on the grid is dependent, therefore, partly on the value of the resistance and partly on the actual point to which the filament end of the grid leak is connected.

"Now the amplifying properties of the valve depend very largely upon the working point on the main characteristic. As we have just seen both the value of the grid leak and the actual point to which we connect the filament end affect the steady voltage at which the grid will settle down and will thus have a considerable influence upon the performance of the valve as an amplifier."

Other Considerations

Amp was keenly interested. "That's fine. It certainly seems to me that there is more than the simple rectification effect to be considered."

"There certainly is." The Professor was most emphatic. "What we have to do, and what most people do not realise, is to choose our values so that we obtain both efficient rectification and good amplifying properties. Now, you know that the

(Continued at foot of next page.)

The New B.B.C. Double- decker Studio

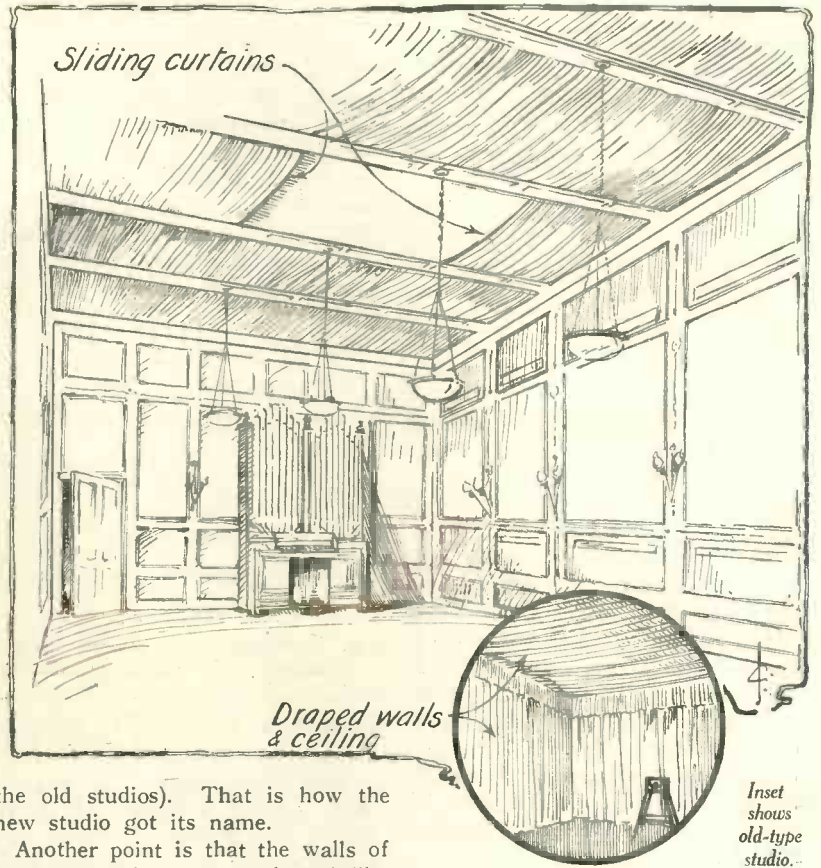

Inset shows old-type studio.

RESULTS obtained from the new double-decker studio at Savoy Hill have come fully up to the engineers' expectations, and by the time this issue is in the reader's hands it will be in general use.

Old and the New

The chief difference between the new studio and the old type (shown in the inset) is its increased height (22ft.—nearly double that of one of

the old studios). That is how the new studio got its name.

Another point is that the walls of the new studio are not draped like those of the old type. But, as can be seen from the sketch reproduced above, the ceiling is provided with sliding curtains. The adjustment of these varies the amount of echo introduced into the broadcasts. The control can be varied within fine limits to give just the right tone.

The value to the broadcast artist of comfortable surroundings has not been forgotten, and the studio is most tastefully decorated. The walls are panelled. No windows are provided, and the studio is insulated from outside noises by a layer of felt behind the panels. **BM/PRESS.**

Half Hours with the Professor

(continued from preceding page)

essential principle of rectification demands the presence of a certain amount of grid current, and the average modern valve will not allow any grid current to flow until the grid is appreciably positive. An actual grid-current curve would be something like this" (picking up an old panel from the bench the Professor roughly sketched Fig. 2) "from which you will see that the grid must be from $\frac{1}{2}$ to 1 volt positive before this current will flow. It is for this reason that the grid leak is usually connected to the positive side of the filament, for, unless grid current can flow there can be no appreciable rectification effect."

"Do you mean that if we connect the grid leak to the negative of the filament the valve will not rectify?"

"No, my boy, I mean that some part of the incoming signal may make the grid sufficiently positive to cause grid current to flow, while in addition we always have a certain amount of anode rectification per stage. Generally speaking, however, a small positive potential on the grid is desirable for rectification purposes.

Small Positive Value

"It does not necessarily follow that the best results are going to be had with the full positive voltage obtained by connecting the grid leak to L.T.+ . In quite a number of cases this does not give good amplifying properties from the valve, at any rate as far as smooth control of reaction is concerned. It is often better to connect the grid leak to a small positive value only, and this is what I have done in the present instance. You saw that I connected a

grid battery in circuit, and actually I connected the end of the grid leak to $1\frac{1}{2}$ volts positive instead of the full 6 volts."

Use of Potentiometer

"That's fine. I'm going to try that when I get home," and Young Amp's eyes gleamed, "and can I place a potentiometer across the L.T. battery and connect the grid leak to the slider?" (See Fig. 3.)

"Yes, it's a very good scheme," said the Professor, "as it enables the best point to be found quickly for any particular valve. You could, of course, mount such a potentiometer on your baseboard, because you only want to set it once and for all."

"Thanks so much. I should like to know more about how the characteristics of the valve affect reaction. Can I come again another time?"

Simple and comparatively cheap to construct, this unit—if you have D.C. (direct-current) mains in your house—will ensure a constant high-tension supply and save you the cost of renewing batteries. It is equally suitable for a one-valver or a large multi-valve receiver.

An H.T.-from-D.C.-mains Unit

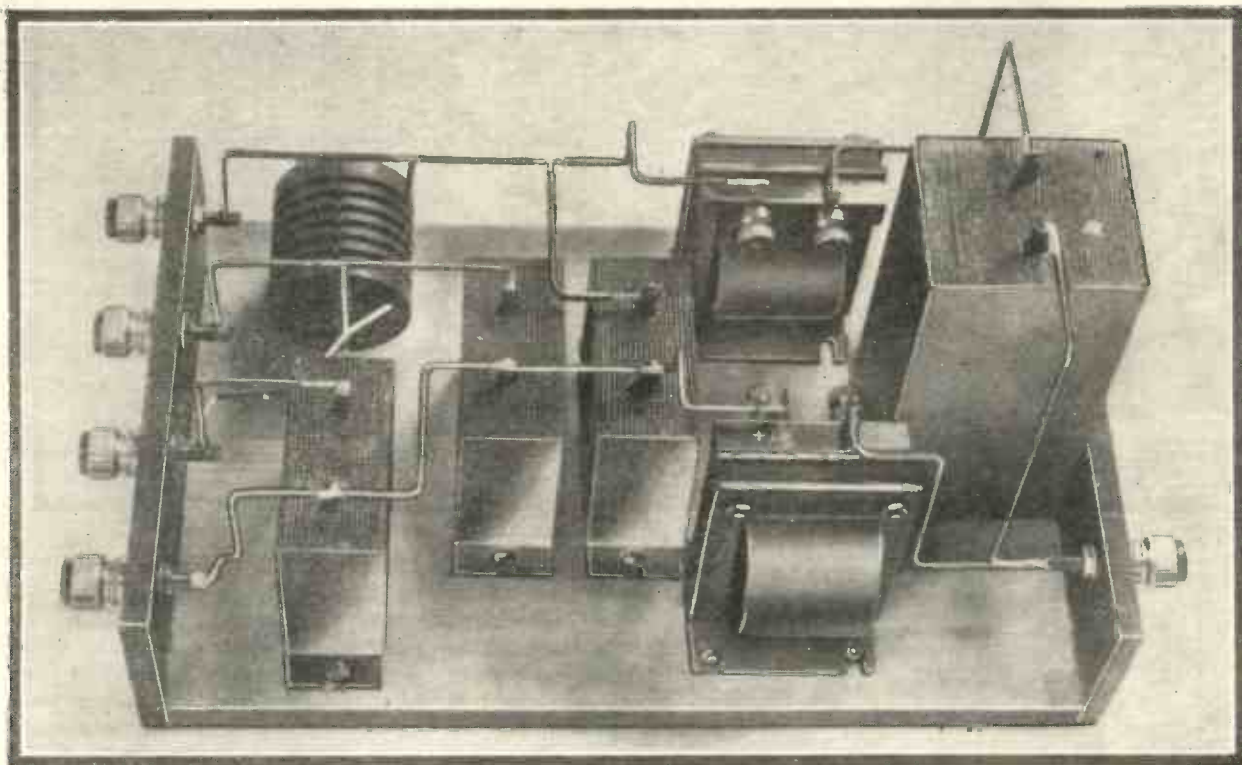

Photograph Showing Disposition of the Components in the Unit for Obtaining H.T. from D.C. Mains.

IT is so simple to use the D.C. electric-lighting mains as a source of H.T. supply that it is well worth the while of those fortunate enough to have their houses wired with D.C. mains to interest themselves in the subject.

Cost of Construction

The initial cost of a suitable unit, of course, is higher than that of an H.T. battery of the dry-cell type, but it must be remembered that whereas the latter requires renewing at frequent intervals (in some cases as often as three or four times a year) the unit, once made, is everlasting and saves its cost within a year or eighteen months.

There need be no fear that the electric-light bill will be increased by the use of the unit. The total current

taken from the mains is so small that in most cases the meter could not register it.

The average set, for instance, takes a total plate current of anything from 5 to 20 milliamperes. On 220-, 200- and 100-volt D.C. mains the power consumed would be 4.2, 4.0, and 2.0 watts respectively, assuming the total plate consumption to be 20 milliamperes. The power consumed is therefore about one-tenth to one-fifth of that taken by an ordinary metal-filament lamp of the 20-watt type.

The total cost of the unit described is approximately £2 15s., but in all probability the constructor will have some of the components in the "junk" box that every enthusiast has in his possession.

It may be mentioned, for instance, that in place of the two iron-cored

chokes specified the secondary windings of old L.F. transformers may be used, thereby saving a considerable cost. At the same time it must be realised that the inductance of transformer secondaries varies between fairly wide limits and in some cases it is possible that unlooked for results will be obtained by the use of unsuitable transformer secondaries.

With D.C. mains we have a fairly constant source of voltage supply, but in all of them there exists what is known as a "ripple" which, if not eliminated, makes itself audible in the phones or loud-speaker.

Tapping Points

Moreover, the voltage of the mains is usually between 200 and 250, although there are 100- and 110-volt D.C. mains in several localities. The

An H.T.-from-D.C.-mains Unit (Continued)

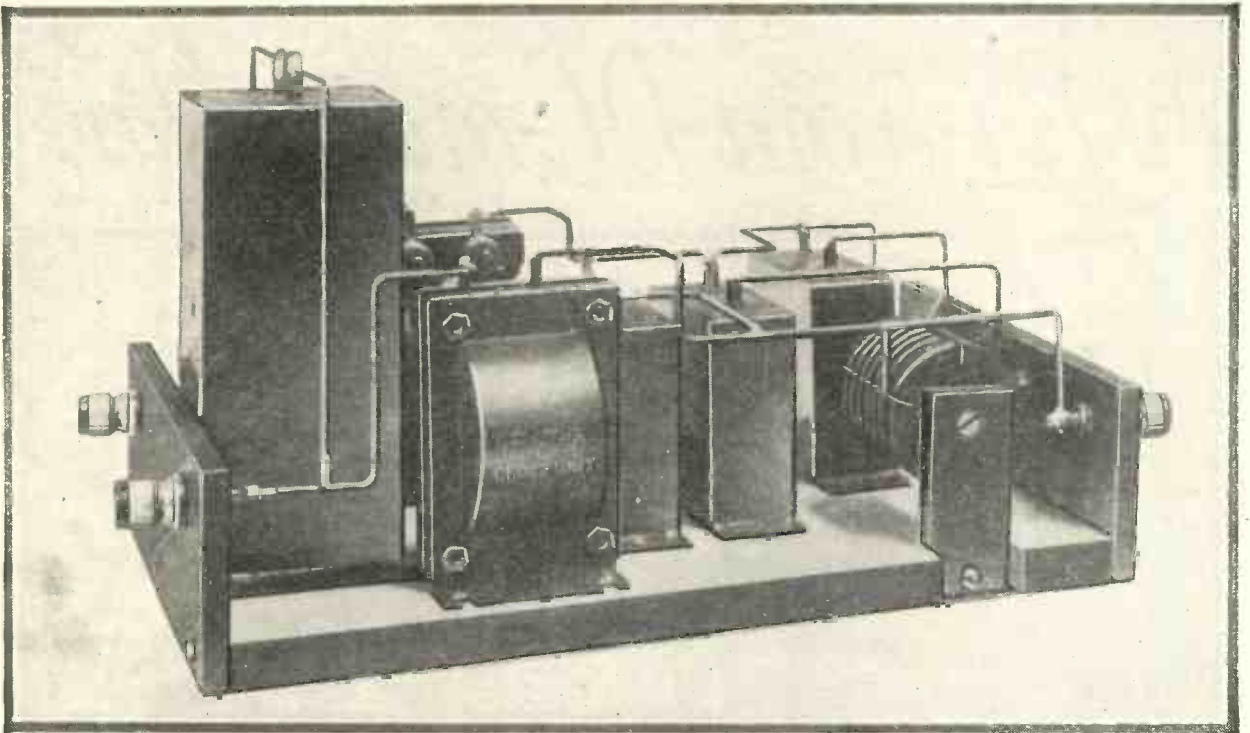

Another Photograph of the Unit for Obtaining H.T. from D.C. Mains.

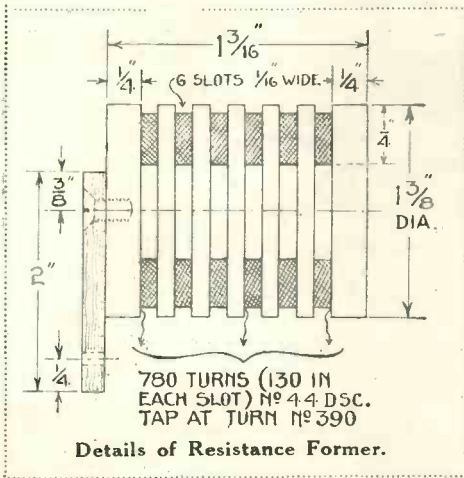

higher voltages are too high for our purpose, so we must provide means for obtaining tapping points at lower voltages suitable for H.F. and detector valves.

This is done by inserting a high resistance in series with the positive lead, taking tappings at various points. The more resistance in circuit the greater will be the voltage drop. With sufficient resistance in circuit we can obtain tappings giving output voltages from 50 to the full voltage of the mains.

The tappings from the resistance

serious occurrence, is apt to be an inconvenience not easily forgiven by the other members of the family.

It is necessary, therefore, that there should be no direct earth connection to the receiver.

may conveniently be brought out to terminals mounted on an ebonite strip.

A point which must not be overlooked is that one pole of the D.C. mains is earthed at the generating station. In nearly all wireless sets there is also an earth connection, and it might easily happen that one pole of the mains is earthed at the generating station and the other pole earthed by the receiver itself, thereby causing a complete short-circuit of the mains. This would mean the "blowing" of the fuses in the house, which, although not a

The earth lead should be joined to one terminal of a large fixed condenser (of 1 or 2 microfarads capacity), and the other terminal connected to the earth terminal of the receiver or to the H.T.-output terminal of the unit (shown in dotted lines in the circuit diagram).

Condenser Values

With regard to the values of the fixed condensers used in the unit, there is one having a value of not less than 2 microfarads connected directly across the mains, while on the output side of the two chokes another fixed condenser also having a minimum value of 2 microfarads is

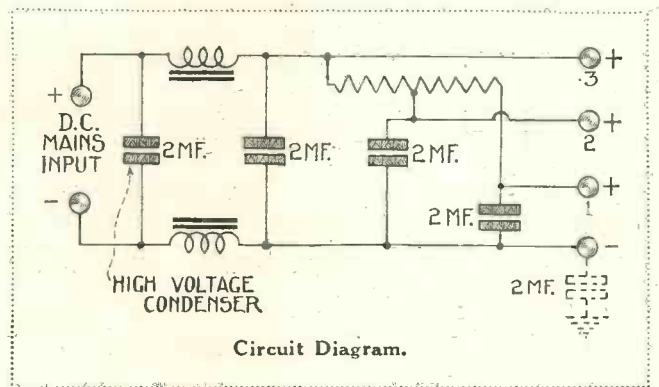

For Use with D.C. Supplies

used. The capacity of this latter condenser, in some cases, may with advantage be increased, especially on D.C. mains where the ripple is very pronounced. In such a case the capacity at this point should be about 6 or 8 microfarads.

The remaining two 2-microfarad condensers are used to shunt the re-

6 terminals (Belling & Lee).
2 ebonite terminal strips, each 5½ in. by 2 in. by ¼ in. thick.

Ebonite resistance-mounting strip, ¾ in. by 2 in. by ¼ in. thick.

Wood baseboard, 9 in. by 5½ in. by ½ in. thick.

Slotted wood or ebonite former, as shown in sketch.

Perforated metal case or wood cabinet, as shown in sketch.

Small quantity of No. 44-gauge d.s.c. Eureka resistance wire (Léwcos).

The slotted bobbin on which the resistance line is wound is turned out of wood or ebonite. It is cylindrical in form and has six slots cut to

the dimensions shown in the accompanying sketch. No. 44-gauge d.s.c. Eureka resistance wire is used for making the resistance, and each slot holds 130 complete turns.

When the first slot has been wound with 130 turns the wire is carried over to the next slot and in this another 130 turns are wound, and so on.

At the finish of the winding of the third slot (at the 390th turn), a tapping loop is left free, about 4 in. long, after which the remaining three slots are each wound with 130 turns

of the wire. The total number of turns is therefore 780.

Fixing Resistance Bobbin

The two ends of the winding are held in position by passing them through small holes drilled through each of the end cheeks of the slotted bobbin. The latter is then screwed to the small ebonite support by means of a 4 B.A. countersunk brass screw passing through a hole drilled through one end of the ebonite support and screwing into a hole, drilled and tapped 4 B.A., in the centre of one end of the bobbin.

The whole is next mounted on the

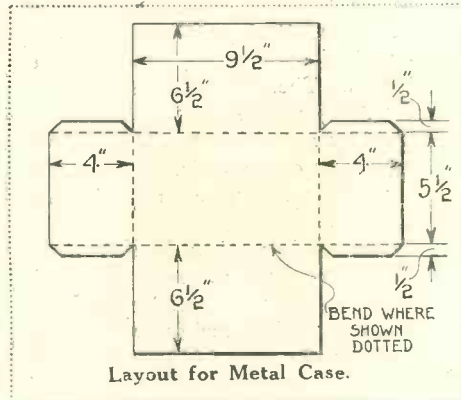
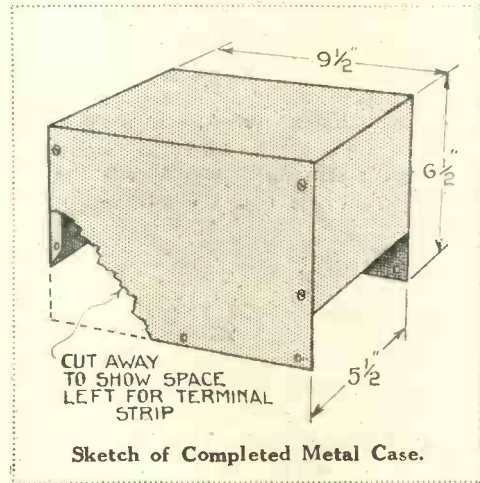

sistance tapplings, and these values will be found to be correct for all D.C. mains.

Components Needed

All the components required for this unit are as follows:—

- 2 iron-cored chokes (A.J.S. or R.I., G.E.C., Climax)
- 3 2-microfarad condensers (T.C.C. or Dubilier).
- 2-microfarad high-voltage condenser (T.C.C. or Dubilier).

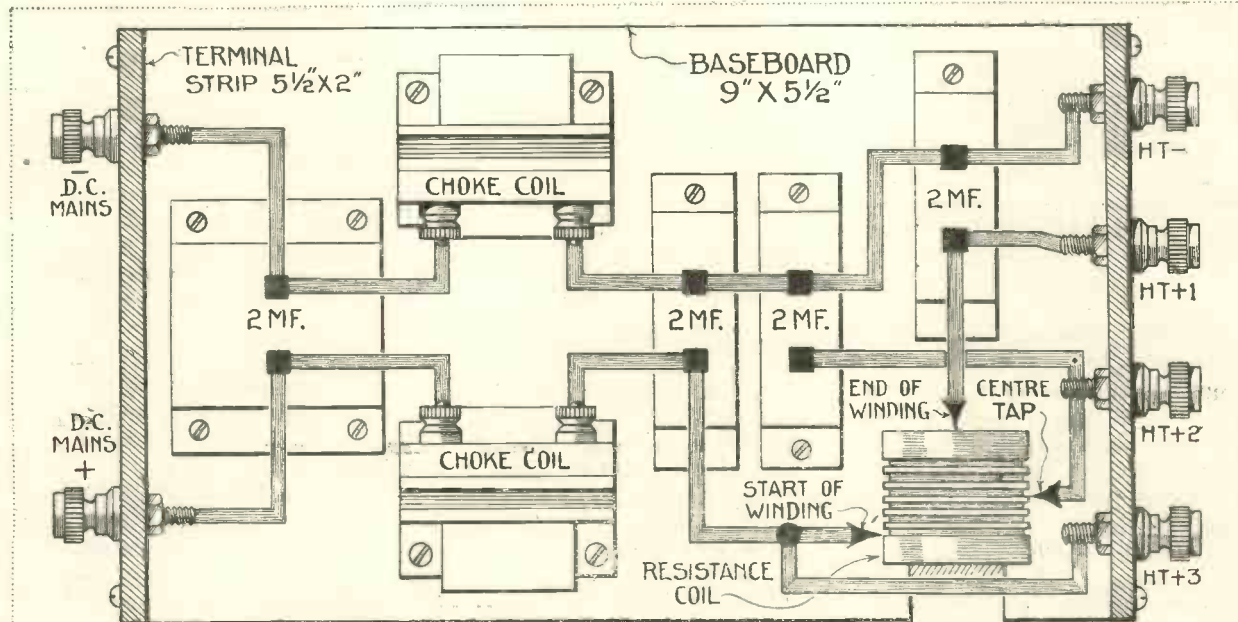

Layout and Wiring Diagram of the Unit for Obtaining H.T. from D.C. Mains.

AN H.T.-FROM-D.C.-MAINS UNIT (Continued)

wood baseboard in the manner shown in the photographs and the wiring diagram.

Terminal Strips

Two terminal strips, $5\frac{1}{2}$ in. long by 2 in., are drilled, one to take the two input terminals, and the other for the four output terminals (three H.T.+ and one H.T.- terminal). One strip is screwed to each end of the baseboard. The positions of the other components may be seen from the wiring diagram.

Wiring is easy and straightforward and should not occupy much time. In fact, the whole unit may be made by a novice well within one to two hours.

Terminal Connections

It should be noted that the terminal marked "H.T.+3" (giving the highest voltage output) is connected to one end of the resistance winding and to one terminal of the choke connected in the positive lead. The centre-tap of the resistance unit is joined to the terminal marked "H.T.+2," while the other end of the winding is connected to "H.T.+1."

The wiring completed, the unit may

be tested on any receiver. First of all remember to insert a fixed condenser of 2-microfarad capacity in the earth lead.

On 200-volt D.C. mains the outputs of the three H.T.+ terminals are 150, 80, and 45 volts, the highest voltage being obtained at the terminal marked "H.T.+3."

The highest voltage should only be used for L.F. power valves, while the 45-volt output is suitable for detector valves, and the 80-volt output for H.F. and ordinary L.F. valves.

Eliminating Ripple

If the ripple of the mains can be heard the capacity shunted across the output terminals of the two chokes should be increased to the amount previously indicated.

If the test is satisfactory the unit may be placed in a protecting case consisting of perforated metal, the dimensions of which are given in a sketch. The metal case should be metallically connected to the H.T.- terminal.

In conclusion we may state that the unit photographed in these pages is in constant use in our constructional laboratories where, for ordinary purposes, it has proved very satisfactory.

alarming extent. Simpkins adjusted everything adjustable, then picked up the daily paper, consulted the programme, and announced triumphantly:

"You will soon hear the dance band playing all the latest fox-trots."

"How perfectly lovely!" exclaimed Gwendoline, and her young man, who had come for this "first-night" performance looked unutterable things into her eyes.

Then Simpkins switched on the valves, turned various and mysterious knobs, with an anxious expression on his face, and waited with bated breath. There was dead silence.

"Are you sure you have everything properly fixed?" asked Mother, who was a bit of a sceptic.

"Of course I have," replied Father proudly.

Nevertheless, when the silence continued he once more turned knobs desperately with nervous fingers; and hastily tightened screws and nuts which were tight enough already.

The moments dragged, and Archie began to giggle; so Simpkins fetched his diagram, and scrutinised it. Then he began to unscrew nuts, remarking that it might make a difference if he reversed two special wires. But there was no sound, and the stillness grew more intense.

"I can't understand it," said Simpkins, and muttered something about a "dud transformer." And with much calling for pliers and screwdrivers set to work to remove the innocent offender. It took some time to insert the new one, and the family gathered round with their heads getting between Simpkins and the light.

At last he gave a big sigh and exclaimed:

"Now we'll have another try."

"I hope it goes this time," said Mother, "for I've wasted twenty-five precious minutes already that I ought to have spent in darning socks."

Simpkins tuned-in once more, and after a few tense moments of suspended animation, a voice came through the loud-speaker as clear as a bell:

"Hullo everybody! This is 4PQ calling. I am sorry that owing to a slight technical defect this station has been silent for twenty-seven minutes. We shall now be able to resume our programme of dance music."

And then the band played.

G. W. M.

THE VINDICATION OF SIMPKINS

IT is a most beautiful feeling to step back from a piece of work over which one has spent many hours of labour, and, viewing it from every angle—with head on one side like a meditative magpie—exclaim: "Finished, and by my hand alone."

And that was just how Simpkins felt when he laid down his tools, only he said: "Thank Heaven, that's done, and now for the testing."

He called up the family, that

doubting family who had scoffed at the idea of his ability to make a three-valve set, even with the aid of books, diagrams, and the conflicting advice of all the enthusiastic neighbours in the road.

And now every nut and wire was apparently fulfilling its duty in that state of life in which it had pleased Simpkins to place it.

The family stood round open-mouthed, absorbing the ether to an

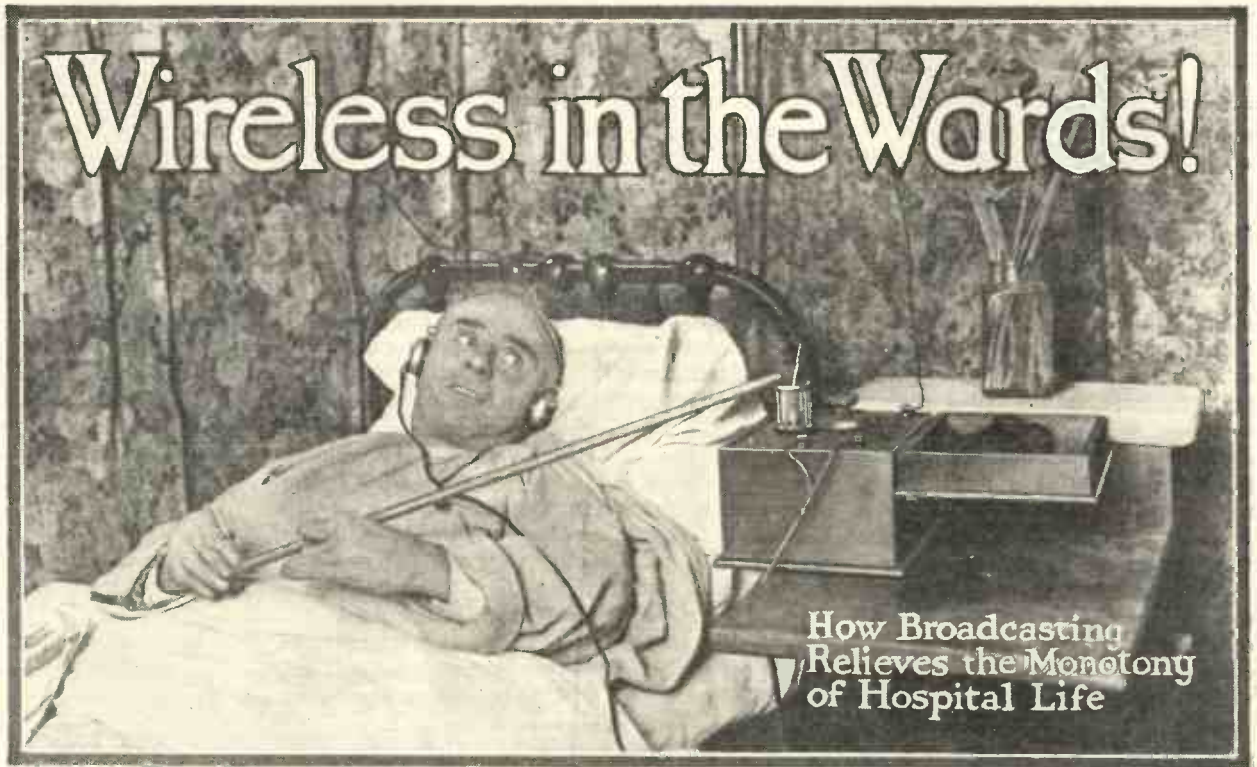

Wireless in the Wards!

How Broadcasting
Relieves the Monotony
of Hospital Life

“**W**IRELESS is on, you chaps!” Only those who have actually experienced it can know the thrill which these few words bring to hospital patients who eagerly adopt this means of whiling away the hours of pain.

I have just been discharged from a London throat, nose and ear hospital in which the cry was always taken up with gusto because many of the patients were being treated for ear trouble, and they judged by the wireless their progress towards recovery.

Special Enjoyment

I was being treated for throat trouble, but I enjoyed the wireless for a very special reason. The patients around me had been assured that after they had been to “the pictures” (the operating theatre) they would probably be able to hear again.

In one particular case a man had not heard for years. He had never hoped to hear again, but he had cheerfully submitted to the operation, and now he heard plainly. He could tell what item was being broadcast in spite of his head being swathed in bandages.

On the other side of me was another man who had undergone many operations. He went again to the operating theatre one afternoon,

and when he woke up next morning he found a pencilled note by his bedside: “You will be able to judge whether the operation was successful by the wireless at one o’clock.”

This, of course, tremendously eased the doctors’ and nurses’ task of telling him bluntly what he could expect.

When we reached for our phones and adjusted them, so did he. But instead of smiling, his face was drawn in anxiety. Impatiently he pushed his bandage farther back. Then the muscles of his face relaxed. His jaw dropped. His eyes grew moist. Warily he replaced the phones. *Would he ever hear again?*

The very fact that we had wireless led to the query: “What about those hospitals which (as yet) are not equipped with wireless installations?”

There are, of course, few London hospitals that have not been so equipped. But to my certain knowledge there are many hospitals up and down the country which most anxiously await the coming of wireless.

Why, there is actually an *isolation* hospital just a few miles south of London, which, for lack of funds, was so handicapped when a friend of mine spent a whole month there earlier in the present year.

Think of it, rigorously isolated

from the rest of the world even at the best of times! What must it be like for patients, especially the much-abused wireless “fans,” to be without this entertainment?

I shuddered at the thought, but took heart of grace in the knowledge that it cannot be long before wireless will enable the patients to keep in touch with events outside without having to wait for next morning’s newspaper.

But, for myself, these were not my only thoughts as I listened. On the principle of looking a gift horse in the mouth, I began to discover how the system (so far as our hospital was concerned) needed improvements. Every wireless enthusiast will appreciate the feeling of dissatisfaction when his own or his friend’s set is not *quite* perfect.

Inconvenient Wall-plugs

Wireless had been installed when the beds were in certain positions. Now, probably for a very good reason, the beds had to be moved, but the wall-plugs for the phones could hardly be rearranged.

The wall-plug was often a yard to one side of the head of the bed. One could listen and hear well enough, but not always lie comfortably in the same position for any length of time, and, in an unthinking moment when a patient eases his

Wireless in the Wards! (Continued)

position, the plug is either pulled out or his head is badly jarred as the phones are tugged off.

Solving the Problem

What would have solved the problem (and, presumably, it arises in other hospitals and sick-bed installations) would have been longer leads coiled within a spring roller attached to the plug (not to the phone, in order to reduce weight). Sufficient length could then be pulled out, and left out (on the principle of a roller blind), and an extra length would have been available for use when the patient wanted to ease his position.

When not in use the lead and phones could be resprung. The idea, in fact, could be universally applied. We all experience the trouble at times, don't we?

In our ward, also, we had a well-meaning Sister who would not allow the earpieces to be detached from the head-band "in case the parts got lost." One admired the ambition, but, privately, I knew she was defeating the very object of their being so made.

It is uncomfortable always to lie flat on one's back. It is worse to have to lie with an earpiece under the head. And it was positive agony for a man to have to forgo his entertainment or listen to it with two earpiece springs tightly clamped across his head—owing to the thickness of his bandages—when he had only one ear in commission.

Then as to the actual volume of sound. We all like to have this as great as possible through our phones. But this blare, while it does not

trouble the throat and nose cases, is just a bit too penetrating for the sensitive drums of people who have just recovered the faculty of hearing.

It seemed to me that each pair of phones could have been fitted with a device for regulating the sound to individual requirements (or necessities). Not being much of a technical man myself, I wondered if this would be too complicated a problem to solve, or would such devices interfere with the volume of sound available to other listeners?

Great Boon

Taking things all round, however, wireless, of course, is one of the greatest boons charity can offer to sufferers. I did not suffer a great deal. I enjoyed my wireless entertainments immensely. L. T.

What Boys Think of Wireless :: By a Schoolmaster

TO ascertain a boy's idea of wireless I directed my class to write an essay and to state their opinions of the various programmes.

When marking the essays I noted the salient comments of different boys, and afterwards ascertained whether the opinions were general or particular by obtaining majority verdicts on all the information, excepting when otherwise stated, given below.

It rather surprised me to read, in several essays, that clapping of hands and the roaring of engines were not enjoyed by some boys. And, further, they were not interested to hear soldiers at drill or ventriloquists.

But other dislikes were not so surprising: "I do not like Sunday programmes," wrote one boy, "there is always a man talking." Another declared that he did not want to hear preaching. Several pupils wrote that they did not like a lady singing, and one boy remarked: "The high notes 'tickle' your ear."

The "hooter" also was not enjoyed, because "it keeps on a long time." Garden hints, morse, and the weather forecast were unappreciated.

In stating what programmes were

enjoyable the essays disclosed no unexpected preference. "I like the Children's Hour because we hear about animals, birds and beasts, history and science," wrote one boy. "They tell you good fairy tales," remarked another, and, very naturally, almost all members of the class did not forget to mention this part of the programme.

But there were one or two dissentient notes because, as one boy expressed it, "some of the fairy tales are rather silly." The Havana, Savoy and Jack Hylton's band were almost without exception very popular. The Roosters came first in favour. "They make you die of laughing," wrote one descriptive writer.

ANY QUESTION

relating to wireless that you ask can be answered by the Technical Staff of the WIRELESS MAGAZINE for a fee of one shilling.

Write out your query on one side of a piece of paper and send it, together with a stamped addressed envelope, a fee of one shilling (stamps or postal order) and the coupon on page iii of the cover, to The Editor, WIRELESS MAGAZINE, La Belle Sauvage, E.C.4.

Most of the essayists like to hear a man singing, and no one wrote other than appreciatively with reference to humorous concerts.

My brief investigation has satisfied me that, on the whole, the wireless programmes for the young do fulfil the purpose of creating interest and giving pleasure to children. Also, that programmes, in general, given mainly for adults likewise provide interest for young folk.

Further, that while there are many debatable arguments in regard to the educational possibilities of wireless, I am perfectly satisfied that under the present system children are acquiring knowledge. For when teaching nowadays the schoolmaster finds himself frequently interrupted by, "Yes, sir, we heard that on the wireless."

The consequence is, finding that much that he sets himself out to teach is already known from outside sources, he is enabled to give a more comprehensive education in other directions.

This wider education, added to an improvement in the technique of teaching, makes the boy at fourteen more educated than he was, at that age, in the past.

THE CRYSTAL GAZER



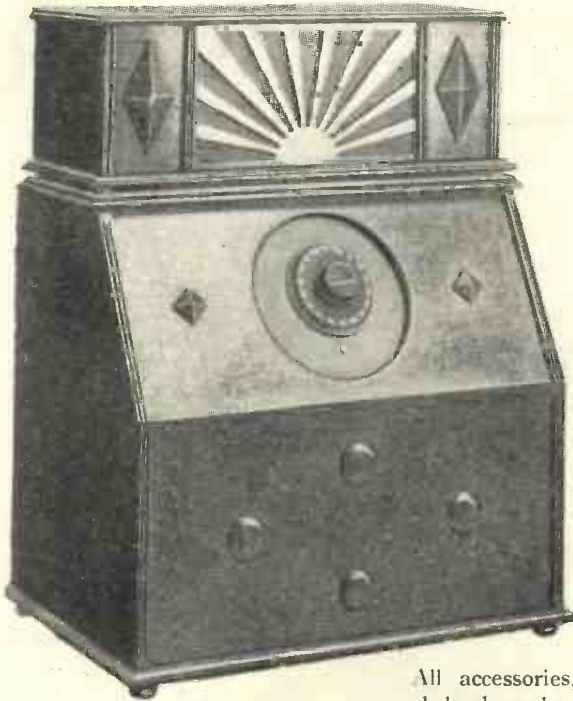

THE ONE-KNOB THREE

ENTIRELY SELF-CONTAINED
SIMPLE TO OPERATE

*Designed, Built and Tested
by the "Wireless Magazine"*

Photograph showing the One-knob Three with Amblicon Cabinette loud-speaker.

manent connections to it can be made.

Tuning must be accomplished with one dial only, so that anybody can easily tune-in the local station or, as an alternative, Daventry.

By connecting the aerial and earth leads to a plug, the only operations required to make the receiver here described function are the insertion of the plug into the jack and the

All accessories, such as batteries and loud-speaker, must be integral with the actual receiver, just as the gramophone is an instrument complete in itself. The only external

THE descriptive phrase, "a family receiver," has been very much overworked in that it has been applied to almost every wireless set, whether or not it is particularly suitable for use by unskilled operators.

Gramophone Standard

Taking the gramophone as a standard whereby simplicity in operation can be compared, the average wireless set is a very complicated affair, requiring quite a considerable amount of technical knowledge on the part of the operator.

With the gramophone all that is necessary for the reproduction of speech and music is the turning of a handle to wind up the motor spring, the insertion of a needle, and the placing of the latter on the correct spot on the record.

In time these operations become perfectly mechanical, requiring no thought.

Some Knowledge Needed

There are very few wireless sets which can be operated mechanically by a person who has not the slightest knowledge of what he is actually doing.

In attempting to design a receiver which, as far as is possible, emulates the gramophone from the standpoint of simplicity, there are the following points to be borne in mind.

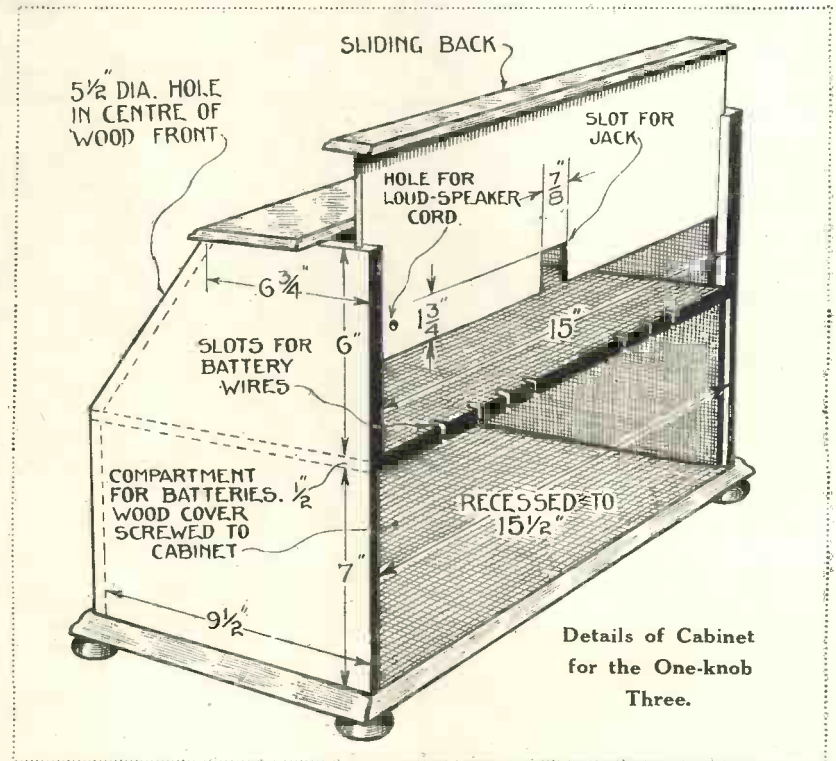

Details of Cabinet
for the One-knob
Three.

connections must be the aerial and earth leads.

The loud-speaker should preferably be built in with the receiver or, what amounts to the same thing, should be fixed to the receiver so that per-

turning of the dial until a station is received at the desired strength on the loud-speaker. The insertion of the plug into the jack automatically completes the filament circuits of the valves.

A special variometer is used for tuning, having a switch incorporated which, through a 180-degree rotation of the dial, enables ordinary broadcast wavelengths to be covered. Through the remaining 180-degree movement the switch comes into action and renders the variometer suitable for reception on the higher wavelengths, such as Daventry's.

Changing Wavelength Range

Thus, to change the wavelength band no extra coils are needed, and there are no external switches. All that must be remembered is that one half of the complete rotation of the dial tunes on the lower broadcast band, while the other half tunes on the higher wavelengths.

Three valves are employed in the circuit, consisting of a detector and two low-frequency amplifiers. Each of the latter is a resistance-capacity coupled stage having high anode and grid resistances, and small coupling condensers.

This system gives a much greater amplification per valve and has the added advantage that reproduction is exceptionally pure. The actual cost, too, is considerably lower than that of transformer couplings, and altogether the arrangement is more compact and easier to wire.

Baseboard Components

With the exception of the variometer all the components are mounted on a horizontal baseboard measuring 15in. by 8½in. by ¾in.

The variometer is mounted on a small sloping ebonite panel, measuring 7½in. by 6½in., supported by two triangular wooden brackets fixed to the baseboard. The method of supporting the sloping panel can be seen from the photographs.

No other controls are mounted on the panel, the filament current of the valves being controlled by the fixed resistances mounted on the baseboard.

A special cabinet is used to house the receiver, having two compartments separated by a wooden partition. The upper compartment contains the actual receiver, a large circular hole being cut in the sloping

The following is a complete list of all the components required, including the batteries and valves used in the original set:—

- Ebonite panel, 6½ in. by 7½ in. by ¼ in. (Clayton or Becol, Radion).
- Ebonite strip, 1½ in. by ¾ in. by ¼ in. (Clayton or Becol, Radion).
- Auto-series-parallel variometer (Marconiphone).
- 3 anti-microphonic valve holders (Lotus or Benjamin).

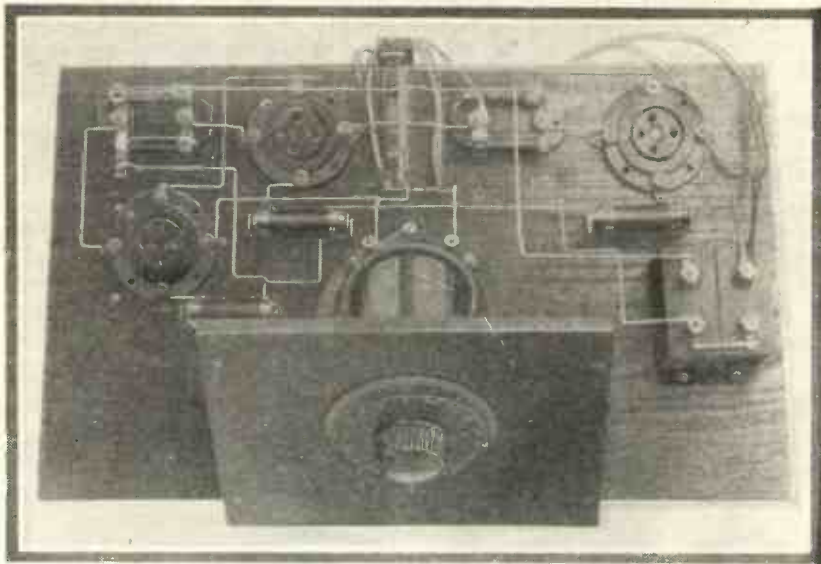

Baseboard View of the One-knob Three.

front of the cabinet to take the tuning control mounted on the panel.

In the bottom compartment all the batteries are housed. As there is plenty of space available the batteries need not be reduced in size as is so often necessary with "all-in" receivers.

Flexible battery leads are soldered to the proper wires in the receiver in the top compartment, and are taken down and connected to the batteries in the bottom compartment of the cabinet.

- 3 Temprytes (Cylton or Peerless, Magnum).
- 2 .006-microfarad fixed condensers with clips (Dubilier or T.C.C.).
- 2 2-microfarad fixed condensers (Dubilier or T.C.C.).
- 4 1-megohm grid leaks (Dubilier or Mullard, Ediswan).
- 4-point jack (Igranic).
- Auto plug (Igranic).
- Cabinet loud-speaker (Amplion).
- Cabinet and baseboard (Unica).
- Length of flex.
- 2 spade connectors (Lissenin).
- 5 wander plugs—3 red, 2 black (Lissenin).
- 6-volt accumulator (Maxel).

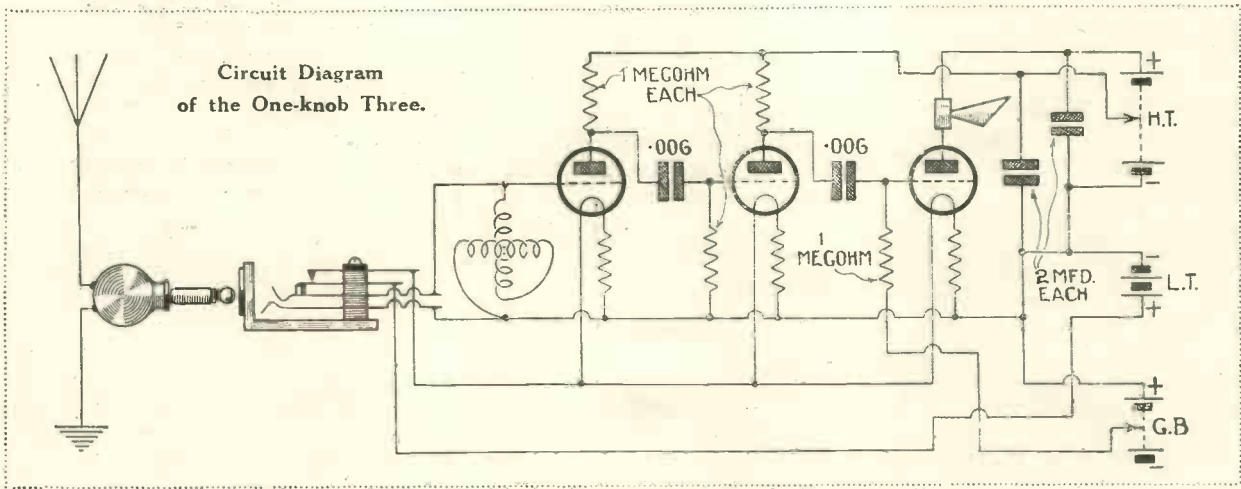

The One-knob Three (Continued)

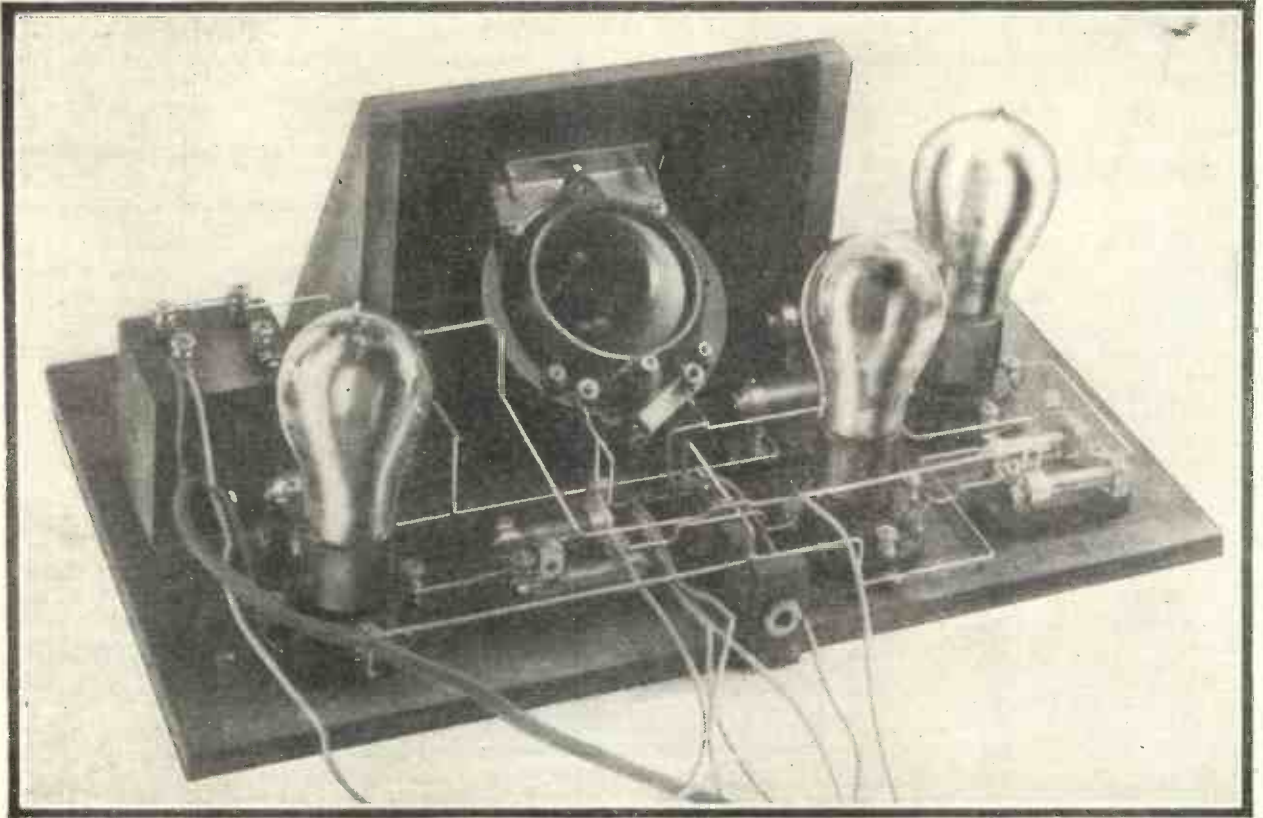

Photograph of the One-knob Three showing Simplicity of Layout.

2 60-volt H.T. batteries (Siemens).
 9-volt grid-bias battery (Siemens).
 2 S.P. 55 Bluespot valves (Cosmos).
 S.P. 55 Redspot valve (Cosmos).

NOTE:—The particular components shown in the photographs and allowed for in the dimensioned layout are in each case mentioned first.

Preparing the Panel

The small ebonite panel should first be cut to size and drilled at each corner for fixing to the triangular wooden brackets by means of four small countersunk brass wood screws. Holes are then drilled for attaching the variometer to the panel, for which purpose five holes are required, four for bolting the variometer in position and a central hole to take the spindle.

To the back edge of the baseboard in an approximately central position a small piece of ebonite, measuring $1\frac{3}{4}$ in. by $\frac{3}{4}$ in., is mounted by means of two brass wood screws. This piece of ebonite carries the aerial, earth, and filament jack and can be clearly seen in the photographs.

The remainder of the components are mounted in the positions shown

in the wiring diagram. The grid leaks and anode resistances must be obtained with metal clips for the purpose of attaching them to the coupling condensers, as shown in the wiring diagram. It will be noticed that only one end of the resistances is connected to each of the terminals of the two coupling condensers.

The resistance of each of the fixed filament resistors depends on the valves employed. Different valves require different values of resistances, and when ordering the latter the make and type of valves employed should be stated.

These resistances are mounted in a special clip holder, screwed to the baseboard, and are easily interchangeable, a fact which has its advantages should it be desired to change the valves usually employed.

H.T. Leads

There are two H.T. + leads, one supplying the detector and first L.F. valve, both of which have high resistances in the plate circuit, and the other supplying the last valve, through the loud-speaker. A two-

microfarad condenser is connected across each of these two leads and H.T.—.

The wiring of the receiver can be clearly followed from the wiring diagram, which contains one or two novel features designed to aid the constructor.

Wiring Up

Every terminal drawn on the wiring diagram is marked with a capital letter of the alphabet. Some, for instance, are marked A. All these terminals should be connected together with one wire or as few wires as possible.

Then all the terminals marked B should be connected together in a similar fashion, and so on, until the wiring is completed.

By carefully following these instructions it is practically impossible to make an error in wiring.

For battery and loud-speaker connections nine flexible leads, each about 18 in. long, are soldered in the correct places to the stiff wire used for wiring-up. The H.T. and G.B. leads should have plugs attached to

An Easy-to-control Family Receiver

the free ends, these plugs being suitably marked to avoid confusion.

Resistance Coupling

With the new system of resistance coupling employed, it is essential that valves having a very high amplification factor are employed. There are several makes of suitable valves which have recently been placed on

the market, among which we can recommend the Cosmos Blue Spot, Mullard PM₅B, Cossor RC, and Ediswan RC₂. Two of these valves should be inserted in the detector and first L.F. valve holders, while a power valve, *requiring the same filament voltage as the preceding two valves*, should be used in the last stage.

In this respect we can recommend the Osram or Marconi DEP₂₁₅, Mullard PM₂ or PM₆, Cossor Stentor Two or Four, Ediswan PV₂, and Cosmos Red Spot.

Battery Connection

As soon as the wiring is completed the receiver can be placed in the upper-portion of the cabinet and the

COMBINED
LAYOUT AND
WIRING
DIAGRAM OF
THE ONE-KNOB
THREE

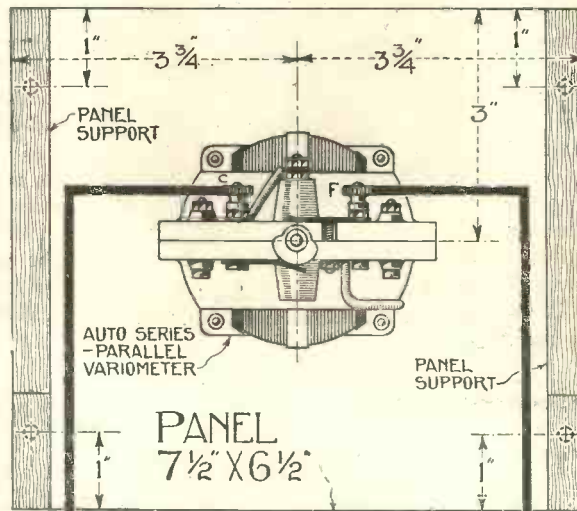

In wiring up from this diagram attention should be paid to the letters alongside the terminal points. All those points marked A should first be connected together with one wire or as few wires as possible; then all those points marked B and so on through the alphabet until the wiring is completed.

It is important that the wiring should be carried out in alphabetical order.

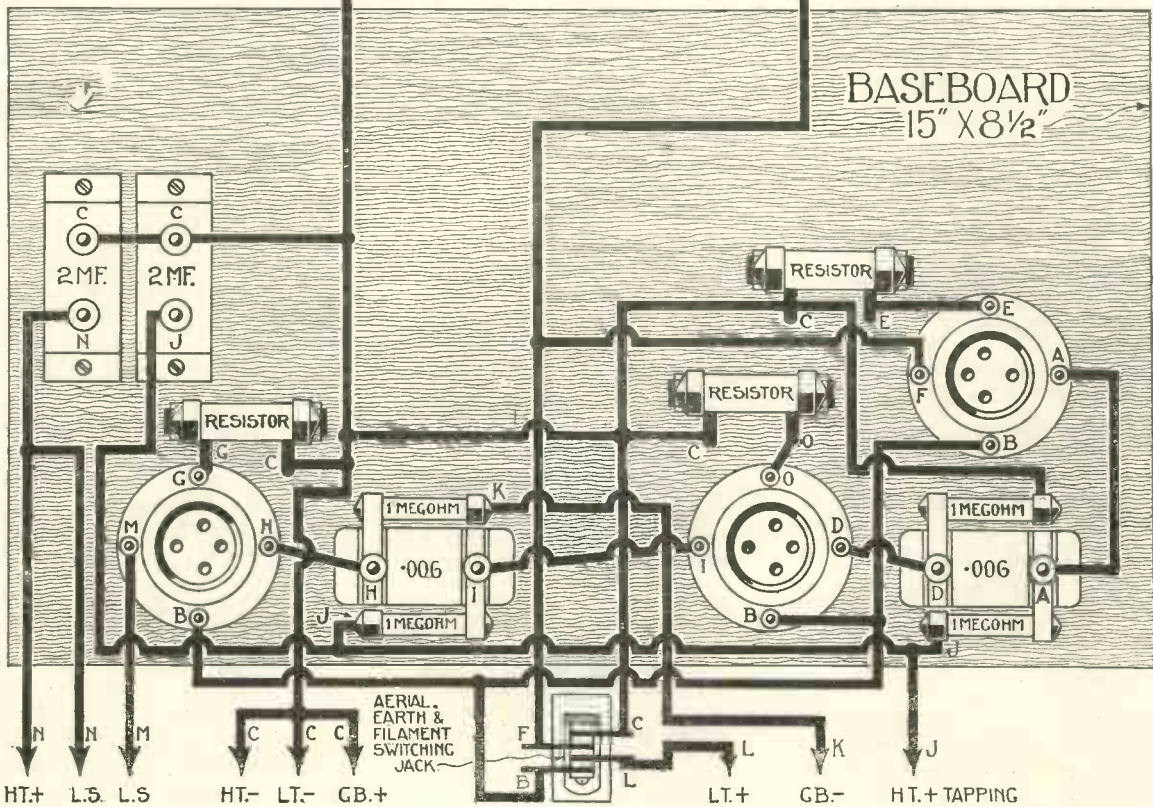

The One-knob Three (Continued)

battery leads connected to the batteries placed in the bottom section of the cabinet.

The aerial and earth leads are connected up to a plug, and it should be particularly noted that the long shank of the plug (as distinct from the small insulated knob at the end) is connected to the earth lead while the insulated knob is connected to the aerial.

Correct Connections

If any doubt is entertained the correct connections can be found by testing the set with the aerial and earth leads connected up one way and then the other, noting which method gives the best results.

Little need be said concerning the tuning, for there is only one tuning control. This control can be turned through 360 degrees, and it will be noted that the local station is received within the first 180 degrees,

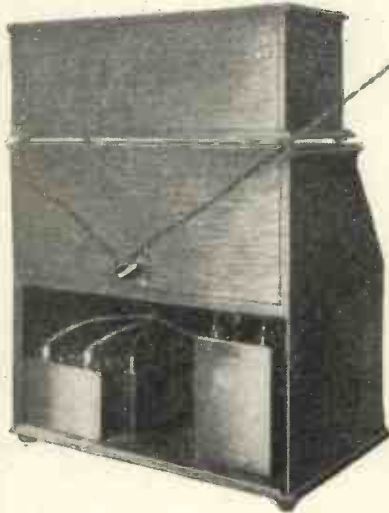

Back View of the One-knob Three with Batteries in Position.

whilst Daventry comes through on the second 180 degrees.

When the local station has been tuned-in the battery voltages should be adjusted until the purest reproduction is obtained. It will be found that 120 volts H.T. can be safely applied to all three valves, the correct grid-bias voltage varying with different makes.

On Test

This receiver was tested in London, where it was the easiest matter to tune-in 2LO and Daventry on the loud-speaker. Both stations were received at full loud-speaker strength, and the quality of reproduction was as perfect as it is possible to obtain with present-day apparatus.

We believe that this receiver, from the points of view of simplicity in operation, cheapness to build and its excellent reproduction, will have a deservedly wide appeal.

Extraordinary Multiple Valves!

TWO most interesting types of multiple valves are now being made in Germany for broadcast reception (writes a German correspondent).

Two Valves—One Filament

The first is known as the Pentatron and comprises two complete valve systems worked off one filament. These two systems do not interfere with each other in the very least, and one system can be used as the detector while the other is used as a high- or low-frequency amplifier.

There are two types on the market, both working off 4 volts. One consumes .06 ampere and has an impedance of about 16,000 ohms, the other takes .15 ampere and has an impedance of only 7,000 ohms. The electron emission (plate current) of the latter type is about 2½ times that of the first-mentioned type.

Half the Number

In using these Pentatrons one is able to cut down the number of valves used by half and save current in addition.

An ordinary valve costs 8s. in

Germany, and the Pentatron 12s. 6d.

The second type of multiple valve is called the Loewe. This is not merely a valve but a whole three-valve resistance-capacity coupled low-frequency amplifier built into one evacuated tube. The saving in space and the reduction of internal capacity are enormous.

The filaments of the three valve systems are connected in series inside the valve and thus form only one filament to the outside observer; this filament takes .17 ampere at exactly four volts pressure, thus making a

rheostat unnecessary when using a four-volt battery. The resistances and condensers inside the valve are of the best possible values, and of good quality. The third and last system is built to function as a power valve.

Smallest "Three-valver"

The valve can therefore be used, with an additional coil and tuning condenser, as a set for loud-speaker reception of the local station, and is most likely the smallest three-valve set yet built.

Loewe also manufactures a second type of multiple valve for high-frequency amplification. Special care is taken to eliminate all harmful capacity and the valve can be used right down to 300 metres or even lower.

Double Grids

It is a two-valve complex working on the aperiodic system and has double grids. Otherwise the valve is much the same as the low-frequency amplifier, the resistances and fixed condensers only having different values.

AT YOUR SERVICE

If your set is not giving the results you think it should; if you do not understand how any particular piece of apparatus works; if you are in trouble over any wireless point—we are ready to help you.

Send your query, together with a stamped addressed envelope, the coupon on p. iii of the cover and a fee of 1s. (postal order or stamps) to The Editor, WIRELESS MAGAZINE, La Belle Sauvage, E.C.4.



Signorina Luisa Rizzi.

Rome (Italy)

SIGNORINA MARIA LUISA BONCOMPAGNI holds the record of being the first lady announcer in Europe! On all occasions when you have listened to the Rome transmissions you will have heard her deep mezzo-soprano voice. Although we may not all be conversant with the Italian language, her clear enunciation and studied delivery gives considerable assistance in understanding her announcements.

She is particularly suited to her work, as for many years she studied the art of elocution, and on one occasion was called upon to recite before Her Majesty Queen Eleana of Italy, at the Villa Margherita.

Her Career

She began her career in 1914 as reader to the *Avaldo Telefonico*, which already at that period was sending out by telephone a vocal newspaper. "Little did I think," she says, "at that time, that my voice, familiar in the city of Rome, would be heard a few years later over the whole of Europe. The idea of an invisible crowd listening to my words brought on microphone fright at the outset, but to-day I feel quite at home with my unseen audience, and my 'good-night, everybody' (Buona notte a tutti) is sent out as a final greeting to all my ether friends."

Signorina Boncompagni personally supervises the children's hour, in the course of which she reads passages

VOICES of the NIGHT!



Signorina Luisa Boncompagni.

from the Holy Book, or narrates stories from the lives of the Apostles. The organisation of all musical and dramatic programmes is in her hands, and on frequent occasions she takes a leading part in theatrical performances. Signorina Boncompagni is not merely an announcer, she is the *deus ex machina* of Radio Roma.

Basle (Switzerland)

Herr Albert Zellweger, whose call "Allo! Rundspruch Basel" must have frequently come to your ears, is not only announcer but also director of programmes at the Basle broadcasting station. For several years he studied electrotechnics, physics and chemistry at the Basle and Berlin

This is the third series of chatty articles on those foreign announcers who are by now almost as familiar to British listeners as are the B.B.C.'s announcers.

This month we are giving brief accounts of four announcers—those at the Rome, Basle, Milan and Buda-Pesth broadcasting stations.

Universities, yet managed in his spare time to become an expert flautist; he frequently contributes to the concerts.

Although he undertook studio duties in June, 1926, for the local radio association, he has not, he says, finished his main work, that of the study of chemistry.

Whilst possessing rather more of a technical than an artistic tempera-

ment, his greatest pleasure is that of personally conducting the children's hour, which, until quite recently, has been of a rather sketchy character.

My Work

"I sit at the piano," he tells me, "sing a few songs or whistle well-known melodies. I read up many fairy tales in order to tell them in simple language to my juvenile listeners. To those of your readers who may have heard these legends I should explain that they are invariably told in our Basle dialect."

With the advent of a fusion between the Basle and Berne stations by which common programmes are now given, Herr Zellweger's duties have been considerably increased, but at odd moments he is frequently found in a corner of the studio with a treatise on physics in his hand!

Milan (Italy)

"Stazione Radiofonica di Milano, Uno-emmi-ee!" A woman's voice? Yes, a lady barrister! Signorina Luisa Rizzi.

The chief announcer of the Milan broadcasting station for many years read for the Bar and is "diplomata del Magistero." But, notwithstanding this success, music had a greater attraction for her, and she abandoned law for this art.

"In my humble opinion," she told me, "the fact that to these two studies I added that of eurhythmics assisted me in my work at the microphone. Studio announcers require

Voices of the Night! (Continued)

peculiar qualities for the special work entrusted to them. It is essential that a speaker should possess individuality, but to express character the voice must be trained. My own duties require my presence in the studio every afternoon and evening, but my efforts have been amply compensated by the many kind letters received from foreign listeners."

When at the microphone Signorina Rizzi considers that she is not merely announcing programme items; she talks to the countless friends she has made in her unseen audience.



Herr Albert Zellweger.

Pesth broadcasting station because (in his own words) "he disliked work." His father, a wealthy factory owner, wished his son to join him, but this did not meet with the latter's



M. Eduard de Scherz.

opened to be one of the stopping places, and a short stay in that delightful spot wound up both the trip and his available cash. On his return home, compelled to earn his own living, luck guided him to the Telephone Gazette or Theatre-phonie, which, as you perhaps know, was a forerunner of the Buda-Pesth broadcasting station.

"To-day," said Monsieur Eduard de Scherz, "I have lost my ideas of 'Grand Seigneur,' and find my present work very fascinating. In a very short time I hope to make announcements in English

Buda-Pesth (Hungary)

Monsieur Eduard de Scherz became the chief announcer of the Buda-

views, and after some months he induced his sire to furnish him with the wherewithal for a grand tour of Europe!

Unfortunately Monte Carlo hap-

and French in addition to the usual German and Magyar calls, in order that distant listeners may find interest in our programmes."

J. GODCHAUX ABRAHAMS.

One-station Listeners

Who Miss Good Things

THE person who listens-in to one station is not fair to himself, or to broadcasting as a whole. He is unfair to himself because he confines himself to one voice, one type of programme, one effect. He is like a man who is always eating the same kind of food, and then wonders why that food does not agree with him. He is unfair to broadcasting as a whole because he does not realise its magnitude and its scope and the glory of its variety.

Magnitude of Broadcasting

When a listener can hear America one moment, London the next, and Berne the third, there comes a consciousness of the magnitude and possibilities of broadcasting.

If our stations specialised in certain subjects or specific music, then there would be something in the plea that one station is adequate; but

with the variety of the stations and yet their great difference we should use as many as possible.

A friend of mine is anxious to learn French; he has begun. All the time, however, he is complaining that there is not sufficient French being broadcast from Daventry and London. He can only get Daventry on his set—he is a one-set man. If he could get the Continental stations his French would be helped considerably.

The linguist has no excuse when there is the great opportunity of learning and polishing his languages through Continental stations.

The one-station man who is a musician is also at a great handicap. He gets good music from the B.B.C. stations, but there are wonderful orchestras and organs on the Continent and in America which give us entirely different interpretations to the same classics that we hear

from our own broadcasting stations.

To say that there is no chance of hearing the best German and American orchestras is an excuse the one-station listener cannot make with honesty.

It is the same with art. There are a few stations on the Continent that specialise in art programmes. High-brow they may be, but here is an opportunity for the student of art that ought not to be missed and need not be missed.

Getting to the Top

The philosopher, the poet, the theologian, the engineer, and the sportsman who wishes to get to the top of his profession has the opportunity of doing so by hearing the experiences of the world's experts by wireless. And the man who gets these chances is he who has a good set to listen by.

E. B. R.

How to Use a Wavemeter

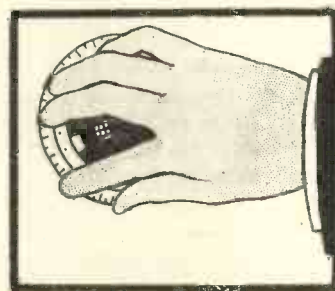

THERE are two kinds of wavemeter in use by amateurs at the present time, the heterodyne and the buzzer. The first contains a valve in whose plate and grid circuits are inductances so coupled as to produce oscillations. By means of a variable condenser the wavemeter can be tuned to any wavelength within the compass of these inductances.

When the heterodyne wavemeter is switched on it transmits oscillations which are picked up by the receiving set. If the difference in the frequency to which the wavemeter is tuned and that of the circuits of the receiving set is between 16 and about 10,000 cycles a second, an audible beat note will be produced in the receivers. If it is greater or less nothing will be heard.

Heterodyne Wavemeters

When tuning with the heterodyne wavemeter we proceed as follows: We set it to the desired wavelength and switch on. As we bring the set near to the point of resonance a note is heard in the phones. If we continue to adjust the receiving set, this note fades out and then comes in again as the condenser dial is moved a little farther.

By tuning the receiving set to the silent point between the squeaks produced by the wavemeter's oscillations we obtain perfect resonance.

The other type of wavemeter contains a small buzzer which must be adjusted until it gives a high-pitched note similar to that made by a mosquito's wings. The buzzer is actuated by a dry battery—usually a single cell suffices—and tuning is done either by an inductance with a condenser in parallel, or by a variometer.

To bring the receiving set into resonance with the wavemeter at any given setting we adjust the variable condensers of the tuned circuits until the high, thin note is heard most loudly in the phones.

So far I have described the means whereby the receiving set is tuned

to the required wavelength. The wavemeter may also be used after a station has been picked up for discovering its wavelength.

With either type proceed as before, but in this case tune the wavemeter and not the receiving set. When resonance has been obtained the wavelength can be read off from the

Many listeners hesitate to use a wavemeter because they think that its efficient operation would be beyond them; this article shows that they are mistaken. A wavemeter is not a difficult instrument to control and with the ether in its present congested state is a boon in the search for distant stations, facilitating, as it does, the tuning of the receiver to any desired wavelength.

dial either directly or with the help of a calibration chart.

Either type of wavemeter is quite simple to use, but the amateur must remember certain rather important points if he wishes to obtain anything like accurate readings. With the heterodyne wavemeter one has to be on one's guard against harmonics.

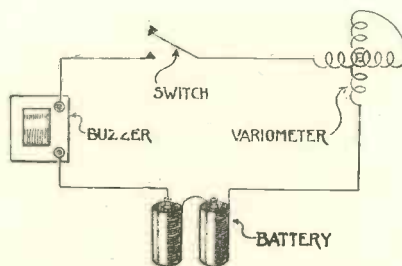

Diagram of Buzzer-wavemeter Circuit.

Thus, if the heterodyne wavemeter were set at 1,500 metres and placed close to the receiving set, the squeak-and-silent-point effect might be observed quite strongly at 750, 500, 375, and 300 metres. It would also occur at 3,000, 4,500, and 6,000 metres. The harmonics however, are considerably less power-

ful than fundamental wavelengths, and they become less and less strong the further removed from it they are.

I have mentioned only the main harmonics and overtones, but there are a great many more than these. To get rid of them, or rather to reduce them to negligible strength, the wavemeter should always be placed so far away from the set that the chirps produced on the fundamental are just comfortably audible. This will make for much sharper tuning and harmonics will cause no trouble.

The buzzer wavemeter may also transmit harmonics, but I must say that I have never found their effects noticeable. The only difficulty in using it lies in the fact that the human ear has to decide the exact point of tuning at which the note is most loudly heard.

Here again distance, if it does not lend enchantment, makes matters very much easier. When the instrument is placed quite close to the aerial-tuning inductance, it may be found that the note is almost equally loud over many degrees of the A.T.C. scale. Move it farther and farther away, and you will find that the tuning becomes very much sharper.

The best position for it is that in which its note is only just heard clearly in the phones when resonance has been obtained. In this case there will be very sharp tuning indeed, and you will have a definite "loud point" on your condenser scale instead of a "loud space" covering many degrees.

Help in Searching

Either type of wavemeter is an enormous help in searching. With a single-valve set employing only one tuning condenser it is fairly easy to be sure that as you search you are going gradually up or down the wavelengths as the case may be, though even here the use of reaction complicates matters, since the degree of coupling has often a considerable effect upon the wavelength.

With the multi-valve set, or with

How to Use a Wavemeter (Continued)

the single-valve fitted with a double-circuit tuner matters are much more difficult, for without the wavemeter one can never be quite sure that as small increases or decreases in the wavelengths are made when searching the circuits are kept in resonance with one another.

Weak Signals

Almost every amateur will have encountered this difficulty when trying round for weak and distant transmissions which cannot be picked up unless all circuits are fairly sharply tuned to their wavelength.

Those who do not possess a wavemeter of any kind can construct for themselves a little device which will be found very helpful for searching. The components required are a buzzer, such as can be purchased very cheaply, a flashlamp battery,

a switch, and either a variometer or a No. 50 coil and a .0005-microfarad variable condenser. The circuit is shown in the diagram.

To use the instrument, tune-in your local station, set the buzzer going and note the reading on the dial of the variometer or variable condenser which gives the loudest buzz. You will now have a point to work from.

Suppose for example that you tune-in Newcastle, whose nominal wavelength is 312.5 metres, with a dial reading of 80°. You now know that if you set the dial to say 85°, and tune until resonance is obtained, you have increased the wavelength of your receiving set, though you do not know exactly by how much.

Advancing in this way a few degrees at the time, you will pick up other stations, whose dial readings

should be recorded. When you have noted a number both above and below your 312.5-metre starting point, you can plot out a chart which will give you a rough calibration of your improvised meter. Foreign stations can generally be identified once their wavelength is approximately known, from the list given each week in *Amateur Wireless*.

Different Wavelengths

Your calibration chart will probably not take the form of a regular curve (or of a straight line if a square-law condenser is used), because comparatively few broadcasting stations work exactly upon the wavelengths assigned to them. In spite of this, however, it will very greatly simplify both searching and the identification of new stations as they are picked up.

J. HARTLEY REYNOLDS.

IN THE NIGHT-WATCHES

THE aerial without jerks jauntily in the quiet night breeze as I write.

It is at this time of the year that my receiver assumes the strength of a twelve-valve, and when my less favoured friends regretfully throw over their lightning switches and stumble to bed with shivering bodies and chattering teeth like the "broadcasters" they are, I, an experimenter, commence to "rake" the ether for those tiny signals which they may never hear.

A Cheery Glow

In a corner of my little hut an old Duplex oil stove glows cheerily, and the moisture on the window panes tells of the frost outside.

My largest pipe is selected from the rack and heavily charged and lighted, and for awhile I listen on 200 metres to the cheery voices of my amateur friends which fill the room from the loud-speaker.

Soon the pipe glows well and when the room is filled with a soft fragrant smoke, and after one more careful listen to these (some of them)

old friends, the set is tuned down to the depths; down to 65 metres.

Things are not so good as usual to-night. Sharp well-defined clicks in the receivers speak of the static discharges somewhere across the Atlantic.

I swing the condenser round and a faint rustling noise rewards my efforts. Tighter goes the coupling of the coils, and I stretch my legs luxuriously in the warmth.

Somewhere in the house a clock chimes the half-hour past eleven, and as it does very faintly I hear the strains of "The Star Spangled Banner." It is KDKA. Just a little tighter goes the coupling and the music swells up.

Those statics are really annoying to-night, and no juggling with traps and condensers which I know of will minimise them on this wavelength.

Now there is a jazz tune. Something altogether new, this. Wonder whether it is copyright over here yet? What an opportunity for the expert in music writing to copy it down and put it on the market before

the American gets it over! Unworthy thought.

Now a song. Something about a white-haired negro, Ma. Again something fresh. Perhaps in a few months time our street organs will have it. How nice to hear it and be forewarned!

Now for a Change!

Let us have a change. Do you hear that? We are now on 93 metres. Don't get frightened, but it is certainly penetrating, and we will move on a bit. It's one of my amateur friends getting ready for his Transoceanic tests in the morning.

His power is not so high as you would imagine, only about 100 watts. That little chirrup? Let us listen. It is ICMP, the American amateur. He is going well to-night—I wonder if our friend will hear him.

Yes, there he is, he's got him. Now they are at it. I don't know how long they will be before they lose touch. The old submarine clock over the set shows that it has just turned 1 o'clock. We had better get a little sleep.

THE ETHERWORM.

Radiophoning to a Train!

A review of recent developments in telephonic communication with and between railway trains

Broadcasting can greatly relieve the monotony of a long train journey, and the photograph shows a loud-speaker in the dining car of the Cornish Riviera Express. On this occasion an Ethodyne seven-valve receiver was used with great success. It is to be hoped that British railway companies will carry on with experiments.



IN the near future it is probable that the booklets of foreign conversational phrases usually sold to the Englishman travelling on the Continent will contain useful sentences conceived on these lines:—"I am travelling to . . ." "Please take me to the radio compartment." "I wish to telephone to my office—to my home—to my fiancée," and so on.

Not So Fantastic

The idea at first may seem a fantastic one, but, as a matter of fact, it only reflects what is already taking place in Germany. On the Berlin-Hamburg, Berlin-Munich, and many other main railway lines such facilities have been provided.

The circuit combines wireless telephony with wired wireless, and permits two-way communication between any passenger on a moving train equipped in this manner, and any person connected with the German telephone system.

Roughly, the method adopted is as follows:—At each terminal point of the main line a transfer station has been erected. Should a town subscriber wish to communicate with a passenger, he would ring up the local exchange in the ordinary manner, and get connected with "trunks," by which junction he would be switched through to the transfer station. On giving the number, or possibly the starting time of the train desired, he would be put into communication with the special radio official in charge of the service, who would call the traveller to the wireless compartment.

Should a passenger desire to speak to an outside subscriber, the connection would be effected in a reverse manner. Moreover, two travellers on separate trains, equipped with the necessary apparatus, can hold conversation with each other in the same way.

For many years previous to the establishment of this organised service experiments had been carried out by Swedish and German inventors; but in most instances, when tested, it was found that the systems, although apparently theoretically perfect, broke down in actual practice. The German Government, however, considerably encouraged the attempts made in the country, and in September, 1918,

further—but in this instance successful—experiments were made on the Marienfelde-Zossen railway line.

It is easy to realise that before a reliable service could be brought into operation many technical difficulties had to be overcome, but by September, 1922, much progress had been made; it was found possible to give a practical demonstration, and two-way conversation was held between an engineer on an express train running between Berlin and Wittenberge, and the hall at Leipzig to which post office and telegraph authorities and other guests had been convened.

Between Moving Trains

Later, on April 4th, 1923, the German Postmaster-General and the Minister of Railways took part in a trial trip in order to prove in a practical manner the possibility of carrying out telephone traffic between moving trains.

To-day the Zugtelefonie A.G., the company to whom a special concession has been granted, is rapidly extending its activities to other points of the country, and although the service is still in the early stages of development, so much use is being made of it by the travelling public that it is being taxed to its fullest capacity.

It should be added that, by the same system, passengers are able to secure the transmission of inland and foreign telegrams, payments being made to the telephone clerk, following which the text is telephoned from the train to the nearest telegraph office for transmission in the ordinary way.

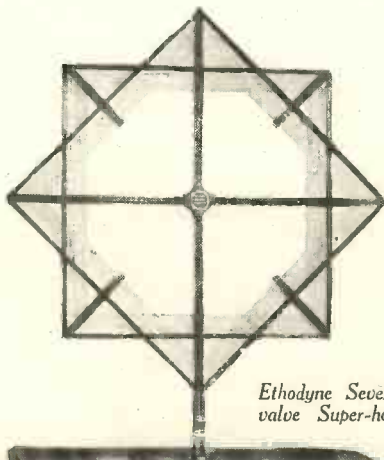

Ethodyne Seven-valve Super-het.

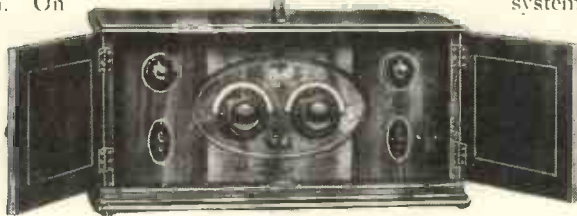

Radiophoning to A Train! (Continued)

Actual telephony transmission from a moving train has also taken place in England, but was purely in the nature of a broadcasting stunt.

It was on the occasion of the Railway Centenary Celebrations in July, 1925, when, as part of their evening programme, the B.B.C. relayed a specially written sketch in the immediate vicinity of the departure platform at King's Cross, and followed up this entertainment by bringing to the ears of listeners a conversation between Mr. R. H. Eckersley and the driver of the Pacific locomotive which was hauling the Scotch express on its way to the North.

At Sixty Miles per Hour!

During the journey to Peterborough, and whilst the Flying Scotsman was travelling at a speed of some sixty miles per hour, a running commentary was made from the cab of the engine, and incidents of the route were announced in order to enable the public to understand the various distinctive noises.

On this occasion an improved type of carbon microphone had been installed on the tender, and was connected to a van which had been specially equipped with a portable transmitter. Above the roof of the coach three aerial wires were installed, and two of the telegraph wires on the side of the track were specially insulated for a distance covering King's Cross station to Welwyn.

The actual receiving set, placed at Hatfield, accepted the signals, duly amplified them, and passed them on to the Savoy Hill headquarters for further distribution to the London transmitters and the B.B.C. simultaneous-broadcast system.

Further Experiments Needed

It seems a pity that further experiments were not carried out at later dates with a view to starting a wireless-telephony service in Great Britain similar to the one in existence in Germany. In the matter of reception of broadcast transmissions on moving trains, considerably more progress has been made on the Continent than in the British Isles.

Since September 1st special radio carriages have been attached to the Austrian express trains running be-

tween Vienna and Salzburg, and Vienna and Graz. These compartments are fitted with a number of headphones, each one connected to a small switch, and for the use of these a payment of approximately 9d. per hour is made to the official in charge.

A system of "checks" has been adopted similar to the chair ticket used by many seaside corporations, the slip being clipped at the hour at which the passenger hires the telephones.

Transmissions are not only picked up from the Vienna and Graz broadcasters, but on those parts of the run in which the train is travelling through deep cuttings, thus hampering reception from these districts, arrangements are made, if programme times are suitable, to switch over to some foreign high-power transmitter, in order not to break the continuity of the entertainment.

Enthusiastically Welcomed

The introduction of broadcast telephony on the Austrian railways has been enthusiastically welcomed by the travelling public, and it is expected that the service will be extended to cover the other main lines of the railway system.

Even in Russia a beginning has been made in the wireless equipment of carriages on the Moscow-Leningrad main line; headphones are available in many compartments, and restaurant cars are fitted with loud-speakers.

During the journey concerts are received from both the Moscow and Leningrad transmitters, and sandwiched between musical items are short news bulletins or stirring talks of a strong communistic flavour. In the United Kingdom the only serious attempt made to demonstrate the possibility of hearing wireless concerts whilst travelling was undertaken by the Burndept Company on March 2nd, 1926.

A seven-valve super-het receiver with its standard frame aerial was installed in one of the compartments of the Great Western Cornish Riviera express, running between Paddington station and Plymouth. On this occasion five loud-speakers and twenty pairs of headphones were successfully operated, and during the major part of the journey concerts were picked

up from British and Continental stations.

As on most of the British railway systems the carriages are equipped with electric lights, some interference was caused by the close proximity of the generators, but the problem of adequate shielding does not present difficulties, and there appears to be no reasons for which travellers should not be given the opportunity of beguiling the tedious hours of long railway runs by listening to wireless entertainments.

Regular Service?

At the time it was stated that the Great Western Railway had expressed the intention of pursuing these experiments with a view to providing a regular service to passengers on their main line.

Finally, the adoption of wireless telephony for the purposes of inter-station communication is reported from France. In view of the great number of accidents which have recently taken place on French railway lines the Government has put forward a plan for a new system of wireless signalling.

In the meantime, however, the Nord-France Railway Company is installing both transmitting and receiving apparatus at Lille and other important centres, in order to ensure communication with distant points in the event of ordinary telephone breakdowns.

Warsaw Experiments

Recent reports from Warsaw intimate that the Polish Ministry of Transport is seriously considering the advisability of equipping the railway system with wireless apparatus, so as to maintain regular communication between trains and stations. Experimental plant is already being tested on two expresses in the neighbourhood of the capital.

Although the reception of broadcast concerts during long journeys at first sight may appear to be a superfluous luxury, it would not be an impossible matter to equip our railways with both receiving and transmitting apparatus, and thus combine, in one move, the many advantages which at the moment are being enjoyed by the Continental traveller.

J. G. A.

How the Valve Wastes Power

All the energy used up in producing light is wasted. That is why dull-emitters are better than bright-emitters.

What an inefficient piece of apparatus even the modern dull-emitter valve is will be apparent to every amateur who reads this article by Com. H. W. SHOVE, D.S.O., R.N.

It is an article that will make many experimenters think.

All the energy supplied by the H.T. battery and used in minimising the space charge between the electrodes is also wasted.

WE live to-day in the Age of the Thermionic Valve. And the great mass of wireless enthusiasts, whether simply listeners or more technically-minded amateurs, are very apt to forget that the valve is only one of a long procession of devices that have had their day, not only as receivers, but as transmitters of ether waves.

Inefficient "Makeshift"

And few indeed realise that the valve itself is such a "makeshift," so inefficient, that it seems inevitable that it must be superseded at no very distant date.

Essentially the valve is not exclusively a wireless invention. It is an "amplifying relay." Its rectifying properties are incidental and require special arrangements (grid condenser and leak or suitable grid bias) to bring them into play.

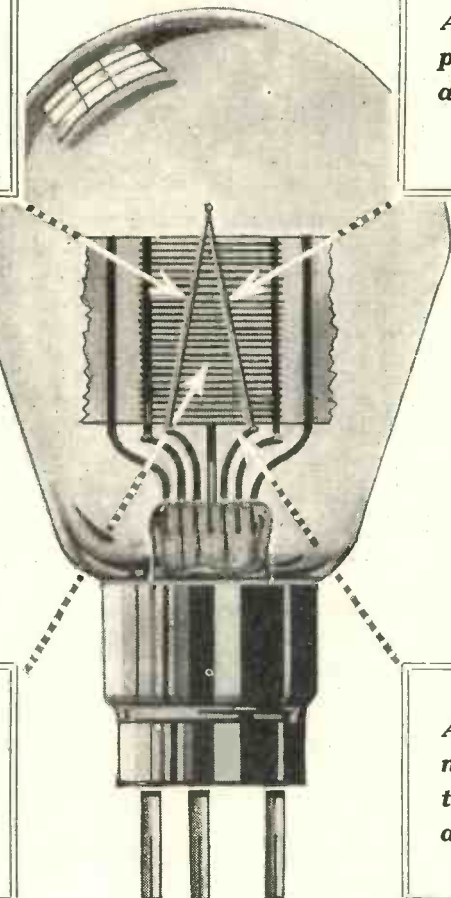

All the energy used up in producing heat is wasted; another reason why the dull-emitter is better.

This illustration shows how some of the waste occurs in the thermionic valve.

Com. Shove is of the opinion that the problem of producing a more efficient valve may be solved by some wireless amateur without elaborate apparatus; it is a new principle that is wanted.

All the electrons that are not trapped by the electrodes of the valve represent another wastage of energy.

What has made the valve so extraordinarily useful in wireless development is its combination of the properties of extreme sensitivity and instant response as a relay with the power of generating oscillations. But, considered from the point of view of efficiency and economy, the valve is very far from ideal for any of its functions.

Let us consider it as a relay. In a valve used for this purpose, the impressed voltages on the grid-filament circuit control the electron stream from filament to anode, the object being to cause amplified fluctuations in a comparatively strong locally-produced current exactly corresponding to those received (either by land-line or wireless), from a distant or weak source. This a properly designed and operated valve will do with almost perfect fidelity.

But the wastage of power is enor-

mous. First, we have to produce our electron stream, on which the grid is to act. This is done by taking advantage of the fact that a hot wire emits a cloud of electrons. Only this incidental emission of electrons is of use to us.

Lost Energy

The whole of the power producing light and heat given off by the filament is utterly lost. The mass of an electron, and therefore the power required to move it, even at immense speed, is inconceivably small. Practically the whole of the energy drawn from the L.T. battery is thus turned into this wasted light and heat.

In the dull-emitter valve the wastage has been cut down by making use of filaments wherein the electron emission bears a higher ratio to the temperature than in the older bright-emitters. But, even in the '06-

How the Valve Wastes Power (Continued)

ampere type of valve, at 3 volts, the 18 watt consumed in the filament must be reckoned practically a dead loss.

Having got our electrons free of the substance of the filament, wastage is by no means at an end. For, unfortunately, they do not move off into space independently of one another. And, being of like (negative) electrical sign, their action on one another is repulsive.

Help Needed

So any given electron leaving the surface of the filament has to meet the opposition of all those already free, tending to "push it back" into the filament again. Without help therefore, comparatively few will ever pass over to the anode.

The ordinary method of overcoming this, the space-charge effect, is to make the anode strongly positive with respect to the filament and so provide a counter-attraction for the negative electrons. This necessitates the use of an anode (H.T.) battery, and introduces another source of wasted power.

The opposition of the space charge requires the expenditure of energy to overcome it in the same way as a high resistance inserted in an ordinary D.C. circuit.

As it is necessary that we provide for fluctuations in either direction (the grid becoming alternately positive and negative about its mean potential), we must make the current from the H.T. battery, whose direction we cannot reverse, large enough to ensure that a decrease, due to a negative grid impulse, shall not entirely stop it. For if we do thus "go over the lower bend," amplification will be unequal.

Mean Anode Current

The mean anode current corresponding to mean grid volts must be adjusted with this end in view. And the power wasted will be measured by the product of this mean current and the H.T. voltage necessary to maintain it against the space charge.

This current is kept down, if we make the grid initially negative by using a grid-biasing battery. And we can effect a greater economy here by using more grid bias when the impressed fluctuations are of small

amplitude; for we can then afford to work nearer to the "lower bend" of the valve characteristic without risk of a large negative impulse taking us over it, with consequent distortion.

This means, in practice, that we can use proportionately more grid bias on the earlier than on the later

YOU CAN'T SOLVE IT?

You don't know to where that connection should go or why your set works well one day and badly the next?

Well, why worry? We keep a staff specially to solve such problems as yours. Let them have your queries.

Please observe the following conditions:

Ask one question at a time; write on one side of the paper only; attach to your query the coupon on cover iii, send it with a stamped addressed reply envelope and a fee of 1s. (postal order or stamps) to: The Editor, WIRELESS MAGAZINE, La Belle Sauvage, E.C.A.

stages of an amplifier. And this point is worthy of consideration in designing a set, the common practice being the exact opposite, that is, to provide more grid bias on the later stages, with the sole object of avoiding distortion through excessive positive impulses, giving rise to an actual flow of current through the grid circuit, and without regard to economy.

There is no waste of power from the grid battery, which is only called upon to supply voltage and not current.

A four-electrode valve can be arranged to overcome the space charge without the use of an H.T. battery, by connecting the inner grid to the positive L.T. This grid then helps the electron flow in a similar manner to the anode of the ordinary valve, its closer proximity to the filament compensating for its lower voltage.

But against the apparent economy so obtained we must consider the loss of electrons which actually "fall into" this grid, and so return to the filament without being of use

in the anode circuit. The proportion of these to the total is a matter of valve design. But it is fairly certain that, whatever its advantages, the method cannot claim power economy.

Though there is only one source of power, the L.T. battery, it has to give out as much as the two batteries of the other system combined.

Small Useful Power

The useful power delivered by a valve, even the last valve of a powerful set working a large loud-speaker, is incredibly small. Of course, the conversion of the electrical to sound energy in the telephones is terribly inefficient. With this we are not here concerned.

But think of the noise of a buzzing blow-fly, given out merely incidentally to its flight. Then think of how many "fly-power" are consumed in heating the filaments of your valves, and in supporting the steady anode current (for the phones are only concerned with the fluctuations). Then set yourself this problem.

How is this waste to be eliminated? Is any detail improvement in the valve going to do it? Or do we not rather require a new arrangement wherein there shall be:—(a) No hot filament; and (b) no steady anode current?

Scientists are already working on these problems. And it is submitted that they are better worth the average amateur's attention than the struggle after marvels of range or volume with inadequate gear in which so many now waste their energy.

New Principle Wanted

Let not the lack of elaborate equipment deter you. It is a principle rather than an elaborate and complete apparatus that we want to evolve. There are great possibilities in the humble crystal, especially in its as yet scantily-investigated oscillating form. And, as it is economy for which we are working, something cheap must be the ultimate solution.

A solution must and will be found. And the solution will revolutionise wireless as much as the valve itself has done. And the inventor, if he knows how to handle his invention commercially, will reap a magnificent reward.

JOTTINGS *on the* MONTH'S PROGRESS

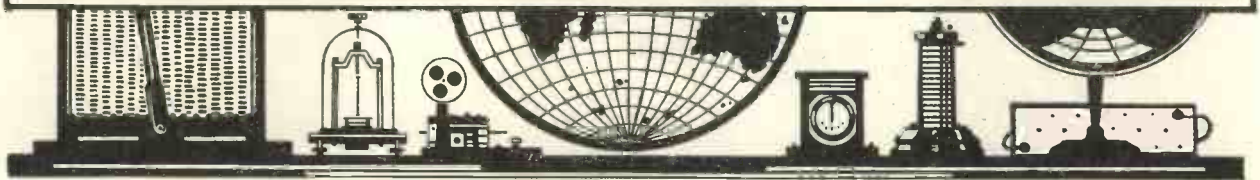

THE commercial development of long-distance wireless communication is rapidly bringing it into keen competition with existing cable systems. Transatlantic high-speed beam telegraphy has been followed by the opening of a direct London-New York telephony service on a non-directional wavelength of 1,550 metres.

Experiments have also shown that it is feasible to use short-wave beam radiation for direct telephony, not only with Canada but also with Australia, a distance of over 11,000 miles.

Transoceanic Speech

The telephonic link between London and New York starts from the Trunk Exchange near St. Paul's Cathedral. From here the message passes by wire to the Rugby station, and is then radiated to the Houlton receiving aerial in Maine, U.S.A. From Houlton the rectified signal passes over 500 miles of land-line to the New York long-distance exchange.

Return Journey

On the return journey the outgoing trunk line from New York feeds a wireless transmitter located in Long Island. The incoming radio waves are picked up on this side at Wroughton, near Swindon, where they are rectified and fed into the London trunk line.

Owing to the five hours' difference in geographical time between the two countries, the New York business day may be said to begin at about 2 p.m. here, so that the effective overlap is limited to four hours, say from 2 p.m. to 6 p.m. English time. During this period experience has shown that atmospheric conditions are, on the whole, quite favourable to clear working. In fact, users are agreeably sur-

prised at the strength and quality of the received messages.

"Secret" Telephony

One criticism that has been levelled against the use of radio as compared with cable communication is its lack of secrecy. So far as the American telephony service is concerned, however, it is by no means a simple matter for the ordinary broadcast listener to overhear private messages.

Although the wavelength used is not outside the normal "loading" of the standard broadcast receiver, the messages are radiated by a special type of transmission which is quite different from that used in ordinary broadcasting.

The method employed is that of suppressing the full carrier wave, and transmitting one only of the modulated sidebands. The sideband radiation is sufficient to carry the message across the intervening 3,000 miles of space, but it cannot be intercepted by an ordinary crystal or valve set.

In order to restore the speech components to their original form it is necessary to apply at the receiving end local oscillations of the same frequency as the missing carrier wave, and this can only be done by the skilful use of a heterodyne or "homodyne" valve operated by the would-be eavesdropper.

Progress in Television

Mr. E. F. W. Alexanderson, whose researches into the properties of plane-polarised waves forms one of the most interesting chapters in recent radio development, has turned his attention to the problem of television. Following a successful demonstration of his apparatus before the American Institute of Electrical Engineers, the inventor expressed his conviction that true television is quite a feasible proposition for the ordinary

broadcast listener, and that it will not be long delayed in spite of certain outstanding difficulties.

Mr. Alexanderson's "transmitter" consists of a series of mirrors mounted at slightly different angles upon a rotating drum. Instead, however, of using only one light source as usual, no less than seven are focussed together. This not only gives a fiftyfold increase in illumination, but also permits the entire screen to be traversed in a small fraction of a second.

Atmospheric Ionisation

The intermittent phenomenon known as the Aurora Borealis, as well as the constant diurnal variation of the earth's magnetism, are both held to corroborate the existence of a highly ionised condition in the upper regions of the atmosphere, such as is required by the theory of the Heavside layer.

Such ionisation is known to be due in part to the ultra-violet light emitted by the sun. In addition, Mr. E. A. Milne has shown that certain atoms of matter, such as those of calcium, emitted in the course of sun-spot activity, may acquire sufficiently high velocities to penetrate deeply into the rarer strata of the atmosphere, and in this way produce further ionisation.

"Cosmic Ray"

Another source of ionisation which must also be taken into account is the so-called "Cosmic ray" recently investigated by Professor Millikan. This is an ultra short-wave radiation of mysterious origin, which is mainly found at high altitudes, though evidence of its existence at lower levels has lately come to light. The generally accepted view is that the "Cosmic ray" reaches our atmosphere from inter-stellar space. R.

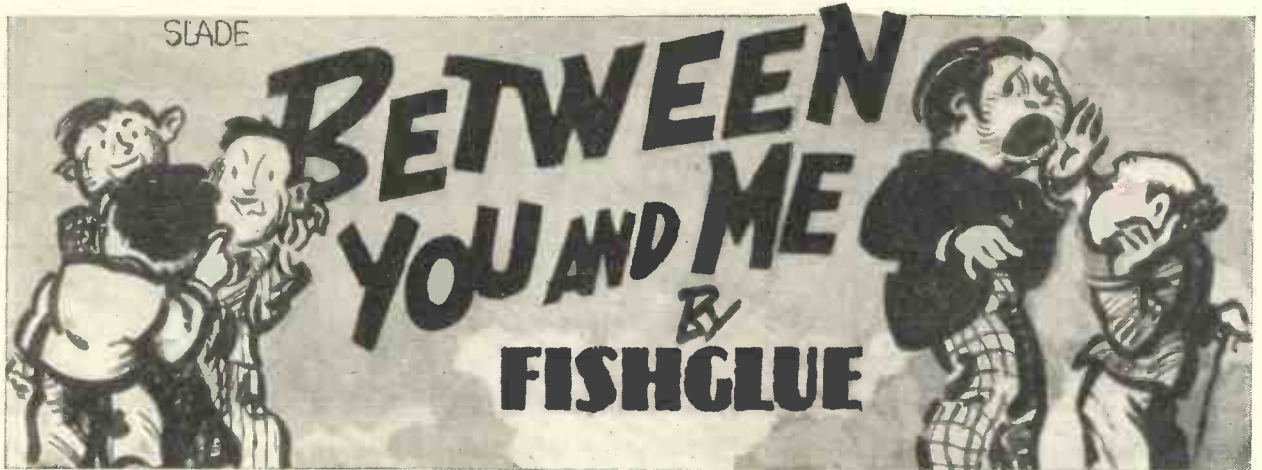

THE Editor wants me to write another article! (He'll probably say he doesn't, if you ask him, but that's only just his modesty.) At any rate, I'm going to try and slip one in, while he's on his holidays, or something like that.

Now last time I promised to tell you all about Condensers, and why, but the weather's much too nice for that, "just at present," so I'm going to give it a miss, "just for the present."

In any case, although I know all about Condensers, for the life of me I can't think Why, just at the moment.

There's been a lot of rather nice songs written lately about forgetting to remember, and moonlight, and rowses of roses, and why don't my dreams come true, and bits of things, and I propose retaining the haunting melody (by first murdering it) and re-writing the words on a more sensible scale.

As the composers don't know my telephone number, and my father's bigger than the Editor, and you don't know where I live, why shouldn't I risk it?

Voilà, then, commençons, et nous voyons ce que nous voyons, which is remarkably true, considering its French:—

I'M TOO SOFT TO REMEMBER.

(By Pelman, Pelman and Pelman.)
 One little lie I couldn't pass by,
 And hadn't the sense to forget;
 You said you'd got Rome, in the
 cellar, at home,
 And your get was a super-het;
 One little tall-tale, carelessly spoken,
 My D.X. record, carelessly broken.

Refrain.

Remember, the night, the night, you
 said,
 "It's Chili!" Remember?
 Remember I swore to believe no
 more.

How silly! Remember?
 Remember the cellar's a draughty
 spot,
 When the fire's gone out it's hardly
 hot,
 So you're bound to get "chilly,"
 Yes, quite a lot.
 But I forgot to remember.

Now Crippen himself couldn't resist
 the pathos in that, could he? Now
 let's try another! Here goes!

**OH, HOW I'VE CURSED THEM
 TO-NIGHT.**

(By I. M. Wild.)



Bits of Things.

Oh, how I've cursed them to-night,
 Cursed them for being low;
 Oh, how I've cursed them to-night,
 More than they'll ever know.
 They went "dead out" after
 awhile,
 Oh, how d'y expect me to smile.
 But while I'm busy "hating"
 The battery's sulphating,
 Oh, please, come and charge it,
 to-night!

That's another sad one!
 Now what about:—

**"WHY DON'T MY DREAMS
 COME TRUE?"**

Of KDKA I've been dreaming,
 And of Chicago, too,
 Wondering if valves once repaired
 can
 Be quite just as good as new.

Oft on a howl I go sailing,
 Searching the wavelengths through,
 But there's no stop on my tuner:
 Why don't my dreams come true?

That's probably quite enough of
 that, so, realising that he who hesi-
 tates is bossed, I'll get on.

I've heard a lot about television,
 lately, sort of stunt that lets a fellow
 see what's going on in Hongkong,
 or, now wait a bit, somewhere
 romantic like, well—Honolulu 'll do,
 only it's nothing to crow about (as
 I heard somebody say, and I thought
 it sounded funny). As I was saying,
 it lets a fellow see what's going on
 in Honolulu when it's night time in
 Italy.

It's going to make it jolly awkward
 for the Ukelele Lady, if she keeps
 on at her old games, but all the same,
 it's wonderful. "How the milk got
 in the coconut" is child's play com-
 pared to it.

Let me say, however, that even
 television is a mere nothing com-
 pared to my new invention, which
 will be on the market shortly (and
 off it again more shortly, as soon
 as it's found there). My instrument
 is the "Teleskoffer," from Scott,
 Latin for grub, or food, nutriment,
 you might say, like Black and White,
 or Allenbury's.

It consists of a box with works
 and bits of things in, and a large
 half-pint horn turned wrong way up.
 ("A large one for the lady and a
 small one for the baby," you re-
 mark? Quite; but pro rata, of
 course.)

Reception consists in lying on your

back with the small end of the funnel in your mouth (yes, the small end, greedy), turning a knob, and then swallowing hard whatever the local food distributor is transmitting.

Of course, there are difficulties. No announcer with a clean face and a stiff collar would like to be heard shouting, "Corn beef calling," or "Café au lait and cream, coming," now, would he?

It might help the Ministry of Health, though! Just fancy, every Saturday night, "2 Full-up calling. Stand by for weekly dose. As much as can be laid on a vernier knob—tasteless on tripe—castor and cod-liver coming—toothpaste to follow." (Sandpapered diaphragms, fitted with tooth brushes, supplied for slight additional charge to standard Teleskoffers.)

The greatest difficulty, however, lies in jamming (no, not cramming, we take no responsibility for that). You see, if 2 Stick K E is transmitting strawberry jam, with cake, at two-minute intervals, and your set is jammed by Spain transmitting pilchards en huiles, and you get mixed up with Switzerland, who is transmitting condensed milk, you're going to go wrong inside.

Then, again, we can't get milk through without the condensers condensing it, or cheese without tuning it, and it's bad enough without making it sing. Also, what happens when it howls? You may say immediately, "Why, f_x or $\frac{d^2y}{dx^2}$ " but it'll be worse than that.

We would then have mathematical menus. For instance, a good break-

fast, delivered on three milliamperes would be

$$P+S+Pe+C_1^3 \text{ or } C_2^3 \\ T^2 \\ (\sqrt{Po+300 \text{ cal.}})$$

Which=porridge with syrup, poached eggs on square toast (because hexagonal would look silly), with three cups of coffee (C_1), or cocoa (C_2) all on top of last night's supper (chipped potatoes).

Excuse me a minute, please, my transmitter's just boiled over. Thank



Awkward for the ukelele Lady.

you! Now that's all the inflammation I can give you at the present. (Reporters, please note.)

Wireless wants advertising, in an interesting way. Let me show you:—

Excuse me again, will you. I must speak to that kitten. It annoys me by a dirty habit it has acquired from its lady parent of spitting on its feet and wiping them on its face. Now! he's all right now, so to continue.

RANDOLPH'S REVENGE.

Seizing her by what hair was on her head, he forced her backwards, and with an oath which the WIRELESS MAGAZINE hasn't got in print, proceeded to choke her (Strangleum, Ltd., for L.F. chokes) in that dare-devil fashion which had made him the darling of the ladies, and set every heart from Broadway to Bootle fluttering.

With her mouth too full for words (her heart was in it, naturellement) (Duddledum's D.E.'s are perfectly silent) she frantically signalled him to desist (use Dirtyite and watch the increase in signal strength).

Randolph choked her again by way of reply. (Our H.T.'s are constant in action.) Struggling from him, she fled across the lawn, and faced him with heaving chest. (Holdem and Upp's for steady aerial equipment.)

"Randolph," she cried, more in sorrow than in anger (fit Koko coils and

save regrets). "That's not love, that's passion," and sadly picking up a plant pot, she hurled it at his head, from across the lawn. (Get a 11et. and go in for D.X. work.)

His eyes swept the gravel path, and his breath came in short, thick pants, as, screaming with pain (Yellum, Yellum and Howl for loud-speakers) he went to tell her mother.

What will happen to her when she goes home? (Buy a Brighto D.E., and the next instalment will be found inside the box. Complete story bound in cloth given with our Four-valve Neutrodynes.)

Now, don't you think that would increase the sales? A man who could resist that isn't human, he deserves all his sons to be wireless announcers.

I'm taking my M.U.D., I beg your pardon, M.I.R.E. (I knew it had got something to do with a dirty road), next week, and I've got an awful lot to remember. I have to talk to myself like this:—

The heating effect= C^2R .

DY by DX is the best way, far.

Its 25 metres to Omaha

And it wouldn't be ohm without $\frac{C}{R}$

C =at best the magnetic shell

The charge all collects at the points.

And if your receiver you'd have

working well,

Be sure to use right-angled joints.

Tinned copper's *au fait*, it's a rather

good way

And soldering, *sans double*, is *de*

rigueur,

And KA, over $4\pi d$, so they say,

Must be worked to the $p+1$ th figure.

And, then, when I've told myself a lot of times, I get a bit mixed, like this:—

How does the busy little bee

Keep the N. Pole on his right?

'Cos he follows the Law of friend

Ampère all day,

And skoffs it all up at night.

(Continued at foot of next page.)



I must speak to that kitten,



What about my back answers?

PHOTOGRAPH · YOUR BROADCAST · RECEPTION!

By Dr. E. E. FOURNIER D'ALBE, F.Inst.P.

THERE are many indications pointing to an impending development of permanent wireless records of broadcasting and other wireless reception. There is no reason why any wireless music or speech received anywhere should be lost beyond recall as soon as it has passed the present moment.

"Inaudible" Reproductions

It is true that we cannot legally make and sell gramophone records of wireless performances without the consent of the performer. But records not intended for audible reproduction are free from any restrictions.

Now that the American Navy Department provides its ships with automatic wireless weather charts, we may expect similar developments to follow with bewildering rapidity. Picture transmission by wireless has reached a point at which it could easily form a part of the daily routine, and it only remains to devise receiving apparatus within the reach of all in order to make it an actuality of considerable importance.

In view of these developments it behoves amateurs to hold themselves prepared to enter this fascinating but hitherto undeveloped field of wireless. The first step will be to get accustomed to the preparation of photographic records of wireless broadcasting.

I have lately had occasion to experiment in this direction, and the results have been sufficiently encouraging to be introduced to the readers of the WIRELESS MAGAZINE.

The very simplest and easiest method of recording broadcast photographically is to take the horn off a loud-speaker and substitute a short funnel, say, 4in. long and 2in. wide at the mouth. Across the opening a thin rubber membrane is stretched, and the funnel is so arranged that the membrane is exactly horizontal. Clean mercury is then poured on to the middle of the membrane until it forms a drop about half an inch in diameter.

Now start the loud-speaker and observe the surface of the mercury.

Any music and speech coming through will produce crimped patterns on the mercury, which change instantly with every change in the sounds. The tuning note preceding Big Ben will, if loud enough, produce a steady pattern which looks as if it were fixed on the surface of the mercury itself, but it will instantly disappear as soon as the tuning note ceases. The patterns can be projected on to a screen and shown to a large audience.

The lively play of these variegated patterns is very interesting to watch, and it would give to a totally deaf person some idea of what was happening in the microphone.

One of the advantages of the mercury-drop system over any system based upon the use of a small mirror is that there is no vibration at all in the pattern so long as the sound remains unchanged. There is thus a correspondence between the steadiness of the sound and the steadiness of the pattern.

In order to make a continuous record of a wireless broadcasting programme it is necessary to take a

cross section of the pattern produced by the mercury drop. The record will then show a series of lines parallel to the displacement of the photographic film which will be closer together in the case of high notes than in the case of low notes.

This is due to the fact that the patterns are formed by the interference of waves travelling towards the centre of the mercury drop with similar waves which have already passed through the centre.

Clean Surface

It can be observed, in fact, that when the waves are dying out they fly out in all directions towards the rim of the drop and disappear over the edge into the rubber. This process takes rather less than a twentieth of a second, so that within that short interval a clean surface is ready to show the next sound.

An article giving full instructions for taking records by this process, with diagrams and actual photographs, appeared in *Amateur Wireless* for December 11th, 1926.

Between You and Me (Continued from previous page.)

And then I have to stop and ask myself about it, all over again.

Now then, what about my back answers? No, kiddies, I've nothing for you to-night. Oh—but just a minute:—

Ukelele Baby writes:—"Can I be an angel, Uncle Fishglue?" Yes! Clean your mamie's shoes.

Oh, again! As it's your birthday, Ermingtrude, if you look under the pan in the pantry, you may find something to your advantage. No! I shouldn't, if I were you! And in any case it spoils the tea when your little brother persists in dropping the crystal in it, and teach him to stir it with his right hand, it's more genteel than the extension handle, now isn't it?

Now for the grown-ups. Willie from Wigan writes:—

My dial sticks at half-past eight,

Further it will not go,
So I thought I'd write—I'm fed up,
quite,
"What'll I do?"—perhaps you'll know.

Well, Willie, sell it to somebody; they're sure to find out what's wrong and let you know jolly quickly.

Our Esperanto Expert from Chyekkolumphnia writes:—

Mein set, es ist broken,
Ce n'est pas au fait.
Reaction's verboten,
Oh! Tyaminaway!

Hard luck, Jacksky, Alphonsonio, but I only answer the easy ones, you know—try the Editor.

But just a minute, I'm going to be like a bride at a wedding, I'm going to be "given away," if there are any more questions like that. So, bye-bye.

With no time for any more,

Yours, FISHGLUE.

5YM Writes on Interesting Matters—



UNLESS something happens very quickly, this winter will go down to history as a thoroughly unsatisfactory one from the short-wave viewpoint. "Patchy" is the word which completely describes the conditions we have been experiencing during the last few months. And the bad patches have been much bigger than the good ones.

For low- and medium-power stations real long-distance work has been possible only on a few occasions each month, and we have not had anything like the number of "records" by low-power stations that were expected.

Regular Working Impossible

One thing we have learned, and that is that it is quite impossible for a low-power station, working on 45 metres, to keep up regular communication over a couple of thousand miles or so during the dark hours. We started off with the idea that any efficiently run station with a power of 50 watts would be able to work with U.S.A. amateurs any night, and that 10-watt stations would be able to get across on any but really bad nights.

Now we know that it wants at least 100 watts, and probably 200 watts, to give anything like sureness in the matter of working the United States. Very often it has seemed easier to work with Australia and New Zealand than with the nearer English-speaking continent.

Why the conditions have been so bad nobody quite knows. Probably it has been due to a disturbed state of the atmosphere. We do know, now, that clouds and mist and fog have a very curious effect on short waves, giving rise to fading of a most pronounced type. It seems likely that when there are quickly-changing cloud bodies between transmitter and receiver we may get not only fading but a complete blotting out of signals.

We shall not really know the reason of our recent bad luck until several years have passed and accurate logs have been kept showing not only the weather conditions at the two ends of the line, but at intervening points as well.

Those of my readers who heard a great deal of KDKA and WGY on the short waves last winter will realise how bad conditions have been. For my own part, I have not had one really good reception from either of those stations, whereas last winter I was receiving them very easily almost any night they were working. And I believe my present receiver to be a much better one than that I had last year.

But it is difficult to tell. If it wasn't that reports are all the same all round, I should begin to suspect the efficiency of my own station.

Bad luck has dogged me in the matter of real long-distance working. Whenever good conditions have come along they have, almost always, coincided with the days on which my batteries were being charged. My power supply is from a 60-watt generator, fed from an 18-volt large-size car battery. The current taken from the batteries is only 6 amperes; but, naturally, they want recharging at least twice a month, and as they are of large capacity they take about four days to get to full charge.

Reserving Power

I shall have to be very severe with myself and refrain from all daylight work, reserving my power for an orgy when decent long-distance conditions do arrive. Maybe we shall get some in the spring, before the nights get too short. By the way, on the subject of long-distance receiving, have any of you tried resistance-capacity coupling, instead of the more normal transformer, between the detector and the output

valve of a short-wave set? Believe me, it is the goods!

You will find that strong signals are a little cut down; but that weak signals come in very well indeed and that you will normally be able to hear many weak stations that you missed before.

The reason is that a transformer is not very sensitive to weak signals. It prevents them getting through to the output. Resistance-capacity coupling will pass any rectified signal that comes to it, and then it is merely a question of the goodness of your ears and phones. Of course, the detector valve must be a high-resistance one; but as most efficient short-wave sets use the Marconi or Osram QX type for this purpose, all is well.

Anode Resistance

This valve works very well indeed with an anode resistance of from 100,000 to 250,000 ohms. You get more amplification out of the bigger resistance, but I prefer the smaller as one need not then use more than 60 volts H.T. to give enough energy for a smooth and efficient reaction feedback.

I have recently been trying high-magnification coupling, which necessitates the use of a 1- to 3-megohm resistance in the anode circuit of the detector. This is splendid for the reception of broadcast telephony, but it will not work on short waves unless a separate reaction valve is provided. This rather complicates matters, so I have given it up and am sticking to the old type of resistance-capacity coupling, using a .01-microfarad condenser, and a $\frac{1}{2}$ -megohm leak in association with a 100,000-ohm wire-wound resistance.

By the way, don't forget a wire-wound resistance is really essential. Even when using only 60 volts H.T. the graphite resistances are liable to be noisy.

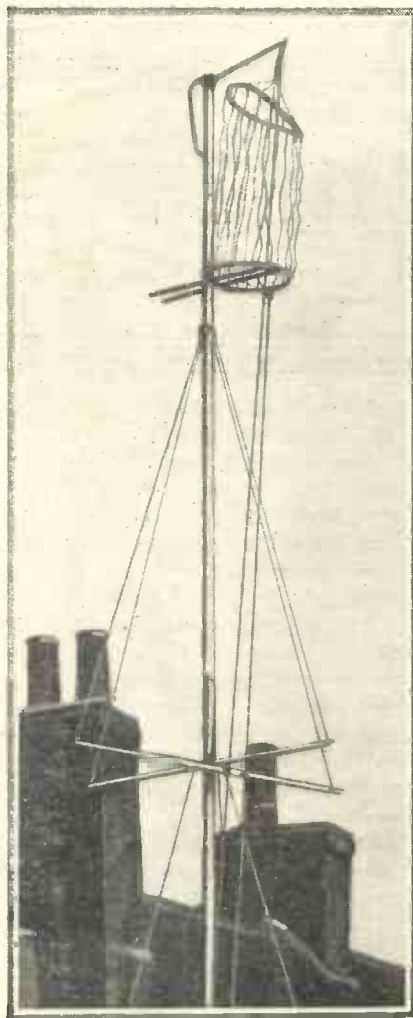

How not to do it!

ANYONE who travels by train to London, or indeed into any of our great cities, cannot help being impressed by the sheer hideousness of quite a large proportion of the forest of aerials that meets his eye.

And the same thing is true not only of the town, but of the country as well, for often one finds both cottages and big houses alike disfigured by unsightly contraptions hardly worthy of the name of aerial.

An Embellishment

There is not the least need to have an aerial of the eye-sore type; it can, in fact, be made an embellishment of any garden or building rather than a disfiguring horror if a little thought is expended on its design and a little care on its erection.

The ugliest type of aerial is that which gives one straight away the impression of flimsiness. One sees everywhere thin poles that have given gradually under the strain imposed upon them until they are warped and

Why Have An Ugly Aerial?

By J. HARTLEY REYNOLDS

twisted and bent in all kinds of queer and ugly ways.

The cost of a sensibly stout pole is so little greater than that of a thin flabby one that there seems little point in choosing the latter, especially when one considers that the strong pole will last for years whilst the fishing-rod affair that some people put up is in danger of coming to an inglorious end whenever the wind becomes a little boisterous.

The average price of a good thirty-foot pole is about 5d. a foot in the rough, that is to say, with the bark still upon it. The bark may be left on that portion that is to be buried, though it is probably better to strip it off and to dress the wood with Solignum or some other preservative.

If you want to make your aerial look really well, remove all the bark and trim up the surface exposed with a spokeshave. This does not take very long to do, and one's trouble is amply repaid by the appearance of the mast when it goes up.

Having smoothed down the pole, give it two coats or, better still, three, of white paint, and provide it with a neat truck. This, besides adding immensely to the appearance of the mast, is a really useful fitting, since it prevents moisture from getting into the grain of the wood at the top.

Your aerial mast treated in this way will look very like a flagstaff, and I have never come across anyone yet who called a flagstaff a disfigurement to a house or garden.

Give your mast a chance by staying it efficiently. Up to a height of thirty feet or a little more one set of stays should be sufficient, and if you have not room for a complete set of four a good back-stay will often do quite well.

Where there is not space for an ordinary back-stay, which should meet its ground anchorage at a point not less than half the height of the mast from its base, the trussing

system, as shown in Fig. 1, will answer very well.

When the height of the mast is much over thirty feet two sets of stays are preferable, one set being taken from near the top of the mast and the other from its mid-point.

In all cases wire should be used for staying purposes, since rope expands in wet weather and contracts in dry. Insulators should be inserted in the stays to prevent them from absorbing energy that should go to the aerial.

House End

And now for the house end of the aerial. Here, again, anything in the way of flimsiness must be avoided. A short mast attached to a chimney-stack—be sure before you do this that the stack is a sound one—looks well and is quite effective. A very good attachment is that shown in Fig. 2, where the pole is firmly anchored to the chimney stack by means of iron bands, which the local blacksmith will be able to make.

Failing a chimney-stack, the attachment at the house end should be made to the highest possible point of the building. This may be done very well by fixing a plate with a ring attached to it to the brickwork by means of Rawlplugs.

Besides their unpleasant appearance

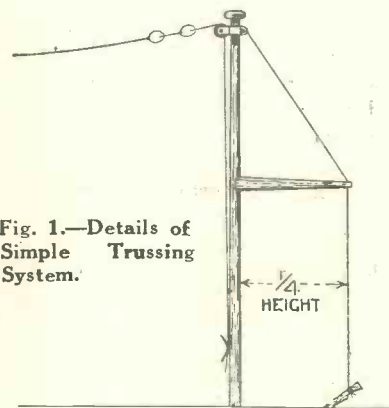

Fig. 1.—Details of Simple Trussing System.

and their liability to collapse in a heavy wind, flimsy masts have one very great drawback from a technical standpoint. There is no doubt that everyone should aim at a minimum height of thirty feet for his aerial. In most places every foot less than this makes an appreciable difference to the strength of reception.

Increased Range and Strength

In the course of experiments which I described some months ago for *Amateur Wireless*, I found that as the aerial was raised foot by foot from fifteen feet upwards there was a rapid increase in both range and signal strength until a height of thirty feet was reached. Above that height there was still an increase in both, though it was not so marked.

Now, if you use thin masts and obtain a height of thirty feet to begin with you will lose a good deal of this as the masts give; that is to say, your aerial will become less and less efficient as time goes on. With stout masts you can maintain your height, and by using wire halliards you can stretch the wire tightly between them so that there is very little sag.

And now for the wires themselves. There is no need, unless you specialise in long-wave reception, as hardly anybody does nowadays, to rig up such a monstrosity as the sausage

aerial. This kind of thing forces itself upon the eye, and even the most enthusiastic wireless man would hardly maintain that it was beautiful.

Actually you will lose nothing in the way of signal strength, whilst you will greatly increase your selectivity, if you employ a single well-insulated wire for your aerial. And

Fig. 2.—Details Effective Chimney Attachment.

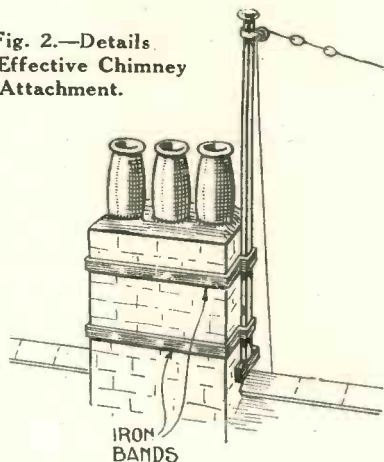

do not make it too long. If the suspended wire is thirty feet or so above the receiving set, then a span of thirty or forty feet is ample.

Should you be unable to obtain even such a span as this, then parallel wires may be used, and these if the work is well done have quite a graceful appearance.

It is essential that the spreaders should be long—the wires should be at least seven or eight feet apart—and they should be painted white in the same way as the mast. They, again, must avoid any kind of flimsiness; nothing looks worse than spreaders which bend under the strain of the wires. The best material to use is bamboo, which, though light, is enormously strong.

Lastly, make your mast fittings neat and trim. The pulley may be quite a small affair and the thin wire halliards should be secured to a cleat fixed four feet or so above the foot of the mast.

Endless Halliards

The halliards themselves should be endless, in which case it is quite impossible for them to slip through the pulley at the top. Satisfactory wire halliards of this kind can be made only if the ends are spliced together, a job which the average amateur will find rather difficult, though it is usually possible to obtain the assistance of a seafaring man, active or retired, who will make the neatest splice in an incredibly short space of time.

Do not have an ugly aerial. There is no reason in the world why you should; in fact, there is almost every reason why you should not.

Do You
Know

The Greater Hard-faced Borrower?

FEW clubs are free from his depredations. Wherever wireless men foregather his call sign is heard. "I say, old man, can you lend me—" I refer, of course, to that fearsome animal, the Greater Hard-faced Borrower.

One specimen in the Widdledup Wireless Club was Skinner. I say "was," for Skinner is now cured, and hides his diminished head.

It was his latest effort, a seven-valve set, that really broke our patience. Liberal estimates agreed that Skinner's only contribution to that set was a valve window and a stick of solder. The rest he had borrowed. He guaranteed that set, whenever he had the opportunity, to receive its own oscillations after they had travelled round the world.

It is peculiarly exasperating to hear

your own components lauded as being beyond price by a man who has borrowed them, when you know you will never see them again.

The cure took place at the annual social of the Wireless Club, and Tompkins—who, living next door, had suffered most—was the humble instrument of justice.

We had prevailed upon Mrs. Smith-Cobblestone, the acknowledged social leader of Widdledup, to be present. And Skinner is a snob. The way he monopolised the great lady, and incidentally praised my coils as incorporated in his set, fairly made my blood boil. When she tired of his ingratiating chatter he cast about for fresh victims.

He spotted Tompkins.

"Here," he whispered to Tompkins, glancing round to see that he

wasn't observed, "I worked this circuit out last night, and I'd like your opinion. You take a three-coil holder and connect—"

"No," broke in Tompkins loudly, looking straight at Mrs. Smith-Cobblestone, "no, sir, I will not lend you a pair of phones until you return my loud-speaker, my transformer, my high-tension battery, my variable condenser, my terminals, my valve holders, my flex—" It took him nearly five minutes to enumerate all the parts of his in Skinner's latest set.

Skinner just wilted.

Last night he knocked meekly at my door, handed in a bulky parcel, and stole silently away. It contained, by the way, a condenser and a soldering bit more than I had lent him.

J. A. D.

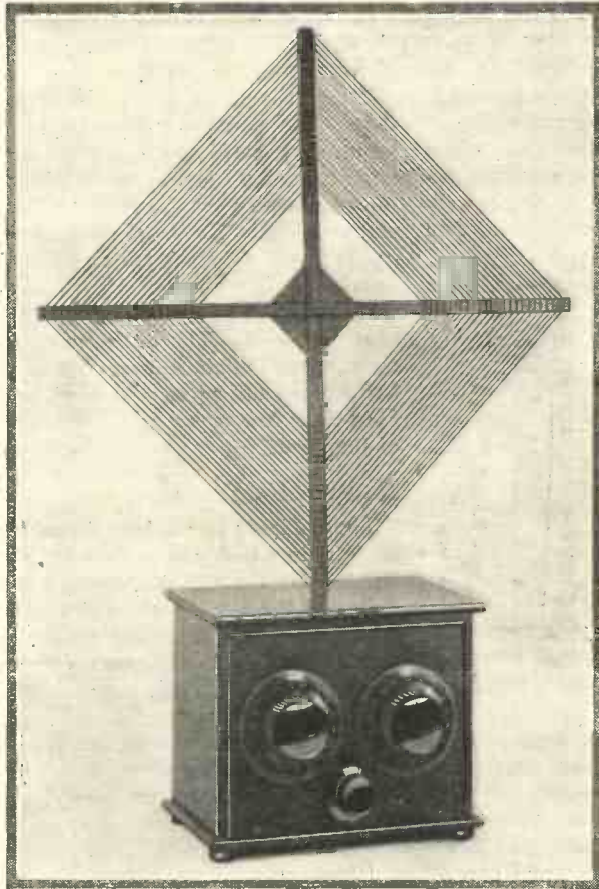

Complete One-valver with Frame Aerial.

THERE must be many people who live in a flat near the centre of a large town where it is impracticable to erect an outdoor aerial or even to obtain an efficient earth. If there is no local broadcasting station the only solution is to build a multi-valve set, using a frame aerial.

For Big Towns

Most of the big towns and cities, however, are supplied by a local station, and it is for such towns as these and for such conditions as just described that the one-valve set illustrated in the accompanying photographs has been designed.

This receiver is intended only for phone reception of the local station and no claims are made that it will bring in many other stations.

Under ideal conditions the reception of one or two other stations is possible and has been done with the original set. Results such as these, however, are the exception and not the rule, and it must be understood that this set is really only a one-station receiver.

The circuit employed is not new, but it has the advantage of being well tried and tested by time. A frame aerial is used to pick up the energy transmitted

A One-valver for a Frame Aerial

Designed, Built and Tested
by the "W.M." Technical Staff

Details of Cabinet and Frame Aerial.

An existing frame aerial can be used if desired.

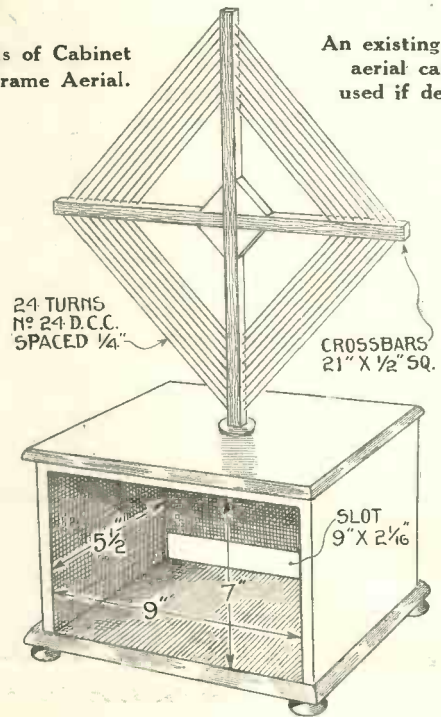

from the local station, and the frame is tuned by a variable condenser.

Reaction is obtained by means of a variable condenser connected between the plate of the valve and the filament end of the frame aerial.

This condenser governs the feed-back of energy from the plate to the grid of the valve.

Components

With the exception of the frame aerial all the components are mounted on a horizontal wood base-board and a vertical ebonite panel, and these are housed in a small cabinet, the dimensions of which are given in the accompanying sketch.

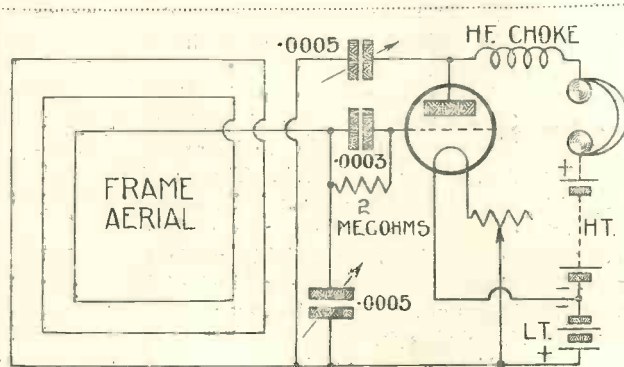

Circuit Diagram of the One-valver.

A complete list of the components required are as follows:—

Ebonite panel, 9 in. by 7 in. (Siemens or Peto-Scott).

2 .0005-microfarad variable condensers, square-law type (Ripaults or G.E.C.).

Valve holder (Artic or Lotus, Benjamin).

H.F. choke (Varley or Ormond).

.0003-microfarad fixed condenser (T.C.C. or Dubilier).

2-megohm grid leak (Ediswan or Dubilier).

Ebonite terminal strip, 9 in. by 2 in. (Becol).

Filament rheostat (Smoothac or Lissen, Wearite).

8 engraved terminals (Belling & Lee, type M).

Cabinet and baseboard (Unica Cabinet Co.).

Frame Aerial

This list does not include the frame aerial, which can easily be made by the constructor himself. Alternatively, one may be bought at a moderate price.

The frame aerial may be wound on two wooden cross pieces of $\frac{1}{2}$ -in. square section, attached to each other in the centre by a halved joint and fixing screw. The dimensions of the arms are shown in the sketch.

Twenty-four slots are cut in each of the four arms, $\frac{1}{4}$ in. apart, and each slot is cut to a depth of $\frac{1}{8}$ in. No. 24-gauge d.c.c. wire is used for winding, and 24 complete turns are wound in the slots.

The ends of the wire are secured and may be brought down to a terminal strip on which are mounted

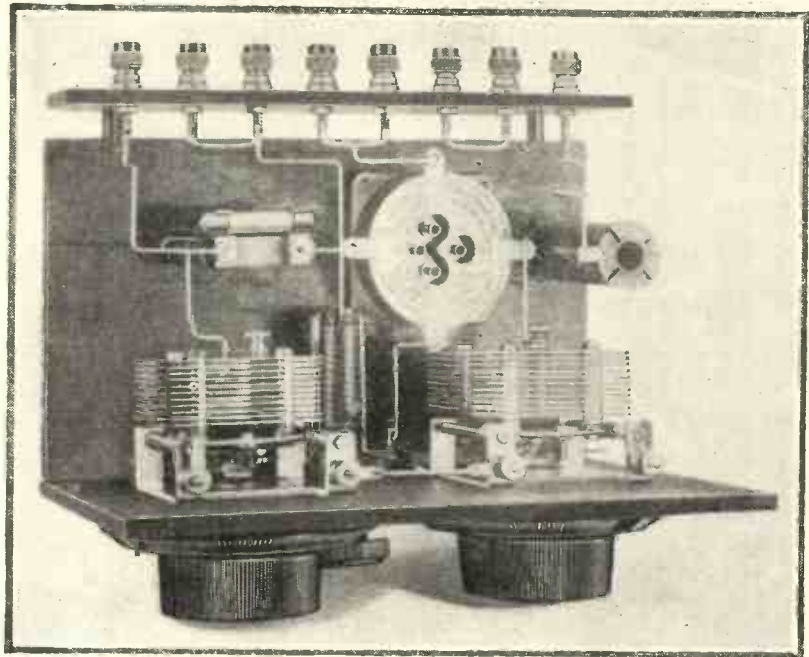

Baseboard View of the One-valver.

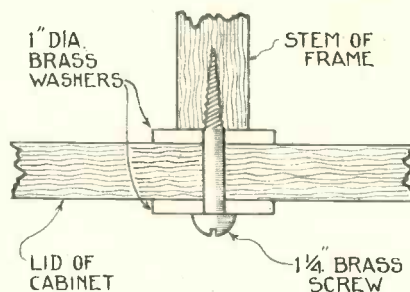

Method of Fixing Aerial to Top of Cabinet.

two terminals, or else the leads may be taken straight to the terminals of the receiver.

On the Panel

On the panel the two variable condensers and the filament rheostat are mounted symmetrically in the positions indicated in the wiring diagram, while the remainder of the components are mounted on the baseboard.

A terminal strip, carrying all the terminals and having a length equal to that of the baseboard, is screwed to the back edge of the latter. The eight terminals are mounted in a row and, from left to right, read as follows:—Phones —, phones +, H.T. +, H.T. —, L.T. —, L.T. +, and the two aerial terminals.

On the baseboard are mounted the grid leak and condenser, valve holder, and the H.F. choke.

Wiring Up

Having mounted the components in the positions indicated and attached the panel to the baseboard by means of two 1-in. brass wood-screws, the set should be wired up as shown in the wiring diagram.

The whole of the wiring should not take longer than half an hour to complete, and the wiring diagram simplifies the process by indicating which components should be connected up first. All the terminals marked A are connected up first, then all those marked B, and so on.

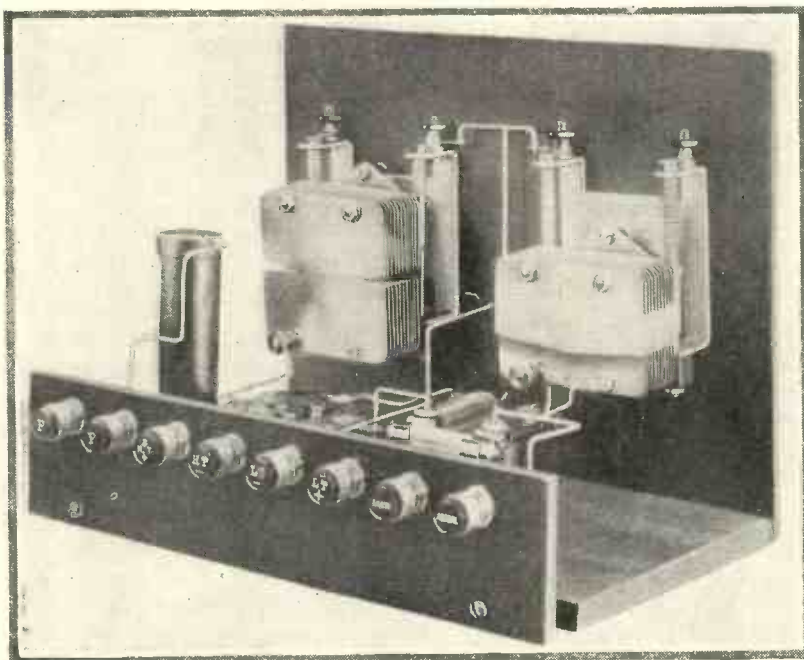

Back View of One-valver showing Condensers.

A One-valver for A Frame Aerial (Continued)

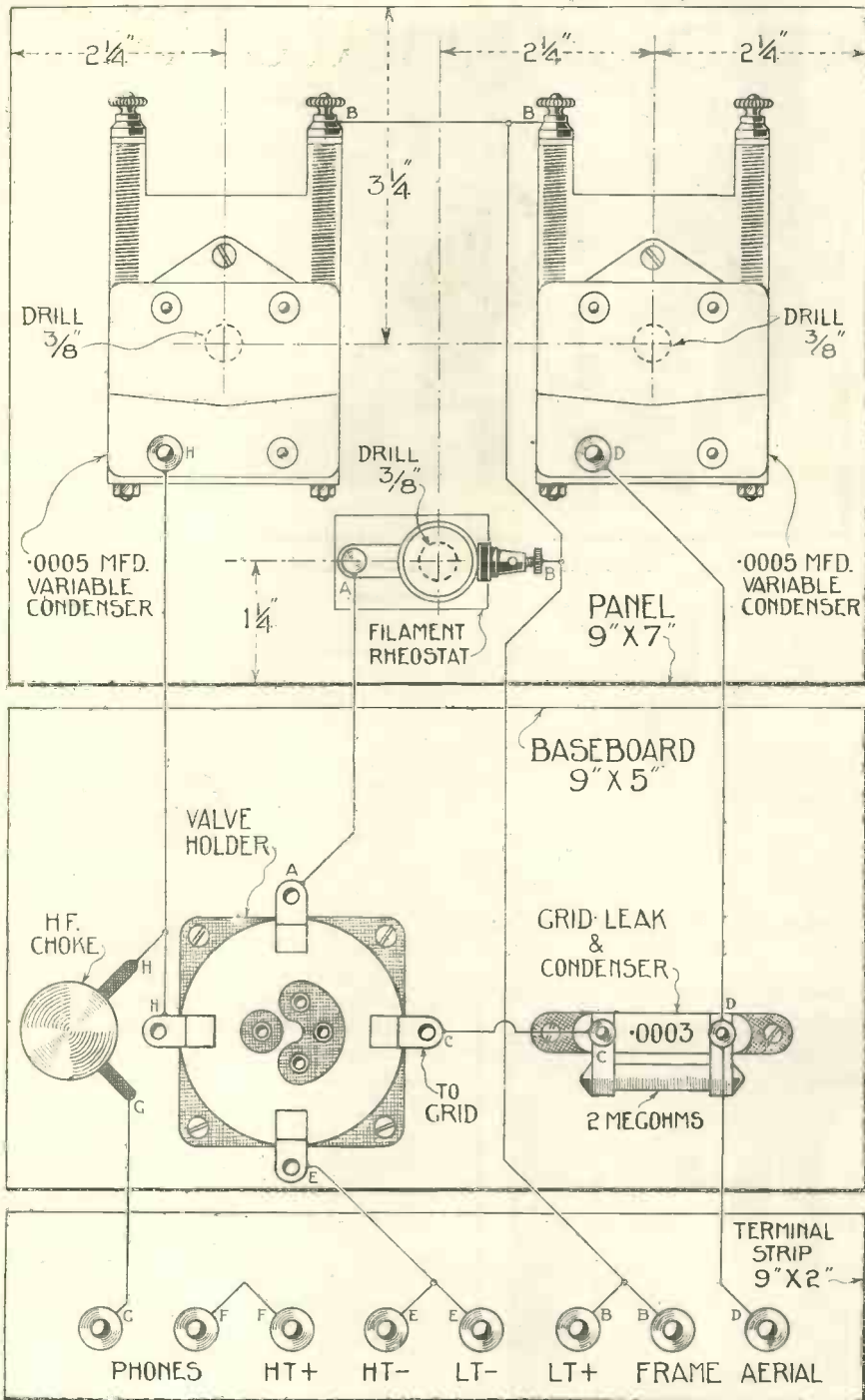

There should be no difficulty about the construction of this efficient one-valver if full use is made of the combined layout and wiring diagram shown above. The layout is shown exactly half scale. When wiring, attention should be paid to the letters at the terminal points. Thus, all the points marked A (two in this case) should first be wired together with one wire or as few wires as possible. Then all those points marked B, and so on through the alphabet, until the wiring is completed.

When the wiring is completed, check it over again with the diagram to make sure that no mistakes have been made, after which the set may be placed in the cabinet.

Suitable Valves

A suitable valve can be chosen from the valve advertisements in this magazine. Of the Mullard valves we can recommend the PM1, L.F., PM3 or PM5; Cossor, Point One (black top); Ediswan, DR2; Osram, DE5B; Cosmos, SP18 (green spot), etc.

In addition a 60-volt H.T. battery is required, together with an accumulator having a voltage suitable for the valve used.

The frame aerial can be pivoted in a hole drilled through the top of the cabinet, or a separate stand may be made. For convenience the latter course is advisable.

Operation

To operate the set, connect the ends of the frame aerial to the two aerial terminals and the batteries and phones to their respective terminals. Place the frame aerial in such a direction that it is pointing to and away from the local station it is desired to receive.

Oscillation Control

Turn the filament rheostat until the valve filament has reached a suitable temperature and place the right-hand variable condenser dial at zero. Now slowly rotate the other condenser dial until signals are heard. If the latter are faint adjust the right-hand dial until a point is reached when the set starts to oscillate. The dial should now be turned a little in the opposite direction.

Stronger Signals

Signals will probably be further strengthened by altering the direction in which the frame aerial points and by adjusting the voltage of the H.T. applied to the plate of the valve.

In conclusion, it may be stated that with the frame aerial described 2LO could be received at good phone strength at about five miles from that station. Signals were louder and more constant than those given by a crystal set connected up to an outdoor aerial.

Was Mars Signalling?

By Dr. E. E. Fournier d'Albe

AN important communication presented by M. Bigourdan to the French Academy of Sciences seems to have been overlooked by our contemporaries.

It appears in No. 19 of the *Comptes Rendus*, and is written by M. R. Jarry Desloges, the director of the Sétif Observatory in Algeria.

He reports many changes in the Martian map since the 1924 opposition. These changes extend from the Cimmerian Sea and the eastern coast of the Syrtis Major.

Changes

The Lacus Solis (Lake of the Sun), which has been closely observed since 1907, shows the most pronounced changes in the last two years, though up to 1924 it appeared remarkably stable.

But the most interesting piece of news concerns the luminous patch or object observed by M. Georges Fournier at the same observatory on the evening of October 24th. It

Map of Mars.

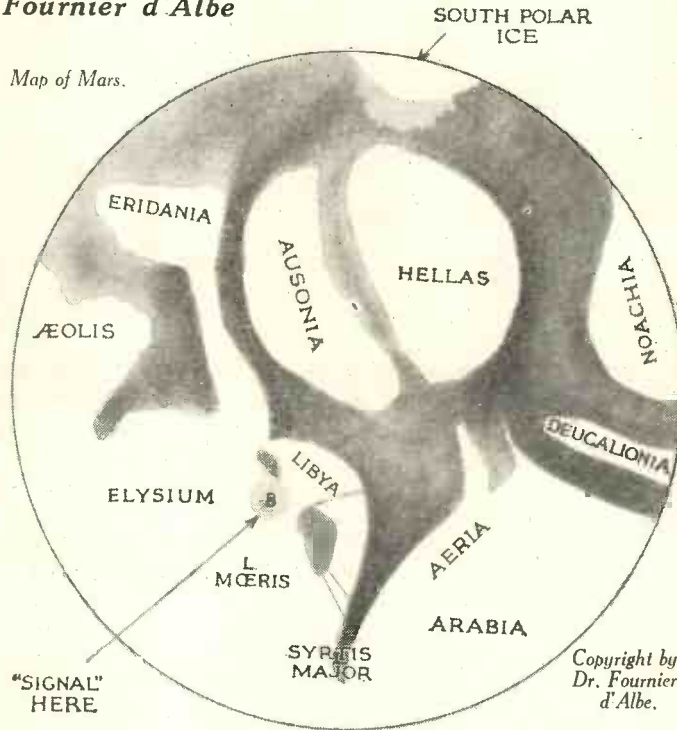

Copyright by Dr. Fournier d'Albe.

covered part of the tract known as Nepenthes and a portion of the Lacus Mæris. The patch (B) is described as "brilliant," and may have been self-luminous.

It was also seen on the following night, but not on the night after that. Nor had it been seen on October 23rd.

It is impossible to say, without a detailed consideration of the Martian illumination and probable temperatures, whether the appearance had a meteorological origin such as a field of snow.

Important

But the observation seems of sufficient importance to be carefully noted and considered in all its bearings.

It is just possible that the Martians have appreciated the impossibility of transmitting wireless signals of sufficient intensity across forty million miles of space, and have used some natural force

to produce a large white patch such as a cloud of steam of sufficient extent to make a perceptible difference to the Martian landscape.

It would be primitive but quite effective, as were the beacon fires round our coasts at the time of the Armada.

Round the Broadcasting Stations

From Kiev

AN announcer who spoke four languages — Russian, German, Italian, and French—within fifteen minutes.

The excellent English of an announcer.

The constant reference to Sovietism.

The bad studio in which the announcer spoke. There was an echo, rumbling noise, and talking all the time the programme was broadcast.

From Lyons (PTT)

A most exquisite organ.
An interesting talk on the dye industry in England.

A noise as if one of the members of the orchestra whistled the air of the selection the orchestra played.

Sarcasm when referring to Toulouse.

Constant jokes against Toulouse.

From Geste

Price lists of coal.

A news bulletin which took 31 minutes to read.

Excerpts from Mr. Bernard Shaw's plays.

An item of news about Scotland that was neither broadcast by the B.B.C. nor published in the English newspapers the following day.

From 5XX

The shipping forecast.

A whisper: "I can't read this."

E. B. R.

Before Building Your Super-het Read This Article on

The P's and Q's of I.F.T.'s

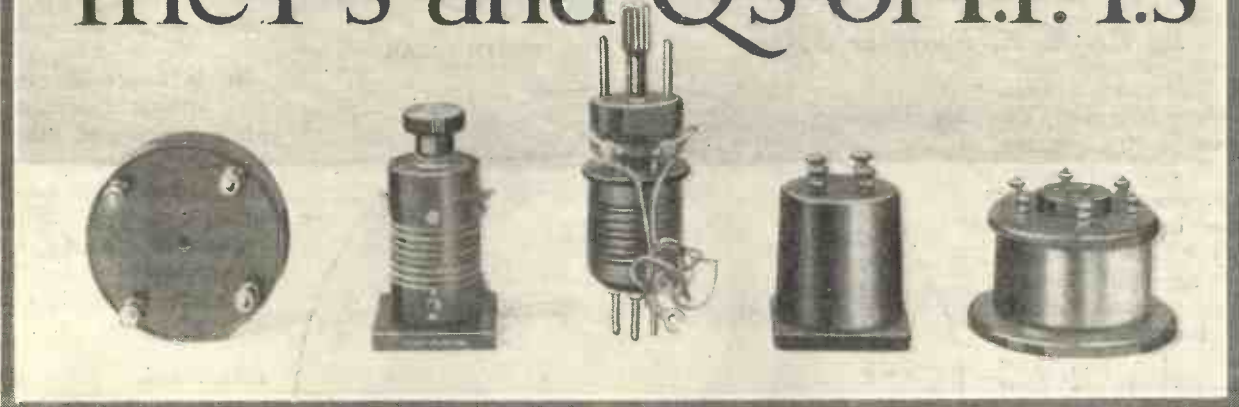

A representative group of intermediate-frequency transformers: left to right, R.I., two McMichael, Bowyer-Lowe and Keystone.

A TYPE of receiver which has lately been accorded well-deserved recognition is the supersonic heterodyne (better known as the super-het), and yet there has been only a very small amount of really useful data regarding it available to the man in the street.

Iron or Air?

In one place he sees iron-cored intermediate-frequency transformers working at a comparatively low frequency, whilst next door, as it were, air-cored transformers working at a much higher frequency are claimed to be superior.

Again, there are advocates of a medium frequency, with a combination of both types, until it becomes hardly a matter for wonder that the prospective constructor is in a state of indecision.

The purpose of these notes is, therefore, to put forward the advantages and disadvantages of both kinds.

The principle of the super-het has already been well covered in the technical Press, so that it will be unnecessary to go over the ground again; and we shall, therefore, confine ourselves to the most important item of its machinery—that is, the intermediate-frequency amplifier.

This usually comprises three stages (with their four attendant transformers and valves), but in one or two cases two stages only are utilised.

We shall, however, deal only with the more usual arrangement.

When iron-cored transformers are employed the frequency band almost always lies somewhere between the following ranges—25,000 cycles and 60,000 cycles—whilst with air-cored instruments this range extends between 60,000 cycles and 150,000 cycles. Thus it will be seen that the amount of latitude allowed is great.

Now let us consider the merits of each of these frequency bands.

It will be realised that the first functions of our amplifier unit consist of two things, namely, to give the greatest possible voltage drop per stage, and to possess optimum selectivity per stage—that is, to amplify only at the frequency for which it is built.

This first requirement is comparatively easy to meet, but the second introduces another important factor.

The wave it is desired to amplify (that is, the beat wave) possesses what are termed side-bands, due to signal modulations present in the circuits of our first valve.

These extend about 12,000 cycles on either side of the beat wave; therefore, should our whole amplifier be tuned too sharply some of these impressed signal modulations, or side-bands, will be cut off and distortion be introduced as a result.

From this it seems that as high a frequency as possible should be chosen, owing to the fact that these side-bands group themselves more closely to the beat wave as this increases its frequency, but there are also other considerations to be taken into account.

As we go into the higher frequencies we also decrease the separation between received frequencies after the heterodyne action has taken place.

To illustrate this, let us suppose that we have two stations transmitting on wavelengths of 350 and 355 metres respectively.

Should our amplifier frequency be 120,000 cycles (that is, 2,500 metres), we must tune the oscillator circuits to approximately 409 metres in order to receive the station operating on 350 metres; at the same time we are heterodyning the 355-metre station to approximately 2,779 metres, which, deducted from our amplifier wavelength of 2,500 metres, gives us a difference of 279 metres.

Increased Wavelength

If our amplifier wavelength were now increased to 5,000 metres (that is, double the former amplifier wavelength), we should heterodyne (when receiving the 350-metre programme) the 355-metre signal to 6,259 metres approximately, which gives us a separation of 1,259 metres, this being a much higher value of separation than we obtained using the former wave of 2,500 metres for the amplifier unit.

Thus it is easily seen that we dare not proceed too far either up or down the frequency scale.

It is quite well known that when using a super-het receiver the same station will appear at two distinct points on the oscillator condenser. This is due to the fact that we may use either the sum or the difference

of the heterodyne and incoming signal frequencies.

This fact has also some bearing upon the choice of our intermediate-frequency amplifier wavelength, as the higher the wavelength we choose the closer together on the oscillator tuning dial these two points will appear, and *vice versa*.

Lastly, we come to what is, perhaps, the greatest factor of all, and this is *noise*.

Audio Frequencies

When we employ a wavelength of, say, 5,000 metres and over, we are verging upon the audio frequencies, and our intermediate-frequency transformers will begin to function as potential low-frequency transformers, with dire results to the quietness of our background.

Many of the super-het transformers sold (I am speaking now of the iron-cored type of instrument, of course), will create quite an appre-

ciable amount of noise, due naturally to their own wave period approaching the audio frequencies already mentioned.

In a practical test which has been carried out with two different types of I.F. transformers, incorporated in similar amplifier units, the following results were obtained:—

Using transformers with iron cores, at an approximate wavelength of 10,000 metres, the amplification factor overall was very slightly in excess of that obtained when tuned air-cored instruments, working at about 3,500 metres, were employed, but the noise-to-signal ratio was very much higher with the amplifier utilising the iron-cored long-wave transformers.

Moreover, the air-cored unit gave appreciably better selectivity, and, possessing as it did the quieter background, proved by far the more efficient unit with which to carry out reception.

So, now, knowing practically all the important factors, we have to make our choice. In the writer's case it is for the air-cored transformers with a natural period of between 3,500 and 4,000 metres.

Of course, when the iron-cored ones are preferred, a tuned air-cored filter transformer will be used, either as input or output, preferably in the latter position, as here it tends to cut out some of the noise amplified by the preceding part of the intermediate-frequency amplifier.

Controlling the Grids

The grids of the valves are generally controlled by means of a potentiometer, but should two stages only be used, a negative bias of between $1\frac{1}{2}$ and 3 volts can with advantage be applied to the grids. In a four-stage amplifier this is usually impracticable, owing to the difficulty of obtaining sufficient stability of operation.

R. F. E.

WIRELESS THROUGH THE LOOKING GLASS

(AFTER LEWIS CARROLL)

*The stations of the B.B.C.
Wrestled with all their might;
They did their very best to make
The wavelengths smooth and bright:
Without avail, because it was
The same thing every night—*

*Europe was jamming lustily,
Each country one by one
Proclaimed its business to be there,
After the day was done—
"But it is rude," the others cried,
"To come and spoil our fun!"*

*"Tho' earths are wet as wet can be,
Tho' aeriels are high;
Tho' atmospherics trouble not,
No storms are in the sky;
Yet ever in howls and mush and morse,
Behold our programmes die!"*

*The Burrows and the Eckersley
Were searching through the crush;
They wept like anything to hear
Such quantities of mush;
"If this were only cleared away,"
They said, "we'd be on plush!"*

*"If seven 'fans' with seven maps
Planned it for half a year,
Do you suppose," the Burrows said,
"That they could get it clear?"
"I doubt it," said the Eckersley,
"But kindly pass the beer."*

*"O stations, come and talk with us!"
The Burrows did beseech,
"A pleasant talk, a tuning-fork,
A master crystal each;
We must begin with only four
To give a wavelength each."*

*The high-power Station heard his call,
And winked at Uncle Rex;
The high-power Station muttered, "Why
Should me this trouble vex?"
Meaning to say he did not care,
Since he was 5XX.*

*But four young stations hurried through,
All eager for the plan;
Their masts were high, their aeriels taut,
Their valves gargantuan;
The voices of their uncles, too,
Were mellow to a man.*

*Four other Stations followed them,
And yet another four;
And thick and fast they came at last,
And more and more and more—
All pushing out harmonics thick,
And heterodynes galore.*

*The Burrows and the Eckersley
Waited a month or so:
Exchanging views upon a wave
Conveniently low:
And all the little Stations stood
And waited in a row.*

*"The time has come," the Burrows said,
"To talk of many things:
Of crystals—ohms—and licences—
Of jazz—and solderings—
And why the novice oscillates,
And whether Reinartz sings."*

*"But wait a bit," the Stations cried,
"Before we have our chat;
For some of us are off our length,
And some of us are flat!"
"No hurry!" said the Eckersley,
They thanked him much for that.*

*"A little room," the Burrows said,
"Is what we chiefly need:
A metre more, a metre less
Will quickly do the deed:
Now, if you're ready, Stations dear,
We can begin to weed."*

*"Not weed us out!" the Stations cried,
Burning a little blue,
"We mustn't be too many, but
We mustn't be too few!"
"I quite agree," the Burrows said,
"I see your point of view."*

*"It was so kind of you to come,
And help to clear the air!"
The Eckersley said nothing but,
"Cut out another pair:
We're getting on quite nicely now,
They're positively rare!"*

*"It seems a shame," the Burrows said,
"To play them such a trick,
After we've let them build so high,
And made them grow so thick!"
The Eckersley said nothing but:
"You'd better do it quick!"*

*"I weep for you," the Burrows said,
"I deeply sympathise."
With sobs and tears he weeded out
Stations of every size.
Holding a milliammeter
Before his streaming eyes.*

*"O Stations," said the Eckersley,
"We've had a lot of fun!
We've cleared the ether, haven't we?"
But answer came there none—
And this was scarcely odd, because
They'd silenced every one.*

G. R. PALMER.

Novelties and New Apparatus

Reviews of the Latest Components

Loud-speaker Extension Socket

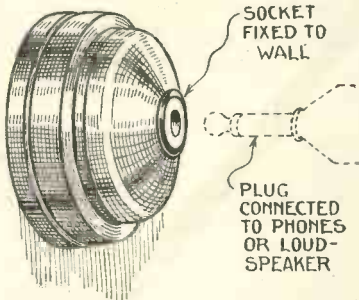

NEAT and simple to install, this loud-speaker or headphone socket will no doubt be found of use by many listeners who wish to carry out reception in more than one room.

The manufacturers are A. F. Bulgin and Co., of 9-11, Cursitor Street, E.C.4.

A.C. Mains Valve

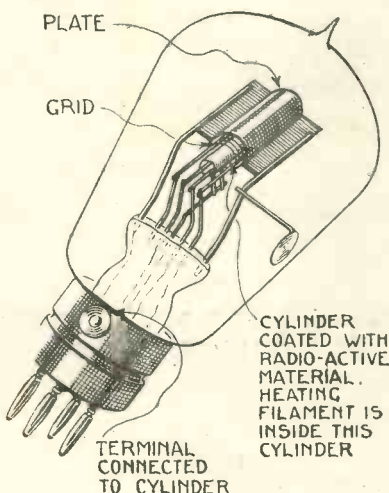

MADE by the M.O. Valve Co., Ltd., and sold by the General Electric Co., of Magnet House, Kingsway, W.C.2, and the Marconiphone Co., Ltd., of 210-212, Tottenham Court Road, W.1, under the names Osram and Marconi respectively, the KL1 is a new departure in valves.

The filament is heated from a transformer off any A.C. mains at 3.5 volts, and the heat radiated causes the coated cathode to emit electrons.

Dimic Screening Case

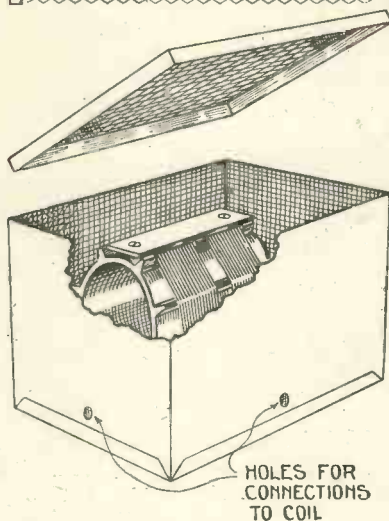

PROVIDED all ready with holes for making connections, this screening case is specially intended for Dimic coils, made by L. McMichael, Ltd., of Wexham Road, Slough, Bucks.

Aerial Insulators

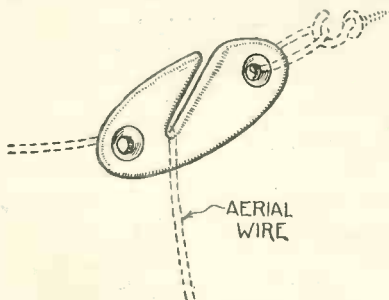

INDOOR-AERIAL erection is simplified by the use of these special porcelain insulators. The method of fixing is clear from the diagram. The manufacturer is E. J. Lever, of 33, Clerkenwell Green, E.C.1.

By fixing a number of these insulators in series it will be seen that it is an easy matter to get several turns of wire round a room.

Treble-duty Indicating Terminals

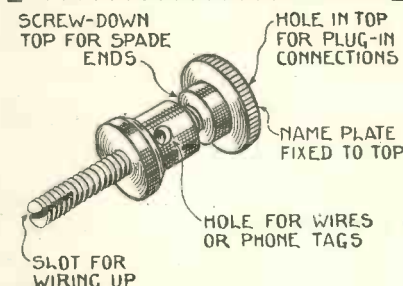

THESE excellently made Ealex terminals can be used for spade, plug-in, or ordinary wire connections, as the sketch above clearly shows.

Altogether, twenty-eight different engravings are stocked by the manufacturers of these terminals.

They are made by J. J. Eastick and Sons, of 118, Bunhill Row, E.C.1.

Univane Variable Condenser

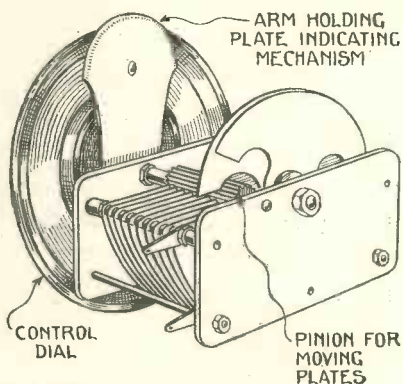

THE principal feature of this variable condenser (made by the Dubilier Condenser Co. (1925), Ltd., of Victoria Road, North Acton, W.3) is that the vanes come into operation one at a time and consecutively by an ingenious system of gearing. This necessitates turning the knob one complete revolution for each vane, and very fine tuning is thus possible.

Valve Holder

MOULDED BAKELITE BODY & VALVE SUPPORT

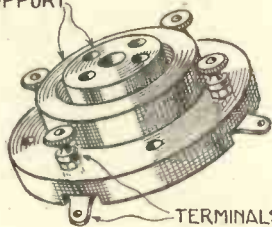

TERMINALS OR SOLDERING TAGS FOR CONNECTION

A NEW anti-vibratory valve holder made by Whiteley, Boneham and Co., Ltd., of Mansfield, Notts, is made with and without terminals.

Vernier Dial

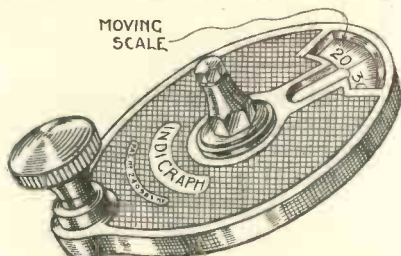

MOVING SCALE

HAVING a reduction ratio of approximately 8 : 1, this Igranic Indigraph vernier knob is very useful for fine tuning; it can be used with either clockwise or anti-clockwise condensers.

The Igranic Electric Co., Ltd., of 149, Queen Victoria Street, E.C.4, are the makers.

Anti-vibratory Adaptor

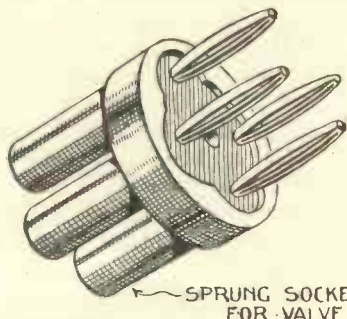

SPRUNG SOCKETS FOR VALVE

MANY set owners who wish to convert their old-type valve holders to the more up-to-date anti-

vibratory type will find a use for this adaptor, which is made by Harlie Bros., of 36, Wilton Road, Dalston, E.8. It can be used with any ordinary type of holder.

High-tension Battery Connector

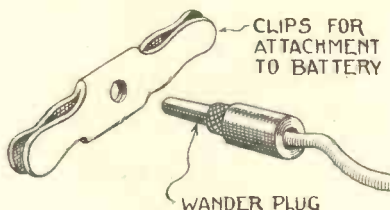

CLIPS FOR ATTACHMENT TO BATTERY

WANDER PLUG

A NEAT connector made by the Lisenin Wireless Co., of 1a, Edgware Road, W.2, will interest those who use ordinary flashlamp cells as H.T. batteries. Each connector is provided with a hole for a winder plug.

A great advantage of making up an H.T. unit in this way is that faulty cells can be easily replaced without scrapping the whole battery.

Enclosed Filament Rheostat

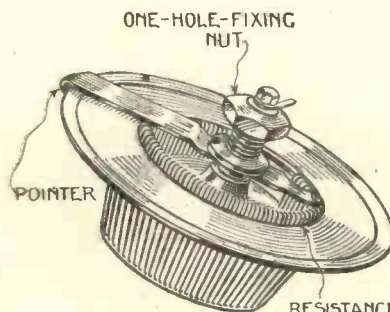

ONE-HOLE-FIXING NUT

POINTER

RESISTANCE WINDING

WITH the resistance winding totally enclosed in the knob, this Benjamin filament rheostat is an exceedingly neat component, and takes up little space on the receiver. It is made in resistances of 6, 15, and 30 ohms.

For ease of adjustment the dial is graduated into 100 degrees.

The manufacturers are Benjamin Electric, Ltd., of Tariff Road, N.17.

RC Valve

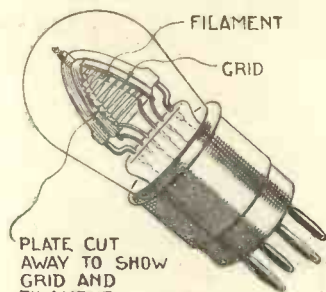

FILAMENT

GRID

PLATE CUT AWAY TO SHOW GRID AND FILAMENT

THE first of a new series of Cossor resistance-capacity valves is the RC2, which has the following characteristics: Fil. volts, 1.8-2.0; fil. current, .1 ampere; max. anode volts, 120; impedance, 70,000 ohms; amp. factor, 35.

The address of the makers is A. C. Cossor, Ltd., of Highbury Grove, N. On test we have found these valves to give really excellent results.

Two-way Coil Holder

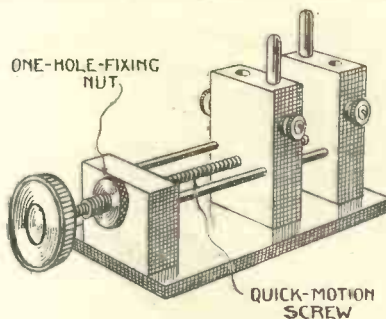

ONE-HOLE-FIXING NUT

QUICK-MOTION SCREW

INTENDED for behind-panel mounting, this Barrie coil holder takes up little room in the set, as the coils do not swing apart and occupy a large space.

It is made by the Enterprise Manufacturing Co., Ltd., of Grape Street, W.C.2.

Owing to the pressure of some special research work that he is undertaking for the WIRELESS MAGAZINE our Research Editor, J. H. Reyner, B.Sc., A.M.I.E.E., is unable to give personal test reports this month.

Broadcast Music of the Month



Miss Maggie Teyte.



Mr. Louis Golding.

IT is still difficult to understand why the B.B.C., with the remedy well within their hands of satisfying everybody, still refrain from employing their two aeri-als—at London and Daventry—for alternative programmes. Then the programme departments could enjoy their educational and propa-ganda schemes while the general public listened-in to the popular concerts.

Out of the huge number of talkers and artists whose names have figured in the B.B.C. schemes for our "moral uplift," as America would put it, it is difficult to make a choice.

The theatre has been very generous, however, in giving its support, and consequently listeners have

had unique opportunities of hearing their favourite actors and actresses speaking in more or less natural tones, as distinct from the rôles in which they are both heard and seen on the stage.

Amongst the stars who have figured in the programmes may be mentioned Lilian Braithwaite, who is, however, no newcomer to broadcasting, for she was heard in the early and more amusing days of wireless. Mdlle. Delysia, the French revue actress, made an appeal in company with Lady Tree last month, singing her song, "Poor Little Rich Girl," from *On With the Dance*.

Mdlle. Delysia was first seen in Paris by Charles Cochran, and he introduced her to the London public. He claims that in all the years—ten, I think—that Delysia has sung for him they have never used a printed contract, but relied on one another's word—surely a unique experience between manager and artist.

More Theatrical Stars

Miss Ethel Irving is another theatrical star, and out of her rôles, innumerable, perhaps the most vivid and dramatic was that in *My Lady Virtue*, which she played so long at the Garrick Theatre. Sir Gerald du Maurier, too, announced to broadcast, will be remembered for many great plays, best loved of all, perhaps, *The Admirable Crichton*; while others are Phyllis Neilson-Terry and Leon M. Lion.

On the variety side we have Violet Lorraine, the revue star, whose Cockney sketches interpolated into the Hippodrome revues make the great feature of the show; then Josephine Trix, of the Trix Sisters; R. A. Roberts, the veteran comedian, with his hardy annual, *Dick Turbin*; and Joe Hayman with his partner, Miss Frank-

lyn. The two last-named are famous American stars, and have toured their acts all over the world.

Mr. Hayman has made the interpretation of the Jew in humour a fine art, and his *Cohen on the Telephone* is one of the best known sketches, both by personal hearing and the records made.

Stayed Twenty-four Years!

They came to England in 1903 with a contract for twenty-four weeks, and they have remained twenty-four years. They were the first wireless artists who broad-cast from WEA F, New York City. Mr. Hayman in his younger days was partner with Harry Houdini, while Mildred Franklyn was a circus rider and trapeze artist, so one may safely say this is not the first time she has been "in the air."

Two other artists united in variety acts only are Roland Merry and Winnie Vaughan. Both have their respective life-partners, but "joining up" after the war continued their theatrical successes.

The names of the instrumentalists, of course, are legion, for each station has its own special favourites.

Many concerted miniature bands have been introduced over the ether, one of the best being the Eugene Cruft Octet. It is led by Mr. Cruft himself, an ex-student of the Royal College of Music, who has since been musical director of many Spas and orchestras, and played at innumerable National Sunday League concerts (always a test of a good artist). He claims that his octet was the

first to specialise in classical and syncopated items.

An interesting item was a performance by the Symphonic String Players. This, as its name denotes, is a society devoted to the playing of classical works, and assisted by famous soloists. Amongst these may be mentioned Dorothy Silk,



Delysia.

Rosina Bucksman, Myra Hess, and Isolde Menges. It is conducted and directed by Herbert Menges, a younger brother of the violinist, already known for his compositions and his work as a conductor.

Beginning his musical career at the mature age of three as a violinist, at nine he turned to the piano, which he has kept to till recently, though subjugating this to his work as conductor and composer.

Amongst the huge number of various soloists a well-known violinist is Miss Murray Lambert; Miss Edith Ashby, pianist; and Lillian Mukle, one of the clever little band of the original artists who played the old-world

Reviewed for the "Wireless Magazine" by Studius



Mr. Frederick Delius.



Miss Murray Lambert.



Mr. Eugene Craft.



Mme. Louise Thibault.

music and instruments for *The Beggar's Opera* at the Lyric Theatre, Hammersmith, as well as for the studio version this month.

Singers

Much variety is necessarily attached to the various singers of the month. It was a great disappointment to most of us not to have heard the B.N.O.C. when stationed so close at Golders Green, but it is expected that we shall hear them on their spring tour, beginning at Manchester with *Pagliacci*.

Stock Company

Some fine singing, however, has been heard, especially from Leonard Gowings, whose voice comes finely over the ether. If only the B.B.C. could be induced to form a stock company of artists who really know how to pitch their voices and articulate clearly, concerts would not be made so boring for lack of sheer inability to hear "what they are singing about." In such a company Mr. Gowings would lead.

We should also want Catherine Aulsebrook, one of the earlier operatic and broadcast stars who was heard this month only at Daventry when she should have been S.B. to all stations.

Joan Elwes and Olga Haley, both famous singers, have been welcomed artists, the former singing from the Faculty of Arts Gallery, in company with Dale Smith.

Amongst the numerous other vocalists of the month mention might be made of Sidney Northcote, Mark Raphael, who gave us a week of

Brahms' songs and might have been heard to far better advantage, James Howell, a clever bass singer of provincial fame, and Reginald Whitehead, another artist who should be heard more frequently.

We do have far too many talks, but sometimes we are fortunate enough to have them by people who really have a right to speak. Langford Reed is one of them, for he has made a study of, and is an authority on his subject—the history of the limerick and so-called nonsense verse.

Then Louise Thibault is widely known, especially for her talks at Birmingham, where she has been stationed over two years, speaking mainly on her experiences during the war in France, and on physical culture, a subject of which both Mme. Thibault herself and her family are noted exponents. Mme. Thibault acted as interpreter in France with the V.A.D.'s.

Amongst the writers whose works are of interest and whose readings before the microphone therefore welcome, may be mentioned the great novelist, Jerome K. Jerome, following close on the footsteps of Anstey. Others include Louis Golding, whose new novel, *Store of Ladies*, is published this month in London and New York.

A special concert was devoted to the English composer, Frederick Delius, whose works are now being freely

recorded and made more popular. A clever broadcast was by the famous conductor, Herman Darewski. It may be remembered that it was his orchestra, when at Bridlington, that was the first to be heard at KDKA in the U.S.A.

A favourite outside broadcast, when not "cut off," has been that given by Signor Colombio, at the Hotel Metropole, and by Leon Van Straten at the Riviera Club.

Carborundum Detectors

INTEREST is reviving in the use of carborundum as an alternative to the softer types of crystal, such as galena and its many derivatives, particularly in connection with crystal-valve reflex sets. Carborundum was, of course, the forerunner of all the crystal detectors, and as regards permanence is probably still the most reliable.

Unfortunately, it requires the use of a small biasing potential in order to get the best results, and probably for this reason it has fallen behind the non-biased crystals in popularity.

Recent researches have shown, however, that by adopting special methods of mounting the carborundum in its cup the biasing voltage can be reduced to very small limits without any loss in signal strength. A single dry-cell will, in fact, give an ample voltage range for the purpose.

Apart from its permanence, when once set, carborundum has a very high value of resistance across the rectifying contact. For this reason it is specially suitable for reflex working.

B. A. R.



Mr. Mark Raphael.



Miss Edith Ashby.

"This is the Truth — if You Think It Is!"

AS wireless began to grow and become a very definite part of our national life, we began also to adjust ourselves to the new conditions. It has pushed out some other things, for we who have come to give it a big part in our daily, and frequently nightly life—think about it, and talk about it to the exclusion of other interests.

Sometimes I wonder what it is that has been cold-shouldered. Many observant readers will have long since realised it. You have only to listen to conversation on the morning train to town, on the home going train in the evening, at lunch—in fact, almost anywhere, and you will admit the truth of my statement.

But there it is.

This new angle has led some of us, perhaps, into loose and careless statement. It is almost unnatural, for it is all so new and amazing. There is no precedent, no guide, no previous experience: all is fresh, and the ground is new.

What then? Is it anything to be surprised at, if foolish folk, who do not always think a little before saying things which some time after seems stupid, make claims which are frivolous, to say the least?

From the modest little claim, our friend goes on to a more elaborate and amazing claim. He means well, I am sure. He just does not stop to consider. The bit gets, somehow, fixed in his mental teeth, and he runs away with his sense. When he started it, it amused us a little; but as he got up steam, he began to be a little boring.

The number of men, and they are not all young, who run around bragging about their wireless doings is increasing, and some of us are decidedly fighting shy of the man who "swings the lead."

But he won't see it. Nothing can kill him. If he was always a beginner, I think we would tolerate him. Often he is one of those fellows whose very manner is of the braggadocio order, whose eyes glint it, who stalks you on the platform, and your heart takes a downward course as he pushes into your carriage.

You are in for it until the terminus is reached.

"Yes, old man, I got San Francisco at 10 o'clock last night."

You politely tell him that you thought it was not possible to get any American station before 11 p.m. You may be wrong, of course. And San Francisco sounded fresh.

That is a flea bite, however. He'll tell you he pulled off a two-way stunt (his own words, not mine) with a man in New Zealand the other night—

"Yes, and on two valves too. What do you think of that? And on a circuit of my own design. Come in and see it to-night." Not if I know it.

Fishermen are not in it with wireless experts to-day.

The most simple of folk are going in for these tall stories. One good man, whose veracity I would never have doubted in the pre-wireless days, told me, with some enthusiasm, and I really could not deny him, that he had heard that famous German station, with the very long name, on a crystal. Well, that is all right, if he enjoyed it.

You believe it once: it grows. You mention it to your wife: it still grows. You speak of it to a friend—it gets bigger. Until the story eventually beats anything that any fisherman had ever told.

No end of honest people tell me they have got America, and when I suggest that it was relayed, they say, "Oh no, I heard it quite distinctly." I am sure that would please Captain Eckersley. And these good people are almost indignant if one gently insists on the fact that the statement is a little exaggerated.

There is an odd psychological element in this new tendency of extravagant claim, in wireless experience, and I should be interested in common with many other observers in seeing it examined. Perhaps Professor Pear will, one of these days, give us the benefit of his conclusions concerning it.

The wonderful things which some of our wireless friends seem to experience are not always confined to amateurs. There are those, who really ought to know better, who are in no sense on the amateur line, who fail to regard their scientific re-

sponsibility in the right perspective. This is a pity, for it misleads the simple, and encourages the careless thinker.

I must tell you the following story which, you may take it, is true. A man was showing off his set to a friend. It was an evening party.

"There, isn't that splendid reception. One valve and Madrid."

"Wonderful... Extraordinary... Amazing... *Ad lib.*" And then:

"London calling. That was our weekly Spanish talk..." Collapse of man. Funny looks. Little sniggers.

Early on, I had the experience myself. "Here's Paris."

"Listen," I said to a Saturday afternoon visitor. And I put in the proper coils. I have a four-valve set.

It was Daventry.

Mine was innocence, and I had not claimed it was Mars. But that is how the lead gets up its impetus. We start on little things, and before long, if we are not careful, we really become expert in delicious inexactitude.

Of course, one expects to give a little licence, but when we are asked to believe the impossible, then I think you will agree that it is time to speak up about it. It is nothing remarkable to switch on to a dozen stations in a night. Most people do it. Anyhow they say so.

I told a well-known member of the B.B.C. that it was my opinion you could not *properly* pick up any other station, even with my selective set, if you lived within a mile or two of Savoy Hill.

"Nonsense," was the reply. Well it wasn't, and isn't, and it's never been done *properly*. And the Captain will agree with me. I can get all sorts of sounds, which less exacting people might be satisfied with. But not me.

Besides why "reach out?" as the Chief would say. "Isn't London good enough?" It is. Quite.

Well, anyhow, the wireless individual of imagination is, perhaps, after all, not to be damned entirely; for one such as he may discover something, one of these days, that will turn life and science backwards. G.

More About Push-pull H. F. Circuits

IN the last issue of the WIRELESS MAGAZINE a receiver was described by J. H. Reyner which operated on a push-pull system. This principle has often been utilised for low-frequency circuits, but has rarely been applied

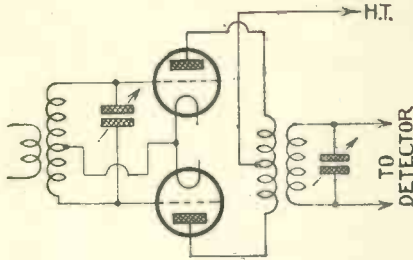

Fig. 1.—J. H. Reyner's Push-pull Circuit.

previously to the high-frequency side of a receiver.

It will be interesting, therefore, to discuss this type of circuit in a little greater detail and to consider some of its advantages and disadvantages.

Simplicity

One of the principal advantages of the arrangement lies in the simplicity that results from its use. The amplification produced is double that normally obtained from a single high-frequency stage, whereas there is still only the same number of tuning controls as is normally associated with single high-frequency amplifying valves. Moreover, stabilisation of the circuit can be achieved in quite a simple manner, and only one neutralising adjustment is necessary, this one neutralising condenser serving to stabilise both valves simultaneously.

At first sight it appears that a push-pull amplifier is equivalent to two high-frequency stages, but on further investigation it will be clear that this is not the case. In a straightforward two-stage high-frequency amplifier we obtain what is known as a cascade effect.

Total Amplification

The signal is amplified by the first valve, and this amplified signal is then again increased in strength by the second valve. Thus, if we have an amplification of 10 for each stage considered individually, then we get a total amplification over the whole stage of 10 multiplied by 10, that is, 100.

In passing, it may be remarked that this true cascade effect is very difficult to obtain, because there is a considerable quantity of circulating energy in an ordinary high-frequency amplifier which results in a loss of efficiency, and the effect of this is that, instead of obtaining a total amplification of 100 over the two stages just considered, we should only obtain something like 40 or 50.

The overall efficiency is considerably improved when screening is adopted, and this is one of the principal reasons for the successfulness of the screened receivers with which J. H. Reyner has been associated to such a large extent.

In the case of a push-pull amplifier we do not obtain the benefit of this cascade effect. We have the amplification of one valve, which is, say,

Great interest has been taken in the system of push-pull high-frequency amplification developed by J. H. Reyner, B.Sc., A.M.I.E.E., and incorporated in his Push-pull H.F. Three (described in last month's issue of the "Wireless Magazine.")

In this article the "W.M." Technical Staff discusses some further points of the system.

10, and the second valve gives an equal amplification if the circuit is symmetrically arranged. The total amplification obtained in the circuit is in this case the sum of the two amplifications, and not the product, so that we should only obtain a theoretical maximum amplification of 20.

This appears to be a very big discrepancy, but, bearing in mind the loss of efficiency which we have just considered, it will be seen that the difference is not so marked.

A Compromise

There is one tuned circuit only in the case of the push-pull amplifier, and we cannot sustain any loss of energy due to stray fields and other causes of this nature, so that we

really do obtain the theoretical amplification factor out of the push-pull arrangement, giving an amplification of 20 as against 40 or 50 with a two-stage amplifier.

Thus, the push-pull arrangement, as far as signal strength is concerned, is about one-half as efficient as the two-stage amplifier of the usual type.

Advantages

On the other hand, we have the advantages that the tuning controls and the neutralising adjustment are reduced to the minimum, so that we are, in effect, obtaining the extra amplification at the price of a valve only, without any extra complications. There is an increasing tendency to-day to view a large number of controls on a wireless receiver with disfavour, so that this arrangement, although admittedly not as efficient as a straightforward circuit, has much to commend it. There is another point in connection with the effect of a valve on the tuned circuit, but this will be considered shortly.

For the present it will be of interest to discuss the number of methods in which push-pull amplification can be employed, in conjunction with the most efficient types of intervalve coupling in neutralised circuits.

The push-pull circuit utilised by Mr. Reyner is shown in Fig. 1. The grid coil has the centre-tap taken to the filaments of the two valves. A special output transformer is employed having a centre tapping on the

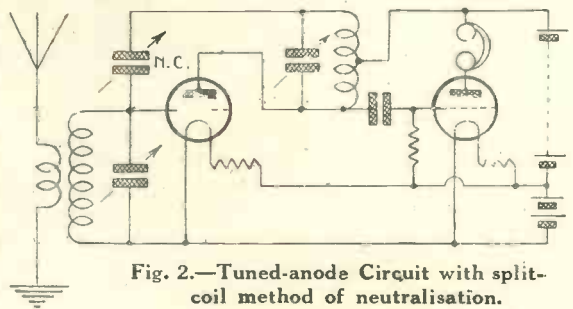

Fig. 2.—Tuned-anode Circuit with split-coil method of neutralisation.

primary winding, one-half of the primary being in the circuit of one valve, and the other half in the other valve circuit. The neutralising condenser serves to stabilise both the valves, neutralisation being accomplished on the first valve by the split-

More About Push-pull H.F. Circuits (Continued)

anode method, and on the second by the split-grid method. This was explained in last month's article.

It is evident that there will be little difficulty in applying this principle to

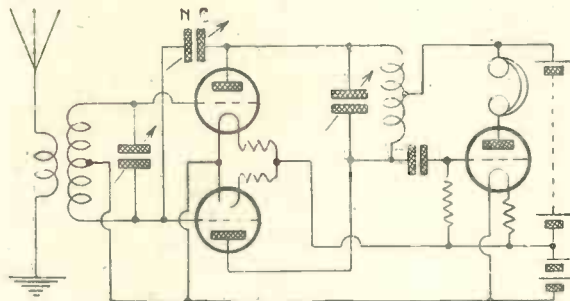

Fig. 3.—Circuit shown in Fig. 2 adapted for the Push-pull System.

the most popular types of high-frequency amplification. There is one particular type of high-frequency coupling which is still a favourite with a large number of readers, namely, the tuned-anode method. This system is reasonably efficient and has the merit of simplicity. If we could combine it with the push-pull method, which also is primarily a simple arrangement, we should possibly obtain something really good.

Fig. 2 shows a simple tuned-anode circuit, using a split-coil method of neutralisation. The tuned-anode coil is centre-tapped, this tapping being taken to the H.T. terminal, while the remote end of the coil is connected back through a neutralising condenser on to the grid of the valve. This gives a symmetrical and stable arrangement, provided it is only used in one stage as shown. If it is applied to two stages, then we obtain interference, due to parasitic oscillations, and different methods have to be resorted to.

"Push-pulled"

Fig. 3 shows an attempt to utilise this circuit as a push-pull arrangement. Here we have the centre-tapped input circuit and the centre-tapped output circuit in the same manner. The detector valve is connected across one half of the output circuit only. This is perfectly satisfactory. At first sight it might appear that this would not make the full use of the push-pull effect, but this is not

the case, however, because what we really wish to utilise is the voltage developed across the tuned circuit.

If we take a portion of this voltage only we are still making use of the push-pull effect, but we are, for purposes of our own, stepping down this voltage by an auto-transformer action before applying it to the detector.

It is not convenient as a practical arrangement to connect the detector valve across the whole of the tuned circuit, although this can quite easily be done if it is considered

desirable to isolate the filament of the detector valve completely or to use a crystal detector. In the latter case, however, the tapping across half of the coil would be even more desirable

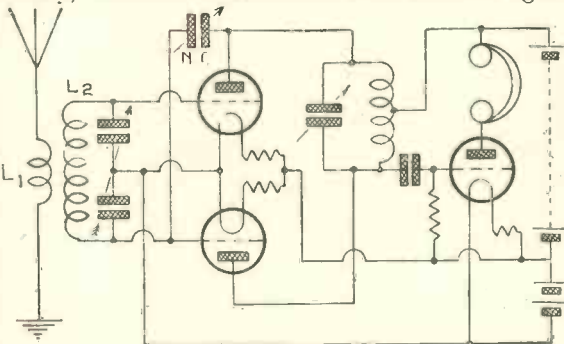

Fig. 4.—Improved Push-pull Circuit.

than in the present case, from the point of view of damping.

Detector Damping

The detector valve imposes a certain amount of load upon the tuned circuit and increases the damping. This is particularly the case where grid-condenser rectification is used, since this method depends for its action on the flow of the small amount of grid current, and damping is thus inevitable.

It pays, therefore, to connect the detector valve across one half of the tuned circuit only. The loss in signal strength is not noticeable, and, in fact, an increase may sometimes be obtained, due to the fact that the tuned circuit is now less heavily damped and can build up to a bigger voltage. Particularly in the case of a crystal, tapping across a portion of

the circuit only is desirable, as is well known.

Parasitic Oscillations

The serious disadvantage of the circuit in Fig. 3 is, however, the danger of parasitic oscillations. It will be seen that we have a split coil in the grid circuit, and another split coil, similar in electrical properties, in the anode circuit. The two halves of these coils will set up parasitic oscillations at their own natural frequency.

This trouble must be obviated by one of the various approved methods. Fig. 4 shows a method of overcoming the trouble by utilising a split condenser on the input side. This will give satisfactory results. The coil L_2 , however, must be increased to double the inductance of the previous coil, because we are now tuning with two .0005-microfarad condensers in series, getting an effective capacity of .00025 microfarad only.

There are various other methods of checking the parasitic oscillations. A method adopted by C. P. Allinson is shown in Fig. 5. He has found that parasitic oscillations may be cured to a large extent by connecting a high-frequency choke in the lead between the centre-point of the coil and the filament. In this method, of course, the ordinary split coil can be utilised with a single condenser. These various circuits can readily be tried, if desired, on the push-pull unit described by J. H. Reyner in last month's issue.

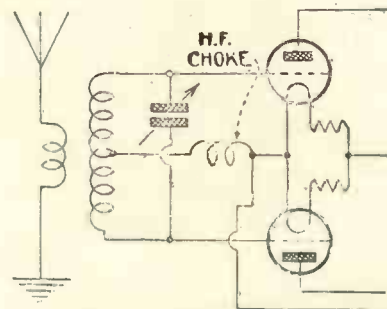

Fig. 5.—C. P. Allinson's method of checking oscillations.

The particular coils utilised for the input and output transformers were mounted on six-pin formers, so that

By the "Wireless Magazine" Technical Staff

those readers who are interested can very easily wind the coils themselves and try a variety of combinations.

A little difficulty may be experienced in the case of the split-condenser circuit, but if it is not desired to use a double tapping then an equivalent tapping may be obtained to some extent by connecting a balancing condenser across the main tuning condenser or by connecting two .0001-microfarad fixed condensers in series, as shown in Fig. 6.

We have still to consider the effect of the valve on the tuned circuit in the case of a push-pull amplifier. This point was left for consideration until after the tuned-anode arrange-

ment had been discussed, because it is easier to understand the effect. Referring back to the simple circuit shown in Fig. 3, it will be appreciated that across the whole tuned circuit we

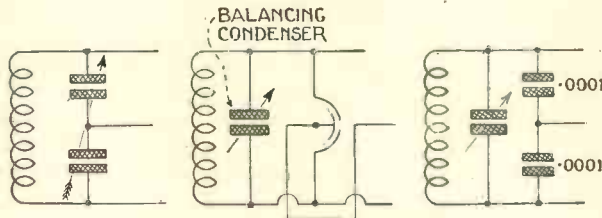

Fig. 6.—Split-condenser Circuits.

have the impedances of the two valves in series.

Thus the effective resistance shunted across the tuned circuit is double what it would be in a normal

circuit in which the valve is connected across the whole of the tuned circuit.

This means that not only have we obtained double the amplification due to the push-pull effect, but we have again obtained a considerable increase in the signal strength and better selectivity due to the fact that the damping imposed by the valve is only one-half of the normal.

On the whole, therefore, as suggested by J. H. Reyner, the method appears to have certain undeveloped possibilities, where a little greater amplification than normal is required on the high-frequency side without the usual increase in complications.

With the Foreign Broadcasters

WHEN you have tuned-in to a German, Austrian or Czech broadcasting station which was relaying an opera or play from a local theatre you must have noticed the absence of applause during the performance. In most of the Continental countries it is an unwritten rule that the audience shall neither clap nor ask for encores during the course of the play, all marks of appreciation being withheld until the end of the act.

German and Austrian Opera

Another small detail which may interest you is that in most German and Austrian opera houses the audience must be seated before the first notes of the overture. If by chance you should arrive after the curtain has been rung up you will have no alternative but to wait outside in the corridors until the end of the act; no possible excuse will avail you to disturb your neighbours by your tardy arrival.

The Continentals take their pleasures seriously, they visit the theatre to hear a play or opera, and you will notice that during the actual performance not a sound is made by the audience. To applaud the first entrance of a star would probably

result in an accelerated exit of the disturber!

Whether by the time these notes are in print all the many schemes put forward by French radio organisations will have reached maturity, I know not, but if so, the life of a wireless fan in Paris will not be envied by colleagues in other countries.

We want to do as much as we possibly can to make wireless simpler and bring it within the reach of everybody.

Many of the difficulties are more apparent than real and can easily be overcome.

If you are in doubt on any point let us know and we will advise you. Just address your problem to:

The Editor,

WIRELESS MAGAZINE,

La Belle Sauvage, E.C.4.

not forgetting to enclose a stamped addressed envelope, a fee of 1s. (postal order or stamps) and the coupon on page iii of the cover.

With Radio-Paris broadcasting throughout the day on 30 kilowatts—its present ambition—with Eiffel Tower relaying on a power of some 50 kilowatts lectures from the Sorbonne University during the mornings and afternoons, and with, added to this, the indefatigable energies of another high-power station, to be put up by a new industrial organisation, and sundry transmitters unofficially erected by the Toms, Dicks and Harries of the French radio world, it appears to me that the listener in the French capital, possessed of an average valve receiver, will be limited entirely to the French entertainments.

Breakdowns

It will only be on occasions of some breakdown or when his compatriots are resting that he will be able to ascertain for himself what other countries are transmitting.

In the opinion of the Paris Press, France should possess the most powerful European station; to-day every French association interested in radio wants to run her "loud-speaker." What the outcome will be is problematical, but everything points to broadcast anarchy!

JAY COOTE.

THE CALLING VOICES By Philip Austin

“GOOD-NIGHT,” said Mr. Appleby affably as he removed the headphones. . . . The rest of the family laughed.

“Ah well,” said Mr. Appleby, “he is such a nice chap, you know—that announcer—no wonder one forgets oneself.”

The Applebys were of that great army of listeners-in—that noble family. Mr. Appleby felt a deep personal friendship for that announcer. He felt on intimate terms with him. On occasion he had been known to call out “Bravo!” Well, his feelings would get the better of him. No harm in that. Many a laugh he had himself at his ineptitude. It was all in the game.

That described Mr. Appleby exactly—all in the game. Misfortune—and he had had his share of it—all in the game! He didn’t “grouse.” Keep smiling! That was the idea.

* * * * *

Dinner disposed of Mr. Appleby settled down to listen-in.

“It is very loud to-night,” he remarked.

“It was great this afternoon,” said Mrs. Appleby.

Mr. Appleby was always so genial and affable when listening-in that it came as no small surprise to his family when on this particular night he suddenly burst out with a series of staccato exclamations: “The villain! the scoundrel! Oh, the fiend!—the dirty skunk!—blue eyes—eh? round face—dark hair!”—Mr. Appleby glared across at his son, a lad of seventeen, who had none of these attributes, being rather inclined to the ginger species. “Fancy that,” said Mr. Appleby feebly—“only fancy that!”

“What’s the matter with you, pa?” asked Mrs. Appleby anxiously. His son glared over at him resentfully. He was at the resentful age. His voice had started to break.

“Matter with me?” echoed Mr. Appleby. “There’s nothing the matter with me—at least nothing that I know of. It’s this confounded viper—this hound—this—this

blighter.” Mr. Appleby finished lamely.

“Oh, come now,” said his spouse sweetly. “You have no need to use such a word of him you know. What’s he done to you?”

“Done to me! Done nothing. Good Heavens, ma, what rubbish you talk. Not but he would, the—the—toad!”

“Oh, he’s a toad now is he? You

thing had disagreed with him. Rapidly she ran over in her mind what she had given him for dinner.

No, it wasn’t her fault. Her conscience was clear. Something gone wrong at the works—or was it with the works Mrs. Appleby meant?

But Mr. Appleby had subsided. His outburst was over. The unexpected broadcasting of a murderer’s description had given rise to it. Mr. Appleby was virtuously indignant at the outrage—outrage in more respects than one, though truth to tell his indignation had *not* been directed at the broadcaster.

No, no, it must not be thought that Mr. Appleby ever, in any way, thought of the announcer other than his very dear friend—Mr. Appleby went further—they had spent many pleasant evenings virtually in one another’s society—they were pals—boon companions—that was it—boon companions!

True, necessitous circumstances demanded that they should keep each other at a distance, but what odds! They were none the less happy! To sully the wireless with the description of a low, common, dirty murderer—Mr. Appleby was sorry for his friend. In the cause of Justice of course—that was the only excuse. The cause of Justice must be upheld. Mr. Appleby was with them there. Well, he would stretch a point. It did not often occur.

“Dear me,” said Mr. Appleby suddenly, “it has gone off.”

“I think you have ‘gone off,’” commented Mrs. Appleby.

“What you want is a new cat-whisker,” supplemented Appleby Junior, in hoarse tones.

Mr. Appleby glared at his offspring. Luckily for this latter the wireless “came on” again and Mr. Appleby’s attention was diverted.

“What’s a ukulele?” he shortly demanded. . . . “Ah! there it’s gone again. Something wrong at the station. He says there will be no further communication with London to-night. What a pity! But what’s a ukulele?”

Mrs. Appleby didn’t know. His

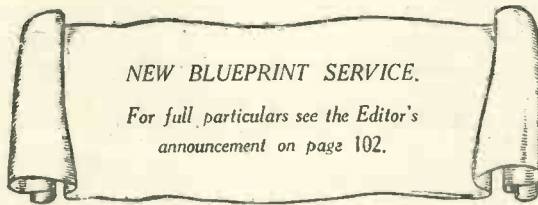

seem to be changing your opinion of him—”

“Changing my opinion! Changing be hanged. What opinion would you have of him—I should like to know?”

“I don’t see a thing wrong with him.” Mrs. Appleby looked narrowly at her husband. He did not seem to have taken any drink. “Well, well now, you will get over it. Think no more about it.”

“Think no more about it! Good Heavens, ma, are you human? What would you think? How would you like to be murdered?”

Murdered! Her affianced husband was asking her this! How would she like to be murdered! Was Mr. Appleby going mad? Her gaze wandered in the direction of the poker.

There was a time when she would not have thought of the poker in connection with Mr. Appleby—but those were the early days. She might still be fair, but she was now fat and forty. She was under no delusions concerning herself. If there was any murdering to be done she would defend herself.

If Mr. Appleby was out for blood he could have it. She would give him a kind of “socks” perhaps that he might not be expecting. Let him look out. Calling people “vipers” indeed, and talking of murdering. The man was off his head. It wasn’t like him. Some-

son thought he had seen one at the Zoo. Mr. Appleby frowned. The wireless had failed at a most inopportune moment. Another second and he would have known what a "ukulele" was. What was it? Confound it. Ah! the dictionary! Not in it. What on earth was the thing? Mr. Appleby was perturbed. He tried to read. But all across the printed page stalked that stark apparition "UKULELE."

He went out into the garden and the birds sang it to him. A frog croaked it. Cats mewed it. Dogs barked it. Hens cackled it. Sheep bleated it. Children called it, or so it seemed. "Ukulele, ukulele, ukulele . . ."

Bedtime came, but no respite. Long hours he lay awake. The usual

night noises whispered to him "ukulele . . ."

Dawn came and found him still awake, the problem unsolved. What was it, this bolt from the blue? Mr. Appleby flattered himself that he knew most things. But this was a corker.

All the way to town he thought of it. "Ukulele!" He heard it in the punching of the conductor's bell, in the rattle of the omnibus, in the cries of newsboys—the roar of the traffic thundered it at him. Arrived at the office the tinkling of the telephone renewed it. In the clatter of the typewriters—there it was again. . . .

Mr. Appleby shrank from making enquiries. He did not wish to display his ignorance. It does not do

for employers to seek educational information from subordinates. Mr. Appleby spent a miserable day. His work suffered. He was glad when the works closed and he could proceed to his home.

That night Mr. Appleby learned what a ukulele was. He was to make acquaintance, for the first time, over the wireless, with the haunting melodies of this weird and fascinating instrument, played by those master exponents, the Hawaiians, from that land of delight where one is welcomed as a brother and parted with so reluctantly—those simple, kindly souls who are already in touch, one could almost think, through the medium of their witching music, with the Calling Voices without!

WHEN SHIPS TALK

:: Can you understand
:: what they say?

NEARLY every broadcast listener hears, quite involuntarily, a large number of morse-code messages from ships and coast stations. As the "spreading" tendency of the spark transmitters makes it almost impossible to avoid hearing these messages, one may as well derive some interest from them!

Transmitted at Low Speed

They are not generally transmitted at a very high speed, so that anyone with a working knowledge of the morse code should be able to decipher them quite easily, except perhaps at those times of the day when "jamming" is at its height on 600 metres.

Broadly speaking, the shipping messages fall into two classes:—Radio-telegrams, and messages reporting particulars about the vessel to a coast station. The former are, of course, in plain language once they have been decoded from the morse.

For the reports, however, the International Signal Code is generally used, and in order to understand them properly you need to know some of the abbreviations in the code.

Each of these abbreviations is composed of three letters, beginning with Q, and having R, S, or T for the second letter. The use of the code saves a lot of time and trouble, for each abbreviation has a definite meaning which, if expressed in ordi-

nary words, would take infinitely longer to transmit.

The code covers a very wide range, but for the purpose of understanding the reports mentioned above you need only learn a few of the abbreviations. Each of these is used in two distinct ways: when followed by a question mark it is used interrogatively, but without the question mark it is a reply or a statement of fact.

For instance, "QRA?" (the first abbreviation in the list) means, "What is the name of your station?" while "QRA s.s. *Soandso*" would mean, "This is the steamship *Soandso*." The use of the code should be quite clear from this example.

When a ship's operator wants to report particulars of his ship to a coast station, he first of all calls up the latter and transmits the letters "TR."

After the coast station has replied, he proceeds to send his report worded something like this:—

"GNF de ABCD TR QRA s.s. *Soandso* QRD Rotterdam QRF London QRB 15 NE."

This message, when decoded, would read as follows:—"To GNF from ABCD. TR: This is the steamship *Soandso*, bound for Rotterdam from London. Present position, 15 miles north-east of your station."

All messages reporting particulars of a ship commence with the letters "TR," then comes QRA followed by the name of the vessel, QRD followed by its destination, QRF preceding the name of the port from which it is coming, and, lastly, QRB followed by figures and a point of the compass indicating its distance (in nautical miles) and direction from the coast station.

Given this information, it is easy for any listener to find the position of the ship on a map.

These messages often end with "QTC?" meaning, "Have you anything to transmit to me?" "QTC" meaning, "I have a message for you," or "QRU," meaning, "I have nothing for you," as the case may be, is sent in reply.

Sometimes the name of the company or line of navigation to which the ship belongs is also given, and this is preceded by the letters "QRG."

Special Abbreviations

Some operators dispense with these abbreviations, and word their reports somewhat after this fashion:—"TR s.s. *Soandso* bnd Rotterdam fm London 15 N.E." The meaning is, of course, the same as in the previous example, only "bnd" and "fm" (short for "bound" and "from" respectively) are substituted for QRD and QRF. W. O.

All's Well With the Accumulator!

If It Is Treated Well!

TOO often the wireless accumulator is regarded as a piece of apparatus that requires no attention at all until it fails to light up the valve filaments sufficiently. Then it is disconnected from the set, taken to a charging station, and a day or two later put back to work, after which its very existence is forgotten until its charge is again exhausted.

Years of Service

That the majority of accumulators will give years of faithful service, although treated in such an offhand manner by their owners, says much for their robustness.

And yet should the battery lose some of its efficiency through sheer neglect the owner often feels inclined to put the blame on the makers and to imagine that the accumulator must have been defective from the first. The truth is that if the accumulator is of a good make, nothing whatever is likely to go wrong for several years provided that it is given reasonable attention.

Unless one is able to charge accumulators at home, the welfare of one's batteries is, to a great extent, in the hands of the people at the charging station. But with a clear knowledge of how an accumulator battery should be looked after it is possible to keep some kind of a check on these people and to know at once if they are mistreating it.

More Used the Better

If an accumulator is to be kept in the best possible condition, it should be remembered that the more it is used the less likely is anything to go wrong. While most other things tend to wear out with use, an accumulator is most likely to deteriorate if left idle for any considerable length of time.

When an accumulator is bought it will be necessary to fill it with acid. This should not be done, however, unless the battery can be charged immediately after filling. The accumulator is to be filled with a solution of chemically pure sulphuric acid in distilled water. Commercial sulphuric acid is quite unsuitable, as it

is usually made from iron pyrites and contains many impurities which will quickly ruin the battery.

It is sometimes stated that rain-water is suitable for use in accumulators, but there is a difficulty in collecting pure rain-water. If it has flowed over the slates of a house it is certain to be impure. Quite a simple arrangement rigged up with ordinary household utensils can easily be improvised for distilling water at home.

When mixing the electrolyte the acid should be added to the water a

People who have not had occasion to use them before taking up radio often imagine that an accumulator is a continual source of trouble. This is far from the truth and this article shows how, if attention is paid to a few simple points, trouble-free accumulator service can be assured.

few drops at a time, and the solution allowed to cool before adding more acid. It is *dangerous* to reverse the procedure and add the water to the acid. The solution should be in the proportion of approximately one part of acid to five of water, and the solution, when cool, should have a specific gravity of 1.2, as measured with a hydrometer.

The cells should be filled to about $\frac{1}{4}$ in. above the level of the tops of the plates, and the battery should then be put on charge as soon as possible. On no account should the battery be allowed to stand for any length of time without being charged once the acid has been put in the cells. Instructions as to the rate of the first charge, and for subsequent charges, will be found on the case of the accumulator, and these rates should under no circumstances be exceeded, although a smaller rate may be used if it is impracticable to charge at the full rate.

There will be three indications when the charging process is completed. First, the voltage of each cell will rise to about 2.6. Second,

the specific gravity of the electrolyte will rise to about 1.22. Third, the cells will "gas," which means that large numbers of bubbles will be seen rising to the surface of the acid.

Fall in Specific Gravity

It should be mentioned that after the electrolyte (of 1.2 specific gravity) has been put into the cells its specific gravity will fall considerably, and will not begin to rise until the battery has been on charge for some time. The charging process should be continued for a couple of hours after the specific gravity has reached its maximum.

If one set of plate begins to gas before the other set, the charging rate should be reduced.

The voltage of each cell, which will be about 2.6 while the charging current is still passing, will fall to about 2.2 volts soon after the accumulator has been taken off charge. It should be understood that the above figures are only approximate; they vary slightly with different makes of accumulator.

Once the battery is fully charged it should be put into use without delay. The maximum discharge rate will probably be stated on the accumulator, and must not be exceeded. In the absence of the maker's figures, note the *actual* ampere-hour capacity of the battery (which is usually about 10 ampere-hours per square foot of active area of the positive plates), and do not discharge at a rate greater than that which, if continued, would totally discharge the battery in eight hours.

Never Totally Discharge

The battery should, however, never be totally discharged. When the voltage has fallen to 1.8 volts per cell (measured while the battery is supplying current) and the specific gravity to 1.18, the accumulator should be recharged at the first opportunity. The voltage of an exhausted battery will rise if it is left out of use for a day or two, and may be sufficient to work the set for a further short period, but it is a very

(Continued on page 174.)

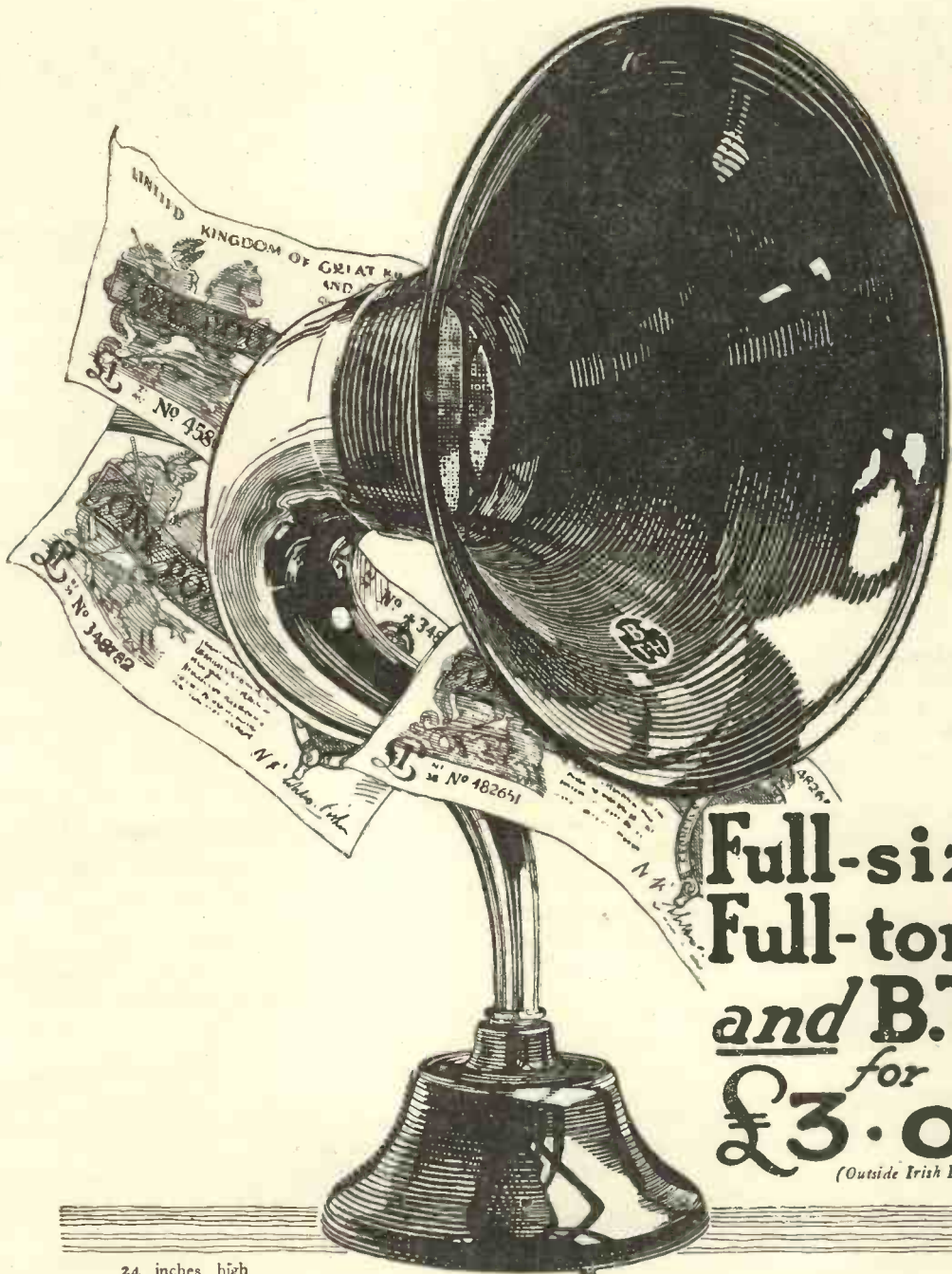

**Full-sized
Full-toned
and B.T.H.
for
£3.0.0**
(Outside Irish Free State)

24 inches high
14 inch flare
Adjustable air gap

FOR all its low price, the C2 can challenge comparison with loud speakers costing two and three times as much. In fact it is doubtful whether there is a better horn loud speaker at any price. Listen to a C2 at your dealer's and then consider the superlative quality of the reproduction given by this very inexpensive instrument—the only full-sized, full-toned loud speaker at or near £3 0 0.



LOUD SPEAKERS

TYPE C.2.
The British Thomson-Houston Co., Ltd.

Ample Stocks Available

2738

Please mention the "Wireless Magazine" when corresponding with advertisers.

All's Well with the Accumulator! (Continued)

dangerous practice to "force" an accumulator in this way.

Discharging Too Slowly

It is also possible to discharge the accumulator too slowly, as, for instance, when a large-capacity battery is used to light the filaments of two or three valves of the .06-ampere type. Care should therefore be taken, when choosing an accumulator, that it has a capacity suited to the work which it will be required to perform.

After the accumulator has been in use for some little time it will be found that the level of the electrolyte has become lower, while the electrolyte itself has become stronger. This is caused by the evaporation of some of the water. The solution should then be restored to its original level and specific gravity corrected by the addition of sufficient *distilled* water. It will be injurious to the accumulator to use tap-water.

Should, however, some of the electrolyte be spilled, acid as well as water will have been lost and sufficient fresh electrolyte of the correct specific gravity should be mixed to replace that which has been spilled.

Two of the commonest troubles which can be caused by misuse or disuse are the disintegration of the positive plates and sulphating. The positive plates will disintegrate very slowly during normal use, but this will not cause any trouble for a very long time.

Cleaning Out the Case

If the disintegration is so rapid that the sediment at the bottom of the cells seems likely to short-circuit the plates, the accumulator must be cleaned out. Amyl acetate will dissolve celluloid, and a little can be used to loosen the joint between the top of the accumulator and the rest of the container, after which careful use of a penknife will enable the top to be detached.

The plates should be removed, the acid emptied out, and the cells thoroughly rinsed with distilled water, after which the accumulator can be re-assembled and the top sealed into place with the help of a little more amyl acetate.

Sulphating is a more serious ailment. A hard yellowish, crystalline

substance forms on the surface of the plates and greatly interferes with the action of the battery. If allowed to go too far, it will cause the plates to expand and finally to burst open the accumulator case.

Upon the first sign of sulphating every effort should be made to save the accumulator before the trouble

has gone too far. Long charges at low rates are often effective, and this treatment should be continued until every sign of sulphate has disappeared.

In some very bad cases it may be necessary to dismantle the battery and scrape off the sulphate with a knife.
J. F. JOHNSTON.

The Loud-speaker Convert

LAST Saturday afternoon I ran across a wireless friend whom I had not seen for many a long month. This particular friend of mine has been most antagonistic towards the loud-speaker in the past. Time after time he has told me that he would not have a loud-speaker at any price.

I once managed to get him to call at my house to listen to my own favourite loud-speaker, and I thought the reproduction on that occasion good enough to convert anybody, but



Ran across a friend.

my friend shook his head and remarked quietly:—

"I prefer the headphones."

When I saw him last Saturday he was carrying a long, narrow parcel under his arm.

"I have just been making a wireless purchase," he said. "I need more high tension so I have bought another section to add to my high-tension accumulator."

"That's very interesting," I said. "I should scarcely have thought, though, that you would have gone in for a high-tension accumulator when you only use headphones."

"I have a loud-speaker now," he said, speaking slowly so that the shock would not be too sudden for me.

"Splendid," I cried. "Why! the last time I saw you do you remember you said you would not have a loud-speaker at any price?"

"Yes, I remember," he said, "but you see I had never heard the cone type of loud-speaker then."

If you knew my friend as I know him you would realise that you could not have a better recommendation for the cone type of loud-speaker.

AERIAL.

Things Heard!

From Graz

Music.

Seven minutes' pause.

Talk on the "Virtue of Punctuality."

Twenty-two minutes' pause.

Same music as before with a considerably depleted orchestra.

A philosophical lecture with constant references to Kant.

Pause for nine minutes until announcer said "Good-night."

From Zurich (Hongg)

Interesting talk on Zwingli.

Lectures on history, botany and music.

Talk from the National Museum.

Description of the cathedral.

Poor music.

Shrill announcer's voice.

A travel talk entitled "from London to Bournemouth."

From Elberfeld

Stock Exchange quotations for twenty minutes.

Steel and iron prices.

"Have you seen a straight Banana?" in English. E. B. R.

Igranic Radio Devices

for short-wave work



IGRANIC Short-Wave Coils are wound with heavy gauge wire, rigidly supported with a minimum of insulating material, which accurately preserves the spacing between turns. The self-capacity and losses are particularly low so that oscillation is obtained easily.

Igranic Short-Wave Coils are made in four sizes for wavelengths of 10 to 100 metres.

PRICES: 2 (turns) 2/6 6 (turns) 2/8
 4 " 2/7 9 " 2/9
 Set of four, 10/-



Igranic 'NONMIC' (Regd.) Valve Holder

IGRANIC "Nonmic" Valve Holders have extremely low self-capacity and are, therefore, particularly suitable for short-wave work. The sockets are suspended by means of special springs, which give extreme resiliency and effectively absorb all shocks.

Made in two types for panel or baseboard mounting; both types fitted with terminals and soldering tags.

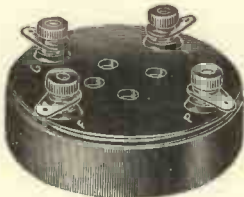

Price for Panel
or Baseboard
Mounting, 3/- each

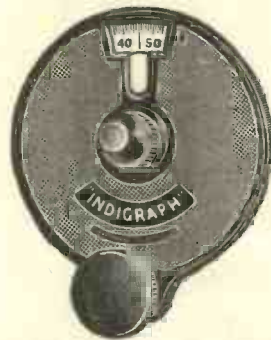

"INDIGRAPH" (Regd.) Vernier Knob and Dial

FOR smooth control, entirely free from backlash, always use "Indigraph" Vernier Knobs and Dials. The scales are provided, reading in opposite directions, so that the "Indigraph" Vernier is suitable for condensers having a clockwise or anti-clockwise movement. Space is provided opposite the dial readings so that records can be made of tuning positions. The Igranic Vernier Knob and Dial is simple to fix and very handsome in appearance. The metal dial acts as a shield against hand-capacity effects - Price 7/6

Write for the new Igranic catalogue List No. J. 217.

Igranic Electric Co., Ltd.,
149, Queen Victoria Street, LONDON.

Igranic-Pacent S.L.F. Variable Condenser

IGRANIC-PACENT Straight-Line Frequency Condensers are particularly suitable for short-wave work as the gradual increase in capacity near the minimum position greatly facilitates fine tuning.

Extremely low losses and negligible minimum capacity.

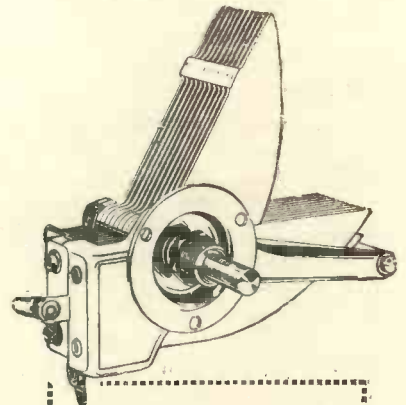

Prices:

·00035 mfd. - 14/6
 ·0005 mfd. - 18/6

GADGETS, HINTS & TIPS

Doing without Rheostats

THE operating temperature of modern low-temperature filaments is not particularly critical, and with valves rated at 2, 4, or 6 volts it is possible, quite satisfactorily, to dispense with rheostats or resistances and run the filaments direct from the accumulator leads.

This point is of great advantage when the operator is experimenting with valves of various voltages in a circuit, saving, as it does, the continual readjustment of rheostats or changing of resistors. D. S. R.

Soldering Joints

WHEN making a T joint between two bare wires, the neatest and most reliable job results from bending the end of one wire right round the other wire before any solder is applied.

A T joint made in this way is practically unbreakable. J. S.

Sets in Dark Corners

IT is sometimes difficult, when a set is placed in a dark corner, to see the controls clearly by artificial light owing to bad shadows. A method of overcoming the difficulty is shown here.

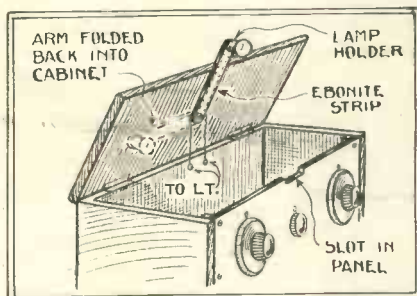

Method of Fixing Lamp.

To the lid of the cabinet is pivoted a strip of ebonite to which is attached a flashlamp bulb, lit by the filament battery. When not required the lamp can be put inside the cabinet out of the way. J. M. D.

Novel Valve Holder

THIS simple valve holder has the double advantage of being at once anti-vibratory and anti-capacity. It



Novel Valve Holder.

is cheap to make and is useful for baseboard mounting.

A square piece of ebonite (2in. by 2in. is a suitable size) is provided with four terminals, and under each terminal is fixed the end of a 3in. length of No. 22-gauge hard brass wire, previously bent to the shape shown in the photograph. C.H.C.

Extended Loud-speaker Leads

WHENEVER long extended leads are used in conjunction with a loud-speaker set a filter should be placed in the leads quite close to the set to prevent the passage of direct currents and prolong the life of the battery.

A simple filter can be made from the secondary of an old L.F. transformer and a 1-microfarad fixed condenser. S. D.

Protecting the Crystal

A CRYSTAL can be protected from atmospheric conditions by a layer of vaseline placed over its exposed surface. Besides protecting the surface of the crystal, the vaseline will also help to keep the catwhisker in position.

Nowadays, of course, the most satisfactory method is to use a detector of the permanent or semi-permanent type. M. D. V.

Poor Earth Connections

FREQUENTLY listeners complain that their sets will not oscillate properly even when everything is known to be in working order and the proper coils and voltages are employed.

When this happens it is time to look at the aerial and earth, especially the latter.

Failure of a set to oscillate is frequently caused by an inefficient earth connection. L. S. P.

Sub-baseboard Wiring

THE neat appearance of the average modern home-constructed receiver can be still further enhanced by making use of the system of sub-baseboard wiring.

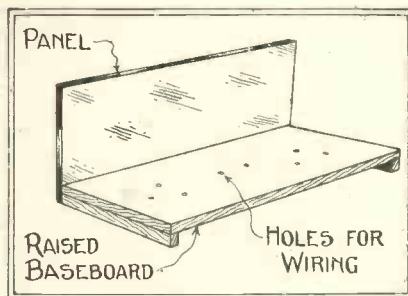

Arrangement of Baseboard.

As can be seen from the diagram, the baseboard is raised, and holes are drilled in it to carry the wiring underneath. In this way the greater part of the wiring is kept out of sight altogether. F. F.

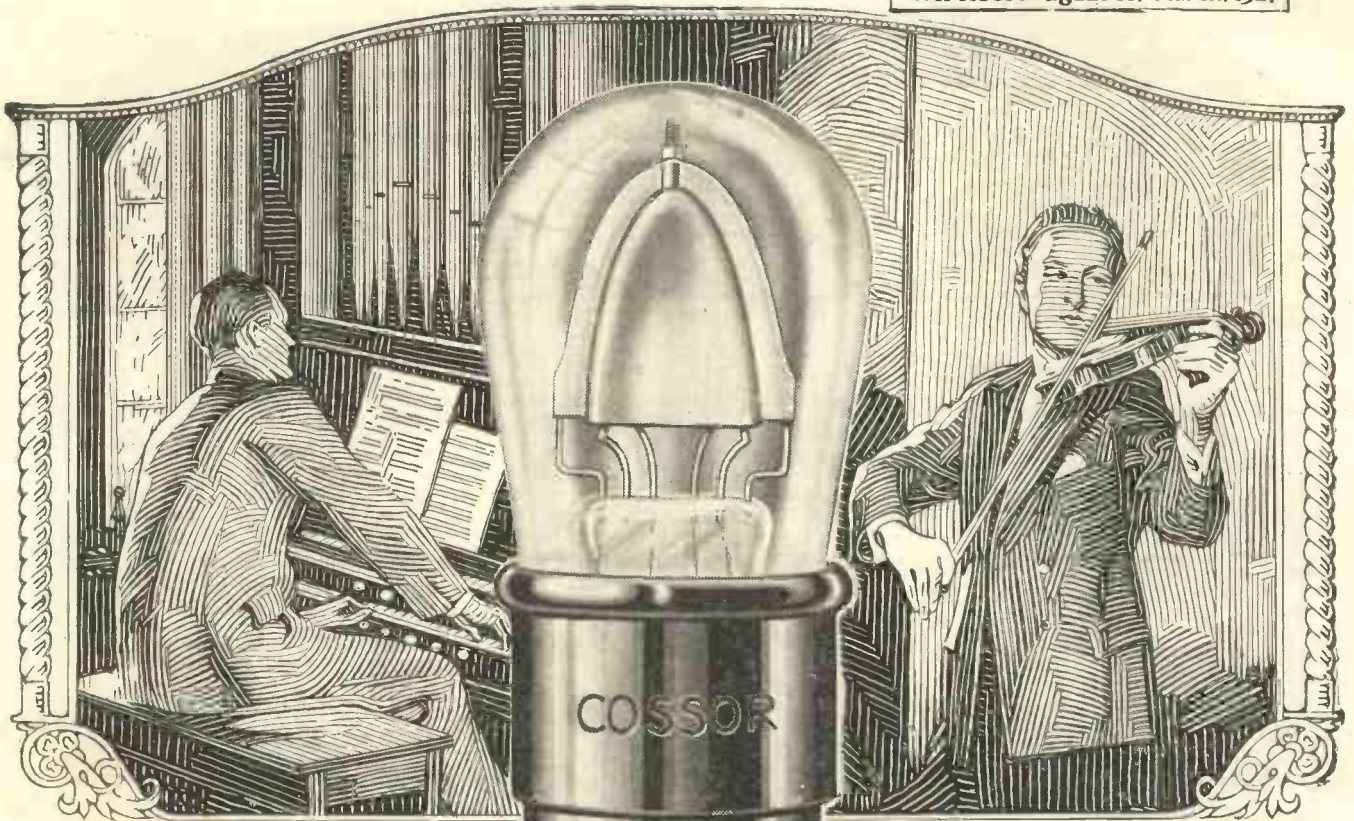

*From the deep
majestic chords
of the organ—*

*—to the highest
notes of the
violin*

**—and every register in between—all
reproduced with startling realism with the
wonderful new Cossor 2-volt R.C. Valve**

The new
Cossor
R. C. 2
14/-

The new
Cossor
R. C. 2
14/-

WIRELESS is undergoing a significant change. The latest trend is towards better tone. Quality of reproduction comes in the fore-front of every broadcast enthusiast's requirements. "Give me" he says "the voice of the living artiste—not a mechanical rendition."

Ever since Broadcasting began tonal purity has been dependent upon the use of suitable L.F. Transformers. And very few Transformers are capable of giving an equal amplification of all frequencies. Even the most expensive ones lose entirely

the very low notes. How, then, can radio approximate to the original when a considerable proportion of the lower registers are missing?

But now a big change is afoot. Transformers will soon be things of the past. Experimenters have long since known that choke or resistance coupling, besides being much cheaper, gives a perfectly equal amplification of every note in the harmonic scale.

But one thing has been lacking—a suitable valve. At last even this difficulty has been removed. The wonderful new Cossor 2-volt R.C. is the solution to this 3-year-old problem. This valve—with an impedance of only 75,000 ohms. has a record amplification factor of 40—the highest yet attained. While its consumption at 1.8 units is only 1 ampere.

Convert your Receiver at once and enjoy the living naturalness and the true beauty of every instrument—and of every voice. The cost is but little—the reward of your labour is great indeed. But be sure you use the new Cossor R.C.—no other valve has the Kalenised filament which is the real secret of its wonderful powers of reproduction.

Cossor

—the valve which serves you longest

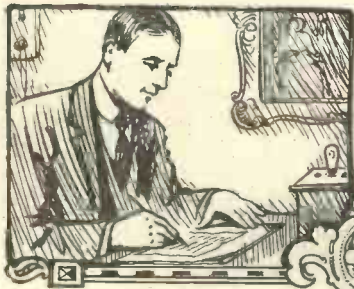

What the Reader Thinks

Our readers contribute items of interest to every listener

Cleaning Stranded Wire

SIR,—Constructors often find that it is difficult to clean the separate strands of flexible wire preparatory to soldering. A very good way of doing this is to spread the ends out fanwise, heat them quickly until red hot, and then plunge them into a little methylated spirits, when it will be found that the strands have regained their copper colour and are very easy to "tin."

I have made up your set, As Good a Set as Money Can Buy, omitting the H.F. switch, and it certainly lives up to its reputation, working a Lissenola attachment on a home-made horn with enough volume for a large room with extraordinary quality at Thornton Heath. It receives many British and foreign stations.—B. C. Wood (Warwick).

In Praise of the B.B.C.

SIR,—Although the organs of the "popular" Press are addicted to the use of the phrase "Public opinion demands," all thinking people—unfortunately the minority—appreciate that "public opinion" is merely the result of the wholesale consumption by the unthinking—unfortunately the vast majority—of ready-made views served up by the "popular" Press.

This is the case with the recent campaign against the B.B.C. and the programmes provided. Ever since the advent of broadcasting the programmes and their failings have been an invaluable "silly season" stunt for the newspaper—one that could be dragged out and rehashed at any time convenient to the editorial whim.

These oft-recurring criticisms, I imagine, have been based on the fact that the B.B.C.'s service has been considerably less than 100 per cent. satisfying to all listeners; yet how many newspapers are 100 per cent. satisfying to their readers? Frankly, of the three or four newspapers I purchase daily none contains more than 40 per cent. of material which I care to read.

A large proportion of any "popular" organ is devoted to sensationalism, which I invariably pass over for other and more dignified items; while those who read the matter I ignore obviously are not interested in that which attracts me—a line of argument which can be pursued almost indefinitely.

Coupled to this fact is the equally relevant one that the appeal of almost any newspaper is strictly limited to those whose political and other views are reflected in its pages; and in providing

only 40 per cent. of interest for a section of the public—say a million people—the average newspaper falls considerably short of the achievement of the B.B.C., which provides possibly the same percentage of interest for a public three or four times as large and covering every age, shade of opinion and social standing.

GOOD THINGS FOR NEXT MONTH

*Another special receiver designed by the Research Editor—
J. H. Reyner, B.Sc.,
A.M.I.E.E.*

A further talk between Professor Megohm and Young Amp.

More about the Paradyne.

A special reference page for the enthusiastic amateur.

Further, it seems to me that the Press of this country has been sadly failing in its duty by not endeavouring to educate the public—at least so far as the English language is concerned.

Much that appears in the average newspaper lacks style and transgresses elementary rules of English grammar, and it is apparent that a journalist is editorially appreciated more for his "news-sense" and knowledge of men and affairs than for his command of the medium through which he has to express himself.

The B.B.C.'s, on the other hand, consistently maintained precept, has done, and is doing, its best to improve both the diction and language of the vast majority—probably without the public realising the fact.

The charge of insincerity, too, is one which can be levelled at the Press, but not at the B.B.C. Many of the technical features in the newspapers are really laughably inaccurate and uninformed. This is particularly the case with the alleged "wireless notes" of the daily Press, which, with two or three notable exceptions, are technically bad and harmful.

Finally, I have been amused to consider the possibility of the B.B.C. in its broadcast talks criticising the service of

the Press—either as a whole or by units. I should rather like to hear a broadcast criticising the *Daily Scream* and its contents—and should then like the *Daily Scream's* response. I fear, however, that I shall not live so long!

There is, too, the fact that anti-B.B.C. propaganda in the Press is definitely harmful to a young and growing British industry employing many thousands of British workpeople.—E. D. WILSON (Harringay, N.4).

The Standard-coil Two-valver

SIR,—I thought it might interest you to know that I have completed the Standard-coil Two-valver described in the February issue. It is by far the best two-valver I have had; its tone is pure and mellow.

Although I have not got quite used to the set yet, I am able to give an account of one night's testing:—

On the loud-speaker I have logged my local station (30 miles) quite strong, and Manchester, Bournemouth, Daventry, Dublin, and Hamburg at fairly good strength.

And on the phones: Oslo, Madrid, Barcelona, Marseilles, Radio Paris, Hilversum, and our own British stations.—GEORGE WALKER (Rookhope, Durham).

Trade Notes

THERE is an impression going about that the original Varley H.F. choke is suitable only for the lower broadcast band of wavelengths; this is not so, and the component is suitable for all wavelengths from 20 to 2,000 metres.

Owing to the increased demand for Camco cabinets, the Carrington Manufacturing Co., Ltd., have found it necessary to acquire larger works. The firm's new address is Sanderstead Road, South Croydon.

The winner of the competition organised by C. A. Vandervell & Co., Ltd., for a name for their H.T. accumulators, is Miss Ruth Fazen, of Putney, S.W.5, who has received a cheque for 75 guineas for the name Silent Sixty. The H.T. accumulator bought by Miss Fazen, which enabled her to compete, was supplied by Capt. Brechenshaw, of Morlands Motors, Ltd., East Sheen, S.W.14, who also received a cheque for 25 guineas.

K.1. THREE VALVE RECEIVER

for Alternating Current Electric Mains

The latest development
in Broadcast Receivers constructed from
MARCONIPHONE and STERLING COMPONENTS
in combination with Type K.L.1 Marconi Valves.

A powerful and simply-operated receiver, which works straight off the house electric supply from alternating current mains, *without accumulators or High Tension batteries*. Easily assembled from the very complete details and full size wiring plan given in the K.1 Constructional Book sent as under.

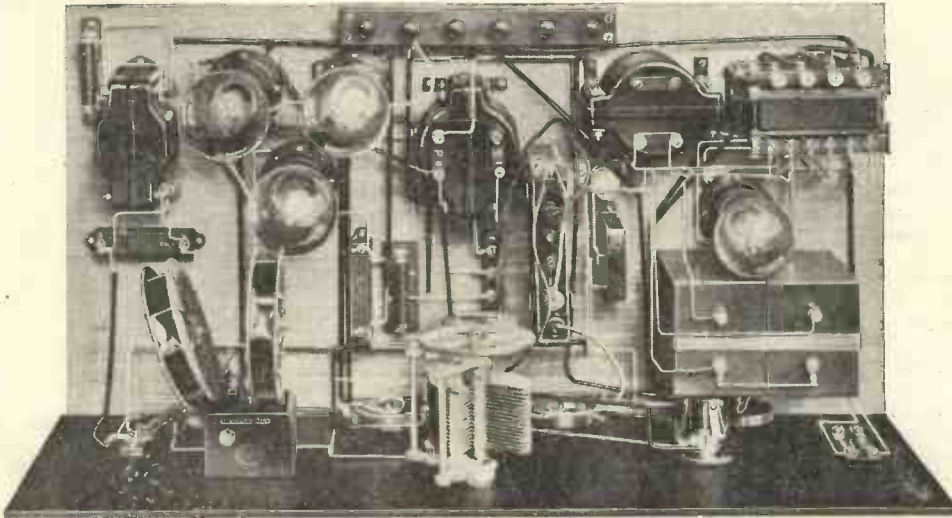

MARCONI-PHONE POWER CHOKE

For High Tension Supply Circuits
Price 25/-

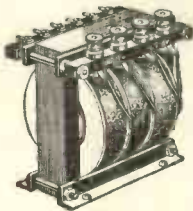

MARCONI-PHONE POWER TRANSFORMERS

For use with indirectly heated cathode valves.
Type 'C' 200-240 volts supply, and Type 'D' for 100-120 volts. 37/6 each.

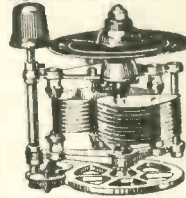

STERLING "MINILOSS" SQUARE LAW CONDENSERS

In 3 capacities
'00025 mfd. 14/-
'0005 mfd. 15/-
'001 mfd. 16/-



MARCONI K.L.1 VALVE

With indirectly heated cathode

OPERATES FROM A.C. ELECTRIC LIGHT MAINS

Price 30/-



Sterling Fixed Condensers

'001 to '00025 mfd. 1/6



Marconiphone Filament Resistance 5/9



Sterling Mansbridge Condensers

'01 to 10 mfd. 2/6 to 20/-



Marconiphone Grid Leak, 1/3 Mounts and Clips 1/3



Antiphonic Valve Holder 2/9

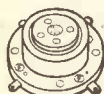

Marconiphone 2 & 3 Valve Switch 3/6

THE MARCONIPHONE COMPANY LTD.
(Sole Agents for Sterling Telephone & Electric Co., Ltd.)
Head Office: 210-212 Tottenham Court Rd., London, W.1.

NO ACCUMULATORS N.T. BATTERIES

To **The MARCONIPHONE COMPANY Ltd.**

Head Office:
210-212, Tottenham Court Road,
London W.1

Please send copy of K.1 Constructional Book with full size wiring plan. 6d. stamps enclosed.

Name.....

Address.....

Town.....

County.....

Use Block Letters

THE WORLD'S BROADCASTING

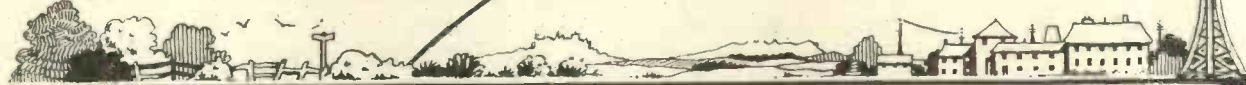

Wave-length in Metres.	Station.	Call Sign.	Wave-length in Metres.	Station.	Call Sign.	Wave-length in Metres.	Station.	Call Sign.
180	Beziere	—	309	Marseilles	—	441.2	Brunn	—
196	Karlsrona	SMSM	310	Zagreb	—	449	Rome	iRO
200	Biarritz	—		Algiers	PTT	454.5	Stockholm	SASA
200.1	Strassburg	—	312.5	Newcastle	5NO	458	Paris	PTT
201.3	Joenkoeping	SMZD	315	Upsala	—	460	Barcelona	Radio Catalana
202.7	Kristinehamn	SMTY	315.8	Milan	—			EAJ13
204.1	Gefle	—	319.1	Dublin	2RN			Trade Union Council
218	Orebro	—	322.6	Breslau	—		Moscow	—
220	Karlstadt	SMXG	325	Barcelona	EAJ1			—
222.2	Strassburg	8GF	326.1	Birmingham	5II			—
229	Umea	—	329.7	Konigsberg	—	461.5	Oslo	—
230	Juan-les-pins	Radio LL	333.3	Naples	—	468.8	Elberfeld	—
				Reykjavik	—		Langenberg	—
238	Bordeaux	—	335	Cartagena	EAJ15	475	Lyons-la-Doua	—
241.9	Münster	—	337	Copenhagen	Radio-raadet	480	Riga	—
245	Toulouse	PTT				483.9	Berlin	—
247.9	Lemberg	—	340	Madrid	EAJ4	491.8	Bournemouth	6BM
250	Eskilstuna	—	340.9	Paris	Petit Parisien	494	Zurich	—
252.1	Bradford	2LS				500	Aberdeen	2BD
	Montpellier	—	344.8	Cadiz	EAJ3		Linkoeeping	—
	Saeffle	SMTS	346	San Sebastian	EAJ8		Mont de Marsan	—
	Kalmar	SMSN	348.9	Prague	—	504	Porsgrund	—
260.9	Malmo	SASC	350	Paris	RadioLL	508.5	Brussels	—
263.2	Bratislava	—	353	Cardiff	5WA	517.2	Vienna	Radio Wien
270.9	Posen	—	357	Seville	EAJ5			—
	Klagenfurt	—	357.1	Graz	—	535.7	Munich	—
272.7	Sheffield	6FL	361.4	London	2LO	545.6	Sundsvall	SASD
275.2	Angers	Radio Anjou		Leipzig	—	555.6	Budapest	Csepel
	Norrkoeping	SMVV	370.4	Bergen	—	566	Berlin	—
	Nottingham	5NG	373	Madrid	EAJ7		Hamar	—
277.8	Leeds	2LS	375	Helsingfors	—	720	Ostersund	—
	Trollaataan	SMXQ	379.7	Stuttgart	—	760	Geneva	HB1
283	Dortmund	—	384.6	Manchester	2ZY	850	Lausanne	HB2
288.5	Edinburgh	—	389.6	Radio Toulouse	—	980	Warsaw	—
291.3	Radio Lyon	2EH	394.7	Hamburg	—	1,010	Moscow	Popoff
	Dundee	2DE		Falun	SMZK	1,050	Hilversum	HDO
294.1	Dresden	—	400	Warsaw	—	1,100	Basle	—
	Hull	6KH	405	Plymouth	5PY	1,110	Kbeley	—
	Innsbruck	—	405.4	Salamanca	EAJ22	1,165	Leningrad	—
	Udde Valla	—	411	Glasgow	5SC	1,200	Boden	SASE
	Radio Agen	—	416.7	Berne	—		Luxemburg	—
294	Stoke-on-Trent	6ST	418	Gothenburg	SASB	1,300	Königswusterhausen	LP
	Swansea	5SX		Bilbao	Radio Vijcaya	1,300	Lille	—
	Varborg	—			EAJ11	1,365	Karlsborg	SAJ
297	Liverpool	6LV	419.5	Bordeaux	—	1,460	Moscow	RDW
300	Koszice	—	420	Moscow	Pere-dacha	1,600	Daventry	5XX
	Seville	EAJ17				1,750	Paris	CFR
303	Nuremberg	—	428.6	Frankfort-on-Main	—	1,800	Carthage	—
306.1	Belfast	2BE		Bilbao	EAJ9	1,950	Norddeich	KAV
306.4	Casablanca	—	436	Fredriksstad	—	2,000	Scheveningen	—
308	Paris	Radio Nituo	440	Reval	—	2,650	Kovno	—
							Paris	FL

LOTUS

THE "MASTER" VALVE HOLDER

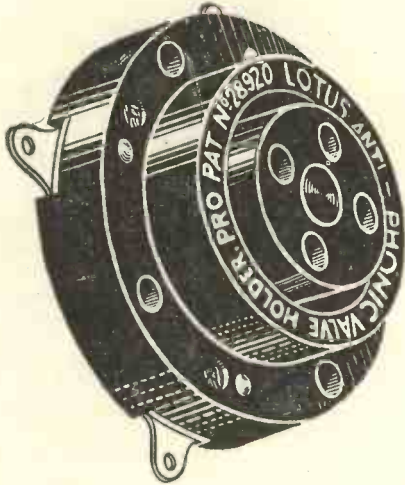

RECOMMENDED BY

Mullard
THE MASTER VALVE

IN evolving the skilful circuits described in "Radio for the Million," the makers of the famous Mullard Master Valves had to choose components that would do justice to their reputation. That is why they recommend Lotus Buoyancy Valve Holders.

Made with every care of the best materials, they can be relied on under any conditions to absorb shock, protect the valves and eliminate microphonic noises.

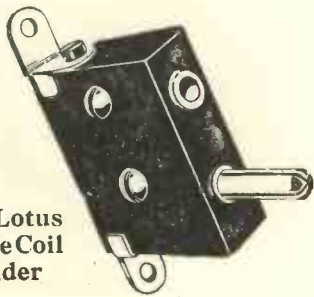

The Lotus Single Coil Holder

Fit them on any set you make and get the best possible results.

LOTUS

BUOYANCY
VALVE HOLDER
ANTI-MICROPHONIC

Valve sockets and springs locked together by a mechanical process, making a definite and permanent connection.
Bakelite moulding, nickel silver springs, and phosphor bronze valve sockets, nickel plated.

PRICES:
VALVE HOLDER 2/3 without terminals
VALVE HOLDER 2/6 with terminals
Combination Grid Leak and Terminal Valve Holder 3/9

Made by the makers of the famous Lotus Vernier Coil Holder
GARNETT, WHITELEY & CO., LTD.,
Lotus Works, Broadgreen Road, Liverpool.

Mention of the "Wireless Magazine" will ensure prompt attention.

J.C. & S.



THERE will be great doings at Como (Italy) this summer, in view of the wireless exhibition to be held there in commemoration of the 100th anniversary of the death of Volta in that city on March 5th, 1827.

Alessandro, Count Volta, the famous physicist, was a child of Como, where he was born in 1745. It is to his inventive genius that we owe the first electric cell, and also a means of measuring current.

Royal Patron

The exhibition to be held will be under the patronage of H.M. the King of Italy, and it is stated that both Signor Mussolini and Senatore Marconi have accepted the joint Hon. Presidency of the Organising Committee.

Como itself, delightfully situated on the lake of that name, is at no great distance from Milan, and I understand that many of the festivities will be relayed to that transmitter for the benefit of listeners in Italy and elsewhere.

Up to the present the Italian stations have not extended their spheres of energy beyond city limits, but the present is considered an excellent opportunity to secure more distant outside broadcasts.

* * * * *

According to the B.B.C. Advisory Committee on spoken English "place names, English and foreign, are a host of trouble in themselves," and efforts are being made to standardise the pronunciation of a number of towns, villages, and hamlets in the United Kingdom.

It seems to me that if such a movement is taking place in the British Isles it can be carried one step further, and that the International Bureau of Geneva could take up the question of settling, once and for all, by which name a country or city should be known.

In connection with broadcast telephony from transmitters in all European countries, the matter is one of considerable importance, inasmuch as

in most instances the native name of the city may be totally different to its appellation in other languages. Would it not be much better if all lands and towns were to retain their original names?

It seems ridiculous that the same locality should bear, according to the various countries, different—and such different—appellations. As an example, may I ask who would possibly recognise Reval when at night the announcer gives the call of "Allo Tallinn?" And again, should you hear from Rome a news bulletin including an item concerning Munich (Bavaria) its Italian translation Monaco would most certainly lead you to believe that the announcer was speaking of the Principality so closely associated with the Monte Carlo gambling tables.

Difficult Names

Can the man in the street recognise Olaszország as Italy, or Frankrijk as France? Why should Switzerland be alternately known as Suisse, Schweiz, Svizza, Svizzera or Svac? If, as I suppose, with your receiver, you tour Europe from time to time, you must have picked up calls from Prague (Praha) or Munich (München). Again, you may have heard Veen for Vienna, or Helsinki instead of Helsingfors.

My contention is that as each country or city or town was labelled by its own inhabitants, so that particular name should be universal. It appears to me just as ridiculous to call London Londres, as it would be for a Mr. Cooper to print on his visiting cards Monsieur Cuvelier when visiting Paris, Kuyper when in Amsterdam, or Fassbinder when in Berlin. Silly, isn't it?

Different German Policy

With the establishment of the new high-power Langenberg transmitter Germany appears to have adopted a different policy in the installation of its broadcasting stations. Until the autumn of last year it had been con-

sidered that for an effective service the best method was that of erecting small relays to take programmes from a main city. In view of the fact that the radius of such stations was strictly limited, and that the exclusive and common wavelengths at the disposal of that country could not possibly cover the number of transmitters which it was deemed necessary to bring broadcasting within the reach of all owners of crystal receivers, it has been decided to reduce the number of stations, and to replace these by a restricted number of high-power transmitters fed by several studios.

Twenty-five Kilowatts

In this connection it may be interesting to note that the Langenberg 25-kilowatt transmitter (aerial energy) is connected to the cities of Düsseldorf, Cologne, Essen, Elberfeld, Dortmund and Muenster, each district having its own studio.

In order to enhance the quality of the transmissions special cables have been laid for both music and speech, all ending at the Elberfeld main switchboard where amplification panels have been installed. At the same time this city is in direct touch with Berlin, thus allowing simultaneous broadcast programmes to be relayed to and from any transmitter in the German broadcasting service.

Steps are now being taken to equip the Reichstag at Berlin with permanent microphones in order that all important speeches may be brought to the ears of German licence holders. Generally speaking, for the Rhineland, the Cologne studio is considered the centre of operations, and a picked orchestra of some sixty musicians has been collected for the performance of symphony concerts. Special land-lines have also been taken to both the Cologne and Düsseldorf opera houses, the performances of which rank amongst the foremost in the German musical world.

The construction of two further high-power stations in Bavaria and Baden is under consideration.

JAY COOTE.

Ask your dealer for this valuable Booklet

Can also be obtained through W. H. Smith & Son.



THE contents include hints on the construction and operation of wireless sets, notes on valves with a comprehensive list of valves recommended for each stage, and diagrams of connections for eleven different circuits.

FERRANTI LTD.

HOLLINWOOD, LANCASHIRE.

FERRANTI ELECTRIC, LIMITED.
Toronto,
Canada.

FERRANTI, INCORPORATED,
140, W. 42nd Street,
New York.

**Dubilier Mansbridge
Condensers**

Wherever a large capacity condenser is needed in your set, see that you make it a Dubilier Mansbridge.

No other condenser in the world has behind it the combined experiences of Dubilier and of Mansbridge.

Do not be misled by low prices: it is eminently worth your while to pay the small amount extra asked for Dubilier Mansbridge Condensers in order to be certain of securing such unfailing service as only they can give.

0.01 mf. to 0.1 mf. . .	2/6 each
0.125 mf. to 0.2 mf. . .	2/8 each
0.25 mf. to 0.3 mf. . .	3/- each
0.4 mf.	3/3 each
0.5 mf.	3/6 each
1.6 mf.	4/- each
2.0 mf.	5/- each
3.0 mf.	8/- each

and other capacities to order.

DUBILIER

REGISTERED TRADE MARK

ADVERT. OF THE DUBILIER CONDENSER CO. (1925) LTD.,
DUCON WORKS, VICTORIA ROAD, NORTH ACTON, W.3.

M.C. 257

When you send your order don't forget to say you "saw it in the 'W.M.'"

QUESTIONS SIMPLY ANSWERED

Below we reproduce some actual replies sent to readers

The 1927 Five

Q.—I have in my possession some 2-megohm and 3-megohm grid leaks. Can these be used in place of those specified for the 1927 Five?—T. C. (Bristol).

A.—You may try the grid leaks of the value you have in your possession, but we are of the opinion that the low values of these will tend to cause instability in the receiver, and if you find this to be the case we strongly recommend that you obtain grid leaks of the values originally specified.—L. C.

Wavetrap

Q.—Will you please tell me how I can construct a wavetrap suitable for working on the broadcast band of wavelengths in conjunction with a proprietary receiver?—F. M. (Ealing).

A.—A suitable wavetrap may be constructed as follows:—Mount upon an ebonite panel 6 in. by 8 in. by $\frac{1}{8}$ in. thick, a variable condenser of .0005-microfarad maximum capacity and a standard plug-in coil holder. Also place two terminals at two corners of the panel at a suitable distance from each other. Connect one terminal to one side of the coil holder and also to one side of the variable condenser. Join the other side of the coil holder and to the other terminal on the panel. Attach the completed panel to a suitable cabinet and join your aerial lead-in wire to one of the terminals of this unit, the other terminal of the unit being connected to the aerial terminal of your receiver. Insert a No. 35, 50 or 60 coil in the coil holder of this wavetrap unit, and tune-in in such a way as to reduce the interfering station's signals to a minimum, whilst the required stations' signals are received at a maximum. The best method of accomplishing this can only be determined by experiment.—C. L.

YOU CAN'T SOLVE IT?

You don't know to where that connection should go or why your set works well one day and badly the next?

Well, why worry? We keep a staff specially to solve such problems as yours. Let them have your queries.

Replies to queries of general interest are published each month, but every querist is answered direct by post.

Please observe the following conditions:

Ask one question at a time; write on one side of the paper only; attach to your query the coupon on cover iii; enclose a fee of 1s. (postal order or stamps); and send it with a stamped addressed reply envelope to: The Editor, WIRELESS MAGAZINE, La Belle Sauvage, E.C.4.

Oscillation in Super-hets

Q.—I have considerable difficulty in getting my super-het receiver to function correctly and free from internal oscillation. I am using potentiometer control for the intermediate-frequency stages, and even this fails to stop the oscillation. Can you please suggest a remedy?—S. E. (Kent).

A.—We suggest that you try connecting a fixed condenser of .0005-microfarad capacity between the plate of the first detector valve and negative low-tension. This condenser will by-pass any frequencies due to the short-wave incoming signals that find their way into the plate circuit of this first valve. Flattening the tuning of the first or second intermediate-frequency transformers will also go far towards remedying this trouble.—C. A. L.

Repairing Celluloid Accumulator Containers

Q.—Recently I discovered a crack down one corner of my accumulator container, and although I am not at present using this cell, I wish to repair it for future use. I would mention that the container is of celluloid, and I would be pleased if you would tell me how to repair the case in the easiest way.—K. D. (Ipswich).

A.—It will be necessary to empty out the acid from your accumulator and thoroughly dry the cracked portion of the container. A suitable celluloid glue can be made up from the following materials:—Celluloid chippings mixed with amyl-acetate to a consistency of thin glue.

This should be applied to the cracked portion of the accumulator, both inside and out, and the liquid allowed to set hard before the accumulator is again put into service.

This glue is highly inflammable, and therefore should not be used in a room where naked lights are burning.—P. M.

Can You Recognise This?

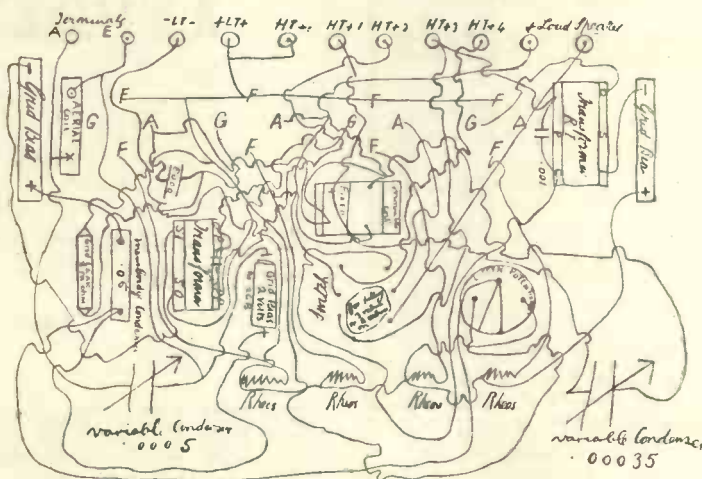

No? Well, our query staff was expected to! It is a wiring diagram of As Good A Set as Money Can Buy.

There is a moral attached to the reproduction of this diagram. Don't draw wiring plans unless you are good at it.

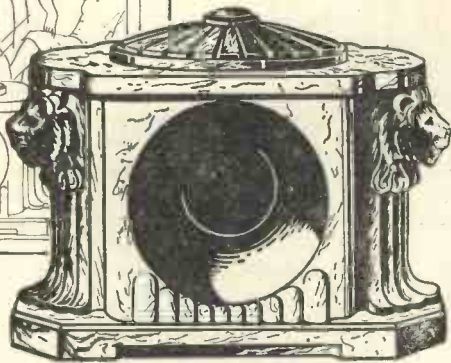
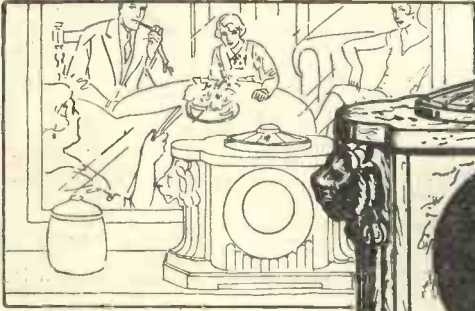

**NO MORE JARRING UNNATURAL
"TRUMPETY" VIBRATIONS! —**

SUB-AGENTS:
 Yorkshire: E. Harper & Co., 10, Manchester Road, Bradford.
 Lancashire & Cheshire: F. A. Hughes & Co., Ltd., 6, Booth Street East, C.-on-M., Manchester.
 South Wales: Watson Bros., 48, Dock Street, Newport.
 Midlands: Foster-Boynston Co., Ltd., 70, Lombard Street, Birmingham.
 Northumberland, Durham, Westmorland and Cumberland: David Bloom, 68, Northumberland Street, Newcastle-on-Tyne.

with
**The MARBLOID
 SALON CONCERT SPEAKER**

MARBLOID "JUNIOR" £3-15s. MARBLOID "SENIOR" £5-10s.

THE old-type loud-speaker, with its "tinny" gramophone-like reproductions, is at last completely superseded. The problem of dispensing with the vibrations which cause the resonant tones in the ordinary loud-speaker is now solved by the *Marbloid Concert Speaker*—the speaker made of imitation marble by a patented process. With this unique material, entirely immune from vibrations, and a perfectly balanced tone-reflector, you will enjoy surprisingly realistic reproductions by using the "Blue Spot" MARBLOID speaker.

Ask your Dealer or write to one of the accompanying addresses for LIST "G.I." of "Blue Spot" Specialities.

Wholesale only:
F. A. HUGHES & CO., LIMITED,
 204-6, Gt. Portland St., London, W.I.
 Telephone: Museum 8630.
 Telegrams: "Distancing, Wesdo, London."



If you want a Loud-Speaker, hear the MARBLOID first!



The name does not rotate

The head does not come off.

The slot and nut eliminate soldering.

The finish is perfect throughout.

Complete patent No. 248,921, 4th March, 1925, and registered designs.

Standard Large Insulated Model (polished black bakelite), Type B, 9d. each. Popular Model (non-insulated), Type M, 6d. each.

28 different engravings stocked. Catalogue free on request.

**BELLING-LEE
 TERMINALS**

Advt. of BELLING & LEE, Ltd., Queensway Works, Ponders End, Middlesex, M.C.I.

Weak Joints need Strong Treatment

An imperfect joint.. a tiny leakage .. gone are the chances of good long-distance reception. The Fluxite Soldering Set will fix all joints quickly, and for ever. No trouble .. no mess .. and so simple!

**FLUXITE 7/6
 SOLDERING SET-complete**

All Hardware and Ironmongery Stores sell FLUXITE in tins, price 8d., 1/4 and 2/8. Another use for Fluxite—Hardening Tools and Case Hardening. Ask for leaflet on improved methods.

FLUXITE, Ltd., (Dept. 332), Rotherhithe, S.E.16.

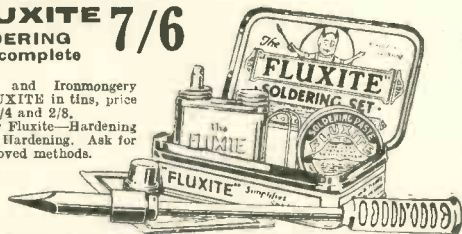

FLUXITE



Varley

*Bi-duplex Wire-wound
Anode Resistance*

Every Varley product marks a step nearer the attainment of the Perfect Wireless Receiver. Our policy right from the beginning has been to introduce Radio components *only* after severe and searching tests—tests which have convinced us that each particular component has been a real contribution to radio design. The latest Varley achievement is a 500,000 ohms Anode Resistance, occupying only the same space as our standard resistances and yet possessing the same advantages. This component is Bi-Duplex wire-wound, with each turn of bare wire separated by pure silk, thereby ensuring real purity of tone, absolute constancy under all conditions, and complete freedom from shorted or leaking turns.

No winding other than the Varley Bi-Duplex admits of the possibility of condensing a component of this value into such a small space without curtailing advantages in some other direction. **Price 16/-.** Clips and Base 1/6 extra.

Varley Bi-Duplex Anode Resistances are made in a complete range of sizes up to 500,000 ohms. Price 4/- to 16/-.

Varley Multi-Cellular H.F. Choke - 9/6.

Varley Multi-Cellular H.F. Choke (Split Coil Type) - 12/6.

Write for particulars of the new Varley Tapped Resistances.



THE VARLEY MAGNET CO.
(Proprietors: Oliver Peil Control Ltd.),
Granville House, Arundel St., London, W.C.2.
Telephone: City 3393.

Specially Written by B.B.C. Officials

What the B.B.C. Is Doing

BY the time these lines are in print a new British station should be heard by listeners, if nothing goes awry with the plans. This will be the test station at Daventry, working on a wavelength varying between 300 and 400 metres and having a power approaching 20 kilowatts. It will be an entirely new station, having no connection with its bigger brother, 5XX (which will continue to use the 1,600-metre wavelength), save that the opportunity has been taken to make use of the adjacent spare land purchased at the time when the site for 5XX was chosen.

some two months depends, to a large extent, the future regional scheme which is contemplated for the British Isles.

This is not the time to discuss in detail the principles on which the B.B.C. is proceeding; but the Corporation does give the assurance that the end in view is that of public-service, the maximum benefit to the maximum number. Various ideals might be pursued to that end; as, for instance, the erection of one or two 50-kilowatt stations, ensuring super-power for every listener in the Kingdom and safeguarding British

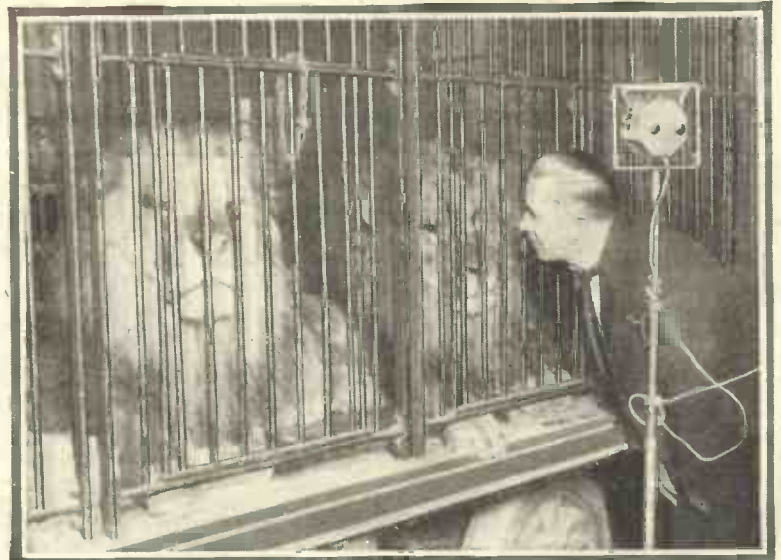

Waiting to broadcast the lions' roars!

Apart from this fact, the new 5GB, as it will probably be called, will operate out of the usual broadcasting hours, transmitting speech and music just like any other broadcasting station. Its plant is the best procurable, and is of a permanent nature. Its aerial, no more than 100 feet in height, is built in sections, so as to be easily portable in case it may be desired to move it to another position later.

What is naturally of supreme interest to listeners is the fact that upon the successful outcome of the tests to be conducted over a period of

listeners from the blanketing effects of the formidably powerful stations which are increasing in number on the Continent.

Again, the B.B.C. might plan for the erection of half a dozen 20-kilowatt stations, working on duplicate transmitters and widely separated wavelengths, so as to provide alternative programmes for crystal users and triple or quadruple programmes for valve users, according to their situation and locality.

Or again, pursuing the policy of *festina lente*, the Corporation might

(Continued on p. 188.)

RANGE ALMOST WITHOUT LIMIT
STUPENDOUS EFFICIENCY
33 STATIONS IN ONE NIGHT
6 VALVE ON 3 VALVES ONLY
RESULTS YOU ALSO CAN GET

AMERICA ON LOUD SPEAKER WITH 3 VALVES ONLY
20 STATIONS ON LOUD SPEAKER
UNPRECEDENTED RESULTS



THESE are typical extracts from the many genuine letters we have received from delighted owners of our 3-valve receiver, which is, without doubt, easily the most efficient modern radio set, and quite equal to the ordinary 5-valve set.

It is a remarkably neat instrument, exceptionally easy to operate, and the batteries and valves are enclosed within the doors of a beautifully finished mahogany cabinet. You are invited to write for our illustrated catalogue of 15 different models, every one a master in its class, and all of which, if desired, can be supplied on the easiest of easy terms.

Your own receiver taken in part exchange with pleasure.
Would you be interested in constructing this receiver? If so, write Constructional Department.

Really a 5-valve set for cash price of £13 : 18 : 6 (37/6 Royalty), or 35/6 deposit secures.

C.S. DUNHAM
Late Radio Engineer to Marcon. Sc Inst. Co's Member of the B.B.C. since its inauguration

Dept. H., 2A, ELM PARK, BRIXTON HILL, LONDON, S.W.2.

Ripaults

Patent Applied for

LATERAL ACTION CONDENSER

Always the best

-and now the cheapest!



Sales have been so remarkably good that it is now possible to add to Lateral Action the further advantage of an efficient Slow-Motion Dial at no extra cost. Consider the cost of a high grade vernier control—and remember that this is fitted as standard to Ripaults' Lateral Action Condenser.

Lateral Action, plus the Slow-Motion Dial, puts within reach of every constructor extraordinary selectivity with any type of valve circuit. Lateral Action is unique in itself and in results. Note that it can be easily substituted for your present Condensers, because it takes up certainly no more room, and possibly less.

PRICES:

.0005, 18/6; .00025, 17/6 (S.L.F. or Sq.L.). Complete with Slow-Motion Dial. Size overall 3 3/4" x 2 1/4" x 1 1/4" (S.L.F. or Sq.L.).

From all good Radio dealers. If out of stock, send Dealer's name and order direct from:

RIPAULTS, LTD.
1 King's Road,
St. Pancras,
LONDON, N.W.1.

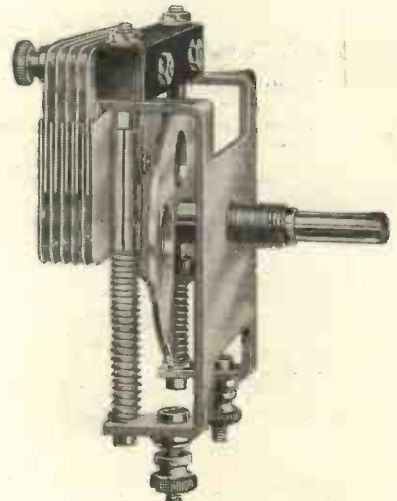

Manufactured and guaranteed by Ripaults Ltd., 1 King's Road, London, N.W.1.

THE LATEST

Abolish Accumulators and fit the New K.L.1 Marconi Valve for using current direct from A.C. Mains for Filament Lighting, together with the K.L.1 Transformer supplying both H.T. and L.T. without Batteries.

NOW IN STOCK. K.L.1 Trans. ... 37/6
K.L.1 Valve ... 30/-

Have you seen the new type "Deekorem" Wall Plug for loud-speaker extension, etc. 3/9 each

The W.B. new All Wood Tone Arm Loud Speaker with T.M.C. Unit, £2 17 6—the Acme of Perfection

and all the latest components for the most up-to-date Circuits now in stock?

OUR INTERNATIONAL RADIO CATALOGUE (3rd Edition) will be sent to all enthusiasts sending 6d. to cover cost of postage and packing.

WILL DAY LTD. (Dept. W.M.),
19, Lisle Street, Leicester Square, LONDON, W.C.2.
Telephone: Regent 4577. Telegrams: "Titles, Westrand, London."



DO YOU KNOW?

That you can have this wonderful **TWO-VALVE** General Radio set installed in your house for **£1 down?**

NOTHING ELSE TO BUY.—The set is complete with **LOUD SPEAKER, HEADPHONES, Dull Emitter Valves, Accumulator, Battery, complete aerial equipment, all cords and plugs, etc.,** and the Royalty is paid

Every set and every part is guaranteed. The price of the complete set is **£1 down** and **20/-** a month for twelve months only, or **£12 cash.**

FREE INSTALLATION.—On receipt of the first payment of **20/-** one of our own Installation Engineers will come to your house *anywhere in the country* and will erect, instal, demonstrate and leave the set playing for you—*free of charge.* It is only necessary to provide an aerial pole if trees, etc., are not available.

By having the set installed by our own Engineers we ensure that you cannot buy a General Radio set that does not give you perfect satisfaction. No other wireless firm gives you this service and this safeguard.

Send a P.C. to-day for our new illustrated catalogue No. 42 Z and full particulars of this unique offer.

General Radio

GENERAL RADIO CO. LTD.
RADIO HOUSE, 235 Regent St., W. 1

PICKETTS CABINETS

For BRITAIN'S BEST!

For your OWN Set! GUARANTEED as supplied to World's Prize Winners and GOLD MEDALLISTS.
Mr. H. H. Anschütz—1st PRIZE at Chicago Exhibition.
Mr. E. Waldo Emerson—International GOLD MEDAL.
"1927 Five," "Fire-side Four," "The Shield Unit," and for every Wireless Receiver—or to your OWN sizes.
Envelope of Cabinet Designs No. 20 FREE.
Picketts Cabinet (M.G.) Works, Bexleyheath.

WET H.T. BATTERIES

British made (round or square) Leclanché Glass Jars 2 1/4 x 1 1/4, for wet H.T. Units. Waxed 1/3 doz., plain 1/- doz., zincs 1/- doz. Grade 1 sacs 1/8 doz. Grade 2 sacs 1/8 doz. Special Non-Solder and non-corrosive Plug-Socket Connector and zinc combined. Reg. design. Each cell a tapped unit, 2/6 doz. Large sacs 3/- doz. Acid-proof Varnish 6d. Jar (Black). Carriage and Packing extra.
Send 1/6 Stamp for instructions and List.

ETON GLASS BATTERY CO. (Dept. G.)
46, St. Mary's Road, Leyton, E.10

A finished **UNICA** Cabinet for the

One-Knob Receiver 55/-

(described in this issue) costs Complete set of parts - - - 36/6

UNICA CABINET Company,
73, Camden Street, N.W.1

What the B.B.C. Is Doing (Continued from p. 186)

decide to get one station of 20 kilowatts working on a medium wavelength, in order to provide at an early date an alternative service within a radius practically equivalent to that served by 5XX. In the latter case, the building-up of a system of higher-power stations would come very gradually and would take, perhaps, a couple of years to complete.

Whichever plan is adopted, it may be stated now that the new station, when built, will be capable of giving service for ten years, with possible adaptations. And perhaps there is no undue optimism in saying that alternative programmes, in one form or another, are nearer to realisation than most people imagine, possibly before next winter.

Fresh Attack on Broadcasting

Information in the possession of the officials at Savoy Hill, as long ago as last autumn, showed that a fresh attack on broadcasting would be carried out at the first opportunity, and that such an attack would have a deeper significance than mere interest in the quality of the programmes, which might superficially be supposed to animate the critics.

But while the motives may have been based on a deeper design, the methods of execution were lacking in spontaneity and skill. The essential fact was, as usual, overlooked that no body of people identified with the conduct of an organisation like broadcasting could be more acutely conscious of the failings in their constructive work than those who are responsible for the broadcasting service.

While the Savoy Hill officials never have been, nor will be, fully satisfied with their handiwork, the premiss that they lack imagination in the consideration of broadcasting as a whole and of the place which it is coming to occupy in the life of the nation is entirely false.

Broadcasting problems are such as no organisation has previously been called upon to face. Looked at from the point of view of the town-dweller, they assume a totally different aspect from that which affects the country-dweller. The different ages among the population, the varying degrees of education and thought, the manifold interests and pursuits, even the social

status of millions, all have their influence on the way in which any individual item of a broadcast programme is received.

Inability to Switch Off

Greatest problem of all that the B.B.C. must face is that of the growing inability of listeners to switch off their sets, a simple expedient that might presumably be resorted to by any who find, as all must necessarily find at some time or other, that although speech is silver, silence can be golden.

If we do not like a book or newspaper we cast it away and read something else. If we do not care for a singer, we do not buy a ticket to go to his recital. With broadcasting, however, people sit and endure the most frightful sufferings, so we are persuaded, rather than use that switch which procures instant relief and brings the golden boon of silence until such time as there is something to hear which will please them.

In 65,870 hours of broadcasting each year, is it to be supposed that there is something to please ten million people all the time? That would be to expect the impossible.

Education Department

Perhaps the most keenly scrutinised of all the activities of the B.B.C. is the work of the Education Department, which has been subjected to a continual fire of criticism from some quarters while gaining many praises from responsible people throughout the land. For some reason it has been supposed that the Corporation's one purpose in life has been to add to the number of talks; and as *ex hypothesi* one cannot stretch the hours of the day, the amount of time left for light forms of entertainment must diminish.

Nothing could be further from the truth. There has been no increase in the number of talks or the amount of educational matter in the important programme hours, that is, between 6.30 and 11 p.m. On the contrary, the late talk, at 9.15 p.m., has been lightened in character and will be frequently dispensed with altogether, being replaced by music or some special feature.

There has been always one educa-
(Continued on page 190.)

CYLDON PARADYNE UNITS

(Pronounced SIL-DON)

for the "PARADYNE FOUR" described in this issue.

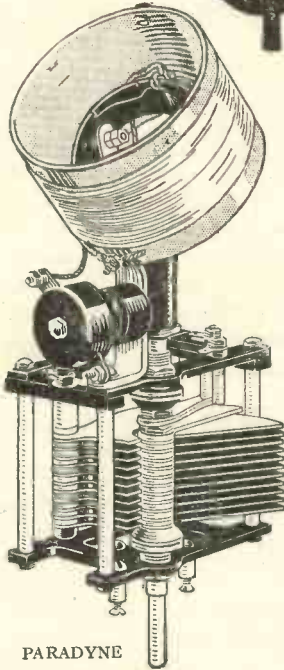

PARADYNE
H.F.
TRANSFORMER.

THE CYLDON Research Department have developed and produced two entirely new components—the PARADYNE UNITS. These have made possible the unique "Paradyne Four" which for constant sensitivity and stable tuning is unequalled by any other circuit.

A New Condenser.

It was necessary to design a special variable condenser for the Paradyne Units. This is on the logarithmic principle and functions to a law between that of the Straight-line Wavelength and Straight-line Frequency condensers. It is called the "Cyldon Log Mid-line" Condenser.

PARADYNE AERIAL COUPLING UNITS, £1-12-6
PARADYNE H.F. TRANSFORMER £1-17-6

MEMO: "Temprytes" are suitable for the "Paradyne Four." Send for free chart specifying resistance required for the particular valve you use.

If any difficulty in obtaining these or other Cyldon Radio components, write direct to

SYDNEY S. BIRD & SONS,
CYLDON WORKS, SARNESFIELD ROAD, ENFIELD TOWN, MIDDSX.

Telephone: ENFIELD 0672.

Coupling Varied as Desired.

The Paradyne Units have an insulated extension to the condenser spindle. On this the variable coupling is fixed so that it can be pivoted to any degree, enabling the coupling to be varied as required. The stator is mounted on a bracket fixed on the condenser.

The Two Units.

The Aerial Coupling Unit has a moving primary with a fixed secondary. The H.F. Transformer Unit is similar except that it has a phasing unit mounted on the bracket.

These units are fixed to the panel in the same manner as variable condensers. Wiring-up is extremely simple.

J. H. REYNER,

B.Sc., A.M.I.E.E.,

IS NOW

Technical Editor

OF

"Amateur Wireless,"

on sale

at all bookstalls
and newsagents

Each Thursday,

3D

Buy your copy now—

is full of good things

that will interest you!

Please mention the "Wireless Magazine" when corresponding with advertisers.

CAXTON WIRELESS CABINETS

THOUSANDS OF SATISFIED CUSTOMERS.

All Polished with new enamel that gives a glass hard surface that cannot be soiled or scratched. Ebonite or Radion Panels Supplied and Perfectly Fitted at low extra cost. SENT FREE—Catalogue of Standard Wireless Cabinets in various sizes and woods.

Elstree "Solodyne"

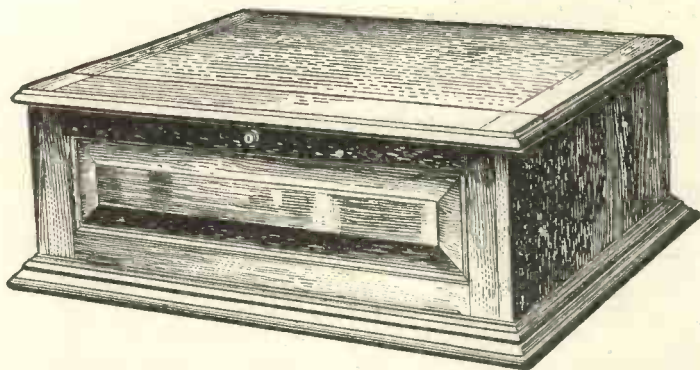

Specially designed for this famous Radio Press Circuit. All details and dimensions conform to their specification, enabling constructors to follow the layout without difficulty.

PRICES:

Light Fumed Oak 61/- Dark or Jacobean Oak 65/- Real Mahogany 68/-

Prices include either "full front" with handsome solid raised panel, as illustrated, or beaded doors, allowing ample space for tuning controls, etc. Glass panelled doors can also be supplied at 3/- extra.

CASH WITH ORDER. CARRIAGE PAID U.K. PROMPT DELIVERY.

Packing Case 5/- extra repaid if Case returned within 14 days Carriage paid to Works.

CAXTON WOOD TURNERY CO., MARKET HARBOROUGH.

OMNORA LTD

THE SET BUILDERS SUPPLY STORES

**BUILD A REALLY GOOD SET
—AND ENSURE SUCCESS.**

Complete Sets of Parts for:	£ s. d.
The Eclectic One-Valver.....	4 2 6
A Standard Coil Two-Valver.....	4 15 0
Miniwave Two-Valver.....	5 18 6
Easy-to-Tune Two-Valver.....	6 12 6
The Music Lovers Three.....	7 5 0
The Push-Pull H.F. Three.....	8 7 6
The Welcome Three.....	11 0 0
All-from-the-Mains Three.....	24 3 0
The Gloria Four.....	10 10 0
The Octopus Four.....	11 10 6
The Fireside Four.....	10 14 0
As Good a Set as Money Can Buy.....	13 26 9
The 1927 FIVE.....	17 8 0
The Compactophone Five.....	13 0 0
The America Seven.....	15 18 0
The Cosmopolitan Nine.....	16 11 6

SPECIAL . . . in this issue:

- A One-Valver for a Frame Aerial.
- The One-knob Three.
- The Paradyne Four.

NEW LISTS.
NOW READY.

* Mark the Set or Sets in which you are interested; cut out this advertisement and post to us together with your name and address. Our "Wireless Magazine" Department will send you detailed price lists by return.

Note.—Where a complete set of components is purchased together, the Marconi Royalty of 12/6 per valve-holder is payable.

Omnora Ltd., Home Construction Specialists,
258, New Cross Road, London, S.E.14.

As the
"Wireless Magazine"
is the best of
the monthlies,
so is
"Amateur Wireless"
the best of
the weeklies.

Catalogues and Pamphlets

Readers can obtain copies of the catalogues noticed below by mentioning the WIRELESS MAGAZINE. Except where stated there is no charge for sending them.

EARLY application to the Mullard Wireless Service Co., Ltd., of Denmark St., W.C.2 (and mention of The WIRELESS MAGAZINE) will secure a free copy of "Radio for the Million," complete with four blueprints of broadcast receivers.

A copy of the Reliability Wireless Guide, No. 9—an encyclopædia of all the best goods by the most reliable makers—has been received from J. H. Taylor & Co., of Macaulay Street, Huddersfield.

Philips rectifiers for accumulator charging and high-tension supply units are the subject of leaflets issued by Philips Lamps, Ltd., of 145, Charing Cross Road, W.C.2.

A fifth edition of 10,000 copies of "Circuits for Building Radio Receivers" has just been put in hand, and copies can be obtained from the Marconi-Phone Co., Ltd., of 210-212, Tottenham Court Road, W.1.

The new R.I. battery charger is described in a folder issued by Radio Instruments, Ltd., of 12, Hyde Street, W.C.1.

From Burndept Wireless, Ltd., of Blackheath, S.E.5, we have received particulars of a new Balkite trickle charger for low-tension accumulators.

A pocket-size 32-page booklet—really a complete catalogue in miniature—has been sent us by the General Electric Co., Ltd., of Magnet House, Kingsway, W.C.2. The same firm has also sent us a folder dealing with H.T. battery eliminators.

Cosmo valves are the subject of a new booklet issued by Metro-Vick Supplies, Ltd., of Trafford Park, Manchester.

Reductions in the prices of Ocron valves are shown by a folder received from Ocron, Ltd., of 32, Charlotte Street, Birmingham.

TRIX

SPECIALITIES

PERMANENT DETECTOR
Giving the utmost sensitivity and stability, designed to extend to fit between any clips up to 2" apart, also one-hole fixing. Nickel-plated No. 344, 2/9.



TRIX SLIT INSULATORS
Shown below full size, provide the most convenient means of erecting indoor and outdoor aerials. Best white porcelain. Wire is simply hooked in the slot. No. 350, per doz. 1/3.

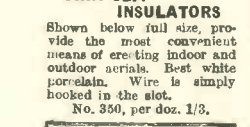

SCREENED COILS
Standard Windings Copper Screens.
Write for our Catalogue W.M. 3, post free.



LEVER PATTERN SWITCH
One-hole fixing, with ON-OFF plate, No. 264, 1/6. Also 1 way, 2 way and 5 point PUSH PULL switches from 1/3.

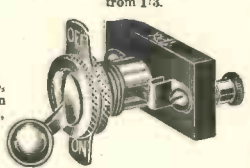

ERIC J. LEVER,
33 Clerkenwell Green
LONDON, E.C.1,
and Branches.
Phone: Clerk. 3014/5.

What the B.B.C. is Doing (Continued)

tional talk between 7 and 8 p.m., the other talk in that hour being mainly of a journalistic nature. The 7.25 p.m. talk is now, however, more frankly educational.

The educational element in the programmes does not spring from the desire of the B.B.C. to force education on its listeners, or from any sense of superiority; but is in response to a definite demand by the bodies responsible for adult education.

B.B.C.

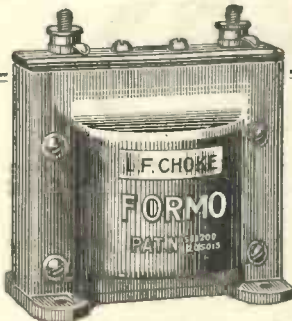

Well-made instrument with winding enclosed in metal screening case, ensuring purity of reproduction and absence of undesired noises.



Send for Catalogue W.M. 1.

L. F. Choke.
As used by J. H. Reyner, B.Sc., in the Loud-speaker Tone Control and Filter Unit described on page 103, and of which a Free Blueprint is given. Will enable you to improve your loud-speaker results. **10/6**

Free to W.M. Readers.

Straight Line Frequency Condenser.

A robust and accurately made component. Can be supplied in either .0003 or .0005 microfarad capacity. Without dial **7/6**

Vernier Logging Dial **6/-**

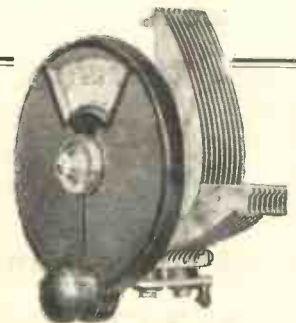

Has adjustable cone bearings. Shaft fits any standard dial with 1/4 in. diameter bore.

THE FORMO COMPANY,
Crown Works, Cricklewood Lane, N.W.2. Phone: 1787
Hampstead. Manchester: Mr. J. B. Levee, 23, Hartley St.,
Levenshulme. Phone: Heaton Moor 475.

A popular appointment

The introduction of regular weekly articles by J. H. REYNER, B.Sc. (Hons.), A.M.I.E.E., has been much appreciated by readers of "Amateur Wireless" and has also attracted many wireless enthusiasts who were acquainted with his work before he was appointed Technical Editor of "Amateur Wireless."

*If you have not seen a recent number
get a copy of the current issue*

**Amateur
Wireless**
And Electrics

The most up-to-date wireless weekly
EVERY THURSDAY 3d.

The Last L.F. Stage Of Your Set Has Something to tell You *

★ You can make your set give better results than your loud speaker gives it credit for by using the right valve in the last L.F. stage.

Volume is by no means the final word in the achievement of better reception, for it can so easily be secured by overloading the L.F. valves with the immediate result that distortion destroys the texture of both music and speech. The secret of perfect purity is to use valves that are able to handle strong signals under normal working conditions.

LLOUD signals are particularly evident when the receiver is situated close to a broadcasting station or when several stages of L.F. amplification are being used.

It is therefore obvious that with an ordinary L.F. valve in the last stage you are either faced with loud, harsh reception with your receiver properly tuned, or faint, but clear reproduction by the use of slight de-tuning. In the main, the loud-

speaker comes in for a great deal of unjustified criticism, due to the incorrect use of one of the best virtues of your set, namely—to give strong signals.

Super Power Valves

The immediate enquiry following the above facts is readily answered by the recommendation to use super power valves.

These valves have been specially designed to handle powerful signals without any trace of distortion.

This ability is due to the fact that they are able to give, as a result of the large grid swing, *all* the fluctuations in anode current that may be required throughout the whole frequency range of broadcasting. This means that the low, sonorous vibrations of the double bass may roll unharmed from your loud-speaker, and the highest trills of a prima donna retain all the pleasure of their original rendering.

Couple these Qualities with those of the Wonderful P.M. Filament

The remarkable merits of the wonderful P.M. filament when embodied in the design of Mullard P.M. Super Power valves result in valves that are absolutely without equal for operation in the last L.F. stage of a receiver. The quality of reproduction that can be secured from even the very largest loud-speaker is a revelation of lifelike reality. This ability is the natural result of the gigantic emission surface available in the Mullard P.M. Filament. No comparison can be made with an ordinary



filament without revealing the increased value offered by the unique P.M. Filament.

All the advantages of long, useful life, low current consumption, and majestic volume possessed by Mullard P.M. Valves are available to the highest degree in Mullard P.M. Super Power Valves. Fit your receiver with Mullard P.M. Valves with the wonderful P.M. Filament and enjoy the best results from your loudspeaker.

Obtainable from all dealers.

INSTALL MULLARD P.M. VALVES WITH THE WONDERFUL P.M. FILAMENT

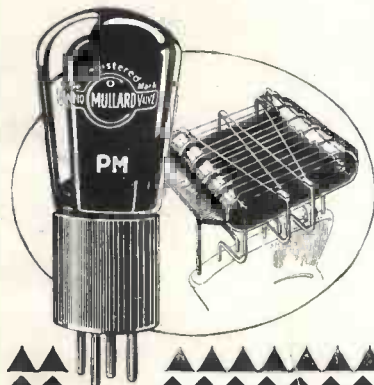

Sectional view of P.M.5 showing generous proportions of P.M. Filament

Mullard

THE MASTER VALVE

6 volt resistance capacity valve
THE P.M.5B (0.1 amp.) 14/-

For 2-volt accumulator
THE P.M.1 H.F. 0.1 amp. 14/-
THE P.M.1 L.F. 0.1 amp. 14/-
THE P.M.2 (Power) 0.15 amp. 18/6
For 4-volt accumulator or 3 dry cells
THE P.M.3 (General Purpose) 0.1 amp. 14/-
THE P.M.4 (Power) 0.1 amp. 18/6
For 6-volt accumulator or 4 dry cells
THE P.M.5x (General Purpose) 0.1 amp. 14/-
THE P.M.6 (Power) 0.1 amp. 18/6
Super power valves for last L.F. stage
THE P.M.254 (4 volts, 0.25 amp) 22/6
THE P.M.256 (6 volts, 0.25 amp) 22/6
These prices do not apply in Irish Free State

ADVT. THE MULLARD WIRELESS SERVICE CO. LTD., MULLARD HOUSE, DENMARK STREET, LONDON W.C.2

W O'Donnell

Wireless Magazine. March. 1927

PLAYER'S MEDIUM NAVY CUT CIGARETTES. With or without Cork Tips.



"Everybody Calling"

FOR

PLAYER'S Navy Cut Tobacco & Cigarettes

MANUFACTURED ONLY FROM



OLD VIRGINIA TOBACCO

REGD NO 154011.