

# SUPPLEMENT

## TO THE POST OFFICE ELECTRICAL ENGINEERS' JOURNAL

Vol. 74 Part 4

January 1982

ISSN 0309-2720

TEC & CGLI:  
GUIDANCE FOR STUDENTS

### Contents

TEC: TRANSMISSION SYSTEMS II .. .. .	49
CGLI: MATHEMATICS C 1981 .. .. .	52
CGLI: TELEPHONY C 1981 .. .. .	58
CGLI: TELEGRAPHY C 1981 .. .. .	62

## TECHNICIAN EDUCATION COUNCIL Certificate Programme in Telecommunications

Sets of model questions and answers for TEC units are given below. The model questions and answers reflect the types and standard of questions that may be set by colleges and answers expected, and include the styles of both in-course and end-of-unit assessments. The model questions and answers therefore illustrate the assessment procedures that students will encounter, and are useful as practice material for the skills learned during the course.

The use of calculators is permitted except where otherwise indicated.

Representative time limits are shown for each question, and care has been taken to give model answers that reflect these limits. Where additional text is given for educational purposes, it is shown within square brackets [ ] to distinguish it from the information expected of students under examination conditions.

We would like to emphasize that the model questions are not representative of questions set by any particular college.

As a general rule, questions are given in italic type and answers in upright type.

### TRANSMISSION SYSTEMS II (U76/006)

Questions 1–20 represent a typical phase test No. 1 as used by the British Telecom External Students Scheme; the total time for this test is 45 min. Similarly, questions 21–33 represent a phase test No. 2 with a total time of 30 min. The two groups of questions may be combined to form a typical end test of 75 min duration.

*Q1 State the bandwidth required for the line transmission of the following signals:*

- (a) music (minimum acceptable bandwidth),
- (b) speech (commercial speech bandwidth),
- (c) telegraph, and
- (d) 625-line video.

(4 min)

- A1 (a) 50–6400 Hz,  
(b) 300–3400 Hz,  
(c) 0–120 Hz, and  
(d) 0–5.5 MHz.

*Q2 State the carrier frequency of a microwave system used for the transmission of digital signals.*

(1½ min)

- A2 11 GHz, or 19 GHz.

*Q3 State the number of 4 kHz telephony channels in:*

- (a) a 4 MHz coaxial system,
- (b) a 12 MHz coaxial system, and
- (c) a 60 MHz coaxial system.

(3 min)

- A3 (a) 960,  
(b) 2700, and  
(c) 10 800.

*Q4 Which one of the following basebands can be transmitted by using a carrier of 12 kHz:*

- (a) 8 kHz,
- (b) 16 kHz,
- (c) 32 kHz, or
- (d) 64 kHz.

(1½ min)

A4 (a) 8 kHz. [Tutorial note: The requirement for successful transmission is that the carrier must have a frequency higher than the highest frequency in the baseband that is to be transmitted.]

*Q5 Calculate the velocity of a signal of frequency 48 kHz and wavelength 5000 m.*

(3 min)

A5 [The velocity,  $v$ , of a signal with frequency,  $f$ , and wavelength,  $\lambda$ , is given by the equation,  $v = f\lambda$ .]

$$\begin{aligned}v &= f\lambda, \\ &= 48 \times 10^3 \times 5 \times 10^3, \\ &= 240 \times 10^6 \text{ m/s.}\end{aligned}$$

*Q6 State the name of the filter represented in the following attenuation/frequency table.*

(2 min)

Frequency (Hz)	1	10	100	10 <sup>3</sup>	10 <sup>4</sup>	10 <sup>5</sup>	10 <sup>6</sup>
Attenuation (dB)	1	2	50	30	20	10	4

A6 Band-stop filter.

*Q7 Draw the latest British Standard symbol for the following filters:*

- (a) low-pass filter, and
- (b) band-pass filter.

(2 min)

A7



*Q8 Which of the following amplitude-modulated waveforms shows a percentage modulation greater than 100%?*

(1 min)

TRANSMISSION SYSTEMS II (U76/006) (continued)

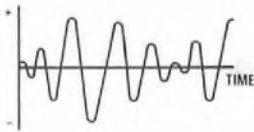

(a)



(b)

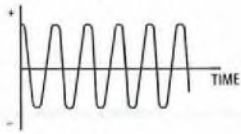

(c)

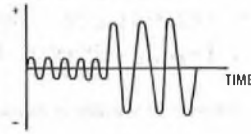

(d)

A8 (b).

Q9 Name the item of equipment that suppresses the carrier in a single-sideband amplitude-modulated system. (1 min)

A9 The modulator.

Q10 State one way by which the signal-to-noise ratio may be increased in a frequency-modulated system for a modulating signal of constant amplitude and frequency. (2 min)

A10 The ways in which the signal-to-noise ratio may be increased are  
(a) by increasing the modulating index, or  
(b) by increasing the frequency deviation.

Q11 Which one of the following waveforms represents a frequency modulated signal? (1 min)

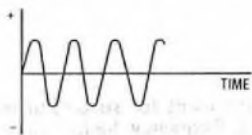

(a)

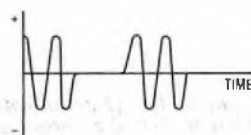

(b)

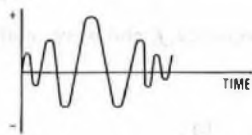

(c)

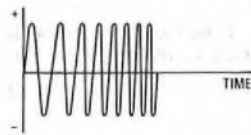

(d)

A11 (d).

Q12 Explain briefly the term FREQUENCY DEVIATION. (3 min)

A12 The term *frequency deviation* describes the amount by which the frequency of a carrier varies from the mean value. The variation depends upon the amplitude and polarity of the modulating signal.

Q13 Explain briefly the term FREQUENCY SWING. (3 min)

A13 The term *frequency swing* is used to describe the difference between the maximum and minimum frequency of a frequency modulated signal due to the amplitude of the modulating signal.

Q14 Explain briefly the term MODULATION INDEX. (3 min)

A14 The term *modulation index* is used to describe the ratio between the frequency deviation and the frequency of the modulating signal, and is expressed as:

$$\text{modulation index} = \frac{\text{frequency deviation}}{\text{frequency of the modulating wave}}$$

Q15 State the practical bandwidth of a frequency-modulated system in terms of its frequency deviation ( $f_d$ ) and modulating signal frequency ( $f_m$ ). (2 min)

A15 The practical bandwidth of a frequency-modulated system is  $2(f_d + f_m)$  Hz.

Q16 State 2 features of the British telephone network that inhibit the passage of digital data signals. (2 min)

A16 Any 2 from the following:

- (a) transmission bridges,
- (b) line amplifiers,
- (c) carrier systems,
- (d) FDM coaxial systems, or
- (e) FDM microwave systems.

Q17 State the name given to the method of modulation by which digital data signals are conveyed by a constant-frequency signal with 2 different amplitudes. (2 min)

A17 Two-level amplitude modulation.

Q18 State why separate paths are sometimes required for transmission and reception on long-distance circuits. (1 min)

A18 To facilitate amplification.

Q19 Sketch a block diagram of a 4-wire amplified circuit showing 2-4 wire conversion units and 2-line amplifiers. (3 min)

A19

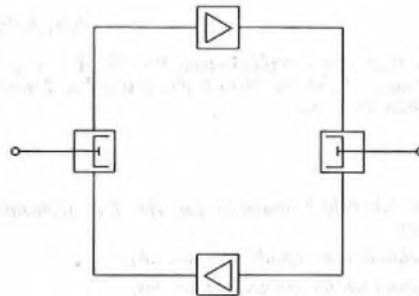

Q20 State 2 ways by which maximum unbalance between the 2-wire side and the balance circuit of a 2-4 wire conversion unit may occur. (3 min)

- A20 (a) By placing a short circuit across the terminals of the 2-wire side.
  - (b) By disconnecting the 2-wire side from its line.
- Alternatively, by applying the conditions stated in (a) and (b) to the balance network.

Q21 State 2 disadvantages of space division as a technique for transmitting signals over a new long-distance route. (2 min)

A21 Any 2 from the following list:

- (a) Costly duct laying.
- (b) Large and bulky cables.
- (c) Each circuit requires separate amplification.
- (d) Additional floor space is required to facilitate the provision of amplifiers.
- (e) High maintenance costs for amplification equipment and cables.

Q22 State the name of the multiplex system that is the least susceptible to line noise. (1 min)

A22 Time-division multiplex.

Q23 How many CCITT channels make up a hypergroup. (1 min)

A23 900 or 960.

TRANSMISSION SYSTEMS II (U76/006) (continued)

Q24 Show using truncated frequency-domain sketches the progress of 2 signals shown in the sketch at points A to C. (4 min)

a single amplitude; other small ranges of amplitude are represented by other discrete amplitudes.

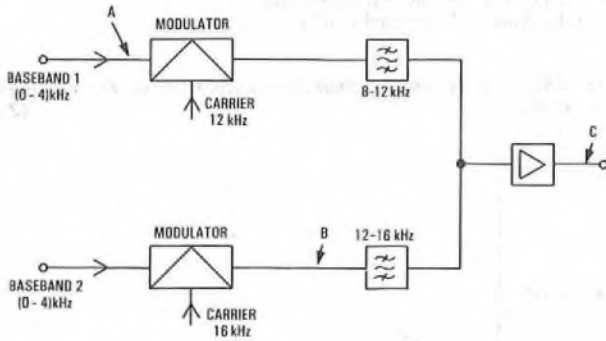

Q27 Calculate the overall power ratio of a 3-part series-connected system whose parts have power ratios of 0.2, 5 and 12. (2 min)

A27 Overall power ratio =  $N_1 \times N_2 \times N_3$  (where  $N_1, N_2, N_3$  are the power ratios of the 3 parts),  
 $= 0.2 \times 5 \times 12,$   
 $= 12.$

Q28 Calculate the absolute power at the output of the system shown in the sketch. Reference power = 1 mW. (5 min)



A28 Overall gain =  $(6 - 3) = 3$  dB (from the summation of the gains and losses).

Overall gain =  $\frac{\text{power at the output}}{\text{power at the input}} = \frac{P_{out}}{P_{in}}$   
 $3 = 10 \log_{10} \frac{P_{out}}{2}$  (where  $P_{out}$  is expressed in milliwatts)  
 $0.3 = \log_{10} \frac{P_{out}}{2}$   
 $\frac{P_{out}}{2} = 10^{0.3}$   
 $P_{out} = 4 \text{ mW}.$

Absolute power =  $10 \log_{10} \frac{\text{actual power}}{\text{reference power}}$   
 $= 10 \log_{10} \frac{4}{1},$   
 $= 10 \log_{10} 4,$   
 $= 10 \times 0.6 = 6 \text{ dBm}.$

A24

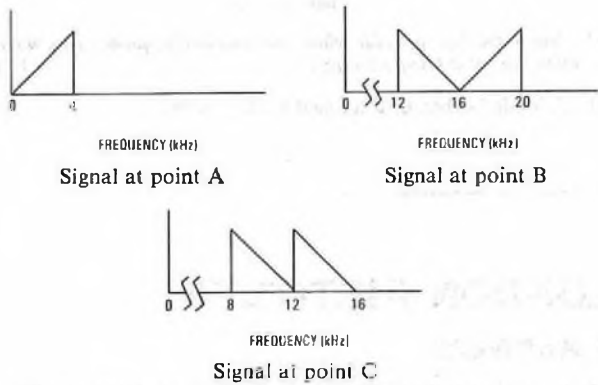

Q25 Which one of the following frequency-domain diagrams represents a CCITT 12-channel group. (1 min)

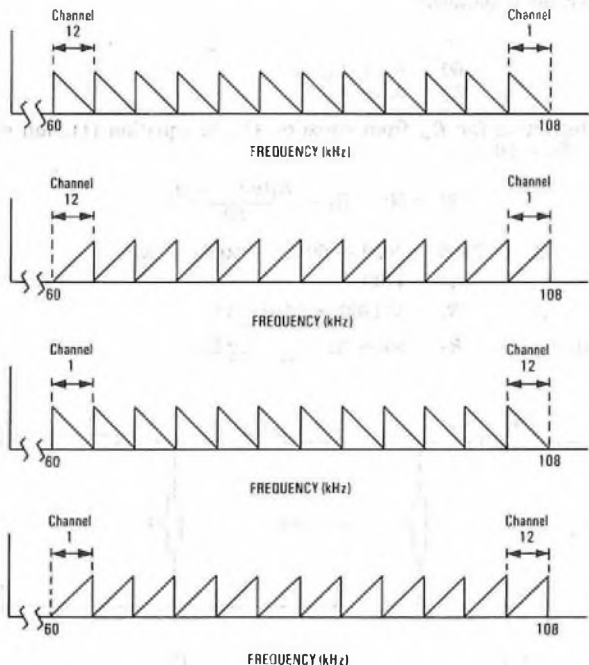

(a) Q29 Calculate the current ratio in decibels of a network having an input current of 200 μA and an output current of 20 μA. (3 min)

A29 Current ratio =  $20 \log_{10} \frac{\text{output current}}{\text{input current}}$   
 $= 20 \log_{10} \frac{20}{200},$   
 $= 20 \times (-1.0),$   
 $= -20 \text{ dB}.$

Q30 Calculate the signal-to-noise ratio of a circuit whose noise power is 0.1 μW when transmitting a signal of power 10 mW. (3 min)

A30 Signal-to-noise ratio =  $10 \log_{10} \frac{\text{signal power}}{\text{noise power}}$   
 $= 10 \log_{10} \frac{10 \times 10^{-3}}{0.1 \times 10^{-6}},$   
 $= 10 \times \log_{10} (100 \times 10^3),$   
 $= 10 \times 5,$   
 $= 50 \text{ dB}.$

A25 (a).

Q26 Explain briefly QUANTIZING. (3 min)

A26 Quantizing is a stage in the production of a time-division multiplex signal where a small range of amplitudes is approximated to

Q31 Match the titles listed below to their respective cables shown in the sketch. (2 min)

- List of cables:  
 (1) Multi-pair internal cable. (5) Quad external cable.  
 (2) Triple-pair external cable. (6) Coaxial cable.  
 (3) Unit-twin external cable. (7) Interstice cable.  
 (4) Coaxial pair. (8) Unit quad cable.



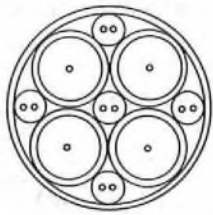

(a)



(b)

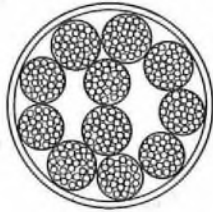

(c)

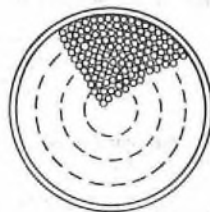

(d)

- A31 (a) 6 (Coaxial cable),  
 (b) 5 (Quad external cable),  
 (c) 3 (Unit-twin external cable), and  
 (d) 1 (Multi-pair internal cable).

Q32 Sketch a typical attenuation/frequency curve for an unloaded audio cable. (2 min)

A32

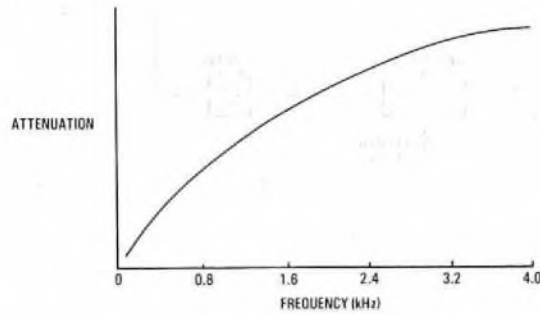

Q33 Name the type of cable whose attenuation/frequency characteristic resembles that of a low-pass filter. (1 min)

A33 A loaded cable, or a lumped-loaded cable.

## CITY AND GUILDS OF LONDON INSTITUTE Questions and Answers

Answers are occasionally omitted or reference is made to earlier Supplements in which questions of substantially the same form, together with answers, have been published. Some answers contain more detail than would be expected from candidates under examination conditions.

### MATHEMATICS C 1981 Students were expected to answer any 6 questions

Q1 A T-network is shown in Fig. 1 below. Resistors  $R_2$ ,  $R_1$  and  $R_2$  are required so that the resistance across terminals A and B is  $40 \Omega$  when C is connected to D and  $60 \Omega$  when C is not connected to D. Calculate the required values for  $R_1$  and  $R_2$ .

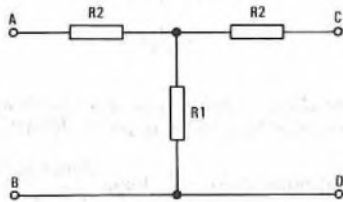

Fig. 1

A1 When C is connected to D, resistors  $R_2$  and  $R_1$  are in parallel and may be replaced by a single resistor  $R$  such that, as shown in sketch (a),

$$\frac{1}{R} = \frac{1}{R_1} + \frac{1}{R_2}$$

$$\therefore R = \frac{R_1 R_2}{R_1 + R_2}$$

Hence,  $40 = R_2 + R$ ,

$$= R_2 + \frac{R_1 R_2}{R_1 + R_2} \dots \dots (1)$$

When C is not connected to D, as shown in sketch (b),

$$60 = R_2 + R_1, \text{ or } R_2 = 60 - R_1. \dots \dots (2)$$

Substituting for  $R_2$ , from equation (2), in equation (1), and since  $R_1 + R_2 = 60$ ,

$$40 = 60 - R_1 + \frac{R_1(60 - R_1)}{60}$$

$$\therefore 2400 = 3600 - 60 R_1 + 60 R_1 - R_1^2$$

$$\therefore R_1^2 = 1200$$

$$\therefore R_1 = \sqrt{1200} = 34.641 \Omega,$$

and,  $R_2 = 60 - R_1 = 25.359 \Omega.$

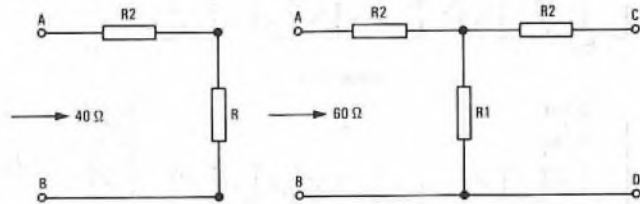

(a)

(b)

Q2 (a) (i) Expand  $(1 + x)^{1/3}$  by the binomial series as far as the term in  $x^4$ . What restriction must be placed on the value of  $x$  for this to be true?  
 (ii) Use this series to evaluate the cube root of  $8.48$  to 4 significant figures.

(b) If  $f = \frac{1}{2\pi\sqrt{LC}}$  show that when  $C$  is increased by a small quantity  $\delta C$ , then  $f$  decreases by approximately  $\frac{50\delta C}{C}$  per cent.

A2 (a) (i)

$$\begin{aligned} (1+x)^{1/3} &= 1 + \frac{1}{3}x + \frac{\frac{1}{3}(\frac{1}{3}-1)}{2!}x^2 + \frac{\frac{1}{3}(\frac{1}{3}-1)(\frac{1}{3}-2)}{3!}x^3 + \\ &\quad \frac{\frac{1}{3}(\frac{1}{3}-1)(\frac{1}{3}-2)(\frac{1}{3}-3)}{4!}x^4 + \dots, \\ &= 1 + \frac{x}{3} - \frac{1 \times 2}{3 \times 3} \times \frac{1}{2 \times 1}x^2 + \\ &\quad \frac{1 \times 2 \times 5}{3 \times 3 \times 3} \times \frac{1}{3 \times 2 \times 1}x^3 - \\ &\quad \frac{1 \times 2 \times 5 \times 8}{3 \times 3 \times 3 \times 3} \times \frac{1}{4 \times 3 \times 2 \times 1}x^4 + \dots, \\ &= 1 + \frac{x}{3} - \frac{x^2}{9} + \frac{5x^3}{81} - \frac{10x^4}{243} + \dots \end{aligned}$$

For the series to be true,  $x$  must lie between  $+1$  and  $-1$ .

(ii)  $(8.48)^{1/3} = (8 + 0.48)^{1/3}$ ,  
 $= \{8(1 + 0.06)\}^{1/3}$ ,  
 $= 2(1 + 0.06)^{1/3}$ ,  
 $= 2\left\{1 + \frac{0.06}{3} - \frac{(0.06)^2}{9} + \frac{5(0.06)^3}{81} - \frac{10(0.06)^4}{243} + \dots\right\}$ ,  
 $= 2(1 + 0.02 - 0.0004 + \frac{0.1}{3} \times 0.0004 - \dots)$ .

The fifth term of the series may safely be disregarded at this stage as it is clear that it will not affect 4 significant figures.

$\therefore (8.48)^{1/3} \approx 2(1.02 - 0.0004 + 0.000013)$ ,  
 $= 2(1.020013 - 0.0004)$ ,  
 $= 2 \times 1.019613 = 2.039226$ ,  
 $= 2.039$ , to 4 significant figures.

(b) When  $C$  increases by a small quantity  $\delta C$ ,

let,  $f' = \frac{1}{2\pi\sqrt{L(C + \delta C)}}$ .

Then,  $f - f' = \frac{1}{2\pi\sqrt{LC}} - \frac{1}{2\pi\sqrt{L(C + \delta C)}}$ .

But,  $\sqrt{L(C + \delta C)} = (LC)^{1/2} \left(1 + \frac{\delta C}{C}\right)^{1/2}$ .

If  $\delta C$  is very small compared with  $C$ ,

$\left(1 + \frac{\delta C}{C}\right)^{1/2} = 1 + \frac{1}{2} \frac{\delta C}{C}$ , from the binomial series.

Hence,  $f - f' = \frac{1}{2\pi\sqrt{LC}} - \frac{1}{2\pi\sqrt{LC} \left(1 + \frac{1}{2} \frac{\delta C}{C}\right)}$ ,

$$\begin{aligned} &= \frac{1 + \frac{1}{2} \frac{\delta C}{C} - 1}{2\pi\sqrt{LC} \left(1 + \frac{1}{2} \frac{\delta C}{C}\right)}, \\ &= \frac{\frac{1}{2} \frac{\delta C}{C}}{2\pi\sqrt{LC} \left(1 + \frac{1}{2} \frac{\delta C}{C}\right)}. \end{aligned}$$

Hence, the percentage decrease in  $f$ ,

$$= \frac{\frac{1}{2} \frac{\delta C}{C}}{2\pi\sqrt{LC} \left(1 + \frac{1}{2} \frac{\delta C}{C}\right)} \times 2\pi\sqrt{LC} \times 100,$$

$\approx 50 \frac{\delta C}{C} \%$ , neglecting  $\frac{1}{2} \frac{\delta C}{C}$  in comparison with unity. QED

Q3 (a) Sketch the voltage waveform  $v = 5 \sin \omega t + 2 \cos 2\omega t$  from  $t = 0$  to  $t = \frac{2\pi}{\omega}$  seconds, by adding two sinusoids, or otherwise.

(b) Estimate from your graph, the positive peak value of this voltage. Check this value, using the differential calculus.

(c) What is the greatest numerical value of  $v$ ?

A3 (a) The waveform, shown in the sketch, is obtained from the following table of values:

$\omega t$ (radians)	0	$\frac{\pi}{6}$	$\frac{\pi}{3}$	$\frac{\pi}{2}$	$\frac{2\pi}{3}$	$\frac{5\pi}{6}$	$\pi$
$\omega t$ (degrees)	0	30	60	90	120	150	180
$\sin \omega t$	0	0.5	0.866	1.0	0.866	0.5	0
$5 \sin \omega t$	0	2.5	4.33	5.0	4.33	2.5	0
$2\omega t$ (degrees)	0	60	120	180	240	300	360
$\cos 2\omega t$	1.0	0.5	-0.5	-1.0	-0.5	0.5	1.0
$2 \cos 2\omega t$	2.0	1.0	-1.0	-2.0	-1.0	1.0	2.0
$v$	2.0	3.5	3.33	3.0	3.33	3.5	2.0

$\omega t$ (radians)	$\frac{7\pi}{6}$	$\frac{4\pi}{3}$	$\frac{3\pi}{2}$	$\frac{5\pi}{3}$	$\frac{11\pi}{6}$	$2\pi$
$\omega t$ (degrees)	210	240	270	300	330	360
$\sin \omega t$	-0.5	-0.866	-1.0	-0.866	-0.5	0
$5 \sin \omega t$	-2.5	-4.33	-5.0	-4.33	-2.5	0
$2\omega t$ (degrees)	420	480	540	600	660	720
$\cos 2\omega t$	0.5	-0.5	-1.0	-0.5	0.5	1.0
$2 \cos 2\omega t$	1.0	-1.0	-2.0	-1.0	1.0	2.0
$v$	-1.5	-5.33	-7.0	-5.33	-1.5	2.0

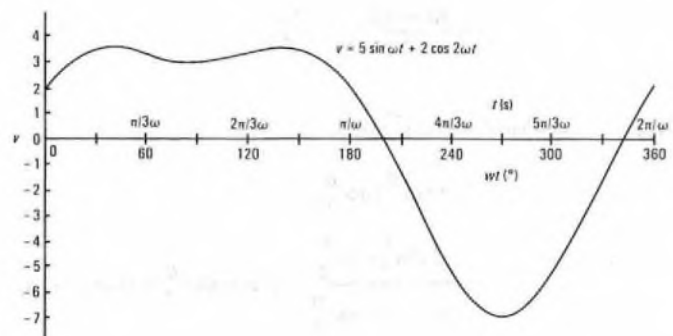

(b) From the graph, the positive peak value of  $v$  is estimated as 3.56.

$v = 5 \sin \omega t + 2 \cos 2\omega t$ .

$\therefore \frac{dv}{dt} = 5\omega \cos \omega t - 4\omega \sin 2\omega t$ .

For maximum or minimum values,  $\frac{dv}{dt} = 0$ .

$\therefore 5\omega \cos \omega t = 4\omega \sin 2\omega t$ , or  
 $5 \cos \omega t = 8 \sin \omega t \cos \omega t$ .

$\therefore \cos \omega t = 0$ , or  $\sin \omega t = \frac{5}{8} = 0.625$ .

$\therefore \omega t = 90^\circ$  or  $270^\circ$  or  $38^\circ 41'$  or  $141^\circ 19'$ .

From the sketch it is clear that the 2 maxima occur at  $\omega t = 38^\circ 41'$  and  $141^\circ 19'$ .

Hence, the positive peak value of  $v$  is given by

$$\begin{aligned} & 5 \sin 38^\circ 41' + 2 \cos 77^\circ 22', \\ & = 5 \times \frac{3}{5} + 2 \times 0.2187, \\ & = 3.125 + 0.4374 = 3.5624. \end{aligned}$$

(c) The greatest numerical value of  $v$  is 7.

**Q4** (a) If  $\alpha$  is obtuse, and  $\sin \alpha = \frac{5}{13}$ , express similarly as a vulgar fraction

- (i)  $\cos 2\alpha$ , and  
 (ii)  $\sin(\alpha - \beta)$ , where  $\beta$  is acute and  $\tan \beta = \frac{3}{4}$ .

(b) If  $\tan \frac{\theta}{2} = t$ , show that  $\tan \theta$ ,  $\sin \theta$ ,  $\cos \theta$  can all be expressed in terms of  $t$ .

Hence, or otherwise, solve the equation  $3 \sin \theta = 4 + 8 \cos \theta$ , for values of  $\theta$  from  $0$  to  $360^\circ$ .

**A4** (a) (i)  $\cos 2\alpha = \cos^2 \alpha - \sin^2 \alpha$ ,  
 $= 1 - 2 \sin^2 \alpha$ ,  
 $= 1 - 2 \times \frac{25}{169}$ ,  
 $= \frac{169 - 50}{169} = \frac{119}{169}$ .

(ii)  $\sin(\alpha - \beta) = \sin \alpha \cos \beta - \cos \alpha \sin \beta$ .

Since  $\sin \alpha = \frac{5}{13}$ ,  
 $\cos \alpha = \frac{\sqrt{13^2 - 5^2}}{13}$ ,  
 $= \frac{\sqrt{169 - 25}}{13} = \frac{12}{13}$ .

Also, since  $\beta$  is the angle in a 3, 4, 5 triangle,  $\sin \beta = \frac{3}{5}$  and  $\cos \beta = \frac{4}{5}$ .

Hence,  $\sin(\alpha - \beta) = \frac{5}{13} \times \frac{4}{5} - \frac{12}{13} \times \frac{3}{5}$ ,  
 $= \frac{4}{13} - \frac{36}{65}$ ,  
 $= \frac{20 - 36}{65} = -\frac{16}{65}$ .

(b)  $\sin \theta = 2 \sin \frac{\theta}{2} \cos \frac{\theta}{2}$ ,  
 $= 2 \tan \frac{\theta}{2} \cos^2 \frac{\theta}{2}$ ,  
 $= \frac{2 \tan \frac{\theta}{2} \cos^2 \frac{\theta}{2}}{\sin^2 \frac{\theta}{2} + \cos^2 \frac{\theta}{2}}$  [since  $\sin^2 \frac{\theta}{2} + \cos^2 \frac{\theta}{2} = 1$ ],  
 $= \frac{2 \tan \frac{\theta}{2}}{\tan^2 \frac{\theta}{2} + 1}$  [on dividing numerator and denominator by  $\cos^2 \frac{\theta}{2}$ ],  
 $= \frac{2t}{1+t^2}$ .  
 $\cos \theta = \cos^2 \frac{\theta}{2} - \sin^2 \frac{\theta}{2}$ ,  
 $= \frac{\cos^2 \frac{\theta}{2} - \sin^2 \frac{\theta}{2}}{\cos^2 \frac{\theta}{2} + \sin^2 \frac{\theta}{2}}$  [since  $\cos^2 \frac{\theta}{2} + \sin^2 \frac{\theta}{2} = 1$ ],

$$\begin{aligned} & = \frac{1 - \frac{\sin^2(\theta/2)}{\cos^2(\theta/2)}}{1 + \frac{\sin^2(\theta/2)}{\cos^2(\theta/2)}}, \\ & = \frac{1 - t^2}{1 + t^2}, \\ \tan \theta & = \frac{\sin \theta}{\cos \theta}, \\ & = \frac{2t}{1+t^2} \times \frac{1+t^2}{1-t^2}, \\ & = \frac{2t}{1-t^2}. \end{aligned}$$

$$3 \sin \theta = 4 + 8 \cos \theta.$$

$$\therefore 3 \times \frac{2t}{1+t^2} = 4 + 8 \times \frac{1-t^2}{1+t^2}, \text{ in terms of } t.$$

$$\therefore 6t = 4 + 4t^2 + 8 - 8t^2.$$

$$\therefore 4t^2 + 6t - 12 = 0.$$

$$\therefore 2t^2 + 3t - 6 = 0.$$

$$\therefore t = \frac{-3 \pm \sqrt{9+48}}{4},$$

$$= \frac{-3 \pm \sqrt{57}}{4},$$

$$= \frac{-3 \pm 7.5498}{4},$$

$$= \frac{4.5498}{4} \text{ or } \frac{-10.5498}{4}.$$

$$\therefore \tan \frac{\theta}{2} = 1.13745 \text{ or } -2.63745.$$

$$\therefore \frac{\theta}{2} = 48^\circ 41' \text{ or } 228^\circ 41' \text{ or } 180^\circ - 69^\circ 14' \text{ or } -69^\circ 14'.$$

Hence,  $\theta = 97^\circ 22' \text{ or } 2 \times 110^\circ 46', \text{ between } 0 \text{ and } 360^\circ,$   
 $= 97^\circ 22' \text{ or } 221^\circ 32'.$

**Q5** (a) Sketch the polar curve  $r^2 = 9 \cos 2\theta$  from  $\theta = 0$  to  $\theta = 2\pi$ .

(b) Convert this polar equation to cartesian co-ordinates, using  $\theta = 0$  as the x-axis, and the pole as the origin of the cartesian system.

(c) State TWO axes of symmetry of the curve sketched.

**A5** (a)  $r^2 = 9 \cos 2\theta$ ,  
 $\therefore r = \pm 3\sqrt{\cos 2\theta}$

$\cos 2\theta$  is negative between  $2\theta = 90^\circ$  and  $270^\circ$ , thus,  $\theta = 45^\circ$  and  $135^\circ$ , and hence  $r$ , will be imaginary between these limits. The curve is therefore sketched from the following table of values, excluding values of  $\theta$  giving rise to imaginary values of  $r$ .

$\theta$	0	10	20	30	40	45
$2\theta$	0	20	40	60	80	90
$\cos 2\theta$	1	0.940	0.766	0.5	0.174	0
$\sqrt{(\cos 2\theta)}$	$\pm 1$	$\pm 0.969$	$\pm 0.875$	$\pm 0.707$	$\pm 0.417$	0
$r$	$\pm 3$	$\pm 2.908$	$\pm 2.626$	$\pm 2.121$	$\pm 1.250$	0

$\theta$	135	140	150	160	170	180
$2\theta$	270	280	300	320	340	360
$\cos 2\theta$	0	0.174	0.5	0.766	0.940	1
$\sqrt{(\cos 2\theta)}$	0	$\pm 0.417$	$\pm 0.707$	$\pm 0.875$	$\pm 0.969$	$\pm 1$
$r$	0	$\pm 1.250$	$\pm 2.121$	$\pm 2.626$	$\pm 2.908$	$\pm 3$

The curve is shown in the sketch (a).

As  $\theta$  varies from  $180^\circ$  to  $360^\circ$ ,  $2\theta$  varies from  $360^\circ$  to  $720^\circ$  and the cosine values repeat those given in the above table in the same order, so that the same curve is traced out again.

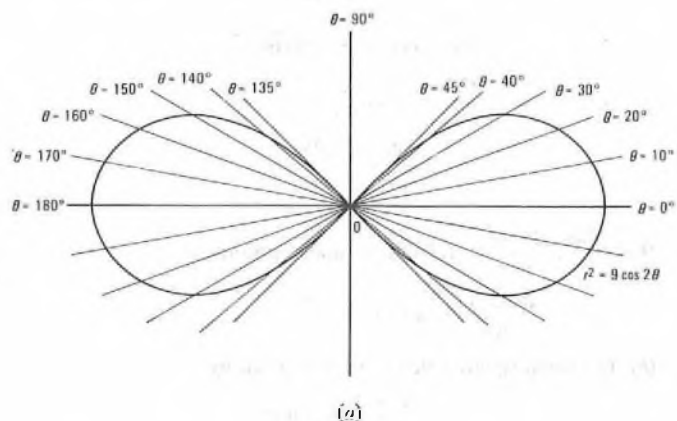

(b) In sketch (b), P, with cartesian co-ordinates  $x$  and  $y$  referred to the axes  $XOX'$  and  $YOY'$ , is any point on the polar curve. If  $OP$  is joined and  $PN$  is the perpendicular from  $P$  to the  $x$ -axis, then from triangle  $OPN$ ,

$$OP = r = \sqrt{(x^2 + y^2)},$$

$$PN = y = r \sin \theta,$$

and,  $ON = x = r \cos \theta.$

$$r^2 = 9 \cos 2\theta,$$

$$= 9(\cos^2 \theta - \sin^2 \theta).$$

Hence,  $x^2 + y^2 = 9 \left( \frac{x^2}{r^2} - \frac{y^2}{r^2} \right)$ , making the above substitutions.

or,  $(x^2 + y^2)^2 = 9(x^2 - y^2).$

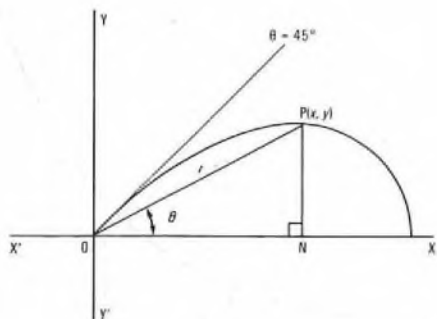

(b)

(c) The curve is symmetrical about the  $x$ - and  $y$ -axes; that is the lines  $\theta = 0^\circ$  and  $\theta = 90^\circ$ .

Q6 (a) Derive and simplify  $\frac{dy}{dx}$  for the following functions

(i)  $y = x^2 e^{-3x},$

(ii)  $y = \frac{2x - 1}{(2 - x)^2},$  and

(iii)  $y = \log_e(x^2 + 4).$

(b) Sketch the graph of ONE of the functions given in (a).

A6 (a) (i)  $y = x^2 e^{-3x}.$

$$\frac{dy}{dx} = x^2 \times (-3e^{-3x}) + 2xe^{-3x},$$

$$= x e^{-3x} (2 - 3x).$$

(ii)  $y = \frac{2x - 1}{(2 - x)^2}.$

$$\frac{dy}{dx} = \frac{(2 - x)^2 \times 2 - (2x - 1) \times 2 \times (2 - x) \times (-1)}{(2 - x)^4},$$

$$= \frac{2(2 - x) + 2(2x - 1)}{(2 - x)^3},$$

$$= \frac{4 - 2x + 4x - 2}{(2 - x)^3},$$

$$= \frac{2(x + 1)}{(2 - x)^3}.$$

(iii)  $y = \log_e(x^2 + 4).$

$$\frac{dy}{dx} = \frac{1}{x^2 + 4} \times 2x = \frac{2x}{x^2 + 4}$$

The graphs of the 3 functions are shown in sketches (a), (b) and (c). In curve (a), there is a maximum value of approximately 0.06 at  $x = 2/3$ , and a minimum of zero at  $x = 0$ .

In curve (b), there is a minimum value of  $-1/3$  at  $x = -1$ , and the curve ascends rapidly to  $+\infty$  on either side of the asymptote at  $x = 2$ .

Curve (c) is symmetrical about the  $y$ -axis and there is a minimum value of  $1.38629$  or  $\log_e 4$  at  $x = 0$ .

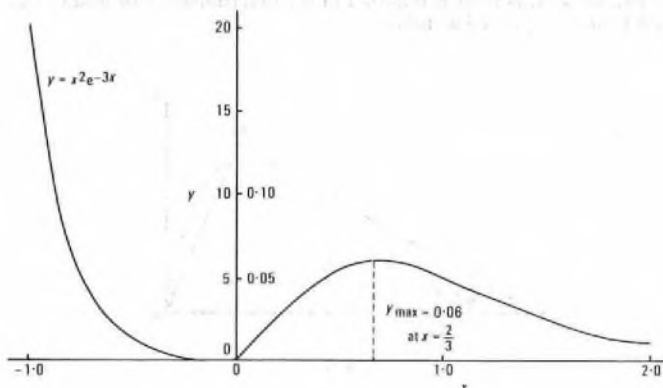

(a)

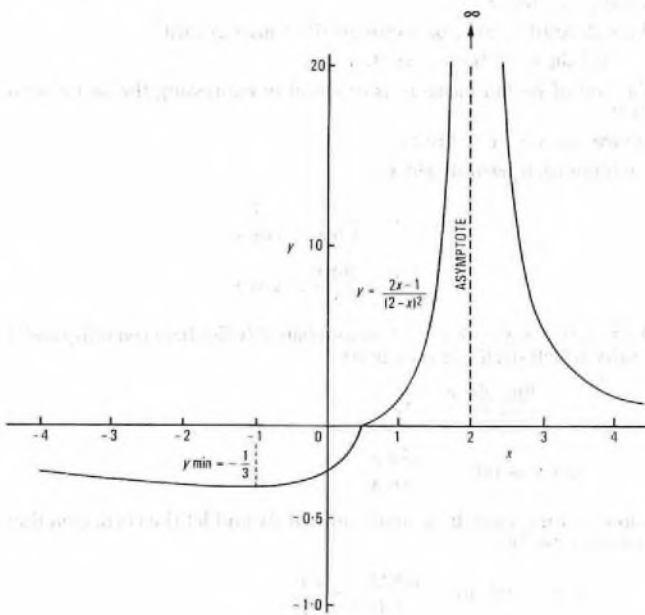

(b)

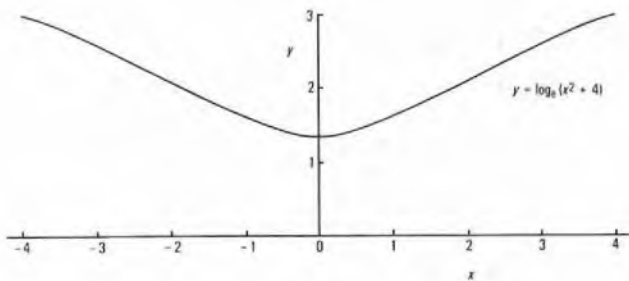

(c)

Q7 (a) Why must the angle be measured in radians when differentiating or integrating trigonometrical functions? Illustrate your answer by proving, from first principles, that

$$\frac{d(\tan x)}{dx} = \sec^2 x.$$

(b) Obtain by Simpson's Rule with 5 ordinates, or otherwise, the root-mean-square of  $\sec \theta$  from  $\theta = 0$  to  $\theta = \pi/3$ .

A7 (a) The use of circular measure simplifies many calculations and, so far as differentiation and integration of trigonometric functions are concerned, is an essential factor in determining the limiting value of  $\sin x/x$  as  $x \rightarrow 0$ .

The use of this limit is required in the determination of  $d(\tan x)/dx$  and it may be proved as follows.

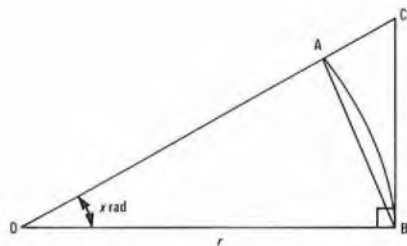

(a)

In sketch (a), AB is the arc of a circle of radius  $r$  and centre  $O$ , and let  $\angle AOB = x$  radians. Since  $x$  has to approach zero,  $x$  is assumed to be less than  $\pi/2$  radians. Let the tangent at  $B$  meet  $OA$  produced in  $C$ . Then  $BC = r \tan x$ .

Area  $\triangle AOB <$  area of sector  $AOB <$  area  $\triangle OBC$ .

$$\therefore \frac{1}{2}r^2 \sin x < \frac{1}{2}r^2 x < \frac{1}{2}r^2 \tan x.$$

The use of radian measure is essential in expressing the sector area as  $\frac{1}{2}r^2 x$ .

Hence,  $\sin x < x < \tan x$ .

Dividing each term by  $\sin x$ ,

$$1 < \frac{x}{\sin x} < \frac{1}{\cos x}.$$

$$\therefore 1 > \frac{\sin x}{x} > \cos x$$

As  $x \rightarrow 0$ ,  $\cos x \rightarrow 1$ , and therefore  $(\sin x)/x$  lies between unity and a quantity which itself tends to unity.

$$\therefore \lim_{x \rightarrow 0} \frac{\sin x}{x} = 1.$$

$$\text{Let } y = \tan x = \frac{\sin x}{\cos x}.$$

Suppose  $x$  increases by a small amount  $\delta x$  and let the corresponding change in  $y$  be  $\delta y$ .

$$\text{then, } y + \delta y = \frac{\sin(x + \delta x)}{\cos(x + \delta x)}.$$

$$\therefore \delta y = \frac{\sin(x + \delta x)}{\cos(x + \delta x)} - \frac{\sin x}{\cos x},$$

$$= \frac{\sin(x + \delta x) \cos x - \cos(x + \delta x) \sin x}{\cos(x + \delta x) \cos x},$$

$$= \frac{\sin(x + \delta x - x)}{\cos(x + \delta x) \cos x}.$$

$$\frac{\sin \delta x}{\delta x}$$

$$\therefore \frac{\delta y}{\delta x} = \frac{\sin \delta x}{\cos(x + \delta x) \cos x}.$$

$$\therefore \frac{dy}{dx} = \lim_{\delta x \rightarrow 0} \frac{\delta y}{\delta x},$$

$$= \frac{\lim_{\delta x \rightarrow 0} \frac{\sin \delta x}{\delta x}}{\cos^2 x}.$$

But,  $\lim_{\delta x \rightarrow 0} \frac{\sin \delta x}{\delta x} = 1$ , from the above proof.

$$\therefore \frac{d(\tan x)}{dx} = \sec^2 x.$$

(b) The mean square value of  $\sec \theta$  is given by

$$\frac{1}{\pi/3} \int_0^{\pi/3} \sec^2 \theta d\theta$$

Five ordinates are obtained over the interval from  $\theta = 0$  to  $\theta = \pi/3$  by division into intervals of  $\pi/12$  or  $15^\circ$ , the required values being deduced from the following table.

$\theta$ (radians)	0	$\frac{\pi}{12}$	$\frac{\pi}{6}$	$\frac{\pi}{4}$	$\frac{\pi}{3}$
$\theta$ (degrees)	0	15	30	45	60
$\sec \theta$	1	1.0353	1.1547	1.4142	2
$\sec^2 \theta$	1	1.0718	1.3333	2	4

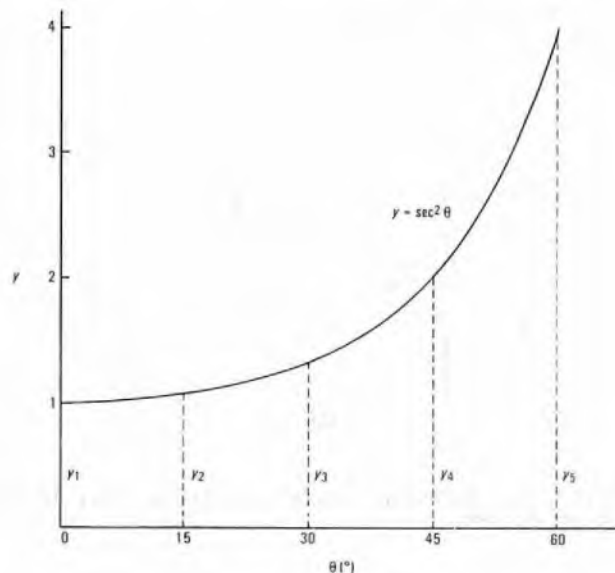

(b)

The graph of  $\sec^2 \theta$  is shown in sketch (b). With reference to the sketch, in which the 5 ordinates are labelled  $y_1, y_2, \dots, y_5$ . Simpson's Rule states that the area under the curve is given by,

$$\frac{1}{3} \times \frac{\pi}{12} \{y_1 + y_5 + 2y_3 + 4(y_2 + y_4)\},$$

$$= \frac{\pi}{36} \{1 + 4 + 2 \times 1.3333 + 4(1.0718 + 2)\},$$

$$= \frac{\pi}{36} (5 + 2.6666 + 4 \times 3.0718),$$



$$= \frac{\pi}{36} (7 \cdot 6666 + 12 \cdot 2872),$$

$$= \frac{\pi \times 19 \cdot 9538}{36} = 1 \cdot 7413.$$

The mean value of  $\sec^2 \theta = \frac{1 \cdot 7413}{\pi/3} = 1 \cdot 6628$ .

The RMS value of  $\sec \theta$  is therefore  $\sqrt{1 \cdot 6628} = 1 \cdot 2895$ .

**Q8 (a)** Calculate the volume of revolution generated when the curve  $y = 3 \sin x$  from  $x = 0$  to  $x = \frac{\pi}{3}$  is rotated through 4 right angles about the  $x$ -axis.

(b) Calculate the mean value of  $y = 0 \cdot 6(1 - e^{-kt})$  from  $t = 0$  to  $t = 4 \times 10^{-3}$  when  $k = 150$ .

**A8 (a)** The sketch shows the curve  $y = 3 \sin x$  rotated through  $2\pi$  rad about the  $x$ -axis, the volume of revolution generated being approximately a cone-shaped volume.

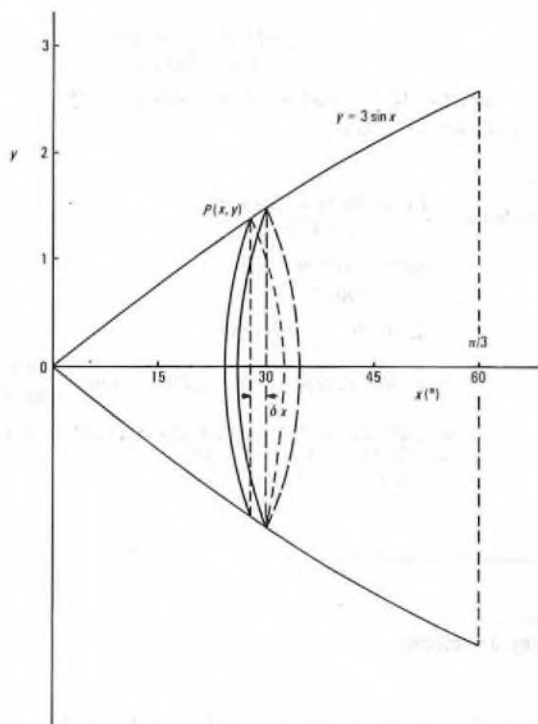

At any point  $P(x, y)$  on the curve, a thin lamina of thickness  $\delta x$  will have a volume of approximately  $\pi y^2 \delta x$  and the total volume of the solid from  $x = 0$  to  $x = \pi/3$  is given by,

$$\int_0^{\pi/3} \pi y^2 dx,$$

$$= \pi \int_0^{\pi/3} 9 \sin^2 x dx,$$

$$= 9\pi \int_0^{\pi/3} \frac{1 - \cos 2x}{2} dx,$$

$$= \frac{9\pi}{2} \left[ x - \frac{\sin 2x}{2} \right]_0^{\pi/3},$$

$$= \frac{9\pi}{2} \left( \frac{\pi}{3} - \frac{\sqrt{3}}{4} \right),$$

$$= \frac{9\pi}{2} (1 \cdot 0472 - 0 \cdot 4330),$$

$$= \frac{9\pi}{2} \times 0 \cdot 6142 = 8 \cdot 683 \text{ units}^3.$$

(b)  $y = 0 \cdot 6(1 - e^{-150t})$ .

$$y_{\text{mean}} = \frac{1}{4 \times 10^{-3}} \int_0^{4 \times 10^{-3}} 0 \cdot 6(1 - e^{-150t}) dt.$$

$$= \frac{10^3 \times 0 \cdot 6}{4} \left[ t - \frac{e^{-150t}}{-150} \right]_0^{4 \times 10^{-3}}$$

$$= 150 \left( 0 \cdot 004 + \frac{e^{-0 \cdot 6}}{150} - \frac{e^0}{150} \right),$$

$$= 150 \left( 0 \cdot 004 + \frac{0 \cdot 5488}{150} - \frac{1}{150} \right),$$

$$= 150 \left( 0 \cdot 004 - \frac{0 \cdot 4512}{150} \right),$$

$$= 0 \cdot 6 - 0 \cdot 4512 = 0 \cdot 1488.$$

**Q9 (a)** The curves  $y = 4 - 3x^2$  and  $y^2 = kx$  intersect in the positive quadrant, where  $x = 1$ .

Calculate

- (i) the value of the constant  $k$ , and
- (ii) the area enclosed between these curves and the  $y$ -axis.

(b) A curve passes through the point  $(0, 2)$  and its gradient at any point is

$$\frac{dy}{dx} = 3y - 4.$$

By integrating  $\frac{dx}{dy}$  (the reciprocal of  $\frac{dy}{dx}$ ) as a function of  $y$ , derive  $x$  in terms of  $y$  as the curve's equation.

**A9 (a) (i)**  $y = 4 - 3x^2$  and  $y^2 = kx$ .

When  $x = 1$ ,  $y = 4 - 3 = 1$ .

Since the curves intersect at this point,

$$kx = 1 \text{ or } k = 1.$$

(ii) The area required is that enclosed between the  $y$ -axis (that is, where  $x = 0$ ) and the intersection point of the curves at  $x = 1$ . The sketch shows the 2 curves plotted over this interval, from the following tables of values.

$x$	0	0.2	0.4	0.6	0.8	1.0
$3x^2$	0	0.12	0.48	1.08	1.92	3.0
$y = 4 - 3x^2$	4	3.88	3.52	2.92	2.08	1.0

$x$	0	0.2	0.4	0.6	0.8	1.0
$y = \sqrt{x}$	0	0.447	0.632	0.775	0.894	1.0

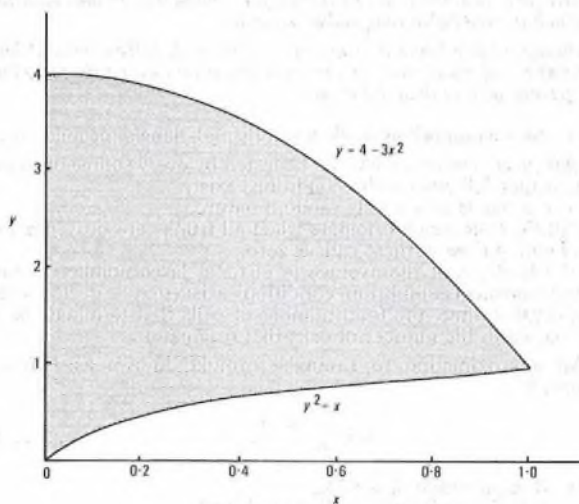

The area required is the area beneath the curve  $y = 4 - 3x^2$  less the curve beneath the curve  $y^2 = x$ ; that is

$$\begin{aligned} \text{Area} &= \int_0^1 (4 - 3x^2) dx - \int_0^1 x^{1/2} dx, \\ &= \left[ 4x - \frac{3x^3}{3} - \frac{x^{3/2}}{3/2} \right]_0^1, \\ &= 4 - 1 - \frac{2}{3} = \frac{22}{3}. \end{aligned}$$

(b)  $\frac{dx}{dy} = \frac{1}{3y-4}$   
 $\therefore x = \int \frac{1}{3y-4} dy$   
 $= \frac{1}{3} \log_e (3y-4) + c,$

where  $c$  is a constant.

When  $x = 0, y = 2$ .

$$\begin{aligned} \therefore 0 &= \frac{1}{3} \log_e 2 + c, \text{ or} \\ c &= -\frac{1}{3} \log_e 2. \\ \therefore x &= \frac{1}{3} \{ \log_e (3y-4) - \log_e 2 \} \\ &= \frac{1}{3} \log_e \frac{3y-4}{2} \end{aligned}$$

$$\therefore \log_e \frac{3y-4}{2} = 3x.$$

$$\therefore \frac{3y-4}{2} = e^{3x}.$$

$$\therefore 3y = 2e^{3x} + 4.$$

Q10 (a) Express the complex number  $z$ , given by

$$z = \frac{3-j}{j5} - \frac{1+j2}{1-j2}$$

in the polar form  $r \angle \theta$ .

(b) In a bridge measurement, the required impedance is found to be

$$\frac{10}{\frac{1}{R} + j\omega C} \text{ ohms,}$$

where  $R$  ohms and  $C$  farads are measured in the balancing arm of the bridge. When  $\omega = 10^4 \text{ rad/s}$ ,  $R = 180 \Omega$ ,  $C = 2.54 \times 10^{-6} \text{ F}$ , calculate

the magnitude and the phase angle of the impedance.

A10 (a)  $z = \frac{3-j}{j5} - \frac{1+j2}{1-j2}$   
 $= \frac{3j+1}{5} - \frac{(1+j2)^2}{1+4}$   
 $= \frac{3j+1-1-j4+4}{5}$   
 $= \frac{4-j}{5}$   
 $= \sqrt{\left(\frac{4}{5}\right)^2 + \left(\frac{1}{5}\right)^2} \angle \tan^{-1} \frac{-1/5}{4/5}$   
 $= \sqrt{0.64 + 0.04} \angle \tan^{-1} \frac{-1}{4}$   
 $= \sqrt{0.68} \angle \tan^{-1} -0.25$   
 $= 0.8246 \angle -14^\circ 2'$

(b)  $\frac{10}{\frac{1}{R} + j\omega C} = \frac{10R}{1 + j\omega CR}$   
 $= \frac{10R(1 - j\omega CR)}{1 + \omega^2 C^2 R^2}$

$$\omega CR = 10^4 \times 2.54 \times 10^{-6} \times 180 = 4.572.$$

$$\therefore \omega^2 C^2 R^2 = 20.9032.$$

Hence,

$$\begin{aligned} \text{impedance} &= \frac{10 \times 180 (1 - j4.572)}{1 + 20.9032} \\ &= \frac{1800 - j8229.6}{21.9032} \\ &= 82.1798 - j375.7259 \\ &= \sqrt{(82.1798)^2 + (375.7259)^2} \angle \tan^{-1} \frac{-375.7259}{82.1798} \\ &= \sqrt{6753.5195 + 141169.95} \angle \tan^{-1} -4.5720 \\ &= \sqrt{147923.47} \angle -77^\circ 40' \\ &= 384.608 \angle -77^\circ 40'. \end{aligned}$$

TELEPHONY C 1981  
 Students were expected to answer any 6 questions

Q1 (a) State FOUR assumptions made when using Erlang's formula.

(b) Give an approximation to Erlang's formula and state the conditions under which it would give reasonable accuracy.

(c) During 5 busy hours a group of 6 registers is fully occupied for a total of 100 s. Calculate whether the average traffic offered during a busy hour is greater or less than 1 Erlang.

A1 (a) The 4 assumptions made when using Erlang's formula are:

(i) All circuits in the group can be tested by every source of traffic; this means that full-availability conditions exist.

(ii) The traffic is of a purely random nature.

(iii) All the calls which originate when all trunks are busy are lost, and the holding time of these calls is zero.

(iv) The traffic is at the average level for a large number of busy hours and statistical equilibrium conditions exist (that is, during a very short interval of time, the total number of calls that terminate is, on average, equal to the number of calls that originate).

(b) An approximation to Erlang's formula, known as Poisson's expression, is

$$B = \frac{A^N e^{-A}}{N!}, \dots \dots (1)$$

where,  $B$  is the grade of service,  
 $A$  is the traffic offered (Erlangs), and  
 $N$  is the number of circuits (or trunks).

The expression can be used if the number of circuits in a group is large and the grade of service is to be good. Provided that  $N \geq 3A$ , reasonable accuracy can be obtained.

(c) If the group of 6 registers is fully occupied for a total of 100 s during 5 busy hours, then for one busy hour the group is fully occupied for an average total of 20 s.

This means that a certain level of traffic will be carried by the 6 registers during the 20 seconds, but any increase in the traffic will cause calls to fail. This implies that calls will fail only during the 20 second period and therefore the probability of failure, or the grade of service,  $B$ , will be numerically equal to,

$$\begin{aligned} &\frac{\text{time registers fully occupied}}{1 \text{ (hour)}} \\ &= \frac{20}{3600} = 0.00556. \end{aligned}$$

Substituting the values  $B = 0.00556$ ,  $N = 6$ , in equation (1).

$$B = \frac{A^6 e^{-A}}{6!} = 0.00556.$$

Hence, to determine whether the traffic offered is greater or less than 1 Erlang; substituting  $A = 1$  in equation (1),

$$B = \frac{1^6 e^{-1}}{6!},$$



$$= 0.00051.$$

Similarly, substituting  $A = 1.75$  in equation (1),

$$B = \frac{1.75^6 e^{-1.75}}{6!},$$

$$= 0.0069, \text{ which is close to the value } 0.00556.$$

Therefore, the conclusion is that the average traffic offered to the group is greater than 1 Erlang.

**Q2** With the aid of circuit sketches, describe the operation of the following features of a unit automatic exchange:

- (a) forced release under PG (permanent glow or permanent call) conditions, and
- (b) trunk offering.

**Q3** With the aid of a circuit sketch of a TXE2 (reed relay) exchange, explain

- (a) the principles of B-switch crosspoint selection, and
- (b) how the crosspoint is operated and held.

**A3** See A10, Telephony C 1975, Supplement, Vol. 69, p. 75, Oct. 1976.

**Q4** For a crossbar exchange:

- (a) Explain the sequence of events which result in the return of
  - (i) ringing tone,
  - (ii) busy tone, and
  - (iii) number unobtainable tone,
 when a subscriber's number is being tested at the conclusion of dialling.
- (b) Outline the circuit arrangements for testing a line which forms part of a small PBX group of lines.

**A4** (a) At the conclusion of dialling, the number of the called subscriber is stored in the register. The register applies to router control X or Y for permission to mark the call. The router control then seizes the appropriate line marker as indicated by the stored thousands and hundreds digits and then sends signals to the marker to operate hundreds and tens relays, giving access to the called subscriber's line circuit. The called subscriber's line is tested by signalling back the condition of the marking wire to the router control.

(i) If the called subscriber's line is free, the marking condition is a negative potential and the router control proceeds to set up the call. The distributor switch-B (DSB) prepares the called subscriber's outlet and marks all free links to the DSAs.

A route relay, unique to this router and line marker, operates confining marking signals from the alerted DSAs to the router setting up this particular call. Each router switch-B (RSB) that receives a mark sends a mark to the RSAs, but only the one that is connected to this call's line transmission relay group (LTRG) will be conditioned to receive marking. The RSA, on receiving a mark, signals to the router control that a free path to the called subscriber is available.

An earth is applied by the router control to the P-wire to operate the RSA bridge magnet via the register and the LTRG. Closure of the RSA crosspoint extends the P-wire earth to operate the bridge magnets in the RSB switch, the DSA and DSB successively, thus closing all crosspoints to complete the connexion.

After the continuity of the positive and negative wires has been checked from the router control through the router and distributor, the called subscriber's K relay is operated. Router control and the register then release, all marking signals are removed, interrupted ringing current is applied to the called subscriber's line from the LTRG, and ringing tone is applied to the calling subscriber's line from the LTRG.

(ii) If the line is busy, the marking condition is earth potential and the router control instructs the LTRG to return busy tone.

(iii) If the line is a spare number, temporarily out of service or has incoming calls barred, the marking condition is positive potential, and the router control instructs the LTRG to return number unobtainable [NU] tone.

If the marking condition is detected as a disconnection, indicating a fault in the marking system, a second attempt is made to set up the call via another router control, and details of the failure are printed on the equipment monitor. If the second attempt fails, NU tone is returned from the LTRG.

(b) See A5 (a), Telephony C 1978, Supplement, Vol. 72, p. 25, Apr. 1979.

**Q5** (a) Explain the purpose and structure of the transit network.

(b) Describe how the called-subscriber-answer signal is transmitted between local exchanges on a long distance routing via a transit switching centre.

**A5** (a) The purpose of the transit network is to enable subscriber trunk dialled (STD) traffic to be routed which would not otherwise be routed over the normal trunk network because of:

- (i) insufficient routing digits being available from the controlling register, or
- (ii) more than 2 trunk links in tandem being required, resulting in increased transmission loss and excessive post-dialling delays.

The transit network has a fast inter-register signalling system and 4-wire switching via low-loss circuits. The transit network enables all group switching centres (GSCs) to be connected to each other by up to 5 transit links in tandem. It also allows GSCs to have access to international switching centres (ISCs) if direct GSC-ISC circuits are not provided. The transit network can be used for alternative routing between GSCs when the normal trunk route is busy.

Sketch (a) shows an outline of the transit network. Access to the transit network is made from GSCs, a call remaining on the transit network until the objective GSC is reached. Each switching centre, known as a transit switching centre (TSC), is identical in design, but the interconnexion between centres results in a hierarchical routing plan. Nine TSCs, known as main switching centres (MSCs), are fully interconnected and 28 TSCs, known as district switching centres (DSCs), are partially interconnected.

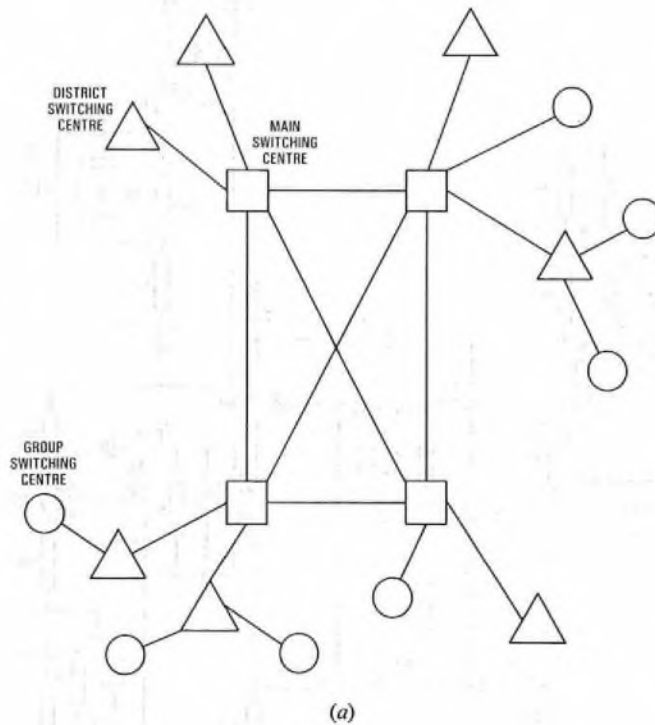

Each GSC has a basic connexion to a parent TSC, which can be either an MSC or a DSC; it can also have auxiliary connexions with other TSCs as thought necessary.

Each DSC has a basic connexion with an MSC and also auxiliary connexions with other TSCs as necessary. A maximum of 5 links and a minimum of 2 links are used between GSCs on a transit switched connexion.

(b) Sketch (b) shows a typical long-distance routing via a transit switching centre.

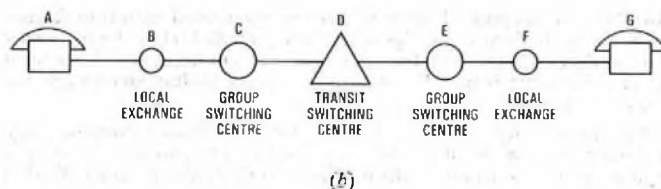

The called subscriber at G, in answering, puts a loop on the line which is detected at local exchange F as an *answer* signal. This is repeated back to the GSC at E either as a reversal if loop-disconnect signalling is used between E and F or as a supervisory signal if a DC signalling system is employed. At E the signal is detected and sent back to D using a supervisory tone in an AC signalling system (typically AC11). At D the signal is sent back to C again using an AC signalling system. At C the signal is detected and is repeated back to the local exchange at B either by a reversal using loop-disconnect signalling or a supervisory signal, if a DC signalling system is used.

**Q6** Consider the circuit of the 1VF (AC9) signalling receiver shown in Fig. 1 below.

- (a) What is the purpose of the tuned circuit associated with transformer T2?
- (b) Explain the functions of diodes D5 and D6.
- (c) Describe the operation of the guard circuit.
- (d) Sketch the emitter current waveform of transistor TR5 when dial pulses of 2280 Hz are received.

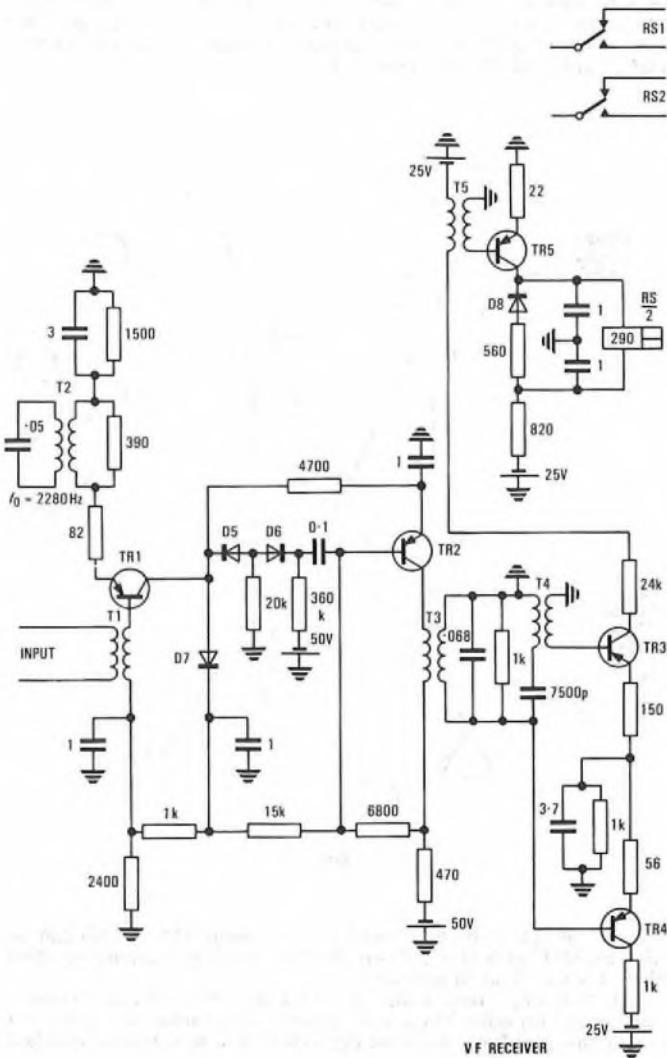

Fig. 1

**A6** (a) The purpose of the tuned circuit associated with transformer T2 is to de-emphasize the signal frequency (2280 Hz) in the transistor TR1 collector. This gives the same effect as emphasizing all received frequencies apart from 2280 Hz, an important preliminary to prevent voice simulation.

(b) The function of diodes D5 and D6 is to form a clipping stage to limit the input signal reaching the base of TR2, so that the output is more or less constant. With no signal both diodes conduct.

positive signal the impedance of D5 increases until, finally, it ceases to conduct. With a negative signal the impedance of D6 increases towards cut-off. The input swing to TR2 is therefore limited and a square-wave output is developed across the output transformer T3.

(c) The transistors TR3 and TR4 plus associated components make up the signal-and-guard comparator circuit.

Should 2280 Hz appear with other frequencies in the speech, the transistor TR4 will conduct on the negative half cycle and will charge the capacitor at the emitter of TR4 to the peak of the guard voltage. The resistor in parallel with this capacitor will provide a discharge path for the capacitor so that the voltage across it will follow the input signal and remain across it for a period of 4 ms after the guard input has ceased. This is a factor in obtaining voice immunity. The guard circuit tends to bias off transistor TR3 until its base is made more negative than its emitter by an input from the 2280 Hz circuit.

(d) The sketch shows the emitter current waveform of transistor TR5 when dial pulses of 2280 Hz are received.

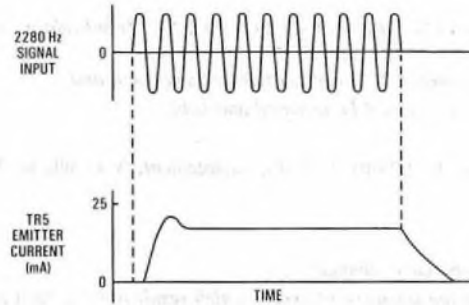

**Q7** (a) Describe the principle of operation of a mechanical type of pulse regenerator.

(b) Explain the factors which influence the delay in pulse repetition that it introduces and estimate the minimum and maximum delays that may occur.

**A7** (a) The basic elements of the mechanical pulse regenerator are shown in the sketch.

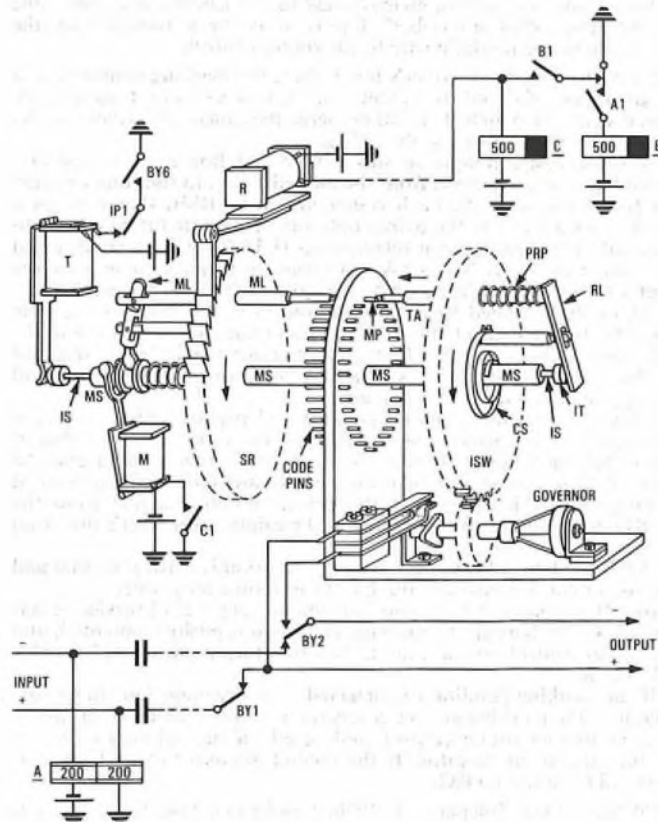



On the initial seizure of relay A, a circuit for magnet R is prepared, and on the first break impulse the marking magnet (M) is operated to withdraw the marking lever (ML) from engagement with the code pins. As each impulse is received, the receiving magnet (R) steps the ratchet wheel. At the end of the first train of pulses, M releases and the marking lever operates the code pin opposite the marking lever. For example, if the first digit is 5 then the fifth code pin from the starting position is operated. Then, in order to send out new pulses, the transmitting magnet (T) is operated which operates the tripping arm (TA) to restore the previously operated code pin. On release of the transmitting magnet the impulse selecting wheel (ISW) rotates under the action of the coiled spring until TA encounters the next operated marking pin. The whole mechanism is so geared that the appropriate number of impulses is sent out whilst TA moves from one marking pin to the next operated pin.

(b) The factors which influence the delay in pulse repetition are:

- (i) the need to store the first incoming pulse train before commencing retransmission to ensure that, should the incoming impulses be of lower frequency than the regenerated impulses, the transmitting side of the mechanism will not overtake the receiving element;
  - (ii) the delay due to pulse distortion;
  - (iii) the delay in repeating the pulses from relay A to magnet R (a small delay); and
  - (iv) the delay due to an incorrectly adjusted dial.
- The minimum delay that may occur would be when the initial digit is a 1 received from a fast dial; that is, approximately 90 ms, plus a relay delay of about 50 ms, giving a total of 140 ms.
- The maximum delay that may occur would be when the initial digit is a 0 from a slow dial, plus the relay delay of 50 ms, giving a total of 1250 ms.

Q8 (a) Explain the principles involved in writing information into, and reading information from, a single ferrite core.

(b) Sketch the threading of a matrix of ferrite cores and explain how its maximum capacity for storing decimal digits is calculated.

(c) Name FOUR other devices suitable for storing decimal digits.

A8 (a) and (b) See A6 (a) and (b), Telephony C 1980, Supplement, Vol. 73, p. 87, Jan. 1981.

In order to store decimal digits, conversion from decimal to binary is required so that, to represent a decimal digit, 4 binary digits or ferrite stores are required. As a practical example, consider a telephone system which requires 5 registers each requiring sufficient ferrite-core matrices for up to 12 digits. As each decimal digit requires a minimum of 4 binary digits (5 when a 2-out-of-5 coding system is employed), then a total of  $5 \times 12 \times 4 = 240$  ferrite cores would be required.

(c) Four other devices suitable for storing decimal digits are

- (i) transistors,
- (ii) relays,
- (iii) magnetic discs or drums, and
- (iv) uniselectors.

Q9 With the aid of a trunking diagram, explain the complete routing of an assistance call from a pay-on-answer coin-box connected to a unit automatic exchange when 100 is dialled. Assume that the traffic is combined with that from levels 9 and 0.

A9 A trunking diagram of the routing of an assistance call from a pay-on-answer coin-box (POACB) connected to a unit automatic exchange (UAX) when 100 is dialled is shown in the sketch. The trunking shows the situation when the auto-manual centre (AMC) is co-sited or close to the GSC (an AMGSC).

At the UAX an originating call from a POACB is allocated a free linefinder/group-selector combination. POACBs are concentrated on level 8 of the linefinder so that a discriminating signal can be sent forward when the mechanism steps to this level. The digit 1 steps the UAX group selector to level 1, which seizes a free junction to the AMGSC via a relay-set and a junction hunter. The traffic at this point is combined with that from levels 9 and 0 of the group selector. The UAX repeats the initial digit 1 to the GSC and stores and repeats the digits 00. At the AMGSC the UAX incoming selector is stepped to level 1, seizes a free second selector which is stepped to level 0. Level 0 is connected to a digit absorption relay-set which absorbs the last

digit 0 and connects the calling POACB to a manual-board-assistance circuit.

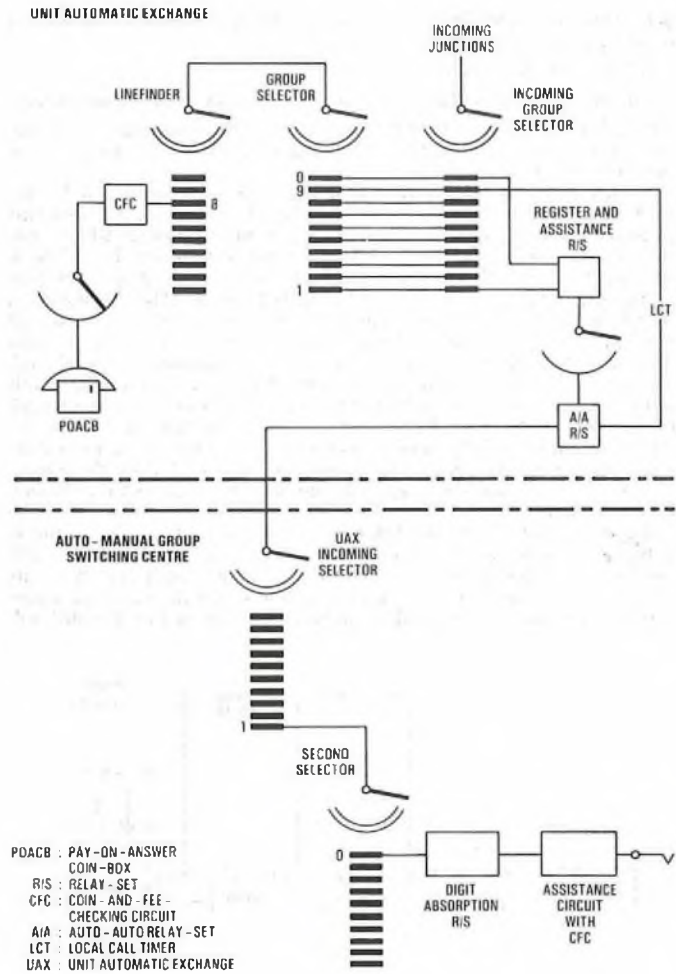

Q10 (a) With the aid of circuit sketches, describe how meter pulses are transmitted from a group switching centre (GSC) to a subscriber's premises.

(b) Explain why different methods are used between the GSC and the local exchange and between the local exchange and the subscriber's premises.

A10 (a) See A8 (b), Telephony C 1978, Supplement, Vol. 72, p. 26, Apr. 1979, and A7 (a), Telephony C 1975, Supplement, Vol. 69, p. 74, Oct. 1976.

(b) The method of signalling meter pulses between the GSC and local exchange uses a line-current reversal, suitably filtered, which is inaudible. This is a form of supervisory signalling which does not affect the line current feed to subscribers at either end of the connexion. In addition, the method is unaffected by earth potential differences between 2 ends of a junction, and is free from signal imitation due to earth and disconnection line faults, contact with other lines and longitudinally-induced voltages from power lines and electric railways. The method of signalling meter pulses from the local exchange to the customer uses AC signalling: any system using DC signalling is likely to cause interruption to speech and data transmission and cause design complications because of the various different customer apparatus line conditions and shared-service arrangements. In addition to this, the AC signalling method does not need a power supply at the customer's end: however, a power supply would be required for a DC signalling method.

**TELEGRAPHY C 1981**  
Students were expected to answer any 6 questions

**Q1** Describe, with the aid of sketches, the operation of equipment in an automatic Telex exchange when

- (a) a subscriber initiates a call, and
- (b) the first digit of the required number is transmitted by the caller.

**A1** (a) [The answer given below is for a typical modern electronic Telex exchange. An answer based on a Strowger Telex exchange would also have been acceptable.]

Sketch (a) shows a typical automatic Telex exchange. Each subscriber is connected to the exchange via a terminator card, and this in turn is connected via 3 buffer cards to a minicomputer which controls the operation of the exchange. Sketch (b) shows the off-hook circuit. When a subscriber initiates a call, the voltage on the forward path is reversed. This is converted to a logical level by the terminator and the load condition is removed from the off-hook counter. This permits the clock pulses applied to the counter to step through until a CARRY-OUT logic condition is produced. The purpose of this counter is to ensure that the equipment responds only to a genuine call condition, and this is determined by the length of time which the call voltage condition has to be present; that is, the time between the initiation of the call voltage and the counter reaching the CARRY-OUT condition. This time can be varied over the range, 0-140 ms by altering the strapping that sets the starting value loaded into the counter.

The CARRY-OUT logic condition serves as the off-hook signal and is applied to 2 bistable circuits and to the driver associated with the off-hook bit in the terminator status register. One bistable circuit then puts the terminator into the NOT-IDLE condition, which, amongst other actions, prevents any more clock pulses being applied to the off-hook

counter. The logic level from the second bistable circuit is converted to a signalling voltage which reverses the polarity on the backward path, thus providing the call-confirmation signal.

Stored in the computer is a module which addresses each terminator status register at 100 ms intervals, looking for the OFF-HOOK condition. When it finds this condition, the module will assign a register to the call. This register consists of a block of memory in which information pertaining to the call will be stored. It will also cause another module to be operated, and this second module temporarily removes the call-confirmation signal and transmits a proceed-to-select message in the following form:

Call Serial Number    Date    Time    PTS (proceed to select)

(b) On receipt of the proceed-to-select message, the caller is able to transmit the selection digits. The signals that make up the first digit will be converted from high signalling level to logic level by the terminator and stored in a buffer register.

Meanwhile, another module in the computer comes into operation and reads the digit stored in the buffer register and transfers this information, either to the register referred to in part (a) above, or to a further block of memory which is linked to it, where the information will await the remaining routing digits.

**Q2** (a) Describe, with the aid of a diagram, the Telex transmission plan, giving typical distortion values, for

- (i) an inland call, and
- (ii) an international call.

(b) Draw a trunking diagram of a Telex gateway exchange.

(c) Explain how an international call is set up through the gateway exchange.

**A2** (a) See A4(a), Telegraphy C 1977, Supplement, Vol. 71, p. 65, Oct. 1978.

(b) and (c) See A9(a), Telegraphy C 1975, Supplement, Vol. 69, p. 71, Oct. 1976.

**Q3** (a) Why is it necessary to provide a filter

- (i) at a teleprinter station connected to an exchange by a pair of twisted wires in a telephone cable,
- (ii) in the send path of each channel in a multi-channel voice-frequency (MCVF) system, and
- (iii) in the receive path of each MCVF channel?

(b) Draw a circuit diagram of EACH type of filter.

(c) Explain, with the aid of graphs, the frequency response of EACH type of filter.

**A3** (a) (i) Teleprinter signals are in square-wave form. These waveforms are made up from a fundamental frequency (dependent on the rate of signalling) together with a large number (theoretically, an infinite number) of the odd harmonics of that fundamental frequency.

Within a multi-pair telephone cable, the higher harmonics could introduce interference into the other pairs of that cable. To avoid this possibility a low-pass filter is provided at the teleprinter station. This filter will pass the fundamental and sufficient low-order odd harmonics for the telegraph signal to remain recognizable, but will attenuate the high-order odd harmonics and so prevent interference.

(ii) A band-pass filter is used to filter out unwanted frequencies; that is, harmonics and/or intermodulation products. This ensures that only those frequencies within the allocated channel band are transmitted to line.

(iii) Again a band-pass filter is used here to separate out the incoming frequencies required for each individual channel, and to exclude any interference frequencies coming from the line which are outside the band for that channel.

(b) See sketches (a) and (b) opposite.

(c) A low-pass filter provides low attenuation at the lower frequencies and high attenuation at frequencies above the cut-off frequency,  $f_c$  (see sketch (c)).

Ideally the cut-off response shape should be a vertical line, but in practice component losses do not provide the ideal response, as shown by the solid line graph in sketch (c).

A band-pass filter provides low attenuation over a limited band of frequencies from  $f_1$  to  $f_2$  (see sketch (d)), and high attenuation at

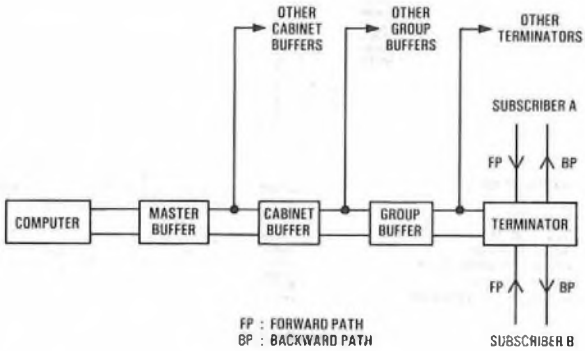

(a)

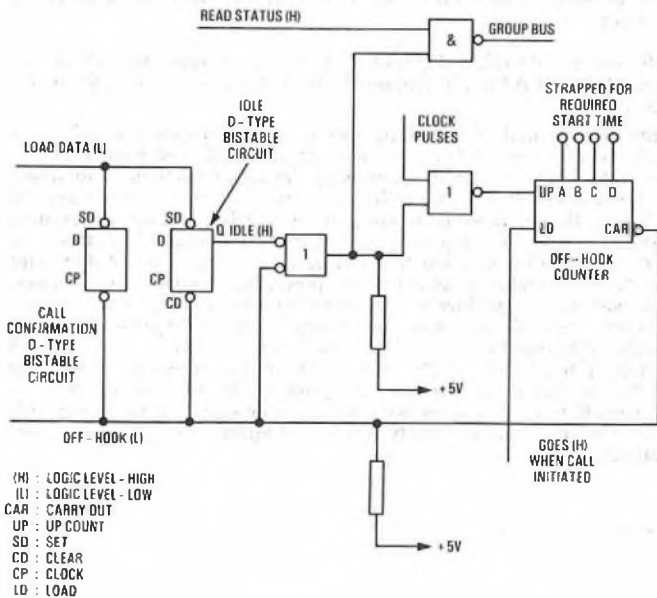

(b)



frequencies outside this limit. The dotted lines show the ideal response, and the solid line indicates the practical response of a good band-pass filter.

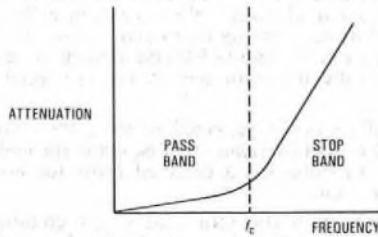
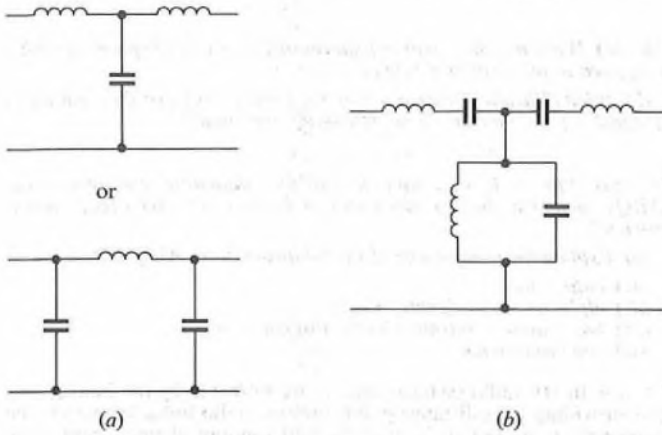

(c) Low-pass filter response

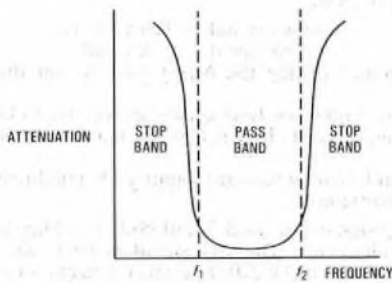

(d) Band-pass filter response

Q4 (a) What considerations would govern the decision to use a message relay system to replace a communications network consisting of private telegraph circuits and Telex terminals?

(b) If a fully automatic system were chosen,

- (i) explain why a rigid message format would be required,
- (ii) give a typical example of the message format, and
- (iii) explain the reasons for EACH section of the format.

(c) State FIVE safeguards which may be provided within an automatic message switch to guard against loss of message.

A4 (a) The considerations governing a decision to change from the use of Telex and leased circuits to an automatic message relay system are:

- (i) finance,
- (ii) speed, and
- (iii) convenience.

Finance, of course, is the prime consideration. The question is, how will the capital, installation, and running costs of a relay system compare with charges for Telex and leased circuits. Generally, where there is a large volume of messages, then the relay system will be financially advantageous. But where the number of messages is comparatively small, then the use of Telex and leased circuits will be cheaper.

Between these extremes, it is not possible to define a break-even point where it becomes viable to change from Telex and leased circuits

to a message relay system. Each case has to be examined on its own merits, and careful calculations of message volume, costs and business convenience must be made. If such an examination indicates a marginal situation, then a decision may well depend on the following considerations:

- (i) If the business, and hence volume of messages, is expanding a relay system may be viable.
- (ii) If the speed of message exchange is a vital factor in the business, then a relay system can provide the necessary speed.
- (iii) The business may regard as important the following advantages which the relay system has over Telex:

- (1) no waiting for engaged lines;
- (2) message queuing system;
- (3) availability of different message priorities;
- (4) automatic switching between the various points on the network;
- (5) duplex working, that is, sending both ways simultaneously, thus providing more efficient use of circuits;
- (6) broadcast facility, in which a message can be sent to all points on the network simultaneously; and
- (7) multi-selection facility, in which a message can be sent to a selected number of points on the network.

(b) (i) A rigid format is essential since the automatic equipment must be able to recognize and take action on the various sections of a message:

- (1) The equipment must be able to recognize the start and the end of each message so that it can deal with each individual message separately.
- (2) Routing instructions take the form of combinations of characters (letters and/or figures), and the equipment must ignore any such combinations occurring in the main text of the message. Therefore, the equipment must be able to differentiate between routing instructions and the text of the message.
- (3) The equipment must recognize the message serial number (in the pilot line) in order that it may use that number to check that there is no missing message.

If a message is not in a rigid format, or is in a format different from the one recognized by the equipment, then that message will be printed out to be dealt with manually at the switching centre.

(ii) A typical message format (IATA) is as follows:

(Note: Phrases and figures in brackets are not part of the format. The phrases are explanatory, and the figures refer to the explanation which follows the format.)

ZCZC (1)	ABC (2)	123 (3)	.....	(Pilot or Heading Line)
QU (4)	BAHTOBA (5)	HKGRRCX (5)	.....	(Address Line)
. (6)	DXBRRCX (7)	120936JP (8)	.....	(Preamble Line)
MESSAGE AND SIGNATURE .....				(Text)
Repetition of figure groups .....				(Collation)
= (9) .....				} (End of Message Sequence)
NNNN (10) .....				

(iii) An explanation of the format is as follows:

- (1) start of message (SOM)
- (2) channel identifier
- (3) message sequence (or serial) number
- (4) priority indicator
- (5) address(es) (2 addresses are shown in the example)
- (6) a full-stop which is the end of address indicator
- (7) originating station
- (8) date and time
- (9) an equals sign indicating the end of the text
- (10) end of message (EOM).

(c) Safeguards which may be provided against loss of message are as follows:

- (i) automatic check of serial numbers;
- (ii) automatic check that SOM and EOM indicators occur alternately thus raising an alarm if a part of a message is missing;
- (iii) messages held in rapid-access short-term store at the transmitting terminal and immediately re-run if necessary;
- (iv) automatic checking and reporting to control point of the status of each circuit in the system;
- (v) provision of duplicate equipment with automatic no-break change-over in the event of equipment failure; and
- (vi) automatic hold to prevent transmission of any further messages on faulty circuits.

Q5 (a) With the aid of a block diagram, explain the operation of a document facsimile receiver.  
 (b) What different standards are necessary to ensure compatibility between machines from different manufacturers?  
 (c) State THREE advantages of facsimile, compared with TELEX, for transmitting documents.

A5 (a) On receipt of a telephone call from the transmitting party and agreement reached on the mode of operation to be used, the facsimile machine is switched to line. The machine may be acoustically coupled to the telephone instrument, or it may be hard-wired to the telephone line. In either case the RECEIVE button is pressed and this initiates the *handshake* process. This consists of the transmitting and receiving machines exchanging interrogation signals which ensure that the 2 machines are working in synchronization. In a frequency-modulated facsimile system, a phasing sequence may be used rather than the *handshake* process which is employed in amplitude-modulated systems.

A motor synchronization circuit controls the motor of the machine and the associated drive module, which causes the drum to rotate and the scanner head to traverse via the helix drive.

The analogue signals received from the telephone line are filtered and passed through the demodulator. The resultant signal is used to control the stylus driver. Hence, a writing voltage is presented at the scanner head and the value of this voltage determines the black or white parameters. Where an electro-sensitive paper is used, the stylus actually burns the paper while traversing the drum.

When transmission and reception of the document is completed, the transmitting machine sends a *stop* signal which operates a *document complete* alarm at the receiving end and switches off the receiving machine.

The operators (sending and receiving ends) may then switch back to voice communication over the telephone circuit to confirm that the document has been received successfully, before clearing down the call.

(ii) It can be used over the existing public switched telephone network and requires no attention while a document is being received.  
 (iii) It provides authenticity of signatures, etc.  
 (iv) It is capable of transmitting diagrams as well as text.

Q6 (a) What are the essential features of Type-A and Type-B signalling as applied to international Telex?  
 (b) What difficulties are caused by the existence of two different types of signalling and how are these difficulties overcome?

Q7 (a) Why is it necessary to provide automatic error-correcting (ARQ) equipment for circuits using high-frequency (HF) radio transmission?  
 (b) Explain the significance of the following in an ARQ system:  
 (i) buffer store,  
 (ii) alpha and beta signals,  
 (iii) the request to retransmit (RQ) signal, and  
 (iv) code conversion.

A7 (a) In HF radio systems, signals are refracted by the ionosphere, thus providing long-distance point-to-point radio links. However, the ionosphere is subject to both cyclic and random changes, and these changes may cause distortion of the HF radio signals being refracted.

In the case of telegraph signals, ionospheric distortion may change a *mark* (Z) signal to a *space* (A) signal or vice versa. Where the 5-unit code is in use, such an alteration of one element will cause a change of character and thus the printing of an error at the receiving terminal.

Automatic error correcting (ARQ) equipment is designed to detect and correct, by fully-automatic means, errors caused by ionospheric distortion.

(b) (i) A buffer store is provided to store the transmitted signals whilst the ARQ system is *cycling*; that is, going through the process of obtaining the correction for a detected error (or errors) caused by ionospheric distortion.

(ii) On a radio path the STOP and START conditions cannot be transmitted as steady DC voltages ( $\pm 80$  V). For a radio link these conditions are replaced by the *beta* and *alpha* signals respectively.

Thus the *beta* signal is transmitted during pauses within a Telex call and the *alpha* signal is transmitted when there is no call (that is, when the circuit is not seized).

That is,  $\alpha$  signal = Telex clear,  
 $\beta$  signal = Telex call.

In leased-circuit working the *beta* signal is sent during all circuit pauses.

The presence of *alpha* or *beta* signals serves also to keep the sending and receiving equipments in synchronization during pauses in signalling.

The *alpha* and *beta* signals are 7-unit code combinations which are not used for characters.

(iii) The RQ signal is a third 7-unit code combination which is not used for any character. The RQ signal is transmitted back to the sending terminal when the ARQ receiver detects an error caused by ionospheric distortion. The RQ signal then triggers off a *correction* cycle in which the last few characters transmitted are recovered from a store at the sending end and re-transmitted.

(iv) The 5-unit code is non-redundant, which means that all possible combinations of the code are used as characters. Any ionospheric distortion which changes the code combination results in a character error.

But, if the 7-unit code is used, all characters can be represented by 3Z/4A combinations. (Leaving 3 spare combinations which are used for the RQ, *alpha* and *beta* signals.) In this code, ionospheric distortion results in a combination which does not represent any character, and which does not have the 3Z/4A ratio. This incorrect ratio is recognized by the ARQ equipment, and is the basic principle on which it works.

Thus, it is necessary to provide code conversion from 5-unit to 7-unit at the sending terminal, and from 7-unit to 5-unit at the receiving terminal. This code conversion at each end allows the ARQ system to be used in conjunction with standard 5-unit teleprinters.

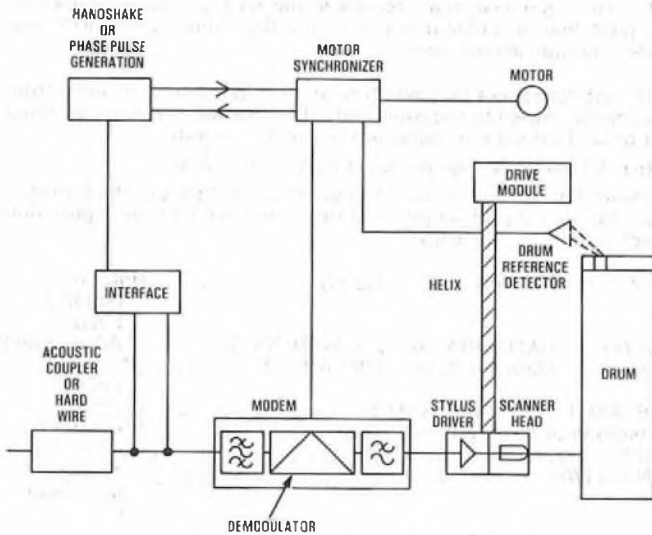

(b)

Requirements for Compatibility	Typical Figures
Index of co-operation	264 $\pm$ 1%
Scanning line length	215 mm
Scanning density	3.85 lines/mm
Input document	A4 (210 $\times$ 297 mm)
Frequency	2100 Hz (white) 1300 Hz (black)
Modulation	FM or AM (same each end)

(c) The advantages of facsimile over Telex are as follows:  
 (i) No typing is required, hence unskilled staff can use the system.

(to be continued)