

RA Roe

THE POST OFFICE © *hd*
ELECTRICAL ENGINEERS'
JOURNAL



Vol. 55 Part 4

JANUARY 1963

CONTENTS

| | Page |
|---|-------------------------|
| A NEW DETECTION SYSTEM FOR TELEVISION AND V.H.F. RADIO RECEIVERS K. G. Burling, A.M.I.E.E., A.M.Brit.I.R.E., and J. C. Fenning | 219 |
| A LINE-CONSTRUCTION VEHICLE W. C. Ward, B.Sc.(Eng.), M.I.E.E. | 226 |
| MONITORING STATION FOR MOBILE-RADIO SERVICES L. T. Arman and E. J. M. Peck | 228 |
| EQUIPMENT FOR THE MEASUREMENT OF SOME CHARACTERISTICS OF THE NOISE IN TELEPHONY AND TELEVISION CHANNELS—D. Turner, B.Sc.(Eng.), A.M.I.E.E. | 231 |
| THE GROUP REFERENCE-PILOT SIGNAL R. W. Naulls | 237 |
| IMPROVEMENTS IN THE TELEPRINTER No. 7 C. E. Easterling, B.Sc., A.M.I.E.E. | 240 |
| NEW CORDLESS P.M.B.X. SWITCHBOARDS—P.M.B.X.s No. 2/3A AND 2/4A C. H. Halliday, A.M.I.E.E., and E. J. Lidbetter | 244 |
| A CONCENTRATOR FOR A TELEGRAPH TAPE-RELAY NETWORK L. A. Meredith | 250 |
| THE BRITISH COMPUTER SOCIETY'S THIRD CONFERENCE, CARDIFF, SEPTEMBER, 1962 | 252 |
| IMPROVEMENTS IN AUTOMATIC ERROR-CORRECTION EQUIPMENT USED ON H.F. RADIO TELEGRAPH SERVICES—A. C. Croisdale, M.B.E., B.Sc.(Eng.), A.M.I.E.E. | 253 |
| PRESSURIZATION OF TELECOMMUNICATION CABLES, Part 1—Principles of Gas Pressuri- zation—J. R. Walters, J. F. Keep and J. F. Craggs | 260 |
| VOLTAGE INCIDENCE AND DURATION COUNTER | 264 |
| THE HIGHGATE WOOD ELECTRONIC TELEPHONE EXCHANGE S. W. Broadhurst, A.M.I.E.E. | 265 |
| SUBSCRIBER-CONTROLLED TRANSFER SERVICE C. D. Vigar, A.M.I.E.E., and J. E. Piesing | 275 |
| NOTES AND COMMENTS | 280 |
| INSTITUTION OF POST OFFICE ELECTRICAL ENGINEERS | 280 |
| REGIONAL NOTES | 281 |
| ASSOCIATE SECTION NOTES | 283, 291 |
| STAFF CHANGES | 285 |
| INDEX TO VOLUME 55 | 288 |
| BOOK REVIEWS | 225, 230, 239, 243, 274 |

Price 2s. 6d. (Post Paid 3s. 6d.)

Published in April, July, October and January by *The Post Office Electrical Engineers' Journal*,
G.P.O., 2-12 Gresham Street, London, E.C.2.

Annual Subscription (post paid): Home and Overseas, 14s. (Canada and U.S.A., 2 dollars 25 cents).

THE POST OFFICE ELECTRICAL ENGINEERS' JOURNAL

Vol. 55 Part 4

JANUARY 1963

A New Detection System for Television and V.H.F. Radio Receivers

K. G. BURLING, A.M.I.E.E., A.M.Brit.I.R.E., and J. C. FENNING†

U.D.C. 621.396.677:621.397.62

Following the introduction of alternative television programs and the rapid increase in the number of television receivers in use, it has become increasingly difficult to detect unlicensed receivers with the existing detector cars. A new system of detection has been developed that overcomes the present difficulties.

INTRODUCTION

THE introduction of television broadcasting by the Independent Television Authority (I.T.A.), coupled with the rapid increase in the number of television receivers in the British Isles, has made the detection of unlicensed receivers by the existing television detectors increasingly difficult. The present system,¹ which was evolved before the I.T.A. came into being, relies on detecting magnetic radiation from the line-deflexion circuits of the television receiver at the second harmonic of the line time-base frequency. The line scan frequencies of the British Broadcasting Corporation (B.B.C.) and I.T.A. transmissions are not accurately synchronized, although each is nominally locked to the 50 c/s mains supply, and the second harmonics of these frequencies may differ instantaneously by several cycles per second. Thus, if two television receivers, one tuned to the B.B.C. and the other to the I.T.A., are close together, the signal received by the detector will be the combined signal from the two time-bases, and the signal-strength meter will follow the amplitude of the combined signal, i.e. it will respond to the beat frequency. This prevents accurate location of the receivers and is the fundamental obstacle to improvement of the existing system.

Further difficulties associated with detecting radiation from the time-base circuits are the low field-strengths encountered, due to improvements in television-receiver design, and the high level of electrical interference occurring at very low frequencies, much of which is generated by the electrical circuits of the detector car itself and cannot be adequately suppressed.

To overcome the difficulties described above a new system of detection has been developed.

†Mr. Burling is in the Home Counties Region; at the time this article was written he was in the Inland Radio Planning and Provision Branch, E.-in-C.'s Office. Mr. Fenning is also in this Branch.

METHODS OF DETECTION

The two most powerful sources of radiation from a modern television receiver are the line time-base circuits and the frequency-changing oscillator. Radiation from the line time-base can be detected owing to the existence of a low-frequency magnetic-induction field. The system in current use for detecting this radiation, although straightforward in design, has the drawbacks mentioned earlier. The frequency-changing oscillator supplies the energy for a radio-frequency electromagnetic wave that can be radiated from the receiver chassis, the aerial feeder and the aerial.

Detection of radiation due to the frequency-changing oscillator is more complicated than the detection of radiation from the line time-base owing to the variety of frequencies at which radiation occurs, the poor frequency-stability of the frequency-changing oscillator and the fact that several receivers in close proximity can radiate signals with very little frequency separation. Techniques have been developed that take account of these factors, however, and the new system is based on detecting radiation caused by the frequency-changing oscillator. All television and v.h.f. broadcast receivers now made commercially are superheterodynes and the new system is therefore fully effective.

Frequency Range of Oscillator Radiations

Television receivers of modern design have a nominal vision intermediate frequency (i.f.) of 34.65 Mc/s, but older sets still in service use frequencies around 13.5 and 16 Mc/s.

Nearly all the oscillators of receivers with an i.f. of 13.5 Mc/s operate at a lower frequency than that of the signal being received, and nearly all the oscillators of receivers with a 16 Mc/s i.f. operate at a higher frequency than that of the signal being received. In modern receivers having the standard i.f. of 34.65 Mc/s the oscillator frequency is invariably higher than that of the signal. V.H.F. sound broadcast receivers employ a 10.7 Mc/s i.f., and the oscillator frequency may be above or below that of the signal being received. At least two television channels may be received in a given area on

most receivers having either 16 or 34.65 Mc/s i.f.s, and in fringe areas a particular program may be received on two or more channels. Oscillator radiations from television and v.h.f. sound receivers therefore cover a wide frequency spectrum, the range being approximately 29-240 Mc/s.

Receivers tuned to the same signal and having the same nominal i.f. do not radiate at precisely the same frequency. The frequency difference between adjacent receivers may vary from a few kilocycles to several megacycles, depending on the tuning adjustment of the receiver. Owing to oscillator temperature-drift and manual operation of the receiver tuning, the frequency of radiation is not constant, and generally a slow drift can be observed. The electrical coupling between the oscillator and aerial circuits in a receiver is small, and oscillator radiation is mainly caused by chassis currents in the turret tuner and receiver, the short electrical paths favouring the radiation of harmonics of oscillators operating on the lower frequencies. By detecting these harmonics, the frequency coverage needed in a detection system may be reduced considerably.

Field Strengths of Oscillator Radiations

The signal that has to be detected is an unwanted radiation from the receiver, and the radio industry is being urged to reduce such radiation in order to minimize interference. The radiation limits specified by the British Standards Institution² at a distance of 3 metres are equivalent to field strengths at a minimum practical detection distance (10 metres) of approximately $20 \mu\text{V/m}$ in the bands used for television and v.h.f. sound broadcasting and $50 \mu\text{V/m}$ outside these bands. The figures specified by the British Standards Institution set a limit to the maximum field strength that may occur in any direction on an open test site. The radiation from a receiver that complies with these recommendations may be considerably lower than this in some directions and be further attenuated by the screening effect of a building.

Aerial Performance Requirements

As well as covering a wide frequency band, oscillator radiations are of random polarization. Most direction-finding aerials respond only to signals polarized in a single plane. Two difficulties arise when an aerial that responds to polarization in a single plane is used to locate the sources of signals of random polarization:

(a) Since the aerial tends to reject signals polarized at right angles to its plane of maximum response, its sensitivity is low to such signals. Experiments have shown that this reduction in sensitivity, which is very large in free space, may still be as great as 26-30 db when reflections are present. Under these conditions, secondary signal pick-up becomes important. Any metallic components of the aerial structure having appreciable dimensions in the plane of polarization of the direct or reflected signal may re-radiate to the aerial elements and cause bearing errors.

(b) Signals usually suffer some rotation of the plane of polarization on reflection, and a linearly polarized aerial may be more sensitive to a wave that has been rotated in this way than to the direct radiation. Thus, the reflected signal may appear to be stronger than that which arrives by the direct path, and a bearing error may result.

These difficulties may be avoided by the use of an aerial that responds to signals of random polarization.

The ideal aerial would be circularly polarized, but negligible errors result from the use of an elliptically polarized aerial with a small axial ratio. Many aerials of this type exist, but to be effective in the required application the aerial must also have a wide frequency band, good directivity and gain, small size, and freedom from beam splitting and tilting (i.e. the electrical and mechanical axes of the aerial must bear a constant relationship to each other when the frequency and plane of polarization are varied). Such a specification leaves a very limited choice in the type of aerial that can be used for the detection system being described.

PRINCIPLE OF OPERATION OF NEW EQUIPMENT

The new equipment consists of a steerable v.h.f. broadband, elliptically-polarized, direction-finding aerial mounted on the roof of an estate car and feeding a sensitive and highly-stable panoramic receiver. Location of unlicensed receivers is achieved by taking bearings from different positions. Thus the room in the house in which the receiver is operating may be determined readily. This differs basically from the existing system, which can normally give only one bearing because the loop aerials used are not steerable. This has not been a serious handicap owing to the low sensitivity of the system, but signals may often be detected at several hundred yards range with the new system and a steerable aerial is therefore essential.

In order to make maximum use of the directional properties of the aerial, a combined periscope and optical projector are mounted on the roof of the car and mechanically coupled to the rotating aerial.

The new system operates over a frequency range of 110-250 Mc/s. By detecting harmonics of radiations from receivers tuned to bands I and II and the fundamental radiations from receivers tuned to band III, receivers tuned to any of the v.h.f. channels used for television and f.m. sound broadcasting can be located.

DESCRIPTION OF NEW EQUIPMENT

Aerial

A number of types of aerial were investigated using scale-model techniques at u.h.f. The aerial finally adopted consists of a tilted dipole in a corner reflector (Fig. 1). End screens have been fitted to the reflector to eliminate beam tilt resulting from the presence of the vehicle roof. An optimum angle of tilt for the dipole was determined that gave elliptical polarization over a $2\frac{1}{2}:1$ frequency range without serious degradation of directivity and gain. A useful frequency range from 110 Mc/s to over 250 Mc/s has been achieved, the lower frequency limit being set by the maximum permissible dimensions of the aerial. The gain of the aerial varies with frequency and plane of polarization, but it is approximately equal to that of a resonant dipole. The half-power beam width varies between 45° and 60° over most of the frequency range, but it increases to 90° at the lower end. The ratio of amplitudes of the main response to all other responses (front-to-back ratio) is generally greater than 20 db, but it falls at lower frequencies when the plane of polarization of the signal lies within certain narrow angles.

With a good signal, a bearing accuracy of about 5° may normally be achieved and, even when the signal-to-noise ratio is poor, the mean of several bearings will usually give this order of accuracy. Thus, location is normally within about $3\frac{1}{2}$ ft laterally at a detection distance of 40 ft.



FIG. 1—DETECTOR CAR AND AERIAL

The aerial is constructed of anodized aluminium-alloy tubing and expanded and flattened sheet, the gauge, mesh dimensions and type of alloy being chosen to give minimum weight and wind resistance and maximum screening efficiency. The screen and dipole are supported by a tubular centre spine and transverse tubes of epoxy-resinated woven fibre glass giving great strength and a degree of shock resilience and eliminating electrically-conducting materials from within the screen. Any component of the aerial may be readily removed for replacement in the event of damage, a welded structure being avoided for this reason.

The assembly is mounted on a 2 in. diameter anodized aluminium-alloy mast tube carrying at its upper end a shrunk-on stainless-steel journal running in a self-aligning nylon sleeve. These materials may be run dry, although a grease-groove is provided. The bearing arrangement allows for flexing of the car body and vertical displacement of the roof. A nylon cam mounted on the stainless-steel journal displaces a roller cam-follower as the aerial rotates, and the linear displacement of the follower is transmitted by a steel shaft sliding in lead-polytetrafluorethylene-loaded sintered-bronze sleeves. This shaft rotates the optical system in a periscope that acts as a sighting device. All the bearing surfaces are designed to operate without lubrication or maintenance for a considerable period. A large-diameter shallow ring, integral with the housing of the self-aligning bearing, transfers the wind load on the aerial to the car roof and eliminates the risk of the thin-steel roof shearing at the bolt holes.

Water sealing at the point where the mast tube penetrates the car roof is achieved with a labyrinth of interleaved sharp-edged rings, spaced to avoid capillary action. Any water which is blown in by wind pressure is trapped in a nylon gutter and discharged on to the car roof. Thus the friction and capillary action associated with a stuffed gland are avoided and the movement of the self-aligning bearing is not restricted.

The lower end of the mast tube is supported by a

self-aligning ball journal that carries the static load of the aerial and is mounted on a platform welded on to the propeller-shaft tunnel of the car at the point where it joins the rear seat box. The load is therefore carried by the strongest part of the car floor. Integral with the lower bearing is a rotating coaxial joint carrying the aerial feeder to a socket on the bearing housing. This joint permits continuous rotation of the mast, and consists of a doubly-tapered coaxial line with mercury-wetted contacts on the inner and outer conductors at the point of largest diameter; the assembly is shown in Fig. 2. This method of construction was chosen because

(i) it avoids variations in coupling when the joint is rotated, such as occur with inductive couplings in this frequency band,

(ii) the coupling loss is insignificant, being immeasurable with ordinary measuring equipment, and there is no variation with frequency such as occurs with a practical capacitive coupling,

(iii) the joint is free from the contact noise inevitable with metal-to-metal contacts employed at very low signal levels,



FIG. 2—LOWER AERIAL-MAST BEARING AND COAXIAL COUPLING

(iv) no contact wear occurs, and

(v) it does not restrict the self-aligning action of the lower bearing.

It is interesting to note that severe contamination of the mercury due to amalgamation or to oil films has no measurable effect on the coupling because the self-capacitance of the very thin contaminating films is

sufficiently high to provide a low-impedance path at the frequencies employed.

The upper half of the coupling, which is carried by the mast tube, has a balance-to-unbalance transformer attached to it, and a screened balanced-twin feeder connects the transformer to the dipole. The degree of balance is sufficient to reject signals induced in the section of feeder passing up the fibre-glass tube. A rubber piston-ring round the upper half of the coupling prevents moisture that has condensed in the mast entering the coupling, and a drain hole is provided in the mast. Glass-loaded polytetrafluorethylene sliding joints are employed to retain the mercury in the coupling, this material being chosen because of its low friction, low rate of wear and its chemical inertness.

A 12 in. diameter steering wheel is mounted on the mast tube at a convenient height for the operator to rotate the aerial with his right hand. When the car is in motion the aerial rotates initially to the position of least wind resistance. The wind pressure then causes progressive stiffening of the upper mast bearing, so that at speeds in excess of 30 mile/h it needs some force to rotate the aerial. The vehicle is, therefore, stable at speed and no clamp is provided for the aerial.

The size of the aerial has been restricted so that the overall height of the vehicle (9 ft 9 in.) is less than that of commercial vehicles normally using tree-lined residential streets. In plan, the aerial at all angles of rotation remains within the outline of the vehicle.

Panoramic Receiver

In order to resolve the radiated signals, which may have a small frequency separation, a narrow i.f. bandwidth is necessary. The frequency stability of such signals is poor, and to avoid laborious searching with a narrow-band receiver, panoramic presentation is employed. The receiver is a triple superheterodyne employing i.f.s of 35 Mc/s, 30 Mc/s and 450 kc/s and having an overall bandwidth of 7 kc/s. Fig. 3 is a block schematic diagram of the receiver. The input stage is a modified 14-position

television turret-tuner employing a low-noise cascade amplifier, frequency-changer and stable oscillator. A high-pass filter is employed in the aerial circuit to prevent i.f. break-through. The tuner, which has continuous frequency coverage from 110 to 250 Mc/s, is followed by a broadband i.f. amplifier having a centre frequency of 35 Mc/s and an overall bandwidth of 8 Mc/s. A buffer stage separates the 35 Mc/s amplifier from the sweep oscillator.

The frequency sweep is achieved by varying the current in an inductor magnetically-coupled to the frequency-determining inductor in the oscillator circuit. This varies the reluctance of the ferrite core and alters the value of the tuning inductance. By this means a constant-percentage frequency sweep is obtained when the centre frequency is varied over a 10 Mc/s range. The amplifier that supplies the biasing current is coupled to the horizontal time-base of the cathode-ray tube (c.r.t.). The drive may be varied so that the frequency sweep may be reduced from a maximum of 8 Mc/s to zero. This enables the operator to select one signal from a number on the screen and expand it as required, filling the screen if necessary. By reducing the sweep to zero the operator may listen to the signal on headphones. Since the overall bandwidth of the receiver is 7 kc/s and the highest input frequency is 250 Mc/s, an extremely low residual frequency-modulation is necessary when zero sweep is required, and the h.t. and heater supplies to the f.m. drive amplifier are derived from an extremely stable source.

The succeeding stages in the receiver are conventional, but extensive filtering and screening have been employed throughout the receiver to ensure the complete absence of internally-generated spurious signals and spurious responses to external signals of the field strengths normally encountered, over the entire sound broadcast and v.h.f. range.

The detected signals are displayed on a 5 in. c.r.t. employing 3 kV e.h.t. The minimum input signal visible above the receiver noise is about 10 db below

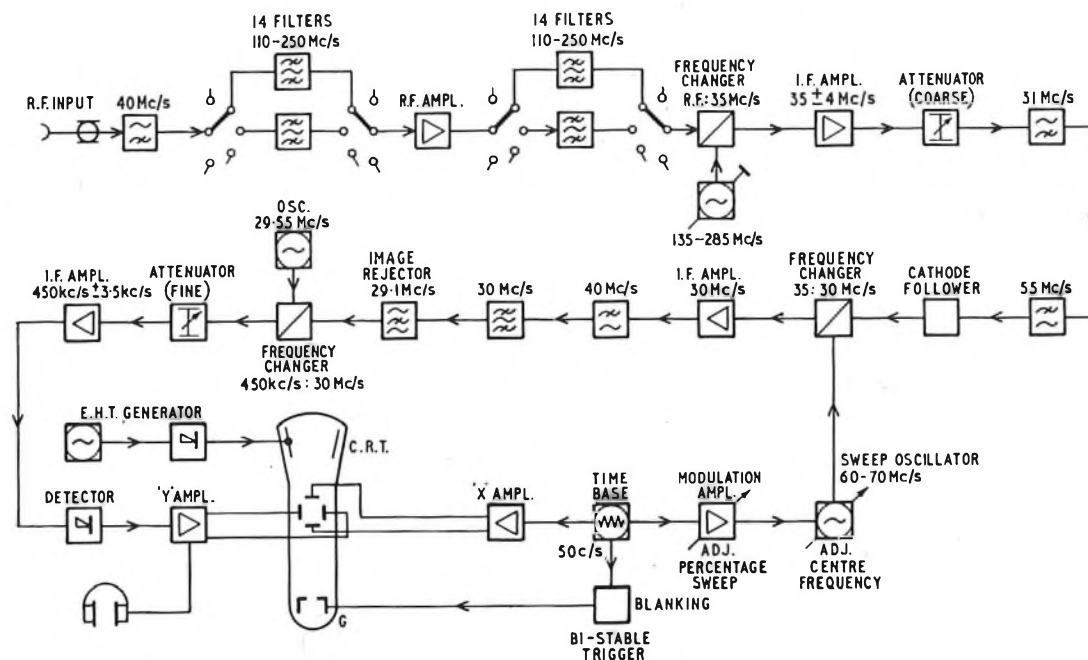

FIG. 3—BLOCK SCHEMATIC DIAGRAM OF PANORAMIC RECEIVER

1 μ V, giving the detector system an overall sensitivity in the region of 1 μ V/m. The intensity of the trace on the c.r.t. is dependent on the number of times the electron beam follows the same path on the screen, a single sweep of the time-base producing a very weak trace. Impulsive interference, being of random frequency and amplitude, does not produce trace-brightening by repetition, and continuous-wave signals of low amplitude can be easily seen in the presence of high-amplitude impulsive noise. Thus it is possible to operate the detector in the presence of ignition noise at least 20 db greater than the wanted signal.

Illuminated dials are provided on the receiver controls, which are grouped for ease of operation in the dark, and a rubber mask shields the c.r.t. from bright daylight and protects the operator from possible injury in the event of an accident to the vehicle. The receiver is mounted so that it can pivot on horizontal shafts projecting through clearance holes in the case at the centre of gravity. It is normally held at the desired angle by clutches that can be released by rotating external handwheels on either side of the case, but residual friction due to spring-loading prevents damage due to rapid movement, and the range is restricted to about 30°. The handwheels also serve to secure the receiver on a tubular-steel stand that is mounted on ball-bearing slides to give fore and aft movement of the receiver. The slides may be locked in any desired position by a ratchet mechanism operated by a push-button on the stand. Fig. 4 shows the receiver mounted on its stand.

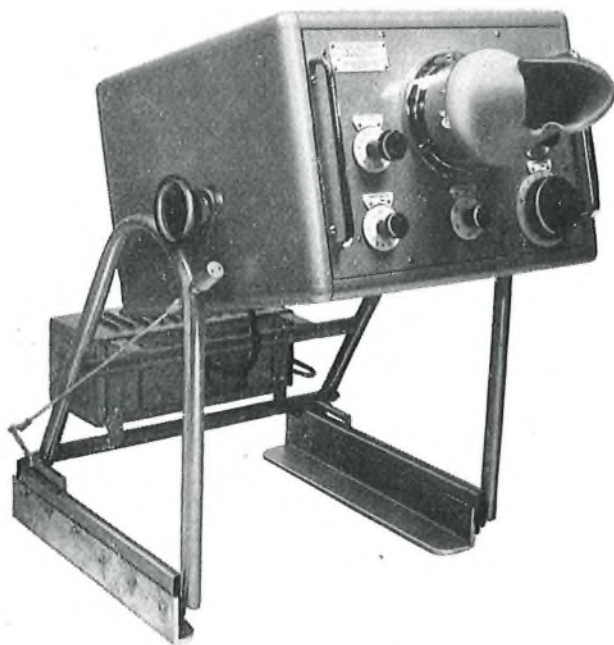

FIG. 4—PANORAMIC RECEIVER MOUNTED ON ITS STAND

Periscope and Optical Projector

In order to utilize fully the directional properties of the aerial a sighting device is necessary. A simple sight attached to the aerial mast inside the car would be unsatisfactory because of the low roof height, the obstructions caused by roof pillars and the occupants' heads and the fact that the sight would rotate with the aerial, requiring the operator to follow suit. Also, such a device would be ineffective in poorly-lit streets. This

problem has been solved by mounting a rotating periscope through the roof of the car and coupling it mechanically with the aerial mast. Scanning periscopes of the submarine type are well known, but these suffer from the disadvantage that the viewer must rotate with the periscope. This rotation may be avoided by interposing a Dove prism in the optical path and contra-rotating it at half the speed of the viewing head. If a useful angle of view and long optical path are required this leads to a complicated and expensive optical and mechanical system, and an alternative system has been devised.

The scanning element of the periscope is a "Prismor" consisting of two right-angled prisms with their hypoteneuses cemented and silvered at the interface. The prism is rotated about a vertical axis parallel to the interface at half the speed of the aerial mast. The angular position of the viewer's line of sight remains constant as the prism scans, and the view is transferred to the operator by two mirrors and four achromatic lenses, all the optical elements being anti-reflection coated. A masking drum with a viewing aperture is rotated round the prism at the same speed as the aerial mast, to exclude extraneous light. The operator views a 25° arc of the external scene with a vertical line superimposed, indicating the direction of propagation of the signal received by the aerial. The magnification of the periscope is slightly greater than unity.

When the ambient-light intensity is too low for effective viewing, a stage carrying a 48-watt projection lamp may be rotated into the optical path by means of an external knob, the eyepiece being simultaneously masked. By means of a switch biased to the off position, the operator may momentarily project a very narrow beam of light on to the house in which the detected receiver is operating. Internal masking prevents the light beam being projected on the offside of the car. The principle of the optical system is illustrated in Fig. 5.

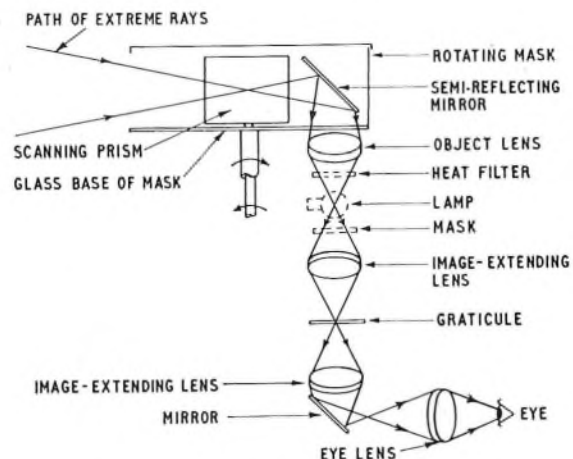

FIG. 5—PRINCIPLE OF OPTICAL SYSTEM

A fully-g geared mechanism coupling the aerial mast to the periscope would use large-diameter gears, owing to the large diameter of the mast. These would be bulky and it would be difficult to reduce backlash without introducing excessive friction. However, since it is not possible to mount the periscope coaxially with the aerial mast, there is a blind spot on the offside of the car (a direction not normally used for detection). The cam drive, already

described in the aerial section, has therefore been employed, the return stroke of the cam taking place at the blind spot. The cam-follower imparts linear motion to a sliding rod carrying a brass rack. The rack engages with a molybdenum-disulphide-loaded nylon pinion, the first in a train of alternate brass and loaded-nylon gears driving the masking drum. The drive to the prism is direct from the first pinion, and the train is loaded by a clock spring on the second pinion, which eliminates backlash and ensures continuous contact between the cam and follower. Miniature ball-journals and lead-polytetrafluorethylene-loaded sintered-bronze bearings are used throughout, and no lubrication or maintenance, apart from occasional replacement of the lamp, are necessary.

Effective water-sealing of the periscope, which is shown in Fig. 6, has been achieved by avoiding an

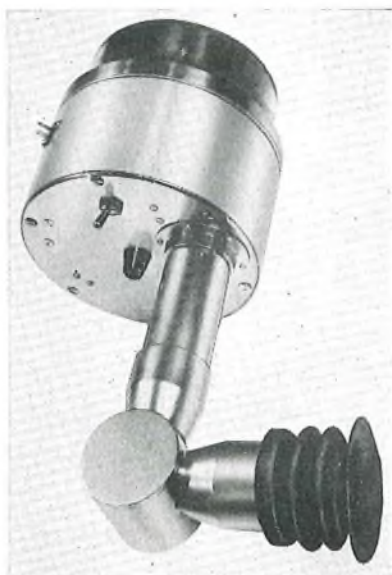

FIG. 6—PERISCOPE

exposed rotating head, the rotating mechanism being enclosed in a fixed glass dome projecting through the roof of the car.

Power Unit

The power supplies are derived from the vehicle battery, and wide variations in supply voltage can occur in service. In order to keep the receiver oscillator drift and residual frequency modulation within acceptable limits it is necessary for the receiver h.t. supplies and some of the heater supplies to be stabilized, a minimum stability of 1 part in 1,000 being required. Also, the efficiency of the power unit must be high because of the limited capacity of the vehicle battery and generator. These considerations preclude the use of a rotary converter or carbon-pile regulator, and, similarly, neither an electronic-valve series stabilizer nor shunt regulator is suitable.

In the power unit described below (Fig. 7), the very low voltage-drop between emitter and collector of a transistor in the current-saturated condition has been exploited, resulting in a regulator and voltage converter of very high efficiency. The high-voltage power supplies are generated by a push-pull self-oscillating transistor inverter, operating at a frequency of 475 c/s and employing a

saturated low-hysteresis transformer. The square-wave output from the transformer secondary windings is rectified by bridge-connected, silicon-junction rectifiers, and filters reduce the output ripple to a few millivolts. A third secondary winding, insulated to withstand a potential of 3 kV from earth, provides an isolated and stabilized a.c. heater supply for the c.r.t., which operates with a negative e.h.t. supply connected to the cathode.

Owing to the minimum achievable voltage-drop across the control element being large, it is usual to employ a series stabilizer in the high-voltage output of an inverter. This voltage-drop is much reduced when a transistor is used as the control element, but a protective circuit is necessary to prevent a destructive voltage appearing across the transistor in the event of a momentarily short-circuited load. Furthermore, a separate regulator is required for each output from the converter, and an unrectified output cannot be stabilized. These difficulties have been avoided by inserting the voltage-control element in the input circuit of the regulator (Fig. 7) and a low-output impedance has been achieved by deriving the error signal for the feedback amplifier from the 300-volt output. Close control is exercised over those outputs that are not included in the feedback loop because of the very low transformer secondary resistance and leakage reactance and the low-resistance ripple filters. The regulated input to the inverter also provides a stable heater supply for the turret tuner and modulation amplifier in the receiver.

Currents up to 10 amp may be handled by the series-regulator transistor, with a minimum voltage drop of 1.2 volts, and a shunt resistor with a large cooling surface reduces the power dissipated in the transistor to a maximum of 15 watts, although the maximum dissipation of the regulator may reach 60 watts when the battery voltage is high. The minimum power loss in the loaded regulator when the battery voltage is low is 10.5 watts.

The silicon-transistor differential amplifier (long-tailed pair) ensures a low temperature-drift and reduces the load on the reference diode by a factor of 40. The overall current-gain of the regulator amplifier at low frequencies is about $4\frac{1}{2}$ million, and a secondary internal negative-feedback path maintains stability by reducing the gain as the frequency increases. Owing to the high transfer impedance of the inverter, which is included in the external feedback loop, the regulator does not entirely remove the ripple in the output and an additional ripple filter has been used.

The power unit can operate with an input voltage range of 11.2–16.5 volts and an ambient-temperature range of 0°–45°C, with a short-term stability of a few millivolts. The total power consumption of the receiver and power unit is about 130 watts.

DETECTION VEHICLE

The detection equipment is mounted in a modified Series 5 Morris Oxford Traveller, the panoramic receiver and power unit being in the position normally occupied by the nearside front passenger seat. The operator sits in the nearside rear seat and a Postal and Telegraph Officer occupies the offside rear seat. A shielded map-reading light is fitted to the rear of the driver's seat for the use of the postal officer. The driver's view is unobstructed by the equipment except for the central mast tube and the periscope, which are visible

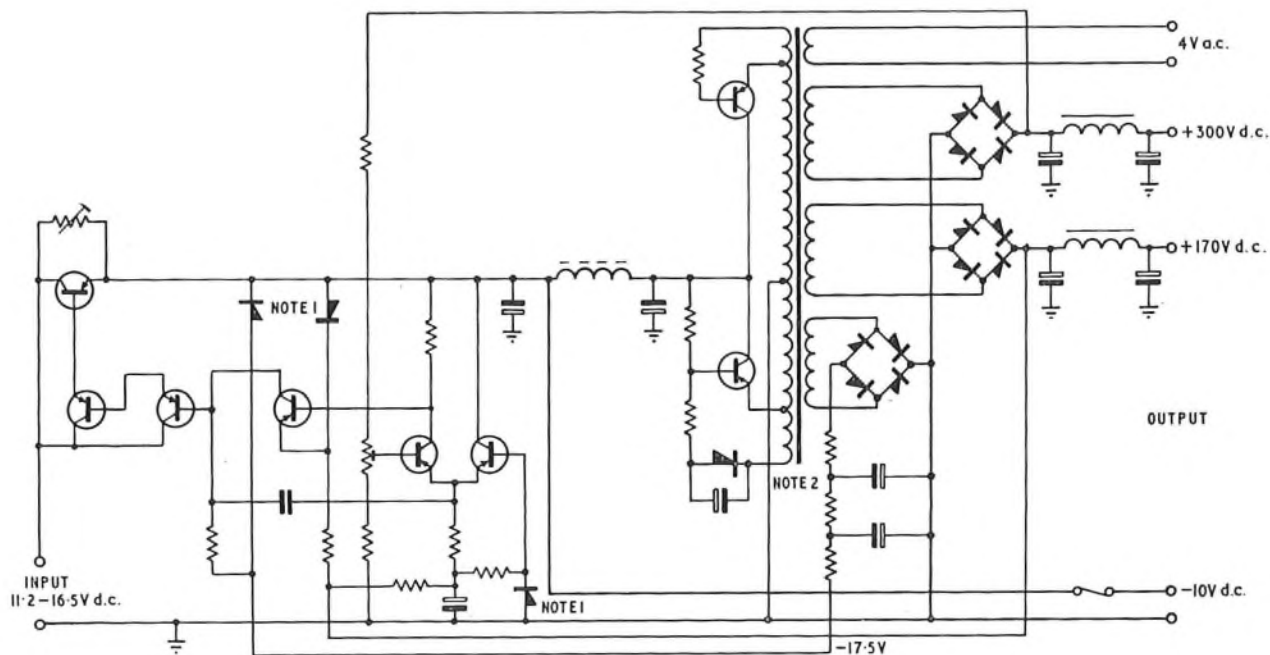

Notes:
 1. Zener diodes.
 2. Saturated low-hysteresis transformer.

FIG. 7—CIRCUIT OF POWER UNIT

in the internal mirror. Wing mirrors are provided, the nearside mirror being adjusted to show the clearance between the aerial and roadside trees when the car is tilted by a steep road camber.

A 3-phase, self-excited a.c. shunt generator, belt-driven by the engine and operating at a maximum speed of 11,000 rev/min, supplies a maximum output of 800 watts. The current in the rotating field-winding of the generator is controlled by a transistor-amplified vibrator-type regulator, and the stator output is rectified by bridge-connected silicon-junction diodes and used to charge the vehicle batteries. The two series-connected 6-volt batteries of 110 ampere-hours capacity are enclosed behind the rear seat in sealed cases vented on the underside of the car. The detection equipment is normally operated with the vehicle stationary and the engine idling. Under these conditions the output of the generator is sufficient to balance the electrical load.

A fully-screened and suppressed ignition system is fitted to the vehicle, and radio-interference suppressors have been fitted to the windscreen wipers, petrol pump, heater booster and clock.

The standard fresh-air, heating and ventilating unit of 2.75 kW capacity utilizes waste engine heat.

CONCLUSION

The equipment was designed by the Post Office Engineering Department and to speed the replacement of the previous system, all the panoramic receivers were produced by the Department. To reduce lost time due to maintenance, the individual units of the equipment are designed to be removed with a minimum of dismantling and exchanged with spare units.

It is expected that the new detection equipment will avoid the difficulties experienced with the existing system and provide more accurate location of receivers, particularly in densely-populated areas. The greater sensitivity of the new equipment should also be useful in sparsely-populated areas, where a close approach to a house may cause an unlicensed receiver to be switched off before it is located.

References

- ¹BRAY, W. J. The Detection of Television Receivers. *P.O.E.E.J.*, Vol. 45, p. 49, July 1952.
- ²British Standard 905:1959. Interference Characteristics and Performance of Radio Receiving Equipment for Aural and Visual Reproduction. (British Standards Institution.)
- ³WHYTE, J. N. A New Optical Method for Wide Angle Tracking. *Instrument Practice*, Vol. 14, p. 36, Jan. 1960.

Book Review

"Solutions of Problems in Electrical Measurements". A. C. Shotton, B.Sc., A.M.I.E.E., A.M.Brit.I.R.E. Sir Isaac Pitman & Sons, Ltd. ix + 141 pp. 94 ill. 15s.

This book has been written to assist students of elementary electrical measurements. It provides detailed solutions to selected problems from past papers of various examining authorities, including The Institution of Electrical Engineers and The City and Guilds of London Institute. The problems are classified under six chapter headings covering units and

dimensions, circuit theorems, bridges and potentiometers, permanent-magnet calculations, instruments, and electronic measurements. Following the solutions given in each chapter there are graded exercises together with their numerical answers.

The standard aimed at by the author is that of the second year of an electrical engineering degree course, with additional material included to meet the requirements of the Higher National Certificate syllabus for electrical measurements.

A Line-Construction Vehicle

W. C. WARD, B.Sc.(Eng.), M.I.E.E.†

U.D.C. 629.114.7 : 621.315.177

A new type of utility vehicle equipped with hydraulically-operated mechanical aids is described. These aids include a derrick that can be rotated through 360°, a pole-hole borer and a heavy-duty winch.

INTRODUCTION

THE line-construction vehicle is essentially a utility vehicle for use by a general-purpose external working party. It is equipped with a versatile power-operated derrick and a heavy-duty winch; a

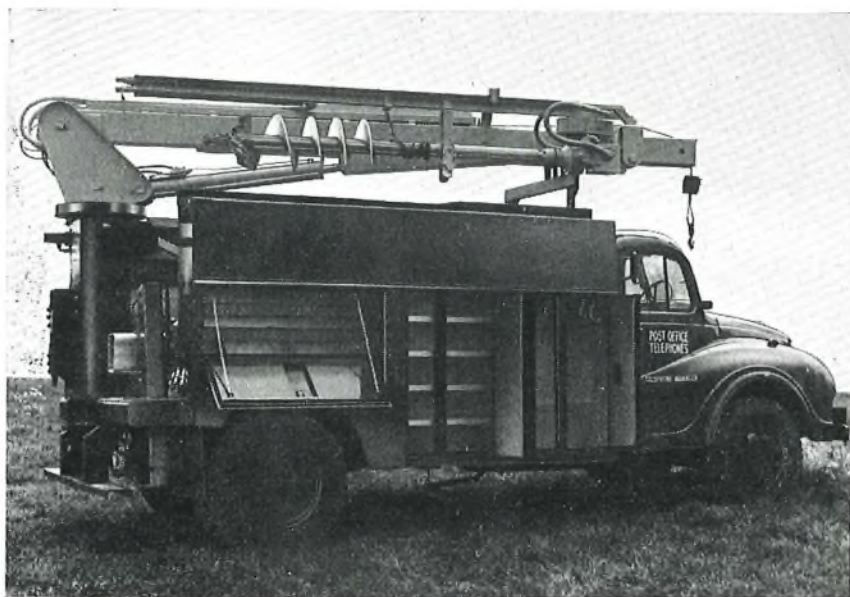

FIG. 1—THE NEW LINE-CONSTRUCTION VEHICLE

pole-hole borer may be permanently attached to the derrick if required. Units of this type have been in use in America for a number of years, but until recently all had derricks, operated either from the front or the rear of the vehicle, that were incapable of rotation. While such units can operate efficiently where there is space to manoeuvre, they would be severely handicapped under the conditions usual in the British Isles, where telecommunications external plant is almost invariably at the roadside, and a large vehicle positioned across the highway could not be tolerated in most situations where it would have to work.

Recently, corner-mounted rotating derricks have been developed in America, and these enable the derrick and pole-hole borer to operate over a large area with the vehicle parked at the kerb-side, and there appears to be good scope for the operation of such equipment in this country. A small number of similarly-equipped vehicles is therefore being obtained for trial. Their use should remove much of the heavy lifting and digging from external work and should increase output. The fact that ample power is available for all operations and that

all loading and unloading can be carried out mechanically should materially reduce accident risks.

THE NEW VEHICLE

A general view of one of the new vehicles is shown in Fig. 1. The chassis is a 5/7-ton British Motor Corporation diesel unit (i.e. a nominal 5-ton chassis with 7-ton 2-speed rear axle). The drive from the rear of the engine is fed to a split-shaft power take-off that enables full engine power to be used, if required, to drive hydraulic pumps for operating the mechanical accessories. This full-power take-off is in effect a mechanical switch that connects the drive either to the back axle for propulsion or to the hydraulic pumps for operating the mechanical aids; it is controlled electrically from a switch in the cab. When the power take-off is coupled to the hydraulic pumps, a brake is applied to the shaft that drives the vehicle rear axle, to take the place of engine braking.

The tandem hydraulic pumps circulate oil at 2,000 lb/in² and 45 and 14.4 gallons/minute, respectively. Alternatively, if facilities for operating a pole-hole borer are not needed, a single pump can be used and a light-duty power take-off, known as an S.A.E. (Society of Automobile Engineers) power take-off, is fitted to the side of the gearbox.

The body is of plated-steel construction and of the open-well type, with cupboards and lockers on the outside; the open well in the body facilitates loading and unloading. The derrick and winch between them can be used to load and unload all heavy stores and tools. The side cupboards and lockers store the lighter tools, stores and clothing; they give good access without the necessity for climbing inside the vehicle, although they have the disadvantage that some are necessarily on the side of the vehicle exposed to traffic.

The vehicle is intended for operation by two men, and the bodywork is not designed for conveying additional staff. The vehicles will probably be used in conjunction with 110-volt generating sets and a range of electrically-operated tools, and these, together with the other mechanical aids, should go far towards mechanizing the work of external working parties.

Derrick

The boom of the derrick is 17 ft 2 in. long from its centre of rotation, but it has an extending section called a "stinger" that extends the length to 23 ft. The derrick reaches from 3½ ft above the ground to a maximum height of 33 ft. It has a head sheave over which the winch-line passes and it can lift 2,000 lb at 23 ft radius. It can be rotated continuously in either direction.

† External Plant and Protection Branch, E.-in-C.'s Office.

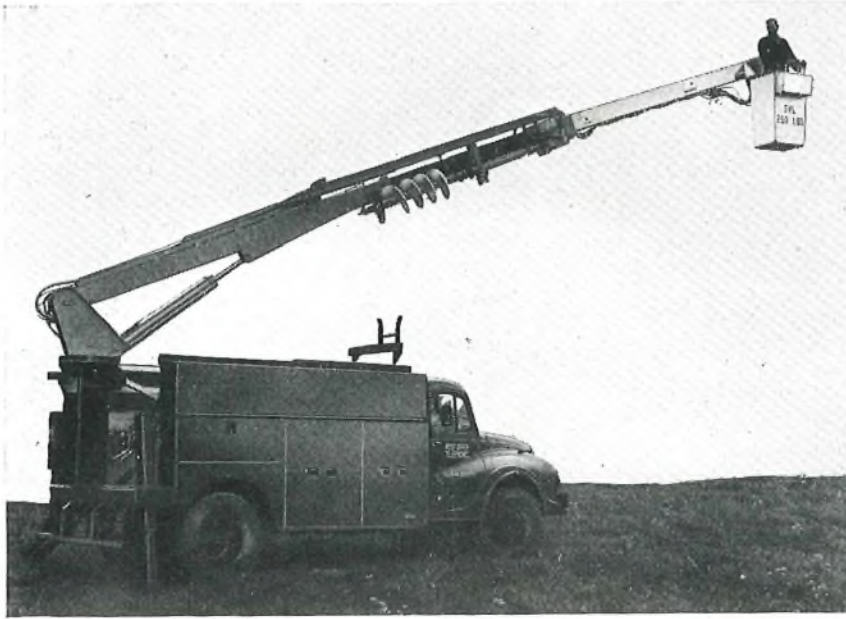

FIG. 2—DERRICK AND PERSONNEL BUCKET IN OPERATION

A fibre-glass boom-extension and personnel bucket can be fitted to the derrick for lifting men aloft, e.g. for tree cutting, aerial-cable maintenance or work on decayed poles. If a personnel bucket is fitted, the hydraulic controls may be extended to the bucket if required, and under these conditions a hydraulic power supply is available on the bucket for operating tools. The whole of the bucket system is insulated to guard against accidents due to contact with power wires. Fig. 2 shows the derrick operating with the personnel bucket in use.

The derrick can be used for a variety of operations, including loading and unloading the vehicle itself, loading and unloading poles on and from pole stacks and stores-carrying vehicles, setting or recovering poles, supporting decayed poles, lifting personnel and steering the pole-hole borer.

When not in use, the boom extension is retracted and the derrick stows diagonally across the vehicle body.

Pole-Hole Borer

The pole-hole borer is driven by a hydraulic motor of approximately 35 h.p. It is suspended at its upper end from the derrick and is strapped back to the derrick when not in use. Downward thrust is applied by the derrick operating under hydraulic pressure, and by control of the derrick position the angle of boring can be determined, e.g. when setting stay anchorages. The pole-hole borer is shown in Fig. 3.

Winch

The heavy-duty winch is mounted immediately behind the cab and is fitted with a wire-rope winch-line 300 ft long that can be passed over the head sheave

of the derrick or can be used for a direct pull. The winch-line runs under a false floor in the vehicle body, so that it is not obstructed by any tools and stores carried in the vehicle.

The winch is driven by a hydraulic motor and has a maximum pull of 15,000 lb. It has a shaft extension, accessible through an aperture in the side of the vehicle body, to which can be attached a wire-recovery reel or a capstan that can, for example, be used for pulling cable.

Stabilizers

Hydraulically-operated stabilizers are provided at the rear end of the vehicle to give the necessary stability when the derrick is in use. These comprise an outrigger on the corner of the vehicle where the derrick is fitted and a simple hydraulic jack on the opposite corner. The stabilizers can be seen in use in Fig. 3.

Auxiliary Functions

At the rear of the vehicle a hydraulic power take-off is provided for operating auxiliaries such as an earth-punner or a 25-ton pole-pulling jack.

Control Panel

A control panel is fitted at the rear of the vehicle so that the operator has a clear view of all the functions. Controls are provided for extending and retracting the stinger, lifting and lowering the boom, rotating the derrick, operating the borer, and controlling the stabilizers, hydraulic power take-off and governed engine speed. The last may be varied according to the power requirements of the operation being performed and is increased or reduced in steps by flicking a switch up or down.

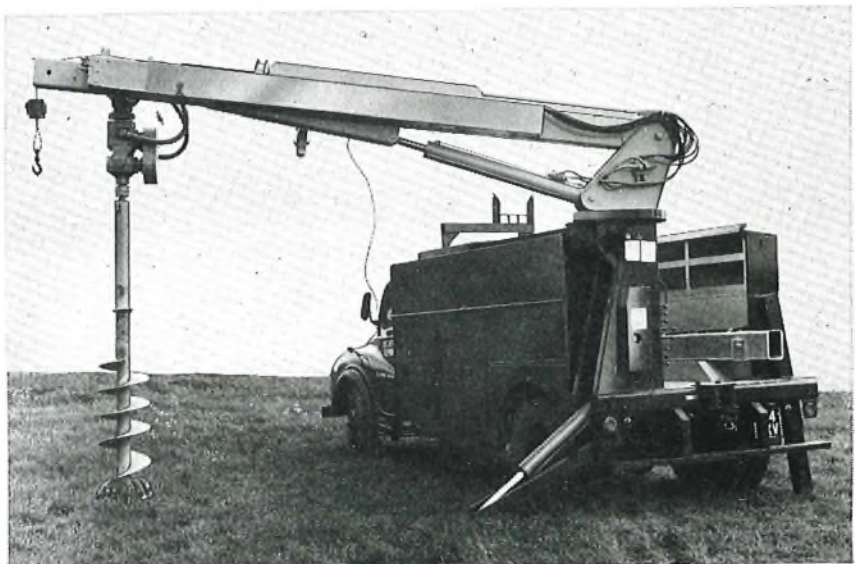

FIG. 3—POLE-HOLE BORER AND VEHICLE STABILIZERS

Monitoring Station for Mobile-Radio Services

L. T. ARMAN and E. J. M. PECK†

U.D.C. 629.114.7:621.396.72:621.396.931

A mobile monitoring station has been provided for observing the operation of v.h.f. mobile-radio services and to obtain a knowledge of conditions in the field. This information is needed by the Post Office for frequency planning, guarding against contravention of the terms of the licences, and also in connexion with the technical development of equipment. A description of the mobile monitoring station is given together with its objectives and general method of operation.

INTRODUCTION

THE use of mobile-radio services in the United Kingdom is described in another article in this Journal.* The Post Office licenses such services, assigns frequencies and exercises control over the technical standards of performance of the equipment used; it has, therefore, considerable responsibility in this matter and in order to carry it out must have knowledge of conditions in the field. V.H.F. mobile-radio services have a comparatively short range and, as it would be out of the question to set up a number of fixed monitoring stations, a mobile station has been provided for field monitoring. The unit is equipped at the moment mainly to deal with services operating in the v.h.f. bands, but additional provision against the development of services in the u.h.f. band has been foreseen.

It will have considerable value as a deterrent against wrongful and irregular use of mobile-radio services and will provide valuable information for frequency planning and general development.

FUNCTIONS OF THE MONITORING STATION

The main functions and objectives of the monitoring station are as follows:

(a) *Observation of Mobile-Radio Services.* Call signs are allocated to each station by the Post Office and it is a condition of the licences that these are used so that transmissions can readily be identified. Good operational discipline whereby the messages are kept brief and confined to the business of the user is necessary for efficient use of the channels. On the technical side the licences also impose standards of accuracy in the use of the assigned carrier frequencies. These points can only be checked by radio monitoring.

(b) *Information on Channel Traffic Density.* This is required generally for statistical purposes and also to resolve problems that may arise in specific frequency assignments.

†Inland Radio Planning and Provision Branch, E.-in-C.'s Office.

*ARMAN, L. T., and PECK, E. J. M. Narrower-Frequency-Band Channels for V.H.F. Land Mobile-Radio Services. *P.O.E.E.J.*, Vol. 55, p. 192, Oct. 1962.

(c) *Investigations of Interference Problems.* As far as possible, with relatively limited specialized equipment at their disposal, cases of interference are dealt with by Post Office Regional or Area staffs. Beyond this point the monitoring unit is brought into use.

(d) *Tests of Systems.* Tests are made by the Post Office on current and on new mobile-radio systems to obtain general technical information. A particular instance was trials of a 25 kc/s channel system set up specifically for the purpose of testing the practicability of 25 kc/s band-width channels for mobile-radio systems.

(e) *Radio Surveys.* These are for various services operated by the Post Office, such as public correspondence services‡ including v.h.f. maritime services. The Post Office does not make surveys for private services.

THE MONITORING VEHICLE

A general view of the vehicle is shown in Fig. 1; it



FIG. 1—THE MOBILE MONITORING STATION VEHICLE

comprises a Reading 26-seater coach-type body, modified for the purpose, on a B.M.C. 3-ton chassis. It is fitted internally with benches, the arrangement of which can be appreciated from Fig. 2. A water-cooled petrol-engine generator-set is fitted within the framework of the vehicle on the nearside just behind the cab, access to it being obtained externally. This provides 230 volts a.c. for the equipment and fluorescent lighting. To minimize running noise in the coach, acoustic insulation is provided and the set is fixed to the body via

‡Public correspondence service—a communication service available to any member of the public.

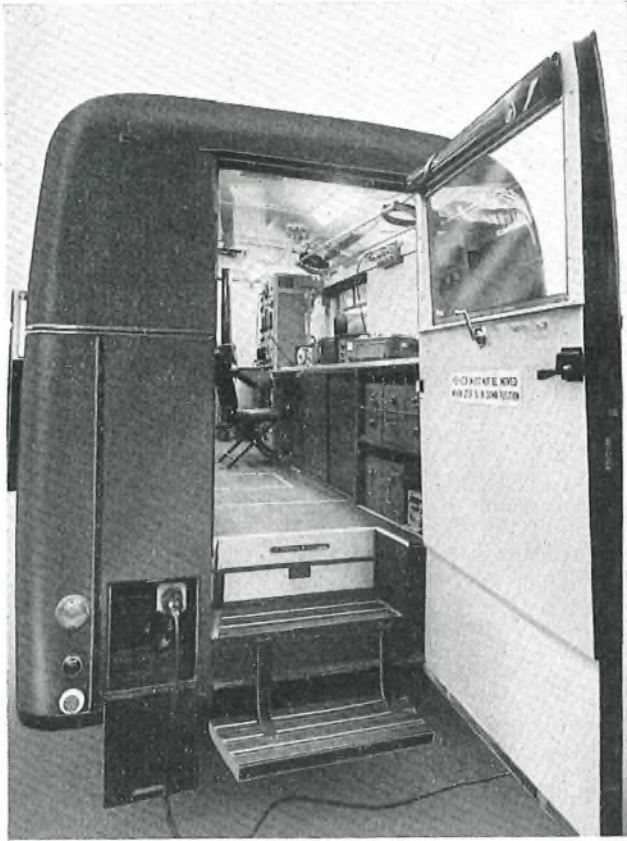

FIG. 2—THE INSIDE OF THE MOBILE MONITORING STATION VEHICLE

rubber mountings. Because of the need to reduce vibration and noise to the minimum, and because the vehicle would often be used in residential areas for long periods, petrol engines, rather than diesel, are used for the vehicle and the generator-set.

ELECTRONIC EQUIPMENT

Frequency-Measuring Set

The rack-mounted frequency-measuring set (visible in Fig. 2) provided in the vehicle has an accuracy of ± 2 parts in 10^8 ; it has a basic frequency standard of 100 kc/s and uses frequency synthesis. Any frequency from zero to 600 Mc/s can be obtained at the output. For frequency measurements the signal to be measured is normally compared with the output of the measuring set by the heterodyne method on an aural basis, but the two signals can be displayed on the oscilloscope provided for this purpose. The accuracy of the measuring set is checked quarterly to within ± 1 part in 10^8 against the appropriate frequency derived from a 100 kc/s Essen-ring oscillator. A receiver is also provided in the vehicle whereby the MSF* transmissions from Rugby on 2.5 Mc/s or 5 Mc/s can be received and be used as a ready check of the measuring set at any time should the occasion arise, e.g. in case of a dispute. Due to propagation conditions the accuracy that can be obtained may be limited to ± 2 parts in 10^7 , but this would normally be adequate.

Radio Transmitters

A transmitter unit which can be tuned to any frequency in the 80 Mc/s and 160 Mc/s bands is provided,

*MSF—the call sign of the transmitter used for the standard-frequency service.

the radio-frequency power output being about 7 watts. It includes a common modulator unit, but the frequency-multiplying, driving and power-amplifier stages are separate for each of the two bands. Oscillator stages are not incorporated; instead, either the output of the frequency-measuring set, or a signal generator, is connected to the transmitter at the appropriate frequency. Only amplitude modulation is catered for at the moment, but the provision of frequency-modulation transmitters is being considered.

Monitoring Receivers

Receivers of a typical communication type are provided, tunable over the 80 Mc/s and 160 Mc/s bands and suitable for amplitude-modulation and frequency-modulation. However, the increasing use of 25 kc/s channel services necessitates a higher degree of selectivity and more precise adjustment than is generally available on normal communication receivers; accordingly consideration is being given to the use of conventional 25 kc/s receivers, as employed on mobile-radio services, together with the frequency-measuring set, or a signal generator, in a manner complementary to the radio transmitters described earlier. Another asset of this type of receiver is its greater sensitivity compared with those at present provided. A tape recorder is also available for connexion to the receivers as required.

Aerials

Facilities are provided for mounting three aerials, one on a retractable telescopic mast, which provides a maximum aerial height of about 35 ft above ground, and the other two on the roof of the vehicle. Two aerials in the latter position are visible in Fig. 1; the telescopic mast is raised through the roof via the block-shaped mounting near the front of the vehicle.

Test Set

Equipment for testing the main characteristics of mobile-radio sets and systems is provided. This comprises a variable-frequency generator and a test set. The range of the former incorporates the frequency ranges used by mobile-radio services in the v.h.f. and u.h.f. bands; it can be used on amplitude-modulation and frequency-modulation equipment and has facilities for modulating the carrier wave with an audio tone of 1 kc/s. The test set includes a deviation meter, an r.f. power meter, an audio power meter and also d.c. meters for current and voltage measurements.

Field-Strength Measuring Set

The field-strength measuring set is the Post Office Interference Measuring Set R12 used for general radio-interference work. It covers the range approximately of 30–200 Mc/s and is normally used in conjunction with a portable telescopic dipole aerial the length of which can readily be adjusted according to the frequency at which measurements are to be made.

Auxiliary Power Supply

As stated earlier there is a 3.7 kW generator driven by a petrol engine to supply power, additional to that obtained from the vehicle and generator-set engines. A 24-volt battery is necessary for the starter winding of the generator set, but only 12 volts is needed for the ignition system, which comprises the starter solenoid, the engine fuel pump and water temperature and oil pressure

alarms. The generator is set to supply 230 volts at 50 c/s; there is a manual regulator to control this voltage, and if need be the frequency can be adjusted or set to another value, e.g. 60 c/s, on the machine. A standard electric running-hour meter is connected to the 230-volt output to record the total number of hours run by the petrol generator. The 230-volt supply is taken via a change-over switch to a distribution fuse box and from there fed to the electronic equipment, fluorescent lighting and, exceptionally, a heater for the coach. The load is maintained at a prescribed figure by the connexion of artificial loads according to the actual load at the time.

It should be noted that the potential output of 3.75

kW from the generator set allows a considerable margin for any additional demand that might arise in the future; a contributory factor to having the large reserve power was that there was no model available between 1.5 kW and 3.75 kW. A public supply of 230 volts a.c. may be used instead of the generator. The 24-volt battery is also used to heat the crystal oven in the frequency-measuring set and provision is made for refresher charging of this battery when a mains supply is used. The 12-volt battery for the vehicle itself is used to supply power when necessary for equipment, such as mobile-radio sets, which may be brought into service for special tests.

Book Reviews

"Miniature and Microminiature Electronics." G. W. A. Dummer, M.B.E., M.I.E.E., Sen.Mem.I.R.E., and V. W. Granville, B.Sc., Ph.D. Sir Isaac Pitman & Sons, Ltd. ix + 310 pp. 218 ill. 45s.

This book by Mr. Dummer and Dr. Granville, both of the Royal Radar Establishment, is the first to be written specifically on miniature constructions for electronic circuits. The last three chapters (out of eight) comprise an introduction to the better-known forms of microminiaturization of circuits.

Chapters 1 and 2 deal with the construction and properties of about 50 different kinds of transistors, diodes, thyristors, photo diodes, field-effect transistors, etc. Chapter 3 describes types of individual miniature and subminiature components for use in transistor circuits, and includes tables of specific types and values with manufacturers' names. Chapter 4 covers printed wiring and potted circuit techniques. Chapter 5 discusses miniaturization of electronic equipment in a general way. Chapters 6, 7 and 8 deal with microcircuits (2-dimensional techniques), micro-modules made by stacking individual components each in the form of a thin ceramic wafer (about 0.3 in² and 0.01 in. thick) and solid circuits (molecular electronics) respectively.

The book is well written and contains a surprisingly large amount of information packed into its 300 pages, considering the range of topics covered. It is an excellent introduction to miniaturization and microminiaturization of electronic equipments. A.A.N.

"Electronic Equipment Reliability." G. W. A. Dummer, M.B.E., M.I.E.E., Sen.Mem.I.R.E., and N. Griffin, A.M.Brit.I.R.E. Sir Isaac Pitman & Sons Ltd. xi + 274 pp. 86 ill. 45s.

The results of Mr. Dummer's energy and hard work in the components field are well known in the form of his numerous books and publications. Mr. Griffin, also of the Royal Radar Establishment, has now joined him in a book on the reliability of electronic equipment.

To quote the authors, "In the military sphere of activity reliability of electronic equipment is fast becoming a major problem, and is meriting a high order of priority." Computers and automation of flight control of aircraft are also referred to, but there is little reference to telecommunication equipment where very high reliability coupled with very long life is required under much milder conditions than that of military equipment, particularly with regard to mechanical shock and vibration. Apart from this limitation the book contains a vast amount of valuable information. Two chapters deal with failure rates and faults in equipments and components. The next two cover the effect of environmental conditions and constructional techniques respectively on reliability. Circuit reliability and

preferred circuits occupy a chapter. The remaining chapters deal with "Testing for Reliability," "Designing for Maximum Reliability," "Human Engineering," "Reliability Prediction and Calculation," and "Reliability in the Future." Much of the information on design and calculation is applicable to telecommunication circumstances.

There are a few typographical errors, e.g. on page 226 in Table 10.3 the number 105 occurs twice where it should really be 10⁵, and in the table on page 256 the speed of operation of magnetic metal film should be 10⁻² μs.

A.A.N.

"Progress in Semiconductors—6." General Editor A. F. Gibson, B.Sc., Ph.D. Heywood & Co., Ltd. x + 334 pp. 162 ill. 65s.

This is the sixth of an annual series devoted primarily to the physics of semiconductor materials. Part of the great activity in this field since the birth of the transistor has been stimulated by the interaction between the physicist, the chemist, the semiconductor-device designer and the device technologist, and occasional papers on the physics of specific devices have accordingly been included in the series. In the present volume the 50-page paper (by Jonscher) covering the physics of six types of semiconductor switching devices will be of special interest to readers of this Journal. The paper on plastic deformation in semiconductors (by Pearson and Vogel) likewise deals with experimental phenomena that can be described in terms of a now quite detailed model and theory.

"Tellurium" (by Blakemore, Long, Nomura and Nussbaum) is a comprehensive review of the structural, mechanical, optical and semiconducting properties of the element in the solid form, but it is evident that, though much progress is reported in the paper, several basic properties, such as the band structure and the recombination mechanisms, have yet to be adequately described. Adams and Keyes discuss theoretically the effects of very strong magnetic fields on the resistivity and Hall effect of solids, and review the available experimental evidence for semiconductors and metals in the light of the theory. Van Wieringen examines the details of the information obtainable about the electronic and atomic structures of semiconductors by means of nuclear magnetic resonance, electron paramagnetic resonance and electron, or hole-cyclotron, resonance experiments.

Nikitine's two papers review the theory and the experimental data for excitons (discrete mobile states of electronic excitation) in semiconductors and ionic compounds, with particularly detailed commentaries on recent results obtained by various workers.

The writing in all the papers is lucid and the diagrams and plates are pertinent and, in general, clear (though some of the latter are a little dated). Apart from the first two papers noted above, the volume will appeal mainly to specialists in the narrower fields.

F.F.R.

Equipment for the Measurement of Some Characteristics of the Noise in Telephony and Television Channels

D. TURNER, B.Sc.(Eng.), A.M.I.E.E.†

U.D.C. 621.317.7:621.391.822

Recommendations have been made by the C.C.I.T.T. and C.C.I.R. for the measurement of some characteristics of the noise in telephony and television channels routed over s.h.f., radio-relay links. Since the purpose is to obtain information on the effect of varying propagation conditions on the incidence of noise as defined, the measurements are required to cover all seasons of the year, and automatic recording is necessary. The characteristics to be measured and the portable equipment designed to make these measurements are briefly discussed.

INTRODUCTION

THE C.C.I.T.T.* and C.C.I.R.‡ have each invited administrations to carry out a program of measurements on s.h.f. radio-relay links to determine the amount of noise power present in the transmission channels and its variation with time due to changes in the propagation path. From this information an estimate can be made of the impairment likely to be suffered by the various forms of transmission using the link, and this, in turn, leads to formulation of the design objectives for the transmission system. The forms of transmission here are, of course, telephone speech and signalling, telegraphy and television. To cover all seasonal variations of the propagation path the period of measurement should last in effect for one year.

Characteristics of noise arising in a radio link may be expressed in a variety of ways. However, some parameter of the noise can usually be chosen that has particular significance in relation to the form of transmission being considered. The C.C.I.T.T. and C.C.I.R. have accordingly recommended the use of the three integrating times, 1 minute, 1 second and 5 milliseconds, in the equipment to be used for noise measurements. The alternative approach of using a single integrating time from which statistics could be deduced in terms of these durations would involve making measurements at such frequent intervals that data analysis would become impracticable.

For telephone speech the period of interest is the duration of a telephone call, and this is taken to be about 3 minutes. However, at the time, this was considered to be an inconveniently long period for measurement, and an integrating time of 1 minute for the equipment was finally recommended. These measurements of noise power were to be carried out, unweighted, in a 3.1 kc/s band, and recorded minute by minute.

For television transmission the recommended integrating time for measurement was 1 second, this being considered to be a significant interval in relation to the visual perception of the effect of noise on a television picture. Here, it was required to determine the length of time for which each of two noise powers was exceeded.

Finally, it was recommended that telephone signalling and telegraphy should be considered together, and measurements made of two critical values of noise

power using an integrating time of 5 milliseconds. The period, 5 milliseconds, was here regarded to be significant in relation to a telegraph signal element of 20 milliseconds duration and at the same time it would enable an assessment to be made of impairment to telephone signalling. In this instance a record was required of both the number of times and the length of time for which each of two noise powers was exceeded hour by hour. It has proved convenient, however, for the reasons given in a later section, to record at the shorter interval of 10 minutes.

The equipment to be described has been designed in accordance with these recommendations and provides facilities for recording:

(a) on a telephone channel

(i) the mean power of the noise during each successive minute,

(ii) the number of times, in each successive period of 10 minutes, that the noise power, measured with an integrating time of 5 milliseconds and referred to a point of zero relative level, exceeds 10^3 pW and 10^6 pW, and

(iii) the aggregate time during each period of 10 minutes for which the above values of noise power are exceeded,

or (b) on a 405-line television channel

(i) the number of times, in each successive period of 10 minutes, that the r.m.s. amplitude of the noise within the range of 10 kc/s–3 Mc/s rises above the values corresponding to signal-to-noise ratios, as defined by the C.M.T.T.§ of 50db, the noise being measured with the appropriate band-defining filters and weighting network, and with a time-constant of 1 second, and

(ii) the aggregate time, during each period of 10 minutes, for which the above amplitudes are exceeded.

From information available it appeared unlikely that noise surges of appreciable duration would occur (as measured with a meter having a time-constant of a few seconds) that rose to much more than 20 db above the non-fading level, but it was desirable for the equipment to have the greatest possible dynamic range. A range of about 30 db has in fact been achieved.

A data-printing-control unit feeding a teleprinter or a tape reperforator has been provided to present the results.

DESCRIPTION OF THE EQUIPMENT

A block schematic diagram of the equipment is shown in Fig. 1. For brevity, the parts of the equipment concerned with integrating times of 1 minute, 1 second and 5 milliseconds are referred to as the 1-minute, 1-second and 5-millisecond channels, respectively.

One-Minute Channel

The value of the noise power, varying with time, is averaged over successive periods of 1 minute by means of a square-law circuit and an integrating motor whose

†Post Office Research Station.

*International Telegraph and Telephone Consultative Committee.

‡International Radio Consultative Committee.

§Joint C.C.I.R./C.C.I.T.T. committee.

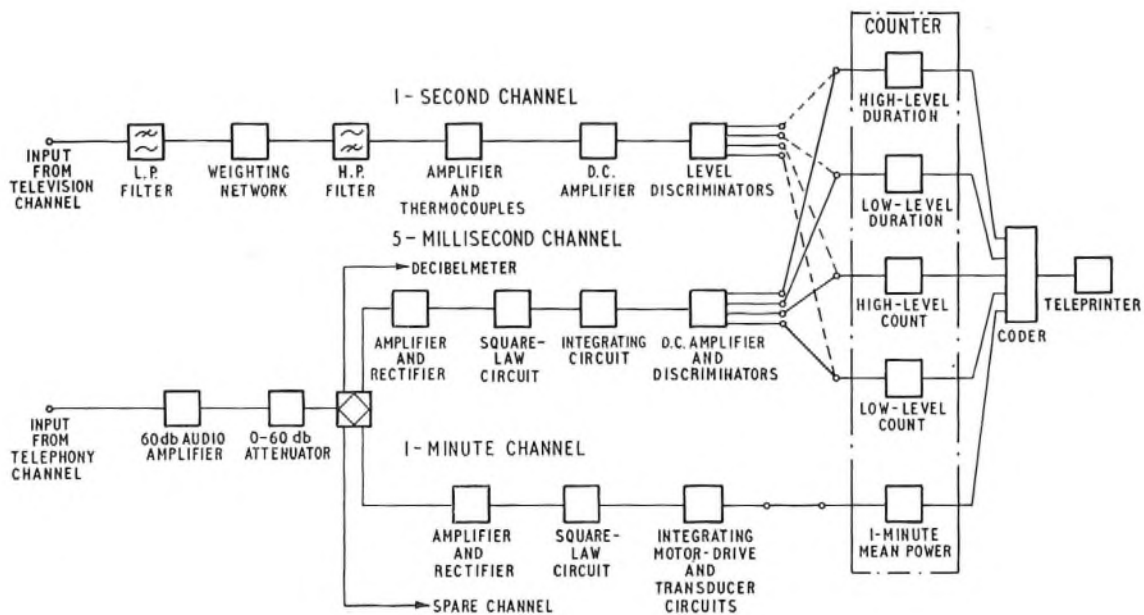

FIG. 1—BLOCK SCHEMATIC DIAGRAM OF NOISE-MEASURING EQUIPMENT

shaft angular-displacement is recorded by a counter and printing-control unit.

The square-law circuit is preceded by a 3-stage transistor amplifier with about 30 db emitter-emitter feedback and an output collector load consisting of a full-wave rectifier circuit; this ensures an adequate unipolar voltage to drive the unbalanced square-law circuit. Provision is made for gain adjustment of the amplifier by the inclusion of a 600-ohm balanced attenuator in the amplifier input.

The square-law circuit is required:

- (a) to produce an output voltage proportional to the square of the input noise voltage,
- (b) to have an input dynamic range of 30–40 db,
- (c) to produce a maximum output voltage of 30–40 volts in 5,000 ohms,
- (d) to be physically unaffected by overloading, and
- (e) to be stable with temperature and power-supply variations.

A circuit fulfilling these requirements has been developed using silicon-junction diodes and a single thermionic valve.

The integrating motor is a permanent-magnet d.c. motor of low inertia, in which friction, iron losses and brush-contact voltage-drop are small, so that the shaft angular-velocity is proportional to the applied voltage. However, since the apparent resistance at the integrating-motor terminals varies with terminal voltage, a zero-impedance driving source is required to realize a wide linear range. The high-voltage output of the square-law circuit made it practicable to use a thermionic-valve d.c. amplifier to drive the integrating motor without undue difficulty from zero drift. Moreover, it was found possible, by the introduction of a bias voltage at the input to the integrating motor, to compensate for the error arising at low inputs, both from the inertia of the motor (even with a zero-impedance source) and from the low but finite impedance of the source. As shown in Fig. 2, the final arrangement comprises a differential d.c. amplifier with the integrating motor connected in the cathode circuit; this provides a ready means of

applying the bias voltage and reduces the effect of drift in the valves.

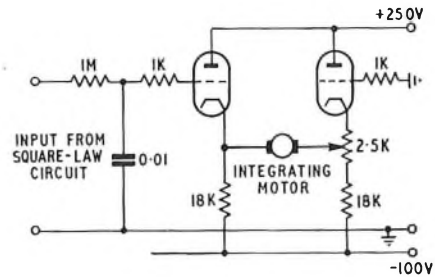

FIG. 2—INTEGRATING-MOTOR DRIVE CIRCUIT

To reduce the loading of the motor shaft to a minimum and thereby extend further the linear range, the mechanical register supplied with the motor was removed and an optical system sensing the shaft rotation was provided. The shaft has been fitted with a cylinder having alternate quarters of its periphery black and white. The cylinder surface is illuminated by a 6.4-volt lamp and lens system. Reflected light illuminates two photo-transistors in anti-phase, and these are followed by a bi-stable trigger circuit that gives a rectangular pulsed output whose amplitude is independent of the shaft angular-velocity. The balanced input makes the circuit substantially independent of changes in temperature, supply voltage and ambient lighting conditions.

A curve showing the relationship between the input to the audio amplifier and the output from the shaft transducer circuit, in terms of shaft revolutions per minute, is shown in Fig. 3.

To enable adjustments of the square-law circuit and motor bias to be made, a 1 kc/s test oscillator, with a fixed output of -45 dbm in 600 ohms, and a centre-zero ammeter have been incorporated.

Five-Millisecond Channel

The noise levels to be measured here, after integration, are 30–40 db higher than those existing for most

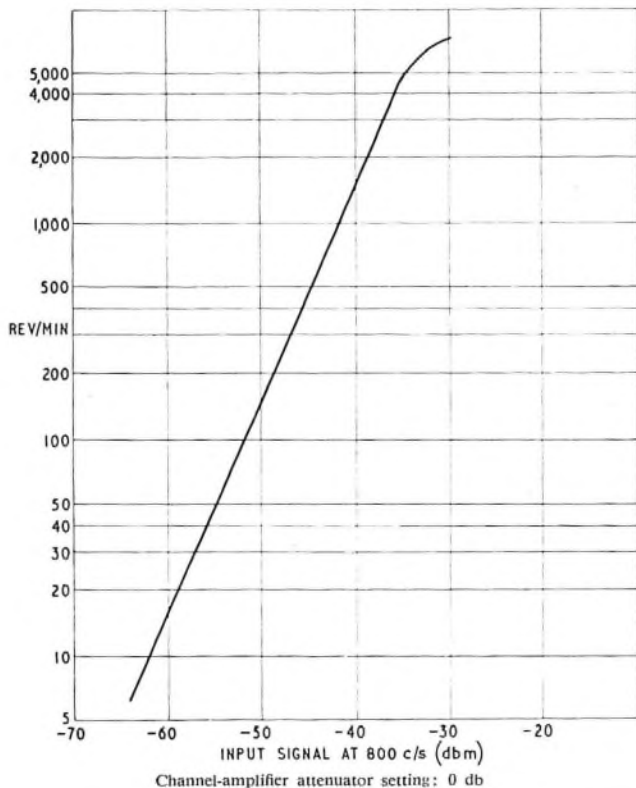

FIG. 3—VARIATION OF MOTOR-SHAFT ANGULAR VELOCITY WITH CHANGE OF INPUT SIGNAL POWER TO THE 1-MINUTE CHANNEL

of the time on the 1-minute channel. Less gain is therefore needed in this channel, and the amplifier is a transistor amplifier of two stages only, with about 30 db emitter-base feedback. The square-law circuit is identical to that described for the 1-minute channel. A margin of 10 db has been fixed between a level at the input to the channel corresponding to -30 dbm_0^* and a point at which non-linearity becomes apparent on the curve relating the input to the 5-millisecond channel and the output from the square-law circuit.

A network that produces an output voltage proportional to the input voltage integrated over the preceding 5 milliseconds is shown in Fig. 4 (a). The circuit may be realized in parallel or series form, but the latter, proving for this application easier to make and adjust, has been adopted. The response of the network to a rectangular pulse of 50 microseconds duration is given in Fig. 4 (b).

The d.c. amplifier follows conventional practice. Two level-discriminators are driven from a common cathode-coupled double-triode amplifier. Each discriminator consists of two pentodes connected as a Schmitt trigger.† The trigger circuits are adjusted so that one responds to an input signal equal to or exceeding a level corresponding to -40 dbm_0 and the other responds similarly to -30 dbm_0 . Two outputs are provided from each trigger. One, a rectangular pulse, opens a gate in the counter and printing-control unit to a 10 kc/s clock-

*dbm₀—decibels relative to 1mW when measured at, or referred to, a point of zero relative level (usually the 2-wire point of the circuit).

†Schmitt trigger—an asymmetrical bi-stable circuit that has a trigger action in one direction when the input exceeds a reference level and in the opposite direction when the input level returns to the reference level.

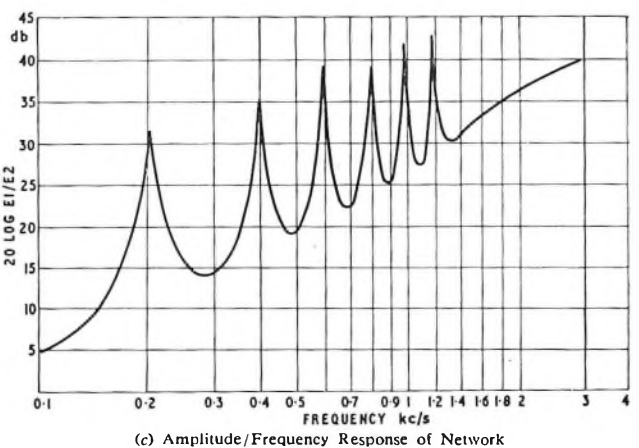
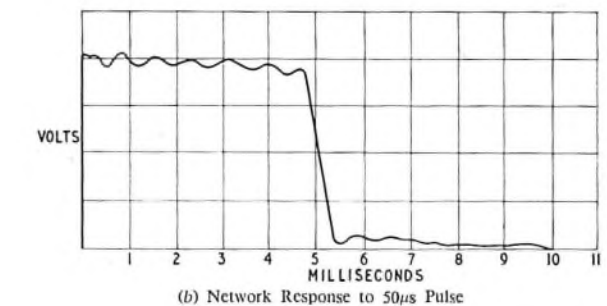
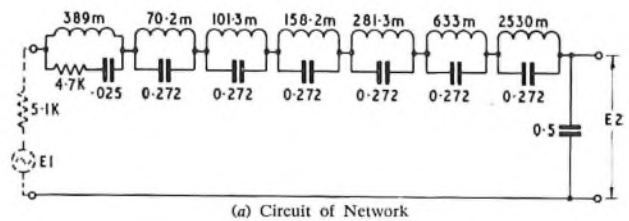

FIG. 4—FIVE-MILLISECOND INTEGRATING NETWORK

pulse supply for the duration of the noise surge. The other, derived by differentiating the rectangular pulse, provides a pulse each time the input signal passes through the critical level. The circuit of the Dekatron counter to which this output is connected is arranged to respond only to those pulses corresponding to positive-going passes of the input signal through the critical level.

It has been necessary to consider the question of “backlash” in the discriminators, i.e. the difference between the levels at which these operate and reset. If there were zero backlash, noise fluctuating, however slightly, about the critical level would result in repeated operations each contributing to the count. This state of affairs, while in accordance with the letter of the C.C.I.T.T. recommendations, is assumed not to represent their intention, which is presumably to record the number of discrete noise surges. For this reason, it seems desirable to have backlash of a few decibels.

Moreover, although the noise under observation will usually have the nature of white noise with a varying envelope, quasi-sinusoidal noise may sometimes be encountered. In this event, the output of the square-law circuit will comprise a d.c. component and a sinusoidal component, and at the critical level the latter will cause repeated operation of the discriminator. Fig 4 (c) shows

the loss/frequency characteristic of the integrating network, which has minima at odd multiples of 100 c/s, decreasing with decrease of frequency. Bearing in mind that the channels on which the noise-measuring apparatus will be used will have a low-frequency cut-off, the effect under discussion is most likely to be evident with sinusoidal noise at 250 c/s, producing a sinusoidal component at 500 c/s at the output of the square-law circuit. It can be shown that at this frequency a backlash of 2 db is required to prevent repeated operation on sinusoidal noise at the critical level.

Having regard to both the above considerations, a backlash of 2 db has been adopted.

A test oscillator associated with the 5-millisecond equipment provides an output at 1 kc/s, modulated at 50 c/s, for connexion to the input of the 5-millisecond channel at either of two levels corresponding to -40 dbm0 or -30 dbm0.

After passing through the square-law and integrating circuits the appropriate unidirectional signal, varying in amplitude by a predetermined amount at 50 c/s, is fed to either discriminator. With this variation in amplitude made just greater than the "backlash" of the discriminator, the discriminator operates at 50 c/s, enabling the correct operation of the counter to be checked.

One-Second Channel

Since the counter and printing-control unit cannot be used simultaneously for measurements on both telephony and television channels, only a single pair of level-discriminators would strictly be necessary. However, the equipment for the 1-second channel was designed after the construction of the equipment described in the earlier sections had been substantially completed. It was then convenient to make the 1-second channel self-contained, and additional discriminators have therefore been provided. The opportunity was taken at the same time to develop discriminators using transistors.

Designs for a low-pass filter and a weighting network suitable for measurements on a 405-line system have been recommended by the C.M.T.T. Filter and weighting networks to these designs are incorporated. In addition, the C.M.T.T. recommend a low-frequency cut-off at 10 kc/s to suppress hum and microphonic noise, and a high-pass filter with a suitable performance has been included.

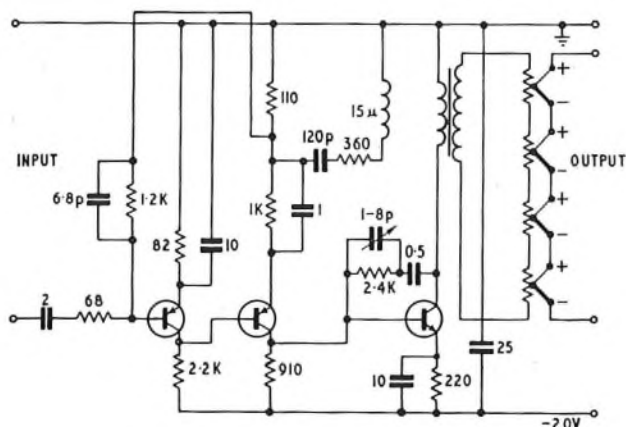

FIG. 5—ONE-SECOND-CHANNEL AMPLIFIER

The amplifier circuit is shown in Fig. 5. The first section has two transistor stages with emitter-base loop feedback. The voltage gain of this section is reduced 23 db by the loop feedback. The output section has a single transistor, base-fed from the high-impedance output of the first section and with collector-base feedback reducing the voltage gain by 20 db. The amplitude/frequency response of the amplifier is sensibly flat from 10 kc/s-4 Mc/s. Overload, defined as the point at which the gain has fallen 1 db, occurs with an input signal of -20 dbm.

It was not found possible, over the bandwidth of this channel (10 kc/s-3 Mc/s), to obtain the square-law relationship required between the noise power and the voltage to be integrated using circuits based on the same principles as described for the 1-minute and 5-millisecond channels. For this channel use has been made of the input-power/output-voltage relationship of a thermocouple; at the same time, by a suitable choice of couple, the required time-constant of 1 second has been incorporated. Since the relatively low-voltage output from a thermocouple restricts the amount of drift that can be tolerated in the following d.c. amplifier, the output voltage has been increased by using four thermocouples in the collector load of the amplifier output stage. Any advantage to be gained by increasing the number of thermocouples further was balanced against the need to maintain the gain/frequency response of the amplifier. To protect the thermocouples from accidental overload, their heaters are connected in series, while the overload point of the amplifier has been arranged to restrict the maximum output current into the heaters to the permitted 50 mA, r.m.s.

The amount of drift that can be tolerated from the d.c. amplifier is dependent on the voltage output from the thermocouples corresponding to the lower of the two noise levels of interest, and the accuracy with which this noise level needs to be determined. The output voltages from the thermocouples corresponding to these noise levels are 2 mV and 12.6 mV, after allowing a margin between the overload point of the amplifier and the higher voltage. The amount of drift that can be tolerated in the d.c. amplifier is therefore determined by the low-level input of 2 mV and the accuracy required at the discriminating level. If this is fixed at 0.5 db, then the drift should not exceed 10 per cent, i.e. 200 μ V.

A diagram of the d.c. amplifier is given in Fig. 6. The amplifier consists of two long-tailed pairs in cascade. Common-mode drift is largely corrected by a loop-feedback connexion from the common-emitter resistor of the output pair to the base connexions of the input pair; this however, leaves the differential drift unaffected. Each transistor of the output pair has local feedback which, by reducing the difference between the base-emitter voltage/collector-current characteristic of the pairs of transistors, contributes to a reduction in differential drift and, in addition, stabilizes the signal gain. However, it has proved necessary to introduce temperature control of the transistors in the d.c. amplifier to bring the drift within the limits given. This has been done by enclosing the transistors of the d.c. amplifier in an aluminium cylinder together with a temperature-sensing transistor that drives the control circuit.

The control circuit consists of a transistor d.c. amplifier, the collector load of the output stage of which is formed by a heating element surrounding the aluminium cylinder. The oven temperature is controlled to about

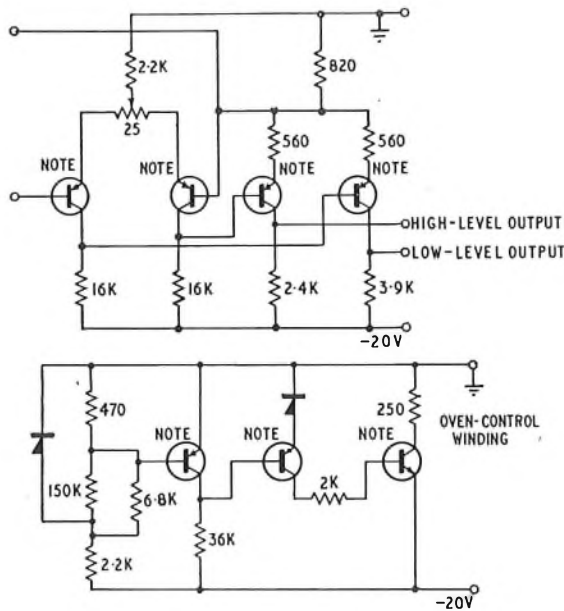

Note: Temperature-controlled transistors

FIG. 6—ONE-SECOND-CHANNEL D.C. AMPLIFIER AND TEMPERATURE CONTROL CIRCUITS

50°C, and for changes from ambient temperatures up to 50°C the voltage drift referred to the input is not greater than 200 microvolts. The voltage gain of the d.c. amplifier in the signal path is 500 times from the input to the low-level open-circuited output.

Two discriminators are provided and are adjusted to respond to two noise levels differing by 8 db. A diagram of the high-level discriminator is given in Fig. 7. The

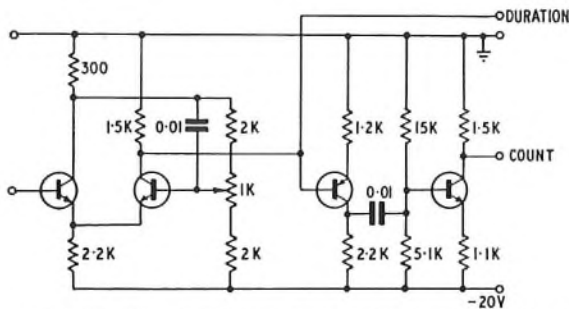

FIG. 7—HIGH-LEVEL DISCRIMINATOR FOR 1-SECOND CHANNEL

first two stages of each discriminator form a bi-stable trigger circuit, and a pulse lasting for the duration of the surge of noise power in excess of the critical level appears at the collector of the second stage, giving an output to hold open the appropriate gate in the counter. The third stage, a pulse inverter, is coupled by a differentiating circuit to an amplifying final stage giving an output to the counter for the count of the number of occurrences of noise above the critical level. The difference in operating levels for the two discriminators is such that in order to operate the transistors of each in their optimum condition the two inputs are fed with signal changes of opposite sense from the preceding d.c. amplifier. As a result the high-level and low-level input stages have n-p-n and p-n-p transistors, respectively.

Counter and Printing-Control Unit

A block schematic diagram illustrating the functioning of the counter and printing-control unit is given in Fig. 8. Since the basic circuits used, i.e. the circuits of gates,

triggers, distributors and the like, are well known in electronic switching, no descriptions of these are given.

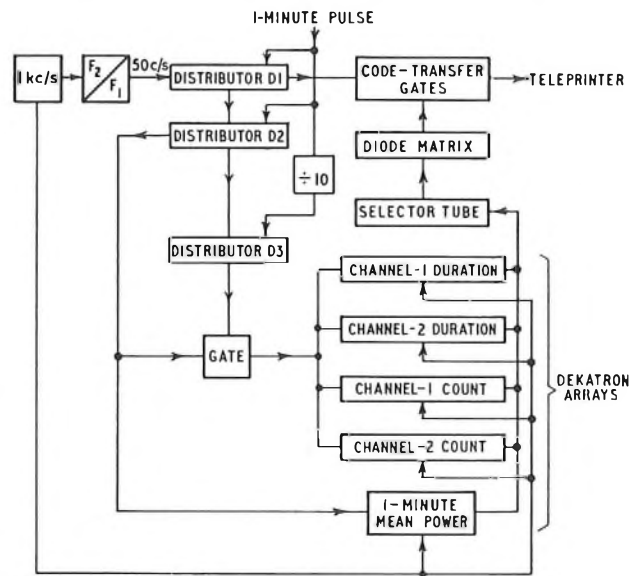

FIG. 8—BLOCK SCHEMATIC DIAGRAM OF COUNTER AND PRINTING-CONTROL UNIT

The unit has the following functions:

(a) It accepts an output from the shaft transducer circuit, counts the number of pulses occurring in each minute and prints this number, which is proportional to the 1-minute mean value of the noise power minute intervals on a Teleprinter 7B.

(b) Over successive periods of 10 minutes it accepts the output from a level-discriminator that is set up to operate when a noise level corresponding to one of two critical values is exceeded, and

(i) counts the number of pulses corresponding to the number of times the set level is exceeded,

(ii) measures the duration of each pulse, adds these durations, and

(iii) records the answers from (i) and (ii) at 10-minute intervals on a Teleprinter No. 7B.

(c) As for (b), but for a noise level corresponding to the other critical value.

The measurement of duration is converted to a counting process by causing the operation of each discriminator to "gate" a 10 kc/s pulse train feeding a counter.

The two channels provided for the purposes given in (b) and (c) above are identical and are referred to as Channel 1 and Channel 2. When used as part of the complete noise-measuring equipment Channel 1 and Channel 2 record information for the lower and higher levels, respectively.

The counter and printing-control unit is normally intended to carry out all of the functions enumerated in (a), (b) and (c). However, by operation of a switch, choice is given of (a) only, i.e. printing at 1-minute intervals the numbers proportional to the 1-minute mean noise power, or of (b) and (c), i.e. printing at 10-minute intervals the numbers relating to duration and count. In this last instance the 1-minute number is also printed, but this may be disregarded. The unit thus requires five arrays of Dekatrons to carry out the required counting functions. The number of Dekatrons in each array is determined by the expected maximum count.

For the 1-minute mean noise-power measurements,

the maximum recommended shaft speed for the integrating motor is 4,000 rev/min, and since the shaft transducer circuit produces two pulses per revolution, the maximum count should not exceed 8,000. However, it is of interest to examine the dynamic characteristic somewhat beyond this figure and a 5-digit counter has been provided.

It was remarked in the introduction that the C.C.I.T.T. has recommended that measurements with an integrating time of 5 milliseconds should be recorded at hourly intervals. With a timing frequency of 10 kc/s a maximum capacity of eight digits for the duration counter is indicated. This has been reduced to seven digits by arranging the printing to occur every 10 minutes, with the added advantage that the distribution of noise is more finely determined. A reduction of the timed period to less than 10 minutes would make the printing time exceed one per cent of the timed period.

The expected maximum count of events was determined by counting the pulsed output from the level discriminators with a commercial counter when a "white noise" generator was connected to the equipment input at differing input levels. The maximum count so determined showed that a 5-digit counter would be suitable for the 10-minute counting period.

Of the five counters it is required to read and print the number recorded on one counter at 1-minute intervals and the numbers on the other four counters at 10-minute intervals.

The sequence of events resulting in the printing of the numbers counted is initiated by a pulse at 1-minute intervals from a contact operated by a synchronous motor, while the timing of all events within the equipment is determined by a 1 kc/s multivibrator.

Referring to Fig. 8, D1, D2 and D3 are distributors with the following functions. Distributor D2, stepped under the control of distributor D1, offers to the 1 kc/s source each Dekatron in the 1-minute array in turn and causes the digit recorded to be transferred to the selector tube. The selector tube then primes the diode matrix so that the digit is established in 5-unit-code form by the relative states of the code-transfer gates. Distributor D1, in its next cycle of operation and before the next step of D2, transfers the coded digit to the teleprinter for printing. At the end of the tenth minute, numbers relating to the noise powers measured in each minute of the preceding 10 minutes will have been printed.

After the 1-minute mean-power array has been restored to acquire more data, distributor D3 offers the remaining four arrays of digits in turn to distributors D1 and D2 for coding and printing. The time taken for distributor D2 to complete one cycle of operation is 1.92 seconds, during which time the measurement of the "1-minute" mean noise power is interrupted. The period of observation strictly speaking is therefore 58.08 seconds. For a similar reason the "10-minute" observation period is properly a period of 592.32 seconds.

FIELD EXPERIENCE

The equipment described (Fig. 9) and an earlier version have each been used for an extensive series of measurements on the Carlisle-Belfast and Thrumster-Widford Hill radio links, respectively. The results have been reported to the C.C.I.T.T.

Where large amounts of data are required to be collected for subsequent statistical analysis, the possibility

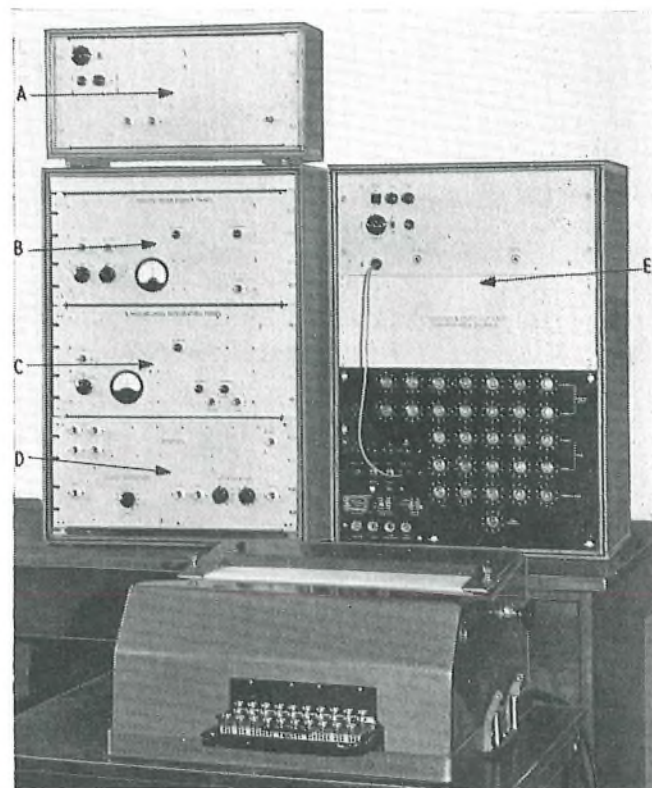

A—1-second channel
B—1-minute channel
C—5-millisecond channel
D—Miscellaneous equipment
E—Counter and printing-control unit

FIG. 9—NOISE-MEASURING EQUIPMENT

of using a punched-tape form of record for subsequent programming and computer analysis has to be considered. The equipment designed can provide equally this form of record or a printed record, but so far the latter has been preferred for the following reasons.

The value of punched-tape recording depends largely upon the relevance of the ingoing data to the experiment in hand. If, as already experienced, large amounts of data are inadmissible, having arisen from causes not under investigation, there is the risk that results finally obtained are not so much wrong, which may be detected, but misleading.

The object of the measurements, carried out so far, has been to record the effect of fading on the noise measured in a channel, and it is essential that effects from other causes be excluded. Experience has emphasized the difficulty of obtaining long recordings free from such other disturbances. For instance, the sudden appearance of pulses at $\frac{1}{2}$ -minute intervals on the normal telephony channel of one link has been noted at a level sufficient to record at the 10^5 pW level in the 5-millisecond channel. These disturbances have persisted for some weeks.

The 5-millisecond channel, having such a short integrating time, is very susceptible to impulsive interference and particular care is necessary therefore in interpreting the results from this channel.

Thus a ready means of visual inspection of the record which permits editing before processing seems essential for this application at present, and in addition has the merit that it permits the rapid calibration and adjustment of the equipment.

The Group Reference-Pilot Signal

R. W. NAULLS†

U.D.C. 621.317.341:621.395.44

The group reference-pilot signal is provided as an aid to maintaining 12-channel groups in the h.f. network. By its use, a uniformly high grade of service can be maintained without taking channels out of use for the purpose of applying test signals.

INTRODUCTION

LINKS in the high-frequency carrier and coaxial network used for trunk circuits are subject to small changes in transmission level due to a variety of causes. Level variations can be caused by changes of power-supply voltage or carrier-frequency level and by necessary adjustments made to the link by maintenance staff. The adjustments that particularly affect the link are those to amplifiers and to equalizers. It is usual, except on very short links, for the line equipment to be fitted with adjustable equalizers to compensate for changes in transmission loss caused by changes in cable temperature. Although on modern line systems this adjustment is done automatically and is continuously variable, the majority of the line systems in the Post Office high-frequency network have temperature equalizers that are adjusted as required. On these systems, since the equalization is altered in discrete steps, the level of received signal is likely to change suddenly by, say, 0.5 db each time the equalization is changed. Such changes are not serious taken alone, but for long-distance carrier groups, which may be routed over several line links in tandem, the cumulative effect of the small changes is to cause the transmission level to vary by several decibels without there being a fault condition present.

The purpose of the group reference-pilot signal is twofold. Firstly, it provides a maintenance aid by means of which the transmission loss of a group may be kept within close limits. The pilot signal is applied to the 12-channel group at its formation, i.e. on the channel translating equipment, and is then treated as an integral part of the group until final demodulation into 12 audio-frequency channels. The pilot signal is thus peculiar to the 12-channel group and is independent of the line systems over which the group may pass. Measurement of the level of the pilot signal on the group distribution frame at the receiving end of the group will enable the transmission loss at the pilot frequency to be readjusted manually to within 0.5 db of the original setting-up figure without the necessity of seeking co-operation from other repeater stations. Secondly, it provides a signal of known level for fault-location purposes without requiring a channel to be taken out of service. This is particularly useful when locating intermittent faults by monitoring a signal over an extended period of time.

GROUP REFERENCE-PILOT SIGNAL

Pilot-Signal Frequency

The ideal frequency for a group reference pilot is in the middle of the group frequency spectrum, i.e. 84 kc/s.

†Main Lines Development and Maintenance Branch, E.-in-C.'s Office.

This is the frequency used for setting up the group initially, and a frequency at this point is affected less than a frequency at either the upper or lower end of the frequency band by any change that may occur in the gain/frequency characteristic. This frequency, however, suffers from the disadvantage that it corresponds to the carrier frequency for channel 7 and would thus be subject to interference from carrier leak. For this reason, the frequency in general use is 84.080 kc/s, the so-called "84 plus delta" frequency. The shift in frequency of 80 c/s is sufficient to avoid carrier-leak interference without increasing unduly the interference from traffic on channel 6. It is worth noting that the French equivalent is 84.140 kc/s and a signal of this frequency is transmitted on all groups to the Continent that pass through or terminate in France.

It is preferable to increase the frequency slightly from the ideal 84 kc/s, rather than decrease it, for two reasons. Firstly, the nearest traffic signal above 84 kc/s is 600 c/s away, corresponding to 3,400 c/s in channel 6, whereas the nearest traffic signal below 84 kc/s is only 300 c/s away, corresponding to 300 c/s in channel 7. Secondly, the nearest traffic signals above 84 kc/s, because they represent a higher audio frequency, contain less energy than those below 84 kc/s and give less interference to the pilot signal. The position of the pilot-signal frequency in relation to the adjacent channels is shown in Fig. 1.

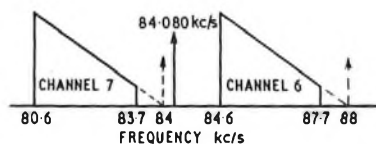

FIG. 1—POSITION OF THE PILOT-SIGNAL FREQUENCY WITHIN THE GROUP SPECTRUM

Frequency Stability

As the pilot signal, situated between channels 6 and 7, is likely to experience interference from speech and signalling on these channels, it is necessary for any pilot-measuring equipment to have a narrow band-pass filter at the input, which, used in conjunction with the channel-equipment filters, reduces the unwanted signals to negligible proportions. This in turn means that the pilot must be controlled within narrow limits of frequency in order that it should not drift outside the pass band of the measuring-set filter. The pilot-signal generator has a long-term frequency accuracy of 1 c/s. To this must be added any frequency change caused by differences in frequency between carrier-generating equipments at the two terminal stations and at intermediate translation points along the route. This additional frequency shift will not normally exceed 2 c/s for groups translated to the high-frequency end of the line spectrum, although it may momentarily exceed this figure if the carrier-generating equipment uses motor-driven capacitors for frequency control. Thus the pilot signal is normally received at the far end of the group within 3 c/s of the nominal frequency.

Pilot-Signal Level

In order that the addition of a pilot signal to every group shall not appreciably increase the loading of line amplifiers that handle a large number of groups, it is necessary for the pilot to be transmitted at a low level. The level used is -20 dbm0, i.e. 20 db lower than the signal that would be produced by applying a 1-milliwatt tone to the 2-wire point of one audio circuit connected to the channel translating equipment.

Level Stability

The level of the signal generated by the pilot-generating equipment must be stable, otherwise the object of using the reference pilot for level monitoring will be defeated. The pilot generators used for this scheme have a stability better than 0.1 db for changes of either ambient temperature or power supplies. The total level variation from all causes including temperature and power supplies is less than ± 0.3 db in any period of 28 days. Each pilot-generating installation comprises a main and standby oscillator with automatic change-over facilities.

INJECTION OF THE PILOT SIGNAL

When deciding on the method of injecting the pilot signal into a group a number of considerations have to be taken into account. The injection network should allow the level of the pilot signal to be independent of the impedance of the transmission path, there should be no crosstalk introduced between groups via the pilot-signal distribution and the loss introduced into the transmission path should be small. The three common methods of injection are the high-resistance tee, the resistive skew hybrid and the coil hybrid. These three methods are shown schematically in Fig. 2.

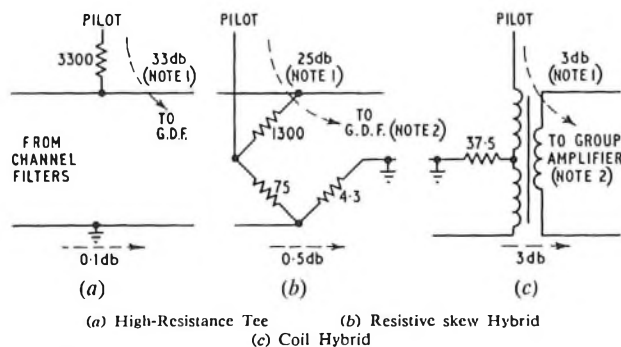

- Notes:
 1. The transmission losses shown are typical but can be altered.
 2. Impedance = 75 ohms.

FIG. 2—METHODS OF INJECTING THE PILOT SIGNAL

For this particular application the high-resistance tee is unsuitable. This is because the impedance of the transmission path at a frequency between two channels is likely to change greatly with a small change of pilot frequency. The channel-filter impedances will also change with time and temperature. Any change in transmission-path impedance alters the ratio of the voltage appearing in the transmission path to the total applied voltage, and thus alters the level of the pilot.

The resistive skew hybrid and the coil hybrid both work on the principle of the Wheatstone bridge and are

not affected by the impedance presented by the channel filters. The resistive hybrid has the advantages that it is cheaper than the coil hybrid and can also be made to introduce a lower loss in the main transmission path. Its disadvantage is that it introduces resistance into the earthed side of the unbalanced circuit, with a consequent risk of increased crosstalk. The resistive hybrid is preferred for use on channel-translating equipments that were in use before the introduction of the reference-pilot scheme and which have to be modified to provide pilot-injection facilities, because these equipments have no amplification in the transmit direction and it is necessary to introduce the smallest possible loss in the transmission path. On the later designs of channel-translating equipment, employing transistors, the loss introduced by the hybrid in the transmission path is not so important, because an amplifier is fitted to amplify the assembled group and ample gain is available. Also, the function of the coil hybrid can be combined with that of the amplifier input transformer, thus overcoming the objection of cost. For these reasons the resistive hybrid is used when it is necessary to modify existing equipment and the coil hybrid is used on new designs of equipment where a common group amplifier is employed in the transmit direction.

MEASUREMENT OF THE PILOT SIGNAL

The pilot signal is measured by a level-measuring panel mounted adjacent to the group distribution frame. The measuring panel has facilities for measuring through or terminated levels in the range -3 db to -65 db, relative to 1 milliwatt, by means of a decibelmeter fitted to the panel. It is also possible to monitor the pilot signal using an externally-fitted recording decibelmeter. Because the pilot signal has to be measured in the presence of traffic signals, the input to the measuring panel consists of a crystal band-pass filter. The filter has a pass band of ± 5 c/s about the 84.080 kc/s frequency, and a typical selectivity curve is shown in Fig. 3. The input filter is followed by a variable attenuator, for the purpose of changing the range, and an amplifier and detector that provide the direct current to

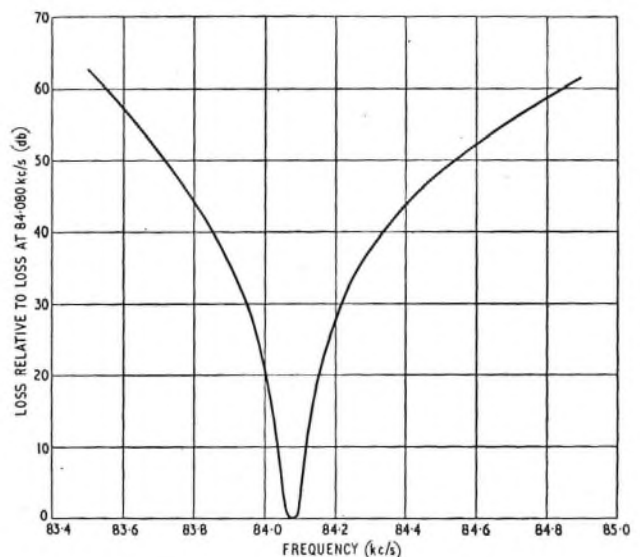

FIG. 3—LOSS/FREQUENCY CHARACTERISTIC OF MEASURING-SET FILTER

the decibelmeter and recorder outlet. A block schematic diagram of the measuring panel is shown in Fig. 4.

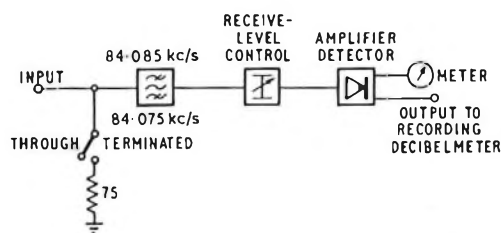

FIG. 4—SCHEMATIC DIAGRAM OF THE MEASURING SET

In practice it was found preferable to filter the input to the measuring panel as the first stage, otherwise the comparatively high level of traffic signals present tended to cause overloading. This arrangement is usually satisfactory, but interference is occasionally experienced from signalling transients in channel 7. This interference appears as the upper sideband of channel 7 which is insufficiently suppressed by the channel-equipment filters. When this occurs it is not possible to obtain a clean trace on the recording decibelmeter, although readings of the internal decibelmeter may still be made between bursts of interference. To meet this difficulty an audio-frequency high-pass filter is fitted temporarily to the audio input of channel 7 when recording takes place on the group. The audio-frequency filter, which has a cut-off frequency of 300 c/s, restricts the low-frequency high-energy transients of signalling that cause the interference.

FUTURE DEVELOPMENTS

The initial use of the group reference-pilot signal is to provide a reference by means of which the overall gain of the group may be adjusted manually. As a logical development of this, a number of other applications have been investigated.

Group Reference-Pilot Automatic Routiners

Routiners have been developed experimentally for periodically testing the levels of the reference-pilot signals at the receiving-end group distribution frame. Routiners are in use at London and Bristol that test the groups in turn and give an alarm if any group reference-pilot signal differs from its correct level by more than 3 db. The routiners test the groups at approximately 2-second intervals, so that, with a fully-equipped routiner catering for 30 groups, each group is tested at intervals of

1 minute. The trial of these routiners has been successful, but it is unlikely that the scheme will be extended because the cost of the routiner makes it an uneconomic proposition for small repeater stations.

Automatic Gain Control

Successful field trials have been carried out using amplifiers that have automatic gain control governed by the level of the group reference-pilot frequency. The amplifiers have a nominal zero gain, and for input variations of up to 4 db give an output variation of approximately one tenth of that of the input. Outside the range ± 4 db the amplifier characteristic changes smoothly from the 10:1 input-to-output ratio mentioned to a 1:1 ratio, i.e. the amplifier behaves as a normal amplifier without automatic gain control. Arrangements can be made for the amplifier to give an alarm when the incoming pilot signal varies 6 db from the nominal level. If amplifiers are to be installed to regulate the group, the additional alarm circuit can be provided cheaply and, being applicable to both large and small repeater stations, replaces the automatic routiner mentioned above.

Busying of Faulty Circuits

Before the advent of subscriber trunk dialling, faulty circuits were often detected first by the traffic staff, who would then take the circuit out of service. With subscriber trunk dialling this facility is lost and some means must be found to perform the function automatically; this can be done by means of the group reference-pilot signal. Basically the scheme is to apply the busy condition to the outgoing circuits affected when the incoming pilot frequency on the group departs from its nominal level by more than 6 db. To ensure that all affected circuits are taken out of service, particularly when only one direction of transmission has failed, arrangements are made to send a signal over the outgoing pilot frequency as soon as the incoming one fails, so that the busy condition is applied to circuits outgoing from either end. Panels for this purpose have been made in the laboratory and tried successfully in the field.

CONCLUSION

The group reference-pilot signal provides a valuable maintenance aid at a low cost per group. The scheme can be put into operation with a minimum of alteration to existing equipment and is capable of other applications connected with the provision of a uniformly high grade of service on the high-frequency network.

Book Review

"Applied Chemistry for Engineers". R. M. E. Diamant, M.Sc., Dip.Chem.Eng., A.M.Inst.F. Sir Isaac Pitman & Sons, Ltd. viii + 300 pp. 117 ill. 30s.

It would generally be regarded as unwise (if not criminally negligent) to allow deadly nightshade to flourish in plantations of blackcurrant bushes. The similarity between the nutritious fruit and the poisonous berries would make the gathering of sustenance a continuing hazard for the unwary. It is a great pity, therefore, that a book of such laudable aims, written with sound concept, and containing much useful material should be contaminated with so many false or misleading statements. Space does not permit the full cataloguing of these confusions of thought on the part of the

author. One may quote however from page 13 (re-iterated on page 30) "If sodium chloride for example is dissolved in water, the insulation effect of the water serves to keep the positively charged sodium ions separate from the negatively charged ions". Plastics (page 118) are defined as "Organic materials of high molecular weight, which, when subjected to heat and pressure in the presence of a catalyst during manufacture form solid objects by polymerising the monomers to polymers". Contrary to the statement on page 269, anti-oxidants are *not* added to lubricating oils to prevent oxidation of the metal bearing.

In its present form the book cannot be recommended. Revised and edited by a panel of practising industrial chemists it could well approach more closely to the claims made on the dust jacket.

J.C.H.

Improvements in the Teleprinter No. 7

C. E. EASTERLING, B.Sc., A.M.I.E.E.†

U.D.C. 621.394.6:621.394.324

The Teleprinter No. 7, introduced 30 years ago, has undergone a continual process of improvement and modernization. The more important changes that have been made are briefly reviewed.

THE Teleprinter No. 7A was first introduced into Post Office service in 1932. As this machine was not suitable for working to some foreign teleprinters using 7-unit transmitters, it was superseded later in 1932 by the Teleprinter No. 7B. This machine is still the standard page-teleprinter provided by the Post Office for private renters, but during the period of 30 years since its introduction many changes have been made to improve its performance and to reduce the amount of maintenance required. Variants of this machine (Teleprinters No. 7D and 7E) have been introduced for use on telex and other automatically-switched networks.

Up to 1939 the most important change was the introduction of the striker transmitter. This placed the transmitting contacts under the control of an accurately-cut timing cam, and resulted in a considerable reduction in the distortion of the transmitted signals.

During the war years effort was concentrated on production to meet the enormously expanding requirements of the Services, and such changes as were introduced were mainly to overcome difficulties due to shortages of materials and labour.

After the war a big program of detailed improvements was started, so that the modern machine gives a much better performance than its early predecessors. At the same time appearance was not neglected, as it was appreciated that a teleprinter needs to blend with modern office furniture and equipment.

The most important changes that have been made are described in the following paragraphs.

Electromagnet

The flux through the permanent magnet of the receiving electromagnet due to the signalling current in the coils is in the same direction as the permanent flux. There is therefore a tendency for the permanent magnet to increase in strength, and this may reach a point where the electromagnet can no longer operate efficiently. On the old-pattern electromagnet, with fixed permanent magnets (Fig. 1 (a)) the only way of reducing the flux was to remove the magnets and either subject them to hammering and similar forms of treatment or replace them by new magnets.

With new magnetic materials becoming available, it was found possible to design a new permanent magnet that not only had more stable characteristics, but because of its smaller size could be mounted across the ends of the pole pieces. It is held in a frame that can be tilted by means of a screw to provide an adjustable air-gap between the magnet and the pole-pieces. (Fig. 1 (b)). The force on the armature can thus be adjusted to the optimum value.

The armature stop-plate, which limits the movement of the armature and prevents it coming in contact with

† Telegraph Branch, E.-in-C.'s Office.

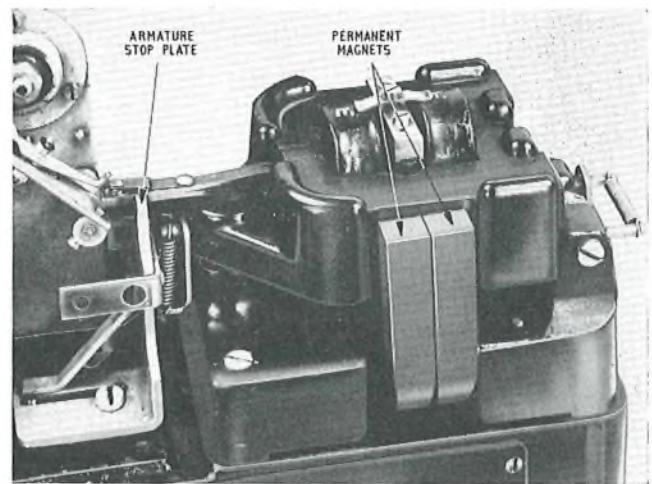

(a) Old-type Electromagnet and Stop-Plate

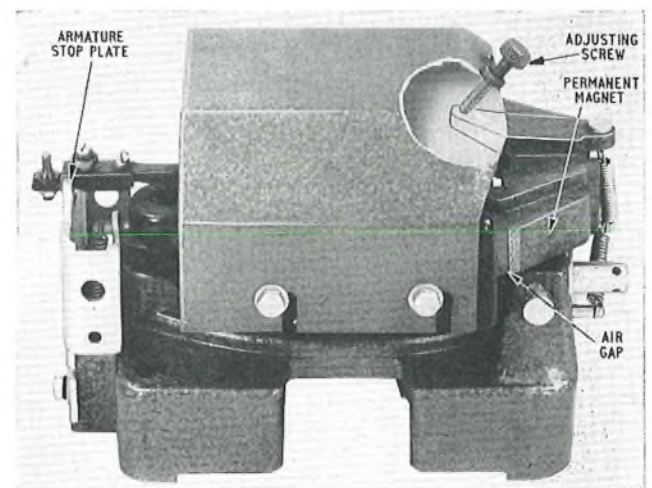

(b) New-type Electromagnet and Stop-Plate
FIG. 1—ELECTROMAGNET ASSEMBLIES

the faces of the pole-pieces, has been removed from the main base of the teleprinter and fixed to the body of the electromagnet, thus making a more rigid and accurately-positioned assembly.

Page-Printing Attachment

On older machines the shock-absorber for the carriage-return operation comprises a cylinder in the platen engaging with a piston at the end of the platen spindle (Fig. 2 (a)). A small hole is bored through the piston to allow the air to escape, and the aperture at the end of the hole can be varied by means of an adjustable valve plate, so as to provide adequate shock-absorption without rebound. This mechanism suffers from two disadvantages. Wear on the platen bearings upsets the concentricity of cylinder and piston, and paper can easily be caught between the cylinder and piston, causing them to jam.

The arrangement just described has now been superseded by a separate enclosed air dash-pot situated below the platen and operated through a lever system (Fig. 2 (b)). The valve which allows the air to escape from the

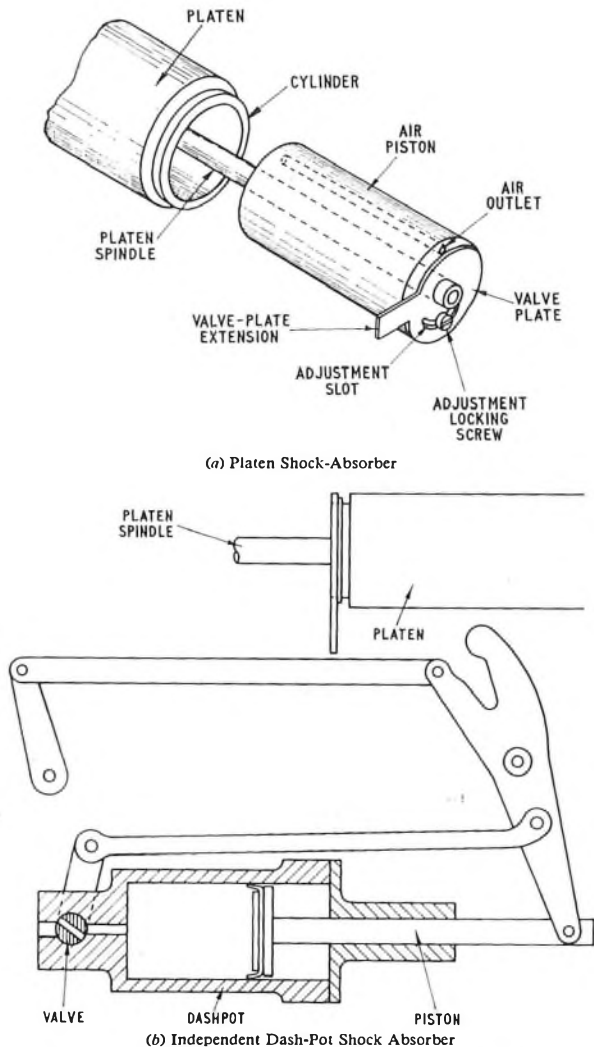

FIG. 2—CARRIAGE-RETURN SHOCK-ABSORBING ARRANGEMENTS

dash-pot is automatically controlled during the operation of the dash-pot so as to provide the maximum cushioning effect without bounce.

The new arrangement showed such a marked decrease in faults that a method has been devised for fitting the dash-pot to the older-pattern page-attachment, and several thousand machines are being modified.

Typehead Clutch

The typehead clutch now being fitted to Teleprinters No. 7 was described in an earlier article,¹ and has continued to give a good performance. In addition to its reduced fault liability, this clutch has the advantage that owing to its faster operation it will function reliably when receiving 7-unit signals at maximum speed. Although it has been agreed internationally that the minimum character length should be 7.4 units, some continental administrations are still using 7 units, and if such signals are sent at maximum speed the old type of clutch occasionally fails to latch.

Receive-Cam Unit

The receive cam used on the older machines controls the selecting, translating and printing functions. Because of the heavy load imposed by the last two functions, a ratchet clutch was employed. This clutch has 60 teeth, and as the shaft rotates in 130 ms the pick-up time varies between 0 and 2.2 ms depending on the relative positions of the ratchet and pawls at the moment of release. This is equivalent to a loss of total margin of $(2.2/20)100 = 11\%$, or $\pm 5.5\%$. Also, because there is insufficient time to carry out all the functions during one revolution of the cam, selection and translation are carried out during one revolution, and printing during the next revolution (when the next character is being selected and translated). As a result the last character of a transmission is not printed unless it is followed by a non-printing combination, e.g. letter-shift.

The new cam unit, known as the overlap cam unit, overcomes both these disadvantages by dividing the functions between three different cams, each being released in turn at the appropriate stage in the revolution of the previous one. The load imposed by selection is small, and it has been possible to use a friction clutch for the selector cam, thus largely eliminating the variable pick-up time and producing a useful increase in margin. The remaining two cams are driven through ratchet clutches, but for these functions accurate timing is not required. Although the selector cam still rotates in 130 ms, the total time available for the rotation of the cams is about 250 ms, so that there is time for printing to take place before the last cam comes to rest, and the last character is not stored in the machine. When receiving at maximum speed however, printing will still be taking place while the next character is being selected.

The new cam unit is also provided with an orientation device that enables the early and late margins to be balanced, and provides an approximate means of measuring margin while the machine is in service. The operation of this mechanism has already been described.¹

At present the new cam unit is only being provided on machines for the telex service, where the increase in margin is particularly valuable on international calls involving a number of links in tandem.

A. C. Motors

For a long time it has been realized that there is an obvious advantage in providing a.c. motors at offices equipped with a.c. mains, thus doing away with the large rectifier required to provide a d.c. motor supply (a small rectifier to provide a d.c. signalling supply would still be required). Difficulty was, however, experienced in designing a governed a.c. commutator motor of satisfactory performance, and synchronous motors were not favoured because of doubts of the mains frequency stability.

The chief difficulties in designing a satisfactory a.c. commutator motor arise from the fiercer governing action, which puts a greater strain on the windings and bearings, and the rapid brush wear. However, by paying particular attention to these points, a motor has now been produced that gives an adequate service on relatively lightly-loaded circuits, and it is now in general use on machines on the telex network.

The a.c. motor is more expensive than the d.c. motor, but is much cheaper than the combined cost of a d.c. motor and rectifier.

Some investigations have recently been carried out into

the stability of the frequency of the a.c. mains. Tests over a period of 18 months showed that a frequency deviation of 0.75 per cent (equivalent to the speed error allowed by the C.C.I.T.T.)* occurred for less than 0.008 per cent of the time. Some further consideration is therefore being given to the possibility of using synchronous motors.

Radio Interference Suppression

Over the 30 years during which the Teleprinter No. 7 has been in use there has been an enormous increase in the use of radio equipment, and the range of operating frequencies has continued to increase. If teleprinters are installed adjacent to radio or television receivers, interference is caused both by the motor and the governor and by the transmitting contacts, and various suppressors in the form of combinations of capacitors and inductors have been added from time to time. This resulted in a somewhat untidy assembly, and a new main-base casting was introduced that provided space for the majority of the radio-interference suppression components underneath the base. Satisfactory suppression both of mains-borne interference and radiated interference is achieved.

Hammer-Grey Finish

Up to about 1946 the painted parts of the teleprinter and its sound-reducing cover were painted in a high-gloss black enamel. This necessitated careful preparation of the parts to obtain a smooth surface on the metal. To avoid this careful preparation, and so reduce costs, a black crackle-finish was then introduced. With this finish, surface inequalities are largely concealed.

Although the black crackle-finish looks quite attractive when new, it soon collects dust and is difficult to clean. It was also felt that the traditional black was not appropriate to modern office décor, so machines are now finished in a hammer-effect grey paint². The use of this finish on the painted parts inside the machine has the additional advantage of improving visibility and thus assisting maintenance. A telex position finished in hammer grey is shown in Fig. 3.

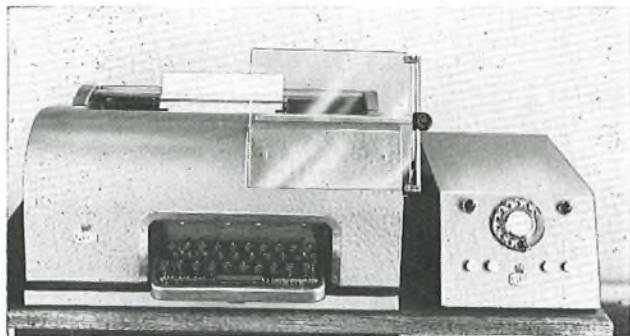

FIG. 3—TELEX POSITION

Keytops

Another change introduced mainly for the sake of appearance is the use of plastic keytops to replace the older assembly of label, cover glass and securing ring.

* C.C.I.T.T.—International Telegraph and Telephone Consultative Committee.

The two types are shown in Fig. 4 and 5. The plastic tops have a slightly concave upper surface.

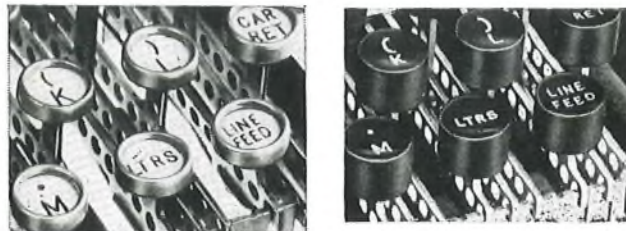

(a) Glass Keytops (b) Plastic Keytops
FIG. 4—OLD-TYPE AND NEW-TYPE KEYTOPS

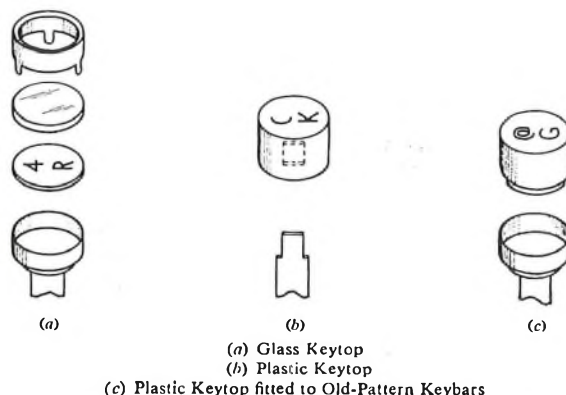

(a) Glass Keytop (b) Plastic Keytop (c) Plastic Keytop fitted to Old-Pattern Keybars
FIG. 5—ATTACHMENT OF KEYTOPS TO KEYBARS

The change to plastic keytops has also shown maintenance economies. In the old arrangement the labels soon became discoloured due to dirt and oil penetrating below the cover glass, and the labour of changing these, which frequently results in broken glasses and securing rings, adds appreciably to maintenance and overhaul costs. Once plastic keytops are fitted they rarely need subsequent attention, and all machines will eventually be fitted with them. For this purpose a method has been evolved of fitting plastic keytops to the old pattern keybar by the use of an adhesive.

The keytops are moulded in a green plastic that blends well with the hammer-grey finish. In manufacture the individual characters, or pairs of characters, are first moulded in white plastic. These are then inserted in another die for the main body of the keytop to be moulded around them. The characters are thus inlaid, and their visibility is not affected by wear.

Auxiliary Facilities

Reperforator Attachment. The use of automatic transmission has been increasing rapidly in recent years, and this tendency has been accelerated by the introduction of proportional-time metering on telex, where there is a financial incentive to transmit at the highest-possible speed.

The preparation of the paper tape on an off-line perforator has been a standard facility for many years, but as such a machine does not provide a printed copy during preparation an operator cannot readily check if the tape has been correctly prepared.

The first development to overcome this problem was the provision of a perforating attachment for the Tele-

printer No. 7.³ A modification of this attachment has been introduced that operates from the receiving mechanism and can also be operated from the keyboard via the local-record circuit. Machines so fitted are proving very popular and about 20 per cent of telex subscribers use them. As telex is a relatively lightly-loaded service, the machine can be used for tape preparation when a call is not in progress, and the provision of a separate off-line machine is avoided.

On-Speed Indication. On telex and other automatically switched networks, arrangements are made for the "who are you" signal to be sent automatically from the exchange to the called teleprinter, and it is therefore essential for the teleprinter to be running at its correct speed before the signal is sent. The sending of the "who are you" signal is therefore delayed until an indication is received from the teleprinter that it has reached governed speed. This indication is provided by a relay connected across, and short circuited by, the governor contacts. These contacts open when the machine reaches governed speed and the relay operates and locks to the mains supply. The relay thus remains operated until the mains supply to the motor is disconnected at the end of the call.

Use Meter. It is generally accepted that the amount of maintenance a machine requires is directly related to the amount it is used. One of the difficulties in adjusting the frequency of maintenance visits in the past has been that of ascertaining how much the machine is used. A cyclo-meter type of meter has now been introduced, operated from the ribbon-drive shaft and suitably geared so that it reads directly in hours of use. After two or three visits the maintenance staff can thus judge the amount of use being

made of the machine and the intervals between subsequent visits can be suitably adjusted.

Conclusion

Although the basic design of the Teleprinter No. 7 is 30 years old, the developments that have taken place have kept it up-to-date and enabled it to meet modern requirements. Maintenance needs have not been overlooked during this period, and many detailed changes have been made with a view to reducing the frequency of maintenance visits. As regards performance, i.e. transmitter distortion, receiving margin and speed stability, it would probably be difficult to make any appreciable improvement without departing from purely mechanical principles. Distortion and margin could possibly be slightly improved by the use of associated electronic apparatus, but whether the degree of improvement would justify the increased cost is questionable.

The Teleprinter No. 7 has proved to be a versatile machine, and it has been found possible to adapt it for a variety of special purposes. One of the major adaptations has been the fitting of a perforating unit and removal of the page-printing attachment to provide a printing reperfocator, i.e. a machine that provides a perforated tape with the corresponding message printed on the tape.³

References

- ¹EASTERLING, C. E., and COLLINS, J. H. The Teleprinter No. 11. *P.O.E.E.J.*, Vol. 46, p. 53, July 1953.
- ²The Use of Hammer Finish on Apparatus. *P.O.E.E.J.*, Vol. 55, p. 43, Apr. 1962.
- ³EASTERLING, C. E. Automatic Teleprinter Working. *P.O.E.E.J.*, Vol. 47, p. 80, July 1954.

Book Review

"Electrical Principles." Prof. H. Cotton, M.B.E., D.Sc., M.I.E.E. Cleaver-Hume Press, Ltd. xii + 423 pp. 258 ill. 15s.

This third edition of a book first published in 1956 contains two new chapters dealing with series and branched circuits, power calculations and electrical resonance. The book is not designed to cover any specific examination syllabus but to serve as a basis for a variety of classes in technical colleges and grammar schools, and for the professional syllabuses of the Institutions of Electrical, Mechanical, Mining and Radio Engineers.

After listing the symbols and abbreviations used, Chapter 1 commences with the question "What is Electricity" and then proceeds to an explanation of the structure of the atom and the motion of electrons. The general arrangement of the chapters is similar to that in most good-class works on electrical fundamentals, the early chapters dealing with magnetism, resistance, units, and calculations, including the use of Kirchhoff's laws, for simple circuits. These are followed by six chapters on the heating and magnetic effects of the electric current, work, power, the magnetization of iron and steel, and electromagnetic induction. Other chapters treat quite adequately the fundamentals of the d.c. generator and motor, cells and accumulators, the conduction of electricity through gases, static electricity and electrical measurements. The final chapters are on elementary a.c. theory and electrical resonance.

The book is well written and printed, the diagrams particularly being very clear and well selected, which one has come to expect from an author with such a long experience of students' requirements. Of great value to students are the many worked-out examples and the additional exercises at the end of each chapter, the answers to the numerical exercises being given at the end of the book.

This book is a worthy addition to existing students' works on elementary electricity.

I.P.O.E.E. Library No. 2406

R. S. P.

"The Basic Principles of Electronics and Telecommunications." M. D. Armitage, B.Sc., A.M.I.E.E., A.Inst.P. Geo. G. Harrap & Co., Ltd. 374 pp. 241 ill. 22s. 6d.

There is usually a time lag of several years between the introduction of new principles or techniques in industrial technology and the reflection of these in school curricula and public examinations. For example, semiconductor devices, particularly transistors, have become established in telecommunications technology in an astonishingly short time—they are already as important as thermionic valves—so that many teachers are having difficulty in keeping their lectures up to date in this respect.

In adding yet another text book to those covering the elementary years of electrical engineering and the Telecommunications Technicians Certificate, Mr. M. D. Armitage has set out to modernize the approach to the teaching syllabus of the City and Guilds examination in Telecommunications Principles "A". Using his experience as a lecturer at one of London's large technical colleges, he has avoided the tendency to compress subject matter because it is elementary. The descriptive style of writing, with a minimum of mathematics to interrupt the flow, holds the interest of the reader who proceeds at a comfortable, almost leisurely, pace well suited to the student who is not above average in his rate of progress. The diagrams are excellent and add much to the ease with which subject matter is presented. Exercises, with answers at the back of the book, are included at the end of each chapter.

This work is suitable for those elementary students of telecommunications who find difficulty in reading the more academic type of text book.

C. F. F.

New Cordless P.M.B.X. Switchboards—P.M.B.X.s No. 2/3A and 2/4A

C. M. HALLIDAY, A.M.I.E.E., and E. J. LIDBETTER†

U.D.C. 621.395.23

The new range of private manual branch exchange switchboards of the cordless type is completed by the introduction of two further switchboards with maximum capacities of three exchange lines and 12 extensions and of four exchange lines and 18 extensions, respectively. These have lamp-signalling and are of compact design similar to, but providing more facilities than, the first switchboard of the series, which provides for only two exchange lines and six extensions.

INTRODUCTION

IN an earlier article¹ a new type of cordless private manual branch exchange (P.M.B.X. No. 2/2A) was described. This type of switchboard was the result of an entirely new approach to the problems of physical design and circuit arrangement; it has a capacity of two exchange lines and six extensions and was the first of a new series of cordless switchboards that has been planned to supersede the existing types. Two larger switchboards similar in general design to the P.M.B.X. No. 2/2A are now being introduced. The first (P.M.B.X. No. 2/3A) has a maximum capacity of three exchange lines and 12 extensions; the second (P.M.B.X. No. 2/4A) is equipped for four exchange lines and 18 extensions. These two switchboards complete the new range of cordless P.M.B.X.s.

As a result of research into present-day requirements, the exchange-line-to-extension ratios of the new switchboards differ from those of the superseded models. The P.M.B.X. No. 2/2A, which is equipped for two exchange lines and six extensions (2+6), replaces the old 2+4 type; the new P.M.B.X. No. 2/3A (3+12) will replace the old 3+9 type and the P.M.B.X. No. 2/4A (4+18) will cater for much of the demand which previously was met by the 5+20 floor-pattern cord type. The remaining demand for the 5+20 switchboard will in future be met by a new floor-pattern cord-type board.

The introduction of the three new cordless P.M.B.X.s has, therefore, made it possible to provide a range of equipment in accordance with modern needs.

FACILITIES PROVIDED

The adoption of the 4-wire extension principle,² which entails running an extra wire plus an earth to each extension telephone for supervisory purposes, has enabled the requisite facilities to be provided in the most economical manner. An auxiliary unit has been designed for use with external-extension circuits that are routed in the public-exchange local-line network and so require conversion from 4-wire to 2-wire working. All the extension circuits on the switchboards can be used as 4-wire extensions if desired. Alternatively, by simple

†Subscribers' Apparatus and Miscellaneous Services Branch, E.-in-C.'s Office.

rearrangement of cords and straps within the switchboards and the connexion of the appropriate auxiliary unit, extension circuits 7-12 on the P.M.B.X. No. 2/3A and extension circuits 10-18 on the P.M.B.X. No. 2/4A can be used for 2-wire extensions, inter-switchboard extensions or private circuits.

The power supply for these switchboards is derived from an external a.c. mains-driven power unit³ supplying 50 volts d.c. and 25 c/s a.c. for ringing purposes.

The main features of the two new cordless P.M.B.X. switchboards are as follows:

- (a) Lamp signalling for exchange lines and extensions.
 - (b) A transmission and signalling limit of 500 ohms for extension circuits and of 935 ohms for exchange-to-extension connexions when connected to an exchange equipped for 1,000-ohm lines.
 - (c) Press-button recall on extension-to-extension calls and extension-to-exchange calls, under all conditions.
 - (d) Individual clearing on extension-to-extension calls.
 - (e) Automatic holding of exchange calls.
 - (f) Follow-on-call trap on incoming exchange calls.
 - (g) Connexion of private circuits and inter-switchboard circuits without modification to the permanent wiring of the switchboard.
 - (h) Connexion between cabling and the switchboard by a flexible cord and connector.
 - (i) Arrangements for the provision of a headset in addition to the operator's handset telephone.
 - (j) Space for the provision of subscriber-trunk-dialling (S.T.D.) trip meters on the switchboard.
- The following additional facilities are provided only on the larger switchboard:
- (k) An "overcall" circuit to enable the operator to answer exchange and extension lines when all connecting links are engaged.
 - (l) Lamp signals to indicate the next free connecting-link circuit available.

PHYSICAL DESIGN

P.M.B.X.s No. 2/3A and 2/4A are similar in design and are shown in Fig. 1 and 2. The switchboards are

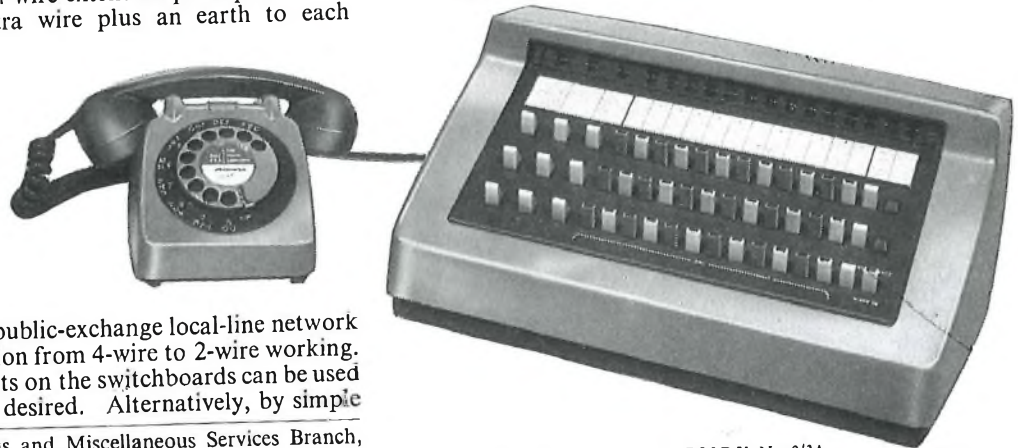

FIG. 1—P.M.B.X. No. 2/3A

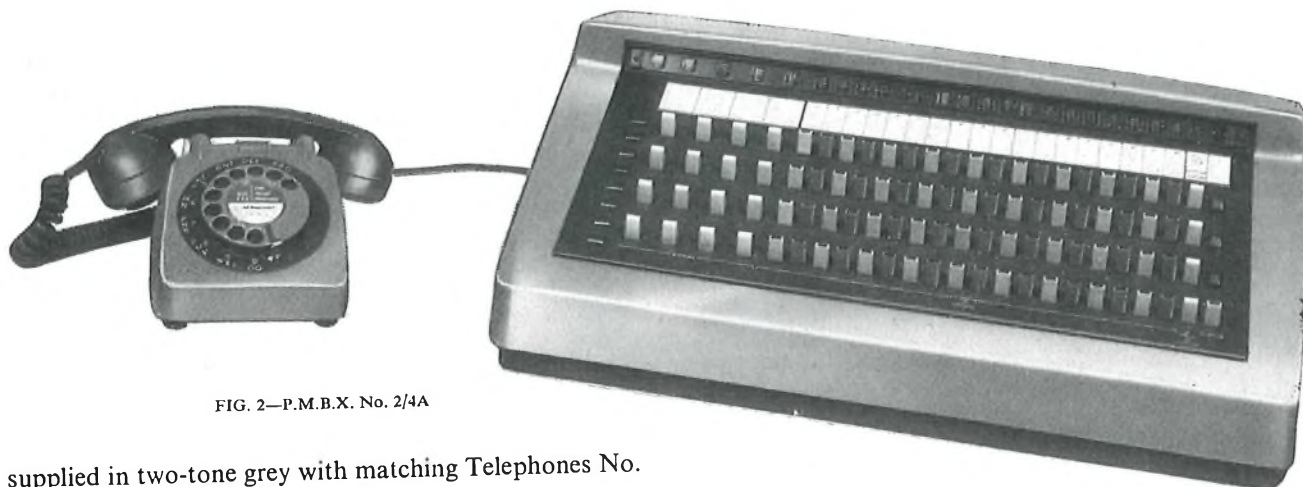

FIG. 2—P.M.B.X. No. 2/4A

supplied in two-tone grey with matching Telephones No. 706 as the operating instruments.

Both switchboards have a metal chassis and a plastic cover. The P.M.B.X. No. 2/3A is approximately 17 in. wide by 8 in. high by 13 in. deep and weighs 33 lb; the P.M.B.X. No. 2/4A is approximately 22 in. wide by 9 in. high by 15 in. deep and weighs 56 lb.

The thermoplastic French-grey covers are made by injection moulding using a co-polymer plastic material that is both economical and attractive in appearance. The leading edge of the cover fits under the front of the face panel, and adjustable plates on the side of the panel form dust seals.

The face panel is finished in elephant-grey stoved p.v.c. (organosol) that provides a durable surface with a leather-grain appearance. The marking required on the face panel is applied by hot stamping into the layer of stoved p.v.c. and the characters are white.

If it is desired to use a headset as the operator's instrument, the Telephone No. 706 is changed for a Telephone No. 710 and a headset jack is provided on the switchboard. The change-over from handset to headset is arranged by providing auxiliary spring-sets in the Telephone No. 710 so that when the handset is on the rest the receiver and transmitter of the headset are brought into circuit. When the handset is lifted the transmission path is automatically switched back to the handset. Under these conditions the normal gravity-switch spring-sets are short-circuited and the connexion of the operator's telephone depends entirely on the operator's telephone key.

The miniature 1,000-type key⁴ has been used instead of the standard lever key. The key handles are coloured light ivory for the exchange lines and operator's keys, and, alternately, light ivory with black inserts and French-grey with black inserts on the extension positions to assist in identifying the keys associated with a particular circuit. The ALARM ON/NIGHT SERVICE key is light ivory with a red insert.

The keys, lamp jacks and circuit-designation label-strips are mounted on the panel in such a manner that all screw heads are concealed. When the lamp cover-strip is removed the lamp-jack screw heads are exposed; by releasing these screws, the lamp jack may be drawn forward to permit lamps to be changed without the use of a lamp extractor or the removal of the switchboard cover.

Arrangements have been made for the provision of subscribers' private trip-meters. These are used on S.T.D. calls and are fitted, as required, in the key panel of the switchboard in line with the appropriate exchange-line keys. For this reason the exchange-line connecting-circuit keys are more widely spaced than the extension keys. The removal of the exchange-line designation strip uncovers a cut-out portion of the panel provided to accommodate the meters; if meters are provided a narrower type of designation strip is used. The meters can be provided on the basis of one meter per exchange line or one meter that can be switched to any of the exchange lines.

When the cover of the switchboard is removed the metal chassis, consisting of three sections, is exposed. The front and rear panels and the base plate form a triangular section when the chassis is closed, as shown for the P.M.B.X. No. 2/3A in Fig. 3. By releasing the screws at the apex, the hinged panels can be opened outwards to permit inspection of the wiring and components. The P.M.B.X. No. 2/4A is similar except that it contains more equipment.

The front panel carries the keys and lamps, and the relays are mounted on the rear panel under a dust cover;

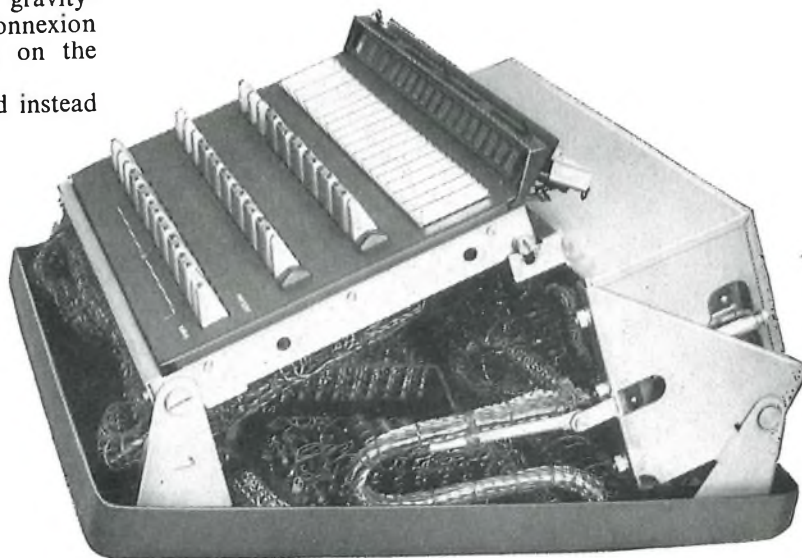

FIG. 3—CHASSIS OF P.M.B.X. No. 2/3A

some static components are mounted on the base together with the connexion blocks. One type of connexion block has soldered connexions that can be rearranged to provide, for example, barring of the connexion of private circuits to exchange lines; the other type is equipped with screw terminals and is used for the connexion of the operator's telephone and the line-circuits. Screw terminals are also provided to permit rearrangement of the straps and cords when 2-wire extensions, private circuits or inter-switchboard extensions are required.

The switchboard is supplied with a multi-way cord already connected, and with the free end terminated on small connectors that plug into a wall-mounting jack assembly cabled to the connexion box. The P.M.B.X. No. 2/3A is equipped with a 68-way cord and P.M.B.X. No. 2/4A with a 100-way cord.

ELECTRICAL DESIGN

For economic reasons a parallel-feed transmission bridge has been adopted for extension-to-extension calls. The bridge is of the new 50-volt design (used on P.M.B.X. No. 2/2A) and consists of a $300 + 300$ -ohm coil with an $0.1 \mu\text{F}$ capacitor across the output to give improved side-tone balance. This combination is suitable for all extension-to-extension calls up to a signalling limit of 500 ohms, with either 300-type or 700-type telephones. Non-removable relay shields fitted to the transmission-bridge relays increase the crosstalk attenuation between circuits to at least 75 db.

A new lamp (Lamp No. 2, 45 volts) has been developed for use on these switchboards. It has a reasonably flat lumens/resistance response over the range 0-500 ohms for the line-plus-telephone loop resistance and its use has obviated the need for a line-signalling relay.

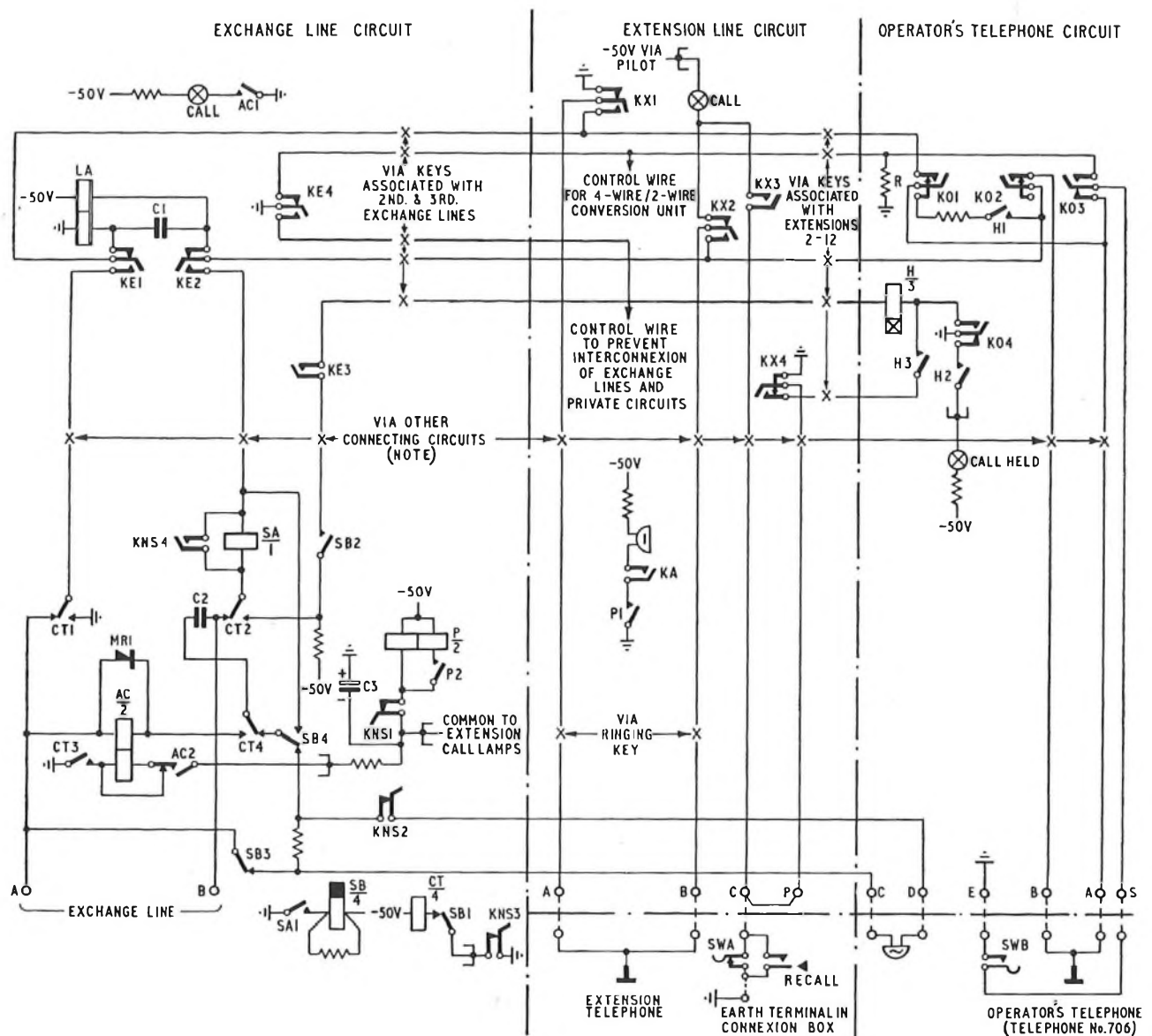

Note: There are five connecting circuits.

FIG. 4—SIMPLIFIED CIRCUIT OF P.M.B.X. No. 2/3A

No hand generator is fitted; the ringing supply is derived from a frequency-dividing mains-operated unit producing a 25 c/s a.c. output.

The switchboard circuits have been designed to operate from a nominal 50-volt d.c. supply, but are capable of operating from a supply in the range 45–55 volts, and this has enabled economies to be made in the design of the power units. Under full-load conditions the current consumption of the P.M.B.X. No. 2/3A is 1 amp and that of the P.M.B.X. No. 2/4A is 2 amp. If auxiliary units are associated with the switchboard, the power consumption is increased and the power units are changed to 2-amp and 4-amp types, respectively. Arrangements have been made to ensure that exchange calls in progress are maintained if a mains failure occurs. For normal installations it is recognized and accepted that extension-to-extension and inter-switchboard calls will fail if the mains supply ceases, but at installations where such a break in service could not be tolerated the switchboard will be operated from a floated-battery system.

CIRCUIT DESCRIPTION AND OPERATION

The 4-wire extension principle is used on all internal extensions and can be applied to external extensions within the curtilage of the subscriber's premises. For external extensions connected via the local-line network it will generally be desirable and more economical to use a 4-wire/2-wire conversion unit. For extensions not requiring a conversion unit the exchange-to-extension transmission and signalling limit is 935 ohms in exchange areas equipped for 1,000-ohm line working, 65 ohms being required for the supervisory relays. On external extensions for which conversion units are required this limit is reduced to 850 ohms, the difference being due to the resistance of the signalling relays in the conversion unit.

Two additional facilities are provided by the circuit of the larger switchboard, the P.M.B.X. No. 2/4A. The first enables a free connecting link to be selected rapidly by means of a free-link signalling system. The second facility, known as overcall, enables the operator to answer a call when all seven connecting links are engaged.

A simplified circuit diagram of the P.M.B.X. No. 2/3A is shown in Fig. 4.

Extension-to-Extension Calls

When a call is originated at an extension by lifting the telephone handset, earth via contact KX1, the telephone loop, contact KX2 and the calling lamp, operates the pilot relay, P, which is connected to –50 volts, and the extension calling lamp glows. Contact P2 connects the low-resistance coil of the P relay in parallel with the high-resistance coil. This prevents the voltage drop across the pilot relay becoming excessive when a number of lamps are glowing simultaneously. Contact P1 causes an audible alarm to be given if the ALARM ON key, KA, is operated. If more than one extension is calling the switchboard, overhearing between the extensions is suppressed by capacitor C3. The call is answered by operating the OPERATOR'S TELEPHONE key, KO, associated with the chosen connecting circuit and the appropriate CONNECT EXTENSION key, KX, and by lifting the handset of the operator's telephone. The transmission-bridge relay, LA, feeds transmitter current to both telephones.

If connexion to another extension is required, the operator checks that the extension is disengaged by observation of the keys, and calls the extension by the operation of the appropriate ringing key. When the called extension answers, the calling lamp glows and the KX key associated with the extension is operated to complete the connexion. The operator then restores key KO and replaces the handset. Either extension can recall the switchboard by depressing the recall button on the extension telephone. An earth (on the fourth wire from the connexion box) is then extended to the C wire (the third wire) and the calling lamp glows while the recall button is pressed. When the call is completed and the extension handset is replaced, earth potential is extended via the auxiliary gravity-switch spring-set, SWA, to the C wire to give a clearing signal on the calling lamp via key contact KX3.

Extension-to-Exchange Calls

If the calling extension requests connexion to an exchange line the CONNECT EXCHANGE key, KE, of a free exchange line is operated. This disconnects the local 50-volt supply from the connecting circuit at contacts KE1 and KE2 and extends the extension to the exchange-line circuit. As relay CT is normally operated, earth via contacts CT1, KE1 and KX1, the extension-telephone loop, contacts KX2 and KE2, relay SA and contact CT2 operates relay SA to –50 volts. Contact SA1 operates relay SB and contact SB1 releases relay CT. Contacts CT1 and CT2 extend the circuit through to the exchange line. Capacitor C2 is connected across relay SA to provide a low-impedance speech path. The exchange-line connecting keys are arranged to prevent any exchange lines being connected together.

Incoming Call on an Exchange Line

Incoming ringing current on an exchange line will operate relay AC over one coil, via contact CT4 operated. Contact AC1 lights the calling lamp and contact AC2 completes a holding circuit for relay AC from an earth via contact CT3 (to provide a locked calling signal on the exchange line until the operator answers) and also operates the pilot relay, P. The circuit is arranged to ensure that, provided the ALARM ON key, KA, is operated, an audible alarm is given at the P.M.B.X. even if the exchange-line calling lamp becomes disconnected. The operation of relay AC is delayed by the short-circuit maintained across the hold coil by contact AC2. This avoids false operation due to line surges when switching takes place. False operation of relay AC can, however, occur under certain conditions if the A and B wires of the exchange line are reversed.

Specific safeguards have also been incorporated to avoid the possibility of lost calls due to misoperation of the switchboard keys. A calling signal is not extinguished (except when a headset is also provided) until the operator's handset has been lifted and both the KE and KO keys have been operated. When the call is answered by the operator, relay SA operates. Relay SA then operates relay SB, which releases relay CT. Contacts CT1 and CT2 extend the operator's telephone loop to the exchange line to trip the ringing if the incoming call is from an automatic exchange. Contact CT3 disconnects the holding circuit for relay AC, and contact AC1 extinguishes the calling lamp. The exchange call can

then be extended to an extension, as already described, or automatic holding conditions can be applied.

Automatic Holding of Exchange-Line Calls

When a call is answered, relay SB is operated by relay contact SA1; -50 volts, via contacts SB2 and KE3 operated, operates relay H to earth at contact KO4. Relay H locks to earth via contacts H3 and KX4 or to earth at the auxiliary gravity-switch, SWA, of the extension telephone if the extension key has been operated. Contact H1 prepares the holding loop across the exchange line, the loop being completed by contact KO1 when the operator restores the KO key to normal. Contact H2 restores the KO key to normal. Contact H2 lights the CALL HELD lamp. This lamp remains as a visual reminder to the operator that supervision of the switchboard is still required. If the line has been switched to an extension the holding circuit is released when the extension answers the call by the auxiliary gravity-switch contacts, SWA, opening. When the holding circuit is removed the CALL HELD lamp is also extinguished. The CALL HELD lamp is common to all connecting circuits.

If the operator wishes to release an exchange call without connecting it to an extension, the holding circuit to relay H is released at contact KE3 when the exchange key is restored. Although relay H is shown in Fig. 4 as a slow-to-operate relay, advantage is taken of its slow release, and in so doing further economy and space saving has been achieved by using 600-type relays instead of 3,000-type relays. The slow release of relay H is particularly important when the automatic holding circuit is used on circuits where line surges are prevalent.

Call Trap

When an exchange-extension call is completed the clearing signal is given on the extension calling lamp only when the extension telephone is replaced. Relay SA then releases and contact SA1 releases relay SB. Contact SB1 restoring to normal permits relay CT, the call-trap relay, to re-operate. Contact CT4 re-connects relay AC and capacitor C2 across the A and B wires of the exchange line, while contacts CT1 and CT2 disconnect the exchange line from the connecting circuit. Thus a follow-on incoming call will be trapped on relay AC and will not ring the extension telephone bell if the call has not been cleared-down at the switchboard.

Free-Link Signalling

A free-link signalling system, similar to the well-known free-line signal (F.L.S.) used on manual switchboards in main exchanges, has been provided to increase the speed of answer. This is particularly important with the P.M.B.X. No. 2/4A as there are 88 circuit keys to scan before selecting a free connecting link. The free-link signals are given by small amber-coloured lamps situated down the left-hand side of the face panel. Two lamps are provided for each row of keys, one for the upward movement and one for the downward movement. The circuit arrangement is shown in Fig. 5. Normally, all lamps are extinguished in the idle condition. As soon as an incoming call is received pilot relay P operates. Contact P1 lights lamp LPA and the operator answers the call using the A connecting link. When the A connecting link is taken into use the relay contacts LA1 and LA2 of the transmission-bridge relay operate and

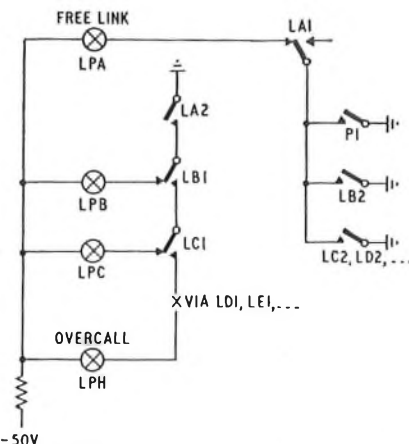

FIG. 5—FREE-LINK-SIGNALLING CIRCUIT ELEMENT

step the free-link signal on to lamp LPB to indicate that the B connecting link should be used for the next call.

The sequence is always the same, but if any link is taken into use out of turn the remaining lamps still glow in the same order, excluding the circuit taken out of sequence if it is still in use. When a circuit becomes disengaged the free-link lamp glows again if it is the first free link in the sequence. On exchange calls arrangements are made to operate the appropriate transmission-bridge relay although it is not used to provide the transmission feed. When all seven connecting links are engaged the eighth lamp, the OVERCALL lamp (LPH), glows. This indicates that all connecting circuits are engaged. Should any exchange or extension call then be received at the switchboard it can be answered on the overflow or overcall circuit.

Overcall

As mentioned above, overcall enables the operator to answer a call when all seven connecting links are engaged. The circuit is shown in Fig. 6. To answer an extension

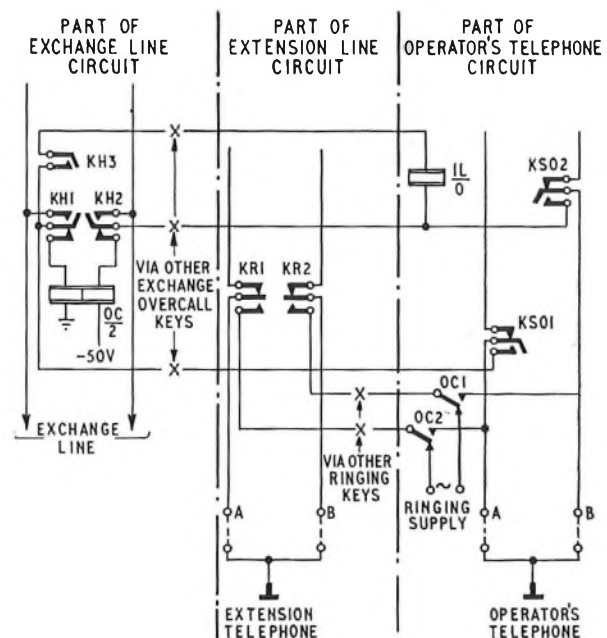

FIG. 6—OVERCALL CIRCUIT ELEMENT

call under these conditions the SPEAK ON OVERCALL key, KSO, is operated and relay OC feeds transmission current to the operator's telephone via contacts KH1 and KSO2, and contacts KSO1 and KH2. Relay OC operates, and contacts OC1 and OC2 changing over disconnect the ringing supply and extend the operator's telephone to the extension RING key, KR. The operator can now speak to the calling extension by holding operated the appropriate KR key. The KSO key must be restored before answering a normal call.

An exchange call is answered by operating the KSO key and the appropriate EXCHANGE OVERCALL key, KH, which locks in the operated position. Contacts KH1 and KH2 disconnect relay OC and connect the exchange line to the operator's circuit. The transmission feed for the operator's telephone is now supplied by the public exchange and contact KH3 connects bridging coil IL to provide a holding condition. This permits the operator to leave the circuit and offer the call to an engaged extension and then, if required, breakdown the connexion and extend the exchange call to the extension. When the call has been dealt with, keys KH and KSO are restored.

Mains Failure

As the switchboard has been designed to work from a mains-operated 50-volt d.c. power-supply unit, the circuits have been arranged so that the exchange-line service is maintained under mains-failure conditions. If a mains failure occurs, relay CT (Fig. 4) releases and contact CT4 connects the bell of the operator's telephone to the first exchange line so as to give an audible indication of an incoming call. The operator can answer the exchange call under mains-failure conditions by operation of the appropriate KE and KO connecting keys and by removing the handset from the operator's telephone. Outgoing exchange calls can also be originated by the operator in the normal manner. The operating instructions for these switchboards will advise the subscriber to connect the remaining exchange lines to selected extensions (as for night-service working) if a mains failure should occur, and the selected extensions will then have direct access to these exchange lines.

Press-Button Recall

Each extension telephone is provided with a press-button key (a make contact in parallel with the auxiliary gravity-switch spring-set) for recall purposes. Operation of the button connects earth potential (on the fourth wire) to the C wire (the third wire). Recall is available on all extension and exchange calls.

Night Service

Night-service arrangements are provided by the NIGHT SERVICE key, KNS, and relief relays that disconnect the pilot relay and the extension calling-lamps.

Key contact KNS3 releases relay CT, which disconnects the AC relay of each exchange line thus rendering the call-trap circuit ineffective. Selected extensions can be connected to the exchange lines by operating the appropriate KE and KX keys as required.

Two-Wire Extensions, Inter-switchboard Extensions and Private Circuits

Additional terminations have been provided on extensions 7-12 of the P.M.B.X. No. 2/3A and on extensions 10-18 of the P.M.B.X. No. 2/4A so that by suitable inter-connexions these extensions can be used for 2-wire extensions, inter-switchboard extensions or private circuits, without alteration to the permanent wiring of the switchboard.

When any of these facilities are required the connexions are made so that the switchboard controls the switching relays in the various auxiliary apparatus units to provide for automatic hold on 2-wire extensions and inter-switchboard extensions, or prohibition of exchange-line connexion to private circuits.

Provision is also made to control the relays in the 4-wire/2-wire conversion unit in order to provide through-dialling facilities on exchange calls. Should the operator enter the circuit on this type of connexion, spring-set SWB on the operator's telephone short-circuits resistor R on the control wire and operates a relay to provide transmission feed from the conversion unit to the extension. On extension-to-extension calls the divided transmission-feed arrangements are applied by earth from contact KE4 normal short-circuiting resistor R.

CONCLUSION

The P.M.B.X.s No. 2/3A and 2/4A incorporate new circuit design, provide better facilities, and should give greater reliability and ease of maintenance. These advantages, coupled with their improved appearance, should make them welcome substitutes for the switchboards they supersede.

ACKNOWLEDGEMENT

The authors wish to thank Ericsson Telephones, Ltd., who, as the liaison manufacturers, worked in close co-operation with the Post Office on these developments.

References

¹HALLIDAY, C. M., and LIDBETTER, E. J. A New Small Cordless P.M.B.X. Switchboard. *P.O.E.E.J.*, Vol. 54, p. 22, Apr. 1961.

²LIDBETTER, E. J. The 4-Wire Extension Principle for Small Cordless P.M.B.X. Switchboards. *P.O.E.E.J.*, Vol. 53, p. 167, Oct. 1960.

³MOORE, M. B. Power Units for Use at Subscribers' Premises. *P.O.E.E.J.*, Vol. 55, p. 49, Apr. 1962.

⁴CLARKSTONE, K. H. A Miniature Lever Key of Improved Design. *P.O.E.E.J.*, Vol. 55, p. 29, Apr. 1962.

A Concentrator for a Telegraph Tape-Relay Network

L. A. MEREDITH†

U.D.C. 621.394.65:621.394.625.2

A telegraph tape-relay concentrator has recently been installed at London Airport. This concentrator has enabled considerable savings in telegraph machines, floor space and operating costs to be achieved compared with the equipment required for the conventional torn-tape relay system that it has replaced.

INTRODUCTION

ONE of the factors contributing to the safety of air travel is an international telegraph system linking the airports of the world. Air movements, weather information and air-traffic-control advices are the types of messages sent on this network. The Ministry of Aviation is responsible for the operation of the system in this country and provides at each airport a centre where messages to and from the airline companies are accepted and relayed to their destination. These centres are called telegraph relay centres (T.R.C.).

At telegraph relay centres using the torn-tape relay method of operation every incoming message is converted by a printing reperforator into a length of punched-paper tape that also has the message printed on it. The operator reads the address from the message preamble and then inserts the tape into an automatic transmitter for onward transmission.

A message may pass through one or more T.R.C.s before reaching its destination, and circuits linking one T.R.C. to another T.R.C. are designed to provide for duplex operation, i.e. to carry messages in both directions simultaneously. The circuits connecting an out-station to a T.R.C. are normally only required to transmit in one direction at a time and are therefore designed for simplex operation. However, if the volume of traffic to an out-station is great enough to justify the cost of extra machines, facilities for duplex operation are provided. In the T.R.C. both types of circuits terminate on at least four machines: a printing reperforator, an automatic transmitter, a serial-numbering transmitter and a monitor teleprinter.

At London Airport some of the circuits from the airline companies were not fully utilized and, to effect an economy in machines and floor space in the T.R.C., it was decided to provide equipment to concentrate 25 simplex circuits on six printing reperforators, six automatic transmitters and six monitor teleprinters. Each circuit retains its individual serial-numbering transmitter, but the other three types of machine (printing reperforator, automatic transmitter and monitor teleprinter) are shared. To assist in tracing calls on the monitor teleprinter the time of transmission is automatically inserted after the serial number before each message is transmitted. Opportunity was also taken to incorporate a routiner for automatically testing the lines and the distant machines every 20 minutes.

When the equipment was brought into service 17 circuits were connected to it, resulting in a saving of 14 printing reperforators, 11 teleprinters and four triple-headed automatic transmitters. The equipment and the operating procedure in the airline offices remained unchanged.

† Telegraph Branch, E.-in-C.'s Office.

DESCRIPTION OF CONCENTRATOR

Incoming Concentrator Console

Fig. 1 shows two console cabinets that together accommodate a maximum of six printing reperforators.

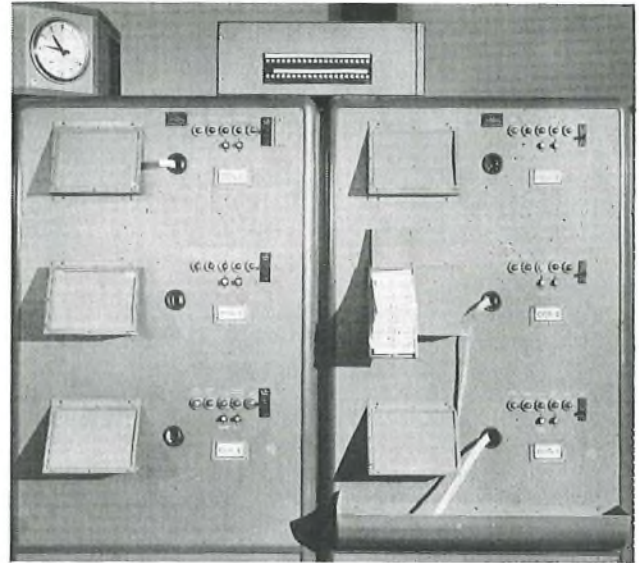

FIG. 1—INCOMING CONCENTRATOR CONSOLE

It is in these consoles that incoming messages are received on perforated tape that is torn off by the operator and inserted in any automatic transmitter on the transmit position for onward re-transmission. Associated with each reperforator is a busying key and lamp to enable the machine to be taken out of service, a calling lamp, a SIMPLEX CLEAR push-button for the forcible release of circuits from the concentrator, and the usual tape-run-out push-button; OVERRIDE, TAPE EXHAUST and FUSE ALARM lamps are also provided.

A panel of lamps, one for each circuit, is mounted on top of the consoles. A circuit lamp glows when an out-station calls the T.R.C. and flashes when a connexion to a printing reperforator has been made.

Outgoing Push-Button Panel and Transmit Position

The transmit position (Fig. 2) contains two triple-headed automatic transmitters (A) providing six message-heads, a push-button and lamp panel (B) and a 4-figure display device (C) for checking the time-injection unit. There is a push-button and lamp for each circuit and for each message transmitter. It is at these positions that the routing of the message being retransmitted is determined; as already described, the destination is read off the message preamble and, after the insertion of the tape in a free automatic transmitter, the appropriate button is pressed by the operator.

Switching Equipment

The line terminating and switching equipment, consisting mainly of Post Office standard 3,000-type relays and

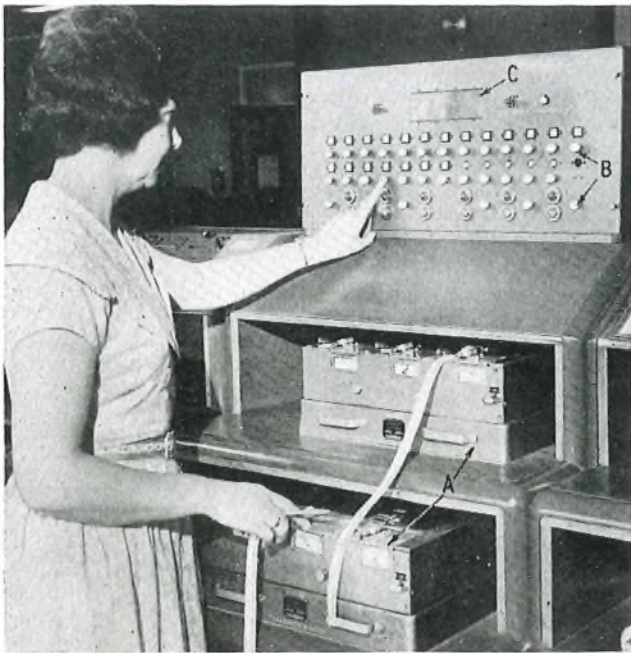

A—Automatic transmitters
B—Push-button and lamp panel
C—Four-figure display

FIG. 2—OUTGOING PUSH-BUTTON PANEL AND TRANSMIT POSITION

uniselectors, is mounted on four standard 19 in. wide racks in separate accommodation. A further six racks accommodate the electronic serial-numbering transmitters.*

OPERATION OF CONCENTRATOR

Fig. 3 shows a block schematic diagram of the system, which functions basically as an incoming concentrator for

* MARSH, H. An Electronic Telegraph Serial-Numbering Transmitter. *P.O.E.E.J.*, Vol. 55, p. 195, Oct. 1962.

the receive channels of the simplex circuits (R wires) and a push-button torn-tape message switching system on the send channels (S wires). The operation of the system is described below by considering separately the passage of messages incoming to and outgoing from the T.R.C.

Incoming Message

The operator at the out-station presses the CALL button, which causes the potential on the R wire to change from positive to negative. This change is detected in the line relay-set at the T.R.C., which indicates to the outgoing equipment that the circuit is engaged and causes unselector LF to search for the calling line. The line is then switched through to the printing reperforator, and a negative potential is returned over the S wire to the out-station to light a lamp indicating to the operator there that the connexion has been established and that the message should be sent. At the end of the message the out-station operator presses a push-button designated CLEAR, and the potential of the R wire is changed back to positive, causing the equipment in the T.R.C. to be released. A positive potential is then returned on the S wire to the out-station to extinguish the lamp and to stop the teleprinter motor.

The function of the load distributor is to allocate in advance the printing reperforator that is to accept the next call, and it normally allocates the reperforators in a cyclic order. During periods of heavy traffic, however, this sequence can be altered and the first printing reperforator to become free is allocated.

Outgoing Message

When any one of the six transmitter heads on the transmit position is loaded with tape and the appropriate circuit push-button on the push-button panel is depressed, unselector CM drives to the circuit outlet and connects a demand signal to the line relay-set of the required line. When the line is free unselector PF, associated with the

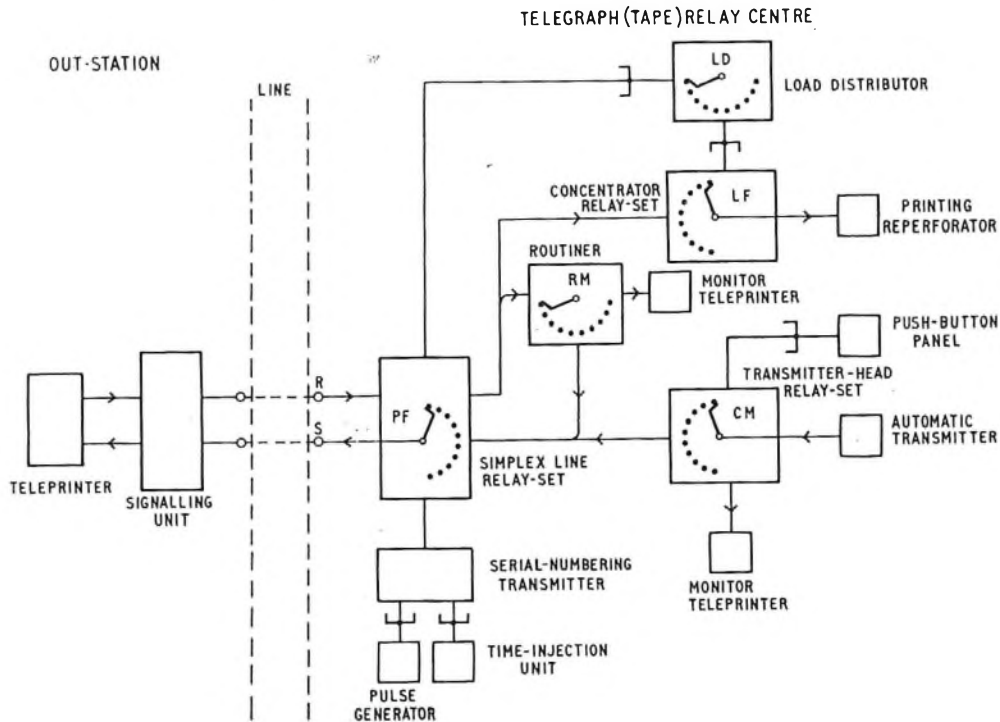

FIG. 3—BLOCK SCHEMATIC DIAGRAM OF CONCENTRATOR

line relay-set, switches to the calling transmitter-head relay-set. The line relay-set then changes the potential of the S wire from positive to negative to start the out-station teleprinter motor. A negative potential is returned on the R wire to the line relay-set, so starting the serial-numbering transmitter. The circuit code, serial number and time are transmitted to the out-station teleprinter and to the monitor teleprinter associated with the transmitter-head. The serial-numbering transmitter is released and the transmitter-head started, transmitting the message to the out-station and to the monitor teleprinter. At the end of the message the "tape out" contacts on the transmitter open and release the equipment; the line potential reverts to positive.

Other features of the design are:

(a) The banks of uniselectors PF and CM are interconnected in such a way that it is impossible for two uniselectors to switch to the same outlet.

(b) If more than one transmitter head is loaded for the same line, the heads transmit sequentially in the order one to six and not in the order of loading.

(c) If the transmission of a message is delayed, an alarm is given after a predetermined time to draw attention to the transmitter head concerned.

Routiner

Every 20 minutes unisector RM in the routiner commences a testing cycle. Engaged lines are stepped over, but the routiner stops on the free ones, tests for the correct line conditions and then causes the serial-numbering transmitter to transmit the circuit code, serial number, time, and the characters "figure shift" and D, which trip the answer-back unit of the teleprinter at the out-station. A check message is then received in the T.R.C. from the out-station, finishing with the characters "figure shift" and J. A monitor teleprinter associated with the routiner records the two messages, and on receipt of the characters "figure shift" and J causes the routiner to step on to the next free line. An alarm is given and the circuit indicated if the routiner fails to complete its testing cycle.

CONCLUSION

The equipment has been working at London Airport since July 1960. It has a capacity for 25 circuits, but the system can be readily adapted to meet requirements for larger centres. A substantial saving has been achieved in telegraph machines as well as in floor space in the operating room.

The British Computer Society's Third Conference, Cardiff, September, 1962

U.D.C. 061.3:681.142

NOTHING startling or epoch-making arose at the British Computer Society's Third Conference, held at Cardiff during 4-7 September 1962. Rather it was a prosaic record of the application of equipment currently available to a market steadily expanding from the traditional fields of mathematical computation and automatic data processing (a.d.p.) into the most important field of factory scheduling.

J. D. W. Janes of H.M. Treasury reported that on Government a.d.p. projects capital expenditure of £1,650 was incurred to replace one man or woman and that only 56 per cent of the total expenditure was spent on the computer equipment itself; an average return on capital of 10 per cent was sought, and achieved. Dr. A. Young revealed that computers in British universities were saturated with computation much more quickly than had been estimated, and this was due to one quarter of the work load arising from faculties not thought originally to have a demand. There was appreciation for his comment that the computing laboratory was the Piccadilly Circus of the university and the place where the faculties, rather to their surprise, found that they had similar problems.

The business concerns pioneering commercial data

transmission were uniformly content with the performance achieved so far, the experience being that very few snags occurred in operation and that undetected transmission errors were small compared with others arising in the data-processing system taken as a whole.

W. S. Elliott of Cambridge University had some interesting observations on the implications of new components for computer design. He estimated that the fault liability of integrated circuits using planar techniques would be 0.001 per cent per annum for the equivalent of 20 integrated components; these circuits would soon be used on account of their reliability, and later their use would be extended when they became cheaper than conventional circuits. Tunnel diodes would form the basis of logic circuits; stores of very large capacity would be of cryogenic type, and those of more modest capacity would use tunnel diodes. The operating speeds that he had in mind were 250 Mc/s for computing and 50 Mc/s for storage. He forecast an increased use of large file stores without revealing what type they might be. A sobering thought was that an examination of the best method of utilizing redundancy to achieve very high reliability in a system might well be a 10-year job.

R.K.H.

Improvements in Automatic Error-Correction Equipment Used on H.F. Radio Telegraph Services

A. C. CROISDALE, M.B.E., B.Sc.(Eng.), A.M.I.E.E.†

U.D.C. 621.391.88.621.394.3:621.371

Error-correction equipment invented by Dr. Van Duuren, of the Netherlands Post Office, has become very widely used because it makes possible a higher standard of performance for radio telegraph circuits. This article reviews developments that have been made to the system to provide automatic phasing of channels and sub-channels, and, also, to improve the performance and reduce the attention required. These improved automatic error-correcting equipments can be used in conjunction with improved frequency-division equipment to give the larger numbers of circuits required between major cities due to the increasing demand for telex circuits.

INTRODUCTION

THE principles of automatic error-correction (ARQ) have been described in this Journal.¹ Development of the equipment itself has been continuous since the original electromechanical equipment, manufactured in Holland, was put into service around 1953-4. Electronic equipment followed, first using hot valves and, later, cold-cathode valves. Now transistor and parametron* equipment has been widely introduced, and the saving in maintenance costs compared with those of older equipment has been very considerable. The use of electronic equipment^{2,3} has encouraged further study to provide improved operating performance and additional refinements. It has been possible, largely within the original basic design produced by Dr. Van Duuren (which was adopted internationally by the C.C.I.T.T.‡ and by the C.C.I.R.§ as Recommendation No. 242⁴) to provide virtually unattended operation while maintaining a low undetected-error rate under all conditions occurring on the radio path.

Appendix 1 gives the definition of terms used in connection with ARQ operation. Appendix 2 indicates the conventions used to describe the polarity of the signal elements in the multiplex system.

BASIC FEATURES OF THE VAN DUUREN SYSTEM

The Van Duuren system employs several fundamental telegraph features that all contribute to a highly satisfactory performance. These features are described briefly below.

(a) *Synchronous Operation With 2-Channel or 4-Channel Time Division.* Time-division working implies that each channel of a number of telegraph channels is given, in rapid succession, exclusive use of a common transmission path. Synchronized transmitting and receiving distributors allocate each channel to the common transmission path for a fixed period. Each character is composed of an exact number of signal elements, and the rate at which signals have to be transmitted over the radio link is the aggregate of the signalling rates of the channels. The use of the common transmission or aggregate signalling

path by the channels of a time-division system may be on the basis of single elements of the first channel, A, alternating with single elements of the second channel, B (termed element interleaving), or single characters of channel A alternating with single characters of channel B (termed character interleaving). In the Van Duuren system, for 2-channel operation, the channels A and B are character interleaved, but for 4-channel operation the elements of the combined A and B channels are interleaved with the elements of two other combined channels, C and D.

Synchronous operation means that the timing of the whole system, e.g. the operation of the distributors referred to above, is controlled from a continuous source—usually a crystal-controlled oscillator. The use of synchronous working permits a higher efficiency in telegraph transmission, since the margin of the equipment⁵ is much higher than when start-stop operation is employed.⁶ It requires a method for checking signal identity to relate the timing, or phase, of the receiver to that of the transmitter; the procedure to obtain this is termed phasing.

It is common practice on synchronous systems to arrange to produce a balanced signal, i.e. equal numbers of X elements and Y elements, on the aggregate path by inverting the polarity of the second channel of a 2-channel system.

(b) *Polarity-Ratio Check.* The system code has seven elements per character, and, out of these seven elements, three must be of one polarity (Z) and four of the opposite polarity (A). This allows all 7-element combinations not complying with the 3 : 4 ratio to be detected as erroneous.

(c) *Transmission Repetition.* Errors detected as described in (b) due to mutilations occurring on the radio path can be corrected by automatically repeating the transmission of the character until it is correctly received; this is the basic principle of the Van Duuren system. It has the great merit of increasing the effective redundancy when conditions are worst, since, with this system, a group of four characters (termed a 4-character repetition cycle) is repeated, and further ingenious checks may be made to ensure that the radio path has regained its reliability before printing is resumed.

The mechanism of automatic repetition has been described in detail previously.^{1,7}

(d) *Temporary Storage of Each Character.* To allow for the repetition procedure described in (c), it is necessary to arrange that characters are called individually for transmission by a pulse. Each character is then held temporarily in an electronic store while being transmitted and checked at the distant end so that, if necessary, it can be repeated again and again, thus safeguarding the traffic offered to the system for transmission.

(e) *Sub-Channel Operation.* The synchronous method of operation facilitates not only the provision of 50-baud channels nominally carrying 400 characters per minute (termed the full-character rate) but also, by a device

† Telegraph Branch, E.-in-C.'s Office.

* The parametron is a logic element, consisting of a coil, a capacitor and resistor, providing positive and negative phase positions relative to a high-frequency excitation source.

‡ International Telegraph and Telephone Consultative Committee.

§ International Radio Consultative Committee.

known as a sub-divider the use of channels of quarter fractions of 400 characters per minute, i.e. 100 characters per minute, with complete privacy for each user. Circuits of this type are leased to firms who have a considerable volume of telegraph traffic.

Privacy is ensured by inverting the polarity of every fourth character on the full-character-rate channel, i.e. sub-channel No. 1, and using this "marking" to locate the reference timing for the scrambling and unscrambling devices used to transmit the sub-channel signals over the main channel of the synchronous system. This inverted character is used to reset, semi-automatically, the device that identifies correctly the sub-channels at the receiving end. Of course, it is not essential that sub-division should be employed on any of the channels of an ARQ system.

OPERATING EXPERIENCE OF C.C.I.R. RECOMMENDATION NO. 242

Practical operating experience with ARQ equipment based on C.C.I.R. Recommendation No. 242, and incorporating the basic Van Duuren features described above, showed that phasing of the system was not always completely satisfactory since:

- (i) an accidental inversion of the polarity of the aggregate signal could result in incorrect routing of the traffic,
- (ii) loss or duplication of characters could occur during phasing,
- (iii) sub-channel operation could only be provided reliably on one channel of a system due to difficulties in re-phasing the sub-channels if more than one channel was sub-divided, and
- (iv) sub-channel phasing was required to be manually controlled.

Phasing requires that the sequence of the signal elements comprising the received radio signal should be determined accurately by the receiver, to enable the channel information to be segregated correctly. The information in each channel is composed of seven elements per character, and this means that every element must be in its correct position within the character as determined by the receiver, which is driven continuously by an oscillator.

For a 2-channel ARQ system operating with a 96-baud aggregate signal, each signal element is $1,000/96 \approx 10$ ms in length. The scanning by the receiver is designed to examine each element at the exact midpoint (see Fig. 1 (a)).

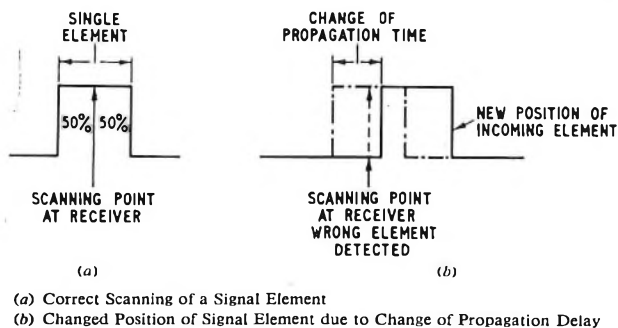

FIG. 1—LOSS OF PHASE DUE TO CHANGE OF PROPAGATION DELAY

If, therefore, a sudden alteration in the route propagation time occurs, e.g. due to the radio propagation time changing, this will cause the incoming elements to be moved in time relative to the receiver scanning, which is

driven at constant speed by an oscillator and can only follow slight variations of the incoming signal transitions. If the sudden change exceeds 50 per cent of the element time, then the scanning will be outside the element and will in fact be reading the polarity of an adjacent element (see Fig. 1 (b)). This is an out-of-phase condition.

Each end of the circuit is driven from a separate oscillator. The small difference in speed that would otherwise exist between the distributors is corrected by making one oscillator the master and arranging that the slave end corrects its speed to exactly that of the master by using the signal transitions as a reference.

A prolonged loss of signal can cause the receiver scanning to change its position gradually relative to the transmitted signal, since, when no signal transitions are available, the corrective action is necessarily inoperative. In normal service it is rare for loss of phase to occur more than once in 24 hours, since a basic oscillator-drive accuracy of 1 in 10^6 at each end, even with tolerances adverse, would still allow the terminals to hold within the correct phase limit and recommence passing traffic after a break in circuit of 15 minutes. Loss of phase usually occurs only as a result of either a prolonged loss of signal or a definite change of propagation delay on the loop provided by the radio links.

There are now about 700 ARQ terminal equipments in operation all over the world, including about 70 in the United Kingdom radio-telegraph terminal at Electra House, London. The continuously changing nature of h.f. radio propagation means that, perhaps several times a day, changes of radio frequency or of route are necessary, and these involve possible changes in the propagation times. The decisions on such changes are made as required and not entirely to a timetable. This involves continuous supervision of the performance of the links, although proposals are being considered for anticipating the need for action so as to prepare for automatic wavelength changing. To re-phase these 70 systems even once per day is a considerable task if carried out by hand; the electromechanical systems can each require up to 5 minutes to re-phase manually. It is therefore desirable to re-phase automatically while traffic is still being offered to the system, without (a) gaining or losing any characters, (b) printing any errors, and (c) unnecessary loss of usable circuit time. This re-phasing should still be possible when using sub-divided channels.

The only check for correct phase position required by Recommendation No. 242 is that a request for repetition (RQ) signal is received on each channel. It is not specified where, in the repetition cycle, the RQ signal should be, since this depends on which end of the system originates the request for repetition, and also on the propagation time of the radio circuit. Thus it is possible for a phase position to be assumed that does not overlap the original repetition cycle completely, causing loss or gain of characters at the other end of the circuit during re-phase.⁸

Unless the repetition cycle has some clear and unambiguous pattern, so that a complete check of the whole duration of the repetition cycle is made before phase is assumed, it will clearly be impossible to avoid errors. Recommendation No. 242 does not provide for such a pattern.

Further thought will show that to avoid the additional possibility of crossed channels under the condition of an inadvertently inverted aggregate signal, it would be

necessary to produce a distinct pattern on the aggregate of all the channels for the repetition-cycle duration. Such a system could, therefore, be called a marked-cycle system.

AUTOMATIC RE-PHASING

Methods of Detection of Out-of-Phase

For the detection of out-of-phase, a device known as the 56 : 56 element count can be used. This is based on the fact that, during the period of the repetition cycle, a known total of X elements and a known total of Y elements must occur on the aggregate signal. For a 4-channel (192-baud) ARQ system this would mean 56 X elements and 56 Y elements. Hence, correct counts of X and Y elements indicate that the radio signal is good; on the other hand a mutilated radio signal will almost always give a different count. If the radio signal is good and if the receiver-phase position is correct, an RQ signal, AZZAZAA, must be received on each channel during every repetition cycle; if however, the RQ signal is not received on each channel then the system must be out-of-phase.

As an alternative to the 56 : 56 count, the existence of continuous errors, i.e. continuous repetition, on all channels for an arbitrary period of either 10 seconds or 5 minutes may be assumed to be due to loss of phase. In practice, since no loss of traffic occurs during re-phasing, there is little disadvantage in phase-hunting if electronic equipment is used, since the re-phase delay and consequent loss of operating time is very short. The use of arbitrary time-constants of 10 seconds or 5 minutes is a matter for choice by the user.

Procedure for Re-phasing

Automatic re-phasing involves, first, detecting automatically that the equipment is out-of-phase, and later, checking that the stepping of the receiver scanning relative to the received signal has resulted in the receiver scanning occurring in the correct position. Usually stepping takes place in one direction only.

Detection of Correct Phase

Detection of correct phase on the original electro-mechanical equipments was achieved by checking only that an RQ signal (AZZAZAA) was received correctly on each channel. However, in addition, the presence of any non 3 : 4 ratio character then occurring during the repetition cycle on any channel can be assumed to be an out-of-phase condition and each method can be used to produce a step change of phase of one element. The combination of the two methods is known as the tested repetition cycle, and the sequence of the checking procedure is shown in the table.

The use of the tested repetition cycle gives rapid phase stepping, which is important because with the marked-cycle method of automatic phasing, described in detail later, it may be necessary to step for the number of elements of the whole cycle less one element, i.e. for a 2-channel system operating a 4-character repetition cycle it may have to step a maximum of $(2 \times 7 \times 4 - 1)$ elements, i.e. 55 elements, but, on average, only 27 steps will be necessary and this may be achieved in about 5 seconds. Twice this period will be required for a 4-channel system, since the rate of stepping can only be decided on the A and B channels, because the C and D channels are element-interleaved and hence overlap the character periods of A and B channels. Other methods of phasing are, however, feasible.

Reduction in Error Rate Due to Use of Tested Repetition Cycle

The use of the tested repetition cycle reduces the error rate though it causes more repetition cycling to occur and thus slightly reduces the telegraph circuit efficiency.⁴ Whether such improvement in error rate is necessary must be decided by the user and may depend on the type of service being provided, e.g. public message, telex or leased circuit, and the nature of the radio link. Although essential for correct phase detection, the tested repetition cycle is optional during traffic, so a switch

Timing Relationship for Correct Phase—2-Channel ARQ System Using Marked Cycle
Sequence of Reception of Received Radio Aggregate Signal

| Traffic Characters | D | C | O | A | G | T | RQ | RQ |
|--|---|---|---|--|---|--|--|--|
| Incoming Signal Elements | YYXXXYY | XYXXXYY | XYYYXXY | XXYYXYX | XXYYYXX | YXXXYYX | XYYXYXX | XYXXYYX |
| Receiver Checks | 3 : 4 ratio | 3 : 4 ratio | 3 : 4 ratio | 3 : 4 ratio | 3 : 4 ratio | 3 : 4 ratio | All elements | All elements |
| Progress of Detection of Correct Phase | 3 : 4 ratio check is satisfactory and polarity is erect | 3 : 4 ratio check is satisfactory and polarity is erect | 3 : 4 ratio check is satisfactory and polarity is erect | 3 : 4 ratio check is satisfactory and polarity is inverted | 3 : 4 ratio check is satisfactory and polarity is erect | 3 : 4 ratio check is satisfactory and polarity is inverted | The seven RQ elements are correct and polarity is inverted | The seven RQ elements are correct and polarity is inverted |
| Decision by ARQ Equipment | This character is character 2 of channel A Check 1 | This character is character 1 of channel B Check 2 | This character is character 3 of channel A Check 3 | This character is character 2 of channel B Check 4 | This character is character 4 of channel A Check 5 | This character is character 3 of channel B Check 6 | This character is character 1 of channel A Check 7 | This character is character 4 of channel B Check 8 |

Notes:

- Checks 1-8 together, i.e. the tested repetition cycle, show that the receiver is in phase with the incoming signal.
- The sequence shown is that occurring when errors are detected at the local end.

may be used to select whether or not the tested repetition cycle is required to be effective during repetition cycles for the correction of errors during the passage of traffic.

Control of Sequence of Re-Phasing

Since the detection of out-of-phase may be by means of different devices at the opposite ends of the circuits there is some merit in pre-arranging the sequence of re-phasing the slave and master ends. In practice the master transmitter decides the exact transmission speed for the whole ARQ system, since the slave receiver locks to the signal from the master transmitter and, having locked, then imposes this speed precisely for transmission between the slave transmitter and the master receiver. It can be arranged that, to prevent the master receiver from phasing until the slave has phased to the master transmitter, the slave transmitter should send a detectable error instead of the RQ combination. This detectable error has been found to be easily identifiable for monitoring purposes, where a 2-channel system is in use, if "AAAAAA" is transmitted instead of the RQ signal when the slave is out of phase.

By preventing the master receiver from phasing until the slave has phased, the danger of losing characters is reduced. On the other hand the marked cycle completely avoids loss of characters anyway. However, the cost of fitting the AAAAAA transmitting device is very small, and transmission of AAAAAA by new type equipment is advantageous when working to old equipment not capable of operating the marked cycle.

THE MARKED-CYCLE SYSTEM

In 1958 Cable & Wireless, Ltd., introduced a system¹⁰ of rapid phasing, when the equipment is carrying traffic, with a negligible probability of losing or gaining characters. This system provided a marked pattern of character polarity inversions for the aggregate signal and called for the use of the tested repetition cycle described earlier. This use of a marking pattern is termed the marked cycle because the marking pattern of the sub-divider, i.e. the inversion of the first of every four characters, is conveniently made the same duration as the repetition cycle (normally four characters), as shown in Fig. 2. It will be seen later that for certain purposes a longer repetition-cycle duration is necessary and marking patterns for 4-character and 8-character repetition cycles have been adopted, both of which are suitable for sub-dividing to $\frac{1}{4}$ -character rate and $\frac{1}{2}$ -character rate sub-channels. The pattern for an 8-character repetition cycle is shown in Fig. 3.

The use of such a marking pattern to permit error-free automatic phasing was proposed at the Los Angeles meeting of the C.C.I.R. in 1959 and, as Report No. 108,¹¹ was adopted unanimously.

Advantages of the Marked-Cycle Pattern of Report No. 108 of the C.C.I.R.

The particular pattern proposed in Report No. 108 has the following characteristics:

(i) It uses the same marking for the AB diplex (see Fig. 2 (c)), whether it is operating as a 2-channel system or whether it forms part of a 4-channel system (see Fig. 2 (e)).

(ii) It is balanced, i.e. has equal numbers of X and Y elements, under all conditions of 2-channel or 4-channel operation, and 4-charac-

ter or 8-character repetition-cycle operation.

(iii) It is comparatively simple to implement on existing equipment by the use of the sub-divider inversion characteristics and connexions to lock the phase of the various distributors.

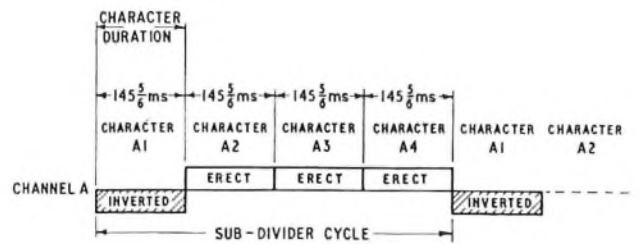

A1 is a character on sub-channel 1, A2 is a character on sub-channel 2, and so on.
(a) Marking on Channel A by Inversion of Polarity of First Character of Sequence of Four Characters A1, A2, A3 and A4 Repeated.

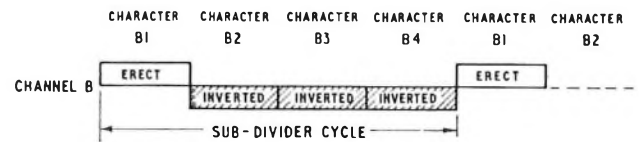

B1 is a character on sub-channel 1, B2 is a character on sub-channel 2, and so on.
(b) Marking on Channel B by Inversion of Polarity of Characters B2, B3 and B4 with Character B1 Erect.

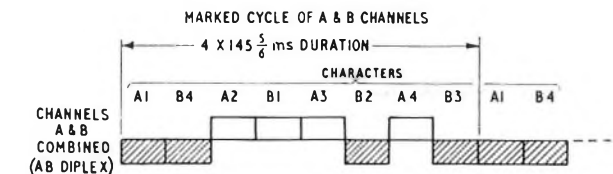

(c) Combination of (a) and (b) to Form a 2-Channel Character-Interleaved Aggregate Signal (Note that Character A1 is followed by Character B4, and so on.)

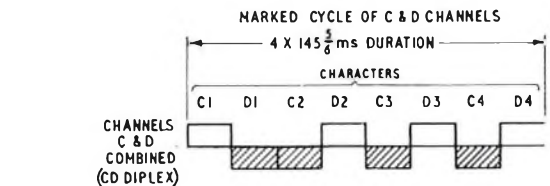

(d) Combination of Characters C2, C3 and C4 Inverted on Channel C and Character D1 Inverted on Channel D to Form a 2-Channel Signal (Note that Character C1 is followed by D1.)

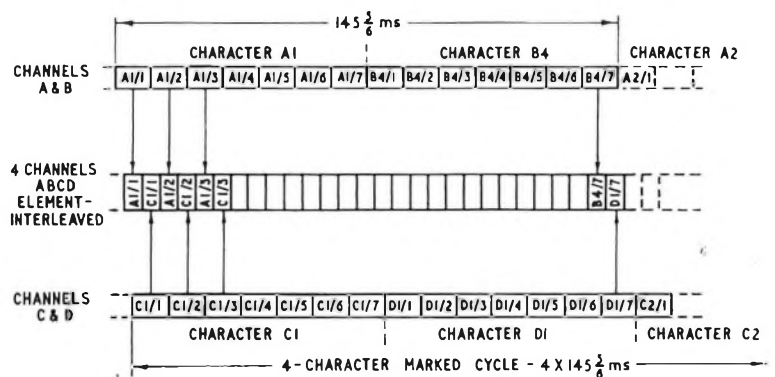

(e) Combination of Channels A, B, C and D to Form a 4-Channel Aggregate Signal. Channels A and B are Interleaved Element by Element with Channels C and D so that the First Element A1/1 of Characters A1 is followed by the First Element C1/1 of Character C1, and so on.

FIG. 2—FORMATION OF 2-CHANNEL AND 4-CHANNEL MARKED CYCLE OF FOUR CHARACTERS

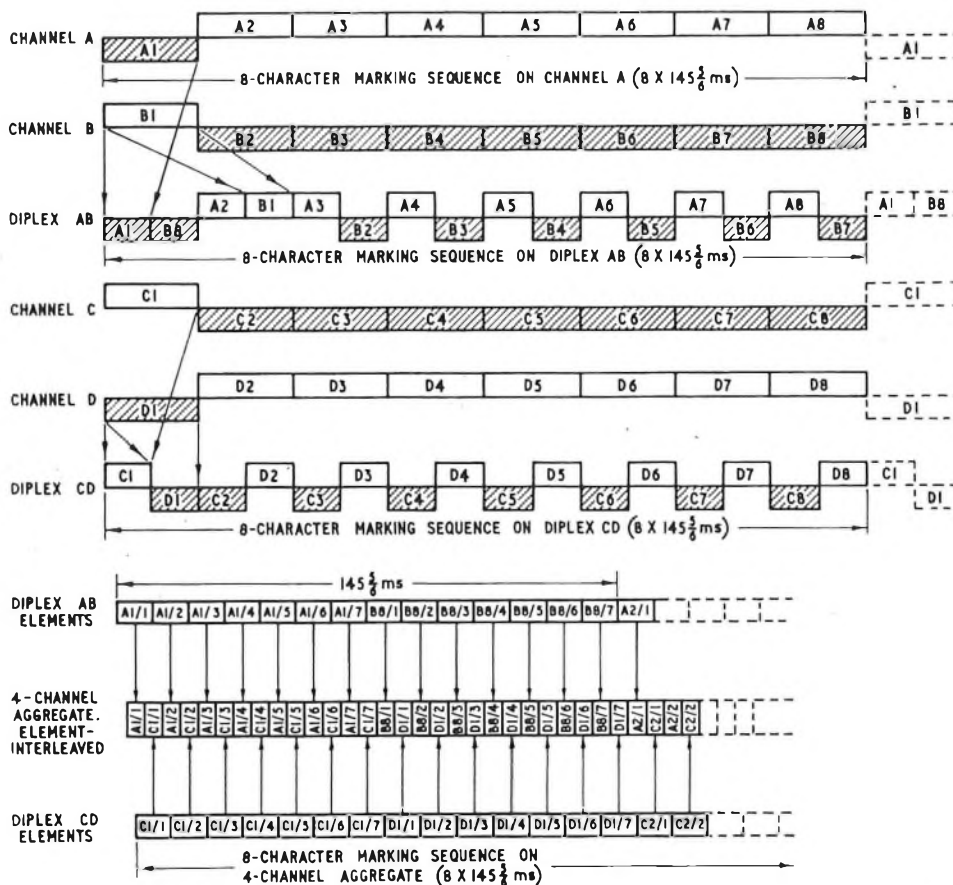

FIG. 3—MARKING PATTERN FOR 8-CHARACTER REPETITION CYCLE

The difference in the phase relationship between the inverted characters in each diplex results in a unique pattern that prevents an in-phase condition being recognized when an inverted aggregate signal is received. The chance of false phase being obtained when the aggregate signal is inadvertently inverted somewhere along its transmission path, e.g. at a radio station, is thus overcome.

Automatic Sub-Channel Phasing

A further advantage of the marked cycle is that it provides for sub-division on any or all channels, which was virtually impracticable on more than one channel with the original ARQ system, since each sub-divider had to be phased individually after channel phase had been obtained. This was because, with sub-dividing, one character in four on the channel is inverted and the sub-dividers had to be removed to obtain channel phase, then replaced to allow the sub-channels to be phased.

When the marked cycle is used the pattern of repetitive inversions can be produced economically by a single device operated directly by the multiplexing of the ARQ system, i.e. one device that will automatically phase channels and sub-channels instead of independent sub-dividing devices on each channel as were used with Recommendation No. 242.

The use of this pattern generator on the main multiplexing equipment is facilitated if it can be part of the basic design, but existing ARQ equipments can be adapted to produce the marking shown in Fig. 2 by the

use of existing type sub-dividers or the addition of a simple counting device simulating the sub-dividing. All new equipment will be compatible, by means of a switch, with old equipment, and, by suitable choice of master and slave terminals, will provide improvement due to the use of the tested repetition cycle even when the marked-cycle system is not employed.

Performance of the Marked-Cycle System

Tests and experience in service have proved that the use of the marking pattern proposed in Report No. 108 is a complete answer to the automatic phasing of channels and sub-channels; the very rare possibility of an incorrect phase position being produced by a combination of particular characters on particular channel positions has not been noticed, possibly since only one cycle would ever be accepted before search would re-commence for correct phase. The probability of such an occurrence is many times less than the average error rate on a radio circuit.

Equipments embodying the marked-cycle system have been in use experimentally for 4 years and in commercial production for 2 years.^{8,12,13} Operating experience has shown (a) that the use of the marking-pattern generator has both simplified and reduced the cost of the equipment necessary to provide sub-dividing, and (b) that automatic phasing of both channels and sub-channels occurs in traffic without the loss or gain of characters experienced with equipment designed solely to Recommendation No. 242.

Linking Channels

It is possible to improve the undetected error rate on an ARQ system by linking the channels¹⁴ so that an error on any channel causes a repetition cycle on all channels. A fade on the radio path will probably affect all channels, but there is a high probability that the first channel to be affected will detect the fade as an error. All the channels will then commence the tested repetition cycle that will ensure that the radio path has recovered before printing is resumed. Since this adds redundancy to the effective protection a small reduction in the flow of traffic will result.

Improved Design of Electronic Equipment

It has been noted that the use of electronic equipment produces a lower error rate than electromechanical equipment because the margin of acceptable distortion⁹ of the telegraph signal is appreciably higher for the electronic equipment. This is a basic improvement in detection efficiency and gives a directly improved performance on radio circuits. Also, the transmitted distortion of the aggregate signals from an electronic equipment is much lower than that from an electromechanical equipment, and this also produces a better telegraph transmission performance.

Where the aggregate signals have to be carried over land-line sections¹⁵ using tandem d.c.-to-d.c. working, appreciable telegraph distortion is liable to occur and, in some circumstances (e.g. radio relays), the use of synchronous regenerators may be advantageous. However, it must be remembered that such devices, as well as the voice-frequency multi-channel equipments, add further propagation delay to the ARQ circuit.

Circuit design now includes safeguards against the failure of any one component causing mis-routing of traffic between one customer and another, a condition that could occur on some older designs.

EFFECTS OF LONG PROPAGATION DELAY

If h.f. radio links only were employed, the maximum loop propagation delay between any two points on the earth would be less than 300 ms. Allowing for equipment timing delays, including a deliberate delay inserted (for equalizing reasons) between the ARQ receiver and the transmitter at the slave terminal and the use of the repetition-request character, RQ, a repetition cycle of four characters would suffice at all times.

In practice this repetition cycle can be employed on most routes even where significant terminal equipment and land-line delay is also incurred, but there are the following special conditions that require a longer repetition cycle:

(a) A radio circuit comprising two links relayed at an intermediate point, and for which the use of a regenerative repeater is advantageous (adding delay).

(b) A radio circuit connected to a submarine telephone cable circuit, it being advantageous for error-correction and telex-call-timing purposes to provide ARQ over the tandem circuit. The propagation velocity of the cable (about 100,000 miles/sec) is appreciably lower than that of radio (186,000 miles/sec.) and, furthermore, additional delay is inevitably introduced by the voice-frequency channelling equipments.¹⁵

(c) Possibly, if a satellite radio link forms part of a tandem link with h.f. radio.

To cater for these conditions a new channel storage unit is being developed that will provide for either $RQ + 3$ stored characters or $RQ + 7$ stored characters in the repetition cycle. Since only a limited number of circuits will require $RQ + 7$ characters the use of the new units will be optional.

In setting up the circuit initially, it is desirable to assess the amount of propagation delay not taken up by the radio-circuit loop, and some ingenious devices have been developed by different manufacturers to indicate this delay.

EXPLOITATION OF ARQ

The original concept of ARQ was to improve the performance of existing radio telegraph circuits. However, the demand for more and more radio telegraph circuits has made it necessary to exploit frequency-division equipment¹⁶ and other devices to give more circuits and then to apply ARQ to maintain a satisfactory performance. Whereas, prior to the use of ARQ, a radio link gave a fairly satisfactory performance, where a skilled operator was employed on, say, single-channel frequency-shift keying¹ of the radio-frequency carrier, such a radio system would now probably be converted to independent-sideband operation (i.s.b.) and might carry telephone circuits as well as six or more 96-baud voice-frequency telegraph channels, each carrying a 2-channel ARQ system. The reduction of transmitted radio-frequency power and bandwidth per telegraph circuit is considerable, and yet ARQ enables a satisfactory error-rate performance to be maintained. The operation of additional telegraph circuits over an existing radio link by frequency and time division can soon prove economic, but until the ARQ equipment reached a high standard of electronic design and automatic operation^{8,13} the cost of maintenance was appreciable.

There is no doubt that modern designs show great savings in maintenance, the reduction in the number of relays being the main factor.

CONCLUSIONS

Using the marking pattern set out in C.C.I.R. Report No. 108 it is possible to design equipment, based on principles developed from C.C.I.R. Recommendation No. 242, that can phase automatically in traffic, without loss or duplication of characters and having the following operating characteristics:

(a) Rephasing in traffic can be achieved in an average time of about 5 seconds, for a 2-channel system.

(b) Fully automatic sub-channel phasing in traffic can be obtained, which greatly simplifies sub-channel operation.

(c) The arrangement of channels is compatible with existing practice when using sub-divided channels.

(d) By the use of the tested repetition cycle in traffic a useful reduction in undetected errors can be achieved.

(e) The marking pattern for the A and B channels does not change with 2-channel or 4-channel operation.

(f) The element count for out-of-phase detection always comprises an equal number of X and Y elements.

It is, in nearly all instances, possible to introduce the marking pattern, proposed in Report No. 108, without difficulty on equipment conforming to Recommendation No. 242. Since the issue of Report No. 108 in 1959, many equipments incorporating these facilities have been manufactured and the system has been proved in service.

Automatic phasing is due largely to the advent of electronic ARQ equipment that in itself has also made a great improvement in reliability and some improvement in performance of ARQ equipment on radio telegraph circuits.

After 10 years of use on radio telegraph circuits all over the world the automatic error-correction system invented by Dr. Van Duuren, now improved to give virtually unattended operation, provides a standard of error-rate performance of radio telegraph channels approaching that of long cable circuits.

ACKNOWLEDGEMENTS

The author thanks colleagues in Cable & Wireless, Ltd., Standard Telephones & Cables, Ltd., and Marconi's Wireless Telegraph Co., Ltd., for assistance in producing this article.

References

- ¹ CROISDALE, A. C. Teleprinting over Long-Distance Radio Links. *P.O.E.E.J.*, Vol. 51, pp. 88 and 219, July and Oct. 1958.
- ² An Electronic Error-Correcting Multiplex Telegraph System. *P.O.E.E.J.*, Vol. 50, p. 44, Apr. 1957.
- ³ KELLER, P. R., and WHEELER, L. K. Automatic Error Correction. *Wireless World*, Vol. 65, p. 28, Jan. 1959.
- ⁴ Recommendation No. 242, Green Book, Documents of the IX Plenary Assembly, Los Angeles (1959) Vol. 1, p. 130, International Radio Consultative Committee.
- ⁵ WHEELER, D. W. E., and COLLIER, E. G. Telegraph Distortion on Physical (D.C.) Lines and Telegraph Machines. *P.O.E.E.J.*, Vol. 52, p. 61, Apr. 1959.
- ⁶ EVANS, H. E., and CROISDALE, A. C. Time-Division Multiplex Telegraphy on the Transatlantic Telephone Cable. *P.O.E.E.J.*, Vol. 54, p. 113, July 1961.
- ⁷ CROISDALE, A. C. Automatic Error-Correction for Long-Distance Radio Telegraphy. *Post Office Telecommunications Journal*, Vol. 12, p. 78, Spring 1960.
- ⁸ KELLER, P. R., and WHELDON, A. J. Recent Improvements in Automatic Error-Correcting Systems for H.F. Telegraph Networks. *Point to Point Telecommunications*, Vol. 6, p. 38 No. 2, Feb. 1962.
- ⁹ CROISDALE, A. C., and HARRISON, A. F. Testing Radio Telegraph Automatic Error-Correcting Equipment. *P.O.E.E.J.*, Vol. 54, p. 245, Jan. 1962.
- ¹⁰ COPPER, E. G. Some Operational Consideration Affecting the Use of Automatic Error-Correcting Equipment on H.F. Telegraph Networks. *Point to Point Telecommunications*, Vol. 3, p. 21, No. 2, 1959.
- ¹¹ Report No. 108, Green Book, Documents of the IX Plenary Assembly, International Radio Consultative Committee, Los Angeles (1959), Vol. 3, p. 70.
- ¹² KELLER, P. R. Automatic Error-Correction on H.F. Telegraph Circuits. *Point to Point Telecommunications*, Vol. 2, No. 2, 1958.
- ¹³ Das Elektronische TOR. *Hasler Mitteilungen*, No. 2, 1960.
- ¹⁴ VAN DUUREN, H. C. A. Error Probability and Transmission Speed on Circuits using Error Detection and Automatic Repetition of Signals. *I.R.E. Transactions on Communications Systems*, Vol. CS-9, p. 38, Mar. 1961.
- ¹⁵ HUNT, C. S. Frequency-Modulated Voice-Frequency Telegraph Systems for Radio Telegraph Services. *P.O.E.E.J.*, Vol. 53, p. 21, Apr. 1960.
- ¹⁶ LAW, H. B. The Detectability of Fading Radiotelegraph Signals in Noise. *Proceedings I.E.E.*, Paper No. 2104R, Mar. 1957 (Vol. 104, Part B, p. 130).

APPENDIX 1

Terms Used in Relation to Multi-Channel ARQ Systems

ARQ System: A system employing an error-detecting code and so arranged that a signal detected as being in error automatically initiates a request for re-transmission of the signal so detected.

Aggregate Signal: The synchronous signal produced by combining the channels. For a 2-channel ARQ system this would comprise seven elements of channel A keyed erect followed by seven elements of channel B keyed inverted in polarity.

Balanced Aggregate Signal: A signal containing equal numbers of X and Y elements.

Character Cycle: The sequence in which each channel has completed one character on the synchronous path.

Repetition Cycle: The sequence of characters (normally four) required by the loop propagation time to provide automatic repetition of traffic.

Marked Cycle: The sequence of characters after which the character marking pattern is repeated. The marked cycle is of the same duration as the repetition cycle.

Marking Pattern: A pattern of inversions of particular characters over a marked cycle.

Tested Repetition Cycle: Check of all the elements of the RQ signals and a ratio check on all characters of a repetition cycle.

RQ Signal or Signal 1: The 7-unit combination AZAZAA used to request a repetition. Also this signal is always transmitted before a character is re-transmitted.

Tested RQ: Check of all the elements of the RQ signal and a ratio check on those characters that follow the RQ signal within a repetition cycle.

Gated RQ: Check for the presence of an unutilized RQ signal during a repetition cycle.

Element Synchronism: Synchronism of elements exists when an element of the local timing completely coincides with an element of the received signal.

Phasing: Situation in which a station is hunting for character or marked-cycle phase. This action is by step changes of one or more elements.

Character-Cycle Phase: Correct phase of characters exists when a character cycle of the local timing completely coincides with a character cycle of the received signal.

Marked-Cycle Phase: Marked-cycle phase exists when the marked cycle of the local timing completely coincides with the marked cycle of the received signal.

Manual Phasing: Phasing by manual action only.

Semi-automatic Phasing: Phasing completed automatically after initiation by push-button.

Automatic Phasing: Phasing completed automatically, after automatic detection of "out-of-phase."

Mutilation: A change or changes in the polarity of received signal elements, due to aberrations on the path.

Transposition: A mutilation which causes no change in the total number of Z or A elements in a character of the received signal.

Time Delay per Route (or End-to-End Time Delay): Sum of radio propagation and circuit time delays in one direction of a route.

Total Loop Time Delay: The sum of forward and backward delays of a route.

Sub-Divided Channel: A part-rate teleprinter channel that is allocated either $\frac{1}{4}$ or $\frac{1}{2}$ of the character rate of a normal channel.

Synchronizing: The action of adjusting element-synchronism (by step changes of fractions of an element).

APPENDIX 2

Polarity Convention

The terms "polarity Z" and "polarity A" are used with reference to the signal elements of 7-unit code combinations. Since, however, these polarities are subject to further inversions in the multiplex system, the following terms are used in this article:

| 7-Unit Code | Aggregate Signal | |
|-------------|------------------|----------------|
| | Erect | Where Inverted |
| A | Y | X |
| Z | X | Y |

In the United Kingdom, X is negative polarity and Y is positive.

In a 7-unit character the four elements of the same polarity correspond to elements of A polarity of the basic code, while the three elements of the opposite polarity correspond to Z polarity.

For radio-frequency-shift keying, the higher radio frequency corresponds to Y polarity and the lower radio frequency to the X polarity. For 4-frequency duplex operation, the relationship between the radio frequencies and the X and Y polarities is as follows:

| Radio Frequency | Channel 1 | Channel 2 |
|--------------------------|-----------|-----------|
| Highest (f_4) | Y | Y |
| Second highest (f_3) | Y | X |
| Second lowest (f_2) | X | Y |
| Lowest (f_1) | X | X |

Pressurization of Telecommunication Cables

Part 1—Principles of Gas Pressurization

J. R. WALTERS, J. F. KEEP and J. F. CRAGGS†

U.D.C. 621.317.333.41:621.315.211.4

This article, which will be published in four parts, describes the application of gas under pressure to telecommunication cables. Part 1 discusses the principles of gas pressurization of cables. Parts 2-4 will describe the equipment used and the operation of gas-pressure systems. Fault-locating techniques will also be discussed.

INTRODUCTION

THERE are two main reasons why the application of gas pressure to telecommunication cables in the United Kingdom has proceeded rather slowly. Firstly, the demand for service during and since the war has resulted in the employment of a large part of the available labour force on extensions to the main and local cable networks and on similar development work. The second reason is the success of present maintenance methods involving regular (or continuous) insulation-resistance testing and highly developed techniques of insulation-fault location and repair well before service is affected. A well-organized fault-repair service has been available at short notice and, because of the practice of placing cables in ducts and providing jointing points at short intervals, it has become normal practice, unless localized mechanical sheath damage has occurred, to replace faulty lengths of cable between jointing points without the need to spend time in locating sheath failures to within very close limits.

However, the demands made on the cable network by subscriber trunk dialling, the increased traffic capacity of modern high-frequency cables and the importance of a high standard of continuity of service have now made it quite certain that the pressurization of main, junction and local cables is amply justified. It is well to remember that in spite of high standards of insulation resistance, at least one sheath fault is brought to light in every 3 miles of trunk and junction cables as they are pressurized, and substantially more sheath faults are found in the local cable network.

First attempts to pressurize cables in this country¹ at the beginning of the present century appeared to be aimed solely at desiccating paper-core cables with compressed air dried by means of calcium chloride, and air compressors together with desiccating cylinders were installed at a number of telephone exchanges for this purpose. At about the same time compressed gas was applied to trunk cables in Stockholm,² but the difficulty of tracing and plugging all the leakages found appears to have discouraged further experiments until the idea of pressurizing a cable and providing an electrical alarm system to indicate a decrease in pressure at any point along the length of cable was conceived in America about 1926.³

Until about 1956 static-pressure (or constant-pressure) systems using nitrogen or dry air at a uniform pressure throughout the length of a cable were used. Hence, the cable had to be completely sealed before the gas-pressure system was brought into regular service, but provision

was usually made for periodically bringing the pressure back to its initial value to compensate for any slight loss of gas or air occurring after all traceable leaks had been found.

A more recent development in North and South America, Australia and also in many European countries is the continuous-flow method using dry air usually provided by means of a compressor. Small leaks are left until they develop into more significant leaks; they can then be cleared in normal working time as part of a routine maintenance program. Suitable devices are provided to indicate the amount of air flowing into the cables (or to indicate an increase in air consumption) and to indicate the pressure at points along gas sections. Since leakages are permitted, there is a fall of pressure along sections of cable, and this will depend on the position and size of the leakages, but the minimum pressure at any point must still be sufficient to ensure that water does not enter the cable.

In Great Britain the experimental pressurization of trunk and junction cables in 1930 and in 1950 has already been described.⁴ The gas-pressure system on seven cables at Leatherhead telephone exchange has now been working satisfactory for more than 12 years, and in 1953⁵ it was decided that all new coaxial and balanced-pair cables should be pressurized. In 1958 work was commenced on the pressurization of all main and junction cables in the Cambridge Telephone Area.

A series of local-cable pressurization experiments was commenced in 1957 in seven telephone exchange areas. The object was to develop suitable equipment for a continuous-flow system and to assess the economic advantages of pressurization as applied to subscribers' cables. A total of 101 miles of cable was pressurized and 197 leaks were traced during the installation period. Fig. 1 shows the improvement due to pressurizing some of the cables in five of the exchange areas; in most of these areas pressure is applied only to cables between the exchange and cabinets. Complaints per underground circuit per annum are indicated for quarterly periods from 1956 to 1962. All cable faults are shown, including conductor faults and faults in cabinets and pillars; pressurization can, of course, only lessen the incidence of faults caused by water penetrating the cable sheaths. The fault rate is shown for each of the exchanges for a period before and after pressurization was applied, and it would appear that a fault incidence of about 0.1 complaints per underground circuit per annum can be expected after the cables have been pressurized. The graphs also show that the random high fault rates due to periodic failures of large underground cables have been significantly reduced.

COMPARISON BETWEEN STATIC-PRESSURE AND CONTINUOUS-FLOW SYSTEMS

The static-pressure system can provide better insurance against loss of service on long cables, but it entails greater expense both in tracing all leakages in the system

† External Plant and Protection Branch, E.-in-C.'s Office.

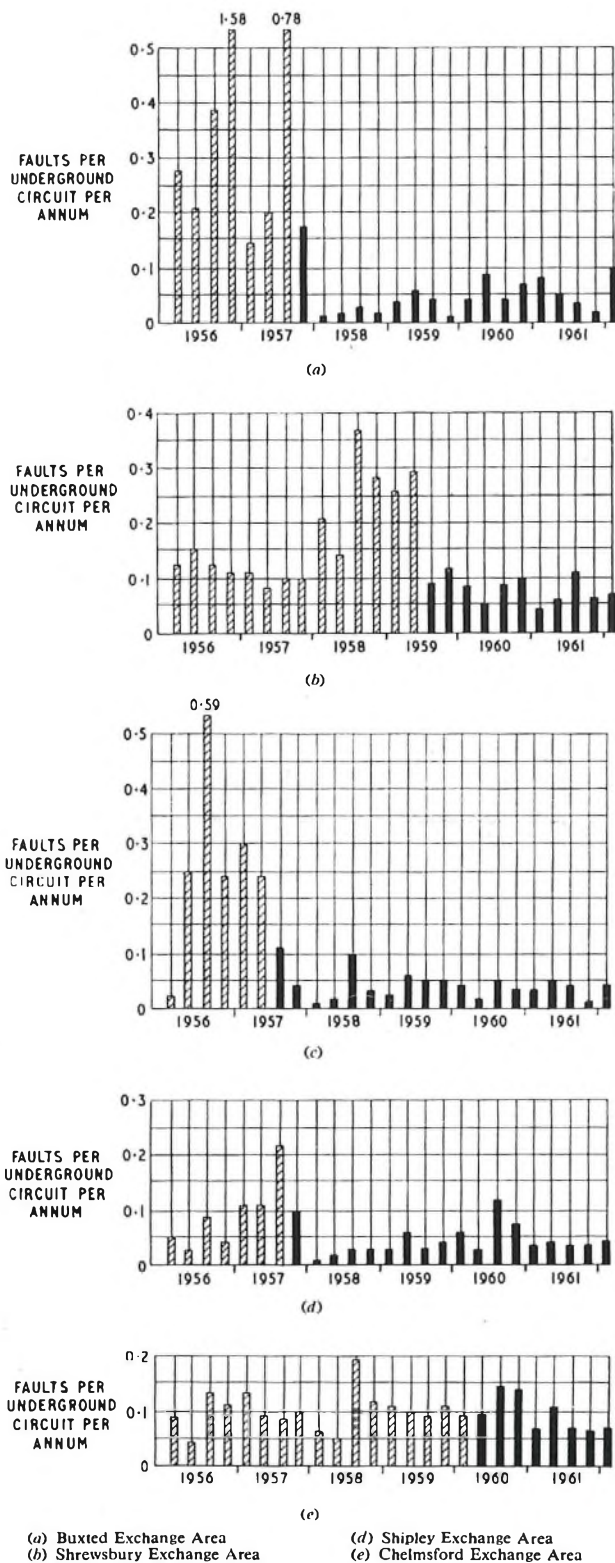

FIG. 1.—EFFECT ON FAULT COMPLAINTS OF PRESSURIZING CABLES IN FIVE EXCHANGE AREAS

when pressure is first applied and in dealing promptly with all subsequent leaks. The additional expense is thought to be justified for main and junction cables, but certain limitations must be noted.

In addition to the expense of maintaining a leak-proof system, the main disadvantage of the static-pressure system is that no external supply of air is automatically available to maintain pressure in a cable in the event of a leakage following major damage to the cable, e.g. its complete or partial severance, although a large reserve exists in the cable because of the high overall pressure. On receipt of an alarm, attention by maintenance staff is needed to re-establish the pressure by connecting an air supply. The location of the leak can then follow when convenient.

The volume of air required for a static-pressure system is substantially less than for a continuous-flow system (except for the initial charging period), but, if air cylinders are used, reserves must be provided both to guard against delays in delivery and because of dependence on a restricted source of supply. Provision must also be made for regularly handling and storing heavy cylinders, for tracing and returning empties, and for dealing with accounts.

The main disadvantage of the continuous-flow system is the need for large uninterrupted supplies of dry air. This usually involves the permanent operation of electrically-driven compressors with associated desiccating equipment. Careful siting of pressure gauges is also required to ensure a minimum safe pressure at remote ends of gas sections. Because of the difficulty of supplying air to a leak through 4 or 5 miles of cable, the advantages of a continuous supply of air may be of limited value for trunk and junction cables.

It is possible that the best of both systems might be achieved if all cables terminating at an exchange were first pressurized by a continuous-flow technique and then the leaks were traced as time and labour permit. The trunk and junction cables could thus be raised to the standard required for a static-pressure system. This procedure is only to be recommended, however, if it is expected that a long period will elapse before it will be possible to complete the fault-locating operation, because, in filling a cable from one end only, long delays occur between the clearance of one leak and the passage of sufficient air past that point to enable the next leak to be located. It is more practicable to combine filling with fault clearance and to fill the cable in steps of several loading-coil sections, clearing the major leaks before finally coupling all sections together.

APPLICATION OF PRESSURIZATION TO LOCAL, JUNCTION AND TRUNK CABLES

Local Cables

The layout of local cables is usually complicated by many changes in cable size, and the pneumatic resistance (see Appendix) of such cables is high; at a distance from the exchange where the numbers of conductors in the cables are small the pneumatic resistances are particularly high. At such points access to the cables is usually rather difficult and, in many instances, the cables are linked together by tie cables.

However, the primary networks between exchanges and cabinets utilize large-diameter cables that are easy to pressurize to good effect, since faults can thereby be avoided in cables containing large numbers of working circuits. More gas seals are required in the cables between cabinets and pillars and a higher standard of sealing is necessary in order to ensure a sufficient supply of air in the event of a large leak or a continuous supply of air to the smaller leaks.

The small distribution cables between pillars and distribution points (d.p.s) are often subjected to much mechanical disturbance, with consequent sheath failures, and they are also the most difficult and expensive to pressurize because, in many instances, the cumulative pneumatic resistance from the exchange is high. Fortunately, each sheath failure affects relatively few circuits.

In such circumstances the advantages of pressurization as applied to local cables can best be attained by concentrating on the cables between exchanges and cabinets and leaving the rest of the cable network, unless local conditions clearly show the desirability of pressurizing from an exchange to pillars or to selected d.p.s. It may be found expedient to pressurize such cables at a later stage.

With the continuous-flow system applied to a local-cable network, an average permanent air flow of up to about 0.2 ft³/hr at 9 lb/in² into each cable is thought to be satisfactory. When the flow exceeds about 0.6 ft³/hr on any cable attempts are made to trace the major leaks. Increases in the rate of flow of air into a cable can indicate a general deterioration in the condition of the sheath or the occurrence of a large leak close to the exchange, but the condition of the cable is indicated more clearly by a fall in pressure at any point in the system.

In the Post Office continuous-flow system a pressure of 9 lb/in² is maintained at the exchange, and a working pressure of 3 lb/in² at remote cable ends is considered adequate. Alarm arrangements are made to indicate when the working pressure at cable ends falls to about 2 lb/in². Intermediate pressure gauges in the cable are set to operate at higher pressures, the settings being dependent on the length of the gas section. In practice, the setting of pressure gauges is determined by reference to a suitable chart (Fig. 2).

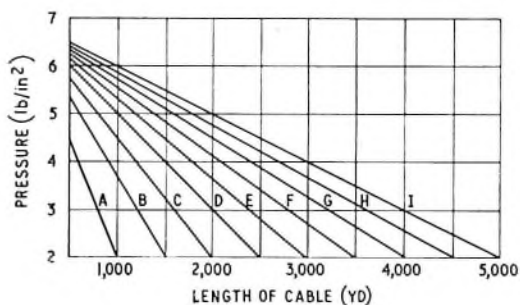

A—500-1,000 yd. B—1,000-1,500 yd. C—1,500-2,000 yd. D—2,000-2,500 yd. E—2,500-3,000 yd. F—3,000-3,500 yd. G—3,500-4,000 yd. H—4,000-4,500 yd. I—4,500-5,000 yd.

FIG. 2—PRESSURE-GAUGE ADJUSTMENT CHART

Most of the cables in the local-cable network between cabinets, pillars and d.p.s lie in dry or moist ducts or in not more than one or two inches of water. In such circumstances small leaks could be safeguarded with an internal pressure of less than 1 lb/in², and this protection is in practice occasionally extended beyond cabinets if the fault history is particularly bad.

Trunk and Junction Cables

The pneumatic resistance of trunk and junction cables is relatively low, and the terminations at the ends and on any branch cables are easily accessible in exchanges or repeater stations. Usually there are fairly long sections in which the cable size remains unchanged, and the cables

are more readily pressurized to a substantially leak-proof standard. An interim maintenance standard has been adopted for cables over 3½ miles long: during a period of 1 month the absolute pressure in the cable at any point at which a pressure gauge is provided should not fall by more than 1 lb/in². In general, it has been possible to maintain cables to this standard with no great difficulty, but there are objections to specifying a permissible leakage by the rate of fall in pressure at a remote point, as a small fault near a gauge would cause the pressure indicated by the gauge to fall at a much quicker rate than would be caused by a leak at a distance from the gauge. It may eventually be necessary to relate the permissible rate of leakage to the position of the leak as determined by initial tests.

The alternative of specifying a permissible flow of air into the cable is not attractive because of the possibility of long lengths of cable causing the flow to be reduced between a leak and any feeding point.

Pressure-indicating devices are provided along the length of a pressurized cable. A pressure gauge with electrical contacts that can be set to operate at any required pressure is usually provided where the cable terminates or is accessible at an exchange or repeater station, and contactors (i.e. pressure-sensitive alarm relays that operate when the pressure falls to a predetermined value) may be fitted in cable joints along the route if a suitable building for mounting a pressure gauge is not available. Generally these alarm devices are provided at distances of between 5 and 9 miles, depending on the pneumatic resistance of the cable.

Air for filling and topping-up purposes is normally obtained from compressors at the larger repeater stations and exchanges at which the cable or its spurs terminate. Cylinders of compressed air are provided for emergency use at selected staffed buildings.

Although there are advantages to be gained from coupling a number of cables together at their terminations, this practice tends to make it difficult to readily identify a leaking cable from a group of several cables. It is also impossible to make any extensive use of routine gauge readings taken at regular intervals of time, because the effect of a large leak in one cable may be masked by the reservoir of air provided by the leak-free cables. It is the practice, therefore, to provide individual pressure gauges and to maintain each cable as a separate gas-pressure system.

Carrier and coaxial cables are connected at intermediate repeater stations in such a manner that under normal operating conditions they are connected pneumatically from one section to the next. This practice facilitates fault locating and avoids a large number of end sections. Faults near ends of cables are difficult to locate; connecting through also ensures that a leak near an intermediate station will be supplied with air from both directions.

System Adopted

The Post Office is now engaged in an extensive program of pressurization of main, junction and subscribers' cables at all large telephone exchanges. In the system that has been adopted air compressors, desiccators and rack equipments are provided for all the cables terminating at these exchanges, and a particular feature of the system is that facilities for constant pressure are provided for main and junction cables and continuous flow is used for the local cables.

References

- ¹ HINES, J. G. Desiccators. *P.O.E.E.J.*, Vol. 4, p. 262, 1911.
- ² KATZCHNER, W. Compressed Gas Control on Trunk Cables. *Fernmeldetechnische Zeitschrift*, 7th Year, No. 8, Aug. 1954.
- ³ GIESE, R. G. Gas Pressure for Telephone Cables. A.I.E.E. Technical Paper 47-77, Dec. 1946.
- ⁴ KEEP, J. F. Field Trial of Pressurized Cable System. *P.O.E.E.J.*, Vol. 48, p. 7, Apr. 1955.
- ⁵ GRIFFITHS, R. J., and BROOKS, H. P. Gas Pressurization to Keep Water out of Cables. *Post Office Telecommunications Journal*, Vol. 12, p. 37, Winter 1959.

APPENDIX

The Flow of Gas in Cables

Pneumatic Resistance

The air space in conventional types of cable occupies between 50 per cent and 70 per cent of the total volume of the core and, although the air paths through the core form a tenuous pattern, the aggregate resistance to the flow of air is sufficiently uniform to permit reasonably accurate estimates of the positions of leaks to be made.

When comparing the rates of flow of compressed air through lengths of uniform cable of various types the following approximate relationship is used:

$$F = P/R,$$

where F = quantity of air discharged from the cable measured in ft^3/hr at atmospheric pressure,

P = total pressure-drop along the cable measured in lb/in^2 ,

R = total resistance to flow of air measured in units of pneumatic resistance (u.p.r.).

The relationship between fall of pressure and pneumatic resistance is assumed to be linear at all pressures likely to be applied to telecommunication cables, but the pressure distribution along a uniform cable freely discharging into the atmosphere is shown in curve A of Fig. 3 and is influenced by the lack of streamline conditions near the leak and by the change in friction experienced in the cable as the density of the air decreases as the pressure drops.

The shape of the pressure curve is changed when cables of different pneumatic resistance per unit length are joined together and compressed air is passed through the cable. An example of the change in slope observed when cables of low pneumatic resistance are joined to cables with a higher pneumatic resistance is shown in curve B of Fig. 3. In the example shown continuous pressure is applied at one end of a cable with low unit pneumatic resistance and a leak is simulated at the far end.

In general, uniform gradients are observed when pressure measurements are made on trunk and junction cables because there are long lengths of the same type and size of cable. More uneven gradients are usually measured in local-cable distribution networks, but allowance can be made for the effects of these variations in pneumatic resistance, and records of the pressures can be kept for each continuous-flow scheme to indicate such changes.

Pressure Gradients Caused by Leakages

The effect of a single leak on the pressure distribution curve along a uniform cable normally maintained at a static pressure of about $9 \text{ lb}/\text{in}^2$ is shown in Fig. 4. Because air flows to the point

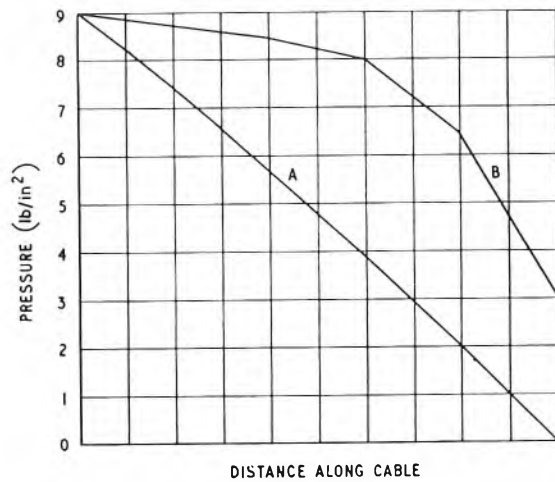

A—Pressure gradient along uniform cable with large leak at far end.
B—Pressure gradients along cables with different pneumatic resistances and with leak at far end.

FIG. 3—PRESSURE GRADIENTS ALONG CABLES WITH LEAKS AT FAR END

of leakage from the supply stored in the cable on either side of the leak, two characteristic curves are produced. The point of intersection of these two curves indicates the pressure within the cable at the leakage and the slope of the curves steadily changes as the pressure falls, the rate depending on the size of the leak, the pneumatic resistance of the cable, the quantity of air remaining in the core and the position of the leak. Pressure curves are shown for 1 hour, 1 day and 4 days after a leak in the cable sheath has occurred.

A small leak from a composite coaxial cable or similar cable with very low pneumatic resistance per unit length will produce shallow pressure gradients because the pressure throughout the cable can equalize reasonably quickly. A similar leak from a cable with a high pneumatic resistance per unit length will produce a much steeper gradient near the leak, and with such cables there is a danger when leaks occur that air stored in the sheath in the vicinity of the leak will be discharged at a greater rate than it can be replenished from remoter sections of cable. The pressure at the leak may then fall appreciably while it remains high at points 2 or 3 miles distant.

When the pressure of the air inside the cable at the fault point falls to less than the pressure of the head of water outside the cable, water will penetrate the sheath perforation and cause damage to the core. With small perforations the pressure of the air at the hole is uniform and equal to the pressure at the cable core, but with holes larger than approximately $\frac{1}{16}$ in. diameter (depending on the pressure in the core and the pneumatic resistance of the cable) the pressure in the middle of the hole will be less than at the circumference and this will be partly due to the presence of the core wrappings. There is a similar variation of air pressure at longitudinal fissures or cracks.

To ensure that water does not enter the cable, pressure gauges with alarm contacts or pressure-sensitive contactors are fitted to

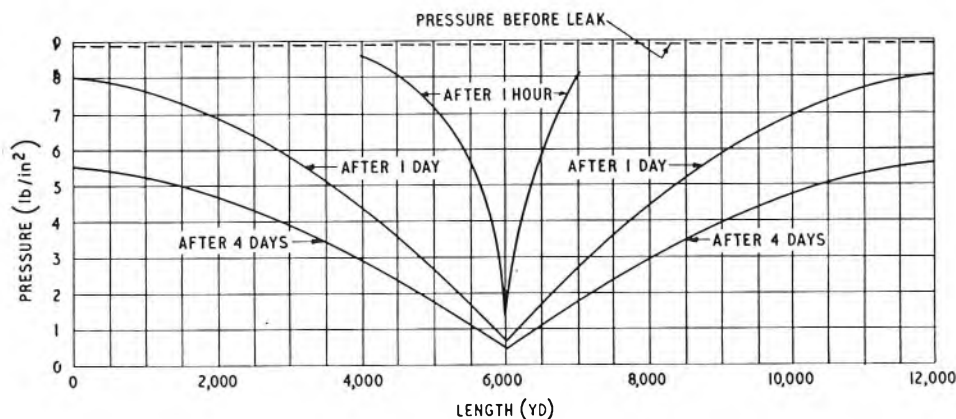

FIG. 4—FALL OF PRESSURE DUE TO LEAK IN STATIC-PRESSURE SYSTEM

the cable at intervals. These devices are set to operate at what is considered to be a minimum safe working pressure for the cable, an allowance being made for the pressure necessary at the middle of perforations. If possible, some allowance should also be made for cable sections where the pneumatic resistances are high and where air needed to stop the ingress of water is likely to be restricted.

The distribution of pressure along a cable continuously supplied with compressed air at constant pressure from one end only and leaking at one point is shown in Fig. 5. In this instance a pressure gradient is maintained along the section to the leak whilst the pressure beyond the leak eventually falls to the pressure within the cable at the point of leakage, the curve then remains constant unless the size of the leak increases. This type of pressure gradient is produced when continuous-flow pressurization is applied to local cables, using pressure equipment installed at the exchange, and a similar gradient is obtained when a leak occurs near one end of a trunk or junction cable having a static-pressure system. The procedure when searching for leaks in these circumstances is to investigate abrupt changes in pressure gradient that cannot be accounted for by changes in pneumatic resistance of cable sections.

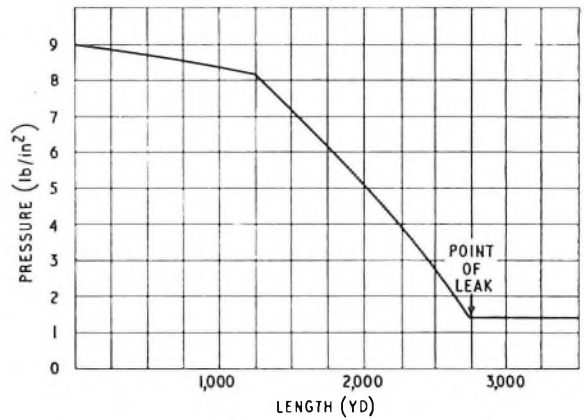

FIG. 5—EFFECT OF A LEAK ON A CONTINUOUS-FLOW SYSTEM

Voltage Incidence and Duration Counter

U.D.C. 621.317.32:621.391.823

As a result of the introduction of 50 c/s a.c. electrified railway systems, a need arose for a method of recording the magnitude and duration of the 50 c/s and the psophometric interference voltages induced in Post Office circuits by such railway systems. These voltages are variable in magnitude and duration, since they depend on train position and load current. Attempts to use recording voltmeters showed that, unless a high paper-speed was used, duration could not readily be measured; high paper-speed is, however, inconvenient to use for prolonged periods and, at any paper-speed, analysis of the results is laborious.

Measurements of both 50 c/s and psophometric induced voltages were required, and these voltages were first converted into d.c. voltages, the former by a simple filter-and-rectifier network and the latter by using a psophometer modified by the addition of a magnetic amplifier giving an output in the range 0–10 volts d.c. The method adopted to record the magnitude and duration of the interfering voltages was to count the number of occasions and the length of time that the derived d.c. voltages fell within preset limits.

The counter used for the above purpose consists of a number of balanced d.c. amplifiers used as voltage-detectors so that the duration and incidence of different levels of the interference voltages can be recorded separately; the prototype in use at present has four such amplifiers. The inputs of all detectors are joined together as shown in the figure, but there is an adjustable negative-bias voltage applied individually to the input of each detector, so that the net input to each detector is the algebraic sum of the input signal and the negative bias. Relay A, connected between the anodes of V2A and V2B, operates when the net input voltage is positive, the rectifier MRA preventing its operation when the voltage is negative. The adjustment of the bias is used to preset the voltage at which the relay will operate, the maximum value being 15 volts. Associated with each detector circuit are two counters (telephone-exchange type sub-

scribers' meters); the operation of the anode relay operates the "occasions" meter once, but the other meter is stepped once per second until the anode relay releases.

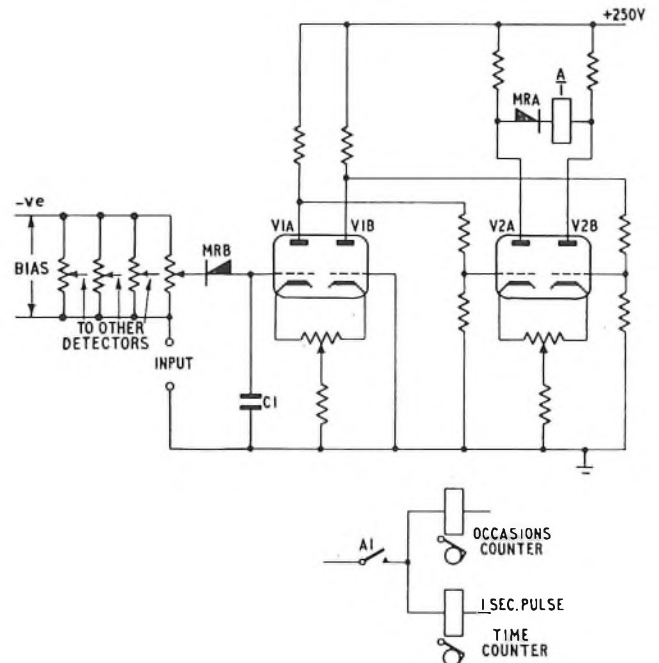

SIMPLIFIED CIRCUIT DIAGRAM OF DETECTOR

The simple d.c. amplifiers used have proved to be stable and give a differential between operate and release input voltages of less than 0.2 volt; this differential is independent of the operate voltage-setting. Rectifier MRB and capacitor C1 are used to increase the operate time-lag so that inaccuracies due to short transients are reduced.

A.G.P.

The Highgate Wood Electronic Telephone Exchange

S. W. BROADHURST, A.M.I.E.E.†

U.D.C. 621.395.345:621.395.722

Fifty years after the first British Post Office experimental automatic exchange was installed at Epsom, the first experimental all-electronic telephone exchange has been put into service at Highgate Wood. The exchange is the first of its type (t.d.m. switched highway) to be used for subscribers' traffic anywhere in the world.

INTRODUCTION

HIGHGATE Wood electronic telephone exchange, the first of its type (time-division multiplex switched-highway system) to be used for subscribers' traffic anywhere in the world, was accepted by the Postmaster General, the Rt. Hon. Reginald Bevins, M.P., on 12 December 1962 from Sir Thomas Spencer, Chairman of Standard Telephones & Cables, Ltd., (Fig. 1) on behalf of the five manufacturers who co-operated with the Post Office in the development, manufacture, installation and commissioning of the exchange.

In 1956 a Joint Electronic Research Committee (J.E.R.C.) consisting of the Post Office, Associated Electrical Industries, Ltd. (then Siemens Edison Swan, Ltd.), Automatic Telephone & Electric Co., Ltd., Ericsson Telephones, Ltd., The General Electric Co., Ltd., and Standard Telephones & Cables, Ltd., was set up to undertake research leading to the development of an electronic telephone switching system. At that time each member organization of the new committee had already done much work on the problems of electronic switching and several lines of approach were available. It was decided to concentrate the joint effort initially on the production of a single experimental system. Of the three possible basic switching methods available—space, time, and frequency division, only the first two appeared to be practicable, and of these a time-division multiplex (t.d.m.) system was chosen as being the most likely to exploit fully the potentialities of the new medium.

The t.d.m. system chosen was the switched-highways system. For the purpose of the experiment it was decided that a complete exchange giving all standard facilities and capable of interworking with the existing network should be built, and it was further stipulated that the exchange should be so designed that it would be demonstrably capable of extension to at least 20,000 lines. These decisions have profoundly influenced the "organization" of the system, particularly in the application of the common-control techniques used and the design of system security.

The exchange was jointly designed by a team drawn from each of the organizations, but the development and manufacture of the system was shared between the manufacturers,

each being free to use the techniques and components with which he was most familiar, or which he considered most suitable, so as to enable a comparative assessment to be made of different techniques, equipment practice and maintenance features.

For these reasons the amount and diversity of the apparatus fitted at Highgate Wood are much greater than would have been the case if the equipment had been designed solely to serve the 600 lines and junctions now in use there. No restrictions were placed on the number of power supplies nor were any new components developed specially for the experiment.

The building of a prototype model was authorized to ensure satisfactory interworking between the various sections to be contributed by the different parties. This model was installed at the Post Office Research Station, Dollis Hill, and shown to the Press in November 1959. Highgate Wood exchange differs from the model in respect of its equipment practice and in some of its logical elements but the greatest change is in respect of the automatic routing and security features now integrated into the system; these the model did not possess.

PRINCIPLE OF T.D.M. SWITCHING

In time-division multiplex telephone exchanges the conversation paths or highways are time shared, i.e. each call is allotted a particular "time slot" or channel defined by a pulse train, and as each pulse in the train appears it is caused to sample the speech wave and its amplitude modulated by it so that a series of signals describing the speech wave is transmitted along the highway. In the switched-highways system the channels



FIG.1—THE POSTMASTER GENERAL ACCEPTING HIGHGATE WOOD EXCHANGE FROM SIR THOMAS SPENCER

† Post Office Research Station.

are at $1\ \mu\text{s}$ separation and sampling occurs at $100\ \mu\text{s}$ intervals, giving a pulse repetition frequency of 10 kc/s and 100 channels in the multiplex. The principle is illustrated in Fig. 2. Speech from source A is sampled 10,000 times a second by pulse train P_a at modulator

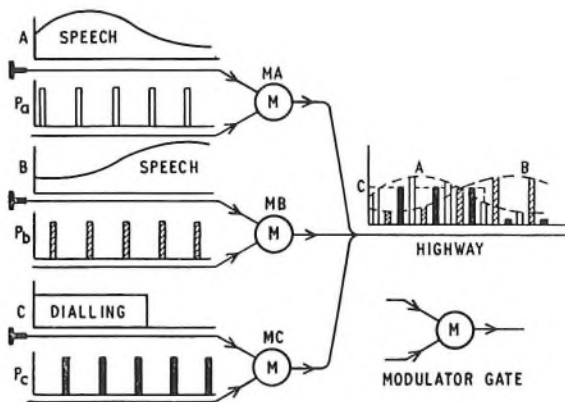

FIG. 2—PRINCIPLE OF TIME-DIVISION MULTIPLEX

gate MA, which is connected to the highway. Sources B and C are similarly sampled but by different pulse trains, P_b and P_c , the interleaved modulated pulses appearing on the common highway. The broken lines show the original waveforms that can be reconstructed from the modulated pulses at the receiving end of the system.

An exchange consists of a number of such highways, each highway serving a group of lines, i.e. subscribers and junctions. Since each highway in a multi-group system can carry between 60 and 65 Erlangs of traffic the number of lines in a group is variable from about 200 to 1,000; at Highgate Wood the maximum number is 800.

All the highways are fully interconnected by means of switching gates. Separate highways are used for inward and outward transmission so that each line requires a 4-wire/2-wire terminating set. The inward highway of each group is connected to the outward highway of every other group as shown in Fig. 3 which illustrates the basic trunking, omitting the setting-up apparatus and the controls.

A speech path from a subscriber in group 1 to a subscriber in group 2 using pulse channel P can be traced from modulator gate MA of the line A in group 1, via the inter-highway gate G, to demodulator gate DB of the line B in group 2. A similar path for the speech in the reverse direction can be traced via the gates operated at pulse time $P + 50$ (P and $P + 50$ mean a pair of pulses half the multiplex cycle time apart, i.e. 50 channel-pulse times apart; such pulses are said to be in antiphase). The reason for using a different pulse position for each direction of transmission is to avoid speech from either line being received by both and appearing as high-level sidetone in the speaker's instrument. Any pair of pulse trains would have served for this purpose but it is convenient to maintain a fixed relationship between them.

DESCRIPTION OF T.D.M. ELECTRONIC TELEPHONE EXCHANGE

To set up a speaking path in a t.d.m. switched-highway system it is clear that control and setting-up apparatus is necessary

- (i) to detect when a new call is initiated,
- (ii) to receive instructions dialled by the caller,
- (iii) to select the required line terminal,
- (iv) to select a pulse channel which is free and available to both the calling and called line, and
- (v) to establish the required connexion and maintain it until release conditions are signalled.

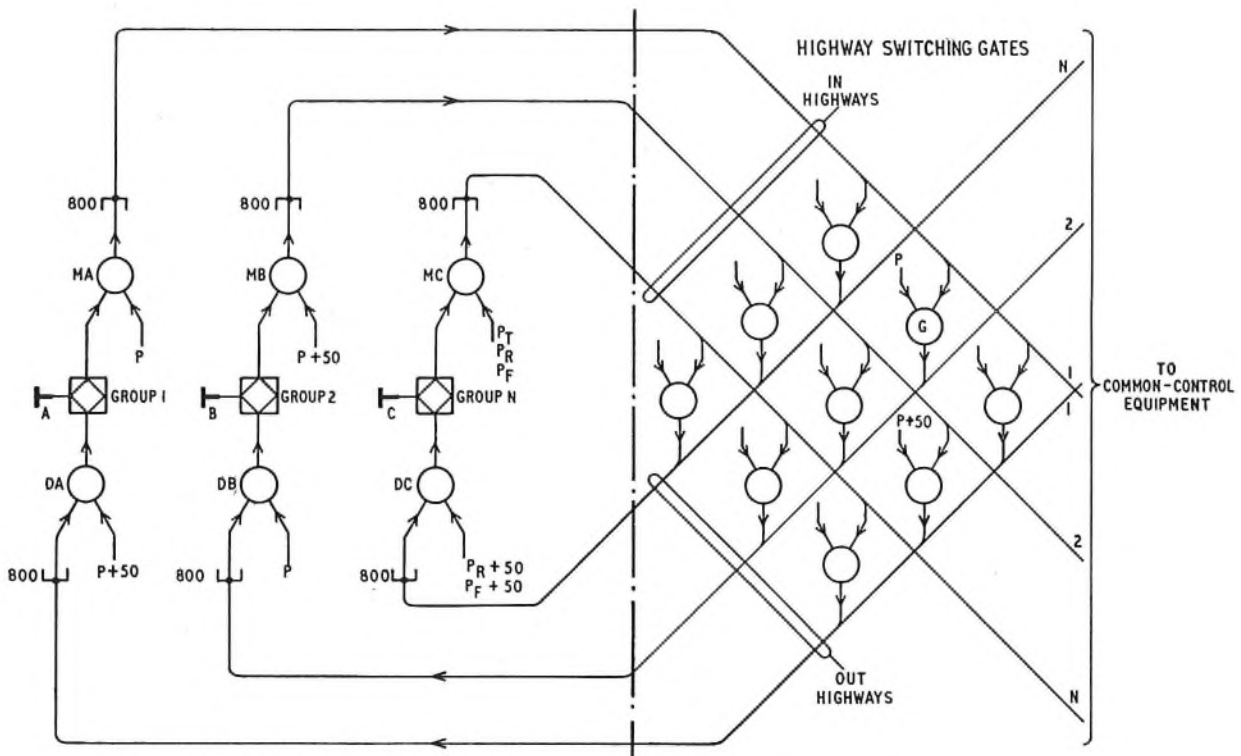

FIG. 3—BASIC TRUNKING FOR T.D.M. SWITCHED-HIGHWAYS SYSTEM

Control of Connexions

For an understanding of the system it is best to take the last of the above requirements first. Referring to Fig. 3, consider the path from subscriber A to subscriber B via the "in" highway of group 1 and the "out" highway of group 2, using channel time P. At any given time many other calls may be using the same highways and, therefore, although gate MA of subscriber A and gate DB of subscriber B must open only at channel time P, the inter-highway gate, G, must open not only at time P but also at each of the channel times which may have been allotted to other calls between the two groups. Hence, each gate in the transmission path must be controlled by a device which can store information relating to the pulse trains to be applied to the gate. It is advantageous if such a device can also generate the pulse trains.

At Highgate Wood these devices, which are known variously as memories or stores, take the form of magnetostriction delay lines, one of which is shown schematically in Fig. 4. A short pulse at the input to the write gate is amplified and applied to an input coil, W,

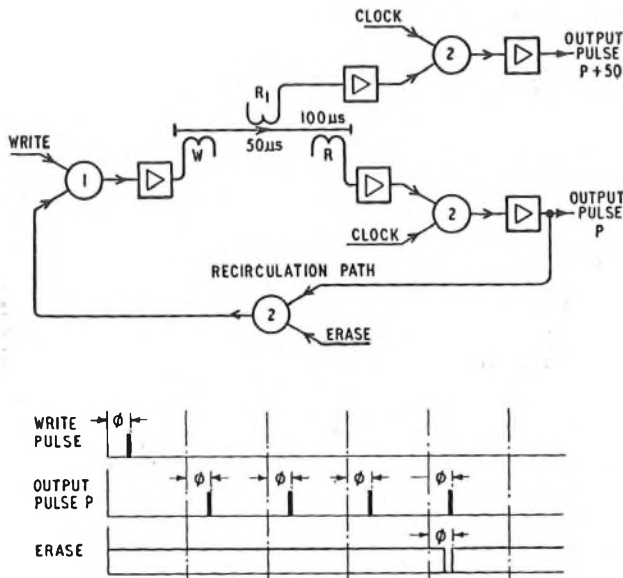

FIG. 4—SCHEMATIC DIAGRAM OF CIRCULATING DELAY LINE

at one end of a wire having magnetostrictive properties, producing a stress wave which travels down the wire and is detected $100\ \mu\text{s}$ later at the output coil, R. An auxiliary coil R_1 is placed at the centre of the wire to detect the pulse $50\ \mu\text{s}$ after it has been written. The output from coil R is amplified, re-timed by a strobe pulse and caused (a) to provide an output to the appropriate gate and (b) to provide a feed-back input to the write gate. Thus, any pulse injected once in the write coil will continue to circulate indefinitely, providing an iterative output from coils R and R_1 . Up to 100 pulses can circulate in this way. To erase any one of the pulses, i.e. to release any connexion controlled by the delay line, the recirculation path is broken at the erase gate for the duration of the appropriate pulse time. The remaining pulses will, however, continue to circulate.

Detecting Calls and Setting-Up Connexions

The incoming lines are continuously scanned to detect new calls. Scanning consists of applying a test pulse

to each of the modulator gates in turn in order to detect the condition of the line. One of the channel pulse times is reserved for use as a test pulse. If, when the line is being scanned, a new call has started the test pulse is gated on to the highway. The detection of this condition in the common-control equipment causes the caller to be connected to a register. The scanning and call-detection process therefore involves control of the line gates and, hence, of the delay-line stores which control them.

Since it is uneconomical to provide an individual delay line for every subscriber's line circuit, a system of coding is used. At Highgate Wood there are 800 lines in a group, which is divided into 8 sub-groups of 100 lines each, arranged in 10 rows of 10 columns. A line equipment position in any group can therefore be defined as a 3-digit number, ZXY , Z defining the sub-group, X the column and Y the row. Using five delay lines per digit and coding their outputs in two-out-of-five code a total of 15 delay lines can be made to serve the line gates of the 800 equipment positions. Fig. 5 illustrates the co-

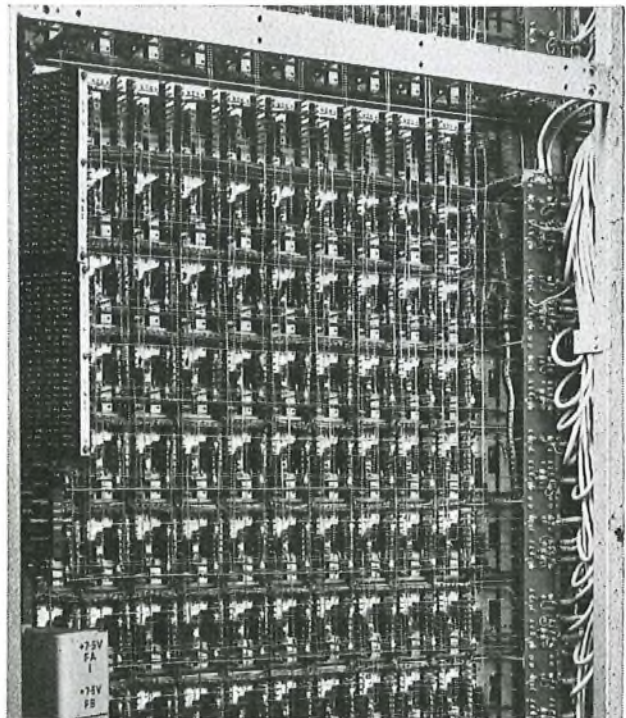

FIG. 5—CO-ORDINATE WIRING USED FOR CONNEXION OF LINE EQUIPMENTS

ordinate-wiring method used for the connexion of line equipments within a 100-line sub-group, and Fig. 6 shows the transmission racks containing line units, highway apparatus and delay-line stores.

The relationship between the subscribers' numbers and their exchange-equipment positions, given by the intermediate distribution frame cross connexions in existing exchanges, is, in this exchange, written into and stored on a magnetic drum. Each track of the drum is divided into 100 parts, one for each line in a sub-group. Four tracks are allocated for each sub-group and each group of tracks is switched sequentially so that as the

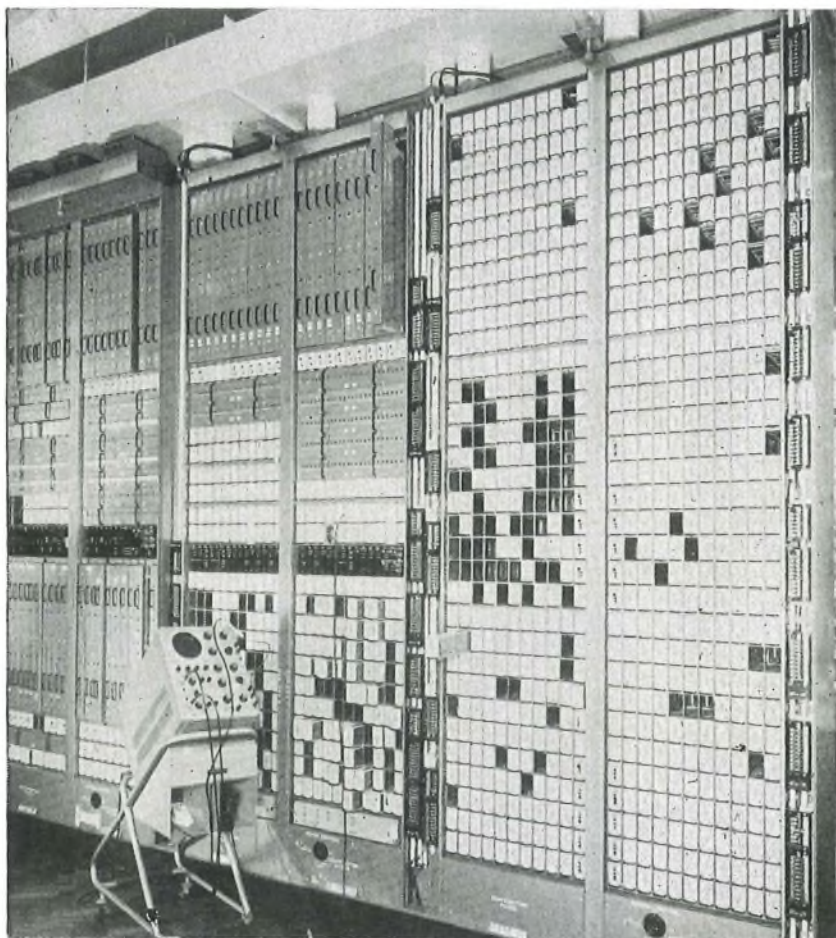

FIG. 6—TRANSMISSION EQUIPMENT RACKS

drum rotates the information relating to each of the equipment numbers, e.g. directory number, class of service, type of line, etc., appears in a fixed sequence at the output of the drum reading heads. That is, the position of the drum at any instant defines the equipment number ZXY of a particular line. Since the drum takes 28 ms to complete a revolution the information for each line is available for $280\ \mu\text{s}$ every $8 \times 28\ \text{ms}$, i.e. 224 ms. (This is the scanning time for subscriber's lines, junctions being scanned at every revolution of the drum).

Fig. 7 shows the principles of line scanning and line selection for one of the groups. The delay lines are arranged in three groups of five delay lines each; of these, only one delay line in the Y set is shown, but the remaining 14 are identical. Each set of delay lines is connected to two decoding matrices one of which is fed from the centre tap of the delay lines. The decoding matrices convert the two-out-of-five combinations into the one-out-of-ten signals necessary to define the line gates.

As the drum revolves it generates waveforms corresponding to the ZXY code of the line it is scanning; these waveforms send signals on six out of 15 leads typified by lead A in the figure. Providing the line is not already engaged as the result of a previous scan a test-pulse generator supplies a test pulse P_T to gate G2. This pulse appears on the outputs of the G1 gates of each of

the six marked delay lines. These outputs are decoded, and, in the case of the X and Z leads, combined to select (a) the line gate, LG, of the subscriber's line circuit as defined by the sub-group Z and the column X, and (b) the gate YG appropriate to the row of 10 line equipments of which the scanned subscriber is one. Only if the subscriber's line, L, is looped is the test pulse permitted to be gated on to the in-highway, and, when the test pulse does so appear, the common-control equipment detects it and prepares to set up the call to a register. This process, which takes about $90\ \mu\text{s}$, occurs during the first half of the $280\ \mu\text{s}$ available in the scanning period. During scanning, the test pulse is prevented from circulating in the delay line by a signal over wire B, which inhibits the circulating path at the test-pulse time. As soon as a call has been detected a busy condition is written on the drum to prevent any set-up being attempted during subsequent scanning times.

When a connexion is to be set up the calling line's ZXY code from the drum is staticized* on six out of 15 leads, typified by lead C in Fig. 7. A device known as the channel selector sends a suitable pulse over the common lead E. This pulse will circulate in the particular set of six of the 15 delay lines and, as a result, pulse signals will appear on the six connect-inward leads and on the corresponding six connect-outward leads appropriate to a particular line. These signals are

combined in their respective decoders and are caused to operate the gates connecting the line to its highways. The selected pulse will continue to circulate in the delay line until the end of the call when it is erased by a pulse signal applied on lead B. As long as the pulse continues to circulate, the line L is connected to its in-highway at the selected pulse time, e.g. time pulse P, but because of the centre-tap output from the delay line, line L is connected to the out-highway $50\ \mu\text{s}$ out of phase, i.e. at time pulse $P + 50$.

The channel selector is simply a device which, on receiving a request to set up a connexion, selects the first free channel available in the group concerned. The group with which it has to deal is defined by the position of the drum, and the channels already in use in the group are signalled to the selector over the busy-channel lead (Fig. 7), to which is applied all the pulses circulating in the delay lines of the group concerned.

The channel selector also controls the delay lines controlling the setting of the inter-highway gates in the switching networks.

Fig. 8 shows the magnetic drum and associated control equipment racks.

* Staticized—converted from a time sequence of states representing digits into corresponding space distribution of simultaneous states.

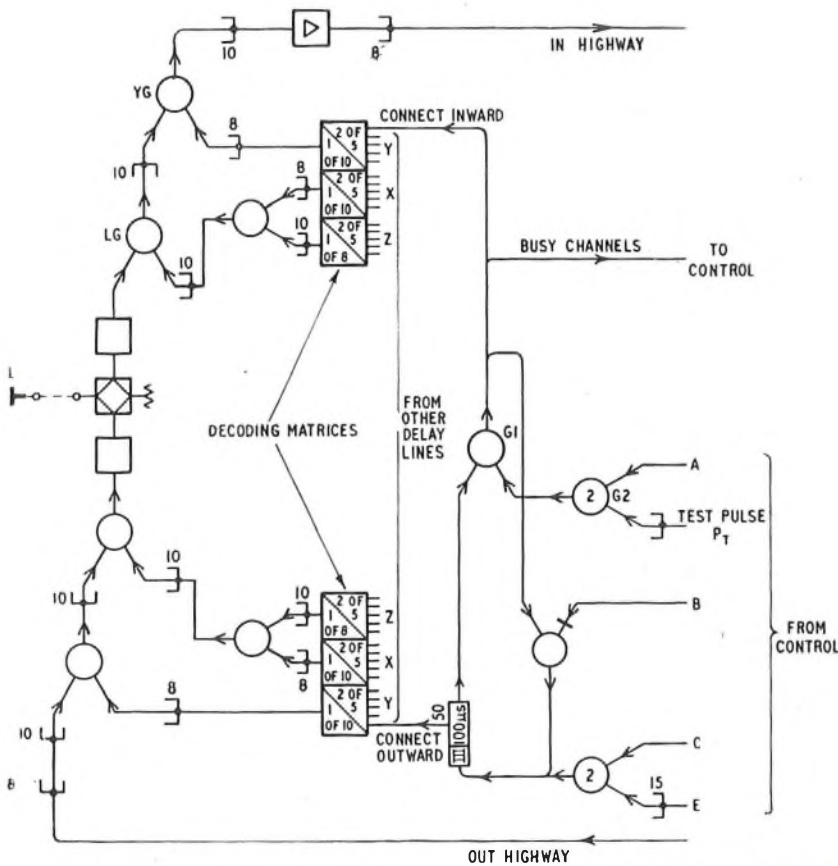

FIG. 7—SCHEMATIC DIAGRAM OF LINE-SCANNING AND LINE-SELECTION EQUIPMENT

Common-Control Equipment

The principles of the common-control equipment used in the system are illustrated by the schematic diagram of Fig. 9, which should be referred to in conjunction with Fig. 3.

Although in practice the various sections of the common control are physically separate pieces of equipment it is easier to follow the broad principles of the system if the common equipment be considered as being in two parts; (a) the control elements which control the setting up and clearance of the calls, receive and send information to and from the lines, and monitor the lines during conversation, and (b) the central memory containing all the permanent and semi-permanent information relating to the lines and junctions, including the translations.

When a subscriber, such as subscriber C in group N (Fig. 3), originates a call, the test pulse P_T is received in the control over the state-of-line lead (Fig. 9). The channel selector, with the knowledge that this is a new call, will select a pulse channel such as P_R that is free both on the in-highway

of group N and the common register highway RH (Fig. 9). The common-control equipment sends a pulse at time P_R to a gate, TG, which opens at the coincidence of this pulse time with that of a group pulse G_{PN} , which defines the number of the group. The pulse enters delay line TD, where it circulates giving an output to modulator gate DG at pulse time $P_R + 50$. These pulses are modulated by dial tone and transmitted via the out-highway to the calling subscriber.

When the subscriber dials, his dial pulses interrupt the pulse train P_R on the in-highway at modulator gate MC (Fig. 3). The dial breaks are counted and stored in the register, which, after sufficient digits have been received, refers to the central memory. If the call is for an outgoing junction a translation is received together with the designation of the equipment number of the outgoing circuit, i.e. its position on the drum. For a local call no translation is required. While the drum is scanning the required equipment number the setting-up apparatus can select the outgoing circuit and set the line gates to open at the pulse time of a channel which the channel selector finds is available on both the calling and called lines' highways. For a locally-terminated call the final connexion is then set up, but for an outgoing-junction call, the highway switch is prevented from operating until the register ceases to send out. The final setting-up involves a change of pulse on the caller's highway so that three different channels may be used in

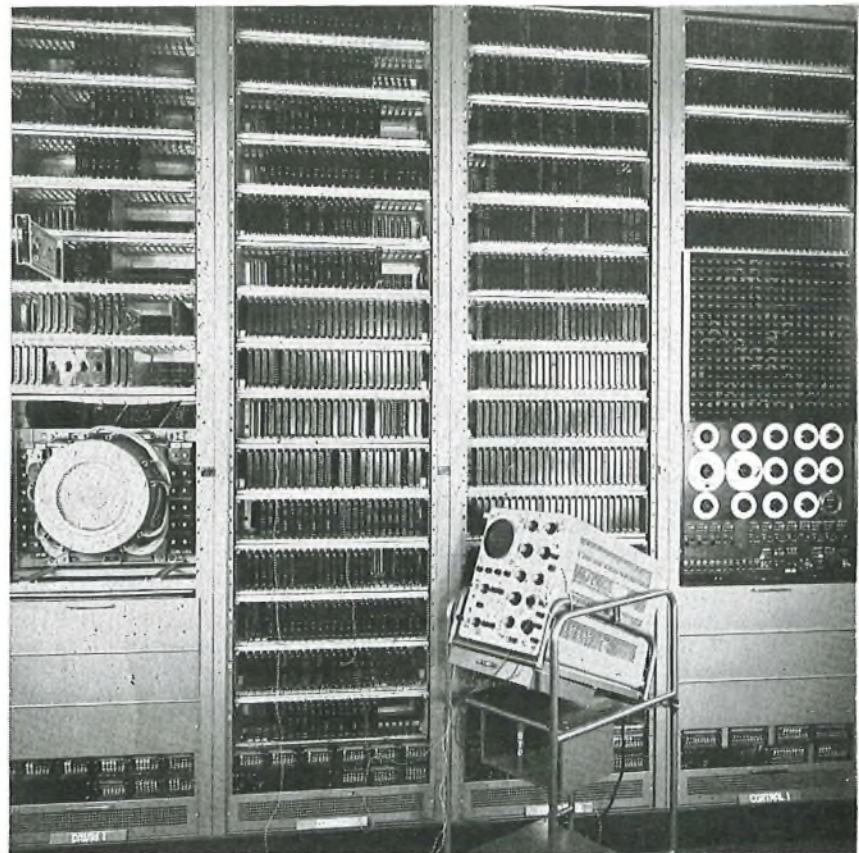

FIG. 8—MAGNETIC DRUM AND ASSOCIATED EQUIPMENT RACKS

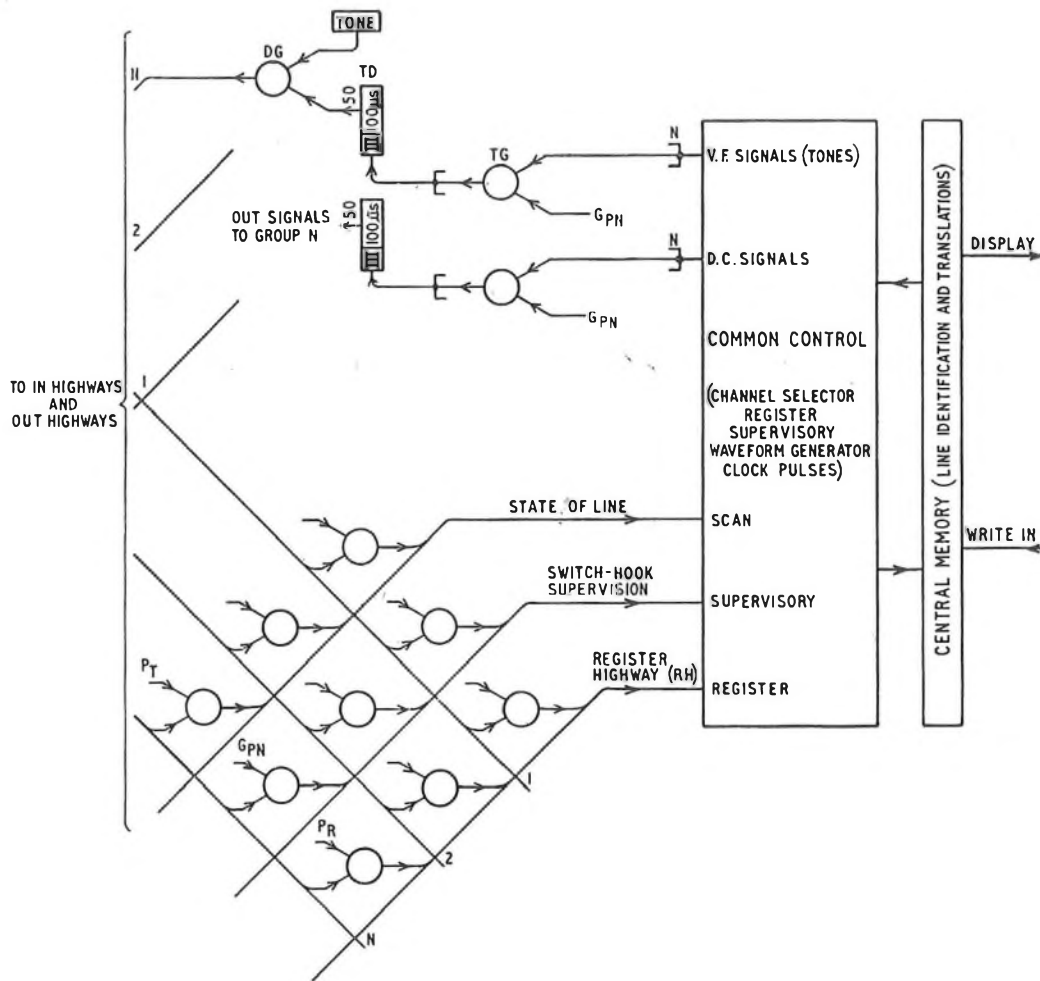

FIG. 9—SCHEMATIC DIAGRAM OF COMMON-CONTROL EQUIPMENT

succession while a call is being set up: a pulse P_T for detecting the call, a pulse P_R to make the register connexion, and a pulse P_F to complete the conversation path. Of these pulses only pulse P_T is fixed and not available for all types of connexion.

Supervisory Equipment

All operations in the exchange are dealt with on a one-call-at-a-time basis, a feature made possible by the speed of operation of electronic components. In the supervisory equipment, which controls the application of tones and signals to the highway channels and which detects the answer and release conditions, each multiplex channel in the exchange is scanned for $1 \mu s$ at $900 \mu s$ intervals. The equipment at Highgate Wood uses a number of $900 \mu s$ delay lines in a parallel arrangement. These act as stores for all the information relating to the highway channels, each channel being given a particular time position in the stores. The equipment is thus capable of looking after 9×100 channels, i.e. a 7,200-line exchange having 800 lines per group. At each channel position in the stores there is recorded a coded pattern indicating the state of a particular call. The pattern changes as the call progresses and logic-circuit elements deduce from these changes the action to be taken, e.g. to

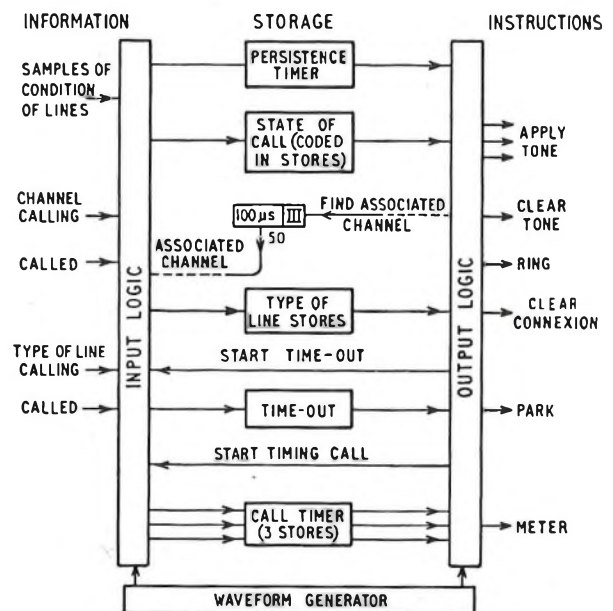

FIG. 10—ORGANIZATION OF SUPERVISORY EQUIPMENT

start or stop ringing, to meter the call or to initiate release of the call. These actions are in turn dependent on the class of service of the lines concerned, and because of this the information relating to the lines, which is permanently stored on the drum, is temporarily transferred to the supervisory equipment, where it is held in store until the connexion needing the information is cleared.

The equipment includes "persistence" timers, the equivalent of the well-known B-relay circuit. If a caller clears, his pulse train is removed from the highway although the gates in the connexion path continue to open at the channel time used by his call. When the supervisory equipment scans this channel it stores the "no-pulse" information and commences to "time out" the condition. If the clear persists long enough, the call is released by signalling from the setting-up apparatus to

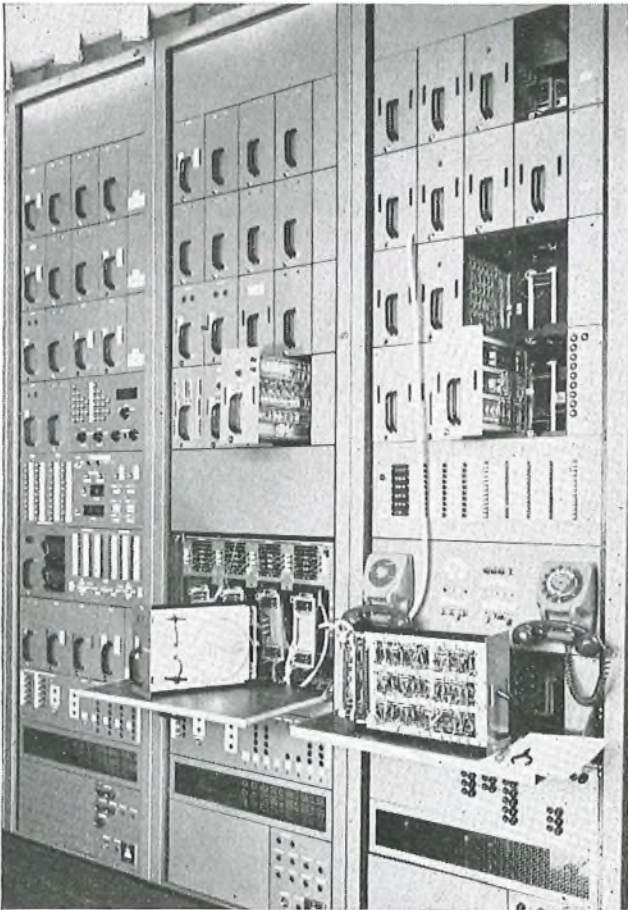

FIG. 11—SUPERVISORY EQUIPMENT AND EXCHANGE-FAULT ANALYSER EQUIPMENT RACKS

the inhibit gates in the circulating paths of the delay-line stores controlling the connexion. The organization of the supervisory equipment is illustrated in Fig. 10, the equipment being mounted on eight racks, two of which are shown at the left-hand side of Fig. 11.

Register

Like the supervisory equipment, the register (Fig. 12) also uses $900 \mu\text{s}$ delay lines for storage purposes but in a

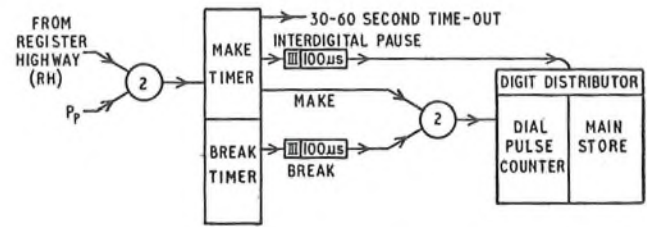

FIG. 12—ORGANIZATION OF REGISTER

different manner. The stores, which are arranged in groups of four, are divided into nine sections of 100 bits to provide 9-digit storage for 100 registers, each digit comprising 4 bits. The input to the register is the single register highway (RH in Fig. 9) over which dial pulses for 100 channels are received. The dial pulses are counted and scanned using $100 \mu\text{s}$ delay lines before being stored serially at the channel-pulse time; an electronic digit distributor steers the dialled digits successively into sections 1, 2, 3, 4, etc., so that the wanted subscriber's number is stored in modified binary form at pulse times P_R , $P_R + 100$, $P_R + 200$, etc. Associated logical circuits process the call in accordance with the class of service and the digits dialled. Fig. 13 shows the register

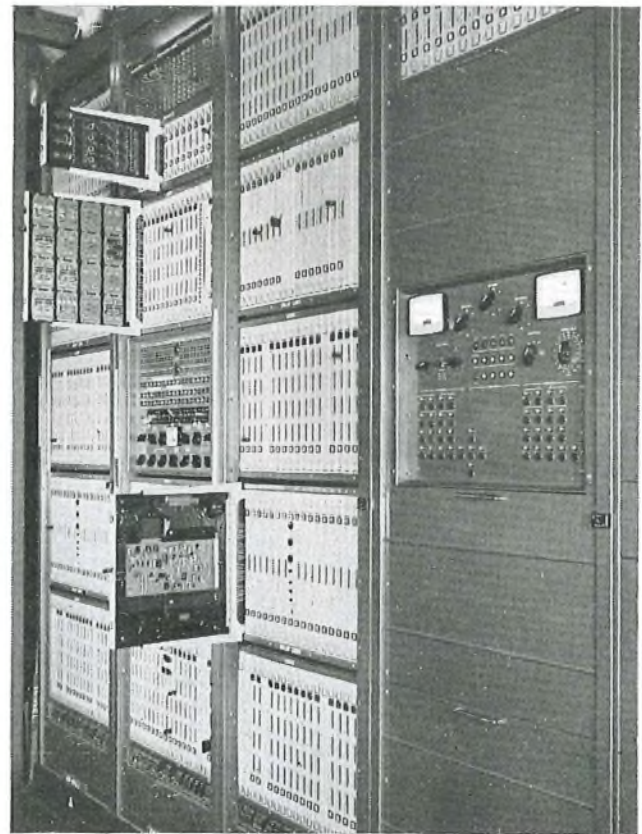

FIG. 13—REGISTER RACKS

racks, with a delay-line unit withdrawn near the bottom of one rack and associated equipment withdrawn higher up the racks to illustrate the sub-assembly construction of the equipment units.

MISCELLANEOUS FACILITIES AND EQUIPMENT

The exchange provides three-way connexions for trunk-offering and interception. Technically this means that an operator using one pulse-channel (P) and its antiphase (P + 50) must be able to speak and listen to a pair of subscribers using a different pair of channel pulses.

No test distributors are fitted, but the test clerk can dial through the exchange to select a line-isolating relay appropriate to the line it is required to test. This relay is necessary because no electronic switch gives the exact equivalent of the open-circuit condition demanded by the present method of line testing.

Because of the low power-handling capacity of electronic equipment it is not possible to transmit high-power ringing current through the exchange switches. Each line termination is therefore provided with a relay operated from a transistor pulse-lengthener which in turn is connected to a signalling highway. The signalling highway is trunked with and controlled in the same manner as the speech highways previously described, and it carries "d.c." signals (coded trains of unmodulated pulses) to control the line terminations (see Fig. 9). These signals, e.g. ringing and metering, are time shared and their cadences are controlled by a waveform generator.

All junctions are terminated in conversion equipments containing the relays necessary to provide such signals as line reversal and the means to repeat the pulse trains generated electronically by the registers.

The equipment provides "parking" facilities. When a line seizes the common equipment but the subscriber fails to dial, a timing-out circuit causes the calling signal to be taken off the highway and the magnetic drum records that this has been done. Lines indicated in this manner are interrogated at every scanning cycle to see if

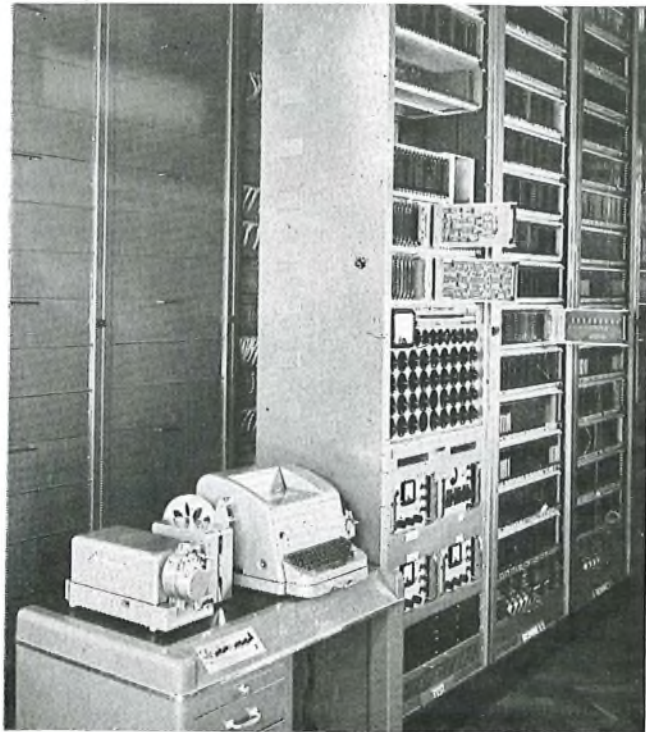

FIG. 14—TEST RACK AND READ-OUT PRINTER

the calling signal persists. The parking indication is removed from the drum when the call is cleared, but number-unobtainable tone (N.U.T.) is transmitted to the caller should he commence to dial before clearing the parking condition. Should the number of lines parked exceed a pre-set total an alarm is given.

The equipment also provides for timing a called-subscriber-held condition and releasing the subscriber, and facilities are provided for the subscribers' meter readings to be recorded on the drum, spare tracks being provided for this purpose. Fig. 14 shows part of the test rack and read-out printer for the meter records, etc.

SYSTEM SECURITY

Despite the experimental nature of this installation it has been designed to provide full service facilities and to carry public traffic under proper maintenance conditions. For this reason the security of the system, i.e. its ability to provide service in the presence of faults, has been carefully studied. At the same time, because little is known of the operation of electronic telephone exchanges in service, the opportunity has been taken of trying out several possible approaches to the problem of maintaining a continuous service.

Although most of the testing routiners can be manually controlled they normally operate continuously, "system time" being allocated for the testing cycles. Thus, certain line positions in each of the sub-group tracks of the drum are allocated for test words, and while these words are being scanned no new call can be set up. The test words cause a particular sub-routine to be initiated and checked, each word covering a limited number of operations, e.g. the initial set-up of a connexion to a register. Such tests may involve every section of the exchange. Other test words are used by the drum equipment for local tests of its own logic circuits.

The transmission highways are completely duplicated and are used alternately every 30 seconds. The path not in use is checked by a routiner. If a fault is detected the change-over is inhibited.

Only one magnetic drum is provided but this has spare tracks which can be switched in as required. The groups of line-connecting stores use the principle of "1-in-*n* sparing," i.e. each group is equipped with an additional spare delay line which can be switched in place of any of the others in the group, the testing and switching being under the control of a routiner. Otherwise the functional sections of the equipment are provided in duplicate: a working section, A, and a spare section, B.

For the register and the supervisory equipments, inputs from the system to the A and B sections are commoned and both sections operate continuously in parallel. For the supervisory equipment the A and B outputs are also commoned, and comparators check that both sections are giving the same digital output, which at any instant should be either a 1 or an 0. If a discrepancy is detected the section giving the 1 output is switched out of service and the equipment left in service is checked by the routiner.

The routiner has two interlocked cycles, one to check the basic operation of the equipment every few seconds and the other to test facilities, such as time-out and metering, for which a much longer time cycle is necessary.

The register routining arrangements are similar except that the outputs from the A and B sections, although continuously compared, are not both commoned to the

outputs to the system. The routiner's test cycle enables it to test the functional operations of both equipments, e.g. the operation of the delay-line stores, while the registers are carrying live traffic.

The control equipment for the drum is designed to cater for a three-group system but, since the exchange is opening with a single group, each of the group equipments of the drum is arranged to deal with one third of the subscribers' lines. In addition a fourth equipment is provided as a standby that can be switched in place of any of the others in the event of a fault.

In the exchange as a whole, some routiners may be performing functional tests of the section of the equipment they serve while others are testing the system during system time. With this routing method, and having regard to the complexity of the information-exchange paths interconnecting the various parts of the system, it is inevitable that a single fault may be indicated by more than one routiner. For this reason all indicated faults are referred to an exchange-fault analyser (right-hand rack in Fig. 11), which analyses the information it receives and decides on the appropriate action to take. This may involve resetting certain of the routiners and the initiation of a series of tests in a preferred order, checking that the appropriate spare equipment has been switched in, and inaugurating a series of test calls. Catastrophic failures, if any occur, will result in the exchange being switched to the electromechanical standby.

EQUIPMENT AND COMPONENTS

The equipment is mounted on 10 ft 6 in. racks, each suite of racks being terminated by an end panel housing the power distribution for the suite. The tops of the racks are connected by hoses to the ventilation trunking, through which the hot air is exhausted by means of ventilation fans; this feature is necessary because of the large numbers of hot valves employed in the system, design having commenced in 1956 before sources of reliable transistors were available.

Various types of equipment modules have been used. This is to some extent dependent on whether valve or transistor circuits have been used, but, in addition, the opportunity has been taken to try out different types of equipment practice. In some instances equipment units consist of similar circuit elements, e.g. toggles or gates, these being interconnected by cross wiring at the back of the racks to give the required circuit sequence. In other cases the equipment giving a complete facility is wired as a unit or made up from an assemblage of small unit cards.

Since equipment practice can profoundly affect not only the factory production but also the ability to trace and clear faults when the equipment is in service it is obviously desirable that these various ideas should be subject to field trial.

The table shows the approximate total numbers of the various electronic components used.

Electronic Components Used at Highgate Wood
Electronic Exchange

| | |
|------------------|---------|
| Valves | 3,000 |
| Transistors | 26,000 |
| Diodes | 150,000 |
| Resistors | 148,000 |
| Capacitors | 50,000 |
| Total Components | 377,000 |

These totals are, of course, far in excess of the actual requirements for Highgate Wood; this is due to the scope of the experiment specified when the development was first authorized. So far the failure rate of the components appears to be low and, although up to the present many of the failures can be attributed to "working-party faults," a fault rate of less than 1 per 2,000 components per annum is confidently expected.

INSTALLATION

Deliveries of the equipment commenced early in 1961, the last rack being received in August of that year. In the course of the design and manufacture it was decided that, since the operation of a multi-group system had been proved on the model at the Post Office Research Station, it would be sufficient initially to provide a single-group transmission system for Highgate Wood but, apart from this, most of the common control would be capable of serving a very large exchange.

The commissioning of the equipment was undertaken by a team which included representatives from each member organization of J.E.R.C. Due to the wide variety of techniques and equipment practice involved and the diversity of the common-control apparatus, the task of the team was many times more arduous than the normal commissioning of an established system. Nevertheless the work was accomplished in about the same time that it would have taken to install standard equipment, and the first effective call from a standard subscribers' station was passed through the exchange on 25 September 1962.

CONCLUSION

During the design and construction of this experimental equipment many lessons have been learned which will prove of great value in the design of future electronic systems. So far the component failure rate has been very low, and although fault tracing is not easy it is clear that substantial improvements in this respect will be possible in future designs.

In a developing art such as electronic switching, rapid developments of new techniques and components are to be expected and already much of the Highgate Wood equipment is obsolescent. Nevertheless the skill and knowledge now acquired by the telecommunications industry could not have been gained except from the experience of building and commissioning a working exchange.

ACKNOWLEDGEMENTS

The successive stages of the development—the research, the system, circuit and equipment design, and the installation and commissioning have all been jointly undertaken by teams drawn from each member organization of J.E.R.C. This has involved close and continuous co-operation at all levels of the joint organization, and acknowledgement must be made of the unstinted support given by all concerned.

The transmission apparatus, including the line stores, was designed by The General Electric Co., Ltd., the drum apparatus was designed jointly by Automatic Telephone & Electric Co., Ltd., and Standard Telephones & Cables, Ltd., the supervisory equipment was designed by Ericsson Telephones, Ltd., the register was designed by Associated Electrical Industries, Ltd., and the exchange-fault analyser by the Post Office Engineering Department.

The author desires to thank his colleagues in the Post Office and the telecommunications industry for their assistance in the preparation of this article and for their cooperation in the great task of getting the exchange into service.

Bibliography

HARRIS, L. R. F. Time Sharing as a Basis for Electronic Telephone Switching. A Switch-Highways System. *Proceedings I.E.E.*, Paper No. 1993R, Mar. 1956 (Vol. 103, Part B, p. 722).

BROADHURST, S. W. An Experimental Electronic Telephone Exchange. *Post Office Telecommunications Journal*, Vol. 12, p. 59, Spring 1960.

HARRIS, L. R. F. Highgate Wood Experimental Electronic Telephone Exchange. General System Description. *British Communications & Electronics*, Vol. 7, p. 897, Dec. 1960.

CAPLIN, J. S. Highgate Wood Experimental Electronic Telephone Exchange. The Transmission Paths and Line Equipment. *British Communications & Electronics*, Vol. 7, p. 900, Dec. 1960.

SIMMONS, B. D. Highgate Wood Experimental Electronic Telephone Exchange. The Register Equipment. *British Communications & Electronics*, Vol. 7, p. 904, Dec. 1960.

ALLUM, R. D., and KNIGHT, R. G. Highgate Wood Experimental Electronic Telephone Exchange. Magnetic Storage Drum Control. *British Communications & Electronics*, Vol. 7, p. 907, Dec. 1960.

MARTIN, A. D. Highgate Wood Experimental Electronic Telephone Exchange. Supervisory Equipment. *British Communications & Electronics*, Vol. 7, p. 910, Dec. 1960.

Various papers relating to Highgate Wood experimental electronic telephone exchange presented at the Conference on Electronic Telephone Exchanges, November 1960. *Proceedings I.E.E.*, Vol. 107, Part B, Supplement No. 20, 1960.

Book Reviews

"Radio for Examinations." H. I. F. Peel, M.Sc.Tech., A.M.I.E.E. Cleaver-Hume Press, Ltd. vii + 364 pp. 277 ill. 55s.

This is a "cram" book, of the type favoured by university students desperately trying to revise an enormous syllabus in the short term before their final examinations. The more conscientious tutors will disparage it, because they will take the idealistic view that students should distil their own notes from a wide range of reading. In this book, however, the student's work has already been partly done—that is, if he is taking radio as a subject for a degree, or in City and Guilds of London Institute advanced telecommunications, or perhaps in an I.E.E. examination. A wide range of items is presented in the concise unambiguous form that would be expected by university examiners. The treatment is largely analytical, mathematics being freely used as is to be expected in a book for students of degree standard. The analyses are all of traditional type, however, and the author makes no claims to originality in this respect.

Probably all the technical content of this book could be found in various places in text books or articles, but Mr. Peel's readers will find that he has not only collected items from many diverse sources but has reduced them to the minimum number of words—or algebraic steps—in a manner calculated to emphasize the important points. In particular, he deserves commendation for his free use of vector diagrams as illustrations to supplement algebraic analyses, and indeed for his general success in explaining fundamental principles quickly and clearly. A book of this nature must be based on considerable experience of lecturing in radio and also on examining advanced students; one can see that the phrase "derive an expression for . . ." leapt very readily to the author's mind when he was writing the first half of "Radio for Examinations" for nearly every page of it suggests that it is an answer to an examination question.

There is so wide a coverage in this book that a list of the contents reads like the syllabus of a complete radio course—the properties of tuned and coupled circuits, valve amplifiers, oscillators, amplitude modulation, transmission lines, the propagation of radio waves, aerials and aerial arrays, direction finding and navigational aids, radio receivers, the cathode ray oscillograph, television and facsimile, v.h.f. techniques, microphones and loudspeakers, filters and attenuators, frequency modulation, radio-telephone systems, transistors. There are appendices on network theorems and various other useful mathematical items.

The value of the book has been greatly increased by the inclusion of a large bibliography; since no subject is given more than outline treatment in the text, bibliographical references are made, in every chapter, to sources for further

reading. A large number of questions taken from appropriate examination papers are collected at the back of the book, grouped in subjects according to chapter numbers.

The author has only been able to compress so much into one volume by eliminating a great deal of relevant descriptive matter. There is no "padding" in this book. Students will thank him for this; and if they copy his presentation and style in their own examination answers they should be the more successful for having studied it carefully. The book is well produced, with excellent line diagrams and can be recommended to advanced students of telecommunications as likely to be of permanent value to them.

I.P.O.E.E. Library No. 2675.

C.F.F.

"Introduction to Feedback Systems." Prof. L. Dale Harris. John Wiley and Sons. xi + 363 pp. 242 ill. 79s.

There has been a tendency for feedback systems to be treated from two quite distinct standpoints: the design of amplifiers and the design of servomechanisms. The common root of both techniques is obvious and well appreciated but the extent to which both systems can be treated by the same methods of analysis and synthesis is perhaps not so well known. This book, from the outset, treats the two classes of problem as only different manifestations of the operation of a common set of principles.

For the student electrical engineer who wishes to acquire an understanding which will enable him to tackle such feedback systems as amplifiers, oscillators, or control systems with equal confidence, this is a book to be recommended. Equally, those steeped in any of the techniques might find the common approach used here enlightening and the modern methods of attack of value.

For analysis and synthesis this book uses the pole-zero, root-locus approach giving the complete (not sinusoidal only) response of the feed-back system. A chapter is included, however, on sinusoidal analysis and the Nyquist Criterion.

The book presents the subject matter in the form of a well-integrated series of lectures with the object of enabling the reader to teach himself. The illusion of the lecture room is fostered by Professor Harris's easy and intimate style. There are no references and no bibliography and the mathematics essential for appreciation of the text is given in appendices.

For readers outside the U.S.A. (and perhaps for some inside) the book would have been improved by a description of the "spirule." This device, which is a protractor-like aid to rapid calculation of points on the locus, is referred to a number of times and the steps in its use in particular cases, are described. This, however, is little help to the reader unfamiliar with the instrument. Otherwise the book is well suited to its purpose.

D.T.

Subscriber-Controlled Transfer Service

C. D. VIGAR, A.M.I.E.E., and J. E. PIESING†

U.D.C. 621.395.348

The circuit principles involved in providing subscriber-controlled transfer facilities are described. In addition to circuits enabling a subscriber to transfer his incoming calls to another subscriber connected to the same exchange, a scheme is available permitting any one subscriber in a group of 10 to transfer his incoming calls to any other selected subscriber of the group, without the assistance of an operator.

INTRODUCTION

THE facility for a subscriber to be able to transfer his incoming calls from his usual telephone to another telephone some distance away is one that has been required ever since the telephone came into commercial use. The business subscriber who requires incoming calls to his business telephone to be received on his home telephone in non-business hours and the doctor who wishes to transfer incoming calls from patients to another doctor during his off-duty periods are typical examples of users of this service. In the days of manual exchanges such a service could easily be provided by inserting pegs in the multiple to show the number to which incoming calls should be transferred. When exchanges were converted to automatic working, transfer facilities were provided by a system of relays remotely operated from the nearest manual board over the trunk-offering selectors, or over a control wire if the subscribers were connected to the exchange at which the manual board was located.

With the advent of subscriber trunk dialling, manual boards are becoming fewer; also, the cost of providing manual-board services is rising. Furthermore, the pace of business life is increasing, and some subscribers prefer a transfer facility that can be brought into operation at the push of a button to one which requires the co-operation of an operator. The subscriber-controlled transfer service has been developed to meet this need. At present three systems are available: a single-transfer system that will transfer the incoming calls from one telephone to another, a cyclic-order system that will transfer the incoming calls from one telephone to the next in a predetermined arrangement of telephones, and a 10-line transfer system in which a subscriber may transfer his incoming calls to any one of up to nine other lines connected to the same transfer system. All these systems are capable only of transferring calls between telephones connected to the same exchange, but methods of transferring calls to telephones connected to nearby exchanges are under development.

An additional final-selector number, called a bypass number, may be permanently connected to any line that has its normal incoming calls transferred, so that the transferring subscriber can receive incoming calls from callers who know the alternative number. For example a doctor can receive calls of a social nature even though his line is switched and calls from his patients are transferred to another doctor.

PRINCIPLE OF CIRCUIT

The basic circuit for the operation of relay TF (the relay that diverts the incoming calls to the receiving line)

† Telephone Exchange Systems Development Branch, E.-in-C.'s Office.

is shown in Fig. 1. The subscriber's line is modified by the insertion of a resistor, R1, in the line circuit and by

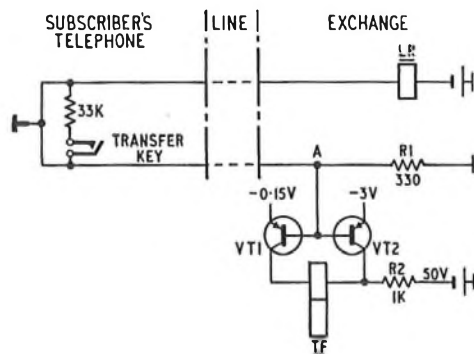

FIG. 1—BASIC CIRCUIT FOR OPERATION OF TRANSFER RELAY

the provision, at the subscriber's telephone, of a 33,000-ohm resistor that is connected across the line by the operation of a locking key. The presence of this 33,000-ohm resistor across the line causes relay TF to operate and incoming calls to be transferred.

When the telephone handset is on its rest and the line condition is normal, point A (Fig. 1) is at earth potential, and both transistors are switched off. When the transfer key is operated the 33,000-ohm resistor is connected across the line, causing the potential at point A to drop to -0.4 volts. This enables transistor VT1 to conduct and relay TF to operate. When the handset is lifted, point A drops to a potential of between 5 and 10 volts, depending on the length of the line, both transistors conduct, and transistor VT2 short-circuits the relay, preventing its operation even though transistor VT1 is also conducting. By this means the operation of the transfer relay is prevented when the handset is lifted.

SINGLE-LINE TRANSFER CIRCUIT

A circuit, using the principle described above, to enable the calls normally received on one line to be transferred to another line on the same exchange is shown in Fig. 2. This circuit can be used at those exchanges where the busy condition on the subscriber's line circuit is indicated by an earth on the P-wire (i.e. director and non-director exchanges and U.A.X.s No. 14). The basic circuit is such that relay TF is held operated when the 33,000-ohm resistor is across the line, and connects the transferring subscriber's final-selector multiple outlets to the receiving line. If the transferring subscriber originates a call while his line is transferred, the operation of relay K will disconnect the base current from transistor VT1 and stop the current flow through the 4,000-ohm coil of relay TF, which will be held over its own contact and the centre coil by the earth from the P-wire of the line circuit. Whenever relay K operates (for either an incoming or an outgoing call) the basic transfer circuit is disconnected and the state of transfer obtaining at the beginning of the call continues until the call is cleared down.

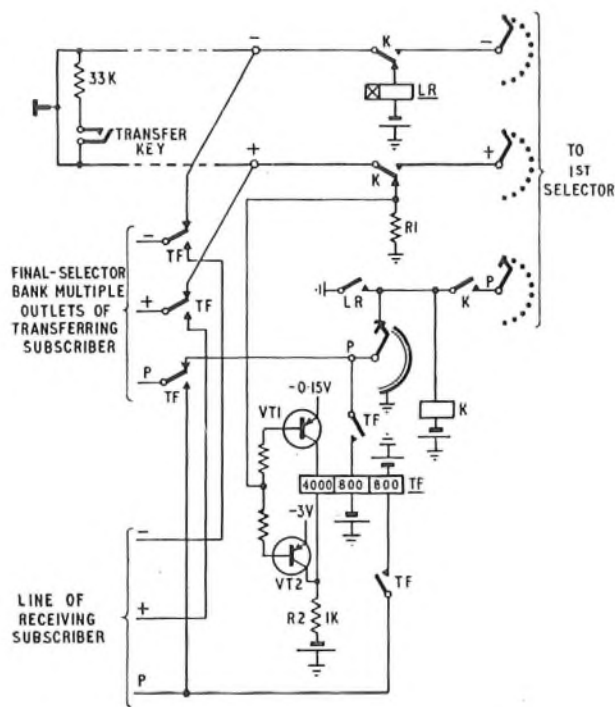

FIG. 2—SINGLE-LINE TRANSFER CIRCUIT

It is necessary to prevent restoration of the transferred line while an incoming call is being taken by the receiving subscriber over the transfer circuit. This is achieved by connecting a third coil of relay TF to the P-wire of the receiving subscriber's line via a TF contact. Although this also prevents the restoration of TF relay when any call is in progress on the receiving subscriber's line (whether through the transfer circuit or not) this is considered less of a drawback than allowing a call in progress to be diverted to the original line.

Restoration of Line Limits

The addition of the 330-ohm resistor, R1, in the subscriber's line circuit reduces the current through relay LR, so that there is a danger of its non-operation on lines approaching 1,000 ohms loop resistance. In order to restore the current flowing through relay LR to its original value, additional current from the -3-volt source is switched to the negative line via resistor R3 by transistor VT3 (Fig. 3). Because the emitter is connected to the -3-volt supply, the transistor will only be switched on when the current flow through resistor R1 is

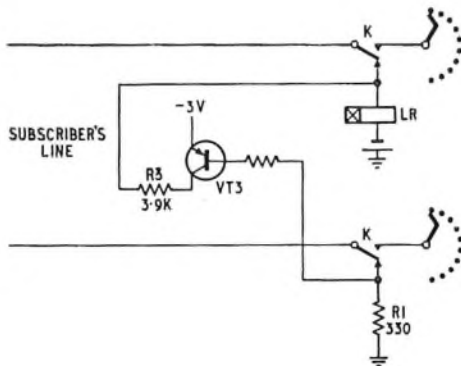

FIG. 3—CIRCUIT FOR RESTORING CURRENT THROUGH RELAY LR TO ITS ORIGINAL VALUE

caused by a looped line; a transfer signal or the operation of relay K will cause the transistor to be switched off. as its base will then be connected to earth through resistor R1.

Transfer Circuits for Use in U.A.X.s

A feature of the majority of U.A.X.s is that the busy condition of the line circuit is given by a disconnection of the P-wire instead of by the earth potential used in other types of exchange. A different circuit is therefore required to hold the TF relay operated for transfer circuits used at these exchanges; such a circuit is shown in Fig. 4. The operate coil is energized in the manner

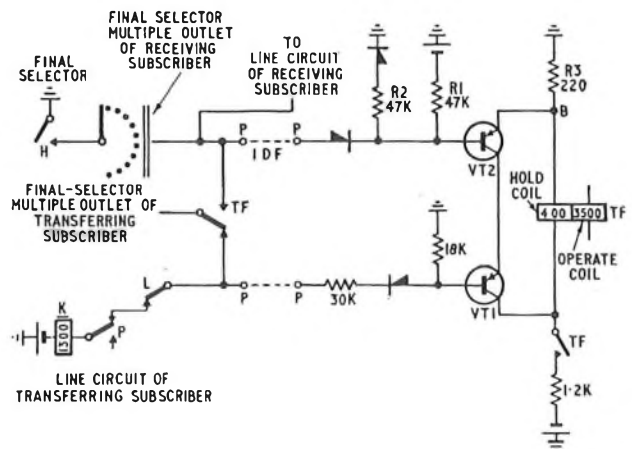

FIG. 4—CIRCUIT USED AT U.A.X.s FOR HOLDING TRANSFER RELAY OPERATED

already described, the relay then operates, and a TF contact completes the hold-coil circuit. When both the transferring and receiving lines are free, transistors VT1 and VT2 will be conducting and will short-circuit the hold coil, so that the relay will release if the transfer condition is removed.

If the transferring subscriber makes an outgoing call, the operation of relay L in the line circuit removes the negative potential from the base of transistor VT1, which ceases to conduct. Relay TF is then held operated by current flowing in its hold coil during the call.

If an incoming call is made to the receiving subscriber when TF relay is operated, the earth connected to the P-wire by either final selector will short-circuit the negative potential applied via resistor R1, and transistor VT2 will cease to conduct. Relay TF will then be held independently of the release of the transfer key until the call has cleared. However, relay TF will still be held operated if the incoming call is from the receiving subscriber's own final-selector number, but this disadvantage cannot be avoided.

The potential at point B is at about -5 volts when relay TF is operated and at about -6.5 volts when relay TF is short-circuited by the transistors. These potentials ensure that the earth potentials applied to the bases of transistors VT1 and VT2 securely switch off these transistors. The current flowing in resistor R1 is arranged to keep transistor VT2 conducting when the P-wires are disconnected.

TEN-LINE GROUP-TRANSFER SCHEME

The 10-line group-transfer scheme gives a fully flexible arrangement allowing any one subscriber in a group to transfer incoming calls to any other subscriber

in the group who is not already transferred. Fig. 5 shows the principle of the scheme, which is suitable for

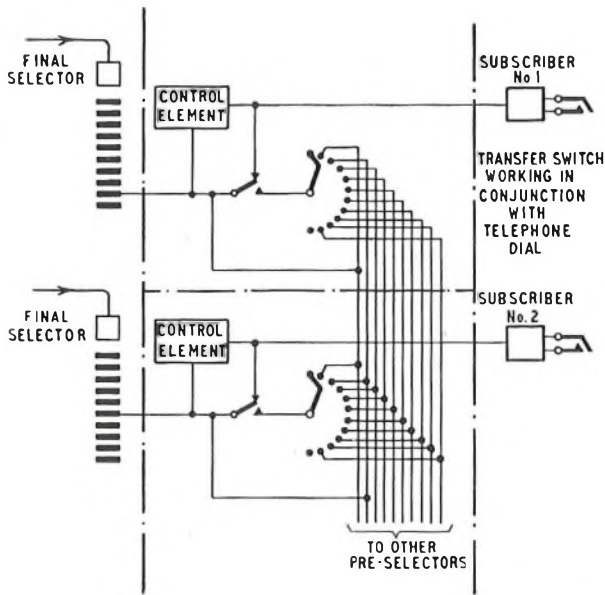

FIG. 5—PRINCIPLE OF 10-LINE TRANSFER SCHEME

preselecting the destination of incoming calls only. Full outgoing service is maintained during transfer. Alternatively, transfer may be made to manual-board circuits or to subscribers who themselves are not provided with transfer facilities.

The switching equipment is seized in the manner described for the single-line circuit, except that a high-speed relay (Fig. 6) is used in the collector circuit of the

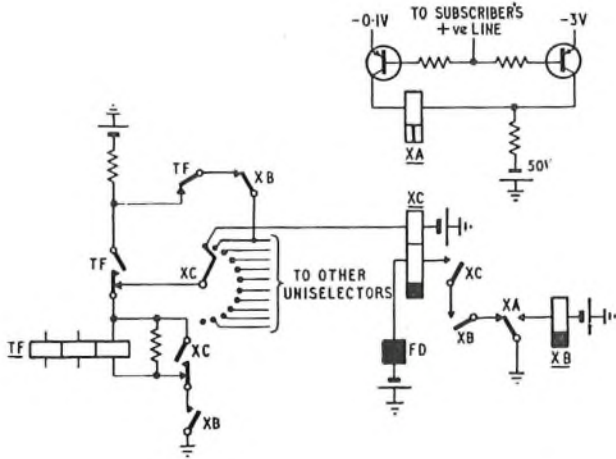

FIG. 6—PULSING AND TESTING CIRCUIT ELEMENT

detector transistor. The transfer is effected by the subscriber operating the transfer key and dialling, with the handset on its rest, any digit from 1 to 0. The negative potentials developed across the 330-ohm resistor in Fig. 7 control the collector current in the transistor element (Fig. 6) and, therefore, the high-speed relay XA. Relays XB and XC control the pulsing of the FD uniselector magnet and, consequently, the movement of the wipers around the uniselector bank. Switching is

only permitted if the receiving circuit is not already transferred, and therefore, at the end of the selecting-digit pulse-train, the TF relay (Fig. 6) is operated by the potential normally present on the appropriate contact of the XC uniselector arc (Fig. 6). If the line is already transferred, or if the position on the uniselector bank is spare, this potential is not present. Other coils of relay TF (Fig. 7) provide holding facilities during outgoing calls and for incoming calls to the receiving line.

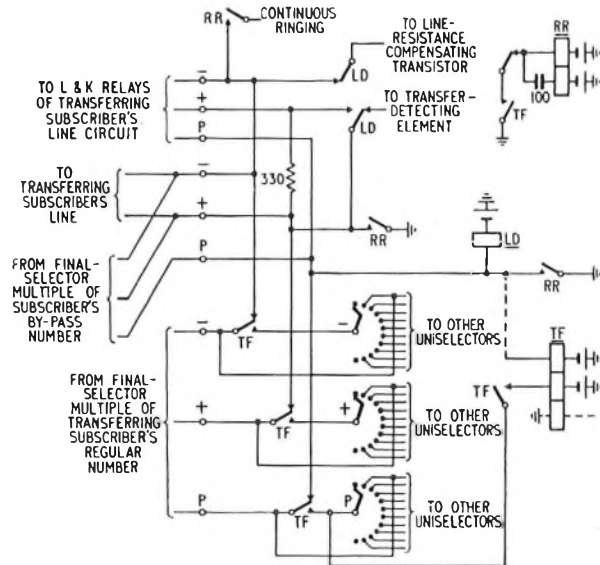

FIG. 7—TEN-LINE SWITCHING CIRCUIT ELEMENT

In view of the fact that transfer is prevented if the subscriber who is to receive the calls is already transferred or if a spare line has been dialled, an audible signal is given to the transferring subscriber when a successful transfer has been made. It is arranged, by means of timed relay RR (Fig. 7), that continuous ringing is applied to the transferring subscriber's line for approximately two seconds.

Full jumpering flexibility is given by relay LD (Fig. 7), which switches the transistor elements in and out of circuit. This method avoids a permanent interconnexion between the transfer switching equipment and a particular subscriber's line circuit.

DISTANT-EXCHANGE TRANSFER

The main problem associated with extending a call to another exchange is one of a possible degrading of the transmission standard. It is therefore proposed that the distant-exchange-transfer scheme should be limited in two ways:

- (i) the two exchanges concerned must have direct junctions between them, and
- (ii) the transferring subscriber's incoming traffic must be predominantly of local origin.

These two limitations are normally acceptable to members of the medical profession, who are the principal users of the transfer service.

The principle of a proposed scheme is shown in Fig. 8. A normal late-choice traffic junction is used, if free, for extending the call, a busy signal being given to a calling subscriber if the junction or the receiving subscriber is engaged.

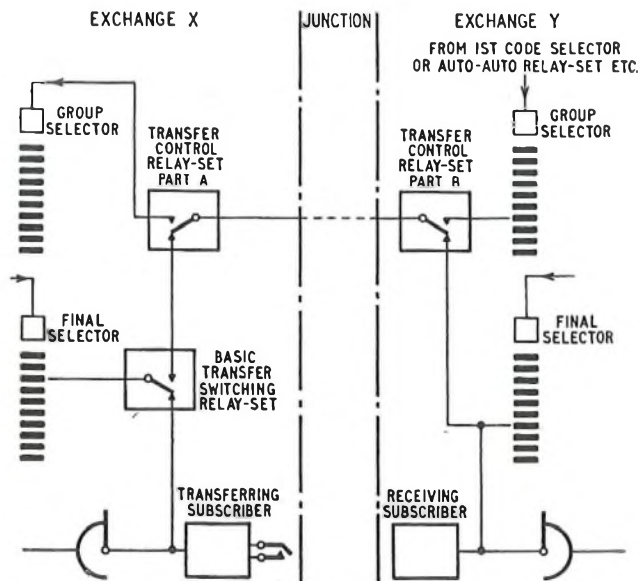

FIG. 8—PRINCIPLE OF PROPOSED DISTANT-EXCHANGE TRANSFER SCHEME

The schematic diagram, Fig. 9, shows the signalling, junction-switching and receiving-subscriber's ringing elements. Relays BG and LS are normally operated over the junction in series with the SEE and I relays at the B end. Relay BG controls the busy conditions on the incoming P-wire under both receiving-subscriber-engaged and junction-engaged conditions. Relay LG, operating to earth on the receiving subscriber's P-wire, releases relay BG, which also releases when the junction-switching relays operate. Initial junction switching is carried out on seizure of the junction by the operation of

relay LD. Battery and earth potentials from relays I and SEE are therefore disconnected, and relays BG and LS at the outgoing end release. Relay LS operates relay TFR for a timed period. The junction is extended through to the selector, and earth on the selector P-wire holds relay TFR and, therefore, maintains the junction switched through.

The SE relay, under normal conditions, in conjunction with the -50-volt potential connected to the TF relay hold coil in the basic transfer circuit, provides a free condition on the final-selector-multiple P-wire. When a call is to be transferred relay SE is operated by the switching relay in the final selector. At the A end, current is fed to the positive wire of the junction via a low resistance instead of a high resistance so that relay SEE at the B end is operated. This relay connects ringing current to the receiving subscriber's line and earths the P-wire in the final-selector multiple. Ringing tone is meanwhile returned from the final selector to the calling subscriber. The character of the ringing at the B end can be altered to give the receiving subscriber an audible indication that the particular call is one that has been transferred. The ringing is tripped in the standard manner and -50 volts and earth are connected to the receiving subscriber's line via relay D. Relay D changes the resistance connected via the I relay to the negative wire of the junction from a high to a low value, causing relay RW to operate. This relay loops the negative and positive wires from the transfer relay-set and trips the ringing current in the final selector. A transmission path is established and relay D therefore controls relay RW for any further supervisory signals.

When two subscribers have mutual transfer facilities at the same exchange, a signal is arranged to be transmitted between the transfer circuits in order to prevent one transfer circuit from functioning when calls to the other subscriber are already being transferred. This aspect of the transfer circuit is described more fully later.

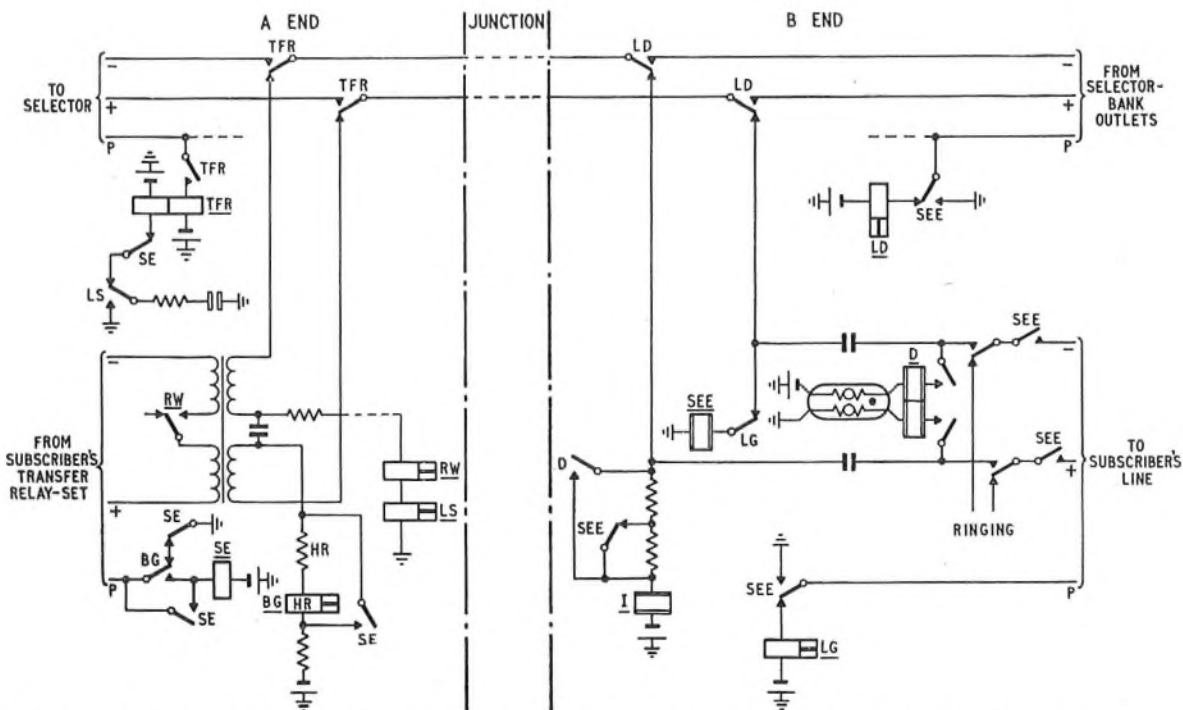

FIG. 9—SIGNALLING, JUNCTION-SWITCHING AND RECEIVING SUBSCRIBER'S RINGING ELEMENTS OF DISTANT-EXCHANGE TRANSFER CIRCUIT

If two subscribers connected to adjacent exchanges have mutual transfer facilities, then it is also necessary that transfer of one circuit should be prevented when the other is transferred. Figure 10 shows a possible method of achieving this using the junction signals that are

OTHER APPLICATIONS OF TRANSFER CIRCUIT

Interconnexion of Two or More Subscribers

It is inherent in the single-line transfer circuits that two subscribers can have mutual transfer facilities and that three or more subscribers can be formed into a transfer ring. The transfer ring may be used if the business of the subscribers concerned allows this more rigid type of transfer. Assuming that three subscribers, A, B and C, are connected together in cyclic order, then subscriber A can transfer to B and B can transfer to C. If B is transferred to C and then A transfers, it would mean that A is transferring to C. C can transfer to A and if B transfers then calls to C will go to A. It is desirable that transfer should be prevented when one of a pair of subscribers is already transferred or, in the transfer ring system, when one of the main subscribers is transferred.

The transfer relay, when operated, extends earth potential as an inhibit signal that can be cross-connected to another transfer circuit. This earth is used to shunt the transistor switching potential on the positive wire of the subscriber's line, thereby preventing the other transfer relay from operating.

The subscriber who is receiving calls can, if desired, preset his transfer circuit to cause calls to be transferred back to the other subscriber, and transfer will automatically take place when this subscriber restores his transfer switch. The removal of the inhibit signal allows the high-resistance loop to become effective.

Night Busing and Night Interception

Two night-service facilities used by private branch exchange (P.B.X.) subscribers can be improved by the use of the basic transfer circuit. The night busing facility provides a means of busing all of a P.B.X. group of lines except the first (or perhaps the first two). The lines that are not bused are connected through the switchboard to the night-service extensions. A similar service is provided in which some lines are transferred to the public-exchange manual board and the remainder of the P.B.X. group is bused. The present method of operating the busing relays is by remote control from the manual board in the same manner as for operator-controlled subscriber's transfer.

By the use of the transfer circuit connected to one line of the P.B.X. group these services can be brought into use under direct control of the subscriber. The basic transistor circuit and TF relay are connected to a late-choice line of the P.B.X. group and the contacts of the TF relay are arranged to operate the transfer and busing relays.

CONCLUSION

The development of the subscriber-controlled transfer equipment (and of the subscriber-controlled night-service equipment) was made possible by the use of transistors. The development is an example of the advantages that can be obtained by the use of semiconductor devices in conjunction with orthodox switching circuits.

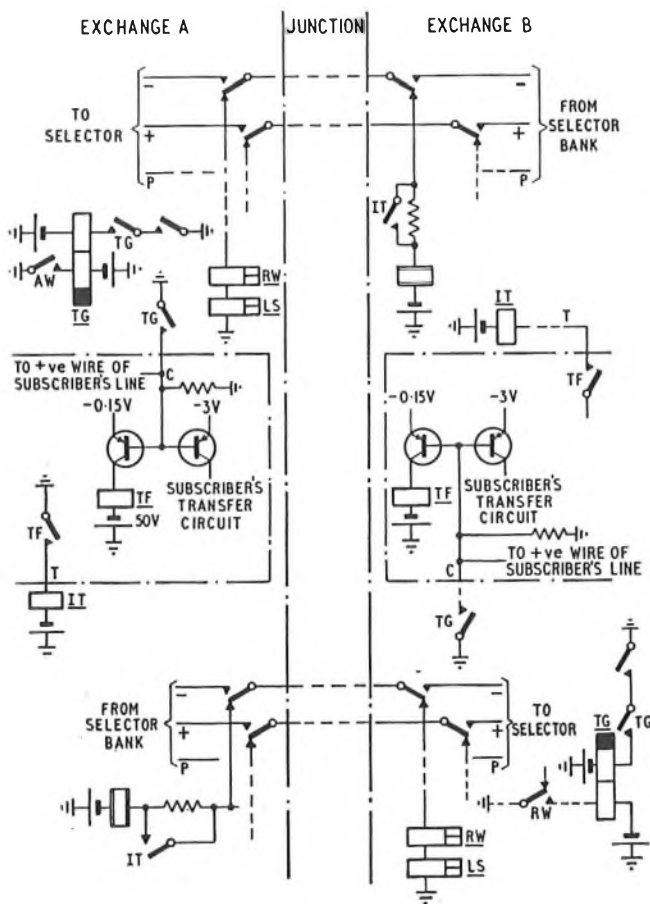

FIG. 10—DISTANT-EXCHANGE MUTUAL TRANSFER INHIBIT CIRCUIT ELEMENT

available. It is arranged that a signal is transmitted back to the transfer switching circuit over the junction not being used, to inhibit the other subscriber's transfer circuit. If the subscriber on exchange A transfers, then the IT relay is operated by the TF relay. Relay IT operates relay RW in the exchange B relay-set by altering the value of the resistance connecting -50 volts to the negative wire. Relay RW in turn operates relay TG, which shunts the exchange B subscriber's transfer circuit. Likewise, the subscriber on exchange B can control the transfer circuit at exchange A. Guard conditions are maintained if the junctions subsequently become engaged.

Notes and Comments

Board of Editors

Mr. E. Davis has resigned from the post of Managing Editor of the Journal and the Council of the Institution has appointed Mr. A. G. Leighton, formerly Deputy Managing Editor, to take his place. Mr. J. Martin, formerly an Assistant Editor, has been appointed Deputy Managing Editor, and the new Assistant Editor is Mr. J. Povey. The Board of Editors takes this opportunity to record its appreciation of the services rendered to the Journal by Mrs. Davis during his ten-year association with the Board, first as a Council nominee, then as Assistant Editor and later as Managing Editor.

Journal Binding

This issue completes Vol. 55 and readers wishing to have the volume bound should refer to page 291 for details.

Supplement and Model Answers Books

Students studying for City and Guilds of London Institute examinations in telecommunications are reminded that the Supplement to the Journal includes model answers to examinations set in all the subjects of the Telecommunication Technicians' Course. Back numbers of the Journal are available in limited quantities only and students are urged to place a regular order for the Journal to ensure that they keep informed of current developments in telecommunications and receive all copies of the Supplement.

Books of model answers are available for some telecommunication subjects and details of these are given at the end of each supplement. These books include a new edition of the model answer book for Elementary Telecommunication Practice.

Institution of Post Office Electrical Engineers

Annual Awards for Associate Section Papers—Session 1961-62

The Judging Committee having adjudicated on the papers submitted by the Local Centre Committees, prizes and Institution Certificates have been awarded to the following in respect of the papers named:

First Prize of £7 7s.

J. McCall, Technical Officer, Aberdeen Centre—"The Television Network Switching Centre."

Prizes of £4 4s. each

C. H. Collins and H. R. Merry, Technical Officers, Reading Centre—"External Planning Group."

K. W. Guy, Technical Officer, Stoke-on-Trent Centre—"Interference Investigations."

J. W. Rowson, Technician I, Colchester Centre—"700 Type Installations."

J. Davidson, Technical Officer, Aberdeen Centre—"An Introduction to the Slide Rule."

In addition, the following papers which were considered worthy of submission to the Judging Committee for the main awards, have been awarded a prize of one guinea each:

L. S. Hurst, Technical Officer, Tunbridge Wells Centre—"Older than the Hills."

J. W. Mitchell, Technician IIA, Tunbridge Wells Centre—"Introduction to the Mark that Man has Left."

The Council of the Institution is indebted to Messrs. R. J. Hines, R. McWhirter and W. E. Adams for kindly undertaking the adjudication of the papers submitted for consideration, and to Mr. R. J. Hines, Chairman of the Judging Committee, for the following report:

Awards in any competition involving original work are inevitably dependent upon the element of luck. The Judging Committee are well aware that another body might have decided differently, for much will depend upon the relative values attached to the readability, relevance, originality, lucidity and so on. Mr. Rowson's paper on 700-type installations certainly won commendation for the fact that it should have stimulated a lively discussion and prompted thought about what is involved in familiarizing staff with new types of apparatus. This paper also possessed the inherent advantage that its subject was one about which everybody has need to know something. Similarly, Messrs.

Collins and Merry in describing the work of an external-planning group have a subject that is of common concern to a large percentage of their potential audience.

The value of a paper to those attending its presentation is considerably enhanced by well-prepared illustrations and demonstrations. In this respect too the paper on the 700-type telephone scores as well as Mr. Davidson's paper on the slide-rule. The latter paper particularly impressed the Judging Committee with the professional competence of the written format.

Although the typescript of a paper gives little indication of the author's capacity to engage the interest of his audience, the Committee gathered the impression that Mr. Guy must have given an entertaining account of the radio-interference investigator's job and they admired the lucidity of his simple explanations of basic technical facts.

Mr. McCall's paper on the television network was really two papers in one in that it covered the whole conception of the switching network as well as describing what is involved in monitoring the quality of the transmitted pictures. This could make somewhat heavy going in one evening but was probably more fully packed than any other paper with useful information not readily available elsewhere.

Two other papers by Messrs. Hurst and Mitchell of Tunbridge Wells under the general title of "The Earth and Its Secrets" broke new ground and must have contributed to a widening of the interest of their hearers.

Allocation of awards between such a diversity of papers was no easy task, but accepting as their criterion the permanent value to the audience of the information conveyed, the Committee recommend as stated.

S. WELCH,
General Secretary.

A new edition of the Library Catalogue will be available shortly. Members should make application to their Honorary Local Secretaries if they require a personal copy, and Associate Section members may obtain copies at a nominal price of 6d. from their Association Section Honorary Local Secretaries.

W. D. FLORENCE,
Librarian.

Regional Notes

Northern Ireland

MEDICAL COLOUR-TELEVISION OUTSIDE BROADCAST

In connexion with the 130th Annual British Medical Association meeting, a request was received for the provision of a vision circuit between the Royal Victoria Hospital, Belfast, and the Methodist College, Belfast. These two sites are approximately 1 mile apart and the circuit was required to enable such subjects as respiratory disability to be presented, with the aid of the facilities available at the local hospital, to members of the British Medical Association who were at the Methodist College.

Consideration was given to providing the circuits by means of either a cable circuit with the appropriate video repeaters or a microwave link. After the relative merits had been considered, the facility was provided using a portable television microwave link. The link provided for the simultaneous transmission of frequency-modulated television and high-quality audio signals in the 6,000-7,000 Mc/s band. The transmitter power output was 1 watt and the manufacturer claimed a range of up to 50 miles under normal conditions. The equipment had a r.f. head associated with the zinc-coated fibre glass parabolic aerial, which was mounted on a tripod fitted with a "pan and tilt" head. It is important with microwave links for most of the first Fresnel zone to be clear of all obstruction. The selection of suitable sites in this instance was difficult, particularly around the Methodist College, and the problem was finally resolved by the provision of additional strengthening on an existing flat roof.

The link was continuously in use each day for a week and proved to be consistently stable and fault-free.

The co-operation and assistance of the Engineering Department and the Television Outside-Broadcast Group of the North Western Region was invaluable. The results suggest that greater use can be made of this type of equipment for the provision of temporary television circuits.

H.G. and W.D.

North Western Region

ALTRINCHAM AUTOMATIC TELEPHONE EXCHANGE

Several new features are incorporated in the equipment provided at Altrincham exchange in the Manchester director area, which was opened on 3 October 1962.

This is the first new director exchange in the Region where the unit principle of equipment layout is employed. This enables better use to be made of the available space, and facilitates subsequent replacement of the equipment in the same accommodation at the end of its useful life. The initial accommodation provides for a 6,900-line subscribers' multiple in two units: the first is a complete unit with a 4,000-line multiple and the second is an incomplete unit with a 2,900-line multiple.

The new designs of main and intermediate distribution frames, which provide additional circuit capacity and take up less floor-space, are employed.

Extensive use is made of the new cable clips developed by the contractors (Ericsson Telephones Ltd.) and economies in cabling costs have thereby been achieved.

An all-cream decor has been provided. Frames, overhead ironwork, plastic cable, switch covers are all finished in a cream colour, which helps to create a clean appearance and should facilitate the maintenance of the equipment.

A maintenance control has been provided in a separate enclosure and the suite of test desks are in the new light-oak finish. To reduce the noise level in the test rooms, the outgoing-junction routiner has been provided in the main apparatus room with a duplicate display panel in the test room.

Two new trunking features have been incorporated in the design:

(i) Level 100 directors have been provided for additional service codes; and

(ii) alternative 1st and 2nd choice outlets for S.T.D. and emergency calls have been provided, to minimize the effect of faults in periods of light traffic.

The telephone-exchange building at Altrincham was one of the first projects of the Joint Post Office and Ministry of Public Buildings and Works, Research and Development Group and the original estimated cost of £48,000 for a conventional design was reduced to an actual cost of £23,000. An external view of the exchange building is shown in the photograph.

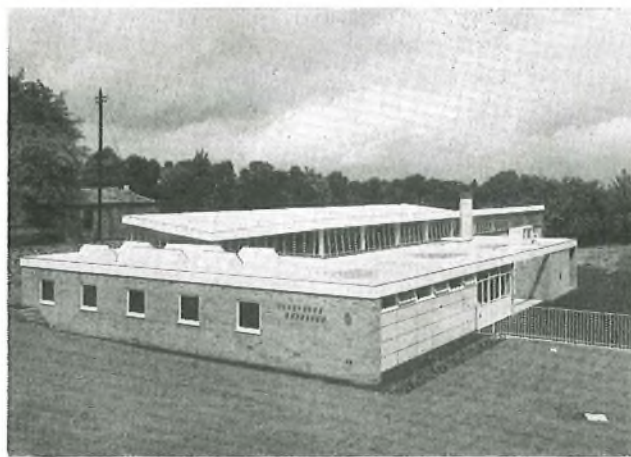

THE TELEPHONE-EXCHANGE BUILDING AT ALTRINCHAM

The design of the equipment made it possible to use a smaller building than had been thought necessary and unusual features of the design of the building made further substantial savings. Elimination of the basement cable chamber saved the expensive excavation work and associated waterproofing problems. The external cables enter just above ground level and are carried on bearers on the wall of the apparatus room where they are enclosed by removable panels.

The needs of heating and ventilating are combined in an oil-fired system, which circulates either warmed or unheated, filtered air through surface ducts.

Floor areas required for future extension of the M.D.F., equipment, and maintenance control are enclosed with light removable partitions and provide the Assistant Engineer's office, normal stock and workroom, construction and contractor's rooms. These will be moved when a building extension becomes necessary.

The final result of careful planning gives 98.8 per cent of the total area as working space and only 1.2 per cent circulation space.

There are a number of interesting features in the structural design. The apparatus room has a light steel frame of uncased stanchions at 12 ft 8 in. centres along the side walls and 25 ft 4 in. down the centre. These support a system of rolled-steel joints carrying both the roof, of timber joists and woodwool slabs, and the ceiling of plasterboard backed with aluminium foil. A glass-fibre mat is draped over the joists and the external bituminous roofing felt has a finish of white spar chippings.

The flush ceiling slopes upwards from the centre line of the building to the walls which have continuous high-level

windows on all sides, ensuring the best natural lighting conditions between the racks. A number of windows at the usual height prevent any "shut in" effect.

Although the majority of the external walls are of cavity brickwork, the end wall of the apparatus room has an asbestos sandwich cladding which allows a future extension to be made without incurring the risk of dust, from demolition, affecting the working equipment.

R.V.A. and G.J.S.

North Eastern Region INTRODUCTION OF S.T.D. IN LEEDS

Subscriber trunk dialling (S.T.D.) facilities were introduced simultaneously at the following exchanges in the Leeds area at 12.45 p.m. on 5 October 1962. The opening ceremony was performed by Miss Mervyn Pike, M.P., Assistant Postmaster General, who made the inaugural call to Sir Keith Joseph, Member of Parliament for Leeds N.E., and Minister of Housing, Local Government and Welsh Affairs, in his Whitehall office.

| Exchange | Equipped Multiple | Working | | Type of Exchange |
|--------------------------------|-------------------|------------|----------|---|
| | | Connexions | Stations | |
| Leeds linked-numbering scheme: | | | | |
| Central | 17,600 | 13,443 | 34,952 | 2,000-type |
| Armley | 4,000 | 2,897 | 4,346 | |
| Chapelton .. | 6,600 | 3,664 | 5,496 | Group-selector satellite 2,000-type |
| Moortown .. | 7,600 | 6,144 | 8,601 | |
| Adel | 5,700 | 4,447 | 6,226 | Group-selector satellite 2,000-type and pre-2,000-type |
| Crossgates .. | 5,900 | 4,165 | 5,415 | |
| Headingley .. | 8,600 | 6,714 | 8,728 | |
| Oakwood .. | 4,500 | 3,319 | 4,315 | |
| Roundhay .. | 4,500 | 3,445 | 4,479 | Discriminator satellite 2,000-type and pre-2,000-type |
| Pudsey | 6,500 | 4,823 | 6,752 | Discriminator remote non-director 2,000-type and pre-2,000-type |
| Horsforth .. | 3,100 | 2,249 | 3,149 | Remote non-director 2,000-type and pre-2,000-type |
| Rawdon | 2,200 | 1,598 | 2,237 | Remote non-director 4,00J-type |
| Totals | 76,800 | 56,908 | 94,696 | |

This operation was another landmark in the progress of automatic telephony in Leeds, where the first automatic exchange with Keith line switches saw service from 1918-46. Indeed, of the twelve exchanges given S.T.D., all except Rawdon formed, with Hunslet, the old Leeds multi-office area. In the past few years they have been converted from early-type Strowger equipment to 2,000-type, though some early equipment remains. Unfortunately Hunslet, a discriminating satellite repeater pre-2,000-type satellite exchange could not be given S.T.D. at present due to accommodation difficulties but the omission will be made good in 18 months time.

The code "0" was replaced by "100" in October 1961 as a first stage in the introduction of S.T.D. though subscribers connected to Central exchange continued to use level 94 for trunk traffic. The second stage, in March 1962, was concerned with the segregation of home and adjacent charging-group exchanges on to levels 8 and 9, respectively, but this segregation could not be made absolute due to the need for economy in equipment required for this extensive rearrangement. Three major routes, to Bradford, Harrogate, and Wakefield, remained on level 8 but these were cleared and level 94 was closed at the opening of S.T.D.

To handle the increasing trunk traffic, there has been a large increase in outlets from the trunk selectors involving a considerable amount of regrading work. On 5 October auto-manual routes were converted to auto-auto working, and certain exchanges were reparented—hardly a straightforward operation since there are three auto-manual switchboards serving the exchanges concerned.

Whilst the opening of an automatic exchange is a parochial affair whose success or failure depends on local effort, the ramifications of S.T.D. are nation-wide. The Leeds

Telephone Area staff acknowledge that the undoubted success of the operation rests on the fine work done by colleagues in other Areas, as well as their own contribution. E.H.

PITCH-FIBRE DUCT AT SHEFFIELD

The construction of the underground plant required to link the new telephone exchange at Sheffield Central to the existing network has been completed recently by contract. This involved the construction of five non-standard man-holes and the laying of 133 yd of 60-way pitch-fibre ducts. In addition two 60-way and one 36-way lead-ins were provided into the new cable chamber.

Due to the design of the new exchange the cable chamber was constructed entirely below ground level on a site falling roughly from north to south and it was anticipated that this would present problems during excavation work as the finished floor level was below the known water level. During the excavation for the foundation work of the north-south wing of the exchange building, a coal seam and an old mine working in which there was a fair flow of water was exposed. Pumping by the building contractor had no apparent effect on the level of this water and so a caisson was constructed around this wing. This solved the problem for the builder, but as the proposed new duct line was outside the steel piling there was the possibility that the duct contractor would encounter the same problems once he excavated below the water level. The problem, however, did not arise during the excavation of the new duct line as the coal seam was exposed unworked, and below this the ground was stable, comprising mainly clay and soft virgin rock.

Due to the fall of the site from north to south, manhole A shown on the sketch, was the lowest point on the new

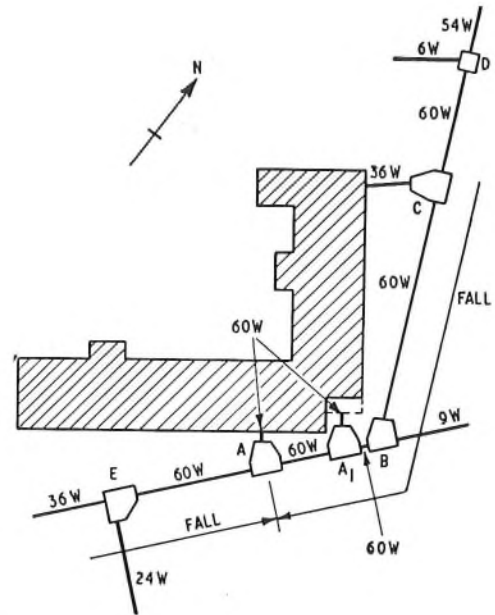

PLAN OF THE DUCT-WAYS, MANHOLES, AND EXCHANGE LEAD-IN AT SHEFFIELD CENTRAL

duct line, with its floor approximately 8 ft below the known water level and also below the nearest main sewer. A 4 in. earthenware drain was laid, therefore, beneath the new 60-way duct line, draining manhole C to manhole B, manhole B to manhole A1, manhole A1 to manhole A, and the existing manhole E back to manhole A. Arrangements were made to empty manhole A by means of an automatic pump, which is fitted in the cable chamber and is operated by the water level in the float chamber in manhole A, the water being pumped into the main sewer.

The new duct work is isolated from the existing network by duct seals fitted at manholes D and E on the 60-way duct

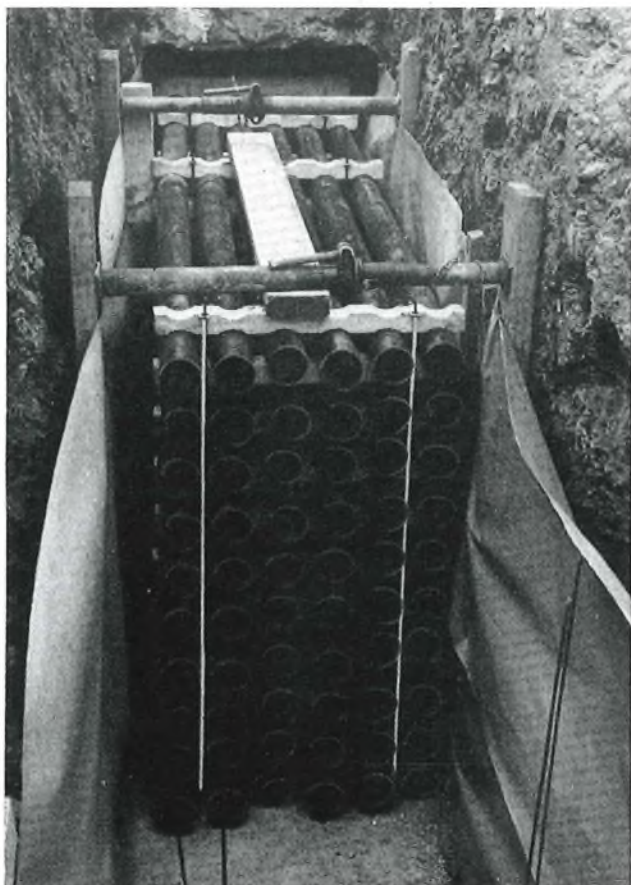

NEST OF PITCH-FIBRE DUCTS BEFORE PLACING THE CONCRETE

and on a 9-way multiple duct which leads into manhole B.

The pitch-fibre ducts were assembled to form a nest using prefabricated concrete spacers held rigidly together by vertical tie bars which were secured by clamping plates with spire nuts at the top as shown in the photograph. The 60-way nest formation was 10 ducts high and 6 ducts wide.

The pipe nests were laid on a 6 in. ready-mixed quality "F" concrete base built up in sections approximately 5 ft long. When several of these 5 ft sections had been completed, concreting was commenced. This again was done in units of 5 ft long, the nest being supported by the concrete spacers and pieces of timber placed at each side between the nest and the trench side.

Ready-mixed concrete, quality "F", was used throughout the work, this being poured down either side of the nest and vibrated inwards using a 2 in. poker. Simultaneously, tamping was carried out between each vertical bank of pipes, to ensure adequate consolidation of the concrete. It was found that the 60-way duct nest, which measured 5 ft by 3 ft, took approximately 1 yd³ of concrete per yard run.

The exchange lead-ins were lead into "windows" incorporating p.v.c. water barriers left in the walls of the new building after consultation with the Ministry of Public Building and Works. During the construction of these it was necessary to have holes cut through the caisson to accommodate the duct nest. Prefabricated angle-iron frames, which held the duct-seal bolts, were cast in the windows by the building contractor for the exchange lead-ins, and by the duct contractor for the manholes where duct seals were to be fitted. These provided a first-class fixture for temporarily securing the wooden templates used to seal the ends of the 60-way and 30-way duct nests during construction.

The non-standard manholes are designed to cater for future cabling operations, giving what should be a very good layout. The manholes are of considerable size having a cubic content of 3,090 ft³ and a floor area of approximately 210 ft².

F.N.

Associate Section Notes

Bletchley Centre

In July a small party visited Messrs. Waterlow & Son at Dunstable. Many interesting products of the printing trade were seen. Members were astounded to see Christmas cards and 1963 calendars, and even holiday brochures for next spring, in full production in the middle of the summer season. The party were then shown one of the latest printing machines which printed on both sides of the paper, dried the paper in a naked flame, refrigerated it, cut the paper, stapled the page and packed the product ready for distribution straight off the machine. This machine, designed by a German engineer, was built in America and shipped across to this country where it took three weeks to assemble ready for the production line. The high-class reproduction of pictures was also viewed with interest.

A midweek visit was paid to the meteorological office at Bracknell in August. The tour commenced in the teleprinter room, where meteorological data is sent to and received from centres all over the world for 24 hours a day throughout the year. Members were mystified by the form of the data until it was explained that the figures were an international language for instrument and optical observations of the weather. The forecasting room was inspected and charts which were to be used for the B.B.C. forecast were seen in course of preparation before being

transmitted to the B.B.C. in London. The Post Office equipment and the computer were also seen before the end of a very enjoyable visit.

Our winter program started in September with a talk on "Fire Prevention in Industry", by Station Officer E. Wright of the Buckinghamshire fire service. He illustrated his talk with an American film on fire prevention and also displayed many large photographs of fire-damaged buildings. He explained the problems that the Factories Acts gave not only to the architect but to the fire-prevention officer of the local fire service. Other items such as automatic fire alarms, providing means of escape from buildings, the storage and treatment of inflammable materials and the problems of fire prevention with these materials were also covered with great interest.

A conference of Associate-Section Centres in the Home Counties Region was held to discuss methods of improving the activities of the Centres, after which a social evening was attended by the delegates. Opportunity was also taken to present Mr. A. H. C. Knox with an illuminated scroll on behalf of the Associate Section membership in appreciation of his activities during his office as President of the Associate Section. The presentation was followed by the showing of 8 mm cine film taken by members on a visit to Holland early this year.

We now have a membership of 98, and would like to see this increased to 100. The committee hopes that by the time of the next report our target will have been reached.

A.J.H.

Reading Centre

The Reading Centre opened its 1962-63 session with a paper on "The Work of The Thames Conservancy", by Mr. Alan Compton, the administration officer of the conservancy. Mr. Compton illustrated his talk with over 90 coloured slides and we recommend this subject to other centres in the Thames water catchment area.

Our Chairman, Mr. D. P. Ridge, left the Area during September for an appointment in East Africa. We were sorry to see such a keen member go, but we wish him success in his new station. His departure meant a rearrangement of the committee and with the new arrangement Mr. D. Gascoine has become Chairman and Mr. P. Curwen the Vice-Chairman.

The secretary and the treasurer attended the recent conference at Bletchley Park. This event we found to be a valuable function in many ways, not the least in that it enabled an exchange of ideas with other Centres. Thank you too, Bletchley Centre, for your excellent hospitality.

H.R.M.

Salisbury Centre

Since the end of April, when the annual general meeting was held, the Centre has been hard at work trying to increase membership. At the close of the last session we had 12 members all of whom were serving as officers or on the committee. In the few short months since April we have increased to 53 and at the time of writing we are still accepting new members.

At the end of July we were invited to Central Telephone Exchange at Southampton by Mr. Vernon and Mr. Compton where the new S.T.D. equipment was demonstrated. Thirty members travelled by road to Southampton and had a highly instructive evening. The Salisbury Centre are hoping that in the near future our colleagues in the Southampton Area will be reforming their own Associate Section Centre to add strength to the South West Regional representation.

A month later the Centre members joined Senior Section members and the Salisbury operating staff on a visit to Bournemouth Airport (Hurn), a municipal airport at Christchurch, Hampshire. We were able to see ferry aircraft loading cars and freight, the fire section, the flying control and, as dusk fell, the airport landing-lighting system.

In mid-September Mr. C. W. Read, Assistant Engineer at Regional Headquarters, Bristol, gave his prize-winning paper "Transistors" to an audience of 40 members. Our Senior Section colleagues once again joined over 70 per cent of the Centre membership to hear a most interesting lecture.

Looking towards the new year we hope to have a visit from a senior member of the Engineering Department's space communications team and it has been arranged that in February 1963 the Centre will visit Southampton to see H.M.T.S. *Monarch* loading cable.

We would like to wish Mr. J. G. Garland, the Centre secretary good luck in his new career in outside industry and thank him for his loyal work over the past years helping to reform the Salisbury Centre.

R.H.

Bristol Centre

The Bristol Centre which opened in April of this year has progressed to a membership of 131. We feel that although this seems to be good progress in a few months, many of those hundreds who are employed in the Area are still unaware of our existence or of the aims and objects of an Associate Section Centre. Please ask your supervising officer about the Centre—the Committee and members will do the rest and make you welcome at our meetings, visits and social events.

On 26 July a very interesting trip was made to the St. Hillary transmitter of I.T.A. and was followed by a well conducted tour of the T.W.W. studios in Cardiff. After sitting under the lights in the announcer's chair in front of the camera, we do not think that any of our members will reach fame as television stars!

On 12 October we had the pleasure of being shown round Hinkley Point atomic power station. The station is not yet completed but we were very interested by this great peaceful use of atomic energy.

A film show planned for 31 October included in the program the only amateur film of the Goonhilly space-communications satellite ground station.

During the rest of this session we hope to have a paper by a representative of Mullard, Ltd. a "quiz" with a nearby Centre, a couple of evening visits and some other entertaining papers.

H.F.N.P.

Bournemouth Centre

The Centre's congratulations go to Mr. P. M. Keefe on his promotion to Assistant Engineer. Mr. Keefe has been our very popular and able secretary since November 1952, and thanks to his efforts the work of the incoming secretary, Mr. A. E. A. Barwell, has been made easier.

This quarter's program included the following items:

25 July: A visit to Vickers-Armstrongs Airworks, Hurn.

22 August: A visit to Poole Gas works.

26 September: A well-received lecture on "Space Travel," by Mr. T. A. P. Colledge, member of the Inter-Planetary Society.

A.E.A.B.

Middlesbrough Centre

The 1962 annual general meeting was held on 3 April and the following officers were elected: *Chairman*: Mr. D. A. Pratt; *Secretary*: Mr. N. Williams; *Treasurer*: Mr. K. Ashworth; *Committee*: Messrs. M. A. Landers, B. Clare, and E. E. Sparkes.

The program for the 1962-63 session was then compiled as follows:

16 October: "A Guide to Television Repairs," by Mr. D. A. Pratt.

6 November: "The Anglo-Swedish Submarine Cable System," by Mr. N. Williams.

December: Visit to I.C.I. Billingham.

January: Film Show.

5 February: "Earth's Natural Satellite," by Mr. C. Cox.

March: Visit—details later.

9 April: Annual general meeting.

N.W.

Aberdeen Centre

The 1962-63 session opened with a film show of several technical subjects. The "Query Corner" at which members' technical questions were answered was also instituted. Other meetings held were as follows: "Motor Cycles Through the Years," by Mr. A. Davidson, Regional Headquarters; "The Saturable Reactor Leading to The Magnetic Amplifier," by Mr. James Davidson; "Developments in Subscribers' Apparatus," by Mr. W. A. Saint. Further meetings this session will include "An Introduction to Computer Programming," by Mr. G. D. Adams, and "T.R.S. Developments," by Mr. A. M. Duff.

We hope to have a trip to the Forth road bridge in March and a 30th Anniversary dinner in April.

D.W.

Dundee Centre

On 3 April the annual general meeting was held and the Committee for the 1962-63 session was elected as follows: *Chairman*: Mr. R. L. Topping; *Vice-Chairman*: Mr. D. L. Miller; *Secretary*: Mr. R. T. Lumsden; *Treasurer*: Mr. R. B. Duncan; *Committee*: Messrs. R. J. Hendry, G. Deuchars, R. C. Smith, D. Cook, B. D. Mackie and J. Glendinning.

(Continued on page 291)

Staff Changes

Promotions

| Name | Region, etc. | Date | Name | Region, etc. | Date |
|--|------------------------------------|---------|---|-------------------------|---------|
| <i>Senior Executive Engineer to Assistant Staff Engineer</i> | | | <i>Assistant Engineer (Limited Competition)—continued</i> | | |
| Bray, P. R. | E.-in-C.O. | 1.1.62 | Wing, R. T. E. | H.C. Reg. to E.-in-C.O. | 14.5.62 |
| Hall, A. W. | N.W. Reg. to E.-in-C.O. | 1.1.62 | Jackson, E. | N.W. Reg. | 14.5.62 |
| <i>Area Engineer to Regional Engineer</i> | | | Moore, R. F. | S.W. Reg. to E.-in-C.O. | 14.5.62 |
| Surman, W. L. | Mid. Reg. | 1.1.62 | Millington, D. | Mid. Reg. to E.-in-C.O. | 14.5.62 |
| <i>Power Engineer to Regional Engineer</i> | | | Smith, T. M. | N.E. Reg. | 14.5.62 |
| Moxon, T. | Scot. to H.C. Reg. | 1.8.62 | Golding, E. C. | L.T. Reg. to E.-in-C.O. | 14.5.62 |
| <i>Area Engineer to Telephone Manager</i> | | | Pearson, L. H. | W.B.C. to E.-in-C.O. | 14.5.62 |
| Neate, A. D. | H.C. Reg. | 8.7.62 | Osborne, J. D. W. | S.W. Reg. to E.-in-C.O. | 14.5.62 |
| <i>Area Engineer to Deputy Telephone Manager</i> | | | Adams, J. | E.T.E. to E.-in-C.O. | 14.5.62 |
| Bavin, A. E. | L.T. Reg. | 3.9.62 | Booth, J. | N.E. Reg. to E.-in-C.O. | 14.5.62 |
| <i>Executive Engineer to Area Engineer</i> | | | Dickson, J. M. | E.-in-C.O. | 14.5.62 |
| Berresford, B. H. | Mid. Reg. | 2.7.62 | Swain, R. S. | E.-in-C.O. | 14.5.62 |
| Herbert, L. J. | L.T. Reg. | 27.8.62 | Hibbard, V. L. J. | L.T. Reg. | 28.5.62 |
| Marsh, S. T. | Scot. | 27.8.62 | Golding, J. E. | E.-in-C.O. | 14.5.62 |
| <i>Executive Engineer to Senior Executive Engineer</i> | | | Lund, A. E. | H.C. Reg. to E.-in-C.O. | 28.5.62 |
| Colyer, J. O. | L.T. Reg. to E.-in-C.O. | 4.7.62 | Plant, K. T. | Mid. Reg. to E.-in-C.O. | 28.5.62 |
| Latimer, E. D. | E.-in-C.O. | 9.7.62 | Lambert, R. S. | H.C. Reg. to E.-in-C.O. | 28.5.62 |
| Thomson, D. | E.-in-C.O. | 9.7.62 | Grimsdale, A. W. | H.C. Reg. to E.-in-C.O. | 28.5.62 |
| Lee, F. J. | E.-in-C.O. | 9.7.62 | Davies, A. J. | W.B.C. | 28.5.62 |
| Jeynes, E. | E.-in-C.O. | 20.7.62 | Reid, J. | N.E. Reg. | 28.5.62 |
| Dadswell, J. E. | Scot. | 23.7.62 | Spanton, J. C. | Mid. Reg. to E.-in-C.O. | 14.5.62 |
| Holmes, D. | N.E. Reg. to Mid. Reg. | 30.7.62 | Wiggins, J. F. | E.T.E. to E.-in-C.O. | 28.5.62 |
| Lillie, S. | H.C. Reg. to E.-in-C.O. | 10.9.62 | Keech, D. E. | H.C. Reg. | 28.5.62 |
| Hogg, T. E. | E.-in-C.O. | 10.9.62 | Doughty, J. E. | E.-in-C.O. | 28.5.62 |
| Harbord, C. | W.B.C. to Scot. | 24.9.62 | Harrison, W. | N.W. Reg. in E.-in-C.O. | 18.6.62 |
| <i>Executive Engineer (Open Competition)</i> | | | Baird, G. B. | Scot. | 28.5.62 |
| Hogg, D. M. | E.-in-C.O. | 16.5.62 | Southall, R. A. | N.W. Reg. to E.-in-C.O. | 28.5.62 |
| Moore, I. G. | E.-in-C.O. | 19.6.62 | Tyers, P. J. | Mid. Reg. | 28.5.62 |
| Rogers, J. D. | E.-in-C.O. | 13.8.62 | Lloyd, W. J. | N.W. Reg. to E.-in-C.O. | 18.6.62 |
| Smith, L. J. | H.C. Reg. | 10.9.62 | Crossley, M. D. | E.-in-C.O. | 18.6.62 |
| Wilson, A. | E.-in-C.O. | 10.9.62 | Pickford, H. D. | N.W. Reg. to E.-in-C.O. | 18.6.62 |
| Ninnim, N. J. H. | E.-in-C.O. | 13.9.62 | Petrie, M. G. | E.-in-C.O. | 18.6.62 |
| Fincham, P. C. | E.-in-C.O. | 15.9.62 | Cadman, J. L. | E.-in-C.O. | 18.6.62 |
| Knight, A. V. | E.-in-C.O. | 19.9.62 | Fletcher, J. H. | E.-in-C.O. | 14.5.62 |
| Bennett, L. A. M. | E.-in-C.O. | 24.9.62 | Hall, G. C. | E.-in-C.O. | 18.6.62 |
| <i>Assistant Engineer to Executive Engineer</i> | | | Day, J. C. | H.C. Reg. | 18.6.62 |
| Sawyers, L. F. | H.C. Reg. | 9.7.62 | Gripton, E. W. | E.-in-C.O. | 18.6.62 |
| Yeates, H. W. | Mid. Reg. | 9.7.62 | Fairbrother, A. T. | N.W. Reg. to E.-in-C.O. | 18.6.62 |
| Cook, D. T. | H.C. Reg. | 23.7.62 | Cowie, W. J. | Scot. | 18.6.62 |
| Gawley, W. J. | N.I. | 9.7.62 | Peacock, R. D. | H.C. Reg. to E.-in-C.O. | 18.6.62 |
| Willoughby, S. J. | E.-in-C.O. to Factories Department | 20.8.62 | Laishley, F. O. | S.W. Reg. | 18.6.62 |
| Lawless, E. R. | E.-in-C.O. | 10.8.62 | Weller, J. A. H. | L.T. Reg. to E.-in-C.O. | 18.6.62 |
| Hetherington, T. | E.-in-C.O. | 10.8.62 | Moss, P. R. | E.-in-C.O. | 18.6.62 |
| Randall, J. J. | E.-in-C.O. | 10.8.62 | Bailey, G. R. | N.W. Reg. to E.-in-C.O. | 18.6.62 |
| Flack, M. | E.-in-C.O. | 10.8.62 | Teesdale, R. J. | W.B.C. to E.-in-C.O. | 28.5.62 |
| Veale, L. | E.T.E. | 10.8.62 | <i>Inspector to Assistant Engineer</i> | | |
| McCann, D. P. | Scot. | 13.8.62 | Davey, F. N. | S.W. Reg. | 2.7.62 |
| McFarlane, H. A. | Scot. | 9.8.62 | Hall, A. | N.W. Reg. | 30.7.62 |
| Seneviratne, C. L. | N.E. Reg. | 31.8.62 | Borrows, S. D. | N.W. Reg. | 30.7.62 |
| Broomfield, C. T. | E.-in-C.O. | 31.8.62 | Smith, W. H. F. | E.T.E. | 2.7.62 |
| Telfer, J. R. | E.-in-C.O. | 3.9.62 | Hall, S. J. | W.B.C. | 15.8.62 |
| Bradley, D. | N.E. Reg. | 3.9.62 | Hart, R. E. | S.W. Reg. | 10.8.62 |
| Higson, R. P. | N.W. Reg. to S.W. Reg. | 10.9.62 | Lukeman, S. R. | S.W. Reg. | 27.8.62 |
| Edmondson, J. S. | N.E. Reg. | 12.9.62 | Milkins, A. E. | L.T. Reg. | 18.9.62 |
| <i>Assistant Engineer (Limited Competition)</i> | | | <i>Technical Officer to Assistant Engineer</i> | | |
| Streete, M. A. | H.C. Reg. to E.-in-C.O. | 18.6.62 | Culshaw, H. | N.W. Reg. | 2.7.62 |
| McKinney, W. J. M. | N.I. | 14.5.62 | Wiffen, D. C. | H.C. Reg. | 20.7.62 |
| Orbell, A. G. | H.C. Reg. to E.-in-C.O. | 14.5.62 | Taylor, J. | N.E. Reg. | 11.7.62 |
| Driver, J. B. | E.-in-C.O. | 14.5.62 | Preston, W. R. | S.W. Reg. | 6.7.62 |
| Ball, J. R. | Mid. Reg. to E.-in-C.O. | 14.5.62 | Keefe, P. M. | S.W. Reg. | 6.7.62 |
| Hampson, M.E. | H.C. Reg. to E.-in-C.O. | 14.5.62 | Tovey, N. C. | S.W. Reg. | 6.7.62 |
| | | | Appleton, R. C. | S.W. Reg. | 13.7.62 |
| | | | Wilde, F. J. | N.W. Reg. | 30.7.62 |
| | | | Blackburn, E. | N.W. Reg. | 30.7.62 |
| | | | Pudney, N. A. | H.C. Reg. | 3.8.62 |
| | | | Smith, D. W. | N.W. Reg. | 21.8.62 |
| | | | Kaye, R. | N.E. Reg. | 7.8.62 |
| | | | Clark, N. D. | N.W. Reg. | 17.8.62 |
| | | | Swarbrick, R. G. | N.W. Reg. | 13.8.62 |
| | | | Peebles, P. J. | Scot. | 24.7.62 |
| | | | Baker, F. C. G. | Scot. | 27.8.62 |

Promotions—continued

| Name | Region, etc. | Date | Name | Region, etc. | Date |
|--|--------------------|----------|--|---|---------|
| <i>Technical Officer to Assistant Engineer—continued</i> | | | <i>Technical Officer to Inspector—continued</i> | | |
| Carty, E. | Scot. | 24.7.62 | Francis, R. J. | L.T. Reg. | 18.9.62 |
| Burbidge, A. E. | S.W. Reg. | 24.8.62 | Smoker, B. W. | L.T. Reg. | 18.9.62 |
| Gardener, W. O. | S.W. Reg. | 16.8.62 | Moyce, W. J. | L.T. Reg. | 18.9.62 |
| Davis, A. F. | Mid. Reg. | 27.8.62 | <i>Technician I to Inspector</i> | | |
| Slight, E. H. | W.B.C. | 15.8.62 | Bain, R. P. B. | Scot. | 2.7.62 |
| Turner, N. E. | N.W. Reg. | 28.12.61 | Parsons, J. H. | S.W. Reg. | 7.8.62 |
| Hall, S. F. | H.C. Reg. | 12.9.62 | Forte, A. | N.E. Reg. | 7.8.62 |
| Caldwell, A. M. | Scot. | 13.9.62 | Boyle, J. | S.W. Reg. | 8.8.62 |
| Page, E. A. W. | Scot. | 17.9.62 | Dewsbury, D. T. W. | Mid. Reg. | 27.8.62 |
| McDougall, A. | Scot. | 13.9.62 | Perry, J. F. | Mid. Reg. | 27.8.62 |
| Boultonwood, H. C. | E.-in-C.O. | 3.9.62 | Johnson, L. W. | N.W. Reg. | 21.8.62 |
| Forrester, E. | N.W. Reg. | 3.9.62 | Gent, G. T. | N.W. Reg. | 21.8.62 |
| Warr, R. G. | L.T. Reg. | 18.9.62 | Hendy, R. W. | N.E. Reg. | 3.9.62 |
| Warren, H. W. | L.T. Reg. | 18.9.62 | Keers, T. | N.I. | 27.8.62 |
| Keyte, A. R. | L.T. Reg. | 18.9.62 | <i>Senior Scientific Officer to Principal Scientific Officer</i> | | |
| Phillips, G. H. | L.T. Reg. | 18.9.62 | Lawson, R. W. | E.-in-C.O. | 30.7.62 |
| Palmer, E. | L.T. Reg. | 18.9.62 | Daglish, H. N. | E.-in-C.O. | 14.8.62 |
| Goodfellow, J. H. | L.T. Reg. | 18.9.62 | <i>Scientific Officer (Open Competition)</i> | | |
| White, C. A. C. | L.T. Reg. | 18.9.62 | White, N. | E.-in-C.O. | 28.6.62 |
| Clasper, J. D. | L.T. Reg. | 18.9.62 | <i>Assistant Experimental Officer (Open Competition)</i> | | |
| Graves, D. O. | L.T. Reg. | 18.9.62 | Eccleston, M. D. | E.-in-C.O. | 30.8.62 |
| Small, R. V. | L.T. Reg. | 18.9.62 | Cameron, J. C. | E.-in-C.O. | 14.9.62 |
| Bottrill, R. | L.T. Reg. | 18.9.62 | <i>Assistant (Scientific) (Open Competition)</i> | | |
| Gibbs, B. | L.T. Reg. | 18.9.62 | Wells, B. C. | E.-in-C.O. | 5.7.62 |
| Sully, G. | L.T. Reg. | 18.9.62 | Rowe, P. C. | E.-in-C.O. | 9.8.62 |
| Morris, L. K. R. | L.T. Reg. | 18.9.62 | Woods, B. J. | E.-in-C.O. | 14.8.62 |
| Walden, W. | L.T. Reg. | 18.9.62 | Cowdry, R. W. | E.-in-C.O. | 28.8.62 |
| Page, J. P. | L.T. Reg. | 18.9.62 | Stamps, H. M. (Miss) | E.-in-C.O. | 11.9.62 |
| Grubb, F. G. | L.T. Reg. | 18.9.62 | Lazell, M. R. | E.-in-C.O. | 13.9.62 |
| Bunn, T. A. F. | L.T. Reg. | 18.9.62 | Sundaran, N. S. K. | E.-in-C.O. | 25.9.62 |
| Dunham, F. | L.T. Reg. | 18.9.62 | <i>Technical Assistant I to Assistant Regional Motor Transport Officer</i> | | |
| Spencer, J. S. | L.T. Reg. | 18.9.62 | Shipway, A. R. | H.C. Reg. to S.W. Reg. | 1.8.62 |
| Snell, G. W. | L.T. Reg. | 18.9.62 | <i>Technical Assistant II to Technical Assistant I</i> | | |
| Chalkley, E. E. | L.T. Reg. | 24.9.62 | Hare, L. V. | H.C. Reg. | 3.9.62 |
| Smart, R. H. | L.T. Reg. | 18.9.62 | <i>Draughtsman to Leading Draughtsman</i> | | |
| Whitney, D. J. | L.T. Reg. | 18.9.62 | Goose, T. R. | N.E. Reg. to E.-in-C.O. | 30.7.62 |
| Rylance, T. E. | L.T. Reg. | 18.9.62 | Johnson, F. C. | N.E. Reg. to E.-in-C.O. | 16.7.62 |
| Bellenger, J. S. | L.T. Reg. | 18.9.62 | Llewellyn, G. L. | W.B.C. to H.C. Reg. | 24.9.62 |
| Toose, M. C. | L.T. Reg. | 18.9.62 | <i>Higher Executive Officer to Senior Executive Officer</i> | | |
| Eade, D. J. | L.T. Reg. | 18.9.62 | Parry, T. R. | E.-in-C.O. | 13.8.62 |
| Hastings, P. | L.T. Reg. | 18.9.62 | <i>Executive Officer to Higher Executive Officer</i> | | |
| King, G. N. | L.T. Reg. | 18.9.62 | Watkins, E. W. H. | E.-in-C.O. | 17.7.62 |
| Gilliver, R. F. | L.T. Reg. | 18.9.62 | Embleton, A. | E.-in-C.O. to Supplies Department | 7.8.62 |
| Whitehorn, E. S. | L.T. Reg. | 18.9.62 | Pearson, E. J. | E.-in-C.O. | 13.8.62 |
| Taylor, D. G. | L.T. Reg. | 18.9.62 | <i>Clerical Officer to Executive Officer</i> | | |
| MacDonald, G. A. | L.T. Reg. | 24.9.62 | Brook, F. R. | E.-in-C.O. | 17.7.62 |
| Everitt, G. N. | L.T. Reg. | 18.9.62 | Medlen, M. J. | E.-in-C.O. | 8.8.62 |
| Oldham, J. F. | N.W. Reg. | 28.9.62 | <i>Retirements and Resignations</i> | | |
| Brown, A. | N.W. Reg. | 28.9.62 | <i>Area Engineer</i> | | |
| Burn, C. B. | N.E. Reg. | 11.9.62 | Chapman, B. E. J. | L.T. Reg. | 9.6.62 |
| Steen, D. R. | N.E. Reg. | 11.9.62 | Johnson, E. W. | L.T. Reg. | 31.8.62 |
| Bell, R. | N.E. Reg. | 28.9.62 | Young, J. E. | L.T. Reg. | 31.8.62 |
| <i>Draughtsman to Assistant Engineer</i> | | | <i>Executive Engineer</i> | | |
| Ralfe, C. A. | L.T. Reg. | 24.9.62 | Pemberton, W. J. | S.W. Reg. | 30.6.62 |
| <i>Technical Officer to Inspector</i> | | | Collett, W. A. | H.C. Reg. | 8.6.62 |
| Ritchie, H. F. G. | Scot. | 2.7.62 | Shields, A. V. | E.T.E. | 1.7.62 |
| Trimm, W. J. | Mid. Reg. | 31.7.62 | Jarman, R. A. | L.T. Reg. | 31.5.62 |
| Parker, S. J. | H.C. Reg. | 2.8.62 | Partridge, J. G. | E.-in-C.O. | 31.8.62 |
| Pyatt, J. H. | Mid. Reg. | 31.7.62 | <i>(Resigned)</i> | | |
| Billings, S. T. | Mid. Reg. | 31.7.62 | <i>Senior Executive Engineer</i> | | |

Retirements and Resignations—continued

| Name | Region, etc. | Date | Name | Region, etc. | Date | | | |
|-------------------------------------|--------------------|---------|---------------------------------------|-------------------------------------|---------|---------------------------------------|---|---------|
| <i>Executive Engineer—continued</i> | | | <i>Assistant Engineer—continued</i> | | | | | |
| Blower, G. A. | E.-in-C.O. | 11.7.62 | Rutherford, W. R. | L.T. Reg. | 28.9.62 | | | |
| Walker, W. A. | N.E. Reg. | 1.9.62 | Titchett, B. (<i>Resigned</i>) | N.W. Reg. | 1.9.62 | | | |
| Pitloh, T. P. | N.E. Reg. | 16.9.62 | Hibbard, V. L. J. | L.T. Reg. | 14.9.62 | | | |
| Bull, W. H. | H.C. Reg. | 28.9.62 | (<i>Resigned</i>) | | | | | |
| <i>Assistant Engineer</i> | | | <i>Inspector</i> | | | | | |
| Hill, C. M. | E.T.E. | 1.7.62 | Kelsey, S. A. | H.C. Reg. | 30.6.62 | | | |
| Huckfield, F. E. | S.W. Reg. | 6.7.62 | McLeod, J. | Scot. | 1.7.62 | | | |
| Percival, C. C. | S.W. Reg. | 14.7.62 | Kingsbury, L. R. | L.T. Reg. | 1.8.62 | | | |
| Bunn, G. C. | S.W. Reg. | 18.7.62 | Pierson, W. J. | N.I. | 25.8.62 | | | |
| Dixon, E. J. | L.T. Reg. | 18.7.62 | Barker, C. A. | Mid. Reg. | 31.8.62 | | | |
| Windsor, H. C. C. | L.T. Reg. | 22.7.62 | Nash, H. W. G. | L.T. Reg. | 31.8.62 | | | |
| Leonard, J. | N.W. Reg. | 22.7.62 | Simpson, J. A. | N.E. Reg. | 31.8.62 | | | |
| Batch, H. R. | H.C. Reg. | 31.7.62 | Vokes, S. A. | S.W. Reg. | 22.8.62 | | | |
| Jeffery, E. G. | E.-in-C.O. | 31.7.62 | Hughes, J. W. | N.W. Reg. | 10.9.62 | | | |
| Wright, F. H. | L.T. Reg. | 3.8.62 | MacKinnon, A. | Scot. | 14.9.62 | | | |
| Coe, H. S. C. | L.T. Reg. | 9.8.62 | Payne, F. | H.C. Reg. | 15.9.62 | | | |
| Haworth, J. | N.W. Reg. | 11.8.62 | Tovey, E. F. | W.B.C. | 21.9.62 | | | |
| Hutchinson, A. J. | Mid. Reg. | 14.8.62 | <i>Assistant Experimental Officer</i> | | | | | |
| Stephens, A. W. | S.W. Reg. | 15.8.62 | Banks, P. H. T. | E.-in-C.O. | 30.6.62 | | | |
| Garner, J. E. | N.W. Reg. | 16.8.62 | (<i>Resigned</i>) | | | | | |
| Hartley, A. A. | L.T. Reg. | 17.8.62 | Haggett, M. E. | E.-in-C.O. | 30.9.62 | | | |
| Suggitt, W. | N.E. Reg. | 26.8.62 | (<i>Resigned</i>) | | | | | |
| Cooper, N. A. | Scot. | 28.8.62 | <i>Assistant (Scientific)</i> | | | | | |
| Nimmo, M. | Scot. | 31.8.62 | Stone, D. J. (<i>Resigned</i>) | E.-in-C.O. | 31.8.62 | | | |
| Bath, R. J. | H.C. Reg. | 31.8.62 | <i>Technical Assistant I</i> | | | | | |
| Mullett, J. G. (<i>Resigned</i>) | H.C. Reg. | 17.8.62 | Brown, J. | E.-in-C.O. | 14.7.62 | | | |
| Goy, D. S. (<i>Resigned</i>) | N.E. Reg. | 31.8.62 | <i>Leading Draughtsman</i> | | | | | |
| Smale, P. H. (<i>Resigned</i>) | E.-in-C.O. | 31.8.62 | Brown, J. | N.E. Reg. | 17.8.62 | | | |
| Spilsbury, J. R. | E.-in-C.O. | 31.8.62 | <i>Senior Executive Officer</i> | | | | | |
| (<i>Resigned</i>) | | | Ford, A. W. | E.-in-C.O. | 21.7.62 | | | |
| Trott, A. | L.T. Reg. | 2.9.62 | <i>Higher Executive Officer</i> | | | | | |
| Hardy, G. A. E. | N.E. Reg. | 6.9.62 | Sims, E. K. (Mrs.) | E.-in-C.O. | 16.7.62 | | | |
| Shorey, A. C. | L.T. Reg. | 7.9.62 | Collett, L. C. | E.-in-C.O. | 31.8.62 | | | |
| Potts, J. R. | Scot. | 9.9.62 | Ellis, J. F. | E.-in-C.O. | 14.9.62 | | | |
| Gibbs, W. F. | Scot. | 10.9.62 | <hr/> | | | | | |
| Holder, T. | Mid. Reg. | 17.9.62 | Transfers | | | | | |
| Smethurst, J. | H.C. Reg. | 18.9.62 | <i>Area Engineer</i> | | | <i>Assistant Engineer—continued</i> | | |
| Jamieson, D. | N.E. Reg. | 18.9.62 | Horne, F. A. | Scot. to Ghana | 19.7.62 | Marshall, N. E. | Scot. to Foreign Office | 12.8.62 |
| Haines, J. P. | Scot. | 19.9.62 | <i>Senior Executive Engineer</i> | | | Barnett, N. V. | Nigeria to E.-in-C.O. | 20.8.62 |
| McGregor, J. P. | Scot. | 22.9.62 | Irwin, A. | E.-in-C.O. to Nigeria | 6.7.62 | Ashworth, C. | N.W. Reg. to War Office | 6.9.62 |
| Rowell, P. C. | H.C. Reg. | 28.9.62 | Kent, S. T. E. | E.-in-C.O. to H.C. Reg. | 16.7.62 | Marshall, N. E. | Foreign Office to Scot. | 20.9.62 |
| | | | Balchin, D. B. | I.T.U. to E.-in-C.O. | 27.8.62 | <i>Senior Scientific Officer</i> | | |
| | | | Mason, H. J. S. | E.-in-C.O. to L.T. Reg. | 3.9.62 | Hale, H. S. | E.-in-C.O. to Admiralty | 31.7.62 |
| | | | Carden, R. W. G. | Pakistan to L.T. Reg. | 13.9.62 | <i>Assistant Experimental Officer</i> | | |
| | | | <i>Executive Engineer</i> | | | Jefford, J. G. | E.-in-C.O. to Admiralty | 23.9.62 |
| | | | Burling, K. G. | E.-in-C.O. to H.C. Reg. | 2.7.62 | <i>Leading Draughtsman</i> | | |
| | | | Drinkwater, R. W. | E.-in-C.O. to War Office | 2.7.62 | Carter, N. | N.W. Reg. to W.B.C. | 14.7.62 |
| | | | Officer, J. E. | E.-in-C.O. to Mid. Reg. | 3.9.62 | Hargrove, K. L. | L.P. Reg. to E.-in-C.O. | 16.7.62 |
| | | | Bartlett, G. A. | E.-in-C.O. to Admiralty | 1.9.62 | <i>Executive Officer</i> | | |
| | | | Blackburn, J. A. | E.-in-C.O. to L.P. Reg. | 3.9.62 | Crook, J. | E.-in-C.O. to Ministry of Education | 16.7.62 |
| | | | Barnett, W. J. G. | E.-in-C.O. to Scot. | 10.9.62 | Hobbs, D. W. | E.-in-C.O. to Ministry of Health | 16.7.62 |
| | | | White, P. S. | E.-in-C.O. to L.T. Reg. | 24.9.62 | Robinson, E. M. | E.-in-C.O. to Approved Employment | 6.8.62 |
| | | | <i>Assistant Engineer</i> | | | Perry, J. | London Reg. to E.-in-C.O. | 7.8.62 |
| | | | Gee, J. A. | Nigeria to E.-in-C.O. | 2.7.62 | Watson, E. M. (Mrs.) | E.-in-C.O. to London Reg. | 9.8.62 |
| | | | Barnes, H. E. | E.-in-C.O. to East Africa | 4.7.62 | Jones, G. A. C. | E.-in-C.O. to Ministry of Education | 20.8.62 |
| | | | Gregson, G. S. | E.-in-C.O. to H.C. Reg. | 9.7.62 | | | |
| | | | Holmes, A. D. | E.-in-C.O. to East Africa | 20.7.62 | | | |
| | | | Dixon, F. W. | E.-in-C.O. to N.E. Reg. | 30.7.62 | | | |
| | | | Russell, R. H. | E.-in-C.O. to L.T. Reg. | 1.8.62 | | | |
| | | | Livermore, R. W. D. | E.-in-C.O. to Australia | 2.8.62 | | | |

The Post Office Electrical Engineers' Journal

Volume 55, April 1962—January 1963

INDEX

| | PAGE NO. | | PAGE NO. |
|---|-------------------|--|-------------|
| A | | | |
| A.C. No. 9, Signalling System | 51 | | |
| Accounting, Engineering Aspects of Depreciation | 113 | | |
| Aerials for Communication with Artificial Earth Satellites, Large Steerable Microwave | 152 | | |
| ALLERY, G. D. The Post Office Engineering Department's Computer | 199 | | |
| ANDREWS, J. D., and BELCHER, P. L. Time-Shared Code Translators for Letter-Sorting Equipment | 173 | | |
| Announcements, Recording and Control of Information-Service | 158 | | |
| ARMAN, L. T., and PECK, E. J. M. Monitoring Station for Mobile-Radio Services | 228 | | |
| ARMAN, L. T., and PECK, E. J. M. Narrower-Frequency-Band Channels for V.H.F. Land Mobile-Radio Services | 192 | | |
| Associate Section Notes | 65, 138, 212, 283 | | |
| Audio-Frequency Transmission Measuring Set Using Transistors, An | 19 | | |
| Automatic Error-Correction Equipment Used on H.F. Radio Telegraph Services, Improvements in | 253 | | |
| B | | | |
| BALCOMBE, F. G., and KNEE, H. Museum Radio Tower | 73 | | |
| BELCHER, P. L., and ANDREWS, J. D. Time-Shared Code Translators for Letter-Sorting Equipment | 173 | | |
| BLAKEY, H., and MISSEN, L. A. Photographing Subscribers' Meters | 162 | | |
| Boocock, R. O. (Promotion to Staff Engineer) | 61 | | |
| BRAY, W. J. Satellite Communication Systems | 97 | | |
| BRAY, W. J., and TAYLOR, F. J. D. Preliminary Results of the Project TELSTAR Communication Satellite Demonstrations and Tests: 10-27 July, 1962 | 147 | | |
| British Computer Society's Third Conference, Cardiff, September, 1962, The (S) | 252 | | |
| BROADHURST, S. W. The Highgate Wood Electronic Telephone Exchange | 265 | | |
| BURLING, K. G., and FENNING, J. C. A New Detection System for Television and V.H.F. Radio Receivers | 219 | | |
| C | | | |
| C.C.I.R. Study Group IV—Space Systems and Radio Astronomy, Washington, D.C., March 1962, The Interim Meeting of (S) | 96 | | |
| Cable-Fault Locator for Submarine Cables, A | 8 | | |
| Cable System, SCOTICE—The United Kingdom to Iceland | 38 | | |
| Cables, A Cable-Fault Locator for Submarine | 8 | | |
| Cables, Coaxial Line Equipment for Small-Diameter | 44 | | |
| Cables, Pressurization of Telecommunication (Part 1) | 260 | | |
| Capacitors and Their Reliability, Electrolytic | 115 | | |
| Circuits for Commercial Renters, Long-Distance Private Telephone | 187 | | |
| CLARKSTONE, K. H. A Miniature Lever Key of Improved Design | 29 | | |
| Coaxial Line Equipment for Small-Diameter Cables | 44 | | |
| Communication Satellite Demonstrations and Tests: 10-27 July 1962, Preliminary Results of the Project TELSTAR | 147 | | |
| Communication Systems, Satellite | 97 | | |
| Communication with Artificial Earth Satellites, Large Steerable Microwave Aerials for | 152 | | |
| Communications, Satellite (S) | 145 | | |
| Compandor Using Junction Transistors, A Speech | 14 | | |
| Computer Society's Third Conference, Cardiff, September, 1962, The British (S) | 252 | | |
| Computer, The Post Office Engineering Department's | 199 | | |
| Computers, On Programming | 125 | | |
| Concentrator for a Telegraph Tape-Relay Network, A | 250 | | |
| C (continued) | | | |
| Conference, Cardiff, September 1962, The British Computer Society's Third (S) | 252 | | |
| Connexions, Telephone Equipment | 166 | | |
| Continental Telephone Services, Integration of the International and | 22 | | |
| Cooling System for High-Power Radio Transmitters | 40 | | |
| CORKE, R. L. An International Experiment in Frequency Comparison | 80 | | |
| Counter, Voltage Incidence and Duration (S) | 264 | | |
| CRAGGS, J. F., WALTERS, J. R., and KEEP, J. F. Pressurization of Telecommunication Cables (Part 1) | 260 | | |
| CRANK, G. J., and HATHAWAY, H. A. A Cable-Fault Locator for Submarine Cables | 8 | | |
| CROISDALE, A. C. Improvements in Automatic Error-Correction Equipment Used on H.F. Radio Telegraph Services | 253 | | |
| D | | | |
| Depreciation Accounting, Engineering Aspects of | 113 | | |
| Detection System for Television and V.H.F. Radio Receivers, A New | 219 | | |
| Dismantling the Long-Wave Masts at Leaffield Radio Station | 129 | | |
| E | | | |
| EASTERLING, C. E. Improvements in the Teleprinter No. 7 | 240 | | |
| Edwards, S. J. (Promotion to Chief Regional Engineer) | 132 | | |
| Electrolytic Capacitors and Their Reliability | 115 | | |
| Electronic Telegraph Serial-Numbering Transmitter, An | 195 | | |
| Electronic Telephone Exchange, The Highgate Wood | 265 | | |
| ENDERSBY, J. C. and SIXSMITH, J. Coaxial Line Equipment for Small-Diameter Cables | 44 | | |
| Engineering Aspects of Depreciation Accounting | 113 | | |
| Equipment and Testing Facilities at the Experimental Satellite Ground Station, Goonhilly Downs, Cornwall | 105 | | |
| Equipment for the Measurement of Some Characteristics of the Noise in Telephony and Television Channels | 231 | | |
| Error-Correction Equipment Used on H.F. Radio Telegraph Services, Improvements in Automatic | 253 | | |
| F | | | |
| Faraday Lecture 1961-62, The | 1 | | |
| Fault Recorder No. 1B (S) | 185 | | |
| FENNING, J. C., and BURLING, K. G. A New Detection System for Television and V.H.F. Radio Receivers | 219 | | |
| Finish on Apparatus, The Use of Hammer (S) | 43 | | |
| Frequency Comparison, An International Experiment in | 80 | | |
| G | | | |
| GAUT, R. G. Engineering Aspects of Depreciation Accounting | 113 | | |
| Goonhilly Downs, Cornwall, Equipment and Testing Facilities at the Experimental Satellite Ground Station, | 105 | | |
| GORTON, B. D. Local-Call Timing at Non-Director Telephone Exchanges | 83 | | |
| GORTON, B. D., and KEARSLEY-BROWN, R. H. G. Subscriber Trunk Dialling at Non-Director Satellite Telephone Exchanges | 86 | | |
| Group Reference-Pilot Signal, The | 237 | | |
| H | | | |
| H.F. Radio Telegraph Services, Improvements in Automatic Error-Correction Equipment Used on | 253 | | |
| HALLIDAY, C. M., and LIDBETTER, E. J. New Cordless P.M.B.X. Switchboards—P.M.B.X.s No. 2/3A and 2/4A | 244 | | |

| | PAGE NO. |
|---|-------------|
| H (continued) | |
| Hammer Finish on Apparatus, The Use of (S) ... | 43 |
| Harbottle, H. R. (Retirement) ... | 60 |
| HATHAWAY, H. A., and CRANK, G. J. A. Cable-Fault Locator for Submarine Cables ... | 8 |
| Highgate Wood Electronic Telephone Exchange, The ... | 265 |
| HIX, K. W. Telephone Equipment Connexions ... | 166 |
| Holmes, M. F. (Promotion to Senior Principal Scientific Officer) ... | 133 |
| Hudson, W. E. (Retirement) ... | 206 |
| HUGGINS, G., and SMITH, G. L. Recording and Control of Information-Service Announcements ... | 158 |
| I | |
| Iceland Cable System, SCOTICE—The United Kingdom to ... | 38 |
| Improvements in Automatic Error-Correction Equip- ment Used on H.F. Radio Telegraph Services ... | 253 |
| Improvements in Installation Methods for Telephone Exchanges ... | 92 |
| Improvements in the Teleprinter No. 7 ... | 240 |
| Information-Service Announcements, Recording and Control of ... | 158 |
| Installation Methods for Telephone Exchanges, Improve- ments in ... | 92 |
| Institution of Post Office Electrical Engineers 62, 134, 207, ... | 280 |
| Integration of the International and Continental Tele- phone Services ... | 22 |
| Interim Meeting of C.C.I.R. Study Group IV—Space Systems and Radio Astronomy, Washington, D.C., March 1962, The (S) ... | 96 |
| International and Continental Telephone Services, Inte- gration of the ... | 22 |
| International Experiment in Frequency Comparison, An ... | 80 |
| J | |
| Joint Use of Poles for Telecommunication and Power Lines, The ... | 31 |
| K | |
| KEARSLEY-BROWN, R. H. G., and GORTON, B. D. Sub- scriber Trunk Dialling at Non-Director Satellite Telephone Exchanges ... | 86 |
| KEEP, J. F., CRAGGS, J. F., and WALTERS, J. R. Pressuri- zation of Telecommunication Cables (Part I) ... | 260 |
| KELSON, D., and MILES, J. V. Signalling System A.C. No. 9 ... | 51 |
| Key of Improved Design, A Miniature Lever ... | 29 |
| KNEE, H., and BALCOMBE, F. G. Museum Radio Tower Knox, A. H. C. (Promotion to Chief Regional Engineer) ... | 73 |
| L | |
| Large Steerable Microwave Aerials for Communication with Artificial Earth Satellites ... | 152 |
| LAVER, F. J. M. On Programming Computers ... | 125 |
| Leafield Radio Station, Dismantling the Long-Wave Masts at ... | 129 |
| LEE, K. W., and RATCLIFFE, K. S. An Audio-Frequency Transmission Measuring Set Using Transistors ... | 19 |
| Letter-Sorting Equipment, Time-Shared Code Translators for ... | 173 |
| LIDBETTER, E. J., and HALLIDAY, C. M. New Cordless P.M.B.X. Switchboards—P.M.B.X.s No. 2/3A and 2/4A ... | 244 |
| Line-Construction Vehicle, A ... | 226 |
| LITTLE, S. J. The Joint Use of Poles for Telecommuni- cation and Power Lines ... | 31 |
| Local-Call Timing at Non-Director Telephone Exchanges Long-Distance Private Telephone Circuits for Commercial Renters ... | 83 |
| Loudspeaking-Telephone No. 3, A Waterproof Loud- speaking Telephone ... | 187 |
| LOWE, W. T. A Waterproof Loudspeaking Telephone— Loudspeaking-Telephone No. 3 ... | 6 |
| M | |
| MARSH, H. An Electronic Telegraph Serial-Numbering Transmitter ... | 195 |
| Masts at Leafield Radio Station, Dismantling the Long- Wave ... | 129 |

| | PAGE NO. |
|--|-------------------|
| M (continued) | |
| MAURER, C. J., and NEWELL, E. Integration of the Inter- national and Continental Telephone Services ... | 22 |
| Measurement of Some Characteristics of the Noise in Telephony and Television Channels, Equipment for the ... | 231 |
| Measuring Set Using Transistors, An Audio-Frequency Transmission ... | 19 |
| MEREDITH, L. A. A Concentrator for a Telegraph Tape- Relay Network ... | 250 |
| Meters, Photographing Subscribers' ... | 162 |
| Metson, G. H. (Appointment as Deputy Director of Research) ... | 59 |
| MILES, J. V., and KELSON, D. Signalling System A.C. No. 9 ... | 51 |
| MILLS, C. S., and ROBERTS, W. G. Improvements in Installation Methods for Telephone Exchanges ... | 92 |
| Miniature Lever Key of Improved Design, A ... | 29 |
| MISSEN, L. A., and BLAKELY, H. Photographing Sub- scribers' Meters ... | 162 |
| Mobile-Radio Services, Monitoring Station for ... | 228 |
| Mobile-Radio Services, Narrower-Frequency-Band Chan- nels for V.H.F. Land ... | 192 |
| Monitoring Station for Mobile-Radio Services ... | 228 |
| MOORE, M. B. Power Units for Use at Subscribers' Pre- mises ... | 49 |
| Motorway Emergency Telephone Systems, Selective Voice-Frequency Signalling for ... | 181 |
| MUMFORD, A. H. Satellite Communications (S) ... | 145 |
| Museum Radio Tower ... | 73 |
| N | |
| Narrower-Frequency-Band Channels for V.H.F. Land Mobile-Radio Services ... | 192 |
| NAULLS, R. W. The Group Reference-Pilot Signal ... | 237 |
| NEW, A. A. Electrolytic Capacitors and Their Reliability New Cordless P.M.B.X. Switchboards—P.M.B.X.s No. 2/3A and 2/4A ... | 244 |
| New Detection System for Television and V.H.F. Radio Receivers, A ... | 219 |
| NEWELL, E., and MAURER, C. J. Integration of the Inter- national and Continental Telephone Services ... | 22 |
| Noise in Telephony and Television Channels, Equipment for the Measurement of Some Characteristics of the Non-Director Satellite Telephone Exchanges, Subscriber Trunk Dialling at ... | 231 |
| Non-Director Telephone Exchanges, Local-Call Timing at ... | 86 |
| Notes and Comments ... | 59, 132, 206, 280 |
| O | |
| On Programming Computers ... | 125 |
| P | |
| P.M.B.X. Switchboards—P.M.B.X.s No. 2/3A and 2/4A. New Cordless ... | 244 |
| Papers and Articles on Telecommunications and Other Scientific Subjects ... | 71 |
| PECK, E. J. M., and ARMAN, L. T. Monitoring Station for Mobile-Radio Services ... | 228 |
| PECK, E. J. M., and ARMAN, L. T. Narrower-Frequency- Band Channels for V.H.F. Land Mobile-Radio Services ... | 192 |
| Photographing Subscribers' Meters ... | 162 |
| PIESING, J. E. and VIGAR, C. D. Subscriber-Controlled Transfer Service ... | 275 |
| Pilot Signal, The Group Reference- Poles for Telecommunication and Power Lines, The Joint Use of ... | 237 |
| Post Office Engineering Department's Computer, The ... | 31 |
| Power Units for Use at Subscribers' Premises ... | 199 |
| Preliminary Results of the Project TELSTAR Communi- cation Satellite Demonstrations and Tests: 10-27 July, 1962 ... | 49 |
| Pressurization of Telecommunication Cables Part 1—Principles of Gas Pressurization ... | 147 |
| Private Telephone Circuits for Commercial Renters, Long-Distance ... | 260 |
| Procter, W. S. (Retirement) ... | 187 |
| Programming Computers, On ... | 132 |
| Progress in the Provision of Subscriber Trunk Dialling ... | 125 |
| | 36 |

| | PAGE NO. | | PAGE NO. |
|---|-------------------|--|-------------|
| R | | T (continued) | |
| Radio Astronomy, Washington, D.C., March 1962, The Interim Meeting of C.C.I.R. Study Group IV—Space Systems and (S) | 96 | Telegraph Serial-Numbering Transmitter, An Electronic Telegraph Services, Improvements in Automatic Error-Correction Equipment Used on H.F. Radio | 195 |
| Radio Services, Monitoring Station for Mobile- | 228 | Telegraph Tape-Relay Network, A Concentrator for a | 253 |
| Radio Services, Narrower-Frequency-Band Channels for V.H.F. Land Mobile | 192 | Telephone Equipment Connexions | 250 |
| Radio Tower, Museum | 73 | Telephone Exchanges, Improvements in Installation Methods for | 166 |
| Radio Transmitters, Cooling System for High-Power | 40 | Telephone Exchanges, Local-Call Timing at Non-Director Telephone Exchanges, Subscriber Trunk Dialling at Non-Director Satellite | 92 |
| RATCLIFFE, K. S., and LEE, K. W. An Audio-Frequency Transmission Measuring Set Using Transistors | 19 | Telephone Exchanges, Local-Call Timing at Non-Director Telephone Exchanges, Subscriber Trunk Dialling at Non-Director Satellite | 83 |
| Recorder, A Time-Interval (S) | 186 | Telephone Systems, Selective Voice-Frequency Signalling for Motorway Emergency | 86 |
| Recorder No. 1B, Fault (S) | 185 | Telephone Systems, Selective Voice-Frequency Signalling for Motorway Emergency | 181 |
| Recording and Control of Information-Service Announcement for Small-Diameter Cables | 44 | Telephony and Television Channels, Equipment for the Measurement of Some Characteristics of the Noise in | 231 |
| Reference-Pilot Signal, The Group | 237 | Teleprinter No. 7, Improvements in the | 240 |
| Regional Notes | 63, 136, 208, 281 | Television and V.H.F. Receivers, A New Detection System for | 219 |
| Reliability, Electrolytic Capacitors and Their | 115 | Television Channels, Equipment for the Measurement of Some Characteristics of the Noise in Telephony and TELSTAR Communication Satellite Demonstrations and Tests: 10-27 July, 1962, Preliminary Results of the Project | 231 |
| Richards, C. E. (Retirement) | 59 | THOMSON, D. A. Speech Compandor Using Junction Transistors | 147 |
| ROBERTS, W. G., and MILLS, C. S. Improvements in Installation Methods for Telephone Exchanges | 92 | Time-Interval Recorder, A (S) | 14 |
| S | | Time-Shared Code Translators for Letter-Sorting Equipment | 186 |
| Satellite Communication Systems | 97 | Timing at Non-Director Telephone Exchanges, Local-Call Tower, Museum Radio | 173 |
| Satellite Communications (S) | 145 | Transfer Service, Subscriber-Controlled | 83 |
| Satellite Demonstrations and Tests: 10-27 July, 1962, Preliminary Results of the Project TELSTAR Communication | 147 | Translators for Letter-Sorting Equipment, Time-Shared Code | 73 |
| Satellite Ground Station, Goonhilly Downs, Cornwall, Equipment and Testing Facilities at the Experimental Satellite Telephone Exchanges, Subscriber Trunk Dialling at Non-Director | 105 | Transmission Measuring Set Using Transistors, An Audio-Frequency | 275 |
| Satellite Telephone Exchanges, Subscriber Trunk Dialling at Non-Director | 86 | Transmitter, An Electronic Telegraph Serial-Numbering | 173 |
| Satellites, Large Steerable Microwave Aerials for Communication with Artificial Earth | 152 | TUCKER, A. A. Long-Distance Private Telephone Circuits for Commercial Renters | 187 |
| SCOTICE—The United Kingdom to Iceland Cable System | 38 | TURNER, D. Equipment for the Measurement of Some Characteristics of the Noise in Telephony and Television Channels | 231 |
| Selective Voice-Frequency Signalling for Motorway Emergency Telephone Systems | 181 | TURNER, G., and SEYMOUR, E. H. Selective Voice-Frequency Signalling for Motorway Emergency Telephone Systems | 181 |
| SEYMOUR, E. H., and TURNER, G. Selective Voice-Frequency Signalling for Motorway Emergency Telephone Systems | 181 | U | |
| Signalling for Motorway Emergency Telephone Systems, Selective Voice-Frequency | 181 | United Kingdom to Iceland Cable System, SCOTICE—The | 38 |
| Signalling System A.C. No. 9 | 51 | Use of Hammer Finish on Apparatus, The (S) | 43 |
| SIXSMITH, J., and ENDERSBY, J. C. Coaxial Line Equipment for Small-Diameter Cables | 44 | V | |
| SMITH, G. L., and HUGGINS, G. Recording and Control of Information-Service Announcements | 158 | V.H.F. Land Mobile-Radio Services, Narrower-Frequency-Band Channels for | 192 |
| Space Systems and Radio Astronomy, Washington, D.C., March 1962, The Interim Meeting of C.C.I.R. Study Group IV—(S) | 96 | V.H.F. Receivers, A New Detection System for Television and | 219 |
| Speech Compandor Using Junction Transistors, A | 14 | Vehicle, A Line-Construction | 226 |
| Staff Changes | 68, 141, 215, 285 | VIGAR, C. D., and PIESING, J. E. Subscriber-Controlled Transfer Service | 275 |
| Submarine Cables, A Cable-Fault Locator for | 8 | Voltage Incidence and Duration Counter (S) | 264 |
| Subscriber-Controlled Transfer Service | 275 | W | |
| Subscriber Trunk Dialling at Non-Director Satellite Telephone Exchanges | 86 | WALTERS, J. R., KEEP, J. F., and CRAGGS, J. F. Pressurization of Telecommunication Cables (Part 1) | 260 |
| Subscriber Trunk Dialling, Progress in the Provision of | 36 | WARD, W. C. A Line-Construction Vehicle | 226 |
| Subscribers' Premises, Power Units for Use at | 49 | WASE, A. E. N. Cooling System for High-Power Radio Transmitters | 40 |
| Switchboards—P.M.B.X.s No. 2/3A and 2/4A, New Cordless P.M.B.X. | 244 | Waterproof Loudspeaking Telephone—Loudspeaking-Telephone No. 3, A | 6 |
| T | | WATT-CARTER, D. E. Dismantling the Long-Wave Masts at Leafield Radio Station | 129 |
| Tape-Relay Network, A Concentrator for a Telegraph | 250 | | |
| TAYLOR, F. J. D. Equipment and Testing Facilities at the Experimental Satellite Ground Station, Goonhilly Downs, Cornwall | 105 | | |
| TAYLOR, F. J. D. Large Steerable Microwave Aerials for Communication with Artificial Earth Satellites | 152 | | |
| TAYLOR, F. J. D., and BRAY, W. J. Preliminary Results of the Project TELSTAR Communication Satellite Demonstrations and Tests: 10-27 July, 1962 | 147 | | |

ASSOCIATE SECTION NOTES (Continued from p. 284)

The Chairman, in making his report, wished it recorded that the Centre was indebted to Mr. J. S. R. Lawson for the very good work put in during his term of office as treasurer and wished him every success on his promotion to Assistant Engineer at Goonhilly Downs Radio Station.

Grateful thanks were also expressed to Mr. J. S. Brown for the excellent work rendered during his term of office as secretary. Best wishes were extended for his new venture into the Regional Drawing Office, Edinburgh.

The winter session opened on 15 September with a visit to Hughes International, Glenrothes, where the intricacies of germanium-diode manufacture were expertly explained. This was followed by a visit to Kincardine Generating Station.

Other items in the Centre's program have been:

- 9 October: "P.O. Standard P.A.B.X. No. 4," by Mr. D. L. Miller.
- 24 October: Visit to No. 28 R.O.C., Craigiebarns, Dundee.
- 6 November: "Perth New Telephone Exchange," by Mr. L. E. Pinner.
- 13 November: Visit to Caledonian Tooth Co., Ltd., Industrial Estate, Dundee.
- 12 December: "Small-Diameter Coaxial Cable," by Mr. A. F. G. Allan, Main Lines Development and Maintenance Branch, Engineering Department.

The future program is as follows:

- 15 January: Film Show.

12 February: "Hydro-Board Protection and Testing," by Mr. R. Reekie.

19 March: "1912 and All That. A Short History of Telecommunications," by Mr. R. B. Munro, Telephone Manager, Dundee.

April: Annual general meeting.

R.T.L.

Edinburgh Centre

The 1962-63 winter session began on 3 October when a number of members visited Scottish Brewers, Ltd., at Fountain Brewery, Edinburgh. Interest was sustained throughout the afternoon and questions were still being asked and answered when time made it necessary to express thanks and depart.

The section continues to prosper and attention is concentrated on means of improving attendances, which, at some of last year's meetings, were disappointing.

D.S.H.

Cornwall Centre

In August our members made a visit to a Bristol Proteus installation at the English China Clay Works at St. Austell. Members were able to see the jet engine run up and automatically switch over to take the full load of the clay pits.

In September some 84 members were able to visit the Goonhilly space-communications satellite ground station where a most interesting morning was spent.

Our winter lecture program will include papers on, "Cornish Mines and Mining," "The Electronic Telephone Exchange," "Space Communications," "Transistors," and "Peaceful Uses of Atomic Energy."

A.R.B.

BOARD OF EDITORS

- D. A. BARRON, C.B.E., M.Sc., M.I.E.E., Chairman.
- L. F. SCANTLEBURY, Whit.Sch., A.C.G.I., D.I.C., M.I.E.E.
- T. H. FLOWERS, M.B.E., B.Sc.(Eng.), M.I.E.E.
- W. J. E. TOBIN, B.Sc.(Eng.), A.C.G.I., D.I.C., M.I.E.E.
- E. J. MARKBY, A.M.I.E.E.
- D. J. HARRIS, B.Sc.(Eng.), A.M.I.E.E.
- R. F. WALDEGRAVE.
- A. G. LEIGHTON, B.Sc.(Eng.), A.M.I.E.E., Managing Editor.
- J. MARTIN, B.Sc.(Eng.), A.M.I.E.E., Deputy Managing Editor.
- J. POVEY, A.M.I.E.E. } Assistant Editors.
- R. A. SUDELL. }
- B. FARR, A.B.I., Secretary-Treasurer.
- B. CROSS, Advertisement Manager.

Copyright

The entire contents of this Journal are covered by general copyright, and special permission is necessary for reprinting long extracts, but editors are welcome to use not more than one-third of any article, provided that credit is given at the beginning or end thus: "From *The Post Office Electrical Engineers' Journal*."

The Board of Editors is not responsible for the statements made or the opinions expressed in any of the articles in this Journal, unless such statement is made specifically by the Board.

Subscriptions and Back Numbers

The Journal is published quarterly, in April, July, October and January, price 2s. 6d. (3s. 6d. post paid) per copy or 14s. per year post paid (2 dollars 25 cents, Canada and U.S.A.). Back numbers will be supplied, if available, price 2s. 6d. (3s. 6d. post paid) per copy. Copies of the April 1959 and all

earlier Journals are no longer available. Orders should be sent to *The Post Office Electrical Engineers' Journal*, G.P.O., 2-12 Gresham Street, London, E.C.2.

Employees of the British Post Office can obtain the Journal through local agents.

Binding

Readers can have their copies of volumes bound at a cost of 15s. by sending the complete set of parts to the local Post Office distribution agent or to *The Post Office Electrical Engineers' Journal*, G.P.O., 2-12 Gresham Street, London, E.C.2.

Remittances

Remittances should be made payable to "*The P.O.E.E.J. Journal*" and should be crossed "& Co."

Advertisements

All correspondence relating to advertisement space reservations, copy, proofs, etc., should be addressed to the Advertisement Manager, *The Post Office Electrical Engineers' Journal*, G.P.O., 2-12 Gresham Street, London, E.C.2.

Communications

With the exceptions indicated above, all communications should be addressed to the Managing Editor, *The Post Office Electrical Engineers' Journal*, G.P.O., 2-12 Gresham Street, London, E.C.2. Telephone: HEADquarters 1234.

Model Answer Books

Books of model answers to certain of the City and Guilds of London Institute examinations in telecommunications are published by the Board of Editors. Details of the books available are given at the end of the Supplement to the Journal.



**BRITAIN'S
FIRST ALL
ELECTRONIC
TELEPHONE
EXCHANGE**

at Highgate Wood,
London, ready for
service

Designed, developed and manufactured by the leading British Telecommunications Manufacturers and handed over to the British Post Office for Public Service.

**Associated Electrical
Industries Limited**

**Automatic Telephone and
Electric Company Limited**

Ericsson Telephones Limited

**The General Electric
Company Limited**

**Standard Telephones and
Cables Limited**

THE PRODUCT OF BRITISH JOINT ELECTRONIC RESEARCH

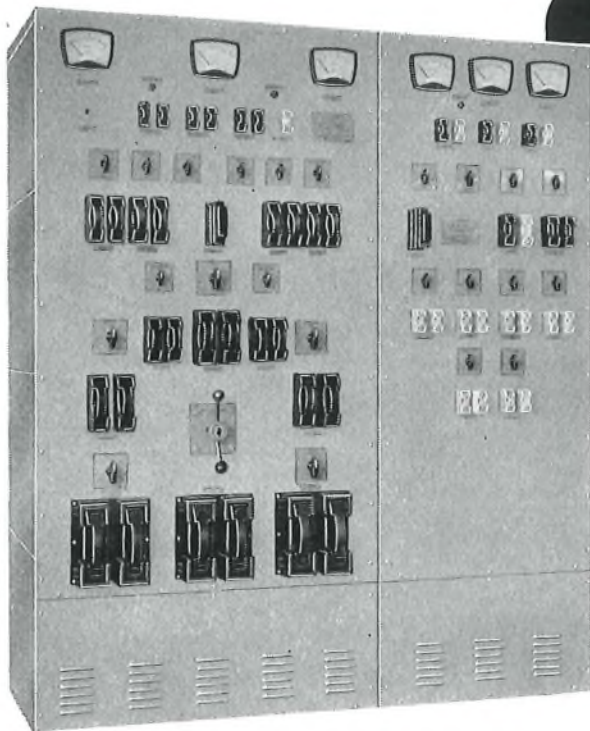

CAYTEL

STABILISED POWER UNITS

DUAL 'CAYTEL' CONSTANT
VOLTAGE FLOAT CHARGERS
FOR THE NORTH OF SCOTLAND
HYDRO-ELECTRIC BOARD

CAYSON
ELECTRICS LTD.
Regd. Trade Mark

Consultants:
KENNEDY & DONKIN

CAYSON ELECTRICS LTD.
HOLYWELL INDUSTRIAL ESTATE, WATFORD, ENGLAND

TEL: WATFORD 41272

For Plugging, Sealing or Caulking...

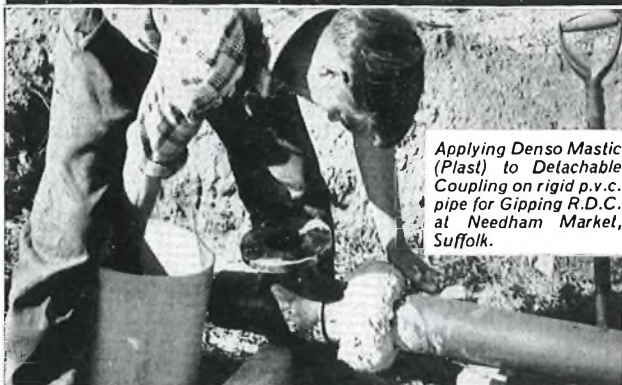

Applying Denso Mastic (Plast) to Detachable Coupling on rigid p.v.c. pipe for Gipping R.D.C. at Needham Market, Suffolk.

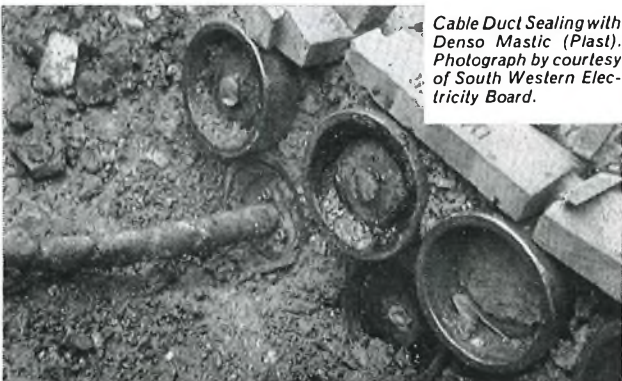

Cable Duct Sealing with Denso Mastic (Plast). Photograph by courtesy of South Western Electricity Board.

use DENSO MASTICS

DENSO MASTICS offer a safe, sure and economical system of protection against penetration by gas, water and air. Completely cold applied, there is a range of DENSO Mastics and sealing compounds, developed to cover a wide range of applications.

WINN AND COALES LTD.,
Denso House, Chapel Road, London, S.E.27
Tel: GIPsy Hill 7511

Also at Manchester, Belfast and Dublin.
Agents throughout the Commonwealth

Typical constant voltage float charger type PO.91B incorporating the TRINISTAT circuit. Output 15 amperes at 27 volts smoothed to 1mV weighted to 800 cycles when operating with a battery.

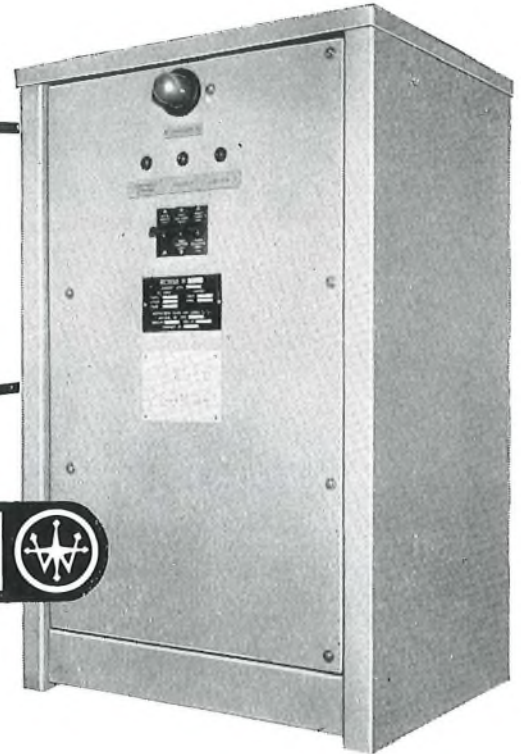

TRINISTAT CONSTANT VOLTAGE RECTIFIER SETS

Salient features of the new Westinghouse TRINISTAT silicon controlled rectifier regulated circuit are:—

- CLOSE LIMITS of voltage regulation irrespective of wide input VOLTAGE and FREQUENCY changes.
- Regulation achieved over ENTIRE LOAD RANGE without use of heavy bleed resistances.
- LOW WEIGHT and REDUCED DIMENSIONS.

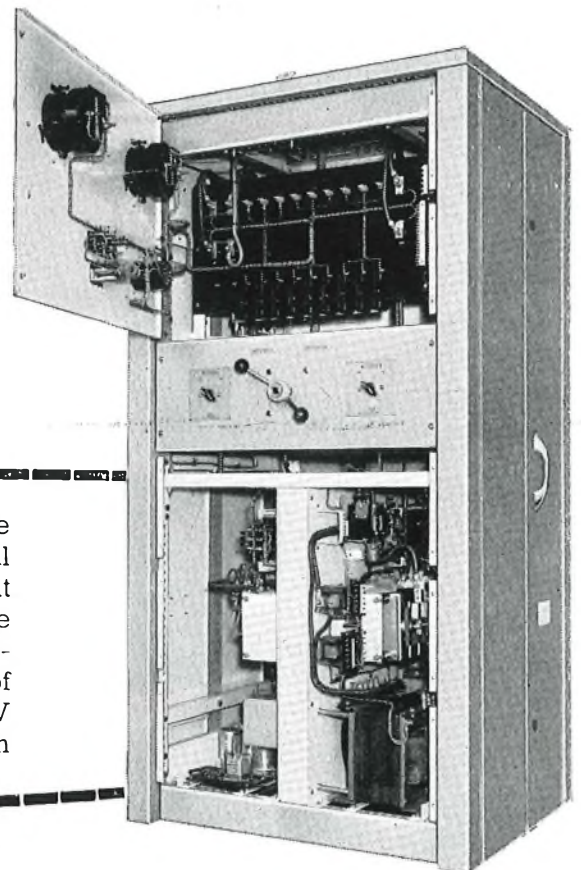

TRINISTAT constant voltage equipment type 6113 designed to achieve a similar technical performance to the PO.91 range of sets but having a greater output. Contained within the lower half of the cubicle only are two independent circuits each having an output of 75 amperes at 50 volts, smoothed to 2mV weighted to 800 cycles when operating with a battery.

*For further information please write to Dept.
POEEJ 1/63 Rectifier Division, (Equipments).*

WESTINGHOUSE BRAKE AND SIGNAL CO. LTD · 82 YORK WAY · KING'S CROSS · LONDON N1

Tel: TERminus 6432



Post Office approved, this STC telephone earpiece gives listening facilities for a second person on the new British Post Office 706 type telephone.

- Conversations can be recorded by stenographer.
- Great time saver and aide memoire for the busy executive.
- Earpiece disconnected when hung-up.
- No 'click' audible when earpiece is brought into use.
- Listener can use extra earpiece when reception is weak or in noisy surroundings.
- Exceptionally light and compact.
- Now available in black, grey and ivory. Subsequently in green, red, yellow and blue.



Write or 'phone for leaflet D/110

Standard Telephones and Cables Limited

TELEPHONE SWITCHING DIVISION,
OAKLEIGH ROAD, NEW SOUTHGATE, LONDON, N.11. ENTERPRISE 1234

BY APPOINTMENT TO
H.R.H. THE DUKE OF EDINBURGH



SUPPLIERS OF MOBILE
RADIO TELEPHONE EQUIPMENT

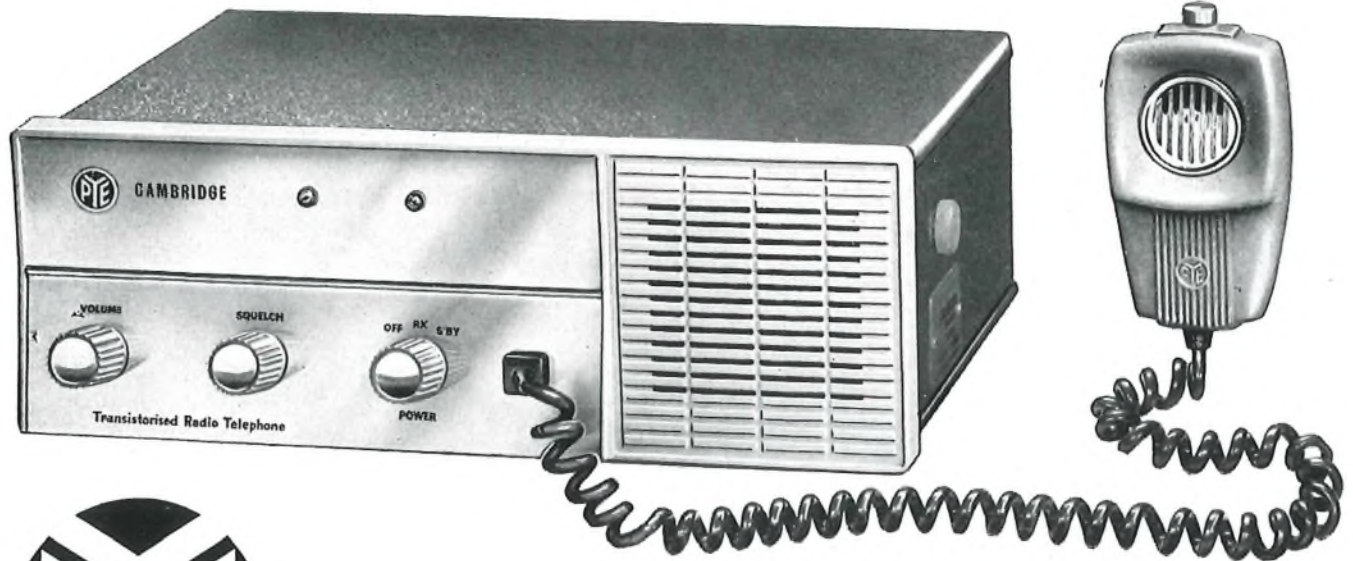

introduce the brilliant new 'CAMBRIDGE'
Transistor
Mobile Radiotelephone

The overwhelming advantages of the fully transistorised receiver have now been made available in this remarkable new mobile radiotelephone, at no additional cost and without sacrifice of the stringent performance requirements hitherto met only by valve receivers. This outstanding Pye product sets a new high standard in mobile radiotelephone design which cannot be surpassed.

- Fully transistorised receiver
- Printed circuit sub-assemblies
- Sealed I.F. block filters
- Dustproof and splashproof
- GPO approved and meeting American and European specifications
- 100 Milliamps receiver drain
- A.M. or F.M. versions
- 25 Kc/s or 50 Kc/s channelling
- Single or six channel

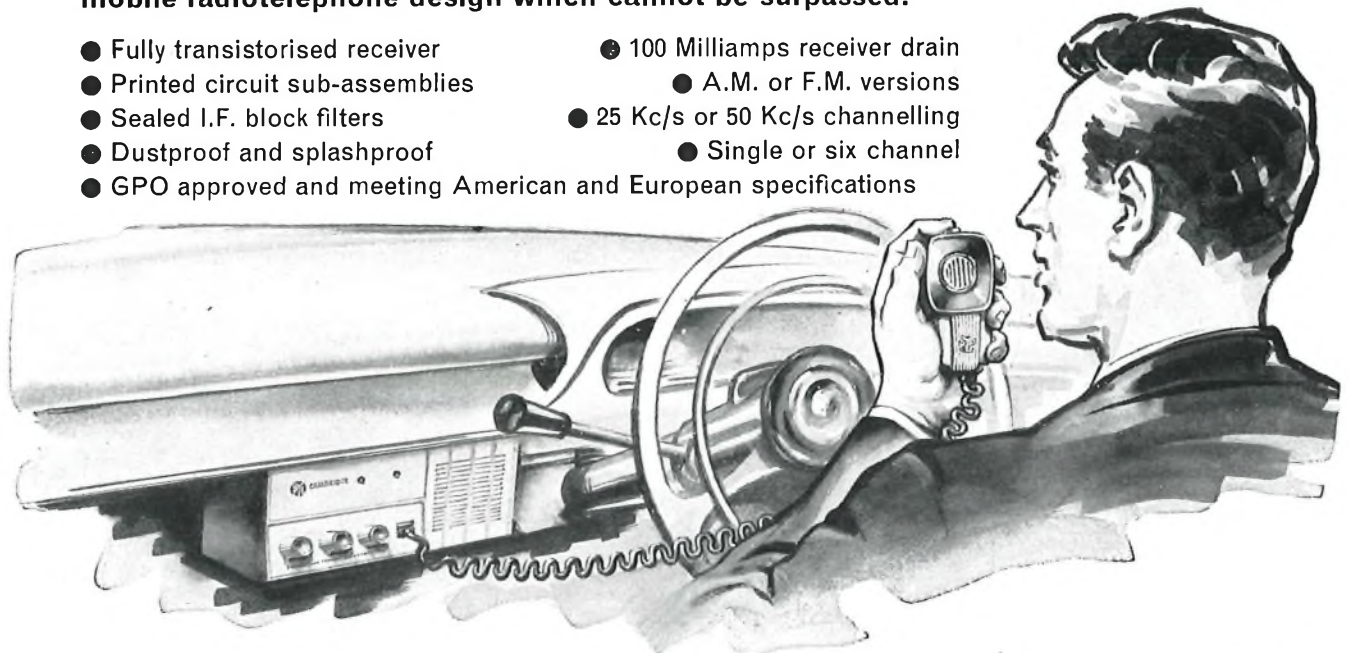

TA-5 a new VF telegraph system

for long distance
or difficult
h.f. radio circuits

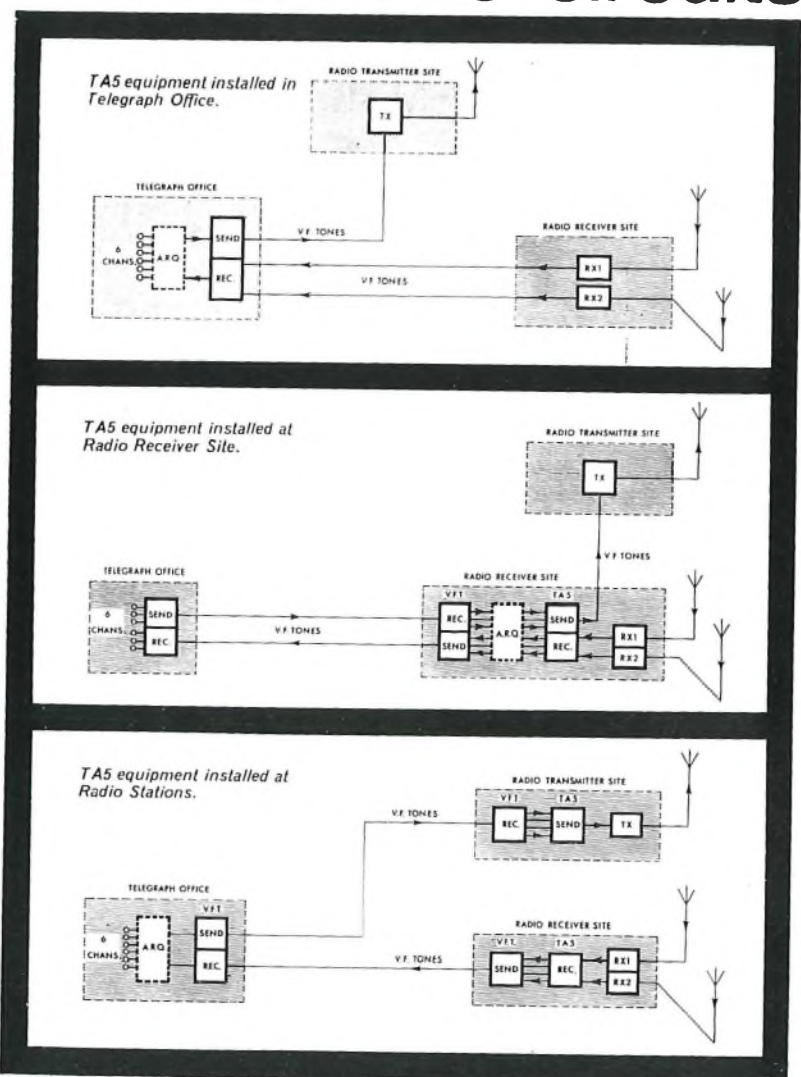
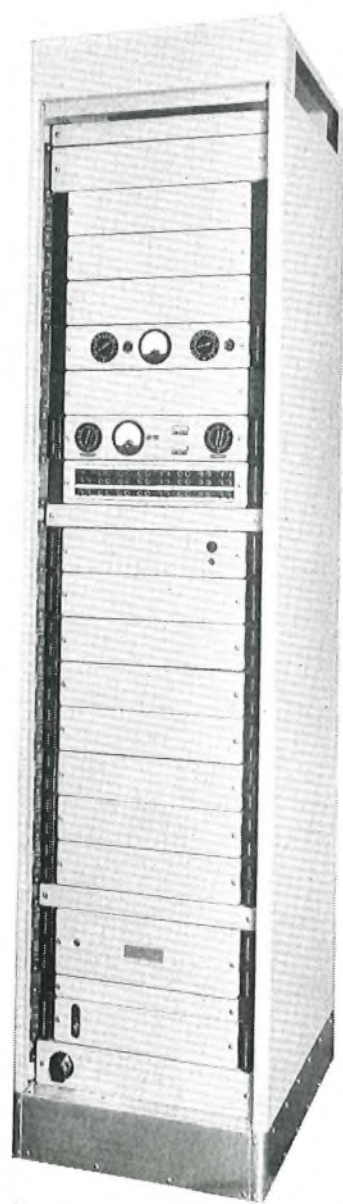

Uses a special system of frequency-shift reception in which two tones per channel are keyed so that one is transmitted during the "mark" and the other during the "space" period. Either tone will reproduce the transmitted signal, thus reducing the effects of the selective fading and interference met in radio telegraph communication. This system will provide six 100-baud channels having independent send and receive apparatus. The system is also designed to use dual space diversity reception.



Write, 'phone or Telex for publication C/2054
Standard Telephones and Cables Limited
 TRANSMISSION SYSTEMS GROUP
 NORTH WOOLWICH - LONDON, E.16
 Telephone: ALBert Dock 1401 - Telex 21645

For **POTTING**



The Epoxy Resins,
used by Whiteley
Electrical Radio, provide
mechanical and climatic
protection, combined
with excellent electrical
insulation, for equipment
used in extremes
of temperature and
humidity.



or **PLOTTING**

The Radio Sonde
enables weather forecasts
for the upper atmosphere
to be taken with great
accuracy.

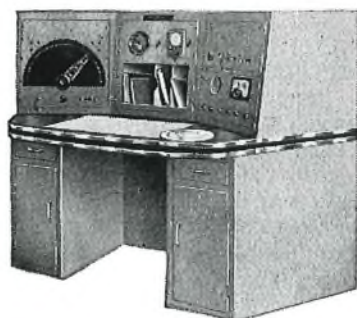
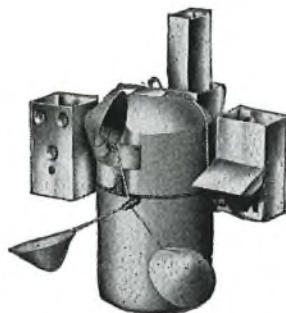

The Radio Sonde
Ground Equipment
enables information
from the Radio Sonde
to be converted into
data on the pressure,
temperature and
humidity in the upper
atmosphere.

GET IN TOUCH WITH

WHITELEY

WHITELEY ELECTRICAL RADIO CO LTD
MANSFIELD · NOTTS Tel: Mansfield 1762/5

WB166

MODEL ANSWER BOOKS

CITY AND GUILDS OF LONDON INSTITUTE
TELECOMMUNICATION TECHNICIANS' COURSE

**TELECOMMUNICATION
PRINCIPLES A**

**TELECOMMUNICATION
PRINCIPLES B**

**ELEMENTARY
TELECOMMUNICATION
PRACTICE**

Price 7s. 6d. each. Post Paid 8s.

The following model answer book, although published for the old Telecommunications Engineering Course, is still useful and is offered at a considerably reduced price.

TELEPHONE EXCHANGE SYSTEMS I
(Telephony and Telegraphy A, Telephony B)

Price 2s. each. Post Paid 2s. 6d.

Orders to

The Post Office Electrical Engineers' Journal
G.P.O., 2-12 Gresham Street, London, E.C.2



BARB PLUGS AND SOCKETS

The Oxley plugs and sockets are rapidly assembled connectors of outstanding electrical and mechanical characteristics, the design of the bush making maximum use of the elastic and insulating properties of polytetrafluoroethylene.

The socket tube is a one-piece component heavily silver plated (with an optional gold flash) slit longitudinally to exploit the elastic properties of the insulating bush so providing the necessary retention of the plug under the most arduous conditions. To fit 0.156 in. dia. chassis hole.

Both plugs and sockets supplied coloured: Black, Brown, Red, Orange, Yellow, Green, Blue, Violet, Grey, and White. Packed in sealed packets of 100. Further details supplied on request.

OXLEY

OXLEY DEVELOPMENTS CO. LTD., ULVERSTON, LANCs.

W5/1G and P.P.M. mount 495-LVA-105B with all-mechanical focus adjustment.



PROGRESS IN MICROWAVE COMMUNICATIONS

Advances in components design have brought far-reaching changes in circuit techniques employed in microwave link repeaters but, for broadband response, the travelling wave tube amplifier maintains its position supreme. This does not imply complacency on the part of the tube manufacturer. On the contrary, continuous efforts are made to produce tubes of better and better performance—improved gain, lower noise factor, higher synchronous saturated output level and reduced phase modulation distortion. During the last decade, STC have maintained a leading position in this field.

The travelling wave tube cannot be considered in isolation. Its correct performance is very much dependent upon its mount which contains a magnetic focusing arrangement

(including devices for trimming the focus of individual tubes) as well as arrangements for coupling the input and output signal to and from the tube helix together with the requisite matching contrivance.

Whilst the mode of operation of the travelling wave tube does not permit much change in the overall length of the mount, economy has been achieved by replacing power consuming solenoids by periodically reversed permanent magnets; forced air systems by convector coolers, and focus-trim deflector coils by mechanical fine adjusting screws.

STC designs are based on a vast experience of manufacturing components for microwave equipment in use in major communication systems installed in 19 countries of the world.

STC
TRAVELLING
WAVE
TUBES

Announcing another NEW Type

abridged data

| Tube Type | Mount Type | RF Connexion (W.B. Flange) | Frequency Range (Gc/s) | Sync. Sat. Output (W) | Gain (dB) | Noise Factor (dB) |
|----------------|--------------|----------------------------|------------------------|-----------------------|-----------|-------------------|
| W5/1G | 495-LVA-105B | UG344/U | 5.85 to 7.2 | 8 to 11 | 35 to 39 | 26 |
| | 495-LVA-105C | CMR137 | | | | |
| | 495-LVA-105D | UG344/U | | | | |
| W5/2G W7/3G | 495-LVA-107B | UG344/U | 5.8 to 6.6 | 16 | 37 to 41 | 27 |
| | 495-LVA-104 | 12A* | 3.6 to 4.2 | 8 to 10 | 28 | 27 |
| W7/4G | 495-LVA-101A | 12A* | 3.6 to 4.2 | 10 | 42 | 27 |

*Transition pieces to WR229 available

Write for brochure MS/113 "STC Microwave Tubes"



Standard Telephones and Cables Limited
VALVE DIVISION · BRIXHAM ROAD · PAIGNTON · DEVON

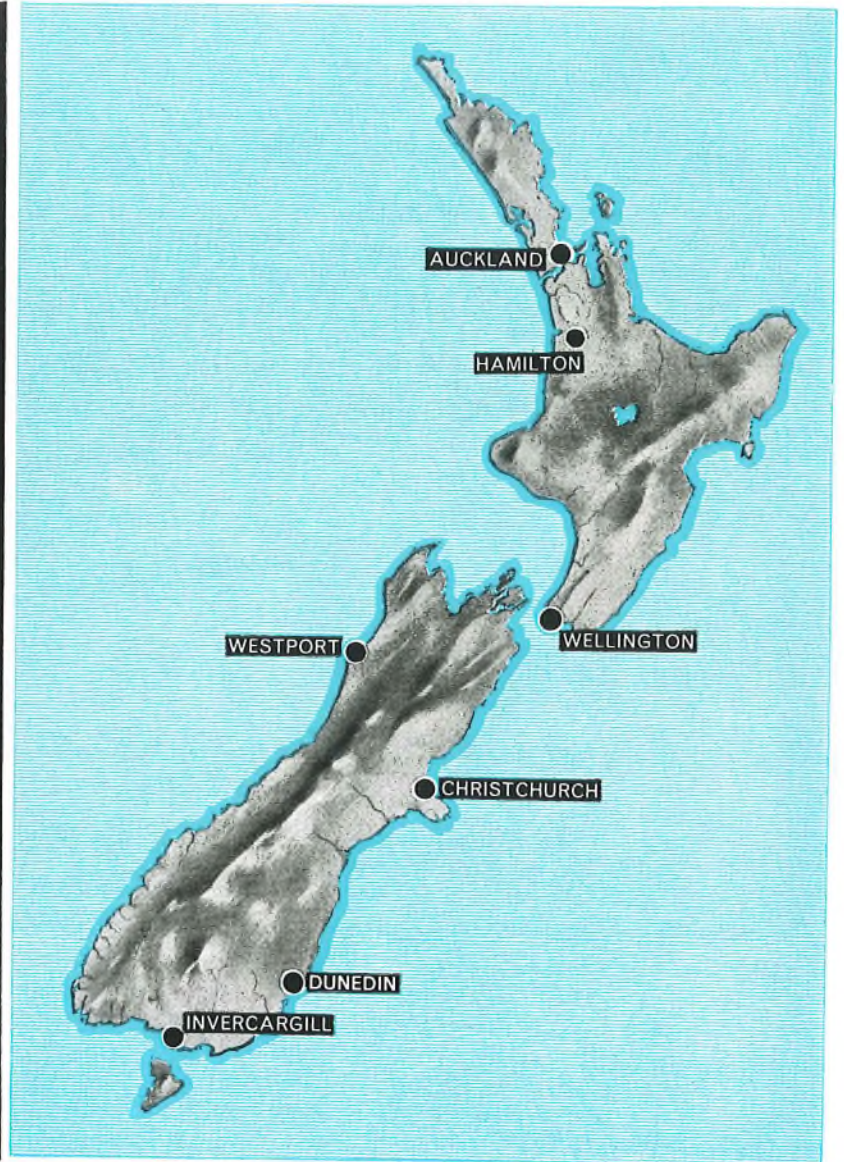
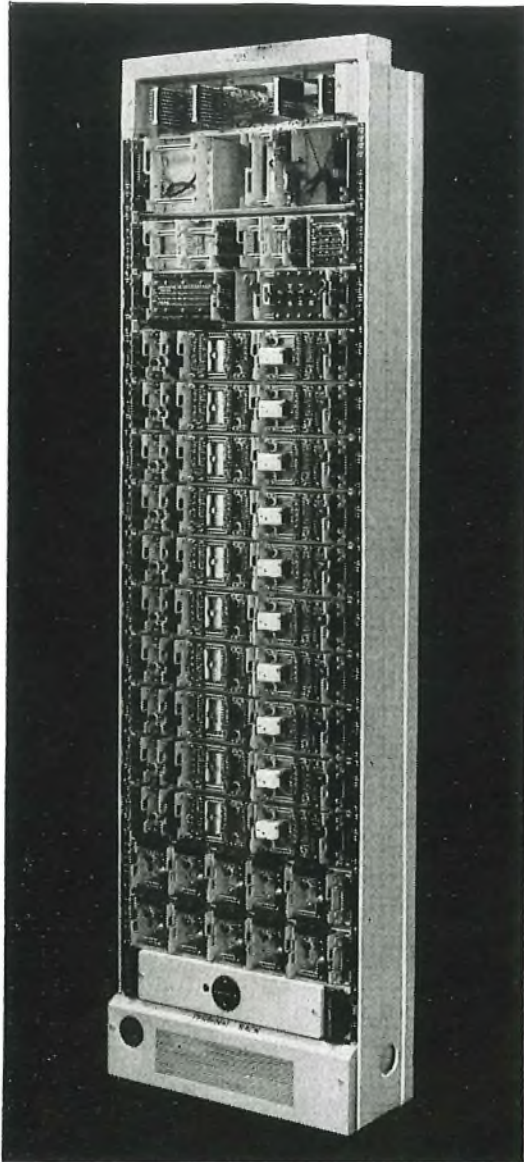

OPEN WIRE LINE EQUIPMENT FOR NEW ZEALAND

G.E.C. (Telecommunications) Ltd has received further orders from the New Zealand Post Office for a range of carrier telephone equipment for use on open-wire lines.

The order includes two types of 12-circuit carrier telephone equipment, rural carrier telephone equipment and a wide range of auxiliary equipment for all systems.

The main items to be supplied are :

12-CIRCUIT CARRIER TELEPHONE EQUIPMENT

12 systems operating with line frequencies 36 kc/s - 143 kc/s
12 systems operating with line frequencies 160 kc/s - 300 kc/s

RURAL CARRIER TELEPHONE EQUIPMENT

90 exchange terminal racks each with a capacity of 10 circuits
24 subscriber terminal units



Everything for Telecommunications

Transmission Division

G.E.C. (TELECOMMUNICATIONS) LTD

Telephone Works · Coventry · England

Works at Coventry and Middlesbrough

STC**SUBMARINE CABLE**

CHOSEN FOR UNDERWATER
COMMUNICATION SYSTEMS
ALL OVER THE WORLD

Submarine telephone cable on order or already
manufactured at the STC Southampton factory:

| | | |
|-----------------------------|-------|------------------|
| Commonwealth Pacific Cable | 2 800 | } nautical miles |
| USA—Bermuda | 820 | |
| Scotland—Faeroes—Iceland | 750 | |
| Puerto Rico—Florida | 715 | |
| UK—Sweden | 536 | |
| UK—Denmark | 315 | |
| UK—Germany No 2 | 253 | |
| UK—Germany No 1 | 250 | |
| Bournemouth—Channel Islands | 140 | |
| UK—Holland | 115 | |
| Wales—Isle of Man | 66 | |
| UK—Belgium | 61 | |

**STC ENGINEER AND MANUFACTURE ALL TYPES OF
SUBMARINE TELEPHONE AND TELEGRAPH CABLE.**



63/2T

Standard Telephones and Cables Limited

SUBMARINE CABLE DIVISION: NEW DOCKS · SOUTHAMPTON · HANTS

TRANSISTORED FREQUENCY GENERATING EQUIPMENT

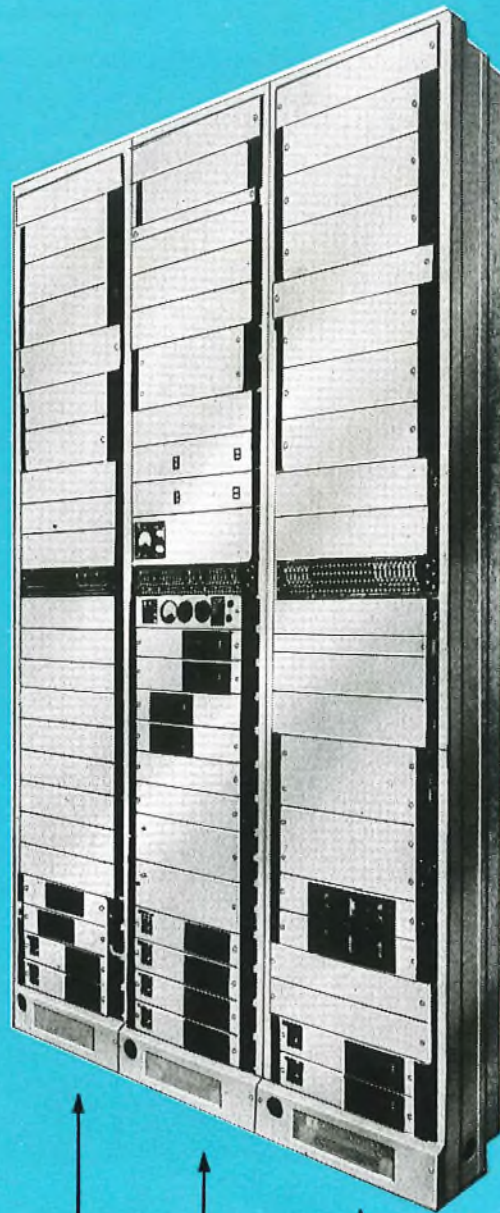

A range of fully transistored frequency generating equipment is now available for systems up to 960 channel capacity. Various degrees of duplication of the active elements are offered to cater for the needs of both minor and major stations. The speed of changeover from working to spare equipment has been increased to avoid mutilation of high-speed data transmission.

*Supergroup harmonic
frequency generating rack*

*Master oscillators and
channel frequency
generating rack*

*Group harmonic
frequency generating rack*

Transmission Division

G.E.C. (Telecommunications) Limited

TELEPHONE WORKS · COVENTRY · ENGLAND

Works at Coventry and Middlesbrough



EVERYTHING

FOR

TELECOMMUNICATIONS

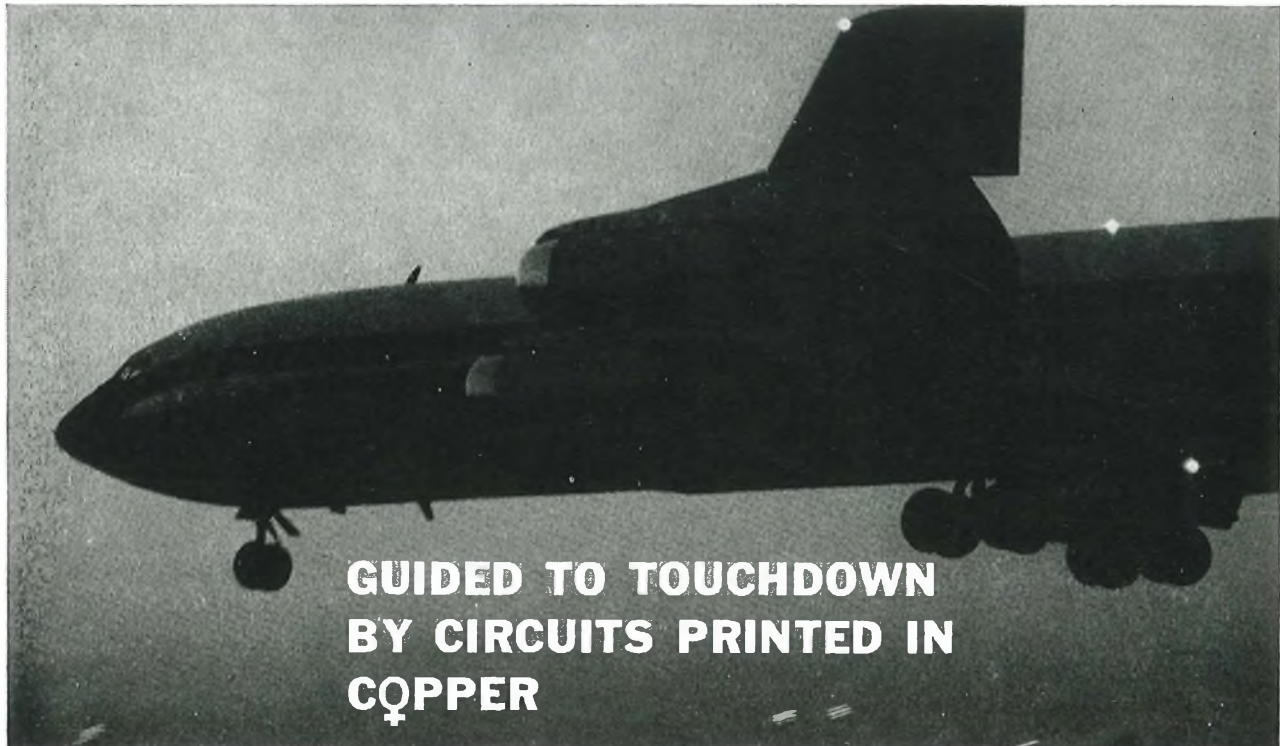

GUIDED TO TOUCHDOWN BY CIRCUITS PRINTED IN COPPER

Today's aircraft landing aids—and the radar systems which are their eyes—have their nerve systems printed in copper. Indeed throughout the whole field of electronics today printed circuits are providing, in a planar form, the wiring and the chassis, neatly, compactly and economically. Printed circuits demonstrate the outstanding electrical conductivity of copper in the way connecting ribbons of minute physical dimension can be used to carry considerable currents without heat problems.



COPPER

The electrolytically deposited copper foil is bonded to the chosen laminate and is usually of one of the following sizes:

| Wt. per sq. ft. | Thickness (approx) |
|-----------------|--------------------|
| 1 oz | .0015 in |
| 2 oz | .003 in |
| 3 oz | .0045 in |

As the accompanying graph shows the connecting line need be only of the order of $\frac{1}{16}$ " to $\frac{1}{8}$ " wide. For instance, conductors of $\frac{1}{8}$ " width in a one-ounce copper-clad laminate will carry up to 7 amperes with only a few degrees rise in temperature.

It is typical of copper that it should be so closely associated with this up-to-the-minute technique, as it is with so many new developments. These will certainly open wider fields for printed circuits, both in producing complete electronic units in micro-modular form, and in heavier current applications, such as automobile wiring.

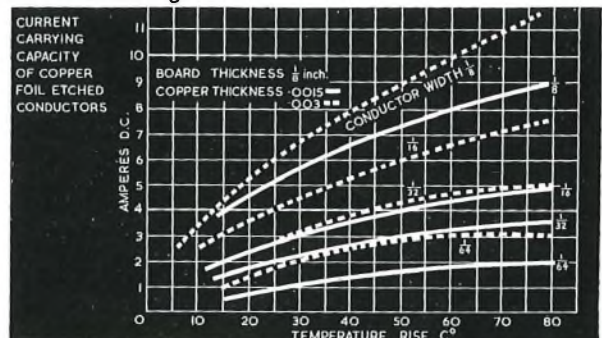

THE FIRST CHOICE METAL OF THE MODERN AGE

For further information please write to: The British Non-Ferrous Metals Federation, 6 Bathurst Street, London W.2.

Minimum space

Minimum power consumption

Minimum maintenance



Transistorised FMVFT

TYPE CT 24A

FOR THE PROVISION OF TELEPRINTER OR DATA TRANSMISSION CIRCUITS

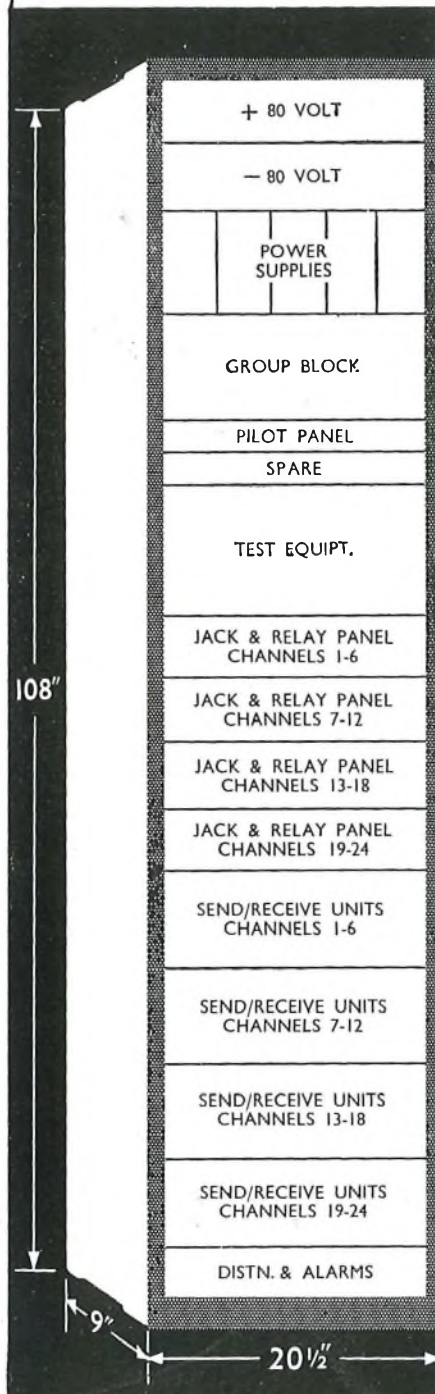

- * CCITT standards of performance
- * 24 channels per rackside
- * 50 baud nominal, with operation up to 80 bauds
- * Plug-in units
- * Optional in-built test equipment comprising:—
 - a) Telegraph test set
 - b) Level measuring set
 - c) Frequency check unit
- * Completely self contained with all power supplies
- * Pilot facility 300 c/s or 3300 c/s

24 frequency modulated channels are provided in the nominal frequency band 420-3180 c/s with 120 c/s separation between adjacent channels. These are built up from 4 sub-groups of 6 channels each in the frequency band 1140-1740 c/s. Compactly assembled plug-in units use printed circuit wiring boards with small encapsulated filter and transformer units. Equipment is protected by bay covers, but test equipment and jackfields are directly accessible at centre of rack.

Bearer Band 300-3400 c/s
Deviation ± 30 c/s from mid frequency
Send level range -15 to -35 dBm
Receive level range -15 to -35 dBm
DC lines Send 20mA double current.
 Receive up to 100 mA.
 Balanced loop and neutral loop conditions on request.

Temperature compensated + 5°C to + 55°C
Power supplies 100-120v or 200-240v AC
 (Battery operation through an inverter as optional extra).

Details of the latest AEI Carrier Telephone and Telegraph Equipment supplied on request

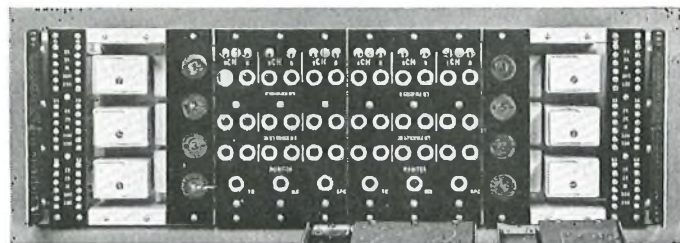

Jack and Relay Panel

Receive Unit
and Send Unit

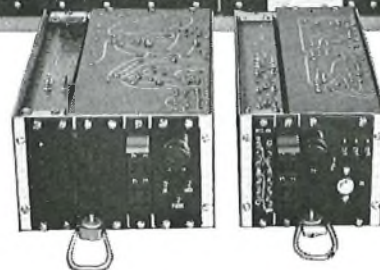

Associated Electrical Industries Ltd

Telecommunications Division, Transmission Department
 Woolwich, London S.E.18, England

Cables: Sieswan London

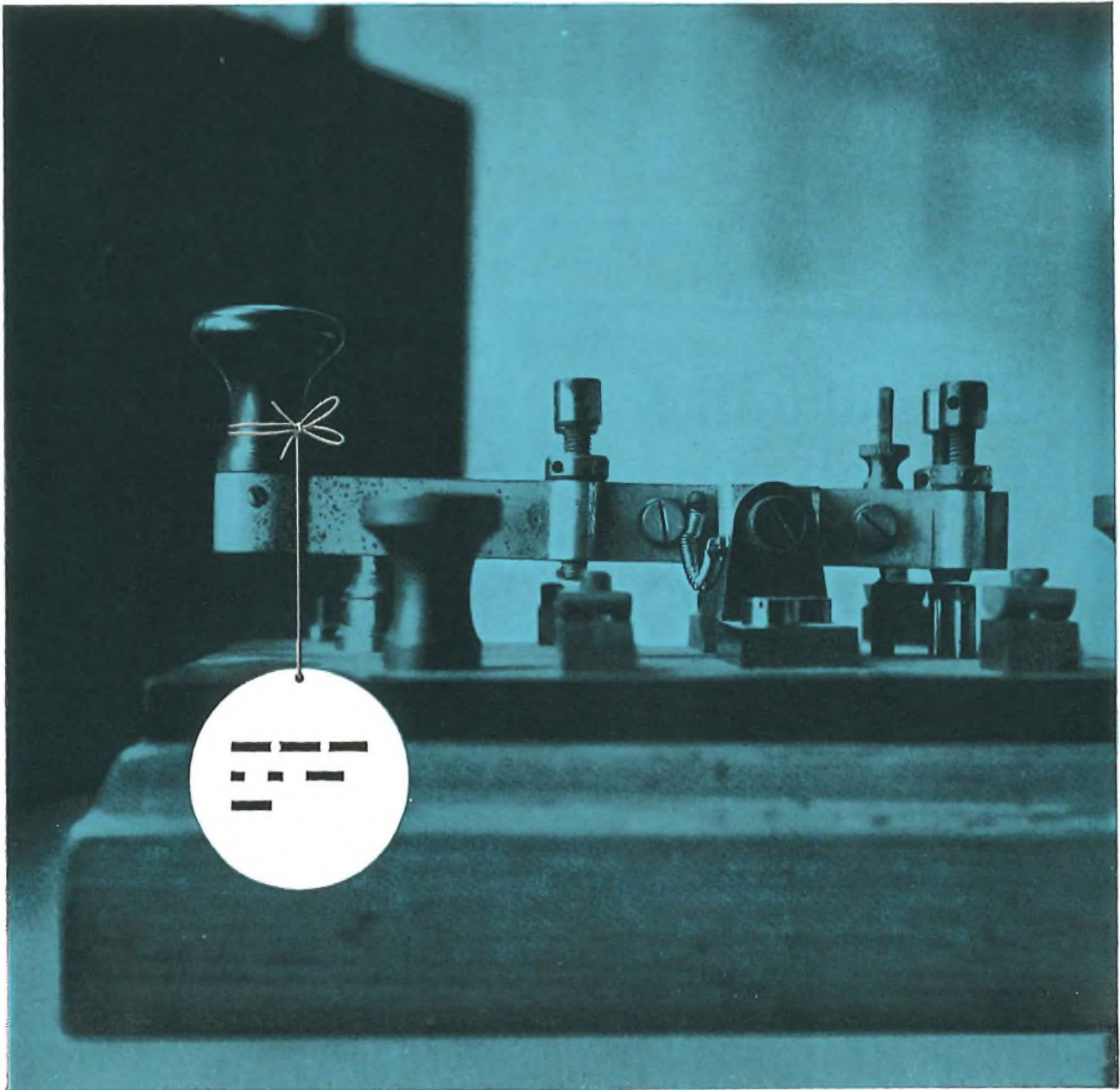

Dots and dashes . . . too slow. They're going o-u-t. FORMICA* industrial laminates play an important part in today's fast talking telecommunications, telephone exchanges and communications satellites. Formica Limited make over 50 industrial laminate grades for industry, including specialised grades famous for their electrical properties for printed circuitry, selector bank insulation and terminal strips. With FORMICA industrial laminates goes a complete Technical Service which includes consultation, investigation, advice. Just write or ring.



Industrial laminates

*FORMICA is a registered trade mark
Formica Ltd., De La Rue House, 84-86 Regent Street, London, W.1
REGent 8020



**SHF 6000 Mc/s
BROADBAND RADIO
EQUIPMENT**

Selected by the
GENERAL POST OFFICE
for -

**THE NEW LONDON-BIRMINGHAM
-MANCHESTER RADIO LINK**

each RF channel having a capacity of

1800 **SPEECH CIRCUITS**
or equivalent

Transmission Division

G.E.C. (TELECOMMUNICATIONS) LTD

TELEPHONE WORKS · COVENTRY · ENGLAND

Works at Coventry & Middlesbrough

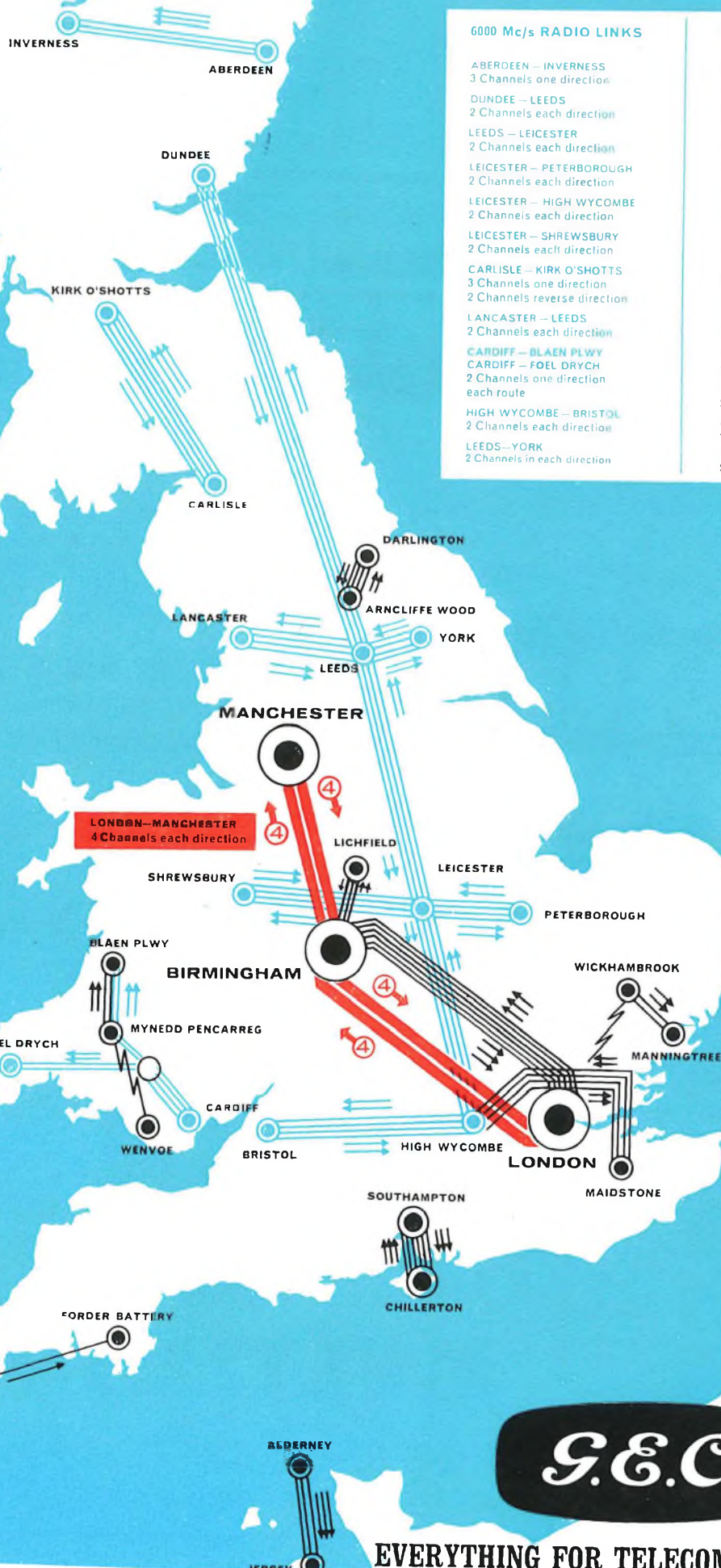

6000 Mc/s RADIO LINKS

- ABERDEEN - INVERNESS
3 Channels one direction
- DUNDEE - LEEDS
2 Channels each direction
- LEEDS - LEICESTER
2 Channels each direction
- LEICESTER - PETERBOROUGH
2 Channels each direction
- LEICESTER - HIGH WYCOMBE
2 Channels each direction
- LEICESTER - SHREWSBURY
2 Channels each direction
- CARLISLE - KIRK O'SHOTT
3 Channels one direction
2 Channels reverse direction
- LANCASTER - LEEDS
2 Channels each direction
- CARDIFF - BLAEN PLWY
CARDIFF - FOEL DRYCH
2 Channels one direction
each route
- HIGH WYCOMBE - BRISTOL
2 Channels each direction
- LEEDS - YORK
2 Channels in each direction

6000 Mc/s RADIO LINKS with 1800 Speech Circuits

- LONDON - BIRMINGHAM - 4 Channels each direction
- BIRMINGHAM - MANCHESTER - 4 Channels each direction

2000 Mc/s RADIO LINKS

- BIRMINGHAM - LICHFIELD
2 Channels one direction
1 Channel reverse direction
- LONDON - BIRMINGHAM
3 Channels each direction
- WICKHAMBROOK - MANNINGTREE
2 Channels one direction
- JERSEY - ALDERNEY
3 Channels one direction,
with music channel
- SOUTHAMPTON - CHILLERTON
3 Channels each direction
- MYNEDD PENCARREG - BLAEN PLWY
2 Channels one direction
- ARNCLIFFE WOOD - DARLINGTON
2 Channels each direction
- GOONHILLY - FORDER BATTERY
1 Channel each direction
- HIGH WYCOMBE - MAIDSTONE
2 Channels in each direction



KEY

- E.C. 6000 Mc/s Radio Links (with 1800 Speech Circuits) █
- 6000 Mc/s RADIO LINKS (Transmission of Telephony) █
- 2000 Mc/s RADIO LINKS (Television or Telephony) █
- OTHER RADIO LINKS █

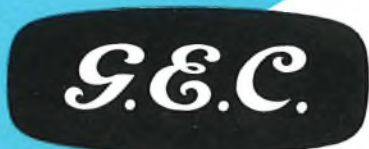

EVERYTHING FOR TELECOMMUNICATION!

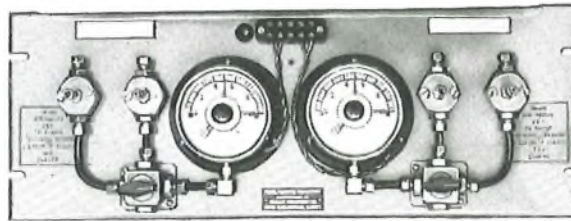

P.O. PANEL PRESSURE INDICATING No. 2.

DRALLIM

HAVE THE EQUIPMENT FOR LINE PRESSURISATION

Drallim products range from simple tube couplings to complex flow control equipment.

Engineers with new ideas applied to new materials combine in Drallim products many unique features. For example: Captive seals in the union nuts to ensure leak free joints from high vacuum to 100/300 p.s.i. and Acrylic blocks for bodies of Drallim flow meters. Drallim Industries supply the most up-to-date equipment to the G.P.O. and other Post Offices.

DRALLIM INDUSTRIES LIMITED

BOURNE WORKS, STATION APPROACH, WHYTELEAFE, BYWOOD 2321

NEW

from **AVO**

Regd Trade Mark

Modern styling in light grey with black engraving.

Constructed to withstand adverse climatic conditions

Ever ready case, including leads, prods and clips.

Improved internal assemblies

New standard of accuracy, using an individually calibrated scale plate:
d.c. ranges 2.25% of f.s.d.
a.c. ranges 2.75% of f.s.d.

Re-styled scale plate for easy, rapid reading.



AVO are proud to present an entirely new version of the now famous MULTIMINOR, styled on modern lines, with new high standards of accuracy, improved internal assemblies, and incorporating panclimatic properties.

The new Mark 4 MULTIMINOR, which supersedes all previous models, is supplied in an attractive black carrying case, which also houses a pair of leads with interchangeable prods and clips. The whole is packed in a strikingly handsome "Astralux" carton. Two kinds of real leather cases are also available if required.

MULTIMINOR *Mk 4*

Write for full details of this great new pocket-size instrument

D.C. CURRENT: 100 μ A f.s.d. — 1A f.s.d. in 5 ranges.
A.C. VOLTAGE: 10V f.s.d. — 1,000V f.s.d. in 5 ranges.
D.C. VOLTAGE: 2.5V f.s.d. — 1,000V f.s.d. in 6 ranges.
D.C. MILLIVOLT range: 0 — 100mV. f.s.d.

RESISTANCE: 0-2M Ω in 2 ranges, using 1.5V cell.

SENSITIVITY: 10,000 Ω /V on d.c. Voltage ranges.
1,000 Ω /V on a.c. Voltage ranges.

AVO LTD

AVOCET HOUSE, 92-96 VAUXHALL BRIDGE ROAD, LONDON, S.W.1.

Telephone: VICTORIA 3404 (12 lines)

M
GROUP



PURSUIT OF PERFECTION

Type CM is a design based on the transistor and modern components. Of these the transformer is one of the most important and it is here that particular improvements have recently been made in size, performance, mounting arrangements and materials. Nylon spools improve winding areas by as much as

**TYPE
CM
CARRIER**

thirty per cent and enable a core as small as 3/16" x 3/16" to be used. The complete transformer is clipped direct to the printed circuit board. The illustration shows the custom built test position on which all characteristics are visually displayed on a comparator basis thus providing a check of great accuracy.



AUTOMATIC TELEPHONE & ELECTRIC COMPANY LIMITED
 Strowger House, Arundel Street, London, W.C.2. Telephone: Temple Bar 9262. Strowger Works, Liverpool, 7
 AT8041

TOR

T.O.R. fully transistorised automatic error detection and correction equipment by Mullard Equipment Limited

now in full production

The Mullard Equipment Limited T.O.R. is a completely new, *fully transistorised* system for the detection and correction of errors due to propagation problems or other interference in Telegraph signals passed over radio circuits. The first transistorised equipment of this type to be in full-scale production in this country, the SL65 offers low power consumption and also a considerable saving in space and maintenance costs.

- High speed automatic rephasing
- Marked character cycle
- 45·45, 50 and 56·88 baud operation
- Aggregate signals in and out transmitted as either d.c. or tone
- Error indication without repetition for one way circuits
- Choice of two or four channels
- Optional 8 character repetition cycle
- Only two types of trigger circuit used
- Front access rack conforming to C.C.I.T. recommendation
- Sealed moisture-resistant conclave boxes
- Meets the general requirements of the G.P.O. and British Services

For full operational details on the T.O.R. write for publication No. 9876 quoting reference A69611

MULLARD EQUIPMENT LIMITED
Manor Royal, Crawley, Sussex
Telephone: Crawley 28787

MULLARD EQUIPMENT LIMITED



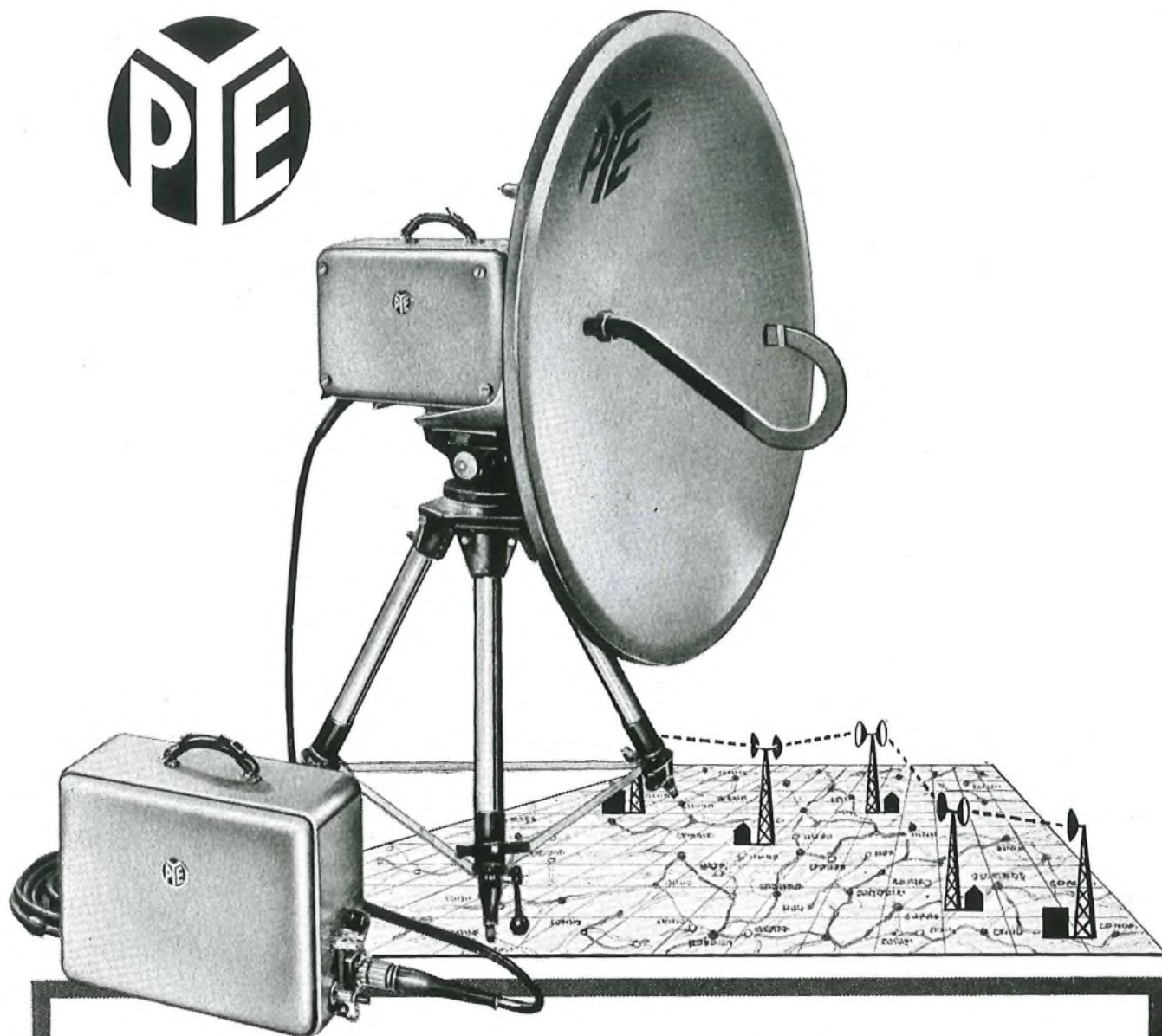

Portable and Fixed Station Equipment for **MICROWAVE TELEVISION LINKS**

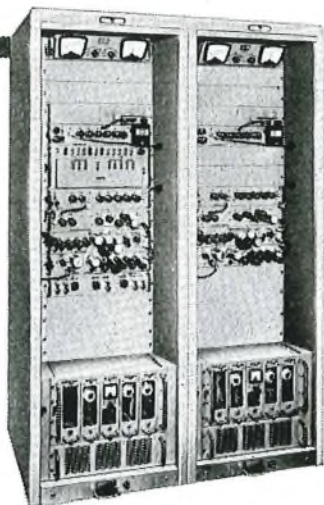

Pye microwave equipments are available in both portable and fixed versions for the transmission of television programmes, including sound, over long distances. With one watt transmitter power, excellent performance can be maintained over single links of up to 50 miles or more. Operating frequencies can be anywhere in the band 5925-7750 Mc/s, with excellent frequency stability. In portable form, complete link comprises four luggage type cases plus aerials and tripods, and is easily assembled on site. Fixed type equipment is mounted in six foot enclosed cabinets, all components being accessible from the front of the cabinet.

PYE TELECOMMUNICATIONS LTD · CAMBRIDGE · ENGLAND

Equipo de radio **S.E.C.** de SHF (Frecuencias Superelevadas) para 1800 Circuitos vocales.

Τῆς **S.E.C.** ὑπερυψηλῆς συχνότητος ἐφόδιον ραδιοφώνου
διὰ τὴν ἀναπαραγωγὴν ἤχου 1.800 κυκλωμάτων.

جى. اى. سى. **S.E.C.** ذات موجات عالية
اجهزة راديو للدورات الكلميه ذات
(S.H.F.)
١٨٠٠

S.E.C. radioutrustning för talkrets 1800 sör centimetervågor

S.E.C. SHF RADIO EQUIPMENT

Alatan radio Ulangan Lampau Kerap
(U.L.K.) untok 1,800 litar uchapan

S.E.C. UKW Radioausrüstungen für 1.800 Sprechkreise



WHATEVER

Equipment Radio **S.E.C.** à SHF pour circuit

vocal 1800



FOR 1800 SPEECH CIRCUITS

LANGUAGE YOU SPEAK -  EQUIPMENT

WILL TRANSMIT IT!

Transmission Division

G.E.C. (TELECOMMUNICATIONS) LTD

Telephone Works · Coventry · England

Works at Coventry and Middlesbrough

EVERYTHING FOR TELECOMMUNICATIONS

BALANCED CABLE MULTIPLY

Fully transistorised underground repeaters are used for the first time in Canada on a 120 channel multiplex carrier cable scheme in Northern Ontario. Northern

Telephone Limited has ploughed in the cable between Sault Ste. Marie and Hearst (about 350 miles) in the ballast along the right-of-way of the Algoma Central & Hudson Bay Railway. Two parallel 60 channel systems, in the band 12-252 kc/s, give 120 telephone circuits on two buried single quad 40 lb. polythene cables.

The line and multiplex equipment is supplied by Etelco Canada Limited. Similar equipment, designed and built by Ericsson Telephones Ltd. is in operation in other parts of the world.

If your communications problem is one of choice between open-wire, radio or cable, a word with our engineers will cost you nothing and may well prove extremely beneficial.

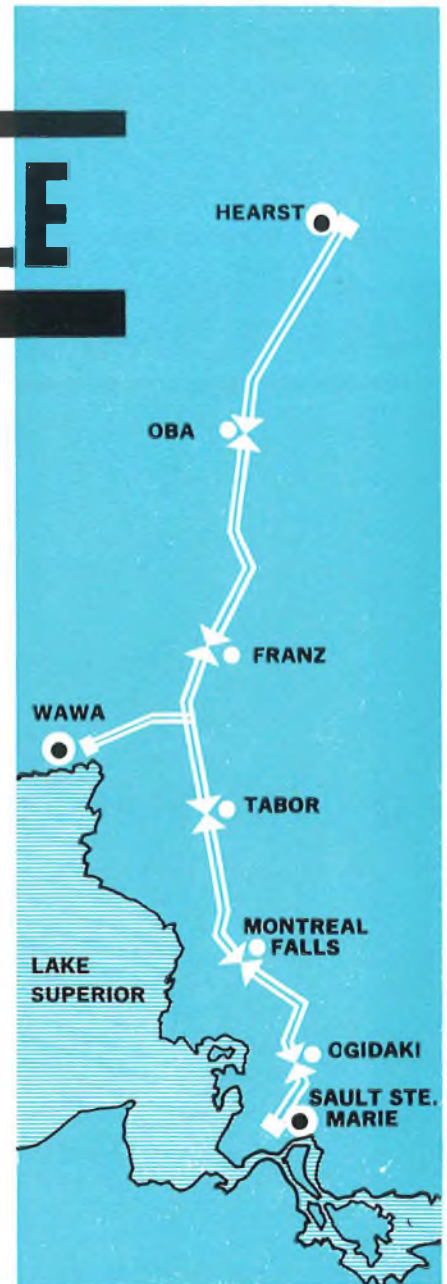
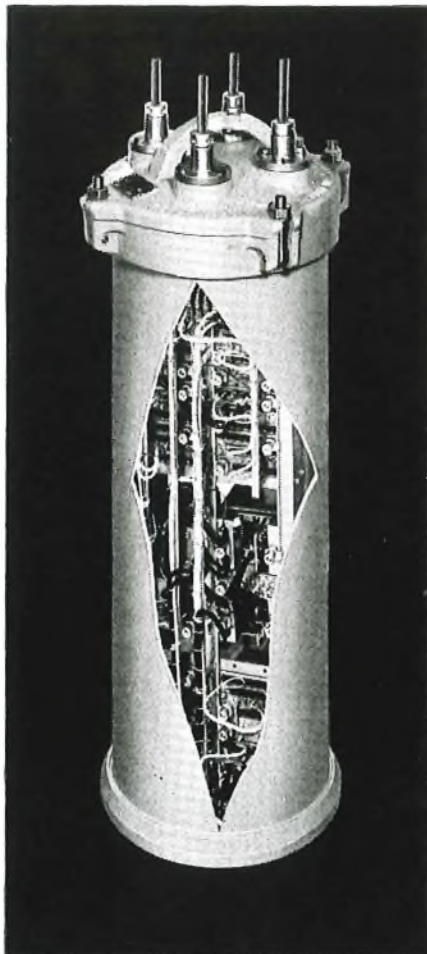

FOUR PAIRS ONLY
Supply 22 subscribers

REMAINING PAIRS
FREED for new subscribers
or other **TMC** Connectors

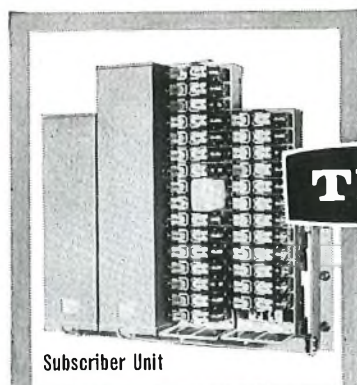

Subscriber Unit

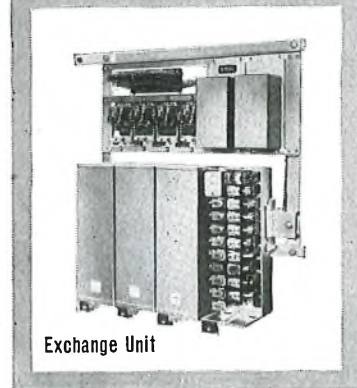

Exchange Unit

TMC

Extensible Line Connector

The TMC Extensible Line Connector provides complete telephone service to ten subscribers using only one exchange line, and is extensible to accommodate twenty-two subscribers using four lines. Thus four pairs out of a cable free the remaining pairs either for new subscribers or for connection to other TMC Extensible Line Connectors, permitting further groups of ten to twenty-two subscribers to be given service.

The equipment is designed around three types of jack-in relay set so that very simple stage-by-stage extension may be made from 10 subscribers working over only one pair to 22 subscribers working over four pairs. It consists of two units—very simple to install and maintain. The compact Subscriber Unit is supplied as a fully wired framework for wall or rack mounting and a weatherproof case, suitable for wall or pole mounting, is available as an optional extra. No battery or power is required at the Subscriber Unit, and no control pairs are needed. The Exchange Unit is also a small framework fully wired.

Tell us of your immediate requirements and your plans for future development, and we will submit quotations and recommendations.

TMC

TELEPHONE MANUFACTURING COMPANY LIMITED

Telephone Equipment Division, Equipment Section

Martell Road • West Dulwich • London S.E.21 • Telephone: Gipsy Hill 2211

A MEMBER OF THE  GROUP OF COMPANIES

FLUSH MOUNTING RESETTABLE METERS

This 3 figure meter as adopted for subscriber trunk dialling is an example from a complete range of electro-mechanical counters. Manual and electrical reset types for indication, pre-determined counting, printing and readout are available.

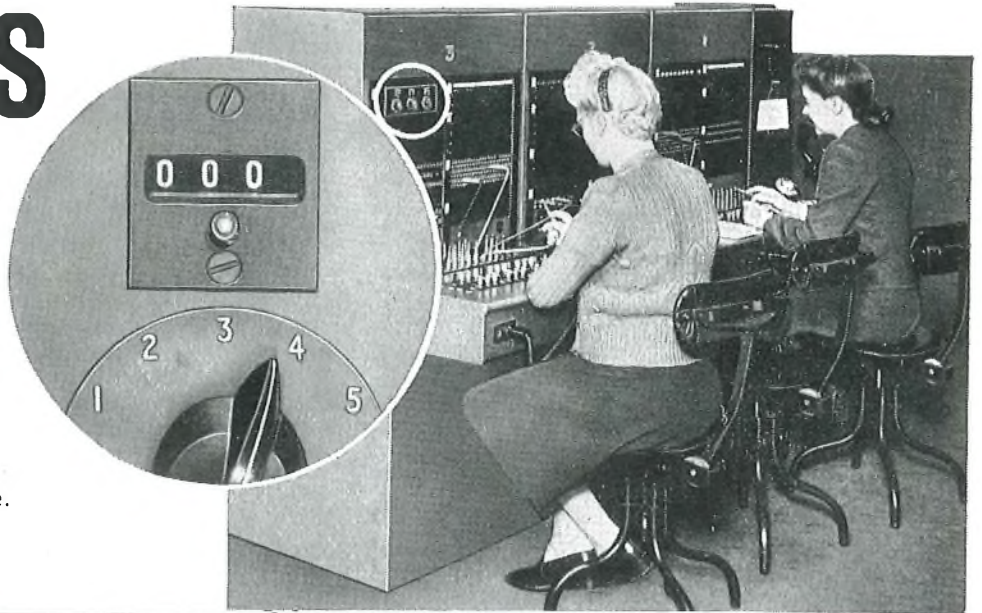

THE STONEBRIDGE ELECTRICAL CO. LTD.

6 QUEEN ANNE'S GATE • LONDON, S.W.1 Telephone: TRAFalgar 1444

CONTROLS & INSTRUMENTS

STONEBRIDGE

Agents and Licensees in U.K. for 'SODECO' Geneva

Ernest Turner

Electrical Measuring Instruments

Ideally matching contemporary panel design, the Ernest Turner Model 703, illustrated here, is enhanced by the flush-fitting surround. A high degree of accuracy is adequately supported by the easy-to-read scale and clean dial layout. Full details of the range of rectangular electrical measuring instruments and flush mountings are contained in Leaflets 85/G and 85/AF, available on request.

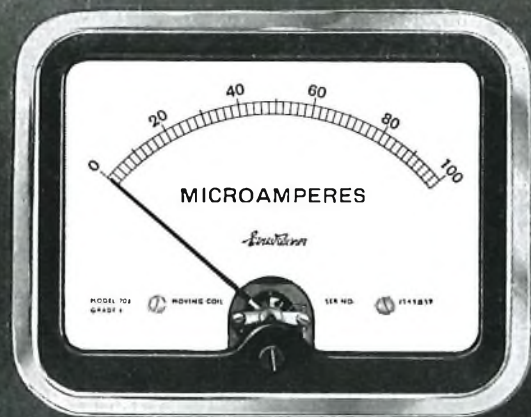

Ernest Turner Electrical Instruments Ltd
HIGH WYCOMBE • BUCKINGHAMSHIRE • ENGLAND

HOW TO PASS YOUR CITY AND GUILDS TELECOMMUNICATIONS EXAMS - BY POST

The new Bennett College Telecommunications Courses were prepared under the supervision of one of the country's top telecommunications men, W. S. Procter, O.B.E., M.I.E.E., F.R.S.E., Formerly Chief Regional Engineer, London Telecommunications Region.

The first and second year subjects are:
FIRST YEAR 1. Practical Mathematics. 2. Engineering Science. 3. Engineering Drawing. 4. Elementary Telecommunications Practice.
SECOND YEAR 1. Mathematics for the Telecommunications A. 2. Telecommunications Principles A. 3. Radio and Line Transmission A. 4. Telephony and Telegraphy A. 5. Line Plant Practice A.
Other subjects will be introduced later.

The certificates awarded by the City and Guilds Institute are of special value to employees of the Post Office Telecommunications Branches, and the Radio and Telecommunications industry, whether engaged in the manufacture or the maintenance and operation of Telecommunications apparatus.

Post this coupon off at once for more information
To: THE BENNETT COLLEGE (DEPT. 24WSP) Sheffield
Please send me details of the new Telecommunications Courses
NAME
ADDRESS
AGE

Personal postal tuition through the famous Bennett College!

TRANSFORMERS

Their Principles and Design for Light Electrical Engineers
by F. C. Connelly, Ph.D., A.M.I.E.E., A.R.C.S., D.I.C.

Laboratory workers, designers, and users of transformers in the light electrical industries will find this a most valuable book. Here, gathered into one volume for the first time, is information about the different types of transformers required in line and radio communication, radio-frequency heating, electronics, portable machine tools, electro-medical equipment, illumination and measuring apparatus. 35/- net.

INFORMATION THEORY AND ITS ENGINEERING APPLICATIONS

by D. A. Bell, M.A., Ph.D., M.I.E.E.
Third Edition

Minor alterations have been made to the existing text and two important new sections added. The interest in digital data transmission has made a chapter on error-detecting and error-correcting digital codes necessary, and since information theory is now applied to the manipulation of information by electronic computers, a chapter on Electronic Computers and Data Processing has been added. 25/- net.

EXPERIMENTAL ELECTRICAL ENGINEERING

by E. T. A. Rapson, M.Sc. (Eng.), A.C.G.I., D.I.C., M.I.E.E.
Fourth Edition

A book covering the experimental work necessary for students taking the Ordinary and Higher National Certificates in Electrical Engineering, and also the B.Sc., and I.E.E., examinations. 12/- net.

PITMAN

PARKER STREET, KINGSWAY, LONDON, W.C.2

GECOLITE FERRITE TOROIDS DISCS

A range of high permeability, close tolerance, ferrite toroids is available suitable for use in pulse and wide band transformer applications.

Ferrite discs, ground to close tolerances and suitable for incorporation in delay lines and transducers can be supplied in a range of permeabilities. Send for leaflet FTD/6112

Salford Electrical Instruments Limited
Peel Works, Silk Street, Salford 3, Lancs.
Tel: BLACKFRIARS 6688.
London Sales Office: BROOK GREEN, HAMMERSMITH, W.6. Tel: Riverside 5245
A subsidiary of THE GENERAL ELECTRIC COMPANY LIMITED OF ENGLAND.

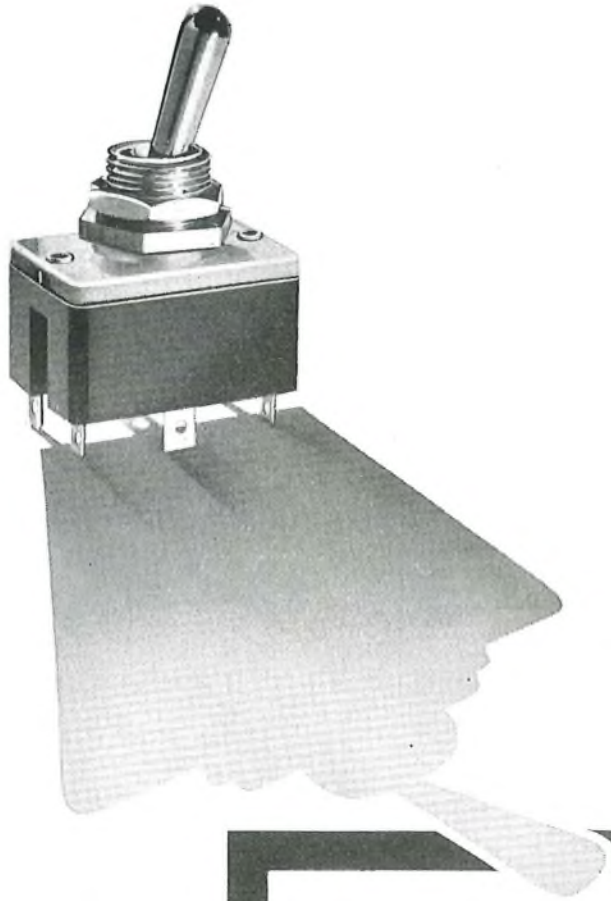

Double pole change-over switch
with quick-make quick-break action

High arc erosion resistance materials
ensure long operational life

Silver plated contacts for low contact
resistance

Rating : 3 amps, 250 volts, DC or AC r.m.s.
Average internal resistance 0.005 ohms

PAINTON RELIABILITY

**in this NEW compact
3 amp. Toggle Switch**

Built to the inflexibly high PAINTON standards

Send for leaflet T.S.5 and sample



Painton & Co. Limited

KINGSTHORPE, NORTHAMPTON. Tel: 34251 (10 lines). Grams: 'Ceil' Northampton. Telex 31576



murphy

MAKE RADIO LINKS

Murphy Radio Link Systems are in use on large and small scale projects the world over. Up to 48 channel capacity VHF & UHF equipments are available for use with any carrier equipment. If radio link systems are of interest to you, our systems planning department will send you full technical information.

KEEP IN TOUCH WITH MURPHY

*Write to: Mr. J. G. Ball,
Murphy Radio Limited, Electronics Division,
Welwyn Garden City, Hertfordshire, England
Telephone WELWYN GARDEN 23434*

TMC

Transistorised 12-Circuit Carrier Telephone System for 2-wire cable working C12H

Equipped on one 9 ft. rackside — ready for immediate delivery the TMC's type C12H is self-contained with 'E and M' signalling, and its own power supply panels, for energisation from battery or a.c. mains.

A terminal may be sub-equipped initially and later extended as required. It embodies transistor circuits giving low power consumption, and is suitable for use in tropical climates. The equipment is grouped in functional units, and mechanical design allows maximum accessibility with minimum disruption of working circuits. Engineers will recognise in the performance specification of this equipment the high standards which characterise TMC products.

Can you benefit by the immediate availability of this economical high quality unit, or do your projects and problems involve other types of modern terminal equipment for multi-channel working? Write to us giving an outline of your immediate or long-term plans for telephone services. Experienced transmission engineers of TMC's Advisory Service will study your problems and give detailed recommendations without delay.

TMC
TELEPHONE MANUFACTURING COMPANY LIMITED

Transmission Division

Sevenoaks Way · St. Mary Cray · Orpington · Kent · Telephone: Orpington 27020

 A MEMBER OF THE  GROUP OF COMPANIES



G.N.T. Tape Reader Model 22



G.N.T. Undulator Model 311

G.N.T.

INSTRUMENTS

- Complete range of Wheatstone equipment
- Complete range of special Morse training equipment
- G.N.T. 5-unit Transmitters with one or two sensing heads
- G.N.T. Converters for Morse or Cable Code to 5-Unit or 5-Unit to Morse or Cable Code
- G.N.T. Tape Readers for 5, 6, 7 or 8 Unit Tape

GREAT NORTHERN TELEGRAPH WORKS

4 SYDHAVN PLADS
COPENHAGEN DENMARK

LONDON OFFICE:
5 ST HELENS PLACE EC3



SOMETHING NEW for MANUFACTURERS !

BONDED FERROBA, a permanent magnet material comprising barium ferrite in a base of P.V.C. or rubber and having the properties of those materials. Extruded into strip. Callendered into sheet. Semi-flexible. Machinable. High electrical resistance.

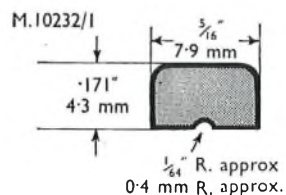
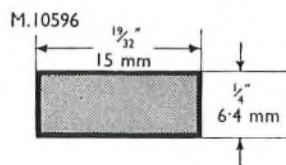
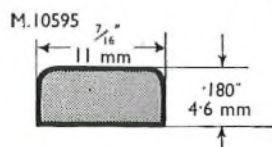
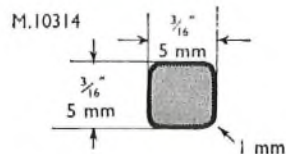

Magnetic characteristics appropriate to very short magnetic lengths and very great cross sectional areas. Not liable to magnetic damage by careless handling. Can be magnetised many ways. High flux densities achievable by concentration in soft pole pieces.

ECLIPSE MAGNETIC PLASTIC STRIP.

Several standard sizes are illustrated. M.10314 was developed for television corrector magnets. M.10232/1, M.10595 and M.10596 are suitable for repulsion and attraction duties, including door closures. Grip vastly superior when incorporated in magnetic "sandwiches". Supplied in strip or in form of finished magnets, in both cases magnetised. Ask for Eclipse Bulletin M.29.

ECLIPSE PLASTIC SHEET MAGNETS.

Two standard thicknesses, .032" (1/32") = 0.8mm. and .065" (1/16") = 1.6mm. Typical uses are picture shift magnets in television, rotors in electric clocks, arc blow-outs, and oil filters. Supplied in form of finished magnets, magnetised ready for use. Ask for Eclipse Bulletin M.30.

| | B rem (Gauss) | BH max (MGO) | H B c (Oersteds) |
|--|------------------|-----------------|------------------------|
| BONDED FERROBA | 1400 | 0.4 | 1150 |
| Alcomax III (The generally accepted standard of reference for all magnets). | 12,500 | 5.1 | 670 |

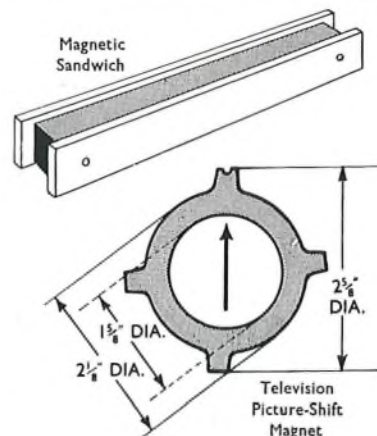

Telephones made from 'Diakon' retain their attractive appearance through years of use



Telephones designed and manufactured by Ericsson Telephones Ltd., Beeston, Nottingham, with cases, handsets and transparent dials made from 'Diakon' I.C.I. acrylic polymer.

'Diakon' acrylic polymer was chosen for these modern telephones because mouldings made from 'Diakon' polymer have so many advantages:—

- no change in surface finish or mechanical properties with age
- good heat stability and high heat distortion temperature
- low water absorption
- resistance to staining by nicotine, lipstick and polishes
- lightness in weight
- wide range of colours which will not fade

Find out more about 'Diakon' polymer, and its many uses in the telecommunications, electric and electronics fields, from your local I.C.I. Sales Office.

'DIAKON' POLYMER

'Diakon' is the registered trade mark for the acrylic polymer manufactured by I.C.I.



IMPERIAL CHEMICAL INDUSTRIES LIMITED · LONDON · S.W.1

NEW MARCONI 'SOLID STATE' AUTOPLEX

The most advanced error correcting
telegraph equipment in existence

ERROR PROOF HF TRAFFIC

WITH

40% less capital cost per channel

75% reduction in size

75% reduction in weight

90% reduction in power consumption

PLUS

Considerable savings in manpower,
spares and maintenance

- * One cabinet houses equipment for two 2-channel circuits which may be operated as one 4-channel circuit
- * Modular construction means greater reliability and greatly simplified maintenance
- * *Built-in* character storage for 4 or 8 character repetition cycle
- * Fully automatic phasing including rephasing in traffic with no loss or duplication of characters
- * Average rephasing time in traffic 4 seconds
- * Mis-routing of sub-channels is impossible even with sub-division on all channels
- * Error rate improvement factor of 100-10,000

* **FERRITRANSISTORIZED** code converters and stores surpass fully transistorized designs by significant reduction in power and saving in space.

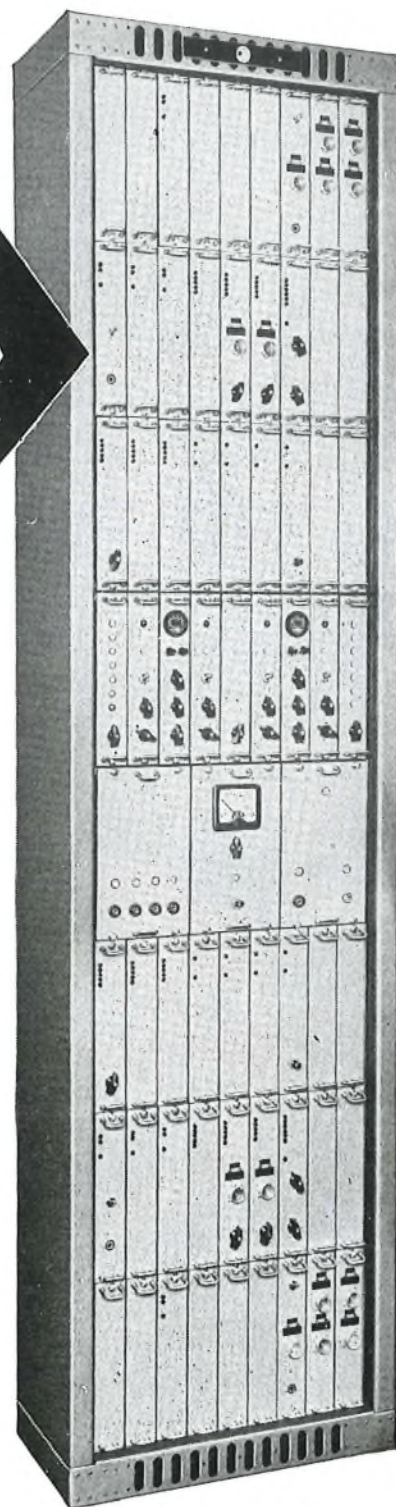

MARCONI SOLID STATE AUTOPLEX

accurate ERROR CORRECTION MULTIPLEX TELEGRAPH SYSTEMS

MARCONI'S WIRELESS TELEGRAPH COMPANY LIMITED · CHELMSFORD · ESSEX · ENGLAND

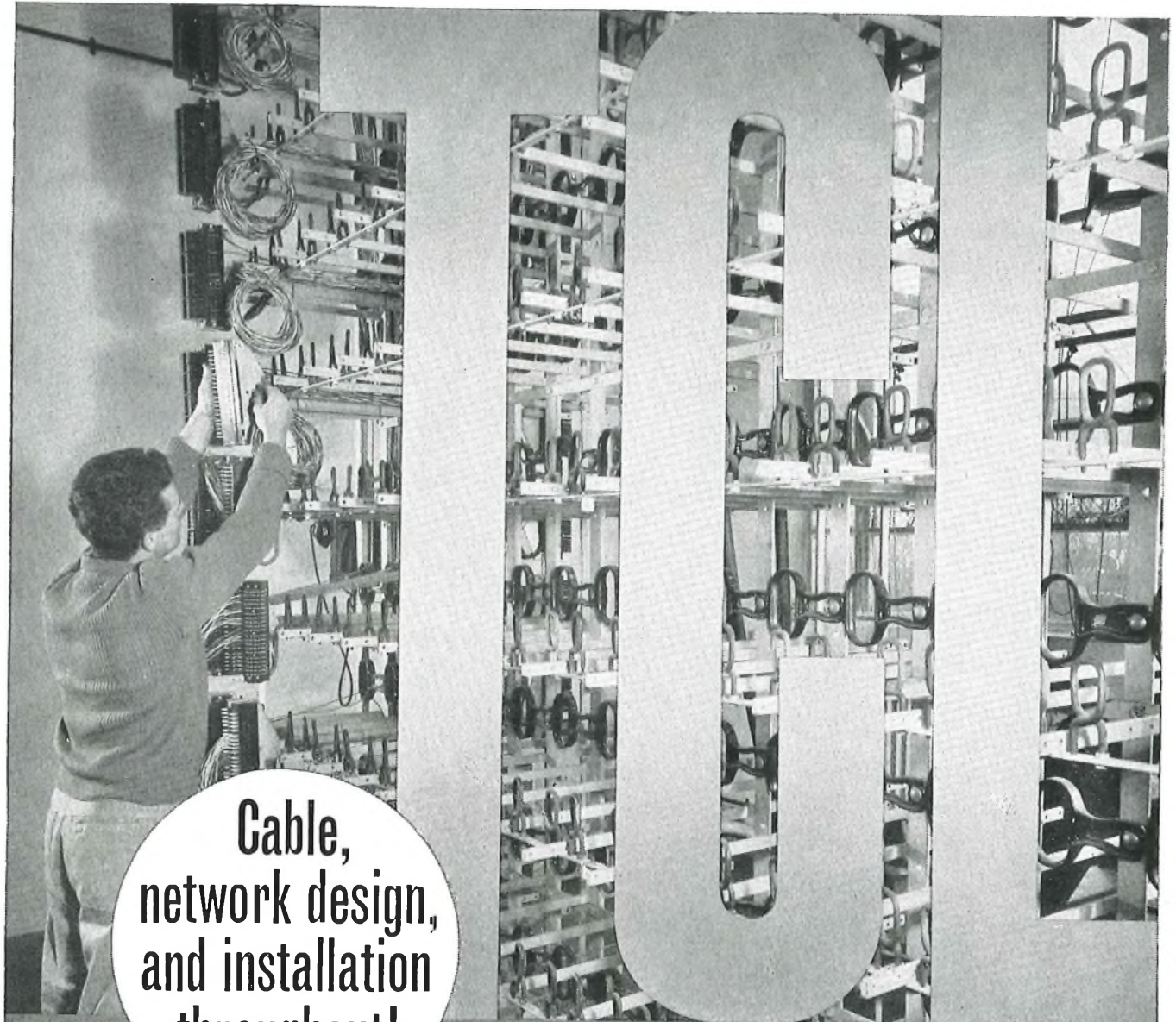

**Cable,
network design,
and installation
throughout!**

TELEPHONE CABLES LIMITED

not only manufacture telephone cables in an immense variety of types, sizes and different kinds of insulation, but also undertake the installation of complete systems and will supply highly experienced technicians to supervise the work throughout. Entrusting the whole project—its design, production and installation—to T.C.L. ensures the greatest speed, efficiency and economy ... and above all—long term reliability in operation.

TELEPHONE CABLES LIMITED, DAGENHAM, ENGLAND · TELEPHONE: DOMINION 6611 · CABLES: DRYCORE DAGENHAM

THE ORGANISATION WITH 125 YEARS' EXPERIENCE.

ADCOLA

REGISTERED TRADE MARK
(Royal Trade Mark)

SOLDERING INSTRUMENTS and EQUIPMENT

Illustrated
L64 $\frac{3}{16}$ " DETACHABLE
BIT MODEL IN
PROTECTIVE
SHIELD L700
FITTED WITH
ACCESSORIES FOR
BIT CLEANING, ETC.

ALL VOLT RANGES
6/7 to 230/250 VOLTS

British and Foreign
Patents and Registered
designs

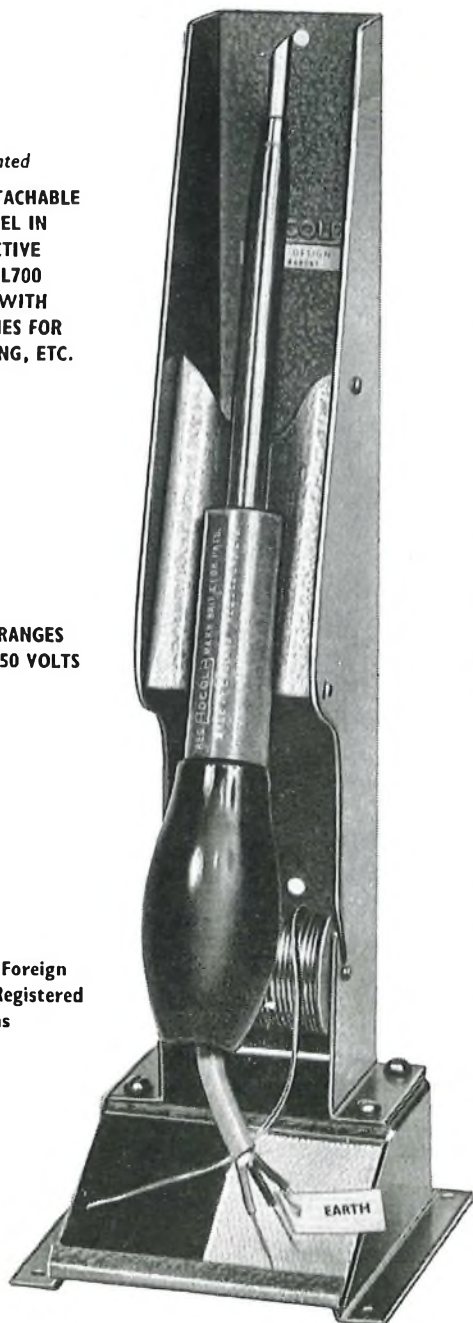

For further information and full illustrated catalogue apply head office

ADCOLA PRODUCTS LIMITED
ADCOLA HOUSE, GAUDEN ROAD,
LONDON, S.W.4

Telephones:
MACaulay 3101 and 4272

Telegrams:
SOLJOINT, LONDON, S.W.4

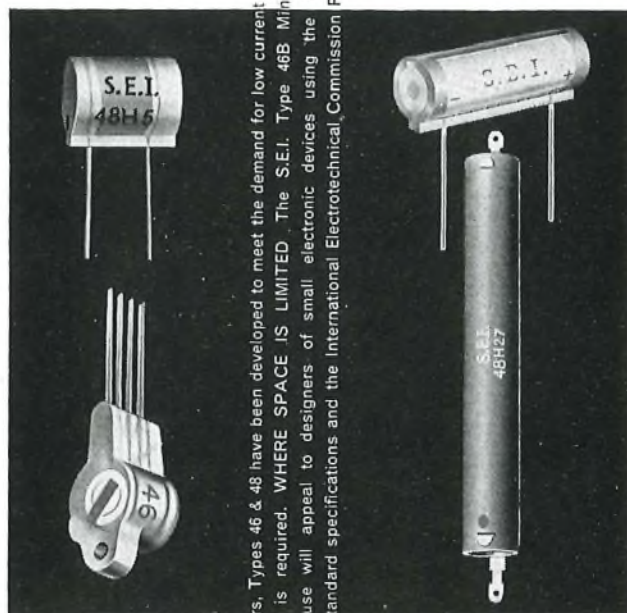

The S.E.I. Tubular Selenium rectifiers, Types 46 & 48 have been developed to meet the demand for low current electronic applications where the reliability and low cost of a metal rectifier is required. WHERE SPACE IS LIMITED The S.E.I. Type 48B Miniature Selenium Bridge Rectifiers provide the solution. Their versatility of use will appeal to designers of small electronic devices using the new low voltage valves. S.E.I. rectifiers meet the requirements of British Standard specifications and the International Electrotechnical Commission Publication 119. Send today for full details.



SALFORD ELECTRICAL INSTRUMENTS LIMITED
PEEL WORKS, SILK STREET, SALFORD 3, LANCS. Tel. Blackfriars 6688 (6 lines)
London Sales Office: BROOK GREEN, HAMMERSMITH, W.6. Tel. Riverside 5246
A Subsidiary of THE GENERAL ELECTRIC COMPANY LIMITED OF ENGLAND

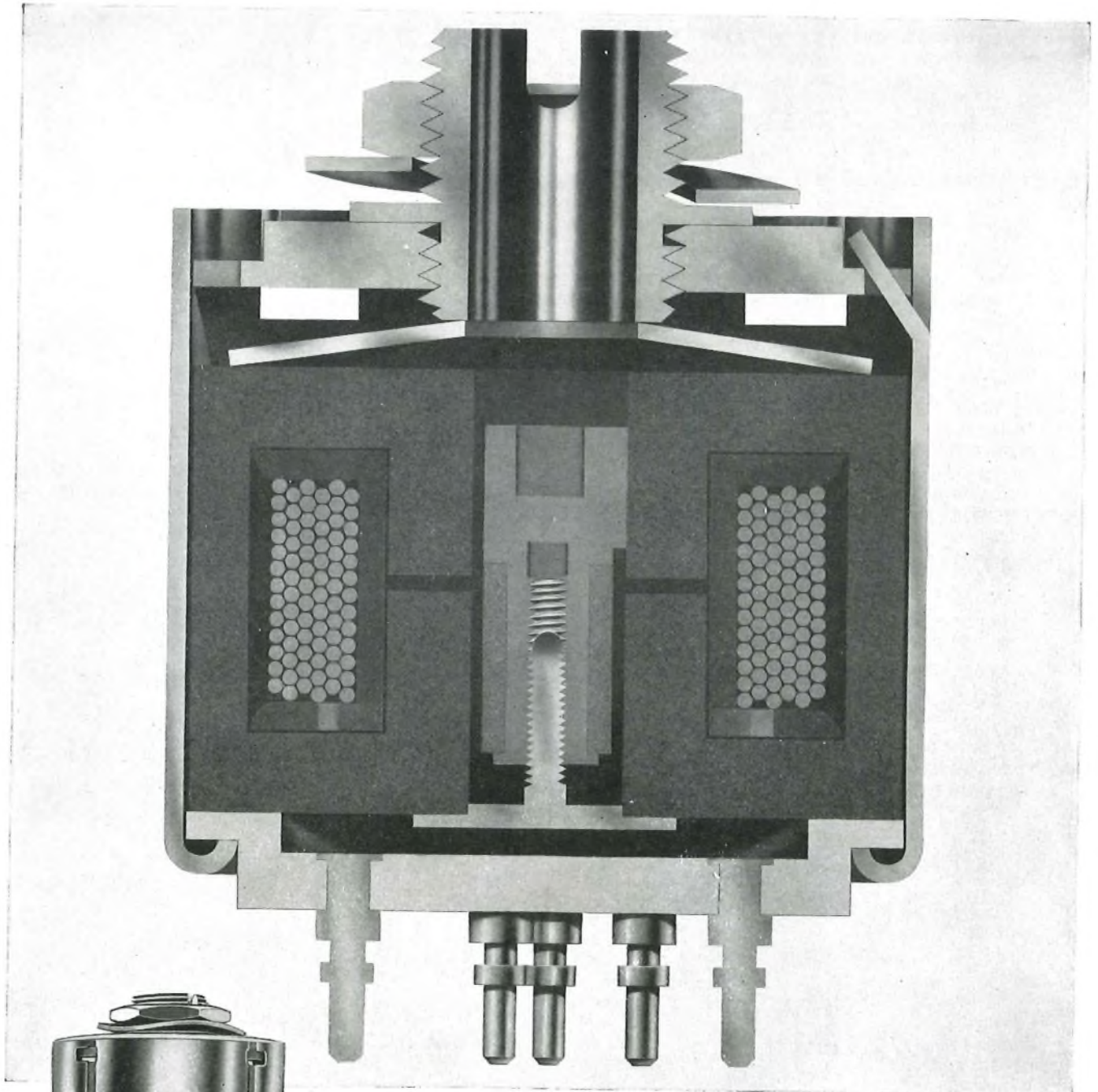

IF YOU LOOK INTO VINKORS YOU'LL FIND . . .

- Precise Inductance without core grinding
- Easy assembly and setting accuracy of 0.02%
- Adjustment of $\pm 7\%$
- Eight sizes from 14 mm. to 45 mm.
- Long term stability of 0.1%
- Single hole or printed circuit mounting
- A frequency coverage up to 2 Mc/s
- A temperature coefficient compatible to polystyrene capacitors



Mullard **VINKOR** ADJUSTABLE POT CORE ASSEMBLIES

Write to Mullard House for full technical details of the wide range of Vinkor assemblies

Please quote reference Z/222/1

MULLARD LIMITED, COMPONENT DIVISION, MULLARD HOUSE, TORRINGTON PLACE, LONDON, W.C.1.

GLAZED VITRIFIED CLAY CONDUITS

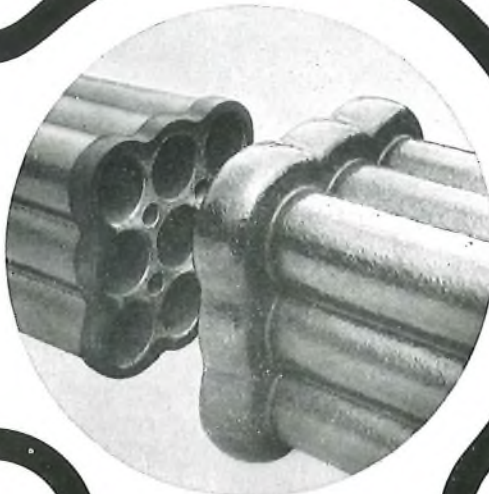

By courtesy of H.M. Postmaster General.

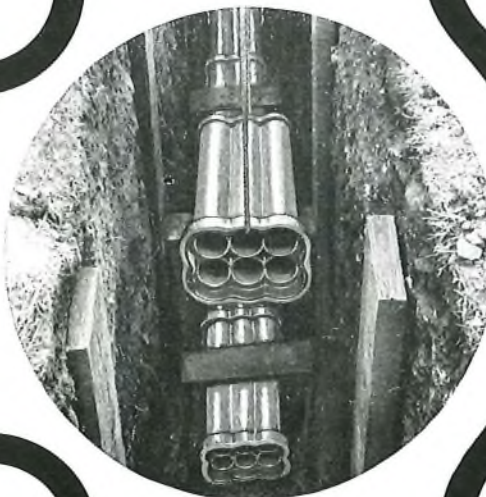

For vital communications . . . the choice is always **GLAZED VITRIFIED CLAY CONDUITS** for: low friction, load bearing, strength, durability and ease of installation.

for information write to the Engineer:

NATIONAL SALT GLAZED PIPE MANUFACTURERS' ASSOCIATION
Hanover Court, Hanover Square, London W.1. Phone: *MAYfair 0364*



remote
rural
areas
need...

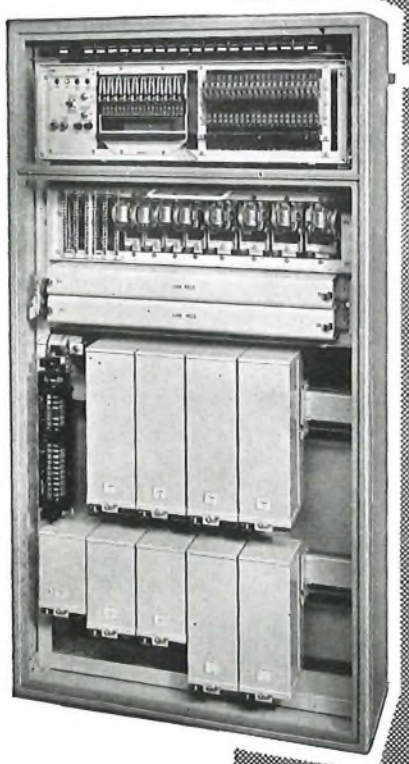

special features

Self contained, portable and robust.
Reliable and efficient with negligible maintenance.
Minimum current drain and battery charging over junctions.
Physical or Carrier junctions to parent exchange.
Equipped with two Rural Carrier channelling units.
Coin-box discrimination.
Variable metering arrangements available.
Forced release and lock-out under P.G. and C.S.H. conditions.
Alarm test circuit to check condition of exchange from the parent exchange.
Alarm extension.
Transistor Ringing and Tone generator.

for further information please write to:

HEAD OFFICE: 22, LINCOLN'S INN FIELDS, LONDON, W.C.2 TEL.: HOL. 6936

MINIRAX

Maintenance difficulties, the lack of a suitable power source, and prohibitive costs have often restricted the introduction of automatic telephone equipment into rural areas.

Minirax, designed to overcome such difficulties, is a small 20 line exchange housed in a single unit and is complete in every detail. It is simple and quick to install because it does not require either special site accommodation or local mains supply.

Power is derived from a 24 volt battery which can be charged over one or more physical junction lines from the higher voltage supply of the parent exchange. If necessary, Minirax can be connected into a telephone network over one physical junction pair only; additional junction circuits being obtained by the use of transistor rural carrier equipment.

The attractively finished pressed steel cabinet is specially designed to exclude dust and is divided into two distinct compartments, the upper one containing line terminators and alarm test panel equipment, allowing changes to lines etc. to be carried out without exposing the switching equipment located in the lower compartment.

The switching equipment, which consists of well proven relays and uniselectors, operates on step-by-step principles, thereby avoiding the use of common equipment. This, together with the above features, ensures a reliable and efficient service without complicated maintenance problems.

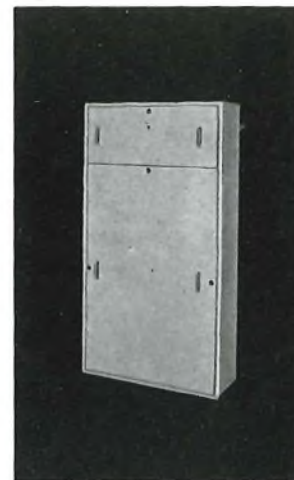

ERICSSON TELEPHONES LTD
ETELCO LTD

SPECIALISTS

IN REPEATERED SUBMARINE TELEPHONE CABLE SYSTEMS

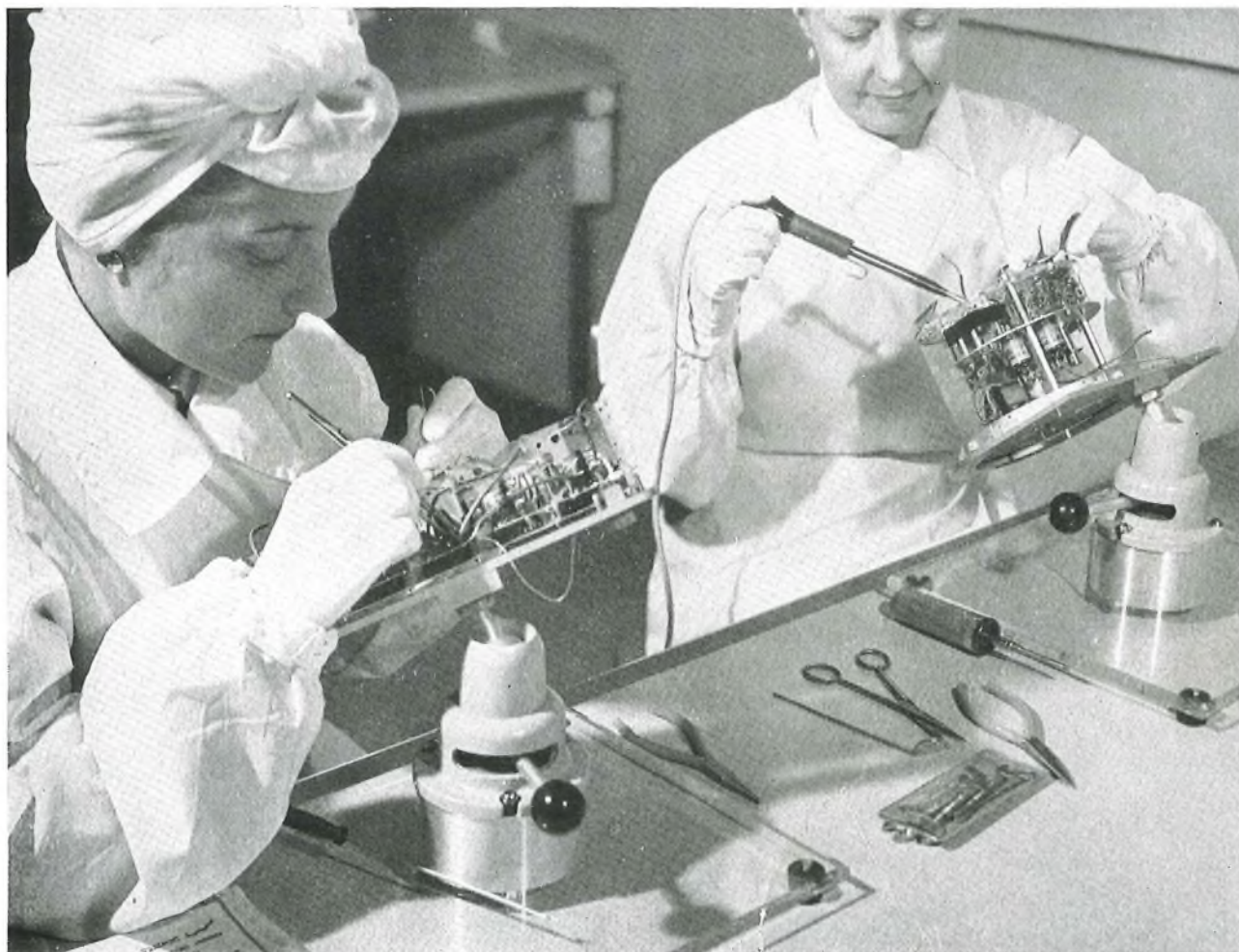

Wiring and assembly of units for Submerged Repeater

Submarine Cables Ltd., specialise in complete submarine telephone cable systems—cable, submerged repeaters, cable laying and terminal equipment.

Submarine Cables Ltd. developed the new unarmoured (lightweight) cable designed by the British Post Office and the Company's factory at Greenwich has supplied this type of cable for the first Commonwealth link (called CANTAT) between Scotland and Canada, to the order of the Canadian Overseas Telecommunication Corporation and Cable and Wireless Ltd. Their Repeater Division at Erith, Kent, has made the submerged repeaters for the CANTAT extension from Newfoundland up the St. Lawrence River, to the order of the Canadian Overseas Telecommunication Corporation.

Submarine Cables Ltd., backed by over a hundred years of experience, are in a position to give expert technical advice on any submarine-cable telecommunications problem.

SUBMARINE CABLES LIMITED

Owned jointly by Associated Electrical Industries Ltd. and British Insulated Callender's Cables Ltd.

HEAD OFFICE: Mercury House, Theobald's Road, London WC1 · Telephone: HOLborn 8711 · Telegrams: Telsiem, London, Westcent. · Cablegrams: Talsiem London WC1 WORKS: Telcon Works, Greenwich: Ocean Works, Erith, Kent.

INDEX TO ADVERTISERS

| | PAGE | | PAGE |
|--|----------------------|--|-------------|
| Adcola Products, Ltd. | 35 | Mullard, Ltd. | 20, 36 |
| Associated Electrical Industries, Ltd. | 14 | Murphy Radio, Ltd. | 29 |
| Automatic Telephone & Electric Co., Ltd. | 19 | National Salt Glazed Pipe Manufacturers' Association ... | 37 |
| Avo, Ltd. | 18 | Neill, James, & Co. (Sheffield), Ltd. | 31 |
| Bennett College, The | 27 | Oxley Developments Co., Ltd. | 8 |
| British Institute of Engineering Technology | 40 | Painton & Co., Ltd. | 28 |
| British Non-Ferrous Metals Federation, The | 13 | Pitman, Sir Isaac, & Sons, Ltd. | 27, 40 |
| Cayson Electrics, Ltd. | 3 | Pye Telecommunications, Ltd. | 6, 21 |
| Drallim Industries, Ltd. | 18 | Salford Electrical Instruments, Ltd. | 27, 35 |
| Engine Applications, Ltd. | 41 | Standard Telephones & Cables, Ltd. | 5, 7, 9, 11 |
| Ericsson Telephones, Ltd. | 24, 38 | Stonebridge Electrical Co., Ltd., The | 26 |
| Formica, Ltd. | 15 | Submarine Cables, Ltd. | 39 |
| G.E.C. (Telecommunications), Ltd. | 10, 12, 16-17, 22-23 | Telephone Cables, Ltd. | 34 |
| Great Northern Telegraph Co., Ltd. | 31 | Telephone Manufacturing Co., Ltd. | 25, 30 |
| Imperial Chemical Industries, Ltd. | 32 | Turner, Ernest, Electrical Instruments, Ltd. | 26 |
| Joint Electronic Research Committee | 2 | Westinghouse Brake & Signal Co., Ltd. | 4 |
| Mallory Batteries, Ltd. | 42 | Whiteley Electrical Radio Co., Ltd. | 8 |
| Marconi's Wireless Telegraph Co., Ltd. | 33 | Winn & Coales, Ltd. | 3 |

RADIO COMMUNICATION

By J. H. Reyner, B.Sc., A.C.G.I., D.I.C., M.I.E.E.
and

P. J. Reyner, M.A.(Cantab.)

This is an entirely new issue in a single volume of J. H. Reyner's original standard work Modern Radio Communication. For this new book, J. H. Reyner has been joined by his son and together they have produced an up-to-date work which covers the syllabus of the City and Guilds Telecommunications Technicians' courses and the corresponding parts of the Institution examinations. It includes a thorough groundwork in the theory of radio communication, starting from an assumed elementary knowledge of electrical phenomena. No advanced mathematics is necessary. Subjects covered include short-wave radio, cathode-ray tube developments, transistors, picture transmission and television, etc. M.K.S. units are used throughout.

Price 55/- net

PITMAN PARKER ST., KINGSWAY
LONDON, W.C.2

VALUABLE FREE BOOK

**Tells You How to Pass Your C. & G.
Examination at First Attempt!**

All Post Office personnel who are anxious to obtain early promotion should at once send for a copy of our handbook "ENGINEERING OPPORTUNITIES" which, among other intensely interesting matter, describes our unique methods of preparation for the CITY AND GUILDS EXAMINATIONS for the Telecommunication Technicians' Certificate and for individual subjects—Mathematics, Engineering Science, Engineering Drawing, Elementary Telecommunication Practice, Telecommunication Principles, Radio and Line Transmission, Telegraphy and Telephony, Line Plant Practice. It also contains details of our courses covering the G.C.E. subjects required for promotion to Assistant Engineer, Telecommunication Traffic Superintendent and other grades; and the City and Guilds examinations in Electrical Engineering Practice, the Grad.Brit.I.R.E. and A.M.S.E. Examinations, in addition to a wide range of non-examination courses in all branches of engineering—Radio and Electronics, Electrical, Mechanical, etc.

We also provide tuition for the Radio Amateurs' Examination and the P.M.G. Certificates for Radio Operators, with or without Morse training. Details are given in the handbook.

**We definitely guarantee
"NO PASS — NO FEE"**

If you intend to make the most of today's opportunities, you cannot afford to miss reading "ENGINEERING OPPORTUNITIES." It tells you everything you want to know to secure advancement, and describes many opportunities you may now be missing through lack of information. Send for your copy today—FREE and without obligation.

**BRITISH INSTITUTE
OF ENGINEERING TECHNOLOGY**
369 COLLEGE HOUSE,
29-31 WRIGHT'S LANE, LONDON, W.8

BIET

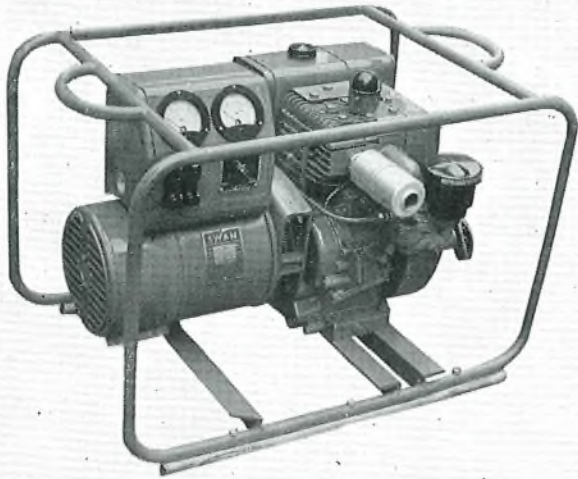

generates everywhere

SWAN

generates everywhere

Swan Generating sets are designed for service throughout the world to provide an electricity supply for domestic lighting and for industrial applications particularly where close frequency and voltage regulation requirements are essential.

The Swan range includes for sets up to 50 kw as standard and up to 150 kw against specific enquiries to customers individual requirements. These include remote control units, portable units, including road towing trailers, and mains failure standby units. All single and three phase voltages are standard in addition to special dual voltage machines, D.C. output machines and sets designed for marine use.

ILLUSTRATED ABOVE
A 600 watt-direct-current generating set, with compound-wound generator, designed to a British General Post Office Specification to provide a supply for lighting and battery charging.



SWAN

SWAN

generates everywhere

SWAN

generates everywhere

ILLUSTRATED RIGHT
A 15 kilo volt-amp fully-automatic standby generating set as supplied to the Syrian Post Office.

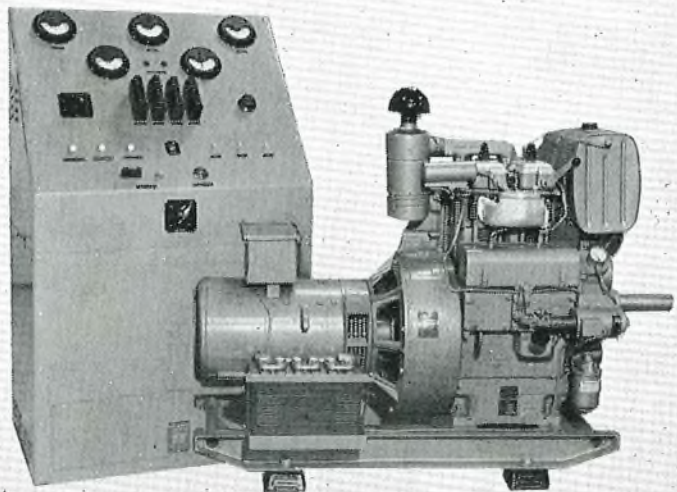

Write now for a copy of a catalogue showing the complete Swan range of petrol or diesel engine generating sets.

ENGINE APPLICATIONS LIMITED

Swan Close Road, Banbury, Oxon.

Tel. Banbury 3134/5

Export Office, Marlin House, 84-86 Grays Inn Road, London, W.C.1

primary cells

Mallory **MERCURY-ZINC ALKALINE SYSTEM**

CHEMISTRY

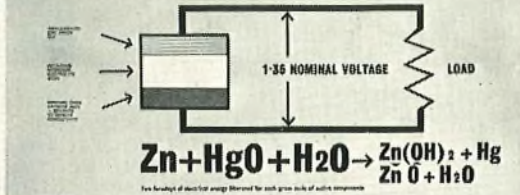

STRUCTURE

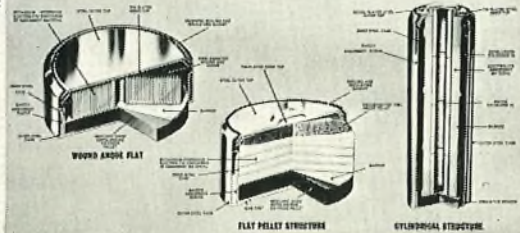

PROPERTIES

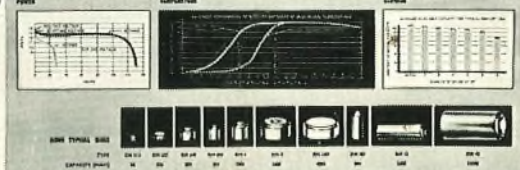

USES



FACTS FOR DESIGNERS
Write for free wall chart which graphically details the mercury-zinc alkaline system in structure and performance.

Mallory, pioneers of the mercury cell system, specialise in providing power for electronic applications. Mercury batteries—some as small as an aspirin—have unique high capacity and constant voltage discharge characteristics, can lie idle for years and still give full power, will withstand extremes of pressure, temperature, mechanical shock.

Wherever they are used, Mallory batteries give a longer fade-free life. They satisfy the exacting power demands of portable transistorised equipment, help the drive to miniaturisation in all fields of battery powered design.

MALLORY BATTERIES LIMITED CRAWLEY SUSSEX *Crawley 26041*

MALLORY *for new ideas in batteries*