

*RA Pac*

*Repealer Stn*

THE POST OFFICE  
ELECTRICAL ENGINEERS'  
JOURNAL



Vol. 52 Part 1

APRIL 1959

## CONTENTS

	Page
THE NEW 700-TYPE TABLE TELEPHONE—TELEPHONE No. 706 H. J. C. Spencer, A.M.I.E.E., and F. A. Wilson, C.G.I.A., A.M.I.E.E., A.M.Brit.I.R.E.....	1
AN INTRODUCTION TO ELECTRONIC COMPUTER SYSTEMS FOR OFFICE USE F. J. M. Laver, B.Sc., M.I.E.E.....	13
THE ELECTRONIC TRAFFIC ANALYSER—A SURVEY OF ITS USE AND LIMITATIONS H. T. McGrath, B.Sc.....	19
RECENT IMPROVEMENTS IN THE INKING SYSTEM OF A RECORDING DECIBELMETER A. C. Nicolls, B.Sc., D.I.C., A.M.I.E.E., and J. C. Harrison, B.Sc., A.R.I.C.....	26
CONCRETE J. P. Harding, B.Sc.(Eng.), A.M.I.C.E., A.M.I.E.E.....	29
AN EFFICIENT ELECTRONIC SWITCH—THE BOTHWAY GATE J. A. T. French, B.Sc.(Eng.), A.M.I.E.E., and D. J. Harding, B.Sc.(Eng.), A.M.I.E.E.....	37
RADIO INTERFERENCE, Part 6—The Control of Radio Interference C. W. Sowton, B.Sc.(Eng.), A.C.G.I., A.M.I.E.E.....	43
EXPERIMENTS IN AERIAL-CABLE CONSTRUCTION J. Bluring, D.F.C., B.Sc., A.M.I.E.E., and H. F. Snow.....	47
EQUIPMENT FOR TRAINING LETTER-SORTING-MACHINE OPERATORS G. A. Wylie, B.Sc.(Eng.), A.M.I.E.E.....	55
TELEGRAPH DISTORTION ON PHYSICAL (D.C.) LINES AND TELEGRAPH MACHINES D. W. E. Wheele, A.M.I.E.E., and E. G. Collier.....	61
A RESONANCE ISOLATOR FOR USE AT 4,000 Mc/s A. D. Cartwright and C. F. Davidson, A.M.I.E.E.....	69
NOTES AND COMMENTS.....	74
INSTITUTION OF POST OFFICE ELECTRICAL ENGINEERS.....	75
REGIONAL NOTES.....	76
ASSOCIATE SECTION NOTES.....	79
STAFF CHANGES.....	84
BOOK REVIEWS.....	18, 25, 42, 60, 68, 73, 75, 83, 87

Price 2/6 net



# THE POST OFFICE ELECTRICAL ENGINEERS' JOURNAL

Vol. 52 Part 1

APRIL 1959

## The New 700-Type Table Telephone—Telephone No. 706

H. J. C. SPENCER, A.M.I.E.E. and F. A. WILSON, C.G.I.A., A.M.I.E.E., A.M.Brit.I.R.E.†

U.D.C. 621.395.721.4:621.395.126.2

The "700-type" transmission circuit was originally included in a prototype telephone the physical design of which was based on that of the 300-type telephone. This article describes an entirely new table telephone incorporating the circuit. Of attractive appearance, the new instrument is being made in a wide range of colours using advanced constructional techniques, including printed wiring. It incorporates an automatic sensitivity regulator, shown to be necessary by trials with the prototype.

### INTRODUCTION

THE 700-type transmission circuit was first introduced by the Post Office in Telephone No. 700 and was described in an earlier article.<sup>1</sup> Using the rocking-armature receiver<sup>2</sup> this very efficient circuit promised considerable economies in the provision of local lines. The physical design of Telephone No. 700 was not new, however, being based on the 300-type telephone to minimize the cost of retooling by the telephone industry. This resulted in the rather dated case of the earlier telephone being retained, which clashed with the curves of the new handset. Subsequently it was decided that the use of Telephones No. 700 by the Post Office would be restricted to trials of transmission properties and that a completely new design of instrument, shaped to satisfy modern tastes but preserving the improved transmission performance, should be designed. This article describes the new telephone, which has been designated Telephone No. 706.

The trials carried out with Telephone No. 700 fully confirmed the high laboratory assessments of its transmission performance but revealed that subscribers with short lines would consider it too loud. After considering the various methods of overcoming this difficulty (they were briefly discussed in the earlier article<sup>1</sup>) it was decided that the solution most suited to Post Office operating conditions was the inclusion in the telephone circuit of a sensitivity regulator controlled by the line current. The transmission circuit of the new telephone has therefore been modified to include a regulator developed for this purpose.

The British telephone manufacturers were invited by the Post Office to submit proposals for a new physical design. The Postmaster General decided that the most promising of these was that submitted by Ericsson Telephones, Ltd. The original design was modified to incorporate changes suggested by the Council of Industrial Design, and in its final form (Fig. 1) was approved by the Council.



FIG. 1.—TELEPHONE NO. 706

### Choice of Moulding Material

Of fundamental importance in the design of the new telephone was the choice of material for the case and handset mouldings. In the past, the bulk of Post Office telephone mouldings have been made in thermosetting phenolic material. This is cheap and has a hard scratch-resistant and stain-resistant surface with good finish. A drawback is that it is naturally a dark colour and the range of alternative colours obtainable by the inclusion of pigments is very restricted. In recent years the use of thermoplastics has much increased and many new ones have become available in quantity. Generally these materials are stronger and less brittle than thermosetting materials and they are available in a wide range of colours. Against these advantages must be set the fact that they are more easily scratched, that some are susceptible to surface staining or chemical attack by such things as ink, furniture polish and cosmetics, and that they are more expensive. Thermoplastics are usually injection moulded, a much more rapid and therefore cheaper process than the compression moulding used for thermosetting materials, and because

† The authors are, respectively, Executive Engineer, Subscriber's Apparatus and Miscellaneous Services Branch, E.-in-C.'s Office, and Executive Engineer, Post Office Research Station.



FIG. 2—THE NEW TABLE TELEPHONES



of their extra strength they can also be used in thinner sections. These factors help to reduce the difference in price.

After considering a number of alternative materials the Post Office decided that polymethyl methacrylate, manufactured in this country by Imperial Chemical Industries, Ltd., under the trade name of Diakon, offered the best compromise between the sometimes conflicting requirements of cost, strength and finish. It is of interest that polymethyl methacrylate has been used by the Post Office in small quantities for coloured telephones since 1937 and has been found an excellent material. It has a translucency which gives it a very attractive appearance, and it has a hard surface, for a thermoplastic, which is not susceptible to staining. The decision to use it for all telephones was influenced by a substantial price reduction made possible by a change to a "dry mixing" moulding technique. This yields its economy by eliminating two manufacturing processes previously necessary to colour the base material and by reducing working stocks of materials.

#### *Colour Range*

The choice of a thermoplastic material for all telephones removes much of the economic necessity for supplying the majority of telephones in black and the new telephone will be supplied to subscribers primarily as a coloured instrument (see Fig. 2). It will be available in a range of six colours:

- Two-tone grey (light French grey with elephant grey)
- Two-tone green (aircraft grey-green with forest green)
- Light ivory
- Concord blue
- Lacquer red
- Topaz yellow

It will also be manufactured in black.

In choosing these colours the Postmaster General was again advised by the Council of Industrial Design, while consideration was also given to the production and maintenance problems of colour matching. Slight differences in the chosen colours are harder to detect by eye than differences in pure colours such as the red and green previously used for Post Office telephones.

The dyes and pigments used have been selected for their light-fastness qualities, and both natural and artificial fading tests that have been proceeding for some years show that all the colours have a light-fastness better than Standard No. 7.<sup>3</sup>

#### *Weight Reduction*

The use of thermoplastic material, helped by the absence of a chassis, has resulted in a considerable reduction in the weight of the telephone. Compared with 5½ lb for the 300-type telephone, the new telephone, conventionally wired, weighs only 3½ lb. The reduction in weight is most noticeable in the handset; the rocking-armature receiver weighs only 1·2 oz and the total weight of the handset is 9 oz, compared with nearly 1 lb for previous handsets. While the weight of the older handsets has been accepted hitherto without question or complaint, use of the new one leaves little doubt that lightness will be a feature much appreciated by subscribers.

#### *Alternative Interior Designs*

Among the designs which had been submitted to the Post Office was one which incorporated printed wiring for connecting the components instead of conventional

wiring. The printed-wiring technique, although still in its infancy, shows promise of manufacturing economy and lends itself particularly to automatic assembly methods. The new telephone has therefore been designed so that it can be manufactured with the components connected by either conventional or printed wiring, the two versions having the same circuit and terminal layout and using the same components. Initially both types will be manufactured, but ultimately, should one be significantly cheaper and be satisfactory in all other respects, it alone may be made for Post Office use. To minimize the cost of the tooling changes that this will involve for some manufacturers, the alternative designs use as many common parts as possible, the differences being largely confined to the base plates.

#### EXTERNAL DESIGN

The chosen shape is essentially simple, obtaining its pleasing effect from its good proportions rather than by styling tricks or exaggerations. The telephone is considerably lower and a little longer and narrower than the 300-type telephone. To accentuate the low look the cover does not quite conceal the black base, which appears in shadow beneath it. The dial, which is fastened to the base and not to the cover, has been set at an angle of 30° to the horizontal, as against the 37° used previously, and has been surrounded by an enlarged number ring, it being felt that with the introduction of subscriber trunk dialling everything possible should be done to reduce the chances of mis-dialling. Above the dial is a rectangular hole, normally closed by a moulded dummy, in which a push-button may be fitted. The push-button used bears its own legend so that separate labelling on the telephone is not needed. To harmonize with the cover, and to provide a comfortable, secure grip, the handset has a rectangular handle section.

#### *The Cover*

The cover is an insert-free moulding with wall thickness varying from 0·11 to 0·14 in. The cradle formed by the cover is shaped to provide a stable rest position to which the handset will naturally gravitate when slightly misplaced. Alternative positions are far enough from the normal to draw attention to incorrect replacement. To meet possible export requirements a carrying handle may be fitted to the cover, as shown in Fig. 3.

The cover is fixed to the telephone by two screws which

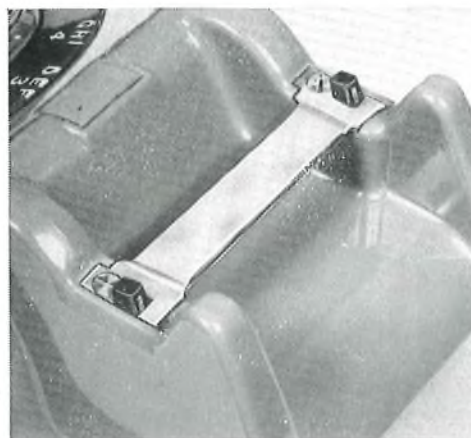

FIG. 3—CARRYING HANDLE FITTED TO TELEPHONE COVER

pass down through the cradle close to the plungers, and in addition it is held to the telephone at the front by moulded projections which hook into recesses in the base.

The external dial number-ring is a transparent moulding with characters reproduced on the back, which is then painted with the background colour. The ring is held in contact with the front of the cover, around the dial, by a spring ring. This allows it enough movement to accommodate slight variations in the position of the dial in the hole, while keeping it correctly orientated.

#### The Handset

The handset has been titled Handset No. 3 and is illustrated in Fig. 4. The design follows generally that



FIG. 4—HANDSET NO. 3

of Handset No. 1,<sup>1</sup> and, in particular, the shape and relative positions of the mouthpiece and earpiece, which were the result of considerable research, have been exactly reproduced. It differs in having a rectangular handle section and in being designed for injection moulding. The problem in designing an injection-moulded handset is to reduce the thickness of material, particularly in the handle, sufficiently to make it easy to mould and to take advantage of the strength of the material. A core withdrawn through the cord entry, as in Handset No. 1, does not hollow the handle sufficiently and in the new handset a much larger core is used. The hole through which this is withdrawn is reduced to the cord-entry size by gluing within it a small auxiliary moulding (see Fig. 5). This method of manufacture has

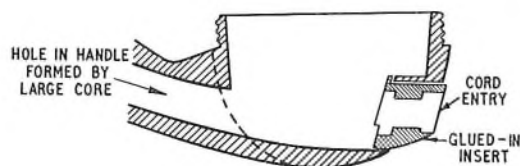

FIG. 5—CROSS-SECTION THROUGH HANDSET

a number of advantages over the alternative method of making the handset from two half-shells stuck together along a longitudinal seam.

In Handset No. 1 the method of holding the cord required its full length to be threaded through the entry hole. This method is inconvenient with the coil type of extensible cord and an alternative method of cord fastening has been devised.<sup>4</sup> In this a grommet is clamped on the cord by a metal ring, two lugs being formed in the ring in the process (see Fig. 6). The cord is fixed to the handset rather as a bayonet-fitting lamp is inserted in

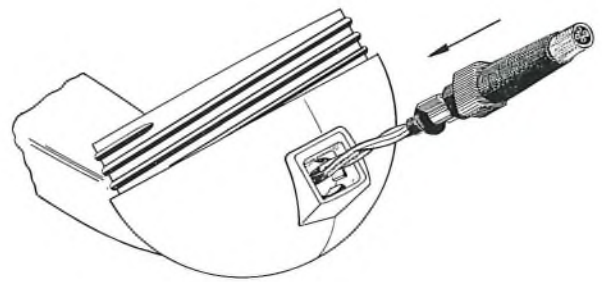

FIG. 6—METHOD OF CORD FASTENING

its holder, and is released by twisting the metal ring inside the handset.

The receiver is held in contact with the earpiece by a spring ring, supported by, and captive on, ribs moulded inside the handset. Other ribs control the position of the receiver and prevent it turning as the earpiece is screwed on.

The transmitter end of the handset is designed to accept either a transmitter of the No. 13 type or a new one under development. Ribs prevent the transmitter turning and others support a spring ring, which will be required when the new transmitter is fitted. The transmitter used at present is the No. 13C. This has a rear spring ring with three tabs to engage with the anti-rotation ribs in the handset, and has a terminal for the cord connexion. A tight-fitting phosphor-bronze plug is used to provide a cord terminal on the rear electrode.

#### INTERNAL DESIGN

Although externally the conventionally-wired and the printed-wiring telephones look alike, their internal arrangements differ considerably and will be described separately. The gravity switch and dial mounting are identical in the two telephones and these features are described first.

#### The Gravity Switch

Most telephones use gravity switches that include plungers sliding in bores in the cases of the telephones. For reliability, particularly in dirty locations, such switches require appreciable force to overcome the friction of the plungers. The light weight of the handset of the new telephone halves the force available and because of this an entirely new switch has been developed. Important features of this are as follows:

(a) The "plungers," which are extensions of a pivoted bracket, do not touch the sides of the generous holes in the cover through which they protrude. The switch is therefore almost friction free and cannot stick due to dirt seizing the plungers.

(b) The weight of the handset is opposed by the spring tensions of the contacts only; the whole weight can therefore be usefully employed.

(c) The spring contacts are comb operated.

The switch (its parts are shown in Fig. 7) is built upon a vertical bracket. This is riveted to the base of the conventionally-wired telephone and to the wiring board of the printed-wiring telephone. At the top of the vertical bracket are tapped holes for the cover fixing screws. It is the fixing of the cover to the telephone at the cradle, rather than at the base as in most telephones, that gives the accurate registration between the plungers and their holes necessary for friction-free



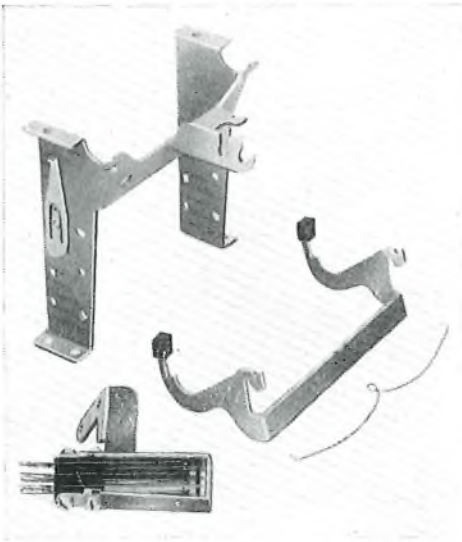

FIG. 7—PARTS OF THE GRAVITY SWITCH

operation. When the cover of the telephone has been removed for maintenance the switch may be locked in the handset-on position by a spring, riveted to the vertical bracket, which hooks over one plunger arm. A touch on the plunger releases the lock so that there is no risk of it being left inadvertently engaged.

The spring-sets are mounted upon the vertical bracket and the contact-operating combs are pushed directly by the transverse bar of the plunger bracket. They differ slightly with the type of telephone. The springs are of nickel silver with palladium contacts. Palladium, which replaces the silver of earlier telephones, has been proved to be the equal of platinum for low-current applications but costs much less. The moving springs are split for their full length, giving a true twin-contact action, and the comb operation ensures accurate twinning and proper sequence of operation. The contacts are protected from dust by clipped-on transparent covers.

#### *Dial Mounting*

Earlier telephones have had the dial mounted in the case. This is an inconvenient arrangement for many reasons and in the new telephone the dial has been mounted on the base. The dial is first held in a mounting in which it is clamped by a band around its body. The bayonet fitting used for so long is thus abandoned although the lugs required for it are still being provided on dials to give interchangeability. The dial in its mounting is supported at the front of the telephone by a simple link plate that bridges the tops of the bell gongs, and at the rear by the gravity-switch bracket.

#### *Conventionally-Wired Layout*

The conventionally-wired telephone interior, which is illustrated in Fig. 8, is built upon a plastic base moulded in a tough resilient grade of polystyrene.

Raised at the front of the base are two domes, perforated to allow egress of sound, on which the bell gongs are mounted. Terminal strips are provided in two ribs moulded across the rear of the base. Also formed in the base moulding are supports on which are riveted the feet of the gravity-switch structure, ribs and holes for



FIG. 8—INTERIOR OF CONVENTIONALLY-WIRED TELEPHONE

locating and fixing the induction coil and capacitor, and a jack for the plug-in automatic regulator. Although complicated in shape the base moulding is produced by a simple tool and it is free of moulded-in inserts, which would retard production; all threads are provided by nuts pressed into holes.

The bell mechanism is fixed directly to the base by two screws, and the induction coil and capacitor are held in moulded locations by simple spring clips. The carbon balance-circuit resistors are supported by their own terminations.

The telephone is wired with p.v.c.-insulated  $6\frac{1}{2}$  lb/mile wire, except for the connexions to the dial, which are made with stranded wire. When the dial is not fitted the ends of the wires are pushed into holes in the base moulding. The connexions to the bell are separate from the cable form and are tag-ended to allow easy removal.

#### *Printed-Wiring Layout*

The printed-wiring telephone (Fig. 9) is built on a pressed-steel base, riveted to which are pillars for mounting the bell gongs and the printed-wiring board. The board is

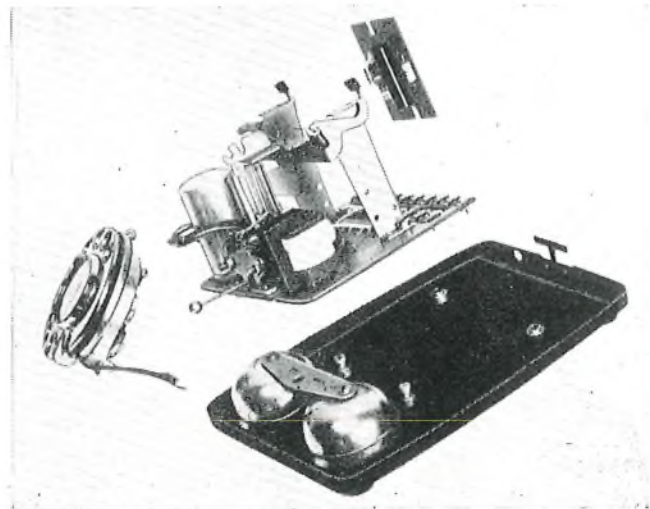

FIG. 9—PRINTED-WIRING TELEPHONE ASSEMBLY

supported about  $\frac{1}{4}$  in. clear of the base on four of the pillars, and to it is riveted the gravity-switch bracket. The fixing points of this coincide with the rear fixings of the board to the base, the board fixing screws actually passing through the feet of the bracket, so that all three parts are held rigidly together at these points. As a result the gravity switch is unaffected by possible warping of the board. Fig. 9 shows an exploded view of the telephone base and of the wiring board. The board is manufactured from  $\frac{3}{32}$  in. thick high-quality synthetic-resin-bonded paper clad on one side with copper 0.0014 in. thick. The wiring pattern is shown in Fig. 10.

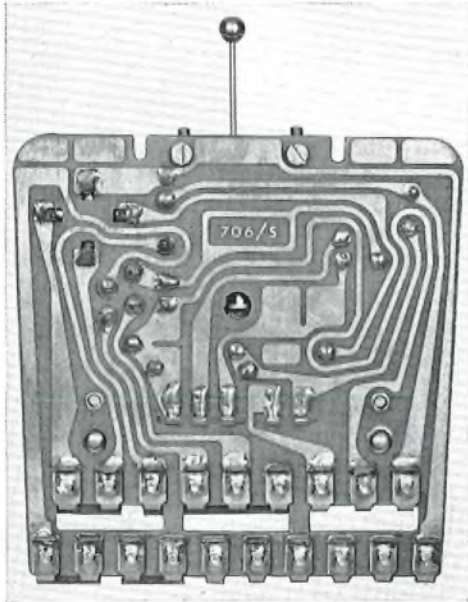

FIG. 10—PRINTED-WIRING PATTERN

The terminals fitted to the rear of the board consist of U-shaped metal plates clipped to the edge and soldered to the wiring pattern. An "edge" for the second row is made by piercing slots across the board and as this weakens the board it is supported under its rear edge by a strip moulding which clips into holes in the base.

The bell mechanism is fastened to the board by the usual two screws but the capacitor and induction coil are not screwed down, being held to the wiring pattern by their soldered connexions. The balance-circuit resistors are mounted directly on the board.

The bell is connected to terminals by tag-ended conventional wiring.

#### NEW COMPONENTS

The components used and proved in Telephone No. 700 could have been used in the new telephone and would have been quite suitable for the conventionally-wired version. Modifications have, however, been made to the physical forms of the capacitor and the induction coil to make them more suitable for the printed-wiring technique and, in the interests of standardization, the new designs have been used in both versions of the telephone. A further component that has been altered is the bell, manufacture of which has been cheapened without loss of efficiency. The telephone has one entirely new component, the automatic regulator.

#### The Induction Coil

The new coil, Coil, Induction, No. 31, is shorter and stouter than the No. 30 coil, which has been described previously.<sup>1</sup> The change in proportions reduces the stresses on the terminal-pin connexions when the coil is secured by them in the printed-wiring telephone. As grain-oriented material is still used for the core the new proportions have resulted in a slight loss in efficiency, the elongated core of the earlier coil being particularly suited to the material. As will be described later, however, the inclusion of a regulator in the telephone has enabled this loss to be compensated for in the circuit design.

The coil bobbin is a phenolic moulding with slots in one cheek through which the winding ends are led out to terminate directly upon five stout terminal-pins. The bobbin is wound throughout with one gauge of wire, which simplifies production. Because of its smooth finish, wrapping of the bobbin before winding is unnecessary and the low electrical stresses between windings have made paper interleaving unnecessary.

The laminations are assembled in the bobbin with one butt joint, equivalent to a small air-gap, and one interleaved joint. They are secured by running an air-drying varnish between them. The parts of the induction coil are shown in Fig. 11, from which the extreme economy

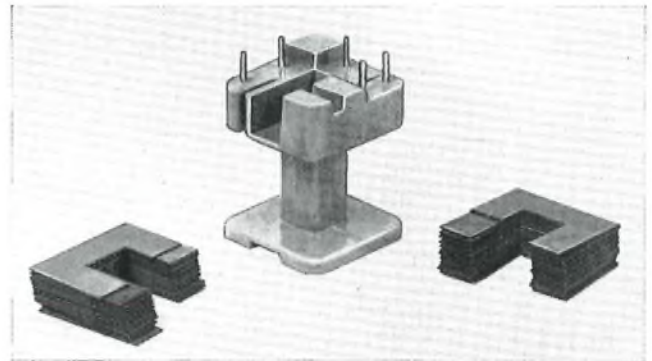

FIG. 11—PARTS OF COIL, INDUCTION, NO. 31

of the design may be judged. The balance-circuit resistors in the new telephone are separate carbon resistors, investigation having shown that if the telephone is designed for their use they are cheaper than non-inductive windings on the induction-coil bobbin. Separate resistors are particularly convenient for use in the printed-wiring telephone because of the flexibility they give to the pattern and the ease with which they can be mounted.

#### The Capacitor

The proportions of the capacitor have been changed in the same way and for the same reason as for the induction coil. In addition, the capacitor has been given springy wiring tags which enable it to be plugged into holes in the wiring board and to remain there on its own until soldered. As ample space is available in the telephone the volume of the capacitor has been increased to make the internal design less critical.

#### The Bell

The changes to the bell do not affect the principle of operation or the performance and the new and old bells are interchangeable. Details of the changes are:





FIG. 12—NEW AND OLD TYPES OF BELL MAGNET

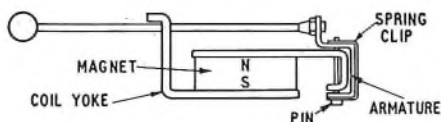

FIG. 13—CROSS-SECTION THROUGH BELL MAGNETIC CIRCUIT

(a) The cast and ground cobalt-steel magnet (the material is too hard for normal machining) is replaced by a moulded ceramic magnet. The new and old magnets are shown in Fig. 12.

(b) The milled and drilled yoke is replaced by one manufactured from sheet by punching and bending operations.

(c) The pivot for the armature has been simplified.

A section through the yoke, magnet and armature pivot is shown in Fig. 13. Apart from economy of manufacture the new design has the following advantages:

- (i) The ceramic magnet has greater retentivity.
- (ii) Adjustment of the air gap is easier.
- (iii) The armature pivot is more easily removed.
- (iv) The hammer ball can be passed through the yoke so that the armature may be removed without demounting the bell.

To fit in the narrower telephone the diameter of the bell gongs has been reduced. Other constants of the gongs have been changed, however, so that the sound given by them is unchanged.

#### The Automatic Sensitivity Regulator

The need for, and electrical design of, the regulator are discussed later. Physically it consists of a small printed-wiring board on which are mounted a multi-

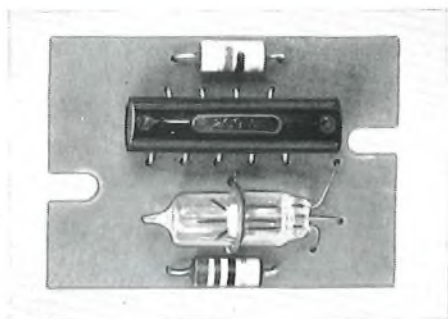

FIG. 14—AUTOMATIC SENSITIVITY REGULATOR

element rectifier, a resistance lamp and two carbon resistors. It is shown in Fig. 14. One end of the wiring board forms a 5-point plug for insertion in the jack in the telephone base; the other end is a dummy plug, insertion of which completes the circuit as an unregulated telephone. Slots are cut in the ends of the board which, in conjunction with a bar in the jack, prevents incorrect insertion. In the design of the plug and jack the emphasis was on reliability of connexion rather than ease of insertion or suitability for frequent insertion. High pressures are used and the jack springs are concave in section, their edges biting into the solder coating of the copper pattern on the board, which forms the plug connexions. Advantages of a plug-in unit for the regulator are as follows:

(a) It facilitates the locating of faults.

(b) A faulty regulator may be changed, instead of a complete telephone.

(c) Production testing is simplified. The regulator can be tested on its own, as are transmitters, etc., and a simple test to prove correct wiring is all that is then needed for the assembled telephone.

#### Feet

The feet are of the push-in type. A domed form has been used in place of an annular ring, to prevent pressure marking of furniture, and they are made from a soft, non-staining artificial rubber. Their anti-sliding properties are superior to those of earlier designs.

#### Cords

The cords fitted to the new telephone are a marked advance on those previously used and the improvements have been achieved with a significant price reduction. The cords have the following features:

(i) *Conductors.* The tinsel is laid up on high-tenacity synthetic yarn, e.g. Terylene, resulting in conductors having half the old diameter with the same tensile strength. Life, as measured by reciprocating tests, has been increased fourfold. The conductors are insulated with extruded p.v.c., which makes them waterproof, of a grade flexible enough to fully utilize the properties of the tinsel.

(ii) *Sheathing.* The cords are made up in round section with a covering of either flexible p.v.c., of a grade chosen to minimize the risk of the plasticizer marring polished surfaces, or of braided synthetic yarn.

(iii) *Terminations.* Clinched-on spade tags have been used for ease of connexion and economy. A double clinch tag has been preferred to the insulation-piercing type as it gives a stronger, more reliable connexion. The tag dimensions make it suitable for the variety of screw sizes met on new and old apparatus.

(iv) *Grommets.* These are fixed to the ends of all cords. They are preferred to strain cords, which are sometimes left untied. Moulded in flexible p.v.c. they prevent sharp bends where cords emerge, and so reduce wear.

Extensible handset cords will be fitted as standard to the telephones. Besides being convenient for subscribers they reduce the tendency of cords to kink and knot up, which increases wear.

The cords are manufactured in the form of a close coil, the retracting force coming from the resilience of the p.v.c. sheath. Cords of this type cost less than textile extensible cords and have a greater extension, up to six times the closed length. Life tests have shown they will withstand over half a million extensions.

*New Terminal Block*

The new block (Block, Terminal, No. 30) is shaped to match the telephone. The mouldings are in high-impact polystyrene, the toughness of this material being preferred to the better finish of polymethyl methacrylate for this application. The mouldings are free of moulded inserts. Threads for the terminals and the cover-fixing screw are provided by pressing nuts into holes. There is an entry for a cord, with grommet, at one end of the block and an additional one can be provided by breaking out a thin section of the cover. Other "knock-outs" provide cable entries. Six terminals are provided, normally linked in pairs to give a three-way block; the links may be removed to give six separate connexions if needed.

**FLEXIBILITY IN USE**

The advantages of making a telephone suitable for a wide range of use have already been discussed in connexion with Telephone No. 700.<sup>1</sup> With the new telephone the need to restrict the number of variations stocked is even greater because of the wide colour range. Measures taken to achieve flexibility include:

- (a) making provision for one push-button in every telephone,
- (b) incorporating an extra spring in the gravity-switch spring-set so that the basic telephone can be converted to shared-service working,
- (c) providing a number of holes for fixing auxiliary parts (these are punched during manufacture at the same time as other holes and add nothing to the cost),
- (d) incorporating a large number of connexion links within the circuit, and
- (e) providing a number of spare terminals for connecting auxiliary components.

These features enable the basic telephone, stocked as Telephone No. 706L with a dial and Telephone No. 706CB with a dial-dummy, to meet all the requirements for a table telephone with or without a push-button. For some purposes auxiliary units have to be added to the telephone by the installer and some of these will be described.

*Shared-Service Adaptor*

The shared-service adaptor (Fig. 15), when fitted in the telephone, makes it suitable for automatic separate-metering systems. It is an assembly of a micro-switch, a push-button and a thermistor and is fixed within the telephone by a single screw.

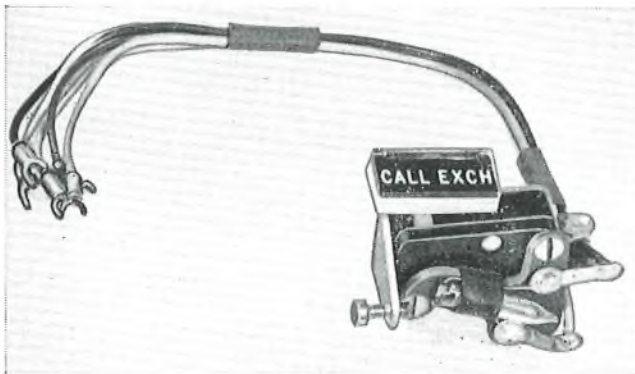

FIG. 15—SHARED-SERVICE ADAPTOR

Hitherto the circuit of shared-service telephones has included a rectifier. This is used to hold the A relay, in the selector seized at the exchange, during a short break in the loop when the telephone calling key is released. The micro-switch has a change-over time of less than 5 ms, which is too short to pulse the A relay so that it enables the rectifier to be omitted.

Connexion of the adaptor to the telephone circuit is made by flexible wires with spade ends. Fig. 16 shows the connexions.

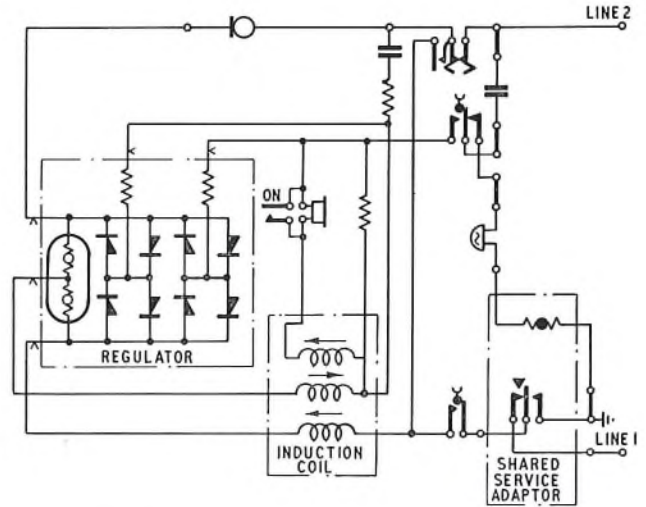

FIG. 16—CIRCUIT OF TELEPHONE NO. 706 MODIFIED FOR SHARED SERVICE

The extra gravity-switch spring enables the new telephone to be used on C.B. common-metering systems without the extra capacitor that has to be added to Telephone No. 332.

*Push-Button Units*

These are assemblies similar to the shared-service adaptor but without the thermistor. There are two, Switch No. 5A-1, which is non-locking, and Switch No. 5A-2, which locks down. Pressure on one end of the push button of Switch No. 5A-2 locks it down; pressure at the other end releases it; Fig. 17 illustrates

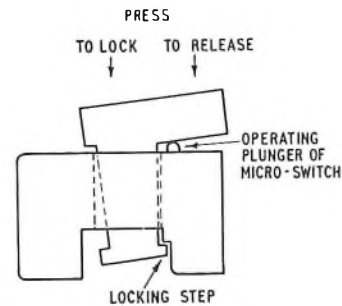

FIG. 17—LOCKING ACTION OF PUSH-BUTTON UNIT

the action. The non-locking push-button has no step. The snap-on tops of the push-buttons form labels. They are transparent mouldings with the characters and backing colour on their undersides.



### Additional Spring-sets

Additional spring-sets can be fitted on the side of the gravity-switch bracket opposite to the normal spring-set. They are similar to those used in the conventionally-wired telephone.

### Local-Battery Unit

A C.B. telephone may be converted into a local-battery telephone by adding to its circuit a choke-coil, a battery and a gravity-switch contact, as shown in Fig. 18. To alternating current the choke can be considered an open-circuit and the battery impedance is negligible so that for speech currents the circuit reduces to the transmitter alone. The choke is a low resistance to direct current, however, and provides a path for the local transmitter polarizing current.

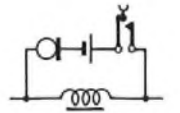

FIG. 18—  
LOCAL-BATTERY  
ADAPTOR CIRCUIT

An assembly comprising the extra parts converts the Telephone No. 706 into an efficient anti-side-tone local-battery instrument. It allows the Post Office to offer local-battery subscribers the latest type of telephone and on subsequent conversion to automatic working it is only necessary to remove the local-battery unit and fit a dial to the telephone, instead of changing the complete instrument. The local-battery instrument is also very suitable for use on long private wires.

### MAINTENANCE ADVANTAGES

To be economical to maintain, a telephone must be reliable so that attention is rarely required, and accessible, so that when faults do occur they can be rapidly found and cleared. On both counts Telephone No. 706 is an improvement on earlier telephones. The following factors should reduce the likelihood of faults occurring:

(a) The moulding material is stronger than thermosetting materials and has been proved satisfactory by many years' service.

(b) The "frictionless" gravity switch with its comb-operated twin-contact spring-set and dust cover should be free of all sticking and contact faults.

(c) The new cords have been proved by accelerated life tests and field trials to be superior to any used previously.

Factors which make the telephone easy to service are as follows:

(i) Only two screws have to be withdrawn to take off the cover and reveal the inside, compared with seven to give full access to a Telephone No. 332.

(ii) The cover is removed without turning the telephone upside down, so that dirt within does not get shaken up, causing further faults.

(iii) Because the dial is fixed on the base a completely working telephone is left when the cover is removed, and there is no risk of the dial cord being trapped in a vulnerable part of the dial when the telephone is re-assembled.

(iv) The bell can be replaced without the use of a soldering iron.

(v) The gravity-switch lock allows the telephone to be worked on without losing incoming calls.

(vi) The plug-in regulator is easily replaced if faulty and helps in fault tracing.

(vii) Spade tags, and grommets in place of strain ties, speed cord changing.

The automatic regulator might be expected to increase fault liability and much attention has therefore been given to the reliability of its components. The reliability of resistors and rectifiers is well known, while the resistance lamp, not to be confused with a barretter, has a robust filament which is much under-run and should therefore have a very long life. Confidence in the components has been established by accelerated life tests.

### TRANSMISSION FEATURES

#### Assessment of Excess Sensitivity of Experimental Telephones and Need for Sensitivity Regulation

The earlier article<sup>1</sup> suggested that the level of transmission performance of the Telephone No. 700 might be sufficiently high to become an embarrassment on short lines. To test the reactions of subscribers, trials were therefore immediately carried out concurrently with subjective assessments in Research Branch. Some 400 extension telephones with very short lines on the Telephone Managers' P.B.X.s at Canterbury and Portsmouth were changed to the Telephone No. 700 and after one month all users were asked to express opinions on the performance of the new instrument. Some 75 per cent of the users classed the reception as too loud on internal calls while some 50 per cent also found it too loud on external calls.

The laboratory test was conducted under more controlled conditions; the conclusions reached were similar to those of the field trial but were capable of being expressed more precisely. The following estimates were made in terms of loudness sensitivity, this criterion being used rather than articulation because it is the loudness of the received signal which is troublesome; articulation at these high levels always approaches 100 per cent:

(a) The maximum loudness sensitivity which a telephone connexion should provide is + 31 db relative to a metre-air-path (monaural listening to a talker at a distance of 1 metre in echo-free surroundings).

(b) If possible, side-tone loudness sensitivities should not exceed + 25 db relative to the metre-air-path.

Approximate ranges of loudness sensitivities are given in Fig. 19, which shows that the greatest loudness

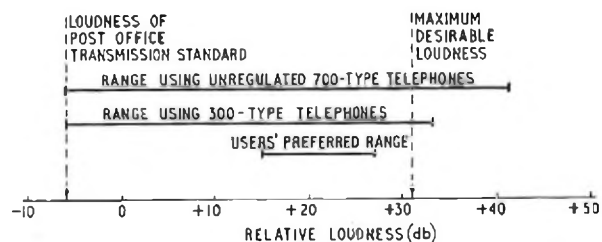

FIG. 19—TELEPHONE LOUDNESS-SENSITIVITY RANGES

sensitivity using Telephones No. 700, i.e. two telephones connected directly via a transmission bridge providing full feeding-current, exceeds the maximum desirable by some 10 db. In fact, a similar connexion employing 300-type sets is also some 2 db too loud. At the other end of the scale, minimum loudness sensitivity is reached when two telephones, each on its maximum local line

for the particular local exchange transmission bridge, are connected together by a junction having a transmission loss of 27 db. The preferred loudness range for telephony, estimated from recent transmission assessments, is also shown in Fig. 19. Thus the economic loudness range for telephone calls in the United Kingdom network at present extends over some 37 db, from 21 db below the minimum preferred to about 4 db above the maximum preferred, i.e. to the maximum desirable.

For all telephones, local-line planning ensures that sensitivities are not less than -6 db relative to a metre-air-path by setting an appropriate limit for each gauge of conductor according to the sensitivity of the instruments available, e.g. 660 ohms T.E.R.\* for the 300-type set and, now, 1,000 ohms T.E.R. for the 700-type set, when each is connected to a 50-volt transmission bridge. That the maximum desirable sensitivity has been exceeded by 2 db using 300-type sets is of little account. However, the excess of 10 db for the Telephone No. 700 is more serious and it was decided that some inexpensive form of regulation should be developed giving approximately 6 db sending, 4 db receiving and at least 7 db side-tone loudness reductions when the telephone is connected to very short lines with, if possible, appropriate reductions for medium lines. The original design objective, that the telephone must be usable on 1,000 ohm T.E.R. lines, was still to be met.

#### Other Considerations

A further need for sensitivity regulation to avoid discomfort for the telephone user is that, with very sensitive instruments, the risk of a subscriber receiving an acoustic shock due to the inevitable pulses of energy fed on to the line by switching operations is greater.

There are also engineering reasons:

(i) The increasing number of the new telephone sets in the network will cause the mean speech voltage appearing at the input of broadband amplifiers feeding carrier systems to rise, thereby increasing the risk of inter-channel crosstalk.

(ii) Near-end crosstalk, which becomes greater for sets of increased sensitivity, can at least be reduced on the short lines.

(iii) Without sensitivity regulation, the large difference in performance between telephones on long and short lines may be noticed by subscribers, so giving rise to complaints from those on the longest lines.

(iv) "Howling" can occur with modern high-sensitivity transducers having poor side-tone suppression when the handset is placed on a desk or table, due to the acoustic coupling between the transmitter and receiver.

(v) There is a loss of secrecy when the received level is high.

#### Choice of Method of Regulation

Of the methods of reducing sensitivity on short lines described in the earlier article,<sup>1</sup> it was decided to adopt that of including a line-current-sensitive regulator within the telephone. The principal reason for this was that it largely overcomes the problem of the private-branch exchange (P.B.X.) extension, which on some calls is on a short line to the P.B.X. only, yet on others may be connected via a long line to the public exchange. The problem can be solved by combinations of attenuated telephones and P.B.X. connecting links but each installation would need individual treatment and thus create administrative difficulties. The decision to use

automatic regulation was further influenced by success in developing an entirely new, comparatively inexpensive device free of the inherent defects of earlier types.

#### The New Transmission Circuit

Fig. 20 shows the transmission circuit of the Telephone No. 706. The basic configuration of the circuit

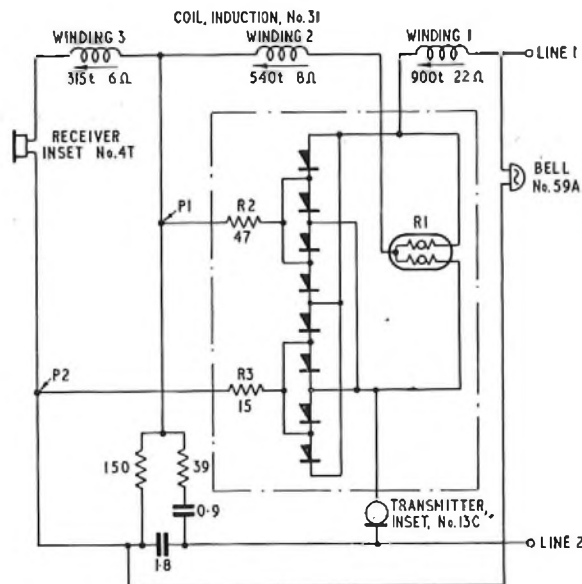

FIG. 20—TRANSMISSION CIRCUIT OF TELEPHONE NO. 706

of Telephone No. 700 has been retained and the circuit of the automatic regulator is shown within the dotted lines. The small, inevitable, long-line loss of the regulator and the slight loss in electrical efficiency of the induction coil, compared with that of the Coil, Induction, No. 30, are compensated for by emphasis on design for long lines and by a slight change of transmission circuit Y ratio.† The Telephone No. 706 is thus equal in transmission performance to the Telephone No. 700 on long lines and the 1,000 ohm T.E.R. limit is still attained. For the Y ratio of 3.3, winding ratios of 1.67 (winding 1: winding 2), and 2.86 (winding 1: winding 3) are used. The windings are connected into the circuit in series-aiding and their sequence on the bobbin has been chosen for maximum overall transmission efficiency. The induction-coil core is designed for maximum inductance at 30 mA, for which the small air-gap of 1-2 mils obtained by using a butt joint is adequate.

The balance network is of asymmetrical  $\pi$  configuration and includes the 1.8  $\mu$ F d.c.-blocking capacitor. The network design allows the use of 15 per cent tolerance capacitors and 10 per cent preferred-value resistors.

#### Automatic Regulator

The regulator<sup>8</sup> is shown within the chain-dotted lines in Fig. 20. Basically it is a variable-loss network of low d.c. resistance inserted in series with the trans-

\* Transmission Equivalent Resistance<sup>6</sup>.

† The Y ratio,<sup>6,7</sup> for a balanced anti-side-tone circuit, is the ratio  $\frac{\text{Transmitter power sent to line}}{\text{Transmitter power wasted in balance}}$  and is the same as  $\frac{\text{Received power wasted in transmitter}}{\text{Received power used in the receiver}}$ .



mitter with connexions to two other points (P1 and P2) in the transmission circuit. It provides a.c. shunt paths between each of these points and the junction between the transmitter and the induction coil windings, the value of the shunt being determined by the magnitude of the line current. A detailed description of its operation is being published elsewhere.<sup>6</sup>

The shunt path to point P1 has an impedance of 60–70 ohms and that to P2 an impedance of 30–40 ohms when the telephone is connected to a short line with full feeding-current, say 95 mA. These values produce sending and receiving losses relative to the Telephone No. 700 of about 6 db and 4 db respectively. The circuit and the loss ratio of the two shunt paths is also such that side-tone is reduced by some 10 db or more according to the impedance of the line. On long lines, having a line current of 30–40 mA, the impedance of both paths rises to several kilohms and therefore the regulator losses are very small.

The resistance of a rectifier element connected in the forward direction falls rapidly when the voltage across it is increased from zero. The change in line current is made to produce a change in the bias voltage applied to a pair of such elements by passing the current through a low-value resistor, R1, as shown in Fig. 21(a). If a single rectifier element were used in a shunt path, noticeable distortion would arise because the element resistance would vary according to the instantaneous value of the speech voltage. This is overcome by connecting two elements in a “push-pull” arrangement, as

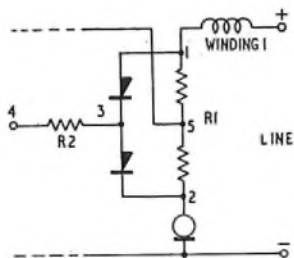

(a) A Simple Regulator, providing a Regulated Resistance Path between Terminals 2 and 4

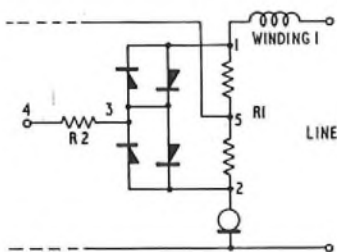

(b) As (a), but Suitable for Either Direction of Line-Voltage Polarity

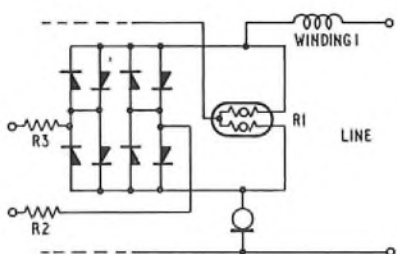

(c) Complete Automatic-Regulator Circuit providing Two Regulated Resistance Paths

FIG. 21—CIRCUIT OF AUTOMATIC SENSITIVITY REGULATOR

shown, to ensure similar treatment for alternate half-cycles and thus reduce distortion. By d.c. driving the elements to a much lower impedance than is required, and adding a series resistor R2 to give the correct total value, distortion in the shunt path is further reduced since part of the path is then linear.

Fig. 21(a) shows also a centre-tap on R1. This is necessary to avoid d.c. paths within the telephone circuit shunting each section of a push-pull pair to a different degree, thus producing unequal d.c. bias. The circuit becomes that of a Wheatstone bridge in which the voltages at points 3 and 5 are equal, and thus d.c. resistance paths across these points have no effect. The resistance of the bell is not catered for by this arrangement and therefore a small degree of unbalance does exist, but the bell resistance (1,000 ohms) is sufficiently high for the effect to be negligible.

In Fig. 21(b) a set of oppositely-poled parallel-connected rectifier-elements has been added. This is necessary so that the circuit can cater for either direction of line polarity. The second shunt path is added in Fig. 21(c) with its appropriate resistor R3 necessary to adjust the path impedance to the required value. In the same diagram R1 is shown as a resistance lamp. The characteristic of the lamp is such that it has a total resistance of 36 ohms at 76 mA, falling to 10 ohms at 30 mA. It can be seen in Fig. 14 and is used in place of a linear resistor for two reasons:

(a) On long lines its resistance, and therefore its unwanted transmission loss, is low.

(b) It provides a greatly increased voltage on short lines for biasing the rectifiers.

Fig. 21(c) includes the complete circuit of the Post Office “Regulator No. 1,” as shown in Fig. 20. The required resistance/voltage characteristic of each section of a push-pull pair of rectifier elements is obtained from two  $\frac{1}{4}$  in. diameter selenium disks in series and the rectifier assembly is mounted in a nylon tube containing 16 plates, tapped at every two and interconnected as in Fig. 21. The rectifier assembly can be seen in Fig. 14.

#### TRANSMISSION PERFORMANCE OF TELEPHONE NO. 706

Full-scale subjective tests are costly and will be delayed until sufficient telephones are available from production lines for average instruments to be selected. Information given here is based mainly on a combination of subjective loudness and pure-tone assessments. So far, in this article, discussion has centred around the very-short-line and very-long-line performance of the telephone. It is equally important that the performance should have the optimum relationship with line length on all intermediate lines. Ideally, regulation should provide a constant and sufficient speech voltage at the junction terminals of the exchange transmission bridge whatever the composition of the local telephone circuit and the characteristics of the talker, and a constant sound pressure in the ear of the listener whatever the speech voltage applied to the junction terminals, i.e. the local telephone circuit should be transmission equalized. Thus considering Fig. 22(a) and (b) the ideal local-telephone-circuit sending and receiving sensitivity characteristics are lines at the appropriate sensitivity level parallel to the line-resistance axis. For any given non-regulated telephone the local-telephone-circuit sensitivity falls with increase of line resistance, as shown typically for the Telephone No. 700. Because its maximum sensitivity is fixed, over the

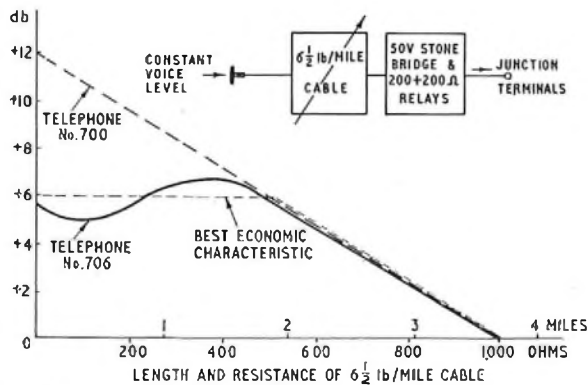

(a) Sending Performance—Output into Junction Terminals with Constant Voice Level at Instrument Transmitter

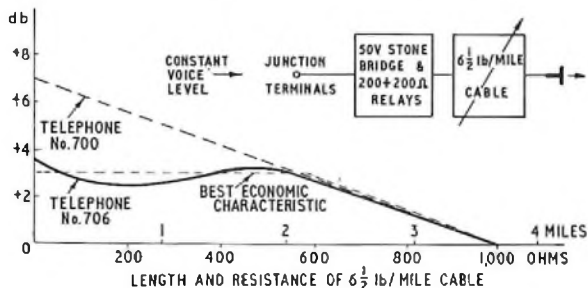

(b) Receiving Performance with Constant Input from Junction Terminals

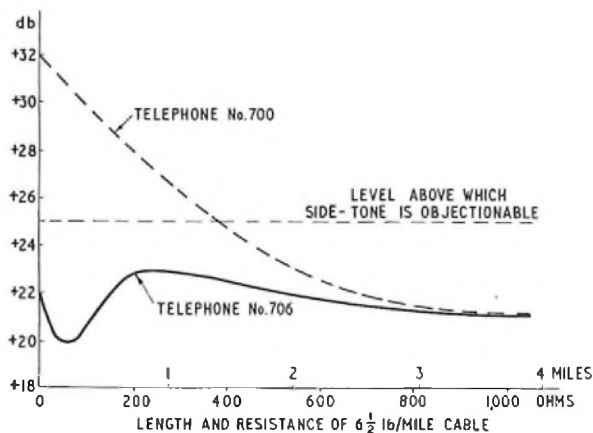

(c) Side-tone Performance Relative to Conditions applying for a Listener at 1 Metre from a Talker in Echo-Free Conditions

Performance is expressed relative to conditions applying to a 1,000 ohm line  
 FIG. 22—TRANSMISSION PERFORMANCE OF TELEPHONE NO. 706

economic line-resistance range of the instrument, the sensitivity must fall below ideal on the higher-resistance lines. The more practical "best economic" characteristic may be predicted as shown by the dotted lines, the ideal and best economic characteristics being identical on the lower-resistance lines.

Cost, of course, precludes the provision of the ideal condition. If the best economic characteristic is provided, then the loudness level on receiving for any connexion will never exceed the maximum desirable and in fact local calls between all subscribers whose lines do not exceed about 500 ohms resistance will have the same overall sensitivity. The actual performance is shown by the full line to be about  $\pm 1$  db from the best characteristic for the particular junction and transmission bridge, the performance being of this order for other types of junction. Fig. 22(c) shows the reduced side-tone level compared

with the Telephone No. 700 and also shows that the Telephone No. 706 has a fairly constant side-tone performance whatever the line length.

#### FUTURE DEVELOPMENT

Telephone design is a continuous process in which all related developments rarely come to fruition together. Changes which will probably be made to Telephone No. 706, and which have been anticipated in the design, include replacement of the inset No. 13 by a new transmitter and modification to the dial to improve its appearance and to reduce its cost. Use of Telephone No. 706 in the more complicated extension plans is also under consideration and a multi-key plinth may be added to it for this purpose. This also has been anticipated in the design to the extent of providing the necessary fixing holes and cable entries in the base. In the transmission field an accurate assessment of the transmission performance, using the latest subjective techniques, remains to be completed.

#### CONCLUSIONS

An aesthetically pleasing telephone has been designed which it is confidently believed is the most sensitive, yet best regulated, telephone in the world to-day.

By its use the cost of line plant and the maintenance of telephone service will be considerably reduced and it is expected that when in quantity production the new telephone will cost no more than the existing instrument.

#### ACKNOWLEDGEMENTS

The new telephone is the product of close co-operation between the Post Office and the whole telephone industry but particular credit is due to the design staff of Ericsson Telephones, Ltd., who were largely responsible for the physical design, and Siemens Edison Swan, Ltd., who designed the printed-wiring interior and base.

The authors wish to thank colleagues in both the Post Office and the design departments of the manufacturers for help in producing this article and to thank Ericsson Telephones, Ltd., for permission to reproduce certain of the illustrations.

The coloured illustration (Fig. 2) is reproduced by arrangement with the manufacturers of the new telephone, The Automatic Telephone and Electric Co., Ltd., Ericsson Telephones, Ltd., The General Electric Co., Ltd., Phoenix Telephone and Electric Works, Ltd., The Plessey Co., Ltd., Siemens Edison Swan, Ltd., Standard Telephones and Cables, Ltd., and The Telephone Manufacturing Co., Ltd.

#### References

- <sup>1</sup> SPENCER, H. J. C., and WILSON, F. A. The New, 700-Type Telephone. *P.O.E.E.J.*, Vol. 49, p. 69, July 1956.
- <sup>2</sup> ROBERTON, J. S. P. The Rocking-Armature Receiver. *P.O.E.E.J.*, Vol. 49, p. 40, Apr. 1956.
- <sup>3</sup> B.S. 1006, Part 2. Determination of Fastness to Daylight of Coloured Textiles (British Standards Institution).
- <sup>4</sup> Patent Application No. 25782/58.
- <sup>5</sup> FUDGE, G. A. E. Introduction and Application of Transmission Performance Ratings to Subscribers' Networks. *I.P.O.E.E. Printed Paper No. 198*, 1949.
- <sup>6</sup> JOHNSON, K. S. Transmission Circuits for Telephonic Communication (The Library Press, 1924).
- <sup>7</sup> SPENCER, H. J. C. Some Principles of Anti-Side-Tone Telephone Circuits. *P.O.E.E.J.*, Vol. 48, p. 208, Jan. 1956.
- <sup>8</sup> Patent Application No. 39958/57.
- <sup>9</sup> WILLIAMS, F. E., and WILSON, F. A. The Design of an Automatic Sensitivity Control for a New Subscriber's Telephone Set—The British Post Office 700-Type Telephone. *Proceedings I.E.E.* Paper No. 2867E. (To be published).



# An Introduction to Electronic Computer Systems for Office Use

F. J. M. LAVER, B.Sc., M.I.E.E.†

U.D.C. 681.142:651.2

The principle of operation of electronic digital computers is described in simple terms, with particular reference to their use in offices for automatic data processing.

## INTRODUCTION

A COMPUTER is a machine that takes in numbers, performs arithmetical operations with them and puts out the results. Computers can be divided into analogue and digital types according to the method used to represent numbers inside the machine. Each type has its merits but this article deals only with digital computers because these have so far found greatest application to office work.

In electronic digital computers brief pulses of electricity are used to represent numbers, and the machine does its arithmetic with electronic equipment which counts and compares groups of pulses. Electronic methods enable such a machine to work many times faster than an ordinary desk calculator, but speed is not the only difference. A desk calculator performs only one arithmetical operation at a time, but an electronic computer automatically performs long sequences of operations without outside assistance. Indeed, high-speed calculation would lose most of its value without fully automatic operation. Numbers representing the primary data or intermediate results of the calculation can be held in stores inside the machine and shuttled between arithmetic units and stores under the control of a schedule of instructions. Moreover, the magnitude of intermediate results of the calculation can be used to choose between alternative courses of subsequent action. The schedule of instructions is known as a program, and as a computer can work to any of an almost unlimited choice of different programs, it can be adapted to a great variety of uses.

## THE GENERAL ARRANGEMENT OF AN ELECTRONIC COMPUTER

A large computer comprises some 3,000 valves and perhaps 100,000 other components, such as crystal rectifiers, resistors, capacitors and inductors. This equipment may be divided into "packages" of two or three valves and associated components for ease of maintenance. The whole occupies a dozen or more large steel cabinets, and consumes 10 to 30 kW of electricity. All of this power is eventually dissipated as heat, which has to be removed by ventilating fans.

The analysis of a simple computation performed by a clerk is a useful way of showing what functional parts are required in an electronic computer. Consider, for example, the calculation of gross wages by multiplying hours worked by rates of pay. The clerk's operations can be divided into the stages listed below.

1. Read "hours worked" from time sheet.
2. Transfer this information from the "reading" to the "writing" functions of the brain.

3. Write hours on scrap pad.
4. Read rate of pay from schedule.
5. Transfer as (2).
6. Write rate on scrap pad.
7. Multiply rate by hours.
8. Write answer on scrap pad.
9. Read answer and transfer as (2).
10. Write answer on pay sheet.

The components needed in a computer to execute corresponding functions are listed below.

(i) An Input Unit reads in the information about "hours worked." This information is converted into electrical signals, consisting of the groups of brief pulses that represent numbers inside the computer.

(ii) The pulses from the input unit pass over Signal Highways to and from the various parts of the machine, being routed as required by opening and closing "switches," which connect or disconnect each functional unit and the signal highways.

(iii) A Working Store holds the numbers used in the calculation while it is in progress.

(iv) A Main Store holds the rates of pay and other information needed for reference, including the program of instructions which controls the operations of the computer.

(v) As (ii).

(vi) As (iii).

(vii) An Arithmetic Unit performs addition, subtraction, multiplication and division.

(viii) As (iii).

(ix) As (ii).

(x) An Output Unit is needed to receive the computed results in the form of electrical signals and convert them into printed characters.

The computer also needs a Control Unit corresponding to the clerk's brain, which directs and co-ordinates the whole operation of the machine in strict accordance with the stored program of instructions. Various kinds of electric power supply are provided by a Common Services Unit. The arrangement of the units in a typical electronic computer is shown in Fig. 1.

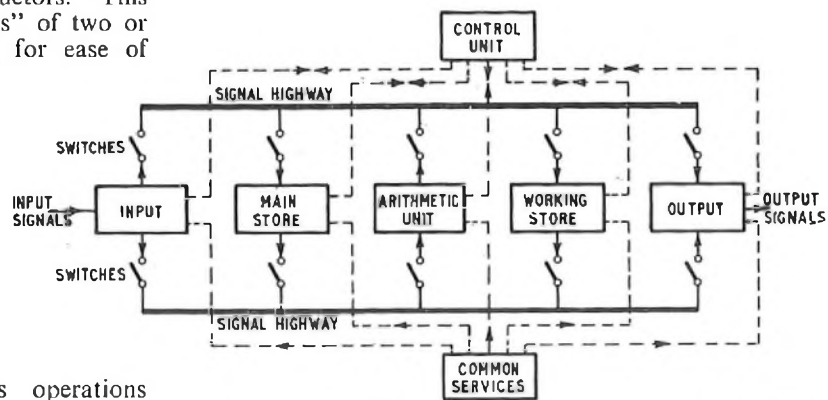

FIG. 1.—BLOCK SCHEMATIC DIAGRAM OF A TYPICAL ELECTRONIC COMPUTER

† Assistant Staff Engineer, Engineering Organization and Efficiency Branch, E.-in-C.'s Office.

### The Representation of Numbers Inside a Computer

Numbers are represented inside a computer by groups of brief electrical pulses. The duration of these is commonly about  $1 \mu s$ , and they flow through the electronic units at the rate of several hundred thousand a second.

A direct way of representing numbers by groups of pulses is in the binary scale of notation. In this there are only two different digits, 0 and 1, so a negative pulse can stand for 0 and a positive pulse for 1. The first eight decimal numbers with their binary and pulse equivalents are represented in Fig. 2. Each 1 or 0 in a binary number

DECIMAL NUMBER	BINARY NUMBER	PULSE GROUP REPRESENTING BINARY NUMBER
0	0	
1	1	
2	10	
3	11	
4	100	
5	101	
6	110	
7	111	
8	1000	

FIG. 2—REPRESENTATION OF NUMBERS INSIDE A COMPUTER

represents one binary digit, usually abbreviated to one "bit." Binary arithmetic follows the same fundamental rules and methods as decimal arithmetic, and conversion between the binary and decimal or other scales is straightforward. For convenience, the pulses are handled in groups of 10 to 50 bits, which are called "words."

Human calculators find decimal arithmetic shorter and simpler than binary for fewer integers have to be written down, and there are fewer carry-overs from place to place. However, the design of an electronic computer is considerably simplified by the use of binary numbers as only two signals have to be distinguished at each stage, instead of ten as in the decimal system. Also, the great speed of the machine reduces the importance of the increased number of operations.

### The Arithmetic Unit

Consider the addition of two single-digit binary numbers. Each number may be either 0 or 1, and the four cases are enumerated in Table 1.

TABLE 1  
Addition of Two Single-Digit Binary Numbers

First Number A	Second Number B	Carry C	Sum S
0	0	0	0
0	1	0	1
1	0	0	1
1	1	1	0

These results can be expressed thus:  
S equals 1 when either A or B equals 1, but not when both A and B equal 1.  
C equals 1 when both A and B equal 1.

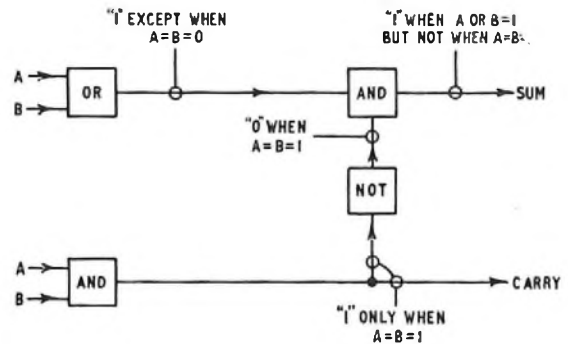

FIG. 3—HALF-ADDER

Fig. 3 shows one method of performing this addition, using electronic units of three different types, namely:

- "And" units, which produce a positive pulse at their output only when positive pulses are applied simultaneously to both of their inputs.
- "Or" units, which produce positive output pulse whenever a positive pulse is present at any of their inputs (they may have more than two).
- "Not" units, which produce a regular output of positive pulses when negative pulses are applied to their input, and vice versa.

In general, addition involves three digits in each position; A, B and the carry from the previous position, and the final sum and carry digits can be derived by applying similar rules to those listed under Table 1, but substituting the initial sum of A and B for A and the carry from the previous position for B. It follows that two arrangements like Fig. 3 can be combined to yield the final result, as in Fig. 4: that of Fig. 3 is

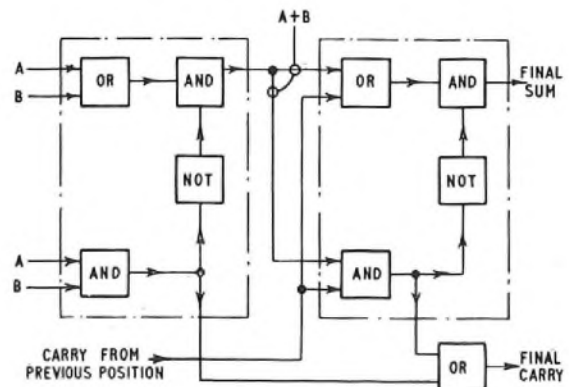

FIG. 4—TWO HALF-ADDEES

therefore called a half-adder. This is not the only arrangement that can be used for binary addition, but the principles are similar in all.

The addition of two binary numbers each having several digits may be carried out "serially" by using a single adder to add corresponding pairs of digits in succession, and storing the carry-over digits temporarily between each step for feeding back to the "previous carry" input; or it may be carried out in "parallel" by



using a separate adder for each pair of digits. The parallel mode is the faster but needs more equipment.

The processes described above for addition can also be combined in different ways for subtraction, multiplication and division. Typical computing times for dealing with the binary equivalents of two 12-digit decimal numbers are: 1/10,000 sec for addition or subtraction, 1/3000 sec for multiplication and 1/1000 sec for division. These times can be very misleading, for much of the total computing time may be absorbed in merely transferring numbers from point to point inside the machine. Time is also required to obtain the instructions from the place where they are held in the machine.

### Internal Storage

The internal storage of numerical information in the computer must be distinguished from the external storage of file data. External stores are unrestricted in capacity but relatively slow in yielding their contents. Internal storage provides very rapid reference to the information in immediate use during the computation, and the effectiveness of the whole computer largely depends on the capacity of its internal storage and the speed of access to any stored item.

Magnetic recording is probably the most popular means of internal storage; the magnetic material is deposited on the surface of a metal drum which rotates rapidly past several small electromagnets, known as recording and reading heads. By passing a current pulse through a recording head a small spot of the magnetic material about 1/100 in. across is magnetized, and when this spot passes a reading head it will induce a pulse in it. A typical magnetic drum is 10 in. in diameter and 5 in. long, and is driven at 3,000 rev/min by an a.c. motor. Such a drum may store 4,000 computer "words" of 32 bits each, say 128,000 bits in all; larger drums have capacities as high as 500,000 bits. The delay before a given word can be extracted from a drum store may be as long as the time of one revolution, but on average is one-half of this, say 1/100 sec for a 3,000 rev/min drum.

Another kind of internal storage uses ultrasonic delay lines, in which a short burst of sound waves with a pitch greatly above audibility represents each bit. In one arrangement the ultrasonic waves pass through a tube filled with mercury at a speed of about 5,000 ft/sec, and as each burst arrives at the far end it is amplified and returned to the start so that it circulates continually through the tube. Each burst lasts about one-millionth of a second, so that one tube 5 ft long can hold about 30 words, and 50 to 100 tubes would be provided in all. The maximum delay in extracting a word from the store may equal the time for one circulation through the tube, say 1/1000 sec. In a more compact arrangement the tube of mercury is replaced by a thin wire of nickel alloy.

Binary digits can be stored in any device which is able to assume either of two distinct states, and arrangements of thermionic valves and telephone relays have both been used as temporary stores. More-recent developments include the use of tiny ring-shaped cores of certain ceramic magnetic materials called ferrites, and of sheets of certain insulating materials known as ferro-electrics. Ferrite-core stores have been described with capacities up to 10,000 words and access times as low as 5  $\mu$ s; such a store might contain 300,000 separate cores (one per bit) each threaded with four separate wires for carrying the reading and writing currents.

Drum and delay-line stores have the disadvantage

that the stored words are available only in an ordered sequence. The potential delays of ordered access can sometimes be avoided by a skilful arrangement of the program of instructions, which ensures that words are only called from storage when they are becoming available; but there are limitations to this technique of "optimum programming." In ferrite and ferro-electric stores all stored words are equally available, and a random selection can be made without delay. These are often called "random-access" stores, and no computer has as much random-access storage capacity as could be usefully employed in clerical work.

An inadequate amount of internal storage, by restricting the length of program that can be stored, and the number of intermediate results that can be held, may reduce the value of a particular computer in some applications, e.g. by making it necessary to put out intermediate results, which then have to make one or more additional passages through the machine for further processing.

### Input

The primary sources of information, or data as it is commonly called, for an office computer are written or printed documents, and ideally these would be automatically converted into electrical pulses at such a speed that they could be directly used by the computer. Typed or printed characters in certain fonts can be read photo-electrically at speeds up to about 200 characters/sec. A simpler process uses special inks containing magnetic oxide of iron, and prints the characters in a code using dots or bars that can be read electromagnetically at 1,000 characters/sec.

Most data are, however, still transcribed by hand from the primary documents on to punched cards or punched paper tape. These may be read directly into the computer but, increasingly, are automatically transcribed on to magnetic tape, to be read later into the computer at the highest possible speed. Table 2 compares the speeds of punched cards, paper tape and magnetic tape. The method of recording on magnetic tape resembles that for magnetic drums, the tape being made of a thin, tough plastic material.

TABLE 2  
Speeds of Punched Cards, Paper Tape and Magnetic Tape

Medium	Speed Range of Medium	Data Input Rate	
		Characters/sec	Bits/sec
Punched cards (80 columns, one alphabetical or numerical character per column)	120 to 600 cards/min	160 to 800	800 to 4,000
Punched paper tape (5 holes per character across the tape)	20 to 100 in./sec	200 to 1,000	1,000 to 5,000
Magnetic tape ( $\frac{1}{2}$ in. wide, 7 tracks, 100 to 300 characters per inch)	100 to 200 in./sec	10,000 to 60,000	70,000 to 400,000

There are clear advantages in speed and accuracy in eliminating transcription, by preparing the primary data so that the computer can read it directly, and by keeping file data as magnetic recordings. Punched paper tapes can be prepared automatically as a by-product of other work; by the operation of a cash register, for example.

Magnetic file records can be kept either on tapes or on metal disks or drums coated with iron oxide. The magnetic storage of file data poses legal and auditing problems, but no really serious technical difficulties are expected.

While human transcription remains, verification is extremely important, and commonly two independent transcriptions are prepared and automatically compared. This process consumes operator and machine time, but saves more valuable time and temper during the computation, as errors can cause much spoilt work before they are detected and corrected.

*Output*

One output required from an office computer is a printed document; outputs in other forms may also be required for subsequent use in the machine. The printing speeds currently available are considerably lower than those of computer outputs, and magnetic tape recording is often used as a buffer between the computer and its printers.

The printers used with computers can be divided into three broad groups, namely, typewriters, mechanical line-at-time printers and non-mechanical printers. Teleprinters are a specialized form of electric typewriter operating at 400 characters/min. Other electric typewriters have speeds in the range 600 to 1,200 characters/min.

Some mechanical line printers use type bars or wheels, which in the faster models are hit against the paper "on the fly" by hammers operated by electromagnets. The fastest speed achieved in this way is 1,800 lines/min for purely numerical characters, or half this speed for a mixture of alphabetical and numerical characters.

Other mechanical printers use thin steel wires to print dot patterns to delineate the characters. Methods range from the use of a single wire per character, which traverses to and fro to trace the desired outline, to a mosaic bundle of  $7 \times 9$  wires for each character. The printing speeds range from 300 to 900 lines/min, each line containing about 100 alphabetical or numerical characters.

Various non-mechanical printers are being developed to avoid the speed limitations imposed by inertia. Some use wire electrodes or cathode-ray tubes to impose character patterns of electric charge upon waxed paper; the patterns are then made visible by dusting on ink powder which clings to the electrified areas, and they are fixed by heating to soften the wax. Printing speeds of 5,000 characters/sec have been achieved. In another method the character outlines are magnetized on to the surface of a rotating cylinder, a sprinkling of iron filings clings to the magnetized areas and is transferred to waxed paper and fixed by heat. One cathode-ray-tube method uses a metal character-stencil to shape the electron beam; it has already achieved a printing speed of 10,000 characters/sec and 100,000 characters/sec seems to be feasible.

The electronic engineers who design computers tend to think in terms of "balanced" operation, in which everything processed by the computer is printed as it is produced. In many applications, however, a large printed output is undesirable—for it presumably has to be read; and the computer should be used to boil the raw data down and down to produce highly concentrated analyses requiring very little printing.

Table 3 compares the speeds of various types of commercial printer.

TABLE 3  
Speeds of Commercial Printers

Printer	Approximate Maximum Printing Speed	
	Lines/min	Characters/sec
Teleprinter	5.7	6.7
Electronic typewriter	15	20
Punched-card tabulator	80 to 150	120 to 225
Wire printers	900	1,500
Wheel printers	1,800	3,000
Electric-charge printers	3,000	5,000
Cathode-ray-tube printers	5,000	10,000

*Control and Common Services*

The control unit co-ordinates the operations of the other parts of the computer, so that they combine to follow the instruction program. Quite often a computer works to a two-stage cycle. In the first stage the control unit selects from the stored program the next order to be obeyed, and in the second stage the order is decoded and converted into control signals which open and close electronic "gates" in various parts of the machine to set up appropriate routings for the execution of the order. When the order has been satisfactorily executed a signal is returned to the control unit to initiate the next cycle.

The common services of the computer include a number of ancillary units which provide:

(a) A continuous supply of "clock" pulses at regular intervals, which can be switched on and off to form the groups of pulses that represent numbers, and which control the timing of the machine.

(b) Power supplies of the various kinds and voltages needed in the electronic units.

(c) Test and monitoring facilities.

PROGRAM

Much of the apparent complexity of a computer resides in its instruction program, rather than in the construction of the machine itself. The program must set out in complete detail each unit operation to be performed by the machine, and because the computer is quite mechanical in action every conceivable contingency has to be anticipated. The programmer must be an analytical thinker who is capable of sustained periods of meticulous work. A large clerical program may contain two or three thousand instructions; mistakes of composition or coding are therefore to be expected and their elimination may take days or weeks rather than hours. Much programming has a tedious near-routine character, and ways are being sought to transfer this work to the computer itself.

A preliminary to writing the program is, of course, the statement of the work that the computer is to do. This work must be broken down into its simplest elements, for although a computer works quickly it only does so in very simple steps. Analysis and rearrangement of clerical work in computer terms has been found to take a great deal of time and effort. As a possibly extreme example, one American insurance company expended 60 man-years of effort on analysing the office processes that were to be performed by a computer and preparing a flow-chart; the consequent program took about two man-months to write and check.



The instructions which form the program are written in a code that specifies the operation to be performed and also certain storage locations or "addresses." The operations include read-input, transfers between stores and the arithmetical unit, arithmetical operations, print-output and so on. The number of store locations specified in an instruction ranges from one to four in different machines; a common type of instruction quotes two addresses, namely, that of the number to be operated on and that of the next instruction. Thus, in a computer with a two-address order code, a typical instruction is 45M63, meaning "Multiply the number stored in magnetic drum position 45 by the number already in the multiplier store: next instruction is in drum position 63." An important type of instruction is conditional; thus, the instruction 70T96 might mean: "Test the sign of the number held in the "results" part of the arithmetical unit; if the number is negative take your next instruction from magnetic drum position 70; if the number is positive take your next instruction from drum position 96. Conditional instructions give the machine great flexibility and a power of decision, although the machine's decision is made only between alternatives previously laid down by the programmer and in strict accordance with his prescribed conditions. Typical conditions are the appearance of a negative, or a positive, or a zero result of the computation, or of a number too large for the capacity of the machine.

#### COMPUTERS IN THE OFFICE

Arithmetical operations consist of sequences of simple logical steps, and electronic computers can perform simple logical operations as well as purely arithmetical ones. For example, a computer can be used for comparing, matching, putting into sequences, merging, sorting and selecting. These operations, and simple arithmetic, are all used in the work of a clerical office, and computers are likely to become familiar pieces of office equipment in large concerns. The office use of computers is often called automatic data processing (A.D.P.) and the general arrangement of one type of large office computer for A.D.P. is shown in Fig. 5. The data on the input documents are punched into cards or into paper tape by girl operators. This is a slow and expensive process with an average rate of about 4 characters/sec, and as the results have to be re-punched to detect the errors of the first operator the effective rate is only 2 characters/sec per operator. The punched cards or tape are then converted to magnetic tape, at speeds of 200 to 800 characters/sec. The magnetic tape can be read into the computer at speeds of 10,000 to 60,000 characters/sec. The diagram shows various types of input equipment flexibly linked by switching stages, which can set up alternative connexions.

The input data are sometimes presented in a random order, in which case the computer can sort them according to a preparatory program, and record the ordered result on magnetic tape for use as a pre-digested input. The sorted input, plus standard data from a master reference file, then enters the computer for processing according to the main program. As well as producing the output documents, an amended master reference file is produced for future use. For example, on payroll work the raw input data might consist of normal and overtime hours worked by each man, together with details of new arrivals, promotions and retirements, and this might first be sorted into pay-

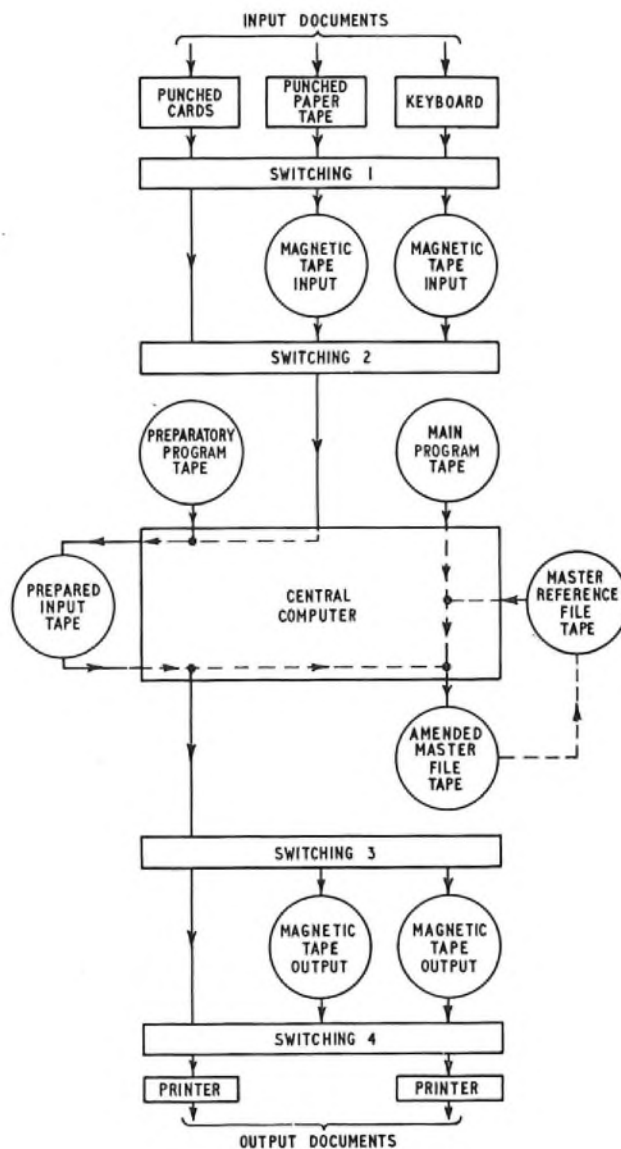

FIG. 5—ARRANGEMENT OF A LARGE OFFICE COMPUTER FOR AUTOMATIC DATA PROCESSING

number order. In this same order the master reference file would list for each man details of pay rates, tax code, allowances and deductions together with cumulative totals.

The main output of results may be recorded at high speed on magnetic tapes, which are removed and subsequently used at slower speeds to control the printing of the final documents—payslips and paysheets in the payroll example. Occasionally, the computer may control the final printer directly or its output may be punched into cards, but these processes are relatively slow. The diagram shows how switching can provide alternative output connexions.

#### OPERATION

High-speed calculation would be useless if it were inaccurate, but experience shows electronic computers to be very accurate. Allied to accuracy is reliability, for the performance of, say, 10,000 additions every second, each using several hundred components in different parts

of the machine, places severe demands on reliability. Even brief or intermittent failures of one component may disturb the final result. The severity of the demands may be eased by the use of extra pulses in the code to check for internal consistency; for example a "parity bit" may be used, so that every valid number has an even number of "1"s. Again, checking processes can be interpolated in the program, but there is no complete substitute for reliable engineering in both design and maintenance.

Maintenance methods vary between letting sleeping dogs lie, and waking them up from time to time to see if they are still alive; that is, between corrective and preventive maintenance. The best answer may well be a compromise between these extremes. The performances obtained with existing designs suggest that a good computer should be able to work for 22 hours a day if necessary, with 2 hours' scheduled maintenance to make up the 24 hours, and that it should be effective for 85 to 95 per cent of its working time. The remaining 5 to 15 per cent is likely to be consumed by clearing unexpected faults. Most of the time needed to clear a fault will be taken up in diagnosis, for the cure will usually be a swift replacement of the faulty unit, followed by its more leisurely repair. Diagnostic programs have been designed which assist the location of computer faults. Although faults do not occupy a large proportion of the total working time, they may occur at any time, and it is sensible to arrange the computer's work to limit the amount that may be spoilt by a single fault.

#### LIMITATIONS AND POSSIBILITIES

The future development of computers can be expected to yield designs that are much improved in speed, size, cost, power consumption and reliability, with inputs read directly from printed documents. Programming is likely to become easier, by the use of translation routines which convert plain language instructions in fairly broad terms into detailed orders in computer code. Again, as machines are applied to office work on an increasing scale, more complex and flexible organizations may be expected to appear. These may enable a single set of electronic equipment to accept, in random order, documents relating to a variety of processes, for the machine

to sort and deal with in terms of a range of stored programs, which it calls on as needed by the flow of work rather than tackling each main process in turn according to a single program. Moreover, in the interests of flexibility and reliability, large machines in widely-separated offices may well be linked by cables so that they function as a unit. These last two concepts are sometimes related to "integrated data processing" (I.D.P.) which visualizes the entire data of a business organization being handled as a single whole. Developments can also be expected in the storage of data, perhaps of electro-chemical methods of the type used so effectively in the brain and by other living organisms.

The less sober literature of computers has dubbed them "electronic brains"; and one American writer, foreseeing a new sphere of industrial unrest, has even asked "How can we be safe against the threat of physical harm from robot machines?" Against this, another of his countrymen has argued that the differences between our computers and our brains are so great that any comparison is foolish. Thus, the human brain is estimated to contain a million times more logical elements than the largest computer. Moreover, these elements seem to be arranged in a random fashion in the brain, compared with the highly organized structure of the computer. Precise organization reduces flexibility of function. It also reduces reliability by increasing the dependence of the whole on particular elements; and it may be that in both these respects computer designers can learn from studies of the brain.

One brain activity not fully shared by computers is the ability to learn. Computers can be instructed to learn; thus, the Cambridge computer EDSAC has worked to a learning program which taught it a conditioned reflex response. However, its director commented: "such a program makes it possible to teach the machine only those things which the programmer had in mind when he wrote the program." The last word may perhaps be left with a lady: Ada Augusta, Countess of Lovelace, was the daughter of Byron, and writing in 1843 about Babbage's Analytical Engine she said: ". . . it has no pretensions whatever to originate anything. It can do whatever we know how to order it to perform."

---

## Book Review

"Electrical Engineering Practice," Vol 1. Sixth edition. J. W. Meares, C.I.E., M.I.E.E. and R. E. Neale, B.Sc., A.M.I.E.E. Chapman & Hall. xiii + 715 pp. 113 ill. 60s. net.

This work, in three volumes, is described as "A Practical Treatise for Electrical, Civil and Mechanical Engineers." This new edition of Vol. I contains no other hint as to the intended scope of the work, which is rather a pity since it is an unusual style of book. The preface to a third edition written in 1916 described the work as "an endeavour to fill the gap between many excellent pocket books of bare data and the highly technical works written for specialists."

The new Vol. I is in three parts, with a detailed index, totalling 715 pages.

Part 1 is entitled "Definitions, Materials, Measurements."

Part 2 is entitled "Generation, Prime Movers, Sale of Electrical Energy."

Part 3 is entitled "Transmission and Control."

A very wide range of subjects is covered in a generally

descriptive manner, often starting from the most elementary principles. The various chapters, contributed by many different authors, are authoritative and for the most part very readable, though design data will usually not be found. It is surprising in Part 2 to find "Generators and their Accessories" dealt with in 50 pages whilst "Water Power" is given 90 pages. Even so the author has managed to include under generators: primary cells, thermo-couples, piezo-electric generators and electrostatic generators as well as d.c. and a.c. electromagnetic generators.

There are very few illustrations in this book and in some sections this is a serious drawback. A description of a Wimshurst machine, for example, is surely unlikely to mean very much to a reader meeting this for the first time unless backed by at least one clearly drawn illustration.

All 16 chapters of the book are followed by references to British Standards, text books and I.E.E. papers for further reading. Perhaps this book is best described as a good companion for the non-specialist engineer, putting him in touch with a wide selection of reading matter on a comprehensive range of subjects.

R. W. H.



# The Electronic Traffic Analyser—a Survey of its Use and Limitations

H. T. McGRATH, B.Sc.†

U.D.C. 621.395.364:621.389

The use made of the electronic traffic analyser since it was first constructed is reviewed, and a number of changes made to increase the flexibility and reliability of the analyser are described. Extensive tests have been made of gradings of different availabilities, formations and numbers of trunks, and the traffic capacity of various alternative-routing schemes has been investigated. The considerable flexibility of the analyser has enabled a great variety of other problems to be investigated and some of these are briefly described. For tests on more complicated trunking schemes than were originally envisaged in the design of the machine, some limitations have become apparent; these are discussed and the desirable features of a new machine are propounded.

## INTRODUCTION

A FULL description of the theory and principles of operation of the electronic traffic analyser has been given in a previous article<sup>1</sup> and elsewhere.<sup>2</sup> No basic changes have been made to the machine since it was constructed, but operating experience over the last five or six years has indicated the need for minor modifications and additions to the facilities provided; these have resulted in greatly increased reliability and flexibility.

The analyser is an analogue device in which random pulses are used to simulate the initiation and release of telephone calls in order to imitate the assumed conditions of pure-chance call-origination and negative exponential holding times on which the traffic tables used by the Post Office are based. The essential components of the electronic traffic analyser are:

(a) A number of "contacts" which correspond to the contacts tested by a selector when it is searching for a free outlet in a grading. They are, in effect, electronic gate circuits which may be opened or closed by registers.

(b) A number of "registers," which correspond to the outgoing trunks in a grading and which are 2-position trigger circuits. The contacts and registers may be interconnected as required by means of plugs and cords to represent different grading formations.

(c) A distribution table of 256 "events" terminals at which connexions are made to the grading groups for the origination of calls and to the reset terminals of the registers for the release of calls.

(d) Neon noise generators and associated equipment which provide a random distribution of pulses to the events terminals of the distribution table.

(e) Counters which are used to count the calls offered to, carried by, and lost from, the grading.

A block schematic diagram of the connexions for a simple grading is given in Fig. 1.

The main program of tests on the analyser has been concerned with the traffic capacity of gradings and with alternative routing problems. In addition to this main program, numerous other problems have been dealt with; these will be called "non-standard" tests in this article to denote that they involved the testing of trunking schemes other than the simple grading and interconnexion schemes for which the analyser was designed. It has, however, been possible to deal with these problems on the analyser because of the con-

† Senior Executive Engineer, Engineering Organization and Efficiency Branch (formerly of the Telephone Development and Maintenance Branch), E.-in-C.'s Office.

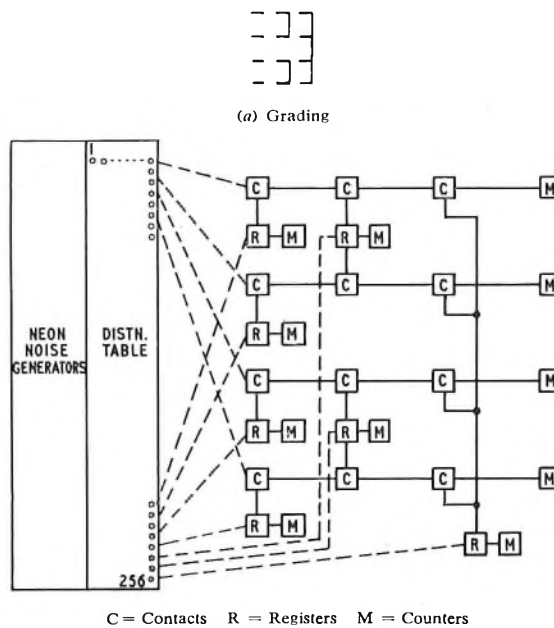

FIG. 1.—ELECTRONIC TRAFFIC ANALYSER CONNEXIONS FOR SIMPLE GRADING

siderable flexibility provided by the original design and the subsequent additions and modifications to certain parts of the machine.

From the experience gained with this type of problem it is now apparent that the scope and flexibility of the analyser cannot be further extended without extensive rebuilding and redesign. Investigations into more-complicated trunking schemes, e.g. link systems, smoothing, will therefore require a new approach.

## MODIFICATIONS AND ADDITIONS

### Counters

The analyser was originally equipped with 16 high-speed binary counters and 90 low-speed counters of the subscribers' electromechanical meter type. The latter were too slow for use when the machine was working at its usual speed of some 250 p.p.s. and consequently independent runs at the low speed of 7 p.p.s. had to be made to check the correct operation of the contacts and registers, etc. A further disadvantage of these counters was that they could not be reset to zero at the commencement of each test.

The high-speed binary counters proved to be unsatisfactory when large numbers of readings were required because of errors frequently introduced during binary-decimal conversion.

With the introduction of the dekatron,<sup>3</sup> a polycathode gas-discharge counting tube, it was decided to re-equip the analyser with counters using these tubes so that all tests could be made at high speed, and all readings would be presented in decimal form. A further advantage was that all counters could be reset to zero by a single switch. Each counter now consists of three dekatrons in a series arrangement giving a 3-decade display. For

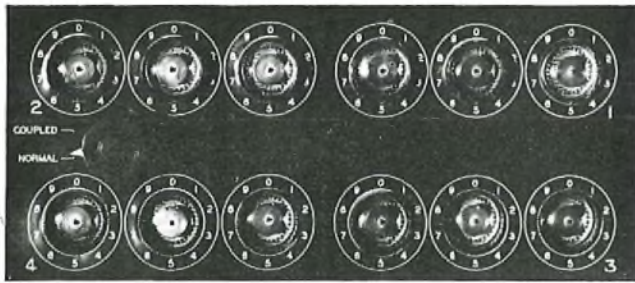

FIG. 2—FRONT VIEW OF HIGH-SPEED COUNTER

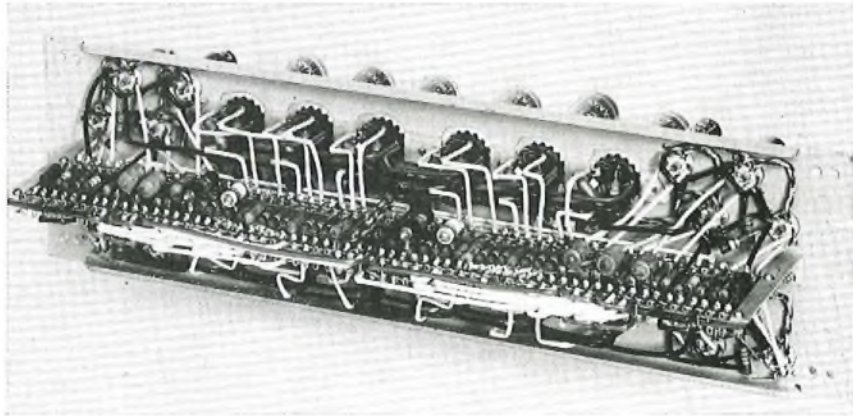

FIG. 3—REAR VIEW OF HIGH-SPEED COUNTER

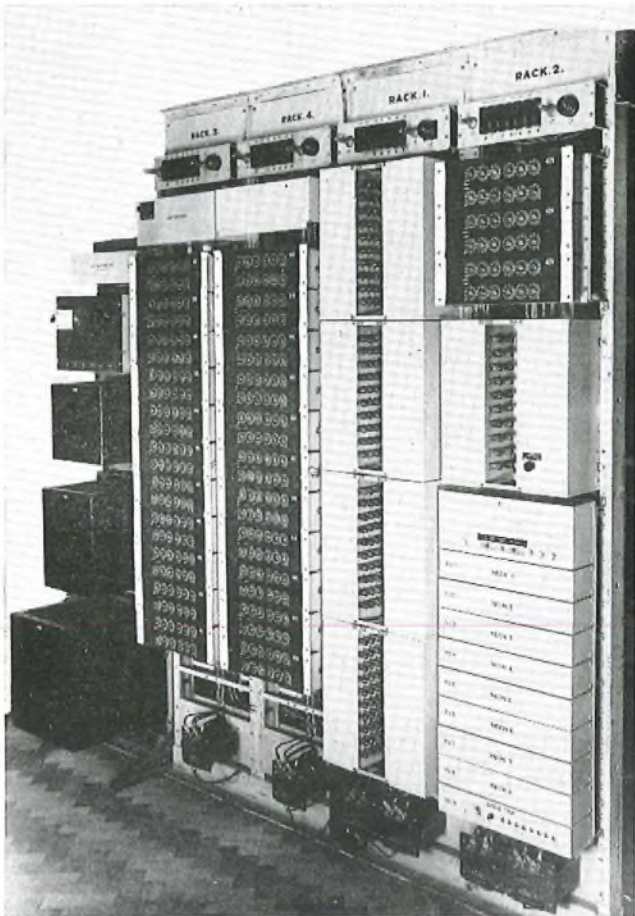

FIG. 4—FRONT VIEW OF ELECTRONIC TRAFFIC ANALYSER FITTED WITH THE NEW HIGH-SPEED COUNTERS

large counts, two such counters may be coupled together to give a 6-decade display. A total of 100 3-decade counters, mounted on 25 panels, were provided. Fig. 2 and 3 show the front and rear view of one of the panels and Fig. 4 shows the front view of the electronic traffic analyser after fitting the new panels.

#### *Routine-Test Equipment*

The original routine-test equipment was arranged so that a cyclic distribution of events was generated at the events table. The changes in the states of a grading caused by this cyclic distribution depend on the way in which connexions are made from the events table to the grading groups and register reset terminals. Thus, by changing the connexions, any combination of seizure and release of the trunks in a grading could be obtained. In general, a thorough check of a grading involved making numerous changes to the distribution-table connexions. The routine-test equipment was, therefore, modified to provide a group-test facility, which allows all the outlets in any grading group to be tested by a predetermined cycle of events, each group being tested in turn, the selection of the group being made by keys mounted on the front of the machine.

#### *Display Panel*

The primary object of the display panel is to assist in checking the correct operation of the contacts and registers used for any particular test. It is used mainly in conjunction with the cyclic and group-test facilities referred to above.

The display consists of a number of neon indicators which are wired out to jacks at the top of the racks. Connexions are made to the registers by plugs and cords in such a way that the display gives a visual indication of the grading formation under test and also shows the occupancy of each of the trunks.

#### *Multi-phase Pulse Supply*

On many tests a number of registers, apart from those used as trunks, are required to perform control functions which may, for example, determine the order of selection or release of trunks. Pulse supplies that are non-coincident with that providing the random drive are needed to operate these control circuits. The pulses are generated by a dekatron-type cold-cathode tube, the 10 cathodes of which are brought out separately and connected to pulse-shaping triggers as required.

#### MAIN PROGRAM OF TESTS

##### *Gradings*

Extensive tests on a large number of gradings of different availabilities, formations, and numbers of trunks have been made. The tests were designed to cover availabilities from 10 to 40 and grades of service in the range 0.1 to 0.001.

In general, a number of tests must be made on each grading formation for each value of traffic offered since the standard deviation of the number of lost calls per test is large in comparison with the mean number of lost calls. The actual number of tests carried out depends



on the degree of accuracy required, the size of grading and the time required for each test.

From the test results, the mean proportion of lost calls may be found for particular gradings and volumes of traffic. Usually this proportion will not be the required figure of, say, 0.01, and therefore a series of tests must be carried out at several values of traffic. The traffic capacity at the required grade of service may then be obtained graphically.

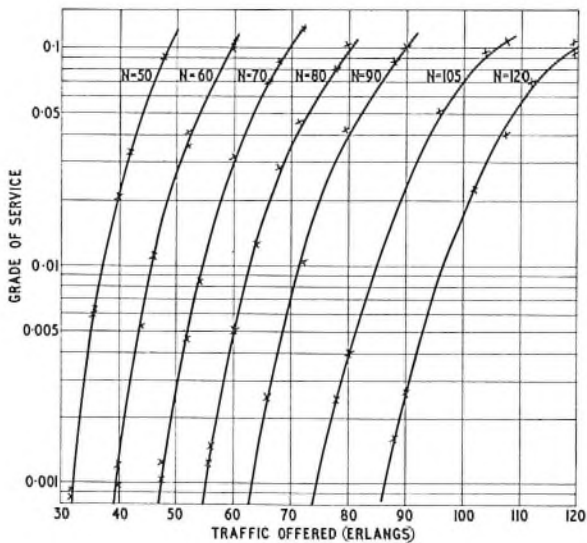

N = Number of trunks      × Denotes analyser results  
 FIG. 5—VARIATION OF GRADE OF SERVICE WITH TRAFFIC OFFERED FOR 40-AVAILABILITY GRADINGS

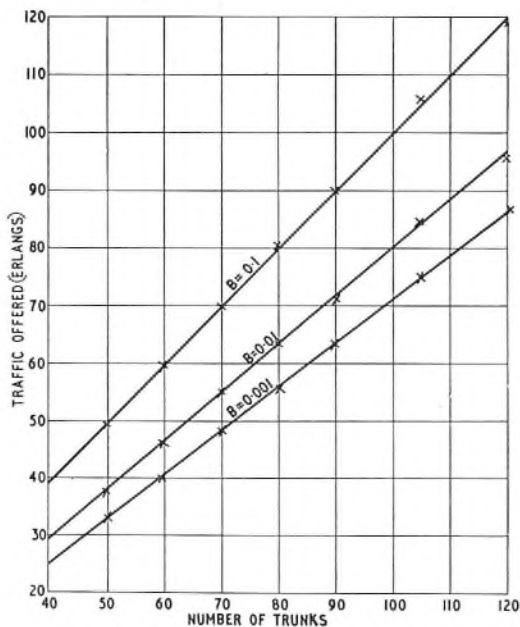

B = Grade of service      × Values from Fig. 5  
 FIG. 6—TRAFFIC CAPACITY OF 40-AVAILABILITY GRADINGS

The results of typical tests on 40-availability gradings are shown in Fig. 5, which illustrates the variation of grade of service (*B*) with traffic offered (*A*) for various numbers of trunks (*N*). For some values of *N* and *A*, gradings with different numbers of groups were tested

and, therefore, more than one result is shown for these cases. The closeness of these results is a measure of the small differences in traffic capacity which exist between grading formations with the same number of trunks but with different numbers of groups.

Fig. 6 shows the traffic capacity of 40-availability gradings for grades of service of 0.1, 0.01 and 0.001, as derived from Fig. 5, and it clearly indicates that a linear relationship between traffic capacity and number of trunks may be safely assumed over the range considered. As would be expected, the straight lines pass through the points corresponding to the traffic capacity of full-availability groups at the appropriate grades of service. For example, the traffic capacity of a full-availability group of 40 trunks at a grade of service of 0.01 is 29.0 erlang and the line for *B* = 0.01 passes through the point, *N* = 40, *A* = 29.0.

The results considered so far apply only where equal volumes of traffic are offered to each of the grading groups. In practice, this is far from being the case, although efforts are made to achieve equality of loading by careful design. The effect of unequal loading is to change the traffic capacity, and these changes were investigated by applying systematically unbalanced conditions to the traffic offered. The total traffic offered to a grading and the sum of the traffic offered to adjacent groups was kept constant, but the amount of traffic offered to adjacent groups was made unequal. Thus, if the traffic offered to groups 1, 3, 5, etc., was *A*<sub>1</sub> and that to groups 2, 4, 6, etc., was *A*<sub>2</sub>, then *A*<sub>1</sub> and *A*<sub>2</sub> were varied subject to the condition that *A*<sub>1</sub> + *A*<sub>2</sub> remained constant. The percentage unbalance was then defined as

$$\frac{A_1 - A_2}{A_1 + A_2} \cdot 100$$

Fig. 7 shows the effect of offering traffic unbalanced in this way to 10-availability gradings and indicates that for unbalances not exceeding 25 per cent the effect on the grade of service is small. Similar sets of curves were obtained for other availabilities but the effects of unbalance become less important with increasing availability and the corresponding curves become flatter.

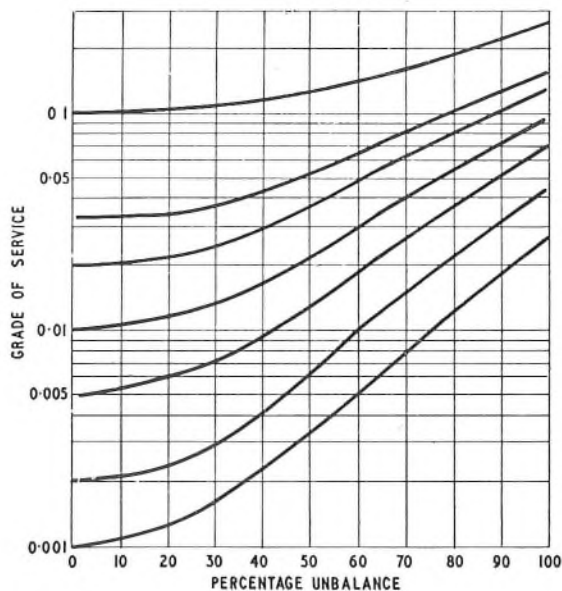

FIG. 7—EFFECT OF UNBALANCED TRAFFIC ON 10-AVAILABILITY GRADINGS

The linear relationship referred to above in connexion with Fig. 6 is also apparent from the results obtained from tests on gradings with other availabilities. As stated earlier, the lines pass through the appropriate full-availability points; therefore, for a given availability and grade of service, the relationship between traffic capacity and number of trunks is completely defined if the slope of the line is known. Analysis of all the results for balanced traffic shows that the value of slope may be calculated with sufficient accuracy from an empirical relationship with the grade of service and the availability. This makes it possible to calculate the traffic capacity of any grading based on standard formation procedure for any availability and any grade of service in the range considered. Details of such calculations are given in the Appendix. In practice, it is usual to allow for the effects of unbalanced traffic and of overload in the preparation of traffic capacity tables. These necessary refinements may be allowed for when required by modification to the procedure outlined in the Appendix.

Comparison of the electronic traffic analyser results with the present Post Office traffic-capacity tables indicates that savings of trunks up to about 6 per cent may be possible in some cases; the percentage saved is shown in Table 1.

The agreement between the present traffic capacity tables, which are based on the results of manual artificial-traffic records taken many years ago, and the electronic traffic analyser results is remarkable when it is remembered that the manual records were necessarily limited in scope to cover the smaller availabilities, and that the results of these records were later applied to larger availabilities and wider ranges of grade of service.

#### Alternative Routing

Under certain conditions it is possible to achieve considerable economy in line plant by the use of alternative routing schemes, and investigations with the analyser have been concerned with the traffic capacity of such schemes and the optimum circuit arrangements.

A very simple scheme is shown in Fig. 8(a); there are three unidirectional components of traffic  $A_1$ ,  $A_2$  and  $A_3$  on the routes A-T, T-B and A-B, respectively. The most economic method of routing traffic  $A_3$  will depend on the distances between the centres and the relative values of  $A_1$ ,  $A_2$  and  $A_3$ .

It may sometimes be cheapest to provide sufficient circuits between A and B to carry traffic  $A_3$  at the specified grade of service, as shown in Fig. 8(b), or it may be cheapest to route the whole of traffic  $A_3$  via T

TABLE 1

Savings of Trunks using Analyser Figures instead of Present Traffic Tables

Availability	Percentage Savings of Trunks						
	$B = 0.1$	$B = 0.033$	$B = 0.02$	$B = 0.01$	$B = 0.005$	$B = 0.002$	$B = 0.001$
10	-3	0	0	+1	+2	+4	+6
20	-1	+2	+2	+2	+2	+3	+3
40	0	+2	+2	+2	+3	+3	+3

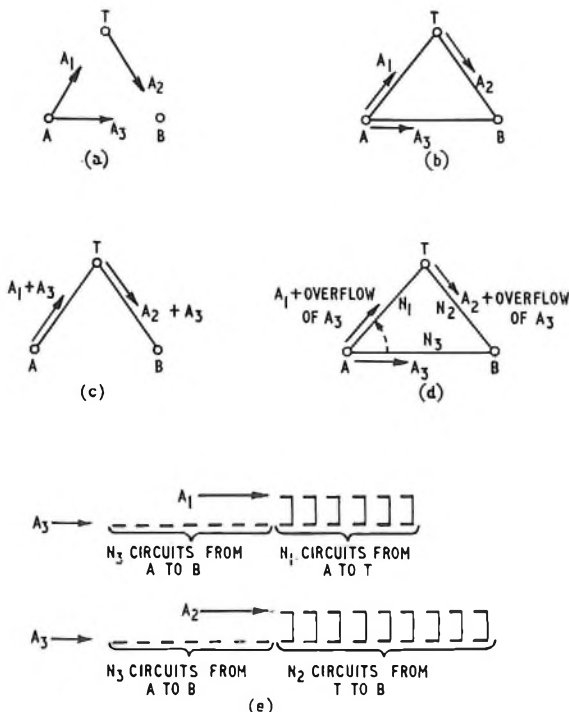

FIG. 8—ALTERNATIVE ROUTING

by providing additional circuits on the routes A-T and T-B to carry this traffic as well as the normal traffic on these routes at the specified grade of service, as shown in Fig. 8(c). It may be, however, that the cheapest method is to provide a limited number of direct circuits between A and B, the traffic which cannot be carried on these circuits being routed via T. This method is called alternative routing and is illustrated in Fig. 8(d) and 8(e).

Calls between A and B are normally completed over the  $N_3$  direct circuits between A and B; if all these direct circuits are engaged, such calls are completed via T. Thus, the  $N_1$  circuits between A and T carry traffic  $A_1$  plus the overflow traffic from the  $N_3$  circuits between A and B. Similarly, the  $N_2$  circuits between T and B carry traffic  $A_2$  plus the overflow traffic from the  $N_3$  circuits between A and B.

The characteristics of overflow traffic are such that the number of circuits required to carry a given volume of traffic with a specified loss is greater than that required for the same volume of pure-chance traffic. In alternative routing schemes, overflow and pure-chance traffic are offered to the same group of trunks and it is in determining the number of trunks required to carry the total traffic that theoretical difficulties arise.

The problem, then, is to determine the values of  $N_1$ ,  $N_2$  and  $N_3$  so that the most economical arrangement of circuits is realized and the traffic components are carried with a specified loss. The arrangement described



may be considered as two asymmetrical gradings, as shown in Fig. 8(e). The two gradings, however, are not independent because there is correlation between the routes A-T and T-B due to the fact that a call from A to B via T uses a circuit on each of these routes. That is, a call from A to B via T, if successful, results in the simultaneous seizure and release of a circuit in each of these routes.

Because of the large number of variables concerned, it would be impracticable to attempt to tabulate the numbers of circuits required even for the simplest schemes. The analyser has, therefore, been used as a means of checking the accuracy of a number of methods which have been proposed for calculating these values.

The test procedure followed is basically the same as that described for gradings. Some of the results obtained from the analyser and by three different methods of calculation (methods A, B, and C) are illustrated in Fig. 9 and relate to the simple schemes referred to above.

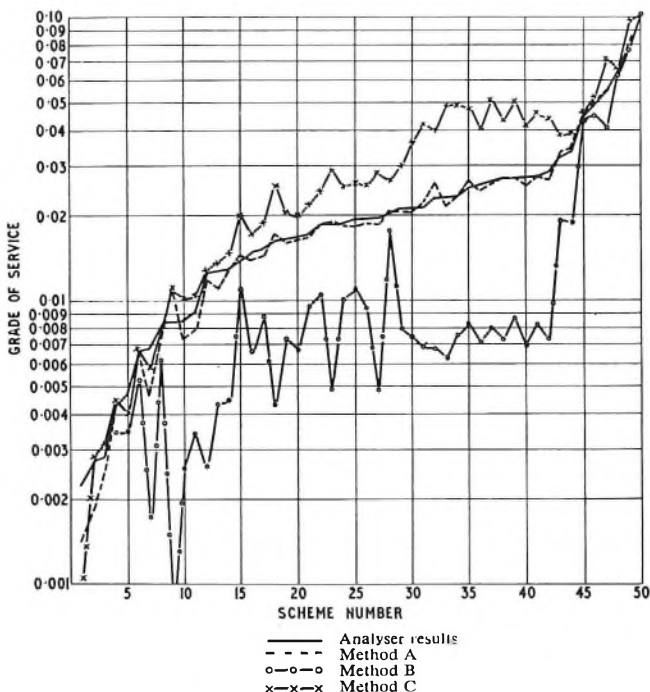

FIG. 9—GRADE OF SERVICE FOR VARIOUS SCHEMES OF ALTERNATIVE ROUTING

Method A is that due to R. I. Wilkinson, which is described fully elsewhere.<sup>4</sup> This method also gives very good results when applied to more-complicated line networks.

By applying different cost factors to the various routes it was possible to arrive at the most economic arrangement in each case. In all cases, the optimum condition occurred when 5-20 per cent of the traffic overflowed to the alternative routes; furthermore, the variation in cost over this range was small. It seems probable, therefore, that on simple schemes an optimum arrangement may be approached by providing direct circuits so that about 10 per cent of the traffic overflows, and then calculating the number of circuits required on the alternative route.

The analyser has, therefore, provided a quick and

easy means of checking a number of theoretical methods for calculating the grade of service and optimum circuit arrangement in alternative routing schemes.

#### NON-STANDARD TESTS

The considerable flexibility provided by the initial design and construction of the electronic traffic analyser has enabled a large variety of problems to be investigated, and the subsequent modifications and additions to the analyser have further extended its scope. The following brief descriptions of some of these investigations give some idea of the types of problem investigated.

##### Traffic Capacity of 2-Home-Position Switches

With the introduction of 2-home-position uniselectors in subscribers' line circuits, information was needed on the effect on traffic capacity of forming two gradings on the 23 outlets. The arrangement is such that traffic overflowing from one of the gradings is offered to the other together with half the total traffic. The test results showed that little loss in capacity results from using such a scheme.

##### Traffic Capacity of Interconnexions on Non-homing Switches

The interconnexion schemes tested were of the homogeneous type, i.e. each trunk is accessible from the same number of grading groups. The analyser connexions were arranged to simulate the non-homing feature so that there was an equal probability of a call being originated and commencing its search at any contact in the grading groups. On this investigation it was impossible to measure the number of lost calls directly and the grade of service was deduced from the traffic carried.

##### Centralized-Service-Observation Sampling Data

With the new centralized-service-observation equipment, observations are made directly on 1st selectors and it is desirable that the number of observations made on a particular selector should be proportional to the traffic carried by that selector. The analyser was arranged to simulate the arrangement of the centralized-service-observation access to the 1st selectors and measurements were made of the number of observations made on various selectors. From these results, rules were formulated for the connexion of 1st selectors to the centralized-service-observation equipment so that representative observations are made.

##### Time-to-Answer Observations

In delay systems, a measure of the service given is obtained by measuring the average delay on delayed calls or the time to answer. Theoretical studies indicated that, to obtain results free from systematic error, it is necessary to observe every  $n$ th call offered to the system and that systematic errors occur if observations are made on the next delayed call which occurs when the observation circuit is free. Theory also indicated that the error would depend on the queue discipline of the delay system.

The analyser was arranged to simulate delay systems and the observation circuits with order-of-arrival answering and random answering. The test results confirmed the theoretical studies.

##### Register-Translator Systems

For subscriber trunk dialling, a number of registers are served by one translator and, for any call, several

demands for routing information may be made to the translator by a register. If the translator is engaged then these demands may be delayed and the cumulative delay may be unsatisfactory from the point of view of the inconvenience to the subscriber and the increase in register holding time due to waiting for the translator.

Analysers tests showed that certain assumptions which were necessary to calculate the distribution of delays were valid.

#### LIMITATIONS OF THE PRESENT MACHINE

The electronic traffic analyser consists in part of a number of simple logical elements which may be connected together in a variety of ways to simulate different trunking schemes. For standard tests, no serious difficulties arise when the full capacity of the machine is in use. However, for tests on more-complicated trunking schemes than were originally envisaged in the design of the machine a number of limitations soon become apparent.

#### *Size of Machine*

The number of registers and contacts and the size of the distribution table are too small for tests to be made on schemes of a realistic size. The difficulty here is that a large number of registers, contacts and events terminals are usually required to perform control functions, e.g. to govern the method of selection or release of trunks. Consequently, the number of registers available for use as trunks is reduced and only small trunking schemes can be tested.

#### *Test Duration*

The time taken to obtain reliable results on non-standard tests is considerable, usually being from two to five times that required for standard arrangements. This is because it is often necessary to divide the basic machine pulse frequency into a number of separate pulse supplies. One of these supplies controls the random drive element of the machine in the usual manner; the other supplies operate the control circuits referred to above.

#### *Faulty Operation due to Spurious or Missing Pulses*

On standard tests it is usual to check that the calls offered to a grading are either carried or lost, as already described. Often, however, it is found that there are small discrepancies which are usually attributable to spurious or lost pulses due to intermittent connexions between cords and plugs or between plugs and terminal pins. In addition, spurious pulses may arise due to capacitive coupling between cords. These errors are easily detectable and curable and do not waste much machine time.

On non-standard tests larger numbers of cords are used and these often carry pulses of larger than normal amplitude. The errors due to the above causes are, therefore, greatly increased. Also, on schemes in which some form of control or memory has to be used, such faults may lead to lock-ups in those circuits and give rise to completely false results. Furthermore, the amount of time required to detect and cure these faults becomes out of proportion to the useful machine time.

The effect of increasing the size of the machine would be to increase the fault liability due to spurious or missing pulses and any change in the basic operating

frequency would involve large-scale modification to the existing equipment.

There is, therefore, little more which can be done to increase the scope of the machine, and for large-scale tests on non-standard schemes a new machine would be required.

#### DESIRABLE FEATURES OF A NEW MACHINE

An ideal machine should be fast-operating, have a large fast-access store for the simulation of trunks and control functions, and should be easily adaptable for dealing with a wide variety of problems. Some of the problems which require study are as follows:

(a) *Alternative routing.*—Complex networks in which a number of switching centres may act as tandem centres for certain classes of traffic.

(b) *Smoothing problems.*—(i) Smoothing of traffic between 1st and 2nd selectors, etc., due to the method of interconnexion; (ii) smoothing of traffic due to small numbers of traffic sources, e.g. as at U.A.X.s, and the effects of unequal calling rates.

(c) *Link systems,* where there may be two or more stages of selection.

(d) *Delay systems.*—Distribution of delays on imperfect groups and on certain combined loss and delay problems.

In addition, for any type of problem, it should be possible to change easily the method of selection of free trunks and the distribution of holding times.

A large fast-operating machine for the special purposes of traffic studies would be a very expensive item to construct and to maintain. Consideration is, therefore, being given to the use of automatic digital computers as traffic machines. The trunking details of a scheme may then be incorporated in the computer program. The program could also be arranged to make the computer generate sets of random numbers which would be used to determine the origination and release of calls. Theoretically, it is possible to use a digital machine for all types of traffic problem. However, the indications at present are that the amount of time required to generate random numbers within the machine and then to determine their significance would be excessive. It may be possible to overcome this difficulty by providing a random element external to, but coupled with, the computer. This method would enable full advantage to be taken of the large storage capacity and flexibility of such computers.

#### CONCLUSION

The present electronic traffic analyser has been very reliable over a number of years and much useful information has been obtained from it. The inherent flexibility of the analyser and a number of modifications and additions to it have enabled the machine to be used on a wide variety of problems not specifically catered for in the original design. The examination of more-complicated trunking schemes would require very extensive changes to the present machine, a new general-purpose traffic machine, or the use of automatic digital computers.

#### ACKNOWLEDGEMENT

The author wishes to thank colleagues in the Telephone Exchange Systems Development Branch and Research Branch of the E.-in-C.'s Office for their assistance in the preparation of this article.



## References

- <sup>1</sup> BROADHURST, S. W., and HARMSTON, A. T. An Electronic Traffic Analyser. *P.O.E.E.J.*, Vol. 42, p. 181, Jan. 1950.
- <sup>2</sup> BROADHURST, S. W., and HARMSTON, A. T. Studies of Telephone Traffic with the Aid of a Machine. *Proceedings I.E.E.*, Paper No. 1415, Sept. 1953 (Vol. 100, Part I, p. 259).
- <sup>3</sup> POLLARD, J. R., and BACON, R. C. The Dekatron. *Electronic Engineering*, Vol. 22, p. 173, May 1950.
- <sup>4</sup> WILKINSON, R. I. Theories for Toll Traffic Engineering in the U.S.A. *Bell System Technical Journal*, Vol. 35, p. 421, Mar. 1956.

## APPENDIX

- Let  $A_o$  = traffic offered to a grading of  $N$  trunks,  
 $A_c$  = traffic carried by a grading of  $N$  trunks,  
 $k$  = availability,  
 $B$  = grade of service,  
 $\alpha_c(k, B)$  = traffic carried by a full-availability group of  $k$  trunks when the grade of service is  $B$ ,  
 $\alpha_o(k, B)$  = traffic offered to a full-availability group of  $k$  trunks when the grade of service is  $B$ ,  
 $\mu_c(k, B)$  = slope of the graph relating to traffic carried and number of trunk lines for a grade of service  $B$  and availability  $k$ .

Analysis of the values of  $\mu_c(k, B)$  obtained from the electronic traffic analyser results showed that the relationship between these values and  $B$  and  $k$  may be expressed sufficiently accurately by

$$\mu_c(k, B) = 0.327 - 0.224 B^{1/k} + 0.897 B^{2/k}$$

Thus the slope of the graph relating traffic carried and number of trunk lines may be calculated for any value of  $B$  in the range 0.1–0.001 and for  $k$  in the range 10–40. Any such line must pass through the appropriate full-availability point; therefore,

$$\frac{A_c - \alpha_c(k, B)}{N - k} = \mu_c(k, B)$$

$$\therefore A_c = N \mu_c(k, B) + \alpha_c(k, B) - k \mu_c(k, B)$$

But  $A_c = (1 - B) A_o$   
and  $\alpha_c(k, B) = (1 - B) \alpha_o(k, B)$

$$\therefore A_o = \frac{\mu_c(k, B)}{1 - B} N + \alpha_o(k, B) - \frac{k \mu_c(k, B)}{1 - B}$$

For example, if the relationship between traffic offered and number of trunks is required for 40-availability gradings at a grade of service of 0.01, we have

$$k = 40$$

$$B = 0.01$$

$$\alpha_c(k, B) = 28.71$$

$$\alpha_o(k, B) = 29.0$$

$$\therefore \mu_c(40, 0.01) = 0.327 - 0.224 (0.01)^{1/40} + 0.897 (0.01)^{2/40}$$

$$= 0.8396$$

$$\therefore A_o = \frac{0.8396}{0.99} N + 29.0 - 40 \times \frac{0.8396}{0.99}$$

$$= 0.848 N - 4.92$$

## Book Review

“The Services Textbook of Radio and Electrical Engineering,” Vol. I, Electrical Fundamentals. G. R. Noakes. xiii + 645 pp. Illustrated. H.M.S.O. 30s.

This is the first of a series of text-books written specially for the three armed Services and the scope of which has been decided by an Inter-Services Panel.

It provides an extremely thorough and up-to-date treatment of the principles of electricity which will be found most valuable to telecommunications engineers.

It adopts the rationalized m.k.s. system of units and the opening chapter provides a comprehensive review of the elements of applied mechanics to illustrate the derivation and mechanical applications of these units. After a descriptive chapter reviewing briefly but quite comprehensively the elements of electrostatics and magnetism treated qualitatively there is a whole chapter on the quantitative treatment of the electric current and its principal effects, followed by chapters on the quantitative theoretical treatment of electrostatics, electromagnetism and electromagnetic induction.

From the start, and throughout the book, emphasis is most properly laid on energy transformation and exchange as the basis of the quantitative understanding of phenomena. This leads the student to a sound appreciation of electrical theory commencing with the conception of the work done by a moving charge along a potential gradient, the idea of e.m.f., transformation of energy into heat in a resistor, etc., and later, when dealing with electromagnetism, induction and alternating currents, to the energy considerations underlying such indices as power-factor and Q-factor and the behaviour of alternating currents in reactive circuits in general.

Chapters, mainly descriptive but containing the necessary quantitative treatment, follow on magnetic materials, electrochemistry and ionization of gases. This brings us to about half-way through the book and here commences a detailed study of applications including chapters on d.c. generators, d.c. motors, alternating currents, resonance, harmonic analysis, polyphase currents, a.c. machines, coupled circuits and networks. All these subjects are covered thoroughly, practically and rigidly with the copious use of diagrams and sketches.

Following this are two interesting chapters, mainly descriptive, on semi-conductors and illumination. The concluding chapter is a comprehensive treatment of measuring instruments.

The typescript is attractive, clear and well spaced-out and easy to read. The arrangement of material is logical and methodical and it is easy to find one's way about the book when using it for reference purposes. This is also assisted by the fact that it is copiously illustrated with diagrams.

The book gives a general impression of an immense amount of material in a very small space but nowhere does the treatment seem scrappy or unduly compressed. This result has been achieved by the elimination of illustrative numerical examples and exercises to be worked by the student, and this is, perhaps, the chief defect of the book. For teaching and study purposes it needs to be supplemented by a source of illustrative examples and exercises both numerical, descriptive and theoretical for the student to work for himself.

The treatment given is one of the most thorough so far produced in a book with such a comprehensive scope. It is thorough and lucid enough for the beginner and the student with a modest objective, and it also includes rigid theory thoroughly and extensively treated to satisfy the needs of the advanced student. The more advanced material included in the body of the chapters is marked so that it may be omitted by the more elementary students, and some of the more rigid theoretical work is included in appendices.

It is not possible to relate the scope of the treatment to an examination syllabus, but the standard would be sufficient for a student reading for a Higher National Certificate or an Engineering Degree in those sections of these syllabuses with which the book deals.

There are a few typographical errors which is almost inevitable in the first edition of a work of this magnitude.

The index seems relatively small and concise for a book of this scope, but nevertheless there are no obvious defects or omissions in it.

The book can be thoroughly recommended both as a text-book and reference book. It should be on the book-shelf of every telecommunications engineer.

*I.P.O.E.E. Library No. 2465*

F. C. M.

# Recent Improvements in the Inking System of a Recording Decibelmeter

A. C. NICOLLS, B.Sc., D.I.C., A.M.I.E.E., and J. C. HARRISON, B.Sc., A.R.I.C.†

U.D.C. 621.317.741.087.61:667.4

The wide use of recording decibelmeters has revealed the need for a standard adjustment of the inking system, and investigations have been carried out on the Decibelmeter No. 14A/CTA using a new capillary pen which gives improved traces, as demonstrated by several tests conducted under varying conditions. The results have been further improved by the use of a new ink which has been developed to overcome the defects of the usual glycerine-based ink. Finally, the specification for the chart paper has been revised to give the optimum performance with the capillary pen and new ink.

## INTRODUCTION

RECORDING decibelmeters are widely used for obtaining permanent records of the variations in transmission level on telephone circuits and on h.f. transmission systems carrying these circuits. In particular, the maintenance of carrier, coaxial and radio links by means of pilot signals necessitates the continuous recording of their transmission level, and to give optimum results it is essential for the recording instruments used to be correctly adjusted.

The work upon which this article is based was carried out on a Decibelmeter No. 14A/CTA because a manufacturer had offered a new pen for trial by the Post Office in this instrument. Subsequently, arrangements have been made to modify all Decibelmeters No. 14A/CTA to use the new pen, and its use is provided for in Decibel-

sions of the hollow pen were such that the writing point and therefore the surface of the paper were below the level of the ink in the reservoir. The rate of ink flow was then dependent on this level difference. Thus variations in the ink flow were produced by the change in ink level in the reservoir and by atmospheric conditions. After refilling the reservoir it was not uncommon to find that the ink flow was over generous, resulting in large blots on the chart.

The ink was often left unattended in the reservoir and evaporation of the water component produced a thickening of the ink and resulted in frequent clogging of the pen bore. Many users adulterated the standard ink and produced inks which either clogged the pens or remained wet on the chart surface, thus causing smudging of the trace as the chart was rolled up.

During 1956 a manufacturer introduced a new pen in which the ink was drawn up out of the reservoir by capillary attraction. This gave controlled flow of the ink and eliminated the formation of blots. Tests on this pen were made and the general suitability of the ink-paper combination was investigated. The tests are outlined in this article and the development of a new ink based on ethylene glycol is described, together with the requirements of a suitable paper for the chart roll.

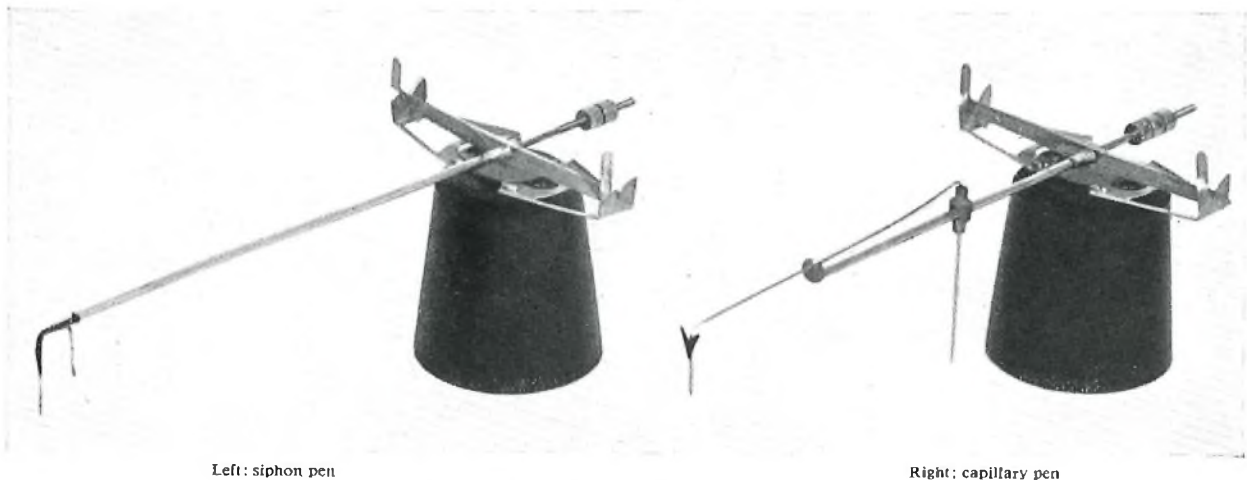

FIG. 1.—PENS FOR RECORDING DECIBELMETERS

meters No. 19A/CTA and 28A/CTA. Descriptions of these three recording decibelmeters have been given elsewhere.\* Prior to 1956 nearly all recording decibelmeters used by the Post Office employed an inking system operating on the siphon principle. The dimen-

† Mr. Nicolls is an Executive Engineer, Main Lines Planning and Provision Branch (formerly Transmission and Main Lines Branch), E.-in-C.'s Office, and Mr. Harrison is a Senior Scientific Officer, London Materials Section, Test and Inspection Branch, E.-in-C.'s Office.

\* PARSONS, A. P., and DIDCOCK, F. E. Recording Decibelmeters. *P.O.E.E.J.*, Vol. 51, p. 145, July 1958.

## THE CAPILLARY PEN

The siphon and capillary pens are shown in Fig. 1, while Fig. 2 shows the capillary pen in position on a Decibelmeter No. 14A/CTA that has been taken out of its case. The pressure of the pen on the chart affects the sensitivity of the instrument and its ability to follow rapidly varying signals. Thus in order to make a satisfactory comparison between this pen and the siphon pen a standard adjustment was determined. The balancing bridges shown in Fig. 1 were used and it was found that for the capillary pen optimum results were



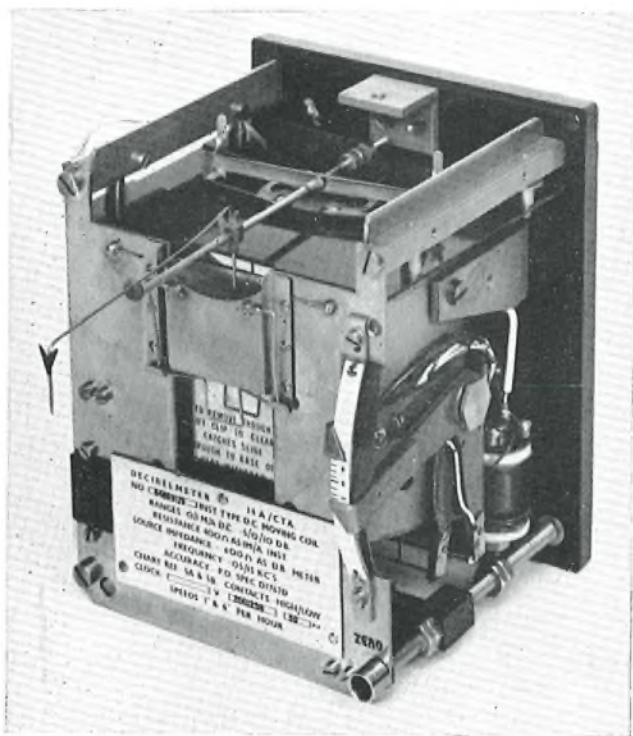

The paper-drive mechanism has been removed so that the pen and ink reservoir can be seen more clearly

FIG. 2—CAPILLARY PEN IN POSITION ON A DECIBELMETER NO. 14A/CTA

obtained when the counterweight on the pen arm was rotated one full turn towards the pivot after an initial balance had been obtained with the pen charged with ink. The pressure of the pen on the chart was then approximately 7 mg. The corresponding adjustment for the siphon pen was a half-turn of the counterweight. A balancing bridge suitable for both capillary and siphon pens has now been introduced for use in the field.

The first capillary pens submitted by the contractor had a bore of 10 mils at the writing point, compared with 5 mils for the siphon pen.

#### COMPARATIVE TESTS

Comparative tests between the new and the old pens were carried out on correctly balanced pens by connecting several decibel meters in parallel to different types of signal. Rapidly varying signals, e.g. speech or music, interrupted steady tones and short pulses were all used. It was invariably found that the capillary pen gave a controlled flow of ink on to the chart whereas the siphon pen gave constant trouble as a result of flooding. The increased size of the bore of the capillary pen reduced the resolving power of the instrument, so that interruptions occurring more frequently than once in 20 seconds were not visible on the chart. More pens were supplied having a 5-mil bore but these showed the same tendency to clog as the siphon pens when used with the ink that was then in common use (Ink for Recording Instruments, Red).

To give the desired improvement using the capillary pen, it was apparent that the ink specification would need to be revised and the problem of frequent clogging investigated. The development of a new ink based on

ethylene glycol is described below. To achieve the best results the paper specification was also revised to ensure that a paper of a suitably high grade was used with the new ink and pen.

Field trials of the capillary pen using the glycol ink were carried out in several locations under various atmospheric conditions and finally the 5-mil bore was adopted. This pen has been designated Pen No. 6A/CTA.

#### REQUIREMENTS OF THE INK AND PAPER

The requirements of the ink used in a recording instrument must be determined in relation to the type of pen and quality of paper used. Pen, ink and paper all affect the final result and in practice it is necessary to fix one of the items and choose the others to work with it. In this instance a new pen was introduced and the ink had to be prepared to give the desired results in terms of quick drying after writing, thin trace and freedom from evaporation in the reservoir.

As mentioned above, the balance of the pen will affect the ability of the instrument to record rapidly varying signals without the pen leaving the paper. The bore of the pen tip affects the ink flow and the thickness of the trace. The 5-mil bore was chosen to give a reasonably thin trace for resolution of short breaks in the signal while the ink had to be chosen to maintain a reasonable rate of flow without blockage.

The ink should possess stability in the reservoir so that its composition is substantially unchanged after about four weeks exposure to the atmosphere. Its viscosity should be low so that high flow rates can be maintained during rapid swings of the pen, and its ability to "wet" the chart roll should ensure rapid sinkage into the paper to give a smudge-proof trace, without undue surface spread.

The paper of the chart roll should be thin, to get a reasonable length of chart in the standard-diameter roll, but it needs to be strong to resist the tearing action of the pins driving the chart. The surface of the paper must be smooth to keep pen friction to a minimum, and should discourage spreading of the ink, while at the same time permitting rapid absorption of the ink into the body of the paper. In addition, the paper must have dimensional stability under conditions of varying temperature and humidity. Any excessive change in dimensions would lead to jamming of the paper or misalignment of the driving pins with the punched holes in the chart.

#### MATERIALS IN USE UP TO 1956

Prior to 1956 the inks used by the Post Office for decibel meters consisted of mixtures of glycerine, water and dye, the exact composition varying from 30 per cent glycerine, in a few proprietary inks used before 1950, to 3 per cent glycerine in the original ink supplied by the Post Office for Decibel meters No. 14A/L. Between 1952 and 1956, however, an 8 per cent glycerine ink was stocked for general use in all recording instruments. These inks, while complying with most of the ideal requirements, have one inherent defect. When they are exposed to the atmosphere they lose water by evaporation, with the result that 30 per cent inks rapidly become too viscous to flow through the pen and 3 per cent inks lose so much of their original volume that the level of the residue falls below the feed to the pen. This considerable reduction in the volume of the ink often

leads to precipitation of dye with subsequent blocking of the pen. One advantage of this type of ink is that it performs tolerably well on a wide variety of papers.

The nature of the paper used for chart rolls has also varied. At different times, the base material has consisted of chemical wood fibre, rag, esparto grass and mixtures of these in various proportions. Satisfactory charts can be produced from most of these, but as the majority of the qualities required are critically dependent on the manufacturing techniques and processes used, specifying only the base material is not enough to ensure satisfactory performance. In respect of these other qualities, specifications for chart rolls issued before 1956 were little more than a request that something suitable should be provided.

#### MATERIALS IN USE SINCE 1956

The introduction of the capillary pen into Decibel-meters 14A/CTA exposed certain limitations in the ink and paper then in use. Accordingly, work was put in hand to improve both these items. In view of the interdependence of the ink and paper it was decided to effect the maximum improvement in the ink first, and then use the improved ink to evaluate the chart rolls. The first possibility explored was that of overcoming the main drawback of glycerine inks, i.e. the tendency of the water content to evaporate. It was known that considerable success had been achieved in reducing evaporation from drinking-water reservoirs in tropical countries by floating films of high-molecular-weight alcohols such as cetyl alcohol. Measurements of the relative evaporation rates of glycerine-water mixtures, with and without films of cetyl alcohol, showed, however, that the useful life of one filling of a decibelmeter trough was only prolonged by approximately 30 per cent and in summer this was insufficient to enable one filling to last as long as a chart roll. A search was therefore made for an alternative base for the ink that would be stable in contact with normal atmospheres.

After a number of materials had been tested, ethylene glycol (normally used as a vehicle antifreeze liquid) was found to be the most suitable. When exposed to the average telephone-apparatus-room atmosphere ethylene glycol absorbs moisture until a stable equilibrium mixture is formed containing approximately 20-25 per cent water and 75-80 per cent glycol. This equilibrium mixture slowly evaporates without further change of composition but the rate is so slow that it can be ignored over periods of 4-5 weeks. This equilibrium mixture has one big advantage over its glycerine counterpart; its viscosity falls within the range required for use with pens of 10-mil and 5-mil bores. Addition of 3-4 per cent of a suitable dye converts the above equilibrium mixture into an ink suitable for use in recording instruments. Field trials have confirmed the superiority of the glycol-based ink, and this material is now stocked as Ink No. 2, Red or Blue. It has the following advantages: a small quantity of ink (approximately one-third of the volume of the reservoir) will outlast a chart roll; practically no precipitation of the dye occurs under normal operating conditions; drying of the trace is slightly faster than previously used inks.

When the new ink was tested on a variety of papers, it was found that the more absorbent papers, which gave passable results with the old inks, were quite

unsuitable for use with glycol-based inks. Inks containing a high percentage of glycol wet paper more readily than those containing a low percentage of glycerine, and on an absorbent paper this leads to a broad woolly trace because the ink spreads sideways. This can be overcome by making the surface of the paper more resistant to wetting than the body of the paper, thus encouraging the ink to move inward rather than sideways. In addition, the smoother the surface of the paper, the less ragged is the trace as the ink is no longer carried away by the capillary attraction of surface irregularities. This may be achieved by the following methods:

(a) Specifying a paper base with a uniform fibre quality, such as chemical wood or esparto grass.

(b) Tub-sizing the paper, i.e. applying a gelatine size by passing the paper in sheet form through a dilute solution of gelatine. This automatically ensures that more size is present on the surface of the paper than in the interior.

(c) Demanding a high-density paper.

(d) Ensuring adequate calendering of the sized paper to produce a smooth finish.

In practice (a), (b) and (c) are fairly easily checked, but (d) is a little more difficult and is best assessed by a practical trial under controlled conditions. Dimensional stability of the paper is a function of the degree of sizing and calendering and is best assessed by ruling a square or circle on the paper and measuring the change in dimensions when transferred from an atmosphere at 40 per cent relative humidity to one at 75 per cent relative humidity. Inclusion of these tests or requirements in the specification for chart rolls should ensure that supplies are of the uniform high quality required to obtain the best performance from the new Inks No. 2. In addition to its use as described above, glycol-based ink has been used for approximately 18 months on multi-pen recorders for producing records at comparatively high speeds. The results have been extremely good, and pen failures during use have been virtually eliminated. Even at speeds of 3 in/min the trace dries quickly enough to avoid smudging as the chart winds on to the receiving spool.

The use of liquid inks containing a high proportion of ethylene glycol does not appear to have been anticipated and they have been made the subject of Patent Application No. 35014/56.

#### CONCLUSION

The introduction of the capillary pen has enabled the quality of records produced by the Decibelmeter No. 14A/CTA to be improved under most conditions. At the same time the opportunity has been taken to revise the paper and ink specifications. With the introduction of a glycol-based ink and high-quality paper, most of the defects of the original system using the siphon pen and glycerine-based ink have been eliminated.

#### ACKNOWLEDGEMENTS

The authors wish to acknowledge the assistance and co-operation given by their colleagues during the investigations described in this article. Thanks are also due to the Record Electrical Co., Ltd., for their assistance in obtaining special samples of pens for the investigation.



# Concrete

J. P. HARDING, B.Sc.(Eng.), A.M.I.C.E., A.M.I.E.E.†

U.D.C. 691.32

Although made from common constituents the specification of concrete is not simple. Obtaining a reliable product consistently still depends to a large extent on the knowledge and experience of the man on the spot whose ability will largely govern the strength, permanence and safety of the work. This article outlines the requirements of the constituents of concrete and discusses its properties and the precautions to be observed in mixing, placing and curing to ensure acceptable quality. Reference is made to the reinforcement of concrete and a short account of the use of pre-stressing is included.

## INTRODUCTION

IN the Post Office, the main uses of concrete are for buildings, where construction is supervised by engineering staff, for manhole and joint-box construction, and for duct lines and the manufacture at factories of various precast products such as concrete couplings and marking posts. Recently some deep tunnelling projects using *in situ* concrete linings have been undertaken where stringent control has been necessary to ensure watertight construction.

As explained later it is generally easier to reach and maintain a high standard of quality with factory control and the precise selection of materials than for small isolated constructional works such as manhole building, although on some large building works the higher cost of inspection and supervision on site may be justified by the improved results obtained.

In an undertaking devoted to telecommunications, generally only a minority will be concerned with the external aspects of construction in which the use of concrete figures. It might be supposed, compared with the detailed and rigid specifications for internal equipment, that concrete, being made from common constituents, could be readily and simply specified and a reliable product consistently obtained. Unfortunately, despite the advances of recent years, the chemistry of concrete remains obscure and, even with laboratory techniques that are difficult and uneconomic to realize in practice, it is not possible to frame a specification to ensure a consistency in performance common in most other fields. Despite the best available specification much still depends on the knowledge and experience of the man on the spot whose ability will largely govern the strength, permanence and safety of the work concerned.

The manufacture of concrete in practice seldom receives the attention it deserves or to the extent which is economic. Designers, whilst approving the material generally, have entertained doubts whether practical manufacture could consistently produce concrete of uniform quality. Unit stresses have thus been set low, and generous and expensive factors of safety have been insisted upon. The way to avoid this is, of course, to eliminate as many uncertainties as possible and to work with suitable materials correctly proportioned and mixed and to ensure these standards are fully maintained in manufacture.

## THE CONSTITUENTS OF CONCRETE

Concrete, a mixture of cement, aggregate and water, has been known for many years. The quality of the constituents, even the water, and their proportions control the ease with which the concrete may be placed

and the strength and durability of the final material. The advances of recent years have been mainly in improved constituents in manufacture or selection and a much closer understanding of the technology of mixes to give the required results consistently at the minimum expense.

Cement, to-day, is invariably to British Standard (B.S.) Specification<sup>1</sup> and of uniform quality—far more so than the quality of the concrete usually made from it. Portland cement, ordinary or rapid hardening, is the most commonly used but high alumina cement and pozzolana material are preferable alternatives in certain circumstances.

Portland cement is manufactured from pulverized clinker fired from shale, clay, limestone or other materials according to local availability. The essential chemical constituents are lime and calcium silicate. Alumina, iron, sodium, potassium, titanium, phosphorous and manganese compounds are usually present in small degrees and probably serve catalytically in the firing process.

The chemical reaction of the cement with water is complex and not fully understood, the different constituents of the cement reacting characteristically and at different rates. Some, such as the lime and alumina, form hydrates, others combine to form compounds containing water of crystallization. The water is usually specified to be clean and free from harmful matter. Organic matter and water from peaty districts are to be avoided but sea water may be tolerated where efflorescence is unimportant.

Rapid-hardening Portland cement differs from ordinary Portland cement only in being more finely ground and in small differences in chemical composition. Both are light in colour.

High alumina cement, dark in colour, is manufactured from limestone and bauxite and contains a much higher alumina and iron oxide content. Concrete made from this cement attains strength much more quickly than Portland cement (see Fig. 1) and is more resistant to sulphates in the soil and to sea water.

Aggregates, fine and coarse, are inert fillers which increase the bulk of the cement and permit concrete of reduced cost. Fine aggregate is usually arbitrarily defined as containing particles not exceeding  $\frac{3}{16}$  in. and coarse aggregate as containing only particles exceeding this limit. Natural sand, crushed rock and washed gravel are the commonest materials and should be hard, strong, clean and durable. Clinker, breeze and coke breeze are sometimes employed but are unsuitable for reinforced sections. Gypsum, alabaster and similar materials containing sulphates are very harmful. Materials which absorb water may disintegrate by freezing and impair the resultant concrete. The function of an aggregate being to increase the bulk of the final concrete at least cost, it should do so by offering the minimum surface area requiring covering by cement. For this reason, particles of a spherical shape, and to a lesser extent cubical, which have the most favourable volume-to-surface ratio, are preferable to angular, prismatic or

†Formerly of the External Plant and Protection Branch, E.-in-C.'s Office.

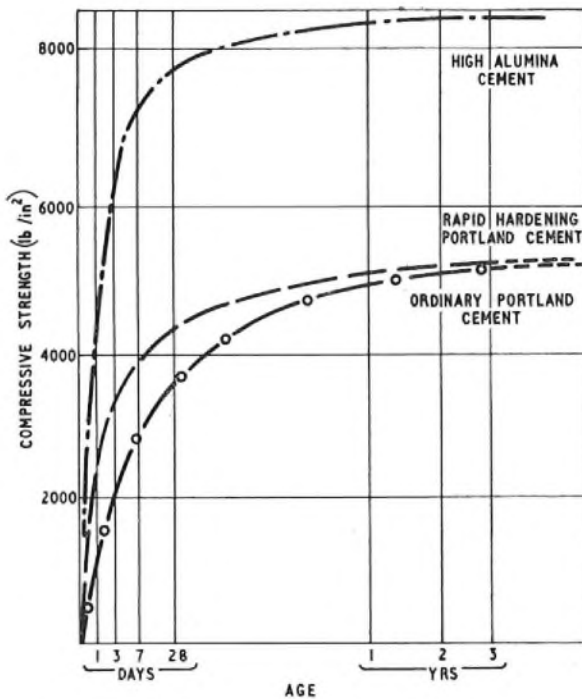

FIG. 1—INCREASE OF COMPRESSIVE STRENGTH OF CONCRETE WITH TIME USING DIFFERENT CEMENTS

flakes which also impart a harsh quality to the mix and diminish its easy placing. The degree to which a particle is flaky or elongated in this respect can be arbitrarily defined and is given in B.S. 812<sup>2</sup>, which also specifies materials.

#### THE MIX, SETTING AND HARDENING

The proportions of the constituents of concrete are commonly quoted by volume although there are distinct advantages in specification by weight. A 1 : 2 : 4 concrete is one utilizing these relative volumes of cement, sand and aggregate respectively. There is in this description no reference to the water content although this generally affects the concrete more critically than any of the other constituents. Concrete, when freshly mixed, is plastic to a degree according to its constituents and, since the chemical reaction of cement and water is relatively slow, some time is required for the concrete to harden. The period is divisible into three phases. The first, the "initial set," takes from about 30 minutes to 8 hours. The second, "the interval of final set," may extend up to 20 hours during which the concrete is load bearing to a limited extent but its surface easily deformed; the final phase is one of progressive hardening and attainment of strength. A typical relationship between the attainment of strength with time is given in Fig. 1 for ordinary and rapid-hardening Portland cements and high alumina cement. It is seen that comparable strengths are obtained with high alumina cement at 1 day, rapid-hardening at 7 days, and ordinary Portland cement at 28 days.

#### THE FACTORS CONTROLLING STRENGTH

The essential properties of concrete are compressive strength and durability when hardened and the ease, dependent on plasticity, with which it can be placed. Its cohesiveness, which controls the risk of segregation when plastic, is also now receiving increased attention. The

compressive strength is usually determined by the test to destruction of a number of 4 in. or 6 in. cubes, the latter being used for aggregate exceeding  $\frac{3}{4}$  in. The load is applied to opposite faces of the cube and it is important that the cube should be representative in every way of the quality of concrete used on the work, be similarly cured and of the age at which the requisite strength is stipulated. Details of the method of filling the test cube, its curing and subsequent testing are given in B.S. 1881 : 1952<sup>3</sup>.

The design of a concrete mix, i.e. the selection and proportioning of the constituent materials, is based on the water/cement ratio first given in 1918 by Abrams. "With given concrete materials and conditions of test the quantity of mixing water used determines the strength of the concrete so long as the mix is of workable plasticity." The variation of strength with the proportion of the mixing water is nearly linear, as shown in Fig. 2.

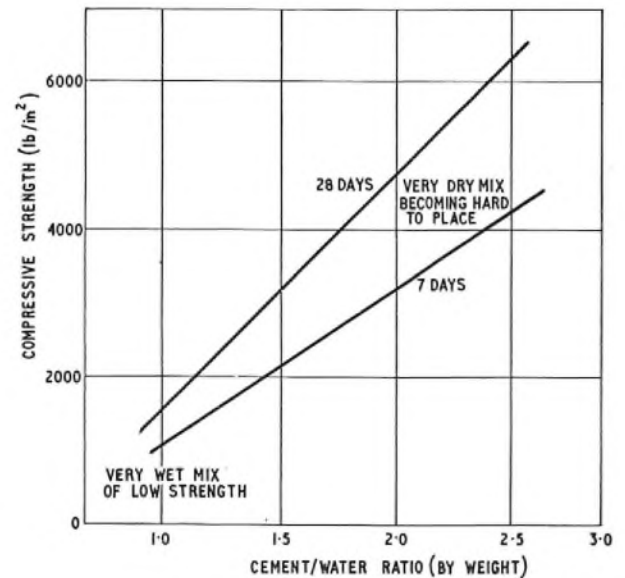

FIG. 2—RELATION BETWEEN COMPRESSIVE STRENGTH OF CONCRETE AND CEMENT/WATER RATIO

The attainment of very high compressive stresses with a high cement/water ratio unfortunately entails placing a stiff mix of low plasticity, and the practical design of a mix resolves itself into attaining the requisite strength with the most economical mix (usually the leanest in cement) of sufficient plasticity. The plasticity is also influenced, to a smaller degree, by the nature and grading of the aggregate, and the tolerable plasticity depends on the mode of placing whether in thick or thin sections and whether vibration or other assistance in compaction is to be used. Alternatively, for a given plasticity and strength, i.e. a concrete of a certain performance, there is a relationship between the particle nature and the aggregate/cement ratio as shown in Fig. 3. Thus for the same performance, the use of a flaky aggregate involves a richer and more expensive mix than one containing more-rounded aggregate. The grading of an aggregate is usually expressed by its "fineness modulus," which is 1 per cent of the sum of the percentages of materials present that are coarser than each of successive sieves ranging from 100 to the inch to 3 in., and is an indication of the surface area of an aggregate. Although not



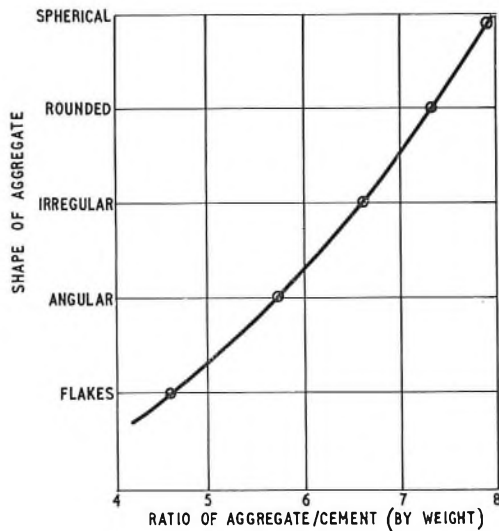

FIG. 3—RELATION BETWEEN PARTICLE SHAPE AND AGGREGATE/CEMENT RATIO FOR CONSTANT PLASTICITY AND STRENGTH

conclusive it is a reasonable guide to allow that aggregates of the same fineness modulus, although differently constituted, will give similar plastic properties in a concrete mix.

The interrelation between the plasticity, expressed by slump, the maximum aggregate size, its fineness modulus and compressive strength (at 28 days) is given in Fig. 4.

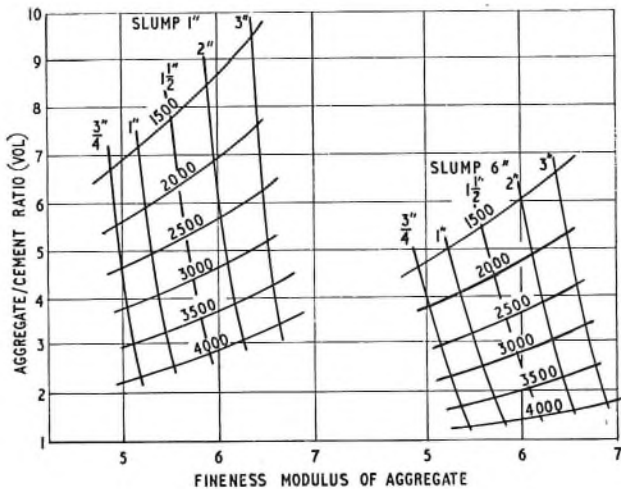

FIG. 4—RELATION BETWEEN STRENGTH, MIX, SLUMP, FINENESS MODULUS OF AGGREGATE AND MAXIMUM PARTICLE SIZE

(The slump is the fall in inches of a sample of the concrete filling a conical mould of prescribed dimensions when it is inverted and withdrawn<sup>3</sup>.) The water/cement ratio is the most significant factor in compressive strength but variations in the mix, grading of aggregate and plasticity (slump) affect the strength indirectly by variation in the water/cement ratio.

The graphs (Fig. 1-3) show that the strength of the concrete increases:

(a) with decrease in slump if the mix and grading of the aggregate are constant.

(b) with an increase in fineness modulus of the aggregate if the slump and mix are constant, and

(c) with an increase in cement/aggregate ratio for the mix if the slump and grading are constant.

The effect of all these variations is to decrease the water/cement ratio and thus, in accordance with Abram's law, an increase in strength ensues. With increase in strength the durability is also improved since the lower water/cement ratio reduces the number and extent of pores in the concrete produced when uncombined water evaporates and exposes them. Small departures from these relationships have recently been observed both in the laboratory and on site but only where high-strength concrete is concerned using mixes rich in cement. It is found that a leaner mix (one containing less cement relative to aggregate), which is less plastic for the same water/cement ratio, can give a slightly greater strength, which is the reverse of the conclusion drawn from the graphs of Fig. 4.

The design of a mix therefore involves firstly the selection of the water/cement ratio to give the required strength. Secondly the mix must be defined to give, with the greatest economy, the necessary plasticity (slump). There are in practice difficulties for which allowance must be made. There will usually be water contained in the aggregate, particularly the fine aggregate (sand). Allowance must be made for this in the mixing water, but also wet sand increases in bulk, as shown in Fig. 5,

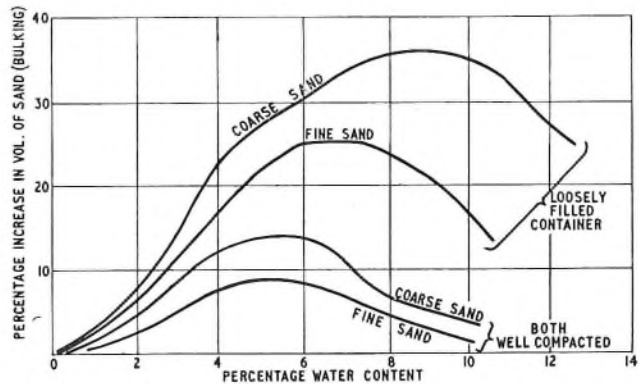

FIG. 5—BULKING OF SAND WHEN DAMP, WITH LOOSE AND COMPACTED FILLING

and if gauged on volume must be corrected for "bulking." Coarse aggregate does not bulk appreciably but can contain up to 2 per cent water, for which allowance must be made. There is some doubt whether it is correct to allow for both surface and absorbed water in an aggregate. There is a preference amongst engineers that surface water only should be allowed for since absorbed water is not available for hydration of the cement, but there is no universally accepted method of assessing this. The plasticity, measured by the slump, is chosen according to site conditions. For placing concrete in thin sections (6 in. or less) a plasticity corresponding to a 5-6 in. slump is appropriate. For mass concrete and concrete roads a slump of 2 in. is satisfactory. For precast work in a factory using vibrators a slump of 1 in. or less is common and can be close to the value giving the maximum compressive strength. This has the incidental advantage that moulds can be struck very quickly after pouring, sometimes immediately, with great economy in mould occupancy.

During the last few years a method of mix design has

been advocated<sup>4</sup> in which vibration is relied upon to give full compaction of the mix and thus the concrete contains no voids at all. This enables a theoretical treatment of the nature of the fine and coarse aggregate to be followed in which, according to the densities of the aggregates and their proportions, the cement paste can be used to fill completely the void space between the particles and no more. On this basis the bulk density of the combined mix of cement, water and fine and coarse aggregates can be expressed in terms of the separate densities of each. By selecting the water/cement ratio, on which strength mainly depends, the aggregate/cement ratio which controls the cost, and the water/aggregate ratio which fixes the workability, the bulk density required of the combined aggregates can be assessed numerically. This enables an aggregate to be specified in terms of the maximum size of the particles and the proportion of fine to coarse material. Graphs prepared from previous experiments are used for this purpose. The workability generally decreases with increase in the total surface area of the combined aggregate, and thus particles of all sections of the aggregate are maintained at maximum size, requiring a sand as coarse as possible consistent with the requirements of overall density.

It may arise, however, that a high bulk density can only be met by such a small amount of sand in the coarse aggregate that the stones jam and are not amenable to ordinary vibration. Increase of the water content is not helpful and even deleterious since the stones are washed of sand and the separation worsened. The solution is to open the grading to allow more voids to contain sufficient sand. This is referred to as gap grading in which particles of certain size in the coarse aggregate are rejected with the object of subsequent replacement by sand.

By choosing the aggregate on the basis of the required bulk density which, in effect, means selecting the correct void ratio to suit the amount of cement and water to be added subsequently, the necessary strength and workability can often be obtained more economically than by any other means, such as specifying the mix conventionally as described earlier.

Thus a mix leaner in cement may be used with economy, which can outweigh the cost of the design work and experiment necessary to produce the optimum proportions. Such a procedure is generally justified on a large work but is not appropriate to much work undertaken by the Post Office such as the building of manholes and duct lines, where only relatively small quantities of material are involved.

#### ADMIXTURES TO IMPROVE PLASTICITY AND REDUCE WATER PERMEABILITY

The plasticity or workability of concrete can be improved by the addition to the cement of an inert fine powder which in effect lubricates the aggregates. Surface-active materials such as sulphonated hydrocarbons, carbohydrate salts or saponin are also effective in increasing plasticity. The precise action of these materials is obscure but wetting power and air-entrainment are usually advanced as the cause. Proprietary compounds having these properties often, in addition, contain calcium chloride, which gives an increase in the rate of attaining strength and offsets the effect of certain of the other additives which delay it.

Materials for improving the waterproof quality of

concrete are widely marketed, usually under proprietary names. They may be inert pore-fillers such as certain silicates or iron filings with ammonium chloride. Inert water-repellent materials such as waxes, mineral oils, bitumen, glue and coal-tar residues are other alternatives. Active water-repellent materials are sodium or calcium soaps, fatty acids, resins, calcium chloride, alkali sulphates and gypsum. Most proprietary waterproofers are mixtures embodying one or more of these materials. Much controversy has arisen concerning the value of these agents. Laboratory tests do not confirm their effect in reducing the permeability of concrete to water under pressure; indeed frequently a reduced permeability results. On the other hand workability is often improved and the concrete may thus be placed with less segregation. Since in practice the passage of water through concrete is more often caused by local porous patches rather than a general permeability the presence of a waterproofer is often successful by assisting the uniformity of mix, although concrete can be made and placed without such aids and be very impermeable.

Accelerators may be included in a concrete mix to hasten the attainment of strength. Additionally, the natural heat evolution during setting and hardening is increased and both these factors assist in placing concrete in cold weather. Calcium chloride is the most commonly used and effective agent for this purpose and, if not exceeding a proportion of 2 per cent of the weight of the cement, is a safe and successful means of concreting in very cold weather. The precise temperature at which concreting may be made safe depends on the mix, the thickness of the sections and local conditions but it is often possible to work at 32°F. There is a slightly increased risk of corrosion of reinforcement but, unless the steel sections are very small, this is generally of no practical importance since it is not progressive with time. This is true of reinforcement fully embedded in concrete as is usual but a fitting such as a manhole step, which protrudes, is liable to corrosion at its point of emergence. The danger of corrosion may be much greater with prestressed construction on account of the much thinner wires commonly used and the higher stresses involved.

#### MIXING AND PLACING

Concrete is usually mixed in a machine, though on very small works hand mixing may be used. A drum containing blades rotates at a peripheral speed of about 200 ft/min. Speeds greater or less by 20 per cent than this optimum are found unsatisfactory and lead to a distinct loss of strength. The quality of concrete improves with increased mixing up to a point but then diminishes. Mixing times of about 1-2 min according to the size of the drum are generally satisfactory. A drum cannot properly mix more concrete than corresponds to about half the content of the drum, which should be marked according to its rated capacity to mix concrete.

After mixing the concrete must be placed correctly. Dropping or the horizontal flow of concrete can result in a serious segregation of the mixture, mainly affecting the coarse aggregate since the movement of concrete other than vertically inevitably involves a differential displacement of its constituents. When placed, concrete must be thoroughly tamped by rod or spade to fill all interstices, particularly where reinforcement is complicated or the mould shape intricate. When spading, coarse aggregate should be worked away from the



shutter, the object being to ensure the presence of ample mortar at the finished surface and to reduce air voids and honeycombing.

Vibration, the application of repeated light blows from a specially made tool, is most beneficial to density, bond, compressive strength and durability but can, if misapplied, lead to the reverse. In practice the greatest misuse of vibration is its application to an already plastic mix. The effect then on an already sufficiently consolidated mix is to cause segregation of the coarse aggregate. Vibration is applicable to a relatively stiff mix (of low slump), in which successful placing would otherwise be impossible, and must not be continued beyond the point at which consolidation is reasonably obtained. The use of vibration beyond this limit causes an excess of water in the upper sections and a deficiency of cement and water in the lower, and the quality of concrete can be seriously impaired in both positions.

#### CONTROL OF QUALITY IN PRACTICE

Despite rigid attention, even in the laboratory, to all the factors known to influence strength, it is still found that cubes from the same mix, prepared and cured identically, can show a variation in strength of 500 lb/in<sup>2</sup> or more. The average of cubes from one mix will also vary from those of another mix prepared in the same way. The strength of cubes might vary between  $\pm 1,500$  lb/in<sup>2</sup> from the required value although most, say 90 per cent, would be within  $\pm 750$  lb/in<sup>2</sup>. Only 1 per cent would differ from the mean by more than  $\pm 1,200$  lb/in<sup>2</sup>. These variations are, in the present state of knowledge, the least that must be expected and ordinary site techniques will fall far short of this. The strength of many test cubes prepared under the same conditions follows a "normal" distribution statistically and the simplest way of comparing the results of different degrees of control is by expression of the "standard deviation."

The significance of the range of strength encountered depends on the frequency at which extremes occur. However, in Table 1 is shown the likely range of strengths

TABLE 1  
Strength of Concrete

Control	Extreme range of strengths (lb/in <sup>2</sup> )	Standard deviation (lb/in <sup>2</sup> )
Full laboratory standard ..	2,000-4,000	400
Excellent practical site supervision. Weight batching—allowances for all factors affecting water content ..	1,800-4,200	500
Good general control. Volume batching—regular slump test for control of plasticity ..	1,500-4,500	700
Little supervision. Rough volume batching—foreman's estimate of reasonable workability (plasticity). .. ..	1,200-4,800	1,000

and the standard deviation to be expected on works according to the degree of control exercised. Alternatively, the values in the second column can be considered as those which may be allowed on a work

without concern but that if a cube strength falling outside these limits should result then, within the category of work concerned, the control can be said to be unsatisfactory and to merit investigation. An excess of water, wrong proportions, imperfect mixing or unsuitable material are the most likely factors in that order.

The range of strengths which can arise is much wider than generally understood and clearly absorbs much of the factor of safety commonly allowed. It does emphasize of course the need to take every reasonable care in control so that the range is no greater than the standard of work allows. British Standard Code of Practice No. 114<sup>6</sup> states that a designing engineer may assume that the compressive strength is assured if the average strength of three test cubes (not differing in their extremes by more than 15 per cent) exceeds the required strength by 15 per cent. It is clear that the reservation in brackets may easily be incompatible with the data of Table 1.

#### CURING

The hydration of cement requires time and a minimum temperature for its satisfactory completion. It follows that the correct quantity of water must be maintained throughout the process of curing until it has all played its part in the reaction. Loss from evaporation or other causes such as leaky or absorbent shutters must evidently be avoided. The hydration of cement practically ceases at about 35°F but concrete at that temperature will not be damaged. When its temperature is raised the process of hardening will begin and continue. The risk of concreting in cold weather is in the possibility of freezing of the partially set material. This produces, by the normal expansion of ice, disruptive forces which the weak mix cannot resist and the bond between the aggregate is weakened or destroyed and the concrete sustains an irreparable loss of strength.

To avoid the loss of water, premature drying out must be avoided and if a large surface of concrete may be exposed to wind and sun it should be covered with sacking or similar material. Shutters, if absorbent, should be drenched with water before use. Concrete work at temperatures below 40°F should either not be attempted or aggregates and water should be raised to a temperature not less than about 60°F before mixing. The temperature of the mix should not drop below about 50°F (the natural generation of heat by the chemical action will usually ensure this) during the first 7 days. If thin exposed sections are involved the generated heat may not suffice and some thermal insulation will be necessary. As earlier quoted the use of an admixture of calcium chloride can give an improvement in this respect.

#### SPECIFICATION OF CONCRETE

The specification of concrete to ensure the requisite strength and durability has commonly been by quoting the volumes of cement and fine and coarse aggregates. The maximum water content is sometimes given additionally. It is clear from the dependence of the product on the factors given in Fig. 4 that these methods alone are insufficient to ensure a given result, and may even operate adversely if allowances for bulking and the nature (fineness modulus) of the aggregate are not considered. The specification of the constituents by weight is evidently better and is now finding favour but it is still necessary to allow for water in the aggregate.

To state the minimum compressive strength, the mix, the slump and/or the water/cement ratio may actually be redundant or exclusive or even impossible of attainment simultaneously with given aggregates.

As with most other specifications it is necessary to balance the usually conflicting requirements of quoting sufficient to ensure that the requisite quality of the product is consistently maintained whilst avoiding such detail and precision that prohibits acceptable alternatives and leads to disputes and claims for extra costs. The quality of concrete cannot be assessed completely by reference to any single property but it is fortunate that most of the desirable ones improve with compressive strength. For example, the tensile, bond and shear strengths are so related as is the watertightness and durability. The density of compacted concrete is also an indication of its quality, although generally of no direct importance in itself.

For these reasons the stipulation of a minimum compressive strength has been widely accepted as a sufficient criterion of quality. It is necessary to specify the age and mode of curing of the test cube in order that a parallel shall exist between the strength of the cube and of the concrete in practice. In order to allow a contractor scope to adopt methods in which he may be equipped or experienced and to utilize local materials as far as possible with economy, there are strong grounds for limiting the specification to one of minimum compressive strength only, particularly where, as is usual, competitive tenders are sought. Because compressive strength is a good criterion of the general quality of concrete this is a fairly safe procedure but shifts the technical competence to manufacture the concrete consistently and economically to the contractor. A compromise is to state, in addition to minimum strength, limits for the proportions of the mix, preferably by quoting permissible extremes for the ratio of cement to total aggregate, thus allowing the contractor to vary the ratio of fine to coarse aggregates.

When specifying the minimum compressive strength, values ranging from 2,000–5,000 lb/in<sup>2</sup> in graduations of not less than 500 lb/in<sup>2</sup> are appropriate. Greater accuracy than this is unattainable consistently and is also generally beyond that to which the stresses or loads for a structure can be assessed.

#### REINFORCEMENT

Reinforcement for ordinary reinforced concrete work is almost invariably mild steel. Square-twisted, twin-twisted or deformed bars are sometimes used and, according to the quality of the concrete, can give slightly improved bond. Such bars are work hardened and permit higher yield stresses and ultimate strength although these factors cannot necessarily be used economically in practice<sup>6</sup>. Almost all reinforcement to-day is manufactured to B.S.785<sup>7</sup>. The yield-point stress, which generally governs the strength of the structure, is in excess of 36,000 lb/in<sup>2</sup> for mild steel and permits a working stress of 18,000 lb/in<sup>2</sup>. The elastic modulus of the steel is about  $30 \times 10^6$  lb/in<sup>2</sup>.

For prestressed concrete, steel in the form of high-tensile-strength wires is general. The wires are cold drawn in diameters varying from about 0.25 in. to 0.05 in. The smaller wires have the highest ultimate tensile strength—values up to 150 tons/in<sup>2</sup> being usual. About 100 tons/in<sup>2</sup> is common for the larger wires. The modulus of elasticity for these high-tensile-strength

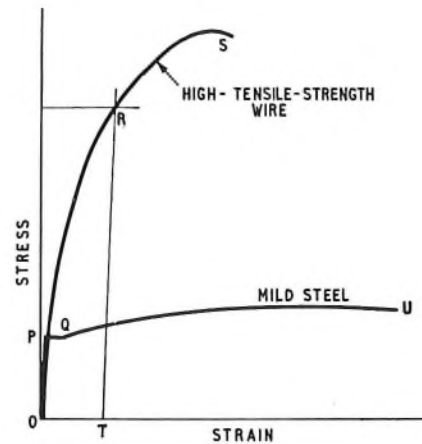

FIG. 6—RELATION BETWEEN STRESS AND STRAIN FOR MILD AND HIGH-TENSILE REINFORCEMENT

wires is unfortunately not appreciably different from that for mild-steel reinforcement and therefore the high strength is only obtainable by a correspondingly higher strain. The stress/strain relation for mild and high-tensile steels is given in Fig. 6. Up to point P the curves for the two materials are almost the same, denoting an equal modulus of elasticity. Mild steel then shows yield to the point Q and failure at U at a stress some 30 per cent higher than the yield stress.

For high-tensile-strength wire the stress is maintained for much higher values with a proportionate or slightly increased strain. The strain or elongation at failure may be about 15–20 per cent for mild steel and 5 per cent for high-tensile-strength wire. If at point R on the curve for high-tensile-strength wire the stress be relieved, the strain will not trace the original curve but will instead follow the straight line RT parallel to the initial line OP. The intercept OT indicates the permanent set on relief of all stress. The stress at R giving rise to this set of, say, 0.2 per cent, is called the 0.2 per cent proof stress.

A steel wire held under stress will suffer creep with time, i.e. it will show an increase in elongation or strain without an increase in stress. The extent of the creep is influenced by the material of the wire, its process of manufacture, the stress concerned and the time involved. It is almost negligible for mild steel at the usual working loads and greatest for the high-tensile-strength wires.

A loss of stress from creep of 15–20 per cent is often allowed for a prestressed structure but the magnitude of the creep can be reduced by subjecting the wires to a short overload before use.

#### CONCRETE UNDER STRESS

Concrete, subjected to compressive stress, undergoes strain like any other material, a typical stress-strain relation being as shown in Fig. 7. The graph is almost linear over the working stress range, justifying an assumed constant elastic modulus, but this clearly does not maintain throughout. Fig. 7 is accurate only for stresses rapidly applied and withdrawn and ignores creep of the concrete. For a stress of appreciable duration (hours, a day or more) there is a marked departure. Fig. 8 shows the effect of time on strain. The elastic strain, applied quickly, is considerably increased by the strain resulting from creep. The creep depends on the magnitude of



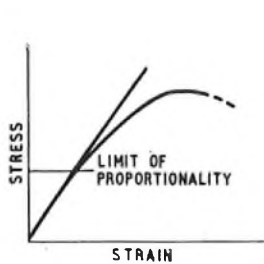

FIG. 7—RELATION BETWEEN COMPRESSIVE STRESS AND STRAIN OF CONCRETE FOR RAPIDLY APPLIED LOADS

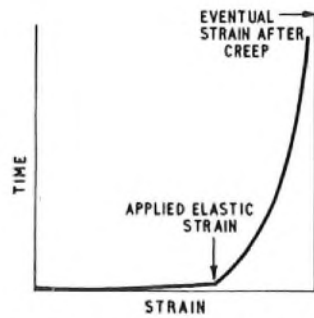

FIG. 8—CREEP OF CONCRETE WITH TIME

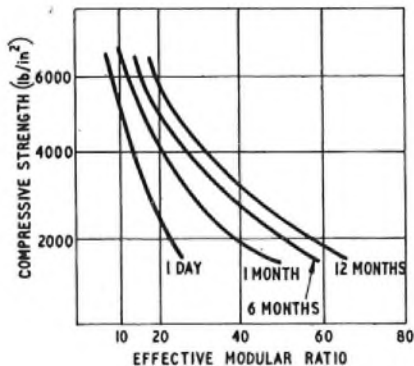

FIG. 9—VARIATION OF EFFECTIVE MODULAR RATIO FOR DIFFERENT TIMES OF APPLIED LOAD

elastic strain and its duration. The eventual creep clearly controls the effective modular ratio\* between the steel and the concrete. Fig. 9 shows possible values for the effective modular ratio for periods up to one year. The effect of creep increases steel stresses but decreases the concrete stress. It is remarkable that with increasing load, although the steel stress may rise up to the yield point, there will be a redistribution of stress at yield of the steel which will continue until failure. The effect of this is that the failing load is almost unchanged and the factor of safety therefore unaffected. This, however, is not true of a prestressed member, where the relative magnitudes are not similar.

#### PRESTRESSED CONCRETE

It can be shown<sup>9</sup> that, because of the negligible tensile strength of concrete, in an ordinary reinforced-concrete section only about one-third of the concrete (that above the neutral axis) is effective and the average stress in this is one-half of the maximum allowable at the surface. This, coupled with the difficulty of using efficiently steel of high tensile strength, sets a limit to the strength of a conventional reinforced section.

Late in the last century attempts were made to improve reinforced concrete by tensioning the reinforcement to throw more or all the concrete into compression, so that after loading little or no tensile stresses were produced and the whole of the concrete section was effective. In these experiments the steel used was not capable of very high tensile stress and the importance of high-quality concrete was not appreciated. As is now

\*Modular ratio: the ratio between the coefficients of elasticity (Young's modulus) of the materials.

well known the prestress was quickly lost on account of creep in the steel and the concrete and the results were disappointing.

In 1908 and subsequently, Eugene Freyssinet, the French engineer, made tests using large prestressed ties of high-tensile-strength wires anchored by wedges in steel plates. Far greater prestresses than before were used, sufficient to accept some loss by creep and plastic flow, which resulted in an effective structure in which the concrete remained in compression under load. During 1928 Faber and Glanville in England had published their researches on creep, and the use of prestressed concrete as a practical technique had begun. Notable advances have since been made in many countries.

Prestressing, which means that the concrete is stressed before the load is accepted, is possible by tensioning the steel either before or after the concrete has cured or hardened. The former is pretensioning, in which steel wires are generally employed and the concrete cast round them. On hardening, the tension at the ends is released and the stress communicated to the concrete by its bond to the steel. An example of this is in the manufacture of railway sleepers in which long lengths of wire are pretensioned and pass through many units. When the concrete has hardened and the stress can be held in the concrete the spacers between units are removed and the wires cut.

Post-tensioning is carried out after the concrete has been cast and hardened. In this the wires are commonly passed through one or more holes cast in the concrete for this purpose and subsequently tensioned against the ends of the units. It is necessary to protect the wires against corrosion in some way since the protection bond of the concrete, as in pretensioning, is not available.

Pretensioning is most suitable for articles of small sectional area and the mass production of a large number of similar units. Railway sleepers, small beams and floor joists are examples of design which can be economically manufactured. A floor joist designed by the Ministry of Works is of pretensioned form and is fitted with timber battens permitting ordinary flooring boards to be nailed on. An alternative flooring poured on a composition board, as shown in Fig. 10, is sometimes used in Post

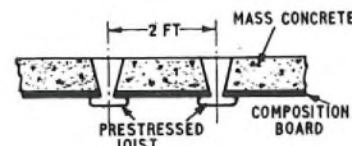

FIG. 10—MINISTRY OF WORKS DESIGN OF FLOOR USING PRESTRESSED UNITS

Office buildings. A form of flooring employing filler blocks supported on a recess at their edges by pretensioned beams and finally covered with concrete is an effective and economic design used on the Continent and in this country. The arrangement is shown in Fig. 11. The pretensioned beams are manufactured in long lengths and cut to the lengths required for particular installations, the filler blocks and final concrete for the eventual surface finish being placed in position on site.

Post-tensioning has some advantages over pretensioning. The wires, when stressed, are secured against the concrete which has already hardened and thus loss of prestress from both elasticity and shrinkage in the

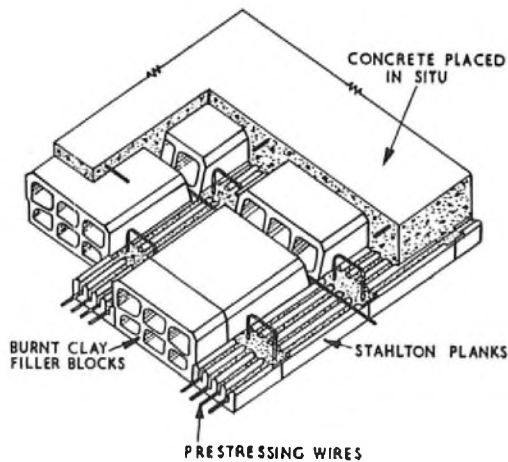

FIG. 11—PRESTRESSED FLOOR DESIGN USING HOLLOW BLOCKS

concrete are avoided. Only losses of stress from creep of the concrete and the steel remain. The wires can, with post-tensioning, be bent or curved as may be of advantage in giving shear reinforcement. Against these advantages must be set the cost of the anchorages, both in material and the labour of stressing and securing, which are nearly independent of the length of the steel. In practice this generally limits the application of post-tensioning to the larger and longer structures. Large roof beams for factories and hangers and beams for bridges are perhaps the most common applications but reservoirs, tanks, aerodrome runways and, latterly, pipes and tunnels have been successfully and economically constructed by the post-tensioning method. An important advantage of prestressed concrete for many of these applications is watertightness. Because, up to the maximum working load or beyond it, the design is usually arranged for the concrete to remain in compression, there is no cracking of the concrete as must occur even at small loads with an ordinary reinforced section. With a prestressed section if an overload results sufficient to put the concrete in tension leaks may occur, but these will close when the load is removed and no permanent harm is done. Prestressing, according to the particular application, can be carried out with only 25 per cent of the steel needed for ordinary reinforced construction and perhaps 10–12 per cent of that needed for structural steelwork. Prestressed concrete can be designed to be entirely free from cracks of any kind under ordinary working loads or shrinkage and is thus a favourable construction for structures containing liquids or otherwise where watertightness is essential. The small quantity of reinforcement required for bending and shear stress enables placing and compaction of concrete to be carried out more readily, and higher working stresses on this

account can be permitted with a reduction in size and weight.

The fire resistance of a prestressed member is potentially lower than for conventional reinforced construction on account of the high-tensile-stress steel wires being more sensitive to high temperature than mild steel. The steel wires are, however, frequently less near the surface than mild steel in ordinary sections and a fire resistance of one hour can be obtained from a concrete cover of  $1\frac{1}{2}$  in. Additional protection is available if necessary by surface finish, e.g. Vermiculite concrete slabs and sprayed asbestos.

#### CODES OF PRACTICE

A Code of Practice on the Structural Use of Reinforced Concrete in Buildings<sup>5</sup> was issued in July, 1957. Increased working stresses in steel and concrete are allowed in these recommendations, e.g. for 1:2:4 concrete, 1,000 lb/in<sup>2</sup> and 20,000 lb/in<sup>2</sup> are now given for concrete and steel respectively. An innovation in the Code is the inclusion of a load-factor method of design. For a material the stress of which is not directly proportional to the load applied, the calculation of the resistance moment on the basis of a certain fraction of the ultimate load permits an economy compared with the stipulation of maximum stress in the materials under working load. The assumption is allowed that, as failure approaches, compressive stresses adjust themselves giving an ultimate resistance exceeding that calculated by the elastic theory. The load-factor method is applicable to both mild and high-tensile-strength steel and can allow a section to be rated 20–25 per cent higher than its strength calculated on elastic deformation.

New codes are in draft for the structural use of prestressed concrete in buildings and for other purposes. In these emphasis is placed on the method to be followed to ensure the utmost consistency in quality of concrete so that the highest strengths can be used with safety and economy which, as discussed earlier in this article, is probably the respect in which construction in concrete most requires improvement.

#### References

- <sup>1</sup> B.S.12: 1947. Portland Cement (Ordinary and Rapid Hardening); B.S.915: 1947. High Alumina Cement; B.S.146: 1947. Portland Blast-furnace Cement; B.S.1370: 1947. Low-heat Portland Cement (British Standards Institution).
- <sup>2</sup> B.S.812: 1951. Methods for the Sampling and Testing of Mineral Aggregates, Sands and Fillers (British Standards Institution).
- <sup>3</sup> B.S.1881: 1952. Methods of Testing Concrete (British Standards Institution).
- <sup>4</sup> STEWART, D. A. The Design and Placing of High Quality Concrete (E. and F. N. Spon, Ltd., 1951).
- <sup>5</sup> B.S.CP114: 1957. Structural Use of Reinforced Concrete in Buildings (British Standards Institution).
- <sup>6</sup> HARDING, J. P. The Economic Design of Manholes: Part 2—Reinforced Concrete Theory. *P.O.E.E.J.*, Vol. 34, p. 85, July 1941.
- <sup>7</sup> B.S.785: 1938. Rolled Steel Bars and Hard Drawn Steel Wire for Concrete Reinforcement (British Standards Institution).



# An Efficient Electronic Switch—the Bothway Gate

J. A. T. FRENCH, B.Sc.(Eng.), A.M.I.E.E., and D. J. HARDING, B.Sc.(Eng.), A.M.I.E.E.†

U.D.C. 621.318.57:621.395.722:621.376.53

A simple non-mathematical explanation is given of an efficient and symmetrical form of pulse amplitude modulation applied to time-division-multiplex transmission in an electronic telephone exchange.

## INTRODUCTION

THIS article describes an amplitude-modulated time-division-multiplex (t.d.m.) system for an electronic telephone exchange which may be operated on a 2-wire basis. Since this system uses the same apparatus for both modulation and demodulation, including the gate which connects the line-circuit apparatus to the t.d.m. highway\* and through which transmission can take place in both directions simultaneously, it has become known as a "Bothway Gate System."

Earlier designs of t.d.m. system<sup>1,2,3</sup> have used a multiplex arranged on a 4-wire basis with a hybrid transformer forming the voice-frequency connexion between the subscriber's line and the modulator and demodulator, which have been connected via separate gates to the ingoing and outgoing highways. In addition to a separate modulator and demodulator and separate gates, these designs have required an individual receiving amplifier per line because the multiplexing results in a large power loss.

In the "Bothway Gate System" apparatus individual to a subscriber consists of a transformer, a low-pass filter, a simple charge-exchange network, which will be described in detail, and a pulse-operated switch. The system operates without amplification and with a small insertion loss of one or two decibels. Mathematical treatments of its operation have appeared in the literature.<sup>4,5</sup>

## PRINCIPLE OF THE BOTHWAY GATE

The principle of this extremely efficient method of converting from an audio-frequency signal to an amplitude-modulated pulse and back again to an audio-frequency signal was discovered first in Sweden,<sup>6,7</sup> and independently in the Post Office and at Standard Telephones and Cables, Ltd.<sup>4,8</sup>

The discovery of the system in the Post Office arose from an examination of the fundamental requirements necessary for the transmission of signals by the amplitude modulation of pulses. These are, firstly, that the pulse repetition frequency (p.r.f.) of each of the interleaved pulse-trains used to carry signals on each independent channel must be at least twice the highest voice-frequency signal to be transmitted. This ensures that the highest modulating frequency is sampled at least twice per cycle. Secondly, that a low-pass filter is required in both the modulator and demodulator to remove the unwanted products of modulation. In general the amplitude modulation of a train of pulses of p.r.f. equal to  $f_p$  by a sine wave of frequency  $f_s$  gives rise to components whose frequencies are:—

$$f_s, 2f_p, \dots, nf_p$$

$$f_p \pm f_s, 2f_p \pm f_s, \dots, nf_p \pm f_s.$$

It will be seen that if the low-pass filter is designed with a cut-off frequency  $f_p/2$  only the modulating frequency  $f_s$  will be transmitted. In a practical case a p.r.f. of 10 kc/s and a filter having a cut-off frequency at 5 kc/s would allow satisfactory transmission up to rather less than 5 kc/s.<sup>1</sup>

An ideal loss-free low-pass filter having a cut-off frequency of 5 kc/s interposed in the connexion between two voice-frequency circuits would have no effect other than delay on the transmission of signals below 5 kc/s between those circuits. The effect of inserting a lossless switch S at the midpoint of the filter, as in Fig. 1, and

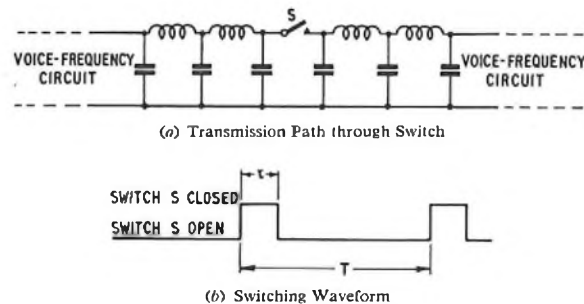

FIG. 1—PRINCIPLE OF THE BOTHWAY GATE

operating it so as to provide a path through the filter only for a short period,  $t$ , at a p.r.f. ( $f_p$ ) of 10 kc/s, was considered.

The reactive components which make up the filter are capable of accepting energy at one rate and releasing it at a different rate. Energy from one voice-frequency circuit is stored in one half of the filter when the switch is open and is transferred to the other half of the filter during the period when the switch is closed.

The operation of the switch will introduce the frequency  $f_p$  and additional modulation products into both halves of the filter but these will not appear at either end of the filter and will not therefore enter the voice-frequency circuits. It is important that there be no mismatch loss at the points of connexion of the filter to the switch; if this condition is met and there is no loss in the switch itself, then there is no apparent reason why transmission through the system should not be loss-free.

In a multi-channel t.d.m. system, the duty ratio (the ratio of time  $t$  for which the switch is closed to the total periodic time  $T$ ) is small and consequently the accumulated energy must be transferred through the switch at a high rate. The design of the switch and of the components of the filter that are connected to it, as well as the design of the filter as a whole, require special consideration to determine the conditions for this rapid transfer of energy without loss. For example, if the voltage to be transferred at the switch is of similar magnitude to that at the voice-frequency-circuit termination, then the current which flows in the switch must be much greater than that

† The authors are, respectively, Senior Executive Engineer and Temporary Senior Executive Engineer, Post Office Research Station.

\* "Highway" is the name given to the common time-shared path which is multiplied to a number of subscribers.

which flows in the voice-frequency circuit; the impedance of the switching circuit must be correspondingly much lower than that of the voice-frequency circuit.

#### DESIGN REQUIREMENTS

##### Pulse-Circuit Impedance

The nature of the pulse-circuit impedance relationship can be determined by consideration of the power transfer from an unmodulated pulse source of e.m.f.  $2E$  and internal impedance  $R_p$  to a storage device in the form of a very large capacitor  $C$  and from this capacitor into a load  $R$ , as shown in Fig. 2 (a). The pulse source is

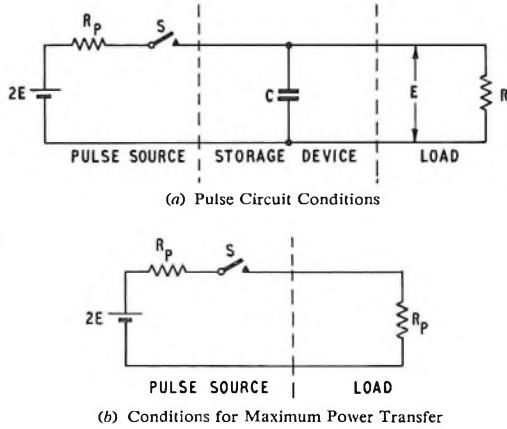

FIG. 2—DETERMINATION OF MAXIMUM POWER TRANSFER CONDITIONS FOR PULSE CIRCUIT

represented by a battery and a switch  $S$ , the periods of operation of the switch shown in Fig. 1 (b) being such that it is closed for time  $t$  and open for time  $(T - t)$ , a steady state being reached in which the voltage across the capacitor changes very little. If the pulse source were to be loaded with a resistor equal to  $R_p$ , which is the condition for maximum power transfer, as in Fig. 2 (b), the power dissipated in this resistor would be  $(E^2/R_p)(t/T)$ , the pulse voltage across it being  $E$ .

If the value of  $R$  in Fig. 2 (a) be chosen such that the voltage across  $R$  is equal to  $E$ , then the power entering  $C$  is  $(E^2/R_p)(t/T)$  and the power leaving  $C$  is  $E^2/R$ . Since there is no loss in  $C$  we have:

$$\frac{E^2}{R_p} \cdot \frac{t}{T} = \frac{E^2}{R}$$

$$\text{or } \frac{R_p}{R} = \frac{t}{T}$$

That is, the ratio of the pulse-circuit resistance to the load-circuit resistance is equal to the duty ratio of the pulses. This is therefore the condition for maximum power transfer from the pulse source to the load resistance. The very large value of  $C$  assumed for this case would not, of course, allow modulation of the pulse amplitude to be transferred to the load  $R$ .

##### Filter Response

The next step is to consider a similar pulse source connected to a low-pass filter terminated in a load resistance  $R$ , as shown in Fig. 3 (a). The first capacitance of this filter is made up in the form of a delay line whose characteristic impedance  $R_0$  is equal to  $R_p$  and whose delay time is equal to half the length of each pulse, i.e.

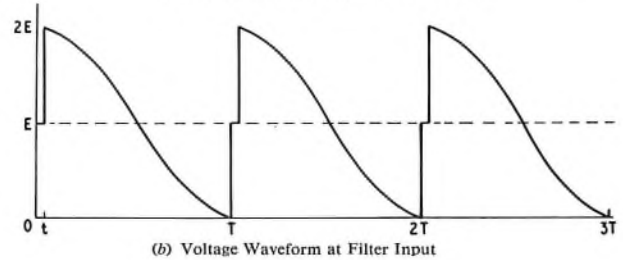
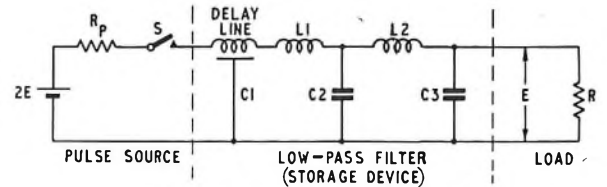

FIG. 3—CONDITIONS FOR MAXIMUM POWER TRANSFER TO A LOW-PASS FILTER

$\frac{1}{2}t$ . A pulse applied to the delay line produces a wavefront of amplitude  $E$  which travels along it until it reaches the end connected to the first inductance of the filter. The current in this inductance produced by the pulse is initially zero and is still very small at the end of the pulse, so that the pulse wavefront is reflected at what is effectively an open-circuited termination, thereby increasing the amplitude at this termination to  $2E$ . At the end of the pulse the whole of the delay line capacitance is therefore charged to  $2E$ , but for the duration of the pulse the input impedance of the delay line is  $R_0$ . Provided that the delay line is initially completely discharged, therefore, the power input to the filter is  $(E^2/R_0)(t/T)$ . The voltage at the input of the filter is shown in Fig. 3 (b).

The low-pass filter has a cut-off frequency of  $1/2T$  which is half the repetition frequency of the pulses. At frequencies below this cut-off frequency the delay line can be assumed to be a lumped capacitance, its inductive components having negligible effect. A filter having a cut-off frequency of  $1/2T$  can be designed so that its response at the input terminals to a pulse at its input passes through zero at times  $T, 2T, 3T$ , etc., after the pulse is applied to it, as shown in Fig. 3 (b), and this is the condition necessary to ensure that the delay line capacitance is completely discharged at the beginning of each pulse. Assuming that the filter is loss free, the whole of the power supplied by the pulse source to the delay line, namely  $(E^2/R_0)(t/T)$ , must be dissipated in  $R$ , and if  $R_0/R = t/T$  this power is equal to  $E^2/R$ . Also, since the filter does not pass the pulse repetition frequency or its harmonics the voltage across  $R$  will have the steady value of  $E$ .

If now it be assumed that the pulse source  $2E$  be amplitude modulated at a frequency which is transmitted by the filter, then clearly the modulating signal will appear across  $R$ .

A complete circuit, as shown in Fig. 4, includes a signal source  $2E$  having resistance  $R$ , a modulator consisting of a low-pass filter LPF1 terminating in the delay line DL1, a periodically-operated switch  $S$ , a demodulator consisting of the filter LPF2 with delay line DL2 as its input capacitor, and a load resistance  $R$ . Delay line DL1 will be charged to  $2E$  in the intervals when the switch  $S$  is open and when switch  $S$  is closed the charge will be transferred to DL2. When the delay



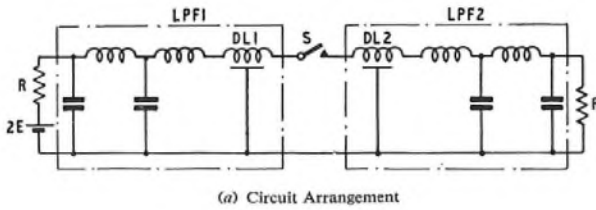

(a) Circuit Arrangement

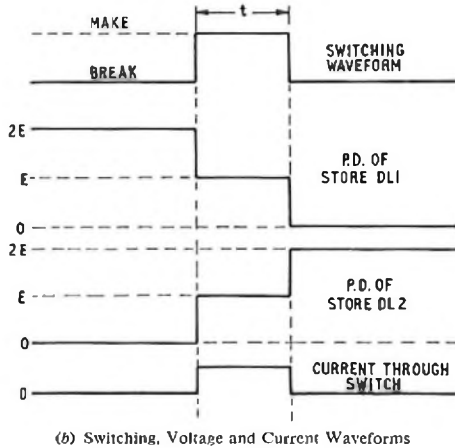

(b) Switching, Voltage and Current Waveforms

FIG. 4—BOTHWAY GATE EMPLOYING DELAY LINES—INTERCHANGE OF CHARGES

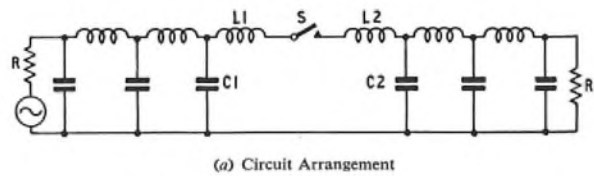

(a) Circuit Arrangement

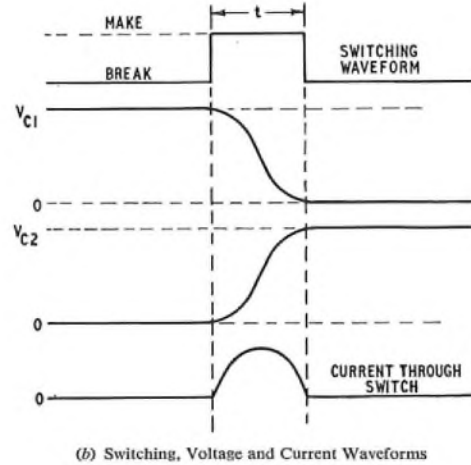

(b) Switching, Voltage and Current Waveforms

FIG. 5—BOTHWAY GATE EMPLOYING SERIES-RESONANT CIRCUITS—INTERCHANGE OF CHARGES

lines are connected together the voltage at the output of DL1 will immediately fall from  $2E$  to  $E$  since it is then correctly terminated by DL2; the voltage at the input of DL2 will rise from 0 to  $E$ . The steps of voltage will travel down the delay lines and be reflected at the high-impedance inductors forming part of the low-pass filters, returning to S after time  $t$ , at which time the switch opens and the potential of DL1 falls to 0 and that of DL2 rises to  $2E$ . The complete transfer of charge from DL1 to DL2 has thus occurred without loss.

If the battery ( $2E$ ) in the circuit is now replaced by a voice-frequency generator producing only those frequencies which will be transmitted by the filter, then the instantaneous voltage of DL1 will follow that of the generator in such a manner that it is of the same amplitude at the switching instants, and subject to the same delay as would occur if S were permanently open. The switch can thus be used to transmit voice-frequency signals from one circuit to another similar circuit. Since these circuits are identical and linear, reciprocal action can occur in which signals are transferred from DL2 to DL1. It is possible for information to be conveyed in both directions simultaneously and in this case the voltages on the two delay lines are interchanged.

As an alternative to the use of delay-line networks, a series-resonant circuit may be used to effect the exchange of charge. In this case the terminal capacitors of the low-pass filter C1 and C2 replace the capacitance of the delay line and store the charge to be transferred. When the switch is closed C1, L1, L2, C2 form a series-resonant circuit and C1 discharges in an oscillatory manner, as shown in Fig. 5. The charge on C1 falls and that on C2 rises until, after one half cycle of the oscillation at time  $t = \pi\sqrt{LC}$ , where  $L = L_1 + L_2$  and  $C = C_1C_2/(C_1 + C_2)$ , their original voltages have been interchanged and at this point the switch is opened. Omission of the inductors L1 and L2 would result in a loss of half the charge.

#### PRACTICAL SYSTEM DESIGN AND PERFORMANCE

##### The Filter

It has already been shown that for maximum efficiency  $R_0/R = t/T$  and the design of a system using filter terminal-capacitors in the form of delay lines may be continued from this point.

The characteristic impedance of the delay line is

$$R_0 = \sqrt{\frac{L}{C}}$$

(where  $L$  is the total inductance and  $C$  the total distributed capacitance) and it has been shown that the delay  $\sqrt{LC}$  is required to be  $t/2$ . From these factors it is readily deduced that

$$C = \frac{t}{2R_0} = \frac{T}{2R}$$

This is the value of capacitance required for loss-free transmission through the system and any departure from this value will result in a mismatch loss.

The low-pass filter in a practical system must be designed as a compromise between a number of factors. The most elementary form of filter is a single shunt capacitor, and more complex arrangements using a dozen or more elements are readily designed. For a given type of filter as it approaches an ideal configuration by the use of more elements the mismatch loss is reduced. The design of the filter must also take into account its time response to the switching pulse. A typical response curve may be seen in Fig. 6, which shows that the voltage impressed upon the terminal capacitor of the filter during switching decays to zero after a period which must be made equal to  $T$ . Overshoot then occurs which in this case amounts to about 20 per cent. In practice subsequent zeros do not occur exactly at multiples of  $T$  due to imperfections of the filter. This means that subsequent switching operations are affected by the residual charge which is left on the terminal capacitor at the switching

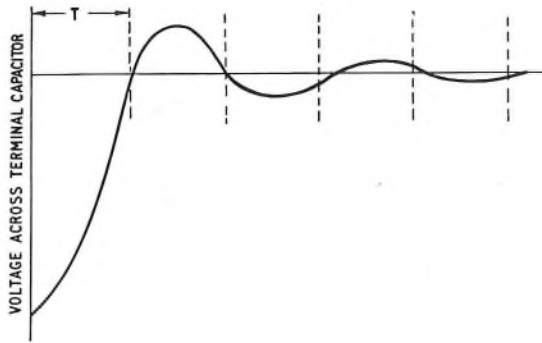

FIG. 6—VOLTAGE/TIME RESPONSE CURVE FOR LOW-PASS FILTER AT OPEN-CIRCUITED END

instant. In the case of an amplitude-modulated transmitted pulse, each successive pulse may be of different amplitude, and the resultant effect of all the pulse responses of one channel is obtained by addition. The result is a loss or gain in transmission efficiency which is frequency dependent and may be termed a switching loss.

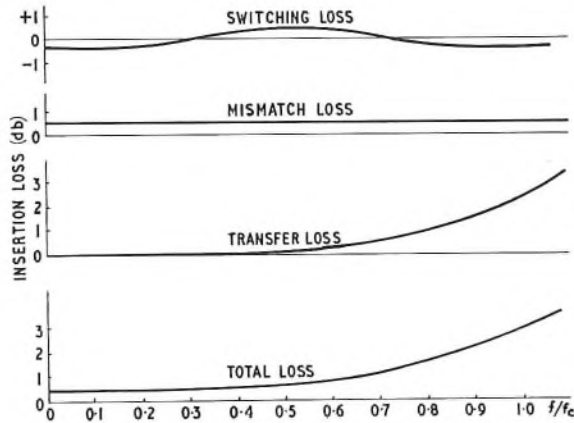

FIG. 7—VARIATION IN TRANSMISSION LOSS

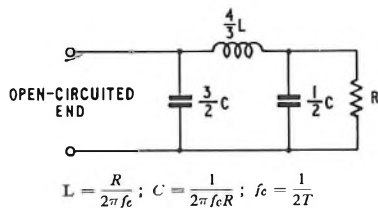

FIG. 8—TYPICAL LOW-PASS FILTER CONFIGURATION

Fig. 7 shows the switching loss, a constant mismatch loss, and also the transfer-loss characteristic for the typical low-pass filter configuration shown in Fig. 8. This filter is a constant- $R$  filter, designed to work between a resistance  $R$  at one end, and an open-circuit at the other end, rather than the more usual case of a resistance  $R$  at both ends. This is probably the most practical type of simple filter where it is essential to reduce the number of elements to a minimum for economic reasons. If the cut-off frequency  $f_c$  is given by  $f_c = 1/2T$ , i.e. half the pulse repetition frequency, then, since  $C = 1/(2\pi f_c R)$ , the terminal capacitance

$$3C/2 = (3/2)(2T/2\pi R) = (3/\pi)(T/2R).$$

The mismatch loss in this case is given by the factor  $\pi/3 = 0.955$  by which this capacitor differs from the ideal value.

One disadvantage of this filter is its insufficient attenuation of the lower sideband ( $f_p - f_s$ ) and of  $f_p$  due to the slow increase in attenuation from  $f_c$  to  $f_p$ . Furthermore, the total-loss characteristic cannot be considered flat above about  $0.6f_c$ , which reduces the effective bandwidth.

One further filter of four elements, which overcomes some of these disadvantages, will be described. It consists of a shunt-tuned series arm,  $L, C_2$ , as shown in Fig. 9,

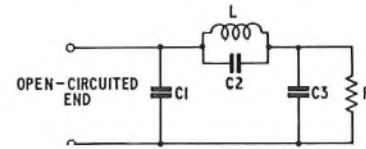

FIG. 9—CONFIGURATION OF A 4-ELEMENT FILTER

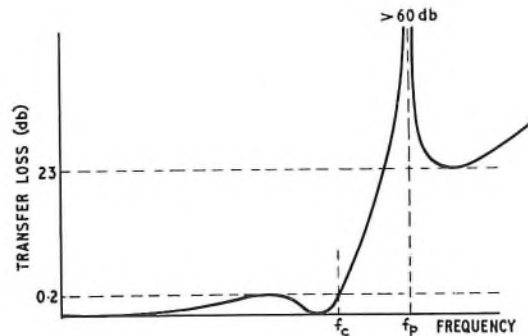

FIG. 10—TRANSFER LOSS OF 4-ELEMENT FILTER

which is arranged to resonate at  $f_p$ , and two shunt capacitors,  $C_1$  and  $C_3$ , as before. The transfer characteristic of a filter of this type is shown in Fig. 10 and it may be observed that a very large transfer loss is obtained at  $f_p$ . The design of this type of filter cannot be dealt with in this article but, as a general guide, some loss must be accepted in the pass band (say 0.2 db), and this influences the loss which is obtained at frequencies higher than  $f_p$  (in this case 23 db). The loss at  $f_p$  may be greater than 60 db, which is adequate for suppression of the p.r.f., and the greatly increased attenuation between  $f_c$  and  $f_p$  effectively suppresses the lower sideband. In this case the value of the charge-exchange storage capacitor is given by  $C_1 + C_2 C_3 / (C_2 + C_3)$ .

### The Switch

The charge-exchange networks and the low-pass filters have so far been considered. The other important element of the system is the switch  $S$ . This is required to transmit a high-power signal with small loss during the channel pulse. It must also switch from one state to the other sufficiently quickly to allow accurate timing in the charge-exchange networks and, finally, must have a very high effective resistance when open. These conditions can be met by using rectifier or transistor circuits.

When investigation of the switching problem commenced only point-contact germanium rectifiers were available and these, although satisfactory from the switching-speed and back-resistance aspects, had a high impedance when conducting, which caused excessive



loss in the switch. Subsequently, in 1954, suitable junction rectifiers became available and in 1956 high-frequency symmetrical transistors. When use is made of junction transistors or rectifiers there is an added crosstalk hazard due to hole-storage effects in the *n*-type base material. This is due to the finite time that is required by the charge carriers to recombine with carriers of opposite sign or to flow into the external circuit.

Two arrangements of the many possible switches will be described. The first arrangement using junction rectifiers is illustrated in Fig. 11, which shows two balanced

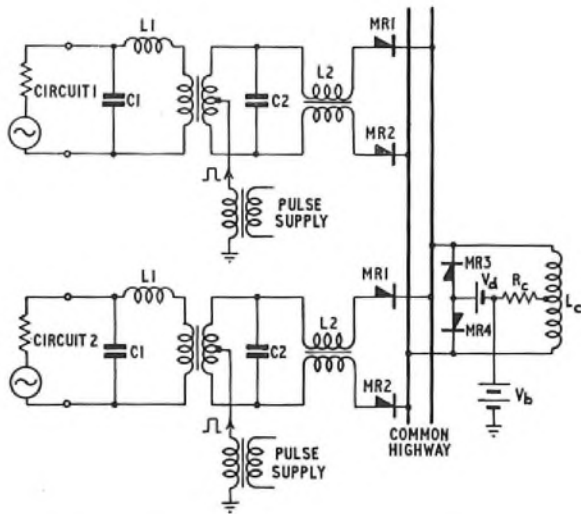
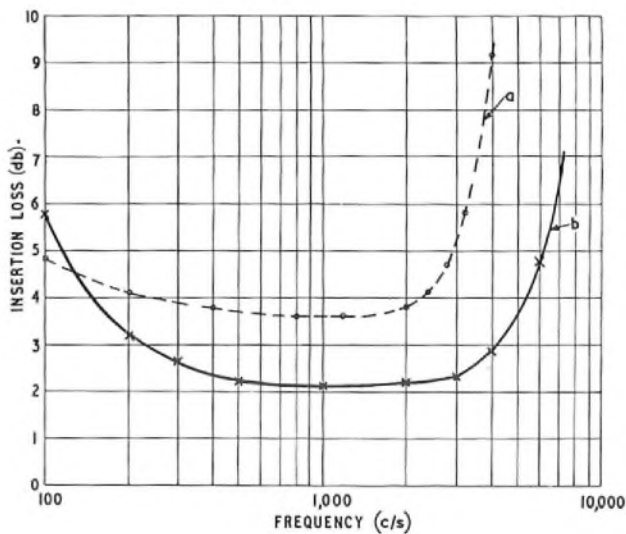

FIG. 11—BALANCED SWITCH USING JUNCTION RECTIFIERS

circuits connected to a common highway.<sup>9</sup> The switching pulses are applied to the centre point of the audio-frequency transformers. These transformers, together with the series-resonant inductors L2 and common choke  $L_C$ , are arranged so that they are non-inductive to the switching-pulse current. The balanced arrangement is one method of avoiding a large p.r.f. signal component



(a) Balanced system using junction rectifiers  
(b) Unbalanced system using symmetrical transistors

FIG. 12—INSERTION LOSS OF A CHANNEL IN A 25-CHANNEL T.D.M. SYSTEM

in the audio transformers. The low-pass filters consist of  $C_1$ ,  $L_1$ ,  $C_2$  and the switching rectifiers are MR1 and MR2. Rectifiers MR3 and MR4 are used for discharging any residual charge remaining on the highway capacitance after the end of a channel pulse, which would otherwise inject crosstalk into the following channel.

The system has been operated with  $3\mu\text{s}$  channel pulses at 10 kc/s p.r.f. and with  $1\mu\text{s}$  spacing between adjacent channels. This allowed a 25-channel system to be constructed whose total insertion loss per channel, including transformers, was about 4 db, as shown in Fig. 12. Further tests showed that the crosstalk and harmonic distortion performance were satisfactory for the operation of a telephone system.

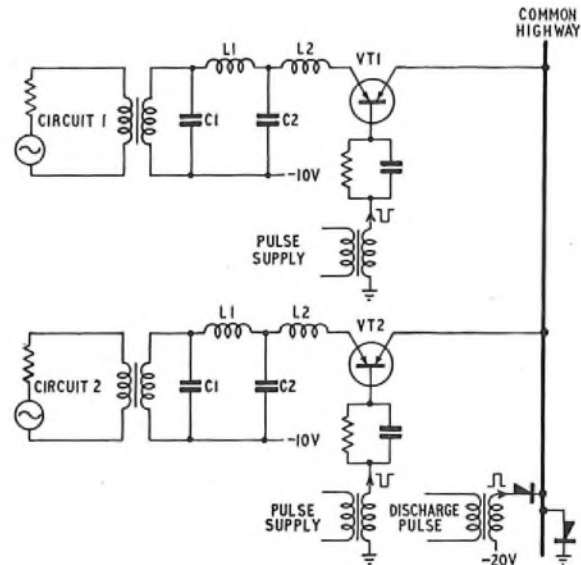

FIG. 13—UNBALANCED SWITCH USING SYMMETRICAL TRANSISTORS

The second arrangement, illustrated in Fig. 13, makes use of symmetrical transistors VT1, VT2, etc., as the switch.<sup>10</sup> As in the previous case,  $C_1$ ,  $L_1$ ,  $C_2$  form a low-pass filter and  $L_2$  is the series-resonant inductor. A negative pulse applied to the base of the switching transistors in two line circuits causes the transistors to "bottom" and the circuits are effectively connected together, allowing exchange of charge via a very small resistance. This system has been operated with  $2\mu\text{s}$  channel pulses and a very simple filter. In order to give adequate circuit band-width, together with efficient suppression of the p.r.f. signal component, the cut-off frequency of the filter was raised to 8.35 kc/s and the p.r.f. to 16.7 kc/s. It may be seen from the insertion-loss characteristic shown in Fig. 12 that the mid-band loss is about 2 db and the high-frequency response is considerably improved compared with the previous arrangement. The low-frequency response is inferior only because of the transformer characteristics. The use of a simple network to discharge the highway capacitance allows a 25-channel system to be operated as before, but with reduced loss and extended frequency band.

Additional channels can be provided if necessary by lowering the p.r.f. to 10 kc/s or slightly less, together with the use of more complex filter designs. Using components at present available this would allow a practical system having 35-40 channels.

## CONCLUSIONS

Theoretical considerations and experiment have shown that the processes of modulation and demodulation for a time-division-multiplex switching system can be carried out very efficiently. These processes are reciprocal and require only a 2-wire connexion involving a low-pass filter network and a bothway gate. Transistors and junction rectifiers at present available enable an electronic switch-unit carrying 25-40 speech channels to provide the basic speech-circuit switching for an electronic telephone exchange. Additional apparatus is, of course, necessary for storage of the pulses which are applied to the gates in order to make the connexions, for the setting up and control of the connexions, and for signalling.

## ACKNOWLEDGEMENT

The authors wish to acknowledge the work of past and present colleagues in Research Branch who were associated with this development.

## References

- <sup>1</sup>FLOWERS, T. H. Introduction to Electronic Automatic Telephone Exchanges. *P.O.E.E.J.*, Vol. 43, p. 61, July 1950.
- <sup>2</sup>FLOWERS, T. H. Electronic Telephone Exchanges. *Proceedings I.E.E.*, Vol. 99, Part 1, p. 181, Sept. 1952.
- <sup>3</sup>SCOWEN, F. A Small Experimental Electronic Automatic Telephone Exchange. *P.O.E.E.J.*, Vol. 47, p. 1, Apr. 1954.
- <sup>4</sup>CATTERMOLE, K. W. Efficiency and Reciprocity in Pulse Amplitude Modulation, Part 1, Principles. *Proceedings I.E.E.*, Paper No. 2474 R, Sept. 1958 (Vol. 105, Part B, p. 449).
- <sup>5</sup>DESOER, C. A. A Network Containing a Periodically Operated Switch Solved by Successive Approximations. *Bell System Technical Journal*, Vol. 36, pp. 1403-1428, Nov. 1957.
- <sup>6</sup>British Patent Specification 737,417, 1953, L. M. Ericsson, Sweden.
- <sup>7</sup>SVALA, G., and JACOB, W. An Electronic Automatic Exchange, *Teknisk Tidskrift*, Oct. 1955, p. 811.
- <sup>8</sup>PRICE, J. G. Efficiency and Reciprocity in Pulse Amplitude Modulation; Part 2, Testing and Applications, *Proceedings I.E.E.*, Paper No. 2475 R, Sept. 1958 (Vol. 105, Part B, p. 463).
- <sup>9</sup>British Patent Application 19150/55.
- <sup>10</sup>TROUSDALE, R. B. Symmetrical Transistor as a Bilateral Switching Element. *Communications and Electronics*, No. 26, p. 400, Sept. 1956.

## Book Reviews

"Telecommunications Principles (in M.K.S. Units)." R. N. Renton, C.G.I.A., M.I.E.E. Sir Isaac Pitman & Sons, Ltd. 446 pp. 661 ill. 45s.

This is the second edition of Mr. Renton's "Telecommunications Principles", first published in 1950. In the review of the first edition that was published in the *Post Office Electrical Engineers' Journal*, a successful future was predicted for this new book and it is pleasing to know that this prophecy has been fulfilled. The first edition used the C.G.S. system of units because the proposals for the M.K.S. units were not generally accepted at that time. In the second edition the book has been thoroughly revised and M.K.S. units have been introduced throughout. This should increase the popularity of the book because most schools are now changing completely to the rationalized M.K.S. system of units in their teaching of electricity and the City & Guilds of London Institute also accept it in the telecommunications examinations. The author originally planned the work so as to cover adequately the syllabus of the examinations in Telecommunications Principles, Grades 1, 2 and 3, of the City & Guilds. This plan remains unchanged in that the scope of the work is unaltered, for not only does it cover the theoretical work generously but also provides an excellent practical environment from which the theory gains perspective in the eyes of the practical engineer. Students at this stage in their reading would already be working to some extent in the telecommunications industry; they would therefore benefit from and appreciate the links between theory and practice that this juxtaposition of analytical and descriptive matter can give. Some sections also include bibliographical references, mostly from this Journal, that amplify the subject matter in the text. Such additions do a great deal to improve the value of a text book because the student learns to regard it as a work of reference that remains in use when his student days are over. While other books gather dust on the shelf, "Telecommunications Principles" continues to be a useful source of information.

The author has been unlucky in that the City & Guilds telecommunications examinations have been reorganized this year so that the syllabuses he gives for Telecommunications (Principles) Grades 1, 2 and 3 are obsolete already. New syllabuses have been used by the City & Guilds for the Telecommunications Technicians' Certificates Examina-

tions Grades A, B and C and these are to replace the present Grades 1, 2 and 3 syllabuses given in the second edition of the book. The value of the book will be greatly increased if the new syllabuses could be printed in later copies. Most of the items in the new syllabuses are covered by the author with possibly the exception of transistors. The many worked examples scattered throughout the text are largely taken from past examination papers of the City & Guilds and are carefully selected to illustrate basic principles; they not only help to clarify the theory given previously in the section, but also provide a good basis for revision when an examination is imminent. Each chapter closes with a summary of the main formulae and items touched on in that section of the book.

This book is excellently produced; it is well printed on good paper and is a handsome volume such as a young student would welcome as a prize.

*I.P.O.E.E. Library No. 2002.*

C. F. F.

"Theory of Electrical Machines." W. S. Wood, B.Sc., A.M.I.E.E. Butterworth Scientific Publications, London. 317 pp. 141 ill. 50s.

This book is intended to provide the subject matter in electrical machines for final-year electrical engineering undergraduates. A knowledge of constructional details of machines is assumed. The introductory topics of generation of c.m.f., armature windings, armature reaction and reactance and torque are discussed in the first three chapters with only occasional reference to particular types of machine. The remaining five chapters deal with transformers, synchronous machines, induction machines (motors, generators and regulators), a.c. commutator machines and d.c. machines. The chapter on d.c. machines includes sections on the various types of rotating amplifiers. The treatment is largely effected by means of equivalent circuits, vector-diagram curves and circle diagrams with a minimum of advanced mathematics. Some 80 questions, taken chiefly from old examination papers of the Royal College of Science and Technology, Glasgow, are included and answers are given but there is a complete absence of worked examples. Some of the more important fundamentals of machine design are given in brief appendices. The book is generally well written and easily understood and will fulfil a useful purpose in its somewhat limited field. M.K.S. units are used. P.G.S.C.



# Radio Interference

## Part 6—The Control of Radio Interference

C. W. SOWTON, B.Sc.(Eng.), A.C.G.I., A.M.I.E.E.†

U.D.C. 347.837:621.396.828

An introduction to the subject of radio interference and a description of the Post Office radio-interference service were given in Parts 1 and 2 of this article. Part 3 described how interference is generated and propagated and dealt with methods of suppression. Radio-interference measuring equipment was described in Part 4 and the special case of interference from radio sets and industrial, scientific and medical apparatus was described in Part 5.

Part 6, which concludes this article, deals with the control of radio interference. A survey is given of the work that has been done both nationally and internationally in the preparation of specifications and codes of practice to encourage voluntary action and also to assist in the preparation of legislation. Details are given of the Regulations that have been introduced in this country to control radio interference and reference is made to the work still to be done in this field.

### INTRODUCTION

IN his introduction the editor of this series of articles\* pointed out that in the United Kingdom the Postmaster General is administratively responsible for the control of radio interference. He drew attention to the fact that, while prior to 1949 the control of radio interference had depended solely on voluntary action, the passing of the Wireless Telegraphy Act, 1949, had given the Postmaster General the power of legislative control. Before considering what voluntary control has achieved and the extent to which legislative control has been exercised, it is of interest to look back some 25 years to see how the foundations of the present structure were laid.

In 1933, the Council of the Institution of Electrical Engineers (I.E.E.) appointed a representative committee to review the subject of interference with radio reception and to make recommendations as to the steps to mitigate such interference, considering:

- (a) the best methods of suppressing interference from electrical plant;
- (b) the desirability, or otherwise, of embodying requirements for interference suppression in specifications for electrical plant; and
- (c) the desirability, or otherwise, of legislation.

This committee was under the chairmanship of the late Sir Clifford Paterson and included representatives of Government Departments, various associations of the Electrical and Radio Industries, the Broadcasting Authority, the Electricity Commission, the Central Electricity Board, the Electricity Supply Associations and many other bodies.

An interim report was made to the Council of the I.E.E. in October 1934, and a final report in July 1936. The report made it clear that the committee did not consider that interference suppression would be effective if it was left solely to voluntary action. They considered that some Authority should be given the power to issue regulations to ensure that electrical apparatus was "interference-free." The committee, in fact, recommended that the Electricity Commissioners should be given the power to issue regulations regarding the suppression of interference with radio reception caused by new and existing electrical apparatus, and that the Post Office should have powers to enforce the application of the regulations.

The committee set up a number of sub-committees to consider in detail the question of suppressing interference from the types of apparatus that formed the chief sources of interference; much of the data for the sub-committees' work being provided by the Electrical Research Association and the Post Office Engineering Department. When the work of the sub-committees had been completed, the main committee decided that standard specifications should be drawn up, dealing with such things as suppression components, interference-measuring apparatus, permissible limits of interference, etc., and at their request the British Standards Institution (B.S.I.) set up a number of committees for this purpose. These and other standards committees, as well as joint I.E.E./B.S.I. Codes of Practice Committees concerned with radio-interference suppression, have been largely responsible in guiding the control of radio interference by voluntary action and their work will be considered in some detail later.

In 1939, consideration was given to the preparation of a Bill to amend the Wireless Telegraphy Acts and it was hoped that if this Bill were passed it would give the Electricity Commissioners powers to make regulations relating to radio interference, as had been recommended by the I.E.E. committee. Unfortunately war prevented this and it was not until the end of the war that the I.E.E. committee was reconstituted. It confirmed the earlier view that, although a large measure of suppression would be obtained by voluntary means, the legislative control of radio interference was necessary and desirable. The Council of the I.E.E., on the basis of the committee's report, recommended to the Postmaster General that legislation providing for the compulsory suppression of electrical interference with radio reception should be introduced and that the necessary powers to make Regulations should be obtained. A new Bill was drafted and eventually became law as the Wireless Telegraphy Act, 1949. Part II of the Act makes "special provision as to interference" and will be considered in detail later.

### CONTROL BY VOLUNTARY ACTION

Some idea of the scope of the work that has been done by the B.S.I. and I.E.E. committees in preparing British Standard specifications and codes of practice relating to radio interference can be obtained from Tables 9 and 10.

The work of these committees continues since the specifications and codes of practice require to be brought up to date from time to time and in particular their scope has to be extended as broadcasting and other radio services use higher frequency bands. Several of the specifications and codes of practice are in fact under review at the present time.

Besides these national committees an international committee on radio interference, the Comité International

† Assistant Staff Engineer, Inland Radio Planning and Provision Branch, E.-in-C.'s Office.

\* Vol. 50, p. 226, Jan. 1958.

TABLE 9  
British Standard Specifications

Specification Number and Date	Title
613 : 1955	Components and Filter Units for Radio Interference Suppression
727 : 1954	Characteristics and Performance of Apparatus for Measurement of Radio Interference.
800 : 1954	Limits of Radio Interference
827 : 1937	Radio Interference Suppression for Trolley-buses and Tramways
833 : 1953	Radio Interference Suppression for Motor Vehicles and Internal Combustion Engines
905 : 1940	Interference Characteristics and Performance of Radio Receiving Equipment for Aural and Visual Reproduction
1597 : 1949	Radio Interference Suppression on Marine Installations

TABLE 10  
British Standard Codes of Practice

Code Number and Date	Title
1001 : 1947	Abatement of Radio Interference caused by Motor Vehicles and Internal Combustion Engines
1002 : 1947	Abatement of Radio Interference from Electro-Medical and Industrial Radio-Frequency Equipment
1006 : 1955	General Aspects of Radio Interference Suppression Measurement and Abatement of Radio Interference in Aircraft (in preparation)

Spécial des Perturbations Radioélectriques (C.I.S.P.R.), was set up under the auspices of the International Electro-technical Commission to promote international agreement on measuring apparatus and methods of measurement and on permissible limits of radio interference.

It is useful to examine what these committees have achieved and how their work has contributed to the control of radio interference by voluntary action. Firstly the national committees have standardized apparatus for measuring radio interference and methods of measurement covering the frequency range 150 kc/s–150 Mc/s, but applicable up to 300 Mc/s, thus covering all frequencies at present used for sound broadcasting and television in this country. Secondly they have agreed a specification for the permissible limits of radio interference that may be generated by electrical apparatus in the frequency bands 200–1605 kc/s and 40–70 Mc/s, covering the long-wave and medium-wave sound-broadcasting bands and Band I television, and have in hand the revision of this specification to extend it up to 300 Mc/s, thus including Band II (frequency-modulated sound broadcasting) and Band III television. The specified limits are recognized to be a compromise between the interests of the users of the radio-frequency spectrum on the one hand, and the makers and users of electrical appliances on the other. They ensure protection from interference in the majority of cases and can be achieved for most appliances with the use of simple and inexpensive suppression components. The manufacturer of electrical appliances thus has available standardized measuring apparatus by means of which he can determine the levels of the interference generated

by his appliance and he knows to what limits it should be suppressed if it is not to cause interference.

In addition, specifications have been agreed for suppression components, capacitors, inductors and resistors, and for filter units, to ensure that these will not impair the safety and reliability of the appliance to which they are fitted. A code of practice has been prepared which gives guidance on the principles and methods of suppressing radio interference, on the choice of suppression components and on the installation of suppression devices. The Post Office Engineering Department provides further assistance to manufacturers and will make radio-interference measurements on samples of electrical appliances and recommend the most suitable methods of suppression. The manufacturer is thus given much guidance and help towards producing "interference-free" electrical appliances. The work of the Post Office Engineering Department in helping the user of electrical apparatus found to be causing interference has already been considered in Part 2\* of this series of articles.

Specifications and codes of practice have been prepared to deal with radio interference from particular classes of apparatus. For example, the ignition systems of motor cars are a major source of interference with television and the suppression of radio interference from motor vehicles and internal combustion engines has been considered by special sub-committees and is covered exclusively in a particular specification and a code of practice. Electro-medical and industrial radio-frequency equipment is a special class of apparatus—it was considered in the preceding article† of this series—and the abatement of interference from such equipment is the subject of a special code of practice. Interference from radio receivers themselves due to line time-base and oscillator radiation was also dealt with in that article. The radio industry under the direction of the British Radio Equipment Manufacturers Association undertook to determine suitable methods of measurement and to recommend acceptable limits of receiver radiation. These have been accepted for incorporation in British Standard 905, which is being revised and will be published shortly.

It has been disappointing that all this work has failed to stimulate much voluntary action towards suppressing radio interference by manufacturers, by dealers or by users. For example, hardly any motor cars were sold with ignition-interference suppression prior to the issue of Regulations, although the method of suppression was simple and well known, had no adverse effect on the performance or reliability of the car engine, and cost very little. Despite the publicity given to the need to suppress existing vehicles the response of car owners was very poor. Roadside tests made by the Electrical Research Association have shown no evidence of any significant amount of voluntary suppression on vehicles manufactured prior to the Regulations. It must, however, be stated that many bodies operating large fleets of motor vehicles did take voluntary action to suppress their vehicles.

In the case of electrical appliances the picture is perhaps slightly better. Prior to the Regulations the majority of appliances were sold unsuppressed and in many cases neither the dealer nor manufacturer was interested in fitting suppressors if an appliance caused interference, leaving this work very largely to the Post Office. Here

\* Vol. 50, p. 227, Jan. 1958.

† Vol. 51, p. 202, Oct. 1958.



again it must be mentioned that some manufacturers did sell appliances that were adequately suppressed and others would supply and fit suppressors on request either free or at a nominal charge. "User" Regulations (referred to later in this article) applying to small motors of the type often used in domestic appliances have, however, resulted in manufacturers fitting suppressors to many appliances and the public are becoming aware of the desirability of purchasing appliances that are "interference-free." In fact the majority of electrical appliances sold to-day are effectively suppressed at least as far as interference to television and frequency-modulated sound-broadcast reception is concerned. It is not, however, usual for manufacturers to provide suppression for long-wave and medium-wave sound-broadcast reception.

The general public as users of electrical appliances are, in general, unaware that they are causing interference until it is brought to their notice by the Post Office as a result of a complaint. They are, with few exceptions, very co-operative and usually agree to the necessary suppression components being fitted and to pay for them. Regulations do of course take care of the exceptions.

The view of the I.E.E. committee before and after the war that suppression by voluntary action alone would not be adequate, and that legislative control was necessary, has been borne out.

#### CONTROL BY LEGISLATION

The Wireless Telegraphy Act, 1949, gave the Postmaster General the power to make Regulations for the control of radio interference from apparatus generating, fortuitously or by design, electromagnetic energy at frequencies not exceeding 3,000,000 Mc/s, but excluding wireless-telegraphy apparatus. The Regulations were to prescribe requirements for apparatus in use—often referred to as "User Regulations," since the onus of complying fell on the user of the apparatus—and for apparatus to be sold, let on hire, etc.—known as "Manufacturer Regulations," since in this case the onus fell on the manufacturer or importer. The Act states that the purpose of the requirements shall be to ensure "that the use of the apparatus does not cause undue interference with wireless telegraphy." It was laid down that Regulations were to be made after consultation with an advisory committee appointed by the Postmaster General from a panel of experts and persons whose interests were concerned, nominated by the I.E.E.

As regards the enforcement of the Regulations it is made clear that failure to comply with the requirements laid down is not of itself an offence but if the Postmaster General is satisfied that any apparatus does not comply and (a) is likely to cause undue interference with a safety-of-life service or (b) is causing undue interference with other services, he can serve a notice requiring that the apparatus shall not be used after a specified date. The person on whom the notice is served has the right of appeal to a tribunal who may direct the Postmaster General to revoke or vary the notice if they are satisfied the apparatus complies with the requirements or that the requirements ought, in the particular case, to be relaxed. Similar powers of enforcement and right of appeal, etc., apply in the case of "Manufacturer Regulations." While the Wireless Telegraphy Act, 1949, thus provides legal powers to control radio interference, the user and manufacturer of electrical apparatus are very adequately safeguarded against unreasonable action.

Since the Act came into force several advisory committees have been appointed and on their advice the Postmaster General has made several Regulations. The first two advisory committees were set up in 1950: one, under the chairmanship of Sir Stanley Angwin, to deal with the question of interference from ignition systems and the second, under the chairmanship of Dr. F. T. Chapman, to deal with interference from refrigeration apparatus. It was felt that interference from ignition systems was the most serious and widespread form of interference to television and should therefore be tackled at once. The second choice was made on the grounds that the number of complaints from refrigerators was then more than twice that from any other single type of appliance. In both cases suppression was comparatively simple and cheap.

A third advisory committee to deal with interference from small electric motors, as used in many domestic appliances such as vacuum cleaners and sewing machines, was appointed in 1952 under the chairmanship of Mr. J. R. Beard, and in 1956 a fourth advisory committee was set up, under the chairmanship of Mr. O. W. Humphries, to deal with interference from industrial, scientific and medical radio-frequency apparatus. The first three advisory committees have reported and as a result of their recommendations Regulations under the Wireless Telegraphy Act have been promulgated. Although an interim report has been made by the fourth committee its work is still in progress and it is not therefore possible to comment on it in this article. The appointment of two further advisory committees is under consideration, one to deal with interference from lamps, including fluorescent lamps and neon signs, and the other to deal with contact devices such as thermostat switches.

The advisory committee on interference from ignition systems reported to the Postmaster General in July 1951 and recommended that regulations under the Wireless Telegraphy Act be made, embodying both "manufacturer" and "user" requirements, for the ignition equipment in motor vehicles and stationary engines. The requirements recommended were that the intensity of the interfering field measured at a distance of 10 metres from the vehicle or engine should not exceed  $50 \mu\text{V}/\text{metre}$  in the frequency range 40–70 Mc/s. It was stated that these requirements could be met by a single resistor in the lead between ignition coil and distributor for some 60–80 per cent of motor cars, and the inclusion, in addition, of resistors in the plug leads would ensure that the requirements were met in all cases. It was also stated that the recommendations were based on the assumption that all reasonable measures were taken to reduce the susceptibility to interference at the receiving installation. The field-strength limits and the frequency range specified were of course designed to permit reasonable freedom from interference with the reception of television in Band I.

Regulations were in fact made in November 1952 to come into force seven months later. The requirements specified in the Regulations are those recommended by the advisory committee but the "user" requirements apply only to vehicles and engines assembled on or after the date on which the Regulations came into force. Moreover the user is deemed to have complied with the requirements if he establishes that the original or similar suppressors in good repair are fitted. It was considered that Regulations embodying the "user" requirements as

recommended by the advisory committee could not have been effectively enforced in practice. It was also thought that publicity on the lines recommended by the advisory committee would encourage owners of existing vehicles to fit suppressors voluntarily.

To-day about 50 per cent of the vehicles on the road are post-Regulation, i.e. were manufactured after 1st July 1953, and these have all been suppressed and cause little or no interference with television either in Band I or Band III or with frequency-modulated sound broadcasting in Band II. Band II, 88–100 Mc/s, and Band III, 174–216 Mc/s, are not in fact covered by the Regulations but suppression to meet the requirements in the frequency range 40–70 Mc/s is, as a general rule, adequate for the higher bands. Only a small proportion of pre-Regulation vehicles are suppressed and these are responsible for most of the ignition interference that is experienced today. These will, however, be gradually replaced and it can be expected that in time all vehicles will be effectively suppressed.

The advisory committee on refrigeration apparatus reported to the Postmaster General in 1952 recommending that Regulations, applying to both “manufacturers” and “users,” should be made specifying the maximum interfering voltage which refrigeration apparatus might inject into the electricity supply mains (or more precisely into a network simulating the mains). It was recommended that this voltage should not exceed 1500  $\mu$ V over the frequency range 200–1605 kc/s and 750  $\mu$ V over the range 40–70 Mc/s. It was considered unnecessary to specify limits for the interference field strength since the interfering energy radiated directly from refrigerators had been found to be much less than that radiated from the mains wiring. It was pointed out that interference was caused only by refrigerators using commutator motors (representing only 8 per cent of the manufacturers’ output and a decreasing proportion) or from a defective or obsolete pattern of thermostat.

Regulations were made in February 1955 on the basis recommended by the advisory committee and came into force in September 1955. To-day very little interference is experienced from refrigerators, mainly because practically all domestic refrigerators use induction-type motors and snap-action thermostat switches. A very few refrigerators are made for d.c. operation with commutator-type motors and these are effectively suppressed to meet the requirements of the Regulations.

The advisory committee on interference from small electric motors reported towards the end of 1953. Their recommendations relate to fractional-horse-power motors of all types such as are used in sewing machines, hair-dryers, vacuum cleaners, drills and fans, thus covering a wide range of appliances responsible for a large amount of radio interference. They recommended that Regulations should embody “user” requirements applying to both existing and new apparatus (small motors whether incorporated in electrical appliances or not and the immediately associated switchgear), in terms of the electromagnetic energy injected into the electricity supply mains (terminal voltage) and radiated (field strength), as follows:

Terminal voltage	$\left\{ \begin{array}{l} 200-1605 \text{ kc/s} - 1500 \mu\text{V} \\ 40-70 \text{ Mc/s} - 750 \mu\text{V} \end{array} \right.$
Field strength	
at 10 metres	$\left\{ \begin{array}{l} 200-1605 \text{ kc/s} - 100 \mu\text{V/metre} \\ 40-70 \text{ Mc/s} - 50 \mu\text{V/metre} \end{array} \right.$

The committee did not recommend that “manufacturer” requirements should be included in the Regulations for the following reasons. Whether a given motor will cause interference depends on the appliance in which it is incorporated and the use to which the appliance is put. In many cases the cost of suppression is a fairly high proportion of the cost of the appliance. It was estimated that possibly only 15 per cent of motor-driven appliances in use in this country caused serious interference. On balance it was more economic overall to suppress appliances as and when they were found to cause interference. It was, however, suggested that consideration should be given to the question of “manufacturer” Regulations in respect of particular appliances known to be major sources of interference, such as sewing machines and hair-dryers.

Regulations for the control of interference from electric motors, specifying the requirements recommended by the advisory committee, were made in February 1955 and came into force on 1st September of that year. They have certainly assisted the Post Office in dealing with cases of interference from electric-motor appliances, especially where the user has not been too co-operative. They have perhaps also made the public aware of the value of buying “interference-free” appliances and have encouraged manufacturers to incorporate suppression voluntarily in many types of appliances manufactured or to provide facilities for suppressors to be fitted when necessary.

#### CONCLUSIONS

A brief outline has been given of what has been achieved in the control of radio interference by voluntary and legislative action. It has taken a long time to reach the present position but much more remains to be done. The work of the Post Office in tracing and suppressing interference continues at much the same level, although it may have passed its peak, and over the last five or six years the emphasis has swung over from sound broadcasting to television. The work of the B.S.I./I.E.E. and the international committees dealing with radio interference also continues, in particular towards extending upwards the frequency range covered by specifications and codes of practice. Advisory committees have yet to deal with interference from lamps and contact devices and perhaps other classes of apparatus and have to consider the question of manufacturer requirements for electric-motor appliances. They also have to consider whether existing Regulations should be extended to higher frequency ranges.

As broadcasting and other radio services expand and the use of electrical appliances grows, the techniques of radio-interference measurement and suppression to improve the control of radio interference will need to be constantly reviewed. It is unlikely that radio interference will ever be completely suppressed but it may be abated to such a degree that it will seldom merit the adjective “undue.”



# Experiments in Aerial-Cable Construction

J. BLURING, D.F.C., B.Sc., A.M.I.E.E., and H. F. SNOW†

U.D.C. 621.315.17:621.315.24

Rising prices and a continuing demand for telephone service have resulted in a quest for cheaper and better methods of subscribers' distribution, and this article describes several promising new methods of aerial-cable construction which are at present being used or are on extensive field trial. These include self-supporting aerial-cables of several different types and aerial cable that is lashed to a suspension wire in the factory.

## INTRODUCTION

THE high demand for telephone service in recent years and the continued rise in the price of engineering stores and labour has led to a quest for cheaper and, where possible, better methods of subscribers' distribution.

The majority of subscribers' circuits include overhead construction, and this part of the distribution network presents some scope for savings in labour and materials. The problem is to find a method of increasing the circuit capacity of existing light overhead routes at present carrying a few wires without recourse to extensive rebuilding and strengthening or, alternatively, to find a cable system that can be erected with less labour.

One way of dealing with the problem is to increase the circuit capacity of existing overhead pairs by using subscribers' carrier or line connector systems. These systems are usually economical only for the longer routes feeding small isolated communities and in most cases the main need is for the economical provision of extra pairs.

The standard method of aerial-cable construction in the British Post Office (i.e. suspension wire and lead-covered cable lashed together) usually entails a large amount of rebuilding and strengthening of pole routes. It also involves a great deal of labour in erection. It is usually considerably more economical to do this rather than provide an underground distribution system, but further savings can be achieved when it is possible to reduce the amount of rebuilding and strengthening required and the time taken to erect aerial cables.

This article reviews some of the new methods of aerial-cable construction that are at present being used or are on extensive field trial in the British Post Office system.

## METHODS OF REDUCING COST OF CONSTRUCTION

The extensive use and the improvement in the quality of plastic materials in recent years has directed attention to the possibility of their use in aerial-cable manufacture and has thereby provided an opportunity for introducing entirely new methods of construction. The reduction in construction cost can be made firstly by dispensing with a suspension wire and allowing the cable sheath or conductors to provide the strength for suspending the cable, and secondly by reducing the weight and size of cables so that smaller suspension wires can be used. The reduction in size and breaking weight of the suspension wire also allows reductions in the amount of rebuilding and the number and size of stays to be provided. The third way construction costs may be lowered is to avoid

the need for lashing the cable to the suspension wire in the field by having the cable bound to the suspension wire in the factory.

Stainless-steel-sheathed cable that requires no suspension wire is already available and it is not proposed to discuss this cable further as it is a standard method of construction which has been described in a previous article.\* New types of cable that require no suspension wire are the plastic sheathed and insulated self-supporting cables that are discussed in some detail below.

The second method of reducing construction costs has been implemented by the introduction of 4/14 suspension wire (four strands of 14 S.W.G. steel wire), now to be changed to 7/16, and the adoption of polythene-sheathed and insulated underground cable for aerial use. This is also now a standard method of construction and it is not proposed to consider this system in detail.

For the third method of reducing costs, trial lengths of polythene cable, factory lashed to 4/14 suspension wire, have been obtained and details of the trials to date are given below.

## THE NEW TYPES OF CABLE

Experiments have been made with many methods of making aerial cables strong enough to obviate the need for a separate suspension wire. The various methods can be classified into three groups:—

(a) The use of high-strength conductors with comparatively light-weight insulant and sheath.

(b) The incorporation in the sheath of steel wire or toughening materials such as nylon.

(c) The provision of a steel strand in the centre of the core of the cable.

Considering the first group, the materials which can be used for the conductors are limited by the high strength and conductivity required and by economics. The most suitable material to meet all these requirements in the United Kingdom is hard-drawn cadmium-copper, and this is the material chosen for the conductors in the first type of plastic self-supporting cable, which will be called Self-Supporting Plastic Aerial Cable, Type A for the remainder of this article.

With the second group of cables the most satisfactory way to make the core and sheath compact and also light is to use a sheath of plastic material with the strengthening moulded into it. The most economical way to achieve this is to mould the plastic sheath around steel wires as well as the core, and to facilitate jointing and manufacture it is best to bunch the steel wires together rather than spread them round the sheath. The second type of plastic self-supporting cable has been made in this way and will be called Self-Supporting Plastic Aerial Cable, Type B for the remainder of this article.

The third group of cables presents problems in the method of attachment to poles and jointing. If a steel wire is placed in the centre of a conventional sheathed cable, termination of the steel without leaving the core exposed is costly as it is necessary to provide expensive joint boxes in which the steel can be terminated and the cable core sealed. Sealing such a box is difficult if it has

†The authors are, respectively, Executive Engineer and Assistant Engineer, External Plant and Protection Branch, E.-in-C.'s Office.

\*MOFFATT, J. J. Stainless-Steel-Sheathed Aerial Cable. *P.O.E.E.J.*, Vol. 36, p. 107, Jan. 1944.

to cater for different size cables, and leading-out pairs for connexion to open wires further complicate the system. The easiest way to overcome these problems is to dispense with the sheath altogether and make the conductor pairs sufficiently weatherproof and anti-abrasive to withstand the normal handling and weathering which an aerial cable suffers in erection and use. This has been the aim with a third type of self-supporting aerial cable called Self-Supporting Plastic Aerial Cable, Type C in this article, but these measures can only be carried out on the conductor insulants to an extent which will not seriously affect the electrical characteristics of the cable. The problem therefore resolves itself into finding a balance between good electrical characteristics for the cable and a robust weather-proof insulant for the wires.

#### SELF-SUPPORTING PLASTIC AERIAL CABLE, TYPE A

##### *The First Field Trial*

The first length (150 yd) of the Type A cable was erected in an exposed situation in the Guildford Telephone Area in November 1953. The cable core comprises 10 pairs of 20 lb/mile hard-drawn cadmium-copper conductors. Each conductor is insulated with coloured polythene in accordance with a colour scheme for wire and pair identification and is applied with an average thickness of 20 mils and a specified minimum of 15 mils. The insulated wires are twinned into pairs.

Two pairs are stranded with a suitable lay to form the centre of the cable and are covered with a helical lapping of 3 mil polythene tape. The remaining pairs of the cable are stranded over the centre in a single layer of opposite lay to the centre. The layer is covered with 3 mil polythene tape and, finally, two helical lappings of 3 mil aluminium tape. The cable is sheathed with black p.v.c. to an average thickness of 0.10 in. with a minimum thickness of 0.08 in., resulting in an overall diameter of the cable of 0.73 in.

For the design of the suspension system the strength of the cable was taken as the total strength of the conductors. This was justified by the results of tensile tests on the cable which showed that the contribution of sheath and insulant to the breaking weight of the cable was negligible. As with most plastic-insulated cables the diameter is larger than that of the equivalent lead-sheathed paper-core cable. This means that a greater projected area is presented to wind pressure under storm conditions and has the effect of restricting the erection tension in still-air conditions and makes comparatively large dips or sags necessary. The greatest dip that is likely to exist with this cable is 5 ft 2 in. for a 70 yd span at a temperature of 100°F.

Tests carried out in the laboratory showed that the usual form of plate clamp (Bracket No. 23) for terminating the cable was unsatisfactory when a tension approaching that which would occur under storm conditions was applied. This was because insufficient grip could be brought to bear on the conductors through the p.v.c. sheath and polythene wire insulation. A bollard type of support has been designed whereby the grip of the cable around a helix of channel section provides a friction grip sufficient to support and hold the cable against the tensioning (see Fig. 1).

The trial length was erected over two spans with a bollard support at each end and a plate clamp at the intermediate pole. A plate clamp was used to assess the effects of a localized grip on a p.v.c. sheath

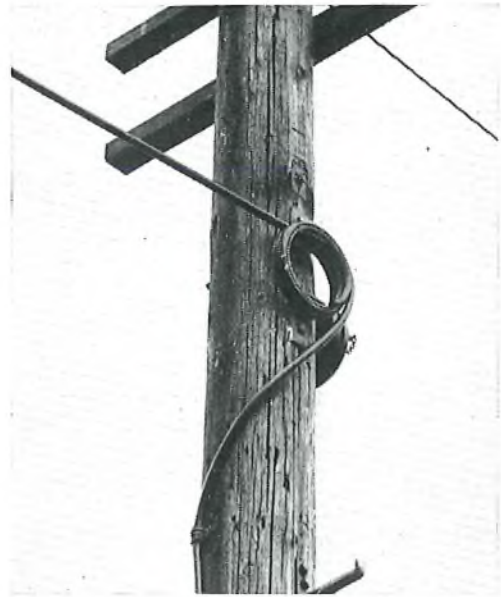

FIG. 1—METHOD OF TERMINATING TYPE A CABLE BY MEANS OF A BOLLARD

and to observe the effects of cold flow of the p.v.c. under pressure.

Erection of the cable was extremely simple. The cable drum was set up in the usual manner and the cable hauled off by hand and laid along the grass verge at the foot of the poles. One end was lifted to the terminating bollard and coiled around the support. The cable at the intermediate pole was similarly lifted and laid over the tubular washer behind the bracket attached to the pole with an arm bolt. At the other end the cable was lifted to the bollard and placed in the channel nearest to the pole; the slack cable was then pulled out by hand.

Tensioning was carried out by temporarily attaching three brackets to the cable on the span but within reach of the pole. The pulling rope was attached to the bracket remote from the tensioning gear and passed over a snatch-block at the head of the pole and thence to the tensioning gear. Tension was applied up to 50 per cent overload and released until the design tension of 200 lb was reached, and the cable was then wound round the terminating bollard and the tensioning gear removed. There was no sign of slipping at the bollard terminal supports although the cable ends were not restrained in any way.

The cable ends were finally secured to the poles with conduit saddles packed with p.v.c. strip, and at the intermediate pole the cable was clamped in the bracket. The pairs of the cable were terminated on terminal blocks in the usual way to facilitate subsequent testing. The condition of the cable to-day after a number of years' exposure is very satisfactory and there is no sign of slipping at the bollards and no damage or stretching of the cable is evident. The rather brutal method of intermediate support was not intended as a standard method of support for this type of cable but rather as an endurance test of sheathing and insulant.

After two years in position the only apparent damage to the cable in this bracket was cold flow; the p.v.c. sheath had taken up the shape of the bracket and flowed out of the longitudinal space between the two bracket plates. A new intermediate support for this cable was



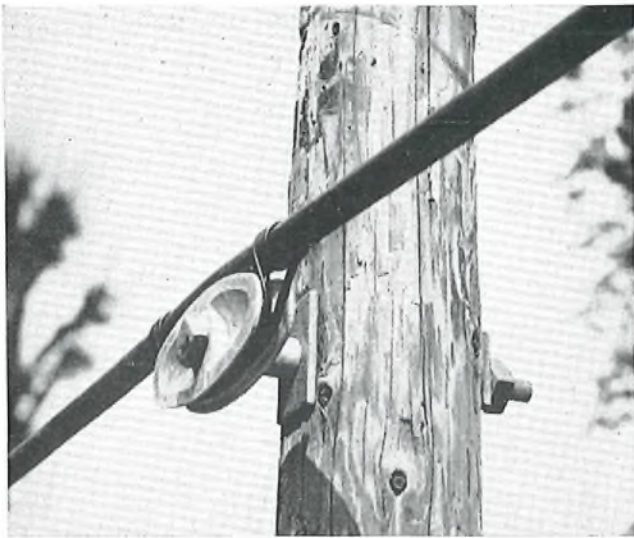

FIG. 2—STRAIGHT-THROUGH SUPPORT FOR TYPE A CABLE

designed and the bracket on the trial length replaced with the new type of support (see Fig. 2). The support consists of a cast light-alloy channel in which the cable can rest with no clamping device. A simple binding prevents any movement of the cable due to vibration, etc. The support can be bolted direct to poles that are in straight sections of the line, and at angles a shackle and eye-bolt allow the channel fitting to assume its natural position under the tension and weight of the cable (see Fig. 3).

#### *Changes in Design of Cable and Supports*

The experience gained in the first field-trial focused attention on the large dips necessary with this type of cable. As a result it was decided to reduce the diameter of the cable as much as possible and the specification was altered accordingly. The sheath thickness was reduced to a minimum of 60 mils and the average insulant on the wires was reduced to 15 mils. These changes reduced the diameter of 10-pair, 20 lb/mile cable from 0.73 in. to 0.53 in., which results in a large reduction in wind loading under storm conditions. The result is that erection tensions in still-air conditions can be increased, with consequent reduction in dips.



FIG. 3—SUPPORT FOR TYPE A CABLE AT ANGLE POLES

It was also decided to try to make the cable suitable for erection at high-voltage power crossings up to 33 kV by suitably modifying the various thicknesses and types of sheath. These experiments were unsuccessful but they did result in a number of odd lengths of cable which could be used for normal construction. Erection of these lengths of cable provided an opportunity for jointing the cable and for terminating two separate lengths on one pole.

The bollard type of termination was used where two cables were attached to the same pole to form a jointing point, and to keep both cables at the same level it was necessary to fix one bollard on each side of the pole. This introduced some difficulty because if one arm-bolt was used for both bollards they could only be set parallel to each other and in every case encountered there was a slight angle at the pole which required that the bollards should be offset from the parallel position. The difficulty was overcome by the use of wedge-shaped packing washers. Later inspection of the poles on which two bollards had been fitted, however, showed that the poles had twisted under the action of the couple applied by the two cables.

Experiments have been carried out with a helical wire support for use in these positions. Steel wires are pre-formed into an elongated helix slightly smaller in diameter than the cable. The two ends of the wire supports are wound on to the cable, leaving a loop to attach to an eye-bolt through the pole. The action of the support is similar to that of the cable grips used for pulling in underground cable, and preliminary indications are that it will meet the requirements of transferring the load to the cable conductors as well as spreading the load over a large sheath area. The disadvantage of these supports is that the helix diameter is rather critical and a support of different size will be required for each cable size; also, attachment is difficult.

A better method, which has been adopted as standard for the present, is to attach two bollards on one side of the pole, one immediately above the other, the upper one being inverted. By taking one length of cable over the lower bollard and the second length under the upper bollard the spans of cable are at the same level for all practical purposes; the difficulties mentioned above are obviated since this method allows the bollards to be offset as necessary at angle poles.

Jointing was carried out by the method normally used for polythene cables, with expanding plug seals, but twisting the hard-drawn cadmium-copper wires was not possible. It was necessary therefore to solder all wire joints, and copper jointing tubes were used to facilitate the work. The joints were fixed to the pole with the expanding plug upwards and the top of the plug was covered with compound to prevent collection of moisture.

A further 200 miles of Type A cable have been purchased for extended field trials. The cable sizes are 10, 15, 20 and 30 pair, all with 20 lb/mile cadmium-copper conductors, and calculations show that the increase of weight and diameter with core size is offset by the additional supporting strength provided by the additional pairs. The erection dips for the various sizes are therefore approximately the same for all cables. The erection tension will of course vary with cable size.

This 200 miles of cable was manufactured with an insulant 15 mils thick, and as a result considerable difficulty was experienced by the manufacturers during the twinning operation. The twisting together of two

insulated wires causes splitting of the polythene in some cases due to the springy nature of the cadmium-copper wire. As a result of this difficulty it will be necessary to revert to a 20 mil thickness of polythene insulant or to use 15 mils of p.v.c. for future orders of this type of cable.

Due to this manufacturing difficulty and the complication of jointing involving the use of jointing tubes, consideration is being given to the possibility of using a Type A cable with annealed conductors, i.e. Polythene Cable, Underground type.

The use of such cable, if it proves practicable, will inevitably lead to some degradation of constructional standards which may be justified in certain circumstances. Some cable of this type has been erected and controlled tests are being carried out.

#### SELF-SUPPORTING PLASTIC AERIAL CABLE, TYPE B

##### *Original Cable and First Trial*

The idea of laying up the steel suspension wire and cable core parallel to each other and moulding a plastic sheath around them was first suggested by the Post Office in 1950. At that time plastics were rather expensive and it was decided that the scheme would not be economical and it was deferred. Later, attempts were made to produce the cable but it was not until 1954 that lengths of suitable telephone cable were made in this way.

The trial lengths of cable consisted of a core of polythene-insulated 10 lb/mile conductors made up in layers and colour coded. A 7/18 steel suspension wire was laid up parallel with the core and a grey p.v.c. sheath extruded around both the suspension wire and the cable. The shape of the cable section is that of an inverted U attached to a circle, the core being centred in the circle and the steel wire in the inverted U (see Fig. 4(a)).

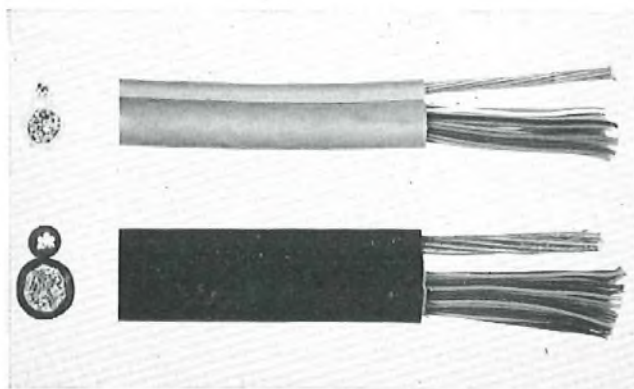

(a) Top—Early Design (b) Bottom—Present Design  
FIG. 4.—SECTIONS OF TYPE B CABLE

The suspension wire was ungalvanized so that it was necessary for all erection fittings to clamp over the p.v.c. covering or for a seal to be made so that no moisture could penetrate to the suspension wire if it was necessary to cut the p.v.c. covering. A cone-type clamp incorporating a seal for the p.v.c. was obtained for terminating the suspension wire, the wire being clamped between the cone-shaped seating and insert of the clamp. The clamp also incorporated an eye for attachment to the pole and a 7/14 steel suspension wire was passed round the pole, through the eye of the clamp, and made off in the standard manner. Intermediate pole fittings were

also obtained for clamping over the sheathed suspension wire.

The first trial length of cable was erected at Derby in the Nottingham Area. It was found that the most satisfactory way to erect the cable was to lay it out along the verge and lift it on to the brackets at each pole. Drawing the cable continuously through cable rollers caused it to twist and it was very difficult to remove these twists before tensioning. At that time every effort was made to avoid twists as they were thought to detract from the appearance of the erected cable. The cone-type clamps were very difficult to fit as the covered suspension wire had to be passed through the p.v.c. sealing gland before being splayed out around the cone-type insert, and one clamp failed after a few weeks' service due to the wire slipping through the clamp. The intermediate clamps also were not particularly successful as they relied entirely upon a groove in the p.v.c. sheath to obtain the grip, although this method of grip enabled them to be fitted without breaking the p.v.c. covering on the suspension wire.

A further length of this trial cable was erected in the Guildford Area and it was decided to terminate the cable by binding the end of the suspension wire round a thimble and then attaching it to the pole by means of a strop of 7/14 wire made off on thimbles, the suspension wire being weatherproofed by the liberal use of paint.

The reason for this change of method was because of the failure in strong wind of the cone-type clamp at Derby. The intermediate clamps on both trials remain as originally fitted but at one severe angle in the Guildford route it was decided to extract the suspension wire from the sheath and clamp it in the normal way with a plate-type clamp as a safety measure, the wire being liberally coated with paint to prevent corrosion.

##### *Specification for Type B Cable*

A specification was prepared for a cable which it was hoped would eliminate all the trouble encountered in the Derby and Guildford trials. The most important feature that needed changing was the method of termination. It was thought that the best way of maintaining the seal over the suspension wire was to design a cable in which the insulated suspension wire could be separated from the cable without breaking the wire or core sheath, enabling the insulated suspension wire to be terminated without exposing the wire. This proved impracticable, however, as tests on a tensile testing machine showed that it was not possible to make a termination on a pole with a p.v.c.-covered steel wire that would stand half the breaking weight of the wire. It was decided therefore to use galvanized steel for the suspension wire so that it could be extracted at terminations without suffering more than normally from atmospheric corrosion.

The shape of the cable was also altered to ensure a better grip over the p.v.c. covering at intermediate poles. The cable was designed so that a section of covered suspension wire and cable core appears as two circles attached along a common chord for a length equal to twice the radial thickness of the sheath (see Fig. 4(b)). The complete cable has a figure-eight section, which makes possible the use of a claw-type grip. The distance between the edges of the claw was made less than the diameter of the suspension wire and there is then no possibility of the suspension wire pulling out of the jaws. The reason why it was decided to use 7/14 steel



suspension wire instead of 4/14 wire was that the larger-diameter wire made bracket tolerances larger. The other main factor influencing this decision was that the Type A cable is suitable for most situations but its main drawback is that very small dips are sometimes necessary but cannot be obtained and it was thought that the Type B cable would be more suitable in these situations if the stronger suspension wire was used, thus permitting much higher tensions with consequent smaller dips.

*Trial of Cable to the New Specification*

It was decided to purchase 200 miles of the Type B cable to the new specification so that extended trials could be carried out in all Regions. The cable has now been issued and lengths have been erected in most Areas. For the first trial it was decided to use a plate clamp designed with a claw grip on straight sections of the route and at angles where the direction of the route changed by up to 35°. At all other points the suspension wire was to be extracted and terminated around the pole. This appeared to be the simplest and cheapest method of erection without any practical experience with the actual cable.

The first length was erected in the Colchester Area by pulling in the cable through snatch blocks and cable rollers and it was evident that it would not be possible to transfer the cable from the rollers to the brackets at large angles without adjustable cable rollers for positioning the cable at the pole. The work of transferring the cable from ordinary cable rollers was much too tedious and difficult with a tensioned 7/14 steel wire to deal with.

The next length, which was erected in the Peterborough Area, was on a very straight route. The cable was erected without difficulty and the whole length of approximately 880 yd was pulled in and tensioned very quickly. Plate clamps (Fig. 5) were used at most poles but at others an eye-bolt shackle and a cast channel support, similar to that used for intermediate pole attachments on Type A cable (Fig. 3), were used because some plate clamps were not available. As a result of these trials it was decided in the future to use a modified Type A cable support at angles where the direction of the route changed by about 5° to 35°. Pulling-in and tensioning is done round the support and the cable is subsequently bound in after terminating. The flexibility

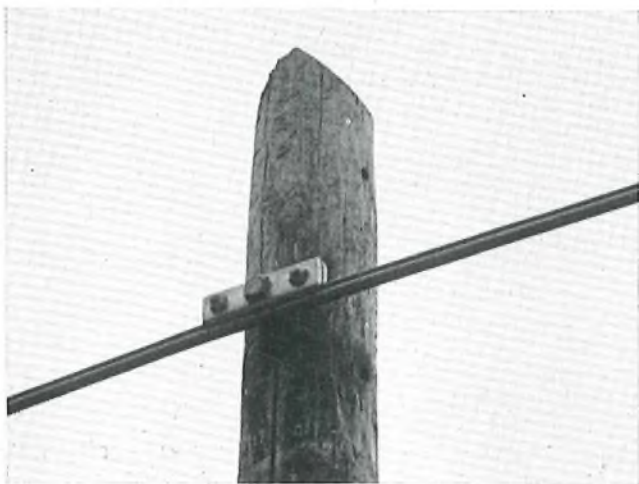

FIG. 5—"STRAIGHT-THROUGH" SUPPORT FOR TYPE B CABLE

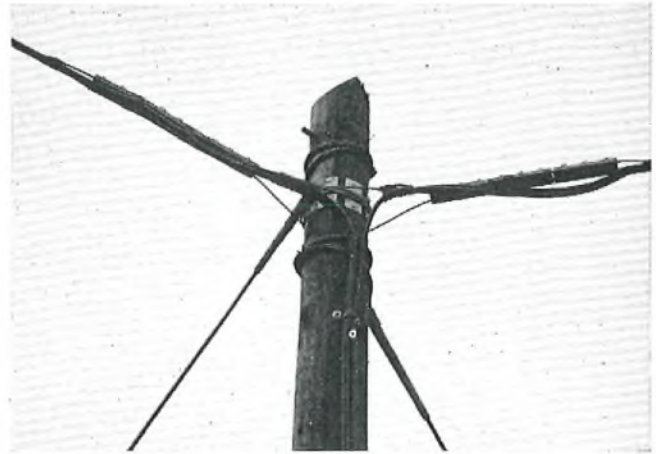

FIG. 6—TERMINATION FOR JOINTING POINT, TYPE B CABLE

afforded by the support mounted on a shackle and eye-bolt allows the cable to take up a resultant position around angles under the forces of tension and gravity.

Fig. 6 shows the method of terminating the cable at a jointing point. Extraction of the suspension wire at terminations is most easily and safely carried out by cutting along the top of the sheath enclosing the suspension wire so that there is no danger of damaging the cable core. It is then only necessary to trim the resulting flanges of p.v.c. around the cable core where it enters the expanding plug joint. The p.v.c. flanges remaining on the cable look quite neat when the cable is attached to the pole and it is safer to leave these flanges attached to the cable rather than try to trim the whole length of cable down the pole. Joints are made as for the Type A cable except that wires may be twisted and do not need soldering.

SELF-SUPPORTING PLASTIC AERIAL CABLE, TYPE C

The Type C cable has a central covered steel wire in the core and no sheath. It was produced by Standard Telephones & Cables, Ltd., for use on all types of circuit, including carrier and other high-grade circuits. When used more generally for subscribers' circuits by the Post Office, it will probably be altered with a view to improving the handling qualities at the expense of degrading some of the electrical characteristics. It consists of a solid steel wire, 0.108 in. in diameter, insulated with 20 mils of black polythene. The conductors are 20 lb/mile annealed copper with a covering of 20 mils of black polythene and a further covering of 10 mils of black p.v.c., the latter giving some anti-abrasive covering and also reducing the change in attenuation between wet and dry conditions. The covered wires are twisted into pairs and the pairs are laid up around the central steel wire, identification being by means of yellow numbers printed on the p.v.c. wire coverings at about 2 in. intervals. One wire only of a pair is numbered for identification of the A and B wires. The cable was obtained in two sizes, the first containing one layer of 6 pairs and the second 16 pairs in two layers, both layers being of the same lay for ease of extraction of the central supporting wire.

*Trial of Type C Cable*

The first trial was carried out at Grantham in the Peterborough Area, and about one mile of the 6-pair cable was erected in a rural situation. Two pairs of the

cable were used for subscribers at points along the route while the rest ran without interruption to the far end of the line and were then connected to an open-wire route.

The cable was attached to the poles by means of brackets shaped like a letter J and attached to the poles by coach screws through the long leg of the bracket. A bolt and plate provided the fixing for the suspension wire on the shorter leg of the bracket (see Fig. 7). Two

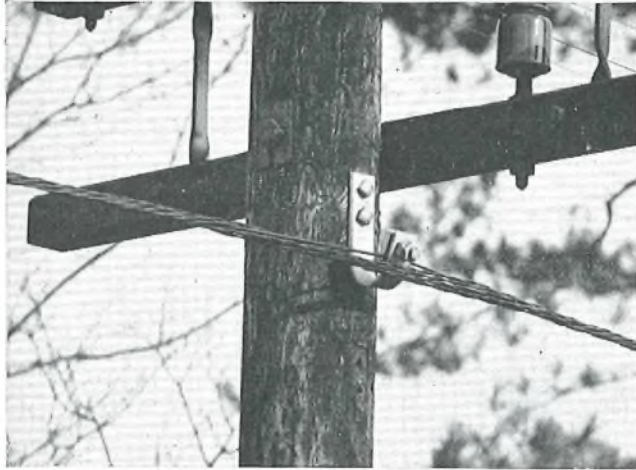

FIG. 7—"J" TYPE INTERMEDIATE SUPPORT FOR TYPE C CABLE

880 yd lengths of the cable were used, the drums being set up at each end of the route and the cable pulled out towards the centre point. The cable was lifted and laid in the bottom of the brackets at each pole as the cable reached it. A length of 880 yd pulled through the brackets quite easily. The two lengths were terminated at the common pole in the centre of the route by making off the steel wire around the pole with U-bolt clamps; each length was then tensioned at the terminal poles at either end of the route. The slack cable was first pulled up by hand and then tensioned by means of a draw-vice. On a subsequent field trial of Type C cable the steel wire was terminated using an experimental plate-type clamp, which is shown in Fig. 8.

The brackets at angle poles were positioned on the outside of the angle so that the cable was not tending to pull the coach screws from the pole. As this method

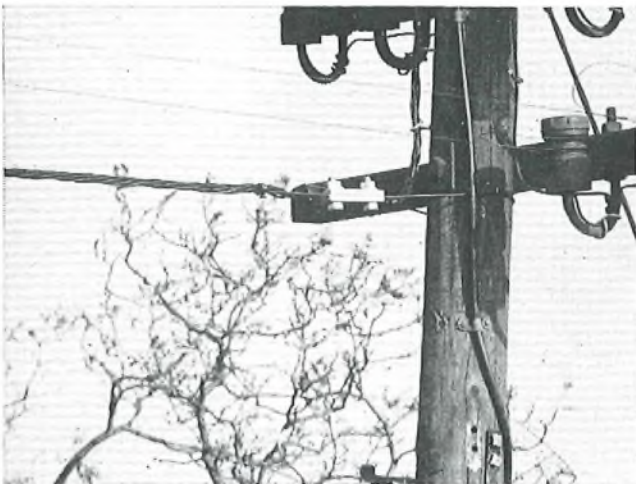

FIG. 8—TERMINATION OF TYPE C CABLE

sometimes introduces difficulties in pulling in the cable, it was decided that in future one fixing hole in all brackets for use at angles is to be made large enough to take an arm bolt so that the brackets can be positioned on the road side of the pole, whatever direction the pull on the cable may be. It was also decided to make the brackets out of transversely curved strip instead of flat strip to ensure that there was no possibility of damage to the cable when it was being pulled in.

No particular difficulties were encountered at Grantham and no special precautions were taken when handling the cable. Before tensioning, the slack cable was pulled out by hand across an arm on each terminal pole. Some damage to the cable was caused by this action but it was not discovered at the time because it was very slight. The normal method would be to use a snatch block on the terminal pole, but as such low erection tensions were involved it was intended to see how quickly and cheaply the cable could be erected. The damage consisted of cracking the p.v.c. and polythene insulant due to the pressure on the corner of the arm. The cracks would probably have gone undetected for years if the wires had been separated by a reasonable air gap. Corrosion occurred, however, between wires due to electrolytic action when the cable became wet and a disconnection fault brought the damage to light. This fault focused attention on the desirability or otherwise of the double insulant on the conductors. It is thought that the good electrical characteristics of the cable can be sacrificed to some extent in an effort to make a more robust cable. The use of two different thin coverings for each wire does not assist in providing mechanical strength and a cable has been obtained with a single covering of 30 mils of polythene only for each wire. While this will provide better electrical characteristics than a 30 mil p.v.c. insulant it has the disadvantage that polythene cannot be numbered.

The pairs of the cable were fanned out and taken direct to the terminating insulators for connexion to the open-wire circuits. The two circuits used for subscribers along the cable route were cut and connected to a 2-pair terminal block attached to the pole; from there to the house connexion was by drop-wire with drop-wire clamps on a house fixture. If open-wire leads had been used for these subscribers the intercepted cable pairs could have been taken direct to the terminating insulators. This procedure necessitates intercepting the pair a yard or more out in the span, then drawing back the pair for terminating in the insulators. To a lesser extent the same procedure is necessary for terminal blocks, with the consequent drawback that a length of 1-pair cable has to be joined to the back end of the cable pair if it is necessary to use it (e.g. for shared service). The final method of dealing with minor points like this will be decided after more extensive trials.

Joining between cable lengths at Grantham was carried out by twisting the conductors and taping them. This is a rather tedious process and a joint made in a similar manner to that employed in underground-distribution cross-connexion pillars and covered by a sleeve has been evolved. The taping method will no doubt be more economical, equally efficient and no more prone to faults than the new joints and, whilst it is perhaps not of very workmanlike appearance or the quickest job, it has its merits. The sleeved joint mentioned above will be much better for maintenance and testing purposes, however, and it has been used for the



trial of the 16-pair cable. When the trials are completed, and if large-scale purchase of the cable is to be made, the method of jointing to be used can be decided, but preliminary indications are that a sleeved joint will be chosen because of its greater flexibility in use.

The trial of the 16-pair cable was carried out in the Colchester Area. "J"-type brackets were ordered for use at intermediate poles and the order specified both the short and long legs of the bracket to be vertical, but due to a misunderstanding brackets similar to those used on the 6-pair cable were delivered and in these the short leg is set at an angle to the vertical. It was found that the cable was inclined to ride up the brackets during pulling in of the cable.

Some difficulty was found in extracting the suspension wire from the 16-pair two-layer cable; the use of wooden wedges solved the problem but using these there is a possibility of damage to the insulant.

Jointing was carried out by the use of terminal strips housed in a jointing sleeve. Individual subscriber's spurs were connected to the main cable by 1-pair leading-in cable joined by means of metal connectors on the lines of power line "line taps." The connectors used were rather large and for future work a smaller and, possibly, insulated type will be obtained.

Termination of the suspension wire was carried out in the normal way by taking it around the pole. A cone-type clamp has been designed for this type of suspension wire, and it will considerably simplify future jobs.

#### *The Future of Type C Cable*

A cost comparison for the Grantham route between using 6-pair Type C cable and using conventional open wires has been made. Allowing annual charges for maintenance of the cable as if it were normal aerial cable the two types work out at almost the same cost. The 16-pair cable will not show economic advantages, however, except where all the 16 pairs can be connected to subscribers within a short distance, and in these cases ring-type distribution points are preferable in urban areas. The cost comparison was based on the price of Type C cable when ordered in a very short length, and it is hoped that some reduction will be possible on large orders. Another point in favour of the cable is that the waste copper for back ends which has been included in the cost can be used for shared-service lines at a later date. The increasing demand for shared-service lines does suggest that the waste copper may not be so great on the average route as it was in the case considered when making the comparison. The lower maintenance costs expected and the decreased possibility of interruptions due to storms, which cause such havoc on rural open-wire lines, indicate that there is a considerable future for this cable. A much more robust insulant for the wires must first be found, however, and the first step has been to obtain cable with the wires covered in polythene only. Erection of this special length will be watched for its handling qualities, and a length with 30-mil high-density polythene insulant is also to be erected before there is any extension of the use of this cable.

#### FACTORY-LASHED POLYTHENE AERIAL CABLE

Consideration has been given to the modification of the present standard method of aerial-cable construction with a view to reducing erection time and eliminating some of the costs that arise with this type of construction.

The labour time which causes most comment is that for transferring the lashing machine to a new span and changing the wire spool. Other costs that are incurred on field lashing of cables are as follows:

(a) The cost of buying and maintaining lashing machines which, though very small compared with the cost of cable, is a consideration.

(b) The supply of suitably wound coils of lashing wire has always been difficult. The main cause of difficulty has been the supply of heavily galvanized steel wire, and the shortage of this wire has been overcome in various ways, the best substitute being p.v.c.-covered copper or steel wire. The covered wire costs more than the standard lashing wire but can usually be obtained without difficulty.

Lashing cable to a suspension wire in the factory offers a method of eliminating the difficulties experienced with field lashing. An attempt was made by the Post Office in 1934 to erect lead cable bound in the factory to a 7/14 steel suspension wire by means of a metal tape. The experiment was unsuccessful, however, because the lashing became loose when the cable was removed from the drum. The cable was also very awkward to handle because of its weight, and the tensions required for erection were high.

The advent of polythene cable offered a better chance of success and 10 miles of polythene cable were ordered in various sizes bound to a 4/14 suspension wire with p.v.c.-covered steel wire at 15 in. lay. It was decided to erect the cable, using the same type of fittings as for Type B cable at angle positions. No difficulty was expected in erecting the cable but the question of slackening of the lashing wire remained to be settled.

The first trial length was erected at Ashford in the Canterbury Area, and while the lashing wire remained reasonably tight it was found that as the cable came off the drum it bulged out at intervals between turns of the lashing wire. The complete length of 800 yd was laid out along the road and the loops appeared at irregular intervals along the whole length. Various methods of taking the cable off the drum were tried in an endeavour to smooth out the cable loops but all attempts were unsuccessful. The whole length of cable was then laid out along the road and the loops were worked out from the centre to the ends of the suspension wire, and the cable was then found to be 12 ft longer than the suspension wire.

The factory lashing had been carried out by passing the cable and suspension wire through a stranding machine with a bobbin of lashing wire turning round it on one of the heads. The cable and wire were pulled through the machine by passing them round a capstan of approximately 6 ft diameter. It was thought that additional cable had been pulled through by this method as the mean diameter of the loops of cable round the capstan was greater than that of the loops of suspension wire.

The manufacturer was consulted and agreed after seeing the erection of some of the cable at Newport in the Cardiff Area that the above explanation was reasonable. In order to eliminate this fault it was necessary to bind the suspension wire and cable sufficiently tightly together before they reached the capstan so that no relative slip could occur. The use of a caterpillar capstan would eliminate the trouble, but machines with this type of capstan are comparatively rare at present, and a method was needed which could be used on machines

with the wheel-type capstan. Reduction in the lay of the lashing wire from the agreed 15 in. would probably overcome the trouble but it would not be a very satisfactory solution as it would mean cutting the lashing wire where the cable is attached to pole brackets. It was decided therefore to increase the distance between the lashing head and the capstan on the machine, thereby increasing the friction between wire and cable. By using the head at the end of the machine remote from the capstan, approximately 18 ft of bound cable and suspension wire was obtainable in the straight run before it turned on the capstan. In addition, slight tension was applied to the cable supply drum and none to the suspension wire drum. These changes resulted in a perfectly "dead" cable and there was no tendency for the suspension wire or the cable to take control, the whole assembly being limp as it was wound off the drum.

The remainder of the length used at Newport was re-lashed by the new method and erected. The erection was simple, using the angle fittings described for Type B cable and plate clamps at straight positions, and no difficulty was experienced in putting the suspension wire into the plate clamps. It was decided then to re-lash the remainder of the 10 miles of cable, keeping a 15 in. lay and watching the erection carefully. The resulting cables were, however, rather disappointing.

#### CONCLUSIONS

One problem that has arisen with plastic aerial cable is that of "dancing" in winds of about 30 miles per hour. The term "dancing" is used to describe the vibration of the cable at a frequency of 0.5 to 4 c/s and amplitudes of from 1 to 5 ft in a 60 yd span. The usual mode of vibration is for a complete wave or half-wave to occur in the span, and the energy involved can be very large. Dancing has occurred on polythene cable lashed to a suspension wire and on the Type B self-supporting cable. No reports have been received of the phenomenon occurring in Type A and Type C cables.

Investigations indicate that the non-circular section of the "dancing" cable is a contributory factor, as the cable acts as an aerofoil and receives lift and drag forces from the wind. Various cases of dancing have occurred on hydro-electric lines in other countries and in these it was usually found that ice had modified the circular cross-section of the cables.

With Post Office self-supporting cables the theory is partially justified by the fact that Type A cable, which is circular in section, has not danced. Only small amounts of this cable have been used, however, and only the trial length on the Hog's Back, near Guildford, is really in an exposed position. With Type B cable considerable success in preventing dancing has been achieved by inserting six complete twists in the cable within a span.

Experiments to find the cause and so prevent dancing are proceeding but practical tests are at the whim of the prevailing weather conditions. Wind-tunnel tests have been carried out at the Royal Aircraft Establishment, Farnborough, but the problems posed in using scale models have limited the usefulness of the results.

The application of plastics as an insulant and as a sheathing material for telephone aerial cables is still very much in the experimental stage in spite of the great progress that has been made to date. The future pattern of aerial-cable construction envisaged is still rather

obscure. The field staffs have shown that with little experience, using the special fittings designed for the purpose, plastic aerial cables can be erected much more rapidly than lead cables. Unfortunately, the savings in time are offset by the relatively high price of plastic-type cables.

It seems therefore that the type of cable that finally emerges as a result of the trials described, and which might be considered a "standard" aerial cable, will be dictated by economic considerations and its performance, i.e. aerodynamic stability.

The authors at present visualize that where aerial cable is used in future by the British Post Office for subscribers' lines the cable will be of the self-supporting type. Remote distribution points at present fed by lead-covered or polythene cable, lashed in the field to a suspension wire, will be fed by a stainless-steel-sheathed aerial cable or self-supporting aerial cable, Type A or B. Stainless-steel-sheathed cable will be used where gunshot or other damage to plastic cable is likely, and elsewhere self-supporting plastic aerial cables will generally be used.

The route strengthening required for each of the cables varies very little and the cheapest cable will usually be chosen as erection time is substantially the same for each cable. The cost comparisons made to date show that overall the Type B cable is the most economical and it is to be introduced as standard for the present and will replace all field-lashed cables; this will not, however, preclude the use of Type A cable should economic or other conditions change. Further slight economies have been made in the Type B cable by reducing the size of the suspension wire incorporated in the cable from 7/14 to 7/16 and by specifying the reduced thickness of insulants now standard for polythene cables.

Type B cable will be suitable for use at low-voltage power crossings provided that the sheath of the suspension wire has not been removed for terminating purposes at either side of the crossing; otherwise the terminating pole must be isolated by means of insulators in the suspension wire. Similar arrangements will be necessary where the cable is terminated on poles used on a "joint-user" basis.

The final network of cables to feed subscribers' distribution points can be improved by the use of a cable similar to the Type C cable described above. It offers many of the advantages of aerial cable together with the flexibility of use of open-wire lines.

The new types of aerial cable described in this article can only be introduced gradually and a lot of experimental work remains to be done, especially on the Type C cable. The rate of introduction will be largely controlled by the money available for capital development but the experimental work described does suggest the beginning of a new era in Post Office overhead distribution which will enable the available money to be used to greater advantage and will reduce maintenance costs in the future.

#### ACKNOWLEDGEMENT

The authors wish to acknowledge the co-operation and assistance of their colleagues in the Test and Inspection Branch of the Engineer-in-Chief's Office and in the Regions and Telephone Areas where the trials were carried out.



# Equipment for Training Letter-Sorting-Machine Operators

G. A. WYLIE, B.Sc.(Eng.), A.M.I.E.E.†

U.D.C. 331.053:681.178

Single-operator letter-sorting machines are being installed at a number of offices. This article describes the methods of training the machine operators and gives details of the equipments developed for use as training aids.

## INTRODUCTION

A COROLLARY of the introduction of letter-sorting machines into sorting offices is a need for training operators to use them. This article describes the methods of training letter-sorting-machine operators and the equipment used as training aids.

The letter-sorting machines coming into use at the present time are all single-operator machines<sup>1</sup> having a maximum of 144 destination boxes to which mail can be directed by the operation of a keyboard having 24 selection keys and two special-purpose keys. A photograph of such a keyboard, forming part of a training desk, is given in Fig. 1. The 24 selection keys are arranged

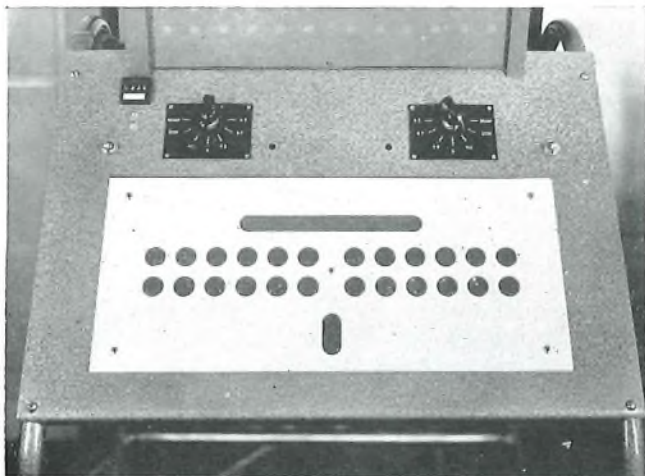

FIG. 1—LETTER-SORTING-MACHINE KEYBOARD FORMING PART OF A TRAINING DESK

in two groups of 12, one group being under the control of the operator's left hand and the other under the control of his right hand. All the 144 selections are obtained by the operator pressing one left-hand key together with one right-hand key.

The special-purpose keys are the "Transport" key and the "Cancel" key. The Transport key is thumb-operated and may be used by the operator to direct any mail that he is unable to sort into a special box for later treatment. The Cancel key enables the operator to cancel an incorrect keying.

From the foregoing it is clear that the main task in training operators is to teach them the correlation between the keys and the 144 destination boxes of the letter-sorting machine. There have been two main approaches to this problem. Firstly by the use of "codes" and more recently by the use of "patterns". The present system of training is based upon the latter method, which will be dealt with at length later in the article. The code system is briefly described below.

## CODE SYSTEM

The code system was used for training seven operators from Bath sorting office prior to the introduction there of the prototype single-operator letter-sorting machine.<sup>2</sup> With this system the letters of the alphabet were allocated to each set of 12 keys as shown below:

A	B	CD	EF	GH	IJK
L	MN	OPQR	S	W	TUVXYZ

Codes were then invented for the (then) 120 selections available to the operator, the codes having as far as possible a logical connexion with a place name, e.g.

code for Guildford—GD

code for Bournemouth—BO

Clearly a number of illogical codes was unavoidable using this method, but by using these for selections having a large amount of traffic this was not a great disadvantage; the logical codes served as a memory aid for the less frequently used selections.

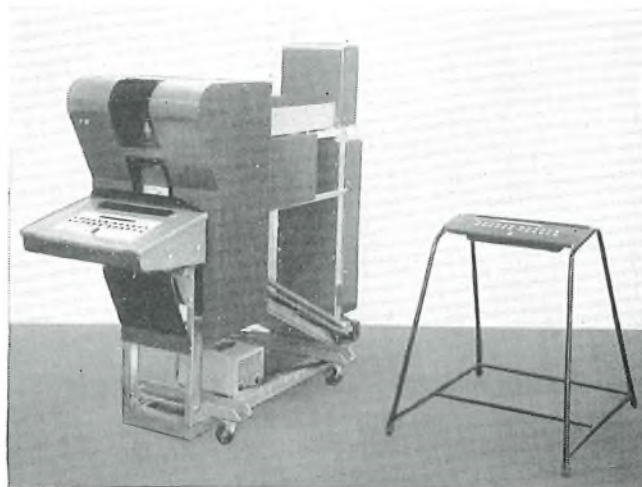

FIG. 2—CARD TRAINER AND DUMMY KEYBOARD

The training of operators by this method was carried out as follows:

(a) The operators were first taught the codes of place names.

(b) The letter designations of the keys were taught.

(c) Stages (a) and (b) above were correlated by the use of "dummy" keyboards, with the instructor calling out place names and the operators pressing the appropriate keys. A dummy keyboard of the type used is shown on the right in Fig. 2.

(d) The operators practised individually on a "card trainer".

The card trainer is a device which simulates, to a large degree, the letter-presentation system of the letter-

† Executive Engineer, Power Branch, E.-in-C.'s Office.

<sup>1</sup> LANGTON, H. J. A Single-Operator Letter-Sorting Machine Part 2—The Production Machine and Future Development. *P.O.E.E.J.*, Vol. 51, p. 188, Oct. 1958.

<sup>2</sup> COPPING, G. P. A Single-Operator Letter-Sorting Machine Part 1—Introduction and the Experimental Machine. *P.O.E.E.J.*, Vol. 51, p. 104, July 1958.

sorting machine. It includes a stack of notched cards upon which are written addresses that are presented in turn to the operator. The correct operation of the keyboard of the card trainer causes the card previously in the operator's view to be replaced by a second card, the first card being restacked out of the operator's view. In the event of an incorrect keying an alarm lamp glows and the card is held stationary. The operation of a press-button causes the error to be recorded and also illuminates a label indicating the correct key combination for the card in the viewing window. The card trainer is shown on the left in Fig. 2.

Using the dummy keyboards and the card trainer, operators from Bath sorting office trained full-time for five weeks, by which time they had achieved a keying rate, with accuracy, of about 45 letters per minute on the card trainer, and were capable of sorting on the letter-sorting machine at about 30 letters per minute; the reduction in keying speed on transfer from the trainer to the letter-sorting machine was anticipated.

Whilst the card trainer was an excellent device, its cost was such that it was impractical to provide one for each trainee and it became necessary to design and build a training aid which would be cheap enough to provide on this basis.

#### EQUIPMENT FOR CODELESS TRAINING

The system decided upon relies on the operator learning the correct keyboard operation for each destination-box selection by observing the patterns set up on a lamp display relating destination names with selection keys. During use the lamp appropriate to the required destination-box selection glows, together with the lamps associated with the keys necessary to be depressed to obtain the selection; the key lamps are arranged below the destination names and have the same spatial relationship as the operators' keys. A training desk is shown on the left in Fig. 3.

Clearly with a device of this nature, provided on the basis of one per operator, it was possible to teach operators the key combinations without reference to codes, the operators learning the keying patterns directly from the display.

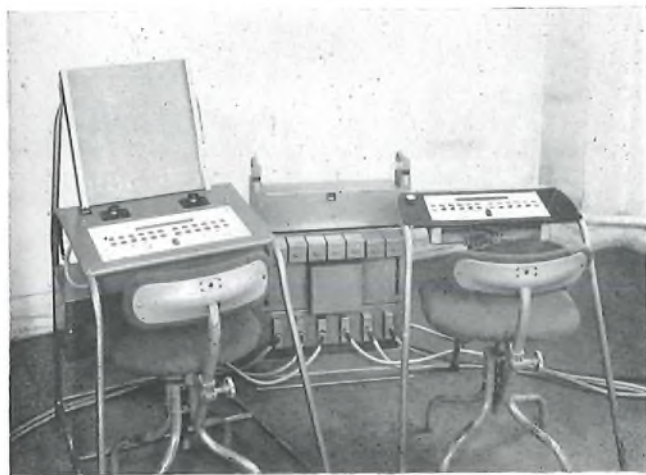

FIG. 3—OPERATOR-TRAINING DESK WITH GROUPING UNIT AND MASTER KEYBOARD

#### Requirements for the Training Equipment

The requirements for the training equipment were as follows:

(a) The area of the lamp display should be as small as possible to avoid operator fatigue.

(b) Upon depression of the correct pair of keys, as indicated by the key lamps, the display should be extinguished and a further display established.

(c) The depression of incorrect keys should have no effect.

(d) The presentation of displays should be in an apparently random order to prevent the operator from tending to learn keying sequences rather than individual keying patterns.

(e) It should be possible to limit the destination names displayed to cover selected groups of keys so that a knowledge of the whole keyboard can be built up in easy stages without frustration to the operator.

(f) It should be possible for one of a number of trainees (or the instructor) to be able to transmit selected keying patterns to a group of trainees from a master position.

In addition to the above requirements, it was decided to offer any other facility that could be provided at little additional cost and which would give trainees alternative tasks to relieve boredom. Two such facilities have been provided. Firstly the equipment has been arranged to work in "reverse", i.e. upon depression of a pair of keys, the appropriate destination name and the appropriate key lamps are illuminated. Apart from the change of task for the operator, it was thought that this facility might be useful during the initial training period for giving fingering practice with the psychological advantage of having "something happen" at each keying. The second additional feature provided allows all the trainees' positions to be linked to one automatic control, the display changing only after all operators have keyed correctly. This latter facility was provided purely as a change of task for the operators and was not considered to have any direct training value.

#### Display Panel

In order to contain the 144 lamps of the destination-name display in as small a space as possible use was made of festoon (trafficator) lamps, which were small enough and of the right shape to illuminate a rectangle measuring  $1\frac{1}{2}$  in.  $\times$   $\frac{1}{2}$  in. and to be completely contained in a box of this size. This size of rectangle was sufficiently large for all destination names, the boxes around the lamps being built up egg-box fashion in 18 horizontal rows of eight per row, using Tufnol for both the base and the "egg box". The boxing-in of lamps was necessary to prevent the partial illumination of adjacent destination names.

The key-lamp display was provided below the destination-name display using P.O. Lamps No. 2. Here the main consideration was that the lamp should have the same spatial relationship as the 24 keys on the letter-sorting-machine keyboard.

The complete display is  $12\frac{1}{2}$  in. wide by 14 in. high and is covered by a removable "display sandwich". The latter consists of a sheet of clear Perspex placed adjacent to the display lamps, a negative transparency containing all the destination names, a sheet of tracing paper and finally a covering sheet of green tinted Perspex. With this arrangement the destination names are visible only when illuminated from behind and the light from



the destination lamps is adequately diffused. A hinged flap is provided to enable the key lamps to be covered when the operator has learned the keying patterns.

The wiring of the display lamps is a compromise between the conflicting requirements that there should not be an obvious spatial relationship between the keying patterns and the destination names and that the arrangement of lamps and keys should be such as to allow a large amount of commoning of connexions.

The destination lamps are arranged electrically in a  $12 \times 12$  matrix, there being a rectifier in series with each lamp. The lamps chosen are rated at 12 volts,  $\frac{1}{4}$  amp, because this rating allows some economy in rectifier design.

### Control Equipment

With the exception of the rectifier units all the equipment for controlling up to seven training desks is mounted on a separate rack; 33-way cables with plug connexions connect the control equipment to the training desks.

The apparently random order of displaying the 144 selections is achieved by using a pair of uniselectors for each training desk, one uniselector being associated with the 12 left-hand keys and the other selector being associated with the 12 right-hand keys. To ensure that all of the 144 selections are displayed a spare arc on the "left-hand" uniselector is used to give this selector an additional step on every 25th step, thus continually altering the phase relationship between the two uniselectors and thereby presenting 144 selections in a series of  $25 \times 24 = 600$ . This effectively meets the requirement that the selections should be displayed in an apparently random order.

To limit the selections presented to the trainee so as to require the operation of selected groups of keys only, an additional uniselector arc (for each half of the keyboard) is used for each of the groups chosen, the keyboard being divided up on each side as shown below.

GROUP 1 (H)	GROUP 2 (4B)
O O O O O O	O X X X X O
O X X X X O	O O O O O O
GROUP 3 (6F)	GROUP 4 (6B)
O O O O O O	X X X X X X
X X X X X X	O O O O O O

The selected keys are marked X and the lettering of the groups corresponds to the indication on the rotary-switch mounted on the training positions (see Fig. 1). The significance of the lettering is as follows:

(H)—"Home" keys—These are the keys upon which the operator's fingers normally rest between keying operations.

(4B)—Centre back-row keys.

(6F)—6 front-row keys.

(6B)—6 back-row keys.

In addition to the above sub-division of the keyboard, it is possible to set the left- or right-hand part of the pattern in any required position. Thus, for example, at the start of training the training desk may be switched to allow training on patterns requiring the operation of the same left-hand group 1 key, thus limiting the cycle to only four selections. All 16 selections of group 1 left-hand against group 1 right-hand may thus be learned

four at a time and then, by switching to group 1 left-hand with group 1 right-hand, the 16 selections may be presented. Similarly a knowledge of the 144 keying patterns may be built up by learning in increments.

It should be noted that when the equipment is set to a single key position on either hand, the sequence is reduced from 600 to 24 or 25. However, as the time taken to learn the few patterns resulting from setting up in this way is comparatively short, the operators are not expected to become aware of the cyclic order of presentation.

The facility of allowing one of the trainees to transmit keying patterns to the remainder of the group (termed "group manual") is provided by means of 24 relays each with eight contacts controlled by a "master" keyboard. By this means a maximum number of seven displays can be provided; the eighth contact on the relay is used for self-locking.

From a postal point of view seven is a convenient number of people to train. Thus seven training desks were manufactured and these, with their common control system, were used at Southampton sorting office to train two groups of seven operators for the prototype letter-sorting machine; seven operators were trained for the inward-sorting plan and seven for the outward-sorting plan. A change from one mode of sorting to another mode of sorting is made merely by changing the "display sandwich".

To familiarize the sorters with the addresses within sorting selections, e.g. the streets in postman's walk No. 40, subsidiary "display sandwiches" were also provided which indicated the addresses within the basic sorting selections. This was particularly necessary for inward sorting, because all the trainees lacked previous experience of sorting to all the postman's walks catered for by the letter-sorting machine.

The training of each group of operators took about five weeks full-time including, after the first two weeks, some time in practising on the letter-sorting machine. Use was made of the facilities both for individual working under the control of uniselectors and for group working under the control of a master keyboard; the latter facility was used frequently both as a change of task and in order to consolidate the work already learned; it also allowed concentration on those selections with which trainees were having difficulty.

### NEW TRAINING EQUIPMENT

After the experience of training operators for the prototype letter-sorting machine it was agreed to use the same system for training operators for the production models. As it was then envisaged that 35 additional training desks would be required (subsequently reduced to 28), the circuit arrangement was reconsidered with a view to economy. Additionally it was required that each training desk should be self-contained so that a single training desk could be left in an office to allow more staff to be trained at a later date should that be necessary.

It was decided, however, that the only facilities required were the individual-working facility (each operator working on his own with automatic control from uniselectors) and the group-manual facility (one operator, or the instructor, setting up patterns for the other trainees to key).

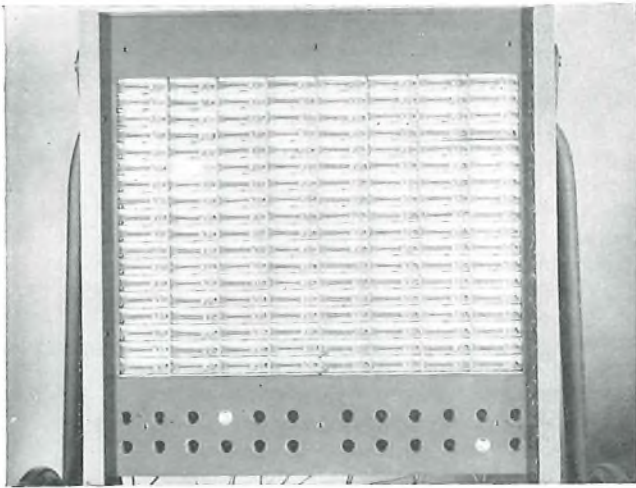

FIG. 4—FRONT OF DISPLAY PANEL WITH DISPLAY SANDWICH REMOVED

### Display Panel

The major design change was the use of neon lamps for the displays rather than filament lamps. This eliminated the need for the 144 rectifier units and also considerably reduced the number of wiring leads required.

Hivac Type 17L neon lamps were used which are wire-ended and which have two identical electrodes extending almost the full length of the envelope; the envelope is similar in size to a switchboard lamp (P.O. No. 2). For the neon display a d.c. supply of about

120 volts is necessary, this giving adequate margin for "striking" the lamps (nominal striking voltage 70).

For ease of wiring the strips forming the horizontal edges of the "egg box" were made of brass so that direct connexion of one of the neon lamp leads could be made to this, the other connexion being brought through the panel to vertical commoning strips. The front of a display panel is shown in Fig. 4.

The sequential display of the 600 keying patterns is again accomplished using two uniselectors for each training desk. A half-wave-rectified 130-volt low-current power supply is provided for each desk, which is adequate for the display lamps. The uniselector stepping is accomplished by allowing 50-microfarad capacitors to charge up from this low-current source during the keying interval; upon keying the capacitors are discharged through the uniselector coils to step the uniselectors. By this means the provision for a 50-volt d.c. supply for uniselector operation is avoided.

The illumination provided by the neon lamps, when operating at their full rated-current, was rather less than was desired, in spite of the fact that the "display sandwich" was modified to use an orange Perspex in place of the green Perspex previously used with the filament lamps. The lamps are arranged therefore to be run at about  $2\frac{1}{2}$  times their full rated-current when first struck and for the current to be reduced to the full rated-value after an interval of about 3 seconds. It was considered that this would give the operators ample time to read the destination name before dimming and yet ensure an adequate life for the lamps.

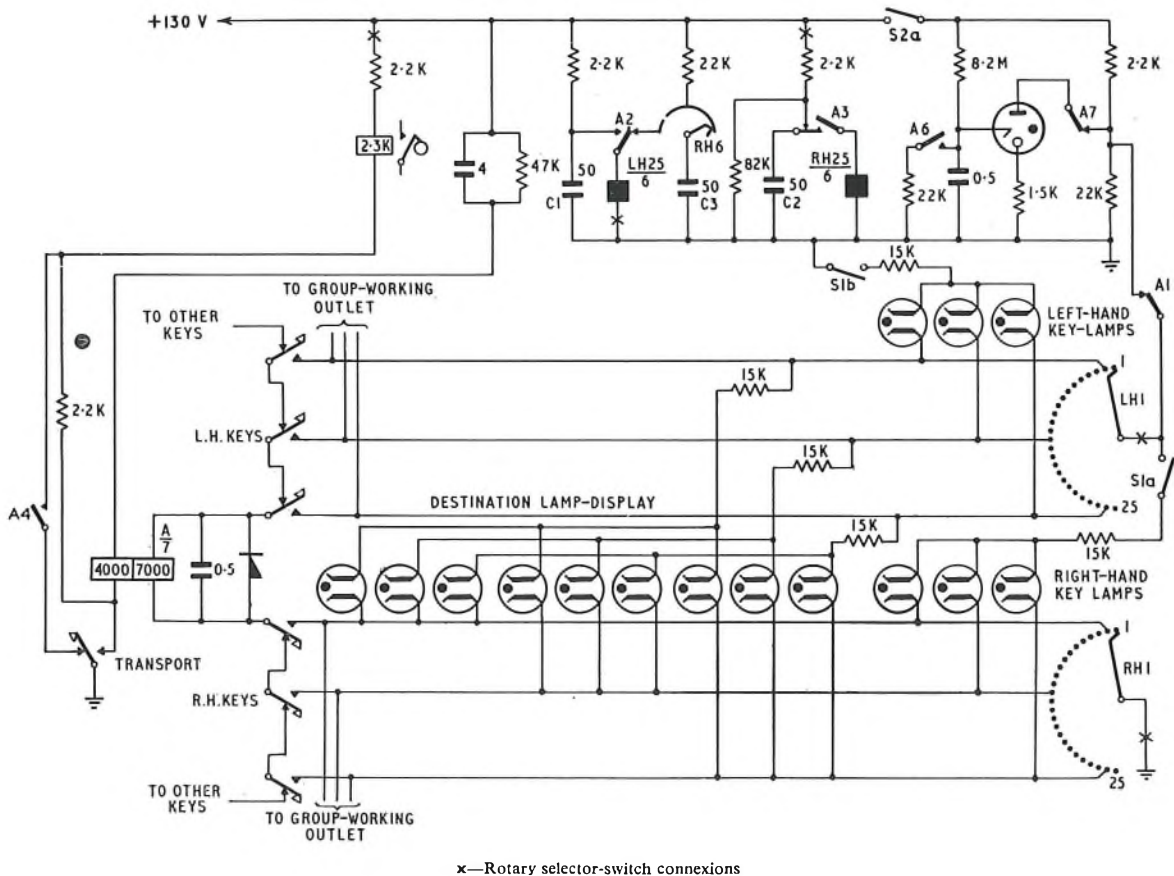

FIG. 5—OUTLINE CIRCUIT OF OPERATOR-TRAINING DESK



The dimming of the lamps is accomplished in effect by degrading the regulation of the supply to the neons, the lamps being supplied via a resistor in the anode circuit of a cold-cathode discharge tube. The triggering of this tube is controlled by a time-constant circuit, which resets at each keying operation. With a slow rate of keying a lamp will appear bright, then dimly glowing and finally it will be extinguished when the operator keys. However, if an operator keys faster than about 20 operations per minute, the time interval is too short for the lamps to be dimmed.

At the time of writing the equipment has been in use for about six months and to date no lamp failures have been reported in spite of the fact that they are over-run. This confirms the results of life tests made on these neon lamps at the design stage.

### Control Equipment

An outline circuit of the training desk is given in Fig. 5. For clarity only 9 of the 144 destination display lamps are shown (in a 3 × 3 matrix); the rotary selector-switch connexions are omitted and only one uniselector arc for each side of the keyboard is shown.

Battery and earth are fed from the left-hand and right-hand uniselectors respectively to a "row" and "column" of the destination display lamp matrix to strike the appropriate key lamps and the appropriate destination lamp.

The operation of the pair of keys corresponding to the display operates the A relay by connecting its coil between the "energized" row and column of the display matrix. Relay contacts A2 and A3 discharge capacitors C1 and C2 through the left-hand and right-hand uniselector coils respectively, thus advancing each uniselector one step, and consequently changing the display.

When the right-hand uniselector reaches the 25th step, capacitor C3 discharges via contact A2 through the drive-magnet coil to give the uniselector one additional step. In this manner the phase relationship between the two uniselectors is changed every half-revolution and complete coverage of the 144 destination displays is obtained.

It will be seen that an exchange-type meter is included in the circuit so as to count the number of correct keyings but not to operate when the Transport key is used.

The capacitor (4 microfarads) in the A relay coil circuit serves two purposes. Its primary function is to pulse operate the A relay upon operation of the Transport key, and its secondary purpose is to hold the relay operated for a brief period after the stepping of the uniselectors has disconnected its operating circuit. It is necessary to pulse operate the A relay for two reasons:

(a) If the A relay were held operated during the whole time that the Transport key was held down, the keying speed would be reduced considerably because whilst the A relay is operated the uniselector-operating capacitors cannot recharge.

(b) If the A relay were held operated the power unit and charging resistors would be overloaded.

The rectifier and capacitor across the A relay coil are provided to prevent the flashing of the neon lamps by the back e.m.f. from the coil.

To avoid the need for two wafers on each of the rotary switches, it was necessary for the right-hand uniselector coil to be switched in the earth line, and for the left-hand uniselector coil to be switched in the h.t.

line, when it was required to prevent the right-hand or left-hand part of the keying pattern from changing. To set one side of the key-lamp display in a particular fixed position, the rotary switch is operated to the "ALL" position. The transport key is then operated until the required key-lamp glows, when the rotary switch is turned to the "OFF" position. In the case of the right-hand rotary switch, switching to "OFF" leaves the uniselector stepping circuit undisturbed apart from the charging supply to the capacitor, which is disconnected, and thus it is necessary for capacitor C2 to be sufficiently discharged before the next keying operation to prevent the uniselector stepping. The 82,000-ohm resistor across the capacitor accomplishes this discharge in a reasonable time without significantly reducing (due to its potentiometer action) the voltage to which the capacitor may charge during normal working.

Switch S1 disconnects the supply to the key-lamp display; an inherent advantage of using neon lamps in place of filament lamps for this display is that only a double-pole switch is required to switch off the two sets of 12 lamps; in the earlier equipment using filament lamps a cover for the key-lamp display was provided in order to avoid the use of a 24-pole switch.

For group-manual working a separate "grouping unit" (Fig. 6) is provided together with an associated

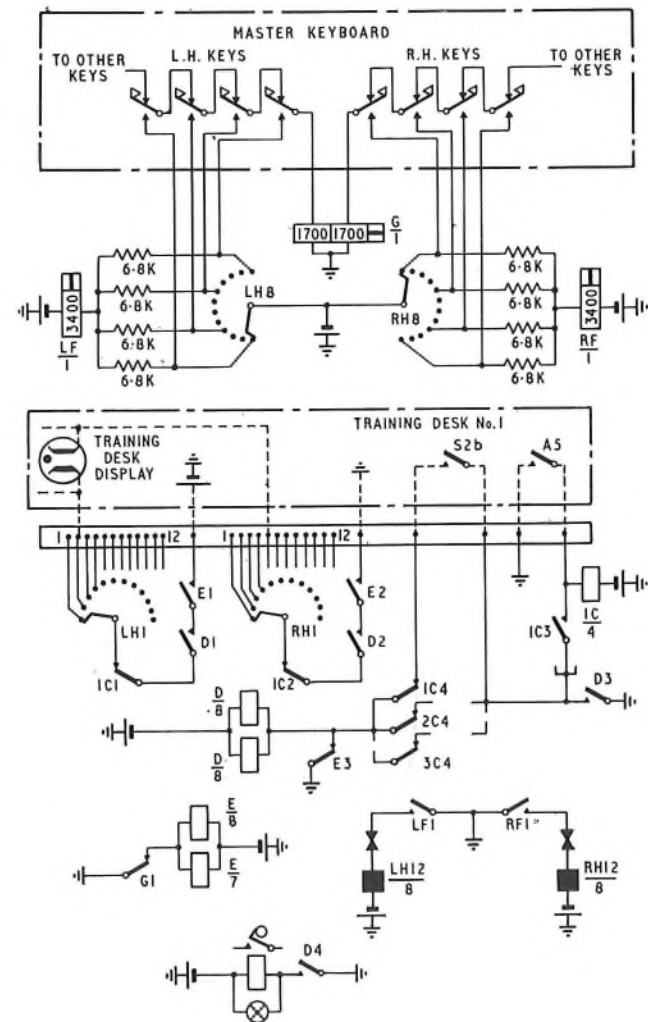

FIG. 6—OUTLINE CIRCUIT OF GROUPING UNIT

“master” keyboard, each training-desk being connected to the grouping unit via a 33-way cable. Fig. 3 shows a grouping unit with its associated keyboard together with one training-desk.

The grouping unit utilizes two 8-arc 12-outlet uniselectors (one for each side of the keyboard). Seven of the arcs are used to provide the seven displays to the training desks and the eighth arc is used as a line-finder under the control of the master keyboard.

When working with the grouping unit, each training desk utilizes its own power supply for the display, and thus it is only necessary to have a 50-volt d.c. supply associated with the grouping unit for operating the uniselectors and relays.

An outline circuit diagram of the grouping unit is given in Fig. 6. It will be seen from the diagram that the depression of a key (or a pair of keys) causes the unselector(s) to hunt and to stop on the appropriate outlet(s). Whilst a unselector is hunting, the battery supply to the lamps is disconnected at contact E1 to prevent the intermittent operation of the training-desk displays.

The correct keying operation on a training desk causes the A relay on that desk to operate and contact A5, which is not used when the desks are working individually, locks the associated C relay (relay 1C for desk No. 1) in the grouping unit. The last training position to be keyed correctly breaks the locking circuit to the D relay in the grouping unit, which extinguishes the supervisory lamp on the master keyboard, indicating that a

further key combination may be transmitted. Training desks not in use would normally be switched off by means of switch S2. Switch contacts S2b on each of such desks then open to allow normal working for the remaining desks.

#### CONCLUSION

It is unlikely that future letter-sorting machines will be controlled by a  $12 \times 12$  keyboard; experimental work at present is directed towards the use of a typewriter-style keyboard for extracting information from addresses on envelopes. Information extracted in this way would be translated automatically into binary code, the code then being impressed on the envelope for automatic sorting in a letter-sorting machine provided with code reading and translation equipment. New training requirements will arise in connexion with such equipment but it is possible that some of the techniques used in the present equipment could be adapted for use other than in association with a  $12 \times 12$  keyboard.

#### ACKNOWLEDGEMENTS

Acknowledgements are due to the Post Office Factories Department, who manufactured the new training equipment, to the Thrissell Engineering Company, who provided the machine keyboards and to Editorial Branch and the drawing offices of the various Regions, who co-operated in producing more than 200 display-sandwich negatives for use at the 10 offices at which the equipments will be used.

## Book Review

“Interference between Power Systems and Telecommunications Lines.” H. R. J. Klewe, Ph.D., M.I.E.E. Edward Arnold (Publishers), Ltd. 356 pp. 78 ill. 70s.

Dr. H. R. J. Klewe, the author of this volume, has made a lifelong study of the material covered. He has served for many years on the C.C.I.T.T. (formerly C.C.I.F.) committee which deals with the problems of interference between power systems, including electrified railways, and telecommunications lines and has had very wide experience of the subject. In both the introduction and the conclusion he has dwelt on the necessity for “friendly co-operation” between both power and telecommunications engineers, and one of his own contributions towards the development of this spirit now lies in having produced a volume which will clarify the problem, and hence lead to better understanding.

With an author of such authority a high standard is to be expected and the reader will not be disappointed. Dr. Klewe's book is in effect both a text book and a detailed survey of the accumulated experience of many years' work in the field covered. It should be of great value not only to present workers in that field but also to advanced students wishing to acquire a knowledge of the fundamental principles. The complexity of the subject is, however, such that it would be difficult to extract readily the information required to answer the occasional question set in the City and Guilds Telecommunication Technicians' Course examinations.

The book opens with an interesting chapter tracing the historical development of the problem of inductive interference. This is followed by a chapter in which is set out

a thorough mathematical treatment of the phenomena of electric and magnetic induction as applied to couplings between power and telecommunications lines. The various parameters affecting the coupling are considered and the screening effect of earthed conductors in the vicinity of the inducing and induced lines is discussed.

For a proper understanding of the problems of magnetic induction, as applied to couplings between power and telecommunications lines, a knowledge of the methods of operation and of the electrical characteristics of power lines is necessary. These are discussed in Chapter 3 which also deals with the problems of calculation of power-line fault currents and the production of harmonics in power systems.

In subsequent chapters the author deals with the effects of power induction on telecommunications circuits both at fundamental frequency (50 c/s) and at frequencies in the audio range.

Chapter 7 deals with various methods of reducing power interference in telecommunications lines by action either on the inducing or induced system and is followed, in Chapter 8, by a short treatise on typical induction problems, some fictional and others based on tests in the United Kingdom, Switzerland and Germany.

For readers interested in further study of the subject matter covered there is a comprehensive list of references (589 in all) which shows clearly the need for assembling in one book a survey of information hitherto not readily accessible. The author, having achieved the objective of a comprehensive survey of a difficult subject, is to be congratulated.

S. J. L.  
D. W. R. C.



# Telegraph Distortion on Physical (D.C.) Lines and Telegraph Machines

D. W. E. WHEELER, A.M.I.E.E., and E. G. COLLIER†

U.D.C. 621.317.34:621.3.018.782.4:621.394.6+621.394.73

The Telegraph Distortion Analyser has been used to make detailed investigations of the telegraph signal distortion introduced by physical (d.c.) lines, telegraph machines and v.f. telegraph channels. This article describes how the work on physical lines and telegraph machines has been carried out and introduces a switched-telegraph-network transmission plan based on the results. The distortion introduced by the v.f. channels of the trunk network of the telegraph automatic switching system is to be the subject of a separate article.

## INTRODUCTION

A TELEGRAPH circuit consists of a source of signals, a transmission path and a receiver. In the United Kingdom signals transmitted over a physical (d.c.) line normally consist of groups of double-current square-wave pulses based on a fundamental transmission speed of 50 bauds, i.e. a minimum pulse duration of 20 ms. The signals may be generated by a teleprinter transmitter, an automatic transmitter or a relay and theoretically should consist of square-wave pulses with a length of 20 ms or some multiple of 20 ms. In practice, however, the pulses are not perfect when generated and undergo further distortion before finally arriving at the receiver. It is clear therefore that the receiving equipment must have adequate margin to permit correct interpretation of these distorted pulses. A limit will be reached when the distortion of the signals applied to the receiver is just within the acceptance margin of the equipment. For maximum efficiency the transmitter must introduce the least possible distortion and the receiver should have a wide margin, thus permitting the inclusion of a maximum length of transmission path between the two instruments. It is therefore of great value to be able accurately to measure transmitted-signal distortion and the distortion introduced by the transmission path; also, to be able to measure the margin of the receiving equipment.

Instruments for the measurement of telegraph distortion have included the earlier synchronous testers and the more recent electronic start-stop testers.<sup>1,2</sup> These indicating instruments are very useful in the field, the observer making a subjective estimate of the general value of distortion. In laboratory work, however, particularly when small changes in distortion are to be measured, a more precise instrument is required.

The Telegraph Distortion Analyser (T.D.A.) has been developed to provide very accurate recording of telegraph distortion. It is an electronic instrument and can be used for start-stop or synchronous measurements. Details of its operation, with an example of its use, have been described in an earlier article.<sup>3</sup> Since the publication of the previous article the analyser has been in extensive use to investigate the distortion introduced on physical lines, telegraph transmitters and v.f. telegraph links. The first part of the present article describes the results of investigation work on physical lines; the second part describes the investigation of telegraph-machine transmitter distortion. A separate article in a future issue of the Journal will describe the results of work on v.f. telegraph links.

Distortion measurements on physical lines have been made in the past, using measuring equipment that was available at the time. Such work was mainly concerned with the determination of limits for point-to-point lines using 20, 40, 70 and 100 lb/mile conductors. With the increasing use of switched systems and the advent of the automatic telex network it was considered that a new approach to the problem using the T.D.A. would be most valuable. In addition, now that 10, 6½, 4 and perhaps even 2½ lb/mile conductors may form part of a telegraph line, a detailed investigation of the effect of conductor weight upon distortion was also desirable.

The results of the distortion investigation on physical lines and v.f. telegraph links have been used as the basis for the determination of telegraph transmission limits suitable for any switched telegraph network. In particular, the results have been applied to both the public teleprinter automatic switching system and the automatic telex system.

## THE TELEGRAPH DISTORTION ANALYSER

Each telegraph-character signal consists of a start signal (space element) followed by the five code elements (combinations of mark and space elements) and ending with a stop signal (mark element) (Fig. 1). The change

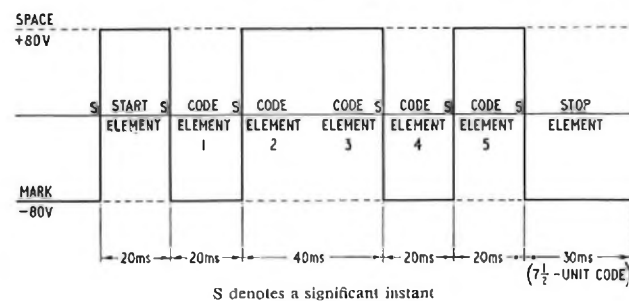

FIG. 1—ELEMENTS OF TELEGRAPH-CHARACTER SIGNAL

from a mark to a space condition, or vice versa, occurs at a significant instant, each of which should occur at an exact multiple of 20 ms from the commencement of the start signal. Any variation of the significant instants from this position is termed distortion and is measured as a percentage of the 20 ms basic-element duration.

The telegraph distortion analyser records all signal transitions or change-overs on a group of 20 meters. Each meter is set to register, in terms of percentage distortion, the significant instants that occur within a predetermined range. All meters together cover the full range from 50 per cent early to 50 per cent late.

One method is to record instants that occur early on meters 1 to 10 and instants that occur late on meters 11 to 20. If each meter is switched to record a 2 per cent range then a typical result after receiving sufficient characters to produce 1,000 significant instants might be as given in Table 1.

† Executive Engineers, Telegraph Branch, E.-in-C.'s Office.

TABLE 1  
Typical Results of Telegraph Distortion Measurements

Meter No.	Range of Distortion (Percentage)	Meter Count	Cumulative Count
1	50 to 18 early	—	—
2	18 to 16 early	—	—
3	16 to 14 early	3	3
4	14 to 12 early	4	7
5	12 to 10 early	11	18
6	10 to 8 early	24	42
7	8 to 6 early	43	85
8	6 to 4 early	78	163
9	4 to 2 early	114	277
10	2 early to 0	152	429
11	0 to 2 late	166	595
12	2 to 4 late	140	735
13	4 to 6 late	108	843
14	6 to 8 late	72	915
15	8 to 10 late	45	960
16	10 to 12 late	21	981
17	12 to 14 late	9	990
18	14 to 16 late	5	995
19	16 to 18 late	3	998
20	18 to 50 late	2	1,000

The table lists the results of a transmission test carried out over two, interconnected, telex subscribers' lines, each consisting of 20 miles of 20 lb/mile artificial quad cable. Interfering signals existed on one wire of the adjacent pair in the quad.

It will be noticed that in addition to the count listed in the third column of Table 1, a cumulative count is listed in the fourth column. The analyser can be set to provide either result but for a rapid practical approach to distortion investigation the cumulative count is of most value. No attempt will be made here to discuss the statistical process in detail, the methods having been described elsewhere,<sup>4</sup> but the means by which the cumulative count is used to provide a distortion measurement is as follows.

The cumulative count when plotted on arithmetic-probability graph paper produces a graph which over its major portion is linear with its ends asymptotic to some limiting values. This is shown in Fig. 2. If a train of more-distorted signals is received the count will change in such a way as to increase the slope of the curve; the slope will decrease if the received signal is distorted less. It will be noticed that the lower abscissa indicates the "percentage of transitions that are earlier

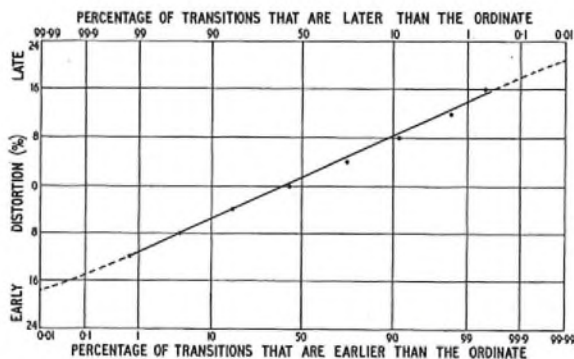

Each of the two lines was 20 miles long and consisted of 20 lb/mile conductors  
FIG. 2—DISTORTION MEASURED OVER TWO INTERCONNECTED  
TELEX SUBSCRIBERS' LINES

than the ordinate," and the 1.0 ordinate value, for example, indicates that one in every 100 transitions is distorted more than approximately 11.5 per cent early. Conversely, considering the upper ordinate, one in every 100 transitions is distorted more than 14 per cent late. This is termed a P(2) value of distortion and is normally stated in terms of the higher value, e.g. 14 per cent, this being the important limit as far as the receiving equipment is concerned.

Most transmission tests have been carried out by recording 10,000 transitions and extrapolating the graph where necessary to provide a P(4) value (i.e. the 0.01 and 99.99 per cent ordinates, e.g. a maximum of 21 per cent for the case shown). These have been found to serve as a very useful basis for comparing transmission results. A P(4) value of distortion therefore indicates that only one element in every 10,000 will have an early or late distortion exceeding this value. If there is any alteration in distortion between one test and the next the change is reflected by a corresponding change in slope of the graph, which therefore provides a very sensitive and accurate indication of the difference in distortion.

#### MEASUREMENTS ON PHYSICAL LINES

##### *The Effect of Interference on Telegraph Signals*

There is normally no ambiguity in determining the instant of transition when measurements of a telegraph signal are made at a point where the signal has a square waveform, since the voltage reversals are instantaneous. In practice, however, this condition exists only at the output of a telegraph-signal transmitter.

After the signal has passed through the line filter the peak-to-peak reversal time becomes significant and occupies a measurable percentage of the element duration, the rise times being further lengthened by transmission over a physical line. The sensitivity of the receiving equipment will then determine at which point of the signal waveform a change-over is effected. As the deformation is symmetrical no significant distortion will be apparent if the receiver is unbiased.

However, the transmission is subject also to interfering signals from other telegraph lines operating in the same cable and, in particular, in the same quad. The coupling between the lines is mainly capacitive and, due to the longitudinal transmission employed, can result in high-amplitude peaks being superimposed upon the telegraph signals. Since the interference is fortuitous the rise times of the signal under examination can be seriously affected by the superimposed peaks in a more or less random manner. Under these conditions, which must be presupposed to exist when making any tests to determine transmission limits, receivers of differing sensitivity may record similar polarity reversals of the received signal at different times.

It is clear, therefore, that if a signal undergoing fortuitous interference is measured by means of a sensitive electronic telegraph-distortion measuring set the distortion values recorded may not be in accord with the quality of the copy obtained on a teleprinter operated by the same signal. Electronic equipment, therefore, is desensitized to an extent sufficient to avoid any great discrepancy when used in the field, but for laboratory work, particularly when using the T.D.A., it is necessary to include in any transmission measurement the effects dependent on receiver sensitivity. An alternative means of terminating a physical circuit with trans-



mission measuring equipment was therefore devised. A Teleprinter 7D terminates the physical line and provides a recorded copy in the normal way. The electromagnet stop-plate, however, is replaced by a stop-plate fitted with two insulated contacts, one on each side of the armature gap and appropriately connected to positive and negative 80-volt supplies. Operation of the electromagnet by a received signal then provides (via the armature and electromagnet casing) a telegraph signal with instantaneous rise times and representing the timing of the mechanical input signal to the teleprinter mechanism. This signal is suitable for operating electronic equipment of any type without producing erroneous readings. It also indicates the overall distortion of the signal due to the complete circuit, including the receiving termination and the electro-mechanical conversion in the electromagnet.

#### Test Conditions

Artificial cable was used to simulate, as far as telegraph signals are concerned, a main transmission line together with an interfering line (or lines) within the same cable quad. The 10 lb/mile and 20 lb/mile artificial cable is built up of 5-mile and 10-mile sections and is included in a unit associated with the T.D.A. The 6½ lb/mile artificial cable was constructed in the laboratory and can be switched in 1-mile steps. Line filters (Filters, Frequency, No. 4B) were available for insertion at appropriate points in the line. Arrangements were made also to enable comparisons to be made between tests carried out on both real and artificial lines.

To obtain the most onerous conditions that would be possible in the field the main-transmission-line signalling voltages were adjusted to  $\pm 74$  volts for all tests. For the same reason the signalling voltages on the interfering line (or lines) were maintained at  $\pm 86$  volts.

It was essential to maintain these voltages between very narrow limits since a change of 1 volt at the transmitting end of the main line was found in some cases to vary the P(4) value of distortion at the receiving end by over 1 per cent.

The complete physical-line test arrangement, shown in Fig. 3, represents a call from one subscriber to another switched via an exchange. "Leak" circuits (not shown in detail in the diagram) are included at the switched point and at the receiving teleprinter; these are necessary for switching and monitoring purposes but they also divert useful signalling currents to earth from the main transmission path. The effect of these "leaks" has been investigated and has resulted in the use of "leak" circuits which introduce a minimum of distortion on the telegraph signal.

Previous tests had shown that the most onerous conditions exist at the transmitter when the teleprinter is operated manually and the local-record-circuit load is being connected and disconnected by the send/receive switch. Hence although some transmissions were automatic the majority of the signals on the main circuit (A wire) were produced by a hand-operated keyboard.

#### Description of One Complete Test

A very large number of tests were carried out, with results that are summarized later in the article. One particular test has been selected and is now described in detail to provide an indication of the actual practical work involved.

The test arrangement used was similar to the one shown in Fig. 3. The line to each subscriber was 25 miles long (i.e. an overall length of 50 miles) and was routed on 20 lb/mile quad cable. The test was made to determine the effect on the line under test of interference caused by transmitting telegraph signals on one wire of an adjacent pair in the same quad, and also to compare the effects

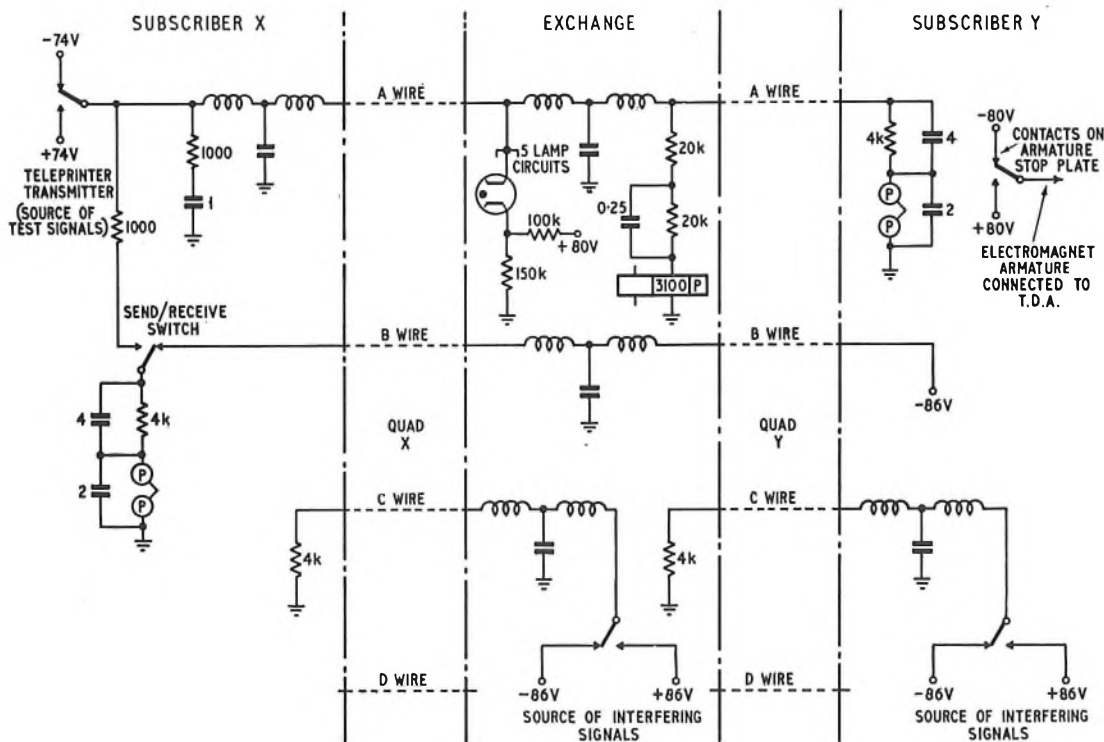

FIG. 3—PHYSICAL-LINE TEST CIRCUIT

obtained when using real and artificial cables. The equipment was set up with  $\pm 74$ -volt transmission on the test line and  $\pm 86$ -volt transmission on the interfering lines.

A total of 10,000 element transitions was recorded on the T.D.A. for each of the following tests:

- (a) With no interference on the X or Y subscriber's circuit.
- (b) With interference on the X subscriber's circuit.
- (c) With interference on the Y subscriber's circuit.
- (d) With interference on both the X and Y subscriber's circuit.

The tests were carried out first with artificial cable and then with real cable for the X and Y circuits.

The T.D.A. percentage cumulative count is shown graphically in Fig. 4 and 5. Listing P(4) values of distortion from these graphs, extrapolated where necessary, the results given in Table 2 are obtained.

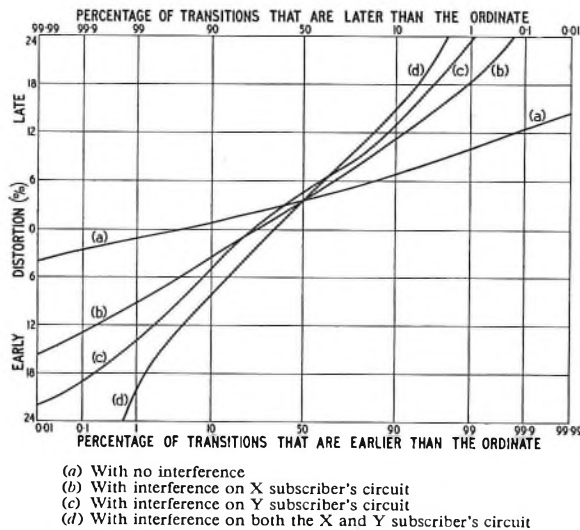

Each of the two lines consisted of an artificial cable equivalent to 25 miles of 20 lb/mile conductor

FIG. 4—DISTORTION MEASURED OVER TWO INTERCONNECTED TELEX SUBSCRIBERS' ARTIFICIAL LINES WITH VARIOUS LEVELS OF INTERFERENCE

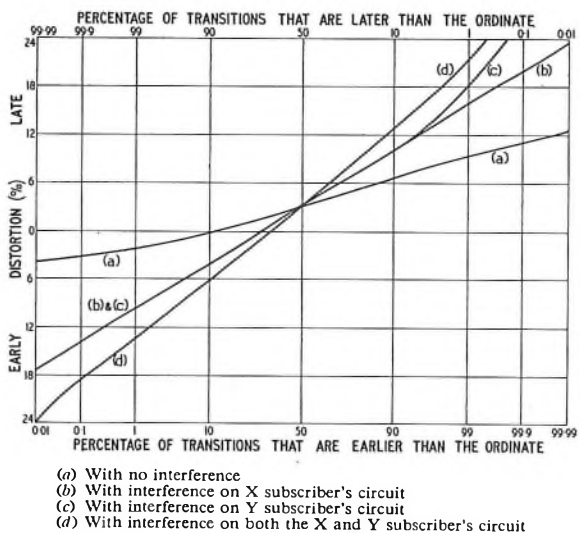

Each of the two lines was 25 miles long and consisted of 20 lb/mile conductors

FIG. 5—DISTORTION MEASURED OVER TWO INTERCONNECTED TELEX SUBSCRIBERS' REAL LINES WITH VARIOUS LEVELS OF INTERFERENCE

TABLE 2  
Distortion Measured with Various Levels of Interference

Interfering Circuit	Test	P(4) Distortion Artificial Line (Fig. 4)		P(4) Distortion Real Line (Fig. 5)	
None	a	4% E	14% L	4% E	12% L
X quad—"C" wire	b	17% E	30% L	17% E	23% L
Y quad—"C" wire	c	24% E	33% L	17% E	30% L
X and Y quads—"C" wires	d	30% E	36% L	24% E	33% L

Note: E = early, L = late

It is clear that with no interference on the line the distortion is low but when maximum interference exists, a P(4) distortion increase of 20 per cent to 25 per cent can be expected. Physical-line limits are therefore, in the main, determined by the maximum interference that can be permitted to exist on a line. A second point to note is that the artificial line produces rather worse distortion than that measured on the real line. This has been found to be the case throughout the tests and therefore ensures that any limits based on artificial-cable tests are adequate for use in the field. Since the curves do not intercept the 50 per cent ordinate at the 0 per cent distortion point but at approximately the 3 per cent (late) distortion point, a late bias is indicated. These curves are typical of the many results obtained.

Summary of Results of Distortion Measurements on 20, 10 and 6½ lb/mile Cables

A summary of measurements on physical lines is best shown by means of a graph, as indicated in Fig. 6.

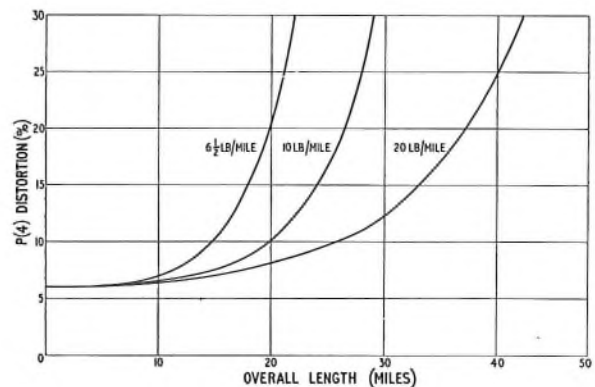

The graph shows the relationship of the P(4) value of start-stop telegraph distortion and the overall length of two interconnected telex subscribers' lines, the two lines being of equal length

FIG. 6—RELATIONSHIP OF P(4) VALUE OF DISTORTION AND LENGTH OF LINES

The curves plot the P(4) value of distortion against cable length for 6½, 10 and 20 lb/mile conductors and indicate the average trend of a large number of measurements.

Important points that may be noted are:

(a) Overall distortion of the transmitting and receiving equipment with zero line length (i.e. directly connected) is 6 per cent.

(b) With a subscriber-to-subscriber distance of less than 10 miles, irrespective of conductor weight, the distortion introduced by the line is negligible.

(c) All curves rise steeply at high distortion values and hence a small change in distance under these con-



ditions can have a highly significant effect on distortion. This effect becomes more noticeable as the conductor size is decreased.

As a consequence of the tests a limiting P(4) distortion value of 25 per cent has been set. This has been chosen to allow a margin of safety when fixing distance limits since, as stated before, these curves represent average rather than maximum values. Working to this limit it can be expected that not more than one transition in 10,000 will suffer 30 per cent distortion under the most adverse conditions. Even then it is very doubtful whether a character error will occur since generally the margin of the receiver will be rather better than 30 per cent.

Thus the maximum allowable distances between subscriber and switching exchange will be:

- (a) 20 miles of 20 lb/mile conductor,
- (b) 14 miles of 10 lb/mile conductor, or
- (c) 10 miles of 6½ lb/mile conductor.

*Milage Conversion Factor with Conductors of Weights other than 20 lb/mile*

The test results have been used to determine a relationship between the distortion measured on conductors of differing weights. Assuming a conversion factor of 1 applies for 20 lb/mile cable, it has been found that factors of 10/7 and 2 will apply for 10 lb/mile and 6½ lb/mile cables respectively. Multiplication of the lengths of low-weight conductor by the appropriate factor then provides the equivalent length (as far as distortion is concerned) of 20 lb/mile conductor. Conversely, given a length of 20 lb/mile conductor, the equivalent lengths of 10 lb/mile and 6½ lb/mile may be determined using the factors 0.7 and 0.5 respectively. Further inspection of the graphs (Fig. 6) shows that the factors are reasonably correct above a distortion value of approximately 10 per cent. Below 10 per cent the factor tends to approach 1 in all cases. To avoid further complexity in applying limits, however, it was decided to apply the former values over the complete range. Any small errors introduced thereby would apply for short distances only and in any case would err in such a way as to maintain the line in a workable rather than an unworkable condition.

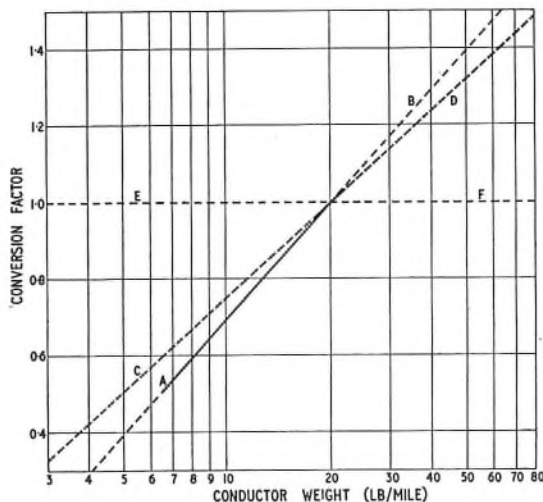

AB = conversion factor when P(4) = 25%  
 CD = conversion factor when P(4) = 10%  
 EF = conversion factor when P(4) = 6%

The conversion factors can be used to convert the lengths of cables of any weight to the equivalent length of 20 lb/mile cable or vice versa

FIG. 7.—DISTORTION CONVERSION FACTORS

If the conversion factors are plotted against conductor weight, with a logarithmic scale for weight, they are found to lie in a straight line, AB, as shown in Fig. 7. Extrapolation of this graph then provides conversion factors for 4 lb/mile and 40 lb/mile conductors. The graphs CD and EF show the conversion factors if P(4) distortion values of 10 per cent and 6 per cent are used as limiting conditions instead of 25 per cent. It is clear that graph AB provides a reasonably accurate conversion factor for P(4) distortion values exceeding 10 per cent.

*Practical Tests to Confirm Line Limits and Conversion Factors*

Practical tests to check the limits were arranged by setting up a complete subscriber-to-subscriber connexion using 10 miles of 6½ lb/mile artificial cable for each subscriber's line. Adverse conditions, including two sources of interference, were applied. One thousand characters, either "plugged" or mixed, were transmitted from the keyboard of a Teleprinter 7B and a number of machines were tested at the receiving end. Over 40 machines were examined and, except for two machines with incorrectly adjusted armatures, no misprinting occurred. When the subscriber line-lengths were each increased to 11 miles, however, misprinting occurred on nine machines.

The effectiveness of the conversion factor was examined by making distortion tests with the T.D.A. over the standard subscriber-to-subscriber test circuit (Fig. 3) but using composite lengths of cable for each subscriber's line. The actual result was then compared with the estimated result obtained by converting the composite length to the equivalent 20 lb/mile length. If the composite line consists of 5 miles of 20 lb/mile, 5 miles of 10 lb/mile and 6 miles of 6½ lb/mile cable, the estimated 20 lb/mile equivalent is

$$5 + \left(5 \times \frac{10}{7}\right) + (6 \times 2) \text{ miles,}$$

a total of 24.14 miles. The graph (Fig. 6) when extrapolated indicates that the P(4) distortion for two interconnected lines each consisting of 24.14 miles of 20 lb/mile conductor (a total of 48.28 miles) is 38 per cent. The actual measured value was 33 per cent.

Over 30 tests using various combinations of 6½, 10 and 20 lb/mile conductors were carried out with similar results, the estimated value of distortion always exceeding the measured value by a few per cent. No attempt was made to ensure absolute agreement between the two values as much additional work would be needed to achieve this—and in any case the difference is such as to ensure that all lines put into service are workable rather than otherwise.

TWO-WAY SIMPLEX

It is generally assumed that switched networks are designed on a one-way simplex basis with the provision of a local record copy at the transmitting station. There may, however, be occasions when a switched line is routed in the same quad as another line not connected to the network, the latter perhaps working on a two-way simplex (i.e. duplex transmission of traffic) basis. Again, it is possible for brief periods of two-way simplex transmission to occur under fault or interruption conditions on a switched line. Limited tests have therefore been carried out to provide some information on

the effect of a two-way instead of a one-way simplex interfering line. The results show that the distortion introduced on a one-way simplex telegraph line is increased if two-way simplex interference exists instead of one-way simplex.

The switched-network limits normally provide sufficient margin to absorb any increase in distortion due to the limited introduction of duplex interference, but if such interference is to be taken into account the line transmission limit for the part of the line over which these conditions occur should be reduced by a factor of 0.7. Alternatively, the length (or equivalent length) of the part of the line affected should be multiplied by a factor of 10/7.

#### SWITCHED NETWORK LIMITS

The results of the work on physical-line limits have been used as the basis for the development of transmission limits for physical (d.c.) lines on switched telegraph networks. Other factors that must also be considered, however, include:

(a) the signalling-resistance limit (to ensure satisfactory transmission of dialling and supervisory signals, etc.),

(b) the maximum number of v.f. telegraph links permitted in conjunction with limiting inter-v.f. and terminal-v.f. physical-line extensions,

(c) the relayed-physical-line limit, and

(d) interconnexion with Continental networks necessitating the introduction of regenerative repeaters.

The investigation of distortion on v.f. links using the T.D.A. will be described in a future issue of the Journal. Relayed-line limits have been determined using the subscriber-to-subscriber test circuit described earlier, but with one circuit relayed. All results have been combined to form a transmission plan for the automatic telex network, a diagram of which is shown in Fig. 8.

#### MEASUREMENTS ON START-STOP TELEGRAPH MACHINES

The telegraph distortion analyser has also proved itself to be a very useful instrument for assessing the performance of telegraph-machine transmitters, particularly when it is desired to determine the effects of different adjustments on the distortion of the signals produced. It also enables objective comparisons to be made between the performances of different types of transmitter mechanism, e.g. between link-operated and striker-operated transmitters. Fig. 9 illustrates the types of curves which are obtained when typical results for various machines are plotted on arithmetic-probability graph paper. As would be expected, the more recent striker-operated transmitters introduce much less distortion than early non-striker-type machines.

When a quick overall estimate of the performance of a transmitter has been obtained by recording the distortion groupings of, say, 10,000 transitions (significant instants of modulation) it is possible to obtain a far better insight into the sources of the distortion by taking 10 more readings, each of say 1,000 transitions, of the 10 possible change-overs which can occur in teleprinter signals (excluding the change-over between stop and start elements). These change-overs may be designated "Start-1, M-S" for the commencement of the first code element, "1-2, M-S" or "1-2, S-M" for the commencement of the second code element, etc.

#### Interpretation of Results

Fig. 10 shows the ten individual curves obtained from measurements on the four mark-to-space and six space-to-mark transitions from a transmitter head of a multiple-headed automatic transmitter (Automatic Transmitter No. 3A).

The transmitting contacts of these automatic transmitters comprise six contact spring-sets connected in parallel (one for each code element and one for the start and stop elements) which operate in sequence as required to produce the telegraph signal for the code which is being sensed by the peckers. Double-current telegraph signals, as normally used for transmission over Post Office lines, are obtained from the contact tongue of a polarized relay which is controlled by the single-current make/break signals

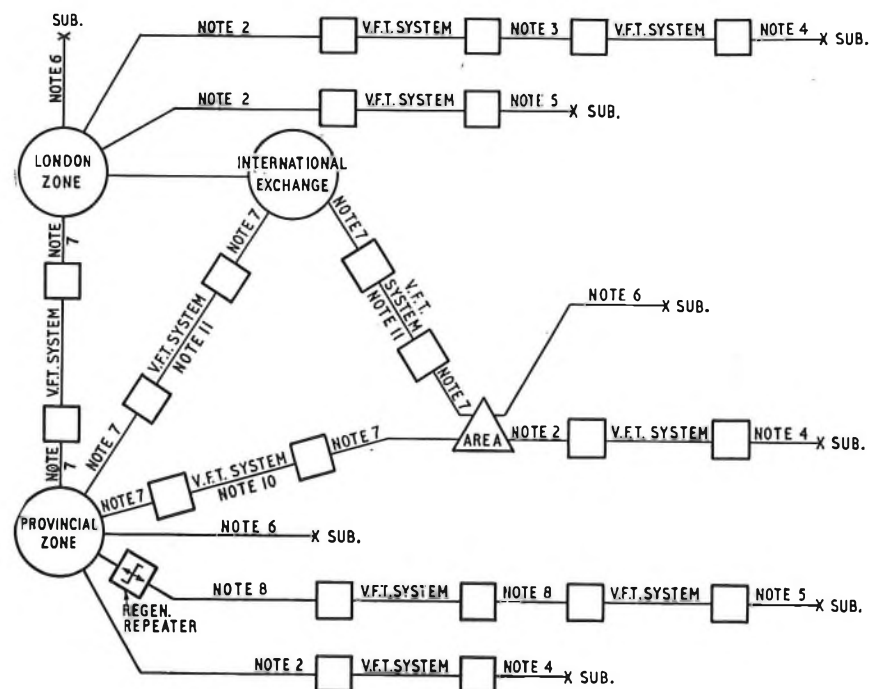

Notes:

1. The distances quoted assume use of 20 lb/mile conductor.
2. 0-2 miles unrelayed (all conductor weights); 2-5 miles, relay outgoing; 5-15 miles, relay incoming at exchange; greater than 15 miles, two-loop relay.
3. 0-10 miles, unrelayed; greater than 10 miles, two-loop relay.
4. 0-10 miles, unrelayed; 10-20 miles, relay incoming at subscriber's premises; greater than 20 miles, two-loop relay.
5. 0-25 miles, unrelayed; 25-30 miles, relay incoming at subscriber's premises; 30-40 miles, relay incoming at v.f. terminal; greater than 40 miles, two-loop relay.
6. 0-20 miles, unrelayed; 20-40 miles, relay incoming at both ends; greater than 40 miles, two-loop relay.
7. 0-5 miles, unrelayed; 5-10 miles, relay incoming at exchange; 10-15 miles, relay incoming at v.f. terminal; greater than 15 miles, two-loop relay.
8. 0-30 miles, unrelayed; 30-40 miles, relay incoming at both ends; greater than 40 miles, two-loop relay.
9. 0-15 miles, relay incoming at both ends.
10. If the distance is such that a v.f. channel is not justified then Note 9 applies for the Area-Zone connexion.
11. All Area and Zone exchanges have a direct link to the International exchange.

FIG. 8—TRANSMISSION LIMITS FOR THE AUTOMATIC TELEX NETWORK



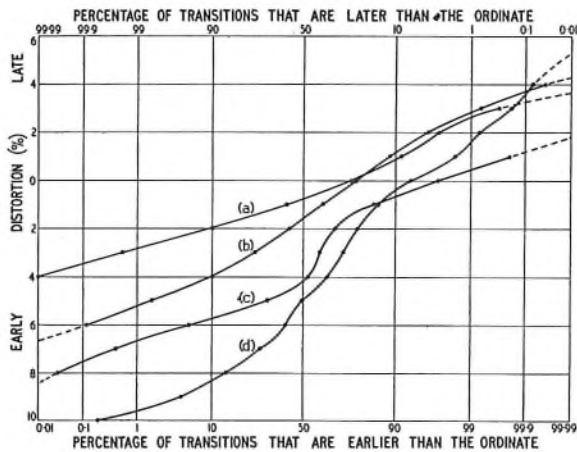

- (a) Automatic Transmitter No. 2D (Striker type)
- (b) Teleprinter No. 7B (Striker type)
- (c) Automatic Transmitter No. 2A (Non-striker type)
- (d) Automatic Transmitter No. 1B, Mark I (Non-striker type)

FIG. 9—DISTORTION INTRODUCED BY TELEGRAPH TRANSMITTERS

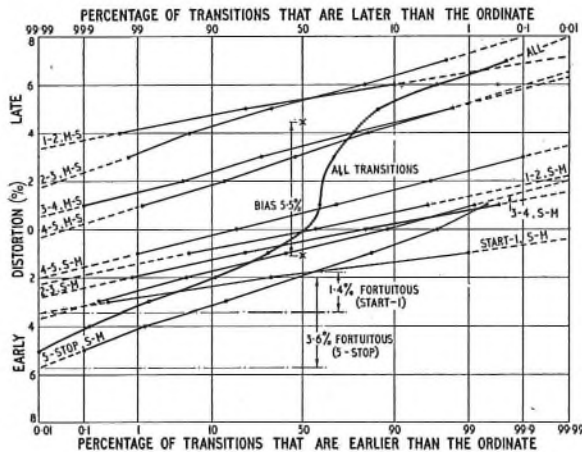

Test results for one transmitter head of a multiple-headed automatic transmitter

FIG. 10—DISTORTION INTRODUCED BY AN AUTOMATIC TRANSMITTER NO. 3A

from the transmitting contacts. The measurements from which Fig. 10 was derived were of double-current signals from this polarized relay.

The ten individual distributions are all roughly "normal" statistical distributions and they therefore plot more or less linearly on the graph paper. The median (50 per cent) point on each distribution curve may be considered to indicate the mean value of distortion of the transitions forming its distribution. The distribution of the ten median values is determined by the characteristic distortion of the machine, which may be influenced by such factors as accuracy of cam profiles, spring pressures or contact gaps, so from examination of these points on the curves an estimate may be made of the characteristic distortion component in the output signal of a machine.

The slope of each curve demonstrates the fortuitous distortion of the transitions about the median value caused by such factors as motor-speed fluctuations, gear back-lash, variation of clutch engagement, etc. The greater the slope the greater the fortuitous distortion. On the sample machine-results that are illustrated, the fortuitous distortion is not the same on all significant

instants and it can be seen that occasional transitions (one in 10,000) are likely to be distorted by about 3-6 per cent more than the median value for transitions at the commencement of the stop-signal elements, whereas the corresponding figure for the commencement of the first code element is about 1.4 per cent.

The distribution curves show also that the marking elements are longer than the spacing elements as the mark-to-space transitions are all late relative to the space-to-mark transitions. This bias-distortion component of the distortion, which is responsible for the double bend in the curve<sup>3</sup> for the distribution of all transitions, is about 5.5 per cent distortion for this particular machine when considered as the difference between the mean values of the mark-to-space and space-to-mark distribution medians.

Measurements such as the comparison of (a) the distortion of the signals from a teleprinter when the keyboard is manually operated and when a character is continuously transmitted under "run-out" conditions, (b) the variation of distortion which occurs as the power-supply voltage applied to a governed motor changes and causes the motor speed to alter, and (c) the effect on the fortuitous distortion of alterations to the spring tensions and governor-arm mass of a centrifugal governor, can be readily made in a short time by using a distortion analyser of the type being discussed.

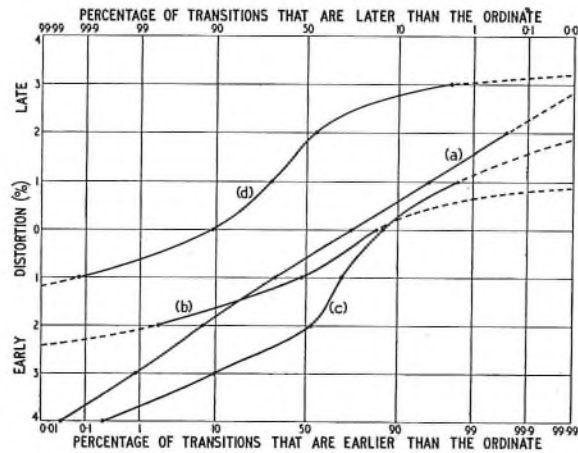

- (a) Governed motor; adjustments normal
- (b) Synchronous motor; adjustments normal
- (c) Synchronous motor; contact-tongue knife-edge displaced 5 mils towards space contact
- (d) Synchronous motor; contact-tongue knife-edge displaced 5 mils towards mark contact

FIG. 11—DISTORTION INTRODUCED BY AN AUTOMATIC TRANSMITTER NO. 2D

Fig. 11 shows a few of the curves which were obtained during tests of a striker-type automatic transmitter (Automatic Transmitter No. 2D). Curve (a) illustrates the signal distortion with all adjustments correct and with the machine powered by its normal governed series-motor; curve (b) shows the signal distortion obtained on the same machine with the same conditions of adjustment but with the series-motor replaced by a synchronous motor. In the latter case the component of the fortuitous distortion that is attributable to the speed fluctuations of the governed motor has been eliminated. Under these conditions of reduced distortion the effect of inaccuracy of alignment of the striker and contact-

tongue knife-edges was investigated, firstly by moving the mean position of the contact-tongue knife-edge by 5 mils towards the space contact (curve (c)) and then by the same amount towards the mark contact (curve (d)). It was found that a misalignment of this magnitude has a significant effect on distortion (1-2 per cent) and it is therefore necessary to stress in the relevant adjustment instructions the need for care in making this particular adjustment. The effects of other maladjustments to transmitting mechanisms may be checked in a similar manner.

The few examples that have been given illustrate some of the ways in which the versatile telegraph distortion analyser can be used in the examination and improvement of the performance of telegraph machines.

#### CONCLUSION

The telegraph distortion analyser records distortion in such a way as to make possible a very accurate and yet rapid practical assessment of distortion. The recordings obtained are independent of observer characteristics, a condition which is difficult, if not impossible, to achieve when reading the indicating display of a telegraph distortion measuring set.

The distortion introduced by telegraph machines, together with the effect of telegraph-signal transmission over conductors of differing weights, with particular reference to those of very low weights, has been investigated. The results, combined with the results of other work on v.f. channels, have provided the basis for a telegraph transmission plan suitable for switched start-stop telegraph networks.

#### ACKNOWLEDGEMENT

The authors wish to acknowledge the assistance rendered throughout this work by their colleagues in the Telegraph Branch.

#### References

<sup>1</sup> WHEELER, L. K., and TISSINGTON, R. S. An Electronic Distortion Measuring Set for Start-Stop Telegraph Signals. *P.O.E.E.J.*, Vol. 32, p. 18, Apr. 1950.

<sup>2</sup> DAIN, G. T. An Improved T.D.M.S. *A.T.E. Journal*, Vol. 9, No. 1, Jan. 1953.

<sup>3</sup> WHEELER, L. K., and FROST, A. C. A Telegraph Distortion Analyser. *P.O.E.E.J.*, Vol. 47, p. 5, Apr. 1954.

<sup>4</sup> DOUST, J. F., and JOSEPHS, H. J. A Simple Introduction to the use of Statistics in Telecommunications Engineering. *P.O.E.E.J.*, Vol. 34, p. 37, Apr. 1941.

## Book Review

"The Junction Transistor and its Applications." Edited by E. Wolfendale, B.Sc.(Eng.), A.M.I.E.E. Heywood & Co., Ltd., London. viii + 394 pp. 397 ill. 84s.

Here, as far as the reviewer is aware, is the first British book which attempts to give a detailed account of the transistor as a circuit element and a description of its basic circuits. It is a joint effort by nine authors from one organization, so that the editor has had no insuperable task in avoiding unnecessary overlapping or big differences in approach. The coverage is fairly wide, but it is debatable whether the space allotted to the various sections correlates with practical importance. Individual readers must judge for themselves—but whereas some will probably think that more space might have been devoted to sinusoidal oscillators, most will be satisfied that enough has been devoted to d.c. converters.

The book opens with a chapter on the physics of transistors, which, the preface suggests, can be passed over by many newcomers. The chapter is partly a general outline of semi-conductors, p-n junctions and the utilization of the properties of junctions in transistors, but it endeavours to show how analysis of the internal mechanisms of transistors leads to an understanding of the overall electrical properties and to useful equivalent circuits. Noise receives some attention. The next two chapters are written so as not to seem to depend on the opening chapter and present some of the same subject matter in terms more commonly used by engineers; thus one, after giving a simpler derivation of one equivalent circuit, describes the electrical properties of the transistor in terms of  $v/i$  relationships, transient response, bias conditions and temperature, while the other goes more deeply into representation by four-terminal networks.

A chapter on biasing arrangements and amplification at audio frequencies follows; Class B operation receives short mention (Class C operation, although less frequently used, is given a short chapter to itself, later on). Amplification at

high frequencies is adequately introduced, along with unilateralization and coupling networks, in the next chapter. A chapter on sinusoidal oscillators is largely descriptive, as is that which follows, on modulators. The use of junction transistors in non-linear circuits (multi-vibrators, blocking oscillators, waveform generators, etc.) and in combination with storage elements is well described in one of the more lengthy chapters. The final chapter, on d.c. converters, is longer than any except the opening chapter; it describes the basis for design, many of the details of design and, more briefly, the properties obtained; key features of the vital components are considered and it would seem that the author has had much practical experience to call on. The book concludes with a brief appendix on the measurement of transistor parameters.

The presentation is generally good and the diagrams purposeful—marred only by a poor photograph of two converters and by the suggestion which some diagrams give that depletion layers grow equally into the p and n regions at a p-n junction as the bias is increased (in fact they grow equally only if the impurity concentrations in two regions are equal—a rare occurrence of no practical significance). Several chapters are well illustrated by practical designs which are carried through in a logical if not detailed way. The writing is also good, despite lapses here and there into vagueness; we find "c.g.s. units," "in a suitable manner," "of a suitable wavelength" (admittedly explained in the next sentence or two) and, far too frequently, "this." Never was "this" so overworked at the beginning of new sections and although the reader can usually decode its meaning by reference to the title of the section, in heavy type one line above, there are occasions when second thoughts are needed.

But despite its blemishes the book has much to commend it; designers and would-be designers of transistor circuits will profit if they read it carefully (first chapter and all) and test as many of the circuit configurations shown as they have time to.

J. R. T.



# A Resonance Isolator for Use at 4,000 Mc/s

A. D. CARTWRIGHT and C. F. DAVIDSON, A.M.I.E.E.†

U.D.C. 621.372.852.223

A brief account of some of the basic magnetic properties of ferrite material is given. It is then shown how these properties can be used in an isolator of the resonance type.

## INTRODUCTION

A PROBLEM which continually confronts the communications engineer is the avoidance of echoes in a transmission system. The problem is particularly acute in microwave frequency-modulated radio systems used for the transmission of multi-channel telephony signals. In these systems echoes result in intermodulation distortion which, in general, increases with both the magnitude and delay of the echo signals. These echoes arise from reflections occurring at unavoidable electrical discontinuities, usually at the ends of the aerial feeders, and the delay introduced is directly proportional to feeder length; such feeder systems necessitate very careful design if the echoes are to be reduced to tolerable magnitudes.

One method of reducing the magnitude of the echo relative to the main signal would be to insert an attenuator in the feeder, for it is evident that the main signal will traverse the attenuator once only but the echo signal will pass through it two additional times.\* This expedient would suffer from the disadvantage that the signal-to-noise power ratio of the system would be degraded by the amount of attenuation introduced. It is now possible, however, to avoid this difficulty by the use of a non-reciprocal attenuator in which the transmission loss in one direction is many times that in the other. These devices, which are known as isolators, are constructed with the aid of a ferromagnetic material of the same basic chemical structure as magnetite, called ferrite. This material is available in many forms and is being put to a great variety of uses. Of almost universal value in all these applications is the property it possesses of extremely low conductivity compared with other ferromagnetic materials. It also possesses other properties which become important at microwave frequencies and it may be useful to deal briefly with some of these before describing one type of isolator.

## FERRITES

### Chemical Composition and Preparation

The chemical formula for magnetite may be written in the form  $\text{FeO} \cdot \text{Fe}_2\text{O}_3$ . In modern ferrites the ferrous ion is replaced by another divalent metal ion of about the same diameter. This may be manganese, magnesium, nickel, zinc or copper. Usually two or more metals are used and a wide range of properties is thus made possible. For instance, the formulae for a nickel-zinc ferrite is  $(\text{ZnO})_a(\text{NiO})_{1-a}\text{Fe}_2\text{O}_3$ , where  $a$  and  $(1-a)$  are the molecular fractions of the simple zinc and nickel oxides.

Ferrites are prepared by first grinding the metal oxides in a ball mill. After milling the oxide mixture is oven dried. The dried mixture may then be pre-sintered by heat treating at a temperature somewhat lower than the final firing temperature. After pre-sintering, the oxide

is pulverized to a particle size瓷ally workable. The oxide mixture is then formed into suitable shapes by die-pressing or extruding, organic additives being introduced to serve as a binder and as a particle lubricant. The prepared shapes are heated gradually to volatilize the organic additive and finally fired at about  $1,200^\circ\text{C}$ . At all stages the process must be carefully controlled if consistent magnetic properties are to be obtained from different batches of material.

### Magnetic Properties

Considering firstly the behaviour of a normal magnetic material, e.g. soft iron, the application of an alternating magnetic field of intensity  $h \sin \omega t$  results in a magnetic induction

$$b = \mu h \sin \omega t$$

where  $\mu$  is the permeability of the material and is a scalar quantity;  $h$  is a vector quantity and  $b$  is in the same direction as  $h$ . In the case of a ferrite that is saturated by a d.c. magnetic field† in the  $z$  direction, the application of an alternating magnetic field of intensity  $h_{max} x \sin \omega t$  produces magnetic induction in both the  $x$  and  $y$  directions; this results from the gyroscopic precession§ of electrons spinning on parallel axes aligned by the d.c. field within the ferrite.<sup>1,2</sup> Thus

$$b_x = \mu h_{max} x \sin \omega t \dots\dots\dots (1)$$

$$b_y = K h_{max} x \cos \omega t \dots\dots\dots (2)$$

$\mu$  and  $K$  are functions of the applied d.c. field and the angular frequency  $\omega$ . Similarly, if the applied alternating magnetic field is  $h_{max} y \sin \omega t$ , then

$$b_x = -K h_{max} y \cos \omega t \dots\dots\dots (3)$$

$$b_y = \mu h_{max} y \sin \omega t \dots\dots\dots (4)$$

It is clear from these four equations that the relationship between the magnetic intensity and the induction is no longer scalar and that the changed sign of the quadrature component of induction as the direction of the applied alternating field changes implies a non-reciprocal property in the material.

Consider now the case where the magnetic intensity applied in the  $xoy$ -plane remains constant in magnitude but rotates in space with angular velocity,  $\omega$ , as shown in Fig. 1, i.e. the field is circularly polarized. Now

$$h_x = h \cos \omega t = h \sin (\omega t + \pi/2)$$

$$h_y = h \sin \omega t$$

From equations (1) to (4) it follows that:

$$b_x = \mu h \sin (\omega t + \pi/2) - K h \cos \omega t$$

$$= (\mu - K) h \sin (\omega t + \pi/2)$$

$$= (\mu - K) h_x$$

$$b_y = K h \cos (\omega t + \pi/2) + \mu h \sin \omega t$$

† The authors are, respectively, Assistant Engineer and Senior Executive Engineer, Post Office Research Station.

\* There will be a series of echoes due to repeated reflections at each end of the waveguide. The primary echo considered here is obviously the most important.

‡ In this article, unless stated otherwise, the magnetic fields are internal fields. The internal field in a magnetic material is less than the external applied field due to the demagnetization effect of the magnetic poles induced in the material.

§ An account of gyroscopic motion which is applicable to electrons spinning in a magnetic field is given in "Dynamics Part 2" by A. S. Ramsey, 2nd Edition (Cambridge University Press, 1944), p. 289.

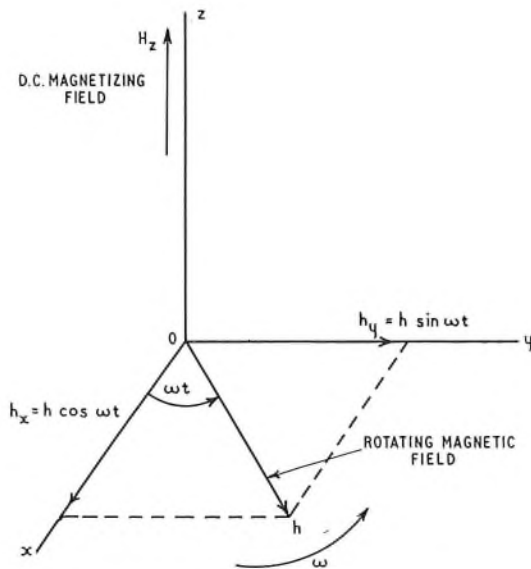

FIG. 1—MAGNETIC FIELDS WITHIN A FERRITE

$$= (\mu - K) h \sin \omega t$$

$$= (\mu - K) h_y$$

It is thus seen that the induction is always in the direction of the applied rotating field and the permeability is, in effect, a scalar quantity  $(\mu - K)$ . If the direction of rotation is reversed it can be shown that the scalar permeability becomes  $(\mu + K)$ . This important property of the material forms the basis of a number of microwave devices. In the present application we are concerned with the resonance which occurs when the frequency of the rotating magnetic field coincides with the natural precession frequency of the spinning electrons within the ferrite. The electron motion induced by the applied rotating field gives rise to losses in the ferrite material and the permeability is in fact complex on this account. As might be expected, the loss is dependent on the direction of rotation of the magnetic field; it is also dependent on the strength of the d.c. magnetizing field  $H_z$ . At a particular value of the d.c. magnetic field,  $H_{RES}$ , gyromagnetic resonance occurs

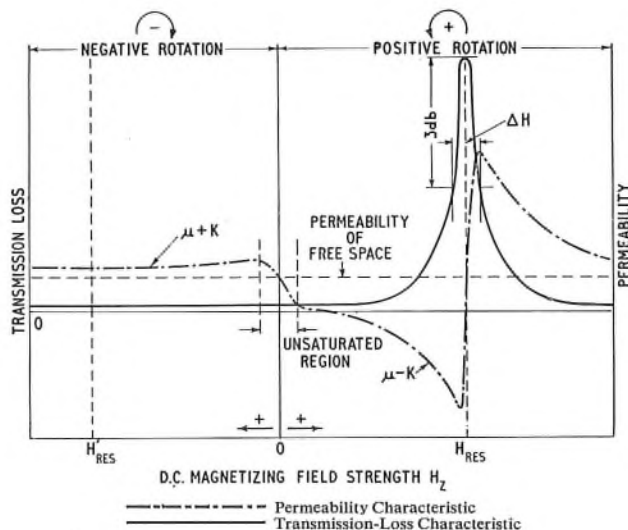

FIG. 2—PERMEABILITY AND LOSS CHARACTERISTICS OF A FERRITE FOR ROTATING FIELDS

and the loss becomes very large, as depicted in Fig. 2.  $H_{RES}$  is related to  $\omega$  according to the equation

$$H_{RES} = -\frac{\omega}{\gamma}$$

Magnetic dipole moment of an electron spinning on its axis  
 where  $\gamma = \frac{\text{Angular momentum of an electron spinning on its axis}}{\text{Angular momentum of an electron spinning on its axis}}$   
 $= -2.8 \text{ Mc/s/oersted}^*$

The loss characteristic of the ferrite, as illustrated in Fig. 2, is of great importance in determining its suitability for microwave applications. A figure of merit can, in fact, be derived from it, given by  $F = 2H_{RES}/\Delta H$ , where  $\Delta H$  is the line-width of the resonance peak at its half-amplitude point.<sup>3</sup> Line-widths of about 500 oersteds are achieved with the polycrystalline materials normally in use and are, to a first order, independent of frequency.  $H_{RES}$  is approximately 1,400 oersteds at 4,000 Mc/s so that  $F$  is normally about 6 at this frequency. It should be noted that for a given material, since  $H_{RES}$  is proportional to resonance frequency and  $\Delta H$  is approximately constant,  $F$  will decrease with decrease in frequency, so that to obtain a good performance at the lower frequencies a narrow line-width is essential. As the frequency falls still further  $H_{RES}$  may fall below saturation value, in which event low field losses become a limiting factor as well.

The ratio of  $\frac{\text{reverse loss (db)}}{\text{forward loss (db)}}$  theoretically obtainable with a resonance isolator is approximately  $(2F)^2$ ; that is to say, under 150 for the present case; in practice less than half this value is currently realized, depending upon the ingenuity of the design.

#### APPLICATION OF THE RESONANCE PHENOMENON TO RECTANGULAR-WAVEGUIDE ISOLATOR DESIGN

The magnetic-field distribution in a rectangular waveguide that is transmitting a  $TE_{01}$  type of wave is shown in Fig. 3.

The  $x$  and  $y$  components of the magnetic field, at a point distant  $x$  from the wall of the guide, are given by:

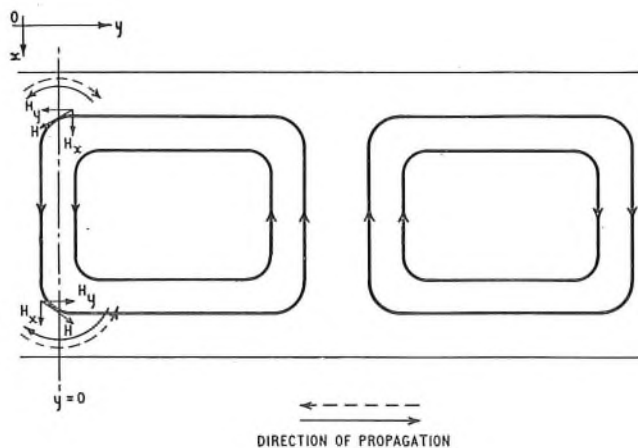

FIG. 3—MAGNETIC FIELD FOR  $TE_{01}$  MODE IN A RECTANGULAR WAVEGUIDE

\*  $\gamma$  is a negative quantity because the magnetic dipole moment and angular momentum are vectors pointing in opposite directions.



$$H_x = H_0 \sin \frac{\pi x}{a} \cos (\omega t - \beta_g y)$$

$$H_y = \frac{\pi}{a \beta_g} H_0 \cos \frac{\pi x}{a} \cos \left( \omega t - \beta_g y - \frac{\pi}{2} \right)$$

where  $a$  = guide width

$\beta_g$  = phase-change coefficient in the guide

$H_0$  = magnetic field due to the source in the  $xz$  plane at  $y = 0$ .

At the  $xz$  plane at  $y = 0$ ,

$$H_x = H_0 \sin \frac{\pi x}{a} \cos \omega t$$

$$H_y = \frac{\pi}{a \beta_g} H_0 \cos \frac{\pi x}{a} \sin \omega t$$

Now the maximum value of  $H_x$  is

$$H_0 \sin \frac{\pi x}{a}$$

and this expression is always positive since  $1 \geq x/a \geq 0$ .

The corresponding maximum value of  $H_y$  is

$$\frac{\pi}{a \beta_g} H_0 \left| \cos \frac{\pi x}{a} \right|$$

At values of  $x$  such that

$$H_0 \sin \frac{\pi x}{a} = \frac{\pi}{a \beta_g} H_0 \left| \cos \frac{\pi x}{a} \right|$$

$$\text{or } \left| \tan \frac{\pi x}{a} \right| = \frac{\pi}{a \beta_g} \dots \dots \dots (5)$$

the resultant magnetic field will rotate with angular velocity  $\omega$  and the amplitude will remain constant; the field is said to be circularly polarized.

At other values of  $x$  the amplitude of the resultant field will not remain constant and the end of the rotating field vector will trace an ellipse; the field is said to be elliptically polarized. The field may, however, be resolved into two circularly-polarized fields rotating in opposite directions, as shown in Fig. 4.

For size 11 waveguide with  $a = 2.372$  in., at a frequency of 4,000 Mc/s, the solutions of equation (5) are

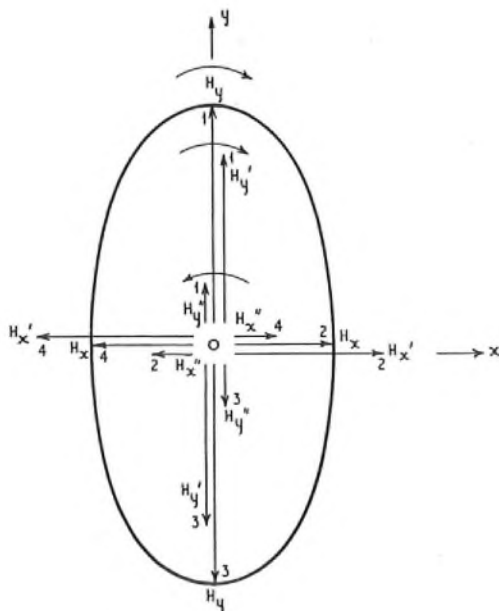

FIG. 4—RESOLUTION OF AN ELLIPTICALLY-POLARIZED FIELD INTO TWO CIRCULARLY-POLARIZED FIELDS ROTATING IN OPPOSITE DIRECTIONS

$x = 0.507$  in. and  $1.865$  in.

Referring now to Fig. 3, if an observer is located in the  $xoz$  plane at a point corresponding to one of the above values of  $x$ , the magnetic field will appear to rotate as the wave progresses along the waveguide. For one solution of equation (5) the magnetic field rotates in one direction and for the other solution the magnetic field rotates in the opposite direction. If the direction of propagation is reversed, then the directions of rotation are reversed.

The above property of the  $TE_{01}$  type of wave is made use of in the resonance isolator in the following manner. A thin plate of suitable ferrite material is inserted in the waveguide, parallel to the narrow wall, at the appropriate value of  $x$  given by the solution of equation (5). A d.c. magnetic field, of value  $H_{RES}$ , is applied to the ferrite in the  $z$  direction so that for the forward direction of transmission the loss in the ferrite is low (corresponding to the field  $H'_{RES}$  of Fig. 2) and for the reverse direction of transmission gyromagnetic resonance occurs which results in a high loss.

#### RESONANCE ISOLATOR FOR USE AT 4,000 MC/S

The isolator to be described is primarily intended for insertion in aerial feeder systems and the performance requirements are fairly stringent. The target specification was as follows:

Forward loss	less than 1 db
Reverse loss	in excess of 20 db
Voltage-standing-wave ratios (v.s.w.r.) in both forward and reverse directions	better than 0.98
Band-width over which the above performance is maintained	at least 200 Mc/s* and preferably 400 Mc/s

A ferrite-loaded waveguide is, owing to the nature of the ferrite, a complex structure and no simple theory is available which enables its performance to be predicted analytically. It has therefore been necessary to design the present isolator on an empirical basis.

A thin ferrite plate mounted in a waveguide parallel to the electric field should obviously be placed at a point where the magnetic field is circularly polarized. If it is placed at a point where the magnetic field is elliptically polarized the forward loss will be increased. This follows from the fact that an elliptically polarized field can be resolved into two circularly polarized fields rotating in opposite directions and one of these components will produce a loss due to gyromagnetic resonance. The field distribution in a waveguide is modified by the insertion of a piece of ferrite since the relative permittivity of the ferrite is fairly high, about 12. Nevertheless it was found that the optimum position for the ferrite agreed reasonably well with that given by the solution of equation (5).

It can be deduced that the position of circular polarization in the empty waveguide varies between 0.45 in. and 0.55 in. from the wall for a variation in frequency from 3,800 Mc/s to 4,200 Mc/s. In view of this it was decided to try a ferrite plate of sufficient thickness to cover this variation. A magnesium-manganese ferrite

\* This band-width is required to enable the isolator to be used in wideband radio relay systems conforming to the frequency plan proposed by the International Radio Consultative Committee (C.C.I.R.), 'Documents of the VIIIth Plenary Assembly, Warsaw, 1956, Vol. 1, pp. 201-203, Recommendation No. 194.'

plate 0.125 in. thick, suitably positioned in the waveguide, resulted in an almost constant reverse loss over the required frequency band. The external magnetic field necessary for ferromagnetic resonance was, however, increased with the increase in ferrite thickness due to demagnetization effects. Reducing the height of the ferrite in the waveguide increased the ratio of reverse-loss/forward-loss but the reverse loss per unit length was reduced; an increased length of ferrite was therefore necessary in order to achieve a satisfactory reverse loss.

The final shape of the ferrite insert was an almost square section which gave a very satisfactory ratio of reverse-loss/forward-loss but a high value of external magnetic field was required to obtain gyromagnetic resonance. In order to achieve this magnetic field with a permanent magnet of reasonable size the narrow dimension of the waveguide was reduced and soft-iron inserts were inserted in the broad face of the waveguide under the pole pieces, thereby reducing the reluctance of the magnetic circuit. The value of the magnetic field required is about 2,800 oersteds.

The reduction in waveguide height necessitated an impedance transforming section at each end of the isolator. The transforming sections take the conventional form of binomial stepped sections<sup>4,5</sup> and as a matter of convenience the two transformers and narrow waveguide were made as a complete unit, as shown in Fig. 5.

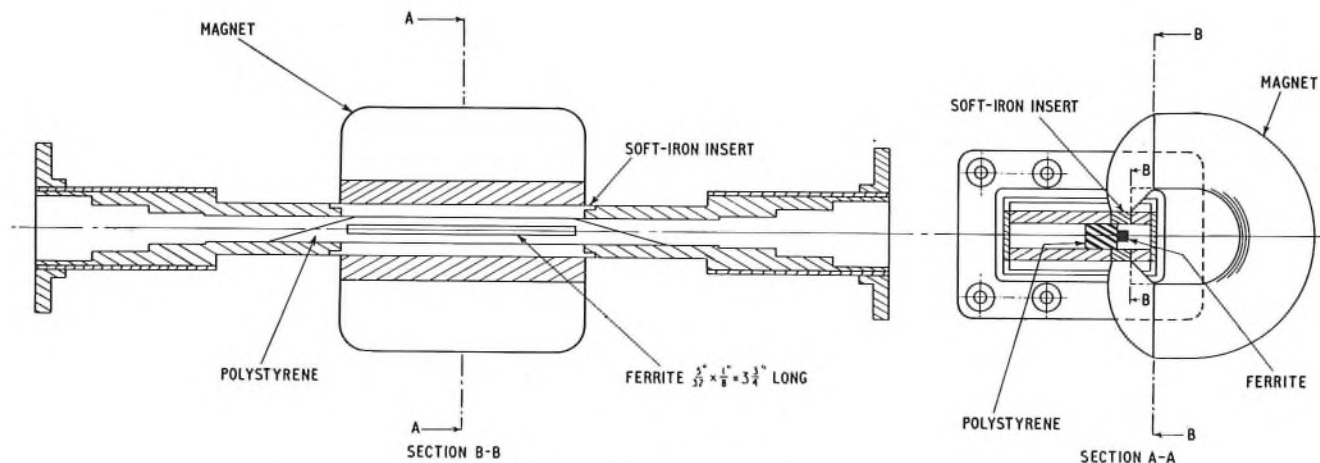

FIG. 5—MECHANICAL ARRANGEMENT

As stated previously, the main function of an isolator is to absorb reflected waves. It is therefore important that this energy is not reflected again by the ferrite and its support before absorption in the ferrite occurs. Hence, the ferrite and its mount must be well matched to the waveguide. A reasonable match can be obtained by tapering the ferrite, but it is preferable to mount it on a tapered dielectric slab. The dielectric slab concentrates the r.f. field in the ferrite and increases the reverse loss. As is to be expected, the dielectric has the greater effect when placed on the side of the ferrite remote from the waveguide wall since the electric field is more intense here than on the side near to the waveguide wall. The reverse-loss/forward-loss ratio is also improved, the dielectric probably reducing the ellipticity of the polarization of the field within the ferrite.<sup>6</sup>

The complete isolator is shown in Fig. 6. It will be

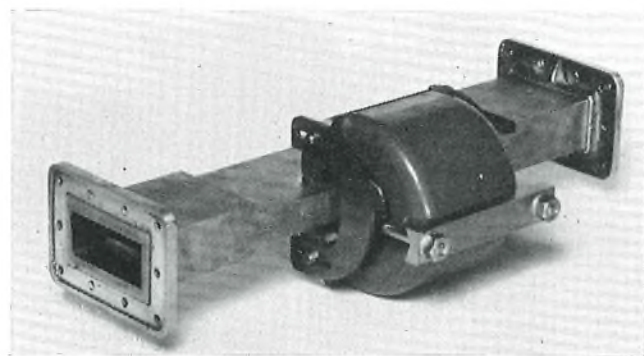

FIG. 6—VIEW OF COMPLETE RESONANCE ISOLATOR

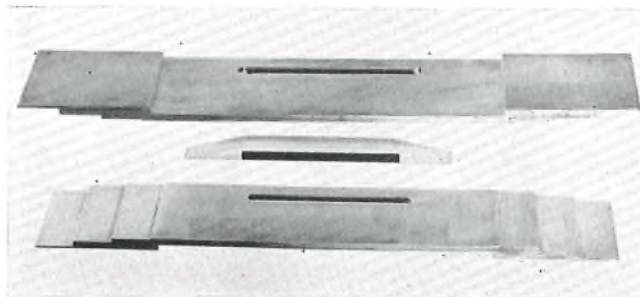

FIG. 7—COMPONENT PARTS OF RESONANCE ISOLATOR

seen that a shunt is provided on the permanent magnet which enables the d.c. magnetic field to be adjusted for optimum performance over the frequency band. Fig. 7 shows the component parts of the isolator.

#### Performance

Fig. 8 shows the measured characteristics of the isolator described above. The reverse loss is slightly below the target specification of 20 db at a frequency of 3,800 Mc/s but it will nevertheless be quite adequate. The desired v.s.w.r. of 0.98 could not be achieved over the full 400 Mc/s frequency band. When, however, the v.s.w.r. is below this figure it could undoubtedly be improved, at least over a limited bandwidth, by fitting capacitive tuning screws in front of the binomial transitions.

The magnesium-manganese ferrite used has a fairly



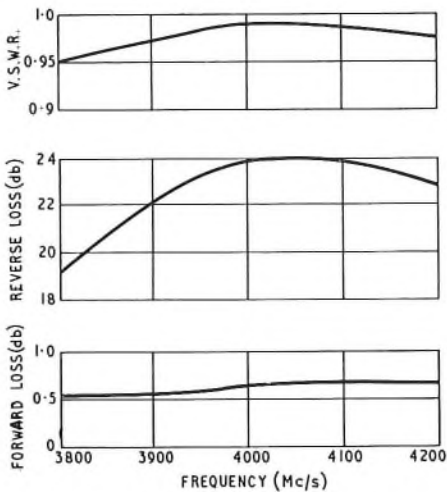

FIG. 8.—PERFORMANCE

high Curie\* temperature, about 300°C, and the isolator performance should not therefore be susceptible to changes in ambient temperature. This was confirmed for a 20°C rise in ambient temperature, there being a negligible change in the attenuation characteristics. The v.s.w.r. was, however, degraded slightly and fell to 0.91 at 3,800 Mc/s.

#### CONCLUSION

The isolator described is of the resonance type in waveguide. It is, however, possible to construct coaxial-line isolators<sup>7</sup> whose principle of operation is essentially the same. Other types of waveguide isolator are possible; for example, the field-displacement isolator,<sup>8</sup> which

\* The Curie temperature is the temperature at which ferromagnetism disappears.

operates with a smaller magnetic field, has a higher reverse-loss/forward-loss ratio and can dissipate more power. The lowest frequency of operation of this type of isolator is, unfortunately, about 4,000 Mc/s, limitations of the ferrite material which is available at present resulting in a high forward loss at lower frequencies. Resonance isolators can, however, be made to operate at frequencies as low as 1,000 Mc/s. It is probable that in the future, yttrium garnet materials having much smaller line-widths will permit the construction of isolators which will have a satisfactory performance at frequencies as low as a few hundred megacycles per second.<sup>9</sup>

#### References

- <sup>1</sup> CLARRICOATS, P. J. B., HAYES, A. G., and HARVEY, A. F. A Survey of the Theory and Applications of Ferrites at Microwave Frequencies. *Proceedings I.E.E.*, Paper No. 2229R, Oct. 1956 (Vol. 104, Part B, Supplement No. 6, p. 267).
- <sup>2</sup> FOX, A. G., MILLER, S. E., and WEISS, M. T. Behaviour and Applications of Ferrites in the Microwave Region. *Bell System Technical Journal*, Vol. 34, No. 1, p. 5, Jan. 1955.
- <sup>3</sup> LAX, B. Frequency and Loss Characteristics of Microwave Ferrite Devices. *Proceedings I.R.E.*, Vol. 44, No. 10, p. 1368, Oct. 1956.
- <sup>4</sup> SOUTHWORTH, G. C. Principles and Applications of Waveguide Transmission (Van Nostrand, 1950), p. 269 et seq.
- <sup>5</sup> COLLIN, R. E. Theory and Design of Wideband Multi-section Quarter-Wave Transformers. *Proceedings I.R.E.*, Vol. 43, No. 2, p. 179, Feb. 1955.
- <sup>6</sup> WEISS, M. T. Improved Rectangular Resonance Isolators. *I.R.E. Transactions on Microwave Theory and Techniques*, MTT-4, p. 240, Oct. 1956.
- <sup>7</sup> DUNCAN, B. J., SWERN, L., TOMIYASU, K., and HANNWACKER, J. Design Considerations for Broadband Ferrite Coaxial Line Isolators. *Proceedings I.R.E.*, Vol. 45, No. 4, p. 483, April 1957.
- <sup>8</sup> WEISBAUM, S., and SEIDEL, H. The Field Displacement Isolator. *Bell System Technical Journal*, Vol. 35, No. 4, p. 877, July 1956.
- <sup>9</sup> HOGAN, C. L. Round-Table Discussion on Design Limitations of Microwave Ferrite Devices. *I.R.E. Transactions on Microwave Theory and Techniques*, Vol. MTT-6, No. 1, p. 104, Jan. 1958.

## Book Review

"Magnetic Tape Recording." H. G. M. Spratt, B.Sc. (Eng.), M.I.E.E. Heywood & Company Ltd. 319 pp. 168 ill. 55s.

Technical advances in magnetic recording have been rapid and, while much has been published on the subject, the information is widely scattered. Mr. Spratt has performed a valuable service in this book in collecting together the essential features of the most important work of recent years. It is well written, and it is probably the most useful book on magnetic recording that has appeared since S. J. Begum's well-known work was published in 1948.

Mr. Spratt writes essentially for the professional engineer, rather than for the informed amateur, but that does not mean that the book is difficult to read; on the contrary, it is written in an easy flowing style which is admirably readable, and yet always maintains a high standard of technical accuracy.

The book is mainly an account of the basic principles of magnetic recording and an enumeration of the characteristics of both the medium and the machines. It commences with a clear and well-written review of the principles of magnetism, with special emphasis on those aspects of importance in magnetic recording.

The principles of magnetic tape recording are then dealt with at some length. This section covers the subject very thoroughly and concludes with an excellent bibliography. The subject of high-frequency bias is well covered, and in the absence of a fully acceptable explanation of its operation the author gives all three of the current theories.

Another section deals in some detail with the manufacture and properties of the tape, and contains a good deal of information which is not readily available elsewhere about the processes of manufacture. Further chapters deal with the requirements and features of recording and reproducing machines, and review the many applications of tape recording. The book concludes with a chapter on standardization of recording characteristics.

The technical standard of the writing is high, and the book is unusually free from errors. One or two of an editorial nature may be noticed—for example, Fig. 153 shows a capstan and pinch-roll drive and not the sprocketed wheel drive which it purports to illustrate—but these are of a trivial nature and do not detract from the value of the work as a whole. Altogether the book may be well recommended to the engineer who seeks information on any aspect of magnetic recording.

F. E. W.

*I.P.O.E.E. Library No. 2500.*

# Notes and Comments

## New Year Honours

The Board of Editors offers congratulations to the following engineers honoured by Her Majesty the Queen in the New Year Honours List:

East Telephone Area, London ..	F. J. Fisk ..	..	..	Technical Officer ..	..	British Empire Medal
Telecommunications Region						
Engineering Department ..	D. C. Walker ..	..	..	Senior Executive ..	..	Member of the Most Excellent
				Engineer ..	..	Order of the British Empire
Lancaster Telephone Area ..	R. W. M. Burns, D.C.M.			Technician, Class I ..	..	British Empire Medal
Leafield Radio Station, Oxford..	A. J. Welberry ..	..	..	Technical Officer ..	..	British Empire Medal
Newcastle upon Tyne Area ..	T. P. Pitloh ..	..	..	Executive Engineer ..	..	Member of the Most Excellent
						Order of the British Empire

## Recent Award

The Board of Editors has learnt with pleasure of the honour recently conferred upon the following engineer:

Belfast Telephone Area ..	J. F. H. Pearcey, T.D. ..	..	..	Major, Royal Corps ..	..	Ordinary Member of the
				of Signals, T.A.		Military Division of the
						Most Excellent Order of the
						British Empire

## E. A. Speight, B.Sc., Ph.D., A.R.C.S., D.I.C.

Dr. Speight, whose promotion to Senior Principal Scientific Officer in charge of the chemical work of the Materials Division of the Research Branch was announced last August, read chemistry at the Royal College of Science, gaining his B.Sc. (1st class honours) and A.R.C.S. in 1923, and a Ph.D. and D.I.C. in 1926.

After a period as a research chemist with British Dyestuffs Corporation (now a part of Imperial Chemical Industries, Ltd.), he joined the Research Branch in 1930. For a while he worked in the chemical laboratory, but an interest in optics led to his being engaged on problems to do with photoelectric cells, sound-film reproduction and letter facing in postal mechanization.

In 1934 Dr. Speight was promoted to Assistant Engineer (old style). It was about this time that the Post Office decided to provide a speaking-clock service. Many will remember the part he played in this project, the London service of which commenced in 1936.

In 1937 Dr. Speight was put in charge of the Physics Group, where thermionic valves and the properties of magnetic and dielectric materials claimed his attention.

Promotion to Executive Engineer (old style) followed in 1939.

From 1944-47 he was in charge of the Acoustics Group. During this time the Scientific Civil Service grades were introduced into the Department and Dr. Speight was transferred to these in 1946 as a Principal Scientific Officer.

In 1949 he returned to the field of chemistry as leader of a newly formed group in the Materials Division. At first he was concerned with radio-chemical work, but later was mainly engaged on the materials side of semiconducting devices.

In past years Dr. Speight was active in Staff Association matters. From 1950-57 he was chairman of the Research Station Social Club and until recently conducted the Station orchestra. His interests outside official duties are music, motoring and foreign travel.

Dr. Speight is respected by his friends and colleagues for his never-failing good humour, kindness and approachability. All who know him will wish him well in his new appointment.

E. V. W.



## Supplement to the Journal

With the introduction of a revised scheme for the telecommunications examinations held annually by the City and Guilds of London Institute it has been necessary to consider the future contents of the Supplement to the Journal. The Board of Editors has decided that when the new syllabus has been fully introduced the model answers in the Supplement will be restricted to the 22 subjects of the Telecommunication Technicians' Course, the program of publication of model answers being arranged so that the change to the new syllabus is made as quickly as possible. It is planned to start publishing model answers to the subjects of the new syllabus in the October 1959 issue of the Supplement.

## Board of Editors

Mr. H. G. Beer has resigned from the Board of Editors, following a change of official duty. The Board wishes to express its appreciation of the valuable services rendered to the Journal by Mr. Beer during the past six years.



# Institution of Post Office Electrical Engineers

## Subscriptions and Income Tax Relief

The Finance Act, 1958, allows, under certain conditions, income tax relief on subscriptions to approved learned societies. The Commissioners of Inland Revenue have approved the Institution of Post Office Electrical Engineers for the purposes of Section 16 of the Act; and the whole of the annual subscription paid by a member who qualifies for relief under that Section will be allowable as a deduction from the amount of his salary assessable to income tax under Schedule E.

The relief applies commencing with the tax year ending 5 April 1959.

Members (Corporate and Corresponding) should make claim for the relief to their appropriate tax offices on Form P358, which can be obtained from the tax office. The form details the conditions under which relief is given and the second only of its two "boxes," which refers among other things to approved learned societies, should be completed before returning the form.

## Retired Members

The following members, who retired during 1958, have retained their membership of the Institution under Rule 11 (a):

A. E. Hayward, Lyncot, Ringwood Road, Ferndown, Dorset.

G. J. S. Little, 91 Cannon Lane, Pinner, Middlesex.

W. F. Smith, 8 Pitfield Drive, Meopham Green, Meopham, Kent.

J. E. Thwaites, 522 Walmersley Road, Bury, Lancashire.

S. WELCH, *Secretary*

## Additions to the Library

Library requisition forms are available from Honorary Local Secretaries, from Associate Section Centre Secretaries and representatives, and from the Librarian, I.P.O.E.E., G.P.O., 2-12 Gresham Street, London, E.C.2.

2519-20 *Mathematics for Higher National Certificate—Vol. 1 and 2.* S. W. Bell and H. Matley (Brit. 1955/1958).

Vol. 1. For students reading mathematics for H.N.C. in Engineering. Vol. II. Covers the work done in the final year of H.N.C. in Electrical Engineering.

2521 *Once Round the Sun.* R. Fraser (Brit. 1958).

The story of the International Geophysical Year, 1957-58.

2522 *The Reproduction of Colour.* R. W. G. Hunt (Brit. 1957).

Covers the fundamental principles of colour reproduction by photography, television or printing, without mathematics or technicalities.

2523 *Electronic Circuits.* E. J. Angelo (Amer. 1958).

Deals with the fundamental concepts and techniques basic to all the topics embraced by the study of electronics.

2524 *The Junction Transistor and its Applications.* E. Wolfendale (Brit. 1958).

Gives a comprehensive introduction for engineers to the junction transistor, its equivalent circuit and its application.

2525 *Basic Electrical Engineering.* J. Shepherd, A. H. Morton and L. F. Spence (Brit. 1958).

A clear and reasonably concise introduction to the subject, aimed at the O.N.C. student: uses the rationalized M.K.S. system of units.

2526 *Atomic Energy.* E. Larsen (Brit. 1958).

A layman's guide to the atomic age.

2527 *Physics and Mathematics in Electrical Communication.* J. O. Perrine (Amer. 1958)

A treatise on conic-section curves, exponentials, alternating currents, electrical oscillations and hyperbolic functions.

W. D. FLORENCE, *Librarian*

## Book Review

"Circuit Analysis of Transmission Lines." J. L. Stewart, John Wiley and Sons, Inc., N.Y. Chapman and Hall, London. 186 pp. 72 ill. 44s.

A transmission line is the basic component of all conventional telephone and telegraph circuits and a knowledge of its properties is required by many of the people who provide and maintain such circuits. Those concerned with manufacturing transmission lines need a specialized knowledge of their internal physical properties, namely the relations between the constants and geometry of the constituent materials and the resulting overall electrical properties; in this respect their requirements are analogous to those of the manufacturer of any other component.

The majority of people, however, encounter the transmission line only as a ready-made component, buying it by the yard as, for example, one buys resistors by the ohm, and are concerned primarily with the external electrical properties that govern how it will perform when connected to other pieces of equipment. "Circuit Analysis of Transmission Lines" caters for readers in just this class.

One possible approach to the subject is to regard the transmission line as a symmetrical two-terminal-pair network (whose terminal pairs may, rather inconveniently, appear in different towns) and to omit any special treatment on the grounds that it is all covered in standard network theory. From some points of view this may be adequate but it depreciates the very special and important part that transmission lines can play. The better way, as given in the

present book, is to subordinate this viewpoint to one which gives a clearer physical picture of the transmission of electrical signals along a line.

The book starts with the simple differential equations governing voltage and current on a uniform line and develops the concept of wave motion along the line by considering the simplest possible solutions to these equations. This leads to a step-by-step discussion of transient waves travelling along and being reflected at the terminals of nearly lossless lines. It is well described and is refreshingly realistic compared with some elementary approaches that try to pamper the student by treating the line as an extended attenuator with the effects of inductance and capacitance explained away as side issues. This simplified description of the transient behaviour is followed by a more conventional study of the sinusoidal steady-state properties. Apart from having the up-to-date flavour of a newly written book this part differs little from what may be found in any textbook on the subject and deserves no special comment. The remainder of the book concerns itself with applications of transmission lines, measurements on lines and finally a description of the Smith chart.

Altogether it is a fairly easy and quite a pleasant book to read, being free of unnecessary mathematics and elementary in content. It is assumed that the book was originally written for the author's undergraduate students at the University of Southern California; in this country it should be suitable for use in any undergraduate or Higher National Certificate course, although, as with many American textbooks, the price may be a deterrent.

H. J. O.

# Regional Notes

## Northern Ireland

### HEATING AND LIGHTING OF ST. GEORGE'S BRANCH POST OFFICE, BELFAST

An unusual method of heating has been adopted in St. George's Branch Post Office, Belfast. It takes the form of hot-water pipes mounted in the ceiling, with heat-insulating material above, and acoustic tiles below, the pipes, thus leaving the floor area completely free from heating fixtures. The system, which was manufactured by Frenger Ceilings Ltd., has been in use for over 12 months and during the past winter satisfactory temperatures were maintained.



ST. GEORGE'S BRANCH POST OFFICE, BELFAST

The space available for the public office is approximately square. As will be seen from the photograph, in order to make the counter as long as possible, it has been arranged almost diagonally across the area. The pattern of the lighting fittings has, therefore, been arranged accordingly and not to match the ceiling panels. This feature is one reason why module-type lighting fittings were not chosen. Another reason is that this type of fitting would have restricted the placing of lights over the public writing-desks because of the end connexions to the heating pipes.

J.L.F.

## Home Counties Region

### STORM DAMAGE AT HORSHAM

A freak storm of unparalleled violence swept across the northern part of the Brighton Telephone Area on the evening of 5 September 1958. The disturbance, which was classified as a tornado, affected an area approximately 6 miles wide running from the south-west to the north-east of the Horsham area. It left a train of devastation in its wake reminiscent of a war-time air raid. The main trouble was caused by a hailstorm, during which hailstones up to 2½ in. in diameter fell for an appreciable time, damaging hundreds of homes, uprooting trees, ruining crops and blocking roads. This was followed by high winds and torrential rain which further increased the devastation. As an indication of the extent of the damage one firm alone supplied over 15,000 sq. ft. of glass, which was used to replace windows and repair greenhouses smashed by hail.

Post Office plant did not escape the storm's ravages and a number of overhead routes were brought down by falling trees. As soon as the peak of the storm had passed, each U.A.X. in the affected area was visited and a preliminary survey of damage made. Faulty lines were disconnected at

the distribution frame and the condition of the power supply was ascertained. A total of seven U.A.X.s were without power due to the overhead power lines suffering the same fate as their Post Office counterparts.

As an indication of the extent to which roads were blocked, a lineman setting out on a 4-mile journey was forced to make many detours and finally travelled over 57 miles before reaching his destination.

By the morning of Saturday, 6 September, a fairly complete picture of the damage was obtained and the necessary plans to deal with the situation were drawn up. As is usual in conditions such as these, the staff rose to the occasion and worked well on the task of restoration.

Altogether some 1,800 faults above the normal average were cleared, the majority of these necessitating the replacement of overhead plant. It is noteworthy that during this time a very heavy load of assistance traffic was thrown on the Horsham manual board, where it was dealt with most efficiently.

H. M. W.

## North-Eastern Region

### MANUAL RELIEF AT CHESTERFIELD EXCHANGE

The Siemens No. 16 exchange at Chesterfield is equipped for a 3,500 multiple, and completely fills the apparatus room. In November 1955, it became clear that relief, of the order of 1,200 multiple, would be necessary before the new building was ready for the installation of a new exchange. The only accommodation available was adjacent to the manual room and the question of providing a manual relief exchange was investigated.

C.B. 10 switchboard positions were ruled out because of lack of accommodation for the line and cut-off relays. C.B.S. No. 2 switchboard positions, modified for C.B. working, were attractive but it was considered undesirable to have separate junction routes from the main and relief switchboards to the outlying exchanges and, in any case, there was no space in the apparatus room for the additional relay-sets that would have been required. The difficulty was overcome by using the modified C.B.S. positions and arranging for a small number of outgoing circuits on each route to appear on the relief switchboard as an extension of the main switchboard multiple.

The main switchboard is operated from a 60-volt battery and the relief switchboard from a 30-volt battery, and it was, therefore, necessary to ensure that these supplies were separated under all possible conditions. This was accomplished by using jacks with auxiliary springs on the relief switchboard outgoing-junction circuits, as shown in the

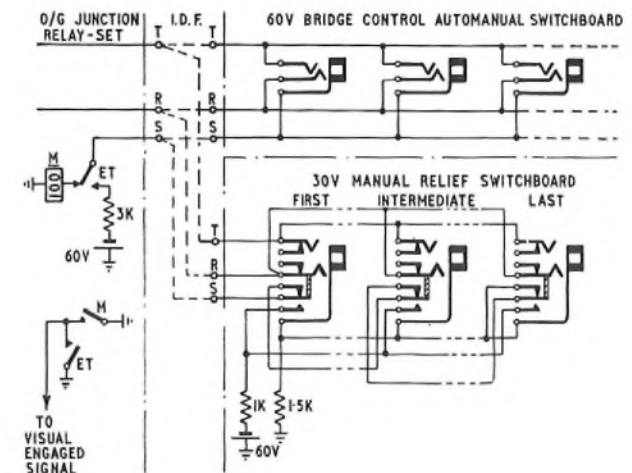

METHOD OF CONNECTING MAIN AND RELIEF OUTGOING-JUNCTION MULTIPLES



diagram. By this means a plug in an outgoing-junction jack of the relief switchboard gives an engaged condition and operates the visual engaged signal on the main switchboard. A plug in an outgoing-junction jack of the main switchboard gives an engaged-test condition to the relief-switchboard multiple, the operator testing for the engaged "click" in the usual way.

The relief-switchboard dials are connected to the 60-volt battery to conform with the main bridge-control switchboard, so that the conditions given by the relief switchboard to the existing Siemens No. 16-type junction equipments are virtually the same as those from the main switchboard. Incoming-junction calls are received at the main switchboard and transferred to the relief switchboard when necessary over tie circuits.

The subscribers connected to the relief switchboard have numbers in the 75xxx range and level 75 has been trunked out to the relief switchboard. No special segregation of subscribers' lines is necessary as the T.E.R. and signalling limits for subscribers connected to the relief switchboard are substantially the same as those for subscribers connected to the automatic exchange.

The relief switchboard has now been brought into service with 1,000 multiple and 900 calling equipments, and no difficulties are being experienced.

A. H. L.

#### DESICCATING A COAXIAL CABLE

A 193 yd section of  $4 \times 0.375$  in. coaxial tubes + 2 pr., 20 lb/mile + 16 pr., 20 lb/mile + 228 pr., 20 lb/mile P.C.Q.T. cable was provided recently in a 6 in. steel pipe laid across the bed of the River Trent near Scunthorpe, Lincolnshire.

During cabling operations the seal on the leading end of the cable was damaged and water penetrated the sheath. As much as possible of the wet cable was cut off and the remaining length desiccated, but in view of the quantity of moisture remaining in the tubes it became obvious that extraordinary treatment would be necessary to salvage the length economically. The currents obtainable with a 3-volt battery connected to the inner and outer conductors of tubes 1, 3 and 4 were respectively 120 mA, 45 mA and 90 mA.

The centre conductors of tubes 1 and 3 were looped at the trailing end of the cable length, and currents of 10 amp, 20 amp and finally 25 amp applied to a loop of 1.128 ohms, which was equivalent to between 0.14 and 0.85 calories per yard per tube. At the same time, dry air at 4 lb/in<sup>2</sup> pressure was passed through a length of metal conduit and into the cable, the conduit passing through a coke brazier. The air coming through the cable at the end distant from the brazier was noticeably warm.

The consequent drying action of current and heated air caused a progressive fall in the currents through the conducting paths and in 10 days, including a weekend during which the cable was left full of carbon dioxide, the insulation improved to a final reading on any tube of 10,000 megohms from centre conductor to outer conductor earthed, and each tube withstood 3 kV for 2 minutes. The insulation resistance of the interstice and audio pairs improved during the operation and is satisfactory.

In fact, tube 3 was cleared in six days, including the weekend, and tube 1 in nine days. Tubes 1 and 4 were used as a loop after tube 3 was cleared.

Whilst the methods used were unorthodox they were considered justified in the circumstances and the cable length will be brought into use if pulse tests are satisfactory.

Some concern was felt that the water in the cable might contain impurities and that with the removal of the water these impurities might be deposited on the insulating disks, but the high-voltage test gives reasonable proof that the disks are still in good condition.

T. A. S. and J. G.

#### North-Western Region

##### MANCHESTER TRUNK MECHANIZATION

A further step was taken in the mechanization of the trunk network in the North-Western Region when the

Manchester Guardian trunk non-director exchange was opened for traffic at 8.0 a.m. on 7 December 1958.

The M.D.F. comprises 45 verticals, and an unusual feature of the frame is the use of connexion strips in place of Protectors H.C. and Test where the circuits are wholly underground; this should reduce fault liability. The switching equipment, consisting of some 219 racks, is arranged symmetrically around an I.D.F. of 67 verticals, reducing cable runs to a minimum. All cable and wire is p.v.c. insulated.

The trunking scheme employs first, second and third selector switching stages, all selectors being of the motor-uniselector group-selector type. The trunk and junction relay-sets provide for a.c. and d.c. signalling, pulse regeneration, and dialling-out facilities to distant manual exchanges. Space has been left for incoming registers to be provided later to cater for S.T.D. traffic.

Adequate testing facilities are provided by six trunk-test racks and two fault-record racks together with 10 automatic routiners of various types. These will be controlled by the new fault-recorder equipment—which can be arranged to operate any routiner, at any time, and make a printed record on a docket of any faults found. Statistical details of the quality of the service provided by the unit will be given by the new centralized-service-observation equipment which has been installed.

The repeater station contains both audio and h.f. equipment. The audio section consists of 2,112 2-wire/4-wire terminating sets, together with line terminating and amplifying equipment. Music-circuit equipment is also included. The h.f. translating equipment serves a number of 24-circuit carrier-cable routes which were diverted to the station. Some 600 carrier channel-ends can be made available.

The exchange power plant is of standard pattern. The batteries are of 4,400 Ah capacity. The repeater station power plant is of the "no-break" type incorporating a motor-alternator which, in the event of a mains failure, is run from a 240-volt battery until the prime-mover supply takes over. Three 279 kW diesel-alternator sets provide a standby power supply in the event of mains failure. They incorporate synchronizing gear so that the three sets can be run in parallel.

Ten CJ cables and 11 trunk cables were diverted to Guardian. In addition six CJ and 13 MU tie cables were provided to points in Telephone House and Central exchange. To allow a minimum of six months for circuit provision with a margin for call-through tests, the cable contract was placed with a tightly programmed schedule of work. All parties concerned, the Engineering Department, the cabling contractor and the Area staff, responded to the need for expediting the work, with the result that all cabling installation work was completed by the target date. Cable interceptions by Area staff were, with one exception, completed 12 months before the transfer date.

Special arrangements were made for the Test and Inspection Branch, Engineering Department, to start acceptance tests on individual cables as soon as they became available. With these arrangements it was possible to complete acceptance testing of all cables three weeks after completion of cable installation.

A total of 1,488 terminating circuits were provided, 782 4-wire amplified and the remainder 2-wire. Of the long-distance circuits, 408 were switched using plant which had been in use for other purposes up to the time of transfer. The lining-up of the circuits was carried out smoothly, greatly facilitated by the excellent co-operation given by the staff at the distant ends in other Areas and Regions.

After preliminary engineering tests on the circuits, extensive traffic trials were made during the period between the completion of the call-through test and the ready-for-service dates. The final engineering tests on the new routes were carried out during 1-5 December 1958 and the switched routes were tested between 10 p.m. and 12 midnight prior to the final transfer on the following Sunday morning.

It will be appreciated that a project of this character needs careful planning and close co-operation between the manufacturers and Post Office staff, and it is worthy of mention that the installation was completed within one week of the original target date of 1 December 1958, which was agreed in May 1956. The success of the operation was due in a large measure to the excellent co-operation afforded by the Engineering Department and other Regions concerned.

### Wales and Border Counties

#### NEATH RIVER BRIDGE—DIVERSION OF POST OFFICE CABLES

The A 48 road crosses the River Neath by a 3-span stone bridge built towards the end of the 18th century, and although a new by-pass bridge has been constructed, there has been no significant easing of traffic at the old bridge, which constitutes something of a bottleneck.

The bridge is 25 ft wide and in its original form did not have footpaths. These were added later by providing brackets attached to the stonework, as shown in the sketch, and carrying an asphalt surface supported by wrought-iron plate.

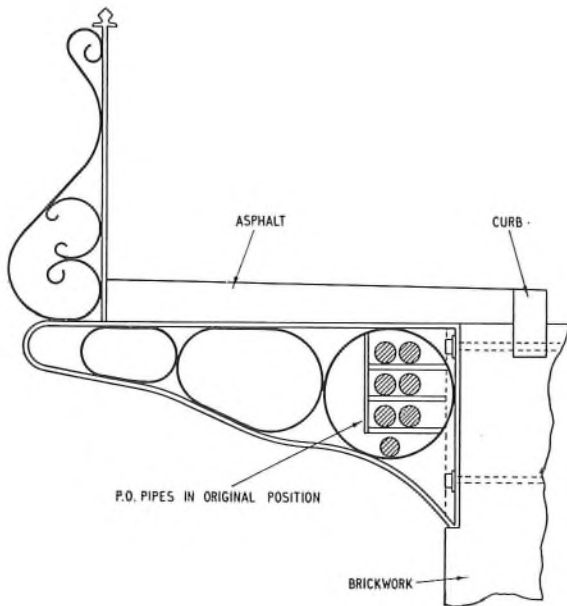

POSITION OF POST OFFICE PIPES UNDER ORIGINAL FOOTPATH

Post Office plant consisted of one C.I. pipe supported in the footway brackets and in use since 1913, together with six steel pipes provided in 1922, accommodated in brackets fixed to the masonry. These pipes carried a total of eight trunk and junction cables and seven local cables. The junction cables varied in size from one of 74 pairs to the largest, a cable comprising 468 pairs and two coaxial tubes.

In 1956 the Post Office was informed by the County Surveyor that the condition of the metalwork supporting the footways had deteriorated to a point where complete reconstruction of the footways had become necessary. The reconstruction work would consist of the provision of four cross-girders of 32 in. x 9 in. section to be positioned at each end of the bridge and over the two intermediate piers. The cross-girders would project at both sides of the bridge and carry two 30 in. x 9 in. section longitudinal girders spaced 3 ft 6 in. apart between webs. The new footpaths would be of reinforced concrete construction carried by the longitudinal girders.

The existing Post Office pipes were at such a level that they would have to be lowered to allow the cross-girders to be dropped into position. Consideration was given to various

methods of lowering and supporting the pipes but, finally, the decision was taken to provide temporary interruption cables in two 4 in. steel pipes. Agreement was reached with the County Surveyor for these pipes to be laid over the surface of the bridge and into the R2-type manholes conveniently situated at each end.

In the preliminary discussions, the County Surveyor pointed out that it would be necessary to move the pipes laterally for a distance of 3 ft and also be able to lift the pipes 1 ft, in order to facilitate the placing in position of the cross-girders. It should be mentioned that, as the bridge could not be closed completely, the cross-girders were to be placed in position in half-sections and connected in the middle of the carriageway. One-way traffic would have to be introduced to enable this operation to be carried out, and also to give the bridge contractor working space.

The necessity to move the temporary pipes in the way mentioned made it essential that there should be slack in the interruption cables at each manhole. The temporary pipes were stopped short of the two manholes and trenches cut to positions where break-throughs could be made into the manholes. It was found convenient to protect the interruption cables between the 4 in. steel pipes and the manhole walls by using sections of steel pole. The steel pole sections could slide back over the 4 in. steel pipes to give access to the cables when it became necessary to ease slack cable out of the manholes.

For the permanent installation, agreement was reached with the County Surveyor that nine new 4 in. steel pipes would be provided, resting on cross-braces connecting the two longitudinal girders, but it was found that these pipes could only be accommodated in an inverted pyramid formation, i.e. four on three on two, due to insistence on the necessity of access for painting the girders. The Post Office were to provide suitable straps to hold the pipes in this formation. The specification for the main work was written to cover the removal by the bridge contractor of the existing pipes and provision of the new pipes as the work proceeded.

The work proceeded as planned. The interruption cables were drawn in at night to avoid obstruction to traffic at a congested spot. A team of 15 jointers worked around the clock for 15 days to a prearranged schedule to effect the change-over of the 2,000 pairs involved.

It may not be generally known that a considerable amount of work has to be carried out by drawing office staff where interruption of trunk and junction cables is concerned. On receipt of the schedule from the works group showing the times at which various cables are liable to interruption, steps have to be taken to minimize difficulty, and in this particular case it meant informing a total of 55 renters of private circuits situated all over the United Kingdom from Westmorland to Cornwall. Following the completion of the diversion the old cables were withdrawn, again at night.

It is significant that although the old cables, including one which was placed in 1923, were recovered without difficulty; the newest cable, in service for only 12 months, could not be moved and it was eventually recovered piecemeal when the old pipes were cut away by oxy-acetylene torch. This cable was a hessian-protected one and it appears that this type of cable may constitute a special problem in recovery.

The provision of the permanent pipes was completed by the bridge contractor without difficulty, and the provision of permanent cable and the change-over took place according to schedule.

It is thought this account of what is a fairly ordinary proceeding for the Post Office may be of interest for the way in which, following agreement with the County Surveyor on the action to be taken, all details relating to work to be carried out for the Post Office by the bridge contractor were written into the main specification. This left the contractor in no doubt as to what he had to do and resulted in a smooth operation which left everyone concerned with a feeling of satisfaction at a job well done.

T. B. G.



# Associate Section Notes

## Stoke-on-Trent Centre

For some time the question of re-forming the Centre, which became inactive in 1948, has been under discussion, and a final decision to do so was taken at a preliminary meeting held on 11 September 1958. This decision was made by a nucleus of 25 enthusiastic members of the staff, who have since expanded the membership to 103, and further increases are expected.

The officers elected for the 1958-59 session are as follows: *Chairman*: H. Todkill (Area Engineer); *Vice-Chairman*: A. E. Fisher; *Secretary*: A. E. Foden; *Assistant Secretary*: R. Barnes; *Treasurer*: C. Bell; *Librarian*: H. L. Williams; *Liaison Officer*: G. R. Stapley; *Committee*: Messrs. C. E. L. Morton, H. S. Ball and R. J. Thomas.

At the first meeting, held on 29 October 1958, an interesting paper on "Review of Transmission in the Midland Region" was given by Mr. G. A. Probert, who is the Regional Liaison Officer between the Senior and Associate Sections.

The November meeting consisted of a film show, at which the following films were shown: "Made for Life," a film about the manufacture of television tubes; "The Oil Rivers," about the oil palms of Western Nigeria; and "Internal Combustion Engine."

In December we had a lecture from Mr. P. Horrocks on "Modern Trends in Telephone Switching," and visited the Central Electricity Authority's power station at Meaford.

At the January 1959 meeting Mr. Alan Iliffe of the North Staffordshire University College gave a lecture on "Experimental Psychology in the Service of Industry." During February visits were made to the Wedgwood Pottery at Barlaston and to the new telephone repeater station in Hanley. During the visit to the repeater station, talks on power equipment, audio and v.f. equipment, cable development and gas pressurization of cables were given by various members of the local staff.

An interesting program for the remainder of the 1958-59 session is in preparation. The attendances at our meetings and the enthusiasm of the officers and members augur well for the future of the new Centre. A. E. F.

## London Centre

This session saw an encouraging increase in the number of members at Centre meetings; at two lectures, one on "Magnetic Tape Recorders" by Mr. F. S. Brasher from the Sheffield Centre, and the other on "The Magnetic Drum as applied to Telecommunications," given by Messrs. J. E. Wright and W. Stones, there were attendances of over 100. This is a very heartening state of affairs, which it is hoped will continue.

The penultimate lecture of the session, in April, on "Plastics and their Applications" will be given by Mr. G. D. Newell of Ericsson Telephones, Ltd. It will cover the processes used in a telephone factory for the preparation, moulding and forming of plastics. The last lecture, which will be followed by the annual general meeting, is "Trick Work in Television Production" and is to be given by Mr. D. R. Campbell, a B.B.C. television engineer. The lecture will deal with the inlay and overlay apparatus used by the B.B.C., and, if possible, will be illustrated with a telerecording of one of the "It's Magic" programs.

The inter-Area technical quiz has been revived this session and six Areas are participating. At the time of writing there have been two close matches, with City Area beating East Area, and West Area beating Long Distance Area. The South-West Area have yet to play their match, in this first round, with Centre Area. Although audiences have been non-existent in spite of publicity and canvassing of members, the teams have enjoyed the contests, thus making them worth running.

A new motor-driven duplicator was bought in the autumn for production of the Quarterly Journal and to enable any duplicating work to be undertaken for the Areas. As an experiment, it is to be used for the production of posters for the Centre meeting in February. Areas have generously contributed towards the cost, and the Centre committee looks forward to equally generous contributions in the form of articles for the Quarterly Journal, from all members.

Two of our members have won Institution awards for papers read during the 1957-58 session. Mr. P. Goodwin of St. Albans exchange received his award at a presentation by the Telephone Manager, North Area, at Bowes Park exchange in December. His prize-winning paper was entitled "An Introduction to the Post Office Standard P.A.B.X.s." The second award was made to Mr. K. Verity, of Long Distance Area, for his paper "Radioactivity and Some Peaceful Applications," the presentation by the Telephone Manager, North-West Area, taking place at the Telephone Manager's office in January.

The London Centre committee have decided not to pursue the matter of an Associate Section diary any further at the present time. The Area chairmen reported only slight interest from their members and this, together with the probable high cost of the project, made the committee decide against it. Interest in an Associate Section tie remains, however, and designs were submitted at the January committee meeting by South-West Area, the originators of the idea, and the Circuit Laboratory. A design from South-West Area was thought to be most suitable, and a report from the Area on the cost of producing the tie is expected at a future meeting. D. W. W.

## Slough Centre

The Slough Centre commenced its winter program in September 1958 and we are very grateful to the following speakers who so kindly gave up their time to talk to us. The meetings were well supported by the Senior and Associate sections.

September 1958: The Telephone Manager of Reading Area, Mr. E. W. Weaver (President), spoke on the duties of a "Telephone Manager."

October 1958: Mr. Rackham, Traffic Division, Reading, presented a lecture and films on "Industrial Automation."

November 1958: Mr. H. J. C. Spencer, Subscribers' Apparatus and Miscellaneous Services Branch, Engineering Department, spoke on the new Telephone No. 706.

December 1958: Films were shown by an ex-member of the Guildford Area, Mr. Wilkinson, on "Integrated Flight System"—navigating and landing a Viscount aircraft; "Commercial Radar"—weather forecasting by means of radar; and "Some Recent Achievements in Electronics."

Once again on behalf of the Slough Centre, thank you, gentlemen, for these very interesting lectures and talks. F. R.

## Guildford Centre

The Guildford Centre has been quite active during the past six months.

Congratulations are extended to our secretary, Mr. E. N. Harcourt, who has been awarded first prize by the Institution for his paper "Cable Corrosion—Some Causes and Cures." He received a cheque for seven guineas and the Institution's certificate of merit at a presentation made by Mr. A. H. C. Knox, President of the Associate Section. The members who heard this interesting lecture will, no doubt, feel this prize was very well deserved.

The winter program has included a tour of Guildford repeater station and Guildford automatic telephone exchange.

Mr. T. O. Robinson gave an interesting lecture on "Time-Keeping Through the Ages" on 23 October 1958. The lecture was illustrated by an impressive display of timepieces of various sizes and ages.

A talk on hobbies was given by members of the Centre in November and was very enjoyable. The hobbies discussed included canoe building, tape recording, cinematography, and wine making.

A monthly film show of engineering and general interest has also been presented at Guildford and Haslemere, and visits have been made to Hurn Airport, L.E.C. Refrigeration, and Rotunda Organ Works.

Forthcoming events include a lecture on S.T.D. by Mr. Wraight, a demonstration of coaxial cable jointing, and visits to Harold Lebus Ltd. (furniture manufacturers) and A.E.C., Ltd. (bus and coach builders). J. F. T. W.

#### Hitchin and Luton Centre

The Centre was formed on 8 July 1958 at the Hitchin automatic telephone exchange. The following officers were elected: *Chairman*: Mr. C. D. S. G. Robertson; *Vice-Chairman*: Mr. S. V. Little; *Treasurer*: Mr. M. W. Hardyman; *Secretary*: Mr. E. T. Nicholls; *Committee*: Messrs. D. W. Edwards, R. G. Baker, G. H. Palmer, D. S. Battams, H. Dharwar and R. N. Alston.

Our efforts from that date until our inaugural meeting were concentrated on increasing our membership and preparing a program.

The inaugural meeting was held at Hitchin automatic telephone exchange, and our president, Mr. A. H. C. Knox, gave a most interesting talk on "Promotions and Appraisements" within the Post Office Engineering Department. We were able to announce our membership as 45 and still growing. We were also happy to welcome members from Baldock radio station. On 1 January 1959 Mr. W. A. J. Paul of Dollis Hill Research Station gave a talk, with films, on cinematography, its use in industry and its special application to the work of the Post Office in all departments.

We are continuing with visits to places of interest, including one to New Scotland Yard.

The Hitchin and Luton Centre are sorry to lose their chairman, Mr. C. D. S. G. Robertson, who is taking up a new appointment, but wish him every success in his new position. E. T. N.

#### Brighton Centre

The annual dinner of the Centre was held on Friday, 5 December 1958. Among the guests were Mr. A. H. C. Knox, President of the Associate Section, and Mr. H. C. Andrews, Telephone Manager of Brighton. This excellent function was attended by some 50 members of the Brighton Centre.

The rest of the Centre's activities have been very well supported. These included film shows, members' lectures and interesting talks by guest speakers, one of which was given on 7 January 1959 by Mr. F. L. N. Samuels Telephone Exchange Systems Development Branch, Engineering Department, who spoke on "The Magnetic Drum." K. R. B.

#### Bishops Stortford Centre

We are happy to report that our membership is still very keen, and the Centre, though small in numbers, is flourishing.

In October 1958, a talk on "Optical Aids to Development and Maintenance" proved extremely interesting, particularly in its application to problems associated with automatic switches.

A talk and demonstration on "The Magnetic Drum," given by Mr. F. L. N. Samuels, Telephone Exchange

Systems Development Branch, Engineering Department, in November 1958 was very interesting and instructive.

In January 1959, after a wait of five years, we were fortunate in making a conducted tour of H.M.T.S. Monarch; this was a real highlight for 20 of our members. Later in the year it is hoped to visit Ford's motor works. J. P.

#### Ipswich Centre

The winter program commenced with a most interesting and instructive film show which included films of the transatlantic cable, radio valve and television tube manufacture, and the theory of transistors. Mr. R. Tungate gave a most instructive and enjoyable paper at our November meeting. The paper was much appreciated, particularly by our external members.

We were very pleased to welcome to our December meeting Mr. A. H. C. Knox, the President of the Associate Section, and Mr. H. W. Harrison, the regional liaison officer, this being their second visit to Ipswich. Mr. Knox presented one of our members, Mr. T. A. D. Clarke, with a certificate won in a recent I.P.O.E.E. essay competition; the photograph shows the presentation. The rest of the evening was



By courtesy of the East Anglian Daily Times

MR. KNOX MAKING THE PRESENTATION TO MR. CLARKE

taken up by a quiz with our Colchester colleagues under their team leader, Mr. F. Radcliffe, Area Engineer. Ipswich, under their team leader Mr. P. E. Buck, were able to even the score having been defeated at Colchester last winter.

The January meeting gave members an opportunity to appreciate the value of photography as a fascinating hobby when our chairman, Mr. P. E. Buck, gave his well-illustrated and interesting talk on the subject.

During February we had a talk by Mr. G. D. Emmerly on "Radio and TV Interference," followed in March by a paper and demonstration on "ERNIE." A. F. G.

#### Bradford Centre

The annual general meeting of the Centre was held at Manchester Road automatic exchange on Wednesday, 4 June 1959. The following officers were elected: *Chairman*: Mr. A. J. Procter-Blain; *Secretary*: Mr. R. C. Siddle; *Treasurer*: Miss E. P. Hawkins; *Librarian*: Mr. D. Relton; *Committee*: Messrs. E. Dennison, M. Firth, C. M. Rowland, M. Farnell, A. Fawbert and B. Rowe.

The program for 1958-59 was arranged as follows:

10 September 1958: Visit to Messrs. Briggs Motor Works, Doncaster.

1 October 1958: Full day visit, by air, to London Airport.

6 November 1958: Evening visit to I.T.A. transmitting station, Emley Moor.

11 December 1958: "Subscriber Trunk Dialling." Paper presented by Mr. T. Barker, Assistant Engineer, North-Eastern Regional Office.



22 January 1959: "Amateur Radio." A talk by Messrs. Dennison and Firth, including practical demonstrations.

19 February 1959: "Promotions and Appraisements." Talk by Mr. A. H. C. Knox, President of the Associate Section. This was a joint meeting with Leeds Centre, held in Leeds.

26 March 1959: "Holidays Abroad." Talk by Mr. J. Redfern, illustrated by colour slides.

16 April 1959: Full-day visit to Ericsson Telephones, Ltd., Beeston.

17 June 1959: Annual general meeting and film show. The visit to Briggs Motors was enjoyed by all, particularly the car owners. The visit to London Airport was a great success, due largely to the novel means of transport. The cloud, which obscured our view at first, soon cleared, and the outward journey was over all too soon. After lunch a tour of the airport was made, and aircraft of many countries were seen, including the new Comet IV's delivered the day before. On the return journey the beauty of some of our towns and cities, when viewed from the air at night, was something to be remembered.

The paper on "Subscriber Trunk Dialling" given by Mr. T. Barker proved most interesting; the questions which followed kept the speaker busy long after the allotted time—I wonder if he did catch that last train to Leeds?

A. J. P. B.

#### Hull Centre

The Hull Centre commenced the 1958-59 session with an excellent paper on "Electronic Switching" given by Mr. M. J. Rubin, Research Branch, Engineering Department. This was followed in November with a paper by Mr. R. F. McLusky, Telephone Exchange Systems Development Branch, Engineering Department, on "General Principles of Subscriber Trunk Dialling." Question time at both meetings went on until after 10 p.m., thus showing the very great interest of the members present.

Our January meeting, one of two joint meetings this session with the Hull Electronic Engineering Society, was about "Problems of Television Outside Broadcasts," the lecture being given by Mr. F. S. Fox of the British Broadcasting Corporation (Engineering Department).

The session continued with the following papers:  
February 1959: "Mobile V.H.F. Communications," by Mr. H. Whelan of Pye Telecommunications Ltd.  
March 1959: "Public Electricity Distribution," by Mr. H. Hilton, of the Yorkshire Electricity Board.

April 1959 (close of session): "Local Problems of S.T.D.," by Mr. H. V. J. Harris, M.B.E., Telephone Manager, Hull Corporation.

The Centre would particularly like to thank the following for their great help on various occasions: Mr. R. W. Palmer, past-president of the Associate Section, and our recently retired Area Liaison Officer, Mr. S. Saner.

L. J.

#### Leeds Centre

Since the last time of writing the Leeds Centre has paid a visit to the Automatic Telephone and Electric Company Ltd., at Liverpool. This was a full day's visit for 25 of our members. The party was received by the training officer, Mr. Prince, who organized a most interesting and instructive tour of the factory. One of the outstanding features was the electronic P.A.B.X. which is worked in conjunction with a Strowger-type P.A.B.X. to handle the large volume of inter-departmental communications within the factory. The party was entertained to lunch and tea in the visitors' dining room where they were joined by Mr. Meredith, the Assistant Works Manager who, strangely enough, graduated from the Leeds Telephone Area. The conversation dwelt upon many topics of kindred interest, and it was with feelings of friendship and goodwill that we made our farewells to return to Leeds after a most enjoyable day.

On Monday, 24 November 1958, an illustrated talk, entitled "Permanent Magnets Summarized," by Mr. F. G.

Tyzack was held at the Griffin Hotel, Boar Lane, Leeds. Mr. Tyzack left no reason to doubt that he was master of his subject and, aided by a most interesting demonstration, provided a very instructive evening. Mr. Tyzack kindly extended an invitation to the Centre to pay a visit to the Magnetic Steel Department of Messrs. James Neill & Co. Ltd., Sheffield, which we accepted with thanks.

On Wednesday, 10 December 1958, we held our annual dinner and social evening at the "Old Fox Hotel" at Wetherby. Although the elements were far from kind, a good attendance was recorded of 73 members and their ladies and friends. The guests of the evening were Mr. F. Wood, Telephone Manager, Messrs. Hopkinson and Gilbey, Area Engineers, with Mrs. Hopkinson and Mrs. Gilbey.

Mr. C. Baker, chairman, in proposing a toast to the guests and members, said how gratifying it was to see such a happy gathering and that the Leeds Centre were endeavouring to extend their social activities so that more opportunities would be made for members and their friends to get together. Mr. F. Wood responded on behalf of the guests and spoke of the steady progress of the Centre, with humorous references to our members' visits, assuring the ladies of the diligent hard work involved. The rest of the evening was spent in alternate periods of dancing and light entertainment provided by Mr. J. Greaves, our host. All agreed that it had been a most enjoyable evening.

On Friday, 16 January 1959, 16 members from Leeds paid a visit to the Magnetic Steel Department of Messrs. James Neill & Co. Ltd., Sheffield. The party were received by Messrs. Cooper and Tyzack who conducted them round the factory and explained very fully the different techniques employed in the production of various types of magnets used in industry. The party were very much intrigued by the numerous practical exhibits which were seen in the demonstration room. It was here that the applications of magnets were illustrated, and each member had the opportunity to magnetize the magnet presented to him. After taking tea at the works, thanks were tendered to Messrs. Cooper and Tyzack and the directors of Messrs. James Neill & Co. Ltd. for making possible such an enjoyable visit.

The Leeds Centre gladly accepted the kind offer of the President of the Associate Section, Mr. A. H. C. Knox, to come to Leeds to give a talk on "Promotions and Appraisements" at the Griffin Hotel, Boar Lane, on Thursday, 19 February 1959.

C. B.

#### Newcastle upon Tyne Centre

On Thursday, 16 October 1958, a paper entitled "Telecommunications in Ceylon" was given by Mr. D. Holmes, Executive Engineer, Newcastle External Planning Group. It was very interesting and gave the members present an insight into the many problems that face the telephone authorities in Ceylon; not only in maintaining telecommunications in difficult country, but also in the management of staff with a variety of religious beliefs.

Mr. A. Forte, of the Newcastle underground staff, gave a paper on 18 November 1958 entitled "Creepage of Underground Cables." It was very gratifying to have one of our own members prepared to give his services and, judging by the discussion that followed, the paper was a great success. Mr. J. E. Collins, Area Engineer, Newcastle upon Tyne, was among the visitors from the Senior Section.

At a meeting of the Newcastle Senior Section of the I.P.O.E.E. held in Rutherford College on 16 December 1958 one of our members, Mr. C. F. Carr, was presented with a cheque by Col. J. Baines, Chief Regional Engineer, North-Eastern Region, for his paper, "The Cathodic Protection of Telephone Cables," which was given in our 1957-58 session.

Mr. F. J. Afield, astronomy correspondent of the *Newcastle Evening Chronicle*, gave his second paper, "Journey into Space Continued," on 13 January 1959 to a very enthusiastic audience. Mr. Afield illustrated his talk with some magnificent slides of the Moon.

R. A. H.

### Scarborough Centre

"Any Questions" provided a very pleasant and instructive evening for the commencement of the 1958-59 session on 28 October. The panel consisted of the York Acting Telephone Manager, Mr. G. E. T. Thomas, the Acting Area Engineer, Mr. T. Jordan, and Executive Engineers Messrs. E. Speechley and N. Heaton. Questions and answers flowed quite freely and 10 p.m. arrived far too soon.

November brought "Fluorescent Lighting" by Mr. W. Bradley and this was followed, on the 5 December 1958, by the annual dinner and dance. This was attended by a number of Senior Section members from York and the North-Eastern Regional Office, and was a most enjoyable function.

To mark the retirement of Mr. A. S. Major, Assistant Engineer, Scarborough, honorary life membership of the



MR. RIVIS MAKING THE PRESENTATION TO MR. MAJOR

Scarborough Associate Section was given. The photograph shows Mr. Major receiving from Mr. D. A. Ravis, chairman of the Centre, the certificate of life membership and a small gift in recognition of his services to the Scarborough Centre.  
W. B.

### Edinburgh Centre

The first visit of the 1958-59 session, on 15 November 1958, was to the B.P. refinery at Grangemouth, where a party of 24 members spent a most interesting morning. The management had kindly arranged for three of their electrical engineers to act as guides. We were first shown the boiler-house where the steam required for the process is generated. As the refinery has its own power generating station, the boilers also provide steam to drive the turbines. As would be expected, the boilers are oil-fired.

We were next taken to the processing plant and shown the various control rooms associated with each section. Each of these control rooms requires attendance by only one engineer, any change in the rate of flow of the product in any section being effected by the operation of a switch or key. We were then shown the storage tanks, railway sidings and distribution division. Finally, one of the chemists showed the party samples of all the finished products and by-products.

It was with regret that a proposed visit to the B.B.C. transmitter at Westerglen had to be cancelled, due to lack of support. This was most disappointing, in view of the fact that many members had requested such a visit and all arrangements had been made.

On 20 January 1959 a most interesting lecture entitled "The Versatile Neon" was given by Mr. T. C. Watters in Rose Street telephone exchange. Nineteen members attended and as our guests we had three Senior Section members.

Mr. Watters began by explaining the basic principles of gas-discharge tubes in general and then dealt with the neon-filled cold-cathode tube, as used in telecommunications. Practical illustrations of uses to which these cold-cathode tubes could be put in telecommunications were demonstrated, including the "one-up" counter and the relaxation oscillator.

At the conclusion of his lecture Mr. Watters introduced Mr. C. J. Macpherson from Post Office Headquarters, Scotland, who demonstrated a small semi-electronic 10-line exchange which he had designed and which can also be utilized as a line connector. This equipment uses cold-cathode tubes.

During the course of the evening Mr. J. Gibson, Area Engineer (Maintenance), as a representative of the Senior Section, presented Mr. J. R. Haggart with a prize of one guinea in recognition of his paper entitled "A Brief Survey of Domestic Electrical Equipment."

Due to the efforts of our liaison officer, Mr. P. A. Lamont, we have recently recruited 13 youths to our membership.

D. M. P.

### Aberdeen Centre

We have pursued a policy this session of at least one member and one guest speaking at each meeting. The majority of our guest speakers are Senior Section members.

The subject matter has been varied, dealing with both administrative and technical aspects of telecommunications. The following are the titles of the lectures given: "The Four Divisions," "Mechanical Aids," "Training," "S.H.F. Radio Systems," "Some Methods of Measuring Noise," "Precision Testing," "Inverness Engineering Division," "Telex," "Impulsing Problems," "Signalling System A.C.5," and "Public Speaking."

Three of the foregoing papers were broadcast from out-stations, Inverness and Wick, over land lines.

We now look forward to a quiz contest with our Dundee colleagues to complete the activities of the session.

J.G.P.

### Pontypridd Centre

The rise of Pontypridd as a town of importance in the county of Glamorgan started approximately 200 years ago, when William Edwards built a bridge, the first in the vicinity, over the River Taff. This bridge vastly improved the road communications between the valleys of the Rhondda, Aberdare and Merthyr, and the sea port of Cardiff.

The prosperity of the town was bound up with coal, the chief product of the area, which was transported through the town by road and canal and eventually by rail, the railway junction for the three valleys being at Pontypridd. There was soon a large works producing anchor chains and, in addition, the town's importance as a market centre increased.

Road, rail, and electric tramcar communications were thriving when the National Telephone Company introduced telephones into the lives of the population. Then the Post Office took over, and the town was served by a manual exchange until 1935. At that date a pre-2000-type non-director exchange was installed, this being one of the first remote non-director exchanges in Wales. The real advantage of the geographical position of Pontypridd as a centre of telephone communication was still not fully utilized because signalling and equipment limitations restricted tandem dialling mainly to manual operators. It was not until the fourth extension of the exchange in 1950 that the provision of new auto-to-auto relay-sets and modification of manual-exchange cord circuits permitted tandem dialling between the adjacent valleys, using Pontypridd exchange as a tandem centre to an extent appropriate to its geographical position. With junctions from 10 automatic and eight manual exchanges terminating at Pontypridd, the amount of through-dialling traffic has increased enormously, especially since the introduction of unit-fee working in January 1958.



In the meantime, whilst all this work for extension of the service given to the public is going on, the engineering staff have taken a new step towards further extension of their education. This has come about by the inauguration of an Associate Section Centre at Pontypridd. The Centre was formed last November. The membership to date is 45, and this covers equally external, subscribers' installation and maintenance groups, and also a wide range of ages, proving that ownership of an inquiring mind is not confined to any particular grade or group.

Our first meeting was held on 15 January 1959 and at this there was a good gathering of members and also several Executive Engineers, who had been specially invited. Mr. R. A. Kibby, Post Office Headquarters, Wales and Border Counties, Engineering Branch, presented his very interesting paper on "Mechanical Aids, Their Use and Maintenance." In conclusion, a few words of thanks were given by Mr. D. Thomas, chairman, Mr. I. Lewis, and Mr. R. I. Davies.

The meeting was concluded by the secretary who spoke about future programs.

#### Haverfordwest Centre

The Haverfordwest Centre had a very good start for their winter program with a talk on 30 October 1958 by Mr. A. H. C. Knox, President of the Associate Section, whose subject was "Promotions and Appraisements." This topic prompted many questions from those at the meeting, which was well attended in spite of the adverse weather conditions. Among the guests were Mr. F. E. Wallcroft, Regional Engineer, and Mr. J. R. Young from Cardiff, and Mr. W. K. Edwards, Area Engineer.

On 18 October 1958 another very pleasant evening was spent with one of our members, Mr. A. J. Panton, Pembroke Dock, giving some hints and tips on how to get better results from our cameras. A film show on 2 December 1958, with some most interesting films by courtesy of the British Iron and Steel Federation, brought our 1958 program to an end.

The new year also started very well with a talk on 13 January 1959 by Mr. C. W. A. Kent, Telephone Manager, Swansea, who took as his subject "My Job." This proved to be most interesting and prompted many varied questions on the different aspects of the Telephone Manager's work.

There was a full and interesting program for the remainder of the session, as follows:

3 February 1959: A lecture on "Atomic Energy," with an introduction to Zeta, was given by Mr. A. G. Lloyd.

24 February 1959: Film show by courtesy of Messrs. Mullard, Ltd., and B.I.C.C. Co., Ltd.

24 March 1959: Some experiments with stereophonic sound using two tape recorders, by three of our members, Messrs. D. W. Davies, B. J. Davies and E. G. Collins.

14 April 1959: An illustrated talk by Mr. B. J. Davies on "Television Receivers and Some Hints on Simple Fault Finding."

Our second annual general meeting will be held on 5 May 1959.

J. H. G. R.

#### Cornwall Centre

Since our last notes appeared in the Journal, membership has increased to over 130, and a very successful session is being held. We were fortunate in obtaining for our meetings the most modern hall in Truro, the Highertown Church Hall, which has the facility for tea-making laid on, as well as being on the secretary's doorstep!

The winter session commenced with a lecture on "Promotions and Appraisements" by the President of the Associate Section, Mr. A. H. C. Knox, who after an interesting lecture left members looking forward to a Promotion Board.

For the October meeting we were fortunate to have Mr. Kelly of the Engineer-in-Chief's Office lecture to us on "Transatlantic Cable Systems," which was of great interest as the Commonwealth Cable Scheme had just been announced. The lecture was supported by the film "Atlantic Link," kindly projected for us by Mr. S. T. Stevens.

The November meeting followed with a discussion on the controversial subject "Subscribers' Complaints in this Area are generally caused by poor maintenance rather than inept planning and construction." This stimulated great interest, and a pleasant evening was rounded off by a talk on U.M.C., U.C.C. and Performance Ratings by our Chairman, Mr. K. E. Spurlock.

The first lecture in 1959 was by Mr. Heath of Truro, on "Cable Balancing and Corrosion," and for February and March there were Mr. C. T. Lamping's (W.B.C.) lecture on "Postal Mechanization" and Messrs. R. A. Kibby's and T. E. Day's (both of W.B.C.) lecture on "Mechanical Aids."

All meetings are well attended and good support is given by the Senior Section, whose nearest Centre is some 60 miles away at Plymouth.

The summer months will soon be with us again and outdoor visits will be the program then.

A. R. B.

## Book Review

"Electric Contacts Handbook." Ragnar Holm. Third Edition. Springer-Verlag, Berlin. 522 pp. 194 ill. 89s. 9d.

In the preface to his book "The Kinetics of Chemical Change," C. N. Hinshelwood remarks, "It is no mere taste for paradox which leads one to doubt whether progress in a subject is reflected only in the increasing size of the books written about it. Encyclopaedias are very valuable works, but in some ways the ideal would be that successive editions of a book should get smaller and smaller." The volume under review shows no tendency towards this desirable situation. It is the most recent version of "Electric Contacts" by the same author, and was last reviewed in this journal in 1948 (Vol. 41, p. 84). For British readers, the change of title is not altogether a happy one. It is a "handbook" of the comprehensive German "handbuch" type and is not, as might otherwise be supposed, a pocket, rule-of-thumb text.

For the new student of contact physics, who does not mind being "thrown in at the deep-end," it provides an extensive introduction to many topics in a subject of very wide and varied scope. But he would be well advised to read as many as possible of the literature references in the original. A copious list is provided, but the text does not always give an indication of their content. For the research-worker in this field, it provides a useful compendium of results. Some, he will know, are now "classical"; some are still controversial; and others are probably inadequate. But the practical designer of equipment will not readily find the kind of information he needs for specifying and testing the performance of contact devices.

The character and style of the book remain unchanged from the last edition, and the comments made in the earlier review are still valid. It will continue to occupy a welcome place amongst the literature on applied physics. Its cost, although high, is not, perhaps, excessive by modern standards.

A. F.

# Staff Changes

## Promotions

Name	Region	Date	Name	Region	Date
<i>Area Engineer to Regional Engineer</i>			<i>Inspector to Assistant Engineer</i>		
Devereux, R. C.	L.T. Reg.	1.10.58	Bailey, J. G.	N.E. Reg.	1.9.57
Hoare, E.	H.C. Reg.	6.10.58	Barron, J.	Scot.	23.8.58
Robertson, C. D. S. G.	H.C. Reg. to S.W. Reg.	5.1.59	Mallon, J.	Scot.	20.9.58
<i>Senior Executive Engineer to Assistant Staff Engineer</i>			Bracken, R. W.	N.E. Reg.	30.6.58
Renton, R. N.	E.-in-C.O.	18.9.58	Hollingworth, G. K.	N.E. Reg.	3.7.58
Smith, J.	E.-in-C.O.	18.9.58	Murphy, J. G.	Mid. Reg.	1.12.58
Copping, G. P.	E.-in-C.O.	18.9.58	Stenton, H. G.	L.T. Reg.	9.12.58
Jowett, J. K. S.	E.-in-C.O.	18.9.58	Martin, H. W. B.	L.T. Reg.	9.12.58
Corke, R. L.	E.-in-C.O.	18.9.58	Coulthard, H. B.	N.W. Reg.	11.12.58
Jago, W. B.	L.T. Reg. to E.-in-C.O.	1.10.58	<i>Technical Officer to Assistant Engineer</i>		
Billen, J. C.	E.-in-C.O.	5.12.58	Webber, A. A.	S.W. Reg.	24.2.58
Harding, J. P.	E.-in-C.O.	21.1.59	Davis, A. E.	N.E. Reg.	14.4.58
Jones, D. G.	E.-in-C.O.	31.12.58	Wilson, N. B.	N.E. Reg.	8.4.58
<i>Executive Engineer to Area Engineer</i>			Meeres, L. K.	N.E. Reg.	24.4.58
Thompson, R. H.	Mid. Reg. to N.E. Reg.	8.9.58	House, B. H.	S.W. Reg. to E.-in-C.O.	7.8.58
Clark, C. W. A.	L.T. Reg.	29.8.58	Roberts, F. J.	N.E. Reg.	9.8.58
Stanier, J. H.	Mid. Reg. to N.W. Reg.	5.8.58	Hayes, E. R. C.	S.W. Reg.	14.4.58
Duggan, W. G.	Mid. Reg.	6.10.58	Slater, R. H.	N.W. Reg.	12.8.58
Gray, K.	W.B.C.	29.10.58	Quested, W. C. M.	H.C. Reg.	3.3.58
Wadeson, D. E.	S.W. Reg. to L.T. Reg.	15.12.58	Rhodes, J.	N.E. Reg.	20.9.58
Chapman, B. E. J.	L.T. Reg.	27.11.58	Henley, F. E.	S.W. Reg.	22.9.58
Stotesbury, K. E.	L.T. Reg.	27.11.58	Bridger, J. E.	H.C. Reg.	12.8.58
<i>Executive Engineer to Senior Executive Engineer</i>			Hill, R. S.	H.C. Reg.	12.8.58
Fudge, E. W.	E.-in-C.O.	11.11.58	Riddle, R. R.	H.C. Reg.	12.8.58
Medcalf, L. W.	L.T. Reg.	27.11.58	Marshall, G.	H.C. Reg.	27.9.58
Rawlinson, W. A.	E.-in-C.O.	9.12.58	Tanner, R. W. C.	H.C. Reg.	10.11.58
Sallis, R. T. G.	E.-in-C.O.	18.12.58	O'Brien, P. J.	L.T. Reg.	28.8.58
Dilworth, R. A.	E.-in-C.O.	6.1.59	Tridgell, V. W.	L.T. Reg.	11.6.58
<i>Executive Engineer (Open Competition)</i>			Weynberg, F. J.	L.T. Reg.	5.5.58
Belcher, P. L.	E.-in-C.O.	20.11.58	Hamblin, K.	E.T.E.	10.11.58
Smith, C. S. A.	E.-in-C.O.	15.12.58	Owen, J. M.	N.W. Reg.	27.11.58
<i>Assistant Engineer to Executive Engineer</i>			Mann, W. A.	Mid. Reg.	20.10.58
Emms, W. G.	H.C. Reg.	21.7.58	Colville, W.	Mid. Reg.	1.12.58
Pyle, D. W.	H.C. Reg.	14.8.58	Love, T. F.	Scot.	8.7.58
Evans, A. W.	N.E. Reg.	22.10.58	Munro, R. M.	Scot.	6.9.58
Ash, F. J.	Mid. Reg.	31.10.58	Jamieson, A. O.	Scot.	6.12.58
Sallnow, C. W.	L.T. Reg.	31.10.58	<i>Technical Officer to Inspector</i>		
Heymer, B. J.	L.T. Reg.	31.10.58	Gatcum, A. W.	S.W. Reg.	10.2.58
Dell, J. H.	W.B.C. to Mid. Reg.	1.12.58	Weatherley, H. S.	E.T.E.	5.3.56
Palmer, J. E.	N.W. Reg.	4.11.58	Stiles, E. J.	L.T. Reg.	15.9.58
Williams, J. I.	N.W. Reg.	4.12.58	Lucken, A. J.	L.T. Reg.	1.9.58
Barrett, F. W.	L.T. Reg. to E.-in-C.O.	15.12.58	Boothman, F. R.	N.E. Reg.	4.5.57
Munro, D. G.	E.-in-C.O.	15.12.58	<i>Technician I to Inspector</i>		
Galloway, J.	E.-in-C.O.	15.12.58	Hawkes, F. G.	Mid. Reg.	1.1.58
Croxson, V. E.	L.T. Reg. to E.-in-C.O.	15.12.58	Munn, H. T.	Mid. Reg.	3.2.58
Purves, R. F.	E.-in-C.O.	15.12.58	Bowen, W. T. J.	S.W. Reg.	16.4.58
Goymer, E. G.	E.-in-C.O.	15.12.58	Neal, G. W.	H.C. Reg.	31.7.58
Iles, A. R.	E.-in-C.O.	15.12.58	Palmer, H. F.	H.C. Reg.	31.7.58
<i>Assistant Engineer (Open Competition)</i>			Thrower, R. C.	H.C. Reg.	31.7.58
Coldrick, E. A.	N.W. Reg.	8.9.58	Allcock, F.	N.W. Reg.	15.8.58
Elliott, J. L. C.	E.-in-C.O.	8.9.58	Murray, W.	N.W. Reg.	25.8.58
Lines, P. D.	E.-in-C.O.	8.9.58	Packman, P. C.	H.C. Reg.	29.7.58
Thomas, V. F.	E.-in-C.O.	8.9.58	Laws, C. S.	H.C. Reg.	2.9.58
Smith, L. J.	E.-in-C.O.	8.9.58	Reed, W. C.	H.C. Reg.	2.9.58
Sanders, A. H.	E.-in-C.O.	8.9.58	Taylor, G.	H.C. Reg.	2.9.58
Maul, D.	E.-in-C.O.	8.9.58	Critchler, W. A. G.	H.C. Reg.	2.9.58
Penny, D. J.	E.-in-C.O.	8.9.58	Glazier, E. F.	H.C. Reg.	2.9.58
Lee, F. W.	E.-in-C.O.	8.9.58	Cosgrove, T. J.	H.C. Reg.	2.9.58
Cope, B.	E.-in-C.O.	8.9.58	Kennedy, F. B.	N.W. Reg.	23.9.58
Matthews, W. R.	E.-in-C.O.	8.9.58	Brennan, L.	N.W. Reg.	23.9.58
Romani, P.	E.-in-C.O.	8.9.58	Jabbitt, A.	Mid. Reg.	5.8.58
<i>Assistant Engineer (Limited Competition)</i>			Johnson, R. A.	Mid. Reg.	7.7.58
Oseman, R. H.	E.-in-C.O.	5.5.58	McCool, R. C.	Mid. Reg.	1.7.58
Gibbs, R. C.	E.-in-C.O.	5.5.58	Alker, B.	Mid. Reg.	1.10.58
			Howell, F. L.	W.B.C.	15.10.58
			Smith, C. R. S.	Mid. Reg.	21.7.58
			Smith, W. E.	Mid. Reg.	13.10.58
			Jennings, D. J.	E.T.E.	1.2.58
			Brock, L. S.	E.T.E.	2.4.58
			Brown, H. W. H.	N.W. Reg.	24.10.58
			Meynell, G. E.	N.W. Reg.	7.11.58
			Hughes, W.	N.W. Reg.	29.12.58



Promotions—continued.

Name	Region	Date	Name	Region	Date
<i>Principal Scientific Officer to Senior Principal Scientific Officer</i>			<i>Technical Assistant II to Technical Assistant I</i>		
Speight, Dr. E. A.	E.-in-C.O.	21.8.58	Withnell, E.	N.W. Reg. to E.-in-C.O.	14.11.58
<i>Experimental Officer to Senior Experimental Officer</i>			Kerr, E.	N.I.	14.11.58
Lord, G. W.	E.-in-C.O.	6.11.58	Boulton, H. G.	E.-in-C.O.	14.11.58
Milne, F. A.	E.-in-C.O.	6.11.58	Edwards, W. T. A.	London Reg.	14.11.58
Johnson, C. B.	E.-in-C.O.	6.11.58	<i>Mechanic-in-Charge I to Technical Assistant II</i>		
<i>Experimental Officer (Open Competition)</i>			Pickles, A.	E.-in-C.O.	9.8.58
Jeffs, E. D.	E.-in-C.O.	22.8.58	<i>Mechanic-in-Charge II to Technical Assistant II</i>		
Okoro, M.	E.-in-C.O.	18.8.58	Cattle, R. W. J.	London Reg.	14.11.58
Woodgate, E. (Mrs.)	E.-in-C.O.	6.11.58	<i>Mechanic A to Technical Assistant II</i>		
<i>Assistant Experimental Officer to Experimental Officer</i>			Rackley, C. E.	H.C. Reg. to E.-in-C.O.	27.12.58
Vincent, C. A. B.	E.-in-C.O.	5.9.58	<i>Leading Draughtsman to Senior Draughtsman</i>		
<i>Scientific Officer (Open Competition)</i>			Pusey, L. M.	L.P. Reg.	1.8.58
Maynard, J. W.	E.-in-C.O.	1.9.58	<i>Draughtsman to Leading Draughtsman</i>		
<i>Assistant Experimental Officer (Open Competition)</i>			Nutt, S. R.	Mid. Reg.	18.9.58
Preston, P. F.	E.-in-C.O.	24.9.58	Balbirnie, K. A.	L.T. Reg.	18.9.58
James, B. E. (Mrs.)	E.-in-C.O.	27.10.58	Hemming, T. E.	Mid. Reg.	18.9.58
<i>Assistant (Scientific) (Open Competition)</i>			Harding, S. J.	E.-in-C.O.	1.10.58
Houghton, F. G.	E.-in-C.O.	12.3.58	Morley, R. J.	E.-in-C.O.	1.10.58
Pratt, J. K. (Miss)	E.-in-C.O.	22.10.58	Harris, E. V.	E.-in-C.O.	1.10.58
Perry, R.	E.-in-C.O.	3.12.58	Daniel, G. J.	E.-in-C.O.	1.10.58
Rowledge, E. (Miss)	E.-in-C.O.	5.12.58	Smith, A. V.	E.-in-C.O.	1.10.58
James, P. M. (Miss)	E.-in-C.O.	17.12.58	Horridge, J. W.	E.-in-C.O.	7.10.58
<i>Motor Transport Officer II to Motor Transport Officer I</i>			Webb, M. E.	E.-in-C.O.	1.10.58
Brownlow, P. E.	E.-in-C.O.	29.8.58	Hayes, G. A.	E.-in-C.O.	1.10.58
<i>Assistant Regional Motor Transport Officer to Motor Transport Officer II</i>			Willis, D. R.	E.-in-C.O.	6.10.58
White, G.	N.I. to E.-in-C.O.	27.10.58	Ranger, A. C.	E.-in-C.O.	1.10.58
<i>Technical Assistant I to Assistant Regional Motor Transport Officer</i>			Paine, G. D.	Factories Dept.	1.10.58
Heath, J. C.	W.B.C.	3.7.58	Wait, L. J. S.	E.-in-C.O.	27.10.58
			McConnachie, J. M.	L.T. Reg. to L.P. Reg.	1.12.58

Retirements and Resignations

Name	Region	Date	Name	Region	Date
<i>Assistant Staff Engineer</i>			<i>Assistant Engineer</i>		
Cohen, I. J.	E.T.E.	19.10.58	Rouse, D. R.	H.C. Reg.	2.8.58
<i>Regional Engineer</i>			Power, W. C. S.	H.C. Reg.	14.8.58
Cooper, M. C.	S.W. Reg.	24.11.58	Kewley, T. W.	N.W. Reg.	22.8.58
<i>Area Engineer</i>			Warwick, A.	Mid. Reg.	28.8.58
Whittingham, L.	W.B.C.	23.9.58	Stanfield, J. W. W.	Mid. Reg.	31.8.58
Piggott, E. C. C.	Mid. Reg.	5.10.58	Holder, T. G.	Mid. Reg.	31.8.58
<i>Executive Engineer</i>			Allen, G. W.	Mid. Reg.	5.9.58
Rushworth, M.	N.E. Reg.	11.7.58	Nolli, L. M.	N.E. Reg.	7.9.58
Whorwood, R. W.	E.-in-C.O.	31.8.58	Plumstead, E. F.	H.C. Reg.	8.9.58
(Resigned)			Clement, C. M.	N.W. Reg.	14.9.58
Feneley, F. S.	H.C. Reg.	8.7.58	Earp, W. E.	Mid. Reg.	26.9.58
Creed, H.	H.C. Reg.	13.8.58	Axon, A. A.	H.C. Reg.	26.9.58
Henderson, R. M.	Scot.	13.8.58	Elwell, R. A. J.	E.-in-C.O.	3.10.58
Quinn, P.	Scot.	31.8.58	Armstrong, C.	W.B.C.	5.10.58
Queen, J.	N.E. Reg.	4.9.58	Elliott, F. A.	L.T. Reg.	12.10.58
Osborne, A. D.	Mid. Reg.	30.9.58	Webb, H. A.	L.T. Reg.	22.10.58
Shaddick, W. G.	E.-in-C.O.	29.9.58	McDaid, N. F.	Scot.	6.9.58
(Resigned)			<i>(Resigned)</i>		
Douglas, A. S.*	W.B.C.	6.10.58	Adlington, J.	Mid. Reg.	2.10.58
Teale, J. C. C.	N.E. Reg.	21.10.58	Smith, G. H.	N.E. Reg.	8.10.58
Thompson, J. E.	N.E. Reg.	31.10.58	Clarke, H. R.	E.T.E.	13.10.58
Medford, R. D.	E.-in-C.O.	30.11.58	Leaper, L. L.	E.-in-C.O.	1.11.58
(Resigned)			Milam, A. E. E.	E.-in-C.O.	7.11.58
Greasley, E. G.*	E.-in-C.O.	9.1.59	Jenkins, A. D. (Resigned)	L.T. Reg.	3.10.58
(Resigned)			King, H. J.	S.W. Reg.	4.10.58
Knights, G. A.	H.C. Reg.	31.12.58	Mockford, A. F.	S.W. Reg.	31.10.58
(Resigned)			MacDonald, A.	Scot.	5.11.58
			Tarrant, W. G.	S.W. Reg.	13.11.58
			Stevens, A. V.	L.T. Reg.	21.11.58

\* Mr. A. S. Douglas and Mr. E. G. Greasley are continuing as disestablished officers with the W.B.C. and E.-in-C.O., respectively.

**Retirements and Resignations—continued.**

Name	Region	Date	Name	Region	Date
<i>Assistant Engineer—continued</i>			<i>Inspector—continued</i>		
Jones, E. A. B.	N.E. Reg.	23.11.58	O'Connor, J. A.	L.T. Reg.	22.12.58
Saner, S.	N.E. Reg.	26.11.58	Farden, E.	N.E. Reg.	15.12.58
Gordon, W. H. J.	Scot.	9.12.58	<i>Experimental Officer</i>		
Clark, J. R.	N.E. Reg.	31.12.58	McKay, E. M.	E.-in-C.O.	30.11.58
Brown, L. C.	Mid. Reg.	31.12.58	(Resigned)		
Buckley, W.	N.E. Reg.	31.12.58	Okoro, M. (Resigned)	E.-in-C.O.	29.12.58
Purslow, J. E.	L.T. Reg.	14.12.58	<i>Scientific Officer</i>		
Manning, F. N. (Resigned)	E.-in-C.O.	2.1.59	Stelzer, I. (Resigned)	E.-in-C.O.	26.9.58
<i>Inspector</i>			<i>Assistant (Scientific)</i>		
Smith, G.	N.W. Reg.	31.7.58	Edwards, P. A.	E.-in-C.O.	30.10.58
Brown, W. C.	N.E. Reg.	1.8.58	Moyler, J. H. (Miss) (Resigned)	E.-in-C.O.	30.11.58
Bryan, A. E.	L.T. Reg.	1.8.58	<i>Motor Transport Officer I</i>		
Clark, W. E.	L.T. Reg.	7.8.58	Marks, R.	E.-in-C.O.	28.8.58
Hills, A. G.	L.T. Reg.	13.8.58	<i>Motor Transport Officer II</i>		
Newton, J.	N.W. Reg.	17.8.58	Swire, W. L.	E.-in-C.O.	30.9.58
Parker, A.	N.W. Reg.	25.8.58	<i>Technical Assistant I</i>		
Robinson, E.	H.C. Reg.	27.8.58	Sewell, W. A. H.	H.C. Reg.	15.8.58
Simpson, F.	N.E. Reg.	28.8.58	<i>Leading Draughtsman</i>		
Clements, A. E.	H.C. Reg.	31.8.58	Kensett, J. F.	N.I.	23.9.58
Butler, A. G.	L.T. Reg.	31.8.58	<i>Higher Executive Officer</i>		
Haynes, W. F.	L.T. Reg.	31.8.58	Harrison, A. E.	E.-in-C.O.	31.8.58
Elliott, A.	N.W. Reg.	31.8.58	<i>Executive Officer</i>		
Friday, L. H.	Mid. Reg.	30.9.58	Wallis, W. G.	E.-in-C.O.	31.10.58
Drury, L.	N.E. Reg.	30.9.58	Dobson, H. (Miss) (Resigned)	E.-in-C.O.	12.8.58
Newton, E. W.	L.T. Reg.	15.10.58	Wallis, W. G.	E.-in-C.O.	3.11.58
Billington, E.	N.W. Reg.	5.11.58	<i>Assistant Staff Engineer</i>		
Winton, H. R.	L.T. Reg.	8.11.58	Creighton, J. L.	European Radio Frequency Agency to E.-in-C.O.	1.1.59
Gregor, F. C. L.	Scot.	11.11.58	<i>Executive Engineer</i>		
Goulding, A. C.	L.T. Reg.	14.11.58	Neill, T. B. M.	E.-in-C.O. to Nigeria	1.9.58
Lovie, F.	N.E. Reg.	24.11.58	White, G.	E.-in-C.O. to Admiralty	11.8.58
Lieberman, H. J.	H.C. Reg.	25.11.58	Rendle, F. R.	E.-in-C.O. to H.C. Reg.	22.9.58
Reed, C. H.	Mid. Reg.	26.11.58	Goodison, H.	E.-in-C.O. to Nigeria	20.9.58
Jones, S.	S.W. Reg.	29.11.58	Sinnicks, A. C.	H.C. Reg. to Nigeria	22.9.58
Leabon, H. C.	Mid. Reg.	2.12.58	Partridge, J. G.	E.-in-C.O. to Cyprus	1.10.58
			Home, J. K.	E.-in-C.O. to Nigeria	2.10.58
			Marklew, S. S. P.	N.W. Reg. to Mid. Reg.	27.10.58
			Ross, J. D.	Min. of Supply to E.-in-C.O.	3.11.58
			Jacobs, D. A.	E.-in-C.O. to Board of Trade	3.11.58
			Newton, F. W.	E.-in-C.O. to Foreign Office	1.12.58

**Transfers**

Name	Region	Date	Name	Region	Date
<i>Assistant Staff Engineer</i>			<i>Assistant Engineer—continued</i>		
Creighton, J. L.	European Radio Frequency Agency to E.-in-C.O.	1.1.59	Watson, A. L.	E.-in-C.O. to Contracts Dept.	15.9.58
<i>Executive Engineer</i>			Lout, J. W.	E.-in-C.O. to L.T. Reg.	15.9.58
Neill, T. B. M.	E.-in-C.O. to Nigeria	1.9.58	Windle, R. W.	L.T. Reg. to E.-in-C.O.	15.9.58
White, G.	E.-in-C.O. to Admiralty	11.8.58	Rumsey, H. D.	S.W. Reg. to Nigeria	5.6.52
Rendle, F. R.	E.-in-C.O. to H.C. Reg.	22.9.58	Everett, D. T.	E.-in-C.O. to Malaya	7.10.58
Goodison, H.	E.-in-C.O. to Nigeria	20.9.58	Codner, W. G.	E.-in-C.O. to Board of Trade	13.10.58
Sinnicks, A. C.	H.C. Reg. to Nigeria	22.9.58	Evans, J.	E.-in-C.O. to Board of Trade	3.11.58
Partridge, J. G.	E.-in-C.O. to Cyprus	1.10.58	Iles, A. R.	War Office to E.-in-C.O.	27.10.58
Home, J. K.	E.-in-C.O. to Nigeria	2.10.58	Birrell, C. F.	E.-in-C.O. to S.T. & C. Ltd.	3.11.58
Marklew, S. S. P.	N.W. Reg. to Mid. Reg.	27.10.58	Hingley, H.	E.-in-C.O. to S.T. & C. Ltd.	3.11.58
Ross, J. D.	Min. of Supply to E.-in-C.O.	3.11.58	Ince, W. C.	E.-in-C.O. to S.T. & C. Ltd.	3.11.58
Jacobs, D. A.	E.-in-C.O. to Board of Trade	3.11.58	Roberts, S.	E.-in-C.O. to N.W. Reg.	17.11.58
Newton, F. W.	E.-in-C.O. to Foreign Office	1.12.58	Farmer, C. C.	E.-in-C.O. to North Borneo	4.1.57
<i>Assistant Engineer</i>			<i>Motor Transport Officer III</i>		
Dix, D. L.	E.-in-C.O. to M.T.C.A.	3.6.57	Mitchell, A. J.	E.-in-C.O. to N.I.	27.10.58
Dainty, C. T. J.	Scot. to E.-in-C.O.	15.9.58	<i>Technical Assistant I</i>		
			Fossey, G. H.	E.-in-C.O. to H.C. Reg.	6.9.58

**Deaths**

Name	Region	Date	Name	Region	Date
<i>Assistant Staff Engineer</i>			<i>Assistant Engineer—continued</i>		
Atkinson, J.	E.-in-C.O.	17.1.59	Godfrey, E.	N.E. Reg.	31.5.58
<i>Executive Engineer</i>			Harrison, G.	H.C. Reg.	8.6.58
Orchard, G. A.	L.T. Reg.	20.5.58	Hayter, T. F. P.	E.T.E.	4.8.58
Brian, R. H.	Mid. Reg.	29.11.58	Dermott, L. G.	Mid. Reg.	15.8.58
<i>Assistant Engineer</i>			Winter, A. V.	H.C. Reg.	19.8.58
Cavie, H. R.	L.T. Reg.	10.5.58	<i>Inspector</i>		
Case, N.	Mid. Reg.	30.5.58	Siddle, G.	H.C. Reg.	21.4.58
			Wilson, W. C.	N.I.	13.10.58



## Book Reviews

"Progress in Semiconductors," Vol. 3. Edited by A. F. Gibson, B.Sc., Ph.D., P. Aigrain and R. E. Burgess. Heywood & Co., London. viii + 210 pp., 44 ill. 55s.

This is the third of a planned annual series of volumes covering recent advances in semiconductor research. Although, like its predecessors, this volume will appeal chiefly to, and is aimed at, those intimately concerned with the physical properties of semiconductor materials and their interpretation in terms of the appropriate physicist's concepts, one paper this year will also be of particular interest to the device technologist.

The volume contains seven papers. That on "The Magnetoresistivity of Germanium and Silicon," by M. Glicksman, includes an outline of a physical model for Hall effect and magnetoresistance which gives qualitative explanations of the dependence of these effects on the crystalline orientation of the specimen, in terms of (a) the existence of more than one effective mobility for each type of charge carrier and (b) the dependence of the effective mass and/or mean free time of the carriers upon the direction of instantaneous motion through the crystal lattice. There follows a concise summary of the quantitative theoretical predictions of particular models, and the bulk of the paper is taken up with the presentation and discussion of recent experimental results.

J. M. Wilson gives an account of "The Chemical Purification of Germanium and Silicon," commencing for each element with a survey of the primary and secondary sources and an outline of the extraction processes. The chemist still has a part to play in the purification, where the highest degree of freedom from significant impurities is required, since the physical process of zone refining, though excellent for most of the significant contaminants, is ineffective (or nearly so) for some. This paper is well worth reading for non-chemists, though one non-chemist would question the over-simplified argument on p. 38 implying that silicon needs in general to be much more highly purified than germanium. It would have been better to have replaced the qualitative "conductivity type" near the top of p. 47 by a straightforward listing of the Hall constant. Farther down this page the mysterious term "vacuum fission" appears as a misprint for, presumably, "vacuum fusion."

J. W. Mitchell's paper on "Electronic Conductivity of Silver Halide Crystals" is a useful review of the experimental evidence now accumulating from several laboratories. Only in the last few years has the need for, and practical possibility of, purification of the crystals to a degree comparable with that now usual for germanium been realized. The electronic and ionic contributions to the conductivity are closely interdependent over certain temperature ranges, and affect both the photo-conductive and photographic characteristics. It is evident from the paper, however, that satisfactory theoretical accounts of the observations have yet to be given.

The paper on "Silicon Junction Diodes," by D. R. Mason and D. F. Taylor, should appeal more directly to many readers of this Journal in their professional capacity. The paper commences with a restatement of the theory of the p-n junction and of the "L-H" junction—the latter being a junction between semiconductor regions of the same conductivity type (n or p), one region being lightly-doped (L-side) and the other heavily-doped (H-side). The properties of a complete diode are then discussed in terms of a three-layer structure of the form  $N^+-N-P^+$  (the superscript plus signs indicating heavy doping) in which the first pair of layers form a H-L junction and the second pair an N-P<sup>+</sup> junction. The numbers of minority carriers that reach the metallic electrode connexions are implicitly assumed to be small enough for the surface recombination processes at these interfaces to be unimportant. The noise

and slope resistance properties of Zener and avalanche diodes are more briefly considered, and a more general structure of a 4-layer form of the sequence  $N^+-N-P-P^+$  is touched upon. (This structure is not to be confused with the P-N-P-N structure proposed by Shockley and now being manufactured for switching applications: the latter structure is not considered in this paper.) The paper proceeds with an interesting discussion, illustrated by micro-sections of junctions produced under different conditions, of the detailed technology of alloying aluminium on to silicon with or without controlled temperature gradient. Further detailed points of device fabrication are mentioned which are pertinent to the reliability of the devices, and a short final section is devoted to some applications. The critical reader will be irritated by the needless use of a variety of systems of units, e.g., thou, mil, micron and inch; and on p. 109 the dimension  $\text{sec}^{-2}$  must clearly be read either as  $\text{cm}^{-2}$  or  $\text{in.}^{-2}$ . The statement on p. 113 that the reliability of silicon diodes increases with life up to at least 5,000 hours needs more qualification and clarification than that given in the text.

"Lifetime of Excess Carriers in Semiconductors" is the subject of the paper by A. Many and R. Bray. This is a detailed and, in places, mathematical paper that will appeal to those closely concerned with understanding, measuring or controlling lifetime. On the other hand the paper contains little that the specialist will not have read already.

M. S. Sodha's paper on "Scattering and Drift Mobility of Carriers in Germanium" is a critical review of the main theoretical approaches to the subject and a likewise critical examination of some of the past claims for experimental support for theories. The discussion includes that of effects at high electric fields.

The subject of "Electronic Processes in Cadmium Sulphide" is reviewed in the paper by J. Lambe and C. C. Klick. Cadmium sulphide is of practical interest both as a detector of radiation from short visible wavelengths down to X-rays (mainly making use of the photoconductive effect) and conversely as a source of radiation (visible) in luminescent devices. It is of theoretical interest for several reasons; thus both holes and electrons play significant parts in its electrical and optical properties although, curiously, it seems to be difficult to produce p-type material; the large distances (millimetres) to which energy can be transported through crystals without radiation or motion of charge is taken to be strong evidence for the existence of "excitons" in the material (an exciton is a mobile hole-electron pair, each component of the pair being bound in the other's electric field). Two minor criticisms: "Schubweg," used on p. 191, is not defined till p. 194;  $\text{cm}^{-2}$  on p. 198 should be  $\text{cm}^2$ .

The volume is, as usual, clearly produced, and the price is lower than that of the earlier volume. F. F. R.

"Metal Rectifier Engineering." E. A. Richards, M.B.E., A.C.G.I., B.Sc.(Eng), M.I.E.E. Sir Isaac Pitman & Sons, Ltd. 209 pp., 118 ill. 37s. 6d.

The author has dealt mainly with current practice in the field of power rectification and although his conclusions are of general application the accent is on the use of selenium and copper oxide: the recent developments employing germanium and silicon are only briefly mentioned. As a textbook for the engineer the book is useful but it is to be regretted that practical illustrations of the use of the formulæ were not included.

Within its scope, however, the book is well planned, lucid and clearly illustrated, and it can be recommended to the student as an excellent introduction to the basic theory of the behaviour of metal rectifiers.

A. J. F.

## BOARD OF EDITORS

D. A. BARRON, M.Sc., M.I.E.E., Chairman.  
L. F. SCANTLEBURY, Whit.Sch., A.C.G.I., D.I.C., M.I.E.E.  
T. H. FLOWERS, M.B.E., B.Sc.(Eng.), M.I.E.E.  
W. J. E. TOBIN, B.Sc.(Eng.), A.C.G.I., D.I.C., A.M.I.E.E.  
A. J. LECKENBY, M.B.E.  
R. F. WALDEGRAVE.  
E. DAVIS, A.M.I.E.E., Managing Editor.  
J. H. BROADHURST, A.M.I.E.E., Editor (Supplement).  
A. G. LEIGHTON, B.Sc.(Eng.), A.M.I.E.E. } Assistant Editors.  
D. M. GAMBIER, A.M.I.E.E. }  
B. FARR, Secretary-Treasurer.

### Copyright

The entire contents of this Journal are covered by general copyright, and special permission is necessary for reprinting long extracts, but editors are welcome to use not more than one-third of any article, provided credit is given at the beginning or end thus: "From the *Post Office Electrical Engineers' Journal*."

The Board of Editors is not responsible for the statements made or the opinions expressed in any of the articles in this Journal, unless such statement is made specifically by the Board.

### Communications

All communications should be addressed to the Managing Editor, *Post Office Electrical Engineers' Journal*, G.P.O., 2-12 Gresham Street, London, E.C.2. Telephone: HEADquarters 1234. Remittances should be made payable to "*The P.O.E.E. Journal*" and should be crossed "& Co."

### Binding Cases

Cases for binding are available, and may be obtained from the local agents for 3s. Subscribers can have their copies of volumes

bound, at a cost of 10s. 6d., by sending the complete set of parts to the local agents or to the *Post Office Electrical Engineers' Journal*, G.P.O., 2-12 Gresham Street, London, E.C.2. Orders for binding for Vol. 1-19 should indicate whether the original binding case with black lettering, or the later pattern with gold, is required. Cases with gold lettering are the only type stocked from Vol. 20 onwards.

### Back Numbers

The price of the Journal, which is published quarterly, is 2s. 6d. (3s. 3d. post free) per copy, or 13s. per annum, post free. Back numbers can be supplied, subject to availability of stocks, at 2s. 6d. (3s. 3d. each post free). Orders for back numbers may be sent to the *Post Office Electrical Engineers' Journal*, G.P.O., 2-12 Gresham Street, London, E.C.2, or to the publishers.

Employees of the British Post Office can obtain the Journal through local agents at the reduced price of 2s. per copy.

### Advertisements

All communications relating to space reservations should be addressed to the Advertisement Editor, *Post Office Electrical Engineers' Journal*, G.P.O., 2-12 Gresham Street, London, E.C.2. Communications regarding advertisement copy, proofs, etc., should be addressed to the Publishers, Messrs. Birch & Whittington (Prop. Dorling & Co. (Epsom) Ltd.), Depot Road, Epsom, Surrey.

### Model Answer Books

Books of model answers to certain of the City and Guilds of London Institute examinations in telecommunications are published by the Board of Editors. Details of the books available are given at the end of the Supplement to the Journal.

## INDEX TO ADVERTISERS

*In this and future issues  
the Index to Advertisers  
will be found  
on the last page of the  
Journal*

### HIGHER ELECTRICAL ENGINEERING

By J. Shepherd, B.Sc., etc., A. H. Morton, B.Sc., etc., and L. F. Spence, B.Sc., etc. Here is the first book to attempt to cover the whole course for the A.1 and A.2 years of the Higher National Certificate in Electrical Engineering in a single volume. Numerous worked and unworked examples are included. 40/- net.

### TELECOMMUNICATIONS

By A. T. Starr, M.A., Ph.D., etc. Here is a new and revised second edition of this well-known work. Specially written to cover the syllabus for the subject of Telecommunications in the London University Degree, it includes mathematical methods of both Fourier Analysis and Operational Calculus as well as a short account of microwave technique and waveguide theory. 37/6 net.

### WHITTAKER'S ARITHMETIC OF ELECTRICAL ENGINEERING

5th Edition, by A. T. Starr, M.A., Ph.D., etc. Here is a new and revised up-to-date edition of this well-known work. With nearly 100 worked examples and over 400 exercises, this book is a valuable aid to the student who wants to be able to calculate quickly and accurately. 10/- net.

### METAL RECTIFIER ENGINEERING

By E. A. Richards, M.B.E., A.C.G.I., etc. Discusses in detail the principles underlying the operations of metal rectifiers. It forms an essential book for engineers wishing to select the right rectifier for a particular job, and so avoid the disappointments that can arise from incorrect working conditions. 37/6 net.

From all booksellers

**PITMAN** TECHNICAL BOOKS

Parker St., Kingsway, London, W.C.2



*ceilings*

# RAWLBOLTS

## For heavy fixing to Ceilings, Walls & Floors

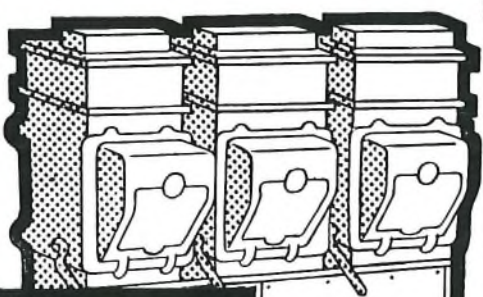

*walls*

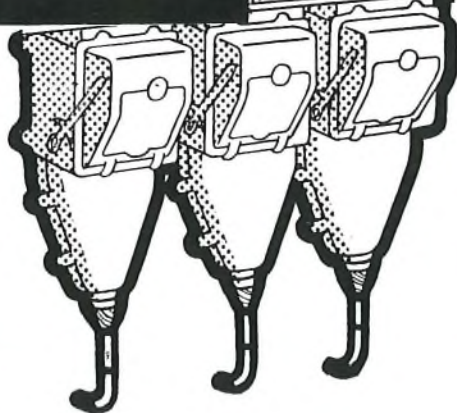

Rawlbolt fixings in concrete, whether in ceilings, walls or floors, are fast and efficient and make real savings in time and money.

Older methods of fixing involve laborious chiselling of holes, grouting in and waiting several days for cement to harden. With Rawlbolts, the job is far simpler and quicker. Drill a hole, insert a Rawlbolt and tighten up. Your equipment is fixed and ready for use immediately.

Civil Engineers, Consulting Engineers, Building Contractors, Structural Engineers are large and regular users of Rawlbolts.

### TWO TYPES OF RAWLBOLT

**LOOSE BOLT TYPE**  
for fixing to floors



**BOLT PROJECTING**  
for fixing to walls and ceilings

For more information, please write for Dimensional Chart of the Rawlbolt Range and full descriptive literature.

*floors*



THE RAWLPLUG COMPANY LTD.,  
CROMWELL ROAD, LONDON, S.W.7.



# FERRANTI 7-Range CLIP-ON INSTRUMENTS

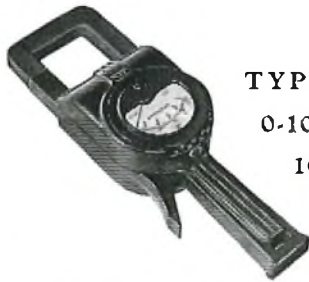

TYPE 'A' AMMETER  
0-10-25-50-100-250-500-  
1000 Amps. Write for  
List IN.17A.



TYPE 'V' VOLT-AMMETER  
0-10-25-100-250-1000 Amps.  
and 0 - 150 - 600 Volts.  
Write for List IN.17V.

7 ranges  
-1 switch



TYPE 'L' AMMETER  
0-10-25-50-100-250-500-  
1000 Amps. Specially  
designed for use on  
porcelain-clad fuses  
and heavy-duty con-  
ductors up to 4"  
dia. Write for  
List. IN.17L.

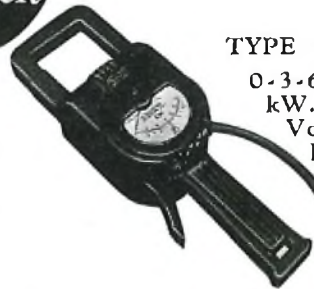

TYPE 'W' WATTMETER  
0-3-6-12-30-60-120-300  
kW. With High Quality  
Voltage Leads, HRC  
Fused Clips and Test  
Prods. Write for  
List IN.17W.



A leather case with shoulder strap is available for all models at an extra charge

FERRANTI LTD · MOSTON · MANCHESTER 10. London Office: Kern House, 36 Kingsway, W.C.2

F1162

## DENSO prevents CORROSION

Whatever the conditions, pipes, cables, conduits, etc. can be protected by Denso . . . above or below ground . . . or under water.

*Corrosion prevention* by the appropriate Denso method is complete and enduring.

With Denso, emergency repairs or temporary seals can be effected quickly and easily, and are proof against moisture or dirt.

For all sealing and plugging, whether temporary or permanent, Denso Mastics are invaluable.



Visit our Stand Nos. 1 and 2 at the Corrosion Exhibition, Royal Horticultural Society's New Hall, Westminster, S.W.1. April 27-30, 1959

**WINN & COALES LTD., DENSO HOUSE, CHAPEL RD., LONDON, S.E.27**

Telephone: GIPsy Hill 4247

Telegrams: Denselte, Westnor, London

Northern Area Headquarters, Denso House, Glebelands Road, Sale, Cheshire.

Telephone: Sale 8271

Telegrams: Denselte, Sale, Cheshire



# Pye MICROWAVE

## Portable

## TV Links

### Type PTC M1000

This transportable long-range television link is suitable for use with the N.T.S.C. colour or monochrome systems, the C.C.I.R. system or the British 405-line system. A sub-carrier f.m. music link circuit is incorporated. The normal frequency range is 6875 to 7425 Mc/s but models can be supplied to cover the range of 5925 to 6425 Mc/s. The r.f. power output is one watt.

The equipment can be operated back-to-back as a demodulator repeater for multi-stage transmission links. Dependent upon siting, each link is capable of transmitting a distance of 50 miles or more.

Transmitter and receiver, as well as an r.f. wave-meter and intercommunication circuits are all contained in four lightweight luggage-type cases. Spun aluminium parabolic reflectors are available in diameters up to 10 ft., and all ancillary equipment can also be supplied.

*Please write for details.*

#### *As supplied to:*

ASSOCIATED TELEVISION LTD.

SCOTTISH TELEVISION LTD.

TYNE-TEES TELEVISION LTD.

CENTRAL REDIFFUSION SERVICES LTD.

PORTUGUESE TELEVISION SERVICE

ATOMIC WEAPONS RESEARCH  
ESTABLISHMENT

and many other users



## MICROWAVE LINKS

# The world-wide influence of



A.T.E. serves the peoples of the world. In more than 70 countries their social, business and industrial life is made more efficient and more satisfying by telecommunications in one or more of its many applications. Chief among these are the telephone and teleprinter operating to transmit the spoken or the written word over a global network of line, cable and radio links. Allied are the remote control systems of electricity distribution networks, hydro electric schemes and railways, the special signalling systems for mines and industry and the many special services forming part of private telephone systems and networks. All these are produced by A.T.E. and its associates from their many factories in England and distributed through their overseas companies and agents. The demand for telecommunication services throughout the world increases, and the research, technical and manufacturing resources of the A.T.E. group are expanding to meet the challenge.



# f a great organisation...

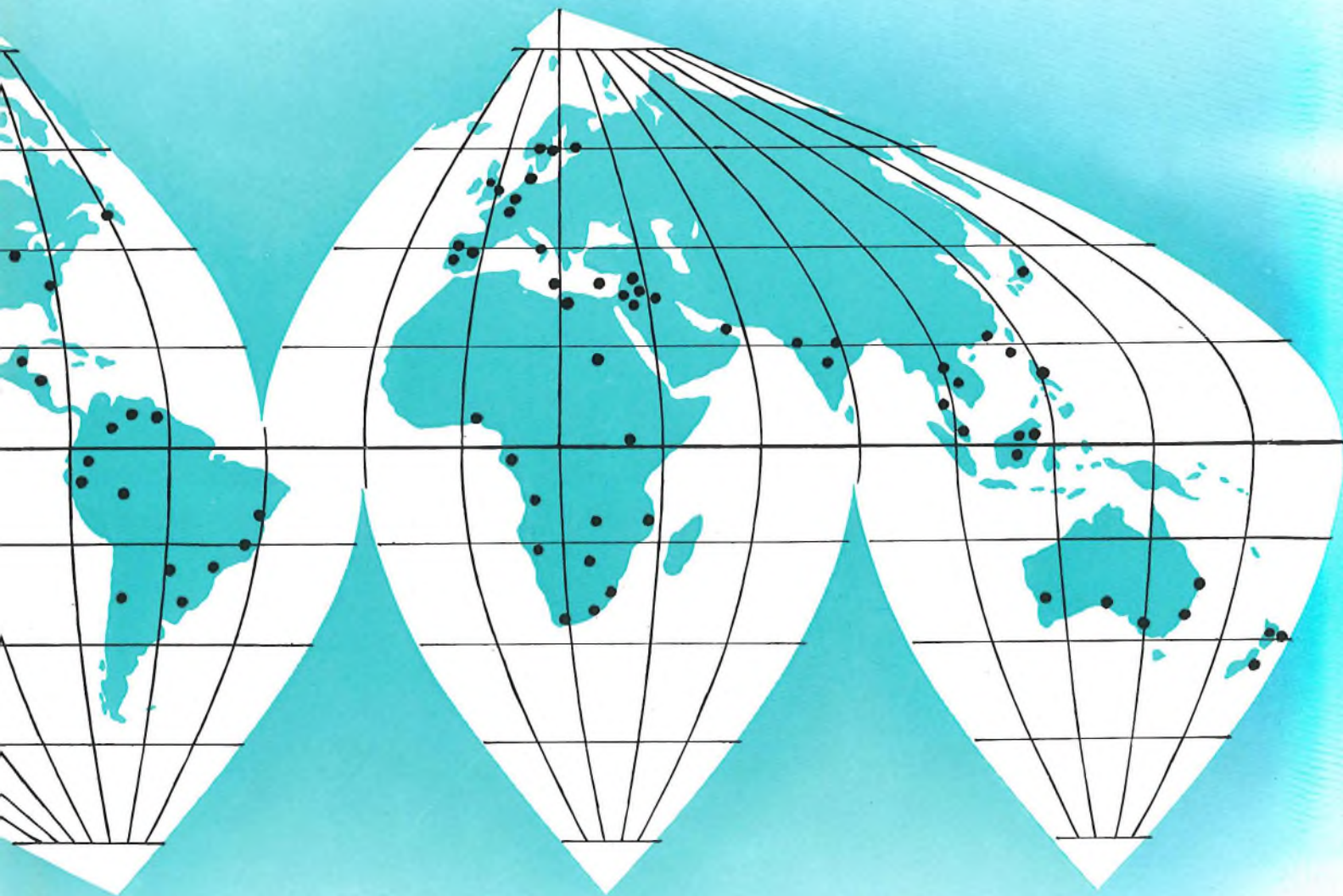

## **AUTOMATIC TELEPHONE & ELECTRIC CO. LTD.**

*Telecommunication Engineers and Consultants—Liverpool—London*



ASSOCIATED DISTRIBUTING COMPANIES, AGENTS AND REPRESENTATIVES IN ALL PARTS OF THE WORLD. JOHANNESBURG, NAIROBI, MELBOURNE, RIO DE JANEIRO, AUCKLAND, LISBON, SINGAPORE, CARACAS, BANGALORE, THE HAGUE, OSLO, STOCKHOLM, ISTANBUL, TORONTO, COPENHAGEN, CAIRO, ATHENS, HELSINKI.



## **TRANS - TAGUS MICROWAVE TELEPHONE LINK**

A development of considerable importance in Portuguese telecommunications is the new microwave radio-telephone system between Lisbon and Montijo. This link, supplied to the order of the Anglo-Portuguese Telephone Company Limited, connects telephone exchanges on the south side of the Tagus with the main Metropolitan automatic network. Initially it provides 60 telephone circuits to supplement an existing submarine cable connection, but at a later stage the capacity will be increased to 240 circuits. The radio equipment, operating in the 2000 mc/s band, has been supplied by Marconi's Wireless Telegraph Co. Ltd., and the associated channelling and signalling equipment by Automatic Telephone and Electric Co. Ltd.

**AUTOMATIC TELEPHONE & ELECTRIC CO. LTD.**

STROWGER HOUSE, ARUNDEL STREET, LONDON, W.C.2



**MARCONI'S WIRELESS TELEGRAPH CO. LTD.**

MARCONI HOUSE, CHELMSFORD, ESSEX, ENGLAND.



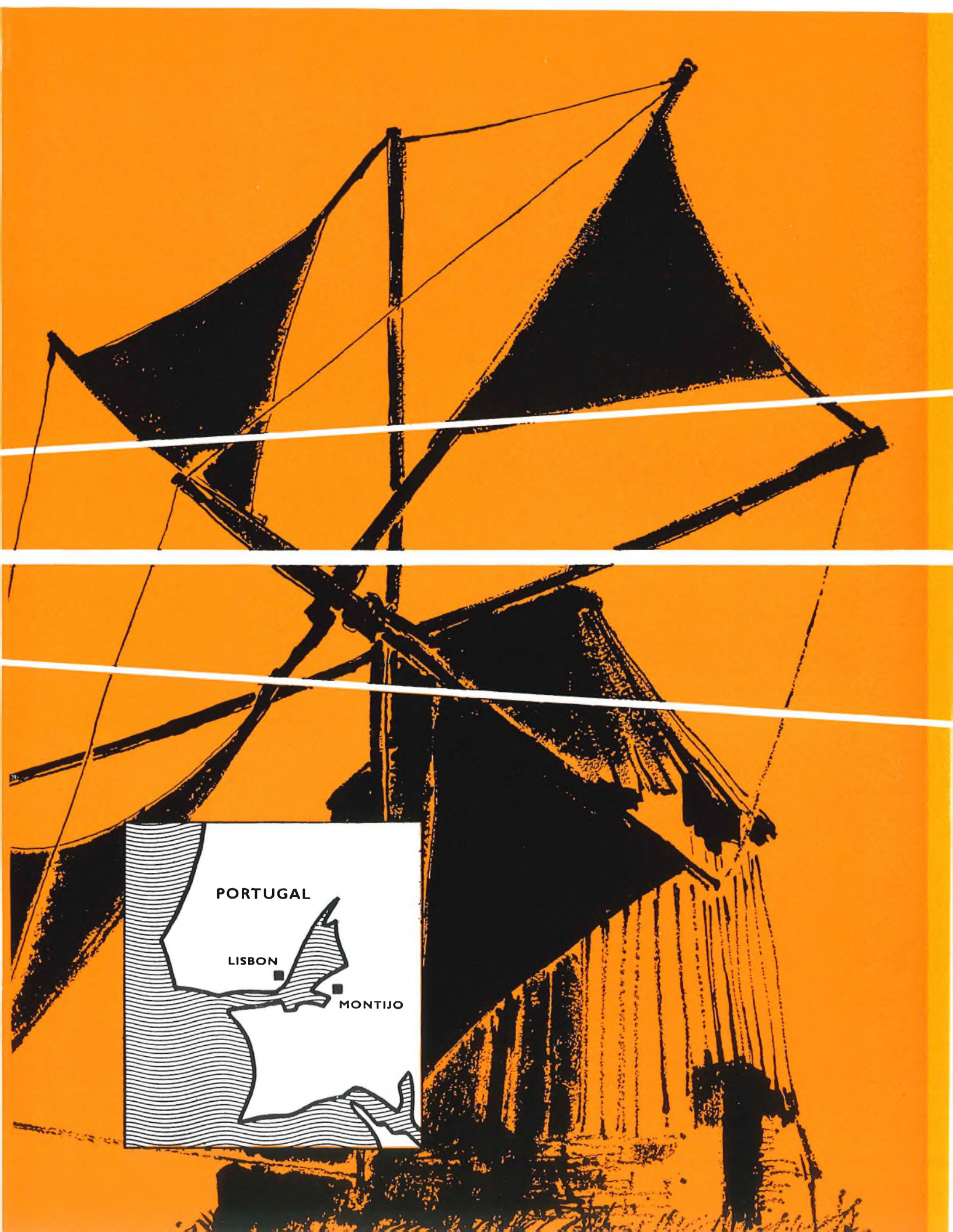



# Introducing the MC10

a NEW 5-Channel

VHF Radio-



*A TYPICAL  
LOCATION  
where this new  
5-Channel Transistorised  
VHF Radio-Telephone  
Terminal will prove  
indispensable in vital  
communications*



# Transistorised Telephone Terminal

**Compact design which at low cost  
provides five high-grade telephone circuits.**

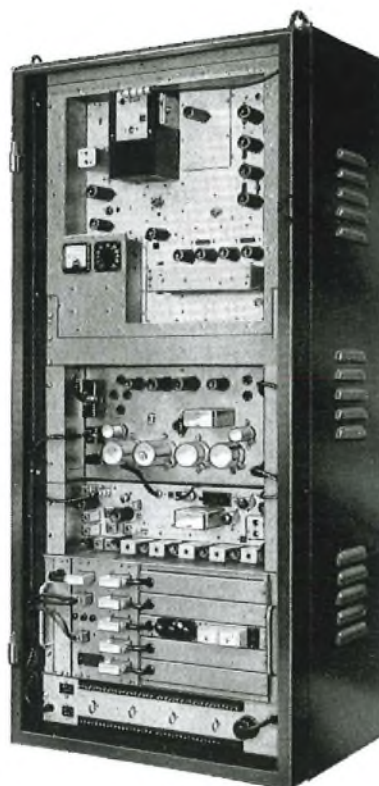

## Radio

Frequency range 156 - 184 Mc/s  
(other frequency ranges are available)  
Transmitter power output 30 watts  
Deviation 75 kc/s  
Receiver Noise Factor 8db  
*All characteristics of the transmitter and  
receiver conform to CCIR specifications*

## Carrier Telephone Equipment

5 Telephone channels · 4 kc/s spaced  
Equipped with Out of Band Signalling  
Facilities for dialling, Ringdown or  
junction working  
Printed Wiring · Plug-in Units  
Crystal frequency control  
Resin cast components

***The result of co-operative enterprise between two great organizations***

***Redifon***

**SIEMENS  
EDISWAN**

### REDIFON LIMITED

Communications Division, Wandsworth, London, S.W.18  
Telephone : VANdyke 7281  
*A Manufacturing Company in the Rediffusion Group*

### SIEMENS EDISON SWAN LIMITED

Transmission Division, Woolwich, London, S.E.18  
Telephone : Woolwich 2020  
*An A.E.I. Company*

## **NEW COMMUNICATION LINK**

## **IN NEW ZEALAND**

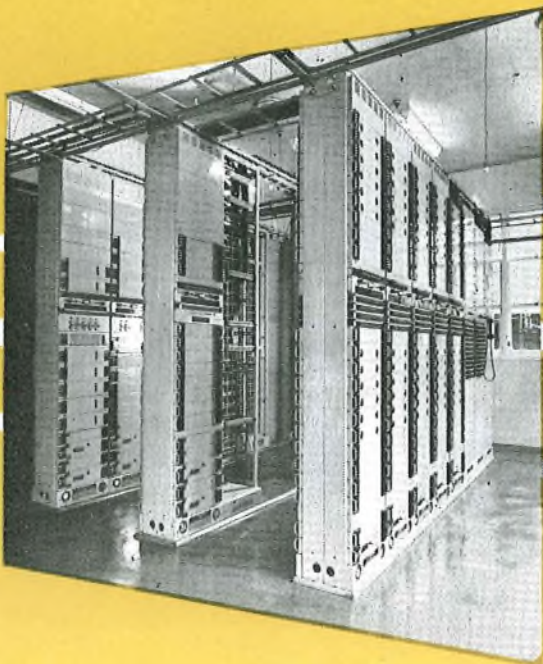

The first section of the new trunk telephone link in the North Island of New Zealand is now in operation, following the commissioning of the multi-channel carrier telephone system operating over a co-axial cable between Auckland and Hamilton. On this section 240 circuits are to be provided initially; the system can be extended to 960 circuits. The new co-axial carrier system will later inter-connect at Hamilton with a wide-band radio link operating to Palmerston-North, and circuits will be extended from the latter point to Wellington over a second co-axial cable. Automatic Telephone and Electric Company Limited has been entrusted by the New Zealand Posts and Telegraphs Department with the supply of all the line transmission and terminal channelling equipment required for both cable and radio sections of the complete route between Auckland and Wellington.



**AUTOMATIC TELEPHONE & ELECTRIC CO. LTD.**

STROWGER HOUSE, ARUNDEL STREET, LONDON, W.C.2



- TERMINAL
- REPEATER
- POWER FEED
- .... CO-AXIAL CABLE
- ⚡ RADIO

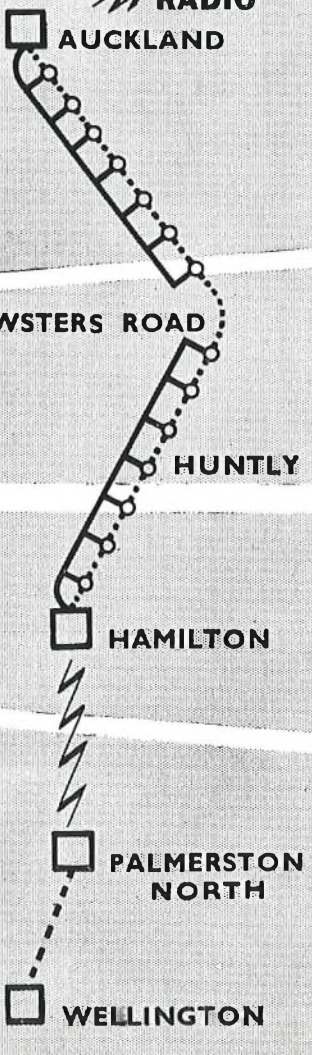





R.A.X.'s provide a  
Metropolitan grade  
of service in  
Rural areas

- ★ Automatic connexion between subscribers.
- ★ Regular subscriber's lines.
- ★ P.B.X. lines.
- ★ Coin box lines.
- ★ Two-party, 2-wire lines.
- ★ Subscriber's meters (with multi-metering).

These, and many other facilities are provided by G.E.C. Rural Automatic Exchanges, which operate for long periods without attention, and are designed to withstand the many climatic conditions experienced throughout the world.

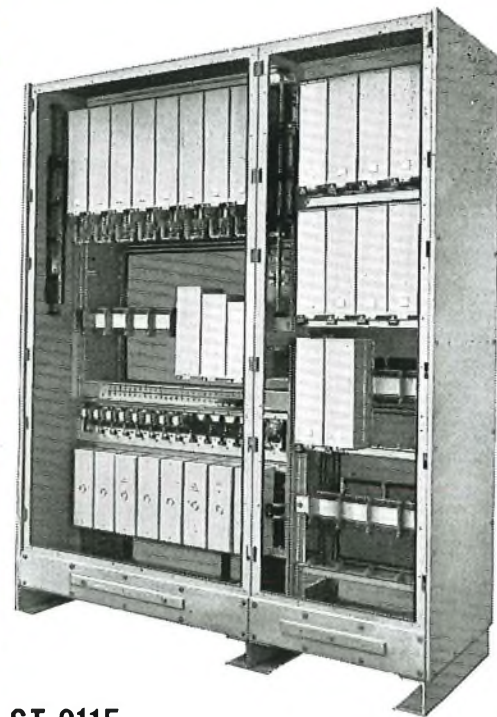

ST 9115



For further details please write to:—

**THE GENERAL ELECTRIC COMPANY LIMITED OF ENGLAND**  
TELEPHONE, RADIO AND TELEVISION WORKS · COVENTRY · ENGLAND

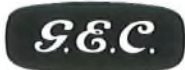



# Whatever happens to the mains supply...

*One of the 14 Austinlite sets for the new micro-wave Radio Link—Kuala Lumpur to Singapore, showing a 14 kVA double engine no-break set, a 16 kVA normally stationary stand-by set and the combined control cubicle.*

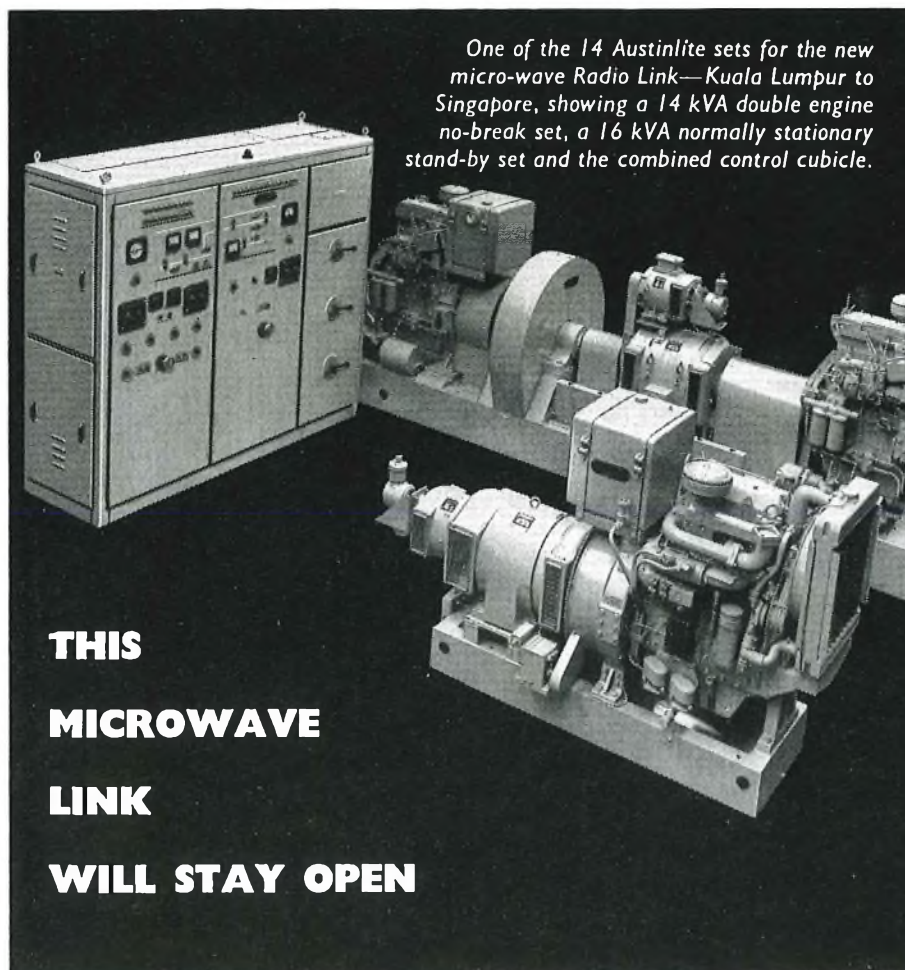

**THIS  
MICROWAVE  
LINK  
WILL STAY OPEN**

The new microwave Radio Link between Kuala Lumpur and Singapore, some 350 miles of jungle, humidity and pests, is assured of an uninterrupted power supply.

At each of the 14 stations along the route, Austinlite "No-Break" Generating power plant will perform a vital role. At three of them there is no mains supply and power will come from twin-engine Austinlite power plant, running night and day. At others, Austinlite equipment will act as stand-by to the mains supply and at certain selected stations Austinlite provide both the primary power and an alternative source for use during maintenance periods.

Austinlite plant, designed for exacting conditions, is supplying stand-by power in many parts of the world.

## AUSTINLITE AUTOMATIC POWER PLANT

CUSTOM BUILT BY

**STONE-CHANCE LIMITED, CRAWLEY, SUSSEX, ENGLAND**

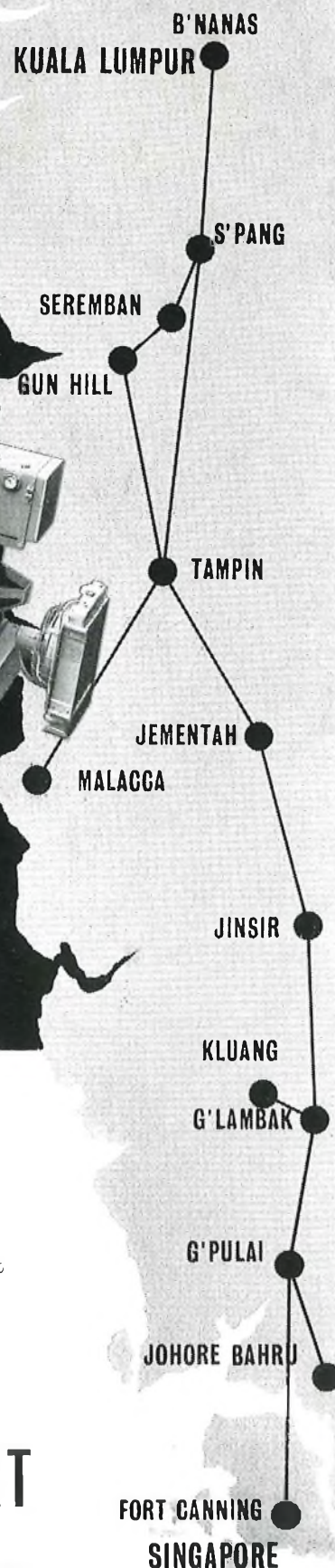

# EASY TO INSTAL — SIMPLE TO EXTEND

**G.E.C.**

## UNIT-TYPE POWER PLANT for TELEPHONE EXCHANGES

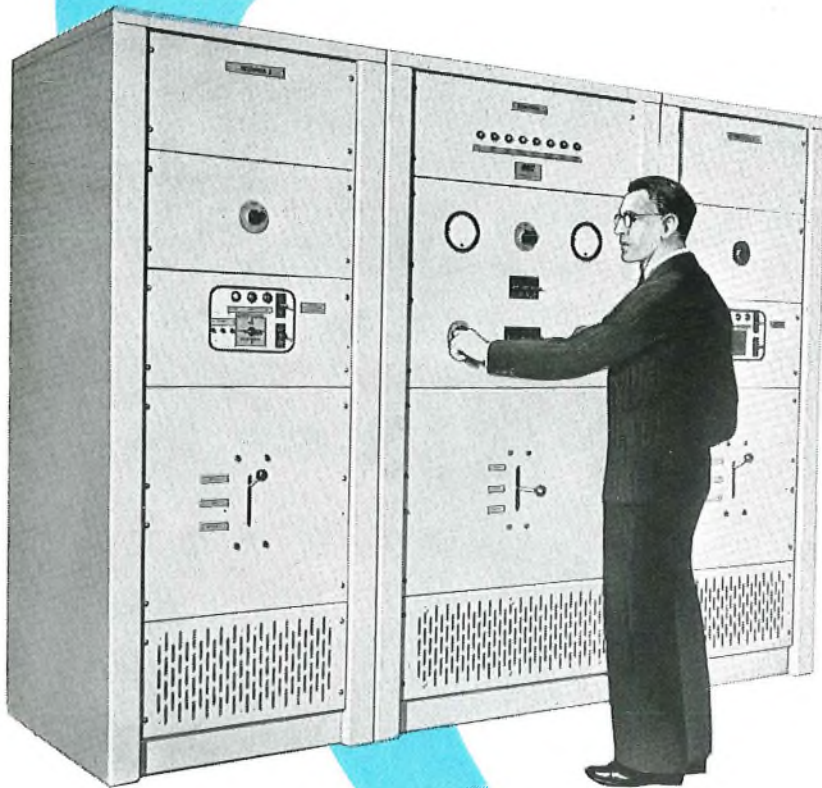

The General Electric Company is now producing a range of power plants of the unit type for use in telephone exchanges.

The units are housed in modern-styled, self-supporting cubicles, which can be joined together to form a suite of uniform appearance. They can be installed faster than earlier types of plant, they occupy less floor space, and they can be extended simply by adding further rectifier units.

The plant operates on the duplicate battery float principle. The rectifiers are automatically regulated and sequentially switched, thus permitting operation for long periods without attention.

A rectifier or battery can readily be isolated for maintenance purposes.

**G.E.C.**

For further details  
please write to:—

**THE GENERAL ELECTRIC COMPANY LIMITED OF ENGLAND**

TELEPHONE, RADIO AND TELEVISION WORKS, COVENTRY, ENGLAND



*Adjusting the scanning unit  
of the electron accelerator.*

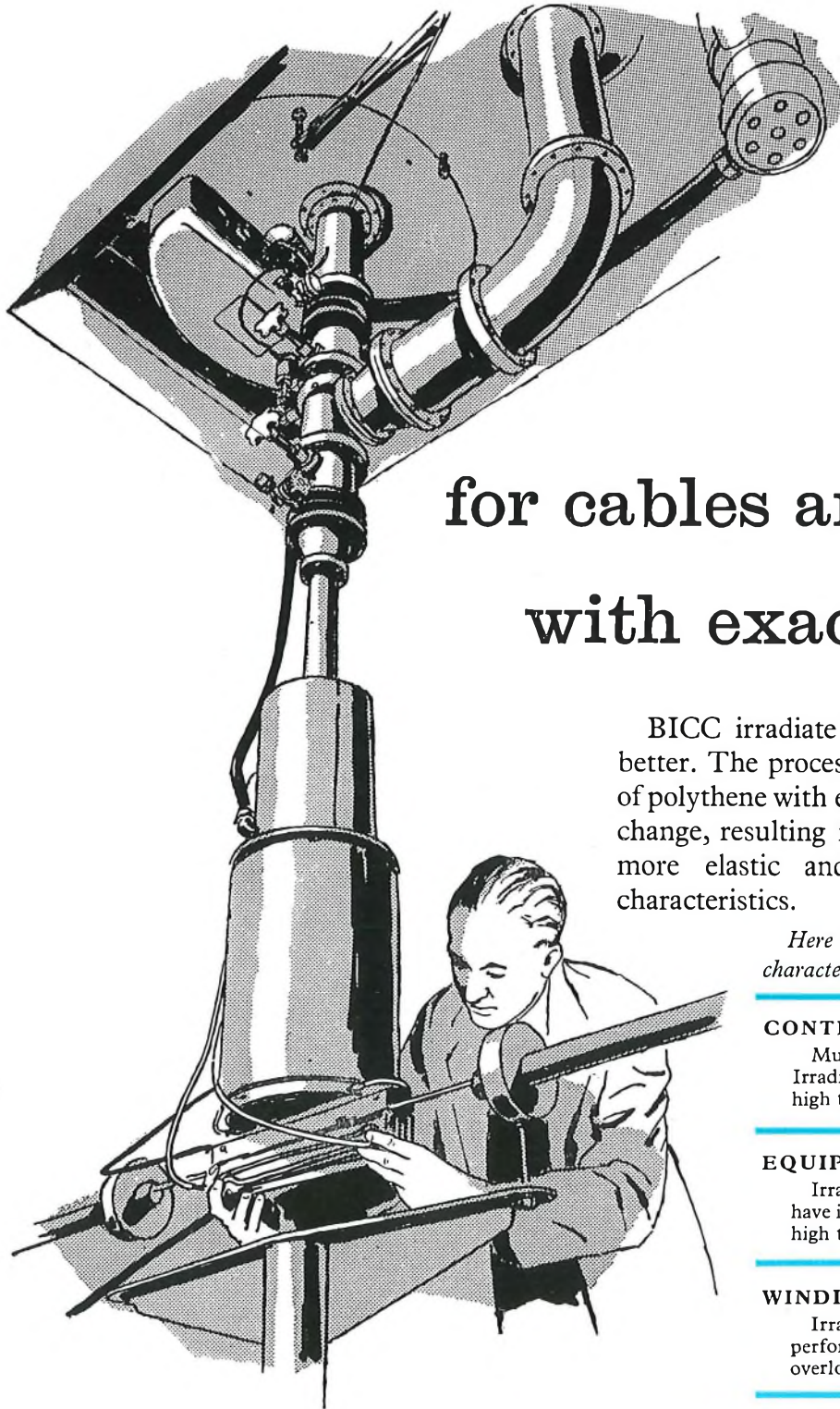

## for cables and wires with exacting duties

BICC irradiate polythene to make good cables better. The process is basically the bombardment of polythene with electrons. This causes a chemical change, resulting in a stronger material, which is more elastic and has improved temperature characteristics.

*Here are some BICC products with improved characteristics resulting from irradiation:—*

### **CONTROL CABLES**

Multi-core cables, insulated and sheathed with Irradiated Polythene, have improved short-term high temperature characteristics.

### **EQUIPMENT WIRES**

Irradiated Polythene insulated equipment wires have improved soldering properties and enhanced high temperature performance.

### **WINDING WIRES**

Irradiated Polythene insulation gives better performance for wires subject to intermittent overload conditions.

### **COAXIAL R/F CABLES**

Irradiated Polythene core permits higher temperature soldering of radio frequency cable terminations.

*Full details of these BICC products are available on request.*

**BICC**

**IRRADIATED  
POLYTHENE**

**cables & wires**

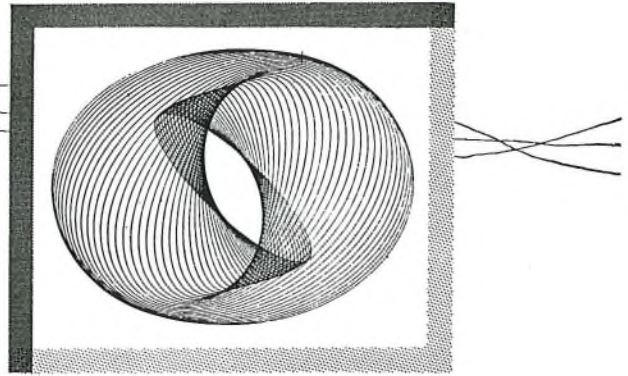

## Extreme toughness, flexibility and resistance

to abrasion, solvents and heat—all these qualities unite in Henley Enamelled Wires to give Industry a consistently high performance product. The superior physical properties of these wires provide exceptional dielectric strength and resistance to elevated temperatures and solvents, regardless of rigorous use. All Henley Enamelled Wires comply with the appropriate British Standards.

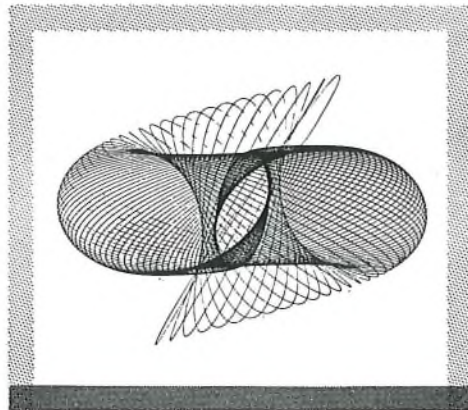
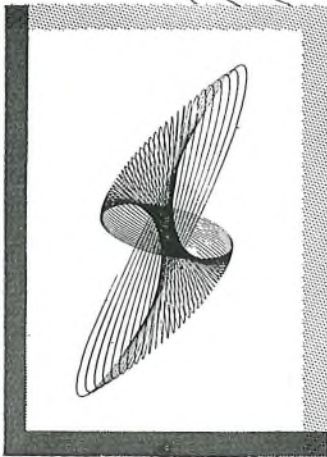
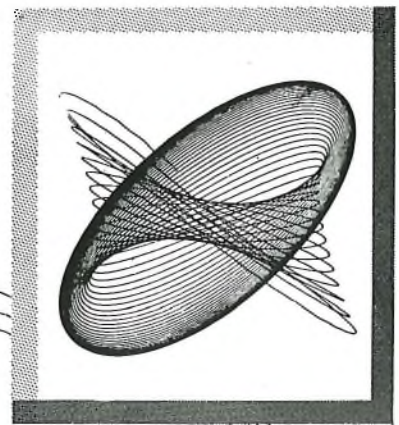

*The following types are available:*

Oleo-Resinous  
Vinyl Acetal Base—Supermex

Polyurethane Base,  
self-fluxing—Superthane

Polyester Base—Superester

*Samples gladly sent on request.*

# HENLEY

## ENAMELLED COPPER WINDING WIRES



BY APPOINTMENT TO  
HIS MAJESTY THE QUEEN  
ELECTRIC CABLE  
MANUFACTURERS

W. T. HENLEY'S TELEGRAPH WORKS CO. LTD  
51-53 Hatton Garden, London, E.C.1. CHAncery 6822





# 5-unit tape transmitter

model 20

Sequential type for single wire transmission.  
For single or double current operation.  
7 $\frac{1}{2}$  unit transmission at 45.5, 50, or 75 bauds

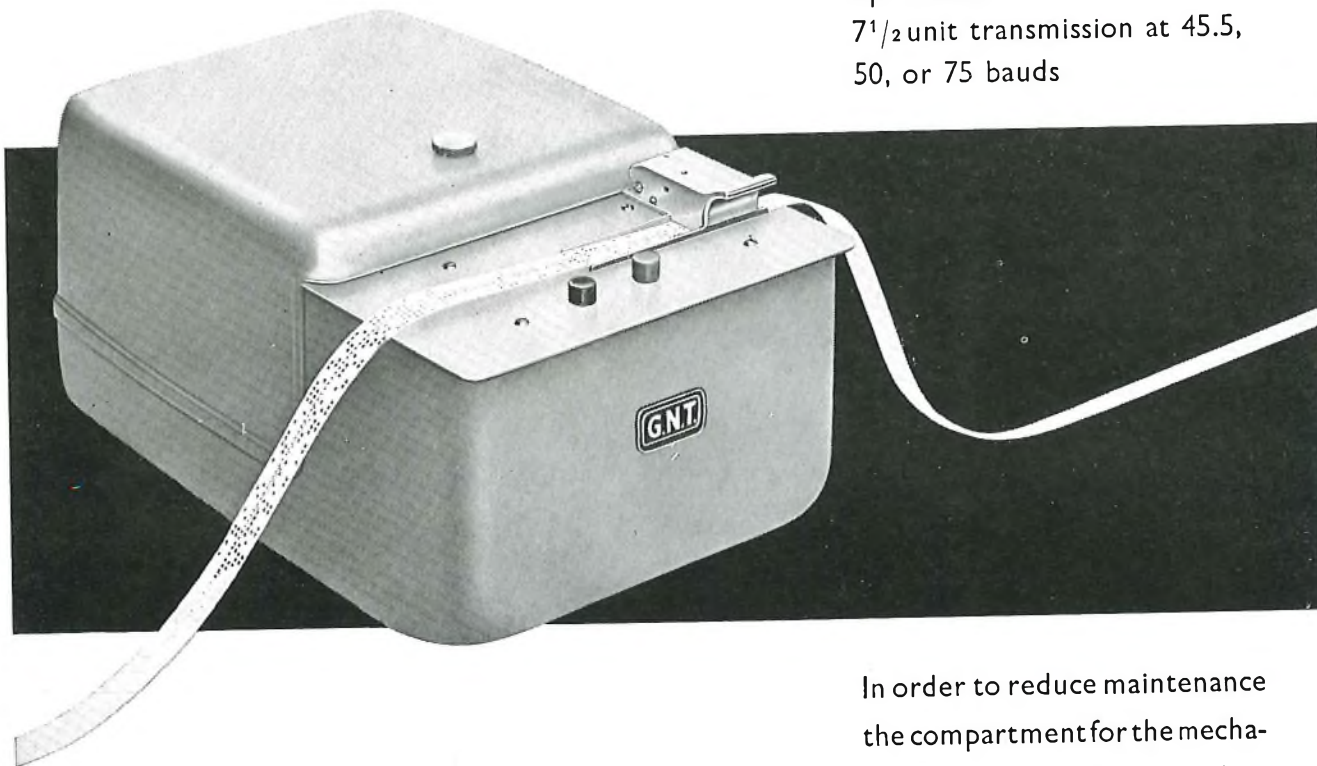

*Meets all the requirements  
of a modern 5-unit tape transmitter.*

In order to reduce maintenance the compartment for the mechanism is pressurised so that dust and paper fluff cannot enter the operating parts.

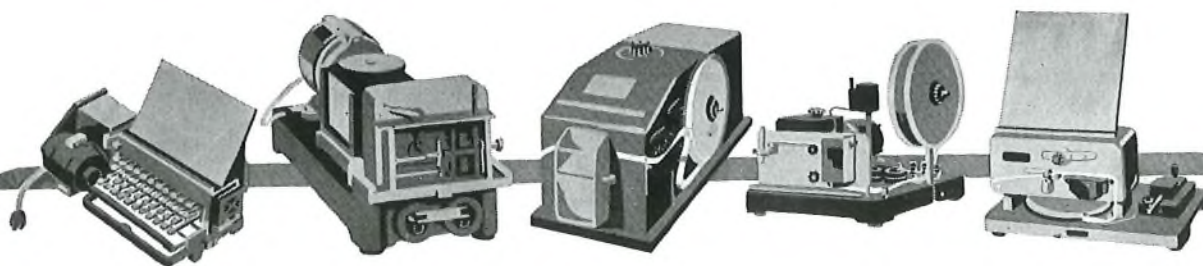

## GREAT NORTHERN TELEGRAPH WORKS

DIVISION OF THE GREAT NORTHERN TELEGRAPH CO. LTD.

4, SYDHAVNS PLADS  
COPENHAGEN SV, DENMARK

LONDON OFFICE: 5, ST. HELEN'S PLACE  
LONDON E. C. 3.



## CONSTANT POTENTIAL RECTIFIERS

*are associated with the d.c. power supplies to*  
**THE SUBSCRIBER TRUNK DIALLING SYSTEM**

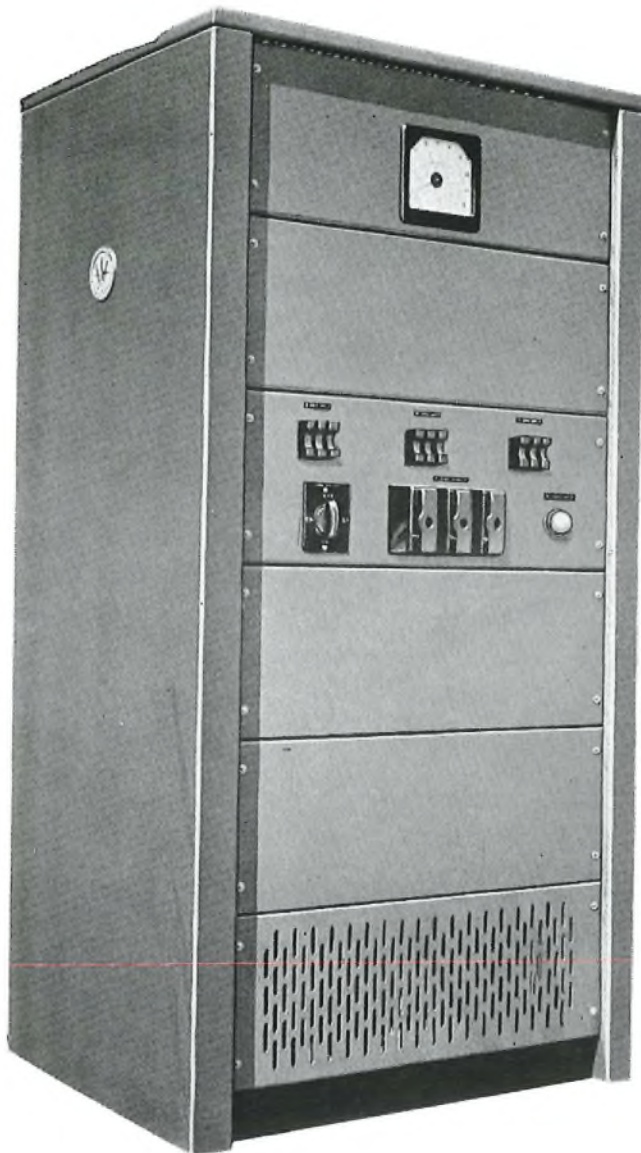

A Westinghouse transducer controlled rectifier set forms the basis of the power supply to the register translator in the new subscriber trunk dialling system. Equipments of this type are designed to stabilise the d.c. output voltage to less than  $\pm 1\%$  over a load range of 10% full load to full load despite simultaneous mains input voltage variations of  $\pm 6\%$  and frequency changes of  $+1\%$  to  $-2\%$ .

**WESTINGHOUSE BRAKE AND SIGNAL CO. LTD., 82 York Way, King's Cross, London, N.1**  
Tel.: TERminus 6432





**You can now specify S.T.C.**

## **Transistors for Entertainment and Industrial Applications**

### **ENTERTAINMENT TYPES**

- (a) TS.7 TS.8 ... ..small signal amplifiers and frequency changers
- (b) TS.9 TS.17 ... ..higher power amplifiers up to several hundred milliwatts
- (c) TS.13 TS.14 ... ..low frequency applications

### **INDUSTRIAL TYPES**

- (a) TK.23A ... ..low frequency telephone and telegraph carrier systems
- (b) TK.20B ... ..switching circuits (computers)
- TK.25B ... ..switching circuits 8 Mc/s and above
- (c) TK.21B TK.24B
- TK.26B TK.27B ...switching circuits and/or small signal amplification
- (d) TK.40A ... ..amplifier and oscillator. Audio frequencies for power of several hundred milliwatts

First in Europe to produce transistors, S.T.C. are now making available to industry a range previously only used in their own equipment. Their long experience of components manufacture coupled with the latest production techniques has resulted in yet another high-quality product.

*Send for literature on the available types.*



***Standard Telephones and Cables Limited***

Registered Office: Connaught House, Aldwych, London, W.C.2

**TRANSISTOR DIVISION: FOOTSCRAY · SIDCUP · KENT**

VHF

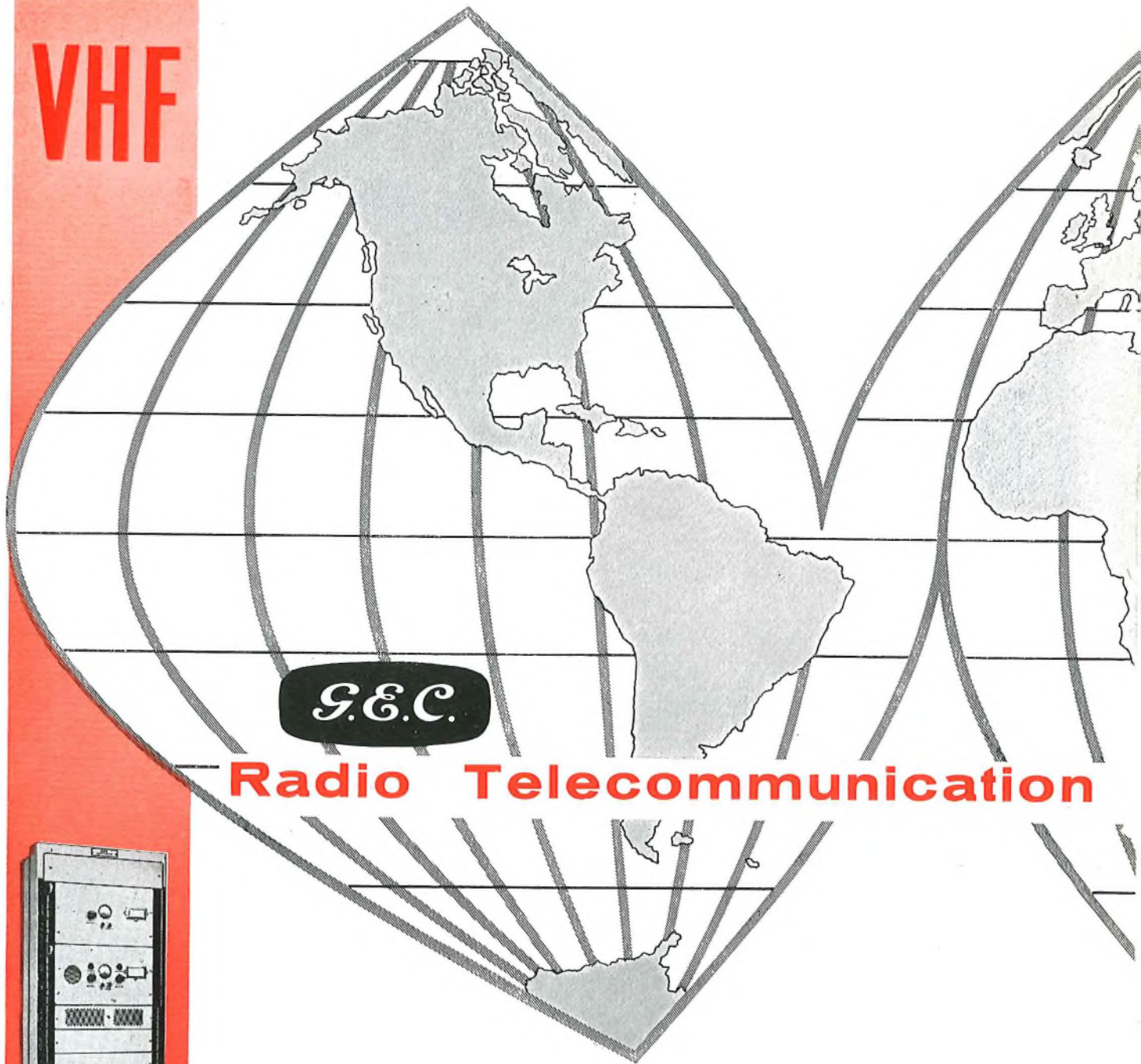

**Radio Telecommunication**

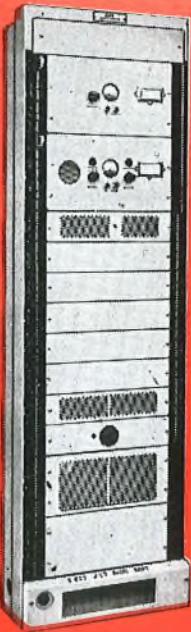

5 circuit V.H.F.  
junction radio  
terminal equipment.

**Over 1000** 5-circuit V.H.F. Junction Radio Equipments have been supplied to 28 countries throughout the world.

*The vast experience gained by G.E.C. in surveying, planning, designing, manufacturing, a*



EVERYTHING FOR TELECOM

**THE GENERAL ELECTRIC COMPANY LIMITED OF ENGLAND**



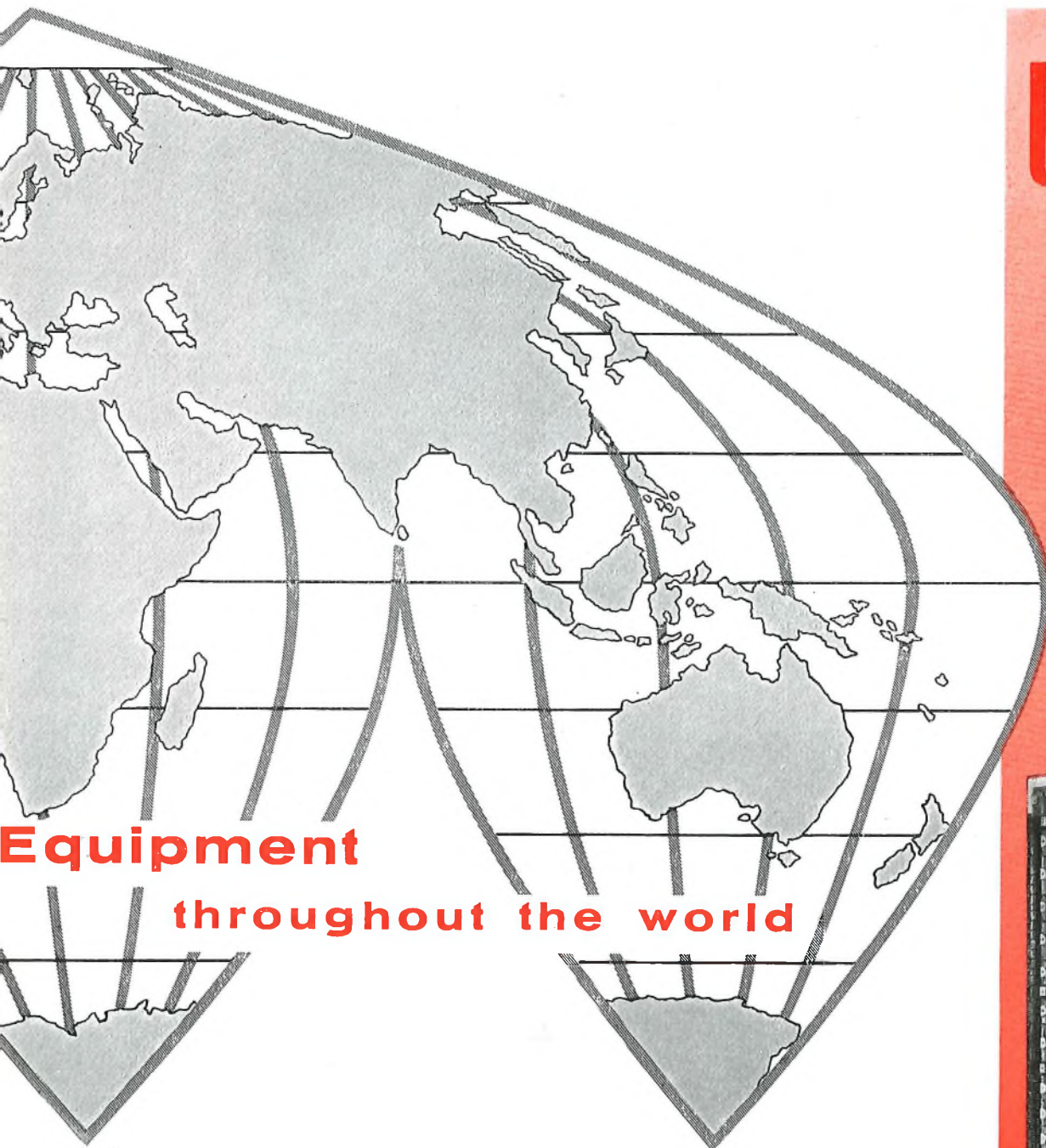

## Equipment throughout the world

Microwave systems providing over 4950 wide band channel miles for television or multi-circuit telephony have been installed or ordered for 7 countries throughout the world.

240-circuit U.H.F.  
radio terminal equipment  
(less covers)

*and installing radio systems in all five continents is available to prospective customers.*

COMMUNICATIONS

TELEPHONE, RADIO AND TELEVISION WORKS, COVENTRY

# UHF



**G.E.C.**



# The new British Post Office Telephone



**but fully tropicalised**

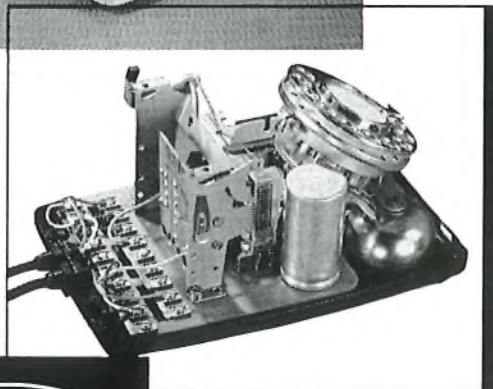

Anticipating the demand from many overseas countries for the new British Post Office telephone, Siemens Edison Swan have developed a model suitable for use in any climate. This instrument is in full tropical finish, ventilated and effectively sealed against dust and insects. Available in colours. It can be supplied with or without automatic transmission regulator and an attenuator for the transmitter is also an optional feature. When the automatic regulator is not supplied, provision is made for adding it at any time.

*For full particulars write to:*

**SIEMENS EDISON SWAN LTD**

*An A.E.I. Company*

Telecommunications Division P.D.7 Woolwich, London, S.E.18

Telephone: Woolwich 2020 Ext. 724



another addition to  
the *SenTerCel* range  
of Silicon Rectifiers

**5 AMPERES**  
RS5 SERIES

**SILICON  
POWER  
DIODES**



- Peak Inverse Voltages from 50V to 400V.
- 5 amperes at 100°C with heat sink.
- Also available assembled as rectifier stacks.

For leaflets describing these and other  
'SenTerCel' silicon devices write



*Standard Telephones and Cables Limited*

Registered Office: Connaught House, Aldwych, London, W.C.2

RECTIFIER DIVISION: EDINBURGH WAY · HARLOW · ESSEX



## **FROM ANY**

**THE ETEPHONE IS ERICSSON'S  
EXPORT VERSION OF  
THE NEW POST OFFICE TELEPHONE**

- **MOULDED IN DIAKON**
- **CAN BE FULLY TROPICALIZED**
- **CARRYING HANDLE IS FITTED**
- **STRAIGHT OR COILED CORDS**
- **DIAL LOCK SWITCH AVAILABLE**
- **CONVERTIBLE TO WALL MOUNTING**
- **IMPROVED MAINTENANCE FACILITIES**





# **POINT OF VIEW — INCOMPARABLE**

**- - - the new E T E L P H O N E**

**- - - in colour**

Colours for the case and handset which have been imaginatively chosen to harmonize with modern decorative schemes and furnishings, have a very high degree of light fastness, important for replacement colour matching.

- **TWO-TONE GREEN**
- **TWO-TONE GREY**
- **CONCORD BLUE**
- **TOPAZ YELLOW**
- **LACQUER RED**
- **BLACK**
- **IVORY**



FOR FURTHER INFORMATION PLEASE WRITE TO:—



**ERICSSON TELEPHONES LIMITED**  
**E TELCO LIMITED**

Head Office:— 22, LINCOLN'S INN FIELDS, LONDON W.C.2  
Works:— BEESTON, NOTTINGHAM AND SUNDERLAND.

TEL: HOLBORN 6936

# STC **NEW**



*The new 12-circuit group sub-rack—a complete wired and tested mechanical unit. A notable advance in the design of carrier telephone equipment.*

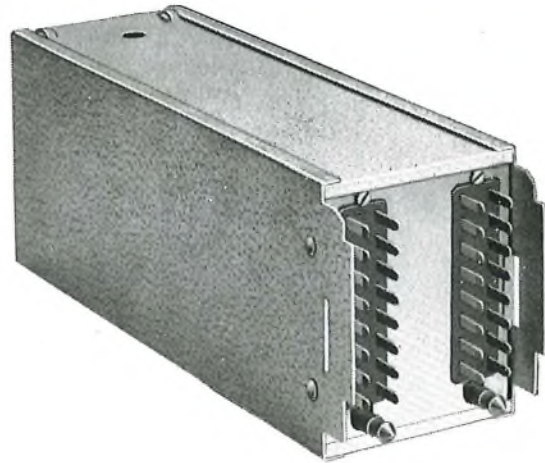

*Standard  
Transmission  
Equipment  
Practice  
No. 5  
uses plug-in apparatus  
units with STRIP-WIRED  
boards giving  
full access to the  
components.*

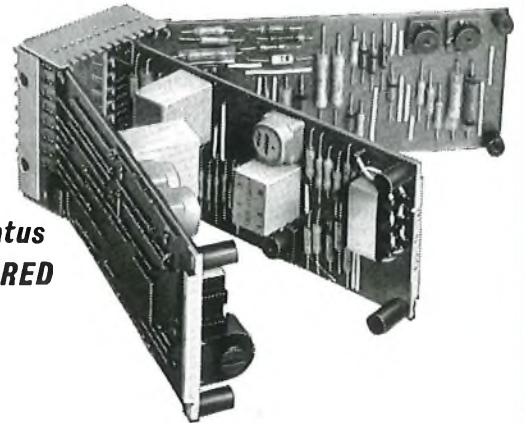



# **ALL-TRANSISTOR CHANNELLING EQUIPMENT TYPE STEP. 5**

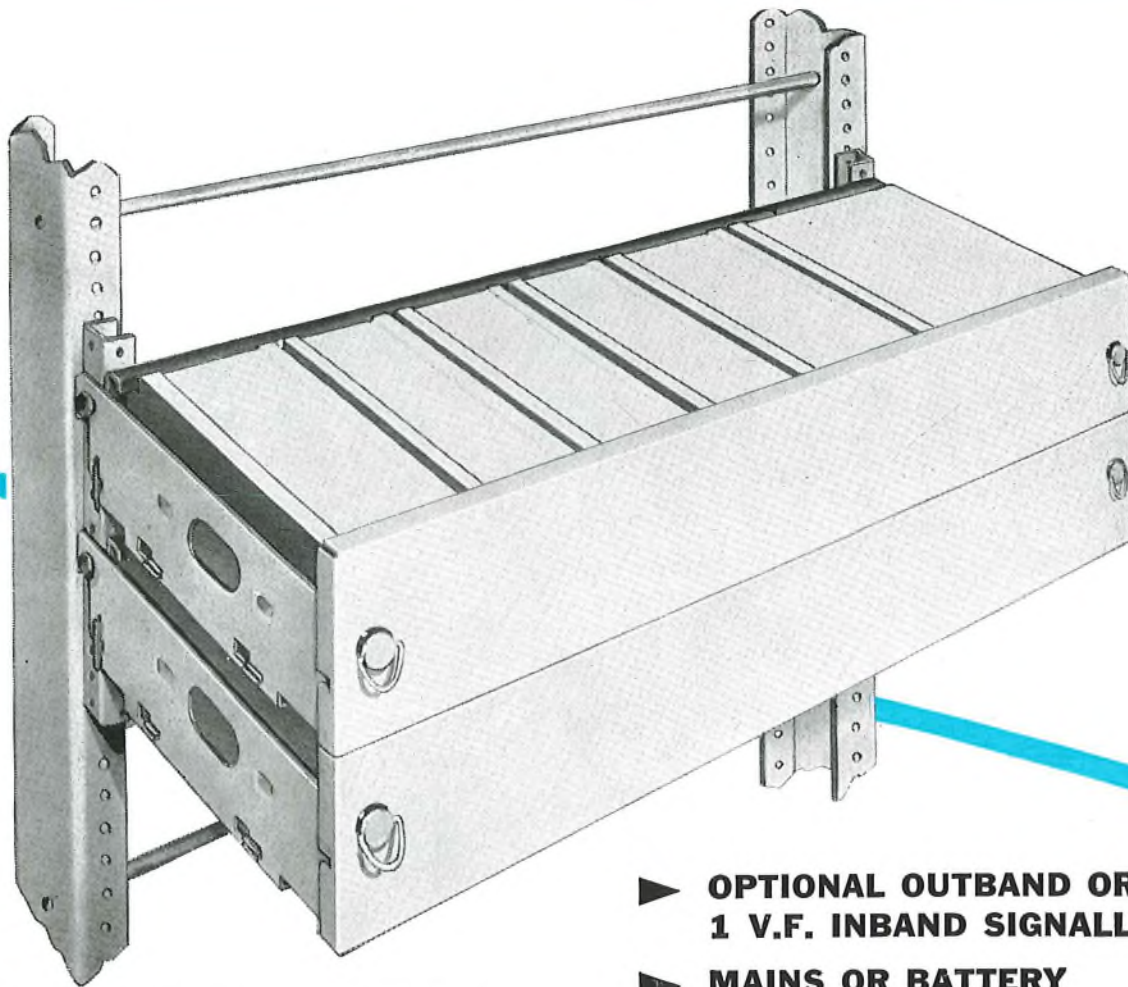

- ▶ **DOUBLED EQUIPMENT DENSITY**
- ▶ **144 WIDE BAND CIRCUITS ON ONE STATION FRAME**
- ▶ **LOW POWER CONSUMPTION**
- ▶ **OPTIONAL OUTBAND OR 1 V.F. INBAND SIGNALLING**
- ▶ **MAINS OR BATTERY OPERATION**
- ▶ **LESS ROOM HEATING**
- ▶ **TEST POINTS EASILY ACCESSIBLE**



*Standard Telephones and Cables Limited*

Registered Office: Connaught House, Aldwych, London, W.C.2

TRANSMISSION DIVISION: NORTH WOOLWICH · LONDON E.16

# Economic trunk dialling

with **1VF**

For many years Siemens Edison Swan has been one of the main world suppliers of Voice Frequency Signalling Equipment for large trunk networks. To meet the needs of local junction and minor trunk networks not requiring the more complex signalling facilities of two-tone systems; an advanced single voice frequency signalling and dialling equipment is also available at low cost.

The design of the system incorporates C.C.I.T.T. performance recommendations. All circuits in a network capable of transmitting speech may be adapted economically for through signalling and dialling. The following are some of the salient features of the equipment:—

- Can be applied to any speech channel.
- Basically simple—does not complicate the line terminal or channelling equipment.
- Can be arranged for unidirectional or bothway signalling and dialling.
- Relay Set mounting in accordance with latest telephone exchange practice; can be installed with the telephone equipment and served from exchange power supplies.
- Uses standard components of latest design throughout.
- Requires negligible maintenance attention.
- Suitable for the introduction of economic subscriber trunk dialling.

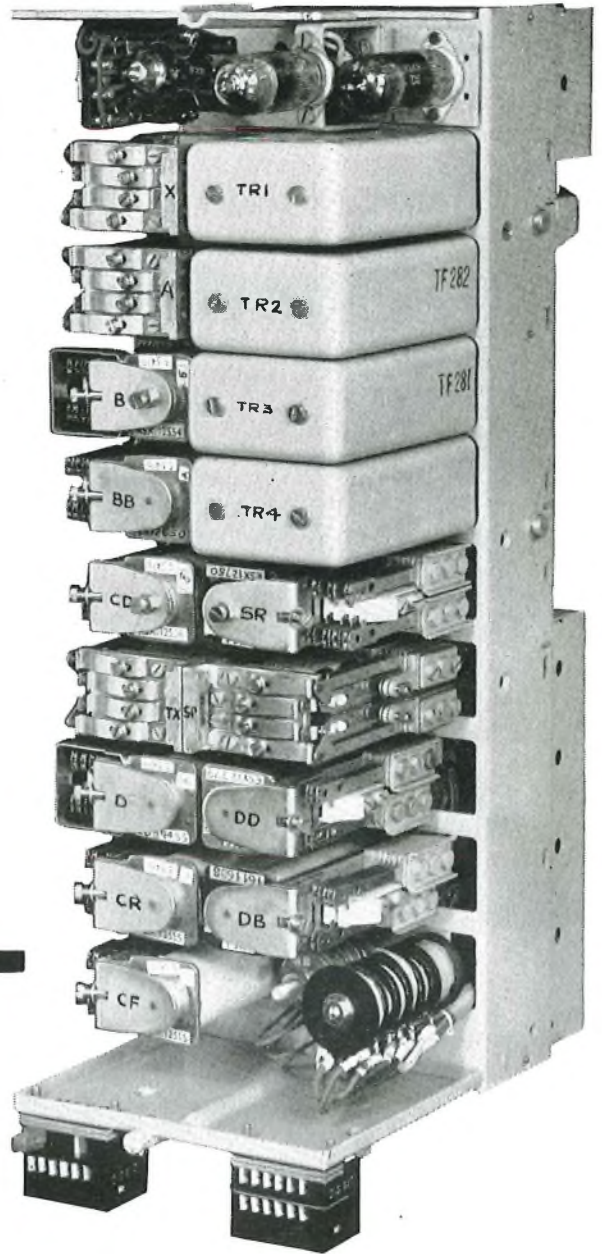

*1VF Terminal Relay Set*



**SIEMENS EDISON SWAN LTD.**

*Telecommunications Division P.D.5,  
Woolwich, London, S.E.18.  
Telephone: Woolwich 2020*



**Performance  
control  
finish**

## The BRT.400 is still the best



**G.E.C.**

The valves used in the "K" version of this long established and popular general purpose communications receiver are internationally standard, thus increasing its appeal to users outside the United Kingdom and to international organisations.

Other outstanding features of performance and presentation are:—

- ★ Six frequency ranges between 150kc/s and 385kc/s and 0.51Mc/s and 30Mc/s.
- ★ Only 3db change in output for 100db change in input.
- ★ Negligible oscillator frequency drift.
- ★ 9kc/s audio rejector filter (optional).
- ★ Clarity of scales on six independently edge-illuminated Perspex strips.
- ★ Operational with crystal controlled oscillator (BRT 405) on any six chosen frequencies.
- ★ Operation from mains supply or standby battery.
- ★ Table or rack mounting models.
- ★ Suitable for all climatic conditions.

*For full details and quotations please write to:*

Electronics Division,

THE GENERAL ELECTRIC CO. LTD., OF ENGLAND,  
Telephone, Radio & Television Works, Coventry.

GEC15

## XB3 . . . the heart of the matter

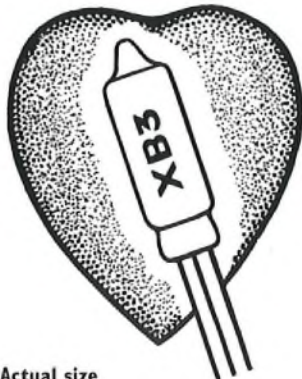

Actual size

The development of the new type 700 Post Office telephone produced a need as well as an opportunity to incorporate the most modern type of automatic regulation.

For this a very small centre tapped resistance lamp was needed, having closely controlled characteristics and providing extreme reliability and long life.

Hivac developed the XB3 (P.O. Bulb Resistance No. 15) specially for this purpose and it is already in production for the new Telephone.

Resistance (each half)  
 $18 \pm 1\frac{1}{2}$  ohms at 77mA  
less than 6 ohms at 30mA



*Photograph of Type 700 Telephone reproduced by courtesy of HM Postmaster General*

for further details write to:—

**Hivac Limited**

A member of the  
Automatic Telephone  
& Electric Group

STONEFIELD WAY · SOUTH RUISLIP · MIDDLESEX · Ruislip 3366

B3



*Photograph by courtesy of  
British European Airways*

## **BEA** EQUIPMENT

### features the Carpenter Polarized Relay

Behind the efficiency of London Airport is the busy B.E.A. Teleprinter Centre gathering and transmitting information. This centre serves most of the airlines operating at London Airport and handles over 20,000 messages each day. Its transmitters must meet the needs of speed, competence and reliability.

For these very reasons, B.E.A. choose Carpenter Polarized Relays for the Telegraph Transmitters.

Carpenter Polarized Relays are available in 5 basic types, each with several variations for special purposes. They have facilitated, and continue to facilitate new developments in the field of electronics. To learn more about them, please write for details.

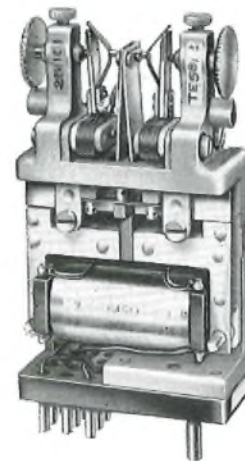

# TMC

## **CARPENTER POLARIZED RELAYS**

TELEPHONE MANUFACTURING COMPANY LIMITED  
Relay Division, Hollingsworth Works, London, S.E.21  
Telephone: GIPsy Hill 2211





## TIME AND SPACE

### and **T.M.C. CAPACITORS**

Reaching into space, man has made time his servant: made protracted processes to be repeated many times in a minute, and disturbances, too fast for the human mind, to be examined at leisure. To do this he uses the analogue computer. And into the integrators of this immensely complex mechanism go T.M.C. Polystyrene Capacitors. The absolute dependability of these capacitors makes them specially chosen for analogue computers manufactured by the following firms:

SHORT BROS. & HARLAND LTD · E.M.I. ELECTRONICS LTD.  
THE SOLARTRON ELECTRONIC GROUP LTD.

The Metallized P.E.T.\* Capacitor, perfect for T.V. cameras, Echo Sounders and Radar Equipment, is another outstanding example of T.M.C.'s ability to produce the ideal capacitor for any particular purpose.

T.M.C.'s knowledge, experience and technical resources will be turned to your specific requirements if you write for full information.

\* polyethylene-terephthalate



# TMC

## CAPACITORS

TELEPHONE MANUFACTURING COMPANY LIMITED

Components Division · Cray Works · Sevenoaks Way · Orpington · Kent

Telephone: Orpington 26611

Two new  
**TMC** carrier  
telephone  
equipments

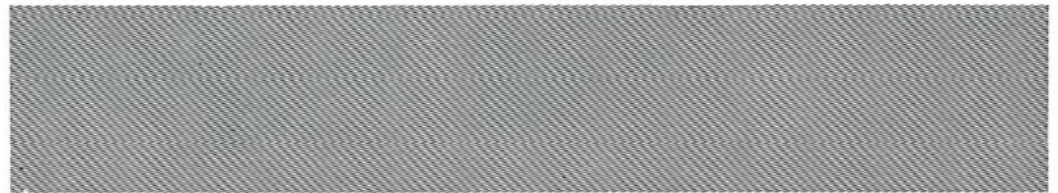

for S.T.D. and T.A.T.

**TELEPHONE MANUFACTURING COMPANY LIMITED**

Transmission Division, Cray Works, Sevenoaks Way, Orpington, Kent



**FOR LOW-COST BEARERS—  
8 CIRCUITS IN 60-108 KC/S BAND  
WITH OUT-BAND SIGNALLING**

- 6 kc/s channel spacing
- Channel bandwidth 300 c/s—3,400 c/s
- Dialling (E & M) or ring-down facilities
- Low-level signalling (-20dbm0) tone-on or tone-off idle
- Five 8-circuit groups on one double-sided 9 foot rack including carrier, signalling and power supplies
- Alternative version for 4-wire balanced-pair cables with complete equipment for two 16-circuit terminals on one double-sided 9 foot rack

Similar to equipment used by  
**THE BRITISH POST OFFICE**  
to provide **SHORT TRUNK CIRCUITS**  
with **OUT-BAND DIALLING**



**FOR HIGH-COST BEARERS—  
16 CIRCUITS IN 60-108 KC/S BAND  
WITH HIGH GRADE CHANNELS**

- 3 kc/s channel spacing
- Channel bandwidth 300 c/s—3,100 c/s
- Two 16-circuit groups on one double-sided 9 foot rack

Developed by  
**THE BRITISH POST OFFICE**  
for use on the  
**TRANS-ATLANTIC TELEPHONE CABLE**

THESE NEW CARRIER TELEPHONE EQUIPMENTS ARE  
THE LATEST ADDITIONS TO THE T.M.C. RANGE OF  
TRANSMISSION EQUIPMENT WHICH INCLUDES

Carrier Telephone and Telegraph Equipment  
for Cable, Open-Wire and Radio  
Transistorised 120 c/s and 170 c/s F.M.  
Telegraph Equipment  
Transistorised V.F. Repeater Equipment  
Transistorised Privacy Equipment

**SELLING AGENTS**

AUSTRALIA AND NEW ZEALAND

**Telephone Manufacturing Co.  
(A'sia) Pty. Ltd., Sydney, N.S.W.**

CANADA AND U.S.A.

**Telephone Manufacturing Co. Ltd.,  
Toronto, Ont.**

ALL OTHER COUNTRIES  
(for Transmission Equipment only)

**Automatic Telephone and Electric  
Co. Ltd., London**

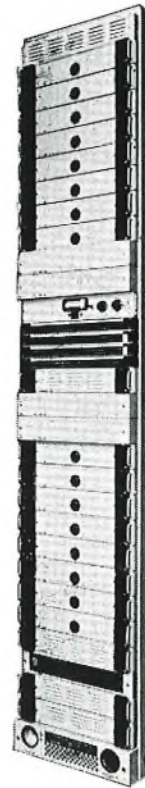

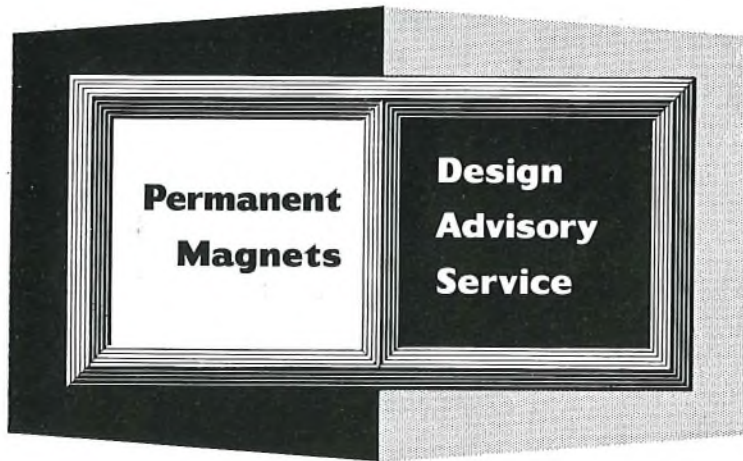

## Television Applications – 1

Advertisements in this series deal with general design considerations. If you require more specific information on the use of permanent magnets, please send your enquiry to the address below, mentioning the Design Advisory Service.

Television receiver circuits have been greatly simplified by the use of permanent magnets which require no current and do not generate heat. The main applications include focusing, ion traps, beam centring, picture correction and magnetic bias for linearity controls.

### TV Focusing

The magnetic focusing of television tubes is achieved by a concentric magnetic field acting as a lens. The focusing action results from the magnetic field which has a rotational symmetry about the axis of the lens.

The focal length  $f$  is given by

$$\frac{1}{f} = \frac{0.0347}{V} \int_{z=-\infty}^{z=+\infty} H_z^2 dz$$

where  $V$  is the potential difference traversed by the electrons before they enter the lens and  $H_z$  is the magnetic field strength along the axis.

Axially magnetised 'Magnadur' 1 rings can be used for focusing and are mounted on the tube neck so that they repel each other. Rings having peak central fields of between 180 and 250 oersteds will focus tubes with EHT voltages from 9kV to approximately 20kV respectively. Adjustment in the magnetic field is obtained by axial movement of one of the rings. This alters the working point of each magnet, thereby varying the field strength, and also affects the leakage field. The further the magnets are from each other, the stronger the central field inside the rings and the greater the focusing effect. Using this focusing system, picture shift can be made by slight movement of a mild steel ring on the face of the magnet nearest to the screen.



TV Tube Focus Unit

### Ion Traps

To avoid ion burn of the screen of a picture tube, the electron gun is set at an angle and a simple magnet assembly giving a uniform diametric field is placed

over the neck of the tube about  $\frac{1}{2}$ " along the beam. This deflects the electrons through the grid and first anode while the heavier ions are relatively unaffected and strike a suitable target in the electrode assembly, and do not reach the screen. A field between 55 and 70 oersteds is normally required for this beam deflection and is obtained from a small cylindrical magnet,  $\frac{3}{8}$ " long and  $\frac{1}{8}$ " in diameter clamped between two mild steel semicircular pole pieces as illustrated.



Typical Ion Trap and Picture Centring Device

### Beam or Picture Centring Devices

Magnets of various types are used to provide the magnetic field necessary to correct or shift the electron beam, so that when it has passed through the deflection coils, the picture is central on the screen. Usually the field required varies between zero and 10 oersteds.

### 'Pin-Cushion' Correction

To achieve good overall focus on 90° and 110° picture tubes, it is advantageous to have a pin-cushion shaped raster. The raster shape can be corrected by magnets placed one on each side of the deflection coils. 'Magnadur' 1 rod magnets  $1\frac{1}{4}$ " long x  $\frac{3}{8}$ " dia. magnetised axially are normally adequate to correct this type of distortion.

By suitable choice of magnets and steel pole pieces, it is possible to increase the line scan width. This technique can be used as a means of making small adjustments to the line width.

### Linearity Controls

A further use for permanent magnets is to provide the magnetic field to bias a Ferroxcube rod on which the linearity coil is wound. Adjustment in linearity can easily be made by moving the magnet so varying the degree of magnetisation of the Ferroxcube rod. A neat arrangement uses a 'Magnadur' tube approximately  $1\frac{1}{4}$ " long x  $\frac{3}{8}$ " dia. with the Ferroxcube rod situated inside and the coil being wound on the end of this rod.

If you wish to receive reprints of this advertisement and others in this series write to the address below.

# Mullard



'TICONAL' PERMANENT MAGNETS  
'MAGNADUR' CERAMIC MAGNETS  
FERROXCUBE MAGNETIC CORES



Cells Secondary Stationary Nos. 12, 13, 14



Cells Secondary Stationary Nos. 9, 10, 11

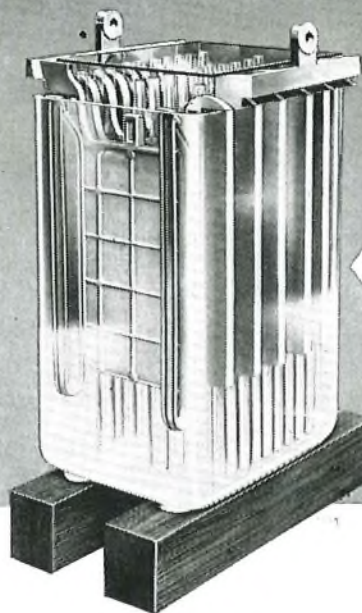

**POWER  
BEHIND  
THE LINES**

TUNGSTONE Batteries have been designed to conform fully with G.P.O. and British Standard Specifications.

These illustrations show the very wide range and type of Cells in regular production for Telephone Exchange work in Great Britain, Australia, New Zealand, India, South Africa, West Indies, etc.

Open Type Cells can be supplied in capacities from 50 a.h. to 700 a.h. in Glass Containers, and from 400 a.h. to 5,000 a.h. in Lead-lined Wooden Boxes — Enclosed Type Cells in capacities from 10 a.h. to 200 a.h.

Cells Secondary Enclosed Nos. 1 to 5

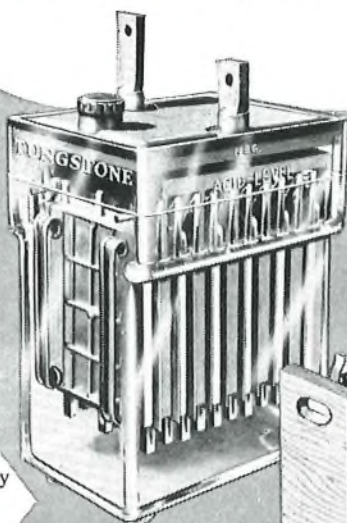

Battery Secondary Portable No. 10

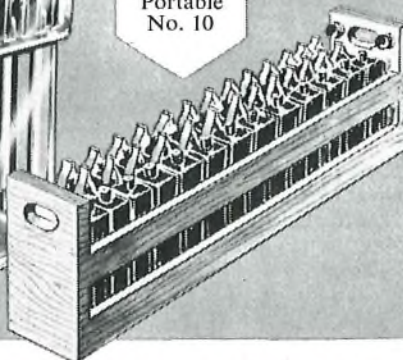

Battery Secondary Portable No. 14

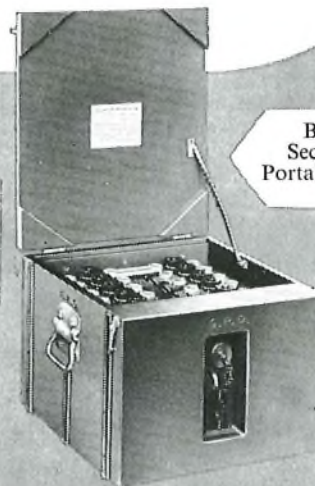

**TUNGSTONE**  
REGD TRADE MARK  
**BATTERIES**

TUNGSTONE PRODUCTS LIMITED

10 SALISBURY SQUARE · LONDON, E.C.4 · FACTORY · MARKET HARBOROUGH · LEICS · ENGLAND



## Precision Measuring Instruments and Electronic Measuring Equipment

AS leading manufacturers of precision instruments for specific requirements and applications, Ernest Turner have over 35 years of experience in dealing with the problems of instrumentation in a rapidly advancing industry. In radio, television, nucleonics, air and marine navigation, medical research, telecommunications, atomic power; in Britain and in many other parts of the world—in tropical and temperate climates\*—on land, sea and in the air Ernest Turner instruments are giving reliable service.



# Ernest Turner



**ERNEST TURNER** ELECTRICAL INSTRUMENTS LTD.

HIGH WYCOMBE BUCKS ENGLAND

Pat: HIGH WYCOMBE 1911-12

Cable: GORGIOUS HIGH WYCOMBE

\*Hermetically sealed instruments to RCS 231 and RCL 231—all preferred ranges fully Type and Design approved—are available, together with many non-preferred ranges, for service in these conditions.

Up-to-date manufacturing methods make . .

# Eclipse

## LOUD SPEAKER MAGNETS

### SUPREME FOR

**PERFORMANCE AND VALUE \***

Investigate the technical and economic advantages of Semi-Columnar Alcomax.

**FINISH \* \* \* \***

Manufacture by Shell-Moulding.

*\*Write for literature*

PM 108/56—Loud Speaker Magnets.

PM 169/57—Semi-Columnar Alcomax Magnets.

Bulletin M 10/57—Eclipse Shell-Moulded Permanent Magnets.



Made by the designers and manufacturers of Eclipse Permanent Magnet Chucks

**JAMES NEILL & CO. (SHEFFIELD) LTD · SHEFFIELD · ENGLAND**

M12



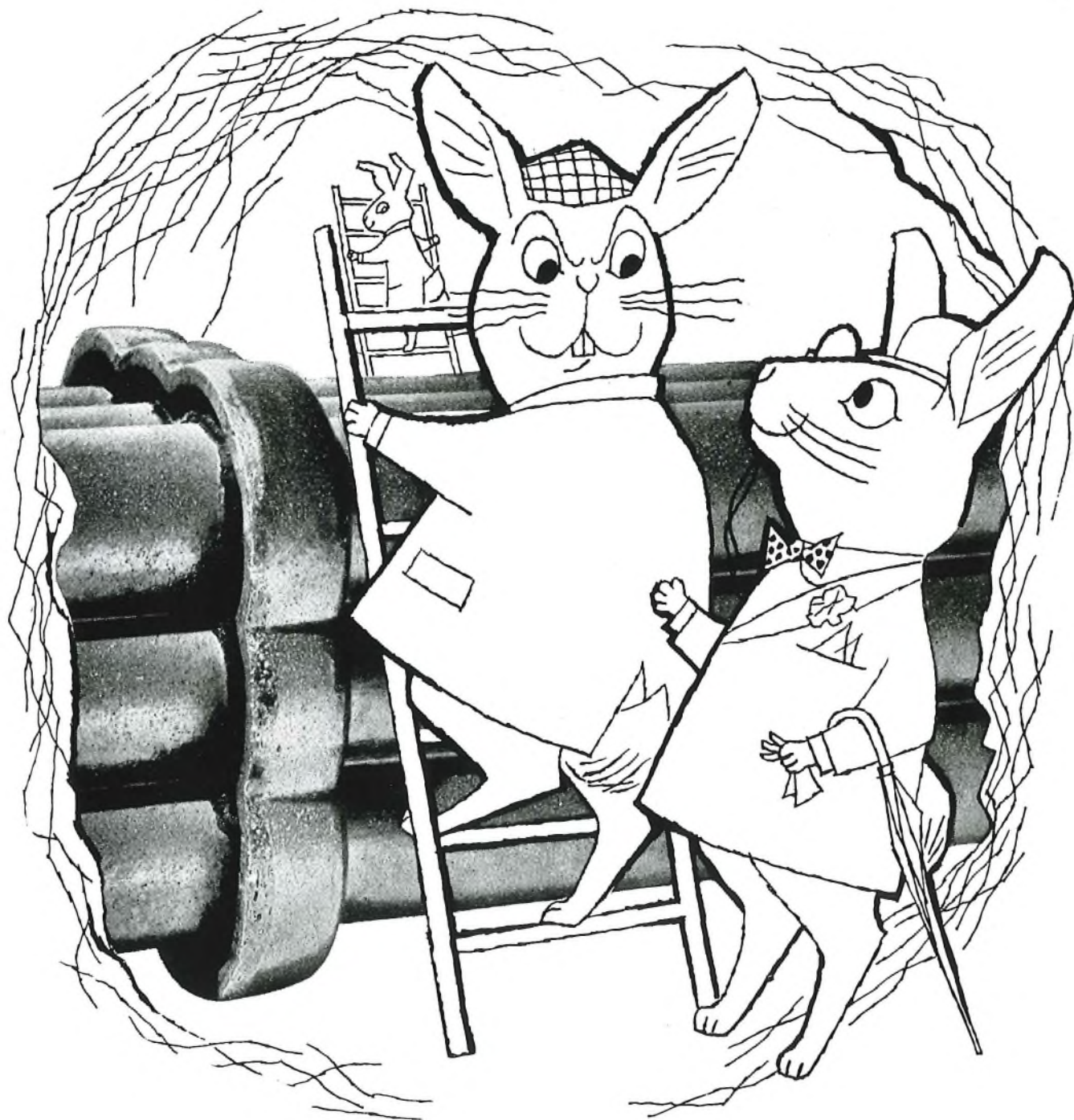

**'Progress!' said the oldest rabbit. 'Pah!** When I was a young bunny they only 'ad single Salt Glazed Pipes down 'ere. Now they got 'em in blooming great bundles and you 'ave to climb up and down blinking ladders to get across the road. Where's it going to end, eh?'

'Where indeed?' said Baron Rabbit. 'Those over there are in bundles of nine, and, by the way, they are conduits, not pipes. They make

them like that to save time and labour in the laying. And the fact that you can get Salt Glazed Conduits in multiples is only one of their advantages. They're glassy smooth inside to prevent abrasion of the cable, they're impermeable, resistant to soil acids, durable —'

'Ho yes? That's all very int'resting', said the oldest rabbit. 'Now give us a shove up this perishing ladder, will yer?'

**Salt Glazed Clay Conduits - for cables, for ever**

NATIONAL SALT GLAZED PIPE MANUFACTURERS' ASSOCIATION

# THE NEW 'FLATPOT' POTENTIOMETER



This most recent addition to the comprehensive range of Painton potentiometers provides the electronic industry with a robust subminiature component that has been developed primarily for use with printed circuits, although its general design makes it eminently suitable for a wide range of applications; it is particularly useful where conditions of vibration pose problems for the design engineer. Its unusual 'linear' construction simplifies mounting and stacking where chassis space is at a premium.

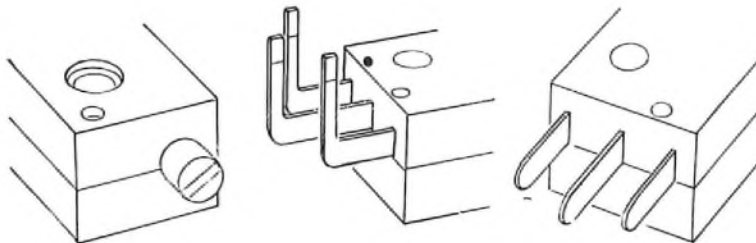
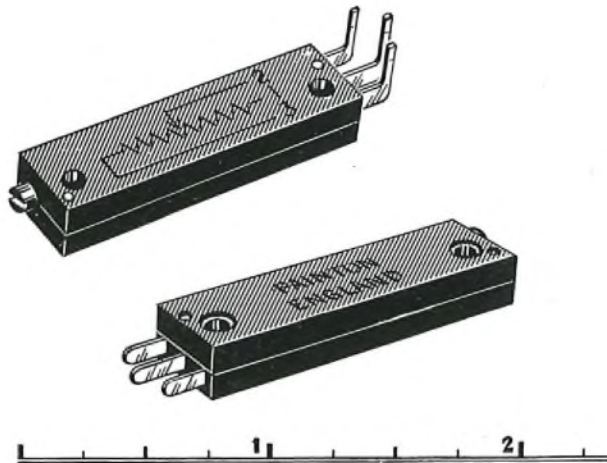

The potentiometer winding, slider and drive are totally enclosed by a nylon filled plastic housing.

The slider is driven by a lead screw, whose head projects from the housing, permitting fine adjustment and resulting in stable settings.

The unique construction ensures rigidity and strength and minimises the likelihood of oxidation of the contact surfaces.

Damage to the mechanism by over-winding is obviated by a slipping nut device.

Straight or 90° terminals are available.

Gaps between terminals and distance between the two locating holes conform to the 0.1 inch module common in printed circuit boards.

**Range:** 10  $\Omega$  to 10K  $\Omega$

**Tolerance:** 10%

**Power Rating:** 1 watt at 20°C ambient

**No. of turns from Zero to maximum resistance:** 25

**Insulation Resistance:** in Excess of 1000M  $\Omega$

**Weight:** 0.1 oz. (approx.)

**Write for technical leaflet**

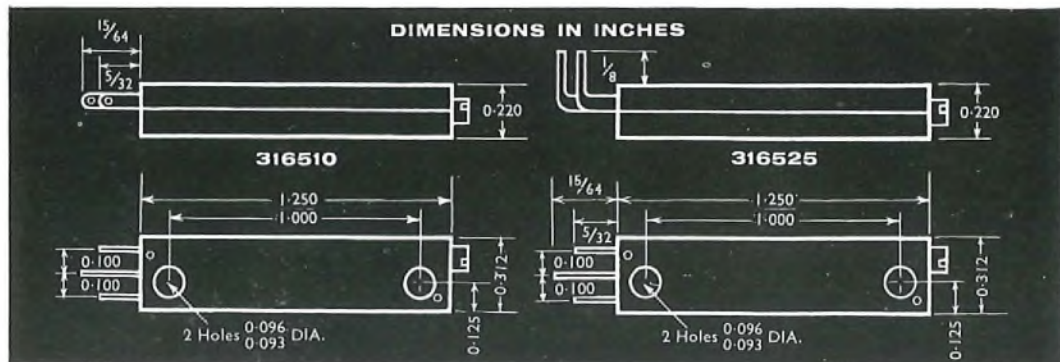

FLATPOT is a Painton Trademark



## Painton & Co. Ltd.

KINGSTHORPE NORTHAMPTON

Tel: 32354-7 Telegrams: 'Ceil, Northampton'



## ***Marconi in Telecommunications***

**The post and  
telegraph  
authorities  
of more than  
80 countries  
use Marconi  
equipment**

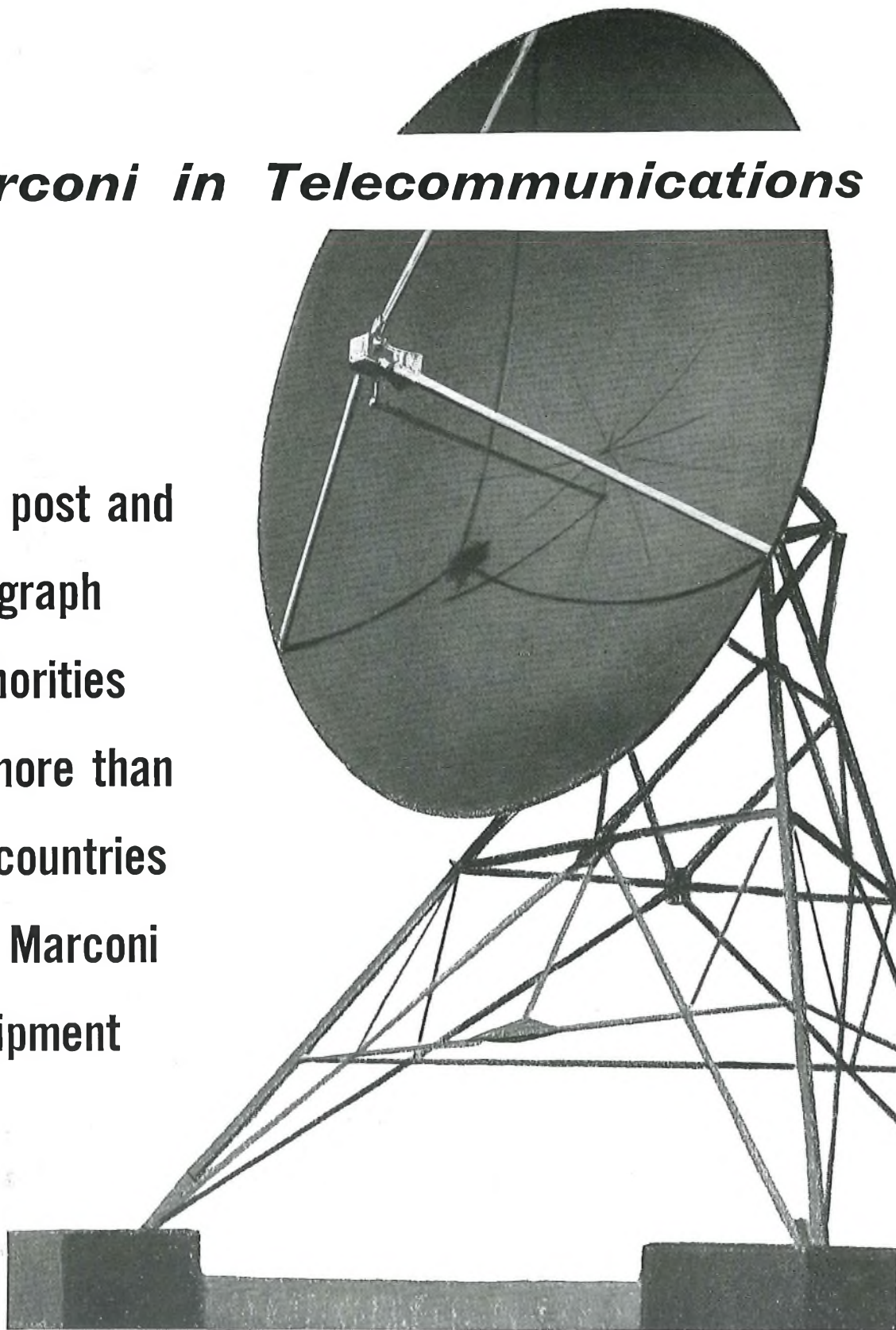

# **MARCONI**

**COMPLETE COMMUNICATION SYSTEMS**  
SURVEYED • PLANNED • INSTALLED • MAINTAINED

# The MULTIMINOR

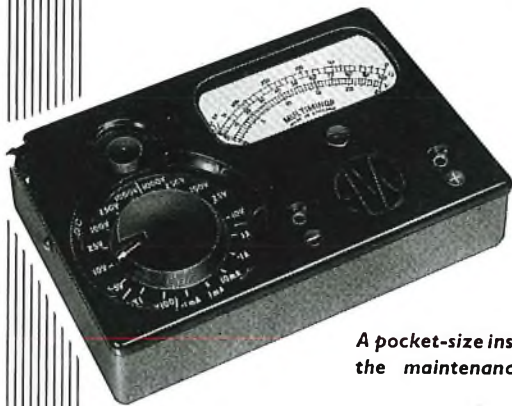

A pocket-size instrument for  
the maintenance engineer

## 19 RANGES

<b>D.C. Voltage</b>	<b>A.C. Voltage</b>
0—100 mV.	0—10 V.
0—2.5V.	0—25 V.
0—10 V.	0—100 V.
0—25 V.	0—250 V.
0—100 V.	0—1000 V.
0—250 V.	
0—1000 V.	
	<b>D.C. Current</b>
	0—100 $\mu$ A
	0—1 mA
<b>Resistance</b>	0—10 mA
0—20,000 $\Omega$	0—100 mA
0—2 M $\Omega$	0—1 A

**Sensitivity:**  
10,000 ohms per volt on D.C.  
voltage ranges.  
1,000 ohms per volt on A.C.  
voltage ranges.

**Accuracy:**  
On D.C. 3% of full scale value.  
On A.C. 4% of full scale value.

Pocket Size: 5 $\frac{1}{8}$  x 3 $\frac{1}{8}$  x 1 $\frac{1}{2}$  inches.  
Weight: 1 lb. approx.

List Price:

# £9:10s.

complete with Test Leads and Clips  
Leather Case if required 32/6

**T**HIS splendid AVO Instrument has been developed to meet a definite demand for a sturdy pocket-size multi-range test meter at a modest price, suitable for use on modern electronic apparatus as well as for radio and television receivers, motor vehicles, and all kinds of domestic appliances and workshop equipment.

Readings are obtainable quickly and easily on a very open scale, and range selection is by means of a robust clearly marked rotary switch of the characteristic AvoMeter type. Measurements of A.C. and D.C. Voltage, D.C. Current, and Resistance are made by means of only two connection sockets.

Write for illustrated leaflet.

Designed and Manufactured by

# AVO Ltd.

AVOCET HOUSE · 92-96 VAUXHALL BRIDGE ROAD · LONDON · S.W.1

Telephone: VICTORIA 3404 (12 lines)

## ADCOLA SOLDERING INSTRUMENTS

$\frac{1}{8}$ " BIT MODEL (CAT: No. 70). Primarily developed for solder jointing of TRANSISTORS & MINIATURE JOINTING.

Possesses the sharp heat for quick action thereby avoiding damage to the component by heat transference.

FULLY INSULATED ELEMENTS IN ALL VOLT RANGES  
DESIGNED FOR BENCH PRODUCTION ASSEMBLY

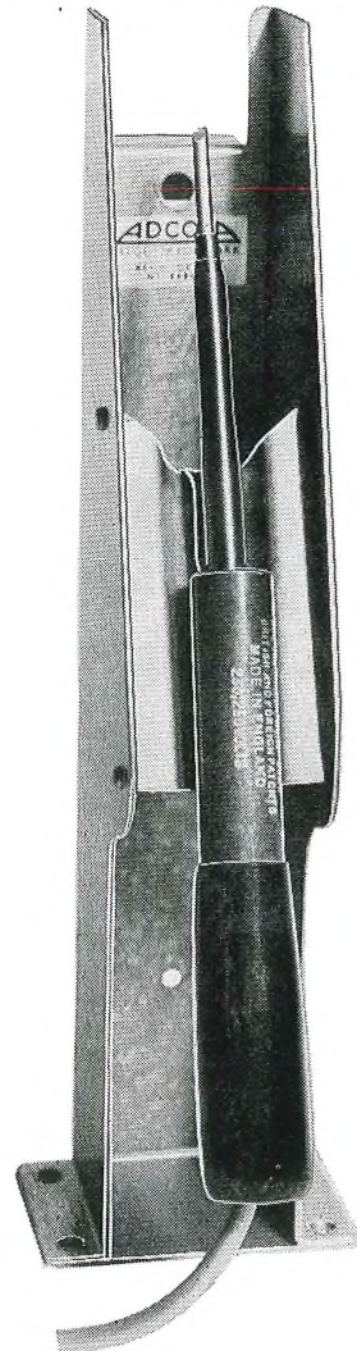

Instrument  
(Cat. No. 70)

Protective  
Shield  
(Cat. No. 68)

Brit: &  
Foreign Pats:

Registered  
Designs etc.

Further information apply

HEAD OFFICE & SALES

### ADCOLA PRODUCTS LTD.

GAUDEN ROAD, CLAPHAM HIGH STREET, LONDON, S.W.4

Telephone: MACaulay 4272, 3101



**TOWN**

**VILLAGE**

**FARMHOUSE**

**CONSTRUCTION SITE**

# Transistorised rural carrier telephone system-TRC7

*in service in many parts of the world*

A PRODUCT OF

**MULLARD EQUIPMENT LIMITED**

A COMPANY OF THE MULLARD GROUP

- Fully transistorised
- Simple installation
- Low power consumption
- Up to seven extra speech channels
- Ideal for temporary extra lines
- Fully tropicalised
- Pole mounted drop-off filters for greater flexibility

*Write for descriptive literature*

Mullard House · Torrington Place  
London · W.C.1 · Tel: LANGHAM 6633





# Lightweight HEAD TELEPHONE SETS AND RECEIVERS

New Scientific Design

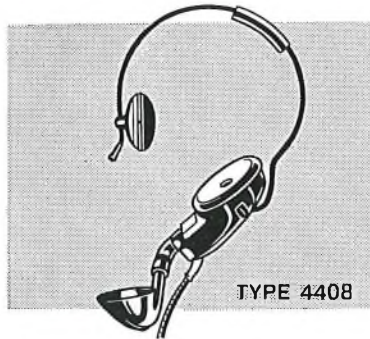

TYPE 4408

#### OPERATOR'S TELEPHONE SET

*This operator's telephone set with independently fixed transmitter and receiver and adjustable head-pad is British Post Office standard apparatus. Weight 4 ozs.*

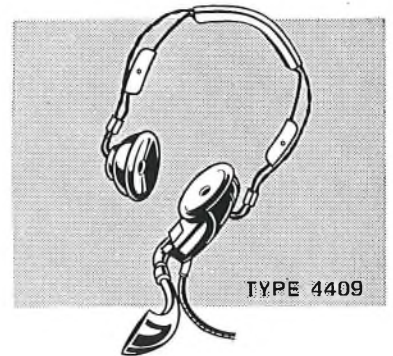

TYPE 4409

#### OPERATOR'S TELEPHONE SET

*Similar to the 4408 Operator's Head Set but with a second receiver. Weight 6 ozs.*

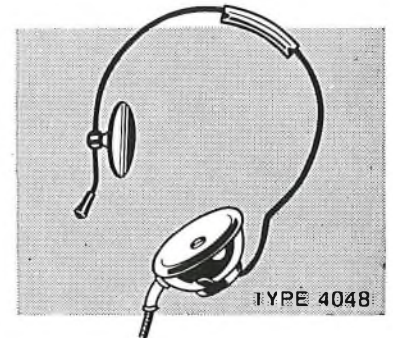

TYPE 4048

#### HEAD RECEIVER

*A single head receiver for use when listening only facilities are required. Weight 2½ ozs.*

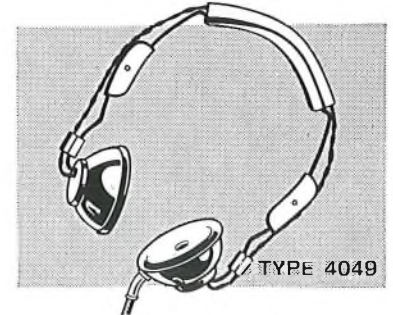

TYPE 4049

#### HEAD RECEIVER

*A double head receiver for use when listening only facilities are required. Weight 4½ ozs.*

Lightweight

Superior performance

Unbreakable Nylon

Compact

These new lightweight operator's Head Telephone Sets have been scientifically designed after a close study of operational requirements. The transmitter is carried in the headset, and the simple adjustments give a limited freedom of movement sufficient to accommodate the natural range of head variations. Loss of transmission by operator's head movements, or by excessive horn movements, is thus avoided. The assembly, which employs resilient nylon mouldings, is supported by a plastic-covered wire headband fitted with adjustable plastic pads to ensure a comfortable fit.

They are of a higher quality and sensitivity both in transmission and reception than those of previous models, or of any other headset available.

These headsets and receivers are in operational use by the British Post Office, Australian Post Office and New Zealand Post Office.

Send for Booklet D/TD.23.



## Standard Telephones and Cables Limited

Registered Office: Connaught House, Aldwych, London, W.C.2

TELEPHONE DIVISION: OAKLEIGH ROAD · NEW SOUTHGATE · LONDON N.11



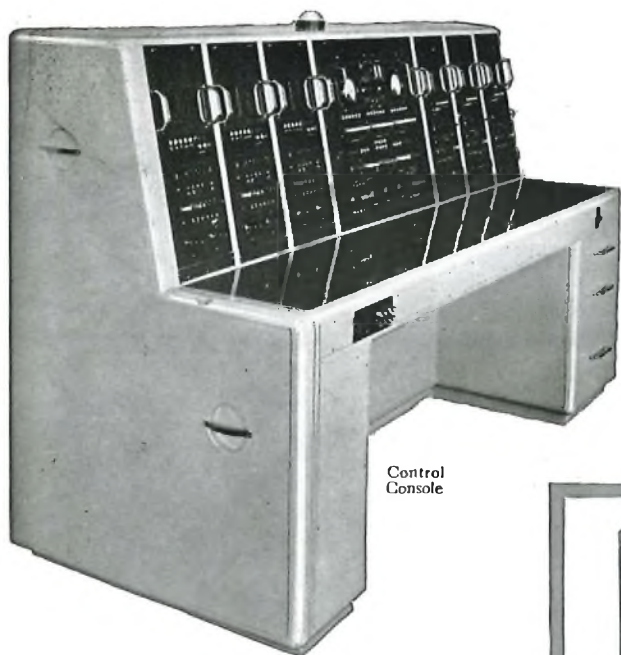

Control Console

## simple or complex

- \* Electronically controlled 5 band privacy equipment.
- \* Channel shifting equipment for I. S. B. transmission.
- \* Centralised control, local or remote.
- \* Full monitoring and supervision facilities.

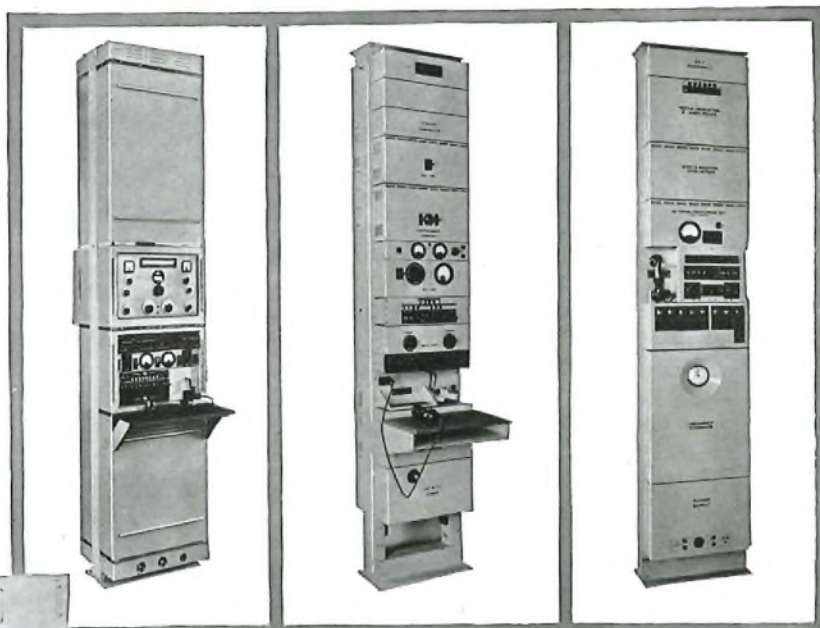

RTT 'F'

RTT 'B'

PRIVACY '5E'

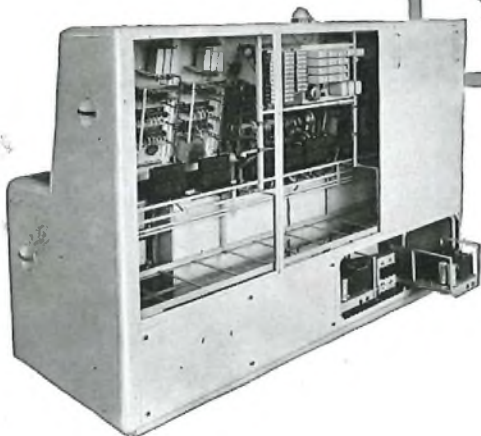

Siemens Ediswan radio telephone terminal equipment provides efficient connection of a land telephone system to a radio transmitting and receiving station.

Privacy equipment of various types is obtainable, and allows a high degree of protection against unauthorised interception of speech on a radio telephone circuit.

There is a wide range of equipment available. Full information will gladly be sent on request.

extending  the frontiers of telecommunications



**SIEMENS EDISON SWAN LTD.** An A.E.I. Company

Telecommunications Division PD8, Woolwich, London, S.E.18. Telephone: Woolwich 2020

Telegrams and Cables: Sieswan Souphone London.

This equipment can also be obtained from Marconi's Wireless Telegraph Company Ltd., Chelmsford, Essex

TAB20P

## INDEX TO ADVERTISERS

	PAGE		PAGE
Adcola Products, Ltd. . . . .	40	Painton & Co., Ltd. . . . .	38
Automatic Telephone & Electric Co., Ltd. . . . .	4-5, 6-7, 10-11	Pirelli-General Cable Works, Ltd. . . . .	45
Avo, Ltd. . . . .	40	Pitman, Sir Isaac, & Sons, Ltd. . . . .	88
British Institute of Engineering Technology . . . . .	44	Pye Telecommunications, Ltd. . . . .	3
British Insulated Callender's Cables, Ltd. . . . .	15	Rawplug Co., Ltd., The . . . . .	1
Ericsson Telephones, Ltd. . . . .	24-25	Redifon, Ltd. . . . .	8-9
Ferranti, Ltd. . . . .	2	Siemens Edison Swan Ltd. . . . .	8-9, 22, 28, 43
General Electric Co., Ltd., The . . . . .	12, 14, 20-21, 29	Smith, Frederick, & Co. . . . .	44
Great Northern Telegraph Co., Ltd. . . . .	17	Standard Telephones & Cables, Ltd. . . . .	19, 23, 26-27, 42, 46
Henleys, W. T., Telegraph Works Co., Ltd. . . . .	16	Stonebridge Electrical Co., Ltd., The . . . . .	45
Hivac, Ltd. . . . .	29	Stone-Chance, Ltd. (Austinlite) . . . . .	13
Marconi's Wireless Telegraph Co., Ltd. . . . .	6-7, 39	Telephone Manufacturing Co., Ltd. . . . .	30, 31, 32-33
Mullard, Ltd. . . . .	34, 41	Tungstone Products, Ltd. . . . .	35
National Salt Glazed Pipe Manufacturers' Association . . . . .	37	Turner, Ernest, Electrical Instruments, Ltd. . . . .	36
Neill, James, & Co. (Sheffield), Ltd. . . . .	36	Westinghouse Brake & Signal Co., Ltd. . . . .	18
		Winn & Coales, Ltd. . . . .	2

## VALUABLE FREE BOOK



**Tells You How to Pass Your C. & G. or Promotion Exam. at First Attempt!**

All Post Office Engineering personnel who are anxious to obtain early promotion should at once send for a copy of our handbook "ENGINEERING OPPORTUNITIES," which among other intensely interesting matter describes our unique methods of preparation for **TECHNICAL APPOINTMENTS IN THE POST OFFICE** (Assistant Engineer—New Style and Assistant Traffic Superintendent), **CITY AND GUILDS EXAMINATIONS** in Principles of Telecommunications (1-5), Radio (1-4), Telephone Exchange Systems (1-3), Telegraphy (1), Line Transmission (1 and 2), Lines Plant Practice (1 and 2), Mathematics for Telecommunications (1-5), Electrical Engineering Practice (Prelim. Inter. and Final), and outlines a wide range of non-examination courses in all branches of Electrical, Mechanical, Civil, Automobile, Aeronautical and Radio Engineering.

**Assistant Engineer and Assistant Traffic Superintendent. Open competitions now resumed. Age extensions for established Civil Servants. Ask us for full details.**

**We definitely guarantee  
"NO PASS—NO FEE"**

If you intend to make the most of today's opportunities, you cannot afford to miss reading "ENGINEERING OPPORTUNITIES." It tells you everything you want to know to secure advancement, and describes many opportunities you may now be missing through lack of information. Send for your copy to-day—FREE and without obligation.

**BRITISH INSTITUTE  
OF ENGINEERING TECHNOLOGY**  
369 COLLEGE HOUSE,  
29-31 WRIGHT'S LANE, LONDON, W.8

# BIET

## for the right connection

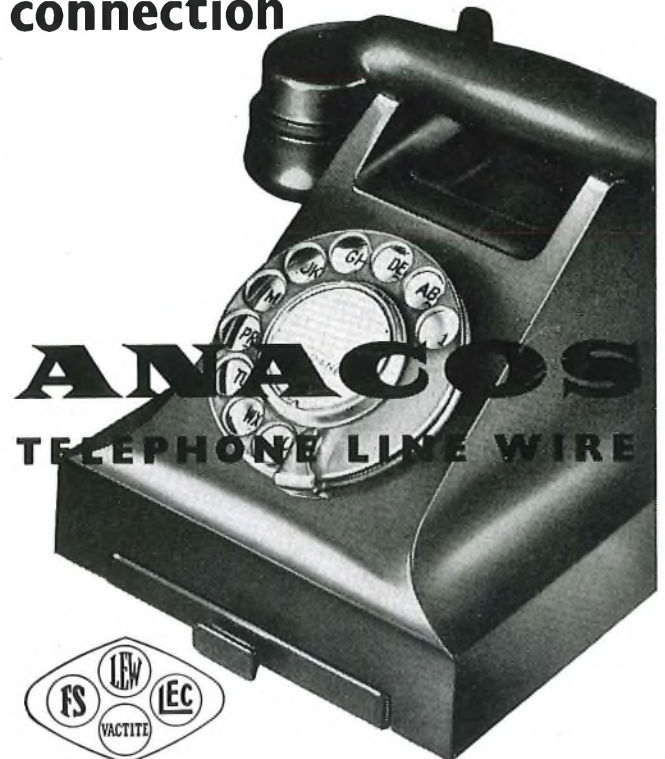

**FREDERICK SMITH AND COMPANY**  
ANACONDA WORKS · SALFORD 3 · LANC'S





**PIRELLI GENERAL**

CABLE WORKS LTD.

PAPER INSULATED TRUNK CABLES  
TELEVISION CABLES  
RADIO FREQUENCY CABLES  
COAXIAL CABLES

PIRELLI-GENERAL CABLE WORKS LIMITED, SOUTHAMPTON

# SUBSCRIBER TRUNK DIALLING METERS

Adopted for the new scheme for the United Kingdom and commencing at **BRISTOL**, these counters are part of a British-made range available for telephone and other systems. The designs are based on extensive Continental experience.

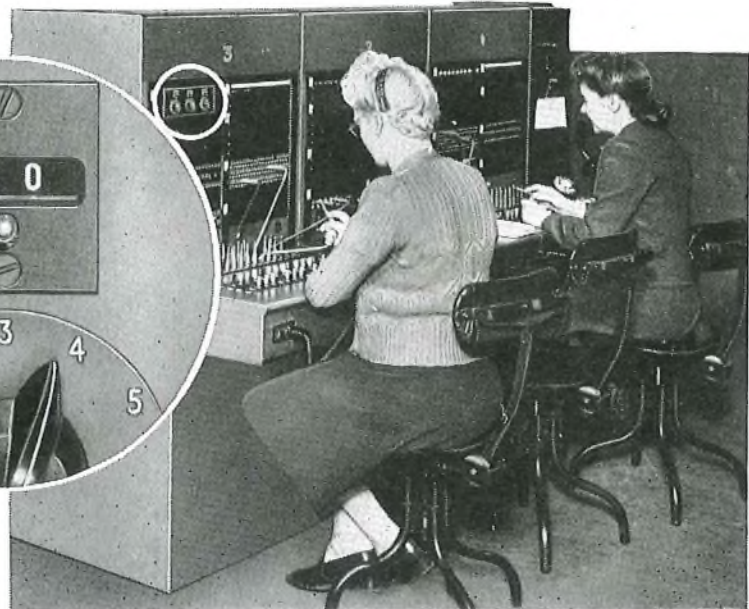
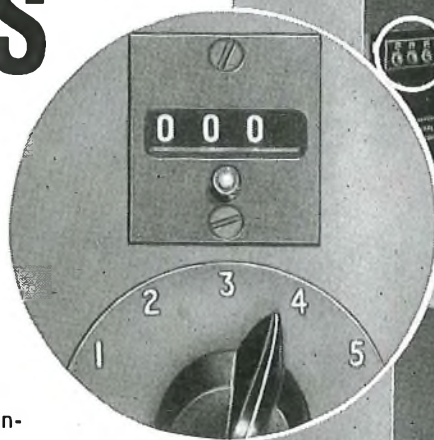

**STONEBRIDGE**  
CONTROLS & INSTRUMENTS

**THE STONEBRIDGE  
ELECTRICAL CO. LTD.**

6 Queen Anne's Gate · London · S.W.1  
Telephone: TRAfalgar 1444



# Standard

presents **THE NEW FULLY AUTOMATIC 4 CHANNEL  
H.F. RADIO LINK CONTROL TERMINAL** *incorporating transistors*

type **TOP 20**

The Radio Link Control Terminal Type TOP 20 is designed for use at terminal stations of international and national high frequency radio telephone links to connect the radio system to the telephone network.

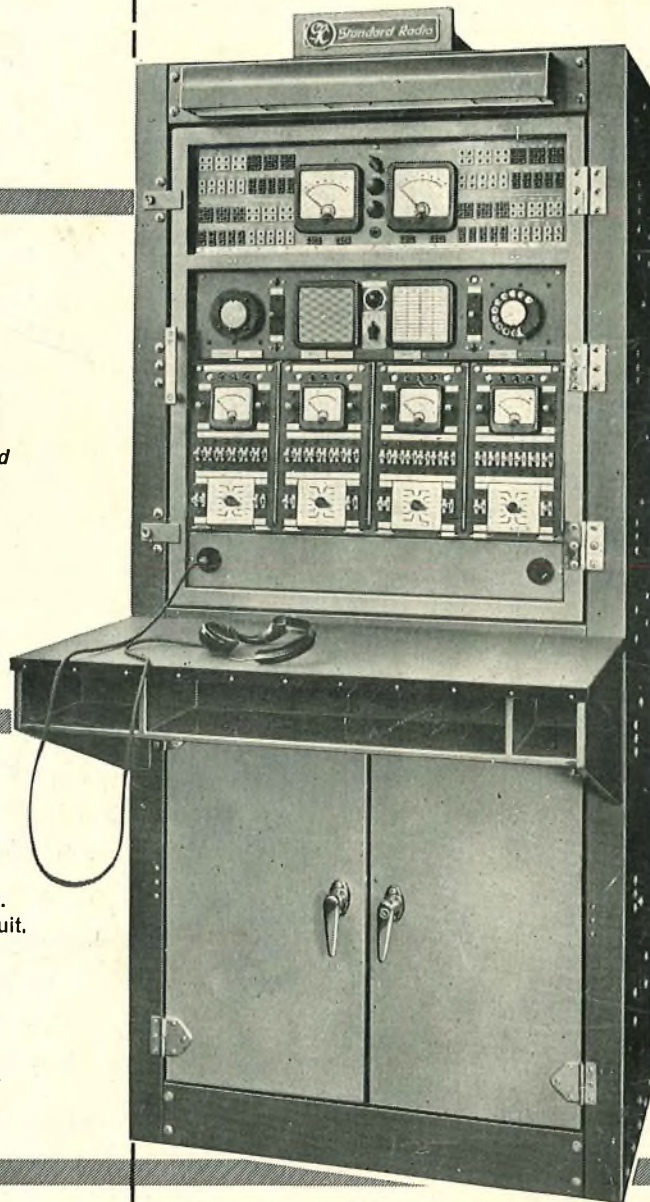
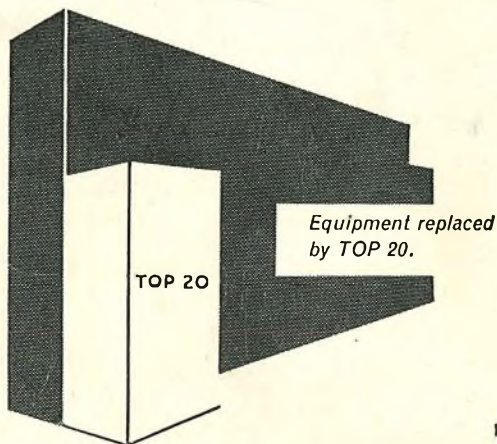

#### ADDITIONAL FEATURES:—

- 1 Only one type of valve used throughout.
- 2 Relay type VODAS switching.
- 3 Four wire Inverter and Shifter for each circuit.
- 4 Automatic station identification for each circuit.
- 5 Circuit and valve check facilities provided.
- 6 Sealed Relays.
- 7 Extremely compact totally enclosed cabinet.
- 8 Strip Unit construction.
- 9 Full tropical specification.
- 10 Supervision of maximum number of channels by one operator.



**SPECIAL  
SYSTEMS  
GROUP**

## *Standard Telephones and Cables Limited*

Registered Office: Connaught House, 63 Aldwych, London, W.C.2.

**RADIO DIVISION • OAKLEIGH ROAD • NEW SOUTHGATE • LONDON, N.11**