

RA Roe Peterfield

THE POST OFFICE ELECTRICAL ENGINEERS' JOURNAL

Vol. 49 . Part 4

JANUARY 1957

12s. 6d. net

The Transatlantic Telephone Cable

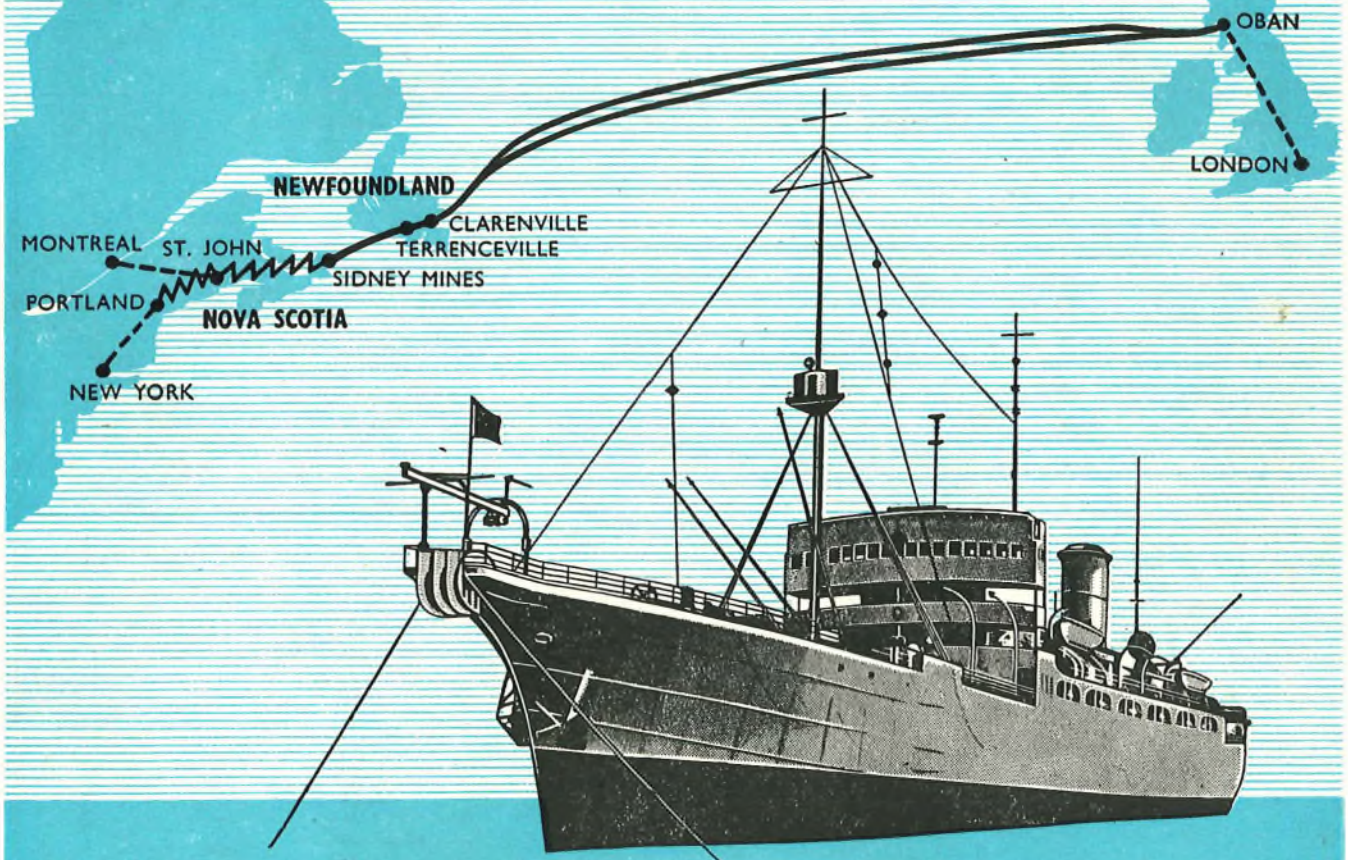

THE INSTITUTION OF POST OFFICE ELECTRICAL ENGINEERS



A Generator Built on Advanced Principles

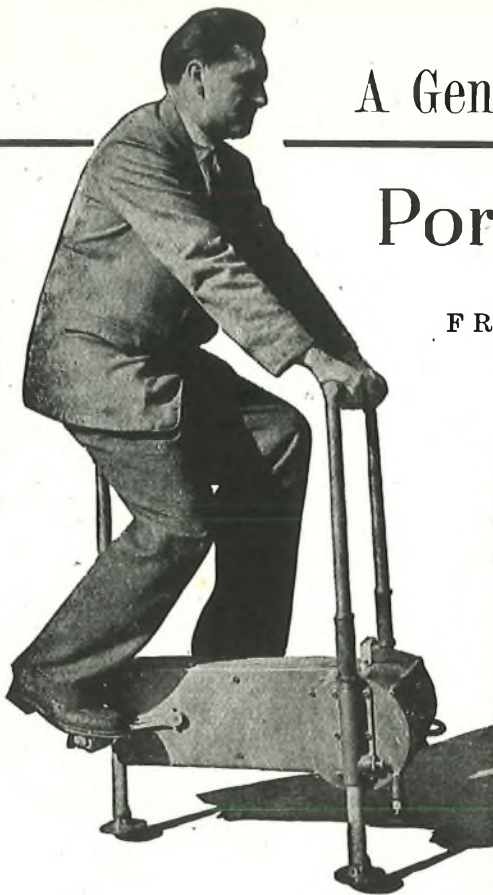

Portable Power

FROM THE **Redifon** **PG.1**



★ Requiring no more energy to operate than riding a bicycle, this generator provides a source of power for small transmitters and receivers or for battery charging in areas where no electrical supplies exist and petrol generators cannot be used. In terms of effort expended for watts output the Redifon PG.1 is far more efficient than any other available equipment. It is designed to operate under all climatic conditions and when folded can be carried for reasonable distances by one man.

REDIFON LIMITED, BROOMHILL ROAD, LONDON, S.W.18. VANDyke 7281
A Manufacturing Company in the Redifusion Group

Radio Communications Division

INFORMATION THEORY AND ITS ENGINEERING APPLICATIONS

By D. A. Bell, Ph.D., M.I.E.E. 2nd Edition. Information theory is the science underlying all exchange of information, and is of special importance in the development of telecommunications and automatic control systems. In this new edition the chapter on "Coding" has been considerably enlarged and a new chapter on "Decoding" has been added. A straightforward presentation of the subject. 25/- net.

RADIO AND ELECTRONIC COMPONENTS

Vol. 3. Fixed Capacitors
By G. W. A. Dummer, M.B.E., M.I.E.E. Discusses the characteristics and specifications of all types of fixed capacitors used in electronic equipment and includes unique comparison charts so that the characteristics of similar types of components can be seen at once. Experimental and future types of fixed capacitors are dealt with and notes on possible faults given. 45/- net.

PITMAN

Parker Street, Kingsway, London, W.C.2

VALUABLE FREE BOOK

Tells You How to Pass Your C. & G. or Promotion Exam. at **First Attempt!**



All Post Office Engineering personnel who are anxious to obtain early promotion should at once send for a copy of our handbook "ENGINEERING OPPORTUNITIES," which among other intensely interesting matter describes our unique methods of preparation for **TECHNICAL APPOINTMENTS IN THE POST OFFICE** (Assistant Engineer—New Style and Assistant Traffic Superintendent), **CITY AND GUILDS EXAMINATIONS** in Principles of Telecommunications (1-5), Radio (1-4), Telephone Exchange Systems (1-3), Telegraphy (1), Line Transmission (1 and 2), Lines Plant Practice (1 and 2), Mathematics for Telecommunications (1-5), Electrical Engineering Practice (Prelim. Inter. and Final), and outlines a wide range of non-examination courses in all branches of Electrical, Mechanical, Civil, Automobile, Aeronautical and Radio Engineering.

Assistant Engineer and Assistant Traffic Superintendent. Open competitions now resumed. Age extensions for established Civil Servants. Ask us for full details

We definitely guarantee
"NO PASS—NO FEE"

If you intend to make the most of today's opportunities, you cannot afford to miss reading "ENGINEERING OPPORTUNITIES." It tells you everything you want to know to secure advancement, and describes many opportunities you may now be missing through lack of information. Send for your copy to-day—**FREE** and without obligation.

BRITISH INSTITUTE
OF ENGINEERING TECHNOLOGY
369 COLLEGE HOUSE,
29-31 WRIGHT'S LANE, LONDON, W.8

BIET

THE POST OFFICE ELECTRICAL ENGINEERS' JOURNAL

Vol. 49

January 1957

Part 4

TRANSATLANTIC TELEPHONE CABLE NUMBER

CONTENTS

	page		page
HER MAJESTY'S TELEGRAPH SHIP MONARCH	280	MANUFACTURE OF SUBMERGED REPEATERS FOR THE NEWFOUNDLAND-NOVA SCOTIA LINK	
FOREWORD*—MERVIN J. KELLY, Ph.D., D.Eng., D.Sc., LL.D., Fellow, American I.E.E., and SIR GORDON RADLEY, K.C.B., C.B.E., Ph.D.(Eng.), President, I.E.E.	281	PART 1—THE ELECTRICAL UNIT—R. A. MEERS, O.B.E., T.D.	400
THE JOINT UNDERTAKING—C. J. GILL	283	PART 2—THE PRESSURE HOUSING—D. MARFLEET	403
TRANSATLANTIC TELEPHONE CABLE SYSTEM-PLANNING AND OVERALL PERFORMANCE*—E. T. MOTTRAM, B.S., M.E., Member, I.R.E., R. J. HALSEY, B.Sc.(Eng.), M.I.E.E., J. W. EMLING, B.S. in E.E., Member, American I.E.E., and R. G. GRIFFITH	284	POWER-FEED SYSTEM FOR THE NEWFOUNDLAND-NOVA SCOTIA LINK*—J. F. P. THOMAS, B.Sc.(Eng.), A.M.I.E.E., and R. KELLY, B.Sc.(Eng.)	405
CO-ORDINATION OF BRITISH AND AMERICAN TRANS- MISSION TECHNIQUES—R. H. FRANKLIN, E.R.D., B.Sc.(Eng.), M.I.E.E., and J. F. BAMPTON, B.Sc.(Eng.), A.M.I.E.E.	291	SUBMERGED REPEATERS LAID IN SHALLOW WATERS AROUND THE BRITISH ISLES	410
CABLE DESIGN AND MANUFACTURE FOR THE TRANS- ATLANTIC SUBMARINE CABLE SYSTEM*—A. W. LEBERT, B.S. in E.E., Member, I.R.E., H. B. FISCHER, B.S. in E.E., and M. C. BISKEBORN, B.S. in E.E., Member, American I.E.E.	295	ELECTRON TUBES FOR THE TRANSATLANTIC CABLE SYSTEM*—J. O. McNALLY, B.S. in E.E., Fellow, I.R.E., G. H. METSON, M.C., Ph.D., M.Sc., B.Sc.(Eng.), A.M.I.E.E., E. A. VEAZIE, B.A., Senior Member, I.R.E., and M. F. HOLMES, B.Sc.	411
THE USE OF POLYTHENE IN SUBMARINE CABLES—J. C. SWALLOW	305	FACILITIES IN THE UNITED KINGDOM FOR THE TRANSATLANTIC TELEPHONE CABLE	
MANUFACTURE OF SUBMARINE CABLE AT OCEAN WORKS, ERITH—F. MATTINGLEY, B.Sc., A.R.I.C.	308	PART 1—GENERAL PLANNING AND PERFORM- ANCE REQUIREMENTS—F. A. HOUGH, M.B.E., M.Sc.(Eng.), A.M.I.E.E.	420
ROUTE SELECTION AND CABLE LAYING FOR THE TRANSATLANTIC CABLE SYSTEM*—J. S. JACK, Capt. W. H. LEECH, O.B.E., D.S.C., and H. A. LEWIS, E.E., Senior Member, I.R.E.	316	PART 2—IMPROVEMENTS TO THE INLAND TRUNK NETWORK—C. E. E. CLINCH, B.Sc.(Eng.), A.M.I.E.E., F.S.S.	421
MODIFICATIONS TO THE CABLE MACHINERY IN H.M.T.S. MONARCH—A. J. THOMSON	328	PART 3—OBAN REPEATER STATION—R. E. G. BACK, A.M.I.E.E., N. F. FELTON, Associate, I.E.E., P. T. F. KELLY, B.Sc.(Eng.), A.M.I.E.E., W. F. J. HALL, and W. J. MARSHALL, A.M.I.E.E.	423
SOME NAVIGATIONAL ASPECTS OF CABLE LAYING ACROSS THE NORTH ATLANTIC	332	PART 4—T.A.T. TEST—J. W. G. HAWARD, B.Sc.(Eng.), A.M.I.E.E.	431
SYSTEM DESIGN FOR THE NORTH ATLANTIC LINK*— H. A. LEWIS, E.E., Senior Member, I.R.E., J. M. FRASER, B.E.E., G. H. LOVELL, B.S. in E.E., and R. S. TUCKER, A.B., S.B., Associate Member, American I.E.E., Senior Member, I.R.E.	333	SPECIAL EQUIPMENT DESIGNED AND MANUFACTURED IN THE UNITED KINGDOM	
REPEATER DESIGN FOR THE NORTH ATLANTIC LINK*— T. F. GLEICHMANN, B.E., A. H. LINCE, B.S. in E.E., M. C. WOOLEY, B.S. in E.E., and F. J. BRAGA, B.E.E., Member, I.R.E.	347	PART 1—GROUP REFERENCE PILOTS—T. E. PUDDICK and E. T. C. HARRIS, B.Sc.(Eng.), A.M.I.E.E.	435
REPEATER PRODUCTION FOR THE NORTH ATLANTIC LINK*—H. A. LAMB, and W. W. HEFFNER, B.S.	359	PART 2—SPECIAL FREQUENCY-TRANSLATING AND FREQUENCY-GENERATING EQUIPMENT— F. B. WILLIS and E. T. C. HARRIS, B.Sc.(Eng.), A.M.I.E.E.	437
POWER-FEED EQUIPMENT FOR THE NORTH ATLANTIC LINK*—G. W. MESZAROS, B.E.E., and H. H. SPENCER, B.S. in M.E., Associate Member, American I.E.E.	371	PART 3—MUSIC CHANNELS—A. J. BENNETT, B.Sc.(Eng.), and E. T. C. HARRIS, B.Sc.(Eng.), A.M.I.E.E.	438
SYSTEM DESIGN FOR THE NEWFOUNDLAND-NOVA SCOTIA LINK*—R. J. HALSEY, B.Sc.(Eng.), M.I.E.E., and J. F. BAMPTON, B.Sc.(Eng.), A.M.I.E.E.	379	PART 4—TELEGRAPH CHANNELS—A. C. CROIS- DALE, M.B.E., B.Sc.(Eng.), A.M.I.E.E., and E. T. C. HARRIS, B.Sc.(Eng.), A.M.I.E.E.	443
REPEATER DESIGN FOR THE NEWFOUNDLAND-NOVA SCOTIA LINK*—R. A. BROCKBANK, Ph.D., B.Sc.(Eng.), A.M.I.E.E., D. C. WALKER, B.Sc.(Eng.), A.M.I.E.E., and V. G. WELSBY, Ph.D., B.Sc.(Eng.), A.M.I.E.E.	389	PART 5—CHANGE-OVER FACILITIES AND MIS- CELLANEOUS EQUIPMENT—F. PYRAH, and C. E. E. CLINCH, B.Sc.(Eng.), A.M.I.E.E., F.S.S.	446
		SWITCHING ARRANGEMENTS IN LONDON FOR TELEPHONE CALLS OVER THE TRANSATLANTIC TELEPHONE CABLE—H. S. WATERS and B. F. YEO, A.M.I.E.E.	449
		OPERATING THE NEW TELEPHONE SYSTEM—A. G. SUTHERLAND	456
		TRAFFIC ON THE TRANSATLANTIC TELEPHONE CABLE DURING ITS FIRST FOUR WEEKS IN SERVICE	458
		INSTITUTION OF POST OFFICE ELECTRICAL ENGINEERS (INCLUDING 50TH ANNIVERSARY CELEBRATIONS)	459
		ASSOCIATE SECTION NOTES	464
		INDEX TO VOL. 49	465

** Reproduced by permission of The Institution of Electrical Engineers and the
American Institute of Electrical Engineers.*

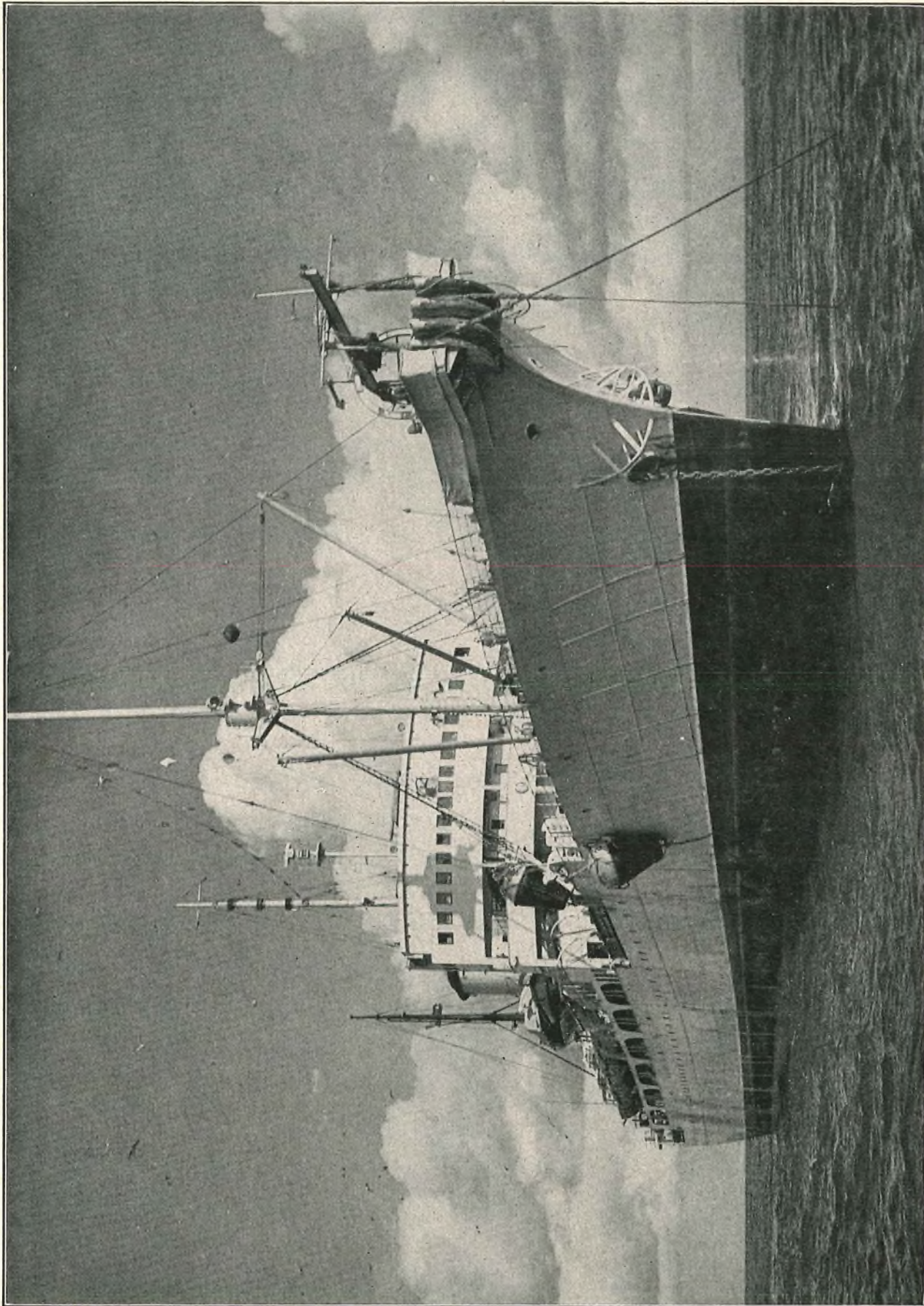

By Courtesy of the *Sunday Graphic*.

HER MAJESTY'S TELEGRAPH SHIP *MONARCH*

(Built for the British Post Office by Swan, Hunter and Wigham Richardson, Ltd., at Neptune Yard, Walker-on-Tyne. Launched 9 Aug., 1945, and commissioned 13 Feb., 1946. Gross tonnage 8,056 and loaded displacement 14,000 tons; length overall, 482 ft 9 in.; breadth, 55 ft 6 in.; draught when fully loaded, 27 ft 10 in.)

FOREWORD*

MERVIN J. KELLY, Ph.D., D.Eng., D.Sc., LL.D., Fellow, American I.E.E., and

Sir GORDON RADLEY, K.C.B., C.B.E., Ph.D.(Eng.), President, I.E.E.†

THE series of papers‡ that follow describe the design, manufacture and installation of the first transatlantic telephone cable system in all its component parts, including the connecting microwave radio-relay system in Nova Scotia. The purpose of this introduction is to set the scene in which this project was undertaken, and to discuss the technical contribution it has made to the development of world communications.

Electrical communication between the two sides of the North Atlantic started in 1866. In that year the laying of a telegraph cable between the British Isles and Newfoundland was successfully completed. Three previous attempts to establish transatlantic telegraph communication by submarine cable had failed. These failures are to-day seen to be the result of insufficient appreciation of the relation between the mechanical design of the cable and the stresses to which it is subjected as it is laid in the deep waters of the Atlantic. The making and laying of deep-sea cables was a new art, and designers had few experiments to guide them.

During the succeeding 90 years, submarine telegraph communication cables have been laid all over the world. Cable design has evolved from the simple structure of the first transatlantic telegraph cable—a stranded copper conductor, insulated with gutta-percha and finished with servings of jute yarn and soft armouring wires—to the relatively complex structure of the modern coaxial cable, strengthened by high-tensile-steel armouring for deep-sea operation. The coaxial structure of the conducting path is necessary for the transmission of the wide frequency bandwidth required for many telephone channels of communication. The optimum mechanical design of the structure for this first transoceanic telephone cable has been determined by many experiments in the laboratory and at sea. As a result, the cable engineer is confident that the risk of damage is exceedingly small, even when the cable has to be laid and recovered under conditions which impose tensile load approaching the breaking strength of the structure.

The great difference between the transatlantic telephone cable and all earlier transoceanic telegraph cables is, however, the inclusion of submerged repeaters as an integral part of the cable at equally spaced intervals and the use of two separate cables in the long inter-continental section to provide a separate transmission path for each direction. The repeaters make possible a very large increase in the frequency band-width that can be transmitted. There are 51 of these submerged repeaters in each of the two cables connecting Clarenville in Newfoundland with Oban in Scotland. Each repeater provides 65 dB of amplification at 164 kc/s, the highest transmitted frequency. The working frequency range of 144 kc/s will provide 35 telephone channels in each cable and one channel to be used for telegraph traffic between the United Kingdom and Canada. Each cable is a one-way traffic lane, all the "go" channels being

in one cable and all the "return" channels in the other.

The design of the repeaters used in the North Atlantic is based on the use of electronic valves and other components, initially constructed or selected for reliability in service, supported by many years of research at Bell Telephone Laboratories. Nevertheless, the use of so many repeaters in one cable at the bottom of the ocean has been a bold step forward, well beyond anything that has been attempted hitherto. There are some 300 valves and 6,000 other components in the submerged repeaters of the system. Many of the repeaters are at depths exceeding 2,000 fathoms (2¼ miles) and recovery of the cable and replacement of a faulty repeater might well be a protracted and expensive operation. This has provided the incentive for a design that provides a new order of reliability and long life.

On the North Atlantic section of the route, the repeater elements are housed in flexible containers that can pass around the normal cable-laying gear without requiring the ship to be stopped each time a repeater is laid. The advantages of this flexible housing have been apparent during the laying operations of 1955 and 1956. They have made it possible to continue laying cable and repeaters under weather conditions which would have made it extremely difficult to handle rigid repeater housings with the methods at present available.

A single connecting cable has been used across Cabot Strait between Newfoundland and Nova Scotia. The 16 repeaters in this section have been arranged electronically to give both-way amplification, and the single cable provides "go" and "return" channels for 60 circuits. "Go" and "return" channels are disposed in separate frequency bands. The design is based closely on that used by the British Post Office in the North Sea. Use of a single cable for both-way transmission has many attractions, including that of flexibility in providing repeated cable systems, but no means has yet been perfected of laying as part of a continuous operation the rigid repeater housings that are required because of the additional circuit-elements. This is unimportant in relatively shallow water, but any operation that necessitates stopping the ship adds appreciably to the hazards of cable laying in very deep water.

The valves used in the repeaters between Newfoundland and Scotland are relatively inefficient judged by present-day standards. They have a mutual conductance of 1,000 micromhos. Proven reliability, lower mechanical failure probability and long life were the criteria that determined their choice. Valves of much higher performance with a mutual conductance of 6,000 micromhos are used in the Newfoundland-Nova Scotia cable, and it is to be expected that long repeated cable systems of the future will use valves of similar performance. This will increase the amplification and enable a wider frequency band to be transmitted, thus assisting provision of a greater number of circuits. If every advantage is to be taken of the higher-performance valves, it will be necessary to duplicate (or parallel) the amplifier elements of each repeater, in the manner described in a later paper, in order to assure adequately long trouble-free performance. This has the disadvantage of requiring the use of a larger repeater housing.

During the three years that have elapsed since the announcement in December, 1953, by the American Telephone and Telegraph Co., the British Post Office and

†Dr. Kelly is with the Bell Telephone Laboratories, Inc., and Sir Gordon Radley is with the British Post Office.

‡This reference is to the papers reproduced by permission of The Institution of Electrical Engineers and the American Institute of Electrical Engineers, which are indicated by an asterisk against their titles. Other articles in this issue of the Journal describe the arrangements made for routing and switching transatlantic traffic in the United Kingdom; special features of the manufacture of cable and equipment in the United Kingdom; and modifications to H.M.T.S. *Monarch* in readiness for laying the cable.

the Canadian Overseas Telecommunication Corporation, of their intention to construct the first transatlantic telephone cable system, considerable progress has been made in the development and use of transistors. The low power drain and operating voltage required will make practicable a cable with many more submerged repeaters than at present. This will make possible a further widening of the transmission band, which could provide for more telephone circuits with accompanying decrease in cost per speech channel, or the widened band could be utilized for television transmission. Much work, however, is yet to be done to mature the transistor art to the level of that of the thermionic valve and thus ensure the constancy of characteristics and long trouble-free life that this transatlantic service demands.

The present transatlantic telephone cable whose technical properties are presented in the accompanying papers, however, gives promise of large reduction in the cost of transoceanic communications on routes where the traffic justifies the provision of large-traffic-capacity repeatered cables. The 36 4-kc/s channels, which each cable of the 2-way system provides, are the equivalent of at least 864 telegraph channels. A modern telegraph cable of the same length without repeaters would provide only one channel of the same speed. The first transatlantic telegraph cable operated at a much lower speed, and transmitted only three words per minute. The greater capacity of future cables will reduce still further the cost of each communication circuit provided in them. Such considerations point to the economic attractiveness, where traffic potentials justify it, of providing broadband repeatered cables for all telephone, telegraph and teletype service across ocean barriers.

The new transatlantic telephone cable will supplement the

service now provided by radio telephone between the European and North American continents. It will add greatly to the present traffic-handling capacity of this service. The first of these radio circuits was brought into operation between London and New York in 1927. As demands for service have grown, the number of circuits has been increased. We are, however, fast approaching a limit on further additions, as almost all possible frequency space has now been occupied. The submarine telephone cable has come, therefore, at an opportune time; further growth in traffic will not now be limited by traffic capacity.

Technical developments over the years by the British Post Office and Bell Telephone Laboratories have brought continuing improvement in the quality, continuity and reliability of the radio circuits. The use of high-frequency transmission on a single sideband with suppressed carrier and steerable receiving aerial are typical of these developments. Even so, the route, because of its location on the earth's surface, is particularly susceptible to ionospheric disturbances which produce quality deterioration and at times interrupt the service completely. The cable transmission will be free of all such quality and continuity limitations. In fact, service of the quality and reliability of the long-distance service in America and Western Europe will be possible. This quality and continuity improvement may well accelerate the growth in transatlantic traffic.

The British Post Office and Bell Telephone Laboratories are continuing vigorous programmes of research and development on submarine cable systems. Continuing technical advance can be anticipated. Broader transmission bands, lower-cost systems and greater assurance of continuous, reliable and high-quality services will surely follow.

The Joint Undertaking[†]

C. J. GILL[‡]

U.D.C. 654.15:621.395.5:621.315.28

"AND WHEREAS it is desired to provide a submarine telephone cable system between the United States and Canada on the west, and the United Kingdom on the east . . ."

SO runs the second recital in the Transatlantic Cable Construction and Maintenance Contract, executed on behalf of the Post Office in November, 1953, by Lord de la Warr, then Postmaster-General.

Behind that recital lay many months of negotiation between the Post Office and the three other parties to the contract, the American Telephone & Telegraph Co., and the Canadian Overseas Telecommunication Corporation (with which the Post Office had for some years operated radio-telephone services to the United States and Canada respectively), and the Eastern Telephone & Telegraph Co., a Canadian subsidiary of the A.T. & T.

Inherent in it, and in all the detailed conditions of contract which followed, was an act of faith in the ability of the designers and manufacturers on both sides of the Atlantic to create, in the short space of three years, an entirely novel medium of transoceanic communication: to link North America and Europe for the first time by telephone cable, and to build the cable to a standard of accuracy and with an expectation of life never before attempted.

Within those three years the system had to be planned and the whole vast interconnected system of submarine and land cables and radio links had to be manufactured and constructed. The final system designs had to be completed and interlocked without delay, so that manufacture could be put in hand. New machinery and techniques had to be developed for placing the cable in deep waters. The route had to be surveyed and established.

Nearly 4,500 miles of cable had to be made to the most exacting specification ever devised, most of it in a factory which had still to be completed, and 146 repeaters had to be built to withstand the rigours of laying and water pressures at depths of up to 2½ miles under the Atlantic, with components of such fidelity as to last for 20 years at least without attention.

The act of faith now stands justified by events. The achievement owes much to the research and practical work by the Post Office and the American Telephone & Telegraph Co. over the past 30 years in submarine cable and repeater development. But of the highest significance has been the way in which all the problems—and these have been many and serious in this great undertaking—have been approached and resolved as common problems by the experts on each side working as a team with a common objective. The contract provided in cold legal terms for a joint undertaking; the warm spirit of international goodwill and co-operation in which it has been carried out has given it a true human meaning.

[†]Principal in charge of the Telephone Division, External Telecommunications Executive.

[‡]Reproduced from the *Post Office Telecommunications Journal* Supplement to the Autumn 1956 issue, by permission of the Editor.

Contracts are necessary, and this one has stood well the practical test of completion. From it has sprung a jointly owned and constructed system extending from the Scottish coast, near Oban, to the Canada-United States border near St. John, New Brunswick. The main Atlantic crossing consists of two cables (one for each direction of transmission) of American design, embodying one-way flexible repeaters at 37-mile intervals. From Clarenville, in Newfoundland, to the Canadian mainland, the Post Office two-way repeater system is used, enabling transmission in both directions over a single cable. From Sydney Mines to the United States border a line-of-sight microwave radio link completes the jointly owned system.

Each of the parties concerned with operating the system has, in accordance with the contract, provided the necessary connexion from the ends of the cable system to the operating terminals in London, New York and Montreal. The 35 high-quality telephone circuits foreseen in the contract are now available—29 to New York and six to Montreal, as are the additional telegraph circuits to Canada, which will strengthen the Commonwealth telegraph network.

The joint system is owned in indivisible shares: 50 per cent by the American Companies, 41 per cent by the Post Office and 9 per cent by the Canadian Overseas Telecommunication Corporation. But the cost, about £15,000,000, has been shared in proportion to use, the Post Office share of 50 per cent having been met entirely in kind by the supply of cable, repeaters and terminal equipment and by the services of H.M.T.S. *Monarch*, which has laid all the sea cable; the difference in value between the shares of ownership and cost establishing the infeasible right of user of circuits in excess of those actually owned.

The contract provides for the joint maintenance of the completed system and for anything else necessary in a joint undertaking: for exchanges of patent rights, for consultation and agreement about the term of specifications and contracts, for keeping accounts, for settlements, and so on. It runs for an initial period of 25 years and may be added to and altered from time to time by agreement; it is perhaps significant of the care and forethought that went into its drafting that only one addition, and that a minor one, has so far been found necessary.

The Atlantic has ever been a proving ground for long-distance overseas communications. The first successful transatlantic telegraph cable, opened in 1866, and Marconi's transatlantic radio experiments in 1901, established patterns for the development of world-wide telecommunications as we know them to-day. The successful completion of this contract marks a fresh major conquest of the Atlantic, providing transoceanic telephony by cable for the first time. This unique development will undoubtedly in its turn set the new pattern, and from now on the telecommunication system of the world can be expected to share in an increasing degree the benefits of submarine cable telephony.

Transatlantic Telephone Cable System- Planning and Overall Performance*

U.D.C. 621.395.52

E. T. MOTTRAM, B.S., M.E., Member, I.R.E.,
R. J. HALSEY, B.Sc.(Eng.), M.I.E.E.,
J. W. EMLING, B.S. in E.E., Member,
and R. G. GRIFFITH† American I.E.E.,

The transatlantic telephone cable system was designed as a connecting link between continent-wide communication networks on the two sides of the Atlantic. The technical planning of the system and the objectives set up so that this role would be fulfilled are the principal subjects of this paper. Typical performance characteristics illustrate the high degree with which the objectives have been realized. Optimum application of the experience of the British Post Office with rigid repeaters and the Bell System with flexible repeaters, together with close co-operation among the administrations, has played a large part in achieving the objectives.

INTRODUCTION

THE transatlantic telephone cable system was planned primarily to connect London to New York and London to Montreal, and thus serve as an inter-connexion between continent-wide networks on the two sides of the Atlantic. Thus, the system has to be capable of serving as a link in line circuits as long as 10,000 miles, connecting telephone instruments supplied by various administrations and used by peoples of many nations. This role as an intercontinental link has therefore been a controlling consideration in setting the basic objectives for the system.

The end sections of the system utilize facilities which are integral parts of the internal networks of the United States, Great Britain and Canada, but the essential new connecting links, extending between Oban, Scotland, and the United States-Canada border, and forming the greater part of the system, were built under an Agreement between the joint owners—the American Telephone & Telegraph Co. and its subsidiary the Eastern Telephone & Telegraph Co. (operating in Canada), the British Post Office, and the Canadian Overseas Telecommunication Corporation. It is thus the joint effort of three nations.

In planning the system, the main centres of interest were, naturally, the two submarine cable links, Scotland-Newfoundland, and Newfoundland-Nova Scotia, which had to meet a unique combination of requirements imposed by water depth, cable length and transmitted band-width.

OVERALL VIEW OF THE SYSTEM

The transatlantic system provides 29 telephone circuits between London and New York, six telephone circuits between London and Montreal, and a single circuit split between London-New York and London-Montreal; this split circuit is available for telegraph and other narrow-band uses. There are also 24 telephone circuits available for local service between Newfoundland and the mainland of Canada, and there is considerable excess capacity over the radio-relay link that crosses the Maritime Provinces of Canada.

A map of the system is shown in Fig. 1; the facilities used, together with the approximate route distances, are shown in Fig. 2. It will be seen that the overall lengths of the London to New York and London to Montreal circuits are 4,078 and 4,157 statute miles respectively. Seven of the New York to London circuits are permanently extended to European Continental centres—Paris, Frankfurt (2), Amsterdam, Brussels, Copenhagen and Berne. The longest circuit is thus New York to Copenhagen, 4,948 miles.

Starting at London, which is the switching centre for United Kingdom and Continental points, 24-circuit carrier cables provide two alternative routes to Glasgow,

† Mr. Mottram is with Bell Telephone Laboratories, Inc., Mr. Halsey is with the British Post Office, Mr. Emling is with Bell Telephone Laboratories, Inc., and Mr. Griffith is with the Canadian Overseas Telecommunication Corporation.

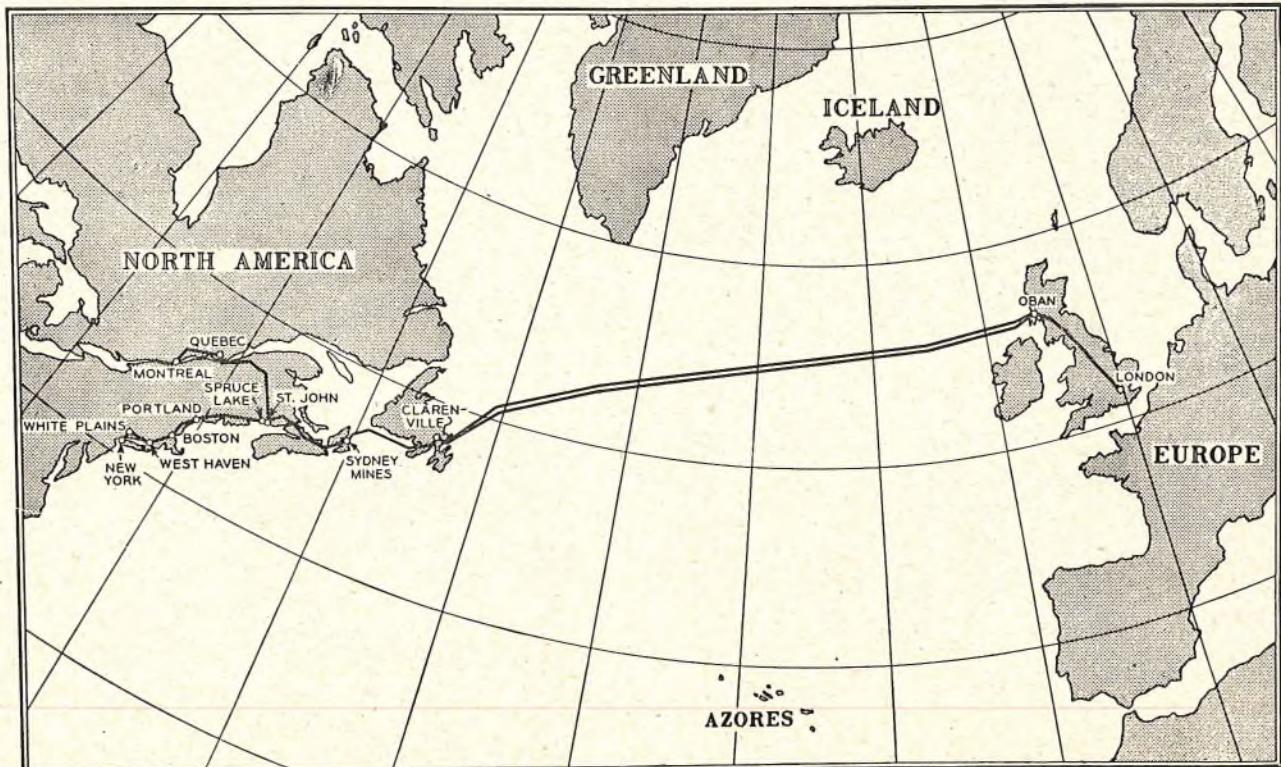
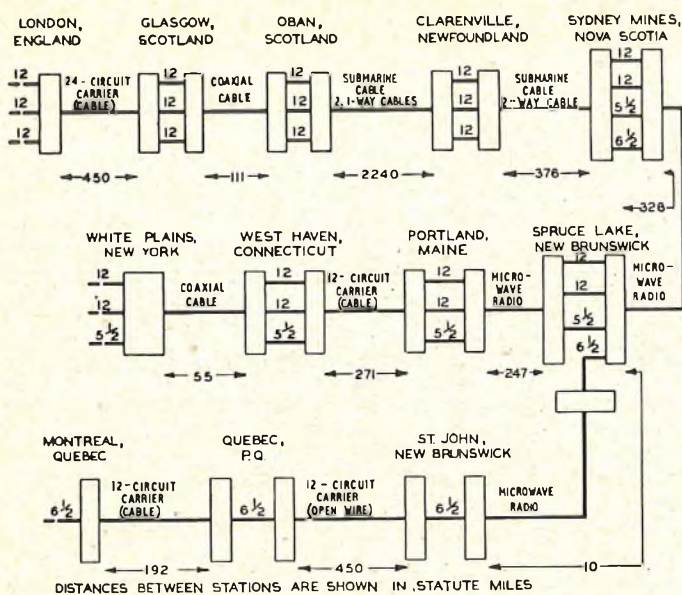

FIG. 1.—ROUTE OF THE TRANSATLANTIC SUBMARINE TELEPHONE CABLE SYSTEM.



Total distances: London–New York, 4,078 miles; London–Montreal, 4,157 miles. Maintenance circuits, U.S.A.–Canada and intra-Canada circuits are not shown.

FIG. 2.—FACILITIES USED FOR THE TRANSATLANTIC SUBMARINE TELEPHONE CABLE SYSTEM.

which are then extended to Oban by a new coaxial cable. Between London and Oban the two routes are fed in parallel at the sending ends, so that a change-over can be effected at the receiving ends only. At a later date, an alternative route out of Oban will be provided by a new coaxial cable to Inverness.

From Oban, a deep-sea submarine link connects to Clarenville, Newfoundland. This link is, in fact, two parallel submarine cables, one used for east-to-west transmission, the other for transmission in the reverse direction. Each cable is roughly 1,950 nautical miles in length and lies at depths varying between a few hundred fathoms on the Continental shelf and about 2,300 fathoms at the deepest point. Each cable incorporates 51 repeaters, in flexible housings, which compensate for the cable attenuation of about 3,200 dB at the top frequency of 164 kc/s. These cables carry 36 telephone circuits plus maintenance circuits, and establish the present maximum capacity of the transatlantic system.

At Clarenville, connexion is made with Sydney Mines, Nova Scotia, by a second cable system which goes 63 statute miles over land to Terrenceville, Newfoundland, and thence about 270 nautical miles in coastal waters at a depth of about 250 fathoms. Although this system is partly on land, it is basically a submarine system in design, the two portions differing only in the protection of the cable. In this link, the two directions of transmission are carried by the same cable, a low-frequency band being used from west to east and a high-frequency band in the opposite direction. In addition to the necessary maintenance circuits, a total of 60 two-way circuits are provided, 36 being used for transatlantic service, and the remainder being available for service between Newfoundland and the mainland. Sixteen two-way repeaters in rigid containers provide close to 1,000 dB gain at this system's top frequency of 552 kc/s.

From Sydney Mines, transmission is by radio-relay to the United States–Canada border and thence to Portland, Maine; this system operates at about 4,000 Mc/s and includes 17 intermediate stations. From Portland, standard 12-circuit carrier and coaxial-cable facilities are used to connect with White Plains, New York, the American switching centre 30 miles north of New York City, where connexion is made to the Bell System network.

The Montreal circuits leave the radio-relay route at Spruce Lake, New Brunswick, a relay station near the border, from which point a short radio spur connects to St. John, New Brunswick, thence to Quebec on a 12-circuit open-wire carrier system and thence to Montreal on a 12-circuit carrier-cable system.

BACKGROUND TO THE SUBMARINE CABLE SYSTEMS

The submarine cable sections have been built upon a long background of experience. Some of the cable laying and design techniques go back to the early telegraph cables of almost a century ago, and Lord Kelvin's analysis of the laying process is still the standard mathematical treatise on the subject. It is also interesting to note that the firm which provided most of the cable is a subsidiary of the organization that manufactured and laid the first successful transatlantic telegraph cable some 90 years ago.

In addition to the long experience in submarine telegraphy, the transatlantic system has drawn on over a quarter of a century of experience of telephone cable work in the British Post Office and the Bell System. Experience in these two organizations has been quite different, but each in its own way has been invaluable in achieving to-day's system.

British Experience.

In Great Britain, communication to the Continent dominated the early work in submarine telephony and led to systems providing relatively large numbers of circuits over short cables laid in shallow water. Early systems were unrepeated, but the advantages of submerged repeaters were apparent. Experimental work, started in 1938, culminated in the first submerged-repeater installation in an Anglesey–Isle of Man cable in 1943. Currently, there are many repeaters in the various shallow-water cables radiating from the British Isles.

These repeaters, although of a size and mechanical structure well-suited to shallow-water applications, are not structurally suited to Atlantic depths. In 1948, the Post Office began to study deep-water problems, and the first laying tests of a deep-water repeater housing were conducted in the Bay of Biscay in 1951. This housing was rigid, like the shallow-water ones, but smaller and double-ended so that the repeater was in line with the cable. Thus the rotation of the repeater, which accompanies the twisting and untwisting of the cable as tension is increased and decreased during the laying operation, could be tolerated. The housing now used by the British Post Office is basically the same as this early deep-water design, although minor modifications have been made to improve the closure and water seals.

A serious study of transatlantic telephony was begun by the Post Office in 1950, when a committee was set up to report on future possibilities of repeated cables. As a result, it was decided in 1952 to engineer a new telephone cable to Scandinavia, 300 nautical miles in length, as a deep-water prototype, even though the requirements of depth, length and channel capacity could all have been met by existing shallow-water designs.

All the Post Office submarine systems are alike in that they use but a single cable, the "go" and "return" paths being carried by different frequency bands. The adoption of this plan was greatly influenced by the conditions under which the art developed. Because North Sea and Channel cables were highly subject to damage from fishing operations, it was desirable to limit the effects of such damage as much as possible. A single-cable system is obviously preferable under these circumstances to a system using separate "go" and "return" cables, which could be put out of service by damage to either cable. Since these systems were designed for shallow-water use, the additional container size required for two-way repeaters was of no

great moment compared to the advantages of a single-cable system.

United States Experience.

In the United States, the cable art developed under very different circumstances. There was, of course, need for communication to Cuba, Catalina, Nantucket and other off-shore locations, some of which involved conditions similar to those existing around the British Isles. The application of carrier working to several of these cables occurred at an early date, but the repeater art was not directed at these shallow-water applications.

For many years, telephone communication to Europe had been an important goal, and some 35 years ago a specific proposal was made by the Bell System to the Post Office for a single continuously-loaded non-repeated cable to provide a single telephone circuit across the Atlantic.

This system was never built, partly because of the economic depression of the early 'thirties and partly because short-wave radio was able to meet the needs at that time. Cable studies and experiments in the laboratory and field were continued, however, and largely influenced subsequent developments. It was at this time that the physical structure of the cable now used in the transatlantic system was worked out. It was also at this time that the harmful effects of physical irregularities in the cable were demonstrated. As cables are laid in deep water, high tensions are developed which unwrap the armour wires that normally spiral about the central structure. As tension changes during the laying process, twisting and untwisting occur which are harmless if distributed along the cable. But obstructions in the cable which prevent rotation, or any other process, such as starting and stopping of the ship, which tends to localize twisting, are likely to cause kinking of the cable and buckling of the conductors.

By 1932, electronic technology had advanced to a point where serious consideration could be given to a wideband system with numerous long-life repeaters laid on the bottom of the ocean and powered by current supplied over the cable from sources on shore.

The hazardous effects of obstructions in the cable, demonstrated in early laying tests, indicated that the chances of a successful deep-sea cable would be greatest if the repeaters were in small-diameter flexible housings which could pass through laying gear without stopping the ship and without restricting the normal untwisting and twisting of the cable. The structure ultimately evolved, consisting of two overlapping layers of abutting steel pressure rings within a flexible waterproof container, was an important influence on the electrical design, since it placed severe limitations on size and placing of individual components.

Because these repeaters were to lie without failure for many years on the ocean bottom, it was necessary either to provide a minimum number of components of the utmost reliability, or to provide duplicate components to take over in case of failure. The size limitation favoured the former approach. Similarly, the need for small size and minimum number of components militated against the use of two-way repeaters with their associated directional filters.

Out of these considerations grew the Bell System approach to solving the transatlantic problem by the use of two cables, each with built-in flexible amplifiers containing the minimum number of components of utmost reliability and a life objective of 20 years or better.

It was not until the end of the Second World War that such a system could be tried. At that time it was decided to install a pair of cables on the Key West-Havana route to evaluate the transatlantic design which had evolved in the pre-war years. After further laying trials, this plan

was completed in May, 1950, with the laying of two cables. Each of these had three built-in repeaters lying at depths down to 950 fathoms. These cables, each about 120 nautical miles in length, carry 24 telephone circuits. They have now been in continuous service for over six years without repeater failure or evidence of deterioration.

EARLY TRANSATLANTIC TECHNICAL DECISIONS

Early in 1952, negotiations concerning a transatlantic cable were again opened between the American Telephone & Telegraph Co. and the British Post Office. As indicated above, at that time each party had been making plans for such a system. Thus it became necessary to evaluate the work on each side of the Atlantic to evolve the best technical solution.

To do this, a technical team from the Post Office visited the Bell Telephone Laboratories in the autumn of 1952, to examine developments in the United States. The work of the preceding 30 years was reviewed in detail, with particular emphasis on the development and manufacture of the 1950 Key West-Havana cables. This was followed by a visit to the Post Office by a Bell Laboratories' team to review similar work in Great Britain. Again the review was comprehensive, covering shallow-water systems as well as plans for deep-water repeaters. Each visit was characterized by a frankness and complete openness of discussion that is perhaps unusual in international negotiations.

As is apparent from the previous discussion, it was found that the basic features of a deep-water design had been completed by the Bell System. Not only had many of the components been under laboratory test for many years, but a complete system had been operating for 2½ years between Havana and Key West. To use a phrase coined at the time, the design had "proven integrity."

Because of the years of proof and the conservative approach adopted to ensure long life, the design was far from modern. The thermionic valves, for example, had characteristics typical of those of the late 1930's, when, in fact, they were designed. Similarly, other components were essentially of pre-war design.

The Post Office, on the other hand, had pioneered shallow-water repeaters and were pre-eminent in this field. Their deep-water designs were still evolving and had not yet been subjected to the same rigorous tests as the Bell System repeaters. This later evolution, however, made possible a much more modern design. The thermionic valves, for example, had a mutual conductance of 6,000 micromhos as compared with about 1,000 in the Bell System repeater, and thus had a potentiality for much greater repeater band-widths.

It was apparent from these reviews that only the American design was far enough advanced to ensure service at an early date. It also appeared to have the integrity so essential to such a pioneering and costly effort as a transatlantic cable. On the other hand, the more modern Post Office design had many elements of potential value. If deep-water laying hazards could be overcome and proof of reliability established, it gave promise of greater flexibility and economy for future systems.

It was on these grounds that Dr. Mervin Kelly for the Bell System and Sir Gordon Radley for the Post Office jointly recommended that the Bell System design be used for the long length and great depths of the Atlantic crossing, and that the Post Office design be used for the Newfoundland-Nova Scotia link, where the shallower water afforded less hazard and better observation of this potentially interesting design. The decision to use the Post Office design was subject to technical review after deep-sea laying tests and further experience with circuits and components. This review, made in June, 1954, confirmed the soundness of the original recommendation.

SYSTEM PLANNING

Planning of the individual systems began as soon as the technical decision just mentioned had been reached. By the time administrative agreements had been reached and the contract signed on the 27th November, 1953, both parties were ready to set up system objectives and an overall system plan. This work, too, was accomplished by a series of technical meetings held alternately in the United States and the United Kingdom, with additional meetings in Canada.

At the first of these meetings, a decision of far-reaching importance was made. It was agreed that each technical problem would be solved, as it arose, so far as possible on the best engineering basis, putting aside all considerations of national pride. Adherence to this principle did much to forward the technical negotiations.

The initial joint meeting was also responsible for establishing most of the basic performance objectives of the system. The target date for opening of service, 1st December, 1956, had been settled even earlier and was, in the event, bettered by nearly 10 weeks.

Service Objectives.

A statement of the manner in which the system would be used and the services to be provided was a necessary preliminary to establishing performance objectives.

It was agreed that the system should be designed as a connecting link between the North American and European long-distance networks. As such it should be capable of connecting any telephone in North America (ordinarily reached through the Bell System or Canadian long-distance networks) with any telephone in the British Isles or any telephone normally reached from the British Isles through the European Continental network. The system would be designed primarily for telephone service but consideration would be given to the provision of other services such as v.f. carrier telegraphy, program (music), and phototelegraphy, as permitted by technical and contractual considerations. It was also agreed that the two submarine cable links should be so planned that it would be possible to utilize the full band-width in any desired manner in the future. Thus, for example, repeater test signals should be outside the main transmission band.

All elements in the submarine cable systems were to be planned for reliable service over a period of at least 20 years.

Transmission Objectives.

The term "objective" was used advisedly in describing the aims of the system. It was agreed that such objectives were not rigid requirements but rather desirable goals which it was believed practical to attain with the facilities proposed. Reasonable departure from these goals, however, would not be reason for major redesign.

Since the transatlantic circuits were to connect two extensive networks, the broad objective was to add as little loss and other forms of impairment as practical. To this end, they were to be designed essentially to the standards of international circuits as defined by the C.C.I.F.† and of circuits connecting main switching points in national networks, as, for example, "regional centres" in the Bell System network and "zone centres" in the Post Office network.

The possibility of increasing the circuit capacity of the system by using channel spacings less than 4 kc/s was obvious. It was decided, however, to adopt, initially at least, the 4-kc/s spacing commonly used in long-distance

† The International Consultative Committee on Telephony (C.C.I.F.) bases its recommendations on a circuit 2,500 km (1,600 miles) in length, with implied *pro rata* increases for noise impairment.

systems on both sides of the Atlantic. This would make possible the use of standard multiplexing arrangements, and it was believed that the number of circuits provided would be adequate for the first few years of operation. It would undoubtedly be desirable to increase the number of circuits in later years, but a decision on the method to be used was left until completion of exploratory work on several methods which promised increased circuit capacity with less degradation than narrow-band operation.

The decision to use standard terminal equipment led, naturally, to acceptance of the principle that the 36 circuits across the Atlantic would be assembled as three 12-channel groups in the range 60–108 kc/s and the 60 circuits between Newfoundland and Nova Scotia as five 12-channel groups, and thence as a supergroup in the range 312–552 kc/s. These are standard modulation stages in the multiplexing arrangements for broadband carrier systems on both sides of the Atlantic. Two of the 12-channel transatlantic groups would be connected to New York and the third would be split to provide 6½ circuits to Montreal and 5½ to New York in accordance with the Agreement.

To provide for program circuits, three eastbound and three westbound channels in each of the three transatlantic groups would be made available when required; equipment would be provided to replace either two or three 4-kc/s telephone channels by a program channel. In order to avoid the agreed group pilot frequencies and to provide service to Montreal, it was agreed to utilize the frequency bands 68–76 kc/s or 64–76 kc/s in the 12-channel groups for this purpose. Terminals of British Post Office design would be used at all points for translation between program and carrier frequencies. The normal Bell System terminals could not be used, since they occupy the frequency ranges 80–88 kc/s and 76–88 kc/s, which are not compatible with the split-group arrangement or with the 84·08-kc/s end-to-end pilot.

Net Loss.

The nominal 1,000-c/s net loss objective between London and New York for calls switched to other long-distance trunks at each end (i.e. the via net loss) was set at 0·5 dB. For calls terminating at either New York or London, the loss would be increased by switching a 3·5-dB pad in London, as recommended by the C.C.I.F., and a 2-dB pad at New York, as standard in the Bell System. Thus, a New York to London call would have a net loss of 6 dB.

Variations from these nominal net losses owing to temperature effects, lack of perfect equalization and regulation, etc., are to be expected, and a standard deviation of 1·5 dB was set as the objective for such variations in the absence of trouble. The allocation of this variation to the various links is shown in Table 1.

TABLE 1
Objectives for Standard Deviations of Net Loss

Link	Standard Deviation (dB)
New York-Portland	0·75
Portland-Sydney Mines	0·75
Sydney Mines-Clarenville	0·5
Clarenville-Oban	0·5
Oban-London	0·75
Total (assuming r.m.s. addition)	1·5
New York-London	
Montreal-London	

It is interesting to note that a smaller variation was allocated to the submarine links than to the overland links.

It was believed that the more stable environment on the ocean bed would make it possible to meet the rather small variation assigned to these links.

While these loss variations are consistent with normal long-distance trunk objectives, they would not be satisfactory if companders were found necessary to meet the noise objectives, and it was agreed that any of the links lying between such companders would have to meet objectives half as large as those in Table 1.

Frequency Characteristics.

For telephone circuits, the frequency characteristic recommended by the C.C.I.F. (Fig. 3) was adopted with the expectation that it could be bettered by a factor of 2 since channel equipments would be included at the circuit terminals only (see the sub-section on connexions between component links).

No specific objectives were agreed for the frequency characteristics of the 12-channel groups as such, but there

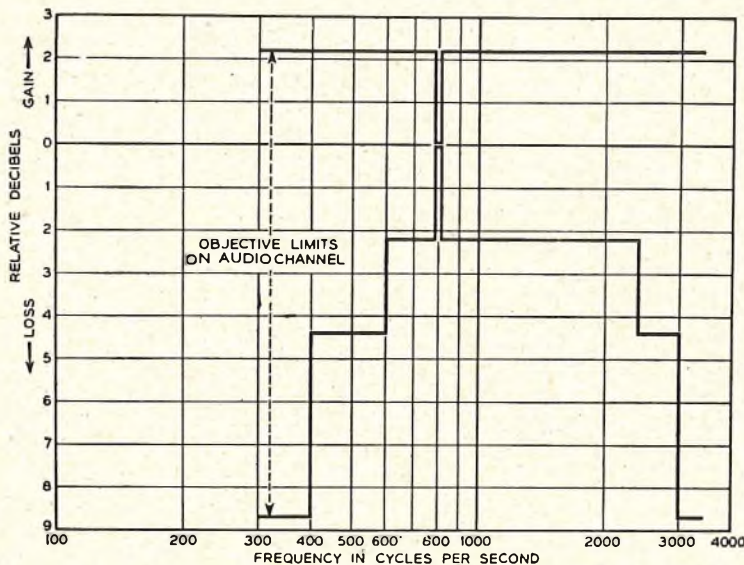

FIG. 3.—C.C.I.F. OBJECTIVE FOR FREQUENCY CHARACTERISTIC OF AUDIO CHANNEL.

was an expectation that ± 2 dB could be achieved except for frequencies adjacent to the filters in the split group.

For program channels, the C.C.I.F. recommendations were also adopted in respect of the two-band (6.4 kc/s) and three-band (10 kc/s) arrangements. To meet the requirements of these channels and of telegraphy, an overall frequency stability objective of ± 2 c/s was adopted.

Noise and Crosstalk.

Noise objectives were established to be reasonably consistent both with Bell System and C.C.I.F. objectives for circuits of transatlantic length.

TABLE 2
R.M.S. Noise Objectives in Busy Hour

Link	Approximate mileage	Noise (dBa)
New York-Sydney Mines	1,000	31
Montreal-Sydney Mines		
Sydney Mines-Clarenville	400	28
Clarenville-Oban	2,000	36
Oban-London	500	28
Total		
New York-London		38
Montreal-London		

The objective for the r.m.s. circuit noise at a zero level point in the busy hour was agreed as 38 dBa (i.e. -46 dBm or 3.9 mV). This was allocated between the various links as in Table 2.

For the program channels, the agreed noise objective was -50 dBm as measured on a C.C.I.F. psophometer with a 1951 program-weighting network.

Statistical data on probable speech levels and distributions at London and New York terminals were provided as a basis for repeater loading studies.

Early planning studies indicated that these objectives would probably be met on all, or nearly all, channels without resort to companders. If, as the system aged, the noise increased owing to increasing misalignment, the use of companders would offer a means for reducing circuit noise below the objectives.

The minimum equal-level crosstalk loss between any two telephone channels was set at 56 dB for any source of potentially intelligible crosstalk. For channels used for v.f. telegraphy, the equal-level crosstalk loss between "go" and "return" directions was set as a minimum at 40 dB; for all program channels, the minimum crosstalk attenuation would be 55 dB.

Restrictions on Telegraph and other Services.

Since the system was being designed primarily for telephone service, it was agreed that a channel used for any other service should not contribute more to the system r.m.s. or peak load than if this channel were used for telephony, except by prior agreement between the Post Office, Bell System and Canadian Overseas Telecommunication Corporation engineering representatives.

Signalling Objectives.

In order to conserve frequency space, it was decided to transmit all calling and supervisory signals within the telephone channel bands, and, to avoid transmission degradation, it was agreed that the signalling power and duration would not amount to more than 9 mWs in the busy hour at a zero-level point; this would not contribute unduly to the loading of the system.

It was agreed that, for initial operation, generator signalling would be employed, but the system design should be such as to permit the use of dialling at a later date.

Echo Suppressors.

Echo control was considered essential, since the via net loss of the transatlantic circuits would be only 0.5 dB, with a one-way transmission time of 35ms. Echo suppressors would be provided initially at New York and Montreal only, and arrangements made in London to cut out such suppressors as may be fitted there on Continental circuits, when these are used for extension of the transatlantic circuits. It was recognized, however, that other suppressors might be encountered in the more remote parts of Continental and United States extensions. The general problem of how best to arrange and operate echo suppressors on very long switched connexions is one which remains for consideration later.

‡ The methods specified by these two bodies for the assessment of circuit noise differ in three respects; the units employed, the frequency weighting employed and the fraction of the busy hour for which the specified noise may occur. The meters concerned are the Bell System 2B Noise Meter (F1A Weighting Network) reading in dBa and the C.C.I.F. Psophometer (1951 Weighting Network) reading in millivolts across 600 ohms. The relationship between readings on the two meters is discussed in a later paper, and it will suffice here to note that, for white noise, dBm (C.C.I.F. psophometer) = dBa (Bell noise meter) - 84.

Maintenance and Operating Services.

Telephone speaker and telegraph (printer) circuits.—The need for telephone and telegraph circuits for maintenance and administration was recognized, and it was agreed to provide the following circuits on the submarine links at frequencies immediately outside the main transmission bands, where inferior and somewhat uncertain characteristics might be expected (Fig. 4):

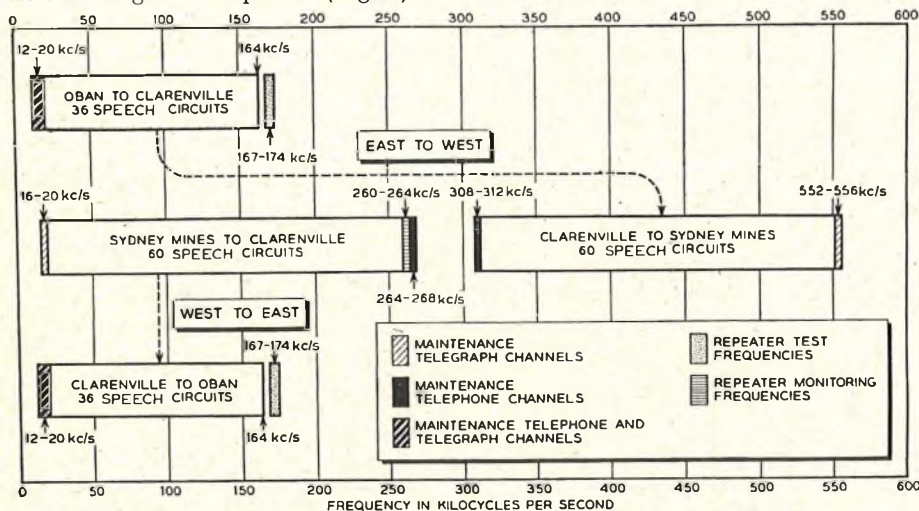

FIG. 4.—FREQUENCY ALLOCATIONS IN SUBMARINE CABLE LINKS.

- A 4-kc/s band, possibly sub-standard in regard to noise, equipped with band-splitting equipment (e.b. banks) to provide two half-bandwidth telephone (speaker) circuits,
- Two frequency-modulated telegraph (printer) circuits. These circuits would be extended over the land circuits to the terminal stations by standard arrangements as needed and would be used to provide the following facilities:
 - An omnibus speaker circuit connecting the principal stations on the route, including Montreal.
 - A speaker circuit for point-to-point communication between the principal stations—i.e. non-continuous.
 - A direct printer circuit between London and White Plains.
 - An omnibus printer circuit as (i) above.

Repeater test frequencies.—In each submarine cable link, test frequency-bands were required for monitoring repeater performance, and these are indicated in Fig. 4.

Pilot frequencies.—It was agreed to provide pilot facilities throughout the route for line-up, maintenance and regulation purposes. In addition to the usual pilots on the inland networks, there would be provided:

- A 92-kc/s pilot in each 12-channel group, continuous only in a particular section of the route and fitted with a recording voltmeter at the receiving end of that section.
- An 84.08-kc/s overall pilot in each 12-channel group as recommended by the C.C.I.F. This would be transmitted continuously over the entire route and would be monitored and recorded at every main station.

Connexions between component links.—At the time that the objectives were being established, a far-reaching decision was made to employ channel equipment at London, New York and Montreal only, and to adopt the frequency band 60–108 kc/s as the standard frequency for connecting the various parts of the overall system. By adopting this band as standard for the transatlantic system, it also became possible to interconnect readily with land systems at each end.

This agreement also facilitated decisions on responsibility for design and manufacture of equipment. For example,

it became logical to define each submarine system as the equipment between points where the 60–108-kc/s band appeared, i.e. the group-connecting frames. Thus, these systems would include not only the cable, repeaters, and power supplies, but also the terminal gear to translate between 60–108 kc/s and the line frequency of the submarine system. It also became logical to assign responsibility for manufacture of all this equipment to the administration

responsible for the specific system design, i.e. responsibility for the Oban–Clarenville link to the Bell System and for the Clarenville–Sydney Mines link to the Post Office.

THE REALIZATION OF THE SYSTEM

With decisions reached on the system objectives and interconnecting arrangements, it became possible to lay out jointly a detailed overall plan and for each administration to proceed with developing and engineering the links under its jurisdiction.

There was an understanding that there should be no deliberate attempt to make the characteristics of one link compensate for those of another, and so it would be incumbent on the administrations to produce the best possible group characteristics on each link.

The overall plan for the system, as finally developed, is shown in Fig. 2. Except for the necessity to split one of the three transatlantic groups in each direction to provide $6\frac{1}{2}$ circuits to Montreal and $5\frac{1}{2}$ to New York, which required specially designed crystal filters, no unusual circuit facilities were required.

Special equipment arrangements were called for at Sydney Mines and Clarenville to provide security for the Montreal–London circuits where they appeared in the same station with White Plains–London circuits. In these cases, a special locked room was constructed to house the equipment associated with the channel group containing the Canadian circuits.

The details of how the two all-important submarine cable links were designed and engineered to meet their individual objectives are given in companion papers. The efficiency and integrity of these two links are the highest that could be devised by engineers on both sides of the Atlantic.

Finally, each section of the connecting links was lined up and tested individually before bringing them all together as an integrated system.

OVERALL PERFORMANCE OF THE SYSTEM

The system went into service on the 25th September, 1956, so soon after completion of some of the links that it was not possible to include all the final equalizers. Nevertheless, after completion of the initial overall line-up, the performance has been found to meet very closely the original objectives. The system went into service without the use of compandors on any of the telephone circuits, but compandors are included in the program equipment. At the time of writing, only the 2-channel program equipment is available for use.

Frequency Characteristics of 12-Channel Groups.

Fig. 5 shows the frequency characteristic of one of the 12-channel groups, link by link and overall, measured at group frequencies corresponding to 1,000 c/s on each channel. In both the complete London–New York groups the deviation from “flat-loss” transmission is within ± 1.5 dB, and some further improvement is to be expected

when the equalization is finalized. For the split group, the characteristics are similar except for the effect of the splitting filters.

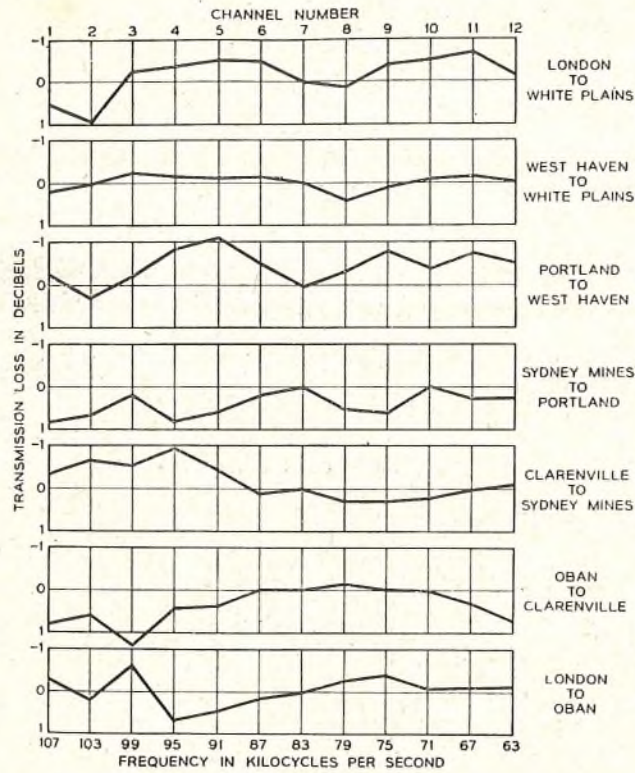

FIG. 5.—FREQUENCY CHARACTERISTIC OF TYPICAL LONDON-NEW YORK GROUP.

Variation of Overall Transmission Loss.

The system has, of course, only been completed for a short time, but the indications so far are that the standard deviation of the transmission loss, as indicated by the 84.08-kc/s group pilots, is well within the objective of

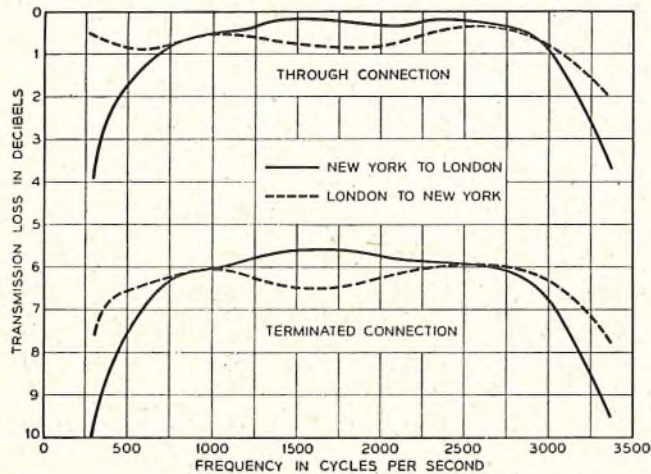

FIG. 6.—FREQUENCY CHARACTERISTIC OF TYPICAL TELEPHONE CIRCUIT.

1.5 dB. Alarms operate when the received pilot level deviates by ± 4 dB, and, so far, these alarms have not operated under working conditions.

Frequency Characteristics of Telephone Circuits.

Fig. 6 shows the measured frequency characteristic of a typical circuit in the two directions of transmission, as measured in the through and terminated conditions. Half the C.C.I.F. limits are, in fact, met on most of the circuits.

Circuit Noise.

The circuit noise, referred to a zero-level point, is as follows:

- London-New York. Best, 31.5 dBa; worst, 38 dBa.
- New York-London. Best, 28.5 dBa; worst, 40.5 dBa.
- London-Montreal. Best, 29.8 dBa; worst, 33.0 dBa.
- Montreal-London. Best, 29.7 dBa; worst, 31.2 dBa.

Two circuits at present exceed the objective of 38 dBa in the New York-London direction only; the higher noise levels refer to the high-frequency channels in the Oban-Clarenville cable. After additional data on the effect of cable temperature variations are accumulated, refinements will be made in the equalization and adjustment of levels on the Oban-Clarenville link. It is expected that the two worst channels can then be made to meet the objectives—still without the use of companders.

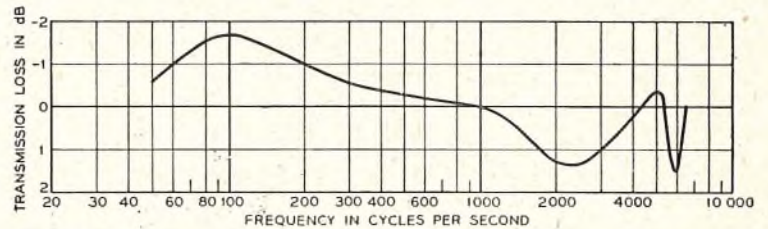

FIG. 7.—FREQUENCY CHARACTERISTIC OF TYPICAL PROGRAM CHANNEL, LONDON-NEW YORK.

Frequency Characteristics of Program Channels.

Fig. 7 shows the measured frequency characteristic of a London-New York program channel; this is typical.

Telegraph Channels, London-Montreal.

In the Agreement it was envisaged that at least six 50-baud telegraph channels could be provided in each direction in the Canadian half-circuit. In fact, 11 such channels have been provided using carriers spaced at 120 c/s and frequency modulation. The telegraph distortion due to the cable system with start-stop signals is about 4 per cent in every case, thus making the circuits suitable for switched connexions, without regeneration, up to the same limits as inland systems.

Tests over the system indicate that the channel speed can be raised satisfactorily to 80 bauds on at least ten of the channels. By the adoption of synchronous working, it appears that time-division-multiplex systems can be operated on these ten channels to double their capacity at a later date.

CONCLUSION

The transatlantic cable system has presented unique problems in system planning and design. It has been necessary to design the system to connect the facilities of many countries and to provide for cable communication of unprecedented length. But the stringent design objectives necessary to meet these requirements have not been the only challenge to the designer. It has been necessary to meet these objectives with a system which for over 2,000 miles of its length could not be altered to the slightest extent once it had been placed on the ocean bottom. Except for adjustments which can be made at the shore terminals of the submarine link, it has not been permissible to make any of the multitude of small design changes, substitutions and adaptations which are so commonly required in new systems to achieve the design objectives.

The success achieved in meeting the original objectives is a measure of the realism of the early planning as well as the diligence with which the design was carried to completion and is a tribute to all who took part in planning, designing and building the system.

Co-ordination of British and American Transmission Techniques

R. H. FRANKLIN, E.R.D., B.Sc.(Eng.), M.I.E.E.,
and J. F. BAMPTON, B.Sc.(Eng.), A.M.I.E.E.†

U.D.C. 621.395.52

This article discusses the problems which faced the systems engineers in planning communication facilities between London, New York and Montreal, due to differences in standards, design of equipment, and nomenclature, and indicates how the final system represents a combination of equipments employing different techniques blended to give an efficient and reliable system with adequate maintenance facilities.

ASSESSMENT OF THE PROBLEM

PRIOR to the announcement of the transatlantic telephone (T.A.T.) cable project, discussion had centred on the types of submerged repeater system to be employed over the sea sections of the route. Once the main decisions were made each party could proceed independently with the design of its specialized equipment to produce a wideband path over the submarine cable links. It was essential that for this part of the work each party should adhere firmly to its own proved techniques.

Subsequently, when planning overall communication facilities from London to New York and Montreal, it became necessary for the standard transmission techniques of each administration to be compared in detail so that satisfactory inter-working could be ensured.

It may be thought that, since the United Kingdom has for many years been planning and providing international communications with European countries, the process of planning systems to North America should present no unusual problems. However, outside North America, international working in all its aspects is guided by the C.C.I.F., which makes recommendations covering almost every point of design of international communication facilities. These recommendations have in practice, if not in fact, the force of law, because they constitute the only common basis of communication technique subscribed to by all the countries linked by lines in Europe, Asia and Africa.

North America, on the other hand, has a telephone network exceeding in size that of the whole of Europe, and its communication techniques have been developed to suit and solve its own particular problems. The Bell System has established standards for operation within the North American continent and these are referred to as the 4,000-mile standard; the C.C.I.F. standards are based on 2,500 km (1,600 miles).

Two decisions made in the first discussion after the T.A.T. cable project had been announced affected the planning considerably. These decisions were:—

- (a) The circuits should pass as "through groups" from London to New York and London to Montreal, i.e. the circuits should not be brought down to audio frequency at any intermediate point. (The circuits are therefore routed as "through groups" for distances of just over 4,000 miles.)
- (b) Equipment at each station should be supplied by the party best able to do so.

The application of these principles meant that at most of the stations on the route the installations would comprise both Post Office and Bell System equipment, and the co-ordination of design has provided some of the most interesting communication exercises of recent times.

† The authors are, respectively, Staff Engineer and Senior Executive Engineer, Transmission and Main Lines Branch, E.-in-C.'s Office

‡ dBm—decibels relative to 1 mW.

§ Example. Psophometer reading of 0.775V (p.d.)

= 1 mW = 0 dBm = 10⁹ pW.
∴ dBa = 10 log 10⁹ - 6 = 84
or dBa = 0 dBm + 84 = 84

In addition to system design many matters affecting the operation of the overall circuits, such as transmission levels, signalling methods, and facilities to be provided over the circuits, required detailed consideration.

STANDARDS AND UNITS

In deciding what the overall performance of the circuits should be the following factors were specified:—

- (a) *Band-width.* The C.C.I.F. requirements for circuits were adopted.
- (b) *Noise.* The Bell System defines telephone circuit noise in terms of its own standard noise meter 2B having an FIA weighting network. On such a set, a tone of 1,000 c/s at -85 dBm‡ produces a meter reading that is called "zero dBa." All noises are then measured in dBa relative to zero dBa. The Post Office measures noise in psophometrically-weighted millivolts, picowatts, or decibels relative to 1 mW. Measurements are made using a psophometer, with a C.C.I.F. 1951 weighting network, on which an 800-c/s tone of 1 mW in 600 ohms produces a meter reading called 0.775 V. All noise is measured relative to this. Precise correlation between the two methods of measurement is possible only when the noise measured is random in character. Fortunately, on the T.A.T. cable system, random noise is a very sound basis for correlation as it constitutes the major component of noise. In fact, for planning purposes the correlation was made on the basis of random noise, which produced the relation

$$\text{dBa} = 10 \log_{10} \text{pW} - 6 = \text{dBm} + 84\text{§}.$$

The C.C.I.F. recommends that for its 2,500-km reference circuit the total noise should not exceed 10,000 pW for 1 per cent of the time in the busy hour. The Bell System 4,000-mile standard is in terms of r.m.s. power over the busy hour, and this definition was accepted as a basis of measurement and a figure of 38 dBa, equivalent to 4 mV weighted, was agreed.

- (c) *Speech Volume.* Peak-program meters are used by the Post Office for measuring speech volumes on broadcast program circuits. The Bell System uses v.u. (volume unit) meters, and these meters are all specified in terms of the mechanical response of the meters with time. Correlation is not possible as the meter performance differs according to the type of signal being measured. It was therefore agreed that where program circuits are incoming to a country, measurements at all points along those circuits will be made in terms of the instrument used by the receiving country.

TERMINOLOGY

The conduct of affairs between nations in the C.C.I.F. involves the rigid and precise translation of technical terms from one language to another, but it might be expected that technical discussion between the English-speaking administrations should present little difficulty. However, for some 30 years the United Kingdom and North

American administrations have built up their technical languages more or less independently, and it was found that different words were used to described similar equipments or facilities, and sometimes particular words had different meanings in the two administrations. A vocabulary of important terms is given in the Appendix.

EQUIPMENT TECHNIQUE

The channel translating equipment of both administrations is broadly similar in that it converts 4-kc/s band-width circuits to the range 60–108 kc/s. An important difference is that at group frequencies the Post Office uses 75-ohm unbalanced circuits and the Bell System uses 135-ohm balanced circuits.

The group translating equipment is also broadly similar in that it converts five groups to the basic supergroup in the range 312–552 kc/s. The supergroup equipment is designed on a 75-ohm unbalanced basis by both administrations.

In the assembly of supergroups into line frequencies there are some differences in frequency allocation, but these differences do not concern the T.A.T. project.

The construction of the channel, group and supergroup equipments, which are typical of the standard transmission equipment of both administrations, does show certain important differences. All the Bell System standard carrier and coaxial equipment is d.c.-operated with 130V and 24V supplies, whereas most modern Post Office equipment is a.c.-driven. The Bell System's racks are 11 ft 6 in. high and components are well spaced on the panels. Wiring practices differ widely. The current Post Office standard of jack-in panels with ready-wired rack frameworks permits installation to be completed rapidly by merely wiring between tag blocks at the top of the racks. In Bell System equipment there are few panel tag blocks, no rack tag blocks are used, and during installation it is often necessary to wire from a component on a particular panel on one rack to another component on a panel on another rack. As a result, installation is a lengthy process, but this is justified on the grounds that it is "once and for all." However, latest designs of overhead racking used by the Bell System results in speedy erection. The racking is manufactured as standardized piece-parts so that any form of racking required can be assembled out of the basic parts, and new buildings have threaded holes in the ceiling at standard spacing to take the racking.

MAINTENANCE TECHNIQUE

Bell System maintenance and current Post Office practice differ in some main aspects. In the Bell System, the frequency-selective method of measurement is used extensively, and the test equipment for this purpose is direct-reading and accurate. The testing facilities include pilot signals that are used on groups and are transmitted over each group section at 92 kc/s. When a group is transmitted over a long distance the route will contain several group sections. Each group section is monitored by a 92-kc/s pilot and maintained within its specified limits by means of screwdriver adjustments on the last receive amplifier in the group section. Normally, the group sections are checked and adjusted daily; consequently the overall group is restored to its nominal condition every day.

Maintenance policy in the Bell System is based on the provision of standby plant which can be switched into service to replace any suspect or faulty item. In this connexion the design of the group as a 135-ohm balanced circuit is important because such circuits can be passed through telephone-type jacks with no-break change-over

facilities, and the cross-patching of groups can be done with virtually no break in the transmission path, as illustrated in Fig. 1.

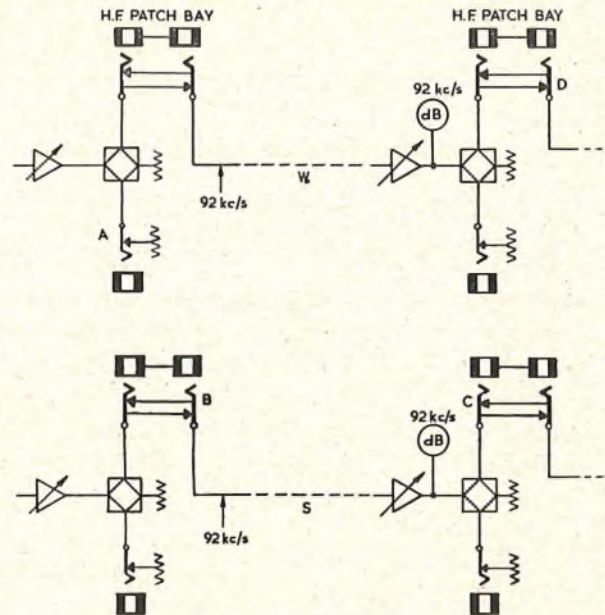

Notes.

Bell System jack symbols are used because there are no British equivalents of the jacks.
W—Working group section.
S—Spare group section.

FIG. 1.—CROSS-PATCHING OF GROUP SECTIONS.

The group section terminates at each end on special double jacks located on a centralized "h.f. patch bay." The contact arrangement shown is in each leg of the 135-ohm balanced circuit, and the circuit is normally through. The insertion of a plug into a jack breaks the through connexion, and connects the plug to the side of the circuit associated with the jack. Another important item is the hybrid coil which follows nearly all amplifiers, and provides a terminated-level test point and a spare outlet.

In order to transmit over the spare group section, S, jack A is patched to jack B. Transmission is then over both W and S. One end of a cord is inserted in jack C, and finally the other end of the cord in jack D. The final insertion of the plug in jack D changes over the group to S with a fast make-before-break change-over action.

Group Reference Pilots used on the T.A.T. Cable.

The Post Office proposed that the test facilities should include the system of overall 84.03-kc/s group reference pilots (one of two systems recommended by the C.C.I.F.), and after some discussion it was agreed that these should be applied on all the transatlantic groups, in addition to the 92-kc/s group section pilots. As the groups pass from London to New York and Montreal without demodulation to audio frequency, these overall group reference pilots offer a very valuable maintenance facility, since they will indicate service performance over the whole route.

The overall groups will thus be maintained by a technique representing a combination of both Bell System and Post Office practice.

The line-up of the groups is a good example of the co-ordination of techniques, the procedure being as follows:—

- (a) The Terminal Control calls upon each Section Control on the route (there are seven sections between London and New York) to adjust its overall equivalent to be as near to the nominal value as possible on the basis of the 92-kc/s section pilots (or, in the one or two sections where these pilots do not exist, by means of an equivalent pilot, such as a line pilot).

- (b) Overall 84 03-kc/s pilot readings are taken and measurements are also made at each of the intermediate stations. These readings are recorded at each station as being the standard for that station, and as the Terminal Control has this information as well it can immediately locate changes to a particular section.
- (c) The overall characteristics of the group can then be measured with the assurance that the performance of each of the group sections is completely specified.

The Use of Recording Decibelometers.

Coupled with the use of the 84·08-kc/s pilot equipment, which was supplied by the Post Office to all T.A.T. stations in the United Kingdom, Canada and U.S.A., the Post Office offered the technique of recording decibelometers. Whereas in the United Kingdom at the present time there are several thousands of these recording decibelometers in use by the maintenance staff on transmission equipment, such recorders do not appear to be used for the maintenance of circuits in North America. These recording decibelometers, when coupled to the 84·08-kc/s pilots, give a continuous record of the service offered by the transatlantic groups. In the group sections some of the 92-kc/s pilots are monitored by recording decibelometers, so enabling each Section Control to be certain of its section performance during the preceding period. There is no doubt that by the use of these recorders many intermittent troubles can be located which otherwise could not be found without a great deal of difficulty. Recording decibelometers are also available to record the level of the 84·08-kc/s pilot at intermediate points and thus locate any intermittent troubles to a particular main section of the route.

Spare Equipment and Change-over Facilities.

The policy of using spare equipment and change-over techniques was studied closely by the Post Office, and in the design of the terminal equipment for the Clarendville-Sydney Mines system small modifications were made to the Post Office equipment to permit the system of cross-patching customary in the Bell System to be used. This was practicable because, as a matter of safety of service, complete duplication of transmission equipment at these stations was adopted.

Fig. 2 indicates how the change-over facilities were incorporated into the Post Office submarine cable system.

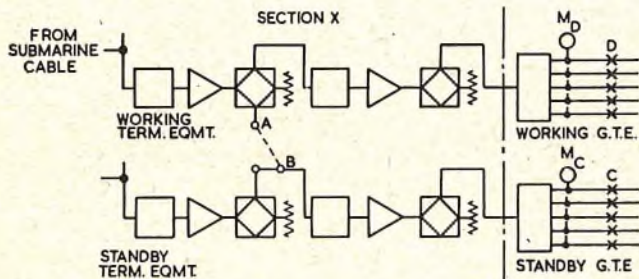

Notes.

- There is a separate 92-kc/s pilot meter M_C , M_D on each group.
 X indicates break jacks on H.F. Patch Bay.
 G.T.E.—Group translating equipment.

FIG. 2.—CHANGE-OVER FACILITIES ON BRITISH SUBMARINE CABLE SYSTEM.

In the event of a fault in section X (Fig. 2) being indicated by the readings on the 92-kc/s pilot meters, M_D , a patch is made between A and B and the 92-kc/s pilot meters M_C are observed. If the correct indication is obtained on the meters this shows that the fault is within Section X and a further patch is then made from C to D on all five groups. The final patch should then restore service at

correct level, without interruption, and permit the faulty equipment to be taken out of service for testing.

PROGRAM (MUSIC-IN-BAND) EQUIPMENT DESIGN

The factors affecting choice and design of the music-in-band equipment are described elsewhere¹ but, as has already been stated, the groups carry two pilots, 84·08 and 92 kc/s, within the group frequency band, as indicated in Fig. 3.

The use of the standard Post Office music-in-band system having a frequency band 84–96 kc/s was impracticable, due to the 92-kc/s pilot, and, similarly, the standard Bell System equipment operating in the range 80–88 kc/s was unsuitable due to the 84·08-kc/s pilot.

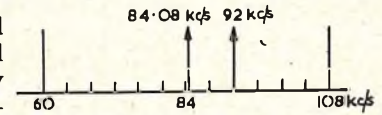

FIG. 3.—GROUP PILOTS.

It was therefore necessary to design new equipments and the final choice of frequency band was 64–76 kc/s. In addition to avoiding the two main group pilots (and others used within the two countries), this had the added advantage that the frequency range was suitable for operating to Montreal where less than 12 circuits are terminated and only the 60–86 kc/s part of a group spectrum is provided.

TRANSMISSION PLAN

With the completion of the T.A.T. cable, London becomes the junction point of three different transmission plans:—

- (a) The European (C.C.I.F.) plan, in which links have an effective loss of zero, a loss of 3·5 dB being added at the ends of the connexion, as indicated in the following examples:—
 London–Paris = 3·5 + 0 + 3·5 = 7 dB
 London–Paris–Rome = 3·5 + 0 + 0 + 3·5 = 7 dB
- (b) The Bell System switching plan, which is similar to (a) except that each link has a “via net loss”[§] which depends on the circuit characteristics, and a loss of 2 dB at each end of the connexion; for example:—
 New York–Chicago = 2 + 0·5 + 2 = 4·5 dB
 New York–Chicago–
 Minneapolis = 2 + 0·5 + 0·5 + 2 = 5·0 dB
- (c) The U.K. plan, in which each link is lined up to “best possible” with ends “open,” the loss per link being of the order of 2 dB; for example:—
 Bristol–Liverpool = 2 dB
 Bristol–Liverpool–Belfast = 2 + 2 = 4 dB

The solution adopted for T.A.T. cable calls is a compromise between (a) and (b), the European end loss of 3·5 dB replacing one of the Bell System 2 dB end losses. Thus,

- New York–London = 2 + 0·5 + 3·5 = 6 dB
 New York–London–Paris = 2 + 0·5 + 0 + 3·5 = 6 dB
 New York–London–Belfast = 2 + 0·5 + 0 + 3·5 = 6 dB

To enable this result to be achieved on the calls to Paris, Belfast, etc., four-wire switching has been used at London.

SIGNALLING

For very many years European practice has been to use as “ringing signals” on repeated circuits a frequency of 500 c/s, interrupted, or modulated, at 20 c/s. In North America a frequency of 1,000 c/s, modulated at 20 c/s, has been used for this purpose. Furthermore, the exact value of the 20 c/s used in Europe is not critical, whereas the North American 20 c/s has to be within the limits

¹ BENNETT, A. J., and HARRIS, E. T. C. Special Equipment Designed and Manufactured in the United Kingdom: Part 3.—Music Channels. (In this issue of the *P.O.E.E.J.*)

[§] See Appendix.

17-21 c/s, and preferably within the limit $18\frac{1}{2}$ -20 c/s. This accuracy is not difficult to achieve in the U.S.A. as the frequency can be derived from the 60-c/s mains supply. But this cannot be done in the United Kingdom.

The solution adopted was for each country to retain its own type of signalling receiver and to send the type of signal needed at the remote end. London therefore sends 1,000/20 c/s to New York and Montreal and receives 500/20 c/s from both.

It is intended to provide operator dialling facilities over the circuits in a few years' time.

CONCLUSION

The planning of the T.A.T. cable project from the point of view of the group and circuit transmission paths has brought about close consideration of the techniques of the United Kingdom and North American administrations. Throughout the planning, the basis has been that problems should be solved in accordance with the best engineering interest irrespective of national interest. Many problems arising out of the considerations mentioned in the paper have been discussed at the conference table, and the decisions made on this basis, although subject to ratification at higher level, have in fact been regarded as a basis for immediate action. Without these discussions and the good-humoured co-operation and unbiased approach of the planning engineers, it is likely that the completion of the joint design would have taken a much longer time.

APPENDIX VOCABULARY OF EQUIVALENT TECHNICAL TERMS (U.S.A. and U.K.)

U.S.A.	U.K.	REMARKS
a facility	—	general term describing all types of communication system
bridged measurement channel bank	through-level measurement channel translating equipment	
channel group	group	includes channel equipment
group	group section	
group bank	group translating equipment	
group connector	through-group filter	
H.F. patch bay	group distribution frame	significant difference in function—see text
hit	short break	"hit" is general term for momentary deviations in performance, positive or negative
J system	12-circuit carrier system (open-wire)	
K system	12-circuit carrier system (cable)	
L system	coaxial system	
long/short	high loss/low loss	applied to circuit loss
on the nose	precisely correct	
TD system	radio-relay system	
terminated measurement	terminated-level measurement	
terminated net loss	no equivalent	defined as the loss of a trunk circuit when it is not used as a link (see "via net loss"), but used to connect two subscribers' lines
toll circuit	trunk circuit	
trouble	fault	
via net loss	no equivalent	defined as the loss of a trunk circuit when it is used as an intermediate link in a switched trunk-circuit connexion

Cable Design and Manufacture for the Transatlantic Submarine Cable System*

A. W. LEBERT, B.S. in E.E., Member, I.R.E.,
 H. B. FISCHER, B.S. in E.E., and
 M. C. BISKEBORN, B.S. in E.E., Member,
 American I.E.E. †

U.D.C. 621.315.28.029.5:621.395.51

The transatlantic cable project required that two repeatered cables be laid in the deep-water crossing between Newfoundland and Scotland, and one across the shallower waters of Cabot Strait. The same structure was adopted for the cables laid in the two locations. This paper discusses the considerations leading to the design of the cable and describes the method of manufacture, the means and equipment for control of cable quality, the process and final inspection procedures, the electrical characteristics of the cable and factors relating to mechanical and electrical reliability of the final product.

DESCRIPTION OF CABLE

GENERAL features of the cable structure adopted for the transatlantic cable project¹ are illustrated in Fig. 1. The cable consists of two basic parts: (i) the coaxial pair, or the electrical transmission path, and (ii) the armour, or outer protection and strength members.

The coaxial pair is made up of three parts: (i) the central conductor, (ii) the insulation and (iii) the outer or return conductor. The central conductor is composed of a copper centre wire surrounded by three helically applied copper tapes. The insulation is a polyethylene[‡] compound which is extruded tightly over the central conductor. The resulting insulated central conductor is called the cable core. The outer or return conductor is composed of six copper tapes applied helically over the insulation.

The protection and strength components shown in Fig. 1 for the type D, deep-water, cable are provided by a

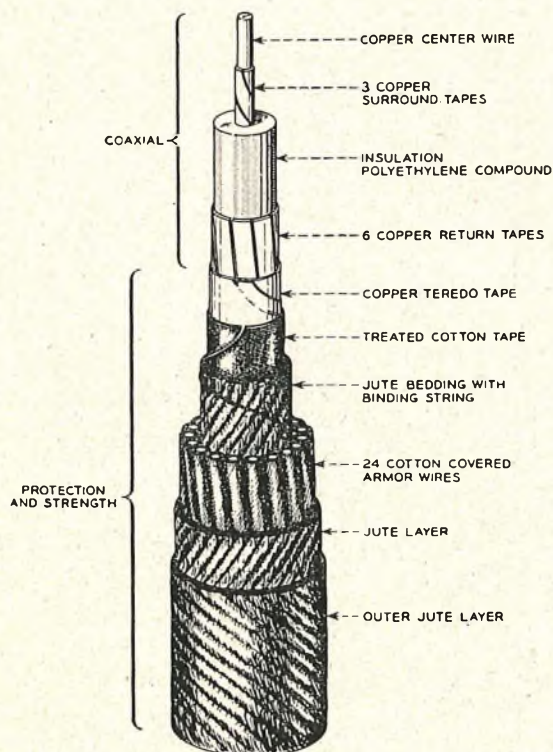

FIG. 1.—STRUCTURAL FEATURES OF THE DEEP-WATER TYPE OF CABLE.

teredo tape of thin copper applied over the outer coaxial conductor, a fabric tape binding, a layer of jute rove for armour bedding, the textile-covered armour wires and, finally, two layers of jute yarn flooded with an asphaltum compound. This type of cable is characterized by the extra tensile strength of its armour wires and by the extra precautions taken to minimize corrosion of these wires.

† The authors are with Bell Telephone Laboratories, Inc.

‡ Commonly known as polythene.

At the shallow-water shore ends, the armour types are characterized by the use of mild steel wires which are increased in diameter in steps as the landing is approached. These types are designated A and B and will be described in detail later.

The transmission loss of this cable structure at the top operating frequency of 164 kc/s is 1.6 dB per nautical mile and is 0.6 dB per nautical mile at 20 kc/s, which is the lower end of the frequency band. The high-frequency impedance of the cable is about 54 ohms.

BASIS OF DESIGN

A coaxial structure was first used for telephone and telegraph service in a submarine installation in 1921 between Key West and Havana. Three coaxial cables with continuous magnetic loading and no submerged repeaters were laid. One telephone circuit and two telegraph circuits were provided in each cable for each direction of transmission.

In 1950, a pair of submarine coaxial cables² which included flexible submerged repeaters was laid between Key West and Havana. Each cable provided 24 speech channels. One cable served as the "go" and the other as the "return" for the telephone conversations. The transatlantic telephone cable design is similar to this cable except that the nominal diameter of the insulation is 0.620 in. instead of 0.460 in. An outstanding difference between the transatlantic and the Key West-Havana systems is cable length—about 2,000 n.m. as compared with 125 n.m. This difference significantly influenced the permissible electrical and mechanical tolerances applying to the cable structure.

The installation of some 1,200 miles of cable with island-based repeaters for a communication and data transmission system for the U.S. Air Force, between Florida and Puerto Rico,³ followed the 1950 submarine cable system. The design of this cable is identical with that of the transatlantic cable, except for differences in the permissible dimensional tolerances on the components of the electrical transmission path. Data obtained on the electrical performance of the Air Force cable provided the transmission characteristics to which the repeaters for the transatlantic project were designed.

The designs of these cable installations were the result of many years of cable development effort, which was guided by the successes and failures of the earlier submarine telegraph cables. The 1950 Key West-Havana and the Air Force cables differed from the earlier structures in one important respect, namely, the lay of the major components. A series of fundamental design studies during the 1930's and 1940's and extensive field tests in the Bahamas in 1948 demonstrated that having the same direction of lay of the major components of a cable was very important in minimizing kinking and knuckling. In addition, other laboratory tests pointed the way to the adoption of new materials and techniques in the manufacture of these cables. These and subsequent improvements in materials and manufacturing techniques were included in the transatlantic cable design.

Since the electrical characteristics of a cable have a direct bearing on the overall system design and performance, considerable emphasis was placed on this phase of the design of the transatlantic cable. The size of central conductor and core used in the Air Force cable resulted in low attenuation and low d.c. resistance. These advantages resulted in the adoption of this size of cable. However, the outside diameter of the core and the diameter of the central conductor of the coaxial pair do not fulfil the requirements generally described as optimum for minimum attenuation. Mathematical analysis shows that there is a preferred diameter ratio which results in minimum transmission loss. For the 0.620-in. core diameter employed in the Air Force cable, the central conductor diameter chosen was smaller than the ideal required to satisfy the preferred diameter ratio. The diameter chosen retained the central conductor size which the Key West-Havana and Air Force cables proved to be satisfactory from a manufacturing standpoint. The choice was also compatible with the d.c. resistance requirement for transmission of power over the cable to each of the repeaters.

While production of the cable was proceeding, cable manufactured to the transatlantic specification was tested near Gibraltar in March, 1955. These tests provided a final evaluation of the mechanical and electrical characteristics of this cable before the actual laying of the transatlantic link.

DETAILS OF STRUCTURAL DESIGN OF CABLE

The structural features of the coaxial pair and of types A, B and D armour are summarized in Fig. 2.

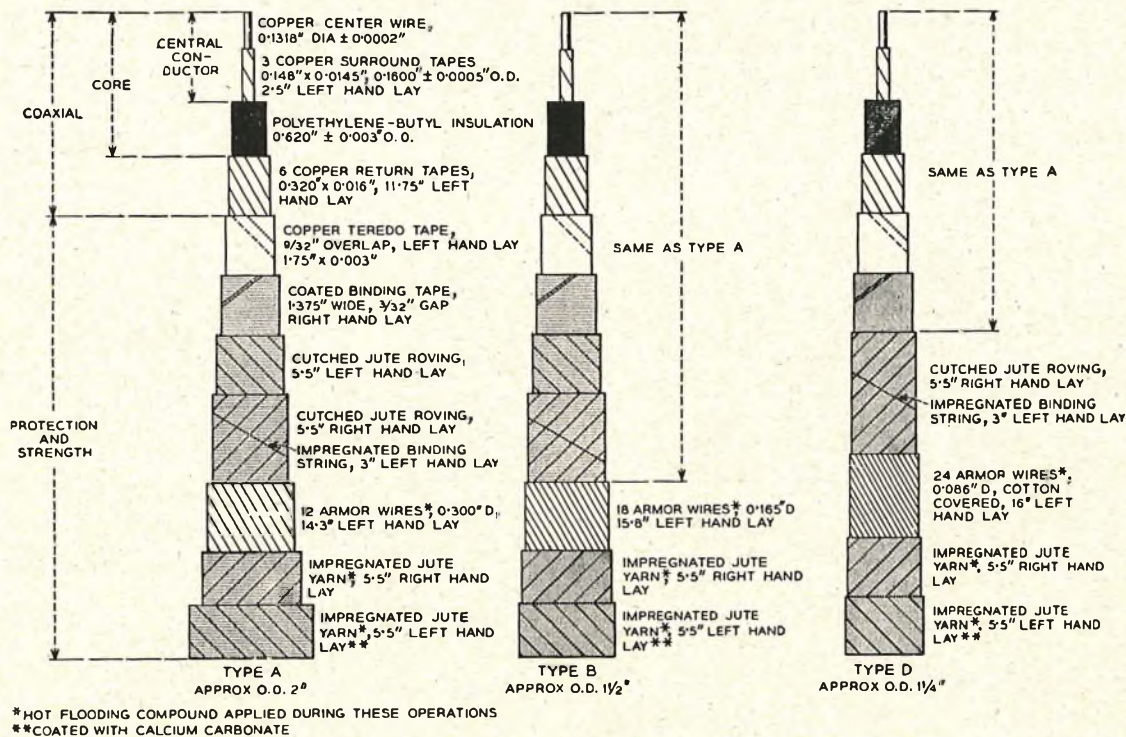

FIG. 2.—DESIGN DETAILS OF THE TYPES OF TRANSATLANTIC TELEPHONE CABLE FOR DIFFERENT DEPTHS OF WATER.

A composite central conductor was chosen to provide a conductive bridge across a possible break in any one of its elements, due to a hidden defect, such as an inclusion of foreign material in the copper. The dimensions of the components of the central conductor were precisely controlled, and the assembly was given a light draw through a precision die to compact and size the assembly.

Use of high-molecular-weight polyethylene (grade 0.3) for core insulation is a major departure from the materials

used in early submarine telephone and telegraph cables. The development of synthetic polymers such as polyethylene has led to the replacement of gutta-percha as cable insulation, since polyethylene possesses better dielectric properties and mechanical characteristics and is lighter in weight.

Ordinary low-molecular-weight polyethylene is subject to environmental cracking, especially in the presence of soaps, detergents and certain oils. High-molecular-weight material is much less subject to cracking, and by adding 5 per cent butyl rubber, further improvement in crack resistance is obtained.

Six copper tapes applied helically over the core comprised the return conductor and thus completed the coaxial structure. The dimensions of these were precisely controlled. The helical structure was chosen to impart flexibility to the coaxial pair.

Insulation of some of the early submarine telegraph cables suffered from attack by marine borers such as the teredo, pholads and limnoria. To protect against such attack, a thin metallic tape was placed over the insulation in the early submarine cables. The necessity for such protection for the transatlantic cables, especially in deep water, may be questioned, but the moderate cost of this protection is considered cheap insurance against trouble. The copper teredo tape was applied directly over the return conductor as a helical serving with overlapped edges to seal the coaxial structure completely from attack by all but the smallest marine organisms.

A cotton tape treated with rubber and asphaltum-tar compound was applied over the teredo tape to impart

mechanical stability to the coaxial structure during manufacture. A small gap between adjacent turns of the helix was specified to permit ready access of water to the return tape structure and to the surface of the core. The use of a gap was based on laboratory tests which showed that transmission loss was dependent to a modest extent on thorough wetting of the exterior of the coaxial pair. Since transmission loss measurements were made on repeater sections of cable shortly after manufacture to determine

whether any length adjustments were required, it was essential that the wetting action be as rapid as possible.

The design of the protection and strength components of the cable was modified according to the depth of the water in which the cable was to be laid. To prevent damage to the coaxial structure by any cutting action of the armour wires during manufacture and laying, a resilient cushion of jute roving was placed between the armour wires and the coaxial structure. For type D cable, a single layer of jute was used; for types A and B cable, the bedding was made up of two layers of jute. To protect this jute from microbiological attack, a cutting treatment was employed. The traditional cutting process consists of treating the jute with a vegetable compound called catechu or cutch.

Armour wires were applied over the jute bedding. The use of heavy or intermediate weight armour wires near shore has been established by experience with ocean cable. This type of armour is generally employed where the cable may be exposed to wave action, bottom currents, rocks, icebergs, ships' anchors and fishing trawlers. A lighter weight structure having higher tensile armour wires is needed in deep water. Table 1 shows the essential differences between the types of armour employed in the transatlantic cable and the approximate range of depths in application:

TABLE 1
Armour Wire

Type	No. of Wires	Diameter	Material	Application
		in.		
A	12	0.300	Mild steel	Down to 350 fathoms
B	18	0.165	Mild steel	350 to 700 fathoms
D	24	0.086	High-strength steel	Greater than 700 fathoms

In addition to the above types of armour, a shore length of 0.6 n.m. was provided with an insulated lead sheath under type A armour to facilitate earthing arrangements and to provide signal/noise improvement.

Where the tensile strength of the armour wires is most important, as in the type D design, each of the wires was protected against corrosion by zinc galvanizing, plus a knitted cotton serving or helically applied tape, the whole assembly being thoroughly saturated with an asphaltum-tar compound. The effectiveness of such protection is clearly apparent when early submarine cables, which used this protection, are recovered and examined. For the heavier-armour types, the protection was similar to that of type D, except that the textile serving was replaced by a dip treatment to coat each wire with an asphaltic compound.

As the armour wires were applied to each type of cable, additional protection was obtained by flooding the cable with a special asphaltum-tar compound and then applying two layers of jute yarn over the wires. The jute yarn was impregnated with an asphaltum-tar compound before application to the cable and then flooded with another asphaltum-tar compound after application. Formulation of cable flooding materials required the use of compounds having a relatively high coefficient of friction to avoid slip of the cable on the ship's cable drum during laying.

To ensure satisfactory handling characteristics during the laying operation, all the metallic elements of the cable were applied with a left-hand direction of lay and the lengths of lay (except for the teredo tape) were chosen so that approximately the same helical length of material was used per unit length of cable. Since the teredo tape was relatively soft and ductile compared with that of the other metallic components, it was not necessary to equate its helical length with that of the other components. Width and lay

of the teredo tape were selected to give a smooth, tight covering.

The choice of direction and length of lay of the jute layers was based on experience with the cable in factory handling and laying trials. Experience, particularly with the direction of lay, has shown that improper choice of lays for the two outer layers of jute may result in a cable that is difficult to coil satisfactorily in storage tanks. The combination of lays selected for the cable components provided good performance in all the handling operations, including the final laying across the Atlantic.

MANUFACTURE OF THE CABLE

Before considering the manufacture of the cable, it should be understood that the repeater gain characteristic was designed to compensate for the loss characteristic of the cable. Therefore, once this loss characteristic was established, it was essential that all cable manufactured should conform with this characteristic.

To obtain the required high degree of conformance, close control had to be kept over all stages of manufacture and over the raw materials. Controls to guide the manufacture of the cable were set up with two broad objectives:

- (i) To produce a structure capable of meeting stringent transmission requirements.
- (ii) To ensure that the manufactured cable could be laid successfully and would not be materially affected by the ocean-bottom environment for the expected life of the cable system.

Attainment of a final product capable of meeting the stringent transmission requirements is described later. Process and raw material controls in manufacture were provided by an inspection team who checked the quality of the various raw materials and the functioning of the several processes during the manufacturing operations. This type of inspection coverage is unique with submarine cable. It ensures the desired final quality by permitting each error or accident to be investigated and corrected on an individual basis.

Cable for the transatlantic crossing was manufactured in America and England. Differences in machinery and equipment in the plants of the two manufacturers necessitated minor differences in the sequence of the operations and in the processes. The sequence of operations in assembly of the cable was as follows:

- (i) Stranding of central conductor.
- (ii) Extrusion of insulation.
- (iii) Runover examination, and repair where necessary.
- (iv) Panning and testing of core.
- (v) Jointing of core.
- (vi) Application of return tapes, teredo tape, fabric tape, jute bedding and binding string.
- (vii) Application of armour wire and outer jute layers.
- (viii) Storage in tanks and testing.
- (ix) Splicing in repeaters and testing.

The only important difference in the sequence of the manufacturing operations at the two manufacturers was the use of separate operations for steps (vi) and (vii) in England and the combination of these operations in one machine in America.

Other minor differences in process methods related to raw materials. For example, the American supplier purchased polyethylene already compounded with butyl rubber and anti-oxidant in granule form, ready for use. The British supplier purchased polyethylene, butyl rubber and anti-oxidant separately, and performed the compounding in the cable factory.

Stranding of Central Conductor.

The central conductor was stranded on a machine which

included a revolving carriage with suitable arbours for the three surround tapes. It was equipped with brakes designed to ensure equal pay-off tension among the tapes and with detectors to stop the strander automatically if a tape broke. Each tape was guided through contoured forming rollers to shape the tape to the centre wire.

The joints between successive reels of wire and tape used in fabrication of the central conductor were butt-brazed. The brazes were staggered to avoid more than one braze in a given cross-section of the conductor. The quality of the brazes in these components was controlled by a qualification technique described below in the subsection on jointing of core lengths.

The strand was drawn through several forming dies to size the finished diameter of the central conductor accurately. No lubrication was used because the removal of the resultant residues, which could contaminate the polyethylene insulation, would have been difficult. The taper in the central conductor diameter due to the die wear was controlled by appropriate replacement of tungsten-carbide dies, where used, or by the use of a diamond die where the rate of die wear was less than 1 or 2 micro-in./mile.

The stranding area in both plants was enclosed and pressurized to guard against dirt and dust settling on the central conductor. A high standard of cleanliness was maintained for parts of the machine which touched the conductor or its components. Undue wear of the guide faces or capstan sheaves was cause for replacement of the sheaves and adjustment of the machine. A photograph of the stranding area is shown in Fig. 3.

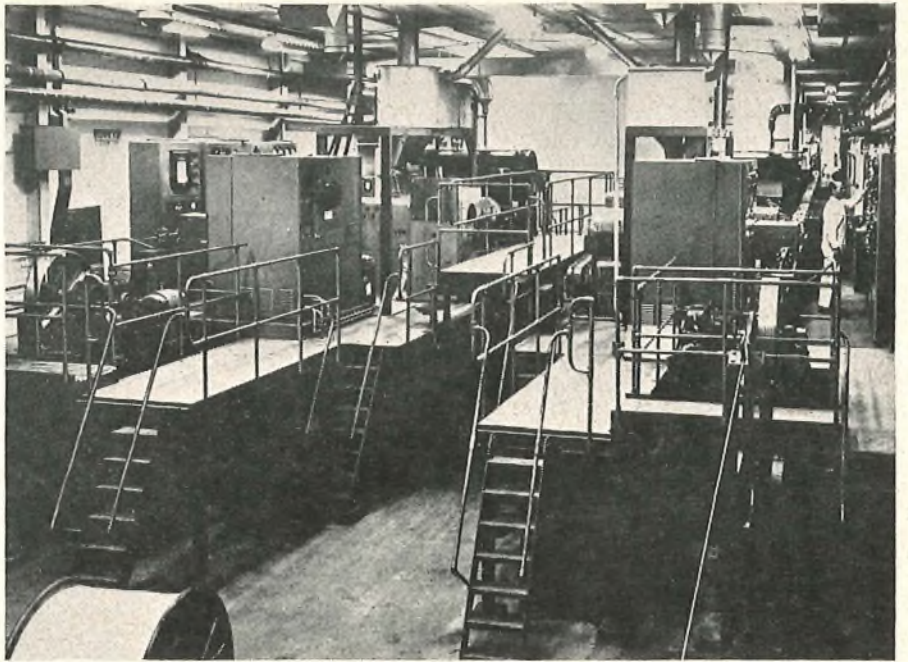

FIG. 4.—VIEW OF TYPICAL MANUFACTURING AREA FOR EXTRUSION OF CORE INSULATION.

Extrusion of Insulation.

To avoid possible contamination of the polyethylene insulating compound in the extruder-hopper loading area, a pressurized enclosure prevented entry of air-borne dust and dirt, and the containers of polyethylene compound were cleaned with a vacuum cleaner before being brought into the hopper area. A fine screen filter placed in the extruder reduced the possibility of contamination in the core.

In passing through the extruder, the central conductor was paid out from a large reel with controlled tension, into the pay-out capstan, through an induction heater, through a vacuum chamber, and thence into the cross-head of the extruder. The induction unit heated the central conductor and provided means for controlling the "shrink back" of the core insulation and the adhesion of the insulation to the conductor. "Shrink back" is a measure of the contained stresses in the insulation.

On the output side of the extruder, the core was cooled in a long sectionalized trough containing progressively cooler water from the input to the output end. The annealing of the polyethylene in the cooling trough also served to hold the "shrink back" of the core to a low value. The extrusion shop is shown in Fig. 4.

An important addition to the extrusion operation consisted of the use of an improved servo system to control the extruder automatically to attain constant capacitance per unit-length of coaxial structure. The system used is described later under control of transmission characteristics.

Run-over Examination.

Following extrusion, the core was subjected to continuous visual and tactual examination in a re-reeling operation called "run-over." The purpose of the run-over operation

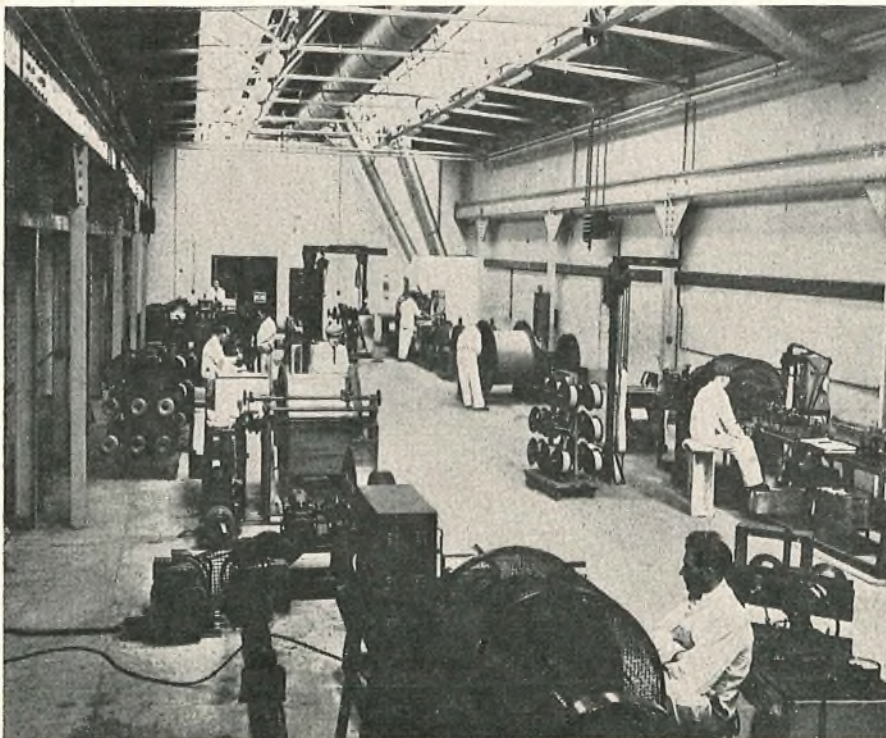

FIG. 3.—VIEW OF TYPICAL MANUFACTURING AREA FOR STRANDING OF CENTRAL CONDUCTOR.

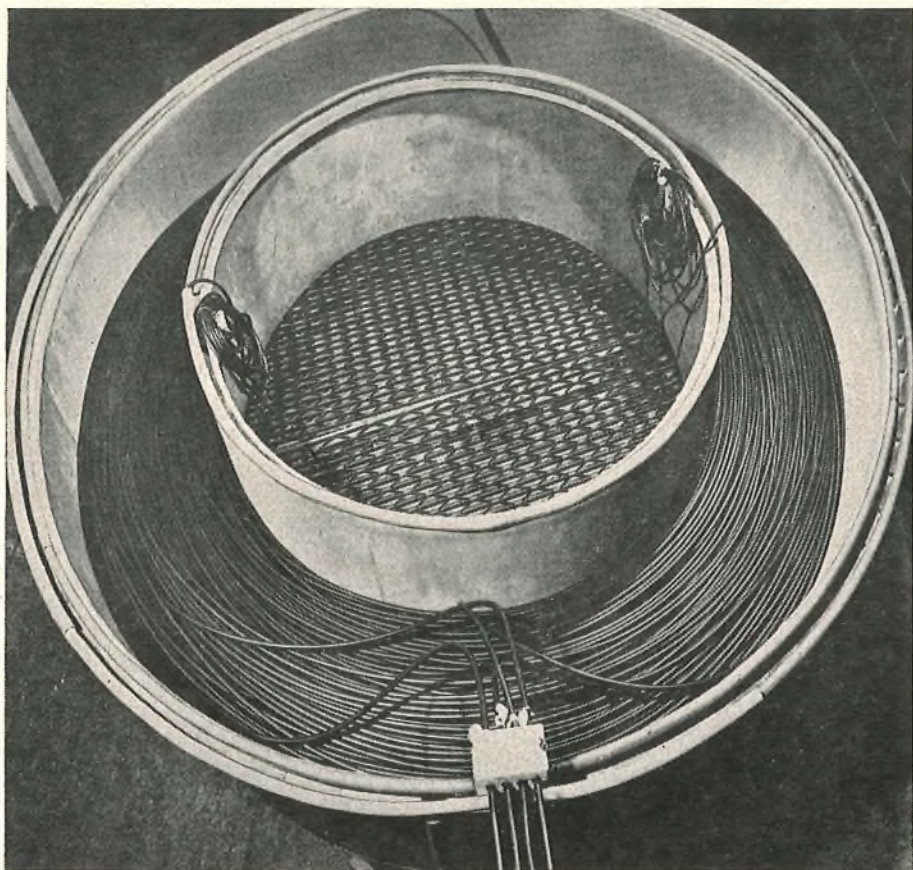

FIG. 5.—SPECIAL WATER TANK OR PAN FOR TESTS ON IMMERSED CABLE CORE.

was the detection of inclusions of foreign material in the dielectric and the presence of abnormally large or small core diameters. Core not meeting specification requirements was cut out or repaired.

In addition to visual inspection of the cable, examination of short lengths of core was made at regular intervals with a shielded source of light arranged to illuminate the interior of the dielectric material. Provision of this internal illumination permitted detection of particles of foreign material well beneath the surface of the core. Strip chart records of the unit-length capacitance of the core obtained during extrusion were used as a guide in searching out regions of uncertainty.

Panning and Testing.

After run-over, the core was coiled in tanks of water, as shown in Fig. 5. Precautions were taken to remove the air dissolved in the water and thus prevent the formation of bubbles on the surface of the core. The water was also temperature-controlled and circulated to maintain uniform temperature throughout the tank. Thermo-couples placed at different levels in the tank determined when the temperature was uniform. Measurements of d.c. conductor resistance, a.c. capacitance, insulation resistance, and electric strength were then made. These measurements are discussed in detail later under electrical measurements.

Joining of Core Lengths.

The cable core was manufactured in lengths much shorter than a repeater section, which necessitated connecting the individual lengths together. Joining techniques consisted of brazing the central conductor with a V-notch type of junction and moulding - in a short section of polyethylene insulation. After silver-soldering the V-joint, a safety wire consisting of four fine-gauge tinned copper wires was bridged across the junction in an open helix and soft-soldered at the ends. Extreme care was taken to remove any excess rosin and to eliminate any sharp points on the ends of the safety wires. The safety wire is intended to maintain continuity of the electrical path in case the braze should fail.

Visual examination of brazes in the actual cable was the only means available for their final inspection. To ensure a high degree of quality, a system was devised for checking the performance of the operator and the brazing machine initially and at frequent intervals, through the use of sample brazes in each of the components, which were tested to destruction. To control the uniformity of brazes, the brazing of the copper wire and tapes was made as automatic as possible by the use of controlled pressure on the components, appropriate sized wafers of silver solder, and an automatically timed heat cycle. The tests on the brazes used to qualify operators and machinery indicated that a high degree of braze performance was achieved.

Pressure and temperature were carefully controlled during the moulding of the insulation over the conductor. Periodic

controlled pressure on the components, appropriate sized wafers of silver solder, and an automatically timed heat cycle. The tests on the brazes used to qualify operators and machinery indicated that a high degree of braze performance was achieved.

Pressure and temperature were carefully controlled during the moulding of the insulation over the conductor. Periodic

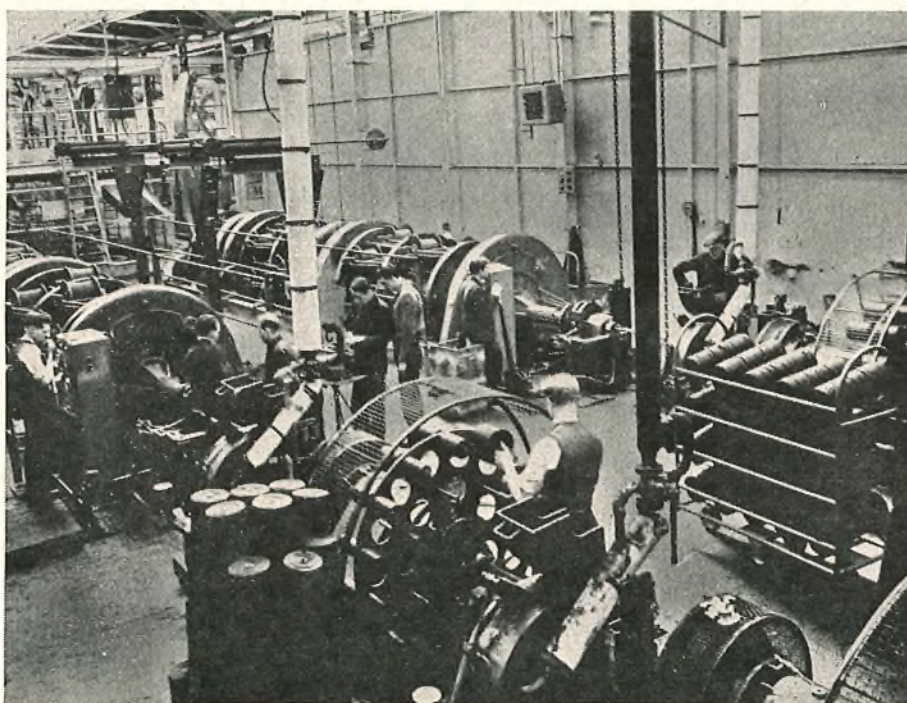

FIG. 6.—VIEW OF SHOP FOR APPLICATION OF CABLE ARMOUR.

checks similar to those described for brazes were made on operator and moulding machine to maintain a satisfactory level of performance. In addition, each moulded joint placed in the actual cable was X-rayed and subjected to a high-voltage test while immersed in water.

Application of Return Tapes and Armour Wires.

After the core lengths were joined together, they were pulled through the return taping and armouring operations. The machine for applying return tapes was designed specifically for the purpose and was similar in characteristics to the corresponding portion of the strand for the central conductor. Controlled pay-out tension, automatic breakage detectors, precision guides, and contoured forming rollers to shape the tape, were incorporated in the construction.

The return tape, teredo tape and fabric tape were applied from taping heads, and the bedding jute and binding string were applied from serving heads in a tandem operation. Another set of tandem operations included the application of armour wires, outer jute layers and the appropriate asphaltum-tar flooding compounds. In the American plant both sets of tandem operations were combined into one continuous production line. In the British plant they were divided into two separate production lines. A view of the armouring-machine area is shown in Fig. 6. Following the application of the flooding compounds, whitening was applied either at the take-up capstan on the armouring line or in the storage tanks as the cable was coiled.

To avoid core damage the flow of hot flooding compound was stopped when the cable in the armouring line was stopped. One of the major sources of such stoppages was the reloading of the various heads.

Storage and Testing.

In a continuous haul-off operation, the cable was conveyed from the armouring machine to the tank house for storage. The cable was coiled in spiral layers, called "flakes." Each flake started at the outside rim of the tank and worked toward the central cone. Several 37-n.m. repeater sections were stored in each tank.

Water was circulated through the cable tanks to establish uniform temperature conditions throughout the mass of cable. When thermo-couples located at appropriate points in the tank indicated that the cable temperature was uniform, measurements were made of attenuation, internal impedance irregularities and terminal impedances, d.c. resistance, d.c. capacitance, insulation resistance and electric strength.

To facilitate these tests without interrupting production, successive repeater section lengths were placed in alternate tanks. By this procedure, a group of four or five sequential repeater section lengths, called an "ocean block," was stored in two tanks. The ends of each repeater section were brought out of the tank to a splicing location. After all tests were completed and the specification requirements met, the repeaters were spliced in. Testing of the ocean block for transmission performance completed the manufacturing operations.

RAW MATERIALS

Stringent requirements were placed on all raw materials used in the manufacture of the transatlantic cable. Detailed specifications covered the basic requirements and the methods of controlling their quality in a sampling inspection procedure. The requirements for the materials were established to ensure that their use would not jeopardize the life of the cable. Since cable life is critically related to the integrity of the insulation, all materials had to be

scrutinized for their tendency to cause environmental cracking. These tests were necessarily made on an accelerated basis. Since no correlation exists at present between accelerated tests and long-term (20-year) life tests, only conservative design selections can be justified.

Close tolerances, such as ± 0.0002 in. for the diameter of the solid centre wire in the central conductor, were specified for all copper components of the coaxial structure. In addition, these components had to be free from slag or other inclusions, and the wire drawing and rolling of the tape had to be controlled to ensure smooth surfaces, edges of prescribed shape and freedom from filamentary imperfections. Compounds used in drawing and rolling operations were selected to minimize the possibility of contaminating or causing cracking of the polyethylene. Residual quantities of compound on the wire or tapes were removed prior to annealing, which was controlled to prevent the formation of oxides and to ensure clean and bright copper.

The permittivity of the polyethylene-butyl-rubber compound was limited to 2.25 to 2.29. These limits were determined by the limited accuracy of the measuring equipment available at the time. Restrictions covered the allowable amount of contamination since its presence in other than minute quantities might reduce the electric strength or degrade the power factor of the compound.

In addition, the melt index (a factor related to molecular weight) of the final insulating compound composed of the polyethylene resin, the butyl rubber, and anti-oxidant, was held to 0.15 to 0.50. The melt index of ordinary polyethylene used for insulation, generally, is 2.0 and higher. Choice of the low index ensured the maximum resistance to environmental cracking.

The cutting and fixing processes used in the manufacture of bedding jute were adjusted to limit the alkalinity of the jute because of the adverse effect of alkaline materials on polyethylene compound. Oils used in the spinning of the jute were selected to obtain types which were not strong cracking agents for polyethylene, and the quantities used were reduced to the workable minimum. The presence of such impurities as bark and roots was restricted to provide the desired fibre strength. The impregnation of the jute was controlled to ensure adequate distribution of the coal tar throughout the fibres without having an excess that would make the jute difficult to handle during the armouring process.

The size, composition and processing of the armour wires were also placed under close control. Purity, tensile strength, and twist requirements were designed to ensure that the wire could be applied to the cable, and welded, and that it could withstand the expected tensions during laying and pick-up. Strength considerations made it mandatory that inclusions of slag or piping of the wire should be eliminated. Piping is an unusual condition encountered during rolling or drawing which results in a hollow shell of steel which may be filled with slag.

CONTROL OF TRANSMISSION CHARACTERISTICS

Broadly, the attainment of a final product capable of meeting the stringent transmission requirements was achieved by the following basic steps:

- (i) Precision control of the dimensions of the copper conductors, including the diameter of the fabricated central conductor.
- (ii) Automatic control of the insulating process to maintain a constant capacitance, thus compensating for deviations in central conductor diameter and permittivity of the insulation.
- (iii) Factory process control, by means of a running average of the measured attenuation characteristic of

current production, to guide the adjustment of suitable parameters when necessary.

As already indicated, precautions were taken to obtain a central conductor that had predictable electrical performance and a controlled taper in overall diameter along its length. The need for such effort is explained by consideration of the factors that determine the attenuation of a coaxial structure.

The attenuation, α , of the cable is directly proportional to the a.c. resistance, R , and inversely proportional to the characteristic impedance Z_0 , as a satisfactory approximation. That is,

$$\alpha = \frac{aR}{Z_0} \text{ decibels per nautical mile}$$

where a is a coefficient depending on the units. It is thus clear that control of α may be attained by control of R and Z_0 . Since the resistance is a function largely of the diameter of the central conductor, and since it is held to close tolerances, the constancy of impedance completes the requirement for attenuation control.

The characteristic impedance of a transmission line is determined by:

$$Z_0 = b\sqrt{\epsilon} \log \frac{D}{d} \text{ ohms}$$

where ϵ is the permittivity of the insulating material, D is the inside diameter of the outer conductor, d is the diameter of the inner conductor, and b is a numerical coefficient. If the permittivity of the insulating material (polyethylene) does not vary, control of the characteristic impedance reduces to control of capacitance. This follows from the fact that the capacitance, C , is related to the ratio D/d as follows:

$$\frac{D}{d} = \text{antilog} \frac{k\epsilon}{C}$$

where k is a numerical coefficient.

Precision control of capacitance during the insulating process is achieved by a double-loop linear servo system, as shown in the simplified block schematic diagram, Fig. 7. The two loops consist, respectively, of one capable of introducing relatively fast capacitance corrections of only modest accuracy and of one capable of highly precise capacitance

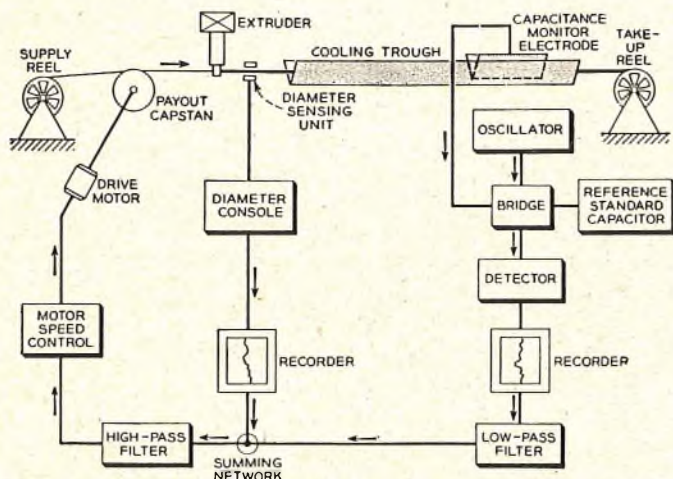

FIG. 7.—SIMPLIFIED BLOCK SCHEMATIC DIAGRAM OF CAPACITANCE MONITOR SERVO-CONTROL SYSTEM.

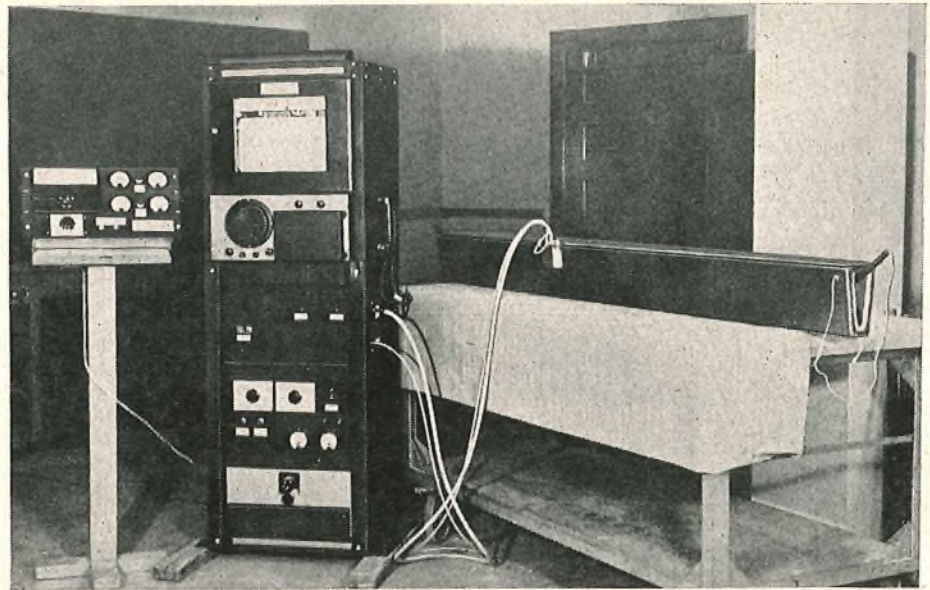

FIG. 8.—CAPACITANCE MONITOR ELECTRODE AND SERVO-CONTROLLER CONSOLE IN LABORATORY.

control on a relatively long-time basis. The servo system controls the capstan pay-out speed of the central conductor feeding into the extruder applying the core insulation, as shown in the diagram. Since the extruder delivers insulating material at a constant rate, an increase in central conductor speed results in a wall of insulation thinner than normal and thus causes an increase in capacitance.

The sensing element for the control loop consists of a capacitance monitor. This is a device capable of measuring the unit-length coaxial capacitance of the cable core continuously as it moves through the water in the trough. Since the capacitance of a polyethylene-insulated core is temperature sensitive, the monitoring electrode must be located at a point in the cooling trough where the temperature of the core is stable and known to a degree commensurate with the overall accuracy objectives. The distance from the extruder to the electrode corresponds to about 10 min of cooling time; hence, a servo system based on this loop would be necessarily slow, owing to the 10-min delay in detecting a drift in capacitance.

Analysis shows that fast capacitance information of only moderate accuracy may be used in combination with the slow loop to speed up the response of the overall system to a satisfactory degree, without sacrifice of precision of the slow loop. The sensing element used for the fast loop consisted of a light-ray diameter gauge, which measures the diameter (changes in diameter are the approximate inverse of the capacitance) of the hot core close to the extruder. The slow and fast data are combined to control the extruder, as shown in the diagram.

The servo constants were chosen to minimize the deviations in unit-length capacitance occurring in core lengths corresponding to less than a quarter-wavelength of the top operating frequency. In other words, the objective for the choice of servo-loop constants was to ensure equality in the capacitance of all quarter-wave sections of core. Echo measurements indicated that a highly satisfactory degree of control was achieved. Overall servo-system performance was such that the standard deviation of the capacitance of the core lengths manufactured for the two crossings was ± 0.1 per cent. The capacitance monitor electrode and the servo-controller console are illustrated in Fig. 8.

Adjustment of Concentricity.

Means for the setting-up and adjustment of the extrusion

process to achieve relatively accurate centring of the conductor in its sheath of insulation was provided by a device called a concentricity gauge. This device operates on the principle that two small, plane electrodes on opposite sides of the core will have different direct capacitances to the central conductor when this is not properly centred.

A simplified block schematic diagram of the concentricity gauge is shown in Fig. 9. Data obtained with two

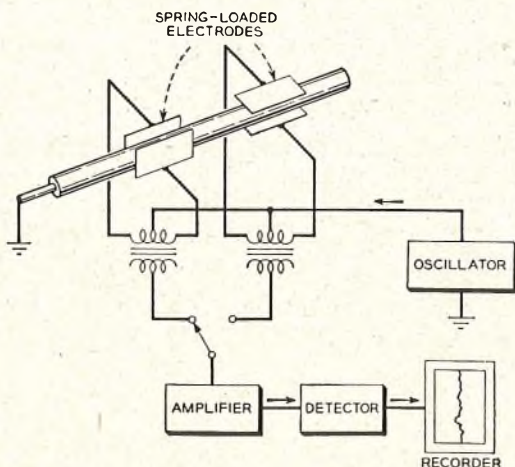

FIG. 9.—SIMPLIFIED BLOCK SCHEMATIC DIAGRAM OF CONCENTRICITY GAUGE FOR CONTINUOUS MEASUREMENT OF CENTRING OF CENTRAL CONDUCTOR.

sets of electrodes displaced 90° were recorded on a strip chart recorder, the output of the two sets of electrodes being displayed alternately. A satisfactory degree of centring was moderately easy to maintain.

ELECTRICAL MEASUREMENTS

To assist in achieving the goal of matching the cable and the repeater characteristics with a minimum of deviation, electrical measurements were made throughout the process and close tolerances were placed on the electrical parameters at each stage of production. Measurements on the repeater-section lengths of cable were used as a final check to determine the extent to which all the controls had been successful. The primary standards used were formulated by the Bureau of Standards in the United States or the National Physical Laboratory in England. These precision standards were used to calibrate the bridges frequently.

The d.c. resistance of the central conductor was measured under constant-temperature conditions with a precision type of Wheatstone bridge. The permissible range of resistance was $2.514\text{--}2.573$ ohms/n.m. at 75°F . In practice, the spread of resistance values was well within these limits.

The core capacitance at 20 c/s was also measured under constant-temperature conditions. For this, the two ends of the central conductor were connected together and the measurements were made between the central conductor and earth, which was provided by the water. A capacitance-conductance bridge was used for the purpose. The capacitance limits set initially were $0.1726\text{--}0.1740$ μF /mile at 75°F . Analysis of the core measurements indicates that at each factory the range of capacitance was held more closely than indicated, which illustrates the benefits of servo control to the insulating process.

The d.c. insulation resistance of the core was also measured by applying 500V for 1 min. A minimum insulation resistance requirement of 100,000 megohm-miles at 75°F was established, but any lengths that had less than 500,000 megohm-miles were scrutinized for possible sources of

trouble and were subject to rejection. As a general rule, insulation resistances considerably in excess of 500,000 megohm-miles were obtained.

The core was also tested at a voltage of 90-kV d.c. for a period of 1 min. This was designed to reveal any gross faults in the core caused by foreign particles which had escaped detection by the other mechanical and electrical tests made on the core.

As discussed under jointing of core lengths, the core lengths were assembled and joined together to form a repeater section of cable. In general, an effort was made to produce the core for a repeater section of cable on a particular strander, extruder and armouring line, and to join the lengths together in the order of manufacture. Practical difficulties, such as the fact that the outputs of two stranders were required to supply one extruder, made it impossible to achieve this objective in all cases.

Capacitance deviations from the desired nominal resulted from a variety of causes, such as inaccurate control of the temperature of the water in the core-cooling troughs and improper adjustment of the control apparatus. To minimize the reflection which would result from joining two lengths of core of widely different capacitances, cores were not joined together if their measured a.c. capacitances differed by more than 0.3 per cent. When such capacitance differences did exist, the core length involved was removed from its normal sequence and placed in a position near the middle of the repeater section.

Because the taping and armouring processes were combined in one production line in the American factory, no other electrical measurements could be made on the components of the cable until it was completely armoured. In the British factory, tests for information purposes only were made on the cable at the coaxial stage. These included measurements of attenuation, internal impedance irregularities and terminal impedances. They served as a means for evaluating the changes in the electrical performance during armouring.

The insulation resistance requirement after armouring and storage under water for at least 24 hours was 100,000 megohm-miles. In addition, the cable had to withstand 50 kV for a period of 1 min without failure.

ATTENUATION MEASUREMENTS

As an aid in achieving the desired uniformity of product, new measuring equipment of improved accuracy was provided. A block schematic diagram of this equipment is shown in Fig. 10. The requirements for this equipment were

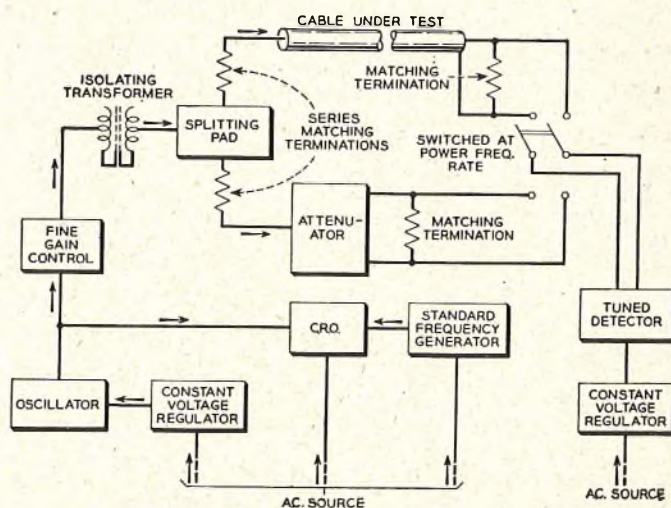

FIG. 10.—SIMPLIFIED BLOCK SCHEMATIC DIAGRAM OF CABLE ATTENUATION MEASURING SET.

that it should be capable of measuring a 37-44-mile section of cable with an absolute accuracy of 0.04 dB and a precision of 0.01 dB in the frequency range of 1-250 kc/s.

The attenuation of the cable was measured at 10-kc/s intervals from 10-210 kc/s and measured values were corrected to 37°F, using the changes in attenuation due to temperature, shown in Fig. 11. By comparing the

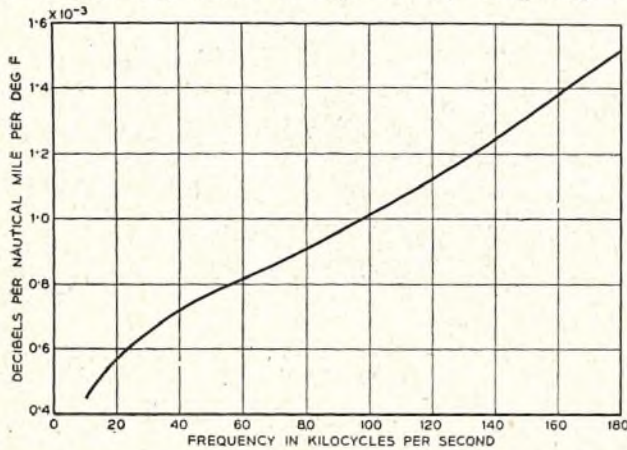

FIG. 11.—CHANGE IN CABLE ATTENUATION DUE TO TEMPERATURE, AS A FUNCTION OF FREQUENCY.

corrected values with the design characteristic shown in Fig. 12, the deviations were determined. Both the attenuation characteristic and the changes in attenuation due to

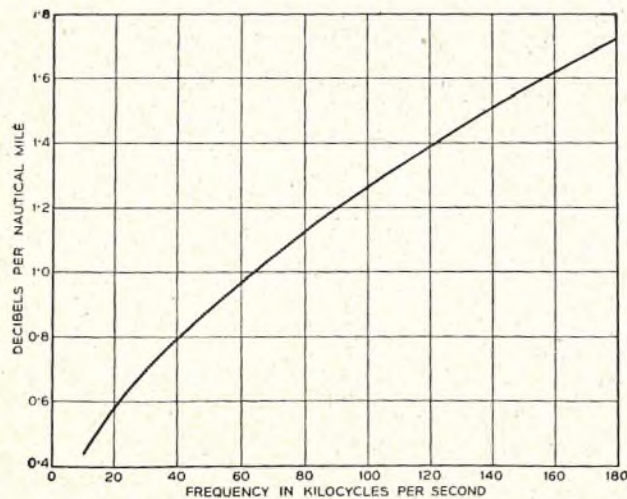

FIG. 12.—DESIGN CHARACTERISTIC OF CABLE ATTENUATION AS A FUNCTION OF FREQUENCY FOR 37°F AND ATMOSPHERIC PRESSURE.

temperature were derived from factory measurements of attenuation made on the Florida-Puerto Rico cable.

By comparing the running average and spread of these deviations with the design requirements, it was possible to assess the performance of the cable and, if required, to make any necessary adjustments in parameters for subsequent sections. In addition, these deviations were used to determine the length adjustment required for each repeater section to keep the sum of the deviations at each frequency in any one ocean block to a minimum. Typical average attenuation deviation characteristics are shown in Fig. 13.

TEMPERATURE AND PRESSURE COEFFICIENTS

Measurements of primary constants were made on 20-ft lengths of cable and core placed in a temperature- and pressure-controlled tank. These measurements were used

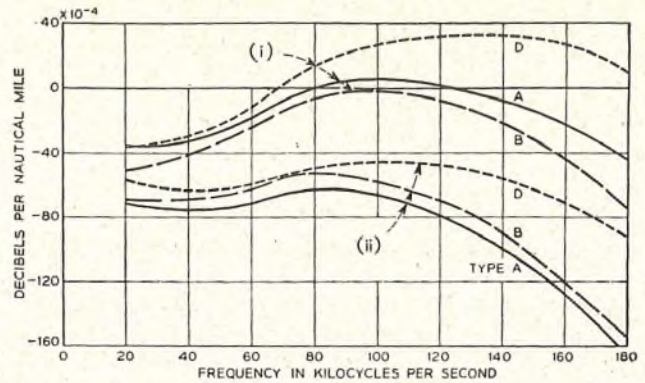

Typical Average Values for Types A, B and D for 37°F and Atmospheric Pressure.
(i) American manufacture. (ii) British manufacture.

FIG. 13.—DEVIATION OF MEASURED CABLE ATTENUATION FROM THE DESIGN CHARACTERISTIC, AS A FUNCTION OF FREQUENCY.

to compute the temperature coefficients of attenuation in order to check the values derived from measurements made on the Florida-Puerto Rico cable section. Additional attenuation measurements were made on several repeater section lengths of cable over a range of temperature from approximately 40°-70°F, to establish further the magnitude of the changes in attenuation with temperature. The measurements indicated that the derived temperature coefficients were accurate to within ± 10 per cent.

Measurements were also made to determine the effect of pressure on the primary constants of the cable. These measurements indicated that capacitance was the only parameter affected by pressure. This capacitance increased linearly 0.1 per cent for each 500 lb/in² of applied pressure. Since the attenuation coefficient, α , is inversely proportional to the impedance, it is evident that, if C is the only parameter affected by pressure, α will also be affected by pressure to an amount equal to approximately one-half the pressure effect on C . The pressure coefficient of α was therefore established as 0.05 per cent per 500 lb/in².

LAYING EFFECT

Analysis of the Florida-Puerto Rico cable data indicated that the measured ocean-bottom attenuation was less than predicted from factory measurements. The differences were large enough to warrant study and indicated that the measurements were in doubt, or sea-bottom conditions were not known accurately, or some unexplained phenomenon was taking place.

In March, 1955, approximately 22 miles of cable of the transatlantic design were laid in 300 fathoms of water off the coast of Spain in the Bay of Cadiz, and another equivalent length was laid in 2,300 fathoms off Casablanca. Precise measurements of attenuation were made in both cases, and it was established that a difference did in fact exist between measured values of attenuation at the ocean bottom and values predicted from factory measurements. It was further established that the difference in 2,300 fathoms was about twice that in 300 fathoms. The measured differences are shown in Fig. 14.

It was established during these trials that the difference should increase slightly with time. Measurements made on the cable in 300 fathoms immediately, and 18 hours, 48 hours and 86 hours after laying indicated that measurable changes in attenuation were taking place. However, the change between 48 and 86 hours was so small that it was concluded that only very small changes would occur in a moderate interval of time. The tests also indicated that the attenuation of the two lengths of cable decreased somewhat during loading of the cable ship.

The total difference between the attenuation at the ocean bottom and the values predicted from factory measurements,

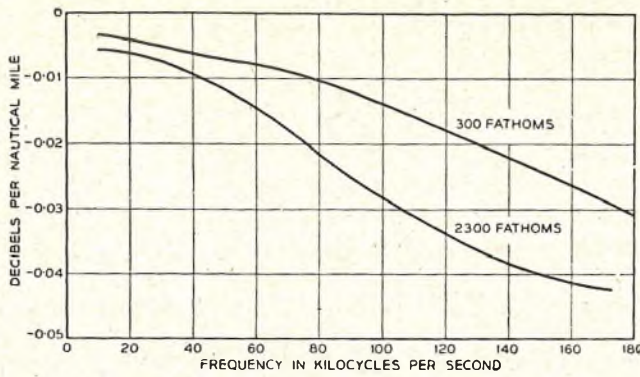

FIG. 14.—LAYING EFFECT OR DEVIATION OF MEASURED ATTENUATION FROM PREDICTED ATTENUATION, AS A FUNCTION OF FREQUENCY, AS OBSERVED IN GIBRALTAR TRIALS.

taking the temperature and pressure coefficients into account, was designated "laying effect." Various theories, such as the consolidation of the central conductor, consolidation of return structure, and changes in the dielectric material have been advanced to explain these differences. Each of these has been under study, but at the time of writing this article, no conclusive explanation has been established.

The shape of the laying-effect/frequency characteristic was such that the adjustment of repeater section lengths in conjunction with several fixed equalizers, which had approximately 4 dB loss at 160 kc/s and 0.6 dB loss at 100 kc/s, would provide a good system characteristic. The subject of equalization is covered in greater detail elsewhere.⁴ The magnitude of the laying effect observed during the laying of the two transatlantic cables substantiated the trial results.

PULSE ECHO MEASUREMENTS

Process controls, such as the use of a capacitance monitor and the jointing of the core in manufacturing sequence, provided the means for controlling the magnitude of reflections due to impedance mismatches. However, to ensure that the final product met these requirements, measurements of terminal impedance and internal irregularities were made using pulse equipment.

A block schematic diagram of the circuit of the echo set is shown in Fig. 15. For the submarine cable tests, a $1.5 \mu\text{s}$ raised cosine pulse was used, and the impedance of the

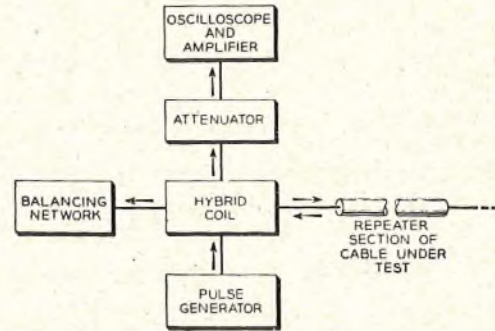

FIG. 15.—SIMPLIFIED BLOCK SCHEMATIC DIAGRAM OF PULSE ECHO SET FOR MEASUREMENT OF TERMINAL IMPEDANCE AND INTERNAL IMPEDANCE IRREGULARITIES.

balancing network was calibrated at 165 kc/s. The 165 kc/s impedance of the repeater sections was maintained well within a range of 54.8 ± 1 ohm. The internal irregularities at the point of the irregularity were maintained at least 50 dB below the magnitude of the measuring pulse. The requirement was 45 dB.

ACKNOWLEDGMENTS

The authors wish to acknowledge the many contributions made by the members of the staff of the Simplex Wire & Cable Co., Submarine Cables, Ltd., the British Post Office, and the Bell Telephone Laboratories groups involved during the course of the design and manufacture of the transatlantic cable.

References.

- ¹ MOTTRAM, E. J., HALSEY, R. J., EMLING, J. W. and GRIFFITH, R. G. Transatlantic Telephone Cable System-Planning and Overall Performance. (In this issue of the *P.O.E.E.J.*)
- ² GILBERT, J. J. A Submarine Telephone Cable with Submerged Repeaters. *Bell System Technical Journal*, Vol. 30, p. 65, 1951.
- ³ HAURY, P. T. and ILGENFRITZ, L. M. Air Force Submarine Cable System. *Bell Laboratories Record*, Vol. 34, p. 321, Sept. 1956.
- ⁴ LEWIS, H. A., FRASER, J. M., LOVELL, G. H., and TUCKER, R. S. System Design for the North Atlantic Link. (In this issue of the *P.O.E.E.J.*)

The Use of Polythene in Submarine Cables

J. C. SWALLOW†

U.D.C. 621.315.616.96:621.315.28

THE DISCOVERY OF POLYTHENE

THERE was no hint in the circumstances in which polythene was discovered either of its remarkable combination of properties or of the uses to which it would eventually be put, least of all in connexion with submarine cables. It was known in the late 19th century that low-molecular-weight polymers‡ of ethylene—oils and greases—could be obtained, but it was not until 1933 that a solid high-molecular-weight polymer was made, and then accidentally. The experiment that led to this result was one in a long-term program started in 1931 in the Research Laboratories of the Alkali Division of Imperial Chemical Industries, Ltd., with the object of investigating the effect on chemical reactions of very high pressures. The full story of this discovery, and the part played in it by chance as well as by human direction and imaginative thought, has been told by M. W. Perrin.¹

The first quantity of polythene made by intent, about 8 grams, was produced in December, 1935, by which time improvements in technique, equipment and layout had removed some of the dangers associated with earlier experiments and had also greatly speeded up the work. A large number of experiments was carried out during the first part of 1936 to establish the conditions under which solid polymers of ethylene could be made and to provide enough of the polymer to determine its properties. In a very short time it was apparent that these properties were certainly of considerable scientific interest. It was by X-ray methods that the crystalline character of the polymer was established and its molecular structure elucidated in some detail.² It did not melt in boiling water but its crystalline texture vanished completely between 110° and 120°C, as seen in the microscope using polarized light. It was chemically inert, had a density of about 0.92 and was essentially non-polar, as was shown by its dielectric properties, despite the inadequate purity of early samples. All these properties were consistent with the purely hydrocarbon structure to be expected from its mode of preparation. Its essentially polymeric nature was also shown by the way in which crude films and threads could be formed which, on stretching, showed the phenomenon of "cold drawing," i.e., of elongation by several hundred per cent under more or less constant load. This behaviour had been described as typical of high-molecular-weight crystalline linear polymers by W. H. Carothers, whose brilliant work in this field has been the subject of a series of publications from the Research Laboratories of the du Pont Co.³

Already in 1936 it was recognized within the team responsible for the development of polythene that they had discovered a substance which should have important commercial potentialities, but what these would be was very much a matter for guesswork. The material appeared to be fairly easy to mould, and was remarkably flexible even at sub-zero temperatures; its dielectric properties were also promising. However, real progress had to await the construction of semi-technical facilities capable of producing the polymer in pound lots, and later on the hundredweight scale, for practical evaluation.

THE RECOGNITION OF POLYTHENE AS THE IDEAL DIELECTRIC FOR SUBMARINE CABLES

This was the position then early in 1938 before more than a few pounds of polythene had been made. At just about that time the similarities between the properties of polythene and those of gutta-percha were noticed by two men,

one within the Company and the other outside. Mr. B. J. Habgood, who had recently joined the staff of I.C.I. (Dyestuffs Division), had had first-hand knowledge of the cable industry, and the similarities struck him quite forcibly. Likewise Mr. J. N. Dean, of the Telegraph Construction & Maintenance Co., who had had many years of experience in the production of submarine cables, noticed the announcement by I.C.I. of the discovery of polythene and appreciated that it might have potentialities as a submarine cable dielectric.

The submarine cable industry had been built up around gutta-percha, a natural product obtained from the bark of certain tropical trees and first introduced into this country about 1845. It had been quickly recognized as a useful material, and, in fact, the first submarine telegraph cable was laid across the English Channel in 1850. Gutta-percha had a most fortunate combination of properties, which met the technical requirements of the time without over-straining the technological facilities. It was tough and flexible, and in a reasonably pure form had adequate stability to oxidation in sea water, though it was rather poor in air. It was crystalline, with a melting point of about 62°C, which made the making of joints a comparatively easy operation even at sea. When molten it was quite easy to handle in the extrusion equipment available. Its electrical properties were quite adequate for telegraphy, although, as time went on and higher-frequency techniques were developed, the makers of submarine cables realized the need for an improved dielectric with a much lower power factor and permittivity than those of gutta-percha. Progress was by modification and the next step was the development by the Bell Telephone Co. of para-gutta, this being a mixture of gutta-percha, deproteinized rubber and paraffin wax, which went some way to meet the required improvements. A high-frequency cable using this material was laid across the Bass Straits.

It was at this stage of technical development that polythene came into the picture. It had certain obvious disadvantages in that its high melting point would lead to difficulties in the jointing of cables, and when molten it was so viscous that it could only be handled with great difficulty on the extrusion equipment available. Furthermore, the electrical properties of early samples were comparable only with those of para-gutta, but nevertheless it was soon realized that if polar impurities could be removed, its power factor should be comparable rather with that of paraffin wax. Events moved rapidly and by the end of 1938 the Telegraph Construction & Maintenance Co. had requested 100 tons of polythene for delivery by the middle of 1939; in July 1939 the first extrusion of submarine coaxial cable core was made.

The advent of the war altered the trend of development in that polythene became the necessary hand-maiden to the development of radar, but towards the end of the war submarine cables using polythene were used across the English Channel for military purposes.

After the war the Post Office, particularly Mr. R. M. Chamney, who was then in charge of the Transmission and Main Lines Branch, took a keen interest in the development, and in collaboration with Submarine Cables, Ltd., produced a design incorporating an air-spaced polythene insulation. A trial cable to the Isle of Wight was followed by the Anglo-

† Mr. Swallow is with Imperial Chemical Industries, Ltd.

‡ Polymers—large molecules made up of a great number of smaller ones (usually all identical) joined together; the numbers involved may be many thousands.

Dutch cable (1947) and the Anglo-Belgian cable (1948). These are, however, very large and expensive cables and the development of submarine repeaters has made a smaller solid-polythene type of cable a more economical proposition.

THE PROPERTIES OF POLYTHENE OF IMPORTANCE FOR CABLE APPLICATIONS

Good dielectric properties, toughness, chemical inertness and flexibility over a wide temperature range were properties which obviously commended polythene for cable applications. The development of polythenes of different types was conditioned by a variety of circumstances, some of which were in a sense accidental. Thus the extrusion equipment which was available in the early days had not been designed for handling polythene, and in some respects it was easier to modify the polymer to fit the equipment than vice versa. One such modification was the incorporation of a minor proportion of polyisobutylene of molecular weight about 100,000. The rubbery polyisobutylene, being a hydrocarbon, had good electrical properties and did not appreciably affect the dielectric properties of the final composition. It did, however, ease the manipulation problems and also improved slightly the low-temperature behaviour of the polythenes in use at that time.

The limitations imposed by the use of fabrication equipment designed for other purposes rapidly diminished in the years after the war. The state has now been reached where, for most purposes, it can be said that the user is able to specify what type of polythene he requires and have confidence in the capabilities of commercial fabricators to produce the polythene in the required form. In general, additives are not used in large amounts with polythene. Small quantities of anti-oxidants are nowadays always incorporated in order to protect the polymer from oxidation during the processes of fabrication and subsequently while in use, but the amounts are very small, much less than 1 per cent, and they can be ignored when considering the physical properties of the polymer. Photo-oxidation may be troublesome in certain applications; it is most satisfactorily inhibited by incorporating a small percentage of carbon black as a "screen," but this is not a problem in submarine cables.

Polyisobutylene is no longer used for the reasons which prompted the original development of compositions based on it. The high-molecular-weight polythenes that can now be made and fabricated are flexible down to temperatures lower than can be obtained with polyisobutylene-polythene compositions. These high-molecular-weight polythenes, such as are made in Great Britain, are also highly resistant to the phenomenon of "environmental cracking" which was at one time somewhat troublesome. This term "environmental cracking" was coined to describe the type of brittle failure which occurred when polythene was stressed in the presence of polar liquids.⁴ The liquids that cause the trouble are not solvents for polythene and they are active only when the polythene with which they are in contact is under biaxial stress, but this is, of course, always the case when cables are bent. Polythenes of low molecular weight are particularly susceptible to environmental cracking, but it was found that their performance could be greatly improved by the addition of some 5 per cent of polyisobutylene or butyl rubber. In fact, the specification for the polythene used in the transatlantic telephone cable called for the addition of 5 per cent of butyl rubber, and this was added to the British polythene although technically it was not necessary; the polythene used had the low Melt Flow Index of 0.3 and specimens made from it showed no signs of failure even after four months in the standard environmental cracking test. (The conditions of this test are, of course, enormously more severe than any that would be encountered by a cable in use.)

The dielectric properties of polythenes have been extensively studied in the past 15 years. Experimentally, it is found that the permittivity is very closely equal to the square of the refractive index; in other words, the polarization in the polymer is almost entirely electronic. The value of the permittivity at 25°C is 2.29.⁵ The variation of permittivity with temperature has been measured by Shackleton,⁶ and he found that it fell by about 5 per cent between -60°C and +90°C. This variation is adequately accounted for by the change in density, although the data are not sufficiently precise to be certain that this is the sole effect. The frequency dependence of permittivity is so small as to be of no practical importance, which is consistent with its non-polar structure and the observed near equality between the value of the permittivity and the square of the refractive index.

The dependence of permittivity on pressure is a property of some interest in submarine cable design, and has been investigated by D. W. McCall of the Bell Telephone Laboratories. He found experimentally the pressure coefficient of permittivity to be 2.3×10^{-5} /atmosphere for pressures up to a few hundred atmospheres, which at the present stage of cable design and operation is too small to be significant. Finally, a most important factor is the effect of water on dielectric properties, since water can never be completely excluded from a submarine cable. Fortunately it is found that, although water may be present in pure polythene up to a concentration of 0.04 per cent, its effect on dielectric properties is negligible.⁷

From the non-polar nature of polythene and the fact that its permittivity exhibits no dispersion with frequency one would expect polythene to show no dielectric loss. In fact the measured values of dielectric loss ($\tan \delta$) are very low, and on the limit of sensitivity of ordinary measuring equipment; the order of magnitude of $\tan \delta$ is 10^{-4} . It is almost certain that these small residual dielectric losses are due to trace amounts of polar groups in the polymer arising from impurities, catalyst fragments, and such small amounts of additives as may be present. For practical purposes, the dielectric losses of polythene may be considered independent of frequency, although refined measurements show that they do rise sluggishly with increase in frequency to a maximum at about 10^9 c/s at room temperature;⁸ similarly the losses rise somewhat with temperature. If the polythene is allowed to oxidize, the level of dielectric losses can rise drastically. It is therefore of the greatest importance in the manufacture of cables that the polythene used should be initially free from polar impurities, should be properly stabilized against oxidation and should be fabricated under carefully controlled conditions.

The mechanical properties of polythene are, of course, also of importance, although some are more relevant than others; for instance, the actual tensile strength is not very critical. In a cable the polythene does not take any of the load, but it is important that it should deform with the cable reversibly and without showing any signs of mechanical failure. The polythene must also be dimensionally stable for an indefinite period of time under any conditions under which the cable may operate. To these requirements may be added that of immunity from "environmental cracking," the circumstances of which have already been described. All these desiderata can now be met with confidence, although the results of quantitative studies of some of these relevant mechanical properties are surprisingly scanty. Thus, the only quantitative data published on long-term creep in tension are those of Gohn, Cummings and Ellis;⁹ these experiments were carried out at 30°C and extended over two years. The creep curves had a typical form: they showed a fairly rapid and substantial initial extension, followed by a slow extension at a gradually decreasing rate. For strains not exceeding about 5 per cent, i.e.,

stresses up to 400 lb/in², the recovery observed on removal of the load was almost complete, and interrupted loading had little effect on the creep behaviour. The stress-relaxation and strain-recovery behaviour to be inferred from these results is important to cable design considerations. Creep in compression has also been rather scantily studied, but semi-quantitative work in the United Kingdom by W. G. Oakes[‡] and in the U.S.A.¹⁰ indicates that polythene behaves in compression in much the same way as in tension.

It has been suggested that polythene rather more transparent than that in general use would have advantages in cables, since it would permit the visual detection of foreign matter and the cable could be inspected continuously in front of a bright light. Opinion differs on the value of this technique but it is probable that more use of it will be made in the future.

THE ACHIEVEMENT OF POLYTHENE

Twenty years ago polythene was a research curiosity, made in gram lots under reaction conditions of temperature and pressure unheard of on the industrial scale. A mere 10 years later the making of the Anglo-Dutch submarine cable marked the greatest technical advance in submarine cable design and performance since the introduction of gutta-percha some 90 years before. This was an entirely British development, and a striking example of co-operation between two industries, the chemical industry and the cable industry. The achievement of dependable multi-channel telephone communication over unlimited distances was in sight. That goal has essentially been achieved in the transatlantic telephone cable, after a further 10 years of development. These 10 years have seen the world-wide recognition of the unique position of polythene in submarine cables, and also the participation of other countries in advances in design, fabrication and in the development of devices such as submarine repeaters. Some idea of the progress made is given by the list, in Table I, of major

[‡] Imperial Chemical Industries, Ltd., Alkali Division.

TABLE I
Polythene Insulated Submarine Telephone Cables

Date	Termini	Length (nautical miles)
1945	England-France (Military Cable)	—
1946	England-Germany (Military Cable)	200
1947	England-Holland	85
1948	England-Belgium	47
1950	Holland-Denmark	142
1950	Florida (Key West)-Havana	125
1954	Scotland-Norway	300
1954	Florida-Caribbean Islands	1,000
1956	Scotland-Newfoundland	1,950

cable projects. For the future, we can look forward confidently to the establishment of an ocean-wide network of cables for multi-channel telephony.

References.

- ¹ PERRIN, M. W. The Story of Polythene. *Research*. Vol. 6, p. 111, 1953.
- ² BUNN, C. W. The Crystal Structure of Long-Chain Normal Paraffin Hydrocarbons. *Transactions of the Faraday Society*. Vol. 35, p. 482, 1939.
- ³ CAROTHERS, W. H. Collected Papers on Polymerisation. Vol. I of *High Polymers, Interscience*, 1940.
- ⁴ WALLDER, V. T. Polyethylene for Wire and Cable. *American I.E.E., Symposium on Polyethylene*, July 1952.
- ⁵ SMITH, ESMOND WASSELL. Polythene as a High-Frequency Dielectric. *Journal I.E.E.*, Vol. 92, Part III, p. 32, 1945.
- ⁶ SHACKLETON, J. W. General Characteristics of Polyethylene. *Transactions of the American I.E.E.*, Vol. 64, p. 912, 1945.
- ⁷ JACKSON, WILLIS, and FORSYTH, J. S. A. Polythene as a High-Frequency Dielectric. *Journal I.E.E.*, Vol. 92, Part III, p. 23, 1945.
- ⁸ OAKES, W. G., and POWLES, J. G. Dielectric Behaviour of Polythene at Very High Frequencies. *Nature*, Vol. 157, p. 840, 1946.
- ⁹ GOHN, G. R., CUMMINGS, J. D., and ELLIS, W. C. *Proceedings of the American Society for Testing Materials*, Vol. 49, p. 1139, 1949.
- ¹⁰ DEL MAR, W. A., and MERRELL, E. J. Polyethylene for Power Cables. *American I.E.E., Symposium on Polyethylene*. July 1952.

Manufacture of Submarine Cable at Ocean Works, Erith

F. MATTINGLEY, B.Sc., A.R.I.C.†

U.D.C. 677.73:621.315.28

The greater part of the submarine cable for the transatlantic telephone cable project was manufactured at a new cable factory, Ocean Works, at Erith, Kent. This article describes the construction of Ocean Works, the manufacture of the cable and the special testing arrangements necessary during manufacture. The splicing into the cable of flexible repeaters, made in U.S.A. and flown to England, is also described together with the special arrangements necessary at Ocean Works for storage of the cable and repeaters and for loading the repeated cable into H.M.T.S. "Monarch."

INTRODUCTION

WHEN the decision to proceed with the transatlantic telephone cable project was taken in 1952, many shorter submarine telephone cables had been manufactured, but it was quickly realized that manufacture of submarine cable in the quantity and with the precision required for the transatlantic project would necessitate the building of a new factory. Thus, when the contract for the greater part (92 per cent) of the transatlantic cable was entrusted to Submarine Cables, Ltd. (owned jointly by Siemens Brothers & Co., Ltd., and The Telegraph Construction & Maintenance Co., Ltd.), the Company had already acquired a site on the River Thames at Erith, Kent, and begun to lay out a completely new plant on the most up-to-date lines. The building of this new factory, "Ocean Works," entailed a vast amount of engineering design, construction and installation work in a very short space of time. The first machine was ready for installation in March, 1954, and by November of that year the factory was sufficiently far advanced for the manufacture of a short length of transatlantic telephone type cable to be demonstrated on 26th November, 1954, the occasion of the official opening by the Postmaster-General—the Earl de la Warr.

Full-scale production commenced in February, 1955. From then onwards work went on by day and by night, Saturdays, Sundays and public holidays included, until some 1,287 nautical miles (n.m.) had been produced. This was the length required to enable H.M.T.S. *Monarch* to sail

for Clarenville on 30th July, 1955, nine days ahead of schedule, to begin the first of the deep-sea lays from the edge of the American continental shelf eastwards to Rockall.

In all some 1,728 n.m. of deep-sea and shore-end cable were produced in time for the 1955 summer shipments.

With scarcely a break in production save that necessary for the overhaul and maintenance of essential machinery, cable manufacture was continued at almost the same rate during the autumn of 1955 and spring of 1956, in order that the second cable would be ready for the *Monarch's* laying programme during the summer.

In addition to the engineering difficulties which had to be surmounted, there were many problems in connexion with the supply of materials. The extremely exacting specifications demanded a hitherto undreamed of precision in the production of copper wire and tapes—to mention only one commodity. It was necessary to make inquiries all over the world to find a suitable source of supply, but after several had been examined and rejected it was decided that the only way to ensure satisfactory supplies was for the Telegraph Construction & Maintenance Co., one of the parent companies of Submarine Cables, Ltd., to install their own rolling plant and develop their own technique. With the help of Richard Johnson & Nephew, Ltd., of Manchester, who also re-equipped their factory similarly, supplies of wire and tape were maintained and the specification requirements were satisfactorily met.

† The author is with Submarine Cables, Ltd.

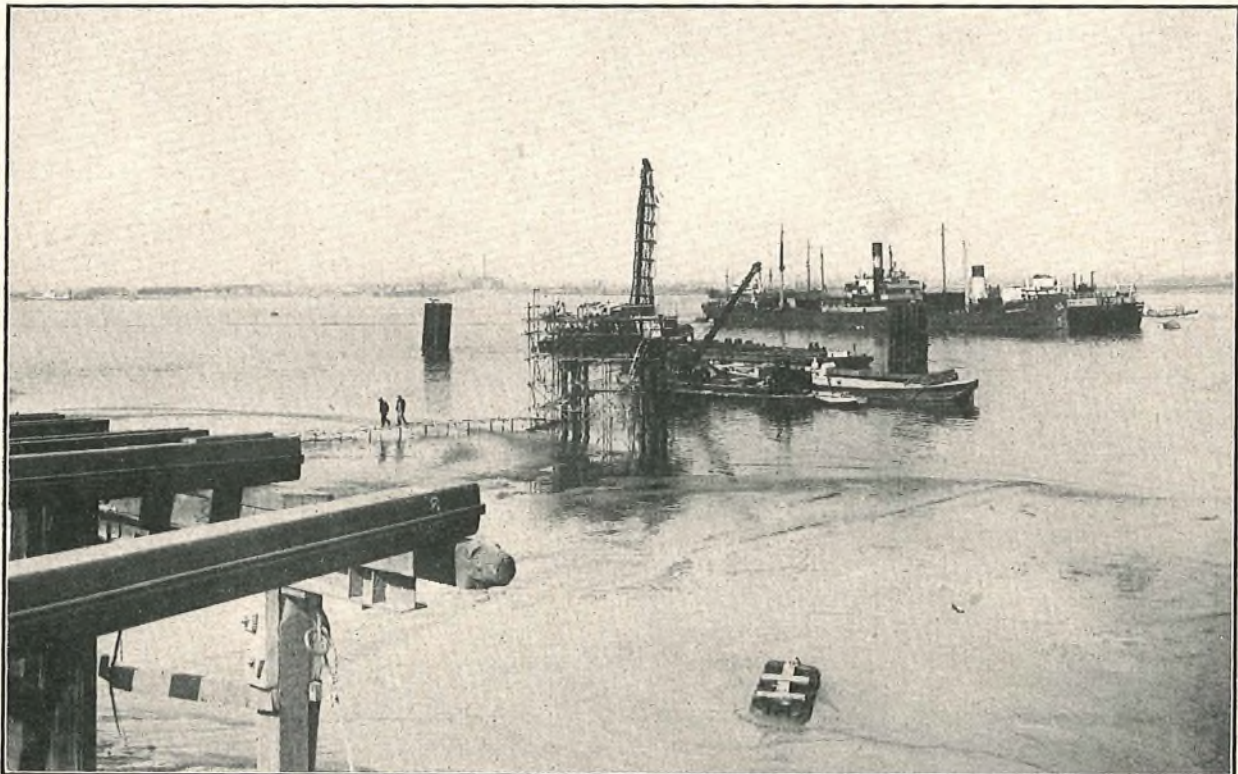

FIG. 1.—VIEW FROM THE SITE, SHOWING NATURE OF FORESHORE ON WHICH THE TANK HOUSE WAS BUILT.

OCEAN WORKS

The factory site at Erith has a river frontage to the Thames of 300 ft. It comprises buildings of an area of rather more than 100,000 ft² divided into 10 bays 35 ft wide by 250 to 300 ft long.

The design of much of the machinery was based on existing machinery which the Company already possessed, with suitable, and often extensive, modifications to meet the exacting requirements of the cable specification.

Twelve cable-storage tanks, each of welded steel construction, 30 ft in diameter and 25 ft high, provide storage for 2,400 n.m. of finished cable. Storage capacity and handling equipment were also provided for 66 repeaters, and in order to obtain accurate test results the temperature of the cable and repeaters had to be maintained within $\pm 1^\circ\text{F}$. This was achieved by a water-circulating system and by housing the tanks in a building 80 ft wide and 200 ft long. The planning and construction of this last project was not helped by the fact that the tank house had to be sited on soft mud 48 ft deep (Fig. 1); to support the tanks and the building (Fig. 2), 480 piles had to be driven

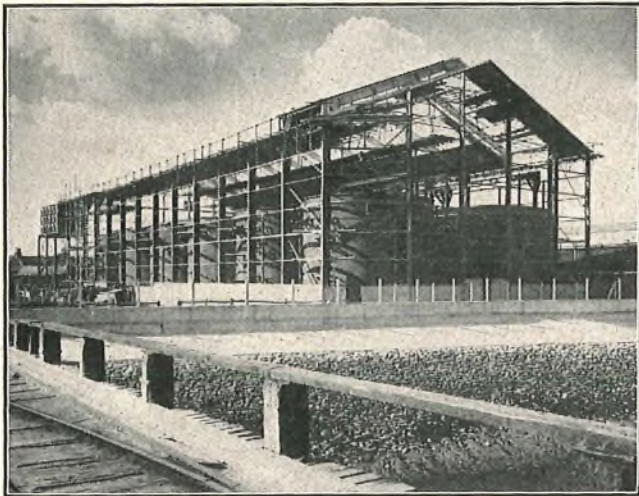

FIG. 2.—THE TANK HOUSE UNDER CONSTRUCTION.

and capped with a reinforced concrete slab. However, by running the planning, design, construction and erection concurrently, tanks were made available to store cable only eight months after the land was occupied.

A berth had to be provided to accommodate H.M.T.S. *Monarch*; it had to be accessible from the main navigable channel of the River Thames and was built some 400 ft off shore. About 250,000 tons of mud and ballast were dredged in four months to form a basin 29 ft below mean low-water spring tides. Three steel-piled flexible breasting dolphins, 120 ft apart, were constructed to absorb the berthing energy of the ship and provide a firm breast while the ship is moored. These dolphins were constructed from 180 tons of specially rolled high-tensile steel sections 90 ft long, driven 35 ft into the river bed. Access to the shore was provided at all stages of the tide by a causeway extending 270 ft riverwards from the wharf.

One of the most outstanding features of the factory is the method of transferring the completed cable from the armouring machines to storage tanks and thence to the cable-laying vessel. Between the armouring machines and the tank house a lattice girder bridge, 50 ft high, was constructed leading on to bridges above the two lines of tanks.

Three cables with repeaters can be transported simultaneously on routes extending 1,000 ft from the land end of the tank house to any point on the ship between the breasting dolphins, at all states of the tide and ship lading. This was made possible by the erection of two towers,

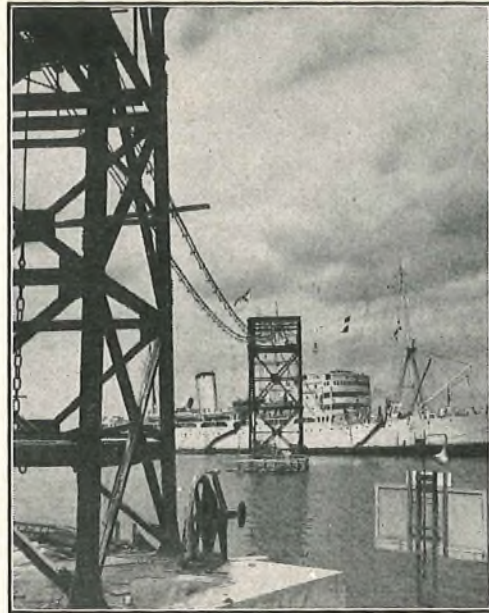

FIG. 3.—CABLE TOWERS, USED FOR LOADING CABLE INTO THE SHIP

shown in Fig. 3, one on the wharf edge and one 260 ft off shore. The cable at all times had to be 42 ft above mean high water at spring tides and it was carried by suspended wire rope spines (two of which were used for loading the cable into *Monarch*, and are shown in use in Fig. 3) from the wharf to the midstream tower and from there to the loading point on the ship. The wharf-edge tower also supports a 200-ft span bridge from the tank house passing over a public footpath, the river flood-defence wall, wharf, foreshore and factory buildings. In the tower itself there is a triple-sheave cable-hauling unit and the tower is supported on 18 steel piles with a reinforced concrete head weighing 250 tons, which was laid in only 48 hours.

The mid-stream tower is 75 ft high and at the top carries anchor points for the six spans and a working platform with handling equipment to transfer cable and repeaters from the inner to the outer spans. The whole tower rests on a 175-ton reinforced concrete head standing on 104-ft steel piles.

The whole of this engineering work was completed in five months and ahead of schedule in spite of all difficulties. The structures were designed, fabricated and erected in three months, actual erection taking 70 days, and the 200-ft span wharf bridge, weighing 130 tons, was in full operational use 14 days after the start of its erection.

MAKING THE CABLE

The cable consists of a polythene-insulated inner copper conductor surrounded by copper tapes forming the outer conductor of the coaxial pair. This core is provided with protective coverings in the form of a layer of jute, acting as a bedding for the steel armour wires, which are helically applied and, finally, an overall serving of tarred jute.

The dimensions of the cables and their components are given in the appendix.

The very exacting specification provided by the Bell Telephone Laboratories, made necessary by the extreme uniformity of electrical characteristics required in the finished cable, necessitated the imposition of very close tolerances on the dimensions of all component parts at all stages of manufacture. The maintenance of this high standard of precision in manufacture was made possible by close supervision throughout and by a comprehensive system of inspection both by the Company's own inspec-

torate and by teams of Post Office and Bell Telephone Laboratories' engineers working in collaboration.

The Central Conductor.

The central conductor was manufactured almost entirely from copper wire and tape produced in the Greenwich factory of the Telegraph Construction & Maintenance Co., Ltd., with a precision never before attempted in the history of copper wire drawing and rolling.

The twisting of the three copper tapes around the central copper wire was carried out in a specially designed and constructed shop,‡ totally enclosed and fed with filtered and conditioned air from a small Plenum plant. Each operative was provided with white overalls and gloves so that the conductor was never touched by bare hands. These extreme precautions to eliminate any form of contamination were rendered necessary by the requirements of the extrusion process which followed.

Insulation of the Central Conductor.

The polythene compound was also prepared in an enclosed, air-conditioned room (Fig. 4). Weighed quantities

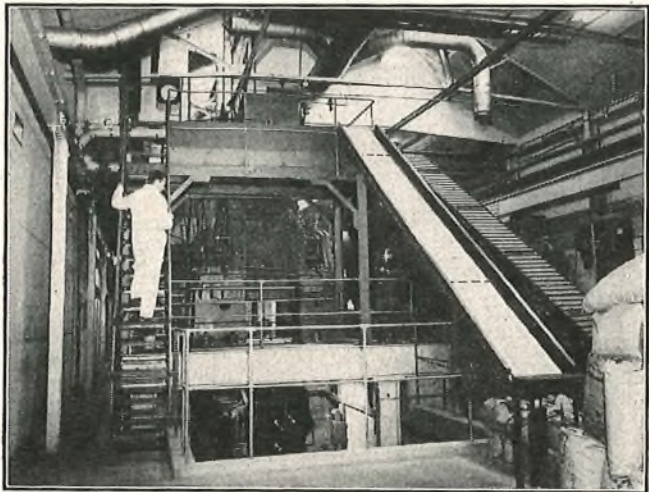

FIG. 4.—POLYTHENE MIXING PLANT.

of the components were introduced into the mixer and the plastic compound extruded hot, in strips 8 in. \times 0.125 in. which were subsequently cooled and cut into $\frac{1}{8}$ -in. cubes. These cubes of compound were conveyed into storage and mixing silos by means of an air blast. Before introduction into the extrusion machine the compound was cold blended, or homogenized. A quantity of about 5 tons was circulated continuously from one silo to another, the amount required to feed the extrusion machines being withdrawn and replaced by an equivalent amount from the storage silos. In this way any slight variation in characteristics that might have been present in the different batches from the mixer were minimized. Finally, the compound passed through a separator which automatically rejected any material contaminated with metal.

The extrusion machine (Fig. 5) was automatically controlled by a series of monitoring devices that recorded and maintained, within the prescribed limits, the diameter of the extruded core, and also ensured that the resultant electrical characteristics of the core were uniform throughout each drum length and from length to length.

A device was also included that indicated and recorded graphically the concentricity of the conductor. Continuous records were maintained of the temperature at various

‡A photograph of the shop is given in Fig. 3 of the paper "Cable Design and Manufacture for the Transatlantic Submarine Cable System" in this issue of the Journal.

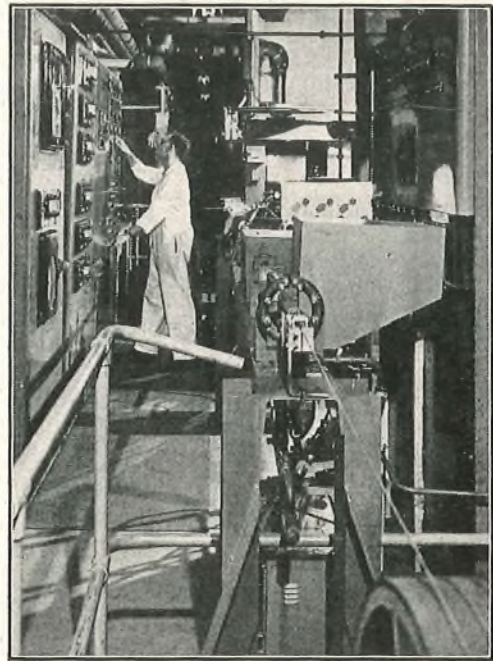

FIG. 5.—EXTRUSION MACHINE.

points in the extruder, the tension in the conductor, and the core diameter at three different positions along the length of the machine, all of which enabled the operator to pin-point any irregularity or abnormal behaviour in any part of the machine.

A feature of the core extrusion which had not hitherto been experienced on large-scale production such as this was the hard grade of polythene specified. In the early stages a considerable amount of experimental and research work was necessary before the conditions of extrusion suitable for the production of core to specification requirements were determined.

One of the most important features in the production of a cable such as this is the examination, testing and jointing of the insulated core. Immediately after extrusion of the insulant, every inch of the core was therefore examined by hand so that any visible or otherwise detectable foreign matter or defect of any kind could be observed and remedial action taken. The dimensions of the core were carefully checked by means of a ring gauge and micrometer measurements were taken at frequent intervals.

After examination the core was coiled into shallow pans which were subsequently filled with de-aerated water, kept at a constant temperature, for electrical testing. In order to reveal any hidden defect which might otherwise escape detection, the insulation was subjected to a d.c. potential of 90 kV for 1 min.

Jointing the Core.

The lengths of core that successfully passed examination and electrical testing were joined together to form a repeater section length of approximately 37.5 n.m.

Jointing of the core was carried out by means of a small injection moulding machine. The two ends of the conductor were brazed together and then the insulation was restored to its normal diameter, by injecting hot polythene compound around the jointed conductor. The completed joint was then examined visually for defects of any kind, its dimensions were accurately checked, and it was photographed in three directions by means of X-rays. Finally the joint was subjected to a d.c. potential of 120 kV for 5 min.

The training of suitable operatives for this exacting work of core jointing in the short time available was a task of

some magnitude and considerable selection was necessary before a suitable team could be brought together.

Before a trainee was permitted to make a joint in actual core he had to qualify by making 10 consecutive joints, each of which had to satisfy all the requirements of the specification. After qualification he had to make one satisfactory control joint on each shift before commencing work. If at any time he made two consecutive joints which failed to pass any of the specification requirements he was considered disqualified and was required to make a further 10 consecutive joints before requalification. A similar system was adopted for the brazing of all copper elements, i.e. wire and tapes, and for the welding of steel armouring wires.

The Outer Conductor and Armouring.

The 37.5 n.m. lengths of core were copper taped (Fig. 6) in continuous lengths and served with jute and then coiled

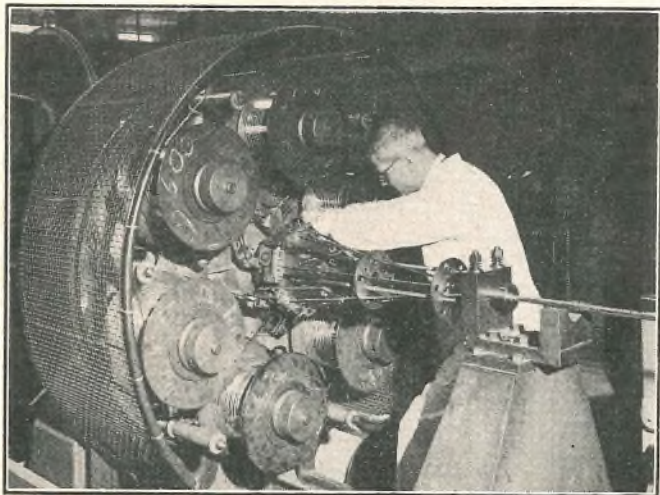

FIG. 6.—COPPER TAPING MACHINE BEING PREPARED FOR USE.

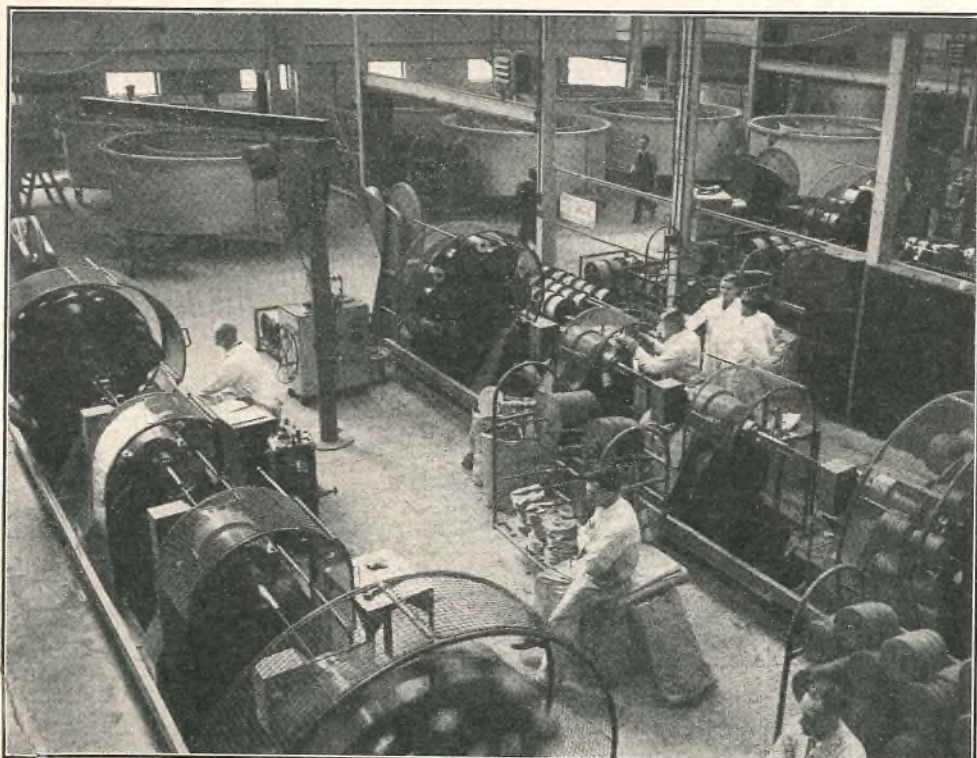

FIG. 7.—MACHINES FOR APPLYING THE COPPER RETURN TAPES AND JUTE BEDDING FOR THE ARMOURING WIRES.

in cylindrical tanks (Fig. 7) which were flooded with water for further electrical testing prior to armouring. After this test, the served core, still in 37.5-n.m. lengths, was armouring with the number of steel wires appropriate to the type of cable required. Finally, the armouring cable was coiled down into the storage tanks, each of which can hold some 200 n.m. of deep-sea cable.

Insertion of Flexible Repeaters in the Cable.

It was at this stage that the flexible repeaters were spliced into the cable. The repeaters, having been carefully unloaded from a special delivery vehicle (a modified ex-R.A.F. trailer), were uncrated and stored in shallow water-filled troughs (Fig. 8) located between the cable tanks. They were then spliced into the cable between each 37.5-n.m. section length so that continuous lengths of cable were built up into "Ocean Blocks" consisting of five repeater sections. The work of splicing in the repeaters is described in detail later. In these lengths the cable was loaded on board ship.

ELECTRICAL TESTING

In the manufacture of submarine cables it has long been the practice to make electrical measurements after every stage of manufacture. The object of these measurements is to ensure freedom from fault and uniformity of the final product and to obtain advance information on the cable's operational characteristics. The electrical specification for the transatlantic telephone cable was written with these objectives. Manufacture of the repeaters had to commence at about the same time as the cable in order to meet delivery dates, and this meant that reliance had to be placed on previously established data. In addition, part of the first cable laid between Clarenville and Oban was made in America. Thus it was necessary to obtain both closely consistent results and high absolute accuracy. Reference standards used in this country and America were calibrated at the National Physical Laboratory and the Bureau of Standards respectively. Some of the testing equipment used at Ocean Works was supplied by the Bell Telephone Laboratories.

Tests on Raw Materials.

Copper.—All copper wire and tape used in the cable was tested for resistance per unit length; the information obtained being given to the customer, the Company's inspection team and to the production department concerned. It was found in certain cases that even the stringent tolerances required by the customer were inadequate to keep within established control limits, and that internal specifications had to be drawn up to even tighter limits.

An indication of the detail required was the specification of resistance measurements on the tinned copper binding wire used in making the safety spiral at joints.

Polythene and Polythene Compound.—Both the polythene resin and polythene compound, when ready for use, were tested for permittivity and power factor.

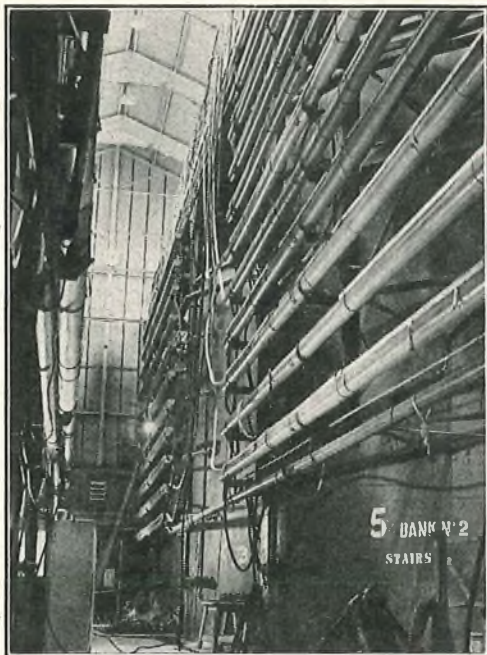

FIG. 8.—CABLE STORAGE TANKS AND THE TROUGHS CONTAINING THE FLEXIBLE REPEATERS.

The measurements were normally made using the Hartshorn and Ward dielectric testing apparatus and for this purpose large numbers of moulded disks were required. Improved equipment was later brought into use but it is too early to state what effect this will have on the control of future production.

Tests of the Central Conductor.

Samples of completed central conductor were taken from each stranding machine at the beginning and end of each run. Before the samples were cut it was necessary to solder the surrounding tapes to the central wire at the ends of the sample. These samples were tested for resistance, weight and dimensions, both of complete conductor and component parts. From an analysis of the results, it was possible to ascertain the behaviour of the forming dies and to predict when a die change would be necessary. The resistivity was calculated from the measurements to check that no measurable work-hardening of the copper had occurred.

Tests on the Core (Insulated Conductor).

For these tests the pans of core were flooded with water and measurements made of conductor resistance, capacitance and insulation resistance, after which a high-voltage test was made.

The acceptance limits for resistance and capacitance were ± 1.0 per cent and ± 0.4 per cent, respectively, but a closer capacitance tolerance was required, for matching purposes, when allocating lengths of core to a repeater section. The specification required the outputs of different extruders to be segregated into different groups, but it was found that the required degree of uniformity could be reached without the need for this grouping. The information obtained from these tests was used to help control all earlier stages of production and also in predicting the precise lengths of individual repeater sections.

Tests on Joints.

All joints in the cable were subjected to a high-voltage test of 120 kV, d.c., for 5 min. The operatives' control and qualification joints were all similarly tested, but at 200 kV, and a selected number only at 500 kV. Practically all joints

withstood this last figure, which is some 200 times greater than the maximum operating stress.

Tests on the Coaxial Pair.

When the outer conductor had been applied to the core the first transmission measurements could be made.

Measurements of insertion loss were made over the frequency range 6–200 kc/s, and the results indicated whether the section length prediction had been made accurately. The results were adjusted to sea-bottom temperature and compared with the design characteristics for purposes of quality control.

The pulse echo response was measured and photographed to provide a permanent record. The position and magnitude of the worst echoes were examined and compared with the records covering the assembly of core into the section.

Finally, a complete series of direct-current tests was made, finishing with a high-voltage test on the complete section, and then, subject to satisfactory results, the section was released for armouring.

Tests on the Armoured Cable.

After armouring, the tests made on the coaxial pair were repeated to test the cable's stability with time, and additional transmission tests were made to assess the temperature coefficient of attenuation.

Some measurements of input impedance were made on selected sections up to frequencies well beyond the transmission range used in the transatlantic system, to provide data for future cables.

Tests on Repeaters and Ocean Blocks.

The repeaters were not in this instance the responsibility of the Company, but all repeaters received at the works were energized and tested at the works by the customer, the Company providing the special test leads needed and assisting in the tests where required.

After the repeaters and cable had been spliced to form ocean blocks, transmission measurements were made. The equipment used to feed power into the cable was actually one of the spare units that was eventually installed at the Oban terminal; a special test room was allocated for this equipment.

Tests While Loading Cable into "Monarch."

While coiling the cable into the tanks on *Monarch* a continuous test voltage was applied to the cable so that if a fault of any kind had developed in any stage of the process it could have been detected and loading stopped immediately. The repeaters were energized and transmission signals fed over the cable so that the ship was in constant communication with the shore station at all times.

SPECIAL TESTING ARRANGEMENTS AND PLANT

The high order of accuracy required meant that special attention to the electrical testing arrangements was necessary. Most requirements were met by using existing methods with extensive refinement of detail but for other tests considerable elaboration of plant was needed.

Tests on Samples of Copper and Central Conductor.

The sample to be tested was tensioned between quick-release clamps, which served as current terminals, several pairs of differently shaped clamps being provided to cater for the various sizes of wire and tape. Two hardened-steel knife-edges were mounted on a base having a small coefficient of thermal expansion. The testing voltage was applied through the knife-edges, which made contact with

the sample at points spaced exactly 3 ft apart. The sample was covered with a lid which, when closed, brought an open-scale thermometer in close proximity to the sample; this scale was viewed through a window provided for that purpose.

The tests were made on a precision Kelvin bridge, and a set of 4-terminal standard resistors with National Physical Laboratory calibration and covering the range of resistances measured were kept for checking purposes. Upwards of 100 samples per day have been tested on this apparatus.

Core Testing.

The core under test was coiled in pans through which was circulated de-aerated salt water at constant temperature; the temperature of the water in the pans being measured by resistance thermometers embedded in the stack of core. For many years it had been known that air bubbles clinging to the core caused inconsistent test results and it had been the practice to treat the core with a wetting agent to assist in reducing the effect. More than two years before the contract for the transatlantic telephone cable was signed experiments were undertaken to find more efficient ways of eliminating the air. Mechanical vibration of the container was tried as well as ultrasonic vibration of the water, with only partial success. Finally the method of de-aeration now in use was recommended, although it could not be tried out until production at the new works had begun. In operation, water from a storage tank is fed to a column where it is subjected to low-temperature boiling and condensation before being fed to the pans of core. A complex heat-exchange system ensures constancy of temperature of the outgoing water and provides high thermal efficiency. The conductivity of the water is increased by adding sodium chloride until the specific gravity is approximately 1.01.

The conductor resistance was measured on a 5-dial Wheatstone bridge. To obtain the utmost accuracy possible, the bridge was checked at intervals of approximately one week against a 5-dial precision resistance-box. Both the bridge and the resistance-box have National Physical Laboratory calibrations. During the period of nearly two years that these checks were made, no significant changes in the bridge were measured.

The capacitance of the core was measured on a substitution bridge using a frequency of 21 c/s. The reason for the choice of this frequency is that a low frequency is needed to eliminate propagation effects (that is, the input admittance should not be modified by series impedance) and it was thought desirable to avoid frequencies that were submultiples of power mains frequencies in either the United Kingdom or North America (i.e. 15, 20, 25, 30 c/s, etc.). The choice of 21 c/s appears to be satisfactory although it was realized that at 21 c/s the mica capacitance standards would exhibit significant dielectric absorption and that it was thus necessary to obtain instruments especially calibrated at this frequency. A system of checking similar to that employed for resistance was used and, in addition, a standard capacitor was sent over from the Bell Telephone Laboratories as a cross-check.

During production of an earlier cable (the Aberdeen-Bergen cable) at Greenwich it had been found that the longer lengths of core appeared to be systematically higher in capacitance than shorter lengths. Calculations were made to show that this was not due to the normal propagation effects and it was found that it was due to insufficient conductivity of the water return path, permitting turn-to-turn inductance to appear. This can be demonstrated readily by testing two parts of a coil so that the inductance terms firstly aid and secondly oppose each other. The magnitude of the effect is such that the capacitance of a 6 n.m. length is measured approximately 0.2 per cent

higher than its true value. It is interesting to note that this turn-to-turn inductance, which has been termed "coil inductance" to distinguish it from the normal coaxial core inductance, is shunted by the water return path. Water has a relatively high permittivity and it is thus advantageous to increase the testing frequency in order to reduce this "length" effect. Too great an increase cannot be tolerated for the reasons stated previously and it appears that a testing frequency of about 100 c/s would be the optimum.

High-Voltage Testing.

For the high-voltage tests made at every stage of manufacture after that of extrusion, four separate sets of apparatus provided the necessary facilities.

200-kV set.—The 200-kV supply was provided by a voltage-doubling rectifier set capable of producing continuously up to 200 kV of either polarity at a current of 10 mA. It was used for testing core in pans, testing joints and testing completed coaxial pair sections. It was necessary to enclose four areas in the factory with safety fences; all the entrances to these areas were brought into a complex interlocking system so that any one area could be isolated as required. High-voltage test leads ran from the set to each area, and a swinging insulated arm, about 8 ft long, selected the test lead and connected the required set of interlocks into circuit while excluding those of other areas. An elevated control platform provided the operator with a view of the area under test.

600-kV set.—The 600-kV set was a rectifying set using a Cockroft-Walton ladder network capable of giving over 600 kV continuously. It was used solely for testing control joints and therefore was situated in an area not interconnected with the factory.

55-kV sets.—Two 55-kV sets were available, one being normally in use in the tank house for testing completed sections of armoured cable. The second was used as a standby and also on board ship when required.

Transmission Testing Equipment.

The attenuation and pulse echo testing apparatus was supplied by the Bell Telephone Laboratories and the Post Office, and the transmission tests are dealt with elsewhere.¹

The Tank House.

The special features of the cable-storage-tank house are the totally enclosed building and the water-circulating system. The extent of the system is indicated by the fact that each tank has 60 inlets of 3 in. diameter, spaced over the whole of the tank wall, through which water was pumped continuously when testing was in progress.

Resistance thermometers were buried between flakes of cable and wired in groups of 30 to the measuring positions. Just before shipping the main lay of cable, over 200 thermometers were in use. It was possible with this installation to determine cable temperature to 0.5°F or better.

Measurement of Cable Length.

Most of the electrical measurements made were converted to a standard length for quality control purposes and a stringent requirement was made on the accuracy of measurement of length. Units were available that gave the required accuracy provided they were maintained and adjusted. All units were therefore checked at intervals of approximately one month against a length of core reserved for this purpose. At each test the standard length of core was compared with an Invar tape standard.

Before production was commenced, measurements were made of the temperature coefficient of extension of the

¹LEBERT, A. W., FISCHER, H. B., and BISKEBORN, M. C. Cable Design and Manufacture for the Transatlantic Submarine Cable System. (In this issue of the *P.O.E.E.J.*)

core and of its load-elongation characteristics. Provided that the temperature was kept within reasonable limits it was not necessary to apply a correction to the length. Care was taken to ensure that the tension in the core was sufficiently small to prevent length correction on this account becoming necessary.

HANDLING AND SPlicing THE FLEXIBLE REPEATERS

Transport and Storage.

The flexible repeaters for use in the main cable were produced in a specially designed and equipped factory in New Jersey, U.S.A., under conditions of the most extreme cleanliness and rigid inspection. The repeaters, together with the tail cables at each end, had an overall length of about 150 ft. They were packed in elaborately designed containers and flown from Newark, New Jersey, to London in specially converted aircraft.

Because of their sensitivity to damage by mechanical shock each repeater casing carried a recording impactograph. This was read and reset at each stage of the journey from New Jersey, U.S.A., to Ocean Works at Erith, so that a detailed record was obtained of all movements during transit. Subsequently, after removal of the repeater from its case, the strictest possible control of all movement was maintained at all times.

It was specified that, up to the time of storage in the ship's cable tanks, the repeater with its tails must at no time be bent to a curvature exceeding that corresponding to a radius of 100 ft, over a length of $14\frac{1}{2}$ ft on each side of the central point. This meant that a length of 29 ft had to be kept rigid within ± 1 ft, which necessitated the use of a securely lashed splint over this whole length.

Repeaters had to be protected against variation in ambient temperature outside the range $+20^{\circ}\text{F}$ to 120°F and the central section of an energized repeater could not be allowed to exceed a temperature of 85°F . These temperatures were controlled by circulating water through the troughs in which the repeaters were stored before and after splicing into the cable.

The Company's responsibility for handling the repeaters commenced the moment they arrived at the works from London Airport in the specially converted covered trailer.

The cases were carefully unloaded on to rubber-tyred trucks and wheeled into the tank house. Here the repeaters were uncrated and lifted by means of a spreader bar and a small overhead crane on to specially constructed stands where the splints were attached. Identification checks had to be made on either end of each repeater to ensure that the input and output ends were correctly orientated before lifting it into its resting place in the temperature-controlled troughs (Fig. 8).

Joining and Splicing the Repeaters into the Cable.

The joining and splicing of a cable section end to a repeater tail called for as much care and almost as much precision in the preparatory stages as during the actual operation.

The required repeater, still securely lashed to its splint, was lifted from its trough, gently lowered to ground level and brought to rest in wooden stands with its cable tail exposed ready to receive the end of the cable section.

In the case of the deep-sea (type D) cable, the 24 impregnated-cotton-taped 0.086-in. diameter high-tensile galvanized steel armouring wires and the 28 similar wires on the repeater tail were unlaidd for distances of 10 ft and 45 ft, respectively. During this operation the original lay and sequence of the armouring wires was retained by means of a series of lay plates, two of which can be seen in Fig. 9.

A 4-ft length of the exposed copper-taped core was cut from the cable end and a 40 ft length similarly cut from

the repeater tail, leaving the unlaidd armour wires in each case uncut.

The unwinding of the jute bedding from the cable end and the five layers of glass-fibre tape from the repeater tail exposed in both cases the compounded-fabric tape which covers the copper barrier tape. Both these tapes were removed from their respective ends, the barrier tape being cut off but the fabric tape coiled back for re-use later.

The next operation, the unlaying of the six copper outer-conductor tapes, necessitated much care and skilful handling to ensure that the lay and form were retained with such a soft and malleable material.

Special retaining clamps were applied over the copper tapes at the positions where the unlaying terminated in order to prevent the possibility of any slackening in those portions still remaining intact on the insulated core.

The core jointing was then carried out exactly as described in the section on cable manufacture; the inner conductor ends being brazed and the insulation restored by injection moulding.

The copper outer-conductor tapes were restored to the original form and position which they occupied on the core as manufactured, and each tape was cut to a length which allowed a slight overlap but ensured that, when brazed to its partner, no undue difference in tension would exist between any of the six tapes. A bight was then made in the jointed insulated core and each corresponding pair of tapes brazed together. The six tapes were then carefully worked back into position on the core and formed down to a snug fit.

A new length of copper barrier tape was then applied, the impregnated-fabric tape restored, and the jute yarns and glass-fibre tape replaced, thus reforming the bedding for the armouring wires.

A carefully controlled tension was applied to the joint during the re-armouring and splicing operations. The 24 unlaidd armouring wires of the cable end were then laidd back over the jute-served coaxial core, with their original lay and sequence, by the skilful manipulation of lay plates (Fig. 9). The wires were then "chased" down on to the bedding so that the diameter was reduced as nearly as possible to its original size, temporary bindings of spun yarn being applied to retain the wires in position. Protective lappings were then applied to the exposed portion of the repeater tail and the 28 armouring wires similarly restored to their original positions and continued to overlay those of the cable end, thus effecting an overlap of something like 40 ft in length. A gradual reduction in the diameter

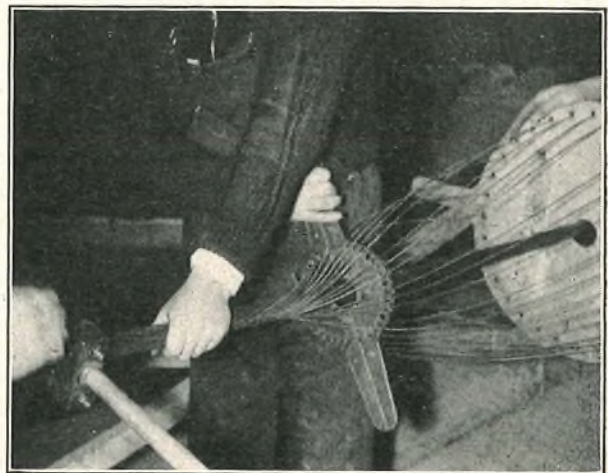

FIG. 9.—THE USE OF LAY PLATES FOR REPLACING ARMOURING WIRES AFTER JOINTING.

over the armouring wires from the repeater to the cable proper was then brought about by "building up" with special impregnated tape over which a closely laid spun yarn was applied and the splice was finished with several coats of asphaltic "slushing compound."

The splicing of repeaters into types "A" and "B" cable called for some difference in procedure and technique from that described above for type "D" cable. For example, when splicing type "A" cable, the heavier armouring wires, 0.300 in. in diameter, were arranged to overlap those of the repeater tail. This involved the difficult task of unlaying these heavier wires for a length of over 50 ft whilst preserving their original lay. Any distortion of these wires would have resulted in undue and inconsistent gaps between the wires after restoration, thus complicating the introduction of the "filler" wires. These "filler" wires were incorporated in the original armouring in order to build up the diameter of the cable and thus produce the gradual taper required.

Much could be written about the care and skill required to comply with the Bell Telephone Laboratories' exacting specification for this work; happily, however, the jointing and splicing teams of Submarine Cables, Ltd., were equal to the task and achieved results to the complete satisfaction of the Company's own and the customer's inspectorate. Breaking-strain tests carried out on specimen splices of the three different types have shown that the spliced portion is in all cases at least as strong as the original cable.

Shipping the Cable and Repeaters.

Shipping the cable with the repeaters inserted at positions approximately 37.5 n.m. apart presented a completely new set of problems.

The comparatively short length of each section of cable not only greatly increased the number of cable ends to be accommodated during storage, but each end, after splicing to the repeater, became a long bight containing the repeater splice, which proved difficult to stow in its correct position for shipping.

Sufficient was known at an early date to design a tank house to meet all requirements and it was with considerable interest that the Company received a dummy repeater for trials. With this repeater it was possible to prove the shipping and handling technique and train personnel in all operations.

The first real repeater was received in May, 1955, and the job of splicing this into its position in the cable was tackled with a considerable degree of confidence, although at the time some 40 to 50 cable ends were arrayed in the tank house, as cable manufacture had progressed in advance of repeater deliveries.

Owing to the requirements for transmission tests on each repeater section, alternate section lengths of cable were coiled into a pair of tanks. This meant that alternate repeaters faced the wrong direction for direct shipping, and, therefore, during the course of paying out through the shipping spans via the mid-stream tower to the ship, every other repeater had to be turned through 180°.

Communication between the ship and shore was very critical owing to the tank changes and re-orientation of repeaters for shipping, but, by using throat microphones, communication from winchmen on board ship to the tank house was possible and movement was kept under complete control. Emergency switches were at hand if at any time the microphones failed to function.

When a 37.5-n.m. section of cable had been loaded into the 41-ft diameter tanks on the cable ship, the splinted repeater was lowered into the tank using a specially

designed shute which enabled the repeater to be kept as rigid as possible during the whole operation. The splints were then removed from the repeater and the repeater positioned against the inside wall of the tank, shoring being used to keep the central portion straight. Shipment was then continued until the next repeater reached the ship, when the repeater storage operation was repeated.

ACKNOWLEDGMENTS

Now that the cables—the longest submarine telephone cables in history—have been successfully laid and the first transatlantic telephone cable system has been inaugurated, Submarine Cables, Ltd., can look back upon the events of the past 2½ years with infinite satisfaction. The momentous decision to acquire the derelict factory site at Erith, the planning and erection of new buildings, the provision and installation of plant and machinery costing over £1,000,000, the training of personnel, the production of 4,200 n.m. of repeated telephone cable to a specification of Draconian severity and the shipment of that cable on board H.M.T.S. *Monarch* in so short a period of time, seem almost unbelievable. But it is now an historic fact that, in spite of many difficulties and setbacks, this triumph of engineering skill was achieved just within the time limit laid down in the contract. It indeed reflects great credit on all concerned at Ocean Works where team work and long hours of hard labour have brought their just rewards. Without this sustained effort, the cable could not have been completed on schedule.

The author wishes to acknowledge with thanks the permission of Submarine Cables, Ltd., to publish this article and also to express his sincere thanks for all the assistance received from colleagues within the Company in the preparation and compilation of this article.

APPENDIX

Conductor.—Centre copper wire 0.1318 in. \pm 0.0002 in. diameter surrounded by three copper tapes 0.148 in. \pm 0.001 \times 0.015 in. \pm 0.0007 in. helically applied with a lay of 2.5 in.

Insulant.—Polythene compound containing 5 per cent butyl rubber extruded to 0.621 in. \pm 0.003 in. diameter.

Return Conductor.—Six copper tapes 0.320 in. \pm 0.002 in. \times 0.016 in. \pm 0.0005 in. helically applied with a lay of 11.75 in.

Binder and Barrier tapes.—Copper tape 1.75 in. \times 0.003 in. applied with overlap. Compounded fabric tape 1.375 in. \times 0.010 in. applied with small gap.

For Type D (deep sea) Cable.

Inner serving.—Single layer of jute rove impregnated with cutch preservative.

Armour.—24/0.086-in. high-tensile galvanized steel wires. (Each wire lapped with impregnated cotton tape.)

Outer serving.—Two layers of tarred jute yarn fully impregnated with compound under, between and over each layer. Overall diameter 1.21 in.

For Type B (intermediate) Cable.

Inner serving.—Layers of jute rove impregnated with cutch preservative.

Armour.—18/0.165-in. galvanized mild steel wire.

Outer serving.—Two layers of tarred jute yarn fully impregnated with compound under, between and over each layer. Overall diameter 1.40 in.

For Type A (shore end) Cable.

Inner serving.—Two layers of jute rove impregnated with cutch preservative.

Armour.—12/0.300-in. galvanized mild steel wire.

Outer serving.—Two layers of tarred jute yarn fully impregnated with compound under, between and over each layer. Overall diameter 1.84 in.

Route Selection and Cable Laying for the Transatlantic Cable System*

J. S. JACK,
Captain W. H. LEECH, O.B.E., D.S.C.
and H. A. LEWIS, E.E., Senior Member I.R.E.†

U.D.C. 621.315.285:621.395.51

The repeatered submarine cables which form the backbone of the transatlantic telephone cable project were installed during the good weather periods of 1955 and 1956. This article considers the factors entering into the selection of the routes, describes the planning and execution of the cable laying, and presents a few sidelights on the human side of the venture. It also covers briefly the routing of some 55 nautical miles of repeatered submarine-type cable which were trenched-in across the neck of the Burin Peninsula in Newfoundland to connect the Terrenceville submarine terminal with the cable station at Clarenville.

INTRODUCTION

IN the days of Cyrus Field, Lord Kelvin and those other foresighted and courageous pioneers of the early trans-oceanic submarine-cable era, the risks involved in selecting a route and laying a transatlantic cable must have been formidable, for not until the third attempt was a cable successfully laid.

To-day the hazards may be somewhat more predictable, our knowledge of the ocean bottom more refined and our tools improved; but the task still remains extremely exacting in its demands for sound engineering judgment, careful preparation, high-quality seamanship and good luck with the weather, for the basic methods now in use are still remarkably like those employed on the *Great Eastern* and other early cable ships, and the meteorological, geographical and topographical problems are unchanged.

In the present transatlantic project—the first trans-oceanic telephone cable system—there are two submarine links. Between Clarenville, Newfoundland, and Oban, Scotland, there lie some 1,850 nautical miles‡ (n.m.) of North Atlantic water, most of it deep and all subject to weather of unpredictable and frequently unpleasant nature. The bridging of this required the laying of two one-way cables over carefully selected routes, using an available cable

†Mr. Jack is with the American Telephone and Telegraph Company, Captain Leech is with the British Post Office and Mr. Lewis is with Bell Telephone Laboratories, Inc.

‡A nautical mile is 6,087 ft, 15·3 per cent longer than a statute mile.

ship, and the presence in these cables of 102 flexible repeaters posed problems quite unique for such long and deep cables, as also did the need for trimming the system equalization during laying so that transmission over the completed system would fall within the prescribed limits.

From Terrenceville, Newfoundland, to Sydney Mines, Nova Scotia, a single cable 270 n.m. long was required through Fortune Bay and across Cabot Strait. While this water is considerably shallower, here again a relatively conventional cable-laying problem was complicated by the presence of repeaters, which in this section comprised 14 rigid units. Trimming of system equalization was also required.

These cables were laid during the spring and summer of 1955 and 1956, and the preparation for the laying required many months of effort in fields which were for the most part quite foreign to the usual scope of land-line telephone activity. Some appreciation of the problems encountered in this phase of the venture may be gained from the following paragraphs.

NORTH ATLANTIC LINK

Route Selection.

The first successful transatlantic telegraph cable was laid across the North Atlantic in 1866; since that date, 15 cables have been laid direct and five more by way of the Azores, the approximate routes being shown in Fig. 1. It is at once evident that the shortest, and possibly the best, routes were

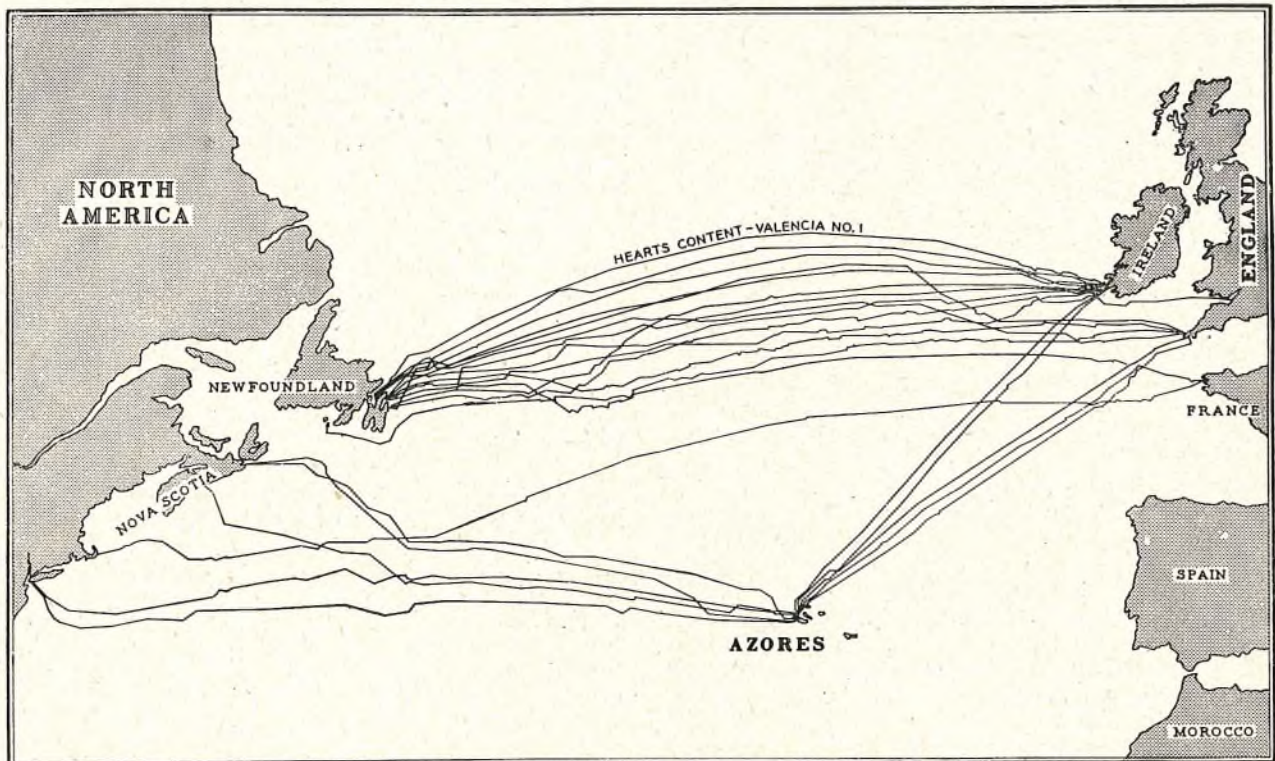

FIG. 1.—TELEGRAPH CABLES IN THE NORTH ATLANTIC.

already occupied, so that selection of routes for the two transatlantic telephone cables could be expected to present some difficulty.

Some of the more important considerations which guided the selection were route length, clearance for repairs, possibility of damage by trawlers and anchors, and terminal locations suitable for repeater stations, with staffing in mind as well as facilities for onward routing, due consideration being given to the strategic aspects of the locations.

Route length.—Obviously, the shorter the length of a submarine route the better, and in the present instance any system length much in excess of about 2,000 n.m. would have resulted in a reduction in the number of speech channels which could be derived from the system.

Fig. 2 shows some of the routes considered in the early planning stages; the distances shown are actual cable lengths and include an allowance for the slack necessary to

and suitable sites for intermediate cable stations could have been found on one of the several islands in the Azores; but difficulties attendant upon landing rights and staffing problems in foreign territory could be foreseen.

Clearance for repairs.—The repair of a faulty cable or repeater necessitates grappling, and in deep water this is likely to be a difficult operation. To avoid imperilling other cables while grappling for the telephone cables and, conversely, to provide assurance against accidental damage to the telephone cables from the grappling operations of others, it was considered essential that the route selected should provide adequate clearance from existing cables. Suitable clearances are considered to be 15–20 miles in the ocean, and less in the shallower waters of the continental shelves.

Trawler and anchor damage possibilities.—It is probable that fishing trawlers cause more interruption of submarine cables than any other outside agency, for cables laid across

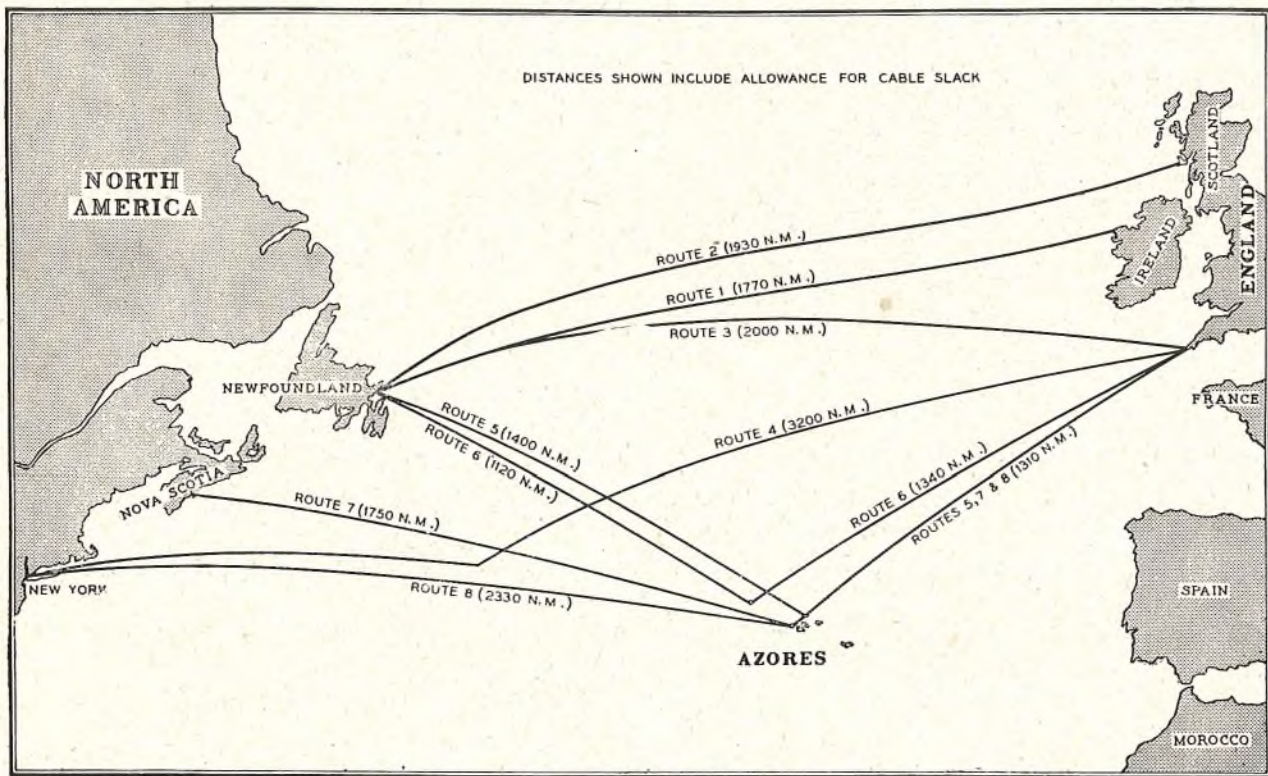

FIG. 2.—TENTATIVE TELEPHONE CABLE ROUTES.

ensure conformance of the cable with the profile of the ocean bottom.

Route 1, from Newfoundland to the Republic of Ireland, at 1,770 n.m., is the shortest route, and was provisionally suggested in 1930 for a new cable; the difficulty of onward transmission of traffic to London made this route unattractive.

Route 2, from Newfoundland to Scotland, compared favourably in length with Route 1, but its adoption was dependent upon location of a suitable landing site in Scotland.

Route 3, from Newfoundland to Cornwall, is approximately 2,000 n.m. in laid length, and would have been very attractive were not so many existing cables terminated in southern Ireland or the south-west corner of Cornwall; this would have led to great congestion and consequent hazards to the telephone cables.

Route 4, from New York to Cornwall, was too long to be considered (3,200 n.m.).

Routes 5, 6, 7 and 8, were indirect via the Azores; they were attractive, since only relatively short lengths were involved,

good fishing grounds are always liable to damage from fouling by the otter boards of the trawls. Final splices, either initial or as a result of repair operations, are particularly vulnerable to damage because of the difficulty in avoiding slack bights at such points. It was therefore desired to avoid fishing grounds if at all possible.

If cables are laid in or near harbours frequented by merchant shipping, damage must be expected from vessels anchoring off shore in depths of less than 30 fathoms, and proposed routes should therefore avoid such areas.

Terminal sites.—The location of the cable terminal stations must be considered from the aspects of the suitability of the shore line for bringing the cables out of the water and the amenities for the staff. This is a most important factor in the retention of a permanent well-trained staff: for example, owing to staff difficulties it was necessary to move a terminal station of one company from the west side of Conception Bay, Newfoundland, to a site within easy reach of St. John's. A further factor in proper siting of the terminals is consideration for onward routing of the circuits carried by the cables.

Finally, in view of the importance of submarine-cable facilities, it is considered desirable to avoid terminal locations in or near a potential military target area, and consideration should be given to underground or protective construction for the terminal stations.

Preliminary selection.—The routes for the telephone cables were considered in the light of the foregoing, and after preliminary discussion it was agreed that the two new cables should lie north of all existing cables, should avoid ships' anchorages, and should lie on the best possible bottom that could be picked, clear of all known trawling areas.

In 1930, the American Telephone and Telegraph Company, in conjunction with the British Post Office, gave serious consideration to the laying of a single coaxial telephone cable between Newfoundland and Frenchport, Ireland (Route 1, Fig. 2). A tentative route was plotted and the cable ship *Dominia* steamed over this, taking a series of soundings; these indicated that good bottom was to be found about 20 miles north of the Heart's Content-Valencia cable of 1873, which was the most northerly of the telegraph cables spanning the Atlantic. Study of this cable's history indicated that faults clear of the continental shelf had been very few since its laying in 1873.

The latest British Admiralty charts and bathymetric charts of the U.S. Hydrographic Office for the North Atlantic Ocean were scrutinized and from these and a study of all other relevant data, two routes were plotted which appeared to fulfil the necessary requirements so far as possible. However, it was agreed that, if possible, the selected routes should be surveyed, so that minor adjustments could be made if desirable.

Landing Sites.

It was next necessary to find suitable landing sites having regard for the decision that the telephone cables should be routed north of all other existing cables, which meant that on the British side it was necessary to pass north of Ireland.

The North Channel, the northern entrance to the Irish

Sea, divides Northern Ireland from Scotland, and had it been suitable, the telephone cables might have been run through it to a terminal station on the south-west coast of Scotland in the vicinity of Cairn Ryan. However, the streams through the North Channel run at 4-5 knots at spring tides, while the bottom is rocky and uneven, with overfalls; any cable laid through it would have a very short life indeed.

It was therefore necessary to search farther north. The west coast of Scotland presents a practically continuous series of deep indentations and bald, rocky cliffs and headlands, while the chain of the Hebrides stretches almost uninterruptedly parallel with, and at short distances from, the coast. It was obviously most desirable to land the cable on the Scottish mainland, and close to rail and road communication if at all possible.

From previous cable maintenance experience it was known that the Firth of Lorne, which separates the island of Mull from the mainland, was a quiet channel, little used by shipping or frequented by trawlers and with moderate tidal streams. Earlier passages of Post Office cable ships through the Firth had yielded a series of echo-sounding surveys which indicated that, except for a distance of about 5-6 miles in the vicinity of the Isles of the Sea, the bottom was fairly regular. Several small bays on the mainland side of the Firth just south of Oban appeared from seaward to be very suitable landing sites, and this was confirmed by a survey party, which selected a small bay, locally named Port Lathiach, for the cable landing and site of the station. The foreshore was mainly firm sand with outcroppings of rock which could be avoided easily when landing the cables. The seaward approach was clear of danger, and there was ample room to land two cables with a separation on the shore of some 30 yd.

Port Lathiach is only about 3 miles from Oban by road, but additional land cables were necessary to carry traffic to the main trunk network. From a strategic aspect, although Oban might only just be considered a target area,

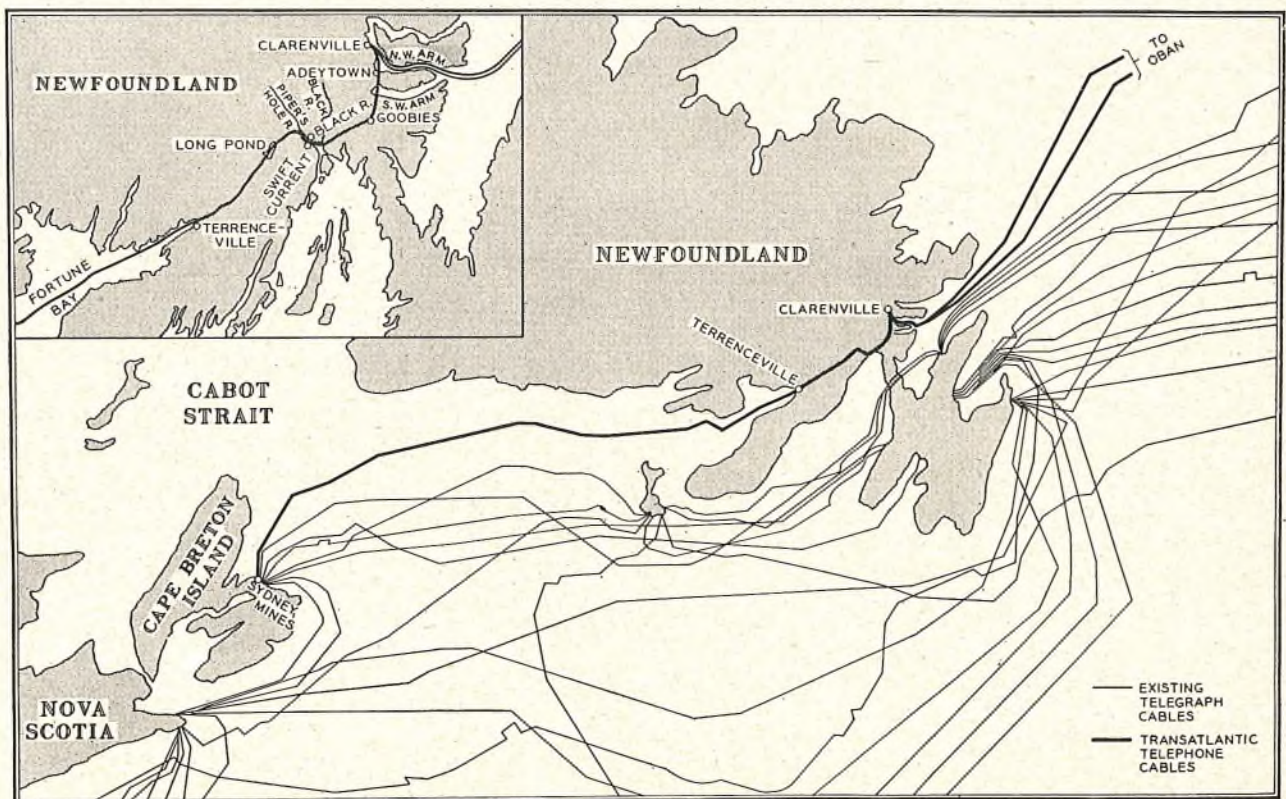

FIG. 3.—CABLE LANDINGS ON NEWFOUNDLAND, AND THE FINAL ROUTE OF THE OVERLAND SECTION OF THE CLARENVILLE-SYDNEY MINES CABLE.

the cable landing was sufficiently remote to be relatively safe, especially if the cable terminal station were sited in the rocky hillside. To ascertain whether any serious chafing or corrosion would result if cables were laid over the uneven bottom of the Firth, some 8 miles of coaxial cable with E-type armouring were laid over the area and recovered

during the summer months are not likely to interfere with the cables.

Having agreed upon Clarenville, Newfoundland, and Oban (Port Lathaich), Scotland, for shore terminations, it was possible to complete the routes for the two cables, as shown in Fig. 4. The final routes are clear of existing cables

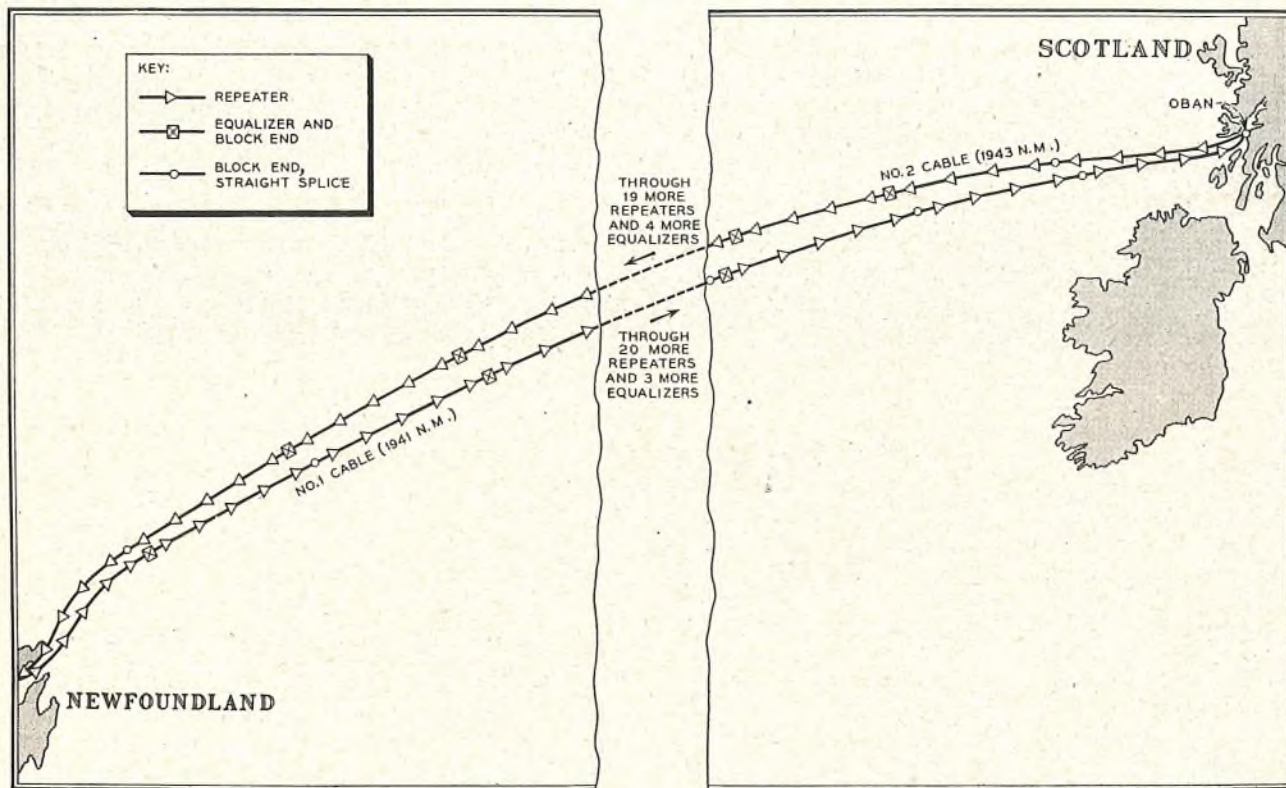

FIG. 4.—TRANSATLANTIC TELEPHONE CABLE ROUTES.

after 2 years; there was no evidence of any chafing or corrosion. It was therefore decided that the telephone cables should be routed through the Firth of Lorne to the cable terminal station at Port Lathaich.

The choice of a suitable cable landing in Newfoundland was more difficult, in view of the rugged and sparsely populated nature of the country. From Fig. 3 it will be seen that the existing telegraph cables spanning the Atlantic land either just north of St. John's, in Conception Bay, or in Trinity Bay. North of Cape Bonavista the coast becomes more broken, and the sea approach is not good. Accordingly, there was no good alternative to routing both telephone cables into Trinity Bay, close to and north-west of the telegraph cable landing at Heart's Content on the southern shore of the bay. A survey party made an extensive examination of all likely places on the western side of the bay from Cape Bonavista in the north to Bull Arm at the southern end of the bay, where, incidentally, the first successful telegraph cable was landed. Careful consideration of all places visited led to the agreement that Clarenville was the best site for a landing and for a cable terminal station.

Clarenville is at the head of the north-west arm of Random Sound. It is a junction on the main railway, and a good road to St. John's will pass through the town in traversing its course from St. John's to Port aux Basques. There is a growing population of some 1,600 inhabitants, with stores and repair facilities of various sorts. Good cable landing sites are available just out of town, and the approach from the sea up the north-west arm presents no navigational difficulties. Such few small vessels as ply to Clarenville

and avoid crossing known trawling areas and anchorages, and the cable stations are well sited with regard to staff amenities, accessibility, and strategic requirements. Soundings taken during the laying of the two cables showed an even bottom except in the Firth of Lorne and one or two places in Trinity Bay. The general profile of the route is shown on Fig. 5.

It is considered that these routes have been selected with

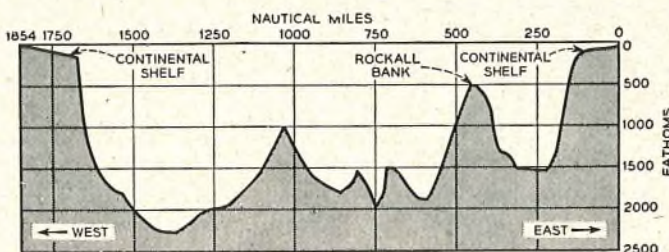

FIG. 5.—PROFILE OF OCEAN DEPTHS BETWEEN CLARENVILLE AND OBAN.

care and meet all of the requirements of a well-planned cable project. Time alone will tell how well the objectives have been met.

CABLE LAYING

Early Methods.

In 1865, when *S.S. Great Eastern* was commissioned to lay the first successful transoceanic telegraph cable, she was fitted out with certain special cable-handling equip-

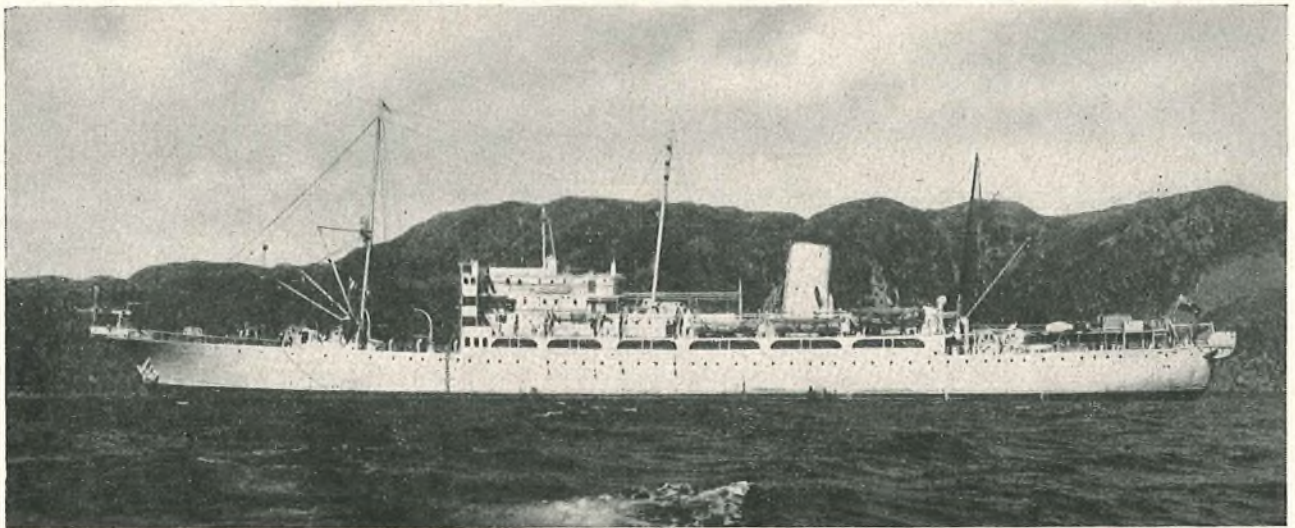

FIG. 6.—H.M.T.S. "MONARCH."

ment, the need for which had been amply demonstrated by events which transpired during two earlier and unsuccessful attempts by H.M.S. *Agamemnon* and U.S.S. *Niagara*. For her assignment, the *Great Eastern* was fitted with three large tanks into which her cargo of cable could be coiled. She was also provided with a large drum about which the cable could be wrapped in the course of its passage from the tanks to the sea. This drum was connected to an adjustable braking mechanism which provided the drag necessary to ensure that the cable pay-out was correct with relation to the speed of the vessel. In addition, a dynamometer was provided so that the stress in the cable would be known at all times. A large sheave fitted to the stern of the ship provided the point of departure of the cable in its journey to the sea bottom.

The *Great Eastern* left Valencia, Ireland, on 13th July, 1866, and arrived off Trinity Bay, Newfoundland, to complete the landing of the western shore end on 27th July; thus was accomplished the laying of the first successful transoceanic submarine cable.

H.M.T.S. "Monarch."

Early in the planning for the transatlantic project it was realized that in no small measure the success of the venture would depend on availability of a vessel suitable for laying the cables. It was fortunate that one of the partners in the enterprise was also the owner and operator of the largest cable ship in the world, and one well suited to the task at hand—the twin-screw cable ship *Monarch* (Fig. 6). Completed in 1946, she is a shelter-deck vessel having the following principal dimensions:—

Length overall	482 ft 9 in.
Breadth moulded	55 ft 6 in.
Depth moulded to shelter deck	40 ft
Gross tonnage	8,056

The ship has an overhanging bow which carries three cable sheaves, a cruiser stern with the after paying-out cable sheave offset on the port quarter, a semi-balanced rudder having extra large surface, and a cellular double bottom extending from the collision bulkhead to the aft-peak bulkhead. Both main and shelter decks are of steel and extend for her complete length.

The cable is carried in four welded-steel cable tanks fixed to the tank-top plating. These are arranged along the ship's centre-line in a fore-and-aft direction, forward of the main propelling machinery space. They are each

41 ft in diameter and have the following capacities:

	Coiling space ft ³	Gross capacity ft ³
No. 1	33,730	40,170
No. 2	31,820	38,460
No. 3	30,865	37,375
No. 4	30,230	36,300

The opening in the shelter deck above each tank is a circular hatch 8 ft in diameter. A watertight cone of steel plates is built in the centre of each tank to prevent fouling of the cable during paying out, and further control is provided by a crinoline (Fig. 7)—a circular spider of steel tubing normally suspended from 1 to 3 ft above the top layer of cable in the tank. This tends to prevent flying

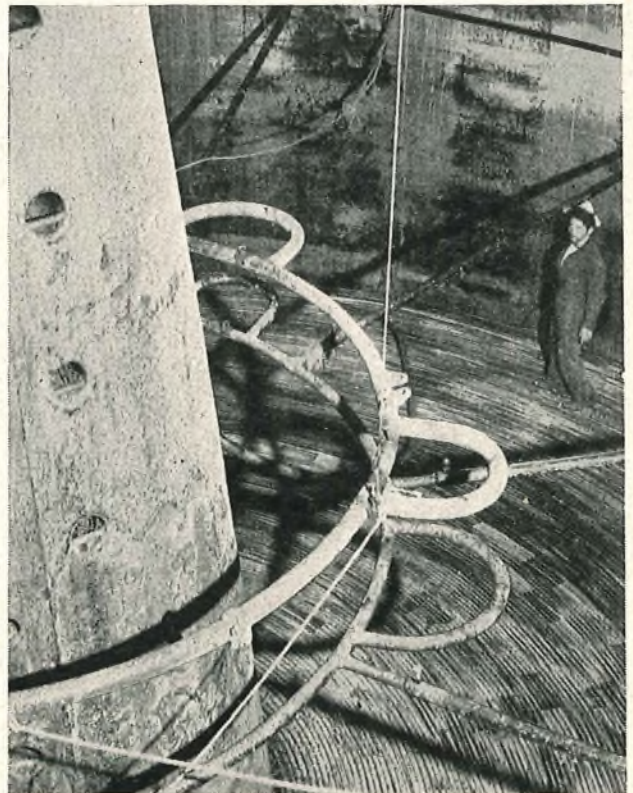

FIG. 7.—INTERIOR OF CABLE TANK, SHOWING CENTRAL CONE, CRINOLINE, AND A "FLAKE" OF CABLE.

bights of cable and also provides a safety platform, in case of trouble, for the men who work in the cable tanks. Each crinoline may be raised and lowered by an electric-motor drive. The maximum cable-carrying capacity is approximately 5,000 long tons,† or almost 2,000 miles of the deep-sea type of cable used on this project, provided that no repeaters are involved.

The *Monarch* is driven by two steam engines; maximum propeller speed is estimated at 110 r.p.m., giving a ship's speed of about 14 knots.

Two cable engines are fitted forward, both capable of being used for picking up or paying out. These are driven by electric motors having a maximum rating of 160 h.p., which will permit picking up at a rate of 0.9 knot with a stress of 20 tons, or 3.5 knots with a stress of 5.3 tons. The drive system is a constant-current one, so designed that a uniform torque may be held at the drum for any setting of the speed control. When paying out, these motors operate as generators to provide electrical braking, and auxiliary mechanical brakes are also fitted.

A single cable engine is fitted aft and this is the main paying-out gear. In addition to the electrical brake, the after engine is also provided with a multiple-drum externally-contracting-band brake, manually adjustable and water cooled, and with a further auxiliary fan brake. The fan shaft is driven in such a manner that when cable is being paid out at approximately $8\frac{3}{4}$ knots the fan will revolve at 1,000 r.p.m. and absorb 120 b.h.p. Adjustments in this are effected by varying the amount of opening in the fan shroud so that as little as 27 b.h.p. may be absorbed.

Dynamometers, both fore and aft, provide for measurement of the cable tension. Taut-wire gear is provided on the starboard quarter to provide an effective means for calculating the amount of slack paid out. With this gear, steel piano wire, anchored to the bottom, is paid out at constant tension and provides a rough measure of distance steamed over the ground. A test room with leads to each cable tank is provided on the shelter deck and fitted with instruments for measuring and locating faults in submarine cables.

Modifications for Flexible Repeaters.

In the normal cable-paying-out process, the cable is drawn from the tank, carried along fairleads to the hold-back gear (a mechanism for applying slight tension to the cable so that it will snub tightly around the drum), and then wrapped around the drum of the cable engine from two to four turns, depending upon the weight of the cable and the depth of the water. At the drum, a fleeting knife is fitted which pushes over the turns already present to make way for the oncoming turn. From the drum the cable passes

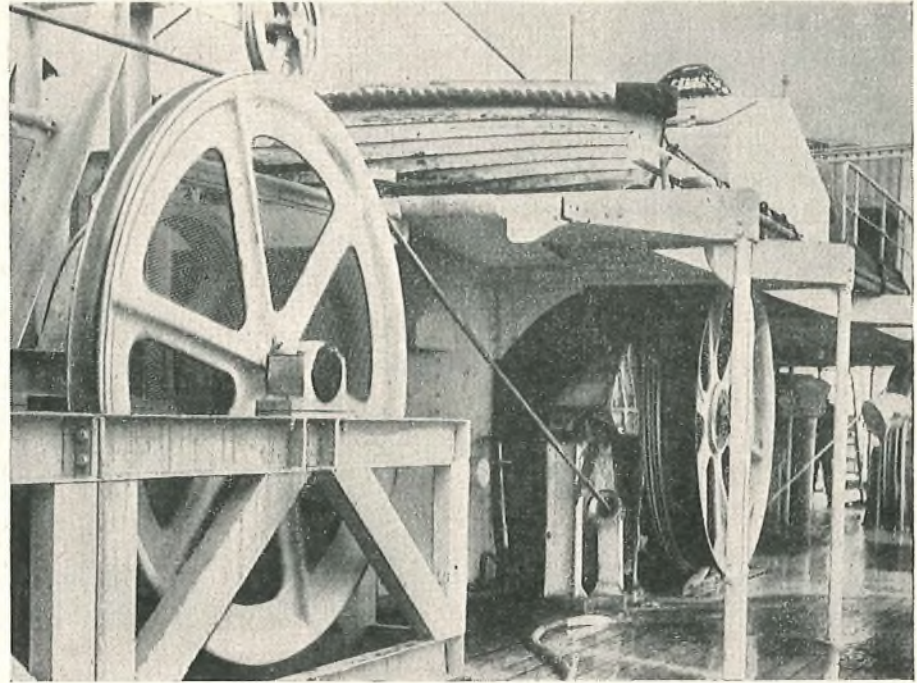

FIG. 8.—GENERAL VIEW OF MODIFIED AFTER CABLE GEAR (ONE OF TWO HOLD-BACK SHEAVES, DRUM WITH FLEETING KNIFE AND IRONING BOARD, AND, AT EXTREME RIGHT, DYNAMOMETER SHEAVE).

through the dynamometer and thence to the payout sheave.

The deep-water flexible repeaters were designed to make them act as much like cable as possible.¹ Despite this, their presence introduced a loading and laying problem, since their ability to bend without injury is limited to a minimum radius of $3\frac{1}{2}$ ft, and their structure is such that unnecessary bending may involve a hazard to their watertightness. Since the majority of the sheaves and drums of the conventional laying gear are considerably smaller than



FIG. 9.—CABLE PAY-OUT OVER THE STERN SHEAVE.

† 1 long ton = 2,240 lb.

7 ft in diameter, a number of modifications were required in the *Monarch's* equipment to accommodate the repeaters.

The modifications included providing the port bow sheave with a flat tread to bring its diameter to 6 ft 10 in., and replacing both forward and after dynamometers by a new design employing 7-ft wheels in a pivoted A-frame bearing on pressure-type load cells. The port and starboard forward drums were replaced with drums of 6 ft 10 in. diameter—the maximum possible without a major change in the complete equipment—and the after drum with one of 7 ft diameter. The forward port and after cable drums were equipped with ironing boards. (An ironing board is a curved shoe placed adjacent to the cable drum and spring loaded so that it will force the flexible repeater to conform to the curvature of the drum as it passes on.)

The forward port and starboard draw-off gear sheaves were replaced with larger ones, 7 ft in diameter, which were made traversable. The after hold-back gear, of the double-sheave type, was also replaced with units having 7-ft sheaves.

Fig. 8 shows a general view of the modified after cable gear, and the 7-ft stern sheave may be seen in Fig. 9. A schematic diagram of the equipment is shown in Fig. 10.

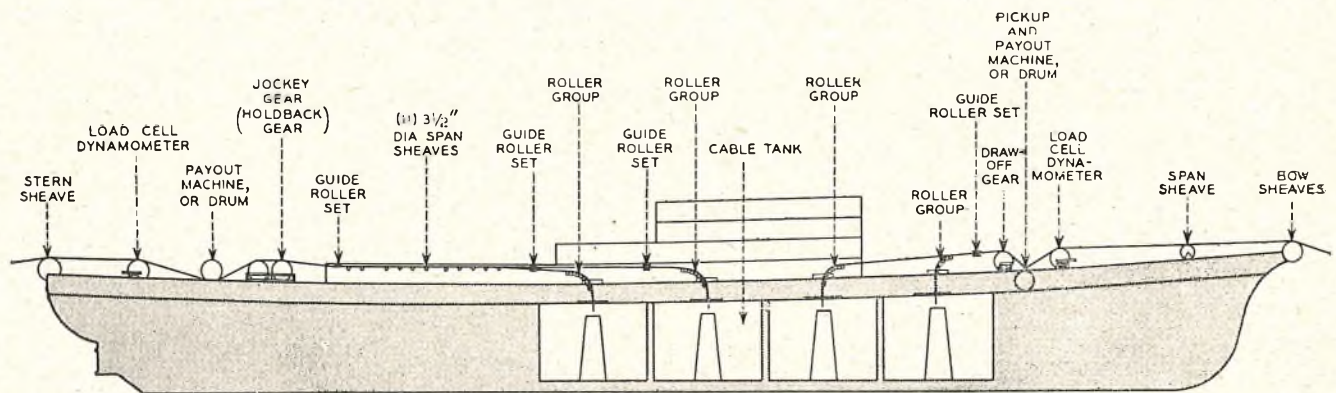

FIG. 10.—SCHEMATIC DIAGRAM OF CABLE GEAR ON H.M.T.S. "MONARCH."

Roller-type fairleads shaped into arcs with a minimum radius of $3\frac{1}{2}$ ft were fitted at each cable-tank hatch, with smaller roller guides at convenient points to ensure fair lead of the cable from the tanks to the cable machinery. Electric hoisting gear was provided for the lower crinoline in each tank, since it was necessary to raise the crinoline whenever a repeater left the tank.

The test room was greatly enlarged and fitted with the equipment necessary for supplying power to the cable and testing the system during laying.

Cable Laying.

When the ship is loaded, the cable is coiled into the tanks in layers, each layer being called a "flake." The coiling is started from the outside of the tank and progresses clockwise towards the centre, so that the armour is untwisted one revolution for each complete turn in the tank. When the cable is paid out in the reverse order, this turn is restored.

Handling of the repeaters during loading presents a problem because of the need to restrict their bending, and after some experimental work, splints were devised to provide the necessary rigidity. These consisted of two angle irons each 12 ft long and equipped at the ends with cold-rolled-steel rods ranging in length from $1\frac{1}{2}$ ft to 6 ft. By this device it was possible to maintain rigidity over the main central portion of the repeater, including the junction of the core tube with the end nosing, and to provide limited flexibility along the outer ends of the core tubes, which are less sensitive to bending. The splints were

removed once the repeaters reached the tank. Repeaters are always stowed at the outside of the flake, where the bending is least, and they are protected with wood dunnage, which must be removed before the repeater is paid out.

With these modifications, all repeaters and equalizers were laid successfully from either the forward or the after gear at a cable speed of around three knots.

TESTING AND EQUALIZATION

Once a submarine cable system has been installed, it is accessible only at the ends for adjustment to improve performance, save at great difficulty and large cost. Since some irregularities cannot be corrected from the ends, the designers must discover, account for and correct these before the cable is finally laid. The laying period offers the last—and all too frequently the first—opportunity for accomplishing this, and this fact, coupled with the broadband design of the link and with the presence in the system of active elements (the repeaters), necessitated a very comprehensive program of tests and measurements during laying.

The program had three specific purposes: (a) to detect immediately any fault that might develop during laying;

(b) to permit the design and execution of corrective system adjustments *en route*, so that transmission performance of the completed link would fall within specified objectives; and (c) to gather data on system characteristics at intermediate points for eventual use in fault location or in ageing studies. The need for (a) and (c) is more or less self-evident, but (b) merits some further discussion.

In an ideal submarine cable system in an average environment, the attenuation of the cable from one repeater to the next would be offset exactly across the frequency band by the gain of the subsequent repeater. Such a result is never achieved in practice, since the temperature and pressure environments (which affect cable attenuation) cannot be known precisely in advance, and the cable structure itself cannot be manufactured for mile after mile without variation in transmission characteristics. Additionally, the mechanics of the laying process induce minor changes in the physical structure of the cable, which are reflected in attenuation changes.

If such deviations from the desired characteristic produced only differences from the specified system gain objective, compensation could be readily applied at the ends of the submarine link; unfortunately, this is only partly the case, and their more important effect is the misalignment of the operating levels of individual repeaters from the design objective.

Misalignment magnitudes must be watched carefully, for at best, misalignment narrows the system latitude for seasonal temperature changes and for ageing, and at worst it can result in intolerable system noise. If a repeater is

preceded by too much cable the signal/noise ratio at the repeater input will be less than desired because of thermal noise. If there is too little cable, the signal level will be too high and the resulting overloading in the repeater will also affect the signal/noise ratio adversely. Once it is present on the signal, the noise cannot be removed, and so the cure for excessive misalignment must be applied before the misalignment has developed. Adjustments at intermediate points along the route must therefore be contemplated.

The program which was evolved to meet the three objectives outlined was meticulously reviewed and practised before the start of laying, and various forms for entering data and plotting and evaluating results were prepared. This was essential to avoid wasting effort or missing valuable data. The wisdom of this was fully apparent to all involved after experience with the close time schedules and the mental tension that developed during the actual laying.

Staff for testing was provided by crews of two or three trained engineers located at the transmitting cable stations and on board ship. Those on the ship served 4½-hour watches at 9-hour intervals, which permitted a reasonable amount of rest, and avoided continuous "dog watch" duty by any one man.

Close contact between ship and station crews was essential, and was achieved by cable and radio speaker circuits. Communication from shore to ship when the cable was energized made use of the standard cable speaker circuit at the cable station for applying a signal in the frequency band 16–20 kc/s. The signal was demodulated and amplified aboard ship by a special stripped version of the same equipment. The radio speaker circuits employed special aerials and equipment at the cable stations, and for the most part, the ship's standard single-sideband telephone set, although other equipment operating at about 300 kc/s was sometimes used for short distances. Radio telegraphy was available as standby when conditions were too poor for the radio telephone sets.

Plans called for energizing the cable at all times except when splices were being made. This was necessary for the measurement program, of course, but also provided additional assurance of safe laying of repeaters, since the glass bulbs and tungsten heaters of the thermionic valves are more resistant to damage when hot. Power for the first half of each crossing was provided from the cable station: beyond this point the required voltage would have become excessive, and so the shipboard supply was inserted into the series power loop and its voltage adjusted in proportion to the amount of the second half of the cable actually in the loop.

Monitoring against the possibility of faults was accomplished by measurement of a 16-kc/s pilot signal transmitted over the cable at all times except when data were being taken or power was reduced. Audible alarm limits were set on the measurement to indicate any significant deviation in transmission. In practice, the received alarms all resulted from frequency or voltage shifts in the primary shipboard supply for the measuring equipment.

During the design of the system,² consideration of the misalignment problem had indicated the desirability of dividing the cable for each crossing into a number of sections, called "ocean blocks." These contained either four or five repeaters, and were 150 to 200 miles in length. In loading the ship, the two ends of each ocean block were left accessible for connexion to the test room and for splicing operations.

Measurements made in the spring of 1955 off Gibraltar had indicated an unexpected change in attenuation called "laying effect,"³ which required some last-minute adjustment of the repeater section lengths. With the incorporation

of these changes it was known that the factory lengths of cable between repeaters were adequate to keep misalignment in an ocean block within reasonable limits. The system could then be equalized between ocean blocks, so that the signal level at the first repeater of a new block would be approximately correct and the total system noise would thus fall within acceptable limits.

This equalization was accomplished in two ways. Some 3 miles of excess cable were provided at the top end[‡] of each ocean block, which could therefore be cut longer or shorter than the nominal spacing of repeaters as indicated by measurements, so that the repeater gains and cable losses would be matched at some frequency (usually 16½ kc/s) in the band. Residual deviations in other parts of the band could then be eliminated if necessary by inserting a simple equalizer,² housed in a container similar to those used for the repeaters. Ten such equalization points were provided in each cable.

In practice, the sending levels were adjusted at the cable station to give test signals at the grids of the output valves of the repeaters that would be flat across the frequency band and at the proper level, if the system equalization were perfect. These signals were measured on the ship at the end of the ocean block being paid out, the results being plotted against distance, with one sheet for each frequency being measured. Because of the laying effect and of temperature and pressure changes on the cable as it progressed to the bottom, these curves displayed a slope.

The loss (or gain) to be ascertained for each frequency was that which would exist when the entire ocean block was on the bottom. To obtain this it was necessary to extrapolate the curves to the distance point representing the end of the block in question, which avoided stopping the ship at the end of the block; it was therefore necessary to estimate the time required for turning over and cutting the cable end at the proper point, and for making one or two splices (depending on whether an equalizer was inserted at the point in question) without stopping the ship. The extrapolated values were compared with objectives for the particular block junction, and the deviations were plotted. Transparent overlays, showing the net effect of several types of equalizer combined with varying amounts of cable around the nominal spacing, greatly facilitated the final decisions on the cutting point and the choice of equalizer. This implementation of the system undersea equalization represented a very large part of the effort required from the testing crews during laying.

Additional data gathered for fault location, ageing studies and other purposes included the precise determination of repeater crystal frequencies on the bottom, gain/frequency runs to show up any fine-grained structure which might exist in the band, line currents and driving voltages.

Conductor resistance and capacitance measurements proved to be of dubious value, the former because of the temperature/resistance characteristic of the valve heaters, and the latter because of polarization effects in the castor-oil-impregnated capacitors used in the repeaters.

For making the above measurements a new test room had been equipped with transmitting and receiving transmission-measuring sets,² including the crystal test panels; the sets were duplicated in case one should develop trouble during laying. The transmitting consoles were required only for calibrating the receiving sets, and for some measurements which were made on individual ocean blocks in the ship's tanks.

Additional equipment in the test room included a cable-current power supply,⁴ and a pulse echo type of fault locator useful from a point in the cable to the adjacent repeater on each side.

[‡]First end out of the cable tank.

LAYING SEQUENCE

H.M.T.S. *Monarch* is the largest cable ship afloat, with capacity of about 2,000 miles of the type D deep-sea cable in her tanks. However, because of the inherent limitation on bending radius, the presence of flexible repeaters in the cable puts an added restriction on the height to which the coil can be permitted to rise in the tanks, so that for repeatered type D cable the capacity is only about 1,600 n.m. Types A and B cable, used in shallower waters, are considerably larger and heavier than type D and consequently can be carried only in shorter lengths.

The ideal laying program would have involved one continuous passage across the North Atlantic from cable station to cable station, but this would have meant carrying more than 1,900 miles of cable, including about 300 miles of type A and just less than 100 miles of type B.

Each cable was therefore laid in three sections. The No. 1 cable (southernmost), which transmits from west to east, was laid in the following sequence: Clarenville to just beyond the mouth of Trinity Bay, a distance of 200 miles; thence about 1,250 miles to Rockall Bank (a submerged plateau); and finally the remaining 500 miles from Rockall Bank to Oban. The No. 2 cable followed the opposite sequence, starting at Oban and proceeding in three sections of 500, 1,250, and 200 miles to the terminal at Clarenville. Shore ends, about $\frac{1}{2}$ mile long, were prepared and laid before they were needed. At each intermediate point, the cable was "buoyed off," with a mushroom anchor, connecting lines and a surface buoy of size appropriate for the depth of water.

The distances given are the actual cable lengths, and exceed the geographical distances between the points involved because of the slack allowance necessary to ensure reasonable conformance of the cable with the contour of the ocean bed. Normally, about 5 per cent slack is considered desirable in deep water, decreasing to zero in shallow water.

All available information indicated that the most favourable weather conditions in the North Atlantic could be expected in the period May–August. Prior to May, ice could be expected along the western sections of the route, and after August, hurricanes were likely, and later the winter storms.

Laying of the No. 1 cable was started on the 28th June, 1955, and completed on the 26th September. The actual laying period was only 24 days, the remainder of the time being spent in transit and in reloading. The No. 2 cable was laid between the 4th June and the 14th August, 1956, about 16 laying-days being involved.

The routine aboard ship during laying consisted in passing out cable at the rate of 6–7 knots for a repeater section length of a little over 37 n.m., slowing down to about 3 knots as the repeater passed through the cable machinery and overboard, then back to cruising speed again. During all of this period the testing crews, both on board ship and at the transmitting cable station, were busy measuring and recording data and planning the equalization trimming. At a point 12 miles before the passage of the penultimate repeater in an ocean block, special measures were required for the equalization program. At this point the speed was reduced to 5 knots and maintained until the splices associated with the connexion to the subsequent ocean block had been completed. The need for this arose from the following considerations. Stopping of the ship in deep water introduces serious possibility of formation of kinks in the cable, and is to be avoided at all costs. To permit continuous laying it was necessary to determine the amount of cable required for equalization, measure out this cable and complete the ocean block splices before reaching the end of the block.

The addition of an equalizer at the end of the block

requires two joints and armour splices. Preparing the cable ends, brazing together the centre conductor and associated tapes, injection moulding the polyethylene around the centre conductor, replacing and overlaying the armour wires and binding the splice takes 10 hours. An allowance of 3 hours is considered necessary for remoulding in the event of a defective joint (which would be disclosed by X-ray photographs). The time allowance required to complete the splicing of ocean blocks is therefore 13 hours, during which time the ship's speed is maintained at 5 knots to minimize the extrapolation of equalization requirements. Even so, the extrapolation covered the last 65 to 70 miles of each ocean block.

During jointing the system power was reduced to avoid any hazard to the members of the jointing crew; it was restored as soon as the mouldings had been X-rayed and the outer or return tapes had been brazed. These activities were so timed that in almost every case the system was energized as each repeater went overboard.

CLARENVILLE–SYDNEY MINES LINK

Route Selection.

With Clarenville selected as the site of the cable terminal station on the western end of the ocean crossing, it was necessary to consider how the system was to be extended to Nova Scotia for connexion to the North American continental network.

A number of alternatives were possible, as described below:

Alternative 1 involved a radio relay across Newfoundland to Port aux Basques, and thence across the Cabot Strait, but a survey revealed that maintenance access to suitable sites would be most difficult, particularly in winter, and primary power was unobtainable.

Alternative 2 involved a poor submarine route around the Avalon Peninsula to, possibly, Halifax, Nova Scotia, the length of the sea cable being about 600 n.m.; it would be necessary to cross many working telegraph cables (Fig. 3) and known trawling areas, and during the winter months any repairs would be costly and prolonged. Moreover, it was not desired to lay another cable out of Trinity Bay, since the route might be wanted for a second transoceanic cable at some time in the future.

Alternative 3 involved a submarine cable from Clarenville out through the north-west arm of Rantem at the head of Trinity Bay, a short land cable across the isthmus, and thence either a submarine cable direct to Sydney, Nova Scotia, or a land crossing of the Burin Peninsula at Garnish and thence by submarine cable to Sydney. This route involved three open-sea sections with one or two land sections. There was rather limited space for a cable in Placentia Bay and the bottom was uneven and rocky. Existing cables laid around the Burin Peninsula have had interruptions which indicate an unsuitable bottom, and fishing trawlers had recently been seen in the vicinity.

Alternative 4 also involved a cable overland, from Clarenville to Terrenceville at the head of Fortune Bay, there to join a direct submarine cable to Sydney Mines. Three short underwater sections would be involved in the Clarenville–Terrenceville link, but these could be in shallow water out of harm's way. The main submarine route from Terrenceville to Sydney Mines would be clear of other cables and would avoid trawling areas and anchorages—a not inconsiderable achievement in view of the congestion of submarine cables and the fishing activity around the south-east corner of Newfoundland. Furthermore, a good landing site in Nova Scotia was available near Sydney Mines.

After due consideration, alternative 4 was chosen as being the most satisfactory from all aspects and the final route is shown in Fig. 3. This is considered to be most likely

to have a good life history. Although it would have been possible to have one continuous land cable between Clarenville and Terrenceville, the three short underwater sections saved a considerable amount of trenching without adding undue hazard to the system.

Clarenville-Terrenceville Installation.

Having decided to route the single-cable system overland from Clarenville to Terrenceville, a number of other matters required decision, the first being the type of cable to be used. Several alternatives were considered, bearing in mind such factors as terrain, access, availability of primary power, possible future expansion of capacity and, of course, interference from static and radio-frequency pick-up. The advantages of using standard solid-dielectric ocean-type coaxial cable with submarine-type repeaters were judged to outweigh all other considerations and left only one problem, namely shielding from interference.

Up to this time, the shore ends of submarine cables used by the British Post Office were shielded for about $\frac{1}{4}$ mile from shore by a lead sheath insulated from the return tapes of the coaxial cable by a polyethylene barrier. Experience indicated that such shielding might not be effective over a long distance on land, and the question was resolved by the use of standard submarine cable to which iron shielding tapes and a plastic jacket had been added.⁵

Through the use of this robust wire-armoured cable and two steel-housed submarine repeaters, no limitations from noise pick-up were placed on the detailed route selection for the overland section. The first idea was to proceed directly across country from Clarenville to Pipers Hole River, saving at least 10 miles over a route that followed the road, and on which advantage might be taken of quite long stretches of water into which the cable could be laid. (Black River Pond, for instance, is $4\frac{1}{2}$ miles long.) This proposal was abandoned after surveys, because of the very rocky nature of the country, and difficulty of access both for construction and any subsequent maintenance; it was therefore decided to follow the general course of the roads.

It was possible to avoid trenching in the rocky, precipitous cliff country from Clarenville to Adeytown by laying about 6 miles of cable in the water of the north-west arm of Random Sound. Similar considerations dictated the laying of 2 miles of cable in the sea across the south-west arm. Thence the route followed the road, at distances ranging from 250 yd to more than a mile, as far as Placentia Bay, taking advantage of the larger ponds where possible, to avoid trenching.

Reaching the 800-ft-high ground beyond Pipers Hole River from the north of Black River proved quite difficult. Here the road is carved out of the foot of the cliffs as far as Swift Current, and the country behind is solid rock. Plans exist for a hydro-electric project involving dams in Pipers Hole River just north of the road crossing, and it is naturally undesirable to bury a cable in such a locality. The river estuary passing by Swift Current presents only a narrow 6-ft-deep navigable channel at low water, but it was decided that this could be used for some 6 miles by employing a barge and a shallow-draught tug for the laying.

Locating a suitable route out of the basin up through wooded gorges to the top took about a week and was difficult, but progress thereafter was straightforward, advantage being taken of ponds such as Long Pond (4 miles) and Sock Pond (3 miles) until the route arrived within 6 miles of Terrenceville. Here it was reluctantly decided to bury the cable in a deep trench on the inner side of the road, since the other side falls sharply to the sea. The desire to avoid roads was due to their instability and the methods used for

construction and repair. This road is dirt only, with no foundations, and in this particular section has been known to slide away into the river bed below.

The final length of cable laid was just short of 55 n.m.

Laying across Cabot Strait.

Coaxial submarine cables in which rigid repeaters are inserted cannot be laid by the existing cable-laying machinery without stopping the ship, removing the turns of cable from the drum, and then passing the repeater by the drum and restoring the turns. Special equipment is also needed for launching the repeater over the bow sheaves.

Modifications to the Ship.—The following equipment was installed on the *Monarch* for laying the cables carrying rigid repeaters.

A gantry over the bow baulks, consisting of a 22-ft steel beam projecting 6 ft beyond the sheaves, was installed for handling repeaters at the bow, and was fitted with an electrically-operated travelling hoist to lift the repeaters over the bow sheaves and lower them into the sea. A standby hand-operated lifting block and traveller were provided to guard against failure of the power point.

A rubber-tyred steerable steel trolley was developed to transport the repeaters from the cable-tank hatches to the bow sheaves, since each repeater weighs about 1,200 lb.

Storage racks were built from steel sections provided with shaped rubber-lined wood blocks and were fitted at each cable tank hatch on the shelter deck; each rack held four repeaters in double tiers. A hand-operated lift was furnished for moving the repeaters from the storage racks to the trolley. A special quick-release grip was provided for use when lifting the repeaters by the electric hoist on the bow gantry. Deflection plates were also fitted on the foredeck around dynamometers and hatches to avoid their fouling the trolley.

Launching rigid repeaters.—The rigid repeaters were stowed in their racks in the order of their laying. The bights for the cable attached to the ends of the repeaters were brought up the sides of the cable tanks, secured along the arms of the crinoline and up the sides of the hatch coamings to the deck, clear of the running length of cable and at a point from where the repeater could be drawn forward along the deck on the trolley.

When a repeater was to be laid, the ship was stopped head to wind. A 6×3 compound rope from the starboard cable drum was secured to the cable just abaft the bow baulks, and sufficient cable was paid out until the tension was taken up by this rope. The turns of the running cable were then removed from the port cable drum and the resulting slack cable was worked overboard by paying-out the starboard drum rope which was holding the tension. When the excess cable had been cleared from the deck, the repeater was carefully hauled along the foredeck on its trolley to the travelling hoist of the overhead gantry. Cable was then drawn from the tank so that the turns could be reformed on deck and replaced on the port cable drum. The repeater was lifted from the trolley and traversed outboard as soon as it was high enough to clear the bow baulks. It was then lowered to the water's edge, and when the tension had again been taken by the cable, the quick-release grip was slipped and the starboard drum rope was cut. Paying-out was then resumed.

Laying program.—On the 1st February, 1956, the *Monarch*, having been refitted, began loading the various sections of cable to be used for the Terrenceville-Sydney Mines route. The sections were all carefully tested and measured in the works before loading. The cable ends were clearly marked and linked together by a length of rope which was not removed until the repeater had been jointed into its connecting sections of cable.

Loading of the cable and splicing-in of repeaters was

finished by the 10th April, and the system was tested and checked. The *Monarch* sailed for Sydney Mines on the 18th April and arrived there on the 30th April. The cable station is situated about $1\frac{1}{2}$ miles inland, with a small lake intervening. A length of type B insulated-outer-conductor lead-covered cable had previously been laid from the station across the lake to a narrow strip of land which separates it from the sea. The joint to the main cable was to be made on this strip. Two medium-sized motor boats were used to tow the end of the double-armoured section of cable from the *Monarch* toward the shore, the cable then being supported by empty oil drums at close intervals. When the motor boats reached shoal water the end of the cable was secured to a landing line and two tractors took over the hauling.

When enough cable was on shore to make the joint and the splice, the drums were cut away and the *Monarch* weighed anchor and paid out the section of double-armoured cable on the agreed route and buoyed-off the end. She then steamed over the proposed route to Terrenceville, taking soundings and sea-bottom temperatures as required, anchoring off Terrenceville on the 3rd May.

Preparations for landing the end were at once put in hand and the ship's motor launches towed the end of the cable towards the cable landing, the cable again being supported by empty oil drums. This end was jointed and spliced to a section of cable which had been laid previously from the Terrenceville cable hut to a sand spit jutting across the head of Fortune Bay about a mile away.

Upon completion of the splice, overall tests were made from the ship to the Terrenceville cable hut, and all being well, paying out toward the buoyed end off Sydney Mines was begun on the 4th May. The first repeater went overboard about 2 hours after the start of laying and the others followed at intervals of approximately $4\frac{3}{4}$ hours.

On the 7th May the cable buoy on the Sydney Mines end was recovered and the end hove inboard. After tests in both directions, the final joint and splice were made.

This operation was completed on the 9th May, and on receipt of a signal that all was well, the *Monarch* proceeded into harbour at Sydney to land testing equipment, a spare equalizer and other equipment.

Equalization and testing.—The cable had been loaded into the ship in repeater section lengths, so cut that when laid at estimated mean annual sea temperature, the expected attenuation would be 60.0 dB at 552 kc/s. A correction for the change in attenuation of the cable when coiled in the factory tanks and when laid in about 100 fathoms had been determined from tests on two 10-mile lengths of cable laid off the Isle of Skye. The correction amounted to a decrease in attenuation when laid of 1.42 per cent. This is essentially an empirical result, and since the mechanism of the change is not fully understood, a possible further inaccuracy of equalization might arise. Sea-bottom temperatures along the route were obtained from information supplied by the Fisheries Research Board of Canada, but unfortunately, this information was rather meagre and varied considerably with locality.

Since the cable equalization built into the repeater differed appreciably from the final determination on laid cable, it was found necessary at a comparatively late stage to introduce an undersea equalizer into the centre of the sea section to eliminate a flat peak of loss of 3.5 dB, expected at about 100 kc/s. So that the last repeater should not lie too near the beach at Sydney Mines, a network simulating 9 miles of cable was also inserted in the undersea equalizer.

The repeaters were spliced into the cable lengths on board the *Monarch* and tests were made at every stage of the work. The equalizer was permanently jointed to the first half-section of seven repeaters and left with an excess length of tail which could be cut as desired during the laying

operation to improve the equalization further. The first and second halves of the system were temporarily connected through power-separation filters, so that the whole system could be energized just prior to laying.

The test routine carried out included attenuation measurements at five frequencies in each direction of transmission; noise, pulse, loop-gain and supervisory measurements; and measurements of conductor and insulation resistance, and of capacitance. The *Monarch* test room, therefore, contained two sets of terminal equipments similar to those installed at Clarenville and Sydney Mines.

It was decided to energize the system continuously during the laying except for the few hours when power had to be removed to make the equalizer splice. This enabled a speaker circuit to be operated over the cable and minimized the number of energizing and warming-up periods. The only disadvantage—considered to be slight—was the necessary omission of insulation-resistance and capacitance measurements during laying, except in the course of the equalizer splicing operation.

The plan was to lay from Terrenceville in the direction of the high-frequency band, and to test the system to the *Monarch* during the laying from this shore station. The overland section between Clarenville and Terrenceville, which contained two repeaters, was connected, with appropriate equalization, after the submarine section was satisfactorily completed and tested.

At Terrenceville, after the cable end had been taken ashore and the beach joint completed, the system was energized from the *Monarch* with a d.c. power earth at Terrenceville for the necessary 4-hour minimum warming-up period. The first set of routine measurements of the laying operation was then carried out. Thereafter, a complete set of measurements on the Terrenceville half of the system was made after every 10 miles of cable had been laid. An occasional check set of measurements was also made on the Sydney Mines part of the system in the tanks.

The primary object of these tests was to determine the length of cable to be inserted between the equalizer and the eighth undersea repeater to obtain the optimum system. In practice this resulted in arranging for a length of cable such that the output level of the eighth repeater at 522 kc/s should be equal to that at the output of the first repeater at the assumed mean annual temperature of 35.1°F.

The estimated length of cable required for this purpose was plotted after each measurement. It became evident soon after laying the fifth repeater (94.6 n.m. of cable laid) that the linear relation obtained could be extrapolated with adequate accuracy to specify safely a length of 6.06 n.m. of cable between the equalizer and the adjacent repeater.

This decision on length was taken, the cable de-energized and the equalizer jointed in, the operation being completed before it was necessary to pay out the splice. During this period, capacitance and conductor and insulation resistances were checked on each half. During the laying of the second half, measurements were made as for the first half. On arrival at the buoyed shore end, a final complete set of measurements was made, and these, suitably corrected for the shore-end length, were transmitted to Sydney Mines so that the first measurements from Sydney Mines to Clarenville could be checked with those obtained on the ship.

CONDITIONS AT SEA

Weather is the big problem in cable laying and repair activities. With few exceptions, the transatlantic project was blessed with remarkably good weather. The exceptions were, however, noteworthy. Heavy snow squalls were encountered during the operations off Terrenceville, while at Rockall Bank, on the first lay, one heavy storm set in as the last repeater in the 1,250-mile section was being paid out, and made its launching and the buoying

of the end very difficult. A second and worse storm—a manifestation of hurricane "Ione"—was encountered upon the return to Rockall, with winds above 100 m.p.h. and very high seas. The ship had given up searching for the Rockall buoy (later reported more than 500 miles away off The Faeroes), and was grappling for the cable when the storm struck. Fortunately, the cable had not then been found, so the ship could head into the wind and ride the storm; she was driven many miles off her course in the process, but the cable was picked up shortly after the storm had moderated.

At the start of the first lay, several icebergs were encountered. One, a small one at the mouth of Random Sound, lay in the path of the cable, and therefore caused an involuntary, though minor, revision of the route. The others, beyond the mouth of Trinity Bay, were larger but also farther away.

Whales and grampuses became common sights, and an occasional bird rested on the ship in mid-ocean, obviously exhausted from its long and presumably unintended journey.

During the laying, daily progress bulletins were sent by radio to the headquarters of all partners. In addition, because this telephone cable system differs considerably from submarine telegraph cables, the officers and crew of the *Monarch* were briefed by the engineering personnel as to the repeater structure, the need for equalization and the general objectives of the venture. This proved to be a very profitable move indeed, for the co-operation of all hands was everything that could be wished. Daily performance bulletins were posted in strategic parts of the ship, so that everyone knew how the evolving system was performing with respect to the objectives.

One-way conversation from shore to ship over the cable was possible all the time the repeaters were energized. This was a source of great satisfaction to the shipboard test crew, since it was concrete evidence that the cable was working. When power was reduced, the recourse to radio-telephone provided a comparison which generally left no doubt as to the future value of the cable.

ACKNOWLEDGMENTS

When the final splice was slipped into the water at Clarendville, on the 14th August, 1956, there was completed a venture quite unique in the annals of submarine cable-laying. And here, perhaps more than in any other phase of the transatlantic project, did the successful conclusion provide evidence of the friendly and harmonious relationships between the different organizations and nationalities involved, and of the close co-ordination of their efforts.

Special mention must be made of Captain J. P. F. Betson and his crew for their superb handling of H.M.T.S. *Monarch*.

References:

¹GLEICHMANN, T. F., LINCE, A. H., WOOLEY, M. C., and BRAGA F. J. Repeater Design for the North Atlantic Link. (In this issue of the *P.O.E.E.J.*)

²LEWIS, H. A., TUCKER, R. S., LOVELL, G. H., and FRASER, J. M. System Design for the North Atlantic Link. (In this issue of the *P.O.E.E.J.*)

³LEBERT, A. W., FISCHER, H. B., and BISKEBORN, M. C. Cable Design and Manufacture for the Transatlantic Submarine Cable System. (In this issue of the *P.O.E.E.J.*)

⁴MESZAROS, G. W., and SPENCER, H. H. Power-Feed Equipment for the North Atlantic Link. (In this issue of the *P.O.E.E.J.*)

⁵HALSEY, R. J., and BAMPTON, J. F. System design for the Newfoundland-Nova Scotia Link. (In this issue of the *P.O.E.E.J.*)

Modifications to the Cable Machinery in H.M.T.S. Monarch

A. J. THOMSON†

U.D.C. 621.315.284

The cable machinery in H.M.T.S. "Monarch" was designed for handling deep-sea telegraph cable, for which a comparatively small bending radius is permissible. A much larger minimum bending radius was necessary to avoid damage to the flexible repeaters in the transatlantic telephone cable, and comprehensive modifications of the cable machinery, from bow to stern, were therefore necessary. Special equipment was also provided on "Monarch" for handling the rigid repeaters in the Newfoundland-Nova Scotia section of the cable.

INTRODUCTION

THE layout of cable machinery fitted on H.M.T.S. *Monarch* is shown schematically in Fig. 1. This layout is normal in cable ships and although certain items on *Monarch* have been modified from time to time for special work, and most recently for the transatlantic telephone (T.A.T.) cable project, the general arrangement is still the same as when the cable machinery was originally installed for laying and repairing submarine telegraph cables of small diameter.

Cable machinery is a fairly specialized type of equipment and the modifications necessary on *Monarch* for handling the T.A.T. cable can be more readily appreciated by considering first the functions of the main items of machinery, and the main items of plant are therefore numbered on Fig. 1 for ease of reference in the following brief description of their functions.

of lifting a load of 20 tons. To prevent lateral traverse of the cable on the drums of the cable engine due to the helix formed by the turns of cable round the drum, and consequent overriding of the cable, wedge-shaped devices, known as fleeting knives, which conform circumferentially to the drums, are fitted.

Hauling-off Gear consists of a V sheave (5) driven from the cable engine, the gear ratio being such that the speed of the sheave is about 5 per cent faster than the speed of the cable drum, and ensures sufficient haul-off tension to keep the turns of cable tight on the drum.

Guide Sheaves and Rollers, fitted in various positions, numbered (6) to (15) in Fig. 1, have the sole function of guiding and supporting the cable on its passage through the ship.

Holding-back Gear (16) is made up of two V sheaves in line, over which the cable passes from the tanks to the after

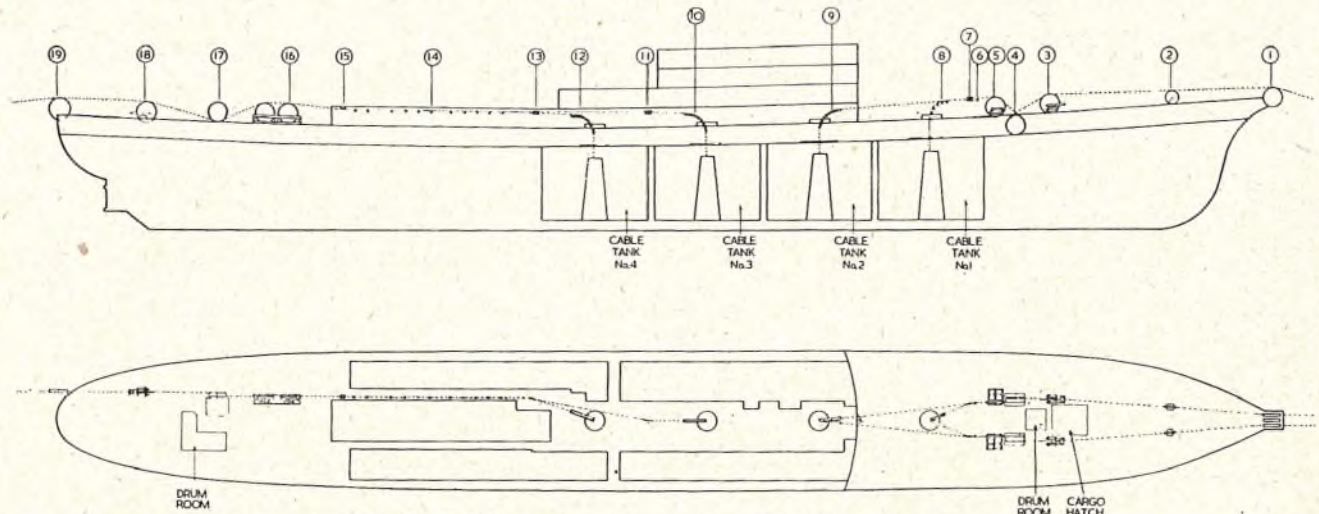

FIG. 1.—LAYOUT OF CABLE MACHINERY IN H.M.T.S. "MONARCH."

Bow Sheaves are the three sheaves (1) secured to the overhanging bow. When a cable is being picked up from the sea-bed it is drawn over the bow sheaves by the cable engines (4), and passed aft into one of the four cable storage tanks. Also, when paying out, the cable is drawn from the tanks and passed over these sheaves.

Span Sheaves or Lead Sheaves are freely rotating sheaves (2) which guide and support the cable.

A Combined Lead Sheave and Dynamometer is a sheave (3) which guides and directs the cable to the correct axial position on the cable drum (4) when picking up and also performs, in a manner explained later, the function of a dynamometer for measuring the tension in the cable by means of an Elliott load cell. A wire strain gauge is incorporated in the cell. This utilizes the well-known strain/resistance relationship of conducting materials and consists of a fine resistance wire of about 0.001 in. diameter bonded to a paper backing and on to which the pressure due to the tension in the cable is transmitted.

The Forward Cable Engines (4) are winding engines capable

of lifting a load of 20 tons. Each sheave is provided with a friction brake and their function is to apply sufficient back tension in the cable to prevent the turns of cable from slipping on the drum of the after cable engine.

The After Cable Engine (17) is similar to the forward cable engine but is designed specifically for paying out cable over long distances and is provided with friction, electrical and fan brakes of sufficient power to maintain the required tension in the cable when being laid in deep water.

The After Dynamometer (18) and *Stern Sheave* (19) perform similar functions to the corresponding items in the bow of the ship.

MODIFICATIONS TO THE CABLE MACHINERY IN H.M.T.S. "MONARCH"

The alterations to the cable-laying equipment were extensive and were required to conform to the Bell Telephone Laboratories' stipulation that the flexible repeaters must at no time be bent round a radius of less than 3 ft 6 in. All the sheaves, cable drums, etc., in *Monarch* were designed for handling deep-sea telegraph

† Senior Chief Engineer, Submarine Branch, E.-in-C.'s Office.

cable and were well below the dimensions required for the T.A.T. cable, and a comprehensive modification from bow to stern was therefore required. As the original cable machinery had been designed and manufactured by The Telegraph Construction and Maintenance Co., the modifications were also entrusted to them. The following is a brief description of the various alterations made for laying the cable containing flexible repeaters, commencing from the bow of the vessel.

Bow Sheaves.

The original 3 ft 3 in. diameter bow sheaves had been replaced in 1954 by a new bow assembly, having V sheaves 6 ft in diameter on the tread, specially for the laying of power cables in the St. Lawrence River, and these were the largest V sheaves which could be fitted to the existing girders. It was, however, found possible to replace the port V sheave by a flat-tread sheave of 6 ft 10 in. diameter (Fig. 2), within the same bearings and without structural alteration, and this dimension was accepted.



FIG. 2.—BOW SHEAVES, WITH NEW FLAT-TREAD PORT SHEAVE.

Load Cell Dynamometers.

The standard dynamometers and lead sheaves on each side of the fore deck were removed and 4 ft 6 in. diameter span sheaves set up midway between the cable engines and the bow sheaves as cable guides. The lead-off sheave on each side of the ship was replaced by a combined lead sheave and load cell dynamometer, 7 ft diameter on the tread. This type of dynamometer, designed and developed by T.C. & M., is novel for use in cable ships.

The cable passes over the dynamometer sheave (Fig. 3), the bearings of which are located on a balanced rocking lever one end of which bears on to the anvil block of the load cell. The strain gauge in the cell is connected to a magnetic amplifier to which are connected tension indicators placed at several points in the ship, i.e. bow, forward drum room, cable engine control, on the bridge, and in the testing room, enabling accurate observation to be made by the ship's personnel on duty at these positions.

Two scales are provided, one reading 0-400 cwt and the other 0-130 cwt. The change-over from light to heavy scale is made by a switch, and lamps are provided to indicate the scale in use. Recorders in the testing room provide a printed record of the cable tension for the whole lay.

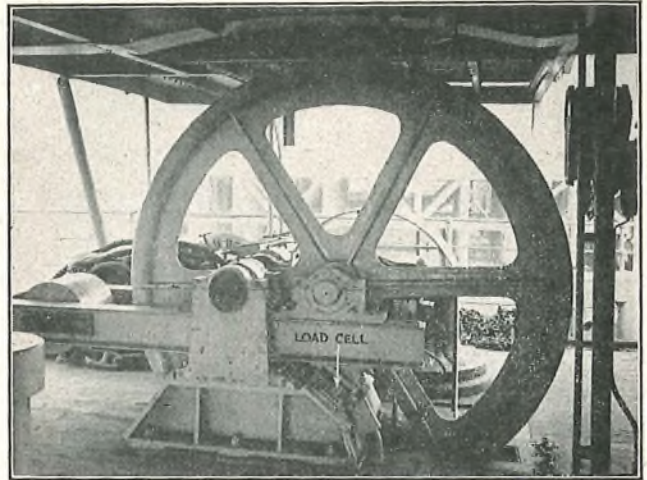

FIG. 3.—DYNAMOMETER SHEAVE.

Forward Cable Engines.

New drums of greater diameter and of increased width were fitted to the port and starboard cable engines to replace the original 5 ft 8 in. diameter drums. Owing to space limitations it was not possible to fit drums 7 ft in diameter; 6 ft 10 in was the maximum diameter which could be accommodated and this was considered close enough to the requirements to be accepted.

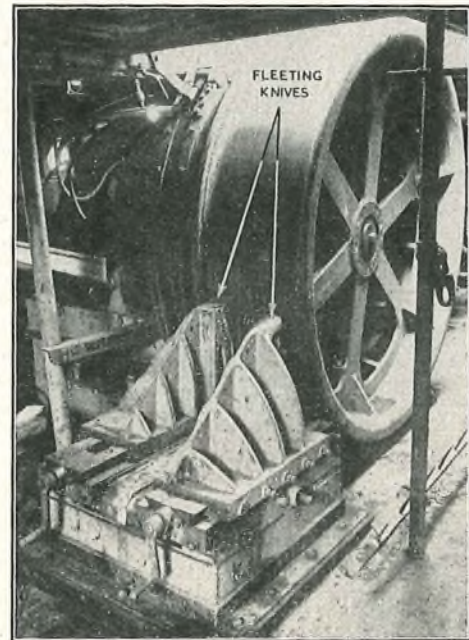

FIG. 4.—FLEETING KNIVES.

New fleeting knives (Fig. 4) of a more robust design were provided to suit the larger drum and were adjustable in fore and aft and athwart-ships directions. A spring-loaded "ironing board" was fitted to the port cable engine to ensure that the flexible repeater would conform closely to the curvature of the drum during its passage round the drum. A photograph of this device is shown in Fig. 5. It consists essentially of a spring-loaded curved steel plate approximately 3 ft long by 1 ft wide, bolted on a strong framework to the ship's structure and adjustable radially to give a clearance slightly less than the diameter of the repeater between its working face and the surface of the cable drum. New hauling-off gears (Fig. 6) with 7-ft diameter sheaves, traversable on the driving shafts, were also installed.

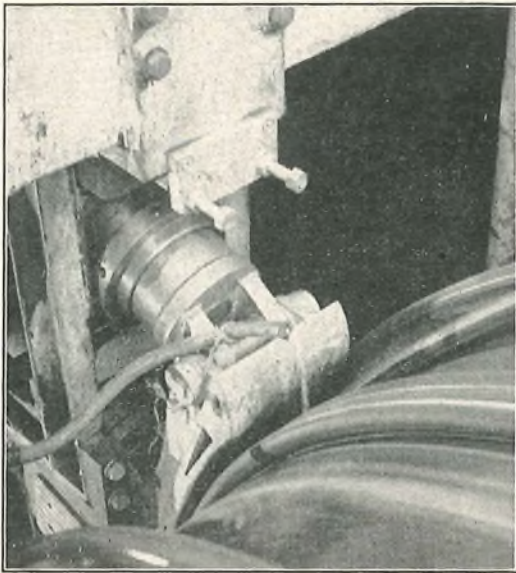

FIG. 5.—IRONING BOARD ON FORWARD PORT DRUM.

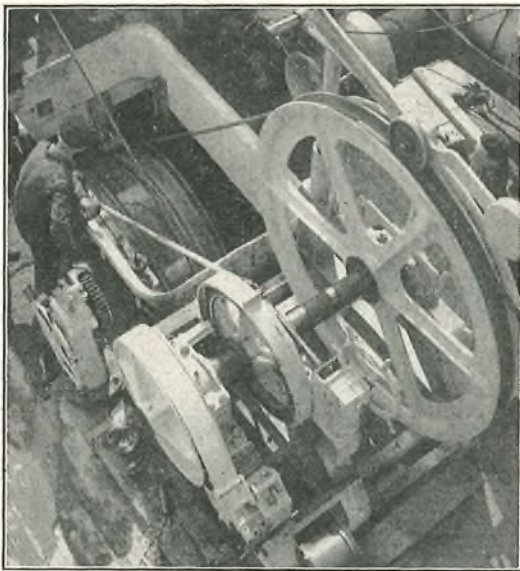

FIG. 6.—FORWARD PORT HAULING-OFF GEAR.

Cable Leads from Tanks.

Roller track cable leads (Fig. 7) conforming to the required radius were provided to replace the existing spider sheaves (Fig. 8) at the tank hatches, and roller groups of four rollers each were fitted at the centre-castle door forward, the forward end of the port alleyway leading aft, and between cable tanks 3 and 4. Rollers on bulkhead brackets at 6-ft intervals were also installed in the port alleyway and a 4-roller group was installed at the doorway aft of this alleyway to guide the cable to the after paying-out machine.

Crinoline Hoisting Gear.

The crinoline[†] is a device inside the cable tank to control the cable and prevent kinking when paying out. An inner ring surrounds the central cone of the tank and is located by an outer ring, which is slightly smaller in diameter than the cable tank, connected to it by radial arms.

[†] The crinoline is illustrated in Fig. 7 of "Route Selection and Cable Laying for the Transatlantic Cable System," in this issue of the *P.O.E.E.J.*

[§] The new stern sheave assembly is illustrated in Fig. 9 of "Route Selection and Cable Laying for the Transatlantic Cable System," in this issue of the *P.O.E.E.J.*

The cable passes up between the inner ring and the cone.

Lifting wires connected to the radial arms are used for raising and lowering the crinoline. The original hand hoisting arrangements for the crinolines were converted to power operation in order that the crinolines could be hoisted rapidly just prior to the repeaters leaving the tanks and so prevent any sharp bending of the repeaters when passing through the inner ring of the crinolines.



FIG. 7.—NEW ROLLER TRACK CABLE LEADS AT CABLE TANK NO. 1.

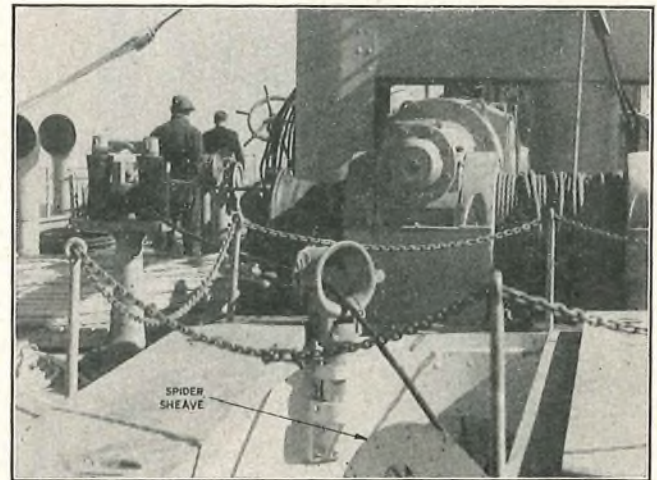

FIG. 8.—FORMER SPIDER SHEAVE AT CABLE TANK NO. 1.

After Paying-out Gear.

A new paying-out drum 7 ft in diameter and of increased width, and appropriately heavier fleeting knives, were fitted to the after paying-out gear, and, as for the forward machine, an "ironing board" (Fig. 9) was also provided. The existing holding-back gear was replaced by a new assembly (Fig. 10) having two 7-ft diameter sheaves.

A combined lead sheave and load cell dynamometer, similar to that fitted on the foredeck, was installed to replace the standard pattern and was located approximately midway between the paying-out drum and stern sheave. A tension indicator in the view of the cable engine driver, with repeats in the after drum room, testing room and bridge, was provided for close checking of the cable tension during laying operations.

Stern Sheaves.

A new stern sheave assembly[§] was fitted, having a 7-ft

diameter sheave and special "whiskers" (the circumferential guards round the outer and lower edges of the sheave) with a 3 ft 6 in. radius in order to avoid unduly sharp bends in the repeater when the direction of the cable leaving the ship and the course of the vessel were not in the same line.

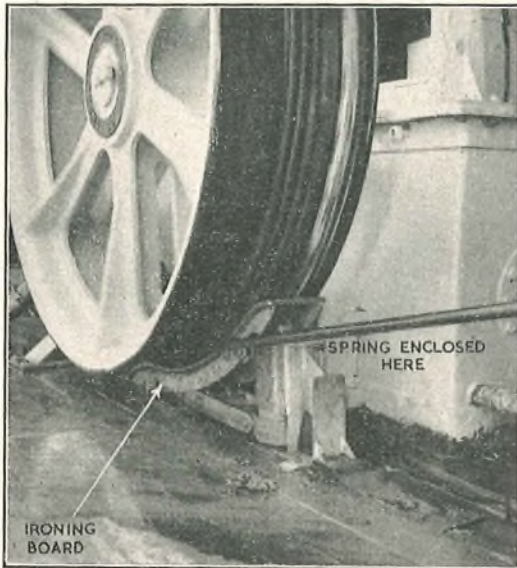

FIG. 9.—IRONING BOARD ON AFTER PAYING-OUT DRUM.

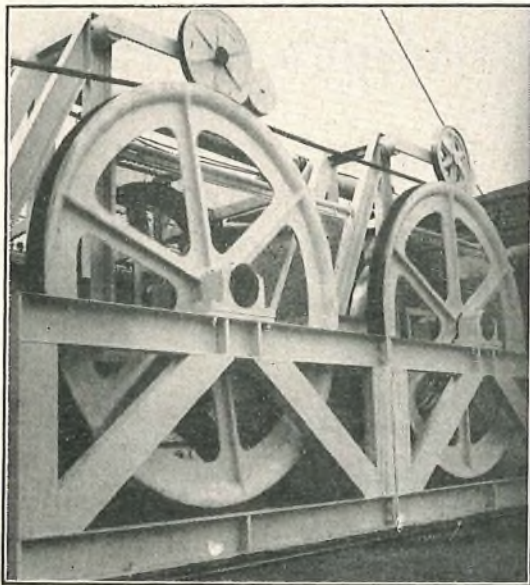

FIG. 10.—AFTER HOLDING-BACK GEAR.

Slackometer and Tachometers.

For accurate control of the slack during laying, a slackometer of entirely new design was developed. A "Selsyn" transmitter is driven by the dynamometer sheave and is connected to a selsyn receiver in the after drum room. The selsyn transmitter is a generator of special design, driven through gearing by the dynamometer sheave, and the receiver is a motor. Both are linked electrically so that the armature speeds are synchronized. Another selsyn transmitter is driven by the sheave of the taut-wire gear and is also connected to a selsyn receiver in the drum room. The selsyn receivers are arranged to drive counters giving an accurate and direct reading of the amount of cable and taut wire paid out. Two counters are provided for both the cable and the wire, one to record the total length and the other arranged for resetting to check short lengths. The unit incorporates a device that compares the length of cable paid out with the length of

wire paid out in a period of time and shows the difference as "percentage slack"; the reading is optically projected on to a small ground-glass screen. A similar unit is fitted in the forward drum room and the counter readings from both forward and aft are repeated in the testing room. Two rotary converters were installed to provide the necessary alternating current. Tachometer generators driven by the dynamometer sheaves show the rate of picking up or paying out, in knots, on indicators located at the forward and after control points.

Miscellaneous Facilities Provided.

Alternating current supply.—An ample supply of alternating current for testing and operation of the jointing and brazing machine was provided by installing a steam-driven alternator with an output of 30 kW at 230V and 50 c/s. A 4-kW step-down transformer, 230/110V, to provide current for jointing and brazing was also installed.

Speaker system.—An amplifier system was installed for direct communication between the cable tanks and cable-engine driver aft, to advise him whenever a repeater was about to leave the cable tank. Previous to this installation the only method of communication was by whistle and word of mouth from man to man, which was slow and liable to misinterpretation.

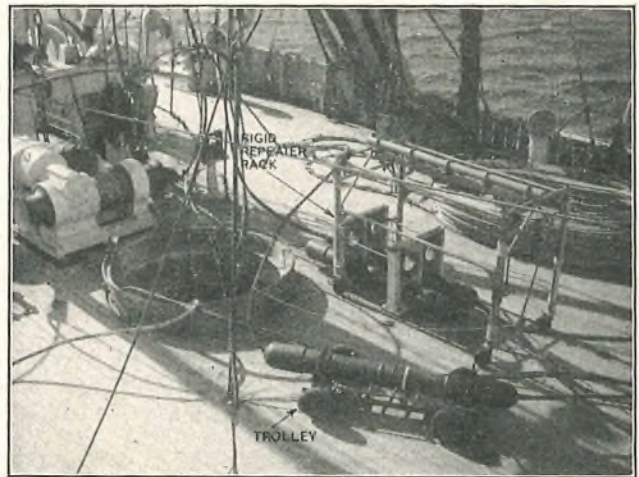

FIG. 11.—STORAGE RACK AND TROLLEY FOR RIGID REPEATERS.



FIG. 12.—OVERHEAD GANTRY AND ELECTRIC HOIST FOR RIGID REPEATERS.

Working facilities.—Six rows of quadruple, double and single J hooks were installed in the centre-castle to hang repeaters and cable while jointing. The centre-castle is the amidships structure in the ship embracing the officers' accommodation and providing also the covered working space.

FACILITIES FOR HANDLING RIGID REPEATERS

A number of special items of equipment for dealing with the rigid repeaters in the Newfoundland–Nova Scotia section of the cable were also provided; they included:—

(a) Storage racks (Fig. 11) built up from steel sections with shaped, rubber-lined, wood blocks, each holding four repeaters in double tiers. One of these racks was fitted, between each adjacent pair of cable tanks, on the shelter deck.

(b) A steel trolley (or truck) shown in the foreground of Fig. 11, developed from the chassis of a "dodgem car," was

provided to transport the repeaters from abaft the cable engine to the bow sheaves.

(c) A gantry over the bow, consisting of a rolled-steel joist 22 ft long and projecting 6 ft beyond the sheaves, was installed for dealing with the rigid repeaters at the bows. The gantry (Fig. 12) is fitted with an electrically operated travelling hoist for lifting the repeaters over the bow sheaves and lowering them into the water. As a standby, a hand-operated lifting block and traveller were provided to guard against failure of the power hoist.

ACKNOWLEDGMENT

It is desired to acknowledge indebtedness to The Telegraph Construction and Maintenance Co., of Greenwich, for their helpful co-operation at all stages of the design, manufacture and installation of the modified cable machinery, and in particular for the development of the new dynamometers, ironing boards and slackometer.

Some Navigational Aspects of Cable Laying Across the North Atlantic

U.D.C. 621.396.932.1 : 621.315.284

IN the present era of electrical aids to navigation, the old astronomical methods of navigation need rarely be used in certain areas. Nowadays, so far as the North Atlantic is concerned the "Decca" system¹ is used inshore and the "Loran" system² in the open ocean.

That both of these methods of electrical position finding are a great asset is as undeniable as the positions so obtained are reliable, and for position finding during the laying and future maintenance of the transatlantic telephone cables it appears that over most of the route sextants and chronometers need only be carried as a precaution against failure of the receivers in the ship or for a general check upon the performance of these receivers. There is, however, a gap of 350 miles or so in the mid-ocean area where positions found by Loran are not of much value.

The value of the electrical aids to navigation was very effectively demonstrated in *Monarch* when the ship left St. John's, Newfoundland, on 16th July, on passage to London, and 5 miles out of St. John's ran into fog with visibility of 2 or 3 cables.† These conditions persisted for three days and nights and the ship continued on her way using radar as her eyes and Loran for position finding until, after 860 miles, the first check on position by solar observation was possible. This check revealed a difference of only 1 mile between the Loran and the astronomical positions; a class of performance that is obviously of the

greatest value. The Loran stations used during this run were those in Newfoundland, Labrador and Greenland.

In 1955 a similarly convincing demonstration based upon the Hebrides, Faeroes and Iceland stations was made when *Monarch* proceeded from Oban, upon completion of the laying of the No. 1 transatlantic telephone cable, to recover a marker buoy in Long. 19° West. This passage was made in bad weather with visibility seldom more than 2 miles and no astronomical observations were obtainable, so the first part of the passage was made on Decca positions, and the later part on Loran. The ship was taken satisfactorily right to the buoy, which was recovered without loss of time, and passage back to London was then resumed.

These aids, as can be seen, have greatly helped to obtain increased efficiency in cable operations and in navigation generally. They contribute to safety at sea very decidedly and on cable operations save a great deal of time which would otherwise be spent in waiting to obtain reliable astronomical positions.

J. P. F. B.

† A "cable" is $\frac{1}{6}$ nautical mile.

¹ O'BRIEN, W. J. Radio Navigational Aids. *Journal of the British Institution of Radio Engineers*, Vol. 7, p. 215, 1947.

² PIERCE, J. A. An Introduction to Hyperbolic Navigation, with particular reference to Loran. *Journal I.E.E.*, Vol. 93, Part III, p. 243, 1946.

System Design for the North Atlantic Link*

H. A. LEWIS, E.E., Senior Member, I.R.E.,
 J. M. FRASER, B.E.E., G. H. LOVELL, B.S. in E.E., and
 R. S. TUCKER, A.B., S.B., Associate Member American I.E.E., †
 Senior Member, I.R.E.

U.D.C. 621.395.52

Specific aspects of the transatlantic cable system are covered in companion papers. The purpose here is to examine the design and performance of the North Atlantic link, including consideration of factors governing the choice of features, a description of the operational design of the link, and an outline of measures available for future application in the event that faults or ageing require corrective action.

DESCRIPTION OF LINK

THAT portion of the transatlantic system¹ which connects Newfoundland and Scotland consists of a physical 4-wire, repeatered, undersea link, with appropriate terminal and power-feeding equipment in cable stations at Clarenville and at Oban. This is shown in outline in Fig. 1.

The various elements comprising the link are shown in block schematic form in Fig. 2. The termination points at each end of the link are the group distribution frames, where the working channels are in three groups in the standard group frequency band, 60-108 kc/s. At the west end, this point provides the interconnexion between the North Atlantic

†The authors are with Bell Telephone Laboratories, Inc.

and the Newfoundland-Nova Scotia links. At the east end, it is the common point between the North Atlantic link and the standard British long-distance plant over which the circuits are extended to London.

Two separate coaxial cables connect Clarenville with Oban, one handling east-to-west transmission, the other west-to-east. Each is about 1,940 nautical miles (n.m.) long. A total of 102 repeaters are installed in the two cables, at nominal intervals of 37.5 n.m. The cables also contain a number of simple undersea equalizers, which are needed to bring system performance within the specified objectives.

The working spectrum of each cable extends from 20 to 164 kc/s, providing for 36 4-kc/s speech channels. Below this band are assigned the telephone speaker and teleprinter

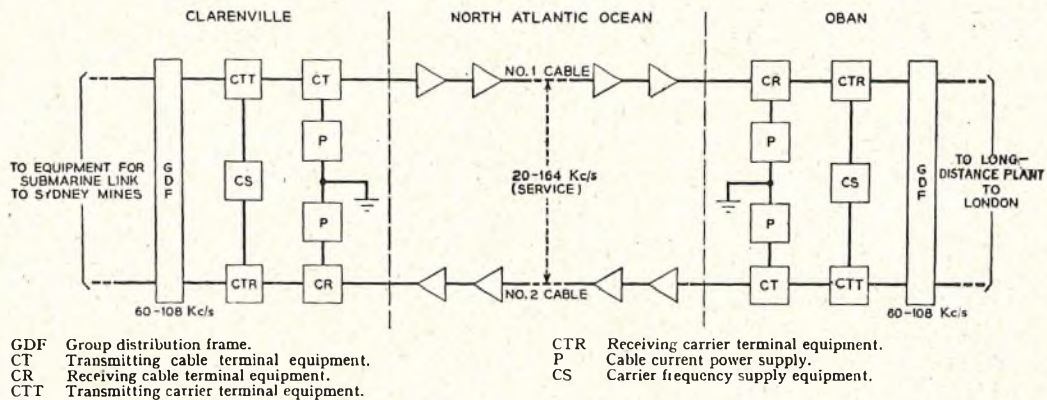

FIG. 1.—NORTH ATLANTIC LINK: OUTLINE DIAGRAM.

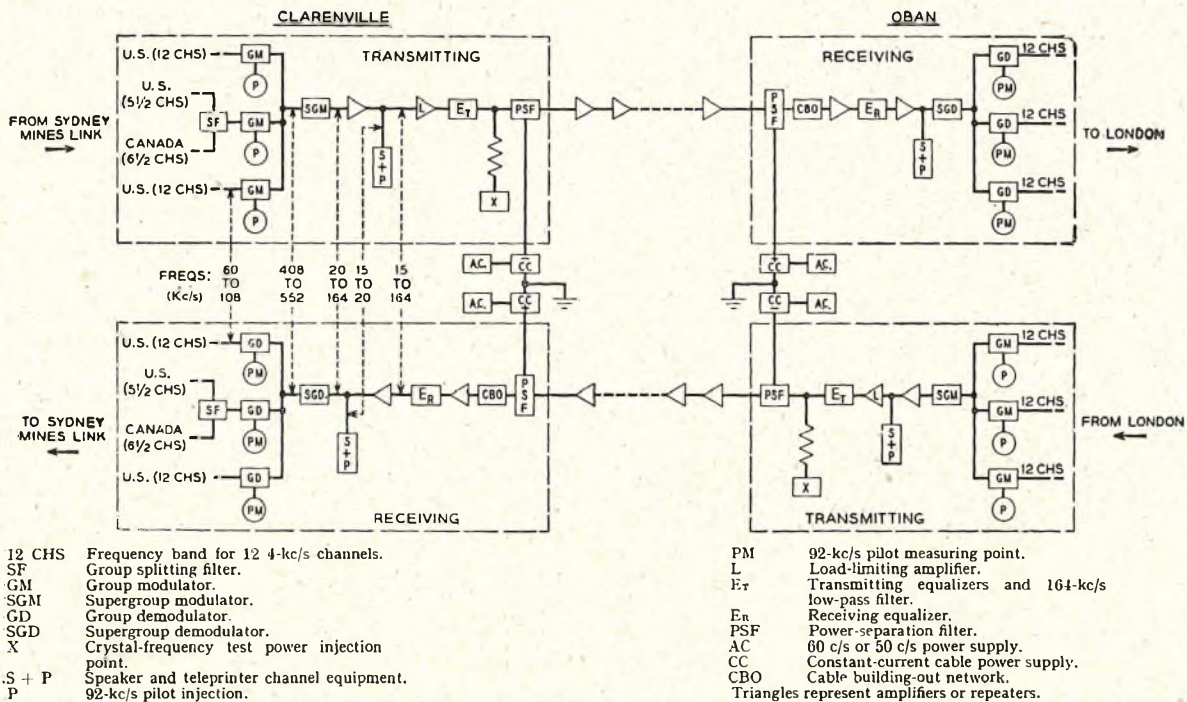

FIG. 2.—NORTH ATLANTIC LINK: BLOCK SCHEMATIC DIAGRAM.

circuits needed for maintenance and administration of the system. Above the working band, between 167 and 174 kc/s, are the crystal frequencies which permit evaluation of the performance of each repeater individually from the shore stations.

The complex signal carried by the cables is derived in the carrier terminal from the signals on the individual audio-frequency circuits by conventional frequency-division techniques such as are employed in the Bell types J, K and L broadband carrier systems. These signals are applied to the cable through a transmitting amplifier which provides the necessary gain and protects the undersea repeaters from harmful overloads. At the incoming end of each cable, a receiving amplifier provides gain and permits level adjustment.

Shore equalizers, next to the transmitting and receiving amplifiers, insert fixed shapes for cable length and level compensation. Adjustable units provide for equalization of the system against seasonal temperature changes on the ocean bed, and some ageing.

The power equipment² at each cable station includes (a) regular primary power with diesel standby, (b) rotary machines for driving the cable-current supplies, with battery standby, (c) battery plants for supplying the carrier terminal bays, and last, but by no means least in complexity, (d) the cable-current supplies themselves. These latter furnish regulated direct current to a series loop consisting of the central conductors of the two cables, with their repeaters. A power-system earth is provided at the mid-point of the cable current supply at each cable station.

FACTORS AFFECTING SYSTEM DESIGN

General.

A repeated submarine cable system differs from the land-line type of carrier system in two major respects. First, the cost of repairing a fault, and of the concurrent out-of-service time, is so great as to put an enormous premium on the integrity of all the elements in the system and on proper safeguards against shore-end induced faults. Secondly, once such a system is resting on the sea bottom, it is accessible for adjustment only at its ends. These two restrictions naturally had a profound influence on the design of the North Atlantic link.

Proven Integrity.

Assurance of reliability dictated the use of elements whose integrity had been proved by successful prior experience. This resulted in the adoption of a coaxial-cable structure explored by the Bell Telephone Laboratories soon after the war, field tested in the Bahamas area in 1948, and applied commercially on the U.S. Air Force Missile Test Range project³ in 1953. It also resulted in the specification of a basic flexible repeater design which had been under test in the Laboratories since before the war, and had been in use on the Key West-Havana submarine cable telephone system since 1950.⁴

The cable adopted was the largest that had been successfully laid in deep water, and its size afforded an important benefit in the form of reduced attenuation. The structure and characteristics of this cable are covered in detail in a companion paper.⁵ Suffice it to point out here that by its adoption for the North Atlantic link, there were specified for the system designers (a) the attenuation characteristic of the transmission medium, (b) the influence on this of the pressure and temperature environments, (c) the contribution of the cable to the resistance of the power loop, and (d) the impedances faced by the repeaters.

The adaptation⁶ of the basic Key West-Havana repeater design to the present project likewise presented the system designers with certain restrictions. Most important, the space and form of the long, tubular structure limited the

size of the high-voltage capacitors in the power-separation filters, and thus their voltage rating, to the extent that this determined the maximum permissible number of repeaters. Likewise the performance of the repeater circuit was at least partially defined because of several factors. One was the effect of the physical shape on parasitic capacitances in the circuit, which in turn reacted on the feedback and hence on the intermodulation performance, gain/band-width and ageing characteristics. Use of the Key West-Havana thermionic valve influenced the above factors and also tended to fix the input noise figure and load capacity.

In similar respects, the principle of proven integrity reacted into the broad consideration of system design. For instance, in a long system having many repeaters in tandem, automatic gain control (gain regulation) in the repeaters provides an ideal method for minimizing the amount of the total system margin which must be allocated to environmental loss variations. However, this would have required the adoption of elements of unproved integrity which might have increased the probability of system failure. So the more simple and reliable alternative was adopted, i.e. fixed gain repeaters with built-in system margins.

System Inaccessibility

The inaccessibility of the undersea system for periodic or seasonal adjustment and the decision to avoid automatic gain regulation were major factors in the allocation of system margins between undersea and shore locations. To avoid wasting such a valuable commodity as margin required the most careful consideration of means of trimming the system during laying. Equalization for control of misalignment in the undersea link is a function of the match between cable attenuation and repeater gain. Generally speaking, these are fixed at the factory. Very small unit deviations from gain and loss objectives could well add to an impressive total in a 3,200-dB system. Accordingly, it was necessary to plan for periodic adjustment of cable length during laying, and, where necessary, insertion of simple "mop-up" undersea equalizers at the adjustment points.

DESIGN OF HIGH-FREQUENCY LINE

Terminology.

The high-frequency line, as the term is used here, includes the cable, the undersea repeaters, the undersea equalizers, and the shore-station power-separation filters, line-frequency transmitting and receiving amplifiers, and associated equalizers.

Repeater Spacing and System Band-width.

As in any carrier system, the attenuation of the line increases with increasing frequency. Hence the greater the band-width of the system, the greater is the number of repeaters needed.

In this system, powered only from its ends, the maximum permissible number of repeaters, and thus the repeater spacing, is determined by a d.c. voltage limitation, as explained later.

With the repeater spacing fixed, and the type of cable fixed, the required repeater-gain/frequency characteristic is known to the degree of accuracy that the cable attenuation is known. The frequency band that can be utilized, then, depends on repeater design considerations, including gain/band-width limitations, signal power capacity, and signal/noise requirements.

The early studies of the transatlantic system were based on "scaling up" the Key West-Havana system. In these studies, consideration was given to extending the band upward as far as possible by using companders⁷ on the top channels, thus lightening the signal/noise requirements on these channels by some 15 dB, provided that they are restricted to telephone service.

As the repeater design was worked out in detail, however, it became evident that a rather sharp upper frequency limit existed. This resulted from the parasitic capacitances imposed by the size and shape of the flexible repeater, the degree of precision required in matching repeater gain to cable loss in such a long system, and the feedback requirements as related to the requirement of at least 20 years' life.

These repeater limitations resulted in the decision to develop a system with 36 channels of 4-kc/s carrier spacing, utilizing the frequency band from 20 to 164 kc/s.

Signal/Noise Design.

Scaling-up of Key West-Havana system.—The length of the North Atlantic link was to be about 16 times that of the Key West-Havana system. The number of channels was to be increased as much as practicable. The length increase entailed an increased power voltage to earth on the end repeaters. Increase in length and in number of channels entailed increased precision in control of variations in cable and repeaters. Work on these and other aspects was carried on concurrently, to determine the basic parameters of the extended system.

Increasing the cable size decreases both the attenuation and the d.c. resistance, and in turn the voltage to earth on the end repeaters. It was soon decided that the largest cable size that could be safely adopted was the one used in the Bahamas tests. This has a centre-conductor sea-bottom resistance of about 2.38 ohms per nautical mile. It consumes about 28 per cent of the total potential drop in cable plus repeaters.

Number of repeaters.—As indicated earlier, the factor which emerged as controlling the number of repeaters was the d.c. voltage to earth on the end repeaters. Considerations which entered into this were: voltage which blocking capacitors could safely withstand over a life of at least 20 years; voltage which other repeater elements such as connecting tapes between compartments could safely hold without danger of breakdown or corona noise; initial power potential and possible need for increasing d.c. cable current later in life to combat repeater ageing; allowance for repair repeaters (see later in sub-section dealing with spare equipment for the undersea link); and a reasonable allowance for increased power potential to offset adverse earth potential.

Let R = D.C. resistance of centre conductor (ohms/nautical mile).

L = Length of one cable, in nautical miles. †

E_{rep} = Voltage drop across one repeater at current I .

I = Ultimate (maximum) line current (amperes).

N = Ultimate number of submerged repeaters, in terms of equivalent normal repeaters.

n = Allowance for repair repeaters, in terms of number of normal submerged repeaters using up same voltage drop.

E_m = Maximum voltage to earth at shore-end repeaters at end of life, and in absence of earth potential.

S = Spacing of working normal repeaters (nautical miles).

Then for the ultimate condition

$$2E_m = LIR - 2SIR + NE_{rep} \quad (1)$$

in which the term $2SIR$ accounts for the sum of the cable voltage drops on the two shore-end cable sections; the sum of their lengths is assumed, for simplicity, to be $2S$. This equation also neglects a small allowance (less than 0.6V per mile) for the voltage drop in cable added to the system during repair operations. Also,

†The length of a cable is greater than the length of the route because of the need to pay out slack. The slack allowance, which averages 5 per cent in deep water on this route, helps to ensure that the cable follows the contour of the bottom.

$$S(N - n + 1) = L \quad (2)$$

because the repeater spacing is determined by the number of working normal repeaters. From equations (1) and (2),

$$2E_m = LIR + NE_{rep} - 2LIR/(N - n + 1) \quad (3)$$

The allowance, n , for repair repeaters was determined after studies of cable-fault records of transoceanic telegraph cables, including average number of faults per year and proportion of faults occurring in shallow water. If the fault occurs in shallow water—as is true in most cases because of trawler activity, ships' anchors and icebergs—the net length of cable added to the system and the resulting attenuation increase are small. Several shallow-water faults might be permissible without adding a repair repeater. Therefore it was decided to let $n = 3$. Since the repair repeater has two valves while the regular repeater has three, $n = 3$ corresponds to about five repair repeaters per cable.

To determine the maximum voltage E_m , it was necessary to consider blocking capacitors and earth potentials.

Based on laboratory life tests, the blocking capacitor developed has an estimated minimum life of 36 years at 2,000V. It is estimated that the life varies inversely as about the fourth power of the voltage. The potential actually appearing on these capacitors is determined by the distance of the repeater from shore, the power potential applied to the system, and the magnitude and polarity of any earth potential.

Earth-potential records on several Western Union submarine telegraph cables were examined. These covered a continuous period from 1938 to 1947, including the very severe magnetic storms of April, 1938, and March, 1940. It was judged reasonable to allow a margin of 400V (200V at each shore station) for magnetic storms during the final years of life of the system.

With an assumed maximum voltage of 2,300V on the end repeaters due to cable-current supply equipment, and 200V per end as allowance for the maximum opposing earth potential which the system would be permitted to offset without automatic reduction of the cable current, the voltage across an end repeater in late years of life (current increased to offset ageing) would normally be 2,300V and would infrequently rise to 2,500V. On the rare occasions when earth potential would rise above twice 200V, the cable current would be somewhat reduced and the transmission affected to a reasonably small extent. In the early years of life, when the cable-current supply voltage would normally be about 2,000V, an opposing earth potential of twice 500V could be accommodated without affecting cable current; according to the telegraph cable records this would practically never occur. With conditions changing in this way over the years, the life of the blocking capacitors in the end repeaters was calculated to be satisfactory.⁶

Accordingly E_m was established as 2,300V.

The system length L was estimated as about 1,985 n.m. and the ultimate current I as 0.25A, with a corresponding ultimate E_{rep} of about 62.8V. Substituting these values and

$$N = 55$$

$$N - n = 52 \text{ working repeaters}$$

in equation (3), gives

$$S = 37.4 \text{ n.m.}$$

Based on a later estimate of $L = 1,955$ n.m., $S = 36.9$ n.m. The repeater design was based on this spacing in the deep-sea temperature and pressure environment. Subsequently, after better knowledge had been obtained of the cable attenuation in deep water, the repeater spacing for the main part of the crossing was changed to about 37.4 n.m. for the eastbound (No. 1) cable and 37.6 for the westbound. Only 51 repeaters were required in each cable.

Number of channels.—The number of channels which could be transmitted was determined by the top and bottom boundary frequencies. In the present case, the bottom

frequency was established at 20 kc/s primarily because of the loss characteristic of the power-separation filters.⁶

Preliminary studies were made to estimate the usable top frequency. For a system having a fixed number of repeaters, this frequency occurs where the maximum permissible repeater gain equals the loss of a repeater section of cable—which varies approximately as the square root of frequency. The repeater gain is the difference between the repeater input and output levels. The minimum permissible transmission level at the repeater input depends on the random noise (fluctuation noise) contributed by cable and repeaters, and on the specified requirement for random noise. The maximum permissible transmission level at the repeater output may depend on the intermodulation noise contributed by repeaters below overload, or on overload on the peaks of the complex multi-channel signal. It was found that, in this system, overload was the controlling factor.

An important consideration was to provide enough feedback in the repeater so that at the end of 20 years the accumulated gain change (μ - β effect) in all the repeaters would not cause the signal/noise performance to fall outside the limits. The usable feedback voltage was scaled from the Key West-Havana design according to the relation that this voltage varies inversely as the five-thirds power of the top frequency. Thermionic-valve ageing was estimated from laboratory life tests on Key West-Havana type of valves.

Concurrently, detailed theoretical and experimental studies were being conducted on the transmission design of a repeater suited to transatlantic use with the chosen type of cable, as discussed in a companion paper.⁶ Intimate acquaintance with the repeater limitations led to a decision in 1953 to develop a system with a working spectrum of 144 kc/s (36 channels) and a top frequency of 164 kc/s. Use of companders would not increase this top frequency appreciably.

Signal/noise design.—When the repeater design was established, the remaining theoretical work on signal/noise ratio consisted in refining the determination of the repeater output and input levels; computations of system noise, and comparison of this with the objectives to establish the margin available for variations; and determination of the necessary measures in manufacturing and cable laying so that these margins would not be exceeded by the deviations from ideal conditions which would occur. These deviations assumed great importance, because they tended to accumulate over the entire length of the system, and because many of them were unknown in magnitude before the system was actually laid.

The repeater levels and the resultant system noise were computed as follows:

It was recognized that the output levels of different repeaters would differ somewhat at any given frequency. The maximum allowable output level of the highest-level repeater was computed by the criterion that the instantaneous voltage at its output grid should be expected to reach the load-limit voltage very infrequently. This is the system load criterion established by Holbrook and Dixon.⁸ It premises that in the busy hour, the load-limit voltage (instantaneous peak value) should be reached 0.001 per cent of the time, or less. It is probable that the level could be raised 2 dB higher than the one computed in this way without noticeable effect on intermodulation noise.

An important factor in the Holbrook-Dixon method is the talker volume distribution. Because of the special nature of this long circuit, a careful study was made of the expected United States talker volumes.

First, recent measurements of volumes on long-distance circuits were examined for the relation between talker volume and circuit length. They showed a small increase

for the longer-distance circuits. This relation was extrapolated by a small amount to reach the 4,000-mile value appropriate to the New York-London distance.

Secondly, an estimate was made of the probable trends in the Bell System plant in the next several years, which might affect the United States volumes on transatlantic cable calls.

The result of this was a "most probable U.S. volume distribution." This distribution, which had an average value of -12.5 v.u. (volume units) at the zero-level point, with a standard deviation of 5 dB, agreed very well with one furnished by the British Post Office and based on calls between London and the European continent. A further small allowance was then made for the contribution of signalling tones and system pilots, which brought the resultant distribution to an average value of -12 v.u. at zero level of the system (the level of the outgoing New York or London or Montreal switchboard), and a standard deviation of 5 dB. It is approximately a normal-law distribution (expressed in volume units), except that the very infrequent high volumes are reduced by load limiting in the inland circuits.

The other data needed for system load computations are the number of channels, and the "circuit activity," i.e. the percentage of time during the busy hour that the circuit is actually carrying signals in a given direction (eastbound or westbound). The circuit activity value used in designing United States long-distance multi-channel circuits is 25 per cent; for the transatlantic system, 30 per cent was used.

The peak value of the computed system multi-channel signal is the same as that of a sine wave having an average power of $+17.4$ dBm at the zero-transmission-level point of the system.

This value, together with the measured sine-wave load capacity of the undersea repeater, determines the maximum permissible output transmission level of the repeater. The measured sine-wave load capacity is about $+13.5$ dBm at 164 kc/s. Hence the maximum permissible output transmission level for the 164-kc/s channel is

$$+13.5 - 17.4 = -3.9 \text{ dB.} \ddagger$$

If the relative output levels of the various submarine repeaters were precisely known, the highest-level repeater could have an output transmission level of -3.9 dB at 164 kc/s. An allowance of about 2 dB was made for uncertainty in knowledge of repeater levels, giving -6 dB as the design value for the maximum repeater output level at 164 kc/s.

The repeater has frequency shaping in the circuit between the grid of its output valve and the cable. The maximum repeater output at lower frequencies is smaller than at 164 kc/s, but the maximum voltage on the output grid, from an overload standpoint, is approximately constant over the 20-164-kc/s band.

The transmission level of the maximum-level repeater output is thus determined, based on load considerations. Another factor which might limit this level is intermodulation noise but this was found to be less of a restriction than the load limitation.

With the output level determined, the random noise and the intermodulation noise for the system can be computed. The random-noise computation is made on the assumption that all repeaters are at the same level, and then a correction is made for the estimated differences in their levels. The equation is

$$N_0 = N_{in} + G - T_l + 10 \log n + d,$$

‡At the time of writing, the No. 1 cable (eastbound) is set up with a somewhat lower maximum output level than this; the safe increase in level will be determined later.

where N_0 = System random noise, dBa, † referred to zero transmission level.

N_{in} = Random noise per repeater, dBa, referred to repeater input level.

G = Repeater gain, dB.

T_i = Transmission level of repeater output.

n = Number of undersea repeaters.

d_r = Increase in noise, dB, due to differing output levels of the various repeaters as compared with the highest-level repeater.

At the top frequency of 164 kc/s, $T_i = -6$ dB as seen above, $G = 60.7$ dB, and N_{in} is about -55.5 dBa, which corresponds to a noise figure of about 2 dB. Hence, for 52 repeaters,

$$N_0 = -55.5 + 60.7 - (-6) + 10 \log 52 + d_r \\ = 28.4 + d_r$$

At lower frequencies, the noise power referred to repeater input is greater because part of the equalization loss is in the input circuit; the repeater gain is less, to match the lesser loss of a repeater section of cable; and the repeater output level is lower on account of the equalization loss from output grid to repeater output. This is shown in Table 1.

TABLE 1

Channel	N_{in} Approximate Input Noise	G Approximate Repeater Gain	T_i Approximate Output Transmission Level	N_0 Resulting Noise
	dBa	dB	dB	dBa
Top frequency	-55.5	60.7	-6	28.4 + d_r
Middle frequency	-53	45	-11	20.2 + d_r
Bottom frequency	-46	22	-19	12.2 + d_r

In order to estimate d_r (which is a function of frequency) before the cable was laid, the factors were studied which might contribute to differences between the levels of the various repeaters. Estimates were made of probable total misalignment, i.e. the level difference between highest-level and lowest-level repeaters. These values, together with estimates of the resulting noise increases, are shown in Table 2. This is based on the assumption that the repeater levels would be distributed approximately uniformly between highest and lowest. The position of a repeater along the cable route is not significant.

TABLE 2

Channel	M Estimated Misalign- ment	d_r Resulting Noise Increase	N_0 Resulting System Random Noise (Approximate)
	dB	dB	dBa
Top frequency	12	7.4	36
Middle frequency	10	6.0	26
Bottom frequency	6	3.4	16

A study was made of the expected intermodulation noise. This noise is affected by repeater level differences, by talker volumes and by circuit activity. It has a time distribution, most attention being given to the r.m.s. intermodulation noise in the busy hour.

Intermodulation noise was computed in two ways: by the Bennett method,⁹ and by the Brockbank-Wass method.¹⁰ Results by the two methods are in fairly good agreement. The values computed by the Bennett method are given in Table 3.

TABLE 3

Channel	Weighted Noise at Zero Transmission Level		
	Second- Order Products	Third- Order Products	Total
Top frequency	8.2	8.5	11.3
Middle frequency	0.2	3.8	5.4
Bottom frequency	-1.8	2.5	3.9

Because noise powers, not dBa, are additive, these values of intermodulation noise would contribute only a very small amount to the total noise in the deep-sea cable system,[§] as previously stated. This confirms the statement made above, that the factor controlling the repeater output level is not intermodulation noise but peak load.

Other possible contributory sources of noise in the deep-sea cable system are noise in the terminal equipment, noise picked up in the shore lead-in cables, and corona noise in the repeaters. The system has been designed so that the expected total of these is small. Hence the estimate of total deep-sea cable system noise, made before cable laying, gave the following values, to the nearest decibel, shown in Table 4.

TABLE 4

Channel	Estimated system r.m.s. noise at 0 dB transmission level		
	dBa	(psophometer) dBm	pW
Top frequency	36	-48	16,000
Middle frequency	26	-58	1,600
Bottom frequency	16	-68	160

Misalignment Control.

Since the noise objective for the deep-sea cable link was set as 36 dBa at the joint meetings,¹ the above estimate led in turn to the objective that the system should be manufactured and laid in such a way that the misalignment, including effects of seasonal temperature change, should be no greater in the top channel than the value assumed in the noise estimates, which was 12 dB. Half of this was allotted to initial misalignment and half to effects of temperature change. Greater misalignments were permissible at lower frequencies.

Control of this misalignment required extensive consideration in the equalization design of the system.

The basic causes of misalignment can be grouped as follows: those producing unequal repeater levels when the system is first laid; those resulting from changes in cable loss produced by changes in sea-bottom temperature; and those from ageing of the cable or repeaters.

There are a large number of possible causes of initial misalignment. While the cable and repeaters were manufactured within very close tolerances to their design objectives, they could not exactly meet those objectives. In addition, the cable loss as determined in the factory must be

† "dBa" is a term used for describing the interfering effect of noise on a speech channel. Readings of the 2B Noise-Meter with F1A weighting may be converted to dBa by adding 7 dB; dBa may be translated to dBm (unweighted) by noting that flat noise having a power of 1 mW over a 3,000-c/s band equals approximately +82 dBa, and that 1 mW of 1,000-c/s single-frequency power equals +85 dBa.

§ The following Table for adding two noises expressed in dBa shows the magnitudes of the increases.

dB difference between larger and smaller noise	2	4	6	8	10	15	20
Resulting dB to be added to larger noise to get sum of the two	2.1	1.4	1	0.6	0.4	0.1	0+

translated to the estimated loss on sea bottom, and the length of each repeater section must be adjusted in the factory so that its expected sea-bottom loss will best match the repeater gain. Possible sources of error in this process include: uncertainty in temperature of the cable when it was measured in the factory, and in its temperature on the sea bottom; uncertainty in temperature and pressure coefficients of attenuation; changes in cable loss between factory and sea-bottom conditions, not accounted for by pressure and temperature coefficients.

These latter changes in cable loss were called "laying effect." The determination of the magnitude of laying effect, and its causes, are discussed in the paper on cable design.⁵ Suffice it to say here that after measuring the loss of a length of cable in the factory and computing the sea-bottom loss, the computed result was a little greater than the actual sea-bottom loss. The difference, i.e. the laying effect, was approximately proportional to frequency and was greater for deep-sea than for shallow-water conditions. Its existence was confirmed by precise measurements on trial lengths of cable, made early in 1955 in connexion with cable-laying tests near Gibraltar.

Laying effect had been suspected from statistical analysis of less precise tests of repeater sections of cable generally similar to transatlantic cable, as measured in the factory and as laid near the Bahamas. However, the repeater design had of necessity been established before the Gibraltar test results were known. The consequence was a small systematic excess of repeater gain over computed cable loss, approximately proportional to frequency, and amounting at the top frequency to about 0.04 dB/n.m. on the average, for deep-sea conditions, and about 0.025 dB/mile for shallow-water conditions. While this difference appears small, it would accumulate in a transatlantic crossing of some 1,600 miles of deep sea, and 350 miles of relatively shallow sea, to about 75 dB at the top frequency. This would be enough to render almost half of the channels useless if no remedial action were taken.

After a system is laid, changes in cable loss or repeater gain may occur. These may be caused by temperature effects and by ageing of cable or repeaters.

Comprehensive studies[‡] of the expected amounts of temperature change were made both before and after the 1955 laying. These gave an estimate of $0 \pm 1^\circ\text{F}$ annual variation in sea-bottom temperature in the deep-sea part of the route (about 1,600 n.m.) and perhaps $\pm 5^\circ\text{F}$ on the continental shelves (about 330 n.m.). Use of these figures leads to a ± 5 dB variation in system net loss at 164 kc/s due to annual temperature changes. If the deep-sea-bottom temperature did not change at all, the estimated net loss variation due to temperature would be about half of this.

The first line of defence against variations leading to misalignment is the design and production of complementary repeaters and cable. This is discussed in companion papers.

Signal/noise changes due to undersea temperature variations were minimized by providing adjustable temperature equalizers at both the transmitting and the receiving terminals, and devising a suitable method of choosing when and how to adjust equalizers.

Partial compensation for laying effect was carried out at the cable factory by slightly lengthening the individual repeater sections. In the 1955 cable, where the factory compensation was based on early data whose application to the transatlantic system was in some doubt, the increased loss compensated for about two-fifths of the Gibraltar laying effect at the top frequency. In the 1956 cable, which had the benefit of the 1955 transatlantic experience, the compensation was increased to nearly twice this amount. Since the loss of the added cable is approximately proportional to the square root of frequency, and the laying

effect is approximately directly proportional to frequency, the proportion of laying effect compensated varied with frequency, and a residual remained which had a loss deficiency rising sharply in the upper part of the transmitted band.

The remainder of the laying effect which was not anticipated in the factory, as well as other initial variations, was largely compensated by measures taken during cable laying at intervals of 150–200 miles. The whole length of the cable was divided into 11 "ocean blocks," each either four or five repeater sections long. At each junction between successive ocean blocks, means were provided to compensate approximately for the excess gain or loss which had accumulated up to that point.

These means were twofold. The first was adjustment of the length of the repeater section containing the junction. For this purpose, the beginning of each block, except the first, was manufactured with a small excess length of cable. This was cut to the desired length as determined by transmission tests made *en route*.

The second means was a set of undersea equalizers. These were fixed series networks, encased in housings similar to the repeater housings but shorter. Six of these equalizers were used at block junctions in the 1955 (No. 1) cable, and eight in the 1956 (No. 2) cable.

Before the nature of the laying effect was known, it had been planned to have equalizers with perhaps several shapes of loss/frequency characteristic; but to combat laying effect, nearly all were finally made with a loss curve sloping sharply upward at the higher frequencies, as shown in Fig. 3. § Because the equalizer components had to be manu-

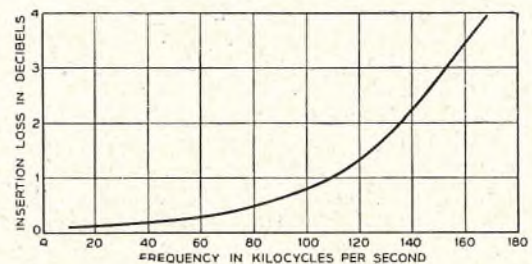

FIG. 3.—UNDERSEA EQUALIZER: LOSS/FREQUENCY CHARACTERISTIC.

factured many months in advance and then sealed into the housings, last-minute designs of undersea equalizers were not practical. The proven-integrity principle prevented the use of adjustable units. Because the equalizers were series type, each ocean-block junction was located approximately in the middle of a repeater section to minimize the effects of reflections between equalizer and cable impedances.

The actual adjustments at block junctions were determined by a series of transmission measurements during laying, as described elsewhere.¹¹

The result of all the precautions taken to control initial misalignment was, in the 1955 cable, to hold the level difference between highest- and lowest-level repeaters to about 6 dB near the top frequency and to values between 4 and 9 dB at lower frequencies, the 9-dB value occurring in the range 50–70 kc/s, where there is noise margin. In the 1956 cable, the level difference was about 4 dB at the top frequency, and 2–7 dB elsewhere in the band.

‡Factual data on deep-sea-bottom temperatures are elusive. Many of the existing data were acquired by unknown methods in unspecified circumstances, using apparatus of unstated accuracies. Statistical analysis of selected portions of the data leads to the quoted estimates.

§This characteristic was based on a statistical analysis of the data on similar cable laid for the Air Force project.³

Shore Equalization.

The equalization to be provided at the transmitting and receiving ends of the North Atlantic link had the following primary functions.

- (a) For signal/noise reasons, to provide a signal level approximately flat with frequency on the grid of the third valve of the undersea repeaters.
- (b) To equalize the system so that the received signal level is approximately constant over the transmitted band.
- (c) To keep the system net loss flat, regardless of temperature variations in the ocean. (A change of 1°F in sea-bottom temperature would cause the cable loss to change by 2.8 dB at 160 kc/s and less than this at lower frequencies. The amplifiers are relatively unaffected by small temperature changes.)
- (d) To provide overload protection for the highest-level repeater.
- (e) To incorporate some adjustment against possible cable ageing.

A portion of the transmitting terminal is shown in block-schematic form in Fig. 4. All the equalizers are constant-

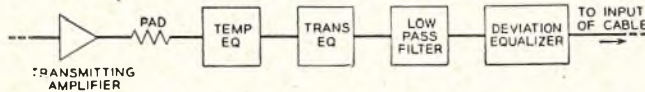

FIG. 4.—TRANSMITTING EQUALIZERS: BLOCK SCHEMATIC DIAGRAM.

resistance 135-ohm unbalanced bridged-T structures. The functions of the various items are as follows:

Low-pass filter: This filter transmits signals up to 164 kc/s and suppresses, by 25 dB or more, signals in the frequency range 165–175 kc/s. Its purpose is to prevent an accidentally applied test signal from overloading the deep-sea repeaters if such a signal were to coincide with the resonance of the crystal used in a repeater for performance checking. The gain of a repeater to a signal applied at the resonant frequency of its crystal is about 25 dB greater than at 164 kc/s.

Transmitting temperature equalizer: It was estimated that the cable-loss change due to temperature variations would not exceed ± 5 dB at the top of the transmitted band. The change in cable loss with frequency due to temperature variations is approximately the same as if the cable were made slightly longer or shorter, and so the temperature equalizer was designed to match the cable loss/frequency characteristic. Temperature equalizers are used both in the transmitting and receiving terminals to minimize the signal/noise degradation caused by temperature misalignment. Each equalizer provides a range of ± 5 dB at the top of the transmitted band, the loss being adjustable in steps of 0.5 dB by means of keys. The panel is shown in Fig. 5.

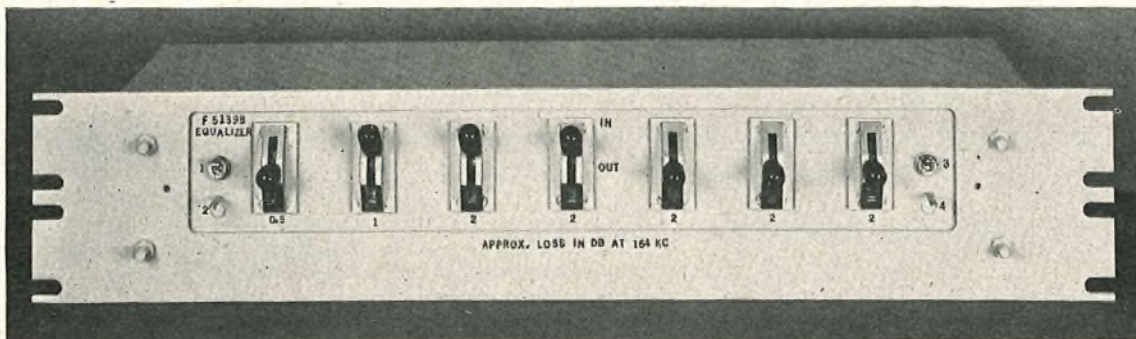

FIG. 5.—TRANSMITTING TEMPERATURE EQUALIZER.

This range might appear to be more than necessary, but it must be borne in mind that the sea-bottom temperature data left much to be desired in precise knowledge of both average and range.

Transmitting equalizer: The transmitting equalizer was so designed that, with the temperature equalizer set at mid-range and with repeaters that match the cable loss, the signal level on the grid of the output valve of the first repeater would be flat with frequency. The loss/frequency characteristic is shown in Fig. 6.

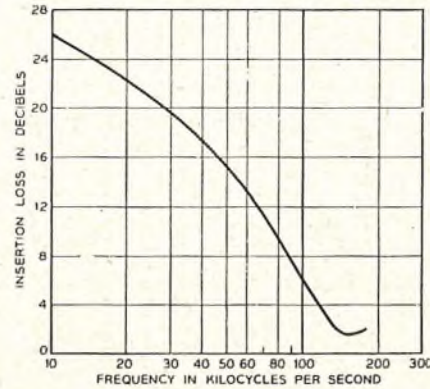

FIG. 6.—TRANSMITTING EQUALIZER: LOSS/FREQUENCY CHARACTERISTIC.

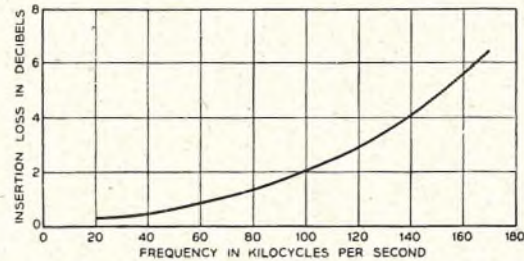

FIG. 7.—TRANSMITTING DEVIATION EQUALIZER: LOSS/FREQUENCY CHARACTERISTIC.

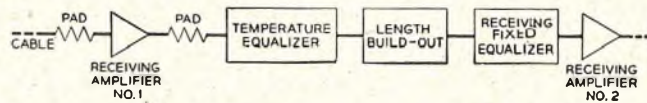

FIG. 8.—RECEIVING EQUALIZERS: BLOCK SCHEMATIC DIAGRAM.

Deviation equalizer: The transmitting deviation equalizer is used to protect the highest-level repeater from overload. The design is based on data obtained during the laying, indicating which repeater was at the highest level at the various frequencies. The characteristic of this equalizer is shown in Fig. 7.

A portion of the receiving terminal is shown in block-schematic form in Fig. 8. The generalized function of the

equalizers is to make the signal-level/frequency curve flat at the input to receiving amplifier No. 2. The specific functions of the various equalizers are as follows:

Cable-length equalizer: In planning the system, an estimate was made of how far the last repeater (receiving end) would be from the shore. Considerations of interference and level dictated a maximum distance not exceeding approximately 32 miles. For protection against wave action, trawlers and similar hazards, the repeater should be no closer than about 5 miles. To take care of this variation, a cable-length equalizer was designed that is capable of simulating the loss of 10 miles of cable, adjustable in 0.5 dB steps at the top of the frequency band. Two of these could be used if needed. Once a system is laid, this equalizer should require no further adjustment unless it is used to take care of cable ageing or a cable repair near shore.

Receiving fixed equalizer: This is the "mop-up" equalizer for the system. A final receiving equalizer (see Fig. 9) had been constructed for the first cross-

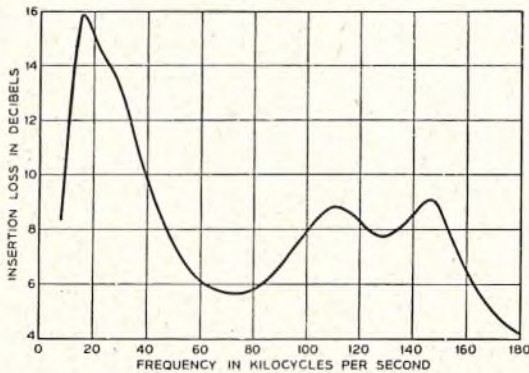

FIG. 9.—RECEIVING FIXED EQUALIZER: LOSS/FREQUENCY CHARACTERISTIC.

ing. Another, "tailored" to the No. 2 cable, will be designed on the basis of data taken after completion.

Receiving temperature equalizer: The receiving temperature equalizer is identical with the transmitting temperature unit.

General. OPERATIONAL DESIGN

The operational design of a transmission system considers the supplementary facilities which are needed for operation of the main transmission facility, for its supervision and for its maintenance. In the present instance, these facilities include the cable-station power plants for driving the carrier terminals and high-frequency line, the carrier terminals themselves and their associated carrier supply bays, the telephone speaker and telegraph equipments needed for maintenance, supervision and administration of the overall system, the pilots, protection devices and alarms, and the maintenance and fault-locating equipment.

Power Supplies.

With the exception of the plants for cable-current supply, the power plants at Clarenville and Oban are relatively conventional, and follow techniques which are standard for

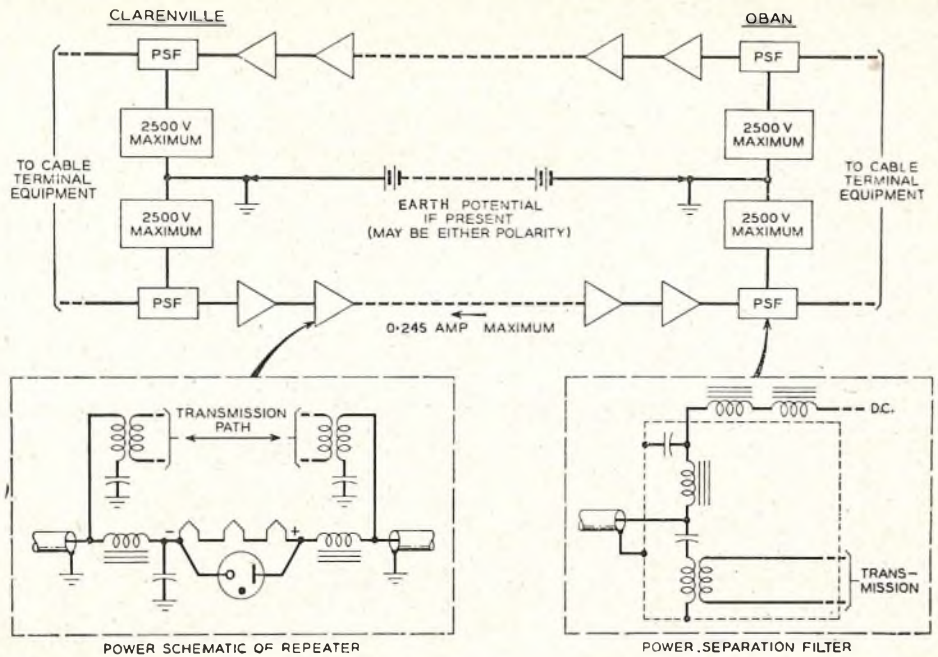

FIG. 10.—CABLE POWER LOOP: ELEMENTARY SCHEMATIC.

the telephone administration of the particular side of the Atlantic on which they are located. They will not be discussed here, although it might be well to point out that at Clarenville the equipment supply is d.c., obtained from floated storage batteries. At Oban, the supply for the Post Office equipment is alternating current from rotary machines driven normally from the station a.c. supply, with storage-battery back-up.

The cable-current supplies for the North Atlantic link, described in a companion paper,² are complex and specialized. It is pertinent to discuss here briefly the requirements which beget this complexity. To assist in this, an elementary schematic diagram of the cable power loop is shown in Fig. 10.

The main requirements that governed the design of these plants are:

- Constant maintenance of uniform and known current in the power loop.
- Protection of h.f. line against faults induced by failures in power bays.
- Protection of h.f. line against damage from power-voltage surges caused by faults in the line itself.

Maintenance of constant and known operating current in the line is very important from the standpoint of system life because of the dependence of the rate of valve ageing on the power dissipated in the heaters.¹²

The principal factor which tends to cause variations in the line current is the earth potential difference which may appear between the terminals of the system. This potential may be of varying magnitude and of either polarity. Consequently, it may either aid or oppose the driving potential applied to a particular cable. The power-circuit regulation is such that the presence of an aiding potential will be completely compensated, while opposing potentials will be compensated only to the degree possible with the maximum of 2,500V applied by the terminal plants. Beyond this point, the line current will be allowed to drop, so as to avoid excessive potential across the power-separation filter capacitors in the shore-end repeaters.

Line faults caused by failures or misoperation of the power supplies must be carefully guarded against. Such failures might result in surges on the line or excessive

voltage or current. Protection against surges takes the form of retardation coils in the terminal power-supply filters, which limit the rate of current change to tolerable values.

Failure of the capacitors in these filters could also create dangerous surges. The protection here takes the form of a large voltage design margin and use of a series-parallel configuration so that the effect of failure of one capacitor element would not be hazardous.

Faults in the h.f. line of importance from the power-feed standpoint are short-circuits to earth and open-circuits. The former tend to result in excessive currents; the latter in excessive voltages. Very fast-acting protection in the terminal power bays is required to cope with these, and series thermionic-valve regulators provide the means.

Terminal Plan.

The plan of design of transmission terminal equipment, shown in Fig. 2, was based on the following objectives:

- (a) Use of standard or modified standard equipment as far as possible.
- (b) To facilitate supply and maintenance of standard equipment, use of Bell System equipment in North America and Post Office equipment in the United Kingdom.
- (c) Provision of full duplicate equipment and means for quick change between regular (working) and alternate (standby).
- (d) Provision of special equipment to fit Canadian requirements.
- (e) Provision of ample telephone and telegraph speaker equipment, partly because there is no alternative undersea route.
- (f) No provision of automatic loss-regulation, because the loss changes are so slow; provision of three pilots as a basis for manual regulation.

Much of the equipment is standard. This includes group modems, through-group filters, pilot supply, frequency-modulated telegraph equipment for teleprinter circuits, etc. Supergroup modulators are modified standard coaxial carrier equipment. The channel modems for speaker and teleprinter circuits are a combination of type C open-wire carrier active equipment, and filters designed for a military carrier system. The transmitting output amplifier is a modified version of one used in the Key West-Havana submarine cable system: the modifications include broader frequency-band, lower modulation and sharper overload cut-off. As in the coaxial carrier system, hybrid coils are provided at points in the American equipment where quick patching is needed.

The agreed Canadian band-width quota is 26 kc/s,¹ corresponding to 6½ telephone channels. The split between the 6½ Canadian channels and the remaining 5½ U.S. channels in the "split group" was accomplished by specially-designed group-frequency splitting filters, with very sharp cut-off. The loss/frequency characteristics of these filters are shown in Fig. 11. The resulting Canadian telephone half-channel was broad enough to accommodate 12 frequency-modulated telegraph channels with 120-c/s telegraph carrier spacing. It is planned to use one of these for automatic regulation of the other 11. The U.S. half-channel is at present unassigned.

Two telephone speakers and two teleprinter circuits are provided for maintenance and administration purposes.

The two speakers occupy a 4-kc/s telephone channel which is the lower sideband of 20 kc/s on the line. The 4-kc/s band is halved by channel-splitting equipment, which yields two narrow-band telephone channels. One of these is reserved for a "local" Clarendville-Oban circuit, available at all times to the staff at these terminals. It constitutes a cleared channel which could be of great benefit in emergencies.

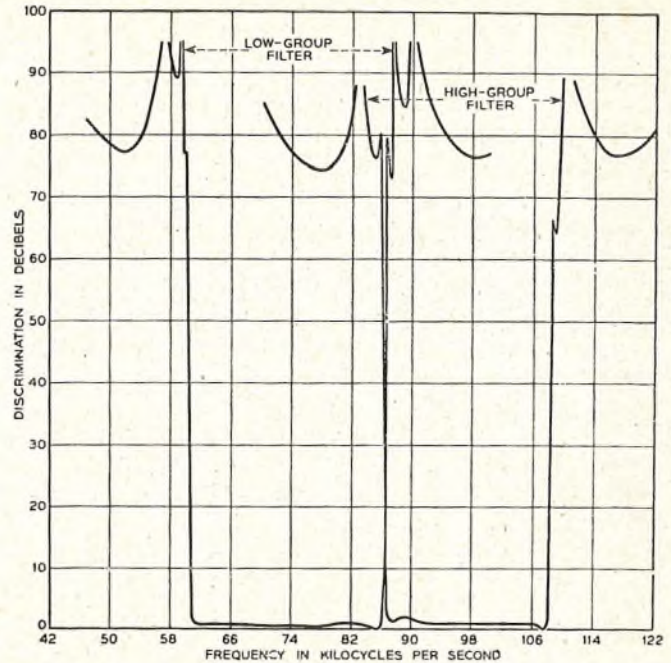

FIG. 11.—SPLITTING FILTERS: LOSS/FREQUENCY CHARACTERISTIC.

The other narrow-band telephone channel, the "omnibus speaker," is extended through to other control points including the metropolitan terminals of the system.

The two teleprinter circuits are frequency-modulated voice-frequency telegraph channels, occupying line frequencies just below 16 kc/s. These are both brought to direct current at Clarendville and Oban, and extended by carrier telegraphy to the metropolitan terminals. One is normally a "through" circuit with teleprinters at the metropolitan terminals only, and the other is an "omnibus" circuit with teleprinters connected at Oban, Clarendville and other control points, permitting message distribution to all connected points.

Group-frequency pilots at 92 kc/s are transmitted over the Clarendville-Oban link only, and blocked at its ends. The line frequencies corresponding to the 92-kc/s group frequencies are 52, 100 and 148 kc/s. These pilots are used for manual regulation and maintenance of the Clarendville-Oban link. Information derived from them governs the manual setting of the temperature equalizers. The sending power of the 92-kc/s pilots is regulated to within ± 0.1 dB variation with time.

Group-frequency pilots at 84.08 kc/s also appear on this link. These, however, are system pilots applied at the metropolitan terminals. They are useful for evaluation of overall system performance and for quickly locating transmission troubles.

Alarms are provided in the manner usual for multi-channel telephone systems. A special feature of the pilot alarm system is the "alarm-relay channel," a third voice-frequency carrier telegraph channel just below the teleprinter channels in line frequency. If all three eastbound 92-kc/s pilots fail to reach Oban, a signal is transmitted over the westbound cable which brings in a major alarm at Clarendville, and vice versa. This major alarm would transmit news of a cable failure immediately to the transmitting cable terminal station. Failure of the pilot supply would, of course, give the same alarm. The alarm-relay channel circuit is arranged so that if it fails it does not give the major alarm.

A special alarm system for the cable-current supply is described in a companion paper.²

Fault Location.

Length and inaccessibility have always imposed difficult requirements on fault-locating techniques for undersea cable systems. Before the advent of repeatered systems, much effort was expended on use of impedance methods, i.e. those involving resistance and electrostatic capacitance measurements to locate a fault to earth, or a break.† Some work has been done also on magnetic pick-up devices towed along the route by a ship.

With the advent of undersea repeaters, the problem has become even more difficult, both because of the effect of the repeater elements on impedance measurements, and also because the fault may interrupt transmission without affecting the d.c. loop.

It has been necessary, therefore, to reassess the whole problem of fault location.

Location of Faults Affecting the D.C. Power Loop.

Three types of measurement are made on submarine cables at present :

- (a) Centre-conductor resistance, assuming a short-circuit or a sea-water exposure at some point, which might be either a fault or a break.
- (b) Dielectric resistance, assuming a pinhole leak through the dielectric and a sea-water exposure.
- (c) Electrostatic capacitance, assuming a centre-conductor break insulated from sea water.

By these methods, faults and breaks in non-repeatered cables can be located, although the accuracy of determination, and indeed the practical success of the operation, is dependent on the nature of the fault, the situation with respect to earth potential, the skill of the craftsman, and many other factors.

The presence of cold repeaters in the circuit adds considerably to the difficulty, both because of the resistance/temperature characteristic of the valve heaters (153 in series with each cable) and because of polarization effects exhibited by the castor-oil capacitors in the transatlantic repeaters. The capacitors have a storage characteristic which varies with the magnitude of applied voltage, the duration of its application, and the temperature.

Because of this, the usual methods of fault location are expected to give results of doubtful accuracy and so a new approach is being made to the problem. The results of the work are beyond the scope of the paper.

Location of Transmission Faults.

The previous sub-section deals with the situation where the d.c. power loop has been opened or disturbed. Of equal importance is the location of transmission faults when the power loop is intact.

For this purpose, use is made of the discrete-frequency crystal provided in each repeater.⁶ This crystal is effectively in parallel with the feedback circuit of the amplifier, and at its resonant frequency the amplifier has a noise peak of the order of 25 dB, with an effective noise band of about 4 c/s. When one repeater fails, it is possible to recognize the noise peak of each amplifier from the receiving end back to the failed unit. The noise peaks from the faulty unit and all preceding amplifiers will be missing, indicating the location of the trouble. Noisy amplifiers can be singled out by an extension of the technique.

Testing and Maintenance.

Routine testing and maintenance activities at Oban and Clarenville can be divided into four parts: for the carrier terminals, for the station power equipment, for the cable-

†In the literature, "fault location" is a generalized term encompassing the field. A "fault" is an exposure of the cable conductor to the sea without a break in the conductor. A "break" is an interruption of the conductor with or without exposure to the sea.

current power units, and for the high-frequency line. Usual methods apply to the first two, and the usual types of existing test equipment were provided for such use, with one exception.

The exception is a newly-designed transmission-measuring system consisting of a sending console and a receiving console. The system employs a decade-type sending oscillator with continuous tuning over the final 1-kc/s range. Provision is made for precise calibration of output level. The receiving console contains a selective detector functioning as a terminating meter of 75-ohm input impedance, and can measure over the range -120 dBm to 0 dBm. Transformers are provided to permit measurement on 135-ohm circuits. The detector can be calibrated for direct reading when used as a terminating meter.

The system covers a frequency range of 10 kc/s to 1.1 Mc/s. It is useful, therefore, for measuring much of the standard British- and U.S.-designed carrier terminal equipment, as well as for normal line-transmission measurements over both the North Atlantic and Cabot Strait links.

A special transmission-measuring set is provided in the receiving console, which facilitates measurements in the crystal-frequency region 166-175 kc/s. As an oscillator, this set is capable of delivering an output of up to +8 dBm into a 75-ohm load, with exceptional frequency stability and finely-adjustable motor-driven tuning. This is useful in locating and measuring the narrow-band response peaks of individual repeater crystals. The oscillator frequency is varied in the region of a particular peak, and the received power is measured at the peak frequency and at nearby frequencies. At the peak frequency, the crystal removes nearly all feedback in the repeater. Changes in repeater internal gain can thus be determined from shore.

As a detector, the set can measure from -110 dBm to -60 dBm in a band-width of about 2 c/s. This enables it to measure crystal noise peaks which may be spaced as closely as 50 c/s. To reduce the random variations in such narrow-band noise, a "slow integrate" circuit, of the order of 10 sec, is provided. Thus the crystal noise peaks can be compared in magnitude with the system noise level at closely adjacent frequencies.

ASSEMBLY AND TEST OF SYSTEM

General.

Assembly and initial testing of the North Atlantic link occupied a span of about three years. Because of the geographical and political factors involved, the job was a difficult one and required close co-operation among individuals in many different organizations on both sides of the ocean.

Clarenville and Oban.

The cable station at Clarenville houses the carrier-terminal, cable-terminating and power equipment at the junction of the North Atlantic and Cabot Strait links. As Newfoundland is an island, shipments of equipment and supplies to Clarenville were carried by sea or air to St. John's, where they were transported over the narrow-gauge tracks of the Canadian National Railway to Clarenville.

At Oban, too, it was necessary to ship by boat or air, with subsequent transportation by train and by lorry.

Undersea Link.

Perhaps the most interesting phase of all was the handling of the undersea section. The actual laying is described elsewhere,¹¹ but much effort was required before the cable ship ever left the dolphins at the cable-manufacturing plants.

Most of the cable was manufactured at a plant near London: a smaller quantity was manufactured at Newington, New Hampshire. As the cable was completed, it was

coiled in repeater-section lengths in huge tanks. The ends of each section were left available at a "splicing platform" where the repeaters, manufactured at Hillside, New Jersey,¹³ were spliced in. Spliced repeaters were located in water-filled troughs for protection against overheating while testing.

All repeaters were armoured at Newington. This involved their transportation by lorry from Hillside to Newington. While this sounds simple, it was actually a very carefully planned and controlled operation because of the need to avoid subjecting the units to any but the most necessary and unavoidable hazards. Consequently, the lorry used for the purpose was specifically selected for size and construction, and was provided with a heating unit in the body. The route was carefully surveyed in advance for unusual hazards, and the speed was limited to a very modest value.

After the repeaters were armoured, those to be incorporated in American-made cable were spliced at Newington. Those destined for connexion in British-made cable were transported by lorry, following the same precautions, to Idlewild Airport, New York. From there they went by special freight plane—one or two at a time—to London Airport. Here they were again transported by road across London.

The repeaters were housed in shipping cases¹³ of a very strange shape and considerable size. These cases were provided with maximum-minimum thermometers and with impactograph devices which would record the maximum acceleration to which the repeaters had been subjected.

When ship-loading time arrived, the cable and its contained repeaters were transported over a system of sheaves from the tanks of the cable manufacturer to the tanks on board ship. This process offered no particular obstacle so far as the cable itself was concerned, but the requirement against unnecessary bending of the repeater meant that a great deal of special attention had to be given to avoiding unnecessary deviations from a straight run, and to lifting the repeaters around sheaves where the direction of the loading line changed materially. Auxiliary protection was provided on each repeater in the form of angle irons with flexible extensions on each end which served to restrict any bending to the core tube region of the repeater and safely limited the magnitude of the bends in this region. One further precaution was observed—that of energizing the repeaters during the loading process. This accomplished two things. First, it permitted continuous testing; secondly, it reduced the hazards of possible damage to the thermionic valves during loading, as the tungsten heaters are much more ductile when hot and the valve glassware is more resistant to shock and vibration.

SYSTEM PERFORMANCE

General.

At the time of writing, the No. 2 cable has just been laid, but the No. 1 cable has had 11 months of successful life under test, a pre-service period of probably greater duration than has been granted to any land system of comparable length and cost. It has been under constant observation and test, largely by the people who will operate it when it goes into service. The pre-service measurements were much more extensive, in quantity and scope, than the routine tests that will be made after the system goes into service.

Net Loss Tests.

Variation of net loss with frequency.—Results of measurements in June, 1956, on the No. 1 cable are shown in Fig. 12 and 13. The former covers the equalized high-frequency line. Fig. 13 gives the corresponding group-to-group frequency response of the deep-sea link. These frequency characteristics will vary a little from time to

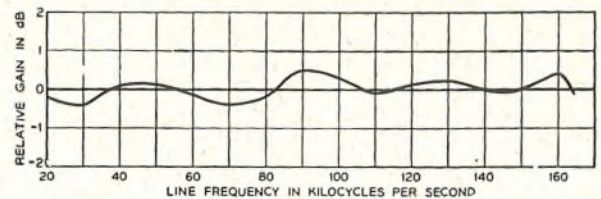

FIG. 12.—GAIN/LINE-FREQUENCY: NO. 1 CABLE.

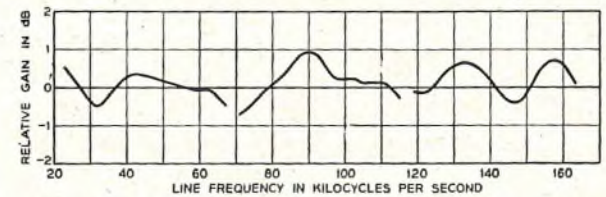

FIG. 13.—GROUP-TO-GROUP FREQUENCY RESPONSE: NO. 1 CABLE.

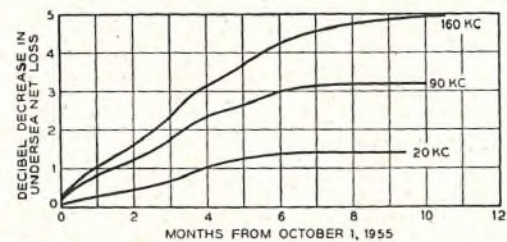

FIG. 14.—CHANGE IN SYSTEM GAIN IN FIRST 11 MONTHS.

time, depending partly on the temperature change since the last adjustment of the temperature equalizer.

The slope in gross cable loss between 20 and 164 kc/s is about 2,100 dB, but the net loss of the equalized high-frequency line over this band varies only about 1 dB.

Variation of net loss with time.—The net loss of the undersea system (cable plus repeaters) has decreased slowly since the system was laid. The decrease is approximately "cable shape," proportional to the square root of frequency. In 11 months it has amounted to about 5 dB at the top frequency. In the early months, the change was almost directly proportional to time, but later the rate slowed, as shown in Fig. 14.

The changes shown in Fig. 14 are due partly to change in cable temperature and partly to slow ageing of the cable. Detailed studies of repeater crystal-frequency changes have resulted in only an approximate separation into temperature effects and ageing. However, it seems reasonable to assume that at the end of a one-year cycle there will be little, if any, net change in the cable temperature averaged over the whole cable length. The greatest possibility of change will be in the shallow-water sections, and crystal measurements indicate that at the end of a year the average temperature of these sections will return nearly to its initial value. Hence about 5 dB seems chargeable to one year's ageing.

Information on long-term changes in transmission loss of earlier cables is meagre. The Key West-Havana cables were accurately measured just after laying, and again five years later. The change in that system from ageing is very small, if indeed there is a change. The structure of that cable is generally like that of the transatlantic cable, although it is smaller and has a perhaps significant difference in construction of the central conductor.

While extrapolation of the transatlantic cable ageing into the future must be speculative, theoretical considerations suggest that its rate of change must decrease.

The above applies to the net loss of the undersea part of the system only. The group-to-group net loss variation with time of the Clarendville-Oban link has been held

within a much smaller range by temperature-equalizer adjustments. Practices have been worked out which it is believed will hold the in-service variation with time to a fraction of a decibel.

Variation of net loss with carrier-frequency power level.—Single-frequency tests of carrier-frequency output power versus input test power were made, up to a test power a little below the estimated overload of the highest-level repeater. An increase of 0.1 dB in system net loss occurs at a power level 2-3 dB below the load limit of the transmitting amplifier. This is about 15 or 16 dB above the expected r.m.s. value of the in-service system busy-hour load. The 0.1 dB change is presumably due to the cumulative effect of smaller changes in several of the undersea amplifiers.

Variation of net loss with d.c. cable current.—Changes in cable current affect the repeater gain to a slight extent, the amount depending on the magnitude and phase of the feedback in the repeater as a function of frequency. Measured changes in the loss of the 2,000-mile system, for currents of 5 and 10 mA less than the normal value of 225 mA, are shown in Fig. 15. Under normal conditions the

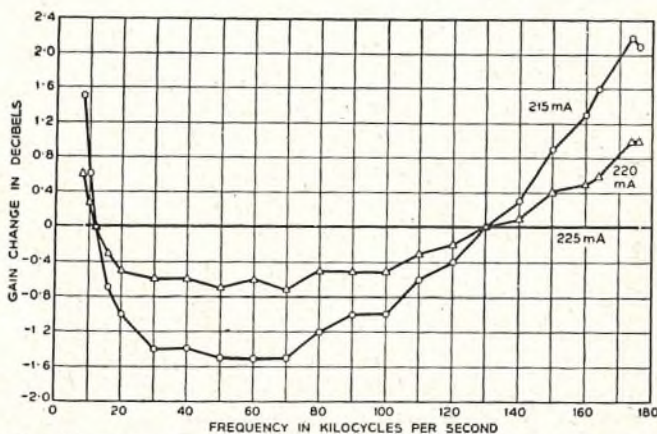

FIG. 15.—EFFECT OF CABLE CURRENT ON SYSTEM GAIN: NO. 1 CABLE.

automatic control will hold the cable-current variation within ± 0.5 mA.

The shape of the curve in Fig. 15 is almost the same as that computed in advance from laboratory measurements on model repeaters.

System Noise.

Measured values of noise on the No. 1 cable system made in the autumn of 1955 and again in the spring of 1956 are shown in Fig. 16. The noise increase is compatible with the decrease in undersea-system net loss during this period.

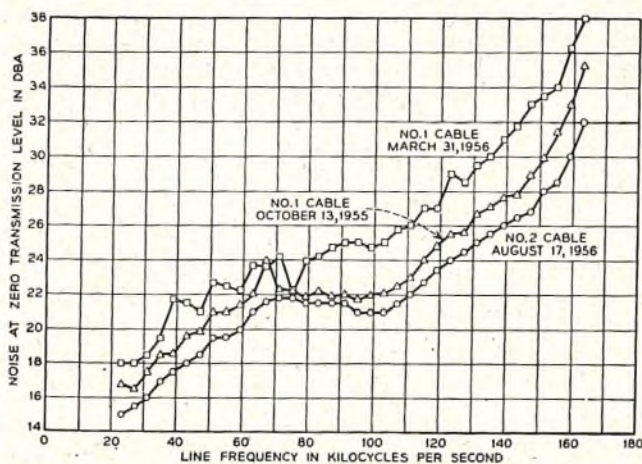

FIG. 16.—CABLE SYSTEM NOISE.

To prevent overload, the loss in the transmitting temperature equalizer has to be increased as the undersea loss decreases; this lowers the levels of the various parts of the undersea system by various amounts.

The noise shown in the top channel exceeds the 36 dBA objective by a small amount. The excess can be recovered, if necessary, by equalization and level changes in the terminals, without recourse to companders.

Fig. 16 shows also the noise on the No. 2 cable system shortly after completion of laying. The noise is lower than on the No. 1 cable. This is because results of experience on the No. 1 cable were utilized in better choice of cable repeater-section lengths, in provision of more undersea equalizers, and in better equalization while laying the 1956 cable.

Intermodulation Tests.

Two-tone intermodulation tests of second- and third-order products were made, using a large number of successive frequency combinations. The highest-level intermodulation products were at least 60 dB below the 1 mW test tones, at zero transmission level. This is approximately the value computed before the system was laid. The levels of most of the intermodulation products were substantially lower than 60 dB. Probably various causes contributed to the good performance, including the effect of misalignment in lowering repeater levels, and small propagation-time differences which minimize in-phase addition of third-order products from successive repeaters.

Telegraph Transmission Tests.

Up to the time of writing, telegraph tests have been made only on the teleprinter maintenance channels, and without a system multi-channel load. With the proposed specific telegraph level of -30 dB (i.e. telegraph signal of -30 dBm per telegraph channel at 0 dB telephone transmission level), the telegraph distortion was too low to measure reliably; it was possible to send clear messages under test conditions with a signal 36 dB weaker than this.

Crystal Tests.

All the peaks of noise at the crystal resonant frequencies were easily discernible.

The crystal gain values all lay in the range from 23.6-27.2 dB, with 60 per cent of them in the range from 25-26 dB. Crystal gain, as used here, is the difference between the system gain at a repeater crystal frequency and the average of the gains at 50 c/s above and below this frequency; the latter value is approximately the gain if the crystal were absent. No significant changes in crystal gain have occurred in 11 months of system life, and none was expected. These measurements are to be continued over the years, as an indication of valve ageing.

A series of measurements of the frequency of each of the 51 repeater crystals versus time has been made. (Any of these frequency determinations can be checked on the same day within ± 0.1 c/s with the special test apparatus and techniques used.) The crystals, intended for the primary purposes of giving information on ageing of the valves in the undersea repeaters and on location of repeater faults, were designed to be extremely stable in frequency, so that measurements on one repeater, made at the land terminal, would not be affected by the combined effect of 50 other crystals at 100 c/s spacings. The crystal frequency varies only about -0.5 c/s per degree Fahrenheit increase in sea-bottom temperature. The change in frequency due to crystal ageing in 11 months undersea is considered to lie in the range 0-0.4 c/s.

Although the crystals were not designed as sea-bottom temperature indicators and are within a repeater housing, it seems likely that, with precise techniques and after further

stabilization, some uniquely accurate information on change of sea-bottom temperature will be obtainable.

In accordance with previous oceanographic knowledge of sea-bottom temperature, the frequency changes have been larger in the crystals near shore. The greatest change has been in the repeater nearest Oban. This is about 17 miles from shore and in water only about 50 fathoms deep. Its frequency change and that of a typical deep-sea repeater are shown in Fig. 17.

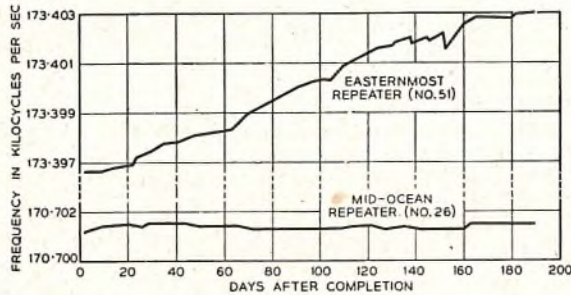

FIG. 17.—RESONANT FREQUENCY VERSUS TIME: SHORE AND DEEP-SEA CRYSTALS.

FUTURE CONSIDERATIONS

Spare Equipment for Cable Stations.

In a system as far-flung geographically as this one, and as important, much thought must be given, not only to the supplies needed for routine replacement of expendable items, but also to major replacements necessitated by fire or other causes. Accordingly, a schedule of spare equipment has been established, divided into two groups—"shelf" and "casualty."

Shelf spares are carried in the station itself, and include items such as dial lights, thermionic valves and dry-cell batteries, which have limited life in normal service. These are maintained in the cable station in quantity estimated as adequate for two years of operation.

Casualty spares embrace those major, essential frames and equipments without which the system cannot be operated. There are two subdivisions: those which are in common use in the telephone plant and are therefore available by "cannibalization," and those which are special to the project, like the cable-current supplies and the cable-terminating bays. The common-use items are not stocked as casualty spares. Spares of the special items are stored in locations remote from the cable stations. In event of catastrophe, these can be drawn out and flown as near the point of need as possible, for onward shipment by available means.

Spare Equipment for the Undersea Link.

Although every effort has been made to produce a trouble-free system, the underwater link is still subject to the hazards of trawlers, icebergs, anchors and submarine earthquakes or landslides. There must be considered, too, the possibility of fault from human failure.

So it is necessary to contemplate the replacement of a length of cable, or a repeater or equalizer. For such contingencies, spare cable of the various armour types has been stored on both sides of the Atlantic. Spare repeaters and equalizers are also available.

In addition, a spare called a "repair repeater" has been stocked. Need for this arises from the fact that, except in very shallow water, a repair cannot be effected without the addition of cable over and above the length which was in the circuit initially. The amount of cable which must be added is a function of water depth, condition of the sea at the time of the repair, and the amount of cable slack available in the immediate vicinity of the point in question.

When excess cable is introduced in amount sufficient to reduce the system operating margins significantly, its loss must be compensated; hence the need for the repair repeater.

A repair repeater is a 2-valve device, essentially like a normal repeater although its impedances are designed to match the cable impedances at input and output ends. However, its gain is sufficient to offset only about 5.3 miles of cable. A second type of repair repeater is under consideration, to compensate for about 15 miles of cable.

Long-Term Ageing.

General.—In a system with some 3,200 dB gross loss at its top frequency between points which are accessible for adjustment, a long-term change in loss of only 1 per cent would have a profound effect on system performance.

For this reason, the repeater design included careful consideration of net gain change over the years.⁶ The degree of control over ageing is such that in a period of at least 20 years, and perhaps much longer, the estimated change in 51 repeaters might total 8 dB added gain at the top frequency. The gain variation with frequency would be proportional to either curve of Fig. 16, and the rate of ageing would be slower in earlier than in later years. Cable ageing was discussed earlier when considering variation of net loss with time.

Means of combating ageing.—The effects of ageing would become important on the top channels first. Remedial measures to improve the signal/noise ratio, especially in the top channels, include: possible increase of transmission level at input of the final transmitting and load-limiting amplifier in the transmitting terminal; pre-distortion ahead of this amplifier; companders; increase of direct current; and undersea re-equalization in later years. This last would be very expensive, and so it is necessary to examine fully the possibilities of the other measures.

The penalty for increasing the transmission level at the input of the transmitting amplifier is more peak-chopping and modulation-noise peaks. The improvement that could be realized in this way is probably fairly small.

Pre-distortion is accomplished by inserting ahead of the transmitting amplifier a suitable shaping network adjusted for gain in the top part of the band and for loss at lower frequencies. A complementary network (restoring network) is placed at the receiving terminal. This measure would improve the signal/noise ratio in the uppermost part of the band and reduce it in lower channels which have less noise. Some 3 dB improvement might thus be realized in the top channel.

Companders would give an effective signal/noise improvement of up to about 15 dB for telephony, but none for services such as voice-frequency telegraphy. Companders would be applied only to those channels needing them. They halve the range of talker volume, but also double the transmission variations between compressor and expander, and thus tend to require some increase in the overall channel net loss. The program (music) channels are already equipped with companders which use up a part of the obtainable advantage.

If the combination of such measures resulted in an effective signal/noise improvement of 20 dB in the top channel, and the ageing were uniformly distributed along the system length, this would counterbalance ageing of some 28 dB in this channel. Thus considerable ageing could be handled without undersea modification.

ACKNOWLEDGMENTS

A system of the complexity of the one described obviously results from teamwork by a very large number of individuals. However, no paper on this subject could be written without acknowledgment to Dr. O. E. Buckley and Messrs. J. J.

Gilbert and O. B. Jacobs, all lately of the Bell Telephone Laboratories. All the early and fundamental Bell System work on repeatered submarine cable systems, and the concept of the flexible repeater, came from these sources and from their co-workers. Messrs. Gilbert and Jacobs have also contributed to the present project.

The cable station at Clarenville was designed by United States architects from requirements furnished by the American Telephone and Telegraph Co. engineers and was approved by the other parties to the enterprise. The building was constructed by a Canadian firm under the supervision of a Canadian architect. The equipment was installed by the Northern Electric Company and tested by representatives of the Bell Telephone Laboratories, Eastern Telephone and Telegraph Company, Northern Electric Company and the British Post Office.

Cable for the undersea link was manufactured by Submarine Cables Ltd., Erith, England, and the Simplex Wire and Cable Corporation, Newington, N.H., U.S.A. The repeaters were made by the Western Electric Company, Hillside, N.J., U.S.A., and armoured by the Simplex Wire and Cable Corporation.

The cable station at Oban was built by British contractors from designs drawn up by the British Post Office. Its equipment was installed by a British electrical contracting firm. Two Western Electric Company installers were present at Oban during the installation of the American-made cable-terminating equipment and of the cable-current supply bays, to provide necessary liaison and interpretation of drawing requirements. The Oban equipment was tested by representatives of the British Post Office, the Bell Telephone Laboratories, and the contractors.

References.

- ¹ MOTTRAM, E. T., HALSEY, R. J., EMLING, J. W., and GRIFFITH, R. R. Transatlantic Telephone Cable System—Planning and Overall Performance. (In this issue of the *P.O.E.E.J.*)
- ² MESZAROS, G. W., and SPENCER, H. H. Power-Feed Equipment for the North Atlantic Link. (In this issue of the *P.O.E.E.J.*)
- ³ HAURY, P. T., and ILGENFRITZ, L. M. Air Force Submarine Cable System. *Bell Laboratories Record*, Vol. 34, p. 321, 1956.
- ⁴ GILBERT, J. J. A Submarine Telephone Cable with Submerged Repeaters. *Bell System Technical Journal*, Vol. 30, p. 65, 1951.
- ⁵ LEBERT, A. W., FISCHER, H. B., and BISKEBORN, M. C. Cable Design and Manufacture for the Transatlantic Submarine Cable System. (In this issue of the *P.O.E.E.J.*)
- ⁶ GLEICHMANN, T. F., LINCE, A. H., WOOLEY, M. C., and BRAGA, F. J. Repeater Design for the North Atlantic Link. (In this issue of the *P.O.E.E.J.*)
- ⁷ CARTER, C. W., DICKIESON, A. C., and MITCHELL, D. Application of Compandors to Telephone Circuits. *Transactions of the American I.E.E.*, Vol. 65, p. 1079, 1946.
- ⁸ HOLBROOK, B. D., and DIXON, J. T. Load Rating Theory for Multi-Channel Amplifiers. *Transactions of the American I.E.E.*, Vol. 59, p. 265, 1940.
- ⁹ BENNETT, W. R. Cross Modulation in Multi-Channel Amplifiers. *Bell System Monograph B-1252*.
- ¹⁰ BROCKBANK, R. A., and WASS, C. A. Non-linear Distortion in Transmission Systems. *Journal I.E.E.*, Vol. 92, Part III, p. 45, 1945.
- ¹¹ JACK, J. S., LEECH, W. H., and LEWIS, H. A. Route Selection and Cable Laying for the Transatlantic Cable System. (In this issue of the *P.O.E.E.J.*)
- ¹² McNALLY, J. O., METSON, G. H., VEAZIE, E. A., and HOLMES, M. F. Electron Tubes for the Transatlantic Cable System. (In this issue of the *P.O.E.E.J.*)
- ¹³ LAMB, H. A., and HEFFNER, W. W. Repeater Production for the North Atlantic Link. (In this issue of the *P.O.E.E.J.*)

Repeater Design for the North Atlantic Link*

T. F. GLEICHMANN, B.E., A. H. LINCE, B.S. in E.E.,
M. C. WOOLEY, B.S. in E.E. and F. J. BRAGA,
B.E.E., Member I.R.E.†

U.D.C. 621.395.641:621.395.51

Some of the considerations governing the electrical and mechanical design of flexible repeaters and their component apparatus are discussed in this paper. This discussion includes a description of the feedback amplifier and the sea-pressure-resisting container that surrounds it. Examples are given of some of the extraordinary measures taken to ensure continuous performance in service.

INTRODUCTION

REPEATERS for use in the transatlantic submarine telephone cable system had to be designed to resist the stresses during laying in deep water, and to withstand the great pressures of water encountered in the North Atlantic route. In anticipation of the need for such a long telephone system in deep water, development work was started over 20 years ago on the design of a flexible repeater that could be incorporated in the cable and be handled as cable by conventional cable-ship techniques. Successful completion, in 1950, of the design and construction of the 24-channel Key West-Havana system¹ led to the adoption of similar repeaters designed for 36 channels for the North Atlantic link as discussed in companion papers.^{2,3}

Repeater transmission characteristics determine, to a large extent, the degree to which system objectives can be met. In this repeater, significant characteristics are:

- (a) *Noise and Intermodulation.*—These were established by the circuit configuration and by the use of the conservative thermionic valve⁴ developed for the Key West-Havana project.
- (b) *Initial Misalignment,* or mismatch of repeater gain and cable loss throughout the transmitted band of frequencies. A match within 0.05 dB was the objective. This affected both the design and the precision required in manufacture.
- (c) *Ageing.*—As thermionic valves lose mutual conductance with age, repeater feedback decreases, repeater gain changes and misalignment is affected. Decrease in feedback increases the gain at the higher frequencies so that the signal input must be reduced to prevent overloading, resulting in a signal/noise penalty. Gain increase is inversely proportional to the amount of feedback; in these repeaters, 33 to 34 dB of feedback was the objective to keep this source of misalignment within bounds.

Because the repeaters are inaccessible for maintenance, facilities are provided to enable the individual repeater performance to be checked from the shore end. This feature also permits a defective repeater to be identified in the event of transmission failure.

REPEATER UNIT

The repeater, for the sake of discussion, may be divided into two parts, (a) the flexible structure, known as the repeater unit, which contains the thermionic valves and other circuit components, and (b) the waterproof container and seals which house the repeater unit.

Circuit.

The circuit of the repeater unit is shown in Fig. 1. It is a three-stage feedback amplifier of conventional design with the cathodes at a.c. earth potential. The amplifier is connected to the cable through input and output coupling networks. Each coupling network consists of a transformer

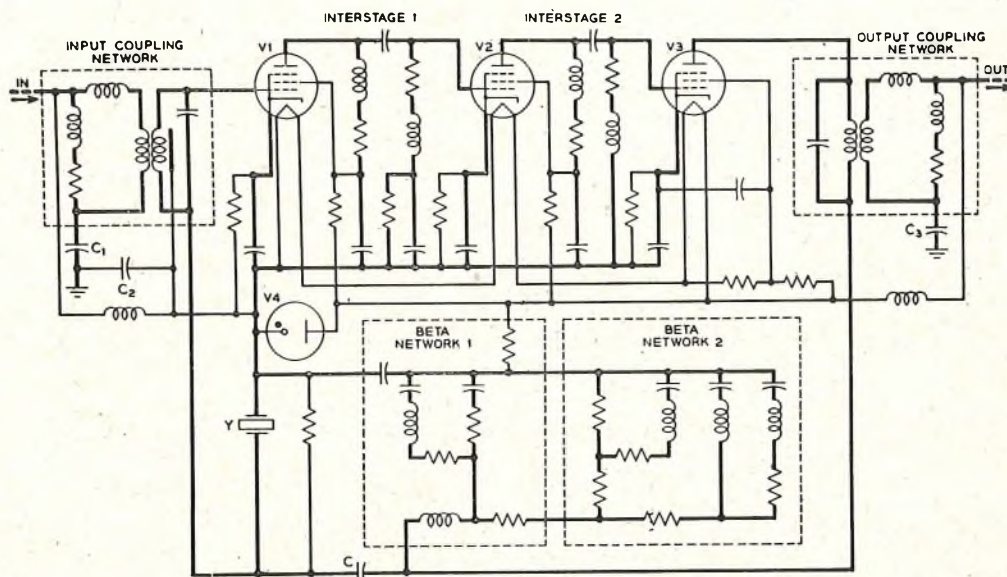

FIG. 1.—SCHEMATIC DIAGRAM OF REPEATER.

plus gain-shaping elements and a power-separation inductor.

The coupling networks directly affect the insertion gain, as do the two feedback networks. The design of the three networks controls the insertion gain of the amplifier. The required gain (inverse of cable loss) is shown in Fig. 2.

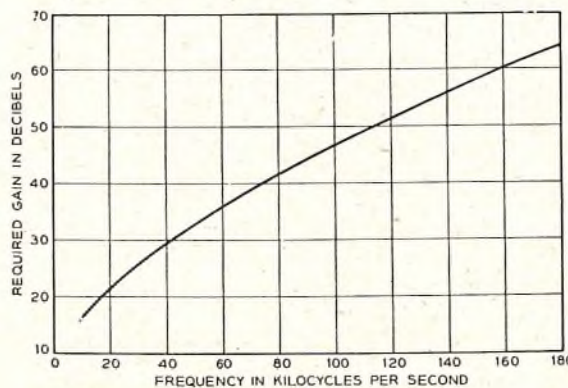

FIG. 2.—REQUIRED INSERTION GAIN.

The 39-dB shaping required between 20 and 164 kc/s is divided approximately equally among the input and output coupling networks and the feedback networks.

The interstage networks are of conventional design. The gain of the first interstage network is approximately flat across the band. The second interstage network has a

† The Authors are with Bell Telephone Laboratories, Inc.

sloping characteristic, the gain increasing with frequency. The gain shaping of these networks offsets the loss of the feedback networks so that the feedback is approximately flat across the band.

Anode and heater power is supplied to the repeater over the cable.⁵ The anode voltage (approximately 52V) is obtained from the potential across the valve heater circuit. The d.c. circuits are isolated from the container by the high-voltage blocking capacitors C_1 , C_2 and C_3 .

Gain Formula.

The circuit of Fig. 1 may be represented by a simplified circuit consisting of an input coupling network, a three-stage amplifier, an output network and a feedback impedance Z_β , as shown in Fig. 3. From Fig. 3 it can be shown that

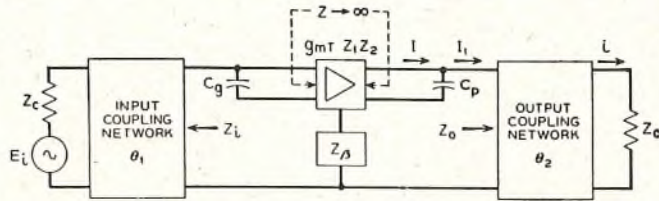

- V = Open-circuit voltage of input coupling network with E_i as the source.
- θ_1 = Gain of input coupling network defined as $e^{\theta_1} = V/E_i$.
- θ_2 = Gain of output coupling network defined as $e^{\theta_2} = i/I_1$.
- Z_1 and Z_2 = Interstage impedances.
- g_{mT} = Product of g_m of three amplifier valves.

FIG. 3.—SIMPLIFIED AMPLIFIER CIRCUIT.

the insertion gain of the repeater is given by:

$$e^\theta = \frac{2e^{\theta_1} e^{\theta_2} Z_c}{Z_\beta} \left[\frac{\rho_i \rho_o g_{mT} Z_1 Z_2 Z_\beta}{1 - \rho_i \rho_o g_{mT} Z_1 Z_2 Z_\beta} \right] \dots \dots \dots (1)$$

for the case when $Z_\beta \ll g_{mT} Z_p Z_o Z_1 Z_2 \gg (Z_o + Z_p)$ and where $\rho_i = Z_o/(Z_i + Z_o)$ and $\rho_o = Z_p/(Z_o + Z_p)$ are "potentiometer terms." The gain of the input network is defined as $e^{\theta_1} = V/E_i$, where V is the open-circuit voltage of the input network with E_i as the source, and the gain of the output network is defined as $e^{\theta_2} = i/I_1$. This expression may be put in familiar form by recognizing that $\rho_i \rho_o g_{mT} Z_1 Z_2 Z_\beta$ is $\mu\beta$, the feedback around the loop.

$$\text{Hence } e^\theta = \frac{2e^{\theta_1} e^{\theta_2} Z_c}{Z_\beta} \cdot \frac{\mu\beta}{1 - \mu\beta} \dots \dots \dots (2)$$

Equation (2) shows that the insertion gain of the repeater is the product of five factors, namely:—

- (i) e^{θ_1} (the gain of the input network)
- (ii) e^{θ_2} (the gain of the output network)
- (iii) Z_c (the cable impedance)
- (iv) Z_β (the feedback impedance)
- (v) $\frac{\mu\beta}{1 - \mu\beta}$ (the $\mu\beta$ effect term).

It should be noted that a number of simplifying assumptions have been made. For example, the effect of grid-anode capacitance has been neglected. In addition, the β circuit has been assumed to be a two-terminal impedance whereas it is actually a four-terminal network. However, in the pass band and to a large extent outside the pass band of the repeater these simplifications give a very good approximation to the true gain of the repeater.

In the pass band $\mu\beta/(1 - \mu\beta)$ is very nearly unity so that the gain-controlling factors are e^{θ_1} , e^{θ_2} , and $1/Z_\beta$, assuming that Z_c is fixed.

Coupling Networks.

The input and output networks are essentially identical. The networks are of unterminated design, and therefore do not present a good termination to the cable at all frequencies;

this results in some ripple in the system transmission characteristic at the lower edge of the band and makes the repeater insertion gain sensitive to variations in the cable impedance. However, this arrangement has the advantage of maximum signal/noise performance, highest gain, and most effective shaping with a minimum of elements. A minimum of elements is important in view of the space restrictions imposed by the flexible repeater structure. The sensitivity of the gain to variations in impedance is minimized by close manufacturing control of the cable and networks.

The schematic circuit of a coupling network is shown in

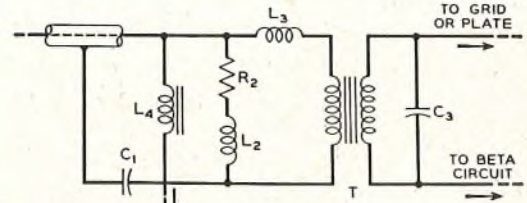
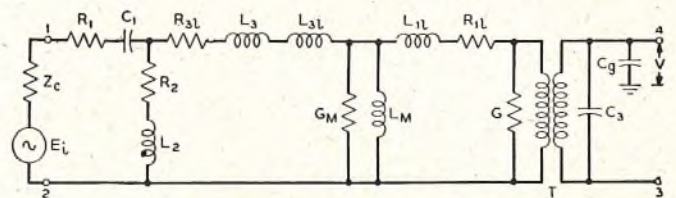

FIG. 4.—COUPLING NETWORK.

Fig. 4 and the equivalent circuit in Fig. 5. The capacitor C_1 and inductor L_4 are part of the power-separation circuit. The effect of L_4 in the transmission band is negligible and it has been omitted from the equivalent circuit. However, C_1 is



- C_1 = High-voltage blocking capacitor
- C_g = Grid-cathode capacitance.
- C_3 = High-voltage-side capacitance.
- Z_c = Cable impedance.
- R_1 = Resistance of C_1 .
- R_{1L} , R_{3L} = Resistance of leakage (low-voltage side).
- L_{1L} , L_{3L} = Leakage (low-voltage side).
- L_M = Mutual inductance.
- G_M = Conductance of L_M .
- G = High-voltage-side conductance.
- L_3 = Leakage build-out.
- T = Ideal transformer.
- R_2 , L_2 = Low-frequency shaping elements.

FIG. 5.—EQUIVALENT CIRCUIT OF COUPLING NETWORK.

in the direct transmission path and has a small effect at the lower edge of the band so that it becomes a design parameter. The combination R_2 , L_2 controls the low-frequency gain shaping of the network. The inductor L_3 builds out the leakage inductance of the transformer and together with the capacitor C_3 , controls the shaping at the top end of the band. These elements are adjusted during manufacture of the networks.

The equivalent circuit is an approximation to the true transformer circuit. By standard network-analysis techniques the ratio V/E_i , the gain of the network, can be obtained. The agreement between measurements and computation is sufficiently close, several hundredths of a decibel, to ensure that the representation is good.

Each coupling network is designed to provide approximately one-third of the total shaping required, or 13 dB. While these networks are outside the feedback path, the impedances which they present to the amplifier are important factors in the feedback design. It can be seen from Fig. 3 that at the amplifier input the proportion of the feedback voltage which will be effective in producing feed-

back around the loop is dependent upon the potentiometer division between the grid-cathode impedance of the first valve and the impedance looking back into the coupling network. The greater the gain shaping of the network, the greater is the potentiometer loss. The maximum gain that can be obtained from the coupling network is limited by the capacitance across the circuit. This capacitance cannot be reduced without increasing the potentiometer loss, and seriously limiting feedback. In this design an acceptable compromise is made when the ratio of network capacitance to grid-cathode capacitance has been

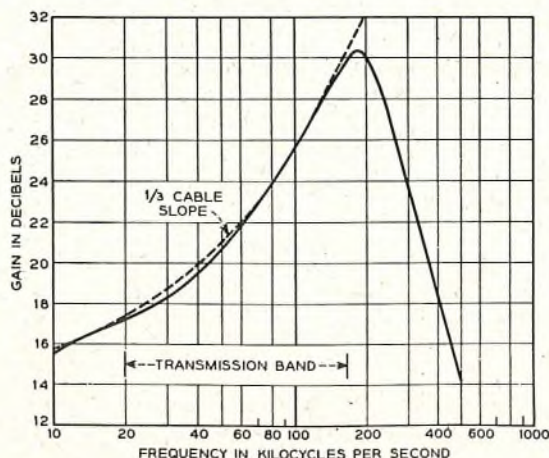

FIG. 6.—GAIN OF INPUT COUPLING NETWORK.

fixed at 1.2, as suggested by Bode.⁶ The gain through the input network and the deviation from one-third cable slope is shown in Fig. 6. A typical potentiometer term is shown in Fig. 7.

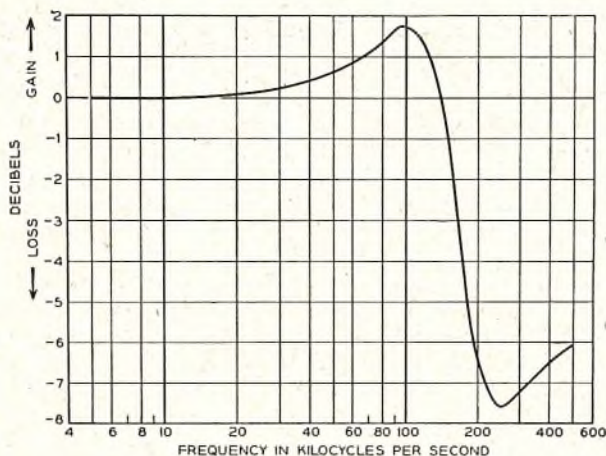

FIG. 7.—INPUT POTENTIOMETER TERM.

Similar considerations apply to the output network with the further restriction that the impedance presented to the output valve should be about 40,000 ohms at the top edge of the band for optimum intermodulation performance.

The coupling networks have a temperature characteristic which must be taken into account in the insertion gain of the repeater. The characteristic is due to variations in the resistance of C_1 and R_2 with temperature. This amounts to 0.005 dB/°F at 20 kc/s decreasing with frequency, becoming negligible above 80 kc/s.

Beta Circuit.

The beta or feedback network is designed to be complementary to the combined characteristics of the input and

output coupling networks and to "mop-up" residual effects, such as those due to $\mu\beta$ effect and coupling-network temperature coefficients. The network also provides the d.c. path for the output-valve anode current.

The configuration of the beta circuit is shown in Fig. 8. In the pass band it is a two-terminal network whose

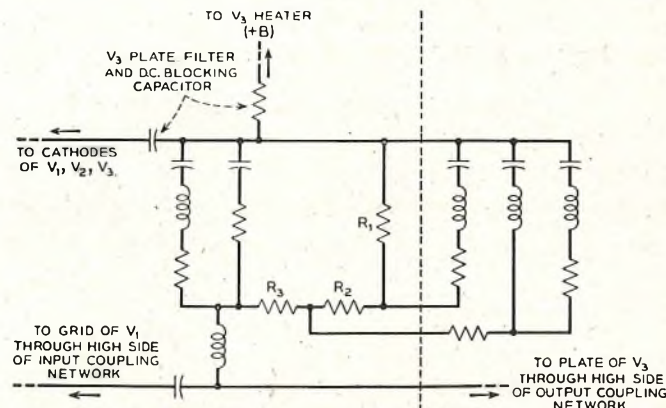

FIG. 8.—BETA NETWORK.

impedance varies from about 300 ohms at 20 kc/s to 70 ohms at 164 kc/s. It consists essentially of two parts. The elements to the left of the dotted line provide the major portion of the shaping. With these the repeater is within ± 0.7 dB of the required gain. The series-resonant circuits to the right of the dotted line reduce this to the ± 0.05 dB set as the objective.

The mopping-up elements are connected to the main portion of the beta circuit through a resistance potentiometer R_1 , R_2 and R_3 . This reduces the elements of the resonant circuit to values which would meet mounting-space and component restrictions.

Built-in Testing Features.

The crystal Y and capacitor C (in Fig. 1) in the feedback path provide the means for checking the repeater from the shore station. The crystal is a sharply-tuned series-resonant shunt on the feedback path which reduces the feedback at the resonant frequency and thus produces a narrow peak in the insertion-gain characteristic of the repeater. The feedback reduction, and hence the peak gain, is controlled by the potential divider formed by the reactance of the capacitor and the series-resonant resistance of the crystal. The crystal and capacitor are chosen so that substantially all the feedback is removed from the repeater. With no feedback the peak gain is proportional to the mutual conductance of the three valves.

At frequencies well off resonance the impedance of the crystal is high, so that no reduction in feedback results. Periodic measurements of gain at the resonant frequency, relative to measurements made at a frequency off resonance, will show any changes in the valves. The crystal frequency is different for each repeater, so that by measuring the gain from the shore stations at the various crystal frequencies it is possible to monitor the performance of the individual repeaters.

The increase in gain at the peak is approximately 25 dB. The crystal frequencies, spaced at 100 c/s intervals, are placed above the normal transmitted band, between 167 and 173.4 kc/s.

Thermal noise, always present at the input to the repeater, is also amplified over the narrow band of frequencies corresponding to the peak gain in each repeater, so that at the receiving end of the line there are a series of noise peaks, one for each repeater. Should a repeater fail, the noise peaks of all repeaters between the faulty repeater and the receiving

end will be present and those from repeaters ahead will be missing. By determining which peaks are missing the location of the failed repeater can be determined. It is obvious that to locate a faulty repeater the power circuit must be intact. To guard against power interruption due to an open-circuited valve heater, a gas-filled valve (V4 in Fig. 1) is connected across the heater circuit as a by-pass.

Loop Feedback.

The design of the feedback loop follows conventional practice. The restrictions limiting the amount of feedback that can be obtained in the transmitted band are well known.⁶ Broadly speaking, the figure of merit of the valves and the incidental circuit capacitances determine the asymptotic cut-off which limits the amount of feedback that can be obtained in the band. With the flexible-repeater circuit, capacitances are rather large because of the severe space restrictions and physical length of the structure. Transit time of $1.8^\circ/\text{Mc/s}$ per valve and a like amount for the physical length of the feedback loop reduced the available feedback by 2 dB.

Margins of 10 dB at phase cross-over and 30° at gain cross-over were set as design objectives. While these may seem to be ultra-conservative in view of the tight controls placed on components and the mechanical assembly, it should be borne in mind that the repeaters are inaccessible and repairs would be costly.

Intermodulation and valve-ageing considerations require a minimum feedback of 33–34 dB. With the restrictions noted above and the effect of the potentiometer terms on the

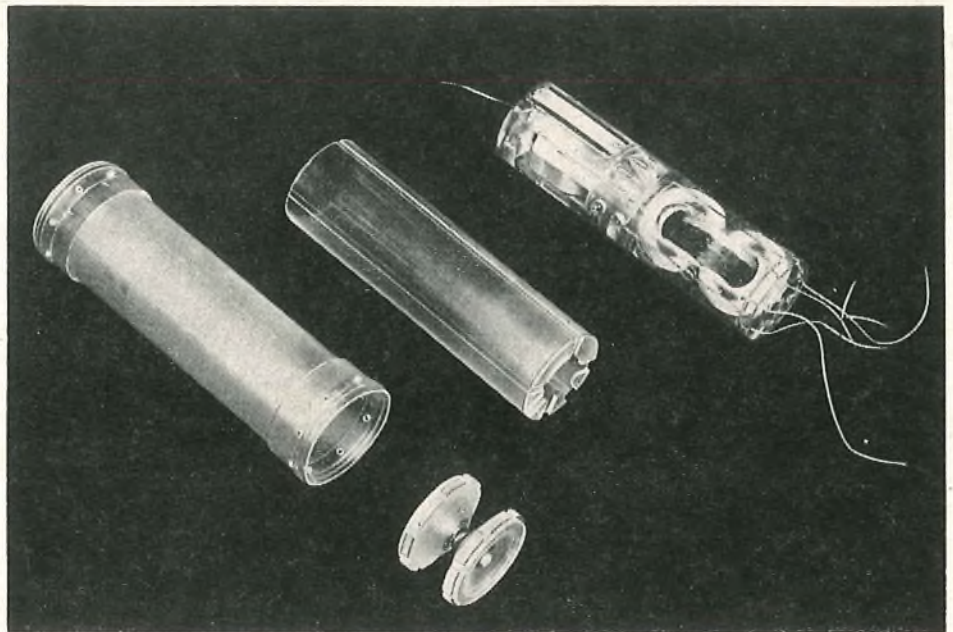

FIG. 11.—NETWORK SECTION.

available feedback, the top edge of the band is limited to about 165 kc/s with the desired feedback.

MECHANICAL DESIGN

To provide a flexible structure the repeater unit is assembled in a number of longitudinal sections mechanically coupled by helical springs and electrically interconnected by means of conducting tapes. The assembly is composed of 17 sections. Fig. 9 and 10 show the sequence of units in a repeater and an assembled unit.

The sections consist of the circuit component, or components, mounted in machined plastic formers and enclosed in a plastic container which in turn is enclosed in a housing of the same material.‡ The sections contain circuit components grouped functionally, such as input coupling network, interstage network, thermionic valve, or high-voltage blocking capacitor. It was necessary to mount the feedback network in two sections because of the large numbers of components involved. A typical network, container and housing are shown in Fig. 11.

The interconnecting tapes are placed in grooves milled in the outer surfaces of the section containers. Wiring spaces are machined into the ends of the containers for connecting network leads to the tapes. The housing is placed over the container and the tapes and is closed by a plastic coupler plate, which also forms part of the inter-section

‡The material used is methyl methacrylate, which was chosen for its physical and chemical stability and good machinability.

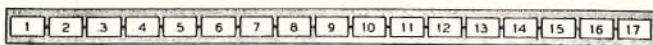

1. Input terminal.
2. Input blocking capacitor.
3. Earthing capacitor.
4. Crystal.
5. Input network.
6. Valve (first stage).
7. First interstage network.
8. Valve (second stage).
9. Second interstage network.
10. Valve (third stage).
11. Output network.
12. Beta network 1.
13. Beta network 2.
14. Gas-filled valve.
15. Drier.
16. Output blocking capacitor.
17. Output terminal.

FIG. 9.—SEQUENCE OF UNITS IN A REPEATER.

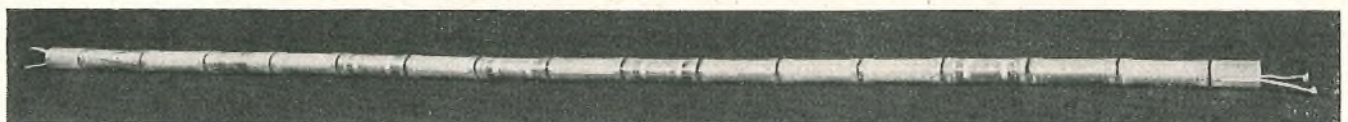
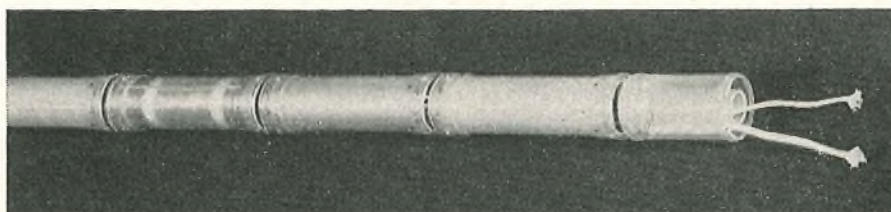

FIG. 10.—OVERALL VIEW OF THE REPEATER UNIT.

couplers. The coupler plates are fastened to the housing with plastic pins.

Between sections the interconnecting tapes are looped toward the longitudinal axis of the repeater unit. The dimensions of the loop are rigidly controlled, so that as the unit is flexed during bending of the repeater, the loops always return to their original location between sections and do not short-circuit to each other or to the metal outer container. The tapes have either an electrical connexion or a lock at one end of each section to eliminate any tendency of the tapes to creep as the repeater unit is flexed.

The interconnexions consist of two copper tapes in parallel to guard against open-circuit should one tape break. The design of the connexions to the tapes is such that once the section is closed there can be no disturbance of the tapes or network leads in the vicinity of the electrical connexions. This type of wiring plan was chosen as the best arrangement for the long structure in keeping with the stringent transmission requirements. Electrically adjacent but physically remote components can thus be interconnected with careful control of parasitic capacitance and couplings to ensure reproducibility from unit to unit in manufacture.

COMPONENTS

The development of passive components for use in the flexible repeater presented a number of unusual problems, the most important being:

- (i) The extreme reliability.
- (ii) The high degree of stability.
- (iii) The limitations on size and shape.
- (iv) An environment of constant low temperature.

The repeaters for the transatlantic system contain a total of approximately 6,000 resistors, capacitors, inductors and transformers. To be 90 per cent certain of attaining the object of 20 years' service without failure of any of these components, the effective average annual failure rate for the components must be not more than one in a million. To ensure this degree of reliability by actual tests would require more than 400 years' testing on 6,000 components. Obviously some other approach to ensure reliability was required. The most obvious avenue, that of providing a large factor of safety, was not open because of space limitations.

Fortunately, with only one exception, the passive components do not *wear* out. Thus the approach to reliability could be made by one or more of the following:

- (i) The use of constructions and materials which have been proved by long use.
- (ii) The use of only mechanically and chemically stable materials.
- (iii) The use of extreme precautions to avoid contamination by materials which might promote deterioration.
- (iv) Special care in manufacture to ensure freedom from potentially hazardous defects.

The philosophy of using only tried and proved types of components dictated the use of wire-wound resistors, impregnated-paper and silvered-mica capacitors, and Permalloy cores for inductors and transformers. While newer and, in some ways, superior materials were known, none of these possessed the necessary long record of trouble-free performance. In some cases, particularly in resistors, this approach resulted in more difficult design problems and also in physically larger components. While the ambient conditions in the repeater, i.e. low temperatures and extreme dryness, are ideal from the standpoint of minimizing corrosion or other harmful effects of a chemical nature, the materials used in the fabrication of components were nevertheless limited to those which are inherently stable and non-reactive. In addition, raw materials were carefully protected from contamination from

the time of their manufacture until they were used, or, wherever possible, they were cleaned and tested for freedom from contaminants just prior to use. Unusually detailed specifications were prepared for all materials.

The effort to achieve extreme reliability also influenced or dictated a number of design factors, such as the minimum wire diameters used in wound components, the use of as few electrical joints as possible and the use of relatively simple structures. These limitations resulted in the use of unencased components in most instances. Wherever possible, the ends of windings were used as terminal leads to avoid unnecessary soldered connexions. This caused the additional hazard of breakage of leads due to handling during manufacture and inspection. This hazard was minimized in most instances by providing the windings with extra turns which were removed just before the component was assembled in the network. Thus the lead wires in the final assembly had never been subjected to severe stress. Where this technique was impracticable, special fixtures and handling procedures were used to prevent undue flexing or stressing of lead wires.

As mentioned above, there was one type of passive component in which life is a function of time and severity of operating conditions; the capacitors, especially those subject to high voltages. Because of this and the fact that the physical and electrical requirements dictated the use of relatively high electric stress in these capacitors, a program of study covering a wide range of dielectric materials was undertaken about 1940. This study showed that none of the usual solid or semi-solid materials used to impregnate paper capacitors were suitable for continuous use at sea-bottom temperatures. Typical results of this program are shown in Fig. 12 and 13. These curves show the performance of capacitors operating at approximately 1.8 times normal electric stress at both room and sea-bottom temperatures. It is evident that even semi-solid impregnants are inferior to liquids at the lower temperature. The

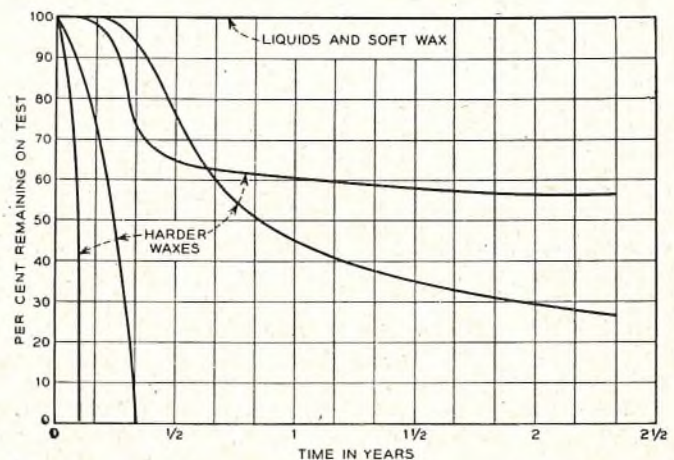

FIG. 12.—ACCELERATED LIFE TESTS ON PAPER CAPACITORS WITH VARIOUS IMPREGNANTS AT ROOM TEMPERATURE (60°-80°F).

need for the maximum capacitance in a given space restricted the field still further, so that the final choice was a design using castor-oil-impregnated kraft paper as the dielectric.

It is well established that the life (L) of impregnated paper capacitors is inversely proportional to the fourth to sixth power of the voltage stress (V); or $L_1/L_2 = (V_2/V_1)^p$ where p ranges from 4 to 6. This fact permits the accumulation of a large amount of life information in a relatively short time. In order to ensure that the capacitor design selected would provide the degree of reliability required, a number of capacitors were constructed and placed on test at voltage

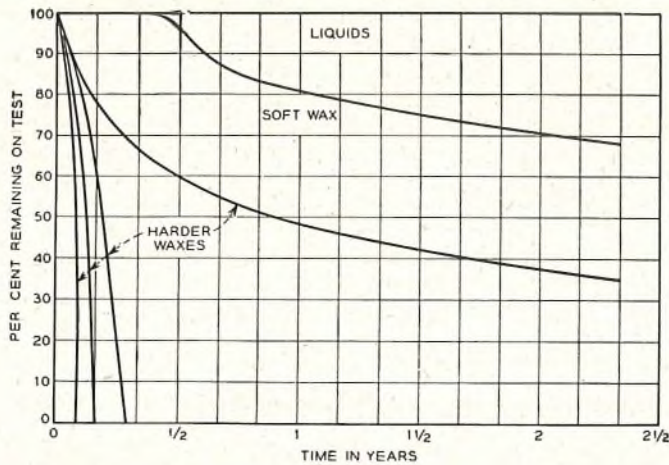

FIG. 13.—ACCELERATED LIFE TESTS ON PAPER CAPACITORS WITH VARIOUS IMPREGNANTS AT 40°F.

stresses ranging from $1\frac{1}{2}$ to $2\frac{1}{4}$ times the maximum expected in service. From the performance of these samples, a prediction of performance under service conditions can be made as follows:—

The total equivalent exposure in terms of capacitor-years at the maximum service voltage can be computed for the samples under test by the following summation:

$$T = N_1 T_1 \left(\frac{V_1}{V_s}\right)^p + N_2 T_2 \left(\frac{V_2}{V_s}\right)^p + \dots + N_r T_r \left(\frac{V_r}{V_s}\right)^p \dots \dots \dots (3)$$

where N_1, N_2, \dots, N_r are the number of samples on test at voltage stresses V_1, V_2, V_r ; T_1, T_2, \dots, T_r are the total times of the individual tests; and V_s is the maximum voltage stress under service conditions.

If, as has been the case in the tests described above, there has been only one failure in the total exposure T , the limits within which the first failure will occur in a system involving a given number of capacitors operating at a voltage stress V_s can be estimated from probability equations. These equations are:

Probability of no failures in exposure time, T ,
 $= e^{-T/L} \dots \dots \dots (4)$

Probability of more than one failure in exposure time, T ,
 $= 1 - (1 + T/L) e^{-T/L} \dots \dots \dots (5)$

where T is obtained from eqn. (3) and L is the total exposure in the same units as T for the service conditions. The solutions of eqn. (4) and (5) for L using any desired probability give the maximum and minimum exposures in capacitor-years, within which the first failure may be expected to occur under service conditions.

However, since the voltage on the capacitors varies from repeater to repeater, it is necessary to determine the equivalent exposure of the system in terms of capacitor-years per year of operation at the maximum service voltage in order to estimate the time to the first failure in the system. This is obtained from eqn. (3) for one-half of one cable by substituting the supply voltage at each repeater for V_1, V_2 , etc., the maximum service voltage for V_s , and the number of capacitors per repeater for N . The total exposure for a two-cable system is then four times this figure. With the data which have been accumulated and the number of capacitors and voltages of the transatlantic system, it is estimated with a probability of being correct nine times in ten that the first "wear-out" failure of a capacitor in the transatlantic system will not occur in less than 16 years or more than 600 years.

There is, of course, the possibility of a catastrophic or early failure due to mechanical or other defects not asso-

ciated with normal deterioration of the dielectric. Such potential failures are not always detected by the commonly used short-time over-voltage test. Thus, for submarine-cable repeaters, all capacitors subjected to d.c. potentials in service are subjected to at least $1\frac{1}{2}$ times the maximum operating voltage for a period of four to six months before they are used in repeaters. Experience indicates that this is adequate to detect potential early failures. The results of this type of testing on submarine-cable capacitors is an indication of the care used in selecting materials and manufacturing the capacitors. Only one failure has occurred in more than 3,000 capacitor-years of testing.

An important aspect of the control of quality of components is the control of the raw materials used in their manufacture. For the transatlantic project, this was accomplished by rigid specifications, thorough inspection and testing, supplemented in some cases by a process of selection.

This can be illustrated by the procedure used for selecting the paper used as the dielectric in capacitors. The manufacturing company normally inspects many lots of capacitor paper during each year. Those lots which were outstanding in their ability to stand up under a highly accelerated voltage test were selected from this regular inspection process. These selected lots were then subjected to a somewhat less highly accelerated life test. Paper which met the performance requirements of this test was slit into the proper widths for use in capacitors. Sample capacitors were then prepared with this paper and so selected that they represented a uniform sampling of the lot at the rate of one sample for approximately each 3 lb of paper. These samples were impregnated with the same lot of oil to be used in the final product. Satisfactory completion of accelerated life and other tests on these samples constituted final qualification of the paper for production of capacitors. Relatively few raw materials were adaptable to such tests or required such detailed and exhaustive inspection as capacitor paper. But the attitude in all cases was that the material must be qualified not only as to its primary constituents or characteristics but also as to its uniformity and freedom from unwanted properties.

To a considerable extent, stability of components is assured by the practice of using only those types of structures which have long records of satisfactory field performance. However, in some cases a product far more stable than usual was required. This was true of the high-voltage capacitors for which other requirements dictated the use of impregnated paper as the dielectric but for which the degree of stability required was comparable to that expected of more stable types of capacitors. So far as possible, stability was built into the components by appropriate design but, where necessary, stabilizing treatment consisting of repeated temperature cycles was used to accelerate ageing processes to reach a stable condition prior to assembly of the repeaters. Temperature cycling or observation over periods up to six months was used also to determine that the components' characteristics were stable.

Exceptional inspection procedures that were followed to ensure reliability and stability are described in detail in a companion paper.⁷

As mentioned earlier, the design and construction of components were simplified by omitting housings or containers, except for oil-impregnated paper capacitors. Adequate mountings for the components were obtained in several ways. Mica capacitors were cemented to small bases of methyl methacrylate which were in turn cemented in suitable recesses in network structures. Inductors and transformers were cemented directly into recesses in the network housings. Fig. 14 illustrates some of these structures and their mounting arrangements; at the bottom is a molybdenum-Permalloy dust-core coil in which a mounting ring of methyl methacrylate, provided with radial fins, is

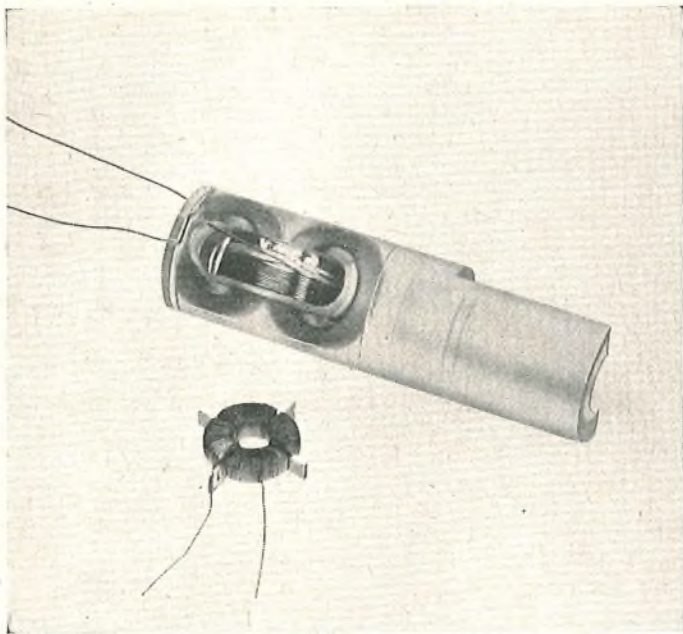

FIG. 14.—MOUNTINGS FOR MOLYBDENUM-PERMALLOY DUST-CORE COIL.

secured around the core by tape and the wire of the winding. Such inductors were mounted by cementing the projecting fins into slots arranged around a recess in the network housing. At the top of Fig. 14 is an inductor which, for electrical reasons, required a core of greater cross-section than could be accommodated in the network when made by the usual toroidal construction. In this case, the effective cross-section of two cores was obtained by cementing the cores in a "figure-of-eight" position and by applying the winding so that it threads the hole in both cores. With these constructions, the cement used to secure the inductors does not come into contact with the wire of the winding, which is thereby not subject to strains produced by curing of the cement.

For economy of space and also to reduce the number of soldered connexions, many of the components' structures contain two or more elements. Inductors and resistors were

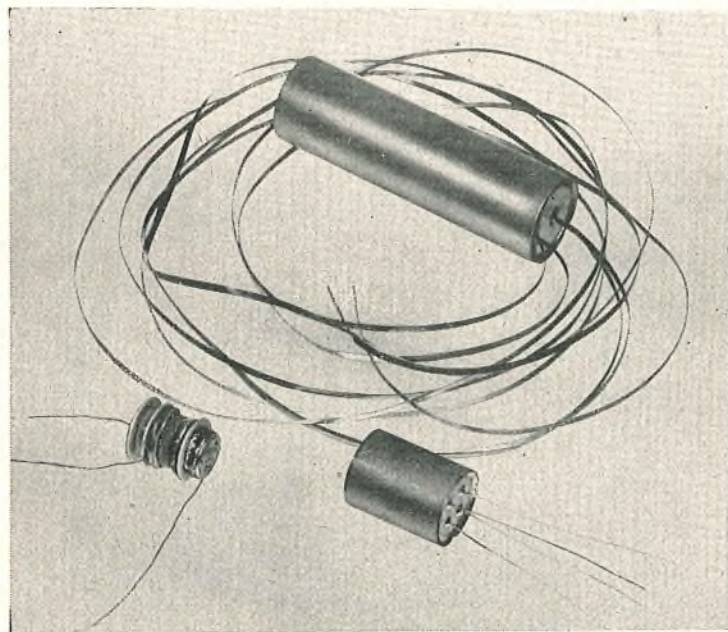

FIG. 15.—VARIOUS METHODS FOR MOUNTING CAPACITORS AND RESISTOR-CAPACITOR COMBINATIONS.

combined by winding inductors with resistance wire. Separate adjustment of inductance and resistance was obtained by adjusting the number of turns for inductance and the length of wire in a small "non-inductive" winding for resistance. The inductor at the bottom of Fig. 14 illustrates one type in which the non-inductive part of the winding is placed on one of the separating fins. Some capacitors and resistors were also combined. Fig. 15 illustrates two of these. The component on the right contains three capacitors and a single resistance in the same container. This construction requires that the resistor parts be capable of withstanding the capacitor drying and impregnation process and also that the resistor contain nothing which would be harmful to the capacitor. The capacitor at the top is a high-voltage type which, apart from valves, represents the largest single component used in the repeater. In this capacitor, the tape terminals which contact the electrodes are brought out through the ceramic cover and are made long enough to reach an appropriate point so as to avoid additional soldered connexions. Such special designs introduced many problems in the manufacture of the components. However, the improved performance of the repeater and the increase in the inherent reliability of the overall system fully justified the greater effort which was required for the production of such specialized apparatus.

POWER BY-PASS GAS-FILLED VALVE‡

The fault-locating facility, referred to previously, requires that the power circuit through the cable be continuous. To protect against an open circuit in the repeater, such as a heater failure, an additional device is required to by-pass the line current. This by-pass must be a high resistance under normal operating conditions since any current taken by this device must be supplied through preceding repeaters. If an open-circuit occurs, the by-pass must carry the full cable current. At full current, the voltage drop should be small to avoid excessive localized power dissipation in the repeater. The device should recover when power is removed so that false operation by a transient condition will not permanently by-pass the repeater.

A gas-filled diode using an ionically-heated cathode has been used to meet these requirements. By making the breakdown voltage safely greater than the drop across the heater circuit, no power is taken by the valve under normal repeater operation. In the event of an open-circuit in the repeater, the voltage across the valve rises and breakdown occurs. Full cable current is then passed through the valve. In the event of false triggering by transients, removal of power from the cable allows the valve to de-ionize and recover. The cathode is a coil of tungsten wire coated with a mixture of barium and strontium oxide. A cold-cathode glow discharge forms when the valve is first broken down. This discharge has a sustaining voltage of the order of 70V. The glow discharge initially covers the entire cathode area. Local heating occurs and some parts of the oxide coating begin to emit electrons thermionically. This local emission causes increased current density and further increases the local heating. The discharge thus concentrates to a thermionic arc covering only a portion of the coil. The sustaining voltage is then of the order of 10V.

Mechanically the valve was designed to minimize the possibility of a short-circuit resulting from structural failure of valve parts. Fig. 16 shows the construction of the valve. The glass envelope and stem structure which

‡Material contributed by Mr. M. A. Townsend.

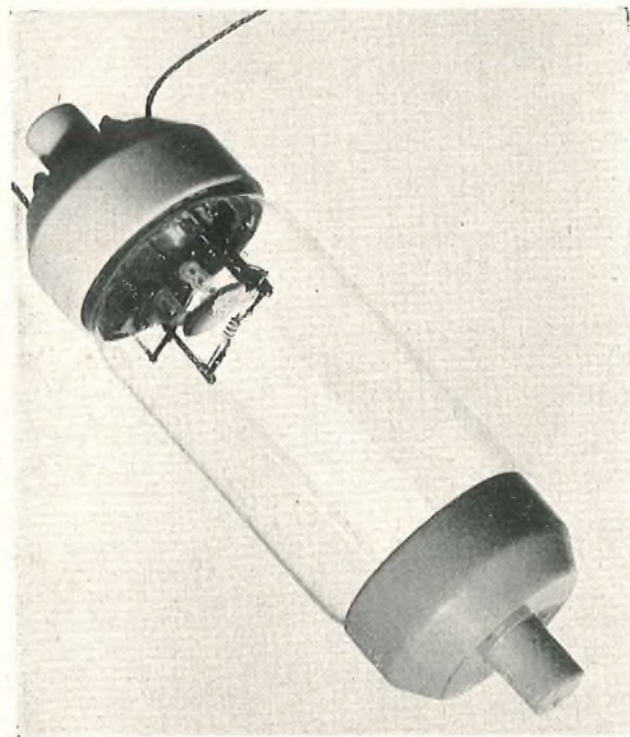

FIG. 16.—THE POWER BY-PASS GAS-FILLED VALVE.

had previously been developed for the hot-cathode repeater valves were used as a starting-point for the design. The anode is a circular disc of nickel attached to two of the stem lead wires. To provide shock resistance, the supporting stem leads are crossed and welded in the centre. To protect against weld failure, a nickel sleeve is used at each end of the cathode coil. It is crimped to hold the coil mechanically in place and then welded at the end for electrical connexion. At the end of the coil, as well as in all other places where it is possible, a mechanical wrap is made in addition to spot welding. An additional precaution is taken by inserting an insulated molybdenum supporting rod through the centre of the cathode coil. The filling gas is argon at a pressure of 10 mm Hg. To provide initial ionization, 1 μg of radium in the form of radium bromide was placed on the inside of the valve envelope. All materials were procured in batches of sufficient size to make the entire lot of valves and carefully tested before being approved for use. The valves were manufactured in small groups and a complete history was kept of the processing of each lot.

For detailed study of valve performance, a number of electrical tests were made. These involved measurements of breakdown voltage, operating voltage as a glow discharge at low current, current required to cause the transition to a thermionic arc, the time required at the cable current to cause transition to the low-voltage arc, and the sustaining voltage at the full cable current.

All the valves were aged by operating at 250 mA on a schedule which included a sequence of short on-off periods (2 min on, 2 min off) followed by periods of continuous operation. A total of 150 starts and 300 hours of continuous operation were used. Following this ageing schedule the valves were allowed to stabilize for a few days and then subjected to a 2-hour thermal treatment or pulse at 125°C. It was required that no more than a few volts change in breakdown voltage should occur during this thermal pulse for a valve to be considered as a possible component for use in repeaters.

After ageing and selection as possible components for repeaters, the valves were stored in a light-proof can at 0°C.

Measurements were made to ensure stability of breakdown voltage and breakdown time.

The quality of each group of 12 valves was further checked by continuous and on-off cycling life tests. The fact that none of these valves has failed on the cycling tests at less than 3,500 hours and 1,500 starts, and no valve on continuous operation has failed at less than 4,200 hours, gives assurance that system valves will start once and operate for the few hours necessary to locate a defective repeater. Long-term shelf tests of representative samples at 70°C and at 0°C give assurance of satisfactory behaviour in the system.

CONTAINER AND SEALS

The design of the flexible enclosure for the flexible repeater unit is basically the same as it emerged from its development stages in the 1930's. It is virtually identical with the structure of the repeaters manufactured by the Bell Telephone Laboratories for the cables laid in 1950 between Key West and Havana.¹

The functions of the enclosure are to protect the repeater unit from the effects of water at great pressure at the ocean bottom; to provide means of connecting the repeater to the cable before laying; and to be slender and flexible enough to behave like cable during laying. How these functions are met in the design may be more readily understood by reference to Fig. 17.

The repeater unit, described earlier, is surrounded by a two-layer carcass of steel rings, end to end. The rings are surrounded in turn by a copper tube $1\frac{3}{4}$ in. in diameter and having a $\frac{1}{2}$ -in. wall.

When a repeater is bent during laying by passing on to the cable-ship drum, the steel rings separate at the outer periphery of the bend and the copper tube stretches beyond its elastic limit. As the repeater leaves the drum under tension the rings separate and the copper stretches on the opposite side, leaving the repeater in a slightly elongated state. At the ocean bottom, hydraulic pressure restores the repeater to its original condition with rings abutted and the copper tube reformed.

The system of seals in each end of the tube consists of (a) a glass-to-Kovar seal adjacent to the repeater unit, (b) a rubber-to-brass seal seaward from the glass seal, and (c) a core tube and core-sleeve seal seaward from the rubber seal.

The glass seal, although capable of withstanding sea-bottom pressures, is primarily a water-vapour barrier and a lead-through for electrical connexion to the repeater circuit. In service it is normally protected from exposure to sea pressures by the rubber seal.

The rubber seal, capable of withstanding sea-bottom pressures, is indeed exposed to these pressures for the life of the repeater, but is not exposed to sea water. It is likewise a lead-through for electrical connexion from the cable to the glass seal.

The core-sleeve seal is an elastic barrier between sea water on the outside and a fluid on the inside. This fluid, polyisobutylene, is a viscous honey-like substance, chemically inert, electrically a good insulator, and a moderately good water-vapour barrier. It fills the long, thin annular space outside the cable core and inside a copper core tube and thus becomes the medium of transmitting to the rubber seal the sea pressure exerted on the core sleeve. It can be seen that the core-sleeve seal has nominally no pressure-resisting function and no electrical function.

The same fluid is also used to fill the space between the glass and rubber seals. Voids at any point in the system of seals are potential hazards to long, trouble-free life. Empty pockets, for instance, lying between the central conductor and the outer conductor, or container, are capable of becoming electrically conducting paths if filled with water

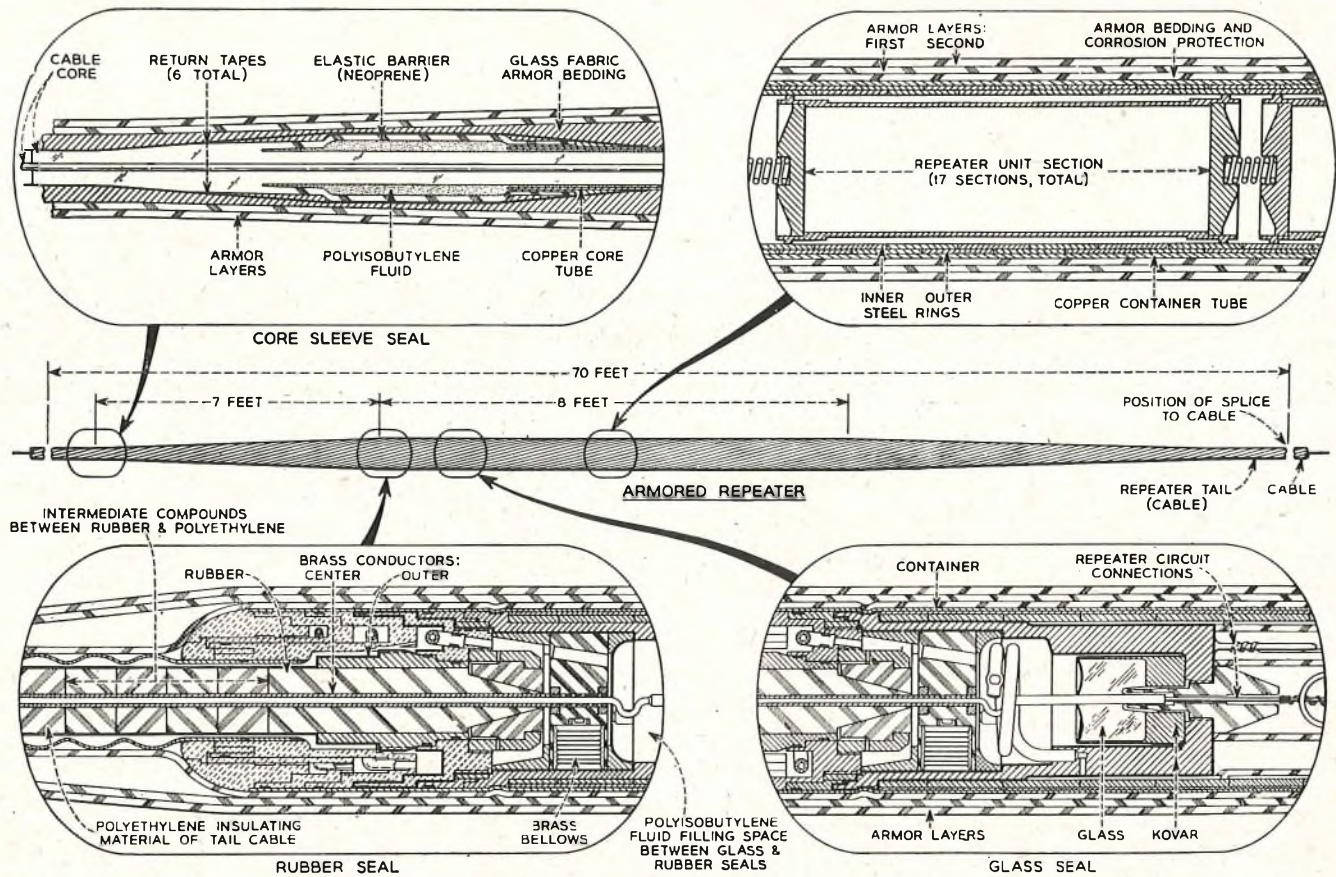

FIG. 17.—DETAILS OF CONTAINER AND SEALS.

vapour. As pointed out in companion papers,^{3,5} the voltage between the repeater (and cable) central and outer conductors is in the neighbourhood of 2,000V at the ends of the transatlantic system.

The filling of the seal interspace with a liquid would defeat one function of the rubber seal if special features were not provided in the rubber seal design. Very slight displacement of the rubber seal toward the glass seal because of sea pressure, or resulting from reduction in volume because of falling temperature, would otherwise build up pressure in the liquid and on the glass seal. This has been avoided by providing a kind of resilience in the interspace chamber. Three small brass bellows, partly compressed, occupy fixed cavities in the chamber. They can compress readily and maintain essentially constant conditions independently of external pressures and temperatures.

The entire repeater assembly, enclosed in copper, is approximately 23 ft long. Tails of cable at each end make the total length about 80 ft. The central conductor of each cable tail is joined to the rubber-seal central conductor with the insulation moulded in place in generally the same manner as in cable-to-cable junctions elsewhere in the system. The outer-conductor copper tapes of the cable tails are electrically connected to the copper core tube.

The copper region is coated with asphalt varnish and gutta-percha tape to minimize corrosion. Over this coating bandage-like layers of glass-fabric tape are built up to produce an outer contour tapering from cable diameter at one end up to repeater diameter and back down to cable diameter at the opposite end. The tape covering is saturated with asphalt varnish. This tape is primarily a bedding for the armour wires that are laid on the outside of both cable tails and repeater to make the repeater cable-like in its tensile properties and capable of being spliced to the cable.

In the region of the repeater proper, where the diameter is double that of cable, extra armour wires are added to produce a layer without spaces. Also, to avoid subjecting the repeater to the torque characteristically present in the cable under the tensions of laying, a second layer of armour wires of opposite lay is added over the first layer. This armoring process is so closely related to the armoring of cable core in a cable factory that it is performed there.

Materials.

Following the design philosophy applied to the repeater components, the materials of construction of the repeater container and seals were chosen for maximum life, compatibility with each other, and for best adaptability to the design intent. Specifications particularly adapted to this use were set up for all of the some 50 different metals and non-metals employed in the enclosure design. In general, the materials are more elaborate than those in usual commercial practice. In most instances, such as that of copper container tubes, the extraordinary inspection for defects and weaknesses, with its resulting rejection rate, resulted in high cost for the usable material.

TESTING

A substantial part of the development work on the repeater enclosure was concerned with devising tests that give real assurance of soundness and stability. It is beyond the scope of this paper to discuss how each part is tested before and after it is assembled, but certain outstanding tests deserve mention.

Steel Ring Tests.

Each of the inner steel rings, before installation, is required to pass a magnetic-particle test to find evidence of hidden metallurgical faults. Each ring is later a partici-

part in a group test under hydraulic pressure simulating the crushing effect of ocean-bottom service but exceeding the working pressures. The magnetic-particle test is repeated.

Helium Leak Tests.

Both glass and rubber seal assemblies, before being installed in repeaters, are required to undergo individual tests under high-pressure helium gas. Helium is used not only because its small molecules can pass through smaller leaks than can water molecules but also because of the excellent mass-spectrometer type of leak detectors commercially available for this technique. While helium is applied at high pressure to the outer wall of the seal, the inner wall is maintained under vacuum in a chamber joined with the leak detector. The passage of helium through a faulty seal at the rate of 10^{-9} cm³/sec can be detected. Stated differently, this is 1 cm³ of helium in 30 years. The relation of water-leak rate to helium-leak rate is dependent on the physical nature of the leak, but if they were assumed to be equal rates, the amount of water which might enter a tested repeater in 20 years would be 0.66 gramme. A desiccant within the repeater cavity is designed to keep the relative humidity under 10 per cent if the water intake were five times this amount.

After the glass seals are silver-brazed into the ends of the copper tube of the repeater the helium test is repeated to check the braze and to recheck the seal. For this test the entire repeater must necessarily be submerged in high-pressure helium. Obviously, in order to sense a possible passage of the gas from the outside to the inside, the leak-detector vacuum system must be connected to the internal volume of the repeater. For this and other reasons a small-diameter tube that by-passes the seal is provided as a feature of the seal design. After the leak integrity of the repeater is established by this means for all but the access tube, the tube is used as a means of vacuum drying the repeater and then filling it with extremely dry nitrogen. Following this, the tube is closed by welding and brazing. This closure is then the only remaining leak possibility and is checked by a radio-isotope leak test.

Radio-isotope Leak Test.

Of various methods of detecting the passage of very small amounts of a liquid or a gas from the outside to the inside of a sealed repeater, a scheme using a gamma-emitting radio-isotope appeared to be the most applicable.

The relatively small region of the welded tube referred to above is surrounded by a solution of a soluble salt of caesium.^{1,7} With the entire repeater in a pressure tank, hydraulic pressure in excess of service pressures is applied for about 60 hours. The repeater is removed from the tank, the radioactive solution is removed and the test region is washed by a special process so as to be essentially free from external radioactivity. A special Geiger counter is applied to the region. If there has been no leak the gamma radiation has a low value. If an intake has occurred of as much as 1 mg of the isotope solution, the radiation count is about four to five times greater than that of the no-leak condition. The rate of leak indicated is an acceptable measure of soundness of the repeater closure.

The helium and subsequent isotope leak tests are not only made on a repeater when its glass seals are installed but are performed again on each rubber seal after it is brazed in place.

Electrical Tests.

Prior to assembly into the repeater the various networks are tested under conditions simulating as nearly as is feasible the actual operating conditions of the particular

network. The input and output coupling networks and the beta networks affect directly the insertion gain and hence are held to very close limits. To ensure meeting these limits, elements which go into a particular network are matched and adjusted as a group before assembly into the network.

Repeater units are tested for transmission performance both before and after closing. These tests consist of μ - β measurements (simultaneous measurements of gain and phase of the feedback loop), noise, intermodulation, insertion gain at many frequencies, exact frequency of the fault-location crystal and crystal peak gain. Intermodulation and crystal-frequency measurements are made with the repeater energized at 225-mA cable current and also at 245 mA as a check on the eventual performance of the whole system initially and after ageing.

PERFORMANCE OF REPEATERS

The phase and gain characteristics of the feedback loop of the repeater are shown in Fig. 18. It will be noted that at the upper edge of the band the feedback is a little less than the 33-34 dB set as the objective. Additional

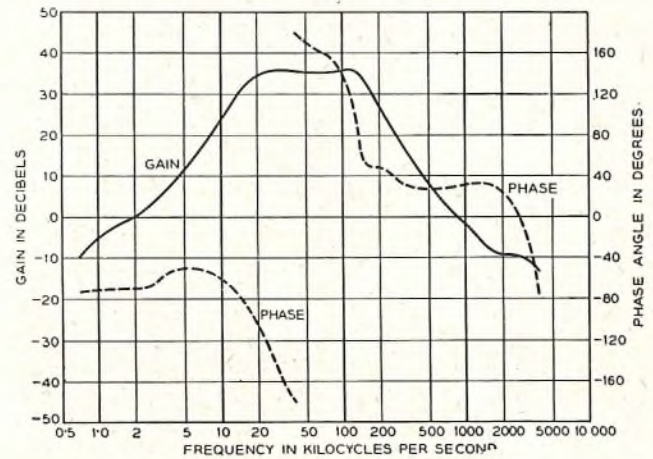

FIG. 18.— μ - β GAIN AND PHASE.

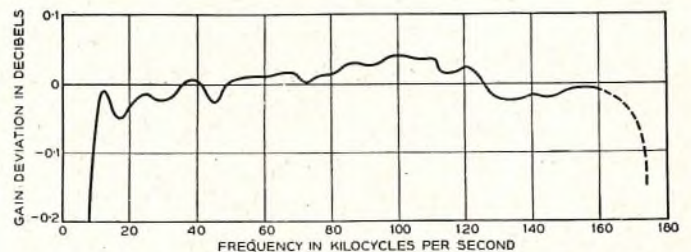

FIG. 19.—REPEATER DEVIATION FROM 36.9-N.M. DESIGN CABLE.

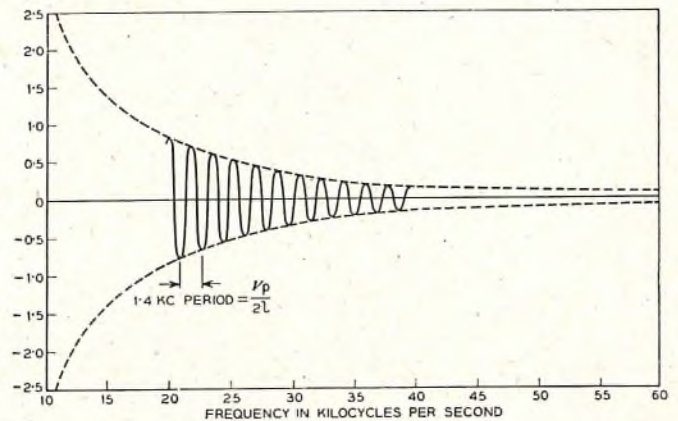

FIG. 20.—INTERACTION RIPPLE FOR THE SYSTEM.

elements could have been used in the interstage networks to increase the feedback but the return per element is small. Since any element is a potential hazard, the lower feedback is acceptable.

The deviation of the insertion gain of the repeater from the loss of 36.9 n.m. of design cable at sea bottom is shown in Fig. 19. This is well within the objective of ± 0.05 dB.

It has been pointed out that the repeater input and output impedances do not match the cable impedance. This results in ripples in the system frequency characteristic due to reflections at the repeater. These are shown in Fig. 20.

The noise performance of the repeater is determined by the input valve and the voltage ratio of the input coupling network. Amplifier noise referred to the input is shown in Fig. 21. At the upper frequencies the repeater

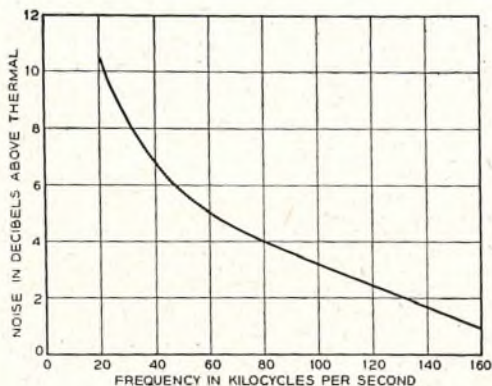

FIG. 21.—REPEATER NOISE.

contribution to cable noise is very small. At the lower frequencies, while the repeater noise is considerably greater than thermal noise, this does not degrade performance because of the lower cable attenuation at these lower frequencies.

Manufacturing Drawings.

Because of the extraordinary nature of many of the manufacturing problems associated with undersea repeaters, it was determined at the outset that a so-called single-drawing system would be used. For this reason, considerably more information is supplied than is normal. The effect is illustrated best in the rather large number of drawings that consist of text material outlining in detail a specific manufacturing technique. Such drawings specify the devices, supplies and work materials needed to perform an operation, and the step-by-step procedure. Of course, these papers are by no means a substitute for manufacturing skill. Primarily they ensure the continuance of practices already proved to be effective with the Havana-Key West project.

REPAIR REPEATER

The "repair repeater," used to offset the attenuation of the excess cable which must be added in making a repair, is basically of the same general design as the line repeater. It employs a two-stage amplifier, designed to match the loss of 5.3 n.m. of cable to within ± 0.25 dB. The larger deviation compared with the line repeater is permissible since few repair repeaters are expected to be added in a cable. The input and output impedances match the cable. As in regular repeaters a crystal and gas-filled valve are provided for maintenance testing. The crystals give approximately 25 dB increase in gain and have frequencies between 173.5 and 174.1 kc/s so as not to duplicate any used in the line repeaters. The crystal-frequency spacing is 100 c/s.

Wherever possible the same components and mechanical

details are used in the repair repeaters as in the line repeaters. When changes in design were necessary, they were modifications of the existing designs rather than new types. The capacitors are like those of the line repeaters. Except for the length of the container, the enclosure is identical with that of the line repeater.

Noise and overload considerations restrict the location of a repair repeater to the middle third of a repeater section.

Undersea Equalizers.

Even though the insertion gain of the line repeater matches the normal loss characteristic of the cable rather closely, uncertainties in the knowledge of the attenuation of the laid cable can lead to misalignment which, if uncorrected, would seriously affect the performance of the system. Misalignment which has cable-loss shape can be corrected by shortening or lengthening the cable between repeaters at intervals as the cable is laid. Other shapes, however, require the addition of networks or equalizers in the line.

With these factors in mind a series of undersea equalizers were designed. The loss shapes were chosen on the basis of a power-series analysis of expected misalignments. The designs were restricted to series-impedance-type equalizers to avoid the necessity for shunt arms and the accompanying high-voltage blocking capacitor required to isolate the cable power circuits. This restriction confines the ultimate location of the equalizers to the middle portion of repeater sections to minimize the reaction of the poor repeater impedance on the equalizer characteristic. The d.c. resistance of equalizers is low so that material increase of the system power supply voltage is not required.

The configurations of two of the equalizers are shown in Fig. 22(a) and 22(b). The loss characteristics are shown in

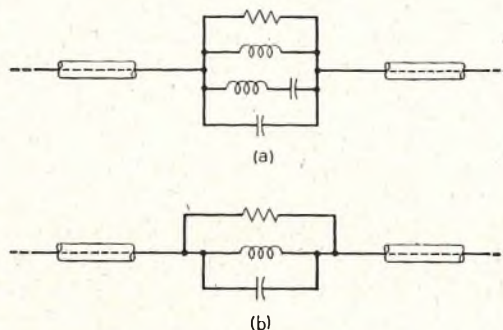

(a) Schematic of Type IV equalizer.
(b) Schematic of Type V equalizer.

FIG. 22.—SCHEMATIC DIAGRAMS OF EQUALIZERS.

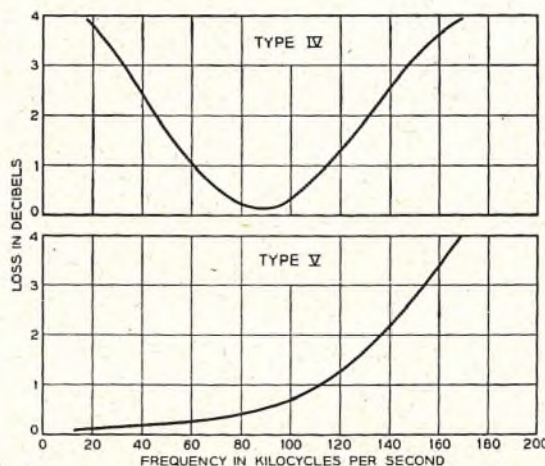

FIG. 23.—EQUALIZER LOSS CHARACTERISTICS.

Fig. 23. Each equalizer has a maximum loss spread in the pass band of about 4 dB, which represents a compromise between keeping the number of equalizers small and at the same time keeping the misalignment within tolerable limits.

The components used are modifications of the repeater components. The mechanical construction is identical with that of the repeater except that with the smaller number of elements, the container is materially shorter than that of a repeater.

ACKNOWLEDGMENTS

Scores of individuals have contributed to the development of these repeaters, some leading to basic decisions, some creating, adapting and perfecting both electrical and mechanical designs. Many of these people have furnished the continuing drive and enthusiasm that are so essential for a team of engineers and scientists having divergent interests. It is nearly impossible to assign relative importance to the work of transmission engineers, apparatus designers, mathematicians and research scientists in the fields of materials and processes. Equally difficult

is any realistic appraisal of the work of all of the technical aides and shop personnel whose contributions are so significant to the final product. The authors, in reporting the results, therefore acknowledge this large volume of effort without mentioning the many individuals by name.

References.

- ¹GILBERT, J. J. A Submarine Telephone Cable with Submerged Repeaters. *Bell System Technical Journal*, Vol. 30, p. 65, 1951.
- ²MOTTRAM, E. T., HALSEY, R. J., EMLING, J. W., and GRIFFITH, R. G. Transatlantic Telephone Cable System—Planning and Overall Performance. (In this issue of the *P.O.E.E.J.*)
- ³LEWIS, H. A., TUCKER, R. S., LOVELL, G. H., and FRASER, J. M. System Design for the North Atlantic Link. (In this issue of the *P.O.E.E.J.*)
- ⁴M McNALLY, J. O., METSON, G. H., VEAZIE, E. A. and HOLMES M. F. Electron Tubes for the Transatlantic Cable System. (In this issue of the *P.O.E.E.J.*)
- ⁵MESZAROS, G. W. and SPENCER, H. H. Power-Feed Equipment for the North Atlantic Link. (In this issue of the *P.O.E.E.J.*)
- ⁶BODE, H. W. Network Analysis and Feedback Amplifier Design. (D. Van Nostrand, 1945.)
- ⁷LAMB, H. A. and HEFFNER, W. W. Repeater Production for the North Atlantic Link. (In this issue of the *P.O.E.E.J.*)

Repeater Production for the North Atlantic Link*

H. A. LAMB and W. W. HEFFNER, B.S.†

U.D.C. 621.395.641:621.395.51

Production of submarine telephone cable repeaters, designed to have a minimum trouble-free life of 20 years, required many new and refined manufacturing procedures. Care in the selection and training of personnel, manufacturing environment, inspection and testing were of great importance in the successful attainment of the ultimate objective. Quality of product is always important in communication systems but the building of electronic equipment for use at the bottom of the ocean, where maintenance is impossible and replacement of apparatus is extremely expensive, required unusual manufacturing methods.

MANUFACTURING OBJECTIVE AND GENERAL PHILOSOPHY

LATE in 1952, the manufacture of flexible repeaters for the North Atlantic link of the transatlantic submarine telephone cable system was allocated to the Company's Kearny works.

In accordance with established practice in initiating radically new products and processes, production of these repeaters was assigned to the Engineer of Manufacture Organization rather than to regular manufacture in the telephone apparatus shops. The task was to produce 122 36-channel carrier repeaters and 19 equalizers capable of operating satisfactorily at pressures up to 6,800 lb/in² on the ocean floor, with minimum maintenance, for a period of at least 20 years. Initial delivery was required in March, 1955 less than a year and a half after the project started.

Quality is always the prime consideration in producing apparatus and equipment for a telephone system. There is an economic breaking point, however, beyond which the return does not warrant the abnormal expenditures required to approach theoretical perfection. The same philosophy applies to all manufactured commodities, be they automobiles, aircraft or telephone systems. In general, all these products are physically available for preventive and corrective maintenance at nominal cost, but in the case of electronic repeaters at the bottom of the ocean, maintenance is impossible and replacement would be extremely expensive.

The general philosophy adopted at the inception of the project was to build integrity into the product to the limit of practicability. To do this, a number of fundamental premises were established, which formed the foundation of all operations involved:

- Manufacturing environment would be provided which, in addition to furnishing a desirable place of work, could be kept scrupulously clean and free from contamination.
- The best available talent would be screened and selected for the particular work involved.
- Wage payments would be based on the daily rate, rather than on an incentive basis, because production schedules and the complexity of the operations did not permit the high degree of standardization essential to effective wage-incentive operation.
- A sense of individual responsibility would be inculcated in every individual on the job.
- Training programs would be established for supervisors, operators and inspectors before any work was done on the project.
- Inspection, on a 100 per cent basis, would be established at every point in the process which could conceivably contribute to, or affect, the integrity of the product.

PREPARATION FOR MANUFACTURE

Manufacturing Location.

It appeared desirable to set up manufacture in a location apart from the general manufacturing area. Experience gained to date has satisfied the company that this was the correct approach, since it provided a number of advantages:

- Administration has been greatly facilitated by having all levels of supervision located in the immediate vicinity of the work.
- The people on the job had to acquire and maintain a new philosophy of perfection of product, rather than a high output at an "acceptable quality level." This was easier at a separate location, since only one philosophy was followed throughout the plant.
- Engineering, production control, service and maintenance organizations were located close to actual production and had no assignments other than the project.
- The small plant, owing to its semi-isolation, tends to produce a very closely knit organization and good team-work.

A large number of manufacturing locations were examined, and the one selected was a one-storey modern structure in Hillside, New Jersey, which provided a gross area of 43,700 ft².

The entire plant is air conditioned; in most cases, the temperature is controlled within 73° to 77°F. The air is filtered through two mechanical and one electrostatic filters. Relative humidity is maintained at a maximum of 40 per cent in all areas but one—the capacitor winding room—in which it is necessary to maintain a maximum humidity of 20 per cent to avoid mechanical difficulty with capacitor paper. While most of the air is recirculated, the air from the cafeteria, cleaning room, locker and toilet rooms is exhausted to the outside atmosphere. Two separate air-conditioning systems are in use. One, of 300 tons capacity, takes care of most of the plant, while a smaller unit of 30 tons capacity serves the capacitor winding, testing and impregnating rooms. Each installation has its own air-filtering and conditioning equipment.

Plant Layout.

The plant layout is illustrated in Fig. 1. All working

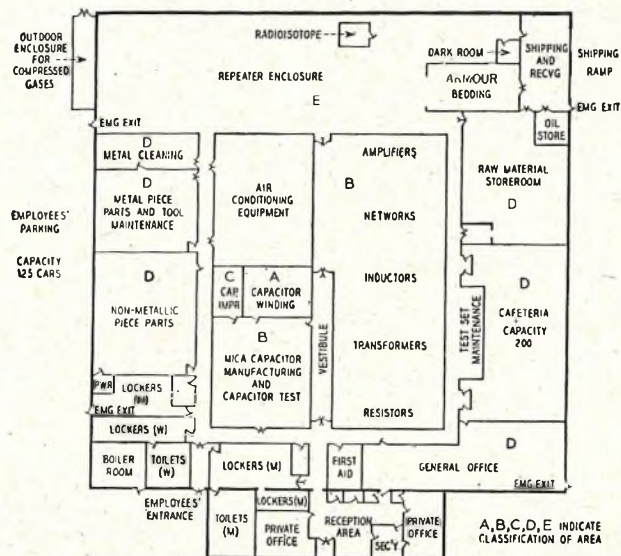

FIG. 1.—PLANT LAYOUT FOR SUBMARINE-CABLE REPEATER SHOP.

† The authors are with the Western Electric Co., Inc.

areas, with the exception of the repeater-enclosure area, are individually enclosed, and walls, from approximately 4 ft above the floor, are almost entirely of reinforced glass. This arrangement facilitated supervision by other than first-line supervisors, who were located with the groups, and provided a means of viewing the operations by the many visitors to Hillside, without contaminating the critical areas or disturbing the operators.

Analysis of Design for Facilities and Operations.

In analysing the design for manufacture there were, of course, numerous instances where conventional methods and facilities were entirely adequate for the job. Since their inclusion would contribute little to this paper, the description will be confined to those cases which are new or unusual.

Collaboration with Research Laboratories in Preparation of Manufacturing Information.

Early in 1953 a co-ordination committee was established, consisting of representatives from the various research laboratories' design groups and production engineers, which met bi-weekly during the entire period preceding initial manufacturing operations. These meetings provided a clearing house for questions and policies of a general nature and served to keep all concerned informed as to the progress of design and the preparations for manufacture.

It is customary, during the later stages of development of any project at the research laboratories, for the production engineers to participate in the preparation of manufacturing information as an aid in pointing the design toward the most economical and satisfactory production methods and facilities. Since the decision to use the Bell System repeater in the transatlantic system was based on the performance of the Key West-Havana installation, and changes in design would require further trials over an extended period, only minor changes to facilitate manufacture were made. Further, since some experience had been gained by the research laboratories in producing repeaters for that installation, it was decided to pool effort in preparing the manufacturing process information, which is normally the Company's responsibility. Close co-operation of the two groups, therefore, has resulted in the production of repeaters which are essentially replicas of those in the initial installation except for the internal changes necessary to increase transmission capacity from 24 to 36 channels.

Other Company Locations and Outside Suppliers.

During the development work on the Key West-Havana repeaters, the Company's Hawthorne Works had furnished the molybdenum-Permalloy cores for certain inductors, the Tonawanda plant had furnished mandrel-related resistance wire, and the Allentown plant had fabricated the glass-seal sub-assemblies. Since the experience gained in this development work was extremely valuable in producing the additional material required for the transatlantic system, and since the facilities for doing the work were largely available, these various locations were asked to furnish similar material for the project. Although the Kearny crystal shop had not been involved in the Key West-Havana project, arrangements were made to make the crystals there for this project, since facilities were available, together with considerable experience in producing precision units.

Sub-contracted Operations.

While it was believed, initially, that all component parts for repeaters should be manufactured by the Company, critical analysis indicated that it was neither desirable nor economical in certain cases. One of the outstanding examples

in this category is the hardened and ground chrome-molybdenum steel rings that constitute the strength members in the repeater and sustain the pressures developed on the ocean bottom. Purchasing the many large and varied machine tools and associated heat-treating equipment necessary to produce these parts would have required a substantial capital expenditure and additional manufacturing space. Arrangements, therefore, were made with a highly-qualified and well-equipped supplier to produce the rings, using material furnished by the Company, which had been previously inspected and tested to very stringent requirements.

The situation attending the manufacture of a relatively small number of comparatively large copper parts used in the rubber and core tube seals was much the same. Here, again, the large-size machine tools and additional manufacturing space, required for only a short time, would have increased the overall cost of the project considerably. These parts, therefore, were sub-contracted in the local area and inspection was done at Hillside.

A safeguard, so far as integrity is concerned, was provided by the fact that these were individual parts that could be reinspected at the time of delivery. No sub-assembly operations that might possibly result in the overlooking of a defect were sub-contracted.

MANUFACTURING CONDITIONS

Two major problems confronted the Company in planning the manufacture of repeaters: to produce units that were essentially perfect, and to prevent the contamination of the product by any substance that might degrade its performance over a long period. It was realized that the product had a definite economic value which the cost of production should not exceed. In many cases, therefore, it was necessary to rely on judgment, backed by considerable manufacturing experience, in determining when the "point of no return" had been reached in refining processes and practices.

The initial approach to this phase of the job was to classify, with the collaboration of the research laboratories, all the manufacturing operations involved as to the degree of cleanliness required. In setting up these criteria, it was necessary to evaluate the importance of contamination in each area and the practicability of eliminating it at the source or to ensure that whatever foreign material accumulated on the product was removed.

A representative case is the machining of piece parts. While the shop area is cleaner, perhaps, than any similar area in industry, the very nature of the work is such that immediate contamination cannot be avoided, since material is being removed in the form of chips and turnings and a water-soluble oil is used as a coolant. In this instance, however, the parts can be thoroughly cleaned and their condition observed before leaving the area. Conversely, in the case of an operation such as the assembly of paper capacitors into a container which is then hermetically sealed, it is essential to ensure that both the manufacturing area and the processes are free from, and not conducive to producing, particles of material which are capable of causing trouble.

The various classifications established for the production areas include specific requirements as to temperature, relative humidity, static pressure with respect to adjacent areas, cleanliness in terms of restrictions on smoking and the use of cosmetics and food, and the type and use of special clothing.

Special Clothing.

Employees' clothing was considered one of the most important sources of contamination, for two reasons:

foreign material could be collected upon it and carried into the manufacturing areas, and various types of textiles in popular use are subject to considerable unravelling and fraying.

After considerable study of many types of clothing, the material adopted was closely-woven Orlon, which has proved to be acceptably lint-free. The complete uniform consists of slacks and shirts for both male and female employees, Orlon surgeon's caps for the men and nylon-visor caps for the women. In addition, shoes, without toe-cap seams, were provided. Nylon smocks were supplied to protect the uniforms while employees moved from locker rooms to entrance vestibules. Two changes of clothing were provided each week.

Employees to whom this special clothing was issued were paired for locker use. Both partners kept their uniforms and special shoes in one locker and their own clothes and shoes in another. At the entrance vestibule to the A, B and C areas (Fig. 1), the employees were required to clean their shoes and to wash their hands. They then removed their smocks and went to their work positions within the inner areas. At any time that it was necessary for employees to leave the work areas, they put on their smocks in the vestibule, and upon their return went through the cleaning procedure again.

Cleaning.

Schedules were established for cleaning the areas at regular intervals, the frequency and methods depending upon the type of manufacturing operations and the activity. Usually, the vinyl-plastic floors were machine scrubbed and vacuum dried. Walls, windows and ceilings were cleaned by hand with lint-free cloths. Manufacturing facilities such as bench tops, which were linoleum covered, were washed daily. Test sets, cabinets, test chambers and bench fixtures were also cleaned daily. Hand tools were cleaned at least once a week by scrubbing with a solution of green soap, rinsing in distilled water, followed by alcohol, and then dried in an oven.

Dust Count.

Since it was impossible to determine what contaminating material in the form of air-borne particles might be encountered from day to day, and what the effect might be during the life of the repeaters, the general approach to this problem was to control, as far as possible, the amount of dust within the plant.

In order to verify, continuously, the overall effectiveness of the various preventive measures, dust counts were made in each classified area at daily intervals, using a Bausch and Lomb dust counter. This device combines, in one instrument, air-sampling means and a particle-counting microscope. Over a two-year period it has been possible to maintain, in certain areas, a maximum dust count of between 2,000 and 3,500 particles/ft³ of air, with a maximum size of 10 microns. Control checks, taken outside the building at the employees' entrance, generally disclosed upwards of 25,000 particles/ft³, a good portion of which are of comparatively large size.

Production and Personnel.

Equipping the plant, obtaining and installing facilities, and selecting and training personnel proceeded on a closely overlapped basis with receipt and analysis of the design information from the research laboratories. Because of the critical nature of the product, provisions were made, not only for the most reliable commercially available utilities and services, but also for emergency lighting service in some areas. Maintenance and service staffs had

to be built up rapidly as the supervisory and manufacturing forces were being developed.

Qualification of All Personnel.

Before employees were assigned to production work, they were required to pass a qualification test established by the inspection organization to demonstrate satisfactory performance. Programs were therefore arranged for "vestibule" training and qualification of new employees. Training was carried out in two stages:

- (i) (a) A period in which the employee received instruction and became acquainted with equipment and requirements.
- (b) A practice period in which the employee developed techniques and worked under actual operating conditions, with all work submitted to regular inspection.
- (ii) A qualification period in which the employee was required to demonstrate that work satisfactory for project use could be produced.

The main objective during stage (i) was progressive quality improvement, and in stage (ii) the maintenance of a satisfactory quality level over an extended period.

All personnel were required to pass qualification tests before being assigned to production work and were restricted to that work unless trained and qualified for other work. Employees trained on more than one job were requalified before being returned to a previous assignment.

Records of the performance of individual operators, started in the training stage, were continued after the employees were assigned to production work. The performance record of the operator was based on results obtained during the inspection of their work, while that of the inspectors was based on special quality-accuracy checks.

PERSONNEL SELECTION AND TRAINING

Selection.

It was apparent that the new manufacturing techniques, including the cleanliness and quality demands, would necessitate that all shop supervisors and employees should be very carefully selected. It also appeared (and this was subsequently confirmed) that, after the careful selection and training of supervisors, long training periods would be required for specially selected shop employees.

In selecting first-line shop supervisors, such factors as adaptability, personality and ability to work closely with the engineers were of paramount importance. For the parts and apparatus for which they were responsible, they were required to learn thoroughly the design, the operations to be performed, the facilities to be used, the data to be recorded, the cleanliness practices to be observed—and in most cases, to prepare themselves to be able to do practically all the operations, because subsequently they had to train selected operators to perform critical operations to very-high-quality standards under rigidly controlled manufacturing conditions. As shop supervisors and employees were assigned to the manufacture of repeaters, they were thoroughly indoctrinated in the design intent and the new philosophy of manufacture.

Standard ability and adaptability tests were used in a large number of cases to assist in proper selection and placing of technicians. Tests for finger and hand dexterity; sustained attention; eyes, including perception and observation; and reaction time of the right foot after a visual stimulus, this being important for induction brazing operations. Other requirements were a high degree of dependability and integrity, involving intellectual honesty and conscientious convictions; capability of performing tedious, frustrating, and exasperating

operations against ultra-high quality standards, verifying their own work; perseverance and capability to adapt easily to changes in assignment and occupation or the introduction of design changes. The Company considered whether or not they would stand up under "fishbowl" operations, wherein they would be subjected to a considerable amount of observation by the management. Also, could they duplicate high quality frequently after qualifying for a particular operation?

During the period of repeater manufacture, the number of employees rose from less than 50 in January, 1954, to a maximum of 304 by February, 1955, after which there was a gradual reduction to about 265 employees for six months and then a gradual falling off as the project neared completion. In the period from May to December, 1954, between 30 and 45 employees were constantly in training prior to being placed on productive work. During 1955 this decreased to practically no employees in training during the mid-part of the year, and thereafter training was required merely to compensate for a small labour turnover and employee reassignment. The labour turnover was very small and attendance was exceptionally good during the Hillside operations.

Training.

The original plan, which was generally followed, was to prove-in the tools for each phase of the job, then follow with an intensive program of training. Indoctrination of laboratory technicians could be considered as "vestibule training" in that they were acclimatized to the area and conditions, given oral instruction in the work, then given practice materials and demonstrations, and, when qualified, were started on making project material. To do this, extra supervisors were required at the beginning of the job. A supervisor trained a few employees, qualified some of them, and began work on the project. Another supervisor was then required to train additional employees, who, as they became qualified, were transferred to the supervisor responsible for making project apparatus. Additional testing of the employees, instruction and re-instruction, and, in some cases, re-training were required. In practically all cases, it was possible to fit an employee selected for work at Hillside into some particular group of operations. The extra emphasis on selection and training created a well-balanced team that later resulted in considerable flexibility. During all this training the supervisors worked closely with engineers and inspectors who understood the design intent and the degree of perfection required.

At the beginning, each technician was trained for only one operation of a particular job. Later, the tours of duty for many technicians were broadened to cover several operations.

Information.

To keep employees informed, the entire group was occasionally assembled and given informative talks on current production plans and future business prospects. Motion pictures were shown of the cable-laying ships and the operations of cable splicing and cable laying. A display board, showing all the repeater components, was mounted on the wall of the cafeteria. This showed the operators just where the parts were used in apparatus; also, just where their products went into the wired repeater unit, and how all electrical apparatus was enclosed against sea pressure in the final repeater. In small groups, all the employees at Hillside were given a short guided tour of the plant to see the facilities and hear a description of the operations being performed in each area. This information was conveyed to everyone at the plant, including those who did not work directly on the product. It was the Company's conviction

that the maintenance men, boiler operators, oilers, station-wagon chauffeurs, janitors and clerical workers were all interested and could do a better job if kept informed of the needs and progress of the project.

MANUFACTURE

Scheduling.

Capacity was provided at the Hillside shop to manufacture a maximum of 14 repeaters in a calendar month. This envisaged six-day operation with some second- and third-shift operations; due allowance was made for holidays and vacations, so that the annual rate would be approximately 160 enclosures per year, an enclosure being either a repeater or an equalizer.

Some of the facilities and raw materials were ordered late in 1953. This ordering expanded early in 1954 and continued through 1955 to include parts to be made by outside suppliers and the parts and apparatus to be made at Hillside. Apparatus designs were not all available at the beginning of the job, and the ultimate quantities required were also subject to sharp change as the project took shape, thus further complicating the scheduling problem.

Because of the time and economic factors involved, coupled with the developmental nature of the product and processes, one of the most difficult and continuing problems was the balancing of production to meet schedules. For this task, there were "tree charts" for the apparatus codes and time intervals in each type of repeater or equalizer for each project. Each chart was prepared from estimates of the time required to accomplish the specified operations and the percentage of good product each major group of operations was expected to produce.

Raw Materials.

Many of the specifications were written around the particular needs of the job and embodied requirements that were considerably more stringent than those imposed on similar materials for commercial use. As a result, it was necessary for many suppliers to refine their processes to the extent required and, in some cases, to produce the material on a laboratory basis.

One example is the container, or repeater enclosure, which consists, in part, of a seamless copper tube approximately $1\frac{3}{4}$ in. in diameter having a $\frac{1}{32}$ -in. wall and approximately 8 ft long. This material was purchased in standard lengths of 10 ft. The basic material was required to be phosphorous-deoxidized copper of 99.80 per cent purity. The tubing, as delivered, had to be smooth, bright and free from dirt, grease, oxides (or other inclusions including copper chips), scale, voids, laps and slivers. Dents, pits, scratches and other mechanical defects could not be greater than 0.003 in. in depth. The tubing had to be concentric within 0.002 in. and the curvature in a 10 ft length had not to exceed $\frac{1}{2}$ in. to facilitate assembly over the steel rings.

Only one supplier was willing to accept orders for the tubes, and then only on the basis of meeting the mechanical requirements on the outside surface. To establish a source of supply, it was necessary to accept the supplier's proposal on the basis that only some of the tubes produced could be expected to meet requirements on the inside as well as the outside surface. Inspection of the inside surface was performed with a 10-ft Borescope.

The supplier then set aside, overhauled and cleaned a complete group of tube-drawing facilities for this project. In addition, a number of refinements were made in lubrication and systematic maintenance of tools. After all refinements were made and precautions taken, however, the yield of good tubes in the first 400 produced was less than 1 per cent. After consultations the yield was increased to approximately 50 per cent.

Satisfactory mica laminations for capacitors presented an unusual problem. Despite care in selection and processing, only 50 per cent of the 250,000 laminations purchased met the extremely rigid requirements for microscopic inclusions and delaminations, and less than 8 per cent survived the capacitor manufacturing processes.

A large number of the parts, and the most complex, are made from methyl-methacrylate (Plexiglass). At the time manufacture began, there was little, if any, experience or information available, either in the company or throughout industry, on machining this material to the required close tolerances and surface finish. Consequently, considerable pioneering effort was expended in this field before satisfactory results were obtained.

The methacrylate parts cover a wide range of size and complexity—from $1\frac{1}{2}$ in. in diameter by $4\frac{7}{8}$ -in. long tubular housing to tiny spools $\frac{1}{8}$ in. in diameter and $\frac{1}{16}$ in. long. Most of the parts are cylindrical in shape, with some semi-cylindrical sections that must mate with other sections to form complete cylinders. Others have thin fins, walls, flanges and projections. Five representative parts are shown in Fig. 2.

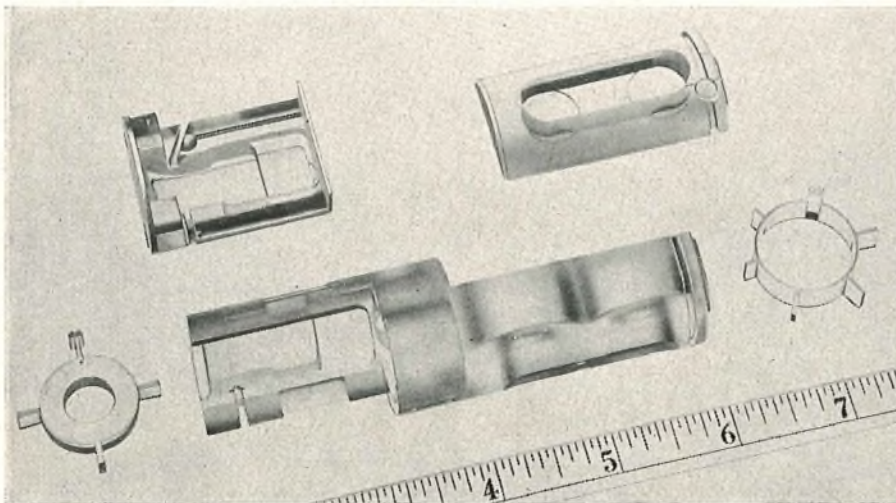

FIG. 2.—REPRESENTATIVE PARTS MACHINED FROM METHYL-METHACRYLATE.

Methyl-methacrylate has a tendency to chip if tools are not kept sharp and care is not used in entry or exit of the tool in the work, particularly in milling. In some cases, it is necessary, with end-milling, to work the cutter around the periphery of the area for a slight depth so that subsequent cuts will not break out at an unsupported area. Normally, with a sharp cutter and a 0.010-in. finish cut, and a slow feed, chipping will not result. High-speed steel tools with zero rake were used for turning and boring. Standard high-speed milling cutters and end mills were used for milling except for the cutting edges, which were honed to a fine finish. Clearance angles of 7° for milling and 10° – 15° for lathe work were found most satisfactory. In lathe work, the general rule was light feeds (0.003–0.005 in.) and small depth of cut. However, the depth of cut could be safely varied over a wide range depending upon many factors, such as type of part, quality of finish, machine and tool rigidity, effective application of coolant, and tooling to support and clamp the part. In one operation of boring a $1\frac{3}{8}$ -in. diameter \times $4\frac{1}{8}$ -in. deep blind hole within ± 0.002 in., the boring terminates in simultaneously facing the bottom of the hole square with its axis. A cut $\frac{1}{32}$ in. deep with a light feed was taken with a specially designed boring tool, the coolant being fed through the shank to the cutting edge. All completely machined parts were annealed for 12 hours at 175°F .

Highlights in Assembly and Brazing.

Repeater units were encased in hardened steel rings which previously had been tested at $10,000\text{ lb/in}^2$ hydraulic pressure. This pressure is approximately 50 per cent higher than the greatest pressure expected at ocean bottom. The steel rings were encased in a copper sheath and closed at each end with a glass-to-Kovar seal, the central conductor coming through the glass to the outside. The copper sheath was then shrunk to the steel rings and glass seals using $6,000\text{ lb/in}^2$ hydraulic pressure, and the glass seal was then high-frequency brazed to the copper sheath.

To keep the ocean-bottom pressure from the glass seals, and also to terminate the cable insulation, a rubber seal is brazed into the copper container tube adjacent to each glass seal. This rubber seal consists of rubber bonded to brass, which has been brazed to the copper portion of the seal. The rubber terminates in polyethylene through five steps of compounds containing successively less rubber and more polyethylene. The polyethylene can be readily bonded to the polyethylene insulation of the cable by moulding. The central conductor passes through a central brass tube in the rubber seal, which is also bonded to the rubber.

To protect the rubber seals from the effects of salt-water immersion for long periods, a copper core tube is brazed over each rubber seal. The core tube is arranged to equalize the pressure inside and out when submerged at ocean-bottom pressure. This is accomplished with a bulge of Neoprene filled with polyisobutylene, on the far end of the core tube, which transmits the pressure to the inside of the core-tube seal.

To make doubly sure that no salt water reaches the rubber seal, a copper cover is brazed into the container outside the core tube connector on each end, and also to the core-tube connector. The interstices between the above four seals are filled with polyisobutylene, which is viscous and inert and has very good insulating qualities.

Each end of the repeater closure (Fig. 3) contains five successive brazed joints. Any one of these 10 brazes, if not perfect, could cause the loss of the repeater closure and jeopardize the entire repeater. All these brazes were made with the repeater in a vertical position to ensure an even distribution of the brazing alloy fillet around the joint.

An upending device was provided at the pit brazing location to raise the repeater on its carrier to a vertical position with either end up and move it into position for brazing. The repeaters were brought into the brazing area on an overhead mono-rail and an electric hoist. The shorter repeater assemblies, before core tube and cable stub assembly, were upended by hand and brazed from a raised platform.

Since the time interval for the shortest braze is 10 sec maximum and the longest is 30 sec, the heat must be intense. It must also be contained within a very narrow band, evenly distributed, and the area protected from oxidation by a somewhat reducing atmosphere. It was therefore necessary to do all these brazes by high-frequency induction heating. A large part of the heat was dissipated by being conducted at a high rate from the copper parts to the water in the cooling jackets used to contain the heat in a very narrow band.

Circulating cooling water within a jacket prevented heat from being conducted down the copper container tube

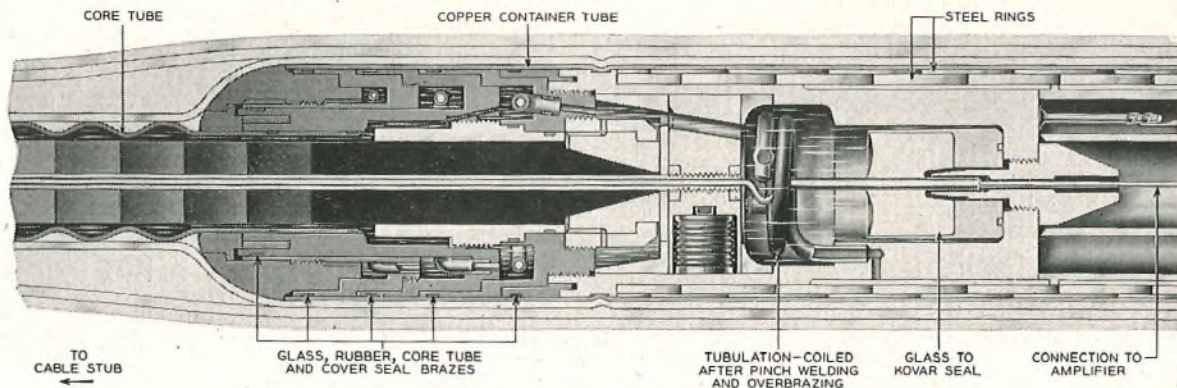

FIG. 3.—SECTIONAL VIEW OF SEAL ASSEMBLY AT EACH END OF REPEATER.

to the preceding seals or to the repeater unit. This water-cooled jacket was positioned only $\frac{3}{8}$ in. below the heating inductor, and the water was in intimate contact with the container tube, which was sealed off at both ends with rubber O-rings. In addition, for the glass-seal braze, the glass inside the seal cavity was kept covered with water during the heat cycle. The water was fed in and siphoned out to a constant level which was kept under observation to ensure that the glass was covered at all times. The rubber seal was also water-jacketed on the inside to prevent deleterious effects of the heat on the rubber insulation around the central conductor. The inner cover braze was quenched before the 10-sec maximum interval had expired to ensure that the heat did not penetrate to the polyisobutylene at a sufficient rate to deteriorate it or the rubber inside.

Distribution of the heat round the container tube at the braze area was controlled by locating the work in the inductor so that the colour came up essentially evenly all the way round and at the proper level to bring a fillet up to the top of the braze joint within the allowable time limit. The time limit was determined by experiment so that none of the previously assembled parts were damaged by the heat. This determination of the proper heat pattern and the prevention of overheating required the development of considerable skill on the part of the operator. The variables encountered made it essential to rely on an operator to control the heat rather than to use the timer.

The area to be heated for brazing was protected from oxidation by enclosing it in a separable transparent plastic box and flooding the interior with a gas consisting of 15 per cent hydrogen and 85 per cent nitrogen. This atmosphere is somewhat reducing and is not explosive. The brazing surfaces of the parts were chemically cleaned immediately before assembly and extreme care was exercised to keep them clean until brazed.

The container tube was shrunk to the respective glass, rubber, core tube and cover seals using hydraulic pressure, so that the surfaces to be brazed and the brazing alloy were in intimate contact within the brazing area. If the parts were clean and kept from oxidizing by the protective atmosphere, the alloy would flow upward by capillary action and form a fillet round the top of the seal, impervious to any leak.

The braze in each case was then leak tested with a helium mass-spectrometer-type leak detector. A gas pressure of helium at least 25 per cent greater than the maximum pressure to be encountered at ocean bottom was used. In addition, a radio-isotope was used to test the effectiveness of the final tubulation pinch welds and overbrazes, which were kept open for the leak tests under high-pressure helium. These tests were made with water pressure about 25 per cent greater than the maximum ocean-bottom pressure.

The completed repeater was inserted in a chamber 80 ft long; the chamber was then filled with water and the pres-

sure raised to 7,500 lb/in² and held at that pressure for at least 15 hours. At the end of this period the closure had to show no sign of crushing or leaking.

The repeater unit sealed in the closure must be extremely dry to function properly. Any water vapour which might remain after the closure is sealed, or enter during the estimated 20-year minimum life, must be absorbed. A sealed desiccator with a thin diaphragm was therefore assembled into the repeater unit sections. After completely drying and sealing the repeater unit except for one small tube, the diaphragm of the desiccator was ruptured by dry nitrogen pressure and, with the enclosure filled with dry nitrogen, the small tube was immediately sealed off. To ensure that the diaphragm was actually broken, a microphone was strapped to the outside of the repeater over the location of the desiccator, and a second microphone arranged at the end of the closure to pick up background noises. A pen recorder was used to record the sound from the two microphones and also the change in nitrogen pressure. Three simultaneous pips on the chart gave definite indication that the diaphragm had ruptured and that the desiccant had been exposed to the internal atmosphere of the repeater.

Quartz Crystal Units Manufactured at Kearny.

The primary purpose of the crystal unit is to provide the means of identifying and measuring the gain level of each repeater in the cable. This basic crystal design is in common use. The exacting specifications for this application, however, imposed many problems and deviations from normal crystal-manufacturing processes.

The raw quartz was specially selected. The manufacturing process of reducing it to the final plate followed the recognized methods through the roughing operations, but the finishing operations were performed under laboratory conditions. Angular tolerances were one-third of normal limits. No evidence of surface scratches, chipped edges or other surface imperfections visible under 30 × magnification were permitted. This resulted in a process shrinkage five times that experienced in normal crystal plate manufacture.

The crystal units were required to meet performance tests at currents as low as 0.001 μ A—far below the current values usually encountered. Improved techniques had to be developed for soldering the gold-plated phosphor-bronze and nickel wires used, because it was found that the electrical performance of the units was directly related to the quality of soldered connexions.

Although one-seventh of the Company's production of quartz crystal units are in glass enclosures, the applicable techniques in glass working required a complete revision. Glass components such as the stem and bulb purchased from established sources were found to be far below the standard prescribed. For example, the supplier of the glass tubing

used in the manufacture of stems was required to meet raw material specifications that embodied coefficient of thermal expansion, softening point of glass, density, refractive index and volume resistivity. The glass stems made from this tubing by regular manufacturers were found unacceptable, and their processes could not be readily adapted. The glass stems contained four lead wires made from 30-mil grade "A" nickel wire, butt-welded to 16-mil light borated Dumet wire. To assure the quality of the metal-to-glass seal, each wire was inspected under $30\times$ magnification for tool marks and other surface imperfections. The finished stem assemblies were inspected under $30\times$ magnification for dimensions, workmanship, cleanliness and minute glass imperfections, and were then individually stored in a sealed plastic envelope.

The glass bulb is known as the T921 design commonly used in the vacuum-tube industry and was obtained from

and the demand that the glass seal should have a minimum of residual tensile stress. These two problems were solved by performing the sealing operation on a single-spindle glass-sealing machine. Accurate positioning of the glassware and sealing fires, together with precise timing and temperature controls, achieved the desired results.

Evaluation of residual stresses was made by inspections using a polarimeter and by a thermal shock test. The maximum safe stress was established at 1.74 kg/mm^2 . The thermal shock test required successive immersion of the unit in boiling water and ice water. The electrical characteristics of these units exceeded all others made previously by the Company. The Q -factor was greater than 175,000—twice that ever previously produced and 17 times that required in the average filter crystal.

Stability of frequency and resistance was assured by a 28-day ageing test. During this period, precise daily

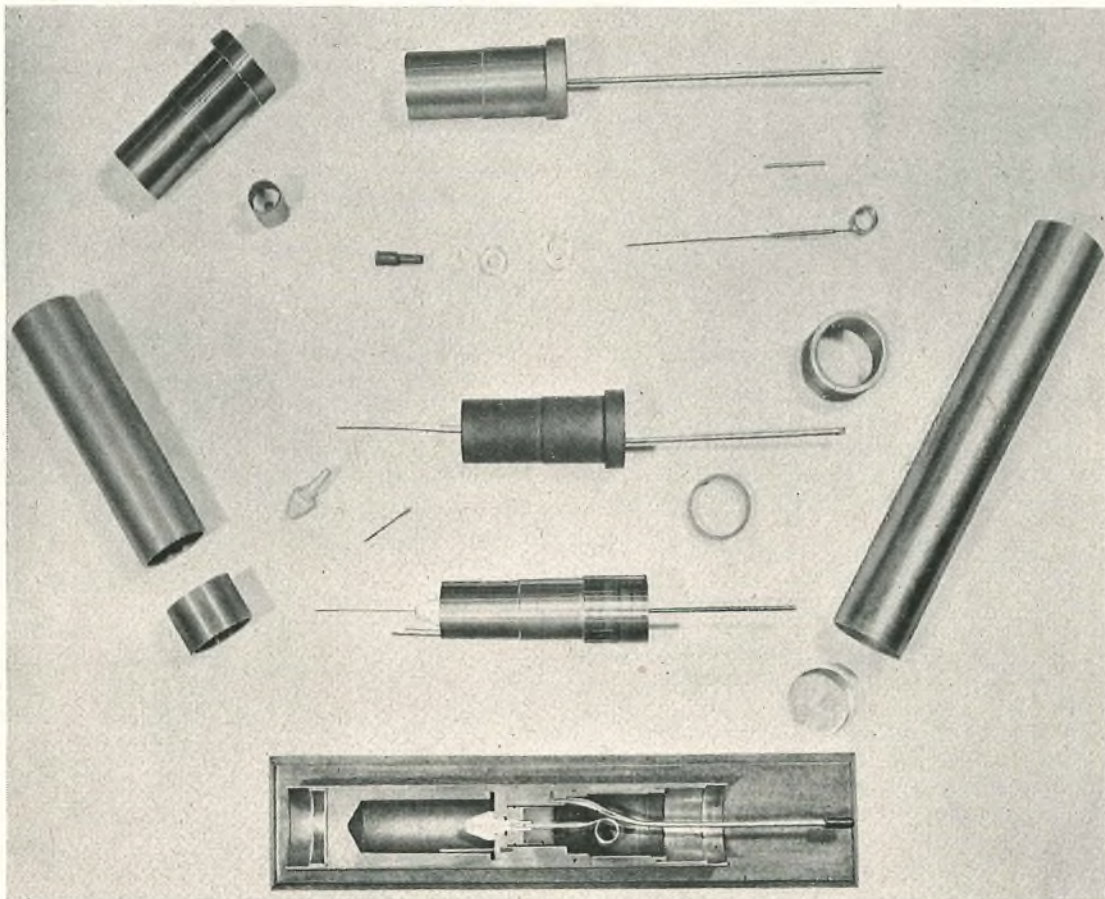

FIG. 4.—COMPONENTS, SUB-ASSEMBLIES, AND SECTIONAL VIEW OF THE GLASS SEAL USED TO CLOSE EACH END OF REPEATER CONTAINER.

commercial sources. The quality, however, did not meet the specifications, and therefore required 100 per cent inspection. Examination under $30\times$ magnification resulted in the rejection of bulbs for presence of scratches, open bubbles, chips and stones. Physical limits for inside and outside diameters as well as wall thickness were causes for additional rejects. Only 1 per cent of the commercial bulbs were found acceptable, and these also were stored in sealed plastic envelopes.

The final major assembly operation consisted in sealing the glass bulb to the stem, which had had the crystal sub-assembly welded to the nickel wires. The techniques for sealing used in quartz-crystal or vacuum-tube manufacture were unsuitable. Two important factors which required the development of new processes were the proximity of soft-soldered connexions to the sealing fires

and resonant-frequency and resistance measurements were recorded against temperature within 0.1°C . The maximum permissible changes were 0.0005 per cent in frequency and $+5$ to -10 per cent in resistance.

Glass Seals Manufactured at Allentown.

The glass seal used to close each end of the container for the repeaters and equalizers was manufactured at the Company's Allentown works.

The unit is essentially a glass-bead-type seal. It insulates the central conductor of the repeater from the container and serves as a final vapour barrier between the cable and the interior of the repeater. As such, it backs up several other rubber and plastic barriers, as shown in Fig. 3.

Fig. 4 shows the various components, sub-assemblies, and a cross-section of the unit. The unit consists of the

basic seal brazed in the Kovar outer shell, to which is brazed a copper extension provided with two brazing-ring grooves. One of these grooves is used in brazing the seal, along with support members, into a length of container tubing in the same way as the seal is ultimately brazed into the repeater. Packaging of the seal in this manner was necessary to pressure test the seal. Under test, in a specially constructed chamber, 10,000 lb/in² of helium gas pressure was applied to the external areas of the packaged glass seal, and a mass-spectrometer-type leak detector was connected through the tubulation to the internal cavity of the packaged unit. In this way, the interface of the glass-to-metal seal, the brazed joints and the porosity of the metal were checked for leakage. The unit was left in this package for delivery, to provide protection during shipment. Before the seal could be used, it was machined from the package by cutting the copper extension to length, leaving the second groove for use in brazing the seal to the repeater and removing the container tubing and the support members.

The basic seal consists of the cup, central conductor and glass. The cup (smaller cylindrical item in the upper left-hand corner of Fig. 4) was machined from Kovar rod. The wall of the cup is tapered from a thickness of 0.025 in. at the base to 0.002 in. at the lip. The last 0.006 in. of the lip is further tapered from this 0.002 in. to a razor edge. The internal surface is better than a 63-micro-in. turned finish and was also liquid honed to give it a uniform matt finish. The central conductor (slim piece in the upper right-hand corner of Fig. 4) was also machined from Kovar rod. Both the cup and central conductor were further processed by pickling, hypersonically cleaning in de-ionized water, and decarburizing. The glass, a borosilicate type of optical quality, was cut from heavy-walled tubing. The glass tubing was hand polished, lapped and etched to remove surface scratches, and to arrive at the specified weight. It was also fire-polished and hypersonically cleaned to remove all traces of surface imperfections and to ensure maximum cleanliness.

In order to make the basic glass seal, the metal parts had to be oxidized under precisely controlled conditions. For the oxidizing operation, a suitable fixture was loaded with brazed shell-cup assemblies, central conductor assemblies, and a Kovar disc, which had been prepared in precisely the same manner as the cups and central conductors. The disc was carefully weighed before and after oxidizing, the increase in weight divided by the area involved yielding the weight gain due to oxidation for each run. Limits of 1.5–2.5 milligrams/in² of oxide were set. This operation was performed by placing the loaded, sealed retort, through which passed a metered flow of dried air, into a furnace for a specified time-temperature cycle.

In the glassing operation the oxidized shell assembly, the carbon mould, and the central conductor were placed in a fixture and held in the proper relationship. The carbon mould served to support the glass, while it was being melted, in that section between the cup and central conductor where the glass was normally unsupported. The prepared cut-glass tubing was loaded into the Kovar cup and the fixture was sealed into the retort. During the glassing cycle, a constant flow of nitrogen passed through the retort to provide an atmosphere which minimized any reduction or further oxidation of the already carefully oxidized parts. After the proper purging period, the retort was placed in the furnace, where the glass melted and formed a bond with the oxidized Kovar of the cup and central conductor to form the seal. After the specified temperature-time cycle, the retort was removed from the furnace, allowed to cool partially and then placed in an annealing oven.

Vertical furnaces and retorts were used for brazing,

decarburizing, oxidizing and glassing. By varying the gases flowing into the retorts, atmospheres which were reducing, oxidizing or neutral were obtained. To provide maximum uniformity of process, separate retorts and holding fixtures were provided for operations involving hydrogen and for air-nitrogen operations, so that a retort or a fixture used for hydrogen treatments was never used for oxidizing or glassing.

Pilot and Regular Production.

The first efforts were called "practice parts and training"; the second, "pilot production." Next, certain items identified as "trial laying repeaters and oscillators" were manufactured for use in proving-in the ship's laying gear. To prove-in the closure manufacturing facilities, a few un-equipped housings were made without the usual electrical components normally in a repeater. Similarly, each of the apparatus components and parts required exploratory and pilot effort before regular production could be undertaken. All this was complicated by the extremely tight mechanical and electrical limits required in the product.

As might be expected, the manufacturing yield of components meeting all requirements was very small during the early stages, but there was substantial improvement as experience was gained. The following are comments on some of the production problems, highlights and yield results.

Paper capacitors.—These were manufactured only after painstaking qualifying trials and tests had been performed on each individual roll of paper. Cycling and life testing, procurement of acceptable ceramic parts and gold-plated tape and cans, selection and matching of rolls of paper for winding characteristics, and similar problems, all had to be completely resolved to a point of refinement previously unattempted for telephone apparatus.

Composite percentage yield for all operations on paper capacitors is shown in Fig. 5. Yield is shown as the ratio of finished units of acceptable quality to the number of units started in manufacture.

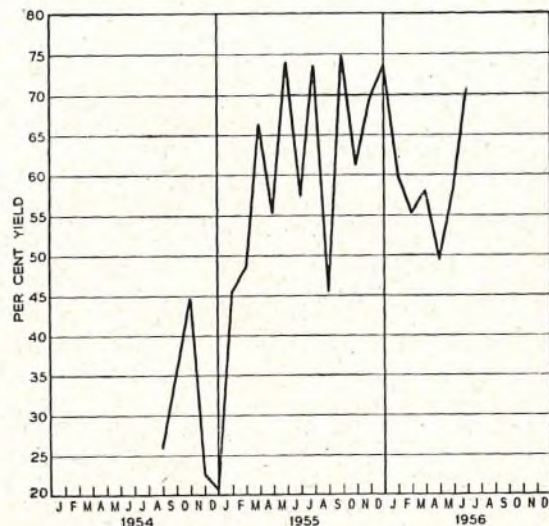

FIG. 5.—PERCENTAGE YIELDS OF PAPER CAPACITORS.

Mica capacitors.—Even the best mica is susceptible to damage in processing. In spite of experience and knowledge of this, the multiple handling of the laminations contributed an unusually high rejection of material as each separate lamination needed to be cleaned and then handled individually many times through the processes. The art of silk screening was applied to deposit silver paste in a specific area or areas on each side of a lamination. A sharply defined

rectangular area was required so that, when the laminations were superimposed one over another, the desired capacitance would be obtained. Cementing of mica laminations on to machined methacrylate forms presented some additional problems through the bowing of the laminations as the cement cured. Obtaining screens that would give the proper length and width for the coated area was another problem. A silk screen woven of strands of silk obviously limits, by the diameter of the threads, the extent to which the dimensions of an opening may be increased or decreased. Beryllium-copper U-shaped terminals were used to clamp the laminations together into a stack. Control of the pressure used in crimping these terminals was found to be very critical in view of the exceptionally close limits on capacitance and stability. Fig. 6 shows the composite yield at various times for all mica capacitors.

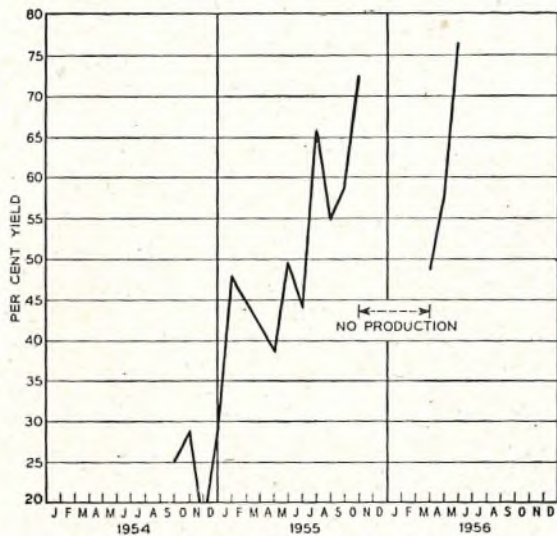

FIG. 6.—PERCENTAGE YIELDS OF MICA CAPACITORS.

Resistors.—There were three designs of ceramic resistors, which were resistance-wire wound on ceramic spools. These were intended to be assembled into the hole inside the core tube on which the paper capacitors were wound. Special winding machines equipped with binocular attachments were required. Other resistors were hand wound on methyl-methacrylate forms, or on the outside of the ceramic containers for certain types of paper capacitors. Again it was necessary to provide periodic samples that could be placed on life test by the research laboratories to ascertain that the manufacturing processes were under control. These samples, in all possible cases, were taken from products that would normally be rejected because of some minor defect, but which would not in any way detract from the validity of the life tests. The making of hard-solder splices between Nichrome resistance wire and gold-plated copper leads, and keeping ceramic parts from coming in contact with metal surfaces and thereby being contaminated because of the abrasive characteristics of the ceramic, were two major problems with resistors. Fig. 7 indicates resistor yields.

Inductors.—There were 20 different designs of inductor, most of which were air-cored, but there were some for which it was necessary to cement Permalloy dust-cores into pockets of the methacrylate form, and then, using wire on a shuttle, to wind by hand the turns required. The inductors varied in size from one smaller in diameter than a pencil to a fairly large "figure-of-eight" inductor with turns having a major diameter of about $1\frac{1}{4}$ in. Each layer of a winding was inspected with a microscope to ensure that the wire had not been twisted or kinked, and that the insulation was

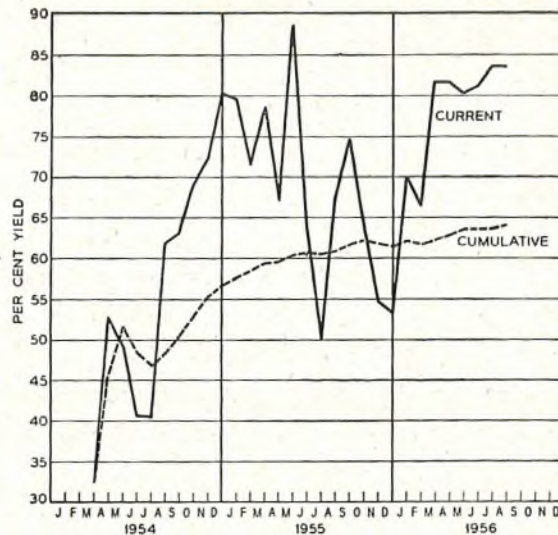

FIG. 7.—PERCENTAGE YIELDS OF RESISTORS.

not damaged or uneven. Some of the shuttles had to be fairly long so that they could hold the amount of wire required for a continuous winding. The operator's handling of a long shuttle, as she moved it down around the openings in the methacrylate part, or placed it on a bench while applying the interleaving tape, demanded considerable dexterity and concentration to ensure that the shuttle was not turned over—which in effect would put a twist in the wire. Although best-known means were used to sort cores for their magnetic properties prior to the time a winding was made, the limits on the inductors themselves were so close that a substantially large number of windings were rejected. The best cores that could be selected, plus the best winding practice, could not produce 100 per cent of the inductors within the required limits. Crazing of the insulation on the wire; cementing together of two methacrylate parts or of Permalloy cores into pockets of methacrylate parts, and handling those inductors having long delicate leads—these were the most troublesome items. Fig. 8 shows the manufacturing yield for inductors.

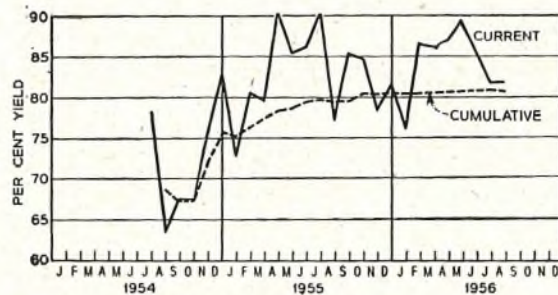

FIG. 8.—PERCENTAGE YIELDS OF INDUCTORS.

Networks.—The networks combined several types of component, such as a mica and a paper capacitor, a resistor and an inductor. Six networks were used in each repeater unit, consisting of two interstage networks, an input, an output and two beta networks. They demanded a most delicate wiring job in that stranded gold-plated copper wires had to be joined in a small pocket in methyl methacrylate, where a minimum amount of heat could be applied; otherwise the methacrylate would have been affected. After soldering, a minimum amount of movement of the stranded wire was permitted, as soldered gold-plated copper wire is quite brittle.

Repeater units.—These are wired assemblies consisting of 17 sections in which there are six networks, three thermionic

valves, one gas-filled valve, one crystal, three high-voltage capacitors, one desiccator and two terminal sections. The successive build-up of these materials left little chance to make a repair because a splice in a lead was not permissible. It was during this assembly stage that a repeater acquired its identity because of the frequency of its particular crystal. A manufacturing yield of 100 per cent was achieved in the assembly and wiring of repeater units.

It was necessary to calibrate the test equipment for this job very closely. The research laboratories and the Company worked at length to calibrate the test sets for individual networks—to bring a network to the fine tolerances required, adjustments were made by minute scraping of the silvered mica on capacitors or by removing turns from wire-wound inductors. The cementing of methacrylate parts, which was troublesome with mica capacitors and inductors, also had to be contended with on networks.

Packing and Shipping Co-ordination.

Repeaters were packed in specially designed 34-ft long aluminium containers, weighing 1,000 lb. Fig. 9 shows two

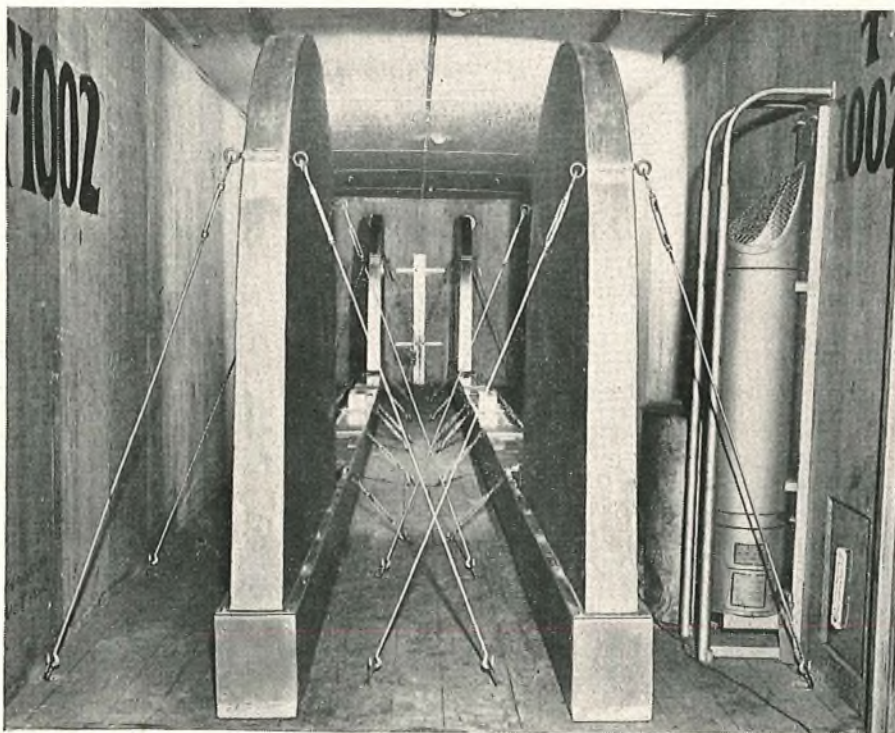

FIG. 9.—TWO REPEATERS IN SHIPPING CONTAINERS MOUNTED IN A LORRY TRAILER FOR TRANSPORTATION.

containers tied down in a long trailer. The repeaters were nested in a pocket of polyethylene bags containing shaped rubberized hair sections in order to cushion them during their subsequent handling and transportation. With each case there was a recorder to register shocks in three planes and a thermometer to register the minimum and maximum temperatures to which the repeater had been exposed. Arrangements were made with a transport company to provide three specially equipped lorry trailers, which could be cooled by dry ice during hot weather and warmed by burning bottled gas during cold weather so as to control the temperature within the 20–120°F called for in the specification.

Appointment of a shipping co-ordinator-supervisor added tremendously to the smooth functioning of services and provided the continuing vigilance required to protect repeaters and deliver them to the right place at the right

time. His responsibility was to co-ordinate all the shipping information and arrangements from the time the item was ready for packing at the Hillside plant, through all transport arrangements to the armouring factory, to the airport, to England, and to follow, with statistical data and reports, each enclosure until it was possible to record the date on which the repeater was laid or stored in a depot.

INSPECTION PLAN AND PROCEDURES

General.

It was evident that the ordinary inspection "screening" would be inadequate to ensure the high degree of integrity demanded and that additional safeguards would have to be provided. These controls were achieved by:

- (a) Selective placing, intensive training and subsequent qualification-testing of all personnel.
- (b) Inspection during manufacturing operations as well as after completion, and regulating inspection so that critical characteristics received repetitive examination during manufacture and assembly.
- (c) A maintenance program for inspection and testing which provided checks at considerably shorter intervals than is considered normal.
- (d) Inspection and operating records and reports that indicated where corrective measures were necessary.
- (e) Records of quality accuracy for all inspection personnel.
- (f) Verification of all data covering process and final inspection.

Selection and Training of Inspection Personnel.

The quality of a product naturally depends upon the skills, attitude and integrity of the personnel making and inspecting it. It was realized that in order to develop the necessary high degree of efficiency in the inspection organization, personnel of very high calibre would be required. These employees would have to be experienced in similar or comparable work; they would have to be precise, accurate and, above all, dependable, in order to reduce the possibility of contamination and damage; they would have to be neat and careful; and they would

require the ability to work in harmony with other employees, often as a member of a team, in an environment where their work would be under constant scrutiny.

Most of the inspection employees selected to work at Hillside were transferred from the Kearny plant and had an average service with the Company of 12 years. They were hand-picked for the attributes outlined above, and the screening was performed by supervision through personal interviews supplemented by occupational tests. These tests, which are in general use, are designed to evaluate background and physical characteristics, and they were given regardless of whether the employee had or had not previously taken them.

The following group of tests is an example of those given to inspectors and testers of apparatus components:

- (i) *Electrical.* A.C. and d.c. theory and application.

- (ii) *Ortho-rater*. Eye test for phoria, acuity, depth, and colour.
- (iii) *Finger dexterity*. Ability and ease of handling small parts.
- (iv) *Special*. Legibility of handwriting, ability to transcribe data and to use algebraic formula in data computations.

Inspection Plan.

The general plan of visual and mechanical inspection consisted of:

- (a) Inspection of every operation performed—and in many cases partial operations—during the course of manufacture. This was of particular importance where the quality characteristics were hidden or inaccessible after completion of the operation.
- (b) Repeated inspection at subsequent points for omissions, damage and contamination.
- (c) Rejection of product at any point where there was failure to obtain inspection or where the results of such inspection had not been recorded.

Most of the visual inspection was performed at the operators' positions to reduce to a minimum the amount of handling that could result in damage and contamination.

Visual inspection covered three general categories:

- (i) Inspection of work after some or all operations had been completed, such as the machining of parts.
- (ii) Inspection at those points where successive operations would cover up the work already performed.
- (iii) Continuous "over-the-shoulder" inspection, where strict adherence to a process was required or where it was impossible to determine, by subsequent inspection, whether or not specific operations had been performed.

Electrical Testing.

The electrical testing, in itself, was not unusual for carrier apparatus and ran the gamut from d.c. resistance through capacitance, inductance and effective resistance to transmission characteristics in the frequency band of 20–174 kc/s. What were unusual were the extremely narrow limits imposed and the number and variety of tests as compared with those usually specified for commercial counterparts.

The following two examples will serve to illustrate the extreme measures taken to prove the integrity of the product:

- (a) One type of resistor is wound with No. 46 mandrelated Nichrome wire to a value of 100,000 ohms ± 0.3 per cent. This resistor received six checks for d.c. resistance, five for instantaneous stability of resistance and two for distributed capacitance, at various steps in the process, which included six days' temperature cycling for mechanical stabilization. The resistor was considered satisfactory, after final analysis of the test results, if: the difference in any two of the six resistance readings did not exceed 0.25 per cent; the change in resistance during cycling was not greater than 0.02 per cent; and the "instantaneous stability" (maximum change during 30 sec) did not vary more than 0.01 per cent. In addition, it was required that the distributed capacitance, minimum 7, maximum 10 pF, should not differ from any other resistor by more than 2 pF.
- (b) For higher-voltage paper capacitors, the 0.004-in. kraft paper, which constitutes the dielectric, was selected from the most promising mill lots which the manufacturers had to offer. This selection was based on the results obtained from tests that involved

examination for porosity, conducting material and conductivity of water extractions. These tests were followed by the winding and impregnation in Halowax of test capacitors. The test capacitors were then subjected to a direct voltage endurance test at 266°F for 24 hours.

Samples of prospective lots of paper, which had passed the above test, were then used to wind another group of test capacitors that were subsequently impregnated with Aroclor and sealed. 1,500V d.c. was then applied to the capacitors at 203°F for 500 hours. In case of failure, a second sampling was permitted.

After the foregoing tests had been passed, the supplier providing the particular mill lot was authorized to slit the paper. Upon receipt, six special capacitors were wound, using a group of six rolls of the paper being qualified. These capacitors were then impregnated, checked for electric strength at 3,000V d.c., and measured for capacitance and insulation resistance. The capacitors were then given an accelerated life test at 2,000V d.c., temperature 150°F, for 25 days. Each lot of six satisfactory test capacitors qualified six rolls of paper for use in the product.

Product capacitors were then wound from approved paper, and the dry units checked for electric strength at 3,000V d.c. The capacitance was checked, the units were assembled into cans and the ceramic covers soldered in place. Each assembly was pressurized with air, through a hole provided for the purpose, and immersed in hot water to determine if leaks were present. The capacitors were then baked, vacuum dried, impregnated, pressurized with nitrogen and sealed off. The completely sealed units were then placed in a vacuum chamber at a temperature of 150°F, 2 mm Hg, for 3 hours to check for oil leaks. The capacitance was rechecked and the insulation resistance measured.

After seven days, the capacitors were unsealed to replenish the nitrogen that had been absorbed by the oil, resealed and again vacuum-leak tested. An X-ray examination was then made of each individual unit to verify internal mechanical conditions. Capacitors were then placed in a temperature chamber and given the following cyclic treatment.

16 hours at 150°F	}	1 cycle
8 hours at 75°F		
16 hours at 0°F		
8 hours at 75°F		

At the end of ten days, or 5 cycles, the insulation resistance and conductance were measured and a norm established for capacitance.

The capacitors were then recycled for ten days, and, if the capacitance had not changed more than 0.1 per cent, they were satisfactory to place on production life test. If the foregoing conditions had not been met, the capacitors were recycled for periods of ten days until stabilized.

At that time, 10 per cent of the capacitors in every production lot were placed on "sampling life test," which consisted in applying 4,000V d.c. at a temperature of 150°F for 25 days. At the same time, the balance of the capacitors in the lot were placed on production life test at 3,000V d.c. at a temperature of 42°F for 26 weeks. At the end of this time, the insulation resistance was measured and the capacitance checked at 75°F and at 39°F. The difference in capacitance at the two temperatures was not to exceed +0.001 or -0.005 μ F, and the total capacitance was not to exceed maximum 0.3726, minimum 0.3674 μ F. The capacitance from start to finish of the life test was not to change more than ± 0.1 per cent.

If all the preceding requirements had been satisfied, the particular lot of capacitors was considered satisfactory for use in the product.

Radio-isotope Test.

Of the many new and involved tests that were developed and applied to the manufacture of repeaters, one of the most interesting was the use of a radio-isotope for the detection of leaks under hydraulic pressure.

The initial closure operations consisted in brazing into each end of the repeater housing a Kovar-to-glass seal. These seals are equipped with small-diameter nickel tubulations which were used to flush and pressurize the repeaters with nitrogen. After these operations had been performed, one of the tubulations was pinch-welded, over-brazed and coiled down into the seal cavity. The repeater was then placed in a pressure cylinder with the open tubulation extending through and sealed to the test cylinder. A mass spectrometer was then attached to the tubulation and the test cylinder pressurized with helium at 10,000 lb/in². At the conclusion of this test the repeater was removed from the test cylinder, and, after breaking the desiccator diaphragm, the remaining open tubulation was pinch-welded and overbrazed. At this point, it became necessary to determine whether the final pinch-weld and overbrazing would leak under pressure.

Since there was no longer any means of access to the inside of the repeater, all testing had to be done from the outside. This was accomplished by filling the glass seal with a solution of radio-isotope caesium 134, which was retained by a fixture. The repeater was then placed in a test cylinder and hydraulic pressure applied, which was transmitted to the radio-isotope. After 60 hours under pressure, the repeater was removed from the cylinder and the seal drained and washed. An examination was then made with a Geiger counter to determine if any of the isotope had entered the final weld.

The washing procedure, after application of the isotope solution, involved some 60 operations with precise timing. At the rubber seal stage, where both ends were tested, these operations were performed concurrently, the entire process being recorded on magnetic tape, which, when played back, furnished detailed instructions and exact timing.

Raw Material Inspection.

As might be expected, raw materials used in the project were very carefully examined and nothing was left to chance. Every bar, rod, sheet, tube, bottle or can of materials was given a serial number and a sample was taken from each and similarly identified. Each sample was then given a complete chemical and physical analysis before each corresponding piece of material was certified and released for processing. In many cases, the cost of inspection far exceeded the cost of the material. However, the discrepancies revealed, and the assurance provided, more than justified the expense.

Detailed records of all raw material inspection were compiled and furnished to the responsible raw-material engineer, who examined them, critically, as an additional precaution before the material was released to the shop.

Inspection Records.

To eliminate, as much as possible, the human element in providing assurance that all prescribed operations had been performed satisfactorily and inspected properly, and the results recorded, a complete history of the product was compiled concurrently with manufacture, using permanent data books of semi-loose-leaf design that require a special machine for removing or inserting pages.

Each book covered a portion of the work involved in producing a piece of apparatus and contained a sequential list of pertinent operations and requirements prescribed in the manufacturing specifications. Space was provided, adjacent to the recorded information, for both the operator

and inspector to enter their initials and the date. A reference page in the front of each book identified the initials with the employees' names. All apparatus was serially numbered and the data were identified accordingly. If a unit was rejected, that serial number was not re-used.

Quality Accuracy.

As mentioned previously, every precaution was exercised in selecting and training the inspection personnel. However, since human beings are not infallible, it was realized at the outset that assurance, to the greatest degree possible, would have to be provided against the probability of errors in observation and judgment. Quality-accuracy evaluation procedures were therefore established for determining the accuracy of each inspector's performance.

Verification and Summary of Data.

As an added measure of assurance as to the integrity of the product, procedures were established for verifying and summarizing the inspection records for each serially numbered component, up to and including complete repeaters.

Verification involved a complete audit of the inspection records to ensure that all process operations were recorded as having been performed satisfactorily, that the prescribed inspections had been made, and that the recorded results indicated that the product met all the specified requirements.

As the verification of a particular piece of apparatus proceeded, a verification report was prepared, which, when completed, contained the most pertinent inspection data, such as:

- (i) Recorded measurements of electrical parameters.
- (ii) Values calculated from measurements to determine conformity.
- (iii) Confirmation that all process and inspection operations had been verified.
- (iv) Identification (code numbers and serial or lot numbers) of materials and components entering into the product at each stage of manufacture.

The verification report usually listed the data for 20 serial numbers of a particular code of apparatus, together with the specified requirements. Included also was a cross-reference to all the inspection data books involved, so that the original data could be located easily. These verification reports were prepared for all apparatus up to and including the finally assembled and tested repeaters.

The following is an indication of the number of items examined in the verification of one complete repeater:

Items verified in data books	17,593
Items verified on recorder charts	1,142
Calculations verified	1,580

20,315

Number of entries on verification reports ..	4,070
--	-------

Verification reports, in addition to presenting the pertinent recorded data, provided a "field" of 20 sets of measurements from which it was easy to spot a questionable variation. For example, it was the practice to examine critically any characteristic of a piece of apparatus, in a group of 20, which varied considerably from the rest, despite the fact that it was still within limits.

While the number of cases turned up in the verification process which have resulted in rejection of the product are relatively few, it is believed that the added assurance provided, and the psychological value obtained, considerably outweigh the cost.

ACKNOWLEDGMENT

The repeaters were designed by the Bell Telephone Laboratories, Inc., and were manufactured by the Western Electric Co., Inc.

Power-Feed Equipment for the North Atlantic Link*

G. W. MESZAROS, B.E.E., and
H. H. SPENCER, B.S. in M.E., Associate Member American I.E.E. †

U.D.C. 621.311.6:621.395.51

Precise regulation of the direct current which provides power for the undersea repeaters in the new transatlantic telephone cable is necessary to maintain proper transmission levels and to assure maximum repeater valve life. The highest possible degree of protection is needed against excessive currents and voltages under a wide variety of possible fault conditions. Furthermore, to minimize the electric stresses, a double-ended series-aiding power feed must be used and the balance of these applied voltages must be maintained in spite of substantial earth potentials. This paper describes the design features which were employed to attain these objectives simultaneously, while eliminating, for all practical purposes, any possibility of even a brief interruption of the system due to power failure.

INTRODUCTION

THE principal objectives in the power plant design for the transatlantic cable system were as follows:

- (a) To stress reliability in order to guarantee continuous d.c. power to the thermionic valves that form an integral part of the submerged repeaters. This is essential, not only to be able to maintain continuous service, but also to prevent cooling and contraction of the repeater components, especially the valves.
- (b) To provide close control of d.c. in the cable to ensure constant cathode temperature and regulated anode and screen potentials for the repeater valves. These operating conditions are essential both for obtaining maximum life from these valves and for maintaining constant transmission level.
- (c) To control and limit the d.c. potentials applied to the cables in order to minimize the electric stresses. The life of certain capacitors in the repeaters is critically dependent upon these stresses. Moreover, momentary high potentials increase the chances of corona formation and insulation breakdown.
- (d) To protect the cable repeaters from the excessive potentials or currents to which they might be subjected after an accidental open- or short-circuit in the cable.
- (e) To compensate for earth potential differences up to 1,000V, of either polarity, that may develop between the earths at Oban and Clarenville during the magnetic storms accompanying the appearance of sunspots and aurora borealis.
- (f) To provide adequate alarms and automatic safety features to ensure safe current and voltage conditions for both the cable and the operating personnel.

DESIGN REQUIREMENTS

Reliable Cable Power.

The first basic problem of design was to select a reliable source of d.c. power for energizing the cable repeaters. Although a string of batteries, on continuous charge, is perhaps the most dependable source of direct current, such an arrangement is not attractive here. A complex set of high-potential switches would be required for removing sections of batteries for maintenance and replacement purposes. Protection of the repeater valves from damage during a cable short-circuit would be difficult. Facilities to accommodate changing earth potentials would be cumbersome. Furthermore, the problem of hazards to personnel would be serious.

The use of commercial a.c. power with transformers and rectifiers to convert to high-potential direct current would expose the cable to power interruptions even with a standby Diesel-driven alternator, owing to the time required to get the engine started. A Diesel plant could be operated on a continuous basis, but this prime power

source would also present a considerable failure hazard even with the best of maintenance care. The 2-motor alternator set, used so successfully in the Bell System L-type carrier telephone system, was adopted as representing the most reliable continuous power source available. This set normally operates on commercial a.c. power, but, when this fails, the directly-coupled battery-operated d.c. motor quickly and automatically takes over the drive from the induction motor, to prevent interruption of the alternator output. Here the storage battery is still the foundation for continuity, but at a more reasonable voltage.

As described later, the possibility of interruption of a system resulting from failure of this 2-motor alternator set has been essentially eliminated by using two such sets, cross-connected to the rectifiers supplying power to the two cables, with a continuously operating spare for each set automatically switched in on failure of the normal set.

The regulating features of the rectifiers will be described later. In the present discussion of reliability, it is sufficient to note that series regulating valves are used, which are capable of acting as high-speed switches, through which two rectifiers can be paralleled. Thus, either rectifier can accept instantaneously the entire load presented by the cable. In each regulator the series valves carrying the cable current are provided in duplicate and connected in parallel to share the cable load, a single valve being capable of carrying the entire load. These current regulators are operated from separate a.c. sources to protect against loss of cable power due to failure of one of the sources of a.c. power.

Cable Potentials.

To minimize the cable potentials, half of the d.c. power is supplied at each end of each cable, the supplies being connected in series aiding. With this arrangement, as shown in Fig. 1, the d.c. cable potential at one end of each

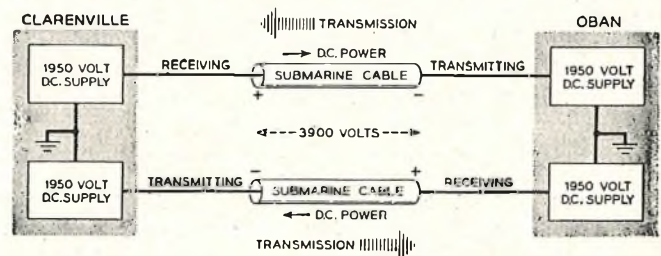

FIG. 1.—CABLE VOLTAGE SUPPLY.

cable is positive with respect to earth while at the other end the potential is negative. This places the maximum potential and risk on the repeaters near the shore ends, which are more readily retrieved, while the repeaters in the middle of the cable, in deeper water, have potentials very near to earth. The power equipment would be simpler with a single-ended arrangement, but at the penalty of doubling the electric stresses in the entire system, which would be prohibitive. A balanced power feed could have been attained at the expense of power-separation filters in

†The authors are with Bell Telephone Laboratories, Inc.

the middle of the cable, or a shunt impedance of appropriate size at the midpoint. The resulting complications, including difficulty in the location of a cable fault, could not be justified for the sake of simplification of power-plant design and operation.

The requirement that minimum cable potentials be maintained during and after severe earth potential disturbances necessitates variable output voltages from the supplies at both ends, and this introduces problems in continuous voltage balance and regulation stability. The design features which yield the required performance are described later.

D.C. Cable-Current Regulation.

The salient requirements in performance of the constant-current regulator are listed below:

- (a) The regulator must have extremely fast response to hold the cable current within a few milliamperes of its nominal value should a short-circuit develop in the cable. Thus damage to the heaters of the repeater valves is avoided, as well as excessive induced transient voltages in the repeater transformers. The probability of a short-circuit is higher near the shore ends, where the water is shallow and sea traffic is a factor. The regulator must be capable of absorbing the reduction in power to the cable, while maintaining current control under normal conditions. This sudden exchange of power from cable to regulator may be as much as 2,000V at 0.25A.
- (b) The cable current should be maintained constant within 0.2 per cent of its nominal value for normal variations in a.c. supply, gradual earth potential changes, and ambient temperature changes. This degree of regulation allows an adequate safety factor in maintaining a constant transmission level.¹
- (c) The regulators, in conjunction with the power-separation filters and the rectifier filters, must limit the power supply noise at the cable terminals to a peak-to-peak value less than 0.02 per cent of the d.c. supply potential.
- (d) The cable current must be adjustable over a range of 225 to 245 mA to compensate for repeater valve ageing.²
- (e) The regulators must operate in parallel in such a way as to ensure continuity of power should one fail or be removed from service for maintenance. This, of course, implies that regulators can be switched in and out of service without causing surges in the cable current or voltage.
- (f) The series-aiding arrangement, with rectifiers at each end of the same cable, must be stable.
- (g) The regulators should be capable of being serviced at low potentials, when in the test position, in order to protect maintenance personnel.
- (h) The current regulator should be of the "fail-safe" type so that impairment of any of the regulator components will not permit excessive rise in cable current. In the event of component trouble, an aural or visual alarm should be given.

It was decided that a high-speed electronic constant-current regulator backed up by a slower-speed servo system,

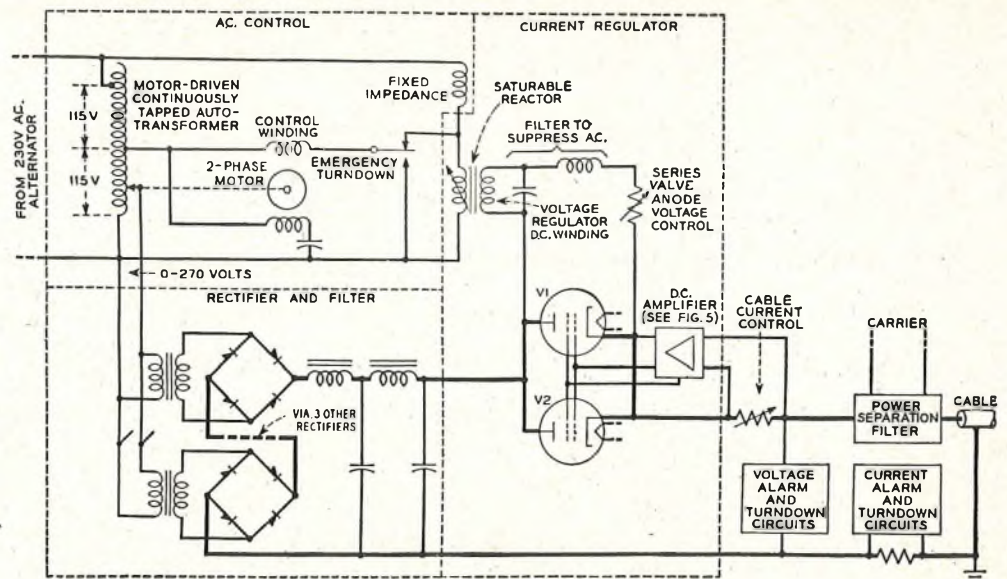

FIG. 2.—SIMPLIFIED CIRCUIT OF THE REGULATING SYSTEM.

as shown in Fig. 2 and discussed in detail later, would best meet the above requirements. In this way, fast response with high gain is combined with wide regulating range, and yet the efficiency is high and the load-handling capabilities of the various components are held to a minimum. With regard to simpler alternatives, the electro-mechanical type of current regulator, using relays and a motor-driven rheostat, is too slow to protect the repeater valves from a cable short-circuit and its accuracy is insufficient to meet the regulation requirements. The all-magnetic type of regulator is possibly most dependable, but it does not readily provide either the speed of response or the wide regulating range needed.

GENERAL DESCRIPTION

Prime and Standby Power Source.

Commercial service is considered the normal prime source of power for the cable, although at the Clarendville terminal commercial power was not available at the time of installation. Anticipating this condition, a reserve plant consisting of three 60-kW Diesel-alternator sets was installed and the distribution circuits were arranged as shown in Fig. 3, to provide partial or total use of the commercial service. Initially, all cable power was supplied by Diesel operation, alternating the prime movers on a weekly basis. These sets are paralleled manually when they are interchanged, to prevent an interruption in the 60-c/s supply. It may be noted that engine No. 1 is arranged as an automatic standby whether prime power is provided by Diesel or by commercial service.

The switching and distribution arrangements are designed to be essentially failure-proof. At Clarendville, for example, two a.c. distribution cabinets, each capable of being fed from two sources, were provided in separate locations. The normal source through engine No. 1 control bay can be readily bypassed directly to the manual Diesels should engine No. 1 control bay be disabled. Furthermore, allocation of charging rectifiers, control circuits, a.c. motors for continuity sets, etc., has been made in such a manner that loss of one cabinet alone will have minimum effect on the cable power supplies or office loads. At Oban, where 50-c/s commercial service is normally used, special distribution arrangements have been provided to give maximum power supply reliability, with three manually operated 50-c/s 90-kVA Diesel-alternator sets arranged for standby service.

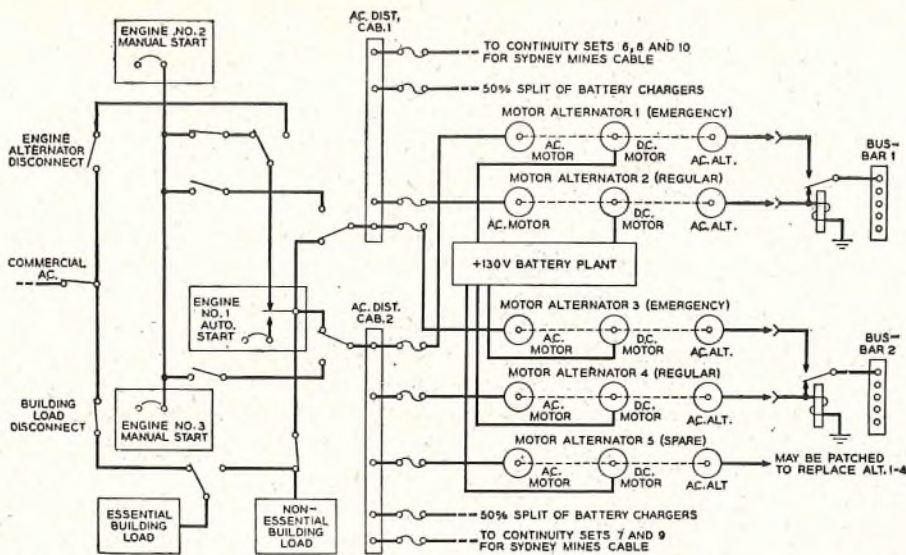

FIG. 3.—CONTINUOUS A.C. POWER.

Continuous A.C. Power from Two-motor Alternators.

At both cable terminals, two reliable a.c. busbars supply power to the d.c. cable-current regulating bays. Each of these busbars is fed from a continuously-operated self-excited single-phase 230V alternator normally driven by a 3-phase induction motor on the same shaft as a 130V d.c. motor. Each regular (working) alternator is backed up by a similar emergency alternator running at no load. A fifth motor-alternator is provided which can be used whenever any other set is out of service for routine maintenance or repair.

As alternator loads are essentially constant and since induction-motor speeds are fairly insensitive to power-supply voltage variations, alternator outputs are set by fixed adjustments of their field rheostats. Supply voltages are monitored to control automatic transfer to d.c. motor drive whenever the supply-voltage drops below 80 per cent of the normal value. Fig. 4 shows the normal running

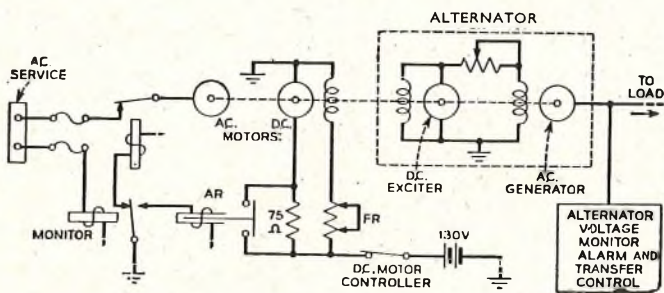

FIG. 4.—TWO-MOTOR ALTERNATOR SET.

circuit for an alternator set, with the d.c. motor connected to the battery through a resistance of 75 ohms inserted in the armature circuit. The field resistor FR is preset so that, when the battery is driving the set, the speed matches that of the a.c. drive when the battery voltage is at the mean discharge value. During a.c. drive, the e.m.f. generated in the d.c. motor armature is a few volts below that of the battery. Accordingly, when the fast-acting contactor AR short-circuits the 75-ohm resistance in the armature circuit, the motor finds itself essentially at the desired operating flux condition and a smooth pick-up of drive occurs. Oscillograms indicate that the interval between failure of a.c. power and operation of contactor AR is less than 0.1 sec. During the transfer from a.c. to d.c. drive, the change in the nominally 230V output is less than 5V.

Return to a.c. drive is delayed approximately 20 seconds after the a.c. supply voltage has returned to normal to allow time for the alternating current to stabilize. Fixed field settings for both d.c. motor and alternator fields provide simple control arrangements with no over-speed or over-voltage hazards which automatic regulators might add. Alternator output is monitored, however, to give alarms for voltage changes exceeding ± 5 per cent and to control transfer to d.c. drive if for any reason the output should drop more than 10 per cent. When the latter occurs, the machine locks on d.c. drive. This feature guards against a.c. motor failure or low a.c. drive speed because of low supply frequency without low supply voltage.

Failure of the alternator output after transfer to d.c. drive causes the set to stop and automatically transfer the load to its emergency alternator. This transfer causes a break in the alternator supply to its busbar, but cable power is maintained constant by the parallel d.c. regulating bay fed from the other alternator busbar.

Battery Plants and Distribution.

Battery power for d.c. motor drive is supplied from a 66-cell 1,680-Ah battery at Clarenville and from two 68-cell 1,680-Ah batteries at Oban. The latter station has double capacity to provide standby power for the a.c. supplies to the inland transmission equipment.

At both cable terminals a control battery for the small alternator plants and the cable d.c. regulating equipment provides 24V and is split so that a fuse or a battery failure on either supply will not interrupt cable power. To guard against so remote a hazard as loss of a common battery for this vital control, two separate 24V power plants have been provided with half of the critical control circuits furnished from each plant.

In addition to supplying d.c. motor power, the 130V battery at Clarenville supplies current to the carrier terminal and test equipment through voltage-dropping resistors which are normally in the circuit to hold the load voltages below a maximum of 135V. These resistors are automatically short-circuited to maintain a minimum load voltage of 125V when the battery voltage drops. A voltage-detecting relay also steps the fixed field adjustment of each d.c. motor when the battery nears its final discharge voltage so that d.c. motor speed is kept within about ± 3 per cent of normal a.c. drive speed during battery operation. The 66-cell battery is floated at 142V by means of voltage-regulated rectifiers and, after a discharge, is recharged by automatic operation of a regulated 100-amp motor-generator set. As indicated in Fig. 3, the rectifiers for this plant are connected so that loss of one service cabinet will still leave sufficient charging capacity to float the load from the other cabinet.

Rectifiers and Associated Controls.

As mentioned earlier, each cable is supplied at all times by two regulating bays in parallel, each capable of taking over the cable load should the other fail. Thus failure of an alternator supply or of a regulating bay will not interrupt the cable power. A spare regulating bay for each cable is arranged for replacing either of the two regulator bays and may be connected in parallel with the other two without overloading the associated 2.5-kVA alternator.

As shown schematically in Fig. 2, the a.c. supply to the rectifiers is controlled by a continuously-tapped variable auto-transformer, operated normally by a 2-phase low-inertia reversible motor, with provision for manual adjustments also. The auto-transformer output is stepped up and rectified by a series arrangement of five rectifiers to give a maximum of 550V each for a total of 2,750V when the auto-transformer is at the upper limit. The high-voltage rectifier output is filtered and supplied through the current-regulating unit, cable-connecting switch, and common cable-control circuit, to the cable. The cable current is regulated by controlling the anode-to-cathode drop across thermionic valves through which this current flows. A d.c. amplifier, which derives its signal from a resistor in series with the total cable current, varies the grid bias of the series regulating valves. The series valves have a control voltage-drop range of from about 150V to the full supply voltage, the d.c. amplifier being capable of driving them to cut-off. However, to protect the series valves and to keep them operating at practically a constant anode voltage of 300V, a servo system automatically raises and lowers the output from the auto-transformer by means of the motor-driven a.c. control unit whenever the series-valve anode voltage varies more than about 25V from the normal value. For example, a 2 per cent change in a.c. input would change the rectifier output of 2,300V (corresponding to a cable supply voltage of 2,000V) by 46V, which would increase the series-valve voltage drop to 346V. This rise in voltage would raise the signal current through the control winding of a saturable reactor which forms one arm of a balanced bridge in the a.c. motor control circuit and thus cause the auto-transformer to be driven down to lower the rectifier output until the series-valve voltage drop was restored again to approximately 300V.

Over-voltage and over-current protection and alarms.—While the power for the cable is electronically regulated, protective features are provided to guard against abnormal cable current or voltage. The first order of protection is a ± 2 per cent cable-current alarm given by a voltage relay which operates from the voltage drop across a resistor in the earth-return circuit to the d.c. bays. A second voltage relay, set for 5 per cent high-cable current, also monitors the current in the earth-return side and, in conjunction with the current monitors on the high-voltage side, limits the cable current by operating the motor-driven auto-transformers until the current is within 5 per cent of normal. The voltage of the unearthed side, however, is much too high for directly connected voltage or current relays. Therefore, magnetic amplifiers have been used to obtain isolated metering of the cable current. Two of these devices measure the current on the unearthed side of the common power supply lead to the cables. Of the three current monitors available, two must operate before "turndown" (reduction of cable-current) functions, to prevent false turndown due to faulty metering.

Voltage protection is provided by means of magnetic amplifiers in shunt across the common power supply to the cable. Here, three monitors are arranged so that any two can reduce power, by means of the turndown control, if the voltage rises to the maximum allowable value for which the voltage relays are adjusted. These monitors draw about 1.5 mA each, but are connected on the supply side of the cable-regulating resistor so as not to affect cable regulation. They guard against excessive voltage resulting from open-circuit where voltages around 4,000V could otherwise occur. They also guard against high voltage due to earth potentials or unbalance between voltage at opposite ends of the cable. When set for a ceiling voltage of 2,600V, a maximum of 3,000V occurs on open-circuit on the first rise, after which the voltage holds within 2,600 \pm 200V as the turndown relays operate

and release to maintain the ceiling voltage. A fourth magnetic-amplifier voltage-detecting relay provides an alarm for ± 5 per cent excursions in cable voltage from the normal value. Other alarms are provided to indicate low output in either of the two parallel regulating bays, relay troubles, loss of magnetic-amplifier a.c. control voltage and fuse failures.

To limit the rate of change in the cable current under short-circuit conditions and to reduce the rise in voltage at the repeaters on open-circuit failure, an inductance of about 36 H is connected in series with the cable circuit, and physically close to the cable termination, so that any failure in the power supply would have the advantage of this surge-limiting element.

Metering.

Metering of the cable current is a very important part of the power-plant design. Not only are the cable-current ammeters needed to set the value of current desired, but their ability to indicate absolute values assists in obtaining stable regulation between the two ends of the cable. The meters provided for this purpose are suppressed-zero 150–300-mA large-scale ammeters with 0.5 per cent error. One of these meters is connected in the unearthed side and another in the earthed side of the cable supply circuit to provide an accuracy check and to indicate any earth-leakage current in the supply circuit. They are connected to very accurate 1-ohm shunts in the cable-current circuits with their shunt leads arranged for switching to a calibration box for checking accuracy and for adjustment. This box employs a Weston cell and galvanometer, acting as a calibration standard at the 225 mA point. Meters calibrated at Oban for 225 mA were expected to be within 0.2 per cent or 0.5 mA of those similarly calibrated at Clarendville, and at present are within about 0.2 mA.

The cable current is also indicated by a recording ammeter. Meters in each regulating bay indicate the division of current between paralleled regulators. These meters have as much as 1 per cent error but are satisfactory for adjusting load balance between parallel bays and also are used in "turnup" of power on a particular bay.

Cable voltage is read on a large-scale voltmeter reading 0–3,000V and having an accuracy within ± 0.25 per cent. Since the accuracy is not critical, this meter is not arranged for calibration. It is normally shunted across the common cable power supply ahead of the cable-current regulating point. It can, however, be switched to read the cable voltage nearer the cable termination. In the latter position, it reduces the cable current by about 1 mA, causing an unbalance in cable regulation, and therefore is not normally left in this position. The cable-supply voltage is also indicated by a recording voltmeter.

Other meters are provided to indicate series-valve anode voltages, d.c. rectifier voltages, a.c. input voltages, series valve currents, test currents for adjusting magnetic-amplifier operating limits, and the difference in current between the positive and negative power supplies to sea-water earth.

D.C. REGULATION

D.C. Amplifier.

The direct-coupled 2-stage amplifier, shown in Fig. 5, is characterized by potentiometer coupling and cold-cathode gas-filled voltage stabilizers. The biases are selected high enough to ensure approximately linear operation even for a short-circuit at the cable terminal. As is apt to be the case in a direct-coupled amplifier, cathode temperature in the low-level stage is critical. In this amplifier, a 5 per cent change in heater voltage results in a 0.5 mA change in the cable current.

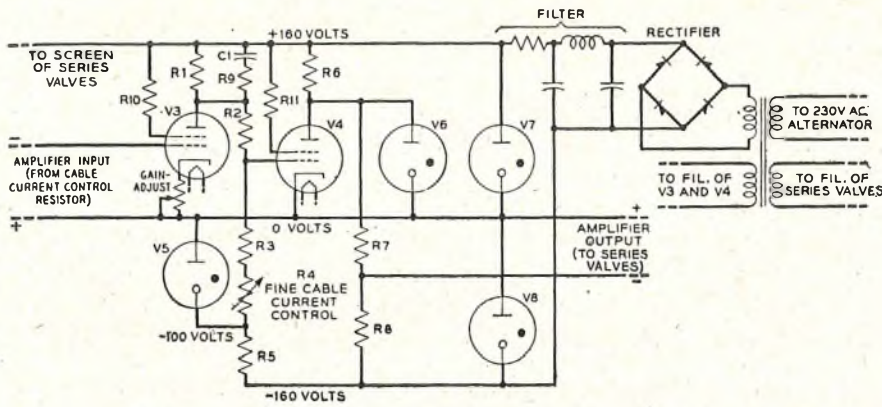

FIG. 5.—TWO-STAGE D.C. AMPLIFIER.

The precision of current regulation originally required in these power supplies can be expressed as representing a source impedance of not less than 100,000 ohms. To meet this requirement, the gain of the d.c. amplifier was made as large as practicable with the anode and screen potentials available from gas-filled regulators. Interstage network impedances are high, to reduce the shunt losses, and are proportioned to provide the large biases mentioned above. Gain adjustment is provided by a variable resistance in series with the cathode of the first stage. This is explained later under system stability.

Shaping of the loop gain and phase characteristics to obtain margins for stable operation is accomplished by means of the RC shunt (R9, C1) across the anode resistor for the first stage. The amplifier gain and phase characteristics without this compensation are shown in Fig. 6. These data

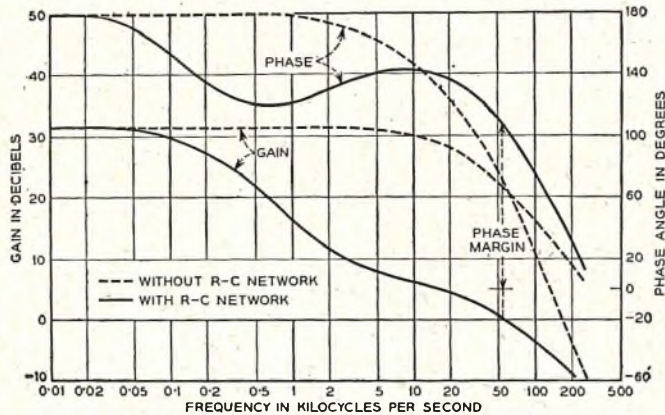

FIG. 6.—D.C. AMPLIFIER GAIN AND PHASE FOR EXPERIMENTAL MODEL.

were obtained by opening the feedback loop at the control grid of the first stage, applying normal d.c. bias plus a variable-frequency a.c. signal to the grid of the valve, and measuring the magnitude and relative phase of the return signal.

The corresponding characteristics with the compensating network in place are also shown in Fig. 6. The compensating network effectively puts a relatively low-impedance shunt across the interstage network at the higher frequencies, resulting in a "step" in the gain characteristic. A secondary effect is the phase shift in the transition region. The calculated "corner frequencies" are 2,800 and 195 c/s, chosen on the basis of the criteria of (a) little effect on regulator gain at 100 or 120 c/s, the most prominent rectifier ripple frequency, and (b) a gain step of something above 20 dB with no appreciable contribution to the phase

shift at frequencies above 30 kc/s. The calculated loss at 120 c/s is 1.2 dB with a maximum phase shift of about 60° at the median frequency. These results agree quite well with the measured data plotted in Fig. 6.

As indicated in Fig. 6, the phase margin at the gain cross-over frequency of 55 kc/s was somewhat over 100° for the experimental model on which these measurements were made. The gain margin could not be measured readily but is clearly substantial. On production units, larger wire sizes and longer leads resulted in lesser, but still satisfactory, stability margins, as shown in Fig. 7, the phase margin being somewhat over 60°. Fig. 7 also shows the characteristics at the extremes of gain control, the range of control being about 8 dB.

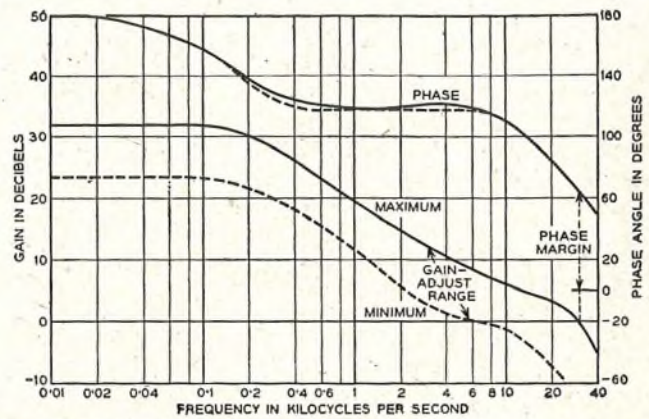

FIG. 7.—D.C. AMPLIFIER GAIN AND PHASE FOR PRODUCTION MODEL.

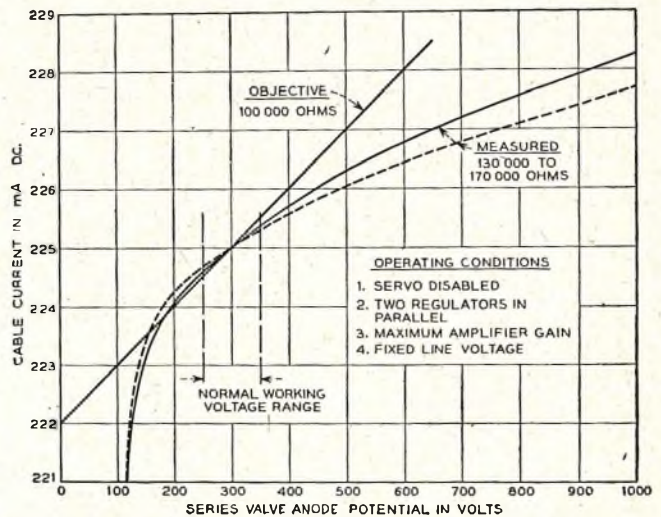

FIG. 8.—LOAD REGULATION.

Fig. 8 shows the measured performance of the d.c. regulators, the servo system being disabled in order to obtain a plot of the performance of the d.c. amplifier and associated circuits. Twenty-two regulator units were manufactured and measured, and the curves of Fig. 8 show the extreme limits observed, the differences between individual regulators being due primarily to differences between thermionic valves. The measured range of source impedance, 130,000–170,000 ohms, allows margin for regulator valve ageing above the 100,000-ohm objective.

A.C. Servo Mechanism.

As noted earlier, the servo system shown in Fig. 2 is part of the current-regulating scheme and holds the series-valve anode potential within reasonable limits by adjusting the rectifier input voltage. In an emergency, a turndown feature, operated from several remote points, either manually or automatically, will reduce the auto-transformer output to zero in less than 2 sec. For simplicity, only the manual turndown feature is shown in Fig. 2. It operates simply by switching one end of the motor control winding from one corner of the bridge to the other, thus applying half of the input voltage to the control winding.

Manual operation of the auto-transformer tap is provided to raise the cable current slowly, either initially or after a turndown. In manual operation a dynamic brake, consisting of a short-circuit on the motor control winding, prevents the motor from creeping or coasting when the operator releases the hand-wheel, as it otherwise would, since the fixed phase of the 2-phase motor is always energized. The turndown feature takes precedence over the short-circuit of the motor control winding automatically, to energize the motor should the operator inadvertently cause abnormally high cable voltage or current.

One essential feature of the servo design is the dead band of the series-valve anode voltage in which the servo remains stationary, even though there are small changes in the incoming signal. This band can be varied from 10 to 100V under control of a gain-adjusting potentiometer across the control winding of the 2-phase motor. Without this dead band, the servo would be constantly in operation, correcting for small random variations in line voltage or earth potentials. Furthermore, since it is extremely difficult to set the current regulators at the two ends of a cable to exactly the same current, the servo dead band permits some margin of error: otherwise the servo associated with the current regulator, trying to regulate for a slightly higher cable current, would drive its rectifier voltage to its stop or maximum output, thus unbalancing the cable voltages.

System Stability†.

A complete analysis of system stability represents an exceedingly formidable, if not impossible, task. It has been established analytically that for a linear network the two d.c. regulators in parallel and the system as a whole are unconditionally stable. The details of this proof are too long to be presented here, but the line of reasoning with respect to the overall system is outlined. The system of Fig. 1 is symmetrical about a vertical plane through the middle of the diagram. Under these conditions the system will be stable if, and only if, the following three simpler systems‡ are stable:

- (a) A power supply short-circuited.
- (b) A power supply feeding an impedance equal to twice that of the half cable short-circuited.
- (c) A power supply feeding an impedance equal to twice that of the half cable open-circuited.

The transfer function of the servo mechanism was measured over the frequency range of principal interest, 0–1 c/s, the behaviour near zero frequency being determined from the asymptotic slope of the unit step response.¶ In this frequency range the d.c. amplifier gain is essentially

a real constant, and the form of the expression for the active impedance of the power supply is such that the a.c. servo feedback loop characteristic alone is sufficient to determine the Nyquist diagram. This diagram for the short-circuited power supply shows that condition (a) above is satisfied. A similar examination of the Nyquist plot, including the readily-computed cable impedance for each of the respective cases, shows that conditions (b) and (c) also are satisfied. Thus the linear analysis indicates stable operation for the system of Fig. 1. This result was confirmed by tests of conditions (a), (b) and (c) individually and by the behaviour of the system as a whole, both in the laboratory with a simulated power network for the cable and in the final installation.

One of the most obscure aspects of the power-system behaviour is that of equilibrium conditions after one or a series of large earth potential disturbances. While the system is stable in the sense that the transient voltage due

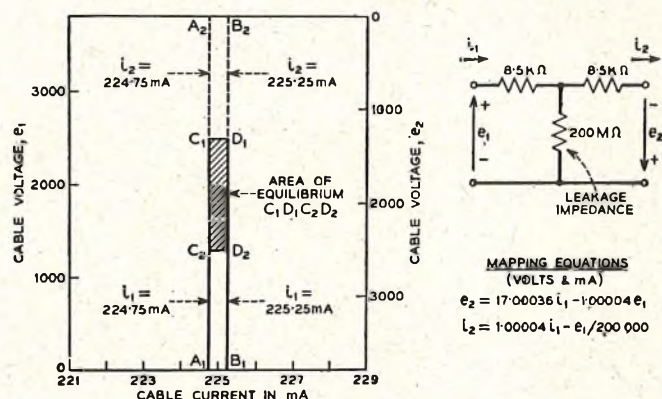

FIG. 9.—EQUILIBRIUM DIAGRAM.

†The analysis briefly summarized here was made by Mr. C. A. Desoer.

‡In this discussion of simpler systems a power supply consists of only the elements shown in Fig. 2.

¶In the course of these time-domain measurements, it was quite apparent that the a.c. control loop could be considered as a linear network only in an approximate sense and thus that the analytical results were primarily useful in interpretation of observed behaviour of the system.

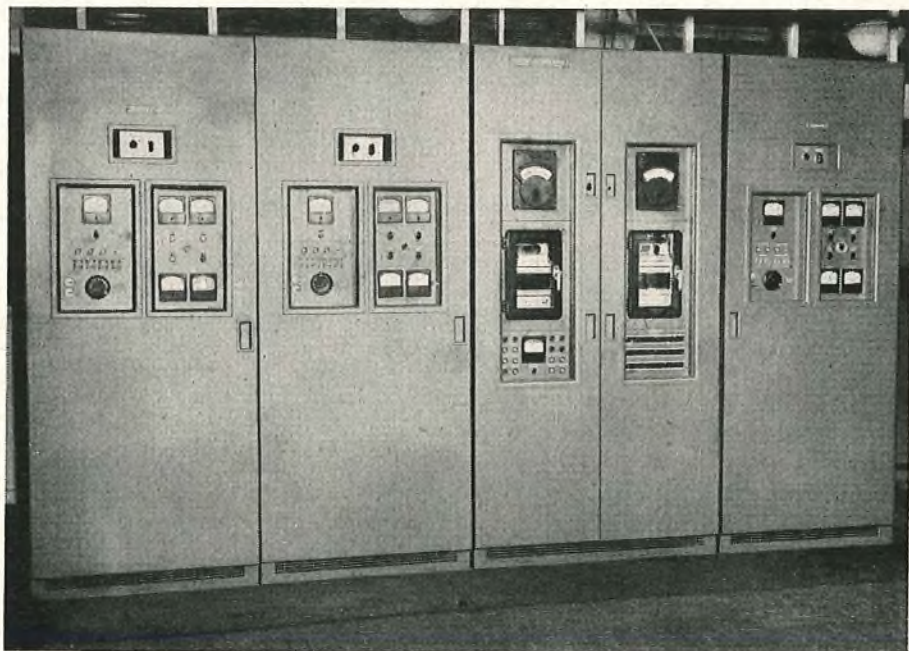

FIG. 10.—D.C. REGULATOR AND COMMON CONTROL BAYS.

to a perturbation will disappear in a finite time once the disturbance has been withdrawn, the range of possible equilibrium positions (disregarding the over-voltage protective feature) is extremely wide, from perhaps 1,300 to 2,500V at the cable terminals. The upper limit of 2,500V is set by the maximum output available from one power plant; this also sets the lower limit of the associated power plant at the far end of the cable. This situation is illustrated diagrammatically in Fig. 9.

The behaviours of the servo mechanisms at the two ends of a given cable are so nearly enough alike that the repeated introduction of simulated earth potential in the laboratory was found not to disturb substantially the equilibrium point. This was true for earth potentials of either polarity up to 1,000V and with these potentials introduced at any

point along the artificial cable. A rate of change of earth potential of 20V per second was adopted in these tests with the thought that such values would be realistic.

With regard to the long-term stability of the equilibrium condition described above, it is, of course, important that the controls which establish the cable current at the two ends of the same cable be adjusted for very nearly the same value. Unless this is done, the cable voltage at one end will gradually increase or decrease and the voltage at the other end will move equally in the opposite direction. This would eventually bring in alarms and necessitate manual readjustment. In this connexion, the voltmeters which indicate the drop through the series regulating valves provide a very convenient magnification of any drift in cable current. The multiplying factor is the effective d.c. impedance of the regulated system, i.e. more than 100,000 ohms. Thus 25V, which is an appreciable fraction of the nominal 300V across the series regulating valves, is equivalent to less than 0.25 mA, which is of the order of 0.1 per cent of normal cable current. As a matter of fact, the behaviour of this voltage provides the final criterion for precise adjustment of cable current to ensure long-term stability.

EQUIPMENT DESIGN

Description.

Fig. 10 shows the complete d.c. equipment for supplying one polarity of power to one cable. Similar equipment provides for the opposite polarity to the other cable. The two equipments are located facing each other across a common aisle with their common control bays directly opposite. Regulator 1, on the right, is normally operated in parallel with regulator 2. Regulator 3 on the left is the spare one, normally off. The common bay, between regulators 1 and 2, includes, among other things, the cable termination and power-separation filter. This equipment and all the live parts of the circuit back to the common point to which the switches in the individual regulator bays are connected is enclosed in a high-voltage compartment.

The paralleling control switches are mounted in high-voltage compartments in their respective regulating bays and must remain completely enclosed, as their common cable connexions are alive during cable operation. These switches have an interrupting capacity of 1A at 3,000V, thus providing a large safety factor over the 0.245A maximum load current.

Fig. 11 illustrates some of the special design features built into the equipment to facilitate maintenance. The high-voltage compartment, shown open, at the top is locked whenever the cable is in

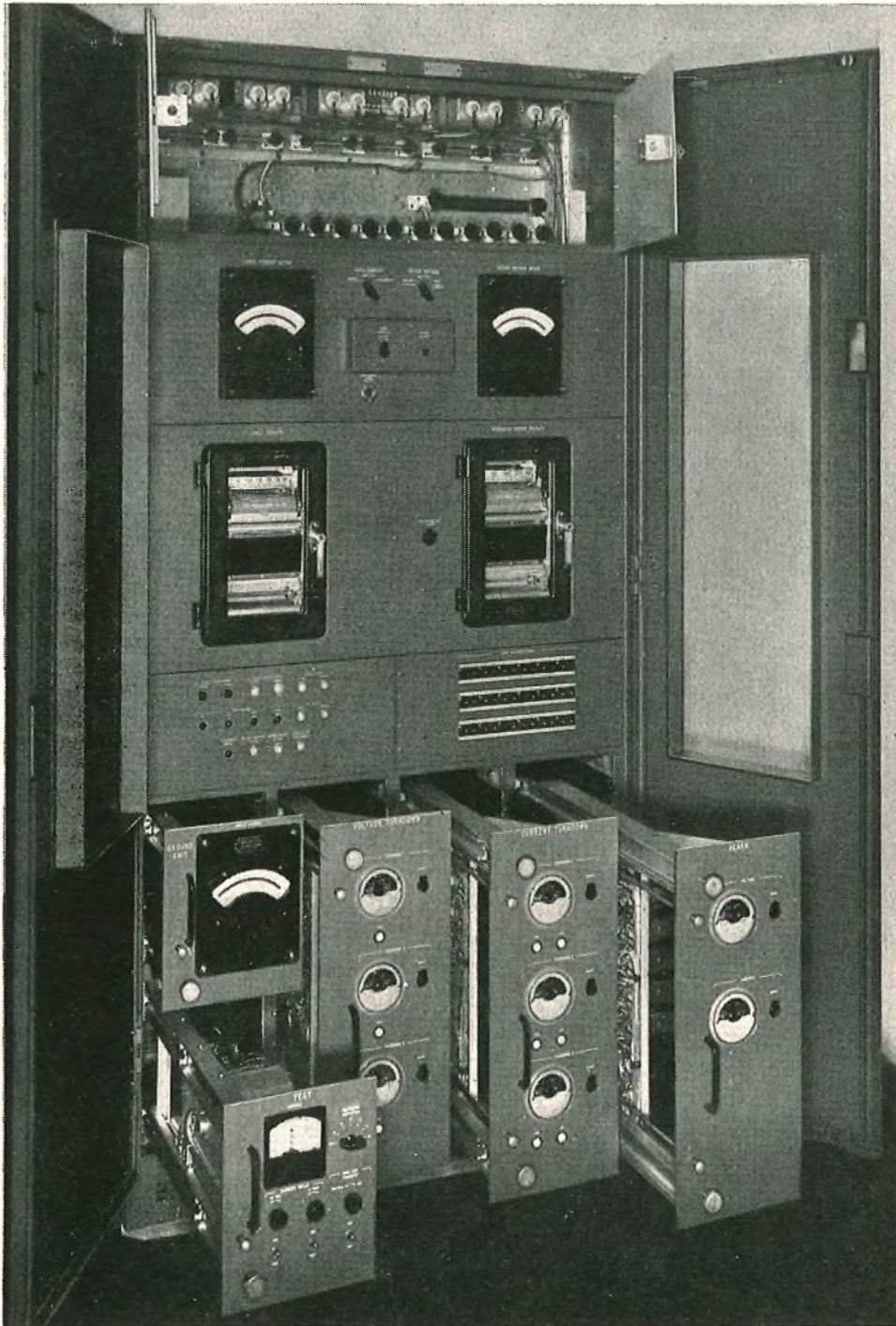

FIG. 11.—COMMON CONTROL BAY.

operation, and this protection feature will be described below. Pull-out drawers at the bottom contain metering shunts, a test unit for adjusting voltage and current protection limits, a voltage protection unit, a current protection unit and an alarm unit. While only one of these compartments is to be pulled out at a time, they are arranged so as not to endanger staff or to affect service during adjustment when open. Doors are provided on all bays to prevent accidental disturbance of adjustments and to guard against damage to controls.

Corona.

The high-voltage a.c. elements of the complete regulator bays were tested for corona with 4,000V a.c. applied, and furthermore, if corona was observed on increasing the applied r.m.s. voltage to 5,000V, it was required to extinguish when the voltage was reduced to 3,500V. The maximum acceptable leakage was 20 μ A at 4,000V across the circuit (200 megohms). A d.c. corona requirement of 4,000V was applied to the d.c. elements of the regulator bays and 5,000V for the common bay, with a maximum permissible leakage of 5 μ A. The higher corona requirements on the common bay were intended to eliminate the necessity for turning down the entire system for repair. A high standard of workmanship is required to provide such performance. There can be no sharp projections and no loose strands of wire. Solder must be applied so as to obtain a rounded smooth joint and high-voltage wiring must be dressed away from exposed earthed metal, busbars, etc., so that the outer braid (other than polyethylene) does not come in contact with metal.

Crosstalk and Outside Interference.

In order to meet the severe crosstalk requirements between receiving and transmitting circuits, and to guard against feeding station noise potentials into the carrier transmission system, arrangements were made so that normally station earths are carefully separated from the outer conductor of the cable and from all circuit elements within the power-separation filter. Pick-up of external radio frequency fields by the power-separation filters was greatly reduced by completely enclosing, in a copper shield, the cable terminal and the power-separation-filter elements nearest to the terminal. The shielding itself and the cans of filter capacitors and oil-filled coils are connected to the return tape of the cable, which is insulated from station earth until it reaches sea water, thus reducing the coupling to the other cable as compared with tying both tapes together at the station or bay-frame earth.

Protection of Personnel.

A key locking system is provided to safeguard against any hazard to personnel from high voltages. In the common bay, the high-voltage compartment can be entered only by operating a switch which short-circuits the cable to earth and releases a key for the compartment doors. In each regulating bay, the key system ensures that the bay is disconnected from the cable and hence from the paralleling power supplies. Where access is required to the interior of any compartment, the key system ensures that the a.c. power to the bay also is switched off.

The test compartment contains pin jacks, provided for maintenance operations, which are always performed with the regulator bay connected to a low-resistance load. Access to this compartment can be obtained with a.c. power connected to the bay. However, for such access, the key system enforces the operation of the output-disconnect switch, which also transfers the bay to a low-resistance load. Moreover, a mechanical interlock with the auto-transformer ensures that the test voltages are reduced to safe values.

In addition to its function in protecting personnel, the key system also ensures that not more than one regulating bay is disconnected at one time so that continuity of service is protected at all times by two parallel regulators.

FACTORY AND SHIP CABLE POWER

In addition to the above cable power supplies at the ocean terminals, similar d.c. cable-current regulating equipment was designed for use at the cable factory and aboard the cable ship *Monarch*. Well protected and closely regulated reliable power was considered essential during the cable loading and laying operations. It was necessary to have power on the cable continuously, except when splices were made, in order to detect a fault immediately, to measure transmission characteristics for equalization purposes and finally to alleviate the strain on the glassware and tungsten filaments of the repeater tubes during the difficult laying period.³

References

- ¹ LEWIS, H. A., FRASER, J. M., LOVELL, G. H., and TUCKER, R. S. System Design for the North Atlantic Link. (In this issue of the *P.O.E.E.J.*)
- ² GLEICHMANN, T. F., LINCE, A. H., WOOLEY, M. C., and BRAGA, F. J. Repeater Design for the North Atlantic Link. (In this issue of the *P.O.E.E.J.*)
- ³ JACK, J. S., LEECH, W. H., and LEWIS, H. A. Route Selection and Cable Laying for the Transatlantic Cable System. (In this issue of the *P.O.E.E.J.*)

System Design for the Newfoundland-Nova Scotia Link*

R. J. HALSEY, B.Sc.(Eng.), M.I.E.E., and
J. F. BAMPTON, B.Sc.(Eng.), A.M.I.E.E.†

U.D.C. 621.395.52

The design and engineering of the section of the transatlantic cable system between Newfoundland and Nova Scotia was the responsibility of the British Post Office. The transmission objectives for this link having been agreed in relation to the overall objectives, the paper shows how these were translated into system and equipment design and demonstrates how, in the event, the objectives were realized.

INTRODUCTION

UNDER the terms of the Agreement,¹ it was the responsibility of the British Post Office to design and engineer the section of the transatlantic cable system between Newfoundland and Nova Scotia. In common with other parts of the system, all specifications were to be agreed between the Post Office and the American Telephone & Telegraph Co., but as both the British and the American types of submerged repeater had been carefully studied and generally approved by the other party prior to the agreement, the basic pattern of the system was clear from the beginning.

The service and transmission objectives for the overall connexions London-New York and London-Montreal were agreed² in early joint technical discussions in New York and Montreal and the agreed total impairments were divided appropriately between the various sections. In this way, the transmission objectives for the Newfoundland-Nova Scotia link were established.

ROUTE

The choice of Clarenville as the junction point of the two submarine sections of the transatlantic system was determined primarily in relation to the Atlantic crossing and the desire to follow a transatlantic route on the north of existing telegraph cables.³ There were a number of possi-

been considered earlier, was to cross Newfoundland by a radio-relay system and to employ a submarine-cable link across Cabot Strait only. The final decision to build a cable system between Clarenville and Sydney Mines raised a number of problems in respect of the route to be followed, concerned primarily with potential hazards to the cable brought about by:

- (a) The existence of very extensive trawling grounds on the Newfoundland Banks.
- (b) The location of considerable numbers of telegraph cables in the vicinity.
- (c) Grounding icebergs.

The route finally selected after thorough on-the-spot investigations^{3,4,5} (Fig. 1) is satisfactory in respect of all these hazards, involving no cable crossings and being inshore of the main fishing grounds. The straight-line diagram of the route is shown in Fig. 2; the total cable length is 326 n.m., of which 54.8 n.m. are between Clarenville and Terrenceville, Newfoundland, where the cable finally enters the sea. The maximum depth of water involved is about 260 fathoms.

CABLE

Choice of Design.

Since 1930, when the Key West-Havana No. 4 cable was constructed,⁶ it has been usual to extrude the insulation of

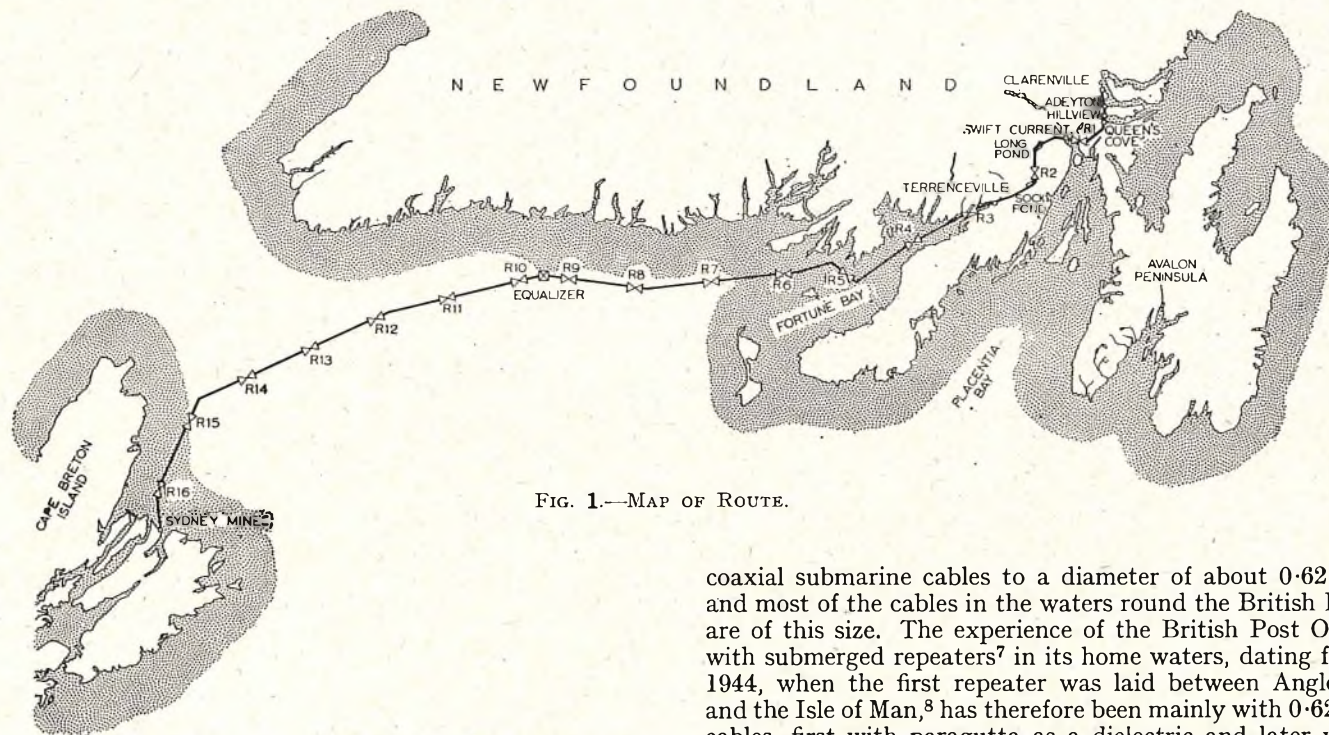

FIG. 1.—MAP OF ROUTE.

bilities for the route between Clarenville and the east coast of Cape Breton Island, the most easterly point which could be reached reliably by the radio-relay system through the Maritime Provinces of Canada. One possibility, which had

coaxial submarine cables to a diameter of about 0.62 in., and most of the cables in the waters round the British Isles are of this size. The experience of the British Post Office with submerged repeaters⁷ in its home waters, dating from 1944, when the first repeater was laid between Anglesey and the Isle of Man,⁸ has therefore been mainly with 0.62-in. cables, first with paragutta as a dielectric and later with polyethylene. Most of these cables were originally operated without repeaters, and the 60-circuit both-way repeaters which are now installed on the routes were designed to match their characteristics.

In planning a new system, the size of cable will be determined by one of the following considerations:

† Mr. Halsey and Mr. Bampton are with the British Post Office.

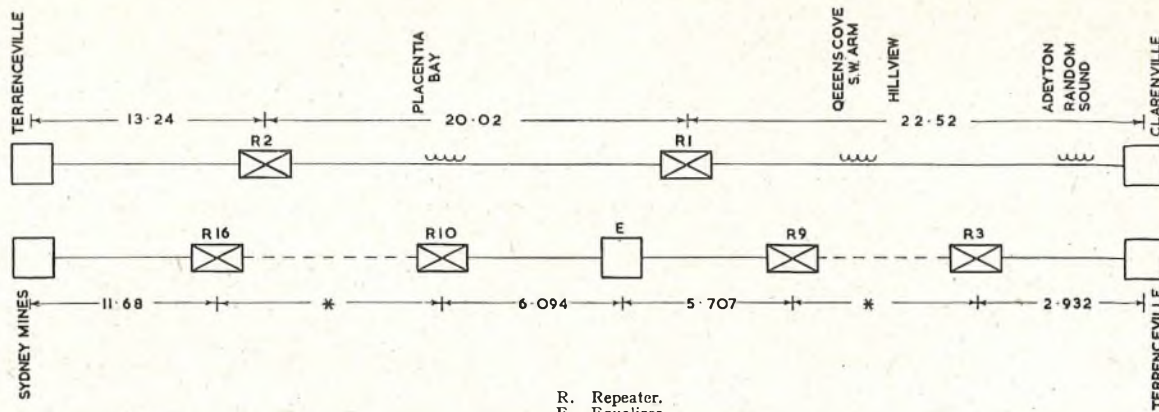

R. Repeater.
E. Equalizer.
All distances are in nautical miles.
* Repeater spacing R3-R9 and R10-R16, 20.4 n.m.
FIG. 2.—STRAIGHT-LINE DIAGRAM OF ROUTE.

- (i) Minimum annual charges for the desired number of circuits.
- (ii) Terminal voltage required to feed the requisite number of repeaters.
- (iii) Maximum number of repeaters or minimum repeater spacing which is considered permissible.
- (iv) Maximum (or minimum) size of cable which can be safely handled by the laying gear in the cable ship.

When the 36-circuit system between Aberdeen, Scotland, and Bergen, Norway, was planned in 1952, the route length (300 n.m.) greatly exceeded that of any other submarine telephone system, and it was decided to use a core diameter of 0.935 in., firstly to keep the number of repeaters as low as seven, and secondly, because the system was intended as a prototype of a possible Atlantic cable. The cable dielectric is polyethylene (Grade 2) with 5 per cent polyisobutylene.

The Oban-Clarenville link is designed to provide the maximum number of circuits on 0.62-in. diameter cable, and the limiting consideration is the terminal voltage required to energize the repeaters.

For the Clarenville-Sydney Mines link it proved possible to design for minimum annual charges. With increasing experience and confidence in submerged repeaters, it was no longer considered necessary to restrict the number of repeaters as for Aberdeen-Bergen, and the terminal voltage requirements were reasonable. At the current prices of cable and repeaters in Great Britain the optimum core diameter for 60 both-way circuits is about 0.55 in., but the increased charge incurred by using 0.62-in. cable is less than 5 per cent (0.62-in. core is optimum for 120 both-way circuits). In order to facilitate manufacture and the provision of spare cable, it was therefore logical to adopt the same design as that proposed for the Atlantic crossing and described elsewhere.^{3,9}

After investigating various possible types of cable for the overland section in Newfoundland, it was decided to use a design essentially the same as the main cable but with additional screening against external interference.⁴ As far as the outer conductor and its copper binding tape, the construction (Fig. 3) is identical with that of the main cable except that the compounded cotton tape is overlapped. Outside this are five layers of soft-iron tapes each 0.006 in. thick, the innermost being longitudinal and the others having alternate right- and left-hand lays at 45° to the axis of the cable. After another layer of compounded cotton tape there is extruded a polyethylene sheath 0.080 in. thick, and the whole is jute served and wire armoured. As a check on the efficiency of the screening, the maximum sheath-transfer impedance at 20 and 100 kc/s was specified as 0.005 ohm per 1,000 yd.

It was thus possible to treat the entire link from Clarenville to Sydney Mines as a uniform whole, using the same type of repeater on land as in the sea. A small hut at Terrenceville contains passive networks only.

Attenuation Characteristics.

When the system was designed, precision measurements of cable attenuation were not available. The design of the Oban-Clarenville link was based on laboratory measurements on earlier 0.62-in. cable of a similar type, but the available data applied only to frequencies up to about 180 kc/s, whereas the Clarenville-Sydney Mines link was to operate at frequencies up to 552 kc/s; extensive extrapolation was therefore involved. As soon as the first production lengths of cable became available in February, 1955, laying trials were carried out off Gibraltar, and it was found that there were serious changes of attenuation on laying, over and above those directly attributable to temperature and pressure effects, and that the assumed characteristics were inaccurate. Although the attenuation in the factory tanks had been in reasonable agreement with that of the earlier cable, there were changes on transfer to the ship's tanks and again on laying, amounting in all to a reduction of about 1.5 per cent at 180 kc/s. This would have been comparatively unimportant had the discrepancy been of "cable shape," i.e. the same fraction of the cable attenuation at all frequencies and therefore exactly compensated by a length adjustment of the repeater sections. As this was not so, and as the cable-equalizing networks in the repeaters were settled by that time, it was clear that precise information had to be obtained in order that suitable additional equalizers could be provided for insertion in the cable on laying.

There are a number of factors which can lead to small

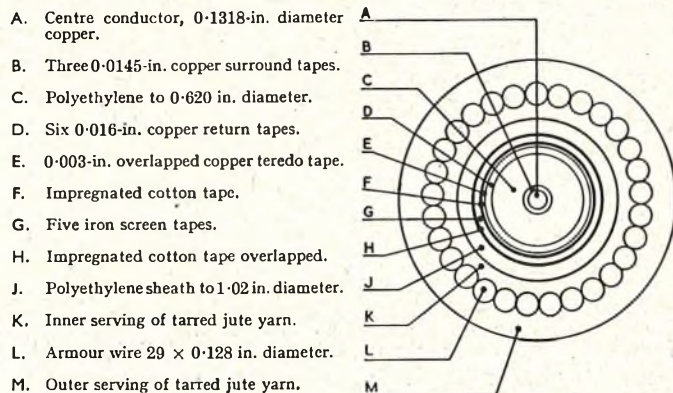

FIG. 3.—CROSS-SECTION OF CABLE ACROSS NEWFOUNDLAND SHOWING MAKE-UP.

changes of attenuation on laying, but most of these tend to increase the losses. The primary reason for the observed changes appears to be contact variations between the various elements of the inner and outer conductors, i.e. the wire and three helical tapes forming the centre conductor, and the six helical tapes forming the return conductor. These contact resistances tend to change with handling, and as a result of a slight degree of "bird caging" when coiled, it seems that the attenuation decreases as the coiling radius increases, and vice versa. Also, the effect of sea pressure is to consolidate the conductors and thereby further reduce the attenuation—an effect which appears to continue on a diminishing basis for a long time after laying.

To obtain reliable data for the Clarenville-Sydney Mines link 10 n.m. of cable with A-type armour was laid at about the mean depth of the system (120 fathoms), off the Isle of Skye. The attenuations, coiled and laid, are shown in Fig. 4, due allowance having been made for temperature and pressure. The ordinates—attenuation/ $\sqrt{\text{frequency}}$ —are such that the value should be approximately constant at high frequencies.

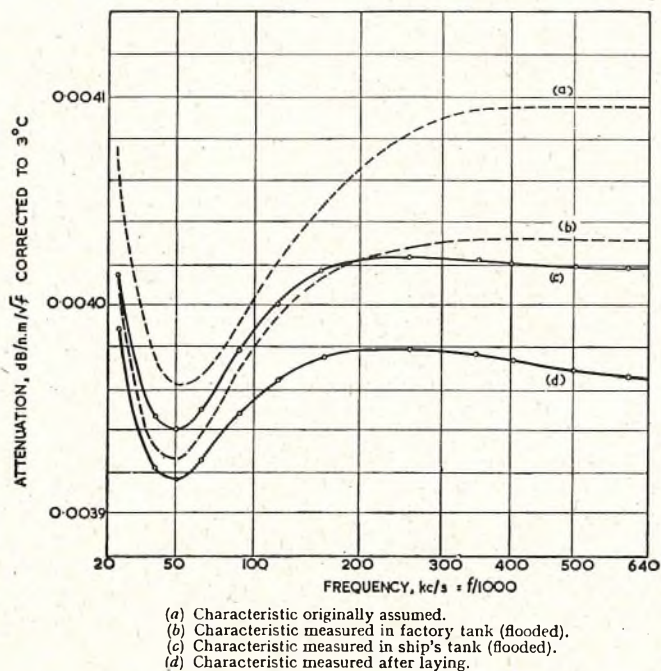

FIG. 4.—CABLE ATTENUATION CHARACTERISTICS: SKYE TRIALS.

In making a final determination of the cutting lengths for the repeater sections, it was assumed that the factory measurements of attenuation would be reduced by 1.42 per cent at 552 kc/s on laying, that the temperature coefficient of attenuation would be +0.16 per cent per degree Centigrade and that the true pressure coefficient of attenuation was negligible at the depths involved.

DESCRIPTION OF SYSTEM

Circuit Provision and Frequency Allocation.

It was originally thought that a design similar to that of the Aberdeen-Bergen system would be suitable for the

Clarenville-Sydney Mines route in that it would provide more circuits (36) than the long section across the Atlantic. This potential excess capacity, which was required for circuits between Newfoundland and the Canadian mainland, disappeared when it was found that 36 circuits could, in fact, be provided over the longer link. The Aberdeen-Bergen design was therefore modified to provide a complete supergroup of 60 circuits, the same capacity as the earlier British projects.⁷ The system thus requires broadband transmission of 240 kc/s in each direction.

In the earlier British projects the frequency bands transmitted are 24-264 and 312-552 kc/s, but for the present purpose the lower band is dropped by 4 kc/s to 20-260 kc/s, so that the lowest frequency is the same as on the Atlantic cables. This enables common frequency-generating equipment to be used at Clarenville for the two links and minimizes crosstalk problems. The main transmission bands and the allocation of the five 12-circuit groups are shown in Fig. 5, together with the ancillary channels; the facilities provided are discussed later.

Submerged Repeaters.

The submerged repeaters employed are fully described elsewhere,¹⁰ and it will suffice to note here that they are rigid units, approximately cylindrical in shape, 9 ft long and 10½ in. maximum diameter. They are capable of withstanding the full laying tension in deep water, although this is of little importance in the present application.

They are arranged for both-way transmission through a common amplifier which has two forward paths in parallel, with a single feedback path. The two halves of the amplifier are so arranged that practically any component can fail in one without affecting the other.

Power-Feeding Arrangements.

The submerged repeaters are energized by constant-current d.c. supplies between the centre conductor and earth, the power units at the two ends being in series aiding and the repeater power circuits being in series with the centre conductor, i.e. without earth connexions, as in Fig. 6. This is the only arrangement by which it is possible to control the supply accurately at every repeater, the insulation resistance of cable and repeaters being sufficiently great that the current in the centre conductor is virtually the same at all points. The constant-current feature of the supply ensures that repeaters cannot be overrun in the event of an earth fault on the system.

On the Oban-Clarenville link the anode voltage is derived from the drop across the valve heaters. This results in the heaters being at a positive potential with respect to the cathodes, a condition which tends to break down the heater-cathode insulation.¹¹ In the American valves this insulation is very robust and the risk is considered to be negligible, but in the current British valves, which have a much higher performance, the arrangement is undesirable. In view of the much smaller number of repeaters it was possible to derive the heater and anode supplies as in Fig. 6 and thus to reverse the sense of the heater-cathode voltage and also to provide an anode voltage of 90, against 55 in the longer link.

With this arrangement the link requires a total supply

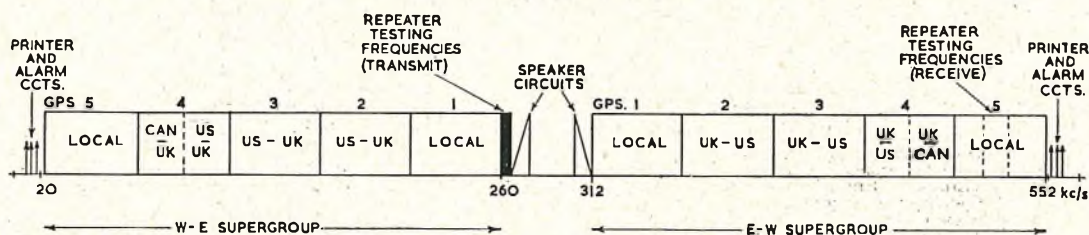

FIG. 5.—FREQUENCY ALLOCATION.

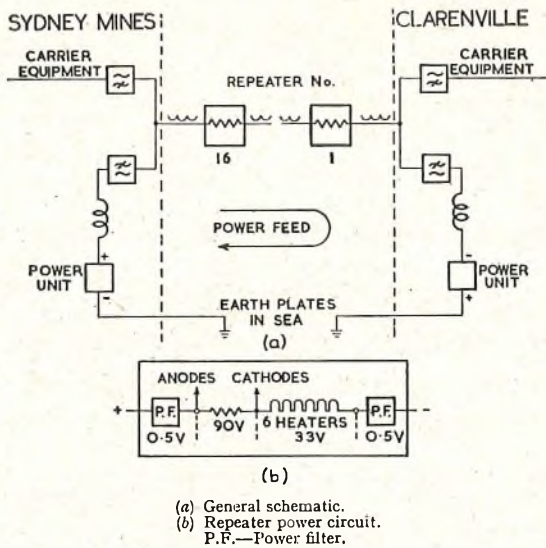

FIG. 6.—POWER-FEEDING ARRANGEMENTS.

voltage of about 2,300. The power-feeding equipment¹² at each terminal station is designed to feed a constant current of 316 mA at this voltage, and it is permissible to energize the system from one end only, if necessary. The repeater capacitors—the limiting factors in respect of line voltage—are rated very conservatively at 2,500V, so that a single-ended supply of 2,300V, with the possibility of superimposed earth-potential differences, is near the desirable maximum. The two terminal power units are therefore designed to operate in series and to share the voltage.

With access to the cable provided at Terrenceville it is possible to operate the power system on the following bases:

- No earth at Terrenceville, power from both ends on a master-and-slave basis (to ensure that the constant-current units do not build up an excessive voltage); this is the normal arrangement.
- No earth at Terrenceville, power from one end only.
- Earth at Terrenceville, with the Clarenville and Sydney Mines power units energizing the land and sea cables respectively; this arrangement has been particularly useful during the installation period.

The presence of high voltages on the cable constitutes a potential danger to personnel, hence special precautions

are taken in the design of the equipment in which the cable terminates and in which high voltages exist or may exist.

The earth connexions for the power circuits at the two ends are via special earth cables and earth plates located about half a mile from the main cable, and metering arrangements are provided to check that the current does in fact take this path. These measures ensure that the current returning via the cable armour is never sufficient to cause serious corrosion.

Arrangement of Terminal Equipment.

Fig. 7 shows the arrangement of the terminal equipment. In accordance with an early agreement defining precisely the various sections of the project, the link is considered to terminate at the group distribution frames at Clarenville and Sydney Mines, i.e. at the 60–108-kc/s interconnexion points.

In addition to the cable-terminating and power-feeding equipments (A and B), the following are provided at the terminals:

- Submarine-cable terminal equipment (C) consisting of repeaters to amplify the signals transmitted to and received from the cable, equalizers and frequency-translating equipment to convert the line frequencies to basic-supergroup frequencies (312–552 kc/s).
- Group-translating equipment (D) to convert the basic supergroup to five separate basic groups (60–108 kc/s) and vice versa.
- Equipment for the location of cable and repeater faults (E and F).
- Speaker and printer circuit equipments (G and H) to provide two reduced-bandwidth telephone circuits, two telegraph circuits and one alarm circuit for maintenance purposes. It is clear that such circuits should be substantially independent of the main transmission equipment.

Two principles were agreed very early in the planning; first, that the engineering of the various links should be integrated as far as possible, and secondly, that the items of equipment at each station should be provided by the party best in the position to do so. In consequence:

- Items of standard equipment were provided by the A.T. & T. Co. at Clarenville and Sydney Mines (and by the Post Office at Oban), thus simplifying maintenance and repair problems.

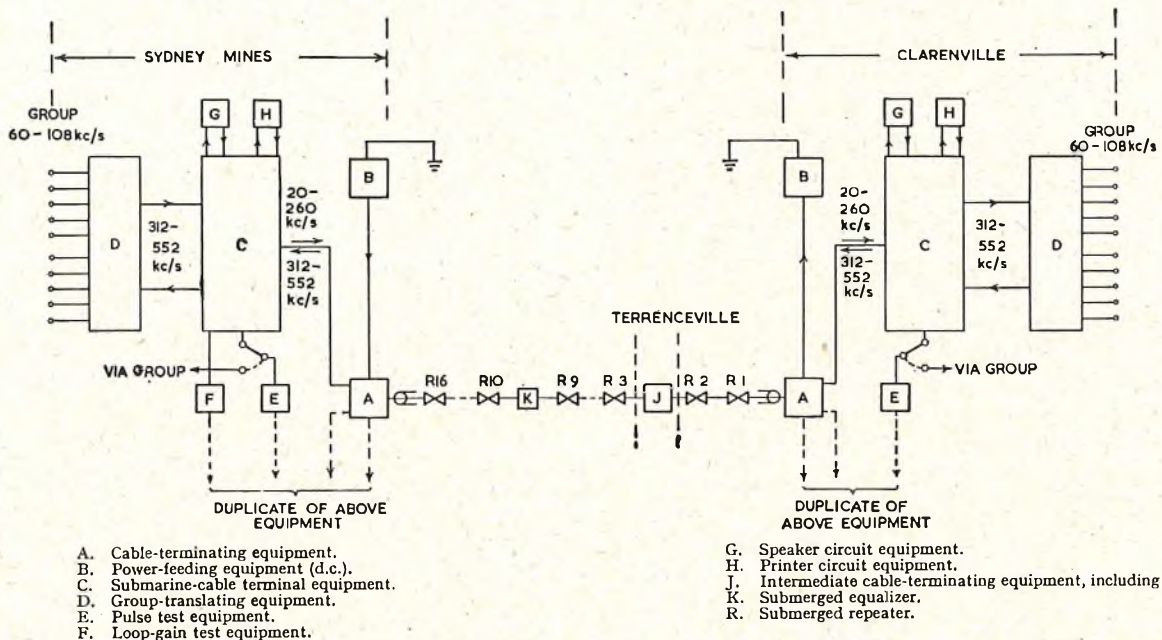

FIG. 7.—ARRANGEMENT OF TERMINAL EQUIPMENT AND REPEATERS.

(ii) Basic power plant and the carrier supplies for supergroup and group translation were provided by the A.T. & T. Co. for both terminal equipments at Clarenville.

(iii) Terminal equipment special to the Clarenville-Sydney Mines link was provided by the Post Office.

In view of the importance of the link, the power-feeding and transmission equipment are completely duplicated.

The submarine-cable terminal equipment is arranged to transmit the basic supergroup directly over the cable in the east-to-west direction. In the west-to-east direction the supergroup is translated to the range 20–260 kc/s, using a 572-kc/s carrier.

DESIGN OF TRANSMISSION SYSTEM

Performance Requirements.

The agreed transmission objectives for the Clarenville-Sydney Mines link were as follows:

Variation of transmission loss.—The variation in the transmission loss of each group should have a standard deviation not greater than 0.5 dB; this implies that the variation from nominal should not exceed 1.3 dB for more than 1 per cent of the time.

Attenuation/frequency characteristics.—Only the overall characteristics of the individual circuits were precisely specified, the limits being the C.C.I.F. limits for a 2,500-km circuit and the target one-half of this. With this objective in view, the group characteristics in each link must clearly be as uniform as is reasonably practicable.

Circuit noise.—The total noise contributed by the link to each channel in the busy hour (i.e. including intermodulation noise) should have an r.m.s. value not exceeding +28 dBa \ddagger (corresponding to -56 dBm) at a point of zero relative level.

Crosstalk.—The minimum equal-level crosstalk attenuation should be 61 dB for all sources of potentially intelligible crosstalk; this was accepted as a target for both near- and distant-end crosstalk. Although go-to-return crosstalk is not important for telephony (it appears as sidetone) and a limit of 40 dB is satisfactory even for voice-frequency telegraphy, it assumes great importance for both-way music transmission; also, it was desired to be non-restrictive of future usage.

Assessment of Requirements.

The design of the high-frequency path to meet the agreed requirements involves consideration of:

- Noise, including fluctuation (resistance and valve) noise and intermodulation.
- Wideband frequency characteristics, including the effects of the directional filters at the terminal and in the repeaters.
- Variations of (a) and (b) in respect of temperature and ageing.

The noise requirement is by far the most important factor in the design of the line system.

The choice of route and cable having been made, the total loss was known and it was necessary to determine the minimum number of repeaters to compensate for this loss and to meet the noise requirement with adequate margin

\ddagger This refers to the reading on a Bell System 2B Noise Meter (FIA weighting network); the noise level (dBa) is relative to a 1-kc/s tone at -85 dBm. In Europe, noise is measured on a C.C.I.F. Psophometer (1951 weighting network), which is calibrated in millivolts across 600 ohms; this is commonly converted to picowatts (pW). The white-noise equivalence of the two instruments is given by $\text{dBa} = 10 \log_{10} \text{pW} - 6 = \text{dBm} + 84$; the agreed limit of +28 dBa is therefore equivalent to 2,513 pW (1.23 mV) or -56 dBm. The corresponding C.C.I.F. requirement at 4.0 pW/km would be 2,400 pW, this value not to be exceeded for more than 1 per cent of the time.

dBm—deci bels relative to 1 mW.

for inaccurate estimates of cable attenuation after laying, temperature variations, ageing and repairs. An attempt to achieve the necessary gain with too few repeaters would result in excessive noise.

Design of the amplifiers in the British repeaters is such that, with both forward paths in operation, the overload point is about +24 dBm, \S and with a loading of 60 channels in each direction, this permits of planning levels of about -4 dBm at the amplifier output after allowing reasonable margins for errors and variations.¹⁰ Previous experience shows that, at such output levels, intermodulation noise can be neglected and the full noise allowance allotted to fluctuation noise. The effect of valve noise is to increase the weighted value of resistance noise by about 1 dB to -137.5 dBm, or -53.5 dBa, at the input to the amplifier in each repeater.

At the highest transmitted frequency the equalizers, power filters and directional equipment introduce losses of about 1 dB and 4 dB at the input and output of the amplifier respectively; these losses must, effectively, be added to the loss in the cable.

Two other pieces of information are necessary before the repeater system can be planned—the permissible transmitting and receiving levels at the shore stations. The transmitting equipment provided at Clarenville can be operated at channel levels up to +20 dBm, and it is logical to allow the same receiving level at the shore end as at intermediate repeaters.

On the above basis it is possible to construct a curve (Fig. 8) relating the total circuit noise to the number of intermediate repeaters, and it is seen that the minimum number is 15, each of which must have an overall gain of 59 dB (amplifier gain, 64 dB) at 552 kc/s. The actual provision is 16 repeaters, each having a gain of 60 dB at 552 kc/s, the additional gain being absorbed in fixed and adjustable networks at points along the route, as indicated in the following section.

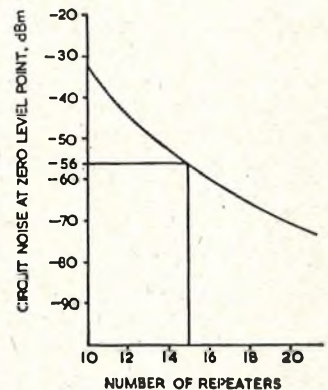

FIG. 8.—VARIATION OF CIRCUIT NOISE WITH NUMBER OF REPEATERS.

Level Diagram.

The actual level diagram (planning levels are shown in Fig. 9) differs somewhat from that which can be deduced directly from the above because of the following considerations:

- The location of the first repeater from Clarenville (i.e. on land) was dictated by topography and the desire to locate both it and the second repeater in ponds; thus the transmitting level at Clarenville is substantially lower than the permissible maximum.
- There are equalizing networks at Terrenceville and facilities for their adjustment to compensate for temperature variations.
- Because of the difference between the actual cable attenuation and that for which the repeaters were planned (see earlier section on attenuation characteristics) it was necessary to include an equalizer unit in the sea, midway between Terrenceville and Sydney Mines. Loss equivalent to 9 n.m. of cable was also introduced at this point to ensure that repeater No. 16 would be sufficiently far from the shore at Sydney Mines.
- Cable simulators are included in the cable-terminating equipment at Sydney Mines to build out this section to a standard repeater section; the actual cable

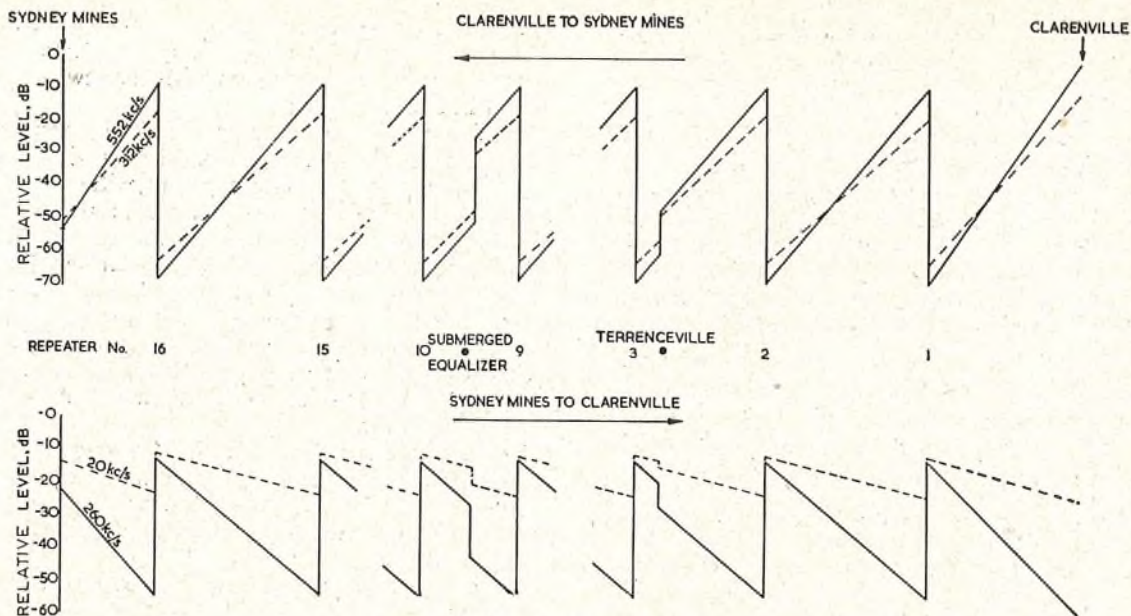

FIG. 9.—SYSTEM LEVEL DIAGRAM.

length was, of course, unknown until the cable was complete.

Taking into account the existence of the intermediate networks, the repeater spacing is such that when both land and submarine cable sections are at mean temperature the compensation is as accurate as possible. In general the highest frequency is of greatest importance in this respect. Since the low-frequency channels experience less attenuation than the high-frequency channels, it is permissible to transmit them at a somewhat lower level, thereby increasing the load capacity of the amplifiers which is available to the high-frequency channels.

Temperature Effects and their Compensation.

The effect of temperature changes is likely to be somewhat complex. The land- and sea-cable sections are expected to behave in different ways in this respect, but data on the manner of variation are not very precise. The submarine cable crosses Cabot Strait, where melting icebergs drifting down from Labrador as late as June can be expected to keep the sea-bottom temperature low until well into the summer; temperatures just below 0°C were, in fact, recorded when the cable was laid in May. On land, the cable is buried 3 ft deep in bog and rock, and traverses many ponds; some data on temperatures under similar conditions in other parts of the world were available.

For planning purposes it was clear that the assumptions made would have to be somewhat pessimistic, and the assumed ranges of temperature, with the corresponding changes of attenuation at 552 kc/s, were:

Sea section	2.3 ± 3°C; ± 4 dB
Land section	7.5 ± 10°C; ± 3 dB

A possible method of circuit adjustment for temperature changes is to increase the gains equally at the sending and receiving terminals as the temperature rises and to reduce them equally as it falls. Under such conditions the effect of temperature variations on resistance noise is not very important; the levels at repeaters near the centre of the route remain substantially constant, and the increase in noise from the repeaters whose operating levels are reduced is partly compensated by the reduction in noise from those whose levels are increased. The effect of the level changes on repeater loading is, however, more important as it is undesirable that any repeater in the link should overload, and additional measures which can be readily adopted to avoid serious changes in repeater levels are clearly desirable.

The estimated change of attenuation of the land sections is seen to be roughly equal to that of the submarine section, so that, from the point of view of temperature changes, Terrenceville is near the electrical centre of the link. It was thus both desirable and convenient to provide adjustment at this point: Fig. 10 illustrates the advantage of seasonal

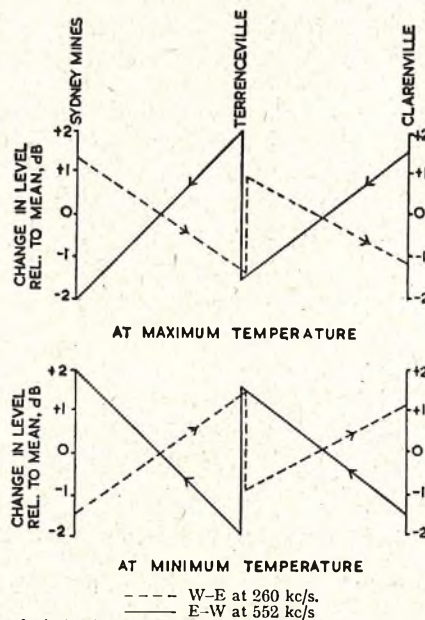

FIG. 10.—DEVIATION FROM MEAN OF TRANSMISSION LEVELS WITH OPTIMUM ADJUSTMENTS OF EQUALIZERS AT SYDNEY MINES, TERRENCEVILLE AND CLARENVILLE.

changes in equalizer setting at Terrenceville, showing the way the output levels of repeaters are likely to vary along the route. The system of temperature compensation adopted therefore involves adjustable networks at both ends of the system and at Terrenceville. All the networks are cable simulators; hence the process of temperature compensation consists, effectively, in adding "cable" when the temperature falls and removing it when the temperature rises.

At Terrenceville, the networks permit of adjustments equivalent to ± 1 n.m. of cable (3 dB at 552 kc/s), but at

Clarenville and Sydney Mines adjustments equivalent to 0.5 dB at 552 kc/s are provided. It should therefore always be possible to maintain the overall loss of the system within ± 0.25 dB, and the level at any repeater should never change by more than ± 2 dB.

System Pilots.

The use of pilot signals applied at constant level at the input of a system with indicating or alarm meters at the receiving end is standard on land systems on both sides of the Atlantic, although the philosophies underlying the methods of use differ. On the submarine cables round the British Isles, with or without submerged repeaters, pilot signals are used to indicate the attenuation of the transmission path; these pilots are normally located just outside the main transmission bands in each direction. In the Clarenville-Sydney Mines system the frequency bands just outside the main transmission bands are occupied by telephone speaker and teleprinter circuits and by monitoring frequencies associated with the repeaters (see Fig. 5); this prevents the use of out-of-band pilots.

Fortunately, the standard Bell System group equipment is designed to apply 92-kc/s pilots to each group and to measure the corresponding received level. Although these are essentially group pilots, being applied and measured at points in the 60-108-kc/s band, it was decided that they could reasonably replace the out-of-band pilots. These pilots are blocked at each end of the system and therefore function as section pilots only.

Normal Post Office practice, both on land and submarine systems, is to use recording level meters to provide a continuous and permanent record of the pilot levels. In the present system such recording meters are used on the 92-kc/s pilots of two groups in each direction of transmission.

In addition to the section pilots the system carries the 84.080-kc/s end-to-end pilots in each of the three transatlantic groups.

MAINTENANCE FACILITIES

Speaker and Printer Circuits.

It was part of the planning of the transatlantic system that two low-grade telephone (speaker) and two telegraph (printer) circuits should be provided over the submarine cables, outside the main transmission bands, and that the speaker circuits in particular should be reasonably independent of the main terminal equipment. One speaker circuit is required for local communication between the terminals of each section, the other to form part of an omnibus circuit connecting the principal stations on the route, including Montreal. The arrangement for teleprinter communication was that one channel should be an overall all-station omnibus circuit, the other being a direct London-New York circuit.

Independent frequency-translating equipment is provided to connect the speaker and teleprinter bands (each 4 kc/s) to the line. The carrier frequencies required for the speaker are provided by independent oven-controlled crystal oscillators, but for the printer circuits the independent generation of high-stability 572-kc/s carriers was not considered to be justified and the main station supplies are used.

Two half-bandwidth telephone circuits are provided in the 4-kc/s speaker bands by the use of standard A.T. & T. band-splitting equipment (EB banks). Signalling and telephone equipment are provided to give the required omnibus facilities on one circuit and local-calling facilities on the other. The arrangement of the speaker and printer equipment at Sydney Mines is shown in Fig. 11.

In the telegraph band a third channel transmits an alarm to the remote terminal when the 92-kc/s pilots incoming from that terminal fail simultaneously.

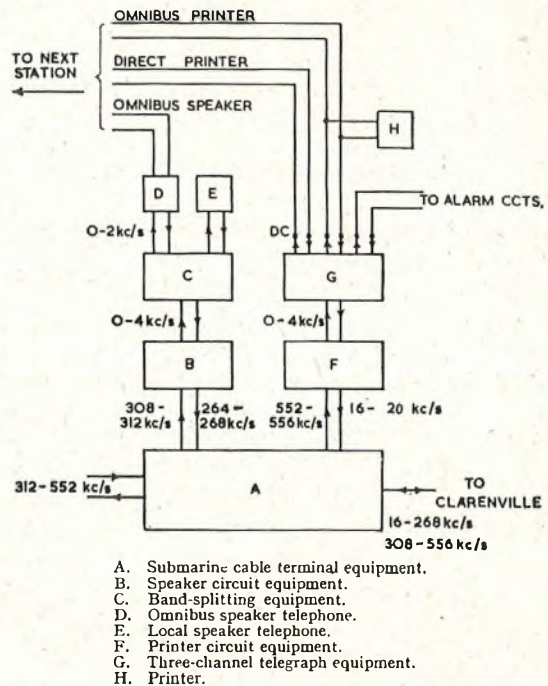

FIG. 11.—ARRANGEMENT OF SPEAKER AND PRINTER EQUIPMENT AT SYDNEY MINES.

Fault Location.

The speedy and accurate location of faults in repeated cables is of very great importance, owing to the number of circuits involved and the difficulty and cost of repairs. The standard d.c. methods which have been applied in the past to long telegraph cables are, of course, available. The application of these methods is, however, recognized as being rather more in the nature of an art than a science and usually requires an intimate knowledge of the behaviour and peculiarities of the particular cable concerned. While the problem appears at first sight to be simple it is complicated by:

- (a) The presence of earth-potential differences along the cable, sometimes amounting to hundreds of volts; these vary with time.
 - (b) Electrolytic e.m.f. generated when the centre conductor is exposed to sea water.
 - (c) Absorption effects in the dielectric of the cable.
- When repeaters are added, the position is further complicated by:
- (d) The lumped resistance of the repeaters, which is current-dependent and exceeds the cable resistance.
 - (e) The lumped capacitance of the repeaters with an absorption characteristic which differs from that of the cable.

It is a great advantage of both-way transmission over one cable that, by introducing some form of frequency changer at each repeater, signals outgoing in one direction can be looped back to the sending terminal. There have been a number of developments based on this principle, and in the Clarenville-Sydney Mines link two methods are available for use. Of these, the so-called "loop-gain" method uses steady signals and depends on selective frequency measurements to discriminate between repeaters; the second is a pulse method in which repeaters are identified on the basis of loop transmission time.

The use of these methods under fault conditions depends on the possibility of keeping the repeaters energized. Work is in progress to develop methods of fault location which are of general application and do not depend on the activity of the repeaters, but these are outside the scope of the present paper.

Loop-gain method.—In the loop-gain method, the frequency changer in the repeater takes the form of a frequency doubler and each repeater is identified uniquely by one of a group of frequencies spaced at 120 c/s and located immediately above the lower main transmission band in the frequency range 260–264 kc/s. Since the frequency changing is in an upward sense, the measuring terminal is Sydney Mines, which transmits the lower band. On the Clarendville side of the directional filters in each repeater is connected, via series resistors, a crystal filter accepting the test frequency appropriate to the repeater (see Fig. 12(a)); this frequency is doubled, filtered and returned to the repeater at the same point at which the original frequency is selected. From this point it passes via the high-pass directional filters through the amplifier and back to Sydney Mines, where the level is measured on a transmission measuring set. Information obtained in this way on each repeater

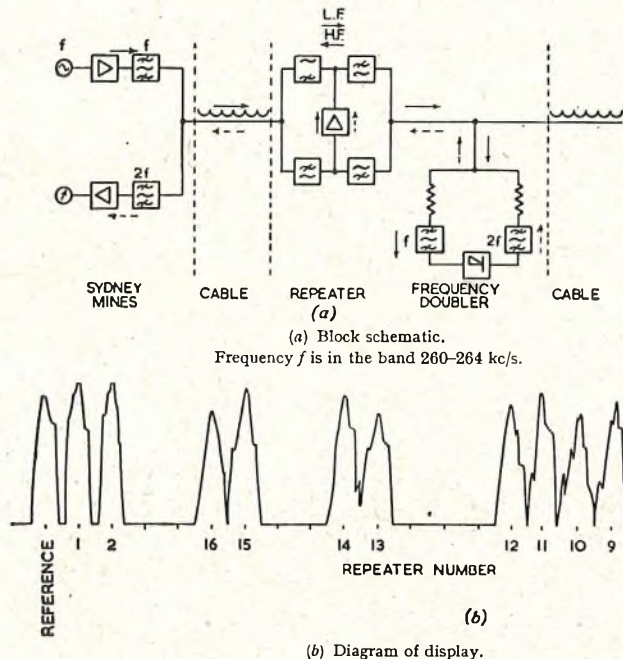

FIG. 12.—FAULT LOCATION: LOOP-GAIN METHOD.

can be compared at any time with that obtained when the system was installed and any gain variations localized. The test equipment provided has the additional facility of an automatic sweep of the test frequency at 4 c/s and a display of the returned-signal levels on a cathode-ray tube as in Fig. 12(b).

Although the transmitted signals lie outside the band of the W-E supergroup, the received signals, 520–528 kc/s, lie within the band of the E-W supergroup, and two channels must be removed from traffic to carry out the tests; these channels are in a "local" group.

Pulse method.—As applied to the present system, the pulse method utilizes the overload characteristic of the amplifier to effect the frequency change in the repeater. At Sydney Mines a continuous train of single-frequency pulses is applied in the lower transmission band, such that either the second or third harmonic is returned in the upper band, as in Fig. 13; at Clarendville two-frequency pulses are applied in the upper band such that either a second-order or third-order difference product is returned in the lower band. The pulse length is 0.15 ms, and the frequencies used are given in Table 1. At Sydney Mines the signals can be sent and received either on the line itself or via the group equipment; in the latter case only one group need be taken out of service. At Clarendville line measurements only are provided for.

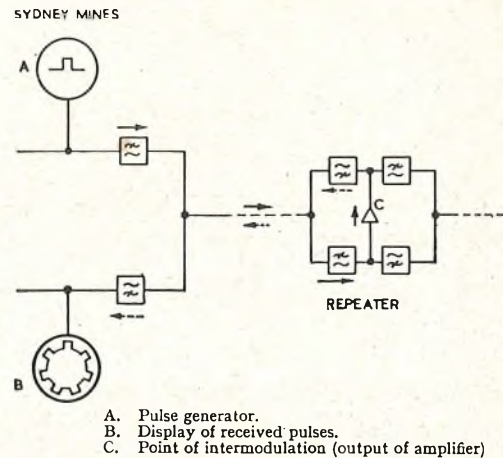

FIG. 13.—FAULT LOCATION: PULSE METHOD.

TABLE 1

Station	Send to line		Product	Receive
	f_1	f_2		
Sydney Mines	kc/s 216 144	kc/s — —	$2f_1$ $3f_1$	kc/s 432 432
Clarendville	530 530	380 340	$f_1 - f_2$ $2f_2 - f_1$	150 150

The primary display is on a cathode-ray tube with a circular time-base, and any one returned pulse can be accurately compared with the reference pulse on a second tube with a linear time-base. The pulse selected for such measurement is automatically blacked out on the primary display.

Usefulness of the loop-gain and pulse methods.—Both methods require that all the repeaters between the testing terminal and the fault can be energized. If the fault is in the cable there is a very high probability that the centre conductor will be exposed to the sea, in

which case the power circuit can be maintained on one side of the fault at least, although it may be somewhat noisy. Since it is permissible to energize the link fully from one end only, the condition can never arise—as it can in the Oban-Clarendville link—that the line current is limited by the maximum permissible terminal voltage.

The loop-gain test is concerned with the amplifiers in their linear regime and gives no indication of the overload point; for this the pulse test must be used. On the other hand, the pulse test does not permit of accurate measurement of levels, since the pulse level reaching a particular repeater may be restricted by the overload of an earlier repeater in the chain. The pulse test is particularly useful in providing a check that both sides of each amplifier are in operation and in locating a fault of this type.

Each method depends for its operation on non-linearity at a point within each repeater and can only identify a fault as lying between two such consecutive points in the link. It is therefore desirable that these points should be as close as possible to the terminals of the repeater in order to ensure that the faulty unit can be identified. In this respect the loop-gain test has the advantage over the pulse test.

EXECUTION OF WORK

Problems due to the remoteness of the site were overcome without undue difficulty with the co-operation of the other

parties concerned in the project, but the present paper would be incomplete without a brief reference to the cable- and repeater-laying operations in Newfoundland and at sea.

The terrain and conditions in Newfoundland were quite unlike those with which the British Post Office normally has to contend, involving trenching and cabling through bog, rock and ponds in country of which no detailed survey or maps were available. Maps were constructed from aerial survey, and alternative routes were explored on foot before a final choice was made. As much use as possible was made of water sections in the sea, river estuary and ponds; some 22 miles were accounted for in this way, leaving about 41 miles to be trenched by machine or blasted. A contractor was engaged for this purpose and to lay the cable in the trench, but all jointing was done by the Post Office. The standards of conductor and core jointing were the same as those in the cable factories and on ship, portable injection-moulding machines and X-ray equipment being specially designed for handling over the bog. A light single-pair cable was also laid in the main cable trench to provide speaker facilities between Clarenville and Terrenceville (which has no public telephone), with intermediate positions for use of the lineman. As a measure of protection against lightning strikes, two bare copper wires were buried about 12 in. apart and 6 in. above the cable. Both the constructional work in Newfoundland⁴ and the laying operation at sea⁵ have been described elsewhere.

TEST RESULTS

In the interval between the completion of the link in May, 1956, and its incorporation in the transatlantic system, tests were carried out to establish its performance and day-to-day variations; an assessment of the annual variations has, of course, been impossible at this date.

Variation of Transmission Loss.

Close observation of the transmission loss of the 92-kc/s pilots on Groups 1 and 5 leads to the following tentative conclusions:

- Over periods of 1 hour the variations are not measurable, i.e. less than ± 0.05 dB.
- Over periods of 24 hours there are no systematic changes; apparently random changes of about 0.1 dB are probably attributable to the measuring equipment.
- Over a period of eight weeks (July and August, 1956) there was a systematic increase in loss of about 0.3 dB. By means of the loop-gain equipment it has been possible to deduce that most of this change has occurred in the land section.

The results indicate that the submarine cable link has better day-to-day stability than the best testing equipment

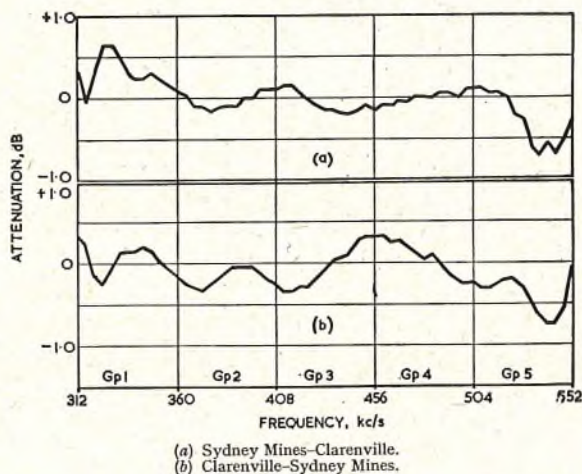

FIG. 14.—ATTENUATION/FREQUENCY CHARACTERISTICS OF SUPER-GROUP.

which it has been possible to provide. Many more data will clearly be necessary before the annual variations can be definitely established, but the present indications are that these will be less than those assumed in the design of the link.

Attenuation/Frequency Characteristics.

The frequency characteristics of the supergroup in the two directions of transmission are shown in Fig. 14. It will be seen that in no transatlantic group does the deviation from mean exceed ± 0.35 dB.

Circuit Noise.

Table 2 shows the noise level on Channels 1 and 12 of each of the five groups, measured without traffic on the system.

TABLE 2

Group	Channel	Noise level	
		Sydney Mines	Clarenville
		dBa	dBa
1	1	25.0	24.5
1	12	24.5	23.2
2	1	24.0	22.5
2	12	23.5	22.0
3	1	24.0	20.5
3	12	25.0	17.5
4	1	24.5	17.5
4	12	24.5	16.5
5	1	24.5	17.5
5	12	27.0	18.0

To assess the magnitude of intermodulation noise, all channels in one direction were loaded simultaneously with white noise and measurements taken on each channel in the opposite direction. From the talker volume data assumed in the design of the system, the expected mean talker power is -11.1 dBm at a point of zero relative level, with an activity of 25 per cent. For an equivalent system loading, therefore, the level of white noise applied to each channel under the above test conditions should be -14.1 dBm. Since this loading gave no sensible increase in the circuit noise, the test levels were raised until a reasonable increase in the noise level was obtained. In order to raise the channel noise to the specified maximum of 28 dBa it was necessary to raise the channel levels to about -1 dBm and -4 dBm in the lower and upper bands respectively. These levels, some 13 dB and 10 dB above the assumed maximum loading of the system, give noise levels at least 26 dB and 20 dB above normal, and it is seen that adequate margins exist for variations and deterioration of the link.

Closely allied to the problem of intermodulation is the overload characteristic of the system. Table 3 shows the measured overload point of the link expressed as an equivalent level at the output of the amplifier in the repeater nearest to the transmitting terminal. It also shows the margin between the channel level at that point and the overload point of the system; according to Holbrook and Dixon¹³ the minimum requirement in this respect is 18 dB.

TABLE 3

Frequency	Equivalent at amplifier in first repeater		
	Channel level	Overload	Margin
kc/s	dB	dB	dB
552	-2	+20	22
312	-4	+24	28
260	-5	+25	30
20	-5	+25	30

The above results justify the assumption made in the design of the link, that intermodulation noise is negligible.

Crosstalk.

The crosstalk requirements are met in all respects.

CONCLUSIONS

The submarine-cable link between Clarenville, Newfoundland, and Sydney Mines, Nova Scotia, was completed in May, 1956, and provides five carrier telephone groups, each capable of carrying 12 high-grade telephone circuits or their equivalent. The transmission objectives have been met in every respect.

Three 12-circuit groups are connected to the three groups across the Atlantic between Scotland and Newfoundland; the other two groups are available to provide 24 circuits between Newfoundland and the mainland of Canada.

ACKNOWLEDGMENTS

It has been the authors' privilege to present an integrated account of the work of many of their colleagues in the Post Office and in industry. Post Office staff have been responsible for designs and for inspection and testing at home and in the field, as well as the laying of the submarine-cable system by H.M.T.S. *Monarch*. In Great Britain, Submarine Cables, Ltd., and the Southern United Telephone Co., Ltd., provided the submarine and overland cables respectively, while Standard Telephones & Cables, Ltd., supplied and contributed much to the design of the submerged repeaters and terminal equipment. On site, the assistance rendered by the Ordnance Survey of Great Britain, the Canadian Comstock Co., Ltd., who laid the cable across Newfoundland, the Northern Electric Co., Ltd., who carried out the terminal equipment installations, and by the other partners in the project, the American Telephone & Telegraph Co.,

Inc., the Canadian Overseas Telecommunication Corporation and the Eastern Telephone & Telegraph Co., has been invaluable.

References

- ¹ "Transatlantic Cable Construction and Maintenance Contract," 27th November, 1953.
- ² MOTTRAM, E. T., HALSEY, R. J., EMLING, J. W., and GRIFFITH, R. G. Transatlantic Telephone Cable System—Planning and Overall Performance. (In this issue of the *P.O.E.E.J.*)
- ³ KELLY, M. J., RADLEY, SIR GORDON, GILMAN, G. W., and HALSEY, R. J. A Transatlantic Telephone Cable. *Proceedings I.E.E.*, Paper No. 1741, Sept., 1954 (Vol. 102, Part B, p. 117).
- ⁴ ROBINSON, H. E., and ASH, B. Transatlantic Telephone Cable—The Overland Cable in Newfoundland. *P.O.E.E.J.*, Vol. 49, pp. 1 and 110, Apr. and July 1956.
- ⁵ JACK, J. S., LEECH, W. H., and LEWIS, H. A. Route Selection and Cable Laying for the Transatlantic Cable System. (In this issue of the *P.O.E.E.J.*)
- ⁶ AFFEL, H. A., GORTON, W. S., and CHESNUT, R. W. A New Key West-Havana Carrier Telephone Cable. *Bell System Technical Journal*, Vol. 11, p. 197, 1932.
- ⁷ HALSEY, R. J., and WRIGHT, F. C. Submerged Telephone Repeaters for Shallow Water. *Proceedings I.E.E.*, Paper No. 1633, Feb., 1954 (Vol. 101, Part I, p. 167).
- ⁸ HALSEY, R. J. Modern Submarine Cable Telephony and the Use of Submerged Repeaters. *Journal I.E.E.*, Vol. 91, Part III, p. 218, 1944.
- ⁹ LEBERT, A. W., FISCHER, H. B., and BISKEBORN, M. C. Cable Design and Manufacture for the Transatlantic Submarine Cable System. (In this issue of the *P.O.E.E.J.*)
- ¹⁰ BROCKBANK, R. A., WALKER, D. C., and WELSBY, V. G. Repeater Design for the Newfoundland-Nova Scotia Link. (In this issue of the *P.O.E.E.J.*)
- ¹¹ METSON, G. H., RICKARD, E. F., and HEWLETT, F. M. Some Experiments on the Breakdown of Heater-Cathode Insulation in Oxide-Coated Receiving Valves. *Proceedings I.E.E.*, Paper No. 1857, Sept., 1955 (Vol. 102, Part B, p. 678).
- ¹² THOMAS, J. F. P., and KELLY, R. Power-Feed System for the Newfoundland-Nova Scotia Link. (In this issue of the *P.O.E.E.J.*)
- ¹³ HOLBROOK, B. D., and DIXON, J. T. Load Rating Theory for Multi-Channel Amplifiers. *Bell System Technical Journal*, Vol. 18, p. 624, 1939.

Repeater Design for the Newfoundland-Nova Scotia Link*

R. A. BROCKBANK, Ph.D., B.Sc.(Eng.), A.M.I.E.E.,
D. C. WALKER, B.Sc.(Eng.), A.M.I.E.E., and
V. G. WELSBY, Ph.D., B.Sc.(Eng.), A.M.I.E.E.†

U.D.C. 621.395.641

The Newfoundland-Nova Scotia link required the provision of 16 submerged repeaters, each transmitting 60 circuits in the bands 20–260 kc/s from Nova Scotia to Newfoundland and 312–552 kc/s in the opposite direction. This paper deals with the design and production of these repeaters. Each repeater has a gain of 60 dB at 552 kc/s and the amplifier consists of two forward amplifying paths with a common feedback network. Reliability is of paramount importance, and production was carried out in an air-conditioned building with meticulous attention to cleanliness and to very rigid manufacturing and testing specifications. The electrical unit is contained in a rigid pressure housing 9 ft long and 10 in. in diameter with the sea cables connected to an armour clamp and a cable gland at each end. A submerged equalizer was provided near the middle of the sea crossing.

INTRODUCTION

THE British Post Office has engineered many shallow-water submerged-repeater systems,¹ and there has been a progressive improvement in design techniques and in the reliability of components, which has been reflected in a growing confidence in the ability to provide long-distance systems having an economic life. The seven-repeater scheme from Scotland to Norway laid in 1954 introduced for the first time repeaters which would withstand the deepest ocean pressure together with an electrical circuit which embodied improved safety and fault-localizing devices. Also, since a repeater is only as reliable as its weakest component, much greater attention and control was directed at this stage to the design, manufacture and inspection of all components, both electrical and mechanical. This repeater design was, in fact, envisaged as a prototype for a future transatlantic project.

In the finalized plans² for the Newfoundland-Nova Scotia cable it was required to carry 60 circuits, so that some redesign of the 36-circuit "prototype" repeater became essential. It was accepted, however, as a guiding principle throughout the redesign that there should be no departure from previous practice without serious consideration and adequate justification. It was obviously not an occasion to experiment with new ideas.

Post Office and Bell Telephone Laboratories experiences were pooled for the project, and the whole technical resources of both organizations were freely available at all times for consultative purposes. Detailed manufacturing and testing specifications were exchanged and approved, and each party was free to inspect the other's production methods. This mutual interchange was undoubtedly highly beneficial, and in the British case it resulted in a still more rigorous control of manufacturing and inspection methods.

PLANNING

General.

Preliminary design calculations indicated that it should be possible to increase the circuit-carrying capacity of the Anglo-Norwegian prototype repeater from 36 to 60 circuits, and tests on a model confirmed that, with frequency bands of 20–264 and 312–552 kc/s, a 60.0-dB gain at 552 kc/s could be realized with satisfactory margins against noise, distortion and overload. This gain fixed the repeater spacing at about 20.0 n.m., so that on the selected route two repeaters would be required on the land section between Clarenville and Terrenceville and 14 in the Terrenceville-Sydney Mines sea section. It was noted that the land repeaters might have to work with an ambient temperature 12°C higher than in the sea repeaters.

Each repeater would need to be energized with a direct current of 316 mA at 124V so that the total route voltage would be about 2,300V. This voltage would be quite acceptable to the repeaters, but for normal operation it was proposed² to feed from both terminals simultaneously, thereby halving the maximum voltage to earth.³

The precise localization of any faulty or ageing repeater would be of paramount importance. It was decided to retain the two supervisory methods which on the prototype had worked satisfactorily in this respect. These consisted of a pulse-distortion equipment requiring no additional components in the repeater, and a loop-gain monitoring set involving a special unit in the repeater and the allocation of a 4-kc/s band (260–264 kc/s) for its operation.

Manufacture and testing of the electrical units was to be carried out by a contractor in a temperature- and humidity-controlled production building, and in order to enable manufacture to start as early as possible, arrangements were made for the contractor to co-operate with the Post Office at an early design stage so that engineering could follow fast on the heels of the design. The outer housing and method of brazing-in the bulkheads had both proved entirely satisfactory on the prototype, and therefore these operations could proceed according to previous production. The Post Office assumed responsibility for the production and testing of the glands, since no contractor had experience of this work.

Forward planning in early 1954 scheduled the first electrical unit to be completed in June, 1955, with units following at five-day intervals. This target was, in fact, delayed until August, 1955, but all 16 working repeaters were available, fully tested, before the commencement of the laying operation in May, 1956.

Distortion Monitoring Equipment.

The pulsed-carrier supervisory method used on previous systems¹ is employed primarily for measuring the distortion on repeaters. Under normal operating conditions the distortion level may be only just noticeable above the noise, but should appreciable distortion occur, e.g. failure of one amplifying path in a repeater, it could be readily located, since the pulse amplitude from the faulty repeater would increase by about 12 dB for second-harmonic distortion and about 18 dB for third-order distortion.

Loop-Gain Monitoring Equipment.

For the loop-gain monitoring equipment¹ the repeaters have to be designed to incorporate a second-harmonic generator operating at a frequency unique to each repeater at 120-c/s spacing in the 260–264-kc/s band. The second harmonics return to Sydney Mines in the 520–528-kc/s band, and two channels must be taken out of service during the measurement.

Levels and Equalization.

Controlling factors.—In practice, deviations from an ideal system wherein all repeaters match the cable and operate at all times at the same levels require the repeaters to be designed with specific margins against overload and intermodulation to meet an agreed maximum noise figure for the system under all working conditions.² Factors involved in assessing these margins and in planning the equalization and level diagram for the system are as follows:

† The authors are with the British Post Office.

(a) Temperature.—The final assumed sea-bottom temperature was 2.3°C , with a maximum annual variation of $\pm 3^{\circ}\text{C}$. The maximum change in attenuation might therefore be ± 4 dB at 552 kc/s. The land section change would be ± 3 dB at 552 kc/s due to a possible $\pm 10^{\circ}\text{C}$ change on a mean of 7.5°C . The effect of these seasonal changes would be reduced by the provision of manually adjusted equalization at Clarenville, Terrenceville and Sydney Mines.

The repeaters show a small change in gain (less than 0.05 dB) during the warming-up period after energization, but the effect of ambient-temperature change is negligible.

(b) Repeater spacing.—The repeater-section cable lengths were to be cut in the cable factory so that the expected attenuation at 552 kc/s, when laid at the presumed mean annual temperature of the location, should be 60.0 dB. An anticipated decrease in attenuation of 1.42 per cent at 552 kc/s was assumed when laid. The assumed mean annual temperature of sections of the route varied between 1.7 and 4.0°C . Temperature corrections employed an attenuation coefficient at 552 kc/s of $+0.16$ per cent per degree centigrade. It was expected that the total error at 552 kc/s, after laying seven repeaters, would not exceed 1.5 dB, and this could be largely corrected as explained in (c).

(c) Cable characteristics.—The cable equalization built into the repeater was based on a cable attenuation characteristic that was later discovered to be appreciably different from the laid characteristic. Cutting the cable as described in (b) overcomes this difficulty at 552 kc/s, where the signal/noise ratio is at a minimum. The new shape of the characteristic, however, indicated that at about 100 kc/s the error would reach 7 dB on the complete route. To reduce this deviation it was decided to introduce a submerged equalizer in the middle of the sea section to correct for half this error and to insert in each of the 4-wire paths of the transmit and receive equipments equalization for one-quarter of this error. There is an appreciable signal/noise margin in hand at this frequency, so that the system would not be degraded below noise specification by these equalizer networks.

It was also decided that the splice at the equalizer which would connect the halves of the link together should not be completed until after the laying operation had commenced. An excess length of cable was provided on the equalizer tail, and this could be cut, at a position indicated by measurements taken during the laying of the first half-section, so that the equalization at the 552-kc/s point could be largely corrected for laying and temperature-coefficient errors. It is not, in practice, easy to separate these two factors.

(d) Repeater characteristic.—The repeater was designed to equalize the original cable-attenuation characteristic to ± 0.2 dB, as this was possible with a reasonable number of components. This variation appeared as a roll in the gain/frequency characteristic, which was expected to be systematic and would therefore lead to a ± 3 -dB roll in the overall response. It was proposed that equalization for this should be provided at the receive terminal. Manufacturing tolerances were expected to be small and random.

(e) Repeater interaction.—At the lower frequencies where the loss in a repeater section is comparatively small, a roll in the overall frequency response will arise due to changes in the interaction loss between repeaters. The design aimed at providing a loop loss

greater than 50 dB which would reduce rolls to less than ± 0.03 dB per repeater section and therefore to about 0.5 dB at 20 kc/s with systematic addition on the whole route.

Planning of levels.—From a critical examination of all these variables it was concluded that the repeater should be designed to have an overload margin of 4 dB above the nominal mean annual temperature condition. It was also desirable for the system to be able to operate within its noise allowance if one path of a twin amplifier failed. Tests on a model amplifier gave overload values of $+24$ dBm \ddagger and $+19$ dBm for two-path and one-path operation, respectively, so that with a single-tone overload requirement of $+18$ dBm \S at a zero-level point, the maximum channel level at the amplifier output would be -3 dBm \S for a single amplifying path.

Thermal-noise considerations (i.e. resistance plus valve noise) fixed the minimum channel level at the repeater input at -69 dBm in order to meet the allowable noise limit of $+28$ dBm \parallel at a zero-level point. At 552 kc/s the amplifier gain is 65 dB, so that the minimum level at the amplifier output is -4 dBm. A system slope of ± 4 dB due to temperature variations, corrected by similar networks at the transmit and receive terminals, would, however, degrade the noise by 0.5 dB. Intermodulation noise was estimated \S on an average busy-hour basis, and it was concluded that the increase in noise at 552 kc/s from this source was negligible—less than 1 dB, even with several repeaters in which the amplifier had failed on one path. At lower frequencies the contribution from intermodulation noise is greater, and at 20 kc/s it exceeds resistance noise. However, at 20 kc/s the total noise is some 8 dB below the specification limit, and therefore again several amplifiers could fail on one path before the noise exceeded the specification limit. Actually it was discovered that the predominant source of third-order intermodulation on the repeater was in the nickel-iron/ceramic seals on high-voltage capacitors and followed a square law with input levels.

From a more detailed examination of the factors briefly mentioned above it was decided that the initial line-up should be based on a nominal flat -3.5 -dBm point at the amplifier output and the final working levels decided upon as the results of tests on the completed link.

With equal loading on the grid of the output valve at all frequencies the worst signal/noise ratio exists at 552 kc/s; some pre-emphasis of the transmit signal should therefore prove to be beneficial. In fact, after completing the tests on the link it was decided to improve the margin on noise by raising the level at 552 kc/s by 2 dB, thus giving a sloping level response at the amplifier output in the h.f. band. To maintain the same total power loading the l.f. band levels were decreased by 1 dB, still retaining a flat response.

Laying.

It was proposed to use laying methods with continuous testing similar to those employed successfully on the Anglo-Norwegian project. The complete link with a temporary

\ddagger dBm—decibels relative to 1 mW.

\S dBm—relative level; i.e. the ratio, in decibels, of the power at a point in a line to the power at the origin of the circuit (usually the 2-wire point).

\parallel dBm—this refers to the reading on a Bell System 2B Noise Meter (F1A weighting network); the noise level (dBm) is relative to a 1-kc/s tone at -85 dBm. In Europe, noise is measured on a C.C.I.F. psophometer (1951 weighting network), which is calibrated in millivolts across 600 ohms; this is commonly converted to picowatts (pW). The white-noise equivalence of the two instruments is given by $\text{dBm} = 10 \log_{10} \text{pW} - 6 = \text{dBm} + 84$; the agreed limit of $+28$ dBm is therefore equivalent to 2,513 pW (1.23 mV). The corresponding C.C.I.F. requirement at 4.0 pW/km would be 2,400 pW, this value not to be exceeded for more than 1 per cent of the time.

splice at the equalizer would be assembled and tested on board H.M.T.S. *Monarch* and laying would proceed from Terrenceville to Sydney Mines in the high-frequency direction of transmission. A detailed description of the actual laying operation is given elsewhere.⁶ After completion of tests on the submarine section the land section to Clarenville would be connected with appropriate equalization at Terrenceville.

DESIGN OF ELECTRICAL UNIT OF SUBMERGED REPEATER General.

The electrical equipment is contained in a hermetically sealed brass cylinder (filled with dry nitrogen) $7\frac{3}{4}$ in. in diameter and 50 in. long, which is bolted at one end to one of the bulkheads of the housing. A flexible coaxial cable

emerges through an O-ring seal at each end, and these are ultimately jointed to the cable glands. The various units forming the complete electrical unit are mounted within a framework of Perspex (polymethyl-methacrylate) bars which forms the main insulation of the repeater, and these units may operate at 3 kV d.c. to the earthed brass cylinder. Fig. 1 shows the construction.

A schematic diagram of the electrical circuit is given in Fig. 2. The direct current for energizing the repeater is separated from the carrier-transmission signals by the A- and B-end power-separating filters, and passes through the amplifier valve heaters and a chain of resistors which develops the 90V h.t. supply for the amplifier. The carrier-frequency signals pass through the same amplifier via directional filters. Equalization is provided in the amplifier feedback circuit (about 20 dB) and in the equalizers and the bridge networks which combine the directional filters. The main purpose of the bridges, however, is to reduce the severe harmonic requirement on the directional filters due to having high- and low-level signals present at the repeater terminals. The whole carrier circuit is designed on a nominal impedance of 55 ohms.

Attached to the B-end of the repeater is the loop-gain supervisory unit and also, via a high-voltage fuse, a moisture-detector unit used primarily during the high-pressure test to confirm that the housing is free from leaks. The latter comprises a series-resonant circuit at about 1.3 Mc/s, in which the inductance is varied by the gas pressure on an aneroid

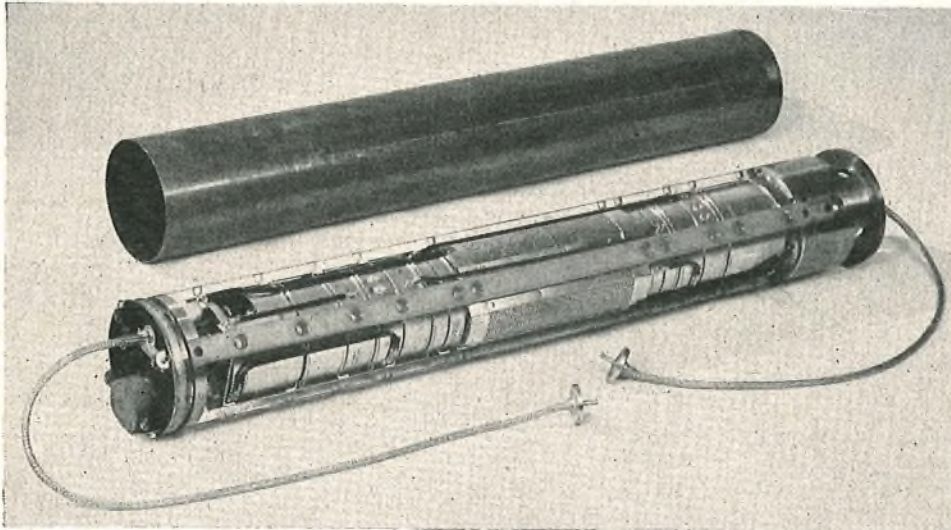

FIG. 1.—INTERNAL UNIT OF SUBMERGED REPEATER.

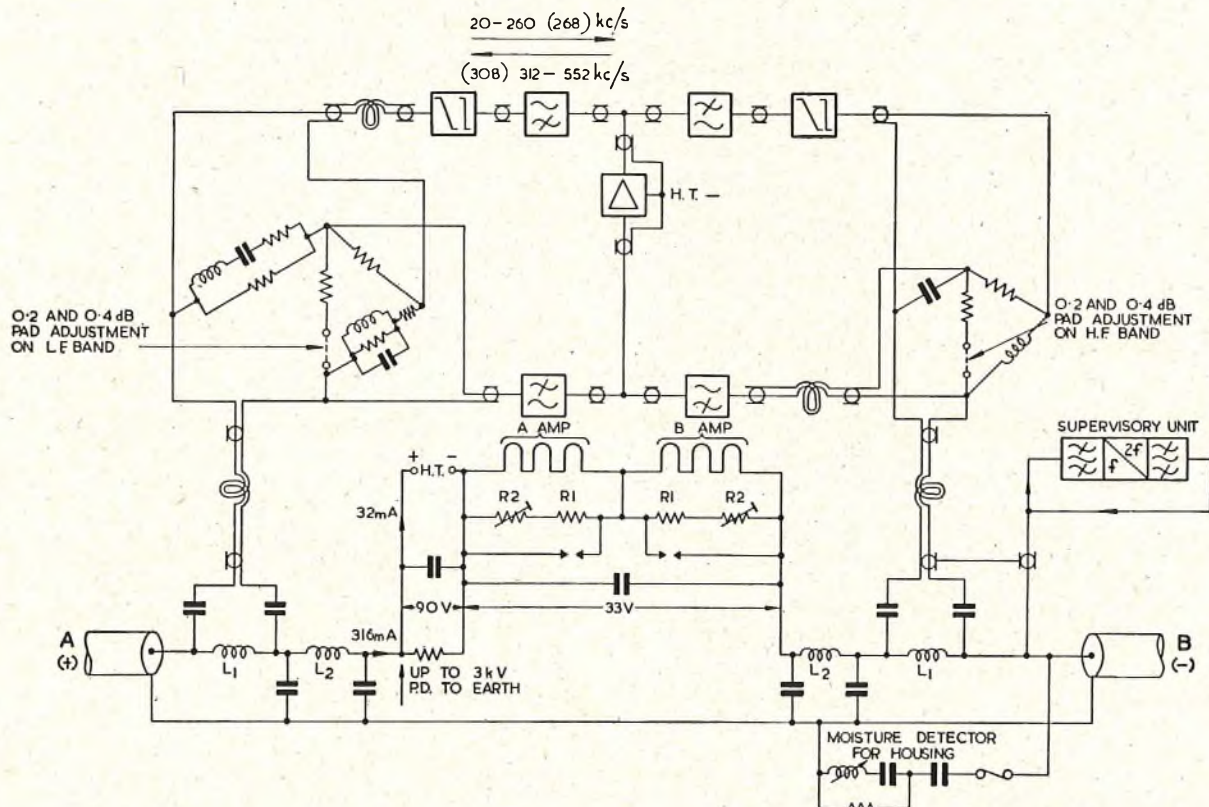

FIG. 2.—SCHEMATIC DIAGRAM OF SUBMERGED REPEATER.

capsule mounted in the space between the electrical unit and the housing. The presence of moisture in this cavity increases the gas pressure owing to the release of hydrogen by the reaction of water vapour with metallic calcium held in a special container. At a later stage the fuse is blown to disconnect this circuit.

The circuit design of the repeater introduces multiple shunt paths across the amplifier, and care has to be taken to ensure that there is adequate attenuation in each path. In general, the design is such that the combination will give a loop loss of at least 40 dB in the working band (to reduce rolls in the gain characteristic) and 20 dB at all frequencies (as a guard against instability) even when one repeater terminal is open- or short-circuited to simulate a faulty cable.

Unit Details.

Power filter.—The power filters are, in effect, a series pair of high-pass and low-pass filters (see Fig. 2). The shunt capacitors may have to withstand 3 kV, and clearances on the input cable and some wiring have to be adequate for this voltage. The inductors have to carry the line current of 316 mA d.c., and the intermodulation must be extremely low (referred to again later when discussing electrical components, inductors).

Directional filter.—The directional filters are a conventional Zobel high-pass and low-pass filter pair with a susceptance-annulling network. Silvered-mica capacitors and carbonyl-iron dust-cored inductors are used. The bridges combining the "go" and "return" filters reduce the distortion due to the ferromagnetic material to an acceptable level.

Bridge and equalizer.—A simple non-resonant bridge is used at the B-end of the repeater, but the A-end bridge is a resonant type and provides a substantial degree of equalization (see Fig. 2).

The equalizers are of conventional form. Trimming capacitors (selected on test) were provided for critical capacitances in order to utilize standard tolerances on all capacitors. Pads of 0.2 dB and 0.4 dB are provided on each equalizer unit so that the repeater low-frequency or high-frequency path can be independently trimmed to give the best match to the target response for the repeater.

The components in the above circuit were small air-cored inductors, silvered-mica capacitors, and wire-wound resistors, except for a few high-resistance ones, which were of the carbon-rod type. Included in this unit are coaxial chokes whose purpose is to separate parts of the circuit to avoid the effect of multiple earthing. They are merely inductors wound with coaxial wire on 2-mil Permalloy C tape ring cores.

Supervisory unit.—The supervisory unit comprises a frequency-selection crystal filter of about 100-c/s bandwidth in the range 260–264 kc/s fed from the low-frequency output end of the repeater via a series resistor. This filter feeds a full-wave germanium point-contact crystal-rectifier bridge which acts as a frequency doubler. The second harmonic in the band 520–528 kc/s is filtered out by a coil-capacitor band-pass filter, and fed back through a resistor to the same point in the repeater. The two series resistors minimize the bridging loss of the unit on the repeater and ensure that a faulty supervisory component has negligible effect on the normal working of the repeater.

D.C. path.—The d.c. path includes a resistor providing the 90V h.t. supply and the heater chain of six valves (see Fig. 2). The voltage drop across the heater chain is not utilized for the amplifier h.t. supply, as the heaters would then be at a positive potential with respect to the cathodes, thereby increasing the risk of breakdown of heater-cathode insulation. There would also be a complication in main-

taining the constant heater current, particularly should the h.t. supply current fail in one path of the amplifier. The normal amplifier h.t. supply current is 32 mA.

It is essential to maintain a d.c. path through the repeater even under fault conditions in order that fault-location methods can be applied. Special care has therefore been taken to provide parallel paths capable of withstanding the full line current. For example, the h.t. resistor actually consists of a parallel-series combination of 10 resistors, and the whole assembly is supported on Sintox (a sintered alumina) blocks which maintain a good insulation at 3-kV d.c. even at high temperatures.

Valve operation for consistent long life indicates the necessity to maintain a specific constant cathode temperature, and to achieve this, valves are grouped according to heater characteristics into six heater-current groups between 259 and 274 mA and stabilized to ± 1 per cent. The appropriate heater-shunt resistor is applied so that the valve operates correctly with 316 mA line current, but for convenience the shunt is taken across each set of three valves, all in one heater group, forming one amplifier path. R1 is fixed (300 ohms) and R2 is selected to suit the valves. R1 is the resistance winding of a special short-circuiting fuse (described later when discussing electrical components); when energized by the full line current should a heater become open-circuited, it causes a permanent direct short-circuit across the heater chain. The line voltage will be temporarily increased by about 95V while the fuse operates (1 min) and will then drop to 12V below normal.

Amplifier.—The amplifier circuit is shown in Fig. 3. It consists of two 3-stage amplifiers connected in parallel between common input and output transformers with a single feedback network. This circuit arrangement allows one amplifier path to fail without appreciably affecting the gain of the complete amplifier (less than 0.1 dB for all faults except those on the grid of V1 and the anode of V3), but the overload point is reduced by about 5 dB and distortion at a given output level is increased (about 12 dB for second harmonics). Care has been taken to ensure that the open- or short-circuiting of a component in one amplifier path will not affect the performance, life or stability of the remaining path, and this involves the duplication of certain components.

Mixed feedback is employed to produce the required output impedance; the current feedback is obtained from the resistor feeding the h.t. supply to the output transformer, and the voltage feedback is developed across a two-turn winding on the output transformer, which also serves as a screen. The output of the feedback network is fed in series with the input signal to the grid of V1. The gain response of the amplifier is chiefly controlled by the series-arm components in the feedback network, which resonate at 600 kc/s.

The input transformer is built out as a filter and steps up in impedance from 55 ohms to 17,000 ohms. Protective impedances minimize the effect of a short-circuit on the grid of one of the first-stage valves. The anode load of the first-stage resonates at 600 kc/s, and is roughly the inverse of the feedback network so as to give constant feedback loop gain over the working frequency band. The output valve has about 5.5 dB of feedback from its cathode resistor, and the pair of output valves feed the output transformer, which steps down from 5,000 ohms to 55 ohms.

Specially designed long-life valves are used.⁷ The first two stages are operated at about 40V on the screens and anodes; each anode current is 3 mA, giving a mutual conductance of 5.1 mA/V. The output stage is operated at 60V on the screen, + 15V on the suppressor grid to sharpen the knee of the V_a/I_a characteristic, and nearly the full h.t. supply of 90V on the anode; the anode current is 6 mA, giving a mutual conductance of 6.6 mA/V. The valve dynamic

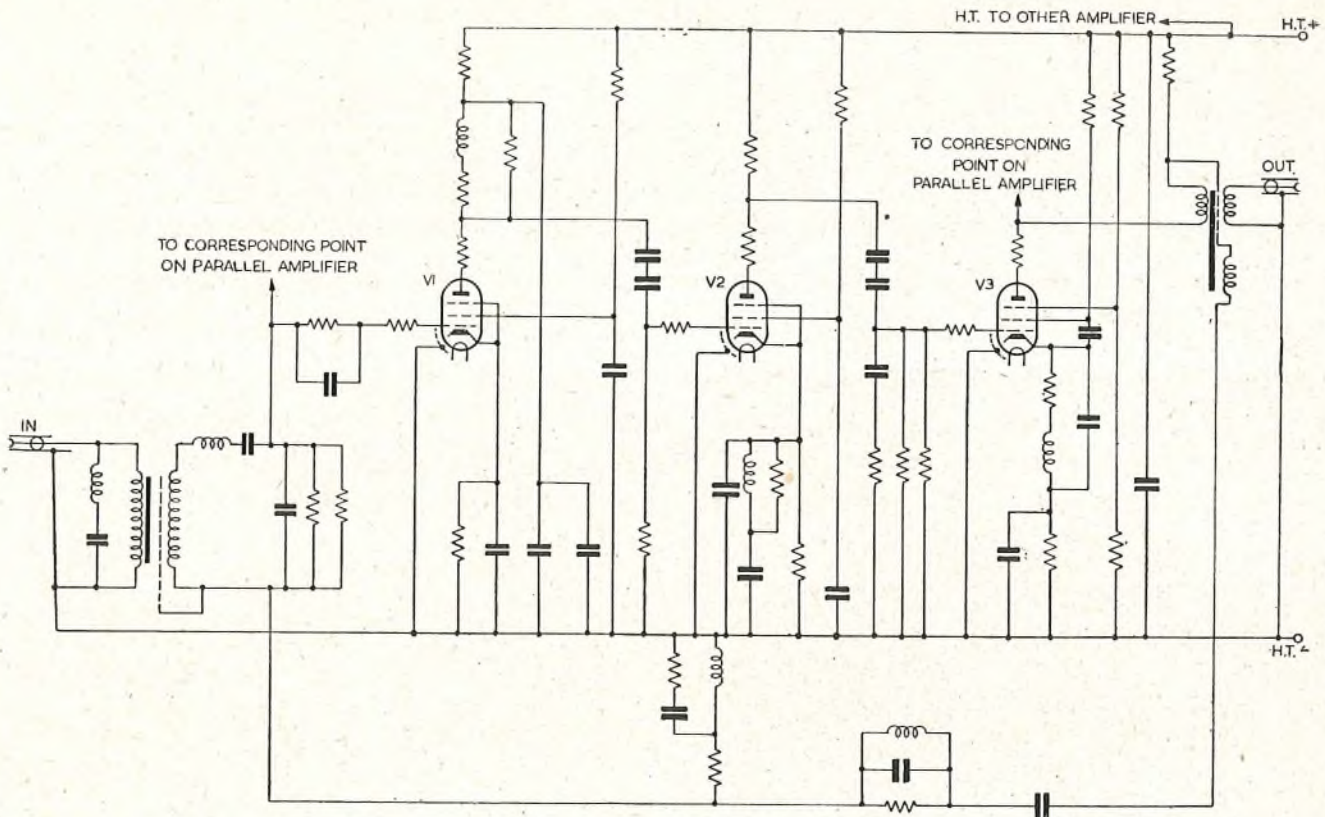

FIG. 3.—AMPLIFIER CIRCUIT.

impedance is approximately 300,000 ohms. To obtain an anode current nearest to the design value (and for which the valves are aged), one of two values of bias resistance can be selected for V1 and V2, and one of three values of bias resistance for V3.

All capacitors subject to the h.t. supply voltage are of the oil-filled paper type, and the others are of the silvered-mica type. Inductors are air-cored spools which are multi-sectioned when used in high-impedance circuits. All resistors are of the solid carbon-rod type, except for the input-transformer termination, which consists of two high-stability cracked-carbon resistors, and those in the feedback network, which are wire-wound.

The input and output transformers employ 2-mil Permalloy C laminations, and the latter core is gapped on account of the polarizing current. A narrow Perspex spool fits the centre limb, and conventional layer windings are used; the screen is a sandwich made of copper foil with adhesive polythene tape.

Mechanical Design Details.

The general arrangement can be seen from Fig. 1. At the A-end is a cast-brass pot containing the resistors providing the amplifier h.t. supply, and as this is bolted directly on to the housing bulkhead, the heat generated is readily conducted away. The remainder of the units are in cylindrical cans mounted in the insulating framework formed by four Perspex bars. These are sprayed with copper on both faces to guarantee the d.c. potential on these surfaces and eliminate the risk of ionization at working voltages. The cans are not hermetically sealed but are dried out with the repeater when it is finally sealed and filled with dry nitrogen. Perforated covers on the amplifier allow air circulation to reduce the ambient temperature.

Fig. 4 shows a typical can assembly, and Fig. 5 the construction of the amplifier. It will be seen that the latter is a double-shelved structure with valves alternating in direction, and an amplifier path is located on each side of the

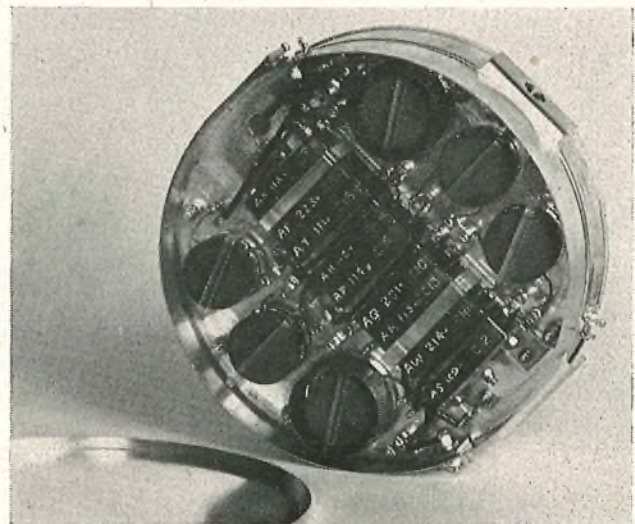

High-pass filter with low-pass filter can on rear.

FIG. 4.—DIRECTIONAL FILTER UNIT.

chassis; the input and output transformers are at opposite ends, and the feedback network is contained in a hermetically sealed can in the centre of the unit (Fig. 6).

All cans are finished with a gold flash which is inert and gives a clean appearance stimulating a high standard of workmanship. Tin plating was formerly used, but it has been shown that tin tends to grow metallic whiskers.⁸ Unfortunately certain capacitor cans had to be tin plated, and extra precautions consisting of wide clearances or protective shields have had to be taken. The risks from growth on soldered surfaces is not thought to be great, as all solders used have less tin content than the eutectic alloy. All connecting wires are gold plated instead of the usual tin plating.

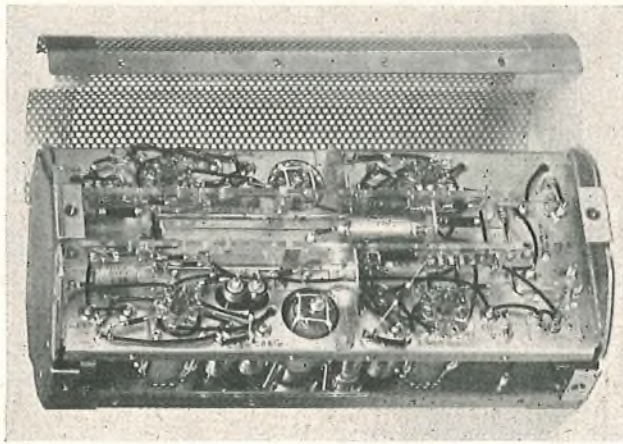

FIG. 5.—AMPLIFIER.

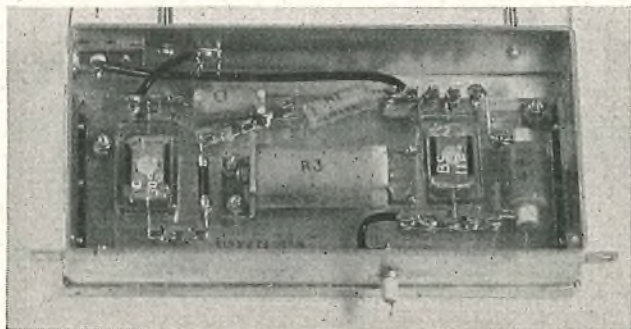

FIG. 6.—FEEDBACK UNIT OF AMPLIFIER.

The insulating sub-panels in units are usually made of Perspex, but where the items are subjected to high temperatures (e.g. resistance box), Sintox, a sintered alumina ceramic, or Micalox is used.

Polytetrafluoroethylene (p.t.f.e.) is another insulant used, and p.t.f.e.-covered wire threaded through copper tube forms the coaxial interconnecting leads between the can units.

Careful attention is paid to the mounting of components. Small resistors, etc., are supported by soldering to tags which are the appropriate distances apart, and multi-limb tags are employed to minimize the number of soldered joints. Where it is essential to solder more than one wire per limb on a tag, they must be soldered at the same time. Larger components are clamped. Valves are mounted in a holder so as to facilitate preliminary testing with "standard valves," and they have a sprung nylon retainer; the final electrical connection is made by soldering on to an extension of the wire leading through the pins.

DESIGN OF INTERNAL UNIT OF SUBMERGED EQUALIZER

The submerged equalizer corrects for the difference between the assumed design cable characteristic and the subsequently determined laid characteristic for equal attenuation lengths at 552 kc/s. It also absorbs the loss of 9 n.m. of cable and has an attenuation of 26.0 dB at 552 kc/s.

The construction is identical with the submerged repeater except for the replacement of all can assemblies,

other than the power filters, by the equalizer cans. Fig. 7 is a schematic diagram of the unit.

ELECTRICAL COMPONENTS

General.

The components used in the repeaters were either designed specially for submerged repeaters or were standard items with improvements. There are approximately 300 components in each repeater of which 110 are in the amplifier. Rigorous control of manufacture and meticulous inspection is imperative to ensure a consistent long-life product, and cleanliness is essential at all stages. In some cases "belt and braces" techniques can be effectively employed, e.g. by using double connexions. Over 1,500 separate soft-soldered connexions are involved in the complete assembly. Much work has been done on components, but only a brief indication can be included here. A range of typical components appears in Fig. 4-6.

Resistors.

Resistors fall into the following categories:

- (a) Power resistors used solely for d.c. purposes (e.g. resistors providing the amplifier h.t. supply). These are wire-wound vitreous-enamelled resistors on Sintox ceramic formers. Nichrome terminal leads are used, and all connexions are brazed.
- (b) H.F. resistors whose tolerance is not close, and often carrying direct current but of low power (e.g. anode load resistances). A modification of a standard carbon-rod resistor is used. The ends of the rod are copper plated and the end caps and terminal leads are soldered on. The tolerance is normally ± 5 per cent, and the maximum rating permitted is about one-quarter of the commercial rating.
- (c) Precise h.f. resistors of resistance below 1,000 ohms (e.g. feedback components). Here wire-wound spool resistors are suitable, and bifilar or reverse layer windings with Lewmex enamel and silk-covered wire are used.
- (d) Precise h.f. resistors of high resistance. For terminating the input transformer a resistance of 17,000 ohms is required. Because it is not possible to make a suitable wire-wound resistor, high-stability cracked-carbon film resistors are used, but to minimize the effect of a disconnexion two are used in parallel.

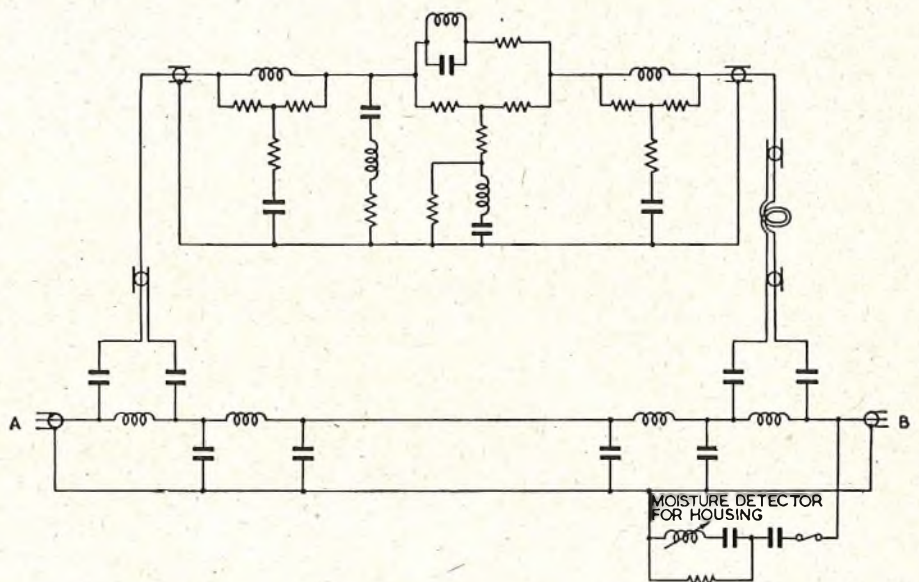

FIG. 7.—SCHEMATIC DIAGRAM OF SUBMERGED EQUALIZER.

Inductors.

The majority of inductors used in the amplifier and equalizer do not require a high Q -factor. They are wound on air-cored ceramic bobbins of four types, and the high-inductance ones are sectionalized. In general, solid wire with Lewmex enamel and double-silk covering is used for the amplifier inductors, and stranded wire for the equalizer inductors.

A high Q -factor inductor is essential in the directional filters, and a carbonyl-iron pot core is used; the Q -factor is about 250 at 300 kc/s. Precise adjustment and stability of inductance is obtained by setting the gap between the halves of the pot core with a cement of Araldite (an epoxy resin) and titanium dioxide. A Perspex former is used.

Special inductors are required in the power filters to take the 316-mA d.c. line current. A wave-wound air-cored coil is used for the carrier-path filter (L_1 in Fig. 2), and a toroid on an a.f. Permalloy dust-core ring for the low-pass filter (L_2 in Fig. 2). Solid wire, with Lewmex and double-silk covering, is used to keep the d.c. resistance to a minimum.

Capacitors.

Capacitors are divided into three categories:

- (a) Those subjected to the full line voltage, which may operate at up to 3 kV.
- (b) Those subjected to the amplifier h.t. supply of 90V.
- (c) Those which have negligible polarization (less than 10V), and which are often required to precise values.

Groups (a) and (b) are of the oil-filled paper type, with, respectively, four layers of 36-micron and three layers of 7-micron kraft paper. The oil is a mineral type loaded with 18 per cent resin, and the capacitors are filled at 60°C and sealed at room temperature.

Small capacitors and those of precise value as in group (c) are silvered-mica capacitors. These are encased in an epoxy resin to give mechanical protection and a seal against moisture. Visual inspection of all mica plates is made before and after silvering, and any with cracks, inclusions, stains or any other abnormality are rejected. Mica is a very variable material, and at times the percentage rejects were high, but probably many of the reasons for rejection would not have been significant as far as the life of the capacitor is concerned. However, experience has shown that even with stringent precautions mica is not an entirely satisfactory dielectric material.

Other Components.

Valves form the subject of a separate paper.⁷ Of the other miscellaneous components used, one of interest is the short-circuiting fuse across the valve heaters. It is constructed like a normal wire-wound resistor on a Sintox tube former, but inside are two cupped copper electrodes filled with a low-melting-point eutectic alloy. If the full line current (316 mA) is passed through the winding, owing to a heater disconnection, the heat generated is sufficient to melt the alloy, which then fuses the two electrodes together. The winding is thus short-circuited, and a permanent connexion is left between the electrodes.

General.

DESIGN OF HOUSING AND GLAND

Although the maximum depth of water in which British rigid-type repeaters were laid did not exceed about 250

fathoms, the housings used for these repeaters were generally of a type designed for use at ocean depths, and when connected into the cable they were amply strong enough to transmit stresses up to the breaking point of any of the cables used.

The part of the housing which is sealed against water pressure consists essentially of a hollow cylinder, machined from hot-drawn steel tube, and closed at both ends by steel bulkheads carrying the cable glands through which the connexions are made to the electrical unit (see Fig. 8). The latter is bolted rigidly to the inner face of the A-end bulkhead. The steel blanks used for the main cylinder and the bulkheads are tested with an ultrasonic crack detector, and after machining they are further subjected to magnetic crack-detection tests.

Each gland has a brass cover which completes the coaxial transmission path and contains a weak solid mixture of polythene and polyisobutylene (p.i.b.). Outside the brass cover is a larger chamber closed by a flexible polyvinylchloride (p.v.c.) diaphragm and containing p.i.b.—a viscous liquid—which prevents sea water coming into

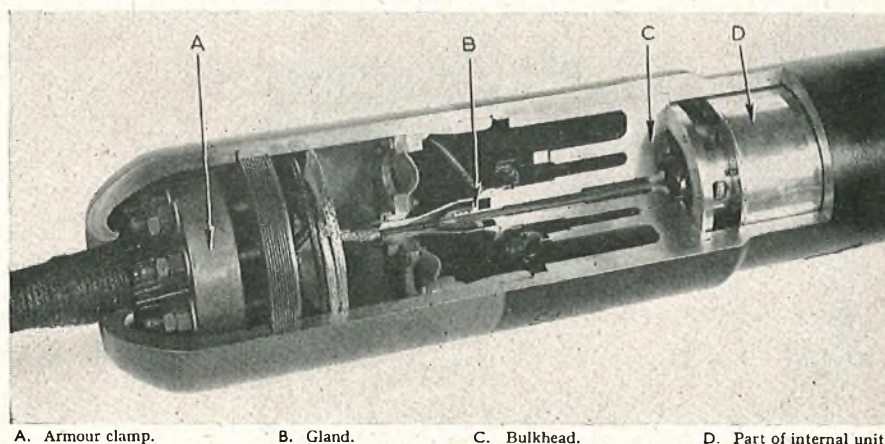

FIG. 8.—DETAILS OF HOUSING CONSTRUCTION.

direct contact with the bulkhead seal and the gland assembly.

Cylindrical extension pieces, screwed on to the main casing, contain the clamps for attaching the repeater housing to the armour wires of the sea cable, and the housing is completed by dome-shaped end covers. Two external annular ridges near the centre of the housing accommodate the special quick-release clamp used for handling the repeater during the laying operation.

Protection against corrosion is provided by shot-blasting the surface and then applying hot-sprayed zinc to a thickness of 0.010 in., followed by two coats of vinyl paint. The A-end of the repeater is finished red. The dimensions of the complete repeater are 8 ft 11 $\frac{3}{8}$ in. \times 10 $\frac{1}{2}$ in. diameter, and its weight is 1,150 lb in air.

Sealing of Housing.

The bulkheads, which register on seatings designed to withstand the axial thrust due to the water pressure, are in the form of discs with extended skirts. A watertight and diffusion-proof seal is formed between the casing and the outer skirt of each bulkhead by a silver-soldering process, using carefully controlled electromagnetic induction heating to raise the jointing region to the required temperature. The diametral clearance between the cylinder and the locating surface of the bulkhead is 0.003 \pm 0.002 in., the diameter of the bulkhead being reduced by 0.004 in. for an axial distance of 3 in. from the rim of the skirt to provide a recess into which the molten solder can flow.

The solder is applied as eight pre-formed No. 16 s.w.g. wire rings which are fitted into place cold and coated with a paste formed by mixing flux powder with dehydrated ethyl alcohol. The generator used for heating has a nominal output of 50 kW at a frequency of about 350 kc/s and is capable of raising the temperature of the jointing region to 750°C in 5 min. The temperature, as indicated by four thermocouples inserted in special holes drilled in the ends of the casing, is maintained at 750°C for a period of 45 min to allow ample time for the entrapped gas and flux pockets to float to the surface. Fig. 9 shows the arrangement for soldering in a bulkhead.

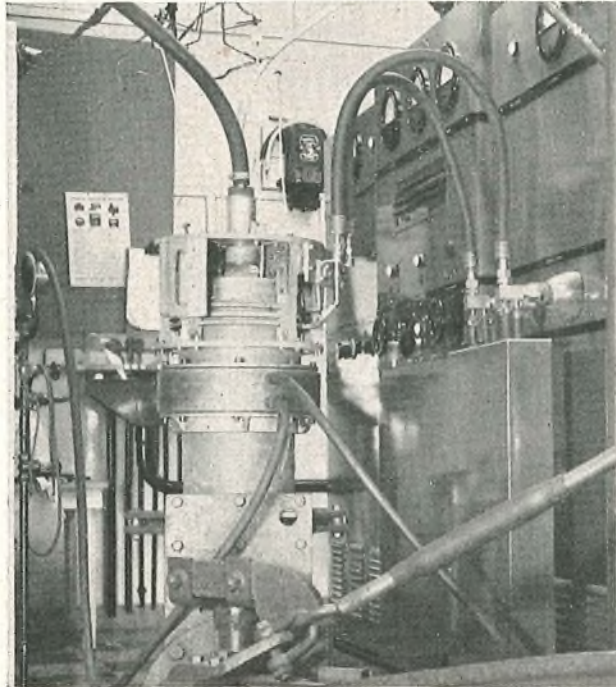

FIG. 9.—SILVER-SOLDERING OF BULKHEAD INTO HOUSING, USING AN INDUCTION HEATER.

The primary object of the outer skirt is to keep the heated region far enough away from the base to prevent the temperature of the latter rising unduly. Temporary water jackets are also clamped over the gland and around the outside of the casing during the sealing operation. A subsidiary skirt on each bulkhead contains a vent hole which serves to allow displaced air to escape as the bulkheads are inserted into the casing. These vents are later used to apply a low-pressure gas-leak test to the bulkhead seals and then to flush the housing with dry nitrogen to remove any trapped moisture. The vents are finally sealed. At this stage the sealed housing is pressure-tested in water at $1\frac{1}{2}$ tons $\frac{1}{2}$ /in² for a period of seven days, a moisture detector, previously described, being used to check that no leakage occurs.

Glands.

The deep-sea gland was developed from the castellated gland which has been used successfully for a number of years in shallow-water repeaters. The basic principle of this gland is very simple and is shown in Fig. 10; the polythene-insulated cable core passes right through the bulkhead, and the initial seal is formed by the contraction, during cooling, of polythene moulded on to the core and enclosing a steel stem, having a castellated profile, which forms part of the bulkhead. Each side of the castellation

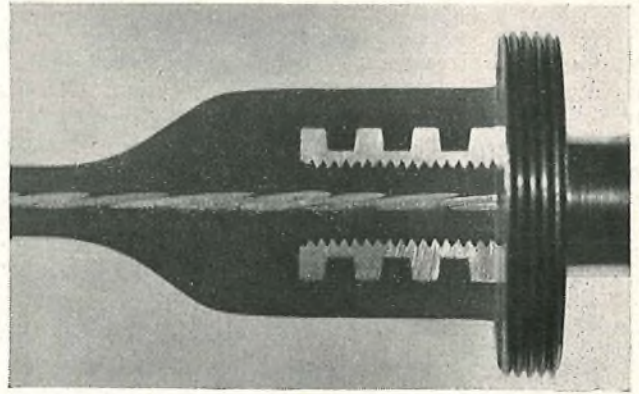

FIG. 10.—SECTION OF HIGH-PRESSURE GLAND.

has a taper of about 7°. The application of water pressure increases the contact pressure between the polythene and the stem, thus making the gland inherently self-sealing. As an additional safeguard, the gland stem is first prepared by a lead plating and anodizing process, followed by the application of a thin film of polythene which forms a chemical bond to the plated surface. The injected polythene merges with this film, thus bonding the moulded portion to the castellated stem. Tests on sample glands, using a radioactive tracer, have shown no measurable (less than 0.001 mg) water diffusion at a pressure of 5 tons $\frac{1}{2}$ /in² over a period of 6 months.

Intrusion of the polythene into the housing, at hydraulic pressures up to at least 6 tons $\frac{1}{2}$ /in², is eliminated by the use of a small-diameter core and by the provision of a screw thread in the hole through which the core passes. During the moulding operation a corresponding thread is formed on the polythene core itself. This method of construction distributes the axial force over a sufficiently wide area to prevent any appreciable creep of the polythene.

The completed gland assemblies were all subjected to a minute X-ray examination, followed by a pressure test at 5 tons $\frac{1}{2}$ /in² for three months. Whilst under pressure, the glands had to withstand a voltage test of 40 kV d.c. for 1 min, to show no ionization effects when a voltage of 3 kV (r.m.s.) at 50 c/s was applied and to have an insulation resistance greater than 20×10^{12} ohms.

MANUFACTURE

General.

The manufacture of the electrical units was carried out in accommodation specifically designed for submerged-repeater production. Temperature was controlled at 68°F and the relative humidity was less than 20 per cent in the component shops and 40 per cent in the assembly and test shops. Filtered air forced into the building maintained a slight positive pressure with respect to the outside and eliminated the ingress of dust. With the exception of the valves and some resistors all components were manufactured in this "dairy" (Fig. 11). Operators were specially selected, and they had to change into clean protective clothing in an ante-room before entering the working area, where no smoking or eating was permitted. All operators were particularly encouraged to report or reject any condition which was abnormal or in which they had not complete confidence. Rigorous inspection and testing was carried out by the contractor at all stages, and a Post Office team collaborated with "floor" inspection and the examination and approval of test results.

The Electrical Unit.

The components, after the most careful examination and testing, which in some cases included an ageing test, were assembled into their cans and then subjected to a

‡ These are long tons. 1 long ton = 2,240 lb.

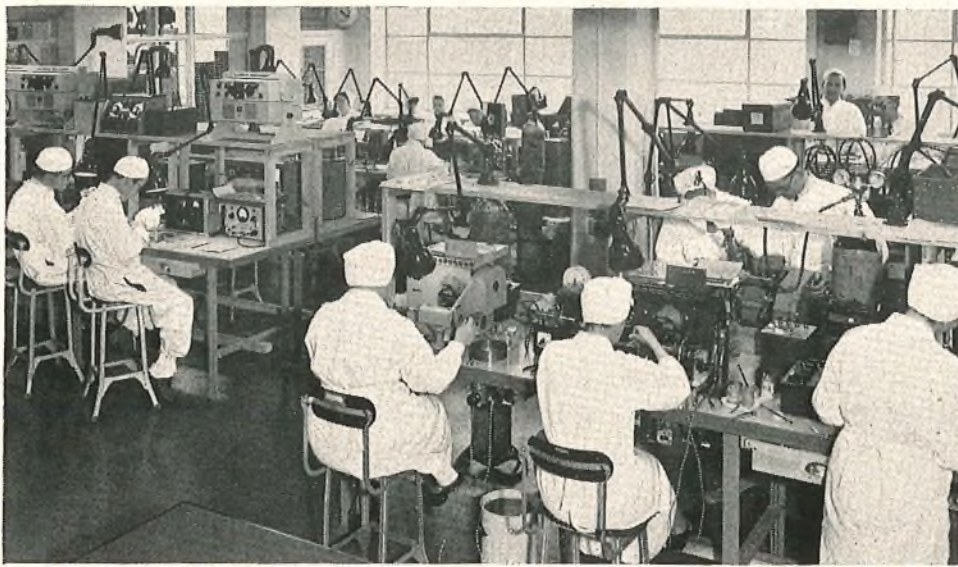

FIG. 11.—COIL PRODUCTION IN THE "DAIRY."

shock test before undergoing detailed electrical characteristic tests. Initial tests on the amplifier were done with a set of "standard" valves, which were later replaced by the final valves for the complete tests. The cans were then assembled in a repeater chassis and the electrical tests required before sealing were performed—these included a gain response to determine the best settings for the trimmer pads in each transmission band. After fitting and sealing the outer brass case, dry nitrogen was blown through the unit for 24 hours and the gas holes then sealed. The overall electrical characteristics were then taken, the repeater was energized for a two weeks' "confidence trial" and the characteristics were rechecked. During the "confidence trial" the gain was continuously monitored on a recorder (duplicated to distinguish between test equipment and repeater variations) on which changes in gain of 0.01 dB were clearly indicated. On satisfactory completion of these tests the unit was ready for housing.

Assembly of Electrical Unit in Housing.

The first step was to complete the moulded joint between the tail cables from the A-end of the electrical unit and the low-pressure side of the appropriate bulkhead. This joint was X-rayed and proof tested at 20 kV d.c. for 1 min. The electrical unit was then bolted to the bulkhead, the slack tail cable being correctly coiled into the recess provided, and the whole assembly was lowered into the housing for the first silver-soldering operation. Following this sealing the tail cable joint was made to the B-end bulkhead, which was then lowered into the housing and sealed.

A leak test was then made by applying an internal air pressure of 5 lb/in² (gauge) and observing the surface when wetted with a solution of a suitable detergent in water. After flushing with dry nitrogen the vents were sealed and the housing was pressure tested. Finally the brass gland covers were fitted and filled with compound, the extension pieces were screwed on, the flexible diaphragms were fitted and the internal space was filled with polyisobutylene. The housing was then ready for further electrical testing.

Tests on Complete Repeater.

After housing, the repeaters were submerged in a tank of water for a three-month electrical "confidence trial." Before and after the trial the complete characteristics were checked and the noise was monitored on both terminals; during the first and last few weeks of the trial the gain was monitored on recorders in both directions. Owing to the insertion and withdrawal of repeaters in the power circuit from time to time, the repeaters were subjected to several power-switching operations and temperature cycles.

Stability of electrical characteristics, particularly gain, between the pre-housing tests and the completion of the "confidence trial" some four months later was regarded as an important criterion of the reliability of a repeater.

Unfortunately test conditions and differences between, and stability of, the testing equipments reduced the accuracy originally expected, but even so, changes of over 0.1 dB were regarded as significant.

Connexion of Repeaters to Cable.

On board the cable ship the cable ends were prepared by making tapered moulded joints to 0.310-in. tail cable, sliding the domed ends of the repeater up the cable and forming the armour wires round the armour clamps. The tapered joint included a castellated ferrule on the centre conductor, which, operating on the principle of the main gland, acts as a barrier against the possible passage of water down the centre conductor into the repeater. The final assembly operation consisted of jointing the tail cables, bolting the armour clamps to the repeater housing and screwing on the domed ends. Fig. 12 shows a completed repeater connected to a cable.

PERFORMANCE

The gains and losses of various sections of the repeater are shown in Fig. 13. Fig. 14 and 15 show, respectively, the harmonic distortion and the stability characteristics of the amplifier with one and two paths operating. The total shunt loss across the amplifier is shown in Fig. 16 as a margin above the amplifier gain. The curves show the result with 55-ohm terminations on the repeater and with a short-circuit on each terminal. Fig. 17 shows the production spread in gain of the 16 repeaters for the system as a deviation from the target value. The highest standard deviation (at 260 kc/s) was only 0.11 dB. In all respects the



FIG. 12.—COMPLETED REPEATER.

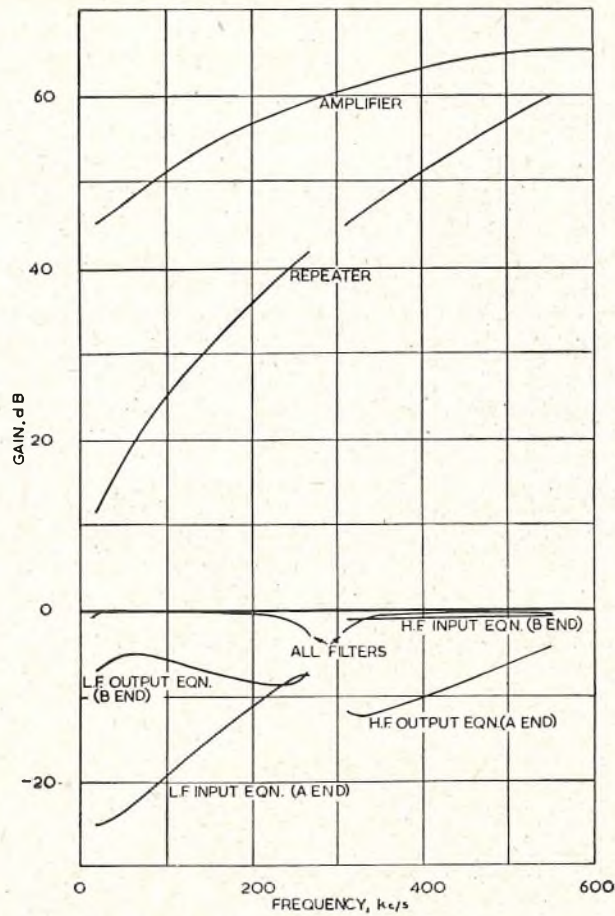

FIG. 13.—REPEATER GAINS AND LOSSES.

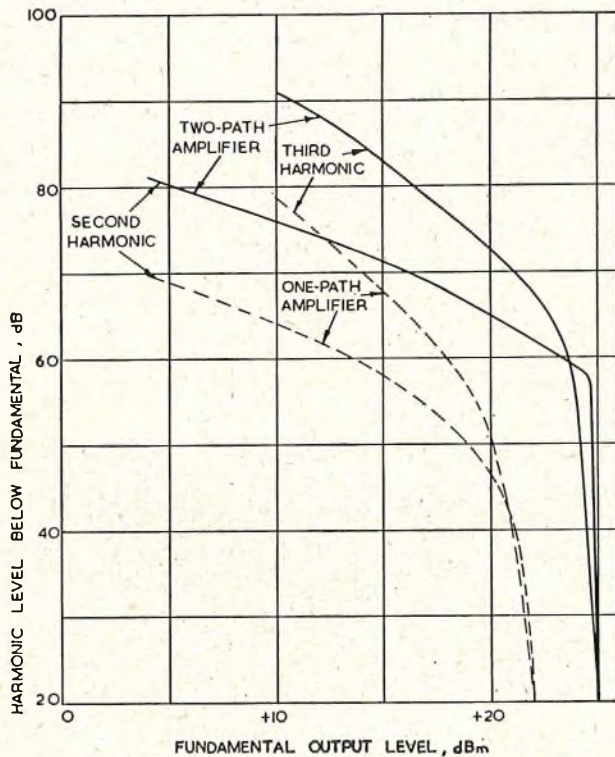

FIG. 14.—AMPLIFIER DISTORTION.

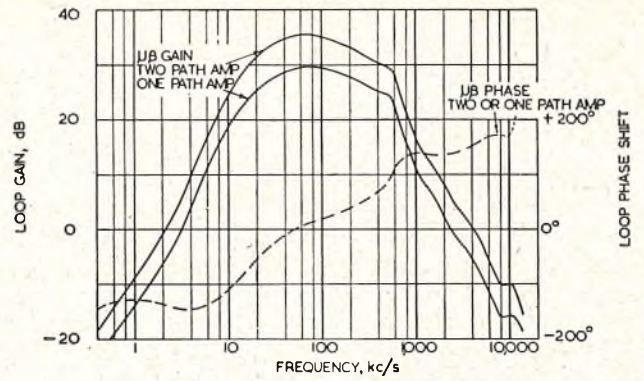

FIG. 15.—AMPLIFIER $\mu\beta$ CHARACTERISTIC.

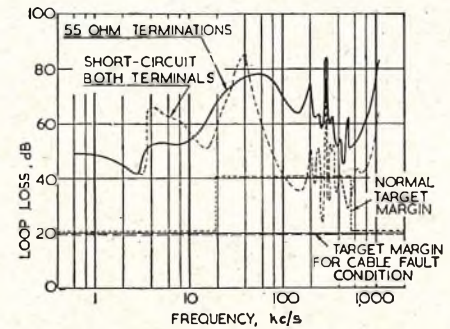

FIG. 16.—REPEATER LOOP LOSS MEASURED AT AMPLIFIER INPUT.

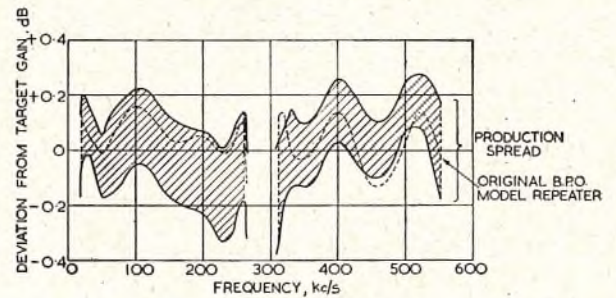

FIG. 17.—REPEATER-GAIN RESPONSE.

production repeaters proved to be very consistent and satisfactory in their performance and differed little from the original laboratory-built model.

Typical electrical characteristics of a repeater and the submerged equalizer are shown in Appendices 1 and 2 respectively.

The characteristics of the completed link are described elsewhere,⁹ but it is of interest to note that the overall tests showed that the link behaved as predicted and met the noise requirement and the design margins.

ACKNOWLEDGMENTS

It will be appreciated that the design and manufacture of these repeaters has been an undertaking of teams rather than of individuals. The authors are very grateful to Standard Telephones & Cables, Ltd., and Submarine Cables, Ltd., for their unsparing efforts to ensure the very highest standards in the engineering, production and testing of these repeaters. Numerous firms have also co-operated in specialized fields, and the authors are very appreciative of their help. The authors also wish to acknowledge the enthusiastic assistance of their many colleagues in the Research Branch of the Post Office in the design and in the supervisory inspection during manufacture.

References

¹ HALSEY, R. J., and WRIGHT, F. C. Submerged Telephone Repeaters for Shallow Water. *Proceedings I.E.E.*, Paper No. 1633, Feb. 1954 (Vol. 101, Part I, p. 167).
 ROCHE, A. H., and ROE, F. O. The Netherlands-Denmark Submerged-Repeater System. *Proceedings I.E.E.*, Paper No. 1635, Feb. 1954 (Vol. 101, Part I, p. 180).
 WALKER, D. C., and THOMAS, J. F. P. The British Post Office Standard Submerged-Repeater System for Shallow-Water Cables, with special mention of the England-Netherlands System. *Proceedings I.E.E.*, Paper No. 1634, Feb. 1954 (Vol. 101, Part I, p. 190).
² KELLY, M. J., RADLEY, SIR GORDON, GILMAN, G. W., and HALSEY, R. J. A Transatlantic Telephone Cable. *Proceedings I.E.E.*, Paper No. 1741, Sept. 1954 (Vol. 102, Part B, p. 117).
³ KELLY, R., and THOMAS, J. F. P. Power-Feed System for the Newfoundland-Nova Scotia Link. (In this issue of the *P.O.E.E.J.*)
⁴ HOLBROOK, B. D., and DIXON, J. T. Load Rating Theory for Multi-Channel Amplifiers. *Bell System Technical Journal*, Vol. 18, p. 624, 1939.
⁵ BROCKBANK, R. A., and WASS, C. A. A. Non-Linear Distortion in Transmission Systems. *Journal I.E.E.*, Vol. 92, Part III, p. 45, 1945.
⁶ JACK, J. S., LEECH, W. H., and LEWIS, H. A. Route Selection and Cable Laying for the Transatlantic Cable System. (In this issue of the *P.O.E.E.J.*)
⁷ McNALLY, J. O., METSON, G. H., VEAZIE, E. A., and HOLMES, M. F. Electron Tubes for the Transatlantic Cable System. (In this issue of the *P.O.E.E.J.*)
⁸ ARNOLD, S. N. Metal Whiskers—a Factor in Design. *Bell System Monograph No. 2338*.
⁹ HALSEY, R. J., and BAMPTON, J. F. System Design for the Newfoundland-Nova Scotia Link. (In this issue of the *P.O.E.E.J.*)

APPENDIX 1

Performance of Typical Submerged Repeater

- (a) Insulation resistance 8,000 megohms (cold).
- (b) D.C. resistance at 20°C.

Current, mA	D.C. resistance, ohms
5	343.0
20	343.2
50	344.2
100	347.9

- (c) Voltage drop at 316 mA 124V.
- (d) Carrier gain (55 ohms) without moisture detector.

Frequency, kc/s	Gain, dB	Frequency, kc/s	Gain, dB
20	11.54	308	44.52
30	13.82	312	44.87
50	17.47	320	45.56
100	25.06	330	46.29
150	30.86	350	47.75
200	35.81	400	51.19
230	38.40	450	54.20
260	40.96	500	57.31
264	41.13	552	60.01
268	40.83		

- (e) Noise level.
 - A terminal (312-552 kc/s) - 59.8 dBm
 - B terminal (20-260 kc/s) - 70.3 dBm

- (f) Harmonic level.
 - 170 kc/s fundamental level at B terminal .. + 10 dBm
 - 340 kc/s second harmonic level at A terminal - 60 dBm
 - 510 kc/s third harmonic level at A terminal .. - 58 dBm

- (g) Supervisory—260-800 kc/s (nominal).

Fundamental level at B terminal, dBm	Second-harmonic level at A terminal, dBm
- 12	- 26
- 2	- 13.8
+ 8	- 3.6

- (h) Moisture detector.
 - Resonant frequency with 30-ft cable tail .. 1,237 kc/s.

- (i) Impedance.

Return loss against 55 ohms

Frequency, kc/s	A-terminal return loss, dB	B-terminal return loss, dB
20	17	8
50	17	13
100	16	15
200	16	4
260	16	4
312	13	21
350	14	14
500	18	16
552	16	25

APPENDIX 2

Performance of Submerged Equalizer

- (a) Insulation resistance 8,000 megohms.
- (b) D.C. resistance at 20°C 9.2 ohms.
- (c) Voltage drop at 316 mA 3.0V.
- (d) Carrier loss (55 ohms)—without moisture detector.

Frequency, kc/s	Loss, dB	Frequency, kc/s	Loss, dB
20	4.28	260	15.90
30	4.23	312	18.26
50	4.87	350	19.96
100	7.47	400	21.75
150	10.35	450	23.16
200	13.04	500	24.55
230	14.52	552	25.97

- (e) Moisture detector.
 - Resonant frequency with 5-ft cable tail .. 1,387 kc/s.

- (f) Impedance.

Return loss against 55 ohms.

Frequency, kc/s	A-terminal return loss, dB	B-terminal return loss, dB
20	35	31
50	19	19
100	25	25
260	34	27
552	30	23

Manufacture of Submerged Repeaters for the Newfoundland–Nova Scotia Link

Special manufacturing arrangements were necessary to reduce to the absolute minimum the risk of failure in service of a submerged repeater due to some cause associated with its manufacture. Part 1 of this article describes the special organization and procedure for the manufacture of the electrical units of the rigid repeaters used in the Newfoundland–Nova Scotia link of the transatlantic telephone cable, and Part 2 describes some of the problems encountered in the manufacture of the pressure-resisting housings and assembly of the repeaters in these housings.

Part 1.—The Electrical Unit

R. A. MEERS, O.B.E., T.D.†

U.D.C. 68:621.375.2:621.315.28

INTRODUCTION

VERY great care was taken to design a submerged repeater that would be as robust and reliable as present knowledge permits, and attention was then directed to the manufacturing problems associated with such a unit. Having produced the optimum design both mechanically and electrically, it was clearly desirable to ensure that the risk of failure due to some cause associated with the manufacture was reduced to the absolute minimum.

Furthermore, since the repeaters could not be adjusted once they had been sealed, it was essential for their performance to be extremely stable and consistent from one repeater to another. This involved close electrical tolerances which were reflected in unusually close mechanical tolerances, and the problems involved were such that the manufacture could not be handled satisfactorily under normal factory conditions.

SPECIAL ORGANIZATION

A special manufacturing organization was therefore set up at the North Woolwich factory of Standard Telephones & Cables, Ltd., and special routines were organized in order to safeguard the product at all stages.

Two special shops were built, both of which were operated under complete air-conditioning, i.e. with clean filtered air, at controlled temperature and humidity, while all personnel working in these shops wore protective clothing.

Every delivery of material (including test gear and process material) to the shops was carefully scrutinized and if necessary cleaned before acceptance; special dust-free containers were introduced for all piece-parts and components; the operators were provided with special trays for collecting wire off-cuts, etc.; and the use in these shops of pins, small paper clips, lead pencils, etc., was prohibited.

A special progress group, shop-planning department and outside-purchasing group were also set up to support these new shops.

While the manufacture of the 21 repeaters (including five spares) required for the job does not, at first sight, appear a major undertaking, it must be borne in mind that every repeater has approximately 300 components, compris-

ing several thousand piece-parts, and every piece-part was treated as an "individual" and subjected to a most rigorous inspection. For some of the more difficult parts, in order to achieve the very high order of perfection required, the wastage rate was very high, a factor which it was difficult to assess in advance, particularly as a fault sufficient to cause rejection was likely to run through a whole batch.

Description of Shops.

The main shop (Fig. 1 and 2) covered the assembly and inspection of all units, i.e. amplifiers, filters, etc., of which there were nine in each repeater. This shop also contained two sub-shops, each completely self-contained, one for the manufacture of capacitors and the other for the manufacture of coils and wire-wound resistors.

The second shop was used for the assembly and testing of the completed repeaters. After assembly in the sea-housing, the repeaters were stored under water in tanks located adjacent to this second shop, and while in the tanks they were subjected to a three-months' confidence run during which their gain was continuously monitored on recording decibel meters, which were mounted on racks (Fig. 3) in the shop and connected to the repeaters through coaxial cables.



FIG. 1.—ASSEMBLY OF UNITS IN THE MAIN SHOP.

† Mr. Meers is with Standard Telephones & Cables, Ltd., Transmission Division.

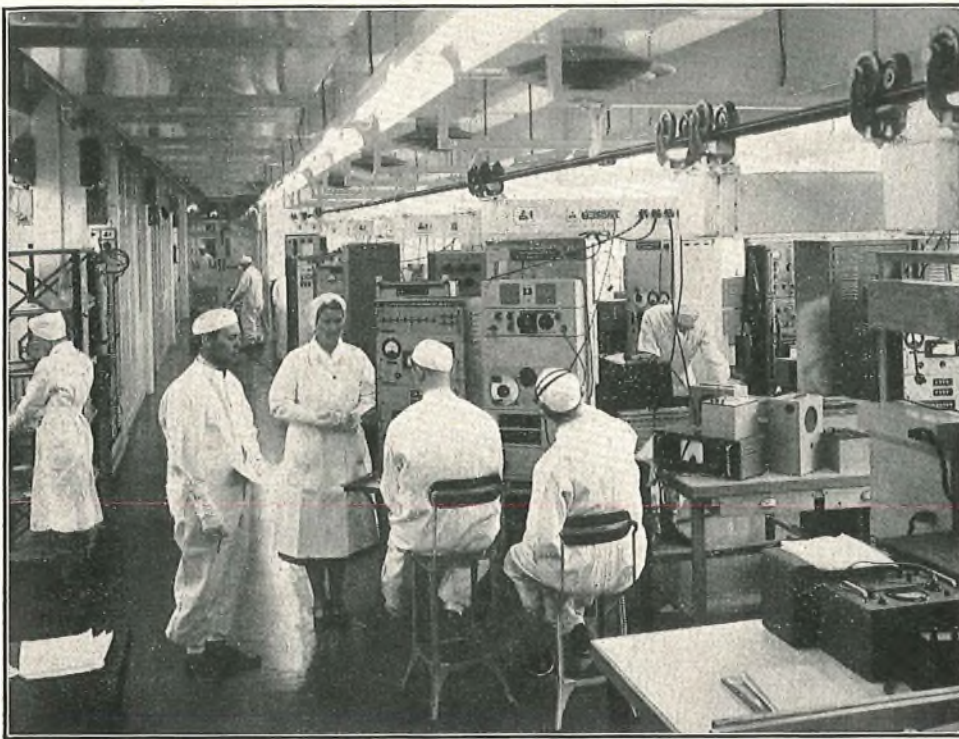

FIG. 2.—TEST EQUIPMENT IN THE MAIN SHOP.



FIG. 3.—RECORDING DECIBELMETERS FOR TESTING THE REPEATERS.

Components and Piece-parts.

Except for short-circuiting fuses, certain types of proprietary resistors and valves, all components were made in these special shops. The valves were made, and the short-circuiting fuses were assembled, at Dollis Hill, and for proprietary resistors the suppliers agreed to modify their standard designs in the light of the special requirements of the work.

The inspection of all this material was extremely rigorous. For example, all wire-wound vitreous-enamelled resistors were checked for pin holes and crazing of the enamel. They were also X-rayed to check that no turns had moved during enamelling.

Special Processes.

A number of special processes were involved in these repeaters, some of which produced new manufacturing problems; for example, the widespread use of the plastic "Perspex."

The final operation prior to assembling in the sea-housing was to fit a protective brass tube over the repeater. Before sealing this tube, the repeater was "washed through" with dry nitrogen for 24 hours and then sealed off, leaving an atmosphere of dry nitrogen in the repeater, the sealing being a hermetic joint. There was only 0.010 in. clearance between the surface of the brass tube and the sea housing and great care was therefore necessary to ensure very good circularity of the tube. Furthermore, in order that the unit should fit truly into the sea housing and that the closure bulkheads should seat squarely, a high degree of rectilinearity of the unit was also essential, a matter which called for some ingenuity.

Control of Raw Material and Process Material.

The Company's standard specifications for all raw material and process material were scrutinized by a joint Post Office/Standard Telephones & Cables committee and changes made where it was considered that long-term reliability might thus be improved. In this work, as in all other aspects of this job, the cost of the finished product was regarded as of secondary importance compared with its reliability.

After the specifications had been agreed they were then "frozen" and reissued under a special coding series specifically for the transatlantic telephone repeaters.

One hundred per cent of all incoming material was inspected both in the normal routine and again by a special Submerged Repeater Inspection Group. Samples were taken from all deliveries in order that, where necessary, destructive tests could be carried out to ensure that the delivery met the specification in every respect. In addition, samples were taken from every sheet, rod, etc., and submitted to analysis, the result of which was awaited before the material was released for use.

Manufacture of Capacitors.

Capacitor manufacture was carried out in a special shop enclosed within the main air-conditioned area of one of the shops, the air in the capacitor shop being controlled to a much lower humidity; the particle filtration was also improved.

Two types of capacitor were made in this shop—oil-impregnated oil-immersed paper capacitors and silvered-mica capacitors—both types being manufactured in various capacitance values and for different working voltages. For all capacitors, absolute cleanliness of materials and processing were essential throughout, and raw materials such as the metallic foil and the special paper used in the construction were subjected to searching tests at all stages. For example, special arrangements were made with the customs authorities for consignments of the special paper to be delivered direct to the Company's factory unopened in order to avoid possible damage by handling.

As another example of the care taken with the selection of material, the selection of mica may be cited. All mica was obtained as "best ruby," specially selected. This was re-selected in the submerged-repeater shop and any mica

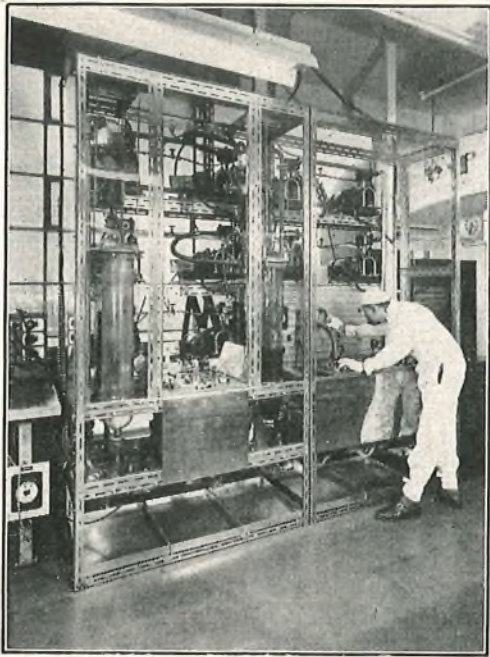

FIG. 4.—EQUIPMENT FOR VACUUM IMPREGNATION OF CAPACITORS

showing minute imperfections such as iridescence or inclusions of air was rejected.

The vacuum impregnating equipment, which can be seen in Fig. 4, was designed and built for the purpose, and was of a special type capable of attaining a very high degree of vacuum, thereby ensuring the removal of any residual moisture from the capacitor unit. Special means of detecting minute oil leakages, should they be present after sealing, were installed, which utilized the fact that the impregnating oil is fluorescent under ultra-violet light.

After every possible precaution had been taken during the manufacture of the capacitors, they were then subjected to the most rigorous tests, not only on the completed capacitor but also at all stages of construction. The final product was given a life test (carried out on all capacitors) under agreed conditions extending over many hundreds of hours. The data obtained from these tests, apart from ensuring maximum reliability and long life, provided valuable information in attaining the highest possible consistency of the product.

Manufacture of Coils.

The manufacture of coils was also carried out in a special shop, adjacent to that used for the capacitors. The humidity and particle filtration were again controlled to the same tight limits.

All coils and wire-wound resistors were of well-tried types, the only difference from standard constructions being a widespread use of "Perspex" or ceramic for spools, insulators, etc., in place of the more conventional bakelite or allied material. The purpose of this change was to use materials believed to be completely sterile, and thus unlikely to affect the repeaters in the years to come. All coils were hand-wound and were either vacuum-dried and impregnated, or mounted in cans which were filled with dry nitrogen and hermetically sealed.

Extreme care was taken in processing to avoid damage to the wires, and to this end the insulation from all terminations was burned off in an electrical heater in a stream of dry nitrogen (so as to avoid oxidation) and at no time were cutters or pliers used for this purpose.

Great care was taken in the design of the repeater to have all joints so located that they were easily soldered and easily visible for inspection. For coils, therefore, all

internal joints were forbidden, and all connexions were brought to external soldering tags.

INSPECTION METHODS

Inspection methods were extremely rigorous. As mentioned earlier, inspection commenced at the raw material and piece-part stage, and as a consequence of this very strict inspection at the early stages of manufacture, coupled with the precautions taken during manufacture, the final product was extremely consistent in respect of electrical performance, and rejections in the later stages of manufacture were almost non-existent.

At all stages of manufacture the only permitted standard of inspection was "perfection," within, of course, the permitted mechanical or electrical tolerances. On occasions articles would be rejected for minor faults; for example, minute scratches on metal cans. Where experience had shown that such minor blemishes were very difficult indeed to eliminate completely and where such points could not possibly affect the life or reliability of the repeater their use was permitted on a "concession" basis. Every such point (however minor) was the subject of joint discussion between Post Office and the Company's engineers, and if agreed, a concession note, duly signed by a delegated engineer, was issued.

Inspections of electrical performance were made at each of certain "natural" breaks during manufacture; namely, on completion of a unit (amplifier (Fig. 5), filter, etc.), on assembly of a repeater, on encapsulating the

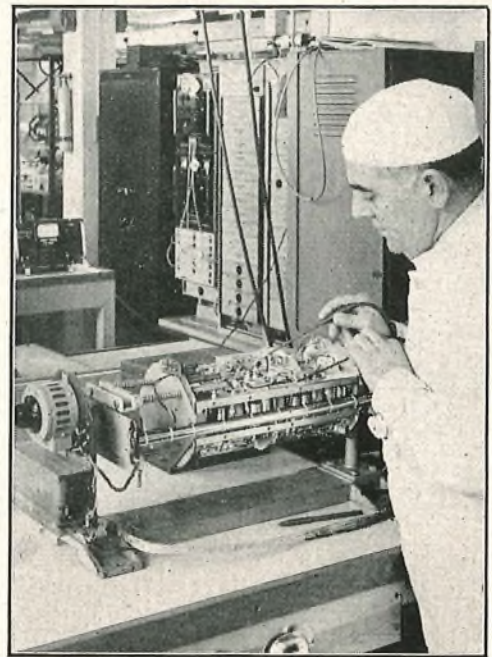

FIG. 5.—TESTING AN ASSEMBLED AMPLIFIER.

repeater in its brass protective shell, after encasing a repeater in its sea-housing, and finally on completion of the three months' confidence run. At each of these stages almost a complete set of electrical measurements was taken. The results of the periodic tests enumerated above (which on any given repeater stretched over some six months) were required to agree within close limits.

The philosophy behind this elaborate and repetitive inspection procedure was to obtain results over as long a period as possible, and thus confirm the long-term stability performance of the repeaters and bring to light any long-term drifts in their characteristics.

On occasions small discrepancies of the order of 0.1 or 0.2 dB occurred between measurements made at different

periods and these discrepancies were invariably tracked down to variations in the test sets rather than in the product.

Records.

At the completion of manufacture all records were collected together in special folders, which contained a list of the serial number of all components used, test results, the signed original of any concession notes (with reasons for their issue) and any other relevant information. These records will be kept permanently and will prove invaluable should the repeaters ever be recovered, since they will

provide a method of assessing the long-term performance of the units and components.

ACKNOWLEDGMENT

To bring this project to a successful conclusion a great deal depended on the integrity of shop and inspection personnel. The work of the associated production departments was also of an abnormal nature and great credit is due to everyone connected with the project for the way in which they met the many unusual problems, and accepted rulings which at times must have been, to say the least, extremely irksome.

Part 2.—The Pressure Housing

D. MARFLEET†

U.D.C. 68:621.375.2—212:621.315.28

BY no means the least of the problems associated with the development of the transatlantic telephone cable was that of housing the electrical elements of the repeaters.

Experience had already been obtained from a repeater laid in the Irish Sea and from others installed in cables to the Continent. The latter types were of similar design to those used in the Newfoundland–Nova Scotia link of the transatlantic cable and only minor improvements were necessary for the 21 rigid repeaters and two equalizers required for this link.

The manner in which these problems were solved, and the design and construction of the housings resulting from collaboration between British Post Office engineers, The Telegraph Construction and Maintenance Co., Ltd. (Telcon), Submarine Cables, Ltd., and Standard Telephones & Cables, Ltd., are described elsewhere.¹ This article is mainly concerned with some of the problems and difficulties encountered in the manufacture of the housing and the assembly of the complete repeater in the housing.

The overall measurements of the assembled repeater unit are 9 ft long \times 10½ in. in diameter, while its weight in air is 10¼ cwt. The housing was machined from hot-drawn mild-steel tube, 1¾ in. thick, at Telcon Works, Greenwich. Its manufacture was governed, as were all elements in the cable, by a specification which laid down close tolerances previously unheard of in this class of work.

Much credit is due to the technicians, craftsmen and workers on the machines and "on the floor," whose skill and ingenuity gave practical expression to the plans of the scientists, engineers and chemists engaged on this project. The highest standard of workmanship was demanded and obtained, subject at all times to a rigorous system of inspection imposed by the manufacturers and by the Post Office staff throughout the period of production, assembly and final testing.

Assembly of the cylindrical brass case containing the electrical unit into the outer housing was carried out at Ocean Works, Erith. To facilitate handling of the considerable weights involved, Standard Telephones & Cables, Ltd., loaded the brass container into a special travelling frame designed to fit working jigs developed at Ocean Works to receive them. These jigs are adjustable to enable work to be carried out at any convenient angle during the process of assembly.

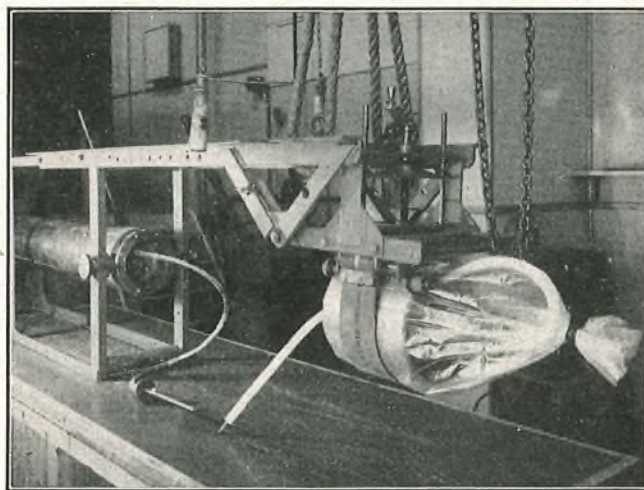

FIG. 6.—ELECTRICAL UNIT AND BULKHEAD, WITH CABLE ENDS READY FOR JOINTING.

Fig. 6 shows the electrical unit in its frame, with additional framework attached for carrying a bulkhead, and the cable ends ready for jointing. The bulkhead had previously been fitted with a polythene gland and tested to a pressure of 5 tons/in² for three months in order to ensure that it was completely watertight. The temporary polythene wrapping of the bulkhead will be noticed; this is but one example of the precautions taken to ensure the highest possible degree of cleanliness throughout. Special acid baths were used to remove even the faintest trace of dust or grease from every component part.

Jointing of the conductor from the electrical unit to the conductor from the water-pressure gland was carried out on an electronically controlled brazing machine especially devised for this task. It will be appreciated that an extremely high standard was demanded for this joint, and it was therefore necessary for it to be photographically X-rayed and examined in detail after the polythene insulation had been moulded round it. In addition, the joint was tested to withstand 20 kV; it was immersed in water and the test potential was applied between the centre conductor and a plate immersed in the water.

After the moulding operation was completed and inspected, the bulkhead was lowered on to the electrical unit and rigidly bolted to it (Fig. 7). The whole was then moved by an overhead conveyor and lowered into the

†Mr. Marfleet is with Submarine Cables, Ltd. (Repeater Section).

¹BROCKBANK, R. A., WALKER, D. C., and WELSBY, V. G. Repeater Design for the Newfoundland–Nova Scotia Link. (In this issue of the P.O.E.E.J.)

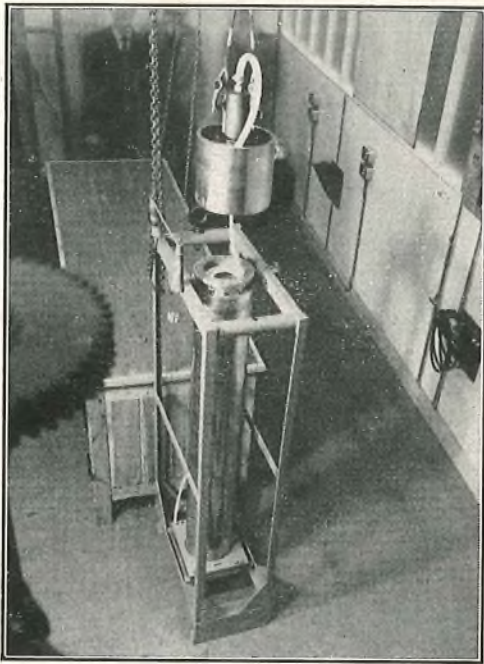

FIG. 7.—LOWERING THE BULKHEAD ON TO THE ELECTRICAL UNIT.

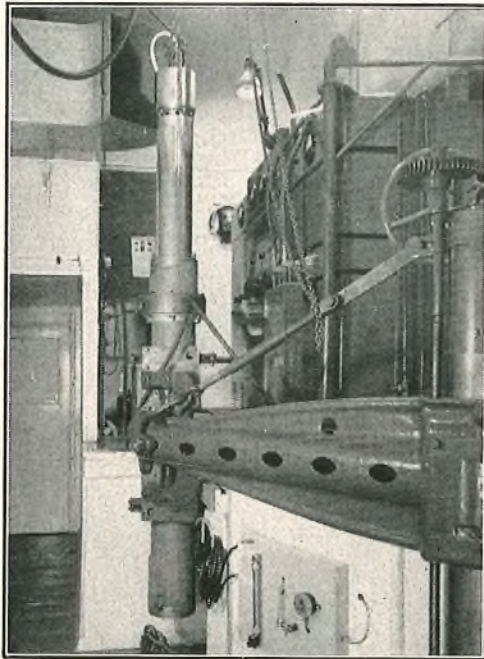

FIG. 8.—LOWERING THE ELECTRICAL UNIT INTO THE PRESSURE HOUSING.

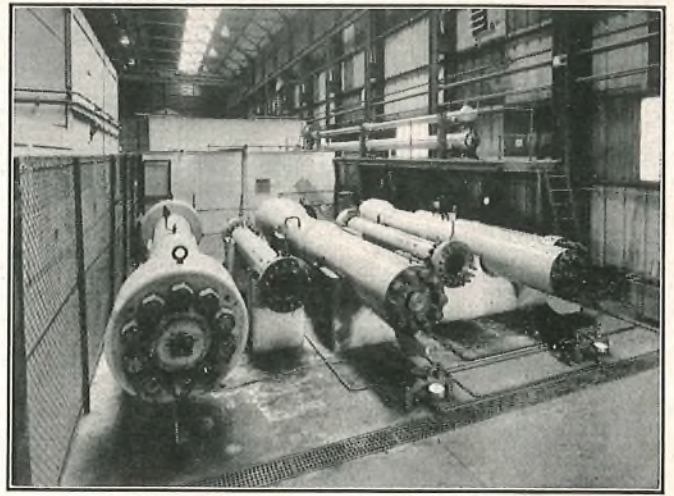

FIG. 9.—PRESSURE-TESTING EQUIPMENT.

housing, which had previously been fitted into the assembly brazing apparatus and filled with dry nitrogen to prevent oxidation. Fig. 8 shows this operation in progress.

Specially prepared flux was applied to the area to be brazed and a predetermined quantity of silver solder placed in position. Water coolers and high-frequency heating-coils were then attached and the preparations for brazing the bulkhead to the main housing were completed.

The same procedure was adopted in assembling the second bulkhead, and a leak test was then made by applying an internal air pressure. The space between the electrical unit and the outer casing was then dried by the use of dry nitrogen, after which the gas flushing holes were sealed.

The repeater was next placed inside a pressure-testing vessel, and a pressure of $1\frac{1}{2}$ tons/in² applied. The pressure-testing equipment, which is shown in Fig. 9, is, however, capable of exerting pressure up to 6 tons/in² if required. During this test, readings were taken on a moisture detector, which was developed especially by the Post Office for sealing into submerged repeaters, and very careful watch was maintained to ensure that there was no intolerable rise in the internal humidity.

Following the pressure test, extension pieces were fitted to the housing and the bulkhead and gland area completely filled with a compound. The compound is held in place by a flexible p.v.c. diaphragm which permits the equalization of pressure between the compound and the sea.

Finally, the complete assembly was shot blasted and sprayed with a layer of zinc as a further protection against corrosion before being submerged in a tank of water to undergo a three months' "confidence trial."

Power-Feed System for the Newfoundland-Nova Scotia Link*

J. F. P. THOMAS, B.Sc.(Eng.), A.M.I.E.E.
and R. KELLY, B.Sc.(Eng.)†

U.D.C. 621.395.52

Design engineers now have available the results of many years of operating experience of submerged-repeater systems supplied from electronic, electromagnetic and rotary-machine power equipments. To meet the very high standards of reliability required for the transatlantic telephone system, a scheme has been evolved that is a combination of new developments and the best features of previous methods. Electronic-electromagnetic equipment forms the basis of an automatic no-break system requiring very little routine maintenance.

INTRODUCTION

THE operating power for the submerged repeaters of the Clarenville-Sydney Mines link is derived from a constant current supplied over the central conductor from power equipments located at the two terminal stations. In order to protect the valves in the repeaters the current must be closely maintained at the design value, irrespective of changes in the mains supply voltage or earth potential differences between the two ends of the link. Automatic tripping equipment must be provided to disconnect the cable supply should the current deviate beyond safe limits, but otherwise there must be the minimum of interruptions due to power-equipment and primary-source failures.

Earlier British Post Office schemes have been powered by electronically-controlled units feeding from one end only.¹ Manual change-over to standby units has been provided at the end feeding power and at the distant end—a method which has satisfactorily met the economic requirements of short schemes.

For the Clarenville-Sydney Mines link a new and more reliable design of equipment has been developed. An automatic no-break system provides an uninterrupted supply to repeaters unless equipments at both ends of the link simultaneously fail to deliver power.

The main improvement in the reliability of the equipment is the replacement of all high-power valves by electromagnetic components. The automatic no-break system takes advantage of the fact that the rating of the repeater isolating capacitors has been chosen to permit single-end feeding. Normally the link is fed from both ends, but in the event of one equipment failing to deliver power the link is powered from the other end without interruption to the cable supply. If the failure is due to a power-equipment fault, double-end feeding can rapidly be re-established by manually switching to the standby. During an a.c. supply failure, single-end feeding must be maintained until the supply is restored. In view of the very reliable no-break a.c. supply provided at both stations, the possibility of a simultaneous a.c. supply failure at both ends of the link is extremely remote.

The power equipments at each end of the link must be capable of supplying the whole of the power to the cable should one end fail, which requires that each should be capable of operating as a constant-current generator. If two constant-current generators are connected in series an unstable combination will result and the unit supplying the higher current will drive the other unit "off load." Manual adjustment could be provided to equalize the currents fed from the two ends, but a different solution has been developed in which one of the units is a constant-current master and controls the line current, while the other unit is a slave whose voltage/current characteristics in the normal operating range is such that its current is always equal to that of the master unit. If the slave unit fails the master unit will

take over the supply; if the master unit fails the slave unit will take over the supply and automatically assume the role of a master unit. The first unit switched on to an unenergized link operates as a master generator and the other unit, on being switched on, automatically operates as a slave. Other than ensuring that the link is safe for energizing, there is no need for any co-operation between the two ends when putting the equipment into service.

DETAILS OF METHOD EMPLOYED

The Master-Slave System of Operations.

The output-current/output-voltage characteristics for the equipments are shown in Fig. 1, and are the same for both

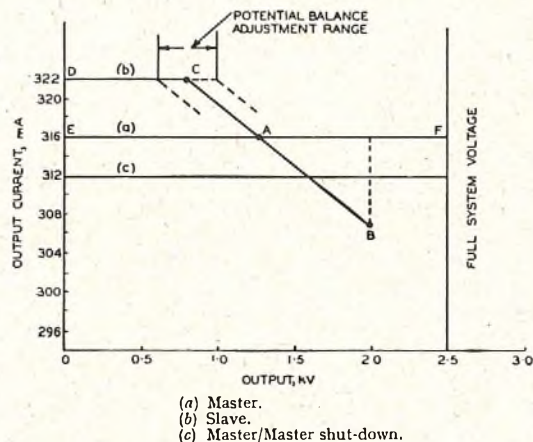

FIG. 1.—OUTPUT-CURRENT/OUTPUT-VOLTAGE CHARACTERISTICS.

regular (working) and alternate (standby) equipments at both ends of the link. Any equipment can operate with any of the characteristics (a), (b) or (c).

Normally the choice between characteristics (a) and (b) is made automatically by the equipment. If the output voltage does not reach 80 per cent of the full link voltage (approximately 2 kV), the unit will have the slave characteristic (b) (DCAB). If the output voltage reaches or exceeds 2 kV, the unit automatically switches to the master characteristic (a) (EAF). Once having switched to the master characteristic the equipment does not automatically change back to the slave characteristic even if the output voltage falls below 2 kV.

When the link is energized, the first equipment switched to line will come on as a slave unit; its output voltage will then pass 2 kV and it will automatically be switched to the master characteristic and the complete link will be energized from one end. The second unit switched to line will come on as a slave unit and, having a higher output current, will drive down the output voltage of the master unit at the other end until the current of the slave unit has become equal to that of the master (DCA in Fig. 1). The output voltage of this equipment will not exceed 2 kV and it will not switch to master. The cross-over point of the two characteristics, A, will determine the potential fed from each end, and this can be adjusted as indicated by the dotted lines near C.

In an emergency, an equipment can be taken out of service by switching off the mains supply, and the link will

† Mr. Thomas is with the British Post Office, and Mr. Kelly is with Standard Telephones & Cables, Ltd.

¹ WALKER, D. C., and THOMAS, J. F. P. The British Post Office Standard Submerged-Repeater System for Shallow-Water Cables, with special reference to the England-Netherlands System. *Proceedings I.E.E.*, Paper No. 1634, Feb. 1954 (Vol. 101, Part 1, p. 190).

then be powered from the distant end only. Should the master end be switched off, the distant slave unit will switch to the master characteristic as soon as its output voltage exceeds 2 kV. This abrupt disconnection of one equipment causes unnecessary voltage surges on the cable, and when an equipment is removed for normal maintenance purposes the following procedure is adopted. The slave equipment is switched to the master characteristic (an external key is provided for changing from master to slave or vice versa, but see the limitation described in the next paragraph). This leaves two master equipments feeding the cable, but any redistribution of voltage is slow since the currents are approximately equal. An external control (master/master shut-down) is then operated on the equipment to be taken out of service, changing its characteristic to that shown in Fig. 1(c). The output voltage of this unit will then be slowly reduced, and when it is zero the equipment can be switched off without causing surges on the cable.

The current deviations occurring over the slave characteristic (b) (from +2 per cent to -3 per cent) are the maximum permitted by the valve design engineers for the valves in the submerged repeaters, and are permitted only for short periods. The circuit associated with the manual switching of the equipment to the slave characteristic is therefore made inoperative if the output voltage exceeds 2 kV, since in this range the slave characteristic is the extension of the line CAB on curve (b) and the current is outside the permitted range.

The slave characteristic over the range CAB is controlled by a voltage-sensitive circuit connected near the output of the equipment, and the stability of the characteristic against input voltage and component ageing is the same as for the master characteristic. Changes in the distribution of the system potential due to supply variations and component ageing are therefore small.

Overall Current and Voltage Distribution.

Facilities have been provided at the junction of the land and sea cables (Terrenceville) to connect a power earth to the centre conductor of the cable. Normally this earth will be disconnected, but during installation it enables the land and sea sections to be energized separately and may subsequently be of assistance in the localization of cable faults near Terrenceville.

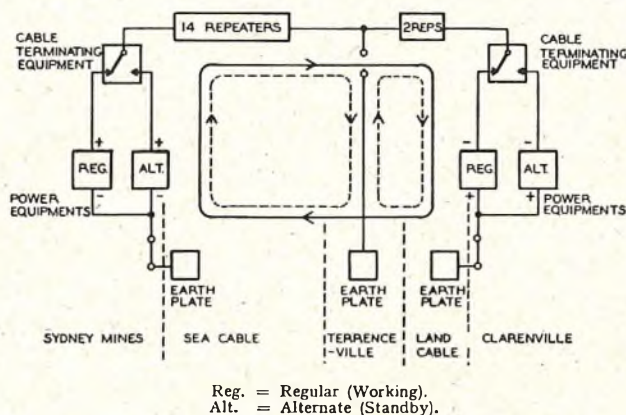

FIG. 2.—CURRENT PATHS ON CLARENVILLE-SYDNEY MINES LINK.

The full line in Fig. 2 shows the current path with normal double-end feeding, while the broken lines show the current paths when an earth is connected at Terrenceville.

The full line (d) in Fig. 3 shows the voltage distribution along the link with normal double-end feeding, the broken lines (a) and (b) show the distribution with single-

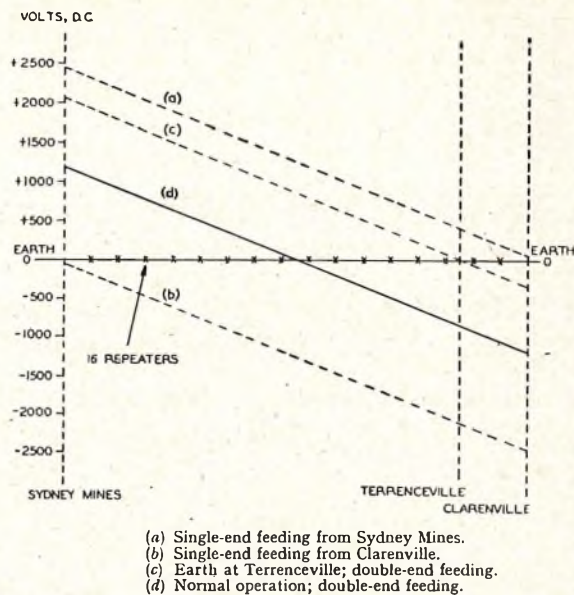

FIG. 3.—POTENTIAL DISTRIBUTION ON CLARENVILLE-SYDNEY MINES LINK.

end feeding from Sydney Mines and Clarenville respectively, and the broken line (c) shows the distribution when a power earth is connected at Terrenceville.

DETAILS OF EQUIPMENTS

Connexion of the Equipment to the Cable.

Each station is provided with two power equipments and one cable-terminating equipment, interconnected as shown in Fig. 4. When the live side of the output of the regular equipment is connected to the cable via SWD and the link LK1, the alternate equipment output is connected to its own dummy load (equivalent of RV1) and vice versa.

The earthy sides of the regular and alternate equipments are commoned and then connected via a removable link, LK2, to the sea earth. A safety resistor R2 connects the sea earth to the station earth to restrict the rise in potential to 100V if the sea earth becomes disconnected. During maintenance on the sea-earth circuit the link LK2 can connect the power-equipment earth to the station earth.

If, for maintenance purposes, it is necessary to feed from the distant end only, the link LK1 can connect the cable to the power-equipment earth and disconnect the live side of both power equipments from the line.

Safety Interlocks.

Safety interlock circuits are installed to protect the maintenance staff if the equipments are used incorrectly; they are not the normal methods employed for controlling the power supplies. With double-end feeding, dangerous voltages are generated at both ends of the system, and when access is gained to any point in the equipments personnel must be protected from the local and distant power sources.

To minimize interruptions to traffic, the units of the cable-terminating equipment have been grouped under three headings (see Fig. 4), namely:

- Transmission equipment (S1) isolated from the d.c. cable supply: this includes cable simulators and monitoring facilities not associated with the power supplies.
- Equipment associated with the d.c. supply that can be made safe without interrupting traffic.
- Equipment that can be made safe only by interrupting traffic.

Group (a) is treated as normal terminal transmission equipment and is not interlocked. Groups (b) and (c), the

power-change-over and cable-terminating boxes respectively, both require that the local power equipments are switched off before they can be made safe. The external panel covers over both boxes have links disconnecting the a.c. supplies to both of the local power equipments when the covers are removed (LK3-LK6). This will not interrupt traffic, since single-end feeding will continue from the distant station.

The doorknob switch of the power-change-over box automatically connects the live lead to earth (at the point B) when the door is opened. This will not interrupt traffic since the impedance of L2 is high at carrier frequencies. Changing over the power equipments and earthing arrangements can therefore be performed without interrupting traffic.

The doorknob switch of the cable-terminating box automatically connects the centre conductor of the cable to earth (at the point A) when the door is opened. Traffic will therefore be interrupted if maintenance work is necessary within this box.

Access is gained to a power equipment by opening one or more of four doors. Each of the doorknob switches disconnects the a.c. supply (SWA) and short-circuits the output of the equipment (SWC).

It will be appreciated that if the correct procedure is adopted the local power equipments will be switched off by SWB after the master/master shut-down procedure (described previously) has been carried out and not by removing the panel covers or opening the doors.

Electrical Details of Power Equipment.

Control method.—Fig. 5 is a functional simplified circuit diagram in which TR1, MR1 and C1 represent a conventional unregulated power unit.

The control circuit compares a signal, V_o , proportional to the output current, with a stable reference signal, V_R , the two signals being applied to the cathode and grid, respectively, of V5; the difference between them is amplified and used to adjust the voltage fed to the rectifier circuit, MR1, to maintain the output current constant.

Ignoring at this stage the auxiliary coil 1/2 of the magnetically-controlled diode V3, the output current flows through the coil 3/4 and controls the voltage across R4 and hence, via the cathode-follower V4, the potential V_o on the cathode of V5. V_R is a function of the output of a conventional electronic constant-voltage power unit (reference power unit) using a neon tube for its reference. The grid-cathode bias of V5 controls the secondary impedance of the transducer TD2 via the amplifier V5, V6, TD1. The gain of the control amplifier and the sign and magnitude of the normal impedance of the secondary of TD2 are arranged to give a fall of approximately 0.25 per cent in the current from full system load to short-circuit.

Two advantages are obtained by employing a magnetically-controlled diode for V3 instead of an electrostatically-controlled valve. The control is directly proportional to the output current, and is not dependent upon the stability of a series resistor, while the control circuits are isolated from the output-circuit voltage, which simplifies maintenance of the more complex parts of the equipment.

Current characteristics.—Without current flowing in the auxiliary coil 1/2 (on V3 in Fig. 5) the equipment has a normal constant-current characteristic, the value of which, 322 mA, is preset by adjusting the mechanical position of the coil assembly along the main axis of V3.

Two neon tubes and two resistors form the bridge V1, V2, R1 and R2, which is balanced when the voltage drop across R1 and R2 equals the constant voltage across V2 and V1, the output voltage at which this occurs being adjusted by RV1. At voltages below balance, current tries to flow from y to x and at voltages above balance it flows from x to y . The balance voltage corresponds to

the voltage at which the slave-unit characteristic changes slope (C in Fig. 1). For voltages below balance the rectifier MR2 prevents current from flowing in the winding 1/2 (on V3), and in this range the constant current of 322 mA is maintained (see DC, Fig. 1). For voltages above balance, current flows in the winding 1/2 and progressively decreases the output current (CAB, Fig. 1). At 80 per cent of the full line voltage, the contacts of relay M disconnect the auxiliary coil 1/2 from the voltage-sensitive bridge and connect it across the reference supply. The current through 1/2 is then set by the fine current control (RV2) to make the output current the required 316 mA. As previously stated, relay M does not automatically switch back when the output voltage drops below 80 per cent of full link voltage; the current characteristic of a master unit is EAF in Fig. 1.

The master/master shut-down characteristic [Fig. 1, curve (c)] is obtained by short-circuiting R3, which causes the constant current to fall to 312 mA. Adjusting RV2 would be equally effective, but short-circuiting R3 does not permanently disturb the normal current setting.

Alarms.—The equipment trips and gives both aural and visual alarms for +20 per cent current, +20 per cent full link voltage and for the failure of certain auxiliary supplies that would damage the equipment.

Aural and visual alarms are provided for ± 1 per cent current and ± 3 per cent voltage and for equipment changes from slave to master characteristic or vice versa. Visual indication is given if the a.c. supply fails.

Reliability.—Where possible, only components of proven integrity have been used. High-power thermionic valves have been excluded and the valve types employed have been specially selected for long life. Electrolytic capacitors have been excluded from all except one position, and in this case the component has been divided into six units in parallel, the failure of all but one of these units causing only a slight increase in the output ripple.

Particular attention has been given to the continuity of the output circuit. A failure of a power equipment for any reason other than an open-circuit in the output will not interrupt traffic, the link changing to single-end feeding from the far end. A disconnection anywhere in the d.c. feed path will disconnect all power from the line. Relatively short-lived components in this part of the circuit have either been duplicated in parallel or shunted by resistors capable of carrying the full line current.

Other facilities.—Each equipment has facilities for checking its overall performance. A variable-ratio transformer can be introduced at SK1 (Fig. 4) and with the dummy load referred to previously the regulation against alternating input voltage and output load can be measured.

Provision is made for checking all the alarms, and the current can be measured at strategic points in the control circuit either when the equipment is normal or with the loop feedback disconnected.

Separate large-size meters are provided for measuring the output voltage and current to an accuracy of ± 1 per cent. A more accurate measurement of current is obtained from potentiometric measurements made across a standard resistor connected in series with the output.

Electrical Details of Cable-Terminating Equipment.

The majority of the electrical features of the cable-terminating equipment have already been considered.

Within the cable-terminating box (Fig. 4) are the power-separating filters; the high-pass filter C1, C2 and L1 passing the carrier frequencies and the low-pass filter L2 the direct current. The transmission equipment represented by the block S1 is for convenience mounted in the cable-terminating cubicle. The extra low-pass filter L3, C3 can be specially

designed to prevent signals that are peculiar to the site (local radio stations, etc.), which are picked up in the power equipment, from being fed to the transmission circuits.

Metering facilities (not shown in Fig. 4) are provided to check the continuity of the sea-earth circuit. A separate insulated wire is connected to the sea-earth plate and the continuity is checked by measuring the voltage drop along the earth cable. Aural and visual alarms are given if the sea earth becomes disconnected.

Current and Voltage Recorders.

Current and voltage recorders are provided for both the regular and the alternate equipments, the values being measured at the points where the outputs of the power equipments enter the cable-terminating equipment.

A magnetic-amplifier unit drives the current recorder, the scale deflection being from -5 per cent to $+5$ per cent of the normal line current. The voltage recorder is connected across the earthy end of a resistance potentiometer, the full-scale deflection being 3 kV.

The magnetic-amplifier and potentiometer units are mounted in the cable-terminating equipment, but the four recorders and their associated supplies and alarms are mounted on a separate rack.

Mechanical Details.

Fig. 6 shows two power equipments and a cable-terminating equipment as installed at each terminal station. The

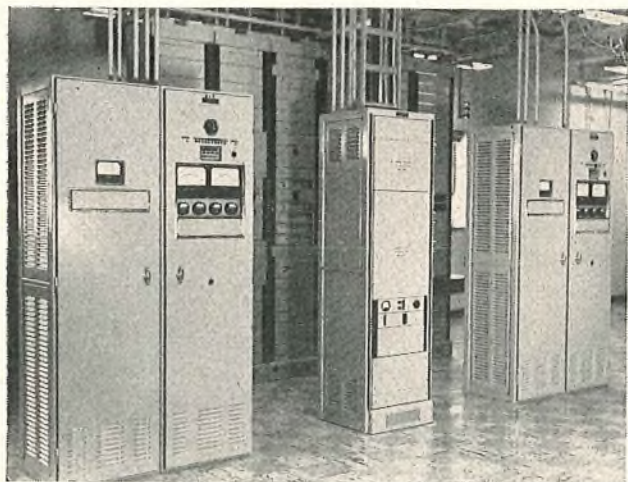

FIG. 6.—POWER AND CABLE-TERMINATING EQUIPMENTS AS INSTALLED AT EACH TERMINAL STATION.

same cubicle frameworks are used for power and cable-terminating equipments, the power equipment consisting of two cubicles bolted side by side and fitted with doors at the front and back.

The top of the cable-terminating cubicle contains the power-change-over box, the centre contains the cable-terminating box, while the transmission and earth-cable test circuits are located near the bottom. The main cable enters the bay at the top and passes behind the power-change-over box into the cable-terminating box. Access to the recorder units and cable simulators is from the rear.

Fig. 7 shows the front of one power equipment with the doors open. The left-hand cubicle contains the main h.v. transformer, the electronic and magnetic parts of the control circuits, the reference power unit and the auxiliary supplies. The other cubicle contains the main rectifier and smoothing circuits, and the associated meter and alarm circuits.

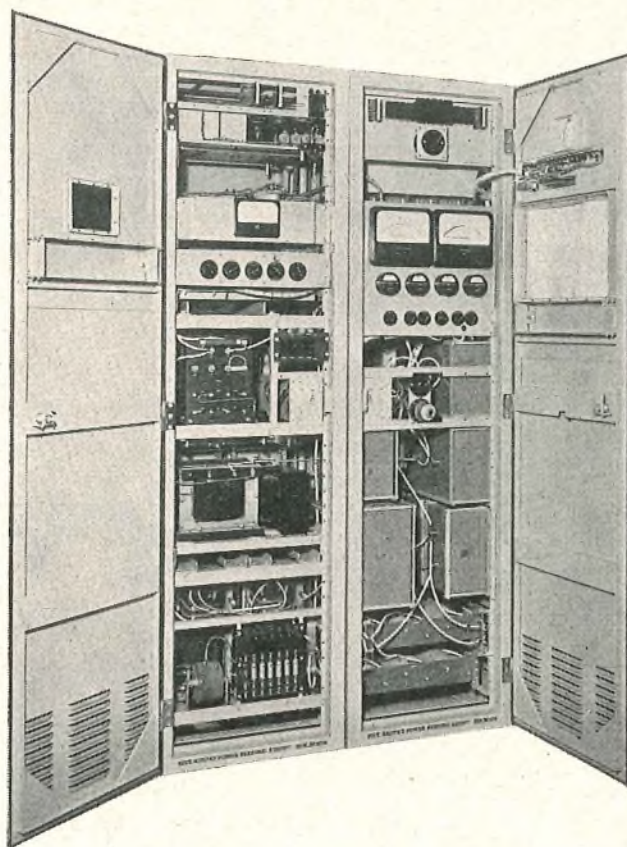

FIG. 7.—POWER EQUIPMENT.

PERFORMANCE

Six power equipments and four cable-terminating equipments were manufactured for the link. Of these, four power equipments and two cable-terminating equipments were provided for the terminal stations and the remainder were for use on H.M.T.S. *Monarch* during the cable laying and subsequently as off-station and training spares.

After individual testing, the power equipments were checked in pairs, energizing a 16-section artificial cable constructed to simulate the Clarendville-Sydney Mines link. These tests were kept running for approximately two weeks on each equipment, and the line current was monitored with expanded-scale current recorders from -1 per cent to $+1$ per cent of the normal current.

The equipments were completed at the beginning of 1956, and have given satisfactory service both at the terminal stations and on board H.M.T.S. *Monarch*. From March to June, 1956, all four units at the terminal stations were operating into their dummy loads, and daily current and voltage readings were well within the required specifications. Since the laying of the sea section the equipments have satisfactorily operated the completed link. While the link is in service the working equipment at each end will be changed at six-monthly periods and the change-over time will be staggered by three months at each end. The equipment coming out of service will be immediately routine checked and adjusted if necessary.

The tests since installation confirm the laboratory and factory results that the regulation is better than ± 1 mA for any alternating input voltage from 195-265V in the frequency range 40-70 c/s for output voltages of 0 to 3 kV. The relatively long correction period of the magnetic-amplifier control circuit (about 0.5 sec) is satisfactory with the type of no-break supply installed at the stations.

Another useful by-product of double-end feeding is that, when there is a shunt fault on the system, the voltages

supplied from the two terminal stations give an indication of the fault position. Many factors will control the accuracy of the location, e.g. magnitude and position of the fault, and how nearly the currents fed from the two ends are equal. Calculations, confirmed by tests made with shunt faults introduced at Terrenceville, show that any continuous shunt fault that will affect transmission (to the extent of operating the 1-dB pilot alarms) will be detected to an accuracy of ± 1 per cent. The limit is set by the accuracy with which the link voltage distribution can be measured.

CONCLUSIONS

The power-feeding system described is suitable for submerged-repeater schemes that can, in an emergency, be temporarily powered from one end only. For locations within reasonable reach of a central catastrophe-spare store the equipment should be sufficiently reliable not to need duplication at both terminal stations. For future schemes this will provide a method which is economically attractive compared with the present single-ended methods and which offers numerous electrical advantages.

The routine maintenance required on the power equipment could be further reduced if the few remaining electronic valves were replaced by electromagnetic components. On schemes where short interruptions to traffic do not involve a relatively high loss of revenue it would then be unnecessary for the local staff to maintain the high-voltage equipment and the expensive no-break a.c. supplies could be abandoned. The latter depends upon the probability of the primary sources at the terminal stations failing simultaneously.

ACKNOWLEDGMENTS

The authors wish to express their thanks to many of their colleagues in the Post Office and Standard Telephones & Cables, Ltd., who have contributed to the developments described in the article. The permission of Standard Telephones & Cables, Ltd., to make use of the information contained in the article is also gratefully acknowledged. The equipments for the Clarenville-Sydney Mines link were manufactured by Standard Telephones & Cables, Ltd., at North Woolwich, London.

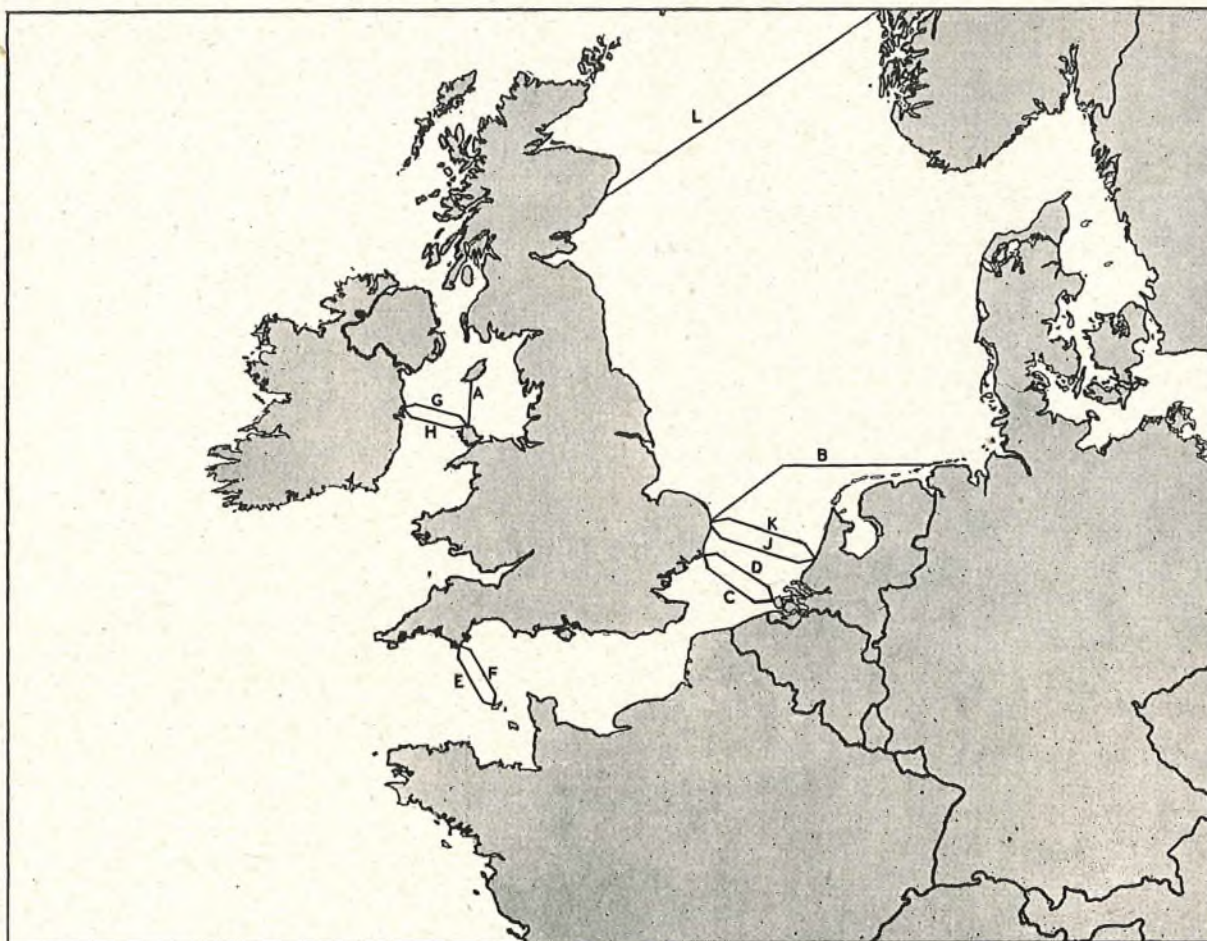

Cable	To	No. of Circuits	No. of Repeaters	Date Repeaters Installed
A	ISLE of MAN	Tests only	1	1943*
B	GERMANY	5	1	1946
C	HOLLAND	60	4	1950
D	HOLLAND	60	4	1951
E	GUERNSEY	60	3	1952
F	GUERNSEY	60	3	1952

Cable	To	No. of Circuits	No. of Repeaters	Date Repeaters Installed
G	IRELAND	60	2	1953
H	IRELAND	60	2	1953
J	HOLLAND	60	4	1954
K	HOLLAND	60	4	1954
L	NORWAY	36	7	1954

* Recovered in 1951.

SUBMERGED REPEATERS LAID IN SHALLOW WATERS AROUND THE BRITISH ISLES.

Electron Tubes for the Transatlantic Cable System*

J. O. McNALLY, B.S. in E.E., Fellow, I.R.E.
G. H. METSON, M.C., Ph.D., M.Sc., B.Sc. (Eng.), A.M.I.E.E.
E. A. VEAZIE, B.A., Senior Member, I.R.E. and
M. F. HOLMES, B.Sc.†

U.D.C. 621.385.5:621.395.51

Electron tubes (thermionic valves) for use in repeatered underwater telephone cable systems must be capable of operating for many years with a reasonable probability of proper functioning. In the new transatlantic telephone cable system, the section between Nova Scotia and Newfoundland contains repeaters developed by the British Post Office Research Station and built around the type 6P12 valve developed there. The repeaters contained in the section between Newfoundland and Scotland are of Bell System design and depend on the 175HQ valve developed at Bell Telephone Laboratories. In the paper the philosophy of repeater and thermionic valve design is discussed, and the fundamental reasons for arriving at quite different valve designs are pointed out. Some of the valve development problems and the features introduced to eliminate potential difficulties are described. Electrical characteristics for the two types are presented and life-test data are given. Fabrication and selection problems are outlined and reliability prospects are discussed.

INTRODUCTION

ELECTRON tubes (thermionic valves) suitable for use in long submarine telephone-cable circuits must meet performance requirements quite different from those imposed by other communication systems. In the home-entertainment field, for example, an average life of a few thousand hours is generally satisfactory; in conventional land-based telephone equipment, where the replacement of a valve may require that a maintenance man travel several miles, an average life of a few years is considered reasonable. But in deep-water telephone cables, such as the new transatlantic system, the lifting of a cable to replace a defective repeater may cost several hundred thousand dollars and disrupt service for an extended period. These factors suggest as an objective for submerged repeaters that the valves should not be responsible for a system failure for many years—possibly 20—after the laying of the cable. Such very long life requirements necessitate special design features, care in the selection and processing of materials used in the valves, unusual procedures in fabrication, detailed testing and long ageing of the valves, and the application of unique methods in the final selection of individual valves for use in the submerged repeaters.

The British Post Office developed the section of the cable between Clarenville, Newfoundland, and Sydney Mines, Nova Scotia, together with the 6P12 valve used in it, the submerged portion containing 84 valves in 14 repeaters. Bell Telephone Laboratories developed the part of the cable between Clarenville, Newfoundland, and Oban, Scotland; this section requires 102 repeaters, including 306 valves, of a type known as the 175HQ. Although a common objective in the development of each of the two sections has been to obtain very long life, the valve designs are quite different.

The Americans decided on the use of a repeater housing that could be treated as an integral part of the cable to facilitate laying in deep water; it is thus little larger than the cable and is sufficiently flexible to be passed over and around the necessary sheaves and drums. In such a housing the space for repeater components is necessarily restricted, and this, combined with the general philosophy that the number of components should be an absolute minimum and that each component should be designed to have the simplest possible structural features, has resulted in a 3-stage, 3-valve repeater in which each valve carries the entire responsibility for the continuity of service.

Prior to the development of the transatlantic cable system, the British had concentrated their efforts on shorter systems for shallow water. The placing of the repeaters on the bottom did not present the serious problems of deep-sea laying, so more liberal dimensions could be allowed for the repeater circuit. A 3-stage amplifier was

developed which consisted of two strings of three valves each, parallel connected, with common feedback. The circuit was so designed that almost any kind of valve failure in one side of the amplifier caused very little degradation of circuit performance. This philosophy of having the continuity of service depend on two essentially independent strings of valves has been carried into the repeater design for the Clarenville-Sydney Mines section of the transatlantic cable. Thus, in this section of the cable, which contains 84 valves in the submerged repeaters, five valve failures occurring randomly in the system will result in a probability of a system failure slightly in excess of 50 per cent; but one failure in the 306 valves in the Newfoundland-Scotland section will result in certain system failure. It is therefore not surprising to find that the valve designed for the Newfoundland-Scotland section of the cable has extremely liberal spacings between elements in order to minimize the hazards of short-circuits. This results in a lower transconductance than in the valves designed for the Nova Scotia-Newfoundland link. Other factors in the design will be recognized as reflecting the different operating hazards involved.

Early models of both types, together with the final valves used in the cable system, are shown in Fig. 1.

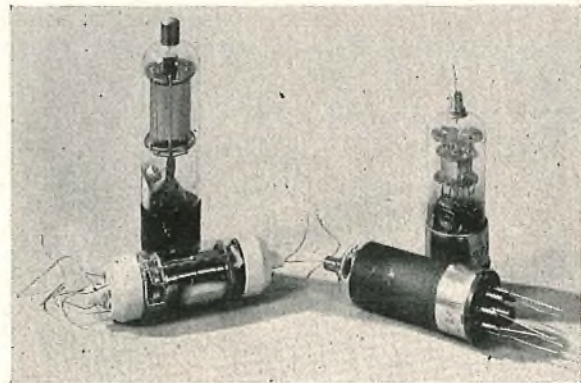

Early models of each type stand behind the final models.
FIG. 1.—FINAL DESIGNS OF VALVES FOR THE NOVA SCOTIA-NEWFOUNDLAND SECTION OF THE CABLE (RIGHT) AND FOR THE NEWFOUNDLAND-SCOTLAND SECTION (LEFT).

VALVES FOR THE NEWFOUNDLAND-SCOTLAND CABLE *Early Development Considerations.*

Work on valves for a proposed transatlantic cable was started in America in 1933, and was preceded by a study of the type which would best fit the needs of the various amplifier systems proposed and by consideration of what might be expected to give the best life performance.

When this project was started, reasonably good valve life had been established for the filament-type valves used in some American repeaters, some groups of valves having average lives of 50,000 or 60,000 hours (6-7 years). Equipotential-

† Mr. McNally and Mr. Veazie are with Bell Telephone Laboratories, Inc. Dr. Metson and Mr. Holmes are at the British Post Office Research Station.

cathode valves were not then used extensively in telephone plant, and there was no long-life experience with them. There appeared to be no basic reason why inherently shorter thermionic life should be expected from the equipotential cathode, and there were several advantages in its use. One was the greater freedom in circuit design afforded by the separation of the cathode from the heater; another was the possibility of operating the heaters in series and using the voltage drop across them for the other circuit voltages; moreover, the overall mechanical reliability would be greater if the cathode were stiff and rigidly supported.

The first equipotential valves made were triodes, designed for push-pull amplifiers where continuity of service might be retained in the event of a valve failure. This circuit was abandoned in favour of a 3-valve feedback amplifier, which was the forerunner of the present repeater. The pentode was preferred to the triode for this amplifier, for obvious reasons, and in 1936 the triode development was discontinued.

Early in the development of the valve three basic assumptions were made, namely (a) that operation at the lowest practical cathode temperature would result in the longest thermionic life, (b) that anode and screen operating voltages should be kept low, and (c) that the cathode current density should be kept as low as practicable.

Assumption (a) was based on the observation of life tests on other types of valves. While the data at the time of the decision were not conclusive, there was definite indication that too high a cathode temperature shortened thermionic life. Little was known about life performance in the temperature range below the values conventionally used.

Assumption (b) had not been supported by any experimental work available at the time of decision, and 60V was the level originally considered for the output stage; this was later reduced when other operating conditions were changed. Subsequent results showed that in this range the voltage effects on thermionic life were relatively negligible.

Assumption (c), suggested the use of a large coated cathode area and thus implied relatively high cathode power. It was decided early in the planning of the repeater that the voltage drop across the three heaters operated in series would be used to supply part or all of the operating anode and screen potentials. For a 60-V anode and screen supply the heater voltage could be as high as 20V; 0.25A was considered a reasonable cable current consistent with voltage limitations at the cable terminals, so that 5.0W were available for each cathode; a coated area of 2.7 cm² was therefore provided. The cathode current, the cathode area and the inter-electrode spacings define the transconductance. Very liberal inter-electrode spacings were provided, consistent with reasonable valve performance: the original design called for a spacing of 0.040 in. between the control grid and the cathode, but this was later reduced to 0.024 in., and a satisfactory design was produced, which gave 1,000 micromhos (1 mA/V) at a cathode current of approximately 2.0 mA. The resulting current density of approximately 0.7 mA/cm² is in sharp contrast with values such as the 50 mA/cm² used currently in valves designed for the more conventional communication uses. Subsequent data indicate that for current densities of this low order the exact value is not critical.

Subsequent Production Programs.

The development of the valve was actively pursued through the years leading up to the Second World War; during the war development activity essentially stopped and it was possible only to keep the life tests in operation. After the war the development of the valve was completed and a small production line was set up, under the direct supervision of the valve development engineers, to make and select valves for a cable between Key West and Havana.

This cable turned out to be a field trial for the transatlantic cable which was to come later. A total of six submerged repeaters, containing 18 valves, were laid, and the cable was put in operation in June, 1950. It has been in operation since that date without valve failure, and periodic observations of repeater performance have indicated no statistically significant change in valve performance during the six years of operation.

Sufficient valves were made at the same time as the Key West-Havana production run to provide those necessary for a future transatlantic cable. They were never used, principally because they had been assembled with tin-plated leads, and, subsequent to the laying of the Key West-Havana cable, tin plating was found to be capable of growing whiskers.¹

In 1953, another production run was made, also in America, for the fabrication of valves for the Newfoundland-Scotland section of the transatlantic cable. On the completion of this job, fabrication was continued to provide valves for a cable between Port Angeles, Washington, and Ketchikan, Alaska. After a pause of several months another run was made to provide valves for a cable to be laid between California and the Hawaiian Islands.

Mechanical Features.

The valve, shown on the left in Fig. 1, is supported in the repeater housing by two soft-rubber bushings into which the projections of the two ceramic end-caps fit. All leads are flexible and are made of stranded beryllium-copper which has been gold-plated before braiding. Both for convenience in wiring in the circuit and to minimize the control-grid-to-anode capacitance, the grid lead has been brought through the end of the valve opposite to the other leads.

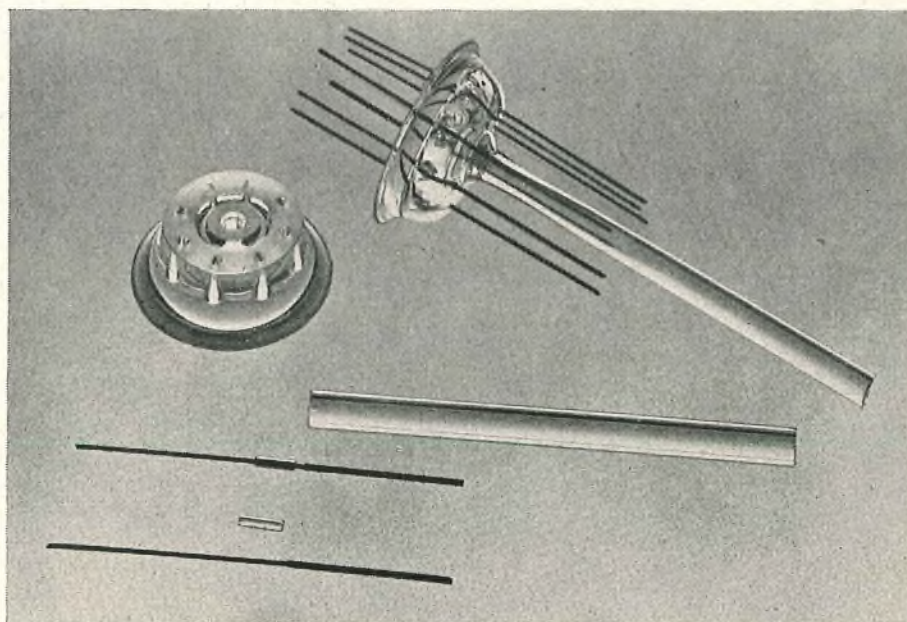

The separate beading of the leads may be noted.

FIG. 2.—PARTS USED IN THE STEM AND A FINISHED STEM OF THE 175HQ VALVE.

A number of somewhat unusual constructional features appear in the valve. The stem on which the internal structure is supported consists of a moulded glass dish into which seven 2-piece beaded Dumet leads are sealed. The parts used in a stem, and also a finished stem, are shown in Fig. 2. It is usual to embed the weld or knot between the Dumet and nickel portions of the lead in the glass seal to provide more structural stiffness. This has not been done in this stem because it was believed that a fracture of a lead at the weld could be more easily detected if it were not supported by the seal. It might be questioned why the modern alloys and flat stem structure have not been used. It is to be remembered that one gas leak along a stem lead would disable the system, and experience built up with the older materials provides greater assurance of satisfactory seals.

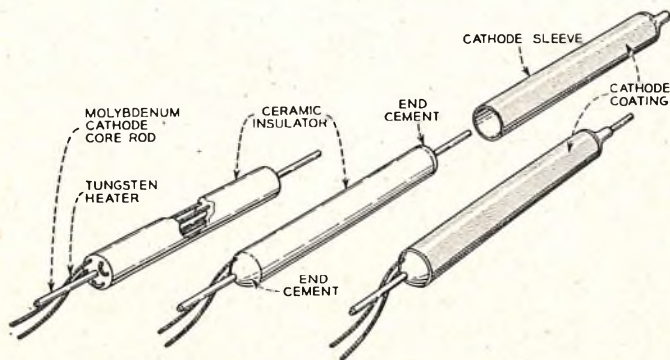

FIG. 3.—HEATER, HEATER INSULATOR AND CATHODE ASSEMBLY OF THE 175HQ VALVE.

The structure of the heater and cathode assembly is novel, as may be seen from Fig. 3. A heater insulator of aluminium oxide is extruded with seven holes arranged as shown. This insulator is supported by a 0.025-in. molybdenum rod inserted in the centre hole. The heater, consisting of about 36 in. of 0.003-in. tungsten, is wound into a helix having an outside diameter of 0.013 in. After dip-coating by well-known techniques the heater is threaded through the six outer holes in the insulator. A suspension of aluminium oxide is then injected into the holes in the insulator so that on final firing the heater becomes completely embedded. The cathode sleeve, which is necked down at one end as shown in Fig. 3, is slipped over the heater assembly and welded to the central molybdenum rod, which becomes the cathode lead. By this means a uniform temperature from end to end of the cathode is obtained. Under normal operating conditions the heater temperature is approximately 1,100°C, which is very considerably less than that found in other valves.

Connexion of the heater to the leads from the stem presented a serious design problem. Crystallization of tungsten during and after welding, and mechanical strains developed by thermal expansion, are frequently the causes of heater breakage. This problem was successfully overcome by the means illustrated in Fig. 4. Short sections of nickel tubing are slipped over the cleaned ends of the heater coil and matching pieces of nickel wire are inserted as cores. These parts are held together by tack welds at the mid-points of the tubing. The heater stem leads are bent, flattened and formed to receive the ends of the heater, which are then fastened by welds as indicated in the drawing.

A serious attempt has been made in the design of the valve to keep to an absolute minimum the number of fastenings that depend entirely on one weld. The grids are of conventional form in which the lateral wires are swaged into notches cut in the side rods or support wires. The

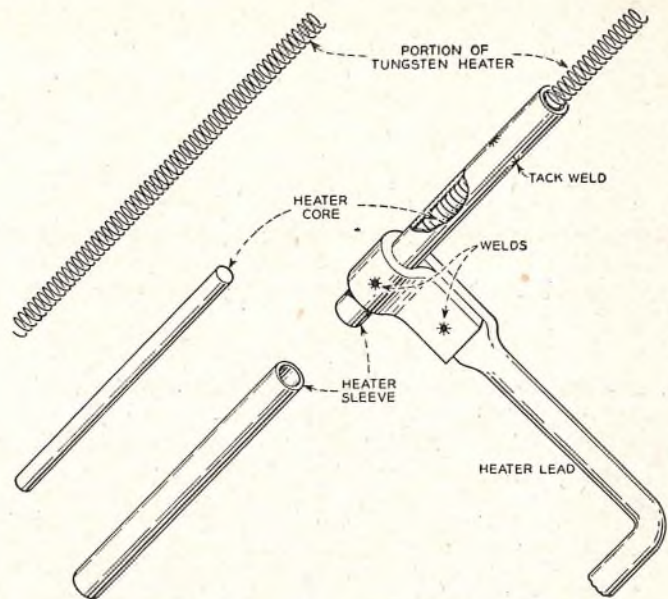

FIG. 4.—HEATER CONNEXION OF THE 175HQ VALVE.

side rods, as well as the lateral wire, are of molybdenum, which produces grids that are considerably stronger than those using more conventional materials.

The upper mica is designed to touch the bulb, which is made to accurate dimensions to receive and hold the mica firmly. The valve in its mounting will withstand a single 500g, 1-ms shock without apparent changes in mechanical structure or electrical characteristics. It is estimated from preliminary laying tests that, in laying operations, accidental or unusual handling would rarely result in shocks exceeding 100g.

Electrical Characteristics and Life.

The average operating electrical characteristics for the 175HQ valves are given in Table 1, and a family of anode-voltage/anode-current curves for a typical valve is given in Fig. 5 for a region approximating to the operating conditions.

TABLE 1

	Stages 1 and 2	Stage 3
Heater current, mA	220	217
Heater voltage, V	18.2	18.4
Heater power, W	4.0	4.0
Control-grid bias, V	- 1.3	- 1.4
Screen voltage, V	38	40
Anode voltage, V	32	51
Screen current, mA	0.3	0.3
Anode current, 1.4 mA	1.3	1.4
Transconductance, micromhos ..	980	1,010
Capacitances (cold, with shield)	All stages	
Input capacitance	9.2 pF	
Output capacitance	15.6 pF	
Anode-control-grid capacitance	0.03 pF	

The development of a long-life valve offers good opportunities to observe effects which are more likely to be missed where shorter lives are satisfactory. For example, some of the earliest valves made, after 20,000 hours on life tests, began to show a metallic deposit on the bulbs. Immediate concern for the lowering of insulation resistance across mica spacers prompted an investigation. The source was traced to the use of anodes made from a grade of nickel from which magnesium as a contaminant was evaporating. A change was made to molybdenum, which has been used successfully since that experience.

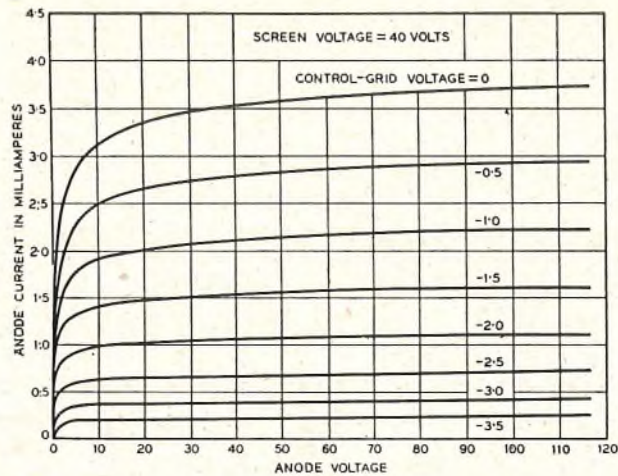

FIG. 5.—TYPICAL ANODE-VOLTAGE/ANODE-CURRENT CHARACTERISTICS FOR A TYPE 175HQ VALVE.

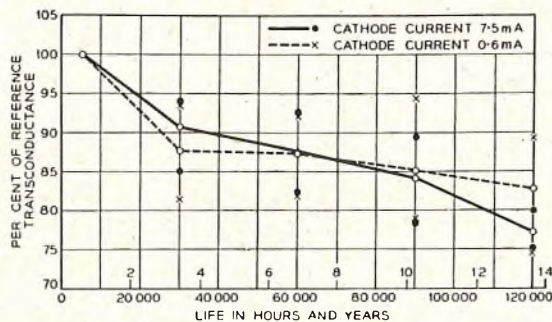

FIG. 6.—RESULTS OF LIFE TESTS ON EIGHTEEN 175HQ VALVES OPERATING AT TWO DIFFERENT CURRENT DENSITIES.

The effect on the thermionic life of operating at different cathode current densities was of interest. Life tests were started in which the cathode current drain in one group of valves was approximately 7.5 mA (2.8 mA/cm^2) and in another group the average cathode current was 0.6 mA (0.2 mA/cm^2). The results presented in Fig. 6, taken after 120,000 hours, or approximately 14 years, show that, at the cathode temperature of approximately 710°C † selected for the test, there is practically no current density effect in this 12:1 current range. The circles indicate average values, while the dots and crosses at each test point show the positions of the extreme valves of the group.

Similar tests set up to show the effect of operating at anode and screen voltages of 60V as compared to 40V indicate no essential differences in performance after eight years of operation.

Cathode temperature is one of the most critical operating variables affecting long thermionic life. As mentioned above, the early development objective was a cathode

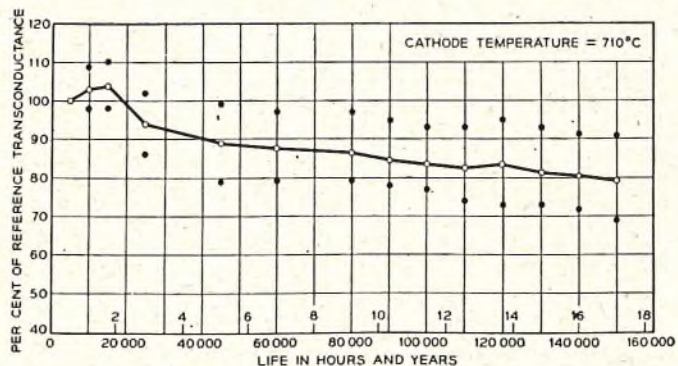

FIG. 7.—RESULTS OF LIFE TESTS ON SIXTEEN 175HQ VALVES OPERATING AT A CATHODE TEMPERATURE OF 710°C .

power of 5.0W, which corresponded to 710°C for the cathode design used at that time. The results of operating at this condition are illustrated in Fig. 7. No valves have been lost from the test where the direct cause has been failure of emission. Several were lost because of mechanical failure resulting from design defects which were subsequently corrected. It will be observed that at the end of 17 years the average transconductance is 80 per cent of its original value, and that of the poorest valve has dropped to 69 per cent. There is reason to believe that test-set difficulties may very well account for a large part of the variation shown in the first three years.

The cathode coatings used in all experimental and final valves for the Newfoundland-Scotland link of the transatlantic cable are the conventional double-carbonate coatings. The cathode base material is a proprietary "220" nickel, the particular melt used for the transatlantic cable being known as "melt 84." A typical analysis for melt 84 nickel cathodes is given in Table 2.

TABLE 2

Typical Analysis of "Inco 220" Nickel Cathode, Melt 84
(Analysis made prior to hydrogen firing)

Impurity	Amount %	Impurity	Amount %
Aluminium	0.008	Manganese	0.11
Boron	<0.004	Silicon	0.033
Cobalt	0.46	Titanium	0.032
Chromium	<0.005	Oxygen	0.0001
Copper	0.028	Sulphur	0.0016
Iron	0.093	Carbon	0.058
Magnesium	0.046		

The relatively high carbon content (0.058 per cent) of melt 84 cathode nickel is capable of producing excessive reduction of barium in the cathode coating.^{2,3} A treatment in wet hydrogen at 925°C for 15 minutes, prior to coating, reduces the carbon in the cathode sleeve to about 0.013 per cent.

Melt 84 was as close as was obtainable in composition to melts 60 and 63 previously used for the Key West-Havana valves. The results of up to five years of life testing were thus available on materials of very similar composition.

One common cause of valve deterioration with life is the formation of an interface layer on the surface of the cathode sleeve. It is known that the rate of development of this layer depends in a complex way on the chemical composition of the nickel cathode-core material. The effect of such a layer is to introduce a resistance in series with the cathode. This results in negative feedback and reduces the effective transconductance. Since the effect of a given feedback resistance in this position is proportional to transconductance, the relatively low value for the 175HQ valve tends to minimize this feedback effect. In addition, the low cathode temperature tends to reduce the rate of formation of interface resistance, and the relatively large cathode area tends to minimize the effect further. The final decision to use melt 84 was based on accelerated ageing tests which showed it to be superior to melts 60 and 63 from an interface standpoint.

The interface problem will be discussed further in a later section.

As the development of the valve proceeded, both the processing of the parts and the cleanliness of the mount assembly were improved and the cathode emission was increased. Life tests indicated that better thermionic

† All cathode temperatures referred to in this paper are "true" temperatures, not uncorrected pyrometer temperatures.

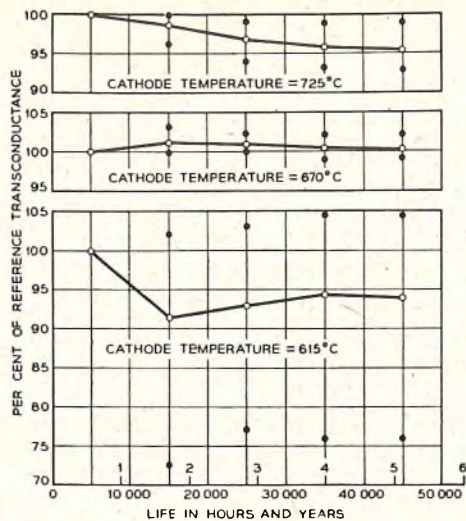

For each of the curves the cathode core material used was half from melt 60 and half from melt 63. The conditions in cable operation are essentially those represented by the centre curve.

FIG. 8.—RESULTS OF OPERATING 36 175HQ VALVES DIVIDED EQUALLY AMONG THREE DIFFERENT CATHODE-TEMPERATURE CONDITIONS.

life might be obtained by operating at a lower cathode temperature. Accordingly, a cathode power of approximately 4.0W was adopted, which corresponds to a temperature of 670°C. A life test, now 45,000 hours or about five years old, shows the results (Fig. 8) of operating groups of valves at three different cathode temperatures. This is a well-controlled test in that the valves for the three groups were picked from valves having common parts and identical fabrication histories. It may be noted that the average of the 725°C lot has lost approximately 5 per cent of the initial transconductance, whereas the 4.0W group after about five years has lost essentially none of its transconductance. The 3.0W (615°C) group shows serious instabilities in its performance. In some of the valves the cathode temperature has not been sufficiently high to provide the required emission.

The design of the repeaters in the Newfoundland-Scotland section of the cable is such that reasonably satisfactory cable performance would be experienced if the transconductance in each valve dropped to 65 per cent of

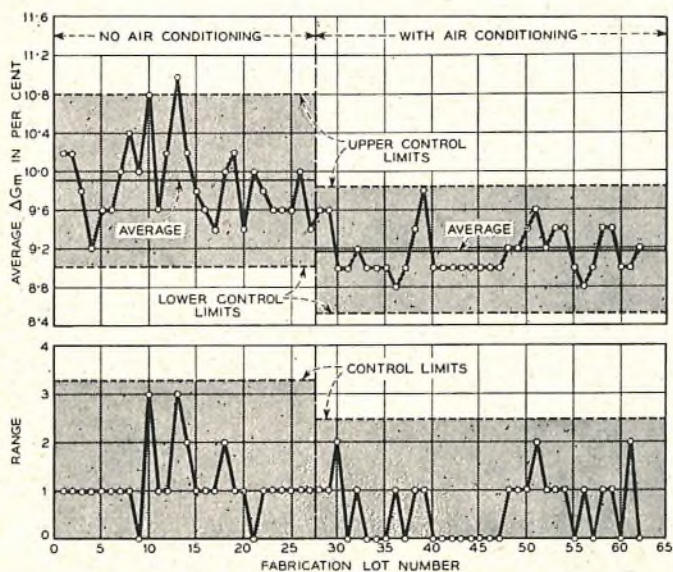

The per cent change in transconductance for normal heater current and a value 20 per cent lower is used as the measure of cathode performance.

FIG. 9.—CONTROL CHART SHOWING THE EFFECT OF AIR CLEANING ON THE CATHODE ACTIVITY LEVEL.

its original value. The life test performance data presented in Fig. 7 and 8, and other tests not shown, indicate that operation of the 175HQ tubes in the transatlantic cable at approximately 4.0W will ensure satisfactory thermionic performance for well over 20 years.

Mention was made that cleanliness in the assembly of the mounts was a factor which affected thermionic activity. Interesting evidence supporting this view was obtained during the fabrication of valves for the Key West-Havana cable. The quality-control type of chart reproduced in Fig. 9 shows the average change in transconductance between two set values of heater current for the first five in each group of approximately 28 valves made, the data being taken after 5,000 hours of ageing. A sharp improvement in thermionic emission was noted at a point on the chart where about one-half of the valves had been fabricated. An examination of the records, which are very carefully maintained, disclosed that the windows of the assembly room were sealed and air cleaning and conditioning were put into effect at the point indicated on the chart. No other changes in processing or materials occurred at this time. A second definite improvement in thermionic emission occurred when the work was moved from the location in New York City to the new and better-controlled environment at Murray Hill in New Jersey.

Fabrication and Selection.

All assembly operators on the production of 175HQ valves wore Nylon smocks to keep down the amount of dust and lint that might otherwise leave their clothing and get into the valves. Rayon-acetate gloves were worn when handling parts as a protection against perspiration. Rubber finger-stalls did not prove satisfactory because they covered too little area and, once contaminated, they did not absorb the contaminant.

The valves for the Newfoundland-Scotland section of the cable were made under the extremely close engineering supervision of many of the original development engineers. All materials going into them were carefully checked, and wherever possible they were tried out in valves. Experience under accelerated ageing conditions was obtained before these materials were used. For example, although during the development period all glass bulbs were used as received without any failures resulting, less than one-quarter of the bulbs bought for the actual cable job passed the inspection requirements. Each batch of heaters was sampled and results were obtained on intermittent and accelerated tests before approval for use.

The fabrication of the valve was carried out with extreme care by operators especially selected for the job. If normal commercial test limits were applied to the valves after exhaust, the yield from acceptable mounts would have been about 98-99 per cent. Yet only approximately one out of every seven valves pumped was finally approved for use in the cable. All valves were given 5,000 hours ageing, and electrical tests were made at six different times during this period. The results of these tests weighed heavily in the final selection. For example, a correlation between thermionic life and gas current had been established during the valve development period, and only valves having control-grid currents due to gas of less than 5×10^{-11} amp, were acceptable. This corresponds to a gas pressure of approximately 2×10^{-7} mm Hg. Very thorough mechanical inspections after the 5,000 hours ageing were made to ensure that there were no observable mechanical deviations that could cause trouble. The history of each group of 28 valves, from which prospective "candidates" for the cable were selected, was reviewed to see if any group abnormalities were found. If there was any suspicion of abnormality all valves in the group were ruled out for use in the cable.

As an aid in the selection of valves for the cable, all pertinent data were put on punched cards. It was then possible to manipulate and present the data in many very helpful ways that would otherwise have been wholly impractical from time and man-power considerations. An overall total of about half a million bits of information was involved.

Reliability Prospects.

Questions are frequently asked concerning the probability of valve failures in the system. There are two classes into which failures naturally fall—catastrophic failures and the type of failure caused by cumulative effects such as the decay of thermionic activity, development of primary emission from the control grid, or the build-up of conductance across mica insulators or glass stems.

The catastrophic failures might include such items as open-circuits caused by weld failures or fatigue of materials, short-circuits caused by parts of two different electrodes coming into contact or being bridged by conducting foreign particles, and gas leaks through the glass or along stem leads. Fortunately these failure rates have been lowered to a point where there are no sound statistical data available in spite of the substantial amount of life testing that has been done. In approximately 4,800 valves made to date, there have been four failures that were not anticipated by the inspections made. All four of these failures were of different types and occurred either at or before 5,000 hours of life. All four were of types more apt to occur during the early hours of ageing and handling.

Of the cumulative types of failure, life testing has indicated no apparent problem with either the growth of insulation conductance or primary emission from the grids. As indicated earlier in this paper, thermionic life results are such that there is reason to be optimistic that no failures will occur in 20 years.

VALVES FOR THE NOVA SCOTIA-NEWFOUNDLAND CABLE *Early Use of Commercial Receiving Valves.*

The development of submerged telephone repeaters in Britain has taken a somewhat different course from that followed in the United States. Off North America, deep seas are encountered as soon as the continental shelf has been passed. Consequently, emphasis has been placed from the beginning on the design of repeaters for ocean depths. In Britain, separated from many countries by only shallow seas, it was natural for development to start with a repeater specially designed for shallow water. Such a repeater was laid in an Anglo-Irish cable in 1944.

The valves used in the amplifier of that repeater were normal high transconductance commercial pentodes, type SP61. These were known, from life-test results, to last at least for two years under conditions of continuous loading. Their performance in the first and subsequent early repeaters exceeded all expectations. So far one valve has failed, and this from envelope fracture, after four years' service. There remain 23 of this type on the sea bed with a service life of 5-6 years, and three valves which have survived ten years.

All these SP61 valves were part of a single batch made in 1942, and their performance set a high standard, but it was found that subsequent batches did not attain the same standard. In 1946, therefore, the British Post Office was faced with the fact that future development of the shallow-water system of submerged repeaters was dependent on the production of a valve which could take the place of the 1942 batch of SP61 tubes. This situation led to the formation of a research team whose terms of reference were, specifically, to produce the replacement valve and, generally, to study the problems presented by the use of

valves in submerged repeaters. Apart from changes in the specific requirements, these terms of reference have remained unchanged from that day to this.

Replacement by the G.P.O. 6P10 Type.

Coincident with the rapid exhausting of stocks of satisfactory SP61 valves for submerged telephone systems, there arose the need for a valve for a submerged telegraph repeater. This latter requirement was complicated by the fact that the telegraph cable was subject to severe overall voltage restrictions which precluded the 630 mA heater current required for the 4-W cathode of the SP61. In order to avoid production of one type of valve for telephone systems and another for telegraph, it was decided that the replacement for the SP61 should have a 2-W cathode with a 300-mA heater.

During 1944 and 1945, a very successful miniature high-slope pentode, the CV138, was produced for the Services; its electrical characteristics were superior to those of the SP61 and, in addition, it had a 2-W cathode. It was therefore decided to base the replacement valves, electrically, on the CV138, at the same time retaining freedom to amend the mechanical features in any way which might seem to favour the specific requirements of submerged repeater usage, in particular, maintenance of the level of transconductance unchanged for long periods. Consequently, three major mechanical changes were made at the outset of the project. The miniature bulb of the CV138 was replaced by one of normal size (approximately 1 in. diameter and 2½ in. long), to reduce the glass temperature and so reduce gas evolution. At the same time a normal press-and-drop seal was substituted for the button base and ring seal of the CV138, since it was felt that, with the techniques available, the former would be more reliable than the latter. With the use of a normal press there immediately followed a top-cap control-grid connexion, so producing a double-ended valve in place of the single-ended CV138.

These three modifications and a number of major changes to improve welding and assembly techniques led to the valve type known as the 6P10 (a pentode (P) with a 6.3-V heater (6) of design mark 10). The 6P10 replaced the SP61 in the 18 shallow-water repeaters laid in various cables after 1951. There are therefore 54 valves type 6P10 in service on the sea bed with periods of continuous loading ranging from two to four years. There has been one failure due to a fractured cathode tape, and one other repeater was withdrawn from service to investigate a high-frequency oscillation associated with a valve. The oscillation cleared, however, before the cause could be identified.

The first 18 valves of this type used in repeaters had conventional nickel cathode-cores; appreciation of the problem of interface resistance led to the use of platinum as a core material for the next 36 valves. The steps leading to this radical change of technique will be described later.

Development of the 6P12 for Long-Distance Systems.

Although submerged-repeater development started naturally in Britain with shallow-water systems, it was inevitable that attention should ultimately turn towards transoceanic cables. The valve requirements for such long-distance systems differ from those for short shallow-water schemes in that operation at a lower anode voltage is essential. A new valve to replace the 6P10 was therefore unavoidable.

By the time emphasis started to shift in Britain from shallow-water to deep-sea systems some considerable experience had been gained on the production techniques required to fit a 6P10 type of valve having a platinum cathode-core for submerged-repeater usage. When it became apparent that a new valve had to be designed for the

first long-distance system, it was resolved to retain as much as possible of the 6P10 structure, in order to take full advantage of familiar techniques. The 6P10 was therefore redesigned for 60-V operation simply by a major adjustment to the screen-grid position and minor alterations elsewhere. The new valve became known as the 6P12 and was used in seven repeaters installed in the Scotland-Norway cable. This scheme was regarded as a proving trial for the Newfoundland-Nova Scotia section of the transatlantic project.

It has always been appreciated that the use of high-transconductance valves with closely spaced electrodes will involve a higher liability to mechanical failure by internal short-circuits. Practical experience in shallow-water schemes, where repeater recovery is a comparatively cheap and simple operation, has shown, however, that such risks seem to be outweighed by the economic advantage accruing from a valve capable of wider frequency coverage. In fact, a failure by internal short-circuit has not yet occurred on any shallow-water system.

This background of experience explains the British choice of a high-transconductance valve for deep-sea systems, but the greater liability to mechanical failure is acknowledged by use of parallel amplifiers. Confidence in this policy has been increased by the successful operation of the Scotland-Norway system.

Problems of Development of the 6P12 Valve.

Since 1946 the main preoccupation of the thermionics group of the research team has been a study of the electrical life processes of high-transconductance receiving valves. This effort has led to a conviction that all changes of electrical performance have their origin in chemical or electrochemical actions occurring in the valve on a micro or millimicro scale of magnitude. The form of change of most importance to the repeater engineer is decay of transconductance and this will be considered briefly as typical of the development effort put into the 6P12 valve.

Transconductance decay in common valves results from two separate and distinct chemical actions occurring in the oxide cathode itself. Both actions are side issues in no way essential to the basic functioning of the cathode, and it seems probable that both can be eliminated if sufficient understanding of their nature is available. The first action is the growth of a resistive interface layer between the oxide matrix and its supporting nickel core, already discussed briefly in the sub-section on electrical characteristics and life. This effect is assumed to be due to silicon contamination of the nickel core metal.

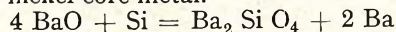

The resistance of the layer of barium orthosilicate rises as it loses its barium activator and approaches the intrinsic state. The effect of the interface resistance is to bring negative feedback to bear on the valve with resulting loss of transconductance. The second deleterious action is loss of electron emission from the oxide cathode by direct destruction of its essential excess barium metal by the oxidizing action of residual gases. Such gases result from an imperfect processing technology.

These two problems have been approached in the 6P12 valve in a somewhat novel manner. The conventional nickel core is replaced by platinum of such high purity (99.999 per cent) that the possibility of appreciable interface growth from impurities can be disregarded. The only factor to be considered is the appearance of high-resistance products of a possible interaction between platinum and the alkaline-earth oxides. Batch tests over a period of 30,000 hours have failed to show any sign whatever of such an action occurring, and British workers now regard the pure platinum-cored valve as being free from the interface resistance phenomenon.

The problem of avoiding gas de-activation of the cathode is a more difficult one and so far has been reduced in magnitude rather than eliminated. It is now appreciated that the dangerous condition arises from "gas generators" left in the valve and not from a true form of residual gas pressure left after sealing-off from the pump. These gas generators are solid components of the valve which give off a continual stream of gas over a prolonged period of time. The gas evolution rates are usually so small that they cannot be detected by reverse-grid-current measurement but they tend to integrate gas by absorption on the cathode and to destroy its activity. The gas generators are usually of finite magnitude and, depending mainly on diffusion phenomena, evolve gas at a rate which falls in approximately exponential fashion with time. The probability of transconductance failure is therefore highest in early life and tends to lessen with time as the generators move to exhaustion.

One particularly useful feature of the platinum-core cathode is its freedom from core oxidation during gas attack, and this leaves the valve free to recover from transconductance failure when the gas attack has passed. Fig. 10 shows the behaviour of a group of 50 valves which

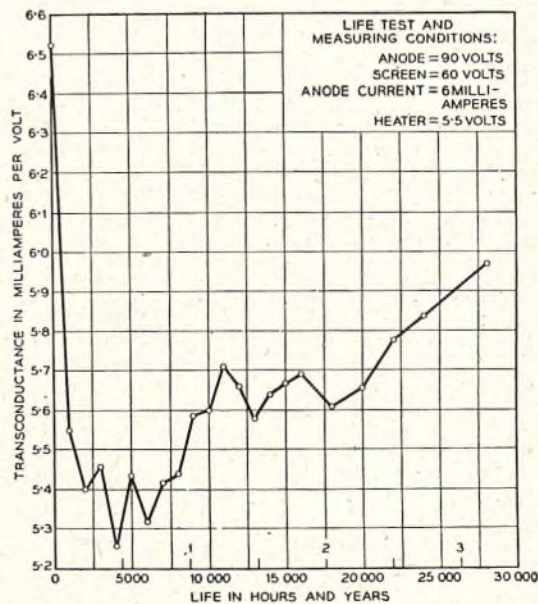

FIG. 10.—BEHAVIOUR OF A GROUP OF 50 VALVES (TYPE 6P12) DELIBERATELY LEFT WITH A "GAS GENERATOR".

have been deliberately left in possession of a component capable of generating carbon monoxide over a prolonged period of time. The curve shows the characteristic recovery of a platinum-core oxide cathode with the gradual passing of what is thought to be a typical gas attack.

One problem that has attracted much attention is the actual manner in which a platinum-core cathode recovers from a gas attack. The mechanism must involve the dissociation of a small fraction of the oxide cathode itself with the retention of barium metal in the oxide lattice and the evolution of oxygen. That such an essential mechanism does in fact exist has been proved by the slow accumulation of barium metal in the platinum core. This accumulation takes the form of a distinctive alloy of barium and platinum and occurs only when the cathode is passing current. The barium regenerative process seems, therefore, to be electrolytic in nature and, depending only on current flow and a stock of oxide, would appear to be virtually inexhaustible.

These few remarks are perhaps sufficient to give some idea of the lines on which the British research effort has run during the past decade. More detailed descriptions have already been presented elsewhere.⁴⁻⁷

Electrical Characteristics.

The main electrical characteristics of the 6P12 are shown in Fig. 11 and 12. The heater voltage used for both sets of curves is 5.5V, the same value as that used in the British amplifier.

Fig. 11 shows the change of transconductance with anode current, with screen voltage as parameter. An anode voltage of 40V and a suppressor voltage of zero correspond with the static operating conditions in the first two stages

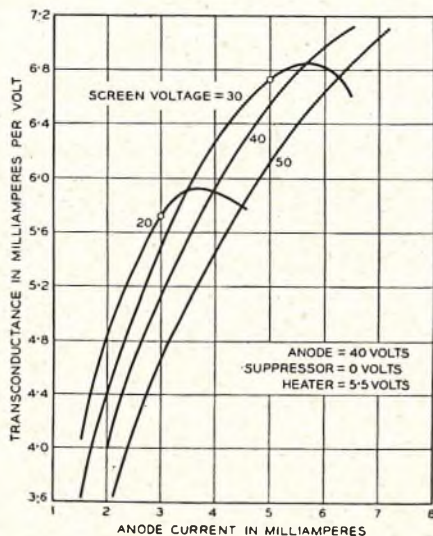

FIG. 11.—TYPICAL TRANSCONDUCTANCE/ANODE-CURRENT CHARACTERISTICS FOR A TYPE 6P12 VALVE (No. 457/6).

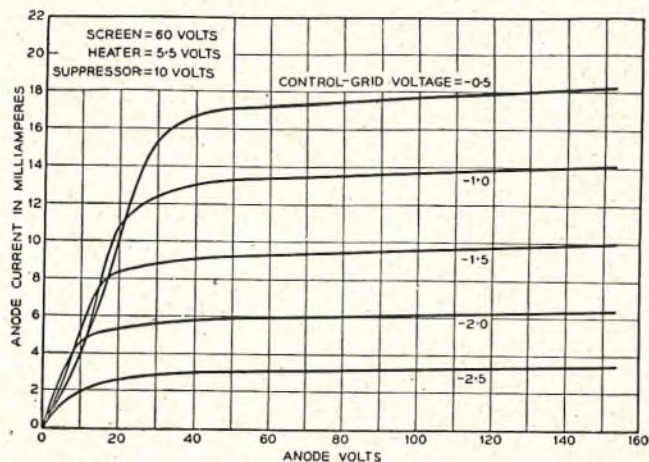

FIG. 12.—TYPICAL ANODE-VOLTAGE/ANODE-CURRENT CHARACTERISTICS FOR A TYPE 6P12 VALVE (No. 457/6).

of both the Scotland-Norway and the British transatlantic telephone amplifiers. The screen voltage and anode current of the first two stages of the British amplifier were chosen to be 40V and 3 mA respectively.

Fig. 12 shows the normal anode-voltage/anode-current characteristics for conditions corresponding to the output stage of the amplifier (static operating point, anode voltage = 90V, screen voltage = 60V, anode current = 6 mA). A final electrical characteristic worthy of comment is the level of reverse grid current. For all specimens tested at the time of selection, after about 4,000 hours of life test, the level is very low, being about 100 μ A per milliampere of anode current.

Life Performance.

The life performance of the 6P12 is still a matter for conjecture. The only concrete evidence available is the

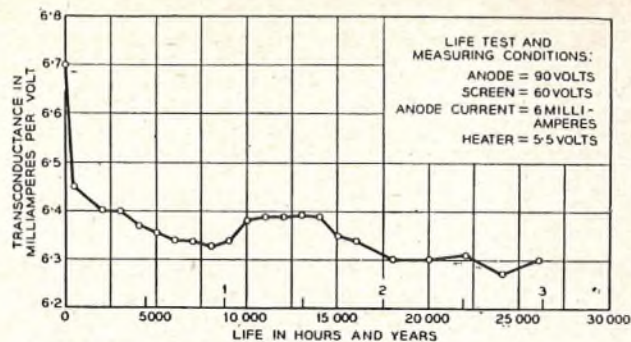

FIG. 13.—BEHAVIOUR OF A GROUP OF 92 6P12 VALVES OVER A PERIOD OF THREE YEARS.

behaviour of a group of 92 valves which were placed on life test some three years ago. The change of the average transconductance of this group (with anode current constant at 6 mA) is shown in Fig. 13. It may be clearly appreciated that there is no definite trend over the past year which permits any firm prediction of life expectancy. Examination of other valve characteristics is equally unproductive from the point of view of prediction of failure.

In the early stages of the test there were eight mechanical failures. The cause in all instances was identified and corrected in subsequent production before the start of the transatlantic telephone cable project.

Mechanical Characteristics.

The chief mechanical characteristics of the 6P12 have been mentioned before in that they are, as explained, very similar to those of the 6P10. A photograph of the interior of the valve is shown in Fig. 14.

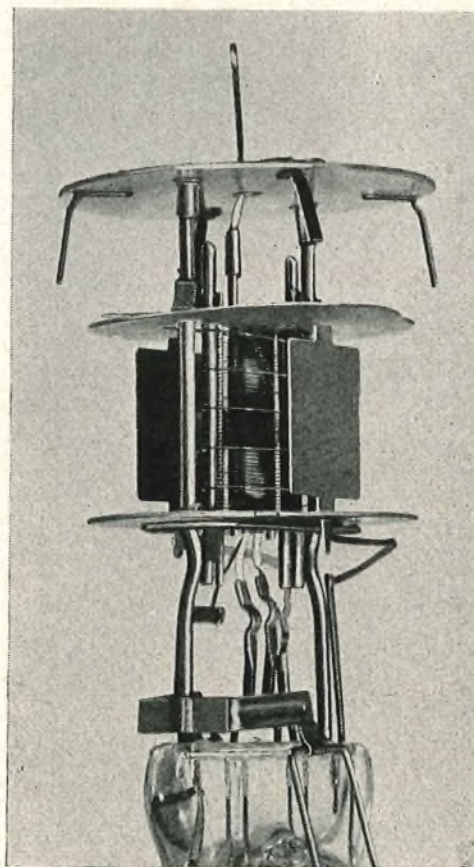

FIG. 14.—INTERIOR OF A 6P12 TYPE VALVE.

Valve-selection Techniques.

Not all the valves found after production to be potentially suitable for the British transatlantic telephone cable amplifier remained equally suitable after the life-test period of about 4,000 hours. A brief account of how the best were selected is given below.

The fact that every valve had to pass conventional static specification limits needs little emphasis here. This test was, however, supplemented by three additional types of specification. First, every valve was tested in a functional circuit, simulating that stage of the amplifier for which it was ultimately intended. Here measurements were made of shot noise (appropriate to first-stage usage) and harmonic generation (appropriate to the output stage) in addition to the usual measurements of transconductance, anode impedance and working point. Secondly, all valves were subject to intensive visual scrutiny in which some 80 specific constructional details were checked for possible faulty assembly. Thirdly, the life characteristics of transconductance, total emission and working point were examined over the test period of about 4,000 hours for unsatisfactory trends. Although this type of specification is more difficult to define precisely, its application is probably more rigorous and exacting than any of the previous specifications.

Only if a valve passed the conventional test and the three supplementary tests was it considered adequate for inclusion in a repeater.

CONCLUSION AND ACKNOWLEDGMENTS

The laying of the present repeated transatlantic cable represents by far the most ambitious use to date of long-life unattended thermionic valves. In this project alone there are 390 valves operating on the ocean bottom. If to this number are added the ocean-bottom valves from earlier shorter systems, those used in the Alaskan cable completed a few months ago and those to be used in the California-Hawaii cable to be laid in 1957, the total number on the ocean bottom will be about 1,000. The capital investment dependent on the satisfactory performance of these valves

is probably about one hundred million dollars—strong evidence of faith in the ability to produce reliable and trustworthy valves.

It is of interest to note that the two groups working on the valves on opposite sides of the Atlantic had no intimate knowledge of each other's work until after the designs had been well established. As a result of subsequent discussions, it has been surprising and gratifying to find how similarly the two groups look at the problems of reliability of valves for submarine cables.

The authors would be completely remiss if they did not mention the contributions of others in the work just described. These projects would have been impossible if it were not for the enthusiastic, co-operative and careful efforts of many people working in varied fields. Over the years, chemists, physicists, electrical and mechanical engineers, laboratory assistants, shop supervisors and operators have all made essential contributions to the projects. It would be impractical and unfair to attempt to single out for mention the work of specific individuals whose contributions are outstanding; there are too many.

References.

¹ COMPTON, K. G., MENDIZZA, A. and ARNOLD, S. M. Filamentary Growths on Metal Surfaces—"Whiskers," *Corrosion*, Vol. 7, p. 327. Oct. 1951.

² BENJAMIN, M. The Influence of Impurities in the Core-Metal on the Thermionic Emission from Oxide-Coated Nickel. *Philosophical Magazine*, Vol. 20, p. 1, 1935.

³ KERN, H. E., and LYNCH, R. T. Initial Emission and Life of a Planar-Type Diode as Related to the Effective Reducing-Agent Content of the Cathode Nickel. *Physical Review*, Vol. 82, p. 574, 1951.

⁴ METSON, G. H., WAGENER, S., HOLMES, M. F. and CHILD, M. R. The Life of Oxide Cathodes in Modern Receiving Valves, *Proceedings I.E.E.*, Paper No. 1137R, June 1951 (Vol. 99, Part III, p. 69).

⁵ METSON, G. H., and HOLMES, M. F. Deterioration of Valve Performance Due to Growth of Interface Resistance, *P.O.E.E.J.*, Vol. 46, p. 193, Jan. 1954.

⁶ CHILD, M. R. The Growth and Properties of Cathode Interface Layers in Receiving Valves. *P.O.E.E.J.*, Vol. 44, p. 176, Jan. 1952.

⁷ METSON, G. H. A Study of the Long-Term Emission Behaviour of an Oxide-Cathode Valve. *Proceedings I.E.E.*, Paper No. 1790R, Apr. 1955 (Vol. 102, Part B, p. 657).

Facilities in the United Kingdom for the Transatlantic Telephone Cable

This article describes the facilities that have been provided in the United Kingdom to ensure efficient utilization and trouble-free performance of the transatlantic telephone cable circuits. Part 1 commences with an outline of the agreements made with the American Telephone and Telegraph Company regarding the performance of the United Kingdom extension of the transatlantic cable from Oban to the main switching terminal in London; then follows a description of the facilities provided in the United Kingdom, which serves as an introduction to the remainder of the article. Part 2 describes the modifications and special overhaul work carried out on the inland section to ensure that the best possible service is given. Part 3 describes the repeater station at Oban, the terminal of the submarine section of the cable, including descriptions of the building, transmission equipment and power plant. The article concludes with a description, in Part 4, of T.A.T. Test, which is in Kingsway repeater station in London and is the focal point of the testing and control in the United Kingdom of the transatlantic telephone cable circuits.

Part 1.—General Planning and Performance Requirements

F. A. HOUGH, M.B.E., M.Sc.(Eng.), A.M.I.E.E.†

U.D.C. 654.15:621.395.44:621.395.5

TRANSMISSION OBJECTIVES

IN New York, in 1953, objectives for the transmission performance of the overall London–New York transatlantic telephone (T.A.T.) cable system were agreed, and the contribution to be expected from each main section was assigned; the share for the London–Oban section being as follows:

Overall Loss.—Standard deviation of net loss, 0.75 dB.

Noise.—2,250 picowatts or 1.25V psophometric voltage in the busy hour at a point of zero relative level.

Crosstalk.—The minimum crosstalk attenuation between equal-level points on any two speech channels should be at least 61 dB for sources of potentially intelligible crosstalk. The equal-level crosstalk loss between go and return directions of any 4-wire circuit used for voice-frequency telegraphy should be at least 45 dB. The equal-level crosstalk loss between go and return directions of a 4-wire circuit carrying separate broadcast programs in the two directions should be much greater than 45 dB (later agreed, 55 dB).

It will be observed that in general the standards are those adopted by the C.C.I.F., but the problem of maintaining a standard deviation as low as 0.75 dB on the 500-mile London–Oban link called for some special measures. The general requirements outlined above, and the special requirements of particular facilities, were responsible in their various ways for many of the complexities of routing and equipment used in the United Kingdom.

The adoption of 0.5 dB "via net loss"‡ for the section between London and New York for calls such as Boston–Paris entailed the introduction of 4-wire switching facilities at the London terminal. The arrangements made in London for 4-wire switching are described elsewhere.¹

DEVIATION OF NOMINAL LOSS AND FREEDOM FROM BREAKDOWN

The facilities required from the network between Oban and London were as follows:

- (a) Extension of 35 speech circuits (or possibly 70 if channel-conservation measures eventually become necessary) of standard nominal 4-kc/s band-width, with a standard deviation from nominal loss of only 0.75 dB. It was considered to be highly desirable that the speech circuits should remain assembled in 12-circuit groups, so that, apart from other considerations, an end-to-end London–New York 84.08 kc/s group pilot signal could be incorporated.

† Chief Regional Engineer, London Postal Region, formerly Assistant Staff Engineer, Transmission and Main Lines Branch, E.-in-C.'s Office.

‡ Via net loss—the loss of a trunk circuit when it is used as an intermediate link in a switched trunk-circuit connexion.

- (b) Extension of two separate half-channels (nominally 2 kc/s) to provide multi-channel voice-frequency telegraph circuits.
- (c) Extension of two telephone speaker and two telegraph circuits for maintenance purposes.
- (d) Extension of up to six music circuits (three in each direction) of up to 10-kc/s band-width.
- (e) Use of individual channels for facsimile transmission.

The first requirement, a major project financially but one which was the most straightforward to achieve, was the provision of carrier groups north of Glasgow since the existing Glasgow–Oban cable was essentially only an audio cable with some 1 + 1 carrier facilities. It was decided to provide the groups between Glasgow and Oban in a new line-regulated coaxial-cable system with no-break power supplies, on a gas-filled cable with two pairs of tubes, the second pair to be equipped as a standby and provided with change-over facilities. Other considerations, indicated below, decided that the cable should also provide screened pairs for music circuits. At the same time a newly developed carrier-generating equipment promised to be available and efforts were made to install the first system in Oban to supply all the station requirements, including those of the American cable system equipment. This carrier-generating equipment² is designed to provide a highly reliable service.

An alternative carrier route out of Oban is obviously desirable. Twelve-circuit or 24-circuit carrier routes link both Glasgow and Edinburgh to Inverness, north of Oban, but it is not yet possible to fill in the gap between Oban and Inverness. Consequently, if there is complete cable failure between Glasgow and Oban the first reserve must continue to be the audio pairs in the Glasgow–Oban–Inverness cables. For this and for other purposes channel equipments are provided at Oban in order to extend the transatlantic circuits on an audio basis into the United Kingdom network. Corresponding channel equipments are required in Glasgow and there are complete change-over facilities to enable 24 telephone circuits to be routed on audio plant between Glasgow and Oban. As a last resort switching arrangements have been made to enable eight transatlantic telephone circuits to be routed via Inverness in the event of failure of both the new coaxial and the old audio cables between Glasgow and Oban. There is appropriate routing of cables around Oban to avoid having all outlets in one duct track.

From Glasgow southwards it will not be possible to provide coaxial routing all the way to London until the new Manchester–Glasgow coaxial cable system is completed. In order to provide complete reliability, six 12-circuit groups are provided by different routes to London, three via Edinburgh and Carlisle, and thence to Leeds, and three via Carlisle and Manchester. These 12-circuit

groups have been provided on 12/24-circuit carrier telephone routes throughout and great efforts were made to finish conversion from 12-circuit to 24-circuit working and other work on these routes prior to the date of lining-up. The special measures taken on these routes to ensure reliability and to endeavour to meet the standard deviation requirement are described in Part 2.

The arrangements made at both London and Oban allow for both working and standby routes for each 12-circuit group to be active; that is to say, to carry the traffic simultaneously, with pilot signals on each displayed at the incoming end. The control and testing officer thus receives immediate indication of failure of one route and can pick up the other route without co-operation from the sending end. Details of these arrangements are described with the station equipment in Part 3. It is possible that in due course semi-automatic high-speed switching will be introduced.

In order to achieve freedom from interruption due to power-supply failure and variations at Oban, and also to provide the necessary special power facilities required by the American equipment there, a very extensive and elaborate power-supply system has been installed which occupies more than half of the total accommodation provided for equipment. The power plant is described in Part 3.

TELEGRAPH FACILITIES

At the first meeting held to discuss inland routings it was laid down that the objective should be to "provide a telegraph link as reliable as that given by the direct current transmission on heavy-gauge wires; that is to say, as good as the Western Underground."

Regrettably, the multiplicity of joints and components in h.f. systems and their power plants, coupled with the fact that these are all accessible to deliberate or accidental interference, inevitably make any h.f. systems fall short of this ideal. Too many short breaks, perhaps not detrimental to telephone working, but sufficient to cause serious inaccuracies in telegraph signals, might be experienced. Consequently, two audio circuits on different routes were assigned as main and reserve circuits. This entailed special arrangements being made at Oban for the injection and extraction of the telegraph half-channel used for multi-channel voice-frequency telegraph working to Montreal. The arrangement is such that this channel also retains its place in the 12-channel group to London and can be used there as a second reserve route if both audio circuits fail.

SPEAKER CIRCUITS

The maintenance speaker circuits are routed out-of-band in the submarine cable system and are injected and extracted from the cable system at a point as near to the cable head as possible. The same considerations dictate that separate routings be assigned between London and Oban. The London-New York point-to-point telegraph circuit and the omnibus telegraph circuit occupy two channels of a 3-channel frequency-modulated voice-frequency telegraph system between London and Oban.

PROGRAM CIRCUITS

It is explained elsewhere³ why the position allocated to music channels in the transatlantic group-frequency spectrum would not be continued inland in the United Kingdom, and why, in addition to considerations of reliability afforded by audio circuits, alternative audio routings were decided upon between Oban and London, leaving the music-in-band equipment in Oban.

This injection and extraction of program circuits, with the attendant switching problems and the possible effect of program circuits, on telegraph circuits introduced considerable complexities of equipment at Oban.³

The work entailed in bringing the program circuits up to a high standard is described in Part 2.

T.A.T. TEST

It was recognized that special testing and patching facilities for these important circuits necessitated special arrangements not consistent with simply adding them to, for example, Continental Test. Full-time attention would be required if the best possible use were to be made of the pilot and alternative routings to reduce the duration of interruptions to a minimum. Also to be considered were the control and testing arrangements for the 4-wire switching equipment, for the voice-frequency telegraph equipment, for the circuit extensions to the operating positions at Wood Street, and their alternative routings and facilities, and for the part-time program and facsimile facilities. All these indicate the need for a special test room adjacent to the carrier terminal and to the semi-automatic equipment. This has been provided and is described in Part 4.

ACKNOWLEDGMENT

In compiling the foregoing introduction to this article, assistance was received from most of the authors of the remaining parts of the article and acknowledgment is therefore due to these authors.

Part 2.—Improvements to the Inland Trunk Network

U.D.C. 621.395.332.3

INTRODUCTION

EXCEPT for the specially-provided Glasgow-Oban coaxial cable and equipment, plant which was provided originally for the inland service is used to carry the transatlantic telephone cable circuits between Oban and London. To give the best possible service on this inland section some modifications and special overhaul work has been carried out on the plant south of Glasgow.

The reasons for carrying out special work on the inland section were four-fold. First, the target performance proposed for the overall London-New York circuits allowed

† Temporary Senior Executive Engineer, Transmission and Main Lines Branch, E.-in-C.'s Office.

C. E. E. CLINCH, B.Sc.(Eng.), A.M.I.E.E., F.S.S.†

only a relatively small variation with time of transmission loss for the United Kingdom inland section. The target figure for the standard deviation of the variation of transmission loss for the inland section is about half that normally present on the national network. Secondly, utmost reliability is required and therefore, in addition to providing alternative routes, a special overhaul was made of all equipment through which the transatlantic circuits are routed. Thirdly, to minimize the amount of interference to the circuits it was desirable that many equipment changes that would have been made during the next few years were expedited to ensure completion in advance of the opening of the transatlantic cable service. Fourthly,

because the London-Oban group sections are only part of much larger carrier groups, and so that replacement circuits can be introduced with minimum disturbance to any circuits in traffic, special attention was given to the equalization of the sections.

IMPROVEMENT OF THE CARRIER GROUPS

The circuits could not be provided between London and Glasgow immediately the decision on the routing was taken because the plant could not be released from the inland trunk service and the conversion from 12-circuit to 24-circuit carrier working was in progress at the time. As each section became available all equipment was overhauled, making maximum use of the now well-established vibration testing methods.⁵ As each section was completed the lines were monitored at 60 kc/s by a recording decibel-meter and every change in level investigated and whenever possible the cause removed.

Equalization.

When 24-circuit working was introduced it was known that the line equalizers would not exactly fit the cable characteristics and the spread of the gain/frequency response would accumulate to about 2.5 dB per 100 miles.⁶ Equalizers to reduce this could not be designed immediately because the introduction of 51-type equipment and the manufacture of equipment by other contractors might have changed the shape of the characteristics to be equalized. Residual equalizers have now been designed and fitted on the T.A.T. routes and the spread of the gain/frequency response over the Group 1 band (12-60 kc/s) between London and Glasgow (400 miles) has been reduced to 0.7 dB.

The effect of temperature changes on the carrier cable has been discussed elsewhere.^{6, 7} The effects on the inland 12-channel groups were overcome temporarily by routine adjustment of all the channel amplifier gains. Temperature equalizers designed to compensate for the change in cable attenuation with changing temperature have now been made for the national network and have been fitted on the transatlantic groups. These equalizers are mounted on the same panel as the residual equalizer. These two equalizers have been engineered as "51-type" construction (Fig. 1) and space is provided to fit them readily on "51-type" equipment. Many of the stations are of earlier forms of

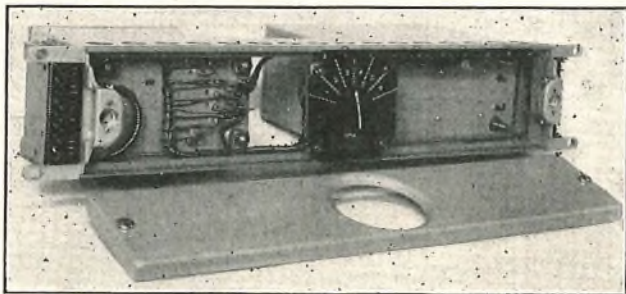

FIG. 1.—24-CIRCUIT TEMPERATURE AND RESIDUAL EQUALIZERS.

construction, however, and adapter plates had therefore to be provided. Where space did not allow the fitting of these panels the main line equalizers were replaced by miniaturized equalizers to allow the temperature and residual equalizers to be fitted.

Through-group equalizers have been fitted at Glasgow and Oban and their use has enabled the spread of the gain/frequency response of the London-Oban group sections to be reduced to ± 0.5 dB.

These equalizers are also of 51-type construction.

Level Stability.

In order to restrict level variations to within a standard deviation of 0.75 dB, automatic-gain-control equipment has been provided, operating from the 60-kc/s pilot on the 24-circuit line link. This pilot is stabilized at the sending end of every 24-circuit line link and is prevented from interfering with subsequent line links by the two separating filters that select Group 1 and Group 2 at the 24-circuit link terminals. No automatic-gain-control device that operates in either the group or 24-circuit line range is at present in general use on the inland network. The equipment had therefore to be specially developed for the T.A.T. groups. The development is based on a form of overhead carrier automatic-gain-control unit but with reduced range and

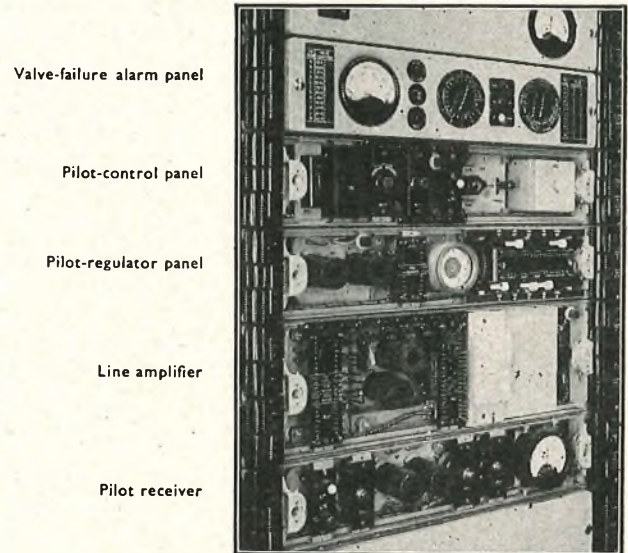

FIG. 2.—60-KC/S AUTOMATIC-GAIN-CONTROL EQUIPMENT.

providing only "flat" gain change. A general view of the equipment is shown in Fig. 2. This equipment reduced changes of ± 6 dB to ± 0.4 dB. If the pilot fails the gain of the equipment does not change.

Modifications to Reduce Interruptions.

Experience has shown that U-links are a cause of interruptions, either due to accidental removal by engineering working parties or due to poor electrical contact, particularly at low-signal-level points, in spite of cleaning and burnishing routines. To reduce the number of faults on the T.A.T. groups the carrier line-amplifier test-links were changed to provide facilities for by-passing the U-links with a soldered strap. Also, the current design of cable terminating racks did not permit easy testing of the phantom circuit without affecting the carrier circuits working on the pairs, and vice versa. The outline of the circuit on the old racks is shown in Fig. 3(a). Wherever possible these racks

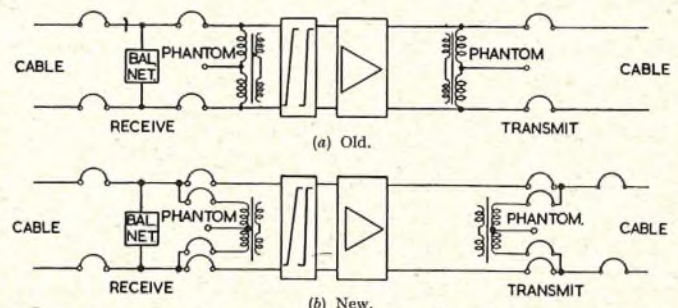

FIG. 3.—ARRANGEMENT OF U-LINKS ON CARRIER CABLE TERMINATING RACKS.

were modified to conform to the circuit shown in Fig. 3(b). This modification could not readily be applied only to the pairs actually carrying the T.A.T. groups and hence it was applied to all pairs passing through the rack. The modification entailed the fitting of U-link panels, re-cabling the racks and arranging for working line links to be taken out of service for the change to be made. To speed the work, distribution of much of the stores required was carried out direct from the manufacturer and supply depots to the stations.

Maintenance Facilities.

It is intended to use the level of the 60-kc/s pilot as a means of locating faults on all the 24-circuit line links in the United Kingdom by having 60-kc/s crystal filters to select the pilot and measuring or recording its level with a suitable amplifier-detector. Rack-mounted pilot-selective measuring equipments were installed at all sub-control stations, and intermediate repeater stations have all been provided with portable measuring sets.

An overall group pilot at 84.08 kc/s is available at each group distribution frame (G.D.F.) between London and New York or Montreal. In the United Kingdom this can be used to check the sections London-Glasgow and Glasgow-Oban. To assist with the tracing of faults in the terminal frequency-translating equipment associated with the coaxial line link a 72-kc/s test signal is provided; it can be measured throughout this equipment with a selective measuring set (Tester RP 3110).

All pilot measuring equipment is provided with facilities for recording the pilot levels to enable intermittent faults to be traced.

IMPROVEMENT OF OCCASIONAL PROGRAM LINKS

To improve the service given by the program circuits, particularly by the prevention of noise faults and fleeting interruptions, every item of plant was rigorously overhauled and each section of route monitored, as is done for the carrier groups. To further reduce interruptions the method of compensating for temperature effects, used on the inland program circuits, was modified to reduce the number of switching operations required at intermediate stations. All program circuit amplifiers were modified to reduce delay distortion, as described elsewhere.³ Delay equalizers will be added if further reduction of delay distortion proves necessary.

IMPROVEMENT OF VOICE-FREQUENCY TELEGRAPH LINE LINKS

The equipment used on voice-frequency telegraph circuits is normally connected via distribution frames to give maximum flexibility of use of the equipment. It was decided to dispense with this flexibility of connexion on the equipment allocated to the T.A.T. service and to cable it permanently so as to reduce the chance of unintentional interruption of the circuits.

POWER SUPPLIES

All connexions on power-distribution busbars and cables between the power plant and T.A.T. cable transmission equipment were examined and defects eliminated. The elimination of defective joints on rack fuse panels in particular resulted in an appreciable improvement in noise level on the circuits. Attention was given to battery connexions, smoothing filters and earthing arrangements where necessary. It was found that although power plant noise levels were, in general, within that specified for the plant, it was in many cases possible to effect considerable improvement by attention to minor defects.

A number of rearrangements of apparatus connexions were made at repeater stations that are common to both normal and standby T.A.T. links so that the apparatus panels on each link are separately fused.

CONCLUSION

The natural growth of the trunk network may prevent the T.A.T. groups staying permanently on their initial routings, although re-arrangement will naturally be kept to a minimum. It is hoped that, as a result of the overhaul carried out and the modifications made, the inland sections of the T.A.T. circuits will give a service equal to the high standards demanded by the transatlantic submarine cable project.

ACKNOWLEDGMENTS

It is desired to acknowledge the co-operation of the Regional and Area staff, who carried out most of the field work, and of the staff of the Exchange Equipment and Accommodation and the Transmission and Main Lines Branches of the E.-in-C.'s Office in carrying out the work described above. Thanks are also due to Messrs. J. Rhodes and C. E. Smith for assistance in the preparation of this article.

Part 3.—Oban Repeater Station

U.D.C. 621.395.724:621.315.28

ACCOMMODATION PROVIDED AT OBAN

THE site chosen for the landing of the submarine cables led to a decision to house the terminal equipment in a tunnel constructed in 60-ft high cliffs rising sharply from the beach of a small bay near Oban. Trial bores showed that the rock was crossed by a number of faults and that the angle of dip of the strata was small, which meant that rock falls were probable during the construction work. Nevertheless, it was decided to proceed with *in situ* concrete construction as this had advantages in speed and in cost.

R. E. G. BACK, A.M.I.E.E., N. F. FELTON, Associate I.E.E.
P. T. F. KELLY, B.Sc.(Eng.), A.M.I.E.E., W. F. J. HALL and
W. J. MARSHALL, A.M.I.E.E. †

Excavation was carried out by blasting, automatic loaders being used to transfer spoil to "dumper" lorries. When excavating for the main equipment tunnel large rock falls occurred and it was eventually found necessary to support the roof as work progressed by using fabricated

† Mr. Back is an Executive Engineer, External Plant and Protection Branch; Mr. Felton is an Executive Engineer, Exchange Equipment and Accommodation Branch; Mr. Kelly is an Executive Engineer, Transmission and Main Lines Branch; Mr. Hall is an Assistant Engineer, Exchange Equipment and Accommodation Branch; and Mr. Marshall is a Senior Executive Engineer, Power Branch, E.-in-C.'s Office.

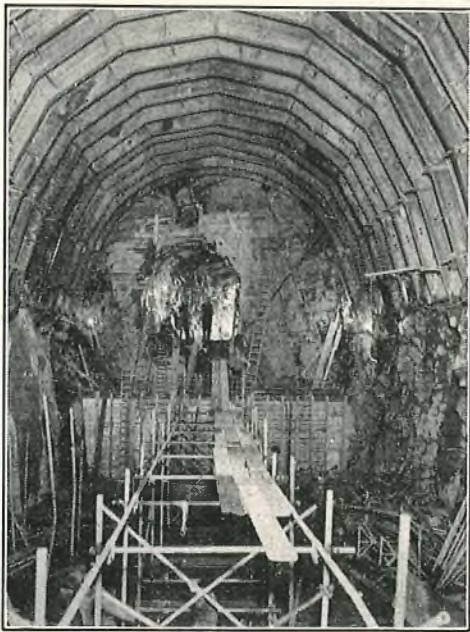

FIG. 4.—MAIN APPARATUS TUNNEL UNDER CONSTRUCTION AT OBAN/B REPEATER STATION.

joists at 4-ft 6-in. centres with corrugated iron sheets between them and the rock face (Fig. 4).

The main apparatus tunnel is 170 ft long and of horse-shoe cross-section (Fig. 5). The lining of un-reinforced concrete was placed in approximately 15-ft lengths, each length being cast in two parts, the main arch and the invert. The concreting of a main arch entailed placing and vibrating approximately 100 yd³ of concrete in a continuous operation.

Adjacent lengths of the lining were joined by forming construction joints of the type shown in Fig. 6. The first water barrier is a 5-in.-wide p.v.c. strip, which is embedded in the concrete; this is backed by a second barrier incorporating a drainage way, which is connected to 9-in. half-round drains in the invert of the tunnel. These drains

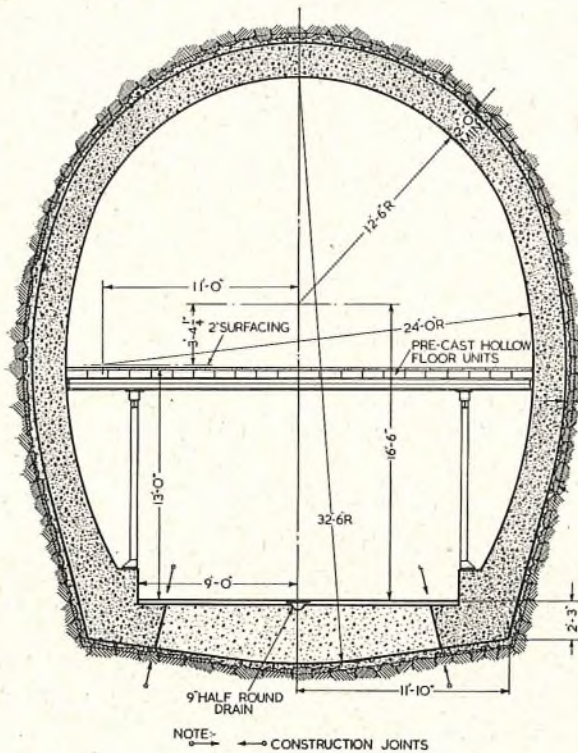
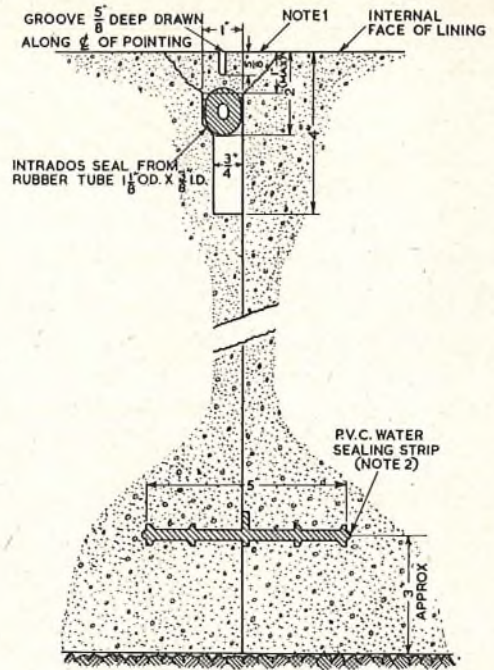

FIG. 5.—CROSS-SECTION OF TUNNEL.



Notes:

1. Joints are pointed in 1:1 Portland cement mortar containing a waterproofing compound.
2. P.V.C. water-sealing strip is continuous around and along the joints.

FIG. 6.—DETAILS OF CONSTRUCTION JOINT.

lead to a sump from which water can be pumped away. In practice it was found difficult to ensure that the outer water barrier was firmly embedded in the concrete and silting has occurred in the drainage ways. This silting has caused water pressure to build up and leaks to occur in the upper section of the tunnel. These leaks have been difficult to rectify permanently, but a method has now been incorporated to reduce the build-up of water pressure.

The apparatus tunnel was divided into an upper and lower floor by a suspended floor formed of pre-cast flooring slabs carried on steel portal frames. A 2-in. screed was placed on the slabs and standard floor finishes applied over this. The accommodation is sub-divided by brick partitions on the lower floor and by lightweight-concrete-block partitions on the upper floor. Special measures were taken to ensure that the entrances and ventilation shafts harmonize with their surroundings as the land forms part of a private estate.

The administrative and welfare block, provided by the Ministry of Works, consists of a single-storey flat-roofed

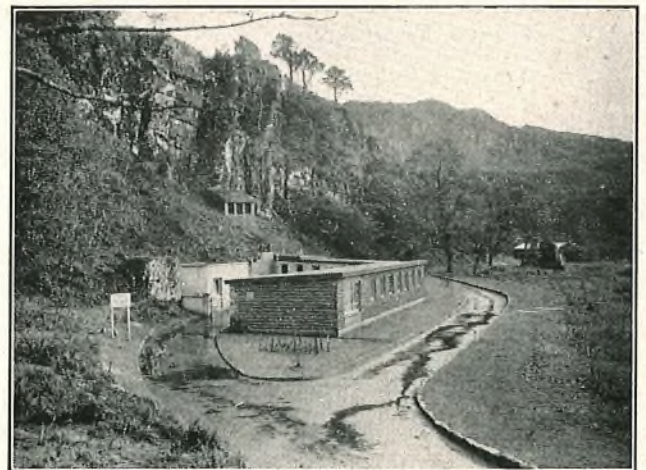

FIG. 7.—WELFARE BUILDING AT OBAN/B REPEATER STATION.

building about 84 ft long and 17 ft wide, and is erected to the west of the cliff face. The external surface of the walls is finished in stone to harmonize with the natural surroundings. The western side looks directly out to sea; the eastern side forms one boundary of a small yard, in the corner of which there is a garage. The southern end of the building connects with a covered way which gives protection from the weather to staff going to and from the tunnel. Fig. 7 shows the welfare building and the covered way connecting it with the tunnel. The accommodation provided by this building consists of offices, a rest room, two small bedrooms for staff obliged to be on call overnight, a store, apparatus-repair and normal-stock accommodation, and the usual toilet facilities.

Completion of the main works, including the provision of the necessary fittings, such as doors and cable brackets, took approximately 15 months from the time the decision was taken to place the T.A.T. cable equipment in a tunnel. Normally a work of this magnitude would take two years or more to complete and its early completion was only possible with the wholehearted co-operation of the Consulting Engineers, Sir William Halcrow & Partners, and the Contractor, John Mowlem and Co., Ltd.

TRANSMISSION EQUIPMENT

The transmission equipment provided at the new repeater station (Oban/B) in connexion with the transatlantic telephone cable system may be conveniently sub-divided into three sections, as follows:

- (i) the "Company"† equipment associated directly with the submarine cable systems;
- (ii) the "interconnecting" equipment consisting of special equipment designed and manufactured in the United Kingdom; and
- (iii) the standard "inland" equipment such as the coaxial terminal equipment and the carrier generating equipment.²

The general design of the interconnecting equipment, which was necessary to integrate the Company equipment with the standard inland network, was based on several distinct requirements. These were:—

† "Company" is used as a general term to describe those members of the Bell System concerned in the design and manufacture of the Oban equipment, i.e. The American Telephone and Telegraph Company, the Bell Telephone Laboratories and the Western Electric Company.

- (a) The h.f. interconnexion between the British Post Office and "Company" equipments would be at basic supergroup frequencies (408–552 kc/s).
- (b) The l.f. interconnexion would be at audio frequencies for the telephone speaker maintenance circuits and d.c. for the teleprinter maintenance circuits.
- (c) All circuits routed over the submarine cable system should be capable of translation to audio frequencies when required for emergency re-routing in the event of inland plant failure.
- (d) Any circuits which might be used as v.f. telegraph line links should be translated to audio frequencies and extended over audio plant within the United Kingdom.
- (e) Any program circuits should be translated to audio frequencies and extended over normal inland program links.
- (f) All special equipment essential to the continuous operation of the transatlantic telephone cable should be duplicated.

Description of H.F. Arrangements.

A simplified block schematic diagram of the arrangements at h.f. is given in Fig. 8.

Company equipment.—The main frequency band transmitted over the submarine cables is 20–164 kc/s, but an additional transmitted frequency band of 15–20 kc/s is occupied by speaker (telephone) and teleprinter (telegraph) maintenance circuits, the 4-kc/s band 16–20 kc/s being allocated to two speaker circuits and the 1-kc/s band 15–16 kc/s to two telegraph circuits. The submarine cable impedance is approximately 55 ohms and this is transformed to the standard submarine-terminal-equipment design impedance of 135 ohms balanced by means of a transformer associated with the cable terminating cubicles.

In the receive direction of transmission (see Fig. 8) the line frequency band of 15–164 kc/s is amplified and equalized so that an approximately flat gain/frequency characteristic is obtained under all submarine cable temperature conditions. At this point the frequency band of 15–20 kc/s is filtered off and the relevant speaker and teleprinter circuits extracted, whilst the frequency band of 20–164 kc/s is modulated with a carrier frequency of 572 kc/s, derived from the special carrier frequency generating equipment (Equipment, Frequency-Generating (E.F.G.), No. 20A⁴), to form the basic supergroup band of frequencies of

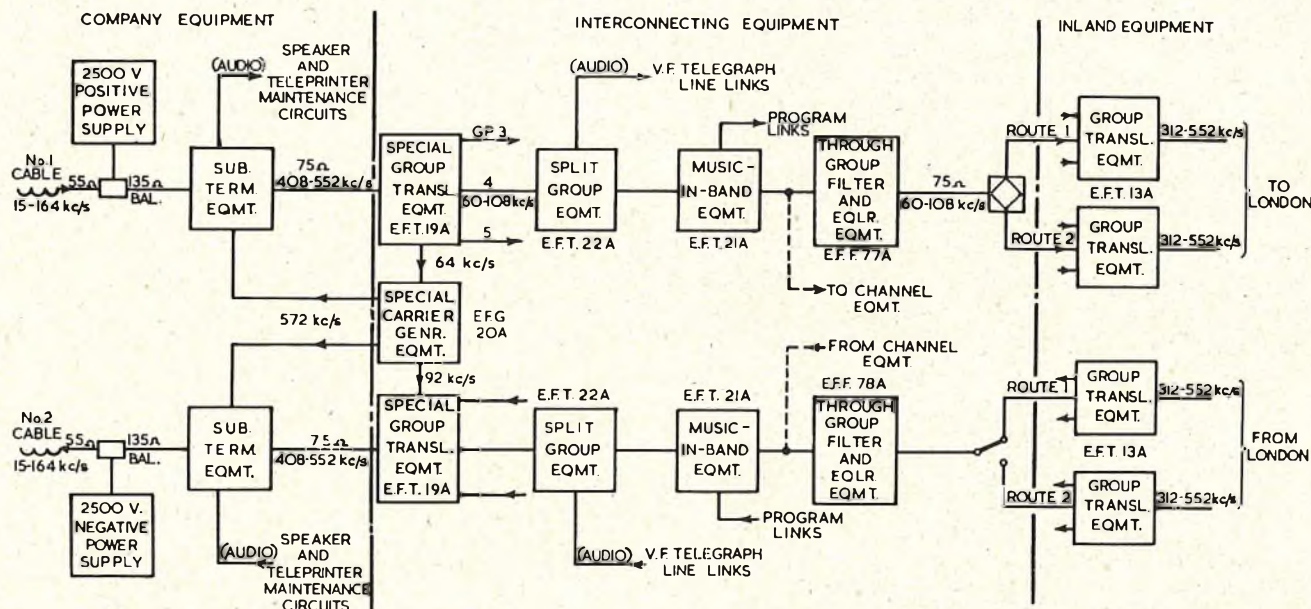

FIG. 8.—SIMPLIFIED BLOCK SCHEMATIC DIAGRAM OF H.F. CIRCUIT.

408-552 kc/s. This frequency band is then extended over 75-ohm h.f. tie pairs via an h.f. patch bay (equivalent to a supergroup distribution frame) to the special group translating equipment (Equipment, Frequency-Translating (E.F.T.), No. 19A⁴) forming part of the "interconnexion" equipment.

In the other direction of transmission the reverse process occurs; the three transatlantic groups, occupying the frequency band of 408-552 kc/s, being modulated with a carrier frequency 572 kc/s and the resultant lower sideband being transmitted to line together with the speaker and teleprinter frequency band of 15-20 kc/s.

Both working and standby equipments are provided throughout; in general, a hybrid coil is provided at the input and output of each amplifying stage to assist in patching and the making of terminated measurements without interrupting traffic.

Interconnecting equipment.—The interconnecting equipment consists of several specially developed items of equipment, among them being the split-group and half-channel injection and extraction equipment (E.F.T. No. 22A), the music-in-band equipment³ (E.F.T. No. 21A) and the special group translating equipment (E.F.T. No. 19A).

The special group translating equipment provides for translation of the three 12-circuit groups to and from the basic supergroup frequency range, 408-552 kc/s, and also provides for injection of 92-kc/s pilot signals into the east-west transmission of the three groups and for extraction of 92-kc/s and 64-kc/s pilots from the west-east transmission. The received 92-kc/s pilots, which are injected at Clarenville, are monitored for maintenance purposes and the 64-kc/s pilot which originates at Sydney Mines is also picked off by this equipment and extended to the special carrier generating equipment (E.F.G. 20A) where it is compared with a 60-kc/s pilot from London. This enables a comparison to be made of the overall frequency synchronization of the transatlantic cable system.

In view of the additional facilities provided by the special group translating equipment it was not possible to maintain the standard group levels of -8 dBr[†] and -37 dBr at the normal G.D.F. without additional amplification. Since it was obvious that the other items of interconnecting equipment would suffer from the same limitation it was decided to provide a "T.A.T." G.D.F. to which all the special items could be cabled and at which non-standard levels could be permitted; this G.D.F. would be connected via tie pairs to an "Inland" G.D.F. where standard levels would be maintained. Both working and standby group translating equipments are provided; in the transmit direction their inputs are connected together via a hybrid coil, and in the receive direction a high-speed switch is provided. Since the transatlantic system is, at this point, reduced to basic group frequencies the special equipment is no longer duplicated in full but, in general, a spare equipment is provided to replace any one of the working equipments if required.

One of the three 12-circuit groups routed over the transatlantic telephone system is a composite group called the "Split Group." This group contains $6\frac{1}{2}$ London-Montreal circuits and $5\frac{1}{2}$ London-White Plains (New York) circuits, of which the Montreal half-channel is used as a v.f. telegraph line link. The split group and half-channel injection and extraction equipment (E.F.T. No. 22A) at Oban enables this group to be split by the use of Company

[†] dBr—relative level; i.e. the ratio, in decibels, of the power at a point in a line to the power at the origin of the circuit (usually the 2-wire point).

[§] dBm0—decibels relative to 1 mW when measured at, or referred to, a point of zero relative level (usually the 2-wire point of the circuit).

$5\frac{1}{2}$ (86-108 kc/s) and $6\frac{1}{2}$ (60-86 kc/s) channel-bandwidth through-group filters, which had already been designed for use at Clarenville and Sydney Mines. The separate half-groups can be connected to standard channel-translating equipments (E.F.T. No. 11A), for emergency re-routing purposes, but normally the half-channels only are connected to the translating equipment for reduction to audio frequencies. In the latter condition the remaining channels pass through the equipment at group frequencies, suitable stop filters being provided in the injection circuit as required to suppress any signals present in the frequency spectrum to be occupied by the half-channels.

Music-in-band equipment (E.F.T. No. 21A) is provided on each of the three transatlantic groups. The band-width of the program channel may be either nominally 6.4 kc/s or 10 kc/s, depending on the number of telephone channels displaced. The group frequency band occupied by the music-in-band equipment is either 68-76 kc/s or 64-76 kc/s, depending on whether 2-channel or 3-channel operation is required, the carrier frequency in both cases being 76 kc/s. Since the Canadian portion of the split group is in the frequency band 60-86 kc/s, two music-in-band circuits are thus available between Oban and White Plains and one between Oban and Montreal. Included as part of the injection equipment are special 2-channel and 3-channel band-stop filters, which are inserted into the group path as necessary whenever a program transmission is required. The switching of these filters is so arranged as to cause no interruption to any telephone channels occupying the remaining frequency band.

Two separate through-group-filter equipments are provided, one in each direction of transmission. In the west-to-east direction the equipment (Equipment, Filter-Frequency (E.F.F.), No. 77A) includes through-group equalizers (Equalizers No. 32A) which are used to equalize any attenuation distortion introduced by the other equipments included as part of the interconnexion equipment. Since the setting of the equalizers would most likely be different for each group, 100 per cent spare equalizers, already set to the correct values, have been supplied. Amplifiers are also fitted on this equipment so that the desired standard levels may be obtained at the point of connexion to the inland equipment. In the other direction of transmission, the equipment (E.F.F. No. 78A) includes a 72-kc/s stop filter in each group path, in addition to standard through-group filters and amplifiers. These filters provide about 20 dB suppression of the 72-kc/s high level ($+3$ dBm0[§]) test signal used for in-service testing of the Glasgow-Oban coaxial cable system. Unless such suppression were provided the signals might interfere with the satisfactory operation of the submarine cable system and the music-in-band equipment.

Inland equipment.—The inland equipment consists of standard group translating equipment (E.F.T. No. 13A), standard carrier generating equipment (621 Series)² and the coaxial line equipment (C.E.L. No. 6A).

A simplified sketch of the group reference pilot (84.08 kc/s) arrangements at Oban is given in Fig. 9. In the west-to-east direction the three transatlantic groups may be selected from either the working or standby special group-translating equipments by means of a high-speed change-over switch located on a rack designated the T.A.T. H.F. Switching Rack, and after passing via the split-group equipment and the music-in-band equipment the groups are monitored by means of group-reference-pilot measuring sets mounted on the same rack. These measuring sets provide a permanent indication of the levels of the group reference pilots as received at Oban over the submarine cable system. On two of the groups the pilot originates at White Plains (New York) whilst on the third group—the "split" group—it originates from Montreal but may

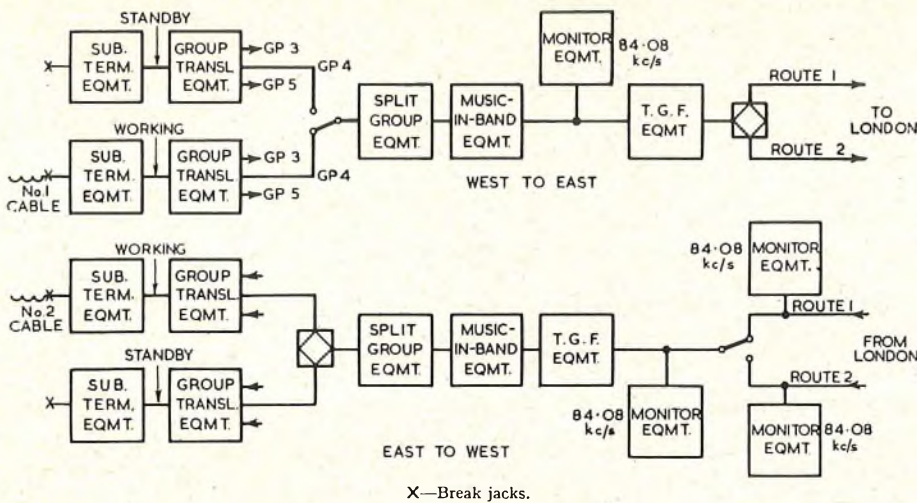

FIG. 9.—MONITORING AND CHANGE-OVER ARRANGEMENTS.

optionally come from White Plains depending on the position of switches at Sydney Mines. After monitoring, the transatlantic groups are connected to an inland h.f. switching rack, where by means of hybrid coils the groups are retransmitted over two routes towards the London terminal.

In the east-to-west direction of transmission, group-reference-pilot measuring sets are connected permanently to each of the groups on each of the two inland routes to provide a permanent indication of the level of the pilot received from London T.A.T. Test. Both routes are extended to the inland h.f. switching rack, where, by means of high-speed change-over switches associated with each group, either of the routes may be selected for each group and extended, after further monitoring, to the interconnecting equipment and the submarine cable system. After passing through the interconnecting equipment the groups are connected via hybrid coils to both the working and standby special translating equipment and thus to the submarine terminal equipment.

Description of L.F. Arrangements.

Speaker and teleprinter maintenance circuits (Fig. 10).—The cable frequency band of the speaker and teleprinter maintenance circuits, 15–20 kc/s, is extracted from the submarine terminal equipment, and by means of C5-type Company channel translating equipment is separated into two channels. Channel 1 feeds a Company “e.b. 2-channel bank” which further divides the channel into two separate half-channels—channel A and channel B. Due to filter cut-offs, the band-width of channels A and B is approximately

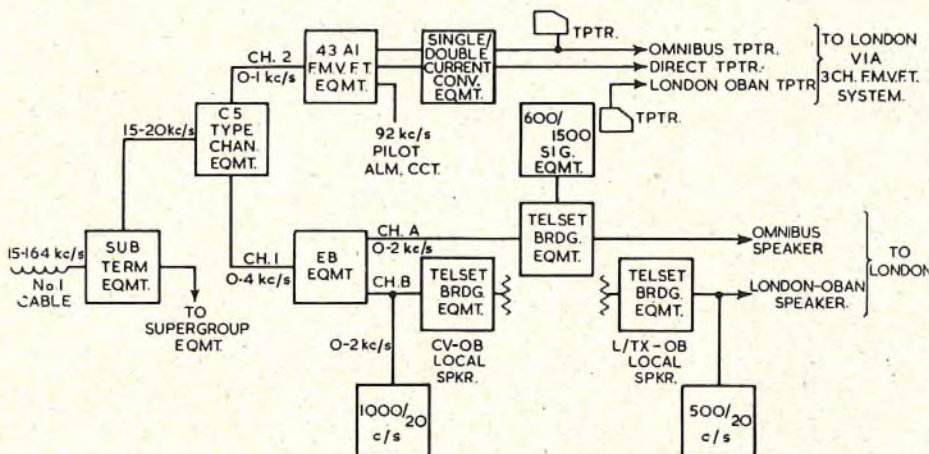

CV = Clarenville; L/TX = T.A.T. Test, London; OB = Oban.

FIG. 10.—SIMPLIFIED BLOCK SCHEMATIC DIAGRAM OF SPEAKER AND TELEPRINTER MAINTENANCE CIRCUITS (WEST TO EAST ONLY).

300–1,600 c/s. Channel B is used for a local Clarenville–Oban speaker and channel A is used for the London–Montreal–White Plains omnibus speaker circuit. The signalling on the local speaker is 1,000/20 c/s whereas on the omnibus circuit selective-calling 600/1,500-c/s equipment of Company design is used. An additional local speaker has been provided linking Oban directly with T.A.T. Test, the signalling being 500/20 c/s. On all the speaker circuits Company “Telset Bridging Units” are used to provide easy cross-patching and interconnecting facilities whilst meeting the requirement of 40-dB echo-path loss for the omnibus speaker. Channel 2 feeds Company-type 43A1 frequency-modulated telegraph equipment and the d.c. channel outputs from this equipment are connected to single-current/double-current conversion units before extension over a 3-channel frequency-modulated telegraph system to T.A.T. Test. Both the omnibus teleprinter circuit and the London–White Plains direct teleprinter circuit are routed over this system, Oban being one of the stations connected permanently to the omnibus circuit.

Program Channels.—Program channels (Fig. 11) may be provided between Oban and White Plains or Montreal by means of the music-in-band equipment provided at these stations. It was deemed necessary at Oban to provide program compandors which could be inserted into the program channel should the noise level become worse than –53 dBm at a zero-level point when measured on a psophometer (C.C.I.F. 1951 broadcast weighting). Since it was essential that electrically equivalent compandors should be used at all stations, Company compandors type 1A, specially modified for 10-kc/s program operation, have been used. To overcome the slight effect which the introduction of the compandors has on the attenuation/frequency characteristic, program equalizers have been provided for use as required.

Extensive program-monitoring equipment has also been provided in the form of volume-unit meters and B.B.C. peak-program meters. In general, peak-program meters will be used to measure the level of program transmission in the east-to-west direction of transmission and v.u. meters in the west-to-east direction of transmission. Standard 12-kc/s pilot monitoring facilities are provided where the program links are connected to inland circuits.

V.F. telegraph circuits.—The Montreal half-channel is translated to audio frequencies by means of the split-group and half-channel injection and extraction equipment (E.F.T. No. 22A). The frequency band-width occupied by the half-channel is nominally 2–4 kc/s. Eleven telegraph channels plus a pilot channel are provided in this range by means of frequency-modulated voice-frequency (f.m.v.f.) telegraph equipment at London and Montreal. Since it was decided to provide both main and reserve routes between London and Oban for this system it was decided to provide for parallel feeding of the routes in a similar manner to that provided for the h.f. groups. In

† Volume unit (v.u.)—the American unit of program volume, measured on a meter having a specific time constant.

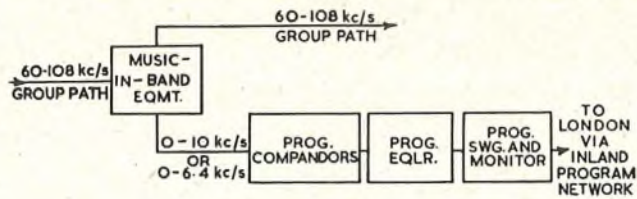

FIG. 11.—SIMPLIFIED BLOCK SCHEMATIC DIAGRAM OF PROGRAM CIRCUITS (WEST TO EAST ONLY).

order to conserve inland plant the 3-channel f.m.v.f. system carrying the teleprinter maintenance channels was associated with the half-channel over the London-Oban section and a pilot of 1,860 c/s was introduced on each of the routes. This pilot is conveniently situated between the frequency bands occupied by the two f.m.v.f. systems and it enables permanent monitoring to be provided. Alarms are actuated by the pilot so that immediate restoration of the link may be made should a fault occur on the working route.

Installation.

The layout of the transmission equipment in the repeater room was planned to cover not only the equipment requirements of the transatlantic telephone cable but also the requirements of the proposed Inverness-Oban coaxial system and an Oban-Tobermory radio link. No provision was made for the installation of audio equipment other than that necessary for the transatlantic circuits.

The 2,500V positive and negative rectifier/regulator cubicles are arranged in two suites along the room close to the entry point of the submarine cables, with the transmission equipment in several suites across the room beyond the power cubicles. The General Electric Co. designed and installed the superstructure and cable racking for the whole room under the initial station installation, including all the special racking necessary for the submarine cables and Company equipment. They also installed, under the guidance of two Western Electric Co. supervisors, all the Company equipment. Fig. 12 shows a view of the Company power cubicles with the transmission suite in the rear.

The suite of transmission equipment adjacent to the power cubicles consists of seven Company racks. These racks are single-sided; four, known as "duct" type and containing the h.f. equipment, being 1 ft 10½ in. wide, and the remaining three being the standard Post Office width of 1 ft 8½ in. and containing the l.f. equipment. The "duct" type racks are so called because of the vertical ducts formed by the flanges of adjacent racks; these ducts are used for carrying the inter-panel and external cabling.

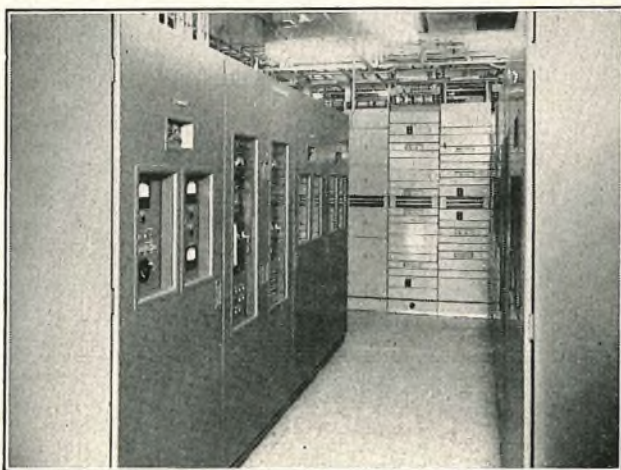

FIG. 12.—CABLE-CURRENT POWER CUBICLES.

The cables are not laced in because after replacement of the duct covers they are hidden from view. External cabling is taken directly to the panel with which it is associated instead of to a terminal strip at the top of the rack as in standard Post Office practice. The panels are screwed to the racks and all electrical connexions are soldered, few connecting links being provided. Test points associated with amplifiers or hybrid coils are concentrated on a centrally-located panel rather than on the individual panels. Power cabling for the suite would in Company practice have consisted of braided v.i.r. cables along the length of suite with teeing clamps screwed to the cables above the racks at which the particular supplies were required. This was not considered suitable for the Oban terminal and the General Electric Co. designed and constructed a light busbar system above the suite for the main and reserve 24V and 130V supplies required by the Company equipment.

The British equipment, apart from one suite of test and audio program racks, is of 51-type construction, fully a.c. operated. A view of the interconnecting equipment is shown in Fig. 13. Both the General Electric Co. and Standard Telephones & Cables were concerned in the installation of this equipment.

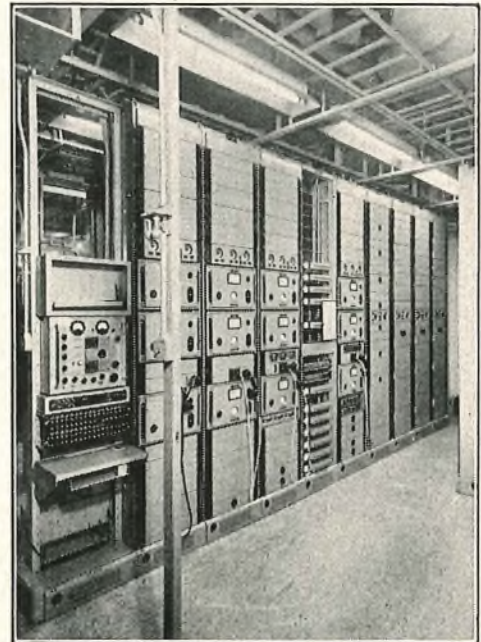

FIG. 13.—INTERCONNECTING EQUIPMENT.

Extensive alarm facilities have been provided at Oban for both the Company and British Post Office transmission and power equipments. Major and minor alarms have been provided in order that distinction may be made, by means of bells of different tones, between alarms necessitating immediate action in the submarine cable system and those associated with the standby and spare equipments. A special alarm rack was designed to meet these requirements.

The repeater room was made available for installation by March, 1955, and the installation of the superstructure was immediately commenced. Certain items of British equipment were also installed in order to provide facilities for audio testing on the submarine cable. The Company equipment arrived on site in April, 1955, and was installed by 1st July, 1955; it was then cabled to the British equipment and through tests made. When H.M.T.S. *Monarch* landed the end of the No. 1 transatlantic cable in August, 1955, at Oban, all was ready for through audio-to-audio tests between Clarendville and Oban.

The installation of the remaining British equipment continued throughout 1955 and 1956, completion being in July, 1956, in readiness for the commencement of through testing of all facilities by the 15th July, 1956.

POWER PLANT

Power for Oban/B repeater station is supplied by the North of Scotland Hydro-Electric Board from their high-voltage network; it is transformed at the sub-station on the site and distributed via a medium-voltage 3-phase 4-wire system to serve the telecommunications and accommodation services loads. Provision is made on the medium-voltage switchboard for the transfer of the loads to standby engine-generator sets.

The inland portion of the telecommunications load consists mainly of power packs requiring a single-phase a.c. supply at 240V. This is supplied from one of two 35-kW continuity sets, manufactured by the Electric Construction Co., Ltd., which are designed to eliminate interruption in the supply to the equipment arising from a failure of the public electricity supply. Each set consists of a mains-driven a.c. motor, a d.c. motor and an a.c. generator with its exciter, coupled in line mechanically, together with the control switchgear contained in two cubicles. All the machines of the continuity sets are provided with plain bearings. A thermostat is fitted in each bearing housing and is arranged to operate an alarm if a bearing becomes overheated. A block schematic diagram of the plant is shown in Fig. 14.

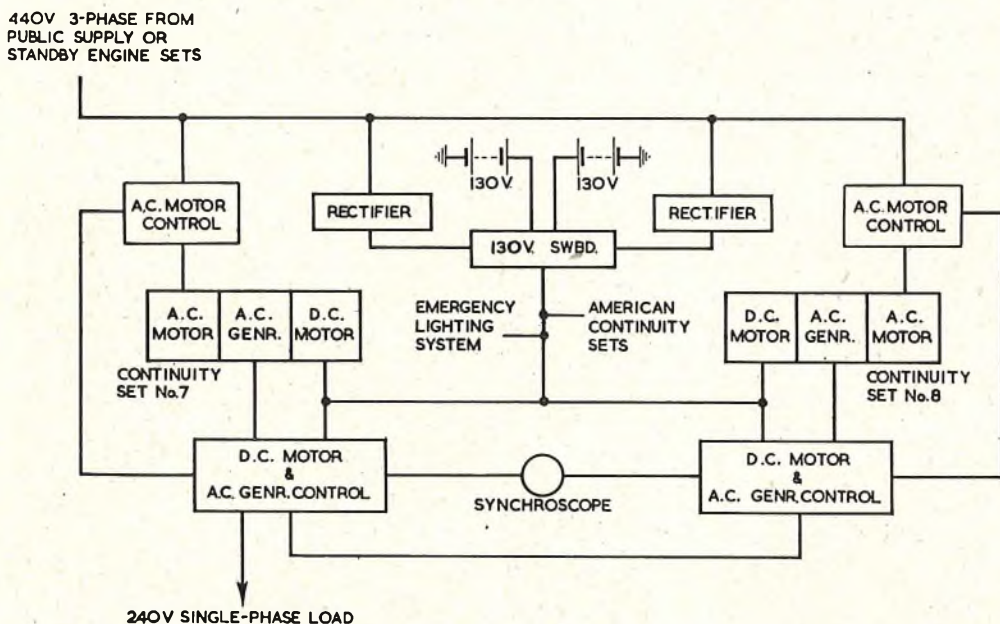

FIG. 14.—BLOCK SCHEMATIC DIAGRAM OF A.C. POWER PLANT FOR INLAND EQUIPMENT AT OBAN/B REPEATER STATION.

Normally the generator of the continuity set supplying the load is driven by the a.c. motor drawing energy from the public supply. An automatic voltage regulator controls the field current of the exciter to maintain the voltage of the a.c. generator within $\pm 1\frac{1}{2}$ per cent of 240V. The asynchronous motor is of the wound-rotor type and the output frequency of the set is 48 c/s when operating with the public supply at nominal frequency. A current of predetermined value is applied to the field circuit of the d.c. motor to ensure that the motor speed will be within the limits acceptable to the transmission equipment when the d.c. motor drive is applied by the closing of a contactor in the armature circuit. In the event of a failure of the

public supply the operation of a monitoring device in the a.c. motor-control cubicle closes this contactor, thereby causing the d.c. motor to take over the drive from the a.c. motor, which has in the meantime been disconnected from the public supply.

Fly-wheels are not used on the continuity sets. The drop in frequency to approximately 43 c/s for about 2 sec during a drive change-over period does not affect the performance of the transmission equipment. Adjustment of the field current of the exciter by the operation of the automatic voltage-regulator compensates to some extent for the fall in voltage which would result from this reduction in speed and prevents the voltage from falling below 95 per cent of the nominal value during these periods.

An alarm is operated if the output frequency varies outside the limits of 45 to 49 c/s. As the frequency range of the public supply is 48 to 51 c/s the speed of the set when it is being driven by the a.c. motor will lie within the acceptable range, but the fall in voltage as the battery becomes discharged during a prolonged period on d.c. motor drive will result in a reduction in speed. If this is sufficient to operate the alarm, correction is applied by the manual adjustment of a rheostat in the supply to the motor field coils. The d.c. motor is used to drive the set until an a.c. supply becomes available from either the mains or a standby engine set. An automatic motor-starter is then operated from a control press-button and on completion of the starter operations the drive is shared between the a.c. and d.c. motors until a second press-button is operated to trip the contactor controlling the supply to the armature of the d.c. motor.

The plant functions in the same way to cover an interruption in the supply to the a.c. motor caused by switching operations on the restoration of the normal supply after a standby engine-set has been used.

The continuity sets are used alternately for weekly periods and the change-over from one to the other is made, without affecting the supply to the transmission equipment, by connecting the generator outputs in parallel for a short period. The idle set is run up to speed under the control of the a.c. motor-starting gear. A press-button is then operated to transfer the drive to the d.c. motor and its speed regulator is adjusted to obtain synchronized outputs from the a.c. generators. The outputs are then connected in parallel, the outgoing machine is shut

down and the incoming set is restored to a.c. motor drive. Fig. 15 shows the continuity sets and the cubicles containing the control gear. The machine in the foreground is the exciter for the a.c. generator, which is next in line. The d.c. motor is at the far end of the shaft. The cables clamped to the bed plates connect the bearing thermostats to the alarm circuit. The cubicles alongside the continuity sets contain the a.c. motor-starting and supply-failure-detection equipments. Those facing the ends of the sets contain the control gear for the d.c. motors and a.c. generators together with monitoring equipments which operate an alarm if the output of an alternator deviates from the prescribed values. Instruments to indicate voltage, current and

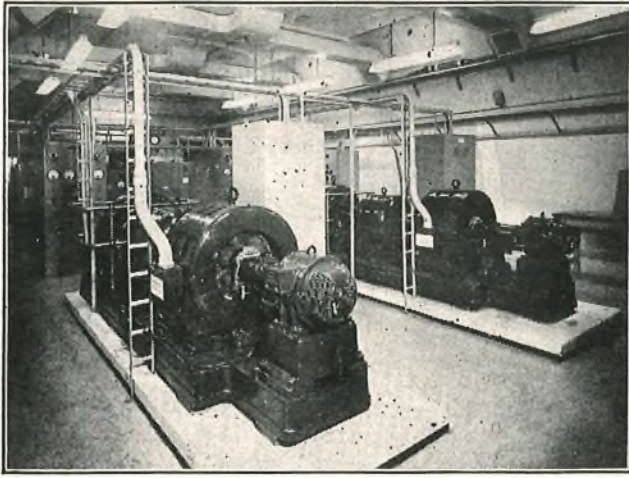

FIG. 15.—A.C. CONTINUITY SETS AND CONTROL CUBICLES.

frequency values for the associated generator are provided on each cubicle. A d.c. voltmeter is used to measure either the voltage of the motor battery or the difference between this supply and the voltage generated by the d.c. motor under a.c. drive conditions. This difference of approximately 5V is adjusted by the operation of the motor-field rheostat, referred to earlier, to a predetermined value to ensure that the speed of the set will be satisfactory in the event of a transfer to d.c. drive. Lamps mounted on each cubicle provide an indication of the source of an alarm arising from a particular set.

The battery that supplies the d.c. motors was manufactured by Chloride Batteries, Ltd. It consists of two sets of two rows of 68 enclosed-type cells connected to form two batteries. These are normally coupled in parallel on the switchboard, providing a battery having a total capacity of 3,360 Ah. This is sufficient to maintain the nominal 130V supply serving the continuity sets, the emergency lighting system and the requirements of the submarine cable section for at least six hours. This provides an ample margin against the possible contingency of the engineer on duty requiring assistance to start the engine standby plant during a failure of the public supply. There is a continuous drain of about 25A on this supply under normal conditions and this is supplied from one of two mercury arc rectifiers with automatic-voltage-regulating equipment and with the batteries connected to float across the load. The second rectifier is a spare and is used for giving periodic conditioning charges to the batteries.

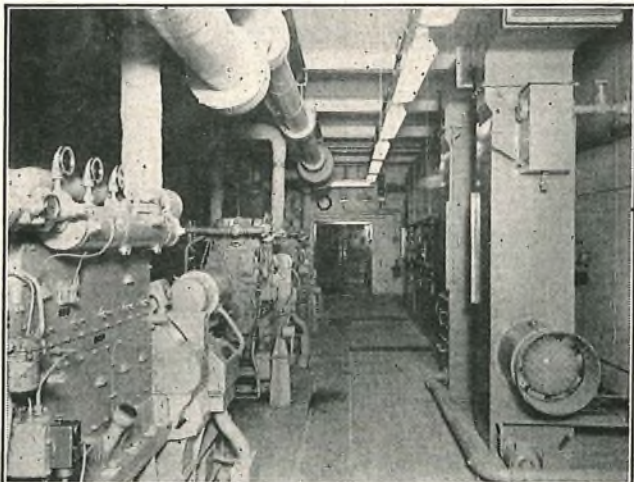

FIG. 16.—ENGINE-GENERATOR SETS AND MEDIUM-VOLTAGE POWER SWITCHBOARD.

Small self-contained floating battery plants provide 130V and 22V feeds to the submarine-cable terminal equipment and auxiliary services. This separate 130V d.c. source is used for the supply to the terminal equipment so as to prevent interference with the telephone circuits arising from the operation of the d.c. motors of the continuity sets.

The switchboard controlling the distribution of the medium-voltage supply to the station is on the right of Fig. 16. Normally the load is supplied via a single feeder between the transforming sub-station and the switchboard. In the event of a failure of the public supply the load is split and transferred to any two of three 90-kVA National Gas Engine Co. engine generating sets to the left of the gangway. The third set is to provide cover for overhaul periods. Switchgear interlocks are fitted to prevent the outputs of the generators, which are of the self-regulating type, from being connected in parallel with each other or with the public supply.

Compressed air is used for starting the engines; starting control and load switching require the attention of a maintenance man. The ample battery reserve, together with the fact that the station will be staffed continuously, made it unnecessary to supply equipment to perform these operations automatically.

Electrically driven pumps with press-button-controlled starters are used to transfer engine fuel from the external storage tanks to three service tanks in the engine room. Each service tank has a capacity to cover 7 hours' running of the associated engine. Fuel-level monitoring switches are connected to the station alarm system to indicate the need to start or stop the fuel pumps.

Engine-cooling water is circulated through the evaporative type coolers seen in the right foreground. One cooler will deal with the water from two engines, the other is a spare. Make-up water is obtained from a pond (Fig. 17)

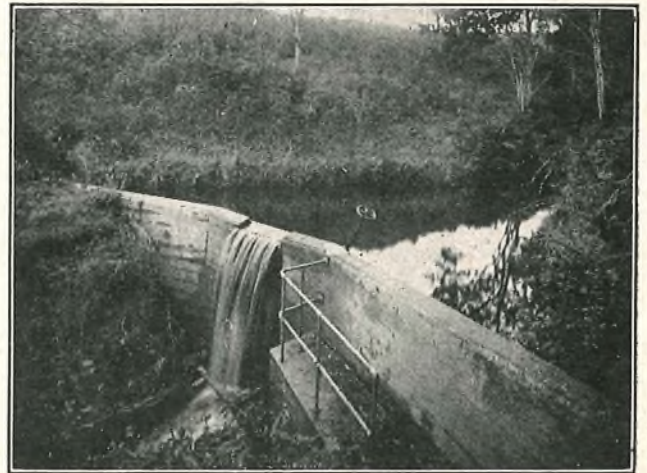

FIG. 17.—POND USED FOR ENGINE-COOLING WATER.

formed by impounding water from a stream on the hillside. Water from the same source is passed through a still fitted in the battery room to provide distilled water for replenishing the batteries.

ACKNOWLEDGMENTS

The authors would like to acknowledge with thanks the work of many colleagues in the Engineer-in-Chief's Office, in Post Office Headquarters, Scotland, and in Scotland West Area, who were concerned in the planning, construction and installation of Oban repeater station.

Part 4.—T.A.T. Test

J. W. G. HAWARD, B.Sc.(Eng.), A.M.I.E.E.†

U.D.C. 621.395.72:621.395.66:621.395.44

INTRODUCTION

THE need for providing a special installation for technical control of the T.A.T. cable circuits in the United Kingdom was recognized at an early stage of the planning of the cable, and in 1954 a working party was formed to determine the facilities for this installation, which by common usage has acquired the title "T.A.T. Test." The working party was also charged with making recommendations for the location, accommodation requirements, method of provision and staffing arrangements for T.A.T. Test.

Full use was made of the experience of many years of continental working. The accepted recommendation was that in addition to acting as circuit control, T.A.T. Test should also function as 12-circuit group control, and as 24-circuit line link control for the period during which the T.A.T. groups would be routed over carrier cables. By concentrating these various functions at one point, procedure so far as overseas administrations were concerned would be simplified. It would also enable fault localization to be carried out with the minimum of delay and provide a central point for obtaining information during a breakdown. Accordingly, as much as possible of the equipment associated with the special facilities provided for the T.A.T. cable system has been concentrated in T.A.T. Test. Limitation of space prevented the carrier line equipment from being included in T.A.T. Test but full control is maintained by duplicating test points in some instances. In consequence the circuits make a number of excursions between the repeater station and test room.

CARRIER CIRCUITS

Receive Direction.

Fig. 18 shows the basic arrangement in block schematic form. The three T.A.T. 12-circuit groups are received at London (Kingsway) repeater station on 24-circuit line links simultaneously over two separate routes, and after amplification and equalization (1)† are extended to T.A.T. Test to the 60-kc/s automatic-gain-control equipment (2).

This equipment provides automatic gain-control on the 24-circuit line link between Glasgow and London by varying the loss through an asymmetrical pad. Test links (3) are provided at the input and output of this equipment to give T.A.T. Test a measure of control over the 24-circuit line links. The circuits are extended back to the repeater station to the receive filter equipment (4). The groups carrying the T.A.T. circuits are extracted and translated from the 12–60-kc/s frequency band into the 60–108-kc/s frequency band in the group demodulating equipment (5), the output of which is connected to special equalizing equipment (6) where residual equalization can be effected. At this point in the circuit the groups are again extended to T.A.T. Test, where they are wired through 12-circuit test links (7), thus maintaining group control within T.A.T. Test.

Equipment for monitoring the group reference pilot (8) is associated with each route. The received level of the incoming pilot of each group from North America is monitored by means of special measuring sets and associated apparatus. Both recording and indicating decibel-meters are arranged to indicate the deviation from normal level of the incoming pilot, an alarm being given if the deviation exceeds certain specified limits. Following this, a group selection panel (9) is provided on which, by means of U-links, one or other of the inland routes, or any group on either route, may be selected and extended to the terminal channel-translating equipment. In order to ensure that only working groups are extended, a duplicate monitoring point (10) is provided after the change-over links.

From this point onwards the two groups containing U.S. circuits only are connected via group test links (11) to channel-translating equipment (12) in the repeater station. The group test links serve as a convenient point for measuring the overall response in the receive direction

† Executive Engineer, London Telecommunications Region.

‡ The numbers in brackets refer to the numbers in Fig. 18.

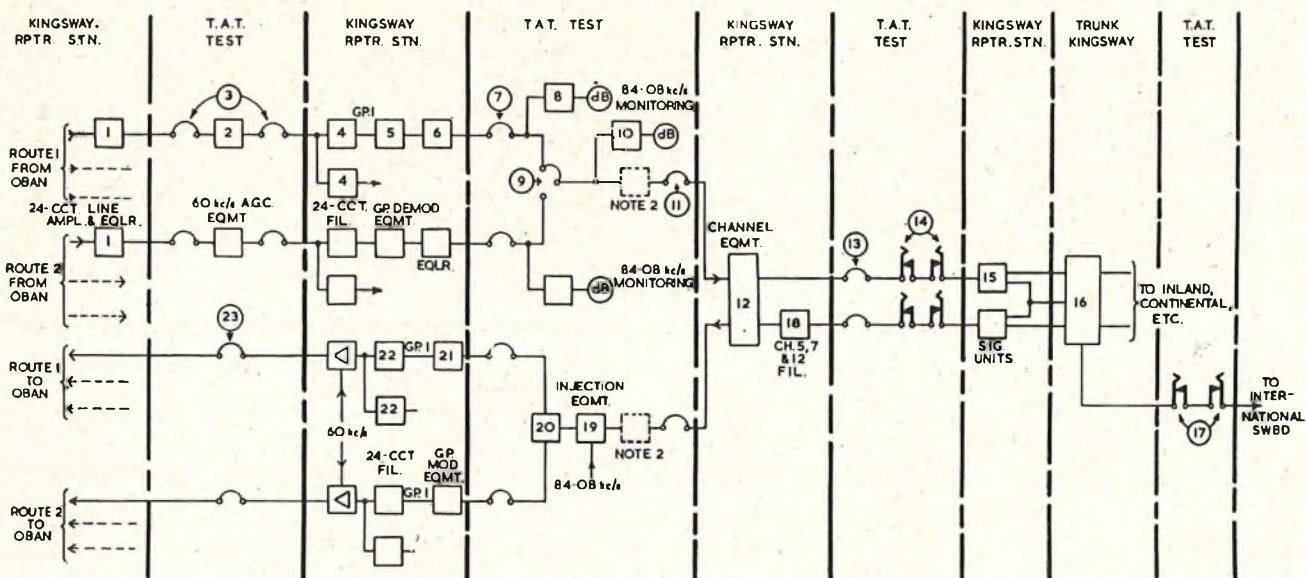

- Notes:
- Three 24-circuit lines are used on each of the two routes into Kingsway but only one line on each route is shown.
 - The arrangement of the 24-circuit line carrying the split group is similar to that shown above; the group-splitting and group-combining equipment is in T.A.T. Test, being connected in circuit between the group-translating equipment and channel-translating equipment.

FIG. 18.—ARRANGEMENT OF CARRIER CIRCUIT IN LONDON FOR THE T.A.T. CABLE SYSTEM.

of transmission and also for connecting a spare channel equipment to the groups if necessary. The third group, the "split" group, which contains $6\frac{1}{2}$ Canadian and $5\frac{1}{2}$ U.S. circuits, is dealt with in a different manner, being first connected to group-splitting equipment in which, by means of filters, the 60-108-kc/s frequency band is separated into 60-86 kc/s and 86-108-kc/s bands appropriate to the Canadian and U.S. "half" groups. Each half-group is amplified and connected via the group test links (11) to the channel-translating equipment (12), complete 12-circuit channel-translating equipment being provided for each of the half-groups.

The audio channels of the transatlantic groups are extended to T.A.T. Test, where channel test links (13) are provided. These serve primarily as a test point for circuit line-up and subsequent faulting. In addition, circuit test jacks (14) provide a suitable test point on the d.c. test racks for testing both line and exchange sides of the circuits. From the test jacks, the majority of the circuits are extended via signalling units (15) to the 4-wire transatlantic relay sets (16) in Kingsway trunk exchange and thence 2-wire to the International Exchange manual board, the circuits again passing via test jacks (17) in T.A.T. Test. An exception to the above routing is that of the through continental circuits, which are routed direct from the 4-wire transatlantic relay sets (16) to Continental Test. The U.S. half-channel (0-2 kc/s of channel 6 of the $5\frac{1}{2}$ -channel group) and the Canadian half-channel (2-4 kc/s of channel 6 of the $6\frac{1}{2}$ -channel group) are connected via channel test links to the v.f. telegraph monitor and change-over equipment described later.

Transmit Direction.

In the transmit direction the 24 circuits forming the two U.S. groups are connected via the signalling units, modified to transmit 1,000/20-c/s signals, circuit test jacks and channel test links in T.A.T. Test and thence to the channel equipments (12) in the repeater station. The six channels of the Canadian and five channels of the U.S. portions of the split group are also extended in a similar manner via circuit test jacks and channel test links but, as in the receive direction, the half-groups are connected to fully-equipped channel-translating equipments (12). Special filters (18) are connected to the input of the channel-translating equipments of channels 5, 7 and 12. These are high-pass filters which attenuate energy arising from switching operations which, when translated into the h.f. band, might cause interference to the 84-08-kc/s, 64-kc/s and 92-kc/s group pilots. The two half-channels are connected via channel test links to the channel-translating equipments.

The two U.S. 12-circuit groups and the split group are extended from the repeater station to the group test links. At this stage the two U.S. groups are connected to 84-08-kc/s injection equipment (19) while the two half-groups are first connected to group-combining equipment before being similarly treated. The group reference pilot is injected into each group by means of a hybrid coil, the appropriate frequency band being cleared by a 84-08-kc/s stop filter. After amplification, each group is connected to a 75-ohm hybrid coil (20) which provides the facility of simultaneously feeding the groups via the 12-circuit links (7) to separate alternative inland routings.

The groups are next extended via tie pairs to the group-modulating equipment (21) in the repeater station and thence to 24-circuit filters (22) and transmit amplifiers. The 60-kc/s pilot is injected on to the 24-circuit links at this point. After passing through T.A.T. Test, where 24-circuit test links (23) are provided, the 24-circuit line links are extended back to the repeater station and thence to their line routings.

PROGRAM CIRCUITS

Interconnexion is made in T.A.T. Test between the transatlantic program circuits and the Inland and Continental networks via local tie circuits.

Broadband Program Circuits.

The transatlantic program circuits, three for each direction of transmission, terminate in T.A.T. Test, where facilities are provided for switching them to various local circuits. One rack of switching equipment caters for each direction of transmission, the circuits being grouped accordingly. The transatlantic circuits and the local ends are interconnected by means of selector switches.

Continuous monitoring of program signals from North America is effected by means of peak-program meters and volume-unit meters wired to fixed points in the program equipment. The circuits from Oban to London may also be continuously monitored on a recorder by means of a 12-kc/s pilot transmitted over the inland section. Monitoring facilities for testing and setting up are provided by means of further peak-program meters and volume-unit meters which can be switched to various points in the equipment in T.A.T. Test.

Special equipment is mounted on a program test rack, e.g. wide-band continuously-variable audio oscillator. A high-fidelity loud-speaker amplifier is also provided.

Narrow-band Program Circuits.

A switching rack is provided which allows for switching single-channel program circuits having a band-width of 3.2 kc/s to local ends, again by means of selector switches. A single-channel program circuit utilizes one of the normal telephone channels in the T.A.T. cable scheme and is patched in T.A.T. Test from the channel test-link sockets into the program-switching equipment as required.

SPEAKER CIRCUITS

T.A.T. Test is the nominated circuit control for the London-New York-Montreal omnibus telephone speaker circuit, which normally terminates there. However, bridging units are provided with facilities for extending the circuit to the Radio Telephony Terminal (Brent Building) for use with radio circuits in the event of failure of the transatlantic cable. Arrangements are also made for termination of the London-Oban speaker, which is intended to be used as a reserve in the event of an inland failure of the omnibus speaker. In addition, the two telegraph circuits (i.e. London-New York direct and London-New York-Montreal omnibus teleprinter circuits) for use with the foregoing speakers terminate in T.A.T. Test.

Apart from long-distance speakers, various local circuits terminate on the d.c. test racks, e.g. to Wood Street switchboard (for extension to radio links), Wood Street testing telephonist (for fault reporting), Inland Trunk Test, Continental Test, B.B.C. (for program control), Electra House (for picture circuit control), etc.

All of the above, with the exception of the teleprinter circuits, are multiplied to various points in the apparatus suites in order to provide ready access during faulting, although in the case of the omnibus telephone circuit, calls can only be originated from the d.c. test racks and the speaker rack.

TELEGRAPH CIRCUITS

Special switching arrangements exist for both the 11-channel frequency-modulated voice-frequency telegraph system and the teleprinter maintenance circuits (three channels).

Four inland routings are provided for the 11-channel equipment, two audio and two h.f. (a channel on the split T.A.T. group). The audio routings have been chosen as main and first reserves and the h.f. routings as second and third reserves. Signals are fed simultaneously over the two audio routes in the transmit direction and on all four routings in the return direction. In the case of the audio routings, selection is made at the receive terminal for each direction, but the h.f. routing is automatically determined by the T.A.T. routing in operation at the time. Changing over from audio to h.f. working for both directions of transmission is controlled at T.A.T. Test by means of U-links.

U-links are also provided for switching from the main to reserve terminal equipment which is installed at Electra House and Kingsway repeater station respectively.

Arrangements on the three-channel teleprinter maintenance circuits are much the same, the chief difference being that second and third reserves on the h.f. equipment are not provided.

PICTURE TELEGRAPH CIRCUITS

Two telephone channels in the T.A.T. cable system have been reserved for picture-telegraph transmission between London and Montreal and will be extended as required, by patching at the channel test links, over 4-wire tie circuits from T.A.T. Test to Electra House, where all picture traffic over the T.A.T. cable will be handled. Amplifier-limiters for the Electra House tie circuits, together with equalizers and filters, are fitted in T.A.T. Test.

TEST RACKS

H.F. Test Rack.

Selective measuring equipment has been provided for making through-level measurements during the initial line-up and subsequently as necessary. A transmission test trolley is also available for use as required.

A.C. Test Racks.

Two duplicate racks incorporating audio measuring and sending equipment have been provided. Between them are two racks of channel-end U-links giving direct access to the 4-wire circuits for normal line-up and faulting. These U-links also serve as a convenient patching point for any special connexions such as cross-connexion of channel-translating equipment, patching picture calls, single-channel program circuits, and emergency routing of channels to R.T.T., Brent, in the event of the breakdown of one cable. By concentrating the patching on these racks the d.c. test racks are kept as clear of patch cords as possible.

D.C. Test Racks.

Two d.c. test racks have been provided. These incorporate certain special facilities in addition to those normally provided on standard trunk test racks. For example, 4-wire test-cord circuits in addition to 2-wire have been included to enable tests to be carried out on the 4-wire audio-switching equipment. Special items of apparatus mounted on the test racks include 84.08-kc/s extension meters, to ensure that the testing officer is always aware of the level of the incoming pilots on all three carrier groups, and clocks showing New York and London time.

SPECIAL CABLING

Because of the considerable distance between T.A.T. Test and Kingsway repeater station, four 24-pair, 40-lb. P.C.Q. carrier cables are used for the h.f. cabling between the two installations.

The routing for the extension of the main circuits from Kingsway to Wood Street (International Exchange) has been arranged so as to minimize the effect of a cable failure. One hundred per cent spare pairs have been provided and the working circuits are equally divided between two cables with switching facilities at each end to enable all the working circuits to be switched to one cable in the event of failure of the other.

ACCOMMODATION AND LAYOUT

Following the decision to locate T.A.T. Test at London, Kingsway, an area of about 500 ft² was made available. The site—the only practicable one—is located some 500 to 600 ft from both the automatic switching and line equipments, necessitating the special cabling arrangements referred to above.

The layout of the equipment, shown in Fig. 19, was governed to a large extent by the need to make the best

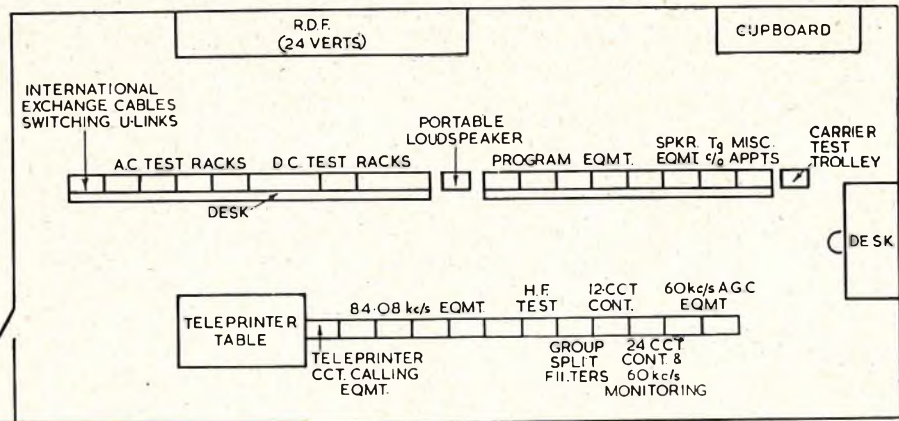

FIG. 19.—LAYOUT OF T.A.T. TEST.

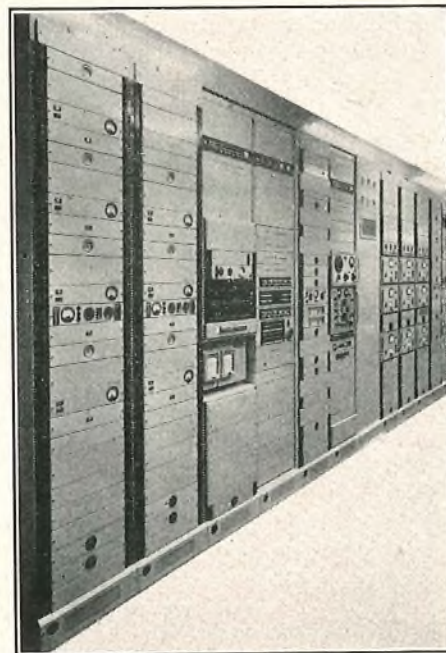

FIG. 20.—SUITE 1, T.A.T. TEST.

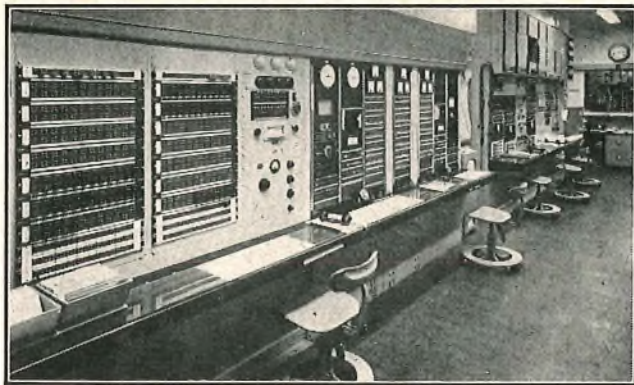

FIG. 21.—SUITE 2, T.A.T. TEST.

possible use of the space available. Thus, the single-sided 51-type racks have been concentrated into Suite 1 (Fig. 20) and mounted back to the wall. The specially designed R.D.F., teleprinter table and cupboard make maximum use of the available space. Suite 2/3 (Fig. 21) comprises 9-ft-high pre-51-type racks with flush-mounted equipment up to a height of 6 ft and a continuous desk on the face side. All overhead cabling is so arranged as to leave the space between the two suites clear.

In accordance with the working party's recommendation, layout and cabling allows for a growth of circuits up to 150.

INSTALLATION

T.A.T. Test is a comparatively small installation but the difficulties encountered were out of all proportion to its size. It is rare to find a single installation that embraces such diverse equipment. Apart from nearly every rack being different, much of the equipment was of untried design because, owing to lack of time, few prototypes had been made. Each rack presented its own problems of construction and installation and, as responsibility for design was widely dispersed, close co-operation with all concerned was essential. The majority of the racks were assembled and wired by the staff of the Long Distance Area, London Telecommunications Region, the remainder being supplied under contract. The entire installation was by Post Office labour.

The accommodation was ready for installation by June, 1955, after building work and decorations had been com-

pleted, and by that time some of the racks had already been wired. By March, 1956, installation was virtually complete apart from one or two racks which were not scheduled to be supplied by contract until a later date. Testing followed, and although, due mainly to changed requirements, a certain amount of construction work was still being carried out up to the opening date, very little interference was caused to the line-up and maintenance staff who took over the control of T.A.T. Test in June, 1956.

CONCLUSION

At the time of writing, T.A.T. Test has already proved its worth. During the lining up of the groups and circuits it quickly established its position as an effective control and the concentration of special equipment and facilities into one installation has undoubtedly been of immeasurable value to the controlling officer.

ACKNOWLEDGMENTS

It is desired to associate with this article all those who were concerned with the design, planning and installation of T.A.T. Test, and, in particular, Mr. F. P. Barnett, of the L.T.R. Headquarters, who was primarily responsible for the co-ordinating work, of which there was an abnormal amount, and of Mr. D. A. Chesterman, of the Long Distance Area, for his work on site.

References.

¹ WATERS, H. S., and YEO, B. F. Switching Arrangements in London for Telephone Calls over the Transatlantic Telephone Cable. (In this issue of the *P.O.E.E.J.*)

² HARRIS, E. T. C. and MUNDAY, S. Carrier Frequency Generating Equipment for Large Carrier and Coaxial Stations. *P.O.E.E.J.*, Vol. 48, pp. 148 and 216, Oct. 1955 and Jan. 1956.

³ BENNETT, A. J., and HARRIS, E. T. C. Special Equipment Designed and Manufactured in the United Kingdom: Part 3.—Music Channels. (In this issue of the *P.O.E.E.J.*)

⁴ WILLIS, F. B., and HARRIS, E. T. C. Special Equipment Designed and Manufactured in the United Kingdom. Part 2.—Special Frequency-Translating and Frequency-Generating Equipment. (In this issue of the *P.O.E.E.J.*)

⁵ MYERS, H. G. Fault Location in Transmission Equipment by Vibration Testing and Continuous Monitoring. *P.O.E.E.J.*, Vol. 42, p. 189, Jan. 1950.

⁶ DYE, F. W. G. The Conversion of Carrier Routes from 12- to 24-Circuit Working. *P.O.E.E.J.*, Vol. 42, p. 26, Apr. 1949.

⁷ PALMER-JONES, C. E. and MACDIARMID, I. F. The Effect of Temperature on the Transmission Characteristics of Carrier Cable. *P.O.E.E.J.*, Vol. 46, p. 65, July 1953.

Special Equipment Designed and Manufactured in the United Kingdom

Several of the facilities provided on the transatlantic telephone cable have required special equipment, which has been designed and manufactured in the United Kingdom and is described in this article. Part 1 deals with the 84.08-kc/s group reference pilots that are transmitted over the 12-circuit groups between London and Oban and over the transatlantic cable. Part 2 describes the frequency translating and carrier generating equipment at Oban. The special music-in-band equipment, which enables a music channel to take the place of two or three telephone channels, is described in Part 3, while Part 4 covers the methods of working telegraph channels over the cable and the precautions taken to guard against failure of the inland route. The article concludes with a description, in Part 5, of the change-over facilities on the 12-circuit groups between London and Oban; also described are miscellaneous items of equipment for the provision of telephone and telegraph circuits for maintenance purpose, program-circuit switching and picture-telegraphy circuits.

Part 1.—Group Reference Pilots

T. E. PUDDICK and E. T. C. HARRIS, B.Sc.(Eng.), A.M.I.E.E.†

U.D.C. 621.395.52:621.315.28:621.373.42

INTRODUCTION

BETWEEN London and Oban there are alternative routings in each direction for the three transatlantic telephone (T.A.T.) 12-circuit groups; the two routes being fed simultaneously with traffic signals so that at the receiving end a rapid change can be made to the alternative route if the working route fails. Associated with each of the six groups in each direction of transmission there is a group reference pilot of 84.08 kc/s. Although this article is concerned with the pilots as used to indicate the state of the inland routes, in fact measurements at Oban are made of the pilots between London and New York and between London and Montreal. These pilots, therefore, give a picture of the overall working of the T.A.T. circuits and a high standard of performance is needed in their generation, injection and measurement.

Variations in the frequency of the pilot have to be accommodated by the band-pass filter in the receive measuring set, which in turn should reject unwanted energy that may affect readings. Oscillator stability was weighed against circuit complexity, the final choice being a crystal oscillator with no oven. Although there is no automatic gain control associated with the pilot at present, there must be automatic standby facilities. Two oscillators are therefore provided, with a change-over panel switching from a failed working oscillator to the standby in less than 100 ms. Under the specified working conditions for temperature

The injection equipment at London is mounted on a special rack. A hybrid coil isolates the generating equipment from the channel translating equipment so that impedance changes in the latter do not cause changes in the pilot level. The injected level is adjusted to an accuracy normally better than ± 0.1 dB. On the same rack is mounted a band-stop filter that introduces appreciable loss in the group bands at the pilot frequency prior to the injection, to attenuate unwanted energy that would otherwise interfere with readings.

A block schematic diagram of the generation and injection of the pilot is shown in Fig. 1.

At the receiving ends of the inland route, London and Oban, there is rack-mounted 84.08 kc/s measuring equipment to enable a continuous check to be kept on the pilots and to give an alarm should they fail. The equipment consists of a narrow-band-pass pilot filter, a detector and an alarm circuit. Under the working conditions quoted later the accuracy of the set should be better than ± 0.25 dB. This figure represents the accuracy that would be obtained under abnormally adverse conditions; over short periods observed changes of 0.1 dB would be assumed to be due to the group under test rather than to the test equipment.

Pilots are extracted by skew hybrid coils on special group distribution frames (G.D.F.) through which the circuits are routed, a loss of 1 dB being introduced into the main path and 24 dB into the pilot path.

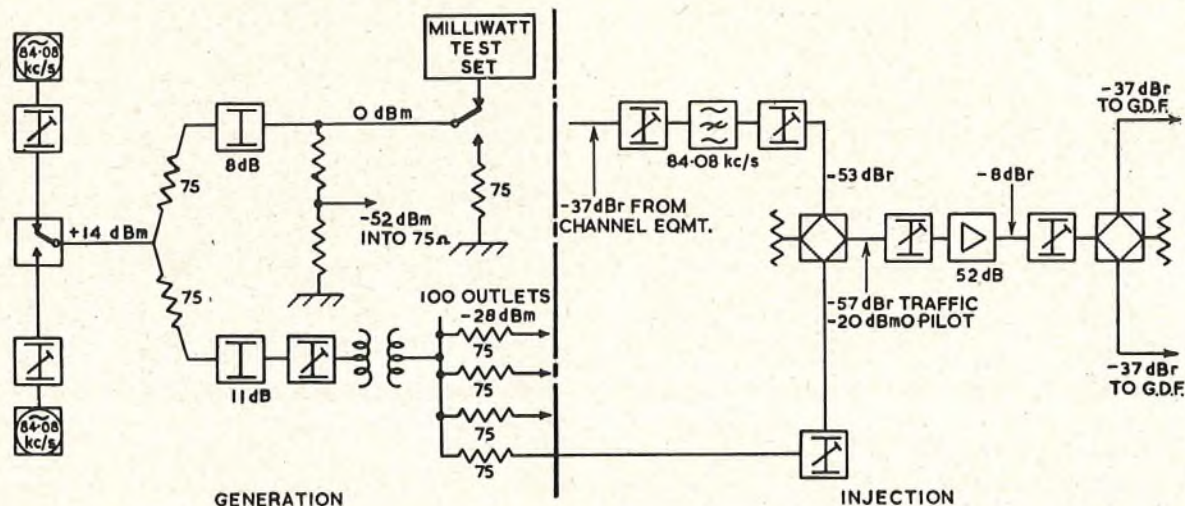

FIG. 1.—GENERATION AND INJECTION OF 84.08-KC/S PILOT SIGNAL.

variations and supply-voltage and frequency changes the generating equipment should meet the following limits:—

- Frequency accurate to ± 4 parts in 10^5 .
- Output level variation ± 0.25 dB.

† Mr. Puddick is with Standard Telephones and Cables, Ltd., and Mr. Harris is a Senior Executive Engineer, Transmission and Main Lines Branch, E.-in-C.'s Office.

GENERATION OF 84.08 KC/S PILOT

Oscillator.

The 84.08-kc/s oscillator is of the cathode-coupled crystal-controlled type with the crystal in the cathode circuit. Two valves (CV 2000) are used in the oscillator circuit and two further valves (CV 2004 and CV 2012) form the stabilized output control. A fifth valve (CV 2004) is

used to monitor the output and operate the alarm and change-over panel. Two pilot-deviation relays are used, one of which operates the non-urgent alarm when the output varies by ± 0.5 dB. The other relay operates the change-over panel and urgent alarm when the output varies by more than ± 3 dB.

Two output controls are provided, both using soldered straps. One is a coarse control providing steps of ± 1 dB and the other is a fine control of ± 0.5 dB in steps of 0.1 dB. The nominal output of $+14$ dB, relative to 1 mW, is thus variable over a range of ± 1.5 dB in 0.1-dB steps. The oscillator is designed to work into a 75-ohm unbalanced load.

The oscillator frequency can be adjusted by means of a coil and condenser in series with the crystal. This circuit enables the oscillator frequency to be adjusted to within 0.25 c/s of its nominal frequency, the range of control being ± 6 c/s.

Long-term frequency-stability is better than ± 3 parts in 10^6 per month, and adverse combinations of an excursion of ambient temperature over the range 15°C to 40°C and 10 per cent changes in h.t. and l.t. voltages do not cause frequency changes greater than ± 3 parts in 10^5 . There is at present a simple frequency-comparison device, using a cathode-ray tube and checking against a high-stability pilot; a more comprehensive comparison panel will be provided later.

Change-over and Alarm Panel.

The change-over and alarm panel accepts the outputs of the working and standby oscillators, both of which are passed to the contacts of a change-over relay. This relay is mounted in a hermetically-sealed unit; a precaution taken to prevent level variations resulting from corrosion of relay contact surfaces. The output of the working oscillator passes via the change-over relay to the load, whilst the standby oscillator is connected to a 75-ohm termination. Crosstalk due to the change-over relay is better than 60 dB and thus avoids measurable beats due to small differences in frequency of the two oscillators. Complete failure of the working oscillator or a change of 3 dB in level will be detected by marginal relays in the oscillators and change-over will be initiated. Provision is also made for monitoring the standby oscillator in respect of failure and level deviation.

Calibration Panel.

The output of the working oscillator is passed via the change-over equipment to a calibration panel with three outlets:—

- (a) An outlet to the milliwatt test set. This outlet can be adjusted to exactly 1 mW by means of the level control on the oscillators. When not required for calibration, this outlet is switched to a dummy load and the milliwatt measuring set is available for external use.
- (b) An outlet at -52 dBm \ddagger for the calibration of the station portable 84.08-kc/s measuring set used for the checking of incoming 84.08-kc/s pilots. The level of -52 dBm is derived by a chain of close-tolerance high-stability resistors from the 1-mW point.
- (c) The distribution outlet. This is provided with variable attenuators for the adjustment of the distribution level to within 0.25 dB of -28 dBm.

The calibration panel is also equipped with a fast-operating switch, which permits external use of the milliwatt test set when not required for calibration purposes and, because of its speed of operation, prevents visible interruptions to recorder charts on monitored groups.

\ddagger dBm—decibels relative to 1 mW.

Distribution Panel.

The distribution panel provides 100 outlets of 84.08 kc/s, sufficient for 100 basic groups. All outlets are in parallel across the low-impedance side of the distribution transformer. This arrangement produces the best crosstalk conditions between outlets because of the low common impedance and also enables all levels to be made identical. A 75-ohm resistor is inserted in series with each outlet, thus providing the group-injection hybrid-coil with a good source impedance. Unused outlets are terminated by 75-ohm resistors.

PILOT INJECTION

One rack-side, when fully equipped, caters for the injection of the 84.08 kc/s pilot into eight groups. The traffic signal at a relative level of -37 dB is fed via an 84.08-kc/s band-stop filter to the combining hybrid, the input and output of the filter panel being equipped with attenuators which have the dual function of adjusting the traffic signal to the correct level for combination and presenting a constant impedance to the G.D.F. and combining hybrid coil.

The 84.08-kc/s signal from the calibration panel, at a level of -28 dB relative to 1 mW, is fed via an attenuator to the other side of the combining hybrid coil and is adjusted to a level of -20 dBm at a point of zero relative level. The combined signal, now at a low level, is passed to a group amplifier having a flat gain of 52 dB over the range 60–108 kc/s and equipped with an input attenuator for overall gain adjustment. A further attenuator and hybrid coil are inserted in the amplifier output and two signal outlets are thus obtained at the original G.D.F. relative level of -37 dB. Of these two outputs only one is utilized, the other being a duplicate path normally terminated by a 75-ohm resistor.

PILOT MEASUREMENT

The 84.08 kc/s measuring set shown in Fig. 2 is intended for making through and terminated level measurements of the group reference pilot whilst the associated group is carrying traffic. The set incorporates a power unit and is housed in a light-alloy carrying-case which may either be

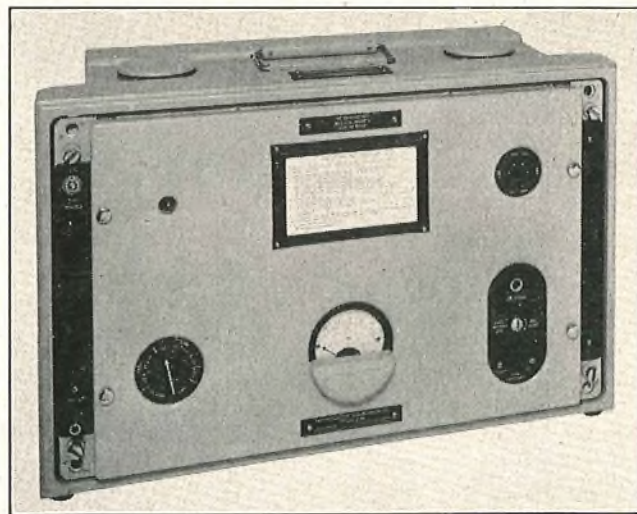

FIG. 2.—84.08-KC/S MEASURING SET.

used in portable form, or, with the aid of simple adaptors, may be mounted on a standard Post Office rack.

The incoming signal passes via a crystal filter, a level-range switch and a three-stage negative-feedback amplifier to a meter-circuit, the filter discrimination being sufficient to avoid interference with the measurements due to speech signals in the adjacent channels. Approximately 40 dB of negative feedback is applied to the amplifier to ensure both

long-term and short-term stability. The meter has shaped pole-pieces and a suppressed zero, enabling a linear decibel scale to be realized.

By making appropriate connexions a recorder and/or an additional meter and an alarm panel may be connected in series with the internal meter. When using a recorder, sporadic interference of little significance from the maintenance aspect may confuse the trace. To overcome this possible trouble a network with a time-constant of about

4 sec may be strapped into circuit.

ACKNOWLEDGMENTS

The authors wish to acknowledge the part played, in the work described, by colleagues in the Transmission and Main Lines Branch of the E.-in-C.'s Office and in Standard Telephones and Cables, Ltd., who supplied the group-reference-pilot equipment for London, Oban, New York and Montreal.

Part 2.—Special Frequency-Translating and Frequency-Generating Equipment

U.D.C. 621.395.52:621.315.28:621.395.44

INTRODUCTION

THE frequency-translating and frequency-generating equipment used in the United Kingdom for the transatlantic circuits was as far as possible that designed for use in the normal inland network. Some equipment, however, particularly at Oban, had to be specially developed and, with the exception of the 84·08-kc/s generators, that equipment is described here. The 84·08-kc/s generators are described in Part 1.

FREQUENCY-TRANSLATING EQUIPMENT

At the interconnexion point of the inland network and the American translating equipment the transatlantic circuits are assembled as Groups 3, 4 and 5 of a basic supergroup (408 to 552 kc/s). Standard group-translating equipment could have been used but special pilots at 64 and 92 kc/s are needed westwards from Oban, and a rack known as Equipment, Frequency-Translating, No. 19A was therefore developed to cater for the pilot injection/extraction as well as for the normal translation. Standard modulators, demodulators and amplifiers are used, the carriers being supplied from the station carrier-generating equipment.

The special pilot equipment consists of a 92-kc/s filter in the transmit path, a hybrid coil for the extraction of 64-kc/s and 92-kc/s pilots from the receive path and a modified group-combining panel. A block schematic diagram of the translating equipment is shown in Fig. 3.

The function of the stop filters, which are of American origin, is to prevent any 92-kc/s signal from the inland network interfering with the 92-kc/s pilots injected at Oban. The 92-kc/s pilot signals for the three groups are obtained from the generating equipment described later and are injected into the transmission path by means of hybrid coils, the level being adjusted to within ± 0.1 dB.

While only one pilot (at 92 kc/s) is injected, two pilots (at 64 and 92 kc/s) are extracted, hybrid coils being used,

† Mr. Willis is with the General Electric Co., Ltd., and Mr. Harris is a Senior Executive Engineer, Transmission and Main Lines Branch, E.-in-C.'s Office.

F. B. WILLIS and

E. T. C. HARRIS, B.Sc.(Eng.), A.M.I.E.E.†

and again there are pads for adjusting the level to within ± 0.1 dB. Each hybrid coil follows a group receive amplifier at which point the group is within the range 60 to 108 kc/s.

FREQUENCY-GENERATING EQUIPMENT

The special frequency-generating equipment (Equipment, Frequency-Generating, No. 20A) at Oban provides the 92-kc/s pilot and the 572-kc/s carrier for the American equipment, and it was a requirement that these be locked to the output of the station master oscillator. The frequency of the incoming 64-kc/s pilot can also be compared with that of the station standard. Fig. 4 shows a block schematic

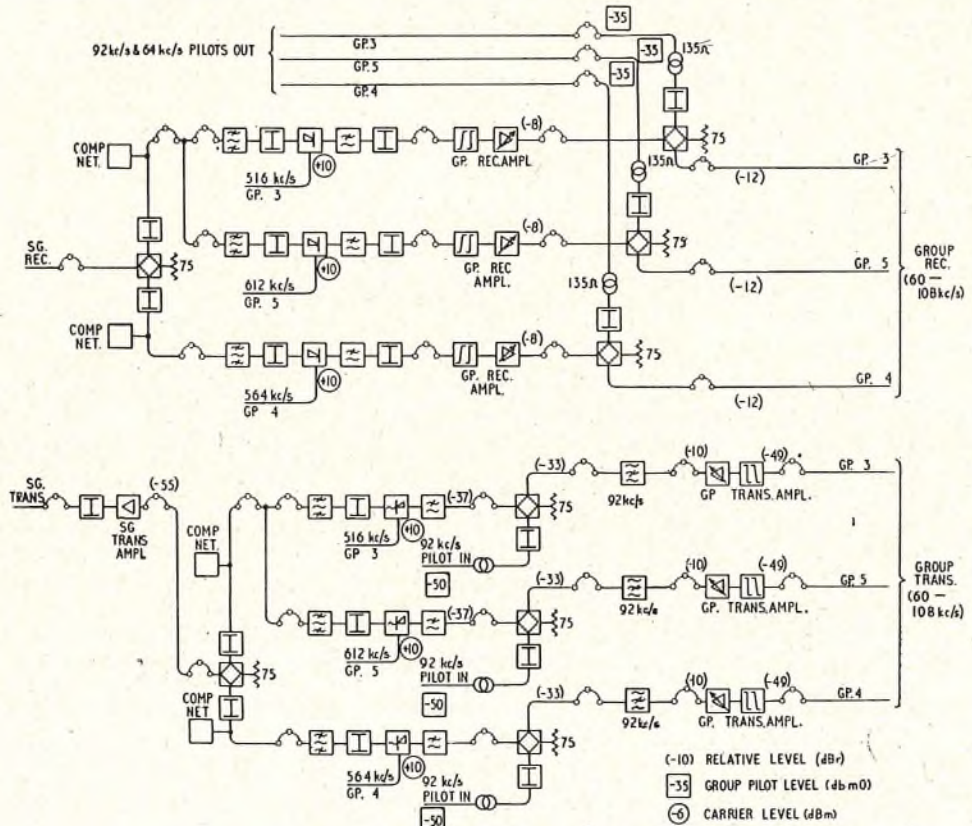
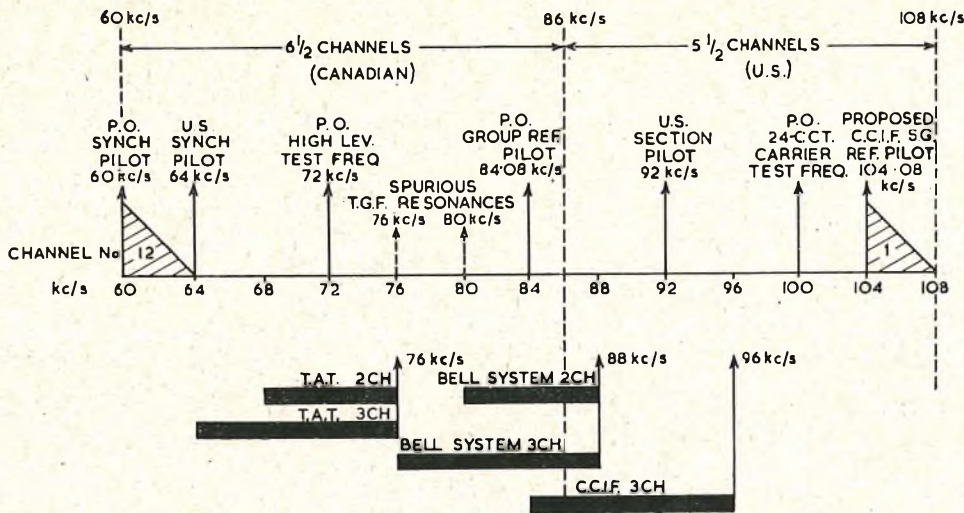

FIG. 3.—BLOCK SCHEMATIC DIAGRAM OF SPECIAL FREQUENCY-TRANSLATING EQUIPMENT.

diagram of the equipment (comprising an Equipment, Frequency-Generating, No. 20A), excluding the 60/64 kc/s frequency comparison panels.

Both the 92-kc/s and the 572-kc/s signals are derived from a 4-kc/s output of the station generating equipment. The 4-kc/s signal is fed to a stabilized amplifier which, in turn, drives a harmonic generator. This amplifier was developed



NOTES:
 1. The inband 72-kc/s high-level test signal is stopped at Oban and does not pass over the submarine cable link.
 2. T.G.F.—through-group filter.

FIG. 6.—FREQUENCY ALLOCATION FOR MUSIC-IN-BAND CIRCUITS.

channel should be made to occupy at will a band of either 50 to 6,400 c/s, displacing two normal speech channels, or 50 to 10,000 c/s, displacing three channels. This maximum band-width influenced the choice of the carrier frequency for the special T.A.T. music-in-band equipment, which was made 76 kc/s despite there being in existence a C.C.I.F. system with a 96-kc/s carrier and a Bell system based on 88 kc/s. The frequency allocation for music-in-band equipment is shown in Fig. 6, which indicates the frequency spectrum of a 12-channel group. The desirable conditions to be achieved were as follows:

- No interference with existing or prospective pilot signals.
- Avoidance of the edges of any filter pass-bands by the low-frequency edge of the music band.
- Avoidance of spurious resonances in the filters.
- Use of music-in-band transmission through to Montreal.
- No interference with national systems.

In the half-group going to Montreal the only available space for a 3-channel system seemed to be the lower side-band of 76 kc/s. Initial proposals were therefore for a special system between Oban and Montreal, with the possibility of using the Bell system in the two complete groups between Oban and New York. It was eventually agreed to use the same system throughout, one important factor being that interference is thereby avoided with the 84.08-kc/s pilot and any possible future automatic-gain-control system associated therewith.

Two further factors affecting the design of the music equipment were the need to suppress any high-level 72-kc/s test signal that may otherwise inadvertently leak on to the cable, which affects the equipment at Oban only, and the need to limit the phase change in the remainder of the group carrying music so that circuits with signals such as telegraphy are not affected when switching music circuits.

Regarding the performance objectives for music circuits and equipment, it is interesting to recall that it took some considerable time to reach agreement with the Americans. On the one hand they, perhaps realistically, were not at all interested in transmission outside the limits 100 to 5,000 c/s, while the Post Office have been accustomed to think in terms of 50 to 10,000 c/s. On the other hand the Americans set fairly high standards for crosstalk and noise which the Post Office judged to be more stringent subjectively than was necessary. Further, in the U.S.A. complex equalization is provided to reduce the delay dis-

tortion at 100 c/s, relative to the minimum group delay in the band, to less than 2 ms for two systems in tandem. It was postulated that a London–New York circuit might be extended across the U.S.A. from New York and across Europe from London, and hence the Americans proposed an objective of 3 ms between London and New York.

The finally agreed target performance standards for circuits between London and New York were as follows:

Attenuation Distortion.—Not to exceed ± 2 dB over the band used (50 to 6,400 c/s or 50 to 10,000 c/s) relative to 1,000 c/s.

Delay Distortion.—Group delay at 100 c/s, relative to minimum delay, not to exceed 6 ms.

Crosstalk.—The ratio of peak signal to peak crosstalk should not be less than 55 dB.

Noise.—The C.C.I.F. 1951 program weighting network will be used by the Post Office for noise measurements and provisionally the weighted noise should not be at a higher level than -50 dBm at a zero level point.

Harmonic Distortion.—At peak input the total harmonic content should not be at a higher level than -30 dB relative to the signal level.

Injection Level.—The injection level should be -3 v.u.† at a zero level point; provisionally this shall be taken as equivalent to $+3$ dB on a B.B.C. peak-program meter.

Some of these figures are targets which it was known could not be attained at the opening date; indeed, the facility for switching to the 3-channel condition, 50 to 10,000 c/s, was not available then. The full requirements should, however, be met about 12 months after the opening date.

The overall limits quoted above have been divided between the New York to Oban carrier and the Oban to London audio sections as indicated in the following paragraphs.

As the major system features affecting noise were settled previously, companders of Bell design and manufacture were provided to bridge the gap between the noise as found and the required limit, the companders being switched into circuit as necessary.

No mention has been made of possible frequency errors between the sending and receiving ends due to differences between the carrier frequencies, since high-accuracy generating equipments are used (one part in 10^7); moreover a check, and if necessary adjustment, can be made by comparing pilots derived from the two ends of the route. The difference in frequency between a signal at the sending end and the corresponding received signal should be much less than half a cycle per second.

MUSIC-IN-BAND EQUIPMENT

Frequency-Translating Equipment.

The circuit of the equipment designed to provide the music injection and extraction facilities at Oban for operating a 2-channel or 3-channel program circuit (music circuit) over the T.A.T. cable is shown schematically in Fig. 7. Similar equipments have been installed at New York and Montreal, but since these are system terminals

† v.u.—volume unit; the American unit of program volume, measured on a meter having a specified time constant.

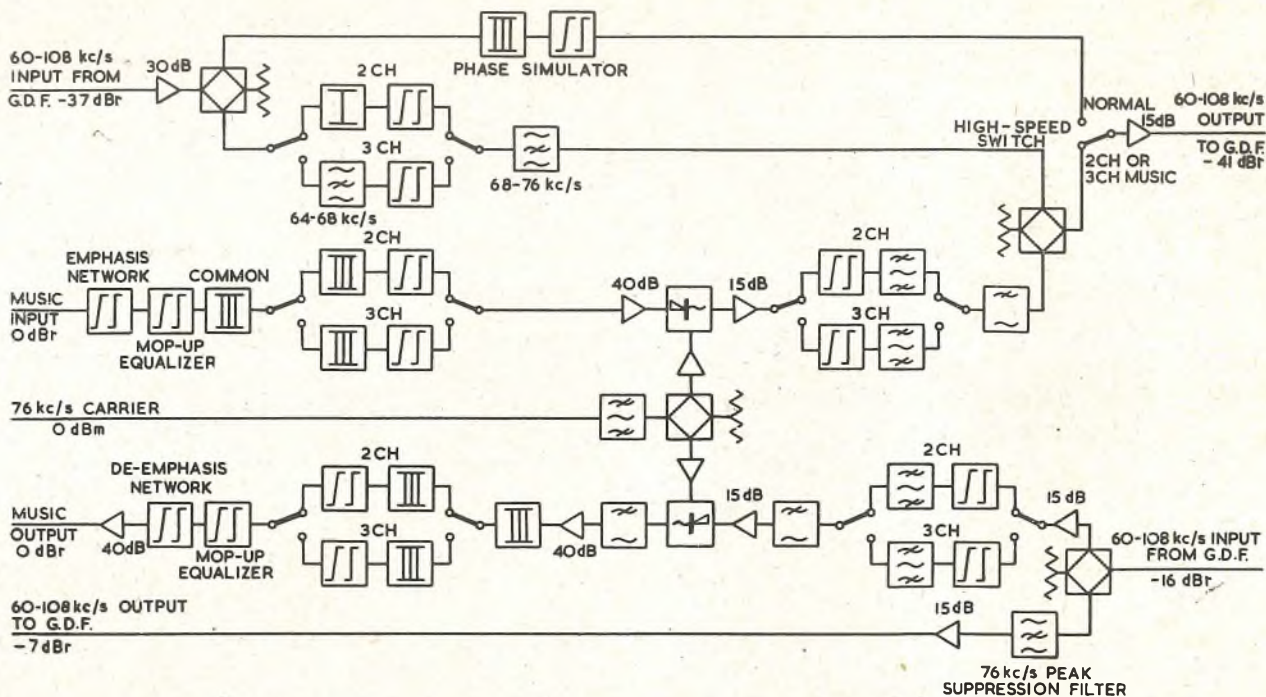

FIG. 7.—SIMPLIFIED BLOCK SCHEMATIC DIAGRAM OF MUSIC-IN-BAND EQUIPMENT AT OBAN.

rather than injection and extraction points along the route their circuits are less complex.

Each equipment is associated with one 12-channel group and occupies two 9-ft rack-sides, so that the total number of rack-sides at Oban is eight, including spare equipment. One rack-side contains the transmit (or injection) circuit and the other the receive (or extraction) circuit.

The music is injected into the telephony path between two G.D.F.s at relative levels of -37 dB and -41 dB, and it is extracted between two G.D.F.s at relative levels of -16 dB and -7 dB. The equipment accepts and delivers the audio frequency music signals at zero relative level in 600-ohm balanced circuits.

The injection circuit incorporates the following features: an emphasis network to take advantage of an uneven energy distribution of the music signal over the audio frequency band for noise reduction; delay equalizer networks to reduce the overall delay distortion, which is introduced by the modulator and band-pass filter; a modulator, with a 76-kc/s carrier, which gives partial suppression of the upper sideband; a band-pass filter to provide additional suppression of the upper sideband and restrict the band-width of the music channel (nominally 69.60–75.95 kc/s when two telephone channels are displaced and 66.00–75.95 kc/s when three are displaced); a change-over panel which enables filters, equalizers, etc., to be selected for either of these band-widths; a hybrid coil where the music signal is combined with the 60–108-kc/s group from which either two or three channels have been displaced.

The extraction circuit is similar, but contains a network having the reverse characteristic of the emphasis network to restore the signal energy distribution to normal.

The 76-kc/s carrier supply is obtained from a standard channel carrier distribution point, and is further filtered because of the greater band-width of the music circuit. Separate amplifiers are used for the modulator and demodulator to reduce the possibility of direct transmit-to-receive crosstalk.

The telephony path into which the music signal is injected contains band-stop filters before the combining hybrid to prevent noise and other interference (e.g. test signals) on

the London–Oban carrier route from causing interference on the T.A.T. cable music circuit. Owing to the presence of these filters an alternative path is provided for the 12-channel group when it is required exclusively for telephony, and in order to cause minimum interference with any telegraph circuits operating over the group, the change-over to and from this alternative path is effected by means of a high-speed make-before-break switch. It has been determined experimentally that to prevent distortion or loss of telegraph characters during change-over the change in phase of any signal in the 60–108-kc/s band should be less than 15° . Thus, it is necessary to provide in the alternative path a network to simulate the phase/frequency characteristic of the band-stop filter.

The telephony path from which the music signal has been extracted contains a band-stop filter (peak-suppression filter) to prevent high-level peaks of the music sideband near 76 kc/s from reaching the demodulator of the adjacent telephone channel and causing interference in the region of 4 kc/s.

The more important items of the circuit are dealt with individually in greater detail in the following paragraphs.

Emphasis and De-emphasis Networks.

The energy distribution of a music signal is such that the lower frequencies are of high level and present inter-modulation problems, while the higher frequencies are of lower level and present noise problems. Less total noise is obtained, therefore, by providing a network which gives some equalization of the energy distribution over the frequency band, and so reduces the range of levels involved. The energy distribution is restored to normal at the remote end of the system by a network having the reverse characteristic.

The characteristic of these networks is based on one which has been used successfully by the Bell Telephone Co. The networks contain close-tolerance components so that the difference between any two emphasis networks, and between any two de-emphasis networks, is less than 0.1 dB at any transmitted frequency. Thus it is possible to obtain accurate matching without having to pair an emphasis network with a particular de-emphasis network on the other side of the Atlantic.

Modulator and Demodulator.

In view of the close proximity in frequency of the upper and lower sidebands of a music signal extending down to 50 c/s, the requirements of a filter to suppress the unwanted sideband would be impossible to meet. For this reason a modulator is used in which, in addition to carrier suppression, the unwanted sideband is partially balanced out. A simplified schematic diagram of the circuit is shown in Fig. 8. The two balanced ring modulators are identical,

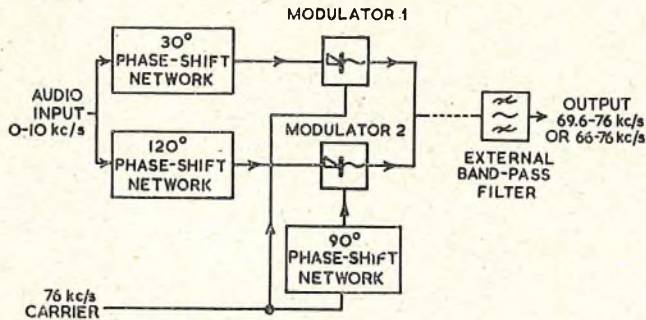

FIG. 8.—BLOCK SCHEMATIC DIAGRAM OF MODULATOR.

but phase-shift networks in the audio path give a phase difference of 90° between the signals reaching the two modulators, and there is a phase difference of 90° in the carriers of the two modulators. The resulting outputs from the individual modulators are such that, when the outputs are paralleled, the upper sidebands cancel. If the output leads of one modulator are reversed, it is the lower sidebands which cancel. The single-sideband demodulator is simply the modulator used in reverse, except that the connexions between one of the balanced ring modulators and the output (input in the case of the demodulator) transformer are reversed, i.e. the lower-sideband demodulator is identical to an upper-sideband modulator and vice versa.

The audio signals produced by frequencies corresponding to the unwanted sideband entering the demodulator are in phase opposition at the outputs of the audio phase-shift networks, whereas those produced by the wanted sideband are in phase. Hence only the wanted sideband will produce an audio frequency output. The output of the demodulator will include frequencies equal to the sum of the carrier and sideband frequencies at a level comparable with the audio frequencies, and a low-pass filter follows the demodulator to prevent these from overloading the audio amplifiers.

In the above paragraphs it has been assumed that the audio phase-shift networks give a phase difference of exactly 90° . This is impossible to achieve in practice over the entire audio frequency range, and the degree of sideband cancellation depends upon the extent to which the ideal phase conditions can be realized in practice. The low frequencies are most important in this respect and the phase difference is adjusted by pre-set controls to be exactly 90° at 70 c/s and 500 c/s. When these controls are correctly set, the unwanted sideband is suppressed by at least 18 dB relative to the wanted sideband for all audio frequencies in the range 50–1,000 c/s. For suppression above 1,000 c/s reliance is placed entirely on the associated band-pass filters.

Carrier Supply.

The standard channel carrier filters give 45 dB discrimination at ± 4 kc/s and only 30 dB at ± 8 kc/s. Signals at these frequencies can cause the appearance of spurious signals within the music pass band, and additional filtration of the carrier is obtained with a filter which has maximum loss at ± 8 kc/s, where it gives a further 50 dB discrimination; at ± 4 kc/s the discrimination is 20 dB.

Filters.

The performance targets used as a basis for design of the various filters of the equipment were that the level of interference from the music circuit into any speech channel of the group, and vice versa, should be less than -60 dBm0.† It is assumed that for the first case the music has a peak power of $+9$ dBm0, but for the second case the level is taken as $+3$ dBm0. The speech level is considered as 0 dBm0 for the first case, but peaking to $+3$ dBm0 in the second. Interference from test tones at 0 dBm0 with the emphasis networks removed should be less than -60 dBm0 in both these cases. In practice the filters give a performance well within these limits.

Band-Pass Filters.

The band-pass filters were designed to cover the requirements of both directions of transmission so that the same design of filter could be used with the modulator and demodulator.

To give the above performance the necessary band-pass filter characteristic was determined almost entirely by the transmit direction, i.e. interference of music with speech channels, the music giving generally more stringent requirements than the test signals. Allowances were made for the effect of emphasis, music-power weighting, the upper-sideband suppression of the modulator, speech weighting, channel filter, and the peak-suppression filter, whose requirements are complementary to, and must be considered in conjunction with, those of the band-pass filter. A further consideration was that, by keeping the start of the cut-off 150 c/s above the carrier frequency, which was permissible with the above allowances, the amount of delay equalization required was considerably reduced.

The complete filter consists of a low-pass filter (76 kc/s) in tandem with a high-pass filter, there being two versions of the latter (68 kc/s and 64 kc/s), which may be selected by U-links for 2-channel or 3-channel working. Each filter

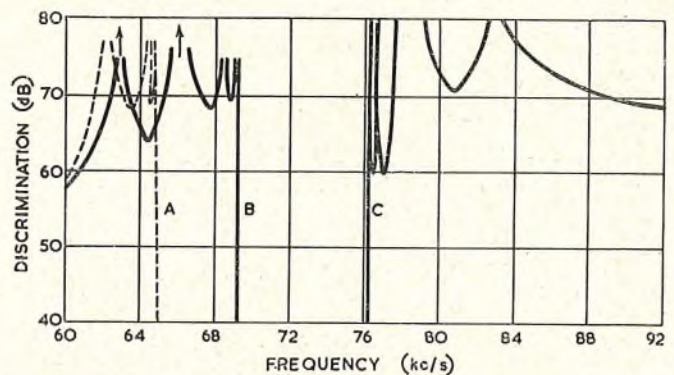

A—Three-channel high-pass filter. B—Two-channel high-pass filter. C—Low-pass filter.
FIG. 9.—TYPICAL CHARACTERISTICS OF BAND-PASS FILTERS.

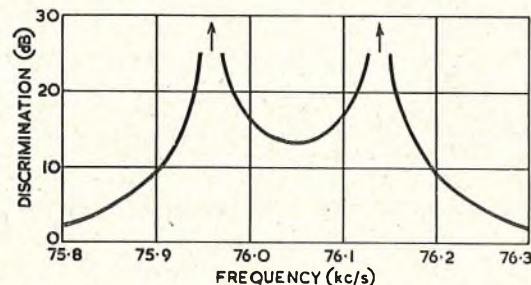

FIG. 10.—TYPICAL CHARACTERISTIC OF PEAK-SUPPRESSION FILTER.

† dBm0—decibels relative to 1 mW when measured at, or referred to, a point of zero relative level (usually the 2-wire point of the circuit).

contains three crystal-filter sections, supplemented by coil-and-capacitor sections. A typical characteristic of the band-pass filter is shown in Fig. 9 and of the peak-suppression filter in Fig. 10.

Band-Stop Filters.

The limiting requirement for the band-stop filters was interference from the speech circuits into the music circuit, the worst conditions occurring when a test tone at 0 dbm0 is applied to a channel displaced for music transmission. Factors affecting the filter requirements are the effect of the band-pass filter in the receive path, the upper-sideband suppression of the demodulator, the de-emphasis network and music weighting (C.C.I.F. 1951).

The filter for 2-channel working consists of a high-pass filter (76 kc/s) and low-pass filter (68 kc/s) in parallel, these being of similar design to those of the band-pass filter. For 3-channel working the stop band is extended by additional coil-and-capacitor sections which are switched in by the change-over U-links. Fig. 11 shows a typical characteristic.

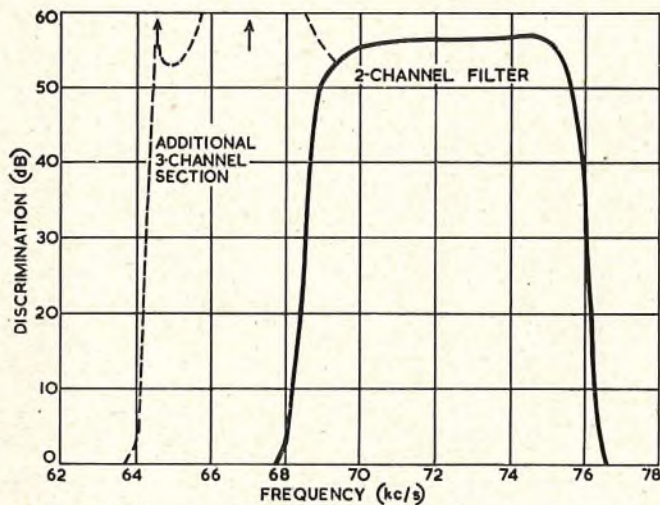

FIG. 11.—TYPICAL CHARACTERISTIC OF BAND-STOP FILTER.

Delay Equalization.

Delay equalization is more easily carried out at audio than at group frequencies. A basic section of the equalizer is shown in Fig. 12. Such a section will delay a small band of frequencies relative to the rest of the band, and to cover the entire frequency band, 25 such sections are necessary for the 2-channel circuit, and 40 sections for the 3-channel circuit. The equalizers will reduce the delay at 100 c/s relative to the minimum delay, for the equipment looped at G.D.F., from over 6 ms to below 3 ms.

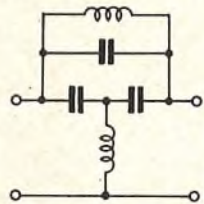

FIG. 12.—SCHEMATIC DIAGRAM OF DELAY EQUALIZER SECTION.

Phase Simulation.

The problem of simulating the phase/frequency characteristic of the filters is still being investigated, but it is known that the phase characteristic of the band-stop filters in the channels adjacent to those in the stop band is such as to require a prohibitive amount of equalization, and the use of channels 8 to 12 for telegraphy is therefore precluded. Thus equalization over the band 80–108 kc/s only will be provided.

Change-over and Switching Arrangements.

All panels that are associated with the change-over (e.g. band-pass and band-stop filters, delay equalizers) are wired to the panels immediately below the valve fail alarm panel, where all U-links and the switch are mounted, as illustrated



FIG. 13.—MUSIC-IN-BAND CHANGE-OVER PANELS.

in Fig. 13. The switch is spring-loaded and has a change-over time of the order of 1 ms.

Owing to the considerable development work involved the equipment is being supplied in two stages, but it is the final circuit which is described above. At the time of writing, stage 1 is complete, and a 2-channel music circuit can be operated over any of the three groups on the T.A.T. cable, but without delay equalization. Stage 2 consists of the provision of filters for 3-channel working, the delay equalizers, and the group-frequency phase simulators for the band-stop filters. On completion of this stage it is expected that all the agreed performance requirements will be met.

LONDON TO OBAN AUDIO ROUTING

Three program links are provided in each direction between London and Oban using carrier-phantom and screened-pair plant. The links are split between three routes to minimize the possibility of a complete breakdown, and if desired one program may be transmitted over all three routes simultaneously, the receiving end having facilities for switching rapidly to any of these routes.

Two links in each direction have a gain/frequency characteristic within ± 0.5 dB in the range 50 to 10,000 c/s, and one circuit in each direction has that spread in the band 50 to 7,000 c/s. The latter will be extended to 10,000 c/s when the plant becomes available.

Delay distortion, which at 100 c/s is mainly due to the effect of transformers, has been reduced from an estimated normal figure of 80 ms, relative to the minimum delay in the band, to 9 ms by reducing the source impedances seen by the transformers. This has been achieved by (a) reducing the output impedance of the line amplifiers, and (b) terminating the incoming end of each cable section with a suitable resistor and using a 600 : 600-ohm transformer instead of the usual 170 : 600-ohm transformer.

Further reduction of delay distortion will be carried out if necessary by means of delay equalizers. The distortion at frequencies above 1,000 c/s is less than 1 ms.

Continuity and stability of overall gain is monitored by means of a recording decibelmeter at the receiving end of each circuit. For this purpose the 10-kc/s links carry a continuous 12-kc/s pilot which is separated from the program signal by a filter at the receive end. The 7-kc/s links carry a 1-kc/s pilot which is disconnected when the link is being used.

ACKNOWLEDGMENTS

The authors wish to acknowledge the part played, in the work described, by colleagues in the Transmission and Main Lines Branch of the E.-in-C.'s Office and by Standard Telephones & Cables, Ltd., who also supplied the music-in-band equipment for Oban, New York and Montreal.

U.D.C. 621.395.52:621.315.28:621.394.441

INTRODUCTION

THE telegraph facilities provided on the T.A.T. cable comprise a number of teleprinter circuits for maintenance use and a multi-channel voice-frequency (v.f.) telegraph system between London and Montreal for public telegraph, telex and private wire services. The maintenance circuits include a direct teleprinter circuit between London and New York, consisting of four v.f. telegraph circuits in tandem, and an omnibus teleprinter circuit providing conference working between London, Oban, Clarenville, Sydney Mines, New York and Montreal. Selective signalling facilities are provided on the omnibus circuit to enable the attention of individual stations to be drawn to particular messages. In addition to the foregoing a London-Oban teleprinter circuit is also provided.

All the telegraph circuits are provided by means of frequency-modulated telegraph channels, and the London-Montreal system, which is operated within half the band-width of a telephone circuit, is equipped for 11 telegraph circuits, at a frequency spacing of 120 c/s, together with a pilot channel for correction of bias distortion caused by frequency difference between terminals.

Tests have shown that the telegraph circuits in the London-Montreal system are capable of transmitting signals at modulation rates up to 80 bauds with distortion less than 8 per cent (except Channel 15 which gives 14 per cent) using Q9S, the C.C.I.T. test signal. Thus the circuits are suitable not only for orthodox start-stop telegraphy but can also be used ultimately to carry 2-channel 6-unit time-division multiplex systems, so enabling each circuit to carry 800 characters per minute, i.e. to have twice the normal traffic carrying capacity of a 120 c/s channel when used for 50 baud start-stop signals.

Fig. 14 is a block schematic diagram of the circuits employed to provide the telegraph facilities, and a description of the methods employed for injection of the voice-frequency telegraph signals into the cable and their subsequent extraction is given later in this article.

VOICE-FREQUENCY TELEGRAPH EQUIPMENT

Detailed consideration was given to the relative merits of amplitude-modulated and frequency-modulated telegraph channels, particularly in relation to their use for the London-Montreal system. The maximum possible traffic-carrying capacity consistent with high-quality performance and avoidance of overloading the submerged repeaters was the prime consideration. After laboratory tests, a decision was taken in favour of frequency-modulated telegraph equipment using a system designed by Standard Telephones and Cables, Ltd., in which the mid-channel frequencies are spaced at 120 c/s and the frequency deviation is ± 30 c/s, the lower frequency corresponding to a marking signal, i.e. stop-signal polarity in the d.c. input. Theory indicates and practical tests confirmed that, compared with amplitude modulation, which is used for the normal Post Office inland system, frequency-modulation permits a 6-dB reduction in the tolerable signal/noise ratio (related to noise distributed evenly over the band) for a given probability of distortion. Furthermore, a frequency-modulated system is insensitive to considerable and rapid level changes and the equipment employed will work over a 30-dB range of input signal level. In addition, the frequency-modulated channels give a considerably better performance at speeds in excess of 50 bauds and are capable of working with tolerable distortion up to speeds slightly in excess of 80 bauds. Laboratory tests without the group splitting filter indicated that the distortion using Q9S signals at 80 bauds did not exceed 7 per cent on any channel, and this was a factor of paramount importance in the choice of system, in view of the desire to exploit the channel band-width to the maximum extent practicable.

One possible disadvantage of frequency modulation is its greater sensitivity to frequency error, such errors being manifested as bias in the received signals. However, in the S.T. and C. equipment employed between London and

† The authors are, respectively, Senior Executive Engineer, Telegraph Branch, and Senior Executive Engineer, Transmission and Main Lines Branch, E.-in-C.'s Office.

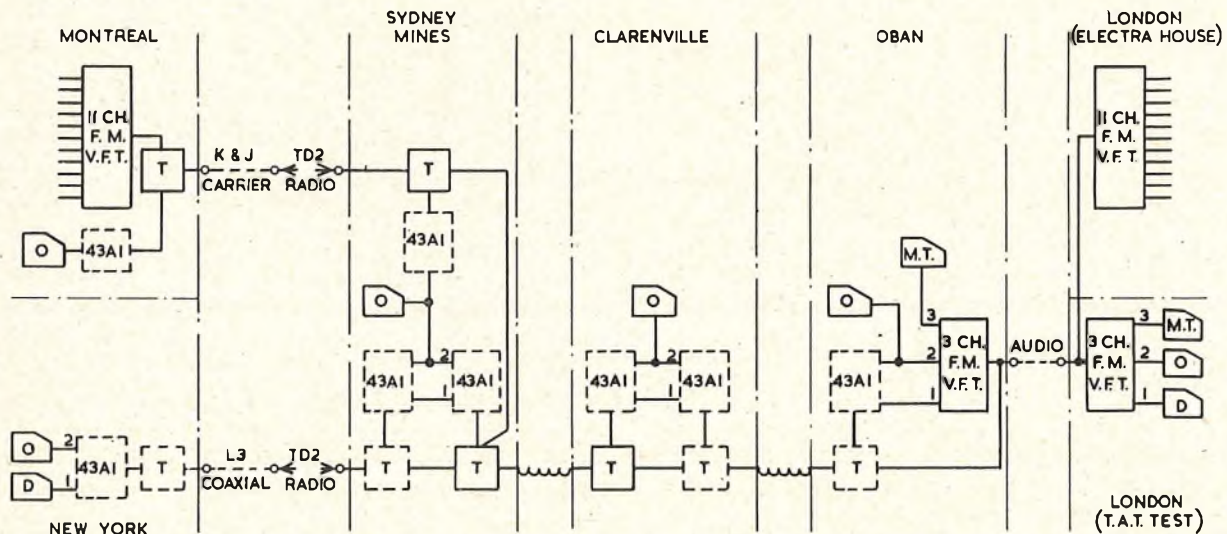

Notes:
1. British equipment is shown by full lines and American equipment by dotted lines.
2. Abbreviations are: 43A1—American v.f. telegraph equipment, type 43A1 (the numbers are the channel numbers); T—translating equipment; O—omnibus teleprinter; D—direct teleprinter; M.T.—monitor and test teleprinter; K carrier—a 12-circuit cable carrier system; J carrier—a 12-circuit open-wire system; TD2 radio—a wideband microwave radio system.

FIG. 14.—BLOCK SCHEMATIC DIAGRAM OF TELEGRAPH CIRCUITS ON THE T.A.T. CABLE.

Montreal a pilot signal is transmitted with the traffic channels which will compensate for frequency errors in the telephone circuit up to 10 c/s. This is considerably in excess of any error expected to occur under normal operating conditions and thus no difficulties in this respect are expected.

It should be observed that, as a frequency-modulated system transmits signals for both mark and space conditions, the aggregate loading on the main-line amplifiers is increased over that from an amplitude-modulated (i.e. ON and OFF) system since, in the latter case, the signalling conditions could be reversed on half the channels. If, therefore, a number of frequency-modulated voice-frequency (f.m.v.f.) systems were established on the cable it might be necessary to use a lower signal level to avoid overloading the amplifiers. A level as low as -30 dBm at a point of zero telephone level is expected to be satisfactory in any circumstances, but at present a channel level of -21 dBm has been allowed. This gives a measured signal/noise ratio in a London-Montreal 120-c/s channel of about -36 dB, which does not cause any appreciable increase in the telegraph channel distortion.

London-Montreal Multi-Channel Voice-Frequency Telegraph System.

The available telephone half-channel derived by the group splitting filter allows a band-width of approximately 2,100 c/s to 3,400 c/s (see Fig. 15) for the f.m.v.f. telegraph

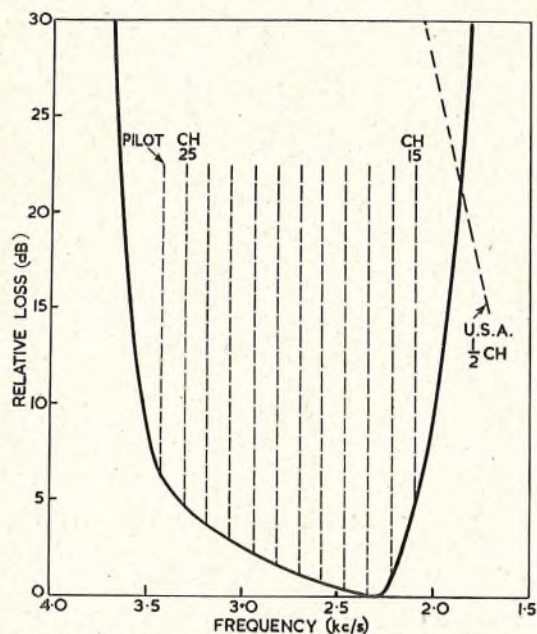

Measured Montreal to London, at audio-frequency, using Route 1 from Glasgow to London
 FIG. 15.—Loss/FREQUENCY CHARACTERISTIC OF CANADIAN HALF-CHANNEL.

system and equipment has been provided for 11 traffic channels and three alternative pilot signals, either 3,420, 3,300 or 2,100 c/s. The pilot signal is unmodulated and thus the frequency of least suitability for traffic purposes will be used as pilot. The optimum pilot frequency of 3,420 c/s has been chosen after through tests with Montreal and frequencies of 3,300 and 2,100 c/s will be available for traffic purposes. Arrangements are included in the pilot receiving equipment to give an alarm if the level of received signal falls 10 dB for a period of 500 ms.

To exploit the ability of the f.m.v.f. system to transmit 80-baud signals, two-circuit time-division-multiplex equipment is being developed, which will operate synchronously and in conjunction with start-stop input and output circuits, enabling each start-stop $7\frac{1}{2}$ -unit 50-baud input

signal to be converted and conveyed over the time-division-multiplex circuit as a 6-unit (synchronous) signal. The aggregate speed of two channels is therefore $6/7\frac{1}{2} \times 50 \times 2 = 80$ bauds.

The telegraph capacity of the London-Montreal system can thus be doubled compared with normal start-stop working without increasing the load on the cable amplifiers.

A point of interest is that the routing of the Canadian half-group from Sydney Mines to St. John is over microwave radio-relay links. This equipment provides automatic change-over to a diversity path to reduce faults caused by fading and equipment failure, but operating experience is awaited to indicate the performance of telegraph systems on this type of link and on the 12-channel carrier system on open wire which exists between St. John and Quebec. The use of an f.m.v.f. telegraph system should, however, contribute materially to ensuring satisfactory performance of the telegraph channels to be operated over the tandem telephone systems between London and Montreal. British equipment has been employed to open the Canadian telex service and also to provide dialling facilities from Montreal, via the teleprinter automatic switching centre in London, to selected public telegraph offices in the United Kingdom.

CABLE SYSTEM MAINTENANCE TELEPRINTERS

Maintenance teleprinter circuits are provided as shown in Fig. 14 by the use of tandem-connected f.m.v.f. channels, injected on the cable outside the working 12-circuit group frequency bands. Both the direct London-New York and the omnibus teleprinter circuits work at 50 bauds instead of the usual American speed of 45.5 bauds. Another difference between American and British telegraph practice is that single-current loop working is used in the U.S.A. whereas double-current signalling (i.e. reversal from +80V to -80V) is employed in the United Kingdom. From New York to Sydney Mines an American f.m.v.f. telegraph system Type 43A1 is used which employs 170-c/s channel-spacing and uses ± 35 -c/s frequency deviation. The terminal teleprinters connected to the channels work single current. Similarly, and to avoid change of practice at Sydney Mines, it was agreed that over the British cable to Clarendville and over the Clarendville-Oban cable 43A1-type equipment should be used. The conversion from single-current to double-current signalling is therefore provided at Oban, as shown in detail in Fig. 16. From Oban to London a 3-channel f.m.v.f. telegraph system is provided using British equipment of the same type as that used on the London-Montreal system. The audio line between London and Oban used for the London-Montreal system also carries the 3-channel London-Oban system and a 1,860-c/s line monitor pilot.

The telegraph signal level on the Clarendville-Oban system is only -30 dBm0, but tests conducted at Oban show very good performance of the f.m.v.f. equipment over the link.

Although there are four tandem links between New York and London and the signal is repeated by relays at each d.c. point, the overall channel distortion is only about 8 per cent and the service should be satisfactory without signal regeneration. Regenerative repeaters can readily be added, however, if necessary.

On the omnibus teleprinter circuit all stations receive all messages, but obviously only one station at a time may send. When Oban is sending, the signals from the teleprinter pass direct to the British 3-channel f.m.v.f.t. equipment (see Fig. 16) and thence to London, and via relay SB to the U.S.A. f.m.v.f.t. equipment; relay LR also operates, LR1 operating the teleprinter receive magnet to provide a local record. Signals received from Clarendville operate relay SA, which transmits the signals to the British f.m.v.f.t. equipment and, via relay LR, operates the tele-

Considering the injection of the half-channel signals into the h.f. path, the 0-2 kc/s and 2-4 kc/s channels are fed into channel 6 modulators, the outputs being at 86-88 kc/s and 84-86 kc/s, respectively. These are combined in a hybrid coil and the 4-kc/s band thus formed combined in a further hybrid coil with the main 60-108 kc/s group from London. Two band-stop filters covering 84-86 kc/s and 86-88 kc/s are included in the main path to prevent noise on the inland route from interfering with signals injected at Oban. By splitting the band in this way it is made possible for the audio injection of one channel to be carried out at London and the other at Oban; this, however, would only be done in very exceptional circumstances.

The final hybrid coil in the outgoing path enables, in effect, the Oban equipment to be set up for either local injection or injection at London.

Corresponding equipment for extracting signals in the half-channels is provided for the return path, although the switching arrangements are simpler since there is no need for the noise-suppression band-stop filters.

A further facility that is provided enables complete channel equipments to be connected in place of the two channel 6 modems so that, in the event of the h.f. line failing, audio speech signals may be injected as well as the telegraph signals. This facility is discussed further in Part 5.

The Kingsway equipment, which is, as stated above, used only in an emergency, is substantially the same as that at Oban. There is, however, no need for the noise-suppression filters, which are therefore omitted.

ACKNOWLEDGMENTS

The authors wish to acknowledge the part played, in the work described, by colleagues in the Telegraph and the Transmission and Main Lines Branches of the E.-in-C.'s Office and by Mr. A. J. Barker, of Standard Telephones & Cables, Ltd.

The voice-frequency telegraph equipment for London, Oban and Montreal was supplied by Standard Telephones & Cables, Ltd.

Part 5.—Change-over Facilities and Miscellaneous Equipment

F. PYRAH and

C. E. E. CLINCH, B.Sc.(Eng.), A.M.I.E.E., F.S.S.†

U.D.C. 621.395.52:621.315.28:621.395.44

CHANGE-OVER FACILITIES

THE T.A.T. cable 12-circuit carrier groups are routed on 24-circuit carrier cables between London and Glasgow and on coaxial cable between Glasgow and Oban. There is no alternative h.f. route between Glasgow and Oban and because of this and the necessity for frequency changing at Glasgow the change-over arrangements at Glasgow and Oban are not straightforward group changes.

Between London and Glasgow there are three standby groups on a different route from the normal working route. Between Glasgow and Oban there are spare equipped tubes in the coaxial cable; also between Glasgow and Oban there are a number of audio circuits which may be used in the event of the Glasgow-Oban h.f. line failing. To enable these alternative routes to be brought into use as quickly as possible the change-over is made as described below. Fig. 18 is a block schematic diagram of the arrangement.

Also described are miscellaneous items of equipment for the provision of telephone and telegraph speaker circuits, program-circuit switching and picture telegraphy circuits.

Twelve-circuit Group Change-over.

At London and Oban the transmit sides of the working and standby line links are joined together through a hybrid coil so that speech signals are transmitted to both lines. At the receive terminal the two lines are terminated on relay contacts to enable a rapid change to be made from one line to the other. The relay is one having high spring-pressures and platinum contacts, to ensure reliability, and a time of operation of less than 3 ms. Manual operation is necessary at present but it is possible that automatic change-over may be provided later by using the group reference pilot.

Coaxial-Line-Link Change-over.

At Glasgow and Oban the transmit sides of the working and standby coaxial line links are connected together through a hybrid coil on the broadband switching rack so that both lines carry signals. At the receive terminal, the lines are connected to a U-link panel and quick-acting switch. Either line link may be brought into use without co-operation from the transmit terminal by operation of this switch, which is connected into circuit by means of the U-links

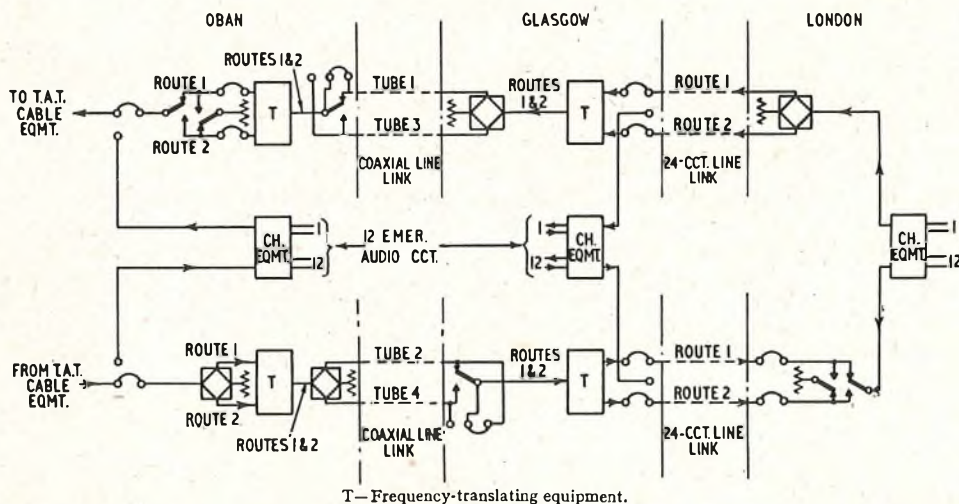

FIG. 18.—BLOCK SCHEMATIC DIAGRAM OF CHANGE-OVER ARRANGEMENTS FOR 12-CIRCUIT GROUPS BETWEEN LONDON AND OBAN.

Change-over to Audio Routing.

As there is only one h.f. cable between Glasgow and Oban, containing both working and standby h.f. line links, arrangements have been made to use audio circuits between these two places in the event of failure of the coaxial cable. These audio circuits are connected to 12-circuit carrier equipment at Glasgow and Oban, the h.f. sides of the equipment being connected to a U-link change-over panel. Thus, in the event of a complete failure of the coaxial line links, the group-translating or the supergroup-translating

† The authors are, respectively, Senior Executive Engineer and Temporary Senior Executive Engineer, Transmission and Main Lines Branch, E.-in-C.'s Office.

equipment at Glasgow or Oban, the 12-circuit groups between London and Glasgow are terminated at Glasgow, routed to Oban over audio plant, re-assembled as 12-circuit groups and connected to the T.A.T. cable supergroup-translating equipment.

SPEAKER CIRCUITS

The speaker circuits considered necessary for the maintenance of the T.A.T. cable system comprise:

- (a) A telephone omnibus speaker linking London and New York and giving full communication facilities between London (T.A.T. Test), Oban, Clarenville, Sydney Mines, Portland, West Haven, New York (White Plains) and Montreal.
- (b) Direct telephone circuits between the main stations.
- (c) A teleprinter circuit terminated at London (Kingsway) and New York (White Plains) with full omnibus facilities at Oban, Clarenville, Sydney Mines and Montreal.
- (d) A direct teleprinter circuit between London and New York.
- (e) A direct teleprinter circuit between London and Oban.

In order to ensure continuity of service, change-over facilities have been provided so that faulty lines or equipment can be patched out. In so far as telephone speaker equipment is concerned this may be done on spare duplicate equipment. On the line side between London and Oban, change-over facilities have been provided so that in the event of failure the omnibus line can be replaced by the line normally used for the direct London-Oban telephone speaker. Direct communication between London and Oban is then obtained over the public network but if a fault on either the omnibus or direct speaker is likely to persist for some time, a temporary direct speaker using London-Glasgow and Glasgow-Oban trunk circuits may be used.

Telephone Speaker Equipment.

The racks of telephone speaker equipment at London and Oban were constructed by the London Telecommunications Region to drawings supplied by the Engineering Department. Each rack accommodates the following equipment:—

- (a) Two-tone signalling equipment.
- (b) Speaker and bridging-circuit panel.
- (c) Change-over U-links and sockets.
- (d) Power supply panels.

The 2-tone signalling equipment, comprising signalling oscillator (600 c/s and 1,500 c/s) and signalling receiver and selector, were obtained from America. The speaker and bridging-circuit panels were constructed in the United Kingdom to a circuit design similar to the American design, but modified to enable two officers at London (T.A.T. Test) to use the omnibus circuit simultaneously. This entailed the provision of an additional amplifier, which provides a transmission path between the two positions in London without giving rise to coupling between the two directions of transmission of the omnibus circuit. It is of interest to note that the London rack uses transistor amplifiers designed by the Post Office.

A similar rack was constructed by the London Telecommunications Region for Montreal but this rack uses conventional amplifiers and was designed to work from 60-c/s mains supplies.

Teleprinter Circuits.

The London-Oban sections of the three teleprinter speaker circuits are provided by means of 3-channel v.f. telegraph equipment at London and Oban and use frequencies below 1,800 c/s. As the v.f. telegraph channels for the public service are in the band 2 to 4 kc/s, the two systems are combined at London and Oban and transmitted over the same line. This line link has a reserve circuit on a different route. In view of the importance of the line, the reserve circuit is completely spare in readiness for being brought into use when required. At London and Oban the transmitting ends of the two lines (working and reserve) are coupled together through a hybrid coil so that telegraph signals are simultaneously transmitted on each line. Thus, on failure of the working circuit, it is only necessary for a change-over of the line to be made at one end. To assist in the maintenance of the circuits, each one has a pilot of 1,860 c/s applied at low level at the transmitting end. This frequency lies approximately midway between the two v.f. telegraph systems. At the receiving end, the pilot is extracted by a filter and its level is continuously recorded on a recording decibelmeter; failure of the tone or a change in its level brings in an audible and visual alarm. Change-over to the alternative line is carried out by U-link switching. A further reserve line link for the public service to Montreal is available over the carrier group having the half-channel, which may be brought into use by U-link switching at London and Montreal, for both speaker and public circuits. Spare v.f. telegraph equipment is available at London and is permanently monitored by arranging the transmit and receive directions to be looped together via the change-over links, as shown in Fig. 19.

The v.f. telegraph change-over and monitor racks, which provide the facilities described above, were also assembled by the London Telecommunications Region to drawings supplied by the Engineering Department, and include the following items:

- (a) U-link sockets to enable change-over of lines and equipment to be made.
- (b) Hybrid coils to couple the speaker and public telegraph channels and the working and reserve main lines.
- (c) Filters for the extraction of the 1,860 c/s test tone.
- (d) Amplifiers for the recording decibelmeters.

The recording decibelmeters are mounted on a separate rack.

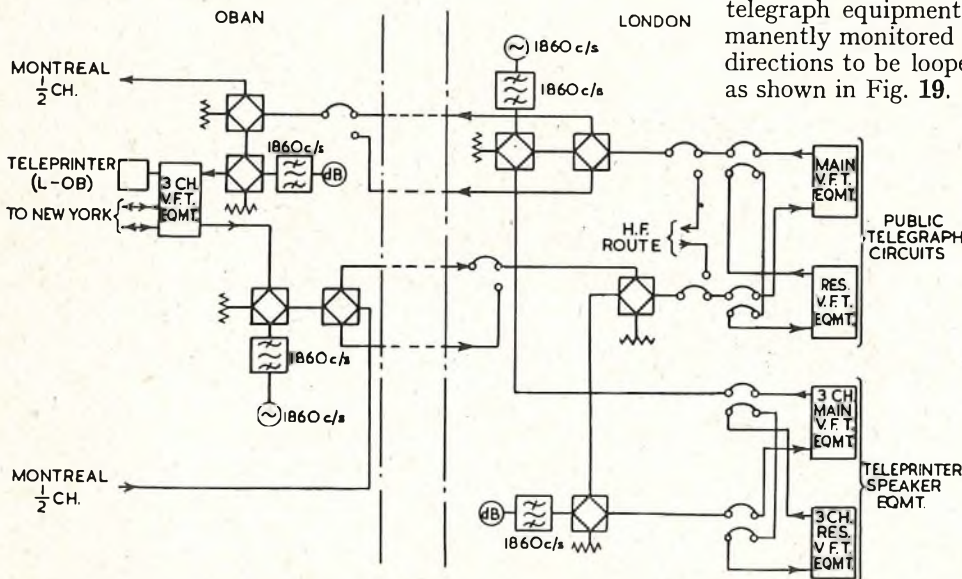
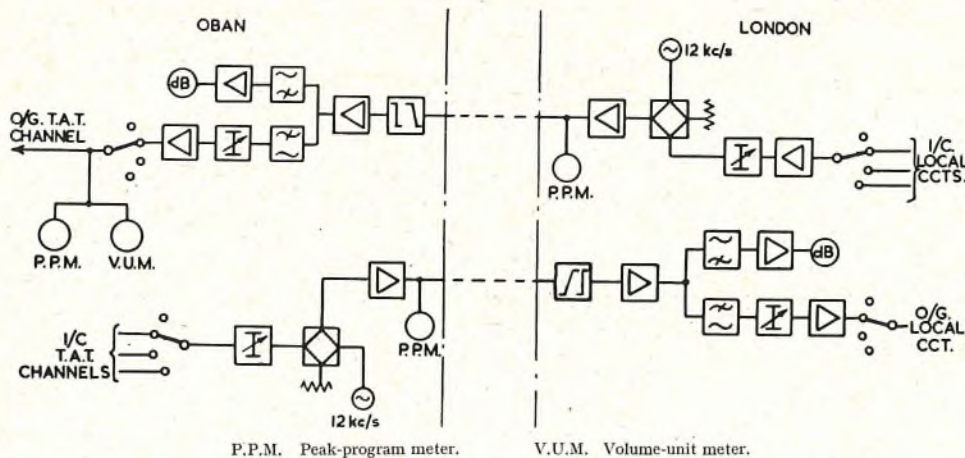

FIG. 19.—BLOCK SCHEMATIC DIAGRAM OF MONITOR AND CHANGE-OVER ARRANGEMENTS FOR V.F. TELEGRAPH CIRCUITS BETWEEN LONDON AND OBAN.



P.P.M. Peak-program meter. V.U.M. Volume-unit meter.

FIG. 20.—BLOCK SCHEMATIC DIAGRAM OF PROGRAM-SWITCHING EQUIPMENT AT LONDON AND OBAN.

PROGRAM-SWITCHING EQUIPMENT

The program-switching equipment (Fig. 20) at London and Oban provides flexibility of interconnexion between local Occasional Program (O.P.) links and the various program links which make up the transatlantic program circuits, and also includes level-monitoring and gain-adjustment facilities.

The equipment at Oban caters for three wideband (6.4 kc/s or 10 kc/s) transatlantic program links in each direction of transmission, three wideband London-Oban O.P. circuits in each direction and a standby link in each direction. The equipment is accommodated on two racks, one for each direction of transmission.

The London equipment caters for (in each direction of transmission) 14 local O.P. links, three London-Oban O.P. links, plus one standby link, and six narrow-band (3.2 kc/s) program circuits. The narrow-band program circuits comprise tie circuits from the switching equipment to the audio test link rack associated with the transatlantic carrier circuits, on which they may be patched to selected channels. The equipment consists of three racks, one accommodating the incoming local O.P. links and outgoing Oban circuits, one accommodating the incoming Oban circuits and outgoing local O.P. links, and a third the incoming and outgoing narrow-band circuits.

All the equipments are basically similar in that each outgoing link is connected to the wipers of a separate multi-position rotary switch, the banks of the switches associated with a group of outgoing circuits being multiplied and connected to the appropriate group of incoming links. The circuit impedances at the switching points are arranged so that up to three outgoing links may be switched to one incoming link with negligible degradation of performance.

At London the Oban O.P. links and the narrow-band tie circuits are provided with auxiliary amplifiers and switch-operated gain-control potentiometers to facilitate rapid adjustment of residual overall loss or gain when a long inter-continental program circuit is set up. Similar facilities are provided at Oban, but they will be used only on the rare occasions when adjustment is required due to a change of gain during transmission of programs.

It is important that the standard levels of program signals shall be rigidly adhered to in order to avoid overload or noise, and in this connexion peak-program meters (for the east-to-west direction) and volume-unit meters (for the west-to-east direction) are permanently connected across the main test points at London and Oban. In addition, a small number of these meters are provided with

multi-position switches wired to other test points to enable levels to be checked throughout the equipment.

The London-Oban O.P. links are provided with 12-kc/s pilot-injection equipment at the transmitting terminal and filters and recording decibelmeters at the receiving terminal to enable the condition of the circuits to be permanently monitored. At present it is possible to use this equipment on two of the three circuits in each direction; the third circuit will be improved later and until this is done a 1-kc/s signal is used for observation during idle periods.

Much of the program equipment, e.g. switching units, peak-

program and volume-unit meters, and filter units, was designed specifically for the T.A.T. cable scheme. These items, constructed by the Transmission and Main Lines Branch Laboratory and by contractors, were assembled on the racks by the London Telecommunications Region, who were also called upon to construct mechanical details and to carry out modifications found to be necessary as the racks neared completion and tests showed the need for such modifications. A program test rack for use at Montreal was also constructed by the London Telecommunications Region.

PICTURE TELEGRAPH EQUIPMENT

Picture telegraphy between London and Montreal will be by means of frequency-modulated signals. The frequency-modulated signals will originate in Electra House.

The equipment provided at T.A.T. Test, London, consists of amplifiers, line equalizers and filters. In the direction London to Montreal the amplifier is arranged to be operated from an h.t. supply of low voltage so that the maximum output is limited. It is necessary to limit the power delivered to one channel on continuous tone to about 10 dB below normal test level to prevent overloading the transatlantic cable amplifiers and the circuit is arranged so that the amplifier cannot deliver a power greatly in excess of this even if high-level signals are applied.

A low-pass filter is used to prevent any harmonics from the amplifier reaching the channel equipment at a high enough level to cause crosstalk to adjacent channels. In the Montreal to London direction a similar low-pass filter is used as an adjunct to the channel filters in the elimination of interference above the working band. An amplifier is used to increase the level of the received signal before transmission to Electra House.

The picture telegraph circuits are terminated on the channel test rack and can be patched into any channel as required. Certain channels have been nominated as "first choice" channels.

The equipment was assembled and wired by the London Telecommunications Region.

At Montreal similar arrangements are made using modified standard equipment.

ACKNOWLEDGMENTS

The authors wish to acknowledge the contributions made by the London Telecommunications Region, Research Branch and the Transmission and Main Lines Branch and Telegraph Branch Laboratories in the design and construction of the equipment described in this article.

Switching Arrangements in London for Telephone Calls over the Transatlantic Telephone Cable

H. S. WATERS and
B. F. YEO, A.M.I.E.E.†

U.D.C. 621.316.5:621.395.5:621.315.28

This article describes the methods of switching transatlantic telephone cable circuits to other circuits for telephone calls between (a) North America and (b) the United Kingdom, other European countries and, by radio, other parts of the world. Special features include 4-wire switching under the control of a remote sleeve-control manual-board.

INTRODUCTION

BEFORE the opening of the transatlantic telephone cable, all telephone calls to North America were completed over radio circuits. International exchange, Wood Street, London, is the controlling point for all United Kingdom radio calls and, when the transatlantic telephone cable project was being planned, it was decided to retain control of the North American services at this exchange. Thus, from an operating point of view, the cable circuits were required to terminate at International exchange.

Furthermore, it was decided that, while the transatlantic circuits would eventually be equipped for dialling in both directions, initially they would be operated on a manual basis using generator signalling. It was also the intention to take advantage of the superior transmission characteristics expected of the cable circuits by providing the same standard of transmission on calls to provincial zone-centre switching points and to European capitals as to the London zone-centre switching point. This requirement led to the introduction of 4-wire switching at London. Because space at International exchange was limited, and for easy access to the trunk network, it was decided to locate the main switching equipment (Fig. 1) at Kingsway, with external tie circuits to International exchange for setting-up and

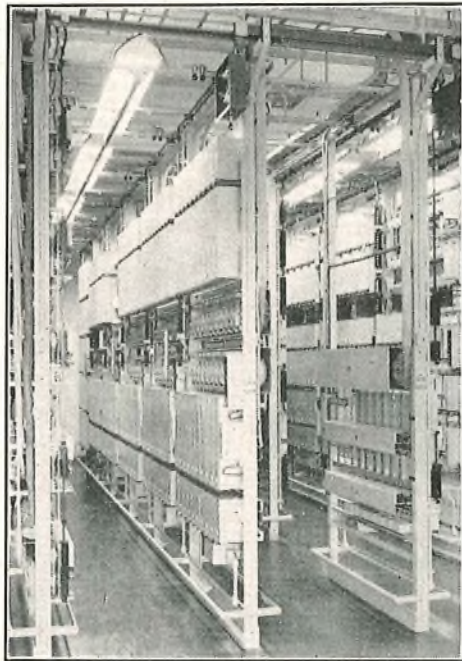

FIG. 1.—THE SWITCHING EQUIPMENT AT KINGSWAY.

supervisory purposes. The arrangements for termination of the transatlantic cable circuits at one exchange (Kingsway) with control at another exchange (International) about a mile away, was further complicated by the need to extend

these cable circuits to a third exchange (Continental) in another building for the completion of calls from America to the rest of Europe.

CIRCULATION OF TRAFFIC

Fig. 2 shows the trunking arrangements for the circulation of traffic to and from North America. Each transatlantic cable circuit is connected via a 4-wire voice-frequency ringer (arranged to send 1,000/20 c/s to North America and receive 500/20 c/s) to a terminating relay-set, which contains a hybrid transformer and provides a 2-wire path to the manual board and a 4-wire path to the banks of motor-uniselectors acting as finders. Each finder is associated with a connecting relay-set, of which there are three types—a selector-connecting relay-set (Fig. 3) for access to subscribers in the United Kingdom, a bothway tie-circuit-connecting relay-set for access to Continental exchange (Faraday Building), and a bothway generator-signalling relay-set for access to certain continental radio exchanges.

A calling signal (500/20 c/s) received from America is converted to d.c. by the 4-wire ringer and relayed through the cable-connecting relay-set and the manual-board relay-set to light the calling lamps on the sleeve-control manual-board at International exchange. The International operator answers and speaks to the American operator with the hybrid coil in the cable-connecting relay-set remaining in circuit. To set up a call to a subscriber in the United Kingdom, the International operator extends the other cord of the cord circuit to an outgoing dialling jack and dials the appropriate code and number via a selector-connecting relay-set and associated 4-wire selector. On restoration of the dialling key, the finder associates the selector-connecting relay-set with the particular transatlantic cable circuit in use, but, while the speak key is operated or the called subscriber is off the line, the cable circuit remains connected to the inland network via the cord circuit.

On calls via provincial zone centres, 4-wire switching through Kingsway is effected in two stages. The first stage is when the called subscriber answers, the 2/4-wire A.C.1 relay-set switching 4-wire so that the International operator speaks via the hybrid coil in the selector-connecting relay-set and proves the 4-wire connexion through the selector train. The second stage is when the speak key is restored, the selector-connecting relay-set and the cable-connecting relay-set then switch through on a 4-wire basis via the finder which has previously associated these two relay sets. The cable-connecting relay-set switches from the 2-wire to the 4-wire condition as the result of a signal received from the A.C.1 relay-set.

On calls to 2-wire points, e.g. a London subscriber, the absence of a signal from an A.C.1 relay-set results in the cable-connecting relay-set remaining in a 2-wire condition. When the speak key is restored, the 2-wire side of the hybrid in the cable-connecting relay-set is switched from the Wood Street tie circuit to one pair of the 4-wire finder and thence on a 2-wire basis to the required subscriber.

In both types of call, therefore, the through connexion is diverted from the International manual board and switched directly through Kingsway. However, the International operator is able to monitor via a high-impedance circuit in

† The authors are, respectively, Senior Executive Engineer and Executive Engineer, Telephone Development and Maintenance Branch, E.-in-C.'s Office.

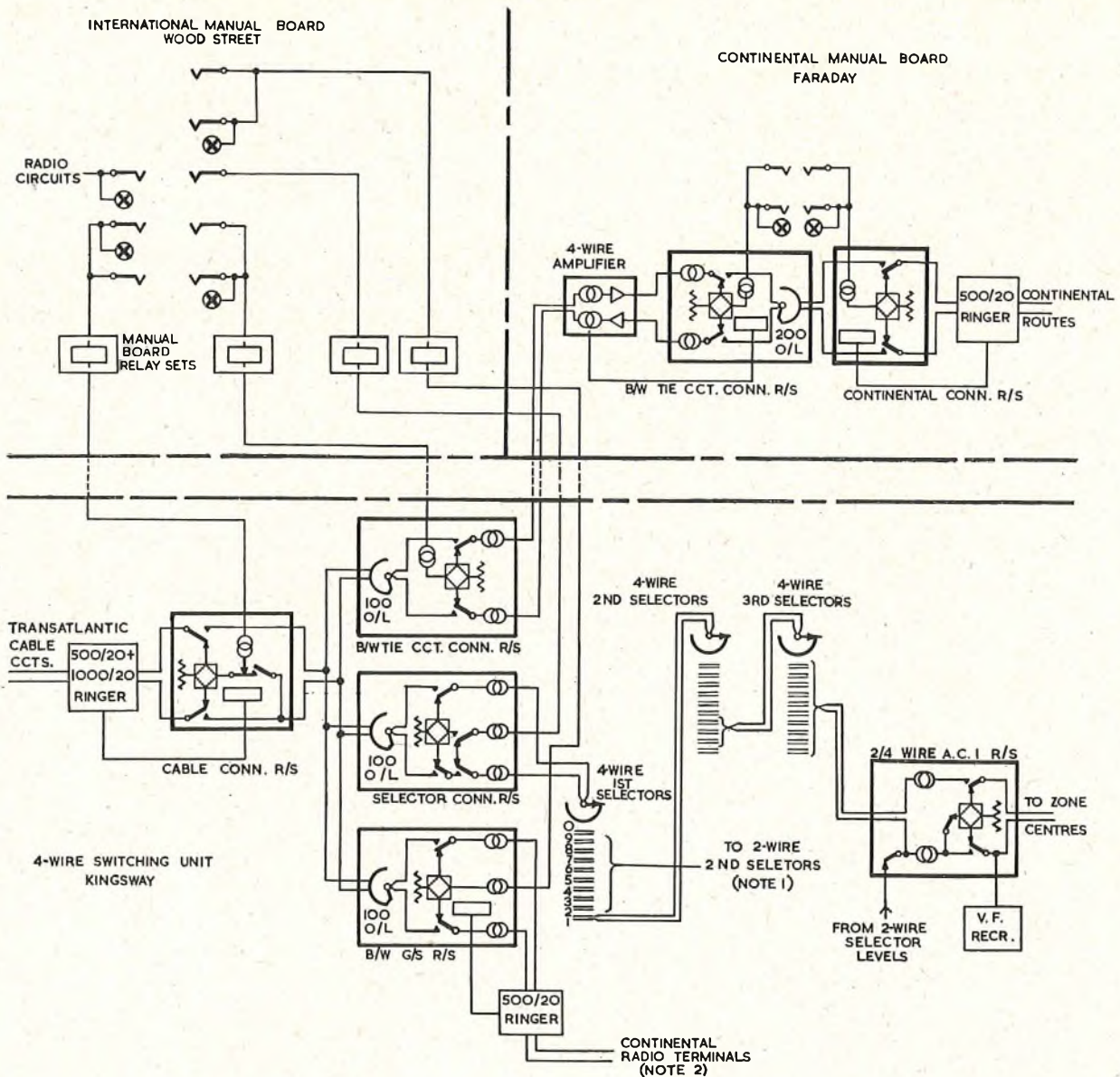

Notes:

1. Two-wire 2nd selectors are mounted on Trunk Kingsway racks and give access to London exchanges and directly-connected group centres.
2. Direct circuits to Paris, Brussels and Amsterdam radio terminals.
3. Trunking arrangements shown are typical only.

FIG. 2.—TRUNKING ARRANGEMENTS FOR THE CIRCULATION OF TRAFFIC TO AND FROM NORTH AMERICA.

the selector-connecting relay-set, and also to receive supervisory signals. The selector-connecting relay-set contains pads (attenuators) which are inserted in each pair when the connexion is completed under 4-wire conditions. This ensures the maintenance of the required transmission standard to the distant zone centre when the two hybrids—one in the cable-connecting relay-set and one in the selector-connecting relay-set—are switched out.

For calls to the continent of Europe the International operator extends the cable circuit, on a manual basis, via a 4-wire amplified tie circuit, to Continental exchange at Faraday building. The circuit is routed via a bothway tie-circuit-connecting relay-set at Kingsway to prepare for 4-wire switching to the cable circuit. At Continental exchange a number of circuits are nominated on each route to the Continent for completing calls from North America and the operator extends the connexion to one of these circuits. They are also used in the normal 2-wire condition by Continental operators for setting up ordinary calls, but provide for 4-wire switching when connected to a tie circuit from International exchange.

When the Continental operator restores her speak key,

the connexion is switched 4-wire at Continental exchange via a finder, in a similar way to the arrangement at Kingsway. When the International operator restores her speak key, the connexion is also switched 4-wire at Kingsway so that the transatlantic cable circuit is extended 4-wire through London to the Continent.

Certain calls from North America require connexion to radio exchanges on the Continent for extension to radio circuits controlled by Continental administrations, e.g. via Paris to North Africa. The circuits to these radio exchanges are terminated on bothway generator-signalling connecting relay-sets (the third of the types previously mentioned), thus providing for 4-wire switching to the transatlantic cable circuits.

The transatlantic cable circuits may also require to be extended to radio circuits that are terminated on a 2-wire basis at International exchange. In this case the 2-wire side of the hybrid coil in the cable-connecting relay-set remains extended to International exchange and the cable and radio circuits are connected via the operator's cord circuit on a 2-wire basis.

Radio circuits may also be connected to the inland

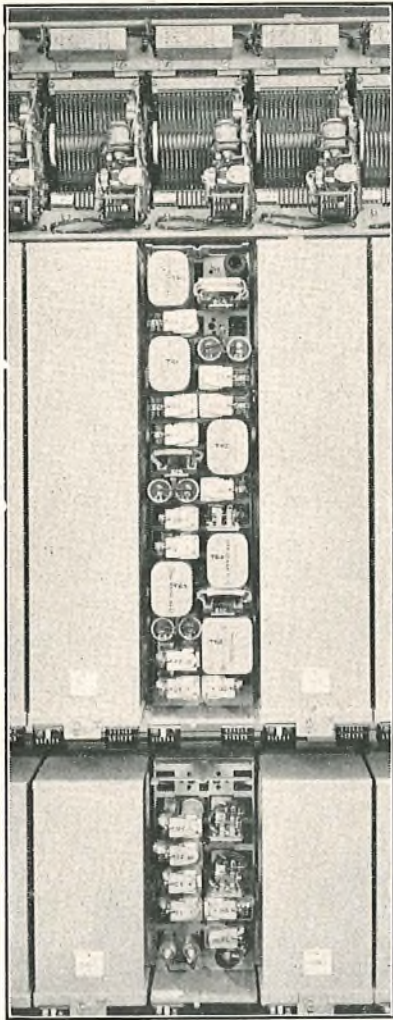

FIG. 3.—SELECTOR-CONNECTING RELAY-SETS WITH 4-WIRE FINDERS.

network, to Continental exchange, and to Continental radio exchanges via the Kingsway 4-wire connecting relay-sets already mentioned. For such connexions the hybrid coils in the connecting relay-sets remain in circuit and transmission is on a 2-wire basis via the operator's cord circuit.

TRANSMISSION ON THE SWITCHED CONNEXIONS

Fig. 4 shows the transmission conditions for various classes of call. For convenience, only levels in the West to East direction are shown. The figures in brackets refer to losses or gains inserted by equipment or lines, while the other figures are the levels relative to sending zero level at the 2-wire test point at New York or Montreal. Except for radio calls, all the conditions shown relate to the connexions when switched through at Kingsway (and Continental exchange where applicable) and with the operator's speak key normal.

Fig. 4 (a) shows a connexion to a London director exchange, assuming the maximum junction loss of 6.5 dB. The only 4-wire selector employed is that associated with the selector-connecting relay-set, and for this call only one of its two speech pairs is used.

Fig. 4 (b) shows the conditions obtaining on a call to a directly-connected group centre. Again, only 2-wire switching is used at Kingsway, and only one 4-wire selector is used. The nominal loss of 3 dB has been assumed for the circuit to the group centre.

Fig. 4 (c) illustrates a connexion set up to a provincial zone centre. In this case, three 4-wire selector stages are used, and both speech pairs are employed in each. The

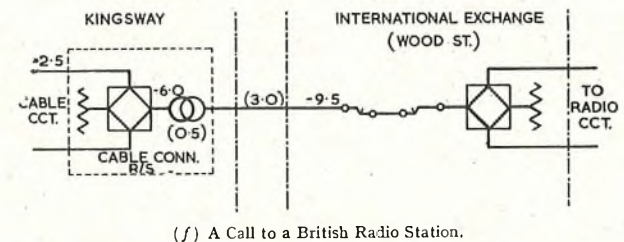
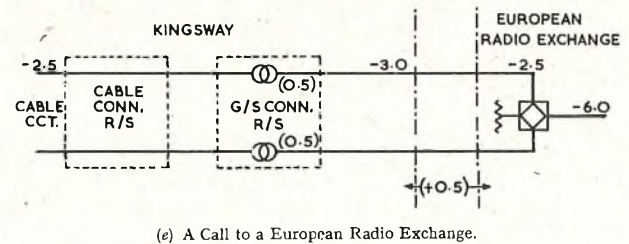
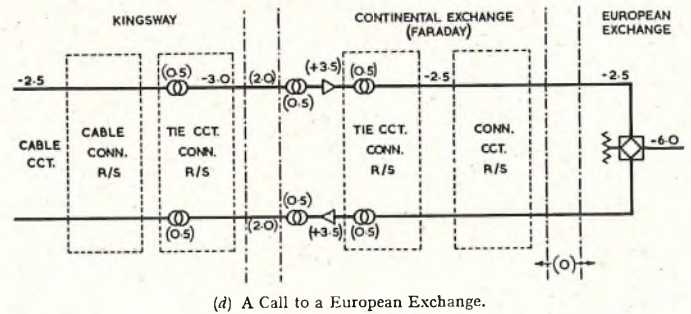
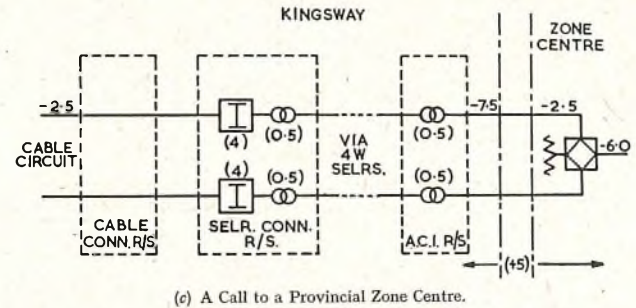
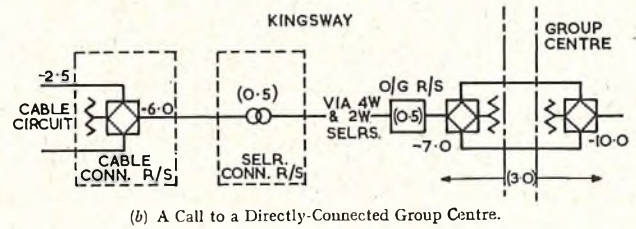
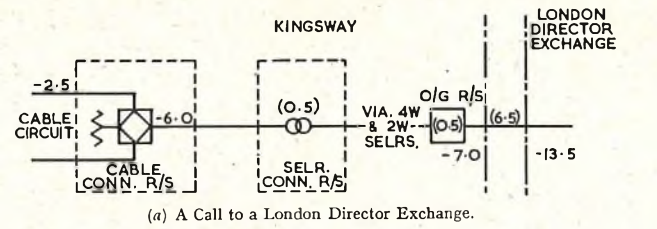

FIG. 4.—TRANSMISSION CONDITIONS ON CALLS FROM NORTH AMERICA.

A.C.1 relay-set provides for joint access—4-wire for transatlantic cable calls and 2-wire for ordinary inland trunk traffic. The zone-centre circuits are lined up to -2.0 dB, 2-wire to 2-wire, giving a gain of 5.0 dB on the 4-wire path. It is therefore necessary to insert a pad in each pair, as shown in the selector-connecting relay-set, to obtain the required level of -6.0 dB at the 2-wire point at the zone centre. One of the pairs through the selector-connecting relay-set is used for 2-wire calls, as in Fig. 4 (a) and Fig. 4 (b), and it is, therefore, a requirement that the pad in this pair is switched into circuit only when the connexion is set up to a zone centre.

It should be mentioned at this point that all calls originating in the United Kingdom for the transatlantic cable circuits are reverted. Thus, calls are first booked at International exchange and then set-up back to the originating subscriber via the dialling circuits and associated connecting relay-sets. This allows through-switching to take place at Kingsway, and gives improved transmission resulting from the elimination of two tie circuits between International and Kingsway exchanges.

Fig. 4 (d) shows a call switched through Kingsway and Continental exchanges to a European exchange. The circuits from Continental exchange to the European exchange are lined up to -7.0 dB, 2-wire to 2-wire, giving zero gain on the 4-wire path.

Fig. 4 (e) shows the conditions obtaining on a call extended to a European radio exchange. The European circuit is lined up to give -7.0 dB, 2-wire to 2-wire, including the transformers in the generator-signalling-connecting relay-set at Kingsway. This results in a gain of 0.5 dB on the 4-wire path.

The conditions applying when a cable circuit is extended to a radio circuit are shown in Fig. 4 (f).

To meet transmission requirements for stability of the circuits, arrangements have been made to terminate the transatlantic cable circuits at all times during the setting-up, progress and clearing of calls. In most instances the terminating impedance is 600 ohms.

SWITCHING PRINCIPLES

Finder Association.

It has been mentioned already that during the setting-up of a call from a transatlantic cable circuit to, say, a United Kingdom subscriber, the finder incorporated in the selector-connecting relay-set associates this relay-set with the particular cable-connecting relay-set in use. Several operators may be setting-up calls at the same time and it is evident that the several finders cannot be allowed to step together or a particular finder might well find the wrong circuit. Thus, bank-marking signals must appear, and finders must be allowed to drive, only on a one-at-a-time basis. Further, since a cable-connecting relay-set may be extended to a radio circuit, and a radio circuit may be extended to a selector-connecting relay-set, a marking signal must not appear on the finder band in the first instance, and the finder associated with the selector-connecting relay-set must not be started in the second. Thus, conditions for preparing to start a finder and to apply a bank-marking signal must be set-up only when a transatlantic cable circuit is extended to one of the three types of connecting circuit. These conditions are applied by means of the through connexion provided by the ring (R) wire of the operator's cord circuit. For calls dialled into the inland network, completion of this R-wire circuit is delayed in the selector-connecting relay-set until the dial key has been restored to normal.

Fig. 5 shows the elements of the R-wire circuit. The potentiometer connected to relay ST provides a potential between earth and $-50V$ which is sufficient to operate

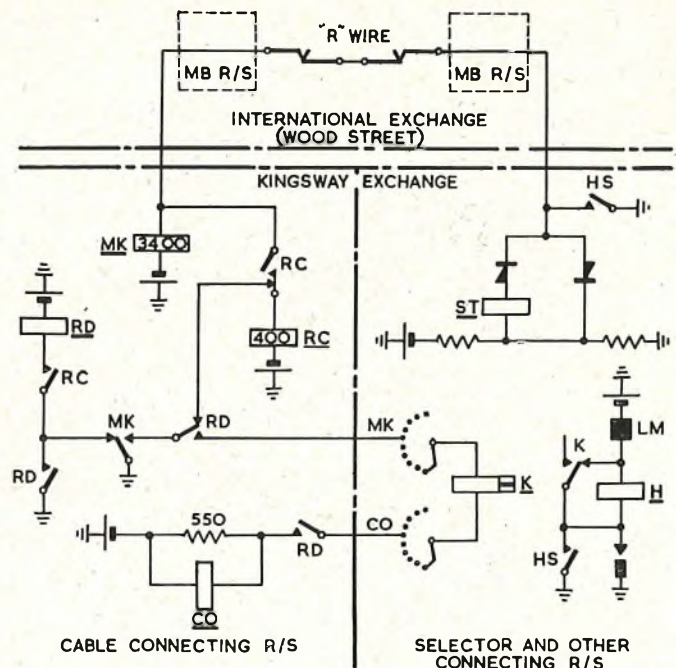

FIG. 5.—FINDER START AND MARKING CIRCUIT ELEMENTS.

relays ST and MK in series. Relay ST, operated, applies to the common one-at-a-time circuit (see Fig. 6) for "permission" to start the finder, a 100-outlet motor-uniselector. In the meantime, relay MK operates relay RC, which connects itself in parallel with relay MK. The relay characteristics are such that this shunting effect causes relay MK to release. Relay MK, releasing, operates RD, which locks. It will be seen that relay K, the cut-drive relay for the finder, is connected to the MK and CO wipers of the finder, and requires battery and earth for operation. At this stage, only the battery is applied, via a contact of relay RD, so that the bank outlet is not yet effectively marked. When the common circuit indicates that this particular association may take place, relay HS (in Fig. 6) operates. One contact of relay HS completes a circuit for the finder latch magnet, and the finder commences to rotate. At the same time, another contact of relay HS connects a full earth to the R-wire and relay MK re-operates. The re-operation of MK completes the marking condition on the finder bank. Thus, the marking condition is not applied until the finder has received the start condition.

It will be seen that the correct sequence to produce a bank marking requires that relay MK should operate, release, then re-operate. Thus, some other condition, such as an earth fault on the R-wire, does not fulfil the require-

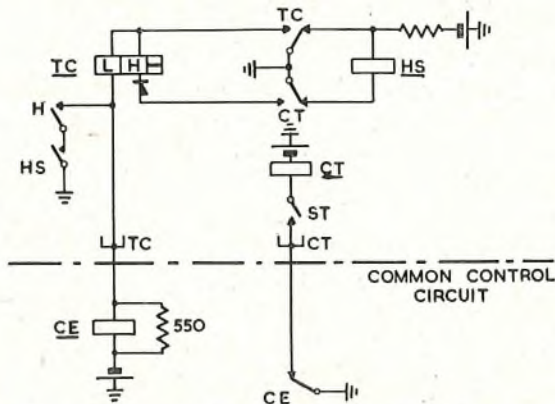

FIG. 6.—FINDER ONE-AT-A-TIME CIRCUIT ELEMENT.

ment and false marking is not applied. This arrangement also allows relay MK to pass a current to operate an earth-connected relay on the R-wire of a radio circuit when a transatlantic cable circuit is connected to it, without causing false marking. On the other hand, when a selector or other connecting relay-set is extended to a radio circuit, the arrangement of rectifiers associated with relay ST short-circuits this relay but allows current to flow to operate the earth-connected relay in the radio circuit without setting up a false start condition.

The arrangements for ensuring "one-at-a-time" finding are shown in Fig. 6. Relays TC, HS, CT are incorporated in each selector-connecting and similar relay-set. A demand on the common circuit is initiated by a contact of relay ST (see Fig. 5), which offers relay CT to the CT lead. Assuming that no other finders are in motion, the common circuit is normal, and earth via contact CE allows relay CT to operate. Contact CT applies an earth to relay TC so that both coils of this relay are connected in series to

via a contact of relay HS; this short-circuits relay TC, which releases. The release of relay TC short-circuits relay HS which releases and removes the earth from the TC common. This releases relay CE, which restores the earth to the CT common and the circuit is now ready to receive further demands. Should a large number of simultaneous demands be made—i.e. many ST relays in different connecting relay-sets operate simultaneously—the situation may arise where so many TC relays are connected in parallel to the TC common that none operate. Relay CE will, however, operate and disconnect the earth from the CT common. All the CT relays will start to release and eventually all but one of the CT relays will have released; that one relay will then maintain an operate path for its TC relay, which will operate and hold.

Although finding is on a "one-at-a-time" basis, the chance of finding the common control circuit engaged—even in the busy hour—is very small. Furthermore, there is ample time while a call is being set-up (e.g. receiving

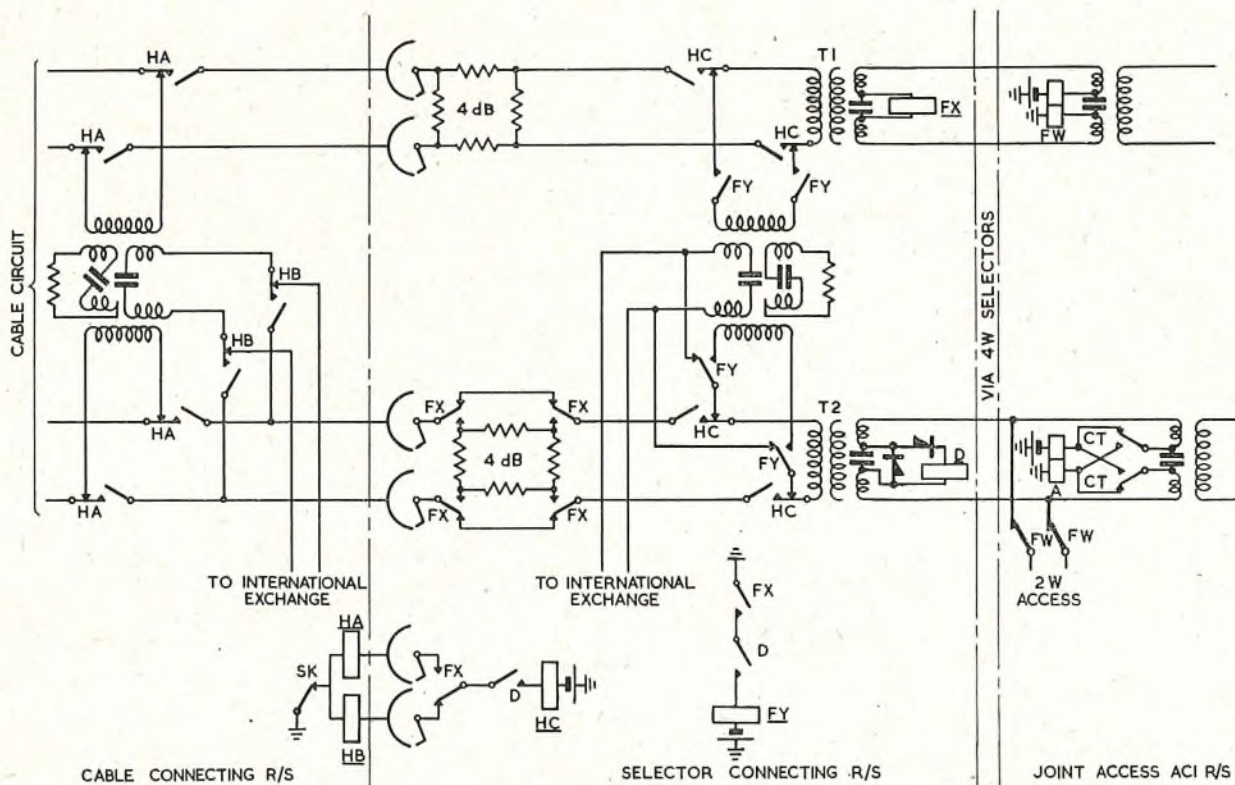

FIG. 7.—SIGNALLING CONTROL CIRCUIT FOR 2-WIRE AND 4-WIRE SWITCHING.

the TC common. Relays TC and CE operate in series, the former operating before the latter. TC shunts its high-resistance coil and both relays hold in series. Should the TC relay of another connecting circuit operate at the same time, neither of the TC relays will hold over its low-resistance winding to the same common point. Should a second TC relay be offered to the TC common just after the first has operated, the potential at the common point is insufficient to operate it. The potential across the second TC relay is further reduced by the rectifier in series with its high-resistance coil, which increases the total resistance when the available potential is low. The operation of relay CE removes the common earth, thus releasing relay CT and preventing the operation of CT relays in other connecting relay-sets should these initiate demands. The release of relay CT completes an operate path for relay HS, which starts the finder, as previously described. When the marked outlet has been found, the wiper-switching relay H (not shown) operates and applies an earth to the TC common

ring-tone, speaking to the called subscriber) during which the demand can be made and association take place.

If, due to a fault, association between a cable-connecting relay-set and one of the other connecting relay-sets does not take place within a fixed time after a start signal has been given, a warning signal in the form of a flashing supervisory lamp is relayed to the operator. At the same time, the common control circuit is released to prevent the faulty connexion from blocking other demands.

Two-wire and 4-wire Switching (Kingsway).

Fig. 7 shows the signalling arrangements whereby 2-wire or 4-wire switching through Kingsway is provided under control of the speak key and the called subscriber answer condition. The diagram illustrates the situation when access has been obtained to a 2/4 wire A.C.1 relay-set, and the wanted subscriber's line is being rung. The operator at International exchange can hear ring tone via the lower speech pair of the selector-connecting relay-set, and the

corresponding pair of intermediate 4-wire selectors and the A.C.1 relay-set. On initial seizure of the A.C.1 relay-set, relay FW operates in series with relay FX in the selector-connecting relay-set. These relays prepare for 4-wire switching in their respective relay-sets. In addition, the 2-wire path of entry into the A.C.1 relay-set is disconnected in order to prevent the 2-wire exchange multiple from adversely affecting the lower speech pair compared with the upper pair. When the called subscriber answers, relay CT in the A.C.1 relay-set operates. The resulting reversal operates relay D in the connecting relay-set, and a contact of relay D completes the circuit for relay FY. Relay FY switches the hybrid coil into circuit so that the operator speaks to the distant zone-centre subscriber on a 4-wire basis through the switching equipment at Kingsway, but 2-wire between Kingsway and International exchanges. Similarly, the operator utilizes the hybrid coil in the cable-connecting relay-set to speak to America. While the speak key is operated, relay SK in the cable-connecting relay-set is operated, and the connexion remains via the operator's cord circuit. When the speak key is restored, the release of relay SK completes the circuit for relay HA in series with relay HC (FX operated). These relays disconnect the hybrid coils from their respective relay-sets and switch the speech wires straight through on a 4-wire basis. It will be seen that, in this condition, a 4-dB pad is inserted in each pair to give the required overall transmission performance, as previously mentioned.

For 2-wire calls to, say, a London subscriber, the operator sets up the connexion via the selector-connecting relay-set, using the lower pair, as before. In this case the other pair of the 4-wire selector is idle because, on the level concerned, only one pair is trunked out to the 2-wire selector stage. Hence relay FX does not operate. When the called subscriber has answered, and the speak key is restored, relay HC operates, but this time in series with relay HB. The hybrid coil in the cable-connecting relay-set remains in circuit with its 4-wire side switched to the lower speech pair. It is this pair which is used through the connecting relay-sets and 4-wire selector as a transmission path for the 2-wire call. The non-operation of relay FX prevents the 4-dB pad from being inserted under these conditions.

Monitoring and Tone Circuit.

It is convenient to show the circuit elements for monitoring and applying 3-minute tone signals on the same diagram (Fig. 8). Transformers T1 and T2 are the same as the bridge transformers shown in Fig. 7. Dealing first with the monitoring facility, it will be seen that each tertiary winding is connected to a grid of the double-triode V1. Each half of the valve is independent of the other, but the outputs are combined via transformer T3, which is eventually connected to the International operator via the tie circuit previously used for setting-up the call. Thus the operator may listen on both pairs without coupling the two together and without drawing power from the transmission paths. Negative feedback is applied to each half of V1 by virtue of the cathode resistors not being bypassed, so that, although the effective gain is zero, the performance remains substantially constant for wide variations of supply voltages and valve parameters.

On normal inland timed calls, the 3-minute tone signal is applied via the tip and ring wires of the operator's cord circuit and both subscribers hear the tone. For calls to North America it was decided that only the United Kingdom subscriber should hear the tone. This requirement, coupled with the fact that with the remote switching arrangements the speech connexion is through Kingsway, has led to the tone being applied in the selector-connecting relay-set and not from the cord circuit. Relay PP (not shown) disconnects the transatlantic cable side of the

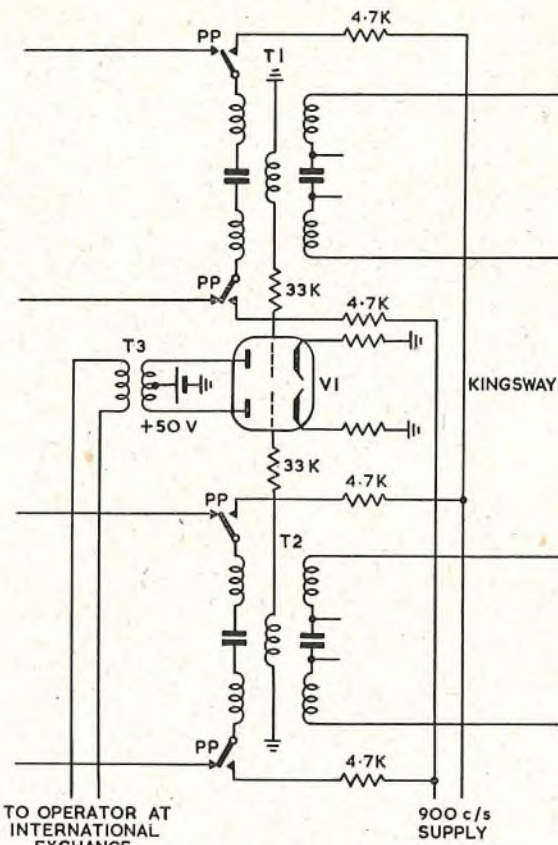

FIG. 8.—MONITORING AND 3-MINUTE TONE CIRCUIT ELEMENT.

relay-set and applies the 900 c/s tone to both inland pairs. It is necessary to apply tone to the lower pair for calls to 2-wire points and to the upper pair on four-wire calls to zone centres, for which it is in the correct direction of transmission to reach the distant subscriber. Relay PP, in the selector-connecting relay-set, is operated by earth pulses from the operator's cord circuit, transmitted over the R wire. The 4,700-ohm resistors in series with the tone supply serve to decouple one pair from the other during application of the tone and also to reduce the tone to a level suitable for injection at this point.

Arrangements have also been made to allow the operator to time calls without applying the tone. This facility may be required on calls incoming from America and on calls switched through London to the Continent.

Echo-Suppressor Switching.

When a call is set-up, via London, from the transatlantic cable to the Continent, it is a requirement that there should be no echo-suppressor on the continental circuit. Most of the continental circuits to which cable circuits may be extended are routed in carrier systems and echo-suppressors are not fitted. A few routes do, however, contain long audio sections and suppressors are associated with these circuits at London. These suppressors must remain connected when the circuits are used for ordinary continental traffic to and from the United Kingdom, and also when the circuits are extended to International exchange and the International operator is speaking on the circuit or has connected it to a radio circuit. Hence the echo-suppressor is required to be inoperative only when a four-wire switched condition exists right through to a transatlantic cable circuit.

Fig. 9 shows the elements of the signalling arrangements within the switching system whereby only this condition gives the required echo-suppressor switching signal. The

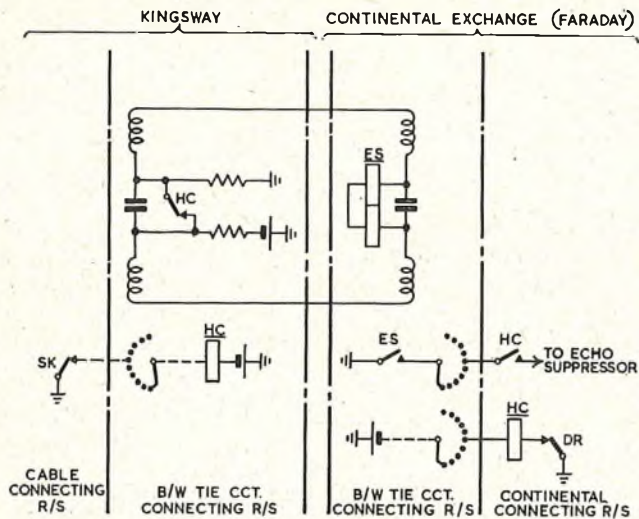

FIG. 9.—ECHO-SUPPRESSOR SWITCHING CIRCUIT.

pair shown in Fig. 9 between Kingsway and Continental exchanges is one of the two speech pairs of the four-wire amplified tie circuit (Fig. 2). It will be seen that an earth is extended to render the echo-suppressor inoperative only when all the following conditions apply:—

- (a) Association between a cable-connecting relay-set and bothway tie-circuit-connecting relay-set has taken place at Kingsway;
- (b) The operator at International exchange has restored the speak key (SK normal and relays HC and ES operated);
- (c) Association between the bothway tie-circuit-connecting relay-set and the continental-connecting relay-set has taken place at Continental exchange;
- (d) The operator at Continental exchange has restored the speak key (DR normal).

Switching at Continental Exchange.

The principle of association between the bothway tie-circuit-connecting relay-set on the one side, and the continental-connecting relay-set on the other, is the same as that for the corresponding connecting relay sets at Kingsway. On routes to the Continent, the circuits with 4-wire switching facilities nominated for extending calls from America total about 140 circuits, and this has necessitated the provision of two 100-outlet finders per connecting relay-set. It is arranged for a start signal to be given only to the finder that has access to the continental circuit in use on a particular call, thus avoiding unnecessary wear on the other finder.

Since the Continental exchange manual switchboard and the switching equipment are in the same building, no external tie-circuits and associated manual-board relay-sets, as provided at Wood Street, are required.

Four-wire Group Selector.

The four-wire group selector is based on that developed for trunk mechanization,¹ i.e. it consists of a motor uniselector with an associated Post Office uniselector acting as a digit switch. Because of the need to switch four speech wires, the availability of the selector is less than that afforded by the 2-wire selector. A total of 120 4-wire outlets is available, plus additional outlets for congestion announcements, etc. The 120 outlets are divided into three groups of 40 outlets, digits 1, 2 and 3 being tied to one group, digits 4, 5 and 6 to the second group, and digits 7, 8, 9 and 0 to the third group. Within these groupings any digit may be given 10 or 20 availability up to the limit of digits and/or outlets.

Conference Facility.

So far, conference calls using the existing transatlantic radio circuits have been set up on a 2-wire switched basis. However, to employ 2-wire switching on conference calls completed over cable circuits between subscribers in North America on the one hand and subscribers in the United Kingdom and Europe on the other, would give inferior transmission as compared with normal calls over the cable. Accordingly, a special conference-amplifier unit will be used in conjunction with 4-wire-switching connecting relay-sets of the same types as used for normal calls. These connecting relay-sets are extended over 2-wire tie circuits to International exchange where they are terminated on a special group of jacks. Calls are set up to the various points on a 2-wire basis and on restoration of the speak key the connexions are switched directly from the amplifier unit to the points concerned (2-wire or 4-wire as appropriate) with the International operator able to monitor on a high impedance basis as for normal calls.

ACKNOWLEDGMENTS

It will be appreciated that the switching scheme described in this article is the result of the work of many colleagues within the Telephone Development and Maintenance Branch. In addition, valuable co-operation was given by the Transmission and Main Lines Branch, External Telecommunications Executive and the London Telecommunications Region. The Kingsway 4-wire switching equipment was manufactured and installed by Siemens Bros., Ltd., Woolwich, who kindly supplied the photographs.

¹ BARNARD, A. J. The Motor Uniselector-Type Group Selector for Trunk Switching. *P.O.E.E.J.*, Vol. 46, p. 108, 1953.

Operating the New Telephone System†

A. G. SUTHERLAND‡

U.D.C. 654.15 : 621.395.5 : 621.315.28

TWENTY-TWO of the 36 circuits of the transatlantic telephone cable system are available for telephone service between the United Kingdom and the United States; six are terminated in Montreal to augment facilities with Canada, and seven are permanently connected through London to give two direct circuits between the United States and Germany, one circuit each to France, Belgium, Holland and Switzerland, and one circuit to Denmark, which also carries American traffic with Norway and Sweden.

The British terminal of the cable circuits between London and the United States and Canada is in the International Exchange at Wood Street in the City, where 12 additional operating positions have been installed to cater for future growth.

In the United States the cable circuits are operated by the American Telephone & Telegraph Co. from the White Plains building, some 30 miles north of New York City, to which the existing London radio-telephone circuits have been transferred from Long Lines building in New York; the direct circuits between the United States and the European countries remain, however, in the Long Lines building. The six circuits to Canada are terminated on the Toll switchboard of the Bell Telephone Co. of Canada in Montreal, where the radio-telephone circuits are operated.

To cover any possible breakdown of the cable system the radio-telephone circuits are being retained and, to ensure that they may be available immediately against any eventuality, they will be used in the normal service in a regular rotation to supplement the cable circuits. Since transmission on the radio channels varies considerably from day to day and over the seasons depending on propagation conditions, they will not be brought into use for the normal day-to-day service unless transmission over the channels is of a high order of merit.

On the route from London to the United States, 14 of the 22 cable circuits, supplemented by six of the existing radio channels, will be used at first, although all the cable circuits will be available for traffic, on a bothway basis, should the need arise at exceptional traffic periods, such as Christmas. Possibly as a result of the publicity about the opening of the cable, there will be a large measure of "curiosity" traffic, and it may therefore prove necessary, temporarily, to bring into use more than the proposed 14 cable circuits. Similar arrangements for using cable circuits and radio channels apply on the London-Montreal route.

Before considering the operating methods on the cable circuits, it might be desirable to look first at the methods used in the early days of the radio-telephone service.

The first telephone circuit with New York opened in January, 1927, when the long-wave telephony transmitter at Rugby was brought into service. The charge for a call at that time was £15 for three minutes, with a report charge of £2. Staff had to be arranged in those days to obtain the maximum paid time from the channels, and operating practice was governed by this requirement. In the beginning, three operators were employed for each radio channel, assisted by the technical operators at the radio-telephony terminal. One operator, known as the "channel operator," had charge of the radio channel itself; a second operator, "the advance caller," prepared the next call by obtaining the United Kingdom subscriber in advance and

holding him until the radio channel became free; and a third monitored the actual call during its progress and recorded details to enable allowances to be made for interruptions caused by fading or noise on the radio channel. It was found possible later to dispense with the monitoring operator, but even now on certain of the more congested radio-telephone routes where the number of channels cannot be increased, an "advance caller" is still necessary.

Radio-telephone services tend to be unreliable, but the transatlantic telephone cable system provides circuits capable of carrying much more traffic with greater ease. In consequence a new approach has been necessary to operating methods.



AERIAL VIEW OF THE WHITE PLAINS BUILDING, SOME 30 MILES NORTH OF NEW YORK CITY.

Although over the years the operating procedure in the International Radio Exchange has been changed with a view to speeding the connexion of calls, it is still largely true that calls for the North American continent have been connected on a delay basis, and facilities have existed for bookings up to two days in advance. Admittedly there has also been a "Now" service—that is, a call wanted at once—but even this type of call was subjected to fairly involved radio operating procedures which hardly permitted immediate connexion. The radio calls were booked on a special suite and tickets were circulated to controlling positions for the various routes. The calls were handled at these positions in wanted time order and subscribers were kept advised of progress. When radio conditions were good and all 15 channels to New York, for example, were operating, delays were small but if bad conditions occurred at a busy time delays amounting to several hours were not uncommon.

With the coming of the cable we hope to give to Canada and the U.S.A. what will virtually be a demand service; although for technical reasons the calling subscriber must replace his receiver and be recalled. All calls, whatever their destinations, are answered by operators having outgoing cable circuits on their switchboards. If the booking proves to be for a radio route (for example, India) the operator merely books the call as hitherto and circulates the ticket for attention elsewhere; booking involves making an appointment from a "time assignment" chart and the allocation of a serial number. If a United Kingdom subscriber wants a call to North America the booking operator establishes the call unless the caller indicates a later time for completion. She continues to obtain a serial number because, for many types of call, an easy means of identifica-

†Reproduced from the *Post Office Telecommunications Journal* Supplement to the Autumn, 1956, issue, by permission of the Editor.

‡Controller, Operations and Planning Branch, External Telecommunications Executive.

tion is still required, but there is no question of relating the call to a particular time.

On the majority of calls the operator plugs into a circuit and asks for the North American number. The North American operator routes the call up to the stage when the called number is rung and then the London operator takes over, dealing direct with the distant subscriber. As an overlapping operation the calling subscriber is regained and immediate connexion is then possible. This procedure was tested over the radio channels with both New York and Canada, with satisfactory results, and it is expected that calls between the United Kingdom and North America will usually be established in some two or three minutes, including inland switching at either end.

Of course a number of calls are not straightforward—directory enquiries, no reply calls, required person not available, and so on—and there are procedures for dealing with these; the arrangements permit personal contact by a controlling operator at all stages with consequent reduction in the doubt and misunderstandings inherent in methods involving divided responsibilities.



OVERSEA SWITCHBOARD IN WHITE PLAINS, NEW YORK, WHERE UNITED KINGDOM-UNITED STATES CIRCUITS TERMINATE.

A point of particular interest concerns the use of the cable circuits for through traffic at either or both ends. In the radio service the connexion of two radio channels in tandem was about the practical limit to commercial speech, so that, while calls from, say, India to the U.S.A. via London were fairly common, they would not normally extend beyond the U.S.A. to, say, Hawaii. With the cable circuits it may still be possible to employ long radio or land line connexions at both ends to effect such switchings. Operating procedures pose several problems and experience will be necessary before we are sure that we have the right solution. In general we work on the following basis: a call over the cable alone will be timed and controlled at the point of entry into the cable; a call over a radio circuit extended to the cable will be controlled at the outgoing point of the radio portion; a call from radio via cable out to radio will be controlled at the outgoing cable point.

As an example of these arrangements, the proposal to use the cable circuits to Canada, to assist the present radio-telephone service to Australia, might particularly be

mentioned. Transmission conditions over the long radio path on the direct circuits to Australia vary considerably with the time of day and the season of the year and there are often long periods when such transmission is not practicable. We now propose to gain experience with the routing of calls to Montreal over the cable circuits and thence to Australia via Vancouver, where a new transmitting station is available.



INTERNATIONAL EXCHANGE, LONDON TERMINAL.

Although they are not strictly part of the cable, the 4-wire (that is, separate "go" and "return" path) switching facilities which have been provided to extend high-quality transmission paths as far as possible, and to cut out cord circuit losses, should be mentioned. When an International operator in London wants to connect a cable call to, say, Leeds, she will dial the Leeds number over selected circuits in the London-Leeds trunk route. When the call is connected the operator, in ordinary course, restores her speak key, and at this stage the call is switched direct from a cable termination to a Leeds 4-wire circuit. The speech path thus bypasses the switchboard and cord circuit but should the operator wish to re-enter the circuit, she restores the speech through the switchboard by operating the speak key. The key in the monitoring position allows a low-loss tapping across the remote 4-wire circuit. Similar 4-wire switching is provided between International and Continental exchanges and between Continental Exchange and European terminals for calls with the European continent.

Introduction of the cable allows the use of the familiar "clocks 44" for timing calls instead of the double stopwatch used on radio calls. On cable calls the operator will be able to start the clock and leave subscribers on the straightforward call, much as on an ordinary inland call. The clocks have been specially modified because the call will not be connected via the cord circuit, and control of the clock by the calling subscriber must come from the remote 4-wire switching point at Kingsway. The 3-min tone signal, moreover, will be transmitted only to the inland subscriber and the operator can disconnect the pips entirely on, for example, transit calls.

Another feature of the cable, which is of more than passing interest to the average citizen who never makes a transatlantic telephone call, will be the use of selected circuits for program broadcast purposes. Some 25 broadcasts a week were made during 1955-56, using normal North Atlantic radio-telephone channels. Reception has, of course, been limited by radio conditions, but the cable will provide music circuits which should be permanently reliable and which can be combined if necessary to give extra band-width (and hence quality) previously unobtainable. The music circuits will also be available as normal

telephone circuits, but at the outset will be taken from the group of spare channels. When in use for programs they will be extended from the White Plains building to the regular New York "Program Office."

Although in the beginning manual methods of operation are being used, within about two years it is expected that automatic facilities will become available and at that stage London operators will dial New York and Montreal numbers, and vice versa. Once dialling is extended beyond these points the problems of routing information become quite considerable. Nevertheless we hope gradually to make dialling access available, in addition, to inland trunk centres, with the result that a high percentage of the traffic will be connected very rapidly. The North American operators will not be dialling through London to points on the European continent because of language difficulties; London operators will perform linguist duties as hitherto.

Although the new cable system is primarily a telephone project, it also provides 11 telegraph channels to Canada; eventually this number will be increased to 22. These telegraph channels will be used to supplement the existing wireless-telegraph circuits and the two transatlantic telegraph cables operated from Electra House on the Victoria Embankment. In addition they will enable telex service to be extended in due course to Canada, and perhaps to Australia, and will meet requests for leased

circuits. Tentative requests for such facilities have already been received.

The telegraph channels are being terminated in the Montreal telegraph office of the Canadian Overseas Telecommunication Corporation (C.O.T.C.) and in London, in such a way that they can be used to the best advantage and can readily be switched as between the public telegraph and telex services, and for leased circuits, some of which might be part time.

The C.O.T.C. has been supplied with a three-position telex switchboard of the standard Post Office type, as well as a number of normal Post Office telex subscribers' installations, and up to six of the telegraph channels with Montreal will be available for telex service with Canada. In addition, three of the telegraph channels will be connected to Britain's teleprinter automatic switching network (T.A.S.) to give direct access between certain London and provincial Cable & Wireless offices and Montreal.

Finally, a word about the photo-telegraphy service. Hitherto, relatively few photo-telegrams have been exchanged with Canada. The more reliable facilities of the cable as compared with radio may, however, attract more traffic and this new link with Canada may also provide a valuable routing to and from Australia, especially during the Olympic Games. Two of the new telephone circuits in the cable have been nominated for picture telegraphy.

Traffic on the Transatlantic Telephone Cable during its First Four Weeks in Service

The transatlantic telephone cable was brought into public use at 6 p.m. on the 25th September, 1956, when 22 of the cable circuits to the United States and six circuits to Montreal were put into service. Public response was most marked, and although normal business hours had already passed, 260 calls were connected on that night. No difficulty was experienced in handling the traffic and calls were readily cleared on demand. During the first 24 hours of public service 588 calls were exchanged between London and the United States and 119 with Canada.

Some of this was probably curiosity traffic which arose from the broadcasts of the formal opening of the cable, and while the traffic fell away a little at first from the high figures recorded, it soon recovered. The average number of calls made daily with the United States over the first few weeks of cable service amounted to 510, an increase of 55 per cent over the average of 330 calls per day which obtained before the opening of the cable. On the service with Canada the average daily total over the same period was 156 calls, an increase of 100 per cent over the daily average of 76 calls obtained previously on radio channels. World events in early November caused material increases in traffic and 683 calls were recorded with the United States on the 8th November and 302 calls with Canada on the 4th November.

The increase in the outgoing traffic has been more pronounced in the full-rate period and this suggests that business people are making more use of the service. A marked feature on the Montreal route is the large increase in calls incoming to the United Kingdom and in particular of those routed via London to the continent of Europe. In addition to the increase in the number of calls there has also been an increase in the average paid time per call.

Table 1 sets out figures for the first four weeks of service compared with the weekly averages before the opening of the cable.

All the cable circuits were kept in service up to the 15th October, while some of the radio channels, retained as a standby, were used for reports and service correspondence only. But after the first three weeks, radio

TABLE 1

	U.S.A.		CANADA	
	Weekly Average		Weekly Average	
	Before opening of cable.	For first four weeks.	Before opening of cable.	For first four weeks.
Outgoing full-rate calls	720	1,178	120	228
Outgoing cheap-rate calls	550	740	110	132
Total outgoing calls	1,270	1,918	230	360
Total incoming calls	1,050	1,653	300	729
TOTAL CALLS	2,320	3,571	530	1,089
Average duration in paid minutes of outgoing calls	6·75 min	8·20 min	6·25 min	7·45 min

circuits were brought into use again for traffic when they were of a sufficiently high standard.

The facilities offered by the cable have been welcomed by the public and many favourable comments have been made about the quality of transmission on the circuits. The reliability of the cable circuits has also had an effect on the percentage of completed calls. During the three weeks immediately preceding the opening of the cable, when radio conditions were reasonably good, the percentage of completed calls varied from 71 to 81 per cent on the New York route and from 81 to 85 per cent on the Montreal route. In the three weeks that followed the opening of the cable circuits the percentage varied from 85 to 89 on the New York route and from 88 to 92 per cent on the Montreal route.

Two of the telegraph channels to Canada provided by the transatlantic telephone cable are in service at Electra House to supplement the facilities given by the existing wireless telegraph circuits and the submarine telegraph cables with Canada. The Canadian Overseas Telecommunications Corporation has installed a telex switchboard in Montreal and international telex service was made available to telex subscribers in Canada early in December over the telegraph circuits in the transatlantic telephone cable. Certain of the Montreal telegraph channels will be connected to the teleprinter automatic switching network (for strictly limited use) early in the New Year.

A. G. S.

Institution of Post Office Electrical Engineers

50th Anniversary Celebrations

The Jubilee celebrations to mark the occasion of the Institution's 50th Anniversary of Foundation, of which advance notice was given in the April and July issues of the Journal, were held in London and by all Provincial Centres during the month of October.

As a fitting prelude to these events the Jubilee issue of the Journal (devoted to articles reviewing the development and growth of the British Post Office telecommunications services and of the mechanization of postal services) was published on 1st October, 1956.

The following brief notes describe the celebrations in London and at Provincial Centres.

Jubilee Meeting and Exhibition (London)

The Institution's Jubilee Meeting was held at The Institution of Electrical Engineers, Savoy Place, London, at 5.30 p.m. on 8th October, 1956. In opening the proceedings, Mr. G. S. Berkeley, Chairman of the London Centre, commented that it was also the first meeting of the 1956-57 session of the London Centre, and that the first local centre meeting was also held in London on 8th October in 1906.

Mr. Berkeley then vacated the chair in favour of Mr. D. A. Barron, Chairman of Council, who, before calling on the President to deliver his address, gave a few dominant facts about the Institution, its objects and achievements. He acknowledged with gratitude the Institution's long and co-operative association with The Institution of Electrical Engineers, which had been extended in a particularly generous fashion on this special occasion. He also expressed the satisfaction that it gave the Institution to have present so many distinguished guests, including the Director-General of the Post Office, members of the Post Office Directorate and Post Office Board, and representatives of Professional Bodies, National Organizations, Industry, Post Office Staff Associations, and of the Institution's Associate Section. Special reference was also made to the presence of representatives of the Commonwealth Countries and Colonial Territories, and of overseas Administrations, and of 10 of the 14 Honorary Members of the Institution. On behalf of Council he thanked all who had sent congratulatory messages on the Institution's 50th Anniversary.

The President, Brig. L. H. Harris, C.B.E., T.D., then delivered his address on "Fifty Years of Telecommunications"† to an interested audience of over 700 members and guests.



BRIG. L. H. HARRIS, C.B.E., T.D., PRESIDENT OF THE INSTITUTION, DELIVERING HIS ADDRESS AT THE JUBILEE MEETING, LONDON.



MEMBERS AND GUESTS AT THE JUBILEE MEETING, LONDON.

After a comprehensive survey of early developments, well illustrated by slides, the President reviewed more recent advances in the field of telecommunications, with some reference to future trends. In conclusion he added that "In the coming years I believe our members will continue to maintain successfully their important contribution to the prosperity of the Institution, the Post Office, the Industry and the Country."

After the address, congratulations to the Institution on attaining its 50th Anniversary, coupled with good wishes for its future welfare, were expressed by Sir W. Gordon Radley, K.C.B., C.B.E., in his threefold capacity as President of the Institution of Electrical Engineers, Director-General of the Post Office, and Honorary Member of the Institution, and by Sir Thomas Spencer, Chairman and Managing Director of Standard Telephones & Cables Ltd., on behalf of the telecommunications industry. The same speakers also expressed their thanks to Brig. Harris for his most interesting address, in which he had captured memories of the past, reviewed the present, and given a glimpse of the future in such a manner as to reveal his grip of the telecommunications field. The formal vote of thanks to the President, when moved by the Chairman at the end of the meeting, was passed with acclamation.

A comprehensive historical exhibition of telecommunications equipment was on display at the Institution of Electrical Engineers, before and after the President's address, and undoubtedly contributed in no small measure to the overall success of the occasion. An Institution display was also featured in the entrance hall of The Institution of Electrical Engineers building, giving a record of past presidents and officers of the Institution, and of members awarded Institution medals during the past 50 years for outstanding contributions to the understanding and development of telecommunications engineering. The country-wide activity of the Institution was portrayed by the list of Local Centres and officers. A display of Institution literature, including a copy of the first Printed Paper, was also included.

Jubilee Dinner-Dance (London)

A total of 460 members and guests participated in an eminently successful dinner-dance held in London on 9th October, 1956, to provide opportunity for a reunion of past and present members, and also to mark the happy relationship that exists between the Institution and all those associated with telecommunications in this country.

†Copies of the President's address were distributed to the Chairmen of Local Centres and were either read, or drawn upon for the Local Centre Chairmen's addresses, at the Centres' own Jubilee meetings.

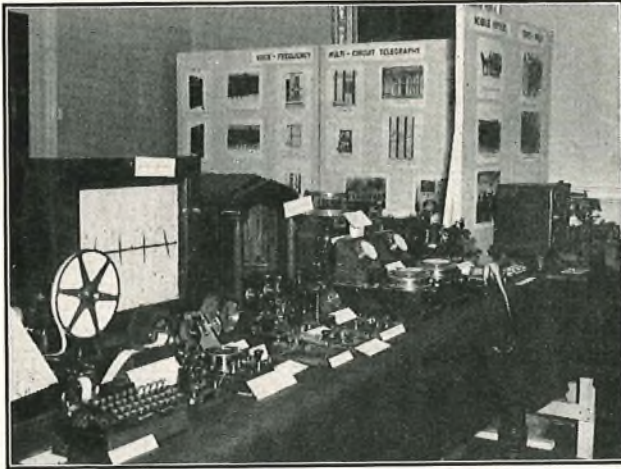

PART OF THE DISPLAY OF TELEGRAPH EQUIPMENT AT THE EXHIBITION IN LONDON.

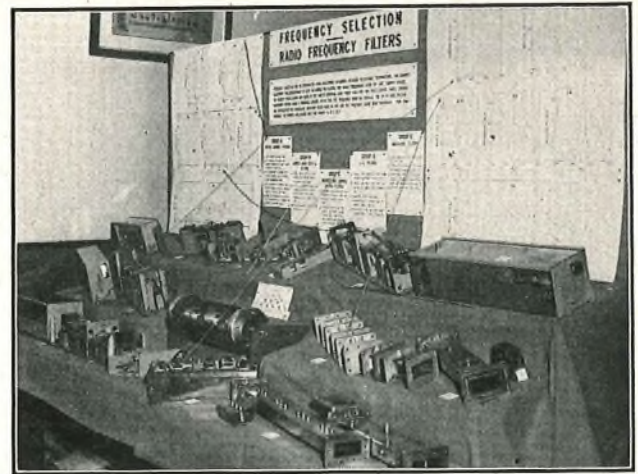

PART OF THE DISPLAY OF RADIO EQUIPMENT AT THE EXHIBITION IN LONDON.

The Institution was honoured on this occasion not only by the presence of the Postmaster-General, Dr. The Rt. Hon. Charles Hill, M.P., but also by many other distinguished guests. After the loyal toast, proposed by the Chairman, Mr. D. A. Barron, the toast of the Institution was proposed by the Postmaster-General in characteristic style, and the response made by the President. The toast of "Our Guests" was proposed by Capt. C. F. Booth, C.B.E., Vice-Chairman of Council, and replied to by Mr. R. E. Robinson, Managing Director of the General Electric Company, Coventry.

Northern and North-Eastern Centres

The Northern and North Eastern Centres combined to commemorate the Institution's Jubilee at York on 16th October, 1956, when a meeting attended by 250 members and guests was held at the Tempest Anderson Hall, Museum Gardens. The address, presented by the Chairman, Lt.-Col. J. Baines, O.B.E., T.D., was followed by a quartette of short reminiscent speeches, which included those of two founder members, Mr. J. W. Atkinson, I.S.O., and Mr. George Bailey, who are still on the N.E. Centre register as retired members. Mr. H. J. V. Harris, M.B.E., Telephone Manager, Hull Corporation Telephone Department, spoke of his early direct association

with the Institution and said how much he appreciated the information about modern telephone development that is made available by the Institution's journal. Mr. W. Stuart, senior lecturer in the Leeds University Electrical Engineering Department, offered his congratulations to the Institution on the attainment of its Jubilee and referred to the great pleasure he had derived from the opportunities given to him on four occasions to address members at their Centre meetings.

After an interesting display of historical and modern exhibits had been viewed, 120 members and guests adjourned to Terry's Restaurant, St. Helens Square, where a buffet tea had been provided. A reception and dinner followed at 7 p.m. Among the guests at the dinner, at which Col. Baines presided, were the Rt. Hon. the Lord Mayor of York, Alderman V. A. Bosworth, J.P., Mr. W. Patterson, Sheriff of York, Mr. C. J. Minter, City Engineer, York, Brigadier D. St. J. Hoysted, Chief Signals Officer, Northern Command, York, and the Head Postmaster of York, Mr. F. Beaumont.

A toast to the I.P.O.E.E. was admirably proposed by Mr. W. K. Fleming, Chairman of the North Midland Centre, The Institution of Electrical Engineers, the response being made by Mr. J. Collins, of the Northern (Newcastle) Centre and vice-chairman of the Regional Committee.



The Chairman's Table at the Jubilee Dinner-Dance, London. At the top (left) L. to R.: Capt. C. F. Booth, C.B.E., and Mrs. Booth; Mr. and Mrs. R. E. Robinson; Dr. The Rt. Hon. Charles Hill, M.P., and Mrs. Hill; Mr. D. A. Barron (Chairman) and Mrs. Barron; Brig. L. H. Harris, C.B.E., T.D., and Mrs. Harris; Sir W. Gordon Radley, K.C.B., C.B.E., and Lady Radley; Sir Ben Barnett, K.B.E., C.B., M.C.

The toast to "Our Guests" was proposed by the Regional Director, N.E. Region, Dr. L. E. Ryall, the response being made by the Rt. Hon. the Lord Mayor of York, Alderman V. A. Bosworth, J.P.

The speeches provided a congenial merging of sincerity and humour and were an outstanding contribution to the Region's celebrations of the Jubilee.

There remained, however, one further item of interest—a "surprise" presentation of a silver cigarette casket to Mr. T. E. Walker in recognition of his services as Honorary Local Secretary of the N.E. Centre over the past 26 years.

Scotland East and Scotland West Centres

A very successful meeting was held in the North British Hotel, Edinburgh, on 9th October, 1956, when the Chairman of the Centre, Mr. R. J. Hines, Chief Regional Engineer, addressed a representative gathering of members, ex-members and guests from all parts of Scotland.

The Chairman for the meeting was Mr. F. N. Lucas, who outlined the purpose of the meeting and welcomed the guests. The total gathering numbered 170, including 25 ex-members and 35 guests from allied interests outside the Post Office Engineering Department. The ex-members included Mr. J. J. McKichan, O.B.E., who was the first Chief Regional Engineer when regionalization started in Scotland, and a number of ex-members from Glasgow. Guests included the Director and Deputy Director, Scotland, and heads of branches at Headquarters, Scotland, representatives from the University of Edinburgh and other educational bodies, the Chairman and Committee of the S.E. Scotland Sub-Centre of The Institution of Electrical Engineers, representatives from the Hydro and Electricity Boards, the Chief Signals Officers of the three Services' Commands in Scotland and communications officers from the Scottish Home Department, the Ministry of Transport (Civil Aviation) and the Edinburgh City Police.

Mr. Hines based his address on that given by the President to the London Centre on 8th October, but, in addition, he highlighted a number of events with special Scottish implications, dealing in particular with the introduction of automatic working to the main cities and the growth of the overhead and underground cable networks. Mr. Hines expressed his thanks to all who had in any way contributed to the preparation of the paper, especially to those retired and long-service members of the staff who had given a lot of very interesting information about the early days, the use of all of which had not been possible in the restricted time available.

Mr. McKichan, in reminiscent and light-hearted vein, thanked Mr. Hines on behalf of all present and, having been invited to do so by the Chairman, added one or two anecdotes from his personal experiences of the earlier days in Scottish telecommunications.

The Chairman then brought the formal proceedings to a close and for the next hour an enjoyable time was spent by all in renewing old acquaintanceships and discussing the past and present whilst refreshments were served.

Displays of cables, telephones, telegraph, transmission and automatic-exchange equipment, old and new, which had been arranged around the room, evinced much interest. The latter included an original Dane Sinclair line-selector switch as used in Coatbridge in 1881, and claimed to be the first attempt ever at the automatization of the telephone network, which was kindly loaned for the occasion, with a sample of the first transatlantic cable, by the Royal Scottish Museum.

Manchester and Liverpool Centre

The celebrations, held at the Civil Service Club in Manchester on 9th October, 1956, began at 4 p.m. with an address by the Chairman, Mr. H. G. Davis, O.B.E., which was listened to with great interest by over 160 members. The address was illustrated by lantern slides of historical and contemporary interest. A number of locally produced slides, which were also shown, evoked memories and reminiscences from the older members, among whom were four retired colleagues, now life members of the Institution, who attended as honoured guests. The address, covering as it did, in masterly fashion, the span of the 50 years of telecommunications history, brought vividly home to all present the tremendous advances that have taken

place, to which our members, and the work of the Institution, have contributed so much. Indications were given of the way ahead, and it was a source of pride to all present that they were helping this great work forward.

Later that evening a most enjoyable dinner was held. The keynote of the evening was informality, and the social that followed gave opportunities for friendly associations which are all too infrequent. The entertainment provided by four artistes, specially engaged for the occasion, was thoroughly enjoyed by all. A party of 40 members travelled from Liverpool to be present and, although forced by the threat of fog to leave rather early, they enjoyed the event sufficiently to suggest that Jubilee Celebrations be held annually!

Preston Centre

The address by the Chairman, Mr. H. G. Davis, O.B.E., set a high standard for the celebrations held in the Bull and Royal Hotel, Preston, on 10th December, 1956. The review of developments over the years and the glimpses into the future were followed with close interest and enjoyment. The references to ERNIE were specially noted, as the installation and maintenance of this national innovation will be the responsibility of local members. Ninety-seven members and guests, including retired members, travelled from all parts of the three Telephone Areas served by the Centre, and the Associate Centres of Carlisle and Lancaster were also represented. Meetings are normally held in the Preston Technical College, and the Centre was pleased to welcome Dr. Wilkinson, Principal of the College, as a guest.

Appropriately on view in the lecture room was a display of the old and the new, the 1904 Northern Underground alongside the modern coaxial cable, and a cradle telephone (No. 16) contrasted with an ivory telephone No. 332, which formed the centre-piece of a photograph in the local press the following day.

After the address, members were joined by their wives and by friends from the Preston Area Sports and Social Society, who had kindly undertaken to arrange the entertainment. Following a high tea of typical Lancashire proportions, the evening was devoted to dancing, games and novelty items to round off an enjoyable and memorable day.

Northern Ireland Centre

The 50th anniversary of the foundation of the Institution was celebrated by the Northern Ireland Centre—which is possibly the youngest in the Institution, having been formed in 1923—by the holding of an exhibition at Telephone House, Belfast, from 1st to 9th October, 1956, which showed the developments that have taken place in telecommunications over the period of the life of the Institution. The part played by the Institution in this development was represented by an exhibit of journals and printed papers which had been issued over the past 50 years. Much interest was evinced in the display and it would be difficult to pick out any item or items which could be said to have excited the curiosity of the visitors more than the others. The collection of early automatic dials loaned by Mr. F. J. Rowbotham; the Gower pencil transmitter loaned by Mr. H. R. S. Kelly, which was reputed to have formed part of the third telephone installed in the Region; and examples of the early cable distribution plugs, prepared by Mr. J. H. McCloud, appeared to draw the attention of most visitors. A topical note which was much appreciated was struck by the display of a very fine model of the cable ship H.M.T.S. *Monarch*, loaned by Mr. C. W. Ebbage, and samples of the transatlantic cable, service over which had just been inaugurated by the Postmaster-General.

The assistance of the Belfast Museum staff in the staging of the exhibits and of the Municipal College of Technology, Belfast, who lent early automatic telephone equipment, was greatly appreciated.

The Jubilee Meeting of the Centre was held on Wednesday, 10th October, when Major Barker, Chairman of the Centre, read the Engineer-in-Chief's address to the Institution. The venue of the meeting was on this occasion the new geology lecture theatre of the Queen's University, Belfast, the use of which had been kindly extended to the Centre by the University Secretary. The exhibition had been moved overnight to the

foyer of the Geology Pavilion and was much admired by those attending the meeting.

Many representatives of the Electrical Industry and the academic sphere of the Province were among the guests attending the meeting, and it would be impossible to mention them all personally, but prominent among them were Mr. Alexander, Principal of the Municipal College of Technology, Belfast, and Dr. Gillies of the same college. Mr. Marshall, Chief Engineer of the Ulster Transport Authority, and Mr. Johnstone, the Postmaster-Controller, were also present.

Major Barker, in opening the meeting, paid tribute to the many engineers who had gone before, those now active in the service and, as a gesture of our appreciation of their work, he extended a very hearty invitation to Mr. E. S. Ritter, retired Assistant Staff Engineer, who was well known to those in the Institution either personally or by reputation, to take the Chair at the meeting on this occasion—a gesture that was much appreciated by the large number of people present.

Wales and Border Counties Centre

To celebrate the Golden Jubilee of the Institution in Wales and Border Counties, a meeting of approximately 200 members and visitors was held at the Reardon Smith Lecture Theatre, on Wednesday, 17th October, 1956, which was addressed by the Chairman of the Centre, Mr. C. E. Moffatt. In this address, Mr. Moffatt described events of national and local interest that had occurred during the years 1906 to 1956. Mr. H. R. Jones, Telecommunications Controller, proposed a vote of thanks to the Chairman and mentioned a number of amusing incidents in his own official career, which had extended over most of the 50 years.

The meeting was followed by a dinner held at the Park Hotel, Park Place, Cardiff, at which the principal guests were Brig. L. H. Harris, C.B.E., T.D., President of the Institution, T. G. Dash, Esq., J.P., Immediate Past-Chairman of the Western Centre, The Institution of Electrical Engineers, Lt.-Col. A. Borlase, T. D. Immediate Past-Chairman of The Institution of Civil Engineers, and Dr. F. North, O.B.E., Keeper of Geology at the National Museum of Wales. The 134 members and guests attending had a thoroughly enjoyable evening and appreciated the opportunity of meeting old acquaintances, among whom were four retired members: Col. H. Carter, Mr. H. C. A. Linck, Mr. F. Platt, and Mr. T. Beer. Mr. Dash, in proposing the toast of The Institution, stressed the close relationship between The Institution of Electrical Engineers and the I.P.O.E.E., and Brigadier Harris, in reply, mentioned Sir Gordon Radley, President of The Institution of Electrical Engineers and Director-General of the Post Office, as an example of the very close link between the two bodies. Entertainment was provided by the B.B.C. comedian Bryn Calvin Thomas, the Cambrian Quartet, and our own Arnold Davies, who is a member of the Welsh National Opera Company, with Percy Adams, of the Engineering Branch, at the piano.

Earlier in the day, in the presence of some 350 members, an exhibition of telecommunications equipment was opened by Brigadier Harris at the National Museum of Wales. The



THE DISPLAY OF MANUAL SWITCHBOARDS AT THE EXHIBITION IN CARDIFF.

exhibits included nearly all the items shown at The Institution of Electrical Engineers, Savoy Place, London, on 8th October, together with additional items provided by Headquarters and local sources.

It is estimated that, in all, some 15,000 people visited the exhibition, including several organized parties of school children and groups from other Post Office departments and industrial concerns. Many students from the University were among the visitors. Thanks must be given to the Headquarters and local staff who worked so hard to make the exhibition a success and to those who, as stewards, voluntarily gave up their time to demonstrate the models and to try to curb the enthusiasm of some of the younger visitors who wanted to make accelerated life tests on all of the working equipment.

Eastern and South Midland Centres

The Jubilee was celebrated by the Eastern and South Midland Centres with special meetings at Cambridge and Reading which were addressed by the Chief Regional Engineer, Mr. W. E. Hudson. Mr. Hudson explained that he would be covering the subject on similar lines to the address given by the President of the Institution at the London meeting.

The Eastern Centre meeting at the Guildhall, Cambridge, on 10th October, 1956, was opened by Mr. R. O. Boocock with a review of the activities of the Eastern Centre since its first meeting in 1907. Other speakers were Dr. E. B. Moullin, Professor of Electrical Engineering in Cambridge University, Mr. S. H. Deacon (aged 81), the first Secretary of the Eastern Centre, and Mr. J. McA. Owen, Regional Director. A vote of thanks was moved by Mr. E. Hoare.

The South Midland Centre meeting was held in the Great Hall at Reading University on 17th October, and was opened by Mr. A. H. C. Knox. Mr. R. Brown, Chairman, Southern Electricity Board, and Mr. J. Dimmick, Principal, Reading Technical College, expressed thanks to the Chairman for his address, and a former Superintending Engineer and Past-Chairman of the Centre, Mr. T. Cornfoot, spoke for retired colleagues.

At both meetings, the guests included representatives of the universities, technical education, The Institution of Electrical Engineers, industry, the Post Office Engineering Union and the Associate Section of the Institution.

There were record attendances of 186 at Reading and 156 at Cambridge, and it was evident when tea was served that there was much mutual enjoyment in the meeting again of so many old colleagues.

Birmingham, Nottingham and Stone-Stoke Centres

The Birmingham, Nottingham and Stone-Stoke Centres combined forces for the Jubilee celebrations in the Midlands, which started with the arrival of over 200 visitors to lunch at the Howard Hall of the Central Training School at Stone on Friday, 12th October, 1956. The program consisted of the presentation of the President's paper "50 Years of Telecommunications" in the afternoon; the viewing of an extensive collection of historical instruments, etc., during the late afternoon and early evening, and a Jubilee Dinner, followed by a dance.

At the afternoon meeting, under the Chairmanship of Mr. H. R. Harbottle, Chairman of the Stone-Stoke Centre, the President's address was read by Mr. L. L. Tolley, Chief Regional Engineer, Midland Region.

The interest of the many historical slides was accentuated by the exhibition, where the visitors were able to see such things as a Hughes "teleprinter" of 1875 (still in use until 1939); the ivory and gilt telephone used by Rothschild 52 years ago; step-by-step automatic equipment used at Epsom in 1912; transmission and radio equipment ranging from the pre-valve era of coherers to transistors; and many other exhibits and historical photographs.

At the Jubilee Dinner in the Howard Hall in the evening, the toast of "The Institution" was proposed by Mr. W. T. Gemmell, Regional Director of the Midland Region, who referred to the occasion being also the 16th anniversary of the Birmingham Centre. The President, Brigadier L. H. Harris, C.B.E., T.D., who had travelled down to be present for the evening function, responded with a witty speech in which he congratulated the

Region on their achievements both past and present. He caused considerable amusement by recounting his experience on leaving the train at Stone, where he purchased Saturdays paper on Friday evening, and read that he had given the speech he was now making. He said he was disappointed not to have read what he was going to say, for it would have helped him considerably at that moment. Mr. R. W. Palmer, Principal of the Central Training School, proposed the toast of "The Guests," and Dr. K. R. Sturley, Head of the B.B.C. Engineering Training Department, responded.

Among those present for the occasion were visitors from industry, from technical colleges and from the Associate Section, but there were also familiar figures in unexpected guises since the school staff at all levels had undertaken the preparation and serving of the dinner—a practical contribution to the success of the evening that richly deserved the praise it earned.

The proceedings concluded with a happy and lively dance organized by the C.T.S. Sports and Social Club. Many of the members and visitors stayed overnight in the school hostel accommodation and were able to be on the spot for the "open day" at the school the following morning.

On the Saturday morning, the reasons for the celebrations switched from "50 Years of Institution Activity" to "10 Years of Training Activity," with an "open day" at the Central Training School to celebrate its 10th birthday. This continued on the Monday and those visitors who took advantage of all the events laid on for their benefit, including the Sunday sporting events and the evening's popular concert, had a very full week-end.

South-Western Centre

The 50th Anniversary of Foundation of the Institution was celebrated on 17th October by a luncheon at the "Berkeley," Queens Road, Bristol. The chair was taken by Mr. A. E.

Morrill, Chairman of the South-Western Centre, some 150 members and visitors being present. The visitors included representatives of the South-Western Electricity Board, The Institution of Electrical Engineers, the British Broadcasting Corporation, The Institution of Mechanical Engineers, The Institution of Civil Engineers, the Associate Section I.P.O.E.E., the S.W. Region Whitley Committee and retired members of the Institution.

Apologies for unavoidable absence, and best wishes, had been received from Mr. L. G. Semple, C.B.E., Regional Director; Mr. J. Ackroyd, Borough Surveyor, Swindon; Mr. G. H. Rawcliffe, University of Bristol; Mr. J. L. Daniels, and Mr. G. O. MacLean, Chief Engineer, South-Western Electricity Board.

Following the Loyal Toast, proposed by the Chairman, Mr. W. J. Pemberton, of Bristol Area, gave a short outline of the history of the Institution and its objects, and concluded with the toast "The Institution." Mr. A. J. Cawsey, Area Engineer, Bristol, welcomed the visitors present, and said that it was very gratifying to see that representatives of the staff and the Associate Section were there, for it was largely by their efforts that the advances in telecommunications had been made. In replying on behalf of the visitors, Mr. A. N. Irons, Chairman of the South-Western Electricity Board, remarked on the very amicable relationship existing between the Central Electricity Authority and the Post Office, and pointed out that this 50th anniversary marked the opening of a new era in the field of electrical engineering as, on that day, H.M. The Queen was opening the first atomic power plant at Calder Hall, Cumberland.

Following this very enjoyable luncheon party, members and guests adjourned to Electricity House for the South-Western Centre Meeting, at which the Chairman read the President's Address, which was illustrated by very interesting lantern slides.

Annual Awards for Associate Section Papers— Session 1955-56

The Judging Committee having adjudicated on the five papers submitted by the Local Centre Committees, prizes of £4 4s. 0d. and Institution Certificates have been awarded to the following in respect of the papers named:—

J. Barfoot, Technical Officer, London Centre (Test Section)—"The Camera Lens Story."

J. E. Bridger, Technical Officer, Tunbridge Wells Centre—"The Coaxial Line Link."

W. T. Waghorn, Technical Officer, Tunbridge Wells Centre—"Circuit Provision."

J. D. Little, Technical Officer, Gloucester Centre—"80+80V Divided Battery Float System."

P. J. Froude, Technical Officer, London Centre (L.P.R.)—"D.C. Machines, Part II."

The Council of the Institution is indebted to Messrs. W. E. Hudson, G. C. Greenwood, and B. Winch for kindly undertaking the adjudication of the papers submitted for consideration.

Review of Prize-winning Associate Section Papers— Session 1955-56

The Council of the Institution is indebted to Mr. W. E. Hudson, B.Sc.(Eng.), Whit.Sch., A.C.G.I., Chairman of the Judging Panel, for the following review of the prize-winning papers.

"The five Associate Section papers that were submitted for judging were all of a very good standard. One or two were perhaps a little long and complex, bearing in mind the time available for delivery.

"The subjects dealt with were varied and in all cases the subject matter was presented in a logical and orderly fashion. Explanatory diagrams were well thought out, clear and easily understood and the standard of draughtsmanship was quite high.

"The following is a brief review of the papers:—

- (a) 'The Camera Lens Story'—In this paper the author describes the development of the camera lens from the earliest type to the present-day very complex types. The defects and distortions inherent in the early lenses are explained, together with the means adopted in each succeeding type for overcoming or reducing the effects of the various defects. A very readable story.
- (b) 'The Coaxial Line Link'—This paper gives a good introduction to the subject of coaxial cable operation. The cable and the associated repeater equipment are described in some detail. The paper also includes descriptions of power feeding arrangements and the supervisory and control system, and emphasizes the precautions taken to ensure the safety of maintenance staff who are required to carry out operations on the cable, which normally carries mains voltages in connexion with the distribution of power to dependent repeater stations.
- (c) 'Circuit Provision'—This paper describes the work of providing long-distance circuits (junction and trunk circuits and private wires) as seen by a circuit provision officer in an Area. It brings together as a connected story much information which is dispersed through numerous instructions and also some which is not on record. The history of a circuit is traced from the inception of need by a traffic officer, through the various processes and forms, including lining-up procedure in the case of a repeated circuit, to the final completion and handing over for traffic.
- (d) '80 + 80V Divided Battery Float System'—A good description is given of this type of telegraph power plant, including explanations of the principles of operation of the three-phase induction motor, the d.c. generator and the voltage-control devices.
- (e) 'D.C. Machines, Part II'—This paper gives descriptions of the principles of operation of various types of d.c. motors. Explanations are given of the methods employed for starting and for controlling the speed."

H. E. WILCOCKSON,
Secretary.

Associate Section Notes

Ayr Centre

The Ayr Centre was formed late in December 1955 and as a result had rather a short, although well-attended, session. Thanks are due to Mr. Bell, the Area Liaison Officer, and to the office-bearers of the Hamilton and Glasgow Centres for helpful assistance in this Centre's inception. The 1956-57 session opened with a visit to the I.C.I. Mobil Factory at Ardeer, and if the attendance at this outing is maintained on other occasions we should have an excellent session.

Activities in this year's program include talks on "The Oban Transatlantic Terminal" and "Radio-Astronomy," and visits to a carpet factory, a coal mine and an observatory.

The membership has now reached the encouraging figure of 67 and should shortly exceed 70.

The following officers were elected at the annual general meeting:—

Chairman: Mr. H. A. M. Pringle; *Secretary:* Mr. A. Edgar; *Treasurer:* Mr. L. R. L. Parry; *Committee:* Messrs. R. H. Bruce, J. Halliday, W. H. Geddes, N. Ireland, J. Scott and F. Woolhouse.

A. E.

Glasgow and Scotland West Centre

The 1956-57 session, now under way, was opened by the Chief Regional Engineer, Scotland, Mr. R. J. Hines, with a talk on "50 Years of Telecommunications." The next talk was by Dr. T. S. Wilson, Medical Officer of Health for the Glasgow Central Division, who spoke about the work of the Public Health Department.

The remainder of the 1956-57 program is as follows:—

"The Transatlantic Cable," by Mr. J. Boag, Assistant Engineer, Oban.

"Energy and the Atom," by Mr. J. R. Atkinson, M.A., lecturer in the Natural Philosophy Department of Glasgow University.

"The Pictorial Record of a Holiday in North America," by Mr. M. W. Ramsay, Telephone Manager.

"Mechanical Developments in Telecommunications," by Messrs. Hubbard and Mack, of the Engineer-in-Chief's Office.

"Automatic Transfer Machines," a joint meeting with the Institution of Production Engineers.

"Auto Maintenance in other Countries," by Mr. R. W. Palmer, Principal of the Central Training School.

Visits are being arranged for the summer months and will be announced later.

J. F.

Edinburgh Centre

A "flying start" was given to the 1956-57 session by Mr. G. C. Henderson who, at the opening meeting on 16th October, gave a most interesting talk on "Space Rockets" to an appreciative audience. In November, due to popular demand, Mr. W. Slater read a paper outlining present and future developments in the Edinburgh conversion scheme; of topical interest to all members. At the time of writing these notes the Centre's annual film show is scheduled for December, and this year it is hoped to include in the program some films on electronic subjects.

Ganton Gas Works was the choice for the first outdoor visit of the winter and the members who made the trip saw and heard many interesting details of this large public utility, which will provide talking points for some time to come. Many other visits are planned for this session, and the Centre committee will gladly supply information to anyone interested.

J. R. H.

Guildford Centre

Since the publication of the last notes from this Centre the committee has been pleased to note a steady increase in membership, which now numbers 150.

During the past months members from this Centre have visited Vauxhall Motors Ltd. at Luton, Evershed & Vignoles Ltd. at Chiswick, and the Union-Castle liners *Arundel Castle* and *Capetown Castle* at Southampton Docks. The two visits

to Southampton also included a coach tour of the docks and a visit, for a small section of each party, to the engine room of the liner visited.

The winter program of the Centre will include a monthly film show of engineering and general interest, including films of the trials in preparation for the proposed cross-channel power cable, of bridge-building in Portugal, production of aluminium and steel, and the manufacture of radio valves.

The program arranged for the session includes talks by Mr. D. O. Jarman, of the Ministry of Works, on the "Erection of a New Telephone Exchange"; by Mr. R. F. G. Gurney, of the Telephone Manager's Office, Guildford, on the "Work of the Traffic Office"; and by Mr. C. F. G. Lee, a Senior Section member, on "The Construction and Operation of Pipe and Electronic Organs."

In presenting this program the committee hope that they have fulfilled the expressed wishes of members and look forward to seeing an increased attendance at all meetings.

E. N. H.

Carlisle Centre

The annual general meeting was held in the King's Head Hotel, Carlisle, on Tuesday, 10th April, 1956, and the following officers were elected:—

Chairman: Mr. J. M. Gibson; *Vice-Chairman:* Mr. H. R. N. Inniff; *Secretary:* Mr. W. A. Harper; *Deputy Secretary and Librarian:* Mr. G. T. Priestley; *Committee:* Messrs. A. Wilson, S. Shane, W. Barker, J. McCall, J. T. Harrison, J. W. Fearn, B. Cook and H. Ainsworth; *Auditors:* Messrs. P. Hurson and J. Priestley.

The program for the remainder of the session is:—

Tuesday, 12th February, 1957.—"Some Practical Aspects of Television," by Mr. H. R. N. Inniff.

Tuesday, 12th March, 1957.—"The History of Railway Signalling and Block Telegraph," by Mr. E. Williams, Signal Engineer, British Railways, Lancaster.

Tuesday, 9th April, 1957.—Annual general meeting.

All these meetings are to be held in the King's Head Hotel, Carlisle.

Darlington Centre

The following program has been arranged for the remainder of the 1956-57 session and it is hoped that Centre members will endeavour to attend all the meetings:—

12th February, 1957.—"Hi-Fi Amplifier Design," by Mr. B. V. Northall, A.M.Brit.I.R.E.

12th March, 1957.—"Motoring—Miscellany," with Sound Films, by Mr. R. Lawson.

26th March, 1957.—"Passenger Lifts—Design and Practice," by Mr. W. J. Costello.

8th April, 1957.—"Things Rural," by Mr. W. H. Everard.

C. N. H.

Hull Joint-Centre

Although, at the time of writing, the 1956-57 session has just begun, there is every hope that this year's program will prove interesting to the Centre's rather varied membership.

The program opened with an interesting film show on electrical engineering subjects and was one of three film evenings in the present session.

It is expected that the highlights of the session will be on Wednesday, 9th January, 1957, and Wednesday, 6th March, 1957, the talks on these occasions being, respectively, "Wired Television Services," by Mr. C. J. Towers, B.Eng. (Chief Engineer, Rediffusion (Yorkshire) Ltd.), and—closing the present session—a talk on "Electronic Circuitry," by Messrs. J. A. Lawrence, G. S. Gregson and F. L. Samuels, of the E.-in-C.'s Office.

A number of visits—advertised at meetings—will be arranged.

L. J.

Newcastle Centre

For the information of all members who did not attend the annual general meeting, the officers and committee elected for the forthcoming session are as follows: *Chairman:* Mr. J. A. Ord; *Vice-Chairman:* Mr. L. D. Laws; *Secretary:* Mr. G. D. Chrisp; *Treasurer:* Mr. J. T. Youngusband; *Committee:* Messrs. H. G. Bayliss, R. A. Hutchinson, J. McNulty, F. Nevin,

(continued on p. 466).

Post Office Electrical Engineers' Journal

Volume 49, April 1956—January 1957

INDEX

This index covers only Part 1 and Part 2 of Vol. 49. Parts 3 and 4 were both special numbers. Part 3, the I.P.O.E.E. Jubilee Number, reviewed the development and growth of British Post Office telecommunications services and mechanization of postal services. Part 4 was devoted to articles dealing with the Transatlantic Telephone Cable. The contents of Part 3 are listed on page 147. The contents of Part 4 are listed on page 279.

A		PAGE NO.	J		PAGE NO.
Accidents Involving Post Office Plant and Staff, Electrical ..		86	Joint Production Council for Engineering and Allied Services, Post Office ..		135
Application of Delay-Line Storage Techniques to the Common Control of Directors, An ..		104	Jones, R. A., and J. Y. Morton. Continuously-Variable Electrical, Acoustical and Mechanical Impedances ..		50
Ash, B., and H. E. Robinson. T.A.T. Cable—The Overland Cable in Newfoundland ..		1, 110	Jubilee Number, I.P.O.E.E. (contents page) ..		147
Associate Section Notes ..		63, 142, 464			
B			L		
Barker, R. C. An Experimental Ringing Circuit for Electronic Exchanges ..		124	Little, S. J. Electrical Accidents Involving Post Office Plant and Staff ..		86
Barnard, A. J., and E. H. A. Beck. The New Centralized Service-Observation System ..		81	M		
Beat Frequencies, The Production of ..		56	McClements, J. S. A Buried Frequency Standard ..		32
Beck, E. H. A., and A. J. Barnard. The New Centralized Service-Observation System ..		81	Manning, D. J. The Introduction of a Telephone Weather Service in London ..		47
Book Reviews 6, 11, 17, 21, 26, 57, 85, 117, 119, 123, 125, 135, 141, 278			Ministry of Transport and Civil Aviation Telegraph Centre, London Airport ..		118
Broadhurst, S. W. An Application of Delay-Line Storage Techniques to the Common Control of Directors ..		104	Morton, J. Y., and R. A. Jones. Continuously-Variable Electrical, Acoustical and Mechanical Impedances ..		50
Buried Frequency Standard, A ..		32	"Mosaic"—An Electronic Digital Computer Part 3 (b).—The Art of Programming (Continued) ..		18
C			Part 4.—Circuitry ..		126
Cable, The Dover-Deal Experimental ..		22	N		
Catt, L. H. A New Standard Power Plant for Medium-sized 50-V Telephone Exchanges ..		93	New Centralized Service-Observation System, The ..		81
Chilver, L. W. J., and A. H. Watkins. New Line Transmission Equipment ..		12	New Line Transmission Equipment ..		12
Coaxial Line Link for Telephony, Setting Up and Testing a ..		98	New Police Telephone and Signalling System, A ..		54
Collier, E. G., and J. H. Collins. The Testing of Telegraph Machines ..		7	New, 700-Type Telephone, The ..		69
Collins, J. H., and E. G. Collier. The Testing of Telegraph Machines ..		7	New Standard Power Plant for Medium-sized 50-V Telephone Exchanges, A ..		93
Computer, "Mosaic"—An Electronic Digital ..		18, 126	Notes and Comments ..		58, 136, 275
Continuously-Variable Electrical, Acoustical and Mechanical Impedances ..		50	P		
Coombs, A. W. M. "Mosaic"—An Electronic Digital Com- puter (Parts 3(b) and 4) ..		18, 126	P.A.B.X., An Experimental Electronically-Controlled ..		34
D			Police Telephone and Signalling System, A New ..		54
Desiccator using Silica Gel, A Portable Foot-Pump ..		46	Porritt, W. R. A. A New Police Telephone and Signalling System ..		54
Dover-Deal Experimental Cable, The Part 2.—Measurements of Gas Flow Characteristics during Installation, Gas-Drying and Gas- Pressure Equipment and Tests on Completed Cable ..		22	Portable Foot-Pump Desiccator using Silica Gel, A ..		46
E			Post Office Joint Production Council for Engineering and Allied Services ..		135
Electrical Accidents Involving Post Office Plant and Staff ..		86	Power Plant for Medium-Sized 50-V Telephone Exchanges, A New Standard ..		93
Electronic Digital Computer, "Mosaic"—An ..		18, 126	Pressurized Waveguide System, A ..		52
Electronic Exchanges, An Experimental Ringing Circuit for Electronically-Controlled P.A.B.X., An Experimental ..		124	R		
Ellis, D. R. B. Time-to-Answer Equipment for Use in Sleeve- Control Exchanges ..		133	Receiver, The Rocking-Armature ..		40
F			Regional Notes ..		60, 138
Frequency Standard, A Buried ..		32	Ringing Circuit for Electronic Exchanges, An Experimental ..		124
H			Robertson, J. S. P. The Rocking-Armature Receiver ..		40
Hayes, H. C. S. The Dover-Deal Experimental Cable (Part 2)		22	Robinson, H. E., and B. Ash. T.A.T. Cable—The Overland Cable in Newfoundland (Part 2) ..		1, 110
Hobbs, J. G. A Pressurized Waveguide System ..		52	S		
I			Safety Arrangements for High-Power Radio Transmitters ..		27
I.P.O.E.E. 50th Anniversary Celebrations ..		459	Sandbach, E. F. Installations in Australia of the British Post Office Speaking Clock Mark II ..		120
Impedances, Continuously-Variable Electrical, Acoustical and Mechanical ..		50	Sellwood, S. J., and A. E. N. Wase. Safety Arrangements for High-Power Radio Transmitters ..		27
Installations in Australia of the British Post Office Speaking Clock Mark II ..		120	Service-Observation System, The New Centralized ..		81
Institution of Post Office Electrical Engineers ..		59, 137, 276, 459	Soldering-Iron Heaters ..		109
Introduction of a Telephone Weather Service in London, The		47	Speaking Clock Mark II, Installations in Australia of the British Post Office ..		120
			Spencer, H. J. C., and F. A. Wilson. The New, 700-Type Telephone ..		69
			Staff Changes ..		65, 144
			Storage Techniques to the Common Control of Directors, An Application of Delay-Line ..		104
			Submerged Telegraph Repeaters ..		49

T

Telegraph Centre, London Airport, Ministry of Transport and Civil Aviation	118
Telegraph Machines, The Testing of	7
Telephone, The New, 700-Type	69
Time-to-Answer Equipment For Use in Sleeve-Control Exchanges	133
Transatlantic Telephone Cable—see contents page of special issue (Part 4, January, 1957)	279
Transatlantic Telephone Cable—The Overland Cable in Newfoundland	
Part 1.—Design of the Cable, Survey of Route and Preparations for Laying the Cable	1
Part 2.—The Cable-Laying Operations in Newfoundland	110
Transmission Equipment, New Line	12

W

Wase, A. E. N., and S. J. Sellwood. Safety Arrangements for High-Power Radio Transmitters	27
Watkins, A. H. Setting Up and Testing a Coaxial Line Link for Telephony	98
Watkins, A. H., and L. W. J. Chilver. New Line Transmission Equipment	12
Waveguide System, A Pressurized	52
Weather Service in London, The Introduction of a Telephone	47
Wilson, F. A., and H. J. C. Spencer. The New, 700-Type Telephone	69

Y

Yeo, B. F. An Experimental Electronically-Controlled P.A.B.X.	34
---	----

(continued from p. 464)

H. Perris and N. Richardson in lieu of H. Patterson, who has resigned from the Department since the annual general meeting.

Summarizing recent activities, two visits have been made. The first was to the Imperial Chemical Industries plant at Billingham and was only possible by members taking one day of their annual leave to attend. The party left by coach at 9 a.m. and returned at approximately 7 p.m., having had an enjoyable trip. The second visit was to the B.B.C. television and f.m. transmitting station at Pontop Pike and also the Post Office television link relay station, some small distance away. Those members who applied to go on the visit but were unlucky in the ballot will perhaps be given another opportunity early in 1957 if a second visit can be arranged with the B.B.C.

Papers to be given during the remainder of the 1956-57 session are:—

- February, 1957.—“Photography,” by Mr. F. Nevin.
 - March, 1957.—“Electrical Installations in Post Office Buildings,” by Mr. F. Lodge.
 - April, 1957, “Railway Signalling,” by Mr. R. B. Williams.
- Several of these papers will be illustrated by apparatus, models, film strip, etc.

Members' attention is drawn to the amount of time and energy put into the preparation of a paper and its delivery, all for the benefit of members. It is up to members to attend meetings, thus giving support and encouragement to the author of the paper and also to the committee, who make the necessary arrangements.

G. D. C.

Sheffield Centre

Due to the apparent lack of interest in the Centre's activities, it looked at one time as if it was in danger of becoming dormant again. However, a nucleus of enthusiasts were determined to have another attempt at attracting greater support, and to that end the committee, though somewhat depleted, was re-formed.

Many good suggestions were brought back from the N.E. Regional Conference at York last May and some of these, together with the Centre's own ideas on different items and better circulation of information to members, were put into practice. The results were quite staggering and, in fact, membership forms ran out. These will be forwarded to all new entrants as soon as supplies are received.

The 1956-57 session started on 6th September with an “Open Night” visit to the local trunk switchboard and 2 v.f. apparatus room and was a great success. On the 4th October a very interesting talk was given by the Telephone Manager, Mr. Loosemore, on “Future Developments in Telecommunications.” The attendance of 52 was quite gratifying.

On 8th November a film show given by British Railways consisted of a series of colour travel films about places at home and abroad, and on 15th November a very interesting visit took place to the telephone factory of Ericsson Telephones, Ltd., Nottingham.

Future items in the program include talks on “Tape Recorders,” “Electronic Switching,” “Promotions and Appraisements” and visits to various places, including a power

station. Members are asked to continue to give their enthusiastic support, and if they have any ideas on any particular subject to let the committee know and they will do their best to arrange an appropriate talk or visit. The officers elected for this session are:—

- Chairman: Mr. J. McInnes; Vice-Chairman: Mr. F. Gosling;
- Secretary: Mr. J. McCall; Assistant Secretary: Mr. J. Watts;
- Treasurer: Mr. S. Shepherd; Librarian: Mr. G. Woodhouse;
- Committee: Messrs. J. Richards, S. Brasher, G. Ridsdale and J. Williams.

J. McC.

Sunderland Centre

The inaugural meeting, presided over by the Area Engineer, Mr. J. E. Collins, was held at Telephone House, Sunderland, on Friday, 12th September. The following officers were elected:—

- Chairman: Mr. W. W. Lloyd; Secretary: Mr. D. A. Collins;
- Committee: Messrs. G. R. Brown, W. Coulson, M. Cummings and J. Howe.

The selection of Mr. A. Beattie, as Vice-Chairman, was confirmed at the first general meeting, at a later date.

A provisional program was at once arranged, the first item of which was a visit to the shipbuilding yard of W. Doxfords & Sons, Ltd., where members present witnessed and had explained the various stages of the building of a ship, from a series of lines and a multitude of figures on paper, through the phase where the ship was like so many iron boxes welded together, to the modern cargo vessel of 11,000 tons moored to the fitting-out quay and being furnished ready to sail on acceptance trials within a week.

On Friday, 26th October, the first general meeting was held, with 20 members present, after which, business being completed, two films, produced by Shell-Mex and B.P., were shown, which were of real interest and educational value. We are indeed grateful to Shell-Mex for the films and to Palmers of Sunderland for the generous loan of the projector.

Arrangements are now in hand for a visit to Ericsson Telephones, Ltd.

D. A. C.

BOOKS RECEIVED

“Wireless World Diary, 1957.” T. J. & J. Smith Ltd., in conjunction with *Wireless World*. 80 pages of reference material plus diary pages of one week to an opening. Size 4½ in. × 3½ in. Leather 6s.; rexine 4s. 3d.

This diary, now in its 39th year of publication, includes in its 80-page reference section many useful design data, base connexions for 600 current valves, frequency allocations, licence regulations and much other technical and general information which it is convenient to have readily available.

“Definitions and Formulae for Students: Modern Physics.” (Third Edition.) L. R. B. Elton, Ph.D. 33 pp. 2s.

The purpose of this booklet is to bring together some of the formulae in modern physics which are frequently required by students. The standard is that of a pass or general degree.

BOARD OF EDITORS

D. A. BARRON, M.Sc., M.I.E.E., Chairman.
L. F. SCANTLEBURY, Whit.Sch., A.C.G.I., D.I.C., M.I.E.E.
H. G. BEER, Whit.Sch., A.C.G.I.
C. E. CALVELEY, O.B.E., E.R.D., B.Sc.(Eng.), M.I.E.E.
T. H. FLOWERS, M.B.E., B.Sc.(Eng.), M.I.E.E.
R. H. DE WARDT, B.Sc.(Eng.), A.C.G.I., A.M.I.E.E.
R. F. WALDEGRAVE.
W. A. HUMPHRIES, T.D., A.M.I.E.E., Managing Editor.
J. H. BROADHURST, A.M.I.E.E.
E. DAVIS, A.M.I.E.E. } Assistant Editors.
A. J. HUTCHISON, Secretary-Treasurer.

Copyright

The entire contents of this JOURNAL are covered by general copyright, and special permission is necessary for reprinting long extracts, but Editors are welcome to use not more than one-third of any article, provided credit is given at the beginning or end thus: "From the *Post Office Electrical Engineers' Journal*."

The Board of Editors is not responsible for the statements made or the opinions expressed in any of the articles in this JOURNAL, unless such statement is made specifically by the Board.

Communications

All communications should be addressed to the Managing Editor, *P.O.E.E. Journal*, Engineer-in-Chief's Office, Alder House, Aldersgate Street, London, E.C.1. Telephone: HEAdquarters 1234. Remittances should be made payable to "*The P.O.E.E. Journal*" and should be crossed "& Co."

Binding Cases

Cases for binding are available, and may be obtained from the Local Agents for 3s. Subscribers can have their copies of volumes bound, at a cost of 10s. 6d., by sending the complete set of parts to the Local Agents or to the *P.O.E.E. Journal*, Engineer-in-Chief's Office, Alder House, Aldersgate Street, London, E.C.1. Orders for binding for Vols. 1-19 should indicate whether the original binding case with black lettering, or the later pattern with gold, is required. Cases with gold lettering are the only type stocked from Vol. 20 onwards.

Back Numbers

The price of the JOURNAL, which is published quarterly, is 2s. 6d. (2s. 9d. post free) per copy, or 11s. per annum, post free. Back numbers can be supplied, subject to availability of stocks, at 2s. 6d. (2s. 9d. each post free) except for Vol. 49, Part 4 (January 1957), the Transatlantic Telephone Cable issue, the price of which is 12s. 6d. (post free). Orders for back numbers may be sent to the *P.O.E.E. Journal*, Engineer-in-Chief's Office, Alder House, Aldersgate Street, London, E.C.1, or to the Publishers.

Employees of the British Post Office can obtain the *Journal* through Local Agents at the reduced price of 2s. per copy.

Advertisements

All communications relating to space reservations should be addressed to the Advertisement Editor, *P.O.E.E. Journal*, Alder House, Aldersgate Street, London, E.C.1. Communications regarding advertisement copy, proofs, etc., should be addressed to the Publishers, Messrs. Birch & Whittington (Prop. Dorling & Co. [Epsom] Ltd.), Depot Road, Epsom, Surrey.

THE INSTITUTION OF POST OFFICE ELECTRICAL ENGINEERS PRINTED PAPERS

The following papers contributed to the proceedings of the Institution have been printed by the authority of the Council and may be obtained, from
"THE LIBRARIAN, THE INSTITUTION OF POST OFFICE ELECTRICAL ENGINEERS, G.P.O. (ALDER HOUSE), LONDON, E.C.1."

The price per copy is 2s. 6d. (2s. 8d. post free) and Corporate Members of the Institution and Members of the Associate Section have the privilege of purchasing copies at the reduced price of 1s. 6d. net. (1s. 8d. post free).

- No. 140. "SOME NON-METALLIC SUBSTANCES AND THEIR CHARACTERISTICS."—Capt. N. F. CAVE-BROWNE-CAVE, B.Sc., A.M.I.E.E. 1931.
†No. 146. "LAYING ARMOURED CABLE BY MEANS OF A MOLE-DRAINER."—L. G. SEMPLE, B.Sc.(Eng.), and R. O. BOOCOCK, B.Sc.(Eng.). 1932.
No. 148. "STORES SPECIFICATIONS AND ACCEPTANCE TESTING."—Capt. J. LEGG, B.Sc., A.M.I.E.E. 1933.
†No. 166. "CHEMISTRY AND COMMUNICATIONS."—D. W. GLOVER, M.Sc., A.I.C. 1937.
†No. 169. "CROSSTALK."—H. C. S. HAYES, A.M.I.E.E., R. A. SEYMOUR and P. R. BRAY, M.Sc.(Eng.), Graduate I.E.E. 1938.
No. 174. "METALLURGY AND COMMUNICATIONS."—E. V. WALKER, B.Sc., A.R.S.M. 1940.
No. 177. "RECENT APPLICATIONS OF THE QUARTZ AND X-RAY SPECTROGRAPHS TO POST OFFICE PROBLEMS."—R. TAYLOR, M.A., Ph.D., B.Sc. 1941.
No. 179. "INTRODUCTION OF U.A.X. MULTI-METERING IN THE LEEDS AREA."—H. G. COPE. 1941.
†No. 182. "LONDON INLAND TRUNK SERVICES."—W. H. SCARBOROUGH, A.M.I.E.E. 1943.
†No. 187. "CABLING PROBLEMS IN SUBWAYS AND TUNNELS."—T. G. TURLEY, A.M.I.E.E. 1945.
†No. 191. "PIEZO-ELECTRIC QUARTZ AND ITS USE IN TELECOMMUNICATIONS."—C. F. BOOTH, M.I.E.E., and J. L. CREIGHTON, A.M.I.E.E. 1946.
†No. 193. "IMPROVEMENTS IN TELEPHONE SIGNALLING."—S. WELCH, M.Sc.(Eng.), A.M.I.E.E., and C. H. J. FLEETWOOD, A.M.I.E.E. 1949.
†No. 196. "WIRE BROADCASTING."—F. HOLLINGHURST, B.Sc.(Eng.), A.C.G.F.C., M.I.E.E., and W. PRICKEIT, A.M.I.E.E. 1949.
†No. 197. "THE POSSIBILITIES OF SUPER-HIGH FREQUENCY RADIO AND WAVEGUIDE SYSTEMS FOR TELECOMMUNICATIONS."—W. J. BRAY, M.Sc.(Eng.), A.C.G.I., D.I.C., A.M.I.E.E. 1948.
No. 198. "INTRODUCTION AND APPLICATION OF TRANSMISSION PERFORMANCE RATINGS TO SUBSCRIBERS' NETWORKS."—G. A. E. FUDGE, A.M.I.E.E. 1949.
†No. 199. "SOME APPLICATIONS OF ELECTRONIC METHODS TO TELEGRAPH APPARATUS."—R. O. CARTER, M.Sc.(Eng.), A.M.I.E.E., and L. K. WHEELER, B.Sc.(Eng.), A.M.I.E.E. 1949.
†No. 200. "TRENDS IN THE DESIGN OF LINE TRANSMISSION EQUIPMENT."—R. J. HALSEY, B.Sc.(Eng.), A.C.G.I., D.I.C., M.I.E.E. 1949.
†No. 201. "TRUNK MECHANISATION."—A. J. THOMPSON and J. H. BROADHURST, A.M.I.E.E. 1951.
No. 202. "THE COLD-CATHODE TUBE IN TELEPHONE SWITCHING CIRCUITS."—J. A. LAWRENCE, A.M.I.E.E. 1952.
†No. 203. "SUBSCRIBER TRUNK DIALLING IN THE UNITED KINGDOM."—D. A. BARRON, M.Sc., M.I.E.E. 1952.
†No. 204. "A.C. SIGNALLING—A REVIEW OF CURRENT PROBLEMS."—B. R. HORSFIELD, A.M.I.E.E., and D. C. SMITH, B.Sc.(Eng.), A.M.I.E.E. 1952.
†No. 205. "COAXIAL CABLES—SOME PRACTICAL ASPECTS OF THEIR DESIGN AND MAINTENANCE."—G. E. ROSSITER, A.M.I.E.E. 1953.
†No. 206. "THE INFLUENCE OF SIGNAL IMITATION ON THE DESIGN OF VOICE FREQUENCY SIGNALLING SYSTEMS."—S. WELCH, M.Sc.(Eng.), A.M.I.E.E. 1953.
†No. 207. "TELEX SERVICE."—R. N. RENTON, A.M.I.E.E. 1954.
No. 208. "COMMON CONTROL AND ELECTRONIC DEVICES IN AUTOMATIC EXCHANGES."—T. H. FLOWERS, M.B.E., B.Sc., M.I.E.E. 1955.

† The Council have awarded Institution Medals for these papers.

INDEX TO ADVERTISERS

	PAGE
Adcola Products, Ltd.	xxix
Airmec, Ltd.	xxxiv
Alton Battery Co., Ltd., The	vi
Austinlite, Ltd.	xxx
Automatic Coil Winder & Electrical Equipment Co., Ltd.	xxxii
Automatic Telephone & Electric Co., Ltd.	v
Bennett College, The	iv
British Electric Resistance Co., Ltd., The	ii
British Institute of Engineering Technology	vii
British Insulated Callender's Cables, Ltd.	xxvii
Christie, W., & Grey, Ltd.	xxxi
Dale Electric (Yorkshire), Ltd.	xvii
Electric Construction Co., Ltd., The	xxix
E.M.I. Institute	xii-xiii, xxiv-xxv
Ericsson Telephones, Ltd.	xxxviii
Eric Resistor, Ltd.	xxxvii
Foster Transformers, Ltd.	xxxii
General Electric Co., Ltd., The	x-xi, xii-xiii, xviii-xix
Great Northern Telegraph Co., Ltd.	xxxvi
Hallam, Sleigh & Cheston, Ltd.	xxvii
Hivac, Ltd.	xxiii
Hot Dip Galvanizers Association	xxxix
Lister, R. A., & Co., Ltd.	xxii
Marconi Instruments	xlii
Mullard, Ltd.	xxviii
National Salt Glazed Pipe Manufacturers' Association	xvi
Painton of Northampton	xlv
Pirelli-General Cable Works, Ltd.	ii
Pitman, Sir Isaac, & Sons, Ltd.	xx
Pye, Ltd.	xxi
Rawplug Co., Ltd., The...	xliii
Record Electrical Co., Ltd., The	ii
Redifon, Ltd.	viii
Siemens Brothers & Co., Ltd.	xxix
Smith, Frederick, & Co.	xiv-xv
Standard Telephones & Cables, Ltd.	xl-xli
Submarine Cables, Ltd.	xxxv
Swan, Hunter, & Wigham Richardson, Ltd.	xxxiii
Sullivan, H. W., Ltd.	xxxvi
Telephone Manufacturing Co., Ltd.	ix
Tungstone Products, Ltd.	xliii
Turner, Ernest, Electrical Instruments, Ltd.	xlv
Westinghouse Brake & Signal Co., Ltd.	xxxiii
Winn & Coales, Ltd.	xxxiii

FREE! *to you!*
-if you seek
SUCCESS!



If you lack qualifications which would get you a better job, more pay and faster progress; if you really want to succeed in your studies for the City & Guilds Certificates... send *now* for this stimulating, important book—“Train your mind to SUCCESS.”

HERE is the amazing story of The Famous Bennett College, its awards, scholarships, medals. Read what eminent educationists have to say about Personal Postal Tuition—The Bennett College way!

READ actual cases taken from its half a million success stories—from Bricklayer to Assistant Manager, from Draughtsman to Director—and many others!

SEE how you will learn when you enrol—how your own personal tutor watches over every step of your progress—how your success is *guaranteed*. **POST THIS COUPON NOW!**

“I GUARANTEE TUITION UNTIL YOU HAVE PASSED”

**Preliminary Course
Telecommunications
Principles I - V
Radio I - IV
Telegraphy I & II
Line Transmission I & II
Mathematics for Telecommunications
Radio Servicing Certificate**

BENNETT COLLEGE
(DEPT. A.24.F.), SHEFFIELD

Please send me, without obligation, a free copy of “Train your mind to SUCCESS” and the College Prospectus on:

SUBJECT _____
NAME _____
ADDRESS _____

AGE (if under 21) _____

Please write in Block Letters

THIS DAY
COULD BE THE TURNING-POINT IN YOUR LIFE.

THIS COUPON
COULD BE YOUR PERSONAL PASSPORT TO SUCCESS.

Send it NOW!

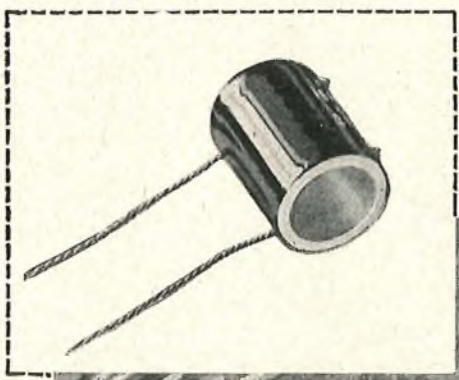

20 Years on the Ocean Bed



The laying of the first trans-Atlantic telephone cable raised the problem of producing components which would keep on working year after year without any need for maintenance.

For the hundreds of vitreous enamelled resistors used on this project, Post Office and Berco engineers were able to utilise our unique production facilities to produce units that would last for more than 20 years without question.

By solving many problems of this kind we have built up a fund of knowledge and experience which is available to all who choose Berco products.

THE LAST WORD IN RELIABILITY



VITREOUS ENAMEL RESISTORS

THE BRITISH ELECTRIC RESISTANCE CO. LTD., Queensway, Ponders End, Middx. 'Phone: Howard 2411. 'Grams: Vitrohm Enfield. BR1351-AH.

Distortion detected - Transmission unaffected

with the T.D.M.S.

The T.D.M.S. 5A and 6A are portable sets designed to measure distortion at any point in a radio teleprinter or line telegraph circuit without interfering with normal transmission. The equipment consists of two units each $18\frac{1}{2}$ " x $11\frac{1}{2}$ " x $13\frac{1}{2}$ " both mains driven and electronically controlled. Either may be used independently for certain tests or both may be used in combination to cover a comprehensive range of testing operations.



T.D.M.S. 5A

Sends an automatic test message, or characters, or reversals at any speed between 20-80 bauds with or without distortion. The CRO has a circular time base for distortion measurements on synchronous signals only, or relay adjustment. Weight 37 lb.

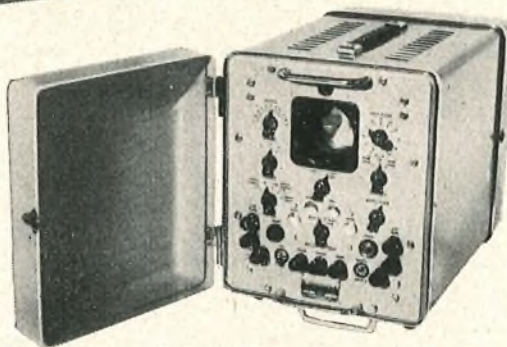

T.D.M.S. 6A

For distortion measurements on working circuits without interrupting service. Each element of a start-stop signal appears separately on the spiral time base display. Adjustable speeds from 20-80 bauds. Weight 33 lb. Higher speed versions can be supplied to order.

You are invited to apply for a copy of a descriptive leaflet.

AUTOMATIC TELEPHONE & ELECTRIC CO. LTD.,

STROWGER HOUSE, ARUNDEL STREET, LONDON, W.C.2.
TELEPHONE : TEMPLE BAR 9262. CABLEGRAMS : STROWGEREX LONDON.



AT14611-BX107



Farmers sometimes grumble, it's said, about quite a number of things.

But you never heard a farmer say 'Trouble with the land, is work-shy men'. You never will—while his men are countrymen. Nobody stands at the countryman's elbow to see that he sticks to the job. Nobody needs remind him that this job or that will call for patience and skill. Nobody had to persuade him to welcome the Machine. All he has said of each new box-of-tricks is 'show me how to work it'. Alton, where Alton batteries are made, is a country town where men are countrymen. Men who haven't yet learnt to believe that what's near enough right is well enough done. Men who are happy to marry the old hand skills to the use of modern machines. Men whose personal standards of workmanship have helped to build a world-wide reputation for Alton Batteries.

ALTON Batteries of Merit

Alton stationary batteries: 10 to 15,000 ah. Also in regular production, renewal plates for all makes of battery, British and Continental.

THE ALTON BATTERY COMPANY LIMITED, ALTON, HANTS · Telephone : ALTON 2267 and 2268 · Telegrams: BATTERY, ALTON

A.30

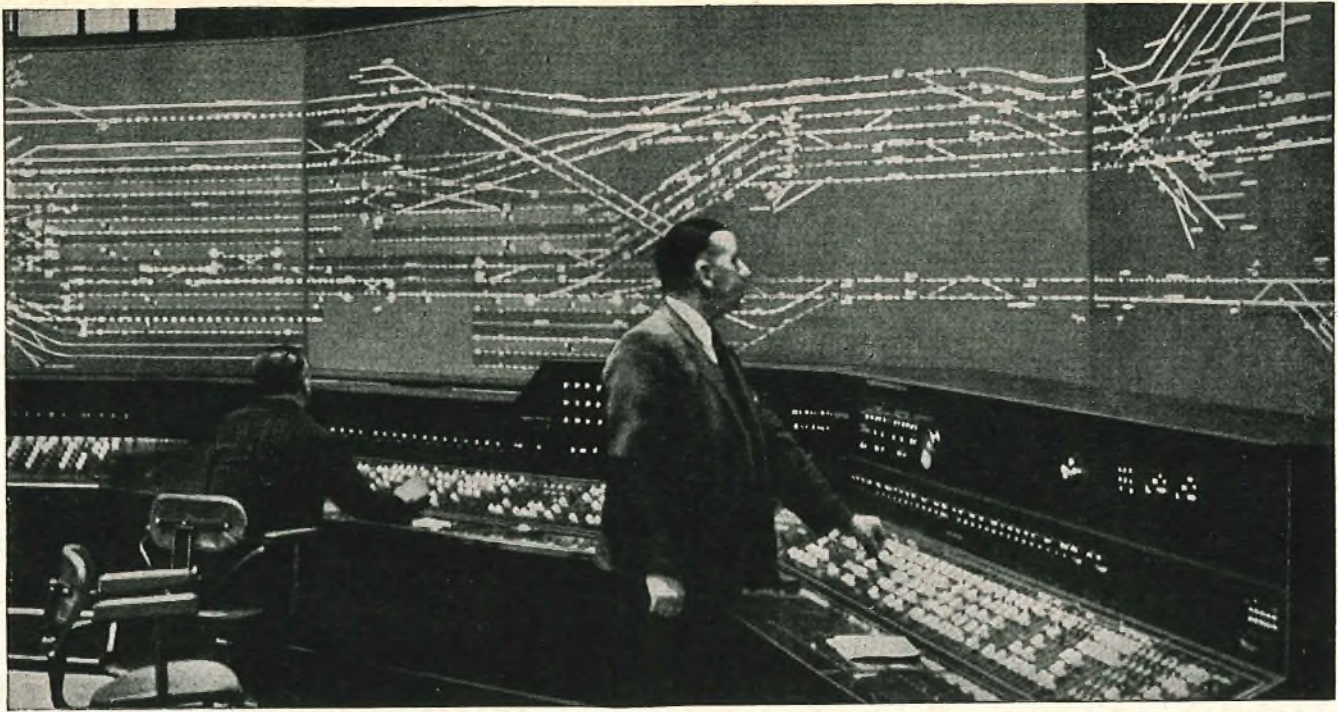

He's looking where you're going!

The World's largest Route Relay Interlocking System is centred in the Signal Box at York. It controls the points, signals and indicators for 825 routes. BICC designed and manufactured over 25 miles of armoured, paper-insulated, lead-sheathed Railway Signalling Cables especially for this important installation.*

We illustrate a 47-core BICC Railway Signalling Cable, one of a range made to British Railways specification and extensively used in this country and overseas. Our research department is continuously developing new cables to meet the most exacting signalling and telecommunications requirements, whether on the railways, in the mines or in industry at large.

If you have a communication problem write to BICC about it. Our engineers will design the cable and, if you wish, install it anywhere in the World.

* Main contractors: Westinghouse Brake & Signal Co. Ltd.

BICC

SIGNALLING CABLES



BRITISH INSULATED CALLENDER'S CABLES LIMITED, 21 Bloomsbury St., London, W.C.1



Amman telephone cable network

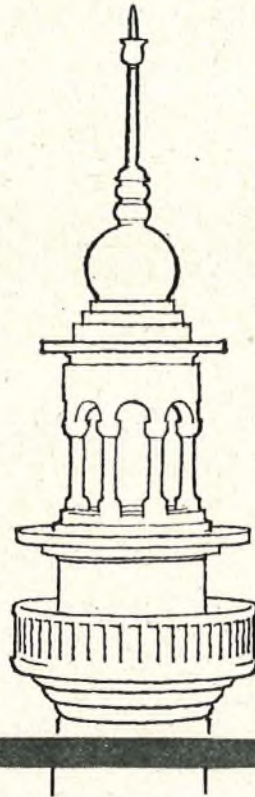

The supply and installation of the extensive telephone cable network required for serving the new Automatic Telephone System for Amman has been entrusted to us by the Ministry of Posts, Telephones, Telegraph and Civil Aviation of the Hashemite Kingdom of Jordan.

The contract totals 800 kilometres of cables and wires of all types together with the necessary distribution pillars and joint boxes, all of which have to withstand the climatic

conditions of this area. Under the supervision of our cable engineering staff, local labour will carry out the installation and jointing of the cables also the erection work required for the open wire lines.

In addition to comprehensive telephone cable networks of this nature, our world-wide experience in telecommunications enables us to offer complete telephone exchange equipments and associated line transmission systems.

Photograph shows 1800 pr. unit type cable for local subscribers circuits.

Siemens Brothers & Co., Limited, Woolwich, London, S.E.18. Telephone: Woolwich 2020

Branches and Agencies throughout the World

Member of the A E I Group of Companies

DESIGNED to meet *G.P.O. specification*

TUNGSTONE PLANTÉ CELLS are being regularly supplied to the British Post Office and Post and Telegraph Departments in many countries overseas. They conform fully to G.P.O. Standard specifications.

OPEN TYPE CELLS

Similar to the illustration here, these are available in glass and/or lead lined wooden boxes in capacities from 100 a.h. to 5000 a.h.

REPLATALS

We are in a position to supply plates for the replating of existing Planté Batteries.

ENCLOSED TYPE CELLS

As illustrated below, these are in moulded glass boxes with sealed-in lid. Capacity range from 10 a.h. to 200 a.h.

PORTABLE TYPE BATTERIES

A range of portable type Batteries is in regular production, made to G.P.O. specifications, for ancillary duties.

Overseas customers are invited to cable or write their enquiries for batteries or parts. Visitors to London are welcome at our offices. (Just off Fleet Street.)

50 Cells. BSSDW. 25.
1200 a.h. at the 9-hour rate.
Installed for the
General Post Office

TUNGSTONE

REGD TRADE MARK

BATTERIES



TUNGSTONE PRODUCTS LTD., 10 SALISBURY SQUARE, LONDON, E.C.4, ENGLAND. CABLES: "DILUTUM" LONDON

TC14

G.E.C.

announce

TRANSMISSION

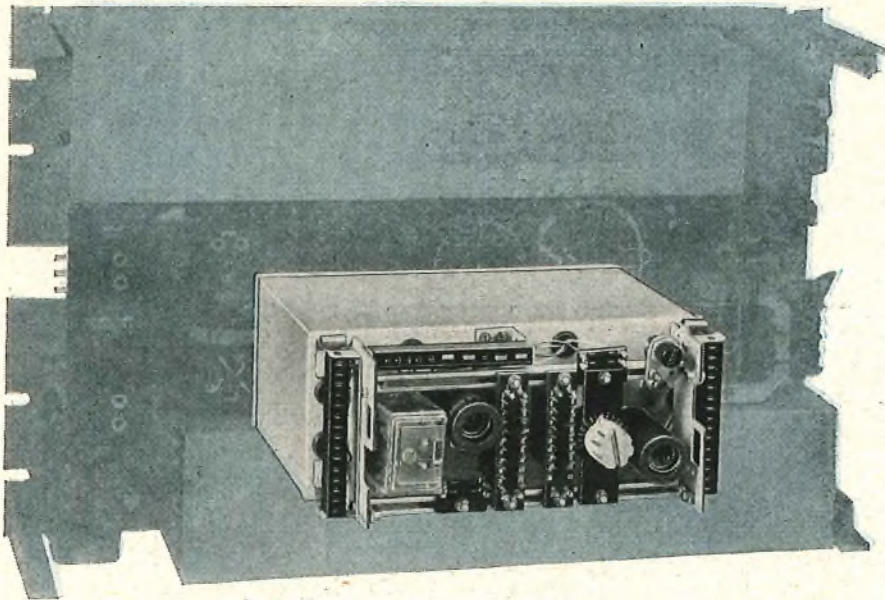

The new channel unit embodying out-of-band signalling equipment compared with an earlier channel panel without signalling facilities.

NEW CHANNEL PANEL

Latest miniaturisation techniques have been employed in the design of a new channel panel, which includes out-of-band signalling at 3825 c/s. Compared to the channel panel in general use only five years ago—for which the signalling equipment was mounted on a separate panel, and which did not incorporate out-of-band signalling—the new panel occupies only one-sixth of the rack space.

There are many advantages to be gained from the use of out-of-band signalling, since the speech and signalling channels are independent. This means that speech and signalling signals can be transmitted simultaneously; consequently

the junction relay sets are much simpler than those required with in-band signalling systems. The equipment can easily be converted from ring-down signalling to dialling application—an important feature to those administrations contemplating trunk-dialling systems in the future.

The new channel panel is being incorporated in the following G.E.C. equipment:

OPEN-WIRE EQUIPMENT—A complete terminal for 3-speech circuits plus four duplex telegraph channels, or for 12-speech circuits, can now be mounted on one single-sided rack 9 ft. high \times 1 ft. 8½ in. wide. For full information write for standard specifications SPO 1011 and SPO 1025.

BASIC GROUP EQUIPMENT — The complete equipment for three high-quality 12-circuit basic groups can now also be mounted on one single-sided rack 9 ft. high \times 1 ft. 8½ in. wide. For full information write for standard specification SPO 3006.

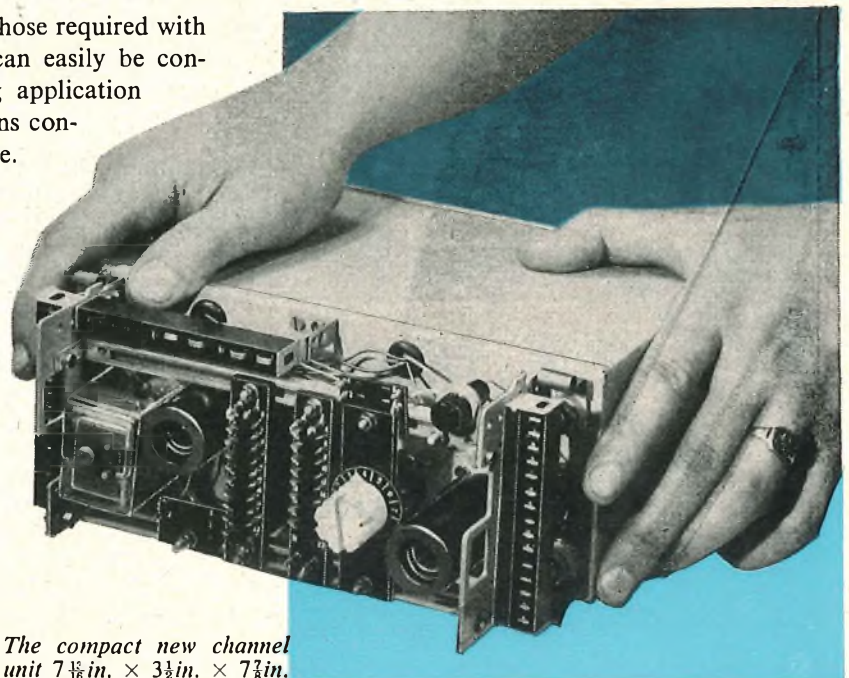

The compact new channel unit 7½ in. \times 3½ in. \times 7¼ in.

latest developments in EQUIPMENT

TRANSISTORISED EQUIPMENT

The use of transistors in transmission equipment has many advantages. For example:

The power consumed is extremely low.

The physical size is small.

The heat dissipated is negligible.

The G.E.C. is producing completely transistorised equipment for the following applications:

RURAL CARRIER SYSTEM — This enables up to ten circuits to be transmitted over one pair of wires, with facilities for terminating one or more circuits at intermediate points. Full information on this equipment is given in standard specification SPO 1030.

VOICE-FREQUENCY TELEGRAPH EQUIPMENT

This extremely compact equipment uses transistors throughout, and operates from a 21-volt d.c. supply. The system employs frequency shift modulation to provide 24-duplex telegraph channels operating at a modulation rate of 50 bauds over any four-wire speech circuit that effectively transmits frequencies between 300 c/s and 3400 c/s. A complete terminal is mounted on a single-sided rack 9 ft. high \times 1 ft. 8½ in. wide. Full information

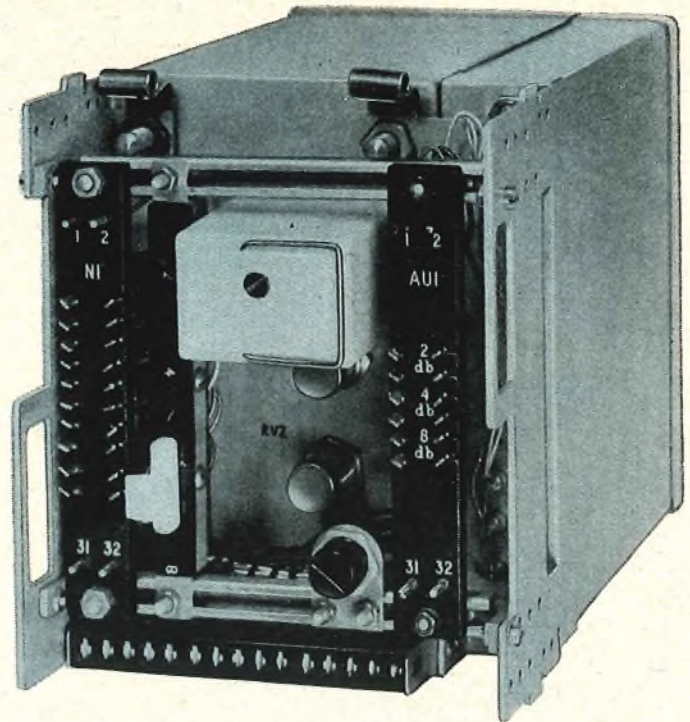

A complete VF telegraph unit including transmitter and receiver.

regarding the equipment is contained in standard specification SPO 1403.

4-WIRE AUDIO AMPLIFIER—This has a maximum gain of 30 dB and is capable of delivering a maximum output of +16 dBm. The gain frequency distortion over the range 300 c/s to 6 kc/s does not exceed 0.5 dB relative to 800 c/s.

NEGATIVE IMPEDANCE REPEATERS—These are of the shunt and series types for use on loaded 2-wire audio cables.

THE GENERAL ELECTRIC CO. LTD., OF ENGLAND

TELEPHONE RADIO AND TELEVISION WORKS · COVENTRY · ENGLAND

THE

G.E.C.

SE50

as a Discriminating Selector Repeater

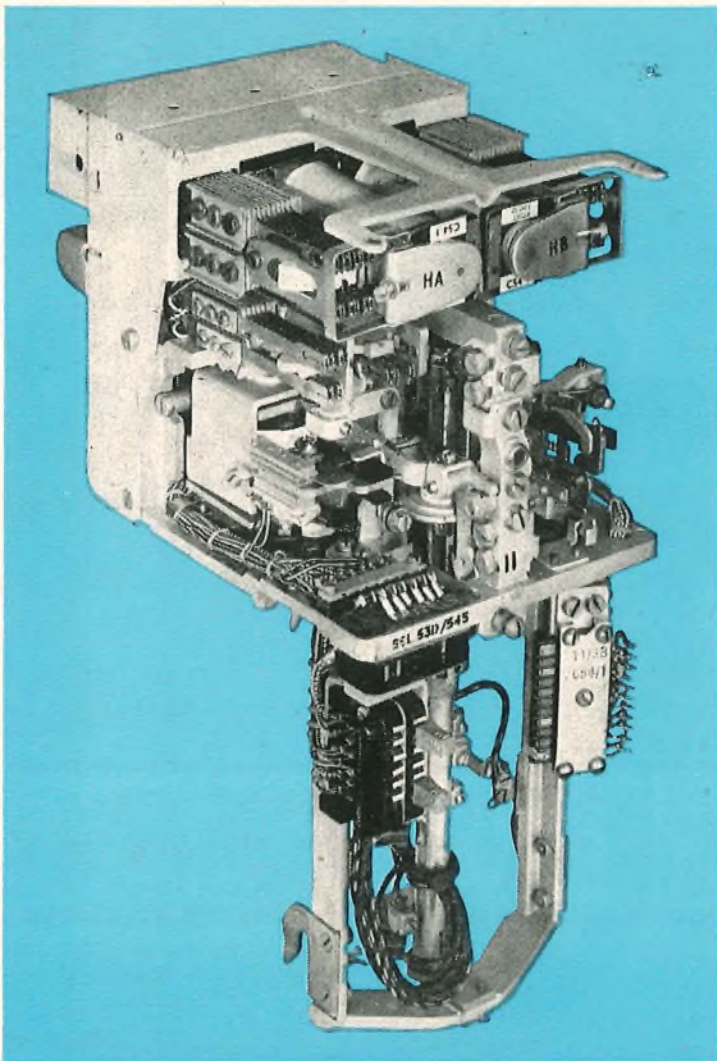

In a recent G.E.C. installation the SE50 selector is used very effectively as a discriminating selector repeater, because its quick release action ensures that the selector restores to its unoperated position during the interdigital pause following an absorbed digit.

The vertical marking bank is attached to the selector frame, and thus does not require independent adjustment when the selector is jacked in or out. The vertical wiper gives constant contact pressure during vertical action, and rotates away from its bank during the rotary motion of the selector shaft, thus eliminating any form of level-marking trouble during rotary hunting.

SE50 selectors are now giving excellent service in all five continents in the various switching stages of automatic exchanges. All adjustments on the mechanism are independent, and can be carried out without disturbing any previously made. In service the switch requires only the minimum amount of maintenance.

Section of a D.S.R. rack in a satellite exchange ▶

**Everything for Telecommunications by Open-Wire Line, Cable and Radio, Single and Multi-Circuit, or T.V. Link—short, medium and long haul. Automatic and Manual Exchanges.*

THE GENERAL ELECTRIC CO. LTD. OF ENGLAND

TELEPHONE RADIO AND TELEVISION WORKS · COVENTRY · ENGLAND

SELECTOR

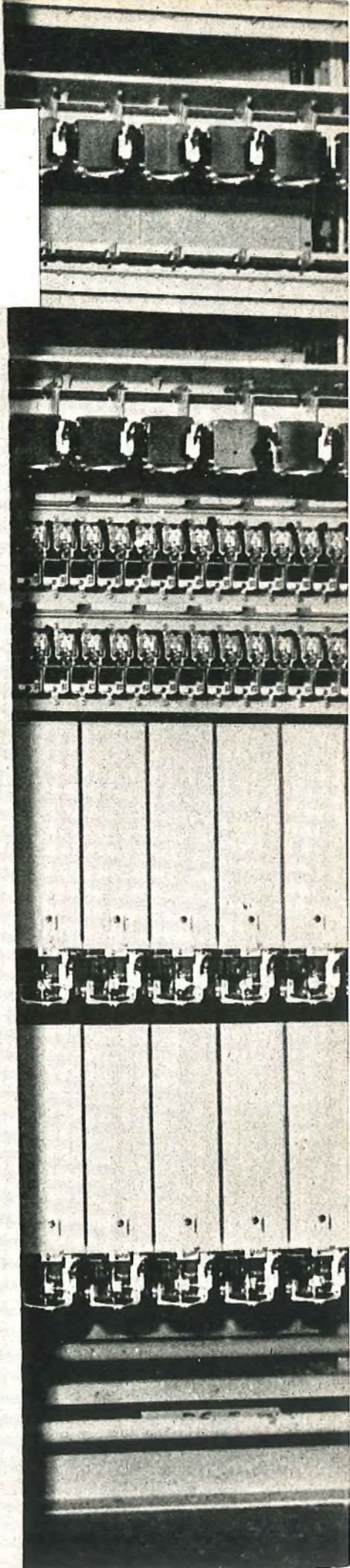
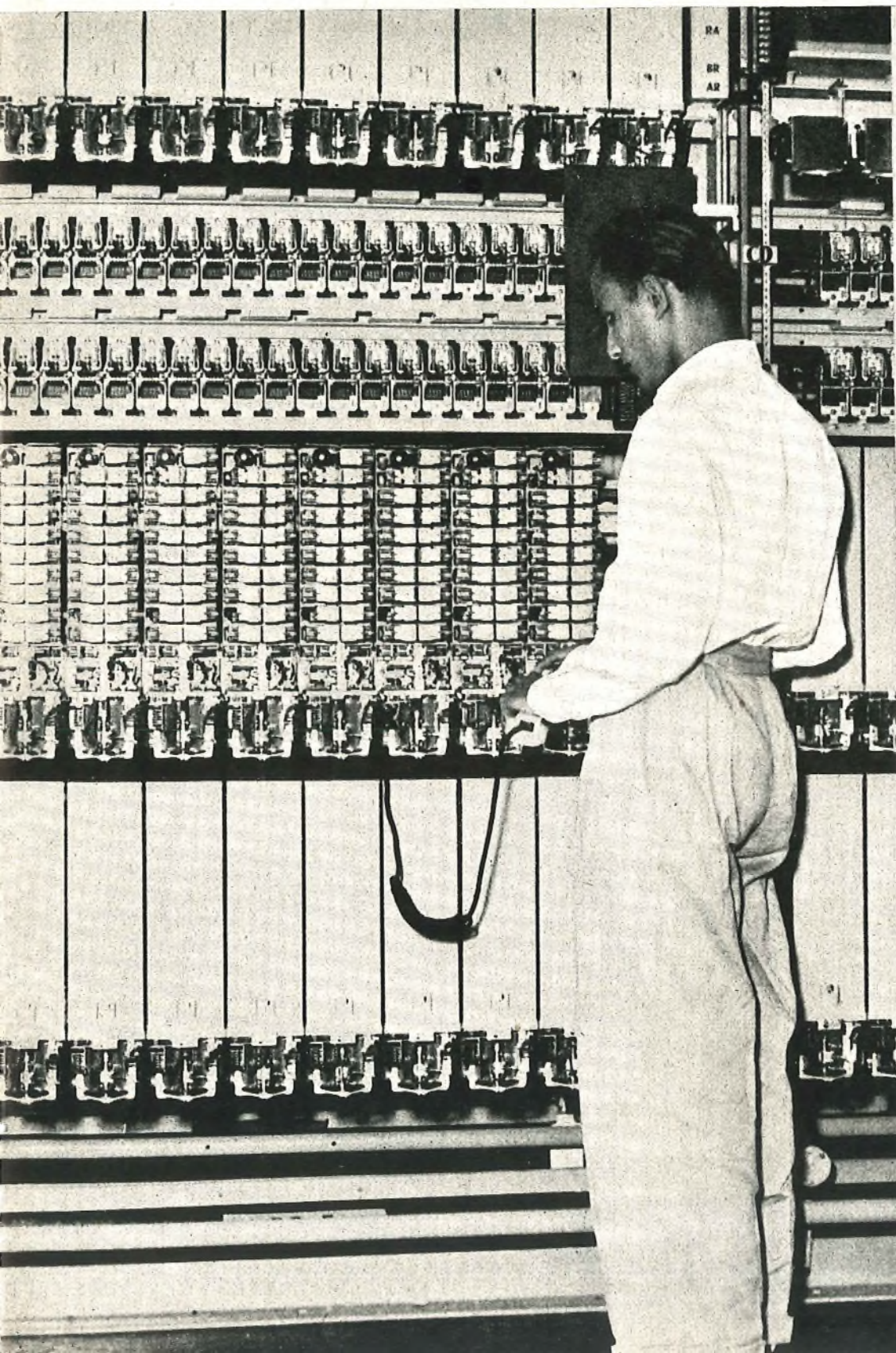

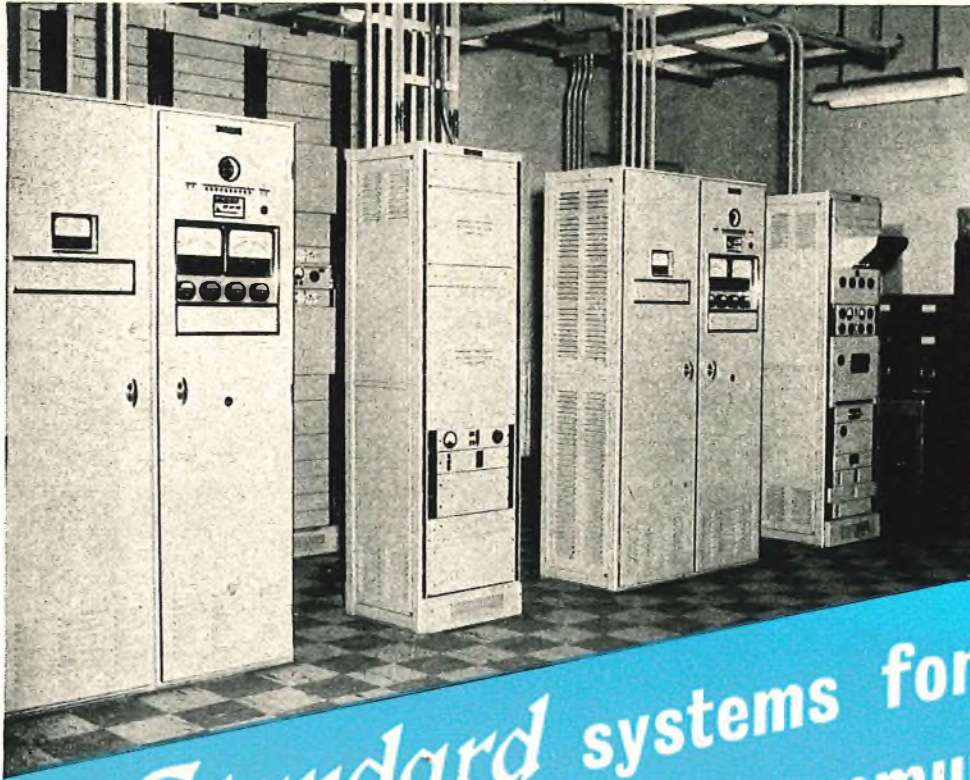

Submerged repeater power supply cubicles at Sydney Mines. Cable terminal cubicle is shown at centre.

Standard systems for Submarine Telecommunications

The transatlantic cable system is an advance in telecommunications which will rank high among the century's major engineering achievements. **Standard** played an important part in the design, manufacture and installation of much of the equipment now in service on the transatlantic route, and have a continuous programme of development in submarine communication systems.



Testing 4 Mc/s co-axial terminal repeater equipment at Oban.



Standard Telephones and Cables Limited
TELECOMMUNICATION ENGINEERS

CONSULT

Standard for **complete submarine communication systems including cable**

Equipments similar to the multi-channel coaxial cable telephone system installed between Glasgow and Oban, the submerged two-way repeaters with their power feeding equipments in the Clarenville-Sydney Mines section of the transatlantic route, the broadcast channelling equipment in New York and Montreal, together with other **Standard** multi-channel apparatus operating over the system, can be supplied for large or small projects.

Standard engineers, experienced in the installation of land and submarine telecommunications systems, can give assistance in the early stages of system route planning for telephone, telegraph or television transmission networks.

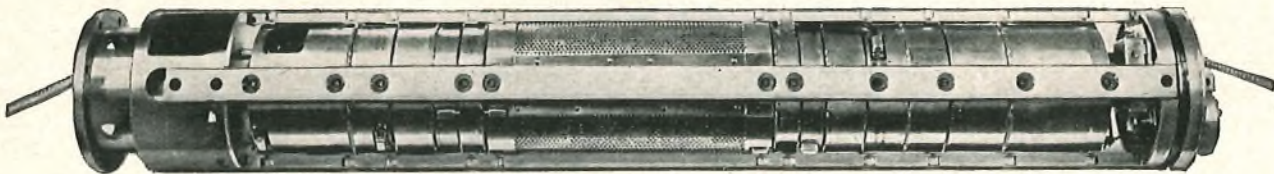

*One of 16 repeaters as laid between
Clarenville and Sydney Mines
shown without sea casing.*

CONNAUGHT HOUSE · ALDWYCH · LONDON W.C.2



By Appointment to the Professional Engineer

PAINTON WINKLER SWITCHES

(Post Office approved: switches rotary Nos. 7 and 8.)

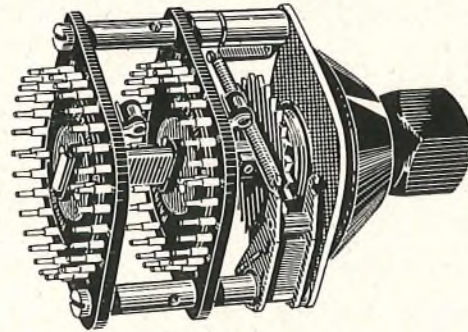
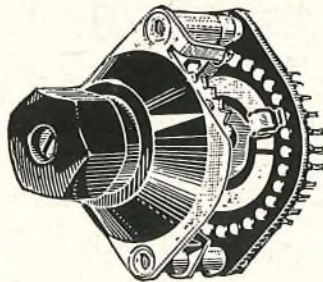
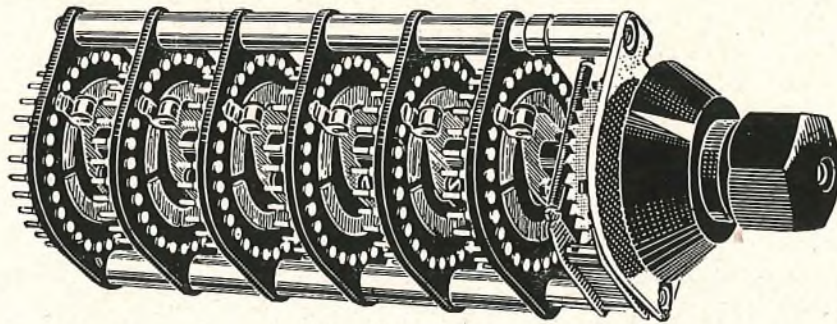

PAINTON
Northampton England

Manufacturers of

ATTENUATORS AND FADERS · STUD SWITCHES · TOGGLE SWITCHES · PUSH BUTTON SWITCHES
FIXED AND ADJUSTABLE WIREWOUND RESISTORS · HIGH STABILITY CARBON RESISTORS
'METLOHM' METAL FILM RESISTORS · WIREWOUND POTENTIOMETERS · MIDGET R.F. CHOKES
KNOBS, DIALS & POINTERS · TERMINALS · PLUGS AND SOCKETS



POWER EQUIPMENT FOR TELECOMMUNICATIONS

"H.M.T.S. MONARCH"

The British Post Office cable ship which laid the first transatlantic telephone cable.

As specialists in the supply of Power Equipment for telecommunication services throughout the world, we designed, in collaboration with the British Post Office, and manufactured Power Equipment for the Oban Terminal Station of this transatlantic cable.



BROCHURE B2100 AVAILABLE TO INTERESTED ENGINEERS ON REQUEST

THE ELECTRIC CONSTRUCTION COMPANY LTD., WOLVERHAMPTON



ERICSSON TELEPHONES LIMITED AND

jointly

A NEW SUBSCRIBERS'

This new telephone is known as the Ericsson 1000 Telephone or the G.E.C. 1000 Telephone according to the manufacturer. It has a standard of performance far superior to its predecessors. In consequence, a better performance can be obtained from existing line plant, and new installations can be planned to extend over longer distances than was formerly possible. For example, for any standard of performance now deemed by an Adminis-

tration to be satisfactory, the permissible length of subscribers' lines can be increased by about 70%. Alternatively, the size of conductor may be reduced, say, from 10 lb to 4 lb (6 mm to 4 mm).

The gentle curved lines of the new case and handset harmonise with modern schemes of decoration whilst retaining the dignity required for office furniture. Two indentations, one on each side of the case near the top, allow the



Better performance
Line economy

THE G.E.C.
1000
TELEPHONE

THE GENERAL ELECTRIC CO. LTD. OF ENGLAND



announce

TELEPHONE INSTRUMENT

instrument to be readily carried from one position to another. The increased curvature of the handset has practical as well as aesthetic value. It tilts the transmitter inset into a more sensitive position for normal use.

In spite of the improved performance of the telephone the sidetone level has been maintained at the lowest practical level.

These telephones can be supplied for working to

automatic or C.B. manual exchanges. The automatic telephones are fitted with dials having a speed of 10 impulses per second, and a **break-to-make** ratio of 2 : 1. Dials having other speeds and ratios can be fitted if required.

All components except the dial are mounted on a single baseplate easily accessible for maintenance. The components are suitably finished to withstand wide variations of temperature and humidity.

*from existing plant
in new networks*

**THE ERICSSON
1000
TELEPHONE**



ERICSSON TELEPHONES LTD., 22 LINCOLN'S INN FIELDS, LONDON, W.C.2

You're years ahead.....

with the



RANGER V.H.F. MOBILE

New channelling and specification standards for mobile radio are being introduced in the United Kingdom and many parts of the world. The "Ranger", Pye's latest V.H.F. mobile, has been designed to anticipate these and will, in fact, meet specifications for the next ten years. The Pye "Ranger" therefore combines superlative performance with the maximum technical life. No matter what your channelling requirements the Pye "Ranger" will meet them.

3 amplitude modulated versions are available

W = 100 Kc/s. channelling for aeronautical and multicarrier schemes.

N = 60 Kc/s., 50 Kc/s. or 40 Kc/s. channelling.

VN = 30 Kc/s., 25 Kc/s. or 20 Kc/s. channelling.

The Ranger has been designed to meet the following leading specifications.

U.S. Federal Communications Commission

Canadian R.E.T.M.A.

Canadian Dept. of Transport

British G.P.O. existing and proposed specifications



Pye Corporation of America,
270, Park Avenue, Building A,
New York 17, N.Y. U.S.A.

Pye Limited, Mexico City.

Pye Limited, Tucuman 829,
Buenos Aires, Argentina.

Pye Radio & Television (Pty.) Ltd.
Johannesburg, South Africa.

Pye Canada Ltd., 82, Northline Road,
Toronto, Canada.

Pye Pty. Ltd.,
Melbourne, Australia.

Messrs. Telecommunications,
Jamestown Road, Finglas, Co. Dublin.

Pye Ltd.
Auckland, C.I., New Zealand.

Pye (France) S.A.
29 Rue Cambon, Paris 1er

PYE LIMITED • • CAMBRIDGE • • ENGLAND

Phone : Teversham 3131

Cables : Pyetelecom, Cambridge

RAWLBOLTS

for **SPEED**

and **STRENGTH**

NO COLD CHISELLING !

NO GROUTING IN !

NO WAITING for cement to harden!

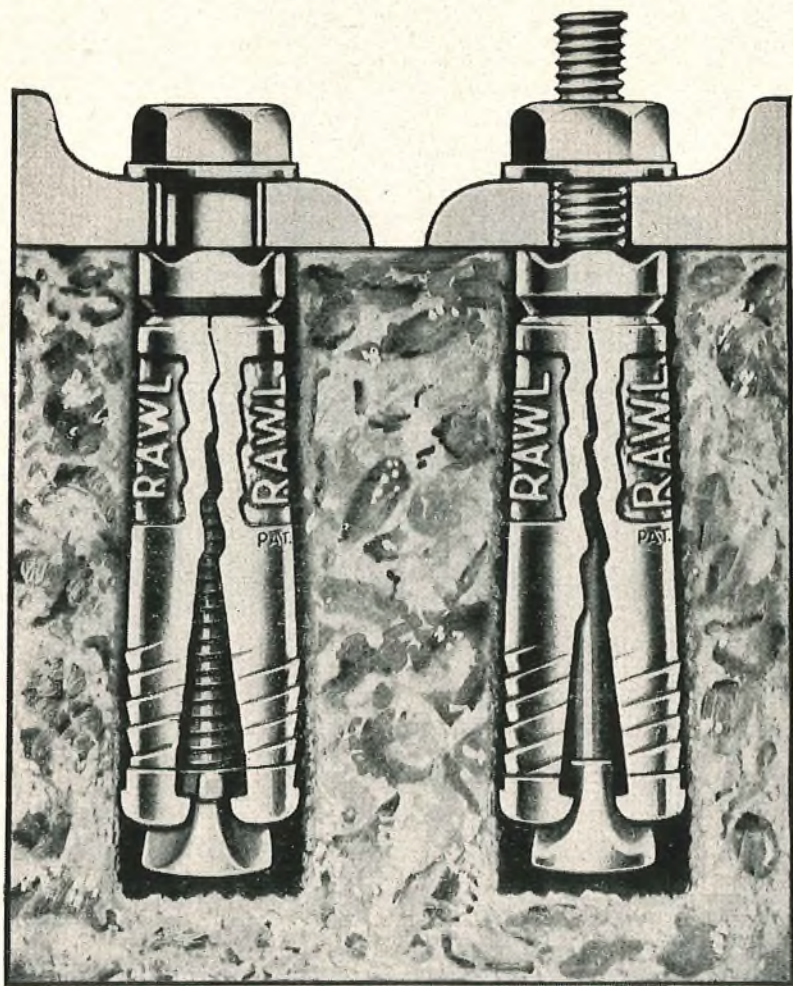

FOR SPEED. If you grout in ragbolts for fixing a machine you have to wait at least *3 days* before this machine can be put into production. If, on the other hand, you use Rawlbolts the machine can be put into production in much less than *3 hours*. Quite apart from this you can move the machine to another position without causing damage to the floor should this subsequently be proved desirable.

FOR STRENGTH. Rawlbolts have earned a sterling reputation for strength and reliability throughout the world—they are used by the million every month. Rawlbolts grip by *expansion*—their strength as a fixing is based on the enormous compressive strength of concrete itself. There are 2 types—as illustrated—loose bolt type shown on left and bolt projecting type on right.

Write now for the latest Rawlplug literature and chart on Rawlbolts and many other time-saving fixing devices.



**THE WORLD'S LARGEST
MANUFACTURERS OF FIXING DEVICES**

TOOLS THAT SAVE TIME. For hole-boring there's a big range of high efficiency Rawlplug tools for use by hand, electric or air power. All are

really tough, long-lasting tools, designed by the world's leading specialists in fixing methods for maximum performance and maximum economy.

THE RAWLPLUG COMPANY LIMITED, CROMWELL ROAD, LONDON, S.W.7

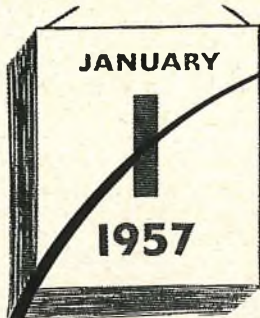

*You'll be
getting your new
Marconi Instruments
Catalogue any
day now!*

If you already have our 1956 catalogue, you will automatically get the 1957 edition in the course of the next week or two. The demand for the catalogue is so great that it makes the task of distribution a fairly lengthy one, so please wait patiently. If you have changed your address, or have any other reason to think your copy may not reach you safely, please let us know. The 1957 catalogue brings the record of Marconi electronic instrumentation in the radio communication and industrial fields up to date and provides a comprehensive survey of all Marconi measuring and test equipment.



Instruments listed include:

AM & FM SIGNAL GENERATORS · AUDIO & VIDEO OSCILLATORS
FREQUENCY METERS · VOLTMETERS · POWER METERS
DISTORTION METERS · FIELD STRENGTH METERS
TRANSMISSION MONITORS · DEVIATION METERS
OSCILLOSCOPES, SPECTRUM & RESPONSE ANALYSERS
Q METERS & BRIDGES

MARCONI INSTRUMENTS LTD · ST. ALBANS · HERTFORDSHIRE · TELEPHONE: ST. ALBANS 56161

London and the South: Marconi House, Strand, London, W.C.2 Tel: COVent Garden 1234

Midlands: Marconi House, 24 The Parade, Leamington Spa. Tel: 1408 North: 30 Albion Street, Kingston-upon-Hull Tel: Hull Central 16347

WORLD-WIDE REPRESENTATION

TC 91

HOT GALVANIZING PREVENTS RUST

ASK ANY ENGINEER ABOUT RUST—he knows its dangers on electrical installations. He also knows that hot galvanizing is the surest means of preventing rust—galvanized pylons for instance have enjoyed rust-free life for 20 years or more. In fact, wherever steel is used . . . in factories and mines, on railways and farms . . . there is no substitute for hot galvanizing. The tenacity and durability of *hot* galvanizing ensure lasting protection with minimum maintenance.

Protection in Depth

Hot galvanizing gives defence in depth. The firmly alloyed zinc keeps out rust—tightly sealing crevices and seams. And if the coating *does* get damaged the steel still won't be attacked because the zinc protects it sacrificially. Hot galvanizing *saves* steel—by eliminating the need for large corrosion allowances and the replacement of rusted parts. Hot galvanizing resists normal atmospheric conditions *twenty times better than steel*.

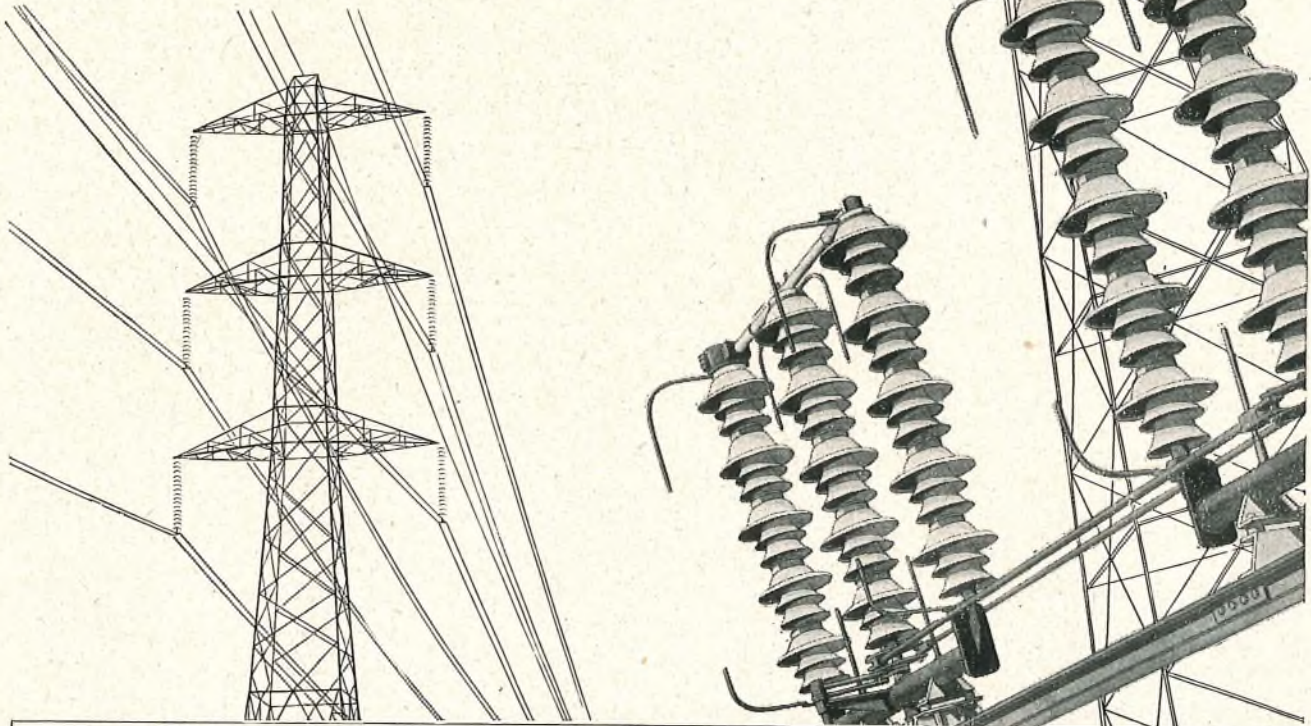

Hot Dip Galvanizers Association

*The Hot Dip Galvanizers Association,
a non-trading body, welcomes enquiries.
Write to 34 Berkeley Square,
London, W.1
Tel. Grosvenor 6636*



Member of the Zinc Development Association



Winners all!

This team of miniature relays has already established many new records for performance and reliability. The development and manufacture of this type of electro-magnetic equipment represents a remarkable advance in relay practice and bears comparison with the finest products of this Company.



M.G. RELAY

Specially designed for electronic and nucleonic applications. High speed. One change-over contact. Glass sealed. Fits standard B.7G base. Exceptionally high endurance.

Dimensions:—

1.625" x .750" DIA



POLARIZED RELAY

Versatile, sensitive and stable. Large winding space. Available with one or two change-over contacts. Dust cover or hermetically sealed. Long or short frame models.

Dimensions:—

Long frame 2.750" x 1.562" x .844"

Short frame 2.375" x 1.562" x .844"



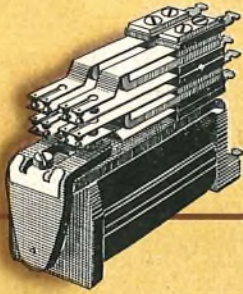

G.P. RELAY

For general purpose applications. Multi-contacts up to 4 units. Open, dust cover or hermetically sealed with normal, heavy duty or low capacitance contacts.

Dimensions :—

Open — 1.546" x 1.109" x .484"

Sealed — 1.768" x 1.288" x .694"

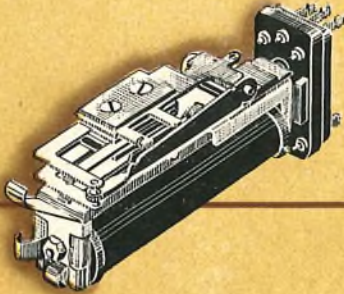

TYPE 1A RELAY

Highly sensitive (10 Milliwatt) non-polarized type with balanced moving system for high 'g' performance. Hermetically sealed with one changeover contact.

Dimensions :—

2.312" x 1.000" x .593"



TYPE 2 RELAY

General purpose type with balanced moving system, in cylindrical metal container. Normal and heavy duty contacts up to 4 change-overs. Hermetically sealed.

Dimensions :—

2.750" x 1.000 DIA.

(2.062" above chassis).



Full particulars are available on request

ERICSSON

TELEPHONES LIMITED

HEAD OFFICE: 22, LINCOLN'S INN FIELDS, LONDON, W.C.2.

TEL: HOL: 6936

WORKS: BEESTON, NOTTINGHAM & SUNDERLAND

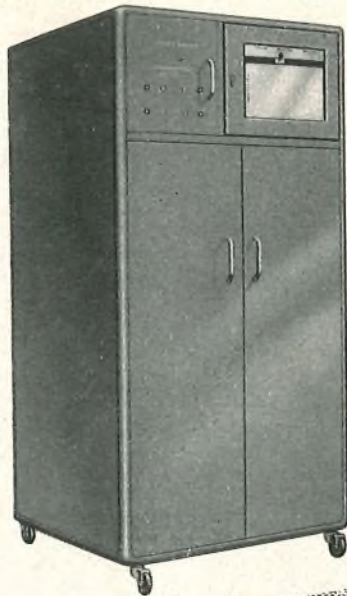

Both ends.....

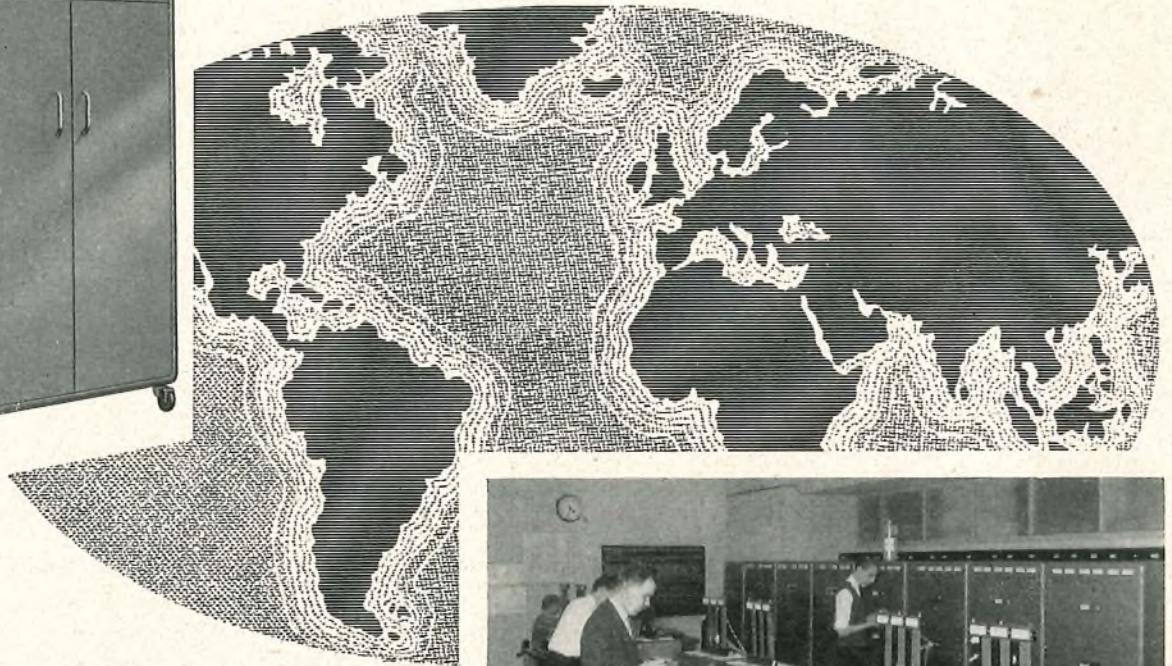

...of the Cable

The universal application of Widney Dorlec Cabinets is well illustrated in these two photographs. The top one is an illustration of an Atmosphere Analyzer Equipment and the other of a complete Telegraph Relay Installation. Both these use Widney Dorlec Cabinets because of their pleasant finish and sound engineering. The Atmosphere Analyzer is manufactured by Harold Kruger Instruments, San Gabriel, California, and the Teleprinter Installation is that of British European Airways, London.



American Agents for Widney Dorlec:—
British Industries Corporation,
80 Shore Road,
Port Washington,
N.Y.

Widney Dorlec

CABINETS · TELESCOPIC MOUNTINGS



HALLAM, SLEIGH & CHESTON LTD., WIDNEY WORKS · BIRMINGHAM 4 · ENGLAND

PHONE: ASTON CROSS 0914. GRAMS: SUPERFINE, BIRMINGHAM

SALES OFFICE: OLDFIELD ROAD · MAIDENHEAD · BERKS. PHONE: MAIDENHEAD 4311

w.d.12.

Perfection in *miniature*

YOU CAN COUNT ON **Hivac** COLD CATHODE TUBES

Continuing development in the field of cold cathode tubes has brought a new

COLD CATHODE TRIODE XC18

This electrically reliable and mechanically robust tube is contained in a 10mm round bulb, 34mms in length $V_{sa} \pm 210V$:
 $V_{ma} \approx 73V$: $V_{st} \approx 68V$.

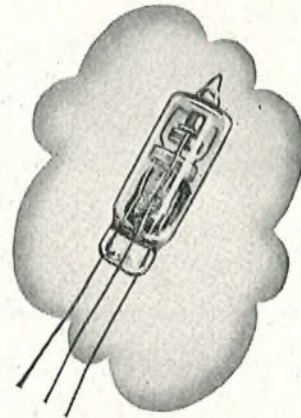

ACTUAL SIZE

DATA SHEET ON REQUEST

Hivac Limited



STONEFIELD WAY

VICTORIA ROAD

SOUTH RUISLIP

MIDDLESEX

Telephone: Ruislip 3366 Cables: HIVAC, RUISLIP

C.8

VIBRATION AND SHOCK ISOLATION

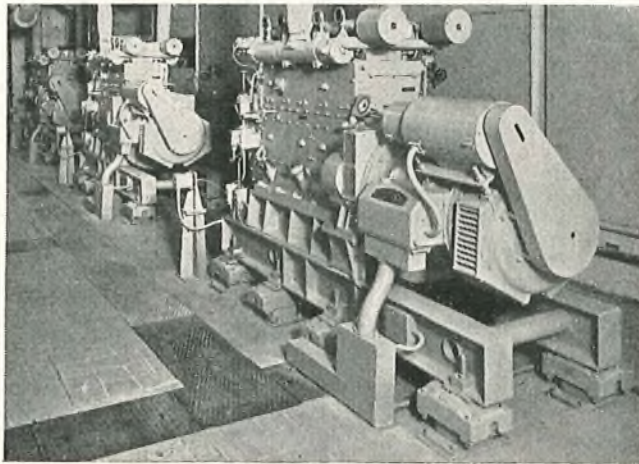

OBAN TRANSATLANTIC
TERMINAL

*Three 5 cylinder
Diesel Engines and
Alternators isolated by type
O.D. steel spring adjustable
antivibration mountings.*

*By courtesy of
H.M. Postmaster-General*

Efficient and economical vibration and shock isolation is primarily dependent upon the selection and correct application of the most suitable material. No single material has the characteristics required for all problems and indiscriminate use can often result in increased rather than reduced transmission.

With the exceptionally wide range of antivibration equipment which we have available and with over 40 years experience in this field we are able to offer a most comprehensive service.

Every problem receives individual consideration and our services include the design of the most suitable arrangement, the provision of fully detailed working drawings, and where necessary, supervision at site and vibration recording.

*Antivibration equipment
supplied by us includes:*

STEEL SPRING UNIT
MOUNTINGS
RUBBER UNIT MOUNTINGS
STEEL SPRING SUSPENSION
SYSTEMS
RUBBER CARPET MOUNTINGS
" CORESIL " CORK PLATES
CORK/RUBBER, FELT AND
OTHER RESILIENT MATERIALS
*Literature will be forwarded
on request.*

W. CHRISTIE AND GREY LIMITED, VIBRATION ENGINEERS
4 LLOYDS AVENUE, LONDON, E.C.3. Telephone : ROYal 7371 (3 lines). Telegrams : Typhagitor, Fen, London.



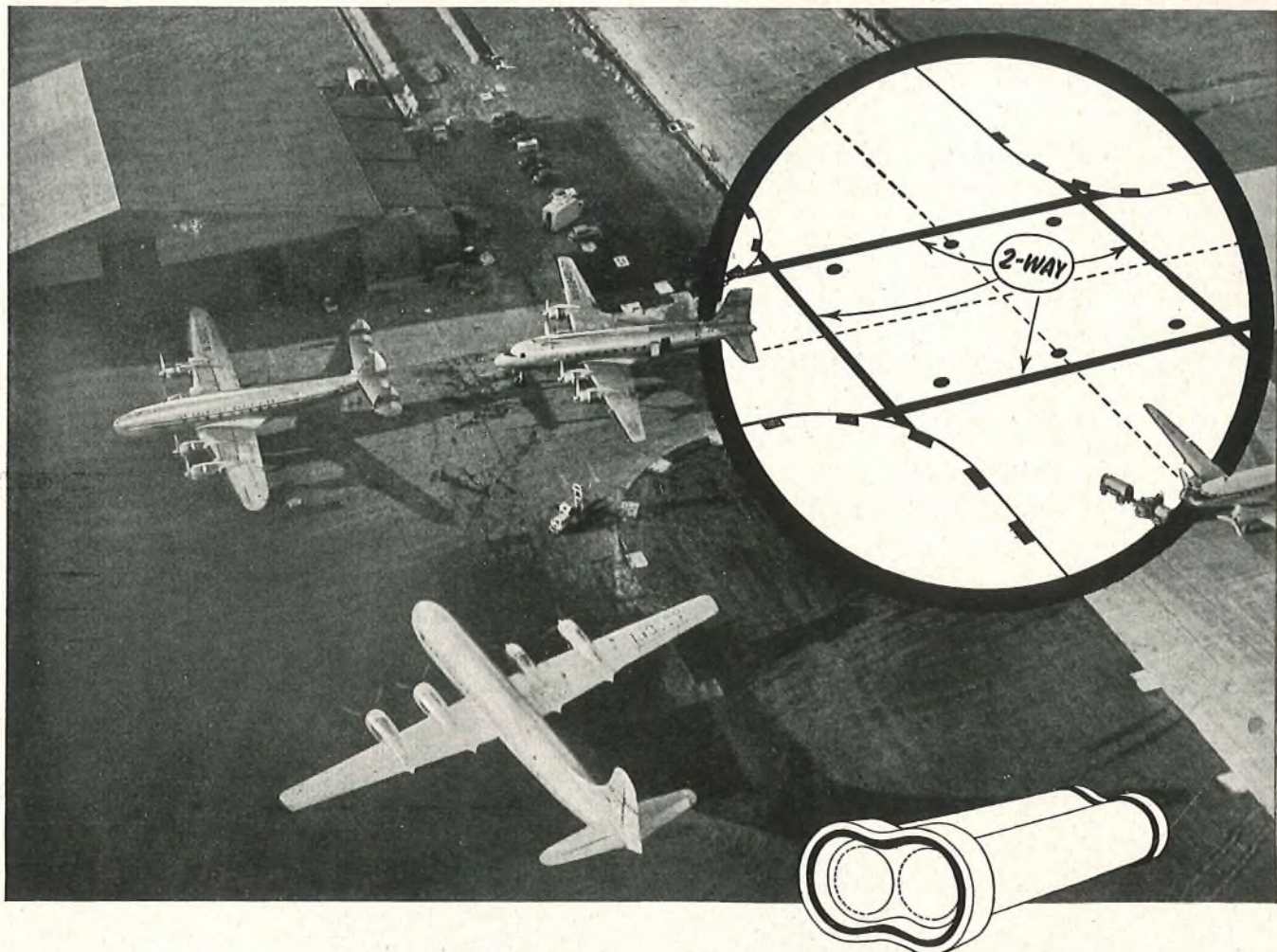

Under an Airport Runway

***If you never
want to have
to dig them
up again
put down***

This is a key point in an airport runway pattern. You lay electric cables under here, to serve the runway lights. Those cables must be easy to get at, easy to service. So you run your cables through conduits — in this case 2-way conduits.

If anything goes wrong with those conduits, if they have to come up again — think of the chaos. Think what would happen at a big airport. Last year in *August alone* London Airport handled nearly 12,900 aircraft and 402,900 passengers. A lot depends on those conduits — you never want to have to dig them up again.

That's why, at London Airport, they put down conduits of salt glazed vitrified clay.

Salt glazed conduits are glassy smooth and hard as nails. They are acid-resisting. Sulphates in the soil cannot corrode them. They go down for good! The same applies to the hundreds of salt glazed *drainpipes* that are out there too. Safe and efficient, salt glazed conduits and pipes can — and do — stay down for centuries.

Salt Glazed



pipes and conduits

NATIONAL SALT GLAZED PIPE MANUFACTURERS' ASSOCIATION

ADCOLA

PRODUCTS LIMITED
(Regd. Trade Mark)

FOR
**SOLDERING INSTRUMENTS
and EQUIPMENT**
SUPPLIED FOR ALL VOLTAGES

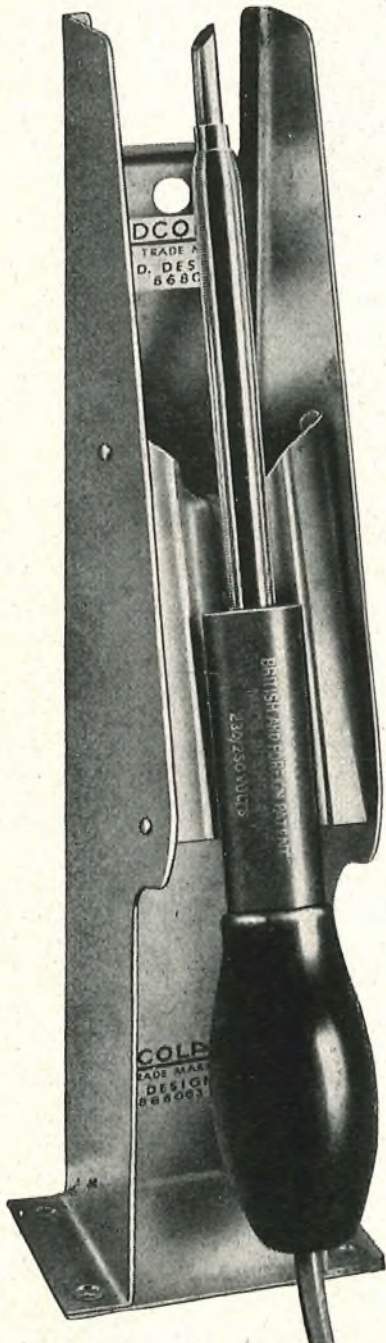

illustrated

**DETACHABLE
BIT
MODEL $\frac{3}{16}$ "**

List 64

**PROTECTIVE
SHIELD**

List 68

Write for Catalogues.....

HEAD OFFICE, SERVICE AND SALES

ADCOLA PRODUCTS LTD.
GAUDEN ROAD, CLAPHAM HIGH STREET, LONDON, S.W.4
Phone: MACaulay 3101, 4272

ANACOS
REGD.

for the
right
connection

telephone
line
wire

FREDERICK SMITH & COMPANY
ANACONDA WORKS, SALFORD, 3, LANCS.
*Incorporated in The London Electric Wire Company and Smiths Limited.
Associated with The Liverpool Electric Cable Co. Ltd. and Vactite Wire Co. Ltd.*

PASS YOUR CITY & GUILDS CERTIFICATES AND P.M.G. CERTIFICATE

We offer comprehensive home training in a wide range of subjects, including P.M.G. Certificates, City and Guilds Grouped Certificates in Telecommunications, A.M.Brit.I.R.E. Examination, Radio Amateur's Licence, Radio and Television Servicing Certificates, General Radio and Television Courses, Radar, Sound Recording, etc. Also Courses in all other branches of Engineering.

With the following Courses, Practical Kits are available.

Radio, Television, Mechanics, Electricity, Chemistry, Photography, Carpentry; also Draughtsmanship, Commercial Art, Amateur S.W. Radio, Languages, etc.

Write now

for FREE BROCHURE stating subjects of interest to:

E.M.I. INSTITUTES

Dept. 97, GROVE PARK ROAD, LONDON, W.4

An Educational Organization serving the E.M.I. Group of Companies, including

"HIS MASTER'S VOICE", MARCONIPHONE, COLUMBIA, etc.

10.64 1/57

Bespoke and Off the Peg



We can supply, economically, standard types of automatically controlled generating plant that fit many of those jobs in which reliability and continuity of supply are essentials. But our *forte* is tailor-made equipment. Sizes? 1.4 to 250 kVA. Quality? Savile Row. We like the problems other people can't fit. The more difficult they are the better we like them. We are, in short, selling experience and brains as much as generating plant. Austinlite stands for an unbroken flow of power, not some rigid pattern of generator and diesel engine on a base. Where this utter reliability of the power supply is an essential our engineers are prepared to go anywhere in the World to discuss the best means of providing it. And our erecting teams will follow them to get the plant running.

Austinlite

AUTOMATIC GENERATING PLANT

Tailor-made by STONE-CHANCE LTD.

They did it this way -
-in 1900!



Photograph by courtesy of British Insulated Callender's Cables Ltd.

It's 1957 - time to get the...

ROLL-A-DRUM

SUPPORTS CABLE DRUMS
WITHOUT JACKS

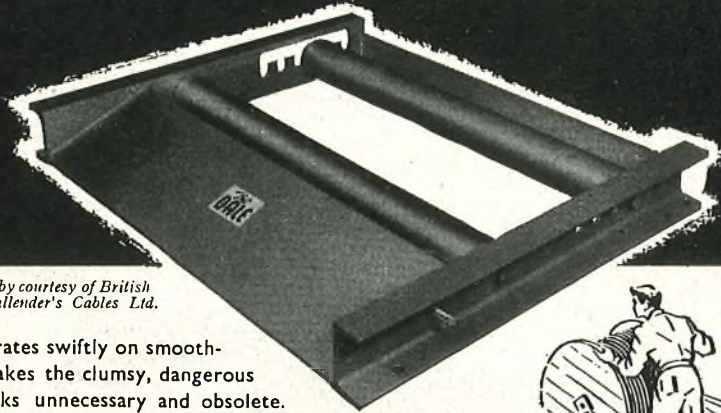

The Roll-A-Drum operates swiftly on smooth-running rollers from ground level. It makes the clumsy, dangerous old method of hoisting cable drums on jacks unnecessary and obsolete.

Only £11. 10s. or £23 according to size. Details of discounts and full information from:



ELECTRIC (YORKSHIRE) LIMITED

ELECTRICITY BUILDINGS, FILEY, YORKS. Tel: 2301 (3 lines)



ZEVA

Electric

SOLDERING TOOLS

for SPEED, ECONOMY
and BETTER WORK

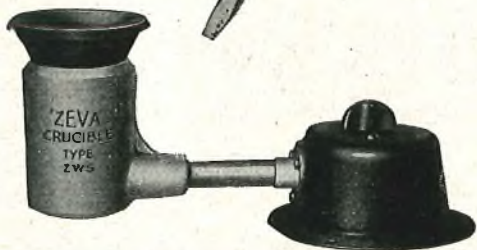

The news that this famous range of Soldering Irons and Crucibles is again available has been welcomed in numerous branches of industry everywhere. Zeva Tools are unquestionably without equal for efficiency, economy and trouble-free long life.

- ZEVA heating elements never need renewal. They last the life of the tool.
- ZEVA Irons can be left switched on all day without detriment to the tool.
- ZEVA current consumption for rated temperature is less than any other make of tool.
- ZEVA initial cost is the only cost.
- ZEVA Irons are guaranteed.

Write for complete
Illustrated Catalogue:—

THE AUTOMATIC COIL WINDER & ELECTRICAL EQUIPMENT CO., LTD.
Avocet House, 92/96 Vauxhall Bridge Road, London, S.W.1
VICtoria 3404 (9 lines)

Z1/P2/ZWS



CONVERTERS

MODEL 2201

FOR CONVERSION OF MORSE CODE OR CABLE CODE PERFORATED TAPE TO 5-UNIT SIGNALS OR 5-UNIT PERFORATED TAPE AT TELEPRINTER SPEED

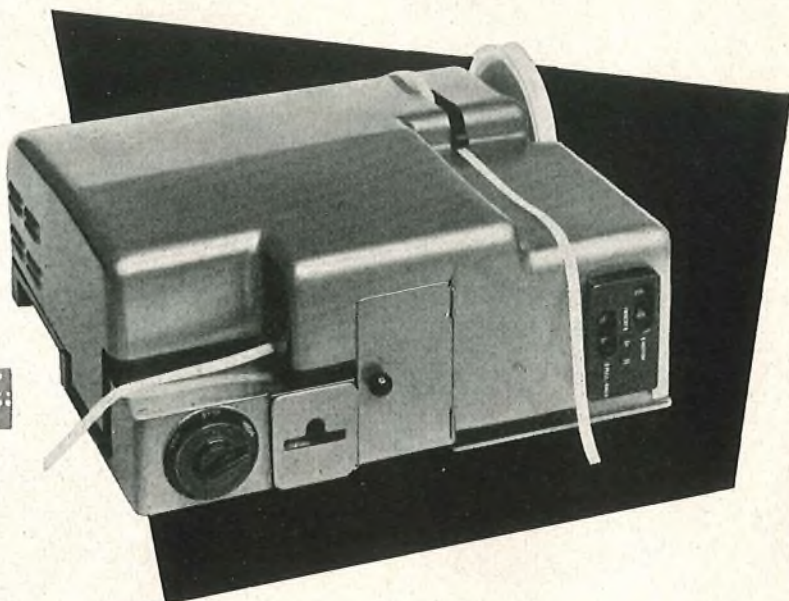
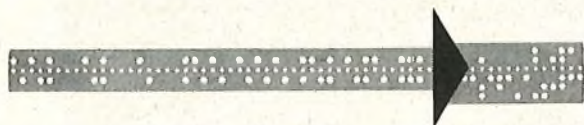

DIMENSIONS: 23" x 21" x 10"

MODEL 2206

FOR CONVERSION OF 5-UNIT PERFORATED TAPE TO MORSE CODE OR CABLE CODE PERFORATED TAPE, AT THE RATE OF 650 CHARACTERS PER MINUTE

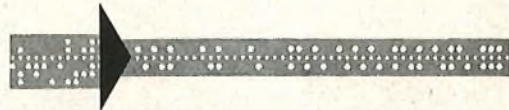
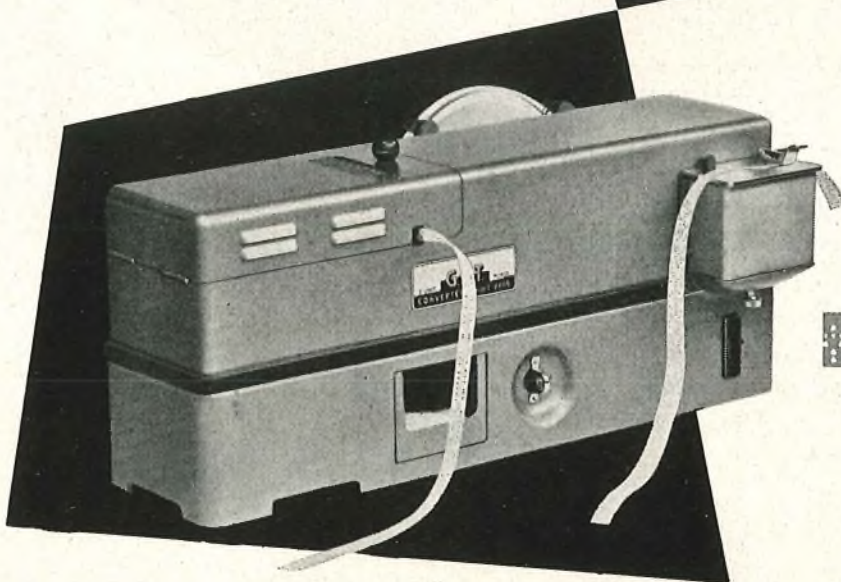

DIMENSIONS: 26" x 12" x 12"

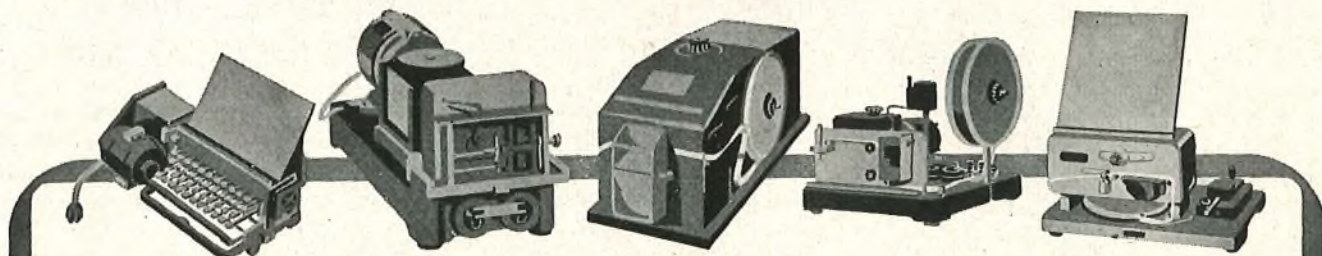

GREAT NORTHERN TELEGRAPH WORKS

DIVISION OF THE GREAT NORTHERN TELEGRAPH CO. LTD.

4, SYDHAVNS PLADS
COPENHAGEN SV, DENMARK

LONDON OFFICE: 5, ST. HELEN'S PLACE
LONDON E. C. 3.

Are **DESULPHOVIBRIO** **DESULPHURICANS** *eating your steelwork?*

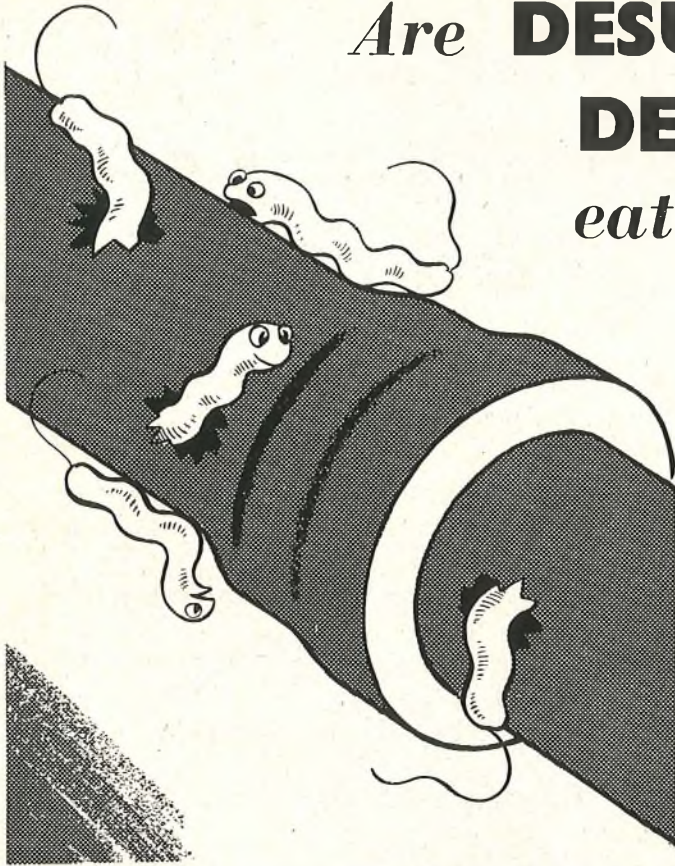

Well, we know they don't literally eat steelwork, but it's a recognised fact that these horrible little bacteria are responsible for the majority of underground corrosion.

It has recently been established that TANNINS are one of the most effective ways of rendering them inactive. After considerable experiment and testing, we have found a suitable method of incorporating the most effective tannins in our DENSO TAPES, and so greatly increasing their already considerable value in the fight against corrosion.

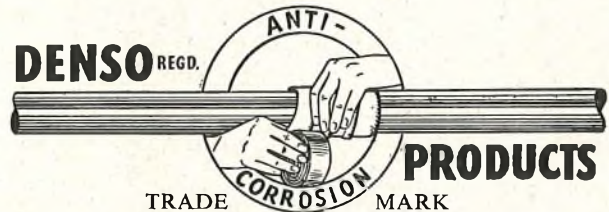

Write for further details to:—

WINN & COALES LTD.,
DENSO HOUSE, CHAPEL ROAD, LONDON, S.E.27
Telephone: GIPsy Hill 4247 (4 lines)

IMPROVEMENT IN THE ACCURACY OF DECADE RESISTANCES

We have pleasure to announce that the well-known and novel

SULLIVAN and GRIFFITHS

DUAL DIAL DECADE RESISTANCE BOXES

FOR ALL FREQUENCIES

Moreover, the windings are now of Manganin in order to reduce the temperature coefficient; more important still, to improve the long period of stability and make them as suitable for all direct-current purposes as they are for alternating currents of all frequencies.

Screened Resistances of guaranteed accuracy exactly similar to our well-known Decade Resistances but specially arranged so that one box of a given number of dials gives many different values of maximum resistance. Thus a three-dial box (as illustrated) may be used for instance for

three decades of Thousands, Hundreds and Tens	a total of 10,000 ohms.
or three decades of Hundreds, Tens and Units	a total of 1,000 ohms.
or three decades of Tens, Units and Tenths	a total of 100 ohms.
or three decades of Units, Tenths and Hundredths,	a total of 10 ohms.

have now been improved in accuracy to

0.05 PER CENT

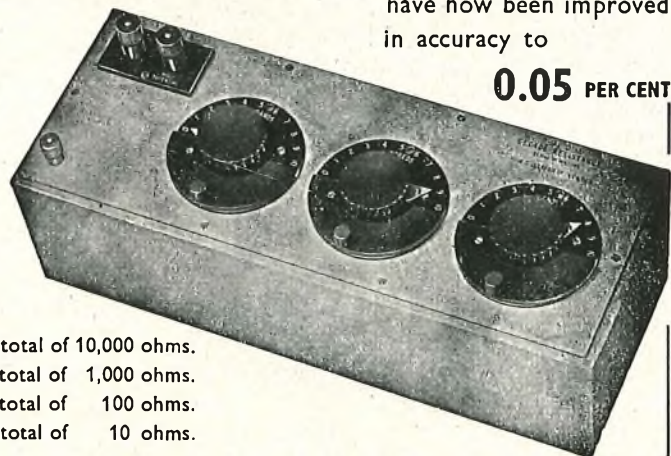

H. W. SULLIVAN LIMITED

LONDON, S.E.15

Telephone: New Cross 3225 (P.B.X.)

The advantages of such a system will be obvious, for in addition to the economy involved much space is saved and the residual resistance and inductance is much reduced.

The resistances are available in 3-dial, 4-dial and 5-dial types with subdivision of 0.001% down to 0.001 ohm if necessary, depending of course on the number of dials incorporated.



AND THE

TRANS-ATLANTIC TELEPHONE CABLE PROJECT

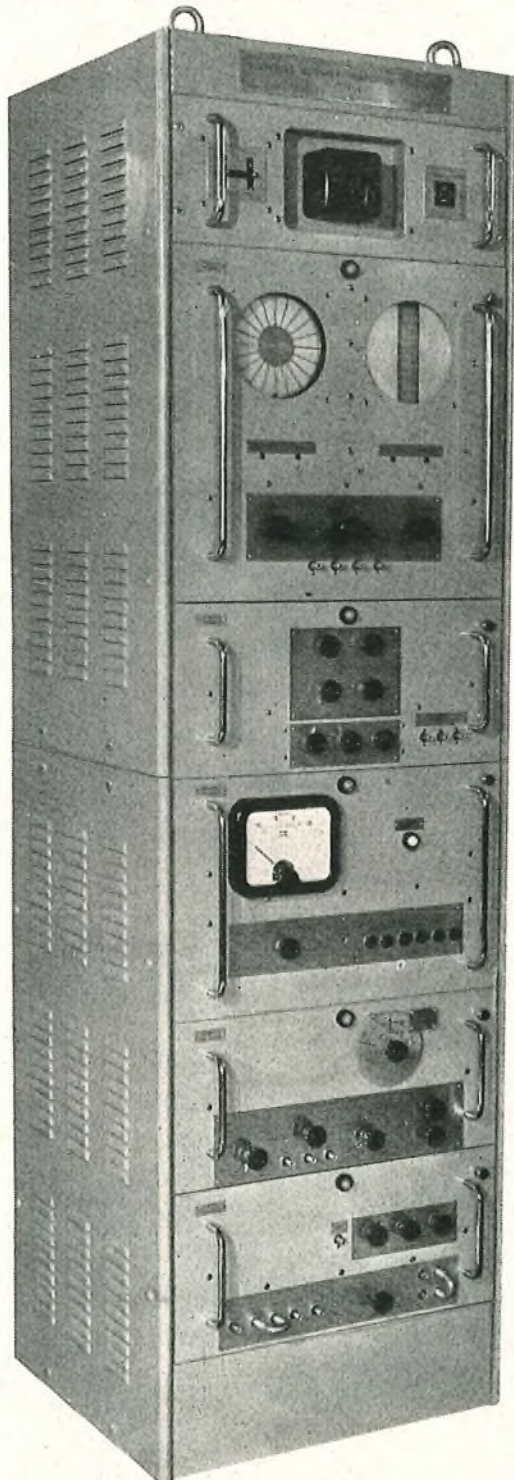

AIRMEC are proud to have been of assistance in providing a telephone service across the Atlantic.

One of the many Airmec equipments used on this project was the Submerged Repeater Monitoring Equipment illustrated on the left which was engineered and manufactured in close collaboration with the Research Branch of the General Post Office.

The very high standard of design and workmanship required for this project is of course a normal feature of every electronic equipment that we manufacture. That is why all the most prominent users of instruments specify AIRMEC automatically.

If you are not already on our Mailing List please write for full catalogue immediately—it will be sent to you without delay.

AIRMEC HIGH WYCOMBE, BUCKINGHAMSHIRE, ENGLAND

L I M I T E D

Telephone: High Wycombe 2060.

Cables: Airmec, High Wycombe

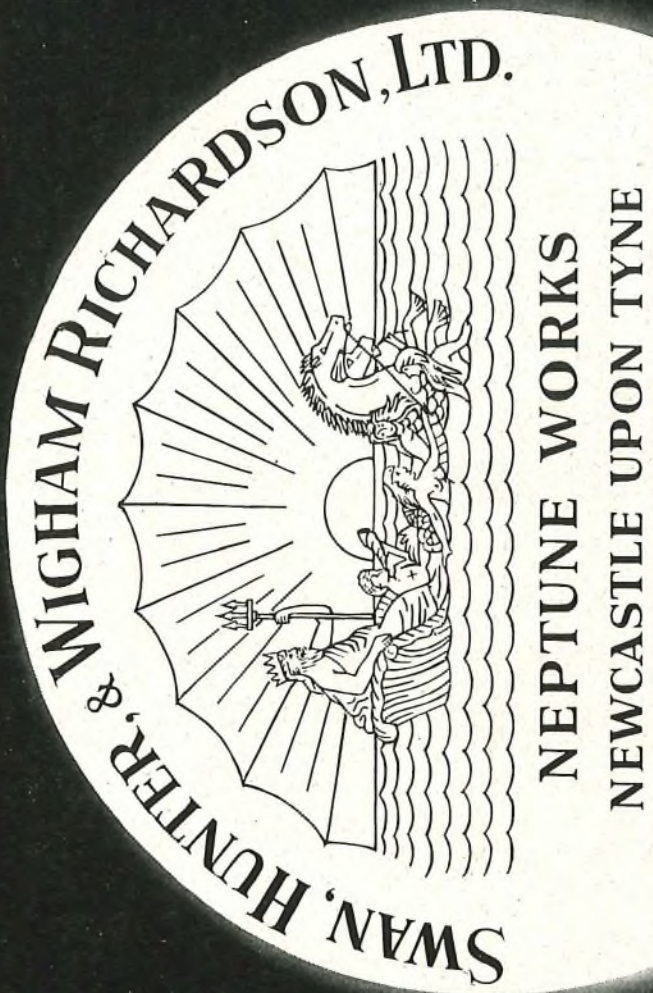

- MARIE LOUISE MACKAY 12
- DOMINIA 13
- ARIEL 14
- IRIS 15
- BULLFINCH 16
- ST. MARGARETS 17
- BULLFROG 18
- BULLHEAD 19
- MONARCH 20
- EDWARD WILSHAW 21
- STANLEY ANGWIN 22
- RECORDER 23

- 1 COLONIA
- 2 PATROL
- 3 CAMBRIA
- 4 GUARDIAN
- 5 TELCONIA
- 6 LORD KELVIN
- 7 MONARCH
- 8 EMILE BAUDOT
- 9 ALERT
- 10 ALL AMERICA
- 11 JOHN W. MACKAY

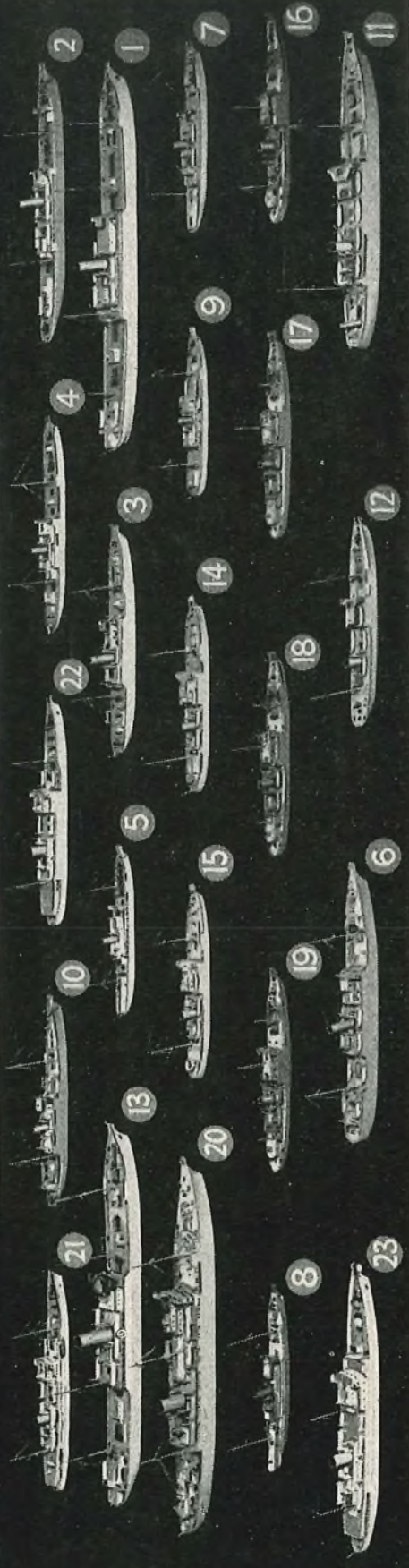

A FLEET OF CABLE SHIPS BUILT AT NEPTUNE WORKS

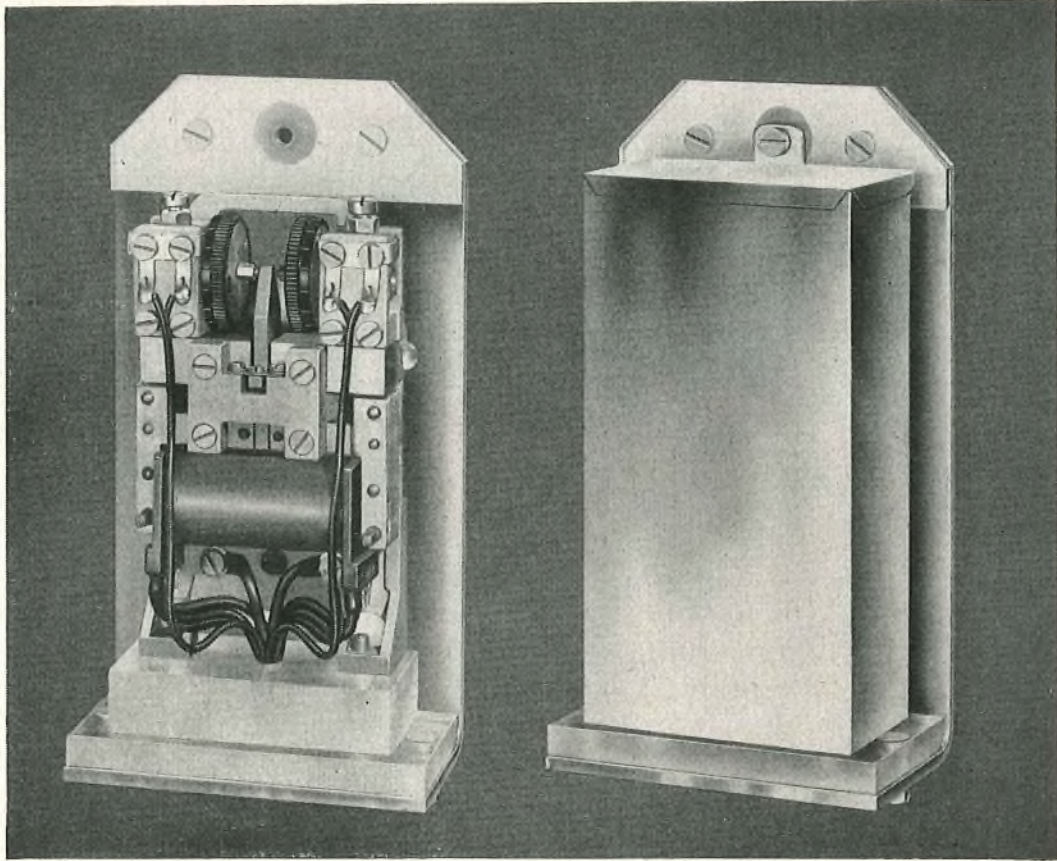

Submerged Repeaters

and the

CARPENTER POLARIZED RELAY

RELIABILITY—the watchword of submarine telephone cable operation, is also that of the Carpenter Polarized Relay—which is why the British Post Office, and other telephone Administrations choose it for use in submerged Repeaters.

Of course it is no ordinary relay that is used—although it is, in fact, only a variation of the standard Type 3 Telegraph Relay.

But since it must maintain its adjustment and function satisfactorily for at least 20 years *without attention*, obviously some modifications to the design were made involving the use of specially mounted solid platinum contacts—doubly locked contact adjusting

screws supported on Mycalex blocks—and duplicated connections throughout.

It is, admittedly, a specialized model, but the engineering skill applied to its development also produced the Type 4 Carpenter Relay, the impulsing element chosen by the British Post Office for use in its VF dialling and Telex circuits—and this same skill is being continuously devoted to the production of the other types of the relay available to, and extensively used in, the Telecommunications, Electronic and Electrical industries.

There is, in fact, a very useful range of Carpenter Polarized Relays suitable for a wide variety of needs—to learn more about them write for details to:



TELEPHONE MANUFACTURING CO. LTD

Contractors to the Governments of the British Commonwealth and other Nations

HOLLINGSWORTH WORKS · DULWICH · LONDON S.E.21
TELEPHONE: GIPSY HILL 2211 · CABLES: BUBASTIS LONDON

TRANSATLANTIC TELEPHONE CABLE

15 Automatic Voltage Regulators

supplied by

FOSTER
TRANSFORMERS LTD.

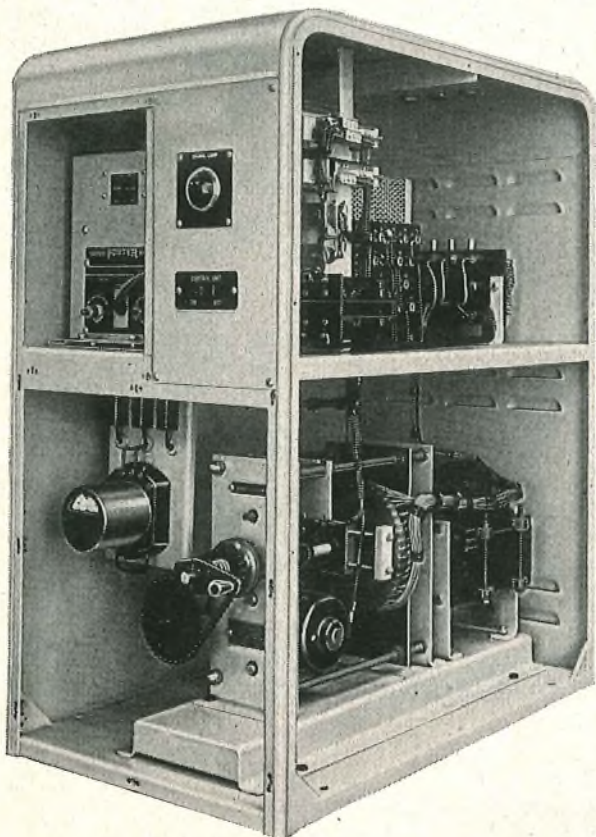

Foster Voltage Regulators have for a number of years been closely associated with telecommunications networks both in this country and abroad and it is with great pride that we are able to associate ourselves with such an outstanding achievement as the Transatlantic Cable project.

Illustrated is one type of Automatic Voltage Regulator which has been installed in Newfoundland and Canada.

The changeover cubicles are provided for switching spare regulators to either of two distributions.

Whilst these equipments are built strictly in accordance with British G.P.O. requirements, they nevertheless incorporate the basic principles of our standard Voltage Regulators which are in use in many varied types of installation all over the world.

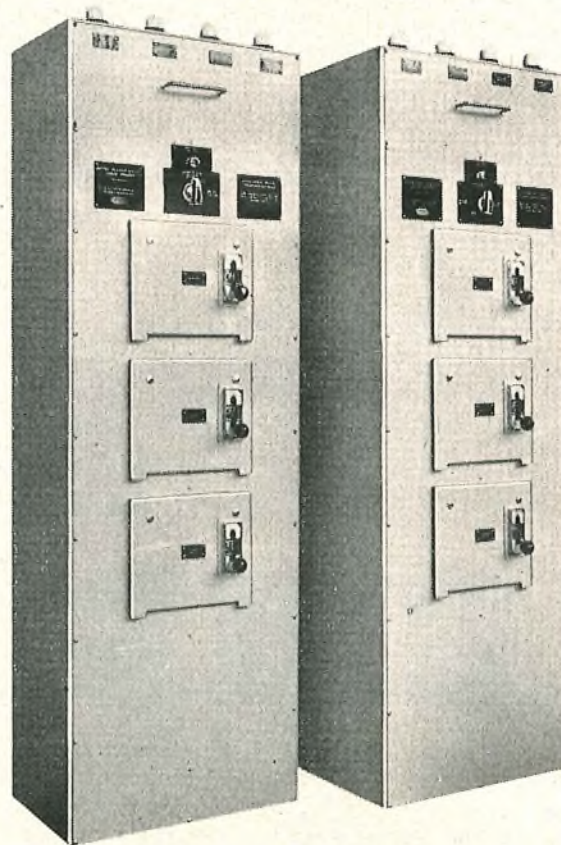

FOSTER TRANSFORMERS LTD., SOUTH WIMBLEDON, LONDON, S.W.19

A 'LANCASHIRE' DYNAMO HOLDINGS' COMPANY

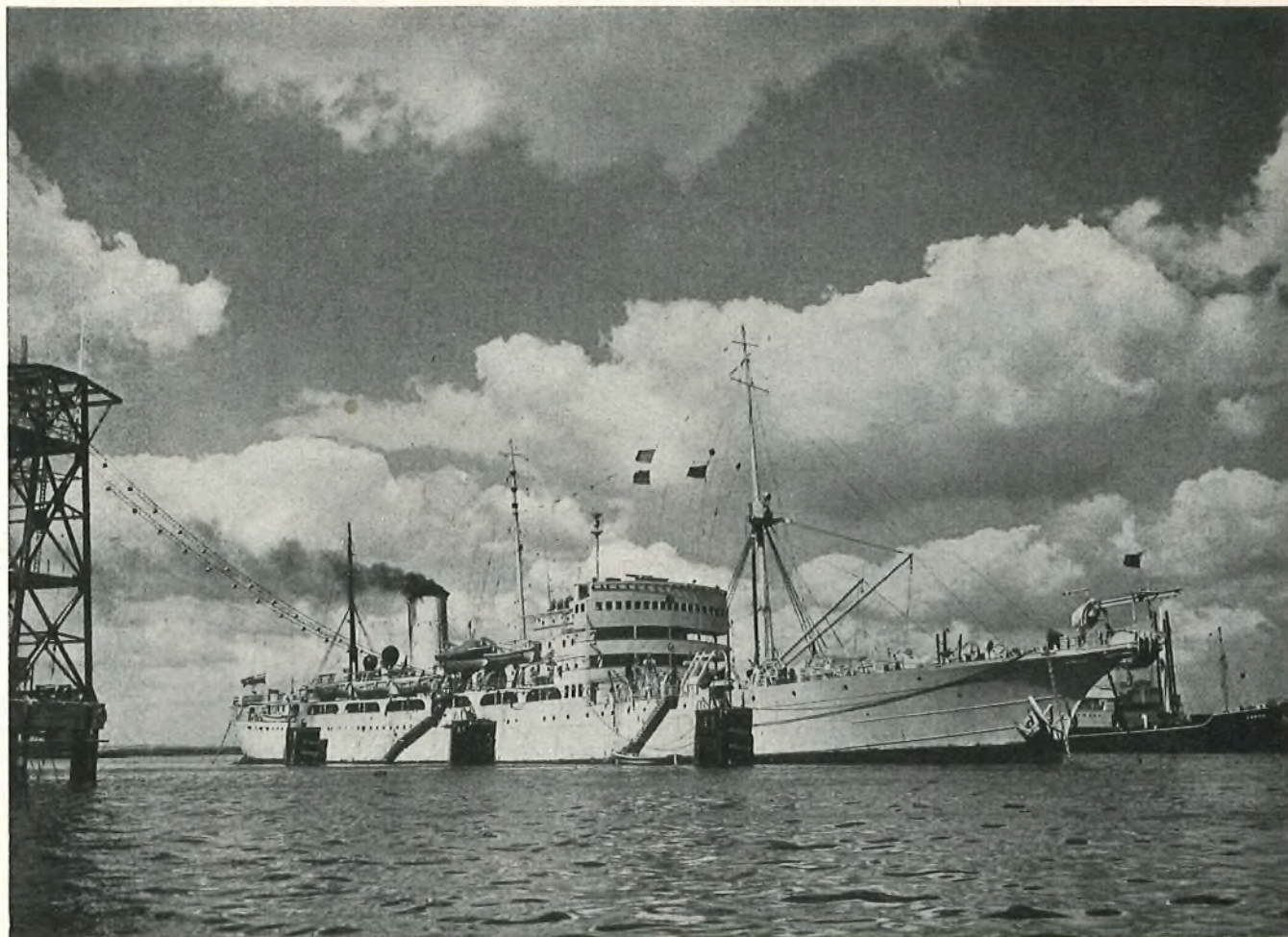

The **TRANSATLANTIC TELEPHONE CABLE**

Our part in this historic engineering achievement was a small one, but we are none-the-less proud of our association with such an achievement, and we feel it a great tribute to the reliability of our products that Erie solid carbon resistors were selected by the British Post Office, and by Standard Telephones & Cables Limited, for use in the British 2-way repeaters, designed to operate continuously for a minimum period of twenty years.

ERIE ★ *Electronic Components*

ERIE RESISTOR LIMITED · CARLISLE ROAD · THE HYDE · LONDON · NW9 · ENGLAND



LISTER

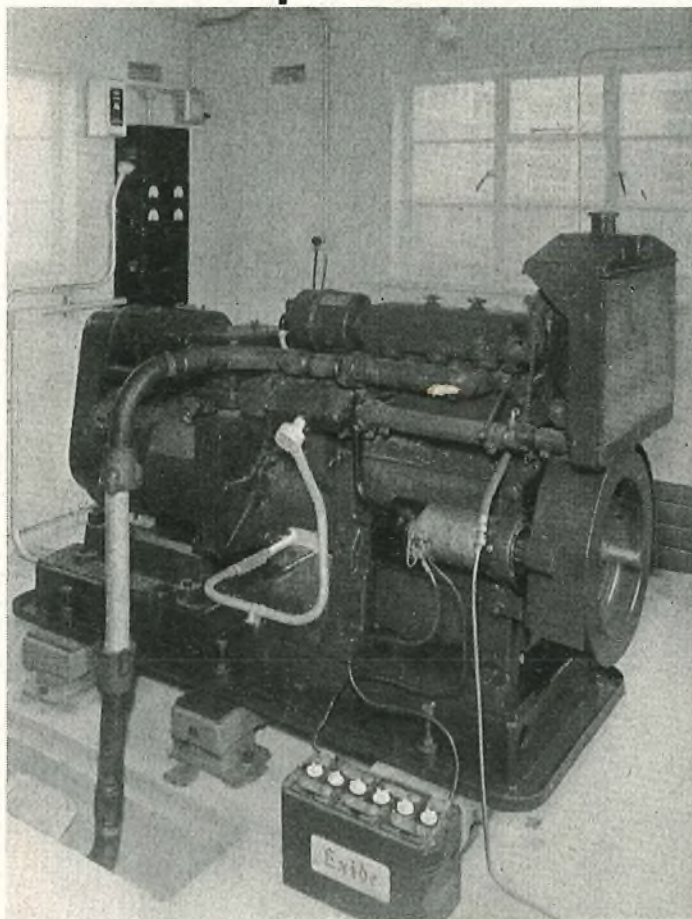

Lister Blackstone Generating Equipment from 1½ to 410 Kilowatts for all purposes and systems of operation.

Generating Equipment

R. A. LISTER & COMPANY LIMITED
DURSLEY GLOUCESTERSHIRE · Phone Dursley 2371.
London Office: Imperial House, Kingsway, W.C.2. Phone: TEMple Bar 9681

**We handled
this job**

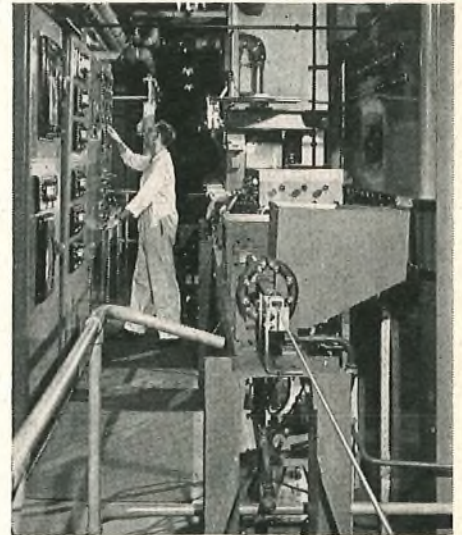

The central copper conductor passes through this extruder to receive an insulation of polythene mixture.

**in white
silk gloves**

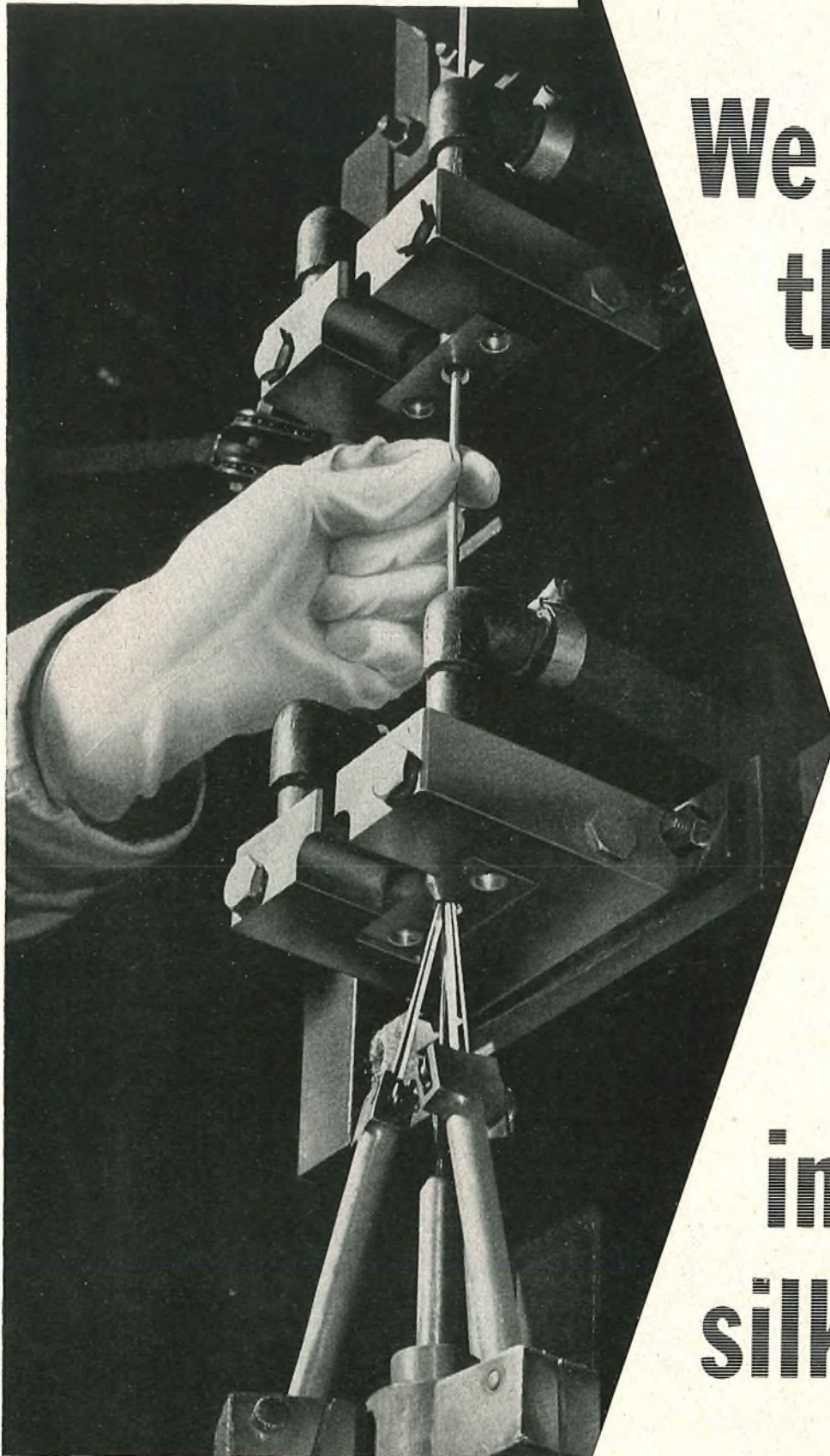

This operator wears white silk gloves to handle the central copper conductor, so as to eliminate all risk of contamination.

The First Transatlantic Telephone Cable.

4,200 nautical miles of the world's most rigidly specified cable ; 92 per cent. of the needs of the first Transatlantic telephone link. It was our job to make it ; and it was a job that we handled—literally and metaphorically—in white silk gloves.

This cable had to be perfect. So in a factory built and equipped specially for the purpose, we tested and re-tested as never before ; by X-ray photography, fluoroscope, tensile machine and high tension current, by every method known to us and the world. Those 4,200 nautical miles were completed in less than two years ; every inch is as near perfection as is known in submarine telephony, here or anywhere in the world.

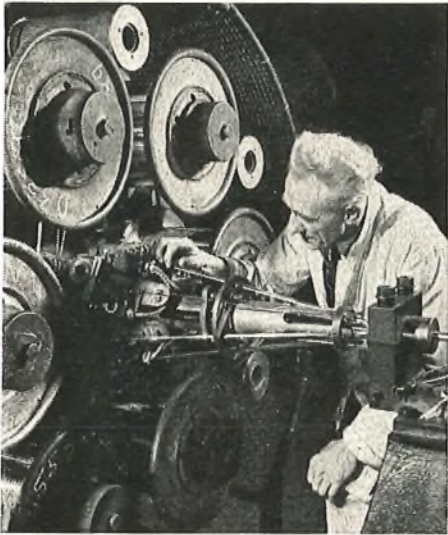

This machine applies to the insulated conductor in one operation the copper return tapes and the jute bedding for the armouring wires.



Storage tanks—each of which holds 200 miles of finished cable—showing troughs containing flexible repeaters spliced into the cable.



HMTS Monarch takes aboard the last section at our Erith works.

We are proud of this achievement on two counts. First, because we were entrusted with so large and responsible a part in the project ; second, because we finished it to our own satisfaction.

SUBMARINE CABLES LIMITED

MERCURY HOUSE, THEOBALD'S ROAD, LONDON, W.C.1

A Company owned jointly by

Siemens Brothers & Co. Limited and The Telegraph Construction & Maintenance Co. Ltd.

HIGH EFFICIENCY POT CORES

CAN NOW BE ADJUSTED ... AFTER MOUNTING
OVER AN AVERAGE RANGE OF 10%
WITH A SETTING ACCURACY OF .5%

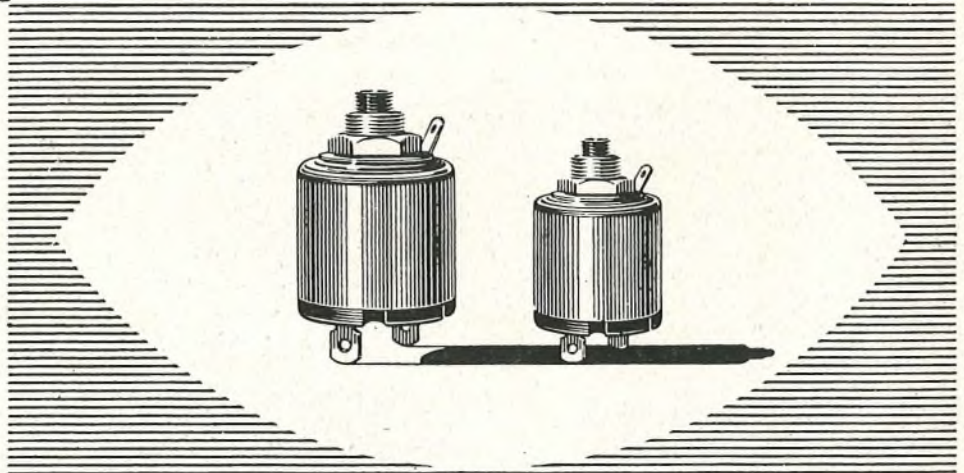

These new Mullard 14mm and 18mm pot cores are completely self contained, simple to mount and easily adjusted after mounting. Unique features include single hole fixing and two or four way terminal plates. Adjustments of inductance are made by means of a screw which varies the position of a magnetic shunt in the centre of the core; in many cases this eliminates the need for trimming capacitors. Designers will see from the brief characteristics listed here that Mullard adjustable pot cores are particularly suitable for use in high grade communications equipment, tuned circuits and filter networks. Those requiring further technical details are invited to write to the address below.

14mm Pot cores

Four types available..... LA32 — 35
Air gaps..... From 0.2mm — 0.5mm
Frequency range..... 10 Kc/s — 100 Kc/s
Q values in the higher frequency range... > 200

18mm Pot cores

Four types available..... LA42 — 45
Air gaps..... From 0.3mm — 1.0mm
Frequency range..... 10 Kc/s — 100 Kc/s
Q values in the higher frequency range... > 300

Mullard



'Ticonal' permanent magnets
Magnadur ceramic magnets
Ferroxcube magnetic cores

MULLARD LTD • COMPONENT DIVISION • MULLARD HOUSE • TORRINGTON PLACE • W.C.1

MC 253a

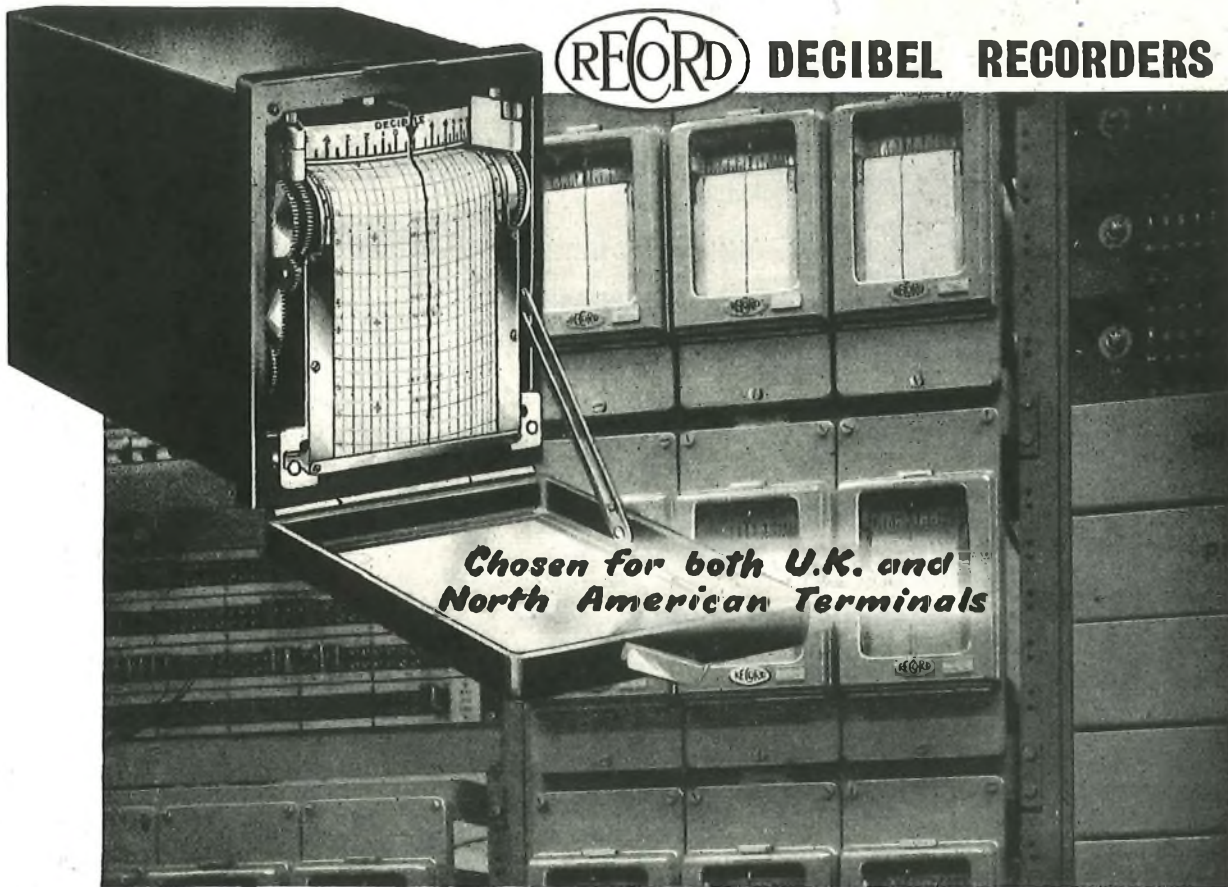

By courtesy of H.M. Postmaster General.

THE RECORD ELECTRICAL CO LIMITED ALTRINCHAM · CHESHIRE · ENGLAND



The

DETECTOR No. 4 Mk. 10

—a TURNER instrument produced for Post Office engineers and combining a high level of sensitivity with accuracy and robust design for work in the field.

**ERNEST TURNER ELECTRICAL INSTRUMENTS LTD.
HIGH WYCOMBE BUCKS ENGLAND**

Telephone: HIGH WYCOMBE 1301-2-3

Telegrams: GORGEOUS, HIGH WYCOMBE

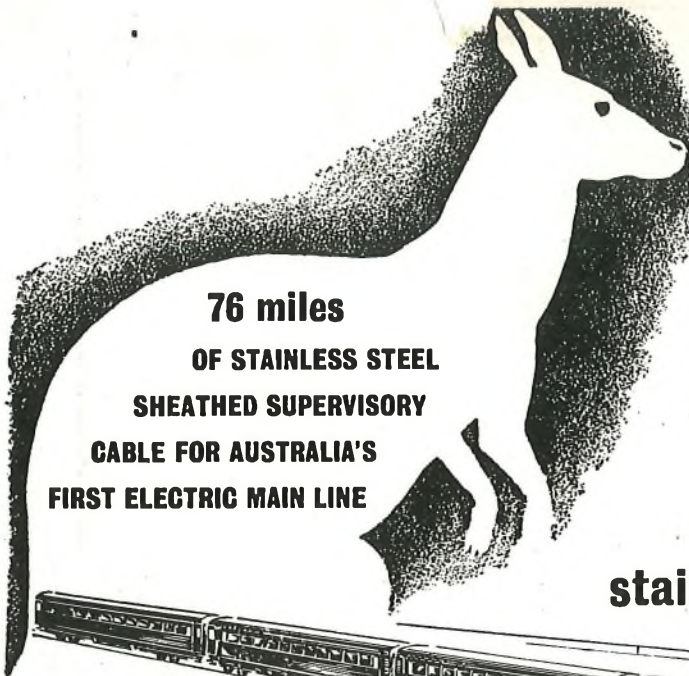

76 miles
OF STAINLESS STEEL
SHEATHED SUPERVISORY
CABLE FOR AUSTRALIA'S
FIRST ELECTRIC MAIN LINE

The first main line electric railway in Australia now extends 98 miles from Melbourne to Traralgon, in the Gippsland District of Victoria. Power for the Gippsland line is taken from the State Electricity Commission's 22,000 volt system at four supply points and converted to 1,500 volt direct current at 16 sub-stations, spaced about 5½ miles apart. All sub-stations and tie-stations are unattended and are connected by a 76-mile long, stainless steel sheathed supervisory cable to the electrical depot at Warragul, where the power engineer has, at his finger tips, the control of any sub-station or tie-station and any 22,000 volt, 1,500 volt or 2,200 volt circuit breaker on the system between Narre Warren and Traralgon. The supervisory cable, which is suspended from the R.S.J. pillars supporting the overhead construction, is completely self-supporting by virtue of the austenitic stainless steel sheath which also possesses excellent corrosion resistance. The cable contains fourteen pairs of wires; 3 pairs being used for the control of various groups of sub-stations and tie-stations, the remainder for feeder switch-gear protection.

PIRELLI-GENERAL
stainless steel sheathed cables

An original Pirelli-General development

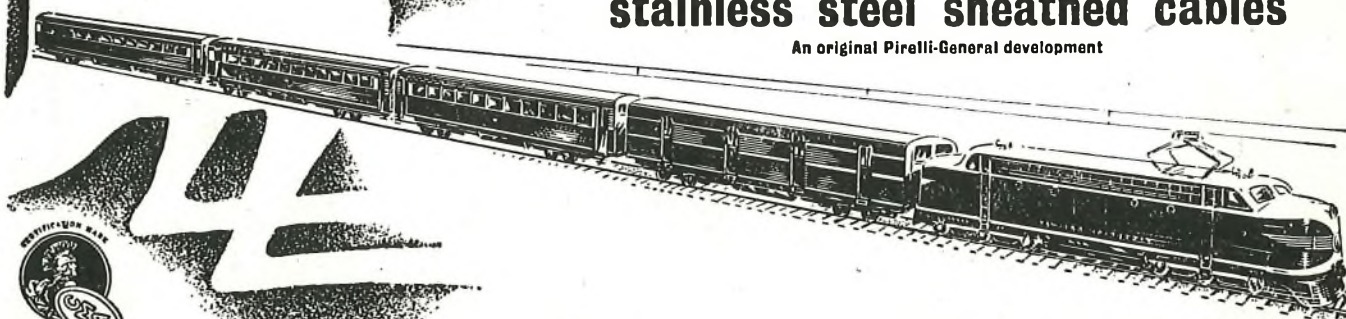

PIRELLI-GENERAL CABLE WORKS LTD., SOUTHAMPTON. Associated Company of the General Electric Co. Ltd

The
TRANSATLANTIC
Cable

WESTALITE rectifiers play an important part in the Glasgow to Oban Section of the Transatlantic Cable system. Repeater stations at Kirkintilloch, Uddingston and Inveraray are equipped with WESTALITE combined charge and float rectifiers for maintaining the motor batteries of the continuity set. The illustration is of the charger installed at Uddingston and is typical of WESTALITE rectifiers for this particular application.

Also, a Westinghouse magnetic discriminator operates a pen recording system, which monitors the H.T. current supplied to the submerged repeater equipment.



Write for details of our rectifiers for telecommunication systems to:

Dept. P.O. 1

WESTINGHOUSE BRAKE & SIGNAL CO. LTD., 82 York Way, King's Cross, London, N.1 **TERminus 6432**

